

Keysight Technologies

Precise VCO Characterization using the B2962A Low Noise Power Source

Keysight B2961A/B2962A 6.5 digit Low Noise Power Source



Precise VCO characterization requires a low noise DC source

To maintain a stable output signal, voltage controlled oscillator (VCO) characterization requires a low noise DC voltage source. For optimal VCO characterization a noise density between $1 \text{ nVrms}/\sqrt{\text{Hz}}$ to $10 \text{ nVrms}/\sqrt{\text{Hz}}$ at 10 kHz is desirable, but conventional power supplies typically cannot achieve this level of performance. However, the Keysight Technologies, Inc. B2962A can meet these requirements. The Keysight B2962A is a dual channel low noise power source that can supply either voltage or current from both channels while simultaneously monitoring voltage and current on both channels. The Keysight B2962A also has an available Ultra Low Noise Filter (ULNF) option that can lower its noise floor to levels that permit precise VCO characterization. Moreover, since the Keysight B2962A has two channels it can source low noise voltage to both the control and supply voltages of the VCO.

Ultra-Low Noise Filter Performance

The noise density of the B2962A with the ULNF is $1 \text{ nVrms}/\sqrt{\text{Hz}}$ at 10 kHz for voltages and currents of up to 42 V and 100 mA (respectively). This in turn corresponds to a noise level of $10 \text{ }\mu\text{Vrms}$ for frequencies ranging from 10 Hz to 20 MHz, which satisfies the phase noise requirements for testing most VCOs.

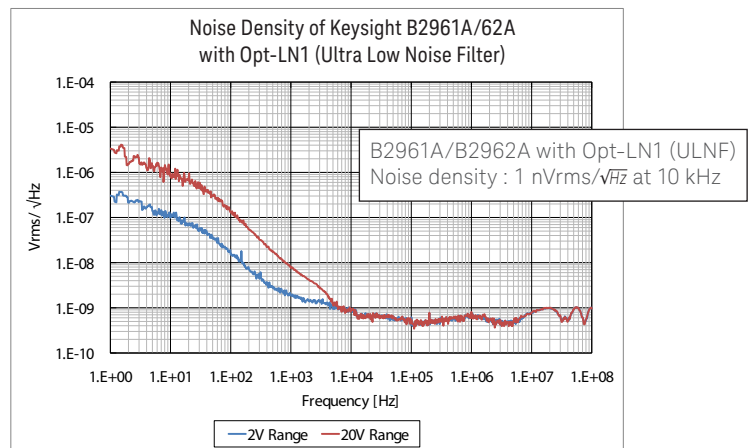

Test Configuration Example

A typical VCO has three-ports: a DC power supply port, a tuning (DC control voltage) port and a signal output port. To characterize a VCO you need at least two low noise DC sources (which the B2962A can supply) and a signal analyzer that can measure parameters such as power, frequency, phase noise, etc. In addition, since the B2962A is able to monitor voltage and current it can also easily check the tuning voltage and current consumption of the DC power supply.

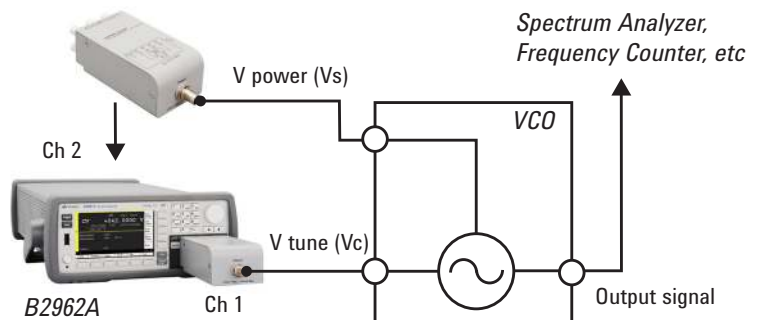

Phase Noise Measurement Example

The graph at the left shows the results of a VCO phase noise measurement for a 791 MHz carrier frequency performed using a Keysight B2962A with the ULNF option and a Keysight E5052B Signal Source Analyzer.

The Keysight E5052B was used to measure the VCO signal output port, but the DC control and DC power outputs of E5052B were not used. Instead, as shown in the test setup diagram on the previous page, the Keysight B2962A with its ULNF option was used to supply low noise voltage to both the DC power supply port and the tuning port.

A VCO's output signal frequency is controlled by the DC voltage at its tuning port. VCOs are extremely sensitive to DC source noise, so a low-noise DC source is crucial for accurate VCO characterization. Unlike comparable power sources, the Keysight B2962A with its ULNF option is capable of providing the clean voltage supplies necessary to correctly characterize modern VCOs.

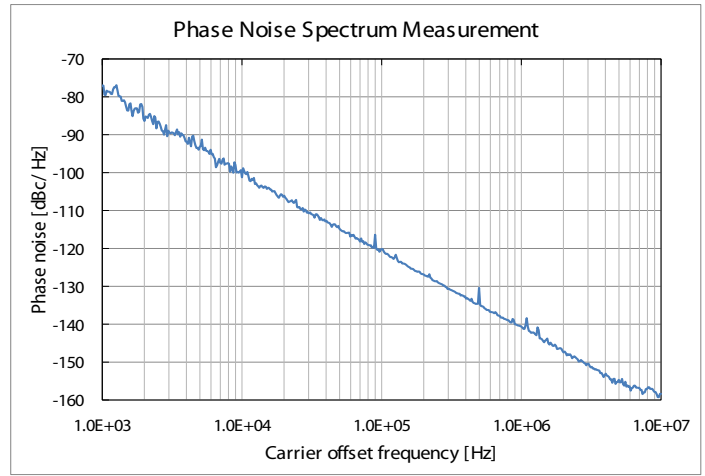

Keysight B2961A/B2962A Low Noise Power Source Key Specifications and Characteristics

Product Number	Option	Max output DC	Max Power	Source Resolution		Noise ¹	
				Digit	Min Resolutions	0.1 to 10 Hz	10 to 20 MHz
B2961/62A	LN1 (ULNF)	42 V 105 mA	4.4 W	6 1/2	100 nV 10 pA	<5 μ Vpp <1 pApp	10 μ Vrms (1 nVrms/ \sqrt{Hz} at 10kHz)

1. Supplemental characteristics

B2961A/B2962A Key Features:

- 6.5 Digit High Resolution and Wide Bipolar Range
- 10 μ Vrms Ultra Low Noise
- Precision 10 kHz Arbitrary Waveform Generation Capability
- Programmable Output Resistance
- Time Domain Voltage/Current Waveform Viewer

To Learn More...

Please visit our website:

www.keysight.com/find/precisionSOURCE

The B2900A Series Precision Instruments

The B2900A series lines up products for both precision source and precision measurement.

www.keysight.com/find/b2900a



For more information on Keysight Technologies' products, applications or services, please contact your local Keysight office. The complete list is available at: www.keysight.com/find/contactus



This information is subject to change without notice.
 © Keysight Technologies 2012, 2014
 Published in USA, August 2, 2014
 5991-1616EN
www.keysight.com