

Secondary Radar Transponder Testing Using the 8990B Peak Power Analyzer

Application Note



Introduction

After a brief review of radar systems and the role of transponders, this application note provides examples of how to effectively test transponders in order to validate their performance and function. Testing is performed using a transponder test set and an Agilent peak performance analyzer (PPA). The measurement examples provided cover interrogation and reply transmit power and pulse profiling, double pulse spacing, and reply delay timing measurement.



Secondary Radar Background

Secondary radar originated from the identification friend or foe (IFF) radar signal system used during World War II and complements the limitations of primary radar systems.

Primary radar works by passively reflecting a radar signal off of the target's reflection or surfaces (called echoes). A limitation of primary radar is that it has difficulty detecting non-metal or composite-based aircraft parts. Another weakness is weather-related. In heavy rain, reflected signals are prone to attenuation, decreasing detection accuracy.

Secondary radar works by transmitting and receiving high-frequency modulated pulses, also called interrogation and reply signals. Figure 1 illustrates the operating principle of secondary radar systems. It begins when the ground station sends interrogation signals to the airborne aircraft. The plane's on board transponder responds to the interrogation signals by transmitting back reply signals.

Modern secondary radar systems are used in both civilian and military aviation operations. The civilian's secondary radar system is called secondary surveillance radar (SSR) and it is primarily used for air traffic control such as in the Air Traffic Control Radar Beacon System (ATCRBS) and the Traffic Collision Avoidance System (TCAS). SSR operates in different modes known by letter designators such as Modes A, B, C, D, and S. Rather than alphabetic modes, the military IFF uses numerical modes 1 through 5. The military and civilian modes operate differently but modes 3 and A are similar and mode 5 is an encrypted version of mode S.

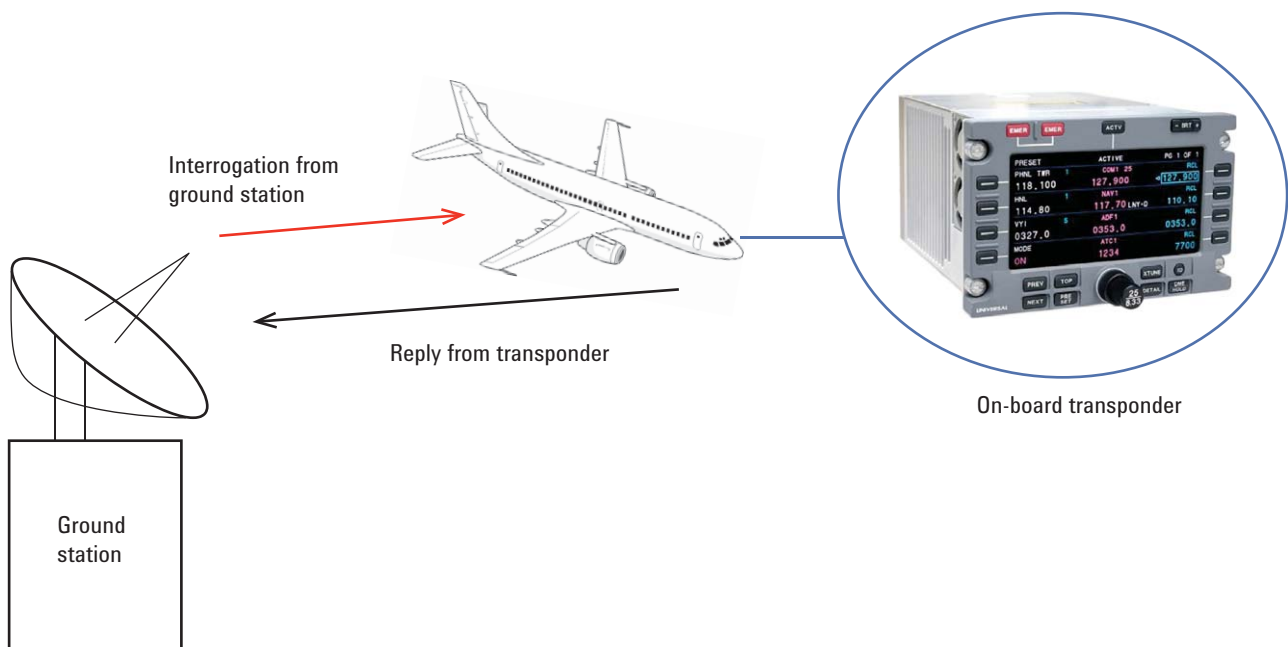

Figure 1. Illustration of the secondary radar operating principle

What is a Transponder and Its Function?

As mentioned previously, transponders are an important part of the secondary radar system. Usually mounted on the under surface of the aircraft's fuselage, the transponder is basically a transmitter and receiver. As shown in the timing diagram in Figure 2, during operation the transponder receives interrogation pulse pairs from the ground station and decodes the requested enquiries. After a certain delay duration, the transponder then responds with a different series of pulses that contain the information requested by the interrogation transmission. The communication exchanges can include information such as the aircraft identifier, altitude, and bearings. The interrogation and reply pulses use different frequencies, depending on the mode of operation.

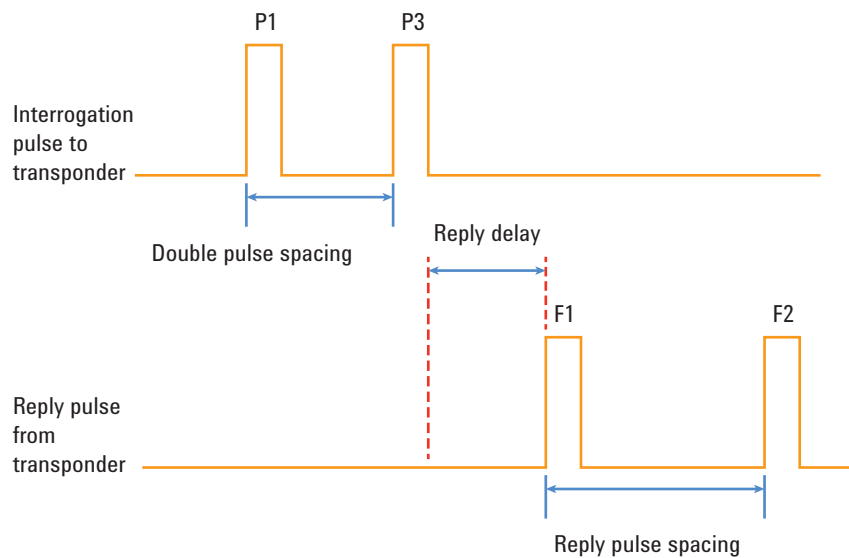

Figure 2. Transponder interrogation and reply pulse pairs timing diagram. (Note: When radar is in use, a P2 interrogation pulse is transmitted and ignored. F1 and F2 refer to framing reply pulses.)

Testing and Validating the Transponder's Performance and Functions

Federal aviation safety standards, such as those defined by the US Federal Aviation Administration, require transponders to undergo periodic maintenance and calibration. This precaution ensures that the transponder is decoding interrogation pulses correctly and subsequently replying with correct pulses. The maintenance also includes performance checks that ensure the transponder transmit/receive functions conform to specifications. Transponder calibrations are typically done using a transponder test sets and the Agilent 8990B peak power analyzer (PPA).

Ultimately these maintenance tasks optimize efficiency and minimize the potential for transponder failure during operation. They also ensure compliance with aviation safety standards. A malfunctioning transponder can result in a catastrophic event. From the military operation perspective, a transponder failure such as an incorrect reply can ultimately mean the difference between life or death.

The following sections demonstrate how the Agilent 8990 PPA is used to perform transponder and transponder test set maintenance and validation. The measurement examples featured are interrogation and reply transmit power and pulse profiling, double pulse spacing, and reply delay timing measurement.

Example 1: IFF transponder reply tests

This example explains how to measure the IFF transponder's simple reply pulse. The objective of the test is to ensure that the transponder generates the correct reply pulses using the correct reply delay. Figure 3 shows the measurement setup.

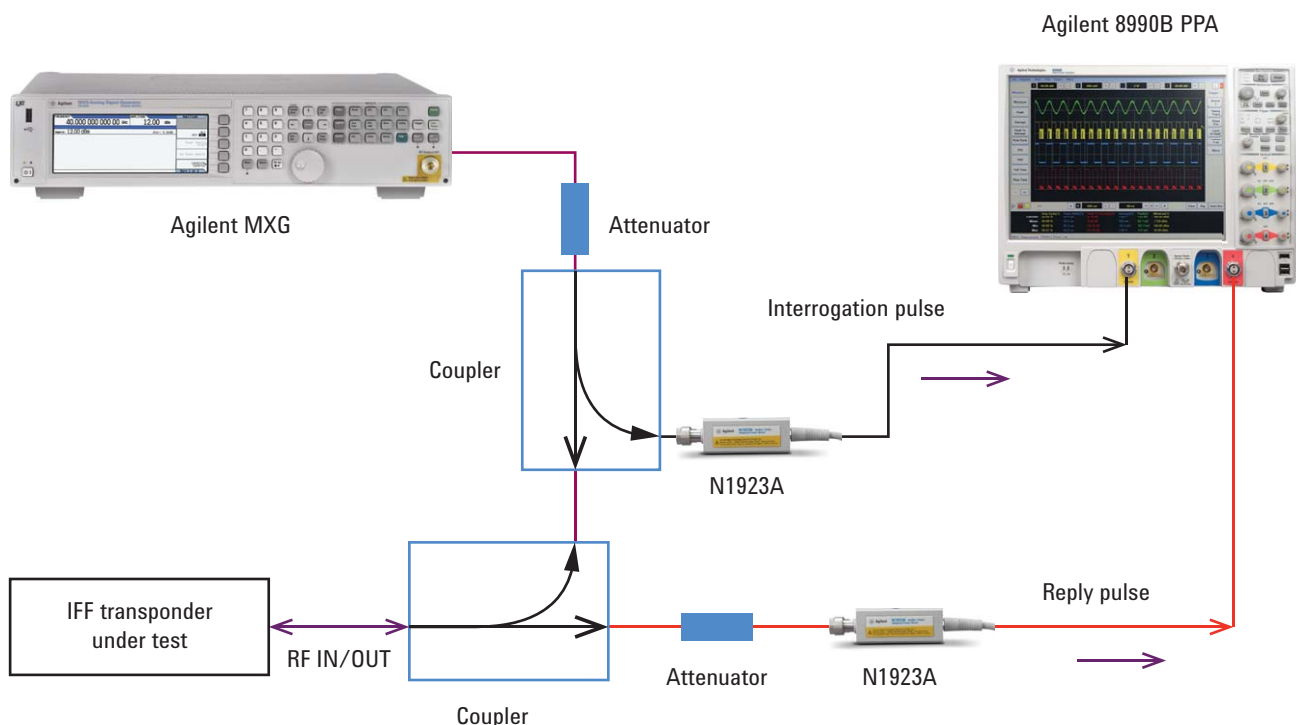

Figure 3. Transponder interrogation and reply pulse measurement

Example 1: IFF transponder reply tests (continued)

1. Connect the transponder under test to a signal generator using directional couplers.
2. Using pulse building software such as Agilent N7620A Signal Studio, construct interrogation pulses according to the operating modes as shown in Table 1. In this application example, the transponder is set to operate using Mode 1 for the interrogation and reply test.

Table 1. Example of the IFF interrogation double pulse specifications

Interrogation frequency	1030 ± 1 MHz
Power	-2 ± 0.1 dBm
PRF	1.0 ± 0.2 kHz
Pulse width	0.85 ± 0.1 μs
Leading edge	< 100 nsec
Trailing edge	< 200 nsec
Pulse spacing	
Mode 1	3.00± 0.2 μs
Mode 2	5.00± 0.2 μs
Mode 3	8.00± 0.2 μs

3. Downloaded the files created to the signal generator to produce the respective interrogation pulses, which are sent to the transponder under test.
4. Use the 8990B PPA to measure the interrogation pulses as shown in Figures 4a and 4b.
 - Note: Before validation measurement is done, it is important to have the couplers, attenuators and cables characterized to obtain the necessary measurement offsets.
 - Note: The pulse shaping measurements such as peak power, pulse width, rise time, and fall time can be easily obtained using the pulse measurement menu tab on the 8990B PPA shown in Figure 4a. The interrogation double pulse spacing can also be measured and verified on the 8990B PPA using the markers-spacing feature as shown in Figure 4b.

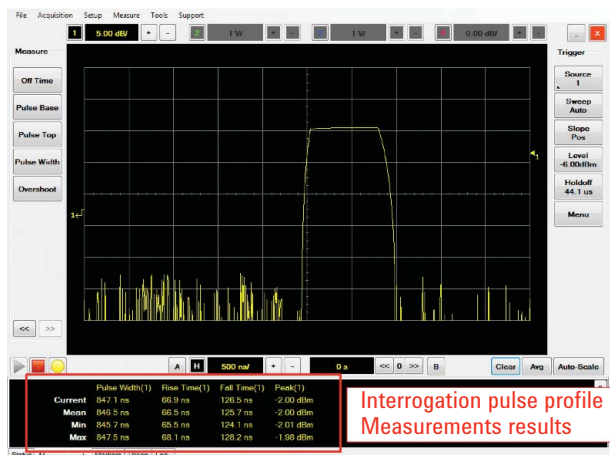

Figure 4a. Interrogation pulse profile measurement on the 8990B PPA

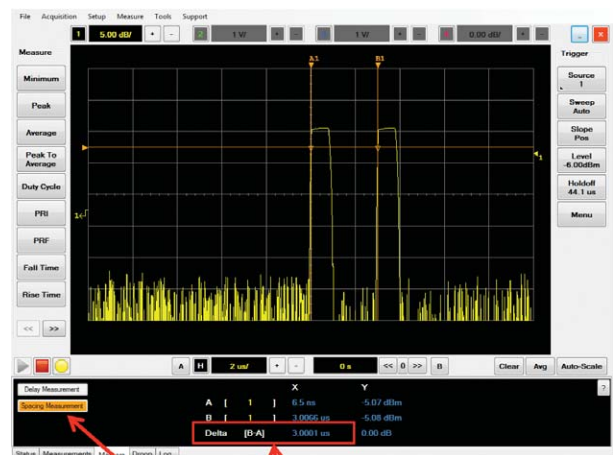

Figure 4b. Interrogation double pulse spacing measurement on the 8990B PPA

Example 2: IFF transponder's reply pulses tests

- Once the interrogation pulse is transmitted to the transponder under test, the transponder will generate a reply double pulse within a certain time delay. For this example, the IFF transponder reply pulse specifications are shown in Table 2.

Table 2. Example of the IFF reply pulse specifications

Reply Frequency	1090 ± 1 MHz
Power	-4 ± 0.1 dBm
PRF	1.0 ± 0.2 kHz
Pulse width	0.5 ± 0.1 μs
Leading edge	< 200 nsec
Trailing edge	< 200 nsec
Pulse spacing	
Mode 1	20.0 ± 0.2 μs
Mode 2	20.0 ± 0.2 μs
Mode 3	20.0 ± 0.2 μs
Reply delay	2.10 ± 0.1 μs

- Using the 8990B PPA, measure and analyze the delay pulses. Figure 5a shows the reply double pulse spacing measurement on the 8990B PPA. Figure 5b shows the delay measurement between the interrogation and reply pulses.
 - Note: Using the same pulse measurement features as noted in Step 4 of the prior section, the PPA can also measure and analyze the pulse profile.

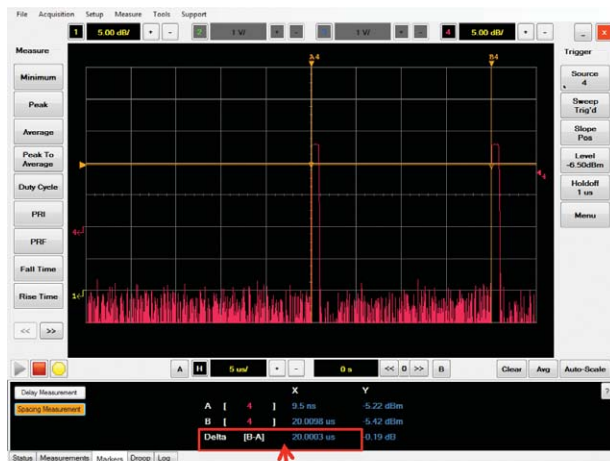

Reply double pulse spacing measurement result

Figure 5a. Reply double pulse spacing measurement on the 8990B PPA



Delay measurement result

Figure 5b. Reply delay measurement result on the 8990B PPA

What is a Transponder Test Set and its Function?

Transponder test sets are used to check, maintain, align, and calibrate on board transponders or interrogators to ensure they meet the necessary operating requirements and performance. Using adjustable power settings and other variable settings, the test set generates and transmits interrogation signals to the transponder under test. The test set also receives and analyzes the RF reply signal from the transponder under test. The resulting system check provides a Go/No-Go indication on the test set.

Transponder test sets are typically bench-type instruments and they come in variety of sizes. They can also operate in multiple modes, which can be chosen by the test technicians. Transponder test sets are found on board aircraft, ground stations, shipboard platforms, or repair depots. Similar to transponders, these test sets are required to undergo thorough periodic maintenance checks and calibration. One of the maintenance tests is the reply delay Go/No-Go. The test setup is shown in Figure 6.

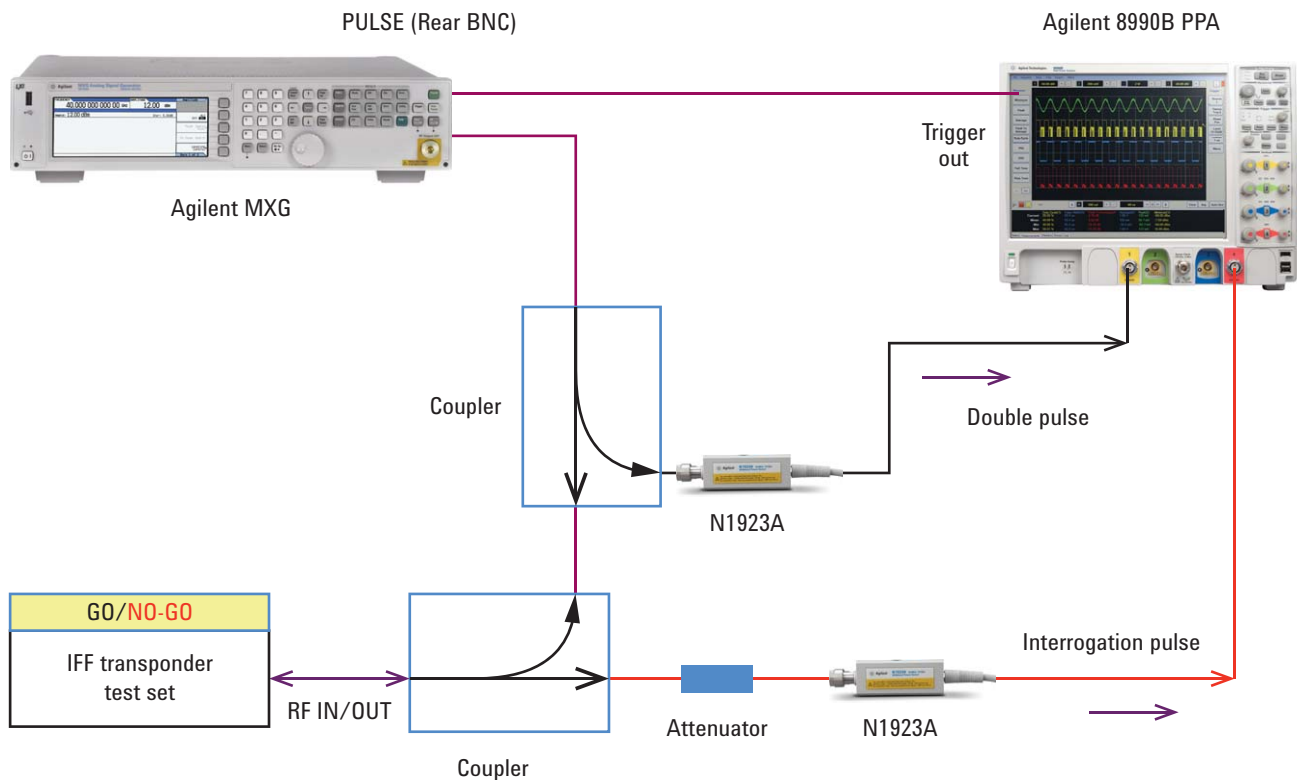

Figure 6. Reply delay timing Go/No-Go test setup using a transponder test set

Example 1: GO/NO GO reply validation on transponder test set

The objective of this test is to ensure the reply delay timing validation done by the transponder test set is accurate and correct. The test is performed as follows:

1. Preset the transponder test set for reply delay timing validation mode.
In this case, the specification of the transponder test set's reply delay is $2.10 \pm 0.1 \mu\text{sec}$.
2. Preset the MXG, select the desired amplitude and carrier frequency. Set the pulse source: Press Pulse>Pulse Source>Adjustable Doublet.
 - Set the Pulse Width to 500 nsec, Pulse 2 Width to 500 nsec, Pulse Delay to 2.1 μsec and Pulse 2 Delay to 20.5 μsec .
3. The testing starts when the transponder test set begins transmitting the interrogation pulses. In this example, these pulses are coupled to the Channel 4 of the 8990B PPA. The PPA triggering source is set to Channel 4. At the same time, outbound trigger signals from the 8990B PPA are connected to the PULSE input at the rear panel of the MXG.
 - Note: The Pulse Delay set in the MXG is the intended reply delay timing which is to be validated by the transponder test set. The reply pulse is also coupled and connected to Channel 1 on the 8990B PPA. The reply delay timing measurement is done on the 8990B PPA using the marker delay measurement feature and referenced in Figure 5b.
4. When the reply delay timing of the transponder test set is within the specifications; the test set will display a Go indication as shown in Figure 7. If the reply delay timing is either above 2.20 μsec or below 2.00 μsec , the test set will indicate a No-Go.
 - Note: If test set displays No-Go, the test set needs to be sent for calibration or repair.



Figure 7. Example of the reply delay timing Go/No-Go specification

5. After the Go indication, check and ensure the 8990B PPA reply delay timing measurement is within the specification.
6. Reduce the Pulse Delay value at the MXG signal generator to 1.90 μsec and check the 8990B PPA measurement result.
7. The transponder test set should indicate No-Go.
 - Note: If not, the test set needs to be sent for calibration or repair.
8. Increase the Pulse Delay value at the MXG signal generator to 2.15 μsec , which is the higher end of the specification.
9. Make sure the transponder test set switches from No-Go to Go.
 - Note: If not, the test set needs to be sent for calibration or repair.

Conclusion

Periodic maintenance and calibration of aircraft transponders and transponder test sets are important for ensuring civilian and military aviation safety. Interrogation and reply pulses to and from the transponders can be measured and analyzed accurately using the Agilent 8990B peak power analyzer. The PPA can be used to measure the pulse profile parameters such as rise time, fall time, pulse width, and PRF, pulse droop. The 8990B PPA is also a useful tool for analyzing the timing relationship between the interrogation and the reply pulses.

Related Agilent Literature

Publication title	Pub number
<i>Agilent 8990B Peak Power Analyzer User's Guide</i>	08990-90005
<i>Agilent N7620A Signal Studio for Pulse Building Technical Overview</i>	5990-8920EN
<i>Secondary Surveillance Radar, Michael C. Stevens, Artech House Inc, ISBN 0-89006-292-7, 1988</i>	



www.agilent.com/find/myagilent

A personalized view into the information most relevant to you.



www.axistandard.org

AdvancedTCA® Extensions for Instrumentation and Test (AXIe) is an open standard that extends the AdvancedTCA for general purpose and semiconductor test. Agilent is a founding member of the AXIe consortium.



www.lxistandard.org

LAN eXtensions for Instruments puts the power of Ethernet and the Web inside your test systems. Agilent is a founding member of the LXI consortium.



www.pxisa.org

PCI eXtensions for Instrumentation (PXI) modular instrumentation delivers a rugged, PC-based high-performance measurement and automation system.

Agilent Channel Partners

www.agilent.com/find/channelpartners

Get the best of both worlds: Agilent's measurement expertise and product breadth, combined with channel partner convenience.



Agilent Advantage Services is committed to your success throughout your equipment's lifetime. To keep you competitive, we continually invest in tools and processes that speed up calibration and repair and reduce your cost of ownership. You can also use Infoline Web Services to manage equipment and services more effectively. By sharing our measurement and service expertise, we help you create the products that change our world.

www.agilent.com/find/advantageservices



www.agilent.com/quality

For more information on Agilent Technologies' products, applications or services, please contact your local Agilent office. The complete list is available at:

www.agilent.com/find/contactus

Americas

Canada	(877) 894 4414
Brazil	(11) 4197 3600
Mexico	01800 5064 800
United States	(800) 829 4444

Asia Pacific

Australia	1 800 629 485
China	800 810 0189
Hong Kong	800 938 693
India	1 800 112 929
Japan	0120 (421) 345
Korea	080 769 0800
Malaysia	1 800 888 848
Singapore	1 800 375 8100
Taiwan	0800 047 866
Other AP Countries	(65) 375 8100

Europe & Middle East

Belgium	32 (0) 2 404 93 40
Denmark	45 45 80 12 15
Finland	358 (0) 10 855 2100
France	0825 010 700*
	*0.125 €/minute
Germany	49 (0) 7031 464 6333
Ireland	1890 924 204
Israel	972-3-9288-504/544
Italy	39 02 92 60 8484
Netherlands	31 (0) 20 547 2111
Spain	34 (91) 631 3300
Sweden	0200-88 22 55
United Kingdom	44 (0) 118 927 6201

For other unlisted countries:

www.agilent.com/find/contactus

Revised: October 11, 2012

Product specifications and descriptions in this document subject to change without notice.

© Agilent Technologies, Inc. 2012
Published in USA, December 3, 2012
5991-1192EN

