

The following article appeared in the December 2012 edition of *NCSLI Measure: The Journal of Measurement Science*, with all rights under copyright of NCSL International.

Spectrum Analyzer CW Power Measurements and the Effects of Noise

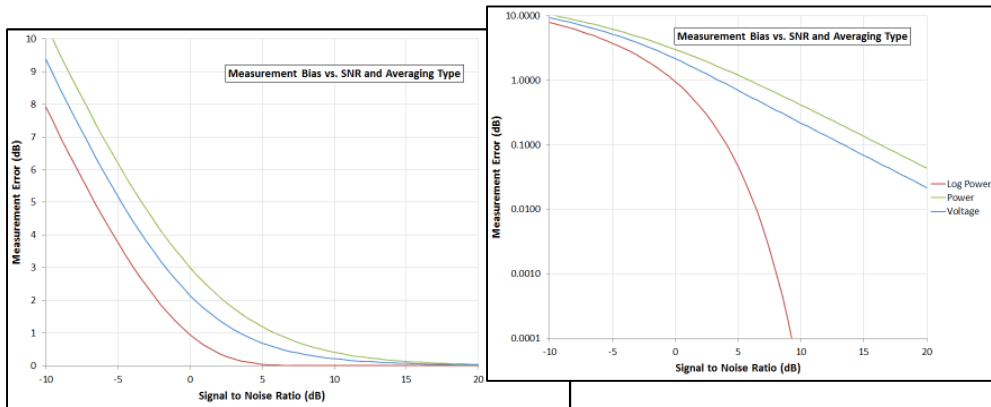

The frequency discrimination capability of spectrum analyzers makes them a key component in the electronic test and measurement industry. They are used in various applications to measure the power of an electrical signal. Although they do not have the same inherent amplitude accuracy as other measurement devices such as broadband power sensors [1], they have superior dynamic range that can extend, in some cases, to the environmental thermal noise limit. Previous work has described the theoretical model of spectrum analyzer power measurements in the presence of noise, but practical guidelines for actual measurements are less forthcoming. This paper examines how to configure a spectrum analyzer to measure a low-power continuous wave (CW) signal so that the trade-off between measurement time and accuracy is optimized. It presents equations describing both the bias and the variance of spectrum analyzer measurements due to noise.

Introduction

The topic of spectrum analyzer power measurements and noise has been previously addressed by articles and application notes such as items [2] and [3] in the list of references at the end of this document. This paper builds on these works and examines in greater detail the practical implications for actual measurements. Spectrum analyzers are capable of a wide range of measurements, but this paper shall simply consider the case of measuring the power of a

continuous wave (CW) signal of known frequency in the presence of noise. It is important to remember the assumption of a CW signal, as different results will be obtained for other signals such as those with pulsed or spread-spectrum characteristics [4].

The model of a spectrum analyzer signal + noise measurement will be reviewed, along with the statistics of noise and signal + noise measurements for various averaging algorithms. Next, a basic block diagram of a spectrum analyzer will be presented and the impact of each component on the measurement will be discussed. Finally, recommendations for configuring the spectrum analyzer will be summarized along with equations describing both the measurement bias and variance due to noise.

Noise Model

A spectrum analyzer is fundamentally a voltage detector. The sophistication of the circuitry producing the detected voltage, as well as the post-processing performed upon it, can be quite impressive, but a CW signal can simply be represented as scalar for our purposes. The detected voltage has a phase component, but scalar spectrum analyzers are unable to detect this and any phase information is lost after the signal passes through the spectrum analyzer's envelope detector. Any noise present before the envelope detector will also have a phase component. The statistics of this noise can be modeled as having two orthogonal components of equal amplitude and Gaussian distribution (see [3] and Fig. 1). All of the Monte Carlo analyses referenced in this paper were performed based on this model.

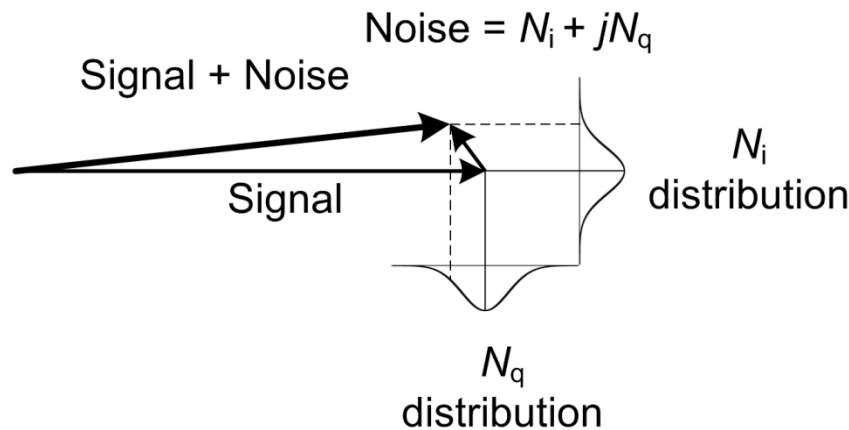

Figure 1. Signal + noise voltage model.

Noise Measurements

Given the noise voltage. $N = \sqrt{N_i^2 + N_q^2}$, the distribution of the noise voltage will be described by the Rayleigh distribution which can be expressed as

$$f(x) = \frac{x}{\sigma^2} e^{-x^2/2\sigma^2}. \quad (1)$$

where $e = 2.71828\dots$ (Euler's number).

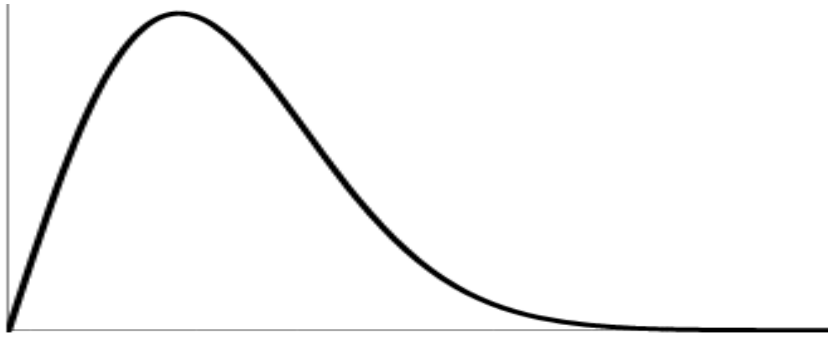

Figure 2. The Rayleigh distribution.

To measure the true noise power we must average power over time. Spectrum analyzers can be configured to average not only power but also voltage and logarithmic power. However, averaging noise on scales other than power will produce results that differ from the true power.

Power averaging

Averaging the noise power on a power scale will, by definition, produce the true average power, but finding the variance of power averaging requires a bit more work. First, we must find the average power when the voltage follows the Rayleigh distribution. This is given by

$$\bar{p} = \int_0^{\infty} \frac{v^2}{R} PDF(v) dv = \frac{2\sigma^2}{R}. \quad (2)$$

where

- \bar{p} = average power
- R = characteristic impedance of the system
- v = instantaneous voltage
- v^2/R = instantaneous power
- $PDF(v)$ = probability distribution function for the voltage.
In this case it is the Rayleigh distribution given by Equation (1).

The variance of power averaging is given by

$$\text{var}(p) = \int_0^{\infty} (p - \bar{p})^2 \text{PDF}(v) dv = \int_0^{\infty} \left(\frac{v^2}{R} - \frac{2\sigma^2}{R} \right)^2 \frac{v}{\sigma^2} e^{-v^2/2\sigma^2} dv, \quad (3)$$

where p is the power, which equals

$$\frac{1}{R^2\sigma^2} \int_0^{\infty} (v^5 - 4v^3\sigma^2 + 4\sigma^4) e^{-v^2/2\sigma^2} dv = \frac{(8\sigma^6 - 8\sigma^6 + 4\sigma^6)}{R^2\sigma^2} = \frac{4\sigma^4}{R^2}. \quad (4)$$

The standard deviation of a noise measurement made on the power scale therefore equals $2\sigma/R$, which is the same as the average power. Converting a power ratio, r_p , from a linear ratio to the equivalent value in decibels (dB) uses the formula

$$r_p(\text{dB}) = 10 \log_{10}[r_p(\text{ratio})] \quad (5)$$

The conversion ratio is given by

$$\frac{d r_p(\text{dB})}{d r_p(\text{ratio})} = 10 \log_{10} e \quad (6)$$

Converting the standard uncertainty from the ratio of 1 into decibels results in

$$1 \times 10 \log_{10} e = 4.34 \text{ dB} \quad (7)$$

Voltage averaging

As developed in the article by A. A. Moulthrop and M. S. Muha [2], averaging the voltage of the noise and then converting the average to power results in a value $\sqrt{\frac{\pi}{4}}$ or 1.05 dB less than the actual noise power.

The variance of the Rayleigh distribution is $\frac{4-\pi}{2}\sigma^2$ and its mean is $\sigma\sqrt{\frac{\pi}{2}}$. Thus, the standard deviation of the Rayleigh distribution is proportional to its mean, and the ratio of these values equals $\sqrt{\frac{4-\pi}{\pi}}$. Converting a voltage ratio, r_v , from a linear ratio to the equivalent value in decibels (dB) uses the following formula

$$r_v(\text{dB}) = 20 \log_{10}[r_v(\text{ratio})] \quad (8)$$

The conversion ratio is given by

$$\frac{d r_v(\text{dB})}{d r_v(\text{ratio})} = 20 \log_{10} e \quad (9)$$

Converting the standard uncertainty $\sqrt{\frac{4-\pi}{\pi}}$ into decibels will equal

$$\sqrt{\frac{4-\pi}{\pi}} 20 \log_{10} e = 4.54 \text{ dB} \quad (10)$$

Logarithmic averaging

In theory we could compute the average power when measuring noise using logarithmic power averaging by evaluating

$$\overline{p}_{\log} = \int_0^{\infty} 10 \log\left(\frac{v^2}{R}\right) PDF(v) dv \quad (11)$$

where $10 \log\left(\frac{v^2}{R}\right)$ is the expression of power in logarithmic form, and comparing this to the value obtained by using power averaging. The above evaluation is quite challenging, but fortunately the value has been shown in the article by A. A. Moulthrop and M. S. Muha [2] to equal $10\gamma \log_{10} e = 2.507 \text{ dB}$, where $\gamma=0.577216\dots$ (Euler's constant).

The derivation in the article by A. A. Moulthrop and M. S. Muha [2] does not extend to the standard deviation of such a measurement, but Monte Carlo analysis results in a value of 5.57 dB, which is consistent with *The noisiness of noise measurements* [5].

Bias of Signal + Noise Measurements

When measuring the power of a CW signal in the presence of noise, the measured power is simply the algebraic sum of the signal and noise powers. The measurement bias, equal to the ratio of the measured signal + noise to the signal amplitude in the absence of noise, is given by

$$\rho_{\text{sns}} = 10 \log_{10} \left(1 + \frac{1}{m}\right) \text{ dB} \quad , \quad (12)$$

where

$$\begin{aligned} \rho_{\text{sns}} &= \text{signal + noise to signal logarithmic power ratio} \\ m &= \text{signal to noise power ratio.} \end{aligned}$$

The cases of measuring the voltage or logarithmic power of a CW signal in the presence of noise are considerably more complex, but Moulthrop and Muha [2] have provided solutions for both of these. When measuring voltage, the measurement bias due to noise equals

$$R_{\text{sns}} = \sqrt{\frac{\pi}{4m}} e^{-m} \sum_{k=0}^{\infty} \left(\frac{m}{2}\right)^k \frac{[1 \cdot 3 \cdot 5 \dots (2k+1)]}{(k!)^2} \quad , \quad (13)$$

where

R_{sns} = signal + noise to signal voltage ratio
 m = signal to noise power ratio.

When measuring the log of the power the measurement bias equals

$$\rho_{\text{sns}} = 10 \log_{10} e \left(-\ln m - \gamma + e^{-m} \sum_{k=1}^{\infty} \frac{m^k}{k!} \left(1 + \frac{1}{2} + \frac{1}{3} + \dots + \frac{1}{k} \right) \right), \quad (14)$$

where

ρ_{sns} = signal + noise to signal logarithmic power ratio (dB)
 m = signal to noise power ratio
 γ = 0.577216..., Euler's constant

Plots of these relationships are shown in Fig. 3 and Fig. 4.

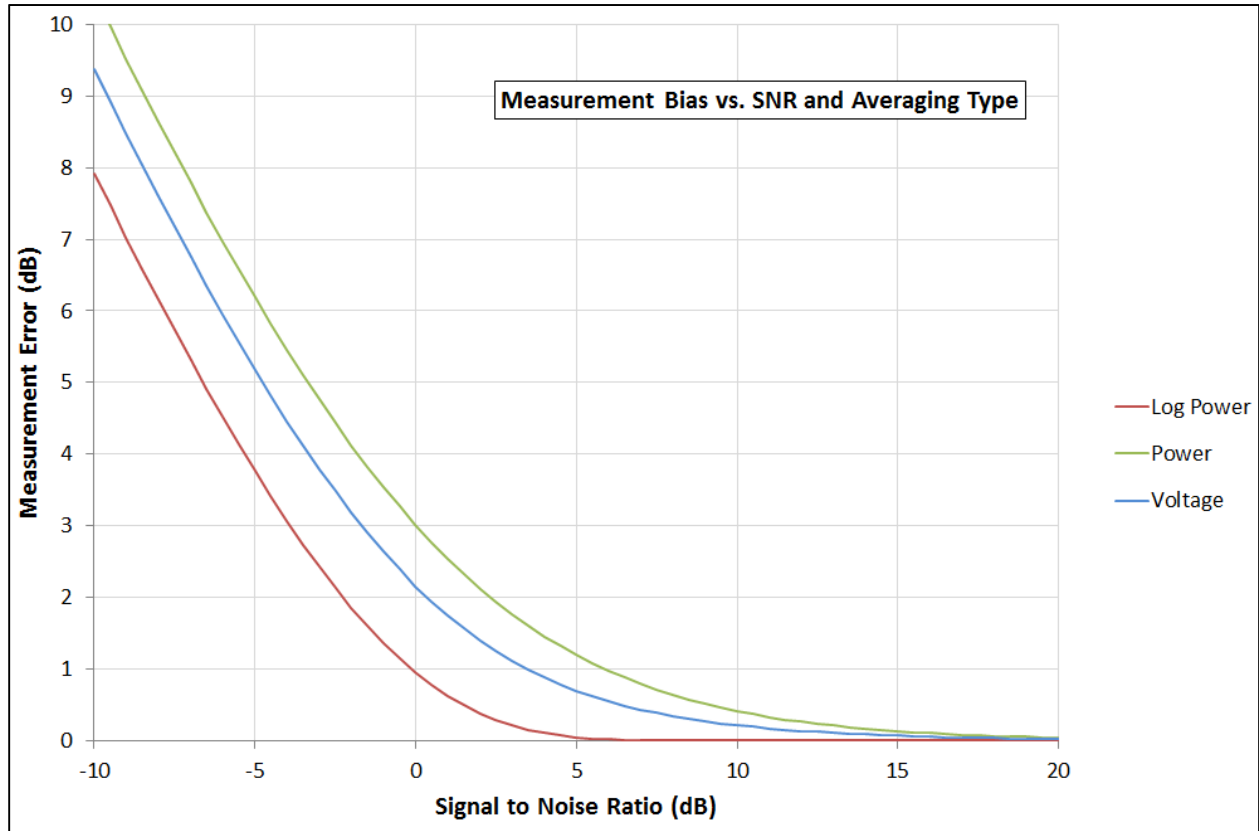

Figure 3. Signal + noise measurement bias (linear scale).

Figure 4 shows that for a signal to noise ratio of 8 dB, logarithmic averaging results in a measurement bias due to noise of approximately 0.001 dB.

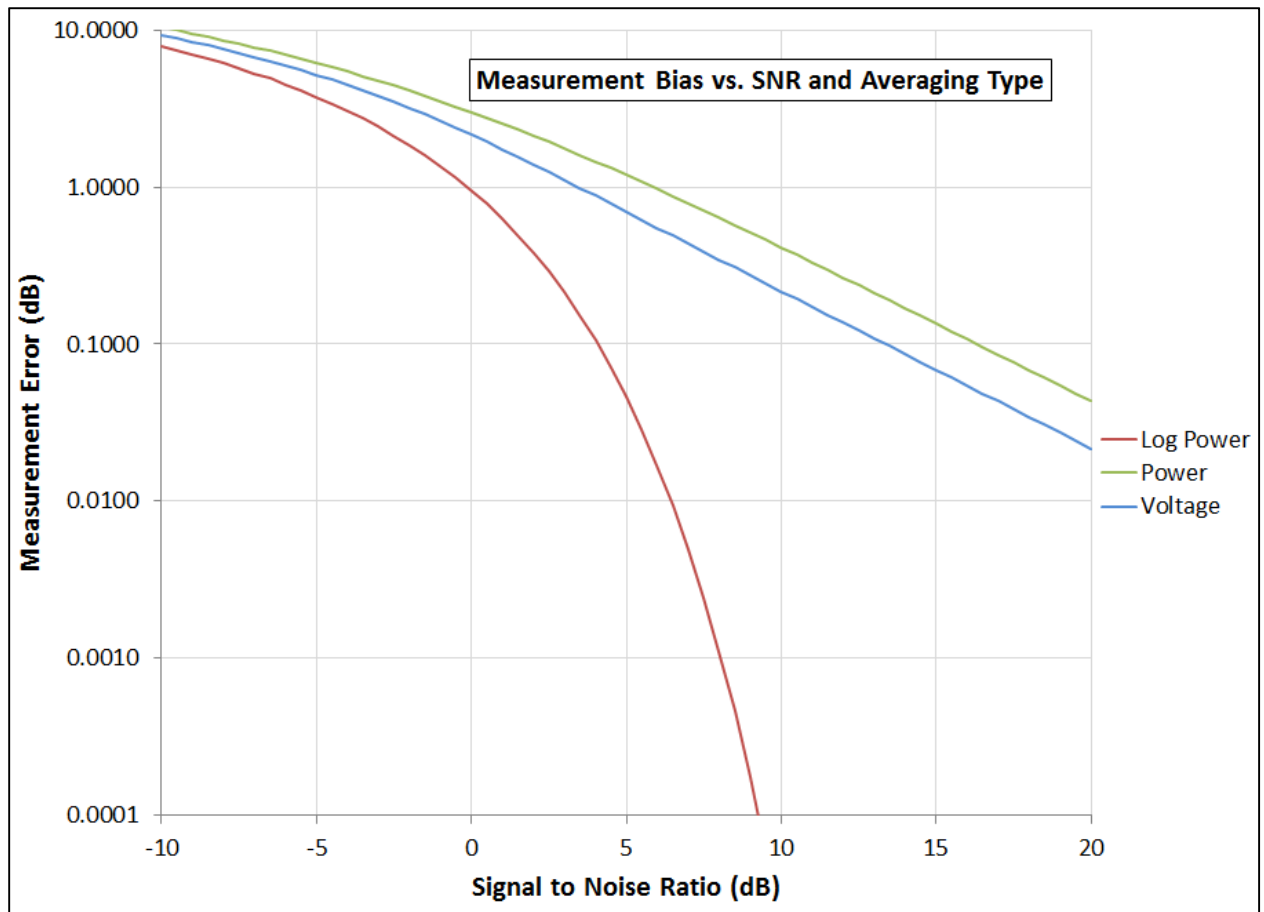

Figure 4. Signal + noise measurement bias (logarithmic scale).

Standard Deviation of Signal + Noise Measurements

As described in the Application Note, Spectrum and Signal Analyzer Measurements and Noise[3], the noise can be broken into two components: one in-phase with the signal and another out of phase. For large signal to noise ratios the out of phase or quadrature component does not affect the signal amplitude, while the in-phase component has a Gaussian distribution. The resulting standard deviation of the overall measurement is described in the N9030A PXA Specifications Guide [6] (p. 40) as

$$\sigma = 20 \log_{10} \left(1 + 10^{-\frac{SNR+3}{20}} \right) \text{ dB} , \quad (15)$$

where

σ = standard deviation of the signal + noise measurement
 SNR = signal to noise ratio (dB)

Expanding the logarithm in a Taylor series, this can be expressed as

$$\sigma = 20 \log_{10} e \left(10^{-\frac{SNR+3}{20}} \right) = 8.69 \left(10^{-\frac{SNR+3}{20}} \right) \text{ dB} . \quad (16)$$

Recognizing that the signal to noise power ratio is defined by

$$m = 10^{\frac{SNR}{10}} \quad (17)$$

and rearranging some terms, we can restate Eq. (16) as

$$\sigma = \sqrt{\frac{2}{m}} 10 \log_{10} e \text{ dB} \quad (18)$$

For large signal to noise ratios, this result is independent of the averaging method – the noise is assumed to be sufficiently small so that the same results are obtained regardless of the measurement units.

5.1. Power averaging

Calculating the variance of a CW signal measurement in the presence of noise when using power averaging can be accomplished by again dividing the noise voltage into in-phase (v_i) and quadrature (v_q) components, and adding this to a signal voltage of amplitude V_s . Both noise components have Gaussian probability distribution functions described as

$$PDF(v_i) = PDF(v_q) = \frac{1}{\sqrt{2\pi\sigma^2}} e^{-\frac{v^2}{2\sigma^2}} = \frac{1}{\sigma} \varphi\left(\frac{v}{\sigma}\right), \quad (19)$$

where $\varphi(x)$ is the standard normal distribution function.

Each noise component will have an average power equal to σ^2/R , total noise power will be $2\sigma^2/R$, the signal power will be V_s^2/R , and the signal to noise power ratio will equal $V_s^2/2\sigma^2$. When using power averaging the signal and noise power add independently; therefore the total power of the signal + noise measurement will equal $(V_s^2+2\sigma^2)/R$.

The variance of the signal + noise measurement is given by integrating the square of the difference between the power and the average power across the probability density functions of the two components of the noise voltage,

$$\text{var}(p) = \iint_{-\infty}^{\infty} (p - \bar{p})^2 PDF(v_i) PDF(v_q) dv_i dv_q . \quad (20)$$

Power for any given value of v_i and v_q equals

$$p = \frac{1}{R} [(V_s + v_i)^2 + v_q^2] = \frac{1}{R} (V_s^2 + 2V_s v_i + v_i^2 + v_q^2), \quad (21)$$

while the average power equals

$$\bar{p} = \frac{V_s^2 + 2\sigma^2}{R} . \quad (22)$$

Combining Eq. (19), (21), and (22) into Eq. (20) produces

$$\begin{aligned} \text{var}(p) = & \frac{1}{R^2} \iint_{-\infty}^{\infty} (4V_s^2 v_i^2 + 4V_s v_i^3 + 4V_s v_i v_q^2 - 8V_s v_i \sigma^2 + v_i^4 + 2v_i^2 v_q^2 - 4v_i^2 \sigma^2 + v_q^4 - \\ & 4v_q^2 \sigma^2 + 4\sigma^4) \frac{1}{\sigma} \varphi\left(\frac{v_i}{\sigma}\right) \frac{1}{\sigma} \varphi\left(\frac{v_q}{\sigma}\right) dv_i dv_q . \end{aligned} \quad (23)$$

Noting that

$$\int_{-\infty}^{\infty} \frac{x}{\sigma} \varphi\left(\frac{x}{\sigma}\right) dx = 0 , \quad (24)$$

$$\int_{-\infty}^{\infty} \frac{x^2}{\sigma} \varphi\left(\frac{x}{\sigma}\right) dx = \sigma^2 , \quad (25)$$

$$\int_{-\infty}^{\infty} \frac{x^3}{\sigma} \varphi\left(\frac{x}{\sigma}\right) dx = 0 , \quad (26)$$

and

$$\int_{-\infty}^{\infty} \frac{x^4}{\sigma} \varphi\left(\frac{x}{\sigma}\right) dx = 3\sigma^4 , \quad (27)$$

we evaluate the components of Eq. (19) as

$$\text{var}(p) = \frac{1}{R^2} [4V_s^2 \sigma^2 + 0 + 0 + 0 + 3\sigma^4 + 2\sigma^4 - 4\sigma^4 + 3\sigma^4 - 4\sigma^4 + 4\sigma^4] = \frac{4\sigma^2}{R^2} (V_s^2 + \sigma^2) . \quad (28)$$

Dividing the square root of the variance by the average measurement power given by Eq. (22) results in the relative measurement standard deviation for power averaging

$$\sigma_{\text{pwr}} = 2\sigma \frac{\sqrt{V_s^2 + \sigma^2}}{V_s^2 + 2\sigma^2} . \quad (29)$$

Finally, substituting in the signal to noise ratio, $m = V_s^2/2\sigma^2$, Eq. (29) simplifies to

$$\sigma_{\text{pwr}} = \frac{\sqrt{1+2m}}{1+m} . \quad (30)$$

The result above is expressed as a power ratio. Multiply this value by $10 \log_{10}(e)$ to convert it to the equivalent value in decibels.

Voltage and logarithmic power averaging

The calculations for the variance of a CW signal measured in the presence of noise when using voltage or logarithmic power averaging are significantly more challenging than that for power averaging. However, equations based on σ_{pwr} that model the behavior fairly well can be used. Equations that closely fit the behavior derived from Monte Carlo analyses take the following form

$$\sigma(m) = \frac{f(m)\sigma_{\text{noise}} + \sigma_{\text{pwr}}(m)}{f(m)+1}, \quad (31)$$

where:

- m = signal to noise power ratio
- σ_{noise} = standard deviation of a noise measurement as a power ratio
This will be 1.045 (4.54 dB) for voltage averaging and 1.283 (5.57 dB) for logarithmic power averaging.
- $\sigma_{\text{pwr}}(m)$ = standard deviation of a signal + noise measurement as a power ratio for power averaging as a function of the signal to noise power ratio

The factor $f(m)$ takes the form

$$f(m) = \alpha \times m^{-\beta}, \quad (32)$$

with α and β determined empirically. Table 1 summarizes values that produce errors of less than 1 % compared to a Monte Carlo analysis.

Averaging type	σ_{noise}	α	β
Voltage	1.045	0.62	1.400
Log power	1.283	3.11	1.733

Table 1. Measurement variance modeling parameters.

The results are summarized in Fig. 5. The plots for voltage and log power averaging were obtained using a Monte Carlo analysis, while the model values for voltage and log power averaging were computed using parameter values from Table 1. Also included for reference is a plot of Eq. (18) which provides a reasonable approximation for larger signal to noise ratios.

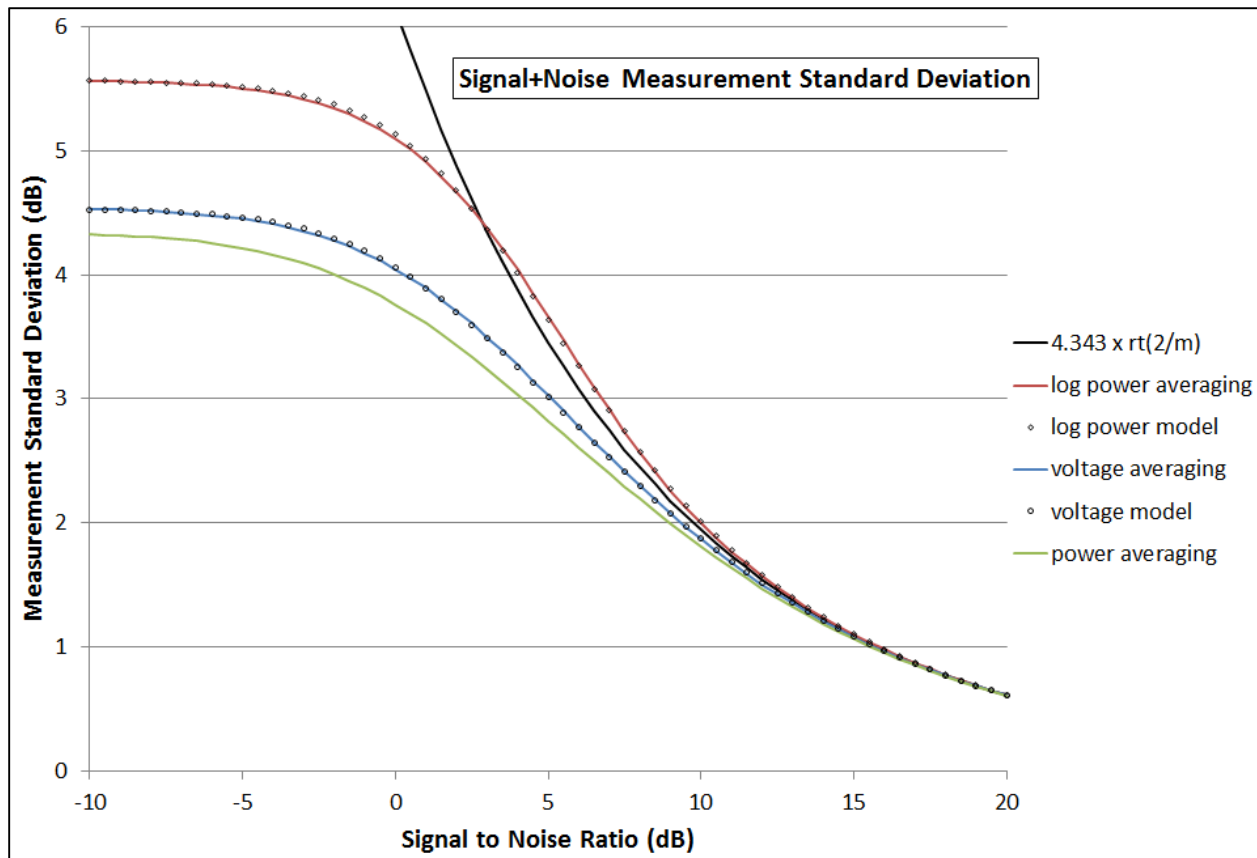

Figure 5. Signal + noise measurement standard deviation.

Measurement Standard Deviation and Averaging

The equations derived so far apply to individual measurements. If multiple measurement samples are averaged together the expected measurement bias does not change but the standard deviation will decrease with the square root of the number of discrete measurement samples. As described in the application note, Spectrum and Signal Analyzer Measurements and Noise [3], the standard deviation can also be decreased by using video bandwidth filtering or by time averaging. When using video bandwidth filtering, if the video bandwidth is less than approximately one-third of the resolution bandwidth the measurement standard deviation is reduced by a factor of $\sqrt{\frac{NBW_{RBW}}{\pi \times VBW}}$. When using time averaging, the measurement standard deviation is reduced by a factor of $\sqrt{t_{int} \times NBW_{RBW}}$.

In these equations, NBW_{RBW} is the equivalent noise bandwidth of the resolution bandwidth used, which is typically close in value to that of the resolution bandwidth itself, VBW is the video bandwidth, and t_{int} is the integration or measurement time.

Optimizing Signal + Noise Measurements

Spectrum analyzer block diagram

A simplified spectrum analyzer block diagram is shown in Fig. 6 (see the application note, Spectrum Analyzer Basics [7], for more information). Each of the major components will be examined in turn for their impact on signal + noise measurements.

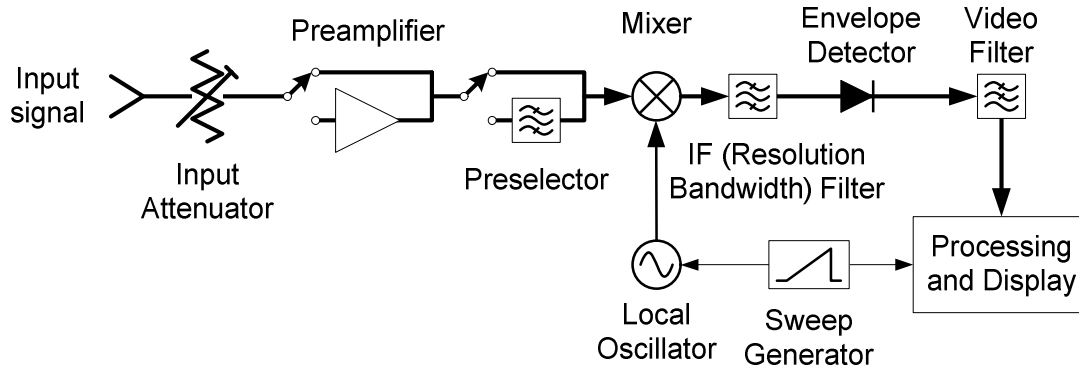

Figure 6. Simplified spectrum analyzer block diagram.

Input attenuator and preamplifier

The input attenuator reduces input power in order to prevent the mixer from being overdriven and distorting the signal. Reducing the power to 10 or 20 dB below the maximum specified mixer level can also result in improved scale accuracy, but such reduction should be carefully considered. Every decibel of input attenuation increases the noise floor by the same amount. As will be shown later, each 3 dB of degradation in the noise floor increases the measurement uncertainty by $\sqrt{2}$. Alternatively, we can keep the measurement uncertainty the same, but at the cost of increasing measurement time by a factor of two. For especially low power measurements, all tradeoffs that affect the noise floor must be very carefully considered.

The preamplifier serves much the same purpose as the input attenuator except that it increases the signal power rather than decreasing it, resulting in an improved noise floor. This is typically only done if the input attenuator is already at zero and if the gain of the preamplifier does not result in the input mixer being overdriven, but the improvement can be well worth it. In the same way that a 3 dB noise floor degradation can double the measurement time, a 15 dB improvement could potentially decrease the measurement time by a factor of 30.

Preselector

The input preselector is used to eliminate spurious mixing products. This is very useful when searching for a signal of unknown frequency but is of no value when, as we are assuming, the signal is a single tone of known frequency. If we are allowed to choose between using and bypassing the input preselector, the choice should be made based on the impact on the noise floor. The correct path to use is not always apparent. Although the input preselector has a certain amount of insertion loss that degrades the noise floor, the band pass characteristics of the preselector can in some cases improve the noise floor – especially at very high input frequencies. Therefore it is important to characterize the effects of both signal paths and choose accordingly.

Frequency span

If the signal frequency is known, then performing a frequency sweep serves no useful purpose – all measurement time should be spent at the frequency of interest. The frequency reference of the spectrum analyzer should be locked to that of the signal source and the spectrum analyzer should be set to zero span.

Sweep time

The sweep time should be chosen based on the desired measurement accuracy, which in turn is based on the normalized signal to noise ratio. Increasing the sweep time by a factor of four will decrease the standard deviation due to noise by a factor of two, and vice-versa. This is independent of the averaging type (voltage, power, or log power). As explained in the next section, it is also independent of resolution bandwidth.

Resolution bandwidth

The choice of resolution bandwidth affects how closely two signals can be spaced and still be detected by the spectrum analyzer, as well as the minimum signal amplitude that can be detected above the noise floor. Signal spacing is not an issue given the measurement assumptions, but the signal must still be sufficiently above the analyzer's noise floor. Referring to Fig. 4, if a signal to noise ratio of at least 8 dB is achieved and if log power averaging is used, the measurement bias due to noise is negligible. The resolution bandwidth should be chosen to achieve this signal to noise ratio, but it is important to understand that reducing the resolution bandwidth further will not improve the variance due to noise.

To understand why, recall that Eq. (16) gives the standard uncertainty for a measurement as

$$\sigma = 8.69 \left(10^{-\frac{SNR+3}{20}} \right) \text{ dB} , \quad (33)$$

where SNR is the signal to noise ratio.

This is true for a sufficiently large signal to noise ratio regardless of the averaging type. This is reduced by time averaging by a factor of $\sqrt{t_{\text{int}} \times NBW_{\text{RBW}}}$. The overall measurement uncertainty when using time averaging is therefore

$$\sigma = \frac{8.69 \left(10^{-\frac{SNR+3}{20}} \right)}{\sqrt{t_{\text{int}} \times NBW_{\text{RBW}}}} \text{ dB} , \quad (34)$$

where

- t_{int} = integration or measurement time
- NBW_{RBW} = equivalent noise bandwidth for the measurement's resolution bandwidth

What happens when the resolution bandwidth is decreased by a factor of 10? The background noise level should decrease 10 dB, reducing the uncertainty for a single measurement (the numerator in Eq. (34)) by a factor of $\sqrt{10}$. However, given that the noise bandwidth is nominally proportional to the resolution bandwidth, the reduction for time averaging (the denominator in Eq. (34)) is also reduced by a factor of $\sqrt{10}$. The two cancel out, and the overall measurement uncertainty is unchanged.

Equation (34) can, in fact, be re-stated in terms of the signal to noise ratio normalized to a 1 Hz resolution bandwidth, the noise bandwidth to resolution bandwidth ratio, and the integration time

$$\sigma = 6.14 \frac{10^{-\frac{SNR_{1Hz}}{20}}}{\sqrt{t_{int} \times \frac{NBW}{RBW}}} \text{ dB} , \quad (35)$$

where SNR_{1Hz} is the signal to noise ratio normalized to a 1 Hz resolution bandwidth.

Because the noise bandwidth to resolution bandwidth ratio never varies far from unity, the measurement uncertainty due to noise is primarily determined by the measurement time and the normalized signal to noise ratio.

This equation also shows the impact of a change in the normalized noise floor. If SNR_{1Hz} decreases by 3 dB then the noise uncertainty increases by a factor of $\sqrt{2}$. Since noise uncertainty goes down with the square root of the measurement time, this 3 dB decrease can be offset by doubling the measurement time.

Noise bandwidth

Equation (35) provides a convenient expression of the measurement uncertainty except for the noise bandwidth to resolution bandwidth ratio – information not typically provided to the end user. If the equivalent noise bandwidth is not available – either from the datasheet, provided from the front panel of the spectrum analyzer, or inferred from information provided by a noise marker, we can still come up with a reasonable approximation based on the filter type. Table 2, obtained from the application note, Spectrum and Signal Analyzer Measurements and Noise [3], provides approximate ratios for 4- and 5-pole synchronously tuned Gaussian filters, as well as FFT and digital IF based filters.

Filter type	Application	NBW/RBW
4-pole sync	Most SAs analog	1.128
5-pole sync	Some SAs analog	1.111
FFT/digital	FFT/digital IF swept SAs	1.056

Table 2. Typical noise bandwidth to resolution bandwidth ratios.

Detector type

The amplitude display of the spectrum analyzer is broken into a number of separate ‘buckets’, also referred to as sweep points. For each bucket a certain number of measurement samples are collected by the envelope detector. The sample(s) used to produce the amplitude displayed is determined by the detector type. Typical detector type selections are:

- “Normal”
- Peak
- Sample
- Negative Peak
- Average

When measuring in zero span it is to our benefit to use all of the information available, which is why the average detector should be used (see the article, *Detector selection for spectrum analyzer measurements* [8]). Equations for the reduction of noise uncertainty, such as Eq. (35), assume the use of the average detector.

Although selecting the average detector ensures that all samples are used, it does not determine how they are combined – this is determined by the averaging type.

Video bandwidth

Video bandwidth averaging is used in much the same way that the average detector can be used to reduce noise uncertainty. In some analyzers when using zero span and the average detector, the video bandwidth controls are disabled. Because video bandwidth averaging provides no additional benefit under these conditions, if it is not otherwise disabled it should simply be set to be wide open.

Averaging type

The choice of averaging type (voltage, power, or log power) should be clear from Fig. 4 and Fig. 5. If the signal to noise ratio is at least 10 dB then all averaging types produce about the same amount of uncertainty due to noise, but log power averaging produces negligible measurement bias compared to the others. It might be tempting to use power averaging to take advantage of the lower noise uncertainty, but this is only true for very low signal to noise ratios and is otherwise offset by the need to measure the background noise in order to eliminate the measurement bias.

Trace averaging and sweep points

Averaging multiple traces is one technique used to reduce noise uncertainty, but for a zero span measurement using the average detector the results are independent of whether they were obtained from a single trace or by averaging multiple traces – the only measurement parameter that matters in this case is the sweep time. One drawback of averaging multiple traces is that there will be dead time between traces as the spectrum analyzer prepares to execute the next

sweep. This non-measurement time can be especially significant for small resolution bandwidths. If possible, the required measurement integration time should be pre-calculated based on the signal to noise ratio, the sweep time set to this value, and a single sweep should be performed.

Optimizing Noise Measurements

In many cases it is quite useful to know the actual noise floor of the spectrum analyzer. Although datasheet values can be used and adjusted based on settings such as input attenuation and resolution bandwidth, the effect on the noise floor for some signal paths is not always specified. Given that a 3 dB difference in the noise floor can translate to a factor of two in the measurement time, accurately knowing the noise floor could be used to decrease the overall measurement time.

The optimal settings for characterizing the noise floor are quite different than for making a signal + noise measurement. Power averaging should be used because this minimizes the measurement variance. The uncertainty of a single noise sample using power averaging has been shown in Eq. (7) to be 4.34 dB, but like signal + noise measurements, this can also be reduced by time averaging. Unlike a signal + noise measurement where the uncertainty is dependent on the signal to noise ratio, a noise measurement has no equivalent signal. For noise measurements using power averaging the uncertainty is simply given by

$$\sigma = \frac{4.34}{\sqrt{t_{\text{int}} \times NBW_{\text{RBW}}}} \text{ dB} . \quad (36)$$

The implication is that, to minimize measurement time, the background noise of the spectrum analyzer should be measured in as wide a resolution bandwidth as practical. As an example, with a 100 kHz resolution bandwidth and a 100 ms measurement period, the standard measurement uncertainty is merely 0.04 dB.

Finally, special care must be taken when measuring noise or noise-like signals to ensure that the spectrum analyzer is not being overdriven or underdriven. As described in the article, *Measuring noise with a spectrum analyzer* [9], the displayed signal may be deceiving as to the actual power at the input mixer or the IF amplifiers. Overdriving the input mixer is not a concern if measuring the spectrum analyzer's background thermal noise, but can occur if measuring a noise-like signal such as a modulated carrier. Keep in mind that the resolution bandwidth *follows* the input mixer, and that the entire power of the signal must be considered when ensuring that the input mixer is not being overdriven. Another cause of error is intermediate frequency (IF) clipping. To prevent such errors the average noise level should be kept 7 dB below the maximum and 14 dB above the minimum of the calibrated range of the IF amplifier.

Summary

Signal + noise measurements

When measuring signal + noise, the measurement parameters in Table 3 are recommended. The measurement bias and standard uncertainties of signal + noise measurements are given in Table 4 and Table 5.

Parameter	Setting
Frequency Span	Zero
Detector Type	Average
Averaging Type	Log Power
Resolution Bandwidth	Sufficient to provide 8 dB SNR

Table 3. Recommended settings for signal + noise measurements.

Averaging type	Bias (dB)
Voltage	$20 \log_{10} e \sqrt{\frac{\pi}{4m}} e^{-m} \sum_{k=0}^{\infty} \left(\frac{m}{2}\right)^k \frac{[1 \cdot 3 \cdot 5 \dots (2k + 1)]}{(k!)^2}$
Power	$10 \log_{10} \left(1 + \frac{1}{m}\right)$
Log Power	$10 \log_{10} e \left(-\ln m - \gamma + e^{-m} \sum_{k=1}^{\infty} \frac{m^k}{k!} \left(1 + \frac{1}{2} + \frac{1}{3} + \dots + \frac{1}{k}\right) \right)$

Table 4. Signal + noise measurement bias.

In Table 4, m equals the signal to noise power ratio. For log power averaging, the measurement bias is 0.001 dB for $m = 8$ dB, and diminishes rapidly for higher values of m .

Averaging type	Standard uncertainty (dB)
Voltage	$\left(1.045f + \frac{\sqrt{1 + 2m}}{1 + m}\right) \times \frac{10 \log_{10} e}{f + 1}; f = 0.62 m^{-1.4}$
Power	$\frac{\sqrt{1 + 2m}}{1 + m} \times 10 \log_{10} e$
Log Power	$\left(1.283f + \frac{\sqrt{1 + 2m}}{1 + m}\right) \times \frac{10 \log_{10} e}{f + 1}; f = 3.11 m^{-1.733}$

Table 5. Standard uncertainty of discrete signal + noise measurements.

For large signal to noise ratios, the measurement uncertainty of a discrete measurement for all averaging types converges to

$$6.14 \left(10^{-\frac{SNR}{20}} \right) \text{ dB} \quad (37)$$

For time averaged measurements, the standard uncertainty is reduced by the square root of the product of the measurement time and the equivalent noise bandwidth of the spectrum analyzer. For example, for large signal to noise ratios the standard uncertainty would be

$$\sigma = 6.14 \frac{10^{-\frac{SNR}{20}}}{\sqrt{t_{\text{int}} \times NBW_{\text{RBW}}}} \text{ dB} \quad (38)$$

Noise measurements

When measuring noise, the measurement parameters in Table 6 are recommended. The bias and standard uncertainties of noise measurements are given in Table 7 and Table 8.

Parameter	Setting
Frequency Span	Zero
Detector Type	Average
Averaging Type	Power
Resolution Bandwidth	prefer wide bandwidths

Table 6. Recommended settings for noise measurements.

Averaging type	Bias (dB)
Voltage	$1.05 = 10 \log_{10} \frac{\pi}{4}$
Power	0
Log Power	$2.51 = 10 \gamma \log_{10} e$

Table 7. Bias of noise measurements.

Averaging type	Standard uncertainty (dB)
Voltage	$4.54 = 20 \sqrt{\frac{4-\pi}{\pi}} \log_{10} e$
Power	$4.34 = 10 \log_{10} e$
Log Power	5.57^1

Table 8. Standard uncertainty of discrete noise measurements.

In the same manner as signal + noise measurements, the standard uncertainty is reduced by the square root of the product of the measurement time and the equivalent noise bandwidth of the spectrum analyzer. For example, when using power averaging, the standard uncertainty due to noise will be given by

$$\sigma = \frac{4.34}{\sqrt{t_{\text{int}} \times NBW_{\text{RBW}}}} \text{ dB} \quad (\text{power averaging}) \quad (39)$$

¹ Value derived from Monte Carlo analysis.

Conclusions

When measuring CW signals of known frequency, and noise is a concern, a spectrum analyzer should be configured for a zero span measurement using the average detector. If necessary, the normalized noise floor can be efficiently determined using power averaging and a wide resolution bandwidth. The signal itself should be measured using log power averaging and the resolution bandwidth set to provide a signal to noise ratio of at least 8 dB. The sweep time can then be set, based on the required measurement uncertainty, using the equations provided in this paper.

References

- [1] J. Gorin, "Achieving amplitude accuracy in modern spectrum analyzers," *Microwaves RF*, vol. 47, no. 9, pp. 90, 92, 94-99, 142, September 2008.
- [2] A. A. Moulthrop and M. S. Muha, "Accurate measurement of signals close to the noise floor on a spectrum analyzer," *IEEE T. Microw. Theory*, vol. 39, no. 11, pp. 1882-1885, 1991.
- [3] Agilent Technologies, "Spectrum and Signal Analyzer Measurements and Noise," *Agilent Technologies Application Note 1303*, <http://cp.literature.agilent.com/litweb/pdf/5966-4008E.pdf>, 2012.
- [4] S. Murray, "Beware of spectrum analyzer power averaging techniques," *Microwaves RF*, vol. 45, no. 12, pp. 57-66, December 2006.
- [5] "The noisiness of noise measurements," *RF Design*, vol. 21, no. 8, p. 38, 1998.
- [6] Agilent Technologies, "N9030A PXA Specifications Guide," <http://cp.literature.agilent.com/litweb/pdf/N9030-90017.pdf>, 2012.
- [7] Agilent Technologies, "Spectrum Analyzer Basics," *Agilent Technologies Application Note 150*, <http://cp.literature.agilent.com/litweb/pdf/5952-0292.pdf>, 2006.
- [8] J. Gorin, "Detector selection for spectrum analyzer measurements," *RF Design*, vol. 26, no. 2, pp. 32-38, 2003.
- [9] "Measuring noise with a spectrum analyzer," *RF Design*, vol. 21, no. 8, p. 32, 1998.