

Agilent U2020 X-Series USB Peak and Average Power Sensors

Programming Guide



Agilent Technologies

Notices

© Agilent Technologies, Inc. 2012–2013

No part of this manual may be reproduced in any form or by any means (including electronic storage and retrieval or translation into a foreign language) without prior agreement and written consent from Agilent Technologies, Inc. as governed by United States and international copyright laws.

Manual Part Number

U2021-90003

Edition

Third Edition, May 10, 2013

Printed in Malaysia

Agilent Technologies, Inc.
5301 Stevens Creek Blvd.
Santa Clara, CA 95051 USA

Warranty

The material contained in this document is provided “as is,” and is subject to being changed, without notice, in future editions. Further, to the maximum extent permitted by applicable law, Agilent disclaims all warranties, either express or implied, with regard to this manual and any information contained herein, including but not limited to the implied warranties of merchantability and fitness for a particular purpose. Agilent shall not be liable for errors or for incidental or consequential damages in connection with the furnishing, use, or performance of this document or of any information contained herein. Should Agilent and the user have a separate written agreement with warranty terms covering the material in this document that conflict with these terms, the warranty terms in the separate agreement shall control.

Technology Licenses

The hardware and/or software described in this document are furnished under a license and may be used or copied only in accordance with the terms of such license.

Restricted Rights Legend

U.S. Government Restricted Rights. Software and technical data rights granted to the federal government include only those rights customarily provided to end user customers. Agilent provides this customary commercial license in Software and technical data pursuant to FAR 12.211 (Technical Data) and 12.212 (Computer Software) and, for the Department of Defense, DFARS 252.227-7015 (Technical Data - Commercial Items) and DFARS 227.7202-3 (Rights in Commercial Computer Software or Computer Software Documentation).

Safety Notices

CAUTION

A **CAUTION** notice denotes a hazard. It calls attention to an operating procedure, practice, or the like that, if not correctly performed or adhered to, could result in damage to the product or loss of important data. Do not proceed beyond a **CAUTION** notice until the indicated conditions are fully understood and met.

WARNING

A **WARNING** notice denotes a hazard. It calls attention to an operating procedure, practice, or the like that, if not correctly performed or adhered to, could result in personal injury or death. Do not proceed beyond a **WARNING** notice until the indicated conditions are fully understood and met.

In This Guide...

- 1 U2020 X-Series Remote Operation** Chapter 1 describes the parameters that configure the U2020 X-Series and helps you determine the settings to optimize performance.
- 2 MEASurement Commands** Chapter 2 explains how to use the MEASure group of instructions to acquire data using a set of high-level instructions.
- 3 CALCulate Subsystem** Chapter 3 explains how the CALCulate command subsystem is used to perform post-acquisition data processing.
- 4 CALibration Subsystem** Chapter 4 explains how the CALibration command subsystem is used to zero and calibrate the U2020 X-Series.
- 5 FORMat Subsystem** Chapter 5 explains how the FORMat command subsystem is used to set a data format for transferring numeric information.
- 6 MEMory Subsystem** Chapter 6 explains how the MEMory command subsystem is used to create, edit, and review frequency-dependent offset tables.
- 7 OUTPut Subsystem** Chapter 7 explains how the OUTPut command subsystem is used to control the recorder and trigger output.
- 8 INPut Subsystem** Chapter 8 explains how the INPut command subsystem is used to set the impedance of the U2020 X-Series trigger input port.
- 9 PStatistic Subsystem** Chapter 9 explains how the PStatistic command subsystem is used to configure the settings of the Complementary Cumulative Distribution Function (CCDF), both in table and trace formats.
- 10 SENSE Subsystem** Chapter 10 explains how the SENSE command subsystem directly affects device-specific settings used to make measurements.

- 11 STATUS Subsystem** Chapter 11 explains how the STATus command subsystem enables you to examine the status of the U2020 X-Series by monitoring the “Device Status Register”, “Operation Status Register”, and “Questionable Status Register”.
- 12 SYSTem Subsystem** Chapter 12 explains how the SYSTem command subsystem is used to return error numbers and messages from the U2020 X-Series, preset the U2020 X-Series, and query the SCPI version.
- 13 TRACe Subsystem** Chapter 13 explains how the TRACe command subsystem is used to configure and read back the measured power trace.
- 14 TRIGger Subsystem** Chapter 14 explains how the TRIGger command subsystem is used to synchronize device actions with events.
- 15 UNIT Subsystem** Chapter 15 explains how the UNIT command subsystem is used to set the U2020 X-Series measurement units to Watts and % (linear), or dBm and dB (logarithmic).
- 16 SERvice Subsystem** Chapter 16 explains how the SERvice command subsystem is used to obtain and set information useful for servicing the U2020 X-Series.
- 17 IEEE-488.2 Command Reference** Chapter 17 contains information on the IEEE-488.2 Common Commands that the U2020 X-Series supports.
- 18 Programming Examples** Chapter 18 provides programming examples for the U2020 X-Series.

Contents

1 U2020 X-Series Remote Operation 1

Introduction 4

Configuring the USB Interface 5

An Introduction to the SCPI Language 6

Zeroing and Calibrating the U2020 X-Series 15

Making Measurements 16

Using Frequency-Dependent Offset Tables 28

Setting the Averaging 35

Setting Offsets 38

Setting Measurement Limits 40

Getting the Best Speed Performance 42

How Measurements are Calculated 46

Status Reporting 47

Saving and Recalling U2020 X-Series Configurations 60

Using Device Clear to Halt Measurements 61

Making Measurements on Wireless Communication Standards 62

2 MEASurement Commands 65

MEASurement Commands 67

CONFigure[1]|2|3|4? 69

CONFigure[1]|2|3|4 Commands 71

CONFigure[1]|2|3|4[:SCALar][:POWER:AC]
[<expected_value>[,<resolution>[,<source list>]]] 72

CONFigure[1]|2|3|4[:SCALar][:POWER:AC]:RELative
[<expected_value>[,<resolution>[,<source list>]]] 74

CONFigure[1]|2|3|4[:SCALar][:POWER:AC]:DIFFerence
[<expected_value>[,<resolution>[,<source list>]]] 76

CONFigure[1]|2|3|4[:SCALar][:POWER:AC]:DIFFerence:
RELative [<expected_value>[,<resolution>[,<source list>]]] 78

CONFigure[1]|2|3|4[:SCALar][:POWER:AC]:RATio

[<expected_value>[,<resolution>[,<source list>]]] **80**

CONFigure[1]|2|3|4[:SCALar][:POWer:AC]:RATio:
RELative [<expected_value>[,<resolution>[,<source list>]]] **82**

FETCh[1]|2|3|4 Queries **84**

FETCh[1]|2|3|4[:SCALar][:POWer:AC]? [<expected_value>[,<resolu-
tion>[,<source list>]]] **85**

FETCh[1]|2|3|4[:SCALar][:POWer:AC]:RELative?
 [<expected_value>[,<resolution>[,<source list>]]] **87**

FETCh[1]|2|3|4[:SCALar][:POWer:AC]:DIFFerence?
 [<expected_value>[,<resolution>[,<source list>]]] **89**

FETCh[1]|2|3|4[:SCALar][:POWer:AC]:DIFFerence:
RELative? [<expected_value>[,<resolution>[,<source list>]]] **91**

FETCh[1]|2|3|4[:SCALar][:POWer:AC]:RATio?
 [<expected_value>[,<resolution>[,<source list>]]] **94**

FETCh[1]|2|3|4[:SCALar][:POWer:AC]:RATio:RELative?
 [<expected_value>[,<resolution>[,<source list>]]] **96**

READ[1]|2|3|4 Commands **98**

READ[1]|2|3|4[:SCALar][:POWer:AC]? [<expected_value>[,<resolu-
tion>[,<source list>]]] **99**

READ[1]|2|3|4[:SCALar][:POWer:AC]:RELative?
 [<expected_value>[,<resolution>[,<source list>]]] **101**

READ[1]|2|3|4[:SCALar][:POWer:AC]:DIFFerence?
 [<expected_value>[,<resolution>[,<source list>]]] **104**

READ[1]|2|3|4[:SCALar][:POWer:AC]:DIFFerence:
RELative? [<expected_value>[,<resolution>[,<source list>]]] **106**

READ[1]|2|3|4[:SCALar][:POWer:AC]:RATio? [<expected_value>[,<resolu-
tion>[,<source list>]]] **109**

READ[1]|2|3|4[:SCALar][:POWer:AC]:RATio:RELative?
 [<expected_value>[,<resolution>[,<source list>]]] **111**

MEASure[1]|2|3|4 Commands **114**

MEASure[1]|2|3|4[:SCALar][:POWer:AC]? [<expected_value>[,<resolu-
tion>[,<source list>]]] **115**

MEASure[1]|2|3|4[:SCALar][:POWer:AC]:RELative?
 [<expected_value>[,<resolution>[,<source list>]]] **117**

MEASure[1]|2|3|4[:SCALar][:POWer:AC]:DIFFerence?
[<expected_value>,<resolution>,<source list>]] **119**
MEASure[1]|2|3|4[:SCALar][:POWer:AC]:DIFFerence:
RELative? [<expected_value>,<resolution>,<source list>]] **121**
MEASure[1]|2|3|4[:SCALar][:POWer:AC]:RATio?
[<expected_value>,<resolution>,<source list>]] **123**
MEASure[1]|2|3|4[:SCALar][:POWer:AC]:RATio:RELative?
[<expected_value>,<resolution>,<source list>]] **125**

3 CALCulate Subsystem 127

CALCulate Subsystem **128**
CALCulate[1]|2|3|4:FEED[1]|2 <string> **129**
CALCulate[1]|2|3|4:GAIN Commands **132**
CALCulate[1]|2|3|4:GAIN[:MAGNitude] <numeric_value> **133**
CALCulate[1]|2|3|4:GAIN:STATe <boolean> **135**
CALCulate[1]|2|3|4:LIMit Commands **137**
CALCulate[1]|2|3|4:LIMit:CLEar:AUTO <boolean> | ONCE **138**
CALCulate[1]|2|3|4:LIMit:CLEar[:IMMEDIATE] **140**
CALCulate[1]|2|3|4:LIMit:FAIL? **141**
CALCulate[1]|2|3|4:LIMit:FCOunt? **142**
CALCulate[1]|2|3|4:LIMit:LOWer[:DATA] <numeric_value> **144**
CALCulate[1]|2|3|4:LIMit:UPPer[:DATA] <numeric_value> **147**
CALCulate[1]|2|3|4:LIMit:STATe <boolean> **150**
CALCulate[1]|2|3|4:MATH Commands **152**
CALCulate[1]|2|3|4:MATH[:EXPRession] <string> **153**
CALCulate[1]|2|3|4:MATH[:EXPRession]:CATalogue? **155**
CALCulate[1]|2|3|4:PHOLd:CLEar **156**
CALCulate[1]|2|3|4:RELative Commands **157**
CALCulate[1]|2|3|4:RELative[:MAGNitude]:AUTO <boolean> | ONCE **158**
CALCulate[1]|2|3|4:RELative:STATe <boolean> **160**

4 CALibration Subsystem 163

CALibration Subsystem **164**
CALibration[1][:ALL] **165**
CALibration[1][:ALL]? **166**
CALibration[1]:AUTO [ONCE|ON|OFF|0|1] **167**
CALibration[1]:ZERO:AUTO [ONCE|ON|OFF|0|1] **169**
CALibration[1]:ZERO:NORMal:AUTO <boolean> **171**

5 FORMat Subsystem 173

FORMat Subsystem **174**
FORMat[:READings]:BORDER <character_data> **175**
FORMat[:READings][:DATA] <character_data> **177**

6 MEMory Subsystem 179

MEMory Subsystem **180**
MEMory:CATalog Commands **181**
MEMory:CATalog[:ALL]? **182**
MEMory:CATalog:STATe? **184**
MEMory:CATalog:TABLE? **185**
MEMory:CLEar Commands **186**
MEMory:CLEar[:NAME] <character_data> **187**
MEMory:CLEar:TABLE **188**
MEMory:FREE Commands **189**
MEMory:FREE[:ALL]? **190**
MEMory:FREE:STATe? **191**
MEMory:FREE:TABLE? **192**
MEMory:NSTates? **193**
MEMory:STATe Commands **194**
MEMory:STATe:CATalog? **195**
MEMory:STATe:DEFine <character_data>,<numeric_value> **196**
MEMory:TABLE Commands **198**
MEMory:TABLE:FREQuency <numeric_value>{,<numeric_value>} **199**

MEMory:TABLE:FREQuency:POINts? **201**
MEMory:TABLE:GAIN[:MAGNitude] <numeric_value>{,<numeric_value>}
202
MEMory:TABLE:GAIN[:MAGNitude]:POINts? **204**
MEMory:TABLE:MOVE <character_data>,<character_data> **205**
MEMory:TABLE:SElect <character_data> **206**

7 OUTPUT Subsystem 209

OUTPut:RECOOrder[1]:FEED <data_handle> **210**
OUTPut:RECOOrder[1]:LIMit:LOWer <numeric_value> **212**
OUTPut:RECOOrder[1]:LIMit:UPPer <numeric_value> **214**
OUTPut:RECOOrder[1]:STATe <boolean> **216**
OUTPut:TRIGger[:STATe] <boolean> **218**

8 INPut Subsystem 221

INPut:TRIGger:IMPedance <character_data> **222**

9 PStatistic Subsystem 225

PStatistic:CCDF:REFeRence:DATA? **226**
PStatistic:CCDF:REFeRence:POWer:AVErAge? **227**
PStatistic:CCDF:REFeRence:POWer:PEAK? **228**
PStatistic:CCDF:REFeRence:POWer:PTAVErAge? **229**
PStatistic[1]:CCDF:CONTInuous <boolean> **230**
PStatistic[1]:CCDF:COUNt <numeric_value> **232**
PStatistic[1]:CCDF:DATA? **234**
PStatistic[1]:CCDF:DATA:MAX <numeric_value> **235**
PStatistic[1]:CCDF:POWer? <numeric_value> **237**
PStatistic[1]:CCDF:PROBAbility? <numeric_value> **238**
PStatistic[1]:CCDF:STORe:REFeRence **239**
PStatistic[1]:CCDF:TABLE? **241**
PStatistic[1]:CCDF:TRACe:POWer:AVErAge? **243**
PStatistic[1]:CCDF:TRACe:POWer:PEAK? **244**

PStatic[1]:CCDF:TRACe:POWer:PTAVerage? **245**
PStatic[1]:CCDF:SWEEp:TIME <numeric_value> **246**
PStatic[1]:CCDF:SWEEp:OFFSet:TIME <numeric_value> **248**
PStatic[1]:CCDF:SWEEp[:STATe] <boolean> **250**
PStatic[1]:CCDF:SWEEp:CYCLes <numeric_value> **252**

10 SENSE Subsystem 255

[SENSe] Subsystem **257**
[SENSe[1]:]AVERAge Commands **258**
[SENSe[1]:]AVERAge:COUNt <numeric_value> **259**
[SENSe[1]:]AVERAge:COUNt:AUTO <boolean> **261**
[SENSe[1]:]AVERAge:RESet **263**
[SENSe[1]:]AVERAge:SDETECT <boolean> **264**
[SENSe[1]:]AVERAge[:STATe] <boolean> **266**
[SENSe[1]:]AVERAge2 Commands **268**
[SENSe[1]:]AVERAge2:COUNt <numeric_value> **269**
[SENSe[1]:]AVERAge2[:STATe] <boolean> **271**
[SENSe[1]:]BANDwidth|BWIDth:VIDeo <character_data> **273**
[SENSe[1]:]BUFFer:COUNt <numeric_value> **275**
[SENSe[1]:]BUFFer:MTYPe <character_data> **277**
[SENSe[1]:]CORRection Commands **279**
[SENSe[1]:]CORRection:CSET2 Commands **280**
[SENSe[1]:]CORRection:CSET2[:SElect] <string> **281**
[SENSe[1]:]CORRection:CSET2:STATe <boolean> **283**
[SENSe[1]:]CORRection:FDOffset|GAIN4[:INPut][:MAGNitude]? **285**
[SENSe[1]:]CORRection:GAIN2 Commands **286**
[SENSe[1]:]CORRection:GAIN2:STATe <boolean> **287**
[SENSe[1]:]CORRection:GAIN2[:INPut][:MAGNitude] <numeric_value>
289
[SENSe[1]:]CORRection:LOSS2 Commands **291**
[SENSe[1]:]CORRection:LOSS2:STATe <boolean> **292**

[SENSe[1]:]CORRection:LOSS2[:INPut][:MAGNitude] <numeric_value> **294**

[SENSe[1]:]DETEctor:FUNCTion <character_data> **296**

[SENSe[1]:]FREQuency[:CW|:FIXed] <numeric_value> **298**

[SENSe[1]:]FREQuency[:CW|:FIXed]:STARt <numeric_value> **300**

[SENSe[1]:]FREQuency[:CW|:FIXed]:STOP <numeric_value> **303**

[SENSe[1]:]FREQuency[:CW|:FIXed]:STEP <numeric_value> **306**

[SENSe[1]:]LIST:FREQuency:STARt <numeric_value> **309**

[SENSe[1]:]LIST:FREQuency:STOP <numeric_value> **311**

[SENSe[1]:]LIST:MTYPe <character_data> **313**

[SENSe[1]:]LIST:POINts <numeric_value> **315**

[SENSe[1]:]LIST:STATe <boolean> **317**

[SENSe[1]:]LIST:TSCoUnt <numeric_value> **319**

[SENSe[1]:]LIST:TSLot:EXCLude:OFFSet:TIME <numeric_value> **321**

[SENSe[1]:]LIST:TSLot:EXCLude:TIME <numeric_value> **323**

[SENSe[1]:]LIST:TSLot:TIME <numeric_value> **325**

[SENSe[1]:]LIST:TSLot:TREF1 <numeric_value> **327**

[SENSe[1]:]LIST:TSLot:TREF2 <numeric_value> **329**

[SENSe[1]:]MRATe <character_data> **331**

[SENSe[1]:]SWEep[1]|2|3|4 Commands **334**

[SENSe[1]:]SWEep[1]:APERture <numeric_value> **335**

[SENSe[1]:]SWEep[1]|2|3|4:AUTO <character_data> **337**

[SENSe[1]:]SWEep[1]|2|3|4:AUTO:REF1|REF2 <numeric_value> **339**

[SENSe[1]:]SWEep[1]|2|3|4:OFFSet:TIME <numeric_value> **341**

[SENSe[1]:]SWEep[1]|2|3|4:TIME <numeric_value> **343**

[SENSe[1]:]TEMPerature? **345**

SENSe[1]:TRACe Commands **346**

SENSe[1]:TRACe:AUToscale **347**

SENSe[1]:TRACe:OFFSet:TIME <numeric_value> **348**

SENSe[1]:TRACe:TIME <numeric_value> **350**

[SENSe[1]:]TRACe:UNIT <character_data> **352**

11 STATus Subsystem 355

STATus Subsystem **356**

Status Register Set Commands **358**

Device Status Register Sets **363**

Operation Register Sets **364**

STATus:OPERation **365**

STATus:OPERation:CALibrating[:SUMMARY] **366**

STATus:OPERation:LLFail[:SUMMARY] **367**

STATus:OPERation:MEASuring[:SUMMARY] **368**

STATus:OPERation:SENSe[:SUMMARY] **369**

STATus:OPERation:TRIGger[:SUMMARY] **370**

STATus:OPERation:ULFail[:SUMMARY] **371**

STATus:PRESet **372**

Questionable Register Sets **373**

STATus:QUEStionable **374**

STATus:QUEStionable:CALibration[:SUMMARY] **375**

STATus:QUEStionable:POWer[:SUMMARY] **376**

12 SYSTem Subsystem 379

SYSTem Subsystem **380**

SYSTem:ERRor? **381**

SYSTem:HELP:HEADers? **387**

SYSTem:PRESet <character_data> **388**

SYSTem:VERSion? **433**

13 TRACe Subsystem 435

TRACe Subsystem **436**

TRACe[1][:DATA]? <character_data> **437**

TRACe[1]:DEFine:DURation:REFerence<numeric_value> **439**

TRACe[1]:DEFine:TRANsition:REFerence <numeric_value>,
<numeric_value> **441**

TRACe[1]:MEASurement:INSTant:REFerence? <numeric_value> **443**

TRACe[1]:MEASurement:PULSe[1]|...|20:DCYCLE? **444**
TRACe[1]:MEASurement:PULSe[1]|...|20:DURation? **445**
TRACe[1]:MEASurement:PULSe[1]|...|20:PERiod? **447**
TRACe[1]:MEASurement:PULSe[1]|...|20:SEPAration? **449**
TRACe[1]:MEASurement:TRANsition[1]|...|20:NEGative:
DURation? **451**
TRACe[1]:MEASurement:TRANsition[1]|...|20:NEGative:
OCCurrence? **452**
TRACe[1]:MEASurement:TRANsition[1]|...|20:POSitive:
DURation? **453**
TRACe[1]:MEASurement:TRANsition[1]|...|20:POSitive:
OCCurrence? **454**
TRACe[1]:MEASurement:REFerence? <numeric_value> **455**
TRACe[1]:STATe <boolean> **457**
TRACe[1]:UNIT <character_data> **459**

14 TRIGger Subsystem 461

TRIGger Subsystem **462**
ABORt[1] **463**
INITiate Commands **464**
INITiate[1]:CONTInuous <boolean> **465**
INITiate[1][:IMMEDIATE] **467**
INITiate:CONTInuous:ALL <boolean> **468**
INITiate:CONTInuous:SEQuence[1] <boolean> **470**
INITiate[:IMMEDIATE]:ALL **472**
INITiate[:IMMEDIATE]:SEQuence[1] **473**
TRIGger Commands **474**
TRIGger[1]:DELay:AUTO <boolean> **475**
TRIGger[1][:IMMEDIATE] **477**
TRIGger[1]:SOURce BUS|EXTernal|HOLD|IMMEDIATE|INTernal[1] **478**
TRIGger[:SEQuence]:DELay <numeric_value> **481**
TRIGger[:SEQuence]:HOLDoff <numeric_value> **483**

TRIGger[:SEQuence]:HYSTeresis <numeric_value> **485**
TRIGger[:SEQuence]:LEVel <numeric_value> **487**
TRIGger[:SEQuence]:LEVel:AUTO <boolean> **489**
TRIGger[:SEQuence]:SLOPe <character_data> **491**
TRIGger[:SEQuence[1]]:COUNt <numeric_value> **493**
TRIGger[:SEQuence[1]]:DELay:AUTO <boolean> **495**
TRIGger[:SEQuence[1]]:IMMediate **497**
TRIGger[:SEQuence[1]]:QUALifier:TIME <numeric_value> **498**
TRIGger[:SEQuence[1]]:SOURce BUS | EXTernal | HOLD | IMMediate | INTer-
nal[1] **500**

15 UNIT Subsystem 503

UNIT Subsystem **504**
UNIT[1]|2|3|4:POWer <amplitude_unit> **505**
UNIT[1]|2|3|4:POWer:RATio <ratio_unit> **507**

16 SERVICE Subsystem 509

SERVice:BIST:CW:ZSET:NUMber? **510**
SERVice:BIST:PEAK[1]:LINearity **511**
SERVice:BIST:PEAK[1]:LINearity:PERRor? **512**
SERVice:BIST:PEAK[1]:ZSET **513**
SERVice:BIST:PEAK[1]:ZSET:NUMber? **514**
SERVice:BIST:RAM:MODE <character_data> **515**
SERVice:BIST:TBASE:STATe <boolean> **517**
SERVice:BIST:VIDeo:STATe <boolean> **519**
SERVice:SECure:ERASe **521**
SERVice:SENSor[1]:CDATe? **522**
SERVice:SENSor[1]:CPLace? **523**
SERVice:SENSor[1]:FREQuency:MAXimum? **524**
SERVice:SENSor[1]:FREQuency:MINimum? **525**
SERVice:SENSor[1]:POWer:AVERage:MAXimum? **526**
SERVice:SENSor[1]:POWer:PEAK:MAXimum? **527**

SERVICE:SENSOR[1]:POWER:USABLE:MAXimum? **528**
SERVICE:SENSOR[1]:POWER:USABLE:MINimum? **529**
SERVICE:SENSOR[1]:RADC? **530**
SERVICE:SENSOR[1]:SNUMBER? **531**
SERVICE:SENSOR[1]:TNUMBER? **532**
SERVICE:SENSOR[1]:TYPE? **533**
SERVICE:SNUMBER? **534**
SERVICE:VERSION:PROCESSOR <character_data> **535**
SERVICE:VERSION:SYSTEM <character_data> **536**

17 IEEE-488.2 Command Reference 537

SCPI Compliance Information **538**

*CLS **539**

*DDT <arbitrary block program data> | <string program data> **540**

*ESE <NRf> **542**

*ESR? **544**

*IDN? **545**

*OPC **546**

*OPT? **547**

*RCL <NRf> **548**

*RST **549**

*SAV <NRf> **550**

*SRE <NRf> **551**

*STB? **553**

*TRG **554**

*TST? **555**

*WAI **556**

18 Programming Examples 557

Example 1: Two Time Slot GSM Measurement **558**

Example 2: Achieve Measurement Speed of >20000 Readings/s **559**

THIS PAGE HAS BEEN INTENTIONALLY LEFT BLANK.

List of Figures

- Figure 1-1** Hierarchical structure of SCPI **6**
- Figure 1-2** Format of <character_data> **9**
- Figure 1-3** Format of <non-decimal numeric> **10**
- Figure 1-4** Format of <NR1> **11**
- Figure 1-5** Format of <NR2> **11**
- Figure 1-6** Format of <NR3> **12**
- Figure 1-7** Format of <string> **13**
- Figure 1-8** Frequency-dependent offset tables **29**
- Figure 1-9** Typical averaged readings **36**
- Figure 1-10** Averaging range hysteresis **36**
- Figure 1-11** Limits checking results **40**
- Figure 1-12** How measurements are calculated **46**
- Figure 1-13** Generalized status register model **48**
- Figure 1-14** Typical status register bit changes **49**
- Figure 1-15** Status system **51**
- Figure 3-1** CALCulate block **128**
- Figure 12-1** IEEE-488.2 arbitrary block program data format **387**

THIS PAGE HAS BEEN INTENTIONALLY LEFT BLANK.

List of Tables

Table 1-1	MEASure? and CONFigure preset states	16
Table 1-2	Range of values for limits	41
Table 1-3	Bit definitions - Status byte register	52
Table 1-4	Bit definitions - Standard event register	53
Table 1-5	Bit definitions - Questionable status registers	54
Table 1-6	Bit change conditions for questionable status register	55
Table 1-7	Bit definitions - Operation status	56
Table 1-8	Bit change conditions for operation status	57
Table 1-9	Bit definitions - Device status register	58
Table 1-10	Bit change conditions for device status register	58
Table 3-1	Measurement units	144
Table 3-2	Measurement units	147
Table 6-1	Frequency and offset factor list	202
Table 11-1	Commands and events affecting the status register	356
Table 12-1	DEfault: U2020 X-Series presets	390
Table 12-2	GSM900: U2020 X-Series presets	392
Table 12-3	GSM900: U2020 X-Series presets for calc setup	393
Table 12-4	EDGE: U2020 X-Series presets	394
Table 12-5	EDGE: U2020 X-Series presets for calc setup	396
Table 12-6	NADC: U2020 X-Series presets	397
Table 12-7	NADC: U2020 X-Series presets for calc setup	398
Table 12-8	BLUetooth: U2020 X-Series presets	399
Table 12-9	BLUetooth: U2020 X-Series presets for calc setup	400
Table 12-10	CDMAone: U2020 X-Series presets	401
Table 12-11	CDMAone: U2020 X-Series presets for calc setup	402
Table 12-12	W-CDMA: U2020 X-Series presets	403
Table 12-13	W-CDMA: U2020 X-Series presets for calc setup	404
Table 12-14	CDMA2000: U2020 X-Series presets	405
Table 12-15	CDMA2000: U2020 X-Series presets for calc setup	406
Table 12-16	iDEN: U2020 X-Series presets	407
Table 12-17	iDEN:: U2020 X-Series presets for calc setup	408
Table 12-18	MCPa: U2020 X-Series presets	409
Table 12-19	MCPa: U2020 X-Series presets for calc setup	410
Table 12-20	RADar: U2020 X-Series presets	410
Table 12-21	RADar: U2020 X-Series presets for calc setup	411

Table 12-22	WL802DOT11A: U2020 X-Series presets	412
Table 12-23	WL802DOT11A: U2020 X-Series presets for calc setup	413
Table 12-24	WL802DOT11B: U2020 X-Series presets	413
Table 12-25	WL802DOT11B: U2020 X-Series presets for calc setup	414
Table 12-26	XEVD0: U2020 X-Series presets	415
Table 12-27	XEVD0: U2020 X-Series presets for calc setup	416
Table 12-28	XEVDV: U2020 X-Series presets	417
Table 12-29	XEVDV: U2020 X-Series presets for calc setup	418
Table 12-30	TDSCdma: U2020 X-Series presets	418
Table 12-31	TDSCdma: U2020 X-Series presets for calc setup	419
Table 12-32	DVB: U2020 X-Series presets	420
Table 12-33	TDVB: U2020 X-Series presets for calc setup	421
Table 12-34	HIPERLAN2: U2020 X-Series presets	422
Table 12-35	HIPERLAN2: U2020 X-Series presets for calc setup	423
Table 12-36	WIMAX: U2020 X-Series presets	423
Table 12-37	WIMAX: U2020 X-Series presets for calc setup	424
Table 12-38	HSDPA: U2020 X-Series presets	425
Table 12-39	HSDPA: U2020 X-Series presets for calc setup	426
Table 12-40	DME: U2020 X-Series presets	427
Table 12-41	DME: U2020 X-Series presets for calc setup	428
Table 12-42	DMEPRT: U2020 X-Series presets	429
Table 12-43	DMEPRT: U2020 X-Series presets for calc setup	430
Table 12-44	LTE: U2020 X-Series presets	431
Table 12-45	LTE: U2020 X-Series presets for calc setup	432
Table 17-1	*ESE mapping	542
Table 17-2	*ESR? mapping	544
Table 17-3	*SRE mapping	551
Table 17-4	*STB? mapping	553

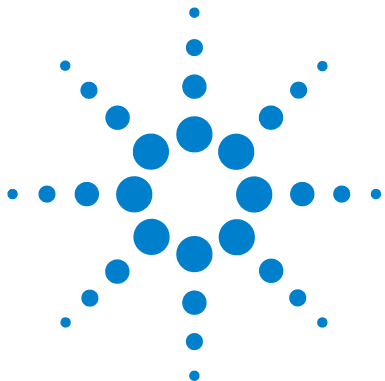

1 U2020 X-Series Remote Operation

- Introduction 4
- Configuring the USB Interface 5
 - Mnemonic forms 6
 - Using a colon (:) 6
 - Using a semicolon (;) 7
 - Using a comma (,) 7
 - Using whitespace 7
 - Using “?” commands 7
 - Using “*” commands 8
 - Syntax conventions 8
 - Syntax diagram conventions 8
 - SCPI data types 9
 - Input message terminators 14
- Zeroing and Calibrating the U2020 X-Series 15
 - Zeroing 15
 - Calibration 15
- Making Measurements 16
 - Using MEASure? 17
 - Using the CONFigure command 20
 - Using the lower-level commands 27



Using Frequency-Dependent Offset Tables	28
• Overview	28
• Editing frequency-dependent offset tables	30
• Selecting a frequency-dependent offset table	33
• Enabling a frequency-dependent offset table	33
• Making the measurement	33
Setting the Averaging	35
• Averaging	35
• Auto-averaging mode	35
• Filter length	37
Setting Offsets	38
• Channel offsets	38
• CALCulate offsets	38
Setting Measurement Limits	40
• Setting limits	40
• Checking for limit failures	41
Getting the Best Speed Performance	42
• Measurement rate	42
• Trigger mode	43
• Output format	44
• Units	44
• Command used	44
• Fast mode	45
How Measurements are Calculated	46

Status Reporting 47

- The general status register model 47
- How to use registers 50
- Device Status register 58
- Using the Operation Complete commands 59

Saving and Recalling U2020 X-Series Configurations 60

- How to save and recall a configuration 60

Using Device Clear to Halt Measurements 61**Making Measurements on Wireless Communication Standards 62**

- Starting a preset example 63

This chapter describes the parameters that configure the U2020 X-Series and helps you determine settings to optimize performance.

Introduction

This chapter contains the following sections:

- “Configuring the USB Interface” on page 5.
- “An Introduction to the SCPI Language” on page 6
- “Zeroing and Calibrating the U2020 X-Series” on page 15.
- “Making Measurements” on page 16.
- “Using Frequency-Dependent Offset Tables” on page 28.
- “Setting the Averaging” on page 35.
- “Setting Offsets” on page 38.
- “Setting Measurement Limits” on page 40.
- “Getting the Best Speed Performance” on page 42.
- “How Measurements are Calculated” on page 46.
- “Status Reporting” on page 47.
- “Saving and Recalling U2020 X-Series Configurations” on page 60.
- “Using Device Clear to Halt Measurements” on page 61.
- “Making Measurements on Wireless Communication Standards” on page 62.

Configuring the USB Interface

The USB interface requires no front panel or remote configuration.

Before connecting the USB cable, make sure that the Agilent IO Libraries software is installed on your PC.

NOTE

For further information on connecting and verifying the U2020 X-Series via USB, refer to the *U2020 X-Series User's Guide*.

NOTE

- For more information on configuring the USB remote interface connectivity, refer to the *Agilent USB/LAN/GPIB Interfaces Connectivity Guide*.
 - If you have installed the IO Libraries Suite, you can access the Connectivity Guide via the IO Libraries Control icon or via the Web at www.agilent.com/find/connectivity.
 - If you have installed other I/O software, refer to the documentation that accompanies the software.
-

An Introduction to the SCPI Language

Standard Commands for Programmable Instruments (SCPI) defines how you communicate with an instrument from a bus controller. The SCPI language uses a hierarchical structure similar to the file systems used by many bus controllers. The command tree is organized with root-level commands (also called subsystems) positioned at the top, with multiple levels below each root-level command. You must specify the complete path to execute the individual lower-level commands.

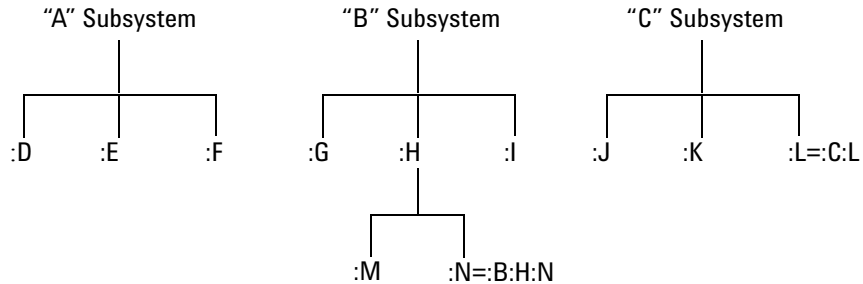

Figure 1-1 Hierarchical structure of SCPI

Mnemonic forms

Each keyword has both a long form and a short form. A standard notation is used to differentiate the short form keyword from the long form keyword. The long form of the keyword is shown, with the short form portion shown in uppercase characters, and the rest of the keyword shown in lower-case characters. For example, the short form of TRIGger is TRIG.

Using a colon (:)

When a colon is the first character of a command keyword, it indicates that the next command mnemonic is a root-level command. When a colon is inserted between two command mnemonics, the colon moves the path

down one level in the present path (for the specified root-level command) of the command tree. You *must* separate command mnemonics from each other using a colon. *You can omit the leading colon if the command is the first of a new program line.*

Using a semicolon (;)

Use a semicolon to separate two commands within the same command string. The semicolon does not change the present path specified. For example, the following two statements are equivalent. Note that in the first statement, the first colon is optional but the third is compulsory.

```
SENS: AVER ON; SENS: AVER: COUN 1
SENS: AVER ON; AVER: COUN 1
```

Using a comma (,)

If a command requires more than one parameter, you must separate adjacent parameters using a comma.

Using whitespace

You *must* use whitespace characters, [tab], or [space] to separate a parameter from a command keyword. Whitespace characters are generally ignored *only* in parameter lists.

Using “?” commands

The bus controller may send commands at any time, but a SCPI instrument may only send responses when *specifically* instructed to do so. Only query commands (commands that end with a “?”) instruct the instrument to send a response message. Queries return either measured values or internal instrument settings.

NOTE

If you send two query commands without reading the response from the first, then attempt to read the second response, you may receive some data from the first response followed by the complete second response. To avoid this, do not send a query command without reading the response. When you cannot avoid this situation, send a device clear before sending the second query command.

Using “*” commands

Commands starting with a “*” are called common commands. They are required to perform the identical function for *all* instruments that are compliant with the IEEE-488.2 interface standard. The “*” commands are used to control reset, self-test, and status operations in the U2020 X-Series.

Syntax conventions

Throughout this guide, the following conventions are used for the SCPI command syntax.

- Square brackets ([]) indicate optional keywords or parameters.
- Braces ({ }) enclose one or more parameters that may be included zero or more times.
- Triangle brackets (< >) indicate that you must substitute a value for the enclosed parameter.
- Bars (|) can be read as “or” and are used to separate alternative parameter options.

Syntax diagram conventions

- Solid lines represent the recommended path.
- Ovals enclose command mnemonics. The command mnemonic must be entered exactly as shown.

- Dotted lines indicate an optional path for by passing secondary keywords.
- Arrows and curved intersections indicate command path direction.

SCPI data types

The SCPI language defines different data formats for use in program messages and response messages. Instruments are flexible listeners and can accept commands and parameters in various formats. However, SCPI instruments are precise talkers. This means that SCPI instruments *always* respond to a particular query in a predefined, rigid format.

<boolean> definition

Throughout this document, <boolean> is used to represent ON|OFF|<Nrf>. Boolean parameters have a value of 0 or 1 and are unitless. ON corresponds to 1 and OFF corresponds to 0.

On input, an <Nrf> is rounded to an integer. A nonzero result is interpreted as 1.

Queries always return a 1 or 0, never ON or OFF.

<character_data> definition

Throughout this document, <character_data> is used to represent character data, that is, A-Z, a-z, 0-9 and _ (underscore). For example: START and R6_5F. The format is defined as:

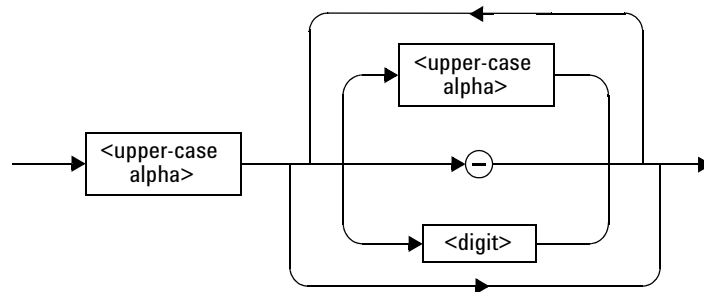

Figure 1-2 Format of <character_data>

<NAN> definition

Not a number (NAN) is represented as 9.91E37. Not a number is defined in IEEE 754.

<non-decimal numeric> definition

Throughout this document, <non-decimal numeric> is used to represent numeric information in bases other than 10 (that is, hexadecimal, octal, and binary). The following syntax diagram shows the standard for these three data structures. For example: #HA2F, #ha4e, #Q62, #q15, #B01011.

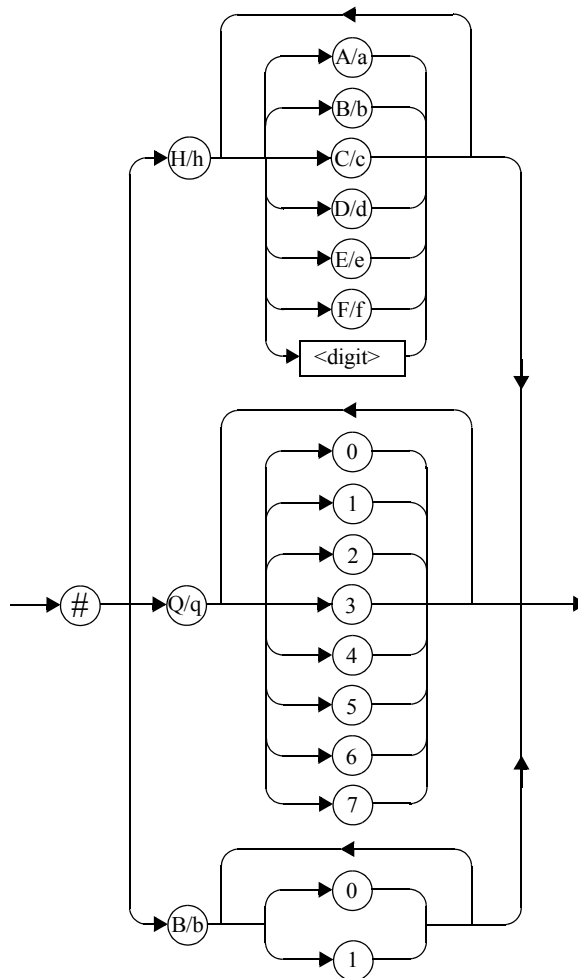

Figure 1-3 Format of <non-decimal numeric>

Refer to section 7.7.4.1 of IEEE 488.2 for further details.

<NRf> definition

Throughout this document, <NRf> is used to denote a flexible numeric representation. For example: +200; -56; +9.9E36. Refer to section 7.7.2.1 of IEEE 488.2 for further details.

<NR1> definition

Throughout this document, the <NR1> numeric response data is defined as:

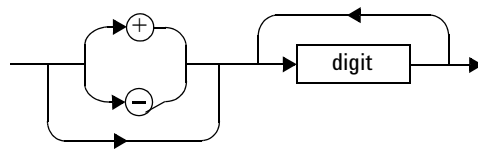

Figure 1-4 Format of <NR1>

For example:

- 146
- +146
- -12345

Refer to section 8.7.2 of IEEE 488.2 for further details.

<NR2> definition

Throughout this document, the <NR2> numeric response data is defined as:

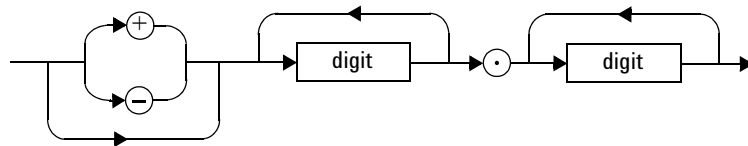

Figure 1-5 Format of <NR2>

For example:

- 12.3
- +1.2345
- -0.123

Refer to section 8.7.3 of IEEE 488.2 for further details.

<NR3> definition

Throughout this document, the <NR3> numeric response data is defined as:

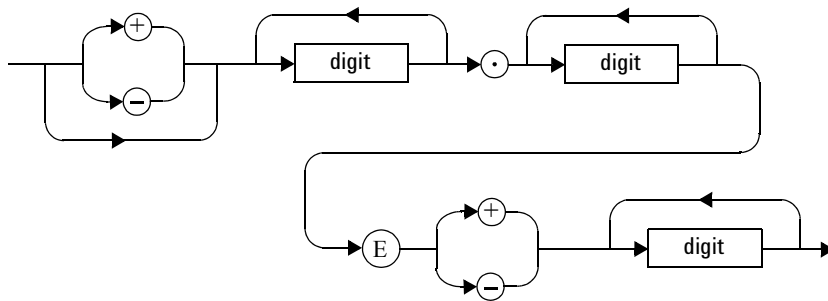

Figure 1-6 Format of <NR3>

For example:

- 1.23E+6
- 123.4E-54
- -1234.567E+90

Refer to section 8.7.4 of IEEE 488.2 for further details.

<numeric_value> definition

Throughout this document, the decimal numeric element is abbreviated to <numeric_value>. For example: <NRf>, MINimum, MAXimum, DEFault, or Not A Number (NaN).

<string> definition

Throughout this document, <string> is used to represent 7-bit ASCII characters.

The format is defined as:

Program Data

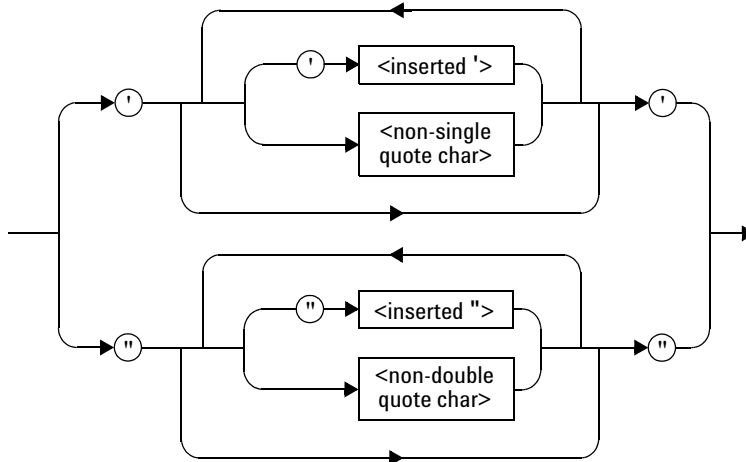

Response Data

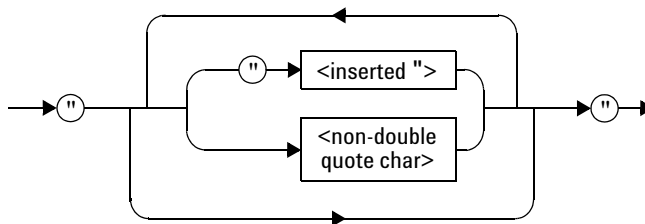

Figure 1-7 Format of <string>

Input message terminators

Program messages sent to a SCPI instrument *must* terminate with a <newline> character. The IEEE.488 EOI (end or identify) signal is interpreted as a <newline> character and may also be used to terminate a message in place of the <newline> character. A <carriage return> followed by a <newline> is also accepted. Many programming languages allow you to specify a message terminator character or EOI state to be automatically sent with each bus transaction. Message termination *always* sets the current path back to the root-level.

Zeroing and Calibrating the U2020 X-Series

Zeroing

Zeroing adjusts the U2020 X-Series for a zero power reading.

The command `CALibration[1]:ZERO:AUTO [ONCE|ON|OFF|0|1]` causes the U2020 X-Series to perform its auto-zeroing routine when enabled.

When 1 or ON is specified, zero is maintained by a combination of zero on-the-fly for measurements and temperature compensation.

Zeroing of the U2020 X-Series occurs automatically:

- on power up.
- every 5 seconds.
- prior to measuring low-level signals, for example, 10 dB above the lowest specified power for the U2020 X-Series.

Calibration

The command used to auto-calibrate the U2020 X-Series is:

```
CALibration[1]:AUTO ONCE
```

It is recommended that you zero the U2020 X-Series before calibrating.

`CALibration[1][:ALL]` allows you to perform calibration with a single command. This calibration consists of zeroing the U2020 X-Series.

You can query the calibration status by sending

```
CALibration[1][:ALL]?
```

If the result is 0, the calibration is successful. If the result is 1, the calibration has failed.

NOTE

The `CALibration[1][:ALL]` command is identical to the `CALibration[1][:ALL]?` query except that no number is returned to indicate the outcome of the calibration sequence. You can examine the **Questionable Status Register** or the error queue to determine if the sequence has passed or failed. Refer to [“Status Reporting”](#) on page 47 for further information.

Making Measurements

The MEASure? and CONFigure commands provide a straightforward method to program the U2020 X-Series for measurements. You can select the measurement expected power level, resolution, and measurement type (single channel, difference, or ratio measurements) in one command. The U2020 X-Series automatically presets other measurement parameters to the default values as shown in [Table 1-1](#) below.

Table 1-1 MEASure? and CONFigure preset states

Command	MEASure? and CONFigure settings
Trigger source (TRIGger:SOURce)	Immediate
Filter (SENSe:AVERAge:COUNT:AUTO)	On
Filter state (SENSe:AVERAge[:STATe])	On
Trigger cycle (INITiate:CONTinuous)	Off
Trigger delay (TRIGger:DELay:AUTO)	On

An alternative method to program the U2020 X-Series is to use the lower-level commands. The advantage of using the lower-level commands over the MEASure? query and CONFigure command is that they give you more precise control of the U2020 X-Series. As shown in [Table 1-1](#), the CONFigure command presets various states in the U2020 X-Series. It may be likely that you do not want to preset these states. Refer to [“Using the lower-level commands”](#) on page 27 for further information.

Using MEASure?

The simplest way to program the U2020 X-Series for measurements is by using the `MEASure?` query. However, this query does not offer much flexibility. When you execute the query, the U2020 X-Series selects the best settings for the requested configuration and immediately performs the measurement. You cannot change any settings (other than the expected power value, resolution, and measurement type) before the measurement is taken. This means you cannot fine tune the measurement, for example, you cannot change the filter length. To make more flexible and accurate measurements, use the `CONFIGure` command. `MEASure?` is a compound command which is equivalent to an `ABORT`, followed by a `CONFigure` and a `READ?`.

MEASure? examples

The following commands show a few examples of how to use the `MEASure?` query to make a measurement. It is advisable to read through these examples in order as they become increasingly more detailed. These examples configure the U2020 X-Series for a measurement (as described in each individual example), automatically place the U2020 X-Series in the “wait-for-trigger” state, internally trigger the U2020 X-Series to take one reading, and then send the reading to the output buffer.

These examples give an overview of the `MEASure?` query. For further information on `MEASure?`, refer to “[MEASure\[1\]|2|3|4 Commands](#)” on page 114.

Example 1 - The simplest method

The following commands show the simplest method of making measurements; using `MEAS1?` results in a `CALCulate1` measurement, and `MEAS2?` in a `CALCulate2` measurement. The channel can be set using the source list parameter (see “[Example 2 - Specifying the source list parameter](#)”), or defaults as in this example.

specifies `CALCulate` subsystem
 ↓
`MEAS1?`
`MEAS2?`

Example 2 - Specifying the source list parameter

The MEASure? query has three optional parameters: an expected power value, a resolution, and a source list. These parameters must be entered in the specified order. If parameters are omitted, they default from the right. The parameter DEFault is used as a placeholder.

The source list parameter is used to specify a measurement channel. The U2020 X-Series supports only one channel. Therefore, the only valid value is (@1). The expected power and resolution parameters are set to their default values, leaving them at their current settings.

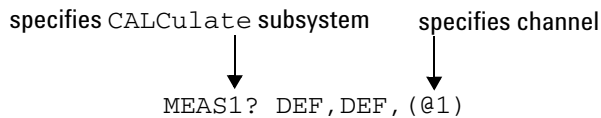

Example 3 - Specifying the expected power parameter

The previous example details the three optional parameters which can be used with the MEASure? query. The first optional parameter is used to enter an expected power value.

The following example uses the expected value parameter to specify a value of -30 dBm. The resolution parameter is defaulted, leaving it at its current setting.

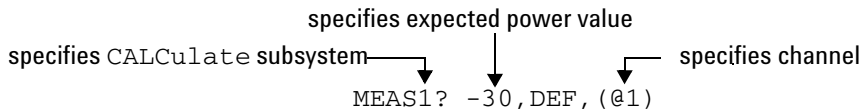

Example 4 - Specifying the resolution parameter

The previous examples detailed the use of the expected value and source list parameters. The resolution parameter is used to set the resolution of the specified CALCulate subsystem. This parameter does not affect the resolution of the data, however it does affect the auto-averaging setting (refer to Figure 1-9).

The following example uses the resolution parameter to specify a resolution setting of 3. This setting represents three significant digits if the measurement suffix is W or %, and 0.01 dB if the suffix is dB or dBm.

Refer to [Chapter 2, “MEASurement Commands”](#) on page 65 for further details on the resolution parameter. The expected power and source list parameters are defaulted in the example. The expected power value remains unchanged at its current setting. Note that as the source list parameter is the last specified parameter, you do not have to specify DEF.

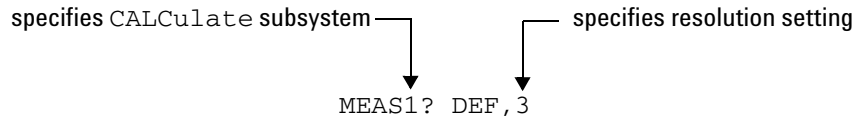

Example 5 - Making a difference measurement

The following example queries the CALCulate2 subsystem to make a difference measurement of Channel A – Channel A. The expected power level and resolution parameters are defaulted, leaving them at their current settings.

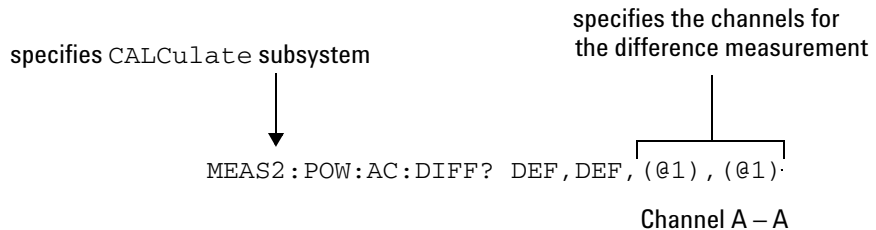

Example 6 - Making a ratio measurement

The following example queries the CALCulate1 subsystem to make a ratio measurement of Channel A/A. The expected power level and resolution parameters are defaulted, leaving them at their current settings.

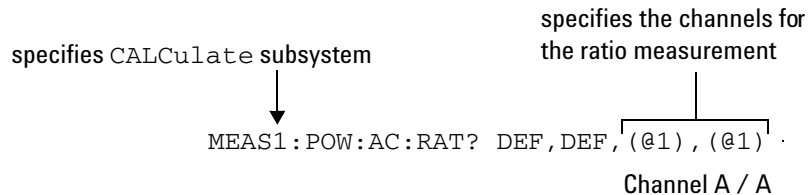

Using the CONFigure command

When you execute this command, the U2020 X-Series presets the optimum settings for the requested configuration (like the MEASure? query). However, the measurement is not automatically started and you can change measurement parameters before making measurements. This allows you to change the U2020 X-Series configuration from the preset conditions. The U2020 X-Series offers a variety of low-level commands in the SENSE, CALCulate, and TRIGger subsystems. For example, if you want to change the averaging, use the [SENSe[1]:]AVERAge:COUNT command.

Use the INITiate or READ? query to initiate the measurement.

Using READ?

CONFigure does not take the measurement. One method of obtaining a result is to use the READ? query. The READ? query takes the measurement using the parameters set by the CONFigure command and then sends the reading to the output buffer. Using the READ? query obtains new data.

Using INITiate and FETCh?

CONFigure does not take the measurement. One method of obtaining the result is to use the INITiate and FETCh? commands. The INITiate command causes the measurement to be taken. The FETCh? query retrieves a reading when the measurement is complete, and sends the reading to the output buffer. FETCh? can be used to obtain the measurement results in a number of different formats without taking fresh data for each measurement.

CONFigure examples

The following program segments show how to use the commands READ?, INITiate, FETCh?, and CONFigure to make measurements.

It is advisable to read through these examples in order as they become increasingly more detailed.

These examples give an overview of the CONFigure command. For further information on the CONFigure commands, refer to [Chapter 2](#), “MEASurement Commands” on page 65.

Example 1 - The simplest method

The following program segments show the simplest method of querying the measurement results of the CALCulate subsystem.

Using READ?

```
*RST          Resets the U2020 X-Series.
CONF1        Configures CALCulate1 - defaults to a Channel A
              measurement.
READ1?       Takes the CALCulate1 measurement.
```

```
*RST          Resets the U2020 X-Series.
CONF2        Configures CALCulate2 - defaults to a Channel A
              measurement.
READ2?       Takes the CALCulate2 measurement.
```

Using INITiate and FETCh?

```
*RST          Resets the U2020 X-Series.
CONF1        Configures CALCulate1 - defaults to a Channel A
              measurement.
INIT1?       Causes Channel A to make a measurement.
FETC1?       Retrieves the CALCulate1 measurement.
```

```
*RST          Resets the U2020 X-Series.
CONF2        Configures CALCulate2 - defaults to a Channel A
              measurement.
INIT1        Causes Channel A to make a measurement.
FETC2?       Retrieves the CALCulate2 measurement.
```

Example 2 - Specifying the source list parameter

The CONFigure and READ? commands have three optional parameters: an expected power value, a resolution, and a source list. These parameters must be entered in the specified order. If parameters are omitted, they default from the right. The parameter DEFault is used as a placeholder.

The following examples use the source list parameter to specify the measurement channel as Channel A. The expected power and resolution parameters are defaulted, leaving them at their current settings.

Although the READ? and FETCh? queries have three optional parameters, it is not necessary to define them as shown in these examples. If they are defined, they must be identical to those defined in the CONFigure command otherwise an error occurs.

Using READ?

ABOR1	<i>Aborts Channel A.</i>
CONF1 DEF,DEF, (@1)	<i>Configures CALCulate1 to make a Channel A measurement using the current expected power and resolution settings.</i>
READ1?	<i>Takes the CALCulate1 measurement.</i>

Using INITiate and FETCh?

ABOR1	<i>Aborts Channel A.</i>
CONF1 DEF,DEF, (@1)	<i>Configures CALCulate1 to make a Channel A measurement using the current expected power and resolution settings.</i>
INIT1	<i>Causes Channel A to make a measurement.</i>
FETC1? DEF,DEF, (@1)	<i>Retrieves the CALCulate1 measurement.</i>

Example 3 - Specifying the expected power parameter

The previous example details the three optional parameters which can be used with the CONFigure and READ? commands. The first optional parameter is used to enter an expected power value.

The following example uses the expected value parameter to specify a value of -30 dBm. The resolution parameter is defaulted, leaving it at its current setting. The source list parameter specifies a Channel A measurement.

Using READ?

ABOR1	<i>Aborts Channel A.</i>
CONF1 -30,DEF, (@1)	<i>Configures CALCulate1 to make a Channel A measurement using an expected power of -30 dBm and the current resolution setting.</i>
READ1?	<i>Takes the CALCulate1 measurement.</i>

Some fine tuning of measurements can be performed using the CONFIGure and READ? commands. For example, in the above program segment, some fine tuning can be performed by setting the filter length to 1024 and the trigger delay off.

```

1 ABOR1
2 CONF1 -30,DEF, (@1)
3 SENS1:AVER:COUN 1024
4 TRIG1:DEL:AUTO OFF
5 READ1?

```

Using INITiate and FETCh?

ABOR1	<i>Aborts Channel A.</i>
CONF1 -30,DEF, (@1)	<i>Configures CALCulate1 to make a Channel A measurement using an expected power of -30 dBm and the current resolution setting.</i>
INIT1	<i>Causes Channel A to make a measurement.</i>
FETC1? -30,DEF, (@1)	<i>Retrieves the CALCulate1 measurement.</i>

Some fine tuning of measurements can be carried out using the CONFIGure command and INITiate and FETCh? commands. For example, in the above program segment, some fine tuning can be carried out by setting the filter length to 1024 and the trigger delay off.

```

1 ABOR1
2 CONF1 -30,DEF, (@1)
3 SENS1:AVER:COUN 1024

```

```
4 TRIG1:DEL:AUTO OFF
5 INIT1
6 FETC1? -30,DEF, (@1)
```

Example 4 - Specifying the resolution parameter

The previous examples detailed the use of the expected value and source list parameters. The resolution parameter is used to set the resolution of the specified CALCulate subsystem. This parameter does not affect the resolution of the data, however it does affect the auto-averaging setting (refer to [Figure 1-9 on page 36](#)).

The following example uses the resolution parameter to specify a resolution setting of 3. This setting represents three significant digits if the measurement suffix is W or %, and 0.01 dB if the suffix is dB or dBm (for further details on the resolution parameter, refer to the commands in [Chapter 2](#), “MEASurement Commands”). Also, in this example, the expected power and source list parameters are defaulted. The expected power value is left unchanged at its current setting. Note that as the source list parameter is the last specified parameter, you do not have to specify DEF.

Using READ?

ABOR1	<i>Aborts Channel A.</i>
CONF1 DEF, 3	<i>Configures CALCulate1 to make a measurement using the current setting of the expected power and source list and a resolution setting of 3.</i>
READ1?	<i>Takes the CALCulate1 measurement.</i>

Some fine tuning of the above program segment can be carried out, for example, by setting the trigger delay off.

```
1 ABOR1
2 CONF1 DEF, 3
3 TRIG1:DEL:AUTO OFF
4 READ1?
```

Using INITiate and FETCh?

ABOR1	<i>Aborts Channel A.</i>
CONF1 DEF, 3	<i>Configures CALCulate1 to make a measurement using the current setting of the expected power and source list and a resolution setting of 3.</i>
INIT1	<i>Causes Channel A to make a measurement.</i>
FETC1? DEF, 3	<i>Retrieves the CALCulate1 measurement.</i>

Some fine tuning of the above program segment can be carried out, for example, by setting the trigger delay off.

```

1 ABOR1
2 CONF1 DEF, 3
3 TRIG1:DEL:AUTO OFF
4 INIT1:IMM
5 FETC1? DEF, 3

```

Example 5 - Making a difference measurement

The following program segment queries the CALCulate2 subsystem to make a difference measurement of Channel A – Channel A. The expected power level and resolution parameters are defaulted, leaving them at their current settings. Some fine tuning of the measurement is carried out by setting the averaging, and the trigger delay to off.

Using READ?

```

ABOR1
CONF2:POW:AC:DIFF DEF, DEF, (@1), (@1)
SENS1:AVER:COUN 1024
TRIG1:DEL:AUTO OFF
READ2:POW:AC:DIFF?
READ2:POW:AC:DIFF? DEF, DEF, (@1), (@1) (A second READ? query is sent to make a Channel A – Channel A measurement using fresh measurement data).

```

Using INITiate and FETCh?

```
ABOR1
CONF2:POW:AC:DIFF DEF,DEF, (@1), (@1)
SENS1:AVER:COUN 1024
TRIG1:DEL:AUTO OFF
INIT1:IMM
FETC2:POW:AC:DIFF?
FETC2:POW:AC:DIFF? DEF,DEF, (@1), (@1) (A second FETCh? query is sent to make a Channel A – Channel A measurement using the current measurement data).
```

Example 6 - Making a ratio measurement

The following program segment queries the CALCulate2 subsystem to make a ratio measurement of Channel A/A. The expected power level and resolution parameters are defaulted, leaving them at their current settings. Some fine tuning of the measurement is carried out by setting the averaging.

Using READ?

```
ABOR1
CONF2:POW:AC:RAT DEF,DEF, (@1), (@1)
SENS1:AVER:COUN 512
READ2:POW:AC:RAT?
READ2:POW:AC:RAT? DEF,DEF, (@1), (@1) (A second READ? query is sent to make a Channel A/Channel A measurement using fresh measurement data.)
```

Using INITiate and FETCh?

```
ABOR1
CONF2:POW:AC:RAT DEF,DEF, (@1), (@2)
SENS1:AVER:COUN 512
INIT1:IMM
FETC2:POW:AC:RAT?
FETC2:POW:AC:RAT? DEF,DEF, (@1), (@1) (A second FETCh? query is sent to make a Channel A/Channel A measurement using the current measurement data.)
```

Using the lower-level commands

An alternative method of making measurements is to use the lower-level commands to set the measurement type. This can be done using the following commands:

```
CALCulate[1] | 2 | 3 | 4 : MATH [ : EXPRESSION ]
CALCulate[1] | 2 | 3 | 4 : RELative [ : MAGNitude ] : AUTO
```

The advantage of using the lower-level commands over the CONFIGure command is that they give you more precise control of the U2020 X-Series. As shown in [Table 1-1](#), the CONFIGure command presets various states in the U2020 X-Series. It may be likely that you do not want to preset these states.

Example

The following example sets the single Channel A measurement on the CALCulate2 subsystem.

ABOR1	<i>Aborts Channel A.</i>
CALC2:MATH:EXPR "(SENS1)"	<i>Sets CALCulate2 to a single measurement.</i>
INIT1	<i>Causes Channel A to make a measurement.</i>
FETC2?	<i>Retrieves the CALCulate2 measurement.</i>

Using Frequency-Dependent Offset Tables

This section describes how to use frequency-dependent offset tables. These tables give you the ability to compensate for frequency effects in your test setup.

Overview

If the `[SENSe[1]:]CORRection:CSET2:STATE` command is OFF, the frequency-dependent offset tables are not used. When `[SENSe[1]:]CORRection:CSET2:STATE` is ON, the frequency-dependent offset tables are used, providing you with a quick and convenient method of compensating for your external test setup over a range of frequencies. Note that when selected, frequency-dependent offset correction is IN ADDITION to any correction applied for sensor frequency response. The U2020 X-Series is capable of storing 10 frequency-dependent offset tables of 512 frequency points each.

To use frequency-dependent offset tables, you:

- 1 Edit a frequency-dependent offset table if necessary.
- 2 Select the frequency-dependent offset table.
- 3 Enable the frequency-dependent offset table.
- 4 Zero and calibrate the U2020 X-Series.
- 5 Specify the frequency of the signal you want to measure. The required offset is automatically set by the U2020 X-Series from the frequency-dependent offset table.
- 6 Make the measurement.

Figure 1-8 illustrates how frequency-dependent offset tables operate.

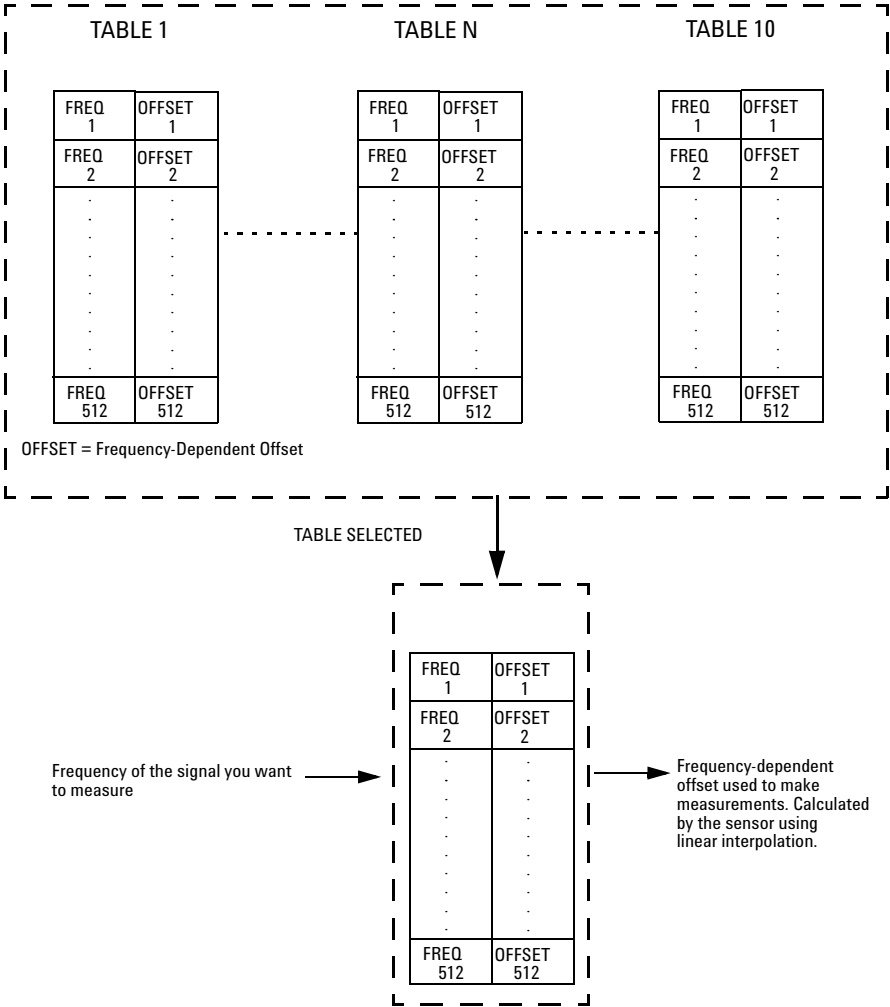

Figure 1-8 Frequency-dependent offset tables

Editing frequency-dependent offset tables

It is not possible to create any additional frequency-dependent offset tables. However, the 10 existing tables can be edited using the MEMORY subsystem. To do this:

- 1 Select one of the existing tables using:

```
MEMORY:TABLE:SELECT <string>
```

For information on naming frequency-dependent offset tables, see “Naming frequency-dependent offset tables” on page 32. For information on the current names you can select, refer to “Listing the frequency-dependent offset table names” on page 31.

- 2 Enter the frequency data using:

```
MEMORY:TABLE:FREQUENCY <numeric_value>{,<numeric_value>}
```

- 3 Enter the offset factors as shown in the table below using:

```
MEMORY:TABLE:GAIN <numeric_value>{,<numeric_value>}
```

Frequency	Offset
Frequency 1	Offset 1
Frequency 2	Offset 2
"	"
Frequency n	Offset n

- 4 If required, rename the frequency-dependent offset table using MEMORY:TABLE:MOVE <string>,<string>. The first <string> parameter identifies the existing table name, and the second identifies the new table name.

NOTE

The legal frequency suffix multipliers are any of the IEEE suffix multipliers, for example, KHZ, MHZ, and GHZ. If no units are specified, the data is assumed as Hz.

PCT is the only legal unit for offset factors and can be omitted.

The frequency and offset data must be within range. Refer to the individual commands in [Chapter 4](#) for their specified ranges.

Any offset values entered into the table should exclude the effect of the U2020 X-Series. Characterization of the test setup independently of the U2020 X-Series allows the same table to be used with any sensor.

Ensure that the frequency points you use cover the frequency range of the signals you want to measure. If you measure a signal with a frequency outside the frequency range defined in the frequency-dependent offset table, then the U2020 X-Series uses the highest or lowest frequency point in the table to calculate the offset.

To make subsequent editing of a frequency-dependent offset table simpler, it is recommended that you retain a copy of your data in a program.

Listing the frequency-dependent offset table names

To list the frequency-dependent offset tables currently stored in the U2020 X-Series, use the following query:

```
MEMory:CATalog:TABLE?
```

The U2020 X-Series returns the data in the form of two numeric parameters and a string list representing all stored tables.

- `<numeric_value>,<numeric_value>{,<string>}`
The first numeric parameter indicates the amount of memory, in bytes, used for storage of tables. The second parameter indicates the memory, in bytes, available for tables.

Each string parameter returned indicates the name, type, and size of a stored frequency-dependent offset table:

```
<string>,<type>,<size>
```

`<string>`, `<type>`, and `<size>` are all character data. `<type>` is always TABL. `<size>` is displayed in bytes.

For example, a sample of the response may look like:

```
560,8020,"Offset_1,TABL,220","Offset_2,TABL,340" . . . .
```

Naming frequency-dependent offset tables

To rename a frequency-dependent offset table, use:

```
MEMory:TABLE:MOVE <string>, <string>
```

The first <string> parameter identifies the existing table name, and the second identifies the new table name.

The following rules apply to frequency-dependent offset table names:

- 1 Table names use a maximum of 12 characters.
- 2 All characters must be upper or lower-case alphabetic characters, or numeric (0-9), or an underscore (_).

No spaces are allowed in the name.

Reviewing table data

To review the data stored in a frequency-dependent offset table, use the following commands:

```
MEMory:TABLE:SELECT "Offset1"
```

Select the frequency- dependent offset table named "Offset1".

```
MEMory:TABLE:SELECT?
```

Query which returns the name of the currently selected table.

```
MEMory:TABLE:FREQuency:POINTs?
```

Query which returns the number of stored frequency points.

```
MEMory:TABLE:FREQuency?
```

Query which returns the frequencies stored in the frequency- dependent offset table (in Hz).

```
MEMory:TABLE:GAIN[:MAGNitude]:POINTs?
```

Query which returns the number of offset factor points stored in the frequency- dependent offset table.

```
MEMory:TABLE:GAIN[:MAGNitude]?
```

Query which returns the offset factors stored in the frequency- dependent offset table.

Modifying data

If you need to modify the frequency and offset factor data stored in a frequency-dependent offset table, you need to resend the complete data lists.

If you have retained the original data in a program, edit the program and resend the data.

Selecting a frequency-dependent offset table

After you have created the frequency-dependent offset table, you can select it using the following command:

```
[SENSE[1]:]CORRection:CSET2[:SElect] <string>
```

To find out which frequency-dependent offset table is currently selected, use the query:

```
[SENSE[1]:]CORRection:CSET2[:SElect]?
```

Enabling a frequency-dependent offset table

To enable the frequency-dependent offset table, use the following command:

```
[SENSE[1]:]CORRection:CSET2:STATe ON
```

If you set `[SENSE[1]:]CORRection:CSET2:STATe` to `ON` and no frequency-dependent offset table is selected, error -221, “Settings conflict” occurs.

Making the measurement

To make the power measurement, set the U2020 X-Series for the frequency of the signal you want to measure. The U2020 X-Series automatically sets the offset factor. Use either `INITiate`, `FETCh?`, or `READ?` to initiate the measurement as shown in the following program segments:

INITiate example

```
ABORt1
CONFIgure1:POWer:AC DEF,1,(@1)
SENS1:CORR:CSET2:SEL "Offset1"
SENS1:CORR:CSET2:STAT ON
SENS1:FREQuency 500MHZ
INITiate1:IMMediate
FETCh1?
```

READ? Example

```
ABORt1
CONFIgure1:POWer:AC DEF,2,(@1)
SENS1:CORR:CSET2:SEL "Offset1"
SENS1:CORR:CSET2:STAT ON
SENS1:FREQuency 500MHZ
READ1?
```

NOTE

If the measurement frequency does not correspond directly to a frequency in the frequency-dependent offset table, the U2020 X-Series calculates the offset using linear interpolation.

If you enter a frequency outside the frequency range defined in the frequency-dependent offset table, then the U2020 X-Series uses the highest or lowest frequency point in the table to set the offset.

To find out the value of the offset being used by the U2020 X-Series to make a measurement, use the

```
[SENSe[1]:]CORRection:FDOFfset|GAIN4[:INPut][:MAGNitude]? query.
```

The response may be an interpolated value.

Setting the Averaging

This section provides an overview of setting the averaging. For more detailed information, refer to the individual commands in [Chapter 10](#), “SENSe Subsystem”.

Averaging

The U2020 X-Series has a digital filter to average power readings. The number of readings averaged can range from 1 to 1024. This filter is used to reduce noise, obtain the desired resolution, and to reduce the jitter in the measurement results. However, the time to take the measurement is increased. You can select the filter length or you can set the U2020 X-Series to the auto-filter mode. To enable and disable averaging, use the following command:

```
[SENSe[1]:]AVERAge[:STATe] <boolean>
```

Auto-averaging mode

To enable and disable the auto-filter mode, use the following command:

```
[SENSe[1]:]AVERAge:COUNT:AUTO <boolean>
```

When the auto-filter mode is enabled, the U2020 X-Series automatically sets the number of readings averaged together to satisfy the filtering requirements for most power measurements. The number of readings averaged together depends on the resolution and the power level currently being measured. [Figure 1-9](#) shows the typical number of averages for each range and resolution when the U2020 X-Series is in the auto-filter mode and set to the normal speed mode.

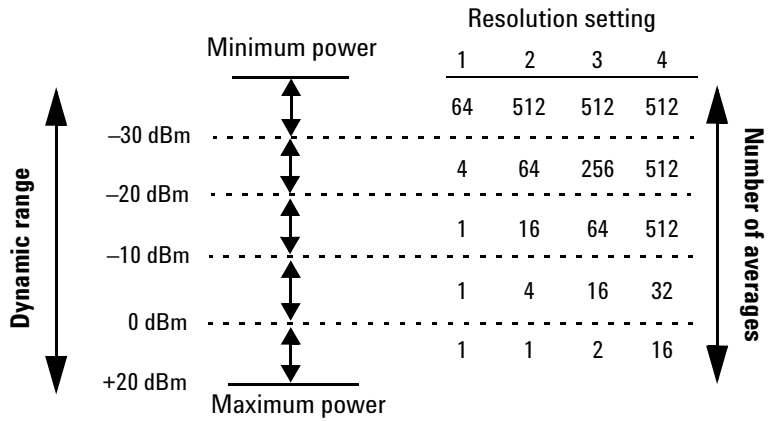

Figure 1-9 Typical averaged readings

Figure 1-10 illustrates part of the U2020 X-Series dynamic range hysteresis.

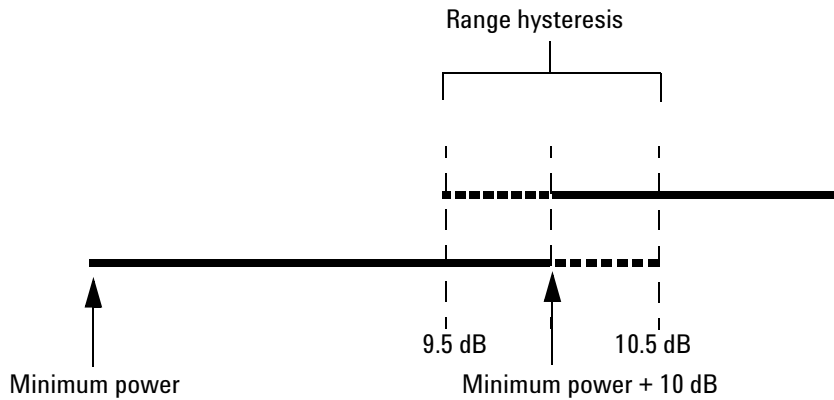

Figure 1-10 Averaging range hysteresis

Filter length

You can specify the filter length using the following command:

```
[SENSE[1]:]AVERAge:COUNT <numeric_value>
```

The range of values for the filter length is 1 to 1024. Specifying this command disables automatic filter length selection. Increasing the value of the filter length reduces measurement noise. However, the time to take the measurement is increased.

Setting Offsets

Channel offsets

The U2020 X-Series can be configured to compensate for signal loss or gain in your test setup (for example, to compensate for the loss of a 10 dB attenuator). You use the SENSE command subsystem to configure the U2020 X-Series. Gain and loss corrections are a coupled system. If you enter an offset value, the state is automatically enabled. However, it can be enabled and disabled using the [SENSE[1]:]CORREction:GAIN2:STATE <boolean> and [SENSE[1]:]CORREction:LOSS2:STATE <boolean> commands.

CALCulate offsets

CALCulate offset values can be entered using the CALCulate[1]|2|3|4:GAIN[:MAGNitude] command. CALCulate[1]|2|3|4:GAIN:STATE must be set to ON to enable the offset value. If you enter an offset value, the state is automatically enabled. This offset is applied after any math calculations (refer to [Figure 1-12](#) on page 46).

Example

The following command sequence details how to use the channel and CALCulate offsets to make a Channel A/A ratio measurement.

The final result is:

$$\left(\left(\frac{A_{dBm} - 10}{A_{dBm} - 10} \right) - 20 \right)_{dB}$$

Command

Send device clear

*RST

CONF:POW:AC:RAT 20DBM,2,(@1),(@1)

Description

Clears the U2020 X-Series interface.

Sets the U2020 X-Series to a known state.

Configures the U2020 X-Series to make the measurement.

UNIT:POW DBM	<i>Sets the measurement unit to dBm.</i>
SENS:CORR:GAIN2 -10	<i>Sets the channel offset to -10 dB.</i>
SENS:CORR:GAIN2:STAT ON	<i>Enables the gain correction.</i>
CALC1:GAIN -20DB	<i>Sets the CALCulate offset to -20 dB.</i>
INIT1:IMM	<i>Initiates the measurement.</i>
FETC:POW:AC:RAT? 20DBM,2, (@1) , (@1)	<i>Retrieves the result.</i>

For further information on channel offsets, refer to [page 286](#). For further information on CALCulate offsets, refer to [page 132](#).

Setting Measurement Limits

You can configure the U2020 X-Series to detect when a measurement is outside of a predefined upper and/or lower limit value.

Limits can be applied to power, ratio, or difference measurements.

Setting limits

The U2020 X-Series can be configured to verify the power being measured against an upper and/or lower limit value. The range of values that can be set for lower and upper limits is -150.00 dBm to $+230.00$ dBm. The default upper limit is $+90.00$ dBm and the default lower limit is -90.00 dBm.

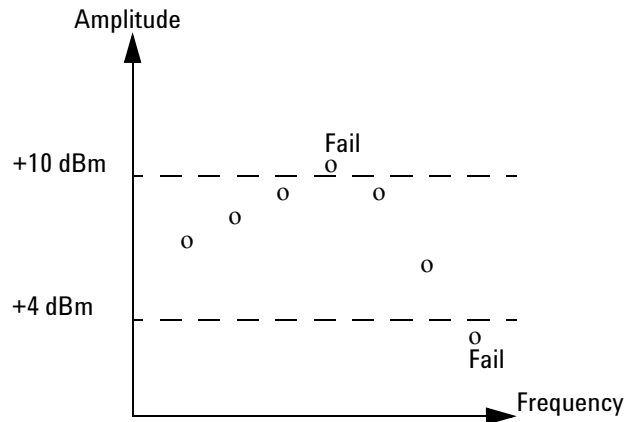

Figure 1-11 Limits checking results

The range of values that can be set for the upper and lower limits and the default values depend on the measurement units in the current measurement line - see [Table 1-2](#).

Table 1-2 Range of values for limits

Units	Maximum	Minimum	Default maximum	Default minimum
dB	+200 dB	-180 dB	60 dB	-120 dB
dBm	+230 dBm	-150 dBm	90 dBm	-90 dBm
%	10.0 Z%	100.0 a%	100.0 M%	100.0 p%
W	100.000 EW	1.000 aW	1.000 MW	1.000 pW

Checking for limit failures

There are two ways to check for limit failures:

- Use the `CALCulate[1]|2|3|4:LIMit:FAIL?` and `CALCulate[1]|2|3|4:LIMit:FCOunt?` queries for limits.
- Use the `STATus` command subsystem.

NOTE

If `TRIGger:DElay:AUTO` is set to ON, then the number of failures returned by `CALCulate[1]|2|3|4:LIMit:FCOunt?` is affected by the current filter settings.

Getting the Best Speed Performance

This section discusses the factors that influence the speed of operation (number of readings/sec) of the U2020 X-Series.

The following factors are those which have the greatest effect upon measurement speed (in no particular order):

- The selected measurement rate (NORMal, DOUBle, FAST).
- The trigger mode (for example, free run, trigger with delay, etc.).
- The output format (ASCii or REAL).
- The units used for the measurement.
- The command used to take a measurement.

In addition, there are other influences in the FAST mode which are described in “Fast mode” on page 45.

The following paragraphs give a brief description of the above factors and how they are controlled from SCPI.

Measurement rate

There are three possible speed settings: NORMal, DOUBle, and FAST. These are set using the [SENSE[1]:]MRATE command.

In the NORMal and DOUBle modes, full instrument functionality is available, but in the FAST mode, limits and ratio/difference math functions are disabled.

Refer to the specifications in the *U2020 X-Series User's Guide* to determine the influence of these speed settings on the accuracy and noise performance of the U2020 X-Series.

Trigger mode

The U2020 X-Series has a very flexible triggering system. For simplicity, it can be described as having three modes:

- **Free Run:** When the U2020 X-Series is in the Free Run mode, it continuously takes measurements. A measurement is in free run when `INITiate:CONTinuous` is set to ON and `TRIGger:SOURce` is set to `IMMEDIATE`.
- **Triggered Free Run:** When the U2020 X-Series is in the Triggered Free Run or Continuous Trigger mode, it takes a new measurement each time a trigger event is detected. A measurement is in triggered free run or continuous trigger when `INITiate:CONTinuous` is set to ON and `TRIGger:SOURce` is not set to `IMMEDIATE`.
- **Single Shot:** When the U2020 X-Series is in the Single Shot mode, it takes a new measurement when a trigger event is detected and then returns to the idle state. A measurement is in single shot when `INITiate:CONTinuous` is set to OFF. Note that a measurement can take several INT/EXT triggers depending on the filter settings. Refer to “`TRIGger[1]:DELay:AUTO <boolean>`” on page 475 for further information.

NOTE

A trigger event can be any of the following:

- The input signal meeting the trigger level criteria.
- Auto-level triggering being used.
- A `TRIGger[1] [:IMMEDIATE]` or `*TRG` command being sent.
- An external TTL level trigger being detected.

Trigger with delay

This can be achieved using the same sequences above (apart from the second) with `TRIG:DEL:AUTO` set to ON. Also, the `MEAS?` query operates in the trigger with delay mode.

In the trigger with delay mode, a measurement is not completed until the U2020 X-Series filter is full. In this way, the reading returned is guaranteed to be settled. In all other modes, the result returned is simply the current result from the filter and may or may not be settled. This

depends on the current length of the filter and the number of readings that have been taken since a change in power level.

When trigger with delay is enabled, the measurement speed can be calculated roughly using the following equation:

readings/sec = speed (as set by [SENSE[1]:]MRATe) / filter length

For example, with a filter length of 4 and [SENSE[1]:]MRATe set to NORMAl, approximately 5 readings/sec are calculated by the U2020 X-Series.

Typically, the free run mode provides the best speed performance from the U2020 X-Series (especially in the FAST mode).

Output format

The U2020 X-Series has two output formats for measurement results: ASCii and REAL. These formats are selected using the FORMat command. When FORMat is set to REAL, the returned result is in the IEEE 754 floating-point format (note that the byte order can be changed using FORMat:BORDER) plus <LF> as an end sentinel of the block.

The REAL format is likely to be required only for the FAST mode as it reduces the amount of bus traffic.

Units

The U2020 X-Series can output results in either linear or log units. The internal units are linear, therefore optimal performance is achieved when the results output are also in linear units (since the overhead of performing a log function is removed).

Command used

In the Free Run mode, FETCh? must be used to return a result.

In other trigger modes, there are a number of queries that can be used, for example, MEASure?, READ?, FETCh?. Note that the MEAS? and READ? queries are compound commands – they perform a combination of other lower-level commands. Typically, the best speed performance is achieved using the low-level commands directly.

Trigger count

To get the fastest measurement speed, TRIG:COUNT must be set to return multiple measurements for each FETCh? query. In the normal mode (peak measurements), a count of 50 is required to attain 3500 or more readings per second.

Fast mode

In the highest speed setting, the limiting factor tends to be the speed of the controller being used to retrieve results from the U2020 X-Series, and to a certain extent, the volume of remote traffic. The latter can be reduced using the FORMat REAL command to return results in the binary format. The former is a combination of two factors:

- the hardware platform being used
- the programming environment being used

How Measurements are Calculated

Figure 1-12 details how measurements are calculated. It shows the order in which the various U2020 X-Series functions are implemented in the measurement calculation.

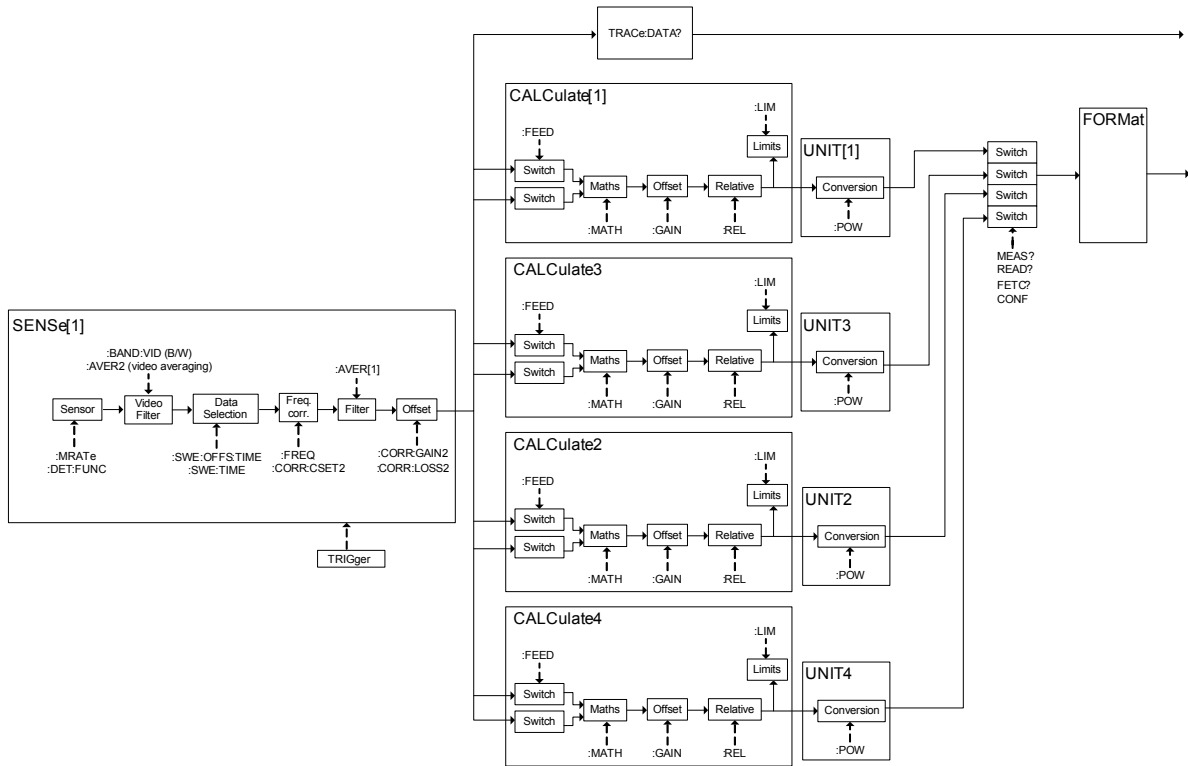

Figure 1-12 How measurements are calculated

The MEASure query in this figure can be replaced with FETCh? and READ?.

Status Reporting

Status reporting is used to monitor the U2020 X-Series to determine when events have occurred. Status reporting is accomplished by configuring and reading status registers.

The U2020 X-Series has the following main registers:

- Status Register
- Standard Event Register
- Operation Status Register
- Questionable Status Register
- Device Status Register

There are other registers that exist “behind” the main registers, and are described later in this chapter.

Status and Standard Event registers are read using the IEEE-488.2 common commands.

Operation and Questionable Status registers are read using the SCPI `STATus` command subsystem.

The general status register model

The generalized status register model shown in [Figure 1-13](#) is the building block of the SCPI status system. This model consists of a condition register, a transition filter, an event register, and an enable register. A set of these registers is called a status group.

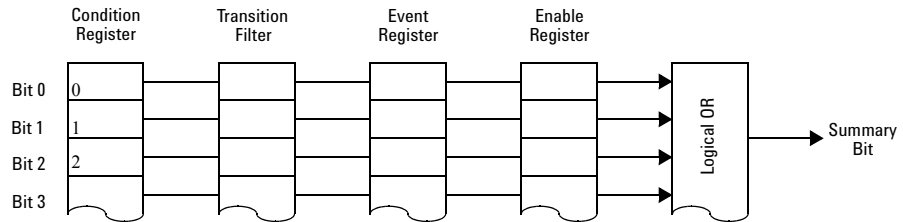

Figure 1-13 Generalized status register model

When a status group is implemented in an instrument, it always contains all of the component registers. However, there is not always a corresponding command to read or write to every register.

Condition register

The condition register continuously monitors the hardware and firmware status of the U2020 X-Series. There is no latching or buffering for this register, it is updated in real time. Condition registers are read-only.

Transition filter

The transition filter specifies which type of bit state changes in the condition registers and sets corresponding bits in the event register. Transition filter bits may be set for positive transitions (PTR), negative transitions (NTR), or both. Transition filters are read-write. They are unaffected by *CLS or queries. After `STATUS:PRESet`, the NTR register is set to 0 and all bits of the PTR are set to 1.

Event register

The event register latches transition events from the condition register as specified by the transition filter. Bits in the event register are latched and on setting, they remain set until cleared by a query or a *CLS. Also on setting, an event bit is no longer affected by condition changes. It remains set until the event register is cleared; either when you read the register or when you send the *CLS (clear status) command. Event registers are read-only.

Enable register

The enable register specifies the bits in the event register that can generate a summary bit. The instrument logically ANDs corresponding bits in the event and enable registers and ORs all the resulting bits to obtain a summary bit. Enable registers are read-write. Querying an enable register does not affect it.

An example sequence

Figure 1-14 illustrates the response of a single bit position in a typical status group for various settings. The changing state of the condition in question is shown at the bottom of the figure. A small binary table shows the state of the chosen bit in each status register at the selected times T1 to T5.

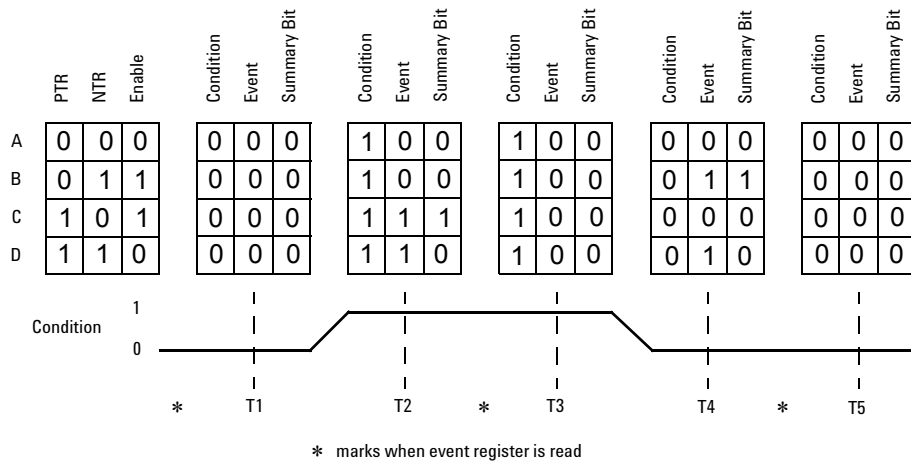

Figure 1-14 Typical status register bit changes

How to use registers

Use the polling method to access the information in status groups.

In this polling method, the U2020 X-Series has a passive role. It only informs the controller that conditions have changed when the controller asks. When you monitor a condition with the polling method, you must:

- 1 Determine which register contains the bit that monitors the condition.
- 2 Send the unique query that reads that register.
- 3 Examine the bit to see if the condition has changed.

Status registers

The Status system in the U2020 X-Series is shown in [Figure 1-15](#). The Operation Status and Questionable Status groups are 16 bits wide, while the Status Byte and Standard Event groups are 8 bits wide. In all 16-bit groups, the most significant bit (bit 15) is not used and is always set to 0.

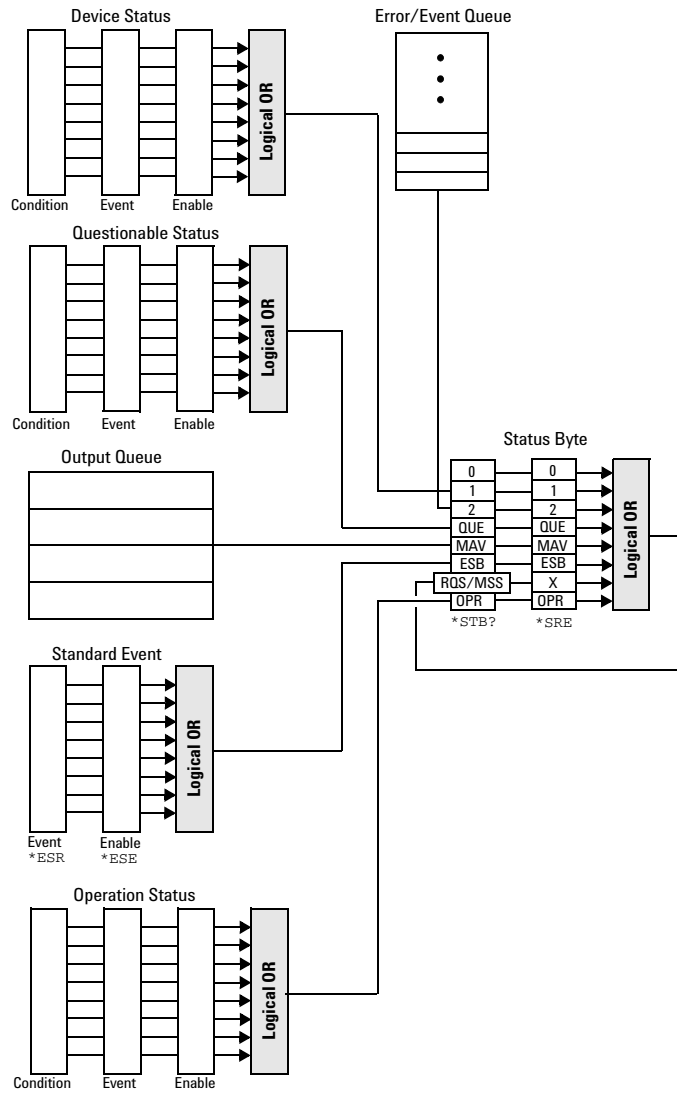

Figure 1-15 Status system

The Status Byte summary register

The status byte summary register reports conditions from other status registers. Query data waiting in the U2020 X-Series output buffer is immediately reported through the “message available” bit (bit 4). Clearing an event register clears the corresponding bits in the status byte summary register. Reading all messages in the output buffer, including any pending queries, clears the message available bit.

Table 1-3 Bit definitions - Status byte register

Bit number	Decimal weight	Definition
0	1	Not Used (Always set to 0)
1	2	Device Status Register summary bit. One or more bits are set in the Device Status Register (bits must be “enabled” in the enable register)
2	4	Error/Event Queue
3	8	Questionable Status Register summary bit. One or more bits are set in the Questionable Status Register (bits must be “enabled” in the enable register).
4	16	Data Available Data is available in the output buffer.
5	32	Standard Event One or more bits are set in the Standard Event register (bits must be “enabled” in the enable register).
6	64	Request Service The U2020 X-Series is requesting service (serial poll).
7	128	Operation Status Register summary bit. One or more bits are set in the Operation Status Register (bits must be “enabled” in the enable register).

Particular bits in the status byte register are cleared when:

- The standard event, questionable status, operation status, and device status are queried.
- The error/event queue becomes empty.
- The output queue becomes empty.

The status byte enable register (SRE, service request enable) is cleared when you:

- cycle the U2020 X-Series power.
- execute a *SRE 0 command.

Using *STB? to read the status byte

The *STB? (status byte query) command is similar to a serial poll except it is processed like any other U2020 X-Series command. *STB? returns the same result as an IEEE-488 serial poll except that the request service bit (bit 6) *is not* cleared if a serial poll has occurred. *STB? is not handled automatically by the IEEE-488 bus interface hardware and the command is executed only after previous commands have completed. Using *STB? does not clear the status byte summary register.

The Standard Event register

The standard event register reports the following types of instrument events: power-on detected, command and syntax errors, command execution errors, self-test or calibration errors, query errors, or when an overlapped command completes following an *OPC command. Any or all of these conditions can be reported in the standard event summary bit through the enable register. You must write a decimal value using the *ESE (event status enable) command to set the enable register mask.

Table 1-4 Bit definitions - Standard event register

Bit number	Decimal value	Definition
0	1	Operation Complete All overlapped commands following an *OPC command have been completed.
1	2	Not Used. (Always set to 0.)
2	4	Query Error A query error occurred, refer to error numbers 410 to 440 in "Error message list".
3	8	Device-Dependent Error A device error occurred, refer to error numbers 310 to 350 in "Error message list".

Bit number	Decimal value	Definition
4	16	Execution Error An execution error occurred, refer to error numbers 211 to 241 in “Error message list”.
5	32	Command Error A command syntax error occurred, refer to error numbers 101 to 178 in “Error message list”.
6	64	User Request
7	128	Power On Power has been turned off and on since the last time the event register was read or cleared.

The standard event register is cleared when you:

- send a *CLS (clear status) command.
- query the event register using the *ESR? (event status register) query.

The standard event enable register is cleared when you:

- cycle the U2020 X-Series power.
- execute a *ESE 0 command.

Questionable Status register

The questionable status register provides information about the quality of the U2020 X-Series measurement results. Any or all of these conditions can be reported in the questionable data summary bit through the enable register. You must write a value using the `STATUS:QUESTIONABLE:ENABLE` command to set the enable register mask.

The following bits in these registers are used by the U2020 X-Series.

Table 1-5 Bit definitions - Questionable status registers

Bit number	Decimal weight	Definition
0 to 2	-	Not used

Bit number	Decimal weight	Definition
3	8	POWer Summary
4 to 7	-	Not used
8	256	CALibration Summary
9	512	Power-On Self-Test
10 to 14	-	Not used
15	-	Not used (always 0)

The condition bits are set and cleared under the following conditions:

Table 1-6 Bit change conditions for questionable status register

Bit number	Meaning	EVENTs causing bit changes
3	POWer Summary	<p>This is a summary bit for the Questionable POWer Register.</p> <ul style="list-style-type: none"> SET: Error –230, “Data corrupt or stale” Error –231, “Data questionable;Input Overload” Error –231, “Data questionable;CALC1 log error” Error –231, “Data questionable;CALC2 log error” Error –231, “Data questionable;CALC3 log error” Error –231, “Data questionable;CALC4 log error” CLEARED: When no errors are detected by the U2020 X-Series during a measurement covering the causes given for it to set.
8	CALibration Summary	<p>This is a summary bit for the Questionable CALibration Register.</p> <ul style="list-style-type: none"> SET: These may be caused by CALibration[1]:ZERO:AUTO ONCE or CALibration[1]:AUTO ONCE or CALibration[1][:ALL] or CALibration[1][:ALL]?. Error –231, “Data questionable;ZERO ERROR” Error –231, “Data questionable;CAL ERROR” CLEARED: When any of the commands listed above succeed and no errors are placed on the error queue.

1 U2020 X-Series Remote Operation

Bit number	Meaning	EVENTs causing bit changes
9	Power-On Self-Test	<ul style="list-style-type: none">• SET: This bit is set when the power-on self-test fails.• CLEARED: When the power-on self-test passes.

Operation status

The operation status group monitors conditions in the U2020 X-Series measurement process.

The following bits in these registers are used by the U2020 X-Series:

Table 1-7 Bit definitions - Operation status

Bit number	Decimal weight	Definition
0	1	CALibrating Summary
1 to 3	-	Not used
4	16	MEASuring Summary
5	32	Waiting for TRIGger Summary
6 to 9	-	Not used
10	1024	SENSe Summary
11	2048	Lower Limit Fail Summary
12	4096	Upper Limit Fail Summary
13 to 14	-	Not used
15	-	Not used (always 0)

The condition bits are set and cleared under the following conditions:

Table 1-8 Bit change conditions for operation status

Bit number	Meaning	EVENTs causing bit changes
0	CALibrating	<p>This is a summary bit for the Operation CALibrating Register.</p> <ul style="list-style-type: none"> • SET: At beginning of zeroing (CALibration:ZERO:AUTO ONCE) and at the beginning of calibration (CALibration:AUTO ONCE). Also for the compound command/query CALibration[:ALL]?, this bit is set when zeroing begins. • CLEARED: At the end of zeroing or calibration.
4	MEASuring	<p>This is a summary bit for the Operation MEASuring Register.</p> <ul style="list-style-type: none"> • SET: When the U2020 X-Series is taking a measurement. • CLEARED: When the measurement is completed.
5	Waiting for TRIGger	<p>This is a summary bit for the Operation TRIGger Register.</p> <ul style="list-style-type: none"> • SET: When the U2020 X-Series enters the “wait for trigger” state. • CLEARED: When the U2020 X-Series enters the “idle” state.
10	SENSE	<p>This is a summary bit for the Operation SENSE Register.</p> <ul style="list-style-type: none"> • SET: When the U2020 X-Series is reading data from EEPROM. • CLEARED: When the U2020 X-Series is not reading data from EEPROM.
11	Lower Limit Fail	<p>This is a summary bit for the Lower Limit Fail Register.</p> <ul style="list-style-type: none"> • SET: If a measurement is made and the lower limit test fails. • CLEARED: If a measurement is made and the lower limit test is not enabled or the test is enabled and passes.
12	Upper Limit Fail	<p>This is a summary bit for the Upper Limit Fail Register.</p> <ul style="list-style-type: none"> • SET: If a measurement is made and the upper limit test fails. • CLEARED: If a measurement is made and the upper limit test is not enabled or the test is enabled and passes.

Device Status register

The device status register set contains bits which give device-dependent information.

The following bit in these registers is used by the U2020 X-Series:

Table 1-9 Bit definitions - Device status register

Bit number	Decimal weight	Definition
0 to 2	-	Not used
3	8	Sensor error
4 to 14	-	Not used
15	-	Not used (always 0)

The condition bit is set and cleared under the following conditions:

Table 1-10 Bit change conditions for device status register

Bit number	Meaning	EVENTs causing bit changes
3	Sensor error	<ul style="list-style-type: none"> • SET: If the EEPROM has failed • CLEARED: In every other condition

Using the Operation Complete commands

The *OPC? and *OPC commands allow you to maintain synchronization between the computer and the U2020 X-Series. The *OPC? query places an ASCII character 1 into the U2020 X-Series output queue when all pending commands are completed. If your program reads this response before continuing program execution, you can ensure synchronization between one or more instruments and the computer.

The *OPC command sets bit 0 (Operation Complete) in the standard event status register when all pending U2020 X-Series operations are completed.

Procedure

- 1 Send a device clear message to clear the U2020 X-Series output buffer.
- 2 Clear the event registers with the *CLS (clear status) command.
- 3 Enable operation complete using the *ESE 1 command (standard event register).
- 4 Send the *OPC? (operation complete query) command and enter the result to assure synchronization.
- 5 Send your programming command string, and place the *OPC (operation complete) command as the last command.
- 6 Send the *STB? (status byte query) command to poll the register. This command does not clear the status byte summary register.

Examples

This example program uses the *OPC? command to determine when the U2020 X-Series has finished calibrating.

```
CAL:AUTO ONCE
*OPC?
MEAS:POW:AC?
```

Saving and Recalling U2020 X-Series Configurations

To reduce repeated programming, up to 10 U2020 X-Series configurations can be stored in the U2020 X-Series non-volatile memory. The error list, remote addresses, frequency-dependent offset table data, and zeroing/calibration information are not stored.

How to save and recall a configuration

U2020 X-Series configurations are saved and recalled with the following commands:

*SAV <NRf>

*RCL <NRf>

The range of values for <NRf> in the above commands is 1 to 10.

Using Device Clear to Halt Measurements

Device clear is an IEEE-488 low-level bus message which can be used to halt measurements in progress. Different programming languages and IEEE-488 interface cards provide access to this capability through their own unique commands. The status registers, the error queue, and all configuration states are left unchanged when a device clear message is received. Device clear performs the following actions.

- All measurements in progress are aborted.
- The U2020 X-Series returns to the trigger “idle state”.
- The U2020 X-Series input and output buffers are cleared.
- The U2020 X-Series is prepared to accept a new command string.

Making Measurements on Wireless Communication Standards

The following sections describe typical measurements you may want to make.

The optimum method of measuring these Wireless Communication Standards is to use the `SYSTEM:PRESet <character_data>` command and use one of the following values.

Refer to “`SYSTEM:PRESet <character_data>`” on page 388 for more details.

- GSM900
- EDGE
- CDMAone
- CDMA2000
- WCDMA
- BLUetooth
- MCPa
- RADar
- WL802DOT11A
- HIPERLAN2
- WL802DOT11B
- XEVDO
- XEVDV
- TDSCdma
- NADC
- IDEN
- DVB
- WiMAX
- DME
- DME-PRT
- HSDPA

- LTE

Starting a preset example

```
10 *CLS !Clears error queue
20 *RST !Resets settings to their default states
30 :SYST:ERR? <read string> !The system error query should
!return "0: No error"
40 SYSTem:PRESet GSM900
```

THIS PAGE HAS BEEN INTENTIONALLY LEFT BLANK.



2 MEASurement Commands

MEASurement Commands	67
CONFigure[1] 2 3 4?	69
CONFigure[1] 2 3 4 Commands	71
CONFigure[1] 2 3 4[:SCALar][:POWer:AC] [<expected_value>,<resolution>,<source list>]]	72
CONFigure[1] 2 3 4[:SCALar][:POWer:AC]:RELative [<expected_value>,<resolution>,<source list>]]	74
CONFigure[1] 2 3 4[:SCALar][:POWer:AC]:DIFFerence [<expected_value>,<resolution>,<source list>]]	76
CONFigure[1] 2 3 4[:SCALar][:POWer:AC]:DIFFerence: RELative [<expected_value>,<resolution>,<source list>]]	78
CONFigure[1] 2 3 4[:SCALar][:POWer:AC]:RATio [<expected_value>,<resolution>,<source list>]]	80
CONFigure[1] 2 3 4[:SCALar][:POWer:AC]:RATio: RELative [<expected_value>,<resolution>,<source list>]]	82
FETCh[1] 2 3 4 Queries	84
FETCh[1] 2 3 4[:SCALar][:POWer:AC]? [<expected_value>,<resolution>,<source list>]]	85
FETCh[1] 2 3 4[:SCALar][:POWer:AC]:RELative? [<expected_value>,<resolution>,<source list>]]	87
FETCh[1] 2 3 4[:SCALar][:POWer:AC]:DIFFerence? [<expected_value>,<resolution>,<source list>]]	89
FETCh[1] 2 3 4[:SCALar][:POWer:AC]:DIFFerence: RELative? [<expected_value>,<resolution>,<source list>]]	91
FETCh[1] 2 3 4[:SCALar][:POWer:AC]:RATio? [<expected_value>,<resolution>,<source list>]]	94
FETCh[1] 2 3 4[:SCALar][:POWer:AC]:RATio:RELative? [<expected_value>,<resolution>,<source list>]]	96
READ[1] 2 3 4 Commands	98



READ[1] 2 3 4[:SCALar][:POWer:AC]? [<expected_value>[,<resolution>[,<source list>]]]	99
READ[1] 2 3 4[:SCALar][:POWer:AC]:RELative? [<expected_value>[,<resolution>[,<source list>]]]	101
READ[1] 2 3 4[:SCALar][:POWer:AC]:DIFFerence? [<expected_value>[,<resolution>[,<source list>]]]	104
READ[1] 2 3 4[:SCALar][:POWer:AC]:DIFFerence: RELative? [<expected_value>[,<resolution>[,<source list>]]]	106
READ[1] 2 3 4[:SCALar][:POWer:AC]:RATio? [<expected_value>[,<resolution>[,<source list>]]]	109
READ[1] 2 3 4[:SCALar][:POWer:AC]:RATio:RELative? [<expected_value>[,<resolution>[,<source list>]]]	111
MEASure[1] 2 3 4 Commands	114
MEASure[1] 2 3 4[:SCALar][:POWer:AC]? [<expected_value>[,<resolution>[,<source list>]]]	115
MEASure[1] 2 3 4[:SCALar][:POWer:AC]:RELative? [<expected_value>[,<resolution>[,<source list>]]]	117
MEASure[1] 2 3 4[:SCALar][:POWer:AC]:DIFFerence? [<expected_value>[,<resolution>[,<source list>]]]	119
MEASure[1] 2 3 4[:SCALar][:POWer:AC]:DIFFerence: RELative? [<expected_value>[,<resolution>[,<source list>]]]	121
MEASure[1] 2 3 4[:SCALar][:POWer:AC]:RATio? [<expected_value>[,<resolution>[,<source list>]]]	123
MEASure[1] 2 3 4[:SCALar][:POWer:AC]:RATio:RELative? [<expected_value>[,<resolution>[,<source list>]]]	125

This chapter explains how to use the MEASure group of instructions to acquire data using a set of high-level instructions.

MEASurement Commands

Measurement commands are high-level commands used to acquire data. They enable you to trade interchangeability against fine control of the measurement process.

Measurement command	Description
MEASure?	Provides the simplest way to program the U2020 X-Series for measurements. MEASure? is a compound command which is equivalent to an ABORT followed by a CONFigure and a READ?. It does not enable much flexibility or control over measurement settings.
CONFigure	Used to change the U2020 X-Series configuration values. CONFigure must then be followed by another command which takes the measurement—for example, INITiate followed by a FETCh?.
READ?	Takes a measurement using parameters previously set up using either CONFigure or lower-level commands. READ? is equivalent to an ABORT followed by an INITiate (which performs the data acquisition) and a FETCh?
FETCh?	Retrieves measurements taken by INITiate*.

* INITiate is described in [Chapter 14](#), “TRIGger Subsystem,” on page 461.

The CONFigure, FETCh?, READ?, and MEASure? commands all have a numeric suffix which refers to a specific CALCulate block.

Optional parameters

CONFigure, FETCh?, READ?, and MEASure? have the following three optional parameters:

- An expected power value
- A resolution
- A source list

Expected power value

The `<expected_value>` parameter sets the expected power level of the measurement.

Resolution

The `<resolution>` parameter sets the resolution of the specified CALCulate block. If you are making a ratio or difference measurement, the `<resolution>` parameters are applied to both channels.

Source list

The `<source list>` parameter is used to define:

- the measurement channel.
- whether the calculation is A-A for a difference measurement or A/A for a ratio measurement.

CONFigure[1]|2|3|4?

This query returns the present configuration of the specified CALCulate block.

Syntax

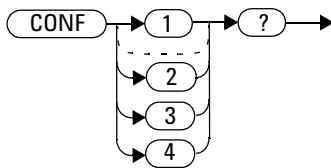

The string returned depends on the settings of the CALCulate:MATH and CALCulate:RELative:STATe commands.

The configuration is returned as a quoted string in the following format:

"<function> <expected_value>,<resolution>,<source list>"

CALCulate:MATH	CALCulate:RELative:STATe	Function	<source list>
(SENSe1)	OFF	:POW:AC	(@1)
(SENSe1)	ON	:POW:AC:REL	(@1)
(SENSe1 - SENSe1)	OFF	:POW:AC:DIFF	(@1),(@1)
(SENSe1 - SENSe1)	ON	:POW:AC:DIFF:REL	(@1),(@1)
(SENSe1 / SENSe1)	OFF	:POW:AC:RAT	(@1),(@1)
(SENSe1 / SENSe1)	ON	:POW:AC:RAT:REL	(@1),(@1)

<expected_value> returns the expected value sent by the last CONFigure command or +20 dBm by default.

<resolution> returns the resolution value in the <NR1> format in the range of 1 through 4.

Example

```
CONF2?
```

Queries the current configuration of the CALCulate2 measurement.

Reset condition

On reset:

- The command function is set to :POWER:AC.
- The expected power level is set to +20 dBm.
- The resolution is set to 3.
- The source list is set to Channel A.

CONFigure[1]|2|3|4 Commands

The CONFigure commands are used on the specified CALCulate block to set:

- the expected power level being measured.
- the resolution of the measurement.
- the channel on which the measurement is to be made.

The CONFigure commands do not make the power measurement after setting the configuration. Use READ?, or alternatively use INITiate followed by a FETCh? to make the measurement.

The CONFigure command also applies the following defaults to the channel in the specified CALCulate block (the channel is specified in the <source list> parameter):

Default settings	Description
INITiate:CONTinuous OFF	Sets the U2020 X-Series to make one trigger cycle when INITiate is sent.
TRIGger:SOURce IMMEDIATE	When TRIG:SOUR is set to BUS or HOLD, sets the U2020 X-Series to make the measurement immediately a trigger is received.
TRIGger:DELay:AUTO ON	Enables automatic delay before making the measurement.
SENSE:AVERage:COUNT:AUTO ON	Enables automatic filter length selection.
SENSE:AVERage:STATe ON	Enables averaging.

CONFigure[1] | 2 | 3 | 4[:SCALar][:POWer:AC] [<expected_value>[,<resolution>[,<source list>]]]

This command is used on the specified CALCulate block to set:

- the expected power level of the measurement.
- the resolution of the measurement.
- the channel on which the measurement will be made.

Syntax

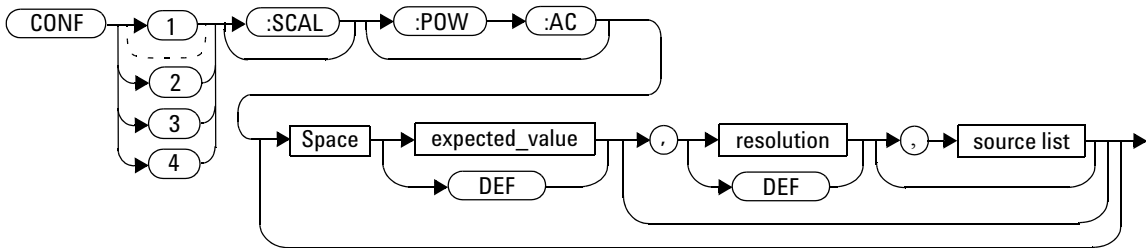

Parameters

Refer to “[Optional parameters](#)” on page 68 for additional details on the parameters in this command.

Item	Description/Default	Range of values
expected_value	A numeric value for the expected power level. The units of measurement are dBm and W. The default units are defined by UNIT:POWer.	sensor-dependent DEF ¹
resolution	A numeric value for the resolution. If unspecified, the current resolution setting is used.	1 to 4 ² 1.0, 0.1, 0.01, 0.001 DEF ¹

Item	Description/Default	Range of values
source list	The channel which the command is implemented on. If unspecified, the current setup is used. If the ratio or difference measurement was set up, it will default to Channel A.	(@1)

¹ The mnemonic DEF means DEFault. This is not equivalent to the DEFault parameter used in the command subsystems. The parameters must be entered in the specified order. If parameters are omitted, they default from the right. The parameter DEFault is used as a placeholder. Specifying DEF leaves the parameter value unchanged.

² When the measurement result is linear, this parameter represents the number of significant digits. When the measurement result is logarithmic, 1 to 4 represents 1, 0.1, 0.01, and 0.001 respectively.

Example

```
CONF1:POW:AC DEF,2,(@1)
```

Configures CALCulate1 to measure the power of Channel A, using the current range and a resolution setting of 2.

CONFigure[1] | 2 | 3 | 4[:SCALar][:POWer:AC]:RELative [<expected_value>[,<resolution>[,<source list>]]]

This command sets the measurement function, range, and resolution of the specified CALCulate block. It sets the measurement function to single channel with relative mode on. The relative value used is that set by the CALCulate:RELative:MAGNitude:AUTO command.

Syntax

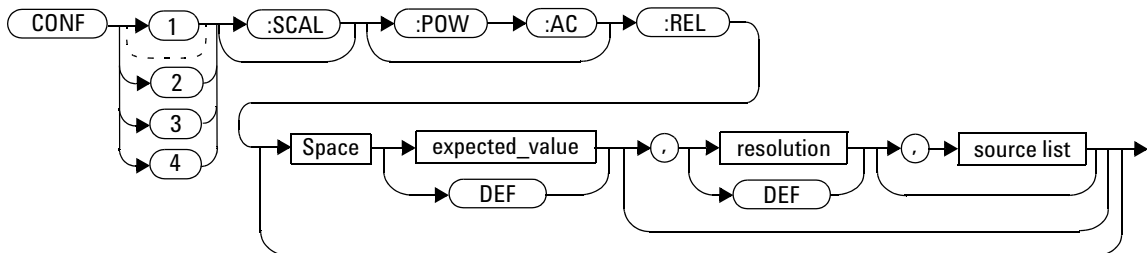

Parameters

Refer to “[Optional parameters](#)” on page 68 for additional details on the parameters in this command.

Item	Description/Default	Range of values
expected_value (for the expected power level)	A numeric value for the expected power level. The units of measurement are dBm and W. The default units are defined by UNIT:POWer.	sensor-dependent DEF ¹
resolution	A numeric value for the resolution. If unspecified, the current resolution setting is used.	1 to 4 ² 1.0, 0.1, 0.01, 0.001 DEF ¹

Item	Description/Default	Range of values
source list	The channel which the command is implemented on. If unspecified, the current setup is used. If the ratio or difference measurement was set up, it will default to Channel A.	(@1)

¹ The mnemonic DEF means DEFault. This is not equivalent to the DEFault parameter used in the command subsystems. The parameters must be entered in the specified order. If parameters are omitted, they default from the right. The parameter DEFault is used as a placeholder. Specifying DEF leaves the parameter value unchanged.

² When the measurement result is linear, this parameter represents the number of significant digits. When the measurement result is logarithmic, 1 to 4 represents 1, 0.1, 0.01, and 0.001 respectively.

Example

```
CONF2:REL -20DBM,3,(@1)
```

Configures CALCulate2 to measure the relative power of Channel A, using an expected power level of -20 dBm and a resolution setting of 3.

CONFigure[1] | 2 | 3 | 4[:SCALar][:POWer:AC]:DIFFerence [<expected_value>[,<resolution>[,<source list>]]]

This command sets the measurement function and resolution of the specified CALCulate block. It sets the measurement function to difference with relative mode off.

Syntax

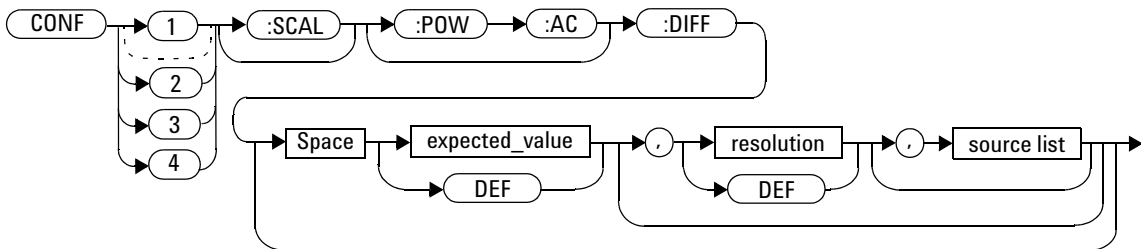

Parameters

Refer to “Optional parameters” on page 68 for additional details on the parameters in this command.

Item	Description/Default	Range of values
expected_value (for the expected power level)	The U2020 X-Series ignores the numeric value entered in this parameter. Any value entered is treated like DEF.	sensor-dependent DEF ¹
resolution	A numeric value for the resolution. If unspecified, the current resolution setting is used.	1 to 4 ² 1.0, 0.1, 0.01, 0.001 DEF ¹

Item	Description/Default	Range of values
source list	This channel list specifies between which channels the difference is calculated. If unspecified and the current setup is a difference measurement, then this difference setup is used, otherwise it defaults to Channel A-A.	(@1),(@1)

¹ The mnemonic DEF means DEFault. This is not equivalent to the DEFault parameter used in the command subsystems. The parameters must be entered in the specified order. If parameters are omitted, they default from the right. The parameter DEFault is used as a placeholder. Specifying DEF leaves the parameter value unchanged.

² When the measurement result is linear, this parameter represents the number of significant digits. When the measurement result is logarithmic, 1 to 4 represents a resolution of 1, 0.1, 0.01, and 0.001 respectively.

Example

```
CONF2:DIFF DEF,1,(@1),(@1)
```

Configures CALCulate2 to make a difference measurement of Channel A - Channel A, using the current range and a resolution of 1.

CONFigure[1] | 2 | 3 | 4[:SCALar][:POWer:AC]:DIFFerence:RELative [<expected_value>[,<resolution>[,<source list>]]]

This command sets the measurement function, range, and resolution of the specified CALCulate block. It sets the measurement function to difference with relative mode on. The relative value used is set by the CALCulate:RELative:MAGNitude:AUTO command.

Syntax

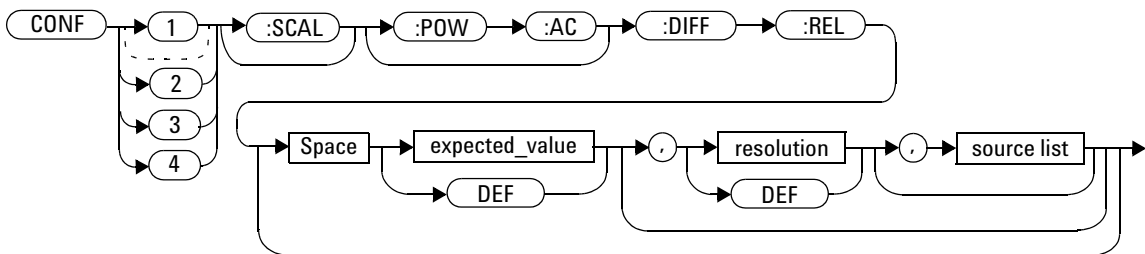

Parameters

Refer to “Optional parameters” on page 68 for additional details on the parameters in this command.

Item	Description/Default	Range of values
expected_value (for the expected power level)	The U2020 X-Series ignores the numeric value entered in this parameter. Any value entered is treated like DEF.	sensor-dependent DEF ¹
resolution	A numeric value for the resolution. If unspecified, the current resolution setting is used.	1 to 4 ² 1.0, 0.1, 0.01, 0.001 DEF ¹

Item	Description/Default	Range of values
source list	This channel list specifies the channels used to calculate the difference. If unspecified and the current setup is a difference measurement, then this difference setup is used, otherwise it defaults to Channel A-A.	(@1),(@1)

¹ The mnemonic DEF means DEFault. This is not equivalent to the DEFault parameter used in the command subsystems. The parameters must be entered in the specified order. If parameters are omitted, they default from the right. The parameter DEFault is used as a placeholder. Specifying DEF leaves the parameter value unchanged.

² When the measurement result is linear, this parameter represents the number of significant digits. When the measurement result is logarithmic, 1 to 4 represents 1, 0.1, 0.01, and 0.001 respectively.

Example

```
CONF1:DIFF:REL DEF,1, (@1) , (@1)
```

Configures CALCulate1 to make a difference measurement of Channel A – Channel A with relative mode on, using the current range and a resolution of 1.

CONFigure[1] | 2 | 3 | 4[:SCALar][:POWer:AC]:RATio [<expected_value>[,<resolution>[,<source list>]]]

This command sets the measurement function, range, and resolution of the specified CALCulate block. It sets the measurement function to ratio with relative mode off.

Syntax

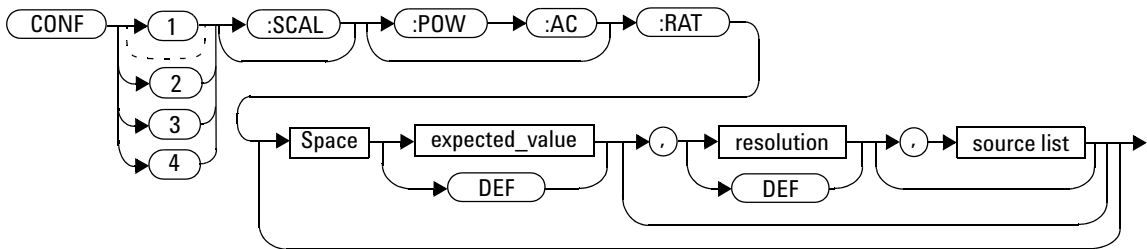

Parameters

Refer to “Optional parameters” on page 68 for additional details on the parameters in this command.

Item	Description/Default	Range of values
expected_value (for the expected power level)	The U2020 X-Series ignores the numeric value entered in this parameter. Any value entered is treated like DEF.	sensor-dependent DEF ¹
resolution	A numeric value for the resolution. If unspecified, the current resolution setting is used.	1 to 4 ² 1.0, 0.1, 0.01, 0.001 DEF ¹

Item	Description/Default	Range of values
source list	This channel list specifies the channels used to calculate the ratio. If unspecified and the current setup is a ratio measurement, then this ratio setup is used, otherwise it defaults to Channel A/A.	(@1),(@1)

¹ The mnemonic DEF means DEFault. This is not equivalent to the DEFault parameter used in the command subsystems. The parameters must be entered in the specified order. If parameters are omitted, they default from the right. The parameter DEFault is used as a placeholder. Specifying DEF leaves the parameter value unchanged.

² When the measurement result is linear, this parameter represents the number of significant digits. When the measurement result is logarithmic, 1 to 4 represents 1, 0.1, 0.01, and 0.001 respectively.

Example

`CONF1:RAT DEF,4,(@1),(@1)` *Configures CALCulate1 to make a ratio measurement of Channel A over Channel A, using the current range and a resolution setting of 4.*

CONFigure[1] | 2 | 3 | 4[:SCALar][:POWer:AC]:RATio: RELative [<expected_value>[,<resolution>[,<source list>]]]

This command sets the measurement function, range, and resolution of the specified CALCulate block. It sets the measurement function to ratio with relative mode on. The relative value used is that set by the CALCulate:RELative:MAGNitude:AUTO command.

Syntax

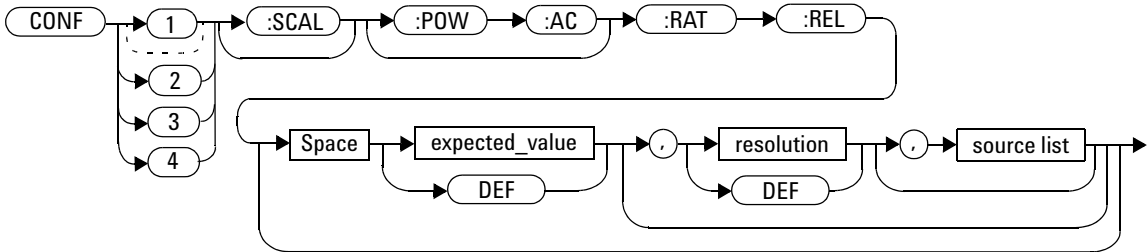

Parameters

Refer to “[Optional parameters](#)” on page 68 for additional details on the parameters in this command.

Item	Description/Default	Range of values
expected_value (for the expected power level)	The U2020 X-Series ignores the numeric value entered in this parameter. Any value entered is treated like DEF.	sensor-dependent DEF ¹
resolution	A numeric value for the resolution. If unspecified, the current resolution setting is used.	1 to 4 ² 1.0, 0.1, 0.01, 0.001 DEF ¹

Item	Description/Default	Range of values
source list	This channel list specifies the channels used to calculate the ratio. If unspecified and the current setup is a ratio measurement, then this ratio setup is used, otherwise it defaults to Channel A/A.	(@1),(@1)

¹ The mnemonic DEF means DEFault. This is not equivalent to the DEFault parameter used in the command subsystems. The parameters must be entered in the specified order. If parameters are omitted, they default from the right. The parameter DEFault is used as a placeholder. Specifying DEF leaves the parameter value unchanged.

² When the measurement result is linear, this parameter represents the number of significant digits. When the measurement result is logarithmic, 1 to 4 represents 1, 0.1, 0.01, and 0.001 respectively.

Example

`CONF1:RAT:REL DEF,1,(@1),(@1)` *Configures the CALCulate1 to make a ratio measurement of Channel A over Channel A with relative mode on, using the current range and a resolution setting of 1.*

FETCh[1]|2|3|4 Queries

The FETCh? queries set the specified CALCulate block measurement function. This can be set to either single channel, difference, or ratio measurements, with relative mode either off or on. They then recalculate the measurement and place the result on the bus. The format of the result is set by FORM[:READ] [:DATA]. Refer to [Chapter 5](#), “FORMat Subsystem,” on page 173 for further information.

The query returns a measurement result when it is valid. The measurement result is invalid under the following conditions:

- When *RST is executed.
- Whenever a measurement is initiated.
- When any SENSE parameter, such as frequency, is changed.

If data is invalid, the FETCh? query is not completed until all data becomes valid. The exceptions to this are, if the U2020 X-Series is in the idle state and the data is invalid, or the U2020 X-Series has been reconfigured as defined above and no new measurement has been initiated. In such cases, the FETCh? routine generates the error -230, “Data corrupt or stale” and no result is returned. A common cause for this error is receiving a FETCh? after a *RST. If the expected value and resolution parameters are not the same as those that were used to collect the data, error -221, “Settings conflict” occurs.

NOTE

When TRIG:SOUR is INT1 or EXT and a new acquisition has been initiated (using the INIT command for example), FETCh? waits until the trigger takes place before executing. If trigger conditions are not satisfied - when the trigger level differs greatly from the signal level for example - this can give the impression that the U2020 X-Series has hung.

To unlock the U2020 X-Series and adjust trigger settings, Device Clear should be executed (this is equivalent to “EXECUTE CLEAR” in Agilent VEE).

FETCh[1|2|3|4[:SCALar]][:POWer:AC]? [<expected_value>[,<resolution>[,<source list>]]]

This command sets the specified CALCulate block measurement function to single channel with relative mode off, recalculates the measurement, and places the result on the bus. The result is a power-based measurement and is expressed in the units defined by UNIT[1] | 2 | 3 | 4 : POWer.

Syntax

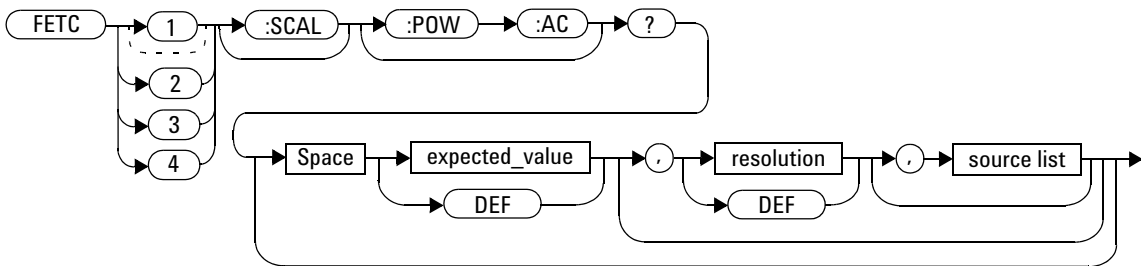

Parameters

Refer to “Optional parameters” on page 68 for additional details on the parameters in this command.

Item	Description/Default	Range of values
expected_value (for the expected power level)	The expected power level parameter can be set to DEF or a numeric value. If a value is entered, it should correspond to that set by CONFIGure otherwise an error occurs. The units of measurement are dBm and W. The default units are defined by UNIT: POWer.	sensor-dependent DEF ¹

Item	Description/Default	Range of values
resolution	A numeric value for the resolution. If it is unspecified, the current resolution setting is used. If a value is entered, it should correspond to the current resolution setting otherwise an error occurs.	1 to 4 ² 1.0, 0.1, 0.01, 0.001 DEF ¹
source list	The channel which the command is implemented on. If unspecified, the current setup is used. If the ratio or difference measurement was set up, it will default to Channel A.	(@1)

¹ The mnemonic DEF means DEFault. This is not equivalent to the DEFault parameter used in the command subsystems. The parameters must be entered in the specified order. If parameters are omitted, they default from the right. The parameter DEFault is used as a placeholder. Specifying DEF leaves the parameter value unchanged.

² When the measurement result is linear, this parameter represents the number of significant digits. When the measurement result is logarithmic, 1 to 4 represents 1, 0.1, 0.01, and 0.001 respectively.

Example

FETC2:POW:AC?

Queries the CALCulate2 measurement result.

Error messages

- If the last measurement is not valid, error -230, “Data corrupt or stale” occurs. A measurement is valid after it has been initiated. It becomes invalid when either a reset occurs or any measurement parameter, for example frequency, is changed.
- If the expected value and resolution parameters are not the same as the current expected value and resolution setting on the specified CALCulate block, error -221, “Settings conflict” occurs.

FETCh[1] | 2 | 3 | 4[:SCALar][:POWer:AC]:RELative? [<expected_value>[,<resolution>[,<source list>]]]

This command sets the specified CALCulate block measurement function to single channel with relative mode on, recalculates the measurement, and places the results on the bus. The result is a ratio-based measurement and is expressed in the units defined by UNIT[1] | 2 | 3 | 4:POWer:RATio. The relative value used is that set by the CALCulate:RELative:MAGNitude:AUTO command.

Syntax

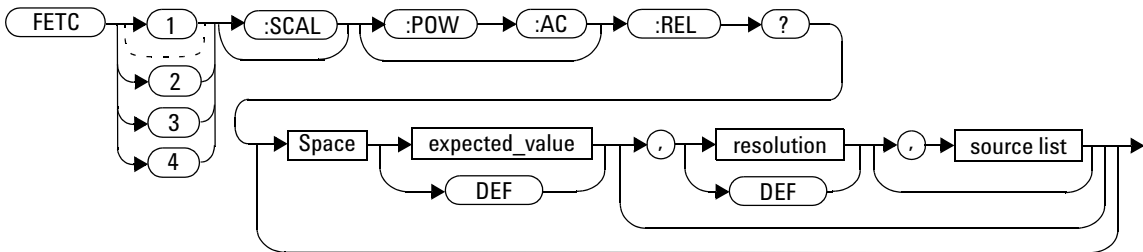

Parameters

Refer to “Optional parameters” on page 68 for additional details on the parameters in this command.

Item	Description/Default	Range of values
expected_value (for the expected power level)	The expected power level parameter can be set to DEF or a numeric value. If a value is entered, it should correspond to that set by CONFIGure otherwise an error occurs. The units of measurement are dBm and W. The default units are defined by UNIT:POWer.	sensor-dependent DEF ¹

Item	Description/Default	Range of values
resolution	A numeric value for the resolution. If it is unspecified, the current resolution setting is used. If a value is entered, it should correspond to the current resolution setting otherwise an error occurs.	1 to 4 ² 1.0, 0.1, 0.01, 0.001 DEF ¹
source list	The channel which the command is implemented on. If unspecified, the current setup is used. If the ratio or difference measurement was set up, it will default to Channel A.	(@1)

¹ The mnemonic DEF means DEFault. This is not equivalent to the DEFault parameter used in the command subsystems. The parameters must be entered in the specified order. If parameters are omitted, they default from the right. The parameter DEFault is used as a placeholder. Specifying DEF leaves the parameter value unchanged.

² When the measurement result is linear, this parameter represents the number of significant digits. When the measurement result is logarithmic, 1 to 4 represents 1, 0.1, 0.01, and 0.001 respectively.

Example

```
FETC1:REL? DEF,2,(@1)
```

Queries the CALCulate1 relative measurement of Channel A, using the current range and a resolution setting of 2.

Error messages

- If the last measurement is not valid, error -230, “Data corrupt or stale” occurs. A measurement is valid after it has been initiated. It becomes invalid when either a reset occurs or any measurement parameter, for example frequency, is changed.
- If the expected value and resolution parameters are not the same as the current expected value and resolution settings on the specified CALCulate block, error -221, “Settings conflict” occurs.

FETCh[1] | 2 | 3 | 4[:SCALar][:POWer:AC]:DIFFerence? [<expected_value>[,<resolution>[,<source list>]]]

This command sets the specified CALCulate block measurement function to power difference with relative mode off, recalculates the measurement, and places the results on the bus. The result is a power-based measurement and is expressed in the units defined by UNIT[1] | 2 | 3 | 4:POWer.

Syntax

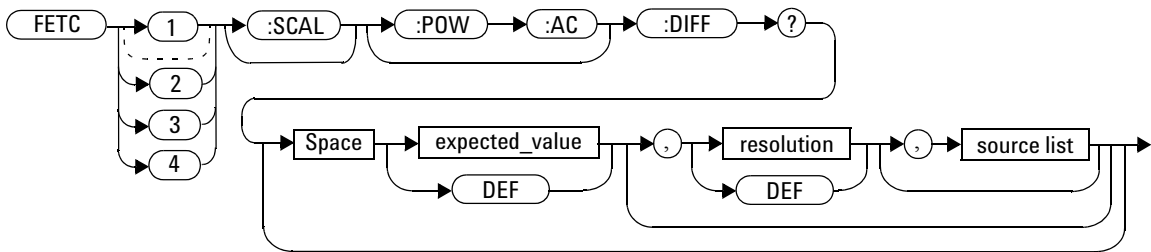

Parameters

Refer to “[Optional parameters](#)” on page 68 for additional details on the parameters in this command.

Item	Description/Default	Range of values
expected_value (for the expected power level)	The expected power level parameter can be set to DEF or a numeric value. If a value is entered, it should correspond to that set by CONFigure otherwise an error occurs. The units of measurement are dBm and W. The default units are defined by UNIT:POWer.	sensor-dependent DEF ¹

2 MEASurement Commands

Item	Description/Default	Range of values
resolution	A numeric value for the resolution. If it is unspecified, the current resolution setting is used. If a value is entered, it should correspond to the current resolution setting otherwise an error occurs.	1 to 4 ² 1.0, 0.1, 0.01, 0.001 DEF ¹
source list	This channel list specifies the channels used to calculate the difference. If unspecified and the current setup is a difference measurement, then this difference setup is used, otherwise it defaults to Channel A-A.	(@1),(@1)

¹ The mnemonic DEF means DEFault. This is not equivalent to the DEFault parameter used in the command subsystems. The parameters must be entered in the specified order. If parameters are omitted, they default from the right. The parameter DEFault is used as a placeholder. Specifying DEF leaves the parameter value unchanged.

² When the measurement result is linear, this parameter represents the number of significant digits. When the measurement result is logarithmic, 1 to 4 represents of 1, 0.1, 0.01, and 0.001 respectively.

Example

```
FETC4:DIFF?
```

Queries the CALCulate4 difference measurement.

Error messages

- If the last measurement is not valid, error -230, “Data corrupt or stale” occurs. A measurement is valid after it has been initiated. It becomes invalid when either a reset occurs or any measurement parameter, for example frequency, is changed.
- If the expected value and resolution parameters are not the same as the current expected value and resolution settings on the specified CALCulate block, error -221, “Settings conflict” occurs.

FETCh[1] | 2 | 3 | 4[:SCALar][:POWer:AC]:DIFFerence:RELative? [<expected_value>[,<resolution>[,<source list>]]]

This command sets the specified CALCulate block measurement function to power difference with relative mode on, recalculates the measurement, and places the results on the bus. The result is a ratio-based measurement and is expressed in the units defined by UNIT[1] | 2 | 3 | 4:POWer:RATio. The relative value used is that set by the CALCulate:RELative:MAGNitude:AUTO command.

Syntax

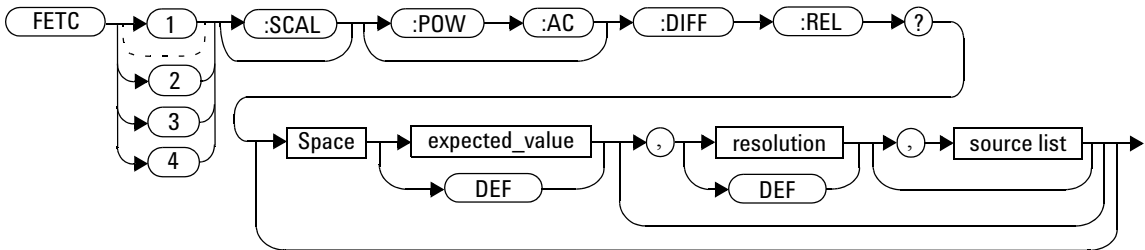

Parameters

Refer to “Optional parameters” on page 68 for additional details on the parameters in this command.

Item	Description/Default	Range of values
expected_value (for the expected power level)	The expected power level parameter can be set to DEF or a numeric value. If a value is entered, it should correspond to that set by CONFIGure otherwise an error occurs. The units of measurement are dBm and W. The default units are defined by UNIT:POWer.	sensor-dependent DEF ¹

Item	Description/Default	Range of values
resolution	A numeric value for the resolution. If it is unspecified, the current resolution setting is used. If a value is entered, it should correspond to the current resolution setting otherwise an error occurs.	1 to 4 ² 1.0, 0.1, 0.01, 0.001 DEF ¹
source list	This channel list specifies the channels used to calculate the difference. If unspecified and the current setup is a difference measurement, then this difference setup is used, otherwise it defaults to Channel A-A.	(@1),(@1)

¹ The mnemonic DEF means DEFault. This is not equivalent to the DEFault parameter used in the command subsystems. The parameters must be entered in the specified order. If parameters are omitted, they default from the right. The parameter DEFault is used as a placeholder. Specifying DEF leaves the parameter value unchanged.

² When the measurement result is linear, this parameter represents the number of significant digits. When the measurement result is logarithmic, 1 to 4 represents of 1, 0.1, 0.01, and 0.001 respectively.

Example

FETC1:DIFF:REL? DEF,3,(@1),(@1) *Queries the CALCulate1 relative difference measurement of Channel A - Channel A, using the current range and a resolution setting of 3.*

Error messages

- If the last measurement is not valid, error -230, “Data corrupt or stale” occurs. A measurement is valid after it has been initiated. It becomes invalid when either a reset occurs or any measurement parameter, for example frequency, is changed.

- If the expected value and resolution parameters are not the same as the current expected value and resolution settings on the specified CALCulate block, error -221, “Settings conflict” occurs.

FETCh[1|2|3|4[:SCALar]][:POWer:AC]:RATio? [<expected_value>[,<resolution>[,<source list>]]]

This command sets the specified CALCulate block measurement function to power ratio with relative mode off, recalculates the measurement, and places the results on the bus. The result is a ratio-based measurement and is expressed in the units defined by UNIT[1|2|3|4:POWer:RATio].

Syntax

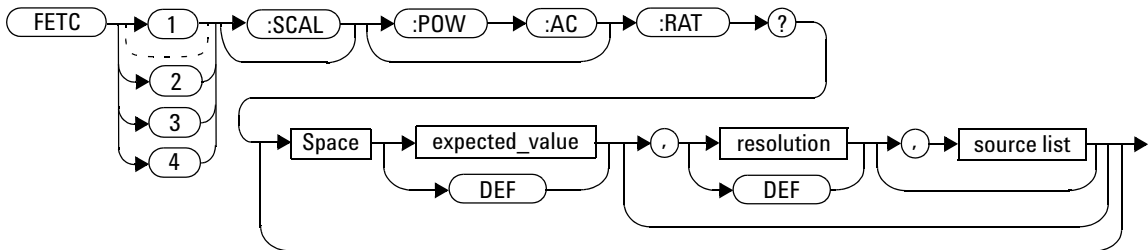

Parameters

Refer to “Optional parameters” on page 68 for additional details on the parameters in this command.

Item	Description/Default	Range of values
expected_value (for the expected power level)	The expected power level parameter can be set to DEF or a numeric value. If a value is entered, it should correspond to that set by CONFigure otherwise an error occurs. The units of measurement are dBm and W. The default units are defined by UNIT:POWer.	sensor-dependent DEF ¹

Item	Description/Default	Range of values
resolution	A numeric value for the resolution. If it is unspecified, the current resolution setting is used. If a value is entered, it should correspond to the current resolution setting otherwise an error occurs.	1 to 4 ² 1.0, 0.1, 0.01, 0.001 DEF ¹
source list	This channel list specifies the channels used to calculate the ratio. If unspecified and the current setup is a ratio measurement, then this ratio setup is used, otherwise it defaults to Channel A/A.	(@1),(@1)

¹ The mnemonic DEF means DEFault. This is not equivalent to the DEFault parameter used in the command subsystems. The parameters must be entered in the specified order. If parameters are omitted, they default from the right. The parameter DEFault is used as a placeholder. Specifying DEF leaves the parameter value unchanged.

² When the measurement result is linear, this parameter represents the number of significant digits. When the measurement result is logarithmic, 1 to 4 represents 1, 0.1, 0.01, and 0.001 respectively.

Example

```
FETC2:RAT? DEF,1,(@1),(@1)
```

Queries the CALCulate2 ratio measurement of Channel A over Channel A, using the current range and a resolution of 1.

Error messages

- If the last measurement is not valid, error -230, “Data corrupt or stale” occurs. A measurement is valid after it has been initiated. It becomes invalid when either a reset occurs or any measurement parameter, for example frequency, is changed.
- If the expected value and resolution parameters are not the same as the current expected value and resolution settings on the specified CALCulate block, error -221, “Settings conflict” occurs.

FETCh[1|2|3|4[:SCALar][:POWer:AC]:RATio:RELative? [<expected_value>[,<resolution>[,<source list>]]]

This command sets the specified CALCulate block measurement function to power ratio with relative mode on, recalculates the measurement, and places the results on the bus. The result is a ratio-based measurement and is expressed in the units defined by UNIT[1|2|3|4:POWer:RATio. The relative value used is that set by the CALCulate:RELative:MAGNitude:AUTO command.

Syntax

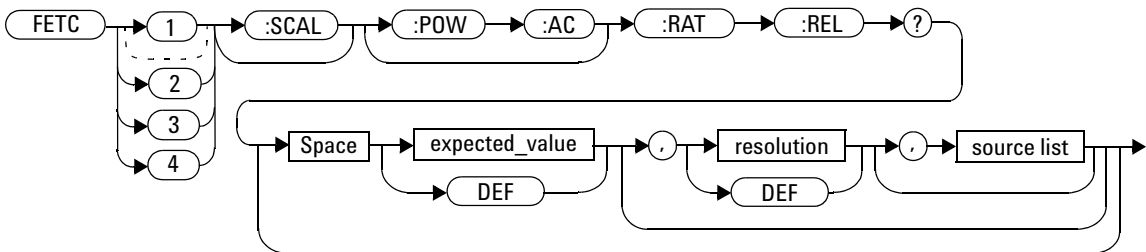

Parameters

Refer to “Optional parameters” on page 68 for additional details on the parameters in this command.

Item	Description/Default	Range of values
expected_value (for the expected power level)	The expected power level parameter can be set to DEF or a numeric value. If a value is entered, it should correspond to that set by CONFigure otherwise an error occurs. The units of measurement are dBm and W. The default units are defined by UNIT:POWer.	sensor-dependent DEF ¹

Item	Description/Default	Range of values
resolution	A numeric value for the resolution. If it is unspecified, the current resolution setting is used. If a value is entered, it should correspond to the current resolution setting otherwise an error occurs.	1 to 4 ² 1.0, 0.1, 0.01, 0.001 DEF ¹
source list	This channel list specifies the channels used to calculate the ratio. If unspecified and the current setup is a ratio measurement, then this ratio setup is used, otherwise it defaults to Channel A/A.	(@1),(@1)

¹ The mnemonic DEF means DEFault. This is not equivalent to the DEFault parameter used in the command subsystems. The parameters must be entered in the specified order. If parameters are omitted, they default from the right. The parameter DEFault is used as a placeholder. Specifying DEF leaves the parameter value unchanged.

² When the measurement result is linear, this parameter represents the number of significant digits. When the measurement result is logarithmic, 1 to 4 represents 1, 0.1, 0.01, and 0.001 respectively.

Example

FETC : RAT : REL ?

Queries the CALCulate1 relative ratio measurement.

Error messages

- If the last measurement is not valid, error -230, “Data corrupt or stale” occurs. A measurement is valid after it has been initiated. It becomes invalid when either a reset occurs or any measurement parameter, for example frequency, is changed.
- If the expected value and resolution parameters are not the same as the current expected value and resolution settings on the specified CALCulate block, error -221, “Settings conflict” occurs.

READ[1]|2|3|4 Commands

The READ? commands are most commonly used with the CONFIGure command to cause a new power measurement to be taken and the result returned to the output buffer. The format of the result is set by FORM[:READ][:DATA]. Refer to [Chapter 5](#), “FORMat Subsystem,” on page 173 for further information.

- For the single channel measurement, the READ? queries are equivalent to:

```
ABORt  
INITiate  
FETCh?
```

- For the difference measurement, the READ:DIFFerence? queries are equivalent to:

```
ABORt  
INITiate  
FETCh:DIFFerence?
```

- For the ratio measurement, the READ:RATio? queries are equivalent to:

```
ABORt  
INITiate  
FETCh:RATio?
```

READ[1|2|3|4[:SCALar][:POWer:AC]? [<expected_value>[,<resolution>[,<source list>]]]

This command sets the specified CALCulate block measurement function to single channel with relative mode off, aborts then initiates the specified channel, calculates the measurement result, and places the result on the bus. The result is a power-based measurement and is expressed in the units defined by UNIT[1|2|3|4:POWer.

NOTE

INITiate:CONTinuous must be set to OFF, otherwise error -213, "INIT ignored" occurs. If TRIGger:SOURce is set to BUS, error -214, "Trigger deadlock" occurs.

Syntax

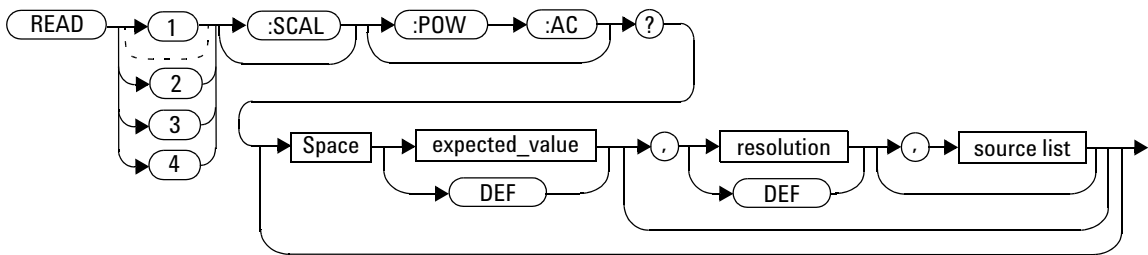

Parameters

Refer to “[Optional parameters](#)” on page 68 for additional details on the parameters in this command.

Item	Description/Default	Range of values
expected_value (for the expected power level)	The expected power level parameter can be set to DEF or a numeric value. If a value is entered, it should correspond to that set by CONFigure otherwise an error occurs.	sensor-dependent DEF ¹

2 MEASurement Commands

Item	Description/Default	Range of values
resolution	A numeric value for the resolution. If it is unspecified, the current resolution setting is used. If a value is entered, it should correspond to the current resolution setting otherwise an error occurs.	1 to 4 ² 1.0, 0.1, 0.01, 0.001 DEF ¹
source list	The channel which the command is implemented on. If unspecified, the current setup is used. If the ratio or difference measurement was set up, it will default to Channel A.	(@1)

¹ The mnemonic DEF means DEFault. This is not equivalent to the DEFault parameter used in the command subsystems. The parameters must be entered in the specified order. If parameters are omitted, they default from the right. The parameter DEFault is used as a placeholder. Specifying DEF leaves the parameter value unchanged.

² When the measurement result is linear, this parameter represents the number of significant digits. When the measurement result is logarithmic, 1 to 4 represents 1, 0.1, 0.01, and 0.001 respectively.

Example

```
READ2:POW:AC?
```

Queries the CALCulate2 measurement.

Error messages

- INITiate:CONTinuous must be set to OFF, otherwise error -213, “INIT ignored” occurs.
- If TRIGger:SOURce is set to BUS or HOLD, error -214, “Trigger deadlock” occurs.
- If the expected value and resolution parameters are not the same as the current expected value and resolution settings on the specified CALCulate block, error -221, “Settings conflict” occurs.

READ[1]|2|3|4[:SCALar][:POWer:AC]:RELative? [<expected_value>[,<resolution>[,<source list>]]]

This command sets the specified CALCulate block measurement function to single channel with relative mode on, aborts then initiates the specified channel, calculates the measurement result, and places the result on the bus. The result is a ratio-based measurement and is expressed in the units defined by UNIT[1]|2|3|4:POWer:RATio. The relative value used is that set by the CALCulate:RELative:MAGNitude:AUTO command.

NOTE

INITiate:CONTinuous must be set to OFF, otherwise error -213, "INIT ignored" occurs. If TRIGger:SOURce is set to BUS, error -214, "Trigger deadlock" occurs.

Syntax

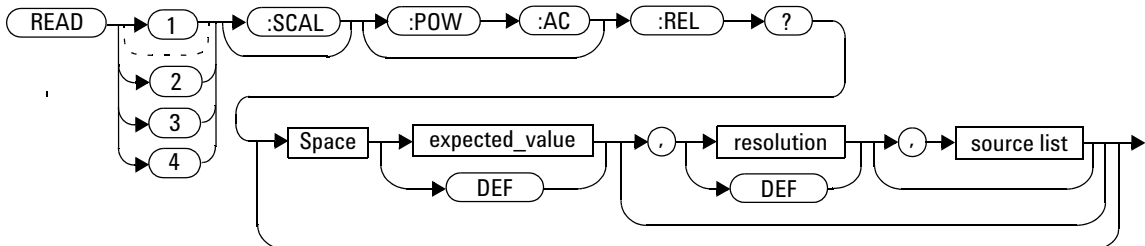

Parameters

Refer to “Optional parameters” on page 68 for additional details on the parameters in this command.

Item	Description/Default	Range of values
expected_value (for the expected power level)	The expected power level parameter can be set to DEF or a numeric value. If a value is entered, it should correspond to that set by CONFIGure otherwise an error occurs.	sensor-dependent DEF ¹
resolution	A numeric value for the resolution. If it is unspecified, the current resolution setting is used. If a value is entered, it should correspond to the current resolution setting otherwise an error occurs.	1 to 4 ² 1.0, 0.1, 0.01, 0.001 DEF ¹
source list	The channel which the command is implemented on. If unspecified, the current setup is used. If the ratio or difference measurement was set up, it will default to Channel A.	(@1)

¹ The mnemonic DEF means DEFault. This is not equivalent to the DEFault parameter used in the command subsystems. The parameters must be entered in the specified order. If parameters are omitted, they default from the right. The parameter DEFault is used as a placeholder. Specifying DEF leaves the parameter value unchanged.

² When the measurement result is linear, this parameter represents the number of significant digits. When the measurement result is logarithmic, 1 to 4 represents 1, 0.1, 0.01, and 0.001 respectively.

Example

READ1:REL? DEF,1,(@1) *Queries the CALCulate1 relative measurement of Channel A, using the current range and a resolution of 1.*

Error messages

- `INITiate:CONTInuous` must be set to `OFF`, otherwise error -213, “INIT ignored” occurs.
- If `TRIGger:SOURce` is set to `BUS` or `HOLD`, error -214, “Trigger deadlock” occurs.
- If the expected value and resolution parameters are not the same as the current expected value and resolution settings on the specified `CALCulate` block, error -221, “Settings conflict” occurs.

READ[1|2|3|4[:SCALAR][:POWER:AC]:DIFFERENCE? [<expected_value>[,<resolution>[,<source list>]]]

This command sets the specified CALCulate block measurement function to the difference mode with relative mode off, aborts then initiates Channel A, calculates the difference measurement result, and places the result on the bus. The result is a power-based measurement and is expressed in the units defined by UNIT[1|2|3|4:POWER.

NOTE

INITiate:CONTinuous must be set to OFF, otherwise error -213, "INIT ignored" occurs. If TRIGger:SOURce is set to BUS, error -214, "Trigger deadlock" occurs.

Syntax

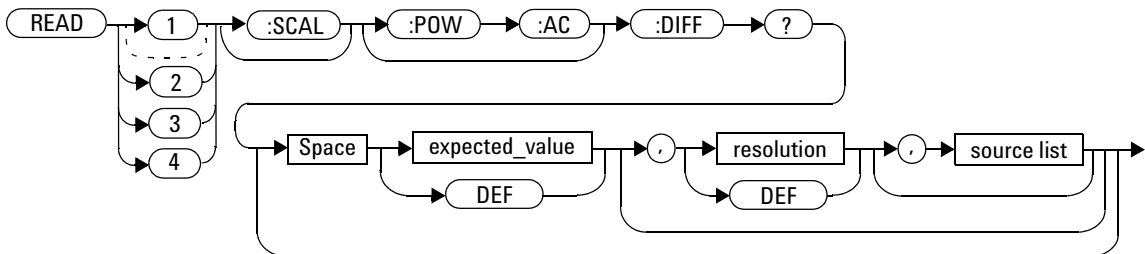

Parameters

Refer to “Optional parameters” on page 68 for additional details on the parameters in this command.

Item	Description/Default	Range of values
expected_value (for the expected power level)	The U2020 X-Series ignores the numeric value entered in this parameter. Any value entered is treated like DEF.	sensor-dependent DEF ¹

Item	Description/Default	Range of values
resolution	A numeric value for the resolution. If it is unspecified, the current resolution setting is used. If a value is entered, it should correspond to the current resolution setting otherwise an error occurs.	1 to 4 ² 1.0, 0.1, 0.01, 0.001 DEF ¹
source list	This channel list specifies the channels used to calculate the difference. If unspecified and the current setup is a difference measurement, then this difference setup is used, otherwise it defaults to Channel A-A.	(@1),(@1)

¹ The mnemonic DEF means DEFault. This is not equivalent to the DEFault parameter used in the command subsystems. The parameters must be entered in the specified order. If parameters are omitted, they default from the right. The parameter DEFault is used as a placeholder. Specifying DEF leaves the parameter value unchanged.

² When the measurement result is linear, this parameter represents the number of significant digits. When the measurement result is logarithmic, 1 to 4 represents 1, 0.1, 0.01, and 0.001 respectively.

Example

READ2:DIFF? *Queries the CALCulate2 difference measurement.*

Error messages

- INITiate:CONTinuous must be set to OFF, otherwise error -213, “INIT ignored” occurs.
- If TRIGger:SOURce is set to BUS or HOLD, error -214, “Trigger deadlock” occurs.
- If the resolution parameter is not the same as the current resolution setting on the specified CALCulate block, error -221, “Settings conflict” occurs.

READ[1]|2|3|4[:SCALar][:POWER:AC]:DIFFerence:RELative? [<expected_value>[,<resolution>[,<source list>]]]

This command sets the specified CALCulate block measurement function to the difference mode with relative mode on, aborts then initiates Channel A, calculates the difference measurement result, and places the result on the bus. The result is a ratio-based measurement and is expressed in the units defined by UNIT[1]|2|3|4:POWER:RATio. The relative value used is that set by the CALCulate:RELative:MAGNitude:AUTO command.

NOTE

INITiate:CONTinuous must be set to OFF, otherwise error -213, "INIT ignored" occurs. If TRIGger:SOURce is set to BUS, error -214, "Trigger deadlock" occurs.

Syntax

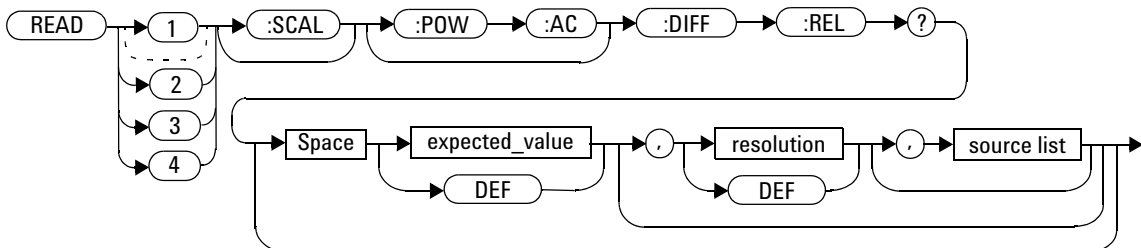

Parameters

Refer to “Optional parameters” on page 68 for additional details on the parameters in this command.

Item	Description/Default	Range of values
expected_value (for the expected power level)	The U2020 X-Series ignores the numeric value entered in this parameter. Any value entered is treated like DEF.	sensor-dependent DEF ¹
resolution	A numeric value for the resolution. If it is unspecified, the current resolution setting is used. If a value is entered, it should correspond to the current resolution setting otherwise an error occurs.	1 to 4 ² 1.0, 0.1, 0.01, 0.001 DEF ¹
source list	This channel list specifies the channels used to calculate the difference. If unspecified and the current setup is a difference measurement, then this difference setup is used, otherwise it defaults to Channel A-A.	(@1),(@1)

¹ The mnemonic DEF means DEFault. This is not equivalent to the DEFault parameter used in the command subsystems. The parameters must be entered in the specified order. If parameters are omitted, they default from the right. The parameter DEFault is used as a placeholder. Specifying DEF leaves the parameter value unchanged.

² When the measurement result is linear, this parameter represents the number of significant digits. When the measurement result is logarithmic, 1 to 4 represents 1, 0.1, 0.01, and 0.001 respectively.

Example

`READ1:DIFF:REL? DEF,4,(@1),(@1)` *Queries the CALCulate1 relative difference measurement of Channel A - Channel A, using the current range and a resolution setting of 4.*

Error messages

- `INITiate:CONTinuous` must be set to `OFF`, otherwise error -213, “INIT ignored” occurs.
- If `TRIGger:SOURce` is set to `BUS` or `HOLD`, error -214, “Trigger deadlock” occurs.
- If the resolution parameter is not the same as the current resolution setting on the specified `CALCulate` block, error -221, “Settings conflict” occurs.

READ[1] | 2 | 3 | 4[:SCALar][:POWer:AC]:RATio? [<expected_value>[,<resolution>[,<source list>]]]

This command sets the specified CALCulate block measurement function to the ratio mode with relative mode off, aborts then initiates Channel A, calculates the ratio measurement result, and places the result on the bus. The result is a ratio-based measurement and is expressed in the units defined by UNIT[1] | 2 | 3 | 4:POWer:RATio.

NOTE

INITiate:CONTinuous must be set to OFF, otherwise error -213, "INIT ignored" occurs. If TRIGger:SOURce is set to BUS, error -214, "Trigger deadlock" occurs.

Syntax

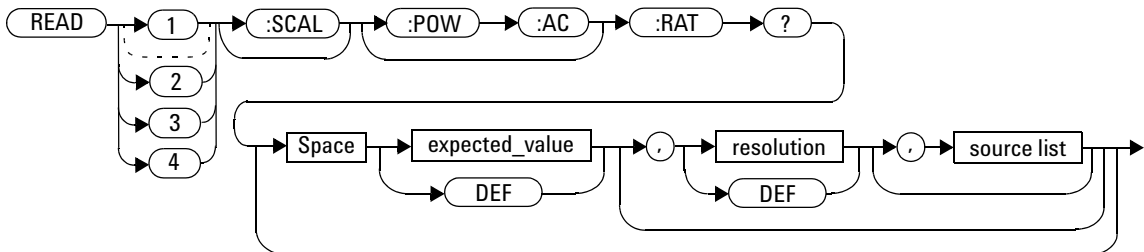

Parameters

Refer to “[Optional parameters](#)” on page 68 for additional details on the parameters in this command.

Item	Description/Default	Range of values
expected_value (for the expected power level)	The U2020 X-Series ignores the numeric value entered in this parameter. Any value entered is treated like DEF.	sensor-dependent DEF ¹

Item	Description/Default	Range of values
resolution	A numeric value for the resolution. If it is unspecified, the current resolution setting is used. If a value is entered, it should correspond to the current resolution setting otherwise an error occurs.	1 to 4 ² 1.0, 0.1, 0.01, 0.001 DEF ¹
source list	This channel list specifies the channels used to calculate the ratio. If unspecified and the current setup is a ratio measurement, then this ratio setup is used, otherwise it defaults to Channel A/A.	(@1),(@1)

¹ The mnemonic DEF means DEFault. This is not equivalent to the DEFault parameter used in the command subsystems. The parameters must be entered in the specified order. If parameters are omitted, they default from the right. The parameter DEFault is used as a placeholder. Specifying DEF leaves the parameter value unchanged.

² When the measurement result is linear, this parameter represents the number of significant digits. When the measurement result is logarithmic, 1 to 4 represents 1, 0.1, 0.01, and 0.001 respectively.

Example

`READ2:RAT? DEF,1,(@1),(@1)` *Queries the CALCulate2 ratio measurement of Channel A over Channel A, using the current range and a resolution of 1.*

Error messages

- INITiate:CONTinuous must be set to OFF, otherwise error -213, “INIT ignored” occurs.
- If TRIGger:SOURce is set to BUS or HOLD, error -214, “Trigger deadlock” occurs.
- If the resolution parameter is not the same as the current resolution setting on the specified CALCulate block, error -221, “Settings conflict” occurs.

READ[1|2|3|4[:SCALar][:POWer:AC]:RATio:RELative? [<expected_value>[,<resolution>[,<source list>]]]

This command sets the specified CALCulate block measurement function to the ratio mode with relative mode on, aborts then initiates Channel A, calculates the ratio measurement result using the new data, and places the result on the bus. The result is a ratio-based measurement and is expressed in the units defined by UNIT[1|2|3|4:POWer:RATio. The relative value used is that set by the CALCulate:RELative:MAGNitude:AUTO command.

NOTE

INITiate:CONTinuous must be set to OFF, otherwise error -213, "INIT ignored" occurs. If TRIGger:SOURce is set to BUS, error -214, "Trigger deadlock" occurs.

Syntax

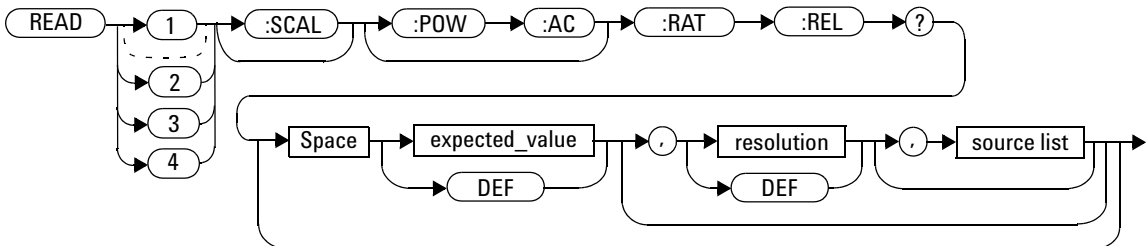

Parameters

Refer to “Optional parameters” on page 68 for additional details on the parameters in this command.

Item	Description/Default	Range of values
expected_value (for the expected power level)	The U2020 X-Series ignores the numeric value entered in this parameter. Any value entered is treated like DEF.	sensor-dependent DEF ¹
resolution	A numeric value for the resolution. If it is unspecified, the current resolution setting is used. If a value is entered, it should correspond to the current resolution setting otherwise an error occurs.	1 to 4 ² 1.0, 0.1, 0.01, 0.001 DEF ¹
source list	This channel list specifies the channels used to calculate the ratio. If unspecified and the current setup is a ratio measurement, then this ratio setup is used, otherwise it defaults to Channel A/A.	(@1),(@1)

¹ The mnemonic DEF means DEFault. This is not equivalent to the DEFault parameter used in the command subsystems. The parameters must be entered in the specified order. If parameters are omitted, they default from the right. The parameter DEFault is used as a placeholder. Specifying DEF leaves the parameter value unchanged.

² When the measurement result is linear, this parameter represents the number of significant digits. When the measurement result is logarithmic, 1 to 4 represents 1, 0.1, 0.01, and 0.001 respectively.

Example

```
READ:RAT:REL?
```

Queries the CALCulate1 relative ratio measurement.

Error messages

- `INITiate:CONTinuous` must be set to `OFF`, otherwise error -213, “INIT ignored” occurs.
- If `TRIGger:SOURce` is set to `BUS` or `HOLD`, error -214, “Trigger deadlock” occurs.
- If the resolution parameter is not the same as the current resolution setting on the specified `CALCulate` block, error -221, “Settings conflict” occurs.

MEASure[1]|2|3|4 Commands

The MEASure? commands configure the U2020 X-Series to perform a power measurement with the given function, relative mode setting, range, and resolution then makes the measurement. The format of the result is set by FORM[:READ][:DATA]. Refer to [Chapter 5](#), “FORMat Subsystem,” on page 173 for further information.

MEASure? is a compound command which is equivalent to:

- For the single channel measurement, the MEASure? queries are equivalent to:

```
ABORT
CONFigure
READ?
```

- For the difference measurement, the MEASure:DIFFerence? queries are equivalent to:

```
ABORT
CONFigure:DIFFerence
READ:DIFFerence?
```

- For the ratio measurement, the MEASure:RATio? queries are equivalent to:

```
ABORT
CONFigure:RATio
READ:RATio?
```

MEASure[1] | 2 | 3 | 4[:SCALar][:POWer:AC]? [<expected_value>[,<resolution>[,<source list>]]]

This command sets the specified CALCulate block measurement function to single channel with relative mode off, aborts, configures the CALCulate block then initiates Channel A, calculates the measurement result, and places the result on the bus.

Syntax

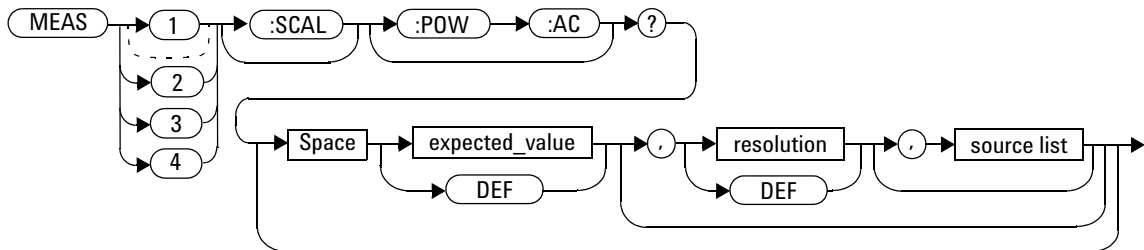

Parameters

Refer to “[Optional parameters](#)” on page 68 for additional details on the parameters in this command.

Item	Description/Default	Range of values
expected_value (for the expected power level)	A numeric value for the expected power level. The units of measurement are dBm and W. The default units are defined by UNIT:POWer.	sensor-dependent DEF ¹
resolution	A numeric value for the resolution. If unspecified, the current resolution setting is used.	1 to 4 ² 1.0, 0.1, 0.01, 0.001 DEF ¹

2 MEASurement Commands

Item	Description/Default	Range of values
source list	The channel which the command is implemented on. If unspecified, the current setup is used. If the ratio or difference measurement was set up, it will default to Channel A.	(@1)

¹ The mnemonic DEF means DEFault. This is not equivalent to the DEFault parameter used in the command subsystems. The parameters must be entered in the specified order. If parameters are omitted, they default from the right. The parameter DEFault is used as a placeholder. Specifying DEF leaves the parameter value unchanged.

² When the measurement result is linear, this parameter represents the number of significant digits. When the measurement result is logarithmic, 1 to 4 represents 1, 0.1, 0.01, and 0.001 respectively.

Example

```
MEAS2:POW:AC? -20DBM,1,(@1)
```

Queries the CALCulate2 measurement of Channel A, using an expected power level of -20 dBm and a resolution setting of 1.

MEASure[1|2|3|4[:SCALar][:POWer:AC]:RELative? [<expected_value>[,<resolution>[,<source list>]]]

This command sets the specified CALCulate block measurement function to single channel with relative mode on, aborts, configures then initiates the specified channel, calculates the measurement result, and places the result on the bus. The result is a ratio-based measurement and is expressed in the units defined by UNIT[1|2|3|4:POWer:RATio. The relative value used is that set by the CALCulate:RELative:MAGNitude:AUTO command.

Syntax

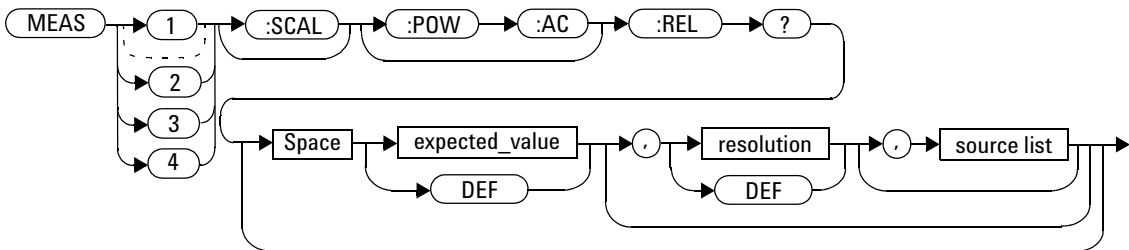

Parameters

Refer to “[Optional parameters](#)” on page 68 for additional details on the parameters in this command.

Item	Description/Default	Range of values
expected_value (for the expected power level)	A numeric value for the expected power level. The units of measurement are dBm and W. The default units are defined by UNIT:POWer.	sensor-dependent DEF ¹
resolution	A numeric value for the resolution. If unspecified, the current resolution setting is used.	1 to 4 ² 1.0, 0.1, 0.01, 0.001 DEF ¹

2 MEASurement Commands

Item	Description/Default	Range of values
source list	The channel which the command is implemented on. If unspecified, the current setup is used. If the ratio or difference measurement was set up, it will default to Channel A.	(@1)

¹ The mnemonic DEF means DEFault. This is not equivalent to the DEFault parameter used in the command subsystems. The parameters must be entered in the specified order. If parameters are omitted, they default from the right. The parameter DEFault is used as a placeholder. Specifying DEF leaves the parameter value unchanged.

² When the measurement result is linear, this parameter represents the number of significant digits. When the measurement result is logarithmic, 1 to 4 represents 1, 0.1, 0.01, and 0.001 respectively.

Example

```
MEAS1:REL? -10DBM,2,(@1)
```

Queries the CALCulate1 relative measurement of Channel A, using an expected power level of -10 dBm and a resolution setting of 2.

MEASure[1] | 2 | 3 | 4[:SCALar][:POWer:AC]:DIFFerence? [<expected_value>[,<resolution>[,<source list>]]]

This command sets the specified CALCulate block measurement function to the difference mode with relative mode off, aborts, configures then initiates Channel A, calculates the difference measurement result, and places the result on the bus. The result is a power-based measurement and is expressed in the units defined by UNIT[1] | 2 | 3 | 4:POWer.

Syntax

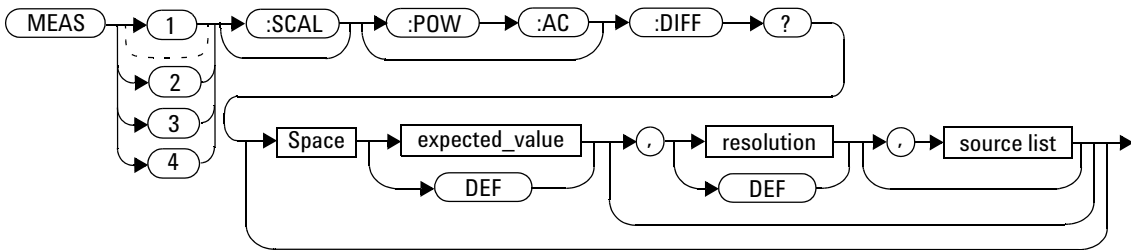

Parameters

Refer to “[Optional parameters](#)” on page 68 for additional details on the parameters in this command.

Item	Description/Default	Range of values
expected_value (for the expected power level)	The U2020 X-Series ignores the numeric value entered in this parameter. Any value entered is treated like DEF.	sensor-dependent DEF ¹
resolution	A numeric value for the resolution. If unspecified, the current resolution setting is used.	1 to 4 ² 1.0, 0.1, 0.01, 0.001 DEF ¹

2 MEASurement Commands

Item	Description/Default	Range of values
source list	This channel list specifies the channels used to calculate the difference. If unspecified and the current setup is a difference measurement, then this difference setup is used, otherwise it defaults to Channel A-A.	(@1),(@1)

¹ The mnemonic `DEF` means `DEFAult`. This is not equivalent to the `DEFAult` parameter used in the command subsystems. The parameters must be entered in the specified order. If parameters are omitted, they default from the right. The parameter `DEFAult` is used as a placeholder. Specifying `DEF` leaves the parameter value unchanged.

² When the measurement result is linear, this parameter represents the number of significant digits. When the measurement result is logarithmic, 1 to 4 represents 1, 0.1, 0.01, and 0.001 respectively.

Example

```
MEAS2:DIFF?
```

Queries the CALCulate2 difference measurement.

MEASure[1]|2|3|4[:SCALar][:POWer:AC]:DIFFerence:RELative? [<expected_value>[,<resolution>[,<source list>]]]

This command sets the specified CALCulate block measurement function to the difference mode with relative mode on, aborts, configures then initiates Channel A, calculates the difference measurement result, and places the result on the bus. The result is a ratio-based measurement and is expressed in the units defined by UNIT[1]|2|3|4:POWer:RATio. The relative value used is that set by the CALCulate:RELative:MAGNitude:AUTO command.

Syntax

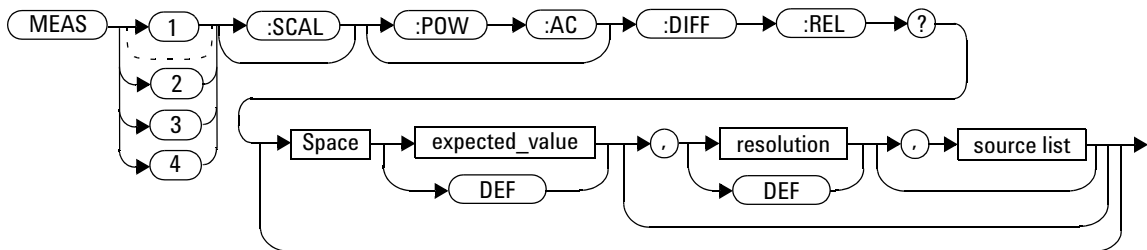

Parameters

Refer to “[Optional parameters](#)” on page 68 for additional details on the parameters in this command.

Item	Description/Default	Range of values
expected_value (for the expected power level)	The U2020 X-Series ignores the numeric value entered in this parameter. Any value entered is treated like DEF.	sensor-dependent DEF ¹
resolution	A numeric value for the resolution. If unspecified, the current resolution setting is used.	1 to 4 ² 1.0, 0.1, 0.01, 0.001 DEF ¹

2 MEASurement Commands

Item	Description/Default	Range of values
source list	This channel list specifies the channels used to calculate the difference. If unspecified and the current setup is a difference measurement, then this difference setup is used, otherwise it defaults to Channel A-A.	(@1),(@1)

¹ The mnemonic DEF means DEFault. This is not equivalent to the DEFault parameter used in the command subsystems. The parameters must be entered in the specified order. If parameters are omitted, they default from the right. The parameter DEFault is used as a placeholder. Specifying DEF leaves the parameter value unchanged.

² When the measurement result is linear, this parameter represents the number of significant digits. When the measurement result is logarithmic, 1 to 4 represents 1, 0.1, 0.01, and 0.001 respectively.

Example

```
MEAS1:DIFF:REL? DEF,3,(@1),(@1)
```

Queries the CALCulate1 relative difference measurement of Channel A – Channel A, using the current range and a resolution setting of 3.

MEASure[1] | 2 | 3 | 4[:SCALar][:POWer:AC]:RATio? [<expected_value>[,<resolution>[,<source list>]]]

This command sets the specified CALCulate block measurement function to the ratio mode with relative mode off, aborts, configures then initiates Channel A, calculates the ratio measurement result, and places the result on the bus. The result is a ratio-based measurement and is expressed in the units defined by UNIT[1] | 2 | 3 | 4:POWer:RATio.

Syntax

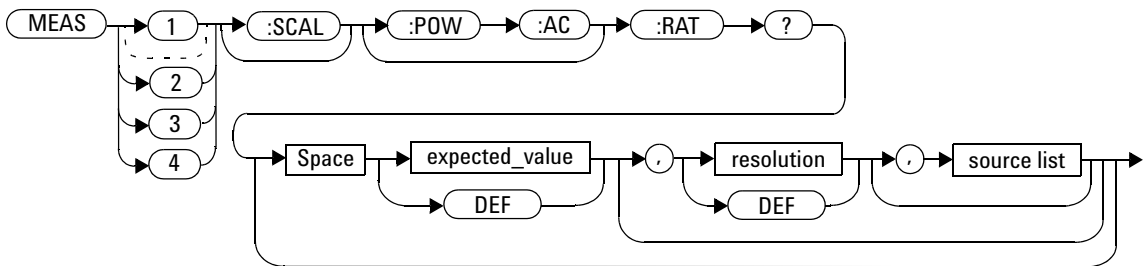

Parameters

Refer to “[Optional parameters](#)” on page 68 for additional details on the parameters in this command.

Item	Description/Default	Range of values
expected_value (for the expected power level)	The U2020 X-Series ignores the numeric value entered in this parameter. Any value entered is treated like DEF.	sensor-dependent DEF ¹
resolution	A numeric value for the resolution. If unspecified, the current resolution setting is used.	1 to 4 ² 1.0, 0.1, 0.01, 0.001 DEF ¹

Item	Description/Default	Range of values
source list	This channel list specifies the channels used to calculate the ratio. If unspecified and the current setup is a ratio measurement, then this ratio setup is used, otherwise it defaults to Channel A/A.	(@1).(@1)

¹ The mnemonic DEF means DEFault. This is not equivalent to the DEFault parameter used in the command subsystems. The parameters must be entered in the specified order. If parameters are omitted, they default from the right. The parameter DEFault is used as a placeholder. Specifying DEF leaves the parameter value unchanged.

² When the measurement result is linear, this parameter represents the number of significant digits. When the measurement result is logarithmic, 1 to 4 represents 1, 0.1, 0.01, and 0.001 respectively.

Example

MEAS2:RAT? DEF,1,(@1),(@1) *Queries the CALCulate2 ratio measurement of Channel A over Channel A, using the current range and a resolution of 1.*

MEASure[1] | 2 | 3 | 4[:SCALar][:POWer:AC]:RATio:RELative? [<expected_value>[,<resolution>[,<source list>]]]

This command sets the specified CALCulate block measurement function to the ratio mode with relative mode on, aborts, configures then initiates Channel A, calculates the ratio measurement, and places the result on the bus. The result is a ratio-based measurement and is expressed in the units defined by UNIT[1] | 2 | 3 | 4:POWer:RATio. The relative value used is that set by the CALCulate:RELative:MAGNitude:AUTO command.

Syntax

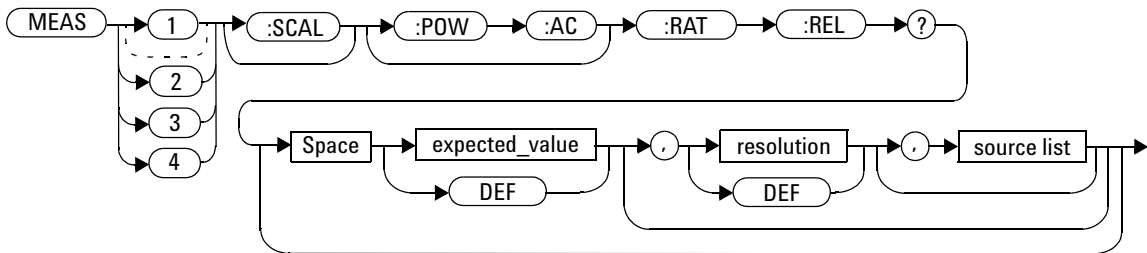

Parameters

Refer to “Optional parameters” on page 68 for additional details on the parameters in this command.

Item	Description/Default	Range of values
expected_value (for the expected power level)	The U2020 X-Series ignores the numeric value entered in this parameter. Any value entered is treated like DEF.	sensor-dependent DEF ¹
resolution	A numeric value for the resolution. If unspecified, the current resolution setting is used.	1 to 4 ² 1.0, 0.1, 0.01, 0.001 DEF ¹

2 MEASurement Commands

Item	Description/Default	Range of values
source list	This channel list specifies the channels used to calculate the ratio. If unspecified and the current setup is a ratio measurement, then this ratio setup is used, otherwise it defaults to Channel A/A.	(@1),(@1)

¹ The mnemonic `DEF` means `DEFault`. This is not equivalent to the `DEFault` parameter used in the command subsystems. The parameters must be entered in the specified order. If parameters are omitted, they default from the right. The parameter `DEFault` is used as a placeholder. Specifying `DEF` leaves the parameter value unchanged.

² When the measurement result is linear, this parameter represents the number of significant digits. When the measurement result is logarithmic, 1 to 4 represents 1, 0.1, 0.01, and 0.001 respectively.

Example

```
MEAS:RAT:REL?
```

Queries the `CALCulate1` relative ratio measurement.

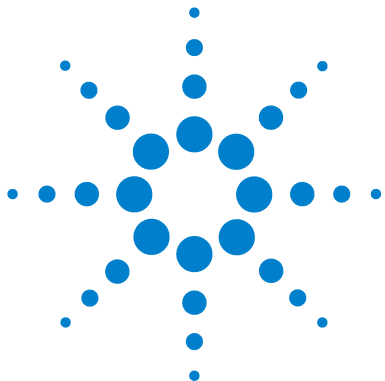

3 CALCulate Subsystem

CALCulate Subsystem	128
CALCulate[1] 2 3 4:FEED[1] 2 <string>	129
CALCulate[1] 2 3 4:GAIN Commands	132
CALCulate[1] 2 3 4:GAIN[:MAGNitude] <numeric_value>	133
CALCulate[1] 2 3 4:GAIN:STATe <boolean>	135
CALCulate[1] 2 3 4:LIMit Commands	137
CALCulate[1] 2 3 4:LIMit:CLEar:AUTO <boolean> ONCE	138
CALCulate[1] 2 3 4:LIMit:CLEar[:IMMEDIATE]	140
CALCulate[1] 2 3 4:LIMit:FAIL?	141
CALCulate[1] 2 3 4:LIMit:FCOut?	142
CALCulate[1] 2 3 4:LIMit:LOWer[:DATA] <numeric_value>	144
CALCulate[1] 2 3 4:LIMit:UPPer[:DATA] <numeric_value>	147
CALCulate[1] 2 3 4:LIMit:STATe <boolean>	150
CALCulate[1] 2 3 4:MATH Commands	152
CALCulate[1] 2 3 4:MATH[:EXPReSSion] <string>	153
CALCulate[1] 2 3 4:MATH[:EXPReSSion]:CATalogue?	155
CALCulate[1] 2 3 4:PHOLd:CLEar	156
CALCulate[1] 2 3 4:RELative Commands	157
CALCulate[1] 2 3 4:RELative[:MAGNitude]:AUTO <boolean> ONCE	158
CALCulate[1] 2 3 4:RELative:STATe <boolean>	160

This chapter explains how the CALCulate subsystem is used to perform post-acquisition data processing.



CALCulate Subsystem

The CALCulate subsystem performs post-acquisition data processing. Functions in the SENSE subsystem are related to data acquisition, while the CALCulate subsystem operates on the data acquired by a SENSE function.

There are four independent CALCulate blocks; the numeric suffix of the CALCulate command determines which CALCulate block is used.

Data from the SENSE block may feed any or all of the CALCulate blocks via the MATH command. Figure 3-1 details where the commands are applied with in the CALCulate block.

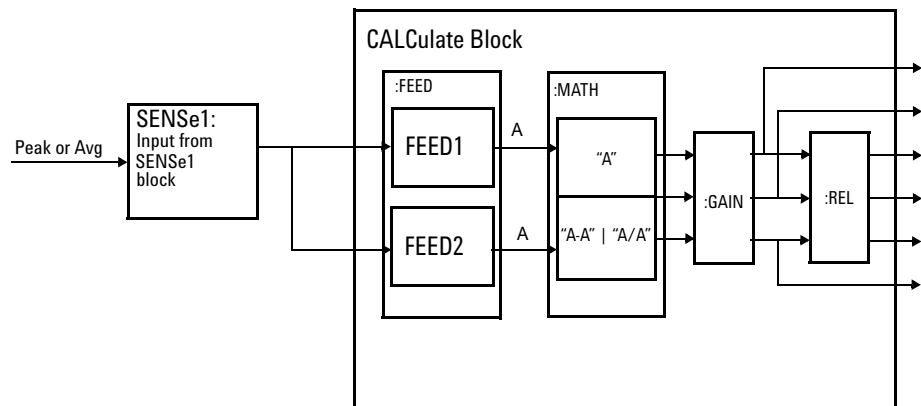

Figure 3-1 CALCulate block

CALCulate[1|2|3|4:FEED[1|2] <string>

This command sets the input measurement mode to be fed to the specified input on the CALC block. It is applied to the measurement after the CALC:MATH:EXPR command has been used to specify which channel the feed is taken from.

Measurement modes are coupled for combination measurements (for example, ratio measurements). For example, if one feed is changed to PTAV, the other is automatically changed to PTAV.

Under certain circumstances, the measurement mode is changed by the CALC:MATH:EXPR command. Refer to [“CALCulate\[1|2|3|4:MATH\[:EXPRession\] <string>”](#) on page 153 for further information.

Syntax

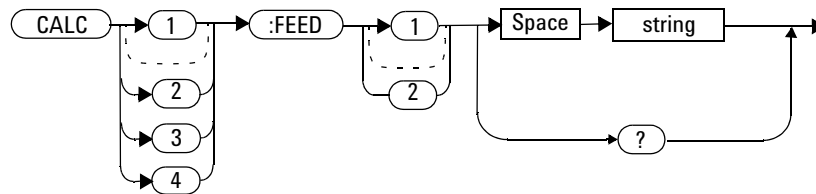

Parameters

Item	Description	Range of values
string	<p>The input measurement type to be fed to the specific input on the CALC block:</p> <ul style="list-style-type: none"> • PEAK: peak power • PTAV: peak to average power • AVER: average power • MIN: minimum power <p>Values may be followed by ON SWEEP[1] 2 3 4 where the numeric specifies the gate to be used for the feed. For example: "POW:PEAK ON SWEEP2".</p> <p>If ON SWEEP[1] 2 3 4 is not supplied, the gate used is left unchanged.</p> <p>A feed of "" (empty string) has no effect if specified.</p>	<p>"POW:PEAK" "POW:PTAV" "POW:AVER" "POW:MIN"</p>

Example

`CALC3:FEED2 "POW:AVER ON SWEEP2"` *Selects the input for FEED2 of CALC3 block to be average power, using gate 2.*

Reset condition

On reset, data_handle is set to :POW:AVER.

Query

`CALCulate[1] | 2 | 3 | 4:FEED[1] 2?`

The query returns the current value of the string.

Query example

CALC1:FEED2?

Queries the current setting of the data_handle on FEED2 of CALC1.

Error messages

- If <string> contains ON SWEEP[1]|2|3|4 and the feed's TRIG:SOUR is not INT or EXT, error -221, "Settings conflict" occurs.
- If CALC:FEED is set to PEAK or PTAV when DET:FUNC is set to AVER, error -221, "Settings conflict" occurs.

CALCulate[1]|2|3|4:GAIN Commands

These commands are used to enter and enable an offset on the specified CALCulate block. The offset is applied to the measurement signal after any math calculation.

The following commands are detailed in this section:

```
CALCulate[1]|2|3|4:GAIN[:MAGNitude] <numeric value>  
CALCulate[1]|2|3|4:GAIN:STATe <boolean>
```

CALCulate[1|2|3|4:GAIN[:MAGNitude] <numeric_value>

This command is used to enter a value for the offset on the specified CALCulate block. The offset is applied to the measurement signal after any math calculation.

Entering a value using this command automatically turns the CALCulate[1|2|3|4:GAIN:STATe command to ON.

Syntax

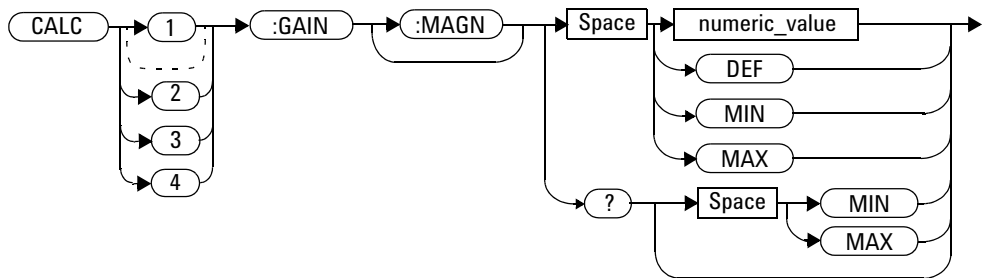

Parameters

Item	Description/Default	Range of values
numeric_value	A numeric value for the CALCulate offset: <ul style="list-style-type: none"> DEF: the default value is 0 dB MIN: -100.000 dB MAX: +100.000 dB 	-100.000 to +100.000 dB DEF MIN MAX

Example

```
CALC2:GAIN 20
```

Enters a CALCulate2 offset of 20 dB.

Reset condition

On reset, the offset is set to 0 dB (DEF).

Query

```
CALCulate[1]|2|3|4:GAIN[:MAGNitude]? [MIN|MAX]
```

The query returns the current setting of the offset or the value associated with MIN and MAX.

Query example

```
CALC1:GAIN?
```

Queries the current setting of the CALCulate1 offset.

Error message

If CALCulate[1]|2|3|4:GAIN[:MAGNitude] is set to ON while [SENSE[1]:]MRATE is set to FAST, error -221, “Settings conflict” occurs.

CALCulate[1]|2|3|4:GAIN:STATe <boolean>

This command is used on the specified CALCulate block to enable and disable the offset set by the CALCulate[1]|2|3|4:GAIN[:MAGNitude] command.

Syntax

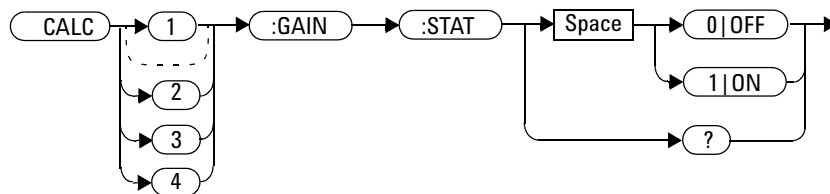

Example

```
CALC2:GAIN:STAT 1
```

Enables the CALCulate2 offset.

Reset condition

On reset, the offset is disabled.

Query

```
CALCulate[1]|2|3|4:GAIN:STATe?
```

The query enters a 1 or 0 into the output buffer indicating the status of the offset.

- 1 is returned when the offset is enabled
- 0 is returned when the offset is disabled

Query example

```
CALC1:GAIN:STAT?
```

Queries whether the CALCulate1 offset is turned on or off.

Error message

If CALCulate[1] | 2 | 3 | 4:GAIN:STATe is set to ON while [SENSe[1]:]MRATe is set to FAST, error -221, “Settings conflict” occurs.

CALCulate[1] | 2 | 3 | 4:LIMit Commands

These commands set the limits on CALCulate blocks which enable you to:

- Set upper and lower level limits
- Query if there has been a failure
- Count the number of failures
- Clear the counter

CALCulate[1]|2|3|4:LIMit:CLEAr:AUTo <boolean> | ONCE

This command controls when the FCO (fail counter) is cleared of any limit failures. The FCO is used to determine the results returned by the CALCulate[1]|2|3|4:LIMit:FAIL? query.

- If ON is specified, the FCO is set to 0 each time a measurement is:
 - Initiated using INITiate[:IMMEDIATE]
 - Initiated using INITiate:CONTinuous ON
 - Measured using MEASure?
 - Read using READ?
- If OFF is specified, the FCO is not cleared by the above commands.
- If ONCE is specified, the FCO is cleared only after the first initialization then starts accumulating any limit failures.

Syntax

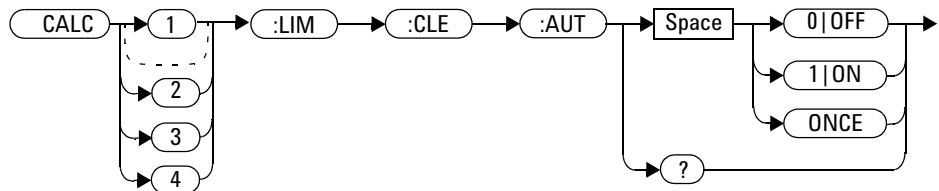

Example

```
CALC1:LIM:CLE:AUT 1
```

Switches on automatic clearing of the FCO for CALCulate1.

Reset condition

On reset, the CALCulate blocks and their measurements are set to ON.

Query

```
CALCulate[1]|2|3|4:LIMit:CLEar:AUTO?
```

The query enters a 1 or 0 into the output buffer indicating whether limit failures are cleared automatically when a new measurement is initiated on the specified CALCulate block.

- 1 is entered into the output buffer when limit failures are cleared automatically when a new measurement is initiated.
- 0 is entered into the output buffer when limit failures are not cleared automatically when a new measurement is initiated.

In the case where limit failures are cleared once, when a query occurs, a 1 is entered into the output buffer if no measurement is initiated. If a measurement is initiated, then 0 is entered.

Query example

```
CALC1:LIM:CLE:AUT?
```

Queries whether the FCO is cleared for CALCulate1.

CALCulate[1] | 2 | 3 | 4:LIMit:CLEAr[:IMMEDIATE]

This command immediately clears the FCO (fail counter) of any limit failures for the specified CALCulate block. The FCO is used to determine the results returned by the CALCulate[1] | 2 | 3 | 4:LIMit:FAIL? query.

Syntax

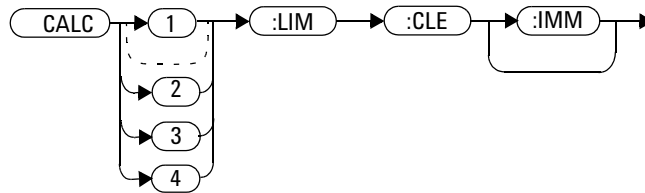

Example

```
CALC2:LIM:CLE:IMM
```

Clears the FCO for CALCulate2.

CALCulate[1]|2|3|4:LIMit:FAIL?

This query enters a 1 or 0 into the output buffer indicating whether there have been any limit failures for the CALCulate block. A limit failure is defined as CALC[1]|2|3|4:LIMit:FCO? being non-zero. The FCO (fail counter) can be zeroed using the CALC[1]|2|3|4:LIMit:CLEar command.

- 1 is returned when one or more limit failures have occurred
- 0 is returned when no limit failures have occurred

Syntax

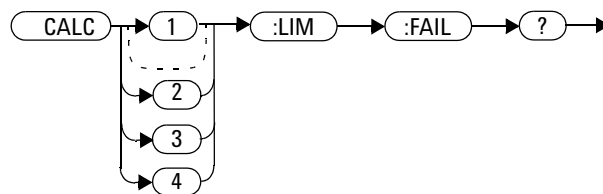

Example

CALC1:LIM:FAIL?

Queries if there have been any limit failures on CALCulate1.

Reset condition

On reset, the buffer is set to zero for all CALCulate blocks.

CALCulate[1]|2|3|4:LIMit:FCOunt?

This query returns the total number of limit failures for the specified CALCulate block.

If the appropriate STATE commands are set to ON, each time a measurement is initiated on the specified CALCulate block and the result is outside the limits, the counter is incremented by one.

If the measured value is equal to a limit, this is a limit pass.

The counter is reset to zero by any of the following commands:

- *RST
- CALCulate[1]|2|3|4:LIMit:CLEar:IMMediate
- CALCulate[1]|2|3|4:LIMit:CLEar:AUTO ON

When CALCulate[1]|2|3|4:LIMit:CLEar:AUTO is set to ON, the counter is set to zero *each* time a measurement is:

- measured using MEASure?
- read using READ?
- initiated using:
 - INITiate[:IMMediate] or,
 - INITiate:CONTinuous ON

When CALCulate[1]|2|3|4:LIMit:CLEar:AUTO is set to ONCE, the counter is set to zero the *first* time a measurement is:

- measured using MEASure?
- read using READ?
- initiated using:
 - INITiate[:IMMediate] or,
 - INITiate:CONTinuous ON

The maximum number of errors is $2^{16}-1$. If more than $2^{16}-1$ errors are detected, the counter returns to zero.

Syntax

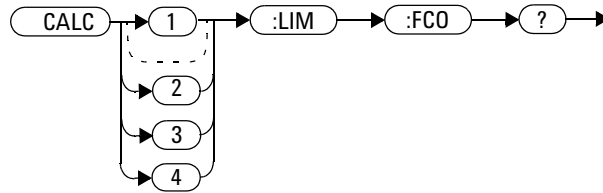

Example

CALC1:LIM:FCO?

Queries the number of limit failures on CALCulate1.

Reset condition

On reset, the counter is set to zero for all CALCulate blocks.

CALCulate[1|2|3|4:LIMit:LOWer[:DATA] <numeric_value>

This command enters a value for the lower test limit for the specified CALCulate block used in the CALCulate[1|2|3|4:LIMit:FAIL? test. The units used are dependent on the current setting of UNIT:POWER and CALCulate:RELative:STATE as shown in Table 3-1. When the measured value is less than the value specified in CALCulate[1|2|3|4:LIMit:LOWer[:DATA], CALCulate[1|2|3|4:LIMit:FAIL? reports a fail. When the measured value is greater than or equal to the limit, a fail is not reported.

Table 3-1 Measurement units

Measurement mode	Measurement type	CALC:REL:STAT OFF		CALC:REL:STAT ON	
		Linear	Log	Linear	Log
Single channel	Avg, Pk	Watt	dBm	%	dB
	Pk-Avg	%	dB	%	dB
Ratio	Avg, Pk, Pk-Avg	%	dB	%	dB
Difference	Avg, Pk	Watt	dBm	%	dB
	Pk-Avg	%	dB	%	dB

Syntax

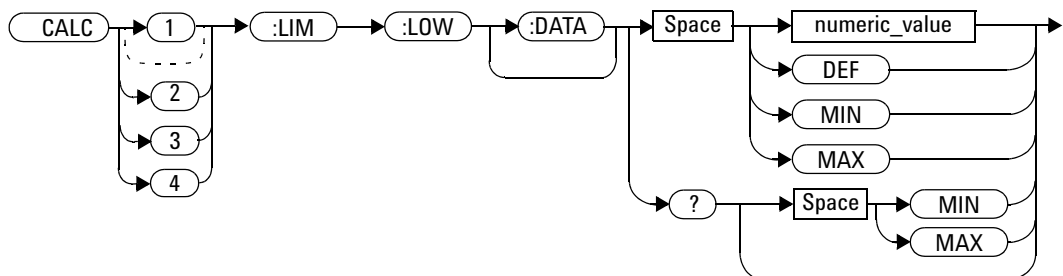

Parameters

Item	Description/Default	Range of values
numeric_value	A numeric value for the lower test limit: <ul style="list-style-type: none"> • DEF: the default is -90.00 dBm or -120 dB • MIN: -150 dBm or -180 dB • MAX: +230 dBm or +200 dB 	-150 to +230 dBm or -180 to +200 dB DEF MIN MAX

Example

```
CALC2:LIM:LOW:DATA 0.1
```

Enters a lower limit for CALCulate2 depending on the units as follows:

dBm = 0.1 dBm

W = 100 mW

dB = 0.1 dB

% = 0.1%

Reset condition

On reset, the lower limit for all CALCulate blocks is set to -90.00 dBm or -120 dB (DEF).

Query

```
CALCulate[1] | 2 | 3 | 4 : LIMit : LOWer [ : DATA ] ? [ MIN | MAX ]
```

The query returns the current setting of the lower limit or the values associated with MIN and MAX for the specified CALCulate block.

Query example

```
CALC2:LIM:LOW:DATA?
```

*Queries the lower limit set for
CALCulate2.*

CALCulate[1|2|3|4:LIMit:UPPer[:DATA] <numeric_value>

This command enters a value for the upper test limit for the specified CALCulate block used in the CALCulate[1|2|3|4:LIMit:FAIL? test. The units used are dependent on the current setting of UNIT:POWer and CALCulate:RELative:STATe as shown in Table 3-2. When the measured power is greater than the value specified in CALCulate[1|2|3|4:LIMit:UPPer[:DATA], CALCulate[1|2|3|4:LIMit:FAIL? reports a fail. When the measured level is less than or equal to the limit, a fail is not reported.

Table 3-2 Measurement units

Measurement mode	Measurement type	CALC:REL:STAT OFF		CALC:REL:STAT ON	
		Linear	Log	Linear	Log
Single channel	Avg, Pk	Watt	dBm	%	dB
	Pk-Avg	%	dB	%	dB
Ratio	Avg, Pk, Pk-Avg	%	dB	%	dB
Difference	Avg, Pk	Watt	dBm	%	dB
	Pk-Avg	%	dB	%	dB

Syntax

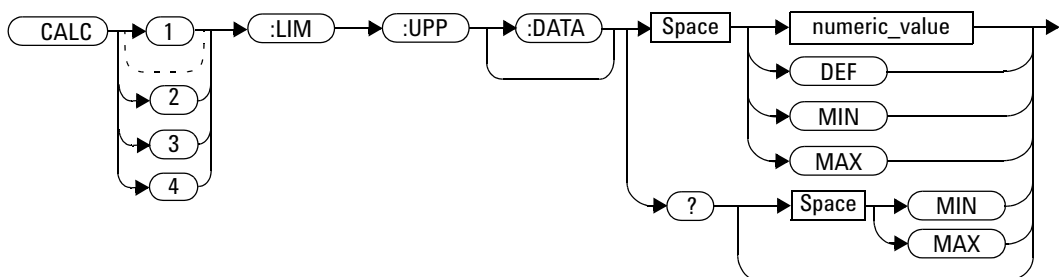

Parameters

Item	Description/Default	Range of values
numeric_value	A numeric value for the upper test limit: <ul style="list-style-type: none"> • DEF: the default is 90.00 dBm or 60 dB • MIN: -150 dBm or -180 dB • MAX: +230 dBm or +200 dB 	-150 to +230 dBm or -180 to +200 dB DEF MIN MAX

Example

CALC2:LIM:UPP:DATA 5

Enters an upper limit for CALCulate2 depending on the units as follows:

dBm = 5 dBm

W = 5 W

dB = 5 dB

% = 5%

Reset condition

On reset, the upper limit for all CALCulate blocks is set to 90.00 dBm or 60 dB (DEF).

Query

CALCulate[1] | 2 | 3 | 4 : LIMit : UPPer [: DATA] ? [MIN | MAX]

The query returns the current setting of the upper limit or the values associated with MIN and MAX for the specified CALCulate block.

Query example

```
CALC2:LIM:UPP:DATA?
```

Queries the setting of the upper limit for CALCulate2.

CALCulate[1|2|3|4]:LIMit:STATe <boolean>

This command enables/disables the test limits for the specified CALCulate block.

Syntax

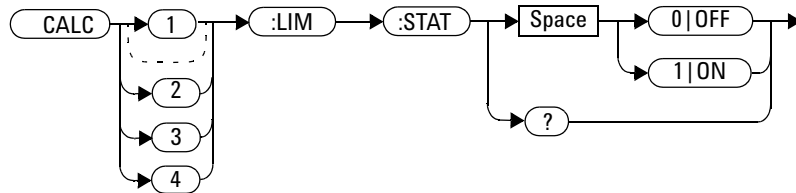

Example

```
CALC2:LIM:STAT 1
```

Enables the limit checking function for CALCulate2.

Reset condition

On reset, limit checking is disabled.

Query

```
CALCulate[1|2|3|4]:LIMit:STATe?
```

The query enters 1 or 0 into the output buffer indicating the status of the limit testing feature for the specified CALCulate block.

- 1 is returned when limit testing is enabled
- 0 is returned when limit testing is disabled

Query example

```
CALC1:LIM:STAT?
```

Queries whether the limit checking function for CALCulate1 is turned on or off.

Error message

If CALCulate[1|2|3|4]:LIMit:STATe is set to ON while [SENSe[1]:]MRATe is set to FAST, error -221, “Settings conflict” occurs.

CALCulate[1]|2|3|4:MATH Commands

These commands define and carry out the following mathematical transformation on SENSE data:

- Single channel
- Difference
- Ratio

The following commands are detailed in this section:

```
CALCulate[1]|2|3|4:MATH[:EXPRession] <string>
```

```
CALCulate[1]|2|3|4:MATH[:EXPRession]:CATalogue?
```

CALCulate[1 | 2 | 3 | 4:MATH[:EXPRession] <string>

This command sets the specified CALCulate block to a single channel, difference, or ratio measurement.

Syntax

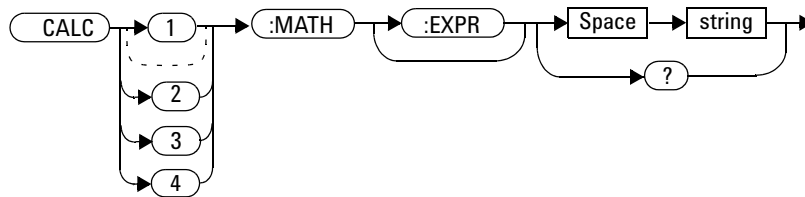

Parameters

Item	Description/Default	Range of values
string	A single string value detailing the measurement type. The default value is SENS1.	“(SENS1)” ¹ “(SENS1-SENS1)” ^{1,2} “(SENS1/SENS1)” ¹

¹ Quotes are mandatory. Either single or double quotes may be used.

² The mathematical operation will be performed in linear scale.

Example

```
CALC2:MATH "(SENS1/SENS1)"
```

Sets CALCulate2 to make a Channel A/A ratio measurement.

Reset condition

On reset, all CALCulate blocks are set to "(SENS1)".

Query

```
CALCulate[1]|2|3|4:MATH[:EXPRession]?
```

The query returns the current math measurement setting on the specified CALCulate block.

Query example

```
CALC1:MATH?
```

Queries the current setting of the math expression on CALCulate1.

Error message

If <string> is not set to "(SENS1)" while [SENSe[1]:]MRATe is set to FAST, error -221, "Settings conflict" occurs.

CALCulate[1] | 2 | 3 | 4:MATH[:EXPRession]:CATalogue?

This query lists all the defined math expressions in the form of comma-separated strings as follows:

```
" (SENS1) ", " (SENS1-SENS1) ", " (SENS1/SENS1) "
```

Each string contains a math expression.

Syntax

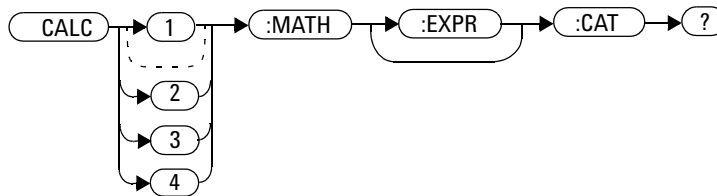

Example

```
CALC1:MATH:CAT?
```

Lists all the defined math expressions.

CALCulate[1] | 2 | 3 | 4:PHOLd:CLEAr

This command clears the peak hold value for a specified CALC block so that a new peak hold value can be set.

NOTE

Clearing the peak hold value for a specified CALC block may affect the peak hold value of other CALC blocks, depending on the CALC channel set up (set by `CALC:MATH:EXPR`).

Syntax

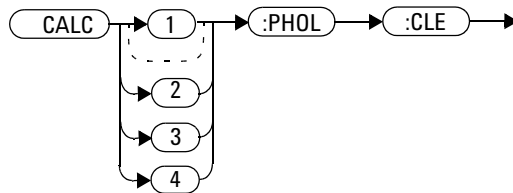

Example

`CALC2:PHOL:CLE`

Clears the peak hold value for CALC2.

Error messages

- If `TRIG:SOUR` is set to `INT1` or `EXT`, error -221, “Settings conflict” occurs.
- If `DET:FUNC` is set to `AVER`, error -221, “Settings conflict” occurs.

CALCulate[1]|2|3|4:RELative Commands

These commands compare the measurement signal to a reference value.

Within the CALCulate block, the relative value is applied to the measurement signal after any math calculations and offsets have been applied.

The commands described in this section:

```
CALCulate[1]|2|3|4:RELative[:MAGNitude]:AUTO <boolean>|ONCE
```

```
CALCulate[1]|2|3|4:RELative:STATE <boolean>
```

CALCulate[1|2|3|4:RELative[:MAGNitude]:AUTO <boolean> | ONCE

This command sets the reference value to be used in the relative measurement. Within the CALCulate block, the relative value is applied to the measurement signal after any math calculations and offsets have been applied.

The value should be set to ONCE to set the reference value to be used in relative measurements. Selecting ONCE sets the reference value to that of the measurement signal after any math calculations and CALCulate offsets have been applied. After the reference value has been set, the command returns to OFF. Setting this command to ONCE turns the CALCulate[1|2|3|4:RELative:STATE command to ON.

If 0|OFF is selected, no reference value is applied to the measurement signal. There is no situation in which you would want to send this command with OFF. OFF is only available because it is required for the query response.

If 1|ON is selected, it causes error -224, “Illegal parameter value” to occur.

Syntax

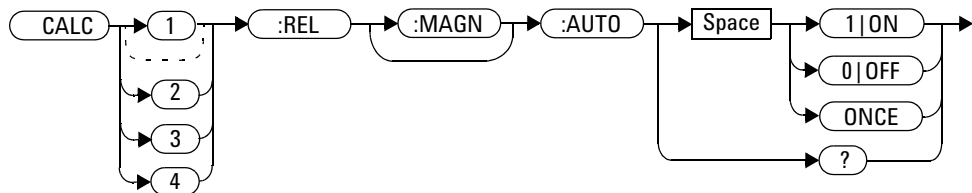

Example

```
CALC1:REL:AUTO ONCE
```

Sets a reference value to be used in the relative measurement on CALCulate1.

Query

```
CALCulate[1]|2|3|4:RELative[:MAGNitude]:AUTO?
```

The query always returns OFF.

Error messages

- If CALCulate:RELative[:MAGNitude]:AUTO is set to ONCE while [SENSE[1]:]MRATE is set to FAST, error -221, “Settings conflict” occurs.
- If the value is set to ON, error -224, “Illegal parameter value” occurs.

CALCulate[1] | 2 | 3 | 4:RELative:STATe <boolean>

This command enables/disables the relative mode. If the command is:

- disabled, the measurement signal remains unchanged.
- enabled, the current relative value set by CALCulate:RELative:MAGNitude:AUTO is applied to the measurement signal.

Syntax

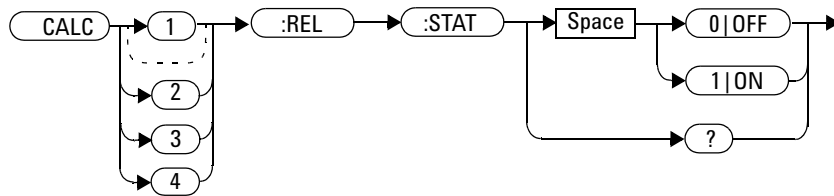

Example

```
CALC1:REL:STAT OFF
```

*Disables the relative mode on
CALCulate1.*

Reset condition

On reset, the relative mode is disabled.

Query

```
CALCulate[1]|2|3|4:RELative:STATe?
```

The query returns a 1 or 0 into the output buffer.

- 1 is returned when the relative mode is enabled
- 0 is returned when the relative mode is disabled

Query example

```
CALC1:REL:STAT?
```

Queries whether the relative mode is turned off or on for CALCulate1.

Error message

If CALCulate:RELative:STATe is set to ON while [SENSe[1]:]MRATE is set to FAST, error -221, “Settings conflict” occurs.

THIS PAGE HAS BEEN INTENTIONALLY LEFT BLANK.



4 CALibration Subsystem

CALibration Subsystem	164
CALibration[1][:ALL]	165
CALibration[1][:ALL]?	166
CALibration[1]:AUTO [ONCE ON OFF 0 1]	167
CALibration[1]:ZERO:AUTO [ONCE ON OFF 0 1]	169
CALibration[1]:ZERO:NORMAL:AUTO <boolean>	171

This chapter explains how the CALibration command subsystem is used to zero and calibrate the U2020 X-Series.



CALibration Subsystem

The CALibration command subsystem is used to zero and calibrate the U2020 X-Series.

The numeric suffix of the CALibration command (CALibration1) refers to Channel A.

Zeroing and calibration of the U2020 X-Series is recommended:

- When connection to the U2020 X-Series is established
- Every 24 hours
- Prior to measuring low-level signals.

The following CALibration commands are overlapped commands:

- CAL:ALL
- CAL:AUTO
- CAL:ZERO:AUTO

An overlapped command allows the U2020 X-Series to continue parsing and executing subsequent commands¹ while it is still executing.

¹ This is only applicable for selected commands.

CALibration[1][:ALL]

NOTE

This command is identical to `CALibration[1][:ALL]?`, however, unlike the query, it does not provide a response to indicate whether the calibration has been successful or not.

This command causes the U2020 X-Series to perform a calibration sequence which consists of:

- 1 Zeroing the U2020 X-Series (`CALibration:ZERO:AUTO ONCE`), and
- 2 Calibrating the U2020 X-Series (`CALibration:AUTO ONCE`).

Syntax

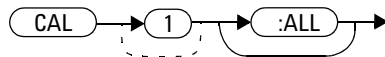

Example

`CAL` *Causes the U2020 X-Series to perform a calibration sequence on Channel A.*

Error messages

- If calibration was not carried out successfully, error -231, “Data questionable;CAL ERROR” occurs.
- If zeroing was not carried out successfully, error -231, “Data questionable;ZERO ERROR” occurs.

CALibration[1][:ALL]?

NOTE

This query is identical to `CALibration[1] [:ALL]`, however, unlike the command, it provides a response to indicate whether the calibration has been successful or not.

This query causes the U2020 X-Series to perform a calibration sequence which consists of:

- 1 Zeroing the U2020 X-Series (`CALibration:ZERO:AUTO ONCE`), and
- 2 Calibrating the U2020 X-Series (`CALibration:AUTO ONCE`).

When the calibration sequence is completed, 0 or 1 is entered into the output buffer to indicate if the sequence was successful. If the result is:

- 0, the calibration has passed
- 1, the calibration has failed

Syntax

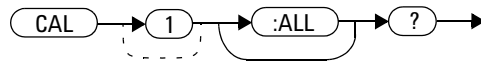

Query example

`CAL?` *Causes the U2020 X-Series to perform a calibration sequence on Channel A and returns a result.*

Error messages

- If calibration was not carried out successfully, error -231, “Data questionable;CAL ERROR” occurs.
- If zeroing was not carried out successfully, error -231, “Data questionable;ZERO ERROR” occurs.

CALibration[1]:AUTO [ONCE | ON | OFF | 0 | 1]

This command auto-calibrates channel A when enabled.

When 1|ON is enabled, auto-calibration is updated every 10 minutes.

0|OFF can be set to disable auto-calibration.

NOTE

The U2020 X-Series should be zeroed before calibration using the CALibration:ZERO:AUTO ONCE command.

Syntax

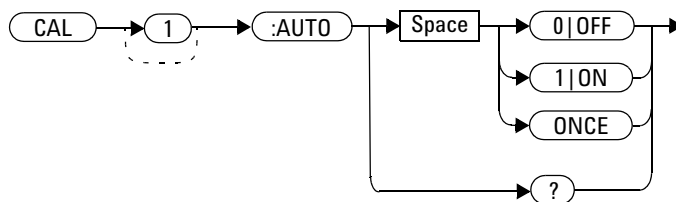

Example

```
CAL:AUTO ONCE
```

Causes the U2020 X-Series to perform a calibration on Channel A.

Reset condition

On reset, auto-calibration is enabled.

Query

```
CALibration[1]:AUTO?
```

The query returns the calibration state.

Error messages

- If calibration was not carried out successfully, error -231, “Data questionable;CAL ERROR” occurs.
- If CAL:AUTO is set to ON while LIST:STAT is set to ON, error -221, “Settings conflict;list mode is running” occurs.

CALibration[1]:ZERO:AUTO [ONCE | ON | OFF | 0 | 1]

This command causes the U2020 X-Series to perform its auto-zeroing routine when enabled. This adjusts the U2020 X-Series for a zero power reading with or without power supplied to the U2020 X-Series.

When 1|ON is enabled, the zero is maintained by a combination of *on-the-fly* zero measurements and temperature compensation. The *on-the-fly* zero measurements are applicable only when the U2020 X-Series is in the NORMa1 measurement mode.

0|OFF can be set to disable auto-zeroing.

NOTE

Ensure that the U2020 X-Series is not connected to the RF source when performing zeroing in the average mode.

Syntax

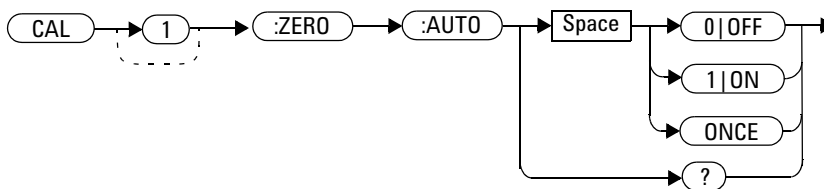

Example

```
CAL:ZERO:AUTO ONCE
```

Causes the U2020 X-Series to perform a zeroing routine on Channel A.

Reset condition

On reset, auto-zeroing is enabled.

Query

```
CALibration[1]:ZERO:AUTO?
```

The query returns the zeroing state.

Error messages

- If zeroing was not carried out successfully, error -231, “Data questionable;ZERO ERROR” occurs.
- If CAL:ZERO:AUTO is set to ON while U2020 X-Series is in the average mode, error -224, “Illegal parameter value;cal:zero:auto” occurs.

CALibration[1]:ZERO:NORMal:AUTO <boolean>

This command provides a quick way of zeroing the NORMAL path of the U2020 X-Series.

This command causes the U2020 X-Series to perform its zeroing routine when ONCE is selected. This adjusts the U2020 X-Series for a zero power reading with or without power supplied to the U2020 X-Series.

The 0|OFF parameter is only required for the query response and is ignored in the command. If 1|ON is selected, it causes the error -224, “Illegal parameter value” to occur.

Syntax

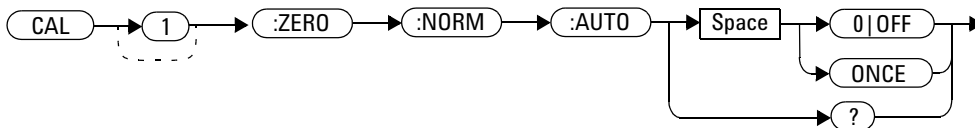

Example

```
CAL:ZERO:NORM:AUTO ONCE
```

Causes the U2020 X-Series to perform a zeroing routine on Channel A.

Query

```
CALibration[1]:ZERO:NORMal:AUTO?
```

The query always returns a value of 0.

Error messages

- If zeroing was not carried out successfully, error -231, “Data questionable;ZERO ERROR” occurs.
- If this command is set to 1|ON, error -224, “Illegal parameter value” occurs.
- If CAL:ZERO:NORM:AUTO is set when the U2020 X-Series is not in the NORMal measurement mode, error -221, “Settings conflict” occurs.



5 FORMat Subsystem

FORMat Subsystem [174](#)

FORMat[:READings]:BORDER <character_data> [175](#)

FORMat[:READings][:DATA] <character_data> [177](#)

This chapter explains how the FORMat subsystem is used to set a data format for transferring numeric information.



FORMat Subsystem

The FORMat subsystem sets a data format for transferring numeric information. This data format is used only for response data by commands that are affected by the FORMat subsystem.

The queries affected are:

- FETCh?
- READ?
- MEASure?

FORMat[:READings]:BORDER <character_data>

This command controls whether the binary data is transferred in normal or swapped Byte ORDer. It is only used when FORMat[:READings][:DATA] is set to REAL.

Syntax

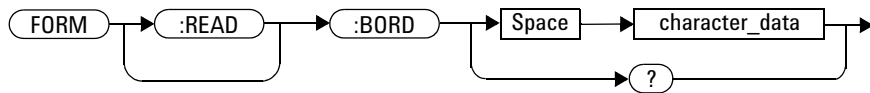

Parameters

Item	Description/Default	Range of values
character_data	Byte order of binary data transfer: <ul style="list-style-type: none"> • NORMAl • SWAPped 	NORMAl SWAPped

Example

FORM:BORD SWAP *Sets the byte order to swapped.*

Reset condition

On reset, this value is set to NORMAl.

Query

```
FORMat[:READings]:BORDER?
```

The query returns the current setting of the byte order. The format of the response is NORMAL or SWAPPed..

Query example

```
FORM:BORD?
```

Queries the current byte order setting.

FORMat[:READings][:DATA] <character_data>

This command sets the data format for transferring numeric information to either ASCII or REAL:

- When the format type is ASCII, numeric data is output as ASCII bytes in the <NR3> format.
- When the format type is REAL, numeric data is output as IEEE 754 64-bit floating point numbers in a definite length block. The result is an 8-byte block per number. Each complete block is terminated by a line feed character.

NOTE

The FORMat data formatting is not affected by the TRACe subsystem data formatting.

Syntax

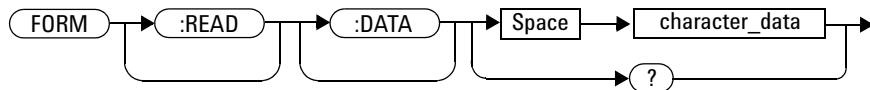

Parameters

Item	Description/Default	Range of values
character_data	Data format for transferring data: <ul style="list-style-type: none"> • ASCII • REAL 	ASCII REAL

Example

```
FORM REAL
```

Sets the format to REAL.

Reset condition

On reset, the format is set to ASCii.

Query

```
FORMat [:READings] [:DATA] ?
```

The query returns the current setting of format: either ASCii or REAL.

Query example

```
FORM?
```

Queries the current format setting.

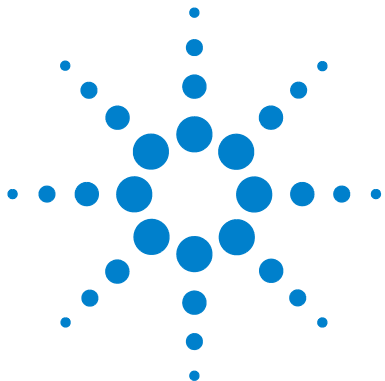

6 MEMory Subsystem

MEMory Subsystem	180
MEMory:CATalog Commands	181
MEMory:CATalog[:ALL]?	182
MEMory:CATalog:STATe?	184
MEMory:CATalog:TABLE?	185
MEMory:CLEar Commands	186
MEMory:CLEar[:NAME] <character_data>	187
MEMory:CLEar:TABLE	188
MEMory:FREE Commands	189
MEMory:FREE[:ALL]?	190
MEMory:FREE:STATe?	191
MEMory:FREE:TABLE?	192
MEMory:NSTates?	193
MEMory:STATe Commands	194
MEMory:STATe:CATalog?	195
MEMory:STATe:DEFine <character_data>,<numeric_value>	196
MEMory:TABLE Commands	198
MEMory:TABLE:FREQuency <numeric_value>{,<numeric_value>}	199
MEMory:TABLE:FREQuency:POINts?	201
MEMory:TABLE:GAIN[:MAGNitude] <numeric_value>{,<numeric_value>}	202
MEMory:TABLE:GAIN[:MAGNitude]:POINts?	204
MEMory:TABLE:MOVE <character_data>,<character_data>	205
MEMory:TABLE:SElect <character_data>	206

This chapter explains how the MEMory command subsystem is used to create, edit, and review frequency-dependent offset tables.



MEMory Subsystem

The MEMory command subsystem is used to:

- Edit and review frequency-dependent offset tables
- Store frequency-dependent offset tables
- Edit and review save/recall registers

Stored tables remain in the U2020 X-Series memory during power down. The U2020 X-Series is capable of storing 10 frequency-dependent offset tables of 512 frequency points each.

MEMory:CATalog Commands

These commands are used to query information on the current contents of the U2020 X-Series:

- Frequency-dependent offset tables
- Save/recall registers

The following commands are detailed in this section:

```
MEMory:CATalog[:ALL]?
```

```
MEMory:CATalog:STATe?
```

```
MEMory:CATalog:TABLE?
```

MEMory:CATalog[:ALL]?

This command lists the stored frequency-dependent offset tables and save/recall registers.

The U2020 X-Series returns the data in the form of two numeric parameters and as many strings as there are stored tables and save/recall registers:

```
<numeric_value>, <numeric_value>{, <string>}
```

- The first numeric parameter indicates the amount of memory, in bytes, used for the storage of tables and registers.
- The second numeric parameter indicates the memory, in bytes, available for the storage of tables and registers.
- Each string parameter returned indicates the name, type, and size of a stored table or save/recall register:
 - <string>, <type>, <size>
 - <string> indicates the name of the table or save/recall register.
 - <type> indicates TABL for frequency-dependent offset tables or STAT for save/recall registers.
 - <size> indicates the size of the table or save/recall register in bytes.

A sample response may look like the following:

```
0,54080,"CUSTOM_A,TABL,0","CUSTOM_B,TABL,0","CUSTOM_C,TABL,0","CUSTOM_D,TABL,0","CUSTOM_E,TABL,0","CUSTOM_F,TABL,0","CUSTOM_G,TABL,0","CUSTOM_H,TABL,0","CUSTOM_I,TABL,0","CUSTOM_J,TABL,0","State1,STAT,0","State2,STAT,0","State3,STAT,0","State4,STAT,0","State5,STAT,0","State6,STAT,0","State7,STAT,0","State8,STAT,0","State9,STAT,0","State10,STAT,0"
```

Syntax

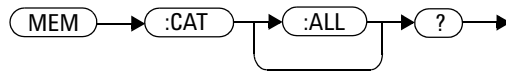

Example

MEM:CAT?

Queries the list of tables and save/recall registers.

MEMory:CATalog:STATe?

This command is used to list the save/recall registers.

The U2020 X-Series returns the data in the form of two numeric parameters and as many strings as there are save/recall registers.

<numeric_value>,<numeric_value>{,<string>}

- The first numeric parameter indicates the amount of memory, in bytes, used for the storage of registers.
- The second parameter indicates the memory, in bytes, available for the storage of registers.
- Each string parameter returned indicates the name, type, and size of a save/recall register:
 - <string>,<type>,<size>
 - <string> indicates the name of the save/recall register.
 - <type> indicates *STAT* for the save/recall register.
 - <size> indicates the size of the save/recall register in bytes.

For example, a sample response may look like:

```
0,23100,"State1,STAT,0","State2,STAT,0","State3,STAT,0","State4,STAT,0",
"State5,STAT,0","State6,STAT,0","State7,STAT,0","State8,STAT,0",
"State9,STAT,0","State10,STAT,0"
```

Syntax

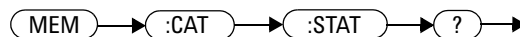

Example

```
MEM:CAT:STAT?
```

Queries the list of save/recall registers.

MEMory:CATalog:TABLE?

This command is used to list the stored frequency-dependent offset tables.

The U2020 X-Series returns the data in the form of two numeric parameters and as many strings as there are stored tables.

```
<numeric_value>,<numeric_value>{,<string>}
```

- The first numeric parameter indicates the amount of memory, in bytes, used for the storage of tables.
- The second parameter indicates the memory, in bytes, available for the storage of tables.
- Each string parameter returned indicates the name, type, and size of a stored table:
 - <string>,<type>,<size>
 - <string> indicates the name of the table.
 - <type> indicates TABL for a table.
 - <size> indicates the size of the table in bytes.

For example, a sample response may look like:

```
0,22240,"STATE0,STAT,0","STATE1,STAT,0","STATE2,STAT,0","STATE3,STAT,0",
"STATE4,STAT,0","STATE5,STAT,0","STATE6,STAT,0","STATE7,STAT,0",
"STATE8,STAT,0","STATE9,STAT,0"
```

Syntax

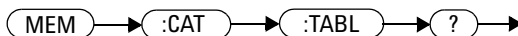

Example

```
MEM:CAT:TABLE?
```

Queries the list of stored tables.

MEMory:CLEar Commands

These commands are used to remove the contents stored in the frequency-dependent offset tables and save/recall registers. These commands remove the data contents but do not affect the name of the associated table or save/recall register.

The following commands are detailed in this section:

```
MEMory:CLEar[:NAME] <character_data>
```

```
MEMory:CLEar:TABLE
```

NOTE

The contents cleared using these commands are non-recoverable.

MEMory:CLEar[:NAME] <character_data>

This command clears the contents of a specified frequency-dependent offset table or save/recall register.

Although the table remains, a MEMory:TABLE:FREQuency|GAIN:POINTs? query returns a 0 as there are no contents in the table.

For frequency-dependent offset tables, this command is an alternative form of the MEMory:CLEar:TABLE command, the only difference being the method in which the table is selected.

NOTE

The contents cleared using this command are non-recoverable.

Syntax

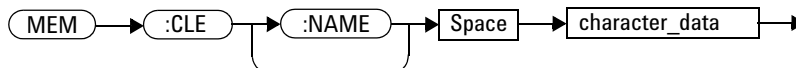

Parameters

Item	Description/Default	Range of values
character_data	Contains an existing table name or save/recall register.	Any existing table name or save/recall register.

Example

```
MEM:CLE "TABLE1"
```

Clears the contents of frequency-dependent offset table "TABLE1".

Error message

If the table or save/recall register name does not exist, error -224, "Illegal parameter value" occurs.

MEMory:CLEar:TABLE

This command is used to clear the contents of the table currently selected using `MEMory:TABLE:SElect`. Although the table remains, a `MEMory:TABLE:FREQuency|GAIN:POINTs?` query returns a 0 as the table contents are empty.

This command is an alternative form of the `MEMory:CLEar[:NAME]` command. The difference is the method in which the table is selected.

NOTE

The contents cleared using this command are non-recoverable.

Syntax



Example

```
MEM:CLE:TABLE
```

Clears the contents of the currently selected table.

Error message

If no table is selected, error -221, “Settings conflict” occurs.

MEMory:FREE Commands

These commands are used to return information on the amount of free memory space available for frequency-dependent offset tables and save/recall registers.

The following commands are described in this section:

MEMory:FREE[:ALL]?

MEMory:FREE:STATE?

MEMory:FREE:TABLE?

MEMory:FREE[:ALL]?

This query returns the amount of memory free for frequency-dependent offset tables and save/recall registers. The format of the response is:

<bytes_available>, <bytes_in_use>

Syntax

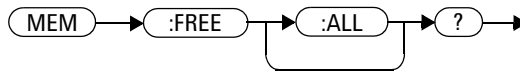

Example

MEM:FREE?

Queries the amount of free memory in total.

MEMory:FREE:STATe?

This query returns the amount of memory free for save/recall registers. The format of the response is:

<bytes_available>, <bytes_in_use>

Syntax

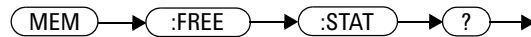

Example

MEM:FREE:STAT?

Queries the amount of free memory for save/recall registers.

MEMory:FREE:TABLE?

This query returns the amount of memory free for frequency-dependent offset tables. The format of the response is:

<bytes_available>, <bytes_in_use>

Syntax

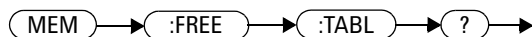

Example

MEM:FREE:TABLE?

Queries the amount of free memory for tables.

MEMory:NStates?

This query returns the number of registers that are available for save/recall. As there are 10 registers, this query always returns 10.

Syntax



Example

MEM:NStates?

Queries the number of registers available for save/recall.

MEMory:STATe Commands

These commands are used to query and define register names.

The following commands are described in this section:

MEMory:STATe:CATaLog?

MEMory:STATe:DEFine

MEMory:STATe:CATalog?

This query returns a list of the save/recall register names in ascending order of register number. The format of the response is:

<string>,<string>,...,<string>

Syntax

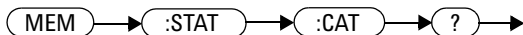

Example

MEM:STAT:CAT?

Queries the register names

MEMory:STATe:DEFine <character_data>,<numeric_value>

This command is used to associate a name with a save/recall register number.

Syntax

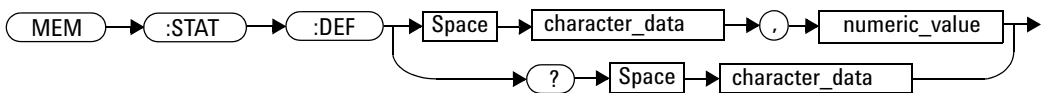

Parameters

Item	Description/Default	Range of values
character_data	Details the register name. A maximum of 12 characters can be used.	A to Z (upper-case) a to z (lower-case) 0 to 9 _ (underscore)
numeric_value	A numeric value (<NRf>) for the register number.	0 to 9

Example

```
MEM:STAT:DEF "SETUP1",4    Names register 4 "SETUP1".
```

Query

```
MEMory:STATe:DEFine? <string>
```

The query returns the register number for the given register name.

Query example

```
MEM:STAT:DEF? "SETUP1"
```

Queries the register number of SETUP1.

Error messages

- If the register number is out of range, error -222, “Data out of range” occurs.
- If the name is invalid, error -224, “Illegal parameter value” occurs.
- If a register with the same name already exists, error -257, “File name error” occurs (command only).

MEMory:TABLE Commands

These commands are used to define a frequency-dependent offset table and to write to and read data from it.

The following commands are described in this section:

```
MEMory:TABLE:FREQuency <numeric_value>{,<numeric_value>}
```

```
MEMory:TABLE:FREQuency:POINTs?
```

```
MEMory:TABLE:GAIN[:MAGNitude]  
<numeric_value>{,<numeric_value>}
```

```
MEMory:TABLE:GAIN[:MAGNitude]:POINTs?
```

```
MEMory:TABLE:MOVE <character_data>,<character_data>
```

```
MEMory:TABLE:SElect <character_data>
```

MEMory:TABLE:FREQuency

<numeric_value>{,<numeric_value>}

This command is used to enter frequency data into the current selected table. Any previous frequency list is cleared before the new frequency list is stored. The frequencies must be entered in ascending order. Entries in the frequency lists correspond with entries in the offset factor lists.

Ensure that the frequency points you use cover the frequency range of the signals that you want to measure. If you measure a signal with a frequency outside the frequency range defined in the table, then the U2020 X-Series uses the highest or lowest point in the table to calculate the offset.

Depending on available memory, the U2020 X-Series is capable of storing 10 frequency-dependent offset tables containing 512 frequency points each.

Syntax

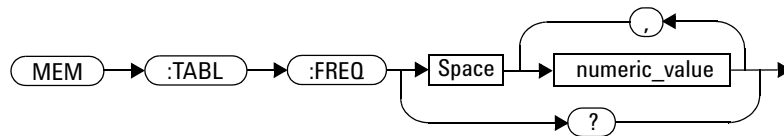

Parameters

Item	Description/Default	Range of values
numeric_value	A numeric value for the frequency. The default unit is Hz.	1 kHz to 1000.0 GHz ^{1,2}

¹ The following measurement units can be used:

Hz

kHz (10³)

MHz (10^6)

GHz (10^9)

² All frequencies are truncated to a multiple of 1 kHz.

Example

`MEM:TABLE:FREQ 200kHz,600kHz` *Enters frequencies of 200 kHz and 600 kHz into the currently selected table.*

Query

`MEMory:TABLE:FREQuency?`

The query returns a list of frequency points for the table currently selected. The frequencies are returned in Hz.

Query example

`MEM:TABLE:FREQ?` *Queries the frequency points in the currently selected table.*

Error messages

- If more than 512 frequencies are in the list, error -108, “Parameter not allowed” occurs.
- If the frequencies are not entered in ascending order, error -220, “Parameter error;Frequency list must be in ascending order” occurs.
- If a table has not been specified using the `MEMory:TABLE:SElect` command, the data cannot be entered into the table and error -221, “Settings conflict” occurs.
- If a frequency is sent which is outside the allowed frequency range, error -222, “Data out of range” occurs.

MEMory:TABLE:FREQuency:POINts?

This query returns the number of frequency points for the table currently selected. The response format is <NRf>. If no frequency values have been set, this command returns 0. If no table is selected, this command returns NAN.

Syntax



Example

MEM:TABLE:FREQ:POIN?

Queries the number of frequency points in the current table.

MEMory:TABLE:GAIN[:MAGNitude] <numeric_value>{,<numeric_value>}

This command is used to enter offsets into the frequency-dependent offset table, currently selected using `MEMory:TABLE:SELEct`. Any previous offset list is cleared before the new offsets are stored.

A maximum of 512 parameters for frequency-dependent offset tables can be sent with this command.

Entries in the frequency lists correspond (as shown in [Table 6-1](#)) with entries in the offset factor lists.

Table 6-1 Frequency and offset factor list

Frequency	Offset
Frequency 1	Offset 1
"	"
Frequency 512	Offset 512

Syntax

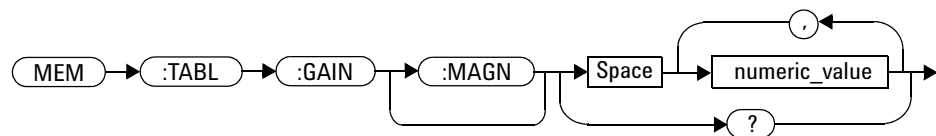

Parameters

Item	Description/Default	Range of values
numeric_value	A numeric value for the offset factors. The unit is PCT.	1.0 to 150.0

Example

```
MEM:TABLE:SEL "Table_1"
MEM:TABLE:GAIN 99.5,97.4
```

Enters offset factors of 99.5% and 97.4% into the frequency-dependent offset table.

Query

```
MEMory:TABLE:GAIN[:MAGNitude]?
```

The query returns a list of offset points for the currently selected table.

Query example

```
MEM:TABLE:GAIN?
```

Queries the offset in the current table.

Error messages

- If more than 512 offsets for frequency-dependent offset tables are in the list, error -108, “Parameter not allowed” occurs.
- If a table is not specified using the MEMory:TABLE:SElect command, the data cannot be entered and error -221, “Settings conflict” occurs.
- If any of the offset factors are outside of the allowed range, error -222, “Data out of range” occurs.

MEMory:TABLE:GAIN[:MAGNitude]:POINts?

This query is used to return the number of offset points for the currently selected table.

If no values have been set, 0 is returned. If no table is selected, NAN is returned.

Syntax

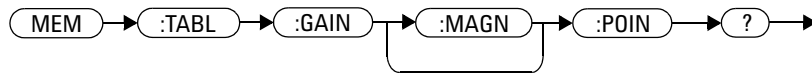

Example

MEM:TABLE:GAIN:POIN?

Queries the number of offset points in the current table.

MEMory:TABLE:MOVE <character_data>,<character_data>

This command is used to rename a frequency-dependent offset table.

Syntax



Parameters

Item	Description/Default	Range of values
character_data (1st parameter)	Contains the existing table name.	Existing table name
character_data (2nd parameter)	Details the new table name. A maximum of 12 characters can be used.	A to Z (upper-case) a to z (lower-case) 0 to 9 _ (underscore)

Example

MEM:TABLE:MOVE "tab1" , "tab1a" *Renames a table named "tab1" to "tab1a".*

Error messages

- If either table name is invalid, error -224, "Illegal parameter value" occurs.
- If the first parameter does not match an existing table name, error -256, "File name not found" occurs.
- If the second parameter matches an existing table name or save/recall register, error -257, "File name error" occurs.

MEMory:TABLE:SElect <character_data>

This command is used to activate a frequency-dependent offset table. A table must be activated before any operation can be performed on it.

Syntax

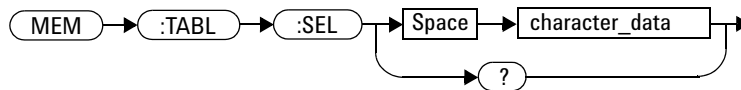

Parameters

Item	Description/Default	Range of values
character_data	Details the new table name. A maximum of 12 characters can be used.	A to Z (upper-case) a to z (lower-case) 0 to 9 _ (underscore)

Example

```
MEM:TABLE:SEL "Table1"
```

Selects a frequency-dependent offset table named "Table1".

Query

```
MEMory:TABLE:SElect?
```

The query returns the name of the currently selected table.

Error message

If the table name is invalid, error -224, “Illegal parameter value” occurs.

THIS PAGE HAS BEEN INTENTIONALLY LEFT BLANK.



7 OUTPut Subsystem

OUTPut:RECOder[1]:FEED <data_handle> 210
OUTPut:RECOder[1]:LIMit:LOWer <numeric_value> 212
OUTPut:RECOder[1]:LIMit:UPPer <numeric_value> 214
OUTPut:RECOder[1]:STATe <boolean> 216
OUTPut:TRIGger[:STATe] <boolean> 218

This chapter explains how the `OUTPut` command subsystem is used to control the recorder and trigger output.



OUTPut:RECOOrder[1]:FEED <data_handle>

This command determines which measurement is sent to the recorder output.

Syntax

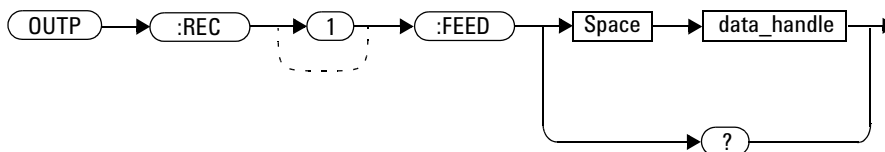

Parameters

Item	Description/Default	Range of values
data_handle	The CALC block specifying the measurement to be sent to the recorder output.	"CALC1" or "CALC" "CALC2" "CALC3" "CALC4"

Example

OUTPut:REC:FEED "CALC1"

Sends the CALC1 measurement to the recorder output.

Reset condition

On reset, data_handle is set to its previous value.

Query

```
OUTPut:REcOrder[1]:FEED?
```

The query returns the current value of `data_handle`.

Query example

```
OUTP:REC:FEED?
```

Queries the value of `data_handle` for the recorder output.

OUTPut:RECOder[1]:LIMit:LOWer <numeric_value>

This command sets the minimum scaling value for the recorder output. The units used are dependent on the units currently set for the CALC block specified in `OUTPut:RECOder[1]:FEED <data_handle>`.

Syntax

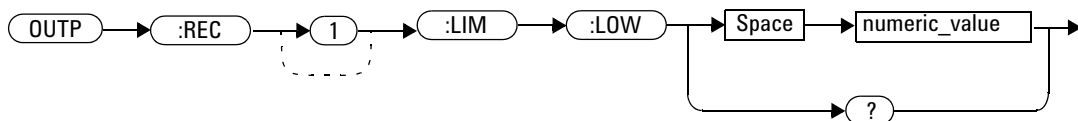

Parameters

Item	Description/Default	Range of values
numeric_value	A numeric value for the minimum scaling value. The units used—dBm, W, or %—are dependent on the units currently set for the CALC block specified in <code>OUTPut:RECOder[1]:FEED <data_handle></code> .	-150 to +230 dBm 1 aW to 100 EW 100 a% to 10 Z%

Example

`OUTPut:RECOder[1]:LIMit:LOW -90` *Sets the minimum scaling value to -90 dBm.*

Reset condition

On reset, the minimum scaling value is set to -150 dBm.

Query

```
OUTPut:REcorder[1]:LIMit:LOWer?
```

The query returns the minimum scaling value.

Query example

```
OUTP:REC:LIM:LOW?
```

Returns the minimum scaling value for the recorder output.

OUTPut:RECOder[1]:LIMit:UPPer <numeric_value>

This command sets the maximum scaling value for the recorder output. The units used are dependent on the units currently set for the CALC block specified in `OUTPut:RECOder[1]:FEED <data_handle>`.

Syntax

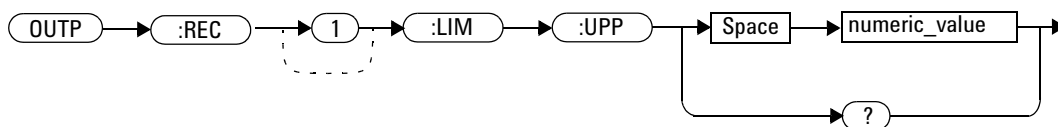

Parameters

Item	Description/Default	Range of values
numeric_value	A numeric value for the minimum scaling value. The units used—dBm, W, or %—are dependent on the units currently set for the CALC block specified in <code>OUTPut:RECOder[1]:FEED <data_handle></code> .	–150 to +230 dBm 1 aW to 100 EW 100 a% to 10 Z%

Example

`OUTPut:RECOder: LIMit:UPP 10` *Sets the maximum scaling value to 10 dBm.*

Reset condition

On reset, the maximum scaling value is set to +20 dBm.

Query

```
OUTPut:REcorder[1]:LIMit:UPPer?
```

The query returns the maximum scaling value.

Query example

```
OUTP:REC:LIM:UPP?
```

Returns the maximum scaling value for the recorder output.

OUTPut:RECOder[1]:STATe <boolean>

This command enables or disables the recorder output.

NOTE

The `OUTPut:TRIGger[:STATe]`, `SERVICE:BIST:VIDEO:STATE`, and `SERVICE:BIST:TBASE:STATE` commands override the `OUTPut:RECOder:STATE` command.

For example, if `OUTPut:RECOder:STATE` is ON and the command `OUTPut:TRIGger[:STATe] ON` is sent, this command overrides the recorder output state and sets it to OFF.

If `OUTPut:TRIGger[:STATe]` is ON and `OUTPut:RECOder:STATE ON` is sent, the recorder output is now routed to the Trig Out port overriding the trigger output command turning the trigger output off.

Syntax

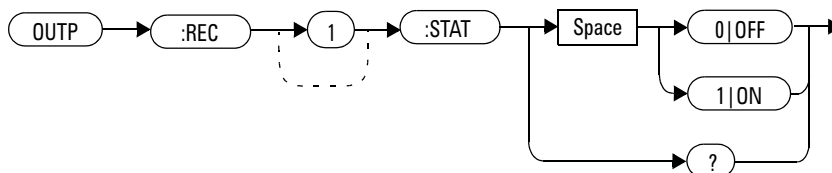

Example

`OUTP:REC:STAT 1` *Enables the recorder output.*

Reset condition

On reset, the recorder output is OFF.

Query

OUTPut:RECOder[1]:STATe?

The query indicates whether or not the recorder output is switched on.

- 1 is returned when the recorder output is switched ON
- 0 is returned when the recorder output is switched OFF

Query example

OUTP:REC:STAT?

Queries the status of the recorder output.

OUTPut:TRIGger[:STATe] <boolean>

This command enables or disables the trigger output signal.

NOTE

The `OUTPut:RECOOrder:STATe`, `SERvice:BIST:VIDEo:STATe`, and `SERvice:BIST:TBASE:STATe` commands override the `OUTPut:TRIGger[:STATe]` command.

For example, if `OUTPut:TRIGger[:STATe]` is ON and the command `OUTPut:RECOOrder:STATe ON` is sent, this command overrides the trigger state and sets it to OFF.

If `OUTPut:RECOOrder:STATe` is ON and `OUTPut:TRIGger[:STATe] ON` is sent, the channel trigger output is now routed to the Trig Out port overriding the recorder output command turning the recorder output off.

Syntax

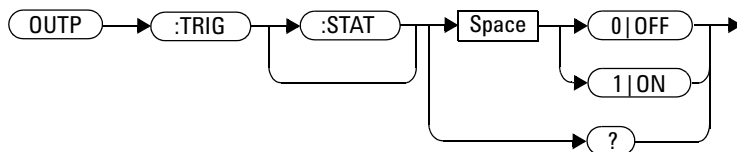

Example

`OUTPut:TRIG 1` *Enables the trigger output signal.*

Reset condition

On reset, the trigger output signal is disabled.

Query

OUTPut:TRIGger[:STATe]?

The query indicates whether or not the trigger output signal is enabled or disabled.

- 1 is returned when the trigger output signal is enabled
- 0 is returned when the trigger output signal is disabled

Query example

OUTP:TRIG?

Queries the status of the trigger output signal.

Error messages

- The trigger output signal can be enabled in any trigger source except for the bus trigger source. If the trigger source is set to bus, error -221, “Settings conflict” occurs.
- If DET:FUNC is set to AVER, error -221 “Settings conflict” occurs.

THIS PAGE HAS BEEN INTENTIONALLY LEFT BLANK.



8 INPut Subsystem

INPut:TRIGger:IMPedance <character_data> [222](#)

This chapter explains how the `INPut` command subsystem is used to set the impedance of the U2020 X-Series trigger input port.



INPut:TRIGger:IMPedance <character_data>

This command sets the impedance of the trigger input port.

Syntax

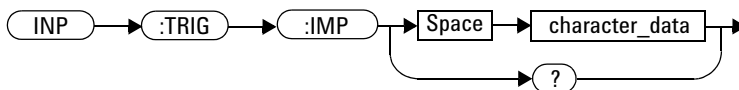

Parameters

Item	Description/Default	Range of values
character_data	Trigger input impedance: <ul style="list-style-type: none"> • LOW: 50 Ω • HIGH: 100 kΩ (default) 	LOW HIGH

Example

INP:TRIG:IMP LOW *Sets the trigger input impedance to low (50 Ω).*

Reset condition

On reset, the trigger input impedance is set to HIGH.

Query

INPut:TRIGger:IMPedance?

The query returns the current trigger input impedance setting.

Query example

INP:TRIG:IMP?

Queries the setting of the trigger input impedance.

Error message

If <character_data> is not set to HIGH or LOW, error -224, "Illegal parameter value" occurs.

THIS PAGE HAS BEEN INTENTIONALLY LEFT BLANK.

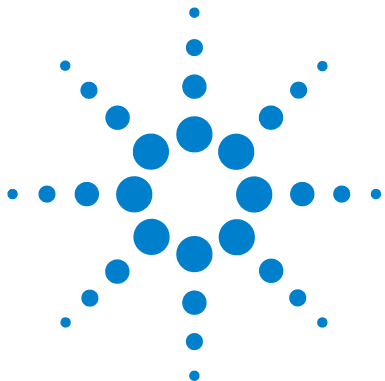

9 PStatistic Subsystem

PStatistic:CCDF:REfERENCE:DATA?	226
PStatistic:CCDF:REfERENCE:POWEr:AVErAge?	227
PStatistic:CCDF:REfERENCE:POWEr:PEAK?	228
PStatistic:CCDF:REfERENCE:POWEr:PTAVErAge?	229
PStatistic[1]:CCDF:CONTInuous <boolean>	230
PStatistic[1]:CCDF:COUNt <numeric_value>	232
PStatistic[1]:CCDF:DATA?	234
PStatistic[1]:CCDF:DATA:MAX <numeric_value>	235
PStatistic[1]:CCDF:POWEr? <numeric_value>	237
PStatistic[1]:CCDF:PROBAbility? <numeric_value>	238
PStatistic[1]:CCDF:STORe:REfERENCE	239
PStatistic[1]:CCDF:TABLE?	241
PStatistic[1]:CCDF:TRACe:POWEr:AVErAge?	243
PStatistic[1]:CCDF:TRACe:POWEr:PEAK?	244
PStatistic[1]:CCDF:TRACe:POWEr:PTAVErAge?	245
PStatistic[1]:CCDF:SWEEp:TIME <numeric_value>	246
PStatistic[1]:CCDF:SWEEp:OFFSet:TIME <numeric_value>	248
PStatistic[1]:CCDF:SWEEp[:STATe] <boolean>	250
PStatistic[1]:CCDF:SWEEp:CYCLes <numeric_value>	252

This chapter explains how the `PStatistic` command subsystem is used to configure the settings of the Complementary Cumulative Distribution Function (CCDF), both in table and trace format.



PStatistic:CCDF:REfERENCE:DATA?

This command is used to retrieve the reference trace data. The reference trace data will be returned only if there is a reference trace saved.

NOTE

This command is only applicable when the NORMAl or DOUBle measurement speed setting is chosen.

NOTE

The reference trace data is returned in the following format:

- The reference trace data maximum X-axis value in dB
- 501 points of the reference trace data

Syntax

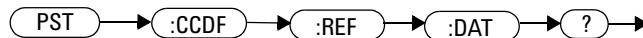

Example

```
PST:CCDF:REF:DAT?
```

Returns the previously saved reference trace data.

Reset condition

On reset, the trace will be cleared.

Error message

If there was no previously saved trace, error -221, "Settings conflict" occurs. You need to check the status of the saved reference trace using `PST:CCDF:STOR:REF?`.

PStatistic:CCDF:REfERENCE:POWer:AVERAge?

This command is used to retrieve average power data of the saved reference trace.

NOTE

This command is only applicable when the NORMAl or DOUBLe measurement speed setting is chosen.

Syntax

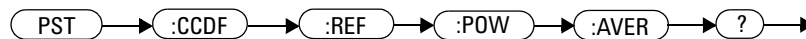

Example

PST:CCDF:REF:POW:AVER? *Returns the average power value of the reference trace.*

Error message

If there was no previously saved trace, error -221, "Settings conflict" occurs. You need to check the status of the saved reference trace using PST:CCDF:STOR:REF?.

PStatistic:CCDF:REference:POWer:PEAK?

This command is used to retrieve the peak power data of the saved reference trace.

NOTE

This command is only applicable when the NORMAl or DOUBLe measurement speed setting is chosen.

Syntax

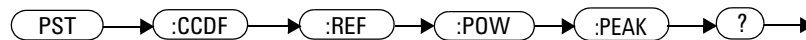

Example

PST:CCDF:REF:POW:PEAK? *Returns the peak power value of the saved reference trace.*

Error message

If there was no previously saved trace, error -221, "Settings conflict" occurs. You need to check the status of the saved reference trace using PST:CCDF:STOR:REF?.

PStatistic:CCDF:REfERENCE:POWer:PTAVerage?

This command is used to retrieve peak-to-average data of the saved reference trace.

NOTE

This command is only applicable when the `NORMAL` or `DOUBLE` measurement speed setting is chosen.

Syntax

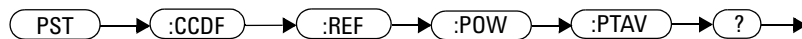

Example

`PST:CCDF:REF:POW:PTAV?` *Returns the peak-to-average power of the saved reference trace.*

Error message

If there was no previously saved trace, error -221, "Settings conflict" occurs. You need to check the status of the saved reference trace using `PST:CCDF:STOR:REF?`.

PStatistic[1]:CCDF:CONTinuous <boolean>

This command is used to turn on or off the CCDF Continuous Refresh mode.

NOTE

This command is only applicable when `INITiate:CONTinuous` is set to ON and the trigger source is set to IMM, INT, or EXT.

Syntax

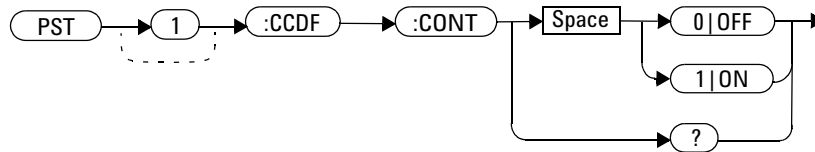

Example

`PST:CCDF:CONT ON` *Turns on the CCDF Continuous Refresh mode.*

Reset condition

On reset, the CCDF Continuous Refresh mode will be turned on.

Query

`PStatistic[1]:CCDF:CONTinuous?`

The query enters 1 or 0 into the output buffer indicating the status of the CCDF Continuous Refresh mode.

- 1 is returned when the CCDF Continuous Refresh mode is enabled
- 0 is returned when the CCDF Continuous Refresh mode is disabled (or CCDF Single Refresh mode is enabled)

Query example

PST:CCDF:CONT?

Queries whether the CCDF Continuous Refresh mode is turned on or off.

Error messages

- If the U2020 X-Series is not in the continuous trigger mode, error -221, "Settings conflict" occurs.
- If the trigger source is set to BUS or HOLD, error -221, "Settings conflict" occurs.
- If PST:CCDF:CONT is set to ON while LIST:STAT is set to ON, error -221, "Settings conflict;list mode is enabled" occurs.

PStatistic[1]:CCDF:COUNT <numeric_value>

This command is used to set the cumulative count for gated and non-gated CCDF.

NOTE

- This command is only applicable when the continuous triggered acquisition is selected and the trigger source is set to IMM, INT, or EXT.
- This command is only applicable when the NORMAl or DOUBle measurement speed setting is chosen.

Syntax

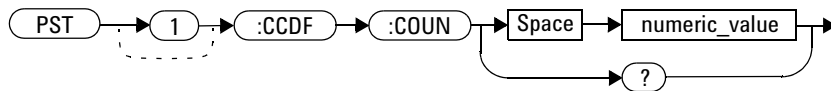

Parameters

There are two sets of allowable range of values as follows:

Item	Description/Default	Range of values
numeric_value	The CCDF cumulative count in numeric value.	Non-gated CCDF: <ul style="list-style-type: none"> • 80M to 8G Note: Increment step is 80M. Any input within the 80M to 8G range will be rounded down to the nearest 80M. Gated CCDF: <ul style="list-style-type: none"> • 1 to $2^{32}-1$

Example

`PST:CCDF:COUN 1.6G` *Sets the CCDF cumulative count to 1.6G.*

Reset condition

On reset, the CCDF cumulative count will be set to the default value, 80M samples.

Query

`PStatistic[1]:CCDF:COUNT?`

The query returns the current numeric value of the CCDF cumulative count.

Query example

`PST1:CCDF:COUN?` *Queries the numeric value of the CCDF cumulative count.*

Error messages

- If the trigger source is set to BUS or HOLD, error -221, "Settings conflict" occurs.
- When setting the cumulative count in non-gated CCDF, the U2020 X-Series must be in the continuous trigger mode, otherwise, error -221, "Settings conflict" occurs.
- If you specify a count of <80M or >8G when in non-gated CCDF, error -222, "Data out of range" occurs.
- If you specify a count of <1 or > $2^{32}-1$ when in gated CCDF, error -222, "Data out of range" occurs.

PStatistic[1]:CCDF:DATA?

This command is used to return 501 probability values in % at different power levels within a certain range, starting from 0 dB until the predefined maximum power level.

NOTE

The maximum power level can be set using this command:

```
PStatistic[1]:CCDF:DATA:MAX <numeric_value>
```

By default, the maximum value is 50 dB.

The power interval between each reading (probability value) is determined by the defined maximum power level divided by 500.

NOTE

This command is only applicable when the NORMAL or DOUBLE measurement speed setting is chosen.

Syntax



Example

```
PST:CCDF:DAT?
```

Returns 501 probability values in % at different power levels within the range of 0 dB to the maximum power level defined.

Error messages

- If the measurement speed is set to FAST, error -221, "Settings conflict" occurs.
- If the trigger source is set to BUS or HOLD, error -221, "Settings conflict" occurs.

PStatistic[1]:CCDF:DATA:MAX <numeric_value>

This command is used to set the maximum value of the X-axis CCDF trace.

Syntax

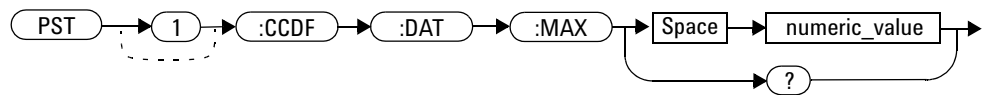

Parameters

Item	Description/Default	Range of values
numeric_value	X-axis CCDF trace maximum value in dB. <ul style="list-style-type: none"> • Minimum value: 5.00 dB • Maximum value: 50.00 dB 	5.00 to 50.00 dB

Example

```
PST:CCDF:DATA:MAX 10
```

Sets the maximum value of the X-axis CCDF trace to 10 dB.

Reset condition

On reset, the maximum value for the CCDF trace X-axis is set to 50 dB.

Query

```
PStatistic[1]:CCDF:DATA:MAX?
```

The query returns the X-axis CCDF trace maximum value.

Query example

```
PST:CCDF:DAT:MAX?
```

Queries the maximum value of the X-axis CCDF trace.

Error messages

- If the parameter set is to <5.0 dB, error -222, "Data out of range;value clipped to lower limit" occurs.
- If the parameter set is to >50.0 dB, error -222, "Data out of range;value clipped to upper limit" occurs.

PStatistic[1]:CCDF:POW? <numeric_value>

This command is used to return the power level at the specified probability.

NOTE

This command is only applicable when the NORMAl or DOUBle measurement speed setting is chosen.

Syntax



Parameters

Item	Description/Default	Range of values
numeric_value	The probability at the queried power. <ul style="list-style-type: none"> • Maximum value: 0% • Minimum value: 100% 	0 to 100%

Example

PST:CCDF:POW? 30 *Queries the power level at 30% probability.*

Error messages

- If the measurement speed is set to FAST, error -221, "Settings conflict" occurs.
- If the trigger source is set to BUS or HOLD, error -221, "Settings conflict" occurs.
- If the parameter specified is <0% or >100%, error -220, "Parameter error" occurs.
- If no parameter is specified, error -109, "Missing parameter" occurs.

PStatistic[1]:CCDF:PROBability? <numeric_value>

This command is used to return the probability at the specified power level.

NOTE

This command is only applicable when the NORMAl or DOUBle measurement speed setting is chosen.

Syntax



Parameters

Item	Description/Default	Range of values
numeric_value	The power level at the queried probability. <ul style="list-style-type: none"> Maximum value: 50.00 dB Minimum value: 0.00 dB 	0.00 to 50.0 dB

Example

PST1:CCDF:PROB? 50 *Queries the probability at a 50 dB power level.*

Error messages

- If the measurement speed is set to FAST, error -221, "Settings conflict" occurs.
- If the trigger source is set to BUS or HOLD, error -221, "Settings conflict" occurs.
- If the parameter specified is <0.0 or >50.0, error -220, "Parameter error" occurs.
- If no parameter is specified, error -109, "Missing parameter" occurs.

PStatistic[1]:CCDF:STORe:REFerence

This command is used to store the CCDF trace as a reference trace.

NOTE

The CCDF trace will be saved as a reference trace in volatile RAM.

NOTE

This command is only applicable when the NORMAl or DOUBLe measurement speed setting is chosen.

Syntax

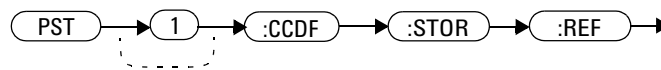

Example

PST:CCDF:STOR:REF *Saves the CCDF trace as a reference trace.*

Reset condition

On reset, the previously saved reference trace will be cleared.

Query

PStatistic[1]:CCDF:STORe:REFerence?

The query enters a 1 or 0 into the output buffer indicating the status of the CCDF reference.

- 1 is returned when there is a saved reference trace
- 0 is returned when there is no saved reference trace

Query example

PST:CCDF:STOR:REF?

Queries whether there is a saved reference trace or not.

Error messages

- If the measurement speed is set to FAST, error -221, "Settings conflict" occurs.
- If the trigger source is set to BUS or HOLD, error -221, "Settings conflict" occurs.

PStatistic[1]:CCDF:TABLE?

This command is used to return the data in CCDF table: average input power, probability at the average input power, peak-to-average power ratio, and sample count.

NOTE

This command will return 10 scalar results in the following order:

- 1 Average input power (in dBm)
- 2 Probability at the average input power (in %)
- 3 Power level (power-to-average power ratio) that has 10% of the power (in dB)
- 4 Power level (power-to-average power ratio) that has 1% of the power (in dB)
- 5 Power level (power-to-average power ratio) that has 0.1% of the power (in dB)
- 6 Power level (power-to-average power ratio) that has 0.01% of the power (in dB)
- 7 Power level (power-to-average power ratio) that has 0.001% of the power (in dB)
- 8 Power level (power-to-average power ratio) that has 0.0001% of the power (in dB)
- 9 Peak-to-average power ratio (in dB)
- 10 Sample count

NOTE

This command is only applicable when the NORMal or DOUBle measurement speed setting is chosen.

Syntax



Example

PST:CCDF:TAB? *Returns the data in CCDF table: average input power, probability at the average input power, power level at various predefined probability steps (10%, 1%, 0.1%, 0.01%, 0.001%, and 0.0001%), peak- to- average power ratio, and sample count.*

Error messages

- If the measurement speed is set to FAST, error -221, "Settings conflict" occurs.
- If the trigger source is set to BUS or HOLD, error -221, "Settings conflict" occurs.

PStatistic[1]:CCDF:TRACe:POWer:AVERage?

This command is used to retrieve the average power value of the trace.

NOTE

This command is only applicable when the NORMAl or DOUBLe measurement speed setting is chosen.

Syntax



Example

PST:CCDF:TRAC:POW:AVER? *Returns the average power value of the trace.*

Error messages

- If the measurement speed is set to FAST, error -221, "Settings conflict" occurs.
- If the trigger source is set to BUS or HOLD, error -221, "Settings conflict" occurs.

PStatistic[1]:CCDF:TRACe:POWeR:PEAK?

This command is used to retrieve the peak power value of the trace.

NOTE

This command is only applicable when the NORMAl or DOUBLe measurement speed setting is chosen.

Syntax



Example

PST:CCDF:TRAC:POW:PEAK? *Returns the peak power value of the trace.*

Error messages

- If the measurement speed is set to FAST, error -221, "Settings conflict" occurs.
- If the trigger source is set to BUS or HOLD, error -221, "Settings conflict" occurs.

PStatistic[1]:CCDF:TRACe:POWer:PTAVerage?

This command is used to retrieve the peak-to-average power value of the trace.

NOTE

This command is only applicable when the NORMAl or DOUBLe measurement speed setting is chosen.

Syntax



Example

PST:CCDF:TRAC:POW:PTAV? *Returns the peak- to- average power value of the trace.*

Error messages

- If the measurement speed is set to FAST, error -221, "Settings conflict" occurs.
- If the trigger source is set to BUS or HOLD, error -221, "Settings conflict" occurs.

PStatistic[1]:CCDF:SWEep:TIME <numeric_value>

This command sets the length of the time-gated period (time gate length) for time-gated CCDF measurements.

NOTE

This command is only applicable when the gated CCDF measurement is enabled.

Syntax

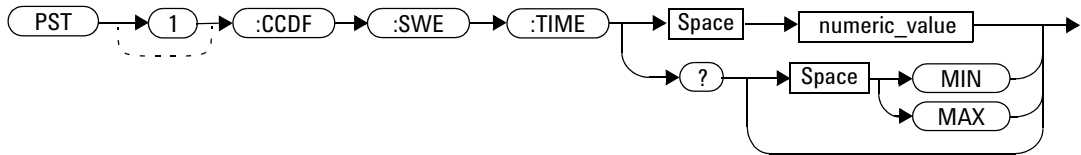

Parameters

Item	Description/Default	Range of values
numeric_value	The length of the time-gated period in seconds <ul style="list-style-type: none"> DEF: the default value is 100 μs Units are resolved to 12.5 ns.	100 ns to 1 s DEF

Example

PST:CCDF:SWE:TIME 0.001 *Sets the length to 0.001 s.*

Reset condition

On reset, the gate is set to 100 μ s.

Query

```
PStatistic[1]:CCDF:SWEep:TIME? [MIN|MAX]
```

The query returns the current setting of the CCDF gate length or the values associated with MIN and MAX.

Query example

```
PST:CCDF:SWE:TIME? Queries the length of the time-gated period.
```

Error message

If the measurement speed is set to FAST, error -221, "Settings conflict" occurs.

PStatistic[1]:CCDF:SWEep:OFFSet:TIME <numeric_value>

This command sets the delay between the delayed trigger point and the start of the time-gated period (the offset time) for CCDF measurements.

NOTE

This command is only applicable when the gated CCDF measurement is enabled.

Syntax

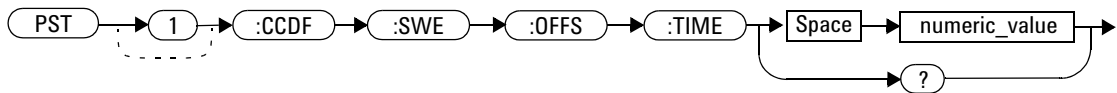

Parameters

Item	Description/Default	Range of values
numeric_value	The delay between the trigger point and the start of the time-gated period, in seconds <ul style="list-style-type: none"> DEF: the default value is 0 s Units are resolved to 12.5 ns.	0 to 1 s DEF

Example

PStatistic:CCDF:SWEep:OFFSet:TIME 0.001 *Sets the delay to 0.001 s.*

Reset condition

On reset, the value is set to 0 s.

Query

```
PStatistic[1]:CCDF:SWEep:OFFSet:TIME?
```

The query returns the current delay between the trigger point and the start of the time-gated period.

Query example

```
PST:CCDF:SWE:OFFS:TIME?
```

Returns the current delay between the trigger point and the start of the time-gated period.

Error message

If the measurement speed is set to FAST, error -221, "Settings conflict" occurs.

PStatistic[1]:CCDF:SWEep[:STATe] <boolean>

This command is used to enable and disable gated CCDF measurements.

NOTE

This command is only applicable when the NORMAl or DOUBLe measurement speed setting is chosen.

Syntax

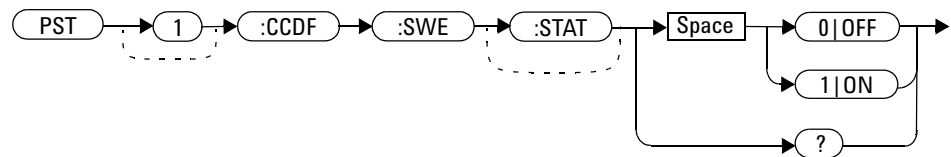

Example

```
PST:CCDF:SWE ON    Enable gated CCDF measurements.
```

Reset condition

On reset, the CCDF sweep state is disabled.

Query

```
PStatistic[1]:CCDF:SWEep[:STATe]?
```

The query enters 1 or 0 into the output buffer indicating the status of the CCDF sweep state.

- 1 is returned when gated CCDF measurements are enabled.
- 0 is returned when gated CCDF measurements are disabled.

Query example

PST:CCDF:SWE?

Queries whether gated CCDF measurements are enabled or disabled.

Error messages

- If the measurement speed is set to FAST, error -221, "Settings conflict" occurs.
- If PST:CCDF:SWE is set to ON while LIST:STAT is set to ON, error -221, "Settings conflict;list mode is enabled" occurs.

PStatistic[1]:CCDF:SWEep:CYCLes <numeric_value>

This command sets the number of sweep cycles for gated CCDF measurements. Changing the number of sweep cycles will affect the cumulative count value set in the PStatistic[1]:CCDF:COUNT command.

NOTE

- This command is only applicable when the gated CCDF measurement is enabled.
- To determine the maximum number of sweep cycles based on the current CCDF gate length, use the PStatistic[1]:CCDF:SWEep:CYCLes? MAX query.

Syntax

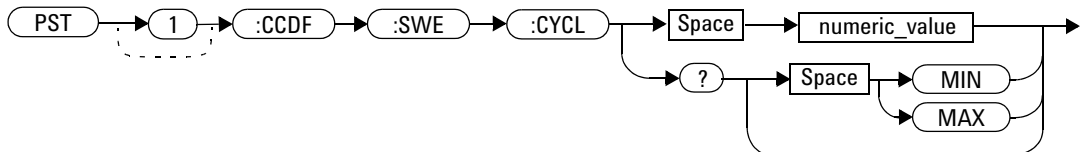

Parameters

Item	Description/Default	Range of values
numeric_value	A numeric value defining the number of sweep cycles. <ul style="list-style-type: none"> • DEF: the default value is 125. 	12.5E-9 to MAX_CYCLES Note: MAX_CYCLES is limited by the CCDF gate length and the maximum cumulative count value,

Example

PST:CCDF:SWE:CYCL 3.5

Sets the CCDF sweep cycles to 3.5 cycles.

Reset condition

On reset, the CCDF sweep cycle is set to 125.

Query

```
PStatistic[1]:CCDF:SWEep:CYCLes? [MIN|MAX]
```

The query returns the current setting of the CCDF sweep cycles or the values associated with MIN and MAX.

Query example

```
PST:CCDF:SWE:CYCL?
```

Queries the current setting of the CCDF sweep cycles.

Error messages

- If the measurement speed is set to FAST, error -221, "Settings conflict" occurs.
- If the number of sweep cycles is $<12.5E-9$, error -222, "Data out of range;lower limit exceeded;no change" occurs.

THIS PAGE HAS BEEN INTENTIONALLY LEFT BLANK.

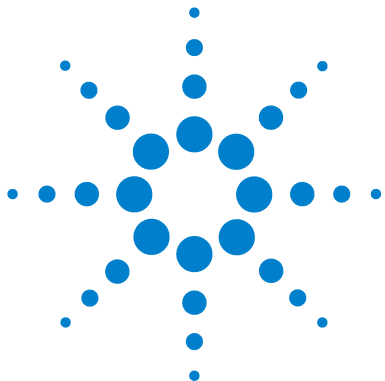

10 SENSe Subsystem

[SENSe] Subsystem	257
[SENSe[1]:]AVERAge Commands	258
[SENSe[1]:]AVERAge:COUNT <numeric_value>	259
[SENSe[1]:]AVERAge:COUNT:AUTO <boolean>	261
[SENSe[1]:]AVERAge:RESet	263
[SENSe[1]:]AVERAge:SDETECT <boolean>	264
[SENSe[1]:]AVERAge[:STATe] <boolean>	266
[SENSe[1]:]AVERAge2 Commands	268
[SENSe[1]:]AVERAge2:COUNT <numeric_value>	269
[SENSe[1]:]AVERAge2[:STATe] <boolean>	271
[SENSe[1]:]BANDwidth BWIDth:VIDeo <character_data>	273
[SENSe[1]:]BUFFer:COUNT <numeric_value>	275
[SENSe[1]:]BUFFer:MTYPe <character_data>	277
[SENSe[1]:]CORRection Commands	279
[SENSe[1]:]CORRection:CSET2 Commands	280
[SENSe[1]:]CORRection:CSET2[:SElect] <string>	281
[SENSe[1]:]CORRection:CSET2[:STATe] <boolean>	283
[SENSe[1]:]CORRection:FDOffset GAIN4[:INPut][:MAGNitude]?	285
[SENSe[1]:]CORRection:GAIN2 Commands	286
[SENSe[1]:]CORRection:GAIN2[:STATe] <boolean>	287
[SENSe[1]:]CORRection:GAIN2[:INPut][:MAGNitude] <numeric_value>	289
[SENSe[1]:]CORRection:LOSS2 Commands	291
[SENSe[1]:]CORRection:LOSS2[:STATe] <boolean>	292
[SENSe[1]:]CORRection:LOSS2[:INPut][:MAGNitude] <numeric_value>	294
[SENSe[1]:]DETEctor:FUNCTion <character_data>	296
[SENSe[1]:]FREQUency[:CW]:FIXed <numeric_value>	298
[SENSe[1]:]FREQUency[:CW]:FIXed:STARt <numeric_value>	300



[SENSe[1]:]FREQUency[:CW :FIXed]:STOP <numeric_value>	303
[SENSe[1]:]FREQUency[:CW :FIXed]:STEP <numeric_value>	306
[SENSe[1]:]LIST:FREQUency:STARt <numeric_value>	309
[SENSe[1]:]LIST:FREQUency:STOP <numeric_value>	311
[SENSe[1]:]LIST:MTYPe <character_data>	313
[SENSe[1]:]LIST:POINts <numeric_value>	315
[SENSe[1]:]LIST:STATe <boolean>	317
[SENSe[1]:]LIST:TSCount <numeric_value>	319
[SENSe[1]:]LIST:TSLot:EXCLude:OFFSet:TIME <numeric_value>	321
[SENSe[1]:]LIST:TSLot:EXCLude:TIME <numeric_value>	323
[SENSe[1]:]LIST:TSLot:TIME <numeric_value>	325
[SENSe[1]:]LIST:TSLot:TREF1 <numeric_value>	327
[SENSe[1]:]LIST:TSLot:TREF2 <numeric_value>	329
[SENSe[1]:]MRATe <character_data>	331
[SENSe[1]:]SWEEp[1] 2 3 4 Commands	334
[SENSe[1]:]SWEEp[1]:APERture <numeric_value>	335
[SENSe[1]:]SWEEp[1] 2 3 4:AUTO <character_data>	337
[SENSe[1]:]SWEEp[1] 2 3 4:AUTO:REF1 REF2 <numeric_value>	339
[SENSe[1]:]SWEEp[1] 2 3 4:OFFSet:TIME <numeric_value>	341
[SENSe[1]:]SWEEp[1] 2 3 4:TIME <numeric_value>	343
[SENSe[1]:]TEMPerature?	345
SENSe[1]:TRACe Commands	346
SENSe[1]:TRACe:AUToscale	347
SENSe[1]:TRACe:OFFSet:TIME <numeric_value>	348
SENSe[1]:TRACe:TIME <numeric_value>	350
[SENSe[1]:]TRACe:UNIT <character_data>	352

This chapter explains how the SENSE command subsystem directly affects device-specific settings used to make measurements.

[SENSE] Subsystem

The SENSE command subsystem directly affects device-specific settings used to make measurements. The SENSE subsystem is optional since this is the primary function of the U2020 X-Series, except for the TRACE commands (SENSE[1]:TRACE:OFFSET:TIME and SENSE[1]:TRACE:TIME). The high-level command CONFIGure uses the SENSE commands to prepare the U2020 X-Series for making measurements. At a lower level, SENSE enables you to change parameters without completely re-configuring the U2020 X-Series.

The numeric suffix of the SENSE command (SENSE1) represents channel A.

[SENSE[1]:]AVERAGE Commands

These commands control the measurement averaging used to improve measurement accuracy. They combine successive measurements to produce a new composite result.

The following commands are detailed in this section:

```
[SENSE[1]:]AVERAGE:COUNT <numeric_value>  
[SENSE[1]:]AVERAGE:COUNT:AUTO <boolean>  
[SENSE[1]:]AVERAGE:RESET  
[SENSE[1]:]AVERAGE:SDETECT <boolean>  
[SENSE[1]:]AVERAGE[:STATE] <boolean>
```

[SENSe[1]:]AVERAge:COUNT <numeric_value>

This command is used to enter a value for the filter length. If [SENSe[1]:]AVERAge:COUNT:AUTO is set to ON, then entering a value for the filter length automatically sets it to OFF. Increasing the value of filter length increases measurement accuracy but also increases the time taken to make a power measurement.

Entering a value using this command automatically sets the [SENSe[1]:]AVERAge:STATe command to ON.

NOTE

For most applications, automatic filter length selection ([SENSe[1]:]AVERAge:COUNT:AUTO ON) is the best mode of operation. However, manual filter length selection ([SENSe[1]:]AVERAge:COUNT <numeric_value>) is useful in applications requiring either high resolution or fast settling times, where signal variations rather than measurement noise need filtering, or when approximate results are needed quickly.

Syntax

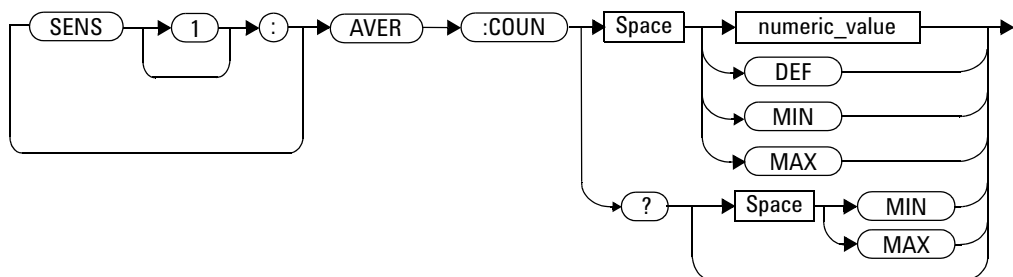

Parameters

Item	Description/Default	Range of values
numeric_value	A numeric value defining the filter length. DEF: the default value is 4 MIN: 1 MAX: 1024	1 to 1024 DEF MIN MAX

Example

```
AVER:COUN 400
```

Sets the filter length to 400.

Reset condition

On reset, the filter length is set to 4.

Query

```
[SENSE[1]:]AVERage:COUNT? [MIN|MAX]
```

The query returns the current setting of the filter length or the values associated with MIN and MAX. The format of the response is <NR1>.

Query example

```
AVER:COUN?
```

Queries the filter length.

Error message

If a filter length value is entered using [SENSE[1]:]AVERage:COUNT while [SENSE[1]:]MRATe is set to FAST, the error -221, “Settings conflict” occurs. However, the filter length value is set but the [SENSE[1]:]AVERage:STATe command is not automatically set to ON.

[SENSe[1]:]AVERage:COUNT:AUTO <boolean>

This command enables and disables automatic averaging.

When the auto filter mode is enabled, the U2020 X-Series automatically sets the number of readings averaged together to satisfy the averaging requirements for most power measurements. The number of readings averaged together depends on the resolution and the power level in which the U2020 X-Series is currently operating. Refer to [Figure 1-9](#) for the typical number of averages for each range and resolution when the U2020 X-Series is in the auto-filter mode and set to the normal speed mode.

Setting this command to ON automatically sets the [SENSe[1]:]AVERage:STATe command to ON.

If [SENSe[1]:]AVERage:COUNT:AUTO is set to OFF, the filter length is set by [SENSe[1]:]AVERage:COUNT. Using [SENSe[1]:]AVERage:COUNT disables automatic averaging.

Auto-averaging is enabled by the MEASure:POWER:AC? and CONFIGure:POWER:AC? commands.

NOTE

For most applications, automatic filter length selection ([SENSe[1]:]AVERage:COUNT:AUTO ON) is the best mode of operation. However, manual filter length selection ([SENSe[1]:]AVERage:COUNT <numeric_value>) is useful in applications requiring either high resolution or fast settling times, where signal variations rather than measurement noise need filtering, or when approximate results are needed quickly.

Syntax

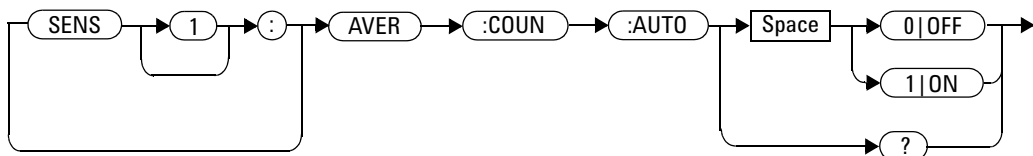

Example

```
AVER:COUN:AUTO OFF
```

Disables automatic filter length selection.

Reset condition

On reset, automatic averaging is enabled.

Query

```
[SENSE[1]:]AVERage:COUNT:AUTO?
```

The query enters a 1 or 0 into the output buffer indicating whether the automatic filter length is enabled or disabled.

- 1 is returned when the automatic filter length is enabled
- 0 is returned when the automatic filter length is disabled

Query example

```
AVER:COUN:AUTO?
```

Queries whether the automatic filter length selection is turned on or off.

Error message

If [SENSE[1]:]AVERage:COUNT:AUTO is set to ON while [SENSE[1]:]MRATe is set to FAST, error -221, “Settings conflict” occurs. However, automatic averaging is enabled but the [SENSE[1]:]AVERage:STATe command is not automatically set to ON.

[SENSe[1]:]AVERage:RESet

This command resets the average filter. The reset will affect the filtering in the manual and auto averaging mode.

Syntax

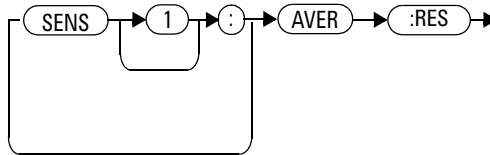

Example

AVER:RES

Resets the average filter.

Error message

If AVER:RES is set while LIST:STAT is set to ON, error -221, “Settings conflict” occurs.

[SENSe[1]:]AVERage:SDEct <boolean>

This command enables and disables step detection. In the AUTO filter mode, the average of the last four values entered into the filter is compared to the average of the entire filter. If the difference between the two averages is greater than 12.5%, the digital filter is cleared. The filter then starts storing new measurement values. This feature shortens the filter time when the input power changes substantially for the filter output to get to its final value. Note that this result appears to settle faster, although true settling to the final value is unaffected.

NOTE

Step detection is automatically disabled when TRIG:DEL:AUTO is ON and INIT:CONT is OFF.

Under these circumstances, the value of SENS:AVER:SDET is ignored but left unchanged (for example, SENS:AVER:SDET retains its current setting which may indicate that step detection is turned ON).

NOTE

With certain pulsed signals, step detection may prevent the final average from being completed and making the results unstable. Under these conditions, SENS:AVER:SDET should be set to OFF.

Syntax

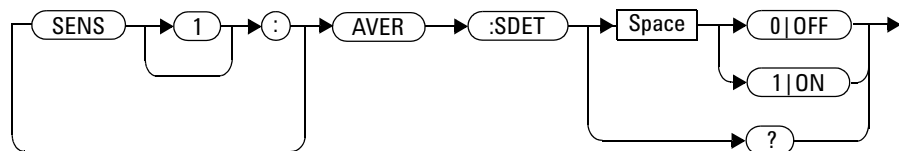

Example

```
AVER:SDET OFF
```

Disables step detection.

Reset condition

On reset, step detection is enabled.

Query

```
[SENSe[1]:]AVERage:SDEtect?
```

The query enters a 1 or 0 into the output buffer indicating the status of step detection.

- 1 is returned when step detection is enabled
- 0 is returned when step detection is disabled

Query example

```
AVER:SDET?
```

Queries whether step detection is turned on or off.

[SENSe[1]:]AVERage[:STATe] <boolean>

This command is used to enable and disable averaging.

Syntax

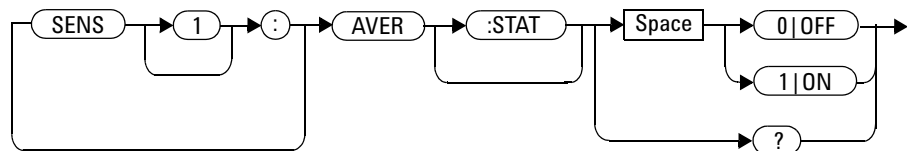

Example

AVER 1 *Enables averaging.*

Reset condition

On reset, averaging is turned ON.

Query

[SENSe[1]:]AVERage[:STATe]?

The query enters a 1 or 0 into the output buffer indicating the status of averaging.

- 1 is returned when averaging is enabled
- 0 is returned when averaging is disabled

Query example

AVER? *Queries whether averaging is turned on or off.*

Error message

If [SENSe[1]:]AVERage:STATe is set to ON while LIST:STAT is set to ON, error -221, “Settings conflict;list mode is running” occurs.

[SENSE[1]:]AVERAge2 Commands

These commands control video averaging used to improve measurement accuracy. They combine successive measurements to produce a new composite result.

The following commands are detailed in this section:

```
[SENSE[1]:]AVERAge2:COUNT <numeric_value>  
[SENSE[1]:]AVERAge2[:STATe] <boolean>
```

[SENSe[1]:]AVERage2:COUNT <numeric_value>

This command is used to enter the video filter length. Video filtering is applied to the traces. Successive traces are combined to reduce noise without affecting the dynamic characteristic of the signal.

Syntax

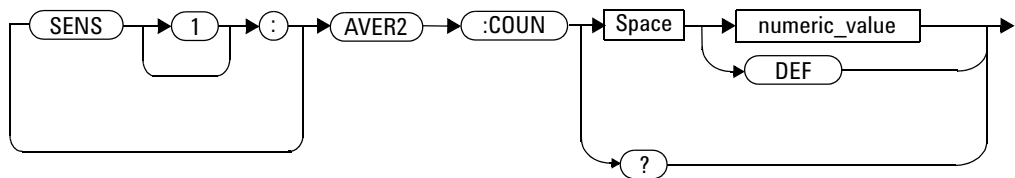

Parameters

Item	Description/Default	Range of values
numeric_value	A numeric value defining the filter length. • DEF: the default value is 4.	1 to 256 ¹ DEF

¹ This is only implemented in powers of 2 (2ⁿ).

Example

AVER2 :COUN 16 *Enters a video filter length of 16.*

Reset condition

On reset, the filter length is set to 4.

Query

```
[SENSe[1]:]AVERage2:COUNT?
```

The query returns the current setting of the video filter length. The format of the response is <NR1>.

Query example

```
AVER2:COUN?    Queries the video filter length.
```

Error message

If DET:FUNC is set to AVER, error -221, “Settings conflict” occurs.

[SENSe[1]:]AVERage2[:STATe] <boolean>

This command is used to enable and disable video averaging.

Syntax

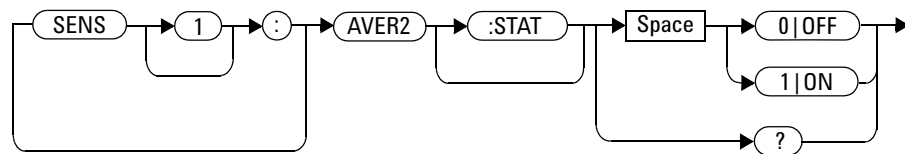

Example

AVER2 1 *Enables video averaging.*

Reset condition

On reset, video averaging is disabled.

Query

[SENSe[1]:]AVERage2[:STATe]?

The query enters a 1 or 0 into the output buffer indicating the status of averaging.

- 1 is returned when averaging is enabled.
- 0 is returned when averaging is disabled.

Query example

AVER2? *Queries whether averaging is turned on or off.*

Error message

If DET:FUNC is set to AVER, error -221, “Settings conflict” occurs.

[SENSe[1]:]BANDwidth | BWIDth:VIDeo <character_data>

This command sets the bandwidth of the U2020 X-Series.

Syntax

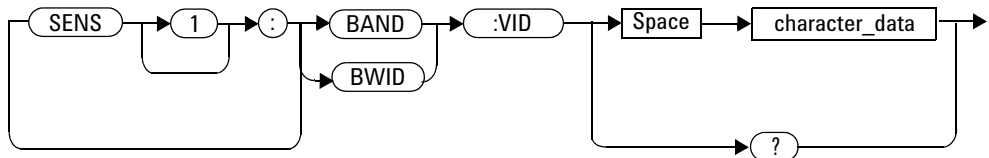

Parameters

Item	Description/Default	Range of values
character_data	Defines the bandwidth.	HIGH MEDium LOW OFF

Values for HIGH, MEDIUM, LOW, and OFF are as shown below:

LOW	MEDium	HIGH	OFF
5 MHz	15 MHz	30 MHz	30 MHz

Example

BAND:VID HIGH

Sets the bandwidth to high.

Reset condition

On reset, the bandwidth is set to OFF.

Query

```
[SENSE[1]:]BANDwidth|BWIDth:VIDeo?
```

The query returns the current bandwidth setting.

Query example

```
BAND:VID?           Queries the current bandwidth setting.
```

NOTE

Selection of LOW, MED, or HIGH video bandwidth turns on the digital FIR filter with passband flatness of ± 0.1 dB. In the OFF state, no corrections are applied and the response has a slow roll-off.

Error message

If DET:FUNC is set to AVER, error -221, “Settings conflict” occurs.

[SENSe[1]:]BUFFer:COUNt <numeric_value>

This command sets the buffer size for triggered measurements and must be used in conjunction with an external trigger. This command can only be set when `FREQ:STEP` is set to 0, otherwise the buffer size will automatically be overwritten by the frequency sweep step value.

Syntax

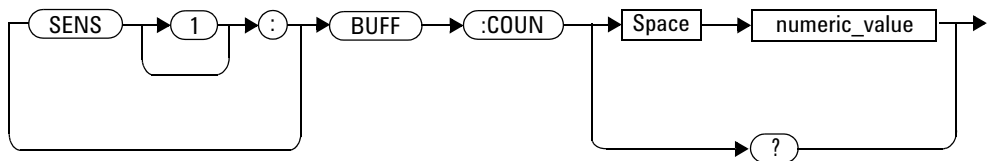

Parameters

Item	Description/Default	Range of values
numeric_value	A numeric value defining the buffer size. Units are resolved to 1.	1 to 4096

Example

```
BUFF:COUN 10
```

Sets the buffer size to 10.

Reset condition

On reset, the buffer size is set to 1.

Query

```
[SENSe[1]:]BUFFEr:COUNT?
```

The query returns the current buffer size. The format of the response is <NR1>.

Query example

```
BUFF:COUNT?
```

Queries the buffer size.

Error messages

- If the limits of the values are exceeded, error -222, “Data out of range;value clipped to upper (or lower) limit” occurs.
- If BUFF:COUNT is set when TRIG:SOUR is not set to EXT, error -221, “Settings conflict. Invalid acquisition mode” occurs.
- If BUFF:COUNT is set when FREQ:STEP is not set to 0, error -221, “Settings conflict. Frequency sweep enabled. Buffer count overridden” occurs.

[SENSe[1]:]BUFFer:MTYPe <character_data>

This command sets the measurement type of the buffered mode.

Syntax

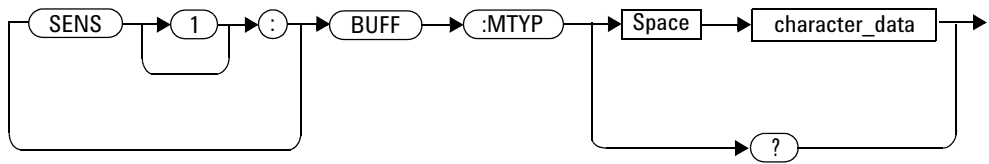

Parameters

Item	Description/Default	Range of values
character_data	Defines the measurement type of the buffered mode.	AVER PEAK PTAV MIN

Example

BUFF:MTYP:AVER *Sets the measurement type to AVER for the buffered mode.*

Reset condition

On reset, the measurement type for the buffered mode is AVER.

Query

```
[SENSe[1]:]BUFFer:MTYPe?
```

The query returns the current measurement type for the buffered mode.

Query example

```
BUFFer:MTYP?
```

Returns the current measurement type for the buffered mode.

Error messages

- If `BUFF:MTYP` is set when `TRIG:SOUR` is not set to `EXT` or `DET:FUNC` is set to `AVER`, error -221, “Settings conflict. Invalid acquisition mode” occurs.
- If the parameter set is a string but it is invalid, error -224, “Illegal parameter value” occurs.

[SENSe[1]:]CORRection Commands

These commands allow changes to be applied to the measurement result. They are used to enter gains or losses, as well as control frequency-dependent offset tables.

The following commands are detailed in this section:

```
[SENSe[1]:]CORRection:CSET2[:SElect] <string>
[SENSe[1]:]CORRection:CSET2:STATE <boolean>
[SENSe[1]:]CORRection:FDOffset|GAIN4[:INPut][:MAGNitude]?
[SENSe[1]:]CORRection:GAIN2[:INPut][:MAGNitude] <numeric_value>
[SENSe[1]:]CORRection:GAIN2:STATE <boolean>
[SENSe[1]:]CORRection:LOSS2[:INPut][:MAGNitude] <numeric_value>
[SENSe[1]:]CORRection:LOSS2:STATE <boolean>
```

[SENSE[1]:]CORRection:CSET2 Commands

These commands are used to select the active frequency-dependent offset table.

The following commands are detailed in this section:

```
[SENSE[1]:]CORRection:CSET2[:SElect] <string>  
[SENSE[1]:]CORRection:CSET2:STATE <boolean>
```

[SENSe[1]:]CORRection:CSET2[:SElect] <string>

This command enters the name of the frequency-dependent offset table to be used.

NOTE

If [SENSe[1]:]CORRection:CSET2:STATE is set to OFF, the selected frequency-dependent offset table is not being used.

Syntax

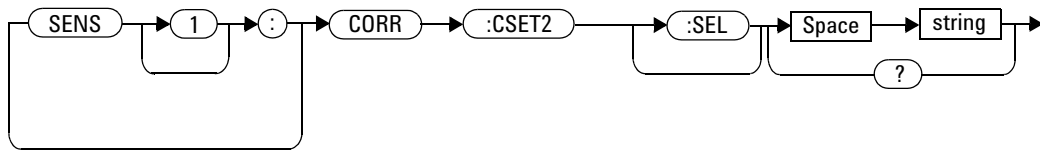

Parameters

Item	Description/Default	Range of values
string	String data representing a frequency-dependent offset table name.	Any existing table name (Existing table names can be listed using MEMory:CATalog:TABLE?).

Example

```
CORR:CSET2 `PW1`
```

Enters the name of the frequency-dependent offset table to be used.

Reset condition

On reset, the selected table is not affected.

Query

```
[SENSe[1]:]CORRection:CSET2[:SElect]?
```

The query returns the name of the selected table as a quoted string. If no table is selected, an empty string is returned.

Query example

```
CORR:CSET2?
```

Queries the frequency-dependent offset table currently used.

Error messages

- If <string> is not valid, error -224, “Illegal parameter value” occurs.
- If a table called <string> does not exist, error -256, “File name not found” occurs.
- When a frequency-dependent offset table is selected, the U2020 X-Series verifies that the number of offset points defined is equal to the number of frequency points defined. If this is not the case, error -226, “Lists not the same length” occurs.

[SENSe[1]:]CORRection:CSET2:STATe <boolean>

This command is to enable and disable the use of the currently active frequency-dependent offset table. When a table has been selected and enabled, the offsets stored in it can be used by specifying the required frequency using the [SENSe[1]:]FREQuency command.

Syntax

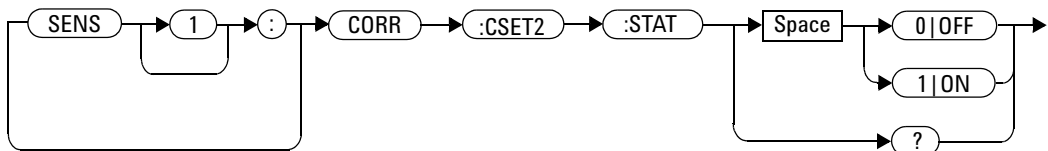

Example

`CORR:CSET2:STAT 1` *Enables the use of the currently active frequency-dependent offset table.*

Reset condition

On reset, the frequency-dependent offset table is not affected.

Query

[SENSe[1]:]CORRection:CSET2:STATe?

The query returns a 1 or 0 into the output buffer indicating whether a table is enabled or disabled.

- 1 is returned when the table is enabled
- 0 is returned when the table is disabled

Query example

```
CORR:CSET2:STAT?
```

Queries whether or not there is currently an active frequency-dependent offset table.

Error message

If you attempt to set this command to ON and no table has been selected using [SENSE[1]:]CORRection:CSET2[:SElect], then error -221, “Settings conflict” occurs and [SENSE[1]:]CORRection:CSET2:STATe remains OFF.

[SENSe[1]:]CORRection:FDOFFset | GAIN4[:INPut][:MAGNitude] ?

This command is used to return the frequency-dependent offset currently being applied.

Syntax

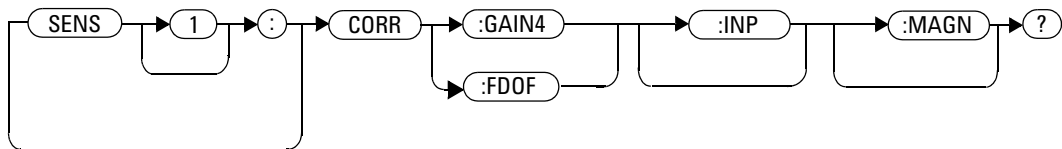

Example

CORR:GAIN4?

Queries the current frequency- dependent offset being applied.

Reset condition

On reset, the frequency-dependent offset is not affected.

[SENSE[1]:]CORRection:GAIN2 Commands

These commands provide a simple correction to a measurement for an external loss/gain.

The following commands are detailed in this section:

```
[SENSE[1]:]CORRection:GAIN2:STATE <boolean>
```

```
[SENSE[1]:]CORRection:GAIN2[:INPut][:MAGNitude] <numeric_value>
```

[SENSe[1]:]CORRection:GAIN2:STATe <boolean>

This command is used to enable/disable a channel offset for the U2020 X-Series setup. The [SENSe[1]:]CORRection:GAIN2[:INPut] [:MAGNitude] command is used to enter the loss/gain value.

Syntax

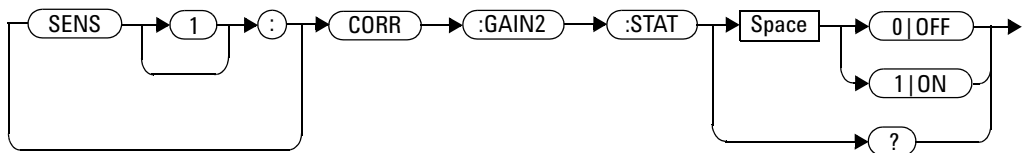

Example

```
CORR:GAIN2:STAT ON
```

Enables the channel offset.

Reset condition

On reset, channel offsets are disabled.

Query

```
[SENSe[1]:]CORRection:GAIN2:STATe?
```

The query enters 1 or 0 into the output buffer indicating the status of the channel offset.

- 1 is returned if a channel offset is enabled
- 0 is returned if a channel offset is disabled

Query example

```
CORR:GAIN2:STAT?
```

Queries whether or not there is a channel offset applied.

Error message

If [SENSe[1]:]CORRection:GAIN2:STATe is set to ON while [SENSe[1]:]MRATe is set to FAST, the error -221, “Settings conflict” occurs.

[SENSe[1]:]CORRection:GAIN2[:INPut][:MAGNitude] <numeric_value>

This command is used to enter a channel offset value for the U2020 X-Series setup, for example cable loss. The U2020 X-Series then corrects every measurement by this factor to compensate for the loss/gain.

Entering a value for GAIN2 using this command automatically turns the [SENSe[1]:]CORRection:GAIN2:STATE command to ON.

Syntax

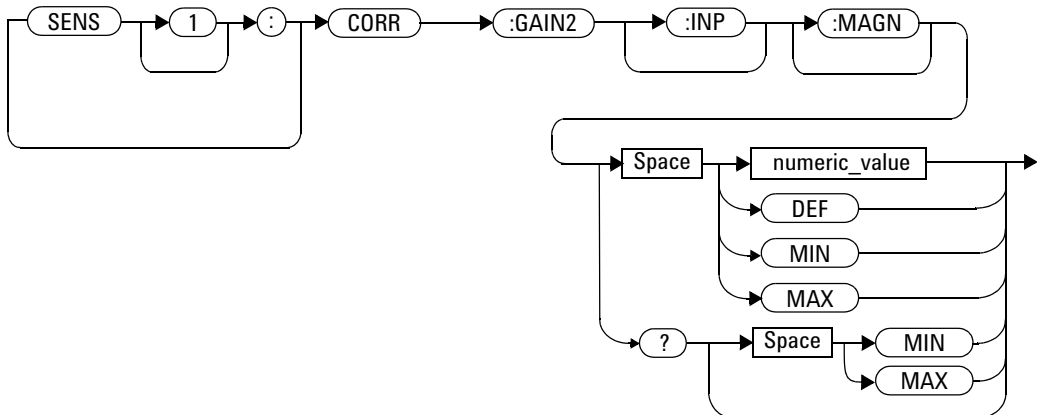

Parameters

Item	Description/Default	Range of values
numeric_value	A numeric value: <ul style="list-style-type: none"> DEF: the default is 0.00 dB MIN: -100 dB MAX: +100 dB 	-100 to +100 dB DEF MIN MAX

Example

`CORR:GAIN2 50` *Sets a channel offset of 50 dB.*

Reset condition

On reset, GAIN2 is set to 0.00 dB.

Query

`[SENSe[1]:]CORRection:GAIN2[:INPut][:MAGNitude]? [MIN|MAX]`

The query returns the current setting of the channel offset or the values associated with MIN and MAX.

Query example

`CORR:GAIN2?` *Queries the current setting of the channel offset.*

Error message

If a loss/gain correction value is entered using `[SENSe[1]:]CORRection:GAIN2[:INPut][:MAGNitude]` while `[SENSe[1]:]MRATe` is set to FAST, error -221, “Settings conflict” occurs. However, the correction value is set but the `[SENSe[1]:]CORRection:GAIN2:STATe` command is not automatically set to ON.

[SENSe[1]:]CORRection:LOSS2 Commands

These commands provide a simple correction to a measurement for an external gain/loss.

The following commands are detailed in this section:

```
[SENSe[1]:]CORRection:LOSS2:STATe <boolean>
```

```
[SENSe[1]:]CORRection:LOSS2[:INPut][:MAGNitude] <numeric_value>
```

[SENSe[1]:]CORRection:LOSS2:STATe <boolean>

This command is used to enable/disable a channel offset for the U2020 X-Series setup. The [SENSe[1]:]CORRection:LOSS2[:INPut] [:MAGNitude] command is used to enter the gain/loss value.

Syntax

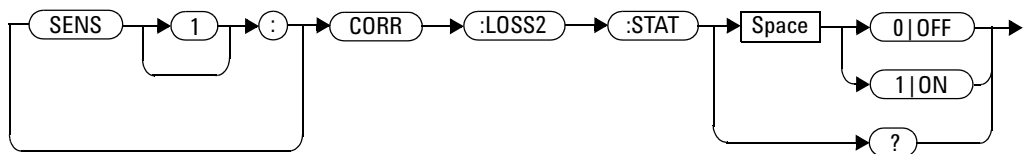

Example

```
CORR:LOSS2:STAT ON
```

Enables the channel offset.

Reset condition

On reset, channel offsets are disabled.

Query

```
[SENSe[1]:]CORRection:LOSS2:STATe?
```

The query enters 1 or 0 into the output buffer indicating the status of the channel offset.

- 1 is returned if a channel offset is enabled
- 0 is returned if a channel offset is disabled

Query example

```
CORR:LOSS2:STAT?
```

Queries whether or not there is a channel offset applied.

Error message

If [SENSe[1]:]CORRection:LOSS2:STATe is set to ON while [SENSe[1]:]MRATe is set to FAST, the error -221, "Settings conflict" occurs.

[SENSe[1]:]CORRection:LOSS2[:INPut][:MAGNitude] <numeric_value>

This command is used to enter a channel offset value for the U2020 X-Series setup, for example system gain or a cable loss. The U2020 X-Series then corrects every measurement by this factor to compensate for the gain/loss.

Entering a value for LOSS2 using this command automatically turns the [SENSe[1]:]CORRection:LOSS2:STATe command to ON.

Syntax

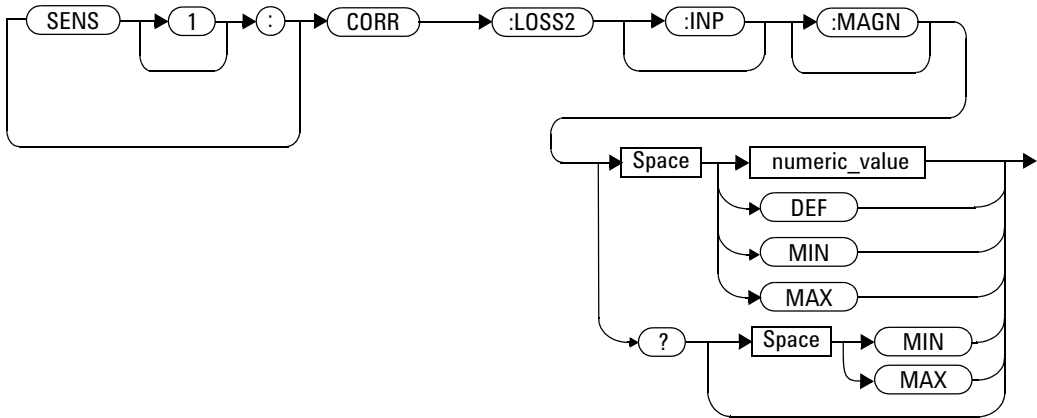

Parameters

Item	Description/Default	Range of values
numeric_value	A numeric value: <ul style="list-style-type: none"> DEF: the default is 0.00 dB MIN: -100 dB MAX: +100 dB 	-100 to +100 dB DEF MIN MAX

Example

`CORR:LOSS2 -50` *Sets a channel offset of -50 dB.*

Reset condition

On reset, LOSS2 is set to 0.00 dB.

Query

`[SENSe[1]:]CORRection:LOSS2[:INPut][:MAGNitude]? [MIN|MAX]`

The query returns the current setting of the channel offset or the values associated with MIN and MAX.

Query example

`CORR:LOSS2?` *Queries the current setting of the channel offset.*

Error message

If a gain/loss correction value is entered using

`[SENSe[1]:]CORRection:LOSS2[:INPut][:MAGNitude]` while `[SENSe[1]:]MRATe` is set to FAST, error -221, “Settings conflict” occurs.

However, the correction value is set but the

`[SENSe[1]:]CORRection:LOSS2:STATe` command is not automatically set to ON..

[SENSe[1]:]DETEctor:FUNCTion <character_data>

This command sets the measurement mode to normal or average.

Syntax

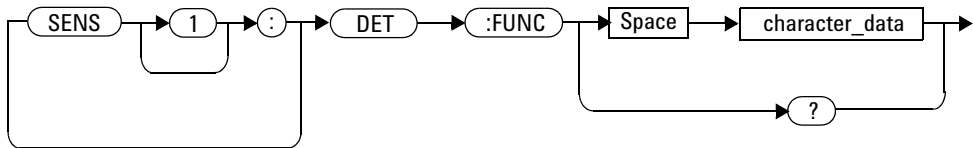

Parameters

Item	Description/Default	Range of values
character_data	Defines the measurement mode: <ul style="list-style-type: none"> NORMal: sets to the normal mode. Normal mode allows time selective measurements on a wide variety of signal types. AVERage: sets to the average mode. Average mode is aimed at constant or bursted waveforms but repetitive measurements. 	NORMal AVERage

Example

```
DET:FUNC NORM
```

Sets the normal measurement mode.

Reset condition

On reset, the mode is set to NORMal.

Query

```
[SENSe[1]:]DETEctor:FUNCTion?
```

The query returns the current measurement mode setting.

Query example

```
DET:FUNC?
```

Queries the current measurement mode setting.

[SENSe[1]:]FREQuency[:CW | :FIXed] <numeric_value>

This command is used to enter a frequency.

Syntax

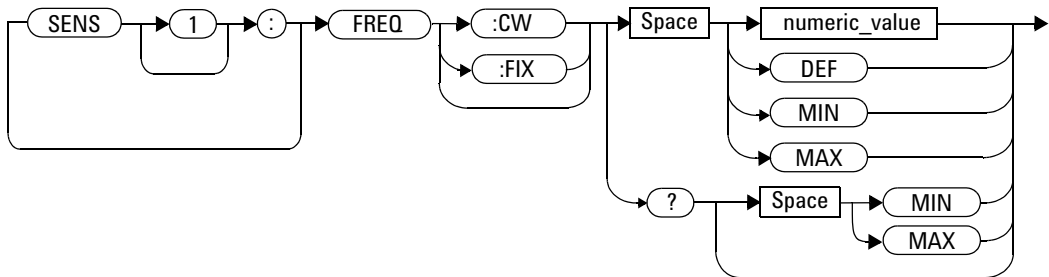

Parameters

Item	Description/Default	Range of values
numeric_value	A numeric value for the frequency: <ul style="list-style-type: none"> DEF: the default value is 50 MHz MIN: 1 kHz MAX: 1000.0 GHz The default units are Hz.	1 kHz to 1000.0 GHz ¹ DEF MIN MAX

¹ The following measurement units can be used:

- Hz
- kHz (10^3)
- MHz (10^6)
- GHz (10^9)

Example

FREQ 500kHz *Enters a frequency of 500 kHz.*

Reset condition

On reset, the frequency is set to 50 MHz (DEF).

Query

[SENSe[1]:]FREQuency[:CW|:FIXed]? [MIN|MAX]

The query returns the current frequency setting or the values associated with MIN and MAX. The unit in which the results are returned is Hz.

Query example

FREQ? *Queries the frequency setting.*

[SENSe[1]:]FREQuency[:CW | :FIXed]:STARt <numeric_value>

This command sets the start frequency for frequency sweep measurements and must be used in conjunction with an external trigger. If `FREQ:STEP` is set to 0, the `FREQ:STAR` command will be set but will not take effect. The `FREQ:STAR`, `FREQ:STOP`, and `FREQ:STEP` commands can be set in any desirable sequence.

NOTE

When the frequency sweep mode is configured with the frequency step size within its range (1 to 4096), the following conditions apply:

- If the frequency stop point is greater than the frequency start point, the frequency range will be swept in an ascending order.
- If the frequency stop point is less than the frequency start point, the frequency range will be swept in a descending order.
- If the frequency stop point and the frequency start point are equal, it is the same as the power sweep mode.

Syntax

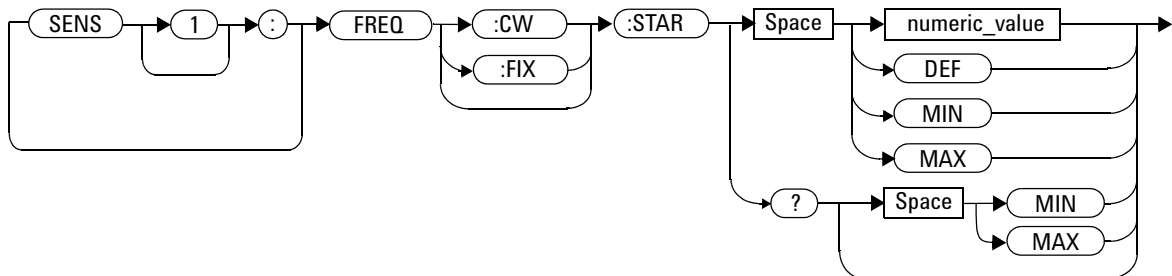

Parameters

Item	Description/Default	Range of values
numeric_value	A numeric value for the start frequency: <ul style="list-style-type: none"> • DEF: the default value is 50 MHz • MIN: 1 kHz • MAX: 1000 GHz Units are resolved to 1 kHz.	1 kHz to 1000 GHz DEF MIN MAX

Example

`FREQ:STAR 500kHz` *Enters a start frequency of 500 kHz.*

Reset condition

On reset, the start frequency is set to 50 MHz (DEF).

Query

`[SENSe[1]:]FREQuency[:CW|:FIXed]:START? [MIN|MAX]`

The query returns the current start frequency setting or the values associated with MIN and MAX. The unit in which the results are returned is Hz.

Query example

FREQ:STAR?

Queries the start frequency setting.

Error message

If limits of the values are exceeded, error -222, “Data out of range;value clipped to upper (or lower) limit” occurs.

[SENSe[1]:]FREQuency[:CW | :FIXed]:STOP <numeric_value>

This command sets the stop frequency for frequency sweep measurements and must be used in conjunction with an external trigger. If `FREQ:STEP` is set to 0, the `FREQ:STOP` command will be set but will not take effect. `FREQ:STAR`, the `FREQ:STOP`, and `FREQ:STEP` commands can be set in any desirable sequence.

NOTE

When the frequency sweep mode is configured with the frequency step size within its range (1 to 4096), the following conditions apply:

- If the frequency stop point is greater than the frequency start point, the frequency range will be swept in an ascending order.
- If the frequency stop point is less than the frequency start point, the frequency range will be swept in a descending order.
- If the frequency stop point and the frequency start point are equal, it is the same as the power sweep mode.

Syntax

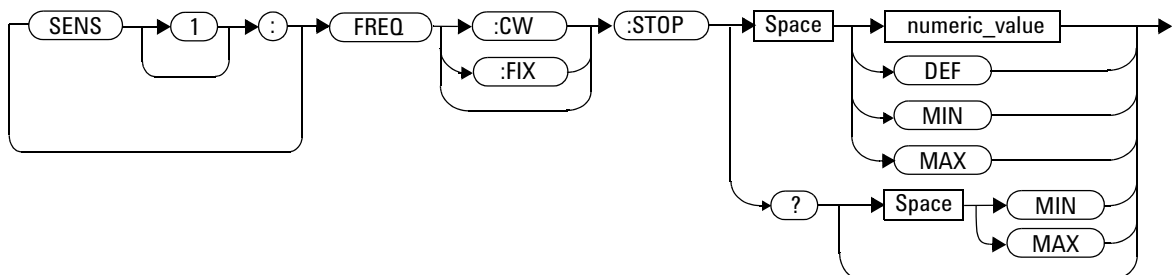

Parameters

Item	Description/Default	Range of values
numeric_value	A numeric value for the stop frequency: <ul style="list-style-type: none"> • DEF: the default value is 50 MHz • MIN: 1 kHz • MAX: 1000 GHz Units are resolved to 1 kHz.	1 kHz to 1000 GHz DEF MIN MAX

Example

`FREQ:STOP 500kHz` *Enters a stop frequency of 500 kHz.*

Reset condition

On reset, the stop frequency is set to 50 MHz (DEF).

Query

`[SENSe[1]:]FREQuency[:CW|:FIXed]:STOP? [MIN|MAX]`

The query returns the current stop frequency setting or the values associated with MIN and MAX. The unit in which the results are returned is Hz.

Query example

FREQ:STOP?

Queries the stop frequency setting.

Error message

If the limits of the values are exceeded, error -222, “Data out of range;value clipped to upper (or lower) limit” occurs.

[SENSe[1]:]FREQuency[:CW | :FIXed]:STEP <numeric_value>

This command sets the number of steps for frequency sweep measurements and must be used in conjunction with an external trigger. The frequency sweep range will be equally divided by the frequency steps. The number of frequency steps can be calculated using the following equation:

$$\text{Step} = \frac{(\text{Stop frequency} - \text{Start frequency} + \text{Interval})}{\text{Interval}}$$

Step = Number of frequency steps

Start frequency = Frequency sweep start point

Stop frequency = Frequency sweep stop point

Interval = Frequency step size

Example:

If the start frequency is 1 GHz, the stop frequency is 5 GHz, and the interval is 0.5 GHz, the number of frequency steps is calculated as follows:

$$\text{Step} = \frac{(5 \text{ GHz} - 1 \text{ GHz} + 0.5 \text{ GHz})}{0.5 \text{ GHz}} = 9$$

The `FREQ:STAR`, `FREQ:STOP`, and `FREQ:STEP` commands can be set in any desirable sequence. The calculated frequency step size will be rounded to the nearest kHz with the minimum size of 1 kHz. When the frequency range is less than the frequency sweep step size, the remaining steps will be repeated with the last frequency point.

Syntax

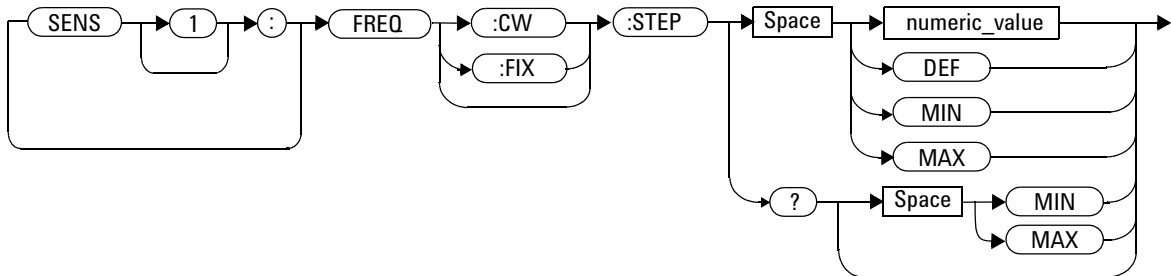

Parameters

Item	Description/Default	Range of values
numeric_value	A numeric value defining the number of steps for frequency sweep measurements. <ul style="list-style-type: none"> DEF: the default value is 0 MIN: 0 MAX: 4096 Units are resolved to 1.	0 to 4096 DEF MIN MAX

Example

```
FREQ:STEP 10
```

Sets the number of frequency steps to 10.

Reset condition

On reset, the frequency step size is set to 0.

Query

```
[SENSe[1]:]FREQuency[:CW|:FIXed]:STEP? [MIN|MAX]
```

The query returns the current number of frequency steps. The format of the response is <NR1>.

Query example

```
FREQ:STEP?
```

Queries the number of frequency steps.

Error messages

- If the limits of the values are exceeded, error –222, “Data out of range;value clipped to upper (or lower) limit” occurs.
- If the acquisition mode is in free run, error –221, “Setting conflict. Invalid acquisition mode” occurs.

[SENSe[1]:]LIST:FREQuency:STARt <numeric_value>

This command sets the start frequency for frequency sweep measurements. Configuring the [SENSe[1]:]LIST:FREQuency:STOP value to be the same as STARt means the frequency will not be changed during the test.

Syntax

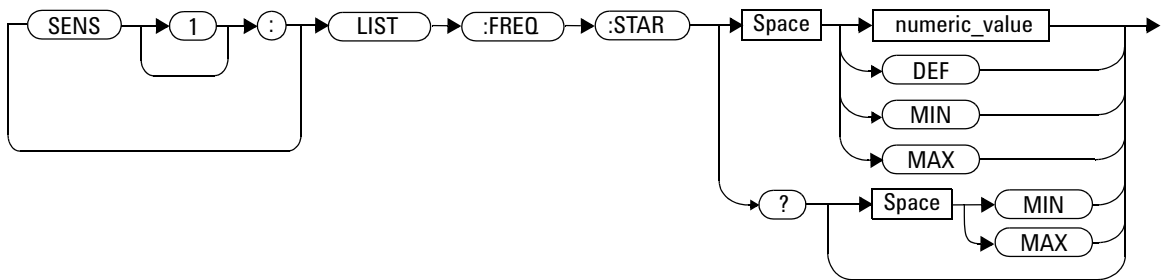

Parameters

Item	Description/Default	Range of values
numeric_value	A numeric value for the start frequency: <ul style="list-style-type: none"> • DEF: the default value is 50 MHz • MIN: 1 kHz • MAX: 1000 GHz Units are resolved to 1 kHz.	1 kHz to 1000 GHz DEF MIN MAX

Example

```
LIST:FREQ:STAR      Enters a start frequency of 500 kHz.  
500kHz
```

Reset condition

On reset, the start frequency is set to 50 MHz (DEF).

Query

```
[SENSE[1]:]LIST:FREQuency:STARt? [MIN|MAX]
```

The query returns the current start frequency setting or the values associated with MIN and MAX. The unit in which the results are returned is Hz.

Query example

```
LIST:FREQ:STAR? Queries the start frequency setting.
```

Error messages

- If the limits of the values are exceeded, error -222, “Data out of range;value clipped to upper (or lower) limit” occurs.
- If LIST:FREQ:STAR is set while a sequence is running, error -221, “Settings conflict;list mode is running” occurs.

[SENSe[1]:]LIST:FREQuency:STOP <numeric_value>

This command sets the stop frequency for frequency sweep measurements. Configuring the [SENSe[1]:]LIST:FREQuency:START value to be the same as STOP means the frequency will not be changed during the test.

Syntax

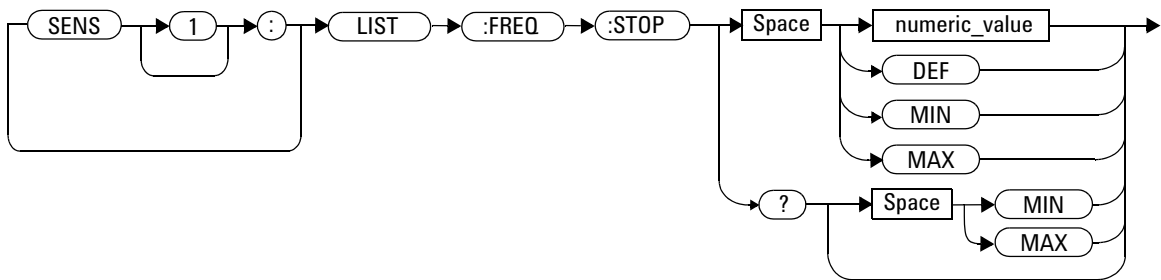

Parameters

Item	Description/Default	Range of values
numeric_value	A numeric value for the stop frequency: <ul style="list-style-type: none"> DEF: the default value is 50 MHz MIN: 1 kHz MAX: 1000 GHz Units are resolved to 1 kHz.	1 kHz to 1000 GHz DEF MIN MAX

Example

```
LIST:FREQ:STOP      Enters a stop frequency of 500 kHz.  
500kHz
```

Reset condition

On reset, the stop frequency is set to 50 MHz (DEF).

Query

```
[SENSE[1]:]LIST:FREQuency:STOP? [MIN|MAX]
```

The query returns the current stop frequency setting or the values associated with MIN and MAX. The unit in which the results are returned is Hz.

Query example

```
LIST:FREQ:STOP? Queries the stop frequency setting.
```

Error messages

- If the limits of the values are exceeded, error -222, “Data out of range;value clipped to upper (or lower) limit” occurs.
- If LIST:FREQ:STOP is set while a sequence is running, error -221, “Settings conflict;list mode is running” occurs.

[SENSe[1]:]LIST:MTYPE <character_data>

This command sets the measurement type to be performed.

Syntax

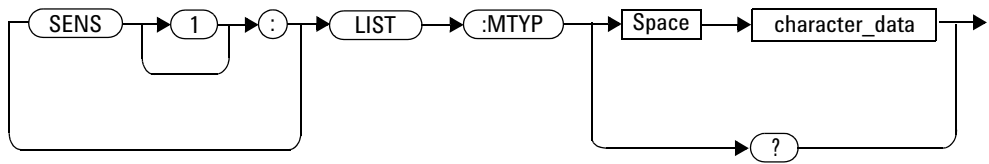

Parameters

Item	Description/Default	Range of values
character_data	Defines the measurement type.	AVER PEAK PTAV MIN

Example

LIST:MTYPE AVER *Sets the measurement type to AVER.*

Reset condition

On reset, the measurement type is AVER.

Query

```
[SENSe[1]:]LIST:MTYPe?
```

The query returns the current measurement type.

Query example

```
LIST:MTYP?
```

Returns the current measurement type.

Error messages

- If LIST:MTYP is set to PEAK, PTAV, or MIN when DET:FUNC is set to AVER, error -221, “Settings conflict” occurs.
- If LIST:MTYP is set while a sequence is running, error -221, “Settings conflict;list mode is running” occurs.

[SENSe[1]:]LIST:POINts <numeric_value>

This command sets the number of measurements to be made. If the values set at [SENSe[1]:]LIST:FREQuency:START and [SENSe[1]:]LIST:FREQuency:STOP are different, this setting will also affect the frequency step during the frequency sweep. The number of measurement points can be calculated using the following equation:

$$\text{Points} = \left(\frac{|\text{Stop frequency} - \text{Start frequency}|}{\text{Frequency step}} \right) + 1$$

Syntax

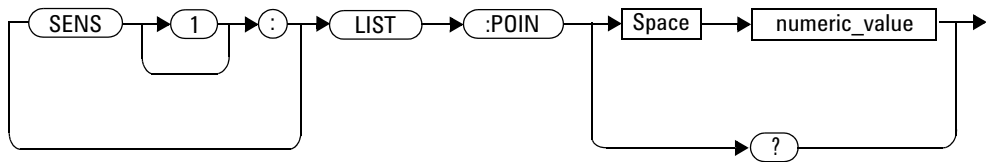

Parameters

Item	Description/Default	Range of values
numeric_value	A numeric value defining the measurement points. Units are resolved to 1.	1 to 4096

Example

```
LIST:POIN 10
```

Sets the measurement points to 10.

Reset condition

On reset, the number of measurement points is set to 1.

Query

```
[SENSe[1]:]LIST:POINTs?
```

The query returns the current setting of the measurement points. The format of the response is <NR1>.

Query example

```
LIST:POIN?
```

Queries the measurement points.

Error messages

- If the limits of the values are exceeded, error -222, “Data out of range;value clipped to upper (or lower) limit” occurs.
- If LIST:POIN is set while a sequence is running, error -221, “Settings conflict;list mode is running” occurs.

[SENSe[1]:]LIST:STATe <boolean>

This command is used to enable/disable the list mode for frequency sweep measurements.

Syntax

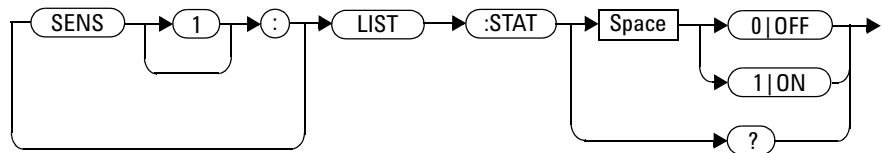

Example

```
LIST:STAT ON
```

Enables the list mode.

Reset condition

On reset, the list mode is disabled.

Query

```
[SENSe[1]:]LIST:STATe?
```

The query enters 1 or 0 into the output buffer indicating the status of the list mode.

- 1 is returned if the list mode is enabled
- 0 is returned if the list mode is disabled

Query example

LIST:STAT?

Queries the list mode status.

Error messages

- If LIST:STAT is set when TRIG:SOUR is not set to EXT, error -221, “Settings conflict;list mode requires EXT trigger source” occurs.
- If LIST:STAT is set while a sequence is running, error -221, “Settings conflict;list mode is running” occurs.

NOTE

If LIST:STAT is set to ON when DET:FUNC is set to NORM,

- SENS:SWE[1] | 2 | 3 | 4: AUTO will be set to OFF.
 - SENS:TRAC:STAT will be set to OFF.
 - PST:CCDF:CONT will be set to OFF.
 - PST:CCDF:SWE:STAT will be set to OFF.
-

[SENSe[1]:]LIST:TSCount <numeric_value>

This command sets the number of slots that will be measured within a burst. Setting the slot to 1 is equivalent to a basic power sweep mode.

NOTE

FETC?, READ?, and MEAS? will return the LIST:TSC number of readings multiplied by the LIST:POIN settings.

Syntax

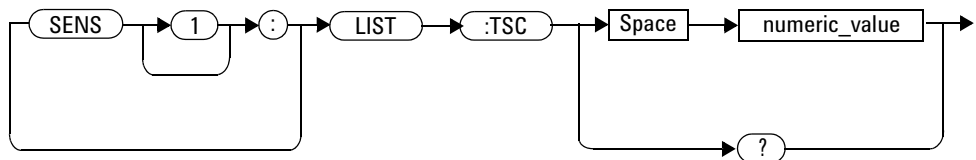

Parameters

Item	Description/Default	Range of values
numeric_value	A numeric value defining the number of slots that will be measured within a burst. Units are resolved to 1.	1 to 16

Example

```
LIST:TSC 4
```

Sets the number of slots to 4.

Reset condition

On reset, the number of slots is set to 1.

Query

```
[SENSe[1]:]LIST:TSC?
```

The query returns the current setting of the number of slots that will be measured within a burst. The format of the response is <NR1>.

Query example

```
LIST:TSC?
```

Queries the number of slots that will be measured within a burst.

Error messages

- If DET:FUNC is set to AVER, error -221, “Settings conflict” occurs.
- If the limits of the values are exceeded, error -222, “Data out of range;value clipped to upper (or lower) limit” occurs.
- If the product of the LIST:TSL:TIME value multiplied by the LIST:TSC value exceeds 1 s, error -221, “Settings conflict;Capture buffer size too large. Please reduce time slot duration or count.” occurs.
- If LIST:TSC is set while a sequence is running, error -221, “Settings conflict;list mode is running” occurs.

[SENSe[1]:]LIST:TSLot:EXCLude:OFFSet:TIME <numeric_value>

This command is used to set the exclusion area offset time relative to the beginning of the time slot.

Syntax

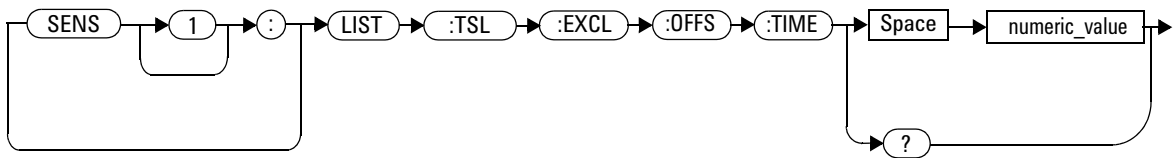

Parameters

Item	Description/Default	Range of values
numeric_value	A numeric value defining the exclusion area offset time. Units are resolved to 12.5 ns.	0.0 s to 0.1 s

Example

```
LIST:TSL:EXCL:OFFS:TIME 0.01
```

Sets the exclusion area offset time to 0.01 s.

Query

```
[SENSe[1]:]LIST:TSLot:EXCLude:OFFSet:TIME?
```

The query returns the current exclusion area offset time.

Query example

LIST:TSL:EXCL:OFFS:TIME? *Returns the current exclusion area offset time.*

Error messages

- If DET:FUNC is set to AVER, error -221, “Settings conflict” occurs.
- If the limits of the values are exceeded, error -222, “Data out of range;value clipped to upper (or lower) limit” occurs.
- If LIST:TSL:EXCL:OFFS:TIME is set while a sequence is running, error -221, “Settings conflict;list mode is running” occurs.

[SENSe[1]:]LIST:TSLot:EXCLude:TIME <numeric_value>

This command is used to set the exclusion duration interval within the time slot. The exclusion duration interval is useful for excluding the mid-amble interval in the GSM slot.

Syntax

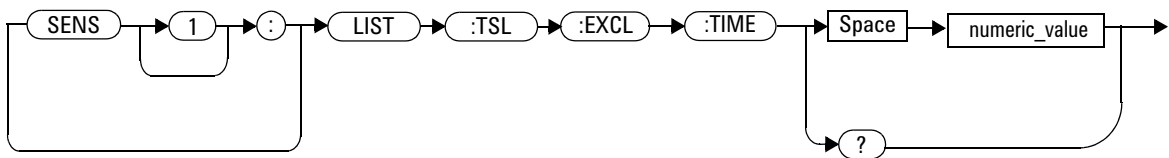

Parameters

Item	Description/Default	Range of values
numeric_value	A numeric value defining the exclusion duration interval within the time slot. Units are resolved to 12.5 ns.	0.0 s to 0.1 s

Example

```
LIST:TSL:EXCL:TIME 0.01
```

Sets the exclusion duration interval to 0.01 s.

Query

```
[SENSe[1]:]LIST:TSLot:EXCLude:TIME?
```

The query returns the current exclusion duration interval within the time slot.

Query example

LIST:TSL:EXCL:TIME?

Returns the current exclusion duration interval within the time slot.

Error messages

- If DET:FUNC is set to AVER, error -221, “Settings conflict” occurs.
- If the limits of the values are exceeded, error -222, “Data out of range;value clipped to upper (or lower) limit” occurs.
- If LIST:TSL:EXCL:TIME is set while a sequence is running, error -221, “Settings conflict;list mode is running” occurs.

[SENSe[1]:]LIST:TSLot:TIME <numeric_value>

This command is used to set the duration of the measurement time slot.

NOTE

This command is only applicable when DET : FUNC is set to NORM.

Syntax

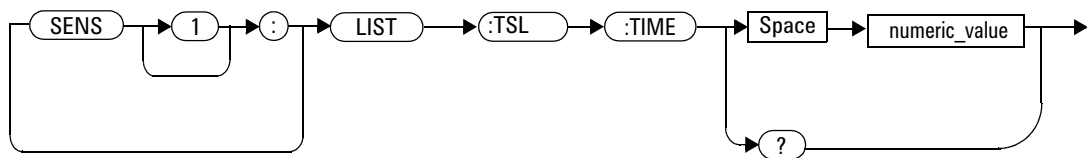

Parameters

Item	Description/Default	Range of values
numeric_value	A numeric value defining the measurement time slot. Units are resolved to 12.5 ns.	12.5 ns to 1 s

Example

```
LIST:TSL:TIME 0.01
```

Sets the measurement time slot to 0.01 s.

Query

```
[SENSe[1]:]LIST:TSLot:TIME?
```

The query returns the current measurement time slot.

Query example

```
LIST:TSL:TIME?
```

Returns the current measurement time slot.

Error messages

- If DET:FUNC is set to AVER, error -221, “Settings conflict” occurs.
- If the limits of the values are exceeded, error -222, “Data out of range;value clipped to upper (or lower) limit” occurs.
- If the product of the LIST:TSL:TIME value multiplied by the LIST:TSC value exceeds 1 s, error -221, “Settings conflict;Capture buffer size too large. Please reduce time slot duration or count.” occurs.
- If LIST:TSL:TIME is set while a sequence is running, error -221, “Settings conflict;list mode is running” occurs.

[SENSe[1]:]LIST:TSLot:TREF1 <numeric_value>

This command is used to set the measurement gate start time within the time slot (in % of the slot duration). The measurement gate start time defines the percentage of the time slot (relative to the beginning of the slot) to be excluded from the measurement. This is useful for removing rising edges and overshoots.

Syntax

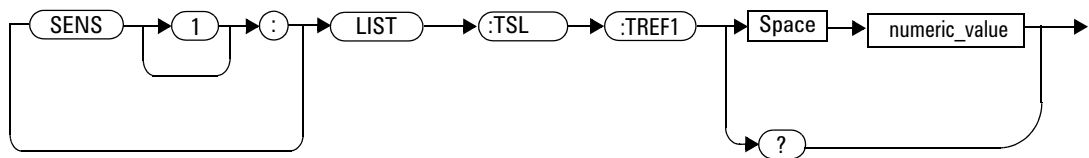

Parameters

Item	Description/Default	Range of values
numeric_value	A numeric value defining the measurement gate start time within the time slot. Units are resolved to 0.1%.	0.0% to 100.0%

Example

```
LIST:TSL:TREF1 10.0
```

Sets the measurement gate start time slot to 10.0%.

Query

```
[SENSe[1]:]LIST:TSLot:TREF1?
```

The query returns the current measurement gate start time slot.

Query example

```
LIST:TSL:TREF1?
```

Returns the current measurement gate start time slot.

Error messages

- If DET:FUNC is set to AVER, error -221, “Settings conflict” occurs.
- If the limits of the values are exceeded, error -222, “Data out of range;value clipped to upper (or lower) limit” occurs.
- If LIST:TSL:TREF1 is set while a sequence is running, error -221, “Settings conflict;list mode is running” occurs.

[SENSe[1]:]LIST:TSLot:TREF2 <numeric_value>

This command is used to set the measurement gate end time within the time slot (in % of the slot duration). The measurement gate end time defines the percentage of the time slot (relative to the end of the slot) to be excluded from the measurement. This is useful for removing falling edges and undershoots.

Syntax

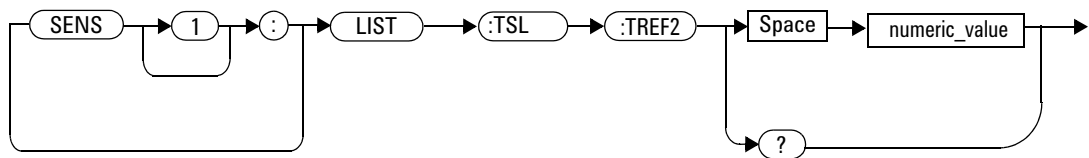

Parameters

Item	Description/Default	Range of values
numeric_value	A numeric value defining the measurement gate end time within the time slot. Units are resolved to 0.1%.	0.0% to 100.0%

Example

```
LIST:TSL:TREF2 10.0
```

Sets the measurement gate end time slot to 10.0%.

Query

```
[SENSe[1]:]LIST:TSLot:TREF2?
```

The query returns the current measurement gate end time slot.

Query example

```
LIST:TSL:TREF2?
```

Returns the current measurement gate end time slot.

Error messages

- If DET:FUNC is set to AVER, error -221, “Settings conflict” occurs.
- If the limits of the values are exceeded, error -222, “Data out of range;value clipped to upper (or lower) limit” occurs.
- If LIST:TSL:TREF2 is set while a sequence is running, error -221, “Settings conflict;list mode is running” occurs.

[SENSe[1]:]MRATe <character_data>

This command sets the measurement speed.

When the U2020 X-Series is set to FAST, the following couplings occur:

Command	Status
[SENSe[1]:]AVERAge:STATe	OFF ¹
[SENSe[1]:]CORREction:GAIN2:STATe	OFF ¹
CALCulate[1] 2 3 4:GAIN:STATe	OFF ¹
CALCulate[1] 2 3 4:RELative:STATe	OFF ¹
CALCulate[1] 2 3 4:MATH:EXPRESSION	"(SENSe1)"

¹ This change only occurs on the speed specified in the [SENSe[1]:]MRATe command. When the specified speed is changed from FAST to NORMAL or DOUBLE, the settings that were in place when FAST was entered are restored.

Syntax

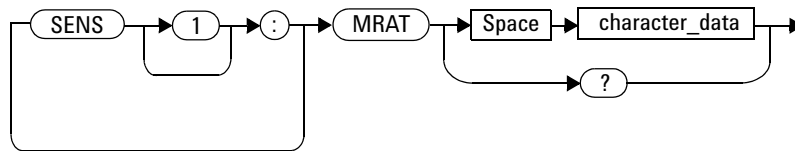

Parameters

Item	Description/Default	Range of values
character_data	A value for the measurement speed: <ul style="list-style-type: none"> NORMAL: 20 readings/second DOUBLE: 40 readings/second FAST: approximately 3500 readings/second The default is NORMAL.	NORMAL ¹ DOUBLE ¹ FAST

¹ When the channel is set to NORMAL or DOUBLE, TRIG:COUNT is set automatically to 1.

Example

```
MRAT DOUB
```

Sets the speed to 40 readings/second.

Reset condition

On reset, the speed is set to NORMAL.

Query

```
[SENSE[1]:]MRATE?
```

The query returns the current speed setting, either NORMAL, DOUBLE, or FAST.

Query example

MRAT?

Queries the current speed setting.

Error message

If <character_data> is not set to NORMAl, DOUBLe, or FAST, error -224, “Illegal parameter value” occurs.

[SENSE[1]:]SWEep[1]|2|3|4 Commands

These commands set the offset time and time gate length as illustrated in the following diagram:

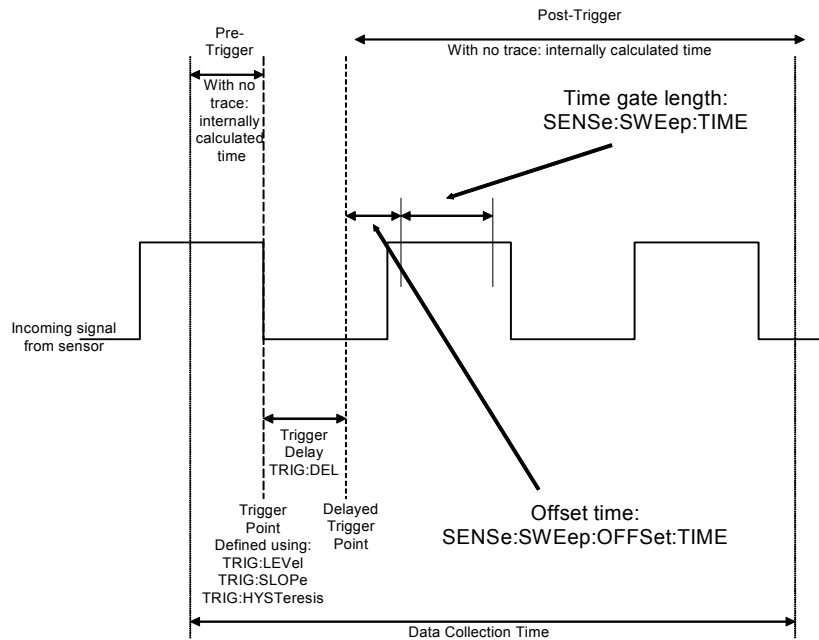

Offset time and time gate length values can be set for up to four measurement gates. The measurement gate number is defined by the numeric value following the `SWEep` component of the command.

The following commands are detailed in this section:

```
[SENSE[1]:]SWEep[1]:APERTure <numeric_value>
[SENSE[1]:]SWEep[1]|2|3|4:AUTO <character_data>
[SENSE[1]:]SWEep[1]|2|3|4:AUTO:REF1|REF2 <numeric_value>
[SENSE[1]:]SWEep[1]|2|3|4:OFFSet:TIME <numeric_value>
[SENSE[1]:]SWEep[1]|2|3|4:TIME <numeric_value>
```

[SENSe[1]:]SWEep[1]:APERture <numeric_value>

This command sets the aperture duration or measurement interval.

Syntax

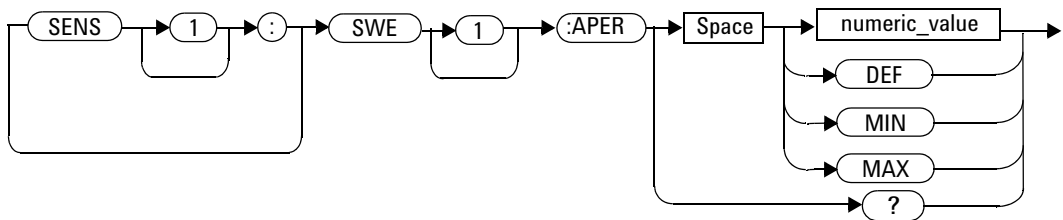

Parameters

Item	Description/Default	Range of values
numeric_value	The aperture duration in seconds. <ul style="list-style-type: none"> DEF: the default value is 50E-3 MIN: 2E-3 MAX: 200E-3 Units are resolved to 2 ms.	2E-3 to 200E-3 DEF MIN MAX

Example

```
SWE:APER 10E-3
```

Sets the aperture duration to 10 ms.

Reset condition

On reset, the aperture duration is set to 50 ms.

Query

```
[SENSe[1]:]SWEep[1]:APERTure?
```

The query returns the current aperture duration.

Query example

```
SWE:APER?
```

Queries the aperture duration.

Error messages

- If the limits of the values are exceeded, error -222, “Data out of range” occurs.
- If SENS:SWE:APER is set when SENS:DET:FUNC is set to NORM or when SENS:MRAT is not set to NORM, error -221, “Settings conflict” occurs.

[SENSe[1]:]SWEep[1] | 2 | 3 | 4:AUTO <character_data>

This command is used to trigger Auto Gating and to turn on or off the Perpetual Gating for the selected gate.

NOTE

This command is only applicable when TRIG : SOUR is set to INT or EXT.

Syntax

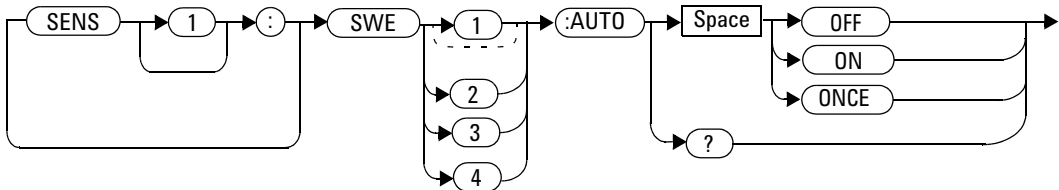

Parameters

Item	Description/Default	Range of values
character_data	The status of Auto Gating and Perpetual Gating. <ul style="list-style-type: none"> ONCE: To turn on Auto Gating ON/OFF: To turn on/off Perpetual Gating 	OFF ON ONCE

Example

SENS : SWE2 : AUTO ON *Turns on Gate 2 Perpetual Gating.*

Reset condition

On reset, Perpetual Gating will be disabled.

Query

```
[SENSe[1]:]SWEep[1]|2|3|4:AUTO?
```

The query returns the current setting of the perpetual gating (0 or 1).

- 1 is returned if the perpetual gating is turned on
- 0 is returned if the perpetual gating is turned off

Query example

```
SWE:AUTO?
```

Returns the current setting of the perpetual gating for Gate 1.

Error messages

- If TRIG:SOUR is not set to INT or EXT, error -221, “Settings conflict” occurs.
- If Auto Gate fails, error -221, “Settings conflict;Auto Once failed” occurs.
- If this command is set to ON or ONCE while LIST:STAT is set to ON, error -221, “Settings conflict;list mode is enabled” occurs.

[SENSe[1]:]SWEep[1] | 2 | 3 | 4:AUTO:REF1 | REF2 <numeric_value>

This command is used to set the Reference 1 and 2 of the selected gate for Auto Gating Marker.

NOTE

This command is only applicable when TRIG : SOUR is set to INT or EXT.

Syntax

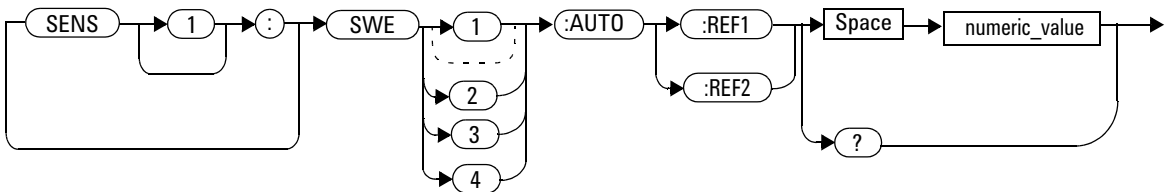

Parameters

Item	Description/Default	Range of values
numeric_value	The values of Auto Gating Marker References 1 and 2 for the selected gate. The combined value of REF1 and REF2 cannot exceed 99.9%.	0.0 to 99.9

Example

```
SWE1:AUTO:REF1 10.0
```

Sets the Auto Gating Marker Reference 1 to 10% for Gate 1.

Query

```
[SENSe[1]:]SWEep[1]|2|3|4:AUTO:REF1|REF2?
```

The query returns the current setting of Auto Gating Marker Reference 1 or 2 for the selected gate in numerical value.

Query example

```
SWE2:AUTO:REF1?
```

Returns the current Gate 2 Reference 1 value of Auto Gating Marker.

Error messages

- If TRIG:SOUR is not set to INT or EXT, error -221, “Settings conflict” occurs.
- If limits of the values are exceeded, error -222, “Data out of range;upper (or lower) limit exceeded;no change” occurs.

[SENSe[1]:]SWEep[1] | 2 | 3 | 4:OFFSet:TIME <numeric_value>

This command sets the delay between the delayed trigger point and the start of the time-gated period (the offset time).

Syntax

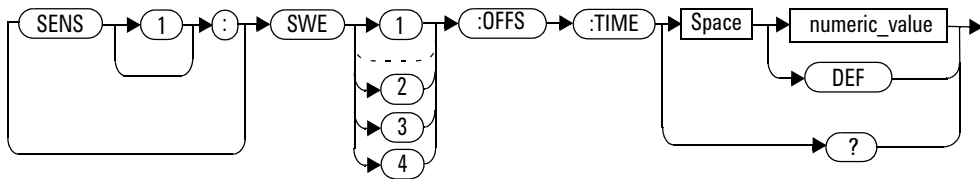

Parameters

Item	Description/Default	Range of values
numeric_value	<p>The delay between the trigger point and the start of the time-gated period.</p> <ul style="list-style-type: none"> DEF: the default value is 0 seconds <p>Units are resolved to 12.5 ns.</p>	<p>-1 to 1 s</p> <p>DEF</p>

Example

SWE3:OFFS:TIME 0.001

Sets the delay to 0.001 s.

Reset condition

On reset, the value is set to 0 s.

Query

```
[SENSe[1]:]SWEep[1]|2|3|4:OFFSet:TIME?
```

The query returns the current delay between the trigger point and the start of the time-gated period.

Query example

```
SWE2:OFFS:TIME?
```

Returns the current delay between the trigger point and the start of the time-gated period for gate 2.

Error message

If DET:FUNC is set to AVER, error -221, “Settings conflict” occurs.

[SENSe[1]:]SWEep[1|2|3|4:TIME <numeric_value>

This command sets the duration of the time-gated period (gate length) for time-gated measurements.

Syntax

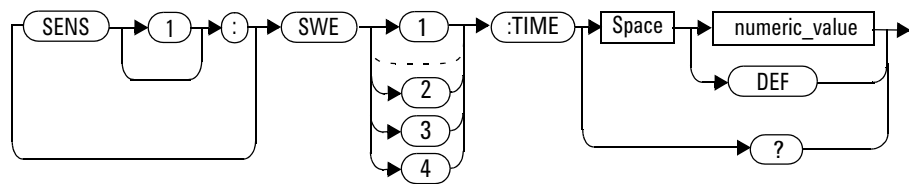

Parameters

Item	Description/Default	Range of values
numeric_value	The duration of the time-gated period in seconds. <ul style="list-style-type: none"> DEF: the default value is 100 μs Units are resolved to 12.5 ns.	0 to 1 s DEF

Example

```
SWE3:TIME 0.001
```

Sets the length to 0.001 s.

Reset condition

On reset, gate 1 is set to 100 μ s and other gates to 0 s.

Query

```
[SENSe[1]:]SWEep[1]|2|3|4:TIME?
```

The query returns the current length of the time-gated period.

Query example

```
SWE2:TIME?
```

Queries the length of the time-gated period for gate 2.

Error message

If DET:FUNC is set to AVER, error -221, “Settings conflict” occurs.

[SENSe[1]:]TEMPerature?

This query returns the U2020 X-Series temperature in degree Celsius.

Syntax

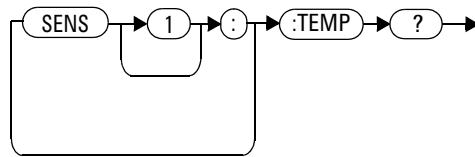

Example

TEMP? *Returns the current U2020 X-Series temperature.*

Reset condition

On reset, this parameter is not affected.

SENSE[1]:TRACe Commands

These commands are used to set:

- The trace capture to be automatically scaled.
- The delay between the delayed trigger point and the start of the trace.
- The duration of the trace.
- The trace units.

The following commands are detailed in this section:

```
[SENSE[1]:]TRACe:AUToscale
```

```
SENSE[1]:TRACe:OFFSet:TIME <numeric_value>
```

```
SENSE[1]:TRACe:TIME <numeric_value>
```

```
[SENSE[1]:]TRACe:UNIT <character_data>
```

SENSe[1]:TRACe:AUToscale

This command automatically scales the trace capture to between 20% to 50% of the x-scale (time axis) with the triggering edge aligned to the center of the trace. This means that the trigger level, trigger delay, holdoff, and gate 1 to 4 duration and offset will be overwritten. Additionally, upon successful autoscaling, the trigger source will be set to INT, and INTI:CONT will remain unchanged. Perpetual gating will also be disabled.

Syntax

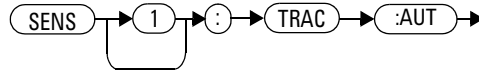

Example

```
SENS:TRAC:AUT
```

Automatically scales the trace capture.

Error messages

- If SENS:TRAC:AUT is set while DET:FUNC is set to AVER, error -221, “Settings conflict” occurs.
- If SENS:TRAC:AUT is set while TRAC:STAT is set to OFF, error -221, “Settings conflict” occurs.
- If SENS:TRAC:AUT is set while TRIG:SOUR is set to EXT, error -221, “Settings conflict” occurs.

SENSe[1]:TRACe:OFFSet:TIME <numeric_value>

This command sets the delay between the delayed trigger point and the start of the trace for the U2020 X-Series.

Syntax

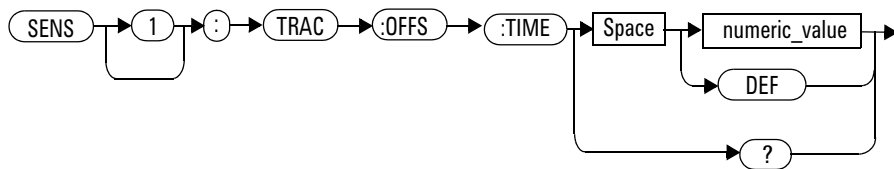

Parameters

Item	Description/Default	Range of values
numeric_value	The length of the delay in seconds. <ul style="list-style-type: none"> DEF: the default value is 0 s Units are resolved to 12.5 ns.	-1 to 1 s DEF

Example

SENSe:TRACe:OFFSet:TIME 0.05 *Sets the delay to 0.05 s.*

Reset condition

On reset, the delay is set to 0 s.

Query

```
SENSe[1]:TRACe:OFFSet:TIME?
```

The query returns the current delay between the delayed trigger point and the start of the trace.

Query example

```
SENS:TRAC:OFFS:TIME?
```

Queries the current delay between the delayed trigger point and the start of the trace.

Error message

If DET:FUNC is set to AVER, error -221, “Settings conflict” occurs.

SENSe[1]:TRACe:TIME <numeric_value>

This command sets the duration of the trace for the U2020 X-Series.

Syntax

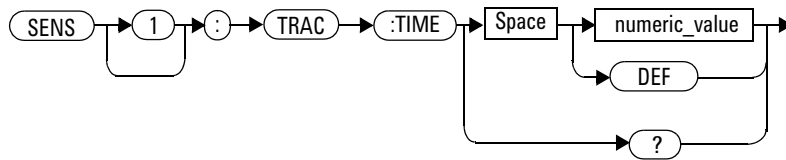

Parameters

Item	Description/Default	Range of values
numeric_value	The duration of the trace in seconds. • DEF: the default value is 100 μ s. Units are resolved to 12.5 ns.	25 ns to 1 s DEF

Example

`SENSe:TRACe:TIME 0.5` *Sets the duration of the trace to 0.5 s.*

Reset condition

On reset, the duration is set to 100 μ s.

Query

```
SENSe[1]:TRACe:TIME?
```

The query returns the current duration of the trace.

Query example

```
SENS:TRAC:TIME?
```

Queries the current duration of the trace.

Error message

If DET:FUNC is set to AVER, error -221, “Settings conflict” occurs.

[SENSe[1]:]TRACe:UNIT <character_data>

This command sets the unit for the trace.

Syntax

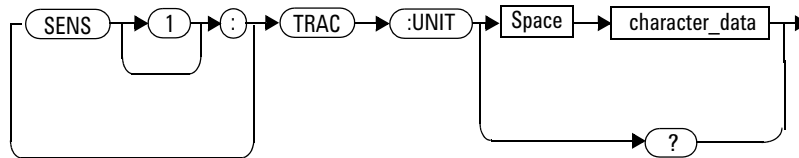

Parameters

Item	Description/Default	Range of values
character_data	<ul style="list-style-type: none"> DBM: dBm W: Watts 	DBM W

Example

```
TRAC:UNIT W
```

Sets the trace unit to Watts.

Reset condition

On reset, the unit is set to dBm.

Query

```
[SENSe[1]:]TRACe:UNIT?
```

The query command returns the current value of `character_data`.

Query example

```
TRAC:UNIT?
```

Queries the current trace unit.

THIS PAGE HAS BEEN INTENTIONALLY LEFT BLANK.

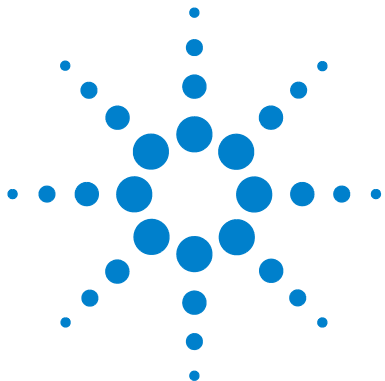

11 STATus Subsystem

STATus Subsystem	356
Status Register Set Commands	358
Device Status Register Sets	363
Operation Register Sets	364
STATus:OPERation	365
STATus:OPERation:CALibrating[:SUMMARY]	366
STATus:OPERation:LLFail[:SUMMARY]	367
STATus:OPERation:MEASuring[:SUMMARY]	368
STATus:OPERation:SENSe[:SUMMARY]	369
STATus:OPERation:TRIGger[:SUMMARY]	370
STATus:OPERation:ULFail[:SUMMARY]	371
STATus:PRESet	372
Questionable Register Sets	373
STATus:QUEStionable	374
STATus:QUEStionable:CALibration[:SUMMARY]	375
STATus:QUEStionable:POWer[:SUMMARY]	376

This chapter explains how the *STATus* command subsystem enables you to examine the status of the U2020 X-Series by monitoring the “Device Status Register”, “Operation Status Register”, and “Questionable Status Register”.



STATus Subsystem

The STATus command subsystem enables you to examine the status of the U2020 X-Series by monitoring the following status registers:

- Device status register
- Operation status register
- Questionable status register

The contents of these and other registers in the U2020 X-Series are determined by one or more status registers.

Table 11-1 summarizes the effects of various commands and events on these status registers:

Table 11-1 Commands and events affecting the status register

Status register	*RST	*CLS	Power on	STATus: PRESet
SCPI Transition Filters (NTR and PTR registers)	none	none	preset	preset
SCPI Enable Registers	none	none	preset	preset
SCPI Event Registers	none	clear	clear	none
SCPI Error/Event Queue enable	none	none	preset	preset
SCPI Error/Event Queue	none	clear	clear	none
IEEE 488.2 Registers ESE SRE	none	none	clear	none
IEEE 488.2 Registers ESR STB	none	clear	clear	none

The contents of the status registers are examined using the following status register set commands:

```
:CONDition?
:ENABle <NRf>|<non-decimal numeric>
[:EVENT?]
:NTRansition <NRf>|<non-decimal numeric>
:PTRansition <NRf>|<non-decimal numeric>
```

Each of these can be used to examine any of the following 11 status registers:

STATus:DEVIce (page 363)

STATus:OPERation (page 365)

STATus:OPERation:CALibrating[:SUMMARY] (page 366)

STATus:OPERation:LLFail[:SUMMARY] (page 367)

STATus:OPERation:MEASuring[:SUMMARY] (page 368)

STATus:OPERation:SENSe[:SUMMARY] (page 369)

STATus:OPERation:TRIGger[:SUMMARY] (page 370)

STATus:OPERation:ULFail[:SUMMARY] (page 371)

STATus:PRESet (page 372)

STATus:QUEStionable (page 374)

STATus:QUEStionable:CALibration[:SUMMARY] (page 375)

STATus:QUEStionable:POWer[:SUMMARY] (page 376)

Examples

- To use the :CONDition? command to examine the STATus:DEVIce register:

```
STATus:DEVIce:CONDition?
```

- To use the :NTRansition command to examine the STATus:OPERation:SENSe[:SUMMARY] register:

```
STATus:OPERation:SENSe[:SUMMARY]:NTRansition
```

This chapter describes the status register set commands and the status registers which they are used to examine.

Status Register Set Commands

This section describes the five status register set commands. Each can be used to examine all of the 11 status registers listed on [page 357](#).

To apply a command to a specific register, prefix the command with the name of the appropriate register. For example, to apply the `:ENABle` command to the `STATus:QUEStionable` register, use the following command:

```
STATus:QUEStionable:ENABle
```

:CONDition?

This query returns a 16-bit decimal-weighted number representing the bits set in the Condition Register of the SCPI Register Set you require to control. The format of the return is `<NR1>` in the range of 0 to 32767 ($2^{15}-1$). The contents of the Condition Register remain unchanged after it is read.

Syntax

.. → :COND → ? →

[:EVENTt]?

This query returns a 16-bit decimal-weighted number representing the bits set in the Event Register of the SCPI Register Set you require to control. The format of the return is `<NR1>` in the range of 0 to 32767 ($2^{15}-1$). This query clears all bits in the register to 0.

NOTE

`[:EVENTt]?` is the default command if the `STATus` SCPI is not accompanied by any of the Status Register Set commands (`:COND`, `:ENAB`, `:NTR`, and `:PTR`).

Syntax

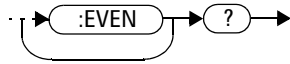

:ENABLE <NRf> | <non-decimal numeric>

This command sets the Enable Register of the particular SCPI Register Set you require to control. The parameter value, when rounded to an integer and expressed in base 2 has its first 15 bits written into the Enable Register of the SCPI Register Set concerned. The last bit (bit 15) is always set to 0.

Syntax

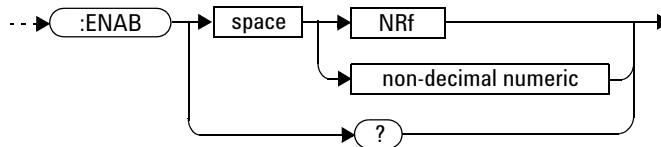

Parameters

Type	Description	Range of values
NRf	The value used to set the Enable Register.	0 to $2^{16}-1$
non-decimal numeric		

Query

:ENABle?

The query returns a 15-bit decimal-weighted number representing the contents of the Enable Register of the SCPI Register Set being queried. The format of the return is <NR1> in the range of 0 to 32767 ($2^{15}-1$).

:NTRansition <NRf> | <non-decimal numeric>

This command sets the Negative Transition Register of the SCPI Register Set you require to control. The parameter value, when rounded to an integer and expressed in base 2 has its first 15 bits written into the Negative Transition Register of the SCPI Register Set concerned. The last bit (bit 15) is always set to 0.

Syntax

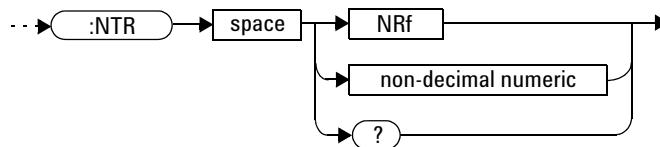

Parameters

Type	Description	Range of values
NRf	The value used to set the NTR Register.	0 to $2^{16}-1$
non-decimal numeric		

Query

:NTRansition?

The query returns a 15-bit decimal-weighted number representing the contents of the Negative Transition Register of the SCPI register set being queried. The format of the return is <NR1> in the range of 0 to 32767 ($2^{15}-1$).

:PTRansition <NRf> | <non-decimal numeric>

This command is used to set the Positive Transition Register of the SCPI Register Set you require to control. The first 15 bits of the input parameter are written into the Positive Transition Register of the SCPI Register Set concerned. The last bit (bit 15) is always set to 0.

Syntax

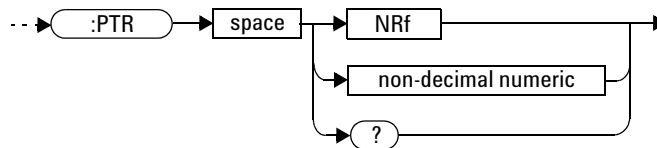

Parameters

Type	Description	Range of values
NRf	The value used to set the PTR Register.	0 to $2^{16}-1$
non-decimal numeric		

Query

:PTRansition?

The query returns a 15-bit decimal-weighted number representing the contents of the Positive Transition Register of the SCPI register set being queried. The format of the return is <NR1> in the range of 0 to 32767 ($2^{15}-1$).

Device Status Register Sets

The status registers contain information which give device status information. The contents of the individual registers of these register sets may be accessed by appending the commands listed in “[Status Register Set Commands](#)”.

The following command descriptions detail the SCPI register you require to control but do not detail the register set commands.

The one device status register set is:

STATus:DEVIce:

The following bit in these registers is used by the U2020 X-Series:

Bit number	Decimal weight	Definition
0 to 2	-	Not used
3	8	Sensor error
4 to 15	-	Not used (bit 15 is always 0)

The sensor error bit (3) is set to:

- 1, if the U2020 X-Series EEPROM has failed.
- 0, for every other condition.

Operation Register Sets

The following registers contain information which is part of the U2020 X-Series normal operation. The contents of the individual registers of these register sets may be accessed by appending the commands listed in “[Status Register Set Commands](#)”.

The following command descriptions detail the SCPI register you require to control but do not detail the Register Set commands.

The seven Operation Register Sets are:

```
STATus:OPERation
STATus:OPERation:CALibrating[:SUMMARY]
STATus:OPERation:LLFail[:SUMMARY]
STATus:OPERation:MEASuring[:SUMMARY]
STATus:OPERation:SENSe[:SUMMARY]
STATus:OPERation:TRIGger[:SUMMARY]
STATus:OPERation:ULFail[:SUMMARY]
```

Further information on these register sets is provided on the following pages.

STATus:OPERation

The operation status register set contains conditions which are a part of the operation of the U2020 X-Series as a whole.

The following bits in these registers are used by the U2020 X-Series:

Bit number	Decimal weight	Definition
0	1	CALibrating Summary
1 to 3	-	Not used
4	16	MEASuring Summary
5	32	Waiting for TRIGger Summary
6 to 9	-	Not used
10	1024	SENSE Summary
11	2048	Lower Limit Fail Summary
12	4096	Upper Limit Fail Summary
13 to 15	-	Not used (bit 15 is always 0)

Syntax

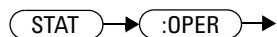

STATUS:OPERation:CALibrating[:SUMMARY]

The operation status calibrating summary register set contains information on the calibrating status of the U2020 X-Series.

The following bit in these registers is used by the U2020 X-Series:

Bit number	Decimal weight	Definition
0	-	Not used
1	2	CALibrating Status
2 to 15	-	Not used (bit 15 is always 0)

This bit is set at the beginning of zeroing (CALibration:ZERO:AUTO ONCE) and at the beginning of calibration (CALibration:AUTO ONCE). Also for the compound command/query CALibration[:ALL]?, this bit is set at the beginning of the calibration sequence.

This bit is cleared at the end of zeroing or calibration.

Syntax

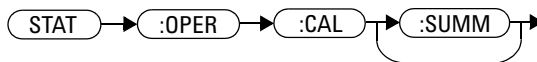

STATus:OPERation:LLFail[:SUMM]ary]

The operation status lower limit fail summary register set contains information on the lower limit fail status of the U2020 X-Series.

The following bits in these registers are used by the U2020 X-Series:

Bit number	Decimal weight	Definition
0	-	Not used
1	2	SENSe LLFail Status
2	-	Not used
3	8	CALCulate1 LLFail Status
4	16	CALCulate2 LLFail Status
5	32	CALCulate3 LLFail Status
6	64	CALCulate4 LLFail Status
7 to 15	-	Not used (bit 15 is always 0)

The appropriate bits are set if a lower limit test fails.

These bits are cleared if a measurement is made and the test is enabled and passes.

Syntax

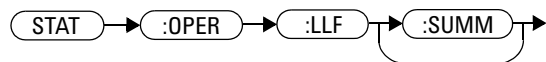

STATus:OPERation:MEASuring[:SUMM]ary]

The operation status measuring summary register set contains information on the measuring status of the U2020 X-Series.

The following bit in these registers is used by the U2020 X-Series:

Bit number	Decimal weight	Definition
0	-	Not used
1	2	MEASuring Status
2 to 15	-	Not used (bit 15 is always 0)

This bit is set when the U2020 X-Series is taking a measurement, and is cleared when the measurement has completed.

Syntax

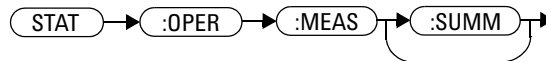

STATus:OPERation:SENSe[:SUMM]ary]

The operation status sense summary register set contains information on the status of the U2020 X-Series.

The following bit in these registers is used by the U2020 X-Series:

Bit number	Decimal weight	Definition
0	-	Not used
1	2	SENSe Status
2 to 15	-	Not used (bit 15 is always 0)

This bit is set when the U2020 X-Series is reading data from the EEPROM, and is cleared when the U2020 X-Series is not reading data from the EEPROM.

Syntax

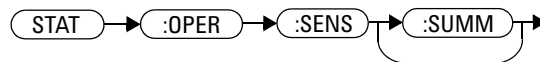

STATus:OPERation:TRIGger[:SUMMary]

The operation status trigger summary register set contains information on the trigger status of the U2020 X-Series.

The following bit in these registers is used by the U2020 X-Series:

Bit number	Decimal weight	Definition
0	-	Not used
1	2	TRIGger Status
2 to 15	-	Not used (bit 15 is always 0)

This bit is set when the U2020 X-Series enters the “wait for trigger” state, and is cleared when the U2020 X-Series enters the “idle” state.

Syntax

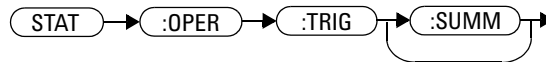

STATus:OPERation:ULFail[:SUMMary]

The operation status upper limit fail summary register set contains information on the upper limit fail status of the U2020 X-Series.

The following bits in these registers are used by the U2020 X-Series:

Bit number	Decimal weight	Definition
0	-	Not used
1	2	SENSe ULFail Status
2	-	Not used
3	8	CALCulate1 ULFail Status
4	16	CALCulate2 ULFail Status
5	32	CALCulate3 ULFail Status
6	64	CALCulate4 ULFail Status
7 to 15	-	Not used (bit 15 is always 0)

The appropriate bits are set if an upper limit test fails.

These bits are cleared if a measurement is made and the test is enabled and passes.

Syntax

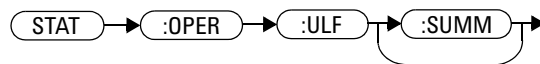

STATUS:PRESet

PRESet sets a number of the status registers to their preset values as shown below – all other registers are unaffected. Bit 15 is always 0.

Register	Filter/Enable	PRESet value
OPERational	ENABLE	all zeros
	PTR	all ones
	NTR	all zeros
QUEStionable	ENABLE	all zeros
	PTR	all ones
	NTR	all zeros
DEVice	ENABLE	all zeros
	PTR	all ones
	NTR	all zeros
All Others	ENABLE	all ones
	PTR	all ones
	NTR	all zeros

Syntax



Questionable Register Sets

The questionable register sets contain information which gives an indication of the quality of the data produced by the U2020 X-Series. The contents of the individual registers in these register sets may be accessed by appending the commands listed in “[Status Register Set Commands](#)”.

The following command descriptions detail the SCPI register you require to control but do not detail the register set commands.

The three questionable register sets are:

```
STATus:QUEStionable
```

```
STATus:QUEStionable:CALibration[:SUMMary]
```

```
STATus:QUEStionable:POWer[:SUMMary]
```

STATUS:QUESTIONABLE

The questionable register set contains information that indicates the quality of various aspects of signals processed by the U2020 X-Series.

The following bits in these registers are used by the U2020 X-Series:

Bit number	Decimal weight	Definition
0 to 2	-	Not used
3	8	POWER Summary
4 to 7	-	Not used
8	256	CALibration Summary
9	512	Power-On Self-Test
10 to 15	-	Not used (bit 15 is always 0)

Bit 3 is set by the logical OR outputs of the `STATUS:QUESTIONABLE:POWER[:SUMMARY]` register set.

Bit 8 is set by the logical OR outputs of the `STATUS:QUESTIONABLE:CALIBRATION[:SUMMARY]` register set.

Bit 9 is set if the power-on self-test fails, and cleared if it passes.

Syntax

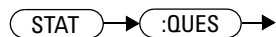

STATus:QUEStionable:CALibration[:SUMMary]

The questionable calibration summary register set contains information which gives an indication of the quality of the data produced by the U2020 X-Series due to its calibration status.

The following bit in these registers is used by the U2020 X-Series:

Bit number	Decimal weight	Definition
0	-	Not used
1	2	Summary of CALibration
2 to 15	-	Not used (bit 15 is always 0)

This bit is set by the following:

- Error -231, “Data questionable;ZERO ERROR”
- Error -231, “Data questionable;CAL ERROR”

This bit is cleared when any of the above conditions succeeds and no errors are placed on the error queue.

Syntax

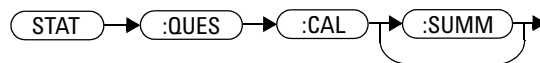

STATUS:QUESTIONABLE:POWER[:SUMMARY]

The questionable power summary register set contains information that indicates the quality of the power data being acquired by the U2020 X-Series.

The following bits in these registers are used by the U2020 X-Series:

Bit number	Decimal weight	Definition
0	-	Not used
1	2	SENSe POWer
2	-	Not used
3	8	CALCulate1 POWer
4	16	CALCulate2 POWer
5	32	CALCulate3 POWer
6	64	CALCulate4 POWer
7 to 15	-	Not used (bit 15 is always 0)

Bit 1 is set when the following error occurs:

- Error -231, “Data questionable;Input Overload”

Bit 3, 4, 5, or 6 is set appropriately when the following errors occur:

- Error -230, “Data corrupt or stale”
- Error -231, “Data questionable;CALC1 log error”
- Error -231, “Data questionable;CALC2 log error”
- Error -231, “Data questionable;CALC3 log error”
- Error -231, “Data questionable;CALC4 log error”

These bits are cleared when no errors or events are detected by the U2020 X-Series during a measurement covering the causes given for it to set.

Syntax

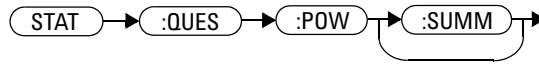

Status Block Diagram

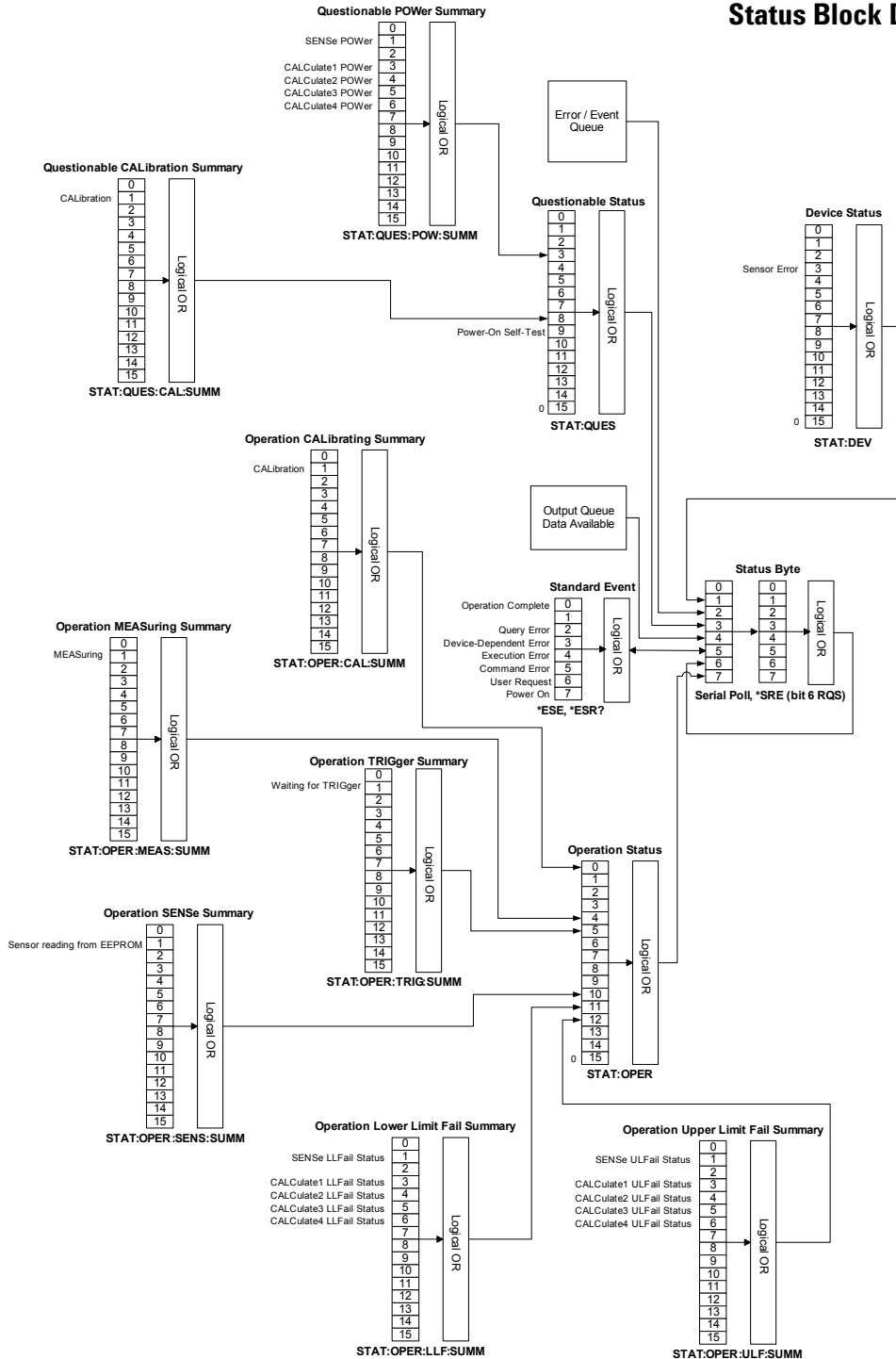



12 SYSTem Subsystem

SYSTem Subsystem	380
SYSTem:ERRor?	381
SYSTem:HELP:HEADers?	387
SYSTem:PRESet <character_data>	388
SYSTem:VERSion?	433

This chapter explains how to use the SYSTem command subsystem to return error numbers and messages from the U2020 X-Series, preset the U2020 X-Series, and query the SCPI version.



SYSTem Subsystem

The `SYSTem` command subsystem is used to:

- return error numbers and messages from the U2020 X-Series.
- preset the U2020 X-Series.
- return all the SCPI commands supported by the U2020 X-Series.
- query the SCPI version.

SYSTem:ERRor?

This query returns error numbers and messages from the U2020 X-Series error queue. When an error is generated by the U2020 X-Series, it stores an error number and its corresponding message in the error queue. One error is removed from the error queue each time this command is executed. The errors are cleared in the order of first-in first-out, that is, the oldest errors are cleared first. To clear all the errors from the error queue, execute the *CLS command. When the error queue is empty, subsequent SYSTem:ERRor? queries return a +0, “No error” message. The error queue has a maximum capacity of 30 errors.

Syntax

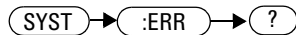

Example

SYST:ERR?

Queries the oldest error message stored in the U2020 X-Series error queue.

Reset condition

On reset, the error queue is unaffected.

Error message

If the error queue overflows, the last error is replaced with -350, “Queue overflow”. No additional errors are accepted by the queue until space becomes available.

Error message list

-56	<p>System error. Invalid sensor model number.</p> <p>An invalid sensor model number is found in the U2020 X-Series EEPROM.</p>
-101	<p>Invalid character</p> <p>An invalid character was found in the command string. You may have inserted a character such as #, \$, or % in the command header or within a parameter.</p> <p>For example, LIM:LOW 0#.</p>
-102	<p>Syntax error</p> <p>Invalid syntax was found in the command string.</p> <p>For example, AVER:COUN: AUTO 1.</p>
-103	<p>Invalid separator</p> <p>An invalid separator was found in the command string. You may have used a comma instead of a colon, semicolon, or blank space; or you may have used a blank space instead of a comma.</p> <p>For example, OUTP:TRIG,1.</p>
-105	<p>GET not allowed</p> <p>A Group Execute Trigger (GET) is not allowed within a command string.</p>
-108	<p>Parameter not allowed</p> <p>More parameters were received than expected for the command. You may have entered an extra parameter, or added a parameter to a command that does not accept a parameter.</p> <p>For example, CAL 10.</p>
-109	<p>Missing parameter</p> <p>Fewer parameters were received than expected for the command. You may have omitted one or more parameters that are required for this command.</p> <p>For example, AVER:COUN.</p>
-112	<p>Program mnemonic too long</p> <p>A command header was received which contained more than the maximum 12 characters allowed.</p> <p>For example, SENSEAVERageCOUNT 8.</p>
-113	<p>Undefined header</p> <p>A command was received that is not valid for the U2020 X-Series. You may have misspelled the command, it may not be a valid command, or you may have the wrong interface selected. If you are using the short form of the command, remember that it may contain up to four letters.</p> <p>For example, TRIG:SOUR0 IMM.</p>

-121	<p>Invalid character in number An invalid character was found in the number specified for a parameter value. For example, SENS:AVER:COUN 128#H.</p>
-123	<p>Exponent too large A numeric parameter was found whose exponent was larger than 32000. For example, SENS:AVER:COUN 1E34000.</p>
-124	<p>Too many digits A numeric parameter was found whose mantissa contained more than 255 digits, excluding leading zeros.</p>
-128	<p>Numeric data not allowed A numeric value was received within a command which does not accept a numeric value. For example, MEM:CLE 24.</p>
-131	<p>Invalid suffix A suffix was incorrectly specified for a numeric parameter. You may have misspelled the suffix. For example, SENS:FREQ 200KZ.</p>
-134	<p>Suffix too long A suffix used contained more than 14 characters. For example, SENS:FREQ 2MHZZZZZZZZZZZZ.</p>
-138	<p>Suffix not allowed A suffix was received following a numeric parameter which does not accept a suffix. For example, INIT:CONT 0Hz.</p>
-148	<p>Character data not allowed A discrete parameter was received but a character string or a numeric parameter was expected. Check the list of parameters to verify that you have used a valid parameter type. For example, MEM:CLE CUSTOM_1.</p>
-151	<p>Invalid string data An invalid string was received. Check to see if you have enclosed the character string in single or double quotes. For example, MEM:CLE "CUSTOM_1".</p>
-158	<p>String data not allowed A character string was received but is not allowed for the command. Check the list of parameters to verify that you have used a valid parameter type. For example, SENS:AVER:COUN:AUTO 'ON'.</p>
-161	<p>Invalid block data A block data element was expected but was invalid for some reason. For example, *DDT #15FET. The 5 in the string indicates that 5 characters should follow, whereas in this example there are only 3.</p>

-211	<p>Trigger ignored</p> <p>Indicates that *TRG or TRIG:IMM was received and recognized by the U2020 X-Series but was ignored because the U2020 X-Series was not in the wait-for-trigger state.</p>
-213	<p>Init ignored</p> <p>Indicates that a request for measurement initiation was ignored as the U2020 X-Series was already initiated.</p> <p>For example, INIT:CONT ON INIT.</p>
-214	<p>Trigger deadlock</p> <p>TRIG:SOUR was set to HOLD or BUS, and a READ? or MEASure? was attempted, expecting TRIG:SOUR to be set to IMMEDIATE.</p>
-220	<p>Parameter error;Frequency list must be in ascending order.</p> <p>Indicates that frequencies entered using the MEMory:TABLE:FREquency command are not in the ascending order.</p>
-221	<p>Settings conflict</p> <p>This message occurs under a variety of conflicting conditions. The following list gives a few examples of where this error may occur:</p> <ul style="list-style-type: none"> • If the READ? parameters do not match the current settings. • If you are in the fast mode and attempting to switch on for example, averaging or limits. • Trying to clear a frequency-dependent offset table when none is selected.
-222	<p>Data out of range</p> <p>A numeric parameter value is outside the valid range for the command.</p> <p>For example, SENS:FREQ 1HZ.</p>
-224	<p>Illegal parameter value</p> <p>A discrete parameter was received which was not a valid choice for the command. You may have used an invalid parameter choice.</p> <p>For example, TRIG:SOUR EX.</p>
-226	<p>Lists not same length</p> <p>This occurs when SENSE:CORrection:CSET2:STATe is set to ON and the frequency and offset lists do not correspond in length.</p>
-230	<p>Data corrupt or stale</p> <p>This occur when the trace data return is invalid.</p>
-231	<p>Data questionable;CAL ERROR</p> <p>The U2020 X-Series calibration failed.</p>
-231	<p>Data questionable;Input Overload</p> <p>The power input to the U2020 X-Series exceeds the maximum range.</p>

-231	Data questionable;CALC1 log error This indicates that a difference measurement in the CALCulate1 block has given a negative result when the units of measurement were logarithmic.
-231	Data questionable;CALC2 log error This indicates that a difference measurement in the CALCulate2 block has given a negative result when the units of measurement were logarithmic.
-231	Data questionable;CALC3 log error This indicates that a difference measurement in the CALCulate3 block has given a negative result when the units of measurement were logarithmic.
-231	Data questionable;CALC4 log error This indicates that a difference measurement in the CALCulate4 block has given a negative result when the units of measurement were logarithmic.
-231	Data questionable;ZERO ERROR The U2020 X-Series zeroing failed.
-310	System error;Sensor EEPROM Read Failed - critical data not found or unreadable This indicates a failure with the U2020 X-Series. Refer to the manual for details on returning it for repair.
-310	System error;Sensor EEPROM Read Completed OK but optional data block(s) not found or unreadable This indicates a failure with the U2020 X-Series. Refer to the manual for details on returning it for repair.
-310	System error;Sensor EEPROM Read Failed - unknown EEPROM table format This indicates a failure with the U2020 X-Series. Refer to the manual for details on returning it for repair.
-310	System error;Sensor EEPROM < > data not found or unreadable Where < > refers to the sensor data block covered, for example, Linearity, Temp - Comp (temperature compensation). This indicates a failure with the U2020 X-Series. Refer to the manual for details on returning it for repair.
-321	Out of memory The U2020 X-Series required more memory than was available to run an internal operation.
-330	Self-test Failed; The -330, "Self-test Failed" errors indicate that you have a problem with the U2020 X-Series. Refer to the service guide for details of what to do with your faulty U2020 X-Series.
-330	Self-test Failed;RAM SelfTest Failed
-330	Self-test Failed;Flash SelfTest Failed
-330	Self-test Failed;Peak Path SelfTest Failed

-330	Self-test Failed;IPC SelfTest Failed
-330	Self-test Failed;Meas Path SelfTest Failed
-350	Queue overflow The error queue is full and another error has occurred which could not be recorded.
-410	Query INTERRUPTED A command was received which sends data to the output buffer, but the output buffer contained data from a previous command (the previous data is not overwritten). The output buffer is cleared when power has been turned off, or after the *RST (reset) command has been executed.
-420	Query UNTERMINATED The U2020 X-Series was addressed to talk (that is, to send data over the interface) but a command has not been received which sends data to the output buffer. For example you may have executed a CONFIGure command (which does not generate data) and then attempted to read data from the remote interface.
-430	Query DEADLOCKED A command was received which generates too much data to fit in the output buffer and the input buffer is also full. Command execution continues but data is lost.
-440	Query UNTERMINATED after indefinite response The *IDN? command must be the last query command within a command string.

SYSTEM:HELP:HEADers?

This query returns a list of all SCPI commands supported by the U2020 X-Series.

Data is returned in the IEEE-488.2 arbitrary block program data format as shown in Figure 12-1 below.

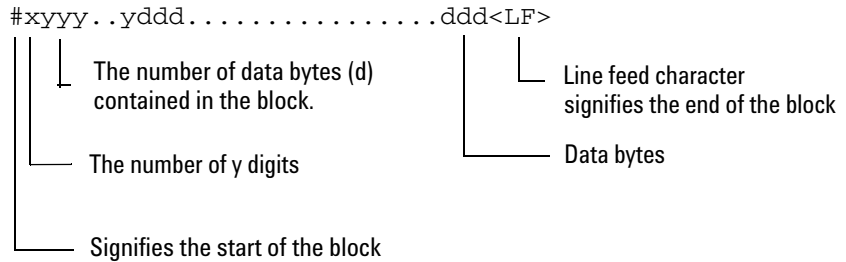

Example: if there are 12435 data bytes, y = 12435 and x = 5

Figure 12-1 IEEE-488.2 arbitrary block program data format

Each point in the trace is represented as an IEEE-754 32-bit floating point number, made up of four bytes in the data block. The MS byte is transmitted first. Each complete block is terminated by a line feed.

Commands are listed in alphabetical order.

Syntax



Example

SYST:HELP:HEAD?

Returns the SCPI commands supported by the U2020 X-Series.

SYSTem:PRESet <character_data>

This command presets the U2020 X-Series to values appropriate for measuring the communications format specified by <character_data>. The U2020 X-Series is preset to default values if no value or the value DEFault is supplied.

NOTE

DEFault settings apply to both *RST and SYSTem:PRESet DEFault unless stated otherwise.

Syntax

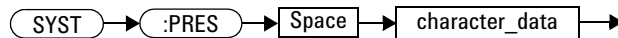

Parameters

Item	Description	Range of values
character_data	A communications format which determines the preset values. Refer to “DEFault” on page 390 onwards for a general description of some of these formats.	DEFault GSM900 EDGE NADC BLUetooth CDMAone WCDMA CDMA2000 IDEN MCPa RADar WL802DOT11A WL802DOT11B XEVDO XEVDV TDSCdma DVB HIPERLAN2 WIMAX HSDPA DME DMEPRT LTE

Example

SYST:PRES DEF

Presets the U2020 X-Series to default values. The same default values are set when the parameter is omitted.

Preset values

DEFault

Table 12-1 shows the U2020 X-Series presets when <character_data> is set to DEFault or omitted.

Table 12-1 DEFault: U2020 X-Series presets

Command	Setting	Comments
CALC [1] 2 3 4 : FEED [1] 2	"POW:AVER"	Select average measurement type
CALC [1] 2 3 4 : GAIN [: MAGN]	0.000 dB	Calc offset value
CALC [1] 2 3 4 : GAIN : STAT	OFF	Calc offset disabled
CALC [1] 2 3 4 : LIM : CLE : AUTO	ON	Clear limit data at INIT
CALC [1] 2 3 4 : LIM : LOW [: DATA]	-90 dBm	Lower limit
CALC [1] 2 3 4 : LIM : STAT	OFF	Calc limits checking disabled
CALC [1] 2 3 4 : LIM : UPP [: DATA]	+90 dBm	
CALC [1] 2 3 4 : MATH [: EXPR]	Sens1	Math expression
CALC [1] 2 3 4 : REL [: MAGN] : AUTO	OFF	Reference value disabled
CALC [1] 2 3 4 : REL : STAT	OFF	Relative offset disabled
FORM [: READ] : BORD	normal	Binary order
FORM [: READ] [: DATA]	ascii	Data format
INIT [1] : CONT	*RST: OFF SYS: PRES ON	U2020 X-Series in idle state U2020 X-Series in wait for trigger state
MEM : TABL : SEL	not affected	Active sensor calibration table
OUTP : REC [1] : FEED	not affected	Previous measurement
OUTP : REC [1] : LIM : LOW	-150 dBm	Minimum scaling value
OUTP : REC [1] : LIM : UPP	20 dBm	Maximum scaling value
OUTP : REC : STAT	OFF	50 MHz reference disabled
OUTP : TRIG : STAT	OFF	Trigger output signal disabled
[SENS [1] :] AVER : COUN	4	Filter length
[SENS [1] :] AVER : COUN : AUTO	ON	Auto-filtering enabled
[SENS [1] :] AVER : SDET	1	Step detection enabled
[SENS [1] :] AVER [: STAT]	ON	Averaging enabled
[SENS [1] :] AVER2 : COUN	4	Video average length

Table 12-1 DEFault: U2020 X-Series presets (continued)

Command	Setting	Comments
[SENS[1]:]AVER2[:STAT]	OFF	Video averaging disabled
[SENS[1]:]BAND BWID:VID	OFF	Sensor video bandwidth set to off
[SENS[1]:]CORR:CSET2[:SEL]	not affected	Selected sensor calibration table
[SENS[1]:]CORR:CSET2:STAT	not affected	Sensor calibration table disabled
[SENS[1]:]CORR:FDOF GAIN4[:INP][:MAGN]	not affected	Return frequency dependent offset
[SENS[1]:]CORR:GAIN2:STAT	OFF	Channel offset disabled
[SENS[1]:CORR:GAIN2[:INP][:MAGN]	0.0 dB	Enter channel offset value
[SENS[1]:]DET:FUNC	NORM	Measurement mode
[SENS[1]:]FREQ[:CW :FIX]	+50.000 MHz	Frequency setting
[SENS[1]:]LIST:STAT	OFF	List mode
[SENS[1]:]LIST:MTYP	AVER	List mode select average measurement type
[SENS[1]:]MRAT	NORM	Measurement speed
[SENS[1]:]SPE	20 readings/second	Speed
[SENS[1]:]SWE[1] 2 3 4:OFFS:TIME	0	Set delay
[SENS[1]:]SWE[1] 2 3 4:TIME	Gate 1: 100 μ s Other gates: 0 s	Set time gated period
[SENS[1]:]TRAC:OFFS:TIME	0	Delay
[SENS[1]:]TRAC:TIME	100 μ s	Duration of trace
TRAC[1]:STAT	OFF	Disable trace capture
TRAC[1]:UNIT	dBm	Trace units
TRIG[1]:DEL:AUTO	ON	Insert settling time delay
TRIG[:SEQ]:DEL	0	Delay between recognition of trigger event and start of a measurement
TRIG[:SEQ]:HOLD	1 μ s	Trigger holdoff
TRIG[:SEQ]:HYST	0 dB	Fall/rise below/above TRIG:LEV
TRIG[:SEQ]:LEV	0 dB	Power level
TRIG[:SEQ]:LEV:AUTO	ON	Enable automatic setting of trigger level
TRIG[:SEQ]:SLOP	POS	Trigger event recognized on rising edge
TRIG[:SEQ[1]]:COUN	1	Trigger events for measurement cycle

Table 12-1 DEFault: U2020 X-Series presets (continued)

Command	Setting	Comments
TRIG[:SEQ[1]]:DEL:AUTO	ON	Enable settling time delay
TRIG[:SEQ[1]]:SOUR	IMM	Trigger source setup
TRIG[:SEQ[1]]:QUAL:TIME	100 ns	Qualification time for stable triggering
UNIT[1] 2 3 4:POW	dBm	Power units
UNIT[1] 2 3 4:POW:RAT	dB	Ratio units

GSM900

The GSM900 setup returns the average power measurement in one GSM time slot, when queried by CALC1.

A GSM900 measurement is started by detecting the rising edge of a GSM RF burst—for example the burst emitted by a GSM mobile—using the internal RF level trigger. The trigger level is set to -15 dBm. Time gating is used to measure the average power in the useful part of a GSM burst.

Table 12-2 GSM900: U2020 X-Series presets

Command	Setting	Comments
<i>Frequency</i>		
[SENS[1]:]FREQ[:CW]:FIX]	+900.000 MHz	Frequency setting
<i>Sensor measurement mode</i>		
[SENS[1]:]DET:FUNC	NORM	Measurement mode
<i>Sensor video bandwidth setup</i>		
[SENS[1]:]BAND BWID:VID	LOW	Sensor video bandwidth
<i>Gate setup</i>		
[SENS[1]:]SWE[1] 2 3 4:OFF:TIME	Gate 1: 20 μ s Gates 2 – 4: 0	Delay between trigger point and time gated period
[SENS[1]:]SWE[1] 2 3 4:TIME	Gate 1: 520 μ s Gates 2 – 4: 0	Length of time gated period for time gated measurements

Table 12-2 GSM900: U2020 X-Series presets (continued)

Command	Setting	Comments
<i>Trigger setup</i>		
TRIG[:SEQ[1]]:SOUR	INT1	Trigger source setup and acquisition mode continuous triggering
INIT:CONT	ON	
TRIG[:SEQ]:LEV:AUTO	OFF	Disable automatic setting of the trigger level
TRIG[:SEQ]:LEV	-15 dBm	Power level
TRIG[:SEQ]:SLOP	POS	Trigger event recognized on the rising edge of a signal
TRIG[:SEQ]:DEL	20 μs	Delay between recognition of trigger event and start of a measurement
TRIG[:SEQ]:HOLD	4275 μs	Trigger holdoff
TRIG[:SEQ[1]]:QUAL:TIME	20 μs	Qualification time for stable triggering
<i>Step detection</i>		
[SENS[1]:]AVER:SDET	1	Step detection enabled
<i>Trace setup</i>		
SENSe[1]:TRAC:LIM:UPP	+20 dBm	Maximum power
SENSe[1]:TRAC:LIM:LOW	-35 dBm	Minimum power
[SENS[1]:]TRAC:OFFS:TIME <numeric_value>	-40 μs	Delay between delayed trigger point and the start of the trace
[SENS[1]:]TRAC:TIME <numeric_value>	700 μs	Length of the trace

Table 12-3 GSM900: U2020 X-Series presets for calc setup

Command	Setting
<i>Calc setup</i>	
Calc1 feed	Gate 1
Calc1 measurement	Average
Calc2 feed	Gate 1
Calc2 measurement	Average

Table 12-3 GSM900: U2020 X-Series presets for calc setup (continued)

Command	Setting
Calc3 feed	Gate 1
Calc3 measurement	Average
Calc4 feed	Gate 1
Calc4 measurement	Average

EDGE

EDGE (Enhanced Data for Global Evolution or Enhanced Data for GSM Evolution) is an enhancement of the GSM standard. Whereas the GSM modulation scheme is GMSK which has constant amplitude, the EDGE modulation scheme is 8PSK which has variable amplitude.

The EDGE setup returns the following measurement results:

- Average power measurement in an EDGE burst, when queried by CALC1.
- Peak-to-average ratio in an EDGE burst, when queried by CALC4.

An EDGE measurement is started by detecting the rising edge of the EDGE RF burst—for example the burst emitted by a mobile—using the internal RF level trigger. The internal level trigger is set to -15 dBm. Trigger level hysteresis is used to prevent the U2020 X-Series re-triggering on the varying power levels within the EDGE burst. Time gating is used to measure the average power and peak-to-average ratio in the useful part of the RF burst.

Table 12-4 EDGE: U2020 X-Series presets

Command	Setting	Comments
<i>Frequency</i>		
[SENS[1]:]FREQ[:CW]:FIX]	+900.000 MHz	Frequency setting
<i>Sensor measurement mode</i>		
[SENS[1]:]DET:FUNC	NORM	Measurement mode
<i>Sensor video bandwidth setup</i>		
[SENS[1]:]BAND BWID:VID	LOW	Sensor video bandwidth

Table 12-4 EDGE: U2020 X-Series presets (continued)

Command	Setting	Comments
<i>Gate setup</i>		
[SENS[1]:]SWE[1] 2 3 4:OFFS:TIME	Gate 1: 20 μ s Gates 2 – 4: 0	Delay between trigger point and time gated period
[SENS[1]:]SWE[1] 2 3 4:TIME	Gate 1: 520 μ s Gates 2 – 4: 0	Length of time gated period for time gated measurements
<i>Trigger setup</i>		
TRIG[:SEQ[1]]:SOUR	INT1	Trigger source setup and acquisition mode continuous triggering
INIT:CONT	ON	
TRIG[:SEQ]:LEV:AUTO	OFF	Disable automatic setting of the trigger level
TRIG[:SEQ]:LEV	-15 dBm	Power level
TRIG[:SEQ]:SLOP	POS	Trigger event recognized on the rising edge of a signal
TRIG[:SEQ]:DEL	0 s	Delay between recognition of trigger event and start of a measurement
TRIG[:SEQ]:HOLD	4275 μ s	Trigger holdoff
TRIG[:SEQ]:HYST	3 dB	Hysteresis
<i>Averaging</i>		
[SENS[1]:]AVER[:STATe]	ON	Averaging on
[SENS[1]:]AVER:COUN	64	Averaging set to 64
TRIG[:SEQ[1]]:QUAL:TIME	20.25 μ s	Qualification time for stable triggering
<i>Step detection</i>		
[SENS[1]:]AVER:SDET	1	Step detection enabled
<i>Trace setup</i>		
SENS[1]:TRAC:LIM:UPP	+20 dBm	Maximum power
SENS[1]:TRAC:LIM:LOW	-35 dBm	Minimum power
[SENS[1]:]TRAC:OFFS:TIME <numeric_value>	-40 μ s	Delay between delayed trigger point and the start of the trace
[SENS[1]:]TRAC:TIME <numeric_value>	700 μ s	Length of the trace

Table 12-5 EDGE: U2020 X-Series presets for calc setup

Command	Setting
<i>Calc setup</i>	
Calc1 feed	Gate 1
Calc1 measurement	Average
Calc2 feed	Gate 1
Calc2 measurement	Average
Calc3 feed	Gate 1
Calc3 measurement	Average
Calc4 feed	Gate 1
Calc4 measurement	Peak to average

NADC

The NADC setup returns the average power measurement of both active time slots in NADC or IS-136 "full rate" transmission, when using both CALC1 and CALC4 respectively.

This assumes that there are two time slots to be measured in each frame, as for example with time slots 0 in the following diagram:

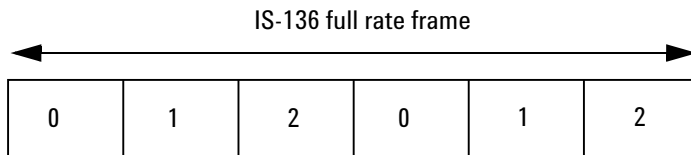

The measurement is started by detecting the RF burst—for example, the burst emitted by a mobile—using the internal RF level trigger. The internal level trigger is set to -15 dBm. Time gating is used to measure the average power in two active time slots which are separated by two inactive time slots.

Table 12-6 NADC: U2020 X-Series presets

Command	Setting	Comments
<i>Frequency</i>		
[SENS[1]:]FREQ[:CW :FIX]	+800.000 MHz	Frequency setting
<i>Sensor measurement mode</i>		
[SENS[1]:]DET:FUNC	NORM	Measurement mode
<i>Sensor video bandwidth setup</i>		
[SENS[1]:]BAND BWID:VID	OFF	Sensor video bandwidth
<i>Gate setup</i>		
[SENS[1]:]SWE[1] 2 3 4:OFF:TIME	Gate 1: 123.5 μ s Gate 2: 20.123 ms Gates 3 – 4: 0	Delay between trigger point and time gated period
[SENS[1]:]SWE[1] 2 3 4:TIME	Gate 1: 6.46 ms Gate 2: 6.46 ms Gates 3 – 4: 0	Length of time gated period for time gated measurements
<i>Trigger setup</i>		
TRIG[:SEQ[1]]:SOUR	INT1	Trigger source setup and acquisition mode continuous triggering
INIT:CONT	ON	
TRIG[:SEQ]:LEV:AUTO	OFF	Disable automatic setting of the trigger level
TRIG[:SEQ]:LEV	-15 dBm	Power level
TRIG[:SEQ]:SLOP	POS	Trigger event recognized on the rising edge of a signal
TRIG[:SEQ]:DEL	0 s	Delay between recognition of trigger event and start of a measurement
TRIG[:SEQ]:HOLD	30 ms	Trigger holdoff
TRIG[:SEQ[1]]:QUAL:TIME	100 ns	Qualification time for stable triggering
<i>Step detection</i>		
[SENS[1]:]AVER:SDET	1	Step detection enabled
<i>Trace setup</i>		
SENS[1]:TRAC:LIM:UPP	+20 dBm	Maximum power
SENS[1]:TRAC:LIM:LOW	-35 dBm	Minimum power

Table 12-6 NADC: U2020 X-Series presets (continued)

Command	Setting	Comments
[SENS[1]:]TRAC:OFFS:TIME <numeric_value>	-0.2 ms	Delay between delayed trigger point and the start of the trace
[SENS[1]:]TRAC:TIME <numeric_value>	28 ms	Length of the trace

Table 12-7 NADC: U2020 X-Series presets for calc setup

Command	Setting
<i>Calc setup</i>	
Calc1 feed	Gate 1
Calc1 measurement	Average
Calc2 feed	Gate 1
Calc2 measurement	Average
Calc3 feed	Gate 1
Calc3 measurement	Average
Calc4 feed	Gate 1
Calc4 measurement	Average

BLUetooth

The BLUetooth setup returns the following measurement results:

- Average power in a Bluetooth DH1 data burst, when queried by CALC1.
- Peak power in the same burst, when queried by CALC4.

The measurement is started by detecting the Bluetooth RF burst using the internal RF level trigger. The internal trigger is set to -15 dBm. Time gating is used to measure the peak and average power in a single Bluetooth DHI data burst which lasts for 366 μ s. The DHI burst does not occupy a full Bluetooth time slot, which lasts for 625 μ s.

Table 12-8 BLUetooth: U2020 X-Series presets

Command	Setting	Comments
<i>Frequency</i>		
[SENS[1]:]FREQ[:CW :FIX]	+2400.000 MHz	Frequency setting
<i>Sensor measurement mode</i>		
[SENS[1]:]DET:FUNC	NORM	Measurement mode
<i>Sensor video bandwidth setup</i>		
[SENS[1]:]BAND BWID:VID	OFF	Sensor video bandwidth
<i>Gate setup</i>		
[SENS[1]:]SWE[1] 2 3 4:OFF:TIME	Gate 1: 0.2 μ s Gates 2 – 4: 0	Delay between trigger point and time gated period
[SENS[1]:]SWE[1] 2 3 4:TIME	Gate 1: 366 μ s Gates 2 – 4: 0	Length of time gated period for time gated measurements
<i>Trigger setup</i>		
TRIG[:SEQ[1]]:SOUR	INT1	Trigger source setup and acquisition mode continuous triggering
INIT:CONT	ON	
TRIG[:SEQ]:LEV:AUTO	OFF	Disable automatic setting of the trigger level
TRIG[:SEQ]:LEV	-15 dBm	Power level
TRIG[:SEQ]:SLOP	POS	Trigger event recognized on the rising edge of a signal
TRIG[:SEQ]:DEL	0 s	Delay between recognition of trigger event and start of a measurement
TRIG[:SEQ]:HOLD	650 μ s	Trigger holdoff
TRIG[:SEQ[1]]:QUAL:TIME	100 ns	Qualification time for stable triggering
<i>Step detection</i>		
[SENS[1]:]AVER:SDET	1	Step detection enabled
<i>Trace setup</i>		
SENS[1]:TRAC:LIM:UPP	+20 dBm	Maximum power
SENS[1]:TRAC:LIM:LOW	-35 dBm	Minimum power
[SENS[1]:]TRAC:OFFS:TIME <numeric_value>	-50 μ s	Delay between delayed trigger point and the start of the trace

Table 12-8 BLUetooth: U2020 X-Series presets (continued)

Command	Setting	Comments
[SENS[1]:]TRAC:TIME <numeric_value>	3.8 ms	Length of the trace

Table 12-9 BLUetooth: U2020 X-Series presets for calc setup

Command	Setting
<i>Calc setup</i>	
Calc1 feed	Gate 1
Calc1 measurement	Average
Calc2 feed	Gate 1
Calc2 measurement	Average
Calc3 feed	Gate 1
Calc3 measurement	Average
Calc4 feed	Gate 1
Calc4 measurement	Peak

CDMAone

The CDMAone setup returns the following measurement results:

- Average power in an IS-95 CDMAone signal (bandwidth <1.5 MHz), when queried by CALC1.
- Peak power, when queried by CALC2.
- Peak-to-average ratio of the signal over a defined, statistically valid number of samples, when queried by CALC4.

The measurement is a continuously gated measurement on a CDMAone signal. Its aim is to measure the peak and average power corresponding to a <0.01% probability that there are no peaks above the returned peak reading. Time gating is therefore set to 10 ms. Triggering is set to occur continuously internally to the U2020 X-Series. The internal trigger is set to AutoLevel. A reading over the 10 ms period is returned and the reading is then re-initiated for the next 10 ms period. In this way, the reading always relates to a position beyond 0.01% on the CCDF curve and will refresh to track any signal or DUT changes.

Table 12-10 CDMAone: U2020 X-Series presets

Command	Setting	Comments
<i>Frequency</i>		
[SENS[1]:]FREQ[:CW]:FIX]	+850.000 MHz	Frequency setting
<i>Sensor measurement mode</i>		
[SENS[1]:]DET:FUNC	NORM	Measurement mode
<i>Sensor video bandwidth setup</i>		
[SENS[1]:]BAND BWID:VID	OFF	Sensor video bandwidth
<i>Gate setup</i>		
[SENS[1]:]SWE[1] 2 3 4:OFF:TIME	Gate 1: 0 s Gates 2 – 4: 0	Delay between trigger point and time gated period
[SENS[1]:]SWE[1] 2 3 4:TIME	Gate 1: 10 ms Gates 2 – 4: 0	Length of time gated period for time gated measurements
<i>Trigger setup</i>		
TRIG[:SEQ[1]]:SOUR	INT1	Trigger source setup and acquisition mode continuous triggering
INIT:CONT	ON	
TRIG[:SEQ]:LEV:AUTO	ON	Enable automatic setting of the trigger level
TRIG[:SEQ]:LEV	AUTO	Automatic power level
TRIG[:SEQ]:SLOP	POS	Trigger event recognized on the rising edge of a signal
TRIG[:SEQ]:DEL	0 s	Delay between recognition of trigger event and start of a measurement
TRIG[:SEQ]:HOLD	1 μ s	Trigger holdoff

Table 12-10 CDMAone: U2020 X-Series presets (continued)

Command	Setting	Comments
TRIG[:SEQ[1]]:QUAL:TIME	100 ns	Qualification time for stable triggering
<i>Step detection</i>		
[SENS[1]:]AVER:SDET	0	Step detection disabled

Table 12-11 CDMAone: U2020 X-Series presets for calc setup

Command	Setting
<i>Calc setup</i>	
Calc1 feed	Gate 1
Calc1 measurement	Average
Calc2 feed	Gate 1
Calc2 measurement	Peak
Calc3 feed	Gate 1
Calc3 measurement	Average
Calc4 feed	Gate 1
Calc4 measurement	Peak to average

W-CDMA

The W-CDMA setup returns the following measurement results:

- Average power in a W-CDMA signal (bandwidth ≤ 5 MHz), when queried by CALC1.
- Peak power, when queried by CALC2.
- Peak-to-average ratio of the signal over a defined, statistically valid number of samples, when queried by CALC4.

The measurement is a continuously gated measurement on a 3 GPP W-CDMA signal. Its aim is to measure the peak and average power corresponding to a <0.01% probability that there are no peaks above the returned peak reading. Time gating is set to 10 ms. Triggering is set to occur continuously internally to the U2020 X-Series. The internal trigger is set to AutoLevel. A reading over the 10 ms period is returned then re-initiated for the next 10 ms period. In this way, the reading always relates to a position beyond 0.01% on the CCDF curve and will refresh to track any signal or DUT changes.

Table 12-12 W-CDMA: U2020 X-Series presets

Command	Setting	Comments
<i>Frequency</i>		
[SENS[1]:]FREQ[:CW]:FIX]	+1900.000 MHz	Frequency setting
<i>Sensor measurement mode</i>		
[SENS[1]:]DET:FUNC	NORM	Measurement mode
<i>Sensor video bandwidth setup</i>		
[SENS[1]:]BAND BWID VID	OFF	Sensor video bandwidth
<i>Gate setup</i>		
[SENS[1]:]SWE[1] 2 3 4:OFF:TIME	Gate 1: 0 s Gates 2 – 4: 0	Delay between trigger point and time gated period
[SENS[1]:]SWE[1] 2 3 4:TIME	Gate 1: 10 ms Gates 2 – 4: 0	Length of time gated period for time gated measurements
<i>Trigger setup</i>		
TRIG[:SEQ[1]]:SOUR	INT1	Trigger source setup and acquisition mode continuous triggering
INIT:CONT	ON	
TRIG[:SEQ]:LEV:AUTO	ON	Enable automatic setting of the trigger level
TRIG[:SEQ]:LEV	AUTO	Automatic power level
TRIG[:SEQ]:SLOP	POS	Trigger event recognized on the rising edge of a signal
TRIG[:SEQ]:DEL	0 s	Delay between recognition of trigger event and start of a measurement
TRIG[:SEQ]:HOLD	1 μ s	Trigger holdoff

Table 12-12 W-CDMA: U2020 X-Series presets (continued)

Command	Setting	Comments
TRIG[:SEQ[1]]:QUAL:TIME	100 ns	Qualification time for stable triggering
<i>Step detection</i>		
[SENS[1]:]AVER:SDET	0	Step detection disabled

Table 12-13 W-CDMA: U2020 X-Series presets for calc setup

Command	Setting
<i>Calc setup</i>	
Calc1 feed	Gate 1
Calc1 measurement	Average
Calc2 feed	Gate 1
Calc2 measurement	Peak
Calc3 feed	Gate 1
Calc3 measurement	Average
Calc4 feed	Gate 1
Calc4 measurement	Peak to average

CDMA2000

The CDMA2000 setup returns the following measurement results:

- Average power in a CDMA2000 signal (bandwidth ≤ 5 MHz), when queried by CALC1.
- Peak power, when queried by CALC2.
- Peak-to-average ratio of the signal over a defined, statistically valid number of samples, when queried by CALC4.

The measurement is a continuously gated measurement on a 3 GPP CDMA2000 signal. Its aim is to measure the peak and average power corresponding to a <0.01% probability that there are no peaks above the returned peak reading. Time gating is set to 10 ms. Triggering is set to occur continuously internally to the U2020 X-Series. The internal trigger is set to AutoLevel. A reading over the 10 ms period is returned, then the reading is re-initiated for the next 10 ms period. In this way, the reading always relates to a position beyond 0.01% on the CCDF curve and will refresh to track any signal or DUT changes.

Table 12-14 CDMA2000: U2020 X-Series presets

Command	Setting	Comments
<i>Frequency</i>		
[SENS[1]:]FREQ[:CW]:FIX]	+1900.000 MHz	Frequency setting
<i>Sensor measurement mode</i>		
[SENS[1]:]DET:FUNC	NORM	Measurement mode
<i>Sensor video bandwidth setup</i>		
[SENS[1]:]BAND BWID:VID	OFF	Sensor video bandwidth
<i>Gate setup</i>		
[SENS[1]:]SWE[1] 2 3 4:OFF:TIME	Gate 1: 0 s Gates 2 – 4: 0	Delay between trigger point and time gated period
[SENS[1]:]SWE[1] 2 3 4:TIME	Gate 1: 10 ms Gates 2 – 4: 0	Length of time gated period for time gated measurements
<i>Trigger setup</i>		
TRIG[:SEQ[1]]:SOUR	INT1	Trigger source setup and acquisition mode continuous triggering
INIT:CONT	ON	
TRIG[:SEQ]:LEV:AUTO	ON	Enable automatic setting of the trigger level
TRIG[:SEQ]:LEV	AUTO	Automatic power level
TRIG[:SEQ]:SLOP	POS	Trigger event recognized on the rising edge of a signal
TRIG[:SEQ]:DEL	0 s	Delay between recognition of trigger event and start of a measurement
TRIG[:SEQ]:HOLD	1 μ s	Trigger holdoff

Table 12-14 CDMA2000: U2020 X-Series presets (continued)

Command	Setting	Comments
TRIG[:SEQ[1]]:QUAL:TIME	100 ns	Qualification time for stable triggering
<i>Step detection</i>		
[SENS[1]:]AVER:SDET	0	Step detection disabled

Table 12-15 CDMA2000: U2020 X-Series presets for calc setup

Command	Setting
<i>Calc setup</i>	
Calc1 feed	Gate 1
Calc1 measurement	Average
Calc2 feed	Gate 1
Calc2 measurement	Peak
Calc3 feed	Gate 1
Calc3 measurement	Average
Calc4 feed	Gate 1
Calc4 measurement	Peak to average

iDEN

The iDEN setup returns the following measurement results:

- Average power in one iDEN training and data pulse, from CALC1.
- Peak power in one iDEN training and data pulse, from CALC2.
- Peak-to-average power in one iDEN training and data pulse, from CALC4.

The measurement is started by detecting the iDEN training burst—for example, the burst emitted by a mobile—using the internal RF level trigger. Time gating is used to measure the average power in the following 15 ms (data pulse). Gate 1 is used to measure this data pulse.

Table 12-16 iDEN: U2020 X-Series presets

Command	Setting	Comments
<i>Frequency</i>		
[SENS[1]:]FREQ[:CW :FIX]	+800.000 MHz	Frequency setting
<i>Sensor measurement mode</i>		
[SENS[1]:]DET:FUNC	NORM	Measurement mode
<i>Sensor video bandwidth setup</i>		
[SENS[1]:]BAND BWID:VID	OFF	Sensor video bandwidth
<i>Gate setup</i>		
[SENS[1]:]SWE[1] 2 3 4:OFF:TIME	Gate 1: 0 μ s Gates 2 – 4: 0	Delay between trigger point and time gated period.
[SENS[1]:]SWE[1] 2 3 4:TIME	Gate 1: 15 ms Gate 2: 90 ms Gate 3: 160 μ s Gate 4: 0	Length of time gated period for time gated measurements.
<i>Trigger setup</i>		
TRIG[:SEQ[1]]:SOUR	INT1	Trigger source setup and acquisition mode continuous triggering
INIT:CONT	ON	
TRIG[:SEQ]:LEV:AUTO	OFF	Disable automatic setting of the trigger level
TRIG[:SEQ]:LEV	-15 dBm	Automatic power level
TRIG[:SEQ]:SLOP	POS	Trigger event recognized on the rising edge of a signal
TRIG[:SEQ]:DEL	0 s	Delay between recognition of trigger event and start of a measurement
TRIG[:SEQ]:HOLD	20 ms	Trigger holdoff
<i>Averaging</i>		
[SENS[1]:]AVER[:STATE]	ON	Averaging on
[SENS[1]:]AVER:COUN	64	Averaging set to 64
TRIG[:SEQ[1]]:QUAL:TIME	100 ns	Qualification time for stable triggering
<i>Step detection</i>		
[SENS[1]:]AVER:SDET	1	Step detection enabled

12 SYSTem Subsystem

Table 12-16 iDEN: U2020 X-Series presets (continued)

Command	Setting	Comments
<i>Trace setup</i>		
SENS[1]:TRAC:LIM:UPP	+20 dBm	Maximum power
SENS[1]:TRAC:LIM:LOW	-30 dBm	Minimum power
[SENS[1]:]TRAC:OFFS:TIME <numeric_value>	0 s	Delay between delayed trigger point and the start of the trace
[SENS[1]:]TRAC:TIME <numeric_value>	100 ms	Length of the trace

Table 12-17 iDEN:: U2020 X-Series presets for calc setup

Command	Setting
<i>Calc setup</i>	
Calc1 feed	Gate 1
Calc1 measurement	Average
Calc2 feed	Gate 1
Calc2 measurement	Peak
Calc3 feed	Gate 1
Calc3 measurement	Average
Calc4 feed	Gate 1
Calc4 measurement	Peak to average

MCPa

Table 12-18 shows the U2020 X-Series presets when <character_data> is set to MCPa.

Table 12-18 MCPa: U2020 X-Series presets

Command	Setting	Comments
<i>Frequency</i>		
[SENS[1]:]FREQ[:CW]:FIX]	+1900.000 MHz	Frequency setting
<i>Sensor measurement mode</i>		
[SENS[1]:]DET:FUNC	NORM	Measurement mode
<i>Sensor video bandwidth setup</i>		
[SENS[1]:]BAND BWID:VID	OFF	Sensor video bandwidth
<i>Gate setup</i>		
[SENS[1]:]SWE[1] 2 3 4:OFF:TIME	Gate 1: 0 s Gates 2 – 4: 0	Delay between trigger point and time gated period
[SENS[1]:]SWE[1] 2 3 4:TIME	Gate 1: 10 ms Gates 2 – 4: 0	Length of time gated period for time gated measurements
<i>Trigger setup</i>		
TRIG[:SEQ[1]]:SOUR	INT1	Trigger source setup and acquisition mode continuous triggering
INIT:CONT	ON	
TRIG[:SEQ]:LEV:AUTO	OFF	Enable automatic setting of the trigger level
TRIG[:SEQ]:LEV	-15 dBm	Power level
TRIG[:SEQ]:SLOP	POS	Trigger event recognized on the rising edge of a signal
TRIG[:SEQ]:DEL	0 s	Delay between recognition of trigger event and start of a measurement
TRIG[:SEQ]:HOLD	1 μ s	Trigger holdoff
TRIG[:SEQ[1]]:QUAL:TIME	100 ns	Qualification time for stable triggering
<i>Step detection</i>		
[SENS[1]:]AVER:SDET	0	Step detection disabled

Table 12-19 MCPa: U2020 X-Series presets for calc setup

Command	Setting
<i>Calc setup</i>	
Calc1 feed	Gate 1
Calc1 measurement	Average
Calc2 feed	Gate 1
Calc2 measurement	Peak
Calc3 feed	Gate 1
Calc3 measurement	Average
Calc4 feed	Gate 1
Calc4 measurement	Peak

RADar

Table 12-20 shows the U2020 X-Series presets when <character_data> is set to RADar.

Table 12-20 RADar: U2020 X-Series presets

Command	Setting	Comments
<i>Frequency</i>		
[SENS[1]:]FREQ[:CW :FIX]	+10.000 GHz	Frequency setting
<i>Sensor measurement mode</i>		
[SENS[1]:]DET:FUNC	NORM	Measurement mode
<i>Sensor video bandwidth setup</i>		
[SENS[1]:]BAND BWID:VID	OFF	Sensor video bandwidth
<i>Gate setup</i>		
[SENS[1]:]SWE[1] 2 3 4:OFF:TIME	Gate 1: 0 Gate 2: 0 Gate 3: 750 ns Gate 4: 0	Delay between trigger point and time gated period

Table 12-20 RADar: U2020 X-Series presets (continued)

Command	Setting	Comments
[SENS[1]:]SWE[1] 2 3 4:TIME	Gate 1: 1.0 ms Gate 2: 250 ns Gate 3: 250 ns Gate 4: 0	Length of time gated period for time gated measurements
<i>Trigger setup</i>		
TRIG[:SEQ[1]]:SOUR	INT1	Trigger source setup and acquisition mode continuous triggering
INIT:CONT	ON	
TRIG[:SEQ]:LEV:AUTO	ON	Disable automatic setting of the trigger level
TRIG[:SEQ]:LEV	AUTO	Automatic power level
TRIG[:SEQ]:SLOP	POS	Trigger event recognized on the rising edge of a signal
TRIG[:SEQ]:DEL	0 s	Delay between recognition of trigger event and start of a measurement
TRIG[:SEQ]:HOLD	1 μs	Trigger holdoff
TRIG[:SEQ[1]]:QUAL:TIME	100 ns	Qualification time for stable triggering
<i>Step detection</i>		
[SENS[1]:]AVER:SDET	0	Step detection disabled
<i>Trace setup</i>		
[SENS[1]:]TRAC:OFFS:TIME <numeric_value>	-250 ns	Delay between delayed trigger point and the start of the trace
[SENS[1]:]TRAC:TIME <numeric_value>	1.5 μs	Length of the trace

Table 12-21 RADar: U2020 X-Series presets for calc setup

Command	Setting
<i>Calc setup</i>	
Calc1 feed	Gate 1
Calc1 measurement	Peak to average
Calc2 feed	Gate 1

12 SYSTEM Subsystem

Table 12-21 RADar: U2020 X-Series presets for calc setup (continued)

Command	Setting
Calc2 measurement	Peak
Calc3 feed	Gate 1
Calc3 measurement	Average
Calc4 feed	Gate 1
Calc4 measurement	Average

WL802DOT11A

Table 12-22 shows the U2020 X-Series presets when <character_data> is set to WL802DOT11A.

Table 12-22 WL802DOT11A: U2020 X-Series presets

Command	Setting	Comments
<i>Frequency</i>		
[SENS[1]:]FREQ[:CW]:FIX]	+5200.000 MHz	Frequency setting
<i>Sensor measurement mode</i>		
[SENS[1]:]DET:FUNC	NORM	Measurement mode
<i>Sensor video bandwidth setup</i>		
[SENS[1]:]BAND BWID:VID	HIGH	Sensor video bandwidth
<i>Gate setup</i>		
[SENS[1]:]SWE[1] 2 3 4:OFF:TIME	Gate 1: 0 Gates 2 – 4: 0	Delay between trigger point and time gated period
[SENS[1]:]SWE[1] 2 3 4:TIME	Gate 1: 25 μ s Gates 2 – 4: 0	Length of time gated period for time gated measurements
<i>Trigger setup</i>		
TRIG[:SEQ[1]]:SOUR	INT1	Trigger source setup and acquisition mode continuous triggering
INIT:CONT	ON	
TRIG[:SEQ]:LEV:AUTO	OFF	Disable automatic setting of the trigger level
TRIG[:SEQ]:LEV	-20 dBm	Power level
TRIG[:SEQ]:SLOP	POS	Trigger event recognized on the rising edge of a signal

Table 12-22 WL802DOT11A: U2020 X-Series presets (continued)

Command	Setting	Comments
TRIG[:SEQ]:DEL	0 s	Delay between recognition of trigger event and start of a measurement
TRIG[:SEQ]:HOLD	1 μ s	Trigger holdoff
TRIG[:SEQ[1]]:QUAL:TIME	25 μ s	Qualification time for stable triggering
<i>Step detection</i>		
[SENS[1]:]AVER:SDET	0	Step detection disabled

Table 12-23 WL802DOT11A: U2020 X-Series presets for calc setup

Command	Setting
<i>Calc setup</i>	
Calc1 feed	Gate 1
Calc1 measurement	Average
Calc2 feed	Gate 1
Calc2 measurement	Peak
Calc3 feed	Gate 1
Calc3 measurement	Average
Calc4 feed	Gate 1
Calc4 measurement	Peak to average

WL802DOT11B

Table 12-24 shows the U2020 X-Series presets when <character_data> is set to WL802DOT11B.

Table 12-24 WL802DOT11B: U2020 X-Series presets

Command	Setting	Comments
<i>Frequency</i>		
[SENS[1]:]FREQ[:CW]:FIX]	+2.400 GHz	Frequency setting

12 SYSTem Subsystem

Table 12-24 WL802DOT11B: U2020 X-Series presets (continued)

Command	Setting	Comments
<i>Sensor measurement mode</i>		
[SENS[1]:]DET:FUNC	NORM	Measurement mode
<i>Sensor video bandwidth setup</i>		
[SENS[1]:]BAND BWID:VID	HIGH	Sensor video bandwidth
<i>Gate setup</i>		
[SENS[1]:]SWE[1] 2 3 4:OFF:TIME	Gate 1: 0 Gates 2 – 4: 0	Delay between trigger point and time gated period
[SENS[1]:]SWE[1] 2 3 4:TIME	Gate 1: 100 μ s Gates 2 – 4: 0	Length of time gated period for time gated measurements
<i>Trigger setup</i>		
TRIG[:SEQ[1]]:SOUR	INT1	Trigger source setup and acquisition mode continuous triggering
INIT:CONT	ON	
TRIG[:SEQ]:LEV:AUTO	OFF	Disable automatic setting of the trigger level
TRIG[:SEQ]:LEV	-20 dBm	Power level
TRIG[:SEQ]:SLOP	POS	Trigger event recognized on the rising edge of a signal
TRIG[:SEQ]:DEL	0 s	Delay between recognition of trigger event and start of a measurement
TRIG[:SEQ]:HOLD	1 μ s	Trigger holdoff
TRIG[:SEQ[1]]:QUAL:TIME	25 μ s	Qualification time for stable triggering
<i>Step detection</i>		
[SENS[1]:]AVER:SDET	0	Step detection disabled

Table 12-25 WL802DOT11B: U2020 X-Series presets for calc setup

Command	Setting
<i>Calc setup</i>	
Calc1 feed	Gate 1
Calc1 measurement	Average

Table 12-25 WL802DOT11B: U2020 X-Series presets for calc setup (continued)

Command	Setting
Calc2 feed	Gate 1
Calc2 measurement	Peak
Calc3 feed	Gate 1
Calc3 measurement	Average
Calc4 feed	Gate 1
Calc4 measurement	Peak to average

XEVDO

Table 12-26 shows the U2020 X-Series presets when <character_data> is set to XEVDO.

Table 12-26 XEVDO: U2020 X-Series presets

Command	Setting	Comments
<i>Frequency</i>		
[SENS[1]:]FREQ[:CW :FIX]	+1900.000 MHz	Frequency setting
<i>Sensor measurement mode</i>		
[SENS[1]:]DET:FUNC	NORM	Measurement mode
<i>Sensor video bandwidth setup</i>		
[SENS[1]:]BAND BWID:VID	LOW	Sensor video bandwidth
<i>Gate setup</i>		
[SENS[1]:]SWE[1] 2 3 4:OFF:TIME	Gate 1: 10 μ s Gates 2 – 4: 0	Delay between trigger point and time gated period
[SENS[1]:]SWE[1] 2 3 4:TIME	Gate 1: 810 μ s Gates 2 – 4: 0	Length of time gated period for time gated measurements
<i>Trigger setup</i>		
TRIG[:SEQ[1]]:SOUR	INT1	Trigger source setup and acquisition mode continuous triggering
INIT:CONT	ON	
TRIG[:SEQ]:LEV:AUTO	ON	Enable automatic setting of the trigger level
TRIG[:SEQ]:LEV	AUTO	Power level

12 SYSTEM Subsystem

Table 12-26 XEVD0: U2020 X-Series presets (continued)

Command	Setting	Comments
TRIG[:SEQ]:SLOP	POS	Trigger event recognized on the rising edge of a signal
TRIG[:SEQ]:DEL	0 s	Delay between recognition of trigger event and start of a measurement
TRIG[:SEQ]:HOLD	1 ms	Trigger holdoff
TRIG[:SEQ[1]]:QUAL:TIME	100 ns	Qualification time for stable triggering
<i>Step detection</i>		
[SENS[1]:]AVER:SDET	0	Step detection disabled
<i>Trace setup</i>		
[SENS[1]:]TRAC:OFFS:TIME <numeric_value>	-40 μ s	Delay between delayed trigger point and the start of the trace
[SENS[1]:]TRAC:TIME <numeric_value>	1 ms	Length of the trace

Table 12-27 XEVD0: U2020 X-Series presets for calc setup

Command	Setting
<i>Calc setup</i>	
Calc1 feed	Gate 1
Calc1 measurement	Peak
Calc2 feed	Gate 1
Calc2 measurement	Average
Calc3 feed	Gate 1
Calc3 measurement	Peak
Calc4 feed	Gate 1
Calc4 measurement	Peak to average

XEVDV

Table 12-28 shows the U2020 X-Series presets when <character_data> is set to XEVDV.

Table 12-28 XEVDV: U2020 X-Series presets

Command	Setting	Comments
<i>Frequency</i>		
[SENS[1]:]FREQ[:CW]:FIX]	+1900.000 MHz	Frequency setting
<i>Sensor measurement mode</i>		
[SENS[1]:]DET:FUNC	NORM	Measurement mode
<i>Sensor video bandwidth setup</i>		
[SENS[1]:]BAND BWID:VID	LOW	Sensor video bandwidth
<i>Gate setup</i>		
[SENS[1]:]SWE[1] 2 3 4:OFF:TIME	Gate 1: 10 μ s Gates 2 – 4: 0	Delay between trigger point and time gated period
[SENS[1]:]SWE[1] 2 3 4:TIME	Gate 1: 810 μ s Gates 2 – 4: 0	Length of time gated period for time gated measurements
<i>Trigger setup</i>		
TRIG[:SEQ[1]]:SOUR	INT1	Trigger source setup and acquisition mode continuous triggering
INIT:CONT	ON	
TRIG[:SEQ]:LEV:AUTO	ON	Enable automatic setting of the trigger level
TRIG[:SEQ]:LEV	AUTO	Power level
TRIG[:SEQ]:SLOP	POS	Trigger event recognized on the rising edge of a signal
TRIG[:SEQ]:DEL	0 s	Delay between recognition of trigger event and start of a measurement
TRIG[:SEQ]:HOLD	1 ms	Trigger holdoff
TRIG[:SEQ[1]]:QUAL:TIME	100 ns	Qualification time for stable triggering
<i>Step detection</i>		
[SENS[1]:]AVER:SDET	0	Step detection disabled
<i>Trace setup</i>		
[SENS[1]:]TRAC:OFFS:TIME <numeric_value>	-40 μ s	Delay between delayed trigger point and the start of the trace

12 SYSTem Subsystem

Table 12-28 XEVDV: U2020 X-Series presets (continued)

Command	Setting	Comments
[SENS[1]:]TRAC:TIME <numeric_value>	1 ms	Length of the trace

Table 12-29 XEVDV: U2020 X-Series presets for calc setup

Command	Setting
<i>Calc setup</i>	
Calc1 feed	Gate 1
Calc1 measurement	Peak
Calc2 feed	Gate 1
Calc2 measurement	Average
Calc3 feed	Gate 1
Calc3 measurement	Peak
Calc4 feed	Gate 1
Calc4 measurement	Peak to average

TDSCdma

Table 12-30 shows the U2020 X-Series presets when <character_data> is set to TDSCdma.

Table 12-30 TDSCdma: U2020 X-Series presets

Command	Setting	Comments
<i>Frequency</i>		
[SENS[1]:]FREQ[:CW :FIX]	+1900.000 MHz	Frequency setting
<i>Sensor measurement mode</i>		
[SENS[1]:]DET:FUNC	NORM	Measurement mode
<i>Sensor video bandwidth setup</i>		
[SENS[1]:]BAND BWID:VID	LOW	Sensor video bandwidth

Table 12-30 TDSCdma: U2020 X-Series presets (continued)

Command	Setting	Comments
<i>Gate setup</i>		
[SENS[1]:]SWE[1] 2 3 4:OFF:TIME	Gate 1: 10 μ s Gates 2 – 4: 0	Delay between trigger point and time gated period
[SENS[1]:]SWE[1] 2 3 4:TIME	Gate 1: 810 μ s Gates 2 – 4: 0	Length of time gated period for time gated measurements
<i>Trigger setup</i>		
TRIG[:SEQ[1]]:SOUR	INT1	Trigger source setup and acquisition mode continuous triggering
INIT:CONT	ON	
TRIG[:SEQ]:LEV:AUTO	ON	Enable automatic setting of the trigger level
TRIG[:SEQ]:LEV	AUTO	Power level
TRIG[:SEQ]:SLOP	POS	Trigger event recognized on the rising edge of a signal
TRIG[:SEQ]:DEL	0 s	Delay between recognition of trigger event and start of a measurement
TRIG[:SEQ]:HOLD	1 ms	Trigger holdoff
TRIG[:SEQ[1]]:QUAL:TIME	100 ns	Qualification time for stable triggering
<i>Step detection</i>		
[SENS[1]:]AVER:SDET	0	Step detection disabled
<i>Trace setup</i>		
[SENS[1]:]TRAC:OFFS:TIME <numeric_value>	-40 μ s	Delay between delayed trigger point and the start of the trace
[SENS[1]:]TRAC:TIME <numeric_value>	1 ms	Length of the trace

Table 12-31 TDSCdma: U2020 X-Series presets for calc setup

Command	Setting
<i>Calc setup</i>	
Calc1 feed	Gate 1
Calc1 measurement	Peak

12 SYSTEM Subsystem

Table 12-31 TDSCdma: U2020 X-Series presets for calc setup (continued)

Command	Setting
Calc2 feed	Gate 1
Calc2 measurement	Average
Calc3 feed	Gate 1
Calc3 measurement	Peak
Calc4 feed	Gate 1
Calc4 measurement	Peak to average

DVB

Table 12-32 shows the U2020 X-Series presets when <character_data> is set to DVB.

Table 12-32 DVB: U2020 X-Series presets

Command	Setting	Comments
<i>Frequency</i>		
[SENS[1]:]FREQ[:CW :FIX]	+660.000 MHz	Frequency setting
<i>Sensor measurement mode</i>		
[SENS[1]:]DET:FUNC	NORM	Measurement mode
<i>Sensor video bandwidth setup</i>		
[SENS[1]:]BAND BWID:VID	OFF	Sensor video bandwidth
<i>Gate setup</i>		
[SENS[1]:]SWE[1] 2 3 4:OFF:TIME	Gate 1: 10 μ s Gate 2: 0 Gates 3 – 4: 0	Delay between trigger point and time gated period
[SENS[1]:]SWE[1] 2 3 4:TIME	Gate 1: 15 ms Gate 1: 90 ms Gates 2 – 4: 0	Length of time gated period for time gated measurements
<i>Trigger setup</i>		
TRIG[:SEQ[1]]:SOUR	INT1	Trigger source setup and acquisition mode continuous triggering
INIT:CONT	ON	
TRIG[:SEQ]:LEV:AUTO	OFF	Disable automatic setting of the trigger level

Table 12-32 DVB: U2020 X-Series presets (continued)

Command	Setting	Comments
TRIG[:SEQ]:LEV	-15 dBm	Power level
TRIG[:SEQ]:SLOP	POS	Trigger event recognized on the rising edge of a signal
TRIG[:SEQ]:DEL	0 s	Delay between recognition of trigger event and start of a measurement
TRIG[:SEQ]:HOLD	20 ms	Trigger holdoff
TRIG[:SEQ[1]]:QUAL:TIME	100 ns	Qualification time for stable triggering
<i>Step detection</i>		
[SENS[1]:]AVER:SDET	1	Step detection enabled

Table 12-33 TDVB: U2020 X-Series presets for calc setup

Command	Setting
<i>Calc setup</i>	
Calc1 feed	Gate 1
Calc1 measurement	Average
Calc2 feed	Gate 1
Calc2 measurement	Peak to average
Calc3 feed	Gate 1
Calc3 measurement	Average
Calc4 feed	Gate 1
Calc4 measurement	Average

HIPERLAN2

Table 12-34 shows the U2020 X-Series presets when <character_data> is set to HIPERLAN2.

Table 12-34 HIPERLAN2: U2020 X-Series presets

Command	Setting	Comments
<i>Frequency</i>		
[SENS[1]:]FREQ[:CW]:FIX]	+5200.000 MHz	Frequency setting
<i>Sensor measurement mode</i>		
[SENS[1]:]DET:FUNC	NORM	Measurement mode
<i>Sensor video bandwidth setup</i>		
[SENS[1]:]BAND BWID:VID	HIGH	Sensor video bandwidth
<i>Gate setup</i>		
[SENS[1]:]SWE[1] 2 3 4:OFF:TIME	Gate 1: 0 Gates 2 – 4: 0	Delay between trigger point and time gated period
[SENS[1]:]SWE[1] 2 3 4:TIME	Gate 1: 25 μ s Gates 2 – 4: 0	Length of time gated period for time gated measurements
<i>Trigger setup</i>		
TRIG[:SEQ[1]]:SOUR	INT1	Trigger source setup and acquisition mode continuous triggering
INIT:CONT	ON	
TRIG[:SEQ]:LEV:AUTO	ON	Enable automatic setting of the trigger level
TRIG[:SEQ]:LEV	AUTO	Power level
TRIG[:SEQ]:SLOP	POS	Trigger event recognized on the rising edge of a signal
TRIG[:SEQ]:DEL	0 s	Delay between recognition of trigger event and start of a measurement
TRIG[:SEQ]:HOLD	1 μ s	Trigger holdoff
TRIG[:SEQ[1]]:QUAL:TIME	100 ns	Qualification time for stable triggering
<i>Step detection</i>		
[SENS[1]:]AVER:SDET	0	Step detection disabled

Table 12-35 HIPERLAN2: U2020 X-Series presets for calc setup

Command	Setting
<i>Calc setup</i>	
Calc1 feed	Gate 1
Calc1 measurement	Average
Calc2 feed	Gate 1
Calc2 measurement	Peak
Calc3 feed	Gate 1
Calc3 measurement	Average
Calc4 feed	Gate 1
Calc4 measurement	Peak to average

WIMAX

Table 12-36 shows the U2020 X-Series presets when <character_data> is set to WIMAX.

Table 12-36 WIMAX: U2020 X-Series presets

Command	Setting	Comments
<i>Frequency</i>		
[SENS[1]:]FREQ[:CW :FIX]	+3.5 GHz	Frequency setting
<i>Sensor measurement mode</i>		
[SENS[1]:]DET:FUNC	NORM	Measurement mode
<i>Sensor video bandwidth setup</i>		
[SENS[1]:]BAND BWID:VID	HIGH	Sensor video bandwidth
<i>Gate setup</i>		
[SENS[1]:]SWE[1] 2 3 4:OFF:TIME	Gate 1: 0 Gates 2: 102 μ s Gates 3 – 4: 0	Delay between trigger point and time gated period
[SENS[1]:]SWE[1] 2 3 4:TIME	Gate 1: 102 μ s Gate 2: 306 μ s Gates 3 – 4: 0	Length of time gated period for time gated measurements

12 SYSTEM Subsystem

Table 12-36 WIMAX: U2020 X-Series presets (continued)

Command	Setting	Comments
<i>Trigger setup</i>		
TRIG[:SEQ[1]]:SOUR	INT1	Trigger source setup and acquisition mode continuous triggering
INIT:CONT	ON	
TRIG[:SEQ]:LEV:AUTO	ON	Enable automatic setting of the trigger level
TRIG[:SEQ]:LEV	AUTO	Power level
TRIG[:SEQ]:SLOP	POS	Trigger event recognized on the rising edge of a signal
TRIG[:SEQ]:DEL	0 s	Delay between recognition of trigger event and start of a measurement
TRIG[:SEQ]:HOLD	4 ms	Trigger holdoff
TRIG[:SEQ[1]]:QUAL:TIME	8 μ s	Qualification time for stable triggering
<i>Step detection</i>		
[SENS[1]:]AVER:SDET	0	Step detection disabled
<i>Trace setup</i>		
[SENS[1]:]TRAC:OFFS:TIME <numeric_value>	-0.2 ms	Delay between delayed trigger point and the start of the trace
[SENS[1]:]TRAC:TIME <numeric_value>	3 ms	Length of the trace

Table 12-37 WIMAX: U2020 X-Series presets for calc setup

Command	Setting
<i>Calc setup</i>	
Calc1 feed	Gate 1
Calc1 measurement	Average
Calc2 feed	Gate 1
Calc2 measurement	Peak
Calc3 feed	Gate 1
Calc3 measurement	Peak to average

Table 12-37 WIMAX: U2020 X-Series presets for calc setup (continued)

Command	Setting
Calc4 feed	Gate 1
Calc4 measurement	Peak to average

HSDPA

Table 12-38 shows the U2020 X-Series presets when <character_data> is set to HSDPA.

Table 12-38 HSDPA: U2020 X-Series presets

Command	Setting	Comments
<i>Frequency</i>		
[SENS[1]:]FREQ[:CW :FIX]	+1900.000 MHz	Frequency setting
<i>Sensor measurement mode</i>		
[SENS[1]:]DET:FUNC	NORM	Measurement mode
<i>Sensor video bandwidth setup</i>		
[SENS[1]:]BAND BWID:VID	OFF	Sensor video bandwidth
<i>Gate setup</i>		
[SENS[1]:]SWE[1] 2 3 4:OFF:TIME	Gate 1: 0 s Gates 2 – 4: 0	Delay between trigger point and time gated period
[SENS[1]:]SWE[1] 2 3 4:TIME	Gate 1: 10 ms Gates 2 – 4: 0	Length of time gated period for time gated measurements
<i>Trigger setup</i>		
TRIG[:SEQ[1]]:SOUR	INT1	Trigger source setup and acquisition mode continuous triggering
INIT:CONT	ON	
TRIG[:SEQ]:LEV:AUTO	ON	Enable automatic setting of the trigger level
TRIG[:SEQ]:LEV	AUTO	Automatic power level
TRIG[:SEQ]:SLOP	POS	Trigger event recognized on the rising edge of a signal
TRIG[:SEQ]:DEL	0 s	Delay between recognition of trigger event and start of a measurement

Table 12-38 HSDPA: U2020 X-Series presets (continued)

Command	Setting	Comments
TRIG[:SEQ]:HOLD	1 μ s	Trigger holdoff
TRIG[:SEQ[1]]:QUAL:TIME	100 ns	Qualification time for stable triggering
<i>Step detection</i>		
[SENS[1]:]AVER:SDET	0	Step detection disabled

Table 12-39 HSDPA: U2020 X-Series presets for calc setup

Command	Setting
<i>Calc setup</i>	
Calc1 feed	Gate 1
Calc1 measurement	Average
Calc2 feed	Gate 1
Calc2 measurement	Peak
Calc3 feed	Gate 1
Calc3 measurement	Average
Calc4 feed	Gate 1
Calc4 measurement	Peak to average

DME

Table 12-40 shows the U2020 X-Series presets when <character_data> is set to DME.

Table 12-40 DME: U2020 X-Series presets

Command	Setting	Comments
<i>Frequency</i>		
[SENS[1]:]FREQ[:CW]:FIX]	+1.1 GHz	Frequency setting
<i>Sensor measurement mode</i>		
[SENS[1]:]DET:FUNC	NORM	Measurement mode
<i>Sensor video bandwidth setup</i>		
[SENS[1]:]BAND BWID:VID	OFF	Sensor video bandwidth
<i>Gate setup</i>		
[SENS[1]:]SWE[1] 2 3 4:OFF:TIME	Gate 1: -2 μs Gate 2: 8 μs Gate 3: 0 Gate4: 0	Delay between trigger point and time gated period
[SENS[1]:]SWE[1] 2 3 4:TIME	Gate 1: 8 μs Gate 2: 50 μs Gate 3: 0 Gate 4: 0	Length of time gated period for time gated measurements
<i>Trigger setup</i>		
TRIG[:SEQ[1]]:SOUR	INT1	Trigger source setup and acquisition mode continuous triggering
INIT:CONT	ON	
TRIG[:SEQ]:LEV:AUTO	ON	Enable automatic setting of the trigger level
TRIG[:SEQ]:LEV	AUTO	Power level
TRIG[:SEQ]:SLOP	POS	Trigger event recognized on the rising edge of a signal
TRIG[:SEQ]:DEL	0 s	Delay between recognition of trigger event and start of a measurement
TRIG[:SEQ]:HOLD	50 μs	Trigger holdoff
TRIG[:SEQ[1]]:QUAL:TIME	100 ns	Qualification time for stable triggering

12 SYSTem Subsystem

Table 12-40 DME: U2020 X-Series presets (continued)

Command	Setting	Comments
<i>Video averaging setup</i>		
[SENS[1]:]AVER2[:STAT]	1	Video averaging is enabled
[SENS[1]:]AVER2:COUN	32	Length of video filter
<i>Step detection</i>		
[SENS[1]:]AVER:SDET	1	Step detection enabled
<i>Trace setup</i>		
SENS[1]:TRAC:LIM:UPP	+20 dBm	Maximum power
SENS[1]:TRAC:LIM:LOW	-30 dBm	Minimum power
[SENS[1]:]TRAC:OFFS:TIME <numeric_value>	-3 μ s	Delay between delayed trigger point and the start of the trace
[SENS[1]:]TRAC:TIME <numeric_value>	53 μ s	Length of the trace
<i>Reference level setup</i>		
TRAC[1]:DEF:TRAN:REF	1%, 81%	Transition reference levels
TRAC[1]:DEF:DUR:REF	25%	Pulse duration reference level

Table 12-41 DME: U2020 X-Series presets for calc setup

Command	Setting
<i>Calc setup</i>	
Calc1 feed	Gate 1
Calc1 measurement	Average
Calc2 feed	Gate 1
Calc2 measurement	Peak
Calc3 feed	Gate 1
Calc3 measurement	Average
Calc4 feed	Gate 1
Calc4 measurement	Peak

DMEPRT

Table 12-42 shows the U2020 X-Series presets when <character_data> is set to DMEPRT.

Table 12-42 DMEPRT: U2020 X-Series presets

Command	Setting	Comments
<i>Frequency</i>		
[SENS[1]:]FREQ[:CW]:FIX]	+1.1 GHz	Frequency setting
<i>Sensor measurement mode</i>		
[SENS[1]:]DET:FUNC	NORM	Measurement mode
<i>Sensor video bandwidth setup</i>		
[SENS[1]:]BAND BWID:VID	OFF	Sensor video bandwidth
<i>Gate setup</i>		
[SENS[1]:]SWE[1] 2 3 4:OFF:TIME	Gate 1: 0 μ s Gate 2: 8 μ s Gate 3: 0 Gate 4: 0	Delay between trigger point and time gated period
[SENS[1]:]SWE[1] 2 3 4:TIME	Gate 1: 6 μ s Gate 2: 50 μ s Gate 3: 0 Gate 4: 0	Length of time gated period for time gated measurements
<i>Trigger setup</i>		
TRIG[:SEQ[1]]:SOUR	INT1	Trigger source setup and acquisition mode continuous triggering
INIT:CONT	ON	
TRIG[:SEQ]:LEV:AUTO	ON	Enable automatic setting of the trigger level
TRIG[:SEQ]:LEV	AUTO	Power level
TRIG[:SEQ]:SLOP	POS	Trigger event recognized on the rising edge of a signal
TRIG[:SEQ]:DEL	0 s	Delay between recognition of trigger event and start of a measurement
TRIG[:SEQ]:HOLD	50 μ s	Trigger holdoff
TRIG[:SEQ[1]]:QUAL:TIME	100 ns	Qualification time for stable triggering

Table 12-42 DMEPRT: U2020 X-Series presets (continued)

Command	Setting	Comments
<i>Video averaging setup</i>		
[SENS[1]:]AVER2[:STAT]	1	Video averaging is enabled
[SENS[1]:]AVER2:COUN	32	Length of video filter
<i>Step detection</i>		
[SENS[1]:]AVER:SDET	1	Step detection enabled
<i>Trace setup</i>		
SENS[1]:TRAC:LIM:UPP	+20 dBm	Maximum power
SENS[1]:TRAC:LIM:LOW	-30 dBm	Minimum power
[SENS[1]:]TRAC:OFFS:TIME <numeric_value>	-2 μ s	Delay between delayed trigger point and the start of the trace
[SENS[1]:]TRAC:TIME <numeric_value>	5 μ s	Length of the trace
<i>Reference level setup</i>		
TRAC[1]:DEF:TRAN:REF	0.25%, 9%	Transition reference levels
TRAC[1]:DEF:DUR:REF	25%	Pulse duration reference level

Table 12-43 DMEPRT: U2020 X-Series presets for calc setup

Command	Setting
<i>Calc setup</i>	
Calc1 feed	Gate 1
Calc1 measurement	Average
Calc2 feed	Gate 1
Calc2 measurement	Peak
Calc3 feed	Gate 1
Calc3 measurement	Average
Calc4 feed	Gate 1
Calc4 measurement	Peak

LTE

Table 12-44 shows the U2020 X-Series presets when <character_data> is set to LTE.

Table 12-44 LTE: U2020 X-Series presets

Command	Setting	Comments
<i>Frequency</i>		
[SENS[1]:]FREQ[:CW]:FIX]	+2.0 GHz	Frequency setting
<i>Sensor measurement mode</i>		
[SENS[1]:]DET:FUNC	NORM	Measurement mode
<i>Sensor video bandwidth setup</i>		
[SENS[1]:]BAND BWID:VID	OFF	Sensor video bandwidth
<i>Gate setup</i>		
[SENS[1]:]SWE[1] 2 3 4:OFF:TIME	Gate 1 – 4: 0	Delay between trigger point and time gated period
[SENS[1]:]SWE[1] 2 3 4:TIME	Gate 1: 1.2 ms Gate 2: 10.0 ms Gates 3 – 4: 0	Length of time gated period for time gated measurements
<i>Trigger setup</i>		
TRIG[:SEQ[1]]:SOUR	INT1	Trigger source setup and acquisition mode continuous triggering
INIT:CONT	ON	
TRIG[:SEQ]:LEV:AUTO	ON	Enable automatic setting of the trigger level
TRIG[:SEQ]:LEV	AUTO	Power level
TRIG[:SEQ]:SLOP	POS	Trigger event recognized on the rising edge of a signal
TRIG[:SEQ]:DEL	0 s	Delay between recognition of trigger event and start of a measurement
TRIG[:SEQ]:HOLD	4 ms	Trigger holdoff
TRIG[:SEQ[1]]:QUAL:TIME	25 μs	Qualification time for stable triggering
<i>Step detection</i>		
[SENS[1]:]AVER:SDET	0	Step detection is disabled

Table 12-44 LTE: U2020 X-Series presets (continued)

Command	Setting	Comments
<i>Trace setup</i>		
[SENS[1]:]TRAC:OFFS:TIME <numeric_value>	-0.2 ms	Delay between delayed trigger point and the start of the trace
[SENS[1]:]TRAC:TIME <numeric_value>	11.0 ms	Length of the trace

Table 12-45 LTE: U2020 X-Series presets for calc setup

Command	Setting
<i>Calc setup</i>	
Calc1 feed	Gate 1
Calc1 measurement	Average
Calc2 feed	Gate 1
Calc2 measurement	Average
Calc3 feed	Gate 1
Calc3 measurement	Peak to average
Calc4 feed	Gate 1
Calc4 measurement	Peak to average

SYSTem:VERSIon?

This query returns the version of SCPI used in the U2020 X-Series. The response is in the form of XXXX.Y, where XXXX is the year and Y is the version number.

Syntax

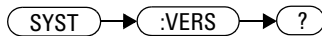

Example

SYST:VERS?

Queries which version of SCPI is used in the U2020 X-Series.

THIS PAGE HAS BEEN INTENTIONALLY LEFT BLANK.



13 TRACe Subsystem

TRACe Subsystem	436
TRACe[1][:DATA]? <character_data>	437
TRACe[1]:DEFine:DURation:REFerence<numeric_value>	439
TRACe[1]:DEFine:TRANsition:REFerence <numeric_value>, <numeric_value>	441
TRACe[1]:MEASurement:INSTant:REFerence? <numeric_value>	443
TRACe[1]:MEASurement:PULSe[1] ... 20:DCYCLE?	444
TRACe[1]:MEASurement:PULSe[1] ... 20:DURation?	445
TRACe[1]:MEASurement:PULSe[1] ... 20:PERiod?	447
TRACe[1]:MEASurement:PULSe[1] ... 20:SEParation?	449
TRACe[1]:MEASurement:TRANsition[1] ... 20:NEGative: DURation?	451
TRACe[1]:MEASurement:TRANsition[1] ... 20:NEGative: OCCurrence?	452
TRACe[1]:MEASurement:TRANsition[1] ... 20:POSitive: DURation?	453
TRACe[1]:MEASurement:TRANsition[1] ... 20:POSitive: OCCurrence?	454
TRACe[1]:MEASurement:REFerence? <numeric_value>	455
TRACe[1]:STATe <boolean>	457
TRACe[1]:UNIT <character_data>	459

This chapter explains how to use the TRACe command subsystem to configure and read back the measured power trace.



TRACe Subsystem

The TRACe subsystem is used to:

- Specify the type of trace to be captured.
- Enable/disable trace capture.
- Specify the trace units.

TRACe1 is associated with Channel A.

NOTE

When making trace measurements, use the following command sequence to synchronize the returned trace data with the measurement:

Command	Comment
TRIG:SOUR INT or TRIG:SOUR EXT	Changes the trigger source to internal or external
INIT:CONT OFF	Trace data can only be retrieved with INIT:CONT OFF
TRAC:STAT ON	Enables trace capture
AVER:STAT OFF or TRIG:DEL:AUTO OFF	No settling time delay for the digital filter to fill
INIT	Initiates a new measurement
FETC?	Fetches the result (waits for the measurement to complete)
TRAC:DATA? MRES ¹	Retrieves the trace data once the measurement has completed

¹ The trace resolution parameter must be provided when this command is used.

TRACe[1][:DATA]? <character_data>

This query returns the trace data. The trace resolution is determined by <character_data>.

Data is returned in the IEEE-488.2 arbitrary block program data format as follows:

```
#xyyy...ydd.....ddd<LF>
```

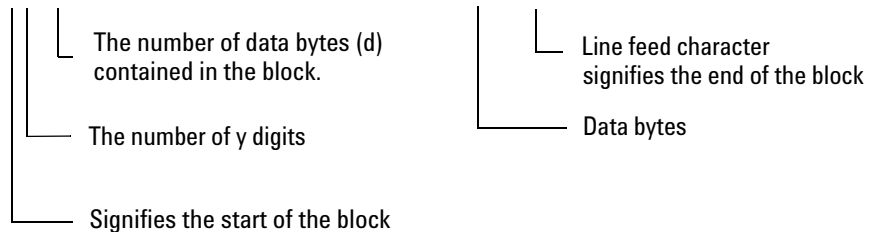

Example: if there are 12435 data bytes, $y = 12435$ and $x = 5$

Each point in the trace is represented as an IEEE-754 32-bit floating point number, made up of four bytes in the data block. The MS byte is transmitted first. Each complete block is terminated by a line feed.

NOTE

The TRACe data formatting is not affected by the FORMat subsystem formatting.

Syntax

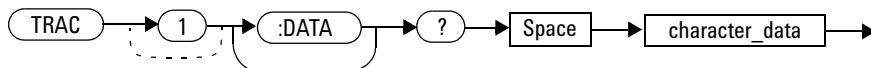

Parameters

Item	Description/Default	Range of values
character_data	<ul style="list-style-type: none"> HRESolution: High resolution. The complete capture buffer at the internal sample rate. The number of points in this trace is not fixed, as it is affected by the <code>SENS:TRACe:TIME</code> setting. MRESolution: Medium resolution. A subset of the capture buffer — the buffer contents are decimated to 1000 data points. LRESolution: Low resolution. A subset of the capture buffer — the buffer contents are decimated to provide 240 data points. 	HRES MRES LRES

Example

```
TRAC? HRES
```

Returns the trace data at high resolution.

Error messages

- If `TRAC:STAT` is off, error -221, “Settings conflict” occurs.
- If the last measurement is invalid, error -230, “Data corrupt or stale” occurs. A measurement is valid after it has been initiated. The measurement is invalid when either a reset occurs or any measurement parameter such as frequency is changed.

NOTE

When `TRIG:SOUR` is `INT1` or `EXT` and a new acquisition has been initiated (using the `INIT` command for example), `TRACe?` waits until the trigger takes place before executing. If trigger conditions are not satisfied - when the trigger level differs greatly from the signal level for example - this can give the impression that the U2020 X-Series has hung.

To unlock the U2020 X-Series and adjust trigger settings, Device Clear should be executed (this is equivalent to “EXECUTE CLEAR” in Agilent VEE).

TRACe[1]:DEFine:DURation:REFerence<numeric_value>

This command defines the reference levels to be used in the calculation of pulse durations. This allows pulse duration measurements between non-standard reference levels.

Syntax

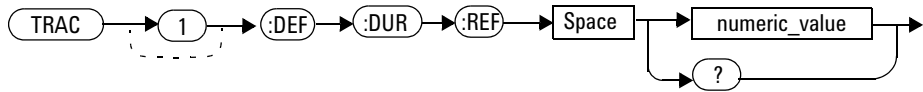

Parameters

Item	Description/Default	Range of values
numeric_value	Reference levels to be used in the calculation of pulse duration	0 to 100 DEF

Example

TRAC:DEF:DUR:REF 25

Sets the trace pulse duration measurements to look for the 25% reference levels.

TRAC:DEF:DUR:REF DEF

Sets the trace pulse duration measurements to look for the 50% reference levels.

Reset condition

On reset, the reference level will become 50%, which is the default value (DEF).

Query

```
TRACe[1]:DEFine:DURation:REFerence?
```

The query returns the numeric value of the reference level used in the pulse duration calculation.

Query example

```
TRAC:DEF:DUR:REF?
```

Queries the value of the reference level used in the trace pulse duration measurement.

TRACe[1]:DEFine:TRANsition:REFerence <numeric_value>, <numeric_value>

This command defines the reference levels to be used in the calculation of transition durations and occurrences. This allows transition measurements between non-standard reference levels.

Syntax

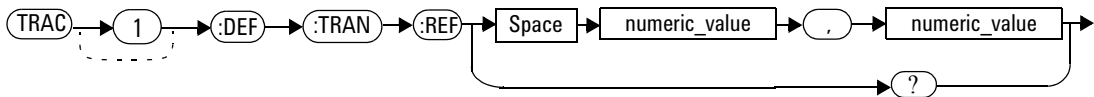

Parameters

Item	Description/Default	Range of values
numeric_value	Reference levels to be used in the calculation of transition durations and occurrences	0 to 100 DEF

Example

TRAC:DEF:TRAN:REF 1,18 *Sets the trace transition measurements to look for the 1% and 81% reference levels.*

TRAC:DEF:TRAN:REF DEF,DEF *Sets the trace transition measurements to look for the 10% and 90% reference levels.*

Reset condition

On reset, the reference level will be set to 10% and 90% respectively.

Query

```
TRACe[1]:DEFine:TRANSition:REFerence?
```

The query returns the trace reference levels used in the transition occurrences calculation.

Query example

```
TRAC:DEF:TRAN:REF?
```

Queries the reference levels used in the calculation of the trace transition durations and occurrences.

TRACe[1]:MEASurement:INSTant:REFerence? <numeric_value>

This command returns the time instant at which the power waveform intersects the reference level supplied as the command parameter. This allows the time instant used to calculate the pulse parameters to be found. It also allows the calculation of the transition between non-standard reference levels.

NOTE

This command is only applicable when the single or continuous triggered acquisition is selected.

Syntax



Parameters

Item	Description/Default	Range of values
numeric_value	Reference level in percentage	-25 to 125%

Example

TRAC:MEAS:INST:REF? 25 *Returns the time instant for the trace when the power is transitioned through the 25% reference level.*

TRACe[1]:MEASurement:PULSe[1] | ... | 20:DCYCLE?

This command returns the duty cycle of the selected pulse in percentage.

Algorithm

Duty Cycle = (pulse duration / pulse period) * 100

where,

pulse duration is the time difference between positive and negative transitions of one pulse, and pulse period is the time difference between two consecutive transition occurrences of the same polarity.

Syntax

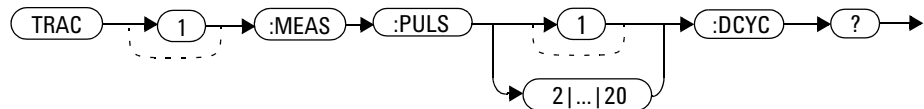

Example

```
TRAC:MEAS:PULS3:DCYC?
```

Returns the duty cycle of the 3rd pulse found on the trace.

Error message

If the free-run acquisition mode is selected, error -221, “Settings conflict” occurs.

NOTE

If you attempt to measure a pulse out of the range of the capture, for example, measure the 5th pulse and there are only four pulses, the U2020 X-Series returns 9.91E37 as the result.

TRACe[1]:MEASurement:PULSe[1] | ... | 20:DURation?

This command returns the difference between a pulse and next transition occurrence instants. As power pulses are by definition positive pulses, the pulse duration is the time difference between positive and negative transitions of one pulse.

Algorithm

If the first transition in the trace is positive,

then

PULSe:DURation = the time that the first negative transition occurs – the time that the first positive transition occurs

else

PULSe:DURation = the time that the second negative transition occurs – the time that the first positive transition occurs.

Syntax

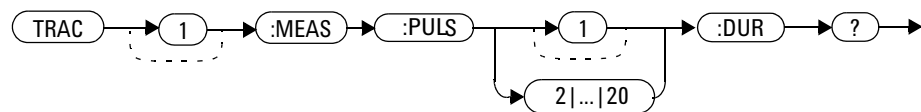

Example

TRAC:MEAS:PULS3:DUR?

Returns the duration of the 3rd pulse found on the trace.

Error message

If the free-run trigger acquisition is selected, error -221, “Settings conflict” occurs.

NOTE

If you attempt to measure a pulse out of the range of the capture, for example, measure the 5th pulse and there are only four pulses, the U2020 X-Series returns 9.91E37 as the result.

TRACe[1]:MEASurement:PULSe[1] | ... | 20:PERiod?

This command returns the pulse period. This is the time difference between two consecutive transition occurrences of the same polarity. The period is equal to the sum of the pulse separation and the pulse duration.

Algorithm

If the first transition in the trace is positive,
then

PULSe:PERiod = the time that the second positive transition occurs – the time that the first positive transition occurs

else

PULSe:PERiod = the time that the second negative transition occurs – the time that the first negative transition occurs.

Syntax

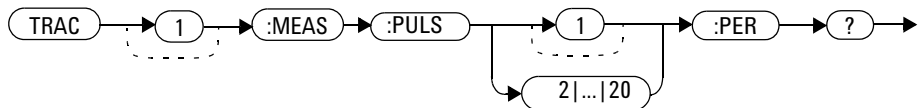

Example

TRAC:MEAS:PULS:PER?

Returns the period of the pulse found on the trace.

Error message

If the free-run trigger acquisition is selected, error -221, “Settings conflict” occurs.

NOTE

If you attempt to measure a pulse out of the range of the capture, for example, measure the 5th pulse and there are only four pulses, the U2020 X-Series returns 9.91E37 as the result.

TRACe[1]:MEASurement:PULSe[1] | ... | 20:SEParation?

This command returns the time difference of the n^{th} and $(n+1)^{\text{th}}$ pulses found on a trace. As power pulses are by definition positive pulses, the pulse separation is the time difference between the negative transition of one pulse and the positive transition of the next pulse.

Algorithm

If the first transition in the trace is positive,
then

$\text{PULSe:SEParation} = \text{the time that the second positive transition occurs} - \text{the time that the first negative transition occurs}$

else

$\text{PULSe:SEParation} = \text{the time that the first positive transition occurs} - \text{the time that the first negative transition occurs.}$

Syntax

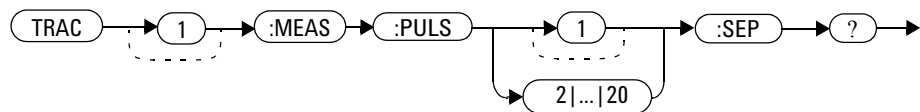

Example

TRAC:MEAS:PULS:SEP?

Returns the time separation of the 1st and 2nd pulses found on the trace.

Error message

If the free-run trigger acquisition is selected, error -221, “Settings conflict” occurs.

NOTE

If you attempt to measure a pulse out of the range of the capture, for example, measure the 5th pulse and there are only four pulses, the U2020 X-Series returns 9.91E37 as the result.

TRACe[1]:MEASurement:TRANsition[1] | ... | 20:NEGative:DURation?

This command returns the n^{th} negative transition duration found on a trace.

Syntax

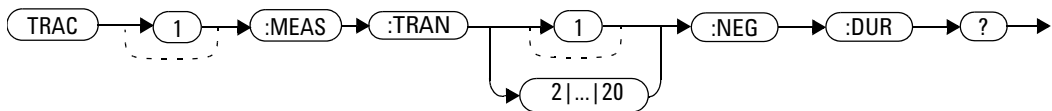

Reset condition

On reset, this parameter is not affected.

Example

```
TRAC:MEAS:TRAN8:NEG:DUR?
```

Returns the 8th negative transition duration found on the trace.

Error message

If the free-run trigger acquisition is selected, error -221, “Settings conflict” occurs.

NOTE

If you attempt to measure a pulse out of the range of the capture, for example, measure the 5th pulse and there are only four pulses, the U2020 X-Series returns +0.0000000E+000 as the result.

TRACe[1]:MEASurement:TRANsition[1] | ... | 20:NEGative:OCCurrence?

This command returns the position, relative to the trigger instant, of the n^{th} occurrence of a negative transition found on a trace.

Syntax

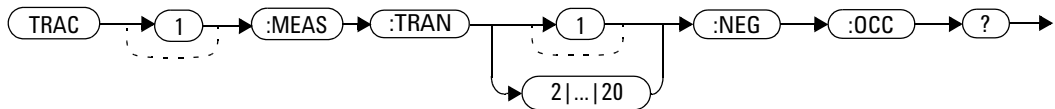

Reset condition

On reset, this parameter is not affected.

Example

`TRAC:MEAS:TRAN7:NEG:OCC?` *Returns the position, relative to the trigger instant, of the 7th occurrence of a negative transition found on the trace.*

Error message

If the free-run trigger acquisition is selected, error -221, “Settings conflict” occurs.

NOTE

If you attempt to measure a pulse out of the range of the capture, for example, measure the 5th pulse and there are only four pulses, the U2020 X-Series returns +0.00000000E+000 as the result.

TRACe[1]:MEASurement:TRANsition[1] | ... | 20:POSitive:DURation?

This command returns the n^{th} positive transition duration found on a trace.

Syntax

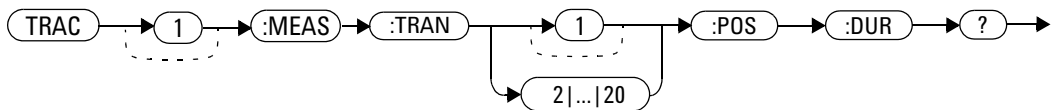

Reset condition

On reset, this parameter is not affected.

Example

`TRAC:MEAS:TRAN10:POS:DUR?` *Returns the 10th positive transition duration found on the trace.*

Error message

If the free-run trigger acquisition is selected, error -221, “Settings conflict” occurs.

NOTE

If you attempt to measure a pulse out of the range of the capture, for example, measure the 5th pulse and there are only four pulses, the U2020 X-Series returns +0.00000000E+000 as the result.

TRACe[1]:MEASurement:TRANsition[1] | ... | 20:POSitive:OCCurrence?

This command returns the position, relative to the trigger instant, of the n^{th} occurrence of a positive transition found on a trace.

Syntax

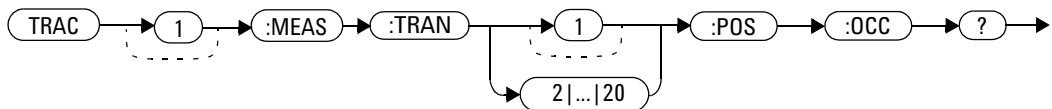

Reset condition

On reset, this parameter is not affected.

Example

TRAC:MEAS:TRAN:POS:OCC?

Returns the position, relative to the trigger instant, of the 1st occurrence of a positive transition found on the trace.

Error message

If the free-run trigger acquisition is selected, error -221, “Settings conflict” occurs.

NOTE

If you attempt to measure a pulse out of the range of the capture, for example, measure the 5th pulse and there are only four pulses, the U2020 X-Series returns +0.00000000E+000 as the result.

TRACe[1]:MEASurement:REFerence? <numeric_value>

This command is used to find the reference power level. This provides the reference power level to calculate the pulse parameters.

Commonly used reference levels are 0%, 10%, 50%, 90%, and 100%. You can set the reference level to measure overshoot at 125% and undershoot at -25%.

Algorithm

$$P_{x\%} = P_{0\%} + x/100 (P_{100\%} - P_{0\%})$$

where:

- $0\% \leq x \leq 100\%$
- $P_{0\%}$ = level of low state
- $P_{100\%}$ = level of high state
- $P_{0\%}$, $P_{100\%}$, and $P_{x\%}$ are all in the same unit of measurement, for example, Watts.

Syntax

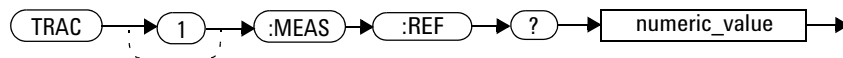

Reset condition

On reset, this parameter is not affected.

Example

```
TRAC:MEAS:REF? 100
```

Returns the high state power for the trace.

Error message

If the free-run trigger acquisition is selected, error -221, “Settings conflict” occurs.

TRACe[1]:STATe <boolean>

This command enables or disables trace capture for the specified channel.

NOTE

This command does not allow ON to be set when SENS:MRAT is set to FAST or TRIG:SOUR is not set to INT or EXT.

Syntax

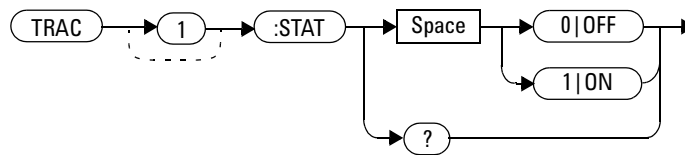

Example

```
TRAC:STAT 1
```

Enables trace capture.

Reset condition

On reset, trace capture is set to OFF.

Query

```
TRACe[1]:STATe?
```

The query command enters a 1 or 0 into the output buffer indicating whether or not trace capture is enabled or disabled.

- 1 is returned when trace capture is enabled
- 0 is returned when trace capture is disabled

Query example

TRAC:STAT?

Queries the current state of trace capture.

Error messages

- If TRAC:STAT is set to ON while LIST:STAT is set to ON, error -221, “Settings conflict;list mode is enabled” occurs.
- If DET:FUNC is set to AVER, error -221, “Settings conflict” occurs.

TRACe[1]:UNIT <character_data>

This command sets the units for the trace.

NOTE

This command is included for compatibility purposes only. It has the same purpose as [SENSE[1]:]TRACe:UNIT <character_data>, which is the preferred command.

Syntax

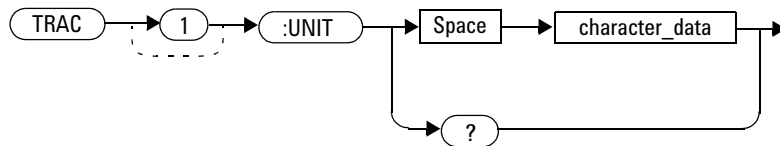

Parameters

Item	Description/Default	Range of values
character_data	<ul style="list-style-type: none"> • DBM: dBm • W: Watts 	DBM W

Example

TRAC:UNIT W *Sets the trace unit to Watts.*

Reset condition

On reset, the unit is set to dBm.

Query

```
TRACe[1]:UNIT?
```

The query command returns the current value of `character_data`.

Query example

```
TRAC:UNIT?
```

Queries the current trace unit.

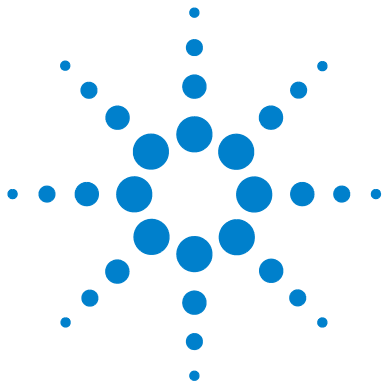

14 TRIGger Subsystem

TRIGger Subsystem	462
ABORt[1]	463
INITiate Commands	464
INITiate[1]:CONTInuous <boolean>	465
INITiate[1][:IMMEDIATE]	467
INITiate:CONTInuous:ALL <boolean>	468
INITiate:CONTInuous:SEQuence[1] <boolean>	470
INITiate[:IMMEDIATE]:ALL	472
INITiate[:IMMEDIATE]:SEQuence[1]	473
TRIGger Commands	474
TRIGger[1]:DELay:AUTO <boolean>	475
TRIGger[1][:IMMEDIATE]	477
TRIGger[1]:SOURce BUS EXTernal HOLD IMMEDIATE INTernal[1]	478
TRIGger[:SEQuence]:DELay <numeric_value>	481
TRIGger[:SEQuence]:HOLDoff <numeric_value>	483
TRIGger[:SEQuence]:HYSTeresis <numeric_value>	485
TRIGger[:SEQuence]:LEVel <numeric_value>	487
TRIGger[:SEQuence]:LEVel:AUTO <boolean>	489
TRIGger[:SEQuence]:SLOPe <character_data>	491
TRIGger[:SEQuence[1]]:COUNT <numeric_value>	493
TRIGger[:SEQuence[1]]:DELay:AUTO <boolean>	495
TRIGger[:SEQuence[1]]:IMMEDIATE	497
TRIGger[:SEQuence[1]]:QUALifier:TIME <numeric_value>	498
TRIGger[:SEQuence[1]]:SOURce BUS EXTernal HOLD IMMEDIATE INTernal[1]	500

This chapter explains how the TRIGger command subsystem is used to synchronize device actions with events.



TRIGger Subsystem

The TRIGger subsystem is used to synchronize device actions with events. It includes the ABORT, INITiate, and TRIGger commands. These are all at the root level in the command hierarchy but they are grouped here because of their close functional relationship.

ABORT[1], INITiate[1], and TRIGger[1] in the commands represent Channel A.

ABORt[1]

This command removes the channel from the wait-for-trigger state and places it in the idle state. It does not affect any other settings of the trigger system. When the INITiate command is sent, the trigger system responds as it did before ABORt was executed.

If INITiate:CONTinuous is ON, then after ABORt, the channel immediately goes into the wait-for-trigger state.

Syntax

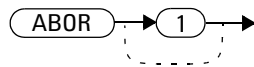

Example

ABOR

Places the channel in the idle state.

INITiate Commands

INITiate commands allow you to place the U2020 X-Series in the wait-for-trigger state.

The INITiate commands are overlapped, which allow the U2020 X-Series to continue parsing and executing subsequent commands¹ while it is still executing.

Note that the pending operation flag is set when the U2020 X-Series enters an idle state, and the flag is cleared when it re-enters the idle state.

The following commands are described in this section:

```
INITiate[1]:CONTinuous <boolean>
INITiate[1][:IMMediate]
INITiate:CONTinuous:ALL <boolean>
INITiate:CONTinuous:SEQuence[1] <boolean>
INITiate[:IMMediate]:ALL
INITiate[:IMMediate]:SEQuence[1]
```

¹ This is only applicable for selected commands.

INITiate[1]:CONTInuous <boolean>

This command sets the U2020 X-Series for either a single trigger cycle or continuous trigger cycles. A trigger cycle means that the U2020 X-Series exits the wait-for-trigger state and starts a measurement.

If INITiate:CONTInuous is set to:

- OFF, the trigger system remains in the idle state until it is set to ON, or INITiate:IMMediate is received. Once this trigger cycle is complete, the trigger system returns to the idle state.
- ON, the trigger system is initiated and exits the idle state. On completion of each trigger cycle, the trigger system immediately commences another trigger cycle without entering the idle state.

NOTE

This command performs the same function as INITiate:CONTInuous:SEQuence[1] <boolean>.

Syntax

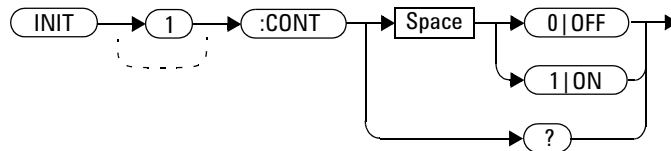

Example

INIT:CONT ON

Initiates the trigger.

Reset condition

On reset (*RST), this command is set to OFF.

Query

```
INITiate[1]:CONTinuous?
```

The query enters a 1 or 0 into the output buffer.

- 1 is returned when there is continuous triggering
- 0 is returned when there is only a single trigger

Query example

```
INIT:CONT?
```

Queries whether the U2020 X-Series is set for single or continuous triggering.

INITiate[1][:IMMediate]

This command sets the U2020 X-Series in the wait-for-trigger state. When a trigger is received, the measurement is taken and the result is placed in the U2020 X-Series memory. If TRIGger:SOURce is set to IMMEDIATE, the measurement begins as soon as INITiate[1][:IMMediate] is executed.

Use FETCH? to transfer a measurement from memory to the output buffer. Refer to “[FETCH\[1\]|2|3|4 Queries](#)” on page 84 for further details.

NOTE

This command performs the same function as INITiate[:IMMediate]:SEQuence[1].

Syntax

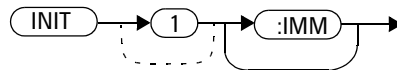

Example

INIT

Places the U2020 X-Series in the wait-for-trigger state.

Error message

If the U2020 X-Series is not in the idle state or INITiate:CONTinuous is ON, error -213, “INIT ignored” occurs.

INITiate:CONTInuous:ALL <boolean>

This command sets all trigger sequences to be continuously initiated.

If INITiate:CONTInuous:ALL is set to:

- ON, trigger sequences are set to be continuously initiated
- OFF, trigger sequences are not set to be continuously initiated

Syntax

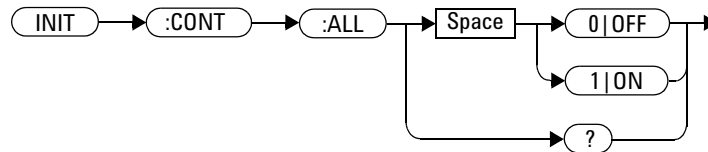

Example

```
INIT:CONT:ALL ON
```

Sets all trigger sequences to be continuously initiated.

Reset condition

On reset (*RST), this command is set to OFF.

Query

```
INITiate:CONTInuous:ALL?
```

The query enters a 1 or 0 into the output buffer.

- 1 is returned when trigger sequences are set to be continuous
- 0 is returned when trigger sequences are not set to be continuous

Query example

```
INIT:CONT:ALL?
```

Queries whether or not trigger sequences are set to be continuous.

INITiate:CONTInuous:SEQuence[1] <boolean>

This command sets the U2020 X-Series for either a single trigger cycle or continuous trigger cycles. A trigger cycle means that the U2020 X-Series exits the wait-for-trigger state and starts a measurement.

If INITiate:CONTInuous:SEQuence[1] <boolean> is set to:

- OFF, the trigger system remains in the idle state until it is set to ON, or INITiate:IMMediate is received. Once this trigger cycle is complete, the trigger system returns to the idle state.
- ON, the trigger system is initiated and exits the idle state. On completion of each trigger cycle, the trigger system immediately commences another trigger cycle without entering the idle state.

NOTE

This command performs the same function as INITiate[1]:CONTInuous <boolean>.

Syntax

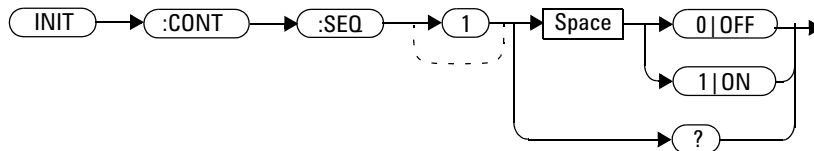

Example

```
INIT:CONT:SEQ ON
```

Initiates the trigger.

Reset condition

On reset (*RST), this command is disabled.

On preset (SYSTem:PRESet) and instrument power-up, this command is enabled.

Query

```
INITiate:CONTinuous:SEQuence[1]?
```

The query enters a 1 or 0 into the output buffer.

- 1 is returned when there is continuous triggering
- 0 is returned when there is only a single trigger

Query example

```
INIT:CONT:SEQ?
```

Queries whether the U2020 X-Series is set for single or continuous triggering.

INITiate[:IMMediate]:ALL

This command initiates all trigger sequences.

Syntax



Example

```
INIT:ALL
```

Initiates all trigger sequences.

Error message

If the U2020 X-Series is not in the idle state or INITiate:CONTinuous is ON, error -213, “INIT ignored” occurs.

INITiate[:IMMediate]:SEQuence[1]

This command sets the U2020 X-Series in the wait-for-trigger state. When a trigger is received, the measurement is taken and the result is placed in the U2020 X-Series memory. If TRIGger:SOURce is set to IMMEDIATE, the measurement begins as soon as INITiate[1][:IMMediate] is executed.

Use FETCH? to transfer a measurement from memory to the output buffer. Refer to “[FETCH\[1\]|2|3|4 Queries](#)” on page 84 for further information.

NOTE

This command performs the same function as INITiate[1][:IMMediate].

Syntax

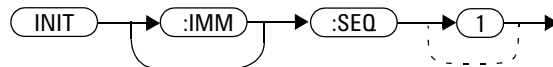

Example

```
INIT:SEQ
```

Places the U2020 X-Series in the wait-for-trigger state.

Error message

If the U2020 X-Series is not in the “idle” state or INITiate:CONTinuous is ON, error -213, “INIT ignored” occurs.

TRIGger Commands

TRIGger commands control the behavior of the trigger system.

The following commands are described in this section:

```

TRIGger[1]:DElay:AUTO <boolean>
TRIGger[1][:IMMediate]
TRIGger[1]:SOURce BUS|EXTErnal|HOLD|IMMediate|INTErnal[1]
TRIGger[:SEquence]:DElay <numeric_value>
TRIGger[:SEquence]:HOLDoff <numeric_value>
TRIGger[:SEquence]:HYSTEResis <numeric_value>
TRIGger[:SEquence]:LEvel <numeric_value>
TRIGger[:SEquence]:LEvel:AUTO <boolean>
TRIGger[:SEquence]:SLOPe <character_data>
TRIGger[:SEquence[1]]:COUNT <numeric_value>
TRIGger[:SEquence[1]]:DElay:AUTO <boolean>
TRIGger[:SEquence[1]]:IMMediate
TRIGger[:SEquence[1]]:SOURce
BUS|EXTErnal|HOLD|IMMediate|INTErnal[1]

```

TRIGger[1]:DELay:AUTO <boolean>

This command is used to determine whether or not there is a settling-time delay before a measurement is made.

When this command is set to:

- ON, the U2020 X-Series inserts a settling-time delay before taking the requested measurement. This settling time allows the internal digital filter to be updated with new values to produce valid, accurate measurement results. The trigger with delay command allows settling time for the internal amplifiers and filters. It does not allow time for delay.

In cases of large power changes, the delay may not be sufficient for complete settling. Accurate readings can be assured by taking two successive measurements for comparison.

- OFF, the U2020 X-Series makes the measurement immediately when a trigger is received.

TRIGger[1]:DELay:AUTO is ignored if TRIGger[1][:IMMEDIATE] is set to ON.

Syntax

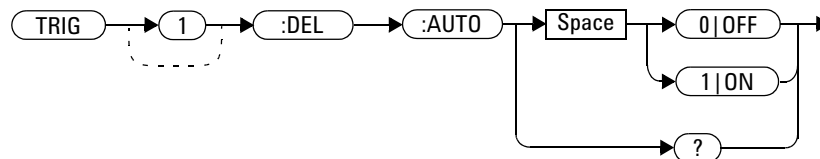

Example

```
TRIG:DEL:AUTO ON
```

Enables a delay.

Reset condition

On reset, TRIGger:DELAy:AUTO is set to ON.

Query

TRIGger:DELAy:AUTO?

The query enters a 1 or 0 into the output buffer indicating the status of TRIGger:DELAy:AUTO.

- 1 is returned when it is ON
- 0 is returned when it is OFF

TRIGger[1][:IMMEDIATE]

This command causes a trigger to occur immediately, provided the U2020 X-Series is in the wait-for-trigger state. When this command is executed, the measurement result is stored in the U2020 X-Series memory. Use `FETCh?` to place the measurement result in the output buffer.

`TRIGger[1]:DELay:AUTO` is ignored if `TRIGger[1][:IMMEDIATE]` is set to ON.

NOTE

This command performs the same function as `INITiate[1][:IMMEDIATE]`.

Syntax

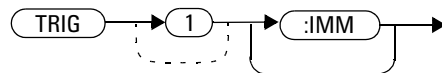

Example

`TRIG`

Causes a trigger to occur immediately.

Error message

If the U2020 X-Series is not in the wait-for-trigger state, then `TRIGger:IMMEDIATE` causes error -211, “Trigger ignored” to occur.

TRIGger[1]:SOURce BUS | EXTernal | HOLD | IMMEDIATE | INTernal[1]

This command configures the trigger system to respond to the specified source. This command only selects the trigger source. Use the INITiate command to place the U2020 X-Series in the wait-for-trigger state.

NOTE

This command has been included for compatibility purposes. It has the same purpose as TRIGger[:SEquence[1]]:SOURce BUS|EXTernal|HOLD|IMMEDIATE|INTernal[1] which is the preferred command.

Syntax

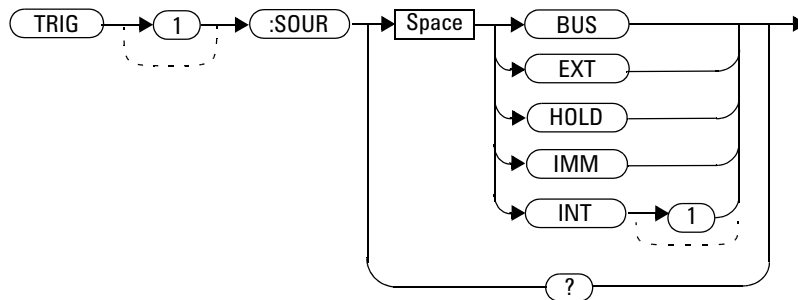

Parameters

Item	Description/Default	Range of values
source	<p>Available trigger sources:</p> <ul style="list-style-type: none"> BUS: the trigger source is the group execute trigger <GET> bus command, a *TRG common command, or the TRIGger:IMMediate SCPI command. EXTernal: the trigger source is the external trigger input. HOLD: triggering is suspended. The only way to trigger the U2020 X-Series is to use TRIGger:IMMediate. IMMediate: the trigger system is always true. If INITiate:CONTinuous is ON, the U2020 X-Series is continually triggering free (free run mode). If an INITiate:IMMediate command is sent, a measurement is triggered then the U2020 X-Series returns to the idle state. INTernal[1]: the trigger source is Channel A. 	BUS EXTernal HOLD IMMediate INTernal[1]

NOTE

The trigger source is set to `IMMediate` upon instrument power-up.

If the trigger source is set to `BUS` or `HOLD`, the `MEASure` and `CONFigure` commands automatically set the trigger source to `IMMediate`.

The `READ?` or `MEASure` commands should not be used if the trigger source is set to `BUS` or `HOLD`.

Example

```
TRIG:SOUR IMM
```

Configures the U2020 X-Series for immediate triggering.

Reset condition

On reset, the trigger source is set to `IMMediate`.

Query

```
TRIGger[1]:SOURce?
```

The query returns the current trigger source of either IMM, BUS, or HOLD.

Query example

```
TRIG:SOUR?
```

Queries the U2020 X-Series trigger source.

Error messages

- If the source is changed to INT or EXT and [SENSE[1]:]MRATE is set to FAST, error -221, “Settings conflict” occurs.
- If TRIG:SOUR is not set to EXT while LIST:STAT is set to ON, error -221, “Settings conflict;list mode is enabled” occurs.
- If the source is changed to INT and DET:FUNC is set to AVER, error -221, “Settings conflict” occurs.

TRIGger[:SEQuence]:DElay <numeric_value>

This command sets the delay between the recognition of a trigger event and the start of a measurement.

Syntax

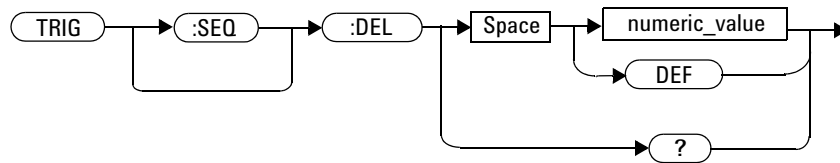

Parameters

Item	Description/Default	Range of values
numeric_value	<p>The delay between the recognition of a trigger event and the start of the measurement, in seconds.</p> <ul style="list-style-type: none"> DEF: the default value is 0 s <p>Units are resolved to 12.5 ns.</p>	<p>–1 to 1 s</p> <p>DEF</p>

Example

```
TRIG:DEL 0.001
```

Sets a delay of 1 ms.

Reset condition

On reset, the trigger delay is set to 0 s.

Query

```
TRIGger[:SEquence]:DElay?
```

The query returns the current setting of the trigger delay.

Query example

```
TRIG:DEL?
```

Queries the trigger delay.

Error message

If the trigger source is not set to INT or EXT while setting TRIGger[:SEquence]:DElay, error -221, “Settings conflict” occurs.

TRIGger[:SEQuence]:HOLDoff <numeric_value>

This command sets the trigger holdoff in seconds.

Syntax

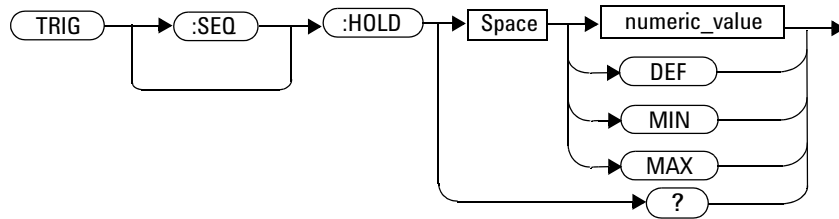

Parameters

Item	Description/Default	Range of values
numeric_value	<p>The trigger holdoff in seconds.</p> <ul style="list-style-type: none"> DEF: the default value is 1 μs MIN: 1 μs MAX: 400 ms <p>Units are resolved to 12.5 ns.</p>	<p>1 μs to 0.4 s</p> <p>DEF</p> <p>MIN</p> <p>MAX</p>

Example

TRIG:HOLD 0.1 *Sets the trigger holdoff to 100 ms.*

Reset condition

On reset, the trigger holdoff is set to 1 μ s.

Query

```
TRIGger[:SEquence]:HOLDoff?
```

The query returns the current trigger holdoff setting.

Query example

```
TRIG:HOLD?      Queries the trigger holdoff setting.
```

Error message

If the trigger source is not set to INT or EXT while setting TRIGger[:SEquence]:HOLDoff, error -221, “Settings conflict” occurs.

TRIGger[:SEQuence]:HYSTeresis <numeric_value>

This command sets:

- How far a signal must fall below TRIG:LEVEl before a rising edge can be detected.
- How far a signal must rise above TRIG:LEVEl before a falling edge can be detected.

Syntax

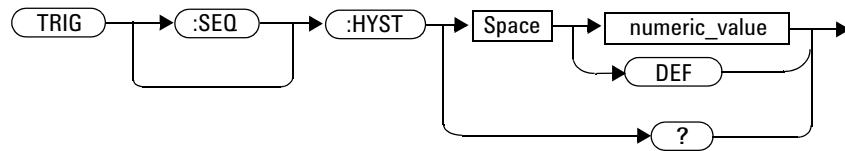

Parameters

Item	Description/Default	Range of values
numeric_value	How far a signal must fall/rise before a rising or falling edge can be detected. DEF: the default value is 0 dB Units are resolved to 0.05 dB.	0 to 3 dB DEF

Example

TRIG:HYST 0.1 *Sets the value to 0.1 dB.*

Reset condition

On reset, the value is set to 0 dB.

Query

```
TRIGger[:SEquence]:HYSTeresis?
```

The query returns the current value in dB.

Query example

```
TRIG:HYST?           Queries the current value.
```

Error message

If the trigger source is not set to INT or EXT while setting TRIGger[:SEquence]:HYSTeresis, error -221, “Settings conflict” occurs.

TRIGger[:SEQuence]:LEVel <numeric_value>

This command sets the power level at which a trigger event is recognized.

Syntax

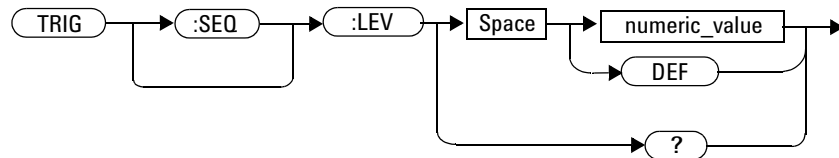

Parameters

Item	Description/Default	Range of values ¹
numeric_value	<p>The power level at which a trigger event is recognized.</p> <ul style="list-style-type: none"> DEF: the default value is 0 dBm <p>Units are resolved to 0.1 dBm.</p>	<p>–40 to 20 dBm</p> <p>DEF</p>

¹ If a channel offset has been previously set, a higher numeric value is permitted. See “Setting Offsets” on page 38 for more information.

Example

```
TRIG:LEV 10
```

Sets the power level for a trigger event to 10 dBm.

Reset condition

On reset, the power level is set to 0 dBm.

Query

```
TRIGger[:SEquence]:LEVel?
```

The query returns the current power level setting.

Query example

```
TRIG:LEV?      Queries the power level setting.
```

Error message

If the trigger source is not set to INT while setting TRIGger[:SEquence]:LEVel, error -221, “Settings conflict” occurs.

TRIGger[:SEQuence]:LEVel:AUTO <boolean>

This command enables/disables automatic setting of the trigger level.

When this command is set to:

- ON, automatic setting of the trigger level is enabled.
- OFF, automatic setting of the trigger level is disabled.
- ONCE, automatic setting of the trigger level is enabled for one trigger event only. The value is then set to OFF.

Syntax

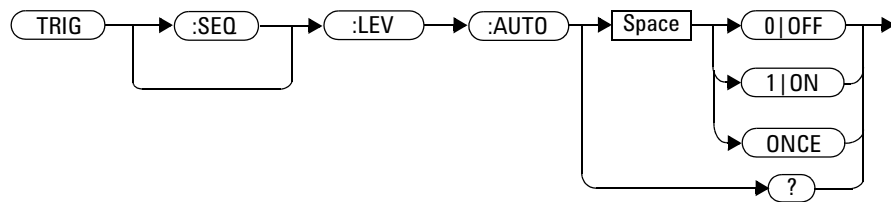

Example

```
TRIG:LEV:AUTO 0
```

Disables the automatic setting of the trigger level.

Reset condition

On reset, the value is set to ON.

Query

TRIGger[:SEquence]:LEVel:AUTO?

The query enters a 1 or 0 into the output buffer indicating the status of TRIGger[:SEquence]:LEVel:AUTO.

- 1 is returned when it is ON
- 0 is returned when it is OFF

Query example

TRIG:LEV:AUTO?

Queries the current setting.

TRIGger[:SEQuence]:SLOPe <character_data>

This command specifies whether a trigger event is recognized on the rising or falling edge of a signal.

Syntax

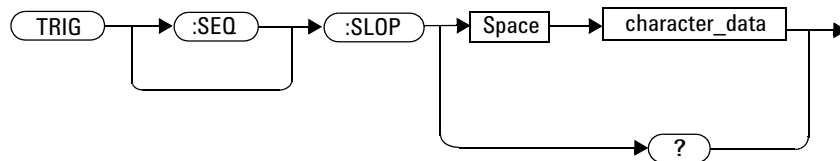

Parameters

Item	Description/Default	Range of values
character_data	How a trigger event is recognized: <ul style="list-style-type: none"> • POSitive: a trigger event is recognized on the rising edge of a signal. • NEGative: a trigger event is recognized on the falling edge of a signal. 	POSitive NEGative

Example

TRIG:SLOP NEG *Sets the trigger event to be recognized on the falling edge of the triggering signal.*

Reset condition

On reset, the value is set to POSitive.

Query

```
TRIGger[:SEquence]:SLOPe?
```

The query returns the current value of <character_data>.

Query example

```
TRIG:SLOP?
```

This command queries the current value of <character_data>.

Error message

If the trigger source is not set to INT or EXT while setting TRIGger[:SEquence]:SLOPe, error -221, “Settings conflict” occurs.

TRIGger[:SEQuence[1]]:COUNt <numeric_value>

This command controls the path of the trigger subsystem in the upward traverse of the wait-for-trigger state. COUNT loops through the event detection/measurement cycle performed. That is, COUNT measurements are performed in response to COUNT trigger events.

COUNT can be set to a value >1 only when [SENSE[1]:]MRATE <character_data> is set to FAST.

When COUNT is set to a value >1,

- CALibration[1]:ZERO:AUTO will switch to OFF automatically. It will be restored to its default setting when COUNT is set to 1.
- Setting a channel from the FAST mode to the NORMAl mode or DOUBle mode will also restore both the CALibration[1]:ZERO:AUTO and COUNT to their default settings automatically.

Syntax

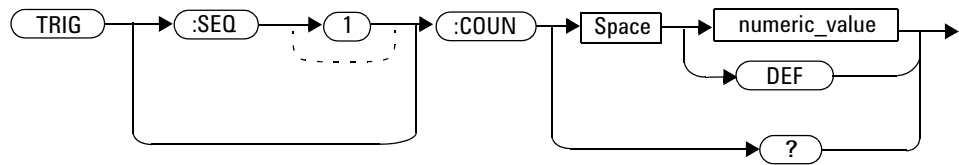

Parameters

Item	Description/Default	Range of values
numeric_value	The number of triggered events for the measurement cycle. <ul style="list-style-type: none"> • DEF: the default value is 1 	1 to 100 DEF

Example

TRIG:COUN 10 *Sets the number of triggered events to 10 for the measurement cycle.*

Reset condition

On reset, the value is set to 1.

Query

TRIGger[:SEQuence[1]]:COUNT?

The query returns the current setting of trigger events.

Query example

TRIG:COUN? *Queries the number of triggered events for the measurement cycle.*

Error message

If COUNT >1 when [SENSE[1]:]MRATE <character_data> is set to NORMAL or DOUBLE, error -221, “Settings conflict” occurs.

TRIGger[:SEQuence[1]]:DELAy:AUTO <boolean>

This command is used to determine whether or not there is a settling-time delay before a measurement is made.

When this command is set to:

- ON, the U2020 X-Series inserts a settling-time delay before taking the requested measurement and for subsequent measurements. This settling time allows the internal digital filter to be updated with new values to produce valid, accurate measurement results. The trigger with delay command allows settling time for the internal amplifiers and filters. It does not allow time for delay.

In cases of large power changes, the delay may not be sufficient for complete settling. Accurate readings can be assured by taking two successive measurements for comparison.

- OFF, no settling-time delay is inserted and the U2020 X-Series makes the measurement immediately when a trigger is received.
- ONCE, a settling-time delay is inserted before taking the requested measurement, for one measurement only.

TRIGger:DELAy:AUTO is ignored if TRIGger[1][:IMMEDIATE] is set to ON.

Syntax

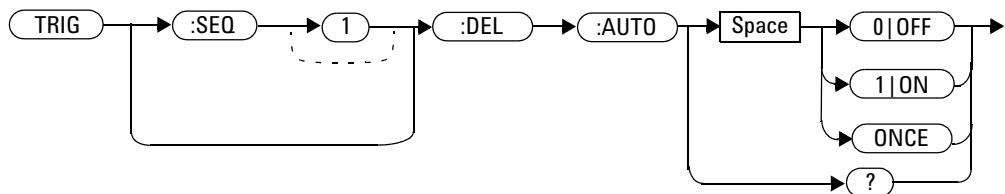

Example

TRIG:DEL:AUTO ON *Enables a delay.*

Reset condition

On reset, TRIGger:DElay:AUTO is set to ON.

Query

TRIGger[:SEquence[1]]:DElay:AUTO?

The query enters a 1 or 0 into the output buffer indicating the status of TRIGger:DElay:AUTO.

- 1 is returned when it is ON
- 0 is returned when it is OFF

Query example

TRIG:DEL:AUTO? *Queries the settling-time delay.*

TRIGger[:SEQuence[1]]:IMMediate

This command provides a one time override of the normal process of the downward path through the wait-for-trigger state. It causes the immediate exit of the event detection layer if the trigger system is in this layer when the command is received. In other words, the U2020 X-Series stops waiting for a trigger and takes a measurement ignoring any delay set by TRIG:DELAy.

Syntax

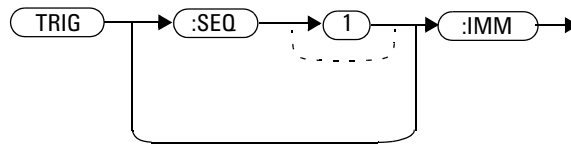

Example

TRIG:IMM

Initiates a measurement.

TRIGger[:SEQuence[1]]:QUALifier:TIME <numeric_value>

This command sets the trigger qualification time for stable triggering when measuring modulated signals.

NOTE

This command is only applicable when TRIG : SOUR is set to INT.

Syntax

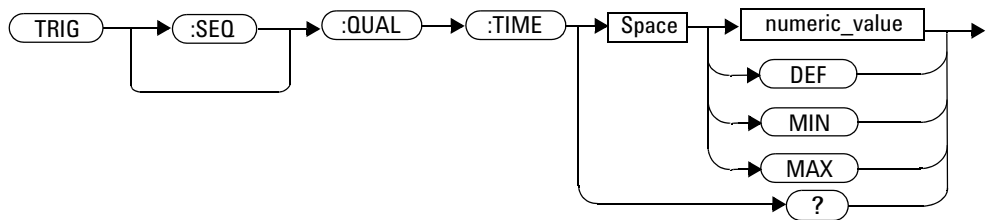

Parameters

Item	Description/Default	Range of values
numeric_value	<p>The trigger qualification time in seconds.</p> <ul style="list-style-type: none"> DEF: the default value is 100E-9 MIN: 25E-9 MAX: 50E-6 <p>Units are resolved to 12.5 ns.</p>	<p>25E-9 to 50E-6</p> <p>DEF MIN MAX</p>

Example

```
TRIG:QUAL:TIME      Sets the trigger qualification time to 1 μs.
1E-6
```

Reset condition

On reset, the trigger qualification time is set to 100 ns.

Query

```
TRIGger[:SEquence[1]]:QUALifier:TIME?
```

The query returns the current trigger qualification time setting.

Query example

```
TRIG:QUAL:TIME?    Queries the trigger qualification time setting.
```

Error messages

- If TRIG:QUAL:TIME is set when DET:FUNC is set to AVER or when TRIG:SOUR is not set to INT, error -221, “Settings conflict” occurs.
- If the limits of the values are exceeded, error -222, “Data out of range” occurs.

TRIGger[:SEQuence[1]]:SOURce BUS | EXTeRnal | HOlD | IMMEDIATE | INTernal[1]

This command configures the trigger system to respond to the specified source. This command only selects the trigger source. Use the INITiate command to place the U2020 X-Series in the wait-for-trigger state.

NOTE

This command has the same purpose as TRIGger[1]:SOURce
BUS | EXTeRnal | HOlD | IMMEDIATE | INTernal[1].

Syntax

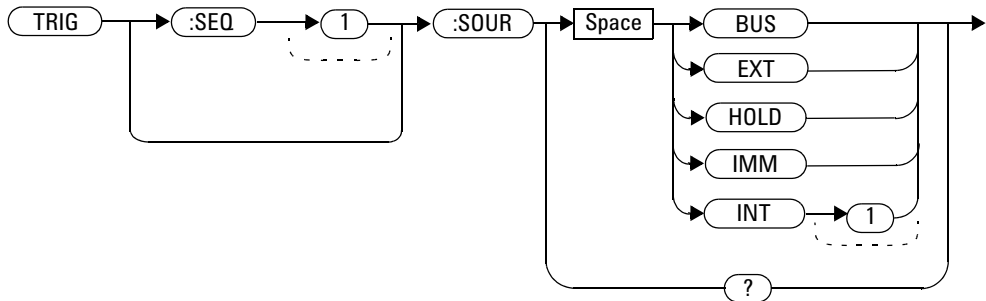

Parameters

Item	Description/Default	Range of values
source	<p>Available trigger sources:</p> <ul style="list-style-type: none"> BUS: the trigger source is the group execute trigger <GET> bus command, a *TRG common command, or the TRIGger:IMMEDIATE SCPI command. EXTernal: the trigger source is the external trigger input. HOLD: triggering is suspended. The only way to trigger the U2020 X-Series is to use TRIGger:IMMEDIATE. IMMEDIATE: the trigger system is always true. If INITiate:CONTinuous is ON, the U2020 X-Series is continually triggering free (free run mode). If an INITiate:IMMEDIATE command is sent, a measurement is triggered then the U2020 X-Series returns to the idle state. INTernal: the trigger source is Channel A. 	BUS EXTernal HOLD IMMEDIATE INTernal[1]

NOTE

The trigger source is set to IMMEDIATE upon instrument power-up.

If the trigger source is set to BUS or HOLD, the MEASure and CONFIgure commands automatically set the trigger source to IMMEDIATE.

The READ? or MEASure commands should not be used if the trigger source is set to BUS or HOLD.

Example

```
TRIG:SOUR IMM
```

Configures the U2020 X-Series for immediate triggering.

Reset condition

On reset, the trigger source is set to IMMEDIATE.

Query

```
TRIGger[:SEquence[1]]:SOURCE?
```

The query returns the current trigger source.

Query example

```
TRIG:SOUR?
```

Queries the current trigger source.

Error messages

- If the trigger source is changed to INT or EXT and [SENSE[1]:]MRATE is set to FAST, error -221, “Settings conflict” occurs.
- If TRIG:SOUR is not set to EXT while LIST:STAT is set to ON, error -221, “Settings conflict;list mode is enabled” occurs.
- If the source is changed to INT and DET:FUNC is set to AVER, error -221, “Settings conflict” occurs.

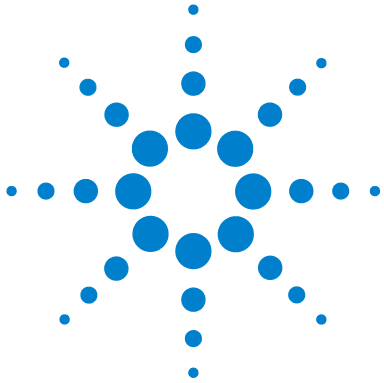

15 UNIT Subsystem

UNIT Subsystem [504](#)

UNIT[1]|2|3|4:POWer <amplitude_unit> [505](#)

UNIT[1]|2|3|4:POWer:RATio <ratio_unit> [507](#)

This chapter explains how the `UNIT` command subsystem is used to set the U2020 X-Series measurement units to Watts and % (linear), or dBm and dB (logarithmic).



UNIT Subsystem

The UNIT command subsystem:

- Sets power measurement units to dBm or Watts.
- Sets measurement ratio units to dB or % (linear).

UNIT commands have a numeric suffix which determines which CALCulate block is set.

The UNIT:POWer and UNIT:POWer:RATio commands are coupled as follows:

- If UNIT:POWer is set to dBm, then UNIT:POWer:RATio is dB.
- If UNIT:POWer is set to W, then UNIT:POWer:RATio is %.

UNIT[1|2|3|4]:POWer <amplitude_unit>

This command sets the power measurement unit for a specified CALCulate block.

- UNIT1:POWer sets the power measurement unit for CALCulate1.
- UNIT2:POWer sets the power measurement unit for CALCulate2.
- UNIT3:POWer sets the power measurement unit for CALCulate3.
- UNIT4:POWer sets the power measurement unit for CALCulate4.

For ratio and relative power measurements:

- If UNIT:POWer is W, the measurement unit is %.
- If UNIT:POWer is DBM, the measurement unit is dB relative.

Syntax

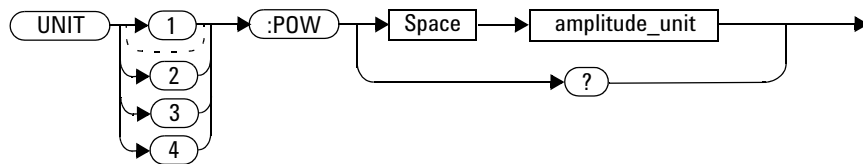

Parameters

Item	Description/Default	Range of values
amplitude_unit	The measurement unit. • The default unit is dBm	W DBM

Example

```
UNIT1:POW DBM
```

*Sets the power measurement unit for
CALCulate1.*

Reset condition

On reset, all CALCulate blocks are set to DBM.

Query

```
UNIT[1] | 2 | 3 | 4:POWer?
```

The query returns the current setting of the power measurement unit.

Query example

```
UNIT2:POW?
```

*Queries which measurement unit is being
used on CALCulate2.*

UNIT[1|2|3|4]:POWer:RATio <ratio_unit>

This command sets the ratio unit for a specified CALCulate block.

- UNIT1:POWer:RATio sets the ratio measurement unit for CALCulate1.
- UNIT2:POWer:RATio sets the ratio measurement unit for CALCulate2.
- UNIT3:POWer:RATio sets the ratio measurement unit for CALCulate3.
- UNIT4:POWer:RATio sets the ratio measurement unit for CALCulate4.

Syntax

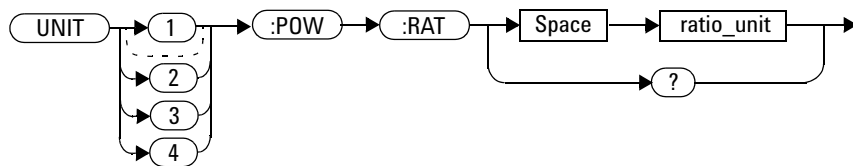

Parameters

Item	Description/Default	Range of values
ratio_unit	The ratio measurement unit. • The default unit is DB	DB PCT

Example

```
UNIT1:POW:RAT DB
```

*Sets the ratio measurement unit for
CALCulate1.*

Reset condition

On reset, the value is set to DB.

Query

```
UNIT[1|2|3|4]:POW:RATio?
```

The query returns the current setting of the ratio measurement unit.

Query example

```
UNIT2:POW:RAT?
```

Queries which ratio measurement unit is being used on CALCulate2.

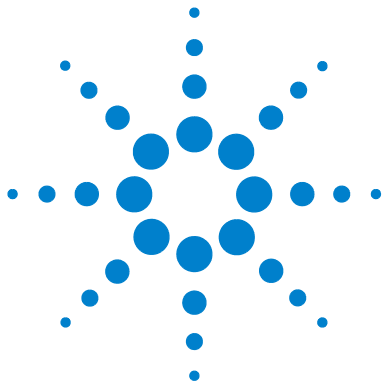

16 SERVice Subsystem

SERVice:BIST:CW:ZSET:NUMber?	510
SERVice:BIST:PEAK[1]:LINearity	511
SERVice:BIST:PEAK[1]:LINearity:PERRor?	512
SERVice:BIST:PEAK[1]:ZSET	513
SERVice:BIST:PEAK[1]:ZSET:NUMber?	514
SERVice:BIST:RAM:MODE <character_data>	515
SERVice:BIST:TBASe:STATe <boolean>	517
SERVice:BIST:VIDeo:STATe <boolean>	519
SERVice:SECure:ERASe	521
SERVice:SENSor[1]:CDATe?	522
SERVice:SENSor[1]:CPLace?	523
SERVice:SENSor[1]:FREQuency:MAXimum?	524
SERVice:SENSor[1]:FREQuency:MINimum?	525
SERVice:SENSor[1]:POWer:AVERAge:MAXimum?	526
SERVice:SENSor[1]:POWer:PEAK:MAXimum?	527
SERVice:SENSor[1]:POWer:USABle:MAXimum?	528
SERVice:SENSor[1]:POWer:USABle:MINimum?	529
SERVice:SENSor[1]:RADc?	530
SERVice:SENSor[1]:SNUMber?	531
SERVice:SENSor[1]:TNUMber?	532
SERVice:SENSor[1]:TYPE?	533
SERVice:SNUMber?	534
SERVice:VERSion:PROcEssor <character_data>	535
SERVice:VERSion:SYSTem <character_data>	536

This chapter explains how the `SERVice` command subsystem is used to obtain and set information useful for servicing the U2020 X-Series.



SERVICE:BIST:CW:ZSET:NUMBER?

This command returns the worst case error in the CW zero test invoked by the SERVICE:BIST:PEAK[1]:ZSET command.

Syntax

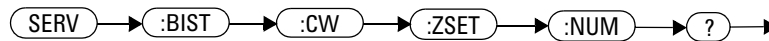

Example

```
SERV:BIST:CW:ZSET:NUM?
```

Queries the worst case error in the CW zero test.

SERVice:BIST:PEAK[1]:LINearity

This command initiates the PEAK linearity test.

Syntax



Example

```
SERV:BIST:PEAK:LIN
```

Initiates the PEAK linearity test.

SERVICE:BIST:PEAK[1]:LINEarity:PERRor?

This query returns the PEAK linearity worst case error.

Syntax

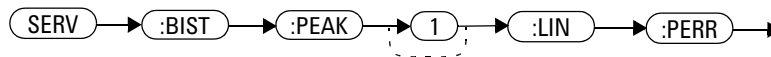

Example

```
SERV:BIST:PEAK:LIN:PERR?
```

Queries the PEAK linearity worst case error.

SERVice:BIST:PEAK[1]:ZSET

This command initiates the zero set and noise test for both peak and CW signals.

NOTE

Ensure that the U2020 X-Series is not connected to the RF source when performing the test.

Syntax

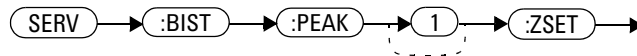

Example

SERV:BIST:PEAK:ZSET

Enables the zero set and noise test.

SERVICE:BIST:PEAK[1]:ZSET:NUMBER?

This command returns the worst case error in the PEAK zero test invoked by "SERVICE:BIST:PEAK[1]:ZSET".

Syntax

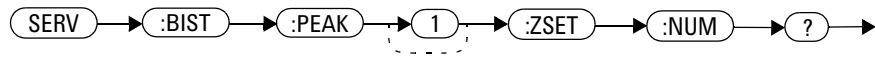

Example

SERV:BIST:PEAK:ZSET:NUM?

Queries the worst case error in the PEAK zero test.

SERvice:BIST:RAM:MODE <character_data>

This command sets the mode of the RAM self-test during U2020 X-Series power on. The result of the RAM self-test will be verified when *TST? is executed.

NOTE

If the mode is set to FULL, the U2020 X-Series power-up duration during power on will be longer by approximately 1 minute to allow thorough RAM self-test.

Syntax

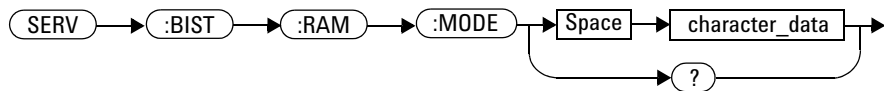

Parameters

Item	Description/Default	Range of values
character_data	RAM self-test mode: <ul style="list-style-type: none"> • OFF: the RAM self-test is turned off during power on • MINimum: the RAM self-test will run a minimum set of tests during power on • FULL: the RAM self-test will run a full set of tests during power on 	OFF MINimum FULL

Example

SERV:BIST:RAM:MODE MIN *Sets the RAM self-test mode to Minimum.*

Reset condition

On reset, the RAM self-test mode is set to OFF.

Query

```
SERVICE:BIST:RAM:MODE?
```

The query returns the current RAM self-test mode.

Query example

```
SERV:BIST:RAM:MODE?
```

Queries the current RAM self-test mode.

Error message

If <character_data> is not set to OFF, MINimum, or FULL, error -224, "Illegal parameter value" occurs.

SERVICE:BIST:TBASE:STATE <boolean>

This command enables the 10 MHz timebase signal on the Trig Out port for testing purposes.

NOTE

The `OUTPUT:RECORDER:STATE`, `OUTPUT:TRIGGER[:STATE]`, and `SERVICE:BIST:VIDEO:STATE` commands override the `SERVICE:BIST:TBASE:STATE` command.

For example, if `SERVICE:BIST:TBASE:STATE` is ON and the command `OUTPUT:TRIGGER[:STATE] ON` is sent, this command overrides the timebase state and sets it to OFF.

If `OUTPUT:TRIGGER[:STATE]` is ON and `SERVICE:BIST:TBASE:STATE ON` is sent, the timebase signal is now routed to the Trig Out port overriding the channel trigger output command turning the trigger output off.

If the command is set to:

- ON/1, the 10 MHz timebase signal is enabled on the Trig Out connector.
- OFF/0, the 10 MHz timebase signal is disabled.

Syntax

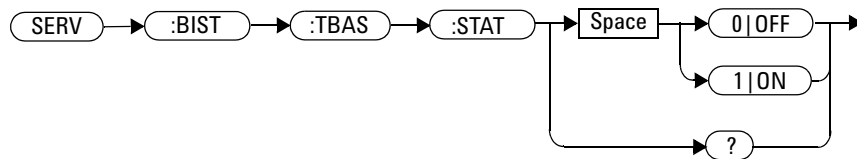

Example

`SERV:BIST:TBAS:STAT OFF` *Disables the 10 MHz timebase signal.*

Reset condition

On reset, the 10 MHz timebase signal is disabled.

Query

`SERVice:BIST:TBASe:STATe?`

The query indicates the status of the 10 MHz timebase.

- 1 is returned when the 10 MHz timebase signal is enabled
- 0 is returned when the 10 MHz timebase signal is disabled

Query example

`SERV:BIST:TBAS:STAT?` *Queries whether the 10 MHz timebase signal is enabled or disabled.*

SERVICE:BIST:VIDEO:STATE <boolean>

This command enables the video output signal on the Trig Out port.

NOTE

The `OUTPUT:RECORDER:STATE`, `OUTPUT:TRIGGER[:STATE]`, and `SERVICE:BIST:TBASE:STATE` commands override the `SERVICE:BIST:VIDEO:STATE` command.

For example, if `SERVICE:BIST:VIDEO:STATE` is ON and the command `OUTPUT:TRIGGER[:STATE] ON` is sent, this command overrides the video output state and sets it to OFF.

If `OUTPUT:TRIGGER[:STATE]` is ON and `SERVICE:BIST:VIDEO:STATE ON` is sent, the video output signal is now routed to the Trig Out port overriding the channel trigger output command turning the trigger output off.

If the command is set to:

- ON/1, the video output signal is enabled on the Trig Out connector.
- OFF/0, the video output signal is disabled.

Syntax

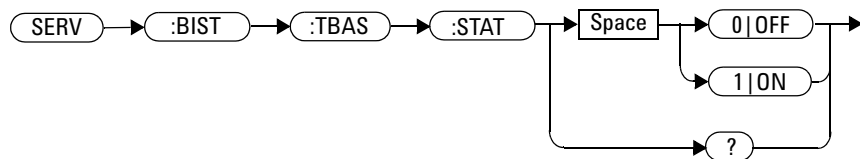

Example

`SERV:BIST:VID:STAT OFF` *Disables the video output signal.*

Reset condition

On reset, the video output signal is disabled.

Query

`SERVICE:BIST:VIDEO:STATE?`

The query indicates the status of the video output signal.

- 1 is returned when the video output signal is enabled
- 0 is returned when the video output signal is disabled

Query example

`SERV:BIST:VID:STAT?` *Queries whether the video output signal is enabled or disabled.*

Error message

If `DET:FUNC` is set to `AVER`, error -221 “Settings conflict” occurs.

SERVice:SECure:ERASe

This command erases the U2020 X-Series memory, for example, before you return it to Agilent for repair or calibration, of all data stored in it.

The memory data erased includes the save/recall states and power-on last states.

Syntax

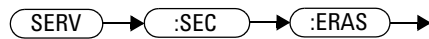

Example

```
SERV : SEC : ERAS
```

Erases the U2020 X-Series memory.

SERVICE:SENSOR[1]:CDATE?

This query returns the calibration date. The calibration date information is stored in the U2020 X-Series EEPROM.

Syntax

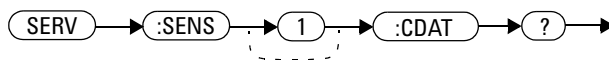

Example

SERV:SENS:CDAT?

Returns the calibration date.

SERVice:SENSor[1]:CPLace?

This query returns the place of calibration. The calibration place information is stored in the U2020 X-Series EEPROM.

Syntax

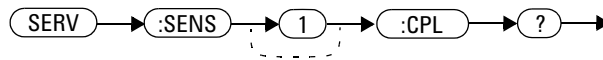

Example

SERV:SENS:CPL?

Returns the place of calibration.

SERVICE:SENSOR[1]:FREQUENCY:MAXIMUM?

This query returns the maximum frequency that can be measured by the sensor.

Syntax

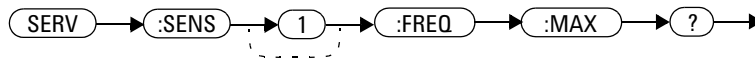

Example

SERV:SENS:FREQ:MAX?

Returns the maximum frequency that can be measured by the sensor.

Error message

If the sensor contains an invalid model number programmed into the EEPROM, error -56, “System error. Invalid sensor model number.” occurs.

NOTE

- For U2021XA, the limit returned is 18 GHz.
- For U2022XA, the limit returned is 40 GHz.

SERvice:SENSor[1]:FREQuency:MINimum?

This query returns the minimum frequency that can be measured by the sensor.

Syntax

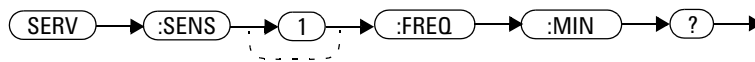

Example

SERV:SENS:FREQ:MIN?

Returns the minimum frequency that can be measured by the sensor.

Error message

If the sensor contains an invalid model number programmed into the EEPROM, error -56, “System error. Invalid sensor model number.” occurs.

NOTE

For U2021XA and U2022XA, the limit returned is 50 MHz.

SERVICE:SENSOR[1]:POWER:AVERAGE:MAXIMUM?

This query returns the maximum average power that can be measured by the U2020 X-Series.

Syntax

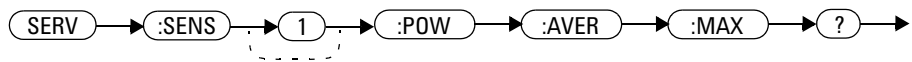

Example

SERV:SENS:POW:AVER:MAX?

Returns the maximum average power that can be measured by the U2020 X-Series.

Error message

If the U2020 X-Series contains an invalid model number programmed into the EEPROM, error -56, “System error. Invalid sensor model number.” occurs.

NOTE

For the U2020 X-Series, the limit returned is 20 dBm.

SERVice:SENSor[1]:POWER:PEAK:MAXimum?

This query returns the maximum peak power that can be measured by the U2020 X-Series.

Syntax

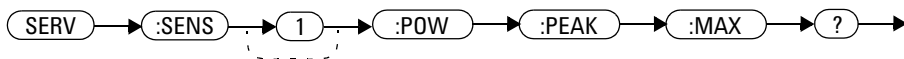

Example

SERV:SENS:POW:PEAK:MAX?

Returns the maximum peak power that can be measured by the sensor.

Error message

If the U2020 X-Series contains an invalid model number programmed into the EEPROM, error -56, “System error. Invalid sensor model number.” occurs.

NOTE

For the U2020 X-Series, the limit returned is 20 dBm.

SERVICE:SENSOR[1]:POWER:USABLE:MAXimum?

This query returns the maximum power that can be accurately measured by the U2020 X-Series.

Syntax



Example

SERV:SENS:POW:USAB:MAX?

Returns the maximum power that can be accurately measured by the U2020 X-Series.

Error message

If the U2020 X-Series contains an invalid model number programmed into the EEPROM, error -56, “System error. Invalid sensor model number.” occurs.

NOTE

For the U2020 X-Series, the limit returned is 20 dBm.

SERvice:SENSor[1]:POWer:USABle:MINimum?

This query returns the minimum power that can be accurately measured by the U2020 X-Series.

Syntax

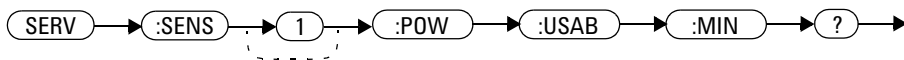

Example

SERV:SENS:POW:USAB:MIN?

Returns the minimum power that can be accurately measured by the U2020 X-Series.

Error message

If the U2020 X-Series contains an invalid model number programmed into the EEPROM, error -56, “System error. Invalid sensor model number.” occurs.

NOTE

For the U2020 X-Series, the limit returned is -40 dBm.

SERVICE:SENSOR[1]:RADC?

This query returns a new raw uncorrected measurement in volts, as a 32-bit signed integer.

Syntax

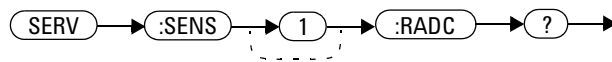

Example

SERV:SENS:RADC?

Returns a new raw uncorrected measurement.

Error message

If INIT:CONT is set to ON, error -221, “Settings conflict” occurs.

SERvice:SENSor[1]:SNUMber?

This query returns the U2020 X-Series serial number. The serial number information is stored in the U2020 X-Series EEPROM.

Syntax

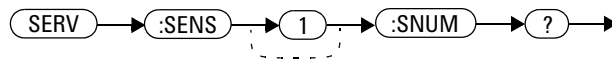

Example

SERV : SENS : SNUM?

Returns the U2020 X-Series serial number.

SERVICE:SENSOR[1]:TNUMBER?

This query returns the tracking number for the U2020 X-Series. The tracking number information is stored in the U2020 X-Series EEPROM.

Syntax

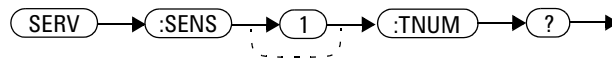

Example

SERV : SENS : TNUM?

Returns the tracking number of the U2020 X-Series.

SERVice:SENSor[1]:TYPE?

This query identifies the sensor type connected and returns the model number stored in the EEPROM.

Syntax

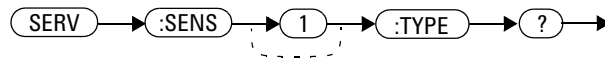

Example

SERV : SENS : TYPE ?

Returns the connected sensor model number.

SERVICE:SNUMber?

This query returns the U2020 X-Series serial number. The serial number information is stored in the U2020 X-Series EEPROM.

Syntax



Example

SERV:SNUM?

Returns the U2020 X-Series serial number.

SERvice:VERSion:PROcessor <character_data>

This command loads the U2020 X-Series with the processor board revision version.

Syntax

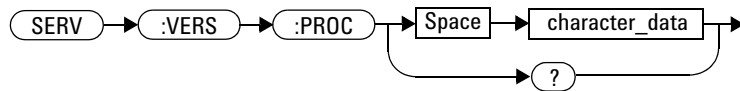

Parameters

Item	Description/Default	Range of values
character_data	Details the processor board revision version. A maximum of 20 characters can be used.	A to Z (upper-case) a to z (lower-case) 0 to 9 _ (underscore)

Example

```
SERvice:VERSion:PROcessor "C"
```

Loads the U2020 X-Series with processor board revision version C.

Query

```
SERvice:VERSion:PROcessor?
```

The query returns the current processor board revision version.

SERVICE:VERSION:SYSTEM <character_data>

This command loads the U2020 X-Series with the system version number.

Syntax

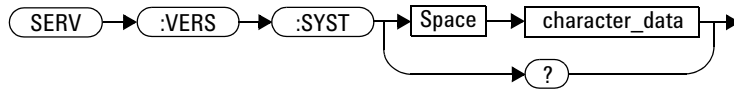

Parameters

Item	Description/Default	Range of values
character_data	Details the system version number. A maximum of 20 characters can be used.	A to Z (upper-case) a to z (lower-case) 0 to 9 _ (underscore)

Example

```
SERV:VERS:SYST "1"
```

Loads the U2020 X-Series with system version number 1.

Query

```
SERVICE:VERSION:SYSTEM?
```

The query returns the current U2020 X-Series system version number.



17 IEEE-488.2 Command Reference

SCPI Compliance Information 538

*CLS 539

*DDT <arbitrary block program data> | <string program data> 540

*ESE <NRf> 542

*ESR? 544

*IDN? 545

*OPC 546

*OPT? 547

*RCL <NRf> 548

*RST 549

*SAV <NRf> 550

*SRE <NRf> 551

*STB? 553

*TRG 554

*TST? 555

*WAI 556

This chapter contains information on the IEEE-488.2 Common Commands that the U2020 X-Series supports.



SCPI Compliance Information

This chapter contains information about the SCPI Common (*) Commands that the U2020 X-Series supports.

The IEEE-488.2 Common Command descriptions are listed below in the alphabetical order.

*CLS	Clear Status	page 539
*DDT and *DDT?	Define Device Trigger	page 540
*ESE and *ESE?	Event Status Enable	page 542
*ESR?	Event Status Register	page 544
*IDN?	Identify	page 545
*OPC and *OPC?	Operation Complete	page 546
*OPT?	Options	page 547
*RCL	Recall	page 548
*RST	Reset	page 549
*SAV	Save	page 550
*SRE and *SRE?	Service Request Enable	page 551
*STB?	Status Byte	page 553
*TRG	Trigger	page 554
*TST?	Test	page 555
*WAI	Wait	page 556

*CLS

The *CLS (Clear Status) command clears the status data structures. The SCPI registers (Questionable Status, Operation Status, and all the other SCPI registers), the Standard Event Status Register, the Status Byte, and the Error/Event Queue are all cleared.

Syntax

*CLS →

*DDT <arbitrary block program data> | <string program data>

The *DDT (Define Device Trigger) command determines the U2020 X-Series response to the *TRG common command. This command effectively turns *TRG into a query, with the measured power being returned.

Syntax

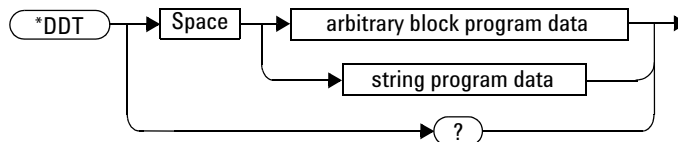

Parameters

Type	Description	Range of values
arbitrary block program data	The command which is executed on a *TRG.	#nN<action> ^{1,2}
string program data		"<action>" ¹

¹ The <action> field of the parameter may contain:

FETC?

FETC1?

FETC2?

*TRG

TRIG1

² The first digit after the # indicates the number of following digits. The following digits indicate the length of the data.

Examples of <arbitrary block program data> parameters are:

- #15FETC? and #206FETC?

Examples of <string program data> are:

- "FETC1?", "FETC?", and "TRIG1;FETC1"

Reset condition

On reset, the <action> field of *DDT is set to *TRG.

Query

*DDT?

The query returns the action which is performed on receipt of a *TRG. This is returned as a <definite-length arbitrary block response data> value in the form of #nN<action> as described on [page 521](#).

Error message

If an invalid parameter is received, error -224, "Illegal parameter value" occurs.

***ESE <Nrf>**

The *ESE (Event Status Enable) <Nrf> command sets the Standard Event Status Enable Register. This register contains a mask value for the bits to be enabled in the Standard Event Status Register. A 1 in the Enable Register enables the corresponding bit in the Status Register, while a 0 disables the bit. The parameter value, when rounded to an integer and expressed in base 2, represents the bit values of the Standard Event Status Enable Register. [Table 17-1](#) shows the contents of this register.

Table 17-1 *ESE mapping

Bit	Weight	Meaning
0	1	Operation Complete
1	2	Request Control (not used)
2	4	Query Error
3	8	Device Dependent Error
4	16	Execution Error
5	32	Command Error
6	64	User Request
7	128	Power On

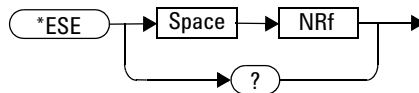
Syntax

Parameters

Type	Description/Default	Range of values
NR1	A value used to set the Standard Event Status Enable Register.	0 to 255

Query

*ESE?

The query returns the current contents of the Standard Event Status Enable Register. The format of the return is <NR1> in the range of 0 to 255.

***ESR?**

The *ESR? query returns the contents of the Standard Event Status Register and then clears it. The format of the return is <NR1> in the range of 0 to 255. [Table 17-2](#) shows the contents of this register.

Table 17-2 *ESR? mapping

Bit	Weight	Meaning
0	1	Operation Complete
1	2	Request Control (not used)
2	4	Query Error
3	8	Device Dependent Error
4	16	Execution Error
5	32	Command Error
6	64	User Request
7	128	Power On

Syntax

*IDN?

The *IDN? query allows the U2020 X-Series to identify itself. The string returned is either:

```
Agilent Technologies,U2021XA,<serial number>,A1.XX.YY
```

```
Agilent Technologies,U2022XA,<serial number>,A1.XX.YY
```

where:

- <serial number> uniquely identifies each U2020 X-Series.
- A1.XX.YY represents the firmware revision with XX and YY representing the major and minor revisions respectively.

Syntax

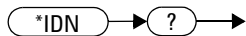

*OPC

The *OPC (Operation Complete) command causes the U2020 X-Series to set the operation complete bit in the Standard Event Status Register when all pending device operations have completed.

Syntax

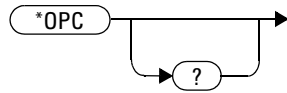

Query

*OPC?

The query places an ASCII 1 in the output queue when all pending device operations have completed.

*OPT?

The *OPT? query reports the options installed in the U2020 X-Series and returns a " " empty string for a standard instrument.

Syntax



***RCL <NRf>**

The *RCL <NRf> (ReCaLI) command restores the state of the U2020 X-Series from the specified save/recall register. An instrument setup must have been stored previously in the specified register.

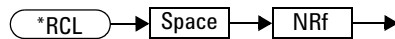
Syntax**Parameters**

Type	Description/Default	Range of values
NRf	The number of the register to be recalled.	1 to 10

Error message

If the register does not contain a saved state, error -224, “Illegal parameter value” occurs.

*RST

The *RST (ReSeT) command places the U2020 X-Series in a known state. Refer to “[SYSTem:PRESet <character_data>](#)” on page 388 for information on the reset values.

Syntax

*RST →

***SAV <NRf>**

The *SAV <NRf> (SAVe) command stores the current state of the U2020 X-Series in the specified register.

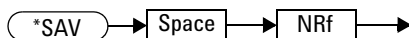
Syntax**Parameters**

Item	Description/Default	Range of values
NRf	The number of the register that the current state of the U2020 X-Series is to be saved to.	1 to 10

***SRE <Nrf>**

The *SRE <Nrf> command enables the bits in the Status Byte enable register. The selected enabled bits are summarized in the “Master Status Summary” (MSS) bit (bit 6) of the Status Byte register. If any of the selected bit condition changes from 0 to 1, a Service Request is generated. [Table 17-3](#) shows the contents of this register.

Table 17-3 *SRE mapping

Bit	Weight	Meaning
0	1	Not used
1	2	Device Status Register Summary
2	4	Error/Event Queue
3	8	QUEStionable Status Register Summary
4	16	Message Available
5	32	Event Status Byte Summary
6	64	Master Status Summary (Request for service)
7	128	OPERation Status Register Summary

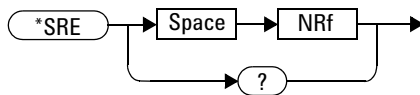
Syntax

Parameters

Type	Description/Default	Range of values
NRf	A value used to set the bits in the Status Byte enable register.	0 to 255

Query

*SRE?

The query returns the current contents of the Status Byte enable register. The format of the return is <NR1> in the range of 0 to 255.

*STB?

The *STB? (STatus Byte) query reads the condition register of the Status Byte register and returns a decimal value which corresponds to the binary-weighted sum of all bits set in the register. The format of the return is <NR1> in the range of 0 to 255. [Table 17-4](#) shows the contents of this register.

Table 17-4 *STB? mapping

Bit	Weight	Meaning
0	1	Not used
1	2	Device Status Register Summary
2	4	Error/Event Queue
3	8	QUEStionable Status Register Summary
4	16	Message Available
5	32	Event Status Byte Summary
6	64	Master Status Summary (Request for service)
7	128	OPERation Status Register Summary

Syntax

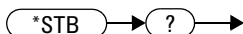

*TRG

The *TRG (TRiGger) command triggers all channels that are in the wait-for-trigger state.

Using the *DDT command may change the function of the *TRG command.

Syntax

`*TRG` →

Error messages

- If TRIGger:SOURce is not set to BUS, error -211, “Trigger ignored” occurs.
- If the U2020 X-Series is not in the wait-for-trigger state, error -211, “Trigger ignored” occurs.

*TST?

The *TST? (TeST) query causes the U2020 X-Series to perform the self-test. The test takes approximately 100 seconds.

The result of the test is placed in the output queue.

- 0 is returned if the test passes
- 1 if the test fails

Syntax



***WAI**

The *WAI (WAIt) command causes the U2020 X-Series to wait until either:

- all pending operations are complete
- the device clear command is received
- power is cycled

before executing any subsequent commands or queries.

Syntax





18 Programming Examples

Example 1: Two Time Slot GSM Measurement [558](#)

Example 2: Achieve Measurement Speed of >20000 Readings/s [559](#)

This chapter provides programming examples for the U2020 X-Series.



Example 1: Two Time Slot GSM Measurement

The following command sequence provides the example to perform the two time slot GSM measurement.

NOTE

“→” indicates the commands that you send to the U2020 X-Series.

Configuration stage

```
→ TRIG:SOUR EXT //Sets the trigger source to external trigger
                    input.
→ OUTP:TRIG ON //Enables the trigger output signal.
→ SENS:LIST:STAT ON //Enables the list mode.
```

List mode setup stage

```
→ SENS:LIST:POIN 100 //Sets the measurement points to 100.
→ SENS:LIST:MTYP AVER //Sets the measurement type to average power.
→ SENS:LIST:TSC 2 //Sets the number of slots to 2.
→ SENS:FREQ:STAR 1GHZ //Sets the start frequency to 1 GHz.
→ SENS:FREQ:STOP 1GHZ //Sets the stop frequency to 1 GHz.
→ SENS:LIST:TSL:TIME 577e-6 //Sets the measurement time slot to 577 μs.
→ SENS:LIST:TSL:TREF1 10 //Sets the measurement gate start time slot to
                            10%.
→ SENS:LIST:TSL:EXCL:TIME 0 //Sets the exclusion duration interval to 0 s.
→ SENS:LIST:TSL:EXCL:OFFS:TIME 0 //Sets the exclusion area offset time to 0 s.
```

Starting/re-starting the sequence and getting the results stage

```
→ INIT:CONT ON //Initiates the trigger sequence.
→ *OPC //Places an ASCII 1 in the output queue when
        all pending device operations have completed.
→ *ESR? //Returns the contents of the Standard Event
        Status Register and then clears it. Repeat this
        command until the sequence is completed (bit
        number is set to 1).
→ FETC? //Fetches the results.
```

Example 2: Achieve Measurement Speed of >20000 Readings/s

Free run mode

The following command sequence provides the example to achieve the measurement speed of >20000 readings/s in the free run mode.

NOTE

“→” indicates the commands that you send to the U2020 X-Series.

```

→ SYST:PRES //Presets the U2020 X-Series to default values.
→ SENS:FREQ 50MHz //Sets the frequency to 50 MHz.
→ INIT:CONT ON //Initiates the trigger sequence.
→ UNIT:POW W //Sets the power measurement unit for CALC1
to W.
→ FORM REAL //Sets the data format to REAL.
→ CAL:ZERO:AUTO OFF //Disables auto-zeroing.
→ CAL:AUTO OFF //Disables auto-calibration.
→ SENS:AVER:SDET OFF //Disables step detection.
→ SENS:DET:FUNC NORM //Sets the measurement mode to normal.
→ SENS:MRAT FAST //Sets the measurement speed to fast mode.
→ TRIG:COUN 100 //Sets the buffer size of the U2020 X-Series to
100 to store 100 measurement readings.
→ FETC? //Fetches the reading.
```

External trigger gated mode

The following command sequences provide the example to achieve the measurement speed of >20000 readings/s in the external trigger gated mode.

NOTE

“→” indicates the commands that you send to the U2020 X-Series.

```

→ SYST:PRES //Presets the U2020 X-Series to default values.
→ SENS:FREQ 50MHz //Sets the frequency to 50 MHz.
→ TRIG:SOUR EXT //Sets the trigger source to external trigger
input.
→ SENS:MRAT FAST //Sets the measurement speed to fast mode.
→ TRIG:COUN 100 //Sets the buffer size of the U2020 X-Series to
100 to store 100 measurement readings.
→ CAL:ZERO:AUTO OFF //Disables auto-zeroing.
→ CAL:AUTO OFF //Disables auto-calibration.
→ SENS:SWE:OFFS:TIME <X> //Sets the delay to X value. The X value
depends on the signal pulse width.
→ SENS:SWE:TIME <Y> //Sets the duration of the time-gated period to
Y value. The Y value depends on the signal
pulse width.
→ UNIT:POW W //Sets the power measurement unit for CALC1
to W.
→ FORM REAL //Sets the data format to REAL.
→ FETC? //Fetches the reading.

```

www.agilent.com

Contact us

To obtain service, warranty, or technical support assistance, contact us at the following phone numbers:

United States:

(tel) 800 829 4444 (fax) 800 829 4433

Canada:

(tel) 877 894 4414 (fax) 800 746 4866

China:

(tel) 800 810 0189 (fax) 800 820 2816

Europe:

(tel) 31 20 547 2111

Japan:

(tel) 0120 (421) 345 (fax) 0120 421 678

Korea:

(tel) (080) 769 0800 (fax) (080) 769 0900

Latin America:

(tel) (305) 269 7500

Taiwan:

(tel) 0800 047 866 (fax) 0800 286 331

Other Asia Pacific Countries:

(tel) (65) 6375 8100 (fax) (65) 6755 0042

Or visit Agilent World Wide Web at:

www.agilent.com/find/assist

Product specifications and descriptions in this document are subject to change without notice. Always refer to the Agilent Web site for the latest revision.

© Agilent Technologies, Inc. 2012–2013

Printed in Malaysia
Third Edition, May 10, 2013

U2021-90003



Agilent Technologies