

Keysight W4630 Series DDR4 BGA Interposer

Installation Guide

Notices

© Keysight Technologies 2014

No part of this manual may be reproduced in any form or by any means (including electronic storage and retrieval or translation into a foreign language) without prior agreement and written consent from Keysight Technologies as governed by United States and international copyright laws.

Manual Part Number

W4631-97000

Edition

Second Edition, October 2014

Available in electronic format only

Keysight Technologies
1900 Garden of the Gods Road
Colorado Springs, CO 80907 USA

Warranty

THE MATERIAL CONTAINED IN THIS DOCUMENT IS PROVIDED "AS IS," AND IS SUBJECT TO BEING CHANGED, WITHOUT NOTICE, IN FUTURE EDITIONS. FURTHER, TO THE MAXIMUM EXTENT PERMITTED BY APPLICABLE LAW, KEYSIGHT DISCLAIMS ALL WARRANTIES, EITHER EXPRESS OR IMPLIED WITH REGARD TO THIS MANUAL AND ANY INFORMATION CONTAINED HEREIN, INCLUDING BUT NOT LIMITED TO THE IMPLIED WARRANTIES OF MERCHANTABILITY AND FITNESS FOR A PARTICULAR PURPOSE. KEYSIGHT SHALL NOT BE LIABLE FOR ERRORS OR FOR INCIDENTAL OR CONSEQUENTIAL DAMAGES IN CONNECTION WITH THE FURNISHING, USE, OR PERFORMANCE OF THIS DOCUMENT OR ANY INFORMATION CONTAINED HEREIN. SHOULD KEYSIGHT AND THE USER HAVE A SEPARATE WRITTEN AGREEMENT WITH WARRANTY TERMS COVERING THE MATERIAL IN THIS DOCUMENT THAT CONFLICT WITH THESE TERMS, THE WARRANTY TERMS IN THE SEPARATE AGREEMENT WILL CONTROL.

Technology Licenses

The hardware and/or software described in this document are furnished under a license and may be used or copied only in accordance with the terms of such license.

Restricted Rights Legend

If software is for use in the performance of a U.S. Government prime contract or subcontract, Software is delivered and licensed as "Commercial computer software" as defined in DFAR 252.227-7014 (June 1995), or as a "commercial item" as defined in FAR 2.101(a) or as "Restricted computer software" as defined in FAR 52.227-19 (June 1987) or any equivalent agency regulation or contract clause. Use, duplication or disclosure of Software is subject to Keysight Technologies' standard commercial license terms, and non-DOD Departments and Agencies of the U.S. Government will receive no greater than Restricted Rights as defined in FAR 52.227-19(c)(1-2) (June 1987). U.S. Government users will receive no greater than Limited Rights as defined in FAR

52.227-14 (June 1987) or DFAR 252.227-7015 (b)(2) (November 1995), as applicable in any technical data.

Safety Notices

CAUTION

A CAUTION notice denotes a hazard. It calls attention to an operating procedure, practice, or the like that, if not correctly performed or adhered to, could result in damage to the product or loss of important data. Do not proceed beyond a CAUTION notice until the indicated conditions are fully understood and met.

WARNING

A WARNING notice denotes a hazard. It calls attention to an operating procedure, practice, or the like that, if not correctly performed or adhered to, could result in personal injury or death. Do not proceed beyond a WARNING notice until the indicated conditions are fully understood and met.

In This Guide

This document provides installation information for the following Keysight products:

- W4633A DDR4 x4/x8 BGA Command and Data Interposer
- E5849A High Data Rate Single-ended ZIF Cable (for use with the W4633A interposer)

Contents

In This Guide 3

1 Introduction

W4630 Series DDR4 BGA Interposer - Introduction 8

W4633A DDR4 x4/x8 BGA Interposer 8

Riser and Optional Grypper Socket 9

E5849A Single-ended ZIF Probe Cable 10

U4201A 90-pin Logic Analyzer Cables 11

Hardware and Software Requirements 12

Mechanical Considerations 13

W4633A Interposer Dimensions 13

Keep-Out Volume 14

DDR3 Probes 17

2 Setting up the W4630-Series Interposers

W4633A Interposer Setup - Overview 20

Soldering the W4633A Interposer and Riser 21

Interposer and Riser Soldering Guidelines 21

Interposer Fabrication Notes 22

Connecting the W4633A Interposer to E5849A Probe Cables 23

W4633A Interposer Wings Pinout 25

Connecting the E5849A Probe Cables to a Logic Analyzer 27

Logic Analyzer Channel Mapping 27

Signals not probed by the Logic Analyzer 28

3 Setting Up the Logic Analyzer for W4630 Series Probes

Before You Start 30

Loading a Configuration File 31

To save a configuration file 31

4 Characteristics, Regulatory, Safety and Storage Information

Operating Characteristics 34

Storage, Inspection, Baking, and Cleaning Guidelines	35
Guidelines for Shelf Life and Solder-ability of W4633A Interposers	35
Cleaning of W4633A Interposer Gold Fingers	35
Safety Information for the E5849A Cable Adapters	36
To clean the instrument	36
Safety Symbols	36
Regulatory Notices	37
WEEE Compliance	37
China RoHS	37

Index

1 Introduction

W4630 Series DDR4 BGA Interposer - Introduction / 8
Hardware and Software Requirements / 12
Mechanical Considerations / 13
DDR3 Probes / 17

This chapter introduces the hardware components that are needed for a W4630-series interposer setup. It also lists the software requirements as well as describes the mechanical considerations such as various dimensions and KOV that you should know before you start setting up and using these interposers.

W4630 Series DDR4 BGA Interposer - Introduction

The DDR4 DRAM BGA Interposers enable probing of embedded DDR4 DRAM (currently x4 and x8) directly at the ball grid array using the Keysight logic analyzers.

The DDR4 interposers interpose between the DRAM being probed and the PC board where the DRAM would normally be soldered. The interposer is designed to be soldered to the PCB footprint for the DRAM on top of either the DDR4 riser included with the W4630 series BGA interposer or an optional Grypper socket (not included with the interposer). The DRAM being probed is then soldered to the top side of the interposer.

Each DRAM signal in the common footprint passes directly from the bottom side of the interposer to the top side of the interposer. Buried probe resistors placed at the DRAM balls connect the probed signals to the rigid flex to mate with the E5849A cables.

The W4630 Series interposers are compatible with the Keysight U4154A AXIe-based Logic Analyzer module. Currently, in this series, Keysight provides the W4633A DDR4 x4/x8 BGA interposers.

W4633A DDR4 x4/x8 BGA Interposer

The W4633A interposer has three flexible wings, each with a set of fingers for Zero Insertion Force (ZIF) connections that connect it to the E5849A single-ended ZIF probe adapter cables. These E5849A cables are then connected to the Logic Analyzer module's pods via U4201A logic analyzer cables.

The interposer comes with Resistor and Capacitor (RC) components installed on its top and bottom.

The following figure shows a W4633A DDR4 BGA interposer top side view, with RC components installed.

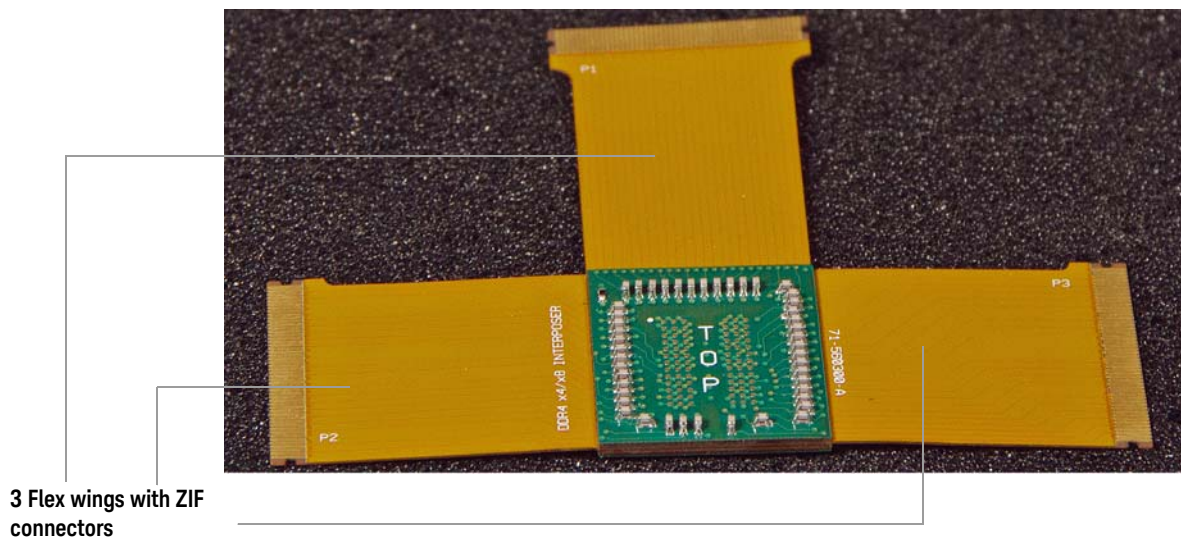

Figure 1 W4633A DDR4 x4/x8 BGA Interposer

W4633A Technical Features Summary

- Probes a 78 ball DDR4 single channel x4 or x8 DRAM chip, JEDEC MO-207M footprint variation DT-z. Maximum of 11 mm x 14 mm DDR4 DRAM package can fit on top of the W4633A interposer without an additional riser or a socket to provide clearance for the RC components.
- RC components network on the W4633A interposer:

- ADD/CMD and half DATA RC on top of the interposer
- Remaining half DATA RC on bottom of the interposer
- GND plane on the bottom side of the three flex wings of the interposer.
- For the three flex wings of the interposer, the recommended bend radius is 1.27MM (0.05") if flex is bent at a rigid portion of the interposer.
- Measurement timing skews within ± 25 psec achieved by matched trace lengths from DDR4 balls to test point.
- Logic analyzer connections are made using E5849A single ended ZIF probe cables. Doors of ZIF connectors attach to the bottom side of flex wings of the interposer.

Riser and Optional Grypper Socket

A DDR4 78 ball riser is provided with each W4633A interposer to provide clearance for bottom-side RC components on the interposer and to allow the interposer to clear surrounding devices. Optionally, you can use a Grypper socket. It is not provided with the interposer.

The following figure displays a riser that is provided with the W4633A interposer.

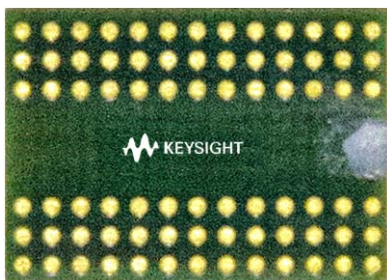

Figure 2 Riser that accompanies the W4633A interposer

NOTE

The DDR4 78 ball riser includes power and ground planes for optimal signal integrity. Due to the power and ground planes, the riser is only compatible with DDR4 78 ball DRAM.

To know how to solder the riser to the interposer and PC board, refer to the topic ["Soldering the W4633A Interposer and Riser"](#) on page 21.

E5849A Single-ended ZIF Probe Cable

Two E5849A probe cables are required to connect the W4633A interposer to a Logic Analyzer module using four U4201A logic analyzer cables.

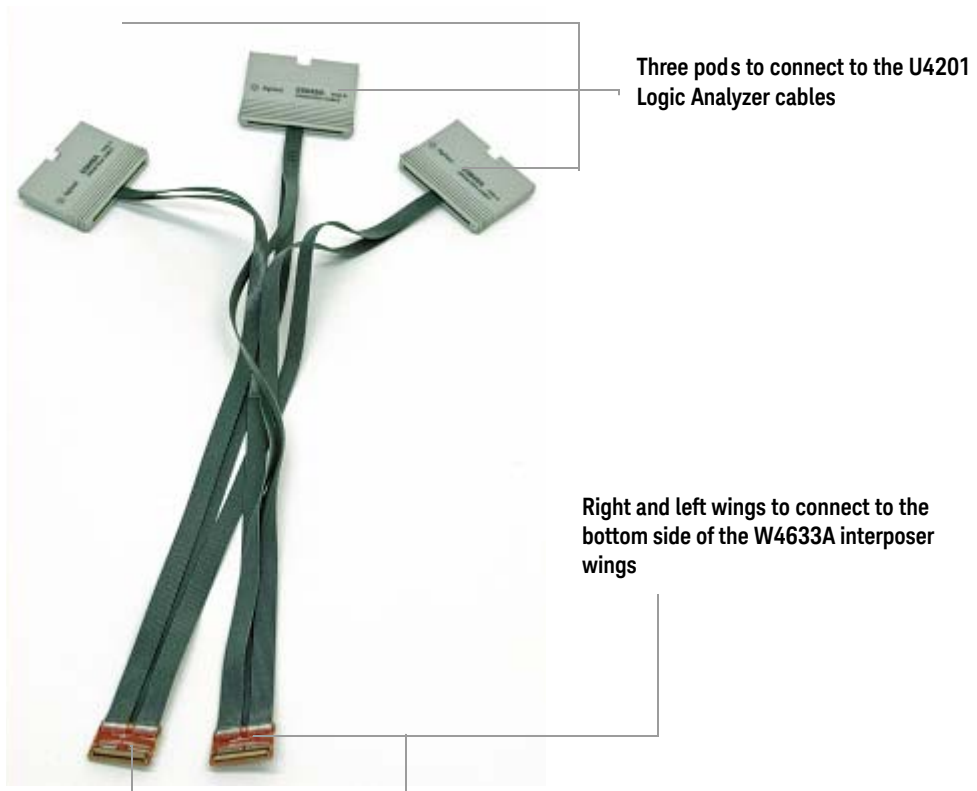

Figure 3 E5849A Single-ended ZIF probe cable

To know how to make connections between the W4633A interposer and E5849A probe cables, refer to the topic ["Connecting the W4633A Interposer to E5849A Probe Cables"](#) on page 23.

U4201A 90-pin Logic Analyzer Cables

The U4201A logic analyzer cable connects the **E5849A** probe cable to pods of the U4154A AXIe-based logic analyzer module.

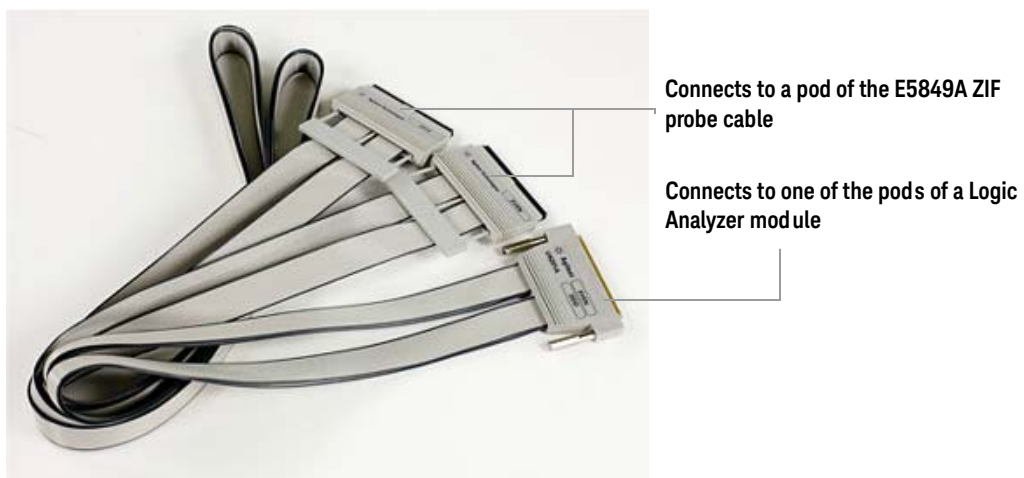

Figure 4 U4201A 90-pin logic analyzer cable

To know how to make connections between the U4201A cable and E5849A probe cable, refer to the topic ["Connecting the E5849A Probe Cables to a Logic Analyzer"](#) on page 27.

Hardware and Software Requirements

Before you start installing the W4630-series probes, ensure that you have the following list of hardware and software components needed for these probes.

Hardware Requirements
U4154A AXIe-based Logic Analyzer Module(s)
M9502A 2-slot or M9505A 5-slot AXIe chassis to install the U4154A module(s)
M9536A embedded controller or host PC with PCI express adapter card for the chassis
W4633A DDR4 x4/x8 BGA Interposer(s)
E5849A 46-ch single-ended ZIF probe cables to connect the W4633A interposer to U4201A Logic Analyzer cables Two E5849A cables needed for each W4633A interposer
U4201A 90-pin Logic Analyzer cables to connect the E5849A probe cables to U4154A module's analysis pods Four U4201A cables needed for each W4633A interposer

Software Requirements	Licensing	Description
Logic and Protocol Analyzer software version 5.80 or higher. (Mandatory)	Not Licensed	Base software platform for configuring and using Keysight's logic analyzer modules.
B4621B DDR 2/3/4 Bus Decoder software version 5.80 or higher. (Recommended)	Licensed	Allows you to decode and view transactions, commands, and data from a DDR2, DDR3, or DDR4 memory bus in your target system.
B4622B DDR 2/3/4 Protocol Compliance and Analysis toolset version 5.80 or higher. (Recommended)	Licensed	A set of tools to: <ul style="list-style-type: none"> evaluate and analyze the captured DDR data. perform real-time or post process compliance. set up a trigger on the specified address. graphically profile the distribution of memory accesses.
DDR Setup Assistant and DDR Eyefinder software version 5.80 or higher. (Recommended)	Not Licensed	A wizard- like application that helps you set up your U4154A logic analyzer properly for DDR/LPDDR memory technologies State mode measurements for ADD/CMD/DATA capture and analysis.

NOTE

You can install the above-mentioned software components by downloading the required executables from the Keysight web site at: www.keysight.com/find/la-sw-download.

The following table displays the number of W4633A BGA interposers and cable adapters required to provide connections to channels of your logic analyzer module.

DRAM	Data Width	Access to	Number of Interposers	Number of ZIF Probes	Number of Cables	Number of Logic Analyzer Modules
x4	x4	Command, Address, Control and Data	One W4633A	Two E5849A	Four U4201A	One U4154A module
x8	x8					

Mechanical Considerations

W4633A Interposer Dimensions

The following figure shows the dimensions of a W4633A DDR4 DRAM BGA interposer.

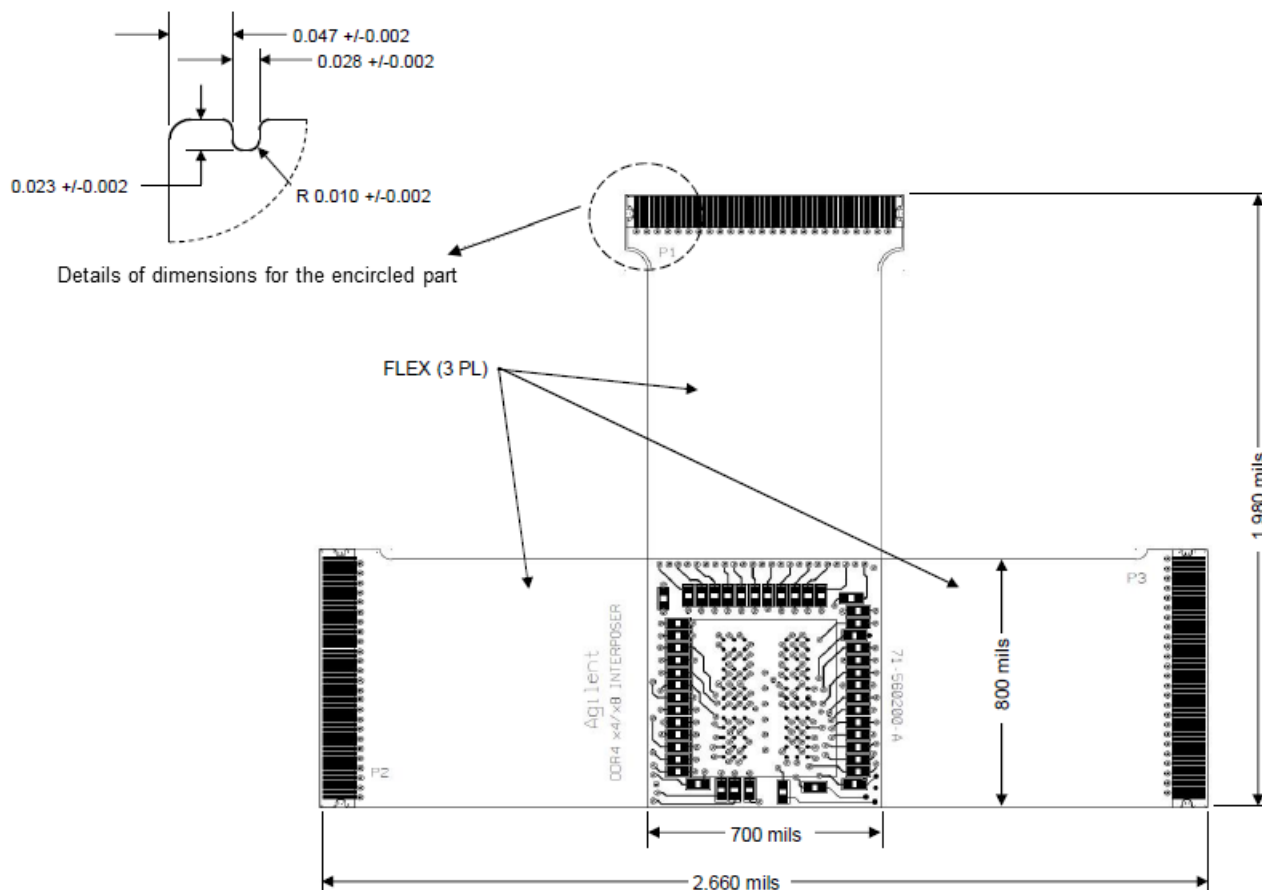

Figure 5 Dimensions of a W4633A interposer

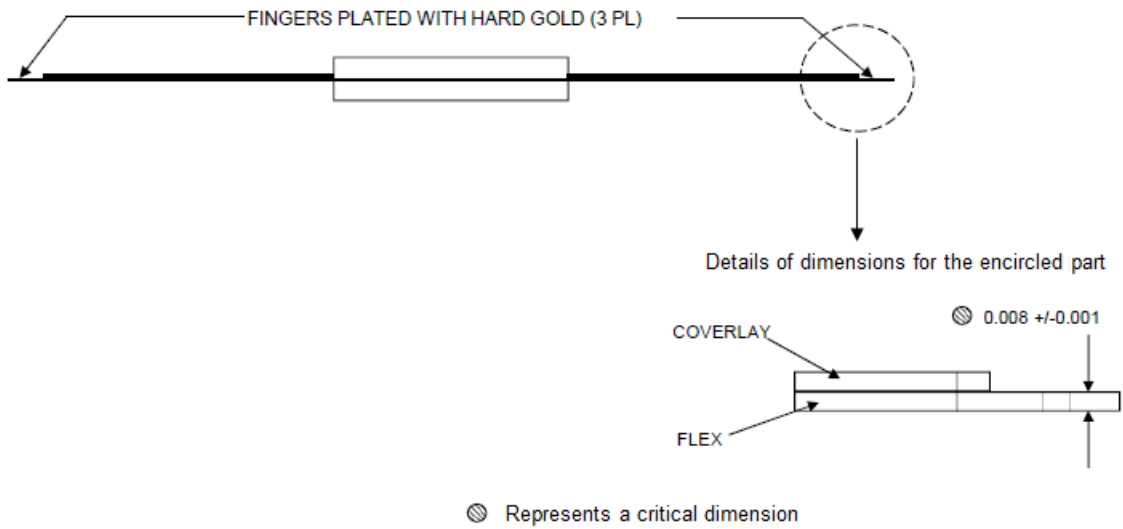
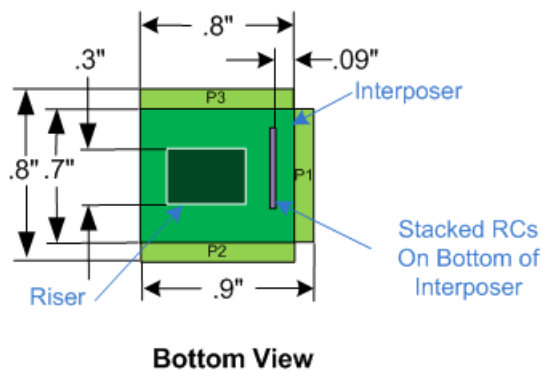
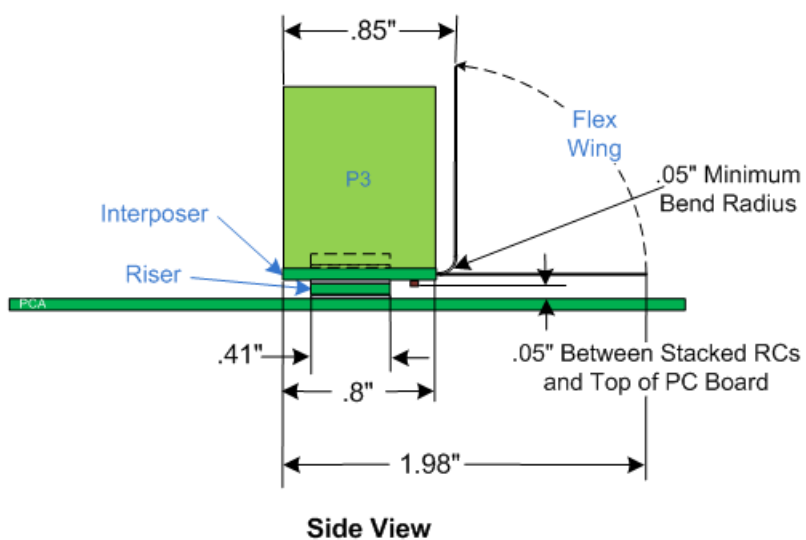
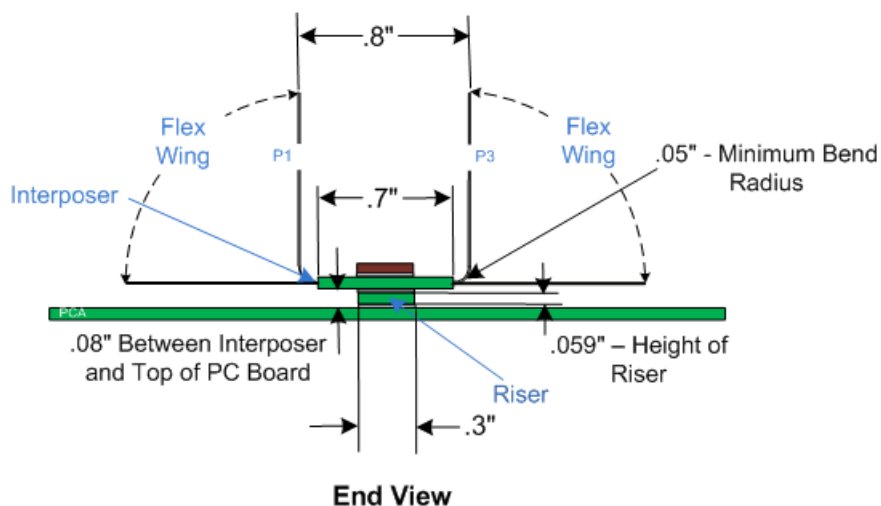

Figure 6 Dimensions of a W4633A interposer's signal finger

Keep-Out Volume

NOTE

You must install the W4633A interposer on a riser (shipped with the interposer) or a grypper socket to provide clearance to surrounding DRAM and RCs on the bottom side of the interposer.



- Notes:**
- P1, P2 and P3 are the Interposer Wings
 - All Dimensions are Nominal

Figure 7 KOV of a W4633A interposer

The following figure shows the KOV of an E5849A probe cable when connected to a W4633A interposer.

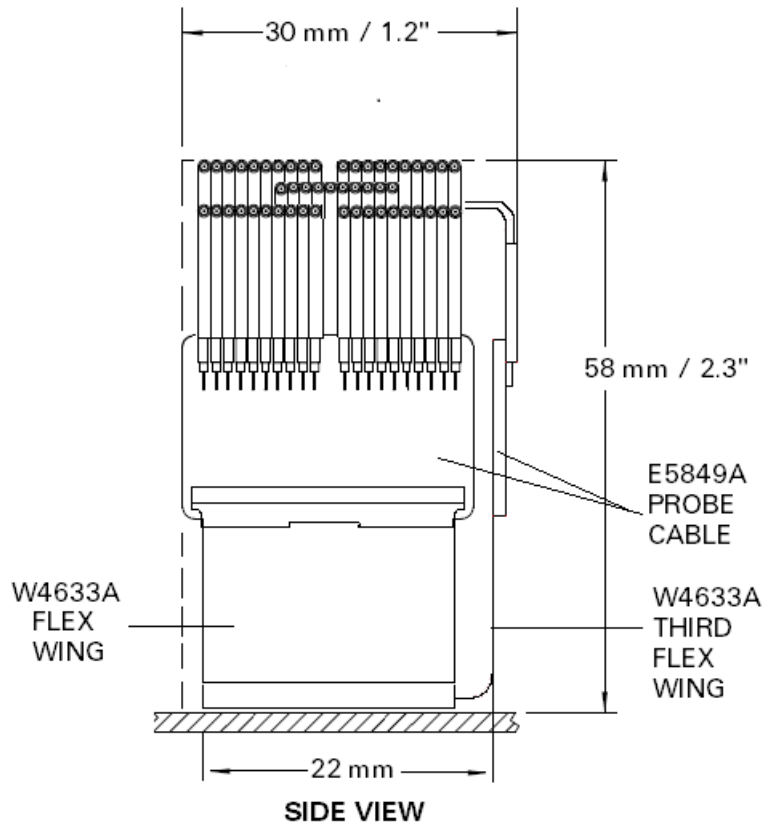

Figure 8 KOV of a W4633A interposer with an E5849A cable (SIDE VIEW)

DDR3 Probes

Keysight also offers equivalent probes for DDR3 memory:

- W3631A DDR3 x16 BGA address/control/data probe for stacked DRAM under 2G.
- W3633A DDR3 x4/x8 BGA address/control/data probe.
- W3636A DDR3 x16 non-stacked DRAM96 ball BGA probe.
- E5845A adapter cable for W3631A and W3636A probes.
- E5847A adapter cable for W3633A probe.
- W3635B DDR3 oscilloscope probe adapter.

2 Setting up the W4630-Series Interposers

W4633A Interposer Setup - Overview / 20
Soldering the W4633A Interposer and Riser / 21
Connecting the W4633A Interposer to E5849A Probe Cables / 23
Connecting the E5849A Probe Cables to a Logic Analyzer / 27

W4633A Interposer Setup - Overview

- 1 Solder the riser, interposer, and memory components. (See [page 21](#))
- 2 Connect the interposer flex wings to E5849A probe cables. (See [page 23](#))
- 3 Connect the E5849A probe cables to a U4154A Logic Analyzer module's pods via U4201A logic analyzer cables. (See [page 27](#))

CAUTION

Use ESD precautions. Electrostatic discharge can damage components on your board or in the interposer. Use a grounded wrist strap and other ESD control measures as appropriate.

NOTE

Do not open the vacuum sealed packs of the W4633A interposer until you are ready to install the interposer. Discard these packs once the package is opened.

Soldering the W4633A Interposer and Riser

The W4633A interposer needs to be attached to the DRAM PCB footprint on the design to be probed with either the riser soldered or an optional Grypper socket (not included with the interposer) installed in between the interposer and PC board. The desired DRAM is soldered to the top side of the interposer. The stack up of these soldered components is illustrated in the following figure.

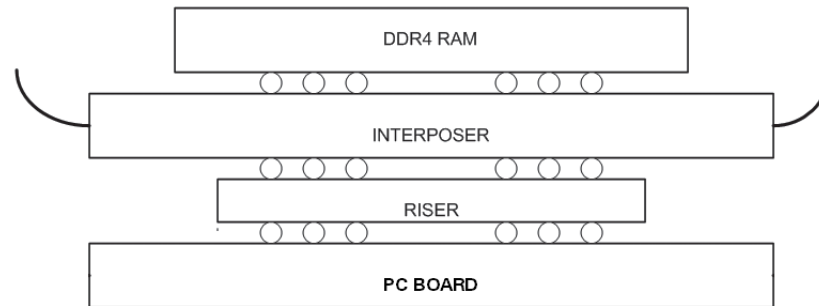

Figure 9 PC board, riser (or optional Grypper socket), interposer, and DRAM stack up

NOTE

A maximum of 11 mm x 14 mm DDR4 DRAM package can fit on top of the W4633A interposer without an additional riser or a socket on the top of the interposer and under DRAM.

Interposer and Riser Soldering Guidelines

- The W4633A interposers are assembled using lead free soldering processes.
- Observe standard lead-free rework guidelines and processes when applying DDR4 memory devices and attaching a riser to an interposer and DIMM.
- Typical time-above-liquidus (220°C in the case of SAC305 solder) is 30 to 90 seconds with 60 seconds as the good nominal target.
- The peak temperature at the SAC305 solder joints should be a minimum of 235°C.
- It is best to limit the peak temperature on the package of the IC at a maximum of 245°C.
- To minimize heating effects on components mounted on the interposer assembly, a leaded solder process can be used to attach a riser, when it is compatible with your prototype debug and validation methodologies.
- When possible use a PCA rework vendor, to attach the riser, interposer and memory components, such as: Circuit Technologies Center. More useful information can be found at: <http://www.circuitrework.com>.

Interposer Fabrication Notes

Operating Environment

The W4633A interposer is constructed of polyimide material that supports solder attachment of the interposer using the higher temperatures required by a lead-free solder process. The coefficient of thermal expansion for the interposer is 55 ppm/degree C. When operating in a soldered-down environment over a wide range of temperatures, the expansion coefficient of the interposer, DRAM, and system being probed must be matched to avoid stress related failure of the solder connections between the Interposer and attached components. The interposer material allows operation over an industrial temperature range of -40 to +85 degrees Celsius (non-condensing), subject to the above constraint.

Mechanical Dimensions

When the W4633A interposer is soldered to a riser, flatness must be maintained on the order of 3.5 mils or less across the BGA footprint to maximize successful soldering to the interposer.

Connecting the W4633A Interposer to E5849A Probe Cables

After soldering the components or installing with a Grypper socket, you can start connecting the W4633A interposer to the E5849A probe cables.

NOTE

Please handle the interposer with care and ensure that the wings on the W4633A interposer are properly latched to the ZIF connectors on the E5849A probe cables.

E5849A cables ship with labels unattached. Use the sheet of labels included with the E5949A to label one as "Cable 1" and a second as "Cable 2".

The following diagram illustrates how the interposer and E5849A cables have to be connected. As illustrated in this diagram:

- Two E5849A cables, *Cable 1* and *Cable 2* are used for a single W4633A interposer.
- The left and right wings of *Cable 1* connect to P1-Data and P2-Address/Command wings respectively of the interposer.
- The right wing of *Cable 2* connects to P3-Address/Command wing of the interposer while the left wing of *Cable 2* has not been used and left unconnected.

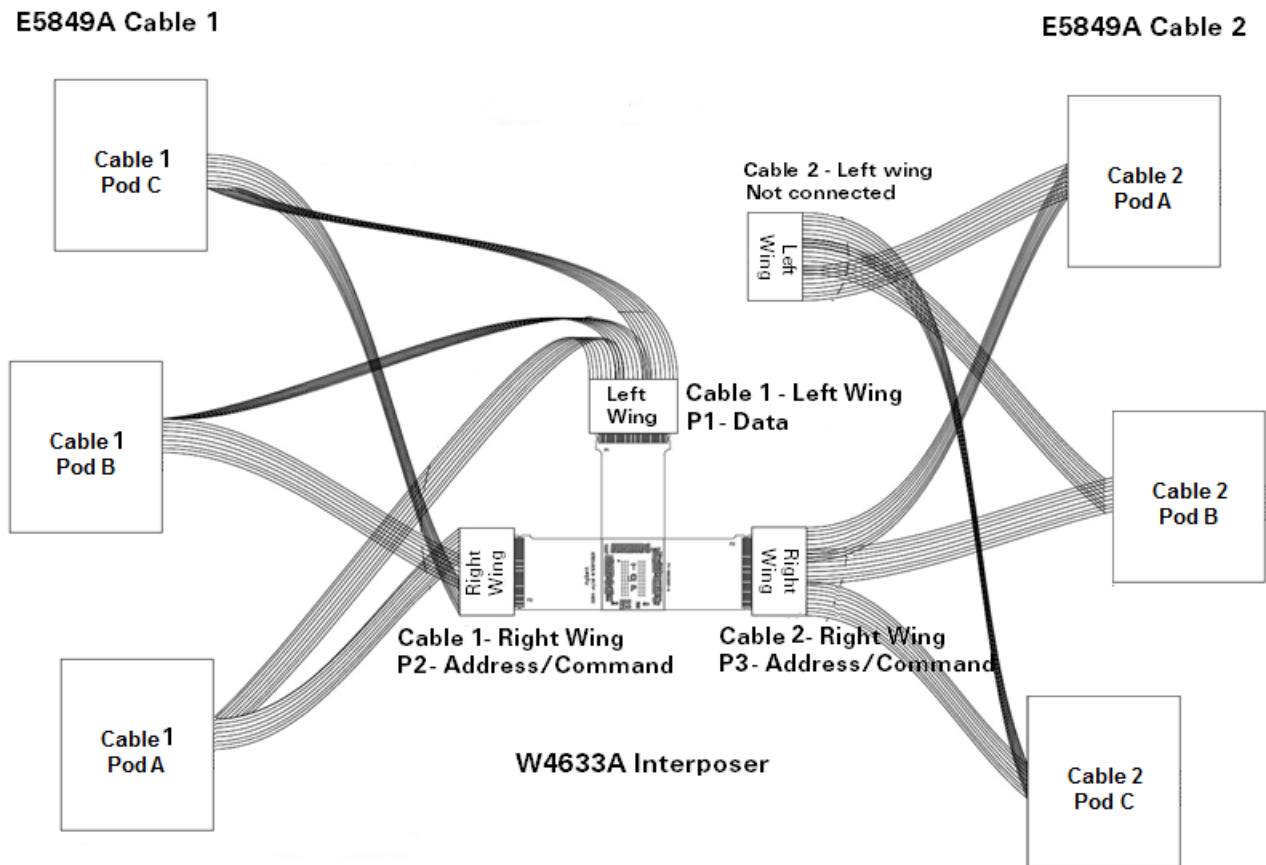

Figure 10 W4633A Interposer and E5849A Cable Connections

ZIF connectors on the E5849A cable connect to the bottom side of the flex wings on the W4633A interposer. ZIF doors close on the ground side of the flex wings. The following picture displays a W4633A interposer with E5849A ZIF connectors attached to its flex wings.

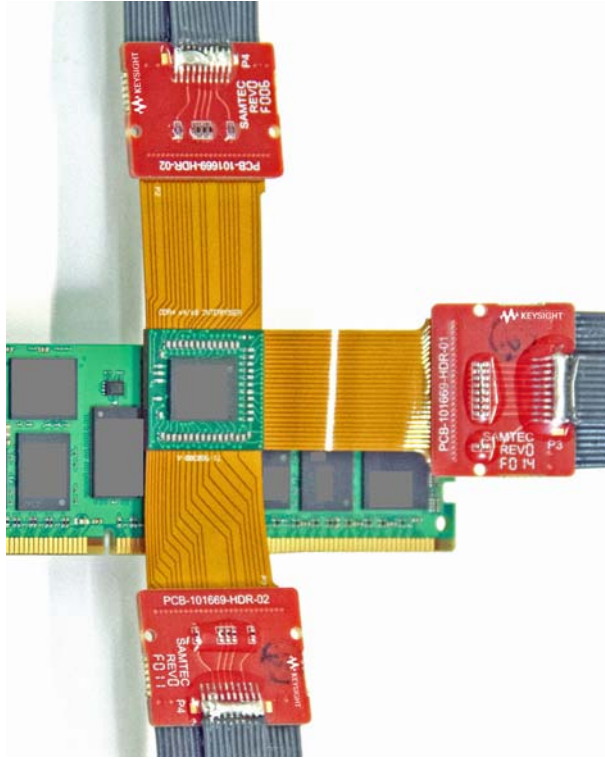
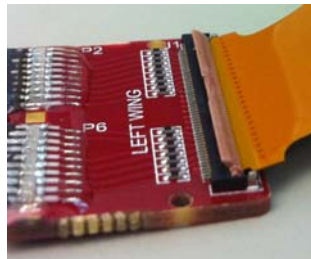

Figure 11 W4633A interposer attached to E5849A ZIF connectors

To attach an E5849A ZIF connector to a flex wing of the W4633A interposer, perform the following three steps.

- 1 Angle the flex wing of the interposer into an E5849A ZIF connector. GND towards door closure.



- 2 Align the E5849A ZIF connector tabs with interposer's wing notches.



- 3 Shut the ZIF door.

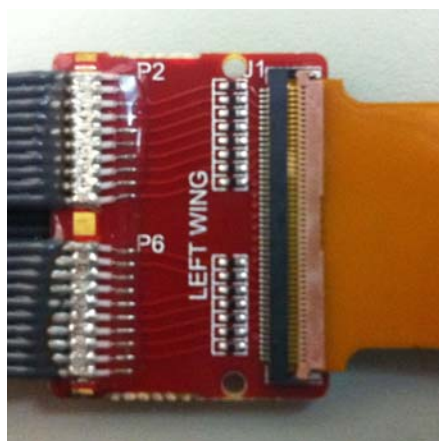

W4633A Interposer Wings Pinout

The following table lists the pinout of the three wings of a W4633A interposer.

Note: Clock inputs are highlighted with yellow in this table.

Table 1 W4633A Interposer Wings Pinout

Pin	W4633A Interposer Wings		
	J1 - DATA	J2 - ADDRESS/COMMAND	J3 - ADDRESS/COMMAND
2	DQ4_2	A2	
4	DQ4_1	PAR	CS#
6	DQ0_2		C1
8	DQ0_1	A0	CAS#
10	TDQS#_2	A11	RAS#
12	TDQS#_1	A8	A12
14	DQS#_2	A6	
16	DQS#_1	BA0	BG1
18	DQS_2	A4	A3
20	DQS_1	RST#	
22	DQ2_2		
24	DQ2_1	PULLDN	
26	DQ6_2	CKE	
28	DQ6_1		BA1
30	DQ7_2		ALERT#
32	DQ7_1	BG0	A5
Pin	E5849A Cable 1 Left Wing Connector	E5849A Cable 1 Right Wing Connector	E5849A Cable 2 Right Wing Connector

2 Setting up the W4630-Series Interposers

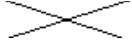
Pin	W4633A Interposer Wings		
	J1 - DATA	J2 - ADDRESS/COMMAND	J3 - ADDRESS/COMMAND
34	DQ3_2	A10	A7
36	DQ3_1	WE#	
38	DQ1_2	ACT#	A1
40	DQ1_1	C0	A13
42	DM#_2		CK
44	DM#_1		CK#
46	DQS_2	C2	A17
48	DQS_1	ODT	A9
50	GND	GND	GND
ODD	GND	GND	GND
Pin	E5849A Cable 1 Left Wing Connector	E5849A Cable 1 Right Wing Connector	E5849A Cable 2 Right Wing Connector

Connecting the E5849A Probe Cables to a Logic Analyzer

In a W4633A interposer setup, you make connections between an E5849A probe cable and a U4154A logic analyzer module by:

- First connecting the E5849A probe cable to a U4201A cable.
- Then connecting this U4201A cable to the relevant Logic Analyzer pod on the front panel of the U4154A module.

The following figure displays the relevant U4154A Logic Analyzer pods that you need to use to connect the right and left wings of the two E5849A probe cables used in a W4633A interposer setup.

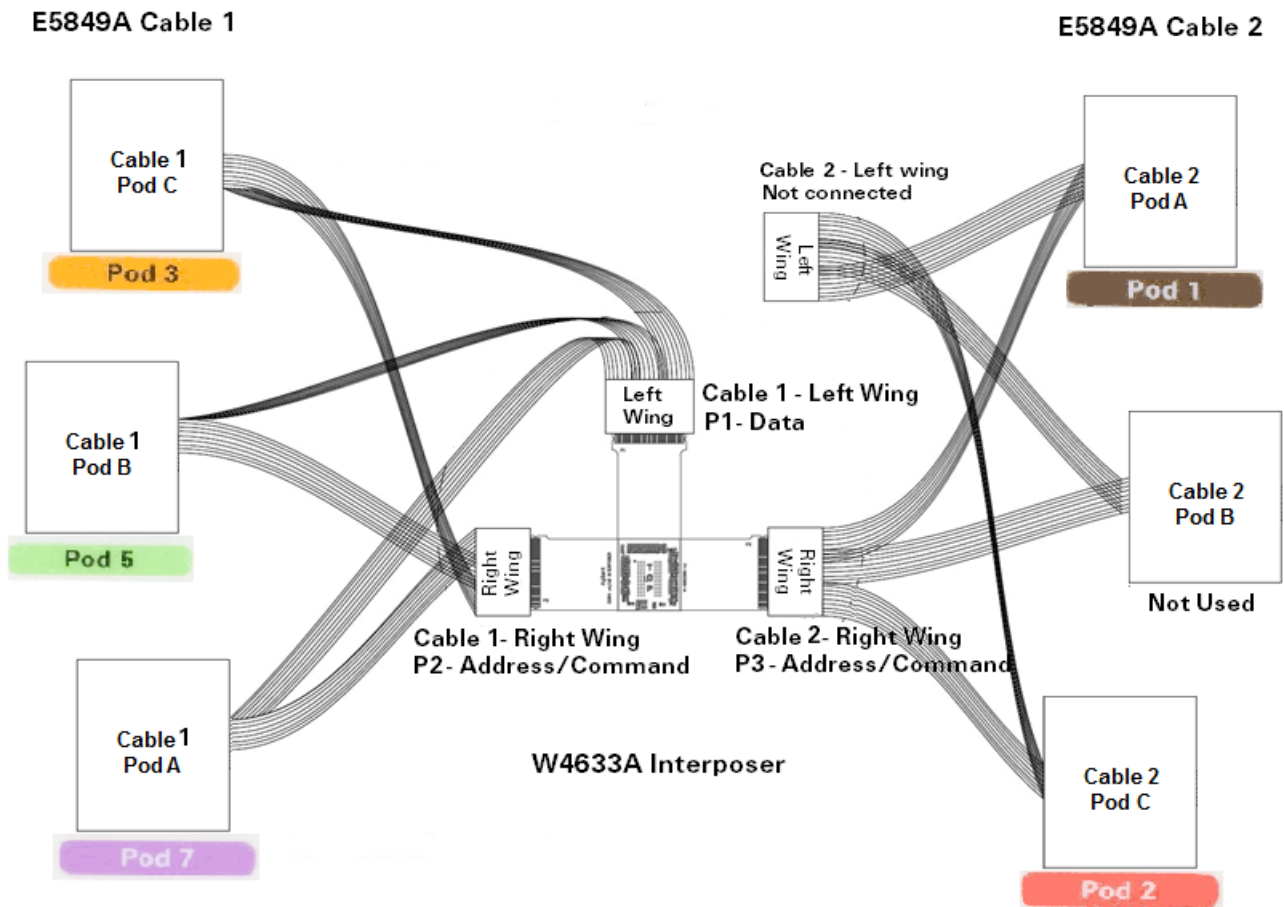

Figure 12 Connections between E5849A probe cables and Logic Analyzer pods

NOTE

You need four U4201A cables to make connections as per the above diagram, One U4201A cable connects Cable 2 Pod A and Pod C to Logic Analyzer. The other three U4201A cables connect Cable 1 Pod A, Pod B, and Pod C each to Logic Analyzer.

Logic Analyzer Channel Mapping



When you connect the E5849A probe cables to a U4154A Logic Analyzer as per the diagram in [Figure 12](#), the logic analyzer channels are mapped to signals as per the table displayed below.

These signals are automatically configured when you load one of the configuration files supplied with the Keysight B4621B decoder software.

The following table lists the mapping between the Logic Analyzer channels and signals when connected to E5849A probe cables, Cable 1 and Cable 2.

Note: Clock inputs are highlighted with yellow in this table.

Table 2 Signals and Logic Analyzer Channels Mapping for the E5849A Probe Cable

LA Channel	E5849A Cable 1 Pods			LA Channel	E5849A Cable 2 Pods		
	Pod A	Pod B	Pod C		Pod A	Pod B	Pod C
0	TDQS#	A6		0			
1	A10		A2	1	A7		
2	TDQS#	WE#	DQ5	2			
3	BG0		BA0	3	A5		BG1
4	DQS#	DQ5		4			C1
5		DQ7	A4	5	BA1		A3
6	DQS#	DQ7	DM#	6			
7		DQ6	PAR	7	ALERT#		CS#
8	ACT#	DQ6	DM#	8	A1		
9	DQ0	DQ2	A0	9			CAS#
10	C0	DQ2	DQ1	10	A13		
11	DQ0	DQS	A8	11			A12
12	ODT	DQS	DQ3	12	A9		
13	DQ4		DQ1	13			
14	C2		A11	14	A17		RAS#
15	DQ4		DQ3	15			
CLK		CKE	RST#	CLK	CK		
CLK#		PULLDN		CLK#	CK#		
LA Channel	Pod 7	Pod 5	Pod 3	LA Channel	Pod 1		Pod 2
U4154A Logic Analyzer Pods				U4154A Logic Analyzer Pods			

Signals not probed by the Logic Analyzer

The following signals are omitted from the Logic Analyzer connections for the W4633A interposer.

Interposer	Signal Name
W4633A	VREFCA, TEN, ZQ

3 Setting Up the Logic Analyzer for W4630 Series Probes

Before You Start / 30
Loading a Configuration File / 31

Before You Start

Ensure that all the software components listed in the topic "[Hardware and Software Requirements](#)" on page 12 are installed on the host computer and the required software licenses are also obtained and installed.

Loading a Configuration File

The mapping of specific signals to logic analyzer channels depends on:

- Which DRAMs are being probed.
- How SRAM circuit is designed.
- Which interposer is being used.
- How the single-ended E5849A cables and logic analyzer cables are arranged when connecting to the W4633A interposer.

Because of these dependencies, there is no single logic analyzer configuration file setup for the W4630-series interposers. A set of DDR4 x4 and x8 configuration files is provided with the Keysight B4621B Decoder software. To obtain this set of configuration files, you must install the B4621B software (licensing of this software is not required for obtaining these configurations). From this set of configuration files, you can load a configuration file that suits your specific requirements.

When you load a configuration file, it will set up the buses and signals, add the decoder tool, and add a listing tool in the Logic Analyzer software GUI.

To load a provided configuration file:

- 1 Close the logic analyzer window, if it is open.
- 2 Select **Start>All Programs>Keysight Logic Analyzer>DDR Bus Decoder Default Configs**.
- 3 Select the DDR bus type.
- 4 Select the **BGA** and then choose a configuration file corresponding to the bus size and speed.

When you click on a configuration file, the Logic and Protocol Analyzer software will start and configure itself to use the decoder.

The logic analyzer Buses/Signals setup dialog allows you to assign descriptive labels to each analyzer channel that associate each channel with the particular DRAM and DRAM signal being probed.

NOTE

If your unique multi-DRAM configuration is not covered by one of the default configurations, you can use the *DDR Custom Configuration Creator* tool installed with the DDR Eyefinder SW package to create your own custom DDR4 BGA configuration.

To save a configuration file

After you set up the logic analyzer, it is strongly recommended that you save the configuration.

To save your work, select **File>Save As...** and save the configuration as an ALA format file.

ALA format configuration files are more complete and efficient than XML format configuration files. See the Logic and Protocol Analyzer online help for more information on these formats.

4 Characteristics, Regulatory, Safety and Storage Information

Operating Characteristics / 34
Storage, Inspection, Baking, and Cleaning Guidelines / 35
Safety Information for the E5849A Cable Adapters / 36
Regulatory Notices / 37

Operating Characteristics

The following operating characteristics are not specifications, but are typical operating characteristics.

Characteristics	Description
Temperature	20° to 40° C (+68° to +104° F)
Altitude	4,600 m (15,000 ft)
Humidity	Up to 50% noncondensing. Avoid sudden, extreme temperature changes which could cause condensation on the circuit board. For indoor use only.

Characteristics	Description
To interposer	Memory bus signals from target system
From interposer	High-density connectors for Keysight U4154A AXIe-based logic analyzer modules

Storage, Inspection, Baking, and Cleaning Guidelines

The following are some of the guidelines for storing, shelf life, and cleaning of the W4633A interposer.

Guidelines for Shelf Life and Solder-ability of W4633A Interposers

If your W4633A Interposer exceeds shelf life (1 year) before solder into application, use the following inspection and baking method.

- Inspect the humidity indicator within moisture proof vacuum sealed bag(s).
- If the humidity indicator shows moisture then bake the board at 120 degrees C for 4 hours and perform the solder-ability test.
- If the test passes, proceed with the assembly (reflow) of interposer.
- If delamination occurs, the interposer cannot be used.

Cleaning of W4633A Interposer Gold Fingers



- Use Isopropyl alcohol to clean W4633A interposer contacts.
- Never use abrasive cleaning materials.

Safety Information for the E5849A Cable Adapters

To clean the instrument

Do not attempt to clean this product.

Safety Symbols

Safety Symbol	Description
	"Caution" or "Warning" risk of danger marked on product. See "Safety Notices" on page 2 and refer to this manual for a description of the specific danger.
	Hazardous voltage symbol.
	Earth terminal symbol: Used to indicate a circuit common connected to grounded chassis.

Regulatory Notices

WEEE Compliance

Safety Symbol	Description
	<p>This product complies with the WEEE Directive (2002/96/EC) marking requirements. The affixed label indicates that you must not discard this electrical/electronic product in domestic household waste.</p> <p><i>Product Category: With reference to the equipment types in the WEEE Directive Annex I, this product is classed as a "Monitoring and Control Instrumentation" product.</i></p> <p>Do not dispose in domestic household waste. To return unwanted products, contact your local Keysight office, or see "www.keysight.com" for more information.</p>

China RoHS

W4633A and E5849A



Index

B

B4621B decoder software, 12
B4622B toolset, 12
bake, 35
bend radius, 9

C

cable connections, 23
characteristics, 33
China RoHS, 37
cleaning instrument, 36
cleaning, interposer, 35
configuration files, 31
configuration files, saving, 31

D

DDR Eyefinder, 12
DDR Setup Assistant, 12
DDR3 probes, 17
dimensions, W4633A interposer, 13
DRAM package, 8

E

E5849A, 10
E5849A channel mapping, 28
equipment required, 12

F

feature summary, 8

H

humidity indicator, 35

I

in this guide, 3
installing the interposer, 19
interposer, inputs to, 34
interposer, outputs from, 34
introduction, 7

K

keep-out volume, 14

L

logic analysis system set up, 29
logic analyzer cable, 11
logic analyzer channel mapping, 27
logic analyzer connections, 27

M

mechanical considerations, 13

O

operating characteristics, 34

P

pinout, 25
probe cable, 10

R

regulatory information, 33
regulatory notices, 37
required probes, cables, LA modules, 12
riser, 9, 14, 21

S

safety information, 33
safety symbols, 36
shelf life, 35
signals not probed, 28
soldering guidelines, 21
soldering processes, 21
soldering temperature, 21
storage guidelines, 35
symbols, safety, 36

U

U4201A, 11, 27

W

W4633A, 8
W4633A interposer setup, 27
WEEE compliance, 37

