

Buy, sell, rent or trade-in this product please click on the link below:
<http://www.avionteq.com/IFR-Aeroflex-FM-AM-1600S-Communication-Service-Monitor.aspx>

AvionTEq

Test with full trust

www.avionteq.com

OPERATION MANUAL



FM/AM - 1600S COMMUNICATIONS SERVICE MONITOR

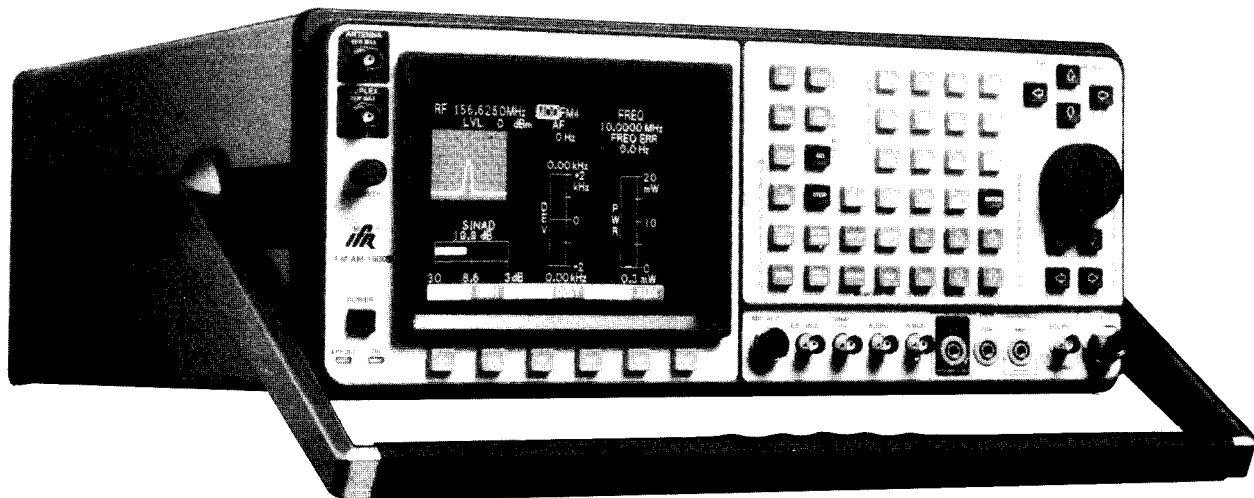

10200 West York Street / Wichita, Kansas 67215 U.S.A. / (316) 522-4981 / TWX 910-741-6952

1002-8600-000

Ver - 2.00

**PUBLISHED BY
IFR SYSTEMS INC.
Wichita, Kansas**

COPYRIGHT © 1991 by IFR SYSTEMS, INC.

All rights reserved. Printed in the United States of America. No part of this publication may be reproduced, stored in a retrieval system, or transmitted in any form or by any means, electronic, mechanical, photocopying, recording or otherwise without the prior permission of the publisher.

WARNING

HIGH VOLTAGE EQUIPMENT

THIS EQUIPMENT CONTAINS CERTAIN CIRCUITS AND/OR COMPONENTS OF EXTREMELY HIGH VOLTAGE POTENTIALS, CAPABLE OF CAUSING SERIOUS BODILY INJURY OR DEATH. WHEN PERFORMING ANY OF THE PROCEDURES CONTAINED IN THIS MANUAL, HEED ALL APPLICABLE SAFETY PRECAUTIONS.

RESCUE OF SHOCK VICTIMS

1. DO NOT ATTEMPT TO PULL OR GRAB THE VICTIM.
2. IF POSSIBLE, TURN OFF THE ELECTRICAL POWER.
3. IF YOU CANNOT TURN OFF ELECTRICAL POWER, PUSH, PULL OR LIFT THE VICTIM TO SAFETY USING A WOODEN POLE, ROPE OR SOME OTHER DRY INSULATING MATERIAL.

FIRST AID

1. AS SOON AS VICTIM IS FREE OF CONTACT WITH SOURCE OF ELECTRICAL SHOCK, MOVE VICTIM A SHORT DISTANCE AWAY FROM SHOCK HAZARD.
2. CALL FOR DOCTOR AND/OR AMBULANCE, IMMEDIATELY.
3. IF BREATHING HAS STOPPED; ADMINISTER CARDIO-PULMONARY RESUSCITATION (CPR), AS NEEDED.
4. IF VICTIM IS BREATHING, ATTEMPT TO CONTROL ALL SERIOUS BLEEDING.
5. KEEP VICTIM WARM, QUIET AND FLAT ON HIS/HER BACK.

WARNING: DEVICES MUST NOT BE INSERTED NOR REMOVED FROM CIRCUITS WITH POWER ON.

CAUTION: INTEGRATED CIRCUITS AND SOLID STATE DEVICES SUCH AS MOS FETS, ESPECIALLY CMOS TYPES, ARE SUSCEPTIBLE TO DAMAGE BY ELECTROSTATIC DISCHARGES RECEIVED FROM IMPROPER HANDLING, THE USE OF UNGROUNDED TOOLS, AND IMPROPER STORAGE AND PACKAGING. ANY MAINTENANCE TO THIS UNIT MUST BE PERFORMED WITH THE FOLLOWING PRECAUTIONS:

- BEFORE USING A CIRCUIT, KEEP ALL LEADS SHORTED TOGETHER WITH VENDOR-SUPPLIED SHORTING SPRINGS OR BY INSERTING LEADS INTO A CONDUCTIVE MATERIAL.
- GROUND THE HAND BEING USED TO REMOVE DEVICES FROM THEIR CONTAINERS WITH A CONDUCTIVE WRISTBAND. REMOVE ALL METAL JEWELRY BEFORE WORKING WITH DEVICES.
- TIPS OF SOLDERING IRONS, AND ALL OTHER TOOLS, MUST BE GROUNDED WHEN USED.
- PC BOARDS, WHEN REMOVED FROM EQUIPMENT, MUST BE SET ON A GROUNDED CONDUCTIVE MAT OR STORED IN A CONDUCTIVE STORAGE BAG. REMOVE ANY BUILT-IN POWER SOURCE, SUCH AS A BATTERY, BEFORE LAYING PC BOARDS ON A CONDUCTIVE MAT OR STORING IN A CONDUCTIVE BAG.
- PC BOARDS, IF BEING SHIPPED TO THE FACTORY FOR REPAIR, MUST BE PACKAGED IN A CONDUCTIVE BAG AND PLACED IN A WELL-CUSHIONED SHIPPING CONTAINER.

THE USE OF SIGNAL GENERATORS FOR MAINTENANCE AND OTHER ACTIVITIES CAN BE A SOURCE OF ELECTRO-MAGNETIC INTERFERENCE (EMI) TO COMMUNICATION RECEIVERS, WHICH CAN CAUSE DISRUPTION AND INTERFERENCE TO COMMUNICATION SERVICE OUT TO A DISTANCE OF SEVERAL MILES.

USERS OF THIS EQUIPMENT SHOULD SCRUTINIZE ANY OPERATION WHICH RESULTS IN RADIATION OF A SIGNAL (DIRECTLY OR INDIRECTLY) AND SHOULD TAKE NECESSARY PRECAUTIONS TO AVOID POTENTIAL COMMUNICATION INTERFERENCE PROBLEMS.

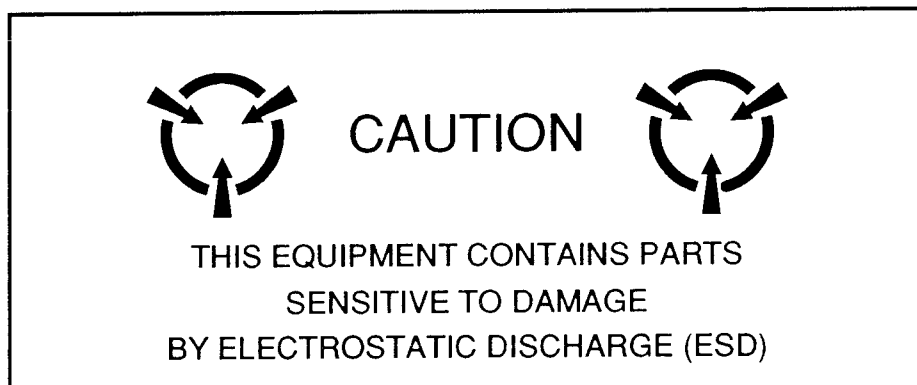

SAFETY FIRST: TO ALL OPERATIONS & SERVICE PERSONNEL

READ AND LEARN THESE PAGES IN THEIR ENTIRETY. THE EXPLANATIONS GIVEN APPLY TO BOTH OPERATORS AND SERVICE PERSONNEL AS A MATTER OF SAFETY WHEN USING THIS PRODUCT AND WHEN REFERENCING THIS MANUAL.

REFER ALL UNIT SERVICING TO QUALIFIED TECHNICAL PERSONNEL.

SAFETY IDENTIFICATION IN TECHNICAL MANUAL

The following terms are used throughout this manual to designate possible safety hazards, which may exist when operating or servicing this equipment:

CAUTION: THIS TERM IDENTIFIES CONDITIONS OR ACTIVITIES WHICH, IF IGNORED, CAN RESULT IN EQUIPMENT OR PROPERTY DAMAGE (E.G., FIRE).

WARNING: THIS TERM IDENTIFIES CONDITIONS OR ACTIVITIES WHICH, IF IGNORED, CAN RESULT IN PERSONAL INJURY OR DEATH.

SAFETY IDENTIFICATION USED IN EQUIPMENT

Areas marked with the terms CAUTION and DANGER are to be addressed before accessing that part of the device. CAUTION and DANGER identify hazards in the following manner:

CAUTION: A HAZARD EXISTS WHICH, IF IGNORED, COULD RESULT IN DAMAGE TO THE DEVICE OR PROPERTY. SUCH A MARKING WILL NOT INDICATE POSSIBILITY OF PERSONAL INJURY.

DANGER: A PERSONAL INJURY HAZARD EXISTS AND SPECIAL PRECAUTIONS MUST BE OBSERVED WHEN REQUIRED TO PERFORM ANY TASK IN THE VICINITY OF THESE MARKINGS.

SAFETY SYMBOLS IN MANUALS & ON UNITS



INFORMATION PRECAUTION: Corresponds with an applicable item on the device and in the manual. This symbol defines specific voltage, current and power requirements, or other related information for safe operation or service of equipment.

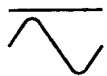

AC OR DC TERMINAL: Terminal which may supply or be supplied with ac or dc voltage.

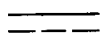

DC TERMINAL: Terminal which may supply or be supplied with dc voltage.



AC TERMINAL: Terminal which may supply or be supplied with ac voltage.



SWITCH OFF: Ac line power to the device is OFF.



SWITCH ON: Ac line power to the device is ON.

POWER SUPPLY

This device is intended for operation from a power source no more than 120 VAC (North American)/240 VAC (European) at a frequency of 50 to 400 Hz. Power supply specifications are provided within the manual.

EQUIPMENT GROUNDING PRECAUTION

When equipment is connected to ac power, it must be properly grounded. Improper grounding of equipment can result in electrical shock anywhere on the device, even if it appears to be insulated.

USE OF PROBES

Check the maximum voltage, current and power ratings of any connector on the equipment in the product specifications prior to connecting it with a probe from a terminal device. Be sure the terminal device performs within these specifications prior to using it for measurement, to prevent electrical shock or damage to the equipment.

POWER CORDS

Power cords are supplied specifically for use with this product for 12 Vdc and 120 VAC operation (U.S.). The power cord must not be frayed or broken when operating this equipment.

USE RECOMMENDED FUSES ONLY

Use only fuses specifically recommended for the equipment at the specified current and voltage ratings.

OPERATION OF EQUIPMENT IN HAZARDOUS ENVIRONMENT

Do not operate equipment in an explosive environment or under any other such dangerous circumstances, unless the equipment has been specifically designated for such use. Environmental requirements are listed with the specifications of this product.

CASE, COVER OR PANEL REMOVAL

Removing protective covers, casings or panels from equipment before operation of this product exposes the operator to electrical hazards which can result in electrical shock or equipment damage. Do not operate this equipment with the case, cover or panels removed.

LIST OF EFFECTIVE PAGES

The manual pages listed below which are affected by a current change or revision, are so identified by a revision number and an asterisk.

Date of issue for original and changed pages are:

Original0 October 1, 1991

TOTAL NUMBER OF PAGES IN THIS MANUAL IS 472 CONSISTING OF THE FOLLOWING:

Pg. No.	Change No.	Pg. No.	Change No.
Title0	4-4 Blank0
Copyright0	4-5 through 4-510
Warning0	4-52 Blank0
Caution0	4-53 through 4-1070
Safety0	4-108 Blank0
Safety (Power Supply)0	4-109 through 4-1360
A0	5-1 through 5-30
B Blank0	5-4 Blank0
i through viii0	6-1 through 6-430
1-1 through 1-160	6-44 Blank0
2-1 through 2-30	7-1 through 7-210
2-4 Blank0	7-22 Blank0
3-1 Blank0	A-1 through A-70
3-2 through 3-310	A-8 Blank0
3-32 Blank0	B-1 through B-100
3-33 through 3-1070	C-1 through C-190
3-108 Blank0	C-20 Blank0
3-109 through 3-1850	D-1 through D-30
3-186 Blank0	D-4 Blank0
4-1 through 4-30	E-1 through E-20

PREFACE

SCOPE

This manual contains instructions for operating the FM/AM-1600S Communications Service Monitor. The instruction level is relatively basic and presupposes no previous experience on the part of the operator with a communication service monitor of this type. A basic understanding of communication electronics and practical troubleshooting methods is helpful. It is strongly recommended that the operator be thoroughly familiar with this manual before attempting to operate the unit.

ORGANIZATION

The FM/AM-1600S Operation Manual is composed of the following sections:

SECTION 1 - INTRODUCTION

Provides an introduction to the unit and a brief overview of unit functions. Specifications are also included in this section.

SECTION 2 - INSTALLATION

Provides a step-by-step procedure for placing the FM/AM-1600S into operation.

SECTION 3 - DESCRIPTION OF CONTROLS, CONNECTORS AND INDICATORS

Identifies and functionally describes all FM/AM-1600S controls, connectors and indicators. Additionally, all CRT Operation Screens and Menus are identified and available parameters listed and explained.

NOTE: As an operating aid, Figures 3-1 and 3-2, which locate and identify all FM/AM-1600S controls, connectors and indicators, are located on a fold-out page. By extending the fold-out page, the operator can reference any front or rear panel control while simultaneously performing any operating procedure contained elsewhere in the manual.

SECTION 4 - OPERATION

Provides instructions for operating the FM/AM-1600S Mode Operating Screens and Menus. In addition, this section contains a selection of basic operating procedures pertaining to all major functions of the Test Set.

SECTION 5 - PERFORMANCE EVALUATION

Identifies and explains procedures the operator can use to insure the FM/AM-1600S is performing properly.

SECTION 6 - REMOTE OPERATION

Provides procedures for configuring and operating the FM/AM-1600S remotely. Lists unit specific commands for remote operations as well as commands mandated by IEEE 488.2 1987.

TABLE OF CONTENTS

SECTION 1 - INTRODUCTION

Paragraph	Title	Page
1-1	General	1-1
1-2	RF Generator	1-1
1-3	Receiver	1-1
1-4	Duplex	1-2
1-5	Audio Function Generators	1-2
1-6	Oscilloscope	1-2
1-7	Spectrum Analyzer	1-2
1-8	Meters	1-2
1-9	Data Entry and Display	1-3
1-10	Specifications	1-3

SECTION 2 - INSTALLATION

Paragraph	Title	Page
2-1	General	2-1
2-2	Precautions	2-1
2-3	Power Up Procedure	2-2

SECTION 3 - DESCRIPTION OF CONTROLS, CONNECTORS AND INDICATORS

Paragraph	Title	Page
3-1	FM/AM-1600S Front Panel	3-3
3-2	FM/AM-1600S Rear Panel	3-9
3-3	Operation Screens and Menu Configurations	3-10
3-3-1	RF Generator Operation Screen	3-11
3-3-2	Receive Operation Screen	3-33
3-3-3	Duplex Operation Screen	3-51
3-3-4	Duplex Transmitter Operation Screen	3-56

Paragraph	Title	Page
3-3-5	Duplex Receiver Operation Screen	3-72
3-3-6	AF Generator Operation Screen	3-91
3-3-7	Oscilloscope Operation Screen	3-99
3-3-8	Spectrum Analyzer Operation Screen	3-109
3-3-9	Meter Operation Screens and Menus	3-119
3-3-10	Auxiliary Functions Menu	3-179

SECTION 4 - OPERATION

Paragraph	Title	Page
4-1	General	4-1
4-1-1	Parameter Memory Operation	4-1
4-1-2	Printing CRT Screens	4-3
4-2	RF Generator Operation	4-5
4-2-1	RF Generator General Operation	4-5
4-2-2	Generating FM Modulated RF Signal	4-19
4-2-3	Generating AM Modulated RF Signal	4-19
4-2-4	Externally Modulating RF Signal Generator	4-20
4-2-5	Generating DTMF Coded RF Signal	4-21
4-2-6	Generating Audio Two Tone Coding	4-22
4-2-7	Generating 5/6 Audio Tone	4-23
4-2-8	Generating DCS Code	4-24
4-2-9	Generating POCSAG Code	4-25
4-2-10	Generating 2805 Code	4-26
4-2-11	Generating Tone Remote Code	4-27
4-2-12	Measuring SINAD Sensitivity, Center Frequency and Modulation Acceptance Bandwidth	4-28
4-2-13	Measuring Receiver IF Bandwidth	4-30

Paragraph	Title	Page
4-3	Receiver Operation	4-31
4-3-1	Receiver General Operation	4-31
4-3-2	Receiving FM Signals	4-41
4-3-3	Receiving AM Signals	4-42
4-3-4	Receiving SSB Signals	4-43
4-3-5	Decoding DTMF Coded Signals	4-44
4-3-6	Decoding Audio CCIR Coded Signals	4-45
4-3-7	Decoding Audio User Defined Coded Signals	4-46
4-3-8	Decoding DCS Coded Signals	4-48
4-3-9	Decoding POCSAG Coded Signals	4-49
4-3-10	Measuring AM or FM Transmitter Distortion	4-50
4-4	Duplex Operation	4-53
4-4-1	Duplex General Operation	4-53
4-4-2	Measuring Linear Amplifier Gain, Compression and Bandwidth	4-65
4-4-3	Measuring Mixer Performance	4-66
4-4-4	Duplex Transmitter Operation	4-68
4-4-5	Duplex Receiver Operation	4-76
4-5	AF Generator Operation	4-89
4-5-1	AF Generator General Operation	4-89
4-5-2	Generating Tone Remote Code	4-94
4-5-3	Generating AF Tone	4-94
4-6	Oscilloscope Operation	4-95
4-7	Spectrum Analyzer Operation	4-99
4-7-1	Spectrum Analyzer General Operation	4-99
4-7-2	Measuring Very Low Power Transmitter Output	4-104
4-7-3	Measuring Transmitter Harmonics	4-105
4-7-4	Measuring Diplexer Tx Loss and Rx Isolation	4-106

Paragraph	Title	Page
4-8	Meter Operation3-109
4-8-1	Audio Frequency Meter Operation4-109
4-8-2	RF Frequency Error Meter Operation4-111
4-8-3	Power Meter Operation4-113
4-8-4	Deviation Meter (Peak) Operation4-115
4-8-5	Modulation Meter Operation4-117
4-8-6	Distortion Meter Operation4-119
4-8-7	SINAD Meter Operation4-121
4-8-8	Signal Strength Meter Operation4-123
4-8-9	Bit Error Rate (BER) Meter Operation4-125
4-8-10	Digital Multimeter Operation4-131
4-8-11	Phase Meter Operation4-133
4-8-12	Deviation Meter (RMS) Operation4-135

SECTION 5 - PERFORMANCE EVALUATION

Paragraph	Title	Page
5-1	General5-1
5-2	Power-Up Self Test5-1
5-3	Self Test5-1

SECTION 6 - REMOTE OPERATIONS

Paragraph	Title	Page
6-1	General6-1
6-2	Operating Procedures6-1
6-3	TMAC (Test Macro Language)6-4
6-4	Command Syntax6-5
6-5	Mandatory IEEE 488.2 Commands6-6
6-6	FM/AM-1600S Specific Commands6-7

SECTION 7 - OPTIONS

Paragraph	Title	Page
7-1	Cellular Option	7-1
7-1-1	Cellular Operation Screens and Menu Configurations	7-1
7-1-2	Cellular Operation	7-11
7-1-3	Cellular Remote Operation	7-19

APPENDICES

Appendix	Title	Page
Appendix A	User I/O Connectors and Pin-Out Tables	A-1
Appendix B	AMPS Cellular Telephone Channel Numbers and Assigned Center Frequencies	B-1
Appendix C	E-TACS Cellular Telephone Channel Numbers and Assigned Center Frequencies	C-1
Appendix D	Abbreviations	D-1
Appendix E	Repacking For Shipping	E-1

LIST OF ILLUSTRATIONS

Figure No.	Title	Page
2-1	Rear Panel Power Up Controls, Connectors and Indicators2-2
2-2	Front Panel Power Up Controls, Connectors and Indicators2-3
3-1	FM/AM-1600S Front Panel Controls, Connectors and Indicators3-2
3-2	FM/AM-1600S Rear Panel Controls, Connectors and Indicators3-2
4-1	Cable Fault Horizontal Marker Setting4-103
5-1	Self Test Menu5-1
5-2	Test Running Counter5-1
5-3	Self Test Failure5-2
5-4	Self Test Pass5-2
5-5	Individual Test Failure5-2
A-1	MIC/ACC Connector Pin IdentificationA-2
A-2	DC OUT Connector Pin IdentificationA-3
A-3	SCSI Connector Pin IdentificationA-4
A-4	GPIO Pin IdentificationA-5
A-5	RS-232 Connector Pin IdentificationA-6
A-6	EXTERNAL VIDEO Connector Pin IdentificationA-7

LIST OF TABLES

Table No.	Title	Page
3-1	"SHIFT" Characters	3-5
3-2	Receiver Modulation Type Parameters	3-35
3-3	User Defined AGC Type Parameters	3-48
4-1	dBm, W and dBW Conversion Table	4-104
6-1	Command Syntax Punctuation Marks	6-6
6-2	Mandatory GPIB Commands	6-6
6-3	FM/AM-1600S Specific Commands	6-7
7-1	FM/AM-1600S Specific Cellular Commands	7-19
A-1	Table of I/O Connectors	A-1
A-2	Pin-Out for MIC/ACC Connector	A-2
A-3	Pin-Out for DC OUT Connector	A-3
A-4	Pin-Out for SCSI Connector	A-4
A-5	Pin-Out for GPIB Connector	A-5
A-6	Pin-Out for RS-232 Connector	A-6
A-7	Pin-Out for EXTERNAL VIDEO Connector Pin Identification	A-7

SECTION 1 - INTRODUCTION

1-1 GENERAL

The FM/AM-1600S is a microprocessor controlled, digitally synthesized communication service monitor which combines the operations of many different test instruments into a single, compact unit. Functions the FM/AM-1600S is capable of performing include:

RF Generator	Receiver
Duplex	AF Generator
Spectrum Analyzer	Oscilloscope
DMM	Deviation (Peak) Meter
Distortion Meter	SINAD Meter
Audio Frequency Meter	Frequency Error Meter
RF Power Meter	Modulation Meter
Signal Strength Meter	Bit Error Rate Meter
Phase Meter	Deviation (RMS) Meter
Tracking Generator	Cable Fault Detector
Digital Radio Paging	Analog Radio Paging
Encode and Decode	Encode and Decode

The FM/AM-1600S utilizes an alphanumeric keypad, dedicated function keys, multitask "Soft" Function Keys and a high-resolution color CRT to display, enter and edit functions and data. Testing with this instrument can be done remotely or manually. The FM/AM-1600S can perform tests from pre-programmed setups or formats determined at the time of the test. Microprocessor controlled memory allows storage and recall of parameters for each of the testing modes as well as storage and recall of Oscilloscope and Spectrum Analyzer traces for signal comparison.

1-2 RF GENERATOR

The FM/AM-1600S is capable of generating modulated or unmodulated carrier signals from 250 kHz to 999.9999 MHz (in 100 Hz steps). The output level is variable from -137 dBm to 0 dBm. Modulation types include AM, FM and PM. Modulation can also be applied from an external source. The RF Generator also functions as a tracking generator for swept measurements or as an offset generator in Duplex Mode. Metering functions available for this operation mode include SINAD, DMM, Distortion and Audio Frequency Level meters. The Oscilloscope and Spectrum Analyzer are also available for use on the RF Generator Operation Screen.

1-3 RECEIVER

The FM/AM-1600S is capable of receiving modulated and unmodulated signals from 250 kHz to 999.9999 MHz (in 100 Hz steps). The FM/AM-1600S receives AM, FM, PM, and SSB modulated signals. Metering functions in the FM/AM-1600S available with the Receiver include RF Power, Modulation, Deviation, Distortion, Frequency Error, AF Frequency, Signal Strength and SINAD meters and counters. The Oscilloscope and Spectrum Analyzer are also available for use on the Receiver Operation Screen. The FM/AM-1600S Receiver is capable of executing user defined frequency scan operations as well as single frequency operations. The Receiver is accessible to "off the air" signals through the ANTENNA IN Connector or the T/R Connector for higher powered signals.

1-4 DUPLEX

The FM/AM-1600S features Duplex Operation from 250 kHz to 999.9999 MHz. The operator has the option of monitoring the transmitter, receiver or both with the CRT. All features available with the RF Generator and Receiver are available in Duplex as well as the ability to use an offset frequency from -999.7499 to +999.7499 MHz to test communication equipment capable of generating and receiving simultaneously on different frequencies.

1-5 AUDIO FUNCTION GENERATORS

Two Audio Function Generators are included in the FM/AM-1600S with a range of 10 Hz through 40 kHz. Signals generated are transmitted as generated or modulated before transmission. Available waveforms include sine, square, triangle, ramp and pulse. The FM/AM-1600S is also capable of creating digital data bit patterns of 100 to 100,000 bits. Data rates include 75, 150, 300, 600, 1200, 2400, 4800 and 16000 bps. Pattern types include random, fixed and user defined.

1-6 OSCILLOSCOPE

The FM/AM-1600S includes a 1 MHz single trace Oscilloscope as one of its major test functions. The Oscilloscope allows input from 1 mV to 50 V/div with a maximum input voltage of 200 Vdc. Sweep rates range from 1 μ s to 100 ms/div. The FM/AM-1600S Oscilloscope has a store and recall ability of up to nine signals. The recalled trace are shown simultaneously with a live trace, giving the operator the opportunity to compare the two traces. Signals available for use include AC, DC, GND, Receiver IF, Demodulated Audio, Function Generators, External Audio, SINAD/BER and RF Power. The Oscilloscope is available for view alone or in all major Operation Modes except where Duplex Transmitter and Receiver are shown simultaneously. Size options for view in other modes are full-size and 1/4-size.

1-7 SPECTRUM ANALYZER

The Spectrum Analyzer monitors internal and external signals from 250 kHz to 999.9999 MHz. Scan widths range from 1 kHz to 100 MHz as well as zero scan. Available log scales are 2 and 10 dB/div with amplitude scale units of dBm, dB μ V, dBmV, dBV, dB μ W and dBW. Memory functions for the Spectrum Analyzer include store and recall of a trace, compare a stored trace to a live trace and peak hold. External signals can be "off the air" through the ANTENNA IN Connector or applied through the T/R Connector. The Spectrum Analyzer has variable attenuation through both connectors. The Spectrum Analyzer also has a tracking generator function with a variable level from -137 to 0 dB. The Spectrum Analyzer is available for display alone or with all RF Generate and Receive functions except where the Duplex Transmit and Receive functions are shown simultaneously. Size options for view in other Modes are full-size and 1/4-size.

1-8 METERS

The FM/AM-1600S provides the meters listed in 1-1 for use as independent test functions as well as synthesizing them into the major mode functions. As independent functions, the meters provide a bar graph display and digital data. On the Major Operations Screens, these meters display as bar graph display and digital data or just as digital data, depending on the Oscilloscope/Spectrum Analyzer display size. The meters are used to monitor both internal and external input.

1-9 DATA ENTRY AND DISPLAY

Unless the FM/AM-1600S is configured for remote testing, all data received by the operator is in the form of screens and menus. Each major test operation has a dedicated operation screen with subordinate setup menus. The microprocessor edits operation screens to reflect changes in parameters imposed by the operator or reflects changes in data delivered by the Unit Under Test (UUT). Individual meters also have dedicated operation screens and subordinate setup menus. The Meter Operation Screens can be accessed through the Mode Operation Screen that is being supported by that specific Meter Operation or through the Meter Menu. Refer to 3-3-9 for a description of the different Meters.

On selecting a specific Mode of Operation, the Operation Screen will appear on the CRT. The parameters shown reflect the parameters last entered in that operation. This specific operation screen is accessed with one of six dedicated MODE Keys. Setup menus on all mode operation screens are accessed from the specific Operation Screen by pressing the SETUP Key. Operator entry and edit of data is performed on the operation screen or on the setup menu. The operation screen and menu have active cursors which the operator can use to access a specific parameter. Once the parameter is accessed, data can be selected with DATA SCROLL Spinner or DATA SCROLL Keys or by using the alphanumeric DATA ENTRY Keypad. Multitask "Soft" Function Keys are also available to perform setup, edit and entry. Each operation screen defines "Soft" Function Keys to fit the specific needs for that operation. These definitions are displayed on the screen above the defined key. Each Operation Screen may have several definitions for each "Soft" Function Key or make a definition unavailable depending on the parameters of the operation. Various functions performed by these multitask keys include toggling between two values, selecting connectors for access, entering data or selecting a field to be edited.

1-10 SPECIFICATIONS

NOTE: A warm-up time of five minutes is required for the following performance requirements:

RF measurements are referenced to 50 Ω .

Accuracy and Resolution stated in percent are referenced to measured or selected value unless otherwise stated.

Where specified resolution exceeds specified accuracy, specified resolution takes precedence.

RF SIGNAL GENERATOR AND MODULATION

RF SIGNAL GENERATOR (T/R CONNECTOR)

Frequency:

Range: 400.0 kHz through 999.9999 MHz

Resolution: 100 Hz

Accuracy: Same as Master Oscillator

Level:

Range: -137.0 to 0.0 dBm, -40 dBm Max
with Reverse Power Present

Resolution:	0.1 dB
Accuracy:	±1.5 dB, 0.0 to ≥-90.0 dBm ±2.5 dB, <-90.0 to -127.0 dBm
Output Impedance:	50 Ω (See Power Meter for return loss).
Spectral Purity:	
Residual FM:	(Post Detection BW: 300 Hz to 3 kHz) <10 Hz RMS from 1.0 to 500.0 MHz <20 Hz RMS for <1.0 and >500.0 MHz
S.S.B. Phase Noise:	<-90 dBc/Hz at 20 kHz from carrier <-80 dBc/Hz for <1.0 MHz <-85 dBc/Hz for ≥930 MHz
Harmonics:	<-26 dBc
Non-Harmonics:	<-50 dBc
Residual AM:	(Post Detection BW: 300 Hz to 3 kHz) <0.10% RMS, 1 to 999.9999 MHz
Input Protection:	See Power Meter.

DUPLEX GENERATOR (DUPLEX OUT CONNECTOR)

Frequency (Independent of Receiver Frequency Setting):

Range:	400.0 kHz to 999.9999 MHz
Resolution:	100 Hz
Accuracy:	Same as Master Oscillator

Level:

Range:	-120.0 to +10 dBm, CW or FM -120.0 to + 7 dBm, AM
Resolution:	0.1 dB
Accuracy:	±1.5 dB, 0.0 to ≥-90.0 dBm ±2.5 dB, <-90.0 to -120.0 dBm
Output Impedance:	50 Ω Nominal (<1.38 VSWR)

Spectral Purity:

Residual FM:	(Post Detection BW: 300 Hz to 3 kHz) <10 Hz RMS from 1.0 to 500.0 MHz <20 Hz RMS for <1.0 and >500.0 MHz
S.S.B. Phase Noise:	<-90 dBc/Hz at 20 kHz from carrier

Harmonics:	<-26 dBc
Non-Harmonics:	<-50 dBc
Residual AM:	(Post Detection BW: 300 Hz to 3 kHz) <0.10% RMS, 1 to 999.9999 MHz
Input Protection:	Up to 65 W for 15 sec with Alarm

RF SIGNAL MODULATION (T/R AND DUPLEX OUT CONNECTORS)

Internal FM:

Deviation:

Range:	Off, ± 100 Hz to ± 100.0 kHz
Accuracy:	<5% from ± 1.0 to ± 25.0 kHz <7% for $<\pm 1.0$ and $>\pm 25.0$ kHz
Resolution:	100 Hz (≤ 25.0 kHz) 500 Hz (> 25.0 kHz)

Modulation:

Rate:	Off, 30.0 Hz to 40.0 kHz up to 20 kbs Digital
Waveforms:	Sine, Square, Triangle, Ramp or Pulse

NOTE: Reference AF Generator for modulation rate accuracy and resolution.

Distortion (Sine Wave only):	<1.0%, at 1 kHz, 0.3 to 3 kHz BW)
------------------------------	-----------------------------------

Internal AM:

RF Generator Range:	500 kHz to 999.9999 MHz
---------------------	-------------------------

Amplitude Modulation:

Range:	Off, 1% to 90%
Accuracy:	5% of setting for 30% to 90% modulation, at 1 kHz 10% of setting for <1 MHz
Resolution:	1%

Modulation:

Rate:	100.0 Hz to 10.0 kHz
Waveforms:	Sine, Square, Triangle, Ramp or Pulse

NOTE: Reference AF Generator for modulation rate accuracy and resolution.

Distortion (Sine Wave Only):

For 30% to 70% Modulation:	<0.7%, (700 Hz to 1.1 kHz) <1.0% (100 Hz to 6.0 kHz) <1.5% (>6.0 to 10.0 kHz) <3.0% (0.5 to 1 MHz [RF]; 0.1 to 10 kHz [AF])
----------------------------	---

Internal Phase:

Phase Modulation

Range: Off, 0.1 to 10.0 radians

Accuracy: <5% at 1 kHz

Resolution: 0.1 radians

Modulation:

Rate: Off, 30.0 Hz to 6.0 kHz

Wave Forms: Sine, Square, Triangle, Ramp or Pulse

NOTE: Reference AF Generator for modulation rate accuracy and resolution.

Distortion: <2.0%

External:

NOTE: External signals input with the same characteristics as the referenced internal modulation sources are supported.

FM Deviation Sensitivity: 5.0 kHz/V_{peak} for <25 kHz
20.0 kHz/V_{peak} for ≥25 kHz

AM Modulation Sensitivity: 20%/V_{peak}

Phase Modulation Sensitivity: 2.0 radians/V_{peak}

FREQUENCY AGILITY (FOR BOTH RF GENERATOR AND RECEIVER)

Settling Time: 1.5 ms to within 1.0 kHz of desired frequency from
1.0 to 100 MHz (25.0 kHz steps)
2.5 ms to within 1.0 kHz of desired frequency from
250.0 kHz to 999.9999 MHz (100 Hz steps)

SIGNAL GENERATORS

AF GENERATORS #1 AND #2

Frequency:

Range: 10.0 Hz to 40.0 kHz

Resolution: 0.1 Hz \leq 2.0 kHz
1.0 Hz $>$ 2.0 kHz

Accuracy (150 Ω load): 0.1%

Level:

Range: 0.7 mVRMS to 2.5 VRMS (150 Ω),
up to 3.0 VRMS (600 Ω)

Resolution: 0.1 mV for 10.0 to 200.0 mV
3% for $>$ 200.0 mV or $>$ 10.0 kHz

Accuracy (150 Ω load): \pm 0.1 mV or 3% for 10 kHz
<5% for $>$ 10 to $<$ 25 kHz

Spectral Purity:

Total Harmonic Distortion
(Sine Wave only): $<$ 0.25%, from 700 Hz to 1.1 kHz
 $<$ 1.0%, for $<$ 700 Hz and $>$ 1.1 kHz

Waveshape: Sine, Square, Triangle, Ramp or Pulse

DIGITAL DATA GENERATOR AND PATTERN GENERATOR FOR BER

Data Rates: 75, 150, 300, 600, 1200, 2400 and 4800 bps;
and 16 kbps

Data Pattern Size: 100 to 100,000 bits

Data Pattern Type: Random, Fixed and User Defined

Accuracy: 1×10^{-8}

Level:

Range: Digital 0.1 to 5.0 V

Resolution: 0.1 V

Accuracy: 3%

AUDIO FREQUENCY COUNTER

Frequency:

Range: 10.0 Hz to 40.00 kHz (In four decade ranges)

Accuracy: Same as Master Oscillator

Resolution: 0.1 Hz from 10.0 Hz to ≤ 2.0 kHz
1.0 Hz from > 2.0 to ≤ 20.0 kHz
10.0 Hz from > 20.0 to 40.0 kHz

Input Waveform: Sine or Square Wave

External:

Level: 0.1 to 10.0 VRMS

Impedance: 1.0 M Ω

Internal Signal Selections: Demod Audio
AF Generators
External Audio

RF ERROR METER/RF COUNTER

RADIO FREQUENCY COUNTER

Frequency:

Range: 250000 to 999,999,990 Hz

Accuracy: Same as Master Oscillator

Resolution: 1 Hz, < 20 MHz
10 Hz, ≥ 20 MHz

Level: -10 to +50 dBm at T/R Connector
-80 to +10 dBm at ANTENNA IN Connector

RADIO FREQUENCY ERROR COUNTER/FREQUENCY METER

Frequency:

Counter Range: 0 Hz to ± 150.000 kHz

Meter Range: 0 to ± 100.0 kHz, in four decade ranges and
Autorange: ± 100 Hz, ± 1 kHz, ± 10 kHz and ± 100 kHz

Counter/Meter Accuracy: Same as Master Oscillator

Counter/Meter Resolution: 1 Hz from ± 1 Hz to $\leq \pm 10.0$ kHz
10 Hz from $> \pm 10$ to ± 150.0 kHz

NOTE: Receiver Bandwidth determines the upper limits.

Counter/Meter Level: -10 to +50 dBm at T/R Connector
 -80 to +10 dBm at ANTENNA IN Connector

RF POWER METER

Frequency:
 Range: 1.5 to 999.9999 MHz

Level:
 Input Level: 0.2 mW to 200.0 W
 Ranges: 20.0 mW, 200.0 mW, 2.0 W, 20.0 W
 200.0 W (Full Scale)
 Resolution: 1% or 0.1 mW
 Accuracy: 10%, ±1 count

Return Loss: 0.25 to 100.0 MHz, <1.15 VSWR
 >100.0 to 400.0 MHz, <1.23 VSWR
 >400.0 to 999.9999 MHz, <1.38 VSWR

Operating Conditions: Continuous On at 50 W and 25.0°C Ambient
 30.0 Sec ON, 2.0 Min OFF
 (at 100 W and 50.0°C Ambient)
 15.0 Sec ON, 2.0 Min OFF
 (at 200 W and 50.0°C Ambient)

NOTE: Over Temperature Alarm provided for all input levels.

RECEIVER

Frequency Range: 400.0 kHz to 999.9999 MHz

Sensitivity: Typically 2 µV for 10.0 dB SINAD in 30 kHz
 IF Bandwidth (1.0 kHz Tone, 3 kHz Deviation,
 10 kHz Audio Bandwidth)

Selectivity:	Mode	Rec. IF BW	Audio BW
	FM 4	300 kHz	75 kHz
	FM 3	300 kHz	20 kHz
	FM 2	30 kHz	10 kHz
	FM 1	30 kHz	3.0 kHz
	PM	30 kHz	3.0 kHz
	AM 1	2.9 kHz	3.0 kHz
	AM 2	30 kHz	10 kHz
	USB	2.9 kHz	3.0 kHz
	LSB	2.9 kHz	3.0 kHz

NOTE: 30 kHz BW is standard, 12.5 or 20 kHz BW Hardware Option is available.

NOTE: 2.9 kHz BW is standard, 6 kHz BW Hardware Option is available. No USB or LSB comes with this option.

Adjacent Channel Rejection:

Receiver Nominal 3.0 dB Bandwidth	> 30.0 dB Down
300 kHz	±485 kHz Max
30 kHz	±52 kHz Max
2.9 kHz	±2.5 kHz Max

NOTE: For USB or AM1 Operation Center Frequency is shifted -1825 kHz according to mode of operation.

Demodulation Output:

Impedance:	600 Ω
Output Level:	AM; 80% = 1.02 ±0.06 VRMS FM1; ±10 kHz = ±2.5 Vp-p, 10% FM2; ±20 kHz = ±2.5 Vp-p, 10% FM3; ±50 kHz = ±2.5 Vp-p, 10% FM4; ±100 kHz = ±2.5 Vp-p, 10% SSB; Beat Tone = 1.15 ±0.10 VRMS PM1; 18.25 Volt/radians, ±10% PM2; 36.5 Volt/radians, ±10% PM3; 91.2 Volt/radians, ±10% PM4; 182.5 Volt/radians, ±10%

Receiver, Antenna Connector:

Input Protection: ≤65 W for 15 Seconds With Alarm

FM DEVIATION METER

Deviation:

Range:	+100 kHz and -100 kHz (+Peak and -Peak), in six ranges and Autorange: ±2 kHz, ±5 kHz, ±10 kHz, ±20 kHz, ±50 kHz and ±100 kHz
Resolution:	50 Hz, ≤20 kHz Ranges 1 kHz, >20 to 100 kHz Ranges
Accuracy:	±3.0% full scale, ±1 count, applies for the following conditions:

Deviation Rate	Receiver IF	Post Audio	Carrier Level
≤1 kHz	30 kHz	3 kHz	-80 dBm
≤3 kHz	30 kHz	15 kHz	-70 dBm
≤10 kHz	300 kHz	20 kHz	-70 dBm

Modulation Rate: 100.0 Hz to 40.0 kHz

Carrier Range: 400.0 kHz to 999.9999 MHz
Carrier Level: -10 to +50 dBm on T/R Connector
-70 to +10 dBm on ANTENNA IN Connector

PM DEVIATION METER

Deviation Range: 0 to 10.0 radians (Peak)
Resolution: 0.02 radians; ≤ 8.0 radians
0.1 radians; > 8.0 radians
Accuracy: $\pm 3.0\%$ full scale, ± 1 count
Modulation Rate: 300.0 Hz to 4.0 kHz
Carrier Range: 400.0 kHz to 999.9999 MHz
Carrier Level: -10 to +50 dBm on T/R Connector
-80 to +10 dBm on ANTENNA IN Connector

AM MODULATION METER

Modulation Range: 1% to 100%
Resolution: 1%
Accuracy: 5% full scale, ± 1 count from 30% to 90%
Modulation Rate: 100.0 Hz to 10.0 kHz
Carrier Range: 400.0 kHz to 999.9999 MHz
Carrier Level: -10 to +50 dBm on T/R Connector
-80 to +10 dBm on ANTENNA IN Connector

DISTORTION METER

Distortion Range: 0.1% to 20.0%
Resolution: 0.1%
Accuracy: $\pm 0.5\%$ Distortion, ± 1 count from 1.0% through 10.0%,
 $\pm 2.0\%$ Distortion, ± 1 count from 10.0% through 20.0%
Signal Frequency: 600 Hz to 1.4 kHz (770 Hz and 1.0 kHz Std.)
Signal Level: 0.1 to 30.0 VRMS, SINAD/BER IN Connector

SINAD METER

Range: 3.0 to 30.0 dB
Resolution: 0.1 dB

Accuracy: ± 1.0 dB, ± 1 count (@ 12 dB SINAD)
Signal Frequency: 600 Hz to 1.4 kHz (770 Hz and 1.0 kHz Std.)
Signal Level: 0.1 to 30.0 VRMS, SINAD/BER IN Connector

DIGITAL MULTIMETER

VOLTMETER (DC/AC)

Ranges: 200.0 mV, 2.000 V, 20.00 V, 200.0 V,
2000 V (full scale) and Autorange (1 M Ω)

NOTE: Maximum voltage is 1000 Vdc or 500.0 VAC (true RMS)

Resolution: 3.5 digit display,
Max. resolution 0.1 on 200.0 mV Scale

Accuracy: $\pm 5\%$, full scale (ac), ± 1 count
 $\pm 1\%$, full scale (dc), ± 1 count

NOTE: AC accuracy applies for AC Volts times kHz product <140.

Frequency: dc, ac mode 50 Hz to 20 kHz

Input Impedance: Selectable $\pm 5\%$
150 Ω
600 Ω (line load)
1 M Ω
User. 1 to 999 Ω (requires external load)

OHMMETER

Ranges: 200.0 Ω , 2.000 k Ω , 20.00 k Ω , 200.0 k Ω ,
2.000 M Ω or 20.00 M Ω (full scale)

Resolution: 3.5 digit display,
Max. resolution 0.1 Ω on 200.0 Ω Scale

Accuracy: $\pm 5\%$ or 0.1 W, ± 1 count

CURRENT METER (DC/AC)

Ranges: 20.00 mA, 200.0 mA, 2.000 A (full scale)
(20.0 A possible using an External Shunt
and setting the voltmeter to 0.2 V scale)

NOTE: 10 A dc or 5 A ac (true RMS) is maximum allowable current.

Resolution: 3.5 digit display, Max. resolution
0.01 mA on 20.0 mA Scale.

Accuracy: $\pm 5\%$ or 0.10 mA, ± 1 count

OSCILLOSCOPE

Display Size:	3.4 inches x 3.8 inches (8.6 x 9.7 cm) Approx. Full Size																		
Vertical Bandwidth (-3dB):	1.0 MHz																		
Input Ranges:	<u>Units per div (8 div on the screen)</u> <table><tr><td>2 mV</td><td>5 mV</td><td>10 mV</td></tr><tr><td>20 mV</td><td>50 mV</td><td>100 mV</td></tr><tr><td>200 mV</td><td>500 mV</td><td>1 V</td></tr><tr><td>2 V</td><td>5 V</td><td>10 V</td></tr><tr><td>20 V</td><td>50 V</td><td></td></tr></table>	2 mV	5 mV	10 mV	20 mV	50 mV	100 mV	200 mV	500 mV	1 V	2 V	5 V	10 V	20 V	50 V				
2 mV	5 mV	10 mV																	
20 mV	50 mV	100 mV																	
200 mV	500 mV	1 V																	
2 V	5 V	10 V																	
20 V	50 V																		
Max Input Voltage:	200 V																		
Accuracy:	±5% of full scale (±10% with x10 probe)																		
Resolution:	1% of full scale, (digital scope data range 0 to 255, in 8 div)																		
Coupling:	dc, ac, GND																		
Horizontal Sweep:																			
Rate:	<u>Units per div (10 div on the screen)</u> <table><tr><td>1 μs</td><td>2 μs</td><td>5 μs</td></tr><tr><td>10 μs</td><td>20 μs</td><td>50 μs</td></tr><tr><td>100 μs</td><td>200 μs</td><td>500 μs</td></tr><tr><td>1 ms</td><td>2 ms</td><td>5 ms</td></tr><tr><td>10 ms</td><td>20 ms</td><td>50 ms</td></tr><tr><td>100 ms</td><td></td><td></td></tr></table>	1 μs	2 μs	5 μs	10 μs	20 μs	50 μs	100 μs	200 μs	500 μs	1 ms	2 ms	5 ms	10 ms	20 ms	50 ms	100 ms		
1 μs	2 μs	5 μs																	
10 μs	20 μs	50 μs																	
100 μs	200 μs	500 μs																	
1 ms	2 ms	5 ms																	
10 ms	20 ms	50 ms																	
100 ms																			
Accuracy:	±1% of full scale																		
Resolution:	1%, (digital scope data sweep, 400 points displayed per sweep)																		
External Input:																			
Impedance:	1.0 MΩ, shunted by 27 pF																		
Internal Signals (DC Coupled):	425.0 kHz IF Demod Audio Function Generator SINAD/BER RF Power External Audio																		

SPECTRUM ANALYZER

Display Size:	3.4 x 3.8 inches (8.6 x 9.7 cm), Approx. Full Size	
Range:	250.0 kHz to 999.9999 MHz	
Frequency Span:		
Range:	0, 1, 2, 5, 10, 20, 50, 100, 200 and 500 kHz 1, 2, 5, 10, 20, 50 and 100 MHz/div	
Accuracy:	±5% of Span Width	
Reference Accuracy:	See Master Oscillator	
Level:		
Vertical Range:	2 or 10 dB/div	
Vertical Resolution:	1 dB (1/2 of a major div)	
Range (Dynamic):	70 dB (1 kHz, 0 dB atten.) at ANTENNA IN Connector	
Bandwidth Switching Error:	<2 dB (5 kHz to 100 MHz mode) <4 dB (1 kHz to 2 kHz mode)	
Overall Accuracy:	±2 dB (normalized) ±4 dB (250 kHz to 400.0 MHz), ±5 dB (400.0 to 999.9999 MHz) ±2.5 dB (>400 MHz normalized)	
Attenuator:	0, 20, 40 dB at ANTENNA IN Connector 40, 60, 80, 100 dB at T/R Connector	
Modes:	<u>Scan Width</u>	<u>Resolution Bandwidth</u>
	100 MHz/div	3 MHz
	50 MHz/div	3 MHz
	20 MHz/div	300 kHz
	5 MHz/div	300 kHz
	2 MHz/div	300 kHz
	1 MHz/div	300 kHz
	500 kHz/div	30 kHz
	200 kHz/div	30 kHz
	100 kHz/div	30 kHz
	50 kHz/div	30 kHz
	20 kHz/div	3 kHz
	10 kHz/div	3 kHz
	5 kHz/div	3 kHz
	2 kHz/div	300 Hz
	1 kHz/div	300 Hz
	0 kHz/div	3 kHz

NOTE: The receiver is fixed on the Center Frequency for monitoring while the analyzer scans as specified.

Receiver Operation Screen Analyzer Display is not available with 1 MHz Scan Width.

BIT ERROR RATE METER (BER)

Data generated by Digital Data Generator. Inputs to BER meter from received RF or from front panel connector.

Range:	1×10^{-1} to 1×10^{-5}
Data Rates:	75, 150, 300, 600, 1200, 2400 and 4800 bps; and 16 kbps
Data Pattern Size:	100 to 100,000 bits
Data Pattern Type:	Random, Fixed, User Definable
Accuracy:	1×10^{-6}
External Input Level:	
Signal Level:	0.1 through 30.0 VRMS, SINAD/BER IN Connector

INPUT/OUTPUT (I/O) CONNECTORS

IEEE-488.1-1987 CONNECTOR	(24 pin Champ Connector)
Interface Capabilities:	SH1, AH1, TEO, L2, LEO, SR1, RL2, PP0, DC1, DT1,C0
RS-232 CONNECTOR (Asynchronous)	(9 pin sub-miniature D, male connector)
Operations Mode:	Off, PC (Input/Output), Printer (Output)
Baud Rates:	300, 600, 1200, 2400, 4800 and 9600 bps
Stop Bits:	1, 2
Parity:	Odd, Even, Mark, Space, None
AUXILIARY BOX INTERFACE (SCSI-1)	(50 pin Champ connector)
Auxiliary Box Interface Connector:	Per ANSI X3.131-1986 standard
EXTERNAL VIDEO	(9 pin sub-miniature D, female connector)
External Computer Monitor Interface:	EGA (Enhanced Graphic Adapter)

MASTER OSCILLATOR

TCXO

Temperature Stability:	± 0.2 ppm (0 to 50°C)
Aging:	± 0.5 ppm per year
Accuracy:	± 0.5 ppm
Adjustment Resolution:	0.005 ppm over 4.0 ppm adjustment range

OPTIONAL OVEN

Temperature Stability:	± 0.05 ppm (0 to 50°C)
Aging:	± 0.25 ppm per year
Accuracy:	± 0.30 ppm

GENERAL CHARACTERISTICS

Dimensions:

(Without Bail Handle): 7.4" (18.8 cm) High, 17" (43.2 cm) Wide
22" (55.9 cm) Deep (With front panel cover on)

(With Bail Handle): 7.4" (18.8 cm) High, 18.8" (47.8 cm) Wide
25" (63.5 cm) Deep (With front panel cover on)

Weight: 48 lbs (21.8 kg)

Operating Temperature Range: 0 to 50°C

POWER REQUIREMENTS

Line: 85 to 135 VAC or 180 to 260 VAC
50 to 400 Hz at 180 W typical

DISPLAY

Type:	Color, 70° deflection, inline
Size:	6.8" (17.3 cm) Diag., 5.6" (14.2 cm) H, 5.2" (13.2 cm) V
Resolution:	640 pixels X 350 Lines

SECTION 2 - INSTALLATION

2-1 GENERAL

This section contains information on preparing the FM/AM-1600S for use. Also listed are installation and operating precautions for safe use of the unit.

2-2 PRECAUTIONS

Before operating this instrument, the operator should be thoroughly familiar with all aspects of this manual.

For operator safety and to prevent damage to this instrument, the following operating precautions should be observed at all times:

WARNING: THE FM/AM-1600S MUST BE CONNECTED TO ELECTRICAL GROUND. CONNECT THE FURNISHED AC POWER CORD TO A PROPERLY GROUNDED 3-PIN RECEPTACLE. DUE TO POTENTIAL SAFETY HAZARDS, USE OF THREE-PRONG TO TWO-PRONG ADAPTOR PLUGS IS NOT RECOMMENDED.

CAUTION: THE DMM AMP CONNECTOR REQUIRES A CURRENT SHUNT WHEN MEASURING CURRENT ABOVE 2 A.

THE T/R CONNECTOR ACCEPTS NO MORE THAN 200 W. MAXIMUM OPERATION TIME FOR MEASUREMENT USING THE T/R CONNECTOR IS:

- CONTINUOUS ON AT 50 W AND 25°C AMBIENT.
- 30 SECONDS ON AND 2 MINUTES OFF AT 100 W AND 50°C AMBIENT.
- 15 SECONDS ON AND 2 MINUTES OFF AT 200 W AND 50°C AMBIENT.

NO MORE THAN 1000 Vdc OR 500 VAC SHOULD BE APPLIED TO THE DMM V Ω CONNECTOR.

NORMAL OPERATION DOES NOT INCLUDE INPUT BEING APPLIED TO DUPLEX OUT CONNECTOR (24), HOWEVER PROTECTION IS PROVIDED TO 10 mW.

MAXIMUM CONTINUOUS INPUT TO ANTENNA IN CONNECTOR (25) IS LIMITED TO 10 mW WITH PROTECTION PROVIDED TO A MAXIMUM INPUT OF 65 W.

THIS EQUIPMENT CONTAINS PARTS SENSITIVE TO DAMAGE BY ELECTRO-STATIC DISCHARGE (ESD).

2-3 POWER UP PROCEDURE

The following procedure should be followed when applying power to the FM/AM-1600S. Refer to Figures 2-1 and 2-2 for specific controls, connectors or indicators.

STEP	PROCEDURE
1.	Place FM/AM-1600S in horizontal operating position.
2.	If connected, remove ac power cord from receptacle.
3.	Determine operating voltage to be used.
4.	Set AC POWER SELECT Switch to required setting (115 or 230 V).

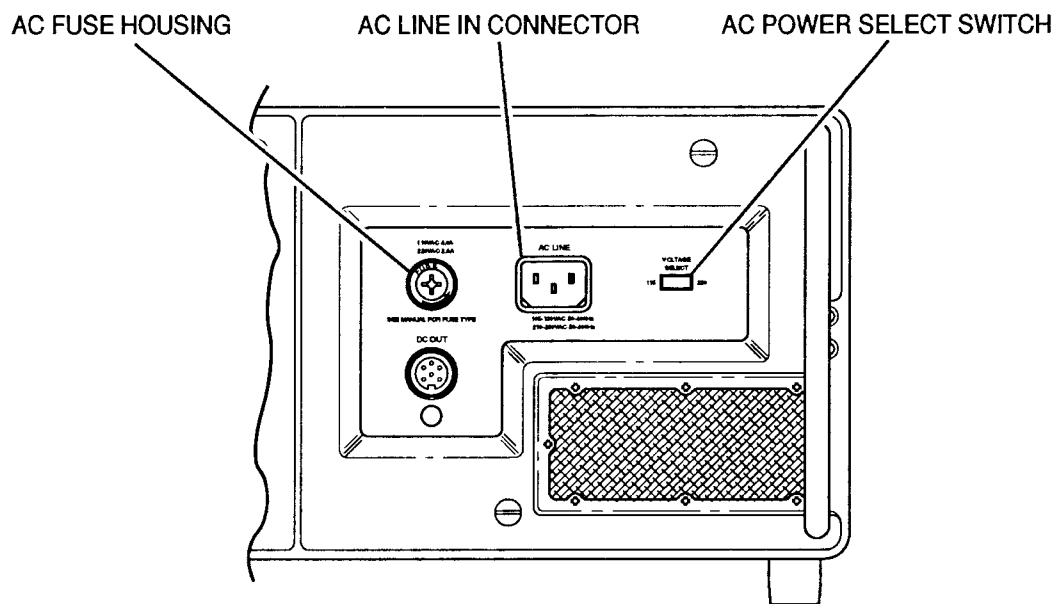

8607005

Figure 2-1 Rear Panel Power Up Controls, Connectors and Indicators

5. Rotate AC FUSE Housing on Rear Panel ccw and remove to expose ac fuse.
6. Insure proper fuse is installed in AC FUSE Housing. A 4.0 A fuse is provided for use with 115 VAC and a 2.0 A fuse is provided for use with 230 VAC.

CAUTION: FOR SAFE OPERATION, REPLACE ONLY WITH FUSE OF SPECIFIED VOLTAGE AND CURRENT RATINGS.

7. Reinstall AC FUSE Housing.

STEP

PROCEDURE

8. Connect power cord provided to AC LINE IN Connector (Figure 2-1). One ac power cord (U.S. only) is provided with unit. Be sure to inspect cord before using it with equipment.

WARNING: A FRAYED OR BROKEN POWER CORD CAN RESULT IN FIRE OR ELECTRICAL SHOCK. DISCARD ALL DAMAGED POWER CORDS AND REPLACE WITH A POWER CORD FREE OF DISFORMATIONS.

9. Plug cord into user provided power source. Insure compatibility with voltage selected for FM/AM-1600S and proper grounding.
10. When power is connected to FM/AM-1600S, POWER APPLIED Indicator lights.
11. Press FM/AM-1600S POWER Switch to ON Position.
12. POWER ON Indicator lights.

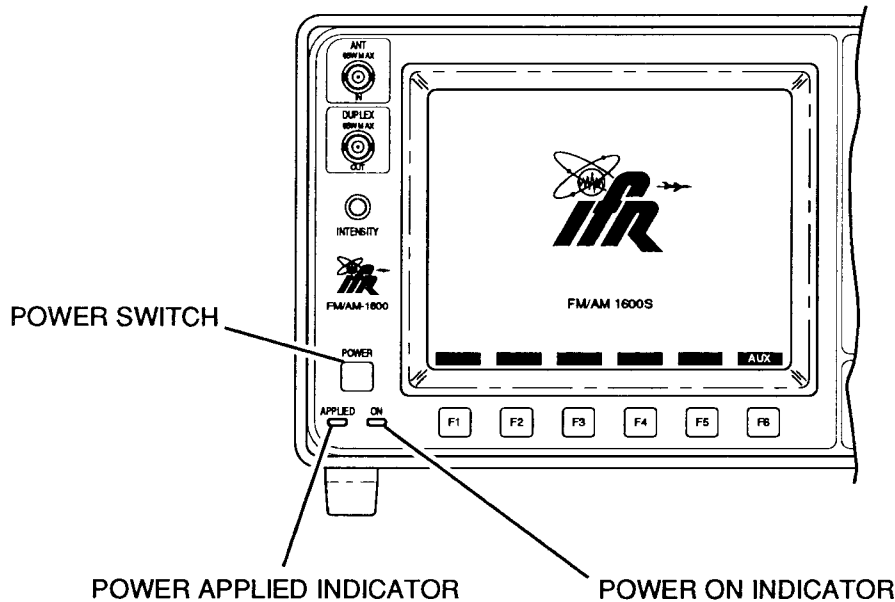

8607006

Figure 2-2 Front Panel Power Up Controls, Connectors and Indicators

SECTION 3 - DESCRIPTION OF CONTROLS, CONNECTORS AND INDICATORS

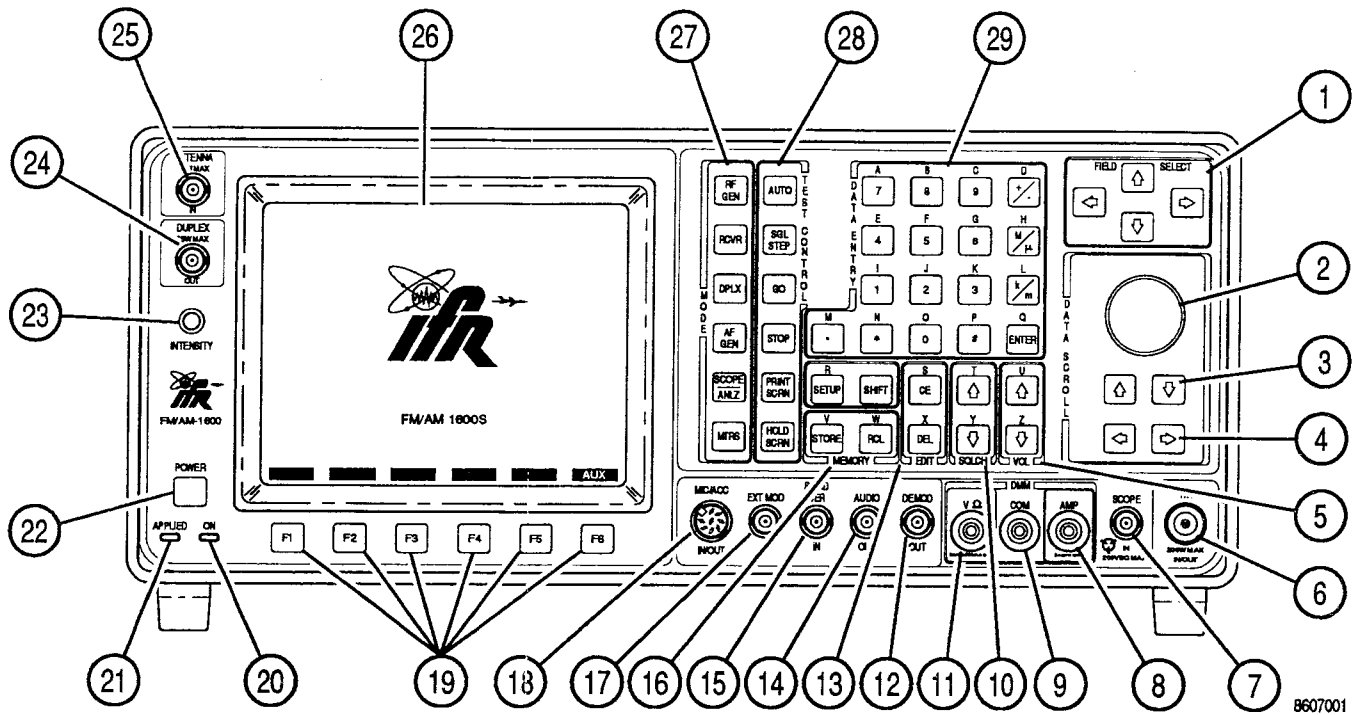

8607001

Figure 3-1 FM/AM-1600S Front Panel Controls, Connectors and Indicators

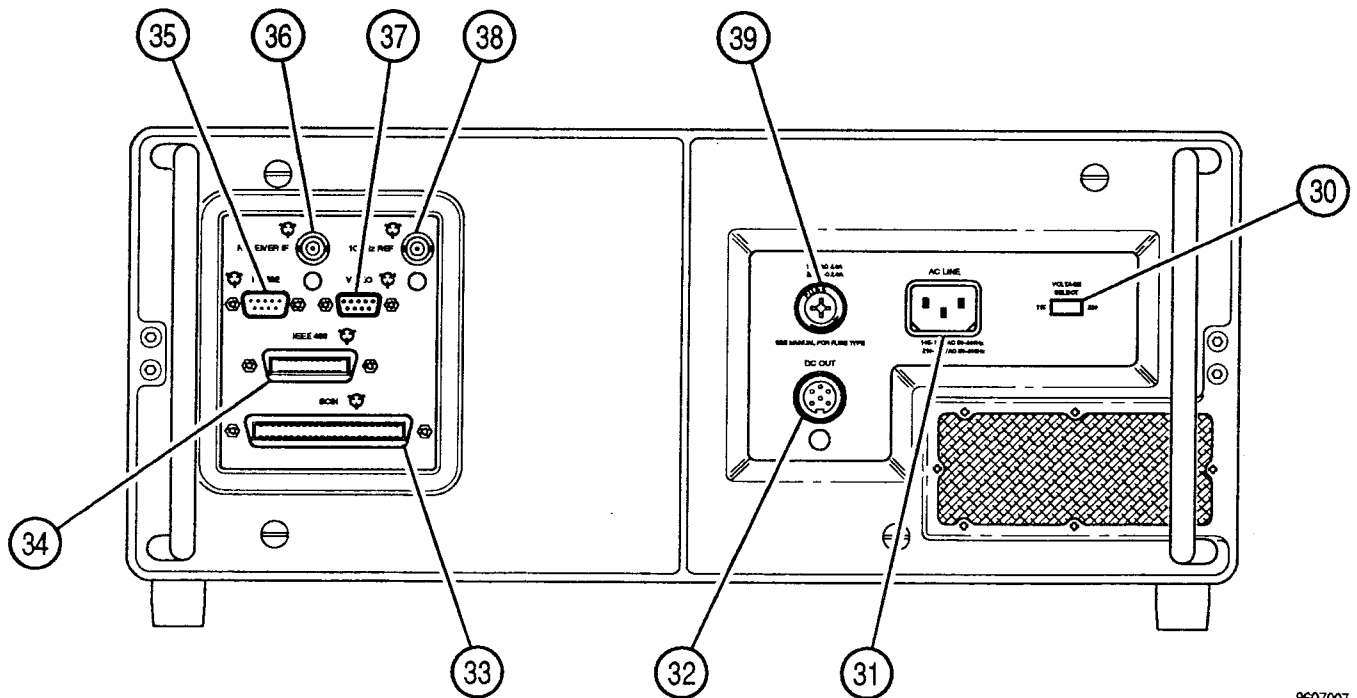

8607007

Figure 3-2 FM/AM-1600S Rear Panel Controls, Connectors and Indicators

1

2

3

4

5

6



17001

0

1. FIELD SELECT Keys
2. DATA SCROLL Spinner
3. DATA SCROLL ↑ and ↓ Keys
4. DATA SCROLL ← and → Keys
5. VOL Keys
6. T/R Connector
7. SCOPE IN Connector
8. DMM AMP Connector
9. DMM COM Connector
10. SQLCH Keys
11. DMM VΩ Connector
12. DEMOD OUT Connector
13. EDIT Keys
14. AUDIO OUT Connector
15. SINAD/BER IN Connector
16. MEMORY and SPECIAL FUNCTION Keys
17. EXT MOD IN Connector
18. MIC/ACC Connector
19. Soft Function Keys
20. POWER ON Indicator
21. POWER APPLIED Indicator
22. POWER Switch
23. CRT INTENSITY Control
24. DUPLEX OUT Connector
25. ANTENNA IN Connector
26. CRT
27. MODE Keys
28. TEST CONTROL Keys
29. DATA ENTRY Keypad
30. AC POWER SELECT Switch
31. AC LINE IN Connector
32. DC OUT Connector
33. SCSI (Small Computer System Interface) Connector
34. GPIB (IEEE-488) Connector
35. RS-232 Connector
36. RECEIVER IF Connector
37. EXTERNAL VIDEO Connector
38. EXTERNAL REFERENCE Connector
39. AC FUSE Housing

17007

3-1 FM/AM-1600S FRONT PANEL

ITEM	DESCRIPTION
1. <u>FIELD SELECT Keys</u>	Up, down, left and right arrow keys are used to place the cursor in the desired data field on a menu or operation screen. FIELD SELECT Keys (←, ↑, →, ↓) move cursor to next data field in the indicated direction.
2. <u>DATA SCROLL Spinner</u>	Rapidly increases or decreases data within a selected field or chooses entries from lists.
3. <u>DATA SCROLL ↑ and ↓ Keys</u>	Steps data within a selected field. Data increases or decreases by a preset amount or next higher or lower data setting appears.
4. <u>DATA SCROLL ← and → Keys</u>	Moves data entry cursor to digit position. When a digit is selected, it becomes the significant digit and the number to its left increments or decrements as the selected digit passes "0".
5. <u>VOL Keys</u>	Increases (↑) or decreases (↓) speaker volume.
6. <u>T/R Connector</u> 	Connector for RF Generator Output and high power input. CAUTION: THE T/R CONNECTOR ACCEPTS NO MORE THAN 200 W. MAXIMUM OPERATION TIME FOR MEASUREMENT USING THE T/R CONNECTOR IS: <ul data-bbox="428 1325 1507 1486" style="list-style-type: none">● CONTINUOUS ON AT 50 W AND 25°C AMBIENT.● 30 SECONDS ON AND 2 MINUTES OFF AT 100 W AND 50°C AMBIENT.● 15 SECONDS ON AND 2 MINUTES OFF AT 200 W AND 50°C AMBIENT.
7. <u>SCOPE IN Connector</u> 	Connector for signal input to digital Oscilloscope. CAUTION: APPLY NO MORE THAN 200 Vdc THROUGH THE SCOPE IN CONNECTOR.

ITEM	DESCRIPTION
------	-------------

8. DMM AMP Connector 

Digital Multimeter (DMM) External Input Connector. Provides input to ac and dc Current Meter.

CAUTION: CURRENT INPUT ABOVE 2 A REQUIRES CURRENT SHUNT.

9. DMM COM Connector 

Digital Multimeter External Input Common Connector. Provides common connection for DMM functions. Connect DMM Probe leads to connectors as follows:

DMM V Ω Connector (11) and DMM COM Connector for ac or dc voltage measurements.
 DMM AMP Connector (8) and DMM COM Connector for ac or dc current measurements.
 DMM V Ω Connector (11) and DMM COM Connector for resistance (ohms) measurements.

NOTE: A set of DMM Probes are included with FM/AM-1600S.

10. SQLCH Keys

Increases (\uparrow) or decreases (\downarrow) Squelch level.

11. DMM V Ω Connector 

Digital Multimeter External Input Connector. Provides input for the DMM ac or dc Voltmeter and Ohmmeter.

CAUTION: NO MORE THAN 1000 Vdc OR 500 VAC SHOULD BE APPLIED TO THE DMM V Ω CONNECTOR.

12. DEMODO OUT Connector

Provides demodulated audio or data from the Receiver.

13. EDIT Keys

a. CE (Clear Entry) Key

Clears selected data entry field.

b. DEL (Delete) Key

Deletes preceding keystroke or character.

14. AUDIO OUT Connector

Provides demodulated audio from Receiver Module, Function Generator output from Monitor Module, EXT MOD signal or SINAD/BER signals for use by the UUT.

15. SINAD/BER IN Connector 

Provides access for signals to SINAD measurement or Bit Error Rate Meter Functions.

CAUTION: APPLY NO MORE THAN 30 VRMS THROUGH THE SINAD/BER IN CONNECTOR.

16. MEMORY and SPECIAL FUNCTION Keys

a. SHIFT Key

Allows direct entry of hexadecimal digits and alpha characters. See Table 3-1 for a complete listing of "SHIFT" characters.

Front Panel Key	2nd Function Character	Front Panel Key	2nd Function Character
7	A	*	N
8	B	0	O
9	C	#	P
+/-	D	ENTER	Q
4	E	SETUP	R
5	F	CE	S
6	G	SQLCH ↑	T
M/μ	H	VOL ↑	U
1	I	STORE	V
2	J	RCL	W
3	K	DEL	X
K/m	L	SQLCH ↓	Y
• (Decimal Point)	M	VOL ↓	Z

Table 3-1 "SHIFT" Characters

b. RCL (Parameter Recall) Key

Recalls previously stored operation screen or test parameters from memory.

c. STORE (Parameter Storage) Key

Stores operation screen or test parameters in memory.

d. SETUP Key

Displays of setup menu for the operating screen on the CRT (26).

ITEM	DESCRIPTION
------	-------------

17. EXT MOD IN Connector 

Connector for external modulation input from AM, FM or PM modulation sources.

CAUTION: APPLY NO MORE THAN 2 Vp-p THROUGH THE EXT MOD IN CONNECTOR.

18. MIC/ACC Connector 

Used as microphone or accessory audio input/output connector.

CAUTION: APPLY NO MORE THAN 2 Vp-p THROUGH THE MIC/ACC CONNECTOR.

19. Soft Function Keys

Functions of Soft Function Keys are dependent on the operating mode.

20. POWER ON Indicator

Green LED illuminates when POWER Switch (22) is pressed to turn power on. LED goes off when POWER Switch (22) is pressed to turn power off.

21. POWER APPLIED Indicator

Yellow LED illuminates when ac power is applied to FM/AM-1600S.

22. POWER Switch

Red power switch used to turn unit power on and off. Under extreme operating conditions (i.e., high temperature indication), power may be switched off under processor control.

23. CRT INTENSITY Control

Adjusts intensity and contrast of the CRT Display (26).

24. DUPLEX OUT Connector 

RF Generator output when unit is in Duplex Mode.

CAUTION: ALTHOUGH DUPLEX OUT CONNECTOR DOES NOT FUNCTION AS AN INPUT CONNECTOR DURING NORMAL OPERATION, DUPLEX OUT CONNECTOR IS PROTECTED TO A MAXIMUM CONTINUOUS INPUT OF 10 mW AND A MAXIMUM INPUT OF 65 W.

ITEM	DESCRIPTION
------	-------------

25. ANTENNA IN Connector 

Antenna Input Connector used to monitor low level "off the air" signals.

CAUTION: MAXIMUM CONTINUOUS INPUT TO ANTENNA IN CONNECTOR IS LIMITED TO 10 mW WITH PROTECTION PROVIDED TO MAXIMUM INPUT OF 65 W.

NOTE: An Antenna is provided with the FM/AM-1600S.

26. CRT

Provides visual information to operator via a 6.8" (5.6" X 4.3") 16-color CRT screen.

27. MODE Keys

Each mode and respective screens and menus are covered in detail in 3-3.

a. RF GEN Key

Accesses RF Generator Operation Screen.

b. RCVR Key

Accesses Receiver Operation Screen.

c. DPLX Key

Accesses Duplex Operation Screen.

d. AF GEN Key

Accesses AF Generator Operation Screen.

e. SCOPE/ANLZ Key

Accesses Oscilloscope or Spectrum Analyzer Operation Screen.

f. MTRS Key

Accesses Meter Menu to select Meter Operation.

28. TEST CONTROL Keys

Used to enter test execution mode or function.

a. AUTO Key







Controls special functions.

b. SGL STEP (Single Step) Key

Controls special functions.

ITEM	DESCRIPTION
c. <u>GO Key</u>	Starts operator controlled functions. Functions affected include Frequency Scan, Cable Fault, BER Tests, DTMF and Encode Functions.
d. <u>STOP Key</u>	Stops operator controlled functions. Functions affected include Frequency Scan Cable Fault, BER Tests, DTMF and Encode Functions.
e. <u>PRINT SCRN Key</u>	Prints current CRT display when connected to an external printer.
f. <u>HOLD SCRN Key</u>	Freezes the current CRT display on the screen.
29. <u>DATA ENTRY Keypad</u>	Provides direct entry of test set parameters into selected data field. Pressing ENTER, K/m or M/ μ Key ends data entry and returns field selection cursor. Parameters are not changed until ENTER Key or a Scale and Unit Key is pressed.
a. <u>"0-9" (Numeric) and "." (Decimal point) Keys</u>	Allows numeric data entry. Numeric keys automatically repeat if held in for more than one second and repeat at an approximate rate of two per second.
b. <u>+/- Key</u>	Toggles the sign of a selected data entry.
c. <u>M/μ and K/m Keys</u>	Scale and Unit Keys, "M/ μ " ($\times 10^6/\times 10^{-6}$) and "K/m" ($10^3/\times 10^{-3}$), are used as multipliers for selected data entry. Toggles to multiply entry by selected factor.
d. <u>ENTER Key</u>	Accesses a selected field and enters selected data in its present configuration.
e. <u># and * Keys</u>	Used for DTMF Functions
f. <u>Alpha Keys</u>	Alpha Keys are accessed by using the SHIFT Key along with the DATA ENTRY, MEMORY, EDIT, SQLCH and VOL Keys. Table 3-1 shows each key and associated alpha character.

3-2 FM/AM-1600S REAR PANEL

ITEM	DESCRIPTION
30. <u>AC POWER SELECT Switch</u>	Allows selection of 115 or 230 VAC power input.
31. <u>AC LINE IN Connector</u> 	Provides input from ac power source. An ac power cord is included with the unit.
32. <u>DC OUT Connector</u> 	Provides operational dc power from the FM/AM-1600S. Specific voltage outputs and current levels are listed in A-3.
33. <u>SCSI (Small Computer System Interface) Bus</u>	Provides a standard, high speed, digital bus for communication.
34. <u>GPIB (IEEE-488) Connector</u>	Allows FM/AM-1600S to control other test modules, transfer test results, drive a plotter or be controlled by an external test controller.
35. <u>RS-232 Connector</u>	Allows FM/AM-1600S to communicate with any serial device, to control other test modules, upload and download parameter sets, transfer test results, drive a printer or be controlled by an external test controller. All commands or data available to the operator at Front Panel are available at RS-232 Connector.
36. <u>RECEIVER IF Connector</u> 	Provides user access to Receiver IF Signal.
37. <u>EXTERNAL VIDEO Connector</u> 	Allows an external CRT (EGA compatible) to be attached to FM/AM-1600S. Attached CRT echoes current display.
38. <u>EXTERNAL REFERENCE Connector</u> 	Allows attachment of an external 10 MHz reference to FM/AM-1600S.
39. <u>AC FUSE Housing</u> 	115 VAC operation requires 4.0 A fuse. 230 VAC operation requires 2.0 A fuse.

3-3 OPERATION SCREENS AND MENU CONFIGURATIONS

The operation screens of the FM/AM-1600S and their accompanying setup menus contain a great deal of information. This information displays differently according to the type of operation screen displayed, the configuration of the screen and signal type and input source used.

Operation screens are accessed by pressing any MODE Key except the MTRS Key. Menus for each operation screen are accessed by pressing the SETUP Key while that Operating Screen is displayed on the CRT.

Pressing the MTRS MODE Key accesses the Meter Menu. The Meter Menu is used to access each Meter Operating Screen. Menus for individual Meters are accessed by pressing the SETUP Key while a Meter Operation Screen is displayed on the CRT.

When editing, use the FIELD SELECT Keys to move the cursor to the parameter to be edited and press ENTER Key to access the data field. Use the DATA ENTRY Keypad to enter numerical data. Use the DATA SCROLL Spinner or DATA SCROLL ↑ and ↓ Keys to select parameters from a list. Parameters with only two possible settings automatically switch to the opposite setting when selected.

3-3-1 RF GENERATOR OPERATION SCREEN

Pressing the RF GEN MODE Key accesses the RF Generator Operation Screen. The index of screen features to identify the operation screen parameters that may be edited, the value range available to each feature and/or its usage.

When editing, use the FIELD SELECT Keys to move the cursor to the parameter to be edited and press ENTER Key to access the data field. Use the DATA ENTRY Keypad to enter numerical data. Use the DATA SCROLL Spinner or DATA SCROLL ↑ and ↓ Keys to select parameters from a list. Parameters with only two possible settings automatically switch to the opposite setting when selected. To access a displayed Meters Operation Screen, move cursor to the Meters Callout and press the ENTER Key.

A. SCREEN PARAMETERS

The following index includes screen parameters and screen parameter attributes. Possible parameter settings are listed where parameters can be changed from the operation screen.

ITEM	DESCRIPTION
	<p>The diagram shows the RF Generator Operation Screen with the following parameters and meters:</p> <ul style="list-style-type: none"> 9: RF 10.0001 MHz 10: Func Gen 11: LEVEL 0 dBm 12: SOURCE (1, 2, 3, Ext, Mic) 1: MOD FM 2: DEVIATION 3.0 kHz 3: AF FREQ 100.0 Hz 4: WAVE Sine 5: DIST 14.0% 6: Meter bar (0, 10, 20%) 7: Meter bar (0, 10, 20%) 8: Grid display

8617003

1. Modulation Sources

Selects Sources and their Modulation. 1 is AF Generator 1, 2 is AF Generator 2, 3 is Signaling Formats, "Ext" is external signals received at the EXT MOD IN Connector and "Mic" is external sources received at the MIC/ACC Connector. Underline indicates last activated Source. Select AM, FM, PM or OFF for Modulation.

NOTE: Different Sources cannot be FM and PM simultaneously. Selecting FM changes PM sources to FM. Selecting PM changes FM sources to PM. Sources that are AM or OFF are not affected.

ITEM	DESCRIPTION
------	-------------

NOTE: Source 2 and 3 cannot be active simultaneously when Source 3 is generating an Audio Signaling Code.

2. Modulation Type

Not an editable parameter. Readout indicates last activated Source Modulation Type. Indicates FM, AM, PM or OFF.

3. Modulation Level

Selects Modulation Level. Range is 0.0 to 100.0 kHz for FM Modulation, 0% to 90% for AM Modulation or 0.0 to 10.0 radians for PM Modulation.

NOTE: When Ext Source is selected, Modulation Level setting assumes the modulating signal applied to the EXT MOD IN Connector is 3.54 VRMS. Modulation Level settings are set higher for lower EXT MOD IN Connector input voltages to achieve the same modulation level as per the following equation:

$$\begin{array}{r} \text{Modulation} \\ \text{Level setting} \\ \text{(kHz, \%, rad)} \end{array} \times \begin{array}{r} \text{EXT MOD IN} \\ \text{Connector} \\ \text{Input (VRMS)} \end{array} \div 3.54 = \begin{array}{r} \text{Actual} \\ \text{Modulation} \\ \text{Level} \end{array}$$

4. AF FREQ

Appears if Source 1 or 2 is the last selected Source. Selects AF frequency. Range is from 0.0 to 40000.0 Hz.

5. WAVE

Appears if Source 1 or 2 is the last selected Source. Selects Wave Form. Select Sine, Square, Ramp, Triangle, Pulse, +1 Lvl, 0 Lvl or -1 Lvl.

6. Soft Function Keys

Soft Function Keys for RF Generator Operating Screen are covered in 3-3-1B.

7. Distortion/SINAD/AF Level/DMM Meter

Displays selected meter. Meter is selected using "Meters" Soft Function Key F4. Accessing Meter Callout displays Meters Operation Screen. Meter displayed as a digital readout if Scope or Analyzer is full size.

8. Oscilloscope or Spectrum Analyzer

Displays Oscilloscope or Spectrum Analyzer Operation. Use "Disp" Soft Function Key F1 to display full size or 1/4 size Oscilloscope, full size or 1/4 size Spectrum Analyzer or set to "None" for no display.

ITEM	DESCRIPTION
9. <u>RF Generator Frequency</u>	Selects frequency from 0.2500 to 999.9999 MHz. Frequency Callout turns yellow when Phase Lock is lost. Regaining Phase Lock does not restore Frequency Callout. To restore Frequency Callout after regaining Phase Lock, reselect the Receiver Operation Mode.
10. <u>10 MHz External Reference Light</u>	Blue asterisk appears when 10 MHz External Reference signal is applied to the EXTERNAL REFERENCE Connector.
11. <u>Oscilloscope Input</u>	Appears with Oscilloscope on. Select Rcvr IF, Demod Audio, RF Pwr Lvl, SINAD/BER, Func Gen, Ext Mod, AC, DC or GND.
12. <u>RF Generator Level</u>	If RF Generator Level Units are set to dBm, select from -137.0 to 0.0 dBm. If RF Generator Level Units are set to Volts, select from 0.031 μ V to 0.224 V.

If Source 3 is the last activated Source, the Operation Screen appears as follows:

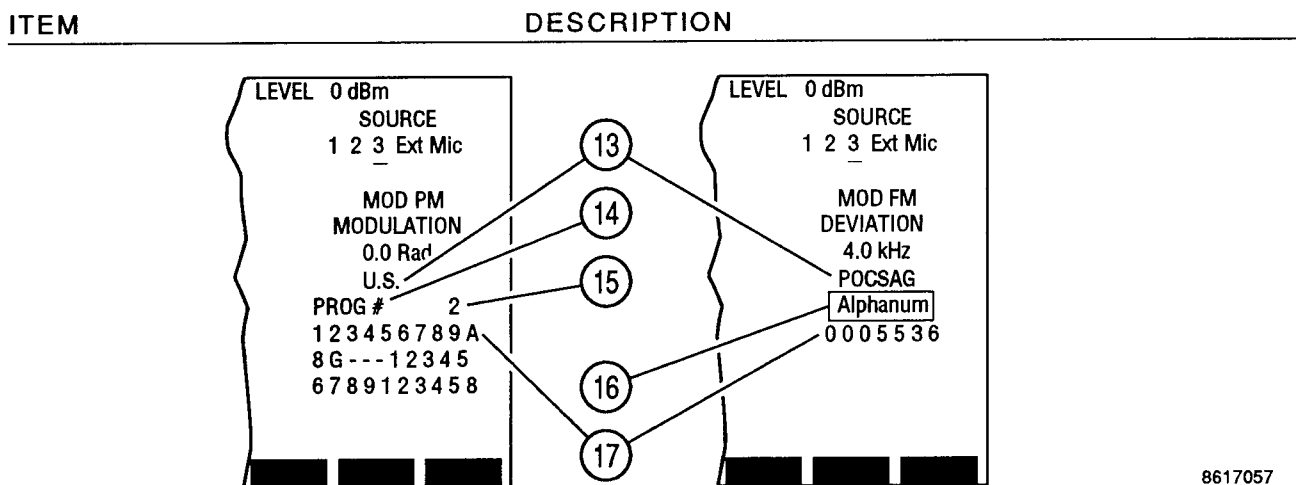

8617057

ITEM	DESCRIPTION
------	-------------

- Accesses Digital Code if Digital Signaling Format is active. Select from:

DCS	DCS INV	POCSAG
-----	---------	--------

- Accesses RCC Code if RCC Signaling Format is active. Select from:

IMTS	MTS	2805
Tone Rem		

NOTE: Signaling Format Type is set from the RF Generator Menu.

14. DIRECT ENTRY/PROG #

Accessing Callout toggles it to the function not shown. Select PROG # to generate a programmed sequence. Select DIRECT ENTRY to allow sequence entry from the Operation Screen. Press GO TEST CONTROL Key to continuously generate a sequence. Press STOP TEST CONTROL Key to stop generating the sequence. Press SGL STEP CONTROL Key to generate the sequence once.

15. Program Number

Does not appear if DIRECT ENTRY is active. Up to 16 sequences can be programmed.

16. POCSAG or Tone Remote Callout

Accesses POCSAG or Tone Remote Function. For POCSAG, select one of the following:

Tone - 1 beep	Tone - 2 beeps	Tone - 3 beeps
Tone - 4 beeps	Numeric	Numeric seq
Alpha lower	Alpha upper	Alphanumeric
Alpha special		

For Tone Remote, select one of the following:

2050 (Monitor)	1950 (F1)	1850 (F2)
1750 (R2 Mute)	1650 (R2 Unmute)	1550 (Repeater Off)
1450 (Repeater On)	1350 (Wild Card 1 On)	1250 (Wild Card 1 Off)
1150 (Wild Card 2 On)	1050 (Wild Card 2 Off)	

17. Tone Sequence Listing

Displays coded sequence. If DIRECT ENTRY is selected, accessing allows entry of sequence unless POCSAG or Tone Remote is in use.

B. SOFT FUNCTION KEYS

The following index lists, by screen, the different Soft Function Key sets available for the RF Generator Operation Screen. Whichever set is accessed last is the set that comes up first when the RF Generator Operation Screen is next accessed. Press "More" Soft Function Key F6 to access the next set of Soft Function Keys.

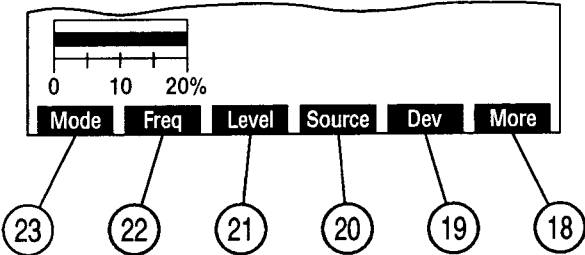
ITEM	DESCRIPTION
	

8617050

18. "More"/"ESC" Soft Function Key F6

"ESC" appears while parameters are accessed for editing. Allows edit procedure to be canceled without changing parameter. "More" displays additional sets of Soft Function Keys.

19. "Dev"/"Mod" Soft Function Key F5

Appears if Modulation is not "OFF". Selects Modulation Level, with a range of 0 to ± 100 kHz for FM, 0% to 90% for AM or 0.0 to 10.0 radians for PM.

20. "Source" Soft Function Key F4

Selects Modulation Source. Select OFF, AM, FM or PM for each Source.

21. "Level" Soft Function Key F3

Selects RF Generator Signal Level. Select from -137.0 to 0.0 for dBm Level Units. Select from 0.031 mV to 0.224 V for voltage Level Units.

22. "Freq" Soft Function Key F2

Selects RF Generator Frequency. Select from 0.2500 to 999.9999 MHz.

23. "Mode" Soft Function Key F1

Selects RF Generator Format. Select Direct or Channel. In Channel Mode, RF Generator Frequency is displayed as a cellular channel number. Cellular Channel System is selected from RF Generator Menu.

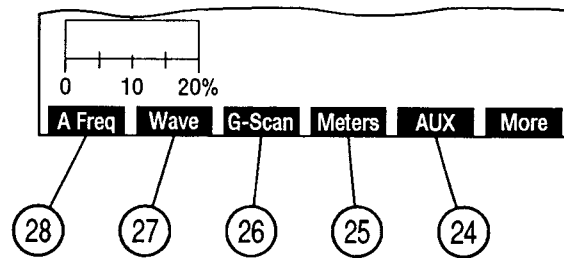

8617049

24. "AUX" Soft Function Key F5

Displays Auxiliary Functions Menu.

25. "Meters" Soft Function Key F4

Displays submenu of available Meters. Select SINAD, DIST (Distortion), AF LVL or DMM.

NOTE: SINAD, Distortion and AF Level Meters measure only SINAD/BER IN Connector Input. DMM measures only DMM Connector Input.

26. "G-Scan" Soft Function Key F3

Activates RF Frequency Scan. RF Generator Scan Parameters are accessed by pressing "Scan" Soft Function Key F1 from the RF Generator Menu.

27. "Wave" Soft Function Key F2

Appears if Source 1 or 2 is the last selected Source. Selects Wave Form. Select Sine, Square, Ramp, Triangle, Pulse, +1 Lvl, 0 Lvl or -1 Lvl.

28. "A Freq" Soft Function Key F1

Appears if Source 1 or 2 is the last selected Source. Selects AF Frequency. Select from 0.0 to 40000.0 Hz.

The following set of Soft Function Keys are accessed when a full size Spectrum Analyzer is used:

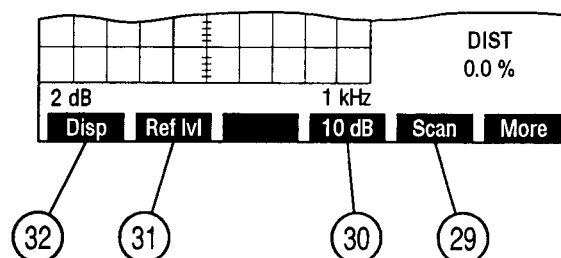

8617028

ITEM	DESCRIPTION
------	-------------

29. "Scan" Soft Function Key F5

Selects Spectrum Analyzer Scan Width. Select from the following:

(0 kHz) Zero Scan	1 kHz	2 kHz
5 kHz	10 kHz	20 kHz
50 kHz	100 kHz	200 kHz
500 kHz	1 MHz	

30. "10 dB/2 dB" Soft Function Key F4

Selects Units/Division Factor. Toggles between 10 and 2 dB/div.

31. "Ref lvl" Soft Function Key F2

Appears with 2 dB/div scale. Adjusts vertical trace position on Spectrum Analyzer.

32. "Disp" Soft Function Key F1

Accesses menu listing Oscilloscope and Spectrum Analyzer displays. Select full or 1/4 size displays for Oscilloscope or Spectrum Analyzer or select none.

The following set of Soft Function Keys are accessed when an Oscilloscope is in use:

ITEM	DESCRIPTION
------	-------------

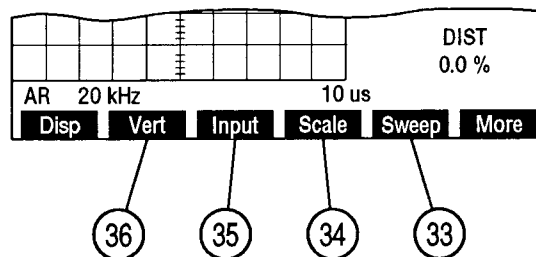

8617034

33. "Sweep" Soft Function Key F5

Appears with full size Oscilloscope and does not appear if "Rcvr IF" is the Oscilloscope Input. Selects Oscilloscope Sweep Rate. Select one of the following:

1 μ s	2 μ s	5 μ s
10 μ s	20 μ s	50 μ s
100 μ s	200 μ s	500 μ s
1 ms	2 ms	5 ms
10 ms	20 ms	50 ms
100 ms		

ITEM

DESCRIPTION

34. "Scale" Soft Function Key F4

Appears with full size Oscilloscope. For AC, DC or GND Oscilloscope Input, select one of the following:

1 mV/div	2 mV/div	5 mV/div
10 mV/div	20 mV/div	50 mV/div
100 mV/div	200 mV/div	500 mV/div
1 V/div	2 V/div	5 V/div
10 V/div	20 V/div	50 V/div

For Func Gen or Ext Mod Oscilloscope Input, select one of the following:

500 mV/div	1 V/div	2.5 V/div
------------	---------	-----------

For RF Pwr Lvl Oscilloscope Input, Oscilloscope Scale reads 2 W/div or 200 W/div. Power Meter Ranges of 20, 50 or 100 mW set Oscilloscope Scale to 2 W/div. All other Power Meter Ranges sets Oscilloscope Scale to 200 W/div.

Oscilloscope Scale is not editable for SINAD/BER or Rcvr IF Oscilloscope Input and "Scale" Soft Function Key F4 does not appear.

35. "Input" Soft Function Key F3

Selects Oscilloscope Input. Demod Audio Oscilloscope Input is not operable. Select one of the following:

Rcvr IF	RF Pwr Lvl	SINAD/BER
Func Gen	Ext Mod	AC
DC	GND	

36. "Vert" Soft Function Key F2

Appears with full size Oscilloscope. Adjusts vertical trace position on Oscilloscope. When Oscilloscope Trace is adjusted below Oscilloscope display, an arrow appears on the right bottom edge of the display. When Oscilloscope Trace is adjusted above Oscilloscope display, an arrow appears on the right top edge of the display.

C. RF GENERATOR MENU

When the RF Generator Operation Screen is displayed on the CRT, pressing SETUP accesses the RF Generator Menu.

MENU ITEM	DESCRIPTION
-----------	-------------

RF GENERATOR MENU

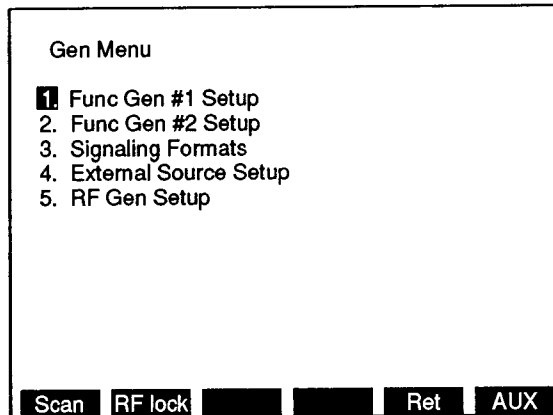

8610077

1. Func Gen #1 Setup

Displays Function Generator #1 Menu.

2. Func Gen #2 Setup

Displays Function Generator #2 Menu.

3. Signaling Formats

Displays Signaling Format Menu featuring DTMF, Audio, Digital and RCC.

4. External Source Setup

Displays External Source Setup Menu.

5. RF Gen Setup

Displays RF Generator Setup Menu.

The following set of Soft Function Keys are available with the RF Generator Menu.

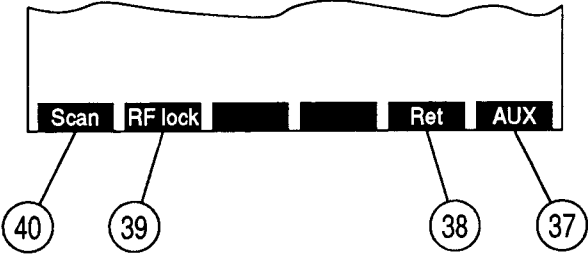
ITEM	DESCRIPTION
	 <p>The diagram shows a horizontal bar representing a soft function key interface. It contains four keys: 'Scan', 'RF lock', 'Ret', and 'AUX'. Below the bar, four circled numbers are connected to the keys by lines: 40 is connected to 'Scan', 39 to 'RF lock', 38 to 'Ret', and 37 to 'AUX'.</p>

8607126

37. "AUX"/"ESC" Soft Function Key F6

"ESC" appears while parameters are accessed for editing. Allows edit procedure to be canceled without changing parameter. "AUX" displays Auxiliary Functions Menu.

38. "Ret" Soft Function Key F5

Returns operation to RF Generator Operation Screen.

39. "RF lock"/"Chan" Soft Function Key F2

- "RF lock" Soft Function Key F2 is displayed for Direct RF Generator Format. Activates RF Lock Function, locking RF Generator Frequency to Receiver RF Frequency and Analyzer RF Frequency. Last frequency entered from among the frequencies locked is the frequency locked on. "RF lock" appears in red when RF Lock Function is active.
- "Chan" Soft Function Key F2 is displayed for Channel RF Generator Format. Displays RF Generator Channel Format Menu.

ITEM	DESCRIPTION
40. <u>"Scan" Soft Function Key F1</u>	Displays RF Generator Frequency Scan Menu.

MENU ITEM	DESCRIPTION
RF GENERATOR FREQUENCY SCAN MENU	

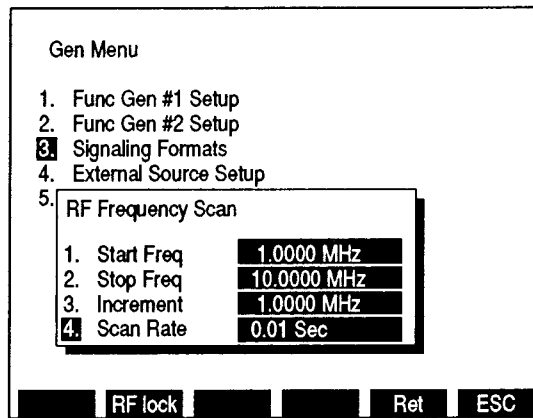

8610084

1. Start Freq

Selects starting frequency for RF Frequency Scan. Range is from 0.2500 to 999.9999 MHz.

2. Stop Freq

Selects upper limit frequency for RF Frequency Scan. Range is from 0.2500 to 999.9999 MHz.

3. Increment

Selects increment between frequencies to be scanned. Range is from 0.0000 to 999.9999 MHz.

4. Scan Rate

Selects time period for each frequency to be generated. Range is from 0.02 to 99.99 sec.

Selecting "1. Func Gen #1 Setup" displays the Function Generator #1 Setup Menu.

MENU ITEM	DESCRIPTION
-----------	-------------

FUNCTION GENERATOR #1 SETUP MENU

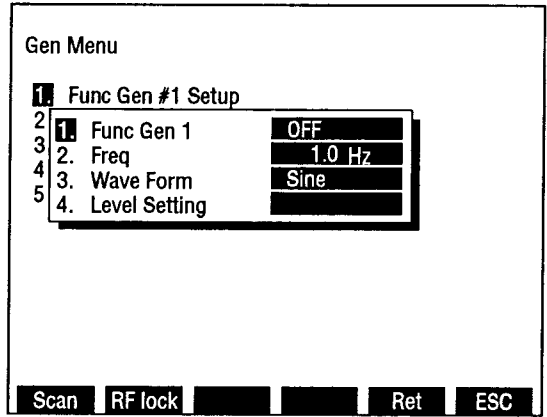

8610051

1. Func Gen 1

Selects Function Generator Modulation Type. Choose AM, FM, PM or OFF.

NOTE: Different sources cannot be FM and PM simultaneously. Selecting FM changes PM sources to FM. Selecting PM changes FM sources to PM. Sources that are AM or OFF are not affected.

2. Freq

Selects Function Generator Frequency. Range is from 0.0 to 40000.0 Hz.

3. Wave Form

Selects Function Generator Wave Form. Choose Sine, Square, Ramp, Triangle, Pulse, +1 Lvl, 0 Lvl or -1 Lvl.

4. Level Setting

Not operational when Function Generator is off. Selects Function Generator Modulation Level. Range is from 0.000 to 100.000 kHz for FM Deviation, 0% to 90% for AM Modulation and 0.0 to 10.0 radians for PM Modulation.

Accessing "2. Func Gen #2 Setup" displays the Function Generator #2 Menu. Function Generator #2 parameters are identical to those of Function Generator #1.

When "3. Signaling Formats" is selected on the Generator Menu, the following menu appears on the CRT:

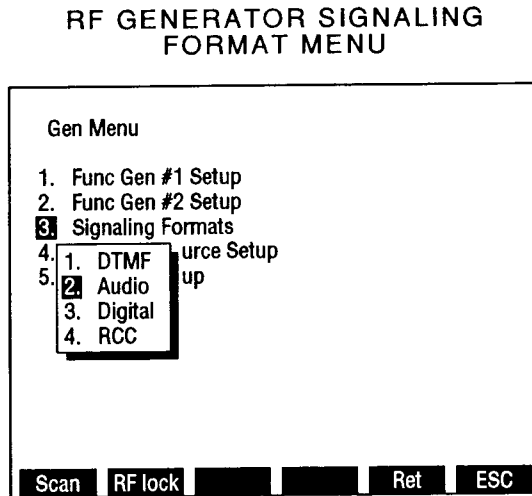

8610080

If DTMF is selected, the DTMF Format Menu appears on the screen:

ITEM

DESCRIPTION

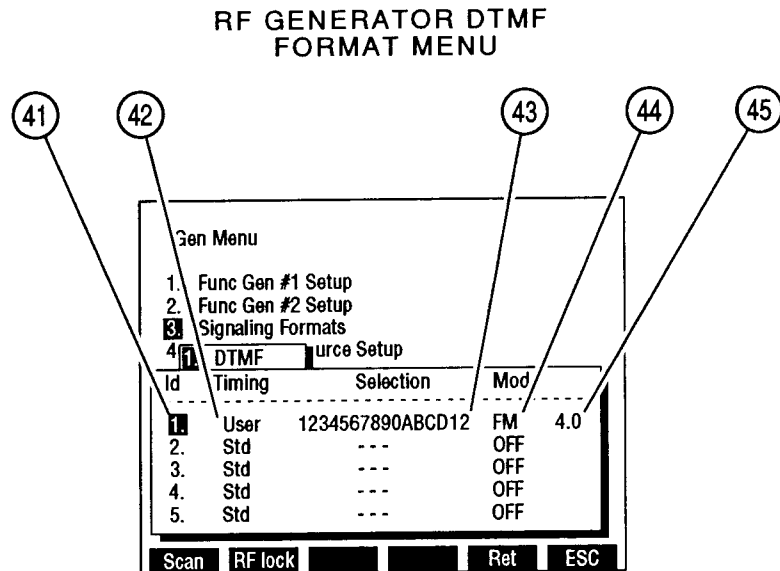

8607054

41. Id

Program Identification number. Used to select a specific sequence from the Operation Screen while using the Program feature. Select 1 to 15.

42. Timing

Selects Std (standard) or User (user defined). If User is selected, two data fields appear allowing entry of desired Mark Timing and Space Timing. Range of both is 25 to 9999 ms.

ITEM

DESCRIPTION

43. Sequence

Selects the desired sequence of up to 15 tones using digits 0 through 9, letters A through D, # character and the * character.

44. Mod Type

Selects AM, FM, PM or OFF for the DTMF modulation.

45. Mod Level

Modulation Level range is 0.0 to 20.0 kHz for FM, 0.0% to 24.5% for AM or 0.0 to 3.0 radians for PM.

If Audio is selected as the Signaling Format, the RF Generator Audio Signaling Format Menu appears on the screen listing 12 Audio Signaling Codes:

RF GENERATOR AUDIO
SIGNALING FORMAT MENU

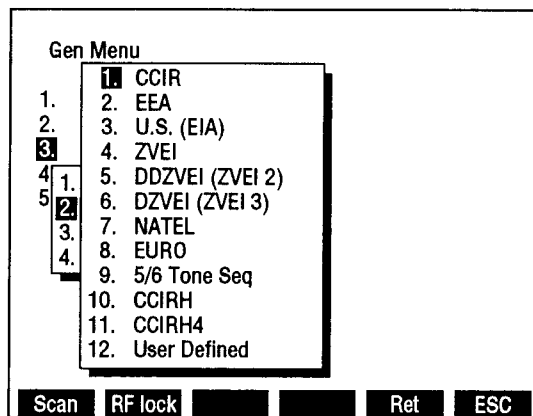

8610081

Selecting an Audio Code displays the Audio Code Sequence Menu:

RF GENERATOR AUDIO
CODE SEQUENCE MENU

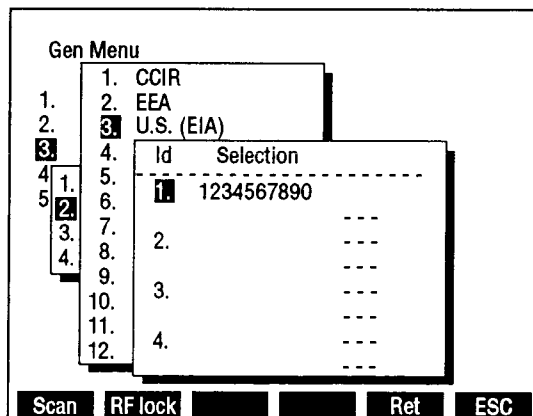

8610082

Select an Id number from 1 to 16. Enter a sequence up to 30 tones in length using the characters 0 through 9, -, A, G and R.

Selecting "12. User Defined" for the Audio Code displays the Audio Code User Defined Menu:

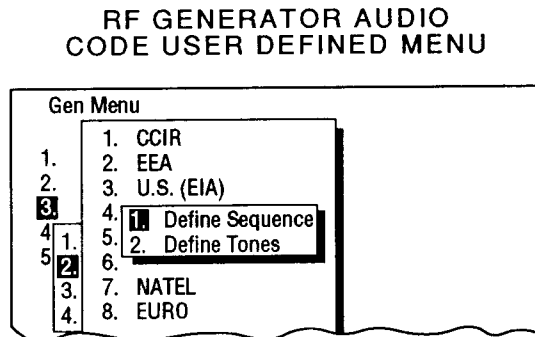

8610159

Selecting "2. Define Tones" displays a menu used to define the desired tones.

ITEM **DESCRIPTION**

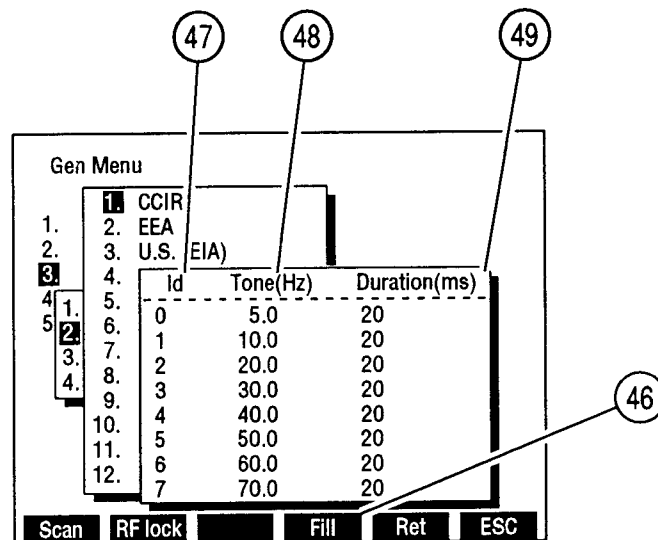

8610155

46. "Fill" Soft Function Key F4

When a Tone or Duration is highlighted, pressing "Fill" Soft Function Key F4 changes all entries below and in the same column to the value highlighted.

47. Id

Selects an Id to represent the tone to be defined. Range of characters for the Id is 0 to 9 and A to T. Defining the tone consists of setting the frequency and duration of the tone.

48. Tone(Hz)

Set "Tone(Hz)" to frequency of desired tone. Range is 0.0 to 9999.9 Hz.

49. Duration(ms)

Set "Duration(ms)" to duration of desired tone. Range is 20 to 9999 ms.

Selecting "Define Sequence" displays the RF Generator Audio Code Sequence Menu. User Defined sequences are selected as other Audio Codes using this menu.

If Digital is selected as the Signaling Format, the Digital Code Menu appears:

RF GENERATOR
DIGITAL CODE MENU

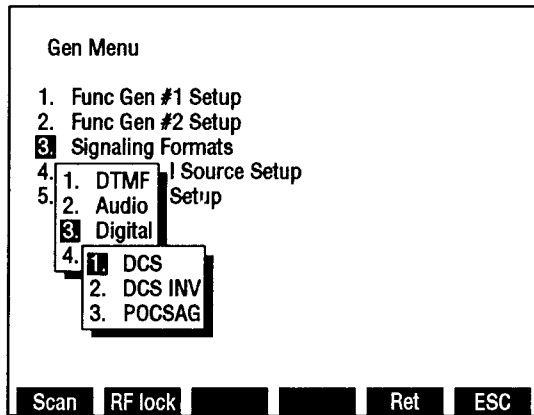

8610142

Selecting DCS or DCS INV displays the DCS Code Menu:

RF GENERATOR
DCS CODE MENU

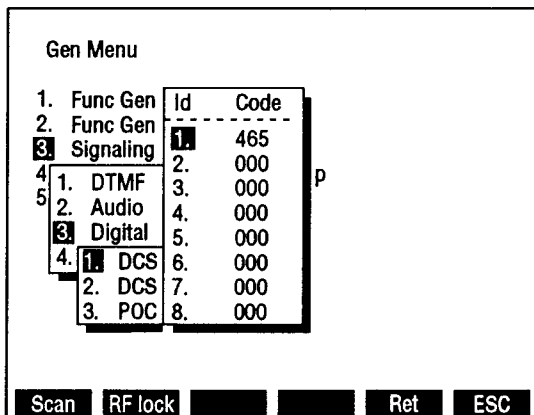

8610083

After selecting the Id number, a 3 digit DCS Code is entered.

Selecting POCSAG from the Digital Code Menu displays the POCSAG Menu:

MENU ITEM	DESCRIPTION
-----------	-------------

**RF GENERATOR
POCSAG MENU**

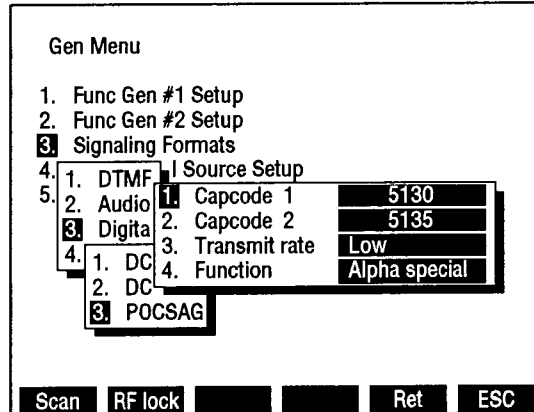

8610143

1. Capcode 1

Selects beginning Capcode of sequence. Sequence generated consist of Capcodes from Capcode 1 through Capcode 2.

2. Capcode 2

Selects ending Capcode of Capcode sequence. Sequence generated consist of Capcodes from Capcode 1 through Capcode 2.

3. Transmit rate

Toggles Transmit Rate to Low or High.

4. Function

Displays POCSAG Function Submenu. Choose one of the following:

Tone - 1 beep	Tone - 2 beeps	Tone - 3 beeps
Tone - 4 beeps	Numeric	Numeric seq
Alpha lower	Alpha upper	Alphanumeric
Alpha special		

If RCC is selected for the Signaling Format, the RCC Code Menu appears:

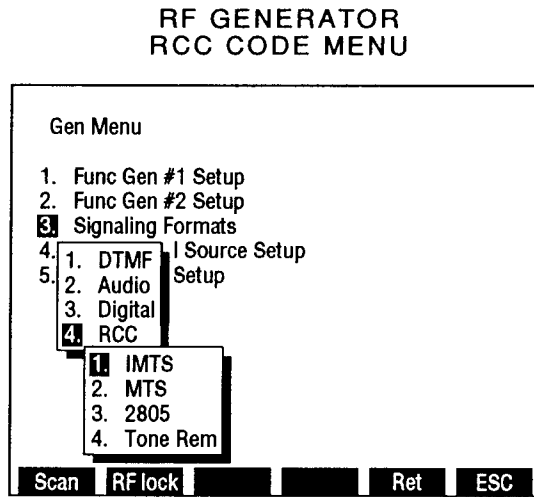

8610144

Selecting IMTS, MTS or 2805 displays the following menu:

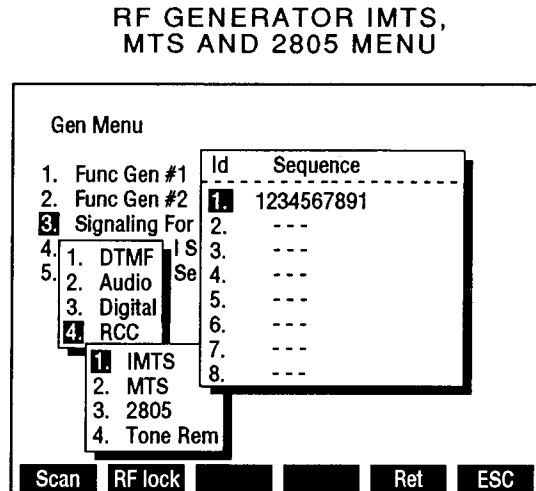

8610145

After selecting an Id, select the sequence to be generated using characters 1 through 9.

If 2805 is selected, "Tone" Soft Function Key F3 appears. Accessing F3 displays the 2805 Tone Freq data field allowing this frequency to be changed. Range of Tone Freq is 0.0 to 40000.0 Hz.

Selecting Tone Rem displays the Tone Remote Function Menu. Select one of the following:

- | | | |
|-----------------------|------------------------|------------------------|
| 2050 (Monitor) | 1950 (F1) | 1850 (F2) |
| 1750 (R2 Mute) | 1650 (R2 Unmute) | 1550 (Repeater Off) |
| 1450 (Repeater On) | 1350 (Wild Card 1 On) | 1250 (Wild Card 1 Off) |
| 1150 (Wild Card 2 On) | 1050 (Wild Card 2 Off) | |

When "4. External Source Setup" is selected on the Generator Menu, the following menu appears on the CRT:

MENU ITEM

DESCRIPTION

RF GENERATOR EXTERNAL
SOURCE SETUP MENU

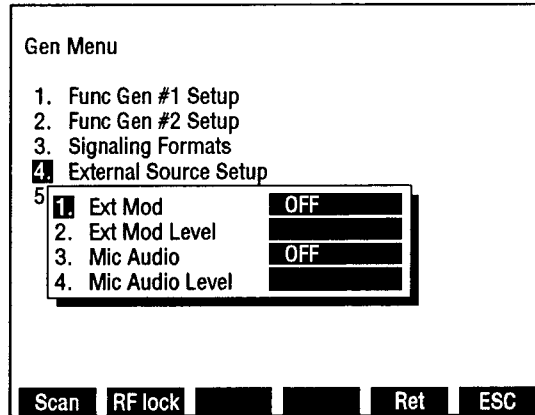

8610053

1. Ext Mod

Select FM, AM, PM or OFF for the External Modulation Type.

2. Ext Mod Level

Selects External Modulation Level. Select from 0.0 to 100.0 kHz for FM, 0% to 90% for AM or 0.0 to 10.0 radians for PM. Field is blank if set to OFF.

NOTE: External Modulation Level setting assumes the modulating signal applied to the EXT MOD IN Connector is 3.54 VRMS. For lower input voltages, Modulation Level setting is set higher to achieve the modulation level desired as per the following equation:

$$\begin{array}{r} \text{Modulation} \\ \text{Level setting} \\ \text{(kHz, \%, rad)} \end{array} \times \begin{array}{r} \text{EXT MOD IN} \\ \text{Connector} \\ \text{Input (VRMS)} \end{array} \div 3.54 = \begin{array}{r} \text{Actual} \\ \text{Modulation} \\ \text{Level} \end{array}$$

3. Mic Audio

Select FM, AM, PM or OFF for Microphone Input Modulation Type.

4. Mic Audio Level

Selects Microphone Input Modulation Level. Select from 0.0 to 100.0 kHz for FM, 0% to 90% for AM or 0.0 to 10.0 radians for PM. Field is blank if set to OFF.

When "5. RF Generator Setup" is selected on the Generator Menu, the RF Generator Setup Menu appears on the CRT:

MENU ITEM DESCRIPTION

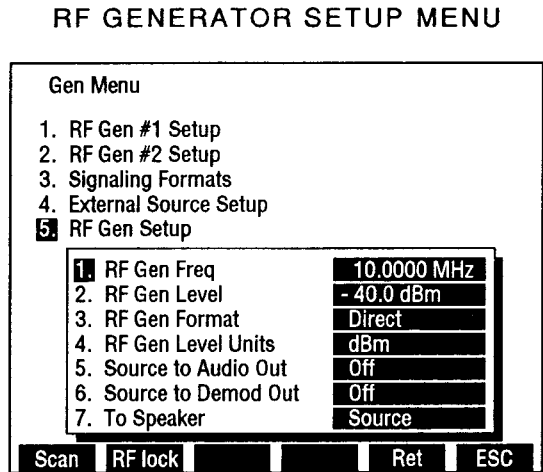

8610074

1. RF Gen Freq

Selects RF Generator frequency. Range is from 0.2500 to 999.9999 MHz.

2. RF Gen Level

Selects RF Generator Output Level. If RF Generator Level Units are set to dBm, range is from -137.0 to 0.0 dBm. If RF Generator Level Units are set to Volts, range is from 0.031 μ V to 0.224 V.

3. RF Gen Format

Selects RF Generator Format. Toggles to Direct or Channel. In Channel Mode, RF Generator Frequency is displayed as a cellular channel number and "Chan" Soft Function Key F2 appears. "Chan" Soft Function Key F2 accesses the RF Generator Channel Format Menu listing available Cellular Channel Formats.

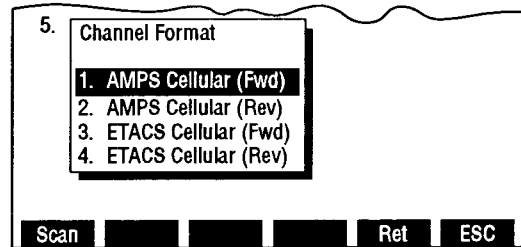

8610181

4. RF Gen Level Units

Selects RF Generator Output Level Units. Toggles units to dBm or Volts.

MENU ITEM	DESCRIPTION
5. <u>Source to Audio Out</u>	Sets routing of AF Generator Output to AUDIO OUT Connector. Accessing toggles routing on or off.
6. <u>Source to Demod Out</u>	Sets routing of AF Generator Output to DEMOD OUT Connector. Accessing toggles routing on or off.
7. <u>To Speaker</u>	Displays menu listing signals to be routed to Speaker. Select None, Source, SINAD/BER or Ext Mod/DTMF. NOTE: Routing the Source to the Speaker disables SINAD and Distortion Meters.

3-3-2 RECEIVE OPERATION SCREEN

Pressing RCVR MODE Key accesses Receive Operating Screen. Use the index of screen features to identify the operation screen parameters that may be edited, the value range available to each feature and/or its usage.

When editing, use the FIELD SELECT Keys to move the cursor to the parameter to be edited and press ENTER Key to access the data field. Use the DATA ENTRY Keypad to enter numerical data. Use the DATA SCROLL Spinner or DATA SCROLL \uparrow and \downarrow Keys to select parameters from a list. Parameters with only two possible settings automatically toggle to the opposite setting when selected. To access a displayed Meters Operation Screen, move cursor to the Meters Callout and press the ENTER Key.

A. SCREEN PARAMETERS

The following index includes screen parameters and screen parameter attributes. Possible parameter settings are listed where parameters can be changed from the Operation Screen.

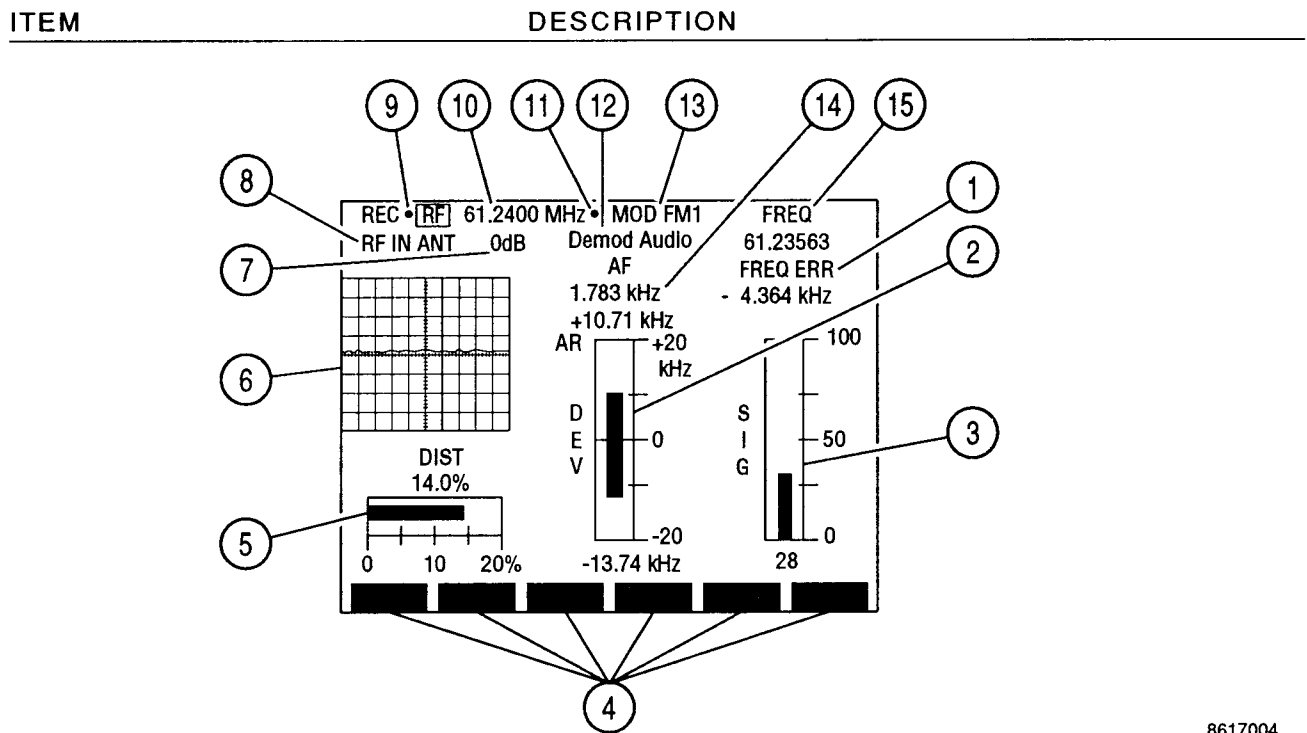

8617004

1. FREQ ERR

Display for Frequency Error Counter. Frequency Error Counter indicates difference between received frequency and Receive Frequency (10) setting.

2. Deviation Meter/Modulation Meter/Phase Meter

Does not appear for USB, LSB or BFO Modulation. Selects Deviation Meter for FM Modulation, Modulation Meter for AM Modulation, or Phase Meter for PM Modulation.

ITEM	DESCRIPTION
3. <u>Signal Strength Meter/Power Meter</u>	Displays Signal Strength Meter (if ANTENNA IN Connector is selected as "RF IN" Source) or Power Meter (if T/R Connector is selected as "RF IN" Source).
4. <u>Soft Function Keys</u>	Soft Function Keys for the Receive Operation Screen are covered in 3-3-2B.
5. <u>Distortion/SINAD/Deviation-RMS Meter</u>	Does not appear for USB, LSB or BFO Modulation. Meter is selected using "Meters" Soft Function Key.
6. <u>Oscilloscope/Spectrum Analyzer/Decode Display</u>	Use "Disp" Soft Function Key to display full size or 1/4 size Oscilloscope, full size or 1/4 size Spectrum Analyzer or set to Decode for the Decode Display. Meters are reduced to digital readouts when a full size display is selected.
7. <u>Receiver Input Attenuation Level</u>	Selects RF Input Attenuation Level. Select 0, 20 or 40 dB.
8. <u>Receiver Input Source</u>	Selects "ANT" (ANTENNA IN) or "T/R" Connector. If "ANT" is selected, the Signal Strength Meter is displayed. If "T/R" is selected, the Power Meter is displayed.
9. <u>Squelch Indicator Light</u>	Green dot appears when squelch is broken.
10. <u>Receiver Frequency</u>	Selects Receiver Frequency. Range is from 0.2500 to 999.9999 MHz. Frequency callout turns yellow when Phase Lock is lost. Regaining Phase Lock does not restore Frequency callout. To restore Frequency callout after regaining Phase Lock, reselect the Receiver Operation Mode.
11. <u>10 MHz External Reference Light</u>	Blue asterisk appears when 10 MHz External Reference Signal is applied to the EXTERNAL REFERENCE Connector.
12. <u>Oscilloscope Input/Analyzer Reference Level</u>	If an Oscilloscope is displayed, select Oscilloscope Input from Rcvr IF, Demod Audio, RF Pwr Lvl, SINAD/BER, Func Gen, Ext Mod, AC, DC or GND. If a full size Analyzer is displayed, field shows the Analyzer Reference Level. Field is blank otherwise.

13. Receiver Modulation Type

Selects Receiver Modulation Type. Table 3-2 lists available modulation types and their parameters.

MODE	RECEIVER IF BANDWIDTH	AUDIO BANDWIDTH (Post Detection Filter)	RECOMMENDED USE
FM1	30 kHz	3 kHz	Land mobile radios at low modulation rates.
FM2	30 kHz	10 kHz	Land mobile radios at moderate modulation rates.
FM3	300 kHz	20 kHz	Commercial FM transmitters or wide-deviation FM transmitters at medium modulation rates.
FM4	300 kHz	75 kHz	Commercial FM transmitters or wide-deviation FM transmitters at high modulation rates.
AM1	2.9 kHz	3.0 kHz	Off the air AM monitoring.
AM2	30 kHz	10 kHz	Direct-connection AM monitoring.
PM	30 kHz	3.0 kHz	Used to demodulate phase modulated signals.
USB	2.9 kHz	3.0 kHz	Upper Sideband used to demodulate Single Sideband carrier.
LSB	2.9 kHz	3.0 kHz	Lower Sideband used to demodulate Single Sideband carrier.
BFO	–	–	Used to generate tone for testing Continuous Wave carriers.
User Defined	3 kHz 30 kHz 300 kHz	All Pass, C weight Low Pass (0.1 to 30 kHz) High Pass (0.5 to 20 kHz) Bandpass (0.5 to 30 kHz)	General purpose usage as defined by user.

Table 3-2 Receiver Modulation Type Parameters

14. Receive Audio Frequency Counter

Displays Audio Frequency Received. Not an editable parameter.

15. RF Frequency Meter

Displays RF Frequency Received. Not an editable parameter.

B. SOFT FUNCTION KEYS

The following index lists Soft Function Keys available for the Receiver Operation Screen:

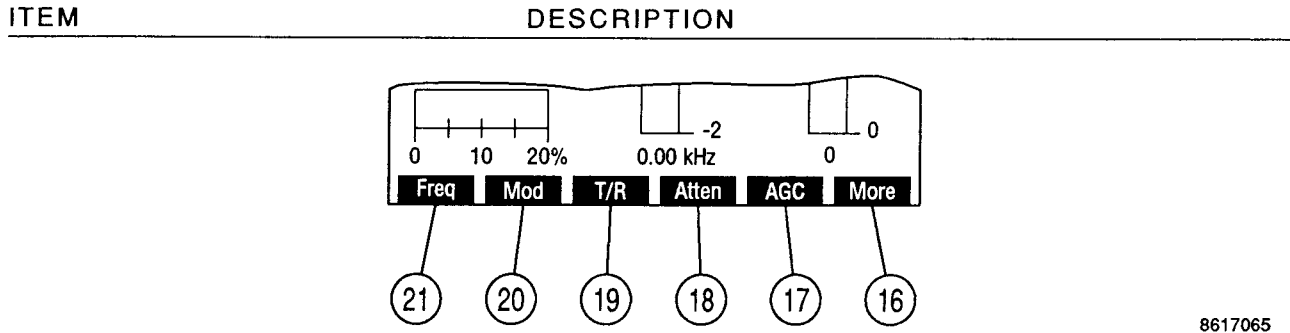

8617065

16. "More"/"ESC" Soft Function Key F6

"ESC" appears while parameters are accessed for editing. Allows edit procedure to be canceled without changing parameter. "More" displays additional sets of Soft Function Keys.

17. "AGC" Soft Function Key F5

Appears when Automatic Gain Control is set to Manual. Adjusts the AGC using the DATA SCROLL Spinner. An AGC Reading does not appear on the Operation Screen and is adjusted precisely from the Receiver Menu.

18. "Atten" Soft Function Key F4

Selects Receive Input Attenuation Level (7). Choose 0, 20 or 40 dB.

19. "T/R" or "Ant" Soft Function Key F3

Selects Receive Input Source (8). Access toggles Source to T/R Connector or Ant (ANTENNA IN) Connector.

20. "Mod" Soft Function Key F2

Selects Receiver Modulation Type (13). Choose one of the following:

- | | | |
|-----|--------------|-----|
| AM1 | FM3 | USB |
| AM2 | FM4 | LSB |
| FM1 | PM | BFO |
| FM2 | User Defined | |

NOTE: See Table 3-2 for description of modulation types.

User Defined Modulation parameters are set from Receiver Menu.

21. "Freq" Soft Function Key F1

Selects Receiver Frequency (10). Range is from 0.2500 to 999.9999 MHz.

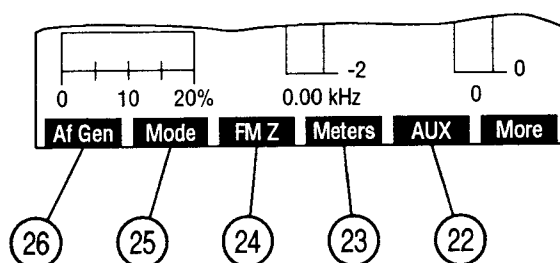

8617011

22. "AUX" Soft Function Key F5

Accesses Auxiliary Functions Menu.

23. "Meters"/"Dist"/"Modul"/"Tune" Soft Function Key F4

- For FM or PM Modulation, "Meters" appears. Pressing F4 displays menu listing available meters. Selects Distortion, SINAD or Deviation-RMS.
- For AM Modulation, "Modul" or "Dist" appears. Pressing F4 toggles between Modulation and Distortion Meter.

NOTE: If Receiver Modulation Type is AM, both Modulation and Distortion Meters are displayed on the Operation Screen, yet only one is active.

- For USB, LSB or BFO Modulation, "Tune" appears. Pressing F4 accesses TUNE and tunes the receiver higher or lower in 125 Hz steps.

24. "FM Z" Soft Function Key F3

Appears if Receiver Modulation Type is FM. Access to zero the Deviation Meter.

25. "Mode" Soft Function Key F2

Displays menu listing the Receiver Operation Modes. Choose Direct (normal operation), Channel or Freq Scan (for Receiver Scanning). Channel Mode displays the RF Receive Frequency as a channel number.

26. "AF Gen" Soft Function Key F1

Displays menu allowing access to Function Generator parameters. Selects F1 Freq, F2 Freq or Level.

- Selecting F1 Freq displays a data field allowing the entry of Function Generator #1 Frequency. Range is from 0.0 to 40000.0 Hz.
- Selecting F2 Freq displays a data field allowing the entry of Function Generator #2 Frequency. Range is from 0.0 to 40000.0 Hz.
- Selecting Level displays a data field allowing the entry of Function Generator Output Level. Range is from 0.0000 to 3.1000 V.

The following set of Soft Function Keys are accessed when a full size Spectrum Analyzer is displayed.

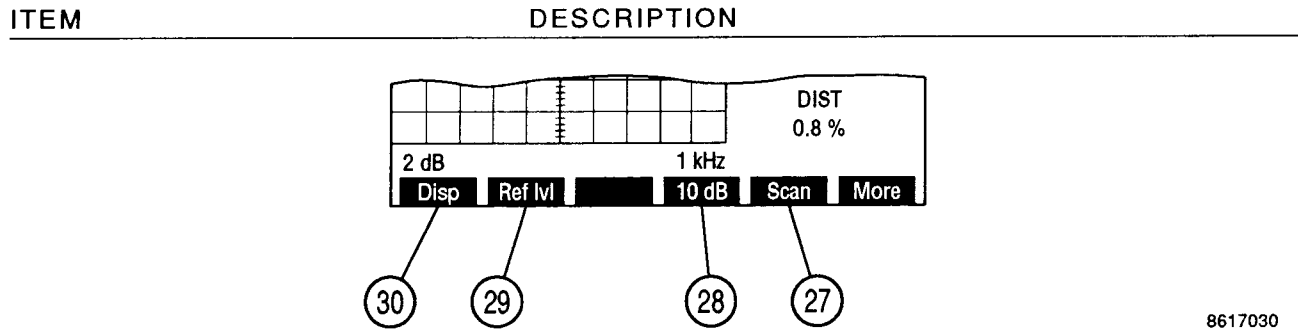

8617030

27. "Scan" Soft Function Key F5

Selects Spectrum Analyzer Scan Width. Selects Zero Scan (0 kHz) or one of the following:

- | | | |
|---------|---------|---------|
| 1 kHz | 2 kHz | 5 kHz |
| 10 kHz | 20 kHz | 50 kHz |
| 100 kHz | 200 kHz | 500 kHz |
| 1 MHz | | |

28. "10 dB/2 dB" Soft Function Key F4

Toggles the Units/Division Factor to 2 or 10 dB/div.

29. "Ref lvl" Soft Function Key F3

Appears when using 2 dB/div scale. Selects the Spectrum Analyzer Reference Level. Range is from +10 to -94 dB.

30. "Disp" Soft Function Key F1

Displays menu listing Oscilloscope and Spectrum Analyzer displays. Select full or 1/4 size displays for Oscilloscope or Spectrum Analyzer or select Decode to display code being decoded.

ITEM	DESCRIPTION
------	-------------

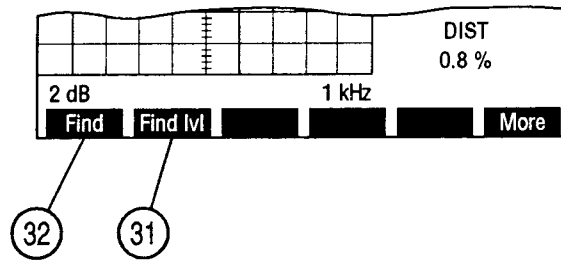

8607055

31. "Find lvl" Soft Function Key F2

Sets Find Reference Level used in the Find Function. When accessed, a red horizontal marker appears displaying the Find Reference Level.

32. "Find" Soft Function Key F1

When activated, finds the first frequency containing a signal with an amplitude greater than the Find Reference Level. Range of the Find Function is 4 to 999.9999 MHz. Signal amplitude must be >-65 dBm.

The following set of Soft Function Keys may be accessed when an Oscilloscope is displayed:

ITEM	DESCRIPTION
------	-------------

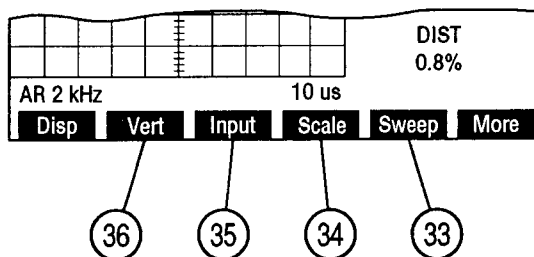

8617045

33. "Sweep" Soft Function Key F5

Appears with full size Oscilloscope and does not appear if "Rcvr IF" is the Oscilloscope Input (12). Selects Oscilloscope Sweep Rate. Choose from the following:

- | | | |
|-------------|-------------|-------------|
| 1 μ s | 2 μ s | 5 μ s |
| 10 μ s | 20 μ s | 50 μ s |
| 100 μ s | 200 μ s | 500 μ s |
| 1 ms | 2 ms | 5 ms |
| 10 ms | 20 ms | 50 ms |
| 100 ms | | |

ITEM	DESCRIPTION
------	-------------

34. "Scale" Soft Function Key F4

Appears with full size Oscilloscope. For AC, DC or GND Oscilloscope Input, select one of the following:

1 mV/div	2 mV/div	5 mV/div
10 mV/div	20 mV/div	50 mV/div
100 mV/div	200 mV/div	500 mV/div
1 V/div	2 V/div	5 V/div
10 V/div	20 V/div	50 V/div

For Demod Audio Oscilloscope Input with FM Receiver Modulation, select one of the following:

2 kHz/div	4 kHz/div	10 kHz/div
20 kHz/div	Autorange	

For Demod Audio Oscilloscope Input with Receiver Modulation other than FM, Oscilloscope Scale is not editable and "Scale" Soft Function Key F4 does not appear.

For Func Gen or Ext Mod Oscilloscope Input, select one of the following:

500 mV/div	1 V/div	2.5 V/div
------------	---------	-----------

For RF Pwr Lvl Oscilloscope Input, Oscilloscope Scale reads 2 W/div or 200 W/div. Power Meter Ranges of 20, 50 or 100 mW set Oscilloscope Scale to 2 W/div. All other Power Meter Ranges set Oscilloscope Scale to 200 W/div.

Oscilloscope Scale is not editable for SINAD/BER or Rcvr IF Oscilloscope Input and "Scale" Soft Function Key F4 does not appear.

35. "Input" Soft Function Key F3

Selects Oscilloscope Input. Choose one of the following:

Rcvr IF	Demod Audio	RF Pwr Lvl
SINAD/BER	Func Gen	Ext Mod
AC	DC	GND

36. "Vert" Soft Function Key F2

Appears with full size Oscilloscope. Adjusts vertical trace position of Oscilloscope. When Oscilloscope Trace is adjusted below Oscilloscope display, an arrow appears on the right bottom edge of the display. When Oscilloscope Trace is adjusted above Oscilloscope display, an arrow appears on the right top edge of the display.

The following set of Soft Function Keys are accessed when Decode Option is selected:

ITEM	DESCRIPTION
------	-------------

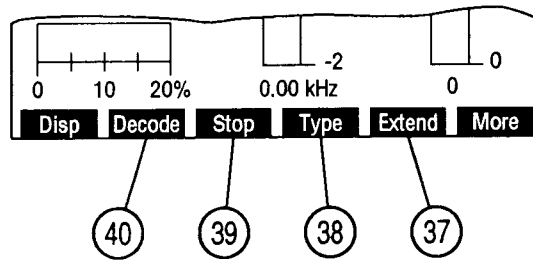

8607056

37. "Extend"/"Input" Soft Function Key F5

Does not appear if DTMF is the selected code.

- If DCS or DCS INV is the selected code, "Input" appears. Pressing F5 displays menu listing available Decode Input Sources. Select Demod Audio, SINAD/BER (with Input inverted) or Ext Mod.
- If Audio or POCSAG is the selected code, "Extend" appears. Pressing F5 displays the Extend Screen.

38. "Type" Soft Function Key F4

Does not appear if DTMF is the selected code. Selects code to be decoded.

- If Audio is the selected Signaling Format, choose one of the following:

CCIR	EEA	U.S.(EIA)
ZVEI	DDZVEI (ZVEI 2)	DZVEI (ZVEI 3)
NATEL	EURO	5/6 Tone Seq
CCIRH	CCIRH4	User Defined

NOTE: RF Generator Audio User Defined Tones are used for decoding.

- If Digital is the selected Signaling Format. Choose one of the following:

DCS	DCS INV	POCSAG
-----	---------	--------

39. "Stop" Soft Function Key F3

Appears when Decode Function is active. Stops the Decode Function.

40. "Decode" Soft Function Key F2

Activates Decode Function. Decode Soft Function Key turns red while decoding.

For Audio Signaling Format, the Extend Screen appears as follows:

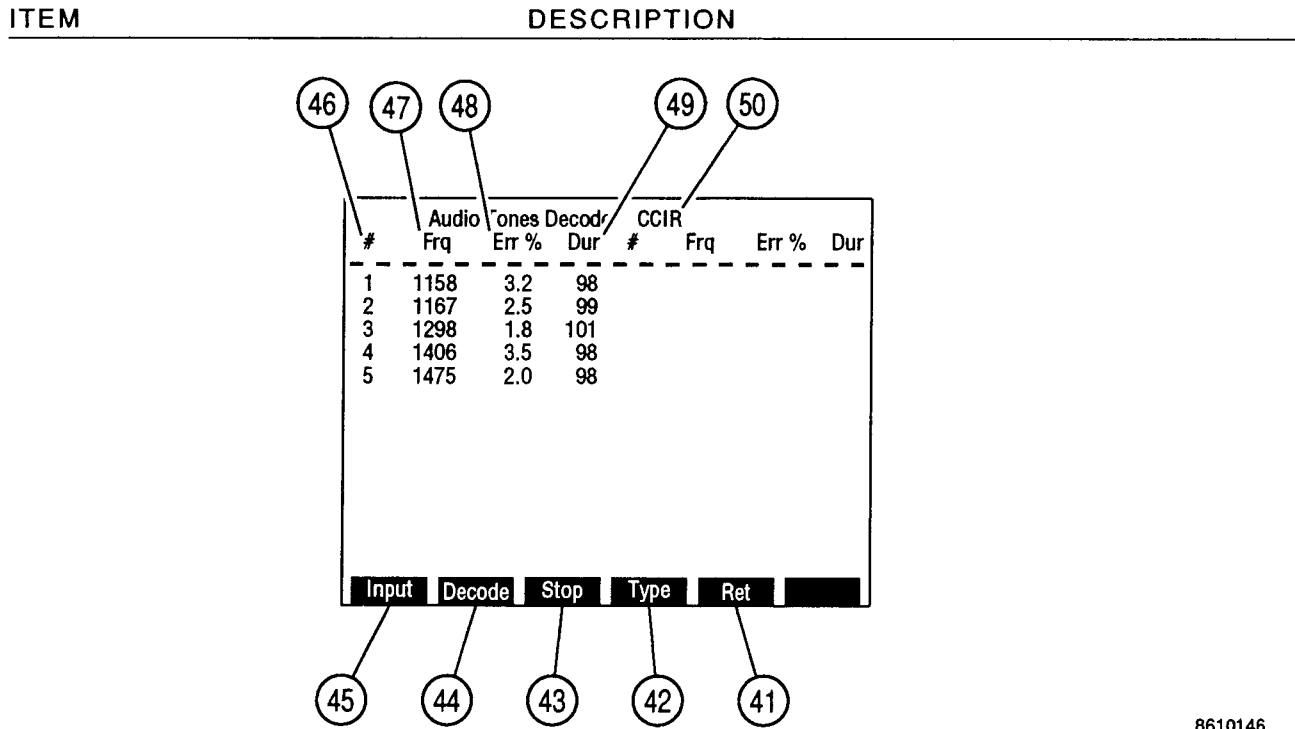

8610146

41. "Ret" Soft Function Key F5

Returns display to the Receiver Operation Screen.

42. "Type"/"Rate" Soft Function Key F4

If the Signaling Format is Audio, "Type" is displayed. Select one of the following Audio codes to decode:

CCIR	EEA	U.S.(EIA)
ZVEI	DDZVEI (ZVEI 2)	DZVEI (ZVEI 3)
NATEL	EURO	5/6 Tone Seq
CCIRH	CCIRH4	User Defined

NOTE: RF Generator Audio User Defined Tones are used for decoding.

If POCSAG is the selected Signaling Format, "Rate" is displayed. Select the POCSAG rate received. Toggles to Low or High.

43. "Stop" Soft Function Key F3

Appears when Decode Function is active. Stops the Decode Function.

44. "Decode" Soft Function Key F2

Activates Decode Function. Decode Callout turns red when active.

ITEM	DESCRIPTION
------	-------------

45. "Input" Soft Function Key F1

Displays menu listing available Decode Input Sources. Select Demod Audio, SINAD/BER (with Input inverted) or Ext Mod.

46. #

Displays Audio Code Digits received.

47. Frq

Displays received frequency for each Audio Code Digit in Hz.

48. Err %

Displays Frequency Error of received frequency in percentage of ideal Audio Code Digit frequency.

49. Dur

Displays Duration of each Audio Code Digit in ms.

50. Audio Code

Selects Audio Code being decoded.

If POCSAG is the Signaling Format, the Extend Screen appears as follows:

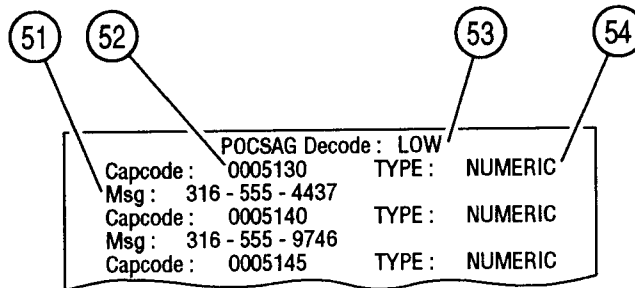

8610147

51. Msg

Displays message received.

52. Capcode

Displays Capcode number received.

53. POCSAG Rate

Displays decoded POCSAG Rate. Toggles using "Rate" Soft Function Key F4.

54. POCSAG Function Type

Displays POCSAG Function received.

C. RECEIVER MENU

When the Receive Operation Screen is displayed on the CRT, press SETUP Key to access the Receiver Menu. Many Receive Operating Screen Parameters are also edited from the Receiver Menu or one of its submenus.

MENU ITEM	DESCRIPTION																						
RECEIVER MENU																							
<div style="border: 1px solid black; padding: 5px;"> <p>Rcvr Menu</p> <table border="1" style="width: 100%; border-collapse: collapse;"> <tr> <td style="width: 50%;">1. Set Rcvr Freq</td> <td style="width: 50%;">95.1000 MHz</td> </tr> <tr> <td>2. Select Mod</td> <td>FM3</td> </tr> <tr> <td>3. Select Rcvr In</td> <td>Antenna</td> </tr> <tr> <td>4. Select Input Atten</td> <td>0 dB</td> </tr> <tr> <td>5. Select AGC Type</td> <td>Auto</td> </tr> <tr> <td>6. Rcvr Out Speaker</td> <td>On</td> </tr> <tr> <td>7. Rcvr Out Audio Out</td> <td>Off</td> </tr> <tr> <td>8. Rcvr Out Demod Out</td> <td>On</td> </tr> <tr> <td>9. Auto Volume Level</td> <td>Off</td> </tr> <tr> <td>10. Operation Mode</td> <td>Freq Scan</td> </tr> <tr> <td>11. Signaling Formats</td> <td>DTMF</td> </tr> </table> <p style="text-align: center;"> Scan RF lock Ret AUX </p> </div>		1. Set Rcvr Freq	95.1000 MHz	2. Select Mod	FM3	3. Select Rcvr In	Antenna	4. Select Input Atten	0 dB	5. Select AGC Type	Auto	6. Rcvr Out Speaker	On	7. Rcvr Out Audio Out	Off	8. Rcvr Out Demod Out	On	9. Auto Volume Level	Off	10. Operation Mode	Freq Scan	11. Signaling Formats	DTMF
1. Set Rcvr Freq	95.1000 MHz																						
2. Select Mod	FM3																						
3. Select Rcvr In	Antenna																						
4. Select Input Atten	0 dB																						
5. Select AGC Type	Auto																						
6. Rcvr Out Speaker	On																						
7. Rcvr Out Audio Out	Off																						
8. Rcvr Out Demod Out	On																						
9. Auto Volume Level	Off																						
10. Operation Mode	Freq Scan																						
11. Signaling Formats	DTMF																						

8610049

1. Set Rcvr Freq

Select Receiver Frequency. Range is 0.2500 to 999.9999 MHz.

2. Select Mod

Selects Receiver Modulation Type. Select one of the following:

FM1	FM2	FM3
FM4	AM1	AM2
USB	LSB	BFO
PM	User Defined	

NOTE: See Table 3-2 for description of modulation types.

3. Select Rcvr In

Selects Receiver Input Source. Toggles between Antenna (ANTENNA IN) or T/R Connector.

4. Select Input Atten

Selects Receiver Input Attenuation. Choose 0, 20 or 40 dB.

5. Select AGC Type

Displays AGC Type Menu.

ITEM	DESCRIPTION
6. <u>Rcvr Out Speaker</u>	Sets Receiver Output routing to Speaker. Toggles between on and off.
7. <u>Rcvr Out Audio Out</u>	Sets Receiver Output routing to AUDIO OUT Connector. Toggles between on and off.
8. <u>Rcvr Out Demod Out</u>	Sets Receiver Output routing to DEMOD OUT Connector. Toggles between on and off.
9. <u>Auto Volume Level</u>	Toggles Automatic Volume Level between on or off.
10. <u>Operation Mode</u>	Displays menu listing the Receiver Operation Modes. Choose Direct (normal operation), Channel or Freq Scan (for Receiver Scanning). Channel Mode displays the Receive Frequency as a cellular channel number.
11. <u>Signaling Formats</u>	Displays menu featuring DTMF, Audio and Digital Functions. Select Format to decode. Selecting Audio displays the Audio Code Menu. Selecting Digital displays the Digital Code Menu.

The following set of Soft Function Keys are available with the Receiver Menu.

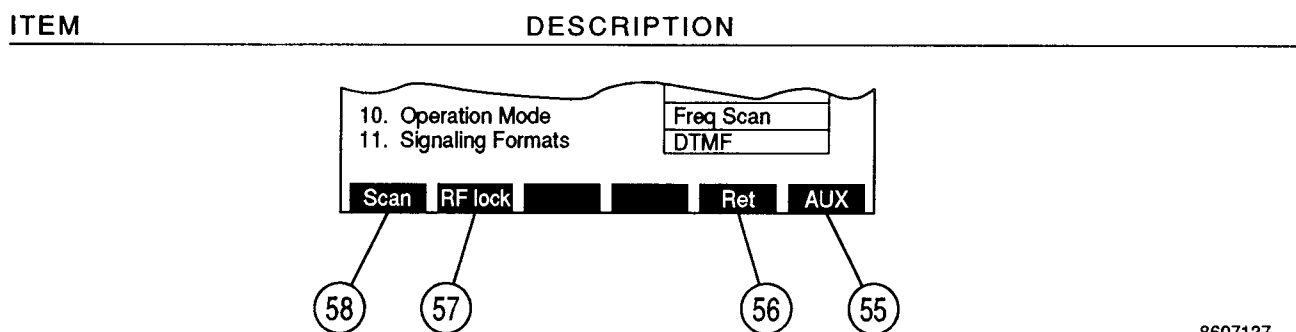

8607127

55. "AUX"/"ESC" Soft Function Key F6
- "ESC" appears while parameters are accessed for editing. Allows edit procedure to be canceled without changing parameter. "AUX" displays Auxiliary Functions Menu.
56. "Ret" Soft Function Key F5
- Returns operation to Receiver Operation Screen.

ITEM

DESCRIPTION

57. "RF lock"/"Chan" Soft Function Key F2

- "RF lock" Soft Function Key F2 activates the RF Lock Function, locking the Receiver RF Frequency to the RF Generator Frequency and the Analyzer RF Frequency. The last frequency entered from among the three frequencies locked is the frequency locked on. The letters "RF lock" appear in red when the RF Lock Function is active.
- "Chan Soft Function Key F2 is displayed for Channel Receiver Operation Mode. Displays Receiver Channel Format Menu.

58. "Scan" Soft Function Key F1

Displays the Receiver RF Frequency Scan Menu.

MENU ITEM

DESCRIPTION

RECEIVER RF FREQUENCY SCAN MENU

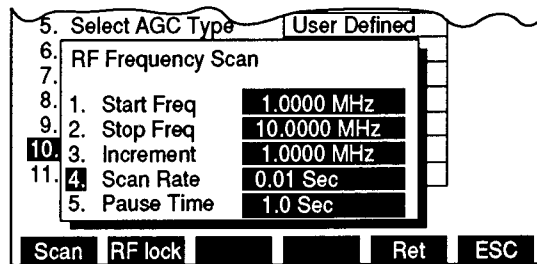

8610092

1. Start Freq

Selects lower limit frequency for scan. Range is from 0.2500 to 999.9999 MHz.

NOTE: Start frequency must be less than Stop frequency for Scan to operate.

2. Stop Freq

Selects upper limit frequency for scan. Range is from 0.2500 to 999.9999 MHz.

3. Increment

Selects increment between frequencies to be scanned. Range is from 0.0000 to 999.9999 MHz.

4. Scan Rate

Selects time period for receiver to sit on a frequency unless squelch is broken. Range is from 0.00 to 99.99 sec.

MENU ITEM	DESCRIPTION
-----------	-------------

5. Pause Time

Selects time period for receiver to sit on a frequency if squelch is broken. Range is from 0.0 to 99.9 sec. If 0.0 is selected, receiver sits on frequency as long as squelch is broken.

If "2. Select Mod" is selected and "User Defined" is selected as the Modulation Type, the User Defined Modulation Menu appears:

MENU ITEM	DESCRIPTION
-----------	-------------

RECEIVER USER DEFINED
MODULATION MENU

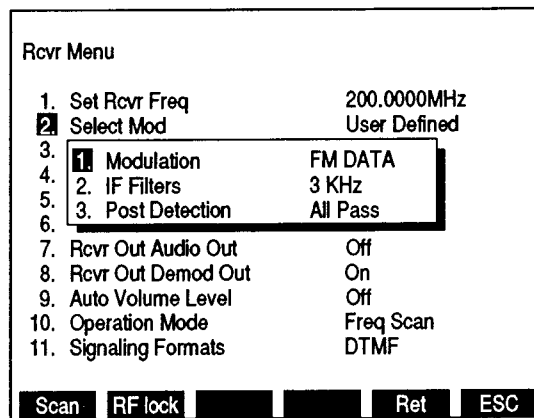

8610059

1. Modulation

Selects User Defined Modulation Type. Choose one of the following:

FM	AM	SSB (Upper)
SSB (Lower)	BFO	FM DATA
PM		

2. IF Filters

Selects User Defined IF Filter. Choose 3, 30 or 300 kHz.

3. Post Detection

Selects Post Detection Filter. Choose All Pass, Low-Pass, High-Pass, Bandpass or C Wt Pass. If Low-Pass, High-Pass and Bandpass are selected, a data field appears to allow the cutoff frequencies to be entered. The ranges of the allowable cutoff frequencies are:

Low-Pass	100 Hz to 30 kHz
High-Pass	500 Hz to 20 kHz
Bandpass low cutoff	500 Hz to 20 kHz
Bandpass high cutoff	100 Hz to 30 kHz

When "5. Select AGC Type" is selected on the Receiver Menu, the following menu appears:

MENU ITEM

DESCRIPTION

RECEIVER AGC TYPE MENU

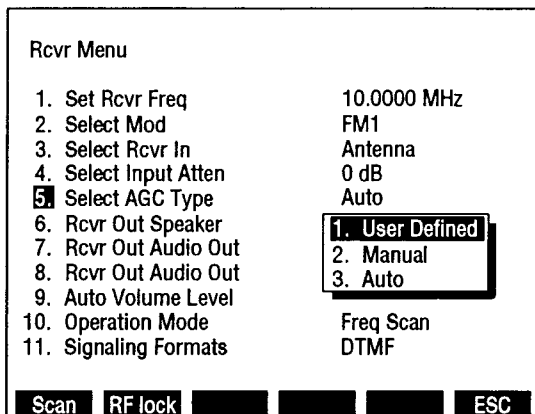

8610062

1. User Defined

Displays User Defined AGC Menu. Table 3-3 list the User Defined AGC Types and their parameters.

AGC TYPE	ATTACK TIME	RELEASE TIME	RECOMMENDED USE
Measurement	500 ms	3 sec	AM signals
Speech	40 ms	3 sec	Off the air monitoring
Data	40 ms	300 ms	Low speed data
High Speed	4 ms	4 ms	High speed data
Type 1	40 ms	40 ms	General purpose as defined by user
Type 2	500 ms	500 ms	General purpose as defined by user
Type 3	3 sec	3 sec	General purpose as defined by user

Table 3-3 User Defined AGC Type Parameters

2. Manual

Selects Receiver AGC Level. Range is 1 to 255. 1 corresponds to minimum IF gain, 255 corresponds to maximum IF gain.

3. Auto

AGC is automatically adjusted.

MENU ITEM

DESCRIPTION

If "10. Operation Mode" is selected, the Receiver Operation Mode Menu appears:

RECEIVER OPERATION MODE MENU

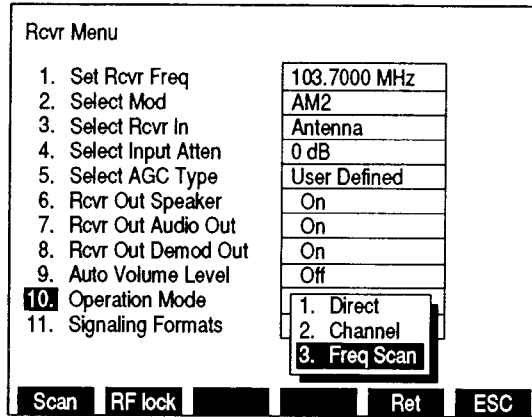

8610086

Select Direct for normal operation. Select Channel to Receive AMPS and ETACS Cellular channels. Select Freq Scan to perform Receiver Frequency Scan. If Channel is selected, "Chan" Soft Function Key F2 appears. Pressing F2 displays the Receiver Cellular Format Menu. Select the desired Format.

RECEIVER CELLULAR FORMAT MENU

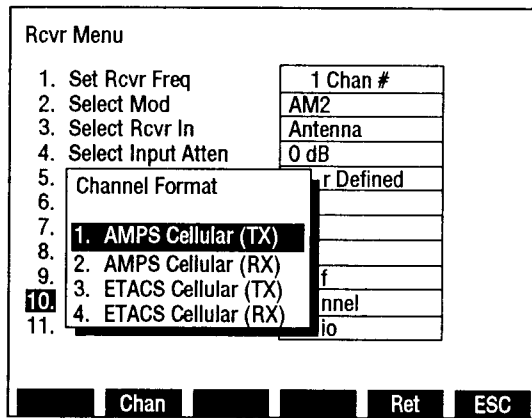

8610085

If "11. Signaling Formats" is selected, the Receiver Signaling Format Menu is displayed. If Audio is selected as the Signaling Format, the Audio Code Menu appears allowing the selection of a Audio Code.

NOTE: Selecting User Defined uses the RF Generator Audio User Defined Tones for decoding.

RECEIVER AUDIO CODE MENU

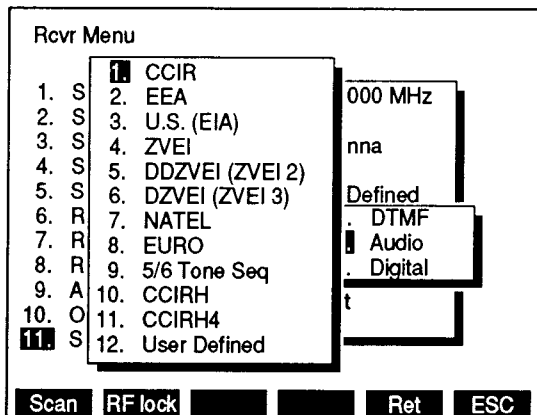

8610106

If Digital is selected as the Signaling Format, the Digital Code Menu is displayed allowing the selection of a Digital Code.

RECEIVER DIGITAL CODE MENU

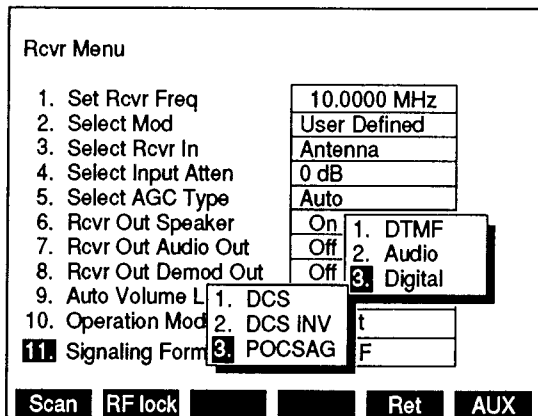

8610165

3-3-3 DUPLEX OPERATION SCREEN

Pressing DPLX MODE Key accesses Duplex Operation Screen. The Duplex Transmitter tests Transmitting UUTs and functions as a Receiver. The Duplex Receiver tests receiving UUTs and functions as a RF Generator. Use the index of screen features to identify the operation screen parameters that may be edited, the value range available to each feature and/or its usage.

When editing, use the FIELD SELECT Keys to move the cursor to the parameter to be edited and press the ENTER Key to access the data field. Use the DATA ENTRY Keypad to enter numerical data. Use the DATA SCROLL Spinner or DATA SCROLL ↑ and ↓ Keys to select parameters from a list. Parameters with two settings automatically switch to the opposite setting when selected. To access a displayed Meters Operation Screen, move cursor to the Meters Callout and press the ENTER Key.

All available Soft Function Keys are displayed on one screen.

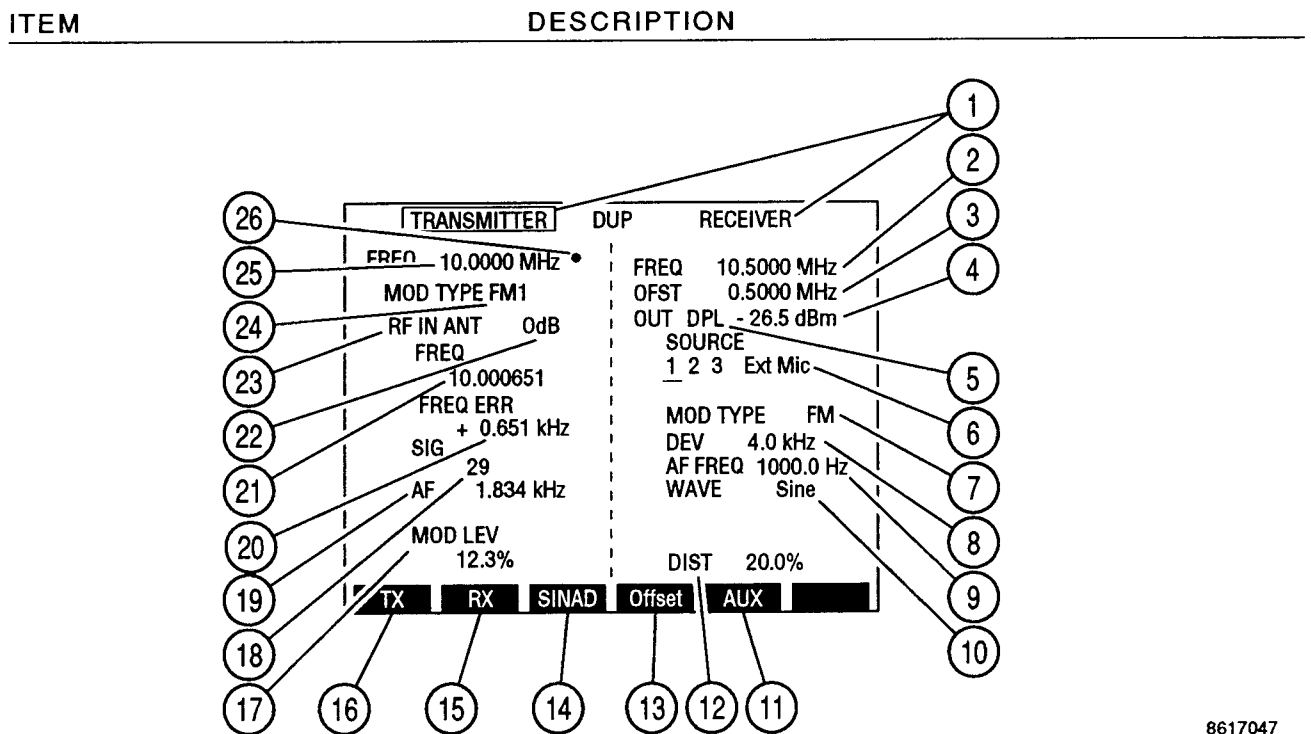

8617047

1. Duplex Screen Labels

With cursor at any left side screen location, press SETUP Key to access Duplex Transmitter Menu. With cursor at any right side screen location, press SETUP Key to access Duplex Receiver Menu.

2. Duplex Receiver Frequency

Select frequency from 0.2500 to 999.9999 MHz. Either the Receiver Frequency or the Offset Frequency is the editable frequency at any one time. The parameter not editable automatically changes so the Offset Frequency added to the Transmitter Frequency is always equal to the Receiver Frequency.

ITEM	DESCRIPTION
3. <u>Duplex Offset Frequency</u>	Selects frequency from -999.7499 to 999.7499 MHz. Either the Receiver Frequency or the Offset Frequency is the editable frequency at any one time. The parameter not editable automatically changes so the Offset Frequency added to the Transmitter Frequency is always equal to the Receiver Frequency.
4. <u>Duplex Receiver Output Level</u>	Selects Duplex Receiver Output Level. Range is -120.0 to 7.0 dBm if DUPLEX OUT Connector is selected for RF Output. Range is -137.0 to 0.0 dBm if T/R Connector is selected for RF Output.
5. <u>Duplex Receiver Output Connector</u>	Selects "DPL" (DUPLEX OUT) or "T/R" as the Duplex Receiver Output Connector.
6. <u>Duplex Receiver Source</u>	Underline indicates last selected Source. Selects AM, FM, PM or OFF. NOTE: Different sources cannot be FM and PM simultaneously. Selecting FM changes PM sources to FM. Selecting PM changes FM sources to PM. Sources that are AM or OFF are not affected.
7. <u>Duplex Receiver Modulation Type</u>	Not an editable parameter. Readout indicates the last selected modulation type. Readout shows FM, PM, AM or OFF.
8. <u>Duplex Receiver Modulation Level</u>	Does not appear if Modulation is set to OFF. Range is from 0.0 to 100.0 kHz for FM, 0.0 to 10.0 radians for PM or 0% to 90% for AM.
9. <u>AF FREQ</u>	Appears when 1 or 2 is the last selected Source. Selects AF frequency. Range is from 0.0 to 40000.0 Hz.
10. <u>WAVE</u>	Appears when 1 or 2 is the last selected Source. Selects Wave Form. Select Sine, Square, Ramp, Triangle, Pulse, +1 Lvl, 0 Lvl or -1 Lvl.
11. <u>"AUX" Soft Function Key F5</u>	Accesses Auxiliary Functions Menu.

ITEM	DESCRIPTION
12. <u>Distortion/SINAD Meter Readout</u>	<p>Displays Distortion Meter, SINAD Meter or OFF Operation. Definition shown for Soft Function Key F3 is the next selection activated when F3 is pressed.</p> <p>NOTE: SINAD and Distortion Meter measure SINAD/BER IN Connector Input only.</p>
13. <u>"Offset"/"R Freq" Soft Function Key F4</u>	<p>Selects Offset or Duplex Receiver Frequency. Range for Offset Frequency is from -999.7499 to 999.7499 MHz. Range for Duplex Receiver Frequency is from 0.2500 to 999.9999 MHz.</p>
14. <u>"Dist"/"SINAD"/"Modul" Soft Function Key F3</u>	<p>Rotates Meter in use. Selects Modulation (17), Distortion (12) or SINAD (12) Meter. Although two Meters are displayed, only one is active.</p>
15. <u>"RX" Soft Function Key F2</u>	<p>Displays Duplex Receiver Operation Screen.</p>
16. <u>"TX" Soft Function Key F1</u>	<p>Displays Duplex Transmitter Operation Screen.</p>
17. <u>Modulation/Deviation/Phase Meter or TUNE</u>	<ul style="list-style-type: none"> ● For AM Modulation, Modulation Meter is displayed. Modulation Meter operation alternates with Distortion and SINAD Meter by pressing Soft Function Key F3. ● For FM Modulation, Deviation Meter is displayed. ● For PM Modulation, Phase Meter is displayed. ● For USB, LSB or BFO, TUNE appears. Accessing TUNE allows Receiver tuning in 125 Hz steps using DATA SCROLL ↑ and ↓ Keys.
18. <u>Signal Strength Meter or Power Meter</u>	<p>Displays Signal Strength Meter (if ANTENNA is selected for Input Connector) or Power Meter (if T/R is selected for Input Connector). Meters are accessed through the Meter Callout or the Meter Menu.</p>
19. <u>Duplex Transmitter AF Meter Readout</u>	<p>Displays Audio Frequency received. AF Meter Operation Screen is accessed through the Meter Callout or the Meter Menu.</p>
20. <u>Frequency Error Meter</u>	<p>Displays difference between frequency setting and frequency received. Frequency Error Meter Operation Screen is accessed through Meter Callout or Meter Menu.</p>

ITEM

DESCRIPTION

21. Frequency Meter Display

Displays frequency actually received. Frequency Meter Operation Screen is accessed through the Meter Callout or the Meter Menu.

22. Duplex Transmitter Input Attenuation Level

Selects 0, 20 or 40 dB.

23. Duplex Transmitter Input Connector

Selects "ANT" (ANTENNA IN) or "T/R" Connector. "ANT" selects the Signal Strength Meter (18). "T/R" selects the Power Meter (18).

24. Duplex Transmitter Modulation Type

Select one of the following:

FM1	FM2	FM3
FM4	AM1	AM2
USB	LSB	BFO
PM	User Defined	

NOTE: See Table 3-2 for description of modulation types.

25. Duplex Transmitter Frequency

Selects from 0.2500 to 999.9999 MHz.

26. 10 MHz External Reference Light

Blue asterisk appears when 10 MHz External Reference Signal is applied to the EXTERNAL REFERENCE Connector.

If 3 is the last selected Duplex Receiver Source (6), the Operation Screen appears as follows:

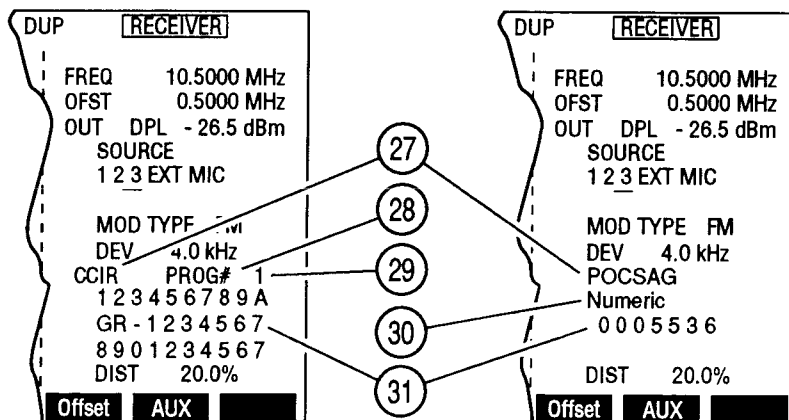

8617058

ITEM	DESCRIPTION
------	-------------

27. Signaling Code Display

- Displays DTMF if DTMF is the selected Signaling Format.
- Accesses Audio Code if Audio Signaling Format is active. Select from:

CCIR	EEA	U.S.(EIA)
ZVEI	DDZVEI(ZVEI 2)	DZVEI (ZVEI 3)
NATEL	EURO	5/6 Tone Seq
CCIRH	CCIRH4	User Defined

- Accesses Digital Code if Digital Signaling Format is active. Select from:

DCS	DCS INV	POCSAG
-----	---------	--------

- Accesses RCC Code if RCC Signaling Format is active. Select from:

IMTS	MTS	2805
Tone Rem		

28. DIRECT ENTRY/PROG #

Accessing Callout toggles to the function not shown. Select PROG # to generate a programmed sequence. Select DIRECT ENTRY to allow sequence entry from Operation Screen. Press GO TEST CONTROL Key to generate sequence continuously. Press SGL STEP TEST CONTROL Key to generate sequence once. Press STOP TEST CONTROL Key to stop generating sequence.

29. Program Number

Appears if PROG # is selected. Up to 16 sequences can be programmed.

30. POCSAG or Tone Remote

Accesses POCSAG or Tone Remote Function. For POCSAG, select one of the following:

Tone - 1 beep	Tone - 2 beeps	Tone - 3 beeps
Tone - 4 beeps	Numeric	Numeric seq
Alpha lower	Alpha upper	Alphanumeric
Alpha special		

For Tone Remote, select one of the following:

2050 (Monitor)	1950 (F1)	1850 (F2)
1750 (R2 Mute)	1650 (R2 Unmute)	1550 (Repeater Off)
1450 (Repeater On)	1350 (Wild Card 1 On)	1250 (Wild Card 1 Off)
1150 (Wild Card 2 On)	1050 (Wild Card 2 Off)	

31. Tone Sequence Listing

Displays coded sequence. If DIRECT ENTRY is selected, accessing allows entry of sequence unless POCSAG or Tone Remote are in use.

3-3-4 DUPLEX TRANSMITTER OPERATION SCREEN

With the Duplex Operation Screen displayed on the CRT, press "TX" Soft Function Key F1 to access the Duplex Transmitter Operation Screen. Use the index of screen features to identify the operation screen parameters that may be edited, the value range available to each feature and/or its usage.

When editing, use FIELD SELECT Keys to move the cursor to the parameter to be edited and press ENTER Key to access the data field. Use the DATA ENTRY Keypad to enter numerical data, Use the DATA SCROLL Spinner or DATA SCROLL ↑ and ↓ Keys to select the parameters from a list. Parameters with only two settings automatically toggle to the opposite setting when selected. To access a displayed Meters Operation Screen, move cursor to the Meters Callout and press the ENTER Key.

A. SCREEN PARAMETERS

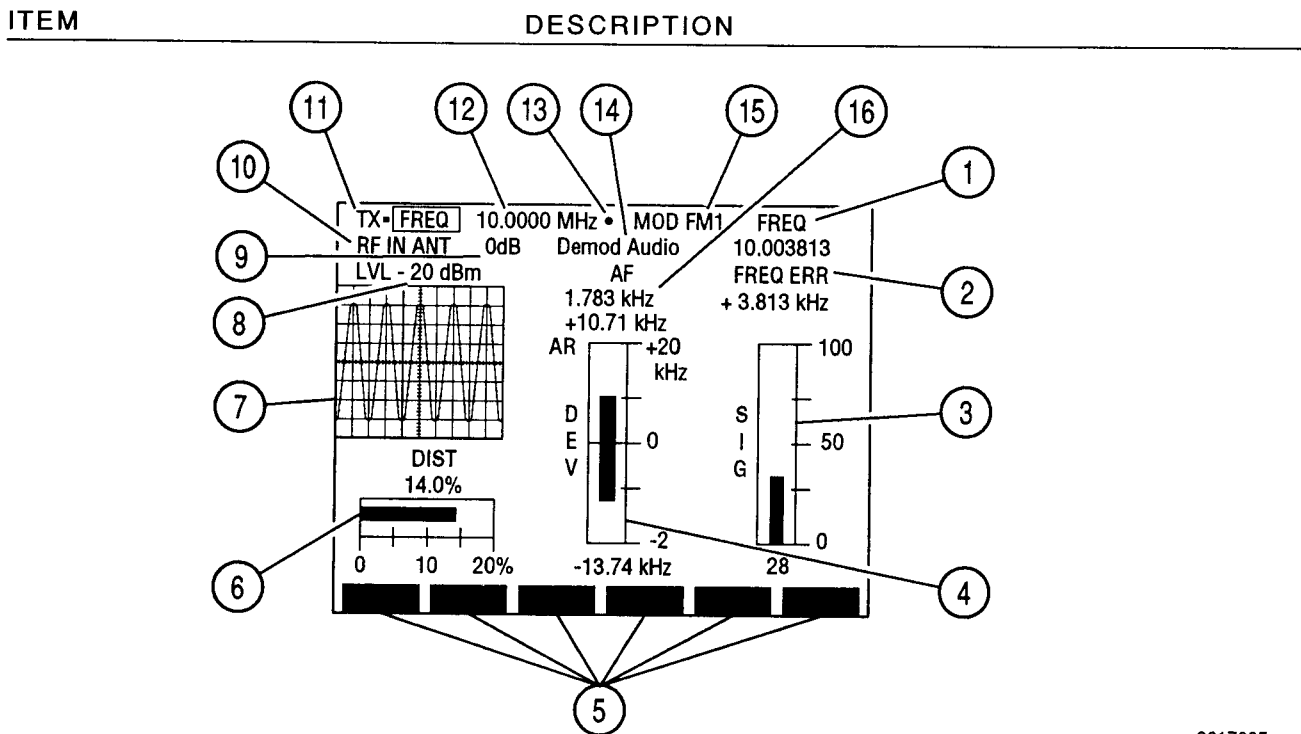

8617005

1. Frequency Meter Display

Displays received Duplex Transmitter Frequency. Frequency Meter Operation Screen is accessed through the Meter Callout or the Meter Menu.

2. Frequency Error Meter Display

Displays difference between received UUT frequency and Duplex Transmitter Frequency Setting. Frequency Error Meter Operation Screen is accessed through the Meter Callout or the Meter Menu.

ITEM	DESCRIPTION
3. <u>Signal Strength Meter or Power Meter</u>	Displays Signal Strength Meter (if "ANT" is selected as Duplex Transmitter Input Connector) or Power Meter (if "T/R" is selected as Duplex Transmitter Input Connector). Meter Operation Screens are accessed through Meter Callouts.
4. <u>Deviation Meter/Modulation Meter/Phase Meter</u>	Does not appear for USB, LSB, or BFO Modulation. Displays Deviation Meter (for FM Modulation), Phase Meter (for PM Modulation) or Modulation Meter (for AM Modulation).
5. <u>Soft Function Keys</u>	Duplex Transmitter Soft Function Keys are covered in 3-3-4B.
6. <u>Selected Meter/TUNE Adjustment</u>	<ul style="list-style-type: none"> ● For AM Modulation, a Distortion Meter is displayed, but active only when selected using "Dist" Soft Function Key F4. ● For FM or PM Modulation, select DIST (Distortion), SINAD or DEV RMS (Deviation-RMS) Meter using "Meters" Soft Function Key F4. ● For USB, LSB or BFO Modulation, the TUNE Adjustment Callout is displayed allowing adjustment in 125 Hz steps using the DATA SCROLL ↑ and ↓ Keys.
7. <u>Signaling Format, Oscilloscope or Spectrum Analyzer</u>	Displays Decode, Oscilloscope or Spectrum Analyzer operation. When full size display, Distortion/SINAD, Deviation/Modulation and Signal Strength/Power Meters display as digital readouts. Selected using "Disp" Soft Function Key F1.
8. <u>Duplex Receiver Output Level</u>	Displayed in top right corner of screen when Oscilloscope or Analyzer are shown full size. Range is -120.0 to +7.0 dBm or .224 μ V to .501 V if DPL is selected for Duplex Receiver Output. Range is -137.0 to 0.0 dBm or .031 μ V to .224 V if T/R is selected for Duplex Receiver Output.
9. <u>Duplex Transmitter Input Attenuation</u>	Select 0, 20 or 40 dB.
10. <u>Duplex Transmitter Input Connector</u>	Selects "ANT" (ANTENNA IN) (signals <10 mW) or "T/R" (signals <65 W) Connector for Duplex Transmitter Input Connector.
11. <u>Duplex Transmitter Operation Screen Callout</u>	Label used for screen identification. Not an editable parameter.

ITEM	DESCRIPTION
------	-------------

12. Duplex Transmitter Frequency

Selects from 0.2500 to 999.9999 MHz.

13. 10 MHz External Reference Light

Blue asterisk appears when 10 MHz External Reference Signal is applied to the EXTERNAL REFERENCE Connector.

14. Oscilloscope Input

Appears with Oscilloscope. Select Receive IF, Demod Audio, RF Power Input, SINAD/BER, Function Generator, External Audio, AC, DC or GND.

15. Duplex Transmitter Modulation Type

Select one of the following:

FM1	FM2	FM3
FM4	AM1	AM2
USB	LSB	BFO
PM	User Defined	

NOTE: See Table 3-2 for description of modulation types. User Defined parameters are set from Duplex Transmitter Menu.

16. Audio Frequency Meter

Displays Audio Frequency received. AF Meter Operation Screen is accessed through the Meter Callout or through the Meter Menu.

B. SOFT FUNCTION KEYS

The following index lists the Soft Function Keys available for the Duplex Transmitter Operation Screen:

ITEM	DESCRIPTION
------	-------------

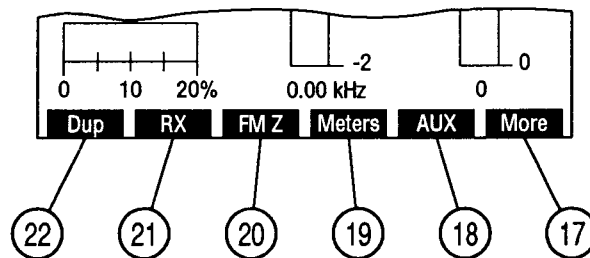

8617056

17. "More"/"ESC" Soft Function Key F6

"ESC" appears while parameters are accessed for editing. Allows edit procedure to be canceled without changing parameter. "More" displays additional sets of Soft Function Keys.

ITEM	DESCRIPTION
------	-------------

18. "AUX" Soft Function Key F5

Displays the Auxiliary Functions Menu.

19. "Meters"/"Dist"/"Modul"/"Tune" Soft Function Key F4

- For AM Modulation, both Distortion and Modulation Meter are displayed. Pressing F4 toggles which meter is active.
- For FM or PM Modulation, displays submenu allowing the selection of the DIST (Distortion), SINAD or DEV RMS (Deviation-RMS) Meter.
- For USB, LSB or BFO Modulation, selects the TUNE Adjustment Callout allowing adjustment in 125 Hz steps using the DATA SCROLL ↑ and ↓ Keys.

20. "FM Z" Soft Function Key F3

Appears with FM Modulation. Zero's Deviation Meter.

21. "RX" Soft Function Key F2

Displays Duplex Receiver Operation Screen.

22. "Dup"/"AGC" Soft Function Key F1

When AGC is set to manual, "AGC" Soft Function Key F5 appears. Allows the adjustment of Receiver AGC Level from the Receiver Operation Screen. When AGC is not set to manual, "Dup" Soft Function Key F5 appears. Displays Duplex Operation Screen.

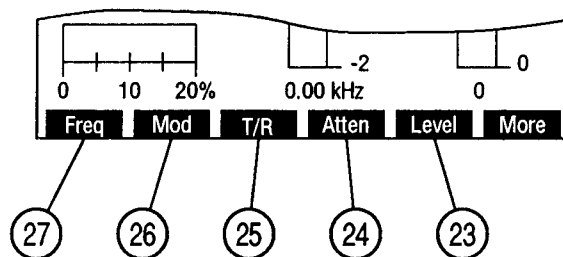

8617008

23. "Level" Soft Function Key F5

Selects Duplex Receiver Output Level. Range is -120.0 to +7.0 dBm or .224 μ V to .501 V. if "DPL" Connector is selected for Duplex Receiver Output. Range is -137.0 to 0.0 dBm or .031 μ V to .224 V if T/R Connector used for Duplex Receiver Output.

24. "Atten" Soft Function Key F4

Selects Duplex Transmitter Input Attenuation. Select 0, 20 or 40 dB.

ITEM	DESCRIPTION
------	-------------

25. "T/R" or "Ant" Soft Function Key F3

Toggles Duplex Transmitter Input Connector between T/R and ANTENNA IN Connector.

26. "Mod" Soft Function Key F2

Selects Duplex Transmitter Modulation Type. Select one of the following:

FM1	FM2	FM3
FM4	AM1	AM2
USB	LSB	BFO
PM	User Defined	

NOTE: See Table 3-2 for description of modulation types.

27. "Freq" Soft Function Key F1

Selects Duplex Transmitter Frequency. Range is 0.2500 to 999.9999 MHz.

The following Soft Function Keys appear when full size Spectrum Analyzer is displayed:

ITEM	DESCRIPTION
------	-------------

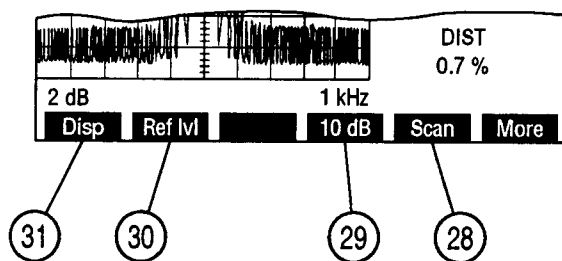

8617031

28. "Scan" Soft Function Key F5

Appears with full size Spectrum Analyzer. Selects Spectrum Analyzer Scan Width. Select from Zero Scan (0 kHz) or:

1 kHz	2 kHz	5 kHz
10 kHz	20 kHz	50 kHz
100 kHz	200 kHz	500 kHz
1 MHz		

29. "10 dB/2 dB" Soft Function Key F4

Appears with full size Spectrum Analyzer. Toggles Units/Division Factor between 10 and 2 dB/div.

30. "Ref lvl" Soft Function Key F2

Appears with full size Spectrum Analyzer with 2 dB vertical scale. Adjusts vertical grid position of the Spectrum Analyzer Trace.

ITEM	DESCRIPTION
------	-------------

31. "Disp" Soft Function Key F1

Submenu appears listing Oscilloscope, Spectrum Analyzer and Decode displays. Select desired display using DATA ENTRY Keypad.

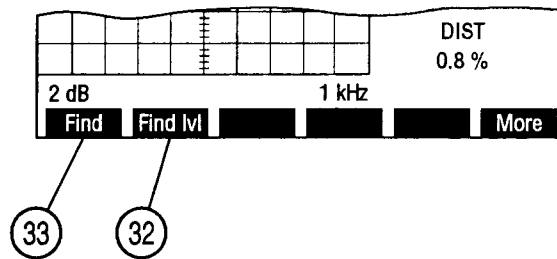

8607107

32. "Find lvl" Soft Function Key F2

Sets Find Reference Level used in the Find Function. When accessed, a red horizontal marker appears displaying the Find Reference Level.

33. "Find" Soft Function Key F1

Finds the first frequency containing a signal with an amplitude greater than the Find Reference Level. Range of the frequencies is 4 to 999.9999 MHz. Signal amplitude must be >-65 dBm.

The following set of Soft Function Keys appear when the Oscilloscope is displayed:

ITEM	DESCRIPTION
------	-------------

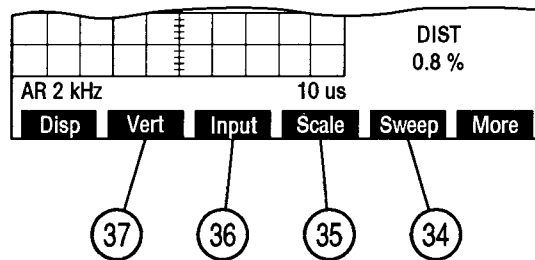

8617043

34. "Sweep" Soft Function Key F5

Does not appear with 1/4 size Oscilloscope or if "Rcvr IF" is used as Oscilloscope Input. Select one of the following:

- | | | |
|-------------|-------------|-------------|
| 1 μ s | 2 μ s | 5 μ s |
| 10 μ s | 20 μ s | 50 μ s |
| 100 μ s | 200 μ s | 500 μ s |
| 1 ms | 2 ms | 5 ms |
| 10 ms | 20 ms | 50 ms |
| 100 ms | | |

ITEM	DESCRIPTION
------	-------------

35. "Scale" Soft Function Key F4

Appears with full size Oscilloscope. Selects Oscilloscope Scale. For AC, DC or GND Oscilloscope Input, select one of the following:

1 mV/div	2 mV/div	5 mV/div
10 mV/div	20 mV/div	50 mV/div
100 mV/div	200 mV/div	500 mV/div
1 V/div	2 V/div	5 V/div
10 V/div	20 V/div	50 V/div

For Demod Audio Oscilloscope Input with FM Modulation, select one of the following:

2 kHz/div	4 kHz/div	10 kHz/div
20 kHz/div	Autorange	

For Demod Audio Oscilloscope Input with Modulation other than FM, Oscilloscope Scale is not editable and "Scale" Soft Function Key does not appear.

For RF Pwr Lvl Oscilloscope Input, Oscilloscope Scale reads 2 W/div or 200 W/div. Power Meter Ranges of 20, 50 or 100 mW set Oscilloscope Scale to 2 W/div. All other Power Meter Ranges set Oscilloscope Scale to 200 W/div.

Oscilloscope Scale is not editable for SINAD/BER or Rcvr IF Oscilloscope Input and "Scale" Soft Function Key F4 does not appear.

36. "Input" Soft Function Key F3

Selects Oscilloscope Input. Select one of the following:

Rcvr IF	Demod Audio	RF Pwr Lvl
SINAD/BER	Func Gen	Ext Mod
AC	DC	GND

37. "Vert" Soft Function Key F2

Appears with full size Oscilloscope. Adjusts vertical Trace position of Oscilloscope. When Oscilloscope Trace is adjusted below Oscilloscope display, an arrow appears on the right bottom edge of the display. When Oscilloscope Trace is adjusted above Oscilloscope display, an arrow appears on the right top edge of the display.

The following set of Soft Function Keys are accessed when the Decode is selected using "Disp" Soft Function Key F1 (31).

ITEM	DESCRIPTION
------	-------------

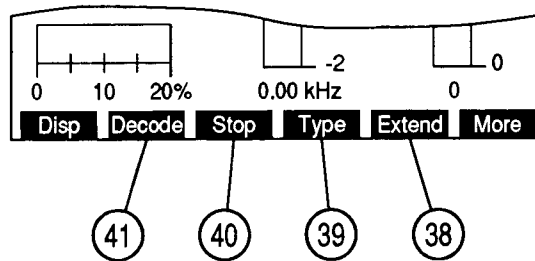

8617044

38. "Extend"/"Input" Soft Function Key F5

Does not appear if DTMF is the selected code.

- If DCS or DCS INV is the selected code, "Input" appears. Pressing F5 displays menu listing available Decode Input Sources. Select Demod Audio, SINAD/BER (with Input inverted) or Ext Mod.
- If Audio or POCSAG is the selected code, "Extend" appears. Pressing F5 displays the Extend Screen.

39. "Type" Soft Function Key F4

Does not appear if DTMF is the selected code. Selects code to be decoded.

- If Audio is the selected Signaling Format, choose one of the following:

CCIR	EEA	U.S.(EIA)
ZVEI	DDZVEI (ZVEI 2)	DZVEI (ZVEI 3)
NATEL	EURO	5/6 Tone Seq
CCIRH	CCIRH4	User Defined

- If Digital is the selected Signaling Format, choose one of the following:

DCS	DCS INV	POCSAG
-----	---------	--------

40. "Stop" Soft Function Key F3

Appears when Decode Function is active. Stops the Decode Function.

41. "Decode" Soft Function Key F2

Activates Decode Function. Decode Soft Function Key turns red while decoding.

For Audio Signaling Format, the Extend Screen appears as follows:

ITEM	DESCRIPTION
47	Audio Frq
48	Audio Err %
49	Audio Dur
50	CCIR #
51	CCIR Frq
46	Input
45	Decode
44	Stop
43	Type
42	Ret

#	Audio Frq	Audio Err %	Audio Dur	CCIR #	CCIR Frq	CCIR Err %	CCIR Dur
1	1158	3.2	98				
2	1167	2.5	99				
3	1298	1.8	101				
4	1406	3.5	98				
5	1475	2.0	98				

8610163

42. "Ret" Soft Function Key F5

Returns display to the Duplex Transmitter Operation Screen.

43. "Type"/"Rate" Soft Function Key F4

If the Signaling Format is Audio, "Type" is displayed. Select the Audio code to be decoded. Choose one of the following:

CCIR	EEA	U.S.(EIA)
ZVEI	DDZVEI (ZVEI 2)	DZVEI (ZVEI 3)
NATEL	EURO	5/6 Tone Seq
CCIRH	CCIRH4	User Defined

If POCSAG is the selected Signaling Format, "Rate" is displayed. Select the POCSAG rate received. Toggles between Low or High.

44. "Stop" Soft Function Key F3

Appears when Decode Function is active. Stops the Decode Function.

45. "Decode" Soft Function Key F2

Activates Decode Function. Decode Callout turns red when active.

46. "Input" Soft Function Key F1

Displays menu listing available Decode Input Sources. Select Demod Audio, SINAD/BER (with Input inverted) or Ext Mod.

ITEM	DESCRIPTION
47. <u>#</u>	Displays Audio Code Digits received.
48. <u>Frq</u>	Displays received frequency for each Audio Code Digit in Hz.
49. <u>Err %</u>	Displays Frequency Error of received frequency in percentage of ideal Audio Code Digit frequency.
50. <u>Dur</u>	Displays Duration of each Audio Code Digit in ms.
51. <u>Audio Code or POCSAG Receive Rate</u>	If Audio is the Signaling Format, the Audio Code is displayed. If POCSAG is the Signaling Format, the POCSAG Receive Rate is displayed.

For POCSAG as the Signaling Format, the Extend Screen appears as follows:

ITEM	DESCRIPTION
<p>The screenshot shows a rectangular display area with the following text: POCSAG Decode : LOW Capcode : 0005130 TYPE : NUMERIC Msg : 316 - 555 - 4437 Capcode : 0005140 TYPE : NUMERIC Msg : 316 - 555 - 9746 Capcode : 0005145 TYPE : NUMERIC Four callout circles are present: 52 points to the first 'Msg' field, 53 points to the first 'Capcode' field, 54 points to the 'POCSAG Decode' field, and 55 points to the first 'TYPE' field.</p>	
52. <u>Msg</u>	Displays message received.
53. <u>Capcode</u>	Displays Capcode number received.
54. <u>POCSAG Rate</u>	Displays POCSAG Rate that is decoded. Toggles between High and Low using "Rate" Soft Function Key F4.
55. <u>POCSAG Function Type</u>	Displays POCSAG Function received.

8610164

C. DUPLEX TRANSMITTER MENU

When the Duplex Transmitter Operation Screen is displayed on the CRT, press the SETUP Key to access the Duplex Transmitter Menu:

MENU ITEM	DESCRIPTION
DUPLEX TRANSMITTER MENU	
Duplex Transmitter Menu	
1. Set Rcvr Freq	95.1000 MHz
2. Select Mod	FM3
3. Select Rcvr In	Antenna
4. Select Input Atten	0 dB
5. Select AGC Type	Auto
6. Rcvr Out Speaker	On
7. Rcvr Out Audio Out	Off
8. Rcvr Out Demod Out	On
9. Auto Volume Level	Off
10. Operation Mode	Freq Scan
11. Signaling Formats	DTMF

8610075

1. Set Rcvr Freq

Selects Duplex Transmitter Frequency. Range is from 0.2500 to 999.9999 MHz.

2. Select Mod

Selects Duplex Transmitter Modulation Type. Select one of the following:

FM1	FM2	FM3	FM4
AM1	AM2	USB	LSB
BFO	PM	User Defined	

NOTE: See Table 3-2 for description of modulation types.

3. Select Rcvr In

Selects Duplex Transmitter Input Connector. Select "Antenna" or "T/R".

4. Select Input Atten

Selects Duplex Transmitter Input Attenuation. Select 0, 20 or 40 dB.

5. Select AGC Type

Displays "Select AGC Type" Menu.

6. Rcvr Out Speaker

Sets Duplex Transmitter Output routing to Speaker. Toggles between on or off.

MENU ITEM	DESCRIPTION
7. <u>Rcvr Out Audio Out</u>	Sets Duplex Transmitter Output routing to AUDIO OUT Connector. Toggles between on or off.
8. <u>Rcvr Out Demod Out</u>	Sets Duplex Transmitter Output routing to DEMOD OUT Connector. Toggles between on or off.
9. <u>Auto Volume Level</u>	Toggles Automatic Volume Level between on or off.
10. <u>Operation Mode</u>	Selects the Duplex Transmitter Operation Mode. Select Direct (normal operation) or Channel. Channel Mode displays the Duplex Transmitter RF as a cellular channel number.
11. <u>Signaling Formats</u>	Displays menu featuring DTMF, Audio and Digital Functions. Selects Format to decode. Selecting Audio displays the Audio Signaling Menu. Selecting Digital displays the Digital Code Menu.

If "2. Select Mod" is selected and "11. User Defined" is selected as the Modulation Type, the User Defined Modulation Menu appears:

MENU ITEM	DESCRIPTION
-----------	-------------

**DUPLEX TRANSMITTER USER
DEFINED MODULATION MENU**

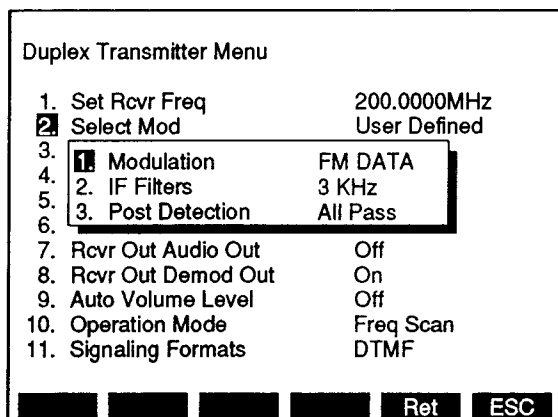

8610060

1. Modulation

Selects User Defined Modulation Type. Select one of the following:

- | | | |
|-------------|-----|-------------|
| FM | AM | SSB (Upper) |
| SSB (Lower) | BFO | PM |
| FM DATA. | | |

2. IF Filters

Selects User Defined IF Filter. Select 3, 30 or 300 kHz.

3. Post Detection

Selects Post Detection Filter. Select All Pass, Low-Pass, High-Pass, Bandpass or C Wt Pass. When Low-Pass, High-Pass and Bandpass are selected, a data field appears to allow the cutoff frequencies to be entered. The ranges of the allowable cutoff frequencies are:

- | | |
|----------------------|------------------|
| Low-Pass | 100 Hz to 30 kHz |
| High-Pass | 500 Hz to 20 kHz |
| Bandpass low cutoff | 500 Hz to 20 kHz |
| Bandpass high cutoff | 100 Hz to 30 kHz |

When "5. Select AGC Type" is selected on the Duplex Transmitter Menu, the following Menu appears:

MENU ITEM

DESCRIPTION

DUPLEX TRANSMITTER
TYPE AGC MENU

Duplex Transmitter Menu

1. Set Rcvr Freq	10.0000 MHz
2. Select Mod	FM1
3. Select Rcvr In	Antenna
4. Select Input Atten	0 dB
5. Select AGC Type	Auto
6. Rcvr Out Speaker	
7. Rcvr Out Audio Out	
8. Rcvr Out Audio Out	
9. Auto Volume Level	
10. Operation Mode	Freq Scan
11. Signaling Formats	DTMF

Ret ESC

8610061

1. User Defined

Displays User Defined AGC Menu. Select Measurement, Speech, Data, High Speed, Type 1, Type 2 or Type 3. See Table 3-3 for description of User Defined AGC Types.

2. Manual

Selects Duplex Transmitter AGC Level. Range is from 1 to 255. 1 corresponds to minimum IF gain, 255 corresponds to maximum IF gain.

3. Auto

AGC is automatically adjusted.

MENU ITEM

DESCRIPTION

If "10. Operation Mode" is selected, the Duplex Transmitter Operation Mode Menu appears:

DUPLEX TRANSMITTER
OPERATION MODE MENU

Duplex Transmitter Menu	
1. Set Rcvr Freq	103.7000 MHz
2. Select Mod	AM2
3. Select Rcvr In	Antenna
4. Select Input Atten	0 dB
5. Select AGC Type	User Defined
6. Rcvr Out Speaker	On
7. Rcvr Out Audio Out	On
8. Rcvr Out Demod Out	On
9. Auto Volume Level	Off
10. Operation Mode	1. Direct 2. Channel
11. Signaling Formats	

Ret ESC

8610122

Select Direct for normal operation. Select Channel to receive AMPS and ETACS Cellular channels. If Channel is selected, "Chan" Soft Function Key F2 appears. Pressing F2 displays the Duplex Transmitter Cellular Format Menu. Select the desired Format.

DUPLEX TRANSMITTER
CELLULAR FORMAT MENU

Duplex Transmitter Menu	
1. Set Rcvr Freq	1 Chan #
2. Select Mod	AM2
3. Select Rcvr In	Antenna
4. Select Input Atten	0 dB
5. Channel Format	r Defined
6.	
7.	
8.	
9.	f
10.	nnel
11.	io

Chan Ret ESC

8610123

If "11. Signaling Formats" is selected, the Duplex Transmitter Signaling Format Menu is displayed. If Audio is selected as the Signaling Format, the Audio Code Menu appears allowing selection of an Audio Code:

DUPLEX TRANSMITTER AUDIO CODE MENU

Duplex Transmitter Menu	
1. S	1. CCIR
2. S	2. EEA
3. S	3. U.S. (EIA)
4. S	4. ZVEI
5. S	5. DDZVEI (ZVEI 2)
6. R	6. DZVEI (ZVEI 3)
7. R	7. NATEL
8. R	8. EURO
9. A	9. 5/6 Tone Seq
10. O	10. CCIRH
11. S	11. CCIRH4
	12. User Defined

000 MHz
Defined
nna

DTMF
Audio
Digital

Ret	ESC
-----	-----

8610162

If Digital is selected as the Signaling Format, the Digital Code Menu appears allowing the selection of a Digital Code:

DUPLEX TRANSMITTER DIGITAL CODE MENU

Duplex Transmitter Menu	
1. Set Rcvr Freq	10.0000 MHz
2. Select Mod	User Defined
3. Select Rcvr In	Antenna
4. Select Input Atten	0 dB
5. Select AGC Type	Auto
6. Rcvr Out Speaker	On
7. Rcvr Out Audio Out	Off
8. Rcvr Out Demod Out	Off
9. Auto Volume L	1. DCS
10. Operation Mod	2. DCS INV
11. Signaling Form	3. POCSAG

1. DTMF
2. Audio
3. Digital

Ret	AUX
-----	-----

8610161

3-3-5 DUPLEX RECEIVER OPERATION SCREEN

With the Duplex Operation Screen displayed on the CRT, press "RX" Soft Function Key F2 to access the Duplex Transmitter Operation Screen. Use the index of screen features to identify the operation parameters that may be edited, the value range available to each feature and/or its usage.

When editing, use FIELD SELECT Keys to move the cursor to the parameter to be edited and press ENTER Key to access the data field. Use the DATA ENTRY Keypad to enter numerical data, Use the DATA SCROLL Spinner or DATA SCROLL ↑ and ↓ Keys to select the parameters from a list. Parameters with only two settings automatically toggle to the opposite setting when selected. To access a displayed Meters Operation Screen, move cursor to the Meters Callout and press the ENTER Key.

A. SCREEN PARAMETERS

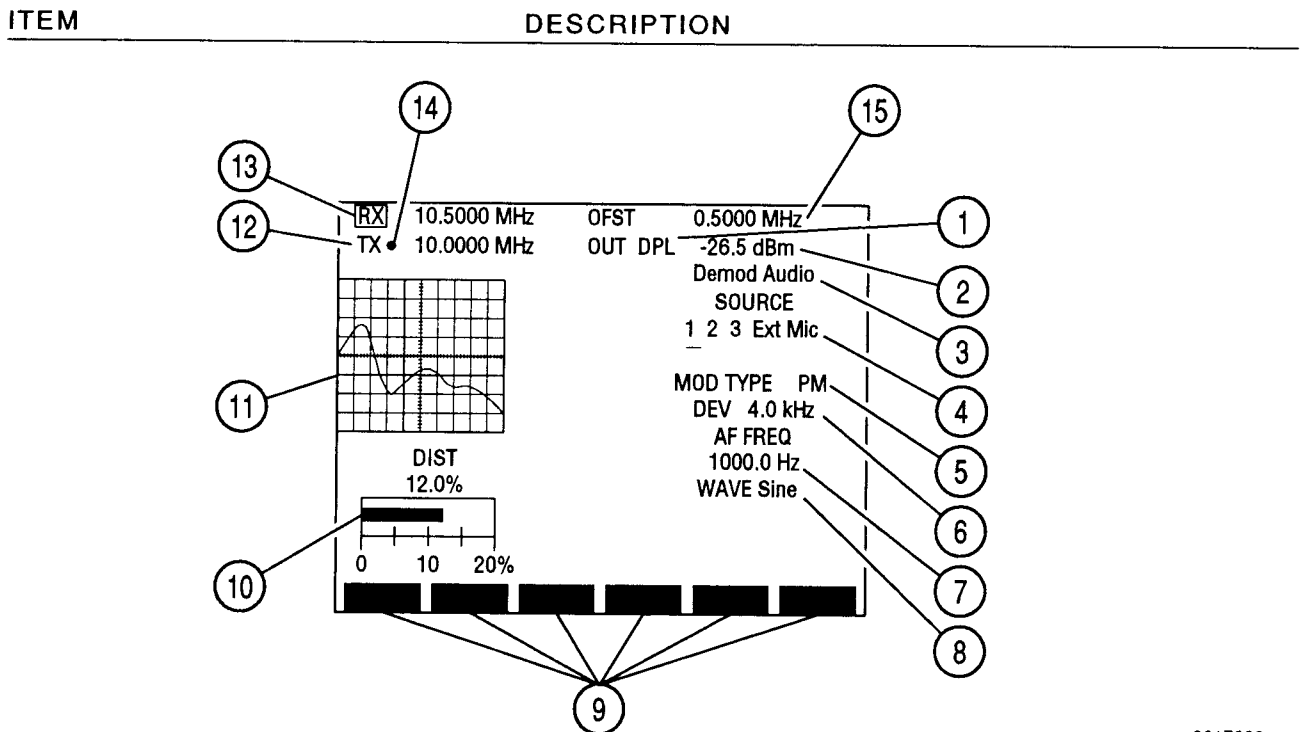

8617006

1. Duplex Receiver Output Connector

Select "DPL" (DUPLEX OUT) or "T/R" Connector for Duplex Receiver Output.

2. Duplex Receiver Output Level

If DPL (DUPLEX OUT) is the Output Connector, range is -120.0 to +7.0 dBm or .224 μ V to .501 V. If T/R is the Output Connector, range is -137.0 to 0.0 dBm or .031 μ V to .224 V.

3. Oscilloscope Input

Appears with Oscilloscope. Select Rcvr IF, Demod Audio, RF Pwr Lvl, SINAD/BER, Func Gen, Ext Mod, AC, DC or GND.

ITEM

DESCRIPTION

4. Duplex Receiver Modulation Source

Underline indicates last selected Modulation Source. Select AM, FM, PM or OFF.

NOTE: Different sources cannot be FM and PM simultaneously. Selecting FM changes PM sources to FM. Selecting PM changes FM sources to PM. Sources that are AM or OFF are not affected.

Source 2 and 3 cannot be active simultaneously when Source 3 is generating an Audio Signaling Code.

5. Duplex Receiver Modulation Type

Not an editable parameter. Readout indicates last selected Source Modulation Type.

6. Duplex Receiver Modulation Level

Appears if a source is active. Range is 0.0 to 100.0 kHz for FM Modulation, 0% to 90% for AM Modulation or 0.0 to 10.0 radians for PM Modulation.

NOTE: When Ext Source is selected, Modulation Level setting assumes the modulating signal applied to the EXT MOD IN Connector is 3.54 VRMS. Modulation Level setting is set higher for lower EXT MOD IN Connector input voltages to achieve the same modulation level as per the following equation.

$$\begin{array}{rcccl} \text{Modulation} & & \text{EXT MOD IN} & & \text{Actual} \\ \text{Level setting} & \times & \text{Connector} & \div & \text{Modulation} \\ \text{(kHz, \%, rad)} & & \text{Input (VRMS)} & & \text{Level} \\ & & & & \div 3.54 \end{array} =$$

7. AF FREQ

Appears if 1 or 2 is the last selected Source. Selects Audio frequency for last selected Source. Range is 0.0 to 40000.0 Hz.

8. Duplex Receiver Wave Form

Appears if 1 or 2 is the last selected Source. Select Sine, Square, Ramp, Triangle, Pulse, +1 Lvl, 0 Lvl or -1 Lvl.

9. Soft Function Keys

Soft Function Keys for Duplex Receiver Operation Screen are covered in 3-3-5B.

10. Distortion/SINAD/AF LVL/DMM Meter

Displays selected meter. Meter is selected using "Meters" Soft Function Key F4. Meters can be accessed through display or through the Meter Menu. Meter displayed as a digital readout if Oscilloscope or Spectrum Analyzer is full size.

NOTE: SINAD, Distortion and AF Level Meters measure only SINAD/BER IN Connector Input. DMM measures only DMM Connectors Input.

ITEM	DESCRIPTION
------	-------------

11. Oscilloscope or Spectrum Analyzer

Displays Oscilloscope or Spectrum Analyzer Operation. Use "Disp" Soft Function Key to display full size or 1/4 size Oscilloscope, full size or 1/4 size Spectrum Analyzer or set to None for no display.

12. Duplex Transmitter Frequency

Selects Duplex Transmitter Frequency. Range is 0.2500 to 999.9999 MHz.

13. Duplex Receiver Frequency

Selects Duplex Receiver Frequency. Range is 0.2500 to 999.9999 MHz. Either the Receiver Frequency or the Offset Frequency is the editable frequency at any one time. The parameter not editable automatically changes so the Offset Frequency added to the Transmitter Frequency is equal to the Receiver Frequency.

14. Squelch Indicator Light

Green dot appears when squelch is broken.

15. Duplex Offset Frequency

Selects Duplex Offset Frequency. Range is -999.7499 to 999.7499 MHz. Either the Receiver Frequency or the Offset Frequency is the editable frequency at any one time. The parameter not editable automatically changes so the Offset Frequency added to the Transmitter Frequency is equal to the Receiver Frequency.

If 3 (Signaling Format) is selected as the Active Source, the Operation Screen appears as follows:

ITEM	DESCRIPTION
------	-------------

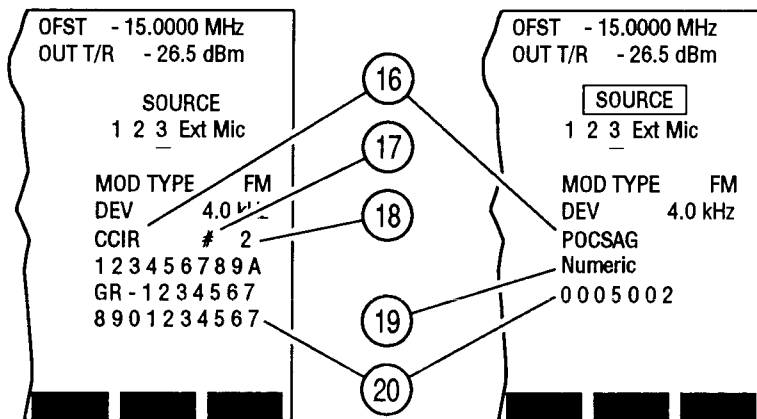

8617075

16. Signaling Code Display

- Displays DTMF if DTMF is the selected Signaling Format.

ITEM	DESCRIPTION
------	-------------

- Accesses Audio Code if Audio Signaling Format is active. Select from:

CCIR	EEA	U.S.(EIA)
ZVEI	DDZVEI(ZVEI 2)	DZVEI (ZVEI 3)
NATEL	EURO	5/6 Tone Seq
CCIRH	CCIRH4	User Defined

- Accesses Digital Code if Digital Signaling Format is active. Select from:

DCS	DCS INV	POCSAG
-----	---------	--------

- Accesses RCC Code if RCC Signaling Format is active. Select from:

IMTS	MTS	2805
Tone Rem		

17. #/DIR

Accessing Callout toggles it to the function not shown. Select # (Program #) to generate a programmed sequence. Select DIR (Direct Entry) to allow sequence entry from the Operation Screen. Press GO TEST CONTROL Key to transmit sequence.

18. Program Number

Does not appear if DIRECT ENTRY is active. Up to 16 sequences can be programmed at a time.

19. POCSAG or Tone Remote

Accesses POCSAG or Tone Remote Function. For POCSAG, select one of the following:

Tone - 1 beep	Tone - 2 beep	Tone - 3 beep
Tone - 4 beep	Numeric	Numeric seq
Alpha lower	Alpha upper	Alphanumeric
Alpha special		

For Tone Remote, select one of the following:

2050 (Monitor)	1950 (F1)	1850 (F2)
1750 (R2 Mute)	1650 (R2 Unmute)	1550 (Repeater Off)
1450 (Repeater On)	1350 (Wild Card 1 On)	1250 (Wild Card 1 Off)
1150 (Wild Card 2 On)	1050 (Wild Card 2 Off)	

20. Tone Sequence Listing

Displays coded sequence. Displays coded sequence. If DIRECT ENTRY is selected, accessing allows entry of sequence unless POCSAG or Tone Remote are in use.

B. SOFT FUNCTION KEYS

The following index lists the sets of Soft Function Keys available for the Duplex Transmitter Operation Screen. Whichever list is accessed last is the list that comes up first when the Duplex Transmitter Operation Screen is next accessed.

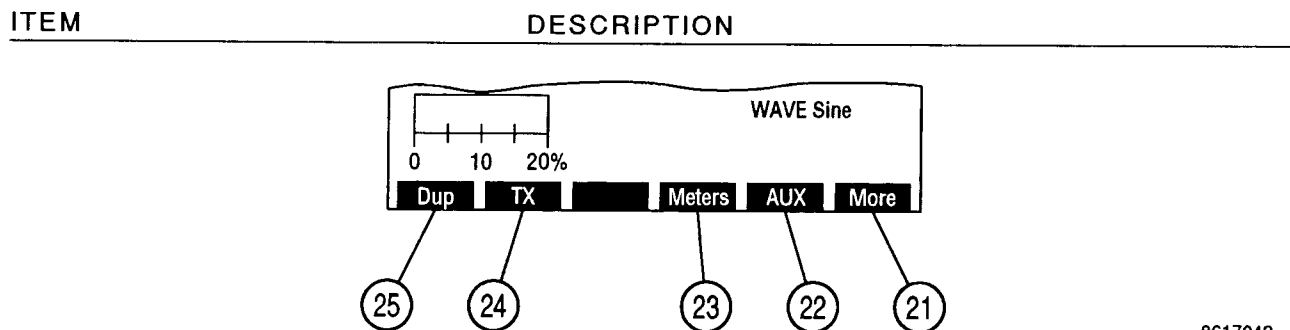

8617042

21. "More"/"ESC" Soft Function Key F6

"ESC" appears while parameters are accessed for editing. Allows edit procedure to be canceled without changing parameter. "More" displays additional sets of Soft Function Keys.

22. "AUX" Soft Function Key F5

Displays Auxiliary Functions Menu.

23. "Meters" Soft Function Key F4

Displays menu listing available Meters. Select SINAD, DIST (Distortion), AF LVL or DMM.

NOTE: SINAD and Distortion Meters measure only SINAD/BER IN Connector Input. DMM measures only DMM Connector Input.

24. "TX" Soft Function Key F2

Displays Duplex Transmitter Operation Screen.

25. "Dup" Soft Function Key F1

Displays Duplex Operation Screen.

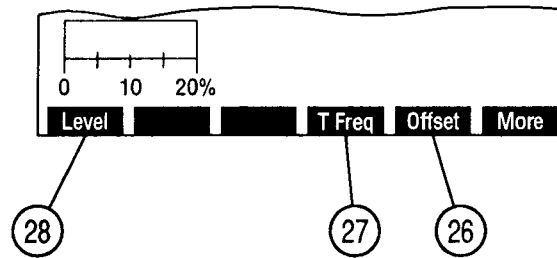

8617013

26. "Offset"/"R Freq" Soft Function Key F5

Toggles which frequency is editable (Offset or Duplex Receiver) and selects frequency. Range for Duplex Receiver Frequency is 0.2500 to 999.9999 MHz. Range for Duplex Offset Frequency is -999.7499 to 999.9999 MHz.

27. "T Freq" Soft Function Key F4

Selects Duplex Transmitter Frequency. Range is 0.2500 to 999.9999 MHz.

28. "Level" Soft Function Key F1

Selects Duplex Receiver Output Level. If DPL is the Output Connector, range is -120.0 to +7.0 dBm or .224 μ V to .501 V. If T/R is the Output Connector, range is -137.0 to 0.0 dBm or .031 μ V to .224 V.

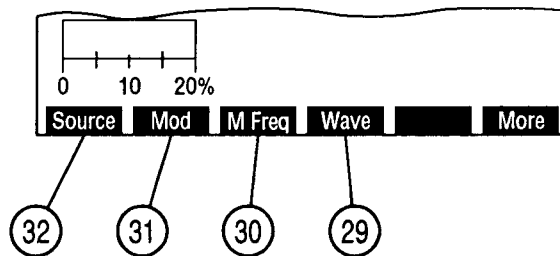

8617014

29. "Wave" Soft Function Key F4

Appears if Source 1 or 2 is the last selected Source. Selects Modulation Wave Form. Select Sine, Square, Ramp, Triangle, Pulse, +1 Lvl, 0 Lvl or -1 Lvl.

30. "M Freq" Soft Function Key F3

Appears if Source 1 or 2 is the last selected Source. Selects Modulation Audio Frequency. Range is 0.0 to 40000.0 Hz.

ITEM	DESCRIPTION
31.	<p><u>"Mod"/"Dev" Soft Function Key F2</u></p> <p>Appears if Source 1 or 2 is the last selected Source. Selects Modulation Level. Range is 0% to 90% for AM Modulation, 0.0 to 100.0 kHz for FM Modulation, 0.0 to 10.0 radians for PM Modulation.</p>
32.	<p><u>"Source" Soft Function Key F1</u></p> <p>Edits Modulation Sources. Select AM, FM, PM or OFF.</p> <p>NOTE: Different sources cannot be FM and PM simultaneously. Selecting FM changes PM sources to FM. Selecting PM changes FM sources to PM. Sources that are AM or OFF are not affected. Press F1 to access and edit Duplex Receiver Source.</p>

The following set of Soft Function Keys are accessed with a full size Spectrum Analyzer Display:

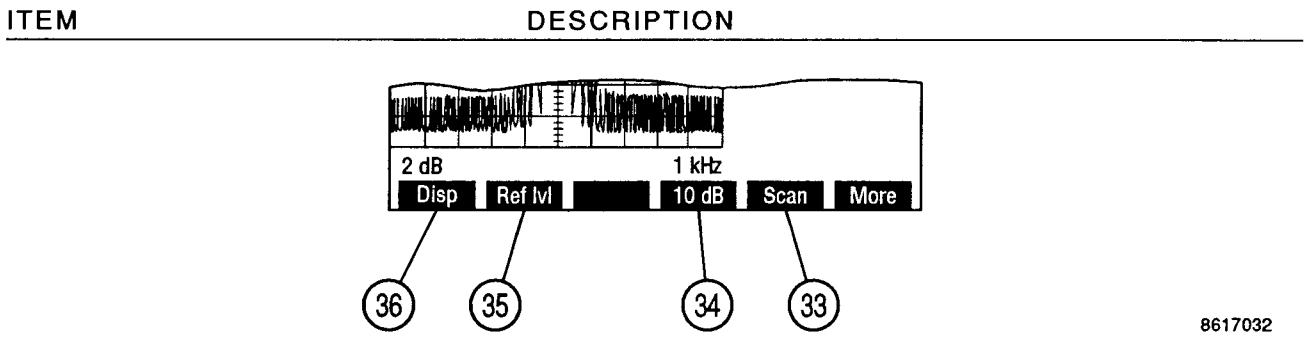

33.	<p><u>"Scan" Soft Function Key F5</u></p> <p>Selects Analyzer Scan Width. Select Zero Scan (0 kHz) or:</p> <table style="width: 100%; border: none;"> <tr> <td style="width: 33%;">1 kHz</td> <td style="width: 33%;">2 kHz</td> <td style="width: 33%;">5 kHz</td> </tr> <tr> <td>10 kHz</td> <td>20 kHz</td> <td>50 kHz</td> </tr> <tr> <td>100 kHz</td> <td>200 kHz</td> <td>500 kHz</td> </tr> <tr> <td>1 MHz</td> <td></td> <td></td> </tr> </table>	1 kHz	2 kHz	5 kHz	10 kHz	20 kHz	50 kHz	100 kHz	200 kHz	500 kHz	1 MHz		
1 kHz	2 kHz	5 kHz											
10 kHz	20 kHz	50 kHz											
100 kHz	200 kHz	500 kHz											
1 MHz													
34.	<p><u>"10 dB/2 dB" Soft Function Key F4</u></p> <p>Toggles Units/Division Factor between 10 and 2 dB/div.</p>												
35.	<p><u>"Ref lvl" Soft Function Key F2</u></p> <p>Appears with 2 dB vertical scale. Adjusts vertical grid position of the Spectrum Analyzer Trace.</p>												
36.	<p><u>"Disp" Soft Function Key F1</u></p> <p>Menu appears listing Oscilloscope displays, Spectrum Analyzer displays and None. Select desired display using DATA ENTRY Keypad.</p>												

The following set of Soft Function Keys are accessed when the Oscilloscope is displayed:

ITEM	DESCRIPTION
------	-------------

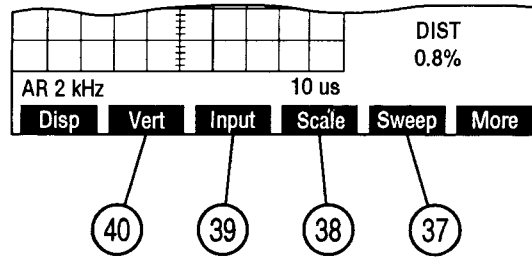

8617086

37. "Sweep" Soft Function Key F5

Appears with full size Oscilloscope except with "Rcvr IF" as Oscilloscope Input. Select one of the following:

- | | | |
|-------------|-------------|-------------|
| 1 μ s | 2 μ s | 5 μ s |
| 10 μ s | 20 μ s | 50 μ s |
| 100 μ s | 200 μ s | 500 μ s |
| 1 ms | 2 ms | 5 ms |
| 10 ms | 20 ms | 50 ms |
| 100 ms | | |

38. "Scale" Soft Function Key F4

Appears with full size Oscilloscope. For AC, DC or GND Oscilloscope Input, select one of the following:

- | | | |
|------------|------------|------------|
| 1 mV/div | 2 mV/div | 5 mV/div |
| 10 mV/div | 20 mV/div | 50 mV/div |
| 100 mV/div | 200 mV/div | 500 mV/div |
| 1 V/div | 2 V/div | 5 V/div |
| 10 V/div | 20 V/div | 50 V/div |

For Func Gen or Ext Mod Oscilloscope Input, select one of the following:

- | | | |
|------------|---------|-----------|
| 500 mV/div | 1 V/div | 2.5 V/div |
|------------|---------|-----------|

For RF Pwr Lvl Oscilloscope Input, Oscilloscope Scale reads 2 W/div or 200 W/div. Power Meter Ranges of 20, 50 or 100 mW set Oscilloscope Scale to 2 W/div. All other Power Meter Ranges set Oscilloscope Scale to 200 W/div.

Oscilloscope Scale is not editable for SINAD/BER or Rcvr IF Oscilloscope Input and "Scale" Soft Function Key F4 does not appear. Oscilloscope is not operable for Demod Audio Oscilloscope Input.

39. "Input" Soft Function Key F3

Selects Oscilloscope Input. Choose one of the following:

- | | | |
|-----------|-------------|------------|
| Rcvr IF | Demod Audio | RF Pwr Lvl |
| SINAD/BER | Func Gen | Ext Mod |
| AC | DC | GND |

ITEM	DESCRIPTION
------	-------------

40. "Vert" Soft Function Key F2

Appears with full size Oscilloscope. Adjusts vertical trace position on Oscilloscope. When Oscilloscope Trace is adjusted below Oscilloscope display, an arrow appears on the right bottom edge of the display. When Oscilloscope Trace is adjusted above Oscilloscope display, an arrow appears on the right top edge of the display.

C. DUPLEX RECEIVER MENU

When the Duplex Receiver Operation Screen is displayed on the CRT or when the cursor is on any parameter on the left side of the Duplex Operation Screen, press SETUP Key to access the Duplex Receiver Menu. Many Duplex Receiver Operating Screen parameters may also be edited from Duplex Receiver Menu or one of its submenus.

MENU ITEM	DESCRIPTION
-----------	-------------

DUPLEX RECEIVER MENU

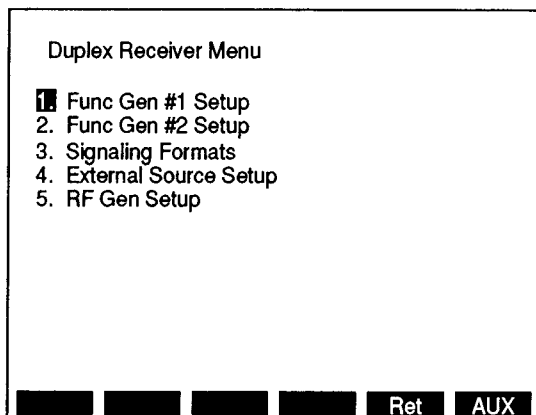

8610072

1. Func Gen #1 Setup

Displays Func Gen #1 Setup Menu.

2. Func Gen #2 Setup

Displays Func Gen #2 Setup Menu.

3. Signaling Formats

Displays Signaling Format Menu featuring DTMF, Audio, Digital and RCC.

4. External Source Setup

Displays External Source Setup Menu.

5. RF Gen Setup

Displays RF Generator Setup Menu.

Selecting "1. Func Gen #1 Setup" displays the Function Generator #1 Setup Menu:

MENU ITEM

DESCRIPTION

FUNCTION GENERATOR #1 SETUP MENU

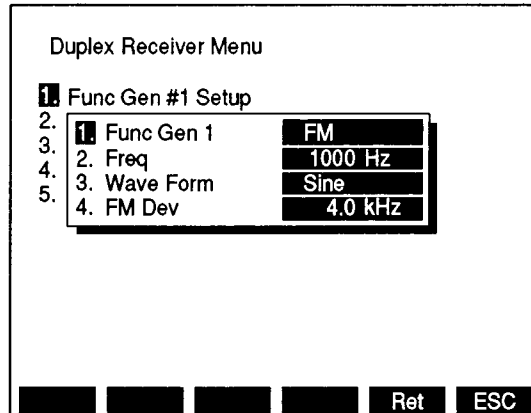

8610057

1. Func Gen 1

Selects Function Generator Modulation Type. Select AM, FM, PM or OFF.

NOTE: Different sources cannot be FM and PM simultaneously. Selecting FM changes PM sources to FM. Selecting PM changes FM sources to PM. Sources that are AM or OFF are not affected.

2. Freq

Selects Function Generator Frequency. Range is 0.0 to 40000 Hz.

3. Wave Form

Selects Function Generator Wave Form. Select Sine, Square, Ramp, Triangle, Pulse, +1 Lvl, 0 Lvl, -1 Lvl.

4. Level Setting

Not operational when Function Generator is off. Selects Function Generator Modulation Level. Range is 0.000 to 100.000 kHz for FM Modulation, 0% to 90% for AM Modulation or 0.0 to 10.0 radians for PM Modulation.

Accessing "2. Func Gen #2 Setup" displays the Function Generator #2 Setup Menu. Function Generator #2 parameters are identical to those of Function Generator #1.

When "3. Signaling Formats" is selected on the Duplex Receiver Menu, the following menu appears on the CRT:

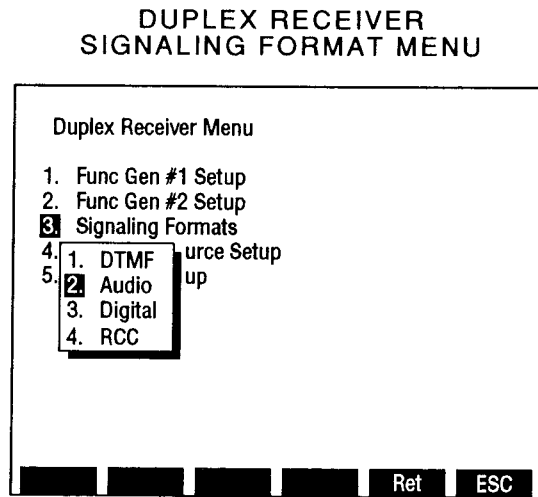

8610090

If "1. DTMF" is selected, the DTMF Format Menu appears on the screen:

ITEM **DESCRIPTION**

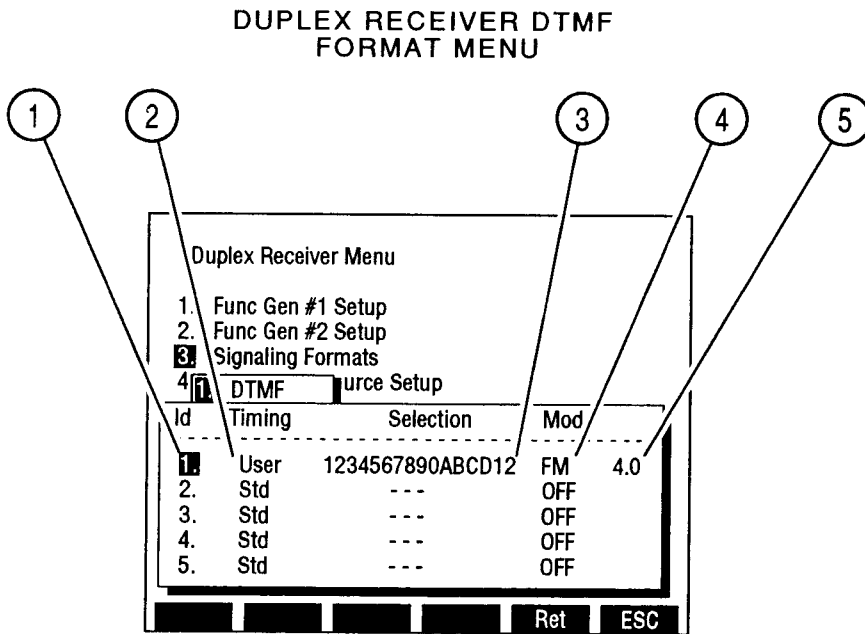

8607057

1. Id

Program Identification number. Used to select a specific sequence from the Operation Screen while using the Program feature.

2. Timing

Choose from Std (standard) or User (user defined). If User is selected, two data fields appear allowing entry of desired Mark Timing and Space Timing. Range of both is 25 to 9999 ms.

ITEM

DESCRIPTION

3. Sequence

Select the desired sequence of up to 15 tones using digits 0 through 9, letters A through D, # character and the * character.

4. Mod Type

Select AM, FM, PM or OFF for the DTMF Modulation.

5. Mod Level

Modulation Level range is 0.0 to 20.0 kHz for FM, 0.0% to 24.5% for AM, 0.0 to 3.0 radians for PM.

If Audio is selected as the Signaling Format, the Audio Code Menu appears:

DUPLEX RECEIVER
AUDIO CODE MENU

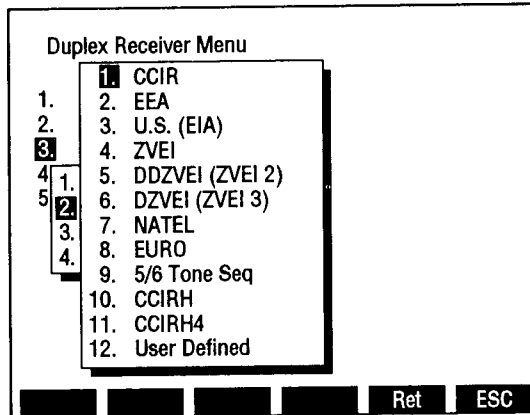

8610089

Selecting an Audio Code displays the Audio Code Sequence Menu:

DUPLEX RECEIVER AUDIO
CODE SEQUENCE MENU

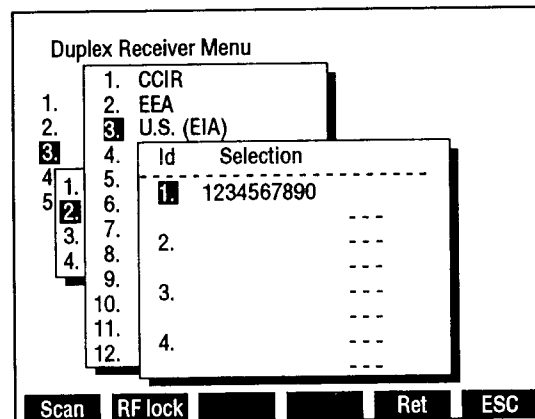

8610088

Select the Id number from 1 to 15. Enter a sequence up to 30 tones in length using the characters 0 through 9, A, G, R and - signifying a blank space.

Selecting "12. User Defined" for the Audio Code displays the Audio Code User Defined Menu:

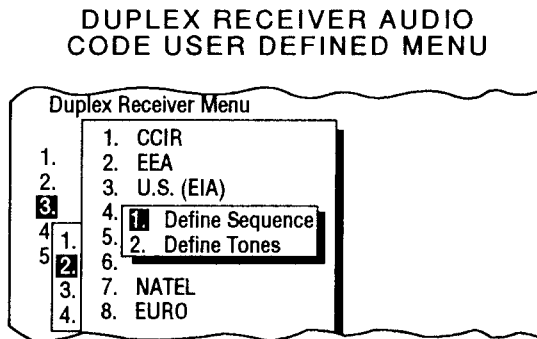

8610170

Selecting "2. Define Tones" displays a menu used to define the desired tones:

ITEM _____ DESCRIPTION _____

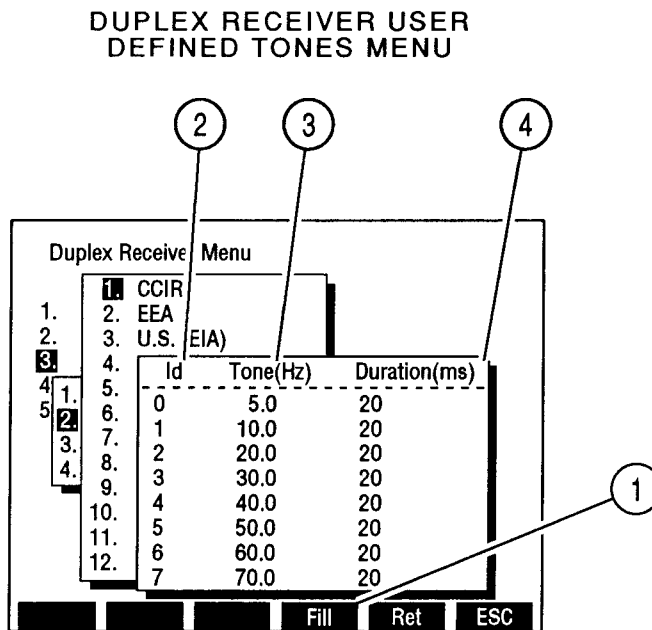

8610154

1. "Fill" Soft Function Key F4

When a Tone or Duration is highlighted, pressing Soft Function Key F4 changes all entries below and in the same column to the value highlighted.

2. Id

Select an Id to represent the tone to be defined. Range of characters for the Id is 0 to 9 and A to T. Defining the tone consists of setting the frequency and duration of the tone.

ITEM

DESCRIPTION

3. Tone(Hz)

Set "Tone(Hz)" to frequency of desired tone. Range is 0.0 to 9999.9 Hz.

4. Duration(ms)

Set "Duration(ms)" to duration of desired tone. Range is 20 to 9999 ms.

Selecting "1. Define Sequence" displays the Duplex Receiver Audio Code Sequence Menu. User Defined sequences are selected as other Audio Codes using this menu.

If "3. Digital" is selected as the Signaling Format, the Digital Code Menu appears:

DUPLEX RECEIVER
DIGITAL CODE MENU

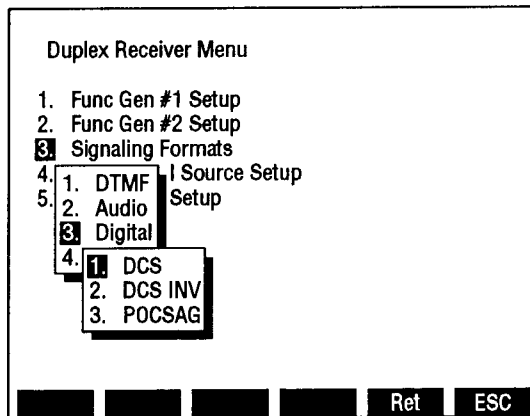

8610150

Selecting DCS or DCS INV displays the DCS Code Menu:

DUPLEX RECEIVER
DCS CODE MENU

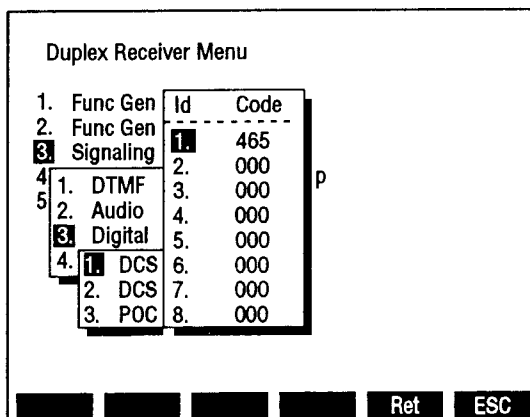

8610087

After selecting the Id number, enter a 3 digit DCS Code.

Selecting POCSAG from the Digital Code Menu displays the POCSAG Menu:

MENU ITEM	DESCRIPTION
-----------	-------------

**DUPLEX RECEIVER
POCSAG MENU**

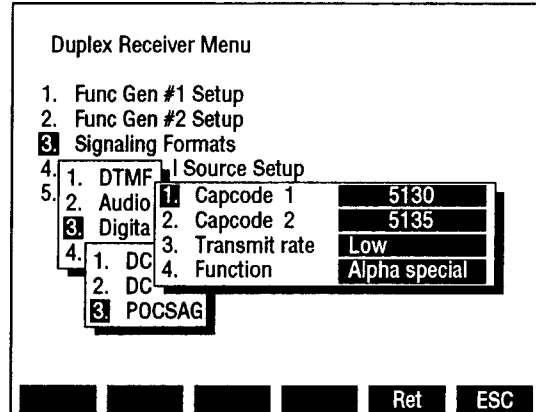

8610151

1. Capcode 1

Selects beginning Capcode of sequence. Sequence generated consists of Capcodes from Capcode 1 through Capcode 2.

2. Capcode 2

Selects ending Capcode of Capcode sequence. Sequence generated consists of Capcodes from Capcode 1 through Capcode 2.

3. Transmit Rate

Toggles Transmit Rate to Low or High.

4. Function

Selects POCSAG Function Submenu. Choose one of the following:

- | | | |
|----------------|----------------|----------------|
| Tone - 1 beep | Tone - 2 beeps | Tone - 3 beeps |
| Tone - 4 beeps | Numeric | Numeric seq |
| Alpha lower | Alpha upper | Alphanumeric |
| Alpha special | | |

If RCC is selected for the Signaling Format, the RCC Code Menu appears:

DUPLEX RECEIVER
RCC CODE MENU

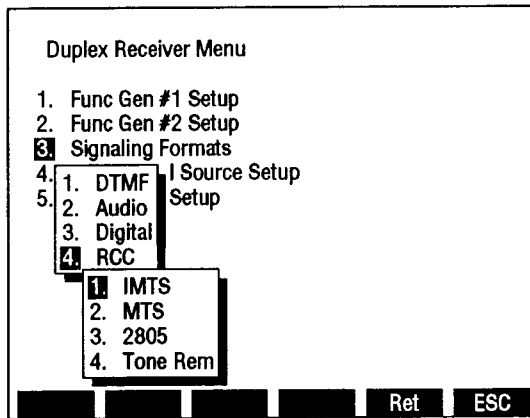

8610152

Selecting IMTS, MTS or 2805 displays the following menu:

DUPLEX RECEIVER IMTS,
MTS AND 2805 MENU

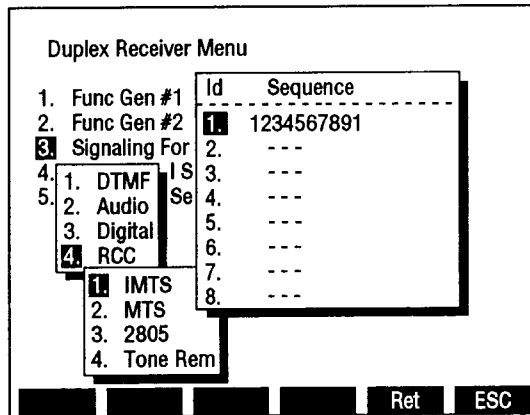

8610153

After selecting an Id, select the sequence to be generated using characters 1 through 9.

If 2805 is selected, "Tone" Soft Function Key F3 appears. Accessing F3 displays the 2805 Tone Freq data field allowing this frequency to be changed. Range of Tone Freq is 0.0 to 40000.0 Hz.

Selecting Tone Rem displays the Tone Remote Function Menu. Select one of the following:

- | | | |
|-----------------------|------------------------|------------------------|
| 2050 (Monitor) | 1950 (F1) | 1850 (F2) |
| 1750 (R2 Mute) | 1650 (R2 Unmute) | 1550 (Repeater Off) |
| 1450 (Repeater On) | 1350 (Wild Card 1 On) | 1250 (Wild Card 1 Off) |
| 1150 (Wild Card 2 On) | 1050 (Wild Card 2 Off) | |

When "4. External Source Setup" is selected on the Duplex Receiver Menu, the following menu appears on the CRT:

MENU ITEM	DESCRIPTION
-----------	-------------

DUPLEX RECEIVER EXTERNAL SOURCE SETUP MENU

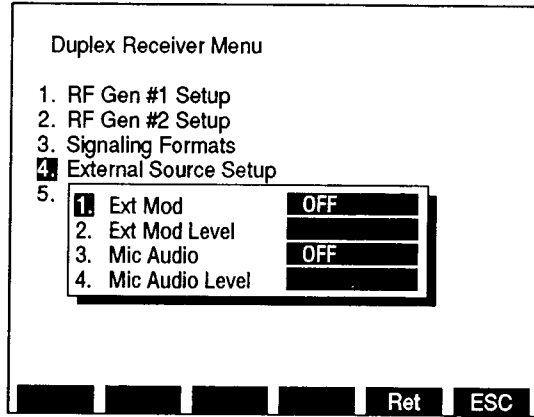

8610056

1. Ext Mod

Selects External Modulation Type. Select FM, AM, PM or OFF.

2. Ext Mod Level

Selects External Modulation Level. Select from 0.0 to 100.0 kHz for FM, 0% to 90% for AM or 0.0 to 10.0 radians for PM. Field is blank if set to OFF.

NOTE: External Modulation Level setting assumes the modulating signal applied to the EXT MOD IN Connector is 3.54 VRMS. For lower input voltages, Modulation Level setting is set higher to achieve the modulation level desired as per the following equation:

$$\begin{matrix} \text{Modulation} \\ \text{Level setting} \\ \text{(kHz, \%, rad)} \end{matrix} \times \begin{matrix} \text{EXT MOD IN} \\ \text{Connector} \\ \text{Input (VRMS)} \end{matrix} + 3.54 = \begin{matrix} \text{Actual} \\ \text{Modulation} \\ \text{Level} \end{matrix}$$

3. Mic Audio

Select FM, AM, PM or OFF for Microphone Input Modulation Type.

4. Mic Audio Level

Selects Microphone Input Modulation Level. Select from 0.0 to 100.0 kHz for FM, 0% to 90% for AM or 0.0 to 10.0 radians for PM. Field is blank if set to OFF.

When "5. RF Gen Setup" is selected on the Duplex Receiver Menu, the Duplex Receiver Setup Menu appears on the CRT:

MENU ITEM

DESCRIPTION

DUPLEX RECEIVER
SETUP MENU

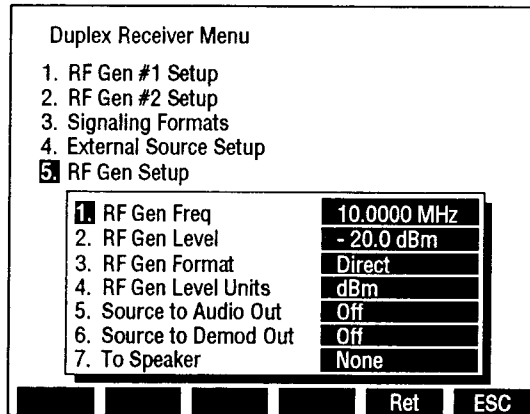

8610073

1. RF Gen Freq

Selects Duplex Receiver Frequency. Range is from 0.2500 to 999.9999 MHz.

2. RF Gen Lvl

If DPL (DUPLEX OUT) is the Output Connector, range is -120.0 to +7.0 dBm or .224 μ V to .501 V. If T/R is the Output Connector, range is -137.0 to 0.0 dBm or .031 μ V to .224 V.

3. RF Gen Format

Selects Duplex Receiver Format. Toggles to Direct or Channel. In Channel Mode, Duplex Receiver Frequency is displayed as a cellular channel number and "Chan" Soft Function key F2 appears. "Chan" Soft Function Key F2 accesses the Duplex Receiver Channel Format Menu listing available Cellular Channel Formats.

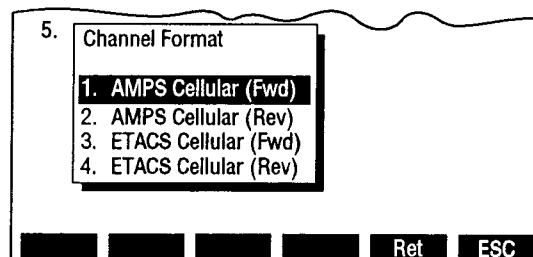

8610182

4. RF Gen Level Units

Selects Duplex Receiver Output Level Units. Accessing toggles units to "dBm" or "Volts".

MENU ITEM

DESCRIPTION

5. Source to Audio Out

Sets routing of Modulation Source to AUDIO OUT Connector. Accessing toggles routing to on or off.

6. Source to Demod Out

Sets routing of Modulation Source to DEMOD OUT Connector. Accessing toggles routing to on or off.

7. To Speaker

Displays menu listing signals to be routed to Speaker. Select None, Source, SINAD/BER or Ext Mod/DTMF.

NOTE: Routing the Source to the Speaker disables SINAD and Distortion Meters.

3-3-6 AF GENERATOR OPERATION SCREEN

Press AF GEN MODE Key to access Function Generator Operating Screen. Use the index of screen features to identify the operation screen parameters that may be edited, the value range available to each feature and/or its usage.

When editing, use the FIELD SELECT Keys to move the cursor to the parameter to be edited and press ENTER Key to access the data field. Use the DATA ENTRY Keypad to enter numerical data. Use the DATA SCROLL Spinner or DATA SCROLL ↑ and ↓ Keys (3) to select parameters from a list. Parameters with only two possible settings automatically switch to the opposite setting when selected. To access a displayed Meters Operation Screen, move cursor to the Meters Callout and press the ENTER Key.

All available Soft Function Keys are on one screen.

A. SCREEN PARAMETERS

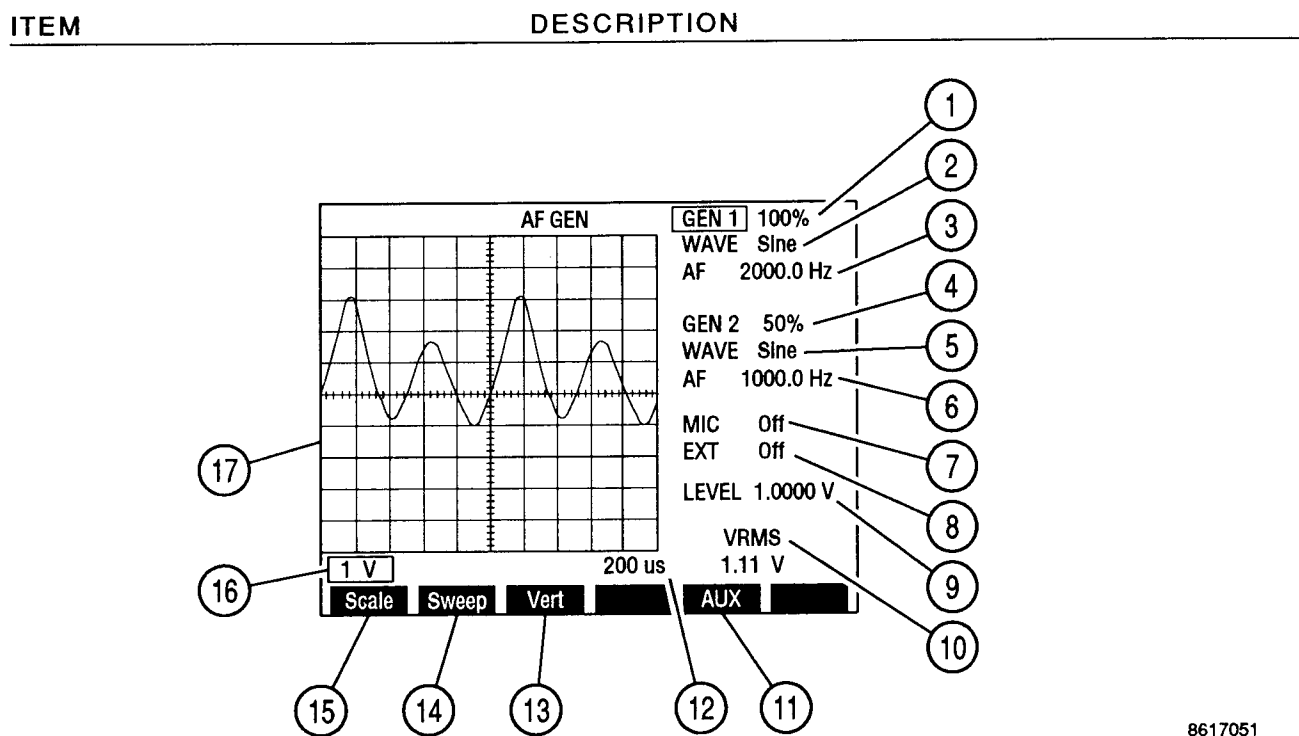

1. GEN 1

Selects Function Generator #1 Status. For Proportional Mode select 0% to 100%; otherwise select on and off. Proportional Mode is selected from AF Gen Menu.

2. WAVE (GEN 1)

Selects Function Generator #1 Output Wave Form. Select Sine, Square, Ramp, Triangle, Pulse, +1 Lvl, 0 Lvl, or -1 Lvl.

3. AF (GEN 1)

Selects Function Generator #1 Audio Frequency. Range is 0.0 to 40000.0 Hz.

8617051

ITEM	DESCRIPTION
------	-------------

4. GEN 2

Selects Function Generator #2 Status. For Proportional Mode select 0% to 100%; otherwise select on or off. Proportional Mode is selected from AF Gen Menu.

5. WAVE (GEN 2)

Selects Function Generator #2 Output Wave Form. Select Sine, Square, Ramp, Triangle, Pulse, +1 Lvl, 0 Lvl, or -1 Lvl.

6. AF (GEN 2)

Selects Function Generator #2 Audio Frequency. Range is 0.0 to 40000.0 Hz.

7. MIC

Selects Function Generator Status at MIC/ACC Connector. For Proportional Mode select 0% to 100%; otherwise select on or off. Proportional Mode is selected from AF Gen Menu.

8. EXT

Selects Function Generator Status at EXT MOD IN Connector. For Proportional Mode select 0% to 100%; otherwise select on or off. Proportional Mode is selected from AF Gen Menu.

9. LEVEL

Selects Function Generator Output Attenuation Level. Range is 0.0000 to 3.1000 V.

10. VRMS

Displays VRMS level of Function Generator Output.

11. "AUX" Soft Function Key F5

Displays Auxiliary Functions Menu.

12. Oscilloscope Sweep Rate

Select one of the following:

- | | | |
|-------------|-------------|-------------|
| 1 μ s | 2 μ s | 5 μ s |
| 10 μ s | 20 μ s | 50 μ s |
| 100 μ s | 200 μ s | 500 μ s |
| 1 ms | 2 ms | 5 ms |
| 10 ms | 20 ms | 50 ms |
| 100 ms | | |

ITEM	DESCRIPTION																		
13. <u>"Vert" Soft Function Key F3</u>	Adjusts vertical position of Oscilloscope Trace by using DATA SCROLL Spinner. When Oscilloscope Trace is adjusted below Oscilloscope display, an arrow appears on the right bottom edge of the display. When Oscilloscope Trace is adjusted above Oscilloscope display, an arrow appears on the right top edge of the display.																		
14. <u>"Sweep" Soft Function Key F2</u>	Selects Oscilloscope Sweep Rate. Select one of the following:																		
	<table> <tbody> <tr> <td>1 μs</td> <td>2 μs</td> <td>5 μs</td> </tr> <tr> <td>10 μs</td> <td>20 μs</td> <td>50 μs</td> </tr> <tr> <td>100 μs</td> <td>200 μs</td> <td>500 μs</td> </tr> <tr> <td>1 ms</td> <td>2 ms</td> <td>5 ms</td> </tr> <tr> <td>10 ms</td> <td>20 ms</td> <td>50 ms</td> </tr> <tr> <td>100 ms</td> <td></td> <td></td> </tr> </tbody> </table>	1 μ s	2 μ s	5 μ s	10 μ s	20 μ s	50 μ s	100 μ s	200 μ s	500 μ s	1 ms	2 ms	5 ms	10 ms	20 ms	50 ms	100 ms		
1 μ s	2 μ s	5 μ s																	
10 μ s	20 μ s	50 μ s																	
100 μ s	200 μ s	500 μ s																	
1 ms	2 ms	5 ms																	
10 ms	20 ms	50 ms																	
100 ms																			
15. <u>"Scale" Soft Function Key F1</u>	Selects Oscilloscope Scale. Select 500 mV, 1 V or 2.5 V.																		
16. <u>Oscilloscope Scale</u>	Selects Oscilloscope Scale. Select 500 mV, 1 V or 2.5 V.																		
17. <u>Oscilloscope</u>	Oscilloscope displays Function Generator Output.																		

B. AF GENERATOR MENU

When the Function Generator Operation Screen is displayed on the CRT, press SETUP Key to access the Function Generator Menu. Many Function Generator Operating Screen parameters are edited from the Function Generator Menu or one of its submenus.

MENU ITEM	DESCRIPTION
-----------	-------------

AF GENERATOR MENU

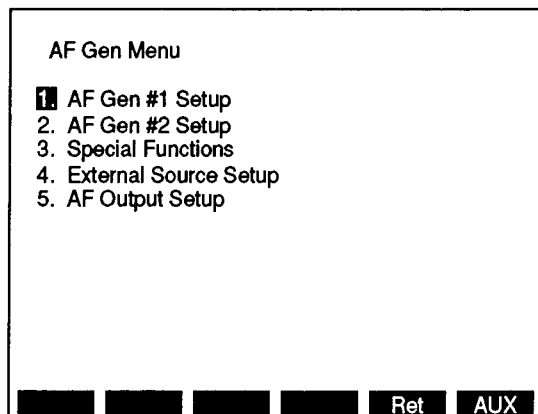

8610013

1. AF Gen #1 Setup

Displays Function Generator #1 Menu.

2. AF Gen #2 Setup

Displays Function Generator #2 Menu.

3. Special Functions

Displays menu listing AF Scan and Tone Remote. Selecting a function displays the Functions Menu.

4. External Source Setup

Displays External Source Menu.

5. AF Output Setup

Displays AF Generator Menu.

Selecting "1. AF Gen #1 Setup" displays the Function Generator #1 Menu:

MENU ITEM

DESCRIPTION

FUNCTION GENERATOR #1 MENU

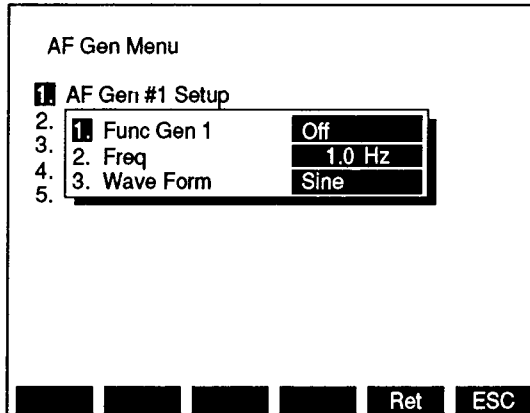

8610014

1. Func Gen 1

Selects Function Generator Status. For Proportional Mode select from 0% to 100%; otherwise select on or off.

2. Freq

Selects Function Generator Frequency. Range is 0.0 to 40000.0 Hz.

3. Wave Form

Selects Function Generator Wave Form. Select Sine, Square, Ramp, Triangle, Pulse, +1 Lvl, 0 Lvl or -1 Lvl.

Selecting "2. AF Gen #2 Setup" displays the Function Generator #2 Menu. Function Generator #2 parameters are identical to those of Function Generator #1.

Selecting "3. Special Functions" displays the Special Functions Menu. Selecting "1. AF Scan" displays the Audio Frequency Scan Menu:

MENU ITEM	DESCRIPTION
-----------	-------------

AUDIO FREQUENCY SCAN MENU

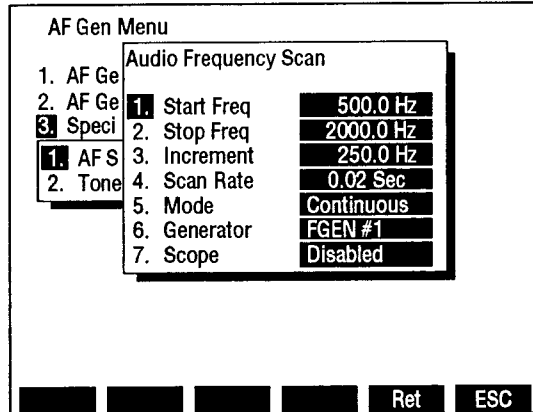

8610102

1. Start Freq

Selects starting frequency for AF Scan. Range is 0.0 to 40000.0 Hz.

2. Stop Freq

Selects ending frequency for AF Scan. Range is 0.0 to 40000.0 Hz.

3. Increment

Selects increment between generated frequencies. Range is 0.0 to 40000.0 Hz.

4. Scan Rate

Blank if "7. Scope" is enabled. Selects length of time each frequency is generated. Range is 0.02 to 99.99 sec.

5. Mode

Selects AF Scan Mode. Choose Continuous or One Shot. Continuous allows AF Scan to repeat until STOP TEST CONTROL Key is pressed. One Shot Mode generates the AF Scan once. Pressing GO TEST CONTROL Key starts the AF Scan regardless of Mode.

6. Generator

Selects Function Generator used for AF Scan. Toggles between Function Generator #1 or Function Generator #2.

7. Scope

Enables or disables Oscilloscope. With enabled Oscilloscope, Scan Rate adjustment is no longer available.

If "3. Special Functions" is selected and "2. Tone Remote" is selected, the Tone Remote Function Menu appears. Select the Tone Remote Function desired.

AUDIO FREQUENCY TONE REMOTE FUNCTION MENU

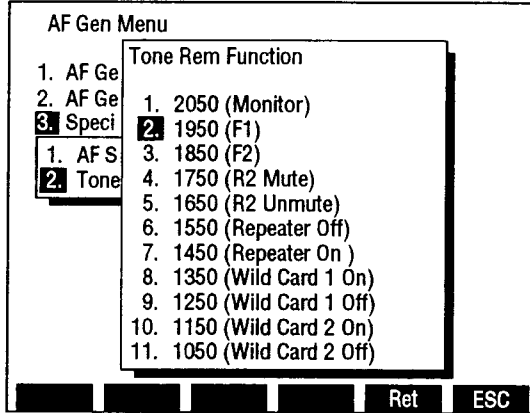

8610158

Selecting "4. External Source Setup" displays the AF Generator External Source Menu:

MENU ITEM	DESCRIPTION
-----------	-------------

EXTERNAL SOURCE SETUP MENU

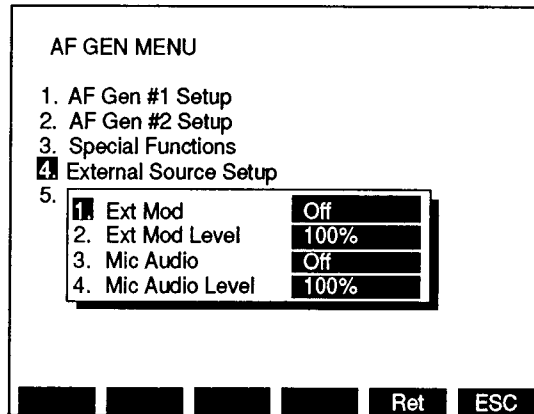

8610016

1. Ext Mod

Selects EXT MOD IN Connector as Function Generator Input. Select on or off.

2. Ext Mod Level

Sets EXT MOD IN Connector's Proportional Level. Range is 0% to 100%. Although displayed, Proportional Level is not activated if Proportional Output is off.

MENU ITEM	DESCRIPTION
3. <u>Mic Audio</u>	Selects MIC/ACC Connector as Function Generator Input. Select on or off.
4. <u>Mic Audio Level</u>	Sets MIC/ACC Connector's Proportional Level. Range is 0% to 100%. Although displayed, Proportional Level is not activated if Proportional Output is off.

Selecting "5. AF Output Setup" displays the AF Output Menu:

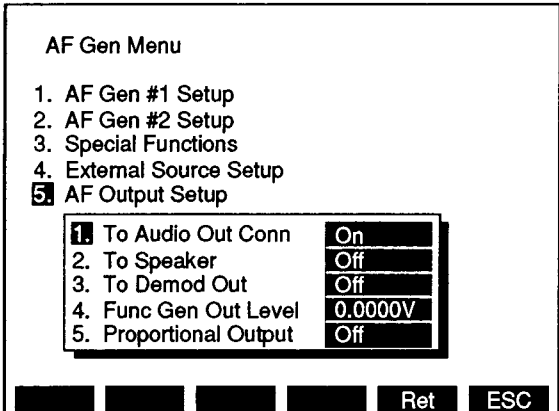
MENU ITEM	DESCRIPTION
AF OUTPUT SETUP MENU	
 <p>The screenshot shows the 'AF Gen Menu' with the following items:</p> <ul style="list-style-type: none"> 1. AF Gen #1 Setup 2. AF Gen #2 Setup 3. Special Functions 4. External Source Setup 5. AF Output Setup <p>Option 5 is selected. A sub-menu for 'AF Output Setup' is displayed with the following items:</p> <ul style="list-style-type: none"> 1. To Audio Out Conn: On 2. To Speaker: Off 3. To Demod Out: Off 4. Func Gen Out Level: 0.0000V 5. Proportional Output: Off <p>At the bottom of the screen, there are buttons for 'Ret' and 'ESC'.</p>	

8610017

1. To Audio Out Conn
Sets routing of Function Generator Output to AUDIO OUT Connector. Select on or off.
2. To Speaker
Sets routing of Function Generator Output to the Speaker. Select on or off.
3. To Demod Out
Sets routing of Function Generator Output to DEMOD OUT Connector. Select on or off.
4. Func Gen Out Level
Stores an Output Attenuation Setting for Proportional Output On and another Setting for Proportional Output Off. Range is 0.0000 to 3.1000 V.
5. Proportional Output
Sets Function Generator Proportional Output to on or off.

3-3-7 OSCILLOSCOPE OPERATION SCREEN

Press SCOPE/ANLZ MODE key to access the Oscilloscope Operating Screen. Since both Spectrum Analyzer and Oscilloscope are accessed with the SCOPE/ANLZ MODE Key, it may be necessary to press SCOPE/ANLZ MODE Key twice to access the Oscilloscope Operation Screen. Use the index of screen features to identify the operation screen parameters that may be edited, the value range available to each feature and/or its usage.

When editing, use the FIELD SELECT Keys to move the cursor to the parameter to be edited and press the ENTER Key to access the data field. Use the DATA ENTRY Keypad to enter numerical data. Use the DATA SCROLL Spinner or DATA SCROLL \uparrow and \downarrow Keys to select parameters from a list. Parameters with only two possible settings automatically switch to the opposite setting when selected. To access a displayed Meters Operation Screen, move cursor to the Meters Callout and press the ENTER Key.

A. SCREEN PARAMETERS

ITEM	DESCRIPTION
------	-------------

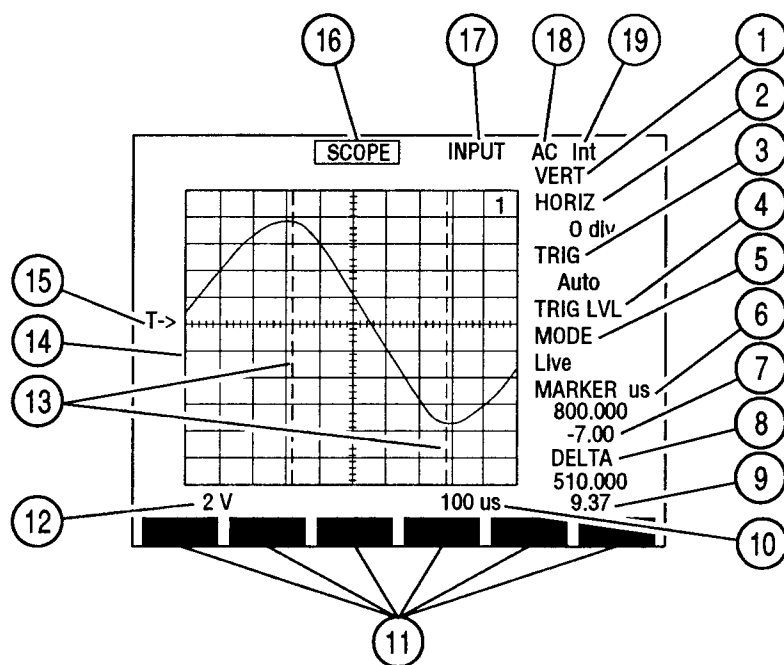

8617052

1. VERT

Adjusts vertical position of Oscilloscope Trace. When Oscilloscope Trace is adjusted below Oscilloscope display, an arrow appears on the right bottom edge of the display. When Oscilloscope Trace is adjusted above Oscilloscope display, an arrow appears on the right top edge of the display.

2. HORIZ

Adjusts horizontal position of Oscilloscope Trace -12 to +12 divisions to allow viewing of pre-trigger and post-trigger information. MARKER (6) readings adjust to reflect new Trace position.

ITEM	DESCRIPTION																		
3. <u>TRIG</u>	Selects Trigger Mode. Select Normal, Auto or One Shot.																		
4. <u>TRIG LVL</u>	Adjusts starting position of Oscilloscope Trace.																		
5. <u>MODE Setting</u>	Displays menu of Oscilloscope Operation Modes. Select Live, Recall, Compare or Average. Live is the normal operation. Recall allows a stored Trace and set of parameters to be recalled. Compare allows the comparing of a recalled Trace and the live Trace. Average Mode averages the new sample with the last Trace to produce the new Trace.																		
6. <u>MARKER</u>	Displays active Marker position relative to Trigger position in Oscilloscope Sweep units. Marker 1 is default marker if neither marker is selected. If "Track" Function is activated, reading corresponds to Marker 1 location.																		
7. <u>Marker Voltage Reading</u>	Appears when AC, DC or GND is the Oscilloscope Input. Reads voltage of Oscilloscope Trace at point of Marker.																		
8. <u>DELTA Reading</u>	Provides time difference between Marker Positions in Oscilloscope Sweep units.																		
9. <u>DELTA Voltage Reading</u>	Appears when AC, DC or GND is the Oscilloscope Input. Reads Trace voltage difference between Marker Positions.																		
10. <u>Sweep Rate</u>	Select one of the following:																		
	<table> <tbody> <tr> <td>1 μs</td> <td>2 μs</td> <td>5 μs</td> </tr> <tr> <td>10 μs</td> <td>20 μs</td> <td>50 μs</td> </tr> <tr> <td>100 μs</td> <td>200 μs</td> <td>500 μs</td> </tr> <tr> <td>1 ms</td> <td>2 ms</td> <td>5 ms</td> </tr> <tr> <td>10 ms</td> <td>20 ms</td> <td>50 ms</td> </tr> <tr> <td>100 ms</td> <td></td> <td></td> </tr> </tbody> </table>	1 μ s	2 μ s	5 μ s	10 μ s	20 μ s	50 μ s	100 μ s	200 μ s	500 μ s	1 ms	2 ms	5 ms	10 ms	20 ms	50 ms	100 ms		
1 μ s	2 μ s	5 μ s																	
10 μ s	20 μ s	50 μ s																	
100 μ s	200 μ s	500 μ s																	
1 ms	2 ms	5 ms																	
10 ms	20 ms	50 ms																	
100 ms																			
11. <u>Soft Function Keys</u>	Soft Function Keys for the Oscilloscope Operation Screen are covered in 3-3-7B.																		

ITEM	DESCRIPTION
------	-------------

12. Oscilloscope Scale

Does not appear for Rcvr IF Oscilloscope Input. For AC, DC or GND Oscilloscope Input, select one of the following:

1 mV/div	2 mV/div	5 mV/div
10 mV/div	20 mV/div	50 mV/div
100 mV/div	200 mV/div	500 mV/div
1 V/div	2 V/div	5 V/div
10 V/div	20 V/div	50 V/div

For Demod Audio Oscilloscope Input, select one of the following:

2 kHz/div	4 kHz/div	10 kHz/div
20 kHz/div		

For Func Gen or Ext Mod Oscilloscope Input, select one of the following:

500 mV/div	1 V/div	2.5 V/div
------------	---------	-----------

For RF Pwr Lvl Oscilloscope Input, Oscilloscope Scale reads 2 W/div or 200 W/div. Power Meter Ranges of 20, 50 or 100 mW set Oscilloscope Scale to 2 W/div. All other Power Meter Ranges set Oscilloscope Scale to 200 W/div.

Oscilloscope Scale is 4 V/div for SINAD/BER and is not editable.

13. Markers

Two Markers are available for use with the Oscilloscope. Markers are selected using Soft Function Keys.

14. Oscilloscope Graticule

Used to measure waveform of INPUT (17) Source.

15. Trigger Level Indicator

Starting position of Oscilloscope Trace adjusts accessing TRIG LVL (4).

16. Oscilloscope Operation Screen Callout

Access to display Spectrum Analyzer Operation Screen.

17. INPUT

Displays INPUT Menu. Select Rcvr IF, Demod Audio, RF Pwr Lvl, SINAD/BER, Func Gen, Ext Mod, AC, DC and GND.

18. Recall Trace Number

Displays number corresponding to recalled trace. Trace numbers possible are 1 through 9 and are displayed only in Compare and Recall Modes.

ITEM	DESCRIPTION
19. <u>Trigger Source</u>	Appears when AC or DC is the Oscilloscope Input. Selects trigger source. Toggles between "Int" (Internal) and "Ext" (External). External trigger input is received at EXT MOD IN Connector.

B. SOFT FUNCTION KEYS

The following index lists the Soft Function Keys available for the Oscilloscope Operation Screen.

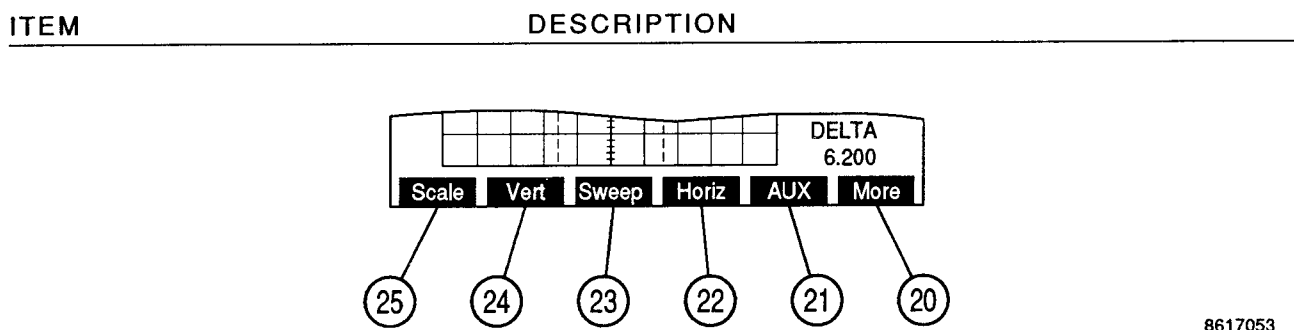

8617053

20. "More"/"ESC" Soft Function Key F6

"ESC" appears while parameters are accessed for editing. Allows edit procedure to be canceled without changing parameter. "More" displays additional sets of Soft Function Keys.

21. "AUX" Soft Function Key F5

Displays Auxiliary Functions Menu.

22. "Horiz" Soft Function Key F4

Adjusts horizontal position of Oscilloscope Trace -12 to +12 divisions. MARKER readings (6) adjust to reflect new Trace position. In this screen configuration, press Soft Function Key F4 to edit Horizontal Oscilloscope Trace.

23. "Sweep" Soft Function Key F3

Selects Oscilloscope Sweep Rate. Select one of the following:

- | | | |
|-------------|-------------|-------------|
| 1 μ s | 2 μ s | 5 μ s |
| 10 μ s | 20 μ s | 50 μ s |
| 100 μ s | 200 μ s | 500 μ s |
| 1 ms | 2 ms | 5 ms |
| 10 ms | 20 ms | 50 ms |
| 100 ms | | |

ITEM	DESCRIPTION
------	-------------

24. "Vert" Soft Function Key F2

Adjusts vertical position of Oscilloscope Trace. When Oscilloscope Trace is adjusted below Oscilloscope display, an arrow appears on the right bottom edge of the display. When Oscilloscope Trace is adjusted above Oscilloscope display, an arrow appears on the right top edge of the display.

25. "Scale" Soft Function Key F1

Selects Oscilloscope Scale.

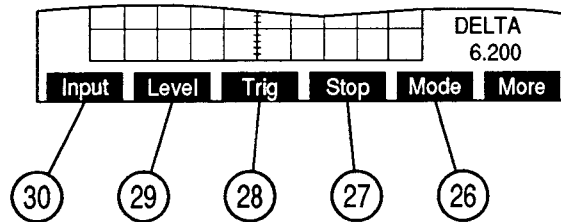

8617054

26. "Mode" Soft Function Key F5

Displays menu of Oscilloscope Operation Modes. Select Live, Recall, Compare or Average.

27. "Stop"/"Arm" Soft Function Key F4

- "Stop" appears for Normal or Auto TRIG Setting (3). Freezes Oscilloscope Trace. While Trace is stopped, Soft Function Key shows "Start" and is used to resume normal Oscilloscope Operation.
- "Arm" appears for One Shot TRIG Setting (3). Holds Trace for one screen until pressed again, then current screen is released and the next screen is held.

28. "Trig" Soft Function Key F3

Selects Trigger Mode. Select Auto, Normal or One Shot.

29. "Level" Soft Function Key F2

Adjusts starting position of Oscilloscope Trace.

30. "Input" Soft Function Key F1

Selects Oscilloscope Input. Select Rcvr IF, Demod Audio, RF Pwr Lvl, SINAD/BER, Func Gen, Ext Mod, AC, DC and GND.

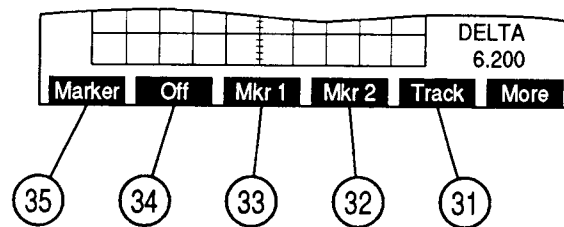

8617055

31. "Track" Soft Function Key F5

Activates Marker Tracking, locking Markers a constant distance apart. To edit marker locations, press "Marker" Soft Function Key F1 (35). Marker Positions are changed using the DATA SCROLL Spinner. Both Markers move, but maintain the same DELTA Reading (8). MARKER (6) displays Marker 1 location.

32. "Mkr 2" Soft Function Key F4

Selects Marker 2 as the active marker. When active, label highlights in red. Access Marker 2 location using "Marker" Soft Function Key F1 (35). Deactivate by pressing "Mkr 1" Soft Function Key F3 (33) or "Off" Soft Function Key F2 (34).

33. "Mkr 1" Soft Function Key F3

Selects Marker 1 as the active marker. When active, label highlights in red. Access Marker 1 location using "Marker" Soft Function Key F1 (35). Deactivate by pressing "Mkr 2" Soft Function Key F4 (32) or "Off" Soft Function Key F2 (34).

34. "Off" Soft Function Key F2

Deactivates and removes Markers from screen. "Off" is highlighted in red when activated.

35. "Marker" Soft Function Key F1

Activates Markers. Edits selected Marker positions. If a Marker is not selected, Marker 1 is edited.

C. SCOPE/ANALYZER (OSCILLOSCOPE) MENU

When the Oscilloscope Operation Screen is displayed on the CRT, press the SETUP Key to access the Scope/Analyzer Menu. Both the Oscilloscope and Spectrum Analyzer Operating Screens are edited from the Scope/Analyzer Menu or one of its submenus.

NOTE: Only one of the "1. Scope" or "2. Analyzer" Menu items may be on at a time, yet both may be turned off.

MENU ITEM	DESCRIPTION
-----------	-------------

SCOPE/ANALYZER MENU

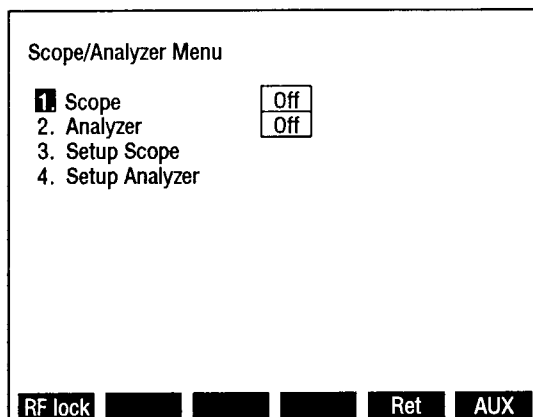

8610018

1. Scope

Selects Oscilloscope display for RF Generator, Receiver, Duplex Transmitter and Duplex Receiver Operation Screens. Select on or off.

2. Analyzer

Selects Spectrum Analyzer display for RF Generator, Receiver, Duplex Transmitter and Duplex Receiver Operation Screens. Select on or off.

3. Setup Scope

Displays "Setup Scope" Menu.

4. Setup Analyzer

Not applicable for Oscilloscope Operation.

Selecting "3. Setup Scope" displays the Oscilloscope Setup Menu:

MENU ITEM

DESCRIPTION

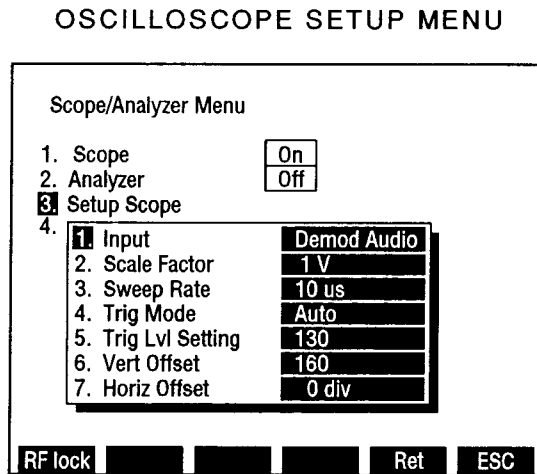

1. Input

Selects Oscilloscope Input. Select Rcvr IF, Demod Audio, RF Pwr Lvl, SINAD/BER, Func Gen, Ext Mod, AC, DC or GND. If AC or DC is selected, a submenu appears allowing selection of trigger source. Select Internal or External. External trigger input is received at EXT MOD IN Connector.

2. Scale Factor

Blank if Rcvr IF is selected for Oscilloscope Input. For AC, DC or GND Oscilloscope Input, select one of the following:

1 mV/div	2 mV/div	5 mV/div
10 mV/div	20 mV/div	50 mV/div
100 mV/div	200 mV/div	500 mV/div
1 V/div	2 V/div	5 V/div
10 V/div	20 V/div	50 V/div

For Demod Audio Oscilloscope Input, select one of the following:

2 kHz/div	4 kHz/div	10 kHz/div
20 kHz/div		

For Func Gen or Ext Mod Oscilloscope Input, select one of the following:

500 mV/div	1 V/div	2.5 V/div
------------	---------	-----------

For RF Pwr Lvl Oscilloscope Input, Oscilloscope Scale reads 2 W/div or 200 W/div. Power Meter Ranges of 20, 50 or 100 mW set Oscilloscope Scale to 2 W/div. All other Power Meter Ranges set Oscilloscope Scale to 200 W/div.

Oscilloscope Scale is 4 V/div for SINAD/BER and is not editable.

MENU ITEM**DESCRIPTION**

3. Sweep Rate

Selects Oscilloscope Sweep Rate. Select one of the following:

1 μ s	2 μ s	5 μ s
10 μ s	20 μ s	50 μ s
100 μ s	200 μ s	500 μ s
1 ms	2 ms	5 ms
10 ms	20 ms	50 ms
100 ms		

4. Trig Mode

Selects Trigger Mode. Select One Shot, Normal or Auto.

5. Trig Lvl Setting

Selects Trigger Level. Range is 0 to 255, 0 signifying the bottom of the Oscilloscope grid and 255 signifying the top.

6. Vert Offset

Selects vertical Trace Level. Range is 0 to 255, 0 signifying the bottom of the Oscilloscope grid and 255 signifying the top.

7. Horiz Offset

Adjusts horizontal position of Oscilloscope Trace to allow viewing of pre-trigger and post-trigger information. Select -12 to +12 divisions.

3-3-8 SPECTRUM ANALYZER OPERATION SCREEN

Press SCOPE/ANLZ MODE Key to access the Spectrum Analyzer Operating Screen. Since both Spectrum Analyzer and Oscilloscope are accessed with the SCOPE/ANLZ MODE Key, it may be necessary to press SCOPE/ANLZ MODE Key twice to access the Spectrum Analyzer Operation Screen. Use the index of screen features to identify the operation screen parameters that may be edited, the value range available to each feature and/or its usage.

When editing, use the FIELD SELECT Keys to move the cursor to the parameter to be edited and press ENTER Key to access the data field. Use the DATA ENTRY Keypad to enter numerical data. Use the DATA SCROLL Spinner or DATA SCROLL ↑ and ↓ Keys to select parameters from a list. Parameters with only two possible settings automatically switch to the opposite setting when selected. To access a displayed Meters Operation Screen, move cursor to the Meters Callout and press the ENTER Key.

A. SCREEN PARAMETERS

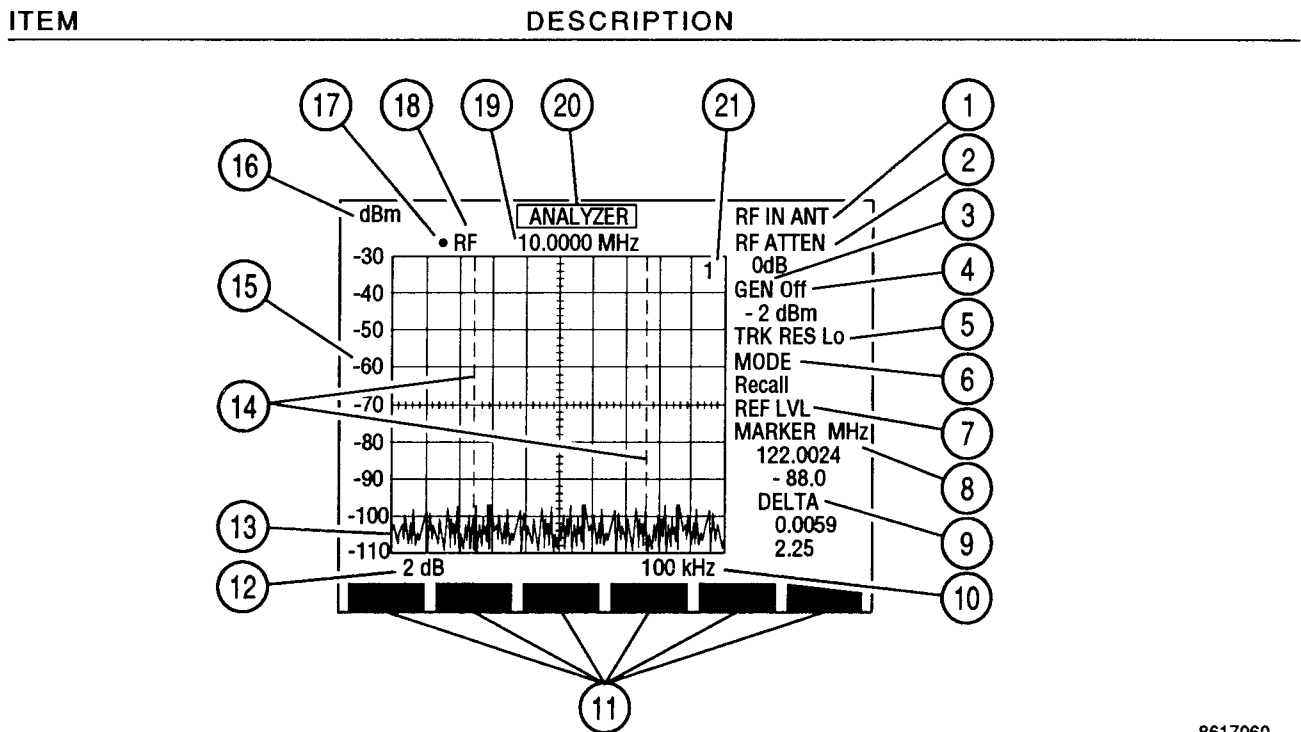

8617060

1. RF IN

Selects "ANT" (ANTENNA IN) or "T/R" Connector. Setting RF Input Source also sets Tracking Generator Output Connector.

2. RF ATTEN

Selects 0, 20 or 40 dB.

ITEM	DESCRIPTION
------	-------------

3. GEN

Selects Tracking Generator Output Level. For T/R RF Input Source, range is 7.0 to -120.0 dBm or 0.224 mV to 0.501 V. For ANTENNA RF Input Source, range is 0 to -137 dBm or 0.031 mV to 0.224 V.

4. Tracking Generator Output Connector

Displays Tracking Generator Output Connector. Tracking Generator Output Connector is set to T/R Connector when "ANT" is selected for RF IN (1). Tracking Generator Output Connector is set to DUPLEX OUT Connector when "T/R" is selected for RF IN (1). "OFF" is displayed when Tracking Generator is off.

5. TRK RES

Selects Tracking Generator Resolution. Toggles between "Lo" and "Hi" resolution. "Lo" allows trace to sweep faster with less resolution. "Hi" resolution gives a slower sweep with greater trace accuracy.

6. MODE

Selects Analyzer Operation Mode. Select Live, Recall (recalls a stored set of parameters with Trace), Compare (compares Live Trace with Recalled Trace), Peak Hold or Average.

7. REF LVL

Appears with 2 dB/div Scale. Adjusts vertical reference of Analyzer Trace using DATA SCROLL Spinner. Analyzer Grid Vertical Scale changes to reflect different reference.

8. MARKER

Access turns active Marker on. Displays Analyzer RF Frequency plus Marker adjustment. With Marker on, Trace amplitude value at Marker crossing appears below Marker reading in Analyzer Grid Units.

9. DELTA Reading

Upper Reading provides readout of frequency difference between Markers. Lower Reading provides difference in signal amplitude between Markers.

10. Scan Width

Selects Zero Scan (0 kHz) or one of the following:

- | | | |
|---------|---------|---------|
| 1 kHz | 2 kHz | 5 kHz |
| 10 kHz | 20 kHz | 50 kHz |
| 100 kHz | 200 kHz | 500 kHz |
| 1 MHz | 2 MHz | 5 MHz |
| 10 MHz | 20 MHz | 50 MHz |
| 100 MHz | | |

ITEM	DESCRIPTION
11. <u>Soft Function Keys</u>	Soft Function Keys for the Spectrum Analyzer Operation Screen are covered in 3-3-8B.
12. <u>Units/Division Factor</u>	Toggles Units/Division Factor between 2 and 10 dB/div.
13. <u>Analyzer Trace</u>	Spectrum Analyzer Trace displays visual readout of amplitude versus frequency of measured input.
14. <u>Markers</u>	When Markers are on, two vertical graduated markers appear on the screen.
15. <u>Analyzer Vertical Scale</u>	Vertical Scale displays in Analyzer Scale Units (16). Numeric vertical scale is dependent on Units/Division Factor (12).
16. <u>Analyzer Scale Units</u>	For "ANT" selected as RF IN (1), select dB μ W, dBm, dBV, dBmV or dB μ V. For "T/R" selected as RF IN (1), select dBW or dBm.
17. <u>Squelch Indicator Light</u>	Green dot appears when squelch is broken.
18. <u>RF</u>	Selects Analyzer RF Frequency (19). Range is 0.2500 to 999.9999 MHz. Center Frequency is forced to 500 MHz if Scan width is 100 MHz.
19. <u>RF Frequency</u>	Displays RF Frequency setting.
20. <u>ANALYZER Operation Screen Callout</u>	Displays Oscilloscope Operation Screen when accessed.
21. <u>Recall Trace Number</u>	Displays number of Recalled Trace. Displayed in Compare and Recall Modes only.

B. SOFT FUNCTION KEYS

The following index lists the sets of Soft Function Keys available for the Spectrum Analyzer Operation Screen.

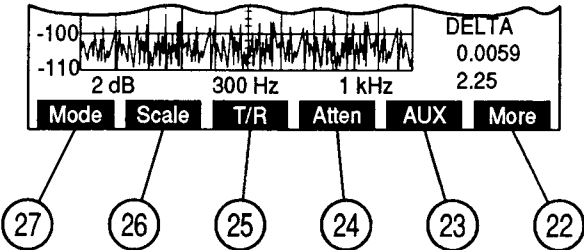
ITEM	DESCRIPTION
	

8617061

22. "More"/"ESC" Soft Function Key F6

"ESC" appears while parameters are accessed for editing. Allows edit procedure to be canceled without changing parameter. "More" displays additional sets of Soft Function Keys.

23. "AUX" Soft Function Key F5

Displays Auxiliary Functions Menu.

24. "Atten" Soft Function Key F4

Selects RF Attenuation. Select 0, 20 or 40 dB.

25. "T/R"/"Ant" Soft Function Key F3

Toggles RF Input Source between "T/R" and "ANT" (ANTENNA IN).

26. "Scale" Soft Function Key F2

Selects Analyzer Grid Scale. For "ANT" selected as RF IN (1), select dB μ W, dBm, dBV, dBmV or dB μ V. For "T/R" selected as RF IN (1), select dBW or dBm.

27. "Mode" Soft Function Key F1

Selects Analyzer Operation Mode. Select Live, Recall, Compare, Peak Hold and Average.

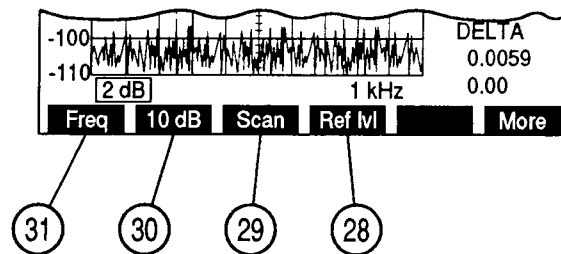

8617062

28. "Ref lvl" Soft Function Key F4

Appears with 2 dB/div Scale. Adjusts vertical reference of Analyzer Trace using DATA SCROLL Spinner. Analyzer Vertical Scale (15) changes to reflect different reference.

29. "Scan" Soft Function Key F3

Selects Analyzer Scan Width. Select 0 kHz or one of the following:

1 kHz	2 kHz	5 kHz
10 kHz	20 kHz	50 kHz
100 kHz	200 kHz	500 kHz
1 MHz	2 MHz	5 MHz
10 MHz	20 MHz	50 MHz
100 MHz		

30. "2 dB"/"10 dB" Soft Function Key F2

Toggles Units/Division Factor (12) between 2 and 10 dB/div.

31. "Freq" Soft Function Key F1

Selects Analyzer RF Frequency. Range is 0.2500 to 999.9999 MHz. Center Frequency is forced to 500 MHz if Scan Width is 100 MHz.

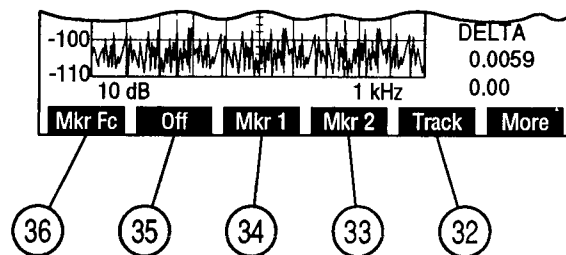

8617059

32. "Track" Soft Function Key F5

Activates Marker Tracking and edits the Markers position. Tracking locks Markers a constant distance apart. Marker positions are changed using the DATA SCROLL Spinner. With Tracking on, MARKER (8) reading displays Marker 1 frequency position and DELTA reading (9) remains constant.

ITEM	DESCRIPTION
------	-------------

33. "Mkr 2" Soft Function Key F4

Selects Marker 2 as the active marker. Accessing MARKER (8) edits Marker 2 position when Marker 2 is active. "Mkr 2" appears in red while Marker 2 is active. Deactivate by pressing "Mkr 1", "Track" or "Off" Soft Function Key. Marker 2 remains visible while not active unless "Off" is chosen.

34. "Mkr 1" Soft Function Key F3

Selects Marker 1 as the active marker. Accessing MARKER (8) Frequency edits Marker 1 position unless Marker 2 is active. "Mkr 1" appears in red while Marker 1 is active. Deactivate by pressing "Mkr 2", or "Off" Soft Function Key. Marker 1 remains visible while not active unless "Off" is chosen.

35. "Off" Soft Function Key F2

Turns Markers off. When off, Markers do not appear on the Analyzer display.

36. "Mkr Fc" Soft Function Key F1

Appears when a Marker is active. Resets RF (18) to the active Marker frequency.

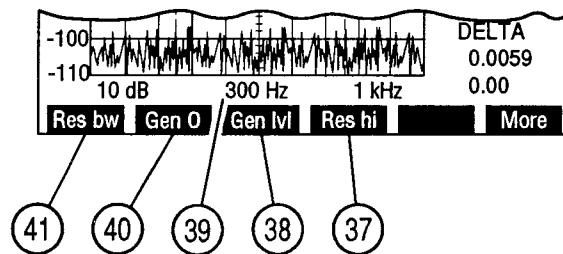

8617063

37. "Res hi"/"Res lo" Soft Function Key F4

Toggles Analyzer Trace resolution between high and low. High resolution produces a more accurate display, low resolution causes the Trace to sweep faster.

38. "Gen lvl" Soft Function Key F3

Selects Tracking Generator Output Level. For T/R Connector RF Input, range is 7.0 to -120.0 dBm or 0.224 mV to 0.501 V. For ANTENNA IN Connector RF Input, range is 0 to -137 dBm or 0.031 mV to 0.224 V.

39. Resolution Bandwidth Setting

Appears if Tracking Generator is on. Selects Resolution Bandwidth. Select 300 Hz, 3 kHz, 30 kHz, 300 kHz or 3 MHz.

ITEM	DESCRIPTION
40.	<p><u>"Gen 0"/"Gen 1" Soft Function Key F2</u></p> <p>Toggles Tracking Generator on or off. Tracking Generator Output Connector (4) is displayed when Tracking Generator is active, "OFF" is displayed when Tracking Generator is off.</p>
41.	<p><u>"Res bw"/"Norm" Soft Function Key F1</u></p> <ul style="list-style-type: none"> ● If Tracking Generator is on, "Res bw" is shown. Selects Resolution Bandwidth. Select 300 Hz, 3 kHz, 30 kHz, 300 kHz or 3 MHz. ● When Tracking Generator is off, "Norm" is shown. Access normalizes the Analyzer Trace on the Analyzer Grid to match the RF Generator Output.

The following set of Soft Function Keys appear if Tracking Generator is off.

ITEM	DESCRIPTION
42.	<p><u>"Fr mode" Soft Function Key F4</u></p> <p>Selects Spectrum Analyzer Frequency Mode. Select Direct or Channel. In Channel Mode, RF Frequency is displayed as a cellular channel number. Cellular Channel System is selected from Spectrum Analyzer Menu</p>
43.	<p><u>"Cbl Flt" Soft Function Key F3</u></p> <p>Starts Cable Fault Operation. Cable Fault determines the distance to point of fault in a cable and displays this length. "Cbl Flt" is displayed in red when active.</p>
44.	<p><u>"Find lvl" Soft Function Key F2</u></p> <p>Sets Find Reference Level used in the Find Function. When accessed, a red horizontal line appears displaying the Find Reference Level.</p>
45.	<p><u>"Find" Soft Function Key F1</u></p> <p>Does not appear when Cable Fault is active. When activated, finds the first frequency containing a signal with an amplitude greater than the Find Reference Level. Range of the Find Function is 4 to 999.9999 MHz. Signal amplitude must be >-65 dB. Find Function does not operate when Scan Width is 100 MHz.</p>

8607062

C. SCOPE/ANALYZER (SPECTRUM ANALYZER) MENU

When Spectrum Analyzer Operation Screen is displayed on the CRT, press the SETUP Key to access Scope/Analyzer Menu.

NOTE: Both "1. Scope" and "2. Analyzer" cannot be active at the same time.

MENU ITEM	DESCRIPTION
-----------	-------------

SCOPE/ANALYZER MENU

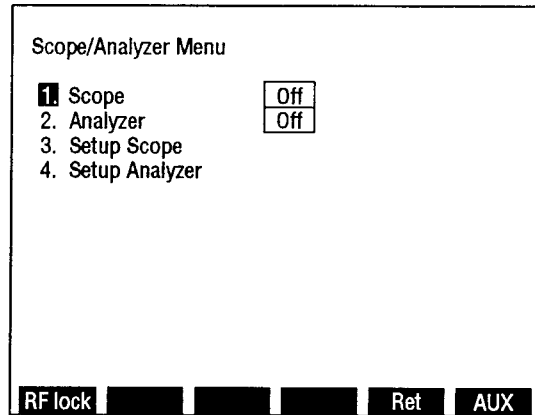

8610018

1. Scope

Selects Oscilloscope display for RF Generator, Receiver, Duplex Transmitter and Duplex Receiver Operation Screens. Select on or off.

2. Analyzer

Selects Spectrum Analyzer display for RF Generator, Receiver, Duplex Transmitter and Duplex Receiver Operation Screens. Select on or off.

3. Setup Scope

Not applicable for Spectrum Analyzer Operation.

4. Setup Analyzer

Displays Setup Analyzer Menu.

5. "Chan"/"RF lock" Soft Function Key F1

- "Chan" Soft Function Key F1 is displayed when Channel is selected as the Spectrum Analyzer Frequency Mode. Displays Spectrum Analyzer Channel Format Menu.
- "RF lock" Soft Function Key F1 is displayed when Direct is selected as the Spectrum Analyzer Frequency Mode. Activates the RF Lock Function, locking the Analyzer RF Frequency to the RF Generator Frequency and the Receiver RF Frequency. Last frequency entered from among the three frequencies locked is the frequency locked on. "RF lock" appears in red when RF lock function is active.

When "4. Setup Analyzer" is selected the Analyzer Setup Menu appears:

MENU ITEM

DESCRIPTION

ANALYZER SETUP
MENU

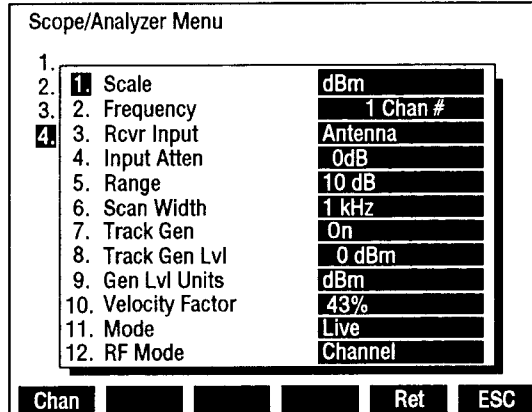

8610069

1. Scale

Selects Vertical Scale Grid. Select dB μ W, dBm, dBV, dBmV or dB μ V for ANTENNA IN Connector RF Input. Select dBm or dBW for T/R Connector RF Input.

2. Frequency

Selects Analyzer RF Frequency. Range is 0.2500 to 999.9999 MHz.

3. Rcvr Input

Selects Analyzer Input Connector. Select ANTENNA IN or T/R Connector.

4. Input Atten

Selects Input Attenuation. Select 0, 20 and 40 dB.

5. Range

Selects Units/Division Factor. Select either 2 or 10 dB.

6. Scan Width

Selects Analyzer Scan Width. Select Zero Scan (0 kHz) or one of the following:

1 kHz	2 kHz	5 kHz
10 kHz	20 kHz	50 kHz
100 kHz	200 kHz	500 kHz
1 MHz	2 MHz	5 MHz
10 MHz	20 MHz	50 MHz
100 MHz		

MENU ITEM	DESCRIPTION
7. <u>Tracking Gen</u>	Toggles Tracking Generator on or off.
8. <u>Tracking Gen Lvl</u>	Selects Tracking Generator Output Level. For T/R Connector RF Input, range is 7.0 to -120.0 dBm or 0.224 mV to 0.501 V. For ANTENNA IN Connector RF Input, range is 0 to -137 dBm or 0.031 mV to 0.224 V.
9. <u>Gen Lvl Units</u>	Toggles Tracking Generator Level Units to dBm or volts.
10. <u>Velocity Factor</u>	Selects Velocity Factor for Cable Fault Operation. Range is 0.0% to 100%.
11. <u>Mode</u>	Selects Analyzer Operation Mode. Select Live, Recall (recalls a stored set of parameters with Trace), Compare (compares Live Trace with Recalled Trace), Average or Peak Hold.
12. <u>RF Mode</u>	Selects Spectrum Analyzer Frequency Mode. Toggles to Direct or Channel. In Channel Mode, RF Frequency is displayed as a cellular channel number and "Chan" Soft Function Key F1 appears. "Chan" Soft Function Key F1 accesses the Format Menu listing available Cellular Channel Formats.

3-3-9 METER OPERATION SCREENS AND MENUS

Each meter has an operation screen and a setup menu. Meter Operation Screens are accessed from other Operation Screens by moving the cursor to the Meter callout and pressing the ENTER Key. When a Meter Operation Screen is accessed from another operation screen, the operator returns to that screen by pressing "Ret" Soft Function Key F6.

Direct access to meters is made through the Meter Menu. Press the MTRS MODE Key to display the Meter Menu. Access the desired Meter Operation Screen by pressing the indicated number key or by moving the menu highlight to the desired menu number and pressing the ENTER Key. Setup Menus for each meter are accessed by pressing the SETUP Key.

Many meter parameters are accessed or enabled from the Meter Operation Screen but some are only accessed from the setup menu for that meter. Use FIELD SELECT Keys to move the Meter Operation Screen cursor to the parameter to be edited and press the ENTER Key to access its data field or to enable or disable the feature. Use the DATA ENTRY Keypad to enter numeric data. Use the DATA SCROLL Spinner or DATA SCROLL ↑ and ↓ Keys to select from lists. Parameters with only two possible settings (such as on/off) automatically toggle to the opposite setting when selected.

Use the index of meter parameters on the following pages to identify the meter parameters which are edited from the Meter Operation Screens and which must be edited from the individual meter's setup menu:

METER MENU

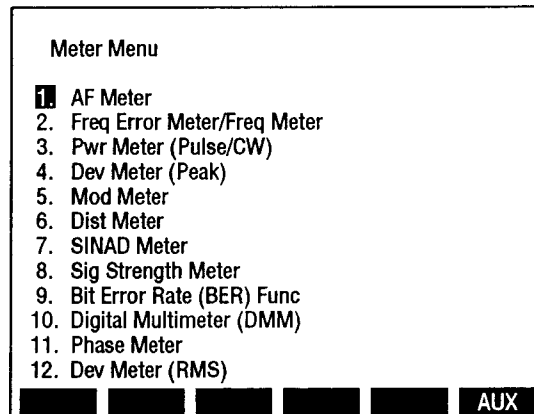

8610001

A. AF METER OPERATION SCREEN

With the Meter Menu is displayed on the CRT, press 1 DATA ENTRY Key to access the AF Meter Operation Screen:

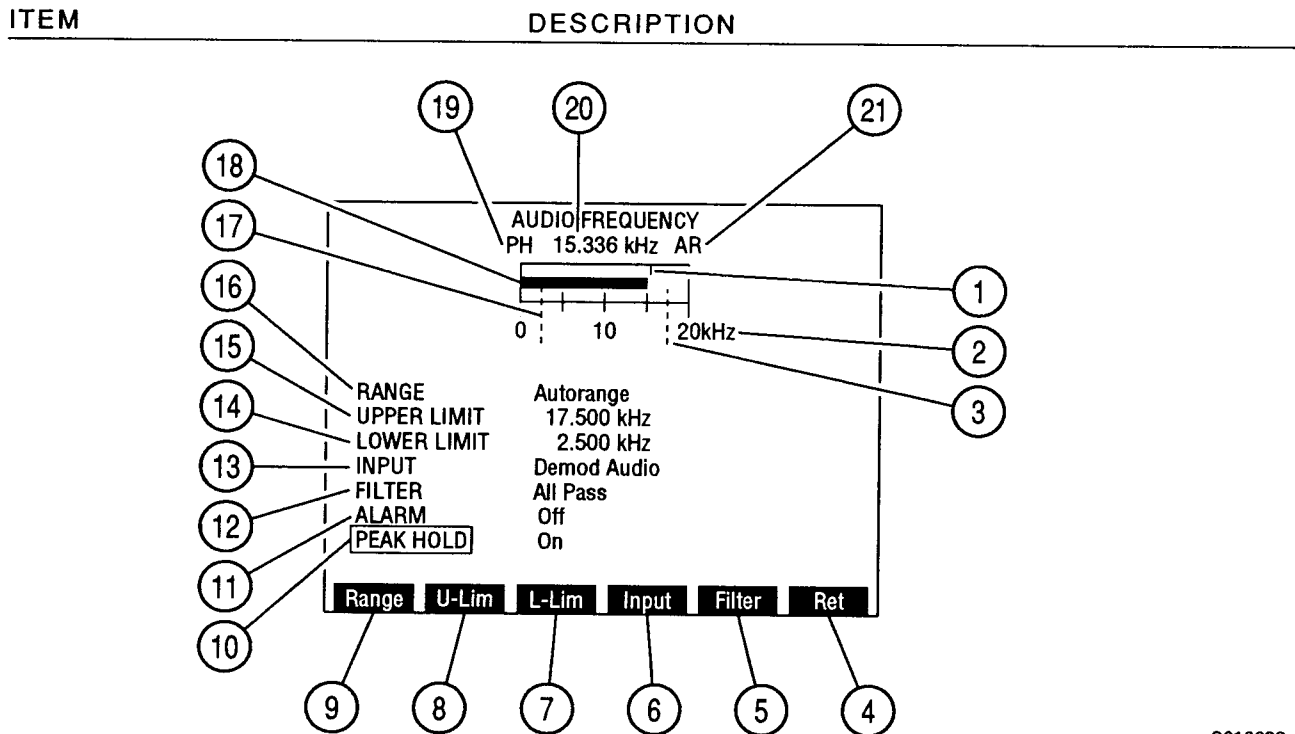

8610038

1. Peak Hold Indicator

Appears when PEAK HOLD is on. Indicator line shows highest point of meter deflection.

2. Meter Range Scale

Meter scale of four divisions is marked from 0 to the limits of the active scale with center division labeled with the midpoint of the range.

3. Upper Limit Indicator

When Upper Limit feature is on, a dotted blue line appears across the meter window at the point on the scale where the limit is set. The indicator appears at the right edge of the meter window if the limit is set higher than the meter range.

4. "Ret"/"ESC" Soft Function Key F6

When editing a parameter, "ESC" is shown. Stops editing process and voids any changes to parameter. "Ret" displays the last accessed Operation Screen.

ITEM	DESCRIPTION
5. <u>"Filter" Soft Function Key F5</u>	Selects AF Filter. Select All Pass, Low-Pass or High-Pass. Cutoff frequencies are set from AF Meter Menu.
6. <u>"Input" Soft Function Key F4</u>	Selects AF Meter Input. Select Ext Mod (EXT MOD IN Connector [17]), Demod Audio, Func Gen Out, SINAD/BER (SINAD/BER IN Connector [15]) or RF Power.
7. <u>"L-Lim" Soft Function Key F3</u>	Activates and selects Lower Limit. Range is 0.000 to 200.0 kHz. Lower Limit is deactivated from AF Meter Menu.
8. <u>"U-Lim" Soft Function Key F2</u>	Activates and selects Upper Limit. Range is 0.000 to 200.0 kHz. Upper Limit is deactivated from AF Meter Menu.
9. <u>"Range" Soft Function Key F1</u>	Selects AF Meter Range. Select Autorange, 200 Hz, 2 kHz, 20 kHz or 200 kHz.
10. <u>PEAK HOLD</u>	Toggles Peak Hold feature on or off.
11. <u>ALARM</u>	Toggles Alarm between off and on. Enabled Alarm sounds when Upper or Lower Limit is exceeded.
12. <u>FILTER</u>	Selects AF Filter. Select All Pass, Low-Pass or High-Pass. Cutoff frequencies are set from AF Meter Menu.
13. <u>INPUT</u>	Selects AF Meter Input. Select Ext Mod (EXT MOD IN Connector), Demod Audio, Func Gen Out, SINAD/BER (SINAD/BER IN Connector) or RF Power.
14. <u>LOWER LIMIT</u>	Activates and selects Lower Limit. Range is 0.000 to 200.0 kHz. Lower Limit is deactivated from AF Meter Menu. An asterisk indicates the limits true value cannot be displayed due to a change in Range Units.

ITEM	DESCRIPTION
15. <u>UPPER LIMIT</u>	Activates and selects Upper Limit. Range is 0.000 to 200.0 kHz. Upper Limit is deactivated from AF Meter Menu. An asterisk indicates the limits true value cannot be displayed due to a change in Range Units.
16. <u>RANGE</u>	Selects AF Meter Range. Select Autorange, 200 Hz, 2 kHz, 20 kHz or 200 kHz.
17. <u>Lower Limit Indicator</u>	When the Lower Limit feature is on, a dotted blue line appears across the meter window at the point on the scale where the limit is set.
18. <u>Meter Indicator Bar</u>	Displays Frequency Error reading. Bar turns red if Upper or Lower Limit is exceeded. Bar turns green if the maximum of the current range is reached.
19. <u>PH</u>	Appears above left corner of the meter window if PEAK HOLD (10) is on.
20. <u>Digital Meter Readout</u>	Provides digital readout of the meter indication. Readout shows highest meter indication reached when PEAK HOLD (10) is on.
21. <u>AR</u>	Appears above upper right corner of the meter window when Autorange is selected for RANGE (16). The Meter Range Scale (2) changes to the next higher scale when meter indicator reaches the edge of the meter window. Range changes to the next lower scale if the meter indicator falls to a level of about 1/2 of the lowest scale division.

With the AF Meter Operation Screen displayed on the CRT, press the SETUP Key to access the AF Meter Menu:

MENU ITEM

DESCRIPTION

AF METER MENU

AF Meter Menu	
1. Select AF Meter In	Demod Audio
2. Select Filter	All Pass
3. Meter Range	Autorange
4. Gate Time	1 Second
5. Select Peak Hold	On
6. Upper Lmt	On
7. Set Upper Lmt	17.500 kHz
8. Lower Lmt	On
9. Set Lower Lmt	2.500 kHz
10. Set Alarm	Off

Ret AUX

8610002

1. Select AF Meter In

Selects AF Meter Input. Select Ext Mod (EXT MOD IN Connector [15]), Demod Audio, Func Gen Out, SINAD/BER (SINAD/BER IN Connector [17]) or RF Power.

2. Select Filter

Selects AF Meter Filter. Select All Pass, Low-Pass or High-Pass. If Low-Pass or High-Pass is selected, a data field appears allowing entry of the cutoff frequency. Range is 0.1 to 30 kHz for the Low-Pass cutoff frequency, 0.5 to 20 kHz for the High-Pass cutoff frequency.

3. Meter Range

Selects AF Meter Range. Select Autorange, 200 Hz, 2 kHz, 20 kHz or 200 kHz.

4. Gate Time

Toggles Gate Time to 1 or 10 sec. Longer Gate Times produce more accurate slower readings.

5. Select Peak Hold

Toggles Peak Hold feature on or off.

6. Upper Lmt

Toggles Upper Limit on or off.

7. Set Upper Lmt

Selects Upper Limit Level. Range is 0.000 to 200.0 kHz. An asterisk indicates the limits true value cannot be displayed due to a change in Range Units.

MENU ITEM	DESCRIPTION
8. <u>Lower Lmt</u>	Toggles Lower Limit on or off.
9. <u>Set Lower Lmt</u>	Selects Lower Limit Level. Range is 0.000 to 200.0 kHz. An asterisk indicates the limits true value cannot be displayed due to a change in Range Units.
10. <u>Set Alarm</u>	Toggles Alarm on or off. Enabled Alarm sounds when an Upper or Lower Limit is exceeded.

B. FREQUENCY ERROR METER

With the Meter Menu displayed on the CRT, press 1 DATA ENTRY Key to access the Frequency Error Meter Operation Screen:

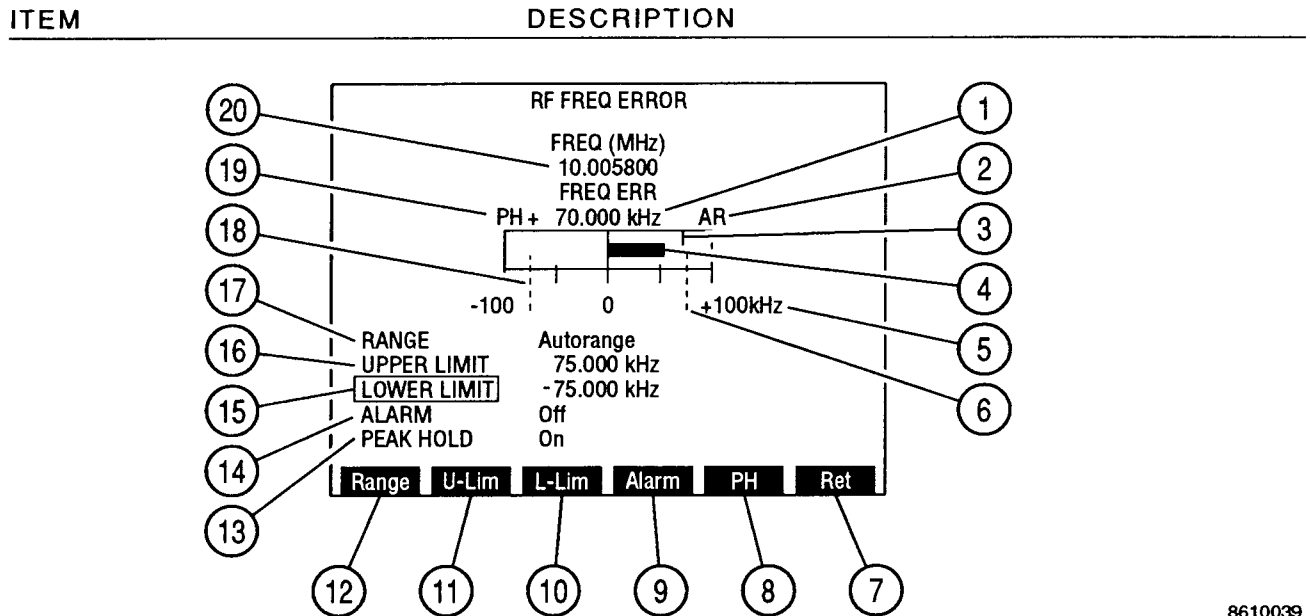

8610039

1. Frequency Error Digital Readout

Provides a digital readout of the difference between the Received Frequency and the Receiver Frequency Setting. Readout shows the highest meter indication reached when PEAK HOLD (13) is on.

2. AR

Appears above upper right corner of the meter window when Aurorange is selected for RANGE (17). The Meter Range Scale (5) changes to the next higher scale when the Meter Indicator Bar (4) reaches the edge of the meter window. The range changes to the next lower scale if the meter indicator bar falls to a level of about 1/2 of the lowest scale division.

3. Peak Hold Indicator

Appears when Peak Hold is on. Indicator line shows highest point of positive meter deflection when the Frequency Error is positive. When Frequency Error is negative, an indicator line appears in the negative half of the meter window and indicates the lowest point of negative meter deflection.

4. Meter Indicator Bar

Displays Frequency Error reading. Bar turns red if Upper or Lower Limit is exceeded. Bar turns green if the current range is surpassed.

ITEM	DESCRIPTION
5. <u>Meter Range Scale</u>	The meter scale of four divisions is marked from "-" the scale limit on the left to "+" the scale limit on the right. The center division of the scale is always marked 0.
6. <u>Upper Limit Indicator</u>	When Upper Limit feature is on, a dotted blue line appears across the meter window at the point on the scale where the limit is set. The line appears at the right edge of the meter window if the limit is set higher than the meter range. The Upper Limit is positive and appears on the right half of the meter window.
7. <u>"Ret"/"ESC" Soft Function Key F6</u>	When editing a parameter, "ESC" is shown. Stops editing process and voids any changes to parameter. "Ret" displays the last accessed Operation Screen.
8. <u>"PH" Soft Function Key F5</u>	Toggles Peak Hold feature on or off.
9. <u>"Alarm" Soft Function Key F4</u>	Toggles Alarm on or off. Enabled Alarm sounds when Upper or Lower Limit is exceeded.
10. <u>"L-Lim" Soft Function Key F3</u>	Activates and selects Lower Limit. Range is 0.000 to 100.000 kHz. Lower Limit is deactivated from Frequency Error Meter Menu.
11. <u>"U-Lim" Soft Function Key F2</u>	Activates and selects Upper Limit. Range is 0.000 to 100.000 kHz. Upper Limit is deactivated from Frequency Error Meter Menu.
12. <u>"Range" Soft Function Key F1</u>	Selects Frequency Error Meter Range. Select Autorange, ± 100 Hz, ± 1 kHz, ± 10 kHz or ± 100 kHz.
13. <u>PEAK HOLD</u>	Toggles Peak Hold feature on or off.
14. <u>ALARM</u>	Toggles Alarm on or off. Enabled Alarm sounds when Upper or Lower Limit is exceeded.

ITEM	DESCRIPTION
15. <u>LOWER LIMIT</u>	Activates and selects Lower Limit. Range is 0.000 to 100.000 kHz. Lower Limit is deactivated from Frequency Error Meter Menu. An asterisk indicates the limits true value cannot be displayed due to a change in Range Units.
16. <u>UPPER LIMIT</u>	Activates and selects Upper Limit. Range is 0.000 to 100.000 kHz. Upper Limit is deactivated from Frequency Error Meter Menu. An asterisk indicates the limits true value cannot be displayed due to a change in Range Units.
17. <u>RANGE</u>	Selects Frequency Error Meter Range. Select Autorange, ± 100 Hz, ± 1 kHz, ± 10 kHz or ± 100 kHz.
18. <u>Lower Limit Indicator</u>	When Lower Limit feature is on, a dotted blue line appears across the meter window at the point on the scale where the limit is set. The line appears at the left edge of the meter window if Limit is set lower than the meter range. The Lower Limit is negative and appears on the left half of the meter window.
19. <u>PH</u>	Indicator appears above left corner of the meter window if PEAK HOLD (13) is on.
20. <u>Received Frequency Digital Readout</u>	Provides a digital readout of the received frequency in MHz.

With the Frequency Error Meter Operation Screen displayed on the CRT, press the SETUP Key to access the RF Frequency Error Meter Menu:

MENU ITEM

DESCRIPTION

RF FREQUENCY ERROR METER MENU

RF Frequency Error Meter Menu	
1. Meter Range	Autorange
2. Gate Time	1 Second
3. Select Peak Hold	On
4. Upper Lmt	On
5. Set Upper Lmt	75.000 kHz
6. Lower Lmt	On
7. Set Lower Lmt	-75.000 kHz
8. Set Alarm	Off

Ret AUX

8610003

1. Meter Range

Selects Frequency Error Meter Range. Select Autorange, ± 100 Hz, ± 1 kHz, ± 10 kHz or ± 100 kHz.

2. Gate Time

Toggles Gate Time to 0.1 or 1 second. Longer Gate Times produce more accurate slower readings.

3. Select Peak Hold

Toggles Peak Hold feature on or off.

4. Upper Lmt

Toggles Upper Limit on or off.

5. Set Upper Lmt

Selects Upper Limit Level. Range is 0.000 to 100.0 kHz. An asterisk indicates the limits true value cannot be displayed due to a change in Range Units.

6. Lower Lmt

Toggles Lower Limit on or off.

MENU ITEM**DESCRIPTION**

7. Set Lower Lmt

Selects Lower Limit Level. Range is 0.000 to 100.0 kHz. Value is negative. An asterisk indicates the limits true value cannot be displayed due to a change in Range Units.

8. Set Alarm

Toggles Alarm on or off. Enabled Alarm sounds when Upper or Lower Limit is exceeded.

C. POWER METER

With the Meter Menu displayed on the CRT, press 3 DATA ENTRY Key to access the Power Meter Operation Screen:

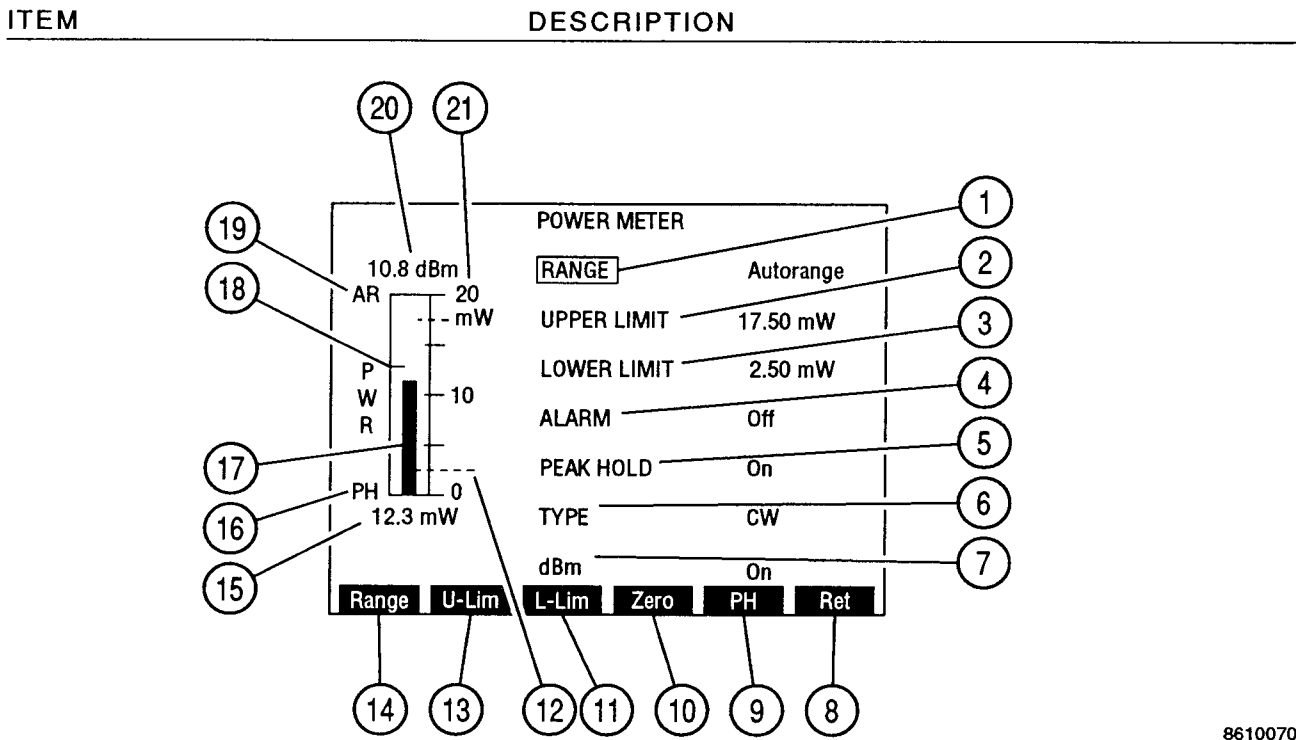

8610070

1. RANGE

Selects Power Meter Range. Select one of the following:

20 mW	50 mW	100 mW
200 mW	500 mW	1 W
2 W	5 W	10 W
20 W	50 W	100 W
200 W	Autorange	

2. UPPER LIMIT

Activates and selects Upper Limit. Range is 0.0 to 200.0 W. Upper Limit is turned off from Power Meter Menu. An asterisk indicates the limits true value cannot be displayed due to a change in Range Units.

3. LOWER LIMIT

Activates and selects Lower Limit. Range is 0.0 to 200.0 W. Lower Limit is turned off from Power Meter Menu. An asterisk indicates the limits true value cannot be displayed due to a change in Range Units.

ITEM	DESCRIPTION
4. <u>ALARM</u>	Toggles alarm on or off. Enabled alarm sounds when Upper or Lower Limit is exceeded.
5. <u>PEAK HOLD</u>	Toggles Peak Hold feature on or off.
6. <u>TYPE</u>	Displays the type of Power Meter in use. CW is the type available at this time.
7. <u>dBm</u>	Toggles dBm readout on or off. Readout appears above Meter Scale when on.
8. <u>"Ret"/"ESC" Soft Function Key F6</u>	When editing a parameter, "ESC" is shown. Stops editing process and voids any changes to parameters. "Ret" displays the last accessed Operation Screen.
9. <u>"PH" Soft Function Key F5</u>	Toggles Peak Hold feature on or off.
10. <u>"Zero" Soft Function Key F4</u>	Zeros Power Meter reading if Range is 20 mW or 20 W.
11. <u>"L-Lim" Soft Function Key F3</u>	Activates and selects Lower Limit. Range is 0.0 to 200.0 W. Lower Limit is turned off from Power Meter Menu.
12. <u>Lower Limit Indicator</u>	When Lower Limit is on, a dotted blue line appears across the meter window at the point on the scale where the Limit is set.
13. <u>"U-Lim" Soft Function Key F2</u>	Activates and selects Upper Limit. Range is 0.0 to 200.0 W. Upper Limit is turned off from Power Meter Menu.

ITEM	DESCRIPTION															
14. <u>"Range" Soft Function Key F1</u>	Selects Power Meter Range. Select one of the following:															
	<table> <tr> <td>20 mW</td> <td>50 mW</td> <td>100 mW</td> </tr> <tr> <td>200 mW</td> <td>500 mW</td> <td>1 W</td> </tr> <tr> <td>2 W</td> <td>5 W</td> <td>10 W</td> </tr> <tr> <td>20 W</td> <td>50 W</td> <td>100 W</td> </tr> <tr> <td>200 W</td> <td>Autorange</td> <td></td> </tr> </table>	20 mW	50 mW	100 mW	200 mW	500 mW	1 W	2 W	5 W	10 W	20 W	50 W	100 W	200 W	Autorange	
20 mW	50 mW	100 mW														
200 mW	500 mW	1 W														
2 W	5 W	10 W														
20 W	50 W	100 W														
200 W	Autorange															
15. <u>Digital Readout</u>	Displays digital readout of the Power Meter in W or mW.															
16. <u>PH</u>	Appears at the lower left corner of the meter window when PEAK HOLD (5) is on.															
17. <u>Meter Indicator Bar</u>	Displays Power Meter reading. Bar turns red when an Upper or Lower Limit is exceeded. Bar turns green if the current range is surpassed.															
18. <u>Peak Hold Indicator</u>	Appears when PEAK HOLD (5) is on. Indicator line shows the highest point of meter deflection.															
19. <u>AR</u>	Appears at the upper right side of the meter window when Autorange is selected for RANGE (1). The Meter Range Scale (21) changes to the next higher scale when the Meter Indicator Bar (17) reaches the edge of the meter window. The range changes to the next lower scale if the Meter Indicator Bar (17) falls to a level of about 1/2 of the lowest scale division.															
20. <u>dBm Readout</u>	Appears when dBm (7) is on. Provides a digital readout in dBm of the meter reading.															
21. <u>Meter Range Scale</u>	The meter scale of four divisions is marked from 0 to the limits of the active scale with the center division labeled with the midpoint of the range.															

With the Power Meter Operation Screen displayed on the CRT, press the SETUP Key to access the Power Meter Menu:

MENU ITEM

DESCRIPTION

POWER METER MENU	
Power Meter Menu	
1. Meter Range	Autorange
2. Measurement Type	CW
3. dBm Enable	On
4. Select Peak Hold	On
5. Upper Lmt	On
6. Set Upper Lmt	17.5 mW
7. Lower Lmt	On
8. Set Lower Lmt	2.5 mW
9. Set Alarm	Off
Ret AUX	

8610004

1. Meter Range

Selects Power Meter Range. Select one of the following:

20 mW	50 mW	100 mW
200 mW	500 mW	1 W
2 W	5 W	10 W
20 W	50 W	100 W
200 W	Autorange	

2. Measurement Type

Displays type of Power Measurement. CW is the type available at this time.

3. dBm Enable

Toggles dBm digital readout on or off.

4. Select Peak Hold

Toggles Peak Hold feature on or off.

5. Upper Lmt

Toggles Upper Limit on or off.

6. Set Upper Lmt

Select Upper Limit Level. Range is 0.0 mW to 200.0 W. An asterisk indicates the limits true value cannot be displayed due to a change in Range Units.

7. Lower Lmt

Toggles Lower Limit on or off.

MENU ITEM	DESCRIPTION
8. <u>Set Lower Lmt</u>	Select Lower Limit Level. Range is 0.0 mW to 200.0 W. An asterisk indicates the limits true value cannot be displayed due to a change in Range Units.
9. <u>Set Alarm</u>	Toggles Alarm on or off. Enabled Alarm sounds when Upper or Lower Limit is exceeded.

D. DEVIATION METER (PEAK)

With the Meter Menu displayed on the CRT, press 4 DATA ENTRY Key to access the Deviation Meter (Peak) Operation Screen:

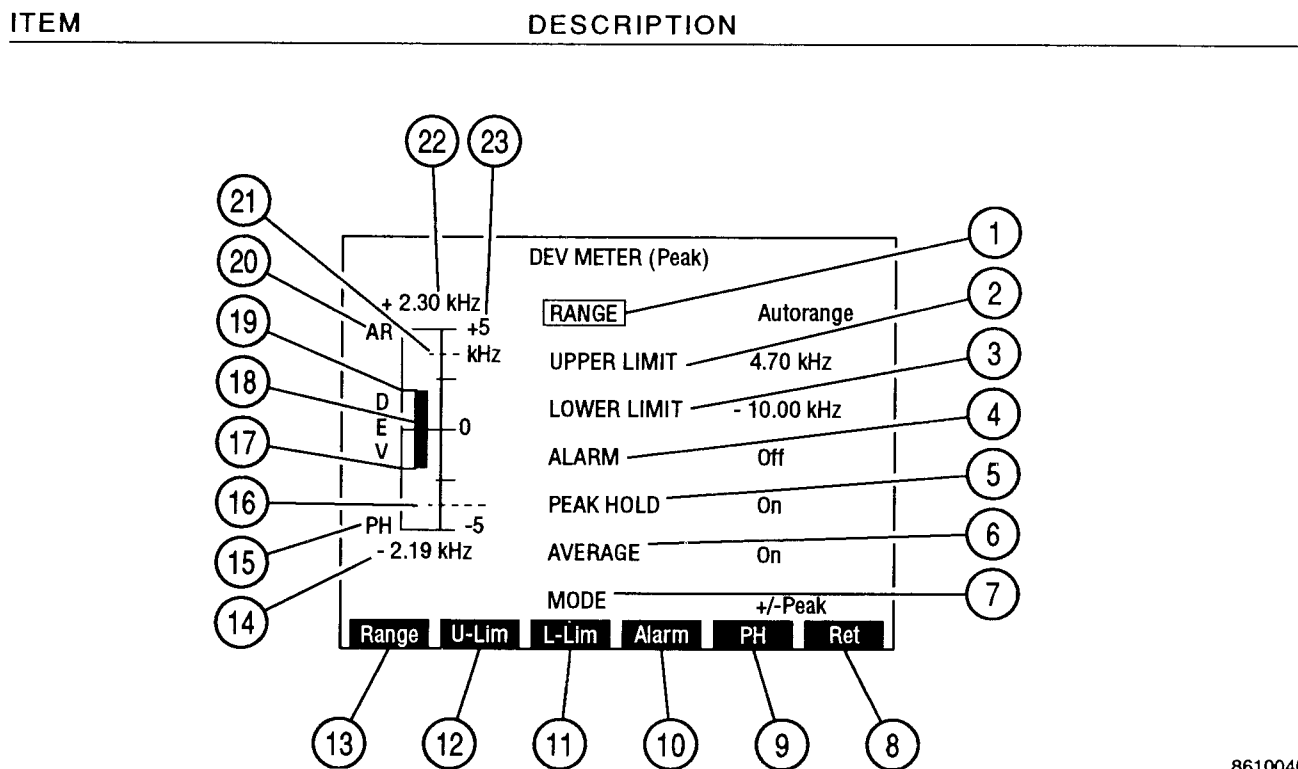

8610040

1. RANGE

Selects Deviation Meter Range. Select Autorange, 2, 5, 10, 20, 50 or 100 kHz.

2. UPPER LIMIT

Activates and selects Upper Limit. Range is 0.0 to 100.0 kHz. Upper Limit is turned off from Deviation Meter Menu.

3. LOWER LIMIT

Activates and selects Lower Limit. Range is 0.0 to 100.0 kHz. Lower Limit is turned off from Deviation Meter Menu.

4. ALARM

Toggles Alarm on or off. Enabled Alarm sounds when Upper or Lower Limit is exceeded.

5. PEAK HOLD

Toggles Peak Hold feature on or off.

ITEM	DESCRIPTION
6. <u>AVERAGE</u>	Toggles Average feature on or off. When on, Meter reads a running average of last 10 readings.
7. <u>MODE</u>	Selects Deviation Meter Mode. Select +Peak, -Peak, +/-Peak or +/-Peak/2. +Peak displays as positive scale. -Peak displays as negative scale. +/-Peak displays as positive and negative scale. +/-Peak/2 displays absolute value of the average of positive and negative deviation readings.
8. <u>"Ret"/"ESC" Soft Function Key F6</u>	When editing a parameter, "ESC" is shown. Stops editing process and voids any changes to parameter. "Ret" displays the last accessed Operation Screen.
9. <u>"PH" Soft Function Key F5</u>	Toggles Peak Hold feature on or off.
10. <u>"Alarm" Soft Function Key F4</u>	Toggles Alarm on or off.
11. <u>"L-Lim" Soft Function Key F3</u>	Activates and selects Lower Limit. Range is 0.0 to 100.0 kHz. Lower Limit is deactivated from Deviation Meter Menu.
12. <u>"U-Lim" Soft Function Key F2</u>	Activates and selects Upper Limit. Range is 0.0 to 100.0 kHz. Lower Limit is deactivated from Deviation Meter Menu.
13. <u>"Range" Soft Function Key F1</u>	Selects Deviation Meter Range. Select Autorange, 2, 5, 10, 20, 50 or 100 kHz.
14. <u>Negative Digital Readout</u>	Provides a digital readout of the positive deviation for + Peak and +/- Peak/2 Modes. Provides a digital readout of the negative deviation in kHz for - Peak and +/- Peak Modes.
15. <u>PH</u>	Appears at the lower left side of the meter window if PEAK HOLD (5) is on.

ITEM	DESCRIPTION
16. <u>Lower Limit Indicator</u>	When the Lower Limit is on, a dotted blue line appears across the meter window at the point on the scale where the limit is set.
17. <u>Lower Peak Hold Indicator</u>	Appears when PEAK HOLD (5) is on and in +/-Peak Mode. Indicates point of lowest negative Deviation Meter deflection.
18. <u>Meter Indicator Bar</u>	Displays Deviation Meter reading. Bar turns red when a Upper or Lower Limit is exceeded. Bar turns green if the current range is surpassed.
19. <u>Upper Peak Hold Indicator</u>	Appears when PEAK HOLD (5) is on. Indicator line shows the highest point of positive Deviation Meter deflection.
20. <u>AR</u>	Appears at the upper right side of the meter window if the RANGE (1) is set for Autorange. The Meter Range Scale (23) changes to the next higher scale when the meter indicator reaches the edge of the meter window. The meter changes to the next lower scale if the meter indicator falls to a level of about 1/2 of the lowest scale division.
21. <u>Upper Limit Indicator</u>	When UPPER LIMIT (2) is on, a dotted blue line appears across the meter window at the point on the scale where the limit is set.
22. <u>Positive Digital Readout</u>	Appears in +/-Peak Mode. Provides a digital readout of the positive deviation in kHz.
23. <u>Meter Range Scale</u>	Displays Meter Scale in four divisions.

With the Deviation Meter Operation Screen displayed on the CRT, press the SETUP Key to access the Deviation Meter (Peak) Menu:

MENU ITEM

DESCRIPTION

DEVIATION METER (Peak) MENU

Deviation Meter (Peak) Menu	
1. Meter Range	Autorange
2. Select Peak Hold	On
3. Upper Lmt	On
4. Set Upper Lmt	1.5 kHz
5. Lower Lmt	On
6. Set Lower Lmt	-1.5 kHz
7. Set Alarm	Off
8. Average	Off
9. Mode	+/-Peak

Ret AUX

8610005

1. Meter Range

Displays submenu allowing the selection of the Deviation Meter Range. Select Autorange, 2, 5, 10, 20, 50 or 100 kHz.

2. Select Peak Hold

Toggles Peak Hold feature on or off.

3. Upper Lmt

Toggles Upper Limit on or off.

4. Set Upper Lmt

Selects Upper Limit Level. Range is 0.0 to 20.0 kHz.

5. Lower Lmt

Toggles Lower Limit on or off.

6. Set Lower Lmt

Selects Lower Limit Level. Range is 0.0 to 20.0 kHz.

7. Set Alarm

Toggles Alarm on or off. Enabled Alarm sounds when Upper or Lower Limit is exceeded.

MENU ITEM**DESCRIPTION**

8. Average

Toggles Average feature on or off. When on, Meter reads a running average of last 10 readings.

9. Mode

Selects Deviation Meter Mode. Select +Peak, -Peak, +/-Peak or +/-Peak/2.

E. MODULATION METER

With the Meter Menu displayed on the CRT, press 5 on the DATA ENTRY Keypad to access the Modulation Meter Operation Screen:

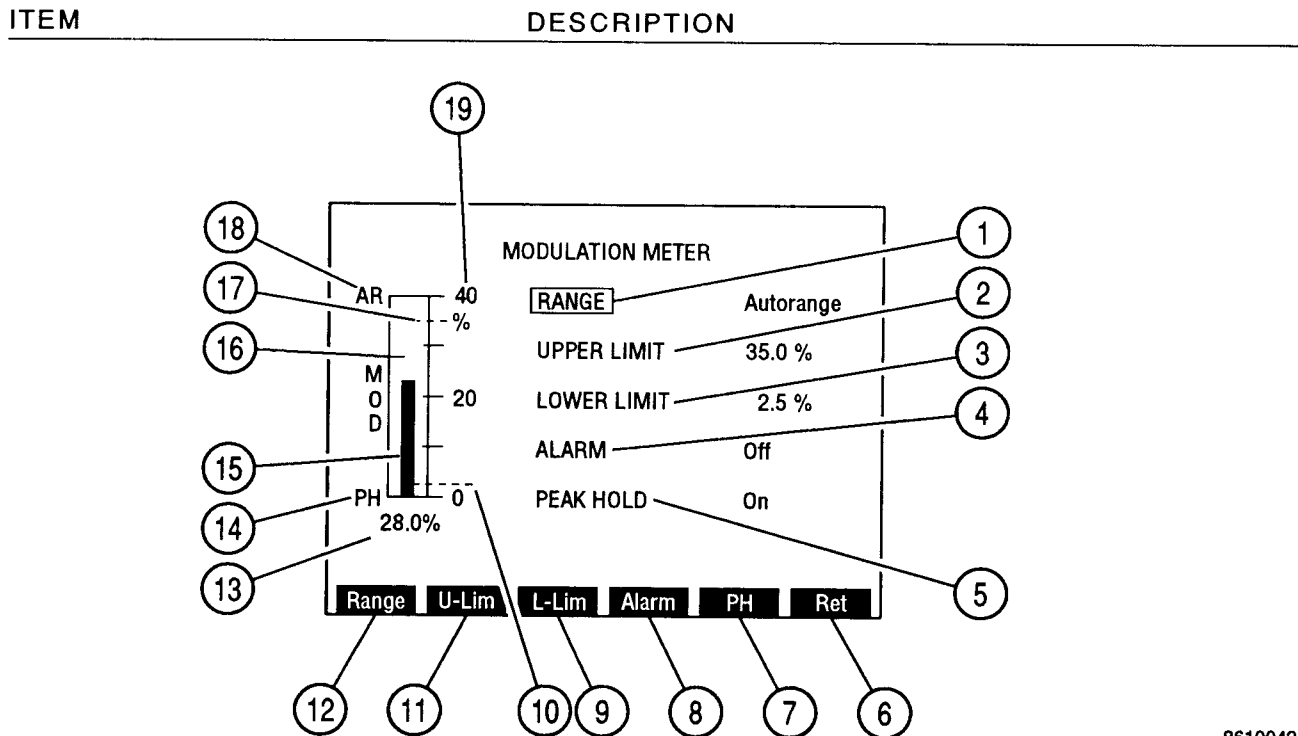

8610042

1. RANGE
Selects Modulation Meter Range. Select Autorange, 40% or 100%.
2. UPPER LIMIT
Activates and selects Upper Limit. Range is 0.0% to 100.0%. Upper Limit is turned off from the Modulation Meter Menu.
3. LOWER LIMIT
Activates and selects Lower Limit. Range is 0.0% to 100.0%. Lower Limit is turned off from Modulation Meter Menu.
4. ALARM
Toggles Alarm on or off. Enabled Alarm sounds when Upper or Lower Limit is exceeded.
5. PEAK HOLD
Toggles Peak Hold feature on or off.

ITEM	DESCRIPTION
6. <u>"Ret"/"ESC" Soft Function Key F6</u>	When editing a parameter, "ESC" is shown. Stops editing process and voids any changes to parameter. "Ret" displays the last accessed Operation Screen.
7. <u>"PH" Soft Function Key F5</u>	Toggles Peak Hold feature on or off.
8. <u>"Alarm" Soft Function Key F4</u>	Toggles Alarm on or off. Enabled Alarm sounds when Upper or Lower Limit is exceeded.
9. <u>"L-Lim" Soft Function Key F3</u>	Activates and selects Lower Limit. Range is 0.0% to 100.0%. Lower Limit is turned off from Modulation Meter Menu.
10. <u>Lower Limit Indicator</u>	When the Lower Limit is on, a dotted blue line appears across the meter window at the point on the scale where the limit is set.
11. <u>"U-Lim" Soft Function Key F2</u>	Activates and selects Upper Limit. Range is 0.0% to 100.0%. Upper Limit is turned off from the Modulation Meter Menu.
12. <u>"Range" Soft Function Key F1</u>	Selects Modulation Meter Range. Select Autorange, 40% or 100%.
13. <u>Modulation Meter Digital Readout</u>	Provides a digital readout of the Modulation Percentage.
14. <u>PH</u>	Appears at the lower left side of the Meter window if PEAK HOLD (5) is on.
15. <u>Meter Indicator Bar</u>	Displays Modulation Meter reading. Bar turns red when an Upper or Lower Limit is exceeded. Bar turns green if the current range is surpassed.
16. <u>Peak Hold Indicator</u>	Appears when PEAK HOLD (5) is on. Indicator line shows the highest point of meter deflection.

ITEM	DESCRIPTION
------	-------------

17. Upper Limit Indicator

When Upper Limit is on, a dotted blue line appears across the meter window at the point on the scale where the limit is set.

18. AR

Appears at the upper right side of the meter window if the RANGE (1) is set for Autorange. The Meter Range Scale (19) changes to the next higher scale when the Meter Indicator Bar (15) reaches the edge of the meter window. The meter changes to the next lower scale if the Meter Indicator Bar (15) falls to a level of about 1/2 of the lowest scale division.

19. Meter Range Scale

The meter scale of four divisions is marked from 0 to the limits of the active scale with the center division labeled with the midpoint of the range.

With the Modulation Meter Operation Screen displayed on the CRT, press the SETUP Key to access the Modulation Meter Menu.

MENU ITEM

DESCRIPTION

MODULATION METER MENU	
Modulation Meter Menu	
1. Meter Range	Autorange
2. Select Peak Hold	On
3. Upper Lmt	On
4. Set Upper Lmt	35.0 %
5. Lower Lmt	On
6. Set Lower Lmt	2.5 %
7. Set Alarm	Off
Ret AUX	

8610006

1. Meter Range

Selects Range. Select Autorange, 40% or 100%.

2. Select Peak Hold

Toggles Peak Hold feature on or off.

3. Upper Lmt

Toggles Upper Limit on or off.

4. Set Upper Limit

Selects Upper Limit Level. Range is from 0.0% to 100.0%.

5. Lower Lmt

Toggles Lower Limit on or off.

6. Set Lower Limit

Selects Lower Limit Level. Range is from 0.0% to 100.0%.

7. Set Alarm

Toggles Alarm on or off. Enabled Alarm sounds when Upper or Lower Limit is exceeded.

F. DISTORTION METER

With the Meter Menu displayed on the CRT, press 6 DATA ENTRY Key to access the Distortion Meter Operation Screen:

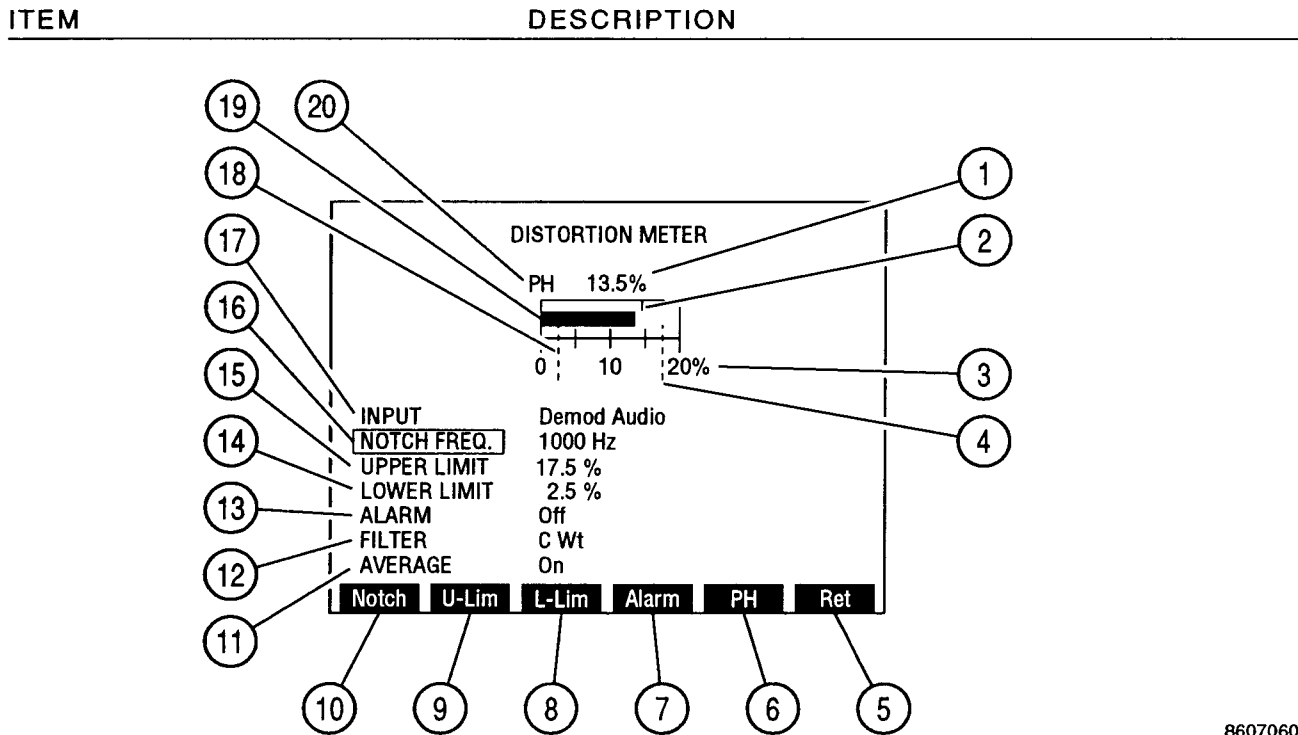

8607060

1. Digital Readout

Provides a digital readout of meter indication.

2. Peak Hold Indicator

Appears when Peak Hold is on. Indicator line shows the highest point of meter deflection.

3. Meter Range Scale

The meter scale of four divisions is marked from 0 to the limits of the active scale with the center division labeled with the midpoint of the range.

4. Upper Limit Indicator

When the Upper Limit is on, a dotted blue line appears across the meter window at the point on the scale where the limit is set. The indicator appears at the right edge of the meter window if the limit is set higher than the meter range.

ITEM	DESCRIPTION
5. <u>"Ret"/"ESC" Soft Function Key F6</u>	When editing a parameter, "ESC" is shown. Stops editing process and voids any changes to parameter. "Ret" displays the last accessed Operation Screen.
6. <u>"PH" Soft Function Key F5</u>	Toggles Peak Hold feature on or off.
7. <u>"Alarm" Soft Function Key F4</u>	Toggles Alarm on or off. Enabled Alarm sounds when Upper or Lower Limit is exceeded.
8. <u>"L-Lim" Soft Function Key F3</u>	Activates and selects Lower Limit. Range is 0.0% to 20.0%. Lower Limit is turned off from Distortion Meter Menu.
9. <u>"U-Lim" Soft Function Key F2</u>	Activates and selects Upper Limit. Range is 0.0% to 20.0%. Upper Limit is turned off from the Distortion Meter Menu.
10. <u>"Notch" Soft Function Key F1</u>	Selects Notch Filter Frequency. Range is 600 to 1400 Hz.
11. <u>AVERAGE</u>	Toggles Average feature on or off. When on, Meter reads a running average of last 10 readings.
12. <u>FILTER</u>	Selects Distortion Meter Filter. Select C Wt or Low-Pass. If Low-Pass is selected, a data field appears allowing entry of cutoff frequency. Range of the cutoff frequency is 0.1 to 30.0 kHz.
13. <u>ALARM</u>	Toggles Alarm on or off. Enable Alarm sounds when Upper or Lower Limit is exceeded.
14. <u>LOWER LIMIT</u>	Activates and selects Lower Limit. Range is 0.0% to 20.0%. Lower Limit is turned off from Distortion Meter Menu.

ITEM	DESCRIPTION
15. <u>UPPER LIMIT</u>	Activates and selects Upper Limit. Range is 0.0% to 20.0%. Upper Limit is turned off from the Distortion Meter Menu.
16. <u>NOTCH FREQ</u>	Selects Notch Filter Frequency. Range is 600 to 1400 Hz.
17. <u>INPUT</u>	Selects Distortion Meter Input. Select Ext Mod (EXT MOD IN Connector [17]), Demod Audio, Func Gen or SINAD/BER (SINAD/BER IN Connector [15]).
18. <u>Lower Limit Indicator</u>	When the Lower Limit is on, a dotted blue line appears across the meter window at the point on the scale where the limit is set.
19. <u>Meter Indicator Bar</u>	Displays Distortion Meter reading. Bar turns red when an Upper or Lower Limit is exceeded. Bar turns green if the current range is surpassed.
20. <u>PH</u>	Appears above the left corner of the meter window if Peak Hold is on.

With the Distortion Meter Operation Screen displayed on the CRT, press the SETUP Key to access the Distortion Meter Menu:

MENU ITEM

DESCRIPTION

DISTORTION METER MENU	
Distortion Meter Menu	
1. Select Dist In	Demod Audio
2. Set Filter Freq	770 Hz
3. Select Peak Hold	On
4. Upper Lmt	On
5. Set Upper Lmt	17.5 %
6. Lower Lmt	On
7. Set Lower Lmt	2.5 %
8. Set Alarm	Off
9. Average	On
10. Filter Select	C wt
Ret AUX	

8610007

1. Select Dist In

Selects Distortion Meter Input. Select Demod Audio, SINAD/BER (SINAD/BER IN Connector [15]), Func Gen or Ext Mod (EXT MOD IN Connector [17]).

2. Set Filter Freq

Selects Notch Filter Frequency. Range is 600 to 1400 Hz.

3. Select Peak Hold

Toggles Peak Hold feature on or off.

4. Upper Lmt

Toggles Upper Limit on or off.

5. Set Upper Lmt

Selects Upper Limit Level. Range is 0.0% to 20.0%.

6. Lower Lmt

Toggles Lower Limit on or off.

7. Set Lower Lmt

Selects Lower Limit Level. Range is 0.0% to 20.0%.

8. Set Alarm

Toggles Alarm on or off. Enabled Alarm sounds when Upper or Lower Limit is exceeded.

MENU ITEM

DESCRIPTION

9. Average

Toggles Average feature on or off. When on, Meter reads a running average of last 10 readings.

10. Filter Select

Selects Distortion Meter Filter. Select C Wt or Low-Pass. If Low-Pass is selected, a data field appears allowing entry of cutoff frequency. Range of cutoff frequencies is 0.1 to 30.0 kHz.

G. SINAD METER

With the Meter Menu displayed on the CRT, press 7 DATA ENTRY Key to access the SINAD Meter Operation Screen:

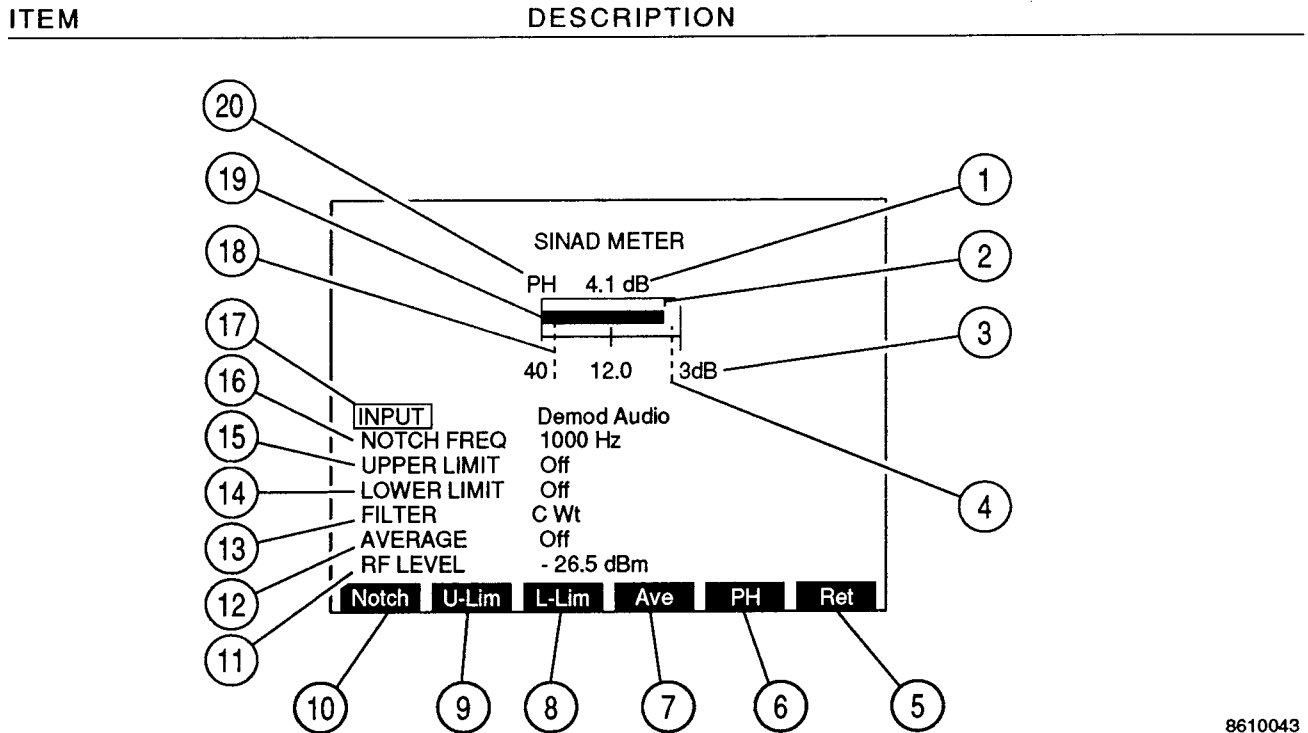

8610043

1. Digital Readout

Provides a digital readout of meter indication.

2. Peak Hold Indicator

Appears when Peak Hold is on. Indicator line shows the highest point of meter deflection.

3. Meter Range Scale

The meter scale of two divisions is marked from 3 to 40 dB with the center division labeled 12.0 dB.

4. Upper Limit Indicator

When the Upper Limit is on, a dotted blue line appears across the meter window at the point on the scale where the limit is set. The indicator appears at the right edge of the meter window if the limit is set higher than the meter range.

ITEM	DESCRIPTION
5. <u>"Ret"/"ESC" Soft Function Key F6</u>	When editing a parameter, "ESC" is shown. Stops editing process and voids any changes to parameter. "Ret" displays the last accessed Operation Screen.
6. <u>"PH" Soft Function Key F5</u>	Toggles Peak Hold feature on or off.
7. <u>"Ave" Soft Function Key F4</u>	Toggles Average feature on or off. When on, Meter reads a running average of last 10 readings.
8. <u>"L-Lim" Soft Function Key F3</u>	Activates and selects Lower Limit. Range is 3.0 to 40.0 dB. Lower Limit is turned off from SINAD Meter Menu.
9. <u>"U-Lim" Soft Function Key F2</u>	Activates and selects Upper Limit. Range is 3.0 to 40.0 dB. Upper Limit is turned off from the SINAD Meter Menu.
10. <u>"Notch" Soft Function Key F1</u>	Selects Notch Filter Frequency. Range is 600 to 1400 Hz
11. <u>RF LEVEL</u>	Appears if RF GEN, Duplex or Duplex Receiver is the last accessed Operation Screen. Displays RF Generator or Duplex Receiver Output Level.
12. <u>AVERAGE</u>	Toggles Average feature on or off. When on, Meter reads a running average of last 10 readings.
13. <u>FILTER</u>	Selects SINAD Filter. Select C Wt or Low-Pass. If Low-Pass is selected, a data field appears allowing entry of cutoff frequency. Range of cutoff frequencies is 0.1 to 30.0 kHz.
14. <u>LOWER LIMIT</u>	Activates and selects Lower Limit. Range is 3.0 to 40.0 dB. Lower Limit is turned off from SINAD Meter Menu.

ITEM	DESCRIPTION
15. <u>UPPER LIMIT</u>	Activates and selects Upper Limit. Range is 3.0 to 40.0 dB. Upper Limit is turned off from the SINAD Meter Menu.
16. <u>NOTCH FREQ</u>	Selects Notch Filter Frequency. Range is 600 to 1400 Hz.
17. <u>INPUT</u>	Selects SINAD Meter Input. Select Demod Audio, SINAD/BER, Func Gen or Ext Mod.
18. <u>Lower Limit Indicator</u>	When the Lower Limit is on, a dotted blue line appears across the meter window at the point on the scale where the limit is set.
19. <u>Meter Indicator Bar</u>	Displays SINAD Meter reading. Bar turns red when an Upper or Lower Limit is exceeded. Bar turns green if the current range is surpassed.
20. <u>PH</u>	Appears above the left corner of the meter window if Peak Hold is on.

With the SINAD Meter Operation Screen displayed on the CRT, press the SETUP Key to access the SINAD Meter Menu:

MENU ITEM

DESCRIPTION

SINAD METER MENU

SINAD Meter Menu	
1. Select SINAD In	Demod Audio
2. Notch Filter Freq	1000 Hz
3. Select Peak Hold	Off
4. Upper Lmt	Off
5. Set Upper Lmt	3.0 dB
6. Lower Lmt	Off
7. Set Lower Lmt	30.0 dB
8. Average	Off
9. Filter Select	C Wt

8610008

1. Select SINAD In

Selects SINAD Meter Input. Select Demod Mod, SINAD/BER, Func Gen or Ext Audio.

2. Notch Filter Freq

Selects Notch Filter Frequency. Range is 600 to 1400 Hz.

3. Select Peak Hold

Toggles Peak Hold feature on or off.

4. Upper Lmt

Toggles Upper Limit on or off.

5. Set Upper Lmt

Selects Upper Limit Level. Range is 3.0 to 40.0 dB.

6. Lower Lmt

Toggles Lower Limit on or off.

7. Set Lower Lmt

Selects Lower Limit Level. Range is 3.0 to 40.0 dB.

8. Average

Toggles Average feature on or off. When on, Meter reads a running average of last 10 readings.

MENU ITEM**DESCRIPTION**

9. Filter Select

Selects SINAD Filter. Select C Wt or Low-Pass. If Low-Pass is selected, a data field appears allowing entry of cutoff frequency. Range of cutoff frequencies is 0.1 to 30.0 kHz.

H. SIGNAL STRENGTH METER

With the Meter Menu displayed on the CRT, press 8 DATA ENTRY Key to access the Signal Strength Meter Operation Screen:

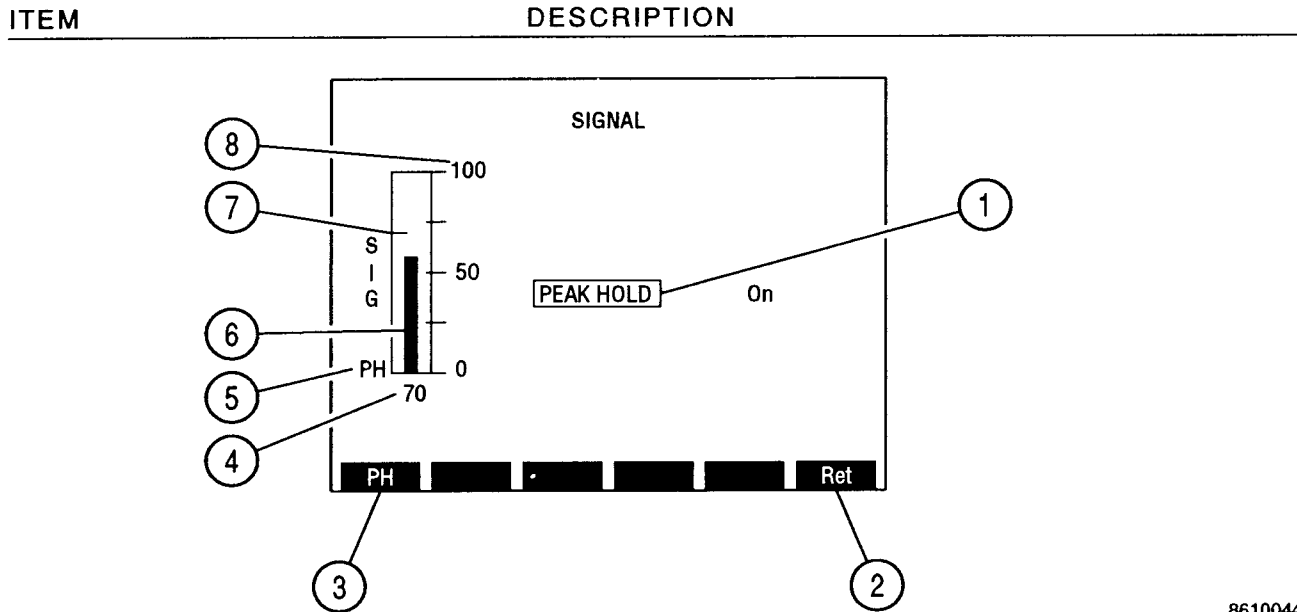

8610044

1. PEAK HOLD

Toggles Peak Hold feature on or off.

2. "Ret" Soft Function Key F6

"Ret" displays the last accessed Operation Screen.

3. "PH" Soft Function Key F1

Toggles Peak Hold feature on or off.

4. Signal Strength Digital Readout

Provides digital Signal Strength Meter readings.

5. PH

When PEAK HOLD (1) is on, this indicator appears beside the lower left corner of the meter window.

6. Meter Indicator Bar

Displays Signal Strength Meter readings.

ITEM	DESCRIPTION
7. <u>Peak Hold Indicator</u>	Appears when PEAK HOLD (1) is on. Indicator line shows the highest point of meter deflection.
8. <u>Meter Range Scale</u>	The meter scale of four divisions is marked from 0 to 100 with the center division marked 50.

With the Signal Strength Meter Operation Screen displayed on the CRT, press the SETUP Key to access the Signal Strength Meter Menu:

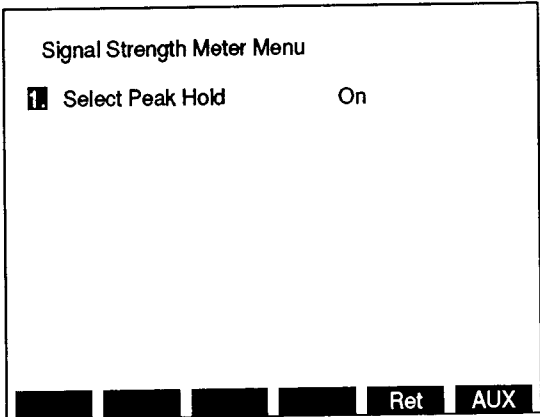
MENU ITEM	DESCRIPTION
SIGNAL STRENGTH METER MENU	
	

8610009

1. Select Peak Hold
Toggles Peak Hold feature on or off.

I. BIT ERROR RATE (BER) METER

With the Meter Menu displayed on the CRT, press 9 DATA ENTRY Key to access the BER Meter Operation Screen. Use the FIELD SELECT Keys to move the cursor to the parameter to be edited and press the ENTER Key to access the parameter data field. For parameters with two settings, access toggles the parameter setting to the other value.

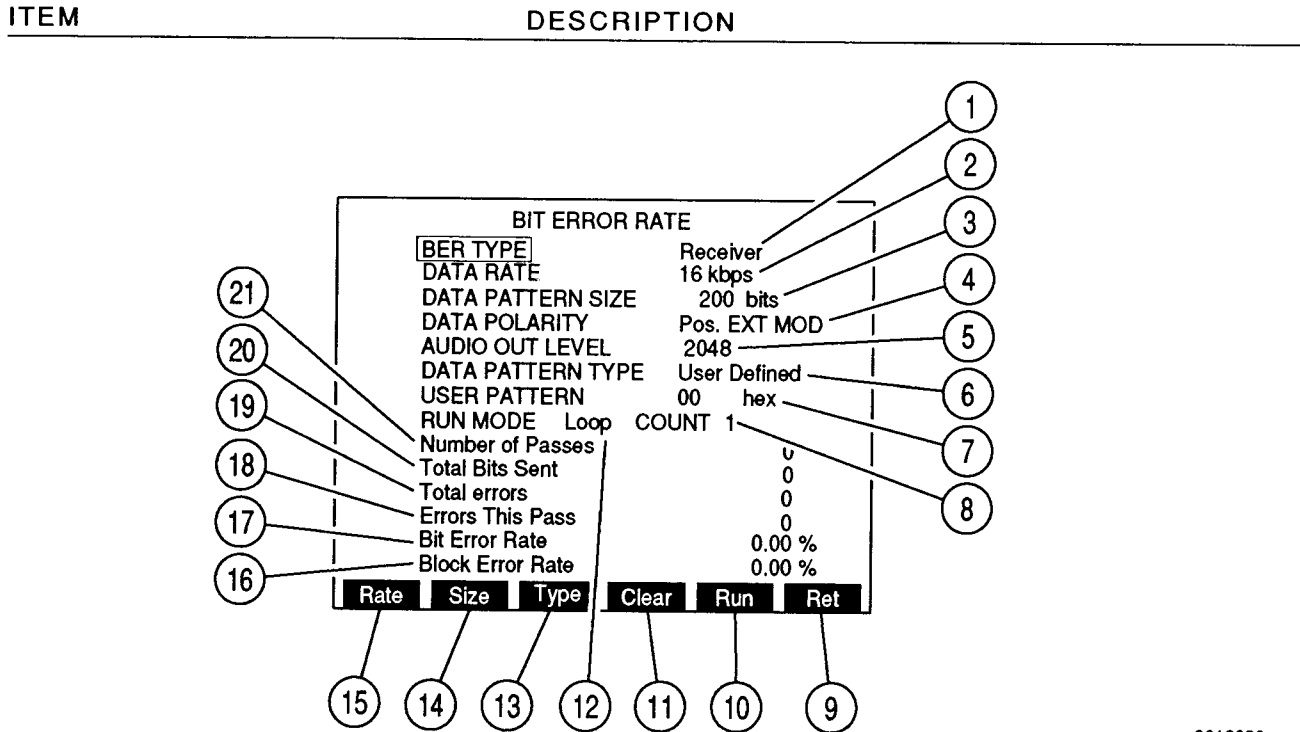

8610030

1. BER TYPE

Selects BER Type. Select Receiver, Generator, Baseband or Duplex.

- With Receiver BER Type, the specified test data is sent through the AUDIO OUT Connector to modulate the UUT. The UUT Output returns to the specified Connector of the Test Set and is demodulated and compared to the original test data.
- With Generator BER Type, the modulated test data is sent to the UUT to be demodulated. The demodulated data is received by the Test Set and compared with the original test data.
- With Baseband BER Type, the test data is sent through the AUDIO OUT Connector to be modulation and then demodulated by the UUT. Demodulated UUT output is received by the Test Set and compared to the original test data.
- With Duplex BER Type, the modulated test data is sent to the UUT to be demodulated and then modulated. This signal is received and demodulated by the Test Set and compared to the original test data.

ITEM	DESCRIPTION									
2. <u>DATA RATE</u>	Selects baud rate of data. Select one of the following:									
	<table> <tr> <td>75 bps</td> <td>150 bps</td> <td>300 bps</td> </tr> <tr> <td>600 bps</td> <td>1200 bps</td> <td>2400 bps</td> </tr> <tr> <td>4800 bps</td> <td>16 kbps</td> <td></td> </tr> </table>	75 bps	150 bps	300 bps	600 bps	1200 bps	2400 bps	4800 bps	16 kbps	
75 bps	150 bps	300 bps								
600 bps	1200 bps	2400 bps								
4800 bps	16 kbps									
3. <u>DATA PATTERN SIZE</u>	Selects number of bits for each pass. Range is from 100 to 100000 bits.									
4. <u>DATA POLARITY</u>	Select Positive received at EXT MOD IN Connector or Negative (inverted) received at SINAD/BER IN Connector.									
5. <u>AUDIO OUT LEVEL/RF GEN LEVEL</u>	<ul style="list-style-type: none"> ● AUDIO OUT LEVEL is displayed for Receiver and Baseband BER Types. Select from 0 to 4095 bits. 0 corresponds to 0 V and 4095 corresponds to 5 V. ● RF GEN LEVEL is displayed for Generator and Duplex BER Types. Range is from -137.0 to 0.0 dBm or 0.001 to .224 V. 									
6. <u>DATA PATTERN TYPE</u>	Select Random, Fixed or User Defined.									
7. <u>USER PATTERN</u>	Appears when "User Defined" is selected as DATA PATTERN TYPE (6). Enter User Pattern in hexadecimal digits using DATA ENTRY Keypad.									
8. <u>Loop COUNT</u>	Appears when Loop is selected as RUN MODE. Select loop count from 1 to 100000.									
9. <u>"Ret"/"ESC" Soft Function Key F6</u>	When editing a parameter, "ESC" is shown. Stops editing process and voids any changes to parameter. "Ret" displays the last accessed Operation Screen.									
10. <u>"Run"/"Stop" Soft Function Key F5</u>	Pressing "Run" Starts BER test and changes Soft Function Key to "Stop". Pressing "Stop" stops BER test.									
11. <u>"Clear" Soft Function Key F4</u>	Clears BER test readout data.									

ITEM	DESCRIPTION									
12. <u>RUN MODE</u>	<p>Selects BER Meter Run Mode. Select from Continuous, One Shot or Loop.</p> <ul style="list-style-type: none"> ● With Continuous Run Mode, the BER tests are run until "Stop" Soft Function Key F5 is pressed. ● With One Shot Run Mode, one pass is completed. The size of the pass is set by DATA PATTERN SIZE (3). ● With Loop Run Mode, the specified number of passes is completed unless "Stop" Soft Function Key F5 is pressed. The number of passes completed is set by the Loop COUNT (8). 									
13. <u>"Type" Soft Function Key F3</u>	Selects DATA PATTERN TYPE (6). Select Random, Fixed or User Defined.									
14. <u>"Size" Soft Function Key F2</u>	Selects DATA PATTERN SIZE (3) (number of bits for each pass). Range is from 100 to 100000 bits.									
15. <u>"Rate" Soft Function Key F1</u>	<p>Selects baud rate of data. Select one of the following:</p> <table data-bbox="306 1068 1089 1163"> <tbody> <tr> <td>75 bps</td> <td>150 bps</td> <td>300 bps</td> </tr> <tr> <td>600 bps</td> <td>1200 bps</td> <td>2400 bps</td> </tr> <tr> <td>4800 bps</td> <td>16 kbps</td> <td></td> </tr> </tbody> </table>	75 bps	150 bps	300 bps	600 bps	1200 bps	2400 bps	4800 bps	16 kbps	
75 bps	150 bps	300 bps								
600 bps	1200 bps	2400 bps								
4800 bps	16 kbps									
16. <u>Block Error Rate</u>	Percentage readout of the ratio of blocks with at least one error versus the number of blocks sent during BER test.									
17. <u>Bit Error Rate</u>	Percentage readout of the ratio of bit errors versus the number or bits sent during BER test.									
18. <u>Errors This Pass</u>	Readout of the number of errors detected during current pass. The number of bits specified by the DATA PATTERN SIZE (3) is processed during each pass.									
19. <u>Total Errors</u>	Readout of the total number of errors occurring during BER test.									
20. <u>Total Bits Sent</u>	Readout of the total number of bits sent during BER test.									

ITEM	DESCRIPTION
------	-------------

21. Number of Passes

Readout of the number of passes made during BER test.

With the BER Meter Operation Screen displayed on the CRT, press the SETUP Key to access the BER Meter Menu. There are 4 different BER METER MENU Screens, one for each BER Type. If "Receiver" is the BER Type, the following screen is displayed:

MENU ITEM	DESCRIPTION
-----------	-------------

RECEIVER BER METER MENU

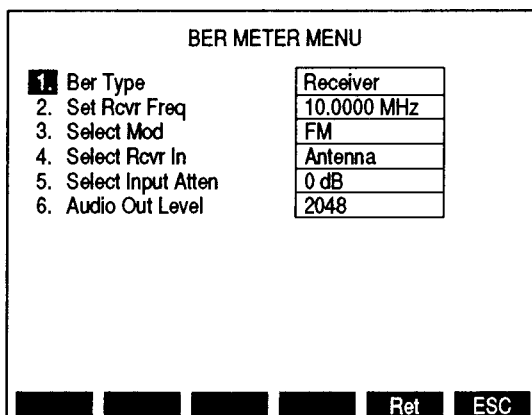

8610094

1. BER Type

Selects BER Type. Select Receiver, Generator, Baseband or Duplex. Changing BER Type changes BER METER MENU.

2. Set Rcvr Freq

Selects Receiver Frequency. Range is from 0.2500 to 999.9999 MHz.

3. Select Mod

Displays Modulation Submenu:

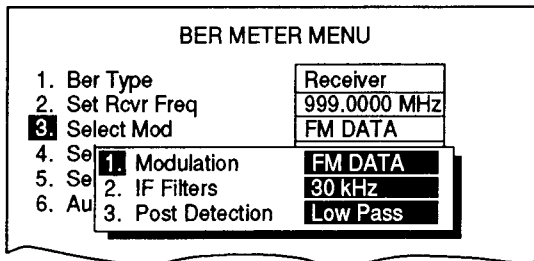

8610095

- Selects Received Modulation. Select FM, AM, SSB (upper), SSB (lower), BFO, PM or FM DATA.
- Selects Receiver IF Filter. Select from 3, 30 or 300 kHz.

ITEM**DESCRIPTION**

- **Select Receiver Post Detection Filter.** Select All Pass, Low-Pass, High-Pass or Bandpass. If Low-Pass, High-Pass or Bandpass is selected, a data field is displayed to allow entry of cutoff frequencies. Range of the cutoff frequencies are:

Low-Pass	0.100 to 30.000 kHz.
High-Pass	0.500 to 20.000 kHz.
Bandpass low	0.500 to 20.000 kHz.
Bandpass high	0.100 to 30.000 kHz.

4. Select Rcvr In

Toggles Receiver Input Connector between Antenna and T/R.

5. Select Input Atten

Selects Input Attenuation. Select 0, 20 or 40 dB.

6. Audio Out Level

Selects Test Data Output Level at AUDIO OUT Connector. Select from 0 to 4095. 0 corresponds to 0 V and 4095 corresponds to 5 V.

If "Generator" is the BER Type, the Generator BER Meter Menu is displayed:

MENU ITEM

DESCRIPTION

GENERATOR BER METER MENU

BER METER MENU	
1. Ber Type	Generator
2. RF Gen Freq	10.0000 MHz
3. RF Gen Level	- 20.0 dBm
4. RF Gen Level Units	dBm
5. RF Gen Mod	FM
6. RF Gen Mod Level	255

Ret ESC

8610097

1. BER Type

Selects BER Type. Select Receiver, Generator, Baseband or Duplex. Changing BER Type changes BER Meter Menu. With Generator BER Type, the modulated test data is sent to the UUT to be demodulated. The demodulated data is received by the Test Set and compared with the original test data.

2. RF Gen Freq

Selects RF Generator Frequency. Range is from 0.2500 to 999.9999 MHz.

3. RF Gen Level

Selects RF Generator Output Level. Range is from 0.0 to -137.0 dBm or 0.031 μ V to 0.224 V.

4. RF Gen Level Units

Selects RF Generator Output Level Units. Toggles between dBm and volts. Also changes RF Generator Output Level Units and Spectrum Analyzer Tracking Generator Output Level Units to units selected.

5. RF Gen Mod

Selects RF Generator Modulation. Select AM, FM, PM or OFF.

6. RF Gen Mod Level

Selects RF Generator Modulation Level. Range is from 0 to 255. Modulation Level setting is a relative setting only. Modulation Level must be measured externally to set accurately.

If "Baseband" is the BER Type, the Baseband BER Meter Menu is displayed:

MENU ITEM	DESCRIPTION
-----------	-------------

BASEBAND BER METER MENU

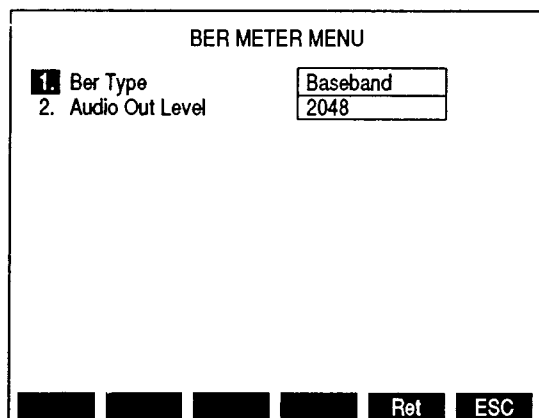

8610096

1. BER Type

Selects BER Type. Select Receiver, Generator, Baseband or Duplex. Changing BER Type changes BER Meter Menu.

2. Audio Out Level

Selects Test Data Output Level at AUDIO OUT Connector. Select from 0 to 4095. 0 corresponds to 0 V and 4095 corresponds to 5 V.

If "Duplex" is the BER Type, the Duplex BER Meter Menu is displayed:

MENU ITEM

DESCRIPTION

DUPLEX BER METER MENU

BER METER MENU	
1. Ber Type	Duplex
2. Set Rcvr Freq	10.0000 MHz
3. Select Mod	FM
4. Select Rcvr In	Antenna
5. Select Input Atten	0 dB
6. RF Gen Freq	10.0000 MHz
7. RF Gen Level	- 20.1 dBm
8. RF Gen Level Units	dBm
9. RF Gen Mod	Off
10. RF Gen Mod Level	128
11. RF Gen Output	T/R

Ret ESC

8610098

1. BER Type

Selects BER Type. Select Receiver, Generator, Baseband or Duplex. Changing BER Type changes BER Meter Menu. With Duplex BER Type, the modulated test data is sent to the UUT to be demodulated and then modulated. This signal is received and demodulated by the Test Set and compared to the original test data.

2. Set Rcvr Freq

Selects Receiver Frequency. Range is from 0.2500 to 999.9999 MHz.

3. Select Mod

Displays Modulation Submenu:

BER METER MENU		
1. Ber Type	Duplex	
2. Set Rcvr Freq	999.0000 MHz	
3. Select Mod	FM DATA	
4. Se	1. Modulation	FM DATA
5. Se	2. IF Filters	30 kHz
6. Au	3. Post Detection	Low Pass

8610172

- Selects Received Modulation. Select FM, AM, SSB (upper), SSB (lower), BFO, PM or FM DATA.
- Selects Receiver IF Filter. Select from 3, 30 or 300 kHz.

MENU ITEM	DESCRIPTION
-----------	-------------

- Select Receiver Post Detection Filter. Select All Pass, Low-Pass, High-Pass or Bandpass. If Low-Pass, High-Pass or Bandpass is selected, a data field is displayed to allow entry of cutoff frequencies. Range of cutoff frequencies are:

Low-Pass	0.100 to 30.000 kHz.
High-Pass	0.500 to 20.000 kHz.
Bandpass low	0.500 to 20.000 kHz.
Bandpass high	0.100 to 30.000 kHz.

4. Select Rcvr In

Selects Receiver Input Connector. Toggles between Antenna or T/R.

5. Select Input Atten

Selects Input Attenuation. Select 0, 20 or 40 dB.

6. RF Gen Freq

Selects RF Generator Frequency. Range is from 0.2500 to 999.9999 MHz.

7. RF Gen Level

Selects RF Generator Output Level. Range is from 0.0 to -137.0 dBm or 0.031 μ V to 0.224 V for T/R RF Gen Output. Range is from 7.0 to -120.0 dBm or 0.224 μ V to 0.501 V for T/R RF Gen Output.

8. RF Gen Level Units

Selects RF Generator Output Level Units. Toggles between dBm and Volts. Also changes RF Generator Output Level Units and Spectrum Analyzer Tracking Generator Output Level Units to units selected.

9. RF Gen Mod

Selects RF Generator Modulation Type. Select AM, FM, PM or OFF.

10. RF Gen Mod Level

Selects RF Generator Modulation Level. Range is from 0 to 255. Modulation Level setting is a relative setting only. Modulation Level must be measured externally to set accurately.

11. RF Gen Output

Selects RF Generator Output Connector. Toggles between "T/R" and "Duplex".

J. DIGITAL MULTIMETER

With the Meter Menu displayed on the CRT, use the FIELD SELECT Keys to highlight "10. Digital Multimeter (DMM)" and press the ENTER Key to access the Digital Multimeter Operation Screen.

NOTE: The Digital Multimeter appears in the Function last used.

The "Install Shunt Between V Ω and COM" message appears when 20 A range is accessed.

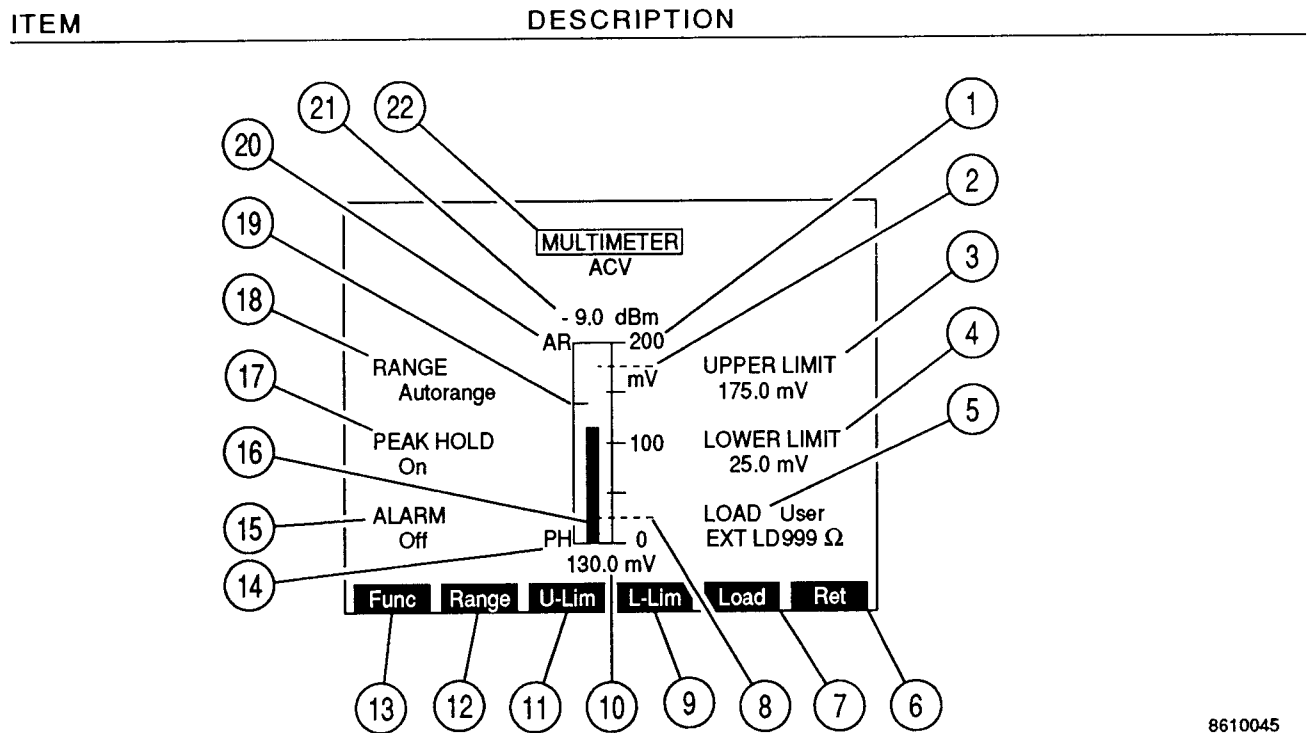

8610045

1. Meter Range Scale

The meter scale of four divisions is marked from 0 to the limits of the active range scale with the center division labeled with the midpoint of the range.

2. Upper Limit Indicator

When Upper Limit is on, a dotted blue line appears across the meter window at the point on the scale where the limit is set. The indicator appears at the window's upper edge if the limit is set higher than the meter range.

3. UPPER LIMIT

Activates and selects Upper Limit. If ACV or DCV is selected as the Function, Range is from 0.0 mV to 1000.00 V. If ACC or DCC is selected as the Function, range is from 0.00 mA to 19.990 A. If Ohm is selected as the Function, range is from 0.000 Ω to 19.990 M Ω . Upper Limit is turned off from the Multimeter Menu. Upper Limit must be < highest value of current range to operate correctly.

ITEM	DESCRIPTION
4. <u>LOWER LIMIT</u>	Activates and selects Lower Limit. If ACV or DCV is selected as the Function, Range is from 0.0 mV to 1000.00 V. If ACC or DCC is selected as the Function, range is from 0.00 mA to 19.990 A. If Ohm is selected as the Function, range is from 0.000 Ω to 19.990 M Ω . Lower Limit is turned off from the Multimeter Menu. Lower Limit must be < highest value of current range to operate correctly.
5. <u>LOAD</u>	Appears when "ACV" is selected as MULTIMETER Function (22). Select 1 MEG, 600 Ω , 150 Ω or User. User allows the use of an external load from 1 to 999 Ω . If User is selected, a callout is displayed for external load entry used to ensure dBm Callout accuracy. The external load is installed by the operator.
6. <u>"Ret"/"ESC" Soft Function Key F6</u>	When editing a parameter, "ESC" is shown. Stops editing process and voids any changes to parameters. "Ret" displays the last accessed Operation Screen.
7. <u>"Load" Soft Function Key F5</u>	Appears when "ACV" is selected as MULTIMETER Function (22). Select 1 MEG, 600 Ω , 150 Ω or User. User allows the use of an external load from 1 to 999 Ω . If User is selected, a callout is displayed for external load entry used to ensure dBm callout accuracy. The external load is installed by the operator.
8. <u>Lower Limit Indicator</u>	When the Lower Limit is on, a dotted blue line appears across the meter window at the point on the scale where the limit is set.
9. <u>"L-Lim" Soft Function Key F4</u>	Activates and selects Lower Limit. If ACV or DCV is selected as the Function, range is from 0.0 mV to 1000.00 V. If ACC or DCC is selected as the Function, range is from 0.00 mA to 19.990 A. If Ohm is selected as the Function, range is from 0.000 Ω to 19.990 M Ω . Lower Limit is turned off from the Multimeter Menu. Lower Limit must be < highest value of current range to operate correctly.
10. <u>Digital Meter Readout</u>	Digital readout of meter in the units set by the meter scale. If Peak Hold is on, the readout reads the highest meter deflection.

ITEM	DESCRIPTION
11. <u>"U-Lim" Soft Function Key F3</u>	<p>Activates and selects Upper Limit. If ACV or DCV is selected as the Function, Range is from 0.0 mV to 1000.00 V. If ACC or DCC is selected as the Function, range is from 0.00 mA to 19.990 A. If Ohm is selected as the Function, range is from 0.000 Ω to 19.990 MΩ. Upper Limit is turned off from the Multimeter Menu. Upper Limit must be < highest value of current range to operate correctly.</p>
12. <u>"Range" Soft Function Key F2</u>	<p>Selects Meter Range.</p> <ul style="list-style-type: none"> ● For Functions ACV or DCV, select Autorange, 200 mV, 2.0 V, 20 V, 200 V or 2000 V. ● For Functions ACC or DCC, select Autorange, 20 mA, 200 mA, 2 A or 20 A. ● For Ohm Function, select Autorange, 200 Ω, 2 kΩ, 20 kΩ, 200 kΩ, 2 MΩ or 20 MΩ.
13. <u>"Func" Soft Function Key F1</u>	<p>Selects Multimeter Function. Select ACV, DCV, ACC, DCC or Ohm.</p>
14. <u>PH</u>	<p>When PEAK HOLD (17) is on, this indicator appears beside the lower left corner of the meter window.</p>
15. <u>ALARM</u>	<p>Toggles Alarm on or off. Enables Alarm sounds when Upper or Lower Limit is exceeded.</p>
16. <u>Meter Indicator Bar</u>	<p>Displays Meter reading. Bar turns red when an Upper or Lower Limit is exceeded. Bar turns green if the current range is surpassed.</p>
17. <u>PEAK HOLD</u>	<p>Toggles Peak Hold feature on or off.</p>

ITEM	DESCRIPTION
18. <u>RANGE</u>	<p>Selects Meter Range.</p> <ul style="list-style-type: none"> ● For Functions ACV or DCV, select Autorange, 200 mV, 2.0 V, 20 V, 200 V or 2000 V. ● For Functions ACC or DCC, select Autorange, 20 mA, 200 mA, 2 A or 20 A. ● For Ohm Function, select Autorange, 200 Ω, 2 kΩ, 20 kΩ, 200 kΩ, 2 MΩ or 20 MΩ.
19. <u>PEAK HOLD Indicator</u>	<p>Appears when PEAK HOLD (17) is on. Indicator line shows the highest point of meter deflection.</p>
20. <u>AR</u>	<p>Appears above the upper left corner of the meter window if the RANGE (18) is set for Autorange. The Meter Range Scale (1) changes to the next higher scale when the Meter Indicator Bar (16) reaches the edge of the meter window. The meter changes to the next lower scale if the Meter Indicator Bar (16) falls to a level of about 1/2 of the lowest scale division.</p>
21. <u>dBm Digital Reading</u>	<p>Appears if ACV is selected for Multimeter Function unless 1 MEG is selected for LOAD. Displays Meter reading in dBm.</p>
22. <u>MULTIMETER</u>	<p>Selects Multimeter Function. Select ACV, DCV, ACC, DCC or Ohm.</p>

With Digital Multimeter Operation Screen displayed on the CRT, press SETUP Key to access the Multimeter Menu:

MENU ITEM	DESCRIPTION
-----------	-------------

MULTIMETER MENU

Multimeter Menu	
1. Multimeter Func	ACV
2. Set Range	Autorange
3. Select Peak Hold	On
4. Upper Lmt	On
5. Set Upper Lmt	175.0 mV
6. Lower Lmt	On
7. Set Lower Lmt	25.0 mV
8. Set Alarm	Off

Ret AUX

8610010

1. Multimeter Func

Selects Multimeter Function. Select ACV, DCV, ACC, DCC or Ohm.

2. Set Range

Selects Meter Range.

- For Functions ACV or DCV, select Autorange, 200 mV, 2.0 V, 20 V, 200 V or 2000 V.
- For Functions ACC or DCC, select Autorange, 20 mA, 200 mA, 2 A or 20 A.
- For Ohm Function, select Autorange, 200 Ω , 2 k Ω , 20 k Ω , 200 k Ω , 2 M Ω or 20 M Ω .

3. Select Peak Hold

Toggles Peak Hold feature between on and off.

4. Upper Lmt

Toggles Upper Limit between on and off.

5. Set Upper Lmt

Selects Upper Limit Level. If ACV or DCV is selected as the Function, range is from 0.0 mV to 1000.00 V. If ACC or DCC is selected as the Function, range is from 0.00 mA to 19.990 A. If Ohm is selected as the Function, range is from 0.000 Ω to 19.990 M Ω . Upper Limit must be < highest value of current range to operate correctly.

MENU ITEM	DESCRIPTION
6. <u>Lower Lmt</u>	Toggles Lower Limit between on and off.
7. <u>Set Lower Lmt</u>	Selects Lower Limit. If ACV or DCV is selected as the Function, range is from 0.0 mV to 1000.00 V. If ACC or DCC is selected as the Function, range is from 0.00 mA to 19.990 A. If Ohm is selected as the Function, range is from 0.000 Ω to 19.990 M Ω . Upper Limit must be < highest value of current range to operate correctly.
8. <u>Set Alarm</u>	Toggles Alarm on or off. Enables Alarm sounds when Upper or Lower Limit is exceeded.

K. PHASE METER

With the Meter Menu displayed on the CRT, use the FIELD SELECT Keys to highlight "11. Phase Meter" and press the ENTER Key to access the Phase Meter Operation Screen:

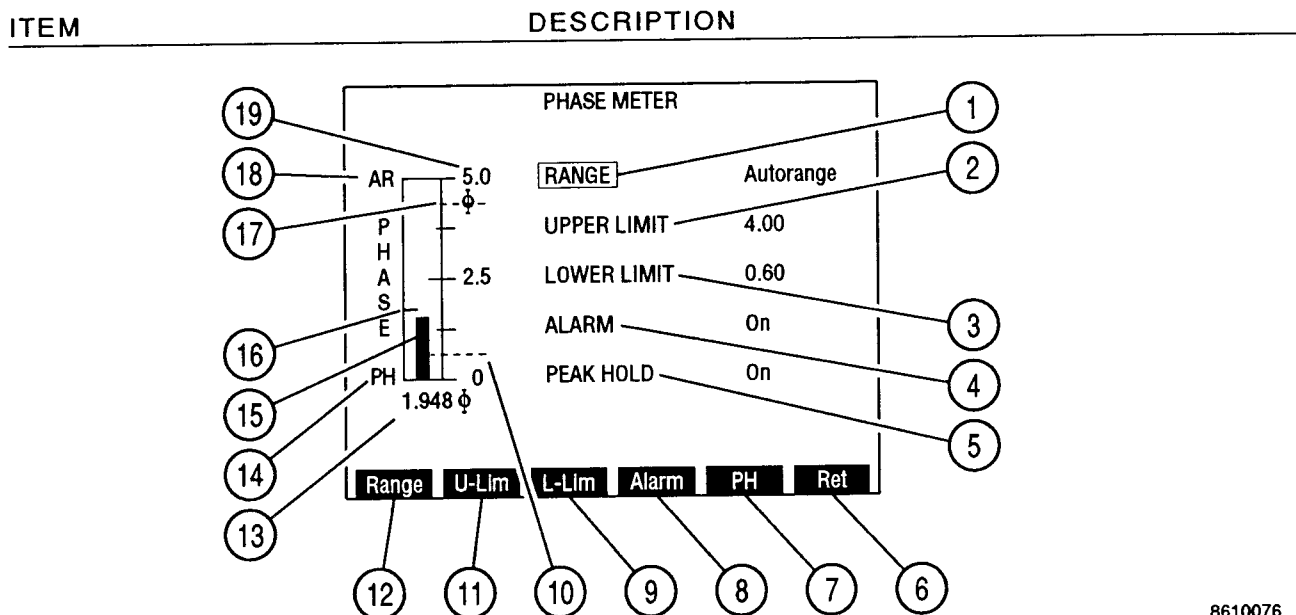

8610076

1. RANGE

Selects Meter Range. Select Autorange, 1, 5, or 10 radians.

2. UPPER LIMIT

Activates and selects Upper Limit. Range is from 0.00 to 10.00 radians. Upper Limit is turned off from Phase Meter Menu.

3. LOWER LIMIT

Activates and selects Lower Limit. Range is from 0.00 to 10.00 radians. Lower Limit is turned off from Phase Meter Menu.

4. ALARM

Toggles Alarm between on and off. Enabled Alarm sounds when an Upper or Lower Limit is exceeded.

5. PEAK HOLD

Toggles Peak Hold feature between on and off.

6. "Ret"/"ESC" Soft Function Key F6

When editing a parameter, "ESC" is shown. Stops editing process and voids any changes to parameters. "Ret" displays the last accessed Operation Screen.

ITEM	DESCRIPTION
7. <u>"PH" Soft Function Key F5</u>	Toggles Peak Hold between on and off.
8. <u>"Alarm" Soft Function Key F4</u>	Toggles Alarm between on and off. Enabled Alarm sounds when an Upper or Lower Limit is exceeded.
9. <u>"L-Lim" Soft Function Key F3</u>	Activates and selects Lower Limit. Range is from 0.00 to 10.00 radians. Lower Limit is turned off from Phase Meter Menu.
10. <u>Lower Limit Indicator</u>	When Lower Limit feature is on, a dotted blue line appears across the meter window at the point on the scale where the limit is set.
11. <u>"U-Lim" Soft Function Key F2</u>	Activates and selects Upper Limit. Range is from 0.00 to 10.00 radians. Upper Limit is turned off from Phase Meter Menu.
12. <u>"Range" Soft Function Key F1</u>	Selects Meter Range. Select Autorange, 1, 5, or 10 radians.
13. <u>Digital Meter Readout</u>	Digital readout of meter in radians. If PEAK HOLD (5) is on, the readout reads the highest meter deflection.
14. <u>PH</u>	Appears beside the meter window lower left corner if PEAK HOLD (5) is on.
15. <u>Meter Indicator Bar</u>	Displays Meter reading. Bar turns red when an Upper or Lower Limit is exceeded. Bar turns green if the current range is surpassed.
16. <u>Peak Hold Indicator</u>	Appears when PEAK HOLD (5) is on. Indicator line shows the highest point of meter deflection.

ITEM	DESCRIPTION
17. <u>Upper Limit Indicator</u>	When Upper Limit feature is on, a dotted blue line appears across the meter window at the point on the scale where the limit is set. The indicator appears at the window's upper edge if the limit is set higher than the meter range.
18. <u>AR</u>	Indicator appears above the upper left corner of the meter window if the RANGE (1) is set for Autorange. The Meter Range Scale (19) changes to the next higher scale when the Meter Indicator Bar (15) reaches the edge of the meter window. The meter changes to the next lower scale if the Meter Indicator Bar (15) falls to a level of about 1/2 of the lowest scale division.
19. <u>Meter Range Scale</u>	The meter scale of four divisions is marked from 0 to the limits of the active range scale with the center division labeled with the midpoint of the range.

With the Phase Meter Operation Screen displayed on the CRT, press the SETUP Key to access the Phase Meter Menu.

MENU ITEM

DESCRIPTION

PHASE METER MENU

Phase Meter Menu	
1. Meter Range	Autorange
2. Select Peak Hold	On
3. Upper Lmt	On
4. Set Upper Lmt	5.00
5. Lower Lmt	On
6. Set Lower Lmt	3.00
7. Set Alarm	Off

Ret ESC

8610093

1. Meter Range

Selects Meter Range. Select Autorange, 1, 5, or 10 radians.

2. Select Peak Hold

Toggles Peak Hold feature on or off.

3. Upper Lmt

Toggles Upper Limit on or off.

4. Set Upper Lmt

Selects Upper Limit. Range is from 0.00 to 10.00 radians.

5. Lower Lmt

Toggles Lower Limit on or off.

6. Set Lower Lmt

Selects Lower Limit. Range is from 0.00 to 10.00 radians.

7. Set Alarm

Toggles Alarm between on and off. Enabled Alarm sounds when an Upper or Lower Limit is exceeded.

L. DEVIATION METER (RMS)

With the Meter Menu displayed on the CRT, use the FIELD SELECT Keys to highlight "12. Dev Meter (RMS)" and press the ENTER Key to access the Deviation (RMS) Meter Operation Screen:

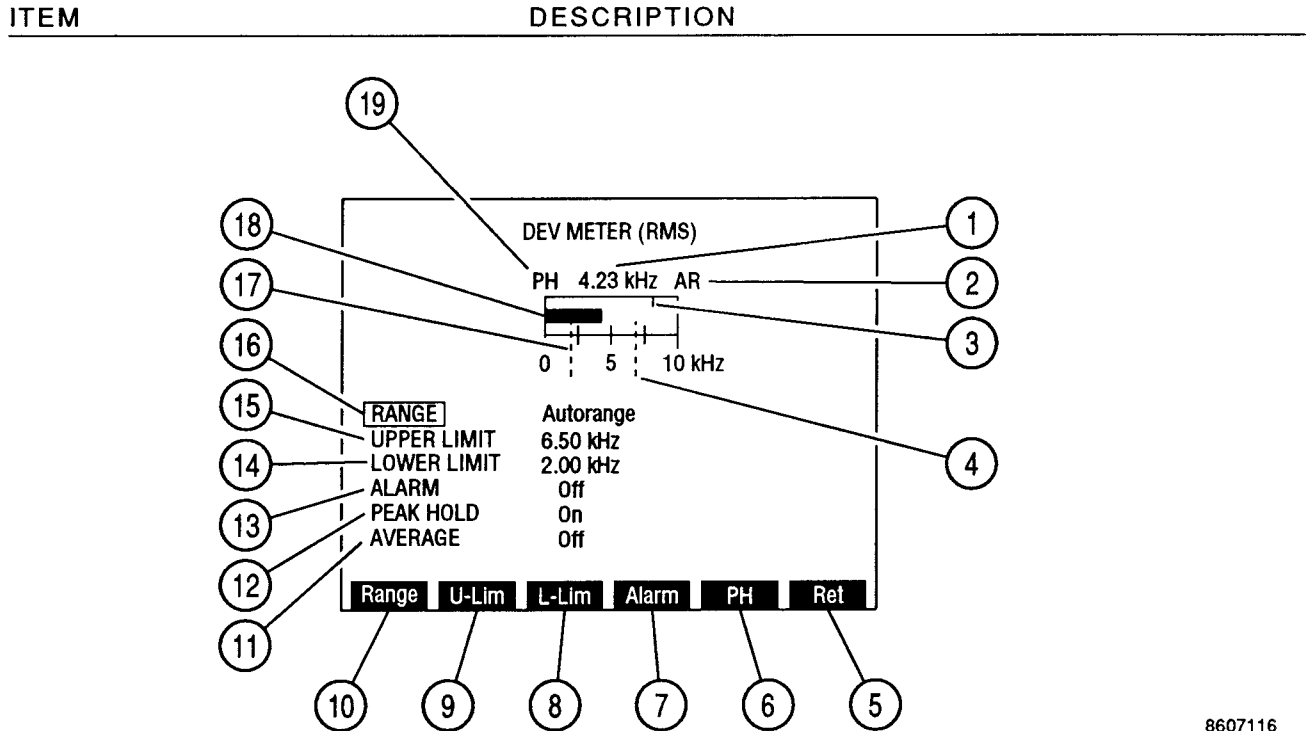

8607116

1. Digital Meter Readout

Digital readout of meter in radians. If PEAK HOLD (12) is on, the readout reads the highest meter deflection.

2. AR

Indicator appears above the upper left corner of the meter window if the RANGE (16) is set for Autorange. The Meter Range Scale changes to the next higher scale when the Meter Indicator Bar (18) reaches the edge of the meter window. The meter changes to the next lower scale if the Meter Indicator Bar (18) falls to a level of about 1/2 of the lowest scale division.

3. Peak Hold Indicator

Appears when PEAK HOLD (12) is on. Indicator line shows the highest point of meter deflection.

4. Upper Limit Indicator

When Upper Limit feature is on, a dotted blue line appears across the meter window at the point on the scale where the limit is set. The indicator appears at the window's upper edge if the limit is set higher than the meter range.

ITEM	DESCRIPTION
5. <u>"Ret"/"ESC" Soft Function Key F6</u>	When editing a parameter, "ESC" is shown. Stops editing process and voids any changes to parameters. "Ret" displays the last accessed Operation Screen.
6. <u>"PH" Soft Function Key F5</u>	Toggles Peak Hold on or off.
7. <u>"Alarm" Soft Function Key F4</u>	Toggles Alarm between on and off. Enabled Alarm sounds when an Upper or Lower Limit is exceeded.
8. <u>"L-Lim" Soft Function Key F3</u>	Activates and selects Lower Limit. Range is from 0.0 to 10.0 kHz. Lower Limit is turned off from Deviation-RMS Meter Menu.
9. <u>"U-Lim" Soft Function Key F2</u>	Activates and selects Upper Limit. Range is from 0.0 to 10.0 kHz. Upper Limit is turned off from Deviation (RMS) Meter Menu.
10. <u>"Range" Soft Function Key F1</u>	Selects Meter Range. Select Autorange, 2, 5, or 10 kHz.
11. <u>AVERAGE</u>	Toggles Average feature on or off. When on, Meter reads a running average of last 10 readings.
12. <u>PEAK HOLD</u>	Toggles Peak Hold feature on or off.
13. <u>ALARM</u>	Toggles Alarm between on and off. Enabled Alarm sounds when an Upper or Lower Limit is exceeded.
14. <u>LOWER LIMIT</u>	Activates and selects Lower Limit. Range is from 0.00 to 10.00 kHz. Lower Limit is turned off from Deviation-RMS Meter Menu.
15. <u>UPPER LIMIT</u>	Activates and selects Upper Limit. Range is from 0.00 to 10.00 kHz. Upper Limit is turned off from Deviation-RMS Meter Menu.

ITEM	DESCRIPTION
16. <u>RANGE</u>	Selects Meter Range. Select Autorange, 2, 5, or 10 kHz.
17. <u>Lower Limit Indicator</u>	When Lower Limit feature is on, a dotted blue line appears across the meter window at the point on the scale where the limit is set.
18. <u>Meter Indicator Bar</u>	Displays Meter reading. Bar turns red when an Upper or Lower Limit is exceeded. Bar turns green if the current range is surpassed.
19. <u>PH</u>	This indicator appears beside the meter window lower left corner if PEAK HOLD (12) is on.

With the Deviation (RMS) Meter Operation Screen displayed on the CRT, press the SETUP Key to access the Deviation Meter (RMS) Menu.

MENU ITEM

DESCRIPTION

DEVIATION METER (RMS) MENU

Deviation Meter (RMS) MENU	
1. Meter Range	10 kHz
2. Select Peak Hold	Off
3. Upper Lmt	On
4. Set Upper Lmt	7.00 kHz
5. Lower Lmt	On
6. Set Lower Lmt	3.00 kHz
7. Set Alarm	On
8. Average	Off

Ret ESC

8610171

1. Meter Range

Selects Meter Range. Select Autorange, 2, 5, or 10 kHz.

2. Select Peak Hold

Toggles Peak Hold feature between on and off.

3. Upper Lmt

Toggles Upper Limit on or off.

4. Set Upper Lmt

Selects Upper Limit. Range is from 0.00 to 10.00 kHz.

5. Lower Lmt

Toggles Lower Limit on or off.

6. Set Lower Lmt

Selects Lower Limit. Range is from 0.00 to 10.00 kHz.

7. Set Alarm

Toggles Alarm between on and off. Enabled Alarm sounds when an Upper or Lower Limit is exceeded.

8. Average

Toggles Average feature on or off. When on, Meters reads a running average of last 10 readings.

3-3-10 AUXILIARY FUNCTIONS MENU

Auxiliary Functions Menu is accessed by "AUX" Soft Function Key. "AUX" Soft Function Key is accessible from initial Power-up Screen, all Mode Setup Menus and the Meter Menu.

To select a specific function, press the number corresponding to the function on the DATA ENTRY Keypad. Use the following Index of Auxiliary Functions for a description of each Function and its Parameters.

MENU ITEM	DESCRIPTION
-----------	-------------

AUXILIARY FUNCTIONS MENU

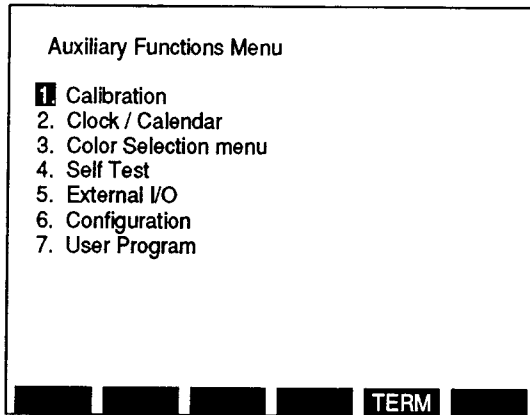

8610091

1. Calibration

Selection accesses submenu for use in calibrating the FM/AM-1600S. Access to submenu requires valid password. Password is factory set and cannot be changed.

2. Clock/Calendar

Accesses Clock/Calendar Setup Menu.

3. Color Selection Menu

Accesses Color Selection Menu allowing the selection of the CRT colors.

4. Self Test

Accesses Self Test Menu. Self Test is covered in detail in Section 5.

5. External I/O

Accesses External I/O Configuration Menu. Connectors include RS-232, GPIB and SCSI.

6. Configuration

Accesses menu detailing the Test Set configuration including the software versions for the Main CPU, Func Gen Board, Monitor Cntl (Control) Board and Counter Board. The Test Set Id number, Options number and total run-time (in minutes) are also listed. If the SCSI bus is turned on from the External I/O Menu, this menu lists the SCSI bus as active or inactive.

Auxiliary Functions Menu	
1.	Calibrations
2.	Clock / Calendar
3.	Configuration Report
4.	Main CPU 2.00
5.	Func Gen Board 01.10S
6.	Monitor Cntl Board 01.10S
7.	Counter Board 01.10S
	ID No. 1610
	Options: 3
	Run - time (Min.) 45958
	SCSI Bus Inact.

TERM ESC

8610184

7. User Program

Executes the User Defined Macro. Macros are loaded into the Test Set through Remote Operation. See Section 6.

8. "TERM" Soft Function Key F5

Access RS-232 Terminal Operation Screen for operating the Test Set as a RS-232 Host. RS-232 External I/O Configuration Parameters must be set for Host operation. Soft Function Keys in this screen allow the use of characters not found on the Front Panel.

Selection of "2. Clock/Calendar" accesses the Clock/Calendar Setup Menu:

MENU ITEM

DESCRIPTION

CLOCK/CALENDAR SETUP MENU

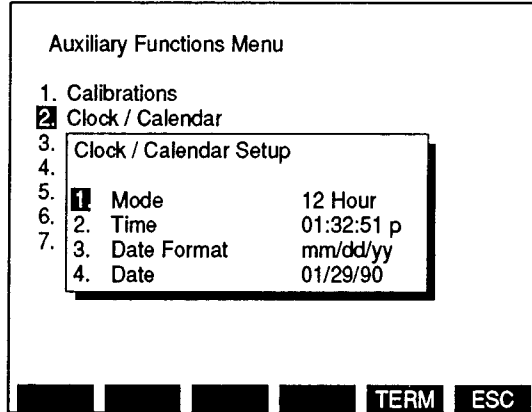

8610022

1. Mode

Selects Clock Mode. Choose from 12 or 24 hour clock formats.

2. Time

Selects current time in hours, minutes and seconds. If in 12 hour clock format, "a" is displayed for am and "p" for pm.

3. Date Format

Selects current date format from mm/dd/yy or dd/mm/yy where mm, dd and yy are two digit representations of month, day and year.

4. Date

Selects current date in digit form listed in Date Format (3).

NOTE: If incorrect data is entered, pressing the "ESC" Soft Function Key allows the user to exit without changing data.

Selection of "3. Color Selection Menu" accesses the Color Selection Menu:

NOTE: Only one color set can be on at a time. Selection different from current setting turns current setting off.

MENU ITEM	DESCRIPTION
-----------	-------------

COLOR SELECTION MENU

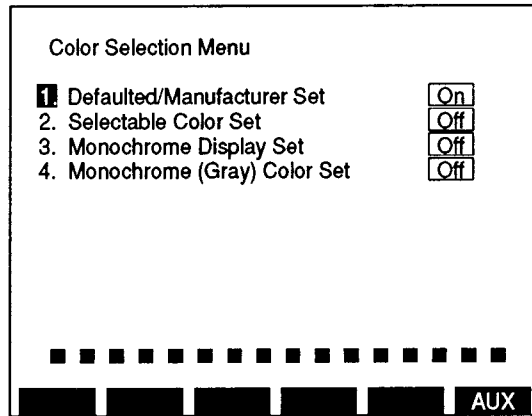

8610023

1. Defaulted/Manufacturer Set

Access sets CRT colors to Manufacturers Settings.

2. Selectable Color Set

When set to on, displays submenu of sets for which to select Color Set. Sets include:

1. Operation Screen Color Set
2. Scope/Analyzer Color Set
3. Menu Screen Color Set
4. Softkey Color Set
5. Cursor Color Set

Selecting specific set accesses another submenu with specific items to be edited for color. When specific item is selected, a cursor appears around currently defined color on the row of colors appearing at the bottom of the menu. Use the DATA SCROLL Spinner or FIELD SELECT Keys to select desired color for item. Press ENTER Key to complete selection.

3. Monochrome Display Set

Access sets CRT colors to Monochrome Display Settings.

4. Monochrome (Gray) Color Set

Access sets CRT colors to Monochrome (Gray) Display Settings.

Selection of "5. External I/O" accesses the External I/O Configure Menu. Through this menu, the user has access to the RS-232, GPIB, and SCSI Connector Configuration Menus. The user can access a specific configuration by selecting the desired using the FIELD SELECT Keys and pressing the ENTER Key. The following index outlines the configuration variables and possible settings.

Selection of "1. RS-232 port" accesses the Configure RS-232 Menu:

MENU ITEM	DESCRIPTION
-----------	-------------

CONFIGURE RS-232 MENU

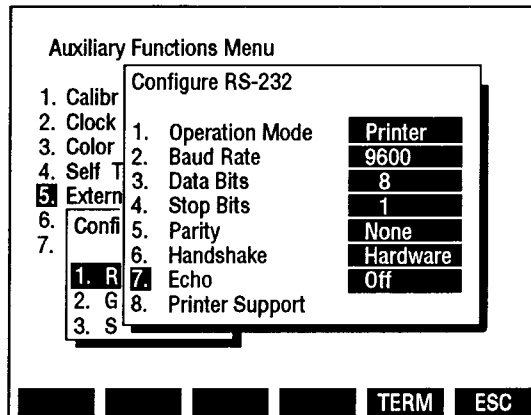

8610026

1. Operation Mode

Selects Off, Host or Printer.

2. Baud Rate

Selects rates of 300, 600, 1200, 2400, 4800, 9600 or 19200 bps.

3. Data Bits

Toggles between 7 and 8 Data Bits.

4. Stop Bits

Toggles between 1 and 2 Stop Bits.

5. Parity

Selects None, Odd, Even, Mark or Space.

6. Handshake

Selects None, Hardware or Xon/Xoff.

7. Echo

Toggles value on or off.

ITEM	DESCRIPTION
------	-------------

8. Printer Support

Accesses the Printer Support Menu.

MENU ITEM	DESCRIPTION
-----------	-------------

PRINTER SUPPORT MENU

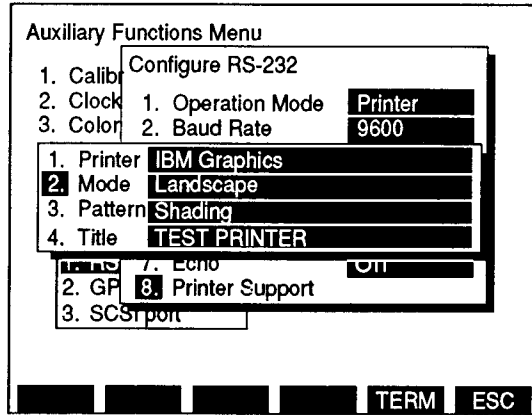

8610099

1. Printer

Selects Epson EX/FX/RX, HP LaserJet II or IBM Graphics.

2. Mode

Selects Landscape or Portrait.

3. Pattern

Selects Shading or Black and White.

4. Title

Enters title of up to 14 characters.

Selection of "2. GPIB port" accesses the Configure GPIB Menu:

MENU ITEM	DESCRIPTION
-----------	-------------

CONFIGURE GPIB MENU

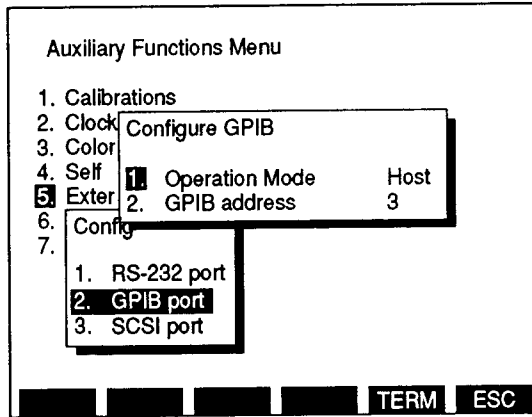

8610025

1. Operation Mode

Selects Off, Talk/Listen, Talk Only or Controller.

2. GPIB address

Selects Test Sets address for GPIB bus operation. Select from 0 to 31.

Selection of "3. SCSI port" accesses the Configure SCSI Menu:

MENU ITEM	DESCRIPTION
-----------	-------------

CONFIGURE SCSI MENU

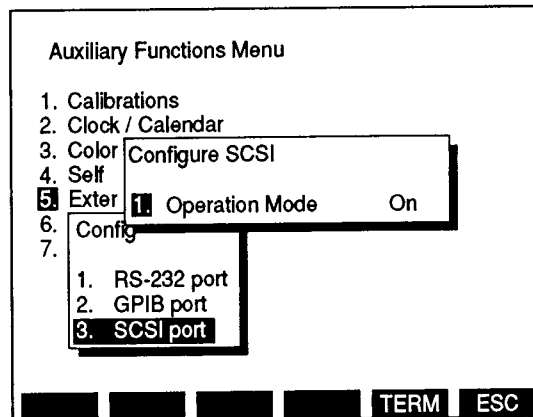

8610036

1. Operation Mode

Selects on or off.

SECTION 4 - OPERATION

4-1 GENERAL

The FM/AM-1600S has six Operation Modes accessed through the MODE Keys (27) (Figure 3-1). Editing operation screens is done in one of the following ways:

- Moving screen cursor to a parameter and pressing ENTER Key to access its data field.
- Accessing the parameter data field using Soft Function Keys (19) (Figure 3-1).
- Accessing and editing parameters on the Operation Screen's Setup Menus and Submenus.

Due to the number of Soft Function Key Definitions, only cursor/ENTER Key access on Operation Screens is discussed in the following paragraphs unless a parameter is only accessed through Soft Function Keys (19) (Figure 3-1) or Setup Menus.

While editing parameter data fields on Operation Screens or Menus, Soft Function Key F6 Definition shows "ESC". Pressing "ESC" Soft Function Key F6 at this time allows escape from the data field without changing its data.

When editing the Setup Menu of an Operation Screen or a meter accessed from an Operation Screen, one Soft Function Key Definition (F5 on menus, F6 on meters) shows "Ret". Pressing "Ret" Soft Function Key returns operation to the last accessed Operation Screen.

4-1-1 PARAMETER MEMORY OPERATION

The FM/AM-1600S allows storage and recall of 9 sets of parameters within each Operation Mode in the following manner:

STEP	PROCEDURE
------	-----------

1. To store a set of parameters:

- Press STORE MEMORY Key to access Store Parameters Menu. Use DATA ENTRY Keypad (29) (Figure 3-1) to select a memory location (1 to 9). A data field appears asking for a title to be entered:

STORE PARAMETERS MENU

Store Parameters Menu (Duplex)

1. STORED PARAMETERS 1

2.

3.

4.

5.

6.

7.

8.

9.

Ret

8610103

- Use DATA ENTRY Keypad (29) (Figure 3-1) to enter a title up to 20 characters in length and press ENTER Key.

NOTE: Press SHIFT Key to toggle DATA ENTRY Keypad (29) (Figure 3-1) to either numeric or alphabetic values. Numeric values are printed on the keys and alphabetic values are printed above keys in blue.

The DEL (Delete) EDIT Key (13) (Figure 3-1) causes a character to be deleted. CE (Clear Entry) EDIT Key (13) (Figure 3-1) causes a blank space to be entered.

- If a set of parameters are already stored under the number chosen, a data field appears with the message "Entry Exists. Delete it?". Press STORE MEMORY Key (16) (Figure 3-1) to toggle entry between yes and no and press ENTER Key.
 - If yes is chosen, use DATA ENTRY Keypad (29) (Figure 3-1) to enter a new title. Press ENTER Key.
 - If no is chosen, use DATA ENTRY Keypad (29) (Figure 3-1) to select another memory location or press "Ret" Soft Function Key F5 to Operation Screen.

2. To recall a set of parameters:

- Press RCL (Recall) MEMORY Key to access Recall Parameters Menu. Use DATA ENTRY Keypad (29) (Figure 3-1) to select memory location. A "Recall?" message and data field appears:

NOTE: If nothing is stored under entry chosen, a "Does Not Exist" message briefly appears. Use DATA ENTRY Keypad (29) (Figure 3-1) to select another entry or press "Ret" Soft Function Key to return to Operation Screen.

RECALL PARAMETERS MENU

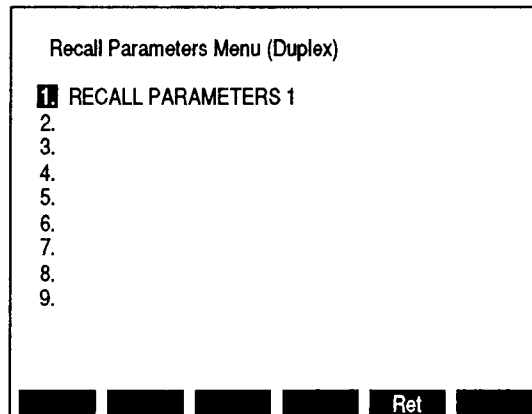

8610105

- Press RCL (Recall) MEMORY Key (16) (Figure 3-1) to toggle between yes and no, and press ENTER Key to activate. If no is chosen, use DATA ENTRY Keypad (29) (Figure 3-1) to select another memory location or press "Ret" Soft Function Key F5 to Operation Screen.

4-1-2 PRINTING CRT SCREENS

A screen print is performed using the following instructions:

STEP	PROCEDURE
1.	Verify RS-232 parameters are set for printing (see 6-2).
2.	Connect Printer to RS-232 Connector (38) (Figure 3-2).
3.	Press PRINT SCRN TEST CONTROL Key (28) (Figure 3-1). If Oscilloscope or Analyzer Operation Screen is displayed, a submenu appears listing print and plot options. Press 1 DATA ENTRY Key (29) (Figure 3-1) to print CRT screen. To plot Oscilloscope Trace, see 4-6. To plot Analyzer Trace, see 4-7.
4.	To stop printing before printing is finished, press STOP TEST CONTROL Key (28) (Figure 3-1).

4-2 RF GENERATOR OPERATION

4-2-1 RF GENERATOR GENERAL OPERATION

Operate RF Generator using the following procedure:

STEP PROCEDURE

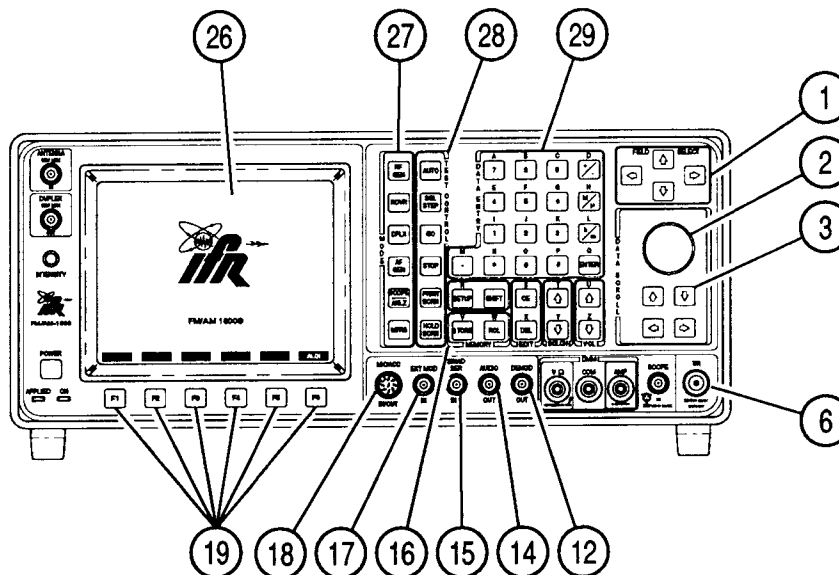

8607058

1. Press RF GEN MODE Key (27) to access RF Generator Operation Screen.

NOTE: When RF Generator Operation Screen is displayed, a signal >100 mW applied to T/R Connector (6) causes Receiver Operation Screen to be displayed.

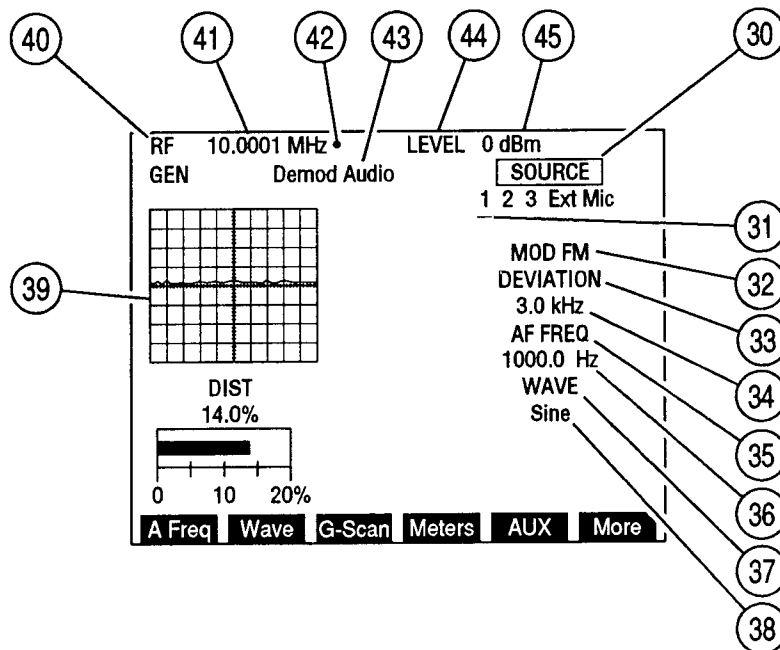

8607101

2. Move cursor to RF (40) and press ENTER Key to access data field (41). Use DATA ENTRY Keypad (29) to enter a frequency (in MHz) and press ENTER Key to activate entered frequency.
3. Move cursor to LEVEL (44) and press ENTER Key to access Output Level data field (45). Use DATA ENTRY Keypad (29) to enter level and press ENTER Key to activate Output Level. If necessary, press "+/-" Key to place a "-" in data field.
4. Move cursor to SOURCE (30) and press ENTER Key to access Modulation Sources. Use FIELD SELECT ← and → Keys (1) to place cursor over desired source and use DATA SCROLL ↑ or ↓ Keys (3) to select desired Modulation Type (32). White indicates OFF, red indicates AM, yellow indicates FM and green indicates PM. Last selected Modulation Type is displayed with Modulation Type Callout (32).

NOTE: If no source is active, data field cursor (31) appears under Source 1 Callout. If more than one source is on, last selected source is indicated by an underline. Source 1 refers to AF Generator 1, Source 2 refers to AF Generator 2, Source 3 refers to Signaling Formats, Ext refers to signals received at EXT MOD IN Connector (17) and Mic refers to signals received at MIC/ACC Connector (18).

5. Move cursor to DEVIATION or MODULATION (33) and press ENTER Key to access data field (34). Use DATA ENTRY Keypad (29) to enter digits of desired deviation frequency or modulation percentage. Press ENTER Key to activate deviation or modulation.

NOTE: When Ext Source is selected, Modulation Level setting assumes the modulating signal applied to the EXT MOD IN Connector (17) is 3.54 VRMS. Modulation Level setting is set higher for lower EXT MOD IN Connector (17) input voltages to achieve same modulation level as per following equation:

$$\begin{array}{rcccl} \text{Modulation} & & \text{EXT MOD IN} & & \text{Actual} \\ \text{Level setting} & \times & \text{Connector} & + & \text{Modulation} \\ \text{(kHz, \%, rad)} & & \text{Input (VRMS)} & 3.54 & \text{Level} \\ & & & = & \end{array}$$

6. If Source 1 or 2 is the last selected Source:
 - Move cursor to AF FREQ (35) and press ENTER Key to access data field (36). Use DATA ENTRY Keypad (29) to enter desired frequency and press ENTER Key to activate Audio Frequency.
 - Move cursor to WAVE (37) and press ENTER Key to access data field (38). Press DATA SCROLL ↑ or ↓ Keys (3) until desired selection appears in data field and press ENTER Key to activate Wave Shape.

7. If Source 3 is not the last selected Source, proceed to step 18. If Source 3 is the last selected Source, Operation Screen appears as follows:

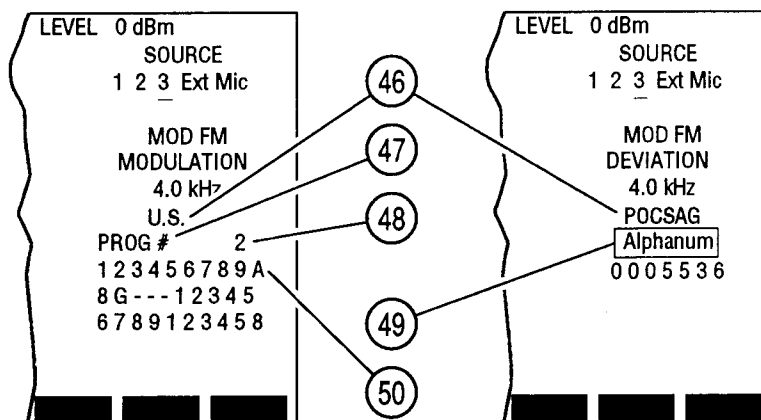

8617080

8. If DTMF is the Signaling Format:
- Move cursor to DIRECT ENTRY/PROG # (47). Press ENTER Key to toggle between Direct Entry and Program features.
 - If PROG is selected, move cursor to Program Number (48) and use DATA ENTRY Keypad (29) to select a programmed sequence. Press ENTER Key.
 - If DIRECT ENTRY is selected, move cursor to sequence (50) and use DATA ENTRY Keypad (29) to enter desired sequence. Press ENTER Key.
9. If DTMF is not the Signaling Format, move cursor to Signaling Code (46) and use DATA SCROLL Keys ↑ and ↓ (3) to select a Signaling Code in the current Signaling Format. Press ENTER Key.
- If POCSAG or Tone Remote is selected as Signaling Code, move cursor to POCSAG or Tone Remote Function Callout (49). Use DATA SCROLL ↑ and ↓ Keys (3) to select a function and press ENTER Key.
 - If a Signaling Code other than DTMF, POCSAG or Tone Remote is selected:
 - Move cursor to DIRECT ENTRY/PROG # (47). Press ENTER Key to toggle between Direct Entry and Program features.
 - If PROG is selected, move cursor to Program Number (48) and use DATA ENTRY Keypad (29) to select a programmed sequence. Press ENTER Key.
 - If DIRECT ENTRY is selected, move cursor to sequence (50) and use DATA ENTRY Keypad (29) to enter desired sequence. Press ENTER Key.
10. To continuously generate Code, press GO TEST CONTROL Key (28). To stop generating Code, press STOP TEST CONTROL Key (28). To generate Code one sequence at a time, press SGL STEP TEST CONTROL Key (28).

- To select a different Signaling Format, press SETUP Key to display Generator Menu. Press 3 DATA ENTRY Key (29) to display Signaling Format Menu:

RF GENERATOR SIGNALING
FORMAT MENU

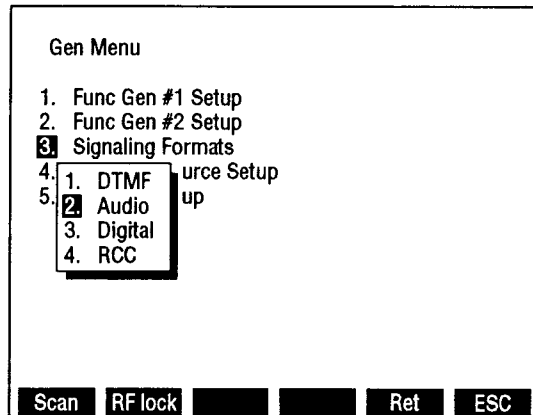

8610080

- Use DATA ENTRY Keypad (29) to select a Signaling Format and press "Ret" Soft Function Key F5.
- To program a Signaling Code sequence, press SETUP Key to display Generator Menu. Press 3 DATA ENTRY Key (29) to display Signaling Format Menu. Use DATA ENTRY Keypad (29) to select a Signaling Format.
- If DTMF is selected, DTMF Signaling Menu appears:

RF GENERATOR DTMF
FORMAT MENU

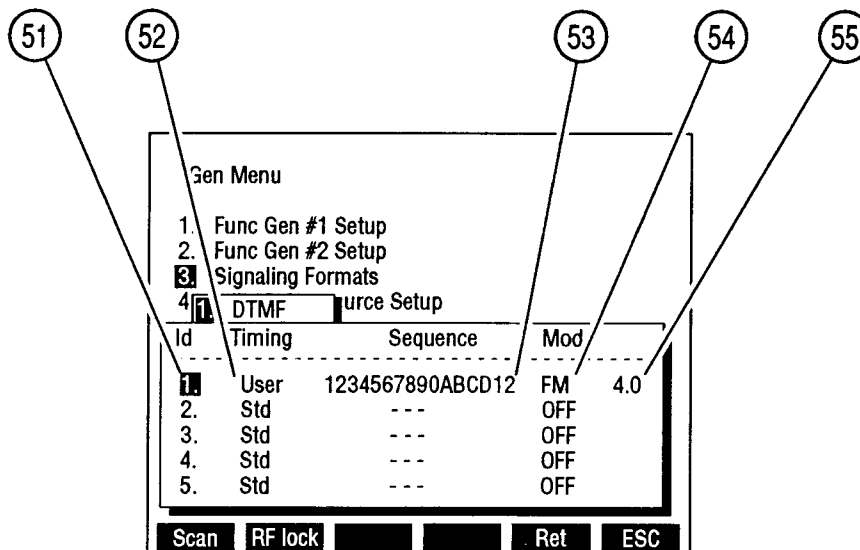

8607123

- Select Id (51) of Sequence to be edited using FIELD SELECT ↑ and ↓ Keys (1).

- Move cursor to Timing column (52) and use DATA SCROLL ↑ and ↓ Keys (3) to select Std (Standard) or User. Press ENTER Key.
- If User is chosen, data fields appear for Mark Timing and Space Timing:
 - Press 1 DATA ENTRY Key (29) and use DATA ENTRY Keypad (29) to enter Mark Timing. Press ENTER Key.
 - Press 2 DATA ENTRY Key (29) and use DATA ENTRY Keypad (29) to enter Space Timing. Press ENTER Key.
 - Press "ESC" Soft Function Key F6.
- Move cursor to Selection column (53) and enter a sequence using DATA ENTRY Keypad (29) and press ENTER Key.

NOTE: Pressing SHIFT Key toggles DATA ENTRY Keypad (29) between numeric and alphabetic characters.

- Move cursor to Mod column (54) and use DATA SCROLL ↑ and ↓ Keys (3) to select Modulation Type and press ENTER Key.
- Move cursor to Modulation Level (55) and use DATA ENTRY Keypad (29) to select Modulation Level and press ENTER Key.
- When all desired sequences are entered, press "Ret" Soft Function Key F5 to return to RF Generator Operation Screen.

15. If Audio is selected as Signaling Format, Audio Code Menu appears:

RF GENERATOR AUDIO CODE MENU

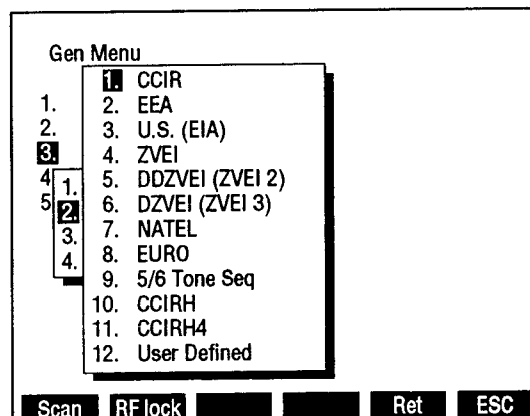

8610081

- Use FIELD SELECT Keys (1) to select an Audio Code and press ENTER Key. Audio Code Sequence Menu appears:

RF GENERATOR AUDIO
CODE SEQUENCE MENU

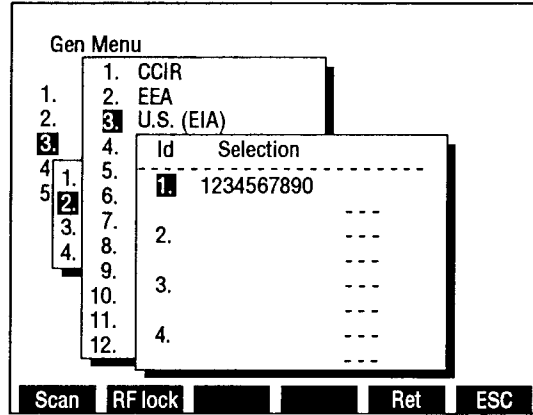

8610082

- Use FIELD SELECT Keys (1) to select an Id and press ENTER Key.
- Use DATA ENTRY Keypad (29) to enter a sequence and press ENTER Key.

NOTE: Pressing SHIFT Key toggles DATA ENTRY Keypad (29) between numeric and alphabetic characters.

- If "12. User Defined" is selected as Audio Code, Audio Code User Defined Menu appears:

RF GENERATOR AUDIO
CODE USER DEFINED MENU

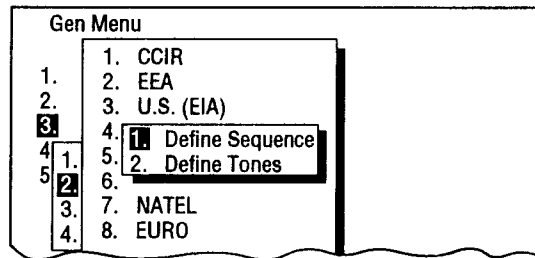

8610159

- Press 2 DATA ENTRY Key (29) to display following menu:

Gen Menu

1.	1. CCIR		
2.	2. EEA		
3.	3. U.S. EIA)		
4.	4.		
4.	5.		
5.	6.		
	7.		
	8.		
	9.		
	10.		
	11.		
	12.		

Id	Tone(Hz)	Duration (ms)
0	5.0	20
1	10.0	20
2	20.0	20
3	30.0	20
4	40.0	20
5	50.0	20
6	60.0	20
7	70.0	20

Scan RF lock Fill Ret ESC

8607119

- Move cursor to Tone(Hz) column (58) of desired Id (57) and use DATA ENTRY Keypad (29) to select a frequency. Press ENTER Key.
- Move cursor to Duration(ms) column (59) and use DATA ENTRY Keypad (29) to select duration. Press ENTER Key.
- With cursor in Tone(Hz) (58) column or Duration(ms) (59) column, press "Fill" Soft Function Key F4 to fill column below cursor with value highlighted by cursor.
- When all desired tones are defined, press "ESC" Soft Function Key F6 to return to Audio Code User Defined Menu.
- Press 1 DATA ENTRY Key (29) to access Audio Code Sequence Menu. User Defined Sequences are selected as other Audio Code Sequences. When all desired sequences have been entered, press "Ret" Soft Function Key F5 to return to RF Generator Operation Screen.

16. If Digital is selected as the Signaling Format, Digital Code Menu appears. Use DATA ENTRY Keypad (29) to select a Digital Code.

- If DCS or DCS INV is selected as the Digital Code, DCS Code Menu appears:

**RF GENERATOR
DCS CODE MENU**

Gen Menu		
1.	Func Gen	Id Code
2.	Func Gen	1. 465
3.	Signaling	2. 000
4.	1. DTMF	3. 000
5.	2. Audio	4. 000
	3. Digital	5. 000
	4. 1. DCS	6. 000
	2. DCS	7. 000
	3. POC	8. 000

P

Scan RF lock Ret ESC

8610083

- Use FIELD SELECT Keys (1) to select an Id and press ENTER Key.
- Use DATA ENTRY Keypad (29) to enter a sequence and press ENTER Key. When all desired sequences are entered, press "Ret" Soft Function Key F5 to return to RF Generator Operation Screen.
- If POCSAG is selected as the Digital Code, POCSAG Menu appears:

RF GENERATOR POCSAG MENU

Gen Menu		
1.	Func Gen #1 Setup	
2.	Func Gen #2 Setup	
3.	Signaling Formats	
4.	1. DTMF	1 Source Setup
5.	2. Audio	1. Capcode 1 5130
	3. Digital	2. Capcode 2 5135
	4. 1. DC	3. Transmit rate Low
	2. DC	4. Function Alpha special
	3. POCSAG	

Scan RF lock Ret ESC

8610143

- Press 1 DATA ENTRY Key (29) to access Capcode 1. Use DATA ENTRY Keypad (29) to enter Starting Capcode and press ENTER Key.
- Press 2 DATA ENTRY Key (29) to access Capcode 2. Use DATA ENTRY Keypad (29) to enter Ending Capcode and press ENTER Key.

- Press 3 DATA ENTRY Key (29) to toggle Transmit rate to low or high.
- Press 4 DATA ENTRY Key (29) to display POCSAG Function Menu:

**RF GENERATOR POCSAG
FUNCTION MENU**

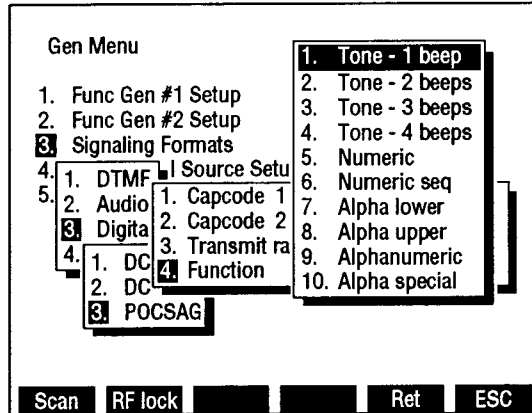

8610173

- Use FIELD SELECT Keys (1) to select a Function Type and press ENTER Key. Press "Ret" Soft Function Key F5 to return to RF Generator Operation Screen.

17. If RCC is selected as the Signaling Format, RCC Code Menu appears. Use DATA ENTRY Keypad (29) to select a RCC Code.

RF GENERATOR RCC CODE MENU

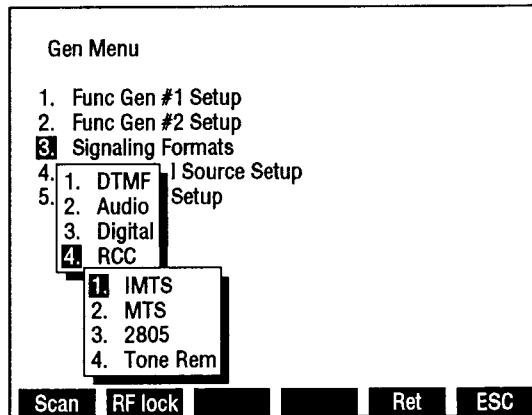

8610144

- If IMTS, MTS or 2805 is selected, RCC IMTS, MTS and 2805 Menu appears:

**RF GENERATOR RCC
IMTS, MTS AND 2805 MENU**

Gen Menu		Id	Sequence
1.	Func Gen #1	1.	1234567891
2.	Func Gen #2	2.	---
3.	Signaling For	3.	---
4.	1. DTMF	4.	---
5.	2. Audio	5.	---
	3. Digital	6.	---
	4. RCC	7.	---
	1. IMTS	8.	---
	2. MTS		
	3. 2805		
	4. Tone Rem		

Scan RF lock Ret ESC

8610145

- Use FIELD SELECT Keys (1) to select an Id and press ENTER Key.
- Use DATA ENTRY Keypad (29) to enter a sequence and press ENTER Key.
- If 2805 is chosen, "Tone" Soft Function Key F3 appears. To edit 2805 frequency, press "Tone" Soft Function Key F3 and use DATA ENTRY Keypad (29) to enter frequency. Press ENTER Key.
- When all desired sequences have been entered, press "Ret" Soft Function Key F5 to return to RF Generator Operation Screen.
- If Tone Rem (Remote) is selected, Tone Rem Function Menu appears:

TOUR REM FUNCTION MENU

Gen Menu		Tone Rem Function	
1.	Func Gen	1.	2050 (Monitor)
2.	Func Gen	2.	1950 (F1)
3.	Signaling For	3.	1850 (F2)
4.	1. DTMF	4.	1750 (R2 Mute)
5.	2. Audio	5.	1650 (R2 Unmute)
	3. Digital	6.	1550 (Repeater Off)
	4. RCC	7.	1450 (Repeater On)
	1. IMTS	8.	1350 (Wild Card 1 On)
	2. MTS	9.	1250 (Wild Card 1 Off)
	3. 2805	10.	1150 (Wild Card 2 On)
	4. Tone Rem	11.	1050 (Wild Card 2 Off)

Scan RF lock Ret ESC

8610174

- Use FIELD SELECT Keys (1) to select a Tone Remote Function and press ENTER Key.
- Press "Ret" Soft Function Key F5 to return to RF Generator Operation Screen.

18. If an Oscilloscope or Spectrum Analyzer display is desired for RF Generator Screen or if this feature is desired in a different size:

- Press "More" Soft Function Key F6 until "Disp" Soft Function Key F1 appears. Press "Disp" Soft Function Key F1.
- A menu appearing in lower left corner of CRT screen displays following options:

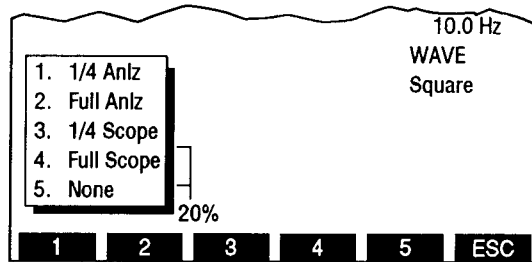

8617084

Select desired screen option using DATA ENTRY Keypad (29).

NOTE: 1/4 size Analyzer Screen parameters are edited by selecting full size Analyzer display, editing parameters and reselecting 1/4 size Analyzer display.

19. If "2. Full Anlz" is selected:

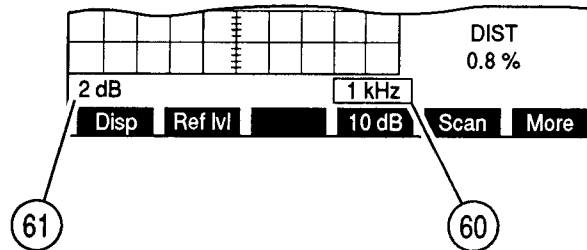

8607108

- Move cursor to Analyzer Scan Width (60) and press ENTER Key to access its data field. Press DATA SCROLL ↑ or ↓ Keys (3) until desired selection appears in data field and press ENTER Key to activate Scan Width desired.
- Move cursor to Units/Division Factor (61) and press ENTER Key to toggle its value between 2 and 10 dB.

20. If "3. 1/4 Scope" is selected:

- Move cursor to Oscilloscope Input (43) and press ENTER Key to access its data field. Press DATA SCROLL ↑ or ↓ Keys (3) until desired selection appears in data field, and press ENTER Key.

NOTE: Remaining Oscilloscope parameters are edited by selecting full size Scope display, changing parameters and reselecting 1/4 size Scope display.

21. If "4. Full Scope" is selected:

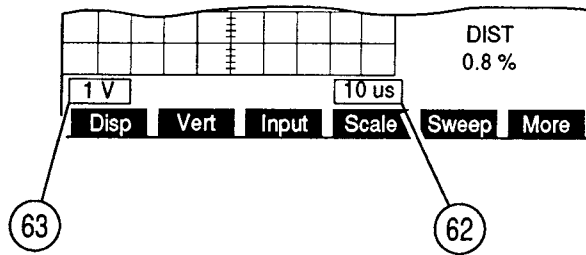

8607106

- Move cursor to Oscilloscope Input (43) and press ENTER Key to access its data field. Press DATA SCROLL ↑ or ↓ Keys (3) until desired selection appears in data field and press ENTER Key.
 - Move cursor to Oscilloscope Sweep Rate (62) and press ENTER Key to access its data field. Press DATA SCROLL ↑ or ↓ Keys (3) until desired selection appears in data field and press ENTER Key.
 - Move cursor to Oscilloscope Scale (63) and press ENTER Key to access its data field. Press DATA SCROLL ↑ or ↓ Keys (3) until desired selection appears in data field and press ENTER Key.
 - If needed, press "More" Soft Function Key F6 until "Vert" Soft Function Key F2 appears. Press "Vert" Soft Function Key F2. Use DATA SCROLL Spinner (2) or DATA SCROLL ↑ or ↓ Keys (3) to adjust vertical position of Oscilloscope Trace. Press ENTER Key.
22. If Modulation Source routed to AUDIO OUT Connector (14) or DEMOD OUT Connector (12) is desired, or if Speaker use is desired, press SETUP Key to display RF Generator Menu. Press 5 DATA ENTRY Key (29) to access RF Generator Setup Menu:

RF GENERATOR SETUP MENU

Gen Menu		
1.	RF Gen #1 Setup	
2.	RF Gen #2 Setup	
3.	Signaling Formats	
4.	External Source Setup	
5.	RF Gen Setup	
1.	RF Gen Freq	10.0000 MHz
2.	RF Gen Level	-40.0 dBm
3.	RF Gen Format	Direct
4.	RF Gen Level Units	dBm
5.	Source to Audio Out	Off
6.	Source to Demod Out	Off
7.	To Speaker	Source

Scan RF lock Ret ESC

8610074

- Press 5 DATA ENTRY Key (29) as needed to enable or disable RF Generator Output to AUDIO OUT Connector (14).

- Press 6 DATA ENTRY Key (29) to enable or disable RF Generator Output to DEMOD OUT Connector (12).
- Press 7 DATA ENTRY Key (29) and use DATA ENTRY Keypad (29) to select a signal to be routed to Speaker.

NOTE: Routing Source to Speaker disables SINAD and Distortion Meters.

- Press "Ret" Soft Function Key F5 to return to RF Generator Operation Screen.
23. To display SINAD, Distortion, AF Level Meter or Digital Multimeter, press "More" Soft Function Key F6 until "Meters" Soft Function Key F4 appears. Press "Meters" Soft Function Key F4 to display a submenu listing available meters. Use DATA ENTRY Keypad (29) to select a meter. To access a meters Operation Screen, move cursor to Meters Callout and press ENTER Key.
- For SINAD Meter Operation Procedures, see 4-8-7.
 - For Distortion Meter Operation Procedures, see 4-8-6.
 - For Digital Multimeter Operating Procedures, see 4-8-10.
- NOTE:** SINAD, Distortion and AF Level Meters measure only SINAD/BER IN Connector (15) Input. DMM measures only DMM Connector Input.
24. To operate RF Generator in Channel Mode, press SETUP Key and 5 DATA ENTRY Key (29) to display RF Generator Setup Menu. Press 3 DATA ENTRY Key (29) until Channel is selected. Press "Chan" Soft Function Key F2 to display Channel Format Menu. Use DATA ENTRY Keypad (29) to select a Channel Format. Press "Ret" Soft Function Key F5 to return to RF Generator Operation Screen.
25. To operate RF Generator in Direct Mode, press "More" Soft Function Key F6 until "Mode" Soft Function Key F1 appears. Press "Mode" Soft Function Key F1 and press 1 DATA ENTRY Key (29) to select Direct Mode.

26. To use RF Generator Frequency Scan, press SETUP Key to access Generator Menu. Press "Scan" Soft Function Key F1 to access RF Generator Frequency Scan Menu:

**RF GENERATOR
FREQUENCY SCAN MENU**

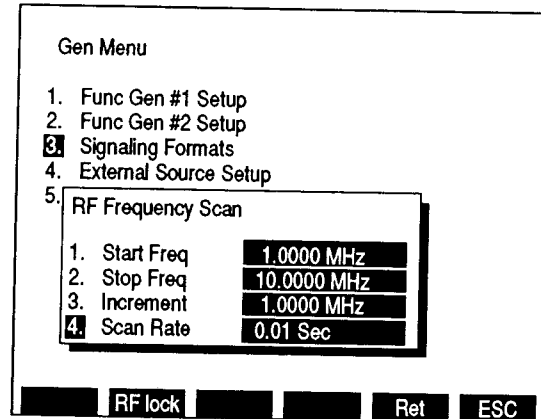

8610084

- Press 1 DATA ENTRY Key (29) to access Starting Frequency. Use DATA ENTRY Keypad (29) to enter Starting Frequency and press ENTER Key.
 - Press 2 DATA ENTRY Key (29) to access Stopping Frequency. Use DATA ENTRY Keypad (29) to enter Stopping Frequency and press ENTER Key.
 - Press 3 DATA ENTRY Key (29) to access Increment. Use DATA ENTRY Keypad (29) to enter Increment and press ENTER Key.
 - Press 4 DATA ENTRY Key (29) to access Scan Rate. Use DATA ENTRY Keypad (29) to enter Scan Rate. Press ENTER Key and "Ret" Soft Function Key F5 to return to Operation Screen.
 - Press "More" Soft Function Key F6 until "G Scan" Soft Function Key F3 appears. Press "G Scan" Soft Function Key F3 to start RF Frequency Scan. Scanning continues repeatedly until "G Scan" Soft Function Key F4 is pressed again.
27. To activate RF Lock Function, press SETUP Key to access Generator Menu. Press "RF lock" Soft Function Key F2. RF Lock locks RF Generator Frequency to Receiver RF Frequency and Analyzer RF Frequency. "RF lock" appears in red when active. Press "RF lock" Soft Function Key F2 to deactivate RF Lock Function.
28. To store or recall a set of screen parameters, see 4-1-1.

4-2-2 GENERATING FM MODULATED RF SIGNAL

EXAMPLE: The following example generates a 90 MHz signal FM modulated with a 1 kHz sine wave. The modulation level is 4 kHz and the RF Output Level is -60 dBm.

STEP	PROCEDURE
1.	Move cursor to RF (40) and press 9 and 0 DATA ENTRY Keys (29) to set RF Generator Frequency to 90.0000 MHz . Press ENTER Key.
2.	Press SETUP Key and 5 DATA ENTRY Key (29) to display RF Generator Setup Menu. Press 4 DATA ENTRY Key (29) until " dBm " is selected for RF Gen Level Units. Press "Ret" Soft Function Key F5.
3.	Move cursor to LEVEL (44) and press +/-, 6 and 0 DATA ENTRY Keys (29) to set RF Generator Level to -60.0 dBm . Press ENTER Key.
4.	Move cursor to SOURCE (30) and press ENTER Key. Use DATA SCROLL ← and → Keys (3) to select AF Generator 1 . Use DATA SCROLL ↑ and ↓ Keys (3) to select FM and press ENTER Key.
5.	Move cursor to DEVIATION (33) and press 4 DATA ENTRY Key (29) to set Deviation to 4.0 kHz . Press ENTER Key.
6.	Move cursor to AF FREQ (35) and press 1, 0, 0 and 0 DATA ENTRY Keys (29) to set AF Frequency to 1000.0 Hz . Press ENTER Key.
7.	Move cursor to WAVE (37) and press DATA SCROLL ↑ and ↓ Keys (3) until " Sine " appears and press ENTER Key.

4-2-3 GENERATING AM MODULATED RF SIGNAL

EXAMPLE: The following example generates an 850 kHz signal AM modulated with a 2 kHz sine wave. The modulation level is 25% and RF Output Level is .224 mV.

STEP	PROCEDURE
1.	Move cursor to RF (40) and press •, 8 and 5 DATA ENTRY Keys (29) to set RF Generator Frequency to 0.8500 MHz . Press ENTER Key.
2.	Press SETUP Key and 5 DATA ENTRY Key (29) to display RF Generator Setup Menu. Press 4 DATA ENTRY Key (29) until " Volts " is selected for RF Gen Level Units. Press "Ret" Soft Function Key F5 to return to RF Generator Operation Screen.
3.	Move cursor to LEVEL (44) and press ENTER Key. Press •, 2, 2, 4 and k/m DATA ENTRY Keys (29) to set RF Generator Level to 0.224 mV .
4.	Move cursor to SOURCE (30) and press ENTER Key. Use DATA SCROLL ← and → Keys (3) to select AF Generator 1 . Use DATA SCROLL ↑ and ↓ Keys (3) to select AM and press ENTER Key.
5.	Move cursor to MODULATION (33) and press 2 and 5 DATA ENTRY Keys (29) to set Modulation to 25 % . Press ENTER Key.

STEP	PROCEDURE
6.	Move cursor to AF FREQ (35) and press 2, 0, 0 and 0 DATA ENTRY Keys (29) to set AF Frequency to 2000.0 Hz . Press ENTER Key.
7.	Move cursor to WAVE (37) and press DATA SCROLL ↑ and ↓ Keys (3) until " Sine " appears and press ENTER Key.

4-2-4 EXTERNALLY MODULATING RF SIGNAL GENERATOR

EXAMPLE: The following example generates a 450 MHz signal FM modulated with an external signal applied to EXT MOD IN Connector (17). The modulation level is 4 kHz and RF Output Level is -65 dBm.

STEP	PROCEDURE
1.	Move cursor to RF (40) and press 4, 5 and 0 DATA ENTRY Keys (29) to set RF Generator Frequency to 450.0000 MHz . Press ENTER Key.
2.	Press SETUP Key and 5 DATA ENTRY Key (29) to display RF Generator Setup Menu. Press 4 DATA ENTRY Key (29) until " dBm " is selected for RF Gen Level Units. Press "Ret" Soft Function Key F5 to return to RF Generator Operation Screen.
3.	Move cursor to LEVEL (44) and press +/-, 6 and 5 DATA ENTRY Keys (29) to set RF Generator Level to -65.0 dBm . Press ENTER Key.
4.	Move cursor to SOURCE (30) and press ENTER Key. Use DATA SCROLL ← and → Keys (3) to select EXT . Use DATA SCROLL ↑ and ↓ Keys (3) to select FM and press ENTER Key.
5.	Move cursor to DEVIATION (33) and press 4 DATA ENTRY Key (29) to set Deviation to 4.0 kHz . Press ENTER Key. Deviation setting assumes EXT MOD IN Connector (17) input is 3.54 VRMS. Deviation settings are set higher for lower EXT MOD IN Connector (17) input voltages to achieve the same deviation level as per following equation:
	$\begin{array}{rcccl} \text{Modulation} & & \text{EXT MOD IN} & & \text{Actual} \\ \text{Level setting} & \times & \text{Connector} & + & \text{Modulation} \\ \text{(kHz, \%, rad)} & & \text{Input (VRMS)} & + & \text{Level} \\ & & & + & 3.54 & = \end{array}$
6.	Apply external modulated signal to EXT MOD IN Connector (17).

4-2-5 GENERATING DTMF CODED RF SIGNAL

EXAMPLE: The following example generates a 450 MHz signal FM modulated with a DTMF Code. The modulation level is 4 kHz and RF Output Level is -60 dBm.

STEP	PROCEDURE
1.	Move cursor to RF (40) and press 4, 5 and 0 DATA ENTRY Keys (29) to set RF Generator Frequency to 450.0000 MHz . Press ENTER Key.
2.	If LEVEL units are volts, press SETUP Key and 5 DATA ENTRY Key (29) to display RF Generator Setup Menu. Press 4 DATA ENTRY Key (29) until " dBm " is selected for RF Gen Level Units. Press "Ret" Soft Function Key F5 to return to RF Generator Operation Screen.
3.	Move cursor to LEVEL (44) and press +/-, 6 and 0 DATA ENTRY Keys (29) to set RF Generator Level to -60.0 dBm . Press ENTER Key.
4.	Move cursor to SOURCE (30) and press ENTER Key. Use DATA SCROLL ← and → Keys (3) to select Source 3 . Use DATA SCROLL ↑ and ↓ Keys (3) to select FM and press ENTER Key.
5.	Move cursor to DEVIATION (33) and press 4 DATA ENTRY Key (29) to set Deviation to 4.0 kHz . Press ENTER Key.
6.	Press SETUP Key to access RF Generator Menu and press 3 DATA ENTRY Key (29). Press 1 DATA ENTRY Key (29) and DTMF Format Menu appears.
7.	Select Id of Sequence to be entered using FIELD SELECT Keys (1) and press ENTER Key.
8.	Move cursor to Timing column and use DATA SCROLL ↑ and ↓ Keys (3) to select Std (standard) or User. If User is chosen, data fields appear for Mark Timing and Space Timing. Use DATA ENTRY Keypad (29) to enter timing desired and press ENTER Key.
9.	Move cursor to Selection column and enter a sequence using DATA ENTRY Keypad (29) and press ENTER Key.
	NOTE: Pressing SHIFT Key toggles DATA ENTRY Keypad (29) between numeric to alphabetic characters.
10.	Move cursor to Mod column and use DATA SCROLL ↑ and ↓ Keys (3) to select modulation. Move cursor to percent modulation and select using DATA ENTRY Keypad (29).
11.	Press ENTER Key and "Ret" Soft Function Key to return to RF Generator Operation Screen.
12.	Move cursor to DIRECT ENTRY/PROGRAM # (47) and press ENTER Key until PROGRAM # appears.
13.	Move cursor to Program Number (48) and use DATA ENTRY Keypad (29) to select a programmed Id.
14.	Press GO TEST CONTROL Key (28) to generate DTMF sequence continually. Press STOP TEST CONTROL Key (28) to stop DTMF sequence. Press STOP TEST CONTROL Key (28) to stop sequence. Press SGL STEP TEST CONTROL Key (28) to generate sequence once.

4-2-6 GENERATING AUDIO TWO TONE CODING

EXAMPLE: The following example generates a 150 MHz signal FM modulated with an Audio Two Tone Code. The modulation level is 4 kHz and RF Output Level is 0 dBm.

STEP	PROCEDURE
1.	Move cursor to RF (40) and press 1, 5 and 0 DATA ENTRY Keys (29) to set RF Generator Frequency to 150.0000 MHz . Press ENTER Key.
2.	If LEVEL units are volts, press SETUP Key and 5 DATA ENTRY Key to display RF Generator Setup Menu. Press 4 DATA ENTRY Key (29) until " dBm " appears. Press "Ret" Soft Function Key F5 to return to RF Generator Operation Screen.
3.	Move cursor to LEVEL (44) and press 0 DATA ENTRY Key (29) to set RF Generator Level to 0.0 dBm . Press ENTER Key.
4.	Move cursor to SOURCE (30) and press ENTER Key. Use DATA SCROLL ← and → Keys (3) to select Source 3 . Use DATA SCROLL ↑ and ↓ Keys (3) to select FM and press ENTER Key.
5.	Move cursor to DEVIATION (33) and press 4 DATA ENTRY Key (29) to set Deviation to 4.0 kHz . Press ENTER Key.
6.	Press SETUP Key to access RF Generator Menu and press 3 DATA ENTRY Key (29). Press 2 DATA ENTRY Key (29) and Audio Signaling Format Menu appears.
7.	Move cursor to "12. User Defined" and press ENTER Key. Press 2 DATA ENTRY Key (29) to access Define Tones Menu.
8.	Move cursor to Tone(Hz) location in 0 row. Press 0 DATA ENTRY (29) Keys and press ENTER Key. Press FIELD SELECT → Key (1) to move cursor to Duration(ms) column. Press 1, 0 and 0 DATA ENTRY Keys (29) and press ENTER Key.
9.	Move cursor to Tone(Hz) location in 1 row. Press 8, 8 and 0 DATA ENTRY Keys (29) and press ENTER Key. Press FIELD SELECT → Key (1) to move cursor to Duration(ms) column. Press 5, 0 and 0 DATA ENTRY Keys (29) and press ENTER Key.
10.	Move cursor to Tone(Hz) location in the 2 row. Press 2, 2, 0 and 0 DATA ENTRY (29) Keys and press ENTER Key. Press FIELD SELECT → Key (1) to move cursor to Duration(ms) column. Press 5, 0 and 0 DATA ENTRY Keys (29) and press ENTER Key.
11.	Press "ESC" Soft Function Key F6 and press 1 DATA ENTRY Key (29) to display Define Sequence Menu. Move cursor to 1 in Id column and press ENTER Key. Press 1, 0 and 2 DATA ENTRY Keys (29) and press ENTER Key. Press "Ret" Soft Function Key F5 to return to RF Generator Operating Screen.
12.	Move cursor to PROG #/DIRECT ENTRY (47) and press ENTER Key until PROG # appears.
13.	Move cursor to Program Number (48), press 1 DATA ENTRY Key (29) to select programmed sequence number 1 and press ENTER Key.
14.	Press GO TEST CONTROL Key (28) to generate sequence continually. Press STOP TEST CONTROL Key (28) to stop sequence. Press SGL STEP TEST CONTROL Key (28) to generate sequence once.

4-2-7 GENERATING 5/6 AUDIO TONE

EXAMPLE: The following example generates a 162 MHz signal FM modulated with an Audio 5/6 Tone Code. The modulation level is 4 kHz and RF Output Level is 0 dBm.

STEP	PROCEDURE
1.	Move cursor to RF (40) and press 1, 6 and 2 DATA ENTRY Keys (29) to set RF Generator Frequency to 162.0000 MHz . Press ENTER Key.
2.	If LEVEL units are volts, press SETUP Key and 5 DATA ENTRY Key (29) to display RF Generator Setup Menu. Press 4 DATA ENTRY Key (29) until " dBm " is selected for RF Gen Level Units. Press "Ret" Soft Function Key F5 to return to RF Generator Operation Screen.
3.	Move cursor to LEVEL (44) and press 0 DATA ENTRY Keys (29) to set RF Generator Level to 0.0 dBm . Press ENTER Key.
4.	Move cursor to SOURCE (30) and press ENTER Key. Use DATA SCROLL ← and → Keys (3) to select Source 3 . Use DATA SCROLL ↑ and ↓ Keys (3) to select FM and press ENTER Key.
5.	Move cursor to DEVIATION (33) and press 4 DATA ENTRY Key (29) to set Deviation to 4.0 kHz . Press ENTER Key.
6.	Press SETUP Key to access RF Generator Menu and press 3 DATA ENTRY Key (29). Press 2 DATA ENTRY Key (29) and Audio Signaling Format Menu appears.
7.	Move cursor to "12. User Defined" and press ENTER Key. Press 2 DATA ENTRY Key (29) to access Define Tones Menu.
8.	Move cursor to Tone(Hz) location in 0 row. Press 9, 0 and 0 DATA ENTRY (29) Keys and press ENTER Key. Press FIELD SELECT → Key (1) to move cursor to Duration(ms) column. Press 1, 5 and 0 DATA ENTRY Keys (29) and press ENTER Key.
9.	Move cursor to Tone(Hz) location in 1 row. Press 1, 1, 0 and 0 DATA ENTRY Keys (29) and press ENTER Key. Press FIELD SELECT → Key (1) to move cursor to Duration(ms) column. Press 8 and 0 DATA ENTRY Keys (29) and press ENTER Key.
10.	Move cursor to Tone(Hz) location in 2 row. Press 1, 2, 0 and 0 DATA ENTRY (29) Keys and press ENTER Key. Press FIELD SELECT → Key (1) to move cursor to Duration(ms) column. Press 8 and 0 DATA ENTRY Keys (29) and press ENTER Key.
11.	Move cursor to Tone(Hz) location in 3 row. Press 1, 3, 0 and 0 DATA ENTRY Keys (29) and press ENTER Key. Press FIELD SELECT → Key (1) to move cursor to Duration(ms) column. Press 8 and 0 DATA ENTRY Keys (29) and press ENTER Key.
12.	Move cursor to Tone(Hz) location in 4 row. Press 1, 4, 0 and 0 DATA ENTRY Keys (29) and press ENTER Key. Press FIELD SELECT → Key (1) to move cursor to Duration(ms) column. Press 8 and 0 DATA ENTRY Keys (29) and press ENTER Key.
13.	Move cursor to Tone(Hz) location in A row. Press 0 DATA ENTRY Key (29) and press ENTER Key. Press FIELD SELECT → Key (1) to move cursor to Duration(ms) column. Press 4 and 0 DATA ENTRY Keys (29) and press ENTER Key.

STEP	PROCEDURE
14.	Press "ESC" Soft Function Key F6 and press 1 DATA ENTRY Key (29) to display Define Sequence Menu. Move cursor to 2 in Id column and press ENTER Key. Press 0 DATA ENTRY Key, press SHIFT Key, press "A" DATA ENTRY Key (29), press SHIFT Key and press 1, 2, 3 and 4 DATA ENTRY Keys (29). Press ENTER Key. Press "Ret" Soft Function Key F5 to return to RF Generator Operating Screen.
15.	Move cursor to PROG #/DIRECT ENTRY (47) and press ENTER Key until PROG # appears.
16.	Move cursor to Program Number (48) and press 1 DATA ENTRY Key (29) to select programmed sequence number 1. Press ENTER Key.
17.	Press GO TEST CONTROL Key (28) to generate sequence continually. Press STOP TEST CONTROL Key (28) to stop sequence. Press SGL STEP TEST CONTROL Key (28) to generate sequence once.

4-2-8 GENERATING DCS CODE

EXAMPLE: The following example generates a 162.4500 MHz signal FM modulated with a DCS Code. The modulation level is 1 kHz and RF Output Level is 0 dBm.

STEP	PROCEDURE
1.	Move cursor to RF (40) and press 1, 6, 2, *, 4 and 5 DATA ENTRY Keys (29) to set RF Generator Frequency to 162.4500 MHz . Press ENTER Key.
2.	If LEVEL units are volts, press SETUP Key and 5 DATA ENTRY Key (29) to display RF Generator Setup Menu. Press 4 DATA ENTRY Key (29) until " dBm " is selected for RF Gen Level Units. Press "Ret" Soft Function Key F5 to return to RF Generator Operation Screen.
3.	Move cursor to LEVEL (44) and press 0 DATA ENTRY Keys (29) to set RF Generator Level to 0.0 dBm . Press ENTER Key.
4.	Move cursor to SOURCE (30) and press ENTER Key. Use DATA SCROLL ← and → Keys (3) to select Source 3 . Use DATA SCROLL ↑ and ↓ Keys (3) to select FM and press ENTER Key.
5.	Move cursor to DEVIATION (33) and press 1 DATA ENTRY Key (29) to set Deviation to 1.0 kHz . Press ENTER Key.
6.	Press SETUP Key to access RF Generator Menu and press 3 DATA ENTRY Key (29). Press 3 DATA ENTRY Key (29) and Digital Menu appears. Press "Ret" Soft Function Key F5 to return to RF Generator Operation Screen.
7.	Move cursor to Signaling Code (46) and press DATA SCROLL ↑ and ↓ Keys (3) until DCS appears. Press ENTER Key.
8.	Move cursor to PROG #/DIRECT ENTRY (47) and press ENTER Key until DIRECT ENTRY appears.

STEP**PROCEDURE**

9. Move cursor to Sequence (50) and press 4, 6 and 5 DATA ENTRY Keys (29). Press ENTER Key.
10. Press GO TEST CONTROL Key (28) to generate sequence continually. Press STOP TEST CONTROL Key (28) to stop sequence. Press SGL STEP TEST CONTROL Key (28) to generate sequence once.

4-2-9 GENERATING POCSAG CODE

EXAMPLE: The following example generates a 930 MHz signal FM modulated with a POCSAG Code. The modulation level is 4 kHz and RF Output Level is 0 dBm.

STEP**PROCEDURE**

1. Move cursor to RF (40) and press 9, 3 and 0 DATA ENTRY Keys (29) to set RF Generator Frequency to **930.0000 MHz**. Press ENTER Key.
2. If LEVEL units are volts, press SETUP Key and 5 DATA ENTRY Key (29) to display RF Generator Setup Menu. Press 4 DATA ENTRY Key (29) until "**dBm**" is selected for RF Gen Level Units. Press "Ret" Soft Function Key F5 to return to RF Generator Operation Screen.
3. Move cursor to LEVEL (44) and press 0 DATA ENTRY Key (29) to set RF Generator Level to **0.0 dBm**. Press ENTER Key.
4. Move cursor to SOURCE (30) and press ENTER Key. Use DATA SCROLL ← and → Keys (3) to select Source **3**. Use DATA SCROLL ↑ and ↓ Keys (3) to select **FM** and press ENTER Key.
5. Move cursor to DEVIATION (33) and press 4 DATA ENTRY Key (29) to set Deviation to **4.0 kHz**. Press ENTER Key.
6. Press SETUP Key to access RF Generator Menu and press 3 DATA ENTRY Key (29). Press 3 DATA ENTRY Key (29) and Digital Menu appears. Press 3 DATA ENTRY Key (29) to display POCSAG Menu.
7. Press 1 DATA ENTRY Key and press 5, 1, 3 and 0 DATA ENTRY Keys (29) to set Capcode 1 to **5130**. Press ENTER Key. Press 2 DATA ENTRY Key (29) and press 5, 1, 3 and 5 DATA ENTRY Keys (29) to set Capcode 2 to **5135**. Press ENTER Key.
8. Press 3 DATA ENTRY Key (29) until "**Low**" appears as the Transmit rate. Press 4 and 9 DATA ENTRY Keys (29) to select **Alphanumeric** as message type.
9. Press "Ret" Soft Function Key F5 to return to RF Generator Operation Screen.
10. Press GO TEST CONTROL Key (28) to generate POCSAG Code. Capcode being generated appears below message type (49). When all capcodes specified are generated, Complete appears. Press SGL STEP TEST CONTROL Key (28) to generate one capcode and pause. Press STOP TEST CONTROL Key (28) to stop generating Code.

4-2-10 GENERATING 2805 CODE

EXAMPLE: The following example generates a 155 MHz signal FM modulated with a 2805 Tone (with frequency reset to 1500 Hz). The modulation level is 4 kHz and RF Output Level is -60 dBm.

STEP	PROCEDURE
1.	Move cursor to RF (40) and press 1, 5 and 5 DATA ENTRY Keys (29) to set RF Generator Frequency to 155.0000 MHz . Press ENTER Key.
2.	If LEVEL units are volts, press SETUP Key and 5 DATA ENTRY Key (29) to display RF Generator Menu. Press 4 DATA ENTRY Key (29) until " dBm " is selected for RF Gen Level Units. Press "Ret" Soft Function Key F5 to return to RF Generator Operation Screen.
3.	Move cursor to LEVEL (44) and press +/-, 6 and 0 DATA ENTRY Keys (29) to set RF Generator Level to -60 dBm . Press ENTER Key.
4.	Move cursor to SOURCE (30) and press ENTER Key. Use DATA SCROLL ← and → Keys (3) to select Source 3 . Use DATA SCROLL ↑ and ↓ Keys (3) to select FM and press ENTER Key.
5.	Move cursor to DEVIATION (33) and press 4 DATA ENTRY Key (29) to set Deviation to 4.0 kHz . Press ENTER Key.
6.	Press SETUP Key to access RF Generator Menu and press 3 DATA ENTRY Key (29). Press 4 DATA ENTRY Key (29) and RCC Menu appears. Press 3 DATA ENTRY Key (29) to display 2805 Menu.
7.	Press "Tone" Soft Function Key F3 to display 2805 Frequency data field. Press 1, 5, 0 and 0 DATA ENTRY Key (29) to set 2805 frequency to 1500.0 Hz . Press ENTER Key.
8.	Move cursor to 1 Id (Identification Number) and press ENTER Key. Press 5, 5, 5, 1, 2, 3 and 4 DATA ENTRY Keys (29) and press ENTER Key.
9.	Press "Ret" Soft Function Key F5 to return to RF Generator Operation Screen.
10.	Move cursor to PROG #/DIRECT ENTRY (47) and press ENTER Key until PROG # appears.
11.	Move cursor to Program Number (48) and press 1 DATA ENTRY Key (29) to select programmed sequence number 1 . Press ENTER Key.
12.	Press GO TEST CONTROL Key (28) to generate sequence continually. Press STOP TEST CONTROL Key (28) to stop sequence. Press SGL STEP TEST CONTROL Key (28) to generate sequence once.

4-2-11 GENERATING TONE REMOTE CODE

EXAMPLE: The following example generates a Tone Remote Code routed to the AUDIO OUT Connector (14) with a High Level Guard Tone at 10 dB.

STEP	PROCEDURE
1.	If LEVEL units are volts, press SETUP Key and 5 DATA ENTRY Key (29) to display RF Generator Setup Menu. Press 4 DATA ENTRY Key (29) until " dBm " is selected for RF Gen Level Units. Press "Ret" Soft Function Key F5 to return to RF Generator Operation Screen.
2.	Move cursor to LEVEL (44) and press +/-, 1, 2 and 0 DATA ENTRY Keys (29) to set RF Generator Level to -120 dBm . Press ENTER Key.
4.	Move cursor to SOURCE (30) and press ENTER Key. Use DATA SCROLL ← and → Keys (3) to select Source 3 . Use DATA SCROLL ↑ and ↓ Keys (3) to select FM and press ENTER Key.
5.	Press SETUP Key to access RF Generator Menu and press 3 DATA ENTRY Key (29). Press 4 DATA ENTRY Key (29) and RCC Code Menu appears. Press 4 DATA ENTRY Key (29) to display Tone Remote Function Menu.
6.	Use DATA ENTRY Keypad (29) to select a Tone Remote Function. Press "ESC" Soft Function Key F6 twice.
7.	Press 5 DATA ENTRY Key (29) to display RF Generator Setup Menu. Press 5 DATA ENTRY Key (29) to toggle "Source to Audio Out" until " On " appears.
8.	Press "Ret" Soft Function Key F5 to return to RF Generator Operation Screen.
9.	Connect a power meter to AUDIO OUT Connector (14). Move cursor to DEVIATION (33) and rotate DATA SCROLL Spinner (2) until AUDIO OUT Connector (14) Output measures 10 dB (approximately 6.1 kHz). Press ENTER Key and disconnect external power meter.
10.	Press GO TEST CONTROL Key (28) to generate sequence. Press STOP TEST CONTROL Key (28) to stop sequence.

4-2-12 MEASURING SINAD SENSITIVITY, CENTER FREQUENCY AND MODULATION ACCEPTANCE BANDWIDTH

STEP	PROCEDURE
1.	Connect T/R Connector (6) to UUT Antenna. Connect SINAD/BER IN Connector (15) to Speaker Audio Out of UUT.
2.	Adjust UUT output to 60% of rated power.
3.	Press RF GEN MODE Key (27) .
4.	Press "More" Soft Function Key until "Meters" is shown for Soft Function Key F4. Press "Meters" Soft Function Key F4 and press 1 DATA ENTRY Key (29) to select SINAD Meter.
5.	Move cursor to Source (30) and press ENTER Key. Use FIELD SELECT Keys (1) to select Source 1 and press DATA SCROLL ↑ and ↓ Keys (3) to select FM Modulation. Press ENTER Key.
6.	Move cursor to DEVIATION (33) and press 3 DATA ENTRY Key (29) to set Deviation to 3.0 kHz . Press ENTER Key.
7.	Move cursor to AF FREQ (35) and press 1, 0, 0 and 0 DATA ENTRY Keys (29) to set AF Frequency to 1000.0 kHz . Press ENTER Key.
8.	Move cursor to WAVE (37) and press DATA SCROLL ↑ and ↓ Keys (3) until " Sine " appears in data field. Press ENTER Key.
9.	Move cursor to SINAD Callout and press ENTER Key. <ul style="list-style-type: none">● Move cursor to NOTCH FREQ and press ENTER Key. Press 1, 0, 0 and 0 DATA ENTRY Keys (29) to set Notch Freq to 1000 Hz and press ENTER Key.● Move cursor to AVERAGE and press ENTER Key until "On" appears.● If red PH is displayed at left end of Meter Indicator Bar (Peak Hold on), press Soft Function Key F5 to toggle Peak Hold off.● Press Soft Function Key F6 to return to RF Generator Operation Screen.
10.	Move cursor to RF (40) and press ENTER Key. Use DATA ENTRY Keypad (29) to set RF Frequency to approximately UUT Receiving Frequency and press ENTER Key.
11.	Move cursor to LEVEL (44) and press ENTER Key. Use DATA SCROLL ↑ and ↓ Keys (3) to adjust RF Out Level until SINAD Meter reads 12 dB. Use FIELD SELECT Keys (1) to move cursor to RF (40) and press ENTER Key. Adjust RF Frequency using DATA SCROLL ↑ and ↓ Keys (3) until a maximum reading is attained on SINAD Meter. RF Frequency shows UUT Receiver's Center Frequency.

STEP**PROCEDURE**

12. Leaving RF Frequency at UUT Receiver's Center Frequency, move cursor to LEVEL (44) and press ENTER Key. Use DATA SCROLL ↑ and ↓ Keys (3) to adjust RF Out Level until SINAD Meter reads 12 dB. RF Out Level reads UUT Receiver Sensitivity.
13. Use DATA SCROLL ↑ and ↓ Keys (3) to increase RF Out Level 6 dB and press ENTER Key.
14. Use FIELD SELECT Keys (1) to move cursor to DEVIATION (33) and press ENTER Key. Use DATA SCROLL Keys (3) to increase Deviation until SINAD Meter again reads 12 dB. Modulation Acceptance Bandwidth is twice Deviation reading.

Example: If Deviation reads 5 kHz, then Modulation Acceptance Bandwidth is 10 kHz.

4-2-13 MEASURING RECEIVER IF BANDWIDTH

STEP	PROCEDURE
1.	Connect UUT Antenna to T/R Connector (6). Connect Audio Out Connector (14) of receiver under test to SINAD/BER Connector of 1600S.
2.	Open squelch fully on receiver under test.
3.	Press RF GEN MODE Key (27) and move cursor to RF (40). Use DATA ENTRY Keys (29) to set frequency to frequency of receiver under test.
4.	Move cursor to SOURCE (30) and press ENTER Key. Use FIELD SELECT ← and → Keys (1) to select Source 1 and use DATA SCROLL ↑ and ↓ Keys (3) to select FM Modulation. Press ENTER Key.
5.	Move cursor to DEVIATION (33) and press 1 DATA ENTRY Key (29) to set Deviation to 1.0 kHz . Press ENTER Key.
6.	Move cursor to AF FREQ (35) and press 1, 0, 0 and 0 DATA ENTRY Keys (29) to set AF Frequency to 1000.0 Hz . Press ENTER Key.
7.	Move cursor to WAVE (37) and use DATA SCROLL ↑ and ↓ Keys (3) until " Sine " appears. Press ENTER Key.
8.	Press "More" Soft Function Key F6 until "Meters" Soft Function Key F4 appears. Press "Meters" Soft Function Key F4 and press 1 DATA ENTRY Key (29) to select SINAD Meter.
9.	If LEVEL (45) units are V or mV, press SETUP Key and press 5 DATA ENTRY Key (29) to display RF Generator Menu. Press 4 DATA ENTRY Key (29) to toggle RF Gen Level Units until " dBm " appears and press "Ret" Soft Function Key F5 to return to RF Gen Operation Screen.
10.	Move cursor to LEVEL (45) and use DATA SCROLL ↑ and ↓ Keys (3) to adjust Output Level until SINAD Meter reads 12 dB. Resulting Output Level is Reference Sensitivity.
11.	Use DATA SCROLL ↑ and ↓ Keys (3) to adjust Output Level 60 dBm above Reference Sensitivity measured in step 10.
12.	Move cursor to RF (40) and press ENTER Key. Press DATA SCROLL → Key (3) until least significant digit is highlighted. Press DATA SCROLL ↑ Key (3) until SINAD Meter reads 12 dB. RF reads Upper Frequency.
13.	Press DATA SCROLL ↓ Key (3) until SINAD Meter reads 12 dB. RF reads Lower Frequency. The difference between Upper Frequency and Lower Frequency is 60 dB skirt width.

4-3 RECEIVER OPERATION

4-3-1 RECEIVER GENERAL OPERATION

Low power (10 mW max) RF signals are monitored "off the air" from ANTENNA IN Connector (25). High power RF signals (10 mW to 50 W) are monitored through T/R Connector (6) using the following procedures:

NOTE: Valid Receiver Operation Screen meter readings are not displayed until Squelch is broken

RECEIVE SCREEN WITH SQUELCH UNBROKEN

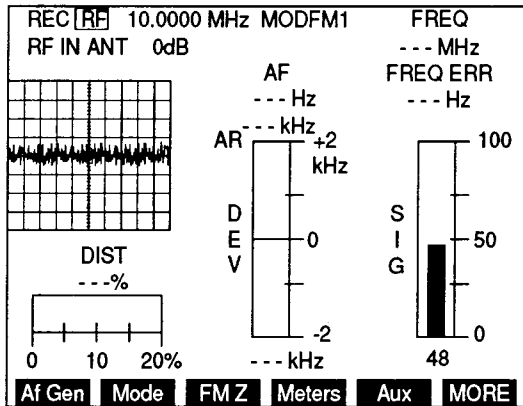

8617069

RECEIVE SCREEN WITH SQUELCH BROKEN

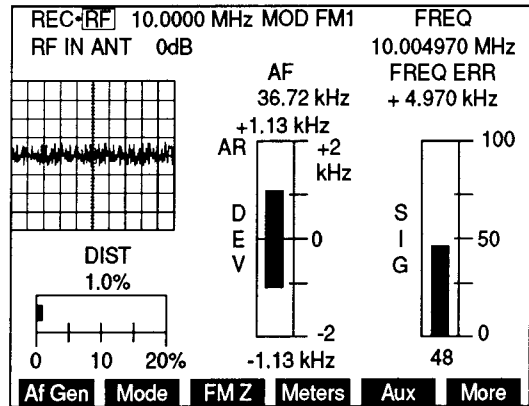

8617070

STEP PROCEDURE

1. If needed, assemble antenna and right angle BNC adapter for antenna input to ANTENNA IN Connector (25) or connect RF signal input to T/R Connector (6).

CAUTION MAXIMUM CONTINUOUS INPUT TO ANTENNA IN CONNECTOR (25) IS LIMITED TO 10 mW WITH PROTECTION PROVIDED TO A MAXIMUM INPUT OF 65 W. MAXIMUM CONTINUOUS INPUT TO T/R CONNECTOR (6) IS LIMITED TO 50 W WITH PROTECTION PROVIDED TO A MAXIMUM INPUT OF 200 W.

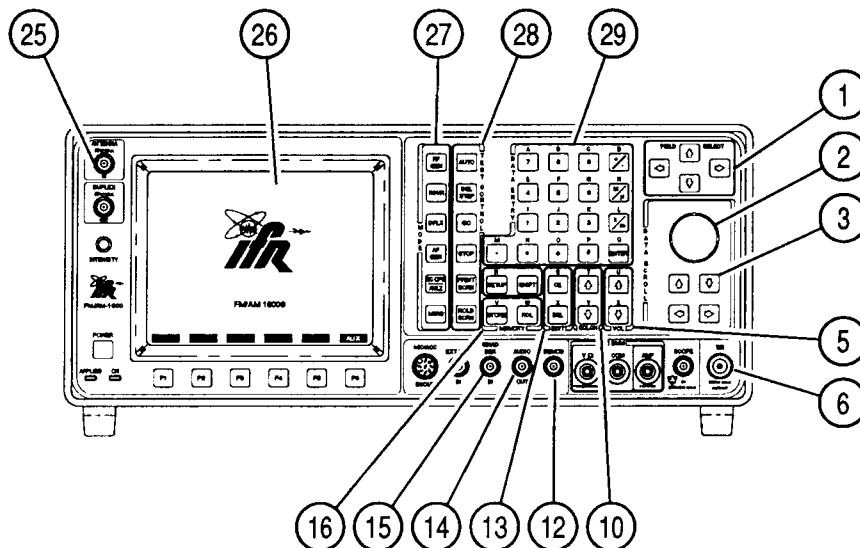

8607085

2. Press RCVR MODE Key (27). Receiver Operation Screen appears on CRT.

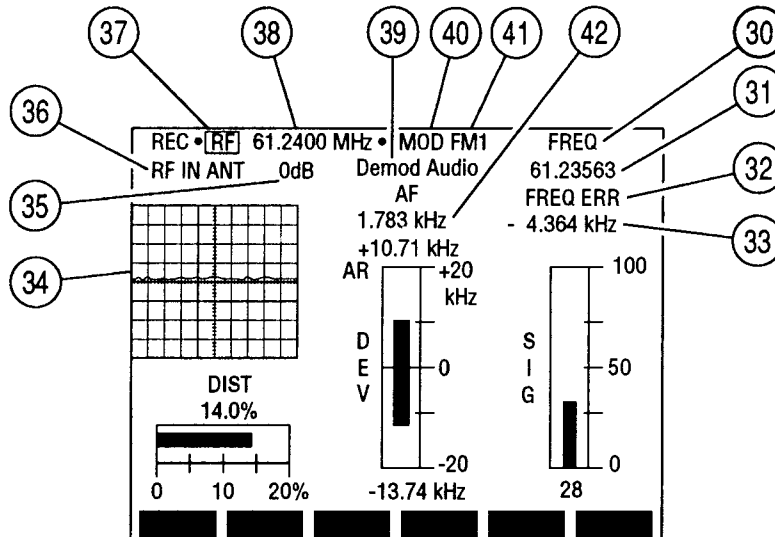

8607059

- Move cursor to RF IN data field (36) and press ENTER Key to toggle RF Input location between "ANT" and "T/R" to match input location of received signal.
- Move cursor to RF (37) and press ENTER Key to access frequency data field (38). Use DATA ENTRY Keypad (29) to enter a frequency (in MHz) and press ENTER Key.

NOTE: RF Frequency Error Meter gives inaccurate results when Deviation Meter readings exceed Deviation Meter Range.
- To adjust squelch level, press a SQLCH Key (10). Squelch data field appears on CRT. Press SQLCH Keys (10) to adjust Squelch and press ENTER Key.
- To adjust volume, press a VOL Key (5). Volume data field appears on CRT. Press VOL Keys (5) to adjust Volume and press ENTER Key.
- Move cursor to Input Attenuation Level (35) and press ENTER Key to access data field. Press DATA SCROLL ↑ or ↓ Keys (3) until desired selection appears in data field and press ENTER Key to activate input attenuation.
- Move cursor to MOD (40) and press ENTER Key to access Modulation Type data field (41). Use DATA SCROLL ↑ or ↓ Keys (3) until desired setting appears in data field and press ENTER Key to activate. See Table 3-2 for description of modulation types.
- If User is selected as Modulation Type, press SETUP Key to access Receiver Menu. Press 2 DATA ENTRY Key (29) to display Receiver Modulation Menu and press ENTER Key. User Defined Modulation Menu appears:

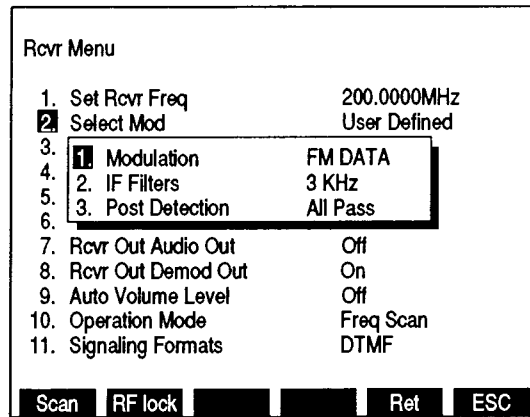

8610059

- Press 1 DATA ENTRY Key (29) and use DATA ENTRY Keypad (29) to select User Modulation Type.
 - Press 2 DATA ENTRY Key (29) and use DATA ENTRY Keypad (29) to select an IF Filter.
 - Press 3 DATA ENTRY Key (29) and use DATA ENTRY Keypad (29) to select a Post Detection Filter. If Low Pass, High Pass or Band Pass is selected, a cutoff frequency data field appears. Use DATA ENTRY Keypad (29) to enter cutoff frequencies and press ENTER Key.
 - Press "Ret" Soft Function Key F5 to return to Receiver Operation Screen.
10. If decoding Signaling Formats is not desired, proceed with step 17.
11. Press SETUP Key to display Receiver Menu, move cursor to "11. Signaling Formats" and press ENTER Key. Use DATA ENTRY Keypad (29) to select a Signaling Format.
- If DTMF is selected, press "Ret" Soft Function Key F5 to return to Receiver Operation Screen.
 - If Audio is selected, Audio Code Menu appears. Use FIELD SELECT Keys (1) to select an Audio Code and press ENTER Key. Press "Ret" Soft Function Key F5 to return to Receiver Operation Screen.

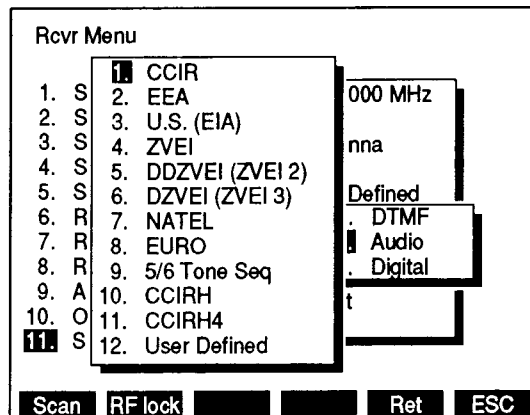

8610106

- If Digital is selected, Digital Code Menu appears. Use DATA ENTRY Keypad (29) to select a Digital Code. Press "Ret" Soft Function Key F5 to return to Receiver Operation Screen.
12. Press "More" Soft Function Key F6 until "Disp" Soft Function Key F1 is displayed. Press "Disp" Soft Function Key F1 to display following submenu:

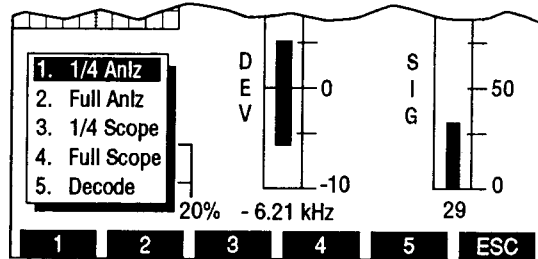

8617081

13. Press 5 DATA ENTRY Key (29) to display Decode Callout (44).

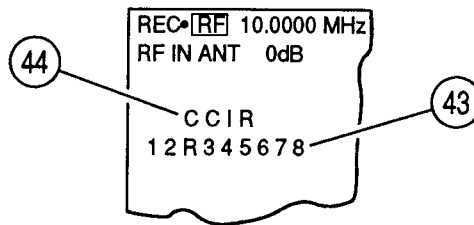

8617066

14. For DTMF Decode, press "Decode" Soft Function Key F2. Decoded digits (43) are displayed under DTMF Callout. To stop decoding, press "Stop" Soft Function Key F3.
15. For DCS or DCS INV Decode:
- To change Input Source, press "Input" Soft Function Key F5. A submenu appears listing Input Sources. Use DATA ENTRY Keypad (29) to select an Input Source.
NOTE: Source "2. SIN/BER (INV)" inverts Input before decoding.
 - Press "Decode" Soft Function Key F2. Decoded digits (43) are displayed under Decode Callout (44). To stop decoding, press "Stop" Soft Function Key F3.

16. For Audio or Digital POCSAG Decode, press "Extend" Soft Function Key F5 to display the following Extend Screen:

Audio Tones Decode: CCIR							
#	Frq	Err %	Dur	#	Frq	Err %	Dur
1	1158	3.2	98				
2	1167	2.5	99				
3	1298	1.8	101				
4	1406	3.5	98				
5	1475	2.0	98				

Input Decode Stop Type Ret

8610175

- To change Input Source, press "Input" Soft Function Key F1. A submenu appears listing Input Sources. Use DATA ENTRY Keypad (29) to select an Input Source.
 - For POCSAG, press "Rate" Soft Function Key F4 to toggle POCSAG Rate to Low or High.
 - For Audio, press "Type" Soft Function Key F4 to access Audio Code Callout. Use DATA SCROLL ↑ and ↓ Keys (3) to select an Audio Code and press ENTER Key.
 - Press "Decode" Soft Function Key F2 to decode. Decoded digits, frequencies, frequency error percentages and time durations are displayed.
 - Press "Stop" Soft Function Key F3 to stop decoding. Press "Ret" Soft Function Key F5 to return to Receive Operation Screen.
17. To set Receiver Output parameters, press SETUP Key to display Receiver Menu.
- Press 5 DATA ENTRY Key (29) to display AGC Type Menu. Use DATA ENTRY Keypad (29) to select an AGC Type.
 - If User Defined is selected as AGC Type, User Defined AGC Type Menu appears. Use DATA ENTRY Keypad (29) to select an User Defined AGC Type.
 - If Manual is selected, a data field appears. Use DATA ENTRY Keypad (29) to enter an AGC Level and press ENTER Key.
 - To route demodulated Received Signal to Speaker, press 6 DATA ENTRY Key (29) to toggle "Rcvr Out Speaker" on.
 - To route demodulated Received Signal to AUDIO OUT Connector (14), press 7 DATA ENTRY Key (29) to toggle "Rcvr Out Audio Out" on.
 - To route demodulated Received Signal to DEMOD OUT Connector (12), press 8 DATA ENTRY Key (29) to toggle "Rcvr Out Demod Out" on.

- Press 9 DATA ENTRY Key (29) to toggle Automatic Volume Level on or off.
 - Press "Ret" Soft Function Key F5 to return to Receiver Operation Screen.
18. If an Oscilloscope or Analyzer Display is not desired, proceed with step 23.
19. Press "More" Soft Function Key F6 until "Disp" Soft Function Key F1 appears. Press "Disp" Soft Function Key F1 to display a menu listing Oscilloscope and Analyzer options. Use DATA ENTRY Keypad (29) to select an option.

NOTE: When LSB is selected for Modulation or 3 kHz is selected as User Modulation IF Filter, the Center Frequency of Receivers Analyzer Display is shifted 1.8 kHz left of the center line.

When USB is selected for Modulation, Center Frequency of Receivers Analyzer Display is shifted 3.6 kHz left of the center line.

1/4 size Analyzer Screen parameters are edited by first selecting full size Analyzer display, changing parameters and then reselecting 1/4 size Analyzer display.

20. If "2. Full Anlz" is selected, following Soft Function Keys are displayed:

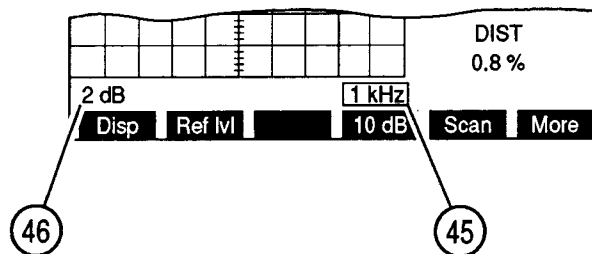

8607079

- Move cursor to Analyzer Scan Width (45) and press ENTER Key to access its data field. Press DATA SCROLL \uparrow or \downarrow Keys (3) until desired selection appears in data field and press ENTER Key to activate Scan Width desired.
- Move cursor to Units/Division Factor (46) and press ENTER Key to toggle Units/Division Factor between 2 and 10 dB.
- If 2 dB is selected for Units/Division Factor, press "Ref lvl" Soft Function Key F2 and use DATA SCROLL Spinner (2) or DATA SCROLL \uparrow and \downarrow Keys (3) to adjust Reference Level. Press ENTER Key.

21. If "3. 1/4 Scope" is selected:

- Move cursor to Oscilloscope Input (39) and press ENTER Key to access its data field. Press DATA SCROLL ↑ or ↓ Keys (3) until desired selection appears in data field and press ENTER Key to activate.

NOTE: The remaining Oscilloscope parameters are edited by selecting full size Scope display, editing desired parameters and reselecting 1/4 size Scope display.

22. If "4. Full Scope" is selected:

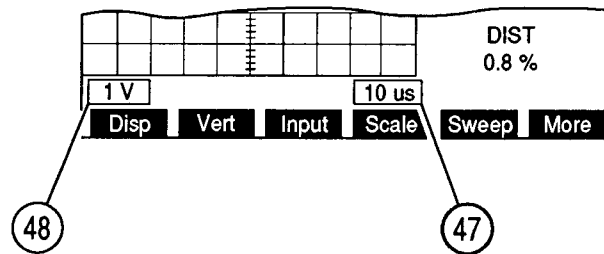

8607080

- Move cursor to Oscilloscope Input (39) and press ENTER Key to access its data field. Press DATA SCROLL ↑ or ↓ Keys (3) until desired selection appears in data field and press ENTER Key to activate.
 - If needed, move cursor to Oscilloscope Sweep Rate (47) and press ENTER Key to access its data field. Press DATA SCROLL ↑ or ↓ Keys (3) until desired selection appears in data field and press ENTER Key to activate.
 - Move cursor to Oscilloscope Scale (48) and press ENTER Key to access its data field. Press DATA SCROLL ↑ or ↓ Keys (3) until desired selection appears in data field and press ENTER Key to activate.
 - If needed, press "Vert" Soft Function Key F2 to edit vertical adjustment of Oscilloscope Trace. Use DATA SCROLL Spinner (2) or DATA SCROLL ↑ or ↓ Keys (3) to adjust vertical position of Oscilloscope Trace.
23. Press "More" Soft Function Key F6 until "Af Gen" Soft Function Key F1 appears. Press "Af Gen" Soft Function Key F1 to display the following submenu:

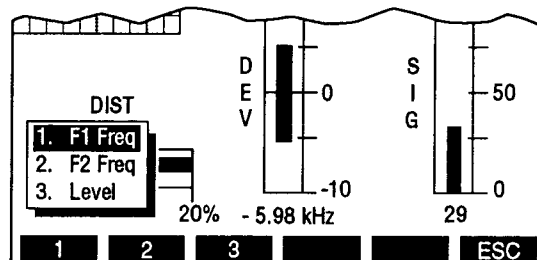

8617082

- To edit AF Generator #1 Frequency, press 1 DATA ENTRY Key. A data field appears displaying the current frequency. Use DATA ENTRY Keypad (29) to enter desired frequency and press ENTER Key.

- To edit AF Generator #2 Frequency, press 2 DATA ENTRY Key (29). A data field appears displaying current frequency. Use DATA ENTRY Keypad (29) to enter desired frequency and press ENTER Key.
 - To edit AF Generator Level, press 3 DATA ENTRY Key (29). A data field appears displaying current level. Use DATA ENTRY Keypad (29) to enter desired level and press ENTER Key.
24. To select a meter, press "More" Soft Function Key F6 until "Af Gen" Soft Function Key F1 appears:
- For FM or PM Modulation (41), press "Meters" Soft Function Key F4 to select SINAD, Distortion or Deviation (RMS) Meter.
- NOTE:** Deviation (RMS) Meter may not operate with Deviation (Peak) Meter Range >10 kHz.
- For AM Modulation (41), press "Modul"/"Dist" Soft Function Key F4 to select Modulation or Distortion Meter. Both Meters are displayed, but only selected meter operates.
 - For USB, LSB or BFO Modulation (41), press "Tune" Soft Function Key F4 and use DATA SCROLL ↑ and ↓ Keys (3) to tune Receiver in 125 Hz steps. Press ENTER Key.
25. To zero Deviation Meter if displayed, press "More" Soft Function Key F6 until "FM Z" Soft Function Key F3 appears. Press "FM Z" Soft Function Key F3. To abort zeroing process, press Soft Function Key F3 before "FM Z" reappears.
26. To edit a Meters settings, move cursor to Callout of Meter to be edited and press ENTER Key. Meter's Operation Screen appears.
- For Frequency Error Meter/Frequency Meter Operation Procedures, see 4-8-2.
 - For AF Meter Operation Procedures, see 4-8-1.
 - For Deviation Meter Operation Procedures, see 4-8-4.
 - For Phase Meter Operation Procedures, see 4-8-11.
 - For AM Modulation Meter Operation Procedures, see 4-8-5.
 - For Distortion Meter Operation Procedures, see 4-8-6.
 - For Power Meter Operation Procedures, see 4-8-3.
 - For Signal Strength Meter Operation Procedures, see 4-8-8.
 - For SINAD Meter Operation Procedures, see 4-8-7.
 - For Deviation (RMS) Meter Operation Procedures, see 4-8-12.

27. To operate Receiver in Channel Mode, press SETUP Key to display Receiver Menu.
- Move cursor to "10. Operation Mode" and press ENTER Key. Press 2 DATA ENTRY Key (29) to select Receiver Channel Mode.
 - Press "Chan" Soft Function Key F2 to display a submenu listing cellular formats. Use DATA ENTRY Keypad (29) to select a cellular format.
 - Press "Ret" Soft Function Key F5 to return to Receiver Operation Screen. Receiver Frequency is displayed by channel number. For a list of AMPS cellular channels and corresponding frequencies, see Appendix B. For a list of E-TACS cellular channels and corresponding frequencies, see Appendix C.
 - To return Receiver Operation Mode to Direct Mode, press SETUP Key to display Receiver Menu. Move cursor to "10. Operation Mode" and press ENTER Key. Press 1 DATA ENTRY Key (29) to select Receiver Direct Mode. Press "Ret" Soft Function Key F6 to return to Receiver Operation Screen.
28. To operate Find Function:
- Press "More" Soft Function Key F6 until "Disp" Soft Function Key F1 appears. Press "Disp" Soft Function Key F1 to display a menu listing Oscilloscope and Analyzer options.
 - Press 2 DATA ENTRY Key (29) to select full size Analyzer.
 - Press "More" Soft Function Key F6 and press "Find lvl" Soft Function Key F2. Find Level is indicated by a red horizontal line. Use DATA SCROLL Spinner (2) or DATA SCROLL ↑ and ↓ Keys (3) to adjust Find Level and press ENTER Key.
 - Press "Find" Soft Function Key F1 to activate Find Function. Receiver Frequency is changed to frequency found.
29. To operate Receiver Scan Function, press SETUP Key to display Receiver Menu. Press "Scan" Soft Function Key F1 to display RF Frequency Scan Menu.

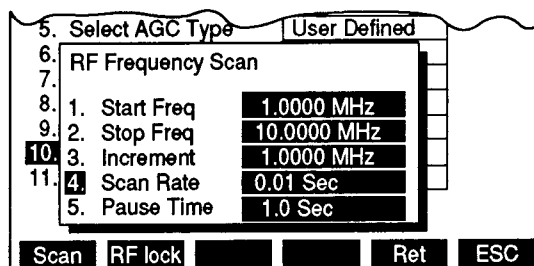

8610092

- Press 1 DATA ENTRY Key (29) and use DATA ENTRY Keypad (29) to enter Starting Frequency (Starting Frequency must be less than Ending Frequency). Press ENTER Key.
- Press 2 DATA ENTRY Key (29) and use DATA ENTRY Keypad (29) to enter Ending Frequency. Press ENTER Key.

-
- Press 3 DATA ENTRY Key (29) and use DATA ENTRY Keypad (29) to enter Increment. Press ENTER Key.
 - Press 4 DATA ENTRY Key (29) and use DATA ENTRY Keypad (29) to enter Scan Rate. Press ENTER Key.
 - Press 5 DATA ENTRY Key (29) and use DATA ENTRY Keypad (29) to enter Pause Time. Press ENTER Key. Zero Pause Time causes receiver Scan to remain on a frequency until squelch is no longer broken.
 - Press "Ret" Soft Function Key F5 to return to Receiver Operation Screen.
 - Press "More" Soft Function Key F6 until "Mode" Soft Function Key F2 appears. Press "Mode" Soft Function Key F2 and press 3 DATA ENTRY Key (29) to select Receiver Frequency Scan Operation Mode.
 - Press GO TEST CONTROL Key (28) to start Receiver Scan. Press STOP TEST CONTROL Key (28) to stop Scanning. Pressing GO TEST CONTROL Key (28) again resumes scanning operation. Press SGL STEP TEST CONTROL Key (28) to single step through scanning operation one increment at a time. Press AUTO TEST CONTROL Key (28) to single step through scanning operation backward one step at a time.
 - To return Receiver Operation Mode to Direct Operation, press "More" Soft Function Key F6 until "Mode" Soft Function Key F2 appears. Press "Mode" Soft Function Key F2 and press 1 DATA ENTRY Key (29) to select Receiver Direct Operation Mode.
30. To activate RF Lock feature, press SETUP Key to display Receiver Menu. Press "RF lock" Soft Function Key F2. "RF lock" appears in red while active.

4-3-2 RECEIVING FM SIGNALS

EXAMPLE: The following example receives a 90 MHz FM modulated signal "off the air" and routes demodulated signal to AUDIO OUT Connector (14) and Test Set Speaker.

STEP	PROCEDURE
1.	Connect external antenna to ANTENNA IN Connector (25).
2.	Move cursor to RF (37) and press 9 and 0 DATA ENTRY Keys (29) to set Receiver Frequency to 90.0000 MHz . Press ENTER Key.
3.	Move cursor to MOD (40), use DATA SCROLL ↑ and ↓ Keys (3) to select a FM Modulation and press ENTER Key.
4.	Move cursor to RF IN (36) and press ENTER Key to toggle RF Input Location until " ANT " (ANTENNA IN Connector [25]) appears.
5.	If Signal Strength Meter reading is greater than 90, move cursor to Receiver Input Attenuation Level (35), press DATA SCROLL Keys ↑ and ↓ (3) to select greater attenuation and press ENTER Key.
6.	Press a SQLCH Key (10) to display Squelch data field. Press SQLCH Keys (10) until squelch is broken and press ENTER Key.
7.	Press SETUP Key to access Receiver Menu. <ul style="list-style-type: none">● Press 6 DATA ENTRY Key (29) to toggle "Rcvr Out Speaker" until "On" appears.● Press 7 DATA ENTRY Key (29) to toggle "Rcvr Out Audio Out" until "On" appears.● Press "Ret" Soft Function Key F5 to return to Operation Screen.
8.	Press a VOL Key (5) to display Volume data field. Press VOL Keys (5) to adjust volume to desired level and press ENTER Key.

4-3-3 RECEIVING AM SIGNALS

EXAMPLE: The following example receives a 850 kHz FM modulated signal and routes demodulated signal to AUDIO OUT Connector (14) and Test Set Speaker.

STEP	PROCEDURE
1.	Connect external antenna to ANTENNA IN Connector (25).
2.	Move cursor to RF (37) and press ●, 8 and 5 DATA ENTRY Keys (29) to set Receiver Frequency to 0.8500 MHz . Press ENTER Key.
3.	Move cursor to MOD (40), use DATA SCROLL Keys ↑ and ↓ (3) to select an AM Modulation and press ENTER Key.
4.	Move cursor to RF IN (36) and press ENTER Key to toggle RF Input Location until " ANT " (ANTENNA IN Connector [25]) appears.
5.	If Signal Strength Meter reading is greater than 90, move cursor to Receiver Input Attenuation Level (35), press DATA SCROLL ↑ and ↓ Keys (3) to select greater attenuation and press ENTER Key.
6.	Press a SQLCH Key (10) to display Squelch data field. Press SQLCH Keys (10) until squelch is broken and press ENTER Key.
7.	Press SETUP Key to access Receiver Menu. <ul style="list-style-type: none">● Press 6 DATA ENTRY Key (29) to toggle "Rcvr Out Speaker" until "On" appears.● Press 7 DATA ENTRY Key (29) to toggle "Rcvr Out Audio Out" until "On" appears.● Press "Ret" Soft Function Key F5 to return to Operation Screen.
8.	Press a VOL Key (5) to display Volume data field. Press VOL Keys (5) to adjust volume to desired level and press ENTER Key.

4-3-4 RECEIVING SSB SIGNALS

EXAMPLE: The following example receives a 14 MHz LSB signal and routes demodulated signal to AUDIO OUT Connector (14) and Test Set Speaker.

STEP	PROCEDURE
1.	Connect coaxial cable from UUT to T/R Connector (6).
2.	Move cursor to RF (37) and press 1 and 4 DATA ENTRY Keys (29) to set Receiver Frequency to 14.0000 MHz . Press ENTER Key.
3.	Move cursor to MOD (40) and use DATA SCROLL Keys ↑ and ↓ (3) until " LSB " appears and press ENTER Key.
4.	Move cursor to RF IN (36) and press ENTER Key to toggle RF Input Location to " T/R ".
5.	Press a SQLCH Key (10) to display Squelch data field. Press SQLCH Keys (10) until squelch is broken and press ENTER Key.
6.	Press SETUP Key to access Receiver Menu. <ul style="list-style-type: none">● Press 6 DATA ENTRY Key (29) to toggle "Rcvr Out Speaker" until "On" appears.● Press 7 DATA ENTRY Key (29) to toggle "Rcvr Out Audio Out" until "On" appears.● Press "Ret" Soft Function Key F5 to return to Operation Screen.
7.	Press a VOL Key (5) to display Volume data field. Press VOL Keys (5) to adjust volume to desired level and press ENTER Key.
8.	If received voice transmissions sound high-pitched or low-pitched, move cursor to TUNE and press ENTER Key. Use DATA SCROLL ↑ and ↓ Keys (3) to adjust Signal Frequency in 125 Hz steps and press ENTER Key.

4-3-5 DECODING DTMF CODED SIGNALS

EXAMPLE: The following example receives a 450 MHz FM modulated DTMF signal and routes demodulated signal to AUDIO OUT Connector (14) and Test Set Speaker.

STEP	PROCEDURE
1.	Connect coax cable from UUT to T/R Connector (6).
2.	Move cursor to RF (37) and press 4, 5 and 0 DATA ENTRY Keys (29) to set Receiver Frequency to 450.0000 MHz . Press ENTER Key.
3.	Move cursor to MOD (40), press DATA SCROLL ↑ Key (3) until " FM1 " appears in data field and press ENTER Key.
4.	Move cursor to RF IN (36) and press ENTER Key to toggle RF Input Location to " T/R ".
5.	Press a SQLCH Key (10) to display Squelch data field. Press SQLCH Keys (10) until squelch is broken and press ENTER Key.
6.	Press SETUP Key to access Receiver Menu. <ul style="list-style-type: none">● Move cursor to "11. Signaling Formats" and press ENTER Key. Press 1 DATA ENTRY Key (29) to select DTMF.● Press 6 DATA ENTRY Key (29) to toggle "Rcvr Out Speaker" until "On" appears.● Press 7 DATA ENTRY Key (29) to toggle "Rcvr Out Audio Out" until "On" appears.● Press "Ret" Soft Function Key F5 to return to Operation Screen.
7.	Press a VOL Key (5) to display Volume data field. Press VOL Keys (5) to adjust volume to desired level and press ENTER Key.
8.	Press "More" Soft Function Key F6 until "Disp" Soft Function Key F1 appears. Press "Disp" Soft Function Key F1 and press 5 DATA ENTRY Key (29).
9.	"Decode" Soft Function Key F2 appears. Press "Decode" Soft Function Key F2. Decoded digits appear below DTMF Callout. To stop decoding, press "Stop" Soft Function Key F3.

4-3-6 DECODING AUDIO CCIR CODED SIGNALS

EXAMPLE: The following example receives a 450 MHz FM modulated Audio signal and routes demodulated signal to AUDIO OUT Connector (14) and Test Set Speaker.

STEP	PROCEDURE
1.	Connect external antenna to ANTENNA IN Connector (25).
2.	Move cursor to RF (37) and press 4, 5 and 0 DATA ENTRY Keys (29) to set Receiver Frequency to 450.0000 MHz . Press ENTER Key.
3.	Move cursor to MOD (40), use DATA SCROLL Keys ↑ and ↓ (3) to select a FM Modulation and press ENTER Key.
4.	Move cursor to RF IN (36) and press ENTER Key to toggle RF Input Location until " ANT " (ANTENNA IN Connector [25]) appears.
5.	If Signal Strength Meter reading is >90, move cursor to Receiver Input Attenuation Level (35), press DATA SCROLL Keys ↑ and ↓ (3) to select greater attenuation and press ENTER Key.
6.	Press a SQLCH Key (10) to display Squelch data field. Press SQLCH Keys (10) until squelch is broken and press ENTER Key.
7.	Press SETUP Key to access Receiver Menu. <ul style="list-style-type: none">● Move cursor to "11. Signaling Formats" and press ENTER Key. Press 2 DATA ENTRY Key (29) to select Audio. Press 1 DATA ENTRY Key (29) to select CCIR.● Press 6 DATA ENTRY Key (29) to toggle "Rcvr Out Speaker" until "On" appears.● Press 7 DATA ENTRY Key (29) to toggle "Rcvr Out Audio Out" until "On" appears.● Press "Ret" Soft Function Key F5 to return to Operation Screen.
8.	Press a VOL Key (5) to display Volume data field. Press VOL Keys (5) to adjust volume to desired level and press ENTER Key.
9.	Press "More" Soft Function Key F6 until "Disp" Soft Function Key F1 appears. Press "Disp" Soft Function Key F1 and press 5 DATA ENTRY Key (29).
10.	"Extend" Soft Function Key F5 appears. Press "Extend" Soft Function Key F5 to display Extend Screen.
11.	Press "Input" Soft Function Key F1 and press 1 DATA ENTRY Key (29) to select Demod Audio Input.
12.	Press "Decode" Soft Function Key F2. Decoded digits, frequencies, frequency errors and time durations are displayed. To stop decoding, press "Stop" Soft Function Key F3.

4-3-7 DECODING AUDIO USER DEFINED CODED SIGNALS

EXAMPLE: The following example receives a 450 MHz FM modulated Audio signal and routes demodulated signal to AUDIO OUT Connector (14) and Test Set Speaker.

STEP	PROCEDURE
1.	Press RF GEN MODE Key (27) and press SETUP Key to display RF Generator Menu. Press 3 and 2 DATA ENTRY Key (29) to display Audio Code Menu.
2.	Move cursor to "12. User Defined" and press ENTER Key. Press 2 DATA ENTRY Key (29) to display Audio Define Tones Menu.
3.	Move cursor to Tone(Hz) location in 0 row. Press 9, 0 and 0 DATA ENTRY (29) Keys and press ENTER Key. Press FIELD SELECT → Key (1) to move cursor to Duration(ms) column. Press 1, 5 and 0 DATA ENTRY Keys (29) and press ENTER Key.
4.	Move cursor to Tone(Hz) location in 1 row. Press 1, 1, 0 and 0 DATA ENTRY Keys and press ENTER Key. Press FIELD SELECT → Key (1) to move cursor to Duration(ms) column. Press 8 and 0 DATA ENTRY Keys (29) and press ENTER Key.
5.	Move cursor to Tone(Hz) location in 2 row. Press 1, 2, 0 and 0 DATA ENTRY (29) Keys and press ENTER Key. Press FIELD SELECT → Key (1) to move cursor to Duration(ms) column. Press 8 and 0 DATA ENTRY Keys (29) and press ENTER Key.
6.	Move cursor to Tone(Hz) location in 3 row. Press 1, 3, 0 and 0 DATA ENTRY Keys (29) and press ENTER Key. Press FIELD SELECT → Key (1) to move cursor to Duration(ms) column. Press 8 and 0 DATA ENTRY Keys (29) and press ENTER Key.
7.	Move cursor to Tone(Hz) location in 4 row. Press 1, 4, 0 and 0 DATA ENTRY Keys (29) and press ENTER Key. Press FIELD SELECT → Key (1) to move cursor to Duration(ms) column. Press 8 and 0 DATA ENTRY Keys (29) and press ENTER Key.
8.	Move cursor to Tone(Hz) location in A row. Press 0 DATA ENTRY Key (29) and press ENTER Key. Press FIELD SELECT → Key (1) to move cursor to Duration(ms) column. Press 4 and 0 DATA ENTRY Keys (29) and press ENTER Key.
	NOTE: Tones 0, 1, 2, 3, 4 and A are now defined. Receiver uses all defined tones as the User Defined Code when decoding.
9.	Press RCVR MODE Key (27) to display Receiver Operation Screen.
10.	Connect external antenna to ANTENNA IN Connector (25).
11.	Move cursor to RF (37) and press 4, 5 and 0 DATA ENTRY Keys (29) to set Receiver Frequency to 450.0000 MHz . Press ENTER Key.
12.	Move cursor to MOD (40) and use DATA SCROLL Keys ↑ and ↓ (3) to select a FM Modulation and press ENTER Key.
13.	Move cursor to RF IN (36) and press ENTER Key until " ANT " appears as RF Input Location.
14.	If Signal Strength Meter reading is greater than 90, move cursor to RF Input Attenuation (35) and press DATA SCROLL Keys ↑ and ↓ (3) to select greater attenuation. Press ENTER Key.

-
15. Press a SQLCH Key (10) to display Squelch data field. Press SQLCH Keys (10) until squelch is broken and press ENTER Key.
 16. Press SETUP Key to access Receiver Menu.
 - Move cursor to "11. Signaling Formats" and press ENTER Key. Press 2 DATA ENTRY Key (29) to select Audio. Audio Code Menu appears. Move cursor to "12. User Defined" and press ENTER Key.
 - Press 6 DATA ENTRY Key (29) to toggle "Rcvr Out Speaker" until "**On**" appears.
 - Press 7 DATA ENTRY Key (29) to toggle "Rcvr Out Audio Out" until "**On**" appears.
 - Press "Ret" Soft Function Key F5 to return to Operation Screen.
 17. Press a VOL Key (5) to display Volume data field. Press VOL Keys (5) to adjust volume to desired level and press ENTER Key.
 18. Press "More" Soft Function Key F6 until "Disp" Soft Function Key F1 appears. Press "Disp" Soft Function Key F1 and press 5 DATA ENTRY Key (29).
 19. "Extend" Soft Function Key F5 appears. Press "Extend" Soft Function Key F5 to display Extend Screen.
 20. Press "Input" Soft Function Key F1 and press 1 DATA ENTRY Key (29) to select Demod Audio Input.
 21. Press "Decode" Soft Function Key F2. Decoded digits, frequencies, frequency errors and time durations are displayed. To stop decoding before decoding process is finished, press "Stop" Soft Function Key F3.

4-3-8 DECODING DCS CODED SIGNALS

EXAMPLE: The following example receives a 450 MHz FM modulated DCS signal and routes demodulated signal to AUDIO OUT Connector (14) and Test Set Speaker.

STEP	PROCEDURE
1.	Connect external antenna to ANTENNA IN Connector (25).
2.	Move cursor to RF (37) and press 4, 5 and 0 DATA ENTRY Keys (29) to set Receiver Frequency to 450.0000 MHz . Press ENTER Key.
3.	Move cursor to MOD (40) and use DATA SCROLL ↑ and ↓ Keys (3) to select an FM Modulation and press ENTER Key.
4.	Move cursor to RF IN (36) and press ENTER Key to toggle RF Input Location until " ANT " (ANTENNA IN Connector [25]) appears.
5.	If Signal Strength Meter reading is greater than 90, move cursor to Receiver Input Attenuation Level (35), press DATA SCROLL Keys ↑ and ↓ (3) to select greater attenuation and press ENTER Key.
6.	Press a SQLCH Key (10) to display Squelch data field. Press SQLCH Keys (10) until squelch is broken and press ENTER Key.
7.	Press SETUP Key to access Receiver Menu. <ul style="list-style-type: none">● Move cursor to "11. Signaling Formats" and press ENTER Key. Press 3 DATA ENTRY Key (29) to select Digital. Press 1 DATA ENTRY Key (29) to select DCS.● Press 6 DATA ENTRY Key (29) to toggle "Rcvr Out Speaker" until "On" appears.● Press 7 DATA ENTRY Key (29) to toggle "Rcvr Out Audio Out" until "On" appears.● Press "Ret" Soft Function Key F5 to return to Operation Screen.
8.	Press a VOL Key (5) to display Volume data field. Press VOL Keys (5) to adjust volume to desired level and press ENTER Key.
9.	Press "More" Soft Function Key F6 until "Disp" Soft Function Key F1 appears. Press "Disp" Soft Function Key F1 and press 5 DATA ENTRY Key (29).
10.	Press "Input" Soft Function Key F5 to display Decode Input Submenu. Press 1 DATA ENTRY Key (29) to select "Demod Audio".
11.	Press "Decode" Soft Function Key F2. Decoded digits appear below DCS Code Callout. To stop decoding, press "Stop" Soft Function Key F3.

4-3-9 DECODING POCSAG CODED SIGNALS

EXAMPLE: The following example receives a 450 MHz FM modulated POCSAG signal and routes demodulated signal to AUDIO OUT Connector (14) and Test Set Speaker.

STEP	PROCEDURE
1.	Connect external antenna to ANTENNA IN Connector (25).
2.	Move cursor to RF (37) and press 4, 5 and 0 DATA ENTRY Keys (29) to set Receiver Frequency to 450.0000 MHz . Press ENTER Key.
3.	Move cursor to MOD (40), use DATA SCROLL Keys (3) to select a FM Modulation and press ENTER Key.
4.	Move cursor to RF IN (36) and press ENTER Key to toggle RF Input Location until " ANT " (ANTENNA IN Connector [25]) appears.
5.	If Signal Strength Meter reading is greater than 90, move cursor to RF Input Attenuation (35), press DATA SCROLL Keys ↑ and ↓ (3) to select greater attenuation and press ENTER Key.
6.	Press a SQLCH Key (10) to display Squelch data field. Press SQLCH Keys (10) until squelch is broken and press ENTER Key.
7.	Press SETUP Key to access Receiver Menu. <ul style="list-style-type: none">● Move cursor to "11. Signaling Formats" and press ENTER Key. Press 3 DATA ENTRY Key (29) to select Digital. Press 3 DATA ENTRY Key (29) to select POCSAG.● Press 6 DATA ENTRY Key (29) to toggle "Rcvr Out Speaker" until "On" appears.● Press 7 DATA ENTRY Key (29) to toggle "Rcvr Out Audio Out" until "On" appears.● Press "Ret" Soft Function Key F5 to return to Operation Screen.
8.	Press a VOL Key (5) to display Volume data field. Press VOL Keys (5) to adjust volume to desired level and press ENTER Key.
9.	Press "More" Soft Function Key F6 until "Disp" Soft Function Key F1 appears. Press "Disp" Soft Function Key F1 and press 5 DATA ENTRY Key (29).
10.	"Extend" Soft Function Key F5 appears. Press "Extend" Soft Function Key F5 to display Extend Screen.
11.	Press "Input" Soft Function Key F1 and press 1 DATA ENTRY Key (29) to select Demod Audio Input.
12.	Press "Decode" Soft Function Key F4. Decoded digits, frequencies, frequency errors and time durations are displayed.

4-3-10 MEASURING AM OR FM TRANSMITTER DISTORTION

STEP	PROCEDURE
1.	Press AF GEN MODE Key (27) and press SETUP Key to access AF Gen Menu.
2.	Press 5 DATA ENTRY Key (29) to access AF Output Menu. Press 1 DATA ENTRY Key (29) to toggle "To Audio Out Conn" until "On" appears.
3.	Press 4 DATA ENTRY Key (29) to access Function Generator Out Level. Press 1 DATA ENTRY Key (29) to set Level to 1.0000 V and press ENTER Key.
4.	Press 5 DATA ENTRY Key (29) to toggle Proportional Output until " Off " appears.
5.	Press "ESC" Soft Function Key F6 and 1 DATA ENTRY Key (29) to access Function Generator 1 Menu.
6.	Press 1 DATA ENTRY Key (29) until Generator is " On ".
7.	Press 2 DATA ENTRY Key (29) and press 1, 0, 0 and 0 DATA ENTRY Keys (29) to set Frequency to 1000.0 Hz . Press ENTER Key.
8.	Press 3 DATA ENTRY Key (29) press 1 DATA ENTRY Key (29) to select " Sine ".
9.	Press MTRS MODE Key (27) to exit AF Gen Menu. Press 6 DATA ENTRY Key (29) to access Distortion Meter Operation Screen.
10.	Move cursor to INPUT and press DATA SCROLL Keys ↑ and ↓ (3) until " SINAD/BER " appears. Press ENTER Key.
11.	Move cursor to NOTCH FREQ and press ENTER Key. Press 1, 0, 0 and 0 DATA ENTRY Keys (29) to set Notch Frequency to 1000 Hz and press ENTER Key.
12.	Move cursor to FILTER and press ENTER Key until " Low Pass " appears. Press FIELD SELECT → Key to move cursor to the cutoff frequency field and press ENTER Key. Press 3 DATA ENTRY Key (29) to set Low-Pass cutoff frequency to 3.000 kHz and press ENTER Key.
	NOTE: FILTER (Post Detection Filter) setting is for general use only. Other settings may be used as needed.
13.	Move cursor to PEAK HOLD and press ENTER Key to toggle Peak Hold until " Off " appears.
14.	Move cursor to AVERAGE and press ENTER Key to toggle Average until " On " appears.
15.	Connect SINAD/BER IN Connector (15) to AUDIO OUT Connector (14). Record Distortion Meter reading as the AF Generator distortion.
16.	Move cursor to INPUT and use DATA SCROLL Keys ↑ and ↓ (3) to select " Demod Audio ". Press ENTER Key.
17.	Disconnect SINAD/BER IN Connector (15) and connect UUT Audio Input to AUDIO OUT Connector (14). Connect Transmitter Output to T/R Connector (6) using 50 Ω coaxial cable.

STEP

PROCEDURE

-
18. Press RCVR MODE Key (27) to access Receiver Operation Screen.
 19. Move cursor to RF (37) and press ENTER Key. Use DATA ENTRY Keypad (29) to select Receiver Frequency (38) to UUT Transmitting Frequency and press ENTER Key.
 20. Use FIELD SELECT Keys (1) to move cursor to MOD (40) and press ENTER Key.
 21. If AM Transmitter is being tested:
 - Use DATA SCROLL Keys ↑ and ↓ (3) to set Receiver Modulation Type (41) to either **AM1** or **AM2**, whichever results in lower Distortion reading.
 - Press "More" Soft Function Key F6 until "Af Gen" Soft Function Key F1 appears and press "Af Gen" Soft Function Key F1. Press 3 DATA ENTRY Key (29) to access AF Generator Output Level. Press DATA SCROLL ↑ and ↓ Keys (3) until Modulation reads **"25 %"** and press ENTER Key.
 - Subtract recorded AF Generator distortion from current Distortion Meter reading. Result is AM Transmitter Distortion.
 22. If FM Transmitter is being tested:
 - Use DATA SCROLL Keys ↑ and ↓ (3) to set Receiver Modulation Type (41) to either **FM1**, **FM2**, **FM3** or **FM4**, whichever results in lowest Distortion reading.
 - Press "More" Soft Function Key F6 until "Af Gen" Soft Function Key F1 appears and press "Af Gen" Soft Function Key F1. Press 3 DATA ENTRY Key (29) to access AF Generator Output Level. Press DATA SCROLL ↑ and ↓ Keys (3) until Deviation reads **5.0 kHz** and press ENTER Key.
 - If Deviation Meter readings are not centered, press "FM Z" Soft Function Key F3 to zero the Deviation Meter.
 - Subtract recorded AF Generator distortion from current Distortion Meter reading. Result is FM Transmitter Distortion.

4-4 DUPLEX OPERATION

Duplex Output signals are routed to T/R Connector (6) or DUPLEX Connector (24). Low-power (10 mW maximum) RF signals are monitored "off the air" from ANTENNA IN Connector (25) or high power RF signals (10 mW to 50 W) are monitored through T/R Connector (6).

CAUTION: MAXIMUM CONTINUOUS INPUT TO ANTENNA IN CONNECTOR (25) IS LIMITED TO 10 mW WITH PROTECTION PROVIDED TO A MAXIMUM INPUT OF 65 W.

MAXIMUM CONTINUOUS INPUT TO T/R CONNECTOR (6) IS LIMITED TO 50 W WITH PROTECTION PROVIDED TO A MAXIMUM INPUT OF 200 W.

NOTE: Valid Duplex Operation Screen meter readings are not displayed until Squelch is broken.

DUPLEX OPERATION SCREEN WITH SQUELCH UNBROKEN

TRANSMITTER		DUP	RECEIVER	
FREQ	10.0000 MHz •		FREQ	10.5000 MHz
MOD TYPE	FM1		OFST	0.5000 MHz
RF IN ANT	OdB		OUT DPL	-26.5 dBm
FREQ	---		SOURCE	
			1 2 3 Ext Mic	
FREQ ERR	+ --- kHz		MOD TYPE	FM
SIG	---		DEV	4.0 kHz
AF	--- kHz		AF FREQ	1000.0 Hz
			WAVE	Sine
DEVIATION	--- kHz		DIST	20.0%
TX		RX	SINAD	Offset
		AUX		

8617088

DUPLEX OPERATION SCREEN WITH SQUELCH BROKEN

TRANSMITTER		DUP	RECEIVER	
FREQ	10.0000 MHz •		FREQ	10.5000 MHz
MOD TYPE	FM1		OFST	0.5000 MHz
RF IN ANT	OdB		OUT DPL	-26.5 dBm
FREQ	10.000651		SOURCE	
			1 2 3 Ext Mic	
FREQ ERR	+ 0.651 kHz		MOD TYPE	FM
SIG	29		DEV	4.0 kHz
AF	1.834 kHz		AF FREQ	1000.0 Hz
			WAVE	Sine
DEVIATION	4.03 kHz		DIST	20.0%
TX		RX	SINAD	Offset
		AUX		

8617089

4-4-1 DUPLEX GENERAL OPERATION

The Duplex Transmitter tests Transmitting UUTs and functions as a Receiver. The Duplex Receiver tests Receiving UUTs and functions as a RF Generator.

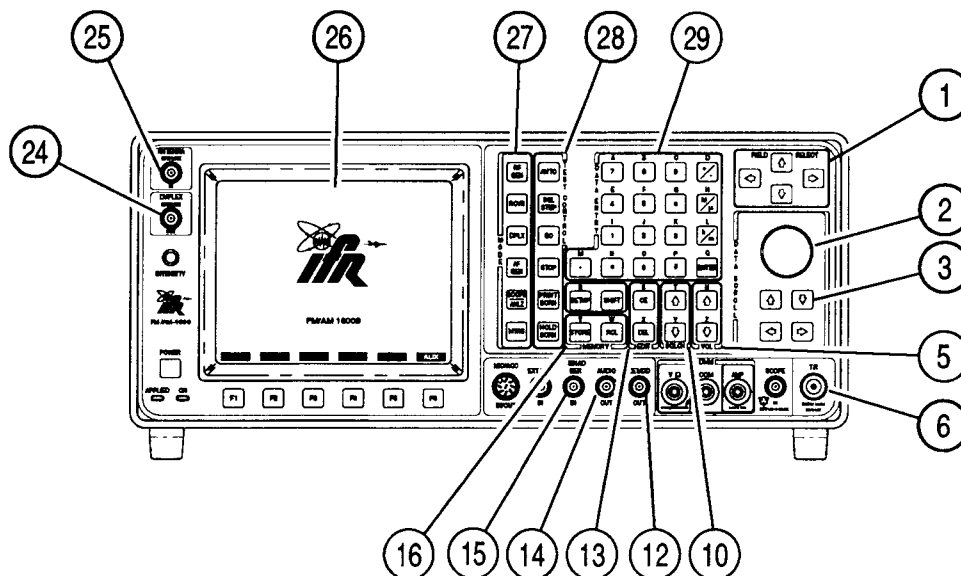

8607086

1. Press DPLX MODE Key (27). Duplex Operation Screen appears on CRT.

NOTE: Duplex Transmitter menu is accessed by pressing SETUP Key when cursor is located in left half of Duplex Operation Screen. Duplex Receiver menu is accessed by pressing SETUP Key when cursor is located in right half of Duplex Operation Screen.

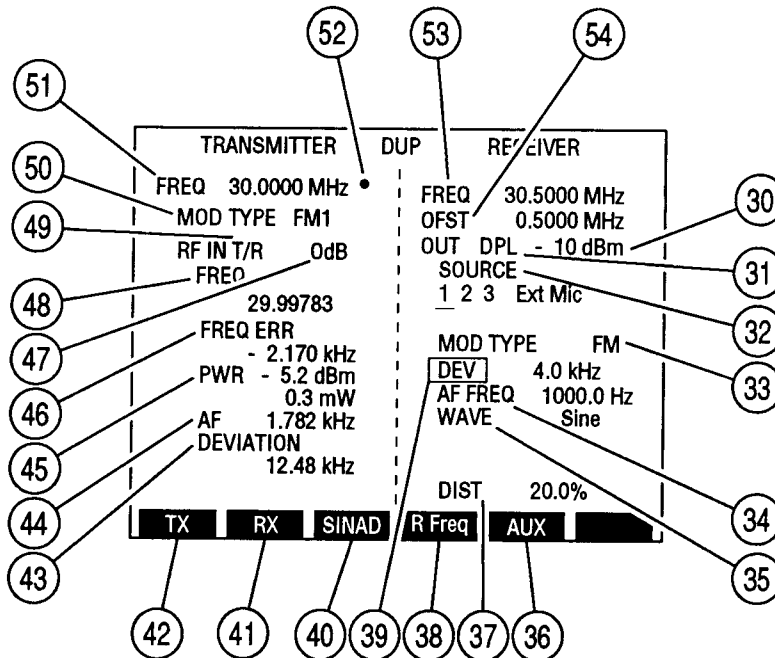

8617087

2. Move cursor to RF IN data field (49) and press ENTER Key to toggle RF Input location between "ANT" and "T/R" to match input location of received signal.
3. Move cursor to FREQ (51) and use DATA ENTRY Keypad (29) to enter desired setting in MHz. Press ENTER Key.

NOTE: RF Frequency Error Meter gives inaccurate results when Deviation Meter readings exceed Deviation Meter Range.
4. To adjust squelch level, press a SQLCH Key (10). Squelch data field appears on CRT. Press SQLCH Keys (10) to adjust Squelch and press ENTER Key.
5. To adjust volume, press a VOL Key (5). Volume data field appears on CRT. Press VOL Keys (5) to adjust Volume and press ENTER Key.
6. Move cursor to Duplex Input Attenuation Level (47) and press ENTER Key. Use DATA ENTRY Keypad (29) to enter desired level and press ENTER Key.
7. Move cursor to MOD TYPE (50) and press ENTER Key. Press DATA SCROLL ↑ or ↓ Keys (3) until desired setting appears in data field and press ENTER Key. See Table 3-2 for description of modulation types.

8. If User is selected for MOD TYPE (50), press SETUP Key to access Duplex Transmitter Menu. Press 2 DATA ENTRY Key (29) to display Duplex Transmitter Modulation Menu and press ENTER Key. User Defined Modulation Menu appears:

**DUPLEX TRANSMITTER USER
DEFINED MODULATION MENU**

Duplex Transmitter Menu	
1. Set Rcvr Freq	200.0000MHz
2. Select Mod	User Defined
3. Modulation	FM DATA
4. IF Filters	3 KHz
5. Post Detection	All Pass
6. Rcvr Out Audio Out	Off
7. Rcvr Out Demod Out	On
8. Auto Volume Level	Off
9. Operation Mode	Freq Scan
10. Signaling Formats	DTMF

Ret ESC

8610060

- Press 1 DATA ENTRY Key (29) and use DATA ENTRY Keypad (29) to select User Modulation Type.
 - Press 2 DATA ENTRY Key (29) and use DATA ENTRY Keypad (29) to select an IF Filter.
 - Press 3 DATA ENTRY Key (29) and use DATA ENTRY Keypad (29) to select a Post Detection Filter. If Low Pass, High Pass or Band Pass is selected, a cutoff frequency data field appears. Use DATA ENTRY Keypad (29) to enter cutoff frequencies and press ENTER Key.
 - Press "Ret" Soft Function Key F5 to return to Duplex Operation Screen.
9. Press "Offset" or "R Freq" Soft Function Key F5 to toggle which frequency is editable. The non-editable parameter, FREQ (53) or OFST (54), appears in red. Move cursor to editable parameter and use DATA ENTRY Keypad (29) to enter desired frequency. Press ENTER Key.
- NOTE:** When Duplex Offset Frequency (OFST) or Duplex Receiver Frequency (RX) is edited, the unedited frequency changes also for their sum to equal the Duplex Transmitter Frequency (TX). Duplex Transmitter Frequency (TX) is not edited from this Operation Screen.
10. Move cursor to Duplex Receiver Output Connector (31) and press ENTER Key to toggle Duplex Receiver Output Connector to "DPL" (DUPLEX OUT Connector) (24) or "T/R" (T/R Connector) (6).
11. Move cursor to Duplex Receiver Output Level (30) and press ENTER Key. Use DATA ENTRY Keypad (29) to enter desired level and press ENTER Key. If necessary, press +/- DATA ENTRY Key (29) to place "-" in data field.

12. Move cursor to SOURCE (32) and press ENTER Key to access active Modulation Source. Use FIELD SELECT ← and → Keys (1) to place cursor over desired source and use DATA SCROLL ↑ or ↓ Keys (3) to select desired Modulation Type. White indicates OFF, red indicates AM, yellow indicates FM and green indicates PM. Last selected Modulation Type is displayed with MOD TYPE Callout (33). Source parameters are shown for last selected source, signified by an underline.

NOTE: If no source is active, data field cursor appears under SOURCE 1. Source 1 refers to AF Generator 1, Source 2 refers to AF Generator 2, Source 3 refers to Signaling Formats, Ext refers to signals received at EXT MOD IN Connector (17) and Mic refers to signals received at MIC/ACC Connector (18).

13. Move cursor to DEV or MOD (39) and press ENTER Key to access its data field. Use DATA ENTRY Keypad (29) to enter digits of desired modulation level and press ENTER Key.
14. If Source 1 or 2 is the last selected Source:
- Move cursor to AF FREQ (34) and press ENTER Key to access its data field. Use DATA ENTRY Keypad (29) to enter desired frequency and press ENTER Key.
 - Move cursor to WAVE (35) and press ENTER Key to access its data field. Press DATA SCROLL ↑ or ↓ Keys (3) until desired selection appears in data field and press ENTER Key.
15. If Source 3 is not the last selected source, proceed with step 26. If Source 3 is the last selected source, Operation Screen appears as follows:

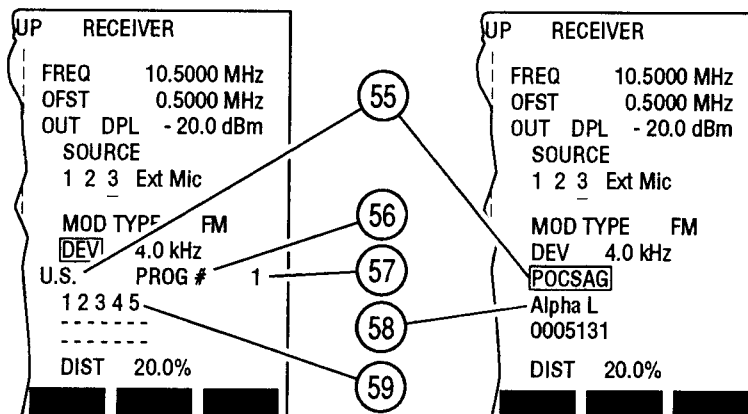

8617091

16. If DTMF is the selected Signaling Format:
- Move cursor to DIRECT ENTRY/PROG # (56). Press ENTER Key to toggle between Direct Entry and Program features.
 - If PROG is selected, move cursor to Program Number (57) and use DATA ENTRY Keypad (29) to select a programmed sequence. Press ENTER Key.
 - If DIRECT ENTRY is selected, move cursor to sequence (59) and use DATA ENTRY Keypad (29) to enter desired sequence. Press ENTER Key.

17. If DTMF is not the selected Signaling Format, move cursor to Signaling Code (55) and use DATA SCROLL ↑ and ↓ Keys (3) to select a Signaling Code from current Signaling Format. Press ENTER Key.
 - If POCSAG or Tone Remote is selected as the Signaling Code, move cursor to POCSAG or Tone Remote Function Callout (58). Use DATA SCROLL ↑ and ↓ Keys (3) to select a function and press ENTER Key.
 - If DTMF, POCSAG or Tone Remote is not selected as the Signaling Code:
 - Move cursor to DIRECT ENTRY/PROG # (56). Press ENTER Key to toggle between Direct Entry and Program features.
 - If PROG is selected, move cursor to Program Number (57) and use DATA ENTRY Keypad (29) to select a programmed sequence. Press ENTER Key.
 - If DIRECT ENTRY is selected, move cursor to sequence (59) and use DATA ENTRY Keypad (29) to enter desired sequence. Press ENTER Key.
18. To continuously generate Code, press GO TEST CONTROL Key (28). To generate Code one sequence at a time, press SGL STEP TEST CONTROL Key (28). To stop generating Code, press STOP TEST CONTROL Key (28).
19. To select a different Signaling Format, press SETUP Key to display Duplex Receiver Menu. Press 3 DATA ENTRY Key (29) to display Signaling Format Menu.

DUPLIX RECEIVER SIGNALING FORMAT MENU

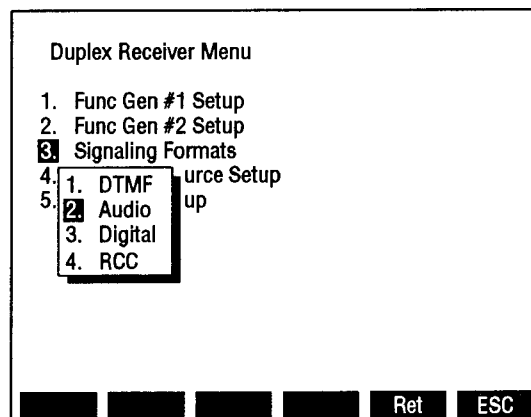

8610090

20. Use DATA ENTRY Keys (29) to select a Signaling Format and press "Ret" Soft Function Key F5.
21. To program a Signaling Code sequence, press SETUP Key to display Duplex Receiver Menu. Press 3 DATA ENTRY Key (29) to display the Signaling Formats Menu. Use DATA ENTRY Keys (29) to select a Signaling Format.

*

22. If DTMF is selected, DTMF Signaling Menu appears:

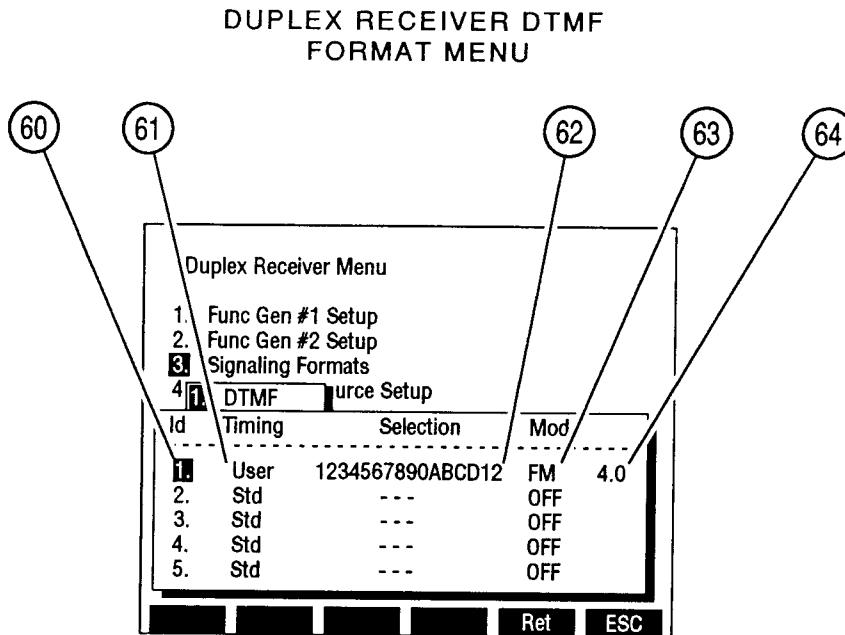

8607128

- Select Id (60) of Sequence to be edited using FIELD SELECT ↑ and ↓ Keys (1).
- Move cursor to Timing column (61) and use DATA SCROLL ↑ and ↓ Keys (3) to select Std (Standard) or User. Press ENTER Key.
- If User is chosen, data fields appear for Mark Timing and Space Timing.
 - Press 1 DATA ENTRY Key (29) and use DATA ENTRY Keypad (29) to enter Mark Timing. Press ENTER Key.
 - Press 2 DATA ENTRY Key (29) and use DATA ENTRY Keypad (29) to enter Space Timing. Press ENTER Key.
 - Press "ESC" Soft Function Key F6.
- Move cursor to Selection column (62), enter a sequence using DATA ENTRY Keypad (29) and press ENTER Key.

NOTE: Pressing SHIFT Key toggles DATA ENTRY Keypad (29) between numeric and alphabetic characters.
- Move cursor to Mod column (63), use DATA SCROLL ↑ and ↓ Keys (3) to select Modulation Type and press ENTER Key.
- Move cursor to Mod Level (64), use DATA ENTRY Keypad (29) to select Modulation Level and press ENTER Key.
- When desired sequences are entered, press "Ret" Soft Function Key F5 to return to Duplex Operation Screen.

23. If Audio is selected as the Signaling Format, Audio Code Menu appears:

DUPLEX RECEIVER AUDIO
CODE MENU

Duplex Receiver Menu

1. CCIR
2. EEA
3. U.S. (EIA)
4. ZVEI
5. DDZVEI (ZVEI 2)
6. DZVEI (ZVEI 3)
7. NATEL
8. EURO
9. 5/6 Tone Seq
10. CCIRH
11. CCIRH4
12. User Defined

Ret ESC

8610089

- Use FIELD SELECT Keys (1) to select an Audio Code and press ENTER Key. Audio Code Sequence Menu appears:

DUPLEX RECEIVER AUDIO
CODE SEQUENCE MENU

Duplex Receiver Menu

1. CCIR
2. EEA
3. U.S. (EIA)
4. Id Selection
5. 1234567890
6. ---
7. ---
8. ---
9. ---
10. ---
11. ---
12. ---

Scan RF lock Ret ESC

8610088

- Use FIELD SELECT Keys (1) to select an Id and press ENTER Key. Use DATA ENTRY Keys (29) to enter a sequence and press ENTER Key.

NOTE: Pressing SHIFT Key toggles DATA ENTRY Keypad (29) between numeric and alphabetic characters.

- If "12. User Defined" is selected as Audio Code, Audio Code User Defined Menu appears:

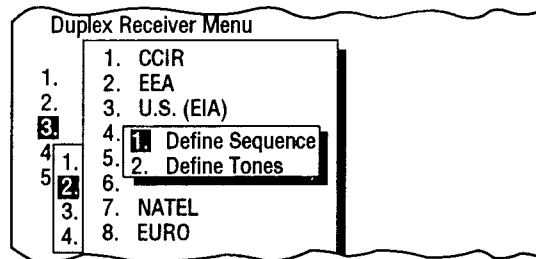

8610170

- Press 2 DATA ENTRY Key (29) to display following menu:

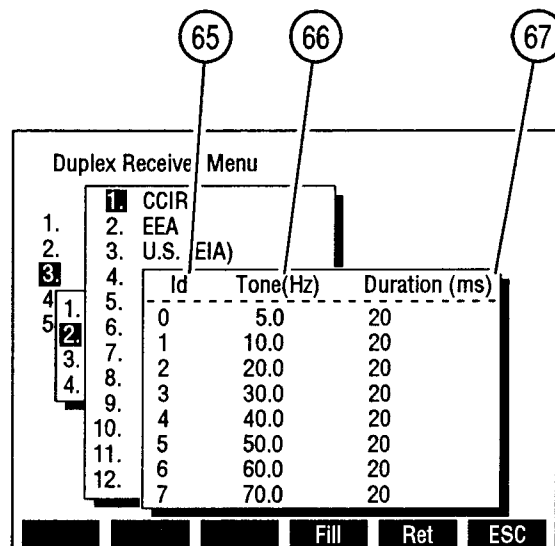

8607129

- Move cursor to Tone(Hz) column (66) of desired Id (65) and use DATA ENTRY Keypad (29) to select frequency. Press ENTER Key.
- Move cursor to Duration(ms) column (67) and use DATA ENTRY Keypad (29) to select duration. Press ENTER Key.
- While cursor is in Tone(Hz) (66) or Duration(ms) columns (67), press "Fill" Soft Function Key F4 to fill column below cursor with value highlighted by cursor.
- When all desired tones are defined, press "ESC" Soft Function Key F6 to return to Audio Code User Defined Menu.
- Press 1 DATA ENTRY Key (29) to access Audio Code Sequence Menu. User Defined Sequences are selected as other Audio Code Sequences. When all desired sequences have been entered, press "Ret" Soft Function Key F5 to return to Duplex Operation Screen.

24. If Digital is selected as Signaling Format, Digital Code Menu appears. Use DATA ENTRY Keypad (29) to select a Digital Code.

- If DCS or DCS INV is selected as Digital Code, the DCS Code Menu appears:

DUPLEX RECEIVER
DCS CODE SUBMENU

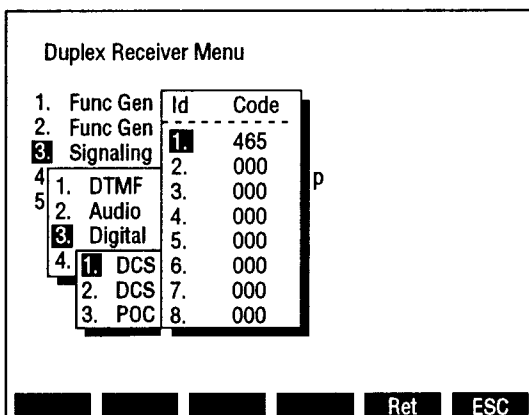

8610087

- Use FIELD SELECT Keys (1) to select an Id and press ENTER Key.
- Use DATA ENTRY Keypad (29) to enter a sequence and press ENTER Key. When all desired sequences have been entered, press "Ret" Soft Function Key F5 to return to Duplex Operation Screen.
- If POCSAG is selected as the Digital Code, POCSAG Menu appears:

DUPLEX RECEIVER POCSAG MENU

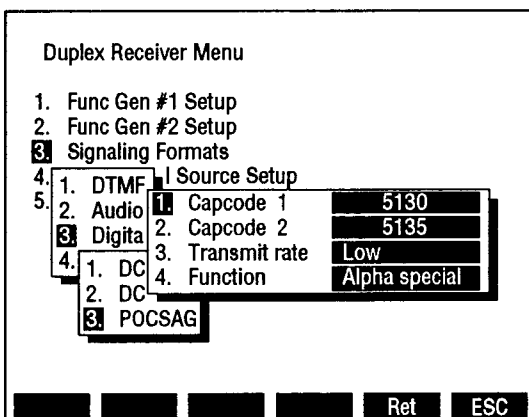

8610151

- Press 1 DATA ENTRY Key (29) to access Capcode 1. Use DATA ENTRY Keypad (29) to enter Starting Capcode and press ENTER.
- Press 2 DATA ENTRY Key (29) to access Capcode 2. Use DATA ENTRY Keypad (29) to enter Ending Capcode and press ENTER.

- Press 3 DATA ENTRY Key (29) to toggle Transmit rate until set as desired.
- Press 4 DATA ENTRY Key (29) to display POCSAG Function Menu:

DUPLEX RECEIVER POCSAG
FUNCTION MENU

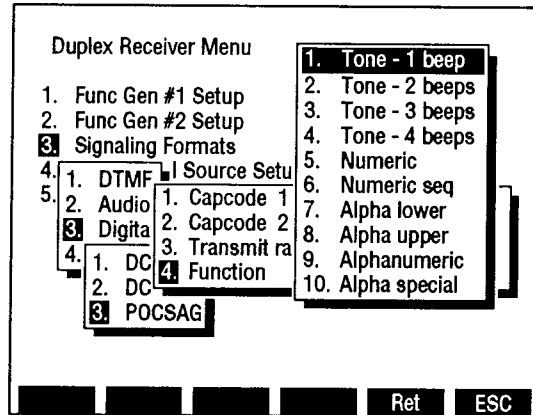

8610176

- Use FIELD SELECT Keys (1) to select a Function Type and press ENTER Key. Press "Ret" Soft Function Key F5 to return to the Duplex Operation Screen.

25. If RCC is selected as the Signaling Format, RCC Code Menu appears. Use DATA ENTRY Keypad (29) to select a RCC Code.

DUPLEX RECEIVER
RCC CODE MENU

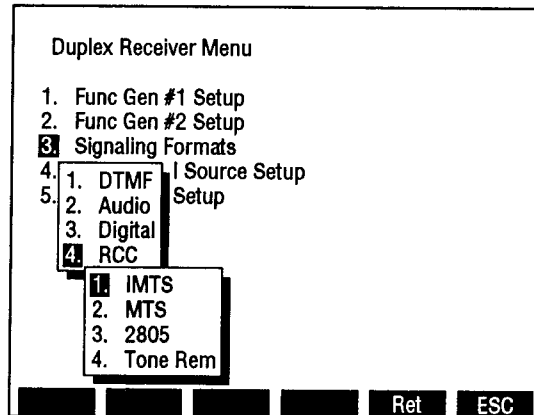

8610152

- If IMTS, MTS or 2805 is selected, RCC Sequence Menu appears:

**DUPLEX RECEIVER IMTS
MTS AND 2805 MENU**

Duplex Receiver Menu	
1. Func Gen #1	Id Sequence
2. Func Gen #2	1. 1234567891
3. Signaling For	2. ---
4. 1. DTMF	3. ---
5. 2. Audio	4. ---
3. Digital	5. ---
4. RCC	6. ---
1. IMTS	7. ---
2. MTS	8. ---
3. 2805	
4. Tone Rem	

Ret ESC

8610153

- Use FIELD SELECT Keys (1) to select an Id and press ENTER Key.
- Use DATA ENTRY Keypad (29) to enter a sequence and press ENTER Key.
- When 2805 is chosen, "Tone" Soft Function Key F3 appears. To edit 2805s frequency, press "Tone" Soft Function Key F3 and use DATA ENTRY Keypad (29) to enter frequency. Press ENTER Key.
- When all desired sequences have been entered, press "Ret" Soft Function Key F5 to return to Duplex Operation Screen.
- If Tone Rem is selected, Tone Remote Function Menu appears:

TONE REMOTE FUNCTION MENU

Duplex Receive		Tone Rem Function	
1. Func Gen	1. 2050 (Monitor)	2. 1950 (F1)	
2. Func Gen	3. 1850 (F2)	3. 1850 (F2)	
3. Signaling F	4. 1750 (R2 Mute)	4. 1750 (R2 Mute)	
4. 1. DTMF	5. 1650 (R2 Unmute)	5. 1650 (R2 Unmute)	
5. 2. Audio	6. 1550 (Repeater Off)	6. 1550 (Repeater Off)	
3. Digital	7. 1450 (Repeater On)	7. 1450 (Repeater On)	
4. RCC	8. 1350 (Wild Card 1 On)	8. 1350 (Wild Card 1 On)	
1. IMTS	9. 1250 (Wild Card 1 Off)	9. 1250 (Wild Card 1 Off)	
2. MTS	10. 1150 (Wild Card 2 On)	10. 1150 (Wild Card 2 On)	
3. 2805	11. 1050 (Wild Card 2 Off)	11. 1050 (Wild Card 2 Off)	
4. Tone Rem			

Ret ESC

8610177

- Use FIELD SELECT Keys (1) to select a Tone Remote Function and press ENTER Key.
- Press "Ret" Soft Function Key F5 to return to Duplex Operation Screen.

26. If Modulation Source routing to AUDIO OUT Connector (14) or DEMOD OUT Connector (12) is desired or if Speaker use is desired, press SETUP Key to display the Duplex Receiver Menu. Press 5 DATA ENTRY Key (29) to access Duplex Receiver Setup Menu.

DUPLEX RECEIVER SETUP MENU

Duplex Receiver Menu		
1.	RF Gen #1 Setup	
2.	RF Gen #2 Setup	
3.	Signaling Formats	
4.	External Source Setup	
5	RF Gen Setup	
1	RF Gen Freq	10.0000 MHz
2.	RF Gen Level	- 20.0 dBm
3.	RF Gen Format	Direct
4.	RF Gen Level Units	dBm
5.	Source to Audio Out	Off
6.	Source to Demod Out	Off
7.	To Speaker	None

Ret ESC

8610073

- Press 5 DATA ENTRY Key (29) as needed to enable or disable Modulation Source routing to AUDIO OUT Connector (14).
- Press 6 DATA ENTRY Key (29) as needed to enable or disable Modulation Source routing to DEMOD OUT Connector (12).
- Press 7 DATA ENTRY Key (29) and use DATA ENTRY Keypad (29) to select a signal to be routed to Speaker.

NOTE: Routing Source to Speaker disables SINAD and Distortion Meters.

- Press "Ret" Soft Function Key F5 to return to Duplex Operation Screen.

27. To display SINAD or Distortion Meter, press Soft Function Key F3 until desired meter (37) appears. To access a meters Operation Screen, move cursor to Meters Callout and press ENTER Key.

- For SINAD Meter Operation Procedures, see 4-8-7.
- For Distortion Meter Operation Procedures, see 4-8-6.

NOTE: SINAD and Distortion Meters measure SINAD/BER IN Connector (15) Input.

28. After parameters of Duplex Operation Screen are set, connect UUT to Test Set:

- For testing using separate transmit and receive lines, apply UUT transmitter output to T/R Connector (6). Connect DUPLEX Connector (24) to RF input of UUT receiver.
- For "off the air" Duplex testing, connect antenna to ANTENNA IN Connector (25). Connect DUPLEX Connector (24) or T/R Connector (6) to RF input of UUT receiver.

4-4-2 MEASURING LINEAR AMPLIFIER GAIN, COMPRESSION AND BANDWIDTH

STEP	PROCEDURE
1.	Press DPLX MODE Key (27). Duplex Operation Screen appears.
2.	Move cursor to Duplex Transmitter Frequency (51) and press 3 and 0 DATA ENTRY Keys (29) to set Duplex Transmitter Frequency to 30.0000 MHz . Press ENTER Key.
3.	Move cursor to RF IN data field (49) and press ENTER Key until " T/R " appears.
4.	Move cursor to Input Attenuation Level (47) and press DATA SCROLL ↑ and ↓ Keys (3) until " 0 dB " appears. Press ENTER Key.
5.	If "Offset" Soft Function Key F4 is displayed, press "Offset" Soft Function Key F4.
6.	Move cursor to OFST (54) and press 0 DATA ENTRY Key (29) to set Duplex Offset Frequency to 0.0000 MHz . Press ENTER Key.
7.	Move cursor to Duplex Receiver Output Connector (31) and press ENTER Key until " DPL " appears.
8.	Move cursor to Duplex Receiver Output Level (30) and press +/-, 1 and 0 DATA ENTRY Keys (29) to set Level to -10 dBm . Press ENTER Key.
9.	Move cursor to PWR (45) and press ENTER Key to display Power Meter Operation Screen.. <ul style="list-style-type: none">● Move cursor to RANGE and press DATA SCROLL ↑ and ↓ Keys (3) until "Autorange" appears. Press ENTER Key.● Move cursor to dBm and press ENTER Key until "On" appears.● Press "Ret" Soft Function Key F6.
10.	Connect DUPLEX OUT Connector (24) to input of Linear Amplifier. Connect T/R Connector (6) to output of Linear Amplifier. Linear Amplifier Gain is the Power Meter dBm reading (45) minus Duplex Receiver Output Level (30).
11.	To test Linear Amplifier for compression, move cursor to Duplex Receiver Output Level (30) and press DATA SCROLL ← and → Keys (3) to highlight the middle digit. While pressing DATA SCROLL ↑ Key (3) to increment Linear Amplifier input 1 dBm at a time, Power Meter reading (45) also increases 1 dBm. Continue pressing DATA SCROLL ↑ Key (3) until Power Meter reading (45) fails to increase 1 dBm when Duplex Receiver Output Level does. Duplex Receiver Output Level (30) reads Linear Amplifiers 1 dBm compression point.

STEP	PROCEDURE
------	-----------

12. To test Linear Amplifier bandwidth:

- Move cursor to Duplex Receiver Output Level (30) and press +/-, 1 and 0 DATA ENTRY Keys (29) to set Level to **-10 dBm**. Press ENTER Key. Move cursor to Duplex Transmitter Frequency (51) and press DATA SCROLL ← and → Keys (3) to highlight 1 MHz digit. Rotate DATA SCROLL Spinner (2) ccw until Power Meter dBm reading (45) decreases by 3 dBm. The Duplex Transmitter Frequency (51) displayed is the low end of the Linear amplifiers frequency span.
- Rotate DATA SCROLL Spinner (2) cw until Power Meter dBm reading (45) again decreases by 3 dBm. The Duplex Transmitter Frequency (51) displayed is the high end of the Linear amplifiers frequency span. The Linear Amplifiers bandwidth is the low end of the frequency span subtracted from the high end of the frequency span.

4-4-3 MEASURING MIXER PERFORMANCE

STEP	PROCEDURE
------	-----------

1. Press SCOPE/ANLZ MODE Key (27). If Oscilloscope appears, press SCOPE/ANLZ MODE Key (27) again. Analyzer Operation Screen appears.
2. Move cursor to RF and press 8, 9, • and 3 DATA ENTRY Key (29) to set Analyzer RF Frequency to **89.3000 MHz**. Press ENTER Key.
3. Move cursor to RF IN and press ENTER Key until "**T/R**" appears.
4. Move cursor to RF ATTEN and press DATA SCROLL ↑ Key (3) until "**0dB**" appears. Press ENTER Key.
5. Move cursor to Analyzer Scale Units and press DATA SCROLL ↑ Key (3) until "**dBm**" appears. Press ENTER Key.
6. Connect T/R Connector (6) to 1st LO Input of mixer. Verify signal is 89.3 MHz and above 0 dBm.
7. Disconnect coaxial cable and press DPLX MODE Key (27). Duplex Operation Screen appears.
8. Move cursor to Duplex Transmitter Frequency (51) and press 1, 0, • and 7 DATA ENTRY Keys (29) to set Duplex Transmitter Frequency to **10.7000 MHz**. Press ENTER Key.
9. Move cursor to RF IN data field (49) and press ENTER Key until "**ANT**" appears.
10. Move cursor to Duplex Transmitter Input Attenuation Level (47) and press DATA SCROLL ↑ Key (3) until "**0dB**" appears. Press ENTER Key.
11. If OFST (54) appears in red, press "Offset" Soft Function Key F4. Move cursor to OFST (54) and press 0 DATA ENTRY Key (29) to set Duplex Offset Frequency to **0.0000 MHz**. Press ENTER Key.
12. Move cursor to OUT data field (31) and press ENTER Key until "**DPL**" appears.

STEP

PROCEDURE

-
13. If a Modulation Source is active, move cursor to SOURCE (32) and press DATA SCROLL ← and → Keys (3) until an active source is highlighted. Press DATA SCROLL ↑ Key (3) until "**OFF**" appears for MOD TYPE (33) and press ENTER Key. Repeat process until all Modulation Sources are off.
 14. Connect coaxial cable between ANTENNA IN Connector (25) and DUPLEX OUT Connector (24).
 15. Move cursor to Duplex Receiver Output Level (30) and rotate DATA SCROLL Spinner (2) until Signal Strength Meter (45) reads 90. Record Duplex Receiver Output Level (30) as the reference level.
 16. Move cursor to OFST (54) and press 8, 9, • and 3 DATA ENTRY Keys (29) to set Duplex Offset Frequency to **89.3000 MHz**. Press ENTER Key.
 17. Connect DUPLEX OUT Connect (24) to Mixer Antenna Input. Connect ANTENNA IN Connector (25) to Mixer Output.
 18. Move cursor to Duplex Receiver Output Level (30) and rotate DATA SCROLL Spinner (2) until Signal Strength Meter (45) reads 90. Duplex Receiver Output Level (30) reading minus the reference level is the mixers loss.

4-4-4 DUPLEX TRANSMITTER OPERATION

Low-power (10 mW maximum) RF signals are monitored "off the air" from ANTENNA IN Connector (25) or high-power RF signals (10 mW to 50 W) are monitored through T/R Connector (6).

CAUTION: MAXIMUM CONTINUOUS INPUT TO ANTENNA IN CONNECTOR (25) IS LIMITED TO 10 mW WITH PROTECTION PROVIDED TO A MAXIMUM INPUT OF 65 W.

MAXIMUM CONTINUOUS INPUT TO T/R CONNECTOR (6) IS LIMITED TO 50 W WITH PROTECTION PROVIDED TO A MAXIMUM INPUT OF 200 W.

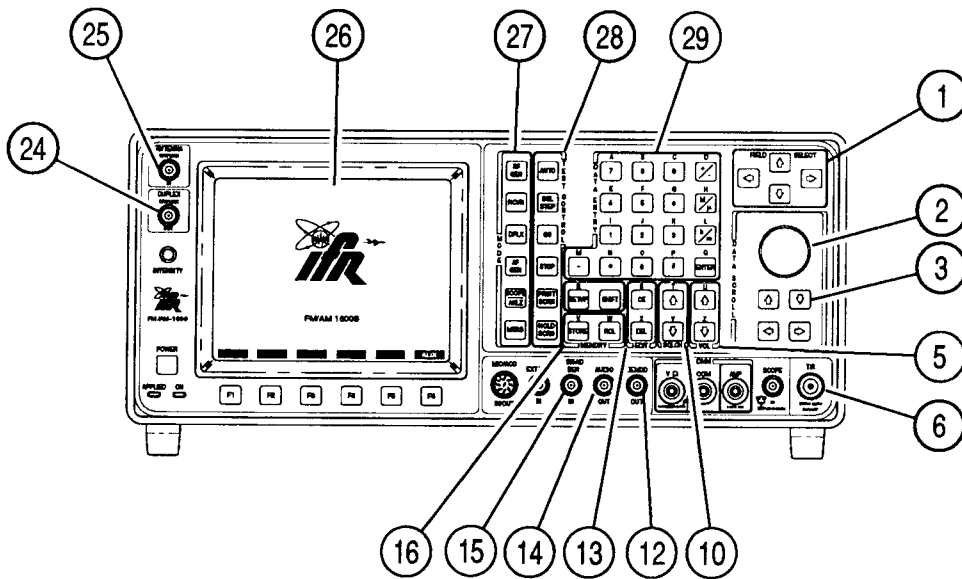

8607086

1. Press DPLX MODE Key (27). Duplex Operation Screen appears on CRT. Press "TX" Soft Function Key F1 and Duplex Transmitter Operation Screen appears on CRT.

NOTE: Duplex Transmitter tests Transmitting UUTs and functions as a Receiver.

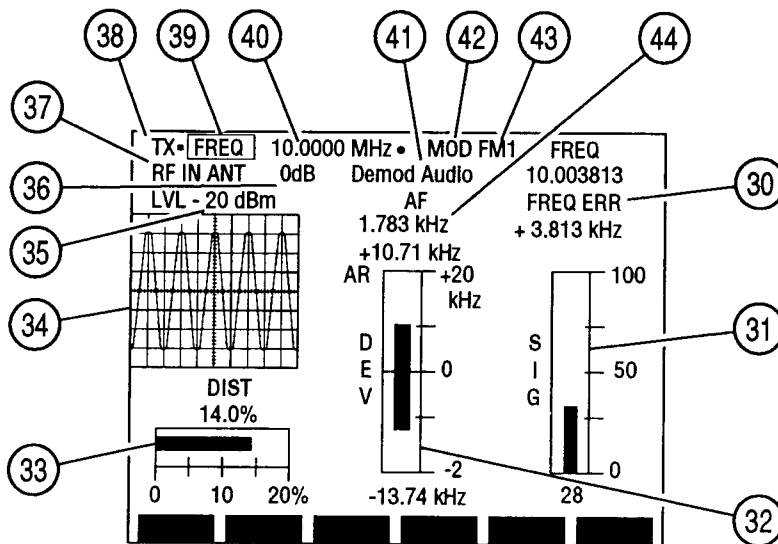

8607064

2. Move cursor to RF IN (37) and press ENTER Key to toggle RF Input location between "ANT" and "T/R" to match input location of received signal.
3. Move cursor to FREQ (39) and press ENTER Key to access data field (40). Use DATA ENTRY Keypad (29) to enter desired setting in MHz and press ENTER Key.

NOTE: RF Frequency Error Meter gives inaccurate results when Deviation Meter readings exceed Deviation Meter Range.
4. To adjust squelch level, press a SQLCH Key (10). Squelch data field appears on CRT. Press SQLCH Keys (10) to adjust Squelch and press ENTER Key.
5. To adjust volume, press a VOL Key (5). Volume data field appears on CRT. Press VOL Keys (5) to adjust Volume and press ENTER Key.
6. Move cursor to Input Attenuation Level (35) and press ENTER Key to access its data field. LVL appears in top right corner of the Operation Screen when Oscilloscope/Analyzer is full size. Use DATA ENTRY Keypad (29) to enter desired level and press ENTER Key.
7. Move cursor to MOD (42) and press ENTER Key to access Modulation Type data field (43). Use DATA SCROLL ↑ or ↓ Keys (3) until desired setting appears in data field and press ENTER Key. See Table 3-2 for description of modulation types.
8. If User is selected for Modulation Type, press SETUP Key to access Duplex Transmitter Menu. Press 2 DATA ENTRY Key (29) to display Duplex Transmitter Modulation Menu and press ENTER Key. User Defined Modulation Menu appears:

Duplex Transmitter Menu	
1. Set Rcvr Freq	200.0000MHz
2. Select Mod	User Defined
3. Modulation	FM DATA
4. IF Filters	3 KHz
5. Post Detection	All Pass
6. Rcvr Out Audio Out	Off
7. Rcvr Out Demod Out	On
8. Auto Volume Level	Off
9. Operation Mode	Freq Scan
10. Signaling Formats	DTMF
Ret ESC	

8610060

- Press 1 DATA ENTRY Key (29) and use DATA ENTRY Keypad (29) to select User Modulation Type.
- Press 2 DATA ENTRY Key (29) and use DATA ENTRY Keypad (29) to select an IF Filter.
- Press 3 DATA ENTRY Key (29) and use DATA ENTRY Keypad (29) to select a Post Detection Filter. If Low Pass, High Pass or Band Pass is selected, a cutoff frequency data field appears. Use DATA ENTRY Keypad (29) to enter cutoff frequencies and press ENTER Key.
- Press "Ret" Soft Function Key F5 to return to Duplex Transmitter Operation Screen.

9. If decoding Signaling Formats is not desired, proceed with step 16.
10. Press SETUP Key to display Duplex Transmitter Menu and move cursor to "11. Signaling Formats" and press ENTER Key. Use DATA ENTRY Keypad (29) to select a Signaling Format.
 - If DTMF is selected, press "Ret" Soft Function Key F5 to return to Duplex Transmitter Operation Screen.
 - If Audio is selected, Audio Code Menu appears. Use FIELD SELECT Keys (1) to select an Audio Code and press ENTER Key. Press "Ret" Soft Function Key F5 to return to Duplex Transmitter Operation Screen.

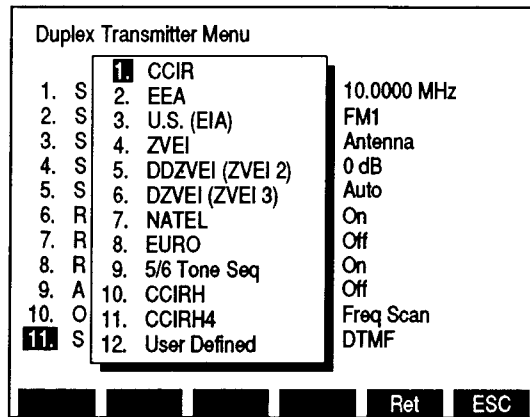

8610116

- If Digital is selected, Digital Code Menu appears. Use DATA ENTRY Keys (29) to select a Digital Code. Press "Ret" Soft Function Key F5 to return to Duplex Transmitter Operation Screen.
11. Press "More" Soft Function Key F6 until "Disp" Soft Function Key F1 is displayed. Press "Disp" Soft Function Key F1 to display following submenu:

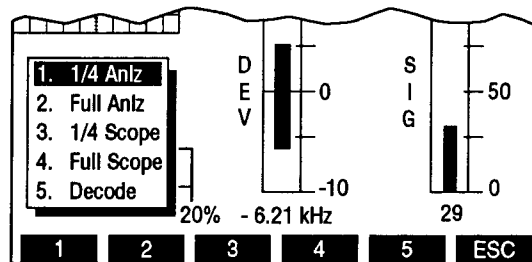

8617081

12. Press 5 DATA ENTRY Key (29) to display Decode Callout (46).

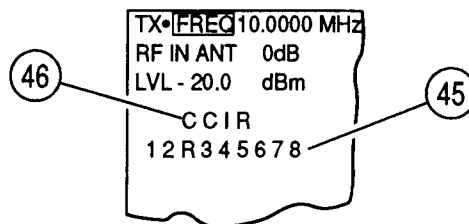

8617083

13. For DTMF Decode, press "Decode" Soft Function Key F2. Decoded digits (45) are displayed under DTMF Callout. To stop decoding, press "Stop" Soft Function Key F3.
14. For DCS or DCS INV Decode:
 - To change Input Source, press "Input" Soft Function Key F5. A submenu appears listing Input Sources. Use DATA ENTRY Keypad (29) to select an Input Source.

NOTE: Source "2. SIN/BER (INV)" inverts Input before decoding.

 - Press "Decode" Soft Function Key F2. Decoded digits (45) are displayed under Decode Callout (46). To stop decoding, press "Stop" Soft Function Key F3.
15. For Audio or Digital POCSAG Decode, press "Extend" Soft Function Key F5 to display following Extend Screen:

Audio Tones Decode: CCIR							
#	Frq	Err %	Dur	#	Frq	Err %	Dur
1	1158	3.2	98				
2	1167	2.5	99				
3	1298	1.8	101				
4	1406	3.5	98				
5	1475	2.0	98				

Input Decode Stop Type Ret

8610175

- To change Input Source, press "Input" Soft Function Key F1. A submenu appears listing Input Sources. Use DATA ENTRY Keypad (29) to select an Input Source.
 - For POCSAG, press "Rate" Soft Function Key F4 to toggle POCSAG Rate to Low or High.
 - For Audio, press "Type" Soft Function Key F4 to access the Audio Code Callout. Use DATA SCROLL ↑ and ↓ Keys (3) to select an Audio Code and press ENTER Key.
 - Press "Decode" Soft Function Key F2 to decode. Decoded digits, frequencies, frequency error percentages and time durations are displayed.
 - Press "Stop" Soft Function Key F3 to stop decoding. Press "Ret" Soft Function Key F5 to return to Duplex Transmitter Operation Screen.
16. To set Duplex Transmitter Output parameters, press SETUP Key to display Duplex Transmitter Menu.
 - Press 5 DATA ENTRY Key (29) to display AGC Type Menu. Use DATA ENTRY Keypad (29) to select an AGC Type.

- If User Defined is selected as AGC Type, User Defined AGC Type Menu appears. Use DATA ENTRY Keypad (29) to select an User Defined AGC Type.
 - If Manual is selected, a data field appears. Use DATA ENTRY Keypad (29) to enter an AGC Level and press ENTER Key.
 - To route demodulated received signal to Speaker, press 6 DATA ENTRY Key (29) to toggle "Rcvr Out Speaker" on.
 - To route demodulated received signal to AUDIO OUT Connector (14), press 7 DATA ENTRY Key (29) to toggle "Rcvr Out Audio Out" on.
 - To route demodulated Received Signal to DEMOD Connector (12), press 8 DATA ENTRY Key (29) to toggle "Rcvr Out Demod Out" on.
 - Press 9 DATA ENTRY Key (29) to toggle Automatic Volume Level on or off.
 - Press "Ret" Soft Function Key F5 to return to Duplex Transmitter Operation Screen.
17. If an Oscilloscope or Analyzer Display is not desired, proceed with step 22.
18. Press "More" Soft Function Key F6 until "Disp" Soft Function Key F1 appears. Press "Disp" Soft Function Key F1 to display a menu listing Oscilloscope and Analyzer options. Use DATA ENTRY Keypad (29) to select an option.

NOTE: When LSB is selected as Modulation or a 3 kHz is selected as User Modulation IF Filter, Center Frequency of Duplex Transmitter Analyzer Display is shifted 1.8 kHz less than center line.

When USB is selected as Modulation, Center Frequency of Duplex Transmitter Analyzer Display is shifted 3.6 kHz less than center line.

1/4 size Analyzer Screen parameters are edited by first selecting full size Analyzer Screen, changing parameters, and then reselecting 1/4 size Analyzer Screen.

19. If "2. Full Anlz" is selected:

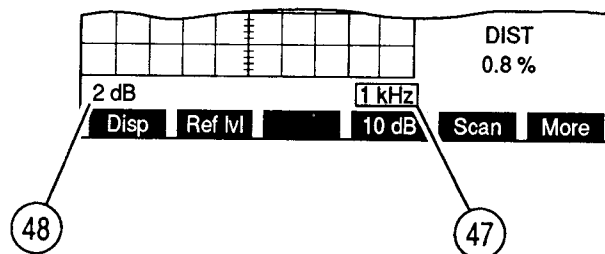

8607104

- Move cursor to Analyzer Scan Width (47) and press ENTER Key to access its data field. Press DATA SCROLL \uparrow or \downarrow Keys (3) until desired selection appears in data field and press ENTER Key to activate Scan Width desired.

- Move cursor to Analyzer Scale (48) and press ENTER Key to toggle Analyzer Scale between 2 and 10 dB.
- If 2 dB is selected for Analyzer Scale, press "Ref lvl" Soft Function Key F2 and use DATA SCROLL Spinner (2) or DATA SCROLL ↑ and ↓ Keys (3) to adjust Reference Level. Press ENTER Key.

20. If "3. 1/4 Scope" is selected:

- Move cursor to Oscilloscope Input (41) and press ENTER Key to access its data field. Press DATA SCROLL ↑ or ↓ Keys (3) until desired selection appears in data field and press ENTER Key to activate.

NOTE: The remaining Oscilloscope parameters are edited by selecting full size Scope display, editing desired parameters and reselecting 1/4 size Scope display.

21. If "4. Full Scope" is selected:

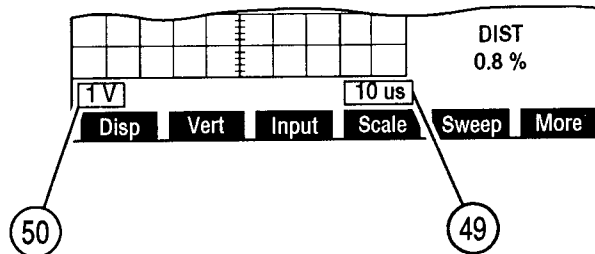

8607110

- Move cursor to Oscilloscope Input (41) and press ENTER Key to access its data field. Press DATA SCROLL ↑ or ↓ Keys (3) until desired selection appears in data field and press ENTER Key to activate.
 - If needed, move cursor to Oscilloscope Sweep Rate (49) and press ENTER Key to access its data field. Press DATA SCROLL ↑ or ↓ Keys (3) until desired selection appears in data field and press ENTER Key to activate.
 - Move cursor to Oscilloscope Scale (50) and press ENTER Key to access its data field. Press DATA SCROLL ↑ or ↓ Keys (3) until desired selection appears in data field and press ENTER Key to activate.
 - If needed, press "Vert" Soft Function Key F2 to edit vertical adjustment of Oscilloscope Trace. Use DATA SCROLL Spinner (2) or DATA SCROLL ↑ or ↓ Keys (3) to adjust vertical position of Oscilloscope Trace.
22. To select a meter, press "More" Soft Function Key F6 until "AUX" Soft Function Key F5 appears:
- For FM or PM Modulation, press "Meters" Soft Function Key F4 to select SINAD, Distortion or Deviation (RMS) Meter.
 - For AM Modulation, press "Modul"/"Dist" Soft Function Key F4 to select Modulation or Distortion Meter. Both Meters are displayed, but only selected meter is functional.

-
- For USB, LSB or BFO Modulation, press "Tune" Soft Function Key F4 and use DATA SCROLL ↑ and ↓ Keys (3) to tune Receiver in 125 Hz steps. Press ENTER Key.
23. To zero Deviation Meter if displayed, press "More" Soft Function Key F6 until "FM Z" Soft Function Key F3 appears. Press "FM Z" Soft Function Key F3. To abort zeroing process, press Soft Function Key F3 before "FM Z" reappears.
24. To edit a Meters settings, move cursor to Callout of Meter to be edited and press ENTER Key. Meter Operation Screen appears.
- For RF Frequency Error Meter Operation Procedures, see 4-8-2.
 - For AF Meter Operation Procedures, see 4-8-1.
 - For FM Deviation (Peak) Meter Operation Procedures, see 4-8-4.
 - For Phase Meter Operation Procedures, see 4-8-11.
 - For AM Modulation Meter Operation Procedures, see 4-8-5.
 - For Distortion Meter Operation Procedures, see 4-8-6.
 - For Power Meter Operation Procedures, see 4-8-3.
 - For Signal Strength Meter Operation Procedures, see 4-8-8.
 - For SINAD Meter Operation Procedures, see 4-8-7.
25. To operate Duplex Transmitter in Channel Mode, press SETUP Key to display Duplex Transmitter Menu.
- Move cursor to "10. Operation Mode" and press ENTER Key. Press 2 DATA ENTRY Key (29) to select Duplex Transmitter Channel Mode.
 - Press "Chan" Soft Function Key F2 to display a submenu listing cellular formats. Use DATA ENTRY Keypad (29) to select a cellular format.
 - Press "Ret" Soft Function Key F5 to return to Duplex Transmitter Operation Screen. Duplex Transmitter Frequency is displayed by channel number. For a list of AMPS cellular channels and corresponding frequencies, see Appendix B. For a list of E-TACS cellular channels and corresponding frequencies, see Appendix C.
 - To return Duplex Transmitter Mode to Direct Operation, press SETUP Key to display Duplex Transmitter Menu. Move cursor to "10. Operation Mode" and press ENTER Key. Press 1 DATA ENTRY Key (29) to select Duplex Transmitter Direct Mode. Press "Ret" Soft Function Key F6 to return to Duplex Transmitter Operation Screen.
26. To operate Find Function:
- Press "More" Soft Function Key F6 until "Disp" Soft Function Key F1 appears. Press "Disp" Soft Function Key F1 to display a menu listing Oscilloscope and Analyzer options.

STEP**PROCEDURE**

- Press 2 DATA ENTRY Key (29) to select full size Analyzer display.
- Press "More" Soft Function Key F6 and press "Find lvl" Soft Function Key F2. Find Level is indicated by a red horizontal line. Use DATA SCROLL Spinner (2) or DATA SCROLL ↑ and ↓ Keys (3) to adjust Find Level and press ENTER Key.
- Press "Find" Soft Function Key F1 to activate Find Function. Duplex Transmitter Frequency (39) changes to frequency found.

4-4-5 DUPLEX RECEIVER OPERATION

STEP PROCEDURE

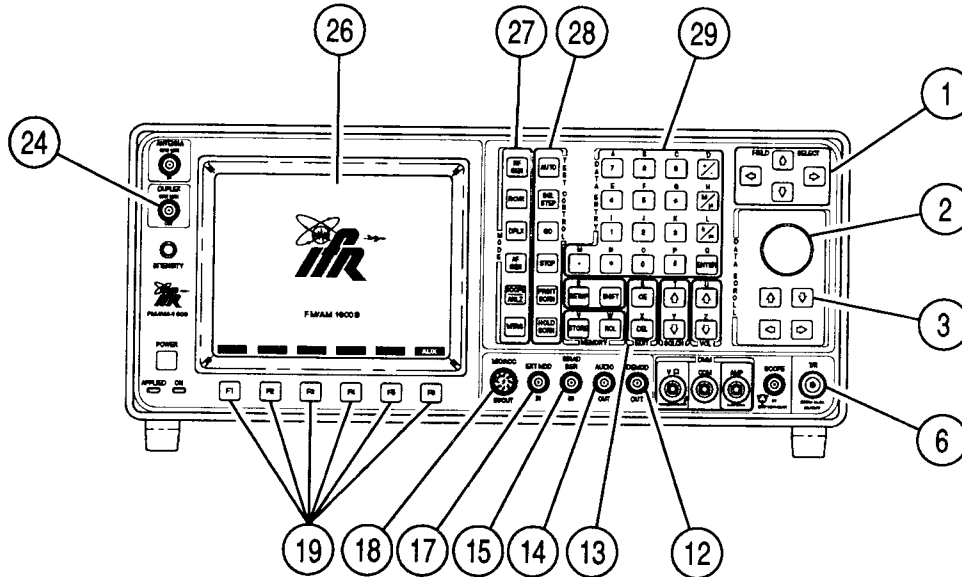

8607087

1. Press DPLX MODE Key (27) press "RX" Soft Function Key F2. Duplex Receiver Operation Screen appears on CRT.

NOTE: Duplex Receiver tests Receiving UUTs and functions as a RF Generator.

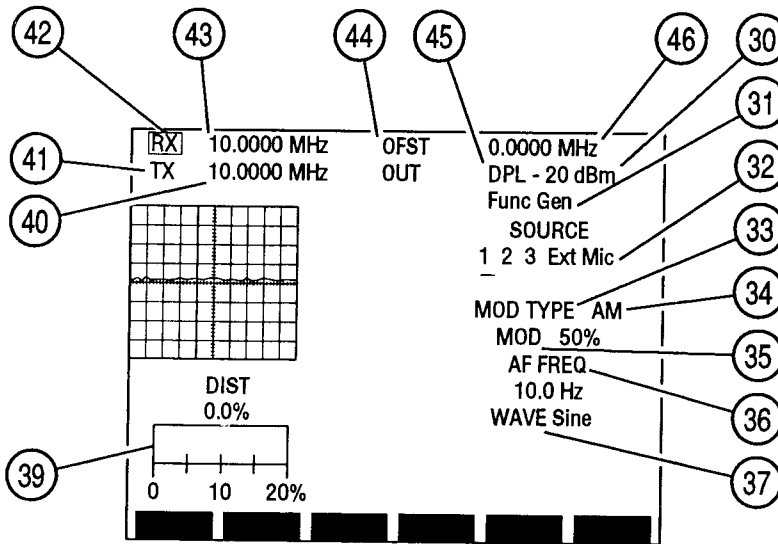

8607065

2. Press "More" Soft Function Key F6 until "Offset" or "R Freq" Soft Function Key F5 appears. Press Soft Function Key F5 to toggle which frequency is editable. Use DATA ENTRY Keypad (29) to enter desired frequency and press ENTER Key.

NOTE: When Duplex Offset Frequency (OFST) or Duplex Receiver Frequency (RX) is edited, the unedited frequency changes also for their sum to equal the Duplex Transmitter Frequency (TX). Duplex Transmitter Frequency (TX) is not edited from this Operation Screen.

3. Move cursor to OUT and press ENTER Key to toggle Duplex Receiver Output location between "DPL" (DUPLEX OUT Connector [24]) and "T/R" (T/R Connector [6]).
4. Move cursor to Output Level (30) and press ENTER Key. Use DATA ENTRY Keypad (29) to enter desired level and press ENTER Key. If necessary, press +/- DATA ENTRY Key (29) to place "-" in data field.
5. Move cursor to SOURCE (32) and press ENTER Key to access active Modulation Source. Use FIELD SELECT ← and → Keys (1) to place cursor over desired source and use DATA SCROLL ↑ or ↓ Keys (3) to select desired Modulation Type (32). White indicates OFF, red indicates AM, yellow indicates FM and green indicates PM. Last selected Modulation Type is displayed with MOD TYPE (34).

NOTE: If no source is active, data field cursor appears under SOURCE 1. If more than one source is on, last selected Source is indicated by an underline. Source 1 refers to AF Generator 1, Source 2 refers to AF Generator 2, Source 3 refers to Signaling Formats, Ext refers to signals received at EXT MOD IN Connector (17) and Mic refers to signals received at MIC/ACC Connector (18).

6. Move cursor to DEV or MOD (35) and press ENTER Key to access its data field. Use DATA ENTRY Keypad (29) to enter digits of desired deviation frequency or modulation percentage and press ENTER Key.

NOTE: When Ext Source is selected, Modulation Level setting assumes the modulating signal applied to the EXT MOD IN Connector (17) is 3.54 VRMS. Modulation Level setting is set higher for lower EXT MOD IN Connector (17) input voltages to achieve the same modulation level as per the following equation:

$$\begin{array}{rcccl} \text{Modulation} & & \text{EXT MOD IN} & & \text{Actual} \\ \text{Level setting} & \times & \text{Connector} & \div & \text{Modulation} \\ \text{(kHz, \%, rad)} & & \text{Input (VRMS)} & & \text{Level} \\ & & & & \text{3.54} & = \end{array}$$

7. If Source 1 or 2 is the last selected Source:
 - Move cursor to AF FREQ (36) and press ENTER Key to access data field. Use DATA ENTRY Keypad (29) to enter desired frequency and press ENTER Key.
 - Move cursor to WAVE (37) and press ENTER Key to access data field. Press DATA SCROLL ↑ or ↓ Keys (3) until desired selection appears in data field and press ENTER Key to activate Wave Shape.

8. If Source 3 is not selected as the last selected Source, proceed with step 19. If Source 3 is the last selected Source, the Operation Screen appears as follows:

9. If DTMF is the Signaling Format:
 - Move cursor to DIRECT ENTRY/PROG # (48). Press ENTER Key to toggle between Direct Entry and Program features.
 - If PROG is selected, move cursor to Program Number (49) and use DATA ENTRY Keypad (29) to select a programmed sequence. Press ENTER Key.
 - If DIRECT ENTRY is selected, move cursor to sequence listing (51) and use DATA ENTRY Keypad (29) to enter desired sequence. Press ENTER Key.

10. If DTMF is not Signaling Format, move cursor to Signaling Code (47) and use DATA SCROLL ↑ and ↓ Keys (3) to select one of Signaling Codes of current Signaling Format. Press ENTER Key.
 - If POCSAG or Tone Remote is selected as Signaling Code, move cursor to POCSAG or Tone Remote Function Callout (50). Use DATA SCROLL ↑ and ↓ Keys (3) to select a function and press ENTER Key.
 - If DTMF, POCSAG or Tone Remote is not selected as the Signaling Code:
 - Move cursor to DIRECT ENTRY/PROG # (48). Press ENTER Key to toggle between Direct Entry and Program features.
 - If PROG is selected, move cursor to Program Number (49) and use DATA ENTRY Keypad (29) to select a programmed sequence. Press ENTER Key.
 - If DIRECT ENTRY is selected, move cursor to sequence listing (51) and use DATA ENTRY Keypad (29) to enter desired sequence. Press ENTER Key.

11. To generate Code, press GO TEST CONTROL Key (28). To stop generating Code, press STOP TEST CONTROL Key (28). To generate Code one tone at a time, press SGL STEP TEST CONTROL Key (28).

12. To select a different Signaling Format, press SETUP Key to display Duplex Receiver Menu. Press 3 DATA ENTRY Key (29) to display Signaling Format Menu:

**DUPLEX RECEIVER SIGNALING
FORMAT MENU**

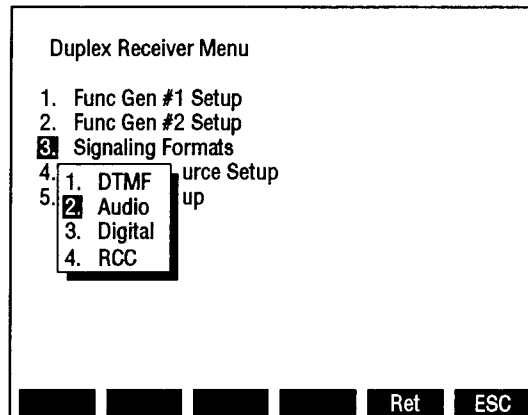

8610090

13. Use DATA ENTRY Keys (29) to select a Signaling Format and press "Ret" Soft Function Key F5.
14. To program a Signaling Code sequence, press SETUP Key to display Duplex Receiver Menu. Press 3 DATA ENTRY Key (29) to display the Signaling Formats Menu. Use DATA ENTRY Keys (29) to select a Signaling Format.
15. If DTMF is selected, DTMF Signaling Menu appears:

**DUPLEX RECEIVER DTMF
FORMAT MENU**

- Select Id (52) of Sequence to be edited using FIELD SELECT ↑ and ↓ Keys (1).

- Move cursor to Timing column (53) and use DATA SCROLL ↑ and ↓ Keys (3) to select Std (Standard) or User. Press ENTER Key.
- If User is chosen, data fields appear for Mark Timing and Space Timing.
 - Press 1 DATA ENTRY Key (29) and use DATA ENTRY Keypad (29) to enter Mark Timing. Press ENTER Key.
 - Press 2 DATA ENTRY Key (29) and use DATA ENTRY Keypad (29) to enter Space Timing. Press ENTER Key.
 - Press "ESC" Soft Function Key F6.
- Move cursor to Selection column (54), enter a sequence using DATA ENTRY Keypad (29) and press ENTER Key.

NOTE: Pressing SHIFT Key toggles DATA ENTRY Keypad (29) between numeric and alphabetic characters.

- Move cursor to Mod column (55), use DATA SCROLL ↑ and ↓ Keys (3) to select Modulation Type and press ENTER Key.
- Move cursor to Mod Level (56), use DATA ENTRY Keypad (29) to select Modulation Level and press ENTER Key.
- When desired sequences are entered, press ENTER Key and "Ret" Soft Function Key F5 to return to Duplex Receiver Operation Screen.

16. If Audio is selected as Signaling Format, Audio Code Menu appears:

DUPLEX RECEIVER AUDIO
CODE MENU

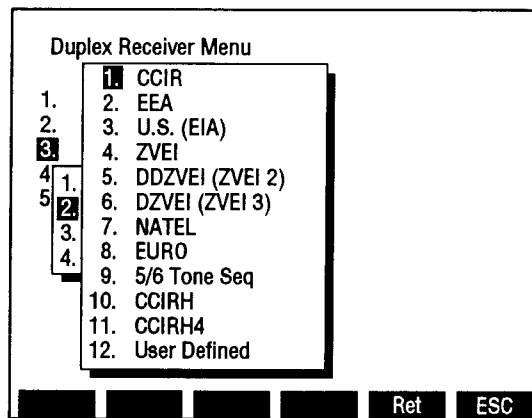

8610089

- Use FIELD SELECT Keys (1) to select an Audio Code and press ENTER Key. Audio Code Sequence Menu appears:

DUPLEX RECEIVER AUDIO CODE SEQUENCE MENU

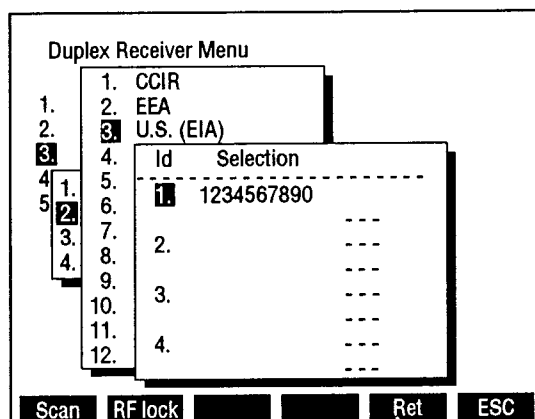

8610088

- Use FIELD SELECT Keys (1) to select an Id and press ENTER Key.
- Use DATA ENTRY Keys (29) to enter a sequence and press ENTER Key.

NOTE: Pressing SHIFT Key toggles DATA ENTRY Keypad (29) between numeric and alphabetic characters.

- If "12. User Defined" is selected as Audio Code, the Audio Code User Defined Menu appears:

DUPLEX RECEIVER AUDIO CODE USER DEFINED MENU

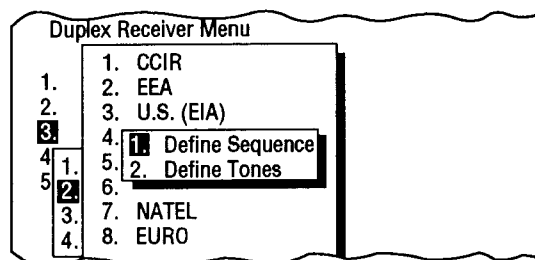

8610170

- Press 2 DATA ENTRY Key (29) to display following menu:

**DUPLEX RECEIVER USER
DEFINED TONES MENU**

Duplex Receive Menu				
1.	1. CCIR			
2.	2. EEA			
3.	3. U.S. EIA)			
4.	4.	Id	Tone(Hz)	Duration (ms)
5.	5.	0	5.0	20
6.	6.	1	10.0	20
7.	7.	2	20.0	20
8.	8.	3	30.0	20
9.	9.	4	40.0	20
10.	10.	5	50.0	20
11.	11.	6	60.0	20
12.	12.	7	70.0	20

Fill Ret ESC

8607129

- Move cursor to Tone(Hz) column (58) of desired Id (57) and use DATA ENTRY Keypad (29) to select frequency. Press ENTER Key.
- Move cursor to Duration(ms) column (59) and use DATA ENTRY Keypad (29) to select duration. Press ENTER Key.
- When cursor is in Tone(Hz) (58) or Duration(ms) columns (59), press "Fill" Soft Function Key F4 to fill column below cursor with value highlighted by cursor.
- When all desired tones are defined, press "ESC" Soft Function Key F6 to return to Audio Code User Defined Menu.
- Press 1 DATA ENTRY Key (29) to access Audio Code Sequence Menu. User Defined Sequences are selected as other Audio Code Sequences. When all desired sequences have been entered, press "Ret" Soft Function Key F5 to return to Duplex Receiver Operation Screen.

17. If Digital is selected as the Signaling Format, Digital Code Menu appears. Use DATA ENTRY Keypad (29) to select a Digital Code.

- If DCS or DCS INV is selected as Digital Code, DCS Code Menu appears:

DUPLEX RECEIVER
DCS CODE SUBMENU

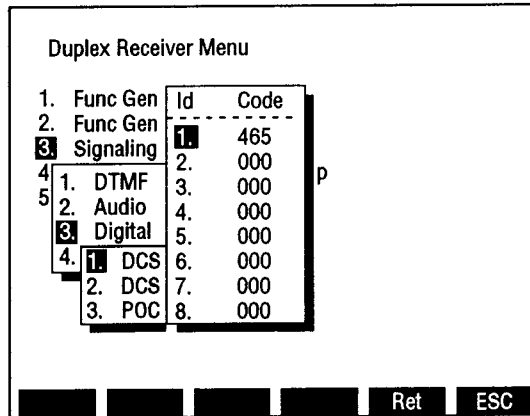

8610087

- Use FIELD SELECT Keys (1) to select an Id and press ENTER Key.
- Use DATA ENTRY Keypad (29) to enter a sequence and press ENTER Key. When all desired sequences have been entered, press "Ret" Soft Function Key F5 to return to Duplex Receiver Operation Screen.
- If POCSAG is selected as the Digital Code, POCSAG Menu appears:

DUPLEX RECEIVER POCSAG MENU

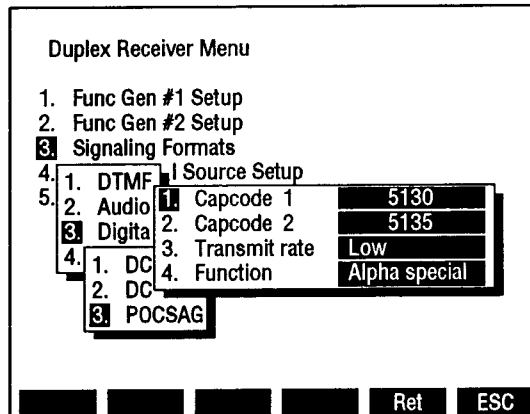

8610151

- Press 1 DATA ENTRY Key (29) to access Capcode 1. Use DATA ENTRY Keypad (29) to enter Starting Capcode and press ENTER.
- Press 2 DATA ENTRY Key (29) to access Capcode 2. Use DATA ENTRY Keypad (29) to enter Ending Capcode and press ENTER.

- Press 3 DATA ENTRY Key (29) to toggle Transmit rate until set as desired.
- Press 4 DATA ENTRY Key (29) to display POCSAG Function Menu:

DUPLEX RECEIVER POCSAG
FUNCTION MENU

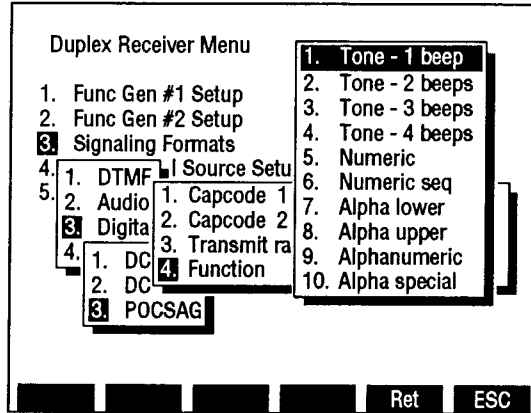

8610176

- Use FIELD SELECT Keys (1) to select a Function Type and press ENTER Key. Press "Ret" Soft Function Key F5 to return to the Duplex Receiver Operation Screen.

18. If RCC is selected as the Signaling Format, RCC Code Menu appears. Use DATA ENTRY Keypad (29) to select a RCC Code.

DUPLEX RECEIVER RCC CODE MENU

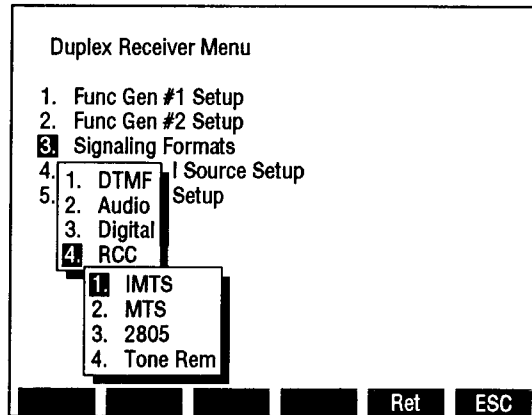

8610152

- If IMTS, MTS or 2805 is selected, RCC Sequence Menu appears:

DUPLEX RECEIVER IMTS,
MTS AND 2805 MENU

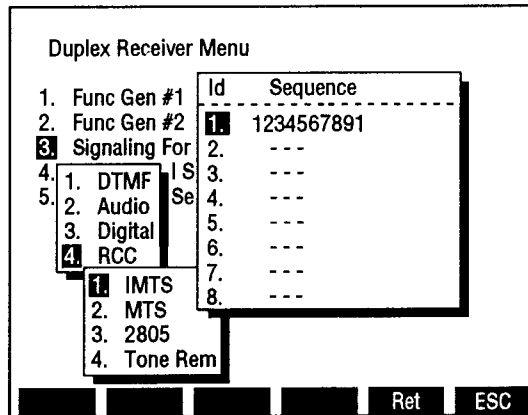

8610153

- Use FIELD SELECT Keys (1) to select an Id and press ENTER Key.
- Use DATA ENTRY Keypad (29) to enter a sequence and press ENTER Key.
- When 2805 is chosen, "Tone" Soft Function Key F3 appears. To edit 2805s frequency, press "Tone" Soft Function Key F3 and use DATA ENTRY Keypad (29) to enter frequency. Press ENTER Key.
- When all desired sequences have been entered, press "Ret" Soft Function Key F5 to return to Duplex Receiver Operation Screen.
- If Tone Rem is selected, Tone Rem Function Menu appears:

STONE REM FUNCTION MENU

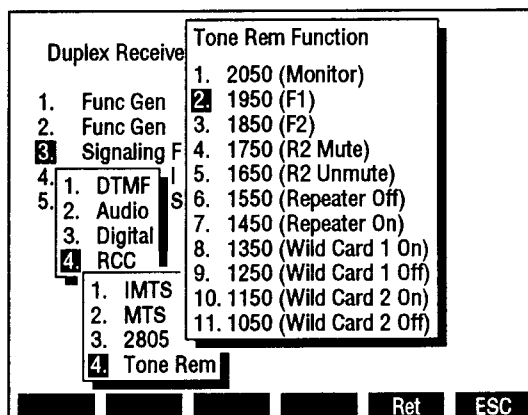

8610177

- Use FIELD SELECT Keys (1) to select a Tone Remote Function and press ENTER Key.
- Press "Ret" Soft Function Key F5 to return to Duplex Receiver Operation Screen.

19. If an Oscilloscope or Spectrum Analyzer display is desired for Duplex Receiver Operation Screen or if this feature is desired in a different size:

- Press "More" Soft Function Key F6 until "Disp" Soft Function Key F1 appears. Press "Disp" Soft Function Key F1.
- A menu appearing in lower left corner of CRT screen displays following options:

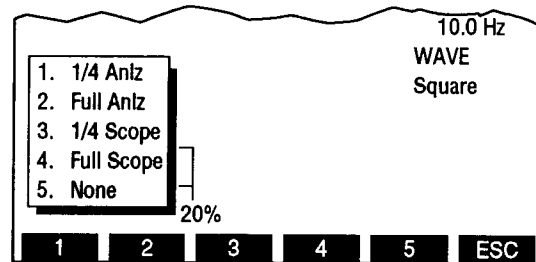

8617084

Select desired screen option using DATA ENTRY Keypad (29).

NOTE: 1/4 size Analyzer Screen parameters are edited by selecting full size Analyzer display, editing parameters and reselecting 1/4 size Analyzer display.

20. If "2. Full Anlz" is selected:

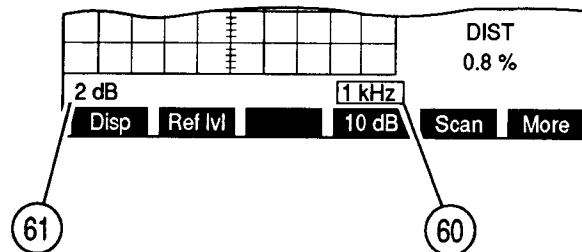

8607109

- Move cursor to Analyzer Scan Width (60) and press ENTER Key to access its data field. Press DATA SCROLL ↑ or ↓ Keys (3) until desired selection appears in data field and press ENTER Key to activate Scan Width desired.
- Move cursor to Units/Division Factor (61) and press ENTER Key to change this parameter. Pressing ENTER Key toggles its value between 2 and 10 dB.

21. If "3. 1/4 Scope" is selected:

- Move cursor to Oscilloscope Input (31) and press ENTER Key to access its data field. Press DATA SCROLL ↑ or ↓ Keys (3) until desired selection appears in data field and press ENTER Key to activate Oscilloscope Input desired.

NOTE: Remaining Oscilloscope parameters are edited by selecting full size Scope display, changing parameters and reselecting 1/4 size Scope display.

22. If "4. Full Scope" is selected:

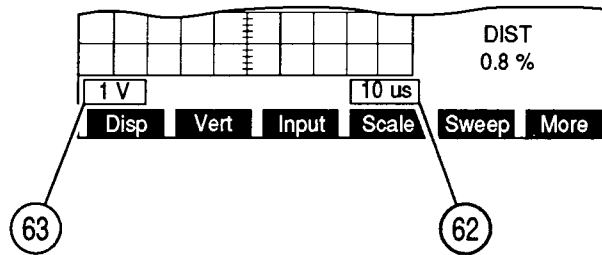

8607078

- Move cursor to Oscilloscope Input (31) and press ENTER Key to access its data field. Press DATA SCROLL ↑ or ↓ Keys (3) until desired selection appears in data field and press ENTER Key to activate selected Oscilloscope Input.
 - Move cursor to Oscilloscope Sweep Rate (62) and press ENTER Key to access its data field. Press DATA SCROLL ↑ or ↓ Keys (3) until desired selection appears in data field and press ENTER Key to activate selected Oscilloscope Sweep Rate.
 - Move cursor to Oscilloscope Scale (63) and press ENTER Key to access its data field. Press DATA SCROLL ↑ or ↓ Keys (3) until desired selection appears in data field and press ENTER Key to activate selected Oscilloscope Scale.
 - If needed, press "More" Soft Function Key F6 until "Vert" Soft Function Key F2 appears. Press "Vert" Soft Function Key F2 and use DATA SCROLL Spinner (2) or DATA SCROLL ↑ or ↓ Keys (3) to adjust vertical position of Oscilloscope Trace. Press ENTER Key.
23. If Modulation Source is desired to be routed to AUDIO OUT Connector (14) or DEMOD OUT Connector (12) or if Speaker use is desired, press SETUP Key to display the Generator Menu. Press 5 DATA ENTRY Key (29) to access RF Gen Setup Menu.

DUPLEX RECEIVER SETUP MENU

Duplex Receiver Menu		
1.	RF Gen #1 Setup	
2.	RF Gen #2 Setup	
3.	Signaling Formats	
4.	External Source Setup	
5.	RF Gen Setup	
1.	RF Gen Freq	10.0000 MHz
2.	RF Gen Level	- 20.0 dBm
3.	RF Gen Format	Direct
4.	RF Gen Level Units	dBm
5.	Source to Audio Out	Off
6.	Source to Demod Out	Off
7.	To Speaker	None
Ret ESC		

8610073

- Press 5 DATA ENTRY Key (29) as needed to enable or disable Modulation Source routing to AUDIO OUT Connector (14).

- Press 6 DATA ENTRY Key (29) as needed to enable or disable Modulation Source routing to DEMOD OUT Connector (12).
- Press 7 DATA ENTRY Key (29) and use DATA ENTRY Keypad (29) to select a signal to be routed to Speaker.

NOTE: Routing Source to Speaker disables SINAD and Distortion Meters.

- Press "Ret" Soft Function Key F5 to return to Duplex Receiver Operation Screen.
24. To display SINAD, Distortion or AF Level Meter or Digital Multimeter, press "More" Soft Function Key F6 until "Meters" Soft Function Key F4 appears. Press "Meters" Soft Function Key F4 to display a submenu listing available meters. Use DATA ENTRY Keypad (29) to select a meter. To access a meters Operation Screen, move cursor to Meters Callout and press ENTER Key.

- For SINAD Meter Operation Procedures, see 4-8-7.
- For Distortion Meter Operation Procedures, see 4-8-6.
- For DMM Operation Procedures, see 4-8-10.

NOTE: SINAD, Distortion and AF Level Meters measure SINAD/BER IN Connector (15) Input. DMM measures only DMM Connector Input.

25. After parameters of Duplex Receiver Operation Screen are set, connect UUT to Test Set:
- For testing using separate transmit and receive lines, apply UUT transmitter output to T/R Connector (6). Connect DUPLEX OUT Connector (24) to RF input of UUT receiver.
 - For "off the air" Duplex testing, connect antenna to ANTENNA IN Connector (25). Connect DUPLEX OUT Connector (24) or T/R Connector (6) to RF input of UUT receiver.

4-5 AF GENERATOR OPERATION

4-5-1 AF GENERATOR GENERAL OPERATION

Operate AF Signal Generator using following procedure:

STEP PROCEDURE

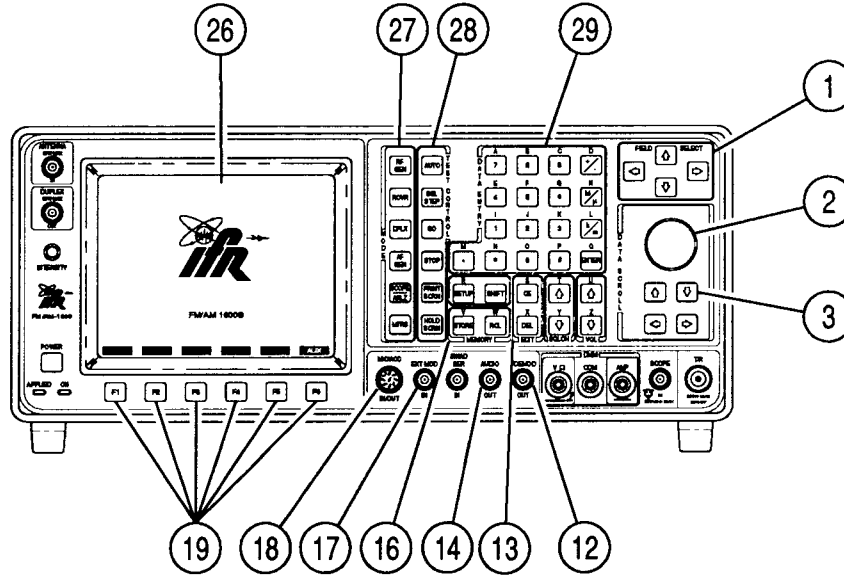

8607088

1. Press AF GEN MODE Key (27). AF Generator Operation Screen appears on CRT:

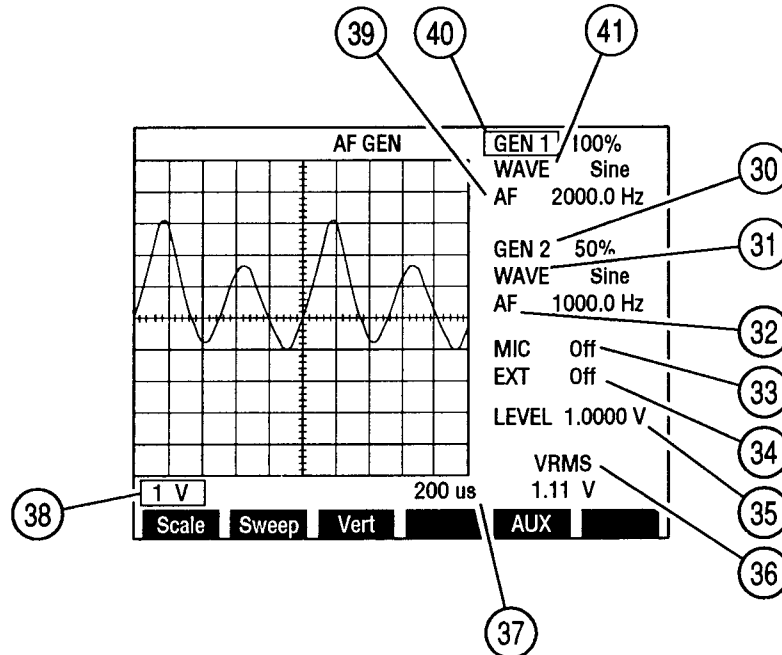

8607066

2. Press SETUP Key and press 5 DATA ENTRY Key (29) to display AF Output Menu:

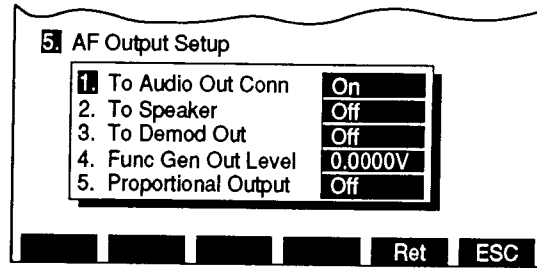

8610178

- Press 5 DATA ENTRY Key (29) to toggle Proportional Output on or off. With proportional Output on, set proportions of the AF Generators and external sources are summed instead of 100% of each. Press "Ret" Soft Function Key F5.
3. Move cursor to GEN 1 (40):
- If Proportional Output is off, press ENTER Key to toggle AF Generator #1 on or off.
 - If Proportional Output is on, press Enter Key and use DATA ENTRY Keypad (29) to enter a proportional percentage. Press ENTER Key.
4. Move cursor to WAVE (41) (GEN 1) and press ENTER Key to access its data field. Use DATA SCROLL ↑ or ↓ Keys (3) until desired selection appears in data field and press ENTER Key.
5. Move cursor to AF (39) (GEN 1) and press ENTER Key to access its data field. Use DATA ENTRY Keypad (29) to enter desired frequency and press ENTER Key.
6. Move cursor to GEN 2 (30):
- If Proportional Output is off, press ENTER Key to toggle AF Generator #2 on or off.
 - If Proportional Output is on, press Enter Key and use DATA ENTRY Keypad (29) to enter a proportional percentage. Press ENTER Key.
7. Move cursor to WAVE (31) (GEN 2) and press ENTER Key to access its data field. Use DATA SCROLL ↑ or ↓ Keys (3) until desired selection appears in data field and press ENTER Key.
8. Move cursor to AF (32) (GEN 2) and press ENTER Key to access its data field. Use DATA ENTRY Keypad (29) to enter desired frequency and press ENTER Key.
9. Move cursor to MIC (33):
- If Proportional Output is off, press ENTER Key to toggle External MIC/ACC Connector (18) Input on or off.

- If Proportional Output is on, press Enter Key and use DATA ENTRY Keypad (29) to enter a proportional percentage. Press ENTER Key.
10. Move cursor to EXT (34):
 - If Proportional Output is off, press ENTER Key to toggle External EXT MOD IN Connector (17) Input on or off.
 - If Proportional Output is on, press Enter Key and use DATA ENTRY Keypad (29) to enter a proportional percentage. Press ENTER Key.
 11. Move cursor to LEVEL (35) and press ENTER Key to access its data field. Use DATA ENTRY Keypad (29) to enter desired output and press ENTER Key to activate AF Generator Output Level.
 12. Measure VRMS Output Level by reading VRMS Digital Readout (36).
 13. Move cursor to Oscilloscope Sweep Rate (37) and press ENTER Key to access its data field. Use DATA SCROLL ↑ or ↓ Keys (3) until desired selection appears in data field and press ENTER Key to activate Sweep Rate.
 14. Move cursor to Oscilloscope Scale (38) and press ENTER Key to access its data field. Use DATA SCROLL ↑ or ↓ Keys (3) until desired selection appears in data field and press ENTER Key.
 15. If needed, press "Vert" Soft Function Key F3 to enable Vertical Adjustment Feature of Oscilloscope. Use DATA SCROLL Spinner (2) or press DATA SCROLL ↑ or ↓ Keys (3) to adjust position of Trace on Oscilloscope grid. When Trace is in desired position, press ENTER Key.
 16. To select AF Generator Outputs, press SETUP Key and 5 DATA ENTRY Key (29) to display AF Output Menu:

AF OUTPUT SETUP MENU

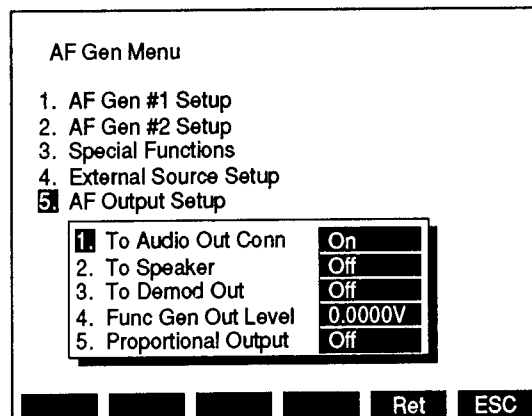

8610017

- For AF Generator Output routed to AUDIO OUT Connector (14), press 1 DATA ENTRY Key (29) to toggle "1. To Audio Out Conn" on or off.

- For AF Generator Output routed to Test Set Speaker, press 2 DATA ENTRY Key (29) to toggle "2. To Speaker" on or off.
 - For AF Generator Output routed to DEMOD OUT Connector (12), press 3 DATA ENTRY Key (29) to toggle "3. To Demod Out" on or off.
 - Press "Ret" Soft Function Key F5 to return to AF Generator Operation Screen.
17. For Audio Frequency Scan, press SETUP Key and 3 DATA ENTRY Key (29) to display Special Functions Menu. Press 1 DATA ENTRY Key (29) to display Audio Frequency Scan Menu:

AUDIO FREQUENCY SCAN MENU

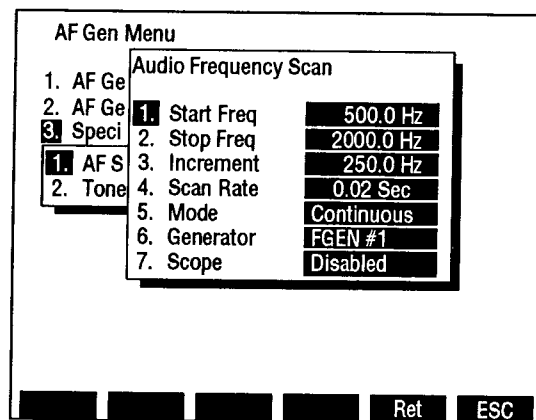

8610102

- Press 1 DATA ENTRY Key (29) and use DATA ENTRY Keypad (29) to enter Starting Frequency.
- Press 2 DATA ENTRY Key (29) and use DATA ENTRY Keypad (29) to enter Stopping Frequency.
- Press 3 DATA ENTRY Key (29) and use DATA ENTRY Keypad (29) to enter Increment.
- Press 4 DATA ENTRY Key (29) and use DATA ENTRY Keypad (29) to enter Scan Rate. Scan Rate data field is blank if "7. Scope" is enabled.
- Press 5 DATA ENTRY Key (29) to toggle Mode between Continuous and One Shot.
- Press 6 DATA ENTRY Key (29) to toggle Source between AF Generator #1 and AF Generator #2.
- Press 7 DATA ENTRY Key (29) to toggle between Scope Enabled and Disabled. Scope Enabled slows Scan Rate.

- When AF Frequency Scan parameters are set, press GO TEST CONTROL Key (28) to start Scan and press STOP TEST CONTROL Key (28) to stop Scan. Pressing SGL STEP TEST CONTROL Key (28) causes the Scan to increment forward once each time Key is pressed. Pressing AUTO TEST CONTROL Key (28) causes the Scan to increment backward once each time Key is pressed.

NOTE: TEST CONTROL Keys (28) operate last accessed Special Function, AF Frequency Scan or Tone Remote Function.

- Press "Ret" Soft Function Key F5 to return to AF Generator Operation Screen.

18. To generate a Tone Remote signal, press SETUP Key and press 3 DATA ENTRY Key (29) to display Special Functions Menu. Press 2 DATA ENTRY Key (29) to display Tone Remote Function Menu:

AF GENERATOR TONE REMOTE FUNCTION MENU

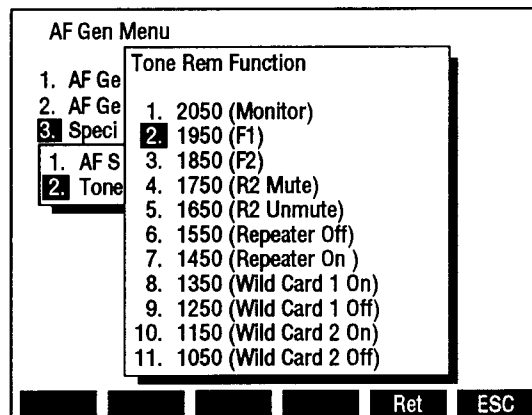

8610158

- Use FIELD SELECT Keys (1) to select a Tone Remote Function and press ENTER Key.
- Press "Ret" Soft Function Key F5 to return to AF Generator Operation Screen.
- Press GO TEST CONTROL (28) to generate Tone Remote Function. Press STOP TEST CONTROL Key (28) to stop generating Tone Remote Function.

NOTE: TEST CONTROL Keys (28) operate last accessed Special Function, AF Frequency Scan or Tone Remote Function.

4-5-2 GENERATING TONE REMOTE CODE

EXAMPLE: The following example generates a Tone Remote Code routed to the AUDIO OUT Connector (14) with a High Level Guard Tone at a 2.5 V (10 dB) level.

STEP	PROCEDURE
1.	Press AF GEN MODE Key (27) to access AF Generator Operation Mode. Press SETUP Key to display AF Gen Menu.
2.	Press 5 DATA ENTRY Key (29) to display the AF Output Setup Menu. <ul style="list-style-type: none">● Press 1 DATA ENTRY Key (29) to toggle "To Audio Out Conn" until "On" appears.● Press 5 DATA ENTRY Key (29) to toggle "Proportional Output" until "Off" appears.● Press "ESC" Soft Function Key F6.
3.	Press 3 and 2 DATA ENTRY Key (29). Move cursor to desired Tone Remote Function and press ENTER Key. Press "Ret" Soft Function Key F5 to return to Function Generator Operating Screen.
4.	Move cursor to GEN 1 (40) and press ENTER Key until " Off " appears.
5.	Move cursor to GEN 2 (30) and press ENTER Key until " Off " appears.
6.	Move cursor to LEVEL (35) and press ENTER Key. Press 2, ● and 5 DATA ENTRY Keys (29) to set Level to 2.5000 V . Press ENTER Key.
7.	Press GO TEST CONTROL Key (28) to generate sequence. Press STOP TEST CONTROL Key (28) to stop sequence.

4-5-3 GENERATING AF TONE

EXAMPLE: The following example generates a 1 kHz sine wave at a 0.1 V level.

STEP	PROCEDURE
1.	Press AF GEN MODE Key (27) to access AF Generator Operation Mode.
2.	Move cursor to GEN 1 (40) and press ENTER Key until " On " appears.
3.	Move cursor to WAVE (41) (GEN 1) and press ENTER Key. Press DATA SCROLL ↑ and ↓ Keys (3) until " Sine " appears and press ENTER Key.
4.	Move cursor to AF (39) (GEN 1) and press ENTER Key. Press 1, 0, 0 and 0 DATA ENTRY Keys (29) to set Audio Frequency to 1000.0 Hz . Press ENTER Key.
5.	Move cursor to LEVEL (35) and press ENTER Key. Press ● and 1 DATA ENTRY Keys (29) to set Level to 0.1000 V . Press ENTER Key.

4-6 OSCILLOSCOPE OPERATION

The Oscilloscope is operated using the following procedures:

STEP	PROCEDURE
------	-----------

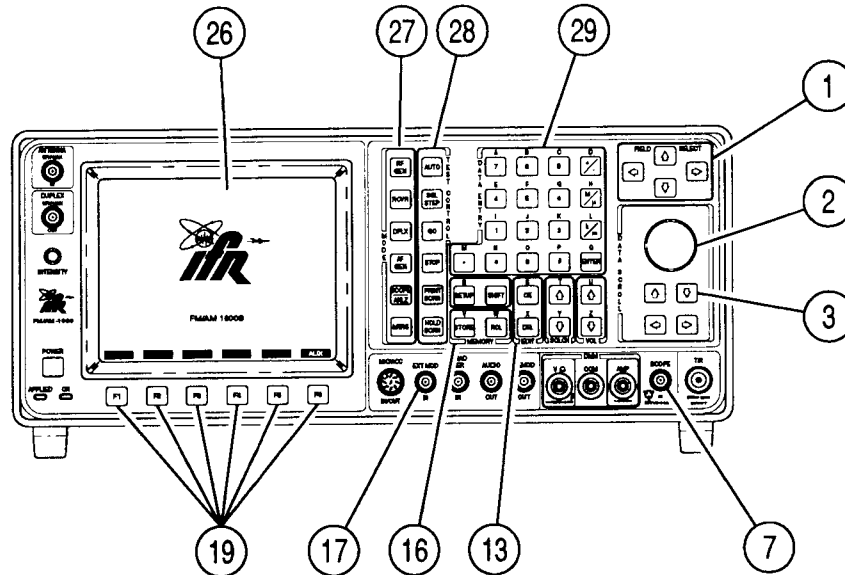

8607089

1. Press SCOPE/ANLZ MODE Key (27). Oscilloscope or Spectrum Analyzer Operation Screen appears on the CRT. If Spectrum Analyzer Operation Screen appears, press SCOPE/ANLZ MODE Key (27) again to access the Oscilloscope Operation Screen.

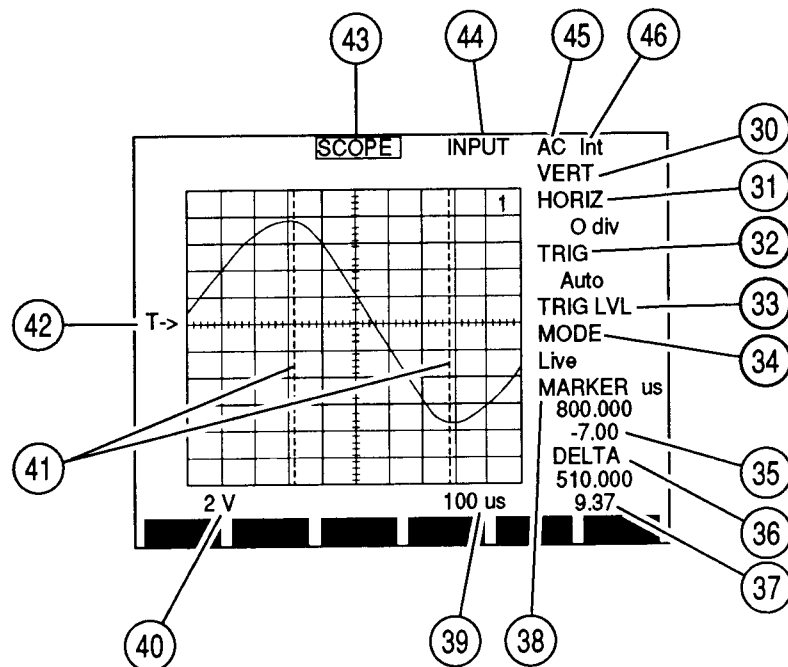

8607067

2. Move cursor to INPUT (44) and press ENTER Key. INPUT Submenu appears overlaying Oscilloscope Operation Screen. Use DATA ENTRY Keypad (29) to select an Input and press ENTER Key.

NOTE: When Rcvr IF is selected for INPUT (44), only INPUT (44) and VERT (30) is editable.

3. If AC or DC is selected for INPUT (44), move cursor to trigger source (46) and press ENTER Key to toggle trigger source (46) to desired setting. For external trigger, apply external trigger input to EXT MOD IN Connector (17).
4. If Func Gen, Ext Mod, AC, DC, GND or Demod Audio with FM Receiver Modulation is selected for INPUT (44), move cursor to Oscilloscope Scale (40) and press ENTER Key. Use DATA SCROLL ↑ or ↓ Keys (3) to select a scale and press ENTER Key.
5. If Rcvr IF is not selected for INPUT (44), move cursor to Sweep Rate (39) and press ENTER Key. Use DATA SCROLL ↑ or ↓ Keys (3) to select a Sweep Rate and press ENTER Key.
6. Move cursor to VERT (30) and press ENTER Key. Use DATA SCROLL Spinner (2) or DATA SCROLL ↑ and ↓ Keys (3) to adjust vertical level of Trace and press ENTER Key.
7. Move cursor to HORIZ (31) and press ENTER Key. Use DATA ENTRY Keypad (29) to select Trace Horizontal Offset value and press ENTER Key.
8. Move cursor to TRIG (32) and press ENTER Key. Use DATA SCROLL ↑ and ↓ Keys (3) to select a Trigger Type and press ENTER Key. Press "More" Soft Function Key F6 until "Trig" Soft Function Key F3 appears.

- If Auto or Norm is selected, press "Start" Soft Function Key F4 to start Trace. With Trace active, Soft Function Key F4 becomes "Stop". Press "Stop" Soft Function Key F4 to freeze Trace.

- If One Shot is selected, press "Arm" Soft Function Key F4 to freeze a new screen of Trace.

9. To adjust Trigger Level, move cursor to TRIG LVL (33) and press ENTER Key. Use DATA SCROLL Spinner (2) or DATA SCROLL ↑ or ↓ Keys (3) to adjust Trigger Level Indicator higher or lower on Oscilloscope Scale and press ENTER Key.

NOTE: Setting Trigger Level in this manner is an approximate setting. To set Trigger Level at an exact point on vertical scale, press SETUP Key and 3 DATA ENTRY Key (29) to access Setup Scope Menu. Press 5 DATA ENTRY Key (29) and use DATA ENTRY Keypad (29) to enter a Trigger Level (0 to 255, 128 corresponding to middle line).

10. Move cursor to MODE (34) and press ENTER Key. Use DATA ENTRY Keypad (29) to select a Mode. To recall a Trace for Recall or Compare Modes, press RCL MEMORY Key (16), use DATA ENTRY Keypad (29) to select a stored Trace and press ENTER Key.

NOTE: When in Recall Mode, only Markers and Oscilloscope Mode are editable.

NOTE: When in Compare Mode, recalled Trace does not change when Oscilloscope parameters are changed.

11. To store a set of Oscilloscope parameters and Trace, see 4-1-1.
12. To use Markers, move cursor to MARKER (38). Press "More" Soft Function Key F6 until "Marker" Soft Function Key F1 appears.
 - For Marker 1 use, press "Mkr 1" Soft Function Key F3, use DATA SCROLL Spinner (2) or DATA SCROLL Keys \uparrow and \downarrow (3) to adjust its position and press ENTER Key. "Mkr 1" appears in red while Marker 1 is the active Marker.
 - For Marker 2 use, press "Mkr 2" Soft Function Key F4, use DATA SCROLL Spinner (2) or DATA SCROLL Keys \uparrow and \downarrow (3) to adjust its position and press ENTER Key. "Mkr 2" appears in red while Marker 2 is the active Marker.

Marker reading shows active Markers position using Sweep Rate units and referencing display's left side as 0. For AC, DC or GND Input, Marker Voltage Reading (35) (voltage at Marker Trace crossing) is displayed in V.

- To lock Markers a constant distance apart, press "Track" Soft Function Key F5. Use DATA SCROLL Spinner (2) or DATA SCROLL \uparrow and \downarrow Keys (3) to adjust both Markers at once. Marker and Marker voltage readings reflect Marker 1 position.

Delta reading shows position difference of the two Markers. DELTA Voltage Reading (37) shows voltage difference of the two Marker Trace crossings.

- To deactivate Markers, press "Off" Soft Function Key F2.

NOTE: If Marker is "Off", Marker Indicator appears on Oscilloscope grid if Marker Callout is accessed. Marker disappears from grid when Marker value is activated.

13. If needed, install Oscilloscope Probe (optional) to SCOPE IN Connector (7) and attach Oscilloscope Probe to desired test points of UUT.
14. To plot Trace via GPIB Connector:
 - Configure GPIB parameters (see 6-2). Connect Plotter to GPIB Connector.
 - Press PRINT SCREEN TEST CONTROL Key (28). If submenu appears listing Print and Plot options, press 2 DATA ENTRY Key (29). The following submenu appears:

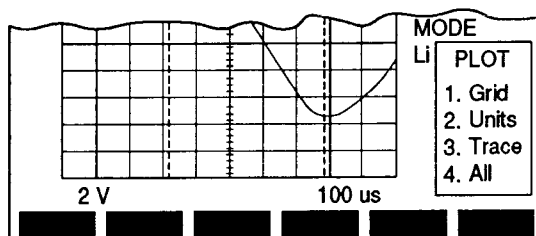

8607120

- Use DATA ENTRY Keys (29) to select items to plot until desired items are plotted.

STEP

PROCEDURE

- After plotting process is completed, press "ESC" Soft Function Key F6.

NOTE: To print CRT screen, see 4-1-2.

4-7 SPECTRUM ANALYZER OPERATION

4-7-1 SPECTRUM ANALYZER GENERAL OPERATION

The Spectrum Analyzer is operated using the following procedures:

STEP	PROCEDURE
------	-----------

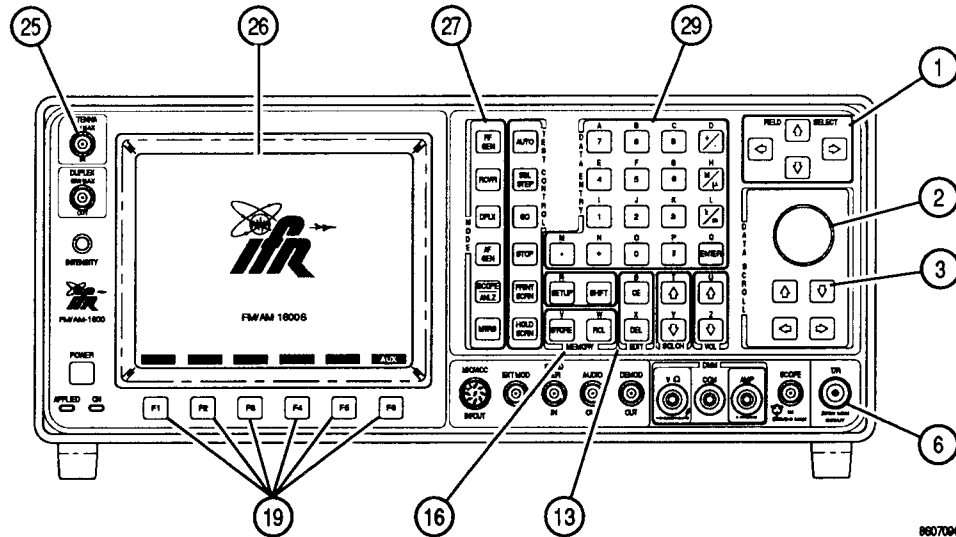

8607090

1. Press SCOPE/ANLZ MODE Key (27). Oscilloscope or Spectrum Analyzer Operation Screen appears on CRT. If Oscilloscope Operation Screen appears, press SCOPE/ANLZ MODE Key (27) again. Spectrum Analyzer Operation Screen appears:

NOTE: AM1 or USB Receiver Modulation is not available for Spectrum Analyzer operation. Spectrum Analyzer is not operable when Receiver Modulation is User with 3 kHz selected as the IF Filter unless BFO or LSB is selected as User Modulation.

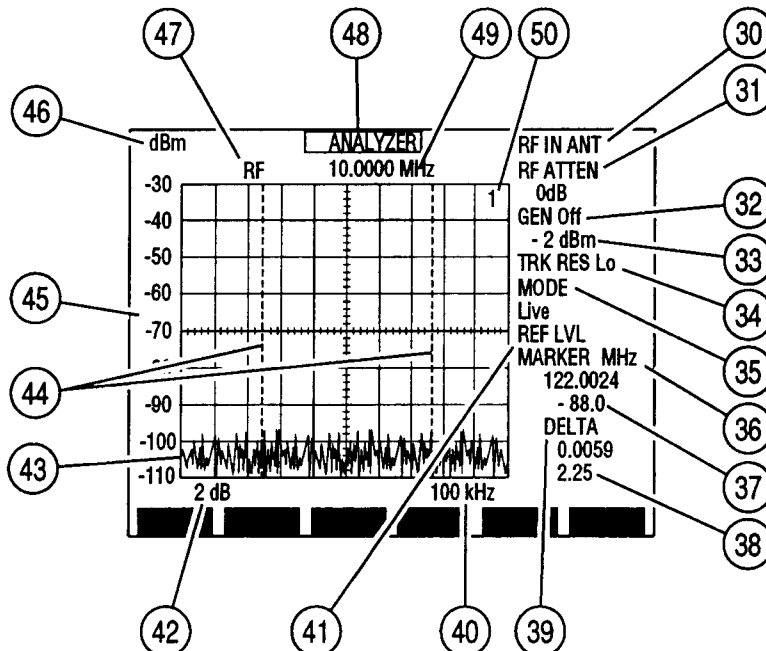

8607068

2. Connect RF Source of Spectrum Analyzer Input Signal to ANTENNA IN Connector (25) or T/R Connector (6).

CAUTION: MAXIMUM CONTINUOUS INPUT TO THE ANTENNA IN CONNECTOR (25) IS LIMITED TO 10 mW WITH PROTECTION PROVIDED TO A MAXIMUM INPUT OF 65 W.

MAXIMUM CONTINUOUS INPUT TO THE T/R CONNECTOR (6) IS LIMITED TO 50 W WITH PROTECTION PROVIDED TO A MAXIMUM INPUT OF 200 W.

3. Move cursor to RF (47) and press ENTER Key to access data field (49). Use DATA ENTRY Keypad (29) to enter frequency and press ENTER Key.
4. Move cursor to RF IN (30) and press ENTER Key to toggle RF Input location between ANTENNA IN Connector (25) and T/R Connector (6).
5. Move cursor to RF ATTEN (31) and press ENTER Key to access RF Attenuation data field. Use DATA SCROLL ↑ or ↓ Keys (3) to select desired attenuation and press ENTER Key.
6. Move cursor to Analyzer Scale (46) and press ENTER Key to activate its data field. Use DATA SCROLL ↑ or ↓ Keys (3) to select desired scale and press ENTER Key.
7. Move cursor to Scan Width (40) and press ENTER Key to access its data field. Use DATA SCROLL ↑ and ↓ Keys (3) to select desired Scan Width and press ENTER Key.

8. To activate Tracking Generator:

- Press "More" Soft Function Key F2 until "Gen lvl" Soft Function Key F3 appears. If "Gen 0" is displayed for Soft Function Key F2, Tracking Generator is activated. If "Gen 1" is displayed for Soft Function Key F2, press "Gen 1" Soft Function Key F2 to activate Tracking Generator.

NOTE: Tracking Generator is routed to T/R Connector (6) if "ANT" is selected for RF IN (30). Tracking Generator is routed to DUPLEX OUT Connector (24) if "T/R" is selected for RF IN (30).

- Move cursor to GEN (32) and press ENTER Key. Use DATA ENTRY Keys (29) to set Tracking Generator Level and press ENTER Key.
 - Move cursor to TRK RES (34) and press ENTER Key to toggle Tracking Generator Resolution between Lo and Hi.
9. To normalize Spectrum Analyzer if Tracking Generator is off, press "More" Soft Function Key F2 until "Norm" Soft Function Key F1 appears. Press "Norm" Soft Function Key F1.
 10. Move cursor to MODE (35) and press ENTER Key to display Spectrum Analyzer Mode Submenu. Use DATA ENTRY Keys (29) to select an Operation Mode and press ENTER Key. To recall a Trace for Recall or Compare Modes, press RCL MEMORY Key (16), use DATA ENTRY Keypad (29) to select a stored Trace and press ENTER Key.

NOTE: When in Recall Mode, only Markers and Analyzer Mode are editable.

NOTE: When in Compare Mode, recalled Trace does not change when Analyzer parameters are changed.

11. If Units/Division Factor (42) is set to 2 dB/div, move cursor to REF LVL (41) and press ENTER Key. Use DATA SCROLL Spinner (2) or DATA SCROLL ↑ and ↓ Keys (3) to adjust Reference Level as desired and press ENTER Key. Analyzer Grid Vertical Scale (45) changes to reflect different reference.
12. To use Markers, press "More" Soft Function Key F6 until "Mkr 1" Soft Function Key F3 appears.
 - For Marker 1 use, press "Mkr 1" Soft Function Key F3, use DATA SCROLL Spinner (2) or DATA SCROLL Keys (3) to adjust its position and press ENTER Key. "Mkr 1" appears in red while Marker 1 is the active Marker.
 - For Marker 2 use, press "Mkr 2" Soft Function Key F4, use DATA SCROLL Spinner (2) or DATA SCROLL Keys (3) to adjust its position and press ENTER Key. "Mkr 2" appears in red while Marker 2 is the active Marker.

Marker reading (36) shows active Markers position in MHz. Marker Amplitude Reading (37) (amplitude at Marker Trace crossing) is displayed in current Analyzer Grid units.

- To lock Markers a constant distance apart, press "Track" Soft Function Key F5. Use DATA SCROLL Spinner (2) or DATA SCROLL Keys (3) to adjust both Markers at once. Marker readings reflect Marker 1 position.

DELTA reading shows position difference of Markers in MHz. DELTA Amplitude Reading (38) shows amplitude difference of each Marker Trace crossing in current Analyzer Grid units.

- To change RF Frequency (49) to active Markers frequency, press "Mkr Fc" Soft Function Key F1.
- To deactivate Markers, press "Off" Soft Function Key F2.

NOTE: If Marker is off, Marker Indicator appears on Analyzer display when Marker Callout is accessed and may be edited. Marker disappears from grid when Marker value is activated.

13. To operate Spectrum Analyzer in Channel Mode, press SETUP Key and 4 DATA ENTRY Key (29) to display Analyzer Setup Menu. Move cursor to "12. RF Mode" and press ENTER Key until Channel is selected. Press "Chan" Soft Function Key F1 to display Channel Format Menu. Use DATA ENTRY Keypad (29) to select a Channel Format. Press "Ret" Soft Function Key F5 to return to Spectrum Analyzer Operation Screen.
14. To operate Spectrum Analyzer in Direct Mode, press SETUP Key and 4 DATA ENTRY Key (29) to display Analyzer Setup Menu. Move cursor to "12. RF Mode" and press ENTER Key until Direct is selected. Press "Ret" Soft Function Key F5 to return to Spectrum Analyzer Operation Screen.

15. To operate Find Function (relocate RF Frequency [49] to first signal with amplitude greater than Find level):
 - If Tracking Generator is on, press "More" Soft Function Key F6 until "Gen 0" Soft Function Key F3 appears. Press "Gen 0" Soft Function Key F2 to deactivate Tracking Generator.
 - Press "More" Soft Function Key F6 until "Find" Soft Function Key F1 appears. Press "Find lvl" Soft Function Key F2. Red horizontal line appears.
 - Use DATA SCROLL Spinner (2) or DATA SCROLL Keys (3) to adjust red horizontal line to desired amplitude level and press ENTER Key.
 - Press "Find" Soft Function Key F1. Find Function searches for lowest frequency with signal amplitude greater than Find level. RF Frequency (49) is also changed to frequency found.

16. To operate Cable Fault Testing:
 - Connect 50 Ω coaxial cable between ANTENNA IN Connector (25) and a coaxial tee connector to T/R Connector (6). Connect coaxial cable under test to other side of coaxial tee connector.
 - Move cursor to GEN (32) and press +/-, 3 and 0 DATA ENTRY Keys (29). Press ENTER Key. If Tracking Generator is on, press "More" Soft Function Key F6 until "Gen 0" Soft Function Key F2 appears. Press "Gen 0" Soft Function Key F2 to turn Tracking Generator off.
 - Move cursor to Scan Width (40) and press DATA SCROLL \uparrow and \downarrow Keys (3) to set Scan Width (40) to 100 MHz. Press ENTER Key.
 - Move cursor to Division/Factor Units (42) and press ENTER Key until 10 dB/div appears.
 - Press "More" Soft Function Key F6 until "Cbl Flt" Soft Function Key F3 appears. Press "Cbl Flt" Soft Function Key F3.
 - Move cursor to VEL FACT (51) and use DATA ENTRY Keypad (29) to enter velocity factor of cable under test. Press ENTER Key.
 - Note location of lowest group of troughs displayed on CRT. Move cursor to Scan Width (40) and press DATA SCROLL \downarrow Key (3) to set Scan Width (40) to 50 MHz. Press ENTER Key.
 - Move cursor to RF (47) and use DATA ENTRY Keys (29) to set Analyzer RF Frequency to center of troughs. Press ENTER Key.
 - Move cursor to Scan Width (40) and use DATA SCROLL \uparrow and \downarrow Keys (3) to set Scan Width (40) until only two or three troughs appear on CRT. Press ENTER Key.
 - Move cursor to Division Factor Units (42) and press ENTER Key to select 2 dB/div.

4-7-2 MEASURING VERY LOW POWER TRANSMITTER OUTPUT

- | STEP | PROCEDURE |
|------|---|
| 1. | Press SCOPE/ANLZ MODE Key (27). If Oscilloscope Operation Screen appears, press SCOPE/ANLZ MODE Key (27) again. |
| 2. | Move cursor to RF (47) and use DATA ENTRY Keypad (29) to enter transmitting frequency of UUT. Press ENTER Key. |
| 3. | If Tracking Generator is on, press "More" Soft Function Key F6 until "Gen 0" Soft Function Key F2 appears. Press "Gen 0" Soft Function Key F2 to turn Tracking Generator "Off". |
| 4. | If needed, move cursor to MODE (35) and press ENTER Key. Press 1 DATA ENTRY Key (29) to select "Live" Mode. |
| 5. | Move cursor to Units/Division Factor (42) and press ENTER Key until "10 dB" appears. |
| 6. | Move cursor to RF ATTEN (31) and press DATA SCROLL ↑ and ↓ Keys (3) until "0 dB" appears. Press ENTER Key. |
| 7. | Move cursor to RF IN (30) and press ENTER Key until "T/R" is selected. |
| 8. | Move cursor to Analyzer Scale Units (46) and press DATA SCROLL ↑ and ↓ Keys (3) until "dBm" appears. Press ENTER Key. |
| 9. | Apply test signal to T/R Connector (6) and read power level using Analyzer Scale (45). |
| 10. | If reading is <-30 dBm, disconnect incoming signal from T/R Connector (6) and apply signal to ANTENNA IN Connector (25). Move cursor to RF IN (30) and press ENTER Key until "ANT" appears. |
| 11. | Press "More" Soft Function Key F6 until "Mkr 1" Soft Function Key F3 appears. Press "Mkr 1" Soft Function Key F3 to highlight Marker Position data field. |
| 12. | Rotate DATA SCROLL Spinner (2) until Marker 1 lies directly on peak of specified signal. Marker Amplitude Reading (37) displays power at point of signal crossing of Marker 1. For dBm, W and dBW conversions, see Table 4-3. |

dBm	W	dBW	dBm	μW	dBW
+50	100	20	-10	100	-40
+40	10	10	-20	10	-50
+30	1	0	-30	1	-60
+20	0.1	-10	-40	0.1	-70
+10	0.01	-20	-50	0.01	-80
0	0.001	-30	-60	0.001	-90

Table 4-1 dBm, W and dBW Conversions

4-7-3 MEASURING TRANSMITTER HARMONICS

STEP	PROCEDURE
1.	Press SCOPE/ANLZ MODE Key (27). If Oscilloscope Operation Screen appears, press SCOPE/ANLZ MODE Key (27) again.
2.	Move cursor to RF (47) and use DATA ENTRY Keypad (29) to enter transmitting frequency under test. Press ENTER Key.
3.	If Tracking Generator is on, press "More" Soft Function Key F6 until "Gen 0" Soft Function Key F2 appears. Press "Gen 0" Soft Function Key F2 to turn Tracking Generator " Off ".
4.	If needed, move cursor to MODE (35) and press ENTER Key. Press 1 DATA ENTRY Key (29) to select " Live " Mode.
5.	Move cursor to RF IN (30) and press ENTER Key until " T/R " appears.
6.	Move cursor to Units/Division Factor (42) and press ENTER Key until " 10 dB " appears.
7.	Apply signal under test to T/R Connector (6) and read power level using Analyzer Scale (45).
8.	If reading is < -30 dBm, disconnect incoming signal from T/R Connector (6) and apply signal to ANTENNA IN Connector (25). Move cursor to RF IN (30) and press ENTER Key until " ANT " appears.
9.	Move cursor to RF ATTEN (31) and press ENTER Key. Press DATA SCROLL ↑ and ↓ Keys (3) until " 0 dB " appears and press ENTER Key.
10.	Move cursor to Scan Width (40) and use DATA SCROLL ↑ and ↓ Keys (3) to adjust Scan Width until fundamental frequency and second harmonic appears alone on CRT.
11.	Press "More" Soft Function Key F6 until "Mkr 1" Soft Function Key F3 appears. Press "Mkr 1" Soft Function Key F3 to highlight Marker Position data field.
12.	Rotate DATA SCROLL Spinner (2) until Marker 1 lies directly on peak of fundamental frequency. Press "Mkr 2" Soft Function Key F4 to activate Marker 2. Rotate DATA SCROLL Spinner (2) until Marker 2 lies directly on peak of second harmonic frequency. DELTA Amplitude Reading (38) displays amplitude difference, in dB, of fundamental frequency and second harmonic.

4-7-4 MEASURING DIPLEXER Tx LOSS AND Rx ISOLATION

STEP	PROCEDURE
1.	Press SCOPE/ANLZ MODE Key (27). If Oscilloscope Operation Screen appears, press SCOPE/ANLZ MODE Key (27) again.
2.	Move cursor to RF (47) and use DATA ENTRY Keys (29) to select a frequency in center of transmitting frequencies. Press ENTER Key.
3.	Move cursor to RF IN (30) and press ENTER Key until " T/R " appears.
4.	Move cursor to RF ATTEN (31) and press DATA SCROLL ↑ Key (3) until " 0dB " appears. Press ENTER Key.
5.	Move cursor to Analyzer Scale Units (46) and press DATA SCROLL ↑ Key (3) until " dBm " appears. Press ENTER Key.
6.	If Tracking Generator is off, press "More" Soft Function Key F6 until "Gen 1" Soft Function Key F2 appears. Press "Gen 1" Soft Function Key F2.
7.	Press "More" Soft Function Key F6 until "Res bw" Soft Function Key F1 appears. Press "Res bw" Soft Function Key F1. Press DATA SCROLL ↑ Key (3) until " 3 Mhz " appears and press ENTER Key.
8.	Move cursor to GEN (32) and press 0 DATA ENTRY Key (29) to set Tracking Generator Output Level to 0.0 dBm . Press ENTER Key.
9.	Move cursor to Scan Width (40) and press DATA SCROLL ↑ and ↓ Keys (3) to select a scan width that displays all of the transmitting frequencies on Analyzer display. Press ENTER Key.
10.	Move cursor to Units/Division Factor (42) and press ENTER Key until " 2 dB " appears.
11.	Move cursor to REF LVL (41) and rotate DATA SCROLL Spinner (2) cw until top of Analyzer Vertical Scale (45) reads 10 dBm. Press ENTER Key.
12.	Connect coaxial cable between DUPLEX OUT Connector (24) and T/R Connector (6). The resulting trace is the Tx reference level. Press STORE MEMORY Key (16) and use DATA ENTRY Keys (29) to select an unused memory location. Press SHIFT Key and T, X, R, E and F DATA ENTRY Keys (29). Press SHIFT Key and ENTER Key.
13.	Disconnect coaxial cable from Test Set and connect DUPLEX OUT Connector (24) to Diplexer Tx input. Connect T/R Connector (6) to Diplexer Tx Output.
14.	Press RCL MEMORY Key (16) and press DATA ENTRY Key (29) used to store Tx reference level trace. Press ENTER Key. Tx reference trace appears frozen on CRT.
15.	Press ENTER Key and press 3 DATA ENTRY Key (29) to select Compare Mode. Tx reference trace (frozen) and Tx Output trace (live) appear on CRT. Difference between Tx reference trace and Tx Output trace is Diplexer Tx loss.
16.	Move cursor to Units/Division Factor (42) and press ENTER Key until " 10 dB " appears.

STEP**PROCEDURE**

17. Disconnect coaxial cables and connect coaxial cable between DUPLEX OUT Connector (24) and T/R Connector (6). Resulting trace is the Rx reference trace. Press STORE MEMORY Key (16) and use DATA ENTRY Keys (29) to select an unused memory location. Press SHIFT Key and R, X, R, E and F DATA ENTRY Keys (29). Press SHIFT Key and ENTER Key.
18. Disconnect coaxial cable from Test Set and connect DUPLEX OUT Connector (24) to Diplexer Tx Input. Connect T/R Connector (6) to Diplexer Rx Input.
19. Press RCL MEMORY Key (16) and press DATA ENTRY Key (29) used to store Rx reference level trace. Press ENTER Key. Rx reference trace appears frozen on CRT.
20. Press ENTER Key and press 3 DATA ENTRY Key (29) to select Compare Mode. Rx reference trace (frozen) and Rx Input trace (live) appear on CRT. Rx Input trace is transmitter leakage into Diplexer Rx.

4-8 METER OPERATION

4-8-1 AUDIO FREQUENCY METER OPERATION

Received or generated Audio Frequency signals are measured using following procedures:

NOTE: The Audio Frequency Meter is accessed from Receive Operation Screen, Duplex Operation Screen, Duplex Transmitter Operation Screen or Meters Menu. Meter reflects readings of last Operation Mode of Test Set.

STEP PROCEDURE

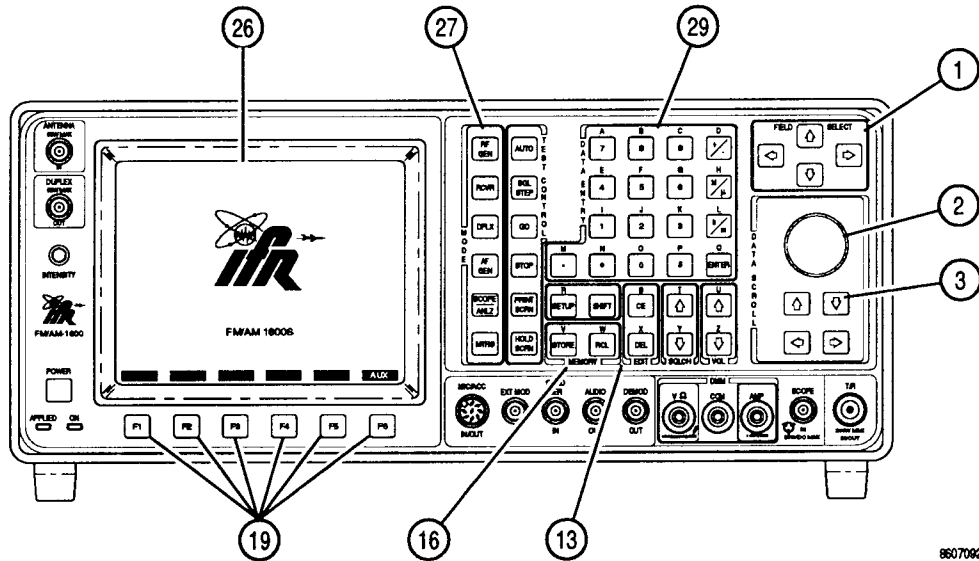

8607092

1. Press MTRS MODE Key (27). Press 1 DATA ENTRY Key (29) to access Audio Frequency Meter Operation Screen.

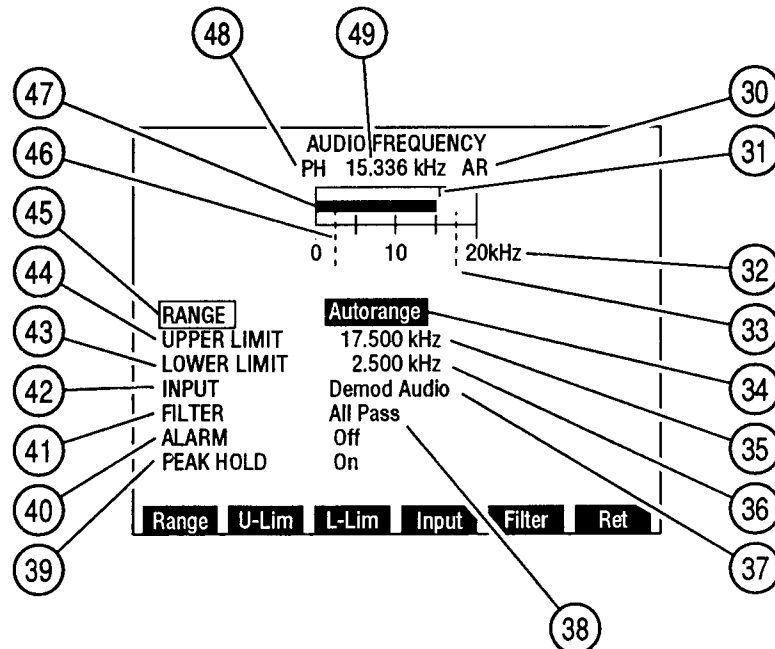

8607069

STEP

PROCEDURE

2. Move cursor to RANGE (45) and press ENTER Key to access data field (34). Press DATA SCROLL ↑ or ↓ Keys (3) to select desired Range and press ENTER Key.
3. Move cursor to UPPER LIMIT (44). Press ENTER Key to activate Upper Limit and access data field (35). Use DATA ENTRY Keypad (29) to enter desired Upper Limit and press ENTER Key. A blue line (33) appears across meter window marking position of Upper Limit.
4. Move cursor to LOWER LIMIT (43). Press ENTER Key to activate Lower Limit and access data field (36). Use DATA ENTRY Keypad (29) to enter desired Lower Limit and press ENTER Key. A blue line (46) appears across meter window marking position of Lower Limit.
5. To deactivate Upper or Lower Limit, press SETUP Key to display AF Meter Menu. Press 6 (Upper Limit) or 8 (Lower Limit) DATA ENTRY Key (29) to toggle Limit off. Press "Ret" Soft Function Key F5 to return to AF Meter Operation Screen.
6. Move cursor to INPUT (42) and press ENTER Key to access data field (37). Use DATA SCROLL ↑ and ↓ Keys (3) to select an Input and press ENTER Key.
7. Press SETUP Key to display AF Meter Menu.
 - Press 2 DATA ENTRY Key (29) to display a Filter submenu. Use DATA ENTRY Keypad (29) to select a Filter. If Low Pass or High Pass is selected, a data field appears. Use DATA ENTRY Keypad (29) to enter cutoff frequency and press ENTER Key.
 - Press 4 DATA ENTRY Key (29) to toggle Gate Time to desired setting. Press "Ret" Soft Function Key F5 to return to Audio Frequency Meter Operation Screen.
8. Move cursor to ALARM (40) and press ENTER Key to enable or disable Alarm. Enabled Alarm sounds when Upper or Lower Limit is exceeded.
9. Move cursor to PEAK HOLD (39) and press ENTER Key to enable or disable Peak Hold feature of AF Frequency Meter. PH (48) appears at lower left of meter window and Peak Hold indicator (31) appears on meter indicating highest point reached by Meter Indicator Bar (47).
10. Measure AF Frequency using Meter Indicator Bar (47) or Digital Meter Readout (49) in Hz or kHz.
11. To store or recall a set of AF Meter parameters, see 4-1-1.
12. To Return to last Operation Screen, press "Ret" Soft Function Key F6.

4-8-2 RF FREQUENCY ERROR METER OPERATION

Received Radio Frequencies and Frequency Error (the difference between Received Radio Frequency and frequency setting of Receive Operation Screen or Duplex Transmitter Operation Screen) is measured using the following procedures:

Frequency Error Meter is accessed from Receive Operation Screen, Duplex Operation Screen or Meter Menu. Meter reflects readings of last Operation Mode of Test Set.

NOTE: When Deviation Meter (Peak) readings exceed Deviation Meter (Peak) Range, the RF Frequency Error Meter may give erroneous results.

STEP	PROCEDURE
------	-----------

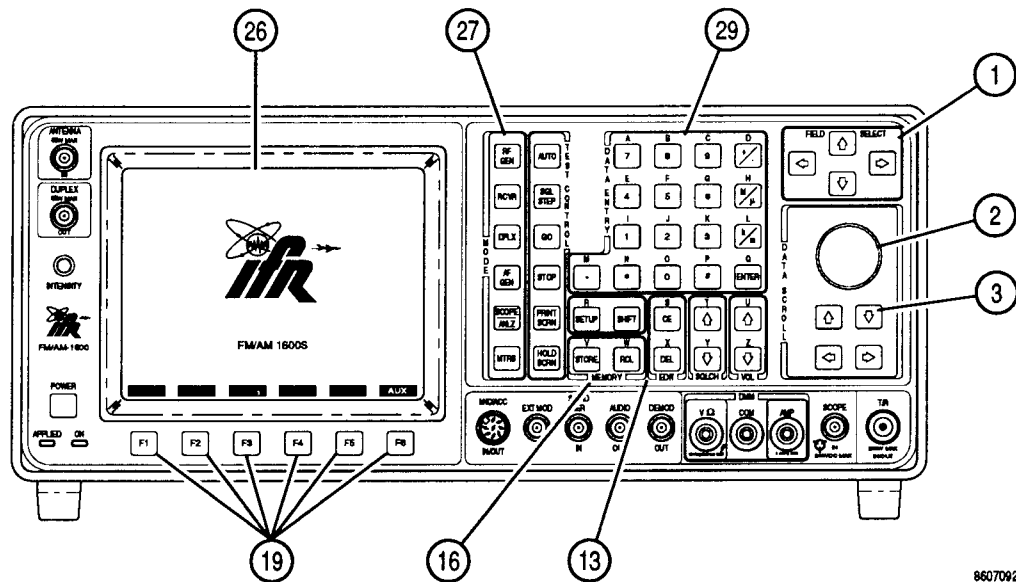

8607092

1. Press MTRS MODE Key (27). Press 2 DATA ENTRY Key (29) to access RF Frequency Error Meter Operation Screen.

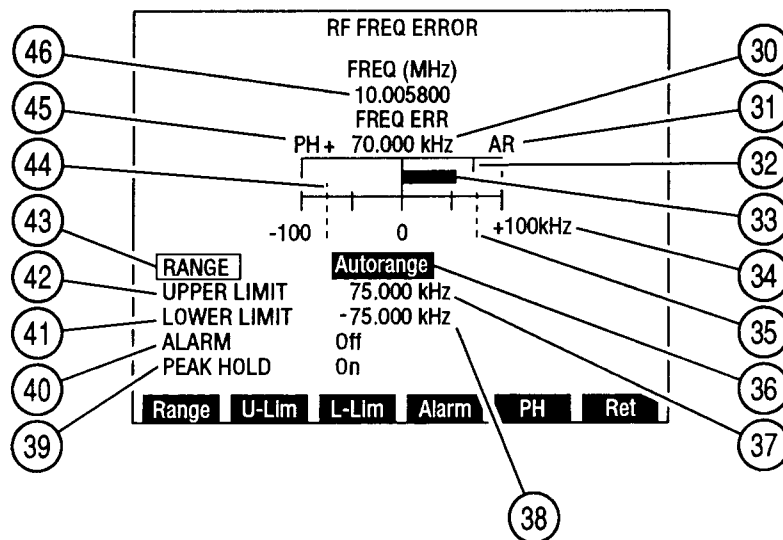

8607070

2. Move cursor to RANGE (43) and press ENTER Key to access data field (36). Rotate DATA SCROLL Spinner (2) or press DATA SCROLL ↑ or ↓ Keys (3) to select desired Range and press ENTER Key.
3. Move cursor to UPPER LIMIT (42). Press ENTER Key to activate Upper Limit and access data field (37). Use DATA ENTRY Keypad (29) to enter desired Upper Limit and press ENTER Key. A blue line (35) appears across meter window marking position of Upper Limit.
NOTE: The Upper Limit for RF Frequency Error Meter is positive and affects only meter bar deflections in right half of meter window (frequency error above Receive RF setting or Duplex Transmitter FREQ setting).
4. Move cursor to LOWER LIMIT (41). Press ENTER Key to activate Lower Limit and access data field (38). Use DATA ENTRY Keypad (29) to enter desired Lower Limit and press ENTER Key. A blue line (44) appears across meter window marking position of Lower Limit.
NOTE: The Lower Limit for RF Frequency Error Meter is negative and affects only meter bar deflections in left half of meter window (frequency error below Receive RF setting or Duplex Transmitter FREQ setting).
5. To deactivate Upper or Lower Limit, press SETUP Key to display RF Frequency Error Meter Menu. Press 4 (Upper Limit) or 6 (Lower Limit) DATA ENTRY Key (29) to toggle Limit off. Press "Ret" Soft Function Key F5 to return to RF Frequency Error Meter Operation Screen.
6. Move cursor to ALARM (40) and press ENTER Key to enable or disable Alarm. Enabled Alarm sounds when Upper or Lower Limit is exceeded.
7. Move cursor to PEAK HOLD (39) and press ENTER Key to enable or disable Peak Hold feature of RF Meter. PH (45) appears at lower left of meter window and Peak Hold indicator (32) appears on meter indicating highest point reached by Meter Indicator Bar (33).
8. Measure Received Frequency using Received Frequency Digital Readout (46). Measure Frequency Error using Meter Indicator Bar (33) or Frequency Error Digital Readout (30).
9. To store or recall a set of RF Frequency Error Meter parameters, see 4-1-1.
10. To return to last Operation Screen, press "Ret" Soft Function Key F6.

4-8-3 POWER METER OPERATION

Power Meter measurements of RF signals received at T/R Connector (6) are measured using following procedures:

NOTE: The RF Power Meter is accessed from Receive Operation Screen, Duplex Transmitter Operation Screen or Meter Menu. Meter reflects readings of last Operation Mode of Test Set.

STEP	PROCEDURE
------	-----------

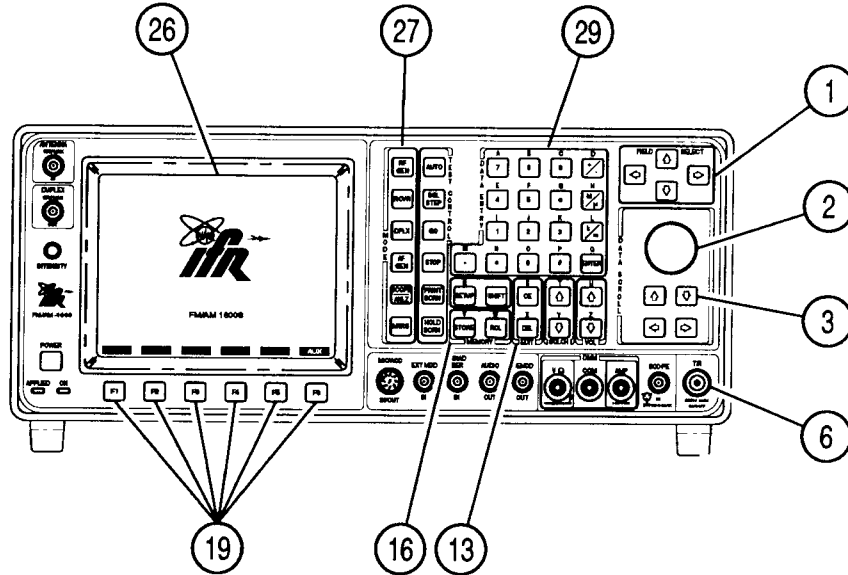

8607093

1. Press MTRS MODE Key (27). Press 3 DATA ENTRY Key (29) to access Power Meter Operation Screen.

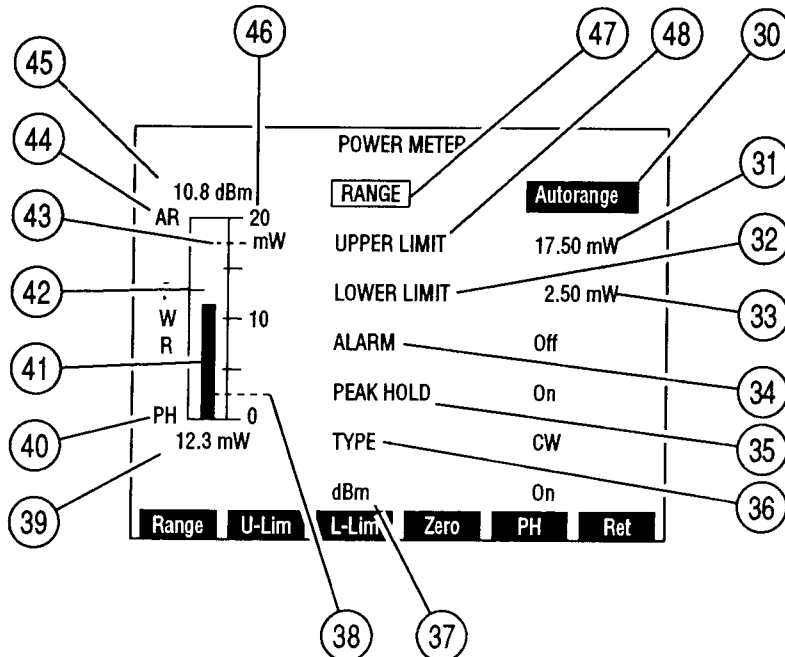

8607071

-
2. Move cursor to RANGE (47) and press ENTER Key to access data field (30). Press DATA SCROLL ↑ or ↓ Keys (3) to select desired Range and press ENTER Key.
 3. Move cursor to UPPER LIMIT (48). Press ENTER Key to activate Upper Limit and access data field (31). Use DATA ENTRY Keypad (29) to enter desired Upper Limit and press ENTER Key. A blue line (43) appears across meter window marking position of Upper Limit.
 4. Move cursor to LOWER LIMIT (32). Press ENTER Key to activate Lower Limit and access data field (33). Use DATA ENTRY Keypad (29) to enter desired Lower Limit and press ENTER Key. A blue line (38) appears across meter window marking position of Lower Limit.
 5. To deactivate Upper or Lower Limit, press SETUP Key to display Power Meter Menu. Press 5 (Upper Limit) or 7 (Lower Limit) DATA ENTRY Key (29) to toggle Limit off. Press "Ret" Soft Function Key F5 to return to Power Meter Operation Screen.
 6. Move cursor to ALARM (34) and press ENTER Key to enable or disable Alarm. Enabled Alarm sounds when Upper or Lower Limit is exceeded.
 7. Move cursor to PEAK HOLD (35) and press ENTER Key to enable or disable Peak Hold feature of Power Meter. PH (40) appears at lower left of meter window and Peak Hold indicator (42) appears on meter indicating highest point reached by Meter Indicator Bar (41).
 8. Move cursor to dBm (37) and press ENTER Key to enable or disable dBm Readout (45) of Power Meter.
 9. To zero Power Meter:
 - Use FIELD SELECT Keys (1) to move cursor to RANGE (47) and press ENTER Key. Use DATA SCROLL Keys ↑ and ↓ (3) to set Range to 20 mW and press ENTER Key.
 - Press "Zero" Soft Function Key F4. Use DATA SCROLL ↑ and ↓ Keys (3) to set Range to desired value and press ENTER Key.
 10. Measure RF Power using Meter Indicator Bar (41) or Digital Readout (39) in W or dBm (45).
 11. To store or recall a set of Power Meter parameters, see 4-1-1.
 12. To Return to last Operation Screen, press "Ret" Soft Function Key F6.

4-8-4 DEVIATION METER (PEAK) OPERATION

Deviation of received FM signals is measured using following procedures:

NOTE: The Deviation Meter (Peak) is accessed from Receive Operation Screen, Duplex Operation Screen, Duplex Transmitter Operation Screen or Meter Menu.

Receiver or Duplex Transmitter modulation must be FM for Deviation Meter measurements.

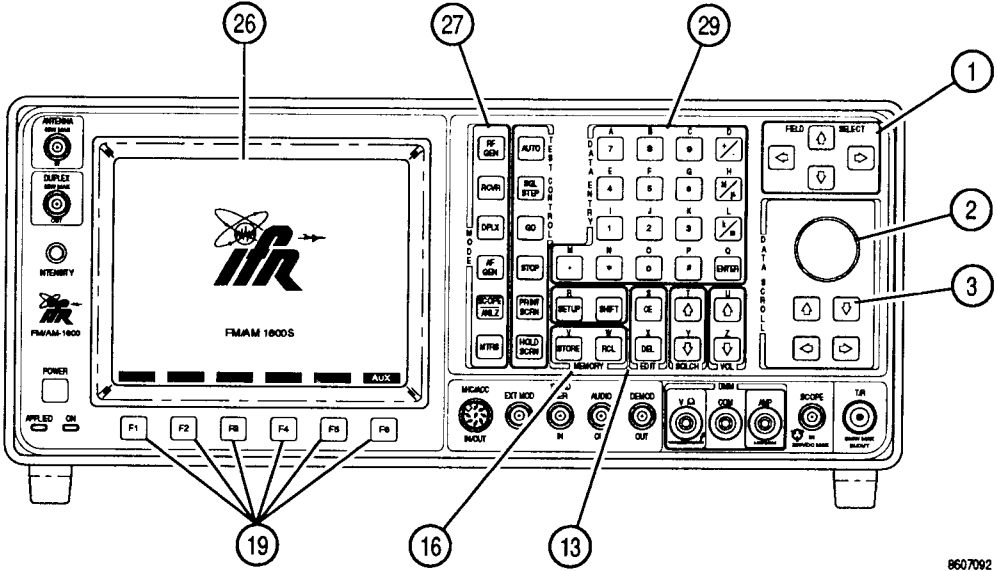
STEP	PROCEDURE
	
1.	<p>Press RCVR MODE Key (27) to display Receiver Operation Screen or press DPLX MODE Key (27) and "TX" Soft Function Key F1 to display Duplex Transmitter Operation Screen. Verify FM modulation is in use. Press "More" Soft Function Key F6 until "FM Z" Soft Function Key F3 appears. Press "FM Z" Soft Function Key F3 to zero Deviation Meter (Peak). Move cursor to Deviation Meter Callout and press ENTER Key to display Deviation Meter (Peak) Operation Screen.</p>
	

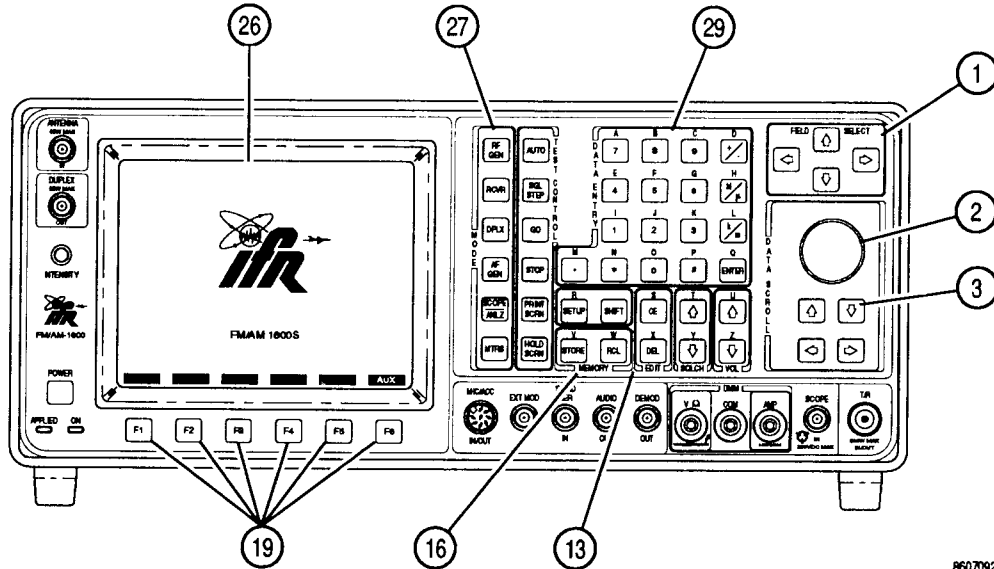

8607092

- Press RCVR MODE Key (27) to display Receiver Operation Screen or press DPLX MODE Key (27) and "TX" Soft Function Key F1 to display Duplex Transmitter Operation Screen. Verify FM modulation is in use. Press "More" Soft Function Key F6 until "FM Z" Soft Function Key F3 appears. Press "FM Z" Soft Function Key F3 to zero Deviation Meter (Peak). Move cursor to Deviation Meter Callout and press ENTER Key to display Deviation Meter (Peak) Operation Screen.

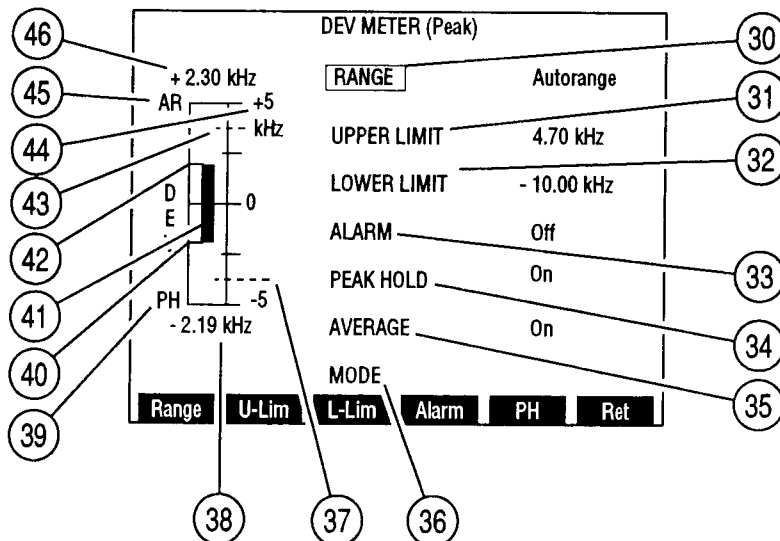

8607072

2. Move cursor to RANGE (30) and press ENTER Key to access data field. Rotate DATA SCROLL Spinner (2) or press DATA SCROLL ↑ or ↓ Keys (3) to select desired Range and press ENTER Key.
3. Move cursor to UPPER LIMIT (31). Press ENTER Key to activate Upper Limit and access data field. Use DATA ENTRY Keypad (29) to enter desired Upper Limit and press ENTER Key. A blue line (43) appears across meter window marking position of Upper Limit.
NOTE: The Upper Limit is positive and affects only meter bar deflections in upper half of meter window.
4. Move cursor to LOWER LIMIT (32). Press ENTER Key to activate Lower Limit and access data field. Use DATA ENTRY Keypad (29) to enter desired Lower Limit and press ENTER Key. A blue line (37) appears across meter window marking position of Lower Limit.
NOTE: The Lower Limit is negative and affects only meter bar deflections in lower half of meter window.
5. To deactivate Upper or Lower Limit, press SETUP Key to display Deviation Meter (Peak) Menu. Press 3 (Upper Limit) or 5 (Lower Limit) DATA ENTRY Key (29) to toggle Limit off. Press "Ret" Soft Function Key F5 to return to Deviation Meter (Peak) Operation Screen.
6. Move cursor to ALARM (33) and press ENTER Key to enable or disable Alarm. Enabled Alarm sounds when Upper or Lower Limit is exceeded.
7. Move cursor to PEAK HOLD (34) and press ENTER Key to enable or disable Peak Hold feature of Deviation Meter (Peak). PH (39) appears at lower left of meter window and a Peak Hold indicator (42) and (40) appears on meter indicating highest and lowest point reached by Meter Indicator Bar (41).
8. Move cursor to AVERAGE (35) and press ENTER Key to enable or disable Deviation Meter Averaging. With Averaging enabled, a running average of last 10 readings are reported.
9. Move cursor to MODE (36) and press ENTER Key. Use DATA SCROLL ↑ and ↓ Keys (3) to select a Mode and press ENTER Key.
10. Measure FM Deviation (Peak) using Meter Indicator Bar (41) or Positive Digital Readout (45) and Negative Digital Readout (38).
11. To store or recall a set of Deviation Meter (Peak) parameters, see 4-1-1.
12. To return to last Operation Screen, press "Ret" Soft Function Key F6.

4-8-5 MODULATION METER OPERATION

Received or generated Modulation signals are measured using following procedures:

NOTE: The Modulation Meter is accessed from Receive Operation Screen, Duplex Operation Screen or Duplex Transmitter Operation Screen. The Modulation Meter must be activated in the Receiver Operation Screen for accurate measurements.

STEP PROCEDURE

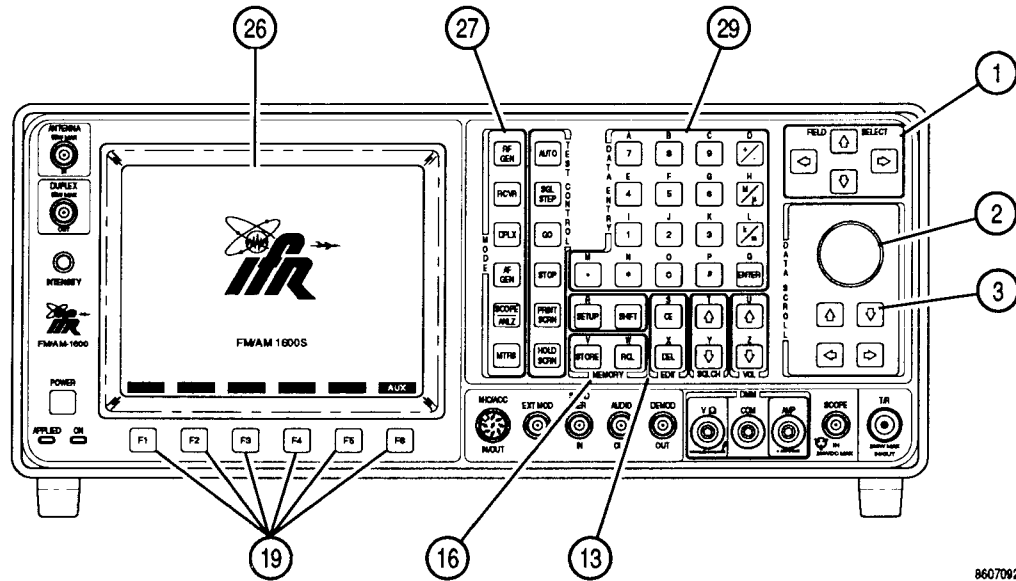

8607092

1. Press RCVR MODE Key (27) to display Receiver Operation Screen or press DPLX MODE Key (27) and "TX" Soft Function Key F1 to display Duplex Transmitter Operation Screen. Verify AM Modulation is in use. Move cursor to Modulation Meter Callout and press ENTER Key to display Modulation Meter Operation Screen.

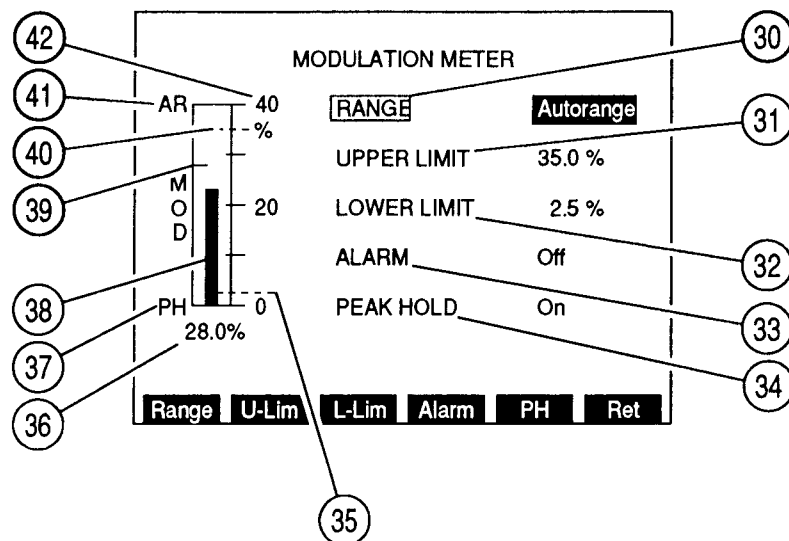

8607073

STEP**PROCEDURE**

2. Move cursor to RANGE (30) and press ENTER Key to access its data field. Rotate DATA SCROLL Spinner (2) or press DATA SCROLL ↑ or ↓ Keys (3) to select desired Range and press ENTER Key.
3. Move cursor to UPPER LIMIT (31). Press ENTER Key to activate Upper Limit and access data field. Use DATA ENTRY Keypad (29) to enter desired Upper Limit and press ENTER Key. A blue line (40) appears across meter window marking position of Upper Limit.
4. Move cursor to LOWER LIMIT (32). Press ENTER Key to activate Lower Limit and access data field. Use DATA ENTRY Keypad (29) to enter desired Lower Limit and press ENTER Key. A blue line (35) appears across meter window marking position of Lower Limit.
5. To deactivate Upper or Lower Limit, press SETUP Key to display Modulation Meter Menu. Press 3 (Upper Limit) or 5 (Lower Limit) DATA ENTRY Key (29) to toggle Limit off. Press "Ret" Soft Function Key F5 to return to Modulation Meter Operation Screen.
6. Move cursor to ALARM (33) and press ENTER Key to enable or disable Alarm. Enabled Alarm sounds when Upper or Lower Limit is exceeded.
7. Move cursor to PEAK HOLD (34) and press ENTER Key to enable or disable Peak Hold feature of Modulation Meter. PH (37) appears at lower left of meter window and Peak Hold indicator (39) appears on meter indicating highest point reached by Meter Indicator Bar (38).
8. Measure AM Modulation using Meter Indicator Bar (38) or Modulation Meter Digital Readout (36).
9. To store or recall a set of Modulation Meter parameters, see 4-1-1.
10. To return to last Operation Screen, press "Ret" Soft Function Key F6.

4-8-6 DISTORTION METER OPERATION

The distortion of received or generated RF signals is measured using following procedures:

NOTE: The Distortion Meter is accessed from RF Generator Operation Screen, Receive Operation Screen, Duplex Operation Screen, Duplex Transmitter Operation Screen or Duplex Receiver Operation Screen. Meter reflects readings of last Operation Mode of Test Set.

STEP	PROCEDURE
------	-----------

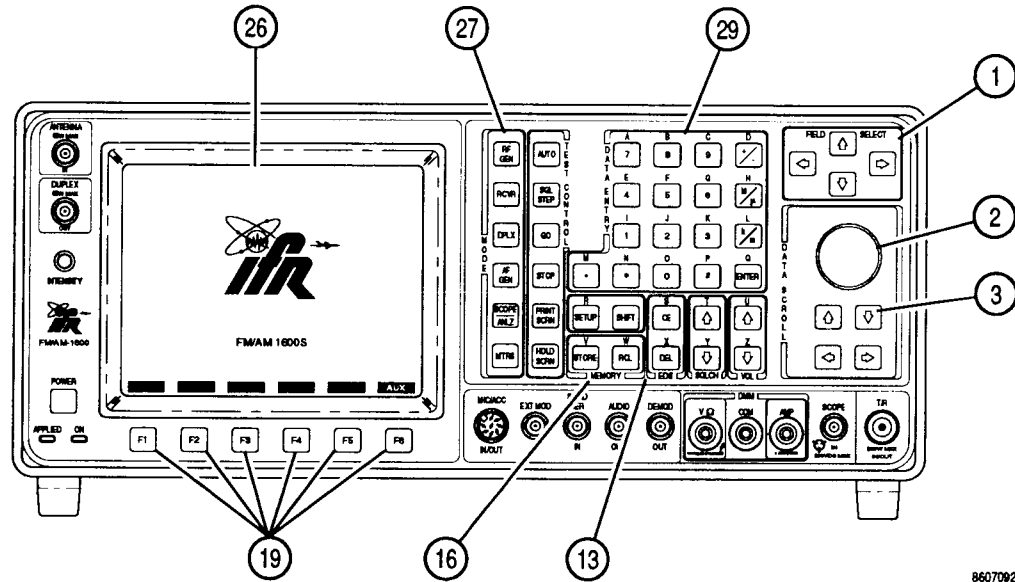

8607092

1. Press MTRS MODE Key (27). Press 6 DATA ENTRY Key (29) to access Distortion Meter Operation Screen.

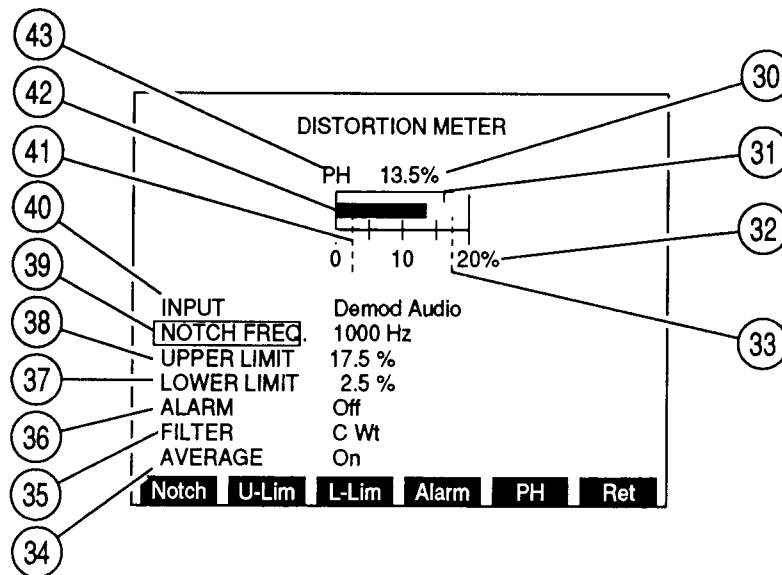

8607074

2. Move cursor to INPUT (40) and press ENTER Key to access data field. Rotate DATA SCROLL Spinner (2) or press DATA SCROLL ↑ or ↓ Keys (3) until desired selection appears in data field and press ENTER Key to activate Distortion Meter Input.
3. Move cursor to NOTCH FREQ (39) and press ENTER Key to access data field. Use DATA ENTRY Keypad (29) to set Notch frequency and press ENTER Key.
4. Move cursor to UPPER LIMIT (38). Press ENTER Key to activate Upper Limit and access data field. Use DATA ENTRY Keypad (29) to enter Upper Limit and press ENTER Key. A blue line (33) appears across meter window marking position of Upper Limit.
5. Move cursor to LOWER LIMIT (37). Press ENTER Key to activate Lower Limit and access data field. Use DATA ENTRY Keypad (29) to enter Lower Limit and press ENTER Key. A blue line (41) appears across meter window marking position of Lower Limit.
6. To deactivate Upper or Lower Limit, press SETUP Key to display Distortion Meter Menu. Press 4 (Upper Limit) or 6 (Lower Limit) DATA ENTRY Key (29) to toggle Limit off. Press "Ret" Soft Function Key F5 to return to Distortion Meter Operation Screen.
7. Move cursor to ALARM (36) and press ENTER Key to enable or disable Alarm. Enabled Alarm sounds when Upper or Lower Limit is exceeded.
8. Move cursor to FILTER (35) and press ENTER Key to toggle Filter between C Wt and Low Pass. If Low Pass is selected, Low Pass cutoff frequency appears. Move cursor to Low Pass frequency data field and press ENTER Key. Use DATA ENTRY Keys (29) to enter a cutoff frequency and press ENTER Key.
9. Move cursor to AVERAGE (34) and press ENTER Key to enable or disable Distortion Meter Averaging. With Averaging enabled, a running average of last 10 readings are reported.
10. Press "PH" Soft Function Key F5 to enable or disable Peak Hold feature of Distortion Meter. When enabled, PH (43) appears at upper left of meter window and Peak Hold indicator (31) appears on meter indicating highest point reached by Meter Indicator Bar (42).
11. Measure Percent Distortion using Meter Indicator Bar (42) or Digital Readout (30).
12. To store or recall a set of Distortion Meter parameters, see 4-1-1.
13. To return to last Operation Screen, press "Ret" Soft Function Key F6.

4-8-7 SINAD METER OPERATION

SINAD of received or generated RF signals are measured using following procedures:

NOTE: The SINAD Meter is accessed from RF Generator Operation Screen, Receive Operation Screen, Duplex Operation Screen, Duplex Transmitter Operation Screen or Duplex Receiver Operation Screen. Meter reflects readings of last Operation Mode of Test Set.

STEP PROCEDURE

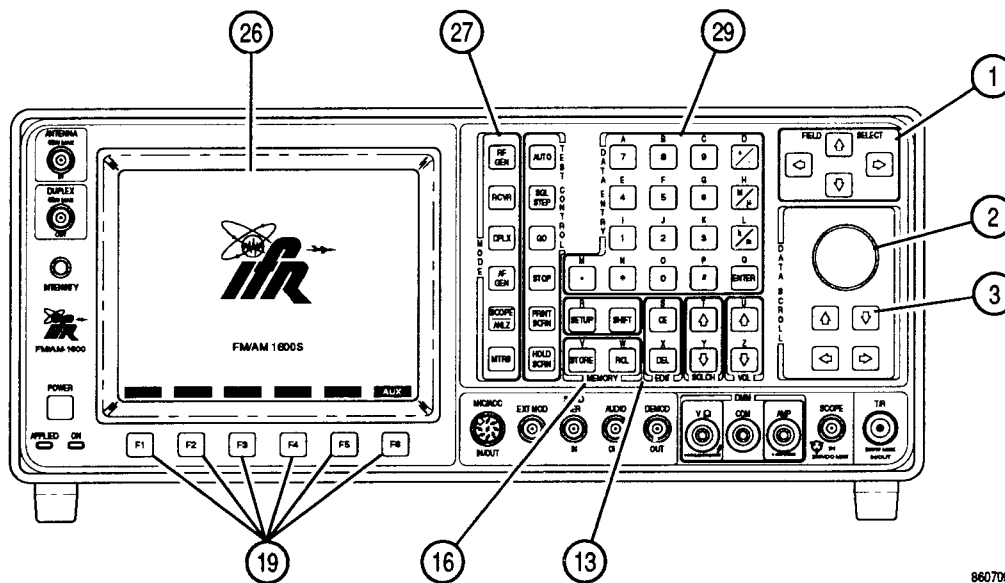

8607092

1. Press MTRRS MODE Key (27). Press 7 DATA ENTRY Key (29) to access SINAD Meter Operation Screen.

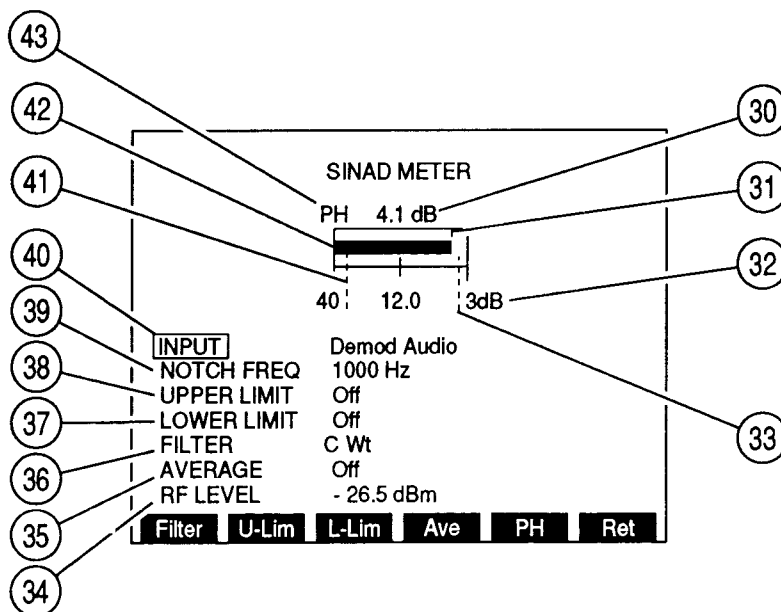

8607075

STEP**PROCEDURE**

2. Move cursor to INPUT (40) and press ENTER Key to access data field. Rotate DATA SCROLL Spinner (2) or press DATA SCROLL ↑ or ↓ Keys (3) until desired selection appears in data field and press ENTER Key to activate Distortion Meter Input.
3. Move cursor to NOTCH FREQ (39) and press ENTER Key to access data field. Use DATA ENTRY Keypad (29) to set Notch frequency and press ENTER Key.
4. Move cursor to UPPER LIMIT (38). Press ENTER Key to activate Upper Limit and access data field. Use DATA ENTRY Keypad (29) to enter Upper Limit and press ENTER Key. A blue line (33) appears across meter window marking position of Upper Limit.
5. Move cursor to LOWER LIMIT (37). Press ENTER Key to activate Lower Limit and access data field. Use DATA ENTRY Keypad (29) to enter Lower Limit and press ENTER Key. A blue line (41) appears across meter window marking position of Lower Limit.
6. To deactivate Upper or Lower Limit, press SETUP Key to display SINAD Meter Menu. Press 4 (Upper Limit) or 6 (Lower Limit) DATA ENTRY Key (29) to toggle Limit off. Press "Ret" Soft Function Key F5 to return to SINAD Meter Operation Screen.
7. Move cursor to FILTER (36) and press ENTER Key to toggle Filter between C Wt and Low Pass. If Low Pass is selected, Low Pass cutoff frequency appears. Use FIELD SELECT Keys (1) to move cursor to Low Pass frequency data field and press ENTER Key. Use DATA ENTRY Keypad (29) to enter a cutoff frequency and press ENTER Key.
8. Move cursor to AVERAGE (35) and press ENTER Key to enable or disable SINAD Meter Averaging. With Averaging enabled, a running average of last 10 readings are reported.
9. If RF Generator or Duplex Receiver Operation Screen is last Operation Screen accessed, RF LEVEL (34) appears. Move cursor to RF LEVEL (34) and press ENTER Key. Use DATA ENTRY Keypad (29) to select RF Generator Level or Duplex Receiver Output Level and press ENTER Key.
10. Press "PH" Soft Function Key F5 to enable or disable Peak Hold feature of SINAD Meter. When enabled, PH (43) appears at upper left of meter window and Peak Hold indicator (31) appears on meter indicating highest point reached by Meter Indicator Bar (42).
11. Measure SINAD using Meter Indicator Bar (42) or Digital Readout (30).
12. To store or recall a set of SINAD Meter parameters, see 4-1-1.
13. To return to last Operation Screen, press "Ret" Soft Function Key F6.

4-8-8 SIGNAL STRENGTH METER OPERATION

Signal Strength measurements of signals received at ANTENNA IN Connector (25) are measured using the following procedures:

NOTE: Signal Strength Meter is accessed from Receiver Operation Screen, Duplex Operation Screen, Duplex Transmitter Operation Screen or Meter Menu. Meter reflects readings of last Operation Mode of Test Set.

STEP	PROCEDURE
------	-----------

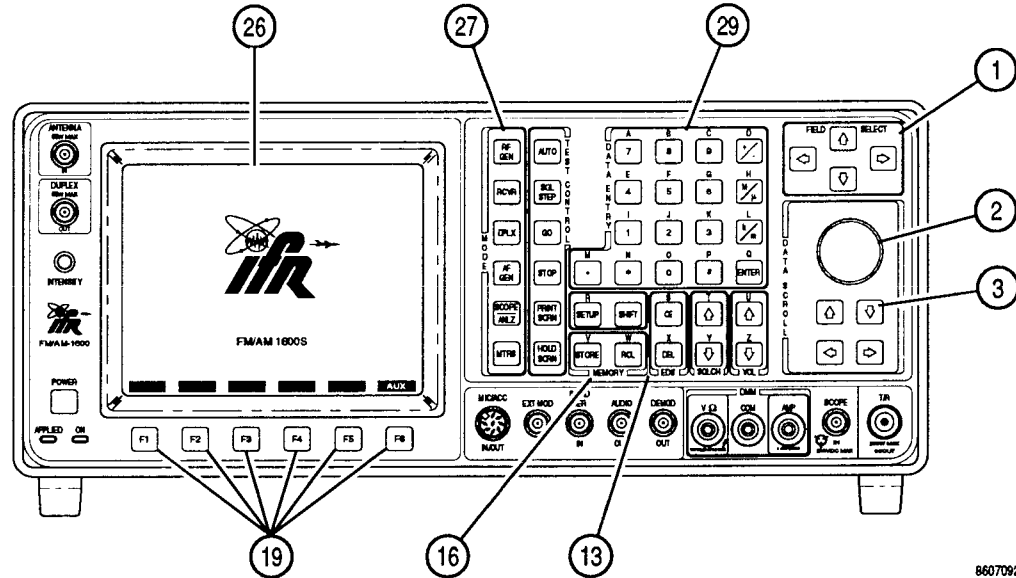

8607092

1. Press MTRRS MODE Key (27). Press 8 DATA ENTRY Key (29) to access Signal Strength Meter Operation Screen.

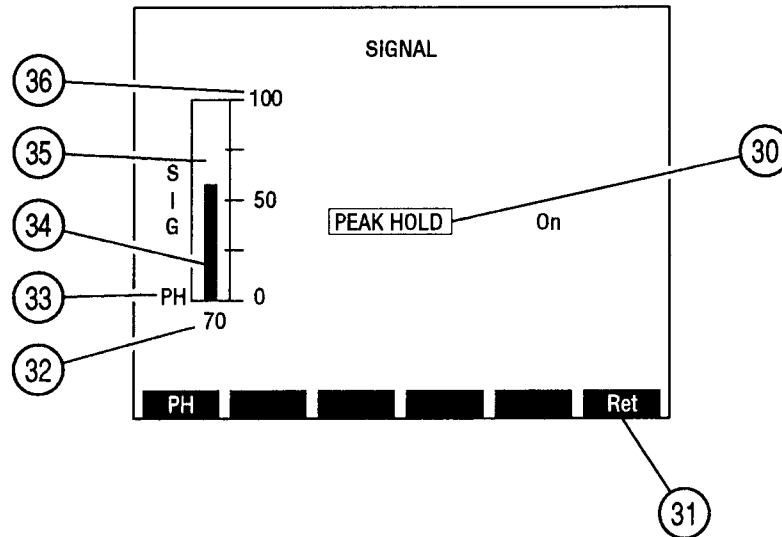

8607105

STEP**PROCEDURE**

2. Move cursor to PEAK HOLD (30) and press ENTER Key to enable or disable Peak Hold feature of Signal Strength Meter. PH (33) appears at lower left of meter window and Peak Hold indicator (35) appears on meter indicating highest point reached by Meter Indicator Bar (34).
3. Measure Signal Strength readings using Meter Indicator Bar (34) or Signal Strength Digital Readout (32).
4. To store or recall a set of Signal Strength Meter parameters, see 4-1-1.
5. To return to last Operation Screen, press "Ret" Soft Function Key F6.

4-8-9 BIT ERROR RATE (BER) METER OPERATION

The Bit Error Rate Meter is operated using the following procedures:

STEP	PROCEDURE
------	-----------

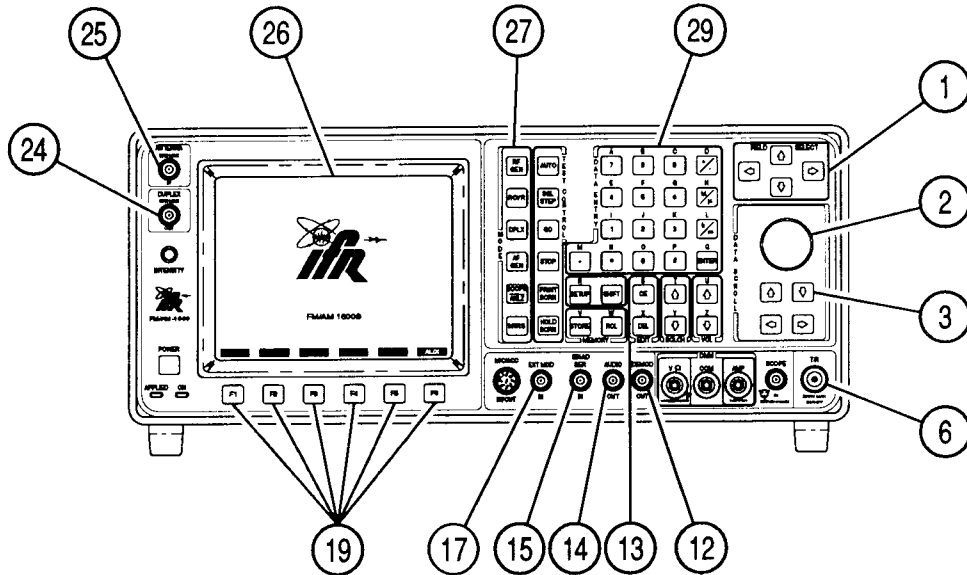

8607098

1. Press MTRS MODE Key (16). Meter Menu appears on CRT. Press 9 DATA ENTRY Key (29) to access BER Meter Operation Screen.

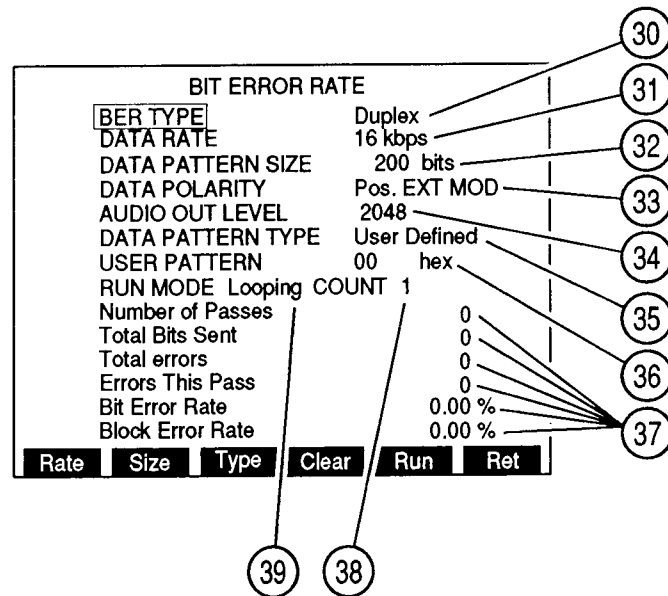

8607076

2. Move cursor to BER TYPE (30) and press ENTER Key. BER TYPE Submenu appears. Use DATA ENTRY Keypad (29) to select a BER Type.

NOTE: The BER Type determines Operation Mode of BER Meter. Each BER Type has its own Setup Menu.

NOTE: With Receiver BER Type, test data is sent through AUDIO OUT Connector (14) to be modulated by UUT. UUT Output returns to ANTENNA IN Connector (25) or T/R Connector (6) of Test Set and is demodulated and compared to original test data.

With Generator BER Type, modulated test data is sent through T/R Connector (6) to UUT to be demodulated. Demodulated data is received by Test Set at SINAD/BER IN Connector (15) (inverted) or EXT MOD IN Connector (17) and compared with original test data.

With Baseband BER Type, test data is sent through AUDIO OUT Connector (14) to be modulated and then demodulated by UUT. Demodulated UUT output is received by Test Set at SINAD/BER IN Connector (15) (inverted) or EXT MOD IN Connector (17) and compared to original test data.

With Duplex BER Type, modulated test data is sent through T/R Connector (6) or DUPLEX OUT Connector (24) to UUT to be demodulated and then modulated. This signal is received at ANTENNA IN Connector (25) or T/R Connector (6), demodulated by Test Set and compared to original test data.

3. If Receiver is selected as BER Type, proceed with step 4. If Generator is selected as BER Type, proceed with step 11. If Duplex is selected as BER Type, proceed with step 18. If Baseband is selected as BER Type, proceed with step 30.
4. For Receiver BER Type, press SETUP Key to display Receiver BER Meter Menu:

RECEIVER BER METER MENU

BER METER MENU	
1. Ber Type	Receiver
2. Set Rcvr Freq	10.0000 MHz
3. Select Mod	FM
4. Select Rcvr In	Antenna
5. Select Input Atten	0 dB
6. Audio Out Level	2048

Ret ESC

8610094

5. Press 2 DATA ENTRY Key (29) and use DATA ENTRY Keypad (29) to enter Receiver Frequency. Press ENTER Key.

6. Press 3 DATA ENTRY Key (29) to access Modulation Menu:

RECEIVER BER MODULATION MENU

BER METER MENU	
1. Ber Type	Receiver
2. Set Rcvr Freq	999.0000 MHz
3. Select Mod	FM DATA
4. Sel	1. Modulation FM DATA
5. Sel	2. IF Filters 30 kHz
6. Au	3. Post Detection Low Pass

8610095

- Press 1 DATA ENTRY Key (29) and use DATA ENTRY Keypad (29) to select a Modulation Type.
 - Press 2 DATA ENTRY Key (29) and use DATA ENTRY Keypad (29) to select IF Filter.
 - Press 3 DATA ENTRY Key (29) and use DATA ENTRY Keypad (29) to select a Post Detection Filter. If a data field appears, use DATA ENTRY Keypad (29) to select cutoff frequencies and press ENTER Key.
 - Press "ESC" Soft Function Key F6.
7. Press 4 DATA ENTRY Key (29) to toggle Receiver Input to either ANTENNA IN Connector (25) or T/R Connector (6).
 8. Press 5 DATA ENTRY Key (29) and use DATA ENTRY Keypad (29) to select an Input Attenuation.
 9. Press 6 DATA ENTRY Key (29) and use DATA ENTRY Keypad to enter an Audio Out Level.
 10. Press "Ret" Soft Function Key F5 to return to BER Operation Screen. Proceed with step 30.
 11. For Generator BER Type, press SETUP Key to access Generator BER Meter Menu:

GENERATOR BER METER MENU

BER METER MENU	
1. Ber Type	Generator
2. RF Gen Freq	10.0000 MHz
3. RF Gen Level	- 20.0 dBm
4. RF Gen Level Units	dBm
5. RF Gen Mod	FM
6. RF Gen Mod Level	255

Ret ESC

8610097

STEP

PROCEDURE

12. Press 2 DATA ENTRY Key (29). Use DATA ENTRY Keypad (29) to set RF Generator Frequency and press ENTER Key.
13. Press 3 DATA ENTRY Key (29). Use DATA ENTRY Keypad (29) to set RF Generator Level and press ENTER Key.
14. Press 4 DATA ENTRY Key (29) to toggle RF Generator Units between dBm and volts.
15. Press 5 DATA ENTRY Key (29). Use DATA ENTRY Keypad (29) to select RF Generator Modulation and press ENTER Key.
16. Press 6 DATA ENTRY Key (29). Use DATA ENTRY Keypad (29) to select RF Generator Modulation Level and press ENTER Key. Modulation Level setting is a relative setting only. Modulation Level must be measured externally to set accurately.
17. Press "Ret" Soft Function Key F5 to return to BER Meter Operation Screen. Proceed with step 30.
18. For Duplex BER Type, press Setup Key to display Duplex BER Meter Menu.
19. Press 2 DATA ENTRY Key (29) and use DATA ENTRY Keypad (29) to set Receiver Frequency and press ENTER Key.
20. Press 3 DATA ENTRY Key (29) to access Modulation Submenu:

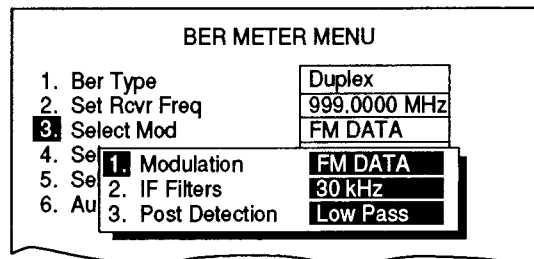

8610172

- Press 1 DATA ENTRY Key (29) and use DATA ENTRY Keypad (29) to select a Modulation Type.
 - Press 2 DATA ENTRY Key (29) and use DATA ENTRY Keypad (29) to select an IF Filter Type.
 - Press 3 DATA ENTRY Key (29) and use DATA ENTRY Keypad (29) to select a Post Detection Filter. If a data field appears, use DATA ENTRY Keypad (29) to select cutoff frequencies and press ENTER Key.
 - Press "ESC" Soft Function Key F6.
21. Press 4 DATA ENTRY Key (29) to toggle Receiver Input to either Antenna or T/R.
 22. Press 5 DATA ENTRY Key (29) and use DATA ENTRY Keypad (29) to select an Input Attenuation.
 23. Press 6 DATA ENTRY Key (29). Use DATA ENTRY Keypad (29) to set RF Generator Frequency and press ENTER Key.

STEP

PROCEDURE

-
24. Press 7 DATA ENTRY Key (29). Use DATA ENTRY Keypad (29) to set RF Generator Level and press ENTER Key.
 25. Press 8 DATA ENTRY Key (29) to toggle RF Generator Units to either dBm or volts.
 26. Press 9 DATA ENTRY Key (29). Use DATA ENTRY Keypad (29) to select RF Generator Modulation and press ENTER Key.
 27. Move cursor to "10. RF Gen Mod Level" and press ENTER Key. Use DATA ENTRY Keypad (29) to set RF Generator Modulation Level and press ENTER Key.
 28. Move cursor to "11. RF Gen Output" and press ENTER Key to toggle RF Generator Output to either Duplex or T/R.
 29. Press "Ret" Soft Function Key F5 to return to BER Meter Operation Screen.
 30. Move cursor to DATA RATE (31) and press ENTER Key. DATA RATE Submenu appears. Use DATA ENTRY Keys (29) to select a Data Rate.

NOTE: If 16 kbps is selected, it is recommended to set IF Filter to 300 kHz and Post Detection Filter to Low-Pass (15 kHz cutoff) for Receiver or Duplex Transmitter Operation.

31. Move cursor to DATA PATTERN SIZE (32) and press ENTER Key. DATA PATTERN SIZE data field highlights. Use DATA ENTRY Keypad (29) to enter Data Pattern Size (100 through 100000) and press ENTER Key.
32. Move cursor to DATA POLARITY (30) and press ENTER Key. Use DATA SCROLL ↑ or ↓ Keys (3) to toggle polarity between "Pos. EXT MOD" and "Neg. SINAD/BER". Press ENTER Key to activate selection.
33. If Receiver or Baseband is selected as BER Type (33), move cursor to AUDIO OUT LEVEL (34) and press ENTER Key. Use DATA ENTRY Keys (29) to set Audio Out Level and press ENTER Key.
34. If Duplex or Generator is selected as BER Type (33), move cursor to RF GEN LEVEL and press ENTER Key. Use DATA ENTRY Keys (29) to set RF Generator Level and press ENTER Key.
35. Move cursor to DATA PATTERN TYPE (35) and press ENTER Key. DATA PATTERN TYPE Submenu appears. Use DATA ENTRY Keypad (29) to select a Data Pattern Type.
36. If "3. User Defined" is selected as DATA PATTERN TYPE (35), USER PATTERN (36) appears:
 - Move cursor to USER PATTERN (36) and press ENTER Key. User Pattern data field is highlighted.
 - Use DATA ENTRY Keypad (29) and SHIFT Key to enter desired pattern in hex digits and press ENTER Key.

NOTE: If "1. Random" or "2. Fixed" is selected as DATA PATTERN TYPE (35), USER PATTERN (36) and User Pattern data field does not appear.

37. Move cursor to RUN MODE (38) and press ENTER Key. RUN MODE Submenu appears. Use DATA ENTRY Keypad (29) to select a Run Mode.
- For Continuous RUN MODE (39), press "Run" Soft Function Key F5. Soft Function Key F5 becomes "Stop". BER Test runs continually until "Stop" Soft Function Key F5 is pressed.
 - For One Shot RUN MODE (39), press "Run" Soft Function Key F5 to run BER Test once. Press "Stop" Soft Function Key F5 to stop BER Test before completion.
 - For Loop RUN MODE (39), COUNT (38) appears. Move cursor to COUNT and use DATA ENTRY Keypad (29) to select number of passes for BER Test. Press ENTER Key. Press "Run" Soft Function Key F5 to start BER Test. Press "Stop" Soft Function Key F5 to stop BER Test before specified passes are completed.
38. Press "Clear" Soft Function Key F4 to reset BER Meter readouts to 0.
39. The BER Meter readouts are interpreted in following manner:
- Number of Passes
Displays number of BER Test passes. One pass consists of a block containing DATA PATTERN SIZE (32) number of bits.
 - Total Bits Sent
Displays total number of bits sent including all passes of BER Tests since last clearing of readouts.
 - Total Errors
Displays total number of errors including all passes of BER Tests since last clearing of readouts.
 - Errors This Pass
Displays number of errors for last pass. One pass consists of a block containing DATA PATTERN SIZE (32) number of bits.
 - Bit Error Rate
Displays percentage of total number of bits that are in error.
 - Block Error Rate
Displays percentage of blocks containing at least one error. A block contains DATA PATTERN SIZE (32) number of bits.

4-8-10 DIGITAL MULTIMETER OPERATION

The Digital Multimeter is operated using the following procedures:

STEP	PROCEDURE
------	-----------

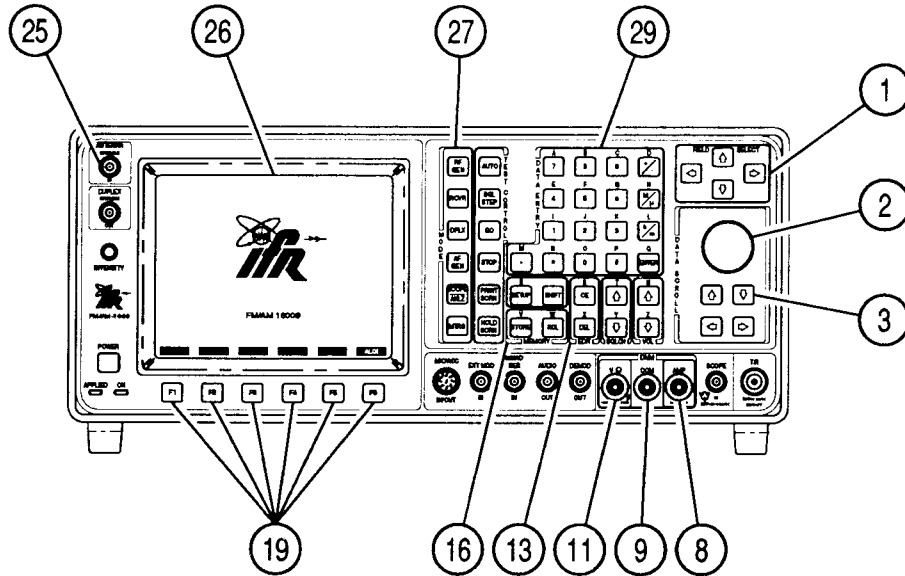

8607099

1. Press MTRS MODE Key (27). Meter Menu appears on CRT. Use FIELD SELECT \uparrow or \downarrow Keys (1) to move cursor to "10. Digital Multimeter" and press ENTER Key. Digital Multimeter Operation Screen appears on CRT.

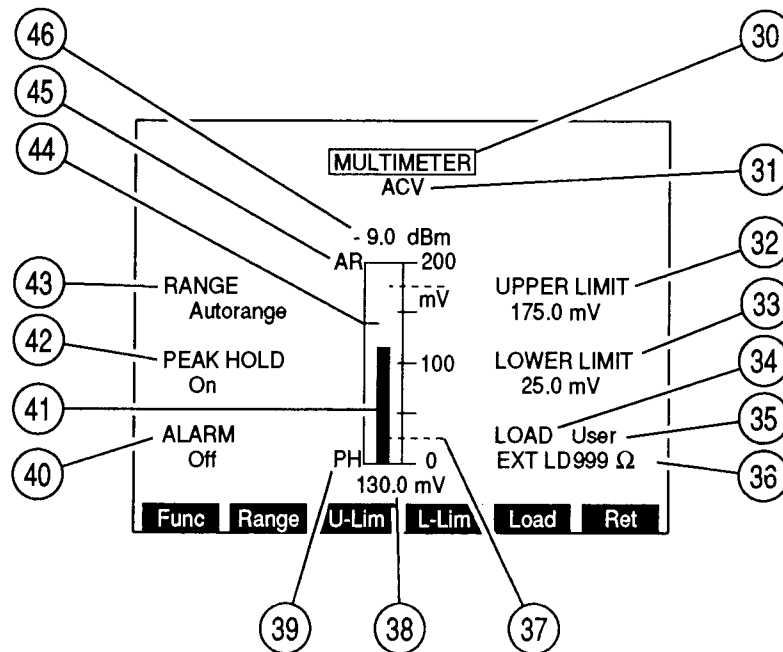

8607077

2. Move cursor to MULTIMETER (30) and press ENTER Key to access MULTIMETER data field (31). Press DATA SCROLL \uparrow or \downarrow Keys (3) until desired Multimeter Function appears in data field and press ENTER Key.

3. Install DMM Probes on Front Panel using following DMM Connectors for indicated DMM Function.

- Voltage Measurements: $V\Omega$ (11) and COM (9)
- Current Measurement: AMP (8) and COM (9)
- Ohmmeter: $V\Omega$ (11) and COM (9)

CAUTION: APPLY NO MORE THAN 1000 VDC OR 500 VAC THROUGH DMM $V\Omega$ CONNECTOR. CURRENT INPUT MORE THAN 2 A REQUIRES CURRENT SHUNT BETWEEN DMM PROBES AND $V\Omega$ AND COM CONNECTORS WITH RANGE (43) SET TO 20 A.

4. Move cursor to RANGE (43) and press ENTER Key to access its data field. Use DATA SCROLL \uparrow or \downarrow Keys (3) to select a Range and press ENTER Key.
 5. Move cursor to PEAK HOLD (42) and press ENTER Key to toggle Peak Hold Feature between on or off. PH (39) appears at lower left of Meter window and Peak Hold indicator (44) appears indicating highest point reached by Meter Indicator Bar (41).
 6. Move cursor to ALARM (40) and press ENTER Key to enable or disable Alarm. Enabled Alarm sounds when Upper or Lower Limit is exceeded.
 7. Move cursor to UPPER LIMIT (32). Press ENTER Key to activate Upper Limit and access its data field. Use DATA ENTRY Keypad (29) to enter Upper Limit and press ENTER Key. A blue line appears across meter window marking position of Upper Limit. Upper Limit must be < highest value of current range to operate correctly.
 8. Move cursor to LOWER LIMIT (33) and press ENTER Key to activate Lower Limit and access its data field. Use DATA ENTRY Keypad (29) to enter Lower Limit and press ENTER Key. A blue line (37) appears across meter window marking position of Lower Limit. Lower Limit must be < highest value of current range to operate correctly.
 9. To deactivate Upper or Lower Limits, press SETUP Key to display Multimeter Menu. Press 4 (Upper Limit) or 6 (Lower Limit) DATA ENTRY Key (29) to toggle Limit off. Press "Ret" Soft Function Key F5 to return to Digital Multimeter Operation Screen.
 10. If "ACV" is selected as Multimeter Function:
 - Move cursor to LOAD (34) and press ENTER Key to access LOAD data field (35). Press DATA SCROLL \uparrow and \downarrow Keys (3) until desired load appears in data field and press ENTER Key.
 - If User is selected as Load, move cursor to EXT LD (36) and press ENTER Key. Use DATA ENTRY Keys (29) to set External Load and press ENTER Key.
- NOTE:** External Load must be installed externally by operator.
11. Connect DMM Probes to UUT test points and observe Meter Indicator Bar (41) and Digital Meter Readout (38).
 12. To store or recall a set of Multimeter parameters, see 4-1-1.

4-8-11 PHASE METER OPERATION

Received or generated Phase Modulation signals are measured using following procedures:

NOTE: The Phase Meter is accessed from Receive Operation Screen, Duplex Operation Screen, Duplex Transmitter Operation Screen or Meter Menu. Meter reflects readings of last Operation Mode of Test Set.

The Receiver or Generator Modulation must be set to PM for measurements by the Phase Meter.

STEP	PROCEDURE
------	-----------

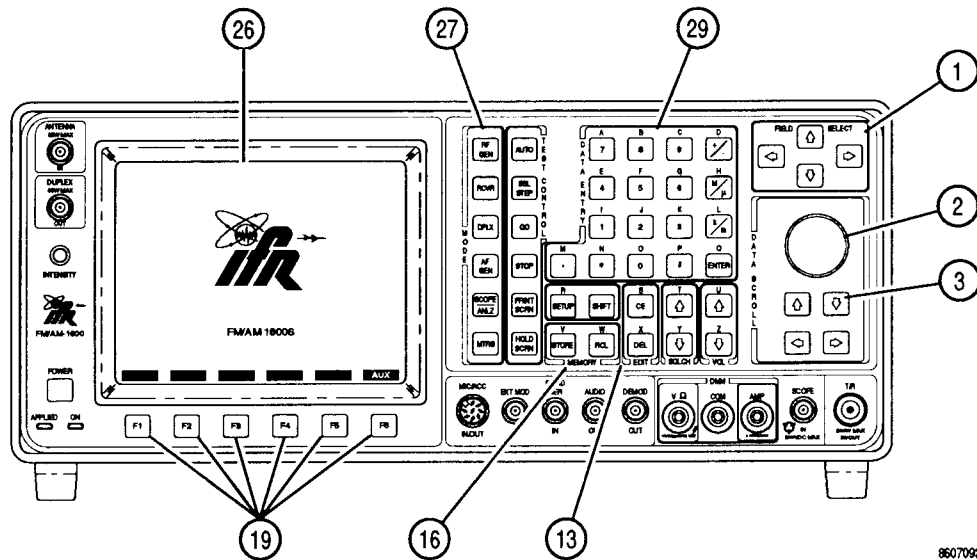

8607092

1. Press MTR MODE Key (27). Meter Menu appears on CRT. Use FIELD SELECT ↑ or ↓ Keys (3) to move cursor to "11. Phase Meter" and press ENTER Key. Phase Meter Operation Screen appears on CRT.

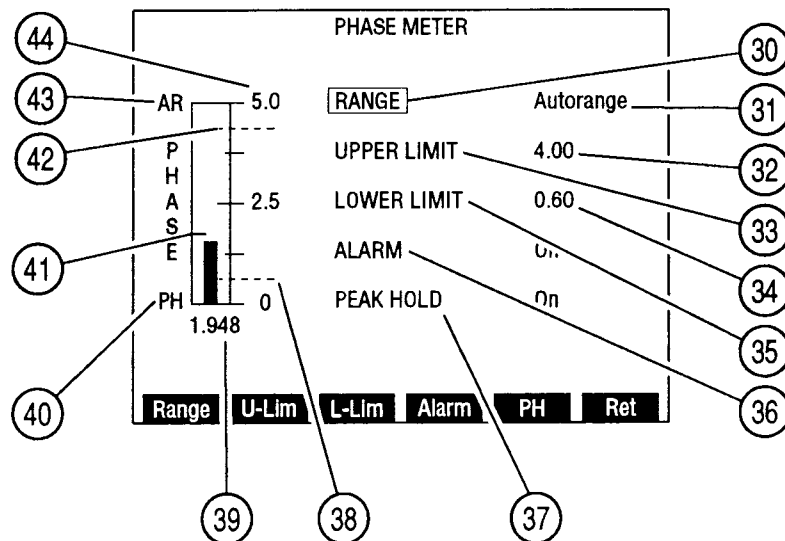

8607083

STEP**PROCEDURE**

2. Move cursor to RANGE (30) and press ENTER Key to access data field (31). Press DATA SCROLL ↑ or ↓ Keys (3) to select desired Range and press ENTER Key.
3. Move cursor to UPPER LIMIT (33). Press ENTER Key to activate Upper Limit and access data field. Use DATA ENTRY Keypad (29) to enter desired Upper Limit and press ENTER Key. A blue line (42) appears across meter window marking position of Upper Limit.
4. Move cursor to LOWER LIMIT (35). Press ENTER Key to activate Lower Limit and access data field. Use DATA ENTRY Keypad (29) to enter desired Lower Limit and press ENTER Key. A blue line (38) appears across meter window marking position of Lower Limit.
5. To deactivate Upper or Lower Limit, press SETUP Key to display Phase Meter Menu. Press 3 (Upper Limit) or 5 (Lower Limit) DATA ENTRY Key (29) to toggle Limit off. Press "Ret" Soft Function Key F5 to return to Phase Meter Operation Screen.
6. Move cursor to ALARM (36) and press ENTER Key to enable or disable Alarm. Enabled Alarm sounds when Upper or Lower Limit is exceeded.
7. Move cursor to PEAK HOLD (37) and press ENTER Key to enable or disable Peak Hold feature of Phase Meter. PH (40) appears at lower left of meter window and Peak Hold indicator (41) appears on meter indicating highest point reached by Meter Indicator Bar.
8. Measure Phase Modulation using Meter Indicator Bar or Digital Readout (39).
9. To store or recall a set of Phase Meter parameters, see 4-1-1.
10. To return to last Operation Screen, press "Ret" Soft Function Key F6.

4-8-12 DEVIATION METER (RMS) OPERATION

RMS Deviation of received FM signals is measured using the following procedures:

NOTE: Deviation Meter (RMS) is accessed from Receive Operation Screen, Duplex Operation Screen, Duplex Transmitter Operation Screen or Meter Menu.

Receiver or Duplex Transmitter modulation must be FM for Deviation Meter (RMS) measurements.

Deviation Meter (RMS) may not operate with Deviation Meter (Peak) Range >10 kHz.

STEP

PROCEDURE

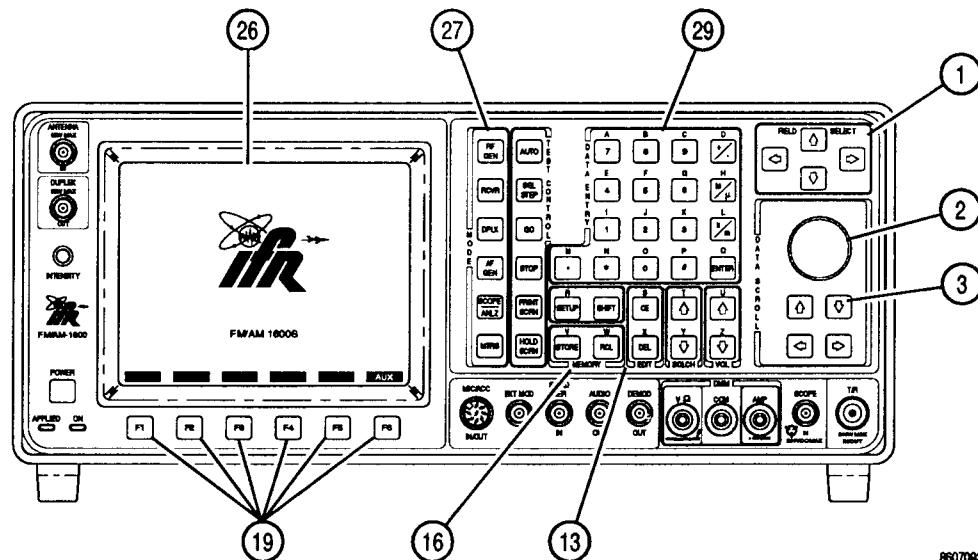

9507092

1. Press RCVR MODE Key (27) to display Receiver Operation Screen or press DPLX MODE Key (27) and "TX" Soft Function Key F1 to display Duplex Transmitter Operation Screen.
2. Press "More" Soft Function Key F6 until "Meters" Soft Function Key F4 appears. Press "Meters" Soft Function Key F4 and press 3 DATA ENTRY Key (29). Move cursor to Deviation Meter (RMS) Callout and press ENTER Key to display Deviation Meter (RMS) Operation Screen.

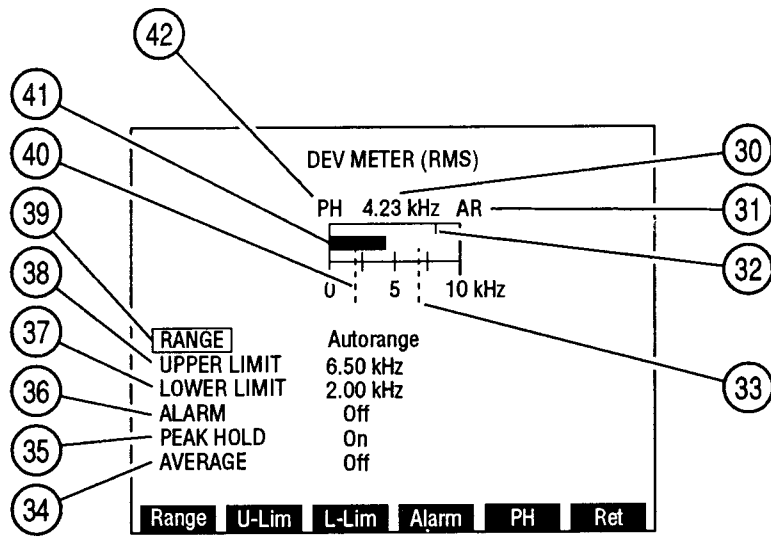

8607122

3. Move cursor to RANGE (39) and press ENTER Key to access data field. Rotate DATA SCROLL Spinner (2) or press DATA SCROLL \uparrow or \downarrow Keys (3) to select desired Range and press ENTER Key.
4. Move cursor to UPPER LIMIT (38). Press ENTER Key to activate Upper Limit and access data field. Use DATA ENTRY Keypad (29) to enter desired Upper Limit and press ENTER Key. A blue line (33) appears across meter window marking position of Upper Limit.
5. Move cursor to LOWER LIMIT (37). Press ENTER Key to activate Lower Limit and access data field. Use DATA ENTRY Keypad (29) to enter desired Lower Limit and press ENTER Key. A blue line (40) appears across meter window marking position of Lower Limit.
6. To deactivate Upper or Lower Limits, press SETUP Key to display Deviation Meter (RMS) Menu. Press 3 (Upper Limit) or 5 (Lower Limit) DATA ENTRY Key (29) to toggle Limit off. Press "Ret" Soft Function Key F5 to return to Deviation Meter (RMS) Operation Screen.
7. Move cursor to ALARM (36) and press ENTER Key to enable or disable Alarm. Enabled Alarm sounds when Upper or Lower Limit is exceeded.
8. Move cursor to PEAK HOLD (35) and press ENTER Key to enable or disable Peak Hold feature of Deviation Meter (RMS). PH (42) appears at lower left of meter window and Peak Hold indicator (32) appears on meter indicating highest point reached by Meter Indicator Bar (41).
9. Move cursor to AVERAGE (34) and press ENTER Key to enable or disable Deviation Meter (RMS) Averaging. With Averaging enabled, a running average of last 10 readings are reported.
10. Measure FM RMS Deviation using Meter Indicator Bar (41) or Digital Readout (30).
11. To store or recall a set of Deviation Meter (RMS) parameters, see 4-1-1.
12. To return to last Operation Screen, press "Ret" Soft Function Key F6.

SECTION 5 - PERFORMANCE EVALUATION

5-1 GENERAL

This section contains information on test procedures for assessing the performance of the FM/AM-1600S. All tests conducted are self tests performed by the unit. No additional equipment is needed to conduct these tests. For maximum benefit, the operator should be thoroughly familiar with all aspects of this manual before performing these procedures.

5-2 POWER-UP SELF TEST

When power is switched on to the FM/AM-1600S, the unit performs a power-up self test. A 1-2-4 beep series sounds if unit is functioning normally and the IFR Logo Screen is displayed. An abnormality causes a break in this sequence or an error message to be displayed on the screen. If an error message occurs, switch power off, wait thirty seconds and power unit on again. If error reoccurs, refer unit to maintenance for corrective action.

5-3 SELF TEST

A more thorough check of the FM/AM-1600S is provided by a user-requested self test. This Self Test is accessible from the Auxiliary Functions Menu. Refer to 3-3-10 for more information on the Auxiliary Functions Menu. From the Auxiliary Functions Menu, select "4. Self Test." This selection displays the Self Test Menu in Figure 5-1.

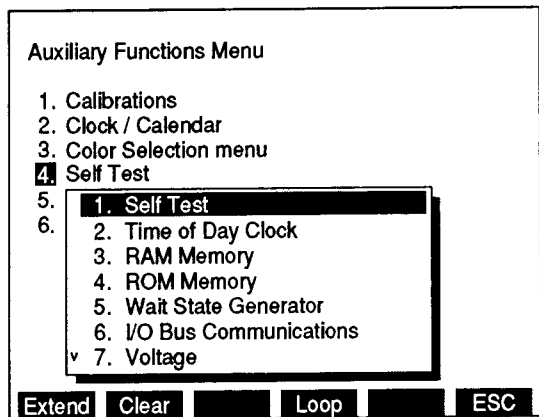

Figure 5-1 Self Test Menu

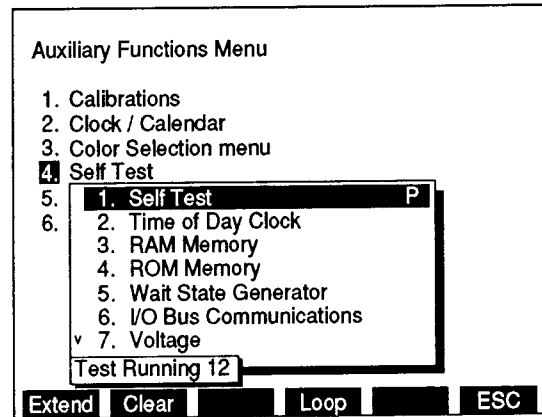

Figure 5-2 Test Running Counter

The Self Test Menu is composed of 22 individual tests including the Self Test. Seven of these items are visible at one time. Access to other parts of the Self Test Menu is available by using the DATA SCROLL Keys (3) (Figure 3-1). The DATA SCROLL ↑ and ↓ Keys (3) (Figure 3-1) scroll the menu up and down one item at a time. The DATA SCROLL ← Key (4) functions as a page up key and the DATA SCROLL → Key (4) functions as a page down key.

To initiate Self Test, insure cursor is on "1. Self Test" and press ENTER Key. A "Test Running" prompt appears with current test number displayed as shown in Figure 5-2.

The Self Test performs all tests and returns a result of "P" for pass or "F" for fail as shown in Figures 5-3 and 5-4. A Self Test failure occurs with even one individual test failure. If Self Test fails, examine the entire menu to determine specific test failures. An "F" prompt is visible to the right of a test which has failed as shown in Figure 5-5. Specific tests that pass do not have a "P" prompt.

NOTE: Failure of a specific test may lead to failure in other specific tests although those modules being tested may be operating properly.

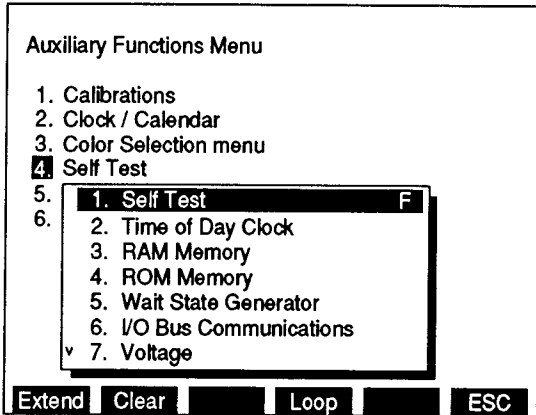

8610064

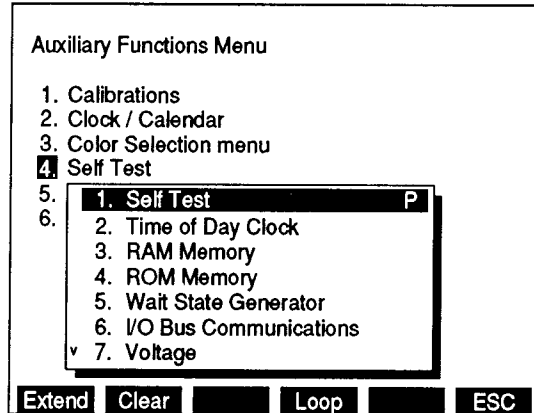

8610065

Figure 5-3 Self Test Failure

Figure 5-4 Self Test Pass

An individual test can be activated by moving cursor to desired test and pressing the ENTER Key. The result of an individual test is returned as "P" for pass or "F" for fail.

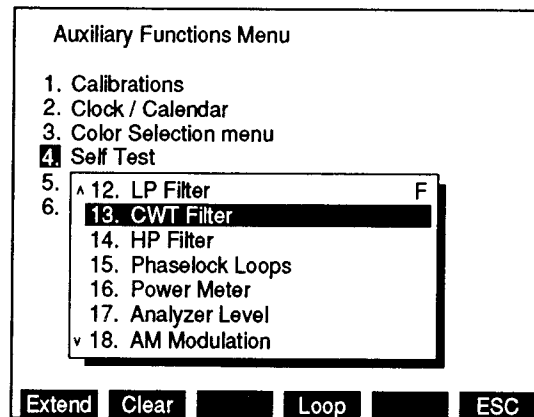

8610046

Figure 5-5 Individual Test Failure

Various Soft Function Keys are defined for use with the Self Test. These Soft Function Keys are displayed and defined as follows:

ITEM	DESCRIPTION
------	-------------

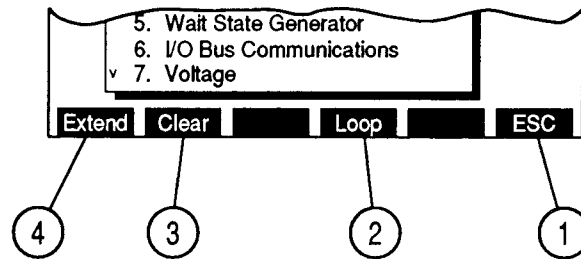

8610068

1. "ESC" Soft Function Key

Exits user from current submenu level to next higher menu.

2. "Loop" Soft Function Key

Activates currently designated test. Test repeats until failure or until "Stop" Soft Function Key (5) is selected. Can be used with Self Test or any individual test.

3. "Clear" Soft Function Key

Erases all test results displayed.

4. "Extend" Soft Function Key

Used on individual tests. If test is composed of multiple tests, "Extend" allows each subtest to be performed and result obtained separately. On some tests, use of "Extend" displays numeric measurement associated with test. On tests where neither of the above apply, selection activates the test and returns "Pass" or "Fail" as a result.

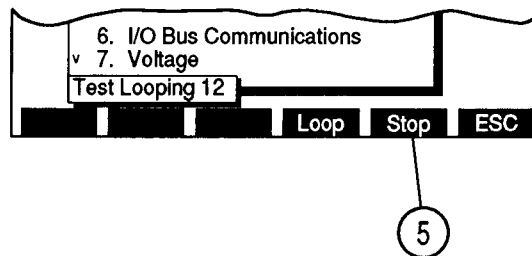

8610067

5. "Stop" Soft Function Key

Discontinues "Loop" function. Posts "P" or "F".

SECTION 6 - REMOTE OPERATION

6-1 GENERAL

The FM/AM-1600S is designed to operate remotely through an external controller. All data available through Front Panel Operation is available through the External Controller. The External Controller can generate any command available except CRT Intensity Control and Power On.

Remote Operation can be performed using the RS-232 Connector or the GPIB Connector. Refer to Appendix A for pin-out information. Location of both connectors is shown in Figure 3-2.

It is important that the operator be familiar with this manual and the Front Panel Operation of the FM/AM-1600S before initiating Remote Operations. Refer to Section 3, as needed, for information regarding Controls, Connectors, Indicators, Operation Screens and Menus. The operator must take care in programming the FM/AM-1600S remotely. An illegal command, normally ignored by the Front Panel, might be executed remotely. For more detailed information concerning remote operation, see the FM/AM-1600S TMAC Users Manual (1002-8600-300).

6-2 OPERATING PROCEDURES

Perform the following steps for Remote Operation of the FM/AM-1600S:

STEP	PROCEDURE
1.	Connect external control device to FM/AM-1600S. Connection is between like connector types; either RS-232 or GPIB.
2.	Press MTRS MODE Key and press "AUX" Soft Function Key F6. Auxiliary Functions Menu appears on CRT:

AUXILIARY FUNCTIONS MENU

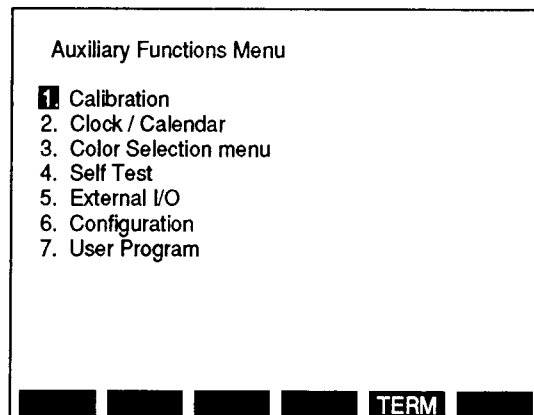

8610091

4. Press 5 DATA ENTRY Key to display External I/O Menu on CRT:

**AUXILIARY FUNCTIONS
EXTERNAL I/O MENU**

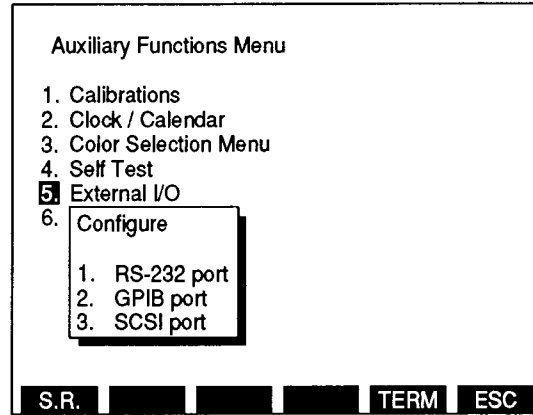

8610078

5. To configure RS-232 Connector:

- a. Press 1 DATA ENTRY Key to display Configure RS-232 Menu:

AUXILIARY FUNCTIONS RS-232 SUBMENU

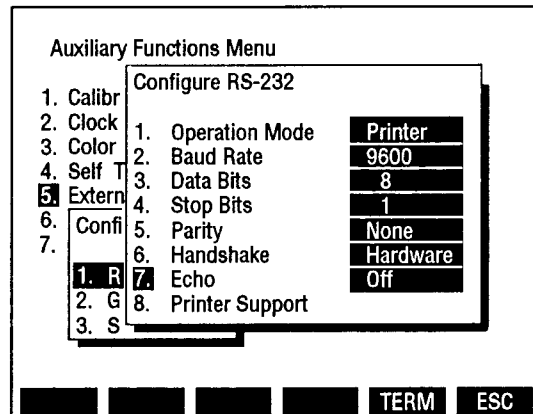

8610026

- b. Press 1 DATA ENTRY Key. Use DATA ENTRY Keypad to select 2. "Host" for talker/listener operation or "3. Printer" to print using RS-232 Connector.
- c. Press 2 DATA ENTRY Key. Use DATA ENTRY Keypad to select Baud Rate in bps.

300
2400
19200

600
4800

1200
9600

- d. Press 3 DATA ENTRY Key to toggle number of Data Bits between 7 and 8.

- e. Press 4 DATA ENTRY Key to toggle number of Stop Bits between 1 and 2.
- f. Press 5 DATA ENTRY Key. Use DATA ENTRY Keypad to select Parity. Select None, Odd, Even, Mark or Space.
- g. Press 6 DATA ENTRY Key. Use DATA ENTRY Keypad to select type of Handshaking. Select None, Hardware or Xon/Xoff.
- h. Press 7 DATA ENTRY Key to toggle Echo on or off.
- i. Press 8 DATA ENTRY Key to display Printer Support Menu:

PRINTER SUPPORT MENU

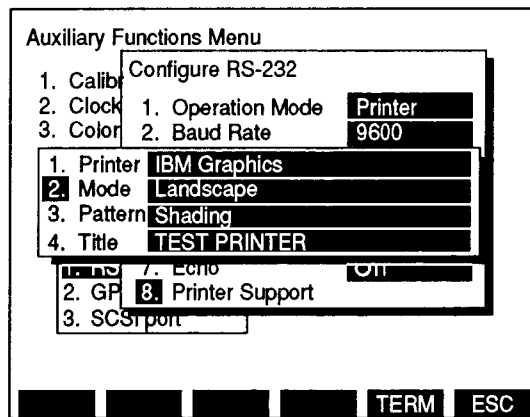

8610099

- Press 1 DATA ENTRY Key. Use FIELD SELECT Keys to select printer. Select Epson EX/FX/RX, HP LaserJet II or IBM Graphics and press ENTER.
- Press 2 DATA ENTRY Key to toggle printer mode between Landscape and Portrait.
- Press 3 DATA ENTRY Key to toggle printer pattern between Black and White and Shading.
- Press 4 DATA ENTRY Key to enter title. Use DATA ENTRY Keypad to enter a title up to 14 characters and press ENTER.
- Press "ESC" Soft Function Key F6.

- To configure GPIB Connector:

- Press 2 DATA ENTRY Key to display Configure GPIB Menu.

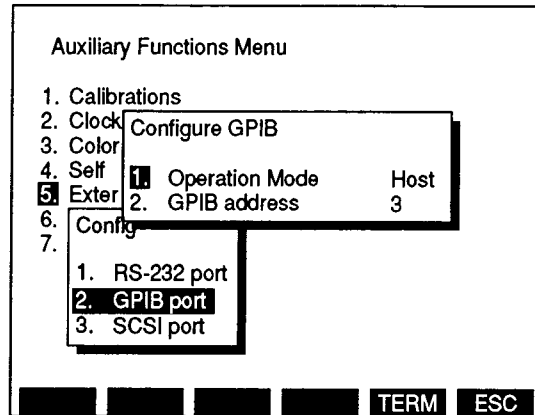

8610025

- Press 1 DATA ENTRY Key. Use DATA ENTRY Keypad to select Off, Talk/Listen (to be remotely controlled), Talk Only (for printing) or Controller (to control other remote devices).
- Press 2 DATA ENTRY Key and use DATA ENTRY Keypad to enter address used for Test Set. Range is from 0 to 31.

6-3 TMAC (TEST MACRO LANGUAGE)

TMAC is used to remotely operate the FM/AM-1600S and provide a format to store and perform user defined test sequences. TMAC is based on the IEEE-488.2 format and also conforms to the SCPI Standard.

One of TMAC's main strengths is the capability to define macros. This allows step by step test procedures to be developed, stored and remotely implemented. Flow control commands allow decision making and looping within the macro. TMAC also provides a variety of data structures to assist in developing test procedures. Developing macros is made easier by allowing a macro to execute by entering the macro name and its parameters. Macros can be executed from other macros with parameters being passed from one macro to the other, allowing complicated procedures to be divided into smaller tasks. Multitasking commands allow several macros to alternate command execution, giving the appearance of being executed simultaneously.

A full explanation of the TMAC Language is beyond the scope of this manual. Table 6-3 lists the specific instrument commands. For a complete explanation of the TMAC Language including the use of macros, variables, data structures, flow control commands, and multitasking commands, see the FM/AM-1600S TMAC Users Manual (1002-8600-300)

6-4 COMMAND SYNTAX

TMAC structures commands hierarchically through the use of the colon (:) delimiter. This concept allows the command paths to be formulated using common key sequences (e.g., To set either of the generator frequencies, :GEN:FREQ 1000 or :RX:FREQ 1000 are employed). Both the generator family of commands and receiver family of commands have common key words.

To allow access to the command paths, the FM/AM-1600S interpreter keeps track of the current path or command level where it expects to find the next command. The current path is determined by using a set of rules. On power-up or after a *RST command, the unit sets the current path to the root command node. This is the highest level of the command tree structure. Also, the end of a message or command line resets the current path to the root node.

When a colon is used as the delimiter between commands, the current path is moved down one level in the command structure (e.g., The colon in GEN:FREQ specifies that FREQ is one level down from GEN). When a colon is used as the first character of a command, it specifies that the command is to be found at the root node. A semicolon is used to separate multiple commands in the same message line. A semicolon does not change the current path.

For example:

```
:FGEN:DATA:STAT ON;BILVL;DEV 5600;ATT 0;RATE 1600;FLT:OUT
```

is equivalent to:

```
:FGEN:DATA:STAT ON  
:FGEN:DATA:BILVL  
:FGEN:DATA:DEV 5600  
:FGEN:DATA:ATT 0  
:FGEN:DATA:RATE 1600  
:FGEN:DATA:FLT:OUT
```

Commands with multiple parameter fields separate the parameters with a comma (,). An example of a multiple parameter command would be: :SCOP:TRACE:GET? 9,200. At least one space is needed between commands and parameters, other spaces or lack of them do not affect the command. This command is also an example of a query command, where the operator is requesting data from the FM/AM-1600S. Query commands contain a question mark (?) at the end of the command and before any parameters.

Commands are entered using a short or a long form. The short form is shown in upper case, the remainder of the long form is shown in lower case.

Various Command Syntax punctuation marks are shown in Table 6-1.

Punctuation Mark	Name	Description
;	Message Separator	Used to separate commands on same line.
:	Compound Command Separator	Allows hierarchy of command structure.
,	Parameter Separator	Separates parameters in multiple parameter command line.
?	Query Command Ending	Requests return of data.
\	End of Line Continuation	Allows command to continue on next line. Command words cannot be broken.

Table 6-1 Command Syntax Punctuation Marks

6-5 MANDATORY IEEE 488.2 COMMANDS

In compliance with IEEE 488.2 1987, Table 6-2 lists reserved commands for remote operations. When these commands are used, they must include the leading asterisk (*).

Mnemonic	Command
*CLS	Clear Status Command
*ESE	Standard Event Status Enable
*ESE?	Standard Event Status Enable Query
*ESR?	Standard Event Status Register Query
*IDN?	Identification Query
*OPC	Operation Complete Command
*OPC?	Operation Complete Query
*OPT?	Returns Software Option of Test Set
*RST	Restart Command
*SRE	Service Request Enable Command
*SRE?	Service Request Enable Query
*STB?	Read Status Byte Query
*TST?	Self Test Query
*WAI	Wait-to-continue
*DMC	Define Macro Command
*LMC?	List Macro Query
*RCL x	Recall Command
*SAV x	Save Command

Table 6-2 Mandatory GPIB Commands

6-6 FM/AM-1600S SPECIFIC COMMANDS

Table 6-3 lists specific instrument commands for the FM/AM-1600S. These commands are broken out by operation type such as Deviation Meter or Oscilloscope commands. These commands are complete commands except where the user must determine a parameter. This field is shown in the command line as x. All possible values or value ranges are listed for commands requiring parameters. For simplicity, boolean values are limited to 0 and 1 in this manual.

COMMAND	RANGE/VALUE	DESCRIPTION
AUDIO FREQUENCY METER COMMANDS		
:M_AF:RANGe:UPPer x	.2, 2, 20, 200	Sets Frequency Range of Audio Frequency Meter in kHz.
:M_AF:RANGe:AUTO		Enables Autorange of Audio Frequency Meter.
:M_AF:UL:STATe x	0 = off, 1 = on	Toggles Upper Limit of Audio Frequency Meter on or off.
:M_AF:UL:LEVel x	0.0000 to 200.0000	Sets Upper Limit Level of Audio Frequency Meter in kHz.
:M_AF:LL:STATe x	0 = off, 1 = on	Toggles Lower Limit of Audio Frequency Meter on or off.
:M_AF:LL:LEVel x	0.0000 to 200.0000	Sets Lower Limit Level of Audio Frequency Meter in kHz.
:M_AF:ALARM x	0 = off, 1 = on	Enables/Disables Over/Under Limit Alarm of Audio Frequency Meter.
:M_AF:PH x	0 = off, 1 = on	Enables/Disables Peak Hold of Audio Frequency Meter.
:M_AF:RESolution x	1/0.1 Hz	Sets Audio Frequency Meter resolution.
:M_AF:STORe x	1 to 9	Stores parameters of Audio Frequency Meter at indicated Store Parameters Menu location.
:M_AF:RCL x	1 to 9	Recalls parameters of Audio Frequency Meter from indicated Recall Parameters Menu location.

Table 6-3 FM/AM-1600S Specific Commands

COMMAND	RANGE/VALUE	DESCRIPTION
:M_AF:INPut:XAUDio		Selects External Audio Input for Audio Frequency Meter.
:M_AF:INPut:DEMOD		Selects Demod Audio Input for Audio Frequency Meter.
:M_AF:INPut:FGEN		Selects Function Generator Input for Audio Frequency Meter.
:M_AF:INPut:SINAD		Selects SINAD Input for Audio Frequency Meter.
:M_AF:INPut:BER		Selects BER Input for Audio Frequency Meter.
:M_AF:INPut:POWer		Selects RF Power Input for Audio Frequency Meter.
:M_AF:FILTer:LPASs:STATe x		Enables/Disables low-pass filter.
:M_AF:FILTer:LPASs:STATe?		Query low-pass filter state.
:M_AF:FILTer:LPASs:FREQuency x	0.1 to 30.0 kHz.	Set low-pass filter freq.
:M_AF:FILTer:LPASs:FREQuency?		Query low-pass filter freq.
:M_AF:FILTer:HPASs:STATe x		Enable/Disable high-pass filter.
:M_AF:FILTer:HPASs:STATe?		Query high-pass filter state.
:M_AF:FILTer:HPASs:FREQuency x	0.5 to 20.0 kHz.	Set high-pass filter freq.
:M_AF:FILTer:HPASs:FREQuency?		Query high-pass filter freq.
:M_AF?		Returns Audio Frequency Meter reading in Hz.
:M_AF:PEAK?		Returns Audio Frequency Meter Peak reading in Hz.
RADIO FREQUENCY ERROR METER COMMANDS		
:M_RF:RANGe:UPPer x	0.1, 1, 10, 100	Sets Frequency Range of Radio Frequency Error Meter in kHz.
:M_RF:RANGe:AUTO		Enables Autorange of Radio Frequency Error Meter.

Table 6-3 FM/AM-1600S Specific Commands (cont)

COMMAND	RANGE/VALUE	DESCRIPTION
:M_RF:UL:STATe x	0 = off, 1 = on	Toggles Upper Limit of Radio Frequency Error Meter on or off.
:M_RF:UL:LEVel x	0.0000 to 100.0000	Sets Upper Limit Level of Radio Frequency Error Meter in kHz.
:M_RF:LL:STATe x	0 = off, 1 = on	Toggles Lower Limit of Radio Frequency Error Meter on or off.
:M_RF:LL:LEVel x	0.0000 to 100.0000	Sets Lower Limit Level of Radio Frequency Error Meter in kHz.
:M_RF:ALARM x	0 = off, 1 = on	Enables/Disables Over/Under Limit Alarm of Radio Frequency Error Meter.
:M_RF:PH x	0 = off, 1 = on	Enables/Disables Peak Hold of Radio Frequency Error Meter.
:M_RF:RESolution x	1, 10	Sets Radio Frequency Error Meter resolution in Hz.
:M_RF:STORe x	1 to 9	Stores parameters of Radio Frequency Error Meter at indicated Store Parameters Menu location.
:M_RF:RCL x	1 to 9	Recalls parameters of Radio Frequency Meter from indicated Recall Parameters Menu location.
:M_RF?		Requests return of Radio Frequency Error Meter reading in Hz.
:M_RF:PEAK?		Requests return of Radio Frequency Error Meter Peak reading in Hz.
POWER METER COMMANDS		
:M_PWR:RANGe:UPPer x	.02, .05, .10, .2, .5, 1, 2, 5, 10, 20, 50, 100, 200	Sets Range Value of Power Meter in Watts.
:M_PWR:RANGe:AUTO		Enables Autorange of Power Meter.

Table 6-3 FM/AM-1600S Specific Commands (cont)

COMMAND	RANGE/VALUE	DESCRIPTION
:M_PWR:UL:STATe x	0 = off, 1 = on	Toggles Upper Limit of Power Meter on or off.
:M_PWR:UL:LEVel x	0.0000 to 200.0000	Sets Upper Limit Level of Power Meter in Watts.
:M_PWR:LL:STATe x	0 = off, 1 = on	Toggles Lower Limit of Power Meter on or off.
:M_PWR:LL:LEVel x	0.0000 to 200.0000	Sets Lower Limit Level of Power Meter in Watts.
:M_PWR:ALARM x	0 = off, 1 = on	Enables/Disables Over/Under Limit Alarm of Power Error Meter.
:M_PWR:PH x	0 = off, 1 = on	Enables/Disables Peak Hold of Power Meter.
:M_PWR:STORe x	1 to 9	Stores parameters of Power Meter at indicated Store Parameters Menu location.
:M_PWR:RCL x	1 to 9	Recalls parameters of Power Meter from indicated Recall Parameters Menu location.
:M_PWR:TYPE:CWeight		Measure average power.
:M_PWR?		Requests return of Power Meter reading in mW.
x=M_PWR?		Query power meter for value.
:M_PWR:PEAK?		Requests return of Power Meter Peak reading in mW.
DEVIATION METER COMMANDS		
:M_DEV:RANGe:UPPer x	2, 5, 10, 20, 50, 100	Sets Range Value of Deviation Meter in kHz.
:M_DEV:RANGe:AUTO		Enables Autorange of Deviation Meter.
:M_DEV:UL:STATe x	0 = off, 1 = on	Toggles Upper Limit of Deviation Meter on or off.
:M_DEV:UL:LEVel x	0.00 to 100.00	Sets Upper Limit Level of Deviation Meter in kHz with .05 kHz resolution.

Table 6-3 FM/AM-1600S Specific Commands (cont)

COMMAND	RANGE/VALUE	DESCRIPTION
:M_DEV:LL:STATe x	0 = off, 1 = on	Toggles Lower Limit of Deviation Meter on or off.
:M_DEV:LL:LEVel x	0.00 to 100.00	Sets Lower Limit Level of Deviation Meter in kHz in .05 kHz resolution.
:M_DEV:ALARM x	0 = off, 1 = on	Enables/Disables Over/Under Limit Alarm of Deviation Meter.
:M_DEV:AVErage x	0 = off, 1 = on	Enables/Disables Averaging of Deviation-RMS Meter.
:M_DEV:PH x	0 = off, 1 = on	Enables/Disables Peak Hold of Deviation Meter.
:M_DEV:STORe x	1 to 9	Stores parameters of Deviation Meter at indicated Store Parameters Menu location.
:M_DEV:RCL x	1 to 9	Recalls parameters of Deviation Meter from indicated Recall Parameters Menu location.
:M_DEV:POS?		Returns positive Deviation Meter reading in kHz.
:M_DEV:NEG?		Returns negative Deviation Meter reading in kHz.
:M_DEV:PEAK:POS?		Returns Positive Deviation Peak reading in kHz.
:M_DEV:PEAK:NEG?		Returns Negative Deviation Peak reading in kHz.
:M_DEV:MODE:BOTH		Read positive and negative deviation.
:M_DEV:MODE:POSitive		Read positive deviation only.
:M_DEV:MODE:NEGative		Read negative deviation only.
:M_DEV:MODE:NORMALize		Read (pos+neg)/2 deviation.

Table 6-3 FM/AM-1600S Specific Commands (cont)

COMMAND	RANGE/VALUE	DESCRIPTION
MODULATION METER COMMANDS		
:M_MOD:RANGe:UPPer x	40, 100	Sets Range Value of Modulation Meter in %.
:M_MOD:RANGe:AUTO		Enables Autorange of Modulation Meter.
:M_MOD:UL:STATe x	0 = off, 1 = on	Toggles Upper Limit of Modulation Meter on or off.
:M_MOD:UL:LEVel x	0.0 to 100.0	Sets Upper Limit Level of Modulation Meter in %.
:M_MOD:LL:STATe x	0 = off, 1 = on	Toggles Lower Limit of Modulation Meter on or off.
:M_MOD:LL:LEVel x	0.0 to 100.0	Sets Lower Limit Level of Modulation Meter in %.
:M_MOD:ALARM x	0 = off, 1 = on	Enables/Disables Over/Under Limit Alarm of Modulation Meter.
:M_MOD:PH x	0 = off, 1 = on	Enables/Disables Peak Hold of Modulation Meter.
:M_MOD:STORe x	1 to 9	Stores parameters of Modulation Meter at indicated Store Parameters Menu location.
:M_MOD:RCL x	1 to 9	Recalls parameters of Modulation Meter from indicated Recall Parameters Menu location.
:M_MOD?		Requests return of Modulation Meter reading in %.
:M_MOD:PEAK?		Requests return of Modulation Meter Peak reading in %.
DISTORTION METER COMMANDS		
:M_DISTortion:SElect:LPASs x	100 to 30000	Selects low-pass filter with cutoff frequency of x Hz.
:M_DISTortion:SElect:CWeight		Selects C-Weight filter.

Table 6-3 FM/AM-1600S Specific Commands (cont)

COMMAND	RANGE/VALUE	DESCRIPTION
:M_DISTortion:FILTER x	600 to 1400	Sets Notch Filter Frequency of Distortion Meter in Hz.
:M_DISTortion:UL:STATe x	0 = off, 1 = on	Toggles Upper Limit of Distortion Meter on or off.
:M_DISTortion:UL:LEVel x	0.0 to 20.0	Sets Upper Limit Level of Distortion Meter in %.
:M_DISTortion:LL:STATe x	0 = off, 1 = on	Toggles Lower Limit of Distortion Meter on or off.
:M_DISTortion:LL:LEVel x	0.0 to 20.0	Sets Lower Limit Level of Distortion Meter in %.
:M_DISTortion:ALARM x	0 = off, 1 = on	Enables/Disables Over/Under Limit Alarm of Distortion Meter.
:M_DISTortion:AVErage		Enables Distortion averaging.
:M_DISTortion:PH x	0 = off, 1 = on	Enables/Disables Peak Hold of Distortion Meter.
:M_DISTortion:STORE x	1 to 9	Stores parameters of Distortion Meter at indicated Store Parameters Menu location.
:M_DISTortion:RCL x	1 to 9	Recalls parameters of Distortion Meter from indicated Recall Parameters Menu location.
:M_DISTortion:INPut:DEMOD		Selects Demod Audio Input for Distortion Meter.
:M_DISTortion:INPut:SINAD		Selects SINAD Input for Distortion Meter.
:M_DISTortion:INPut:BER		Selects BER Input for Distortion Meter.
:M_DISTortion:INPut:XAUdio		Selects External Audio Input for Distortion Meter.
:M_DISTortion?		Returns Distortion Meter reading in %.
x=M_DISTortion?		Query for value.
:M_DISTortion:PEAK?		Returns Distortion Meter Peak reading in %.

Table 6-3 FM/AM-1600S Specific Commands (cont)

COMMAND	RANGE/VALUE	DESCRIPTION
SINAD METER COMMANDS		
:M_SINAD:SElect:LPASs x	100 to 30000	Selects low-pass filter with cutoff frequency of x Hz.
:M_SINAD:SElect:CWeight		Selects C-Weight filter.
:M_SINAD:FILTer x	770, 1000	Sets Notch Filter Frequency of SINAD Meter in Hz.
:M_SINAD:UL:STATe x	0 = off, 1 = on	Toggles Upper Limit of SINAD Meter on or off.
:M_SINAD:UL:LEVel x	3.0 to 30.0	Sets Upper Limit Level of SINAD Meter in dB.
:M_SINAD:LL:STATe x	0 = off, 1 = on	Toggles Lower Limit of SINAD Meter on or off.
:M_SINAD:LL:LEVel x	3.0 to 30.0	Sets Lower Limit Level of SINAD Meter in dB.
:M_SINAD:ALARM x	0 = off, 1 = on	Enables/Disables Over/Under Limit Alarm of SINAD Meter.
:M_SINAD:PH x	0 = off, 1 = on	Enables/Disables Peak Hold of SINAD Meter.
:M_SINAD:STORE x	1 to 9	Stores parameters of SINAD Meter at indicated Store Parameters Menu location.
:M_SINAD:RCL x	1 to 9	Recalls parameters of SINAD Meter from indicated Recall Parameters Menu location.
:M_SINAD:INPut:DEMOD		Selects Demod Audio Input for SINAD Meter.
:M_SINAD:INPut:SINAD		Selects SINAD Input for SINAD Meter.
:M_SINAD:INPut:BER		Selects BER Input for SINAD Meter.
:M_SINAD:INPut:XAUDio		Selects External Audio Input for SINAD Meter.
:M_SINAD?		Returns SINAD Meter reading in dB.

Table 6-3 FM/AM-1600S Specific Commands (cont)

COMMAND	RANGE/VALUE	DESCRIPTION
x=M_SINAD?		Query for value.
:M_SINAD:PEAK?		Returns SINAD Meter Peak reading in dB.
SIGNAL STRENGTH METER COMMANDS		
:M_SIG:PH x	0 = off, 1 = on	Enables/Disables Peak Hold of Signal Strength Meter.
:M_SIG:STORe x	1 to 9	Stores parameters of Signal Strength Meter at indicated Store Parameters Menu location.
:M_SIG:RCL x	1 to 9	Recalls parameters of Signal Strength Meter from indicated Recall Parameters Menu location.
:M_SIG?		Returns Signal Strength Meter reading.
:M_SIG:PEAK?		Returns Signal Strength Meter Peak reading.
x=M_SIG?		Query for value.
AF LEVEL METER		
:M_VRMS?		Returns voltage RMS reading.
BIT ERROR RATE (BER) METER COMMANDS		
:M_BER:TYPE:GENerator		Sets Bit Error Rate Meter Type to Generator.
:M_BER:TYPE:RECeive		Sets Bit Error Rate Meter Type to Receiver.
:M_BER:TYPE:DUPlEx		Sets Bit Error Rate Meter Type to Duplex.
:M_BER:TYPE:BASEband		Sets Bit Error Rate Meter Type to Baseband.
:M_BER:SIZE x	100 to 100000	Sets Bit Error Rate Meter Block Size in bits.

Table 6-3 FM/AM-1600S Specific Commands (cont)

COMMAND	RANGE/VALUE	DESCRIPTION
:M_BER:SIZE?	100 to 100000	Returns Bit Error Rate Meter Block Size setting in bits.
:M_BER:PATtern:RANDom		Sets Bit Error Rate Meter Data Pattern to "Random."
:M_BER:PATtern:FIXED		Sets Bit Error Rate Meter Data Pattern to "Fixed."
:M_BER:PATtern:USER x	8 Bit Pattern	Sets Bit Error Rate Meter Data Pattern to "User Defined" (8-bit pattern).
:M_BER:RATE x	75, 150, 300, 600, 1200, 2400, 4800, 16000	Sets Bit Error Rate Meter bit rate in bps.
:M_BER:RATE?	75, 150, 300, 600, 1200, 2400, 4800, 16000	Returns Bit Error Rate Meter rate setting in bps.
:M_BER:POLarity:POSitive		Sets Bit Error Rate Meter data polarity to "Pos. EXT AUDIO" setting.
:M_BER:POLarity:NEGative		Sets Bit Error Rate Meter data polarity to "Neg. SINAD/BER" setting.
:M_BER:STORe x	1 to 9	Stores parameters of Bit Error Rate Meter at indicated Store Parameters Menu location.
:M_BER:RCL x	1 to 9	Recalls parameters of Bit Error Rate Meter from indicated Recall Parameters Menu location.
:M_BER?		Returns Bit Error Rate Meter reading in %.
x=M_BER?		Query for value.
DIGITAL MULTIMETER COMMANDS		
:M_DMM:FUNCTion:VOLTage:DC		Sets Digital Multimeter Function for DC Voltage measurement.
:M_DMM:FUNCTion:VOLTage:AC		Sets Digital Multimeter Function for AC Voltage measurement.

Table 6-3 FM/AM-1600S Specific Commands (cont)

COMMAND	RANGE/VALUE	DESCRIPTION
:M_DMM:FUNCTION:CURRENT:DC		Sets Digital Multimeter Function for DC Current measurement.
:M_DMM:FUNCTION:CURRENT:AC		Sets Digital Multimeter Function for AC Current measurement.
:M_DMM:FUNCTION:RESistance		Sets Digital Multimeter Function for Resistance (ohm) measurement.
:M_DMM:FUNCTION?		Returns Digital Multimeter Function setting.
:M_DMM:RANGE:UPPer x	If ACV or DCV function: .2, 2, 20, 200, 2000 If ACC or DCC function: .02, .2, 2, 20 If RESistance Function: .2, 2, 20, 200, 2000, 20000	Sets Range Value of Digital Multimeter for selected function.
:M_DMM:RANGE:AUTO		Sets Digital Multimeter for selected function to Autorange.
:M_DMM:UL:STATe x	0 = off, 1 = on	Toggles Upper Limit of Digital Multimeter on or off.
:M_DMM:UL:LEVel x	If ACV or DCV function: 0.0000 to 1000.0 (V) If ACC or DCC function: 0.0000 to 19.99 (A) If RESistance Function: 0.000 to 19999 (Ohm)	Sets Upper Limit Level of Digital Multimeter.
:M_DMM:LL:STATe x	0 = off, 1 = on	Toggles Lower Limit of Digital Multimeter on or off.
:M_DMM:LL:LEVel x	If ACV or DCV function: 0.0000 to 1000.0 (V) If ACC or DCC function: 0.0000 to 19.99 (A) If RESistance Function: 0.000 to 1999999 (Ohm)	Sets Lower Limit Level of Digital Multimeter.
:M_DMM:ALARM x	0 = off, 1 = on	Enables/Disables Over/Under Limit Alarm of Digital Multimeter.
:M_DMM:PH x	0 = off, 1 = on	Enables/Disables Peak Hold of Digital Multimeter.

Table 6-3 FM/AM-1600S Specific Commands (cont)

COMMAND	RANGE/VALUE	DESCRIPTION
:M_DMM:INPut:IMPedance x	150, 600, 1e6	Sets input impedance in ohms for Digital Multimeter ACV or DCV measurement functions.
:M_DMM:STORe x	1 to 9	Stores parameters of Digital Multimeter at indicated Store Parameters Menu location.
:M_DMM:RCL x	1 to 9	Recalls parameters of Digital Multimeter from indicated Recall Parameters Menu location.
:M_DMM?		Returns DMM reading depending on current range and function settings.
x=M_DMM?		Query for DMM reading depending on current DMM range and function.
PHASE METER COMMANDS		
:M_PM:RANGe:UPPer x	2, 5, 10	Sets Range Value of Phase Meter in radians.
:M_PM:RANGe:AUTO		Enables Autorange of Phase Meter.
:M_PM:UL:STATe x	0 = off, 1 = on	Toggles Upper Limit of Phase Meter on or off.
:M_PM:UL:LEVel x	0.00 to 10.00	Sets Upper Limit Level of Phase Meter in radians.
:M_PM:LL:STATe x	0 = off, 1 = on	Toggles Lower Limit of Phase Meter on or off.
:M_PM:LL:LEVel x	0.00 to 10.00	Sets Lower Limit Level of Phase Meter in radians.
:M_PM:ALARM x	0 = off, 1 = on	Enables/Disables Over/Under Limit Alarm of Phase Meter.
:M_PM:PH x	0 = off, 1 = on	Enables/Disables Peak Hold of Phase Meter.
:M_PM:STORe x	1 to 9	Stores parameters of Phase Meter at indicated Store Parameters Menu location.

Table 6-3 FM/AM-1600S Specific Commands (cont)

COMMAND	RANGE/VALUE	DESCRIPTION
:M_PM:RCL x	1 to 9	Recalls parameters of Phase Meter from indicated Recall Parameters Menu location.
:M_PM?		Requests return of Phase Meter reading in .01 radians.
DEVIATION-RMS METER COMMANDS		
:M_DRMS:RANGe:UPPer x	2, 5, 10	Sets Range Value of Deviation (RMS) Meter in kHz.
:M_DRMS:RANGe:AUTO		Enables Autorange of Deviation-RMS Meter.
:M_DRMS:UL:STATe x	0 = off, 1 = on	Toggles Upper Limit of Deviation-RMS Meter on or off.
:M_DRMS:UL:LEVel x	0.00 to 10.00	Sets Upper Limit Level of Deviation-RMS Meter in kHz.
:M_DRMS:LL:STATe x	0 = off, 1 = on	Toggles Lower Limit of Deviation-RMS Meter on or off.
:M_DRMS:LL:LEVel x	0.00 to 10.00	Sets Lower Limit Level of Deviation-RMS Meter in kHz.
:M_DRMS:ALARM x	0 = off, 1 = on	Enables/Disables Over/Under Limit Alarm of Deviation-RMS Meter.
:M_DRMS:AVErage x	0 = off, 1 = on	Enables/Disables Averaging of Deviation-RMS Meter.
:M_DRMS:PH x	0 = off, 1 = on	Enables/Disables Peak Hold of Deviation-RMS Meter.
:M_DRMS:STORE x	1 to 9	Stores parameters of Deviation-RMS Meter at indicated Store Parameters Menu location.
:M_DRMS:RCL x	1 to 9	Recalls parameters of Deviation-RMS Meter from indicated Recall Parameters Menu location.

Table 6-3 FM/AM-1600S Specific Commands (cont)

COMMAND	RANGE/VALUE	DESCRIPTION
:M_DRMS?		Requests return of Deviation-RMS Meter reading in kHz.
OSCILLOSCOPE OPERATION SCREEN COMMANDS		
:SCOPE:STATe x	0 = off, 1 = on	Enable/Disable Oscilloscope Operation Screen.
:SCOPE:SCALE x	For Demod Audio Input and FM Modulation: 1,2, 4, 10, 20 (kHz) For AC, DC or GND input: 2, 5, 10, 20, 50, 100, 200, 500,1000, 2000, 5000, 10000, 20000, 50000 (mV) For Func Gen or Ext Mod Input: 500, 1000, 2500	Sets Oscilloscope vertical scale.
:SCOPE:SCALE?	For Demod Audio Input and FM Modulation: 1,2, 4, 10, 20 (kHz) For AC, DC or GND input: 2, 5, 10, 20, 50, 100, 200, 500,1000, 2000, 5000, 10000, 20000, 50000 (mV) For Func Gen or Ext Mod Input: 500, 1000, 2500	Returns Oscilloscope scale setting.
:SCOPE:SWEEP x	1, 2, 5, 10, 20, 50, 100, 200, 500, 1000, 2000, 5000, 10000, 20000, 50000, 100000	Sets Oscilloscope horizontal sweep rate in μ s.
:SCOPE:SWEEP?	1, 2, 5, 10, 20, 50, 100, 200, 500, 1000, 2000, 5000, 10000, 20000, 50000, 100000	Requests return of Oscilloscope sweep rate setting in μ s.
:SCOPE:SOURce x	EXT, INTernal	Selects External Scope Input or Internal routing Scope Input.
:SCOPE:INTernal x	IF, DEMOD, POWer, SINAD, FUNCtion, XAUDio	Sets Oscilloscope Input to: Receiver IF Demodulated Audio RF Power Level SINAD/BER Function Generators External Audio
:SCOPE:INPut:FILTer:LPASs:STATe x	0 = off, 1 = on	Enables Oscilloscope Input from Low Pass Filter.

Table 6-3 FM/AM-1600S Specific Commands (cont)

COMMAND	RANGE/VALUE	DESCRIPTION
:SCOPE:INPut:FILT:LPAS:FREQuency x	0.2 to 50	Sets Low-Pass Filter Frequency in kHz.
:SCOPE:INPut:FILTer:HPASs:STATe x	0 = off, 1 = on	Enables Oscilloscope Input from High-Pass Filter.
:SCOPE:INPut:FILT:HPAS:FREQuency x	0.2 to 100	Sets High-Pass Filter Frequency in kHz.
:SCOPE:INPut:FILT:CWEIGHT:STATe x	0 = off, 1 = on	Enables Oscilloscope Input from C-Weight Filter.
:SCOPE:INPut:FILTer:NOTch:STATe x	0 = off, 1 = on	Enables Oscilloscope Input from internal Notch Filter.
:SCOPE:INPut:FILT:NOT:FREQuency x	0.5 to 1.5	Sets Notch Filter width in kHz.
:SCOPE:COUPling x	AC, DC, GRO	Sets Oscilloscope internal coupling.
:SCOPE:TRIGger:x	ONE, NORM, AUTO	Sets Oscilloscope Trigger Mode.
:SCOPE:ARM		Arms Oscilloscope (Ignored if not in "One-Shot" mode).
:SCOPE:LEVel x	0 to 255	Sets Trigger Level.
:SCOPE:VERTical x	1 to 10	Sets Vertical Offset of Oscilloscope Trace in the number of grid divisions.
:SCOPE:HORIZontal x	1 to 10	Sets Horizontal Offset of Oscilloscope center line in the number of grid divisions.
:SCOPE:FULL		Sets Oscilloscope for "full size" display on RF Generator, Receive, Duplex Transmitter and Duplex Receiver Operation Screens.
:SCOPE:QTR		Sets Oscilloscope for "1/4 size" display on RF Generator, Receive, Duplex Transmitter and Duplex Receiver Operation Screens.

Table 6-3 FM/AM-1600S Specific Commands (cont)

COMMAND	RANGE/VALUE	DESCRIPTION
:SCOPE:STORE x	1 to 9	Stores parameters of Oscilloscope Operation Screen at indicated Store Parameters Menu location.
:SCOPE:RCL x	1 to 9	Recalls parameters of Oscilloscope Operation Screen from indicated Recall Parameters Menu location.
:SCOPE:LIVE		Put Scope into Live Mode.
:SCOPE:AVERAGE x	1 to 100	Put Scope into Average Mode with number of average samples specified.
:SCOPE:COMPARE x	1 to 9	Put Scope into Compare Mode. Compares against given stored trace number.
:SCOPE:MARKer1:STATE x	1=ON, 0=OFF	Enables/disables Oscilloscope Marker 1.
:SCOPE:MARKer1:STATE?	1=ON, 0=OFF	Returns state of Oscilloscope Marker 1.
:SCOPE:MARKer1:POINT? x	0 to 100	Sets Oscilloscope Marker 1 graticule position in .25 graticule resolution (100 graticules in grid or 10 per grid division).
:SCOPE:MARKer1:POINT?	0 to 100	Returns Oscilloscope Marker 1 horizontal position in graticules.
:SCOPE:MARKer1:TIME?		Returns Oscilloscope Marker 1 horizontal position in ms.
:SCOPE:MARKer1:AMPLitude?		Returns vertical value of trace at Marker 1 in V.
:SCOPE:MARKer2:STATE x	1=ON, 0=OFF	Enables/disables Oscilloscope Marker 2.
:SCOPE:MARKer2:STATE?	1=ON, 0=OFF	Returns state of Oscilloscope Marker 2.
:SCOPE:MARKer2:POINT? x	0 to 100	Sets Oscilloscope Marker 2 graticule position in .25 graticule resolution (100 graticules in grid or 10 per grid division).

Table 6-3 FM/AM-1600S Specific Commands (cont)

COMMAND	RANGE/VALUE	DESCRIPTION
:SCOPE:MARKer2:POINT?	0 to 100	Returns Oscilloscope Marker 2 horizontal position in graticules.
:SCOPE:MARKer2:TIME?		Returns Oscilloscope Marker 2 horizontal position in ms.
:SCOPE:MARKer2:AMPLitude?		Returns vertical value of trace at Marker 2 in V.
:SCOPE:MARKer:STATe x	0=OFF, 1=ON	Enables/disables Oscilloscope Marker 1.
:SCOPE:MARKer:STATe?	0=OFF, 1=ON	Returns state of Oscilloscope Marker 1.
:SCOPE:MARKer:POINT? x	0 to 100	Sets Oscilloscope Marker 1 graticule position in .25 graticule resolution (100 graticules in grid or 10 per grid division).
:SCOPE:MARKer:POINT?	0 to 100	Returns Oscilloscope Marker 1 horizontal position in graticules.
:SCOPE:MARKer:TIME?		Returns Oscilloscope Marker 1 horizontal position in ms.
:SCOPE:MARKer:AMPLitude?		Returns vertical value of trace at Marker 1 in V.
:SCOPE:MARKer:AOFF		Turns off all markers.
:SCOPE:TRACK x	1=ON, 0=OFF.	Enables/Disables Oscilloscope tracking.
:SCOPE:DELTA:AMPLitude?		Returns amplitude difference between Marker 1 and Marker 2.
:SCOPE:DELTA:POINT?		Returns horizontal difference between markers in graticules.
:SCOPE:DELTA:TIME?		Returns horizontal difference between markers in ms.

Table 6-3 FM/AM-1600S Specific Commands (cont)

COMMAND	RANGE/VALUE	DESCRIPTION
:SCOPE:TRACE:DATA x,y,z	x is storage location number 1 to 9 y is horizontal offset 0 to 399 z is data location where point is placed 0 to 255	Creates abstract trace, pixel by pixel, at the specified memory location.
:SCOPE:TRACE:DATA? x,y,z	x = storage location number 0 to 9 y = horizontal offset 0 to 399 (Optional; default = 0) z = number of points to be returned (Optional; default = 400)	Returns trace data points from desired stored trace or live trace (0). All data points are returned unless otherwise specified by optional parameters.
:SCOPE:TRACE:MAX? x,y,z	x = storage location number 0 to 9 y = horizontal offset 0 to 399 (Optional; default = 0) z = number of points to be returned (Optional; default = 400)	Returns x,y position of maximum vertical point in trace. Entire trace is considered unless otherwise specified by optional parameters.
:SCOPE:TRACE:MIN? x,y,z	x is storage location number 1 to 9 y = horizontal offset 0 to 399 (Optional; default = 0) z = number of points to be returned (Optional; default = 400)	Returns x,y position of minimum vertical point in trace. Entire trace is considered unless otherwise specified by optional parameters.
:SCOPE:TRACE:GET? x,y	x is storage location number 1 to 9 y is horizontal offset 0 to 399	Returns point at location specified. Point returned is vertical pixel value 0 to 255.
SPECTRUM ANALYZER COMMANDS		
:ANLZ:SCAN x	1, 2, 5, 10, 20, 50, 100, 200, 500, 1000, 2000, 5000, 10000, 20000, 50000, 100000	Sets Spectrum Analyzer Scan Width in kHz.
:ANLZ:SCAN?	1, 2, 5, 10, 20, 50, 100, 200, 500, 1000	Returns Spectrum Analyzer Scan Width.
:ANLZ:FREQuency x	250 to 999999.9	Sets Spectrum Analyzer Frequency in kHz.
:ANLZ:FREQuency?	250 to 999999.9	Returns Spectrum Analyzer Frequency in kHz.
:ANLZ:STATe x	0 = OFF, 1 = ON	Enables/Disables Spectrum Analyzer.

Table 6-3 FM/AM-1600S Specific Commands (cont)

COMMAND	RANGE/VALUE	DESCRIPTION
:ANLZ:FULL		Sets Spectrum Analyzer for "full size" display on RF Generator, Receive, Duplex Transmitter and Duplex Receiver Operation Screens.
:ANLZ:QTR		Sets Spectrum Analyzer for "1/4 size" display on RF Generator, Receive, Duplex Transmitter and Duplex Receiver Operation Screens.
:ANLZ:STORe x	1 to 9	Stores parameters of Spectrum Analyzer Operation Screen at indicated Store Parameters Menu location.
:ANLZ:RCL x	1 to 9	Recalls parameters of Spectrum Analyzer Operation Screen from indicated Recall Parameters Menu location.
:ANLZ:LIVe		Put Analyzer into Trace Mode.
:ANLZ:AVERage x	1 to 100	Put Analyzer into Average Mode. The sample number may be specified. Default is 100.
:ANLZ:PEAK		Put Analyzer into Peak Hold Mode.
:ANLZ:COMPare x	1 to 9	Put Analyzer into Compare Mode. Compares against given stored trace number.
:ANLZ:SCALe x	2, 10	Sets Analyzer Scale to 2 or 10 dB.
:ANLZ:SCALe?	2, 10	Returns scale setting.
:ANLZ:SCALe:UNIT:DBM		Set reference scale to dBm.
:ANLZ:SCALe:UNIT:DBMV		Set reference scale to dBmV.
:ANLZ:SCALe:UNIT:DBUV		Set reference scale to dB μ V.
:ANLZ:SCALe:UNIT:DBV		Set reference scale to dBV.

Table 6-3 FM/AM-1600S Specific Commands (cont)

COMMAND	RANGE/VALUE	DESCRIPTION
:ANLZ:SCALE:UNIT:DBUW		Set reference scale to dB μ W.
:ANLZ:SCALE:UNIT:DBW		Set reference scale to W (T/R Connector only).
:ANLZ:SCALE:UNIT:UNIT?		Query reference setting. T/R Connector returns dBm and dBW only. ANT does not return dBW.
:ANLZ:MARKer1:STATe x	0 = off, 1 = on	Enables/Disables Spectrum Analyzer Marker 1.
:ANLZ:MARKer1:POINT? x	0.5 to 100.0	Sets Spectrum Analyzer Marker 1 graticule position in .25 graticule resolution (100 graticules in grid or 10 per grid division).
:ANLZ:MARKer1:POINT?		Returns Spectrum Analyzer Marker 1 position in graticules.
:ANLZ:MARKer1:FREQuency?		Returns Spectrum Analyzer Marker 1 position in kHz.
:ANLZ:MARKer1:AMPLitude?		Returns Spectrum Analyzer Trace value at the point where it crosses Marker 1. This value will be in units of the Spectrum Analyzer reference setting.
:ANLZ:MARKer2:STATe x	0 = off, 1 = on	Enables/Disables Spectrum Analyzer Marker 2.
:ANLZ:MARKer2:POINT? x	0.5 to 100.0	Sets Spectrum Analyzer Marker 2 graticule position in .25 graticule resolution (100 graticules in grid or 10 per grid division).
:ANLZ:MARKer2:POINT?		Returns Spectrum Analyzer Marker 2 position in graticules.
:ANLZ:MARKer2:FREQuency?		Request return of Spectrum Analyzer Marker 2 position in kHz.

Table 6-3 FM/AM-1600S Specific Commands (cont)

COMMAND	RANGE/VALUE	DESCRIPTION
:ANLZ:MARKer2:AMPLitude?		Returns Spectrum Analyzer Trace value at the point where it crosses the Marker 2. This value will be in units of the Spectrum Analyzer reference setting.
:ANLZ:MARKer:STATe x	0 = off, 1 = on	Enables/Disables Spectrum Analyzer Marker 1.
:ANLZ:MARKer:POINT? x	0.5 to 100.0	Sets Spectrum Analyzer Marker 1 graticule position in .25 graticule resolution (100 graticules in grid or 10 per grid division).
:ANLZ:MARKer:POINT?		Returns Spectrum Analyzer Marker 1 position in graticules.
:ANLZ:MARKer:FREQuency?		Returns Spectrum Analyzer Marker 1 position in kHz.
:ANLZ:MARKer:AMPLitude?		Returns Spectrum Analyzer Trace value at the point where it crosses the Marker 1. This value will be in units of the Spectrum Analyzer reference setting.
.ANLZ:MARKer:AOFF		Deactivates all markers.
:ANLZ:TRACK x	0 = off, 1 = on	Enables/disables Marker tracking function.
:ANLZ:DELTA:AMPLitude?		Returns vertical difference between two markers in current vertical scale units.
:ANLZ:DELTA:POINT?		Returns horizontal difference in frequency between two markers in graticules.
:ANLZ:DELTA:FREQuency?		Returns horizontal difference in frequency between two markers in MHz.
:ANLZ:TRACE:DATA x,y,z	x is storage location number 1 to 9 y is horizontal offset 0 to 399 z is data location where point is placed 0 to 255	Creates abstract trace, pixel by pixel, at the specified memory location.

Table 6-3 FM/AM-1600S Specific Commands (cont)

COMMAND	RANGE/VALUE	DESCRIPTION
:ANLZ:TRACE:DATA? x,y,z	x = storage location number 0 to 9 y = horizontal offset 0 to 399 (Optional; default = 0) z = number of points to be returned (Optional; default = 400)	Returns trace data points from desired stored trace or live trace (0). All data points are returned unless otherwise specified by optional parameters.
:ANLZ:TRACE:MAX? x,y,z	x = storage location number 0 to 9 y = horizontal offset 0 to 399 (Optional; default = 0) z = number of points to be returned (Optional; default = 400)	Returns x,y position of maximum vertical point in trace. Entire trace is considered unless otherwise specified by optional parameters.
:ANLZ:TRACE:MIN? x,y,z	x = storage location number 1 to 9 y = horizontal offset 0 to 399 (Optional; default = 0) z = number of points to be returned (Optional; default = 400)	Returns x,y position of minimum vertical point in trace. Entire trace is considered unless otherwise specified by optional parameters.
:ANLZ:TRACE:GET? x,y	x is storage location number 1 to 9 y is horizontal offset 0 to 399	Returns point at location specified. Point returned is vertical pixel value 0 to 255.
:ANLZ:TRACK:STATe x	0 = off, 1 = on	Enables/Disables Spectrum Analyzer Tracking Generator.
:ANLZ:TRACK:STATe?		Returns status of Tracking Generator.
:ANLZ:TRACK:RESolution:HIGH		Sets Tracking Generator to high resolution trace.
:ANLZ:TRACK:RESolution:LOW		Sets Tracking Generator to low resolution trace.
:ANLZ:TRACK:RESolution?		Returns Tracking Generator resolution setting.
:ANLZ:TRACK:LEVel x	-127 to 0	Sets Tracking Generator output level in dBm.
:ANLZ:TRACK:LEVel?		Returns Tracking Generator output level.
:ANLZ:TRACK:BWIDth x	.3, 3, 30, 300, 3000	Sets Tracking Generator Bandwidth in kHz.

Table 6-3 FM/AM-1600S Specific Commands (cont)

COMMAND	RANGE/VALUE	DESCRIPTION
:ANLZ:INPut:ANTenna		Set Analyzer input to ANT. Analyzer screen should already be displayed.
:ANLZ:INPut:TR		Set Analyzer input to T/R. Analyzer screen should already be displayed.
:ANLZ:INPut:Attenuation?		Set analyzer attenuation value.
:ANLZ:INPut:Attenuation x	0, 20, 40	Query analyzer attenuation value.
:ANLZ:INPut?		Query analyzer input setting.
:ANLZ:TOP?		Query top of screen scale value.
:ANLZ:RLEVel?	0 to 64	Query scalar offset used in 2 dB/div scale.
:ANLZ:FIND:FREQuency?		Search for the freq with the largest amplitude in the Receiver spectrum.
:ANLZ:FIND:REFeRence x		Set the Find freq amplitude search level in dB.
:ANLZ:FIND:REFeRence?		Query the reference setting.
:ANLZ:TRACK:BWIDth?		Returns value of current Tracking Generator bandwidth.
RECEIVER COMMANDS		
:RECeive:SQUelch x	0.0 to 1.0	Turn squelch up or down.
:RECeive:SQUelch? x	0.0 to 1.0	Returns squelch setting.
:RECeive:VOLUme x	0.0 to 1.0	Turns volume up or down.
:RECeive:VOLUme? x	0.0 to 1.0	Returns volume setting.
:RECeive:FREQuency x	250.0 to 999999.9	Sets Receiver RF Frequency from 250 kHz to 999.9999 MHz in 1 kHz steps.
:RECeive:FREQuency?	250.0 to 999999.9	Returns RF Frequency.

Table 6-3 FM/AM-1600S Specific Commands (cont)

COMMAND	RANGE/VALUE	DESCRIPTION
:RECeive:MODulation:x	FM1, FM2, FM3, FM4, AM1, AM2, USB, LSB, BFO, PM	Sets Receiver Modulation Type.
:RECeive:MOD:USER:MODulation:x	FM, AM, USB, LSB, BFO, PM, DATA	Sets Receiver Modulation Type - User Selected Modulation.
:RECeive:MOD:USER:FILTer x	3, 30, 300	Sets User selected IF Filter in kHz.
:RECeive:MOD:USER:POST:APASs		Sets User selected Post Detection - All Pass.
:RECeive:MOD:USER:POST:HPASs x	0.5 to 20.0	Sets User selected Post Detection High-Pass Filter cutoff in kHz.
:RECeive:MOD:USER:POST:LPASs x	0.1 to 30.0	Sets User selected Post Detection Low-Pass Filter cutoff in kHz.
:RECeive:MOD:USER:POST:BPASs x,y	Range for lower cutoff is 0.5 to 20, for upper cutoff 0.1 to 30	Sets User selected Post Detection Bandpass Filter cutoff in kHz.
:RECeive:MODulation:USER:POST:CWT		Sets User selected Post Detection C-Weighted Filter.
:RECeive:MODulation?		Returns Modulation Type.
:RECeive:INPut:ANTenna		Selects Antenna Receiver input.
:RECeive:INPut:TR		Selects T/R Connector Receiver input.
:RECeive:INPut:ATTenuation x	0, 20, 40	Sets IF Block Attenuator in dB.
:RECeive:OUTput:SPEAKer x	0 = off, 1 = on	Turns Speaker output to on or off.
:RECeive:OUTput:DEMODO x	0 = off, 1 = on	Turns Demod output to on or off.
:RECeive:OUTput:AUDio x	0 = off, 1 = on	Turns Audio output to on or off.
:RECeive:AGC:MANual x	0 to 255	Sets AGC Manual mode level.
:RECeive:AGC:AUTO		Selects AGC Auto mode.

Table 6-3 FM/AM-1600S Specific Commands (cont)

COMMAND	RANGE/VALUE	DESCRIPTION
:RECeive:AGC:USER x	MEASure, SPeech, DATA, HIGH, TYPE1, TYPE2, TYPE3	Selects AGC User Type.
:RECeive:OFF:USB x	0.200 to 30000	Sets Receiver Offset Frequency - USB in kHz.
:RECeive:OFF:LSB x	0.200 to 30000	Sets Receiver Offset Frequency - LSB in kHz.
:RECeive:DISToRtion		When followed by screen:receiver command, insures Distortion Meter is shown.
:RECeive:SINAD		When followed by screen:receiver command, insures SINAD Meter is shown.
:RECeive:MODMeter		When followed by screen:receiver command, insures Modulation Meter is shown.
:RECeive:DTMF:STATe x	0 = off, 1 = on	Enable/Disable DTMF decoding.
:RECeive:DTMF?		Returns decoded digits or -1 if nothing decoded.
:RECeive:POCSAG:STATe x	0 = off, 1 = on	Enable/Disable POCSAG decoding.
:RECeive:POCSAG:RATe x	0 = LOW, 1 = HIGH	Sets POCSAG rate to decode.
:RECeive:POCSAG:RATe?		Returns POCSAG Rate. 1 for high, 0 for low.
:RECeive:POCSAG:CAPcode?		Returns received capcode or -1 if not available.
:RECeive:POCSAG:TYPE?		Returns POCSAG Function Type or -1 if not available.
:RECeive:POCSAG:MESSAge?		Returns POCSAG message string or -1 if not available.
:RECeive:DCS:STATe x	0 = off, 1 = on	Enables/Disables DCS decoding.
:RECeive:DCS:NORMAl?		Returns received DCS digits or -1 if normal DCS not received.

Table 6-3 FM/AM-1600S Specific Commands (cont)

COMMAND	RANGE/VALUE	DESCRIPTION
:RECeive:DCS:INVert?		Returns received DCS digits or -1 if inverted DCS not received.
:RECeive:TONE:STATe	0 = off, 1 = on	Enables/Disables Audio Tone decoding.
:RECeive:TONE:TYPE x	CCIR, EEA, EIA, ZVEI, DDZVEI, DZVEI, NATEL, EURO, TONE56, CCIRH, CCIRH4, USER	Sets Audio Tone Type decoded.
:RECeive:TONE?		Returns received Audio Tone sequence or -1 if not available.
:RECeive:FIND:FREQuency?		Returns first frequency with amplitude greater than Find Reference.
:RECeive:FIND:REFeRence x		Sets Find Reference Level in dB.
:RECeive:FIND:REFeRence?		Returns Find Reference Level in dB.
:RECeive:SCAN:STARt x	250.0 to 999999.9	Receivers Scan starting frequency in kHz.
:RECeive:SCAN:STOP	250.0 to 999999.9	Receivers Scan stopping frequency in kHz.
:RECeive:SCAN:INCRement x	250.0 to 999999.9	Sets Receiver Scan increment in kHz.
:RECeive:SCAN:RATE x	0.00 to 99.99	Sets time, in sec, frequency is received if squelch not broken.
:RECeive:SCAN:PAUSE x	0.00 to 99.99	Sets time, in sec, frequency is received if squelch is broken.
:RECeive:SCAN:CONTInue		Starts or continues Receiver Scan.
:RECeive:SCAN:PAUSE?		Returns 1 if paused, 0 if not.
:RECeive:SCAN:ABORT		Aborts Receiver Scan.
:RECeive:SCAN:FREQuency?		Returns frequency currently being scanned.
:RECeive:STORE	1 to 9	Stores parameters.

Table 6-3 FM/AM-1600S Specific Commands (cont)

COMMAND	RANGE/VALUE	DESCRIPTION
:RECEive:RCL	1 to 9	Recalls parameters.
RF GENERATOR COMMANDS		
:GENerator:FREQUency x	250.0 to 999999.9	Sets Generator RF Frequency 250 kHz to 999.9999 MHz in 1 kHz steps.
:GENerator:FREQUency?	250.0 to 999999.9	Requests RF Frequency.
:GENerator:LEVel:DBm x	-137.0 to 0.0	Sets Output level in dBm, 1 dB steps.
:GENerator:LEVel:DBm?	-137.0 to 0.0	Returns output level.
:GENerator:STORe x	1 to 9	Stores parameters.
:GENerator:RCL x	1 to 9	Recalls parameters.
:GENerator:DISToRTion		When followed by screen:generator command, insures Distortion Meter is shown.
:GENerator:SINAD		When followed by screen:generator command, insures SINAD Meter is shown.
:GENerator:AF		When followed by screen:generator command, insures AF Meter is shown.
:GENerator:DMM		When followed by screen:generator command, insures DMM Meter is shown.
:GENerator:DTMF x,y,z	Range of y and z - 25 to 9999	x is string to be encoded. y is mark time in ms. z is space time in ms.
:GENerator:POCSAG:BEEP x,y	Range of x, 1 to 4. Range of y is 0 to 9999999	Generates Beep Tone specified by x for capcode y.
:GENerator:POCSAG:RATE x	0 = low, 1 = high	Sets generated POCSAG rate.
:GENerator:POCSAG:RATE?		Returns current POCSAG rate. 1 for high, 0 for low.

Table 6-3 FM/AM-1600S Specific Commands (cont)

COMMAND	RANGE/VALUE	DESCRIPTION
:GENerator:POCSAG:NUMeric x	0 to 9999999	Generates a numeric message for capcode x.
:GENerator:POCSAG:ALPHA:LOWer x	0 to 9999999	Generates a lower case message for capcode x.
:GENerator:POCSAG:ALPHA:UPPer x	0 to 9999999	Generates an upper case message for capcode x.
:GENerator:POCSAG:ALPHA:NUMeric x	0 to 9999999	Generates an alphanumeric message for capcode x.
:GENerator:POCSAG:ALPHA:SPECial x	0 to 9999999	Generates a special character message for capcode x.
:GENerator:DCS:NORMal x	000 to 777	Generates DCS octal code in normal mode.
:GENerator:DCS:INVert x	000 to 777	Generates DCS octal code in inverted mode.
:GENerator:DCS:STOP		Stops DCS transmit.
:GENerator:IMTS x	0 to 9	Generates IMTS sequence up to 16 characters.
:GENerator:MTS	0 to 9	Generates MTS sequence up to 16 characters.
:GENerator:DIAL x	0 to 9	Generates 2805 pulse sequence up to 16 characters.
:GENerator:FREQuency x	0.0 to 40000.0	Sets pulse tone frequency to x Hz.
:GENerator:FREQuency?		Returns current 2805 pulse frequency.
:GENerator:TREMote x	2050, 1950, 1850, 1750, 1650, 1550, 1450, 1350, 1250, 1150, 1050	Generates sequence for given frequency in Hz.
:GENerator:TREMote		Stops Tone Remote guard tone.
:GENerator:TONE:TYPE x		Sets Audio Type to generate.
:GENerator:TONE:USER:DEFine x, y, z	Range of y is 0.0 to 9999.9. Range of z is 20 to 9999	Defines the first character of string x with frequency y in Hz and duration z in ms.

Table 6-3 FM/AM-1600S Specific Commands (cont)

COMMAND	RANGE/VALUE	DESCRIPTION
:GENerator:TONE x	0 to 9, A, G, R or -	Generates sequence x using Audio tone previously defined.
:GENerator:OUTput:DEMOD x	0 = off, 1 = on	Turns Demod output to on or off.
:GENerator:OUTput:AUDio x	0 = off, 1 = on	Turns Audio output to on or off.
DUPLEX COMMANDS		
:DUPlex:INPut:FREQUency x		Sets Duplex Transmitter Frequency.
:DUPlex:INPut:FREQUency?		Sets Duplex Transmitter Frequency.
:DUPlex:INPut:MODulation:x	FM1, FM2, FM3, FM4, AM1, AM2, USB, LSB, BFO, PM	Sets Duplex Transmitter Modulation Type.
:DUPlex:INPut:MOD:USER:MODulation:x	FM, AM, USB, LSB, BFO, PM, DATA	Sets Duplex Transmitter Modulation Type - User Selected Modulation.
:DUPlex:INPut:MOD:USER:FILTer x	3, 30, 300	Sets User selected IF Filter in kHz.
:DUPlex:INPut:MOD:USER:POST:APASs		Sets User selected Post Detection - All Pass.
:DUPlex:INPut:MOD:USER:POST:HPASs x	0.5 to 20.0	Sets User selected Post Detection High-Pass Filter cutoff in kHz.
:DUPlex:INPut:MOD:USER:POST:LPASs x	0.1 to 30.0	Sets User selected Post Detection Low-Pass Filter cutoff in kHz.
:DUP:INP:MOD:USER:POST:BPAS x,y	Range for lower cutoff is 0.5 to 20.0. Range for upper cutoff is 0.1 to 30.0.	Sets User selected Post Detection Bandpass Filter with cutoffs in kHz.
:DUPlex:INPut:MOD:USER:POST:CWT		Sets User selected Post Detection - C Weighted Filter.
:DUPlex:INPut:MODulation?		Returns Modulation type.
:DUPlex:INPut:ANTenna		Selects Antenna Receiver input.
:DUPlex:INPut:TR		Selects T/R Connector Receiver input.

Table 6-3 FM/AM-1600S Specific Commands (cont)

COMMAND	RANGE/VALUE	DESCRIPTION
:DUPlEx:INPut:ATTenuation x	0, 20, 40	Sets IF Block Attenuators in dB.
:DUPlEx:INPut:FIND:FREQuency?		Search for the freq. with the largest amplitude in the Receiver spectrum.
:DUPlEx:INPut:REFerence x		Set the Find freq. amplitude search level in dB.
:DUPlEx:INPut:REFerence?		Query the reference setting.
:DUPlEx:INPut:MODMeter		When followed by SCREEN:DUPlEx command, insures Modulation Meter is shown.
:DUPlEx:INPut:DISToRtion		When followed by SCREEN:DUPlEx command, insures Distortion Meter is shown.
:DUPlEx:INPut:SINAD		When followed by SCREEN:DUPlEx command, insures SINAD Meter is shown.
:DUPlEx:OUTput:FREQuency x		Sets RF Generator Frequency.
:DUPlEx:OUTput:FREQuency?		Returns Duplex Generator Frequency.
:DUPlEx:OUTput:OFFSet		Sets RF Generator relative to Duplex Receiver Frequency.
:DUPlEx:OUTput:OFFSet?		Returns Offset.
:DUPlEx:OUTput:LEVel:DBm x	-127.0 to 0.0	Sets Duplex output level.
:DUPlEx:OUTput:LEVel:DBm?	-127.0 to 0.0	Returns Duplex output level.
:DUPlEx:OUTput:DUPlEx		Changes output to Duplex Connector.
:DUPlEx:OUTput:TR		Changes output to T/R Connector.
:DUPlEx:OUTput:DEMOD x	0 = off, 1 = on	Turns Demod output to on or off.

Table 6-3 FM/AM-1600S Specific Commands (cont)

COMMAND	RANGE/VALUE	DESCRIPTION
:DUPlEx:OUTput:AUDio x	0 = off, 1 = on	Turns Audio output to on or off.
:DUPlEx:OUTput:DISToRtion		When followed by SCREEN:DUPlEx command, insures Distortion Meter is shown.
:DUPlEx:OUTput:SINAD		When followed by SCREEN:DUPlEx command, insures SINAD Meter is shown.
:DUPlEx:OUTput:AF		When followed by SCREEN:DUPlEx command, insures AF Meter is shown.
:DUPlEx:OUTput:DMM		When followed by SCREEN:DUPlEx command, insures DMM Meter is shown.
:DUPlEx:STORe	1 to 9	Stores parameters.
:DUPlEx:RCL	1 to 9	Recalls parameters.
AF MODULATION COMMANDS		
:FGEN:GEN1:STATe x	0 = off, 1 = on	Turns AF GENerator 1 to on or off.
:FGEN:GEN1:FREQuency x	0.0 to 40000.0	Sets AF GENerator 1 Frequency in Hz.
:FGEN:GEN1:FREQuency?	0.0 to 40000.0	Returns AF GENerator 1 Frequency in Hz.
:FGEN:GEN1:MODulation x	AM, FM, PM or OFF	Sets Modulation type.
:FGEN:GEN1:MODulation?	AM, FM, PM or OFF	Returns Modulation type.
:FGEN:GEN1:MODL x	0 to 100 for AM 0.0 to 100.0 for FM 0.0 to 10.0 for PM	Sets Modulation level. AM in %, FM in kHz, PM in radians.
:FGEN:GEN1:MODL?	0 to 100 for AM 0.0 to 100.0 for FM 0.0 to 10.0 for PM	Returns Modulation level. AM in %, FM in kHz, PM in radians.
:FGEN:GEN1:SHAPE: x	SIN, SQU, RAMP or TRI	Selects Wave Shape.
:FGEN:GEN1:SHAPE:PULse:DCYCLe 50		Selects Pulse Shape with 50% Duty Cycle.

Table 6-3 FM/AM-1600S Specific Commands (cont)

COMMAND	RANGE/VALUE	DESCRIPTION
:FGEN:GEN1:SHAPE:DC x	1, 0, -1	Sets DC Level to -1, 0 or 1.
:FGEN:GEN1:LEVel x	0 to 255	Sets Generator Attenuator setting in DAC steps.
:FGEN:GEN1:LEVel?	0 to 255	Returns Attenuator level.
:FGEN:GEN2:STATe x	0 = off, 1 = on	Turns AF GENERator 2 to on or off.
:FGEN:GEN2:FREQuency x	0.0 to 40000.0	Sets AF GENERator 2 Frequency in Hz.
:FGEN:GEN2:FREQuency?	0.0 to 40000.0	Returns AF GENERator 1 Frequency in Hz.
:FGEN:GEN2:MODulation x	AM, FM, PM or OFF	Sets Modulation type.
:FGEN:GEN2:MODulation?	AM, FM, PM or OFF	Returns Modulation type.
:FGEN:GEN2:MODL x	0 to 100 for AM 0.0 to 100.0 for FM 0.0 to 10.0 for PM	Sets Modulation level. AM in %, FM in kHz, PM in radians.
:FGEN:GEN2:MODL?	0 to 100 for AM 0.0 to 100.0 for FM 0.0 to 10.0 for PM	Returns Modulation level. AM in %, FM in kHz, PM in radians.
:FGEN:GEN2:SHAPE:SIN	SIN, SQU, RAMP or TRI	Selects Wave Shape.
:FGEN:GEN2:SHAPE:PULse:DCYCLe 50		Selects Pulse Shape with 50% Duty Cycle.
:FGEN:GEN2:SHAPE:DC x	1, 0, -1	Sets DC Level to -1, 0 or 1.
:FGEN:GEN2:LEVel x	0 to 255	Sets Generator Attenuator setting in DAC steps.
:FGEN:GEN2:LEVel?	0 to 255	Returns Attenuator level.
:FGEN:GEN3:MODulation x	AM, FM, PM or OFF	Sets Modulation type.
:FGEN:GEN3:MODulation?	AM, FM, PM or OFF	Returns Modulation type.
:FGEN:GEN3:MODL x	0 to 100 for AM 0.0 to 100.0 for FM 0.0 to 10.0 for PM	Sets Modulation level. AM in %, FM in kHz, PM in radians.
:FGEN:GEN3:MODL?	0 to 100 for AM 0.0 to 100.0 for FM 0.0 to 10.0 for PM	Returns Modulation level. AM in %, FM in kHz, PM in radians.
:FGEN:DATA:STATe x	0 = off, 1 = on	Sets Digital Data Generator to on or off.

Table 6-3 FM/AM-1600S Specific Commands (cont)

COMMAND	RANGE/VALUE	DESCRIPTION
:FGEN:DATA:MODulation x	AM, FM, PM or OFF	Selects Modulation type.
:FGEN:DATA:MODulation?	AM, FM, PM or OFF	Returns Modulation type.
:FGEN:DATA:MODL x	0 to 100 for AM 0.0 to 100.0 for FM 0.0 to 10.0 for PM	Sets Modulation level. AM in %, FM in kHz, PM in radians.
:FGEN:DATA:MODL?	0 to 100 for AM 0.0 to 100.0 for FM 0.0 to 10.0 for PM	Returns Modulation level. AM in %, FM in kHz, PM in radians.
:FGEN:DATA:PATtern:FIX		Selects Data Type - Fixed Pattern.
:FGEN:DATA:PATtern:RND x		Selects Data Type - Pseudo-Random Pattern.
:FGEN:DATA:PATtern:USR x		Selects Data Type - User Enter Pattern.
:FGEN:DATA:SIZE x	100 to 100,000	Selects Data block size in bits.
:FGEN:DATA:SIZE?	100 to 100,000	Returns Block size setting.
:FGEN:DATA:RATE x	75, 150, 300, 600, 1200, 1600, 2400, 4800, 16000	Sets Rate in bps.
:FGEN:DATA:TTL		Sets Data Level (0 to 5 V).
:FGEN:DATA:BILVL		Sets Data Level (± 5 V).
:FGEN:DATA:FILTer x	IN/OUTput	Sets Data Filter IN/OUTput.
:FGEN:EXT:STATe x	0 = off, 1 = on	Turns External Mod to on or off.
:FGEN:EXT:MODulation x	AM, FM, PM, OFF	Sets Modulation type.
:FGEN:EXT:MODulation?	AM, FM, PM, OFF	Returns Modulation type.
:FGEN:EXT:MODL x		Sets External Attenuation.
:FGEN:EXT:MODL?		Returns External Attenuation.
:FGEN:EXT:LEVel x	0 to 255	Sets Generate Attenuator setting in DAC steps.
:FGEN:EXT:LEVel?	0 to 255	Returns Attenuator setting.
:FGEN:MIC:STATe x	0 = off, 1 = on	Turns MIC/ACC to on or off.
:FGEN:MIC:MODulation x	AM, FM, PM, OFF	Sets Modulation type.

Table 6-3 FM/AM-1600S Specific Commands (cont)

COMMAND	RANGE/VALUE	DESCRIPTION
:FGEN:MIC:MODulation?	AM, FM, PM, OFF	Returns Modulation type.
:FGEN:MIC:MODL x		Sets MIC Attenuator.
:FGEN:MIC:MODL?		Returns MIC Attenuator.
:FGEN:MIC:LEVel x	0 to 255	Sets Generate Attenuator setting in DAC steps.
:FGEN:MIC:LEVel?	0 to 255	Returns Attenuator setting.
:FGEN:OUTput:LEVel x	0 to 3.276	Sets Audio output level in Volts.
:FGEN:OUTput:LEVel?	0 to 3.276	Returns Audio output level.
:FGEN:OUTput:SPEAKer x	0 = off, 1 = on	Sets Speaker output to on or off.
:FGEN:OUTput:SPEAKer?	0 = off, 1 = on	Returns whether Speaker is enabled.
:FGEN:OUTput:DEMod x	0 = off, 1 = on	Sets Demod output to on or off.
:FGEN:OUTput:DEMod?	0 = off, 1 = on	Returns value of Demod output enable.
:FGEN:OUTput:AUDio x	0 = off, 1 = on	Sets Audio output to on or off.
:FGEN:OUTput:AUDio?	0 = off, 1 = on	Returns value of Audio output enable.
:FGEN:PROPortional x	0 = off, 1 = on	Sets Proportional output enable.
:FGEN:PROPortional?	0 = off, 1 = on	Returns value of proportional state.
:FGEN:STORe x	1 to 9	Stores screen parameters.
:FGEN:RCL x	1 to 9	Recalls screen parameters.
:FGEN:FSK x	0 = off, 1 = on	Selects GEN1 and GEN2 as the two tones for a FSK implementation. GEN1 is the designated true tone and GEN2 is the designated false tone. Frequency and level of each must be independently set.

Table 6-3 FM/AM-1600S Specific Commands (cont)

COMMAND	RANGE/VALUE	DESCRIPTION
GENERIC MEASUREMENT COMMANDS		
MEASure:VOLTage:DC?		Returns DMM DC voltage reading.
MEASure:VOLTage:AC?		Returns DMM AC voltage reading.
MEASure:VOLTage:SUPply? x	-15,5,15	Returns Supply voltage specified.
MEASure:CURRent:DC?		Returns DMM DC current reading.
MEASure:CURRent:AC?		Return DMM AC current reading.
MEASure:RESistance?		Returns DMM resistance reading.
MEASure:POWer?		Returns Power Meter reading.
MEASure:AUDio?		Returns AF Meter demodulated audio freq. reading.
MEASure:FREQuency?		Returns RF Meter reading.
MEASure:PHASe?		Returns Phase Meter reading in radians.
MEASure:TEMPerature:AMBient?		Returns ambient temperature in °C.
MEASure:TEMPerature:POWer?		Returns Power Term temperature in °C.
MEASure:SQUelch?		Returns 1 if squelch broken, 0 otherwise.
MEASure:MIC?		Returns 1 if receiving MIC/ACC Input, 0 otherwise.
MISCELLANEOUS COMMANDS		
:DELAY x		Delays strobe in seconds.
:PAD x	0, 20, 40	Sets Attenuator pads.
:PWR_PAD:STATe x	0 = off, 1 = on	Sets Power Pad on or off.

Table 6-3 FM/AM-1600S Specific Commands (cont)

COMMAND	RANGE/VALUE	DESCRIPTION
:PTT:STATe x	0 = off, 1 = on	Sets the Push to talk pin on MIC/ACC Connector.
:SCREEN:RECeive		Renews Receiver Screen.
:SCREEN:GENerator		Renews Gen Screen.
:SCREEN:DUPlax		Renews Duplex Screen.
:SCREEN:SCOPE		Renews Scope Screen.
:SCREEN:ANLZ		Renews Analyzer Screen.
:SCREEN:AF		Renews AF Counter Screen.
:SCREEN:FREQUency		Renews Freq Meter Screen.
:SCREEN:POWEr		Renews Power Meter Screen.
:SCREEN:DEV		Renews Deviation Screen.
:SCREEN:MODulation		Renews Mod Meter Screen.
:SCREEN:DIS TORTion		Renews Distortion Screen.
:SCREEN:SINAD		Renews SINAD Meter Screen.
:SCREEN:SIG		Renews Signal Strength Screen.
:SCREEN:DMM		Renews DMM Screen.
:SCREEN:FUNC		Renews Function Generator Screen.
:SCREEN:BER		Renews BER Meter Screen.
:SCREEN:USER		Renews Blank Screen for user.
:SETUP:RECeive		Configures hardware for Receiver routing.
:SETUP:GENerator		Configures hardware for Generator routing.
:SETUP:DUPlax		Configures hardware for Duplex routing.
:SETUP:SCOPE		Configures hardware for Scope routing.

Table 6-3 FM/AM-1600S Specific Commands (cont)

COMMAND	RANGE/VALUE	DESCRIPTION
:SETUP:ANLZ		Configures hardware for Analyzer screen routing.
:SETUP:FUNC		Configures hardware for AF GENerator screen routing.
:SETUP:DUPTX		Configures hardware for Duplex - TX routing.
:SETUP:DUPRX		Configures hardware for Duplex - RX routing.
:FLUSH		Flush query data to remote.

Table 6-3 FM/AM-1600S Specific Commands (cont)

SECTION 7 - OPTIONS

7-1 CELLULAR OPTION

7-1-1 CELLULAR OPERATION SCREENS AND MENU CONFIGURATIONS

The Cellular Monitor Screen is accessed from the Receiver Menu. If the Cellular Option is installed, "Cellr" Soft Function Key F3 appears on the Receiver Menu. Pressing "Cellr" Soft Function Key F3 displays the Cellular Monitor Screen on the CRT. The Voice Channel Screen, Mobile Voice Channel Screen and Cellular Menu are accessed from the Cellular Monitor Screen.

A. CELLULAR MONITOR SCREEN

Press "Cellr" Soft Function Key F3 to access the Cellular Monitor Screen. Use the index of screen features to identify the parameters that are edited and the value range available with each feature and/or usage.

ITEM	DESCRIPTION
------	-------------

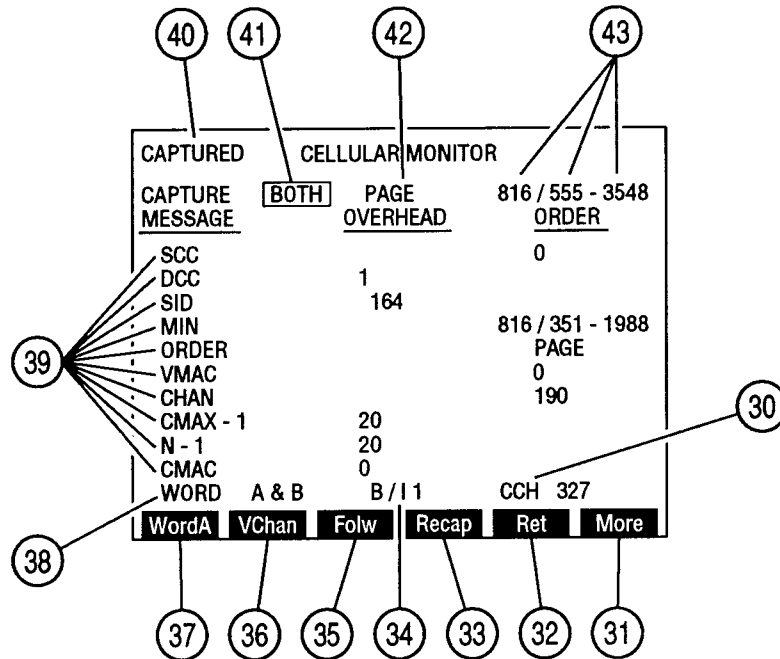

8610126

30. CCH

Selects Control Channel. Range is from 1 to 1023. Channels 313 to 354 are usually Control Channels. Channels 313 to 333 are System A channels and channels 334 to 354 are System B channels.

31. "More" Soft Function Key F6

"ESC" appears while parameters are accessed for editing. Allows edit procedure to be canceled without changing parameter. "More" displays additional sets of Soft Function Keys.

ITEM	DESCRIPTION
32. <u>"Ret" Soft Function Key F5</u>	Returns operation to the Receiver Operation Screen.
33. <u>"Recap" Soft Function Key F4</u>	Appears when Capture is on. Restarts Capture Function. The CAPTURED Indicator (40) disappears until a Capture reoccurs.
34. <u>B/I</u>	Displays the Busy/Idle Bit status: 0 for Busy, 1 for Idle. Not an editable parameter.
35. <u>"Folw" Soft Function Key F3</u>	Activates the Follow Function. When a Voice Channel is assigned, the Follow Function displays the Voice Channel Screen on the CRT and monitors the assigned channel. If a Handoff occurs, the Voice Channel Screen monitors the new Voice Channel. If the call is dropped, Follow returns the Cellular Monitor Screen to the CRT and monitors the selected CCH (Control Channel) (30) for the next Voice Channel assignment.
36. <u>"VChan" Soft Function Key F2</u>	Displays Voice Channel Screen.
37. <u>"Word" Soft Function Key F1</u>	Selects Word A, Word B or Word A & B (38). Soft Function Key F1 definition displays the next choice.
38. <u>WORD</u>	Displays current Word choice.
39. <u>MESSAGE Listing</u>	Ten messages can be monitored at one time and are selected from Cellular Setup Menu.
40. <u>CAPTURED Indicator</u>	Red CAPTURED Indicator is displayed when a Capture occurs and continues to show until "Recap" Soft Function Key F4 is pressed or until another screen is chosen.
41. <u>CAPTURE Data Field</u>	Select OFF, ORDER, MIN or BOTH. Capture freezes the data displayed on the Cellular Monitor and Voice Channel Screen when a specified ORDER or MIN Number is received. Selecting BOTH requires the Order and MIN Number to be received before a Capture takes place.

ITEM	DESCRIPTION
------	-------------

NOTE: When BOTH is chosen as the Capture Field, and VC DES is the ORDER, a Capture displays the Voice Channel Screen on the CRT.

42. ORDER

Selects Order to Capture on:

- | | |
|--------------------------------|------------------------------------|
| PAGE | MAINTNC (Maintenance) |
| ALERT | PWR LVL (Change Power Level) |
| RELEASE | DIR RTRY (Directed Retry) |
| REORDER | AUT REG (Autonomous Registration) |
| S ALERT (Stop Alert) | A INTCP (Abbreviated Intercept) |
| AUDIT | A REORD (Abbreviated Reorder) |
| SND ADDR (Send Called-Address) | A ALERT (Abbreviated Alert) |
| INTRCPT (Intercept) | VC DES (Voice Channel Designation) |

43. MIN Number

Selects MIN Number to Capture. Editable in three separate data fields.

Press "More" Soft Function Key F6 for the next set of Soft Function Keys.

ITEM	DESCRIPTION
------	-------------

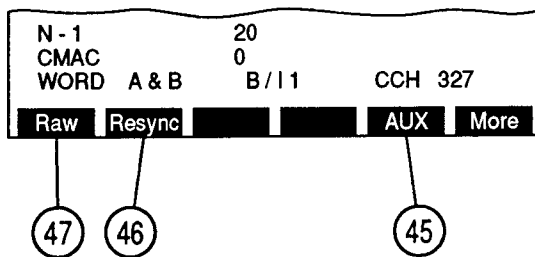

8607114

45. "AUX" Soft Function Key F5

Displays the Auxiliary Functions Menu.

46. "Resync" Soft Function Key F2

Accesses a new set of Control Channel Data when the Raw Data Monitor is displayed,

47. "Raw" Soft Function Key F1

Displays the Raw Data Monitor over the Cellular Monitor Screen. Pressing "Raw" Soft Function Key F1 again removes the Raw Data Monitor.

NOTE: Raw Data Monitor is not fully functional at this time.

B. CELLULAR SETUP MENU

When the Cellular Monitor Screen is displayed on the CRT, press the SETUP Key to access the Cellular Setup Menu. The Cellular Setup Menu is divided into 2 screens, Pages 1 and 2. When the Cellular Setup Menu is accessed, Page 1 appears on the CRT. Page 2 is accessed by pressing "Page 2" Soft Function Key F2. Soft Function Key F1 becomes "Page 1" and pressing this key accesses Page 1 of the Cellular Setup Menu. Up to 10 of the possible 40 Messages can be chosen to be displayed on the Cellular Monitor Screen at one time. Following is the list of Messages and descriptions:

ITEM DESCRIPTION

CELLULAR SETUP					
USE 0-9 TO MAKE YOUR SELECTIONS					
SCC	0	END	X	OLC	X
DCC	1	WFOM	X	BIS	X
SID	2	ACT	X	REGINCR	X
MIN	3	NAWC	X	CHANPOS1	X
ORDER	4	S	X	CHANPOS2	X
VMAC	5	E	X	NEWACC	X
CHAN	6	REGH	X	MBUSY - PGR	X
CMAx - 1	7	REGR	X	MSZTR - PGR	X
N - 1	8	DTX	X	MBUSY - OTH	X
CMAC	9	RCF	X	MSZTR - OTH	X
REGID	X	CPA	X	LOC CONTRL	X

Page 2 Ret AUX

8610180

1. SCC

SCC (Supervisory Audio Tone Color Code) indicates SAT frequency the mobile station is receiving. SCC is displayed in the ORDER Column.

SCC	SAT FREQ (Hz)
00	5970
01	5970
10	6030
11	-

2. DCC

DCC (Digital Color Code) is displayed in the OVERHEAD Column.

3. SID

SID (System Identification Number) is displayed in the OVERHEAD Column.

4. MIN

MIN (Mobile Identification Number) is displayed in the ORDER Column.

5. ORDER

Order Type is displayed in the ORDER Column.

ITEM	DESCRIPTION
6. <u>VMAC</u>	VMAC (Voice Mobile Attenuation Code) sets initial Mobile Station power level when assigning Mobile Station to a channel. VMAC is displayed in the ORDER Column.
7. <u>CHAN (Voice Channel)</u>	Displays the designated Voice Channel in the ORDER Column.
8. <u>CMAx-1</u>	CMAx is the number of Channels to be scanned by Mobile Station when accessing a system. CMAx-1 is displayed in the OVERHEAD Column.
9. <u>N-1</u>	N is the number of Paging Channels to be scanned by the Mobile Equipment and is displayed in the OVERHEAD Column.
10. <u>CMAC</u>	CMAC (Control Mobile Attenuation Code) specifies maximum power level allowed for Mobile Station transmitting on Reverse Control Channel. CMAC is displayed in the OVERHEAD Column.
11. <u>REGID</u>	REGID (Registration Identification) is the last registration number received on Forward Control Channel and is displayed in the OVERHEAD Column.
12. <u>END</u>	End Indication Bit is set to 1 in the last word of the Overhead Message; 0 otherwise. End Indication bit is displayed in the OVERHEAD Column.
13. <u>WFOM</u>	WFOM (Wait For Overhead Message) bit is 1 if Mobile Station must wait for Overhead Message; 0 otherwise. WFOM is displayed in the OVERHEAD Column.
14. <u>ACT</u>	ACT (Global Action) value is displayed in the OVERHEAD Column.
15. <u>NAWC</u>	NAWC (Number of Additional Words Coming) is displayed in the OVERHEAD Column.
16. <u>S</u>	S (Serial Number) bit is 1 if Mobile Station must send its Serial Number to access the system; 0 otherwise. S is displayed in the OVERHEAD Column.

ITEM	DESCRIPTION
------	-------------

17. E

E (Extended Address) bit is 1 if Mobile Station must send Min1 and Min2; 0 if Mobile Station needs to send Min1. E is displayed in the OVERHEAD Column.

18. REGH

REGH (Registration for Home Mobile Stations) is set to 1 to allow registration of Home Mobile Stations; 0 otherwise. REGH is displayed in the OVERHEAD Column.

19. REGR

REGR (Registration for Roaming Mobile Stations) is set to 1 to allow registration of Roaming Mobile Stations; 0 otherwise. REGR is displayed in the OVERHEAD Column.

20. DTX

DTX (Discontinuous Transmission) Bits are displayed in the OVERHEAD Column.

DTX BITS	DEFINITION
10	Low level ≥ 8 dB below high level
11	No minimum for low level
00	DTX not allowed
01	-

21. RCF

RCF (Read Control-Filler) bit is 1 if Mobile Station must read Control-Filler Message before accessing system; 0 otherwise. RCF is displayed in the OVERHEAD Column.

22. CPA

CPA (Combined Paging/Access) bit is 1 if access functions and paging functions are on the same set of Control Channels. CPA is displayed in the OVERHEAD Column.

23. OLC

OLC (Overload Control Class) is displayed in the OVERHEAD Column. Mobile Stations are assigned 1 or more of 16 possible control fields. Each 1 represents an allowed field, 0 represents a restricted field.

24. BIS

BIS (Busy-Idle Status) bit is 1 if Mobile Station must check for idle-to-busy transition on Reverse Control Channel when accessing. BIS is displayed in the OVERHEAD Column.

ITEM	DESCRIPTION
25. <u>REGINCR</u>	REGINCR (Registration Increment) bit identifies increments between Mobile Station registrations. REGINCR is displayed in the OVERHEAD Column.
26. <u>CHANPOS1</u>	CHANPOS1 (Channel Position 1) is the channel position of access channel relative to the first access channel (from Word 3 of the Directed Retry Message) and is displayed in the OVERHEAD Column.
27. <u>CHANPOS2</u>	CHANPOS2 (Channel Position 2) is the channel position of access channel relative to the first access channel (from Word 4 of the Directed Retry Message) and is displayed in the OVERHEAD Column.
28. <u>NEWACC</u>	New Access Channel Starting point is displayed in the OVERHEAD Column.
29. <u>MBUSY-PGR</u>	MBUSY-PGR (maximum number of busy occurrences allowed for page responses) is displayed in the OVERHEAD Column.
30. <u>MSZTR-PGR</u>	MSZTR-PGR (maximum number of seizure attempts allowed for page responses) is displayed in the OVERHEAD Column.
31. <u>MBUSY-OTH</u>	MBUSY-OTH (maximum number of busy occurrences allowed for other accesses) is displayed in the OVERHEAD Column.
32. <u>MSZTR-OTH</u>	MSZTR-OTH (maximum number of seizure attempts allowed for other accesses) is displayed in the OVERHEAD Column.
33. <u>LOC CONTRL</u>	Local Control message is used to customize the operation of the Mobile Station. The 5 bit message is displayed in the OVERHEAD Column.

Press "Page 2" Soft Function Key F1 to access Page 2 of the Cellular Setup Menu.

ITEM	DESCRIPTION
------	-------------

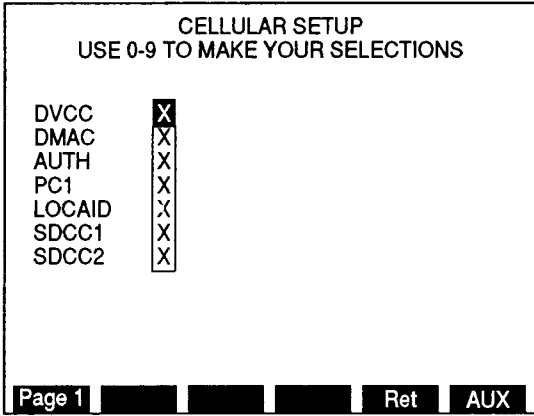

8610179

34. DVCC

DVCC (Digital Verification Color Code) is displayed in the OVERHEAD Column.

35. DMAC

DMAC (Digital Mobile Attenuation Code) sets initial Mobile Station power level when assigning Mobile Station to a channel. DMAC is displayed in the OVERHEAD Column.

36. AUTH

Authentication bit is set to 1 if processing of initiated call is allowed. Authentication bit is displayed in the OVERHEAD Column.

37. PCI

PCI (Protocol Capability Indicator) is set to 1 if Base Station is capable of digital operation. PCI is displayed in the OVERHEAD Column.

38. LOCAID

LOCAID (Location Area Identifier) is used to identify changes in location area. LOCAID is displayed in the OVERHEAD Column.

39. SDCC1

SDCC1 (Supplementary Digital Color Code 1) is 2 additional bits supplementing the DCC. SDCC1 and SDCC2 together increase the number of color codes from 4 to 64. SDCC1 is displayed in the OVERHEAD Column.

40. SDCC2

SDCC2 (Supplementary Digital Color Code 2) is 2 additional bits supplementing the DCC. SDCC1 and SDCC2 together increase the number of color codes from 4 to 64. SDCC2 is displayed in the OVERHEAD Column.

C. VOICE CHANNEL SCREEN

Pressing "VChan" Soft Function Key F2 when in the Cellular Monitor Screen displays the (Forward) Voice Channel Screen on the CRT. By pressing "MChan" Soft Function Key F2, the Voice Channel Screen becomes the Mobile (Reverse) Voice Channel Screen and Soft Function Key F2 Definition becomes "CChan".

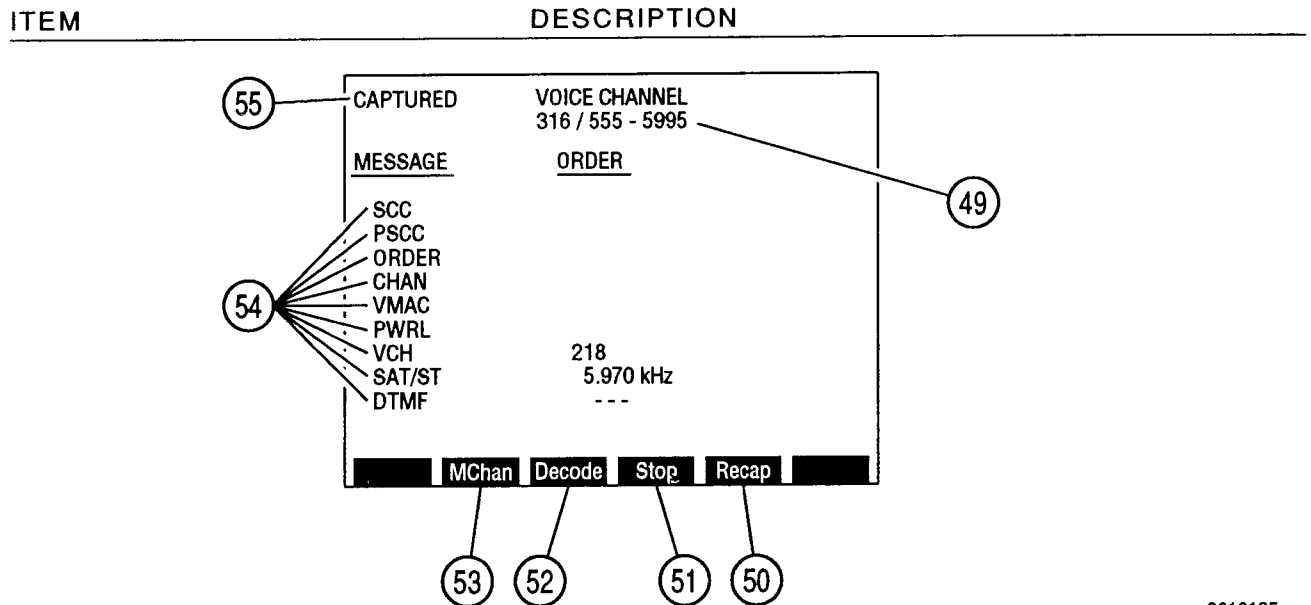

8610125

49. Mobile Identification Number

Displays Mobile Identification Number of Mobile Unit as decoded from the Voice Designation Order.

50. "Recap" Soft Function Key F5

Restarts Capture Function and unfreezes Voice Channel Screen.

51. "Stop" Soft Function Key F4

Appears when Decode is active. Stops Decode Function.

52. "Decode" Soft Function Key F3

Starts DTMF Decoding Function. Appears in red when active and continues until "Stop" Soft Function Key is pressed.

53. "MChan"/"CChan" Soft Function Key F2

When (Forward) Voice Channel Screen is displayed, "MChan" accesses the Mobile (Reverse) Voice Channel Screen. When Mobile (Reverse) Voice Channel Screen is displayed, "CChan" (Control Channel) accesses the Cellular Monitor Screen.

ITEM**DESCRIPTION**

54. Voice Channel Messages**● SCC**

SCC (Supervisory Audio Tone Color Code) indicates SAT frequency the mobile station is receiving.

SCC	SAT FREQ (Hz)
00	5970
01	5970
10	6030
11	-

● PSCC

PSCC (Present SAT Color Code) displays Color Code for the present Voice Channel.

● ORDER

Displays specified ORDER.

● CHAN

Displays new Voice Channel designated for Handcuff.

● VMAC

VMAC (Voice Mobile Attenuation Code) sets initial Mobile Station power level when assigning Mobile Station to a channel.

● PWRL

PWRL (Power Level of Change Power Order) displays Power Level of the Change Power Order.

● VCH

VCH displays current Voice Channel.

● SAT/ST

Displays SAT Frequency.

● DTMF

The decoded DTMF is displayed 16 digits at a time.

55. CAPTURED

Red CAPTURED Indicator is displayed when a Capture occurs.

7-1-2 CELLULAR OPERATION

The Receiver must be configured for Cellular Operation. When editing, use the FIELD SELECT Keys (1) to move the cursor to the parameter to be edited and press ENTER Key to access the data field. Use the DATA ENTRY Keypad (29) to enter data. Use the DATA SCROLL Spinner (2) or DATA SCROLL Keys (3) to select parameters from a list.

A. RECEIVER SETUP FOR CELLULAR OPERATION

STEP	PROCEDURE
------	-----------

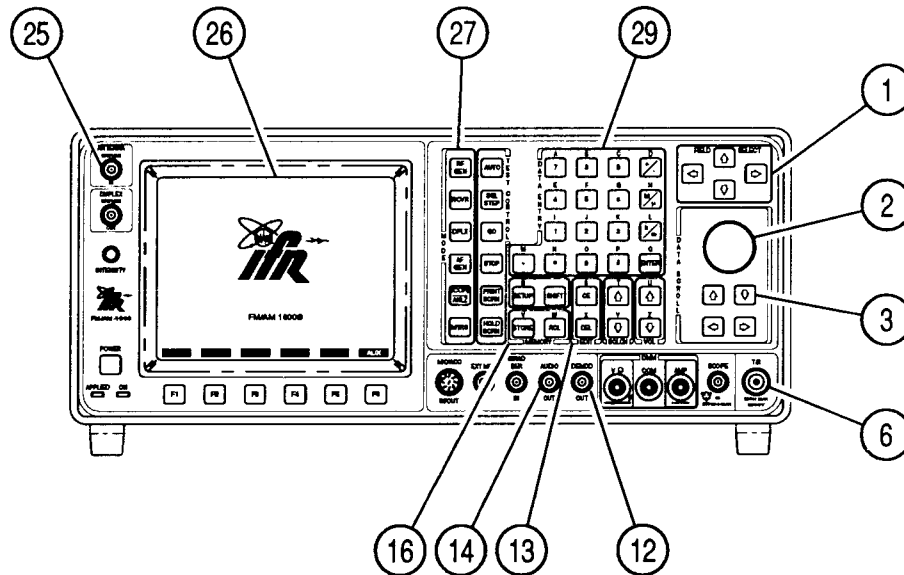

8607100

1. Install Antenna to ANTENNA IN Connector (25) for "off the air" reception. For signals greater than -30 dB (Signal Strength Meter reading greater than 100), route Cellular input through T/R Connector (6).

CAUTION: MAXIMUM CONTINUOUS INPUT TO THE ANTENNA IN CONNECTOR (25) IS LIMITED TO 10 mW WITH PROTECTION PROVIDED TO A MAXIMUM INPUT OF 65 W.

MAXIMUM CONTINUOUS INPUT TO THE T/R CONNECTOR (6) IS LIMITED TO 50 W WITH PROTECTION PROVIDED TO A MAXIMUM INPUT OF 200 W.

2. Press RCVR MODE Key (27) and SETUP Key to access Receiver Menu. Press 2 DATA ENTRY Key (29) to access Receiver Select Modulation Menu:

RECEIVER SELECT MODULATION MENU

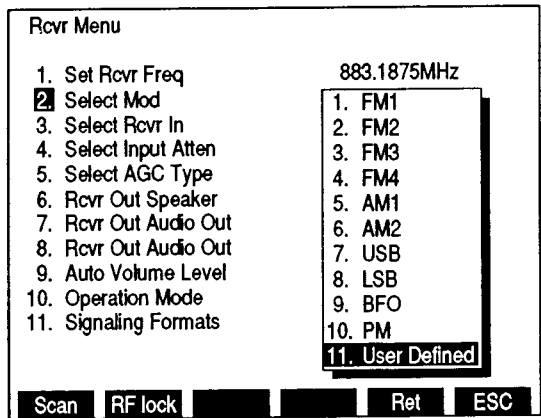

8610115

- Use FIELD SELECT Keys (1) to move cursor to "11. User Defined" and press ENTER. User Defined Menu appears on CRT:

RECEIVER USER DEFINED MENU

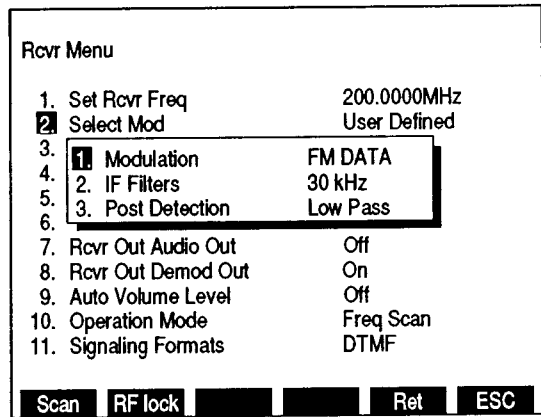

8610132

- Press 1 DATA ENTRY Key (29) to access User Defined Modulation Menu. Press 7 DATA ENTRY Key (29) to select "FM DATA":

RECEIVER USER DEFINED MODULATION MENU

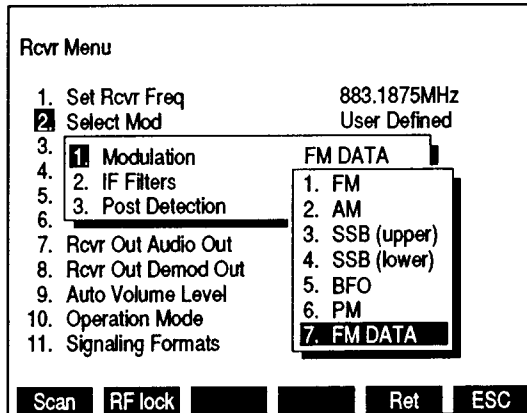

8610130

- Press 2 DATA ENTRY Key (29) to access User Defined IF Filter Menu. Press 2 DATA ENTRY Key (29) to select "30 kHz":

RECEIVER USER DEFINED IF FILTER MENU

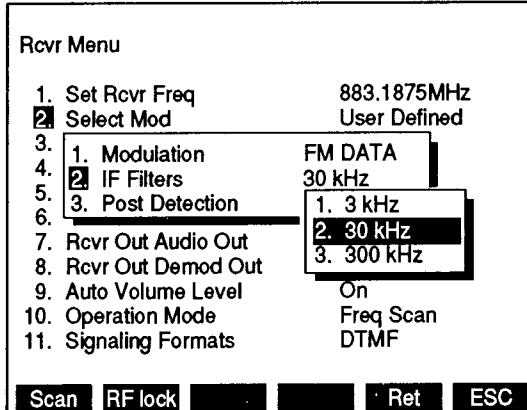

8610111

- Press 3 DATA ENTRY Key (29) to access User Defined Post Detection Menu. Press 2 DATA ENTRY Key (29) to select "Low Pass":

RECEIVER USER DEFINED
POST DETECTION MENU

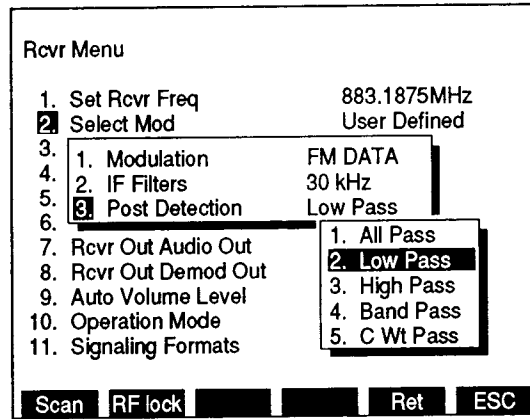

8610129

- Low Pass data field appears. Press 1 and 5 DATA ENTRY Keys (29) to set cutoff frequency to 15.000 kHz and press ENTER. Press "ESC" Soft Function Key F6 to remove User Defined Menu.
- Press 3 DATA ENTRY Key (29) and ENTER Key to select either "Antenna" (for receiving Cellular input through ANTENNA IN Connector [25]) or "T/R" (for receiving Cellular input through T/R Connector [6]).
- Press 5 DATA ENTRY Key (29) to access Receiver AGC Menu. Press 1 DATA ENTRY Key (29) to access AGC User Defined Menu. Press 4 DATA ENTRY Key (29) to select "High Speed":

RECEIVER AGC USER
DEFINED MENU

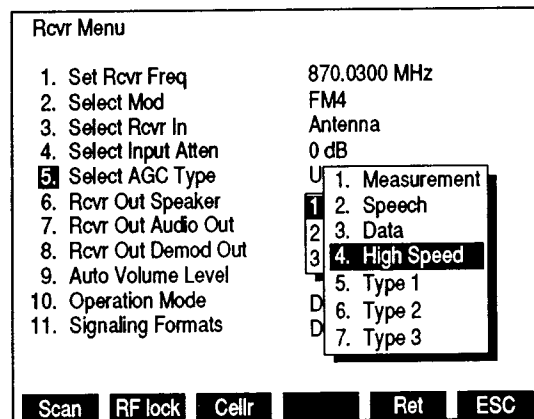

8610128

- To route demodulated signal to Test Set Speaker, press 6 DATA ENTRY Key (29) until "On" is selected for "6. Rcvr Out Speaker".

STEP**PROCEDURE**

11. To route demodulated signal to AUDIO OUT Connector (14), press 7 DATA ENTRY Key (29) until "On" is selected for "7. Rcvr Out Audio Out".
NOTE: The Bandwidth for AUDIO OUT Connector (14) is limited by Low Pass Filter setting in step 7.
12. To route demodulated signal to DEMOD OUT Connector (12), press 8 DATA ENTRY Key (29) until "On" is selected for "8. Rcvr Out Demod Out".
NOTE: The SAT and Overhead Data is filtered out by C Weighted Filter installed with DEMOD OUT Connector (12).
13. Previous Receiver parameter settings can be stored using Store Parameters Menu, see 4-1-1.
14. Press MTRS MODE Key (27) to access METER Menu. Press 4 DATA ENTRY Key (29) to access Deviation Meter Operation Screen. Press "Range" Soft Function Key F1, use DATA SCROLL Keys (3) to select 10 kHz and press ENTER Key. Press "Ret" Soft Function Key F6 to return to Receiver Operation Screen.
15. Press SETUP Key for Receiver Menu to appear on CRT. Press "Cellr" Soft Function Key F3 to access Cellular Monitor Screen.

B. CELLULAR MONITOR SCREEN OPERATION

STEP PROCEDURE

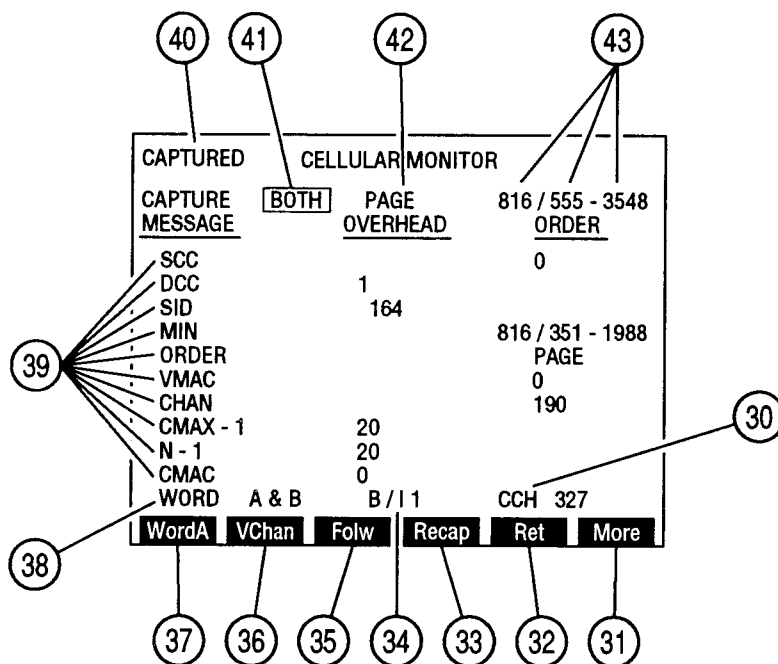

8610126

1. Use FIELD SELECT Keys (1) to move cursor to CCH (Control Channel) (30) and press ENTER Key. Use DATA ENTRY Keypad (29) to select a Control Channel and press ENTER Key. Range is from 1 to 1023.

NOTE: Channels 313 to 354 are usually Control Channels. Channels 313 to 333 are System A channels and channels 334 to 354 are System B channels.

2. If desired, use FIELD SELECT Keys (1) to move cursor to Capture Condition (41) and press ENTER Key. Use DATA SCROLL Keys (3) to select a Capture Condition and press ENTER Key.
 - If ORDER or BOTH is selected for Capture Condition (41), use FIELD SELECT Keys (1) to move cursor to ORDER (42) and press ENTER Key. Use DATA SCROLL Keys (3) to select an ORDER and press ENTER Key.
 - If MIN or BOTH is selected for Capture Condition (41), use FIELD SELECT Keys (1) to move cursor to each part of MIN Number (43) and press ENTER Key. Use DATA ENTRY Keypad (29) to enter a MIN Number one part at a time.
3. To reset a captured screen, press "Recap" Soft Function Key F4 (33).
4. If "Raw" is displayed for Soft Function Key F1, press "More" Soft Function Key F6 (31). Press Soft Function Key F1 (37) until WORD (38) displays desired setting.
5. Press "Folw" Soft Function Key F3 (35) to activate Follow Function. Press "Folw" Soft Function Key F3 (35) again to turn Follow off.

6. Press SETUP Key to access Cellular Menu:

CELLULAR SETUP					
USE 0-9 TO MAKE YOUR SELECTIONS					
SCC	0	END	X	OLC	X
DCC	1	WFOM	X	BIS	X
SID	2	ACT	X	REGINCR	X
MIN	3	NAWC	X	CHANPOS1	X
ORDER	4	S	X	CHANPOS2	X
VMAC	5	E	X	NEWACC	X
CHAN	6	REGH	X	MBUSY - PGR	X
CMAX - 1	7	REGR	X	MSZTR - PGR	X
N - 1	8	DTX	X	MBUSY - OTH	X
CMAC	9	RCF	X	MSZTR - OTH	X
REGID	X	CPA	X	LOC CONTRL	X

Page 2 Ret AUX

8610180

7. To access Page 2 of Cellular Setup Menu, press "Page 2" Soft Function Key F1. Soft Function Key F1 becomes "Page 1". To return to Page 1 of Cellular Setup Menu, press "Page 1" Soft Function Key F1.

CELLULAR SETUP	
USE 0-9 TO MAKE YOUR SELECTIONS	
DVCC	X
DMAC	X
AUTH	X
PC1	X
LOCAID	X
SDCC1	X
SDCC2	X

Page 1 Ret AUX

8610179

8. Use FIELD SELECT Keys (1) to move cursor to right of Messages to be monitored on Cellular Monitor Screen. Select a Message by pressing a numeric DATA ENTRY Key (29). Number chosen determines order displayed (0 first, 9 last).
9. To remove a Message from being selected, move cursor to right of Message and press any nonnumeric DATA ENTRY Key (29). Selecting two Messages with same digit voids selection of first Message. After desired Messages have been selected, press "Ret" Soft Function Key F5 to return to Cellular Monitor Screen.
10. To access RAW DATA Monitor, press "More" Soft Function Key F6 until "Raw" is displayed for Soft Function Key F1. Press "Raw" Soft Function Key F1 and RAW DATA Monitor appears over Cellular Monitor Screen.

NOTE: Raw Data Monitor is not fully functional at this time.

11. To view another set of raw data, press "Resync" Soft Function Key F2. To remove RAW DATA Monitor, press "Raw" Soft Function Key F1.

C. VOICE CHANNEL AND MOBILE VOICE CHANNEL SCREEN OPERATION

Press "VChan" Soft Function Key F2 to access (Forward) Voice Channel Screen. Press "MChan" Soft Function Key F2 to access Mobile (Reverse) Voice Channel Screen. Operation is the same for both Screens.

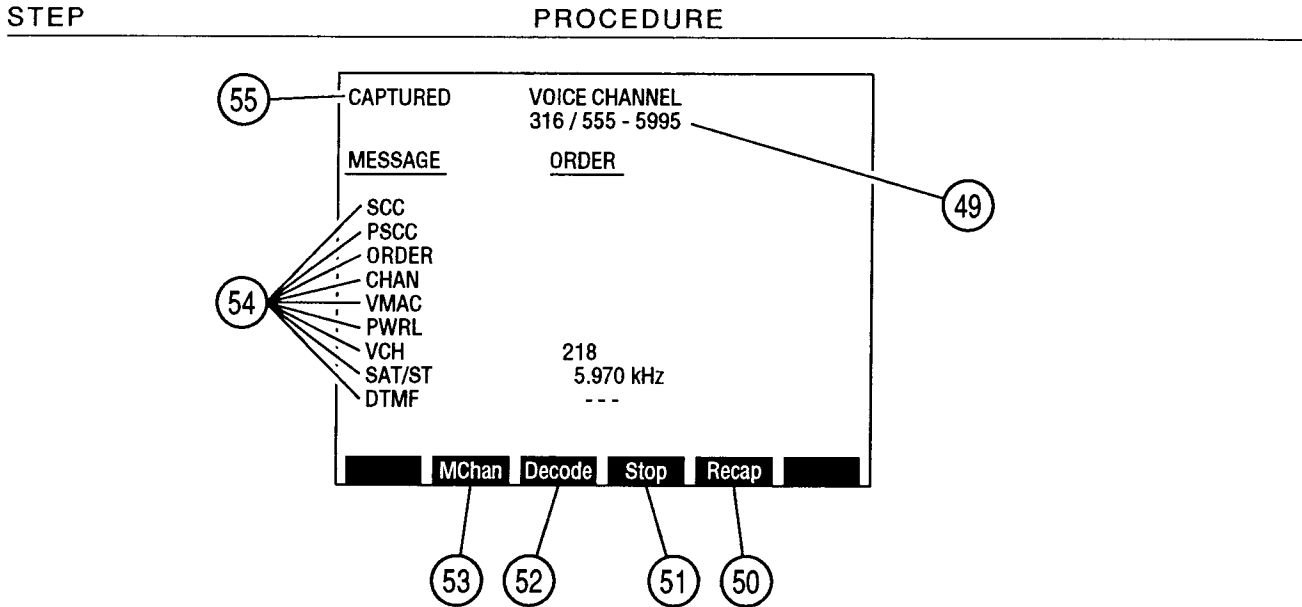

8610125

1. To restart a Capture, press "Recap" Soft Function Key F5 (50). Capture Function can only be initiated from Cellular Monitor Screen.
2. To decode DTMF, press "Decode" Soft Function Key F3 (52). Press "Stop" Soft Function Key F4 (51) to stop decoding.
3. To access Mobile (Reverse) Voice Channel Screen while in (Forward) Voice Channel Screen, press "MChan" Soft Function Key F2 (53).
4. When in Mobile (Reverse) Voice Channel Screen, Soft Function Key F2 definition becomes "CChan" (Control Channel). Pressing F2 returns operation to Cellular Monitor Screen.

7-1-3 CELLULAR REMOTE OPERATION

The Cellular Option can be remotely operated similar to other Operation Modes of the FM/AM-1600S. To perform the setup for Remote Operation, see Section 6. The Cellular TMAC Commands are listed in Table 7-1.

The Cellular Monitor Screen must be displayed when executing most of the Cellular commands. A command for displaying the Cellular Monitor Screen, :SCREEN:CELL, is included in the table of commands. Most of the Cellular Commands are time dependent and holds the last decoded information. Once the command has been read, the information may not be available until decoded from another stream sequence. Recording the readings prevents the loss of information.

Table 7-1 lists the Cellular Remote Operation Commands. The Commands short (abbreviated) form is shown in upper case while the remainder of the long form is shown in lower case. These commands are complete except where the user must determine a parameter shown by x. The parameter value or value range is listed where applicable.

COMMAND	RANGE/VALUE	DESCRIPTION
:SCREEN:CELL		Displays Cellular Screen.
:CELL:WORDA		Selects decoding of stream A words.
:CELL:WORDB		Selects decoding of stream B words.
:CELL:BOTH		Selects decoding of both stream A and B words.
:CELL:WORD?		Requests word selection.
:CELL:CHANnel x	1 to 1023	Selects a cellular frequency by channel number.
:CELL:CHANnel?		Requests currently selected cellular number.
:CELL:DCC?		Returns latest DCC value or -1 if not available.
:CELL:SCC?		Returns latest SCC value or -1 if not available.
:CELL:SID?		Returns latest SID value or -1 if not available.
:CELL:MIN?		Returns latest MIN value or -1 if not available. Returning format is: AAA/DDD-DDDD.
:CELL:VMAC?		Returns latest VMAC value or -1 if not available.
:CELL:VCHAN?		Returns latest VCHAN value or -1 if not available.
:CELL:CMAx_1?		Returns latest CMAx value or -1 if not available.
:CELL:N_1?		Returns latest N-1 value or -1 if not available.

Table 7-1 FM/AM-1600S Specific Cellular Commands

COMMAND	RANGE/VALUE	DESCRIPTION
:CELL:CMAC?		Returns latest CMAC value or -1 if not available.
:CELL:END?		Returns latest END value or -1 if not available.
:CELL:WFOM?		Returns latest WFOM value or -1 if not available.
:CELL:ACTion?		Returns latest ACT value or -1 if not available.
:CELL:NAWC?		Returns latest NAWC value or -1 if not available.
:CELL:S?		Returns latest S value or -1 if not available.
:CELL:E?		Returns latest E value or -1 if not available.
:CELL:REGH?		Returns latest REGH value or -1 if not available.
:CELL:REGR?		Returns latest REGR value or -1 if not available.
:CELL:REGID?		Returns latest REGID value or -1 if not available.
:CELL:DTX?		Returns latest DTX value or -1 if not available.
:CELL:RCF?		Returns latest RCF value or -1 if not available.
:CELL:CPA?		Returns latest CPA value or -1 if not available.
:CELL:OLC?		Returns latest OLC value or -1 if not available.
:CELL:BIS?		Returns latest BIS value or -1 if not available.
:CELL:REGINCR?		Returns latest REGINCR value or -1 if not available.
:CELL:CHANPOS1?		Returns first channel position field from directed retry message or -1 if not applicable.
:CELL:CHANPOS2?		Returns second channel position field from directed retry message or -1 if not applicable.
:CELL:CHANPOS3?		Returns third channel position field from directed retry message or -1 if not applicable.
:CELL:CHANPOS4?		Returns fourth channel position field from directed retry message or -1 if not applicable.

Table 7-1 FM/AM-1600S Specific Cellular Commands (cont)

COMMAND	RANGE/VALUE	DESCRIPTION
:CELL:CHANPOS5?		Returns fifth channel position field from directed retry message or -1 if not applicable.
:CELL:CHANPOS6?		Returns sixth channel position field from the directed retry message or -1 if not applicable.
:CELL:NEWACC?		Returns New Access Channel or -1 if not available.
:CELL:MAXbusy:PGR?		Returns Maximum Busy field for page response or -1 if not available.
:CELL:MAXbusy:OTHer?		Returns Maximum Busy field for other accesses or -1 if not available.
:CELL:MAXSztr:PGR?		Returns Maximum Seizure tries for page response or -1 if not available.
:CELL:MAXSztr:OTHer?		Returns Maximum Seizure tries for other accesses or -1 if not available.

Table 7-1 FM/AM-1600S Specific Cellular Commands (cont)

APPENDICES

APPENDIX A - USER I/O CONNECTORS AND PIN-OUT TABLES

A-1 TABLE OF I/O CONNECTORS

CONNECTOR NAME	CONNECTOR TYPE	SIGNAL IN/OUT	SIGNAL TYPE
T/R	"N" TYPE	IN/OUT	RF, 65 W MAX
SCOPE IN	BNC	IN	Analog, 200 Vdc MAX
DMM AMP	Banana Jack	IN	ac/dc, 2 A MAX
DMM COM	Banana Jack	IN	GND
DMM V Ω	Banana Jack	IN	ac/dc, 1 kVdc or 500 VAC MAX
DEMOD OUT	BNC	OUT	Audio
AUDIO OUT	BNC	OUT	Audio
SINAD/BER IN	BNC	IN	Analog - SINAD Digital - BER
EXT MOD IN	BNC	IN	Audio
MIC/ACC	8 Pin DIN	IN/OUT	See Pin-Out (A-2)
DUPLEX OUT	BNC	OUT	RF
ANTENNA IN	BNC	IN	RF, 10 mW MAX
AC LINE IN	AC Power In	IN	90 - 260 VAC Switchable 115/230 V
DC OUT	6 Pin Lumberg	OUT	See Pin-Out (A-3)
SCSI	50 Pin Champ	IN/OUT	See Pin-Out (A-4)
GPIB (IEEE-488)	24 Pin Champ	IN/OUT	See Pin-Out (A-5)
RS-232	9 Pin, D	IN/OUT	See Pin-Out (A-6)
RECEIVER IF	BNC	OUT	>-30 dBm leveled
EXTERNAL VIDEO	9 Pin, D	OUT	Video, EGA Format, IBM Compatible
EXTERNAL REFERENCE	BNC	IN	10 MHz >0dB

Table A-1 Table of I/O Connectors

A-2 PIN-OUT TABLE FOR MIC/ACC CONNECTOR

Pin Number	Signal Name	Signal Type	I/O
1	PTT-Out	TTL	Programmable Out
2	Mic Audio	Audio	In
3	Demod Audio	Audio	Out
4	ACC-2	TTL	Programmable In
5	+15 Vdc	10-15 Vdc, 1 mA	Out
6	ACC-1	TTL	Programmable In
7	Mic Switch	TTL	Programmable In
8	GND		

Table A-2 Pin-Out for MIC/ACC Connector

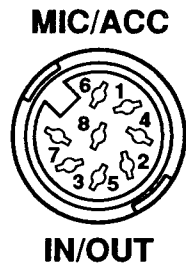

8618013

Figure A-1 MIC/ACC Connector Pin Identification

A-3 PIN-OUT TABLE FOR DC OUT CONNECTOR

Pin Number	Signal Type
1	+5 Vdc, 3 A MAX
2,4,6	GND
3	+15 Vdc, 1.5 A MAX
5	-15 Vdc, 100 mA MAX

Table A-3 Pin-Out for DC OUT Connector

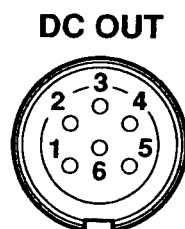

8618014

Figure A-2 DC OUT Connector Pin Identification

A-4 PIN-OUT TABLE FOR SCSI CONNECTOR

Pin Number	Assignment	Pin Number	Assignment
1-25,35-37,39,40,42	Digital GND	38	TERM PWR
26	SD0	41	ATN
27	SD1	43	BSY
28	SD2	44	ACK
29	SD3	45	RST
30	SD4	46	MSG
31	SD5	47	SEL
32	SD6	48	C/D
33	SD7	49	REQ
34	SD8	50	I/O

Table A-4 Pin-Out for SCSI Connector

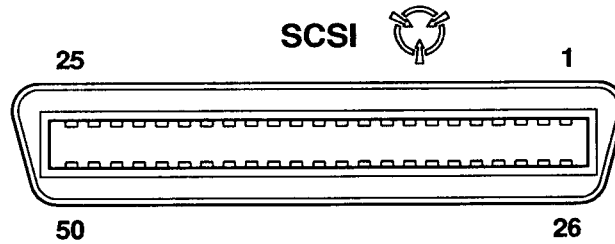

Figure A-3 SCSI Connector Pin Identification

Use of the SCSI Connector conforms with the Common Command Set (CCS) of the Small Computer System Interface (SCSI) published by the ANSI X3T9.2 Committee as X3T9.2/85-52 Rev 4.B.

8618015

A-5 PIN-OUT TABLE FOR GPIB CONNECTOR

Pin Number	Assignment	Pin Number	Assignment
1	DIO 1	10	SRO
2	DIO 2	11	ATN
3	DIO 3	12	Digital GND
4	DIO 4	13	DIO 5
5	EOI	14	DIO 6
6	DAV	15	DIO 7
7	NFRD	16	DIO 8
8	NDAC	17	REN
9	IFC	18-24	Digital GND

Table A-5 Pin-Out for GPIB Connector

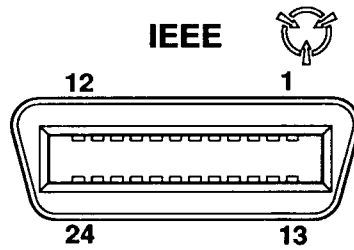

8618016

Figure A-4 GPIB Pin Identification

Use of the GPIB Connector is in compliance with ANSI/IEEE Standard 488.2-1987.

A-6 PIN-OUT FOR RS-232 CONNECTOR

Pin Number	Assignment
1	4.7 k Ω + 15 Vdc
2	TX DATA
3	RX DATA
4	N/C
5	Digital GND
6	4.7 k Ω + 15 Vdc
7	CTS
8	RTS
9	N/C

Table A-6 Pin-Out for RS-232 Connector

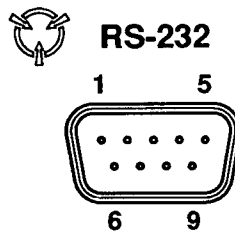

8618017

Figure A-5 RS-232 Connector Pin Identification

A-7 PIN-OUT FOR EXTERNAL VIDEO CONNECTOR

PIN NUMBER	ASSIGNMENT
1	Digital GND
2	Secondary Red
3	Primary Red
4	Primary Green
5	Primary Blue
6	Secondary Green
7	Secondary Blue
8	Horizontal Sync
9	Vertical Sync

Table A-7 Pin-Out for EXTERNAL VIDEO Connector

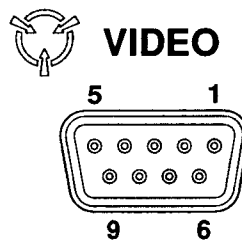

8618019

Figure A-6 EXTERNAL VIDEO Connector Pin Identification

APPENDIX B - AMPS CELLULAR TELEPHONE CHANNEL NUMBERS AND ASSIGNED CENTER FREQUENCIES

Channel Number	Mobile Transmit (MHz)	Mobile Receive (MHz)	Channel Number	Mobile Transmit (MHz)	Mobile Receive (MHz)
1	825.030	870.030	49	826.470	871.470
2	825.060	870.060	50	826.500	871.500
3	825.090	870.090	51	826.530	871.530
4	825.120	870.120	52	826.560	871.560
5	825.150	870.150	53	826.590	871.590
6	825.180	870.180	54	826.620	871.620
7	825.210	870.210	55	826.650	871.650
8	825.240	870.240	56	826.680	871.680
9	825.270	870.270	57	826.710	871.710
10	825.300	870.300	58	826.740	871.740
11	825.330	870.330	59	826.770	871.770
12	825.360	870.360	60	826.800	871.800
13	825.390	870.390	61	826.830	871.830
14	825.420	870.420	62	826.860	871.860
15	825.450	870.450	63	826.890	871.890
16	825.480	870.480	64	826.920	871.920
17	825.510	870.510	65	826.950	871.950
18	825.540	870.540	66	826.980	871.980
19	825.570	870.570	67	827.010	872.010
20	825.600	870.600	68	827.040	872.040
21	825.630	870.630	69	827.070	872.070
22	825.660	870.660	70	827.100	872.100
23	825.690	870.690	71	827.130	872.130
24	825.720	870.720	72	827.160	872.160
25	825.750	870.750	73	827.190	872.190
26	825.780	870.780	74	827.220	872.220
27	825.810	870.810	75	827.250	872.250
28	825.840	870.840	76	827.280	872.280
29	825.870	870.870	77	827.310	872.310
30	825.900	870.900	78	827.340	872.340
31	825.930	870.930	79	827.370	872.370
32	825.960	870.960	80	827.400	872.400
33	825.990	870.990	81	827.430	872.430
34	826.020	871.020	82	827.460	872.460
35	826.050	871.050	83	827.490	872.490
36	826.080	871.080	84	827.520	872.520
37	826.110	871.110	85	827.550	872.550
38	826.140	871.140	86	827.580	872.580
39	826.170	871.170	87	827.610	872.610
40	826.200	871.200	88	827.640	872.640
41	826.230	871.230	89	827.670	872.670
42	826.260	871.260	90	827.700	872.700
43	826.290	871.290	91	827.730	872.730
44	826.320	871.320	92	827.760	872.760
45	826.350	871.350	93	827.790	872.790
46	826.380	871.380	94	827.820	872.820
47	826.410	871.410	95	827.850	872.850
48	826.440	871.440	96	827.880	872.880

Table B-1 Cellular Channel Numbers and Frequencies

Channel Number	Mobile Transmit (MHz)	Mobile Receive (MHz)	Channel Number	Mobile Transmit (MHz)	Mobile Receive (MHz)
97	827.910	872.910	145	829.350	874.350
98	827.940	872.940	146	829.380	874.380
99	827.970	872.970	147	829.410	874.410
100	828.000	873.000	148	829.440	874.440
101	828.030	873.030	149	829.470	874.470
102	828.060	873.060	150	829.500	874.500
103	828.090	873.090	151	829.530	874.530
104	828.120	873.120	152	829.560	874.560
105	828.150	873.150	153	829.590	874.590
106	828.180	873.180	154	829.620	874.620
107	828.210	873.210	155	829.650	874.650
108	828.240	873.240	156	829.680	874.680
109	828.270	873.270	157	829.710	874.710
110	828.300	873.300	158	829.740	874.740
111	828.330	873.330	159	829.770	874.770
112	828.360	873.360	160	829.800	874.800
113	828.390	873.390	161	829.830	874.830
114	828.420	873.420	162	829.860	874.860
115	828.450	873.450	163	829.890	874.890
116	828.480	873.480	164	829.920	874.920
117	828.510	873.510	165	829.950	874.950
118	828.540	873.540	166	829.980	874.980
119	828.570	873.570	167	830.010	875.010
120	828.600	873.600	168	830.040	875.040
121	828.630	873.630	169	830.070	875.070
122	828.660	873.660	170	830.100	875.100
123	828.690	873.690	171	830.130	875.130
124	828.720	873.720	172	830.160	875.160
125	828.750	873.750	173	830.190	875.190
126	828.780	873.780	174	830.220	875.220
127	828.810	873.810	175	830.250	875.250
128	828.840	873.840	176	830.280	875.280
129	828.870	873.870	177	830.310	875.310
130	828.900	873.900	178	830.340	875.340
131	828.930	873.930	179	830.370	875.370
132	828.960	873.960	180	830.400	875.400
133	828.990	873.990	181	830.430	875.430
134	829.020	874.020	182	830.460	875.460
135	829.050	874.050	183	830.490	875.490
136	829.080	874.080	184	830.520	875.520
137	829.110	874.110	185	830.550	875.550
138	829.140	874.140	186	830.580	875.580
139	829.170	874.170	187	830.610	875.610
140	829.200	874.200	188	830.640	875.640
141	829.230	874.230	189	830.670	875.670
142	829.260	874.260	190	830.700	875.700
143	829.290	874.290	191	830.730	875.730
144	829.320	874.320	192	830.760	875.760

Table B-1 Cellular Channel Numbers and Frequencies (cont)

Channel Number	Mobile Transmit (MHz)	Mobile Receive (MHz)	Channel Number	Mobile Transmit (MHz)	Mobile Receive (MHz)
193	830.790	875.790	241	832.230	877.230
194	830.820	875.820	242	832.260	877.260
195	830.850	875.850	243	832.290	877.290
196	830.880	875.880	244	832.320	877.320
197	830.910	875.910	245	832.350	877.350
198	830.940	875.940	246	832.380	877.380
199	830.970	875.970	247	832.410	877.410
200	831.000	876.000	248	832.440	877.440
201	831.030	876.030	249	832.470	877.470
202	831.060	876.060	250	832.500	877.500
203	831.090	876.090	251	832.530	877.530
204	831.120	876.120	252	832.560	877.560
205	831.150	876.150	253	832.590	877.590
206	831.180	876.180	254	832.620	877.620
207	831.210	876.210	255	832.650	877.650
208	831.240	876.240	256	832.680	877.680
209	831.270	876.270	257	832.710	877.710
210	831.300	876.300	258	832.740	877.740
211	831.330	876.330	259	832.770	877.770
212	831.360	876.360	260	832.800	877.800
213	831.390	876.390	261	832.830	877.830
214	831.420	876.420	262	832.860	877.860
215	831.450	876.450	263	832.890	877.890
216	831.480	876.480	264	832.920	877.920
217	831.510	876.510	265	832.950	877.950
218	831.540	876.540	266	832.980	877.980
219	831.570	876.570	267	833.010	878.010
220	831.600	876.600	268	833.040	878.040
221	831.630	876.630	269	833.070	878.070
222	831.660	876.660	270	833.100	878.100
223	831.690	876.690	271	833.130	878.130
224	831.720	876.720	272	833.160	878.160
225	831.750	876.750	273	833.190	878.190
226	831.780	876.780	274	833.220	878.220
227	831.810	876.810	275	833.250	878.250
228	831.840	876.840	276	833.280	878.280
229	831.870	876.870	277	833.310	878.310
230	831.900	876.900	278	833.340	878.340
231	831.930	876.930	279	833.370	878.370
232	831.960	876.960	280	833.400	878.400
233	831.990	876.990	281	833.430	878.430
234	832.020	877.020	282	833.460	878.460
235	832.050	877.050	283	833.490	878.490
236	832.080	877.080	284	833.520	878.520
237	832.110	877.110	285	833.550	878.550
238	832.140	877.140	286	833.580	878.580
239	832.170	877.170	287	833.610	878.610
240	832.200	877.200	288	833.640	878.640

Table B-1 Cellular Channel Numbers and Frequencies (cont)

Channel Number	Mobile Transmit (MHz)	Mobile Receive (MHz)	Channel Number	Mobile Transmit (MHz)	Mobile Receive (MHz)
289	833.670	878.670	337	835.110	880.110
290	833.700	878.700	338	835.140	880.140
291	833.730	878.730	339	835.170	880.170
292	833.760	878.760	340	835.200	880.200
293	833.790	878.790	341	835.230	880.230
294	833.820	878.820	342	835.260	880.260
295	833.850	878.850	343	835.290	880.290
296	833.880	878.880	344	835.320	880.320
297	833.910	878.910	345	835.350	880.350
298	833.940	878.940	346	835.380	880.380
299	833.970	878.970	347	835.410	880.410
300	834.000	879.000	348	835.440	880.440
301	834.030	879.030	349	835.470	880.470
302	834.060	879.060	350	835.500	880.500
303	834.090	879.090	351	835.530	880.530
304	834.120	879.120	352	835.560	880.560
305	834.150	879.150	353	835.590	880.590
306	834.180	879.180	354	835.620	880.620
307	834.210	879.210	355	835.650	880.650
308	834.240	879.240	356	835.680	880.680
309	834.270	879.270	357	835.710	880.710
310	834.300	879.300	358	835.740	880.740
311	834.330	879.330	359	835.770	880.770
312	834.360	879.360	360	835.800	880.800
313	834.390	879.390	361	835.830	880.830
314	834.420	879.420	362	835.860	880.860
315	834.450	879.450	363	835.890	880.890
316	834.480	879.480	364	835.920	880.920
317	834.510	879.510	365	835.950	880.950
318	834.540	879.540	366	835.980	880.980
319	834.570	879.570	367	836.010	881.010
320	834.600	879.600	368	836.040	881.040
321	834.630	879.630	369	836.070	881.070
322	834.660	879.660	370	836.100	881.100
323	834.690	879.690	371	836.130	881.130
324	834.720	879.720	372	836.160	881.160
325	834.750	879.750	373	836.190	881.190
326	834.780	879.780	374	836.220	881.220
327	834.810	879.810	375	836.250	881.250
328	834.840	879.840	376	836.280	881.280
329	834.870	879.870	377	836.310	881.310
330	834.900	879.900	378	836.340	881.340
331	834.930	879.930	379	836.370	881.370
332	834.960	879.960	380	836.400	881.400
333	834.990	879.990	381	836.430	881.430
334	835.020	880.020	382	836.460	881.460
335	835.050	880.050	383	836.490	881.490
336	835.080	880.080	384	836.520	881.520

Table B-1 Cellular Channel Numbers and Frequencies (cont)

Channel Number	Mobile Transmit (MHz)	Mobile Receive (MHz)	Channel Number	Mobile Transmit (MHz)	Mobile Receive (MHz)
385	836.550	881.550	433	837.990	882.990
386	836.580	881.580	434	838.020	883.020
387	836.610	881.610	435	838.050	883.050
388	836.640	881.640	436	838.080	883.080
389	836.670	881.670	437	838.110	883.110
390	836.700	881.700	438	838.140	883.140
391	836.730	881.730	439	838.170	883.170
392	836.760	881.760	440	838.200	883.200
393	836.790	881.790	441	838.230	883.230
394	836.820	881.820	442	838.260	883.260
395	836.850	881.850	443	838.290	883.290
396	836.880	881.880	444	838.320	883.320
397	836.910	881.910	445	838.350	883.350
398	836.940	881.940	446	838.380	883.380
399	836.970	881.970	447	838.410	883.410
400	837.000	882.000	448	838.440	883.440
401	837.030	882.030	449	838.470	883.470
402	837.060	882.060	450	838.500	883.500
403	837.090	882.090	451	838.530	883.530
404	837.120	882.120	452	838.560	883.560
405	837.150	882.150	453	838.590	883.590
406	837.180	882.180	454	838.620	883.620
407	837.210	882.210	455	838.650	883.650
408	837.240	882.240	456	838.680	883.680
409	837.270	882.270	457	838.710	883.710
410	837.300	882.300	458	838.740	883.740
411	837.330	882.330	459	838.770	883.770
412	837.360	882.360	460	838.800	883.800
413	837.390	882.390	461	838.830	883.830
414	837.420	882.420	462	838.860	883.860
415	837.450	882.450	463	838.890	883.890
416	837.480	882.480	464	838.920	883.920
417	837.510	882.510	465	838.950	883.950
418	837.540	882.540	466	838.980	883.980
419	837.570	882.570	467	839.010	884.010
420	837.600	882.600	468	839.040	884.040
421	837.630	882.630	469	839.070	884.070
422	837.660	882.660	470	839.100	884.100
423	837.690	882.690	471	839.130	884.130
424	837.720	882.720	472	839.160	884.160
425	837.750	882.750	473	839.190	884.190
426	837.780	882.780	474	839.220	884.220
427	837.810	882.810	475	839.250	884.250
428	837.840	882.840	476	839.280	884.280
429	837.870	882.870	477	839.310	884.310
430	837.900	882.900	478	839.340	884.340
431	837.930	882.930	479	839.370	884.370
432	837.960	882.960	480	839.400	884.400

Table B-1 Cellular Channel Numbers and Frequencies (cont)

Channel Number	Mobile Transmit (MHz)	Mobile Receive (MHz)	Channel Number	Mobile Transmit (MHz)	Mobile Receive (MHz)
481	839.430	884.430	529	840.870	885.870
482	839.460	884.460	530	840.900	885.900
483	839.490	884.490	531	840.930	885.930
484	839.520	884.520	532	840.960	885.960
485	839.550	884.550	533	840.990	885.990
486	839.580	884.580	534	841.020	886.020
487	839.610	884.610	535	841.050	886.050
488	839.640	884.640	536	841.080	886.080
489	839.670	884.670	537	841.110	886.110
490	839.700	884.700	538	841.140	886.140
491	839.730	884.730	539	841.170	886.170
492	839.760	884.760	540	841.200	886.200
493	839.790	884.790	541	841.230	886.230
494	839.820	884.820	542	841.260	886.260
495	839.850	884.850	543	841.290	886.290
496	839.880	884.880	544	841.320	886.320
497	839.910	884.910	545	841.350	886.350
498	839.940	884.940	546	841.380	886.380
499	839.970	884.970	547	841.410	886.410
500	840.000	885.000	548	841.440	886.440
501	840.030	885.030	549	841.470	886.470
502	840.060	885.060	550	841.500	886.500
503	840.090	885.090	551	841.530	886.530
504	840.120	885.120	552	841.560	886.560
505	840.150	885.150	553	841.590	886.590
506	840.180	885.180	554	841.620	886.620
507	840.210	885.210	555	841.650	886.650
508	840.240	885.240	556	841.680	886.680
509	840.270	885.270	557	841.710	886.710
510	840.300	885.300	558	841.740	886.740
511	840.330	885.330	559	841.770	886.770
512	840.360	885.360	560	841.800	886.800
513	840.390	885.390	561	841.830	886.830
514	840.420	885.420	562	841.860	886.860
515	840.450	885.450	563	841.890	886.890
516	840.480	885.480	564	841.920	886.920
517	840.510	885.510	565	841.950	886.950
518	840.540	885.540	566	841.980	886.980
519	840.570	885.570	567	842.010	887.010
520	840.600	885.600	568	842.040	887.040
521	840.630	885.630	569	842.070	887.070
522	840.660	885.660	570	842.100	887.100
523	840.690	885.690	571	842.130	887.130
524	840.720	885.720	572	842.160	887.160
525	840.750	885.750	573	842.190	887.190
526	840.780	885.780	574	842.220	887.220
527	840.810	885.810	575	842.250	887.250
528	840.840	885.840	576	842.280	887.280

Table B-1 Cellular Channel Numbers and Frequencies (cont)

Channel Number	Mobile Transmit (MHz)	Mobile Receive (MHz)	Channel Number	Mobile Transmit (MHz)	Mobile Receive (MHz)
577	842.310	887.310	625	843.750	888.750
578	842.340	887.340	626	843.780	888.780
579	842.370	887.370	627	843.810	888.810
580	842.400	887.400	628	843.840	888.840
581	842.430	887.430	629	843.870	888.870
582	842.460	887.460	630	843.900	888.900
583	842.490	887.490	631	843.930	888.930
584	842.520	887.520	632	843.960	888.960
585	842.550	887.550	633	843.990	888.990
586	842.580	887.580	634	844.020	889.020
587	842.610	887.610	635	844.050	889.050
588	842.640	887.640	636	844.080	889.080
589	842.670	887.670	637	844.110	889.110
590	842.700	887.700	638	844.140	889.140
591	842.730	887.730	639	844.170	889.170
592	842.760	887.760	640	844.200	889.200
593	842.790	887.790	641	844.230	889.230
594	842.820	887.820	642	844.260	889.260
595	842.850	887.850	643	844.290	889.290
596	842.880	887.880	644	844.320	889.320
597	842.910	887.910	645	844.350	889.350
598	842.940	887.940	646	844.380	889.380
599	842.970	887.970	647	844.410	889.410
600	843.000	888.000	648	844.440	889.440
601	843.030	888.030	649	844.470	889.470
602	843.060	888.060	650	844.500	889.500
603	843.090	888.090	651	844.530	889.530
604	843.120	888.120	652	844.560	889.560
605	843.150	888.150	653	844.590	889.590
606	843.180	888.180	654	844.620	889.620
607	843.210	888.210	655	844.650	889.650
608	843.240	888.240	656	844.680	889.680
609	843.270	888.270	657	844.710	889.710
610	843.300	888.300	658	844.740	889.740
611	843.330	888.330	659	844.770	889.770
612	843.360	888.360	660	844.800	889.800
613	843.390	888.390	661	844.830	889.830
614	843.420	888.420	662	844.860	889.860
615	843.450	888.450	663	844.890	889.890
616	843.480	888.480	664	844.920	889.920
617	843.510	888.510	665	844.950	889.950
618	843.540	888.540	666	844.980	889.980
619	843.570	888.570	667	845.010	890.010
620	843.600	888.600	668	845.040	890.040
621	843.630	888.630	669	845.070	890.070
622	843.660	888.660	670	845.100	890.100
623	843.690	888.690	671	845.130	890.130
624	843.720	888.720	672	845.160	890.160

Table B-1 Cellular Channel Numbers and Frequencies (cont)

Channel Number	Mobile Transmit (MHz)	Mobile Receive (MHz)	Channel Number	Mobile Transmit (MHz)	Mobile Receive (MHz)
673	845.190	890.190	721	846.630	891.630
674	845.220	890.220	722	846.660	891.660
675	845.250	890.250	723	846.690	891.690
676	845.280	890.280	724	846.720	891.720
677	845.310	890.310	725	846.750	891.750
678	845.340	890.340	726	846.780	891.780
679	845.370	890.370	727	846.810	891.810
680	845.400	890.400	728	846.840	891.840
681	845.430	890.430	729	846.870	891.870
682	845.460	890.460	730	846.900	891.900
683	845.490	890.490	731	846.930	891.930
684	845.520	890.520	732	846.960	891.960
685	845.550	890.550	733	846.990	891.990
686	845.580	890.580	734	847.020	892.020
687	845.610	890.610	735	847.050	892.050
688	845.640	890.640	736	847.080	892.080
689	845.670	890.670	737	847.110	892.110
690	845.700	890.700	738	847.140	892.140
691	845.730	890.730	739	847.170	892.170
692	845.760	890.760	740	847.200	892.200
693	845.790	890.790	741	847.230	892.230
694	845.820	890.820	742	847.260	892.260
695	845.850	890.850	743	847.290	892.290
696	845.880	890.880	744	847.320	892.320
697	845.910	890.910	745	847.350	892.350
698	845.940	890.940	746	847.380	892.380
699	845.970	890.970	747	847.410	892.410
700	846.000	891.000	748	847.440	892.440
701	846.030	891.030	749	847.470	892.470
702	846.060	891.060	750	847.500	892.500
703	846.090	891.090	751	847.530	892.530
704	846.120	891.120	752	847.560	892.560
705	846.150	891.150	753	847.590	892.590
706	846.180	891.180	754	847.620	892.620
707	846.210	891.210	755	847.650	892.650
708	846.240	891.240	756	847.680	892.680
709	846.270	891.270	757	847.710	892.710
710	846.300	891.300	758	847.740	892.740
711	846.330	891.330	759	847.770	892.770
712	846.360	891.360	760	847.800	892.800
713	846.390	891.390	761	847.830	892.830
714	846.420	891.420	762	847.860	892.860
715	846.450	891.450	763	847.890	892.890
716	846.480	891.480	764	847.920	892.920
717	846.510	891.510	765	847.950	892.950
718	846.540	891.540	766	847.980	892.980
719	846.570	891.570	767	848.010	893.010
720	846.600	891.600	768	848.040	893.040

Table B-1 Cellular Channel Numbers and Frequencies (cont)

Channel Number	Mobile Transmit (MHz)	Mobile Receive (MHz)	Channel Number	Mobile Transmit (MHz)	Mobile Receive (MHz)
769	848.070	893.070	817	849.510	894.510
770	848.100	893.100	818	849.540	894.540
771	848.130	893.130	819	849.570	894.570
772	848.160	893.160	820	849.600	894.600
773	848.190	893.190	821	849.630	894.630
774	848.220	893.220	822	849.660	894.660
775	848.250	893.250	823	849.690	894.690
776	848.280	893.280	824	849.720	894.720
777	848.310	893.310	825	849.750	894.750
778	848.340	893.340	826	849.780	894.780
779	848.370	893.370	827	849.810	894.810
780	848.400	893.400	828	849.840	894.840
781	848.430	893.430	829	849.870	894.870
782	848.460	893.460	830	849.900	894.900
783	848.490	893.490	831	849.930	894.930
784	848.520	893.520	832	849.960	894.960
785	848.550	893.550	833	849.990	894.990
786	848.580	893.580	834	850.020	895.020
787	848.610	893.610	835	850.050	895.050
788	848.640	893.640	836	850.080	895.080
789	848.670	893.670	837	850.110	895.110
790	848.700	893.700	838	850.140	895.140
791	848.730	893.730	839	850.170	895.170
792	848.760	893.760	840	850.200	895.200
793	848.790	893.790	841	850.230	895.230
794	848.820	893.820	842	850.260	895.260
795	848.850	893.850	843	850.290	895.290
796	848.880	893.880	844	850.320	895.320
797	848.910	893.910	845	850.350	895.350
798	848.940	893.940	846	850.380	895.380
799	848.970	893.970	847	850.410	895.410
800	849.000	894.000	848	850.440	895.440
801	849.030	894.030	849	850.470	895.470
802	849.060	894.060	850	850.500	895.500
803	849.090	894.090	851	850.530	895.530
804	849.120	894.120	852	850.560	895.560
805	849.150	894.150	853	850.590	895.590
806	849.180	894.180	854	850.620	895.620
807	849.210	894.210	855	850.650	895.650
808	849.240	894.240	856	850.680	895.680
809	849.270	894.270	857	850.710	895.710
810	849.300	894.300	858	850.740	895.740
811	849.330	894.330	859	850.770	895.770
812	849.360	894.360	860	850.800	895.800
813	849.390	894.390	861	850.830	895.830
814	849.420	894.420	862	850.860	895.860
815	849.450	894.450	863	850.890	895.890
816	849.480	894.480	864	850.920	895.920

Table B-1 Cellular Channel Numbers and Frequencies (cont)

Channel Number	Mobile Transmit (MHz)	Mobile Receive (MHz)	Channel Number	Mobile Transmit (MHz)	Mobile Receive (MHz)
865	850.950	895.950	1007	824.520	869.520
866	850.980	895.980	1008	824.550	869.550
991	824.040	869.040	1009	824.580	869.580
992	824.070	869.070	1010	824.610	869.610
993	824.100	869.100	1011	824.640	869.640
994	824.130	869.130	1012	824.670	869.670
995	824.160	869.160	1013	824.700	869.700
996	824.190	869.190	1014	824.730	869.730
997	824.220	869.220	1015	824.760	869.760
998	824.250	869.250	1016	824.790	869.790
999	824.280	869.280	1017	824.820	869.820
1000	824.310	869.310	1018	824.850	869.850
1001	824.340	869.340	1019	824.880	869.880
1002	824.370	869.370	1020	824.910	869.910
1003	824.400	869.400	1021	824.940	869.940
1004	824.430	869.430	1022	824.970	869.970
1005	824.460	869.460	1023	825.000	870.000
1006	824.490	869.490			

NOTE: Channel Numbers 800 through 866 are not presently assigned to any to any Cellular Telephone System.

Channel Numbers 800 through 866 are not presently assigned to any to any Cellular Telephone System.

Frequencies for Channel Numbers 867 through 989 are not assigned and are not used by Cellular Telephone Systems. Channel Number 990 is not assigned to any system.

Table B-1 Cellular Channel Numbers and Frequencies (cont)

APPENDIX C - E-TACS CELLULAR TELEPHONE CHANNEL NUMBERS AND ASSIGNED CENTER FREQUENCIES

Channel Number	Mobile Transmit (MHz)	Mobile Receive (MHz)	Channel Number	Mobile Transmit (MHz)	Mobile Receive (MHz)
0	889.9875	934.9875	48	891.1875	936.1875
1	890.0125	935.0125	49	891.2125	936.2125
2	890.0375	935.0375	50	891.2375	936.2375
3	890.0625	935.0625	51	891.2625	936.2625
4	890.0875	935.0875	52	891.2875	936.2875
5	890.1125	935.1125	53	891.3125	936.3125
6	890.1375	935.1375	54	891.3375	936.3375
7	890.1625	935.1625	55	891.3625	936.3625
8	890.1875	935.1875	56	891.3875	936.3875
9	890.2125	935.2125	57	891.4125	936.4125
10	890.2375	935.2375	58	891.4375	936.4375
11	890.2625	935.2625	59	891.4625	936.4625
12	890.2875	935.2875	60	891.4875	936.4875
13	890.3125	935.3125	61	891.5125	936.5125
14	890.3375	935.3375	62	891.5375	936.5375
15	890.3625	935.3625	63	891.5625	936.5625
16	890.3875	935.3875	64	891.5875	936.5875
17	890.4125	935.4125	65	891.6125	936.6125
18	890.4375	935.4375	66	891.6375	936.6375
19	890.4625	935.4625	67	891.6625	936.6625
20	890.4875	935.4875	68	891.6875	936.6875
21	890.5125	935.5125	69	891.7125	936.7125
22	890.5375	935.5375	70	891.7375	936.7375
23	890.5625	935.5625	71	891.7625	936.7625
24	890.5875	935.5875	72	891.7875	936.7875
25	890.6125	935.6125	73	891.8125	936.8125
26	890.6375	935.6375	74	891.8375	936.8375
27	890.6625	935.6625	75	891.8625	936.8625
28	890.6875	935.6875	76	891.8875	936.8875
29	890.7125	935.7125	77	891.9125	936.9125
30	890.7375	935.7375	78	891.9375	936.9375
31	890.7625	935.7625	79	891.9625	936.9625
32	890.7875	935.7875	80	891.9875	936.9875
33	890.8125	935.8125	81	892.0125	937.0125
34	890.8375	935.8375	82	892.0375	937.0375
35	890.8625	935.8625	83	892.0625	937.0625
36	890.8875	935.8875	84	892.0875	937.0875
37	890.9125	935.9125	85	892.1125	937.1125
38	890.9375	935.9375	86	892.1375	937.1375
39	890.9625	935.9625	87	892.1625	937.1625
40	890.9875	935.9875	88	892.1875	937.1875
41	891.0125	936.0125	89	892.2125	937.2125
42	891.0375	936.0375	90	892.2375	937.2375
43	891.0625	936.0625	91	892.2625	937.2625
44	891.0875	936.0875	92	892.2875	937.2875
45	891.1125	936.1125	93	892.3125	937.3125
46	891.1375	936.1375	94	892.3375	937.3375
47	891.1625	936.1625	95	892.3625	937.3625

Table C-1 E-TACS Cellular Channel Numbers and Frequencies

Channel Number	Mobile Transmit (MHz)	Mobile Receive (MHz)	Channel Number	Mobile Transmit (MHz)	Mobile Receive (MHz)
96	892.3875	937.3875	143	893.5625	938.5625
97	892.4125	937.4125	144	893.5875	938.5875
98	892.4375	937.4375	145	893.6125	938.6125
99	892.4625	937.4625	146	893.6375	938.6375
100	892.4875	937.4875	147	893.6625	938.6625
101	892.5125	937.5125	148	893.6875	938.6875
102	892.5375	937.5375	149	893.7125	938.7125
103	892.5625	937.5625	150	893.7375	938.7375
104	892.5875	937.5875	151	893.7625	938.7625
105	892.6125	937.6125	152	893.7875	938.7875
106	892.6375	937.6375	153	893.8125	938.8125
107	892.6625	937.6625	154	893.8375	938.8375
108	892.6875	937.6875	155	893.8625	938.8625
109	892.7125	937.7125	156	893.8875	938.8875
110	892.7375	937.7375	157	893.9125	938.9125
111	892.7625	937.7625	158	893.9375	938.9375
112	892.7875	937.7875	159	893.9625	938.9625
113	892.8125	937.8125	160	893.9875	938.9875
114	892.8375	937.8375	161	894.0125	939.0125
115	892.8625	937.8625	162	894.0375	939.0375
116	892.8875	937.8875	163	894.0625	939.0625
117	892.9125	937.9125	164	894.0875	939.0875
118	892.9375	937.9375	165	894.1125	939.1125
119	892.9625	937.9625	166	894.1375	939.1375
120	892.9875	937.9875	167	894.1625	939.1625
121	893.0125	938.0125	168	894.1875	939.1875
122	893.0375	938.0375	169	894.2125	939.2125
123	893.0625	938.0625	170	894.2375	939.2375
124	893.0875	938.0875	171	894.2625	939.2625
125	893.1125	938.1125	172	894.2875	939.2875
126	893.1375	938.1375	173	894.3125	939.3125
127	893.1625	938.1625	174	894.3375	939.3375
128	893.1875	938.1875	175	894.3625	939.3625
129	893.2125	938.2125	176	894.3875	939.3875
130	893.2375	938.2375	177	894.4125	939.4125
131	893.2625	938.2625	178	894.4375	939.4375
132	893.2875	938.2875	179	894.4625	939.4625
133	893.3125	938.3125	180	894.4875	939.4875
134	893.3375	938.3375	181	894.5125	939.5125
135	893.3625	938.3625	182	894.5375	939.5375
136	893.3875	938.3875	183	894.5625	939.5625
137	893.4125	938.4125	184	894.5875	939.5875
138	893.4375	938.4375	185	894.6125	939.6125
139	893.4625	938.4625	186	894.6375	939.6375
140	893.4875	938.4875	187	894.6625	939.6625
141	893.5125	938.5125	188	894.6875	939.6875
142	893.5375	938.5375	189	894.7125	939.7125

Table C-1 E-TACS Cellular Channel Numbers and Frequencies (cont)

Channel Number	Mobile Transmit (MHz)	Mobile Receive (MHz)	Channel Number	Mobile Transmit (MHz)	Mobile Receive (MHz)
190	894.7375	939.7375	237	895.9125	940.9125
191	894.7625	939.7625	238	895.9375	940.9375
192	894.7875	939.7875	239	895.9625	940.9625
193	894.8125	939.8125	240	895.9875	940.9875
194	894.8375	939.8375	241	896.0125	941.0125
195	894.8625	939.8625	242	896.0375	941.0375
196	894.8875	939.8875	243	896.0625	941.0625
197	894.9125	939.9125	244	896.0875	941.0875
198	894.9375	939.9375	245	896.1125	941.1125
199	894.9625	939.9625	246	896.1375	941.1375
200	894.9875	939.9875	247	896.1625	941.1625
201	895.0125	940.0125	248	896.1875	941.1875
202	895.0375	940.0375	249	896.2125	941.2125
203	895.0625	940.0625	250	896.2375	941.2375
204	895.0875	940.0875	251	896.2625	941.2625
205	895.1125	940.1125	252	896.2875	941.2875
206	895.1375	940.1375	253	896.3125	941.3125
207	895.1625	940.1625	254	896.3375	941.3375
208	895.1875	940.1875	255	896.3625	941.3625
209	895.2125	940.2125	256	896.3875	941.3875
210	895.2375	940.2375	257	896.4125	941.4125
211	895.2625	940.2625	258	896.4375	941.4375
212	895.2875	940.2875	259	896.4625	941.4625
213	895.3125	940.3125	260	896.4875	941.4875
214	895.3375	940.3375	261	896.5125	941.5125
215	895.3625	940.3625	262	896.5375	941.5375
216	895.3875	940.3875	263	896.5625	941.5625
217	895.4125	940.4125	264	896.5875	941.5875
218	895.4375	940.4375	265	896.6125	941.6125
219	895.4625	940.4625	266	896.6375	941.6375
220	895.4875	940.4875	267	896.6625	941.6625
221	895.5125	940.5125	268	896.6875	941.6875
222	895.5375	940.5375	269	896.7125	941.7125
223	895.5625	940.5625	270	896.7375	941.7375
224	895.5875	940.5875	271	896.7625	941.7625
225	895.6125	940.6125	272	896.7875	941.7875
226	895.6375	940.6375	273	896.8125	941.8125
227	895.6625	940.6625	274	896.8375	941.8375
228	895.6875	940.6875	275	896.8625	941.8625
229	895.7125	940.7125	276	896.8875	941.8875
230	895.7375	940.7375	277	896.9125	941.9125
231	895.7625	940.7625	278	896.9375	941.9375
232	895.7875	940.7875	279	896.9625	941.9625
233	895.8125	940.8125	280	896.9875	941.9875
234	895.8375	940.8375	281	897.0125	942.0125
235	895.8625	940.8625	282	897.0375	942.0375
236	895.8875	940.8875	283	897.0625	942.0625

Table C-1 E-TACS Cellular Channel Numbers and Frequencies (cont)

Channel Number	Mobile Transmit (MHz)	Mobile Receive (MHz)	Channel Number	Mobile Transmit (MHz)	Mobile Receive (MHz)
284	897.0875	942.0875	331	898.2625	943.2625
285	897.1125	942.1125	332	898.2875	943.2875
286	897.1375	942.1375	333	898.3125	943.3125
287	897.1625	942.1625	334	898.3375	943.3375
288	897.1875	942.1875	335	898.3625	943.3625
289	897.2125	942.2125	336	898.3875	943.3875
290	897.2375	942.2375	337	898.4125	943.4125
291	897.2625	942.2625	338	898.4375	943.4375
292	897.2875	942.2875	339	898.4625	943.4625
293	897.3125	942.3125	340	898.4875	943.4875
294	897.3375	942.3375	341	898.5125	943.5125
295	897.3625	942.3625	342	898.5375	943.5375
296	897.3875	942.3875	343	898.5625	943.5625
297	897.4125	942.4125	344	898.5875	943.5875
298	897.4375	942.4375	345	898.6125	943.6125
299	897.4625	942.4625	346	898.6375	943.6375
300	897.4875	942.4875	347	898.6625	943.6625
301	897.5125	942.5125	348	898.6875	943.6875
302	897.5375	942.5375	349	898.7125	943.7125
303	897.5625	942.5625	350	898.7375	943.7375
304	897.5875	942.5875	351	898.7625	943.7625
305	897.6125	942.6125	352	898.7875	943.7875
306	897.6375	942.6375	353	898.8125	943.8125
307	897.6625	942.6625	354	898.8375	943.8375
308	897.6875	942.6875	355	898.8625	943.8625
309	897.7125	942.7125	356	898.8875	943.8875
310	897.7375	942.7375	357	898.9125	943.9125
311	897.7625	942.7625	358	898.9375	943.9375
312	897.7875	942.7875	359	898.9625	943.9625
313	897.8125	942.8125	360	898.9875	943.9875
314	897.8375	942.8375	361	899.0125	944.0125
315	897.8625	942.8625	362	899.0375	944.0375
316	897.8875	942.8875	363	899.0625	944.0625
317	897.9125	942.9125	364	899.0875	944.0875
318	897.9375	942.9375	365	899.1125	944.1125
319	897.9625	942.9625	366	899.1375	944.1375
320	897.9875	942.9875	367	899.1625	944.1625
321	898.0125	943.0125	368	899.1875	944.1875
322	898.0375	943.0375	369	899.2125	944.2125
323	898.0625	943.0625	370	899.2375	944.2375
324	898.0875	943.0875	371	899.2625	944.2625
325	898.1125	943.1125	372	899.2875	944.2875
326	898.1375	943.1375	373	899.3125	944.3125
327	898.1625	943.1625	374	899.3375	944.3375
328	898.1875	943.1875	375	899.3625	944.3625
329	898.2125	943.2125	376	899.3875	944.3875
330	898.2375	943.2375	377	899.4125	944.4125

Table C-1 E-TACS Cellular Channel Numbers and Frequencies (cont)

Channel Number	Mobile Transmit (MHz)	Mobile Receive (MHz)	Channel Number	Mobile Transmit (MHz)	Mobile Receive (MHz)
378	899.4375	944.4375	425	900.6125	945.6125
379	899.4625	944.4625	426	900.6375	945.6375
380	899.4875	944.4875	427	900.6625	945.6625
381	899.5125	944.5125	428	900.6875	945.6875
382	899.5375	944.5375	429	900.7125	945.7125
383	899.5625	944.5625	430	900.7375	945.7375
384	899.5875	944.5875	431	900.7625	945.7625
385	899.6125	944.6125	432	900.7875	945.7875
386	899.6375	944.6375	433	900.8125	945.8125
387	899.6625	944.6625	434	900.8375	945.8375
388	899.6875	944.6875	435	900.8625	945.8625
389	899.7125	944.7125	436	900.8875	945.8875
390	899.7375	944.7375	437	900.9125	945.9125
391	899.7625	944.7625	438	900.9375	945.9375
392	899.7875	944.7875	439	900.9625	945.9625
393	899.8125	944.8125	440	900.9875	945.9875
394	899.8375	944.8375	441	901.0125	946.0125
395	899.8625	944.8625	442	901.0375	946.0375
396	899.8875	944.8875	443	901.0625	946.0625
397	899.9125	944.9125	444	901.0875	946.0875
398	899.9375	944.9375	445	901.1125	946.1125
399	899.9625	944.9625	446	901.1375	946.1375
400	899.9875	944.9875	447	901.1625	946.1625
401	900.0125	945.0125	448	901.1875	946.1875
402	900.0375	945.0375	449	901.2125	946.2125
403	900.0625	945.0625	450	901.2375	946.2375
404	900.0875	945.0875	451	901.2625	946.2625
405	900.1125	945.1125	452	901.2875	946.2875
406	900.1375	945.1375	453	901.3125	946.3125
407	900.1625	945.1625	454	901.3375	946.3375
408	900.1875	945.1875	455	901.3625	946.3625
409	900.2125	945.2125	456	901.3875	946.3875
410	900.2375	945.2375	457	901.4125	946.4125
411	900.2625	945.2625	458	901.4375	946.4375
412	900.2875	945.2875	459	901.4625	946.4625
413	900.3125	945.3125	460	901.4875	946.4875
414	900.3375	945.3375	461	901.5125	946.5125
415	900.3625	945.3625	462	901.5375	946.5375
416	900.3875	945.3875	463	901.5625	946.5625
417	900.4125	945.4125	464	901.5875	946.5875
418	900.4375	945.4375	465	901.6125	946.6125
419	900.4625	945.4625	466	901.6375	946.6375
420	900.4875	945.4875	467	901.6625	946.6625
421	900.5125	945.5125	468	901.6875	946.6875
422	900.5375	945.5375	469	901.7125	946.7125
423	900.5625	945.5625	470	901.7375	946.7375
424	900.5875	945.5875	471	901.7625	946.7625

Table C-1 E-TACS Cellular Channel Numbers and Frequencies (cont)

Channel Number	Mobile Transmit (MHz)	Mobile Receive (MHz)	Channel Number	Mobile Transmit (MHz)	Mobile Receive (MHz)
472	901.7875	946.7875	519	902.9625	947.9625
473	901.8125	946.8125	520	902.9875	947.9875
474	901.8375	946.8375	521	903.0125	948.0125
475	901.8625	946.8625	522	903.0375	948.0375
476	901.8875	946.8875	523	903.0625	948.0625
477	901.9125	946.9125	524	903.0875	948.0875
478	901.9375	946.9375	525	903.1125	948.1125
479	901.9625	946.9625	526	903.1375	948.1375
480	901.9875	946.9875	527	903.1625	948.1625
481	902.0125	947.0125	528	903.1875	948.1875
482	902.0375	947.0375	529	903.2125	948.2125
483	902.0625	947.0625	530	903.2375	948.2375
484	902.0875	947.0875	531	903.2625	948.2625
485	902.1125	947.1125	532	903.2875	948.2875
486	902.1375	947.1375	533	903.3125	948.3125
487	902.1625	947.1625	534	903.3375	948.3375
488	902.1875	947.1875	535	903.3625	948.3625
489	902.2125	947.2125	536	903.3875	948.3875
490	902.2375	947.2375	537	903.4125	948.4125
491	902.2625	947.2625	538	903.4375	948.4375
492	902.2875	947.2875	539	903.4625	948.4625
493	902.3125	947.3125	540	903.4875	948.4875
494	902.3375	947.3375	541	903.5125	948.5125
495	902.3625	947.3625	542	903.5375	948.5375
496	902.3875	947.3875	543	903.5625	948.5625
497	902.4125	947.4125	544	903.5875	948.5875
498	902.4375	947.4375	545	903.6125	948.6125
499	902.4625	947.4625	546	903.6375	948.6375
500	902.4875	947.4875	547	903.6625	948.6625
501	902.5125	947.5125	548	903.6875	948.6875
502	902.5375	947.5375	549	903.7125	948.7125
503	902.5625	947.5625	550	903.7375	948.7375
504	902.5875	947.5875	551	903.7625	948.7625
505	902.6125	947.6125	552	903.7875	948.7875
506	902.6375	947.6375	553	903.8125	948.8125
507	902.6625	947.6625	554	903.8375	948.8375
508	902.6875	947.6875	555	903.8625	948.8625
509	902.7125	947.7125	556	903.8875	948.8875
510	902.7375	947.7375	557	903.9125	948.9125
511	902.7625	947.7625	558	903.9375	948.9375
512	902.7875	947.7875	559	903.9625	948.9625
513	902.8125	947.8125	560	903.9875	948.9875
514	902.8375	947.8375	561	904.0125	949.0125
515	902.8625	947.8625	562	904.0375	949.0375
516	902.8875	947.8875	563	904.0625	949.0625
517	902.9125	947.9125	564	904.0875	949.0875
518	902.9375	947.9375	565	904.1125	949.1125

Table C-1 E-TACS Cellular Channel Numbers and Frequencies (cont)

Channel Number	Mobile Transmit (MHz)	Mobile Receive (MHz)	Channel Number	Mobile Transmit (MHz)	Mobile Receive (MHz)
566	904.1375	949.1375	613	905.3125	950.3125
567	904.1625	949.1625	614	905.3375	950.3375
568	904.1875	949.1875	615	905.3625	950.3625
569	904.2125	949.2125	616	905.3875	950.3875
570	904.2375	949.2375	617	905.4125	950.4125
571	904.2625	949.2625	618	905.4375	950.4375
572	904.2875	949.2875	619	905.4625	950.4625
573	904.3125	949.3125	620	905.4875	950.4875
574	904.3375	949.3375	621	905.5125	950.5125
575	904.3625	949.3625	622	905.5375	950.5375
576	904.3875	949.3875	623	905.5625	950.5625
577	904.4125	949.4125	624	905.5875	950.5875
578	904.4375	949.4375	625	905.6125	950.6125
579	904.4625	949.4625	626	905.6375	950.6375
580	904.4875	949.4875	627	905.6625	950.6625
581	904.5125	949.5125	628	905.6875	950.6875
582	904.5375	949.5375	629	905.7125	950.7125
583	904.5625	949.5625	630	905.7375	950.7375
584	904.5875	949.5875	631	905.7625	950.7625
585	904.6125	949.6125	632	905.7875	950.7875
586	904.6375	949.6375	633	905.8125	950.8125
587	904.6625	949.6625	634	905.8375	950.8375
588	904.6875	949.6875	635	905.8625	950.8625
589	904.7125	949.7125	636	905.8875	950.8875
590	904.7375	949.7375	637	905.9125	950.9125
591	904.7625	949.7625	638	905.9375	950.9375
592	904.7875	949.7875	639	905.9625	950.9625
593	904.8125	949.8125	640	905.9875	950.9875
594	904.8375	949.8375	641	906.0125	951.0125
595	904.8625	949.8625	642	906.0375	951.0375
596	904.8875	949.8875	643	906.0625	951.0625
597	904.9125	949.9125	644	906.0875	951.0875
598	904.9375	949.9375	645	906.1125	951.1125
599	904.9625	949.9625	646	906.1375	951.1375
600	904.9875	949.9875	647	906.1625	951.1625
601	905.0125	950.0125	648	906.1875	951.1875
602	905.0375	950.0375	649	906.2125	951.2125
603	905.0625	950.0625	650	906.2375	951.2375
604	905.0875	950.0875	651	906.2625	951.2625
605	905.1125	950.1125	652	906.2875	951.2875
606	905.1375	950.1375	653	906.3125	951.3125
607	905.1625	950.1625	654	906.3375	951.3375
608	905.1875	950.1875	655	906.3625	951.3625
609	905.2125	950.2125	656	906.3875	951.3875
610	905.2375	950.2375	657	906.4125	951.4125
611	905.2625	950.2625	658	906.4375	951.4375
612	905.2875	950.2875	659	906.4625	951.4625

Table C-1 E-TACS Cellular Channel Numbers and Frequencies (cont)

Channel Number	Mobile Transmit (MHz)	Mobile Receive (MHz)	Channel Number	Mobile Transmit (MHz)	Mobile Receive (MHz)
660	906.4875	951.4875	707	907.6625	952.6625
661	906.5125	951.5125	708	907.6875	952.6875
662	906.5375	951.5375	709	907.7125	952.7125
663	906.5625	951.5625	710	907.7375	952.7375
664	906.5875	951.5875	711	907.7625	952.7625
665	906.6125	951.6125	712	907.7875	952.7875
666	906.6375	951.6375	713	907.8125	952.8125
667	906.6625	951.6625	714	907.8375	952.8375
668	906.6875	951.6875	715	907.8625	952.8625
669	906.7125	951.7125	716	907.8875	952.8875
670	906.7375	951.7375	717	907.9125	952.9125
671	906.7625	951.7625	718	907.9375	952.9375
672	906.7875	951.7875	719	907.9625	952.9625
673	906.8125	951.8125	720	907.9875	952.9875
674	906.8375	951.8375	721	908.0125	953.0125
675	906.8625	951.8625	722	908.0375	953.0375
676	906.8875	951.8875	723	908.0625	953.0625
677	906.9125	951.9125	724	908.0875	953.0875
678	906.9375	951.9375	725	908.1125	953.1125
679	906.9625	951.9625	726	908.1375	953.1375
680	906.9875	951.9875	727	908.1625	953.1625
681	907.0125	952.0125	728	908.1875	953.1875
682	907.0375	952.0375	729	908.2125	953.2125
683	907.0625	952.0625	730	908.2375	953.2375
684	907.0875	952.0875	731	908.2625	953.2625
685	907.1125	952.1125	732	908.2875	953.2875
686	907.1375	952.1375	733	908.3125	953.3125
687	907.1625	952.1625	734	908.3375	953.3375
688	907.1875	952.1875	735	908.3625	953.3625
689	907.2125	952.2125	736	908.3875	953.3875
690	907.2375	952.2375	737	908.4125	953.4125
691	907.2625	952.2625	738	908.4375	953.4375
692	907.2875	952.2875	739	908.4625	953.4625
693	907.3125	952.3125	740	908.4875	953.4875
694	907.3375	952.3375	741	908.5125	953.5125
695	907.3625	952.3625	742	908.5375	953.5375
696	907.3875	952.3875	743	908.5625	953.5625
697	907.4125	952.4125	744	908.5875	953.5875
698	907.4375	952.4375	745	908.6125	953.6125
699	907.4625	952.4625	746	908.6375	953.6375
700	907.4875	952.4875	747	908.6625	953.6625
701	907.5125	952.5125	748	908.6875	953.6875
702	907.5375	952.5375	749	908.7125	953.7125
703	907.5625	952.5625	750	908.7375	953.7375
704	907.5875	952.5875	751	908.7625	953.7625
705	907.6125	952.6125	752	908.7875	953.7875
706	907.6375	952.6375	753	908.8125	953.8125

Table C-1 E-TACS Cellular Channel Numbers and Frequencies (cont)

Channel Number	Mobile Transmit (MHz)	Mobile Receive (MHz)	Channel Number	Mobile Transmit (MHz)	Mobile Receive (MHz)
754	908.8375	953.8375	801	910.0125	955.0125
755	908.8625	953.8625	802	910.0375	955.0375
756	908.8875	953.8875	803	910.0625	955.0625
757	908.9125	953.9125	804	910.0875	955.0875
758	908.9375	953.9375	805	910.1125	955.1125
759	908.9625	953.9625	806	910.1375	955.1375
760	908.9875	953.9875	807	910.1625	955.1625
761	909.0125	954.0125	808	910.1875	955.1875
762	909.0375	954.0375	809	910.2125	955.2125
763	909.0625	954.0625	810	910.2375	955.2375
764	909.0875	954.0875	811	910.2625	955.2625
765	909.1125	954.1125	812	910.2875	955.2875
766	909.1375	954.1375	813	910.3125	955.3125
767	909.1625	954.1625	814	910.3375	955.3375
768	909.1875	954.1875	815	910.3625	955.3625
769	909.2125	954.2125	816	910.3875	955.3875
770	909.2375	954.2375	817	910.4125	955.4125
771	909.2625	954.2625	818	910.4375	955.4375
772	909.2875	954.2875	819	910.4625	955.4625
773	909.3125	954.3125	820	910.4875	955.4875
774	909.3375	954.3375	821	910.5125	955.5125
775	909.3625	954.3625	822	910.5375	955.5375
776	909.3875	954.3875	823	910.5625	955.5625
777	909.4125	954.4125	824	910.5875	955.5875
778	909.4375	954.4375	825	910.6125	955.6125
779	909.4625	954.4625	826	910.6375	955.6375
780	909.4875	954.4875	827	910.6625	955.6625
781	909.5125	954.5125	828	910.6875	955.6875
782	909.5375	954.5375	829	910.7125	955.7125
783	909.5625	954.5625	830	910.7375	955.7375
784	909.5875	954.5875	831	910.7625	955.7625
785	909.6125	954.6125	832	910.7875	955.7875
786	909.6375	954.6375	833	910.8125	955.8125
787	909.6625	954.6625	834	910.8375	955.8375
788	909.6875	954.6875	835	910.8625	955.8625
789	909.7125	954.7125	836	910.8875	955.8875
790	909.7375	954.7375	837	910.9125	955.9125
791	909.7625	954.7625	838	910.9375	955.9375
792	909.7875	954.7875	839	910.9625	955.9625
793	909.8125	954.8125	840	910.9875	955.9875
794	909.8375	954.8375	841	911.0125	956.0125
795	909.8625	954.8625	842	911.0375	956.0375
796	909.8875	954.8875	843	911.0625	956.0625
797	909.9125	954.9125	844	911.0875	956.0875
798	909.9375	954.9375	845	911.1125	956.1125
799	909.9625	954.9625	846	911.1375	956.1375
800	909.9875	954.9875	847	911.1625	956.1625

Table C-1 E-TACS Cellular Channel Numbers and Frequencies (cont)

Channel Number	Mobile Transmit (MHz)	Mobile Receive (MHz)	Channel Number	Mobile Transmit (MHz)	Mobile Receive (MHz)
848	911.1875	956.1875	895	912.3625	957.3625
849	911.2125	956.2125	896	912.3875	957.3875
850	911.2375	956.2375	897	912.4125	957.4125
851	911.2625	956.2625	898	912.4375	957.4375
852	911.2875	956.2875	899	912.4625	957.4625
853	911.3125	956.3125	900	912.4875	957.4875
854	911.3375	956.3375	901	912.5125	957.5125
855	911.3625	956.3625	902	912.5375	957.5375
856	911.3875	956.3875	903	912.5625	957.5625
857	911.4125	956.4125	904	912.5875	957.5875
858	911.4375	956.4375	905	912.6125	957.6125
859	911.4625	956.4625	906	912.6375	957.6375
860	911.4875	956.4875	907	912.6625	957.6625
861	911.5125	956.5125	908	912.6875	957.6875
862	911.5375	956.5375	909	912.7125	957.7125
863	911.5625	956.5625	910	912.7375	957.7375
864	911.5875	956.5875	911	912.7625	957.7625
865	911.6125	956.6125	912	912.7875	957.7875
866	911.6375	956.6375	913	912.8125	957.8125
867	911.6625	956.6625	914	912.8375	957.8375
868	911.6875	956.6875	915	912.8625	957.8625
869	911.7125	956.7125	916	912.8875	957.8875
870	911.7375	956.7375	917	912.9125	957.9125
871	911.7625	956.7625	918	912.9375	957.9375
872	911.7875	956.7875	919	912.9625	957.9625
873	911.8125	956.8125	920	912.9875	957.9875
874	911.8375	956.8375	921	913.0125	958.0125
875	911.8625	956.8625	922	913.0375	958.0375
876	911.8875	956.8875	923	913.0625	958.0625
877	911.9125	956.9125	924	913.0875	958.0875
878	911.9375	956.9375	925	913.1125	958.1125
879	911.9625	956.9625	926	913.1375	958.1375
880	911.9875	956.9875	927	913.1625	958.1625
881	912.0125	957.0125	928	913.1875	958.1875
882	912.0375	957.0375	929	913.2125	958.2125
883	912.0625	957.0625	930	913.2375	958.2375
884	912.0875	957.0875	931	913.2625	958.2625
885	912.1125	957.1125	932	913.2875	958.2875
886	912.1375	957.1375	933	913.3125	958.3125
887	912.1625	957.1625	934	913.3375	958.3375
888	912.1875	957.1875	935	913.3625	958.3625
889	912.2125	957.2125	936	913.3875	958.3875
890	912.2375	957.2375	937	913.4125	958.4125
891	912.2625	957.2625	938	913.4375	958.4375
892	912.2875	957.2875	939	913.4625	958.4625
893	912.3125	957.3125	940	913.4875	958.4875
894	912.3375	957.3375	941	913.5125	958.5125

Table C-1 E-TACS Cellular Channel Numbers and Frequencies (cont)

Channel Number	Mobile Transmit (MHz)	Mobile Receive (MHz)	Channel Number	Mobile Transmit (MHz)	Mobile Receive (MHz)
942	913.5375	958.5375	989	914.7125	959.7125
943	913.5625	958.5625	990	914.7375	959.7375
944	913.5875	958.5875	991	914.7625	959.7625
945	913.6125	958.6125	992	914.7875	959.7875
946	913.6375	958.6375	993	914.8125	959.8125
947	913.6625	958.6625	994	914.8375	959.8375
948	913.6875	958.6875	995	914.8625	959.8625
949	913.7125	958.7125	996	914.8875	959.8875
950	913.7375	958.7375	997	914.9125	959.9125
951	913.7625	958.7625	998	914.9375	959.9375
952	913.7875	958.7875	999	914.9625	959.9625
953	913.8125	958.8125	1000	914.9875	959.9875
954	913.8375	958.8375	1329	872.0125	917.0125
955	913.8625	958.8625	1330	872.0375	917.0375
956	913.8875	958.8875	1331	872.0625	917.0625
957	913.9125	958.9125	1332	872.0875	917.0875
958	913.9375	958.9375	1333	872.1125	917.1125
959	913.9625	958.9625	1334	872.1375	917.1375
960	913.9875	958.9875	1335	872.1625	917.1625
961	914.0125	959.0125	1336	872.1875	917.1875
962	914.0375	959.0375	1337	872.2125	917.2125
963	914.0625	959.0625	1338	872.2375	917.2375
964	914.0875	959.0875	1339	872.2625	917.2625
965	914.1125	959.1125	1340	872.2875	917.2875
966	914.1375	959.1375	1341	872.3125	917.3125
967	914.1625	959.1625	1342	872.3375	917.3375
968	914.1875	959.1875	1343	872.3625	917.3625
969	914.2125	959.2125	1344	872.3875	917.3875
970	914.2375	959.2375	1345	872.4125	917.4125
971	914.2625	959.2625	1346	872.4375	917.4375
972	914.2875	959.2875	1347	872.4625	917.4625
973	914.3125	959.3125	1348	872.4875	917.4875
974	914.3375	959.3375	1349	872.5125	917.5125
975	914.3625	959.3625	1350	872.5375	917.5375
976	914.3875	959.3875	1351	872.5625	917.5625
977	914.4125	959.4125	1352	872.5875	917.5875
978	914.4375	959.4375	1353	872.6125	917.6125
979	914.4625	959.4625	1354	872.6375	917.6375
980	914.4875	959.4875	1355	872.6625	917.6625
981	914.5125	959.5125	1356	872.6875	917.6875
982	914.5375	959.5375	1357	872.7125	917.7125
983	914.5625	959.5625	1358	872.7375	917.7375
984	914.5875	959.5875	1359	872.7625	917.7625
985	914.6125	959.6125	1360	872.7875	917.7875
986	914.6375	959.6375	1361	872.8125	917.8125
987	914.6625	959.6625	1362	872.8375	917.8375
988	914.6875	959.6875	1363	872.8625	917.8625

Table C-1 E-TACS Cellular Channel Numbers and Frequencies (cont)

Channel Number	Mobile Transmit (MHz)	Mobile Receive (MHz)	Channel Number	Mobile Transmit (MHz)	Mobile Receive (MHz)
1364	872.8875	917.8875	1411	874.0625	919.0625
1365	872.9125	917.9125	1412	874.0875	919.0875
1366	872.9375	917.9375	1413	874.1125	919.1125
1367	872.9625	917.9625	1414	874.1375	919.1375
1368	872.9875	917.9875	1415	874.1625	919.1625
1369	873.0125	918.0125	1416	874.1875	919.1875
1370	873.0375	918.0375	1417	874.2125	919.2125
1371	873.0625	918.0625	1418	874.2375	919.2375
1372	873.0875	918.0875	1419	874.2625	919.2625
1373	873.1125	918.1125	1420	874.2875	919.2875
1374	873.1375	918.1375	1421	874.3125	919.3125
1375	873.1625	918.1625	1422	874.3375	919.3375
1376	873.1875	918.1875	1423	874.3625	919.3625
1377	873.2125	918.2125	1424	874.3875	919.3875
1378	873.2375	918.2375	1425	874.4125	919.4125
1379	873.2625	918.2625	1426	874.4375	919.4375
1380	873.2875	918.2875	1427	874.4625	919.4625
1381	873.3125	918.3125	1428	874.4875	919.4875
1382	873.3375	918.3375	1429	874.5125	919.5125
1383	873.3625	918.3625	1430	874.5375	919.5375
1384	873.3875	918.3875	1431	874.5625	919.5625
1385	873.4125	918.4125	1432	874.5875	919.5875
1386	873.4375	918.4375	1433	874.6125	919.6125
1387	873.4625	918.4625	1434	874.6375	919.6375
1388	873.4875	918.4875	1435	874.6625	919.6625
1389	873.5125	918.5125	1436	874.6875	919.6875
1390	873.5375	918.5375	1437	874.7125	919.7125
1391	873.5625	918.5625	1438	874.7375	919.7375
1392	873.5875	918.5875	1439	874.7625	919.7625
1393	873.6125	918.6125	1440	874.7875	919.7875
1394	873.6375	918.6375	1441	874.8125	919.8125
1395	873.6625	918.6625	1442	874.8375	919.8375
1396	873.6875	918.6875	1443	874.8625	919.8625
1397	873.7125	918.7125	1444	874.8875	919.8875
1398	873.7375	918.7375	1445	874.9125	919.9125
1399	873.7625	918.7625	1446	874.9375	919.9375
1400	873.7875	918.7875	1447	874.9625	919.9625
1401	873.8125	918.8125	1448	874.9875	919.9875
1402	873.8375	918.8375	1449	875.0125	920.0125
1403	873.8625	918.8625	1450	875.0375	920.0375
1404	873.8875	918.8875	1451	875.0625	920.0625
1405	873.9125	918.9125	1452	875.0875	920.0875
1406	873.9375	918.9375	1453	875.1125	920.1125
1407	873.9625	918.9625	1454	875.1375	920.1375
1408	873.9875	918.9875	1455	875.1625	920.1625
1409	874.0125	919.0125	1456	875.1875	920.1875
1410	874.0375	919.0375	1457	875.2125	920.2125

Table C-1 E-TACS Cellular Channel Numbers and Frequencies (cont)

Channel Number	Mobile Transmit (MHz)	Mobile Receive (MHz)	Channel Number	Mobile Transmit (MHz)	Mobile Receive (MHz)
1458	875.2375	920.2375	1505	876.4125	921.4125
1459	875.2625	920.2625	1506	876.4375	921.4375
1460	875.2875	920.2875	1507	876.4625	921.4625
1461	875.3125	920.3125	1508	876.4875	921.4875
1462	875.3375	920.3375	1509	876.5125	921.5125
1463	875.3625	920.3625	1510	876.5375	921.5375
1464	875.3875	920.3875	1511	876.5625	921.5625
1465	875.4125	920.4125	1512	876.5875	921.5875
1466	875.4375	920.4375	1513	876.6125	921.6125
1467	875.4625	920.4625	1514	876.6375	921.6375
1468	875.4875	920.4875	1515	876.6625	921.6625
1469	875.5125	920.5125	1516	876.6875	921.6875
1470	875.5375	920.5375	1517	876.7125	921.7125
1471	875.5625	920.5625	1518	876.7375	921.7375
1472	875.5875	920.5875	1519	876.7625	921.7625
1473	875.6125	920.6125	1520	876.7875	921.7875
1474	875.6375	920.6375	1521	876.8125	921.8125
1475	875.6625	920.6625	1522	876.8375	921.8375
1476	875.6875	920.6875	1523	876.8625	921.8625
1477	875.7125	920.7125	1524	876.8875	921.8875
1478	875.7375	920.7375	1525	876.9125	921.9125
1479	875.7625	920.7625	1526	876.9375	921.9375
1480	875.7875	920.7875	1527	876.9625	921.9625
1481	875.8125	920.8125	1528	876.9875	921.9875
1482	875.8375	920.8375	1529	877.0125	922.0125
1483	875.8625	920.8625	1530	877.0375	922.0375
1484	875.8875	920.8875	1531	877.0625	922.0625
1485	875.9125	920.9125	1532	877.0875	922.0875
1486	875.9375	920.9375	1533	877.1125	922.1125
1487	875.9625	920.9625	1534	877.1375	922.1375
1488	875.9875	920.9875	1535	877.1625	922.1625
1489	876.0125	921.0125	1536	877.1875	922.1875
1490	876.0375	921.0375	1537	877.2125	922.2125
1491	876.0625	921.0625	1538	877.2375	922.2375
1492	876.0875	921.0875	1539	877.2625	922.2625
1493	876.1125	921.1125	1540	877.2875	922.2875
1494	876.1375	921.1375	1541	877.3125	922.3125
1495	876.1625	921.1625	1542	877.3375	922.3375
1496	876.1875	921.1875	1543	877.3625	922.3625
1497	876.2125	921.2125	1544	877.3875	922.3875
1498	876.2375	921.2375	1545	877.4125	922.4125
1499	876.2625	921.2625	1546	877.4375	922.4375
1500	876.2875	921.2875	1547	877.4625	922.4625
1501	876.3125	921.3125	1548	877.4875	922.4875
1502	876.3375	921.3375	1549	877.5125	922.5125
1503	876.3625	921.3625	1550	877.5375	922.5375
1504	876.3875	921.3875	1551	877.5625	922.5625

Table C-1 E-TACS Cellular Channel Numbers and Frequencies (cont)

Channel Number	Mobile Transmit (MHz)	Mobile Receive (MHz)	Channel Number	Mobile Transmit (MHz)	Mobile Receive (MHz)
1552	877.5875	922.5875	1599	878.7625	923.7625
1553	877.6125	922.6125	1600	878.7875	923.7875
1554	877.6375	922.6375	1601	878.8125	923.8125
1555	877.6625	922.6625	1602	878.8375	923.8375
1556	877.6875	922.6875	1603	878.8625	923.8625
1557	877.7125	922.7125	1604	878.8875	923.8875
1558	877.7375	922.7375	1605	878.9125	923.9125
1559	877.7625	922.7625	1606	878.9375	923.9375
1560	877.7875	922.7875	1607	878.9625	923.9625
1561	877.8125	922.8125	1608	878.9875	923.9875
1562	877.8375	922.8375	1609	879.0125	924.0125
1563	877.8625	922.8625	1610	879.0375	924.0375
1564	877.8875	922.8875	1611	879.0625	924.0625
1565	877.9125	922.9125	1612	879.0875	924.0875
1566	877.9375	922.9375	1613	879.1125	924.1125
1567	877.9625	922.9625	1614	879.1375	924.1375
1568	877.9875	922.9875	1615	879.1625	924.1625
1569	878.0125	923.0125	1616	879.1875	924.1875
1570	878.0375	923.0375	1617	879.2125	924.2125
1571	878.0625	923.0625	1618	879.2375	924.2375
1572	878.0875	923.0875	1619	879.2625	924.2625
1573	878.1125	923.1125	1620	879.2875	924.2875
1574	878.1375	923.1375	1621	879.3125	924.3125
1575	878.1625	923.1625	1622	879.3375	924.3375
1576	878.1875	923.1875	1623	879.3625	924.3625
1577	878.2125	923.2125	1624	879.3875	924.3875
1578	878.2375	923.2375	1625	879.4125	924.4125
1579	878.2625	923.2625	1626	879.4375	924.4375
1580	878.2875	923.2875	1627	879.4625	924.4625
1581	878.3125	923.3125	1628	879.4875	924.4875
1582	878.3375	923.3375	1629	879.5125	924.5125
1583	878.3625	923.3625	1630	879.5375	924.5375
1584	878.3875	923.3875	1631	879.5625	924.5625
1585	878.4125	923.4125	1632	879.5875	924.5875
1586	878.4375	923.4375	1633	879.6125	924.6125
1587	878.4625	923.4625	1634	879.6375	924.6375
1588	878.4875	923.4875	1635	879.6625	924.6625
1589	878.5125	923.5125	1636	879.6875	924.6875
1590	878.5375	923.5375	1637	879.7125	924.7125
1591	878.5625	923.5625	1638	879.7375	924.7375
1592	878.5875	923.5875	1639	879.7625	924.7625
1593	878.6125	923.6125	1640	879.7875	924.7875
1594	878.6375	923.6375	1641	879.8125	924.8125
1595	878.6625	923.6625	1642	879.8375	924.8375
1596	878.6875	923.6875	1643	879.8625	924.8625
1597	878.7125	923.7125	1644	879.8875	924.8875
1598	878.7375	923.7375	1645	879.9125	924.9125

Table C-1 E-TACS Cellular Channel Numbers and Frequencies (cont)

Channel Number	Mobile Transmit (MHz)	Mobile Receive (MHz)	Channel Number	Mobile Transmit (MHz)	Mobile Receive (MHz)
1646	879.9375	924.9375	1693	881.1125	926.1125
1647	879.9625	924.9625	1694	881.1375	926.1375
1648	879.9875	924.9875	1695	881.1625	926.1625
1649	880.0125	925.0125	1696	881.1875	926.1875
1650	880.0375	925.0375	1697	881.2125	926.2125
1651	880.0625	925.0625	1698	881.2375	926.2375
1652	880.0875	925.0875	1699	881.2625	926.2625
1653	880.1125	925.1125	1700	881.2875	926.2875
1654	880.1375	925.1375	1701	881.3125	926.3125
1655	880.1625	925.1625	1702	881.3375	926.3375
1656	880.1875	925.1875	1703	881.3625	926.3625
1657	880.2125	925.2125	1704	881.3875	926.3875
1658	880.2375	925.2375	1705	881.4125	926.4125
1659	880.2625	925.2625	1706	881.4375	926.4375
1660	880.2875	925.2875	1707	881.4625	926.4625
1661	880.3125	925.3125	1708	881.4875	926.4875
1662	880.3375	925.3375	1709	881.5125	926.5125
1663	880.3625	925.3625	1710	881.5375	926.5375
1664	880.3875	925.3875	1711	881.5625	926.5625
1665	880.4125	925.4125	1712	881.5875	926.5875
1666	880.4375	925.4375	1713	881.6125	926.6125
1667	880.4625	925.4625	1714	881.6375	926.6375
1668	880.4875	925.4875	1715	881.6625	926.6625
1669	880.5125	925.5125	1716	881.6875	926.6875
1670	880.5375	925.5375	1717	881.7125	926.7125
1671	880.5625	925.5625	1718	881.7375	926.7375
1672	880.5875	925.5875	1719	881.7625	926.7625
1673	880.6125	925.6125	1720	881.7875	926.7875
1674	880.6375	925.6375	1721	881.8125	926.8125
1675	880.6625	925.6625	1722	881.8375	926.8375
1676	880.6875	925.6875	1723	881.8625	926.8625
1677	880.7125	925.7125	1724	881.8875	926.8875
1678	880.7375	925.7375	1725	881.9125	926.9125
1679	880.7625	925.7625	1726	881.9375	926.9375
1680	880.7875	925.7875	1727	881.9625	926.9625
1681	880.8125	925.8125	1728	881.9875	926.9875
1682	880.8375	925.8375	1729	882.0125	927.0125
1683	880.8625	925.8625	1730	882.0375	927.0375
1684	880.8875	925.8875	1731	882.0625	927.0625
1685	880.9125	925.9125	1732	882.0875	927.0875
1686	880.9375	925.9375	1733	882.1125	927.1125
1687	880.9625	925.9625	1734	882.1375	927.1375
1688	880.9875	925.9875	1735	882.1625	927.1625
1689	881.0125	926.0125	1736	882.1875	927.1875
1690	881.0375	926.0375	1737	882.2125	927.2125
1691	881.0625	926.0625	1738	882.2375	927.2375
1692	881.0875	926.0875	1739	882.2625	927.2625

Table C-1 E-TACS Cellular Channel Numbers and Frequencies (cont)

Channel Number	Mobile Transmit (MHz)	Mobile Receive (MHz)	Channel Number	Mobile Transmit (MHz)	Mobile Receive (MHz)
1740	882.2875	927.2875	1787	883.4625	928.4625
1741	882.3125	927.3125	1788	883.4875	928.4875
1742	882.3375	927.3375	1789	883.5125	928.5125
1743	882.3625	927.3625	1790	883.5375	928.5375
1744	882.3875	927.3875	1791	883.5625	928.5625
1745	882.4125	927.4125	1792	883.5875	928.5875
1746	882.4375	927.4375	1793	883.6125	928.6125
1747	882.4625	927.4625	1794	883.6375	928.6375
1748	882.4875	927.4875	1795	883.6625	928.6625
1749	882.5125	927.5125	1796	883.6875	928.6875
1750	882.5375	927.5375	1797	883.7125	928.7125
1751	882.5625	927.5625	1798	883.7375	928.7375
1752	882.5875	927.5875	1799	883.7625	928.7625
1753	882.6125	927.6125	1800	883.7875	928.7875
1754	882.6375	927.6375	1801	883.8125	928.8125
1755	882.6625	927.6625	1802	883.8375	928.8375
1756	882.6875	927.6875	1803	883.8625	928.8625
1757	882.7125	927.7125	1804	883.8875	928.8875
1758	882.7375	927.7375	1805	883.9125	928.9125
1759	882.7625	927.7625	1806	883.9375	928.9375
1760	882.7875	927.7875	1807	883.9625	928.9625
1761	882.8125	927.8125	1808	883.9875	928.9875
1762	882.8375	927.8375	1809	884.0125	929.0125
1763	882.8625	927.8625	1810	884.0375	929.0375
1764	882.8875	927.8875	1811	884.0625	929.0625
1765	882.9125	927.9125	1812	884.0875	929.0875
1766	882.9375	927.9375	1813	884.1125	929.1125
1767	882.9625	927.9625	1814	884.1375	929.1375
1768	882.9875	927.9875	1815	884.1625	929.1625
1769	883.0125	928.0125	1816	884.1875	929.1875
1770	883.0375	928.0375	1817	884.2125	929.2125
1771	883.0625	928.0625	1818	884.2375	929.2375
1772	883.0875	928.0875	1819	884.2625	929.2625
1773	883.1125	928.1125	1820	884.2875	929.2875
1774	883.1375	928.1375	1821	884.3125	929.3125
1775	883.1625	928.1625	1822	884.3375	929.3375
1776	883.1875	928.1875	1823	884.3625	929.3625
1777	883.2125	928.2125	1824	884.3875	929.3875
1778	883.2375	928.2375	1825	884.4125	929.4125
1779	883.2625	928.2625	1826	884.4375	929.4375
1780	883.2875	928.2875	1827	884.4625	929.4625
1781	883.3125	928.3125	1828	884.4875	929.4875
1782	883.3375	928.3375	1829	884.5125	929.5125
1783	883.3625	928.3625	1830	884.5375	929.5375
1784	883.3875	928.3875	1831	884.5625	929.5625
1785	883.4125	928.4125	1832	884.5875	929.5875
1786	883.4375	928.4375	1833	884.6125	929.6125

Table C-1 E-TACS Cellular Channel Numbers and Frequencies (cont)

Channel Number	Mobile Transmit (MHz)	Mobile Receive (MHz)	Channel Number	Mobile Transmit (MHz)	Mobile Receive (MHz)
1834	884.6375	929.6375	1881	885.8125	930.8125
1835	884.6625	929.6625	1882	885.8375	930.8375
1836	884.6875	929.6875	1883	885.8625	930.8625
1837	884.7125	929.7125	1884	885.8875	930.8875
1838	884.7375	929.7375	1885	885.9125	930.9125
1839	884.7625	929.7625	1886	885.9375	930.9375
1840	884.7875	929.7875	1887	885.9625	930.9625
1841	884.8125	929.8125	1888	885.9875	930.9875
1842	884.8375	929.8375	1889	886.0125	931.0125
1843	884.8625	929.8625	1890	886.0375	931.0375
1844	884.8875	929.8875	1891	886.0625	931.0625
1845	884.9125	929.9125	1892	886.0875	931.0875
1846	884.9375	929.9375	1893	886.1125	931.1125
1847	884.9625	929.9625	1894	886.1875	931.1875
1848	884.9875	929.9875	1895	886.1625	931.1625
1849	885.0125	930.0125	1896	886.1875	931.1875
1850	885.0375	930.0375	1897	886.2125	931.2125
1851	885.0625	930.0625	1898	886.2375	931.2375
1852	885.0875	930.0875	1899	886.2625	931.2625
1853	885.1125	930.1125	1900	886.2875	931.2875
1854	885.1875	930.1875	1901	886.3125	931.3125
1855	885.1625	930.1625	1902	886.3375	931.3375
1856	885.1875	930.1875	1903	886.3625	931.3625
1857	885.2125	930.2125	1904	886.3875	931.3875
1858	885.2375	930.2375	1905	886.4125	931.4125
1859	885.2625	930.2625	1906	886.4375	931.4375
1860	885.2875	930.2875	1907	886.4625	931.4625
1861	885.3125	930.3125	1908	886.4875	931.4875
1862	885.3375	930.3375	1909	886.5125	931.5125
1863	885.3625	930.3625	1910	886.5375	931.5375
1864	885.3875	930.3875	1911	886.5625	931.5625
1865	885.4125	930.4125	1912	886.5875	931.5875
1866	885.4375	930.4375	1913	886.6125	931.6125
1867	885.4625	930.4625	1914	886.6375	931.6375
1868	885.4875	930.4875	1915	886.6625	931.6625
1869	885.5125	930.5125	1916	886.6875	931.6875
1870	885.5375	930.5375	1917	886.7125	931.7125
1871	885.5625	930.5625	1918	886.7375	931.7375
1872	885.5875	930.5875	1919	886.7625	931.7625
1873	885.6125	930.6125	1920	886.7875	931.7875
1874	885.6375	930.6375	1921	886.8125	931.8125
1875	885.6625	930.6625	1922	886.8375	931.8375
1876	885.6875	930.6875	1923	886.8625	931.8625
1877	885.7125	930.7125	1924	886.8875	931.8875
1878	885.7375	930.7375	1925	886.9125	931.9125
1879	885.7625	930.7625	1926	886.9375	931.9375
1880	885.7875	930.7875	1927	886.9625	931.9625

Table C-1 E-TACS Cellular Channel Numbers and Frequencies (cont)

Channel Number	Mobile Transmit (MHz)	Mobile Receive (MHz)	Channel Number	Mobile Transmit (MHz)	Mobile Receive (MHz)
1928	886.9875	931.9875	1976	888.1975	933.1975
1929	887.0125	932.0125	1977	888.2125	933.2125
1930	887.0375	932.0375	1978	888.2375	933.2375
1931	887.0625	932.0625	1979	888.2625	933.2625
1932	887.0875	932.0875	1980	888.2875	933.2875
1933	887.1125	932.1125	1981	888.3125	933.3125
1934	887.1975	932.1975	1982	888.3375	933.3375
1935	887.1625	932.1625	1983	888.3625	933.3625
1936	887.1975	932.1975	1984	888.3875	933.3875
1937	887.2125	932.2125	1985	888.4125	933.4125
1938	887.2375	932.2375	1986	888.4375	933.4375
1939	887.2625	932.2625	1987	888.4625	933.4625
1940	887.2875	932.2875	1988	888.4875	933.4875
1941	887.3125	932.3125	1989	888.5125	933.5125
1942	887.3375	932.3375	1990	888.5375	933.5375
1943	887.3625	932.3625	1991	888.5625	933.5625
1944	887.3875	932.3875	1992	888.5875	933.5875
1945	887.4125	932.4125	1993	888.6125	933.6125
1946	887.4375	932.4375	1994	888.6375	933.6375
1947	887.4625	932.4625	1995	888.6625	933.6625
1948	887.4875	932.4875	1996	888.6875	933.6875
1949	887.5125	932.5125	1997	888.7125	933.7125
1950	887.5375	932.5375	1998	888.7375	933.7375
1951	887.5625	932.5625	1999	888.7625	933.7625
1952	887.5875	932.5875	2000	888.7875	933.7875
1953	887.6125	932.6125	2001	888.8125	933.8125
1954	887.6375	932.6375	2002	888.8375	933.8375
1955	887.6625	932.6625	2003	888.8625	933.8625
1956	887.6875	932.6875	2004	888.8875	933.8875
1957	887.7125	932.7125	2005	888.9125	933.9125
1958	887.7375	932.7375	2006	888.9375	933.9375
1959	887.7625	932.7625	2007	888.9625	933.9625
1960	887.7875	932.7875	2008	888.9875	933.9875
1961	887.8125	932.8125	2009	889.0125	934.0125
1962	887.8375	932.8375	2010	889.0375	934.0375
1963	887.8625	932.8625	2011	889.0625	934.0625
1964	887.8875	932.8875	2012	889.0875	934.0875
1965	887.9125	932.9125	2013	889.1125	934.1125
1966	887.9375	932.9375	2014	889.2075	934.2075
1967	887.9625	932.9625	2015	889.1625	934.1625
1968	887.9875	932.9875	2016	889.2075	934.2075
1969	888.0125	933.0125	2017	889.2125	934.2125
1970	888.0375	933.0375	2018	889.2375	934.2375
1971	888.0625	933.0625	2019	889.2625	934.2625
1972	888.0875	933.0875	2020	889.2875	934.2875
1973	888.1125	933.1125	2021	889.3125	934.3125
1974	888.1975	933.1975	2022	889.3375	934.3375
1975	888.1625	933.1625	2023	889.3625	934.3625

Table C-1 E-TACS Cellular Channel numbers and Frequencies (cont)

Channel Number	Mobile Transmit (MHz)	Mobile Receive (MHz)	Channel Number	Mobile Transmit (MHz)	Mobile Receive (MHz)
2024	889.3875	934.3875	2036	889.6875	934.6875
2025	889.4125	934.4125	2037	889.7125	934.7125
2026	889.4375	934.4375	2038	889.7375	934.7375
2027	889.4625	934.4625	2039	889.7625	934.7625
2028	889.4875	934.4875	2040	889.7875	934.7875
2029	889.5125	934.5125	2041	889.8125	934.8125
2030	889.5375	934.5375	2042	889.8375	934.8375
2031	889.5625	934.5625	2043	889.8625	934.8625
2032	889.5875	934.5875	2044	889.8875	934.8875
2033	889.6125	934.6125	2045	889.9125	934.9125
2034	889.6375	934.6375	2046	889.9375	934.9375
2035	889.6625	934.6625	2047	889.9625	934.9625

Table C-1 E-Tacs Cellular Channel Numbers and Frequencies (cont)

APPENDIX D - ABBREVIATIONS

A		C	
A	Ampere	CW	Continuous Wave
ac	Alternating Current	C Wt	C Weight
AF	Audio Frequency		D
A Freq	Audio Frequency	DAC	Digital to Analog Converter
AGC	Automatic Gain Control	DCS	Digital Coded Squelch
AM	Amplitude Modulation	dB	Decibels
amp	Ampere	dBm	Decibels relative to 1 milli-watt
ANLZ	Analyzer		
ANSI	American National Standards Institute	dc	Direct Current
ANT	Antenna	DCS	Digital Coded Squelch Codes
AR	Autorange	Demod Audio	Demodulated Audio
ASCII	American National Standard Code for Information Interchange	Dev	Deviation
Atten	Attenuation	Disp	Display
Auto	Automatic	Dist	Distortion
AUX	Auxiliary	div	Division(s)
	B	DMM	Digital Multimeter
BFO	Beat Frequency Oscillator	DPL	Duplex
BER	Bit Error Rate	DPLX	Duplex
bps	Bits per second	DTMF	Dual Tone Multi-Frequency
	C	Dup	Duplex
Cbl Flt	Cable Fault		E
CCH	Control Channel	ERR	Error
ccw	Counterclockwise	ESC	Escape
Cont	Continued	ESD	Electrostatic discharge
CRT	Cathode Ray Tube	E-TACS	Enhanced Total Access Communications System
		EXT MOD	External

	F		L
Fig	Figure	LSB	Single Sideband Lower
FM	Frequency Modulation	lvl	Level
Folw	Follow		M
freq	Frequency	M-Freq	Audio Frequency
Func	Function	MHz	Megahertz (1000000 Hertz)
Func Gen	Function Generator	MIC	Microphone Source
	G	Mkr	Marker
G-Scan	RF Generator Scan	mod	Modulation
Gen	Generator	modul	Modulation
GND	Ground	ms	Millisecond
GPIB	General Purpose Interface Bus	MTRS	Meters
	H	mV	Millivolt
Hz	Hertz	mW	Milliwatt
Hex	Hexadecimal		N
Horiz	Horizontal	Neg	Negative
	I		O
Id	Identification	OFST	Offset Frequency
IF	Intermediate Frequency		P
IEEE	Institute of Electrical and Electronic Engineers	PH	Peak Hold
I/O	Input/Output	PM	Phase Modulation
	K	Pos	Positive
kbps	Kilobits per second	PROG	Program
kHz	Kilohertz (1000 Hertz)	PWR	Power (switch)
	L		R
L-lim	Lower Limit	RCL	Recall
Lmt	Limit	Rcvr	Receiver
		Recap	Recapture

	R		T
Ref	Reference	Tone Rem	Tone Remote
Res	Resolution	Trig	Trigger
Ret	Return	Trk	Tracking
RF	Radio Frequency	Tx	Duplex Transmitter (Receiving) Frequency
RF Pwr Lvl	RF Power Level		
			U
R freq	Receiver Frequency	U-lim	Upper Limit
RMS	Root Mean Square	USB	Single Sideband Upper
Rx	Duplex Receiver (Transmitting) Frequency	UUT	Unit Under Test
	S		V
SCRN	Screen	V	Volt
SCSI	Small Computer System Interface	VAC	Alternating current voltage
sec	Second	VChan	Voice Channel
SGL	Single	Vdc	Direct current voltage
SIG	Signal Strength	Vert	Vertical
SQLCH	Squelch	VOL	Volume
SSB	Single Side Band	VRMS	Voltage Root Mean Square
	T		W
TERM	Terminal	W	Watt
T Freq	Duplex Transmitter Frequency		

APPENDIX E - REPACKING FOR SHIPPING

E-1 SHIPPING INFORMATION

IFR Test Sets returned to factory for calibration, service or repair must be repackaged and shipped subject to the following conditions:

E-1-1 AUTHORIZATION

Do not return any products to factory without authorization from IFR Customer Service Department.

CONTACT: IFR Systems, Inc.
Customer Service Dept.
10200 West York Street
Wichita, Kansas 67215-8935

Telephone: 800-835-2350

TWX: 910-741-6952

E-1-2 TAGGING TEST SETS

All test sets must be tagged with:

- Owner's identification and address.
- Nature of service or repair required.
- Model No. and Serial No.

E-1-3 SHIPPING CONTAINERS

Test Sets must be repackaged in original shipping containers using IFR packing materials. If original shipping containers and materials are not available, contact IFR Customer Service Department for shipping instructions.

E-1-4 FREIGHT COSTS

All freight costs on non-warranty shipments are assumed by the customer. (See "Warranty Packet" for freight charge policy on warranty claims.)

E-2 REPACKING PROCEDURE (Figure E-1)

- Make sure bottom packing mold is seated on floor of shipping container.
- Adjust handle to lay unlocked against Test Set as shown.
- Place Elastic Retainer around Test Set to secure handle.

- Carefully wrap Test Set with polyethylene sheeting.
- Place Test Set into shipping container, making sure Test Set is securely seated in bottom packing mold.
- Place top packing mold over top of Test Set and press down until mold rests solidly on bottom packing mold.
- Close shipping container lids and seal with shipping tape or an industrial stapler. Tie all sides of container with break resistant rope, twine or equivalent.

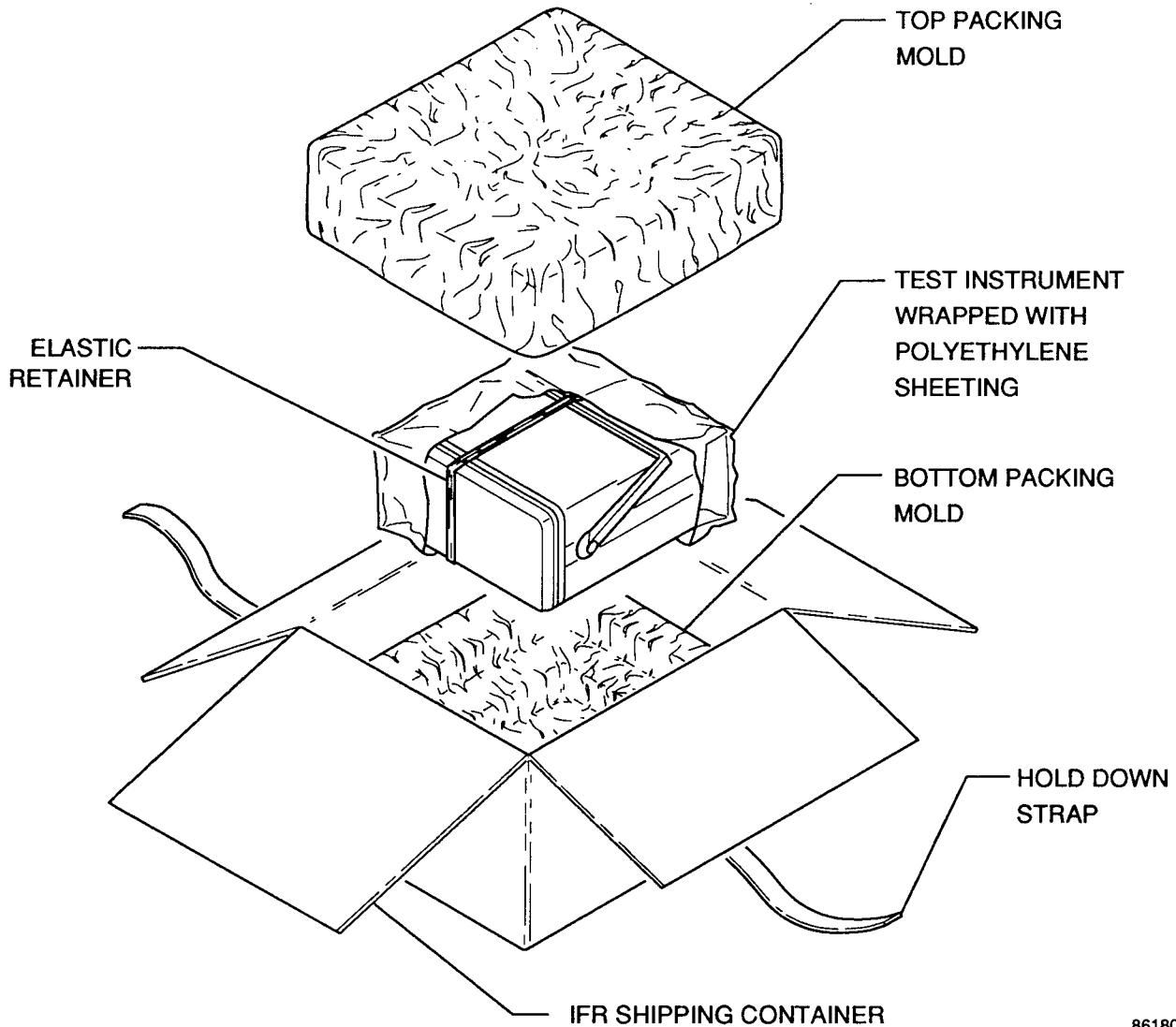

8618018

Figure E-1 Repacking for Shipment

INDEX

2805 Signaling Format	
Duplex Receiver	
Generating	4-78
Selection	4-85
Example, Generating 2805 Code	4-26
RF Generator	
Generating	4-7
Selection	4-14

A

Abbreviations	D-1
AF Generator	
Examples	
Generating AF Tone	4-94
Generating Tone Remote Code	4-94
Frequency Scan	4-92
Menu	3-94
Operation	4-89
Operation Screen and Soft Function Keys	3-91
Specifications	1-7
AF Meter	
Menu	3-123
Operation	4-109
Operation Screen	3-120
Specifications	1-8
AM Modulation Meter	
Menu	3-143
Operation	4-117
Operation Screen	3-140
Specifications	1-11
AMPS Cellular Channel Numbers, Table of	B-1
Audio Signaling Format	
Receiving	
Duplex Transmitter	
Decoding	4-70
Selection	4-70
Examples	
Decoding Audio CCIR Signals	4-45
Decoding Audio User Defined Coded Signals	4-46
Receiver	
Decoding	4-34
Selection	4-33
Generating	
Duplex Receiver	
Encoding	4-78
Selection	4-80
Examples	
Audio Two Tone Coding	4-22
5/6 Audio Coding	4-23
RF Generator	
Encoding	4-7
Selection	4-9
Auxiliary Functions Menu	3-179

B

Bit Error Rate (BER) Meter	
Menu	3-159
Operation	4-125
Operation Screen	3-156
Specifications	1-15

C

Cable Fault Operation	4-102
Calendar Setup Menu	3-181
Cellular Option	
Operation	7-11
Operation Screen	7-1
Receiver Setup for Cellular Operation	7-11
Remote Commands	7-19
Remote Operation	7-19
Setup Menu	7-4
Voice Channel Operation	7-18
Voice Channel Screen	7-9
Cellular Channel Formats	
Receiver	4-39
RF Generator	4-17
Spectrum Analyzer	4-101
Clock Setup Menu	3-181
Color Selection Menu	3-182
Commands, Remote Operation	
Cellular	7-19
Mandatory IEEE 488.2 Specific, FM/AM-1600S	6-6
Specific, FM/AM-1600S	6-7
Configuration Menu	3-180

D

DCS	
Receiving	
Duplex Transmitter	
Decoding	4-70
Selection	4-70
Example, Decoding DCS Signal	4-48
Receiver	
Decoding	4-34
Selection	4-34
Generating	
Duplex Receiver	
Encoding	4-78
Selection	4-83
Example, Generating DCS Code	4-24
RF Generator	
Encoding	4-7
Selection	4-12

D (continued)

DCS INV (Inverted)	
Receiving	
Duplex Transmitter	
Decoding	4-70
Selection	4-70
Receiver	
Decoding	4-34
Selection	4-34
Generating	
Duplex Receiver	
Encoding	4-78
Selection	4-83
RF Generator	
Encoding	4-7
Selection	4-12
Deviation Meter (Peak)	
Menu	3-138
Operation	4-115
Operation Screen	3-135
Specifications	1-10
Deviation Meter (RMS)	
Menu	3-178
Operation	4-135
Operation Screen	3-175
Digital Data Generator (BER) Specifications	1-7
Digital Signaling Format	
Receiving	
Duplex Transmitter	
Decoding	4-70
Selection	4-70
Examples	
Decoding DCS Coded Signals	4-48
Decoding POCSAG Signals	4-49
Receiver	
Decoding	4-34
Selection	4-33
Generating	
Duplex Receiver	
Encoding	4-78
Selection	4-83
Examples	
Generating DCS Code	4-24
Generating POCSAG Code	4-25
RF Generator	
Encoding	4-7
Selection	4-12
Digital Multimeter (DMM)	
Menu	3-169
Operation	4-131
Operation Screen	3-165
Specifications	1-12
Distortion Meter	
Menu	3-147
Operation	4-119
Operation Screen	3-144
Specifications	1-11

D (continued)

DTMF	
Receiving	
Duplex Transmitter	
Decoding	4-70
Selection	4-70
Example, Decoding DTMF Signals	4-44
Receiver	
Decoding	4-34
Selection	4-33
Generating	
Duplex Receiver	
Encoding	4-78
Selection	4-79
Example, Generating DTMF Signal	4-21
RF Generator	
Encoding	4-7
Selection	4-8
Duplex	
Examples	
Measuring Linear Amplifier Gain, Compression and Bandwidth	4-65
Measuring Mixer Performance	4-66
Operation	4-53
Operation Screen	3-51
Receiver (Duplex)	
Menu	3-80
Operation	4-76
Operation Screen	3-72
Oscilloscope display	4-86
Soft Function Keys	3-76
Spectrum Analyzer display	4-86
Specifications	1-4
Transmitter (Duplex)	
AGC Parameters, User Defined	3-48
Decoding	4-70
Find Function	4-74
Menu	3-66
Modulation Type Parameters	3-35
Operation	4-68
Operation Screen	3-56
Oscilloscope display	4-72
Soft Function Keys	3-58
Spectrum Analyzer display	4-72
E	
E-TACS Cellular Channel Numbers, Table of	C-1
F	
Find Function	
Receiver	4-39
Spectrum Analyzer	4-102
Frequency Error Meter	
Menu	3-128
Operation	4-111
Operation Screen	3-125
Specifications	1-8

F (continued)

Frequency Scan	
AF Generator	4-92
Receiver	4-39
RF Generator	4-18

G

GPIB Menu, Configure	3-185
----------------------	-------

I

IMTS Signaling Format	
Duplex Receiver	
Encoding	4-78
Selection	4-84
RF Generator	
Encoding	4-7
Selection	4-13
Installation	2-1
I/O Connectors	
DC Out Pin-Out Table	A-3
GPIB Pin-Out Table	A-5
MIC/ACC Pin-Out Table	A-2
RS-232 Pin-Out Table	A-6
SCSI Pin-Out Table	A-4
Specifications	1-15
Table of	A-1
Video Pin-Out Table, External	A-7

M

Memory Operation, Parameter	4-1
Meter	
Operation	4-109
Operation Screens and Menus	3-119
Modulation Meter (AM)	
Menu	3-143
Operation	4-117
Operation Screen	3-140
Specifications	1-11
MTS Signaling Format	
Duplex Receiver	
Encoding	4-78
Selection	4-84
RF Generator	
Encoding	4-7
Selection	4-13
Multimeter, Digital (DMM)	
Menu	3-169
Operation	4-131
Operation Screen	3-165
Specifications	1-12

O

Oscilloscope	
Duplex Receiver, displayed with	4-86
Duplex Transmitter, displayed with	4-72
Marker Operation	4-97
Menu	3-106
Operation	4-95
Operation Screen	3-99
Plotting display	4-97
Receiver, displayed with	4-36
RF Generator, displayed with	4-15
Soft Function Keys	3-102
Specifications	1-13

P

Packing for shipping	E-1
Performance Evaluation	5-1
Phase Meter	
Menu	3-174
Operation	4-133
Operation Screen	3-171
Specifications	1-11
POCSAG	
Receiving	
Duplex Transmitter	
Decoding	4-70
Selection	4-70
Example, Decoding POCSAG Signal	4-49
Receiver	
Decoding	4-34
Selection	4-34
Generating	
Duplex Receiver	
Encoding	4-78
Selection	4-83
Example, Generating POCSAG Code	4-25
RF Generator	
Encoding	4-7
Selection	4-12
Power Meter (RF)	
Menu	3-133
Operation	4-113
Operation Screen	3-130
Specifications	1-9
Power Requirements	1-16
Power Up Procedure	2-2
Printer Support Menu	3-184
Printing CRT Screens	4-3

R

RCC Signaling Format	
Duplex Receiver	
Encoding	4-78
Selection	4-84
Examples	
Generating 2805 Code	4-26
Generating Tone Remote Code	4-27
RF Generator	
Encoding	4-7
Selection	4-13
RF Frequency Error Meter	
Menu	3-128
Operation	4-111
Operation Screen	3-125
Specifications	1-8
Recalling Parameters	4-1
Receiver	
AGC Parameters, User Defined	3-35
Channel Format, Cellular	4-39
Decoding	
Extend Screen	3-42
Operation	4-34
Examples	
Decoding Audio CCIR Coded Signals	4-45
Decoding Audio User Defined Signals	4-46
Decoding DCS Coded Signals	4-48
Decoding DTMF Coded Signals	4-44
Decoding POCSAG Coded Signals	4-49
Measuring AM or FM Transmitter Distortion	4-50
Receiving AM Signals	4-42
Receiving FM Signals	4-41
Receiving SSB Signals	4-43
Find Function	4-39
Frequency Scan	
Menu	3-46
Operation	4-39
Menu	3-44
Modulation Types Parameters, Table of	3-35
Operation	4-31
Operation Screen	3-33
Oscilloscope display	4-36
RF Lock Operation	4-40
Signaling Formats	
Audio	4-33
Digital	4-34
DTMF	4-33
Soft Function Keys	3-36
Specifications	1-9
Spectrum Analyzer display	4-36
Remote Operation	
Command Syntax	6-5
Mandatory IEEE 488.2 Commands	6-6
Operating Procedures	6-1
Specific Commands, FM/AM-1600S	6-7
Repacking for Shipping	E-1

R (continued)

RF Generator	
Channel Format, Cellular	4-17
Examples	
Generating 2805 Code	4-26
Generating 5/6 Audio Tone	4-23
Generating AM Modulated Signal	4-19
Generating Audio Two Tone Coding	4-22
Generating DCS Code	4-24
Generating DTMF Coded Signal	4-21
Generating Externally Modulated Signal	4-20
Generating FM Modulated Signal	4-19
Generating POCSAG Code	4-25
Generating Tone Remote Code	4-27
Measuring Receiver IF Bandwidth	4-30
Measuring SINAD Sensitivity, Center Frequency and Modulation Acceptance Bandwidth	4-28
Frequency Scan	
Menu	3-21
Operation	4-18
Menu	3-19
Operation	4-5
Operation Screen	3-11
Oscilloscope display	4-15
RF Lock Operation	4-18
Signaling Formats	
Encoding	4-7
Selection	
Audio	4-9
Digital	
DCS	4-12
DCS INV (inverted)	4-12
POCSAG	4-12
DTMF	4-8
RCC	
2805	4-13
IMTS	4-13
MTS	4-13
Tone Remote	4-13
Soft Function Keys	3-15
Specifications	1-3
Spectrum Analyzer display	4-15
RF Lock	
Receiver	4-40
RF Generator	4-18
Spectrum Analyzer	4-103
RF Power Meter	
Menu	3-133
Operation	4-113
Operation Screen	3-130
Specifications	1-9
RS-232 Menu, Configuration	3-183

S

Scanning	
AF Generator	4-92
Receiver	4-39
RF Generator	4-18
SCSI Menu, Configure	3-185
Shipping, Repacking for	E-1
Signal Generator, AF	
Examples	
Generating AF Tone	4-94
Generating Tone Remote Code	4-94
Frequency Scan	4-92
Menu	3-94
Operation	4-89
Operation Screen and Soft Function Keys	3-91
Specifications	1-7
Signal Strength Meter	
Menu	3-155
Operation	4-123
Operation Screen	3-154
SINAD Meter	
Menu	3-152
Operation	4-121
Operation Screen	3-149
Specifications	1-11
Specifications	1-3
Spectrum Analyzer	
Cable Fault	4-102
Channel Format, Cellular	4-101
Duplex Receiver, displayed with	4-86
Duplex Transmitter, displayed with	4-72

S (continued)

Examples	
Measuring Diplexer Tx Loss and Rx Isolation	4-106
Measuring Transmitter Harmonics	4-105
Measuring Very Low Power Transmitter Output	4-104
Find function	4-102
Marker Operation	4-101
Menu	3-117
Operation	4-99
Operation Screen	3-109
Plotting display	4-103
Receiver, displayed with	4-36
RF Generator, displayed with	4-15
Soft Function Keys	3-112
Specifications	1-14
Tracking Generator Operation	4-100
Storing Parameters	4-1

T

Tone Remote Encoding	
AF Generator	4-93
Duplex Receiver	
Encoding	4-78
Selection	4-85
Example, Generating Tone Remote Code	4-94
RF Generator	
Encoding	4-7
Selection	4-13
Tracking Generator Operation	4-100

