

# MAINTENANCE MANUAL W/ILLUSTRATED PARTS CATALOG

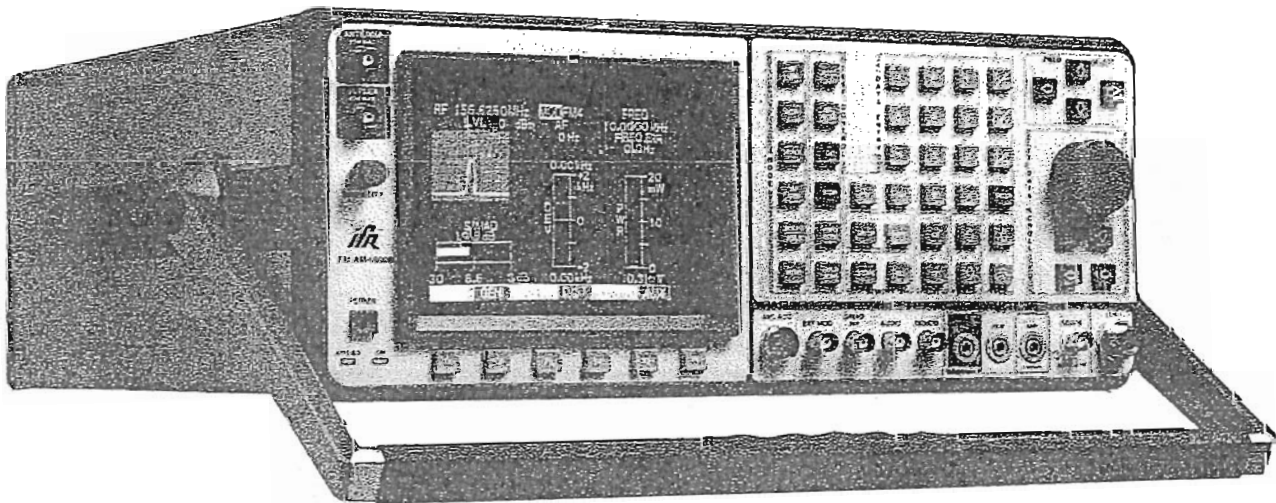

## FM/AM - 1600S COMMUNICATIONS SERVICE MONITOR



10200 West York Street / Wichita, Kansas 67215 U.S.A. / (316) 522-4981 / TWX 910-741-6952

1002-8600-400



**WARNING!**  
**HIGH VOLTAGE EQUIPMENT:**  
**FOR QUALIFIED SERVICING TECHNICIANS ONLY**

THIS EQUIPMENT CONTAINS CERTAIN CIRCUITS AND COMPONENTS OF EXTREMELY HIGH VOLTAGES, CAPABLE OF CAUSING SERIOUS BODILY INJURY OR DEATH. WHEN PERFORMING MAINTENANCE PROCEDURES ON THIS EQUIPMENT, HEED ALL WARNINGS THAT FOLLOW AND REFER TO THE "SAFETY FIRST" PAGES IN THE OPERATION MANUAL FOR PRECAUTIONARY MEASURES.

1. BE SURE TO SERVICE ONLY WHEN ANOTHER PERSON IS PRESENT WHO IS CERTIFIED TO PERFORM FIRST AID FOR ELECTRICAL SHOCK AND CARDIO-PULMONARY RESUSCITATION (CPR). STEPS IN THE PROCEDURES BELOW MARKED WITH AN ASTERISK (\*), ASSUME SUCH CERTIFICATION.
2. EXERCISE CAUTION WHILE SERVICING EQUIPMENT WHEN POWER IS TURNED ON. TURN OFF POWER TO THE UNIT BEFORE REMOVING COVERS, PANELS, PC BOARDS, CANNISTERS, OR BEFORE ENGAGING IN ANY OTHER ACTIVITY THAT COULD RESULT IN DIRECT CONTACT WITH AN ELECTRICAL CURRENT, SUCH AS REMOVING AND SOLDERING COMPONENTS.
3. TO PREVENT ELECTRICAL SHOCK OR EQUIPMENT DAMAGE, ALWAYS CHECK THAT YOUR EQUIPMENT IS PROPERLY GROUNDED PRIOR TO CONNECTING WITH POWER SOURCE. THIS EQUIPMENT IS CAPABLE OF PRODUCING A MAXIMUM OF 120 VAC (U.S./CANADA) OR 240 VAC (EUROPE).

**RESCUE AND FIRST AID FOR SHOCK VICTIMS**

1. STOP MOMENTARILY TO ASSESS THE SITUATION. CALL FOR HELP FROM YOUR FIRST AID REPRESENTATIVE. DO NOT ATTEMPT TO PULL OR GRAB THE VICTIM.
2. IF POSSIBLE, TURN OFF ELECTRICAL POWER SOURCE AND REMOVE POINT OF CONTACT FROM VICTIM.
3. IF YOU CANNOT TURN OFF ELECTRICAL POWER: USE A WOODEN POLE, ROPE OR SOME OTHER DRY INSULATING MATERIAL TO PUSH, PULL OR LIFT THE VICTIM TO SAFETY.
4. SEND FOR A DOCTOR AND/OR AMBULANCE.
- \*5. IF VICTIM'S BREATHING HAS STOPPED: YOUR FIRST AID REPRESENTATIVE SHOULD IMMEDIATELY BEGIN TO TAKE STEPS IN ADMINISTERING CPR.
- \*6. IF VICTIM IS BREATHING: ATTEMPT TO CONTROL ALL SERIOUS BLEEDING, IF NEEDED.
7. IF THERE IS NO BLEEDING OR BLEEDING IS STOPPED: KEEP VICTIM WARM AND FLAT ON HIS/HER BACK.

**WARNING: DEVICES MUST NOT BE INSERTED NOR REMOVED FROM CIRCUITS WITH POWER ON.**

**CAUTION: INTEGRATED CIRCUITS AND SOLID STATE DEVICES SUCH AS MOS FETS, ESPECIALLY CMOS TYPES, ARE SUSCEPTIBLE TO DAMAGE BY ELECTROSTATIC DISCHARGES RECEIVED FROM IMPROPER HANDLING, THE USE OF UNGROUNDED TOOLS, AND IMPROPER STORAGE AND PACKAGING. ANY MAINTENANCE TO THIS UNIT MUST BE PERFORMED WITH THE FOLLOWING PRECAUTIONS:**

- BEFORE USING A CIRCUIT, KEEP ALL LEADS SHORTED TOGETHER WITH VENDOR-SUPPLIED SHORTING SPRINGS OR BY INSERTING LEADS INTO A CONDUCTIVE MATERIAL.
- GROUND THE HAND BEING USED TO REMOVE DEVICES FROM THEIR CONTAINERS WITH A CONDUCTIVE WRISTBAND. REMOVE ALL METAL JEWELRY BEFORE WORKING WITH DEVICES.
- TIPS OF SOLDERING IRONS, AND ALL OTHER TOOLS, MUST BE GROUNDED WHEN USED.
- PC BOARDS, WHEN REMOVED FROM EQUIPMENT, MUST BE SET ON A GROUNDED CONDUCTIVE MAT OR STORED IN A CONDUCTIVE STORAGE BAG. REMOVE ANY BUILT-IN POWER SOURCE, SUCH AS A BATTERY, BEFORE LAYING PC BOARDS ON A CONDUCTIVE MAT OR STORING IN A CONDUCTIVE BAG.
- PC BOARDS, IF BEING SHIPPED TO THE FACTORY FOR REPAIR, MUST BE PACKAGED IN A CONDUCTIVE BAG AND PLACED IN A WELL-CUSHIONED SHIPPING CONTAINER.

THE USE OF SIGNAL GENERATORS FOR MAINTENANCE AND OTHER ACTIVITIES CAN BE A SOURCE OF ELECTRO-MAGNETIC INTERFERENCE (EMI) TO COMMUNICATION RECEIVERS, WHICH CAN CAUSE DISRUPTION AND INTERFERENCE TO COMMUNICATION SERVICE OUT TO A DISTANCE OF SEVERAL MILES.

USERS OF THIS EQUIPMENT SHOULD SCRUTINIZE ANY OPERATION WHICH RESULTS IN RADIATION OF A SIGNAL (DIRECTLY OR INDIRECTLY) AND SHOULD TAKE NECESSARY PRECAUTIONS TO AVOID POTENTIAL COMMUNICATION INTERFERENCE PROBLEMS.

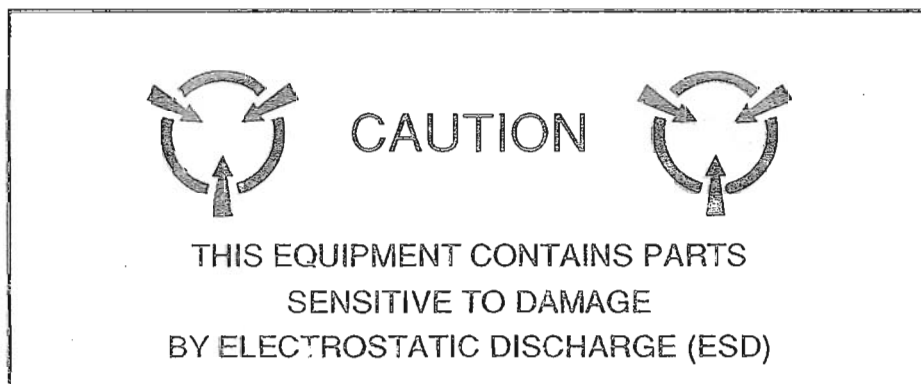



## LIST OF EFFECTIVE PAGES

The manual pages listed below which are affected by a current change or revision, are so identified by a revision number and an asterisk.

Date of issue for original and changed pages are:

Original ..... 0 ..... April 1, 1992  
 Revision ..... 1 ..... August 1, 1992

**TOTAL NUMBER OF PAGES IN THIS MANUAL IS 236 CONSISTING OF THE FOLLOWING:**

Pg. No.	Change No.	Pg. No.	Change No.
Title .....	0	3-34 .....	0
Copyright .....	0	* 3-34a through 3-35 .....	1
Warning .....	0	3-36 .....	0
Caution .....	0	* 3-37 through 3-38 .....	1
* A .....	1	3-39 .....	0
* B Blank .....	1	* 3-40 through 3-41 .....	1
i through ix .....	0	3-42 .....	0
* x .....	1	* 3-43 through 3-47 .....	1
1-1 .....	0	3-48 through 3-50 .....	0
1-2 Blank .....	0	* 3-51 through 3-54 .....	1
1-3 .....	0	3-55 through 3-58 .....	0
1-4 Blank .....	0	* 3-59 .....	1
2-1 through 2-31 .....	0	3-60 .....	0
2-32 Blank .....	0	* 3-61 .....	1
2-33 through 2-41 .....	0	3-62 .....	0
2-42 Blank .....	0	4-1 through 4-37 .....	0
2-43 through 2-45 .....	0	4-38 Blank .....	0
2-46 Blank .....	0	5-1 through 5-2 .....	0
2-47 through 2-71 .....	0	* 6-1 through 6-2a .....	1
2-72 Blank .....	0	* 6-2b Blank .....	1
3-1 through 3-6 .....	0	6-3 through 6-6 .....	0
* 3-7 through 3-8 .....	1	7-i through 7-v .....	0
3-9 through 3-13 .....	0	7-vi Blank .....	0
* 3-14 .....	1	7-1 .....	0
3-15 through 3-17 .....	0	7-2 Blank .....	0
* 3-18 through 3-21 .....	1	7-3 through 7-12 .....	0
3-22 through 3-24 .....	0	A-1 through A-2 .....	0
* 3-25 .....	1	B-1 .....	0
3-26 .....	0	B-2 Blank .....	0
* 3-27 .....	1	C-1 through C-2 .....	0
3-28 .....	0	D-1 through D-4 .....	0
* 3-29 through 3-31 .....	1	Index 1 through Index 3 .....	0
3-32 .....	0	Index 4 Blank .....	0
* 3-33 .....	1		



# PREFACE

## SCOPE

This manual contains maintenance instructions for the FM/AM-1600S Communication Service Monitor. The information in this manual enables the servicing technician to:

- Service, test or replace any major assembly within the FM/AM-1600S.
- Maintain the operating conditions of the FM/AM-1600S to expected performance standards.
- Understand the principles of operation as they relate to the overall operation of the FM/AM-1600S as well functional operation within the major assemblies.

## ORGANIZATION

The FM/AM-1600S Maintenance Manual with Illustrated Parts Catalog is composed of the following sections:

### SECTION 1 - INTRODUCTION

Provides a brief description of the electrical and mechanical configuration of the FM/AM-1600S, intended to familiarize the technician with the overall structure of the set.

### SECTION 2 - THEORY OF OPERATION

Describes how the FM/AM-1600S operates on three levels of complexity: 1) at a systems level, 2) at an interactive functional level and 3) functionally at an assembly level. Block diagrams accompany each level discussed.

### SECTION 3 - CALIBRATION

Provides step by step procedures for calibrating the FM/AM-1600S. This procedure is to be used at normal calibration intervals or after repair or replacement of an assembly.

### SECTION 4 - REPLACEMENT PROCEDURES

Provides step by step procedures for removing and installing major assemblies within the FM/AM-1600S.

### SECTION 5 - PREVENTIVE MAINTENANCE

Contains routine instructions for cleaning and inspecting the FM/AM-1600S.

### SECTION 6 - MECHANICAL ASSEMBLIES, PC BOARDS AND SCHEMATICS

Contains drawings to aid the technician in isolating a dysfunctional major assembly.

### SECTION 7 - ILLUSTRATED PARTS CATALOG

Provides information on ordering replaceable components within the FM/AM-1600S.

### APPENDICES

Contains useful supplementary maintenance data.

# TABLE OF CONTENTS

## SECTION 1 - INTRODUCTION

Paragraph	Title	Page
1-1	General . . . . .	1-1
1-2	Electrical Description . . . . .	1-1
1-3	Mechanical Description . . . . .	1-1

## SECTION 2 - THEORY OF OPERATION

Paragraph	Title	Page
2-1	General . . . . .	2-1
2-2	System Theory of Operation . . . . .	2-1
2-3	Functional Theory of Operation . . . . .	2-4
2-3-1	Receive Operation . . . . .	2-4
2-3-2	Generate Operation . . . . .	2-6
2-3-3	Spectrum Analyzer Operation . . . . .	2-8
2-3-4	System Control (Processor) Operation . . . . .	2-10
2-3-5	Video Operation . . . . .	2-11
2-3-6	Remote Operation . . . . .	2-12
2-4	Module Theory of Operation . . . . .	2-13
2-4-1	General . . . . .	2-13
2-4-2	Processor PC Board Assembly . . . . .	2-14
2-4-3	Memory PC Board Assembly . . . . .	2-18
2-4-4	RF I/O PC Board Assembly . . . . .	2-20
2-4-5	Power Supply Assembly . . . . .	2-22
2-4-6	Auxiliary Power Supply PC Board Assembly . . . . .	2-24
2-4-7	Receive IF Assembly . . . . .	2-26
2-4-8	Analyzer RF Assembly . . . . .	2-28
2-4-9	Receiver Assembly . . . . .	2-30

Paragraph	Title	Page
2-4-10	Analyzer Log/IF Assembly . . . . .	.2-34
2-4-11	Digitizer PC Board Assembly . . . . .	.2-36
2-4-12	Counter PC Board Assembly . . . . .	.2-38
2-4-13	Monitor Assembly . . . . .	.2-40
2-4-14	Monitor Control PC Board Assembly . . . . .	.2-44
2-4-15	1st LO Assembly . . . . .	.2-48
2-4-16	2nd LO Assembly . . . . .	.2-50
2-4-17	3rd LO Assembly . . . . .	.2-52
2-4-18	Power Term Assembly . . . . .	.2-54
2-4-19	Function Generator PC Board Assembly . . . . .	.2-56
2-4-20	90 MHz Generator Assembly . . . . .	.2-58
2-4-21	Generator IF Assembly . . . . .	.2-60
2-4-22	Attenuator PC Board Assembly . . . . .	.2-62
2-4-23	DMM Assembly . . . . .	.2-64
2-4-24	Video Controller PC Board Assembly . . . . .	.2-66
2-4-25	CRT Assembly . . . . .	.2-68
2-4-26	External I/O PC Board Assembly . . . . .	.2-70

### **SECTION 3 - CALIBRATION**

Paragraph	Title	Page
3-1	General . . . . .	.3-1
3-1-1	Safety Precautions . . . . .	.3-1
3-1-2	ESD Precautions . . . . .	.3-2
3-2	Test Equipment Requirements . . . . .	.3-2
3-3	Dissassembly Requirements . . . . .	.3-2
3-4	Calibration Adjustments . . . . .	.3-2
3-5	Controls, Connectors and Indicators . . . . .	.3-2

Paragraph	Title	Page
3-6	Completion of Calibration Test Procedures . . . . .	3-2
3-7	Calibration Record . . . . .	3-2
3-8	Calibration Procedures . . . . .	3-10
3-8-1	Power Supply Calibration . . . . .	3-10
3-8-2	VCXO Calibration . . . . .	3-13
3-8-3	Metering DVM Calibration . . . . .	3-15
3-8-4	Func Gen Level and VRMS Meter Calibration . . . . .	3-17
3-8-5	GEN Output Level Calibration . . . . .	3-21
3-8-6	RF Null Calibration . . . . .	3-23
3-8-7	Signal Meter Calibration . . . . .	3-25
3-8-8	FM Calibration . . . . .	3-26
3-8-9	Deviation Meter Calibration . . . . .	3-28
3-8-10	Modulation Meter Calibration . . . . .	3-32
3-8-11	Phase Meter Calibration . . . . .	3-34
3-8-12	Distortion Meter Calibration . . . . .	3-36
3-8-13	SINAD Meter Calibration . . . . .	3-39
3-8-14	GEN Modulation Calibration . . . . .	3-42
3-8-15	Scope Calibration . . . . .	3-47
3-8-16	Spectrum Analyzer Calibration . . . . .	3-51
3-8-17	Digital Multimeter Calibration . . . . .	3-55
3-8-18	Power Meter Calibration . . . . .	3-58

#### SECTION 4 - OPERATION

Paragraph	Title	Page
4-1	General . . . . .	4-1
4-1-1	Safety Precautions . . . . .	4-1
4-1-2	ESD Precautions . . . . .	4-1

Paragraph	Title	Page
4-2	Equipment Requirements . . . . .	4-1
4-3	Replacement Procedures . . . . .	4-2
4-3-1	Replace Top Case Assembly . . . . .	4-2
4-3-2	Replace Bottom Case Assembly . . . . .	4-3
4-3-3	Replace Digitizer PC Board Assembly . . . . .	4-4
4-3-4	Replace Counter PC Board Assembly . . . . .	4-5
4-3-5	Replace Analyzer Log/IF Assembly . . . . .	4-6
4-3-6	Replace Analyzer RF Assembly . . . . .	4-7
4-3-7	Replace 3rd LO Assembly . . . . .	4-8
4-3-8	Replace 90 MHz Generator Assembly . . . . .	4-9
4-3-9	Replace Receiver Assembly . . . . .	4-10
4-3-10	Replace Monitor Assembly . . . . .	4-11
4-3-11	Replace Monitor Control PC Board Assembly . . . . .	4-12
4-3-12	Replace Function Generator PC Board Assembly . . . . .	4-13
4-3-13	Replace RF I/O PC Board Assembly . . . . .	4-14
4-3-14	Replace Memory PC Board Assembly . . . . .	4-15
4-3-15	Replace Processor PC Board Assembly . . . . .	4-16
4-3-16	Replace Video Controller PC Board Assembly . . . . .	4-17
4-3-17	Replace External I/O PC Board Assembly . . . . .	4-18
4-3-18	Replace Power Supply Assembly . . . . .	4-19
4-3-19	Replace CRT Assembly . . . . .	4-20
4-3-20	Replace Fan . . . . .	4-22
4-3-21	Replace Front Panel Assembly . . . . .	4-23
4-3-22	Replace Rear Panel Connector PC Board Assembly . . . . .	4-24
4-3-23	Replace Rear Panel Assembly . . . . .	4-25
4-3-24	Replace DMM Assembly . . . . .	4-26
4-3-25	Replace 2nd LO Assembly . . . . .	4-27

Paragraph	Title	Page
4-3-26	Replace 1st LO Assembly . . . . .	4-28
4-3-27	Replace Auxiliary Power Supply PC Board Assembly . . . . .	4-29
4-3-28	Replace Receive IF Assembly . . . . .	4-30
4-3-29	Replace Generator IF Assembly . . . . .	4-31
4-3-30	Replace Attenuator PC Board Assembly . . . . .	4-32
4-3-31	Replace Power Term Assembly . . . . .	4-33
4-3-32	Replace 10 MHz Frequency Standard . . . . .	4-34
4-3-33	Replace External Reference Connector . . . . .	4-35
4-3-34	Replace Motherboard PC Board Assembly . . . . .	4-36

**SECTION 5 - PREVENTIVE MAINTENANCE**

Paragraph	Title	Page
5-1	External Cleaning . . . . .	5-1
5-2	Internal Cleaning . . . . .	5-1
5-3	Visual Inspection . . . . .	5-2

**SECTION 6 - MECHANICAL ASSEMBLIES, PC BOARDS & SCHEMATICS**

Paragraph	Title	Page
6-1	General . . . . .	6-1
6-2	Index of FM/AM-1600S Drawings . . . . .	6-1
6-3	Table of FM/AM-1600S Coaxial Cables . . . . .	6-1

**SECTION 7 - ILLUSTRATED PARTS CATALOG**

Paragraph	Title	Page
	Introduction . . . . .	7-i
	Parts Listing . . . . .	7-1



## APPENDICES

Appendix	Title	Page
Appendix A	Test Equipment Requirements . . . . .	A-1
Appendix B	dBm to Microvolt Conversion Chart . . . . .	B-1
Appendix C	Repacking for Shipping . . . . .	C-1
Appendix D	Abbreviations . . . . .	D-1

## INDEX

Index . . . . .	Index-1
-----------------	---------

## LIST OF ILLUSTRATIONS

Figure No.	Title	Page
1-1	FM/AM-1600S Composite Diagram . . . . .	1-3
2-1	FM/AM-1600S Block Diagram . . . . .	2-3
2-2	Receive Function Block Diagram . . . . .	2-5
2-3	Generate Function Block Diagram . . . . .	2-7
2-4	Spectrum Analyzer Block Diagram . . . . .	2-9
2-5	Processor Function Block Diagram . . . . .	2-10
2-6	Video Operation Block Diagram . . . . .	2-11
2-7	Remote Operation Block Diagram . . . . .	2-12
2-8	Processor PC Board Assembly Block Diagram . . . . .	2-17
2-9	Memory PC Board Assembly Block Diagram . . . . .	2-19
2-10	RF I/O PC Board Assembly Block Diagram . . . . .	2-21
2-11	Power Supply Assembly Block Diagram . . . . .	2-23
2-12	Auxiliary Power Supply PC Board Assembly Block Diagram . . . . .	2-25
2-13	Receive IF Assembly Block Diagram . . . . .	2-27
2-14	Analyzer RF Assembly Block Diagram . . . . .	2-29
2-15	Receiver Assembly Block Diagram . . . . .	2-33
2-16	Analyzer Log/IF Assembly Block Diagram . . . . .	2-35
2-17	Digitizer PC Board Assembly Block Diagram . . . . .	2-37
2-18	Counter PC Board Assembly Block Diagram . . . . .	2-39
2-19	Monitor Assembly Block Diagram . . . . .	2-43
2-20	Monitor Control PC Board Assembly Block Diagram . . . . .	2-47
2-21	1st LO Assembly Block Diagram . . . . .	2-49
2-22	2nd LO Assembly Block Diagram . . . . .	2-51
2-23	3rd LO Assembly Block Diagram . . . . .	2-53
2-24	Power Term Assembly Block Diagram . . . . .	2-55
2-25	Function Generator PC Board Assembly Block Diagram . . . . .	2-57

Figure No.	Title	Page
2-26	90 MHz Generator Assembly Block Diagram . . . . .	.2-59
2-27	Generator IF Assembly Block Diagram . . . . .	.2-61
2-28	Attenuator PC Board Assembly Block Diagram . . . . .	.2-63
2-29	DMM Assembly Block Diagram . . . . .	.2-65
2-30	Video Controller PC Board Block Diagram . . . . .	.2-67
2-31	CRT Assembly Block Diagram . . . . .	.2-69
2-32	External I/O PC Board Assembly Block Diagram . . . . .	.2-71
3-1	Module Replacement and Calibration Requirements . . . . .	.3-3
3-2	Calibration Adjustments and Test Points . . . . .	.3-4
3-3	Processor PC Board Assembly Test Points . . . . .	.3-11
3-4	2nd LO Assembly Calibration Points . . . . .	.3-11
3-5	1st LO Assembly Test Points . . . . .	.3-12
3-6	Power Supply Assembly Calibration Points . . . . .	.3-12
3-7	VCXO Calibration Test Setup . . . . .	.3-13
3-8	Monitor Control PC Board Assembly Calibration Points . . . . .	.3-16
3-9	Func Gen Level and VRMS Meter Calibration Setup . . . . .	.3-18
3-10	Function Generator PC Board Assembly Calibration Points . . . . .	.3-20
3-11	Low Frequency and High Frequency Location . . . . .	.3-22
3-12	Receive IF Assembly Calibration Points . . . . .	.3-24
3-13	FM Calibration Test Setup . . . . .	.3-26
3-14	Deviation Meter Calibration Test Setup . . . . .	.3-28
3-15	Modulation Meter Calibration Test Setup . . . . .	.3-32
3-16	Phase Meter Calibration Test Setup . . . . .	.3-34
3-17	Distortion Meter Calibration Test Setup . . . . .	.3-36
3-18	SINAD Meter Calibration Test Setup . . . . .	.3-39
3-19	Digitizer PC Board Assembly Calibration Points . . . . .	.3-48
3-20	Oscilloscope Calibration Setup . . . . .	.3-48

Figure No.	Title	Page
3-21	Analyzer Log/IF Assembly Calibration Points . . . . .	3-53
3-22	DMM Digital PC Board Assembly Calibration Points . . . . .	3-56
3-23	DMM Relay PC Board Assembly Calibration Points . . . . .	3-57
3-24	Power Term Assembly Calibration Points . . . . .	3-59
3-25	Power Meter Calibration Test Setup . . . . .	3-60
6-0	FM/AM-1600S System Block Diagram with RF Overview . . . . .	6-2a
6-1	FM/AM-1600S System Interconnect Diagram . . . . .	6-3
6-2	Motherboard PC Board Assembly Schematic . . . . .	6-4
6-3	Motherboard PC Board Assembly Diagram . . . . .	6-5
6-4	Rear Panel Connector PC Board Assembly Circuit Schematic . . . . .	6-6
7-1	Shipping Kit . . . . .	7-3
7-2	FM/AM-1600S Installation . . . . .	7-4
7-3	Front Cover Assembly . . . . .	7-9
7-4	Accessories . . . . .	7-10
7-5	.05 PPM Oven Oscillator Installation (Opt-02) . . . . .	7-12
C-1	Repacking for Shipment . . . . .	C-2

### LIST OF TABLES

Table No.	Title	Page
3-1	Output Level Range Chart . . . . .	3-21

# SECTION 1 - INTRODUCTION

## 1-1 GENERAL

This section contains a brief description of the internal electrical and mechanical configuration of the FM/AM-1600S, providing the technician with an overall view of the product structure.

## 1-2 ELECTRICAL DESCRIPTION

The FM/AM-1600S is a microprocessor based communications service monitor capable of generating and receiving modulated RF signals from 250 kHz to 999.9999 MHz. The unit is capable of operating as a separate receiver and generator as well as full Duplex Mode with an offset of  $\pm 999.9749$  MHz. Integral to the unit are a Spectrum Analyzer, Oscilloscope and Digital Multimeter (DMM). Metering functions available include the following:

Power Meter	Distortion Meter	SINAD Meter
Deviation Meter	Modulation Meter	Phase Meter
Signal Strength Meter	Bit Error Rate (BER) Meter	Freq Error Meter

Assemblies that make up the FM/AM-1600S include:

- Digitizer PC Board Assembly
- Counter PC Board Assembly
- Analyzer Log/IF PC Board Assembly
- Analyzer RF Assembly
- 3rd LO Assembly
- 90 MHz Generator Assembly
- Receiver Assembly
- Monitor Assembly
- Monitor Control PC Board Assembly
- Function Generator PC Board Assembly
- RF I/O PC Board Assembly
- Memory PC Board Assembly
- Processor PC BOARD Assembly
- Video Controller PC Board Assembly
- External I/O PC Board Assembly
- Power Supply Assembly
- CRT Assembly
- DMM Assembly
- Generator IF Assembly
- Attenuator PC Board Assembly
- Power Termination Assembly
- Auxiliary Power Supply PC Board Assembly
- Receive IF Assembly
- 1st LO Assembly
- 2nd LO Assembly
- TCXO Assembly (Oven Oscillator Assembly is Optional Replacement)

## 1-3 MECHANICAL DESCRIPTION

Figure 1-1 is an exploded composite view of the FM/AM-1600S, identifying and locating major assemblies for the maintaining technician.

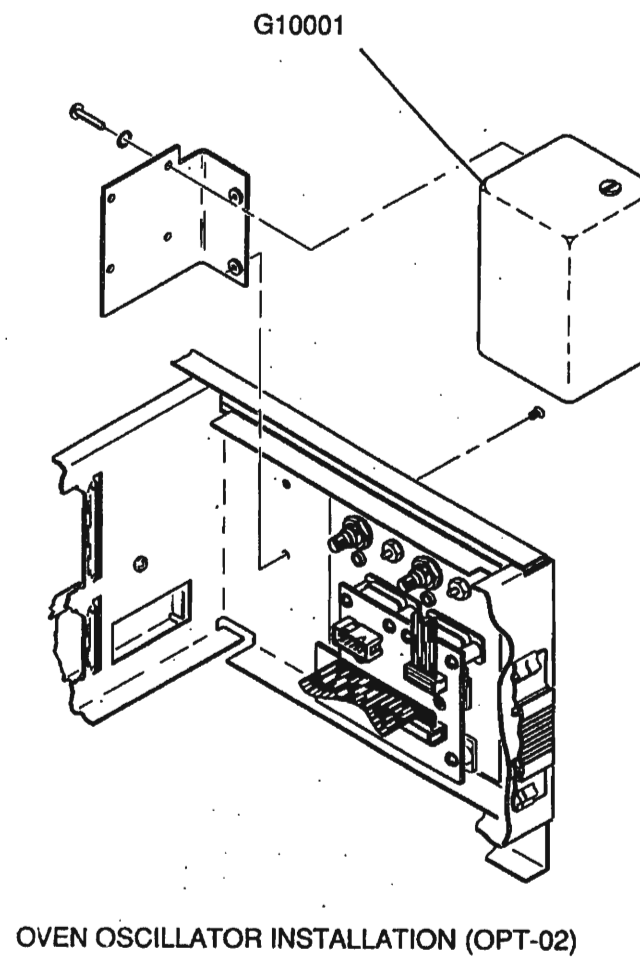
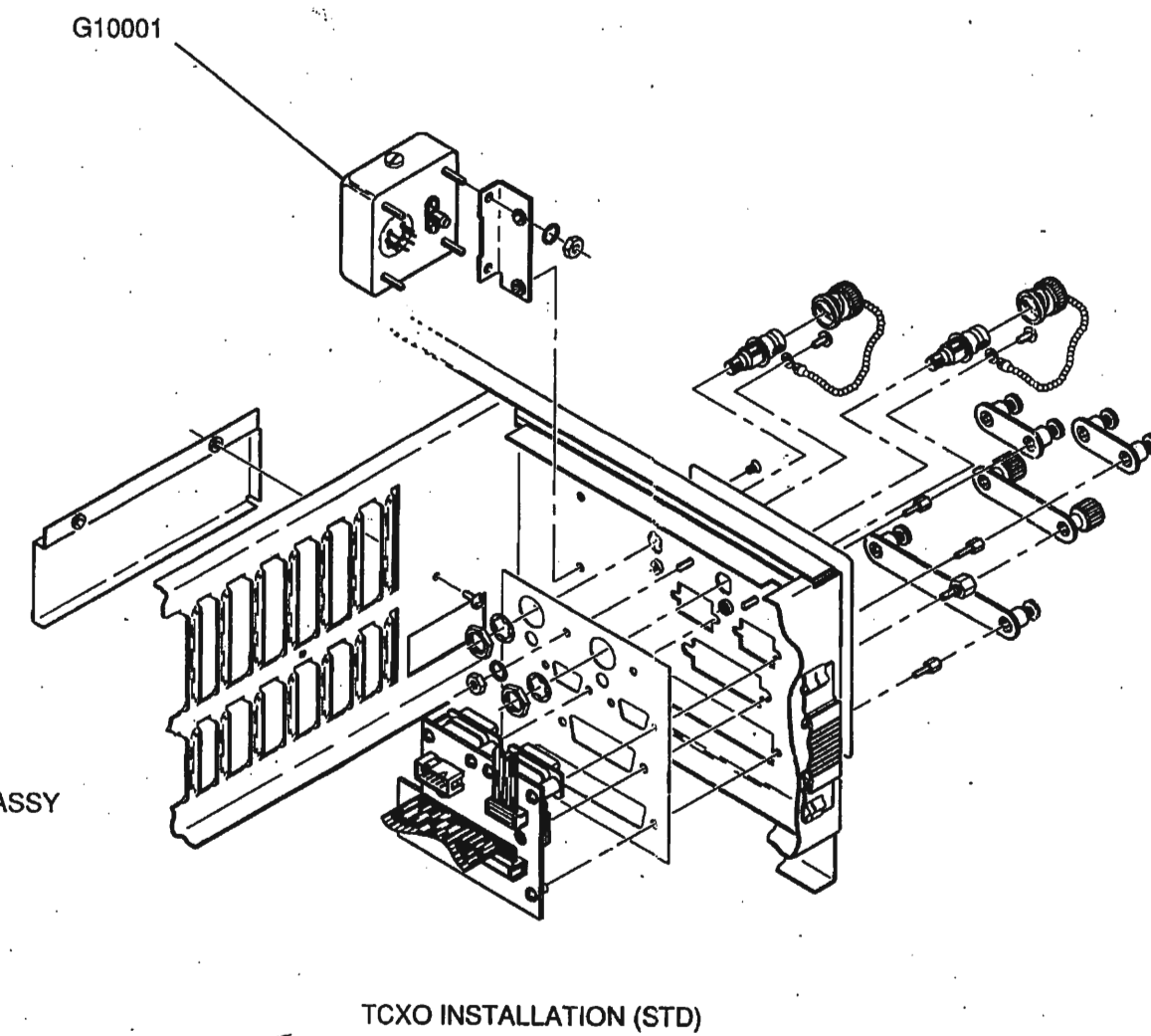
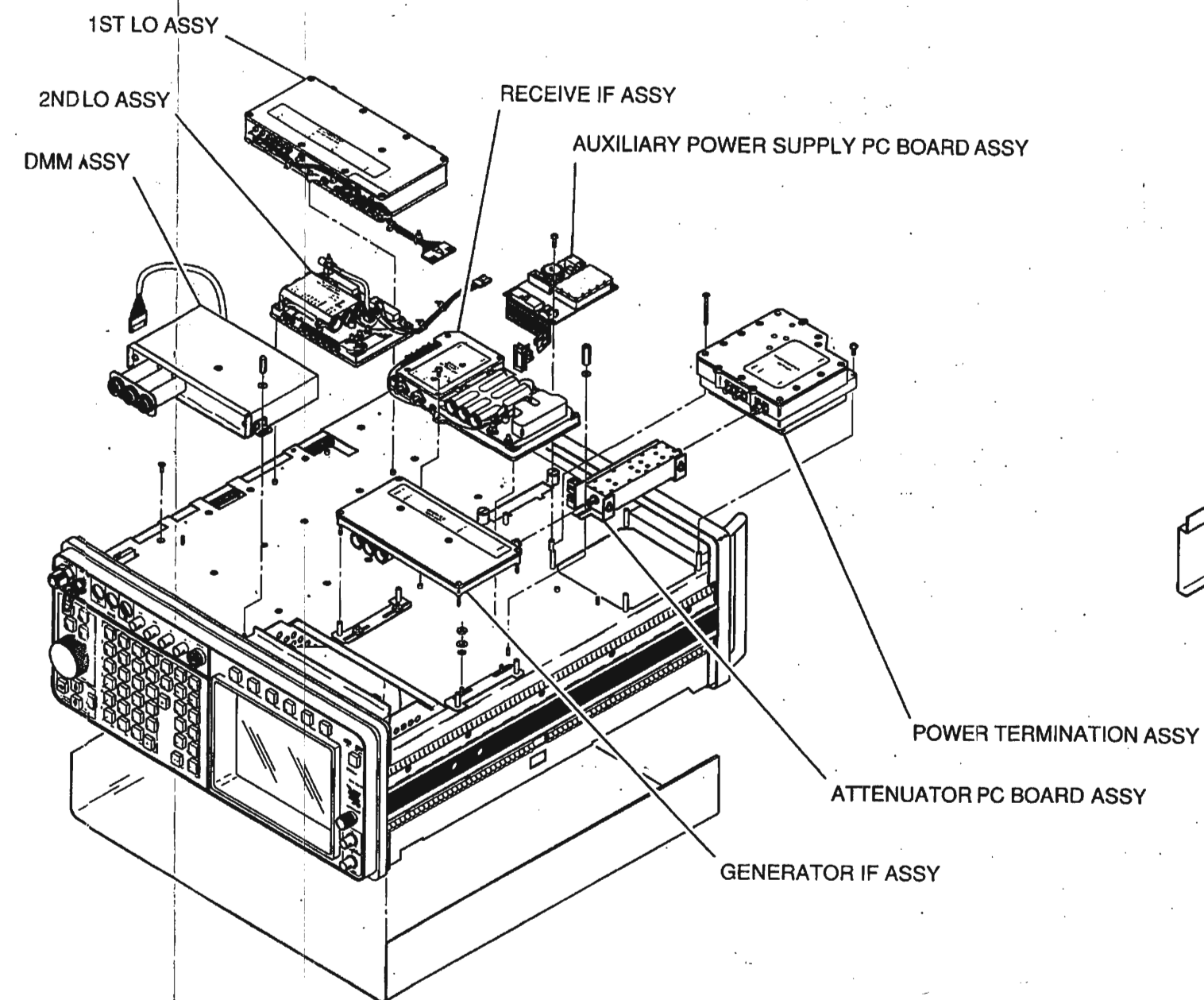
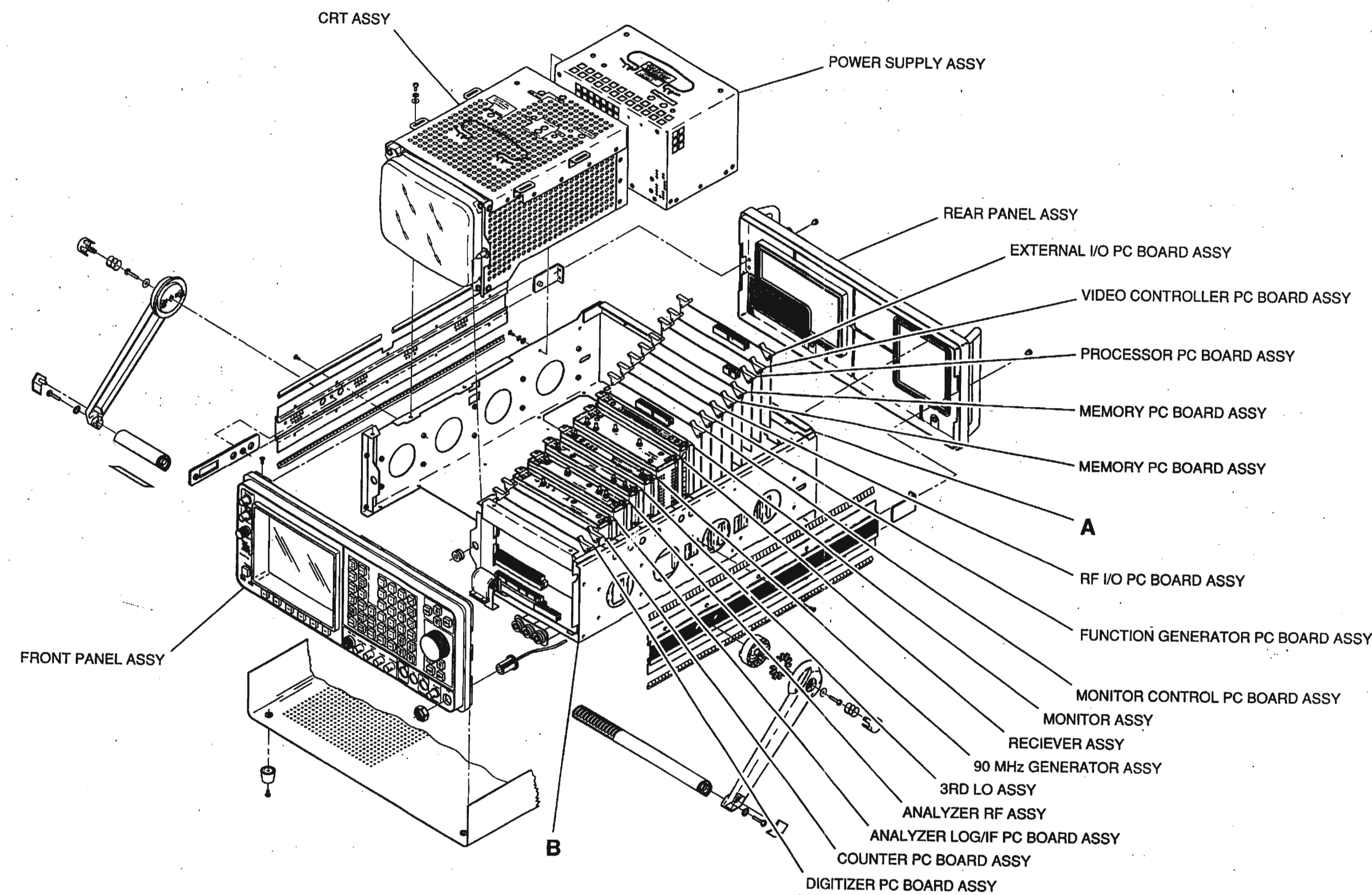

DETAIL B

DETAIL A

Figure 1-1 FM/AM-1600S Composite Diagram



# SECTION 2 - THEORY OF OPERATION

## 2-1 GENERAL

This section is included to provide the maintenance technician with a concept of how the FM/AM-1600S operates. Theory of Operation is divided into three sections with each level more detailed in explaining the actions performed within the FM/AM-1600S. The sections include:

1. System Theory of Operation

System Level information is a simplified explanation of the unit functions.

2. Functional Theory of Operation

Functional Theory describes the signal path during each basic operation, lists general effects of the different areas on the signal and details the different modules involved.

3. Module Theory of Operation

Module Theory of Operation explains the process in each module to functional block level. Dependencies on other modules and signal manipulation in the module are described at a functional level.

## 2-2 SYSTEM THEORY OF OPERATION

The FM/AM-1600S is a microprocessor based communications service monitor capable of generating and receiving modulated RF signals from 250 kHz to 999.9999 MHz. The unit is capable of operating as a separate receiver and generator as well as full Duplex Mode with an offset of  $\pm 999.9749$  MHz. Integral to the unit are a Spectrum Analyzer, Oscilloscope and Digital Multimeter (DMM). Metering functions available include the following:

Power Meter	Distortion Meter	SINAD Meter
Deviation Meter	Modulation Meter	Phase Meter
Signal Strength Meter	Bit Error Rate (BER) Meter	Freq Error Meter

Receiving signals is done with a triple conversion superheterodyne receiver. Modulations decoded include FM, AM, PM, FM DATA and SSB. The received signal is converted in the Receive IF Assembly to a 10.7 MHz IF Signal. The 10.7 MHz IF Signal is demodulated in the Receiver Assembly and passed to the Monitor Assembly where demodulated signals are routed as required. Signals can be received at the ANTENNA IN Connector or the T/R Connector. Signals received at the T/R Connector are attenuated in the Power Term Assembly.

Generated signals can be transmitted both modulated and unmodulated. Modulation types available include FM, AM and PM. Signals originate in the Function Generator PC Board Assembly, where they are passed to the 90 MHz Generator Assembly for conversion to a 90 MHz IF Signal. The 90 MHz IF signal is mixed to the RF output frequency in the Generator IF Assembly. The RF Signal is then passed to the Attenuator PC Board Assembly where it is attenuated to the desired output level and applied to the T/R Connector through the Power Term Assembly.

Separate Receive and Generate functions allow full Duplex operation. Received signals are accepted at the ANTENNA IN Connector and the T/R Connector. Generated signals are available at the DUPLEX OUT Connector or the T/R Connector. Routings are the same as if the Receiver and Generator were operating alone, but operation is simultaneous.



The Function Generator PC Board Assembly for the FM/AM-1600S provides audio and serial data modulation for the Generate function as well as a baseband signal available at the Speaker, DEMOD OUT Connector or AUDIO OUT Connector. Wave shapes available include Triangle, Square and Sine for the audio signals and  $\pm 5$  V for the serial data. Audio frequencies available are 0 to 40 kHz.

The Spectrum Analyzer signal starts in the Receive IF Assembly with a 90 MHz IF Signal. That signal is processed in the Analyzer RF Assembly into a swept 10.7 MHz IF signal and sent to the Analyzer Log/IF Assembly. The 10.7 MHz IF Signal is converted in the Analyzer Log/IF Assembly to a dc voltage for the Digitizer PC Board Assembly. This dc voltage, called ANLZR VIDEO, is converted to a digital signal by the Digitizer PC Board Assembly and passed to the Processor PC Board Assembly for display on the CRT Assembly.

The Oscilloscope signal starts from the Monitor Assembly where input from the required source is routed to the Digitizer PC Board Assembly. There, the analog signal is converted to digital data and passed to the Processor PC Board Assembly for display by the CRT Assembly.

The CRT Display is controlled by the Video Controller PC Board Assembly. Data provided by the Processor PC Board Assembly is processed and stored by the Video Controller PC Board Assembly. Processed data to be displayed is passed to the CRT Assembly by the Video Controller PC Board Assembly.

The DMM Assembly measures ac and dc current, ac and dc voltage and resistance. In all cases, measurements are converted to dc voltage, then converted to digital data and passed to the Counter PC Board Assembly for measurement. The Counter PC Board Assembly then routes the measurement to the Processor PC Board Assembly.

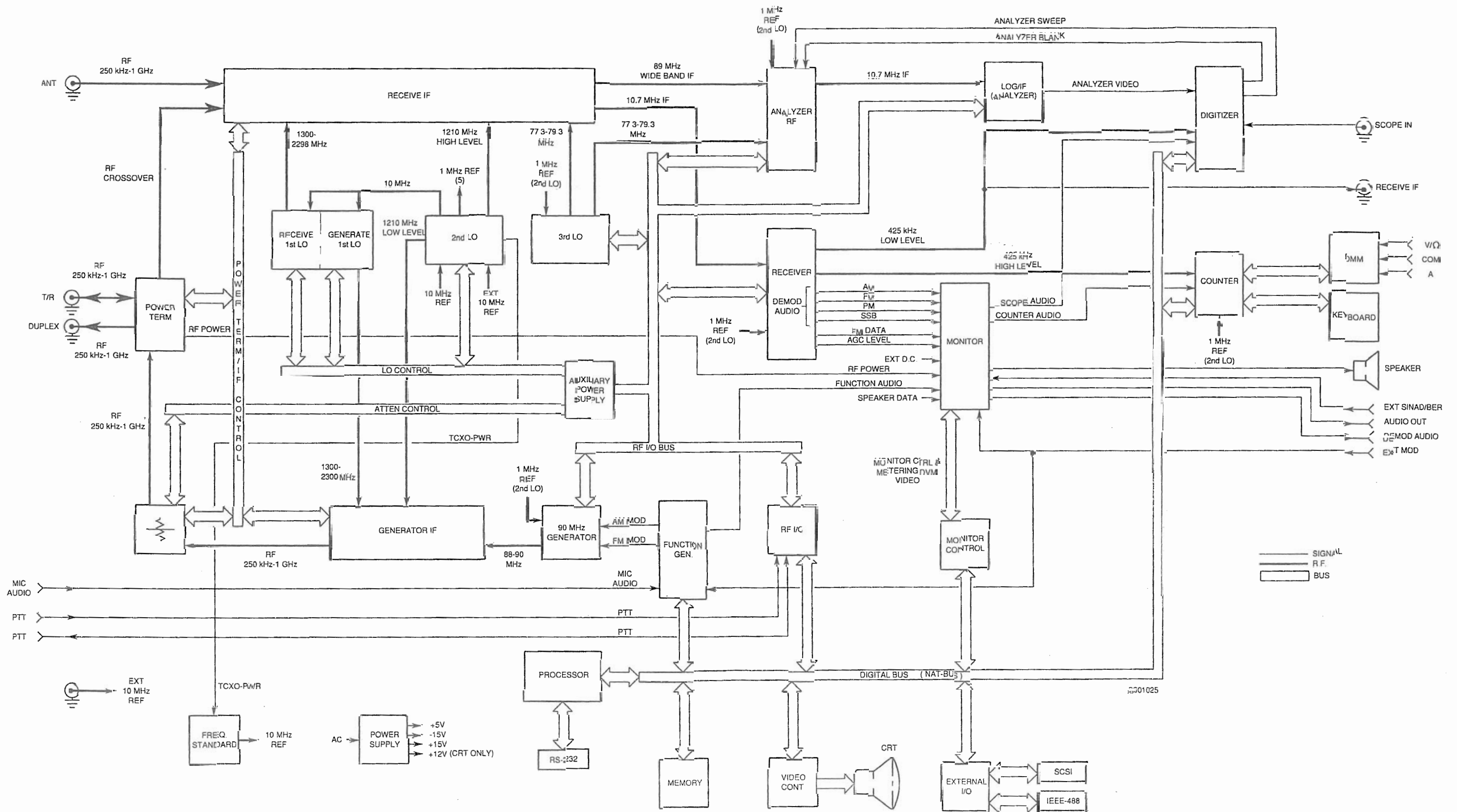

Figure 2-1 FM/AM-1600S Block Diagram

## 2-3 FUNCTIONAL THEORY OF OPERATION

### 2-3-1 RECEIVE OPERATION

Signals are received by the FM/AM-1600S through two connectors, the ANTENNA IN Connector and the T/R Connector. Signals received through the ANTENNA IN Connector are passed directly to the Receive IF Assembly where the incoming signal is attenuated by a 3 dB pad, primarily for impedance matching, but is also used as a load for input signals >10 mW. The signal passing through the T/R Connector is processed by the Power Term Assembly. From the Power Term Assembly, the signal passes to the Receive IF Assembly where the two Receive Channels merge. Additionally, the signal is sampled in the Power Term Assembly for measuring the power level of the signal. Measurement of the level is performed in the Monitor Assembly.

In the Receive IF Assembly, the RF signal is attenuated as selected by the operator and mixed into two IF signals. One IF signal (89 MHz IF) goes to the Analyzer RF Assembly for use by the Spectrum Analyzer. The other IF signal (10.7 MHz IF) goes to the Receiver Assembly which is eventually demodulated to the audio or data signal. Input signals used include 1300-2298 MHz (1st LO Assembly), 1210 MHz (2nd LO Assembly), 77.3-79.3 MHz (3rd LO Assembly) and control signals from the Attenuator PC Board Assembly.

The 10.7 MHz IF Signal is processed in the Receiver Assembly into demodulated audio signals and data signals for the Monitor Assembly as well as 425 kHz signals for use by the Digitizer PC Board Assembly and the Counter PC Board Assembly. Input signals used by the Receiver Assembly include the 10.7 MHz IF signal from the Receive IF Assembly, which is the received signal, the 1 MHz Reference signal from the 2nd LO Assembly, and control signals for selecting bandwidth and data lines for specific demodulation types. Signals produced include:

Signals to the Monitor Assembly:

FM DEMOD  
FM DATA

AM DEMOD  
SSB DEMOD

PM DEMOD  
AGC LEVEL

425 kHz low (-20 dBm) to the Digitizer PC Board Assembly and RECEIVER IF Connector  
425 kHz high (-10 dBm) to the Counter PC Board Assembly

The Monitor Assembly performs the signal routing needed to match signals to measuring devices as required. The Monitor Assembly takes the DEMOD AUDIO and DATA Signals from the Receiver Assembly as well as other internal and external signals and routes them to the following areas:

AUDIO OUT Connector  
Speaker  
Monitor Control PC Board Assembly

DEMOD OUT Connector  
Counter PC Board Assembly  
SCOPE AUDIO

Signals processed by the Monitor Assembly include:

FM DEMOD  
FM DATA  
BER/SINAD Connector Input  
EXT MOD Connector Input

PM DEMOD  
SSB DEMOD  
Function Generator Audio  
DTMF IN

AM DEMOD  
SIGNAL LEVEL  
RF PWR LVL  
DTMF OUT

Demodulation signals are filtered, as required, in the Monitor Assembly, through programmable high-pass, low-pass, bandpass or C-weight filters. Control signals are passed to the Monitor Assembly by the Monitor Control PC Board Assembly.

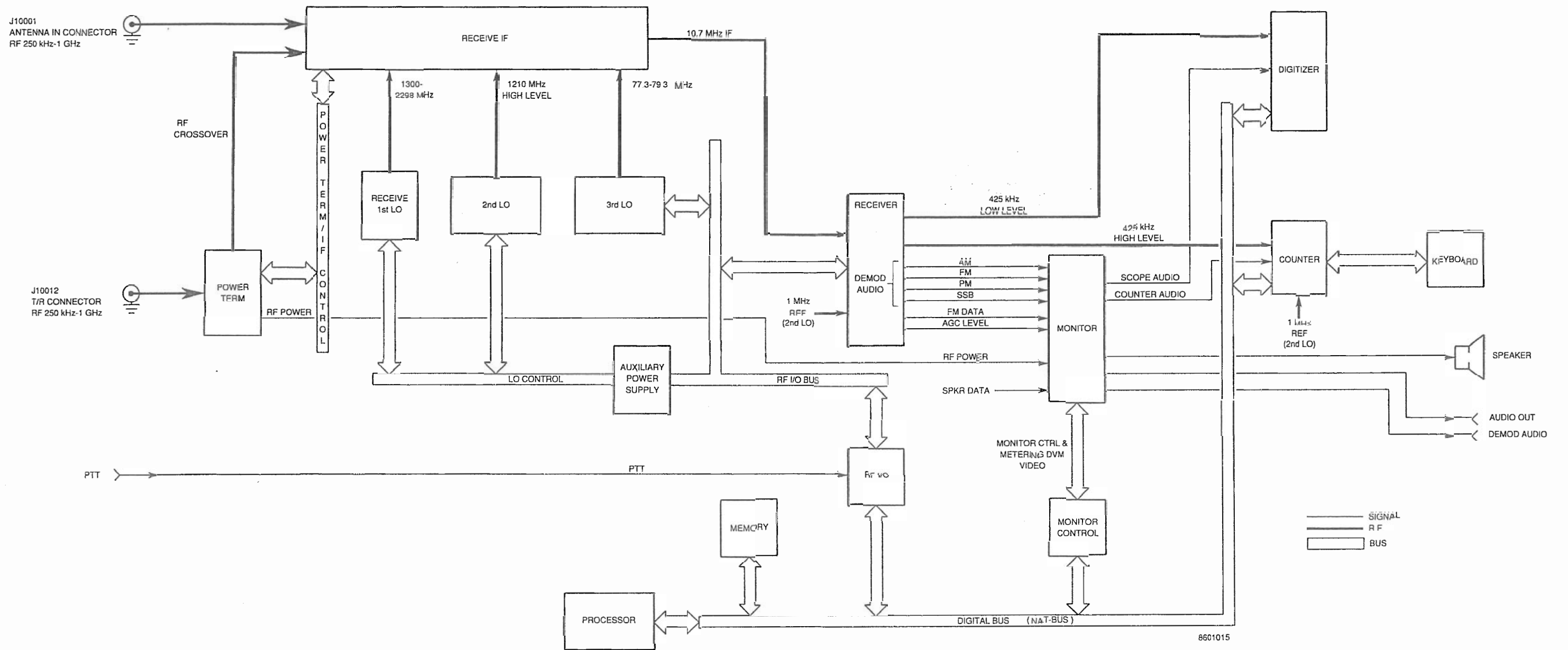

Figure 2-2 Receive Function Block Diagram

## 2-3-2 GENERATE OPERATION

The Function Generator PC Board Assembly has two audio sources capable of generating sine, square and triangle wave sources from 0 to 40,000 Hz at 0 to 5 Vp-p. These sources can be activated simultaneously at equivalent or differing levels and also in conjunction with other modulation sources. The other internal source available in the Function Generator PC Board Assembly is a Serial Data Generator. This signal can be filtered and attenuated before being passed on.

External modulation sources include EXT MOD IN Connector Signals and MIC/ACC IN Connector Signals. These sources can be filtered and attenuated before being passed on.

Each modulation source is presented to the Audio Switching Matrix in the Function Generator PC Board Assembly. The Audio Switching Matrix has five different inputs and three different outputs. For each input, only one of three outputs can be selected; however, all five inputs can be active simultaneously. The three outputs available include: FM MOD OUT, AM MOD OUT and FUNCTION GENERATOR AUDIO OUT to the AUDIO OUT Connector. The FM MOD OUT and AM MOD OUT signals are available directly to the 90 MHz Generator Assembly.

The Function Generator PC Board Assembly passes the modulation signal to the 90 MHz Generator Assembly where the signal is mixed into an 88 to 90 MHz IF signal. The modulating source is processed differently depending on whether the modulation signal is AM MOD OUT or FM MOD OUT from the Function Generator PC Board Assembly. Processor PC Board Assembly Control and Data Signals are converted to serial format by the RF I/O PC Board Assembly and passed to the 90 MHz Generator Assembly. A 1 MHz Reference Signal from the 2nd LO Assembly is the only other external signal required by the 90 MHz Generator Assembly. If phase modulation is desired, the FM MOD signal is integrated to provide the phase modulation signal required.

The 88 to 90 MHz IF Signal is passed to the Generator IF Assembly. Here, the signal is mixed to form the final RF Signal. The 1st LO and 2nd LO Assemblies provide the signals for the mixers in the Generator IF Assembly. The 1210 MHz Signal (2nd LO Assembly) and the 88 to 90 MHz IF Signal are mixed with a 1298 to 1300 MHz IF Signal resulting. The IF Signal is mixed with a 1300 to 2298 MHz Signal (1st LO Assembly) resulting in a final .250 to 1000 MHz RF Signal. The RF Signal is amplified to provide a +10 to +20 dBm level and passed to the Attenuator PC Board Assembly.

The Attenuator PC Board Assembly takes the RF Signal from the Generator IF Assembly and attenuates the signal to the required level. Control of the Attenuator PC Board Assembly originates in the Processor Assembly. Processor PC Board Assembly Control and Data Signals are converted to serial format by the RF I/O PC Board Assembly and passed through the Auxiliary Power Supply to the Attenuator PC Board Assembly. The attenuated RF Signal is then passed to the Power Term Assembly. The Attenuator PC Board Assembly also decodes the Control and Data Signals from the Processor PC Board Assembly for the Receive IF and Power Term Assemblies.

The Power Term Assembly routes the attenuated RF Signal to the selected output connector, either the T/R Connector or the Duplex Connector. Control of the Power Term Assembly originates in the Processor PC Board Assembly. Processor PC Board Assembly Control and Data Signals are converted to serial format by the RF I/O PC Board Assembly and passed through the Auxiliary Power Supply to the Attenuator PC Board Assembly. In the Attenuator PC Board Assembly, the serial data is converted to parallel format and passed to the Power Term Assembly as control signals.

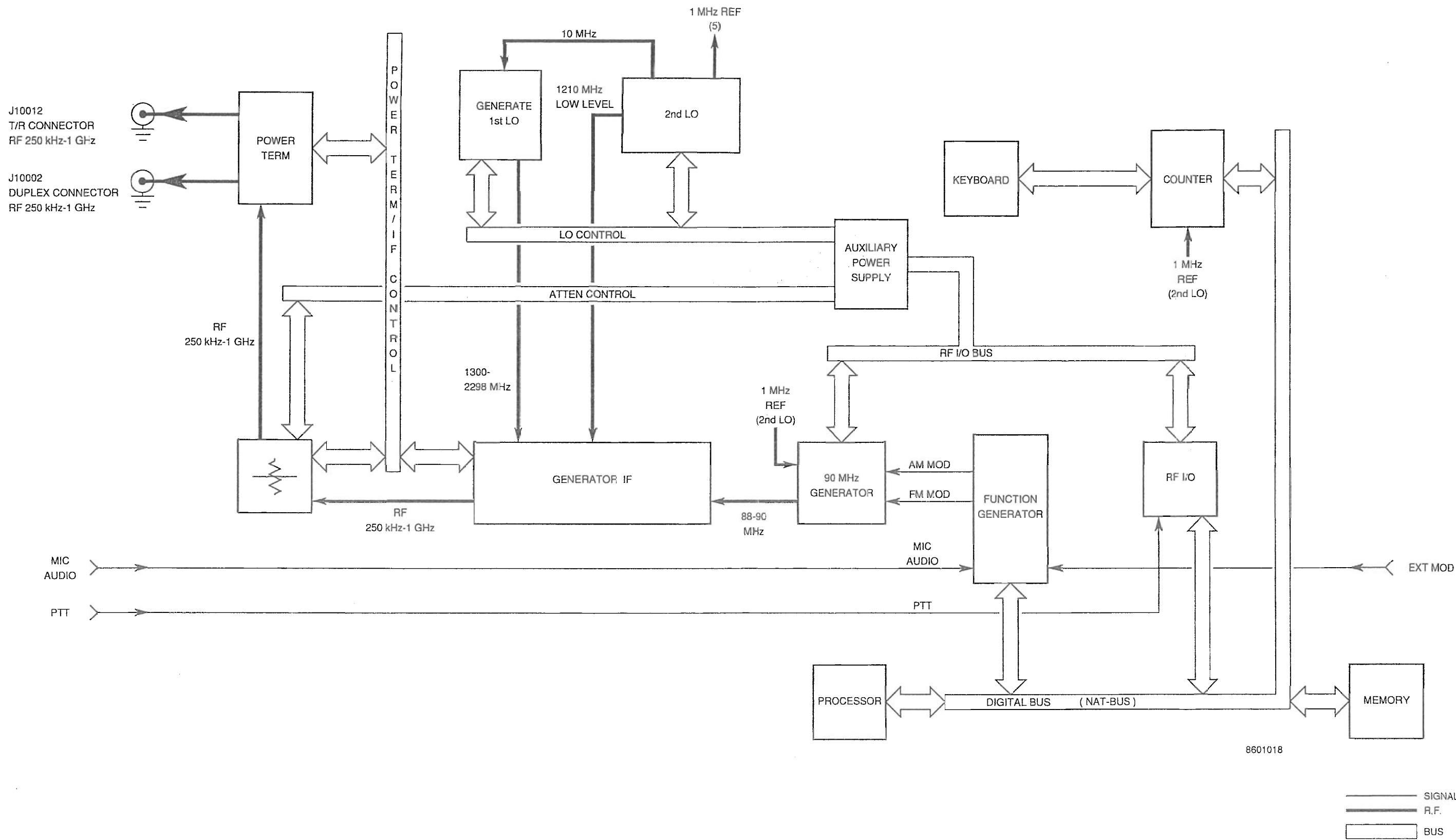

8601018

Figure 2-3 Generate Function Block Diagram

### 2-3-3 SPECTRUM ANALYZER OPERATION

Signals are received as stated in 2-3-1. The received signal is converted in the Receive IF Assembly to an 89 MHz IF Wideband Signal and passed to the Analyzer RF Assembly. In the Analyzer RF Assembly, the 89 MHz IF wideband signal is converted to a 10.7 MHz IF signal for the Analyzer Log/IF Assembly. Input signals used for conversion include 77.3-79.3 MHz signal from the 3rd LO Assembly and 1 MHz Reference Signal from the 2nd LO Assembly. Signals generated in the Digitizer PC Board Assembly are used to sweep the wideband signal. Signals from the Digitizer include ANLZR BLANK and ANLZR SWEEP. Control signals for sweep scaling originate in the Processor PC Board Assembly. Processor PC Board Assembly Control Signals are converted to serial format by the RF I/O PC Board Assembly and passed to the Analyzer RF Assembly.

The Analyzer Log/IF Assembly takes the 10.7 MHz IF from the Analyzer RF Assembly and converts it to the ANALYZER VIDEO Signal. The ANALYZER VIDEO Signal is passed to the Digitizer PC Board Assembly. Control signals for bandwidth selection originate in the Processor PC Board Assembly. Processor PC Board Assembly Control Signals are converted to serial format by the RF I/O PC Board Assembly and passed to the Analyzer Log/IF Assembly.

The ANALYZER VIDEO Signal is in the form of an analog voltage. This analog voltage is converted to digital data and passed to the Processor PC Board Assembly. Control signals for the Digitizer PC Board Assembly originate in the Processor PC Board Assembly and are passed through the NAT-BUS.

The Processor PC Board Assembly passes the data to the Video Controller PC Board Assembly for eventual display on the CRT. Traces can also be stored in Memory for future reference.

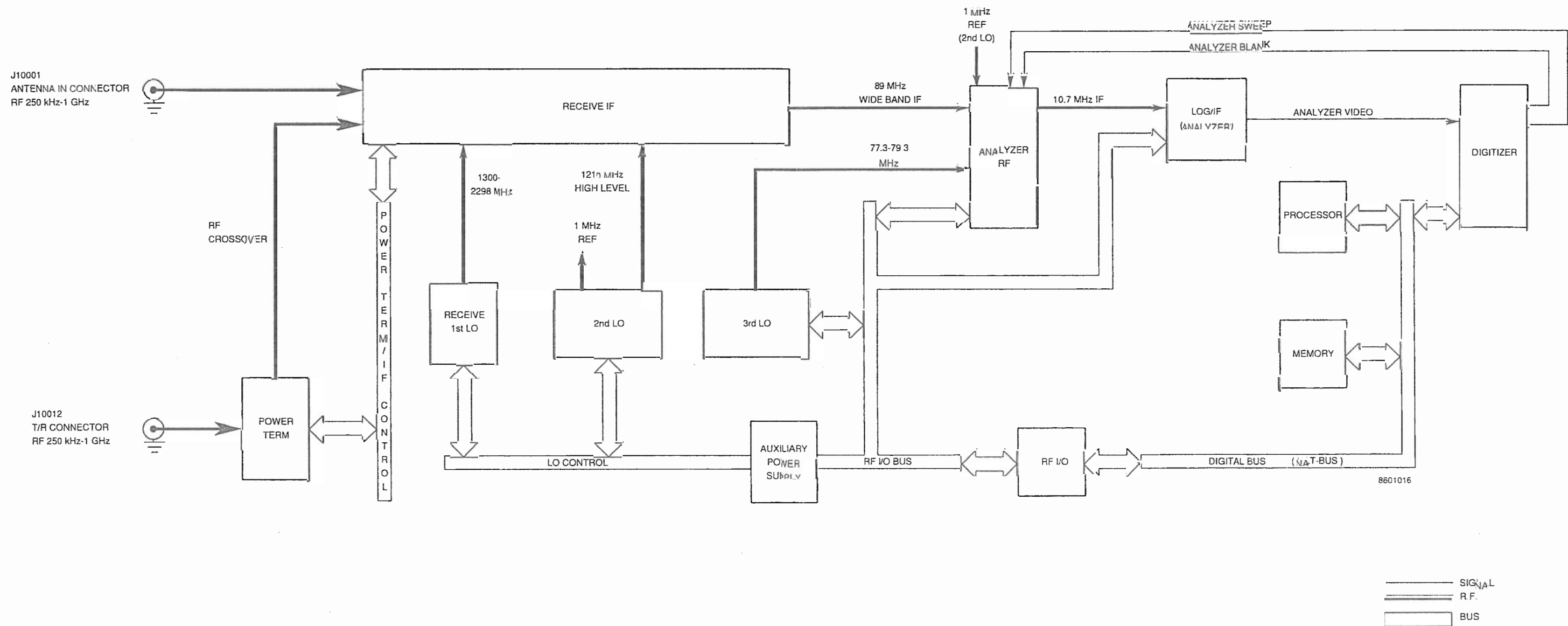

Figure 2-4 Spectrum Analyzer Block Diagram



#### 2-3-4 SYSTEM CONTROL (PROCESSOR) OPERATION

The Processor PC Board Assembly provides the overall control for the system. The basis of the Processor PC Board Assembly is an Intel 80376 embedded microcontroller. The 80376 is a 32 bit processor with a 24 bit address bus and 16 bit data bus. To speed up the system, an Intel 82370 Integrated System Peripheral Device (ISP) is attached to provide supervision for DMA and Interrupt Requests and Acknowledges. Interface to the unit is provided by an AT-like bus called the NAT-BUS.

Memory required for the system is contained in the Processor PC Board Assembly and two Memory PC Boards. One memory board contains EPROM for the computer code. The other memory board contains SRAM, memory for parameter storage, trace storage and user programs. Some of the SRAM is battery-backed for non-volatile storage.

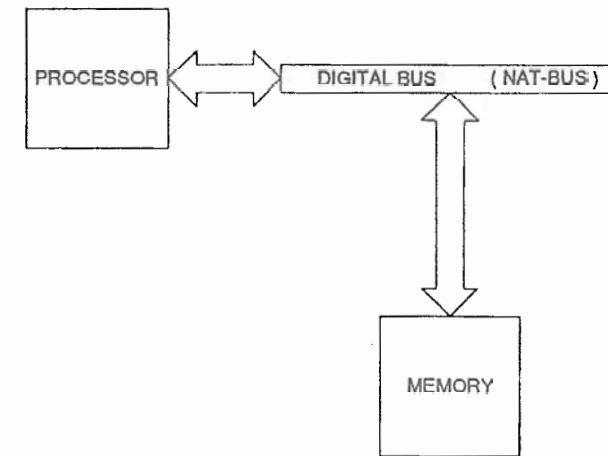

Figure 2-5 Processor Function Block Diagram

8601033

## 2-3-5 VIDEO OPERATION

Control of Video Operation is provided by the Video Controller PC Board Assembly. Data is passed to the Video Controller PC Board Assembly from the Processor PC Board Assembly through the NAT-BUS. The Video Controller PC Board Assembly accumulates the video data in video RAM, processes the data and passes appropriate analog signals to the CRT Assembly. The CRT tube use is a color EGA monitor. An external connector is provided for using an external EGA Monitor.

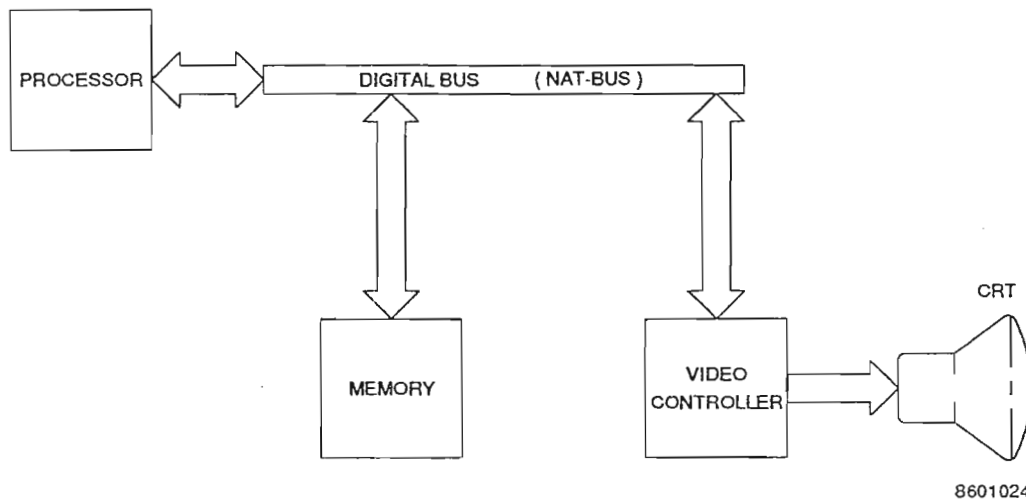

Figure 2-6 Video Operation Block Diagram

## 2-3-6 REMOTE OPERATION

Remote Operation can take place through three different connectors. The SCSI Connector and GPIB Connector operate by passing data in a parallel format, while the RS-232 Connector uses a serial format. The SCSI Connector and GPIB Connector communicate with the Processor PC Board Assembly through the NAT-BUS and External I/O PC Board Assembly. The RS-232 Connector is connected directly to the Processor PC Board Assembly.

The SCSI Connector is used in accordance with the Small Computer System Interface. The primary use of the SCSI Connector is for auxiliary units available from IFR. Use of this connector requires a protocol that has been tailored by IFR for exclusive use with their products.

The GPIB Connector is used in accordance with IEEE-488 Standards. Primary use for this connector is remote operation with programming provided by the user. Programs written to utilize this connector are in IFR's Test Macro (TMAC) Language. Address for this connector is set from the Auxiliary Functions Menu.

The RS-232 Connector is used in a manner similar to the GPIB Connector. The primary use for this connector is to allow the user to attach to the unit and operate it remotely. Programs written to utilize this connector are in IFR's Test Macro (TMAC) Language. Configuration control for this connector is provided through the Auxiliary Functions Menu.

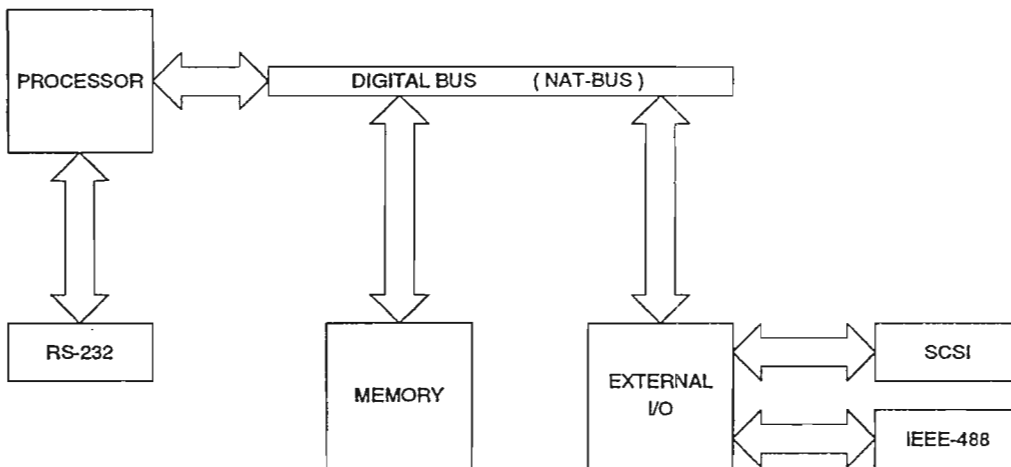

8601019

Figure 2-7 Remote Operation Block Diagram

## 2-4 MODULE THEORY OF OPERATION

### 2-4-1 GENERAL

The information in this section provides the maintenance technician with information about the operation of each specific assembly. Information provided is functional level only. Block diagrams outline function and not type, quantity or location of components. Listings of pin numbers of signals are provide with block diagrams to aid the technician in tracing signals in and out of the assembly. Additional supporting drawings are available in Section 6.

A list of the assemblies covered follows listed by paragraph and page:

PARAGRAPH	TITLE	PAGE
2-4-2	PROCESSOR PC BOARD ASSEMBLY	2-14
2-4-3	MEMORY PC BOARD ASSEMBLY	2-18
2-4-4	RF I/O PC BOARD ASSEMBLY	2-20
2-4-5	POWER SUPPLY ASSEMBLY	2-22
2-4-6	AUXILIARY POWER SUPPLY PC BOARD ASSEMBLY	2-24
2-4-7	RECEIVE IF ASSEMBLY	2-26
2-4-8	ANALYZER RF ASSEMBLY	2-28
2-4-9	RECEIVER ASSEMBLY	2-30
2-4-10	ANALYZER LOG/IF ASSEMBLY	2-34
2-4-11	DIGITIZER PC BOARD ASSEMBLY	2-36
2-4-12	COUNTER PC BOARD ASSEMBLY	2-38
2-4-13	MONITOR ASSEMBLY	2-40
2-4-14	MONITOR CONTROL PC BOARD ASSEMBLY	2-44
2-4-15	1ST LO ASSEMBLY	2-48
2-4-16	2ND LO ASSEMBLY	2-50
2-4-17	3RD LO ASSEMBLY	2-52
2-4-18	POWER TERM ASSEMBLY	2-54
2-4-19	FUNCTION GENERATOR PC BOARD ASSEMBLY	2-56
2-4-20	90 MHz GENERATOR ASSEMBLY	2-58
2-4-21	GENERATOR IF ASSEMBLY	2-60
2-4-22	ATTENUATOR PC BOARD ASSEMBLY	2-62
2-4-23	DMM ASSEMBLY	2-64
2-4-24	VIDEO CONTROLLER PC BOARD ASSEMBLY	2-66
2-4-25	CRT ASSEMBLY	2-68
2-4-26	EXTERNAL I/O PC BOARD ASSEMBLY	2-70

## 2-4-2 PROCESSOR PC BOARD ASSEMBLY

The Processor PC Board Assembly provides the overall control for the system. The CPU is an Intel 80376 embedded microcontroller. The 80376 is a 32 bit processor with a 24 bit address bus and 16 bit data bus. To speed up the system, an Intel 82370 Integrated System Peripheral Device is attached to provide supervision for DMA and Interrupt Requests and Acknowledges. Additional controller circuits include the following:

- MAX 690 Supervisory Circuit controls power-up RESET and Nonmaskable Interrupt actions. RESET affects the 80376, the 82370 and other I/O Devices. The RESET signal from the MAX 690 becomes the RESDRV signal on the NAT-BUS.
- Memory Select Circuit controls what section of memory is being used.
- Wait State Circuit inserts 1 to 16 wait states into I/O processing, as needed.
- Real-time clock containing time-of-day clock, alarm, 100 year calendar, programmable interrupt, square wave generator and 50 bytes of memory. A lithium power source is included in the package to keep the clock updated when power is not applied.

Memory available on the Processor PC Board Assembly includes 128kX8 ROM and 64kX8 RAM. The ROM is used for part of the system code. The RAM is used for storing program global parameters.

The AT Compatible I/O Channel (NAT-BUS) contains:

- 16 bit bidirectional data bus
- 24 bit address line bus
- 9 levels of interrupt
- Memory and I/O Read/Write lines
- Clock and timing lines
- 5 channels of DMA control lines
- 7 memory refresh timing control lines

The following table lists the NAT-BUS Signals and defines their function.

SIGNAL	I/O	DESCRIPTION
8 MHz CLK	O	8 MHz System Clock. Divide-by-four of clock crystal.
RESDRV	O	Resets system logic at power-up or low voltage. Active on falling edge of clock and is active high.

SIGNAL	I/O	DESCRIPTION
SA0-SA19	O	Address bits 0 to 19. Used to address memory and I/O devices. A0 is least significant bit (LSB) and A19 is most significant bit (MSB). Generated by CPU or ISP. Address lines are active high.
SD0-SD15	I/O	Data bits 0 to 15. Provide data bits 0 to 15 for data bus. D0 is least significant bit (LSB) and D15 is most significant bit (MSB). Data lines are active high.
BALE	O	Bus Address Latch Enable. Provided by AT compatible signal generator and used on system board to latch address. Available to I/O channel as indicator of valid processor address (when used with AEN).
$\overline{\text{BUS/RDY}}$	I	I/O Channel Ready. Pulled low (not ready) by a memory or I/O device to lengthen I/O or memory cycles. Allows slower devices to attach to I/O channel. Devices using this line sets it low upon detecting valid address and read or write command.
IRQ3-IRQ7 IRQ9-IRQ12	I	Interrupt Request Lines 3 to 7 and 9 to 12. Used to signal that I/O device requires attention. Priorities in descending order are IRQ 9 to IRQ 12, then IRQ 3 to IRQ 7. IRQ lines are active high. Line is high until acknowledged by processor.
$\overline{\text{IOR}}$	O	I/O Read Command. Instructs I/O device to put data on data bus. Initiated by processor or ISP. Signal is active low.
$\overline{\text{IOW}}$	O	I/O Write Command. Instructs I/O device to read data from data bus. Initiated by processor or ISP. Signal is active low.
$\overline{\text{MEMR}}$	O	Memory Read Command. Instructs memory to put data on data bus. Initiated by processor or ISP. Signal is active low.
$\overline{\text{MEMW}}$	O	Memory write command. Instructs memory to store data on data bus. Initiated by processor or ISP. Signal is active low.
DRQ0-DRQ3 DRQ5	I	DMA Request lines. Asynchronous channel request lines used by peripheral devices to gain DMA service. They are prioritized with DRQ5 highest and DRQ0 lowest. A request is generated by bringing line high until corresponding DACK lines is activated.

SIGNAL	I/O	DESCRIPTION
$\overline{\text{DACK0}}, \overline{\text{DACK1}}$ $\overline{\text{DACK3}}, \overline{\text{DACK5}}$	O	DMA Acknowledge lines. These lines are used to acknowledge a DMA request from peripherals. Numbers correspond the DMA Request commands.
$\overline{\text{REFRESH}}$	O	DMA Acknowledge 0. Refreshes system dynamic memory.
AEN	O	Address Enable. Use to disconnect processor and inactive devices during DMA transfers. When this line is high (active), the DMA controller has control of address bus, data bus, read commands and write commands for both memory and I/O.
T/C	O	Terminal Count Pulse. Provides pulse to signal when terminal count is reached during DMA transfer. Signal is active high.
SBHE	I/O	BUS HIGH ENABLE. Indicates transfer of data on high byte of data bus, SD8 to SD15.
$\overline{\text{MASTER}}$	I	Not Used.
$\overline{\text{MEM CS16}}$	I	Indicates present data transfer is 1 wait-state, 16 bit cycle.
OWS	I	Zero Wait State. Indicates to the processor that it can complete current bus cycle without wait states. This is an active low line.
LA17-LA23	I/O	Signals used to address memory and I/O devices within the system. Gives system 16 Megabytes of addressing capability. Signals are valid when BALE is high. Signals are not latched and therefore may not be valid for entire cycle. These signals may be generated by the CPU or other processors or DMA Controllers on the I/O Channel.
$\overline{\text{I/O CS16}}$	I	Indicates current data transfer is a 16 bit, 1 wait state I/O cycle. This is an active low signal.

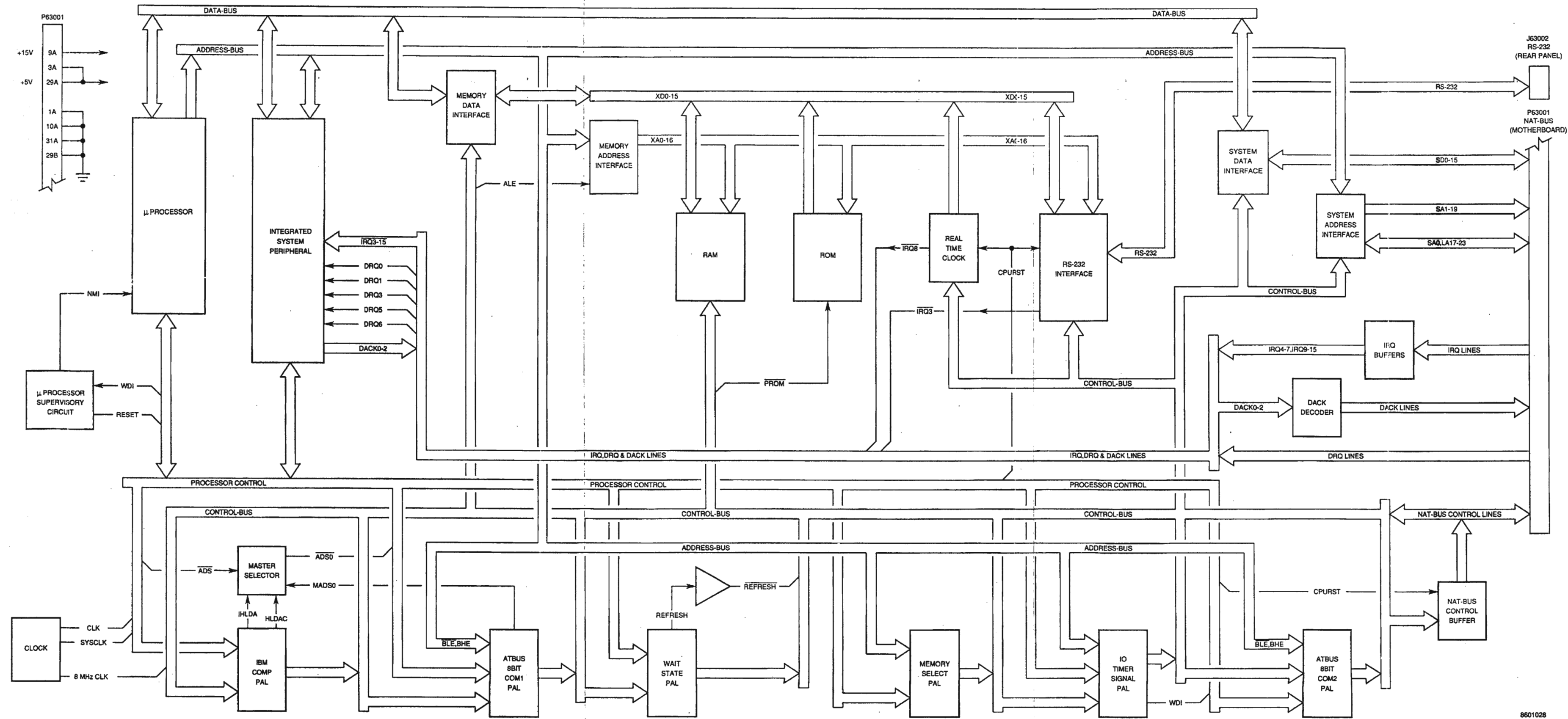

RS-232 (J63002)	
Signal	Pin
+15V	1,2
TXD	3
RXD	5
CTS	4
RTS	6
GND	9,10

NAT-BUS (P63001)		IRQ LINES	
Signal	Pin	Signal	Pin
SD0-SD15		IRQ4	24A
SD0	9C	IRQ5	23A
SD1	8C	IRQ6	22A
SD2	7C	IRQ7	21A
SD3	6C	IRQ9	4A
SD4	5C	IRQ10	7B
SD5	4C	IRQ11	9B
SD6	3C	IRQ12	11B
SD7	2C	IRQ13	25A
SD8	21B	IRQ14	17B
SD9	22B	IRQ15	19B
SD10	23B		
SD11	24B		
SD12	25B		
SD13	26B		
SD14	27B		
SD15	28B		
SA1-SA16			
SA1	30C	DRQ0	16B
SA2	29C	DRQ1	18A
SA3	28C	DRQ3	16A
SA4	27C	DRQ5	20B
SA5	26C	DRQ6	6A
SA6	25C		
SA7	24C		
SA8	23C		
SA9	22C		
SA10	21C		
SA11	20C		
SA12	19C		
SA13	18C		
SA14	17C		
SA15	16C		
SA16	15C		
LA17-LA23			
LA17	31C	8 MHz CLK	20A
LA18	15B	SBHE	2B
LA19	13B	IOWR	13A
LA20	12B	IORD	14A
LA21	10B	MEMW	11A
LA22	8B	MEMR	12A
LA23	4B	BALE	28A
		AEN	11C
		RESET DRV	2A
		REFRESH	19A
		IOCHRDY	10C
		MEMCS16	3B
		IOCS16	5B
		T/C	27A
		O/S	8A
		SPKDATA	1B

Figure 2-8 Processor PC Board Assembly Block Diagram



### 2-4-3 MEMORY PC BOARD ASSEMBLY

Current configuration for the FM/AM-1600S is two memory PC Boards. One PC Board contains EPROM and the other SRAM. The EPROM is used for system code. The SRAM is used for global variables, TMAC Remote Language and System Heap. Some of the SRAM is battery backed and is considered non-volatile.

Circuit configuration is identical on both cards. Jumpers are used to configure addressing to fit almost any memory type to 64K bytes for ROM and 32K bytes for RAM. Each Memory Block is made up of two memory devices to create the 16 bit word configuration. There are up to eight Memory Blocks on each card.

Address and Data lines coming in are buffered before selected device reads data. The buffers used in the Data Buffer are bidirectional, allowing both read and write. LA17 through LA23 lines are used as chip select lines in the Decode Logic.  $\overline{\text{MEMR}}$  (Memory Read) lines are routed to all memory devices.  $\overline{\text{MEMW}}$  (Memory Write) lines are routed to all RAM devices. If a wait state is required, a  $\overline{\text{MEM CS16}}$  (16 data bits, 1 wait state device) signal is returned to the Processor PC Board Assembly.



NAT-BUS (P49001, P64001)	
SD0-SD15	
Signal	Pin
SD0	9C
SD1	8C
SD2	7C
SD3	6C
SD4	5C
SD5	4C
SD6	3C
SD7	2C
SD8	21B
SD9	22B
SD10	23B
SD11	24B
SD12	25B
SD13	26B
SD14	27B
SD15	28B
SA1-SA15	
Signal	Pin
SA1	30C
SA2	29C
SA3	28C
SA4	27C
SA5	26C
SA6	25C
SA7	24C
SA8	23C
SA9	22C
SA10	21C
SA11	20C
SA12	19C
SA13	18C
SA14	17C
SA15	16C
SA16	15C
LA17-LA23	
Signal	Pin
LA17	15B
LA18	13B
LA19	12B
LA20	10B
LA21	8B
LA22	6B
LA23	4B

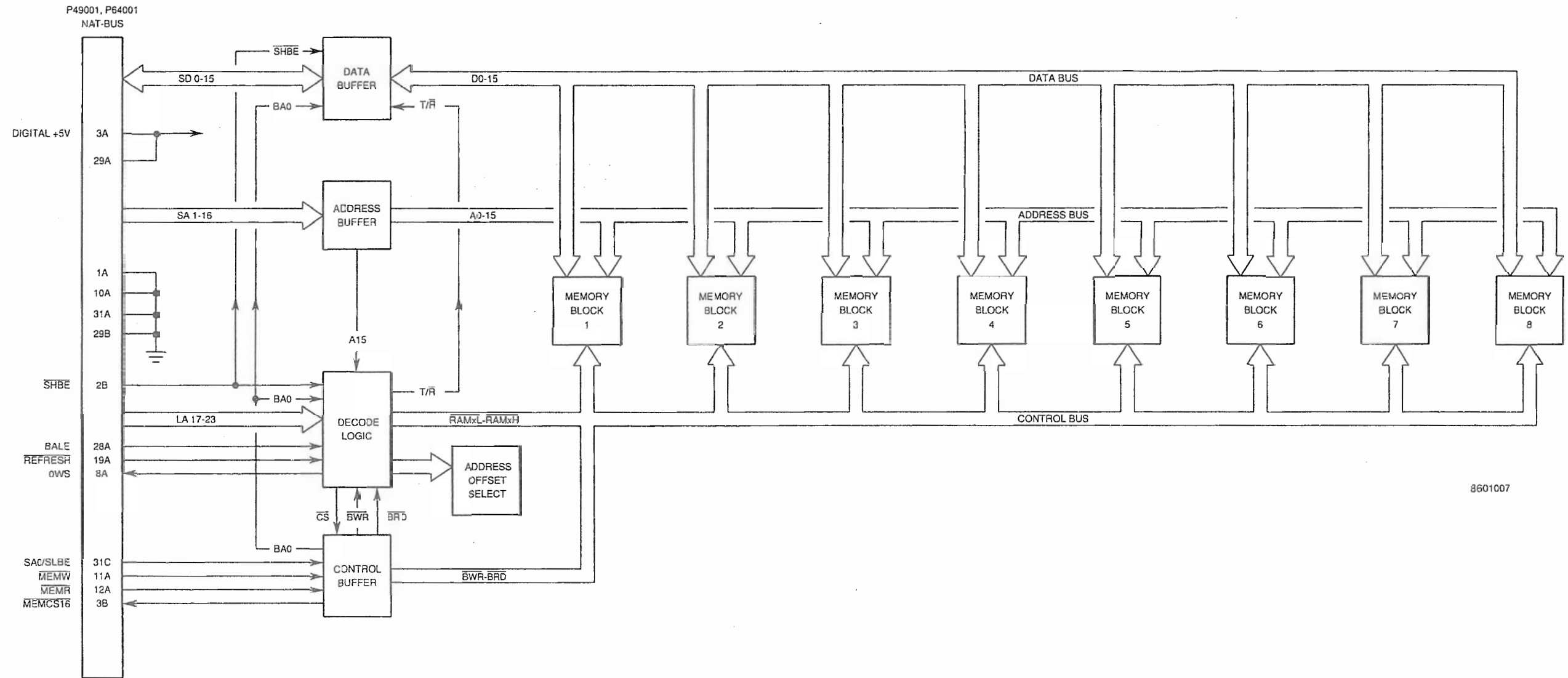

Figure 2-9 Memory PC Board Assembly Block Diagram

#### 2-4-4 RF I/O PC BOARD ASSEMBLY

The RF I/O PC Board Assembly performs one primary function and several secondary functions. The primary function is to convert the data presented by the Processor PC Board Assembly from parallel to serial format, using the Parallel-To-Serial Converter, for the modules attached to the RF I/O BUS. Included in that function are clock and latch functions for the transmission of serial data. Clock and Data Signals are presented to all attached modules simultaneously, however, Latch Signals are unique to each module. Selection of a latch line by the Processor PC Board Assembly Data attaches the Serial Data Bus to the specific assembly. The Latch Decoder is used to decode the upper byte (D8-D15) of data from the processor to determine the specified I/O device. The Parallel-To-Serial Converter passes the serial data to the Latch Decoder to place on the RF I/O Bus.

The second function of the RF I/O PC Board Assembly is to provide a return path to the Processor PC Board Assembly from the assemblies attached to the RF I/O BUS. Status signals provided to the RF I/O PC Board Assembly through the RF I/O BUS by the separate modules are assembled and latched to the NAT-BUS as a 16 bit word. Status lines returned to the RF I/O PC Board Assembly include:

STATUS-1stA (1st LO Receive)	STATUS-1stB (1st LO Generate)
STATUS-3rd (3rd LO)	STATUS-2nd
STATUS-GEN	ANLZR-LOCK (Analyzer Phase Lock)
ALARM	POWERMODE
SPR	DC DET (Power Supply)
MIC-SW	ACC-1
ACC-2	

The RF I/O PC Board Assembly receives inputs from both the NAT-BUS and the RF I/O BUS. The signals provided by the NAT-BUS that are used by the RF I/O PC Board Assembly include:

Address Lines (SA0-SA11)	Data Lines (SD0-SD15)	I/O Read ( $\overline{IOR}$ )
Upper Byte Enable ( $\overline{SHBE}$ )	Address Latch Enable (BALE)	I/O Write ( $\overline{IOWR}$ )

Outputs to the NAT-BUS include the Data Lines (SD0-SD15) which contain the Status Lines and the signal for 1 I/O Wait State (I/O CS16).

The data is passed to the RF I/O PC Board Assembly in two bytes. Each action performed by the RF I/O PC Board Assembly uses the data in a different manner. The EXTERNAL AGC D/A Converter uses only D0-D7 for creating the EXT AGC signal for the Receiver Assembly. The VCXO D/A Converter uses D0-D12 to provide the digital information needed to create the analog VCXO Signal. When the CONTROL INTERFACE is active, D0-D7 are used to select the appropriate control signal. The lower byte (SD0-SD7) contains the control data while the upper byte (D8-D15) contains the information to latch the specified assembly which is read by the Latch Decoder.

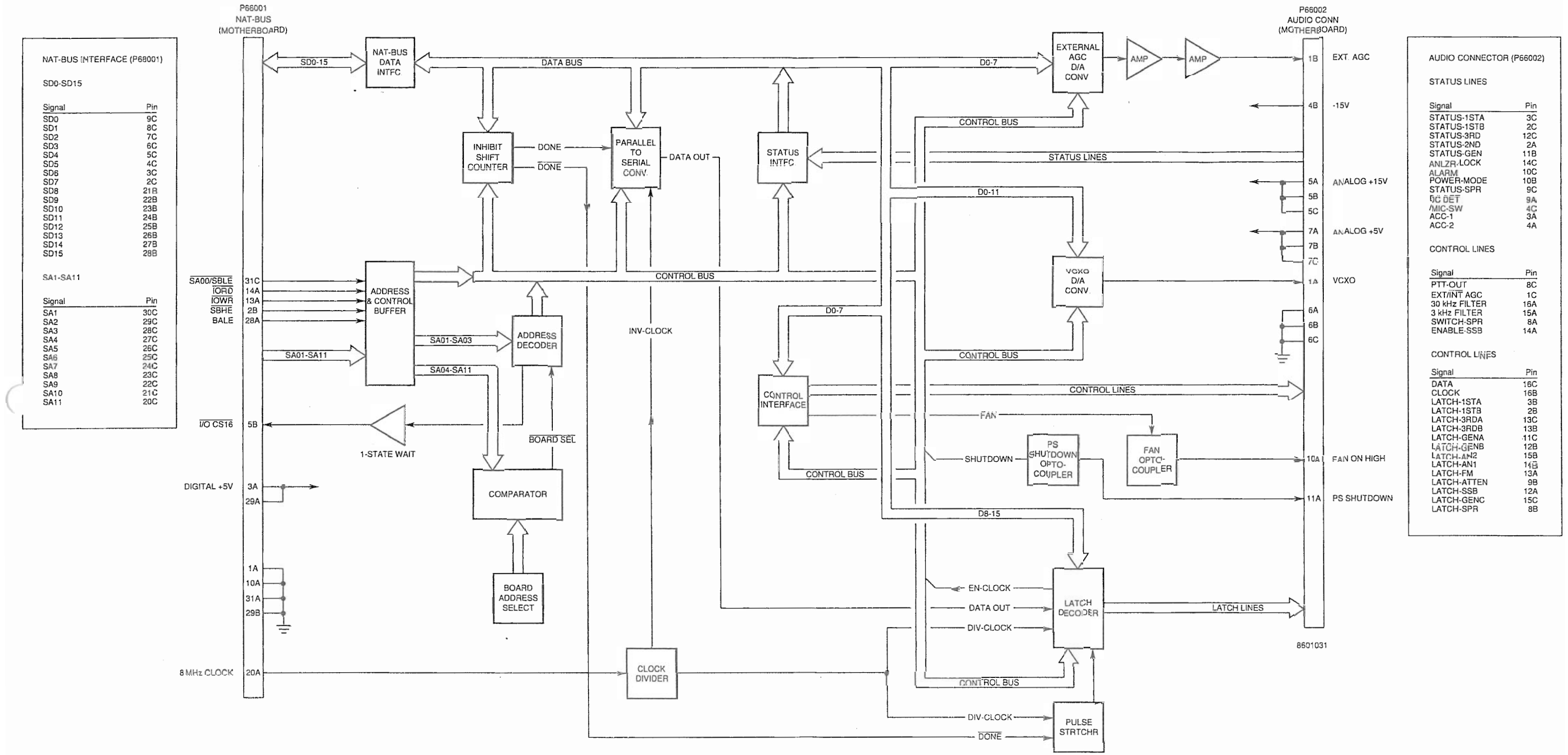

Figure 2-10 RF I/O PC Board Assembly Block Diagram

## 2-4-5 POWER SUPPLY ASSEMBLY

The Power Supply Assembly converts the 120/240 VAC input into dc voltages used in the FM/AM-1600S. The voltages provided include +12 Vdc,  $\pm 15$  Vdc and +5 Vdc. Multiple lines are available for positive voltages to provide power to various sections of the unit. All voltages are filtered to remove ripple from the final output.

Anytime there is voltage present at the AC IN Input, power is applied to the FM/AM-1600S up to the AC IN RELAY. This is visible on the front panel with the POWER APPLIED Indicator. The power is passed through the AC POWER SELECT Switch (shown in Figure 2-11 as the 120/220V SW) to the TRANSFRMR & RECT. FILTER. An EMI FILTER is present to isolate internal or external interference from entering or exiting the unit. The AC POWER SELECT Switch is also tied to the LINE RECTIFIER & VOLTAGE DOUBLER to provide proper configuration information. The TRANSFRMR & RECT. FILTER provides a dc voltage to run the +12 V Regulator. The +12 V source is used to provide the PWR APPLIED LED Signal to activate the POWER APPLIED Indicator. The signal is also an input for the DC DET NOR GATE.

Once the POWER Switch is pressed, a PWR ON SW Signal is sent to the PWR ON LATCH. This LATCH activates the POWER ON LED CURRENT SOURCE, sending out the PWR ON LED Signal to illuminate the POWER ON Indicator. The PWR ON LATCH also activates the POWER CYCLE DELAY. Inputs from the POWER CYCLE DELAY, +12V REG and the PWR ON LATCH are passed to the DC DET NOR GATE. Once all signals are active, the DC DET Line goes low, passing the status information to the RF I/O PC Board Assembly.

The signal from the POWER CYCLE DELAY is also passed inverted to the RELAY DRIVER. An additional input for the RELAY DRIVER is the signal to the PWR ON LED CURRENT SOURCE from the PWR ON LATCH. These signals activate the RELAY DRIVER, closing the AC IN RELAY. The ac voltage is passed through the LINE FILTER, for keeping spurious signals from passing back through the line, to the LINE RECTIFIER & VOLTAGE DOUBLER. The LINE RECTIFIER & VOLTAGE DOUBLER provides approximately +300 Vdc to a POWER MOSFET Switcher that operates at approximately 100 kHz rate. The POWER MOSFET passes a 300 Vp-p square wave to the SWITCHING TRANSFORMER which has +15 V, +5 V and -15 V as outputs. Various controls regulate the source and draw on the different outputs. The MAG AMPLIFIER regulates the output from the SWITCHING TRANSFORMER to accommodate variable loading on the +15 V output. The SWINGING CHOKE effectively filters any switching power surges that occur in the +15 V load. The +5V SAFETY SWITCH grounds the +5 V signal if an overvoltage occurs. Additionally, a feedback circuit is used to control the pulse width of the POWER MOSFET, which provides voltage regulation. The +5 V CLEANUP FILTER provides a signal to the +5 V ERROR AMP, which sets the +5 V output. The error signal activates the OPTOCOUPLER, providing a path to the PWM (Pulse Width Modulator) which controls the pulse width to the POWER MOSFET. The -15 V line has a -15V REGULATOR to provide voltage regulation. All voltage lines pass through a COMMON-MODE FILTER used to help remove 100 kHz spikes. The +15 and +5 V lines also go through a Clean-Up Filter before being distributed to the various supply lines.

One of the +15 V supply lines is passed through the SCOPE +12V REG to provide +12 Vdc to the CRT Assembly. All other supply lines are filtered by Low-Pass Filters and passed to all assemblies as required.

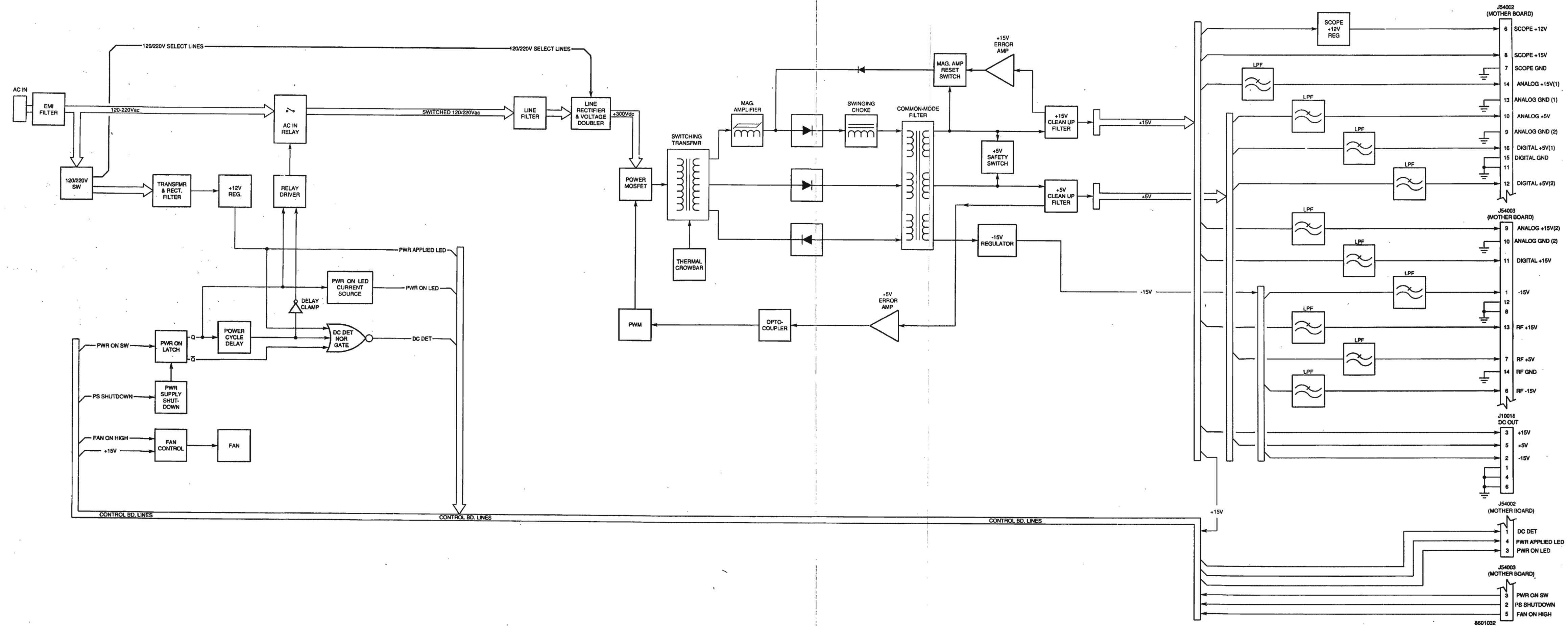

Figure 2-11 Power Supply Assembly Block Diagram

## 2 ; AUXILIARY POWER SUPPLY PC BOARD ASSEMBLY

The Auxiliary Power Supply PC Board Assembly performs 4 functions:

- Provides interface from 1st LO, 2nd LO and Attenuator PC Board Assemblies to the RF I/O PC Board Assembly.
- Disperses +5 and  $\pm 15$  Vdc from the Power Supply Assembly to the 1st LO, 2nd LO and Attenuator PC Board Assemblies.
- Provides 34 Vdc to 1st LO Assembly.
- Takes TCXO-PWR line from 2nd LO Assembly and generates an appropriate signal for STATUS-2ND (2nd LO status line).

The Auxiliary Power Supply PC Board Assembly provides a feedthrough interface for the 1st LO and Attenuator PC Board Assemblies to and from the RF I/O PC Board Assembly through the RF I/O BUS. Information passed from the RF I/O BUS includes latch, clock and serial data signals. Information passed to the RF I/O BUS are status signals from the 1st LO and Attenuator Assemblies.

The Auxiliary Power Supply PC Board Assembly also passes +5 and  $\pm 15$  V to the 1st LO, 2nd LO and Attenuator Assemblies. The 1st LO Assembly also requires a +34 V source. This is generated in the Auxiliary Power Supply PC Board Assembly and is not used by any other assembly.

2nd LO Assembly passes TCXO-PWR Signal to the Auxiliary Power Supply PC Board Assembly which passes the signal to the RF I/O BUS and also sets the appropriate signal for a status signal for the 2nd LO Assembly. If the TCXO-PWR Signal is high, the STATUS-2ND Line is high.





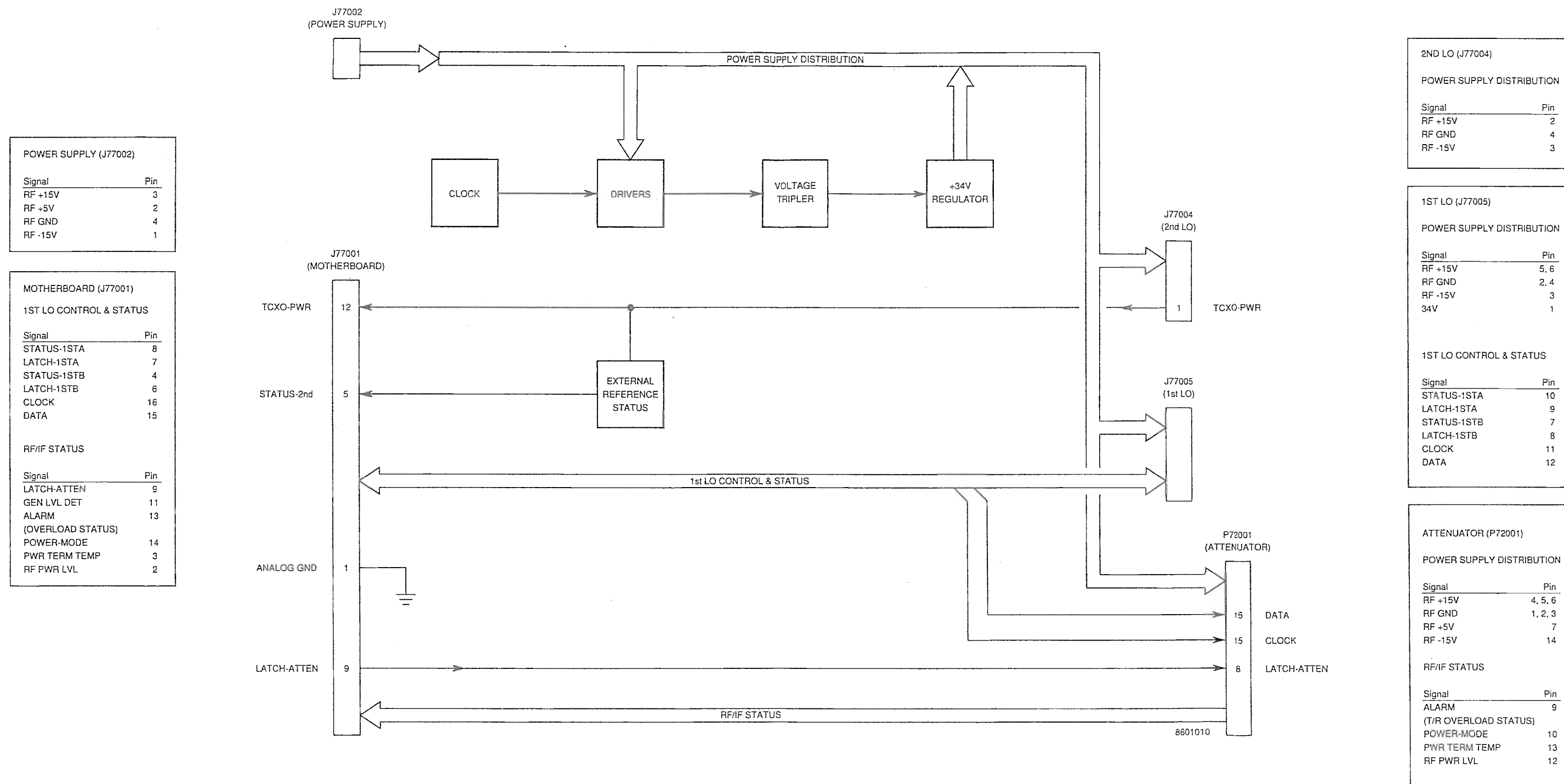

Figure 2-12 Auxiliary Power Supply PC Board Assembly Block Diagram

## 2-4-7 RECEIVE IF ASSEMBLY

Signals can be received into the FM/AM-1600S through two connectors, the ANTENNA IN Connector and the T/R Connector. These signals are processed differently until they reach the Receive IF Assembly where the two channels merge into one. Signals received through the ANTENNA IN Connector are passed directly to the Receive IF Assembly where the incoming signal is attenuated by a 3 dB pad, primarily for impedance matching. The signal passing through the T/R Connector is processed by the Power Term Assembly. From the Power Term, the signal passes to the Receive IF Assembly where the two Receive Channels merge.

Selection of the connector to be used starts in the Processor PC Board Assembly based user selection. The data is passed to the RF I/O PC Board Assembly to place on RF I/O BUS. The data passes through the Auxiliary Power Supply PC Board Assembly to the Attenuator PC Board Assembly. The serial data is converted to control signals and become the Antenna/(T/R) SEL Signal. If the switch is set for the ANTENNA IN Connector and the signal is too high in level, the switch automatically changes to select the T/R Connector and return an ALARM Signal to the Processor PC Board Assembly through the path described in reverse order.

In the Receive IF Assembly, the RF Signal is attenuated as selected by the operator. Attenuation is set using two 20 dB attenuators. The amount of attenuation selected is passed to the Receive IF Assembly in the same manner as described for the ANTENNA/(T/R) SELECT Signal. These switchable attenuators are used to reduce signal level above -30 dBm.

The attenuated signal then passes through a 1050 MHz Low-Pass Filter and is presented to the 1st Mixer. The 1st Mixer transforms the RF signal into a 1300 MHz IF signal. The LO signal is from the 1st LO Assembly (1300-2298 MHz). For RF signals below 10 MHz, the 1st LO signal is 1300 to 1310 MHz. To remove leakage to the IF output, a null circuit splits, attenuates and phase shifts the LO signal to place in the IF signal path. This null signal cancels out the LO input from the 1st LO Assembly.

The 1300 MHz IF Signal from the 1st Mixer is passed through 1300 MHz Bandpass Filters and is amplified before being presented to the 2nd Mixer. The 2nd Mixer transforms the 1300 MHz IF Signal into a 88 to 90 MHz IF Signal. This signal is amplified and passed to the Analyzer RF Assembly and the 3rd Mixer of the Receive IF Assembly. The LO Signal for the 2nd Mixer is generated by the 2nd LO at a frequency of 1210 MHz.

The signal passed to the 3rd Mixer by the 2nd Mixer is amplified and filtered by a 88-90 MHz Bandpass Filter. The 3rd Mixer mixes this 88 to 90 MHz IF Signal with the 77.3 to 79.3 MHz LO Signal from the 3rd LO to form the final 10.7 MHz IF Signal. This signal is passed through a 21 MHz Low-Pass Filter, is amplified and then passed to the Receiver Assembly.

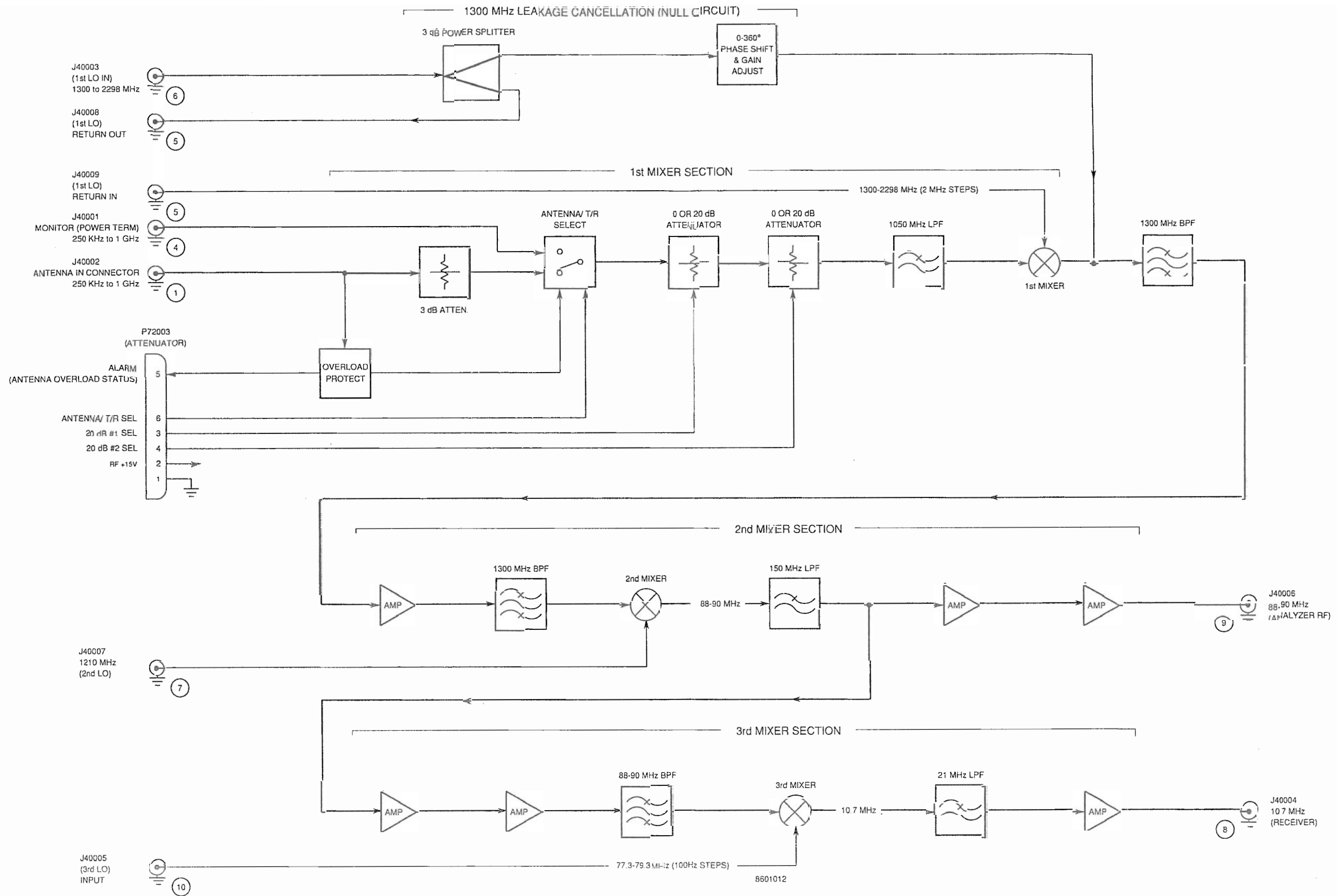

Figure 2-13 Receive IF Assembly Block Diagram

#### 2-4-8 ANALYZER RF ASSEMBLY

In the Analyzer RF Assembly, the 89 MHz IF Wideband Signal is converted to a 10.7 MHz IF Signal for the Analyzer Log/IF Assembly. Input signals used for conversion include a 77.3-79.3 MHz Signal from the 3rd LO Assembly and 1 MHz Reference Signal from the 2nd LO Assembly. Signals generated in the Digitizer PC Board Assembly are used to sweep and phase lock the Sweep VCO. Signals from the Digitizer PC Board Assembly include ANLZR BLANK and ANLZR SWEEP. Control signals for sweep scaling originate in the Processor PC Board Assembly. Processor control signals are converted to serial format by the RF I/O PC Board Assembly and passed to the Analyzer RF Assembly.

The 89 MHz IF Wideband Signal is presented to the Analyzer RF Assembly by the Receive IF Assembly. The incoming signal is first filtered by a 89 MHz Bandpass Filter (12 MHz Bandwidth) before it is passed to the 1st Mixer, where it is mixed with the signal from the Sweep VCO to form the 33.3 MHz IF Signal. Two 33.3 MHz Bandpass Filters (3 MHz bandwidth) filter the 33.3 MHz IF Signal. The filtered signal is passed to the 2nd Mixer. The 2nd Mixer converts the 33.3 MHz IF Signal to a 10.7 MHz IF Signal using the signal generated by the 44 MHz VCO. The 10.7 MHz IF Signal is then filtered by two 10.7 MHz Bandpass Filters (3 MHz Bandwidth) and passed to the Analyzer Log/IF Assembly.

The Sweep VCO Signal has a frequency band of 116.3 to 128.3 MHz. The ramp function is generated in the Digitizer PC Board Assembly and passed to the Analyzer RF as the ANLZR SWEEP Signal. This signal is scaled and amplified before being used as the tune sweep signal for the Sweep VCO. The Digitizer PC Board Assembly also generates the ANLZR BLANK Signal that interrupts the ANLZR SWEEP Signal, stops the 44 MHz LO Signal and enables the Lock Detect circuit. This signal also enables the phase lock system for the 116.3-128.3 MHz VCO, locking the frequency of the Sweep VCO. Additional Control Signals are passed from the Processor PC Board Assembly through the RF I/O PC Board Assembly. These signals, CLOCK, DATA and LATCH-AN2, are converted from serial to parallel format and used to select the Sweep Scaling for the ANLZR SWEEP Signal. The presence of a ZERO SCAN Signal from the Processor stops the 44 MHz LO Signal from reaching the 2nd Mixer.

The signal from 44 MHz VCO is also fed back into a phase lock system. In the phase lock system the 44 MHz signal is divided by 44 to a 1 MHz signal. This signal is compared to the 1 MHz Reference Signal from the 2nd LO Assembly. If phase lock occurs, a signal, 44 MHz LOCK, goes to the Lock Detect.

The Sweep VCO Signal is also passed to the 3rd Mixer as the first stage of the phase lock system for the Sweep VCO. Using the 77.3-79.3 LO Signal from the 3rd LO Assembly, the 3rd Mixer converts the Sweep VCO Signal to a 44 MHz Signal. This signal is frequency divided to 1 MHz. This signal is compared to the 1 MHz reference from the 2nd LO. If these two signals match, a signal, SWEEP LOCK, is sent to the Lock Detect.

If the SWEEP LOCK and the 44 MHz LOCK signals are present at the Lock Detect simultaneously, a signal, ANLZR-LOCK, goes to the RF I/O PC Board Assembly. The presence of the ANLZR BLANK Signal from the Digitizer PC Board Assembly disables this circuit.

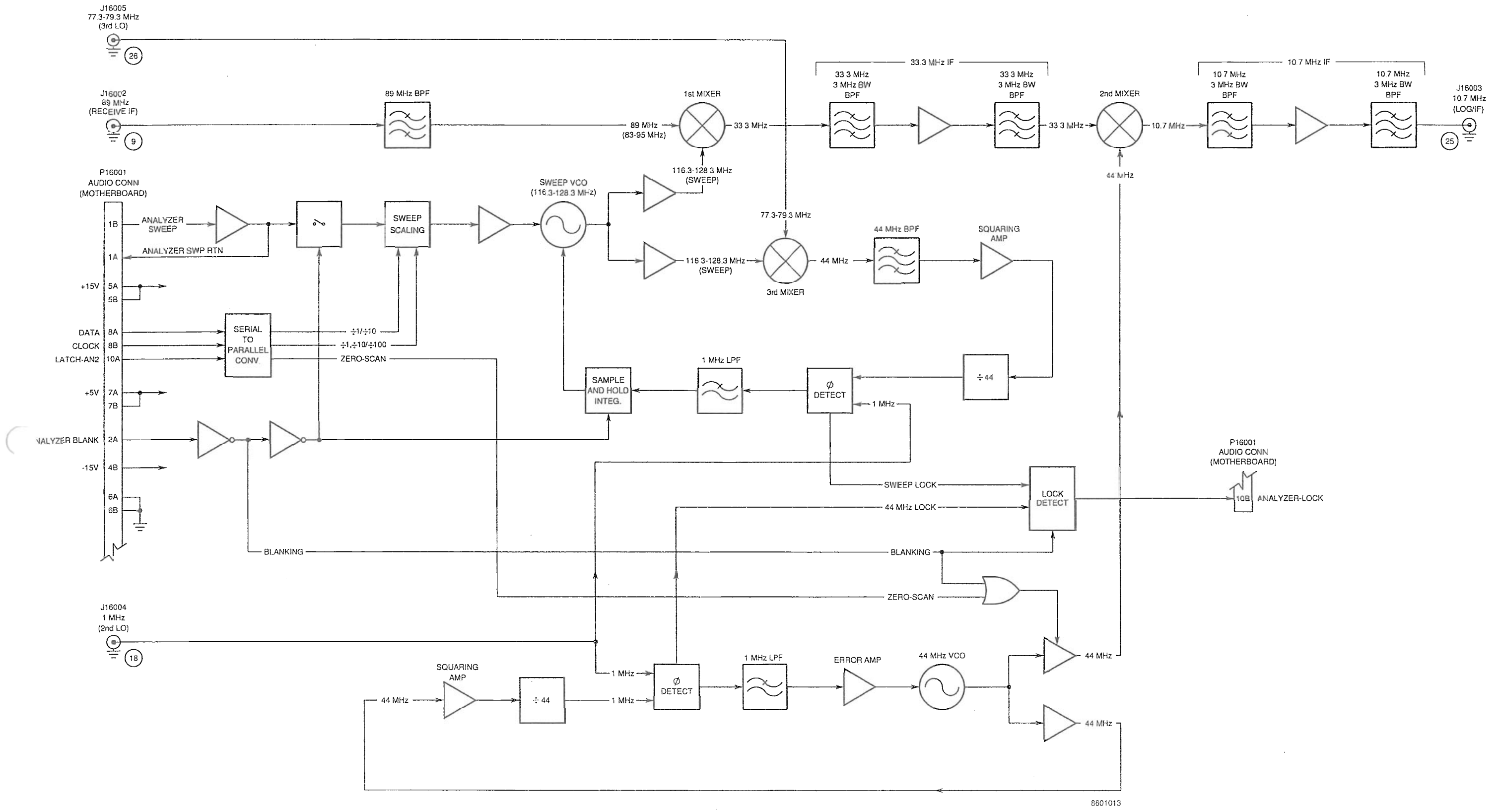

Figure 2-14 Analyzer RF Assembly Block Diagram

## 2-4-9 RECEIVER ASSEMBLY

The 10.7 MHz IF Signal is processed in the Receiver Assembly into audio signals and data signals for the Monitor Assembly as well as 425 kHz signals for use by the Digitizer PC Board Assembly and the Counter PC Board Assembly. Demodulated signals routed to the Monitor Assembly include:

FM DEMOD  
FM DATA

AM DEMOD  
SSB DEMOD

PM DEMOD  
AGC LEVEL

The Receiver is physically divided into two sections, the Receiver Amp Assembly and the Receiver Demodulation PC Board Assembly. The Receiver Amp Assembly is responsible for converting the 10.7 MHz IF Signal to the 425 kHz signal used by the Digitizer PC Board Assembly, Counter PC Board Assembly and the Receiver Demodulation PC Board Assembly. The Receiver Demodulation PC Board Assembly is responsible for demodulation of the 425 kHz signal. The final demodulated signal is passed to the Monitor Assembly. A detailed explanation of the process in each PC Board follows:

### Receiver Amp Assembly

The 10.7 MHz IF from the Receiver IF Assembly is amplified and filtered by an IF Bandpass Filter. The filter is selected by control signals from the RF I/O PC Board Assembly that are enabled by the Processor PC Board Assembly. If there is no filter selection signal active, the 10.7 MHz Signal passes through a 500 kHz Bandwidth Bandpass Filter. The control signals select either a 30 kHz Bandwidth Bandpass filter with the 30 kHz BANDWIDTH CONTROL Signal or a 3 kHz Bandwidth Bandpass Filter with the 3 kHz BANDWIDTH CONTROL Signal. Once filtered, the 10.7 MHz IF Signal is amplified by selective AGC Amplifiers using the AGC Feedback signal from the Receiver Demodulation PC Board Assembly. The signal is then sent to a Mixer and mixed with an 11.125 MHz Phase Locked Oscillator to obtain a 425 kHz IF Signal. This signal is sent to the Receiver Demodulation PC Board Assembly through two channels. One channel is to the FM Detector, the other channel is to the AM Detector after passing through another AGC Amplifier. The standard for the 11.125 MHz Oscillator is the 1 MHz Reference Signal from the 2nd LO Assembly.

### Receiver Demodulation PC Board Assembly

The Receiver Demodulation PC Board Assembly receives the 425 kHz IF Signal through two channels, the AM Detector and the FM Detector. The signal passed to the AM Detector is passed to four areas:

- AM Detector
- SSB Detector
- 425 kHz Signal to Digitizer PC Board Assembly (-20 dBm)
- 425 kHz Signal to Counter PC Board Assembly (-10 dBm)

## 4-10 ANALYZER LOG/IF ASSEMBLY

The 10.7 MHz IF Signal is sent to the Analyzer Log/IF Assembly from Analyzer RF Assembly. The Processor PC Board Assembly sends information on Resolution Bandwidth through the NAT-BUS to the RF I/O PC Board Assembly where the data is converted to serial format. The RF I/O PC Board Assembly passes the serial data to the Analyzer Log/IF Assembly where the information is decoded in the Bandwidth Select Area into signals for setting the Pin Diode Switches to proper settings. Select lines are sent to the specified filter, attenuator or amplifier which generates the conditions to set the Pin Diode Switches to proper settings. The first switch selects the input path for the second switch. Selections include:

Wide Band Attenuator	300 kHz Bandpass Filter	30 kHz Bandpass Filter
----------------------	-------------------------	------------------------

The output of the second switch is the input of the third switch which selects the input path for the fourth switch. Selections include:

3 kHz Bandpass Filter	300 Hz Bandpass Filter	Broadband Amplifier
-----------------------	------------------------	---------------------

Once the signal passes through the last Pin Diode Switch, it goes to a Logarithmic Amplifier. The amplified signal then passes to an AM Detector. The AM Detector converts the 10.7 MHz IF to a voltage level. This voltage is amplified and passed to the Digitizer PC Board Assembly as the ANLZR VIDEO Signal.





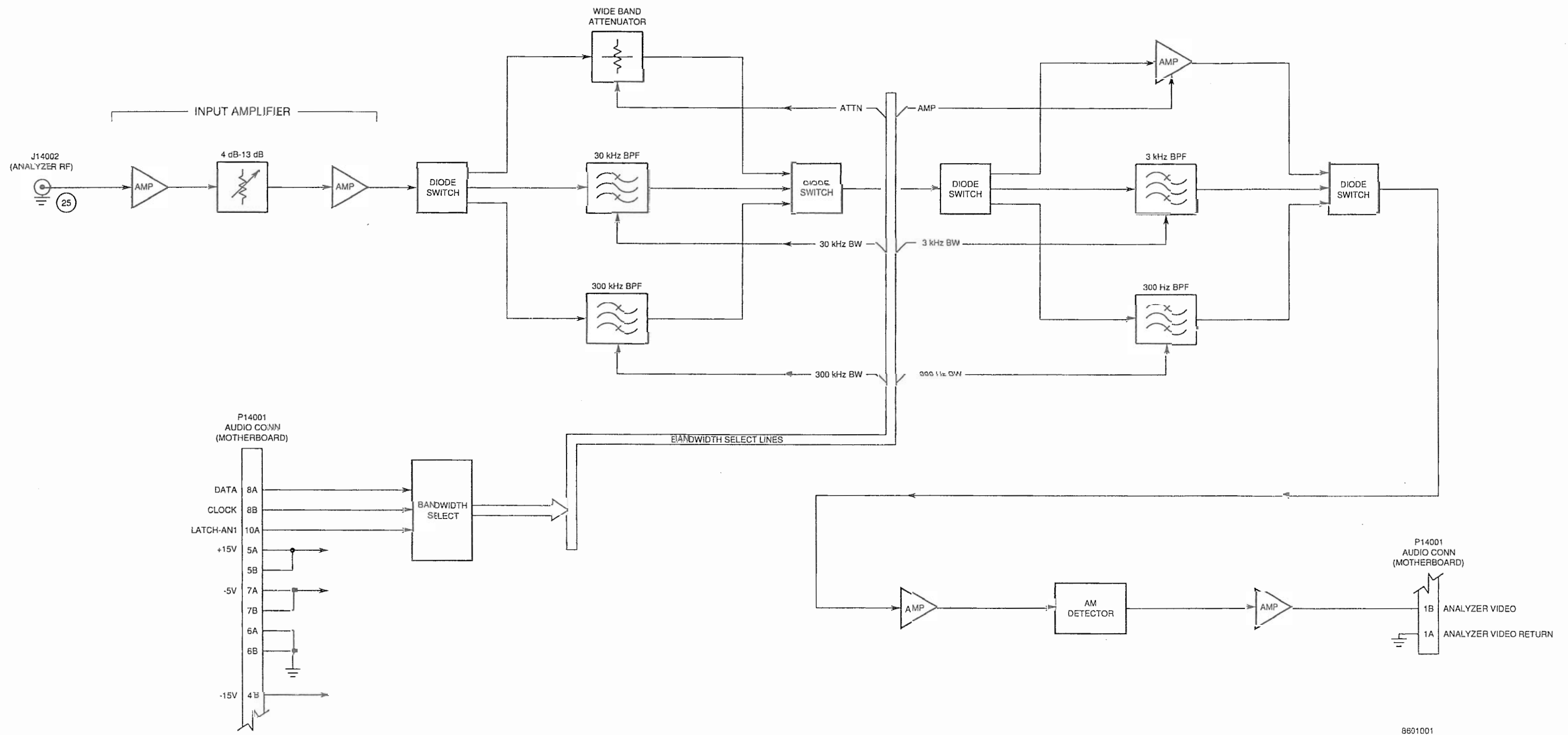

Figure 2-16 Analyzer Log/IF Assembly Block Diagram

## 2-4-11 DIGITIZER PC BOARD ASSEMBLY

The primary operation of the Digitizer PC Board Assembly is the conversion of analog data into digital data to be passed to the Processor PC Board Assembly. Additionally the Digitizer generates the ANLZR SWEEP Signal and ANLZR BLANK Signal used by the Analyzer RF Assembly to sweep the 89 MHz IF Signal. Inputs for the Digitizer are:

SCOPE IN Connector	Receive IF (425 kHz)
Analyzer Video	Scope Audio

Input signals are processed differently, but once processed, follow the same basic path. The signal, once selected, is scaled by the  $\pm 1/\pm 2/\pm 5$  Scaling Circuit, amplified and converted to digital data in a Flash A/D Converter. The digital data is then stored in on-board RAM until it is passed to the Processor PC Board Assembly through the NAT-BUS.

Scope Audio, Analyzer Video and Receiver IF Input Signals are selections for the SCOPE/IF/ANALYZER Selector. Selection is made by CONTROL REGISTERS as set by control signals sent by the Processor PC Board Assembly through the NAT-BUS. The selected signal is routed to the SCOPE/INTERNAL SELECTOR. Digital Control Lines from the CONTROL REGISTERS choose the required signal. The signal, once selected, is scaled by the  $\pm 1/\pm 2/\pm 5$  Scaling Circuit as required, amplified and converted to digital data in a FLASH A/D CONVERTER. The digital data is then stored in on-board SRAM until it is passed to the Processor PC Board Assembly through the NAT-BUS. If an offset of vertical position of signal is desired, an offset voltage is applied to the Amplifier before being passed to the FLASH A/D CONVERTER.

The other selection of the SCOPE/INTERNAL SELECTOR is the processed SCOPE IN Connector. The SCOPE IN Connector Signal can be AC, DC or GND (Ground) coupled. The Coupled signal can be sent through a SCOPE PREAMP if 1 mV/Div sensitivity is required. Selection is initiated by PREAMP Signal from CONTROL REGISTERS through the FRONT END CONTROL Bus. The signal goes through a  $\pm 1/\pm 10/\pm 100/\pm 1000$  Scaling Attenuator. The signal then is passed the SCOPE/INTERNAL SELECTOR. The signal is then processed as described for the internal signals.

The ANLZR SWEEP Signal is generated by the SWEEP RAMP GENERATOR. The SWEEP COUNTER counts up the value for the SWEEP RAMP GENERATOR which builds the ANALYZER SWEEP Signal. The SWEEP COUNTER is clocked by the DIVIDER and disabled by the ANALYZER BLANKING Signal. The Frequency-to-Voltage Converter, generated by the COUNTER/TIMER, scales the ANLZR SWEEP Signal.

The ANALYZER BLANKING Signal is generated by the COUNTER/TIMER. The ANALYZER BLANKING Signal is used both internally to reset the SWEEP COUNTER and passed to the Analyzer RF Assembly for use in sweeping the 89 MHz IF Signal.

An internal 40 MHz CLOCK provides the time base for the Digitizer PC Board Assembly. This 40 MHz is divided into 4, 8 and 20 MHz Clocks by the CLOCK DIVIDER. The WRITE CLOCK SELECTOR provides the selected clock to the CONTROL Bus.

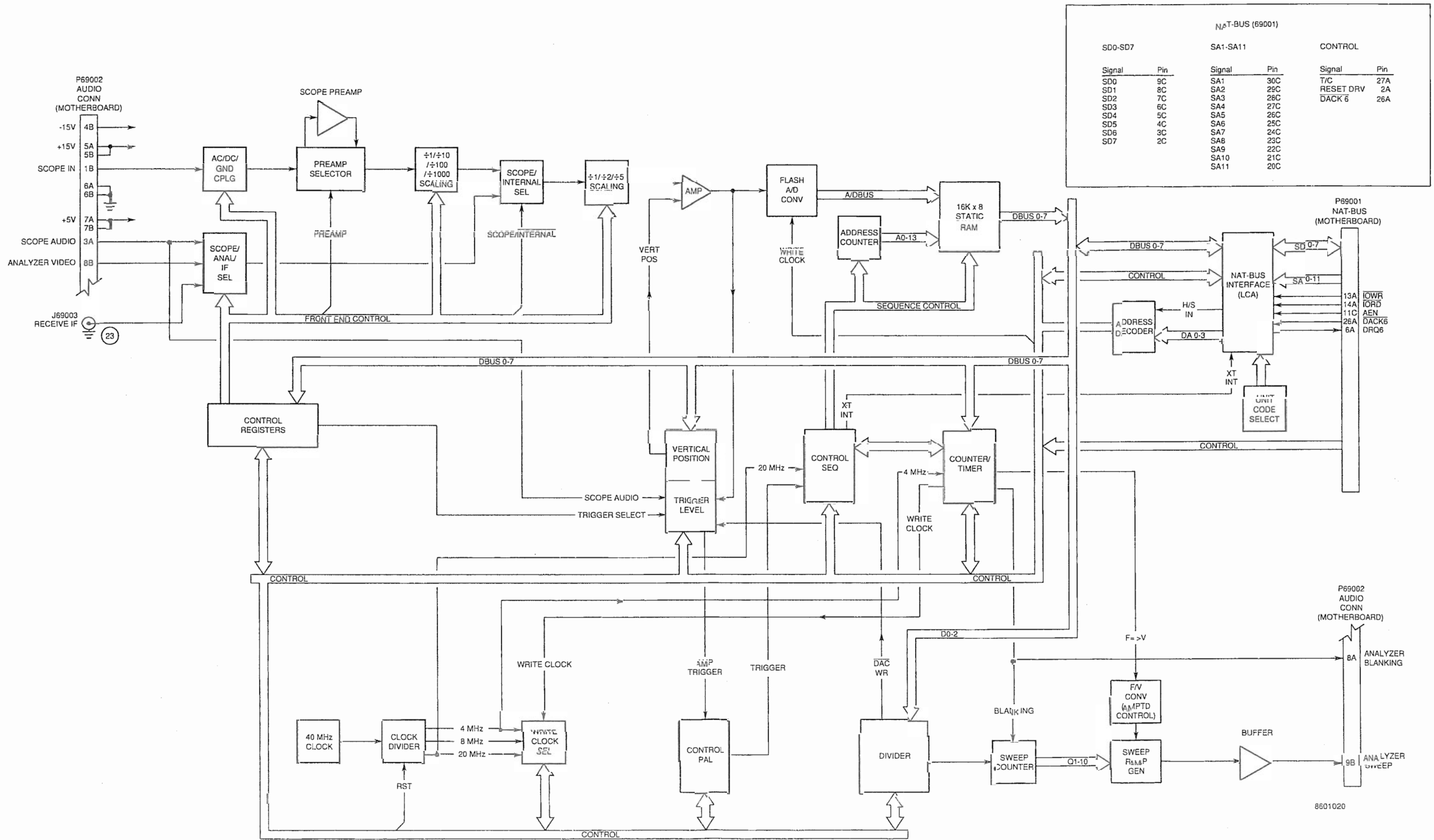

Figure 2-17 Digitizer PC Board Assembly Block Diagram<sup>1</sup>

## 2-4-12 COUNTER PC BOARD ASSEMBLY

The Counter PC Board Assembly performs the following functions:

- Count Audio and IF Frequencies.
- Monitor and Control the DMM.
- Monitor DATA ENTRY Keypad and DATA SCROLL Spinner and provide data to Processor PC Board Assembly.

The Counter PC Board Assembly acts as a slave controller to the Processor PC Board Assembly. It performs the above functions on command and interrupts the Processor PC Board Assembly as needed with Keyboard/Spinner information. Information is passed between the Counter PC Board Assembly and the Processor PC Board Assembly on the NAT-BUS.

The CPU CONTROL SECTION controls the actions of all other major sections of the Counter PC Board Assembly. The CPU CONTROL SECTION consists of the Zilog Super 8 Microprocessor, ROM, SRAM and a decoder for translating address and data signals into control signals for the various sections of the Counter PC Board Assembly. The NAT-BUS INTERFACE provides the connection between the Processor PC Board Assembly (through the NAT-BUS) and the CPU CONTROL SECTION.

The COUNTER FUNCTION INTERFACE counts the frequency of the Audio and the 425 kHz IF Signals. Counting the 425 kHz IF Signal provides the RF Error from the frequency of the Receiver. The COUNTER FUNCTION uses the 1 MHz Reference Signal from the 2nd LO Assembly as the frequency time base for counting frequency. Control signals are passed to the COUNTER FUNCTION INTERFACE by the CPU CONTROL SECTION through the CONTROL BUS. Data from the COUNTER FUNCTION INTERFACE is returned through the DATA BUS to the CPU CONTROL SECTION, which passes the data through the NAT-BUS to the Processor PC Board Assembly.

The Counter PC Board Assembly both reads and writes to the DMM Assembly. Communication with the DMM Assembly is conducted through the DMM INTERFACE. Data to and from the DMM Assembly is in serial format, therefore a clock and latch system is required as well as a data line in and a data line out. The described signals are:

DMM DATA IN	DATA TO DMM
DMM CLOCK	DMM/INEN
DMM/OUTEN	

The Counter PC Board Assembly also reads the DATA ENTRY Keypad and the DATA SCROLL Spinner. Reading Spinner counts requires SPINA and SPINB signals from the DATA SCROLL Spinner and a 2 MHz clock derived from the 8 MHz Clock on the NAT-BUS. Use of a key on the DATA ENTRY Keypad or the DATA SCROLL Spinner causes an interrupt in the CPU CONTROL SECTION Control. This Interrupt alerts the Processor PC Board Assembly that new data has been entered. Enable signals for reading the DATA ENTRY Keypad are provided by the CPU CONTROL SECTION to the KEYBOARD INTERFACE. Enable signals for reading the DATA SCROLL Spinner are provided by the CPU CONTROL SECTION to the SPINNER INTERFACE. Data resulting from reading either the DATA SCROLL Spinner or the DATA ENTRY Keypad is returned to the CPU CONTROL SECTION through the DATA BUS.

NAT-BUS INTERFACE (P67001)	
SD0-SD7	
Signal	Pin
SD0	9C
SD1	8C
SD2	7C
SD3	6C
SD4	5C
SD5	4C
SD6	3C
SD7	2C
SA0-SA11	
Signal	Pin
SA0	31C
SA1	30C
SA2	29C
SA3	28C
SA4	27C
SA5	26C
SA6	25C
SA7	24C
SA8	23C
SA9	22C
SA10	21C
SA11	20C
CONTROL LINES	
Signal	Pin
AEN	11C
DACK1	17A
DACK0	14B
DACK3	15A
IOWR	13A
IORD	14A
IRQ6	22A
IRQ13	25A
IRQ4	24A
IRQ5	23A
IRQ12	11B
DRQ1	18A
DRQ6	6A
DRQ3	16A
RESET DRV	2A

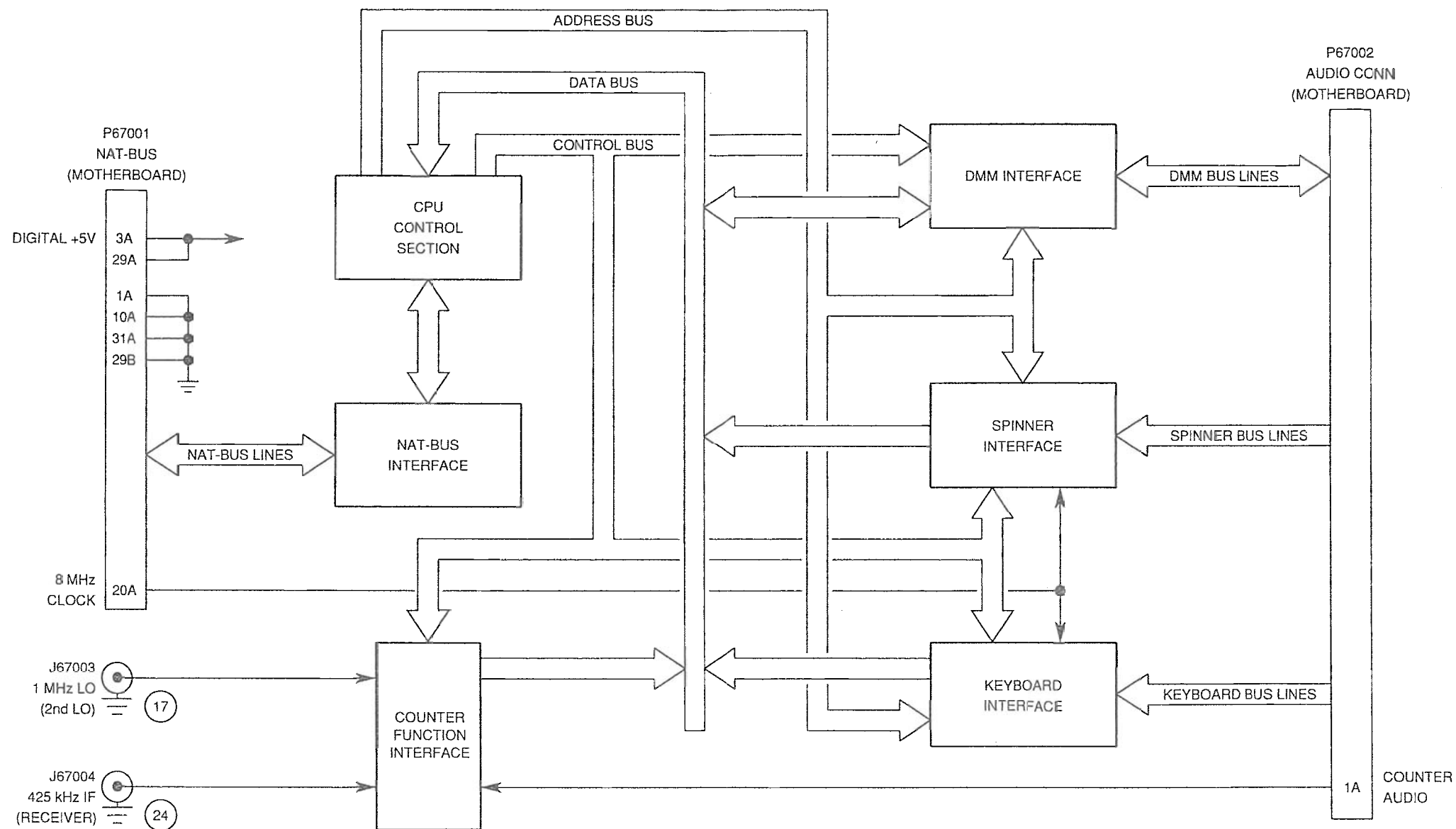

AUDIO CONNECTOR (P67002)	
DMM BUS LINES	
Signal	Pin
DMM CLOCK	2C
DMM/INEN	3C
DMM/OUTEN	4C
DATA TO DMM	1C
DMM DATA IN	1B
SPINNER BUS LINES	
Signal	Pin
SPINA	8B
SPINB	8C
KEYBOARD BUS LINES	
Signal	Pin
KEY ROW 1	9B
KEY ROW 2	10B
KEY ROW 3	11B
KEY ROW 4	12B
KEY ROW 5	13B
KEY ROW 6	14B
KEY ROW 7	15B
KEY ROW 8	16B
KEY COL 1	9C
KEY COL 2	10C
KEY COL 3	11C
KEY COL 4	12C
KEY COL 5	13C
KEY COL 6	14C
KEY COL 7	15C
KEY COL 8	16C

Figure 2-18 Counter PC Board Assembly Block Diagram

8601029

## 2-4-13 MONITOR ASSEMBLY

The Monitor Assembly acts as a switching network to switch audio and analog signals through selected filters to desired outputs. The Monitor Control PC Board Assembly provides control of the Monitor Assembly in selecting the required path. Input Signals accepted by the Monitor Assembly include:

AM DEMOD	FM DEMOD
PM DEMOD	SSB DEMOD
FM DATA	RF PWR LVL
SINAD/BER IN Connector	Function Generator Audio
EXT MOD IN Connector	DTMF IN
Analog Signals	

After filtering, amplifying and/or attenuating, the input signal is switched to the selected output. Outputs available include:

- DVM (Digital Voltmeter on the Monitor Control PC Board Assembly)
- DATA (Monitor Control PC Board Assembly)
- DTMF OUT (Monitor Control PC Board Assembly)
- SPEAKER
- DEMOD AUDIO OUT (DEMOD OUT Connector)
- SCOPE AUDIO (Digitizer PC Board Assembly)
- COUNTER AUDIO (Digitizer PC Board Assembly)
- AUDIO OUT (AUDIO OUT Connector)

The switching within the Monitor Assembly is done with CROSSPOINT Switches. These switches allow up to 4 inputs and 4 outputs. Each input can be tied to each output, however each output can have only 1 input. Selection of a new input for a specific output turns off any other inputs that have been previously selected.

CROSSPOINT #1 is used to select signals not passed by the Receiver Assembly. Control Data from the Monitor Control PC Board Assembly selects the required routing for the selected outputs. The following input signals are routed through CROSSPOINT #1:

RF PWR LVL	SINAD/BER IN Connector
Function Generator Audio	EXT MOD IN Connector
DTMF IN	

The available outputs for CROSSPOINT #1 are:

CROSSPOINT #2	CROSSPOINT #4
AUDIO OUT Connector	DATA (Monitor Control PC Board Assembly)

Demodulated signals are presented to the Monitor Assembly by the Receiver Assembly. Control data from the Monitor Control PC Board Assembly selects the DEMOD Signal by setting the AUDIO SELECTOR. Selected DEMOD is then presented to the SQUELCH GATE. The signal level is checked by the SQUELCH circuitry. If adequate level is present, the SQUELCH circuitry closes the switch in the SQUELCH GATE, allowing the signal to pass to CROSSPOINT #2. Inputs for CROSSPOINT #2 include:

DEMOD Signal	CROSSPOINT #1 Output
High-Pass Filter Output	Low-Pass Filter Output

CROSSPOINT #2 Switch outputs include:

Through "C"-Weight Filter to CROSSPOINT #3 and Volume control circuitry to speaker.  
Through Low-Pass Filter to CROSSPOINT #3 and CROSSPOINT #4.  
Through High-Pass Filter to CROSSPOINT #3 and CROSSPOINT #4.  
CROSSPOINT #3 and CROSSPOINT #4.

CROSSPOINT #3 Switch outputs include:

Through "+" Peak Detector to DVM Selector  
Through "-" Peak Detector to DVM Selector  
Through AGC and Notch Filter to CROSSPOINT #5 Switch  
Through AGC to CROSSPOINT #5 Switch  
To CROSSPOINT #5 Switch

CROSSPOINT #4 Switch inputs include:

From CROSSPOINT #2 Switch through Low-Pass Filter  
From CROSSPOINT #2 Switch through High-Pass Filter  
From CROSSPOINT #2 Switch  
From CROSSPOINT #1 Switch

CROSSPOINT #4 Switch outputs include:

To CROSSPOINT #5 Switch	Counter Audio (Counter PC Board Assembly)
AUDIO OUT Connector	DATA (Monitor Control PC Board Assembly)

CROSSPOINT #5 Switch inputs include:

From CROSSPOINT #3 through AGC and NOTCH Filter  
From CROSSPOINT #3 through AGC  
From CROSSPOINT #3  
From CROSSPOINT #4

CROSSPOINT #5 Switch outputs include:

Through RMS TO DC Converter to DVM Selector.  
To Demodulation Audio Out Signal  
To Scope Audio Signal

DVM Selector chooses DVM input signal. Sole output is to the DVM on the Monitor Control PC Board Assembly. DVM Selector inputs include:

RF PWR LVL	"+" PEAK LEVEL
"-" PEAK LEVEL	RMS (converted to DC)
+15V TEST	+5V TEST
-15 TEST	Analog Signals

Analog Signals include:

Unit Ambient Temperature (Monitor Control PC Board Assembly)  
SIG LVL MTR (Receiver Assembly)  
Power Term Temperature (Power Term Assembly)





AUDIO CONNECTOR (P12001)	
Signal	Pin
ANALOG	
SG LVL MTR	10A
SPKDATA	13A
PWR TERM TEMP	11A
EXT DC	13B

MONITOR CONTROL CONN (J12002)	
Signal	Pin
CONTROL	
CP ADDR 0	8
CP ADDR 1	9
CP ADDR 2	10
CP ADDR 3	11
CP DATA IN	12
CP STROBE 1	13
CP STROBE 2	14
CP STROBE 3	15
CP STROBE 4	16
CP STROBE 5	17
MUXADDR 0	18
MUXADDR 1	19
MUXADDR 2	20
MUXADDR 3	21
MUX ENABLE	22
INC	1
U/D	2
CS SQ	3
CS PA	4
SQ ENFORCE	28
SQ CN	29
VOL MAN/ALC	32
AMP TEMP	34
LPF SEL	31
LPF CLK	5
LPF CLK	6
HPF CLOCK	7
"N" CLK	23
AM SEL	24
FM SEL	25
PM SEL	26
SSB DEL	26
FM DATA SEL	26

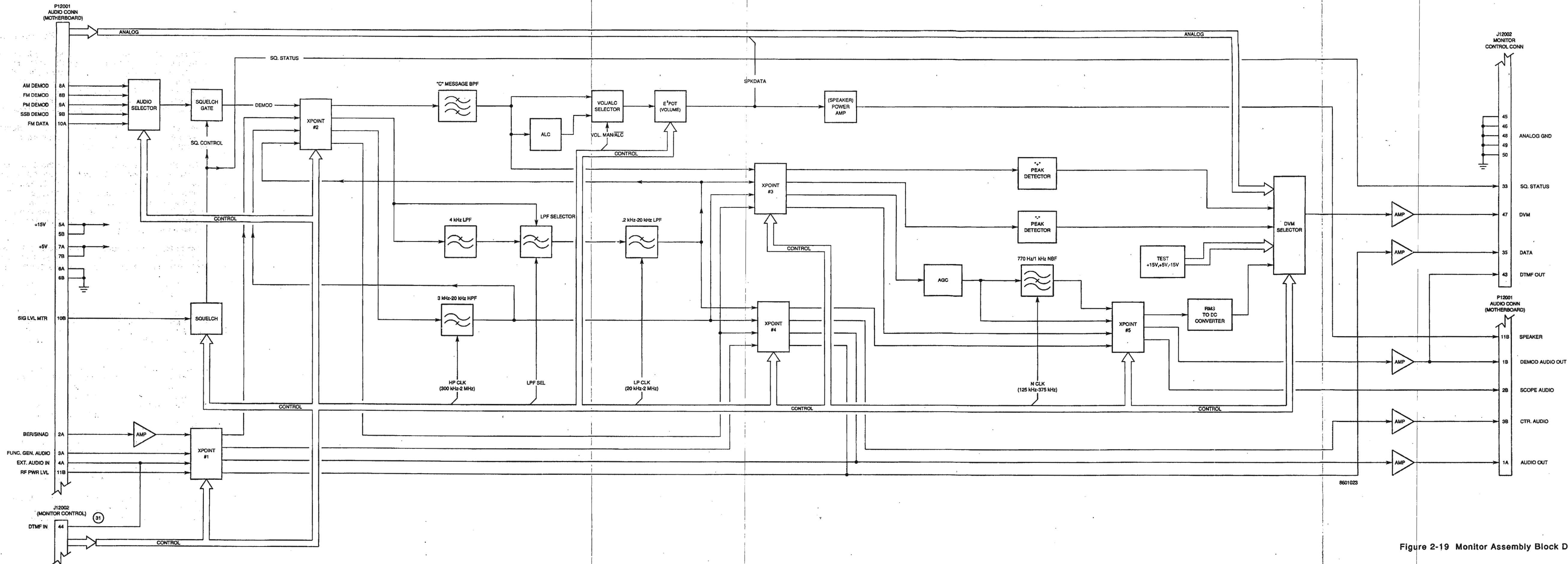

Figure 2-19 Monitor Assembly Block Diagram

Another action performed in the Monitor Control PC Board Assembly is that performed by the DVM (Digital Voltmeter). The DVM measures the dc voltage of the signal passed by the Monitor Assembly and passes the measurement data to the Super 8 Processor. Control signals for the DVM are Memory Mapped and decoded by the MEMORY MAP DECODER PALS. Data is passed from the DVM through the Address/Data Bus. Address lines (A0-A2), from the Super 8 Processor, are used to calibrate the DVM.

The filters used on the Monitor Assembly require clocks to function properly. The FILTER CLK GENERATOR provides the clocks required for the filters on the Monitor Assembly. These clocks are derived from the onboard 6/12 MHz Clock.



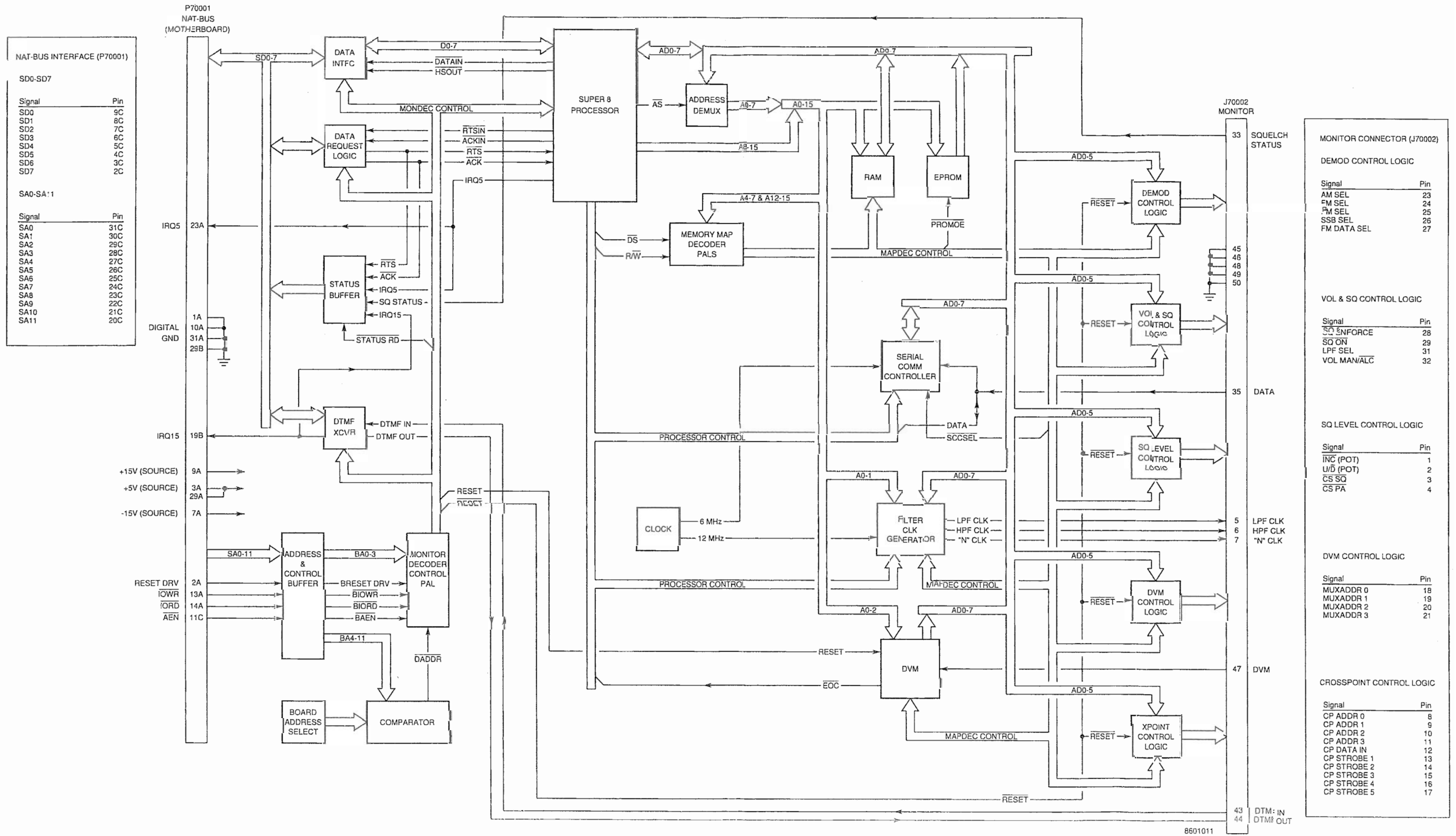

Figure 2-20 Monitor Control P'CB Board Assembly Block Diagram

## 2-4-15 1ST LO ASSEMBLY

The 1st LO Assembly is responsible for generating a phase-locked signal (1300-2298 MHz) for upconverting received signals and downconverting IF Signals to be generated. The 1st LO Assembly is actually composed of the Receive 1st LO Assembly and the Generate 1st LO Assembly. The two operate independent of each other, but perform in exactly the same manner. The description below makes no distinction between the two other than to describe input and output signal differences. Internal Operation is the same in either case.

The 1st LO Assembly is passed the frequency information from the RF I/O PC Board Assembly through the Auxiliary Power Supply. The data signals originate in the Processor PC Board Assembly and are passed to the RF I/O PC Board Assembly through the NAT-BUS. The RF I/O PC Board Assembly converts the parallel format data to serial format and passes the data to the appropriate section of the 1st LO Assembly. The received data is converted back to parallel format in the SERIAL DATA INTERFACE. In the parallel format, this data represents the frequency of the required LO Signal and is used to set the DIGITAL PLL DIVIDER & COMPARATOR and the DIGITAL PLL LOOP FILTER frequencies.

The LO signal is based on a VCO which is tuned by DC TUNE and AC TUNE Signals. The DC TUNE Signal provides the coarse tune, while the AC TUNE Signal is used to fine tune the VCO. The data from the Processor PC Board Assembly presets the DIGITAL PLL DIVIDER & COMPARATOR to a frequency that is close to the required frequency. The Reference for the DIGITAL PLL DIVIDER & COMPARATOR is a 125 kHz signal derived from the 10 MHz Standard Signal. The 10 MHz Signal passes through a  $\div 10$  Divider to form a 1 MHz Signal. This 1 MHz Signal is phase shifted as needed to correct phase shift error. The 1 MHz Signal passes through a  $\div 8$  Divider within the DIGITAL PLL DIVIDER & COMPARATOR to create a 125 kHz signal. The signal generated by the DIGITAL PLL DIVIDER & COMPARATOR passes through the DIGITAL PLL LOOP FILTER at high gain as set by the GAIN SWITCH Signal from the CONTROL SIGNAL TIMER which is also set by the information from the Processor PC Board Assembly. From the DIGITAL PLL LOOP FILTER, the signal passes through two 40 kHz Low-Pass Filters to filter out any of the 125 kHz Reference Signal that leaked into the signal path. The filtered signal is then presented as the DC TUNE Signal to the VCO. Once the VCO has locked on to the Operating Frequency, the GAIN SWITCH Signal switches the DIGITAL PLL LOOP FILTER to low gain operation, to reduce conflict with the AC TUNE Signal. Additionally, a 1ST STATUS Signal (one for Receive and one for Generate) is generated to the Auxiliary Power Supply PC Board Assembly.

Feedback is routed to two areas within the 1st LO Assembly to establish a phase-lock condition. The first signal is the VCO TO DIVIDER Signal. The VCO TO DIVIDER Signal is passed through a  $\div 256/\div 272$  Prescaler before being presented to the DIGITAL PLL DIVIDER & COMPARATOR. The MOD (Modulus) CONTROL Signal determines the prescale value used. Using the 125 kHz Reference, the DIGITAL PLL DIVIDER & COMPARATOR adjusts the output to correct the final output signal.

After a period of time determined by the CONTROL SIGNAL TIMER, the second signal, the VCO TO SAMPLER Signal, is amplified and passed through the sampler, which is clocked by the PULSE GENERATOR. The PULSE GENERATOR uses the 2 MHz signal from the REFERENCE DIVIDER as a reference. The sampled signal is then amplified by the SAMPLER ERROR AMPLIFIER. The signal is then amplified by the SAMPLER LOOP GAIN Amplifier. The GAIN BAND CONTROL Signal sets the Amplifier according to the frequency of the required signal. The amplified signal is then passed to a 400 kHz Low-Pass Filter with a 2 MHz Trap. Once filtered, the signal is the AC TUNE SIGNAL. The signal from the SAMPLER LOOP GAIN Amplifier is also passed through the PHASE ERROR DETECT Circuitry which controls the Reference Phase Shift. The Reference Phase Shift adjusts the phase of the 1 MHz Reference to match the phase of the AC TUNE Signal and the DC TUNE Signal.

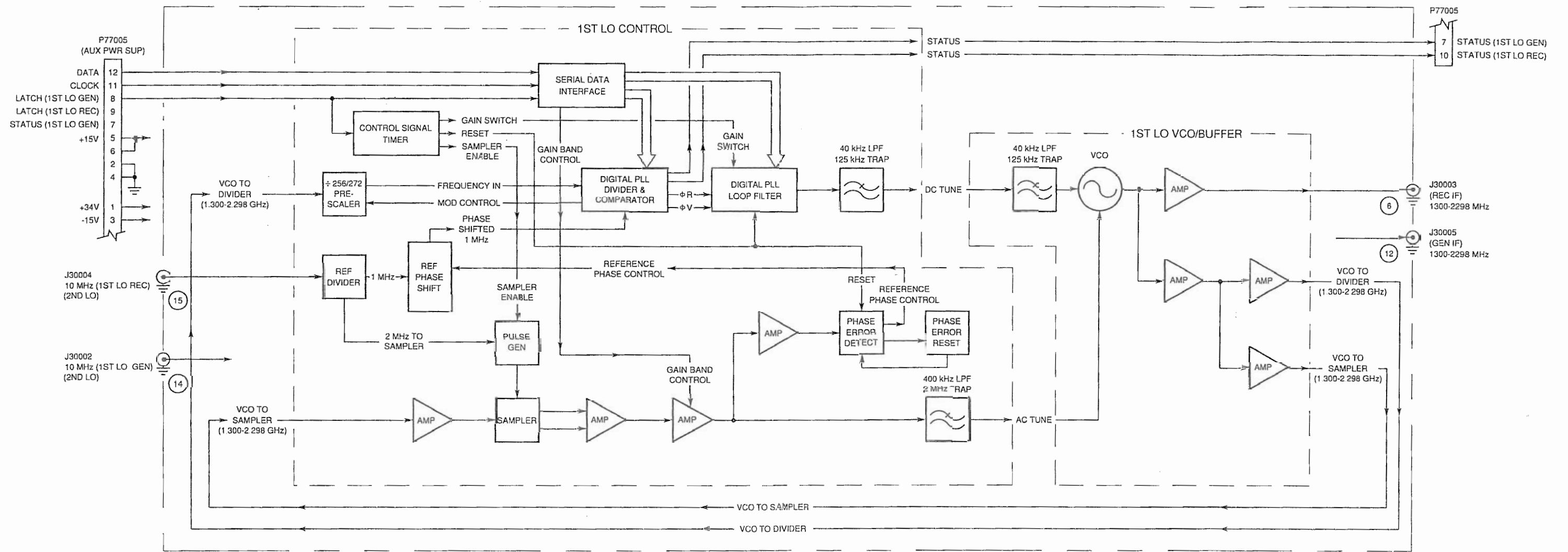

8601017

Figure 2-21 1st LO Assembly Block Diagram

## 2-4-16 2ND LO ASSEMBLY

The 2nd LO Assembly is used to generate the 1210 MHz signal used by the Receive IF and Generate IF Assemblies. The 2nd LO is passed a 10 MHz signal for a reference signal. The 2nd LO has a possibility of two sources for that 10 MHz signal. The default is the TCXO (or the Oven if the option is installed) contained in the unit. The second choice is an external 10 MHz Reference. If the 2nd LO detects the presence of an external standard, it switches to this signal and disables TCXO Power.

The 10 MHz signal is amplified and passed through a x11 Multiplier to generate a 110 MHz signal. The 110 MHz signal is passed through a 110 MHz Bandpass Filter and then a 200 MHz Low-Pass Filter. The filtered signal is then amplified and passed through a 110 MHz Bandpass Filter and amplified again. The filtered signal is then multiplied by a x11 Multiplier to generate a 1210 MHz signal. The 1210 MHz Signal is then passed through a 3-pole Mechanical Bandpass Filter. The resulting signal (1210 MHz LO) is amplified and used by both the Receive IF and the Generator IF Assemblies.

The signal from the 10 MHz Standard is also used by the 1st LO Assembly. After the signal is amplified for the first x11 Multiplier, it is amplified again and split into three 10 MHz Signals. Two signals pass through a 10 MHz Bandpass Filter and are sent to the 1st LO Assembly, one signal for the Receive function and one for the Generate function.

The Third 10 MHz Signal is passed through a ÷10 Frequency Divider to create a 1 MHz Reference signal. This 1 MHz Reference signal is applied to six Buffers to create six 1 MHz Reference signals. The 1 MHz Reference signals are used by the following:

Counter PC Board Assembly	Analyzer RF Assembly	3rd LO Assembly
90 MHz Generator Assembly	Receiver Assembly	

In addition to the generated signals mentioned, the 2nd LO passes the TCXO PWR Signal to the TCXO and to the Auxiliary Power Supply PC Board Assembly. This is an analog signal that enables the TCXO output and also is used as a status signal to pass back to the Processor PC Board Assembly.



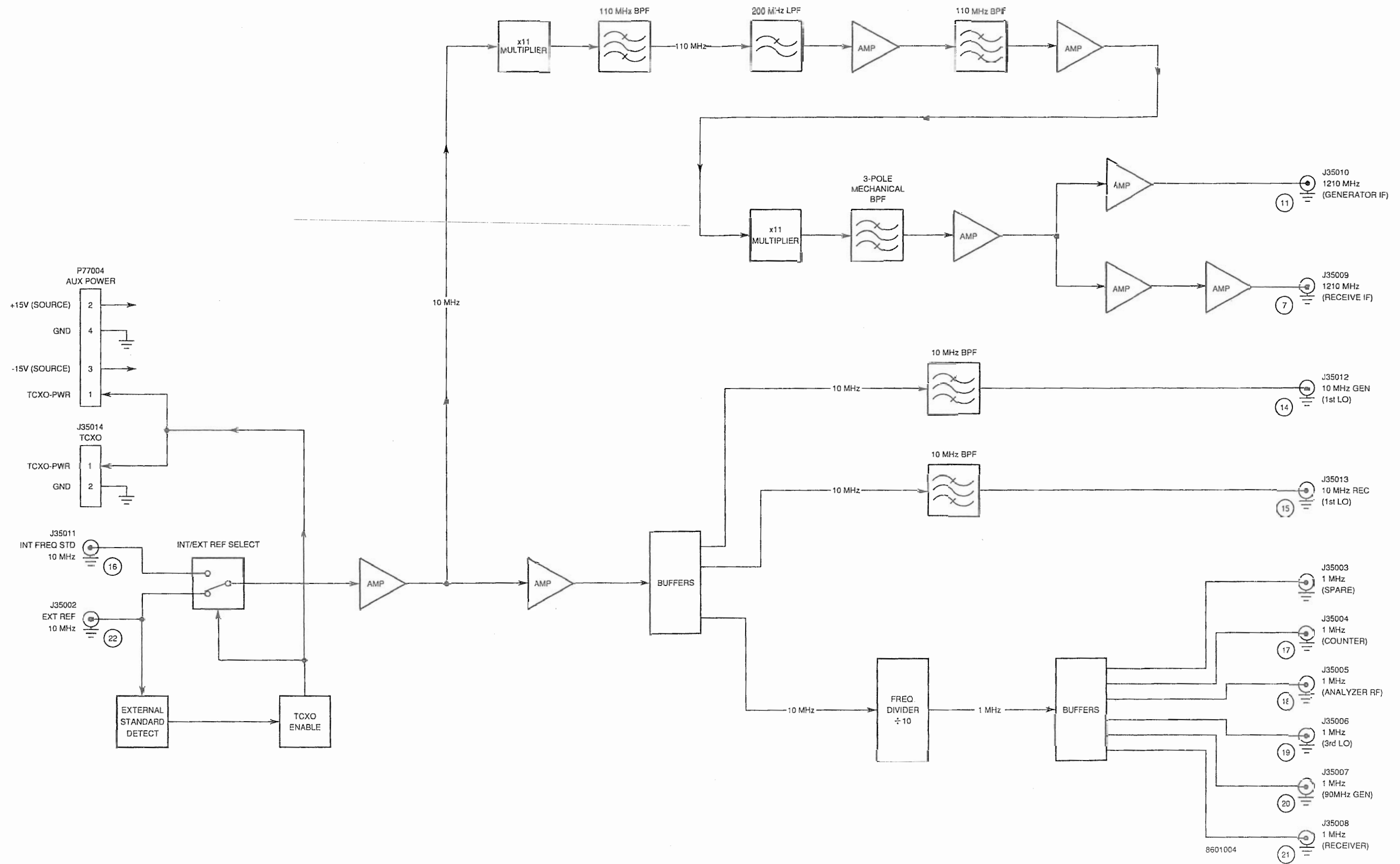

Figure 2-22 2nd LO Assembly Block Diagram

## 2-4-17 3RD LO ASSEMBLY

The output for the 3rd LO Assembly is a 77.3-79.3 MHz Signal to the Receive IF and Analyzer RF Assemblies. The inputs for the 3rd LO Assembly include the 1 MHz Standard from the 2nd LO Assembly and frequency data from the RF I/O PC Board Assembly. The data from the RF I/O PC Board Assembly is initiated in the Processor PC Board Assembly. The RF I/O PC Board Assembly receives the data from the Processor PC Board Assembly through the NAT-BUS and converts the data from parallel format to serial format and passes the data to the 3rd LO Assembly. The internal mechanism of the 3rd LO Assembly consists of three major loops.

The first loop is the 780.125 to 800 MHz Coarse Loop. The 780-800 MHz VCO is pretuned by the data passed by the RF I/O PC Board Assembly. This data is converted by a D/A Converter to an analog voltage and passed to the 780-800 MHz VCO. The same analog voltage is used to pre-position the 77.3-79.3 MHz VCO in the Summation Loop. The signal generated by the 780-800 MHz VCO takes two paths. First, the signal is passed back through a +64/+65 Divider and compared to a Phase Lock Loop 125 kHz Reference which uses the 1 MHz Reference as a clock. The comparison initiates a Phase Lock Loop after proper adjustment of the VCO frequency. The PLL comparator outputs a LOCK DETECT signal to the Lock Detect Circuit once the Phase Lock Loop condition exists.

The second path for the 780 to 800 MHz signal is through a +10 Divider for an effective range of 78.0125 to 80 MHz with an increment of 12.5 kHz. This signal is mixed with the output of the Summation Loop creating a 700-712.4 kHz signal which is passed through a Low-Pass Filter, an Amplifier, a BUFFER and presented to a Phase Detector. The phase detector compares the output of this signal with the signal presented by the 350-356.2 MHz Fine Loop.

The 350-356.2 MHz Fine Loop Operates similar to the 780-800 MHz Coarse Loop. The 350 MHz VCO is pretuned by the data passed by the RF I/O PC Board Assembly after it is passed through a D/A Converter. The analog voltage created is used to pretune the 350 MHz VCO. The signal generated by the 350 MHz VCO takes two paths. First, the signal is passed back through a +64/+65 Divider and compared to a Phase Lock Loop 50 kHz Reference which uses the 1 MHz Reference as a clock. The comparison initiates a Phase Lock Loop after proper adjustment of the VCO frequency. The PLL comparator outputs a LOCK DETECT signal to the Lock Detect Circuit once the Phase Lock Loop condition exists.

The other path for the output of the 350 MHz VCO is through a +5 Divider and a +100 Divider to divide the 350-356.2 VCO signal by 500. The resulting signal (700-712.4 kHz) is passed to the PHASE DETECTOR.

The output of the Summation VCO is mixed with the output of the Coarse Loop to form a 700-712.4 kHz signal for input to the Phase Detector. This signal is compared against the output of the Fine Loop. This Phase Detect/Charge Pump output tunes the Summation VCO to the correct frequency. If the Summation VCO frequency exceeds the Coarse Loop frequency, the Summation VCO is tailed low by a comparator. The Summation VCO is then freed and the system is allowed to function normally. Once the Summation VCO is properly tuned and phase lock is achieved, the Phase Detector outputs a Summation Loop Lock Detect signal to the Lock Detect Circuit.

Once all three loops are phase locked and Lock Detect signals are available, the Lock Detect Circuit outputs a 3rd LO Status Signal and extinguishes the Lock LED.

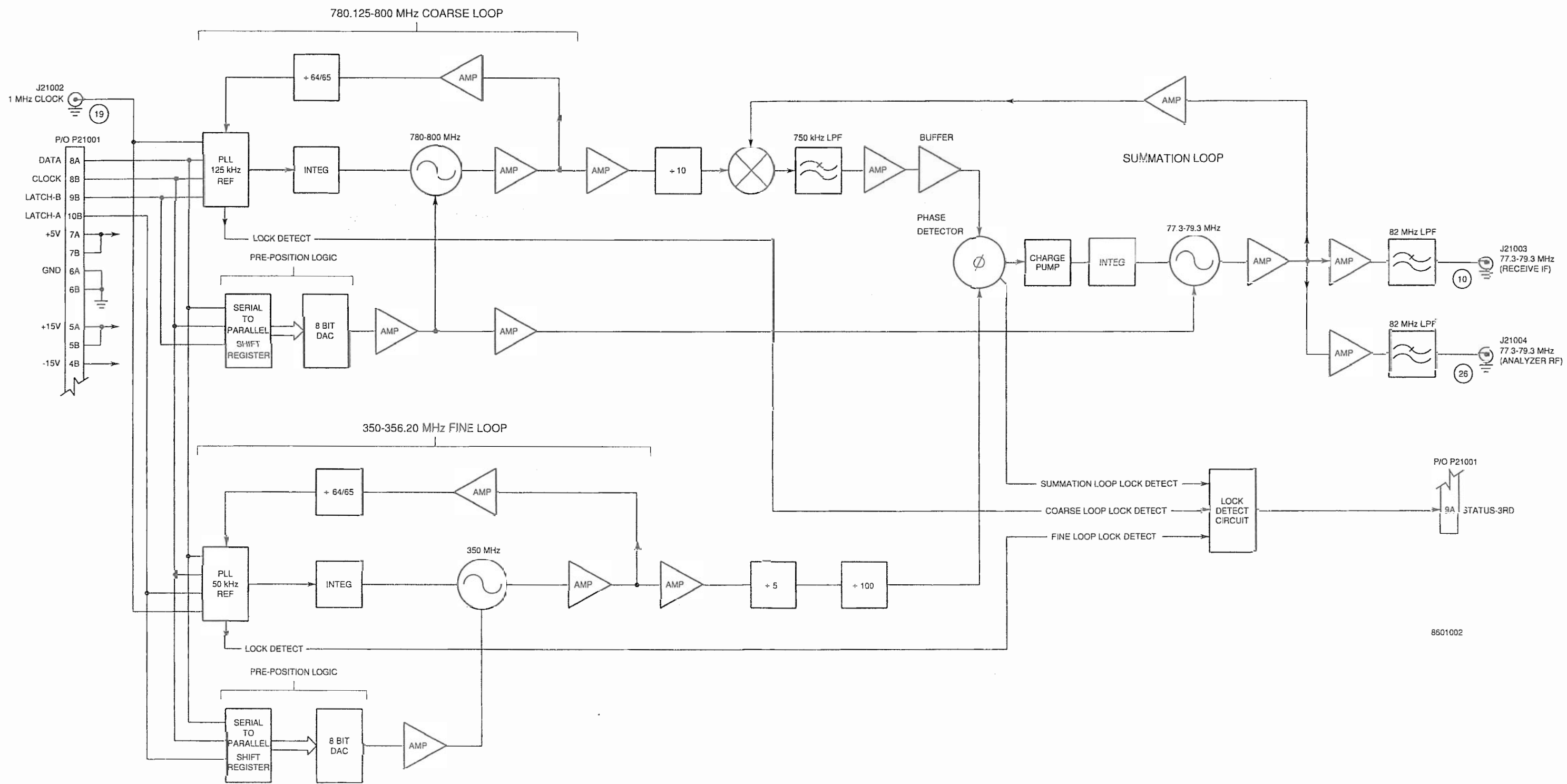

Figure 2-23 3rd LO Assembly Block Diagram

## 2-4-18 POWER TERM ASSEMBLY

The primary purpose of the Power Term Assembly is to isolate the signal coming into the T/R Connector from the rest of the FM/AM-1600S. Additionally the Power Term Assembly is used to pass the RF Signal from the Attenuator PC Board Assembly out through either the T/R Connector or the DUPLEX OUT Connector. Switching between the DUPLEX OUT Connector and the T/R Connector for Duplex Operation is performed in the Power Term Assembly.

If the T/R Connector is selected for input, then the signal is processed by the Power Term Assembly before being passed to the Receive IF Assembly. The signal from the T/R Connector is attenuated by a 10 dB Pad. The attenuated signal is then either processed by a switchable 20 dB Pad or passed on without attenuation. Selection is provided by the 20 dB PAD Signal from the Attenuator PC Board Assembly. The Signal then passes through a 30 dB Pad. This attenuated signal is passed to the Receive IF Assembly for processing.

Additionally, when the signal passes through the 10 dB Pad, the input is split and passed through a 7 dB Pad to the LEVEL DETECTOR. The LEVEL DETECTOR passes the signal as a dc voltage to both the LOW PWR AMP and the HIGH PWR AMP. The selection of the path used is determined by the level of the signal. The LOW PWR AMP is used for signals  $\leq 2$  W. The level is sensed by the COMPARATOR tied to an output of the GAIN AND OFFSET Amplifier that follows the LOW POWER AMP. If a level exceeding 2 W is sensed, the COMPARATOR passes a low voltage signal to the RF I/O PC Board Assembly which causes the RF I/O PC Board Assembly to send a RANGE SELECT Signal that selects the HIGH PWR AMP Path. Additionally, if the 20 dB PAD is bypassed in the routing from the T/R Connector to the Receive IF Assembly, it is switched in to attenuate the signal and protect the circuitry internal to the FM/AM-1600S. The output of the switch is passed to the Monitor Assembly for measuring RF Power of the incoming signal.

The Power Term Assembly is also where the output signal is connected to the appropriate connector for Duplex Operation. For Generate Operation, the T/R Connector is the only selection. The DUPLEX Signal sets the Switch to route the source from the Attenuator PC Board Assembly to the DUPLEX OUT Connector and routes the T/R Connector to a 50  $\Omega$  Termination. This signal is also sampled by a LEVEL DETECTOR, which converts the signal to a dc voltage. This dc voltage is passed to a COMPARATOR to determine if the signal exceeds .25 W. If the signal exceeds .25 W, the COMPARATOR outputs a voltage level that disconnects the input from the Attenuator PC Board Assembly and the 3 dB Pad becomes the load for the DUPLEX OUT Connector. Additionally, the voltage is passed as an ALARM Signal, to let the Processor PC Board Assembly know that the power level exceeded limitations. The Processor will generate an error message to alert the operator. The 3 dB Pad between the Switch and the DUPLEX OUT Connector is present for VSWR matching and input protection.

Because of the heat generated when high level signals are attenuated by the various attenuators in the Power Term Assembly, a Temperature Sensor monitors the temperature within the Power Term Assembly. The sensed temperature is passed to the Monitor Assembly in the form of a dc voltage. If the temperature exceeds certain limitations, the unit will provide operator warnings.

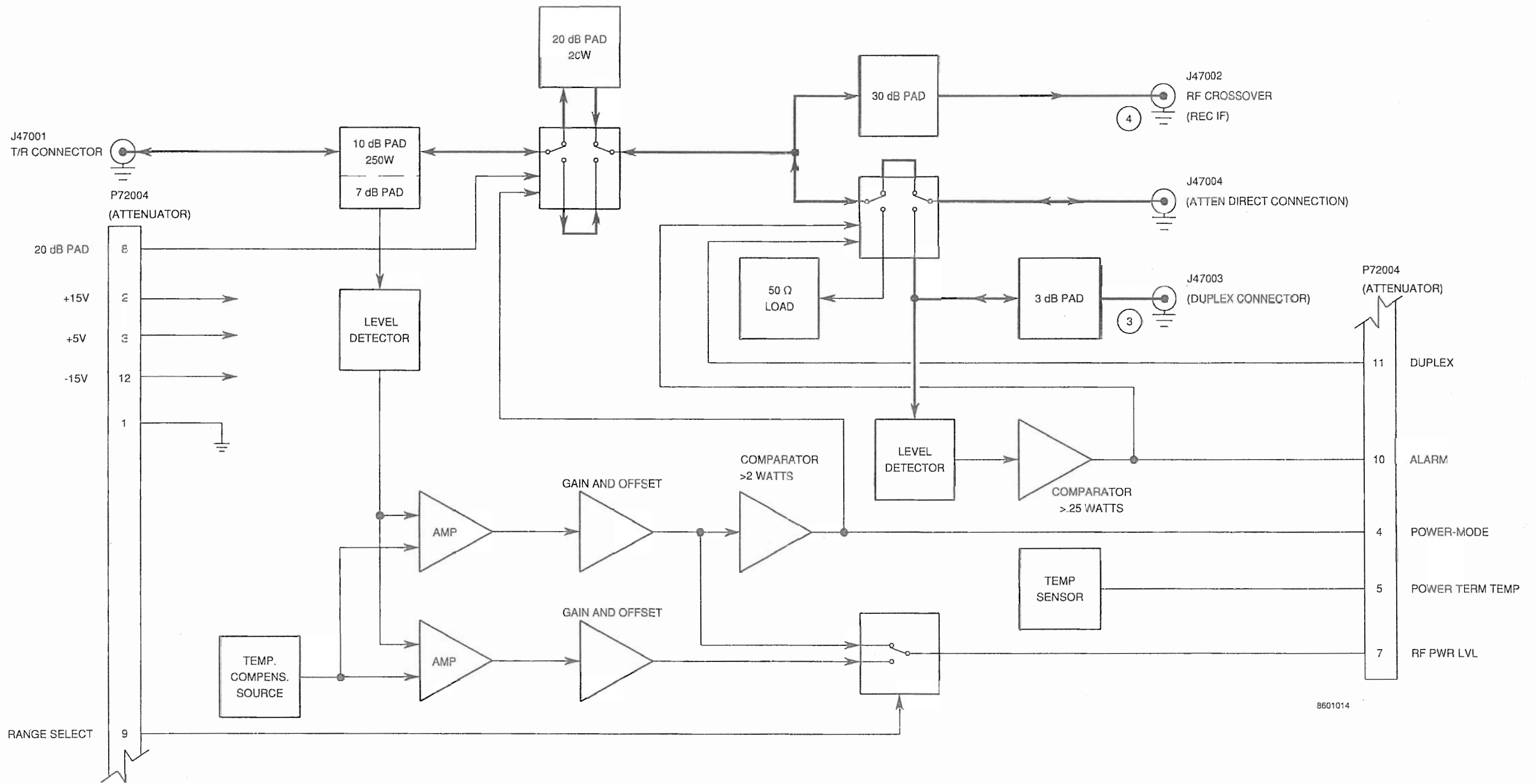

Figure 2-24 Power Term Assembly Block Diagram

## 2-4-19 FUNCTION GENERATOR PC BOARD ASSEMBLY

The Function Generator PC Board Assembly synthesizes the audio signals and serial data that the FM/AM-1600S generates. The Function Generator PC Board Assembly is microprocessor controlled with an interface to the Processor PC Board Assembly. The microprocessor, a Zilog Super 8, serves as slave processor to the Processor PC Board Assembly. The Function Generator PC Board Assembly processes the following signals:

GEN1 Output	GEN2 Output
Serial Data.	EXT MOD IN Connector input
MIC/ACC Connector input	DTMF

The two audio generators use a procedure that encompasses both analog and digital processes. The Processor PC Board Assembly passes requirements to the Super 8 Microprocessor. The Super 8 Microprocessor passes information to the XILINX concerning wave shape, frequency and required synthesizer for generating audio tones. The XILINX instructs the proper PROM (one for each audio generator) which wave shape to write and provides the clock for the selected frequency. The output from the PROM is processed by a D/A Converter as the first step of the analog process. The resulting signal is then filtered by both a fixed Low-Pass Filter and a Wave Shaping Filter selected by the Super 8 Microprocessor. The resulting signal level is 5 Vp-p. The Generator Attenuator attenuates the signal to the required output level. The final output location for this signal is selected by the Audio Switching Matrix.

Both EXT MOD IN Connector signals and MIC/ACC Connector signals are imported and passed through an attenuator for setting the signal level. The resulting signals are passed to the Audio Switching Matrix for output selection.

Data signals can be generated by either the Super 8 Microprocessor or the SERIAL-COMMUNICATION CONTROLLER. The resulting signal can be passed as raw data or filtered and attenuated. The filtered signal is sent to the Audio Switching Matrix. The unaltered signal is available directly for output. Level changing to bipolar ( $\pm 6$  V) and TTL levels is also available at the same time filtering is done. The Filter available is a 300 Hz Low-Pass Filter for use in signalling formats.

The Audio Switching Matrix is presented with five different inputs and selects three different outputs for each. For each input, only one output can be selected, however, all five inputs can be active simultaneously. The three outputs available include: FM MOD OUT, AM MOD OUT and FUNCTION GENERATOR AUDIO OUT to the AUDIO OUT Connector. The FM MOD OUT and AM MOD OUT signals are available directly to the 90 MHz Generator Assembly from the Audio Switching Matrix. The FUNCTION GENERATOR AUDIO OUT is processed by another attenuator, giving a wider dynamic range and then filtered by a 60 kHz Low-Pass Filter. This signal is then presented to the AUDIO OUT Connector. Selections for the Audio Switching Matrix are passed from the Processor PC Board Assembly to the Super 8 Microprocessor for processing.

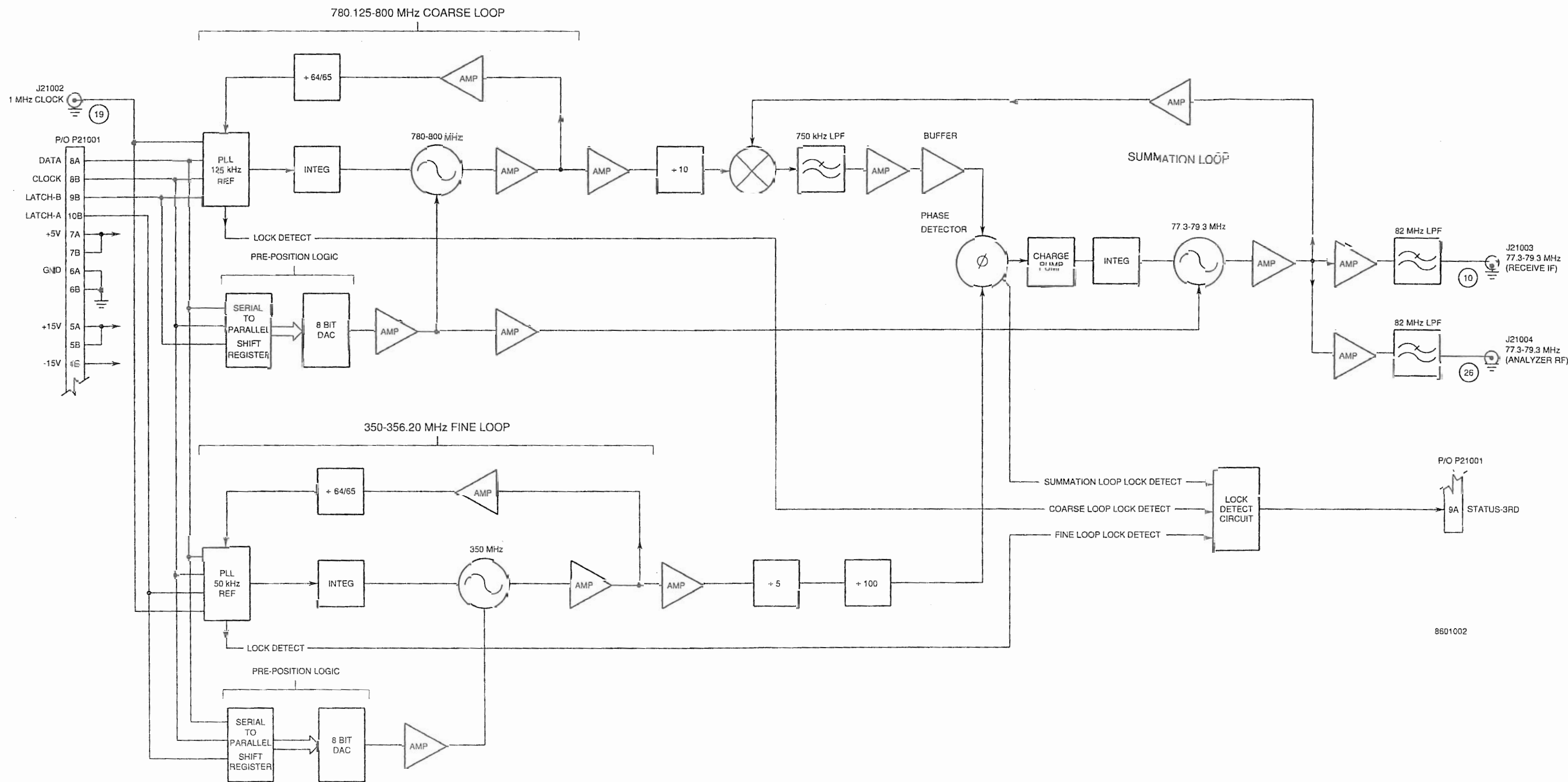

8601002

Figure 2-23 3rd LO Assembly Block Diagram



## 2-4-19 FUNCTION GENERATOR PC BOARD ASSEMBLY

The Function Generator PC Board Assembly synthesizes the audio signals and serial data that the FM/AM-1600S generates. The Function Generator PC Board Assembly is microprocessor controlled with an interface to the Processor PC Board Assembly. The microprocessor, a Zilog Super 8, serves as slave processor to the Processor PC Board Assembly. The Function Generator PC Board Assembly processes the following signals:

GEN1 Output	GEN2 Output
Serial Data.	EXT MOD IN Connector input
MIC/ACC Connector input	DTMF

The two audio generators use a procedure that encompasses both analog and digital processes. The Processor PC Board Assembly passes requirements to the Super 8 Microprocessor. The Super 8 Microprocessor passes information to the XILINX concerning wave shape, frequency and required synthesizer for generating audio tones. The XILINX instructs the proper PROM (one for each audio generator) which wave shape to write and provides the clock for the selected frequency. The output from the PROM is processed by a D/A Converter as the first step of the analog process. The resulting signal is then filtered by both a fixed Low-Pass Filter and a Wave Shaping Filter selected by the Super 8 Microprocessor. The resulting signal level is 5 Vp-p. The Generator Attenuator attenuates the signal to the required output level. The final output location for this signal is selected by the Audio Switching Matrix.

Both EXT MOD IN Connector signals and MIC/ACC Connector signals are imported and passed through an attenuator for setting the signal level. The resulting signals are passed to the Audio Switching Matrix for output selection.

Data signals can be generated by either the Super 8 Microprocessor or the SERIAL COMMUNICATION CONTROLLER. The resulting signal can be passed as raw data or filtered and attenuated. The filtered signal is sent to the Audio Switching Matrix. The unaltered signal is available directly for output. Level changing to bipolar ( $\pm 6$  V) and TTL levels is also available at the same time filtering is done. The Filter available is a 300 Hz Low-Pass Filter for use in signalling formats.

The Audio Switching Matrix is presented with five different inputs and selects three different outputs for each. For each input, only one output can be selected, however, all five inputs can be active simultaneously. The three outputs available include: FM MOD OUT, AM MOD OUT and FUNCTION GENERATOR AUDIO OUT to the AUDIO OUT Connector. The FM MOD OUT and AM MOD OUT signals are available directly to the 90 MHz Generator Assembly from the Audio Switching Matrix. The FUNCTION GENERATOR AUDIO OUT is processed by another attenuator, giving a wider dynamic range and then filtered by a 60 kHz Low-Pass Filter. This signal is then presented to the AUDIO OUT Connector. Selections for the Audio Switching Matrix are passed from the Processor PC Board Assembly to the Super 8 Microprocessor for processing.



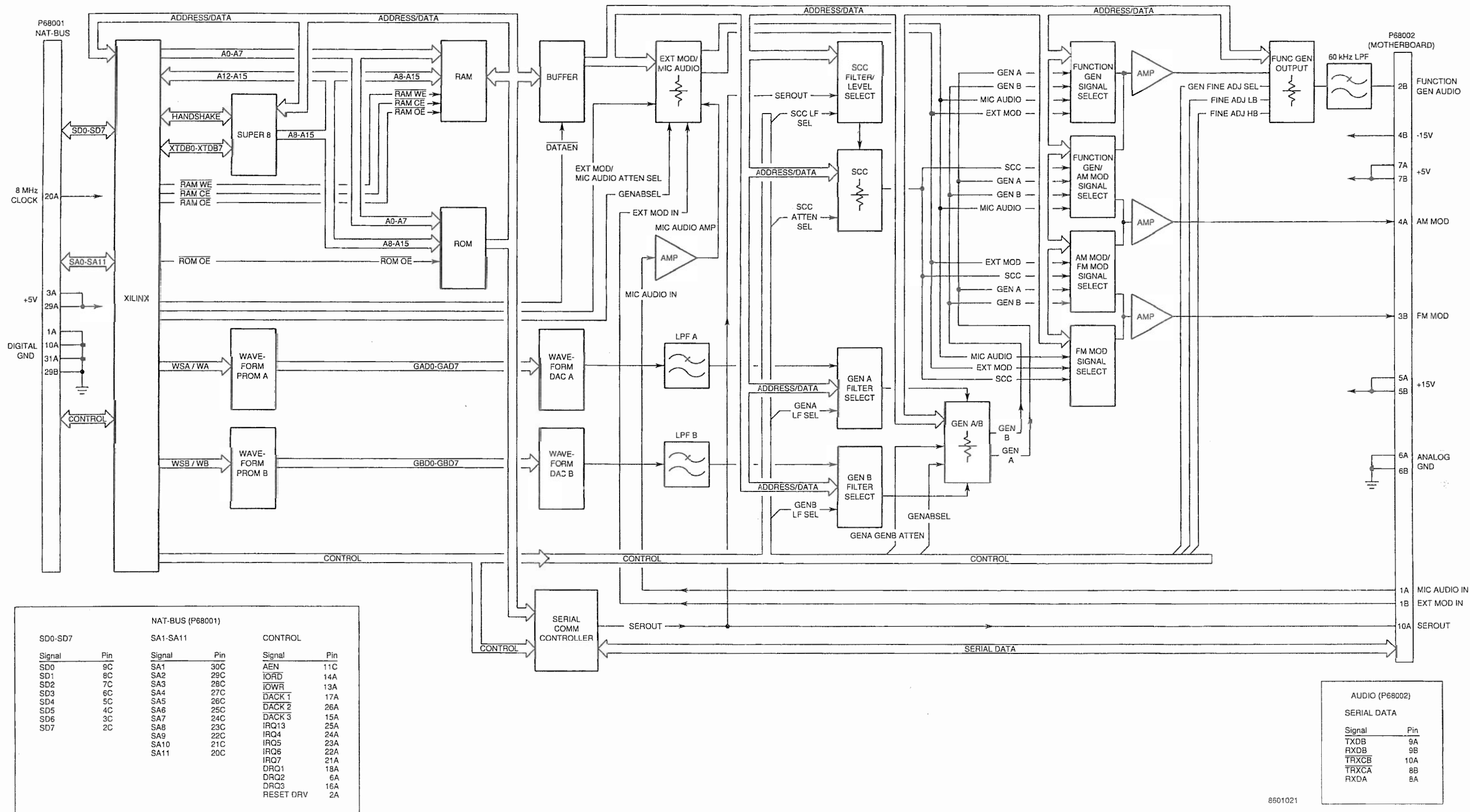

Figure 2-25 Function Generator PC Board Assembly Block Diagram

## 2-4-20 90 MHz GENERATOR ASSEMBLY

The 90 MHz Generator Assembly provides an 88.0001 to 90 MHz Modulated IF signal to the Generator IF Assembly. The 90 MHz Generator Assembly consists of two loops, of which the outputs are summed to make a final signal. This signal is attenuated and filtered before being provided to the Generator IF Assembly. In the process, modulation is added to the signal. The location where modulation is added is dependent on modulation type.

The Coarse Loop is passed data by the RF I/O PC Board Assembly from data generated in the Processor PC Board Assembly. The LATCH GEN B Signal is used to identify the Coarse Loop PLL FREQ Synthesizer. This data is integrated and used to tune a 780-800 MHz VCO. The VCO output is fed back to the Coarse Loop PLL FREQ Synthesizer, through a  $\pm 64/\pm 65$  Divider, to establish a phase lock condition. Once the VCO is phase locked, the Coarse Loop PLL FREQ Synthesizer passes a signal to the LOCK DETECT Circuit. The output of the 780-800 MHz VCO is passed through a  $\pm 10$  Divider, an Amplifier and sent to a mixer for mixing with the output of the Fine Loop. For speed, a preposition system is in place for initializing the 780-800 MHz VCO close to the required frequency. Data used is the same data used by the Coarse Loop PLL FREQ Synthesizer.

The Fine Loop is passed data by the RF I/O PC Board Assembly from data generated in the Processor PC Board Assembly. The LATCH GEN A Signal is used to identify the Fine Loop PLL FREQ Synthesizer. This data is integrated and used to tune a 10 MHz VCO. The VCO output is fed back to the Fine Loop PLL FREQ Synthesizer, through a  $\pm 128/\pm 129$  Divider, to establish a phase lock condition. Once the VCO is phase locked, the Fine Loop PLL FREQ Synthesizer passes a signal to the LOCK DETECT Circuit. An additional signal added to the 10 MHz VCO is either the FM Modulation or Phase Modulation signal. FM Modulation from the Function Generator is differentiated to produce a Phase Modulation signal. Data from the RF I/O PC Board Assembly selects between the two. This signal is added to the 10 MHz VCO signal to produce a 10 MHz IF Signal. The final product is amplified and mixed with the output from the 78-80 MHz LO produced in the Coarse Loop. This 88-90 MHz IF Signal is filtered through an 88-90 MHz Bandpass Filter.

Once the signal is filtered, it is attenuated. The Attenuator is digitally controlled by the signals passed by the RF I/O PC Board Assembly. The LATCH GEN C Signal is used to identify the data as being for the Digital Controlled Attenuator. AM Modulation from the Function Generator Assembly is also summed with the DIGITALLY CONTROLLED ATTENUATOR. The GEN LVL DET Signal is fed back from the Generator IF Assembly to maintain the proper RF Output Level. The final product is passed through a 90 MHz Low-pass Filter and to the Generator IF Assembly.

Once both the Fine Loop and the Coarse Loop are phase locked, both loops pass signals to the LOCK DETECT Circuit. When both signals are present, the LOCK DETECT generates a STATUS-GEN Signal that is passed back through the RF I/O PC Board Assembly to the Processor PC Board Assembly signifying that the 90 MHz Generator is in a phase locked condition.

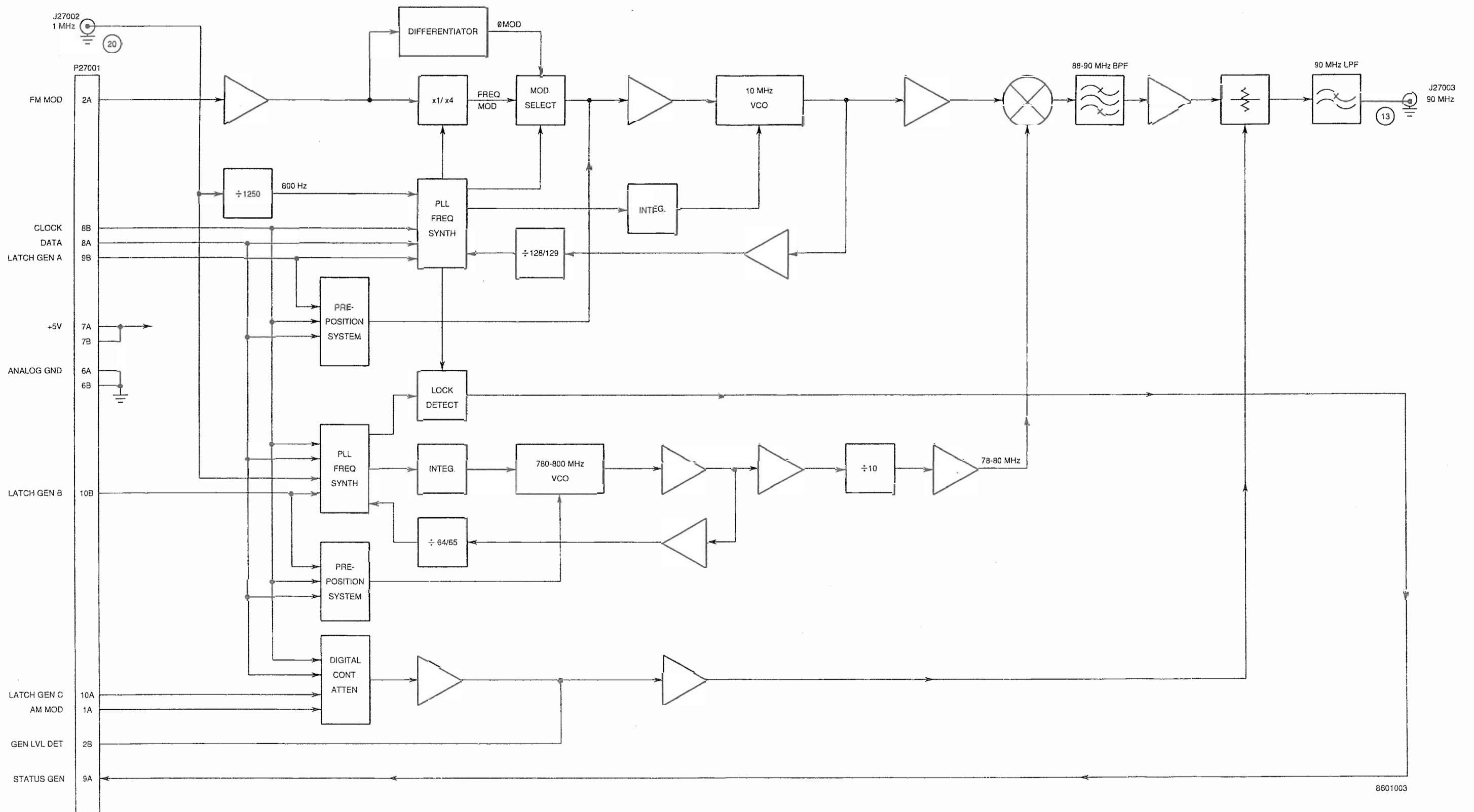

Figure 2-26 90 MHz Generator Assembly Block Diagram

#### 2-4-21 GENERATOR IF ASSEMBLY

The Generator IF Assembly is responsible for taking the 88 to 90 MHz IF Signal from the 90 MHz Generator Assembly and transforming it into the final RF Signal. Signals from the 1st LO Assembly (1.3 to 2.298 GHz LO) and the 2nd LO Assembly (1210 MHz LO) are used to transform the signal.

The 88 to 90 MHz IF Signal passed from the 90 MHz Generator Assembly is presented to the GEN IF 1st Mixer. The GEN IF 1st Mixer adds the 1210 MHz LO Signal (2nd LO Assembly) with this signal to produce a 1300 to 2298 MHz IF signal. This signal passes through a 1299 MHz Mechanical Bandpass Filter. The 1298 to 1300 MHz IF Signal is filtered through a 1.5 GHz Low-Pass Filter into a mixer where it is combined with a 1300 to 2298 MHz LO (1st LO Assembly). This mixer converts the signal to the final output frequency (.250 to 1000 MHz). The RF Signal passes through a 1.1 GHz Low-Pass Filter and is amplified to provide the +10 to +20 dBm level required. The RF Signal is then passed to the Power Term Assembly.

The RF Signal also passes through a coupler where the output level is detected. This circuit produces the GEN LVL DET Signal and is routed through channels to the 90 MHz Generator Assembly where it is used for setting the Attenuator.

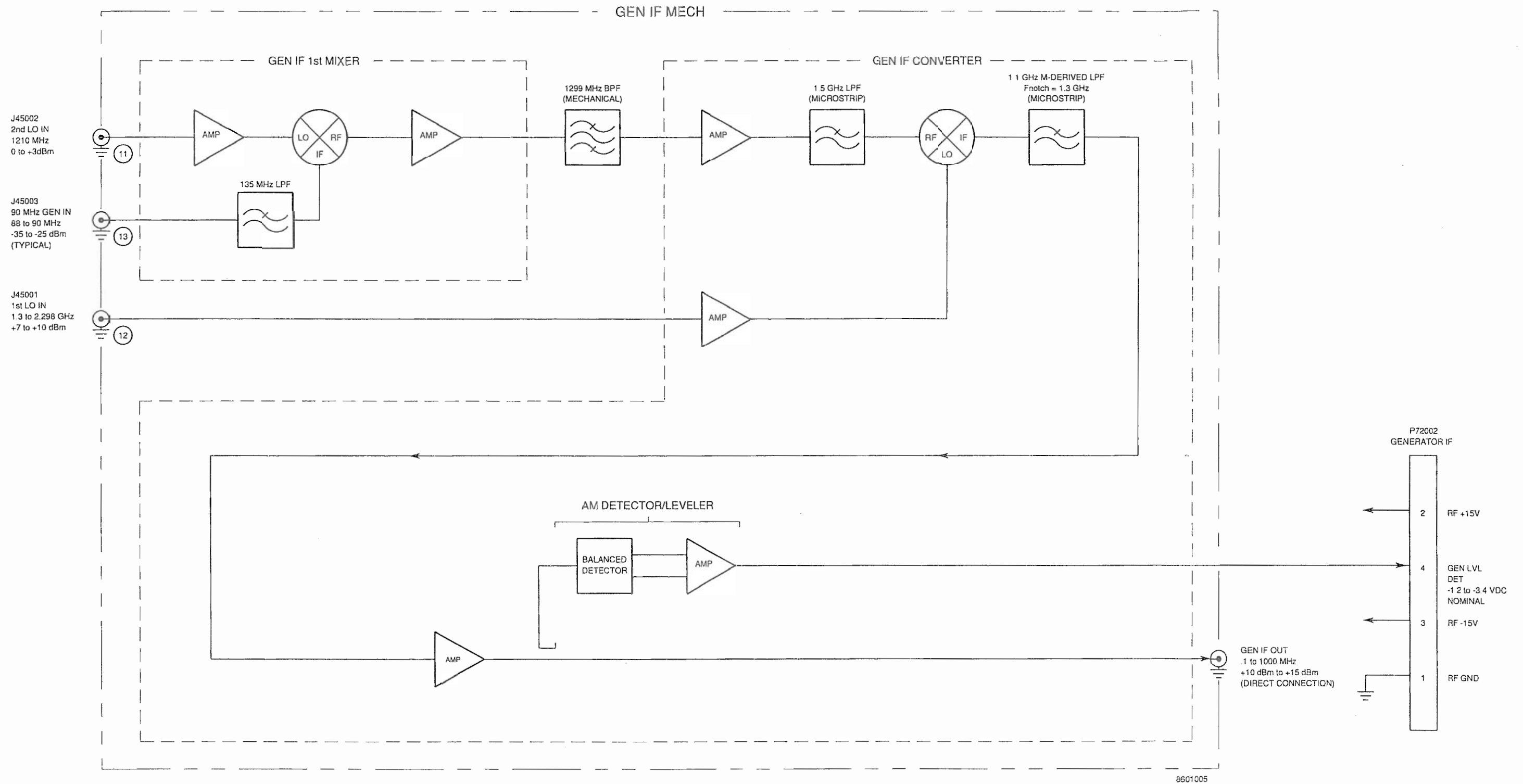

Figure 2-27 Generator IF Assembly Block Diagram

## 2-4-22 ATTENUATOR PC BOARD ASSEMBLY

The Attenuator PC Board Assembly performs the following functions

- Acts as a common bus for supplying power to the Generator IF Assembly, Receive IF Assembly and Power Term Assembly.
- Decodes serial data generated by the RF I/O PC Board Assembly into control lines for the Power Term and Receive IF Assemblies.
- Attenuates the RF Signal generated in the Generator IF Assembly before it is passed to the Power Term Assembly.
- Returns status signals from the Generator IF Assembly, Receive IF Assembly and Power Term Assembly to the RF I/O PC Board Assembly.

The Attenuator PC Board Assembly distributes  $\pm 15$  and +5 Vdc from the Auxiliary Power Supply to the Generator IF Assembly, Receive IF Assembly and Power Term Assembly.

Control signals for the Attenuator PC Board Assembly originate in the Processor PC Board Assembly. These signals are passed to the RF I/O PC Board Assembly through the NAT-BUS. The RF I/O PC Board Assembly converts the data into a serial format and passes the data to the Attenuator PC Board Assembly through the Auxiliary Power Supply PC Board Assembly. The data is accepted by the Attenuator PC Board Assembly when the appropriate Latching signal (LATCH-ATTEN) is generated. The serial data is converted to parallel format and split into control signals. DECODER #1 passes control signals to the Power Term and Receive IF Assemblies. It also passes the control signal for the 1 dB setting of ATTENUATOR. DECODER #2 is used to control the remainder of the ATTENUATOR settings.

The Attenuator PC Board Assembly both passes control signals and accepts status signals for the Power Term Assembly. The Attenuator PC Board Assembly decodes the following control lines for the Power Term Assembly:

DUPLEX (selects DUPLEX OUT Connector as output connector)  
RANGE SELECT (sets switch selecting signal for RF PWR LVL Signal)  
20dB PAD (activates additional 20 dB attenuator in signal path from T/R Connector)

The status signals accepted from the Power Term Assembly include:

ALARM (T/R Connector Overload)      POWER-MODE  
POWER TERM TEMP                      RF POWER LEVEL

Status signals are also accepted from the Receive IF and Generator IF Assemblies. The Generator IF Assembly passes the GEN LEVEL DET Signal for eventual use by the 90 MHz Generator Assembly. ANTENNA OVERLOAD STATUS is provided for the Processor PC Board Assembly by the Receive IF Assembly.

Control signals provided to the Receive IF Assembly include:

ANTENNA  $\overline{T/R}$  SEL                      20 dB PAD #1 SEL                      20 dB PAD #2 SEL

The Attenuator PC Board Assembly is also responsible for attenuating the RF signal from the Generator IF Assembly before it enters the Power Term Assembly. Generator IF and Power Term Assemblies are directly connected to the Attenuator PC Board Assembly. Attenuation settings are 0 to 127 dB.

AUXILIARY POWER SUPPLY (J72001)	
POWER SUPPLY DISTRIBUTION	
Signal	Pin
RF +15V	4, 5, 6
RF +5V	7
RF GND	1, 2, 3
RF -15V	14
RF/IF STATUS	
Signal	Pin
GEN LVL DET	11
ALARM (OVERLOAD STATUS)	9
POWER-MODE	10
PWR TERM TEMP	13
RF PWR LVL	12

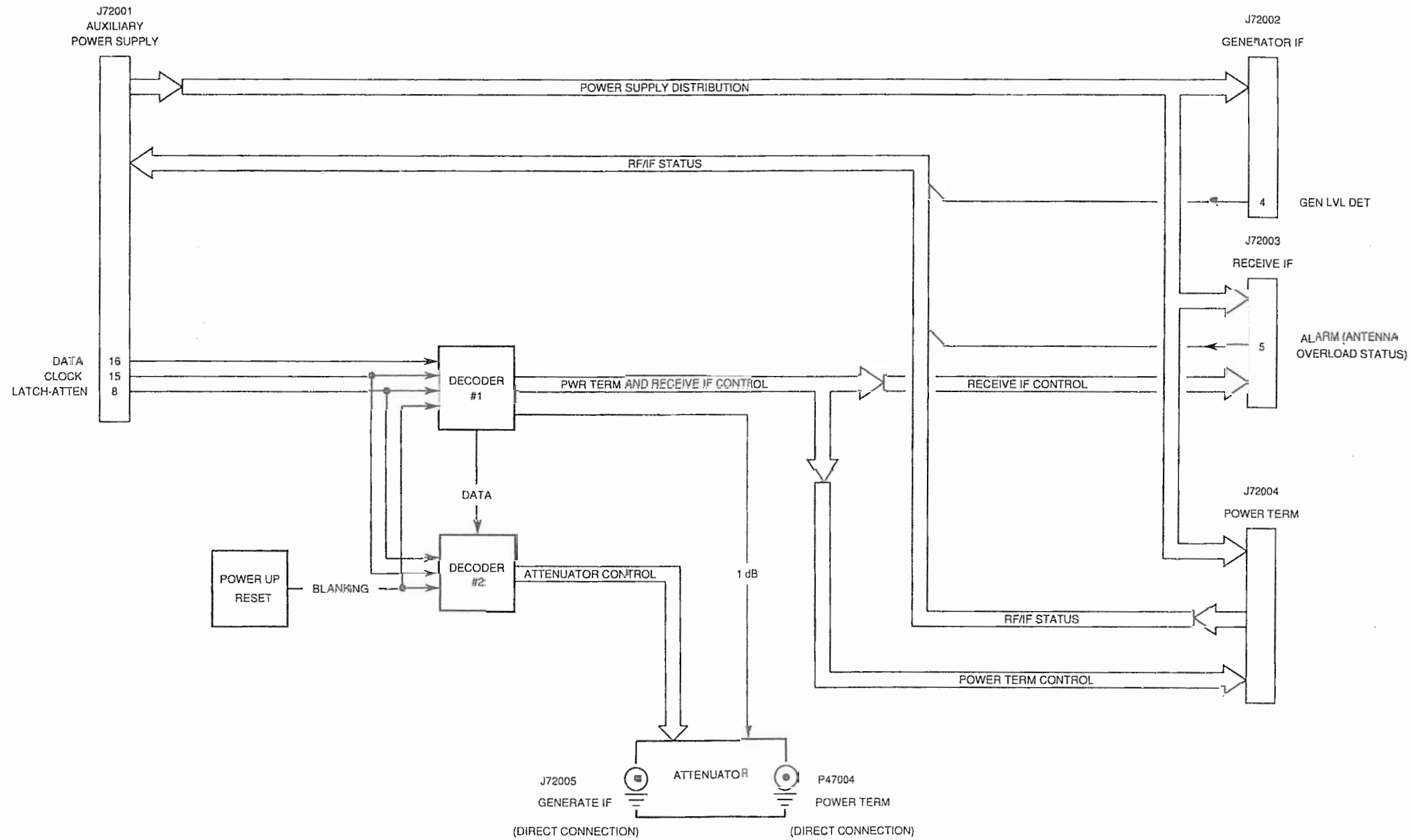

GENERATOR IF CONNECTOR (J72002)	
POWER SUPPLY DISTRIBUTION	
Signal	Pin
RF +15V	2
RF GND	1, 3
RF -15V	3

RECEIVE IF CONNECTOR (J72003)	
POWER SUPPLY DISTRIBUTION	
Signal	Pin
RF +15V	2
RF GND	1
RECEIVE IF CONTROL	
Signal	Pin
ANTENNA T/R SEL	6
20dB PAD #2 SEL	4
20dB PAD #1 SEL	3

POWER TERM CONNECTOR (J72004)	
POWER SUPPLY DISTRIBUTION	
Signal	Pin
RF +15V	2
RF GND	1
RF +5V	3
RF -15V	12
RF/IF STATUS	
Signal	Pin
ALARM (T/R OVERLOAD STATUS)	9
POWER-MODE	10
PWR TERM TEMP	13
RF PWR LVL	12
POWER TERM CONTROL	
Signal	Pin
DUPLEX	11
RANGE SELECT	9
20dB PAD	8

8601009

Figure 2-28 Attenuator PC Board Assembly Block Diagram

## 2-4-23 DMM ASSEMBLY

The DMM Assembly converts current, voltage or resistance into digital data for the Counter PC Board Assembly. The Counter PC Board Assembly interprets the data and passes the measurement to the Processor PC Board Assembly. Resolution of the DMM is  $3\frac{1}{2}$  digits. Control data from the Counter PC Board Assembly is passed to the DMM Assembly in serial format. Required signals are DMM CLOCK Signal, DMM/INEN Signal (Enable) and DATA TO DMM Signal. This data is passed to the SERIAL TO PARALLEL RELAY DRIVER and through isolators to the SERIAL TO PARALLEL CONVERTER. Both sets of circuitry convert the serial data into parallel format. This data is then used to control the following areas:

CURRENT RANGE SELECT Switch	(V/OHMS)/AMPS SELECT Switch
VOLTS/OHMS SELECT Switch	LOAD SELECT Switch
VOLTAGE RANGE SELECT Switch	OHMS TO VOLTAGE CONVERTER
AC/DC SELECT Switch	VOLTS/OHMS SELECT Switch
1V/.1V REF SELECT Switch	OHMS/ΩMS SELECT Switch

The path taken by the signal to be measured is dependent on the SELECT switches. Different paths are taken based on whether the measurement is voltage, current or resistance. Another important selection for voltage or current signals is whether ac or dc measurement is desired.

The path for measuring current starts at the DMM AMP Connector (represented in Figure 2-29 as AMPS). Signals then pass through the CURRENT RANGE SELECT circuitry where the current signal is passed through a fixed resistance and a voltage level is extracted. The (V/OHMS)/AMPS SELECT Switch passes the analog voltage. The analog voltage then has two paths available. If the measurement to be made is for ac current measurement, the RMS voltage passes through the RMS TO DC CONVERTER, converting the RMS voltage to a dc voltage. If the analog voltage is already a dc voltage (dc current measurement is required), then the RMS TO DC CONVERTER is bypassed. The AC/DC SELECT Switch passes the required analog signal. This analog signal is routed to the VOLTS/OHMS SELECT Switch where the signal is passed to the A/D Converter and the dc voltage level is converted to digital data. This digital data is converted from parallel to serial format, passed through the DATA FROM DMM ISOLATOR to the Counter PC Board Assembly.

Voltage signals enter from the DMM VΩ Connector and are immediately referenced to ground through the Load specified by the LOAD SELECT Switch. The Voltage signal is then switched to the VOLTAGE RANGE SELECT by the VOLTS/OHMS SELECT Switch. The VOLTAGE RANGE SELECT produces an analog signal based on the incoming voltage being referenced to ground through a load that is dependent on the range selected for the measurement. If the measurement to be made is for ac current measurement, the RMS voltage passes through the RMS TO DC CONVERTER, converting the RMS voltage to a dc voltage. If the analog voltage is already a dc voltage (dc current measurement is required), then the RMS TO DC CONVERTER is bypassed. The AC/DC SELECT Device passes the required analog signal. This analog signal is routed to the VOLTS/OHMS Select Device where the signal is passed to the A/D Converter where the dc voltage level is converted to digital data. This digital data is converted from parallel to serial format, passed through the DATA FROM DMM ISOLATOR to the Counter PC Board Assembly.

Resistance is measured between the DMM VΩ Connector and the DMM COM Connector. A small current is passed out the DMM VΩ Connector and back in the DMM COM Connector. The resulting voltage between the two connectors is read by the OHMS TO VOLTAGE CONVERTER and switched to the A/D Converter. The parallel format digital data is converted to serial data and passed to the Counter PC Board Assembly.



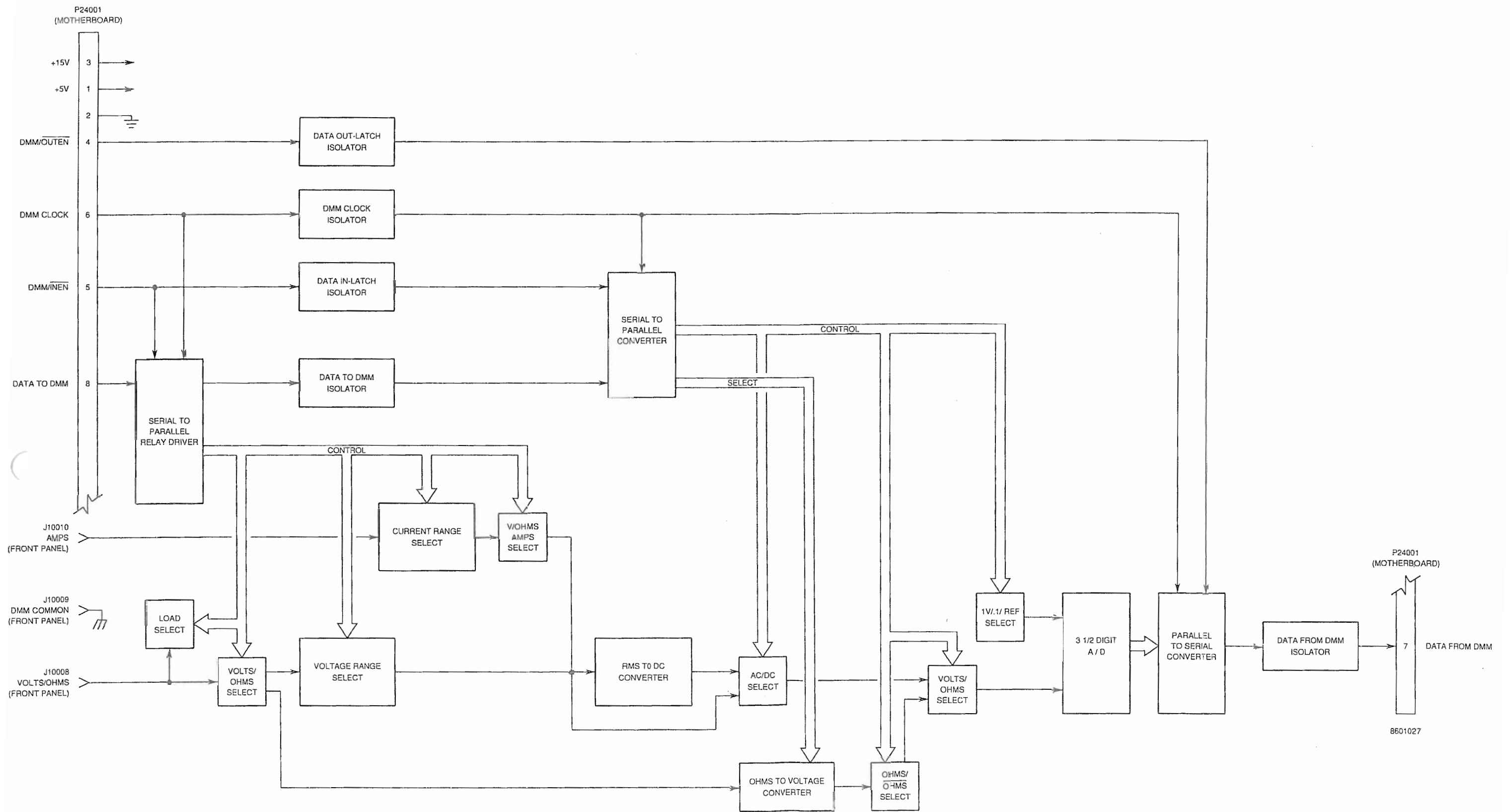

Figure 2-29 DMM Assembly Block Diagram

## 2-4-24 VIDEO CONTROLLER PC BOARD ASSEMBLY

The Video Controller PC Board Assembly is responsible for processing digital video information before passing it on to the CRT Assembly. The Video Controller PC Board Assembly is composed of the following sections:

- Video Graphics Array (VGA)
- Video RAM (256k in 8-64X4 bit configuration)
- Monitor Interface
- Data Interface
- Address Interface
- Control Interface
- Video Setup Circuitry

The Monitor, Data and Control Interfaces interpret the incoming signals from the NAT-BUS into the signals required for the Video Controller PC Board Assembly. This system is bidirectional with signals returned the NAT-BUS processed by the same Interfaces.

The controller of the Video Controller PC Board Assembly is the Video Graphics Adapter. Upon power-up, the Video Setup Circuitry initializes the Video Graphics Adapter. This assembly interprets data and passes the appropriate signals to the CRT through the Monitor Interface. Signals provided to the CRT are:

Primary Blue  
Secondary Blue  
V Sync

Primary Green  
Secondary Green  
H Sync

Primary Red  
Secondary Red

Data storage is provided by the 256k VRAM. This is dynamic memory requiring refreshing.

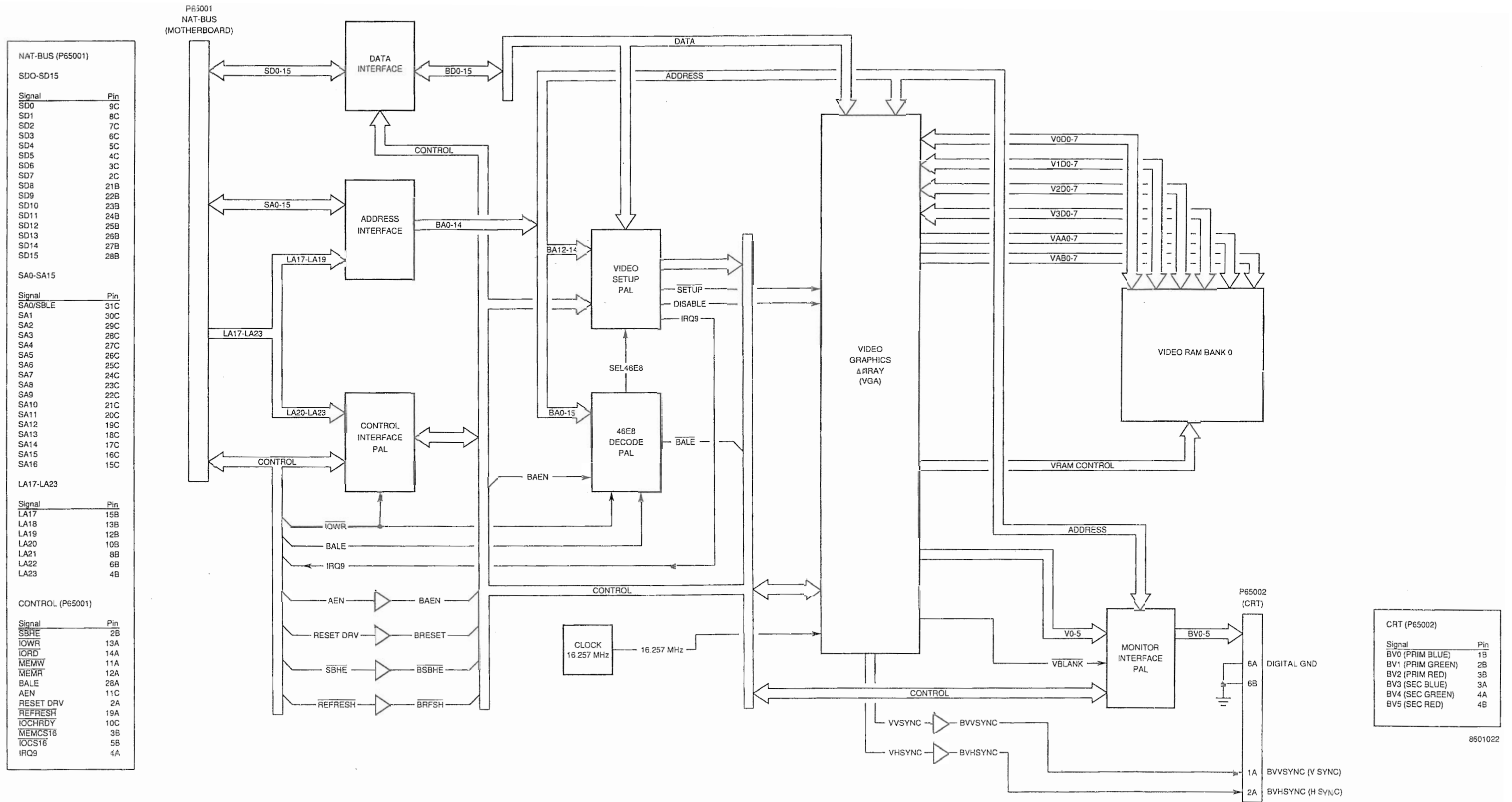

Figure 2-30 Video Controller PC Board Block Diagram

## 2-4-25 CRT ASSEMBLY

The CRT Assembly takes the signals from the Video Controller PC Board Assembly and creates an image on the CRT. Inputs are the signals from the Video Controller PC Board Assembly as well as +12 and +15 Vdc from the Power Supply. The six color signals pass through a resistive network to create the three final analog signals. These three colors are combined in the CRT to produce the 16 color variations available with this unit.

The VERT SYNC Signal from the Video Controller PC Board Assembly is inverted and passed to the Vertical Deflection Oscillator. The Vertical Deflection Oscillator then generates the signal to deflect the image vertically and passes it to the Vertical Yoke.

The HORIZ SYNC Signal from the Video Controller is used in three ways:

- To create the BLANKING signal for the CRT.
- To deflect the image horizontally on the CRT.
- To clock the PULSE WIDTH MODULATOR.

Deflecting the image horizontally is done by passing the HORIZ SYNC signal to the Horizontal Deflection Oscillator which generates the Horizontal Deflection Signal and passes it to the Horizontal Yoke. Feedback returns from the Horizontal Yoke to the Flyback Transformer. The Flyback Transformer then supplies the ANODE, FOCUS and SCREEN Voltages to the CRT.

Another use of the HORIZ SYNC Signal is to create the Blanking Signal. The HORIZ SYNC Signal is passed to the CLAMP GATE to generate the Blanking Signal to the COLOR/BLANKING CONTROLLER.

The HORIZ SYNC Signal is also used to clock the PULSE WIDTH MODULATOR which controls the HIGH POWER SWITCHER and FLYBACK TRANSFORMER. The HORIZ SYNC Signal supplied by the Video Controller is inverted before being passed to the PULSE WIDTH MODULATOR.

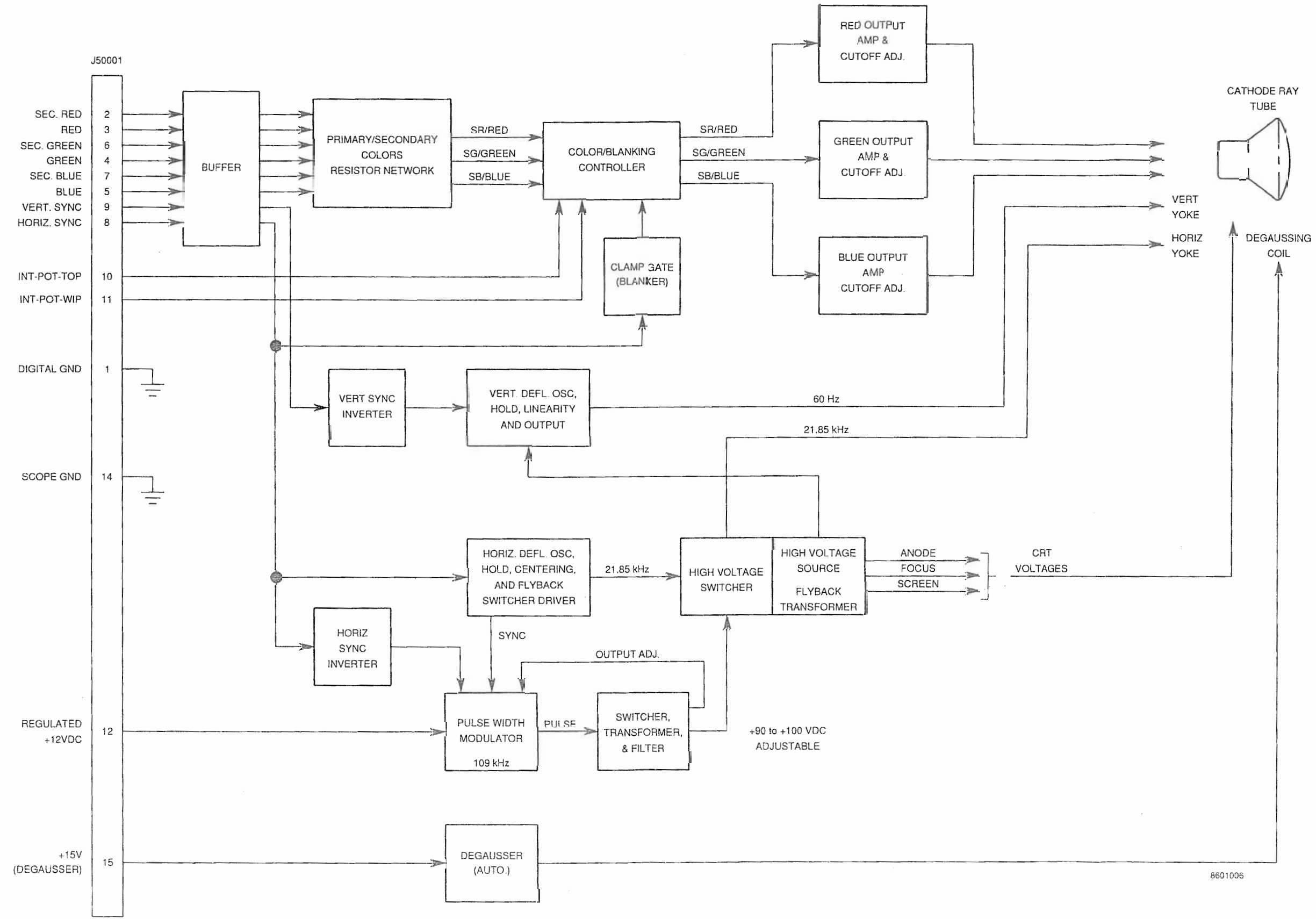

8601006

Figure 2-31 CRT Assembly Block Diagram

## 2-4-26 EXTERNAL I/O PC BOARD ASSEMBLY

The External I/O PC Board Assembly provides the bidirectional communication link between the Processor PC Board Assembly and the GPIB and SCSI Connectors. Data and Control signals are passed to the External I/O PC Board Assembly through the NAT-BUS. Signals are returned to the Processor PC Board Assembly from the External I/O PC Board Assembly in the same manner. Control signals select which connector will be active and which controlling circuitry to use. The control and data signals are translated and passed through the appropriate connector. Return data takes the same path in reverse.

The GPIB Connector uses the GPIB CONTROLLER as the controlling device for remote operation. Use of this connector is in accordance with IEEE-488. The GPIB CONTROLLER accepts and passes data through the GPIB DATA TRANSCEIVER. Likewise, control signals pass through the GPIB CONTROL TRANSCEIVER. Clock signals for the GPIB CONTROLLER are provided by a clock within the assembly. Interrupt and DMA requests for GPIB are passed through the NAT-BUS INTERFACE to the NAT-BUS. DMA Acknowledge signals are returned along the same path in reverse.

The SCSI Connector uses the SCSI PROCESSOR as the controlling device for remote operation. Use of this connector is in accordance with ANSI X3.131-1986. This connector is used only with IFR Systems, Inc. equipment. Use of this connector requires a special protocol.

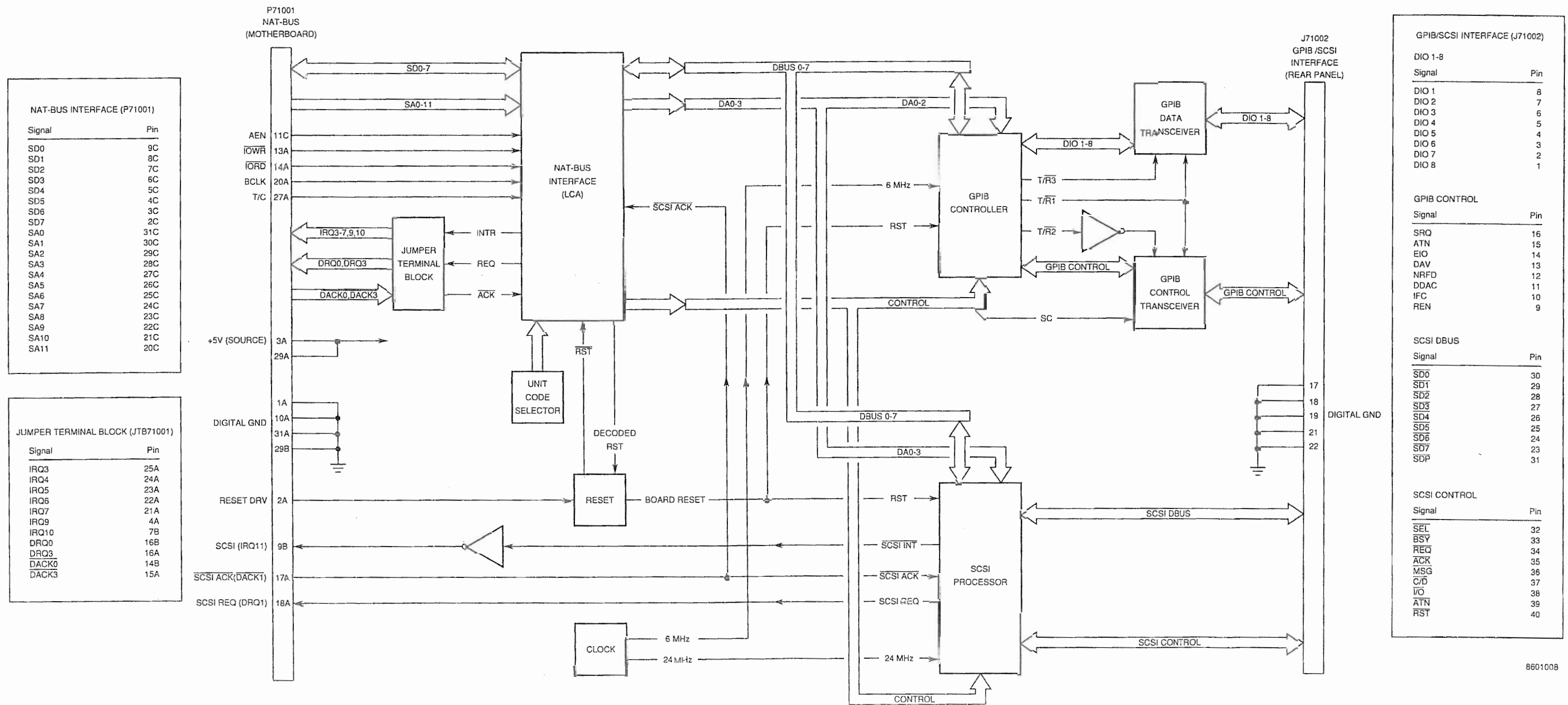

Figure 2-32 External I/O PC Board Assembly Block Diagram







# SECTION 3 - CALIBRATION

## 3-1 GENERAL

This section contains calibration procedures for the following assemblies and systems:

PROCEDURE	TITLE	PAGE
3-8-1	Power Supply Calibration . . . . .	3-10
3-8-2	VCXO Calibration . . . . .	3-13
3-8-3	Metering DVM Calibration . . . . .	3-15
3-8-4	Func Gen Level and VRMS Meter Calibration . . . . .	3-17
3-8-5	GEN Output Level Calibration . . . . .	3-21
3-8-6	RF Null Calibration . . . . .	3-23
3-8-7	Signal Meter Calibration . . . . .	3-25
3-8-8	FM Calibration . . . . .	3-26
3-8-9	Deviation Meter Calibration . . . . .	3-28
3-8-10	Modulation Meter Calibration . . . . .	3-32
3-8-11	Phase Meter Calibration . . . . .	3-34
3-8-12	Distortion Meter Calibration . . . . .	3-36
3-8-13	SINAD Meter Calibration . . . . .	3-39
3-8-14	GEN Modulation Calibration . . . . .	3-42
3-8-15	Scope Calibration . . . . .	3-47
3-8-16	Spectrum Analyzer Calibration . . . . .	3-51
3-8-17	Digital Multimeter Calibration . . . . .	3-55
3-8-18	Power Meter Calibration . . . . .	3-58

These procedures should be performed as a result of one or more of the following conditions:

1. If, during the course of normal operation, the FM/AM-1600S or any major function thereof fails to meet the performance specifications.
2. If a module is found to be defective and requires replacement.
3. If the recommended 12 month calibration interval is due.

Figure 3-1 lists the calibration procedures required based on the replacement of a specific module. All procedures must be performed for the recommended annual calibration.

### 3-1-1 SAFETY PRECAUTIONS

As with any piece of electronic equipment, extreme caution should be taken when working with "live" circuits. Certain circuits and/or components within the FM/AM-1600S contain extremely high voltage potentials, CAPABLE OF CAUSING SERIOUS BODILY INJURY OR DEATH (see following WARNINGS)! When performing the calibration procedures in this section, be sure to observe the following precautions:

**WARNING: THE CRT ASSEMBLY CARRIES A VOLTAGE POTENTIAL OF OVER 18000 VDC WHEN THE FM/AM-1600S IS ENERGIZED.**

**REMOVE ALL JEWELRY OR OTHER COSMETIC APPAREL BEFORE PERFORMING ANY CALIBRATION PROCEDURES INVOLVING LIVE CIRCUITS.**

**HEED ALL WARNINGS AND CAUTIONS CONCERNING MAXIMUM VOLTAGES AND POWER INPUTS.**

### 3-1-2 ESD PRECAUTIONS

**CAUTION:** THESE CALIBRATION PROCEDURES SHOULD ONLY BE PERFORMED IN AN ESD ENVIRONMENT AND ALL PERSONNEL PERFORMING THE PROCEDURES SHOULD KNOW ACCEPTED ESD PRACTICES OR BE ESD CERTIFIED.

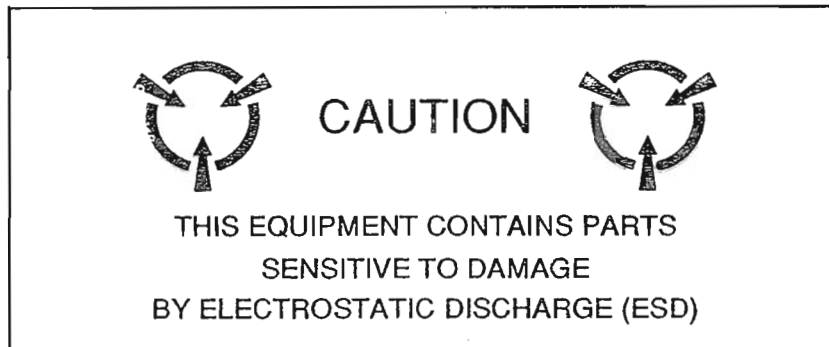

### 3-2 TEST EQUIPMENT REQUIREMENTS

Appendix A contains a comprehensive list of test equipment suitable for performing any of the procedures listed in this manual. Any other equipment meeting the specifications listed in Appendix A may be substituted in place of the recommended models.

**NOTE:** For certain procedures in this manual, the equipment listed in Appendix A may exceed the minimum required specifications.

### 3-3 DISASSEMBLY REQUIREMENTS

To perform any of the calibration procedures contained in this section, the Top and Bottom Case Assemblies must be removed from the FM/AM-1600S (refer to 4-3-1 and 4-3-2).

### 3-4 CALIBRATION ADJUSTMENTS

Before making any calibration adjustments, always observe the measurement. If the measurement is within the tolerances given, do not proceed with that adjustment. When an adjustment is required, attempt to obtain a precise measurement, instead of just within tolerance.

### 3-5 CONTROLS, CONNECTORS AND INDICATORS

The front and rear panel controls, connectors and indicators specified in the calibration procedures are followed by an item number. Refer to Figures 3-1 and 3-2 in the FM/AM-1600S Operation Manual for the location of these items.

### 3-6 COMPLETION OF CALIBRATION TEST PROCEDURES

Upon completion of a specific calibration procedure, the calibration procedure may be terminated. Control settings, operating commands and test equipment do not carry over from one procedure to another and are not assumed at the beginning of a procedure.

### 3-7 CALIBRATION RECORD

A Calibration Record is provided for recording the results obtained while performing the Calibration Procedures. It is recommended the technician reproduce copies of the Calibration Record, rather than use the copy in this manual.

<p>IF THIS ASSEMBLY IS REPAIRED OR REPLACED</p> <p>THE FOLLOWING CALIBRATION PROCEDURES MUST BE PERFORMED</p>	POWER SUPPLY CALIBRATION 3-8-1	VCXO CALIBRATION 3-8-2	METERING DVM CALIBRATION 3-8-3	FUNC GEN LEVEL AND VRMS METER CALIBRATION 3-8-4	GEN OUTPUT LEVEL CALIBRATION 3-8-5	RF NULL CALIBRATION 3-8-6	SIGNAL METER CALIBRATION 3-8-7	FM CALIBRATION 3-8-8	DEVIATION METER CALIBRATION 3-8-9	MODULATION METER CALIBRATION 3-8-10	PHASE METER CALIBRATION 3-8-11	DISTORTION METER CALIBRATION 3-8-12	SINAD METER CALIBRATION 3-8-13	GEN MODULATION CALIBRATION 3-8-14	SCOPE CALIBRATION 3-8-15	SPECTRUM ANALYZER CALIBRATION 3-8-16	DIGITAL MULTIMETER CALIBRATION 3-8-17	POWER METER CALIBRATION 3-8-18
DIGITIZER PC BOARD ASSEMBLY															●	●		
COUNTER PC BOARD ASSEMBLY																		
ANALYZER LOG/IF ASSEMBLY																●		
ANALYZER RF ASSEMBLY																●		
3rd LO ASSEMBLY							●	●	●	●	●							
90 MHz GENERATOR ASSEMBLY					●									●				
RECEIVER ASSEMBLY							●	●	●	●	●							
MONITOR ASSEMBLY				●			●	●	●	●	●	●	●					●
MONITOR CONTROL PC BOARD ASSEMBLY			●	●			●	●	●	●	●	●	●					●
FUNCTION GENERATOR PC BOARD ASSEMBLY				●										●				
RF I/O PC BOARD ASSEMBLY		●																
MEMORY PC BOARD ASSEMBLY	●	●	●	●	●		●	●	●	●	●	●	●	●		●		●
PROCESSOR PC BOARD ASSEMBLY																		
VIDEO CONTROLLER PC BOARD ASSEMBLY																		
EXTERNAL I/O PC BOARD ASSEMBLY																		
CRT ASSEMBLY																		
POWER SUPPLY ASSEMBLY	●	●	●	●	●	●	●	●	●	●	●	●	●	●	●	●	●	●
FRONT PANEL ASSEMBLY																		
REAR PANEL CONNECTOR PC BOARD ASSEMBLY																		
REAR PANEL ASSEMBLY																		
DMM ASSEMBLY																	●	
2nd LO ASSEMBLY		●			●									●				
1st LO ASSEMBLY					●	●	●							●				
AUXILIARY POWER SUPPLY PC BOARD ASSEMBLY	●																	
RECEIVE IF ASSEMBLY						●	●	●	●	●	●					●		
GENERATOR IF ASSEMBLY					●									●				
ATTENUATOR PC BOARD ASSEMBLY					●													
POWER TERM ASSEMBLY					●													●
MOTHERBOARD PC BOARD ASSEMBLY																		

8602001

Figure 3-3 Module Replacement and Calibration Requirements

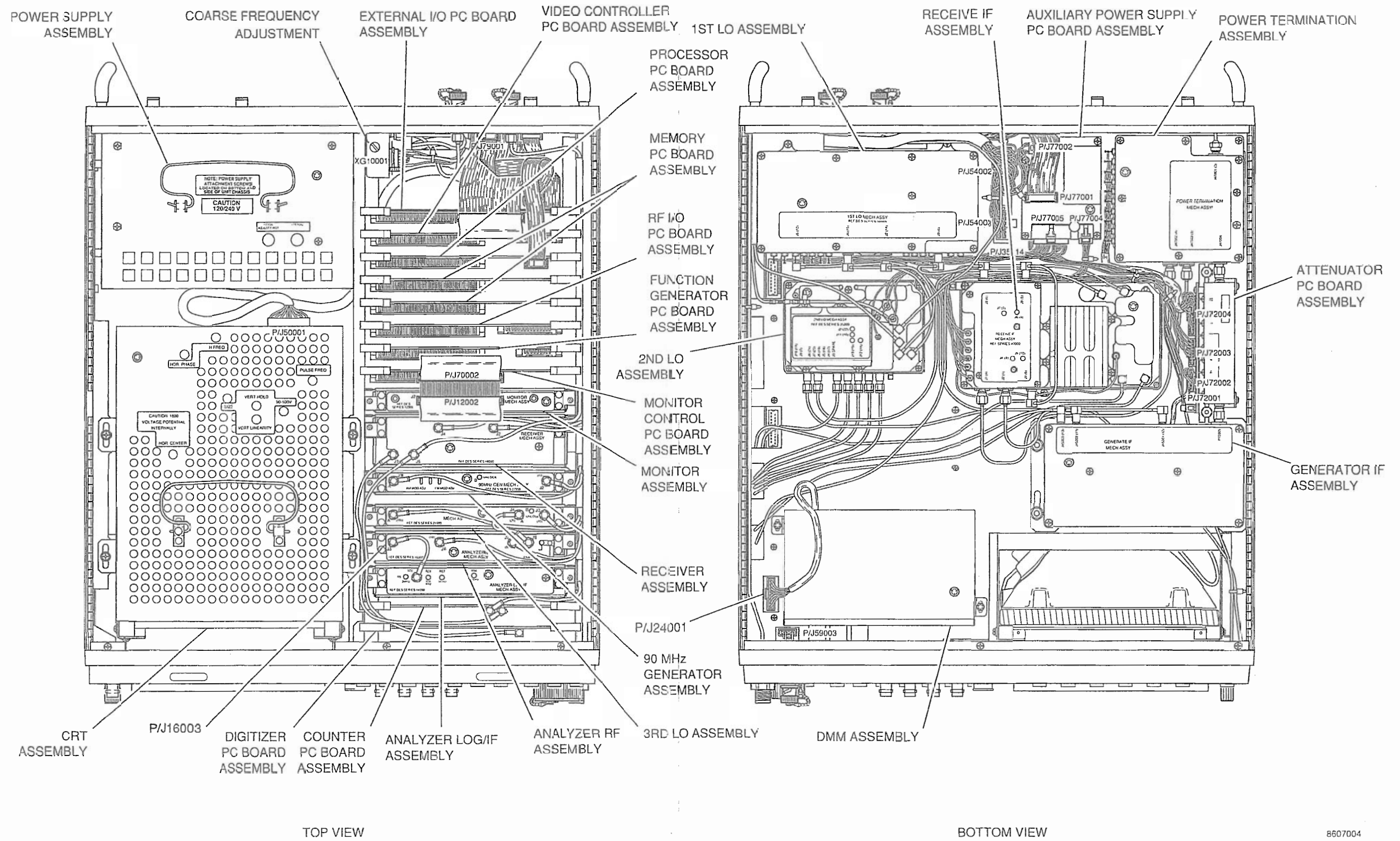

Figure 3-2 Calibration Adjustments and Test Points

## FM/AM-1600S CALIBRATION RECORD

Technician: \_\_\_\_\_ S/N: \_\_\_\_\_

Date: \_\_\_\_\_

PARA #	STEP	DATA	RESULT
3-8-1	4	+5 Vdc (+5.0 V to +5.1 V)	_____
	6	+15 Vdc (+15.0 V to +15.1 V)	_____
	7	-15 Vdc (-15.0 V to -15.5 V)	_____
	9	+12 Vdc (+11.8 V to +12.1 V)	_____
	11	+34 Vdc (+33 V to +35 V)	_____
3-8-2	8	900 MHz ( $\pm 450$ Hz)	_____
	19	Waveform is $\geq 1$ mVp-p.	_____ (✓)
3-8-3	3	4.0960 V ( $\pm 0.002$ V)	_____
3-8-4	11	2.5 Vrms ( $\pm 0.5$ mVrms)	_____
	16	199.9 mV ( $\pm 0.03$ mV)	_____
	18	2.500 V ( $\pm 0.5$ mV)	_____
	29	0.000 V ( $\pm 10$ mV)	_____
	32	0.000 V ( $\pm 10$ mV)	_____
	34	VRMS Meter is $\leq 10\%$ of DMM reading.	_____ (✓)
	3-8-5	17	250 kHz RF Low Frequency
		0 dBm ( $\pm 1.0$ dB)	_____
		499 kHz RF High Frequency	_____ (✓)
		0 dBm ( $\pm 1.0$ dB)	_____
		500 kHz RF Low Frequency	_____ (✓)
		0 dBm ( $\pm 1.0$ dB)	_____
		999 kHz RF High Frequency	_____ (✓)
		0 dBm ( $\pm 1.0$ dB)	_____

FM/AM-1600S CALIBRATION RECORD (Cont'd)

PARA #	STEP	DATA	RESULT
		1 MHz RF Low Frequency	_____ (√)
		0 dBm (±1.0 dB)	_____
		49 MHz RF High Frequency	_____ (√)
		0 dBm (±1.0 dB)	_____
		50 MHz RF Low Frequency	_____ (√)
		0 dBm (±1.0 dB)	_____
		124 MHz RF High Frequency	_____ (√)
		0 dBm (±1.0 dB)	_____
		125 MHz RF Low Frequency	_____ (√)
		0 dBm (±1.0 dB)	_____
		199 MHz RF High Frequency	_____ (√)
		0 dBm (±1.0 dB)	_____
		200 MHz RF Low Frequency	_____ (√)
		0 dBm (±1.0 dB)	_____
		399 MHz RF High Frequency	_____ (√)
		0 dBm (±1.0 dB)	_____
		400 MHz RF Low Frequency	_____ (√)
		0 dBm (±1.0 dB)	_____
		599 MHz RF High Frequency	_____ (√)
		0 dBm (±1.0 dB)	_____
		600 MHz RF Low Frequency	_____ (√)
		0 dBm (±1.0 dB)	_____
		799 MHz RF High Frequency	_____ (√)
		0 dBm (±1.0 dB)	_____

FM/AM-1600S CALIBRATION RECORD (Cont'd)

PARA #	STEP	DATA	RESULT
		800 MHz RF Low Frequency	_____ (✓)
		0 dBm ( $\pm 1.0$ dB)	_____
		999 MHz RF High Frequency	_____ (✓)
		0 dBm ( $\pm 1.0$ dB)	_____
3-8-6	10	<0 dBm minimum amplitude for 1st LO Signal	_____ (✓)
3-8-7	10	Signal is <100 at -33 dBm.	_____ (✓)
	11	Signal is 100 (99 to 100) at -30 dBm.	_____ (✓)
3-8-8	20	FREQ ERR is $<\pm 10$ Hz.	_____
	29	0 V ( $\pm 40$ mV)	_____
3-8-9	29	Deviation reading is within 3% ( $\pm 1$ Count) of reading on the Measuring Receiver ( $\pm 100$ Hz, <3.4 kHz deviation).	_____
	36	Deviation reading is within 3% ( $\pm 1$ Count) of reading on the Measuring Receiver ( $\pm 100$ Hz, <3.4 kHz deviation).	_____
	43	Deviation reading is within 3% ( $\pm 1$ Count) of reading on the Measuring Receiver ( $\pm 100$ Hz, <3.4 kHz deviation).	_____
	50	Deviation reading is within 3% ( $\pm 1$ Count) of reading on the Measuring Receiver ( $\pm 100$ Hz, <3.4 kHz deviation).	_____
	54	Deviation (RMS) reading is within 10% ( $\pm 1$ Count) of reading on the Measuring Receiver .	_____
3-8-10	21	Modulation reading is within 5% of Full Scale ( $\pm 1$ Count) of the reading on Measuring Receiver.	_____
3-8-11	14	Phase reading is within 3% ( $\pm 1$ Count).	_____
	23	Phase reading is within 10% ( $\pm 1$ Count).	_____
3-8-12	24	Distortion reading is within $\pm 0.5\%$ ( $\pm 1$ Count).	_____
3-8-13	24	SINAD reading is within $\pm 1$ dB ( $\pm 1$ Digit).	_____
3-8-14	15	Verify Residual AM is <0.10% RMS.	_____



FM/AM-1600S CALIBRATION RECORD (Cont'd)

PARA #	STEP	DATA	RESULT
3-8-14	23	AM Modulation setting is 5% of setting less Peak Residual AM.	_____
	34	Verify Residual FM is <140 Hz RMS.	_____
	40	5 kHz Deviation reading is within 5% of Deviation setting less Peak Residual FM.	_____
	52	80 kHz Deviation reading is 5% of Deviation setting less Peak Residual FM.	_____
	58	Verify and record Residual PM is <0.5 Rad peak.	_____
	62	6 Radian reading is within 5% of radian setting less Residual PM reading.	_____
3-8-15	9	Adjust R69044 for 0.000 Vdc ( $\pm 0.01$ Vdc).	_____
	11	Adjust R69039 for 0.000 Vdc ( $\pm 0.01$ Vdc).	_____
	42	One cycle is displayed.	_____ (✓)
	46	Delta is 500 $\mu$ s and 120 mV ( $\pm 8$ mV).	_____
3-8-16	27	Trace is centered ( $\pm 1$ Minor Divison).	_____ (✓)
	34	Signal peaks with Major Divisions.	_____ (✓)
	36	-40 dBm ( $\pm 4$ dB)	_____
	38	Center frequency peak level varies <2 dB between all ranges.	_____ (✓)
	42	Each 10 dB step decreases level 10 dB ( $\pm 2$ dB).	_____ (✓)
3-8-17	9	1.000 Vdc ( $\pm 0.05$ Vdc)	_____
	12	100 mV ( $\pm 0.5$ mV)	_____
	16	100 k $\Omega$ ( $\pm 10$ k $\Omega$ )	_____
	18	1 k $\Omega$ ( $\pm 100$ $\Omega$ )	_____
	23	Meter reading is 7 V ( $\pm 1$ V).	_____
	27	Meter reading is 1 V ( $\pm 0.1$ V).	_____

FM/AM-1600S CALIBRATION RECORD (Cont'd)

PARA #	STEP	DATA	RESULT	
3-8-18	5	Calculate power level at 0.2 mW.	_____	
		Calculate power level at 1400 mW.	_____	
		Calculate power level at 2000 mW.	_____	
		Calculate power level at 50000 mW.	_____	
		Calculate power level at 112500 mW.	_____	
	19	0 V ( $\pm 1.0$ mV)	_____	
	21	0 V ( $\pm 1.0$ mV)	_____	
	24		4.00 V (+0 mV, -50 mV)	_____
			2.0 W ( $\pm 0.2$ W)	_____
	31		2.00 V ( $\pm 20$ mV)	_____
			50 W ( $\pm 5.0$ W)	_____
	40		Power Meter Zero raw data Zero value is momentarily displayed.	_____ (✓)
	42		Power Meter Zero raw data Zero value is momentarily displayed.	_____ (✓)
	45		Power Meter reading is displayed.	_____ (✓)
	49		0.2 mV ( $\pm 0.1$ mV)	_____
	55		Power Meter reading is displayed.	_____ (✓)
	58		Power Level of 50 W ( $\pm 5$ W)	_____
	61		Power Level of 2 W ( $\pm 0.2$ W)	_____

## 3-8 CALIBRATION PROCEDURES

### 3-8-1 POWER SUPPLY CALIBRATION

PREREQUISITES: None

EQUIPMENT REQUIRED: 1 Digital Multimeter (DMM)

FIGURE REFERENCES: Figure 3-3  
Figure 3-4  
Figure 3-5  
Figure 3-6

STEP	PROCEDURE
1.	Apply power to FM/AM-1600S. Allow 5 minute warm-up period. Insure IFR Logo Menu, with no error message, is displayed on CRT (26).
2.	Connect DMM ground lead to chassis ground on FM/AM-1600S.
3.	Connect DMM positive lead to RN63002, Pin 1 (Figure 3-3).
4.	Verify +5 Vdc (+5.0 V to +5.1 V). Adjust R57037 (Figure 3-6) if needed.
5.	Connect DMM positive lead to FL35001 (Red Wire) (Figure 3-4) and negative lead to ground lug (Black Wire) (Figure 3-4).
6.	Verify +15 Vdc (+15 to +15.1 V). Adjust R57025 (Figure 3-6) if needed.
7.	Connect DMM positive lead to FL35003 (Yellow Wire) (Figure 3-4). Verify -15 Vdc (-15 to -15.5 V).
8.	Remove power from FM/AM-1600S. Disconnect P/J54002 (Figure 3-6). Apply power to FM/AM-1600S.
9.	Connect DMM positive lead to P54002, Pin 6 (Figure 3-6). Verify +12 Vdc (+11.8 to +12.1 V).
10.	Remove power from FM/AM-1600S. Connect P/J54002 (Figure 3-6). Apply power to FM/AM-1600S.
11.	Connect DMM positive lead to FL30016 (Violet Wire) (Figure 3-5). Verify +34 Vdc (+33 to +35 V).
12.	Remove power from FM/AM-1600S and disconnect test equipment.

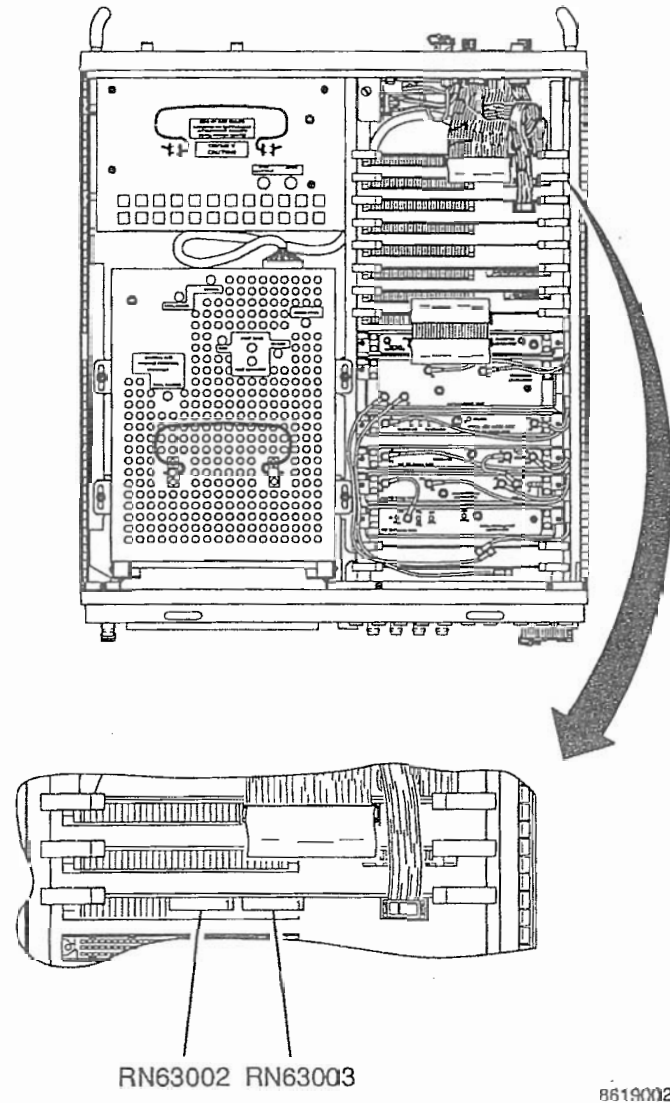

Figure 3-3 Processor PC Board Assembly Test Points

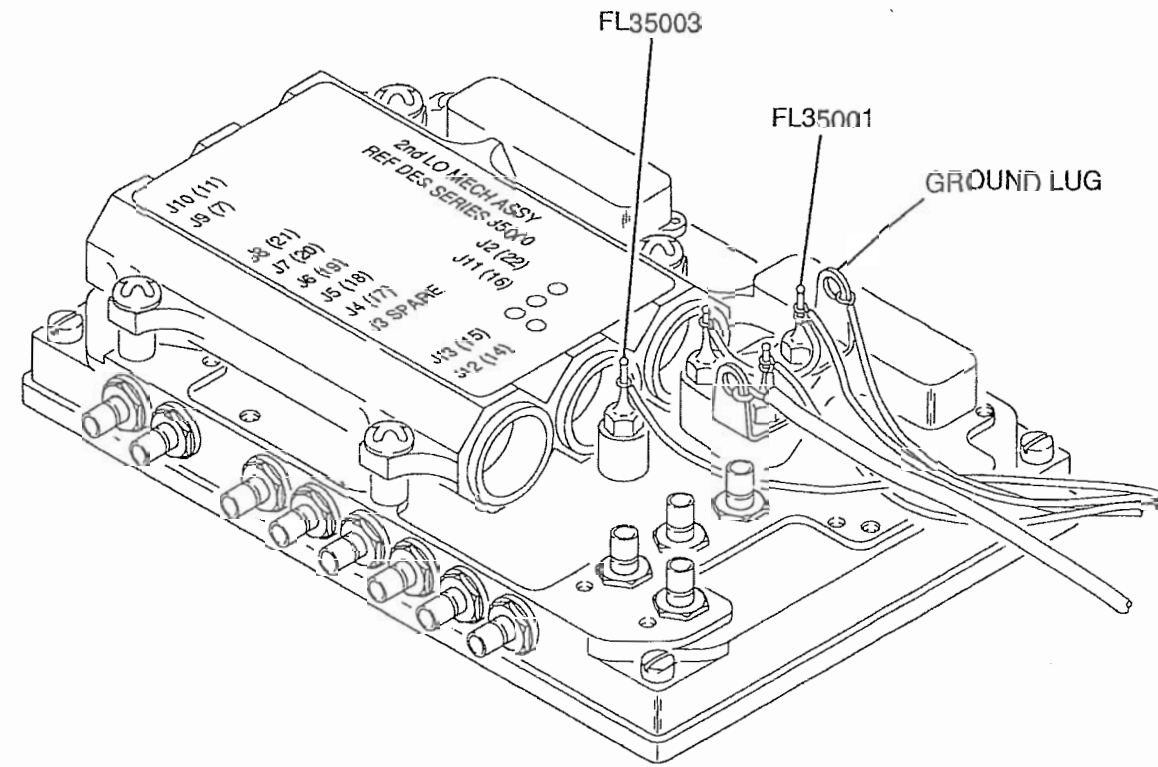

Figure 3-4 2nd LO Assembly Calibration Points

8607159

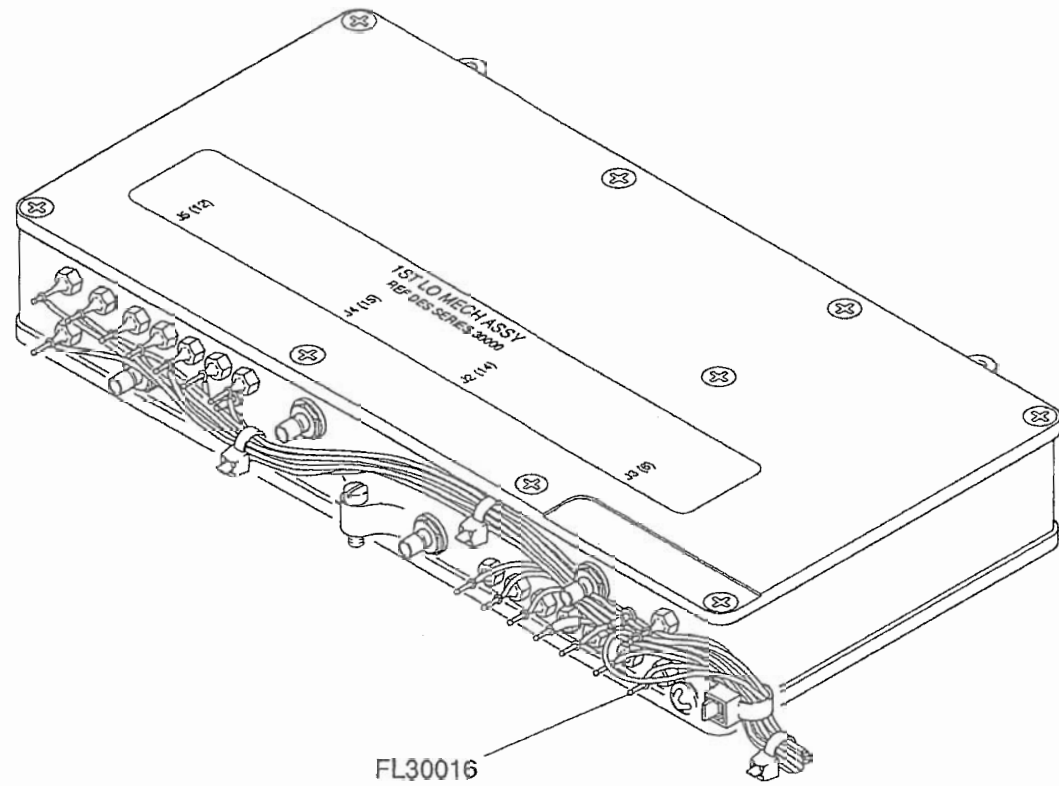

Figure 3-5 1st LO Assembly Test Points

8607160

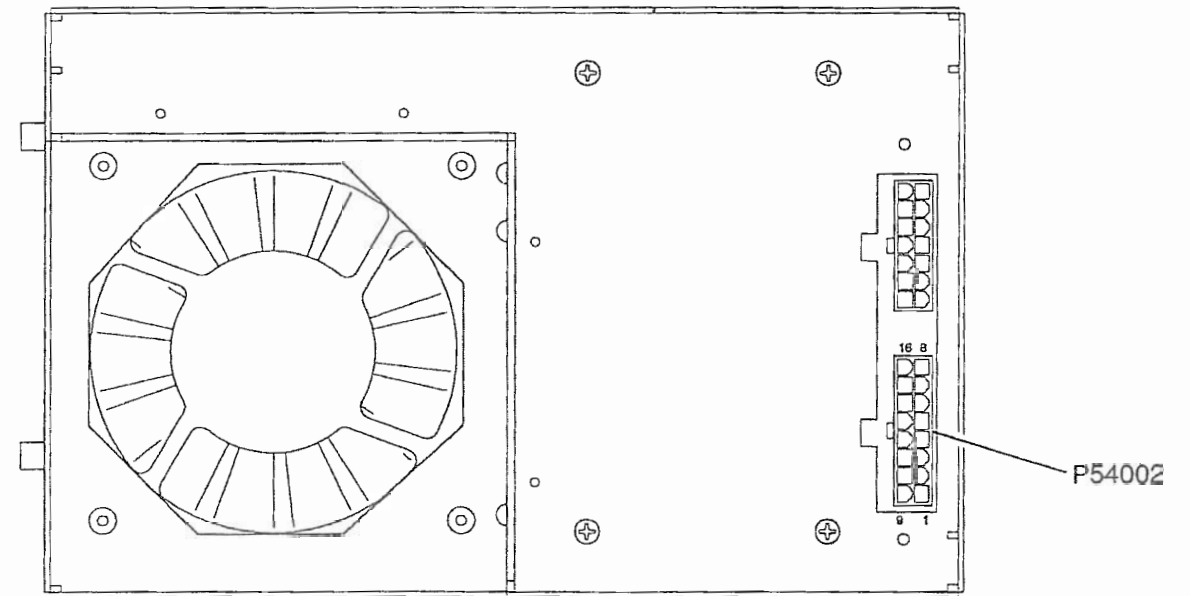
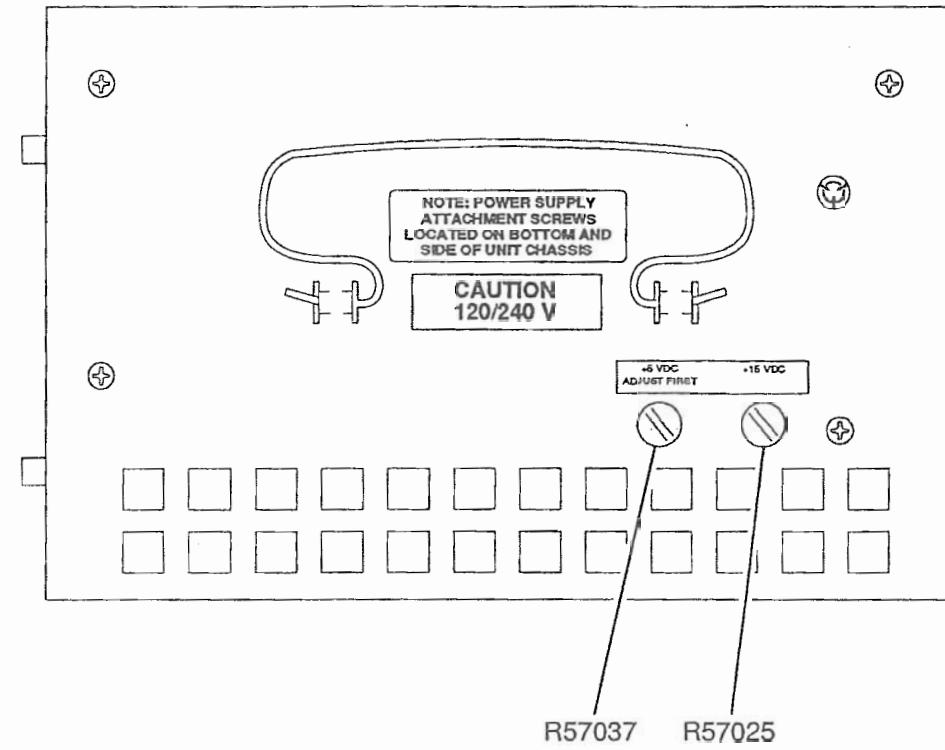

Figure 3-6 Power Supply Assembly Calibration Points

8607161

## 3-8-2 VCXO CALIBRATION

PREREQUISITES: 3-8-1 Power Supply Calibration

EQUIPMENT REQUIRED: 1 Measuring Receiver with Sensor Power Head  
1 Oscilloscope  
1 10 MHz Frequency Standard (Oven Oscillator Option Only)  
3 Coaxial Cables (BNC-BNC)

FIGURE REFERENCES: Figure 3-7

STEP	PROCEDURE
------	-----------

1. Apply power to FM/AM-1600S. Allow 5 minute warm-up period. Insure IFR Logo Screen, with no error message, is displayed on CRT (26).
2. Connect T/R Connector (6) to Measuring Receiver Sensor Power Head (Figure 3-7).

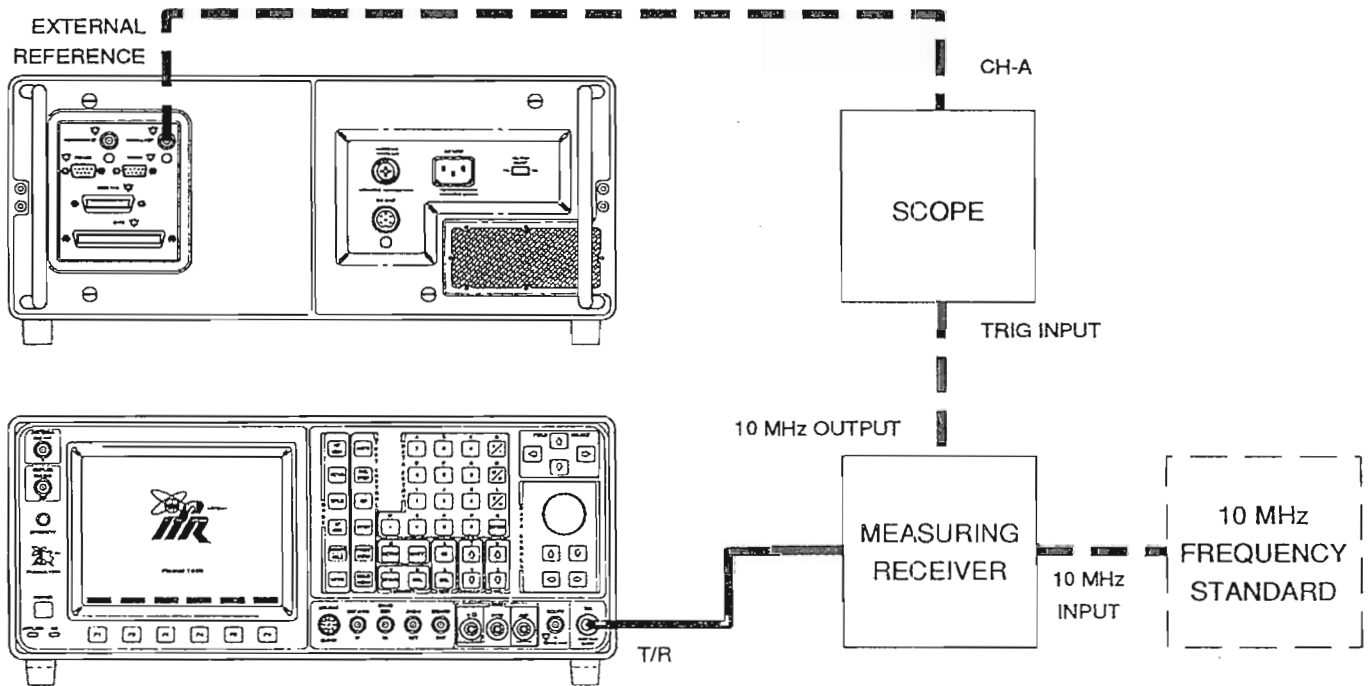

8606001

Figure 3-7 VCXO Calibration Test Setup

3. Press RF GEN MODE Key (27). Use FIELD SELECT Keys (1) to select RF data field.
4. Press ENTER Key to highlight RF data field. Use DATA ENTRY Keypad (29) to set to **900.0000 MHz**. Press ENTER Key.
5. Use FIELD SELECT Keys (1) to move cursor to LEVEL. Press ENTER Key.
6. Use DATA ENTRY Keypad (29) to set data field to **0.0 dBm**. Press ENTER Key.

## STEP

## PROCEDURE

7. Connect 10 MHz output on Measuring Receiver to Oscilloscope Trigger input and 10 MHz output from External 10 MHz Frequency Standard to 10 MHz Input on Measuring Receiver (Oven Oscillator Option Only) (Figure 3-7).
8. Verify frequency displayed on Measuring Receiver is 900 MHz ( $\pm 450$  Hz). If frequency is within tolerance, continue at step 21.
9. Connect EXTERNAL REFERENCE Connector (38) to Oscilloscope Ch-A input (Figure 3-7).
10. Set Oscilloscope controls as follows:

CONTROL	SETTING
V/Div	2 mV/Div
Sweep	20 ns
Trigger	Ext

11. Press SETUP Key and "AUX" Soft Function Key F6. Auxiliary Functions Menu is displayed on CRT (26) and "1. Calibration Menu" Selection is highlighted.
12. Press ENTER Key. Password Window is displayed. Use DATA ENTRY Keypad (29) to press SHIFT, **C**, **S**, **M**, **A**, **T**, **E**, SHIFT and ENTER Keys to access Calibration Menu.
13. Use FIELD SELECT Keys (1) to move cursor to "12. VCXO Calibration". Press ENTER Key. Select Attn submenu appears with highlighted data field.
14. Using DATA SCROLL Keys (4), slew cursor to least significant digit in Select Attn field.
15. Use DATA SCROLL Keys (3) or DATA SCROLL Spinner (2) to adjust waveform on Oscilloscope for minimum motion and/or rotation. Press ENTER Key. If adjustment range is  $< 0$  or  $> 4095$ , set Select Attn field to **2048** and perform steps 16 through 18, otherwise continue at step 19.
16. Remove screw on top of 10 MHz Frequency Standard to access coarse frequency adjustment pot (Figure 3-2).
17. Adjust for minimum motion of waveform on Oscilloscope.
18. Replace screw in 10 MHz Frequency Standard and repeat steps 9 through 15.
19. Verify waveform displayed on Oscilloscope is  $\geq 1$  mVp-p.
20. Proceed at step 8.
21. Remove power from FM/AM-1600S and disconnect test equipment.

### 3-8-3 METERING DVM CALIBRATION

PREREQUISITES: 3-8-1 Power Supply Calibration

EQUIPMENT REQUIRED: 1 Digital Multimeter (DMM)

FIGURE REFERENCES: Figure 3-8

STEP	PROCEDURE
1.	Connect DMM negative lead to TP70003 (Figure 3-8) and positive lead to TP70002 (Figure 3-8).
2.	Apply power to FM/AM-1600S. Allow 5 minute warm-up period. Insure IFR Logo Screen, with no error message, is displayed on CRT (26).
3.	Verify DMM displays 4.0960 V ( $\pm 0.002$ V). Adjust R70018 (Figure 3-8) if necessary.
4.	Remove power from FM/AM-1600S and disconnect test equipment.



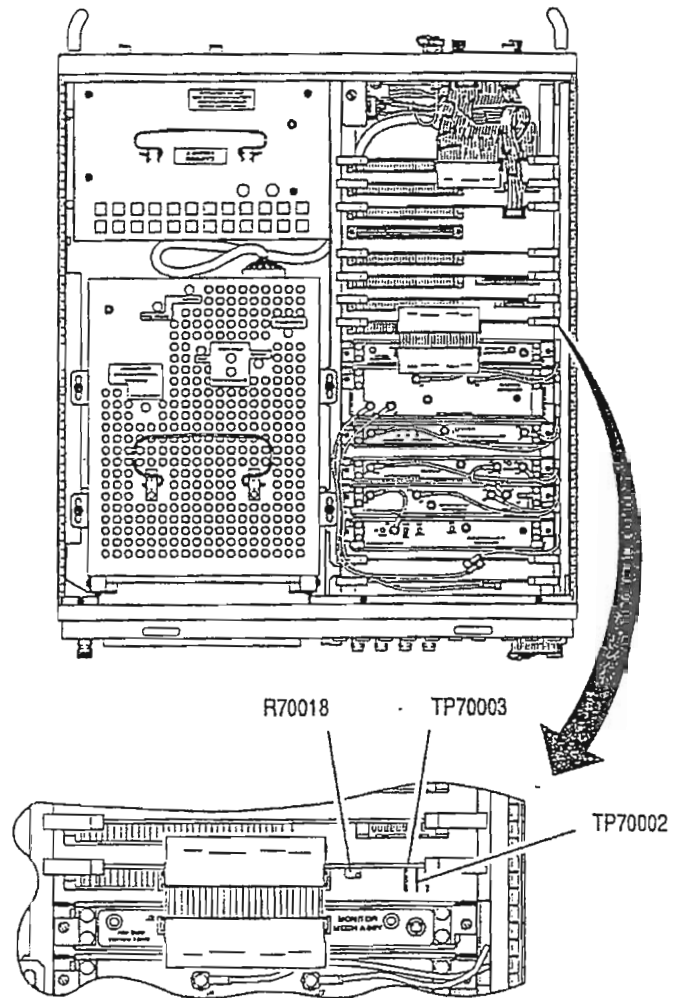

8619003

Figure 3-8 Monitor Control PC Board Assembly Calibration Points

### 3-8-4 FUNC GEN LEVEL AND VRMS METER CALIBRATION

PREREQUISITES: 3-8-1 Power Supply Calibration

EQUIPMENT REQUIRED: 1 Extender Board (7010-7839-900)  
1 150  $\Omega$  Load  
1 Digital Multimeter (DMM)  
1 Coaxial Cable (BNC-BNC)

FIGURE REFERENCES: Figure 3-9  
Figure 3-10

STEP	PROCEDURE
------	-----------

#### FUNC GEN LEVEL CALIBRATION

1. Remove Function Generator PC Board Assembly (4-3-12). Install Extender Board. Install Function Generator PC Board Assembly on Extender Board.
2. Apply power to FM/AM-1600S. Allow 5 minute warm-up period. Insure IFR Logo, with no error message, is displayed on CRT (26).
3. Press AF GEN MODE Key (27). AF Generator Operation Screen is displayed on CRT (26).
4. Press SETUP Key. AF Generator Menu is displayed and "1. Func Gen #1 Setup" is highlighted.
5. Press 5 on DATA ENTRY Keypad (29) to access AF Gen Setup submenu.
  - a. Press 1 on DATA ENTRY Keypad (29), if necessary, to set "1. To Audio Out Conn" **On**.
  - b. Press 2 on DATA ENTRY Keypad (29), if necessary, to set "2. To Speaker" **On**.
  - c. Press 5 on DATA ENTRY Keypad (29), if necessary, to set "5. Proportional Output" **Off**.
  - d. Press "ESC" Soft Function Key F5.
6. Press AF GEN MODE Key (27) to return to AF Generator Operation Screen.
7. Connect coaxial cable between AUDIO OUT Connector (14) and DMM input through 150  $\Omega$  load (Figure 3-9).
8. Set DMM to VAC RMS and Auto Ranging.
9. Use FIELD SELECT Keys (1) to move cursor to GEN 1. WAVE. Press ENTER Key. Use DATA SCROLL Keys (3) to select **Sine**. Press ENTER Key.
10. Use FIELD SELECT Keys (1) to move cursor to LEVEL. Press ENTER Key to highlight field.
11. Use DATA ENTRY Keypad (29) to set level to **2.5000 V**. Press ENTER Key. Verify 2.5 Vrms ( $\pm 0.5$  mVrms). If correct, proceed at step 34.
12. Press SETUP Key and "AUX" Soft Function Key F6. Auxiliary Functions Menu is displayed on CRT (26) and "1. Calibration Menu" Selection is highlighted.

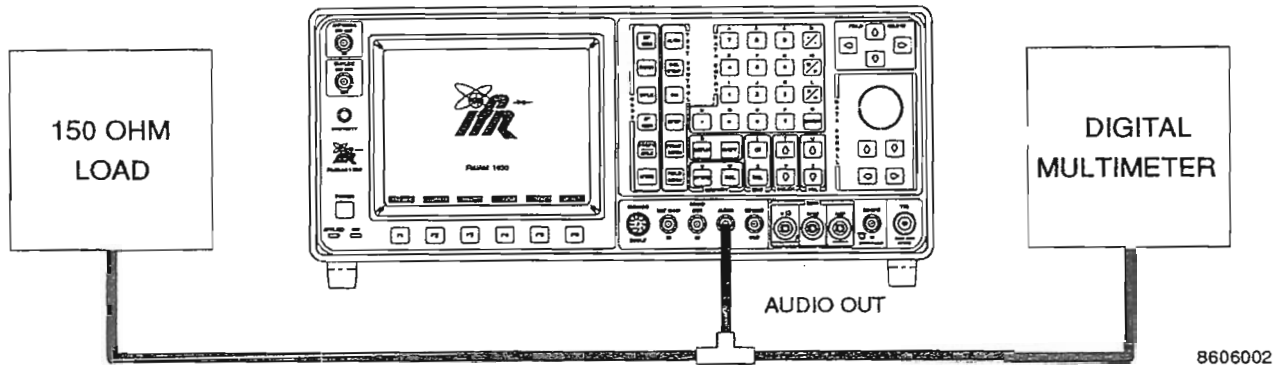

8606002

Figure 3-9 Func Gen Level and VRMS Meter Calibration Setup

13. Press ENTER Key. Password Window is displayed. Use DATA ENTRY Keypad (29) to press SHIFT, **C**, **S**, **M**, **A**, **T**, **E**, SHIFT and ENTER Keys to access Calibration Menu.
14. Press SHIFT and **F** on DATA ENTRY Keypad (29). Func Gen Level Calibrations submenu is displayed.
15. Press 1 on DATA ENTRY Keypad (29) to highlight 1. 199.9 mV data field.
16. Use DATA SCROLL Keys (3) to edit value in highlighted data field until reading on DMM equals 199.9 mV ( $\pm 0.03$  mV). Press ENTER Key. If unable to calibrate, go to step 21.
17. Press 2 on DATA ENTRY Keypad (29) to highlight 2. 2.5 V data field.
18. Use DATA SCROLL Keys (3) to enter value in highlighted data field until reading on DMM equals 2.500 V ( $\pm 0.5$  mV). Press ENTER Key. If unable to calibrate, go to step 21.
19. Press "ESC" Soft Function Key F6.
20. Proceed at step 34.
21. Press SETUP Key. AF Generator Menu is displayed and "1. Func Gen #1 Setup" is highlighted.
  - a. Press ENTER Key. Func Gen 1 submenu appears.
  - b. Press ENTER Key to set 1. Func Gen 1 to **Off**.
  - c. Press 2 on DATA ENTRY Keypad (29) to highlight Freq data field. Use DATA ENTRY Keypad (29) to set frequency to **1000.0 Hz**. Press ENTER Key.
  - d. Press 3 on DATA ENTRY Keypad (29). Waveform submenu is displayed.
  - e. Press 7 on DATA ENTRY Keypad (29) to set waveform to **0 Lvl**.
  - f. Press "ESC" Soft Function Key F6.

22. Press 2 on DATA ENTRY Keypad (29) to access Func Gen 2 submenu. Press 1 on DATA ENTRY Keypad (29), if necessary, to set Func Gen 2 to **On**.
  - a. Press 2 on DATA ENTRY Keypad (29) to highlight Freq data field. Use DATA ENTRY Keypad (29) to set frequency to **1000.0 Hz**. Press ENTER Key.
  - b. Press 3 on DATA ENTRY Keypad (29). Waveform submenu is displayed.
  - c. Press 7 on DATA ENTRY Keypad (29) to set waveform to **0 Lvl**.
  - d. Press "ESC" Soft Function Key F6.
23. Press 5 on DATA ENTRY Keypad (29) to access AF Gen Setup submenu.
  - a. Press 1 on DATA ENTRY Keypad (29), if necessary, to set "1. To Audio Out Conn" **On**.
  - b. Press 2 on DATA ENTRY Keypad (29), if necessary, to set "2. To Speaker" **On**.
  - c. Press 5 on DATA ENTRY Keypad (29), if necessary, to set "5. Proportional Output" **Off**.
  - d. Press "ESC" Soft Function Key F6.
24. Press AF GEN MODE Key (27) to return to AF Generator Operation Screen.
25. Connect DMM positive lead to P68002, Pin 2B (Figure 3-10) and negative lead to P68002, Pin 6B (Figure 3-10).
26. Set DMM to Vdc and Auto Ranging.
27. Use FIELD SELECT Keys (1) to move cursor to LEVEL. Press ENTER Key to highlight Field.
28. Use DATA ENTRY Keypad (29) to set level to **3.1**. Press ENTER Key.
29. Verify 0.000 V ( $\pm 10$  mV) is displayed on DMM. Adjust R68022 (Figure 3-10) if necessary.

**NOTE:** If exact logic levels are not required by user, R68022 (Figure 3-10) may be adjusted to enable ac output of GEN2 equal to GEN1.
30. Use FIELD SELECT Keys (1) to move cursor to GEN 2. Press ENTER Key to set GEN 2 **Off**.
31. Use FIELD SELECT Keys (1) to move cursor to GEN 1. Press ENTER Key to set GEN 1 **On**.
32. Verify 0.000 V ( $\pm 10$  mV) is displayed on DMM. Adjust R68023 (Figure 3-10) if necessary.
33. Repeat steps 6 through 20.

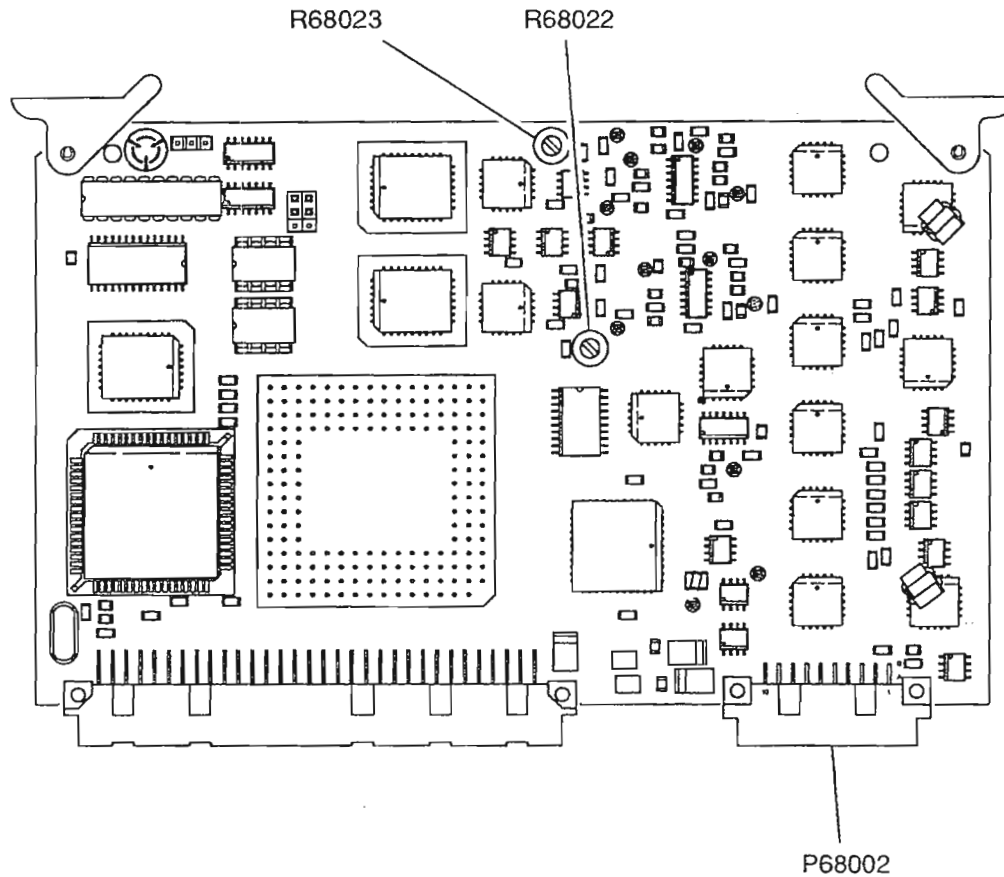

8607167

Figure 3-10 Function Generator PC Board Assembly Calibration Points

**VRMS METER CALIBRATION**

34. Verify VRMS Meter is  $\leq 10\%$  of reading displayed on DMM.
35. Press SETUP Key and "AUX" Soft Function Key F6. Auxiliary Functions Menu is displayed on CRT (26) and "1. Calibration Menu" Selection is highlighted.
36. Press ENTER Key. Password Window is displayed. Use DATA ENTRY Keypad (29) to press SHIFT, **C**, **S**, **M**, **A**, **T**, **E**, SHIFT and ENTER Keys to access Calibration Menu.
37. Press 8 on DATA ENTRY Keypad (29) to access METER Cal VRMS Screen. Press ENTER Key to access "Proper Reading" data field.
38. Use DATA ENTRY Keypad (29) to enter digits of DMM Vrms reading. Press ENTER Key.
39. Press "Ret" Soft Function Key F5 and "ESC" Soft Function Key F6 to terminate procedure.
40. Remove power from FM/AM-1600S, disconnect test equipment and reinstall Function Generator PC Board Assembly.

### 3-8-5 GEN OUTPUT LEVEL CALIBRATION

PREREQUISITES: 3-8-1 Power Supply Calibration

EQUIPMENT REQUIRED: 1 Measuring Receiver with Sensor Power Head

FIGURE REFERENCES: Figure 3-11

- | STEP | PROCEDURE |
|------|-----------|
|------|-----------|
1. Apply power to FM/AM-1600S. Allow 5 minute warm-up period. Insure IFR Logo Screen, with no error message, is displayed on CRT (26).
  2. Connect T/R Connector (6) to Measuring Receiver input.
  3. Press RF GEN MODE Key (27). RF Generator Operation Screen is displayed on CRT (26).
  4. Use FIELD SELECT Keys (1) to move cursor to LEVEL. Press ENTER Key to highlight data field.
  5. Use DATA SCROLL Keys (3) or DATA SCROLL Spinner (2) to set data field to 0. Press ENTER Key.
  6. Press SETUP Key and "AUX" Soft Function Key F6. Auxiliary Functions Menu is displayed on CRT (26) and "1. Calibration Menu" Selection is highlighted.
  7. Press ENTER Key. Password Window is displayed. Use DATA ENTRY Keypad (29) to press SHIFT, **C**, **S**, **M**, **A**, **T**, **E**, SHIFT and ENTER Keys to access Calibration Menu.
  8. Use FIELD SELECT Keys (1) to move cursor to "14. Gen Output Lvl Cal" field. Press ENTER Key.
  9. Perform steps 10 to 15 for Ranges 1 to 9 listed in Table 3-1.

RANGE	LOW FREQUENCY	HIGH FREQUENCY
1	250 kHz	499 kHz
2	500 kHz	999 kHz
3	1 MHz	49 MHz
4	50 MHz	124 MHz
5	125 MHz	199 MHz
6	200 MHz	399 MHz
7	400 MHz	599 MHz
8	600 MHz	799 MHz
9	800 MHz	999 MHz

Table 3-1 Output Level Range Chart

10. Move Curser to data field listing Low Frequency for current Range. Verify Low Frequency and note output level in dBm using Measuring Receiver.

11. Press "High" Soft Function Key F1. Verify High Frequency and note output level in dBm using Measuring Receiver. Press "Low" Soft Function Key F1.
12. Verify Step 10 output is as much above 0.0 dBm as Step 11 output is below 0.0 dBm. (Refer to Figure 3-11.) If two output magnitudes match and are opposite in sign, continue with next Range.

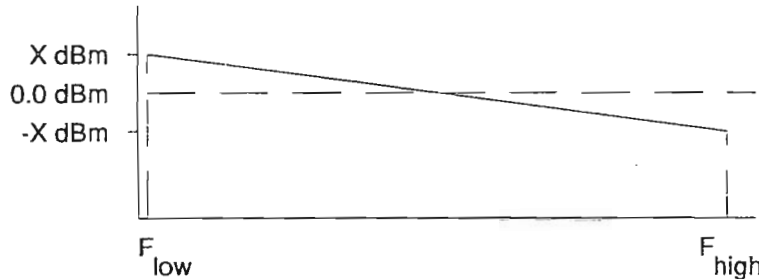

Figure 3-11 Low Frequency and High Frequency Location

13. Press ENTER Key.
14. Use DATA SCROLL Keys (3) to move cursor to least significant digit in data field and edit data. If magnitude of Low Frequency output is greater than magnitude of High Frequency output, decrease value. If magnitude of Low Frequency output is less than magnitude of High Frequency output, increase value. Press ENTER Key.
15. Repeat steps 10 through 14 until levels match as closely as unit allows. Continue with next Range.
16. Press "ESC" Soft Function Key F6 twice.
17. Press RF GEN MODE Key (27). Verify Low Frequency output and High Frequency output for each Range listed in Table 3-1 are 0 dBm ( $\pm 1.0$  dB).
18. Remove power from FM/AM-1600S and disconnect test equipment.

### 3-8-6 RF NULL CALIBRATION

PREREQUISITES: 3-8-1 Power Supply Calibration

EQUIPMENT REQUIRED: None

FIGURE REFERENCES: Figure 3-12

STEP	PROCEDURE
1.	Apply power to FM/AM-1600S. Allow 5 minute warm-up period. Insure IFR Logo, with no error message, is displayed on CRT (26).
2.	Press SCOP/ANLZ MODE Key (27) to access Analyzer Operation Screen.  <b>NOTE:</b> Both Oscilloscope and Spectrum Analyzer are accessed with SCOP/ANLZ MODE Key (27). It may be necessary to press Key twice to access Analyzer Operation Screen.
3.	Use FIELD SELECT Keys (1) to move cursor to RF and press ENTER Key to highlight data field.
4.	Use DATA ENTRY Keypad (29) to enter <b>0.2500 MHz</b> into data field. Press ENTER Key.
5.	Use FIELD SELECT Keys (1) to move cursor to RF IN. Press ENTER Key to select <b>ANT</b> .
6.	Use FIELD SELECT Keys (1) to move cursor to RF ATTEN. Press ENTER Key.
7.	Use DATA SCROLL Keys (3) to set data field to <b>40 dB</b> .
8.	Use FIELD SELECT Keys (1) to move cursor to Scan Width (kHz/Div). Press ENTER Key to highlight data field.
9.	Use DATA SCROLL Keys (3) or DATA SCROLL Spinner (2) until data field displays <b>1 MHz</b> . Press ENTER Key.
10.	Alternately adjust R39002 (Figure 3-12) and R39003 (Figure 3-12) and verify minimum amplitude (<0 dBm on Analyzer Operation Screen) for 1st LO Signal.  <b>NOTE:</b> R39002 and R39003 are interactive and adjustment is extremely sensitive.
11.	Remove power from FM/AM-1600S.



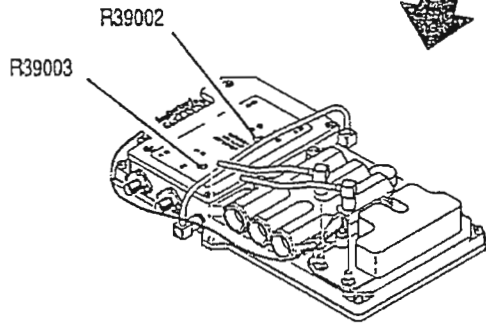
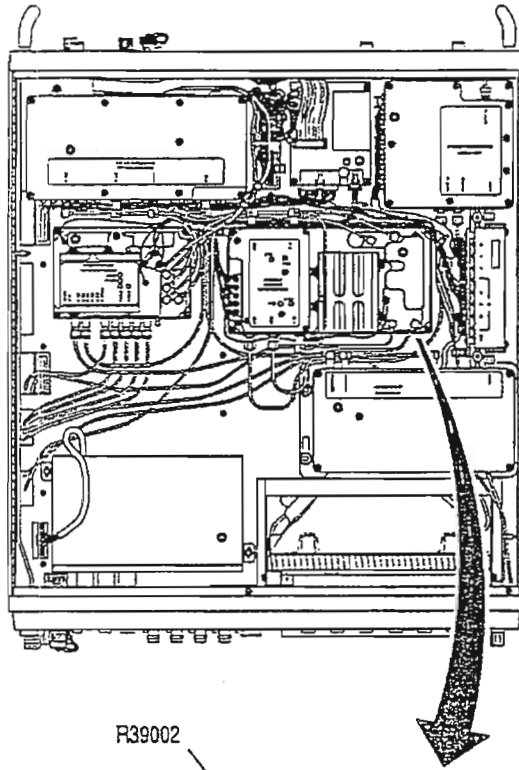

8619001

Figure 3-12 Receive IF Assembly Calibration Adjustments

### 3-8-7 SIGNAL METER CALIBRATION

PREREQUISITES: 3-8-1 Power Supply Calibration

EQUIPMENT REQUIRED: 1 RF Signal Generator (HP8640B)  
1 Coaxial Cable (BNC-BNC)

FIGURE REFERENCES: None

STEP	PROCEDURE
1.	Apply power to FM/AM-1600S. Allow 5 minute warm-up period. Insure IFR Logo, with no error message, is displayed on CRT (26).
2.	Press RCVR MODE Key (27) to access Receive Operation Screen.
3.	Use FIELD SELECT Keys (1) to move cursor to RF and press ENTER Key to highlight data field.
4.	Use DATA ENTRY Keypad (29) to enter <b>121.1000 MHz</b> into data field and press ENTER Key.
	<b>NOTE:</b> RF Signal Generator frequency may be varied to desired user needs.
5.	Use FIELD SELECT Keys (1) to move cursor to RF ATTN field and press ENTER Key to highlight data field.
6.	Use DATA SCROLL Keys (3) to set data field to <b>0 dB</b> . Press ENTER Key.
7.	Use FIELD SELECT KEYS (1) to move cursor to MOD field. Press ENTER Key.
8.	Use DATA SCROLL Keys (3) to set data field to <b>FM1</b> . Press ENTER Key.
9.	Connect ANTENNA IN Connector (25) to Signal Generator output.
10.	Set Signal Generator output for 121.100000 MHz at -33 dB. Verify signal is <100.
11.	Set Signal Generator output for 121.100000 MHz at -30 dB. Verify signal is 100 (99 to 100). If within tolerance, proceed at step 17.
12.	Press SETUP Key and "AUX" Soft Function Key F6. Auxiliary Functions Menu is displayed on CRT (26) and "1. Calibration Menu" Selection is highlighted.
13.	Press ENTER Key. Password Window is displayed. Use DATA ENTRY Keypad (29) to press SHIFT, spell <b>C, S, M, A, T, E</b> , press SHIFT and press ENTER Keys to access Calibration Menu.
14.	Press 7 on DATA ENTRY Keypad (29). METER Cal Signal Menu is displayed.
15.	Press ENTER Key to highlight data field. Use DATA ENTRY Keypad (29) to enter <b>100</b> and press ENTER Key.
16.	Press "RET" Soft Function Key F5 and "ESC" Soft Function Key F6 to terminate procedure.
17.	Remove power from FM/AM-1600S and disconnect test equipment.

### 3-8-8 FM CALIBRATION

PREREQUISITES: 3-8-1 Power Supply Calibration

EQUIPMENT REQUIRED: 1 RF Signal Generator (HP8640B)  
 1 Oscilloscope  
 2 Coaxial Cables (BNC-BNC)

FIGURE REFERENCES: Figure 3-13

STEP	PROCEDURE
------	-----------

1. Apply Power to FM/AM-1600S. Allow 5 minute warm-up period. Insure IFR Logo, with no error message, is displayed on CRT (26).
2. Press RCVR MODE Key (27) to access Receive Operation Screen.
3. Connect Signal Generator output (Figure 3-13) to ANTENNA IN Connector (25).

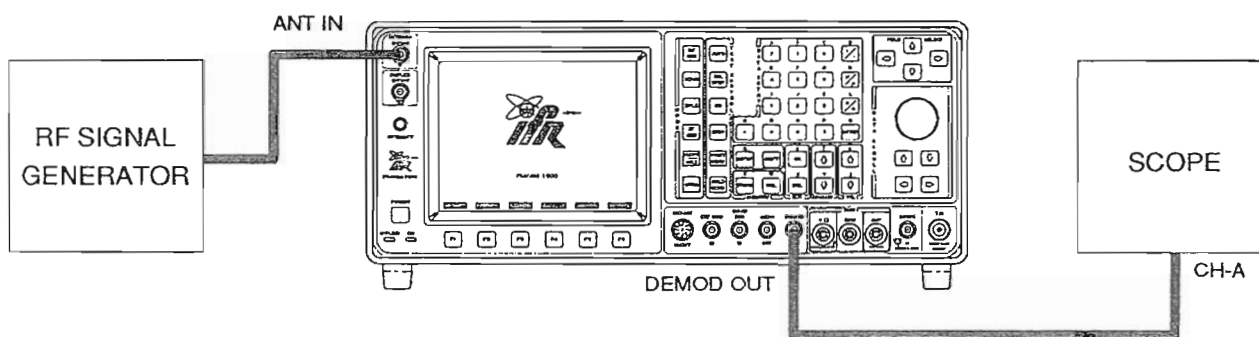

8606005

Figure 3-13 FM Calibration Test Setup

4. Set RF Signal Generator output for 121.100000 MHz at -50 dBm.
5. Connect DEMOD OUT Connector (12) to Oscilloscope Ch-A (Figure 3-13).
6. Set Oscilloscope controls as follows:

CONTROL	SETTING
V/Div	20 mV
Trigger	Auto
Sweep	500 $\mu$ s
Coupling	DC

7. Press SETUP Key to access Receiver Menu.
8. Use FIELD SELECT Keys (1) to move cursor to "1. Set Rcvr Freq". Press ENTER Key to highlight data field.
9. Use DATA ENTRY Keypad (29) to enter **121.1000 MHz** into data field. Press ENTER Key.

## STEP

## PROCEDURE

10. Press 2 on DATA ENTRY Keypad (29). "2. Select Mod" submenu appears.
11. Press 1 on DATA ENTRY Keypad (29) to select **FM1**.
12. Press 3 on DATA ENTRY Keypad (29). Press any DATA ENTRY Keypad (29), if necessary, to select **Antenna** in data field. Press ENTER Key.
13. Press 4 on DATA ENTRY Keypad (29). "Select Input Atten" submenu appears.
14. Press 1 on DATA ENTRY Keypad (29) to set data field to **0 dB**.
15. Press 5 on DATA ENTRY Keypad (29). "Select AGC Type" submenu appears.
16. Press 1 on DATA ENTRY Keypad (29) to set data field to **User Defined**.
17. Press 1 on DATA ENTRY Keypad (29) to set data field to **Measurement**.
18. Press 8 on DATA ENTRY Keypad (29), if necessary, to set "Rcvr Out Demod Out" to **On**.
19. Press "Ret" Soft Function Key F5 to return to Receive Operation Screen.
20. Verify FREQ ERR is  $<\pm 10$  Hz.
21. Press SETUP Key and "AUX" Soft Function Key F6. Auxiliary Functions Menu is displayed on CRT (26) and "1. Calibration Menu" Selection is highlighted.
22. Press ENTER Key. Password Window is displayed. Use DATA ENTRY Keypad (29) to press SHIFT, **C, S, M, A, T, E**, SHIFT and ENTER Keys to access Calibration Menu. Use FIELD SELECT Keys (1) to move cursor to "11. FM Calibration". Press ENTER Key.
23. Use DATA SCROLL Keys (4) to move cursor to least significant digit.
24. Use DATA SCROLL Keys (3) or DATA SCROLL Spinner (2) to adjust Frequency Offset until 0 V ( $\pm 40$  mV) is displayed on Oscilloscope.
25. Press ENTER Key to enter Frequency Offset into data field.
26. Press "ESC" Soft Function Key F6 to terminate procedure.
27. Press RCVR MODE Key (27) to access Receive Operation Screen.
28. Press "More" Soft Function Key F6 until "FM Z" Soft Function Key F3 appears. Press "FM Z" Soft Function Key F3.
29. Verify 0 V ( $\pm 40$  mV) is displayed on Oscilloscope. If measurement is not within tolerance, Monitor Assembly requires repair.
30. Remove power from FM/AM-1600S and disconnect test equipment.

### 3-8-9 DEVIATION METER CALIBRATION

PREREQUISITES: 3-8-1 Power Supply Calibration  
3-8-8 FM Calibration

EQUIPMENT REQUIRED: 1 Measuring Receiver  
1 Power Splitter  
1 RF Signal Generator (HP8640B)  
2 Coaxial Cables (BNC-BNC)

FIGURE REFERENCES: Figure 3-14

- | STEP | PROCEDURE  |
|------|--|
| 1.   | Apply power to FM/AM-1600S. Allow 5 minute warm-up period. Insure IFR Logo, with no error message, is displayed on CRT (26). |
| 2.   | Connect Power Splitter to Signal Generator RF Output (Figure 3-14).  |

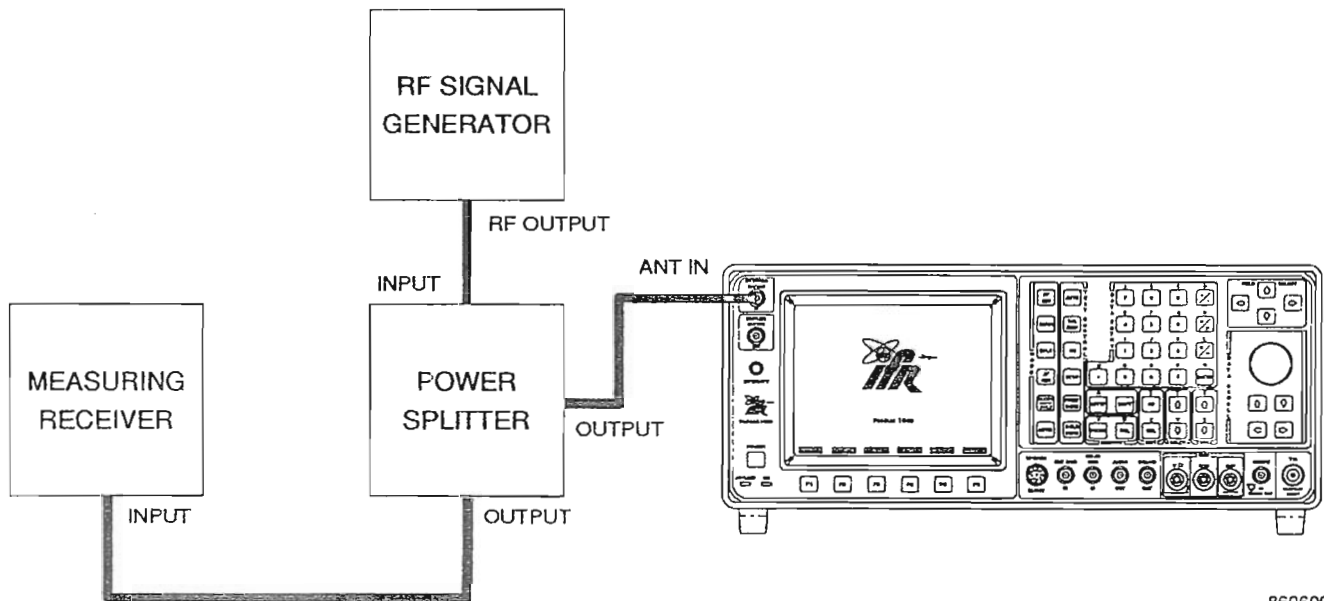

8606006

Figure 3-14 Deviation Meter Calibration Test Setup

3. Set Signal Generator output for 121.100000 MHz at 0 dBm with no modulation.
4. Connect Measuring Receiver input to one output on Power Splitter and ANTENNA IN Connector (25) to other output on Power Splitter (Figure 3-14).

5. Set Measuring Receiver controls as follows:

CONTROL	SETTING
Detector	Peak+
Low-Pass Filter	3 kHz
Measurement	FM

6. Press RCVR MODE Key (27). Receive Operation Screen is displayed on CRT (26).
7. Use FIELD SELECT Keys (1) to move cursor to RF. Press ENTER Key to highlight data field.
8. Use DATA ENTRY Keypad (29) to set data field to **121.1000 MHz**. Press ENTER Key.
9. Use FIELD SELECT Keys (1) to move cursor to RF IN field. Use DATA ENTRY Keypad (29) to set data field to **ANT**.
10. Use FIELD SELECT Keys (1) to move cursor to RF ATTN field. Press ENTER Key to highlight data field.
11. Use DATA SCROLL Keys (3) to set data field to **40 dB**.
12. Press SETUP Key. Press 2 on DATA ENTRY Keypad (29) to access "2. Select Mod" submenu.
13. Use FIELD SELECT Keys (1) to move cursor to "11. User Defined" data field. Press ENTER Key.
14. Press 1 on DATA ENTRY Keypad (29) to access "Modulation" submenu. Press 1 on DATA ENTRY Keypad (29) to select "1. FM".
15. Press 2 on DATA ENTRY Keypad (29) to access "IF Filters" submenu. Press 3 on DATA ENTRY Keypad (29) to select "3. 300 kHz".
16. Press 3 on DATA ENTRY Keypad (29) to access "Post Detection" submenu. Press 2 on DATA ENTRY Keypad (29) to select "2. Low Pass". Use DATA ENTRY Keypad (29) to set "Low Pass Filter Freq" data field to **3.000 kHz**. Press ENTER Key.
17. Press RCVR MODE Key (27). Receive Operation Screen is displayed on CRT (26).
18. Press "More" Soft Function Key F6 until "FM Z" Soft Function Key F3 appears. Press "FM Z" Soft Function Key F3 and verify plus (+) and minus (-) deviation is within 100 Hz. If deviation error is >100 Hz, perform FM Calibration Procedure (3-8-8).
19. Press SETUP Key and "AUX" Soft Function Key F6. Auxiliary Functions Menu is displayed on CRT (26) and "1. Calibration Menu" Selection is highlighted.
20. Press ENTER Key. Password Window is displayed. Use DATA ENTRY Keypad (29) to press SHIFT, **C, S, M, A, T, E**, SHIFT and ENTER Keys to access Calibration Menu.
21. Press 2 on DATA ENTRY Keypad (29) to access "DEV METER (Peak)" submenu.
22. Set Signal Generator output to 8 kHz deviation.

STEP	PROCEDURE
22.	Set Signal Generator output to 8 kHz deviation.
23.	Press "Range" Soft Function Key F1 until <b>+10 kHz</b> Range is displayed with AR (Auto Range) OFF. Press ENTER Key to highlight "Proper Reading" data field.
24.	Use DATA ENTRY Keypad (29) to enter value displayed on Measuring Receiver into data field. Press ENTER Key.
25.	Set Measuring Receiver Detector to Peak-.
26.	Use DATA ENTRY Keypad (29) to enter value displayed on Measuring Receiver in highlighted data field. Press +/- on DATA ENTRY Keypad (29) and ENTER Key.
<b>NOTE:</b> A negative value is displayed.	
27.	Verify deviation reading is within 3% ( $\pm 1$ Count) of reading on Measuring Receiver ( $\pm 100$ Hz, <3.4 kHz deviation).
28.	Press "Range" Soft Function Key F1 to set Range to <b>20 kHz</b> .
29.	Set Signal Generator output for 16 kHz deviation.
30.	Set Measuring Receiver Detector to Peak+.
31.	Press ENTER Key. Use DATA ENTRY Keypad (29) to enter value displayed on Measuring Receiver into data field. Press ENTER Key.
32.	Set Measuring Receiver Detector to Peak-.
33.	Use DATA ENTRY Keypad (29) to enter value displayed on Measuring Receiver in highlighted data field. Press +/- on DATA ENTRY Keypad (29) and ENTER Key.
34.	Verify deviation reading is within 3% ( $\pm 1$ Count) of reading on Measuring Receiver ( $\pm 100$ Hz, <3.4 kHz deviation).
35.	Press "Range" Soft Function Key F1 to set Range to <b>50 kHz</b> .
36.	Set Signal Generator output for 40 kHz deviation.
37.	Set Measuring Receiver Detector to Peak+.
38.	Press ENTER Key. Use DATA ENTRY Keypad (29) to enter value displayed on Measuring Receiver into data field. Press ENTER Key.
39.	Set Measuring Receiver Detector to Peak-.
40.	Use DATA ENTRY Keypad (29) to enter value displayed on Measuring Receiver in highlighted data field. Press +/- on DATA ENTRY Keypad (29) and ENTER Key.
41.	Verify deviation reading is within 3% ( $\pm 1$ Count) of reading on Measuring Receiver ( $\pm 100$ Hz, <3.4 kHz deviation).
42.	Press "Range" Soft Function Key F1 to set Range to <b>100 kHz</b> .

## STEP

## PROCEDURE

43. Set Signal Generator output for 80 kHz deviation.
44. Set Measuring Receiver Detector to Peak+.
45. Press ENTER Key. Use DATA ENTRY Keypad (29) to enter value displayed on Measuring Receiver into data field. Press ENTER Key.
46. Set Measuring Receiver Detector to Peak-.
47. Use DATA ENTRY Keypad (29) to enter value displayed on Measuring Receiver in highlighted data field. Press +/- Key and ENTER Key.
48. Verify deviation reading is within 3% ( $\pm 1$  Count) of reading on Measuring Receiver ( $\pm 100$  Hz,  $< 3.4$  kHz deviation).
49. Press "Ret" Soft Function Key F5 and "ESC" Soft Function Key F6.
50. Set Signal Generator output for 11.312 kHz deviation.
51. Set Measuring Receiver controls for following:

<u>CONTROL</u>	<u>SETTING</u>
Detector	RMS
Low-Pass Filter	3 kHz
Measurement	FM

52. Press MTRS Key to select METERS Operation Mode. Use FIELD SELECT Keys (1) to highlight "12. Dev Meter (RMS)" field. Press ENTER Key to access Deviation Meter (RMS).
53. Move Cursor to RANGE Field using FIELD SELECT Keys (1). Select **10 kHz** using DATA SCROLL Keys (3). Press ENTER Key.
54. Verify Deviation Meter (RMS) reading matches Measuring Receiver reading ( $\pm 10\% \pm 1$  count). If in tolerance, continue with step 62.
55. Press "AUX" Soft Function Key F6. Auxiliary Functions Menu is displayed on CRT (26) and "1. Calibration Menu" Selection is highlighted.
56. Press ENTER Key. Password Window is displayed. Use DATA ENTRY Keypad (29) to press SHIFT, **C, S, M, A, T, E**, SHIFT and ENTER Keys to access Calibration Menu.
57. Press 3 on DATA ENTRY Keypad (29) to access "3. Dev Meter (RMS) Cal" field.
58. Press ENTER Key. Enter value displayed on Measuring Receiver into data field using DATA ENTRY Keypad (29). Press ENTER Key.
59. Press "Ret" Soft Function Key F5 and "ESC" Soft Function Key F6.
60. Remove power from FM/AM-1600S and disconnect test equipment.



### 3-8-10 MODULATION METER CALIBRATION

PREREQUISITES: 3-8-1 Power Supply Calibration  
3-8-8 FM Calibration

EQUIPMENT REQUIRED: 1 Measuring Receiver  
1 Power Splitter  
1 RF Signal Generator (HP8640B)  
2 Coaxial Cables (BNC-BNC)

FIGURE REFERENCES: Figure 3-15

STEP	PROCEDURE
------	-----------

1. Apply power to FM/AM-1600S. Allow 5 minute warm-up period. Insure IFR Logo, with no error message, is displayed on CRT (26).
2. Connect Power Splitter to Signal Generator RF Output (Figure 3-15).

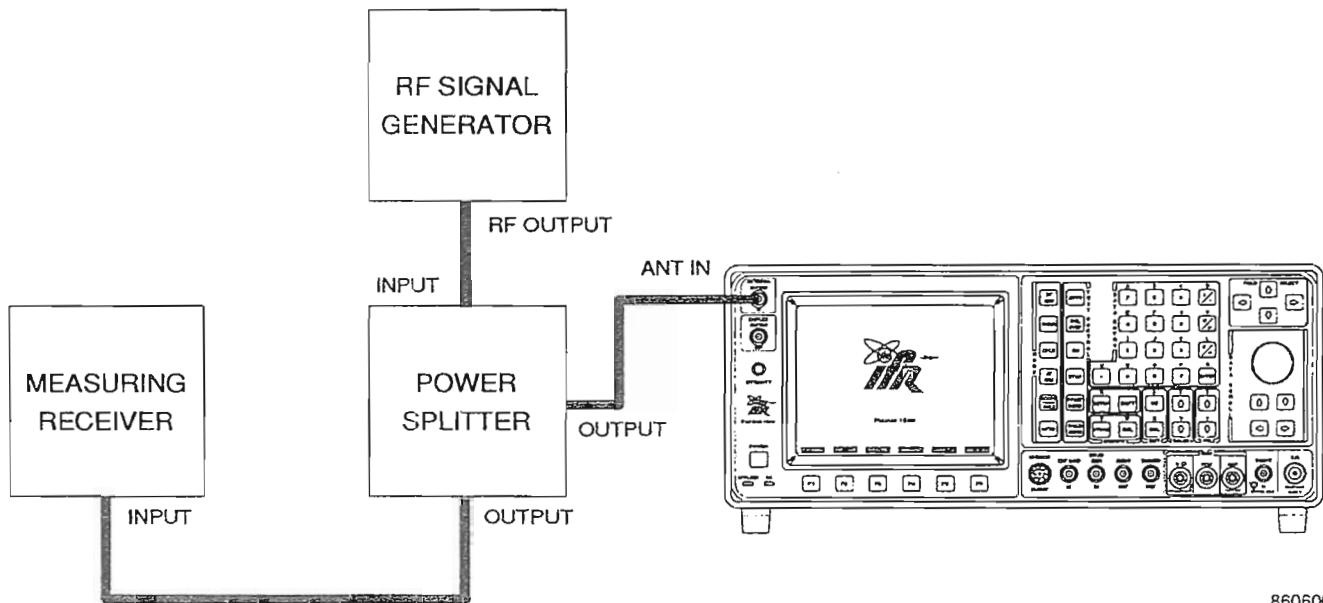

8606006

Figure 3-15 Modulation Meter Calibration Test Setup

3. Set Signal Generator output for 121.100000 MHz at 0 dBm with 80% AM modulation and 1 kHz tone.
4. Connect Measuring Receiver input to one output on Power Splitter and ANTENNA IN Connector (25) to other output on Power Splitter (Figure 3-15).

5. Set Measuring Receiver controls as follows:

CONTROL	SETTING
Detector	Peak+
Low-Pass Filter	15 kHz
Detector	AM

6. Press RCVR MODE Key (27). Receive Operation Screen is displayed.
7. Use FIELD SELECT Keys (1) to move cursor to RF. Press ENTER Key to highlight data field.
8. Use DATA ENTRY Keypad (29) to set data field to **121.1000 MHz**. Press ENTER Key.
9. Use FIELD SELECT Keys (1) to move cursor to RF IN field. Use DATA ENTRY Keypad (29) to set data field to **ANT**.
10. Use FIELD SELECT Keys (1) to move cursor to RF ATTEN field. Press ENTER Key to highlight data field.
11. Use DATA SCROLL Keys (3) to set data field to **40 dB**.
12. Use FIELD SELECT Keys (1) to move cursor to MOD. Press ENTER Key to highlight data field.
13. Use DATA SCROLL Keys (3) to enter **AM2** into data field. Press ENTER Key.
14. Use FIELD SELECT Keys (1) to move cursor to MOD Meter. Press ENTER Key to access "MODULATION METER" submenu.
15. Press ENTER Key to highlight RANGE data field. Use DATA SCROLL Keys (3) to set Data Field to **100%**. Press ENTER Key.
16. Press SETUP Key and "AUX" Soft Function Key F6. Auxiliary Functions Menu is displayed on CRT (26) and "1. Calibration Menu" Selection is highlighted.
17. Press ENTER Key. Password Window is displayed. Use DATA ENTRY Keypad (29) to press SHIFT, **C, S, M, A, T, E**, SHIFT and ENTER Keys to access Calibration Menu.
18. Press 4 on DATA ENTRY Keypad (29) to access METER CAL MODULATION Screen.
19. Press ENTER Key to highlight Proper Reading data field.
20. Use DATA ENTRY Keypad (29) to enter value displayed on Measuring Receiver into data field. Press ENTER Key.
21. Verify modulation reading is within 5% of Full Scale ( $\pm 1$  Count) of reading on Measuring Receiver.
22. Press "Ret" Soft Function Key F5 and "ESC" Soft Function Key F6 to terminate procedure.
23. Remove power from FM/AM-1600S and disconnect test equipment.

### 3-8-11 PHASE METER CALIBRATION

PREREQUISITES: 3-8-1 Power Supply Calibration  
3-8-8 FM Calibration

EQUIPMENT REQUIRED: 1 Measuring Receiver  
1 Power Splitter  
1 RF Signal Generator (HP8640B)  
2 Coaxial Cables (BNC-BNC)

FIGURE REFERENCES: Figure 3-16

- | STEP | PROCEDURE  |
|------|--|
| 1.   | Apply power to FM/AM-1600S. Allow 5 minute warm-up period. Insure IFR Logo, with no error message, is displayed on CRT (26). |
| 2.   | Connect Power Splitter to Signal Generator RF Output (Figure 3-17).  |

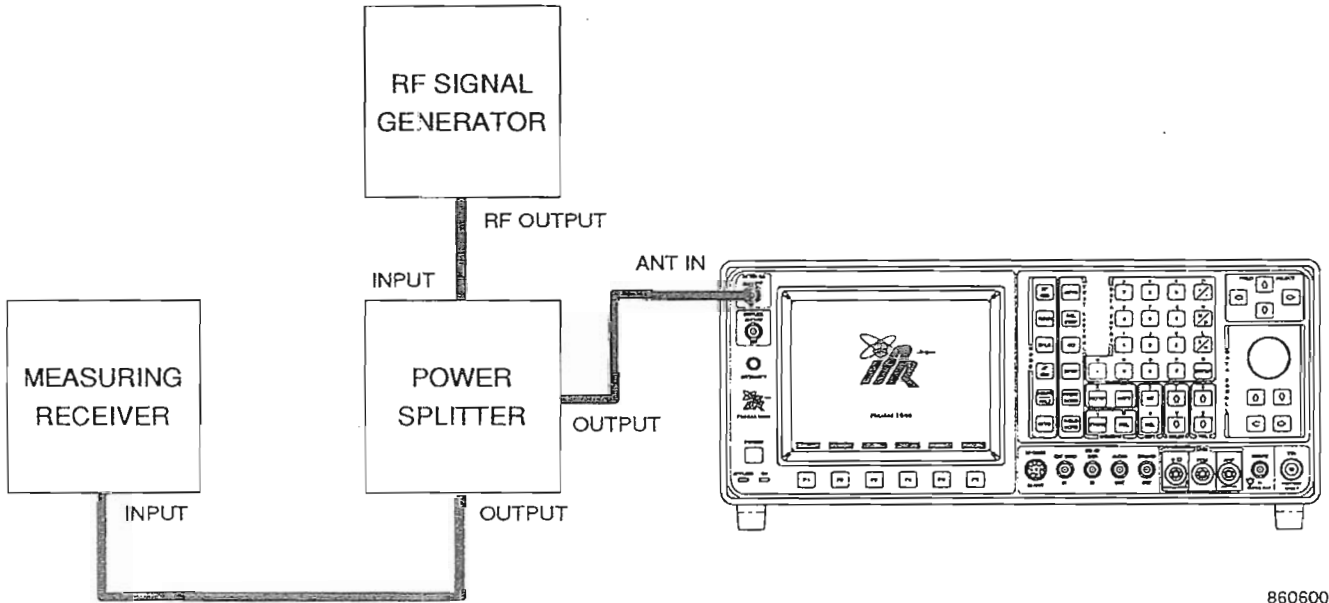

8606006

Figure 3-16 Phase Meter Calibration Test Set

3. Set Signal Generator output for 121.100000 MHz at 0 dBm with 6 kHz of deviation and 1 kHz rate.
4. Connect Measuring Receiver input to one output on Power Splitter and ANTENNA IN Connector (25) to other output on Power Splitter (Figure 3-16).

5. Set Measuring Receiver controls as follows:

CONTROL	SETTING
Detector	Peak+
Low-Pass Filter	15 kHz
Measurement	$\phi$ M (Phase)

6. Press RCVR MODE Key (27). Receive Operation Screen is displayed on CRT (26).
7. Use FIELD SELECT Keys (1) to move cursor to RF. Press ENTER Key to highlight data field.
8. Use DATA ENTRY Keypad (29) to set data field to **121.1000 MHz**. Press ENTER Key.
9. Use FIELD SELECT Keys (1) to move cursor to RF IN field. Use DATA ENTRY Keypad (29) to set data field to **ANT**.
10. Use FIELD SELECT Keys (1) to move cursor to RF ATTN field and press ENTER Key to highlight data field.
11. Use DATA SCROLL Keys (3) to set data field to **40 dB**. Press ENTER Key.
12. Use FIELD SELECT Keys (1) to move cursor to MOD. Press ENTER Key to highlight data field.
13. Use DATA SCROLL Keys (3) to set data field to **PM**. Press ENTER Key
14. Verify phase reading is within 3% ( $\pm 1$  Count) of reading on Measuring Receiver.
15. Press SETUP Key and "AUX" Soft Function Key F6. Auxiliary Functions Menu is displayed on CRT (26) and "1. Calibration Menu" Selection is highlighted.
16. Press ENTER Key. Password Window is displayed. Use DATA ENTRY Keypad (29) to press SHIFT, **C, S, M, A, T, E**, SHIFT and ENTER Keys to access Calibration Menu.
17. Press 9 on DATA ENTRY Keypad (29) to access Phase Meter submenu.
18. Use ENTER Key to highlight Proper Reading field. Use DATA ENTRY Keypad (29) to enter value displayed on Measuring Receiver into data field. Press ENTER Key.
19. Press "Ret" Soft Function Key F5 and "ESC" Soft Function Key F6 to terminate procedure.
20. Set Signal Generator output for 8.5 kHz deviation.



21. Set Measuring Receiver controls for following:

CONTROL	SETTING
Detector	RMS
Low-Pass Filter	15 kHz
Measurement	$\phi$ M (Phase)

22. Press MTRS Key to select METERS Operation Mode. Use FIELD SELECT Keys (1) to highlight "13. Phase Meter (RMS)" field. Press ENTER Key to access Phase Meter (RMS).
23. Verify Phase Meter (RMS) reading matches Measuring Receiver reading ( $\pm 10\% \pm 1$  count). If in tolerance, continue with step 29.
24. Press "AUX" Soft Function Key F6. Auxiliary Functions Menu is displayed on CRT (26) and "1. Calibration Menu" Selection is highlighted.
25. Press ENTER Key. Password Window is displayed. Use DATA ENTRY Keypad (29) to press SHIFT, **C**, **S**, **M**, **A**, **T**, **E**, SHIFT and ENTER Keys to access Calibration Menu.
26. Use FIELD SELECT Keys (1) to move cursor to "10 Phase Meter (RMS) " field.
27. Press ENTER Key. Enter value displayed on Measuring Receiver into data field using DATA ENTRY Keypad (29). Press ENTER Key.
28. Press "Ret" Soft Function Key F5 and "ESC" Soft Function Key F6.
29. Remove power from FM/AM-1600S and disconnect test equipment.

### 3-8-12 DISTORTION METER CALIBRATION

PREREQUISITES: 3-8-1 Power Supply Calibration  
3-8-4 Func Gen Level And VRMS Meter Calibration

EQUIPMENT REQUIRED: 1 Audio Analyzer  
2 Coaxial Cables (BNC-BNC)  
1 BNC Tee Connector

FIGURE REFERENCES: Figure 3-17

STEP	PROCEDURE
1.	Apply power to FM/AM-1600S. Allow 5 minute warm-up period. Insure IFR Logo, with no error message, is displayed on CRT (26).
2.	Connect Test Equipment as follows (Figure 3-17): <ol style="list-style-type: none"><li>Connect BNC Tee Connector to AUDIO OUT Connector (14).</li><li>Connect Audio Analyzer to one side of BNC Tee Connector.</li><li>Connect Coaxial Cable to other side of BNC Tee Connector and SINAD/BER IN Connector (15).</li></ol>

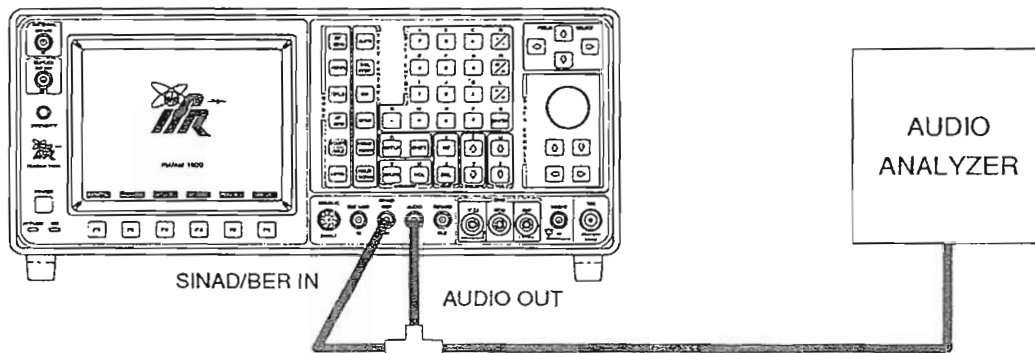

8606007

Figure 3-7 Distortion Meter Calibration Test Setup

- Set Audio Analyzer to DIST and Low-Pass Filter to 80 kHz.
- Press AF GEN MODE Key (27). AF Generator Operation Screen is displayed on CRT (26).
- Press SETUP Key to access AF Generator Menu.
- Use 5 on DATA ENTRY Keypad (29) to highlight "AF Output Setup" submenu.
- Press 1 on DATA ENTRY Keypad (29) to set "1. To Audio Out Conn" to **On**.
- Press 5 on DATA ENTRY Keypad (29) to set "5. Proportional Output" to **On**.

9. Press AF GEN MODE Key (27) to return to AF Generator Operation Screen.
10. Use FIELD SELECT Keys (1) to move cursor to GEN 1. Press ENTER Key to highlight data field. Use DATA SCROLL Keys (3) to enter **100%** into data field. Press ENTER Key.
11. Use FIELD SELECT Keys (1) to move cursor to WAVE. Press ENTER Key to highlight data field. Use DATA SCROLL Keys (3) to enter **Sine** into data field. Press ENTER Key.
12. Use FIELD SELECT Keys (1) to move cursor to AF. Press ENTER Key to highlight data field. Use DATA SCROLL Keys (3) to enter **1000.0 Hz** into data field. Press ENTER Key.
13. Use FIELD SELECT Keys (1) to move cursor to GEN2. Press ENTER Key to highlight data field. Use DATA SCROLL Keys (3) to enter **10%** into data field. Press ENTER Key.
14. Use FIELD SELECT Keys (1) to move cursor to WAVE. Press ENTER Key to highlight data field. Use DATA SCROLL Keys (3) to enter **Sine** into data field. Press ENTER Key.
15. Use FIELD SELECT Keys (1) to move cursor to AF. Press ENTER Key to highlight data field. Use DATA SCROLL Keys (3) to enter **2400.0 Hz** into data field. Press ENTER Key.
16. Use FIELD SELECT Keys (1) to move cursor to MIC. Press ENTER Key to highlight data field. Use DATA SCROLL Keys (3) to set data field to **Off**. Press ENTER Key.
17. Use FIELD SELECT Keys (1) to move cursor to EXT. Press ENTER Key to highlight data field. Use DATA SCROLL Keys (3) to set data field to **Off**. Press ENTER Key.
18. Use FIELD SELECT Keys (1) to move cursor to LEVEL. Press ENTER Key to highlight data field. Use DATA SCROLL Keys (3) to set data field to **1.0000 V**. Press ENTER Key.

**NOTE:** To center waveform on CRT (26), select "Vert" Soft Function Key F3. Use DATA SCROLL Spinner (2) to center waveform.

19. Press MTRS Key to access Meter Menu.
20. Use 6 on DATA ENTRY Keypad (29) to access "DISTORTION METER" submenu.
21. Use FIELD SELECT Keys (1) to move cursor to INPUT. Press ENTER Key to highlight data field. Use DATA SCROLL Keys (3) to set data field to **SINAD/BER**. Press ENTER Key.
22. Use FIELD SELECT Keys (1) to move cursor to NOTCH FREQ. Use DATA ENTRY Keys to set data field to **1 kHz**. Press ENTER Key.
23. Press SETUP Key to access Distortion Meter Menu.
24. Use FIELD SELECT Keys (1) to move cursor to FILTER. Press ENTER Key to select Low Pass. "Low Pass Filter Freq" field appears. Use DATA ENTRY Keypad (29) to enter **4.000 kHz** frequency. Press "Ret" Soft Function Key F5.
25. Verify distortion reading is within  $\pm 0.5\%$  ( $\pm 1$  Count) of reading on Audio Analyzer. If reading is within tolerance, continue at step 30.
26. Press SETUP Key and "AUX" Soft Function Key F6. Auxiliary Functions Menu is displayed on CRT (26) and "1. Calibration Menu" Selection is highlighted.



**STEP****PROCEDURE**

---

27. Press ENTER Key. Password Window is displayed. Use DATA ENTRY Keypad (29) to press SHIFT, **C**, **S**, **M**, **A**, **T**, **E**, SHIFT and ENTER Keys to access Calibration Menu.
28. Press 5 on DATA ENTRY Keypad (29) to access Distortion Meter submenu. Press ENTER Key to highlight "Proper Reading" Field.
29. Use DATA ENTRY Keypad (29) to enter value displayed on Audio Analyzer into "Proper Reading" data field. Press ENTER Key.
30. Proceed at step 24.
31. Press "Ret" Soft Function Key F5 and "ESC" Soft Function Key F6 to terminate procedure.
32. Remove power from FM/AM-1600S and disconnect test equipment.

### 3-8-13 SINAD METER CALIBRATION

PREREQUISITES: 3-8-1 Power Supply Calibration  
3-8-4 Func Gen Level And VRMS Meter Calibration

EQUIPMENT REQUIRED: 1 Audio Analyzer  
2 Coaxial Cables (BNC-BNC)  
1 BNC Tee Connector

FIGURE REFERENCES: Figure 3-18

STEP	PROCEDURE
------	-----------

1. Apply power to FM/AM-1600S. Allow 5 minute warm-up period. Insure IFR Logo, with no error message, is displayed on CRT (26).
2. Connect Test Equipment as follows (Figure 3-18):
  - a. Connect BNC Tee Connector to AUDIO OUT Connector (14).
  - b. Connect Audio Analyzer to one side of BNC Tee Connector.
  - c. Connect Coaxial Cable to other side of BNC Tee Connector and SINAD/BER IN Connector (15).

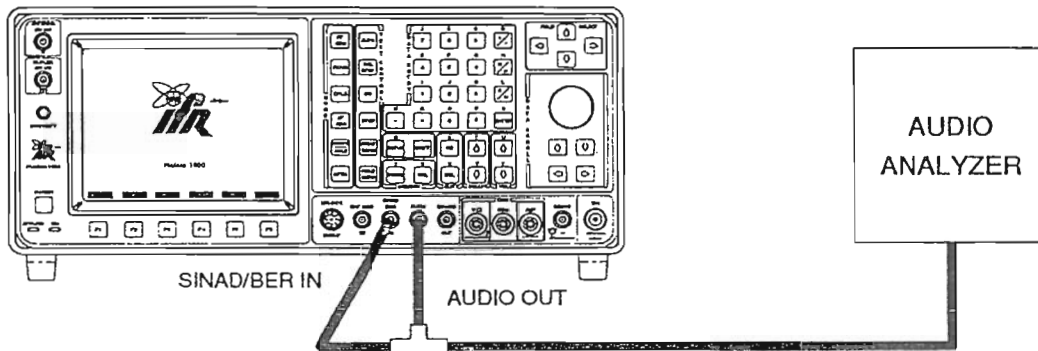

8606008

Figure 3-18 SINAD Meter Calibration Test Setup

3. Set Audio Analyzer controls as follows:

CONTROL	SETTING
Measurement	SINAD
Low-Pass Filter	80 kHz
Frequency	1000 Hz

4. Press AF GEN MODE Key (27). AF Generator Operation Screen is displayed on CRT (26).
5. Press SETUP Key to access AF Generator Menu.
6. Press 5 on DATA ENTRY Keypad (29) to highlight "AF Output Setup" submenu.

## STEP

## PROCEDURE

7. Press 1 on DATA ENTRY Keypad (29) to set "1. To Audio Out Conn" to **On**.
8. Press 5 on DATA ENTRY Keypad (29) to set "5. Proportional Output" to **On**.
9. Press AF GEN MODE Key (27) to return to AF Generator Operation Screen.
10. Use FIELD SELECT Keys (1) to move cursor to GEN 1. Press ENTER Key to highlight data field. Use DATA SCROLL Keys (3) to enter **100%** into data field. Press ENTER Key.
11. Use FIELD SELECT Keys (1) to move cursor to WAVE. Press ENTER Key to highlight data field. Use DATA SCROLL Keys (3) to enter **Sine** into data field. Press ENTER Key.
12. Use FIELD SELECT Keys (1) to move cursor to AF. Press ENTER Key to highlight data field. Use DATA SCROLL Keys (3) to enter **1000.0 Hz** into data field. Press ENTER Key.
13. Use FIELD SELECT Keys (1) to move cursor to GEN2. Press ENTER Key to highlight data field. Use DATA SCROLL Keys (3) to enter test value into data field. Use 32% test value for 10 dB SINAD test and 25% test value for 12 dB SINAD test. Press ENTER Key.
14. Use FIELD SELECT Keys (1) to move cursor to WAVE. Press ENTER Key to highlight data field. Use DATA SCROLL Keys (3) to enter **Sine** into data field. Press ENTER Key.
15. Use FIELD SELECT Keys (1) to move cursor to AF. Press ENTER Key to highlight data field. Use DATA ENTRY Keypad (29) to enter **2400.0 Hz** into data field. Press ENTER Key.
16. Use FIELD SELECT Keys (1) to move cursor to MIC. Press ENTER Key to highlight data field. Use DATA SCROLL Keys (3) to set data field to **Off**. Press ENTER Key.
17. Use FIELD SELECT Keys (1) to move cursor to EXT. Press ENTER Key to highlight data field. Use DATA SCROLL Keys (3) to set data field to **Off**. Press ENTER Key.
18. Use FIELD SELECT Keys (1) to move cursor to LEVEL. Press ENTER Key to highlight data field. Use DATA SCROLL Keys (3) to set data field to **1.0000 V**. Press ENTER Key.  
**NOTE:** To center waveform on CRT (26), select "Vert" Soft Function Key F3. Use Spinner Control to center waveform. Press ENTER Key.
19. Press MTRS MODE Key to access Meter Menu.
20. Press 7 on DATA ENTRY Keypad (29) to access "SINAD METER" submenu.
21. Press SETUP Key. Use FIELD SELECT Keys (1) to move cursor to "10. Readout Res.". Press ENTER Key to toggle data field until **.1 dB** is displayed. Press "Ret" Soft Function Key F5.
22. Use FIELD SELECT Keys (1) to move cursor to INPUT. Press ENTER Key to highlight data field. Use DATA SCROLL Keys (3) to set data field to **SINAD/BER**. Press ENTER Key.
23. Use FIELD SELECT Keys (1) to move cursor to Set Filter Freq. Press ENTER Key to set data field to **1 kHz**.

## STEP

## PROCEDURE

- 
24. Use FIELD SELECT Keys (1) to "Low Pass Filter Freq" field appears. Use DATA ENTRY Keypad (29) to enter **4.000 kHz** frequency.
  25. Verify SINAD reading is within  $\pm 1$  dB ( $\pm 1$  Digit) of reading on Audio Analyzer. If reading is within tolerance, continue at step 30.
  26. Press SETUP Key and "AUX" Soft Function Key F6. Auxiliary Functions Menu is displayed on CRT (26) and "1. Calibration Menu" Selection is highlighted.
  27. Press ENTER Key. Password Window is displayed. Use DATA ENTRY Keypad (29) to press SHIFT, **C, S, M, A, T, E**, SHIFT and ENTER Keys to access Calibration Menu.
  28. Press 6 on DATA ENTRY Keypad (29) to access SINAD Meter submenu. Press ENTER Key to highlight "Proper Reading" field.
  29. Use DATA ENTRY Keypad (29) to enter value displayed on Audio Analyzer into "Proper Reading" data field.
  30. Proceed at step 24.
  31. Press "Ret" Soft Function Key F5 and "ESC" Soft Function Key F6 to terminate procedure.
  32. Remove power from FM/AM-1600S and disconnect test equipment.

### 3-8-14 GEN MODULATION CALIBRATION

- PREREQUISITES:
- 3-8-1 Power Supply Calibration
  - 3-8-2 VCXO Calibration
  - 3-8-3 Metering DVM Calibration
  - 3-8-4 Func Gen Level And VRMS Meter Calibration
  - 3-8-5 Gen Output Level Calibration
  - 3-8-8 FM Calibration
  - 3-8-9 Deviation Meter Calibration
  - 3-8-10 Modulation Meter Calibration

EQUIPMENT REQUIRED: 1 Measuring Receiver with Sensor Power Head

FIGURE REFERENCES: Figure 3-2

STEP	PROCEDURE								
1.	Apply power to FM/AM-1600S. Allow 5 minute warm-up period. Insure IFR Logo, with no error message, is displayed on CRT (26).								
2.	Connect T/R Connector (6) to Measuring Receiver with Sensor Power Head.								
3.	Set Measuring Receiver controls as follows:								
	<table border="1"><thead><tr><th>CONTROL</th><th>SETTING</th></tr></thead><tbody><tr><td>Measurement</td><td>AM</td></tr><tr><td>Low-Pass Filter</td><td>15 kHz</td></tr><tr><td>Detector</td><td>Peak+</td></tr></tbody></table>	CONTROL	SETTING	Measurement	AM	Low-Pass Filter	15 kHz	Detector	Peak+
CONTROL	SETTING								
Measurement	AM								
Low-Pass Filter	15 kHz								
Detector	Peak+								
4.	Press RF GEN MODE Key (27). RF Generator Operation Screen is displayed on CRT (26).								
5.	Press Disp Soft Function Key F1.								
6.	Use FIELD SELECT Keys (1) to select "2. Full Anlz".								
7.	Press "Scan" Soft Function Key F5.								
8.	Use DATA SCROLL Keys (3) to select <b>1 kHz</b> . Press ENTER Key.								
9.	Use FIELD SELECT Keys (1) to move cursor to RF. Press ENTER Key to highlight data field.								
10.	Use DATA ENTRY Keypad (29) to set value in data field to <b>121.1000 MHz</b> . Press ENTER Key.								
11.	Use FIELD SELECT Keys (1) to move cursor to LEVEL. Press ENTER Key to highlight data field.								
12.	Use DATA ENTRY Keypad (29) to set data field to <b>0.0 dBm</b> .								
13.	Use FIELD SELECT Keys (1) to move cursor to SOURCE. Press ENTER Key to highlight data field.								
14.	Set all MOD fields to OFF.								

## STEP

## PROCEDURE

15. Record Peak Residual AM displayed on Measuring Receiver. Verify Peak Residual AM is <0.10%.
16. Use DATA SCROLL Keys (3) to set MOD field 1 to AM. Press ENTER Key.
17. Use FIELD SELECT Keys (1) to move cursor to MODULATION. Press ENTER Key to highlight data field.
18. Use DATA ENTRY Keypad (29) to set data field to **90%**. Press ENTER Key.
19. Use FIELD SELECT Keys (1) to move cursor to AF FREQ. Press ENTER Key to highlight data field.
20. Use DATA ENTRY Keypad (29) to set data field to **1000.0 Hz**. Press ENTER Key.
21. Use FIELD SELECT Keys (1) to move cursor to WAVE. Press ENTER Key to highlight data field.
22. Use DATA SCROLL Keys (3) to set data field to **Sine**. Press ENTER Key.
23. Verify AM Modulation reading on Measuring Receiver is within  $\pm 5\%$  of FM/AM-1600S setting less Peak Residual AM. If reading is within tolerance, continue at step 30.
24. Press SETUP Key and "AUX" Soft Function Key F6. Auxiliary Functions Menu is displayed on CRT (26) and "1. Calibration Menu" Selection is highlighted.
25. Press ENTER Key. Password Window is displayed. Use DATA ENTRY Keypad (29) to press SHIFT, **C, S, M, A, T, E**, SHIFT and ENTER Keys to access Calibration Menu.
26. Use DATA SCROLL Keys (3) to move cursor to "13. Gen Modulation". Press ENTER Key to access Gen Modulation Cal submenu.
27. Press 1 on DATA ENTRY Keypad (29) to highlight "AM Modulation (90%)" data field.
28. Use DATA SCROLL Keys (3) to set modulation reading on Measuring Receiver to "90%" plus Peak Residual AM reading recorded in step 15.  
**NOTE:** If AM Modulation setting is out of tolerance and adjustment range is <175 or >180, perform steps 28a and 28b.
  - a. Use DATA ENTRY Keypad (29) to set data field to **180**.
  - b. Adjust R28080 (AM MOD ADJ) (90 MHz Generator PC Board Assembly) (Figure 3-2), if necessary, to set modulation reading on Measuring Receiver to 90% plus Residual AM recorded in step 15.
29. Proceed at step 23.
30. Press RF GEN MODE Key (27). RF Generator Operation Screen is displayed on CRT (26).
31. Set Measuring Receiver to measure FM and activate 3 kHz low-pass filter.

STEP	PROCEDURE
32.	Use FIELD SELECT Keys (1) to move cursor to SOURCE. Press ENTER Key to highlight data field.
33.	Use DATA SCROLL Keys (3) to select <b>1</b> . Use DATA SCROLL Keys (3) to set MOD to <b>OFF</b> . Press ENTER Key.
34.	Record Peak Residual FM displayed on Measuring Receiver. Verify Residual FM is <140 Hz.
35.	Use DATA SCROLL Keys (3) to set MOD field to <b>FM</b> . Press ENTER Key.
36.	Use FIELD SELECT Keys (1) to move cursor to DEVIATION. Press ENTER Key to highlight data field.
37.	Use DATA ENTRY Keypad (29)s to set data field to <b>5.0 kHz</b> . Press ENTER Key.
38.	Use FIELD SELECT Keys (1) to move cursor to AF FREQ. Press ENTER Key to highlight data field.
39.	Use DATA ENTRY Keypad (29) to set data field to <b>905.8 Hz</b> , which selects 2nd Carrier Bessel Null.
40.	Verify 5 kHz deviation reading on Measuring Receiver is within 5% of deviation setting less Peak Residual FM. If deviation is within tolerance, continue at step 47.
41.	Press SETUP Key and "AUX" Soft Function Key F6. Auxiliary Functions Menu is displayed on CRT (26) and "1. Calibration Menu" Selection is highlighted.
42.	Press ENTER Key. Password Window is displayed. Use DATA ENTRY Keypad (29) to press SHIFT, <b>C, S, M, A, T, E</b> , SHIFT and ENTER Keys to access Calibration Menu.
43.	Use DATA SCROLL Keys (3) to move cursor to "13. Gen Modulation Cal". Press ENTER Key to highlight data field.
44.	Press 2 on DATA ENTRY Keypad (29) to select "2. FM Deviation (20 kHz)".
45.	Use DATA SCROLL Keys (3) to set FM Deviation on Measuring Receiver to 20 kHz plus Peak Residual FM reading recorded in step 34.
<b>NOTE:</b> If FM Modulation setting is out of tolerance and adjustment range is <195 or >205, perform steps 45a and 45b.	
a.	Use DATA ENTRY Keypad (29) to set data field to <b>200</b> .
b.	Press RF GEN MODE Key (27). Adjust, as necessary, R28014 (FM MOD ADJ) on 90 MHz Generator PC Board Assembly (Figure 3-2) for minimum amplitude of carrier (<-35 dBc on Analyzer Display).
46.	Proceed at step 40.
47.	Press SETUP Key and "AUX" Soft Function Key F6. Auxiliary Functions Menu is displayed on CRT (26) and "1. Calibration Menu" Selection is highlighted.

## STEP

## PROCEDURE

48. Press ENTER Key. Password Window is displayed. Use DATA ENTRY Keypad (29) to press SHIFT, **C, S, M, A, T, E**, SHIFT and ENTER Keys to access Calibration Menu.
  49. Use DATA SCROLL Keys (3) to move cursor to "13. Gen Modulation Cal". Press ENTER Key to highlight data field.
  50. Use FIELD SELECT Keys (1) to move cursor to "3. FM Deviation (80 kHz)".
  51. Use DATA SCROLL Keys (3) to set FM Deviation on Measuring Receiver to 80 kHz plus Peak Residual FM reading recorded in step 35. Press ENTER Key.
  52. Verify 80 kHz deviation reading on Measuring Receiver is within 5% of deviation setting less Peak Residual FM. If deviation is within tolerance, continue at step 54.
- NOTE:** If FM Modulation setting is out of tolerance and adjustment range is <195 or >205, 90 MHz PC Board Assembly is defective. Remove power from FM/AM-1600S, repair 90 MHz Generator Assembly and continue with step 53.
53. Use DATA ENTRY Keypad (29) to set data field to **200** and proceed at step 1.
  54. Press RF GEN MODE Key (27). RF Generator Operation Screen is displayed on CRT (26).
  55. Set Measuring Receiver controls as follows:

CONTROL	SETTING
Measurement	PM
High-Pass Filter	300 Hz
Low-Pass Filter	3 kHz

56. Use FIELD SELECT Keys (1) to move cursor to SOURCE. Press ENTER Key to highlight data field.
57. Use DATA SCROLL Keys (3) to select 1. Use DATA SCROLL Keys (3) to set to **OFF**. Press ENTER Key.
58. Record Residual PM displayed on Measuring Receiver. Verify Residual PM is <.05 Rad peak.
59. Use DATA SCROLL Keys (3) to set MOD field to **PM**. Press ENTER Key.
60. Use FIELD SELECT Keys (1) to move cursor to MODULATION. Press ENTER Key to highlight data field.
61. Use DATA ENTRY Keypad (29) to set data field to **6.0 Rad**. Press ENTER Key.
62. Verify 6 Rad reading on Measuring Receiver is within 5% of Rad setting less Residual PM reading from step 58. If within tolerance, continue at step 70.
63. Press SETUP Key. Press "AUX" Soft Function Key F6. Auxiliary Functions Menu is displayed with cursor over "1. Calibration".



**STEP****PROCEDURE**

---

64. Press ENTER Key. Password Window is displayed. Use DATA ENTRY Keypad (29) to press SHIFT, **C**, **S**, **M**, **A**, **T**, **E**, SHIFT and ENTER Keys to access Calibration Menu.
65. Use DATA SCROLL Keys (3) to move cursor to "13. Gen Modulation Cal". Press ENTER Key to highlight data field.
66. Press 4 on DATA ENTRY Keypad (29) to select "4. Phase Modulation (6 Rad)".
67. Use DATA SCROLL Keys (3) to adjust data value until Phase Modulation on Measuring Receiver is 6 Rad plus Residual PM recorded in step 58. Press ENTER Key.
68. Press "ESC" Soft Function Key F6 twice to terminate procedure.
69. Proceed at step 62.
70. Remove power from FM/AM-1600S and disconnect test equipment.

### 3-8-15 SCOPE CALIBRATION

PREREQUISITES: 3-8-1 Power Supply Calibration  
3-8-4 Func Gen Level And VRMS Meter Calibration

EQUIPMENT REQUIRED: 1 Digital Multimeter (DMM)  
1 Extender Board (7010-7839-900)  
1 BNC Tee Connector  
1 150  $\Omega$  Load  
2 Coaxial Cables (BNC-BNC)

FIGURE REFERENCES: Figure 3-19  
Figure 3-20

STEP	PROCEDURES
1.	Remove Digitizer PC Board Assembly (4-3-3). Install Extender Board. Install Digitizer PC Board on Extender Board.
2.	Apply power to FM/AM-1600S. Allow 5 minute warm-up period. Insure IFR Logo Menu, with no error message, is displayed on CRT (26).
3.	Press SCOPE/ANLZ Key. Oscilloscope Operation Screen is displayed with cursor over SCOPE.  <b>NOTE:</b> If Analyzer Operation Screen is displayed, press SCOPE/ANLZ MODE Key to access Oscilloscope Operation Screen.
4.	Connect DMM positive lead to TP69004 (Figure 3-19) and negative lead to TP69016 (Figure 3-19).
5.	Use FIELD SELECT Keys (1) to move cursor to INPUT. Press ENTER Key to highlight data field.
6.	Press 9 on DATA ENTRY Keypad (29) to set data field to <b>GND</b> .
7.	Press "Scale" Soft Function Key F1 to select Scale data field.
8.	Use DATA SCROLL Keys (3) to set data field to <b>10 mV</b> . Press ENTER Key.
9.	Adjust, if needed, R69044 (Figure 3-19) for 0.000 Vdc ( $\pm 0.01$ V) on DMM.
10.	Press ENTER Key to highlight "Scale" data field. Use DATA SCROLL Keys (3) to set data field to <b>2mV</b> . Press ENTER Key.
11.	Adjust, if needed, R69039 (Figure 3-19) for 0.000 Vdc ( $\pm 0.01$ V) on DMM.
12.	Connect BNC Tee Connector to SCOPE IN Connector (7).
13.	Connect Coaxial Cable between BNC Tee Connector and AUDIO OUT Connector (14). Connect other Coaxial Cable between BNC Tee Connector and DMM input through 150 $\Omega$ Load (Figure 3-20).
14.	Press AF GEN MODE Key (27). AF Generator Operation Screen is displayed with cursor over GEN1.

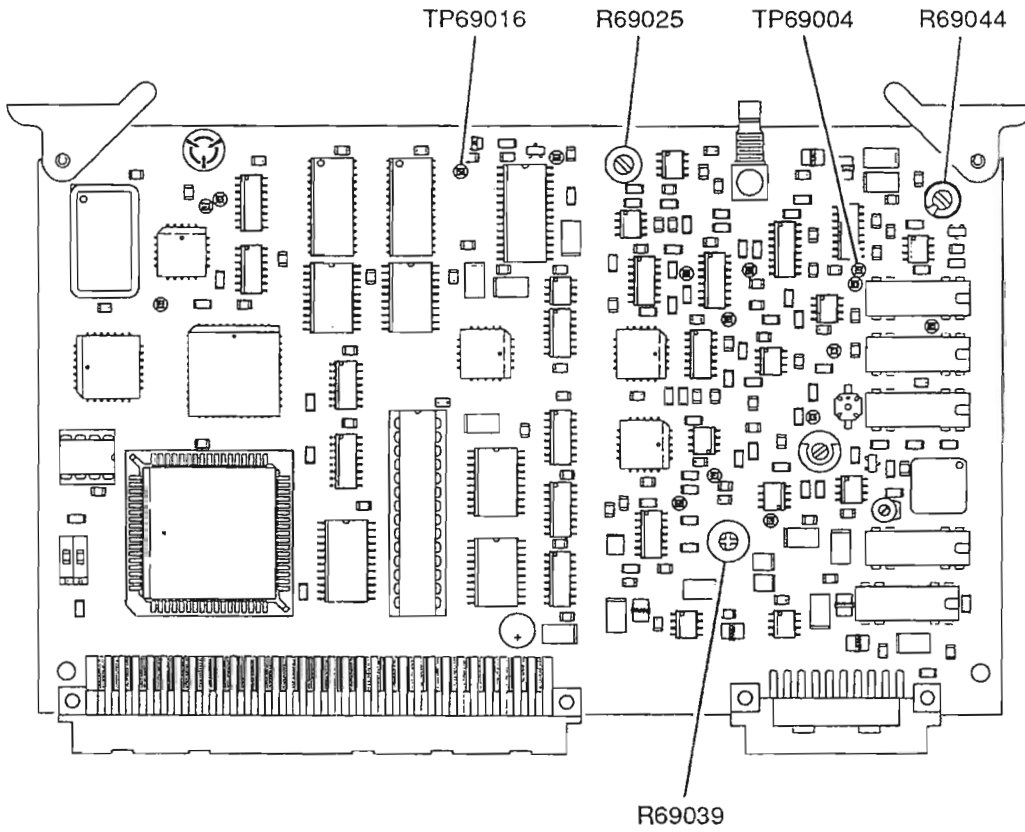

8607165

Figure 3-19 Digitizer PC Board Assembly Calibration Points

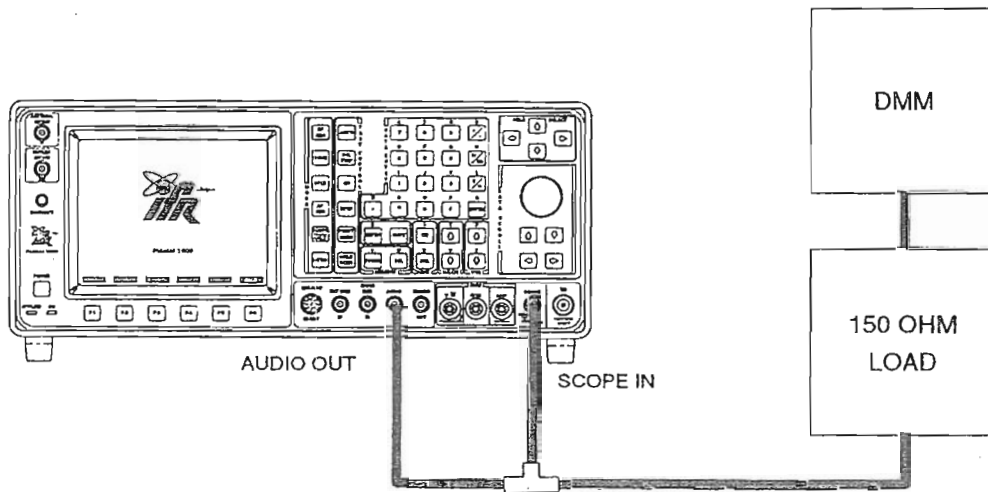

8606010

Figure 3-20 Oscilloscope Calibration Setup

## STEP

## PROCEDURES

15. Press SETUP Key to access AF Generator Menu. Press 5 on DATA ENTRY Keypad (29) to access data field.
16. Press 5 DATA ENTRY Keypad (29) to select Proportional Output. Press ENTER Key to set Proportional Output data field to **Off**.
17. Press "ESC" Soft Function Key F6 and AF GEN MODE Key (27) to return to AF Generator Operation Screen with cursor over GEN1.
18. Press ENTER Key to set GEN1 data field to **On**.
19. Use FIELD SELECT Keys (1) to move cursor to WAVE. Press ENTER Key to set data field to **Sine**.
20. Use FIELD SELECT Keys (1) to move cursor to AF. Press ENTER Key to highlight data field.
21. Use DATA ENTRY Keypad (29) to set data field to **1000.0 Hz**. Press ENTER Key.
22. Use FIELD SELECT Keys (1) to move cursor to GEN2. Press ENTER Key to set data field to **Off**.
23. Use FIELD SELECT Keys (1) to move cursor to LEVEL. Press ENTER Key to highlight data field.
24. Use DATA ENTRY Keypad (29) to set data field to **0.0424 V**. Press ENTER Key.
25. Use DATA SCROLL Keys (4) to move cursor to least significant digit.
26. Use DATA SCROLL Keys (3) to adjust output for 42.43 mVrms ( $\pm 0.12$  mV) on DMM. Press ENTER Key.
27. Press **SCOPE/ANLZ** Key. SCOPE Operation Screen is displayed on CRT (26).
28. Use FIELD SELECT Keys (1) to move cursor to Scale. Press ENTER Key to highlight data field.
29. Use DATA SCROLL Keys (3) to set data field to **20 mV**. Press ENTER Key.
30. Use FIELD SELECT Keys (1) to move cursor to INPUT. Press ENTER Key to access submenu.
31. Press 7 on DATA ENTRY Keypad (29) to set data field to **AC**.
32. Use FIELD SELECT Keys (1) to move cursor to Sweep. Press ENTER Key to highlight data field.
33. Use DATA SCROLL Keys (3) to set data field to **100  $\mu$ s**. Press ENTER Key.
34. Use FIELD SELECT Keys (1) to move cursor to VERT. Press ENTER Key.
35. Use DATA SCROLL Keys (3) or DATA SCROLL Spinner (2) to center waveform. Press ENTER Key.

36. Use FIELD SELECT Keys (1) to move cursor to HORIZ. Press ENTER Key to highlight data field.
37. Use DATA ENTRY Keypad (29) to set data field to **0 div**. Press ENTER Key.
38. Use FIELD SELECT Keys (1) to move cursor to TRIG. Press ENTER Key to highlight data field.
39. Use DATA SCROLL Keys (3) to set data field to Auto. Press ENTER Key.
40. Use FIELD SELECT Keys (1) to move cursor to TRIG LVL. Press ENTER Key.
41. Use DATA SCROLL Keys (3) or DATA SCROLL Spinner (2) to position trace start on center graticule.
42. Verify one cycle is displayed on CRT (26). Press ENTER Key.
43. Press "More" Soft Function Key F6 until "Mkr1" Soft Function Key F1 appears.
44. Press "Mkr1" Soft Function Key F3. Use FIELD SELECT Keys (1) to move cursor to MARKER. Press ENTER Key to highlight data field. Use DATA ENTRY Keypad (29) to set data field to **250.000**.
45. Select "Mkr2" Soft Function Key F4. Use FIELD SELECT Keys (1) to move cursor to MARKER. Press ENTER Key to highlight data field. Use DATA ENTRY Keypad (29) to set data field to **750.000**.
46. Verify DELTA is **500  $\mu$ s** and **120 mV** ( $\pm 8$  mV). Adjust, if necessary, R69025 (Figure 3-19).
47. Remove power from FM/AM-1600S, disconnect test equipment and reinstall Digitizer PC Board Assembly.

## 3-8-16 SPECTRUM ANALYZER CALIBRATION

PREREQUISITES: 3-8-1 Power Supply Calibration  
3-8-14 Scope Calibration

EQUIPMENT REQUIRED: 1 RF Signal Generator (HP8640B)  
1 Extender Board (7010-7839-600)  
1 Coaxial Cable (BNC-BNC)  
1 Coaxial Cables (SMB-SMB)

FIGURE REFERENCES: Figure 3-2  
Figure 3-21

STEP	PROCEDURE
1.	Disconnect P/J16003 (Figure 3-2) from Analyzer Log/IF Assembly (Figure 3-2).
2.	Remove Analyzer Log/IF Assembly from FM/AM-1600S (4-3-5).
3.	Remove Cover from Analyzer Log/IF Assembly and install Analyzer Log/IF PC Board Assembly on Extender Board.
4.	Install Extender Board in FM/AM-1600S.
5.	Install SMB-SMB coaxial cable in place of Coaxial Cable 25 (Figure 5-1).
6.	Apply power to FM/AM-1600S. Allow 5 minute warm-up period. Insure IFR Logo, with no error message, is displayed on CRT (26).
7.	Press SCOPE/ANLZ MODE Key. Analyzer Operation Screen is displayed on CRT (26). <b>NOTE:</b> If SCOPE Operation Screen is displayed, press SCOPE/ANLZ MODE Key to access Analyzer Operation Screen.
8.	Set Signal Generator output frequency to 500 MHz at -40 dBm without modulation.
9.	Connect Signal Generator to ANTENNA IN Connector (25).
10.	Press SETUP Key. Scope/Analyzer Menu is displayed.
11.	Press 2 on DATA ENTRY Keypad (29) to turn Analyzer <b>On</b> .
12.	Press 4 on DATA ENTRY Keypad (29) to access Analyzer Setup Menu.
13.	Press ENTER Key to access "1. Scale" data field. Use DATA SCROLL Keys (3) to select <b>dBm</b> . Press ENTER Key.
14.	Use FIELD SELECT Keys (1) to move cursor to "12. RF Mode". Press ENTER Key to select <b>Direct</b> .
15.	Press 2 on DATA ENTRY Keypad (29). Press ENTER Key to access "2. Frequency" data field. Use DATA ENTRY Keypad (29) to enter <b>500 MHz</b> . Press ENTER Key.

## STEP

## PROCEDURE

16. Press 3 on DATA ENTRY Keypad (29). Press ENTER Key to select **Antenna** for "3. Rcvr Input" data field.
17. Press 4 on DATA ENTRY Keypad (29). Press ENTER Key to access "4. Input Atten" data field. Use DATA SCROLL Keys (3) to select **0 dBm**. Press ENTER Key.
18. Press 5 on DATA ENTRY Keypad (29). Press ENTER Key to select **10 dB** for "5. Range" data field.
19. Press 6 on DATA ENTRY Keypad (29). Press ENTER Key to access "6. Scan Width" data field. Use DATA SCROLL Keys (3) to select **20 kHz**. Press ENTER Key.
20. Press 7 on DATA ENTRY Keypad (29). Press ENTER Key to select **Off** for "7. Track Gen" data field.
21. Use FIELD SELECT Keys (1) to move cursor to "11. Mode" data field. Press ENTER Key to access "11. Mode" data field. Use DATA SCROLL Keys (3) to select **Live**. Press ENTER Key.
22. Press SCOPE/ANLZ MODE Key. Analyzer Operation Screen is displayed on CRT (26).  
**NOTE:** If Scope Operation Screen is displayed, press SCOPE/ANLZ Key to access Analyzer Operation Screen.
23. Adjust R17011 (ANLZR CENTER) on Analyzer RF PC Board Assembly (Figure 3-2), as needed, to center trace on Analyzer Operation Screen.
24. Use FIELD SELECT Keys (1) to move cursor to Scan Width Data Field. Press ENTER Key.
25. Alternate Scan Width between **20 kHz** and **200 kHz**, making adjustments to R17011 (ANLZR CENTER) on Analyzer RF PC Board Assembly (Figure 3-2), as needed, to minimize centering error.
26. Set Scan Width to **1 kHz**. Press ENTER Key.
27. Verify trace is centered on center graticule ( $\pm 1$  Minor Division). If trace is within tolerance, continue with step 33.
28. Press SETUP Key. Press "AUX" Soft Function Key F6. Auxiliary Functions Menu is displayed with cursor over "1. Calibration".
29. Press ENTER Key. Password Window is displayed. Use DATA ENTRY Keypad (29) to press SHIFT, **C**, **S**, **M**, **A**, **T**, **E**, SHIFT and ENTER Keys to access Calibration Menu.
30. Use DATA SCROLL Keys (3) to move cursor to "16. Anlz Horz Offset". Press ENTER Key to access "Points Offset" data field.
31. Use DATA ENTRY Keypad (29) to enter **35** in "Points Offset" data field. Press ENTER Key.
32. Proceed at step 27
33. Use FIELD SELECT Keys (1) to move cursor to Scan Width Data Field. Press ENTER Key. Set Scan Width to **2 MHz**. Press ENTER Key.

34. Adjust R17028 (DISP ADJ) (Analyzer RF PC Board Assembly) (Figure 3-2), as needed, for display of one peak on display with no loss in signal level.
35. Set Signal generator to 500 MHz at -40 dBm with no modulation.  
**NOTE:** User may select desired frequency.
36. Verify center frequency peak is -40 dBm ( $\pm 4$  dB) on CRT (26). Adjust R15005 (Figure 3-21) if necessary.

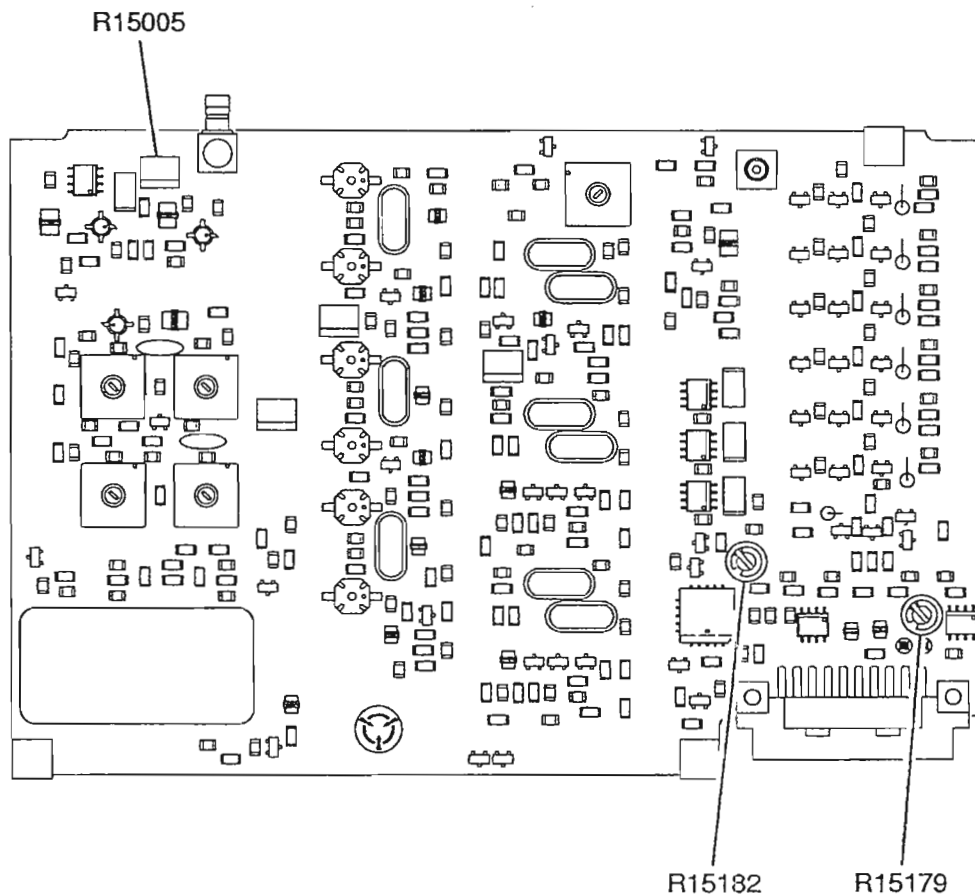

8607166

Figure 3-21 Analyzer Log/IF Assembly Calibration Points

37. Use FIELD SELECT Keys (1) to move cursor to Scan Width field. Press ENTER Key to highlight data field.
38. Use DATA SCROLL Keys (3) to step through all Scan Width settings. Verify center frequency peak level, between all ranges, varies  $< 2$  dB.



39. If particular Scan Width is not within tolerance, adjust appropriate Resolution Bandwidth filter Trimpot identified on top of Analyzer Log/IF Assembly and repeat step 38.

<u>Scan Width</u>	<u>Resolution Bandwidth</u>
1 MHz	300 kHz
500 kHz	30 kHz
200 kHz	30 kHz
100 kHz	30 kHz
50 kHz	30 kHz
20 kHz	3 kHz
10 kHz	3 kHz
5 kHz	3 kHz
2 kHz	300 Hz
1 kHz	300 Hz

40. Set Scan Width to **5 kHz**. Press **ENTER** Key.
41. Set Signal Generator for -30 dBm. Note level on Spectrum Analyzer Operation Screen.
42. Step Signal Generator from -30 dBm to -90 dBm. Verify each 10 dB step on FM/AM-1600S decreases level 10 dB ( $\pm 2$  dB). If in tolerance, go to step 45.
43. Set Signal Generator for -40 dBm output. Adjust R15179 (Figure 3-21), as needed, for proper display.
44. Set Signal Generator for -90 dBm output. Adjust R15182 (Figure 3-21), as needed, for proper display.
45. Proceed at step 41.
46. Remove power from FM/AM-1600S. Disconnect accessory test equipment. Reinstall Analyzer Log/IF PC Board Assembly into Analyzer Log/IF Assembly and reinstall Analyzer Log/IF Assembly into FM/AM-1600S. Reconnect Coaxial Cable 25.

### 3-8-17 DIGITAL MULTIMETER CALIBRATION

PREREQUISITES: 3-8-1 Power Supply Calibration

EQUIPMENT REQUIRED: 1 Digital Multimeter (DMM)  
1 Calibrator

FIGURE REFERENCES: Figure 3-2  
Figure 3-22  
Figure 3-23

STEP	PROCEDURE
1.	Remove DMM Assembly from FM/AM-1600S (4-3-24).
2.	Remove cover from DMM Assembly and reconnect P/J24001.
3.	Connect DMM positive lead to TP26001 (Figure 3-22) and negative lead to TP26003 (Figure 3-22).
4.	Apply power to FM/AM-1600S. Allow 5 minute warm-up period. Insure IFR Logo Menu, with no error message, is displayed on CRT (26).
5.	Press MTRS MODE Key. Meter Menu is displayed on CRT (26).
6.	Use FIELD SELECT Keys (1) to move cursor to "10. Digital Multimeter (DMM)" field. Press ENTER Key. Multimeter Operation Screen is displayed on CRT (26).
7.	Press "Func" Soft Function Key F1. Use DATA SCROLL Keys (3) to set MULTIMETER to <b>Ohm</b> . Press ENTER Key.
8.	Press "Range" Soft Function Key F2. Use DATA SCROLL Keys (3) to set RANGE to <b>20 kΩ</b> . Press ENTER Key.
9.	Verify 1.000 Vdc ( $\pm 0.05$ Vdc) is displayed on DMM. Adjust R26013 (Figure 3-22) if needed.
10.	Press "Func" Soft Function Key F1. Use DATA SCROLL Keys (3) to set MULTIMETER to <b>DCV</b> . Press ENTER Key.
11.	Press "Range" Soft Function Key F2. Use DATA SCROLL Keys (3) to set RANGE to <b>20 V</b> . Press ENTER Key.
12.	Verify 100 mV ( $\pm 0.5$ mV) is displayed on DMM. Adjust R26016 (Figure 3-22) if needed.
13.	Disconnect DMM and connect DMM V $\Omega$ Connector (11) to Calibrator.
14.	Set Calibrator output to 100 k $\Omega$ .
15.	Press "Func" Soft Function Key F1. Use DATA SCROLL Keys (3) to set MULTIMETER to <b>Ohm</b> . Press ENTER Key.
16.	Press "Range" Soft Function Key F2. Use DATA SCROLL Keys (3) to set RANGE to <b>200 kΩ</b> . Press ENTER Key. Verify meter reading is 100 k $\Omega$ ( $\pm 10$ k $\Omega$ ).
17.	Set Calibrator output to 1 k $\Omega$ .

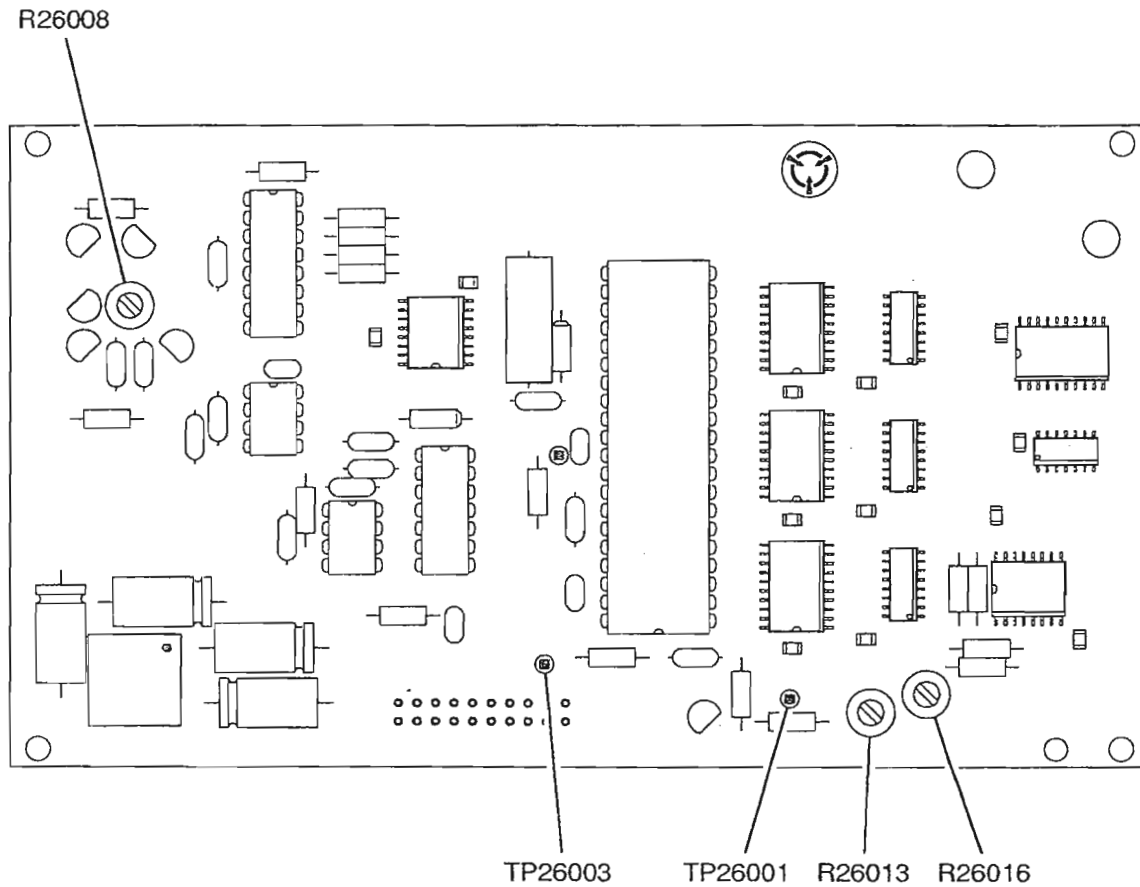

8607168

Figure 3-22 DMM Digital PC Board Assembly Calibration Points

18. Press "Range" Soft Function Key F2. Use DATA SCROLL Keys (3) to set RANGE to 2 k $\Omega$ . Press ENTER Key. Verify meter reading is 1 k $\Omega$  ( $\pm 100 \Omega$ ).
19. Adjust, if needed, R26008 (Figure 3-22) to obtain proper measurement between both ranges.
20. Set Calibrator output to 20 kHz Sine Wave at 7 Vrms.
21. Press "Func" Soft Function Key F1. Use DATA SCROLL Keys (3) to set MULTIMETER to **ACV**. Press ENTER Key.
22. Press "Range" Soft Function Key F2. Use DATA SCROLL Keys (3) to set RANGE to 20 V. Press ENTER Key.
23. Verify meter reading is 7 V ( $\pm 1$  V).

**NOTE:** AC V accuracy applies for AC Volts multiplied by kHz frequency product. Resultant should be <140.

24. Adjust, if necessary, C25011 (Figure 3-23) to obtain proper level.
  25. Set Calibrator output to 20 kHz Sine Wave at 1 Vrms.
  26. Use "Range" Soft Function Key F2 to set RANGE to 2 V. Press ENTER Key.
  27. Verify meter reading is 1 V ( $\pm 0.1$  V).
- NOTE:** AC V accuracy applies for AC Volts multiplied by kHz frequency product. Resultant should be  $< 140$ .
28. Adjust, if necessary, C25010 (Figure 3-23) to obtain proper level.
  29. Repeat steps 20 through 28 for best overall response.
  30. Remove power from FM/AM-1600S, disconnect test equipment and reinstall DMM Assembly.

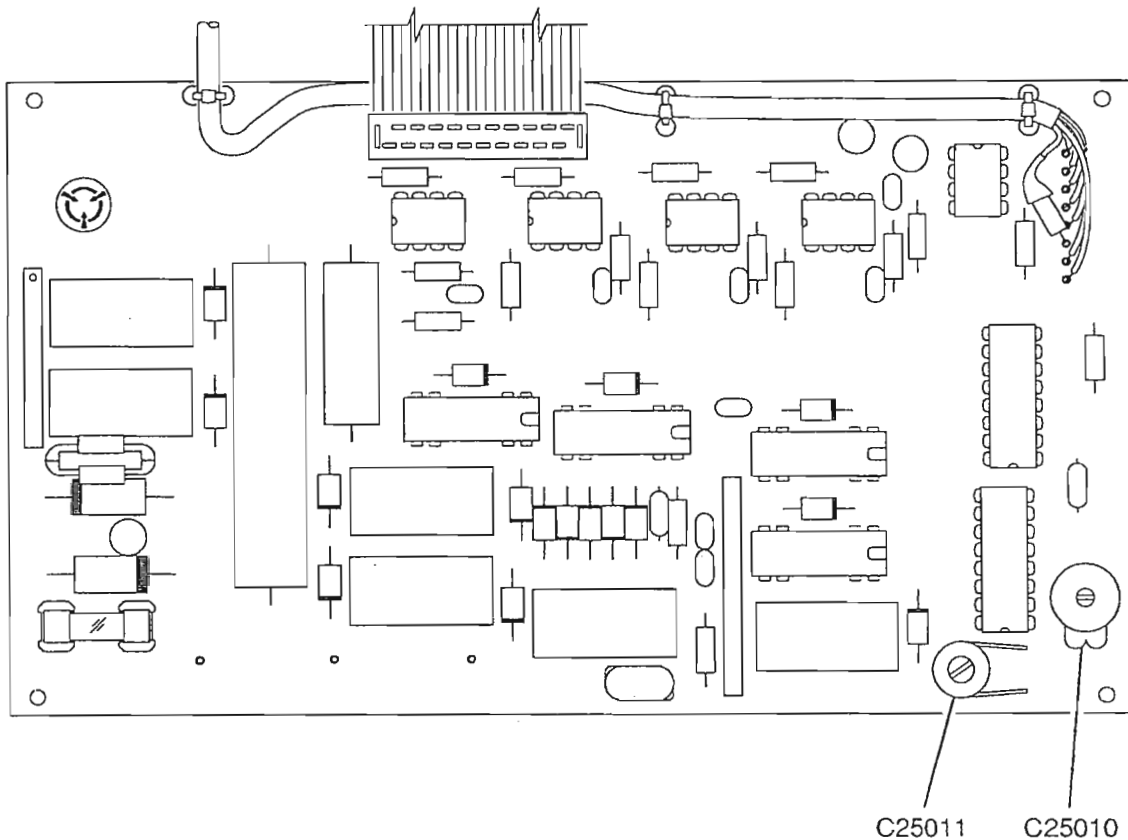

8607164

Figure 3-23 DMM Relay PC Board Calibration Points

## 3-8-18 POWER METER CALIBRATION

PREREQUISITES: 3-8-1 Power Supply Calibration

EQUIPMENT REQUIRED: 1 RF Signal Generator (Fluke 6061A)  
1 Measuring Receiver  
1 Coaxial Coupler (Reflectometer)  
1 Digital Multimeter (DMM)  
1 200 W RF Amplifier  
1 10 W RF Amplifier  
1 Power Attenuator  
1 20dB Attenuator  
1 Coaxial Cable (Type N-Type N)  
1 Coaxial Cable (BNC-BNC)

FIGURE REFERENCES: Figure 3-24  
Figure 3-25

STEP	PROCEDURE
1.	Connect DMM positive lead to FL47009 and negative lead to GL47001 (Figure 3-24).
2.	Apply power to FM/AM-1600S. Allow 5 minute warm-up period. Insure IFR Logo, with no error message, is displayed on CRT (26).
3.	Set Signal Generator RF output to 150 MHz.
4.	Connect T/R Connector (6) to Coaxial Coupler output (Figure 3-25).
	<b>NOTE:</b> The Coaxial Coupler must be certified at frequencies (Cert Attn Level) used $\pm 0.03$ dB.
5.	Use following formula to calculate and record power level at 0.2 mW, 1400 mW, 2000 mW, 50000 mW, and 112500 mW: $\text{Log (milliwatts) X } 10 - (\text{Cert Attn Level}) = \text{dBm (Power Level)}$
6.	Connect 10 W RF Amplifier Output to Coaxial Coupler Main Line Input (Figure 3-25).
7.	Connect Measuring Receiver Sensor through 20 dB Attenuator to Coaxial Coupler Coupled Mainline Power Output (Figure 3-25). Reference Measuring Receiver RF Power reading to TRUE attenuation of 20 dB Attenuator.
8.	Connect Signal Generator RF output to 10 W RF Amplifier input (Figure 3-25). Set Signal Generator RF output to OFF.
9.	Press RF GEN MODE Key (27). RF Generator Operation Screen is displayed on CRT (26).
10.	Use FIELD SELECT Keys (1) to move cursor to LEVEL. Press ENTER Key to highlight data field.
11.	Use DATA SCROLL Keys (3) to set data field to <b>-137 dBm</b> . Press ENTER Key.
12.	Press RCVR MODE Key (27). Receive Operation Screen is displayed on CRT (26).
13.	Use FIELD SELECT Keys (1) to move cursor to RF. Press ENTER Key to highlight data field.

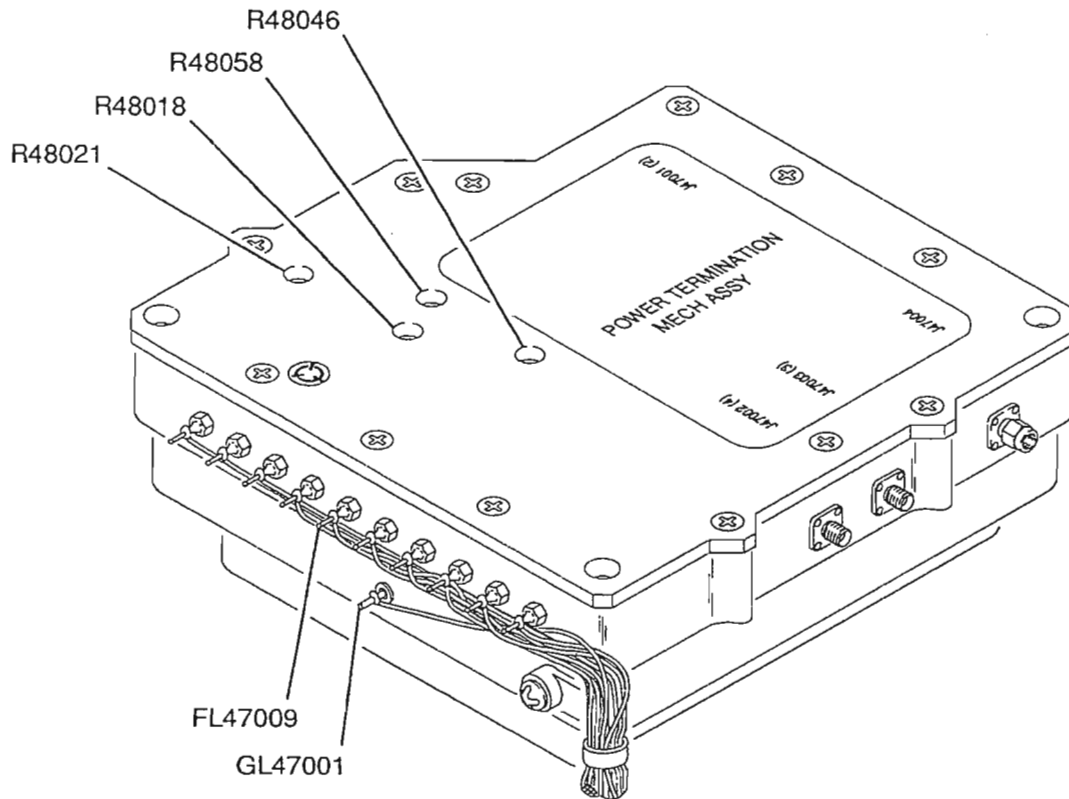

Figure 3-24 Power Term Assembly Calibration Points

8607158

14. Use DATA ENTRY Keypad (29) to set data field to **150.0000 MHz**. Press ENTER Key.
  15. Use FIELD SELECT Keys (1) to move cursor to RF IN. Press ENTER Key to select **T/R**.
  16. Use FIELD SELECT Keys (1) to move cursor to PWR. Press ENTER Key to access POWER METER Operation.
  17. Press "Range" Soft Function Key F2 to highlight RANGE data field.
  18. Use DATA SCROLL Keys (3) to set data field to **20 mW**. Press ENTER Key.
  19. Verify 0 V ( $\pm 1.0$  mV) is displayed on DMM. Adjust R48021 (Figure 3-24) if needed.
- NOTE:** If adjustment is required, remove aluminum tape from Power Term Assembly to access Trimpots.
20. Press ENTER Key to highlight RANGE data field. Use DATA SCROLL Keys (3) to set data field to **20 W**. Press ENTER Key.

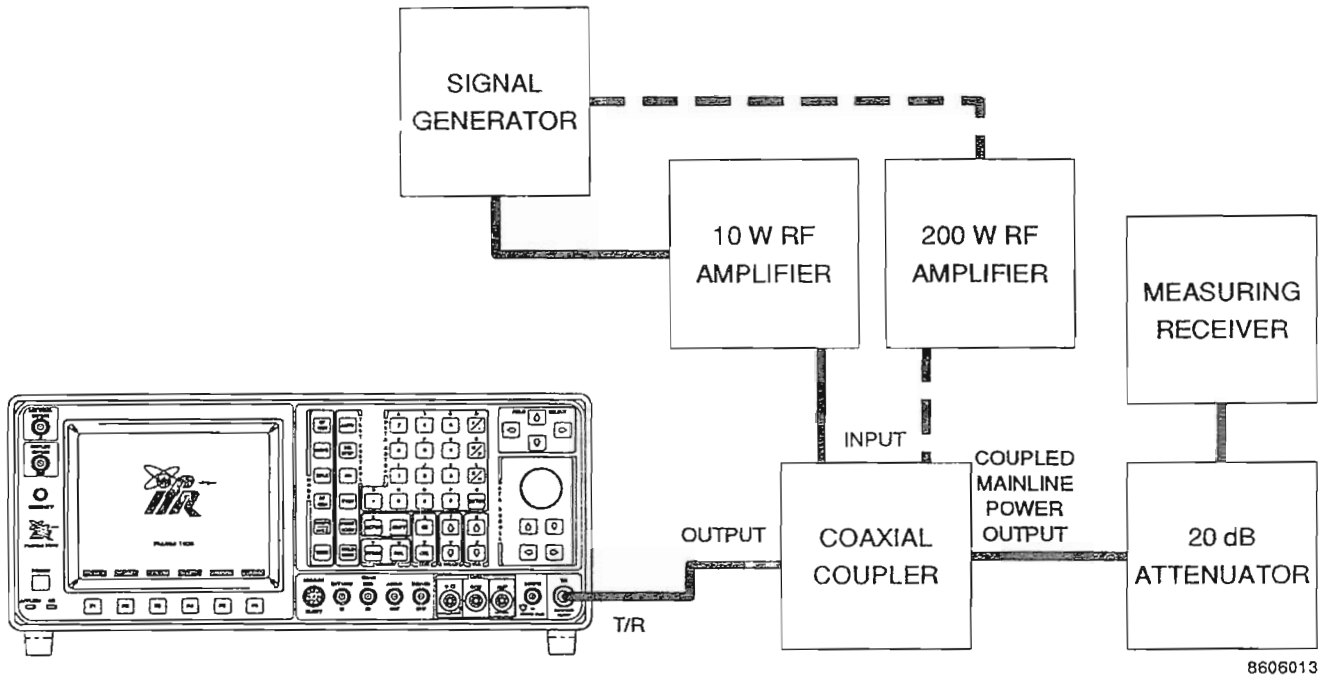

Figure 3-25 Power Meter Calibration Test Setup

21. Verify 0 V ( $\pm 1.0$  mV) is displayed on DMM. Adjust R48018 (Figure 3-24) if needed.
22. Press ENTER Key to highlight RANGE data field. Use DATA SCROLL Keys (3) to set data field to 2 W. Press ENTER Key.
23. Set Signal Generator RF output to ON. Adjust Signal Generator RF output level until reading on Measuring Receiver is equal to calculated power level in step 5 for 2000 mW.
24. Verify 4.00 V (+0 mV, -50 mV) is displayed on DMM and 2.0 W ( $\pm 0.2$  W) is displayed on CRT (26).
25. Adjust, if necessary, R48058 (Figure 3-26).

**NOTE:** R48021 and R48058 are interactive, so it is necessary to verify 0 V ( $\pm 1.0$  mV) is displayed on DMM with Power Term Assembly cover installed and Signal Generator RF output set to OFF.

26. If detected voltage in step 24 is not within tolerance, alternately adjust R48021 and R48058 until proper power level is obtained.
27. Set Signal Generator RF output to OFF.
28. Remove 10 W RF Amplifier from Signal Generator output and connect 200 W RF Amplifier to Signal Generator output (Figure 3-28).
29. Press ENTER Key to highlight RANGE data field. Use DATA SCROLL Keys (3) to set data field to 200 W.

## STEP

## PROCEDURE

30. Set Signal Generator RF output to ON. Adjust Signal Generator RF output level until reading on Measuring Receiver is equal to calculated power level in step 6 for 50000 mW.
31. Verify 2.00 V ( $\pm 20$  mV) is displayed on DMM and 50 W ( $\pm 5.0$  W) is displayed on CRT (26).
32. Adjust R48046 (Figure 3-26) if needed.  
**NOTE:** R48018 and R48046 are interactive, so it is necessary to verify 0 V ( $\pm 1.0$  mV) is displayed on DMM with Signal Generator RF output set to OFF.
33. If detected voltage in step 32 is not within tolerance, alternately adjust R48018 (Figure 3-24) and R48046 (Figure 3-24) until proper level is obtained.
34. Set Signal Generator RF output to OFF.
35. Remove 200 W RF Amplifier from Signal Generator output and connect 10 W RF Amplifier to Signal Generator output (Figure 3-27).
36. Press SETUP Key and "AUX" Soft Function Key F6. Auxiliary Functions Menu is displayed on CRT (26) and "1. Calibration Menu" Selection is highlighted.
37. Press ENTER Key. Password Window is displayed. Use DATA ENTRY Keypad (29) to press SHIFT, **C, S, M, A, T, E**, SHIFT and ENTER Keys to access Calibration Menu.
38. Press 1 on DATA ENTRY Keypad (29) to access "Power Meter" submenu.
39. Press "Range" Soft Function Key F1 to select **20 mW** full scale range with Auto Range Off.
40. With Signal Generator RF output set to OFF, press "Zero" Soft Function Key F2. Verify Power Meter Zero raw data Zero value is momentarily displayed.
41. Press "Range" Soft Function Key F1 to select **20 W** full scale range.
42. With Signal Generator RF output set to OFF, press "Zero" Soft Function Key F2. Verify Power Meter Zero raw data Zero value is momentarily displayed.
43. Press "Range" Soft Function Key F1 to select **2 W** full scale range.
44. Set Signal Generator RF output to ON. Adjust Signal Generator RF output level until reading on Measuring Receiver is equal to calculated power level in step 5 for 1400 mW.
45. Verify power reading is displayed on CRT (26). Press ENTER Key.
46. Use DATA ENTRY Keypad (29) to enter **1.40 W**. Press ENTER Key.
47. Adjust Signal Generator RF output level until reading on Measuring Receiver is equal to calculated power level in step 5 for 0.2 mW.
48. Press "Range" Soft Function Key F1 to select **20 mW** full scale Range.
49. Verify 0.2 mW ( $\pm 0.1$  mW) is displayed on meter.
50. Repeat steps 38 through 49 until measurements are within specification.



## STEP

## PROCEDURE

- 
51. Set Signal Generator RF output to OFF.
  52. Remove 10 W RF Amplifier from Signal Generator output and connect 200 W RF Amplifier to Signal Generator output (Figure 3-27).
  53. Press "Range" Soft Function Key F1 to select **200 W** full scale Range.
  54. Set Signal Generator RF output to ON. Adjust Signal Generator RF output level until reading on Measuring Receiver is equal to calculated power level in step 6 for 112500 mW.
  55. Verify power reading is displayed on meter. Press ENTER Key.
  56. Use DATA ENTRY Keypad (29) to enter **112.50**. Press ENTER Key.  
**CAUTION:** MAXIMUM OPERATING ON TIME IS 30 SECONDS FOR 100 W at 50° C WITH AN OFF TIME OF TWO MINUTES.
  57. Adjust Signal Generator RF output level until reading on Measuring Receiver is equal to calculated power level in step 5 for 50000 mW.
  58. Verify power level of 50 W ( $\pm 5$  W) is displayed on CRT (26).  
**CAUTION:** MAXIMUM OPERATION ON TIME IS 30 SECONDS FOR 100 W at 50° C WITH AN OFF TIME OF TWO MINUTES.
  59. Press "Range" Soft Function Key F1 to select **20 W** full scale Range.
  60. Adjust Signal Generator RF output level until reading on Measuring Receiver is equal to calculated power level in step 5 for 2000 mW.
  61. Verify power level of 2 W ( $\pm 0.2$  W) is displayed on CRT (26).
  62. Press "Ret" Soft Function Key F5 and "ESC" Soft Function Key (F6) to terminate procedure.
  63. Remove power from FM/AM-1600S and disconnect test equipment.

# SECTION 4 - REPLACEMENT PROCEDURES

## 4-1 GENERAL

This section contains instructions for replacement of any assembly contained in the unit. The instructions given are for removal of each assembly. Prerequisite instructions are listed as needed. Reassembly is in reverse order of removal instructions unless otherwise noted.

### 4-1-1 SAFETY PRECAUTIONS

Power should be removed from the unit before any replacement procedure is initiated.

**WARNING: DANGEROUS VOLTAGES ARE PRESENT WITH CASE ASSEMBLIES REMOVED IF POWER IS PRESENT.**

### 4-1-2 ESD PRECAUTIONS

**CAUTION: THE REPLACEMENT PROCEDURES FOR THE FM/AM-1600S SHOULD ONLY BE PERFORMED IN AN ESD ENVIRONMENT AND ALL PERSONNEL PERFORMING THE CALIBRATION PROCEDURES SHOULD HAVE KNOWLEDGE OF ACCEPTED ESD PRACTICES AND/OR BE ESD CERTIFIED.**



## 4-2 EQUIPMENT REQUIREMENTS

TOOL	SIZE
WRENCH, OPEN END	5/16", 1/2" and 3/4"
NUT DRIVER	1/4"
HEX-HEAD WRENCH	9/64"
SCREWDRIVER	slotted and phillips type

## 4-3 REPLACEMENT PROCEDURES

### 4-3-1 REPLACE TOP CASE ASSEMBLY

**WARNING: DANGEROUS VOLTAGES ARE PRESENT WITH CASE ASSEMBLIES REMOVED IF POWER IS PRESENT.**

STEP	PROCEDURE
------	-----------

1. Disconnect ac power.
2. Loosen four captive screws (1).
3. Slide rear panel assembly (2) toward rear.
4. Remove top case assembly (3).

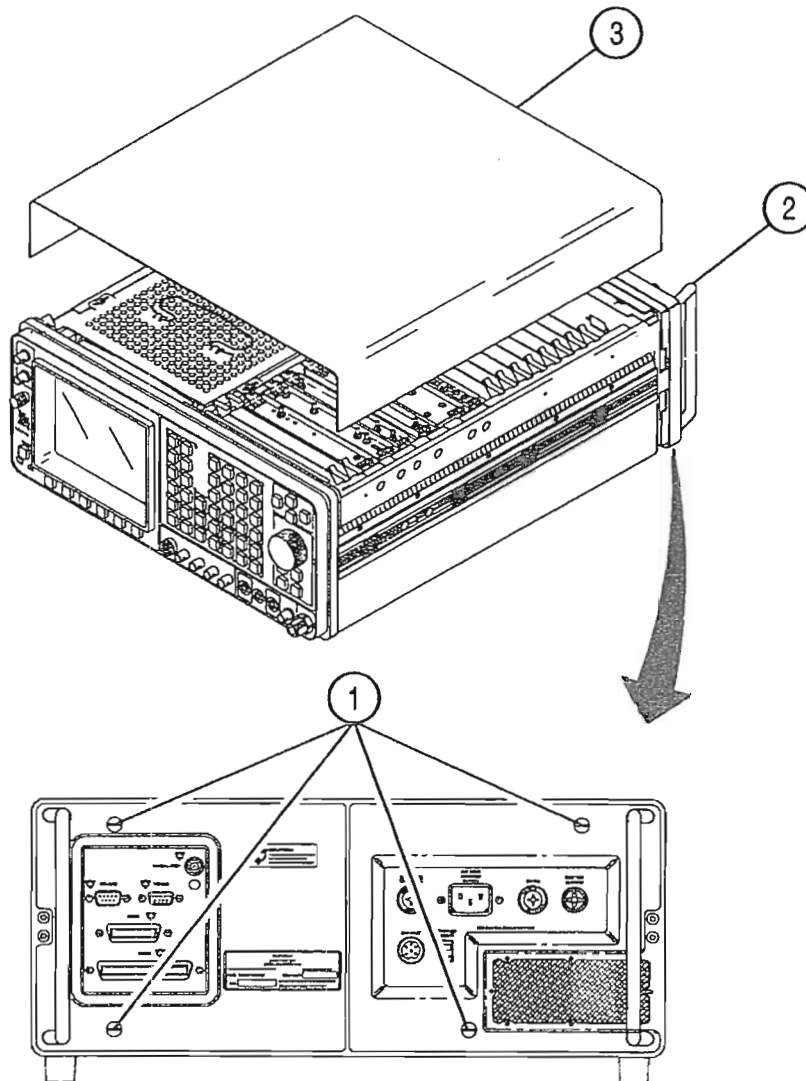

8621001

## 4-3-2 REPLACE BOTTOM CASE ASSEMBLY

**WARNING: DANGEROUS VOLTAGES ARE PRESENT WITH CASE ASSEMBLIES REMOVED IF POWER IS PRESENT.**

STEP

PROCEDURE

1. Remove ac power cable.
2. Loosen four captive screws (1).
3. Slide rear panel assembly (2) toward rear.
4. Remove bottom case assembly (3).

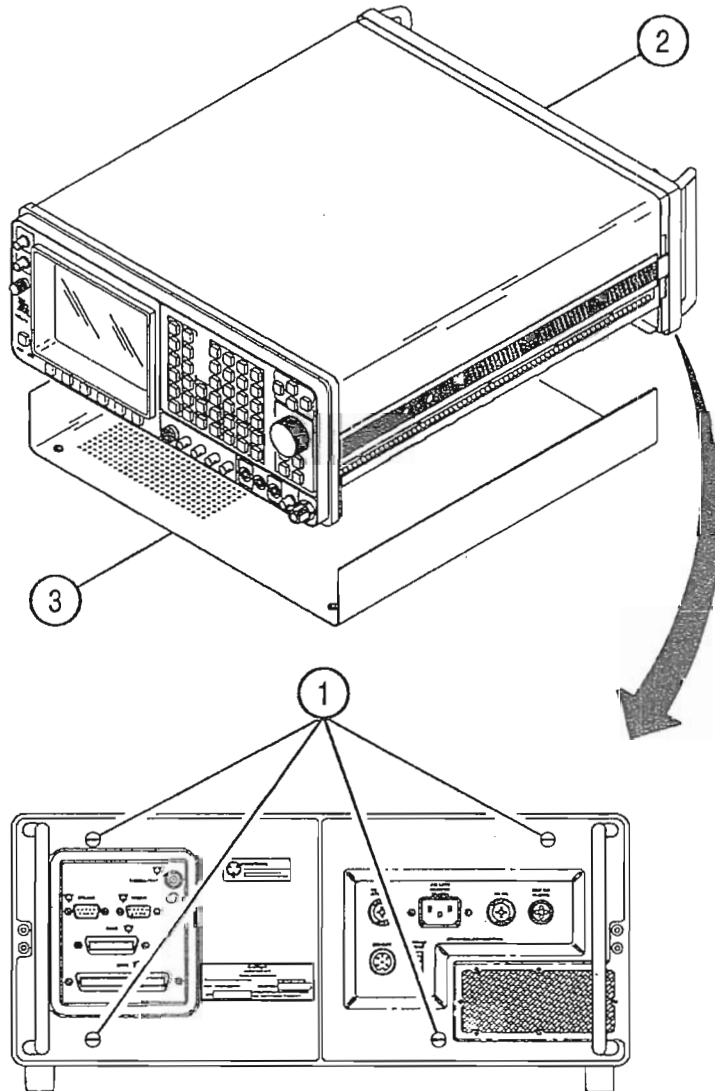

8621002

### 4-3-3 REPLACE DIGITIZER PC BOARD ASSEMBLY

PRELIMINARY PROCEDURES: Remove Top Case Assembly (para 4-3-1)

STEP	PROCEDURE
------	-----------

---

1. Disconnect coaxial cable connector (1).
2. Raise card ejectors and remove Digitizer PC Board Assembly (2).

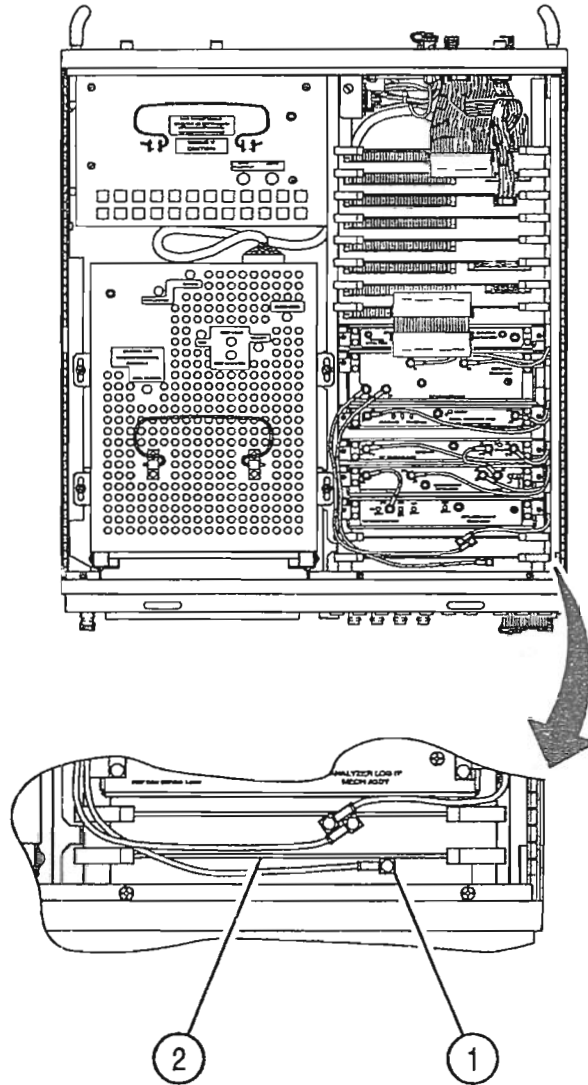

8621003

## 4-3-4 REPLACE COUNTER PC BOARD ASSEMBLY

PRELIMINARY PROCEDURES: Remove Top Case Assembly (para 4-3-1)

STEP PROCEDURE

---

1. Disconnect three coaxial cable connectors (1) (2) (3).
2. Raise card ejectors and remove Counter PC Board Assembly (4).

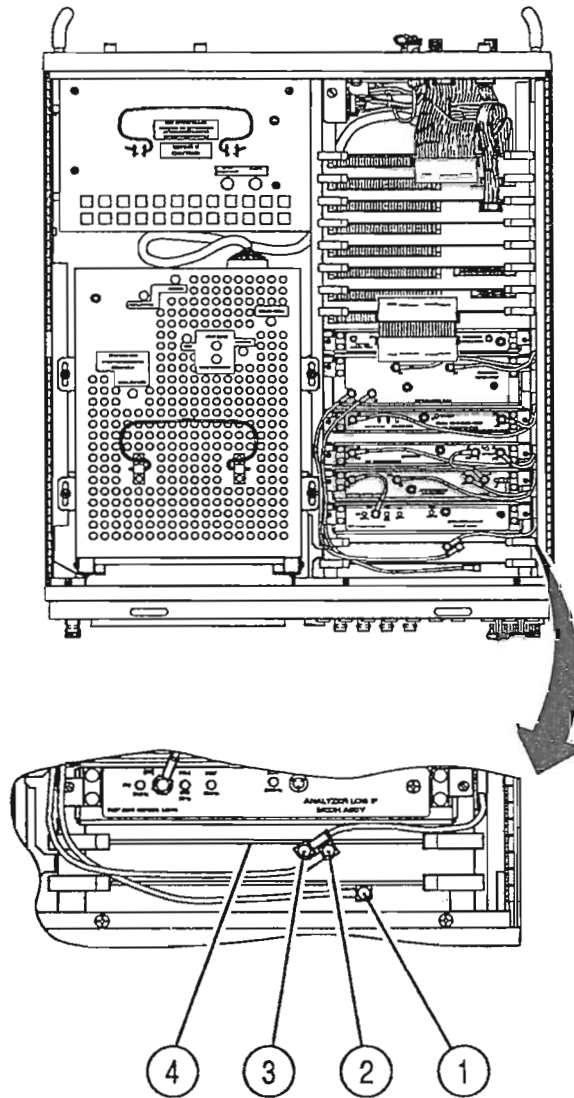

8621004

### 4-3-5 REPLACE ANALYZER LOG/IF ASSEMBLY

PRELIMINARY PROCEDURES: Remove Top Case Assembly (4-3-1).

STEP	PROCEDURE
------	-----------

1. Disconnect three coaxial cable connectors (1) (2) (3).
2. Loosen two captive screws (4).
3. Remove Analyzer Log/IF Assembly (5).

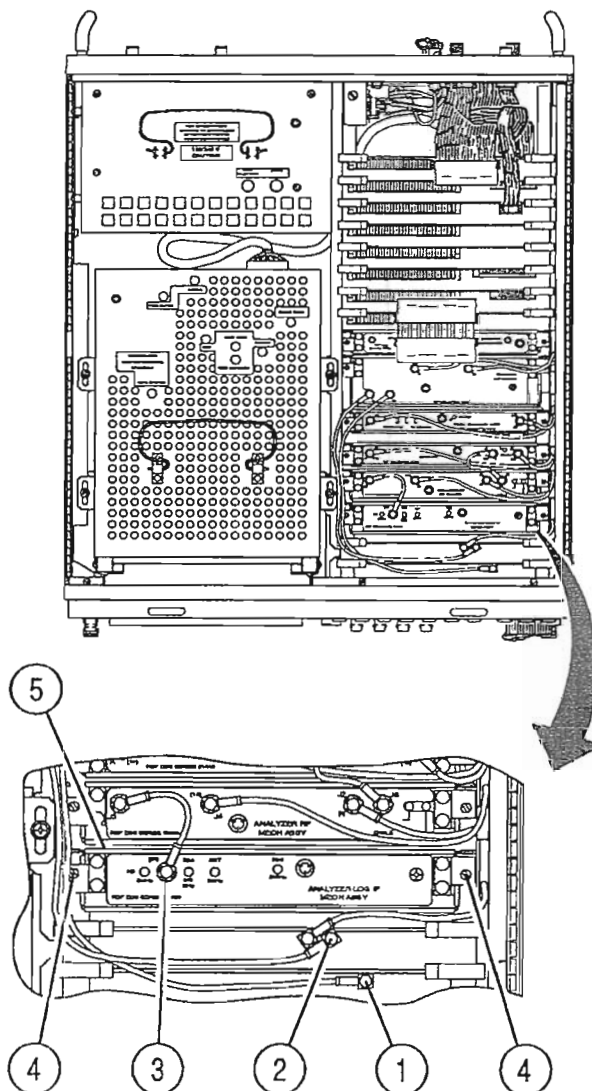

8621005

## 4-3-6 REPLACE ANALYZER RF ASSEMBLY

RELIMINARY PROCEDURES: Remove Top Case Assembly (4-3-1)

STEP PROCEDURE

---

1. Disconnect six coaxial cable connectors (1) (2) (3) (4) (5) (6).
2. Loosen two captive screws (7).
3. Remove Analyzer RF Assembly (8).

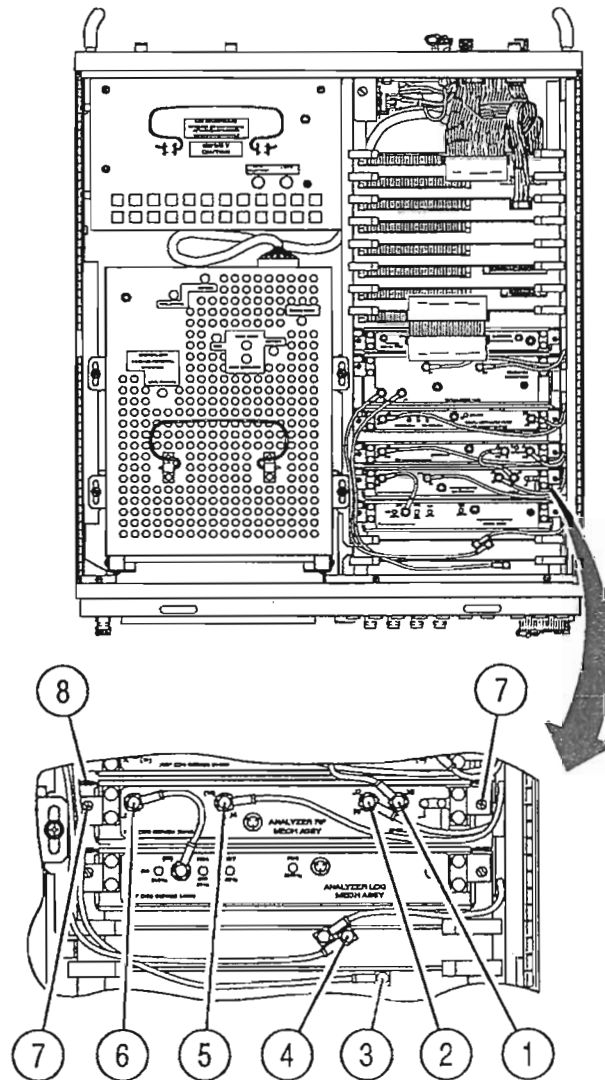

8621006



## 4-3-7 REPLACE 3rd LO ASSEMBLY

PRELIMINARY PROCEDURES: Remove Top Case Assembly (4-3-1)

STEP	PROCEDURE
------	-----------

1. Disconnect five coaxial cable connectors (1) (2) (3) (4) (5).
2. Loosen two captive screws (6).
3. Remove 3rd LO Assembly (7).

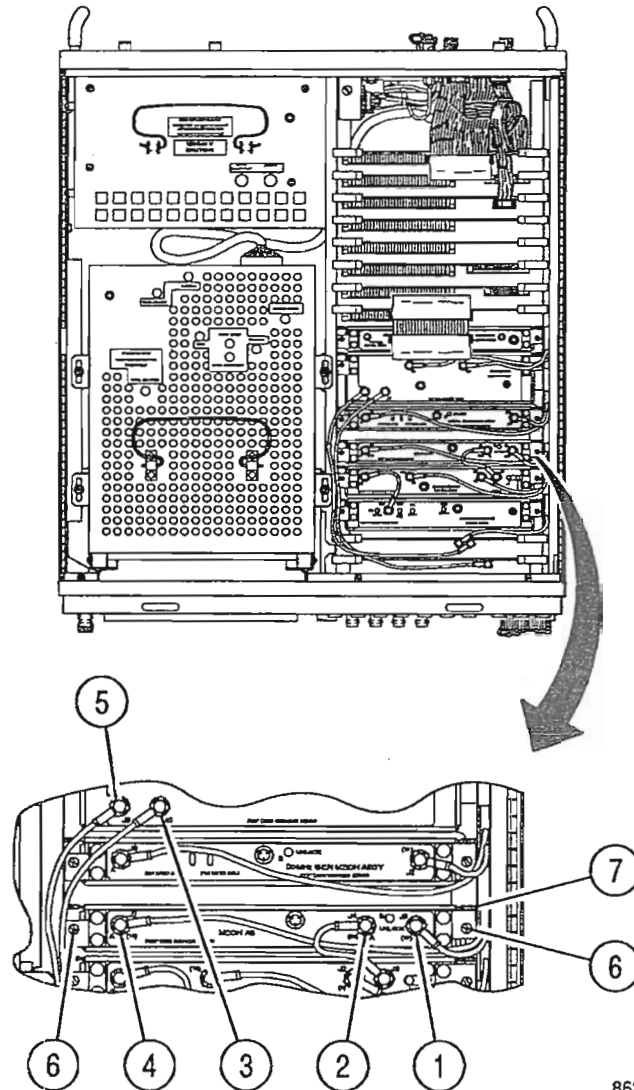

8621007

## 4-3-8 REPLACE 90 MHz GENERATOR ASSEMBLY

PRELIMINARY PROCEDURES: Remove Top Case Assembly (4-3-1)

STEP	PROCEDURE
------	-----------

1. Disconnect four coaxial cable connectors (1) (2) (3) (4).
2. Loosen two captive screws (5).
3. Remove 90 MHz Generator Assembly (6).

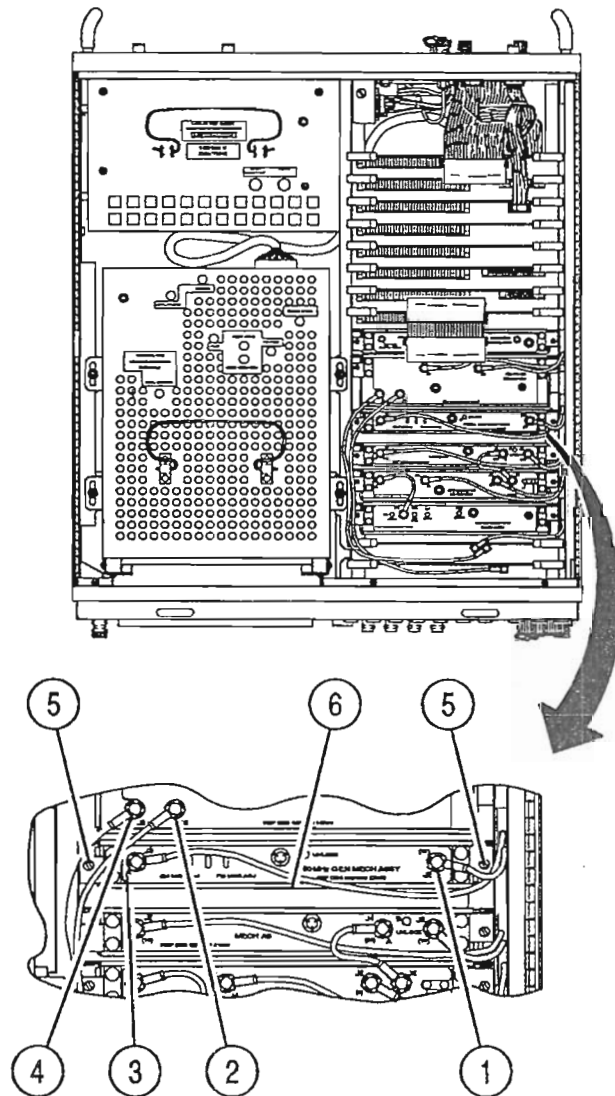

8621008

## 4-3-9 REPLACE RECEIVER ASSEMBLY

PRELIMINARY PROCEDURES: Remove Top Case Assembly (4-3-1)

STEP PROCEDURE

---

1. Disconnect four coaxial cable connectors (1) (2) (3) (4).
2. Loosen two captive screws (5).
3. Remove Receiver Assembly (6).

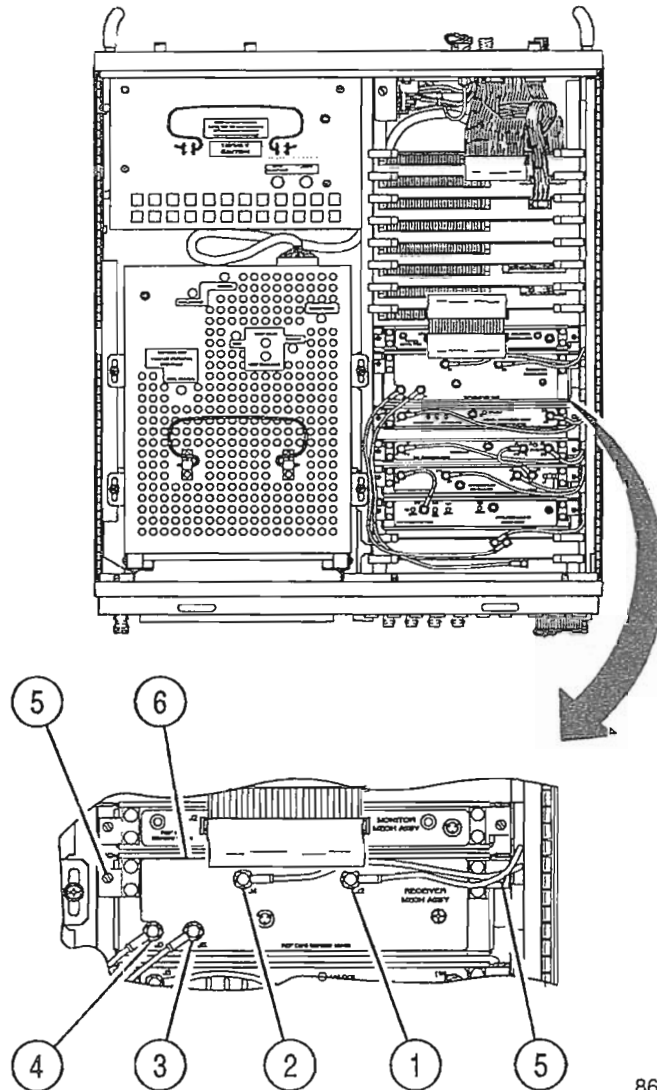

8621009

## 4-3-10 REPLACE MONITOR ASSEMBLY

PRELIMINARY PROCEDURES: Remove Top Case Assembly (4-3-1)

STEP	PROCEDURE
------	-----------

1. Disconnect ribbon cable connector (1).
2. Loosen two captive screws (2).
3. Remove Monitor Assembly (3).

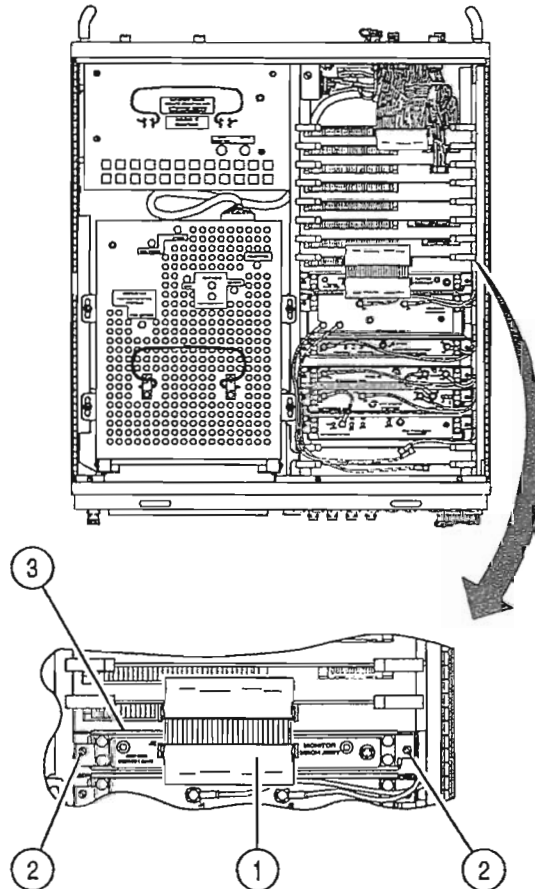

8621010

# 4-3-11 REPLACE MONITOR CONTROL PC BOARD ASSEMBLY

PRELIMINARY PROCEDURES: Remove Top Case Assembly (4-3-1)

STEP PROCEDURE

---

1. Disconnect ribbon cable connector (1).
2. Raise card ejectors and remove Monitor Control PC Board Assembly (2).

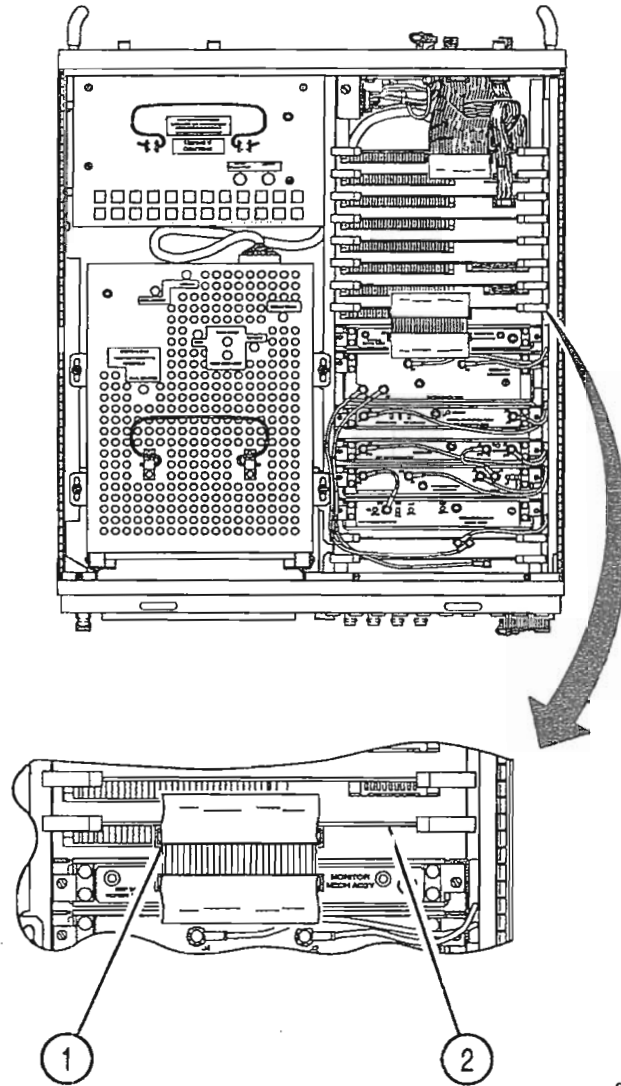

8621011

## 4-3-12 REPLACE FUNCTION GENERATOR PC BOARD ASSEMBLY

PRELIMINARY PROCEDURES: Remove Top Case Assembly (4-3-1)

STEP PROCEDURE

---

1. Raise card ejectors and remove Function Generator PC Board Assembly (1).

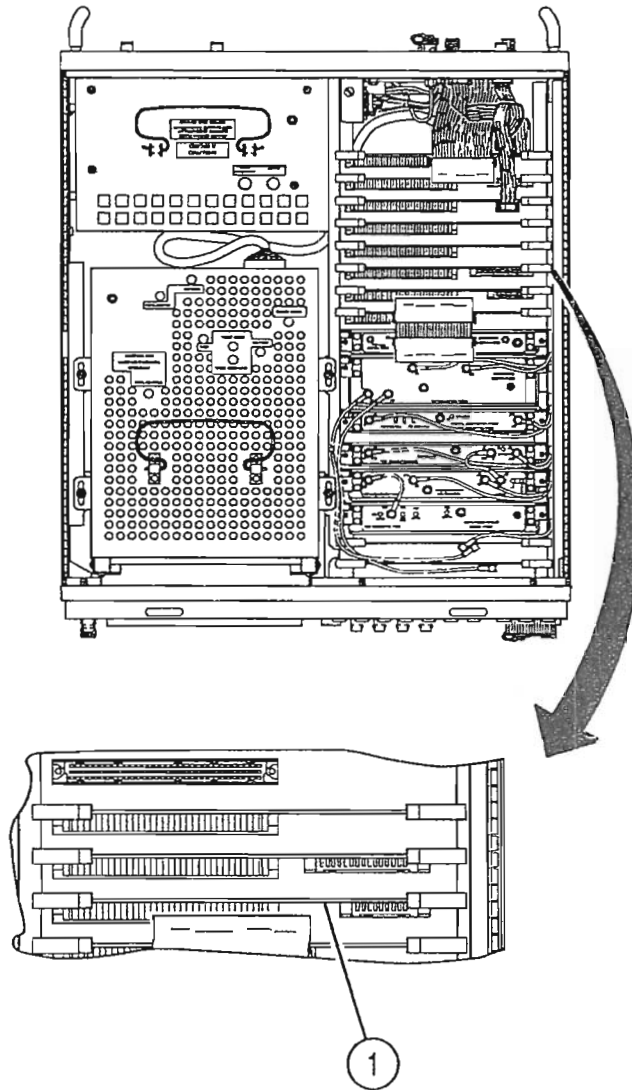

8621012

# 4-3-13 REPLACE RF I/O PC BOARD ASSEMBLY

PRELIMINARY PROCEDURES: Remove Top Case Assembly (4-3-1)

STEP PROCEDURE

---

1. Raise card ejectors and remove RF I/O PC Board Assembly (1).

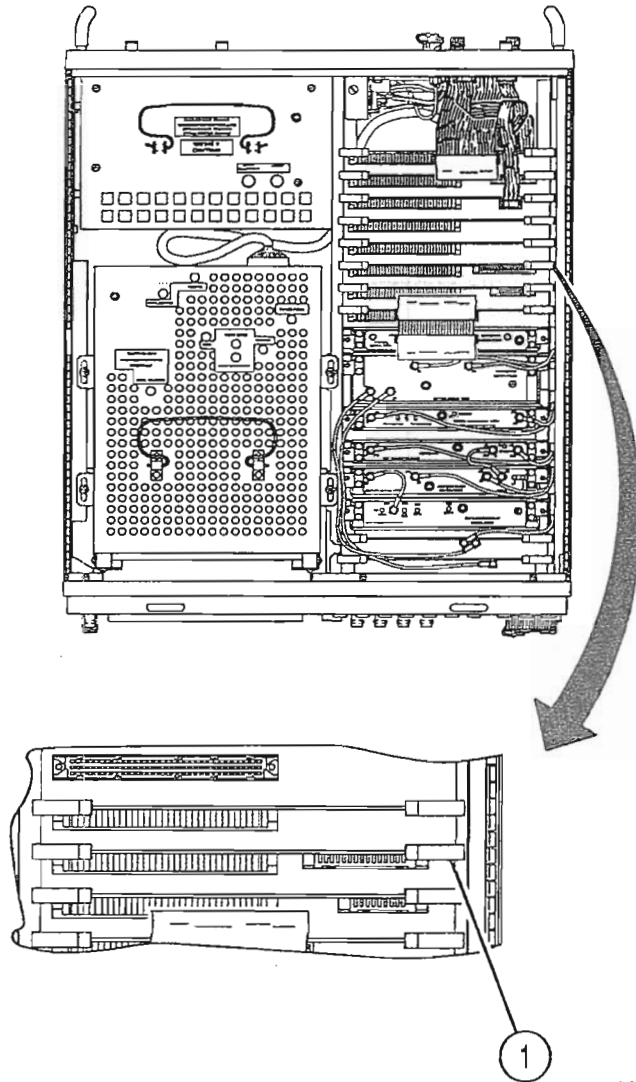

8621013

## 4-3-14 REPLACE MEMORY PC BOARD ASSEMBLY

PRELIMINARY PROCEDURES: Remove Top Case Assembly (4-3-1)

STEP PROCEDURE

---

1. Raise card ejectors and remove Memory PC Board Assembly (1).

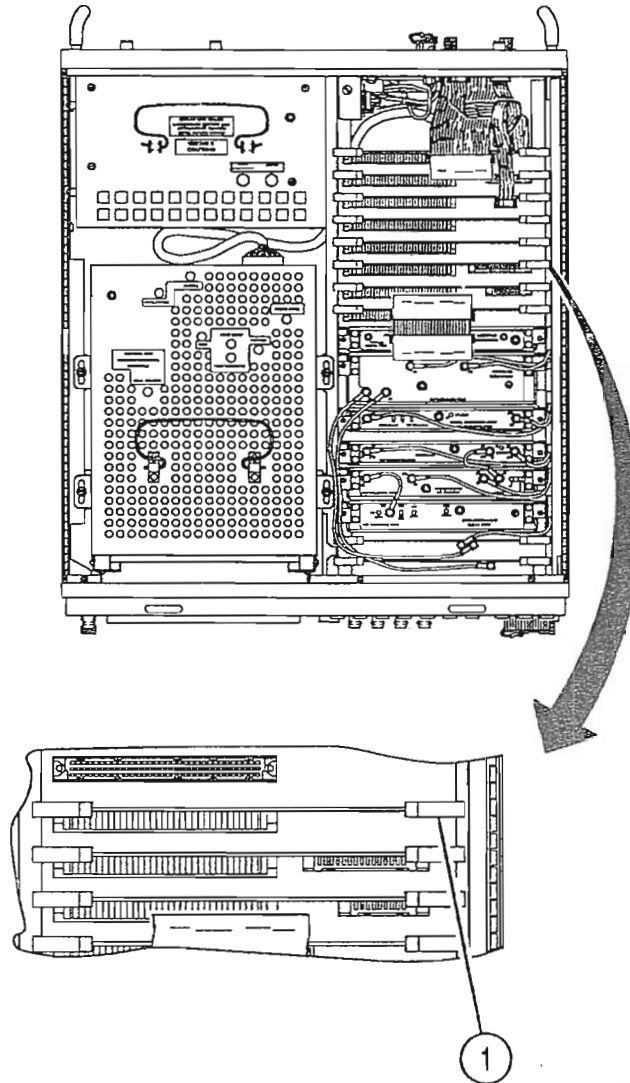

8621014



## 4-3-15 REPLACE PROCESSOR PC BOARD ASSEMBLY

PRELIMINARY PROCEDURES: Remove Top Case Assembly (4-3-1)

STEP PROCEDURE

---

1. Disconnect ribbon cable connector (1).
2. Raise card ejectors and remove Processor PC Board Assembly (2).

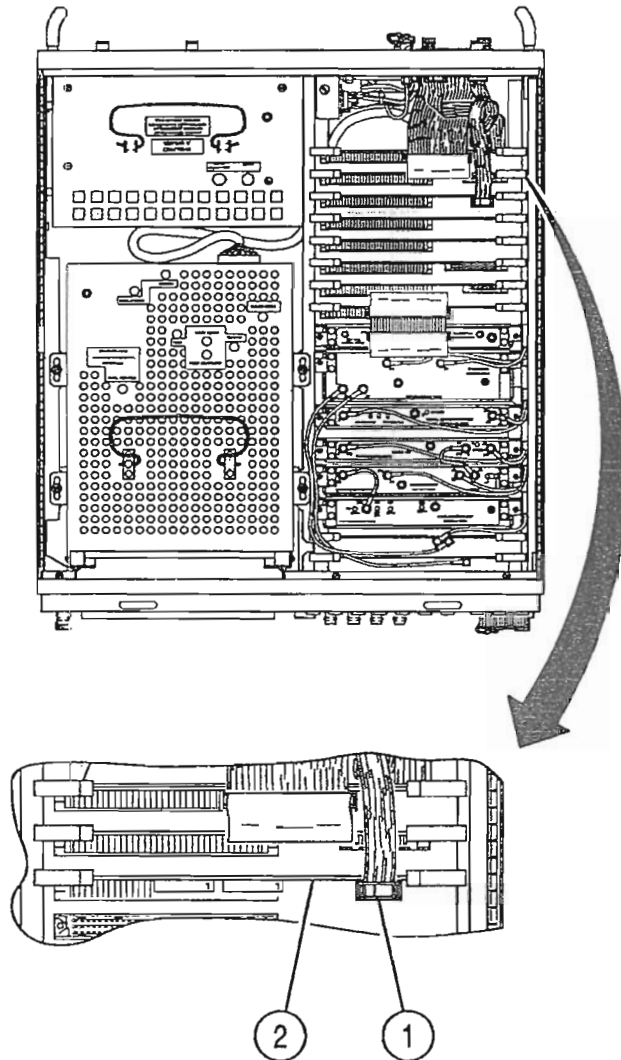

8621015

## 4-3-16 REPLACE VIDEO CONTROLLER PC BOARD ASSEMBLY

RELIMINARY PROCEDURES: Remove Top Case Assembly (4-3-1)

STEP	PROCEDURE
------	-----------

---

1. Disconnect ribbon cable connector (1).
2. Raise card ejectors and remove Video Controller PC Board Assembly (2).

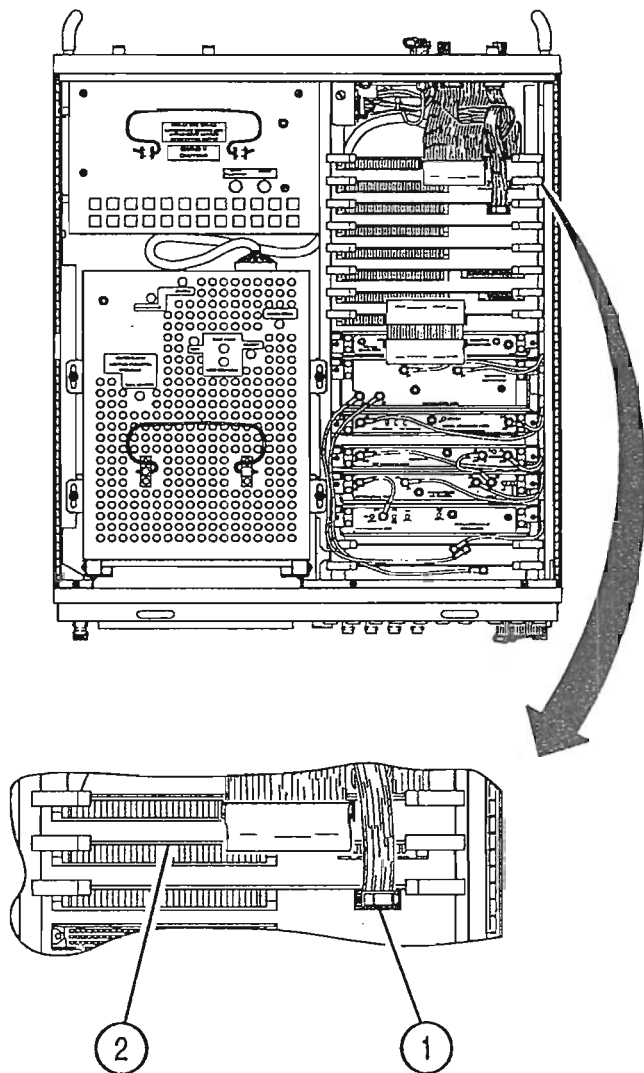

8621016

## 4-3-17 REPLACE EXTERNAL I/O PC BOARD ASSEMBLY

PRELIMINARY PROCEDURES: Remove Top Case Assembly (4-3-1)

STEP	PROCEDURE
------	-----------

---

1. Disconnect two ribbon cable connectors (1) (2).
2. Raise card ejectors and remove External I/O PC Board Assembly (3).

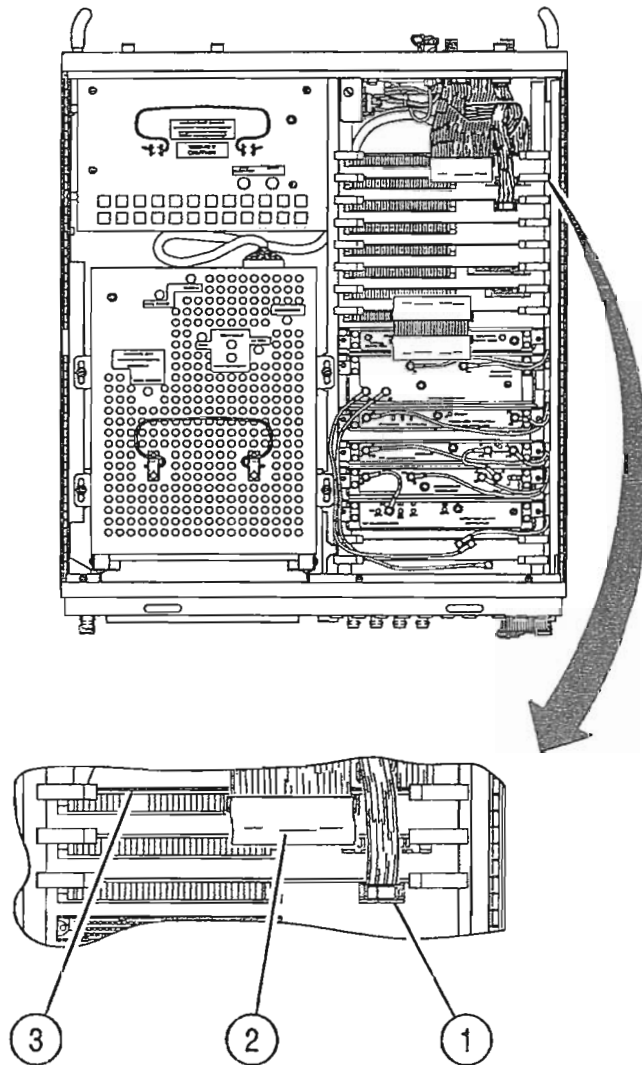

8621017

## 4-3-18 REPLACE POWER SUPPLY ASSEMBLY

PRELIMINARY PROCEDURES: Remove Top Case Assembly (4-3-1)  
Remove Bottom Case Assembly (4-3-2)

STEP	PROCEDURE
------	-----------

1. Disconnect two wire cable connectors (1).
2. Loosen two captive screws (2).
3. Disconnect wire cable connector (3).
4. Remove two screws and washers (4).
5. Slide Power Supply Assembly (5) toward front.
6. Raise handle (6) and remove.

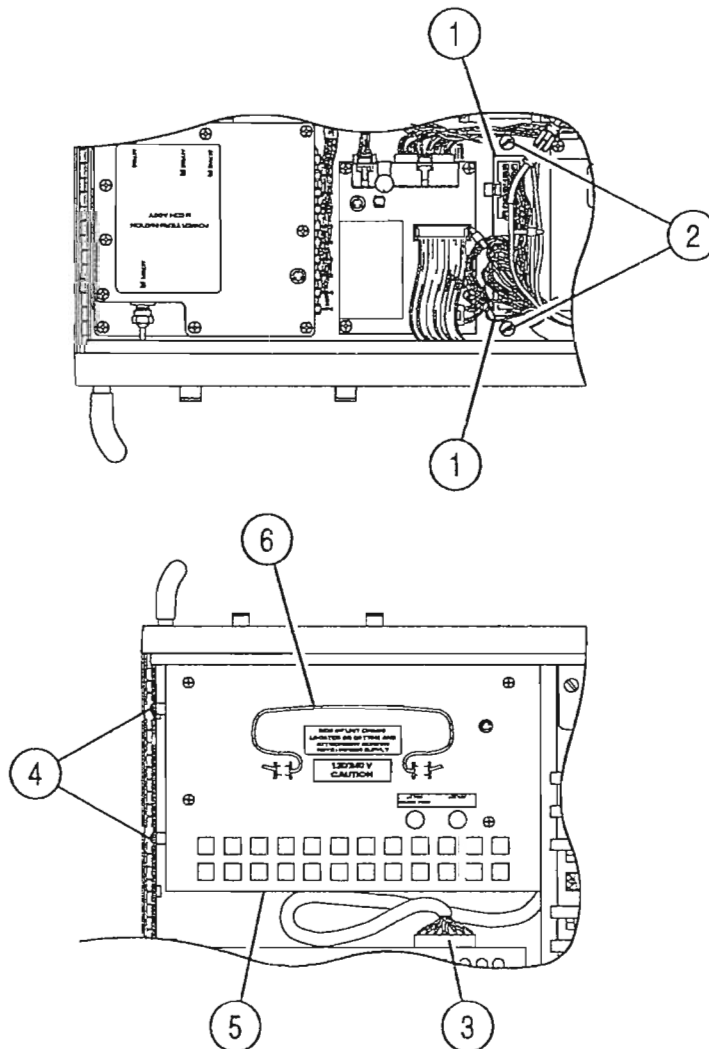

8621019

## 4-3-19 REPLACE CRT ASSEMBLY

PRELIMINARY PROCEDURES: Remove Top Case Assembly (4-3-1)

### REMOVE

STEP	PROCEDURE
1.	Remove four screws and washers (1).
2.	Disconnect wire cable connector (2).
3.	Slide CRT Assembly (3) toward rear.
4.	Raise handle (4) and remove.

### INSTALL

STEP	PROCEDURE
1.	Install CRT Assembly (3) on chassis (5) aligning screw holes.
2.	Slide CRT Assembly (3) toward front until guide pins (6) are seated in grommets.
3.	Install four screws and washers (1).
4.	Lay handle (4) toward rear.
5.	Reconnect wire cable connector (2).



## 4-3-20 REPLACE FAN

### PRELIMINARY PROCEDURES:

Remove Top Case Assembly (4-3-1)  
Remove Bottom Case Assembly (4-3-2)  
Remove Power Supply Assembly (4-3-19)

### STEP

### PROCEDURE

1. Remove 21 screws (1).
2. Remove cover (2).
3. Disconnect wire cable connector (3).
4. Disconnect ribbon cable connector (4).
5. Remove four screws (5).
6. Remove Fan (6).

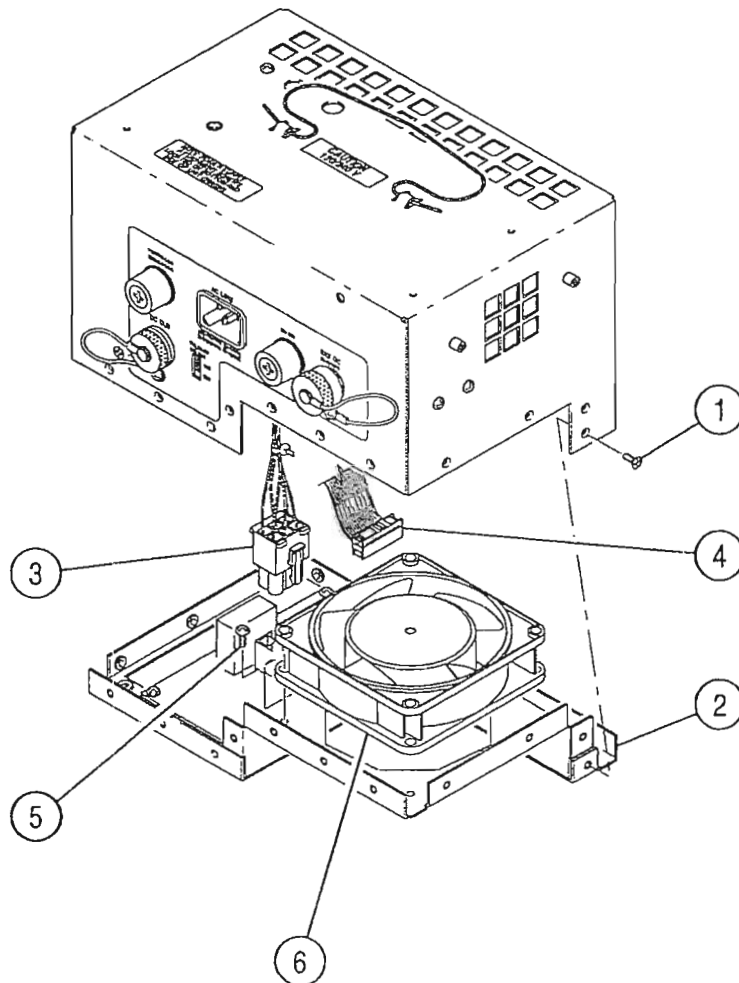

8621020

## 4-3-21 REPLACE FRONT PANEL ASSEMBLY

RELIMINARY PROCEDURES:                    Remove Top Case Assembly (4-3-1)  
   Remove Bottom Case Assembly (4-3-2)

STEP	PROCEDURE
------	-----------

1. Remove nut (1).
2. Disconnect wire cable connector (2).
3. Remove eight screws (3).
4. Lift Front Panel Assembly (4) off Chassis Assembly (5).
5. Disconnect two ribbon cable connectors (6).
6. Disconnect two coaxial cable connectors (7).

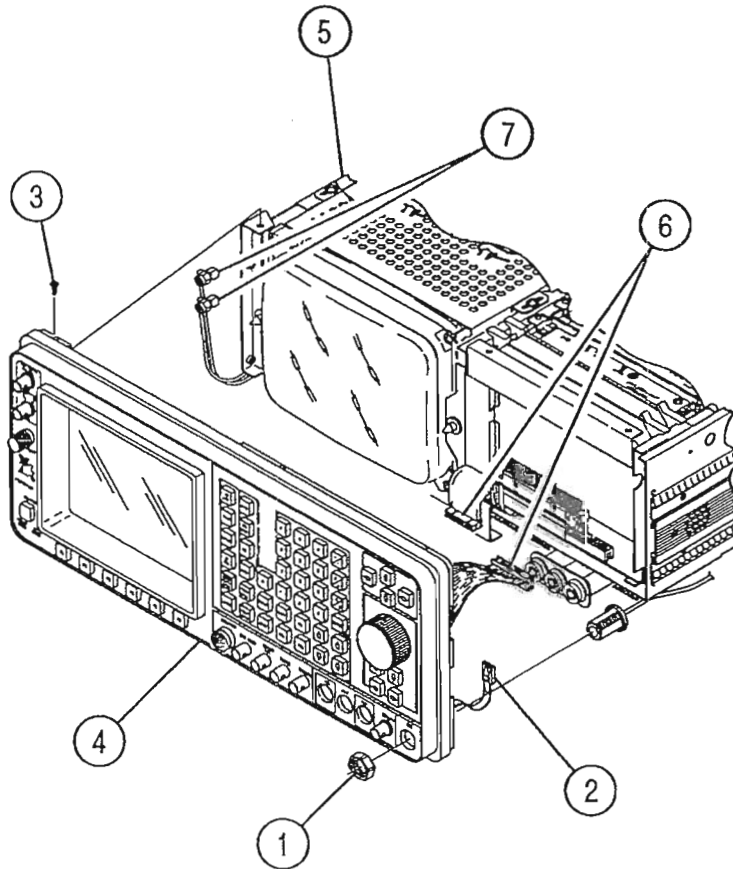

8621021



## 4-3-22 REPLACE REAR PANEL CONNECTOR PC BOARD ASSEMBLY

PRELIMINARY PROCEDURES: Remove Top Case Assembly (4-3-1)

STEP PROCEDURE

---

1. Disconnect three ribbon cable connectors (1).
2. Remove eight shell nuts (2).
3. Remove Rear Panel Connector PC Board Assembly (3) from Rear Panel Assembly (4).

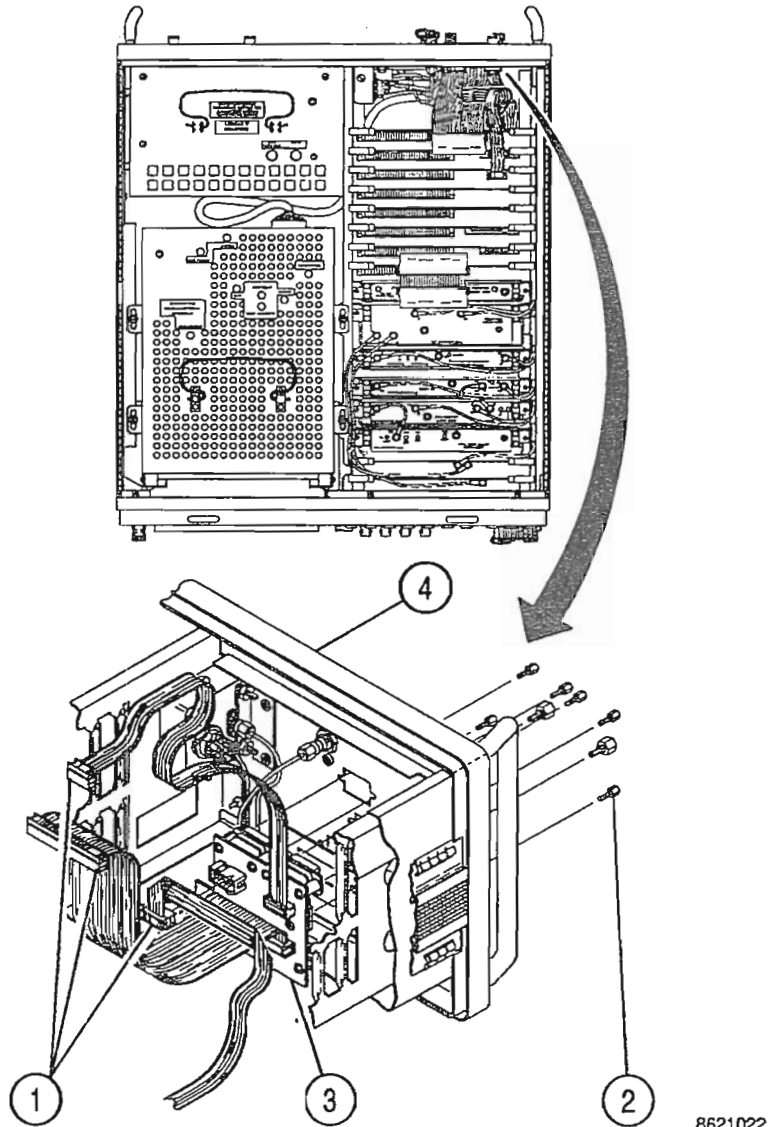

## 4-3-23 REPLACE REAR PANEL ASSEMBLY

PRELIMINARY PROCEDURES:      Remove Top Case Assembly (4-3-1)  
   Remove Bottom Case Assembly (4-3-2)

STEP	PROCEDURE
------	-----------

1. Remove four screws (1).
2. Remove Rear Panel Assembly (2).

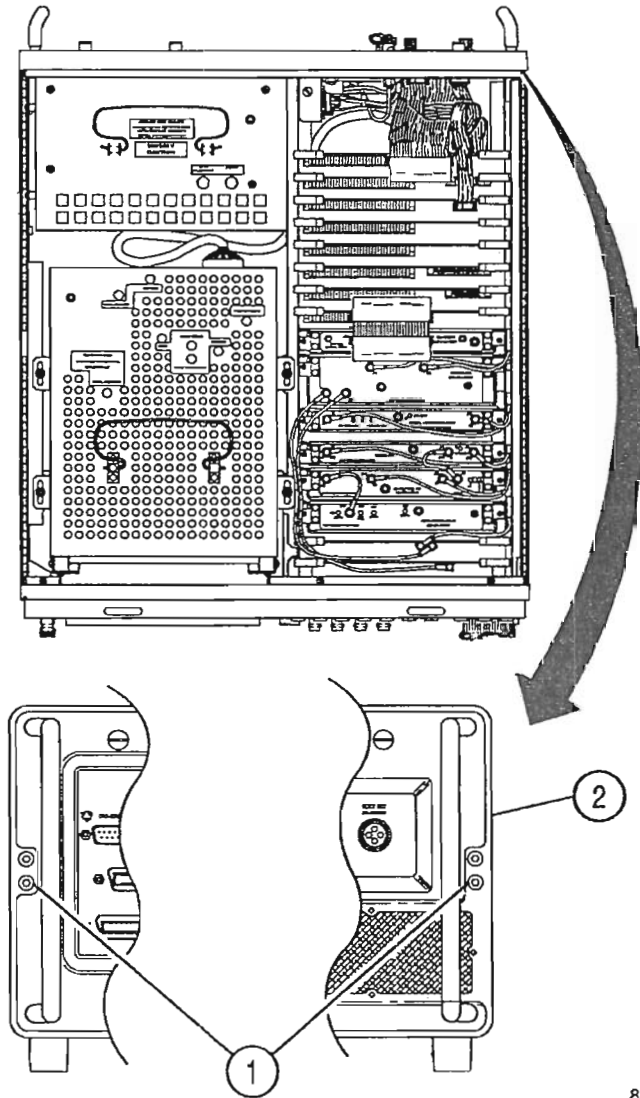

8621023

## 4-3-24 REPLACE DMM ASSEMBLY

PRELIMINARY PROCEDURES: Remove Bottom Case Assembly (4-3-2)

STEP	PROCEDURE
------	-----------

---

1. Disconnect wire cable connector (1).
2. Remove two spacer nuts and washers (2).
3. Slide DMM Assembly (3) to rear and remove.

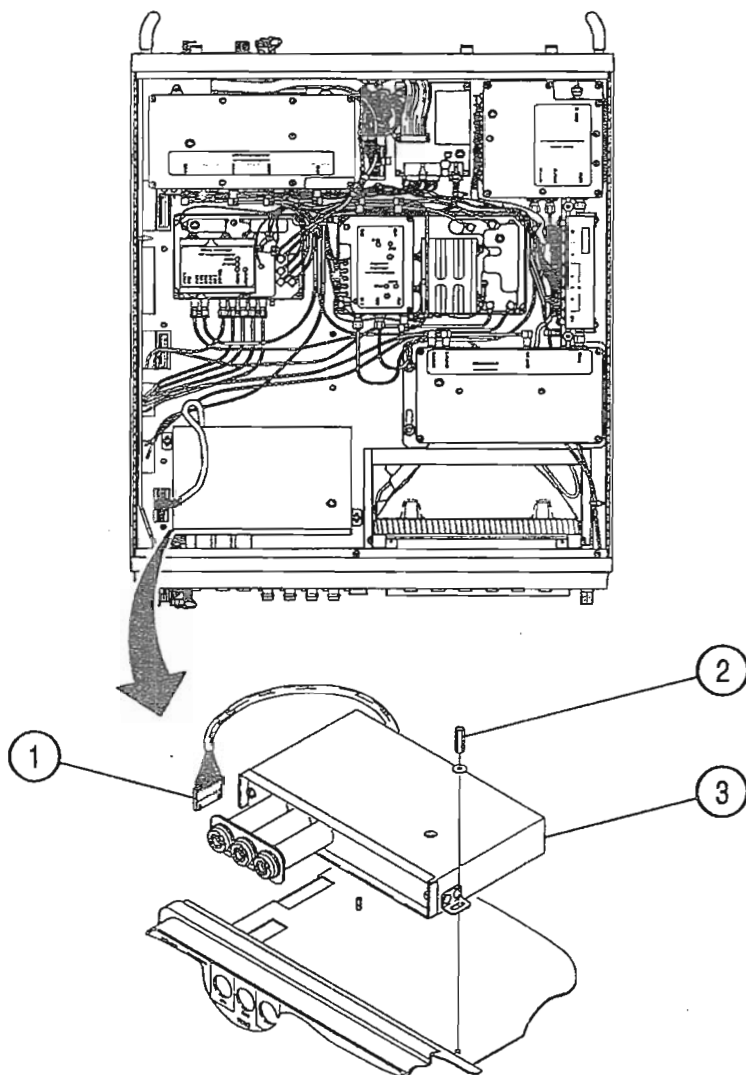

8621024

## 4-3-25 REPLACE 2nd LO ASSEMBLY

PRELIMINARY PROCEDURES: Remove Bottom Case Assembly (4-3-2)

STEP PROCEDURE

---

1. Disconnect eleven coaxial connectors (1).
2. Disconnect two wire cable connectors (2).
3. Loosen four captive screws (3).
4. Remove 2nd LO Assembly (4).

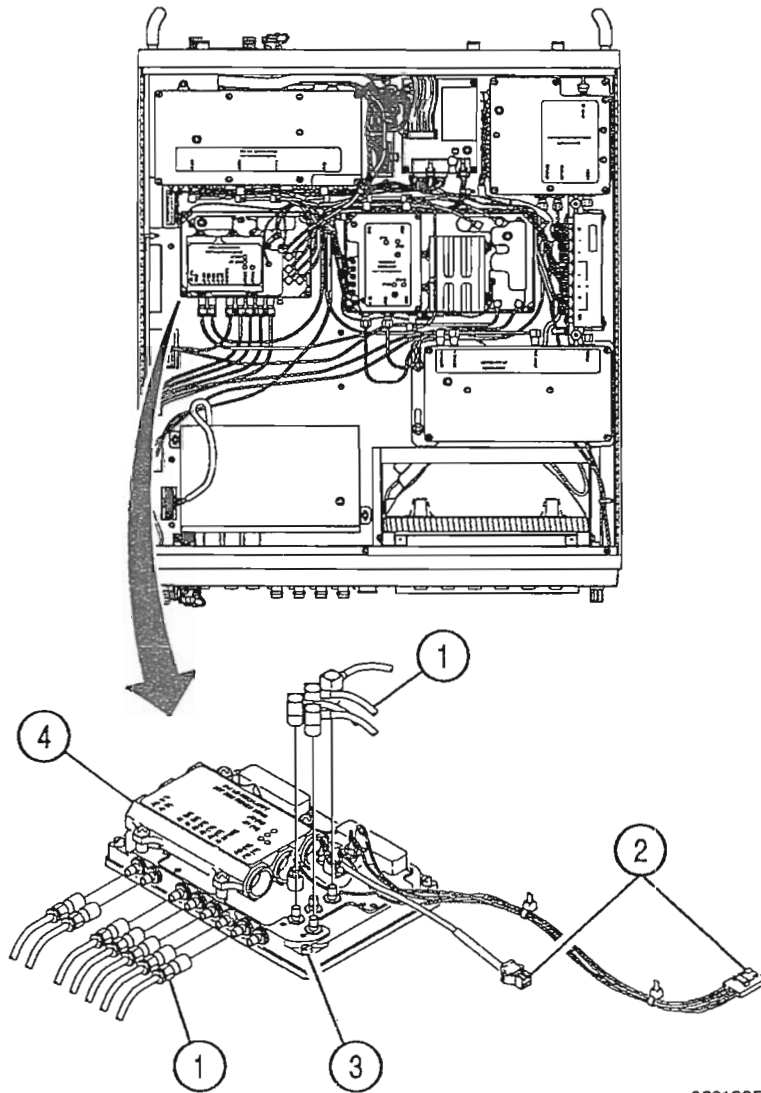

8621025

## 4-3-26 REPLACE 1st LO ASSEMBLY

PRELIMINARY PROCEDURES: Remove Bottom Case Assembly (4-3-2)

STEP PROCEDURE

---

1. Disconnect four coaxial cable connectors (1).
2. Disconnect wire cable connector (2).
3. Loosen three captive screws (3).
4. Remove 1st LO Assembly (4).

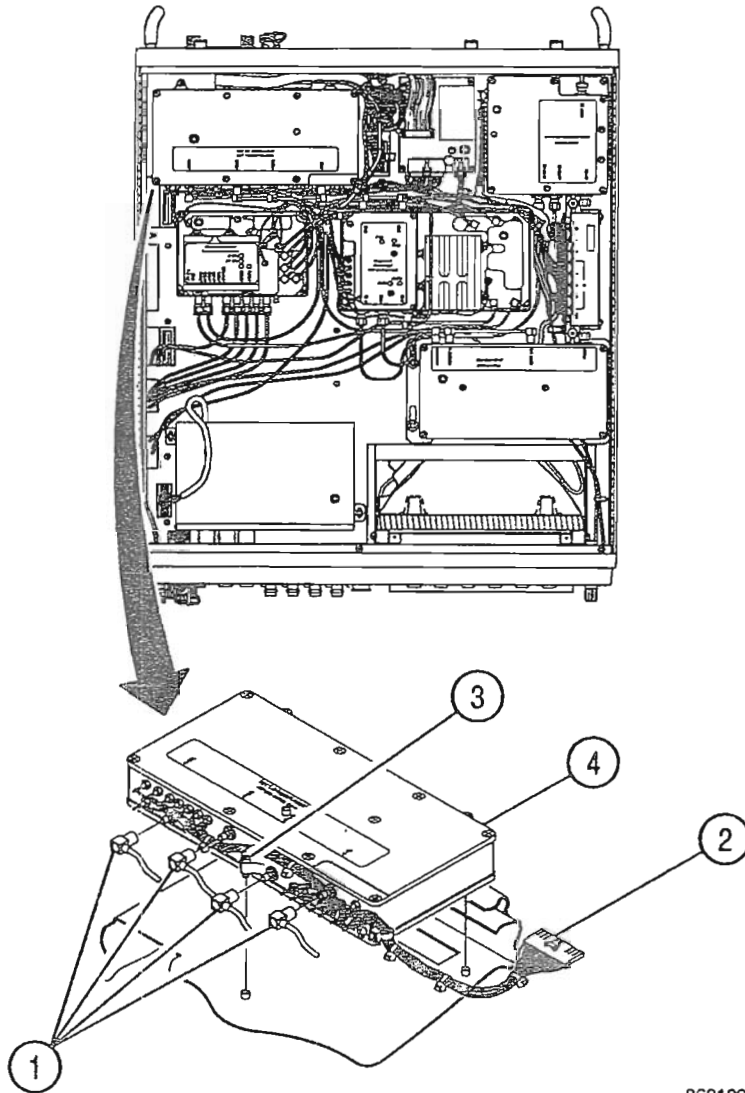

8621026

## 4-3-27 REPLACE AUXILIARY POWER SUPPLY PC BOARD ASSEMBLY

PRELIMINARY PROCEDURES: Remove Bottom Case Assembly (4-3-2)

STEP	PROCEDURE
------	-----------

1. Disconnect three wire cable connectors (1).
2. Disconnect two ribbon cable connectors (2).
3. Loosen four screws (3).
4. Remove Auxiliary Power Supply PC Board Assembly (4).

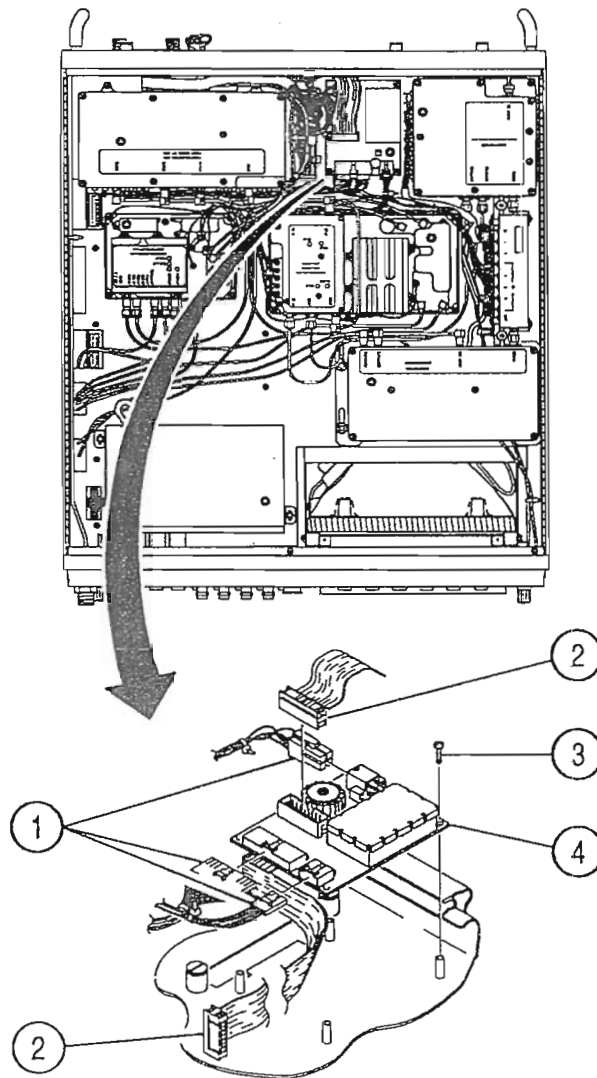

8621027

## 4-3-28 REPLACE RECEIVE IF ASSEMBLY

PRELIMINARY PROCEDURES: Remove Bottom Case Assembly (4-3-2)

STEP PROCEDURE

---

1. Disconnect seven coaxial cable connectors (1).
2. Disconnect wire cable connector (2).
3. Remove two screws (3).
4. Remove Receive IF Assembly (4).

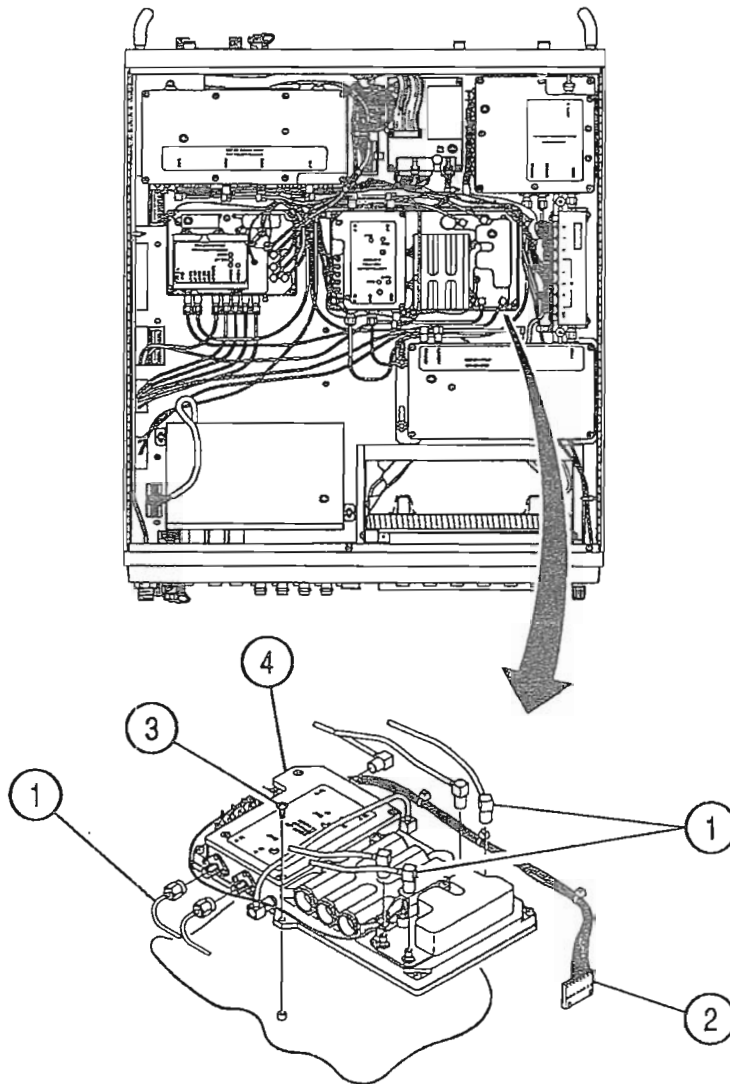

8621028

## 4-3-29 REPLACE GENERATOR IF ASSEMBLY

PRELIMINARY PROCEDURES: Remove Bottom Case Assembly (4-3-2)

STEP PROCEDURE

---

1. Disconnect wire cable connector (1).
2. Disconnect three coaxial cable connectors (2).
3. Loosen four nuts (3) securing each bracket.
4. Disconnect coaxial cable connector (4).
5. Loosen four captive screws (5).
6. Remove Generator IF Assembly (6).

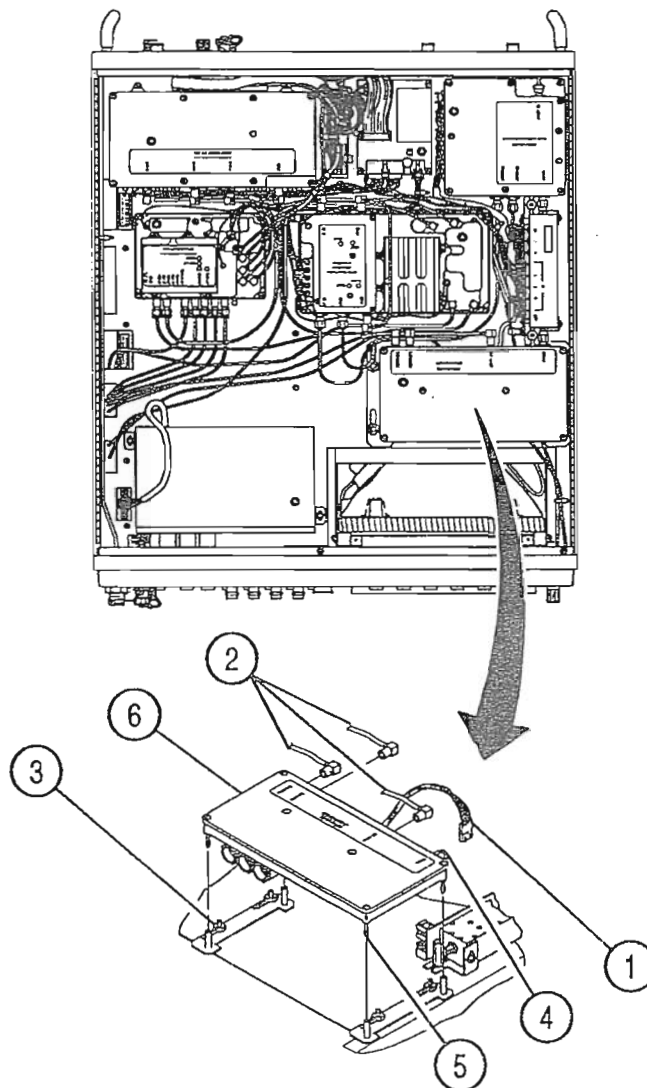

8621029



## 4-3-30 REPLACE ATTENUATOR PC BOARD ASSEMBLY

PRELIMINARY PROCEDURES: Remove Bottom Case Assembly (4-3-2)

STEP	PROCEDURE
------	-----------

1. Disconnect three wire cable connectors (1).
2. Disconnect ribbon cable connector (2).
3. Loosen two nuts (3) securing each bracket.
4. Disconnect two coaxial cable connectors (4) (5).
5. Remove two screws and washers (6).
6. Remove Attenuator PC Board Assembly (7).

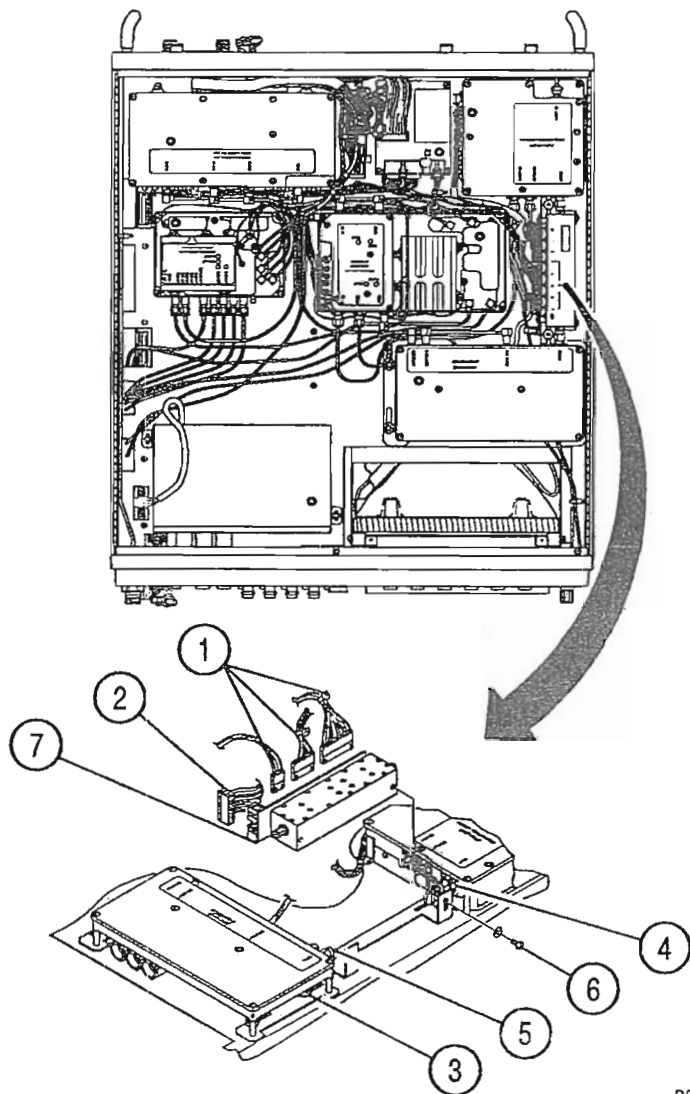

8621030

### 4-3-31 REPLACE POWER TERM ASSEMBLY

PRELIMINARY PROCEDURES: Remove Bottom Case Assembly (4-3-2)

STEP PROCEDURE

---

1. Remove wire cable connector (1).
2. Disconnect three coaxial cable connectors (2).
3. Loosen two nuts (3) securing each bracket.
4. Loosen nut (4) securing each bracket.
5. Disconnect coaxial cable connector (5).
6. Loosen four captive screws (6).
7. Remove Power Term Assembly (7).

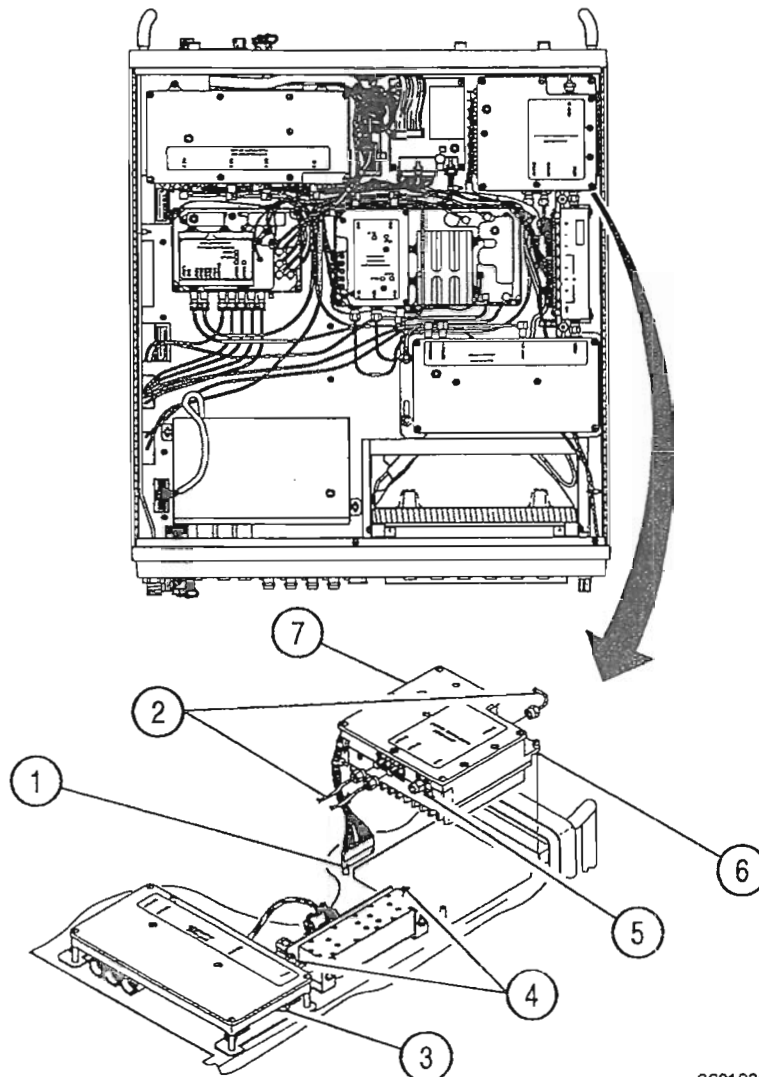

8621031

## 4-3-32 REPLACE 10 MHz FREQUENCY STANDARD

### PRELIMINARY PROCEDURES:

Remove Top Case Assembly (4-3-1)  
Remove Bottom Case Assembly (4-3-2)  
Remove Rear Panel Assembly (4-3-23)

### STEP

### PROCEDURE

1. Disconnect coaxial cable connector (1).
2. Disconnect wire cable connector (2).
3. Remove two screws (3).
4. Remove 10 MHz Frequency Standard (4).
5. Remove two nuts and washers (5).
6. Remove bracket (6) from 10 MHz Frequency Standard (4).

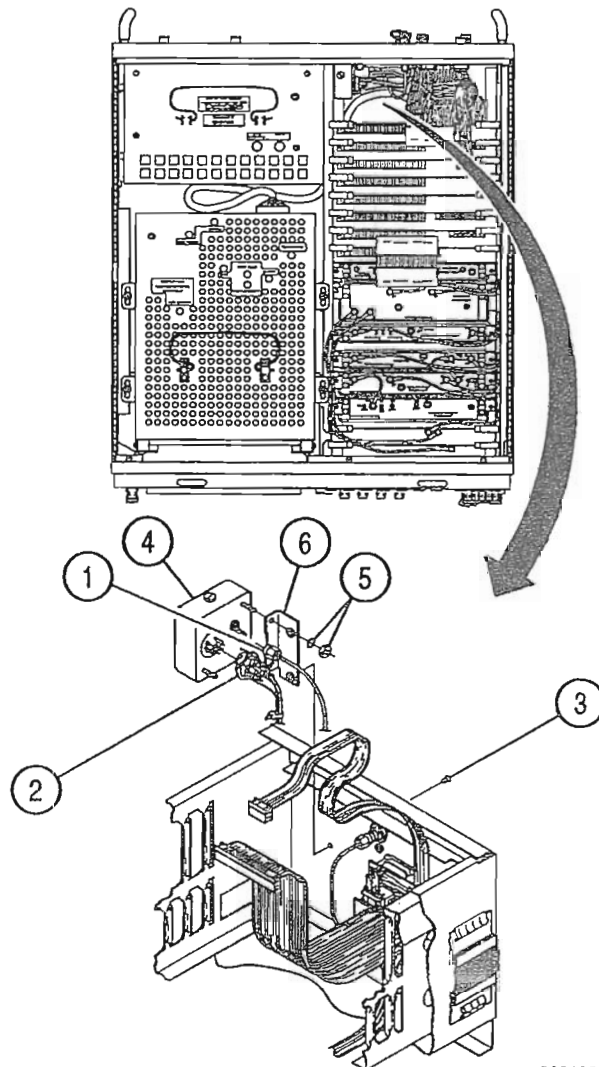

8621032

### 4-3-33 REPLACE EXTERNAL REFERENCE CONNECTOR

PRELIMINARY PROCEDURES:            Remove Top Case Assembly (4-3-1)  
   Remove Bottom Case Assembly (4-3-2)  
   Remove Rear Panel Assembly (4-3-23)

STEP	PROCEDURE
------	-----------

1. Disconnect coaxial cable connector (1).
2. Remove nut and lock washer (2).
3. Remove External Reference Connector (3) from Chassis Assembly (4).

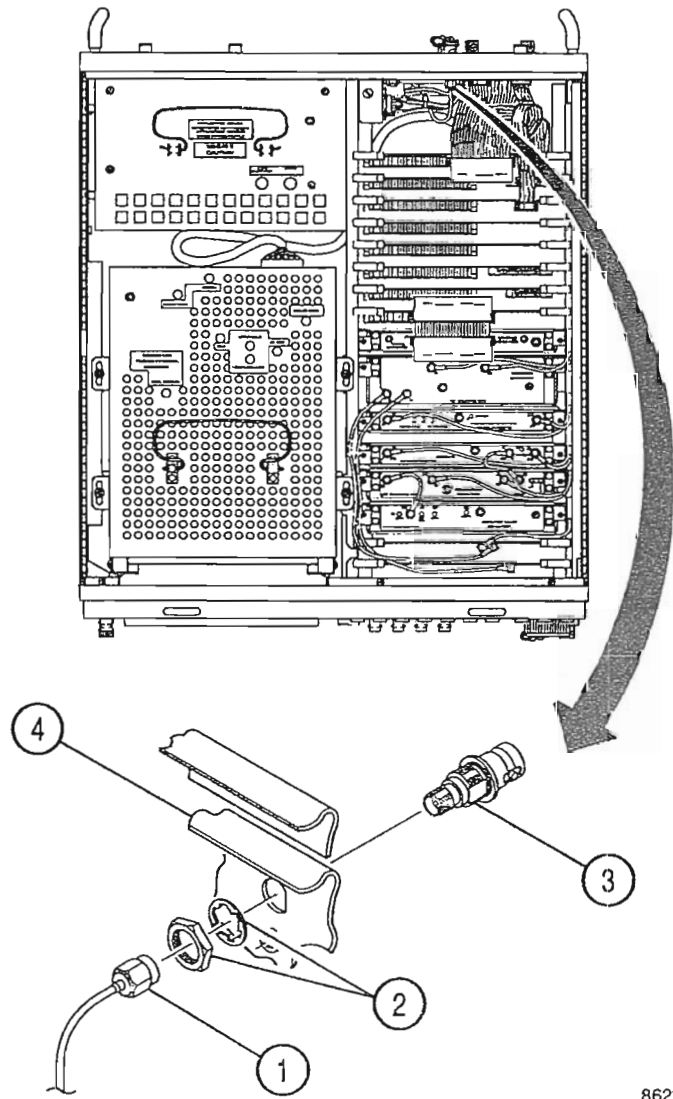

8621034

## 4-3-34 REPLACE MOTHERBOARD PC BOARD ASSEMBLY

### PRELIMINARY PROCEDURES:

Remove Top Case Assembly (4-3-1).  
Remove Bottom Case Assembly (4-3-2).  
Remove Digitizer PC Board Assembly (4-3-3).  
Remove Counter PC Board Assembly (4-3-4).  
Remove Analyzer Log/IF Assembly (4-3-5).  
Remove Analyzer RF Assembly (4-3-6).  
Remove 3rd LO Assembly (4-3-7).  
Remove 90 MHz Generator Assembly (4-3-8).  
Remove Receiver Assembly (4-3-9).  
Remove Monitor Assembly (4-3-10).  
Remove Monitor Control PC Board Assembly (4-3-11).  
Remove Function Generator PC Board Assembly (4-3-12).  
Remove RF I/O PC Board Assembly (4-3-13).  
Remove Memory PC Board Assembly (4-3-14).  
Remove Processor PC Board Assembly (4-3-15).  
Remove Video Controller PC Board Assembly (4-3-16).  
Remove External I/O PC Board Assembly (4-3-17).  
Remove Power Supply Assembly (4-3-18).  
Remove DMM Assembly (4-3-24).  
Remove 2nd LO Assembly (4-3-25).  
Remove 1st LO Assembly (4-3-26).  
Remove Receive IF Assembly (4-3-28).

### STEP

### PROCEDURE

---

1. Remove two screws (1).
2. Remove video cable panel (2).
3. Disconnect three wire cable connectors (3).
4. Disconnect four ribbon cable connectors (4).
5. Remove two screws (5).
6. Remove bracket (6).
7. Remove 18 screws (7).
8. Remove Motherboard PC Board Assembly (8).





# SECTION 5 - PREVENTIVE MAINTENANCE

## 5-1 EXTERNAL CLEANING

**CAUTION:** DISCONNECT POWER FROM TEST SET TO AVOID POSSIBLE DAMAGE TO ELECTRONIC CIRCUITS.

- | STEP | PROCEDURE  |
|------|--|
| 1.   | Clean front panel, switches and display face with soft lint-free cloth. If dirt is difficult to remove, dampen cloth with water and liquid detergent.                              |
| 2.   | Remove grease, fungus and ground-in dirt from surfaces with soft lint-free cloth dampened (not wet) with denatured alcohol.  |
| 3.   | Remove dust and dirt from connectors with soft-bristled brush.<br><b>NOTE:</b> Cover connectors, not in use, with suitable dust cover to prevent tarnishing of connector contacts. |
| 4.   | Clean cables with soft lint-free cloth.  |
| 5.   | Paint exposed metal surface to avoid corrosion.  |

## 5-2 INTERNAL CLEANING

**CAUTION:** DO NOT MOVE COMPONENTS ON CIRCUIT BOARDS OR DISASSEMBLE CONNECTORS NEEDLESSLY TO AVOID POSSIBLE DAMAGE.

DO NOT OPEN COMPLEX INTERNAL MODULES FOR SOLE PURPOSE OF CLEANING AND INSPECTION.

THE PREVENTIVE MAINTENANCE PROCEDURES FOR THE FM/AM-1600S THAT REQUIRE REMOVAL OF CASE ASSEMBLIES SHOULD ONLY BE PERFORMED IN AN ESD ENVIRONMENT AND ALL PERSONNEL PERFORMING THE PROCEDURES SHOULD HAVE KNOWLEDGE OF ACCEPTED ESD PRACTICES AND/OR BE ESD CERTIFIED.

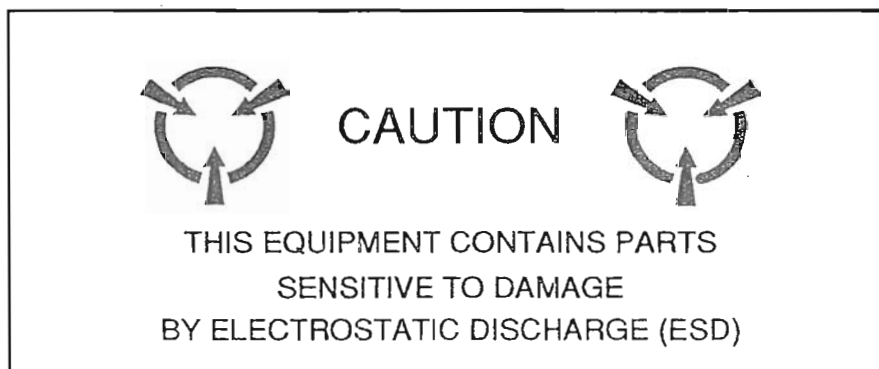

- | STEP | PROCEDURE  |
|------|--|
| 1.   | Remove dust with hand-controlled dry air jet of 15 psi (1.054 kg/cm <sup>2</sup> ) and wipe internal chassis parts and frame with soft lint-free cloth moistened with alcohol. |
| 2.   | Clean switches and controls with contact cleaner.  |



## 5-3 VISUAL INSPECTION

### STEP

### PROCEDURE

---

1. Inspect Chassis for:
  - Tightness of sub-assemblies and chassis mounted connectors.
  - Corrosion or damage to metal surfaces.
2. Inspect Capacitors for:
  - Loose mounting, deformities or obvious physical damage.
  - Leakage or corrosion around leads.
3. Inspect Connectors for:
  - Loose or broken parts, cracked insulation and bad contacts.
4. Inspect Circuit Boards for:
  - Corrosion or damage to connectors.
  - Damage to mounted components including crystals and ICs.
  - Freedom from foreign material.
5. Inspect Resistors for:
  - Cracked, broken, charred or blistered bodies.
  - Loose or corroded soldering connections.
6. Inspect Semiconductors for:
  - Cracked, broken, charred or discolored bodies.
  - Seals around leads being in place and in good condition.
7. Inspect Switches for:
  - Loose levers, terminals and switch body contact to frame.
  - Bent or loose line switch contacts.
8. Inspect Wiring for:
  - Broken or loose ends and connections.
  - Proper dress relative to other chassis parts.

**NOTE:** Verify laced wiring is tight with ends securely tied.

# SECTION 6 - MECHANICAL ASSEMBLIES, PC BOARDS & SCHEMATICS

## 6-1 GENERAL

This section contains selected drawings to aid the technician in testing the FM/AM-1600S. Drawing types include Mechanical Assemblies and Schematics. An Index of diagrams available is listed in 6-2.

## 6-2 INDEX OF FM/AM-1600S DRAWINGS

FIGURE	TITLE	PAGE
6-0	FM/AM-1600S System Block Diagram with RF Overview . . . . .	6-2a
6-1	FM/AM-1600S System Interconnect Diagram . . . . .	6-3
6-2	Motherboard Assembly Schematic . . . . .	6-4
6-3	Motherboard PC Board Assembly Diagram . . . . .	6-5
6-4	Rear Panel Connector Assembly Schematic . . . . .	6-6

## 6-3 TABLE OF FM/AM-1600S COAXIAL CABLES

The following table identifies the coaxial cables in the FM/AM-1600S by number and function. The signal frequency and signal level for each coaxial cable is given for each possible mode of operation. Refer to the FM/AM-1600S System Interconnect Diagram for the Assemblies that are connected by the coaxial cables.

COAX NUMBER	FUNCTION	SIGNAL FREQUENCY	SIGNAL LEVEL (NOMINAL)
1	Antenna Input (1)	0.2500 to 999.9999MHz	- 30 dBm Max
2	Transmit/Receive Input/Output	0.2500 to 999.9999MHz	200 W Max
3	Duplex Generator Output	0.2500 to 999.9999MHz	+7 to -120 dBm
4	Power Term Crossover To Receive IF Assembly Receive Mode (2) Generate Mode (3)	0.2500 to 999.9999 MHz 0.2500 to 999.9999 MHz	-40/-60 dBc 0/-20 dBc
5	Mixer Null Crossfeed	1.3 to 2.298 GHz	+7 dBm
6	1st LO Assembly to Receive IF Assembly	1.3 to 2.298 GHz	+7 dBm
7	2nd LO Assembly to Receive IF Assembly	1210 MHz	+7 dBm
8	Receive IF Assembly to Receiver Assembly Receive at Antenna Connector Mode (1) Receive at T/R Connector Mode(1), (2) Generate Mode (3)	10.7 MHz	+3 dBc -32/-52dBc -12/-32 dBc
9	Receive IF Assembly to Analyzer RF Assembly Receive at Antenna Connector Mode (1) Receive at T/R Connector Mode (1), (2) Generate Mode (3)	83 to 95 MHz	0 dBc -37/-57 dBc 12/-32 dBc
10	3rd LO Assembly to Receive IF Assembly	77.3001 to 79.3 MHz	+7 dBm

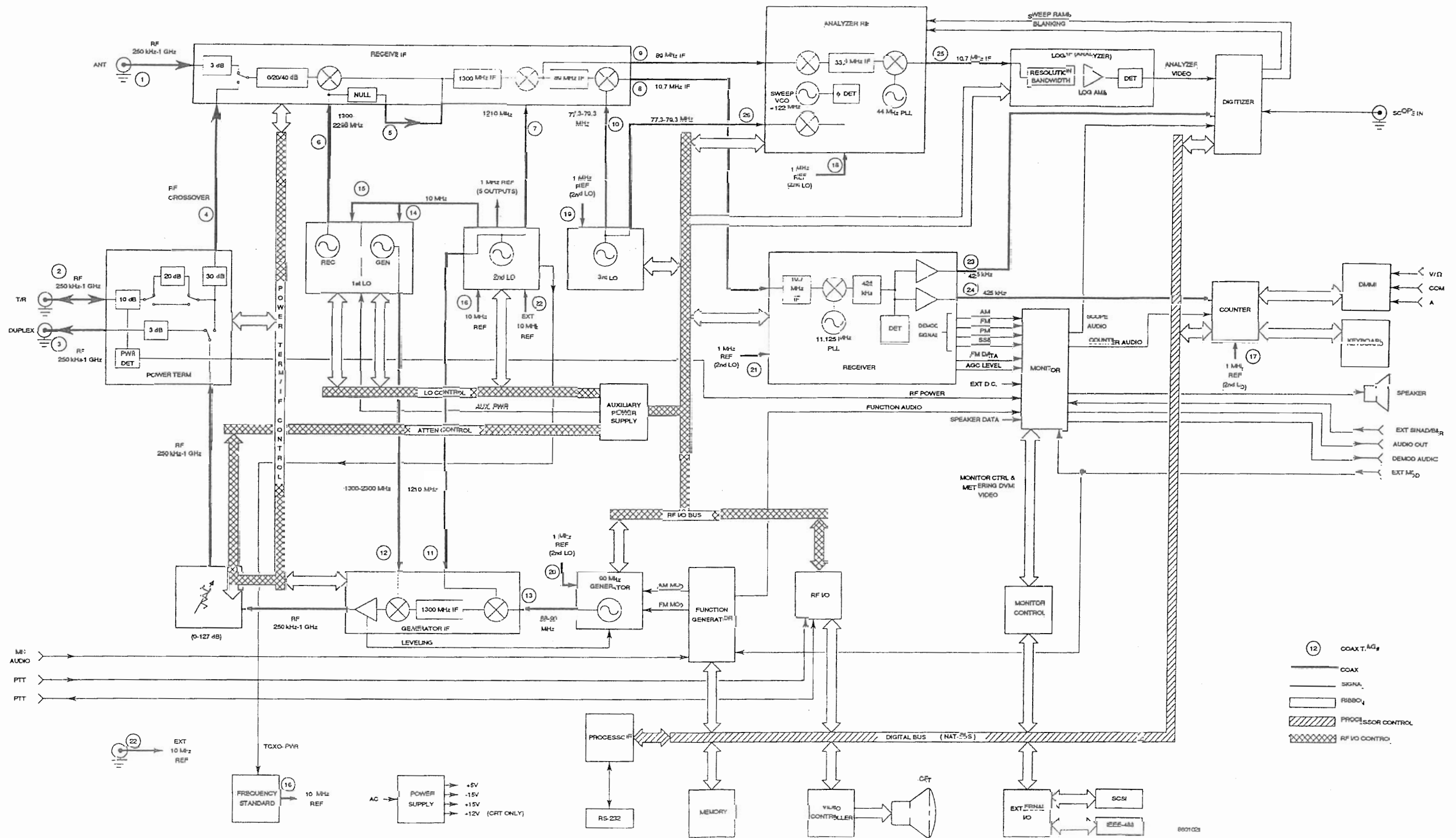

Figure 6-0 FM/AM-1600S System Block Diagram with RF Overview

COAX NUMBER	FUNCTION	SIGNAL FREQUENCY	SIGNAL LEVEL (NOMINAL)
11	2nd LO Assembly to Generator IF Assembly	1210 MHz	0 dBm
12	1st LO Assembly to Generate IF Assembly	1300 to 2298 MHz	+7 dBm
13	90 MHz Generator Assembly to Generator IF Assembly	88.0001 to 90 MHz	Leveled (>-10 dBm Open Loop)
14	Reference to Generate 1st LO Assembly	10 MHz	+7 dBm
15	Reference to Receive 1st LO Assembly	10 MHz	+7 dBm
16	TCXO Output	10 MHz	3 Vp-p
17	Reference to Counter PC Board Assembly	1 MHz	TTL
18	Reference to Analyzer RF Assembly	1 MHz	TTL
19	Reference to 3rd LO Assembly	1 MHz	TTL
20	Reference to 90 MHz Generator Assembly	1 MHz	TTL
21	Reference to Receiver Assembly	1 MHz	TTL
22	External Reference	10 MHz	>1 Vp-p
23	Receiver Assembly to Digitizer PC Board Assembly	425 kHz	
24	Receiver Assembly to Counter PC Board Assembly	425 kHz	
25	Analyzer RF Assembly to Analyzer Log/IF Assembly Receive at ANTENNA IN Connector Mode (1) Receive at T/R Connector Mode (1), (2) Generate Mode (3)	10.7 MHz	+10 dBc -27/-47 dBc -7/-27 dBc
26	3rd LO Assembly to Analyzer RF Assembly	77.3001 to 79.3 MHz	+7 dBm

**NOTE:**

- (1) indicates that the 0/20/40 dB Attenuator is assumed to be in the 0 dB position. If another selection is made, attenuation factor must be considered.
- (2) Indicates <2 W and >2 W meter settings respectively.
- (3) Value is relative to T/R Generate output level. Dual values represent <-20 dBm and >-20 dBm output levels respectively. A fixed attenuation setting of 20 dB is used in the Receive IF Assembly for Simplex Generate Operation.

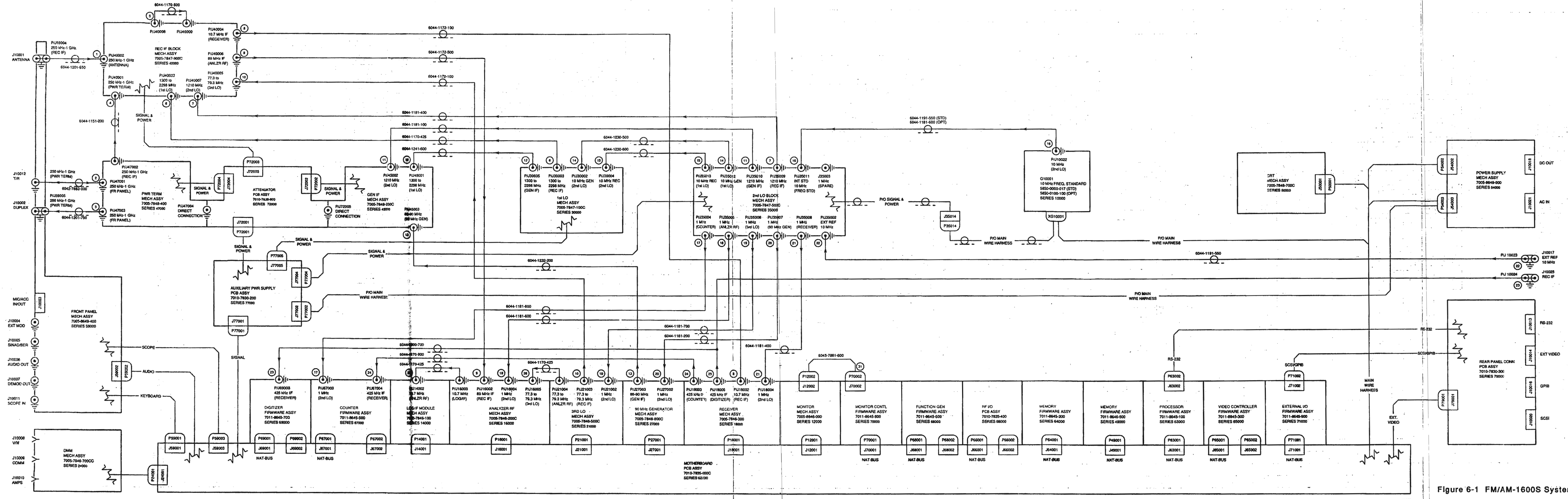
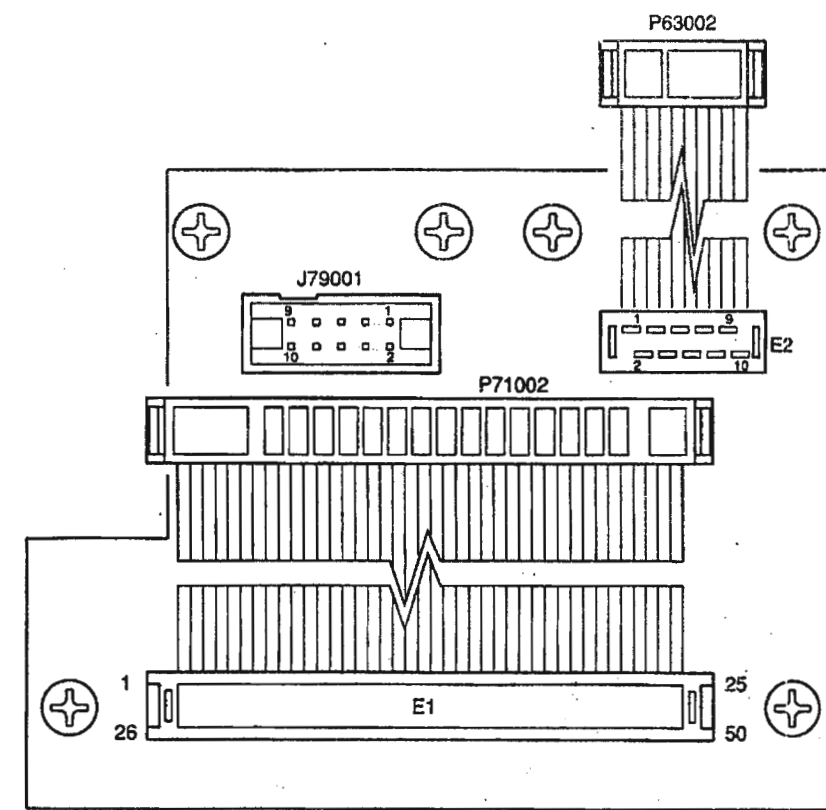

Figure 6-1 FM/AM-1600S System Interconnect Diagram









REAR PANEL CONNECTOR PC BOARD ASSEMBLY  
(7010-7830-300-D4)

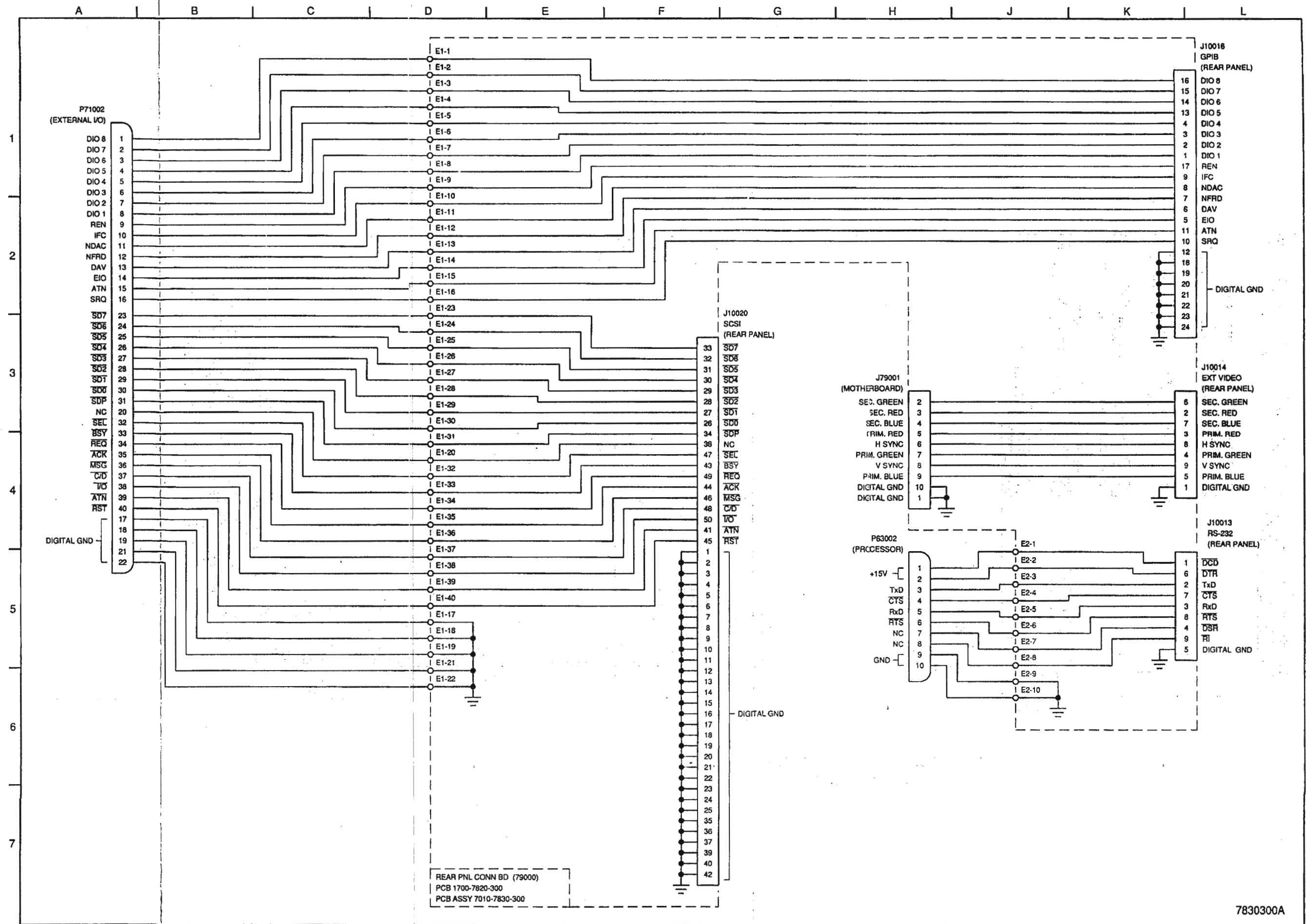
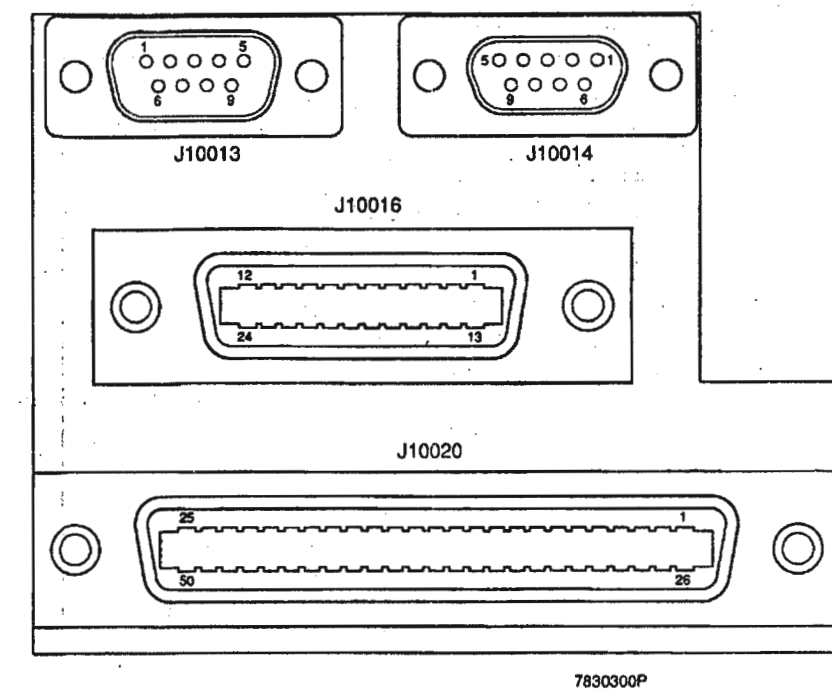

7830300A

Figure 6-4 Rear Panel Connector Assembly Schematic  
(0000-7830-300-D2)