

# **MAINTENANCE MANUAL**

## **DUAL MODE/TRI-BAND CELLULAR SYSTEM ANALYZER**

### **IFR-1900**

PUBLISHED BY  
IFR AMERICAS, INC.

COPYRIGHT © IFR Americas, Inc. 1999

All rights reserved. No part of this publication may be reproduced, stored in a retrieval system, or transmitted in any form or by any means, electronic, mechanical, photocopying, recording or otherwise without the prior permission of the publisher.

10200 West York / Wichita, Kansas 67215 U.S.A. / (316) 522-4981 / FAX (316) 524-2623

THIS PAGE INTENTIONALLY LEFT BLANK.

# **WARNING:**

## **HIGH VOLTAGE EQUIPMENT**

**THIS EQUIPMENT CONTAINS CERTAIN CIRCUITS AND/OR COMPONENTS OF EXTREMELY HIGH VOLTAGE POTENTIALS, CAPABLE OF CAUSING SERIOUS BODILY INJURY OR DEATH. WHEN PERFORMING ANY OF THE PROCEDURES CONTAINED IN THIS MANUAL, HEED ALL APPLICABLE SAFETY PRECAUTIONS.**

### **SAFETY FIRST: TO ALL SERVICE PERSONNEL**

**REFER ALL SERVICING OF UNIT TO QUALIFIED TECHNICAL PERSONNEL.**

#### **CASE, COVER OR PANEL REMOVAL**

Removing protective covers, casings or panels from this unit exposes the technician to electrical hazards that can result in electrical shock or equipment damage.

#### **SAFETY IDENTIFICATION IN TECHNICAL MANUAL**

This manual uses the following terms to draw attention to possible safety hazards, that may exist when operating or servicing this equipment.

**CAUTION:** THIS TERM IDENTIFIES CONDITIONS OR ACTIVITIES THAT, IF IGNORED, CAN RESULT IN EQUIPMENT OR PROPERTY DAMAGE (e.g., FIRE).

**WARNING:** THIS TERM IDENTIFIES CONDITIONS OR ACTIVITIES THAT, IF IGNORED, CAN RESULT IN PERSONAL INJURY OR DEATH.

#### **SAFETY SYMBOLS IN MANUALS AND ON UNITS**



**CAUTION:** Refer to accompanying documents.



**AC OR DC TERMINAL:** Terminal that may supply or be supplied with ac or dc voltage.



**DC TERMINAL:** Terminal that may supply or be supplied with dc voltage.



**AC TERMINAL:** Terminal that may supply or be supplied with ac or alternating voltage.



**SWITCH OFF:** AC line power to the device is OFF.



**SWITCH ON:** AC line power to the device is ON.

#### **EQUIPMENT GROUNDING PRECAUTION**

Improper grounding of equipment can result in electrical shock.

#### **USE OF PROBES**

Check the specifications for the maximum voltage, current and power ratings of any connector on the unit before connecting it with a probe from a terminal device. Be sure the terminal device performs within these specifications before using it for measurement, to prevent electrical shock or damage to the equipment.

#### **POWER CORDS**

Power cords must not be frayed or broken nor expose bare wiring when operating this equipment.

#### **USE RECOMMENDED FUSES ONLY**

Use only fuses specifically recommended for the equipment at the specified current and voltage ratings.

**CAUTION:** INTEGRATED CIRCUITS AND SOLID STATE DEVICES SUCH AS MOS FETS, ESPECIALLY CMOS TYPES, ARE SUSCEPTIBLE TO DAMAGE BY ELECTROSTATIC DISCHARGES RECEIVED FROM IMPROPER HANDLING, THE USE OF UNGROUNDED TOOLS AND IMPROPER STORAGE AND PACKAGING. ANY MAINTENANCE TO THIS UNIT MUST BE PERFORMED WITH THE FOLLOWING PRECAUTIONS:

- BEFORE USE IN A CIRCUIT, KEEP ALL LEADS SHORTED TOGETHER EITHER BY THE USE OF VENDOR-SUPPLIED SHORTING SPRINGS OR BY INSERTING LEADS INTO A CONDUCTIVE MATERIAL.
- WHEN REMOVING DEVICES FROM THEIR CONTAINERS, GROUND THE HAND BEING USED WITH A CONDUCTIVE WRISTBAND.
- TIPS OF SOLDERING IRONS AND/OR ANY TOOLS USED MUST BE GROUNDED.
- DEVICES MUST NEVER BE INSERTED INTO NOR REMOVED FROM CIRCUITS WITH POWER ON.
- PC BOARDS, WHEN TAKEN OUT OF THE SET, MUST BE LAID ON A GROUNDED CONDUCTIVE MAT OR STORED IN A CONDUCTIVE STORAGE BAG. REMOVE ANY BUILT-IN POWER SOURCE, SUCH AS A BATTERY, BEFORE LAYING PC BOARDS ON A CONDUCTIVE MAT OR STORING IN A CONDUCTIVE BAG.
- PC BOARDS, IF BEING SHIPPED TO THE FACTORY FOR REPAIR, MUST BE PACKAGED IN A CONDUCTIVE BAG AND PLACED IN A WELL-CUSHIONED SHIPPING CONTAINER.

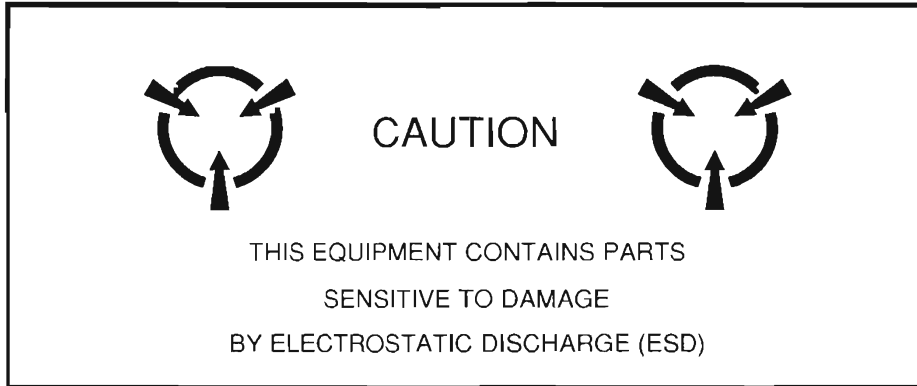

**CAUTION:** SIGNAL GENERATORS CAN BE A SOURCE OF ELECTROMAGNETIC INTERFERENCE (EMI) TO COMMUNICATION RECEIVERS. SOME TRANSMITTED SIGNALS CAN CAUSE DISRUPTION AND INTERFERENCE TO COMMUNICATION SERVICES OUT TO A DISTANCE OF SEVERAL MILES. USERS OF THIS EQUIPMENT SHOULD SCRUTINIZE ANY OPERATION THAT RESULTS IN RADIATION OF A SIGNAL (DIRECTLY OR INDIRECTLY) AND SHOULD TAKE NECESSARY PRECAUTIONS TO AVOID POTENTIAL COMMUNICATION INTERFERENCE PROBLEMS.

**CAUTION:** KEEP ALL VENT OPENINGS CLEAR AND UNOBSTRUCTED FOR PROPER EQUIPMENT COOLING AND CONTINUED RELIABILITY. DO NOT OPERATE EQUIPMENT IN THE VERTICAL POSITION ON PULS CARPET OR UPHOLSTERY TO AVOID IMPAIRING THE AIR EXHAUST. WHEN OPERATING THE TEST SET IN THE NORMAL HORIZONTAL OR TILT BAIL POSITION, MAINTAIN AT LEAST 1.6 INCHES (≈ FOUR CENTIMETERS) OF CLEARANCE BETWEEN THE EQUIPMENT REAR EXHAUST FAN SCREEN AND OBJECTS OR WALLS.

# LIST OF EFFECTIVE PAGES

The manual pages listed below affected by a change or revision, are identified by a revision number.

Date of Issue for original and changed pages are:

Original ..... 0 ..... April 2000

**TOTAL NUMBER OF PAGES IN THIS MANUAL IS 312 CONSISTING OF THE FOLLOWING**

Pg. No.	Rev No.	Pg. No.	Rev No.
Title/Copyright.....	0	2-1 through 2-72.....	0
Warning.....	0	3-1 through 3-60.....	0
Caution.....	0	4-1 through 4-12.....	0
A through D.....	0	FP-1 through FP-50.....	0
i through vi.....	0	A-1 through A-8.....	0
1-i through 1-ii.....	0	INDEX-1 through INDEX 3.....	0
1-1 through 1-90.....	0	INDEX-4 blank.....	0

THIS PAGE INTENTIONALLY LEFT BLANK.

# PREFACE

## SCOPE

This manual contains maintenance instructions for the 1900CSA. The information in this manual enables servicing technicians to:

- Service, test or replace any major assembly within the 1900 CSA.
- Maintain operating conditions of the 1900CSA to the expected performance standards.
- Understand principles of operation, relating to the overall operation of the 1900CSA as well as functional operation within the major assemblies.

## ORGANIZATION

The 1900CSA Maintenance Manual is composed of the following chapters:

### CHAPTER 1 - INTRODUCTION

Provides general information including the purpose of equipment. Detailed function descriptions showing the relationships of all assemblies, including block diagrams, are furnished in this chapter.

### CHAPTER 2 - MAINTENANCE INSTRUCTIONS

Provides information for unpacking, servicing and adjustments for equipment upon receipt of material. Troubleshooting guidelines are contained in this chapter.

### CHAPTER 3 – REPLACEMENTS/ADJUSTMENTS

Provides step by step procedures for removing and installing major assemblies within the 1900CSA.

### CHAPTER 4 - PARTS LIST

Provides part lists for ordering replaceable parts within the 1900CSA.

### CHAPTER 5 - MECHANICAL ASSEMBLIES, PC BOARDS AND SCHEMATICS

Contains foldout drawings to aid the technician in isolating a dysfunctional major assembly.

THIS PAGE INTENTIONALLY LEFT BLANK.



## TABLE OF CONTENTS

---

### CHAPTER 1 INTRODUCTION

<b>SECTION 1 GENERAL INFORMATION .....</b>	<b>1-1</b>
1-1-1 SCOPE .....	1-1
1-1-2 NOMENCLATURE CROSS-REFERENCE LIST .....	1-1
<b>SECTION 2 EQUIPMENT DESCRIPTION AND DATA .....</b>	<b>1-1</b>
1-2-1 EQUIPMENT CHARACTERISTICS, CAPABILITIES, AND FEATURES.....	1-1
1-2-2 EQUIPMENT DATA.....	1-1
1-2-3 SAFETY, CARE AND HANDLING .....	1-1
<b>SECTION 3 PRINCIPLES OF OPERATION .....</b>	<b>1-1</b>
1-3-1 GENERAL FUNCTIONAL DESCRIPTION.....	1-1
1-3-2 DETAILED FUNCTIONAL DESCRIPTION. ....	1-2

### CHAPTER 2 MAINTENANCE INSTRUCTIONS

<b>SECTION 1 SERVICE UPON RECEIPT.....</b>	<b>2-2</b>
2-1-1 SERVICE UPON RECEIPT OF MATERIAL.....	2-2
2-1-2 PRELIMINARY SERVICING AND ADJUSTMENT OF EQUIPMENT.....	2-2
2-1-3 TROUBLESHOOTING SYMPTOM INDEX .....	2-3
2-1-4 TROUBLESHOOTING GUIDELINES.....	2-4
2-1-5 EQUIPMENT INSPECTION. ....	2-4
2-1-6 TROUBLESHOOTING TABLE .....	2-5
<b>SECTION 2 TROUBLESHOOTING TESTS.....</b>	<b>2-22</b>
2-2-1 POWER FAULTS TEST .....	2-22
2-2-2 BEEP SEQUENCE TEST.....	2-25
2-2-3 LCD ABNORMALITY TEST .....	2-27
2-2-4 KEYBOARD KEY TEST. ....	2-28
2-2-5 SELF TEST FAILURE TEST.....	2-30
2-2-6 DMM TEST .....	2-44
2-2-7 PERFORMANCE TEST .....	2-47
2-2-8 FREQUENCY AGILITY TEST .....	2-68

### CHAPTER 3 REPLACEMENTS/ADJUSTMENTS

<b>SECTION 1 REPLACEMENTS.....</b>	<b>3</b>
3-1-1 REPLACE 34A3 TOP CASE .....	3
3-1-2 REPLACE 34A2 BOTTOM CASE .....	4
3-1-3 REPLACE 34A5A32 DIGITIZER .....	5
3-1-4 REPLACE 34A5A30 COUNTER .....	6

# TABLE OF CONTENTS

<b>CHAPTER 3 REPLACEMENTS/ADJUSTMENTS (continued)</b>	
3-1-5	REPLACE 34A5A7 ANALYZER LOG/IF ..... 7
3-1-6	REPLACE 34A5A8 ANALYZER RF ..... 8
3-1-7	REPLACE 34A5A40 3rd LO ..... 9
3-1-8	REPLACE 34A5A41 90 MHz GENERATOR ..... 10
3-1-9	REPLACE 34A5A9 RECEIVER ..... 11
3-1-10	REPLACE 34A5A6 MONITOR ..... 12
3-1-11	REPLACE 34A5A33 MONITOR CONTROL ..... 13
3-1-12	REPLACE 34A5A31 FUNCTION GENERATOR ..... 14
3-1-13	REPLACE 34A5A29 RF I/O ..... 15
3-1-14	REPLACE 34A5A27 FLASH MEMORY (INSTRUMENT) ..... 16
3-1-15	REPLACE 34A5A26 PROCESSOR ..... 17
3-1-16	REPLACE 34A5A28 VIDEO CONTROLLER ..... 18
3-1-17	REPLACE 34A5A35 EXTERNAL I/O ..... 19
3-1-18	REPLACE 34A5A22 POWER SUPPLY ..... 20
3-1-19	REPLACE 34A5A23 FRONT PANEL ..... 22
3-1-20	REPLACE 34A5A38 REAR PANEL CONNECTOR ..... 23
3-1-21	REPLACE 34A5A5 REAR PANEL ..... 24
3-1-22	REPLACE 34A5A11 DMM ..... 25
3-1-23	REPLACE 34A5A15 2nd LO ..... 26
3-1-24	REPLACE 34A5A13 1st LO ..... 27
3-1-25	REPLACE 34A5A37 AUXILIARY POWER SUPPLY ..... 28
3-1-26	REPLACE 34A5A16 RF RECEIVE IF ..... 29
3-1-27	REPLACE 34A5A20 GENERATOR IF ..... 30
3-1-28	REPLACE 34A5A36 ATTENUATOR ..... 31
3-1-29	REPLACE 34A5A21 POWER TERMINATION ..... 32
3-1-30	REPLACE 34A5A39 MASTER OSCILLATOR ..... 33
3-1-31	UPLOAD INTERFACE SOFTWARE PROCEDURE ..... 35
<b>SECTION 2 ADJUSTMENTS. .... 36</b>	
3-2-1	POWER SUPPLY ADJUSTMENT ..... 40
3-2-2	METERING DVM ADJUSTMENT ..... 41
3-2-3	FUNC GEN LEVEL AND VRMS METER ADJUSTMENT ..... 41
3-2-4	GEN OUTPUT LEVEL ADJUSTMENT ..... 43
3-2-5	RF NULL ADJUSTMENT ..... 44
3-2-6	SIGNAL METER ADJUSTMENT ..... 44
3-2-7	FM ADJUSTMENT ..... 45

## TABLE OF CONTENTS

<b>CHAPTER 3 REPLACEMENTS/ADJUSTMENTS (continued)</b>	
3-2-8	DEVIATION METER ADJUSTMENT ..... 46
3-2-8	MODULATION METER ADJUSTMENT ..... 48
3-2-9	PHASE METER ADJUSTMENT ..... 48
3-2-10	DISTORTION METER ADJUSTMENT ..... 50
3-2-11	SINAD METER ADJUSTMENT ..... 51
3-2-12	GEN MODULATION ADJUSTMENT ..... 52
3-2-13	SCOPE ADJUSTMENT ..... 55
3-2-14	SPECTRUM ANALYZER ADJUSTMENT ..... 56
3-2-15	POWER METER ADJUSTMENT ..... 58
<b>SECTION 3 PREPARATION FOR STORAGE OR SHIPMENT..... 60</b>	
3-3-1	PACKAGING ..... 60
3-3-2	ENVIRONMENT ..... 60
 <b>CHAPTER 4 PARTS LIST</b>	
<b>SECTION 1 GENERAL ..... 4-2</b>	
4-1-1	COMPOSITE ASSEMBLY ..... 4-2
4-1-2	CASE ASSEMBLY ..... 4-5
4-1-3	LID ASSEMBLY ..... 4-6
4-1-4	FRONT PANEL ASSEMBLY ..... 4-7
4-1-5	REAR PANEL ASSEMBLY ..... 4-9
4-1-6	COAX KIT ASSEMBLY ..... 4-10
4-1-7	WIRE HARNESS & RBN CABLE ..... 4-12

### LIST OF ILLUSTRATIONS

Figure 1-1.	A22 Power Supply Functional Block Diagram ..... 1-3
Figure 1-2.	A26 Processor (Instrument) Functional Block Diagram ..... 1-6
Figure 1-3.	A31 Function Generator Functional Block Diagram ..... 1-8
Figure 1-4.	A28 Video Controller Functional Block Diagram ..... 1-10
Figure 1-5.	A33 Monitor Control Functional Block Diagram ..... 1-12
Figure 1-6.	A30 Counter Functional Block Diagram ..... 1-14
Figure 1-7.	A23 Front Panel Functional Block Diagram ..... 1-16
Figure 1-8.	A36 Power Termination Functional Block Diagram ..... 1-18
Figure 1-9.	A16 Receive IF Functional Block Diagram ..... 1-21
Figure 1-10.	A13 1st LO Functional Block Diagram ..... 1-24
Figure 1-11.	A15 2nd LO Functional Block Diagram ..... 1-27

## TABLE OF CONTENTS

Figure 1-12.A40 3rd LO Functional Block Diagram. ....	1-30
---	------

### LIST OF ILLUSTRATIONS

Figure 1-13.A1 Receiver Functional Block Diagram. ....	1-32
Figure 1-14.A6 Monitor Functional Block Diagram. ....	1-34
Figure 1-15.A8 Analyzer RF Functional Block Diagram.....	1-36
Figure 1-16.A7 Analyzer Log/IF Functional Block Diagram. ....	1-38
Figure 1-17.A32 Digitizer Functional Block Diagram. ....	1-40
Figure 1-18.A41 90 MHz Generator Functional Block Diagram.....	1-42
Figure 1-19.A20 Generator IF Functional Block Diagram.....	1-45
Figure 1-20.A36 Attenuator Functional Block Diagram.....	1-48
Figure 1-21.A22 RF I/O Functional Block Diagram.....	1-50
Figure 1-22.A31 Auxiliary Power Supply Functional Block Diagram. ....	1-53
Figure 1-23.A35 External I/O Functional Block Diagram. ....	1-56
Figure 1-24.A11 DMM Functional Block Diagram.....	1-58
Figure 1-25.TDMA Power Distribution PC Board Assembly Block Diagram.....	1-59
Figure 1-26.TDMA Processor Firmware Assembly.....	1-63
Figure 1-27.Flash Memory PC Board Assembly Block Diagram .....	1-65
Figure 1-28.DSP Firmware Assembly Block Diagram .....	1-70
Figure 1-29.TDMA External I/O Firmware Assembly Block Diagram .....	1-72
Figure 1-30.Internal I/O Firmware Assembly Block Diagram .....	1-78
Figure 1-31.TDMA 10.7 MHz Receiver PC Board Assembly Block Diagram .....	1-81
Figure 1-32.RF Modem PC Board Assembly Block Diagram .....	1-86
Figure 1-33.Baseband Mux PC Board Assembly Block Diagram .....	1-90

### LIST OF TABLES

Table 1-1. TDMA Power Distribution PC Board Assembly Signals.....	1-60
Table 1-2. TDMA NAT-BUS Signals.....	1-62
Table 1-3. DSP Firmware Assembly Signals.....	1-69
Table 1-4. Internal I/O Firmware Assembly Signals .....	1-76
Table 1-5. TDMA 10.7 MHz Receiver PC Board Assembly Signals .....	1-80
Table 1-6. RF Modem PC Board Assembly Signals.....	1-84
Table 1-7. Baseband Mux PC Board Assembly Signals .....	1-87

## **TABLE OF CONTENTS**

### **LIST OF FOLDOUTS**

#### **CHAPTER 5 MECHANICAL ASSEMBLIES, PC BOARDS AND SCHEMATICS**

Figure FO-1 Test Set Functional Block Diagram.....	FP-2
Figure FO-2 Test Set (34A5) Assembly, Cable Locator and Interconnect Diagram.....	FP-5
Figure FO-3 34A5A1 Assembly Component Locator Diagram.....	FP-12
Figure FO-4 34A5A2 Assembly Component Locator Diagram.....	FP-13
Figure FO-5 34A5A3A1 Motherboard Assembly Component Locator and Wiring Diagram .....	FP-14
Figure FO-6 34A5A3A2 TDMA Motherboard Assembly Component Locator and Wiring Diagram .....	FP-18
Figure FO-7 34A5A6, 34A5A7 and 34A5A8 Assemblies Component Locator Diagrams .....	FP-22
Figure FO-8 34A5A9 and 34A5A40 Assemblies Component Locator Diagrams .....	FP-23
Figure FO-9 34A5A11 DMM Assembly Component Locator Diagram .....	FP-24
Figure FO-10 34A5A41 Assembly Component Locator Diagram.....	FP-25
Figure FO-11 34A5A13 1 <sup>st</sup> LO Assembly Component Locator and Wiring Diagram.....	FP-26
Figure FO-12 34A5A14 PC Board Assembly Component Locator Diagram .....	FP-27
Figure FO-13 34A5A15 2 <sup>nd</sup> LO Assembly Component Locator and Wiring Diagram.....	FP-28
Figure FO-15 34A5A17 PC Board Assembly Component Locator Diagram .....	FP-30
Figure FO-16 34A5A18 PC Board Assembly Component Locator Diagram .....	FP-31
Figure FO-17 34A5A19 Firmware Assembly Component Locator Diagram.....	FP-32
Figure FO-18 34A5A20 Generator IF Assembly Component Locator Diagram .....	FP-33
Figure FO-19 34A5A21 Power Termination Assembly Component Locator and Wiring Diagram .....	FP-34
Figure FO-20 34A5A22 Power Supply Assembly Component Locator Diagram.....	FP-35
Figure FO-21 34A5A23 Front Panel Assembly Component Locator Diagram.....	FP-36
Figure FO-22 34A5A24/34A5A26 PC Board Assembly Component Locator Diagram .....	FP-37
Figure FO-23 34A5A25/34A5A27 PC Board Assembly Component Locator Diagram .....	FP-38
Figure FO-24 34A5A28 PC Board Assembly Component Locator Diagram .....	FP-39
Figure FO-25 34A5A29 PC Board Assembly Component Locator Diagram.....	FP-40
Figure FO-26 34A5A30 PC Board Assembly Component Locator Diagram.....	FP-41
Figure FO-27 34A5A31 PC Board Assembly Component Locator Diagram.....	FP-42
Figure FO-28 34A5A32 PC Board Assembly Component Locator Diagram.....	FP-43
Figure FO-29 34A5A33 PC Board Assembly Component Locator Diagram .....	FP-44
Figure FO-30 34A5A34/34A5A35 PC Board Assembly Component Locator Diagram .....	FP-45
Figure FO-31 34A5A36 Attenuator Assembly Component Locator Diagram .....	FP-46
Figure FO-32 34A5A37 Auxiliary Power Supply Assembly Component Locator and Schematic Diagram ....	FP-48
Figure FO-33 34A5A38 Rear Panel Connector PC Board Assembly Wiring Diagram.....	FP-50

# TABLE OF CONTENTS

---

## APPENDIX A COAXIAL SIGNALS, USER I/O CONNECTORS, AND PIN OUT TABLES

### TABLES

Table A-1. Coaxial Signals .....	A-2
Table A-2. User I/O Connectors .....	A-4
Table A-3. Pin-Outs for MIC/ACC Connector .....	A-5
Table A-4. Pin-Outs for SERIAL Connector .....	A-6
Table A-5. Pin-Outs for External Video Connector .....	A-7

### FIGURES

Figure A-1. MIC/ACC Connector Pin Identification .....	A-5
Figure A-2. Serial Connector Pin Identification .....	A-6
Figure A-3. External Video Connector Pin Identification .....	A-7

**CHAPTER 1 INTRODUCTION****CHAPTER TABLE OF CONTENTS**

<b>SECTION 1</b>	<b>GENERAL INFORMATION .....</b>	<b>1-1</b>
1-1-1	SCOPE .....	1-1
1-1-2	NOMENCLATURE CROSS-REFERENCE LIST .....	1-1
<b>SECTION 2</b>	<b>EQUIPMENT DESCRIPTION AND DATA.....</b>	<b>1-1</b>
1-2-1	EQUIPMENT CHARACTERISTICS, CAPABILITIES, AND FEATURES.....	1-1
1-2-2	EQUIPMENT DATA.....	1-1
1-2-3	SAFETY, CARE AND HANDLING .....	1-1
<b>SECTION 3</b>	<b>PRINCIPLES OF OPERATION .....</b>	<b>1-1</b>
1-3-1	GENERAL FUNCTIONAL DESCRIPTION.....	1-1
1-3-2	DETAILED FUNCTIONAL DESCRIPTION.....	1-2

**LIST OF FIGURES**

Figure 1-1.	A22 Power Supply Functional Block Diagram.....	1-3
Figure 1-2.	A26 Processor (Instrument) Functional Block Diagram.....	1-6
Figure 1-3.	A31 Function Generator Functional Block Diagram.....	1-8
Figure 1-4.	A28 Video Controller Functional Block Diagram.....	1-10
Figure 1-5.	A33 Monitor Control Functional Block Diagram.....	1-12
Figure 1-6.	A30 Counter Functional Block Diagram.....	1-14
Figure 1-7.	A23 Front Panel Functional Block Diagram.....	1-16
Figure 1-8.	A36 Power Termination Functional Block Diagram.....	1-18
Figure 1-9.	A16 Receive IF Functional Block Diagram.....	1-21
Figure 1-10.	A13 1st LO Functional Block Diagram.....	1-24
Figure 1-11.	A15 2nd LO Functional Block Diagram.....	1-27
Figure 1-12.	A40 3rd LO Functional Block Diagram.....	1-30
Figure 1-13.	A9 Receiver Functional Block Diagram.....	1-32
Figure 1-14.	A6 Monitor Functional Block Diagram.....	1-34
Figure 1-15.	A8 Analyzer RF Functional Block Diagram.....	1-36
Figure 1-16.	A7 Analyzer Log/IF Functional Block Diagram.....	1-38
Figure 1-17.	A32 Digitizer Functional Block Diagram.....	1-40
Figure 1-18.	A41 90 MHz Generator Functional Block Diagram.....	1-42
Figure 1-19.	A20 Generator IF Functional Block Diagram.....	1-45
Figure 1-20.	A36 Attenuator Functional Block Diagram.....	1-48
Figure 1-21.	A22 RF I/O Functional Block Diagram.....	1-50
Figure 1-22.	A31 Auxiliary Power Supply Functional Block Diagram.....	1-53
Figure 1-23.	A35 External I/O Functional Block Diagram.....	1-56

## CHAPTER 1 INTRODUCTION

Figure 1-24.	A11 DMM Functional Block Diagram.....	1-58
Figure 1-25.	A14 TDMA Power Distribution PC Board Assembly Block Diagram.....	1-59
Figure 1-26.	A24 TDMA Processor Firmware Assembly Block Diagram .....	1-63
Figure 1-27.	A25 Flash Memory PC Board Assembly Block Diagram.....	1-65
Figure 1-28.	A19 DSP Firmware Assembly Block Diagram.....	1-70
Figure 1-29.	A34 TDMA External I/O Firmware Assembly Block Diagram.....	1-72
Figure 1-30.	A2 Internal I/O Firmware Assembly Block Diagram .....	1-78
Figure 1-31.	A1 TDMA 10.7 MHz Receiver PC Board Assembly Block Diagram .....	1-81
Figure 1-32.	A18 RF Modem PC Board Assembly Block Diagram.....	1-86
Figure 1-33.	A17 Baseband Mux PC Board Assembly Block Diagram .....	1-90

### ***LIST OF TABLES***

Table 1-1.	TDMA Power Distribution PC Board Assembly Signals.....	1-60
Table 1-2.	TDMA NAT-BUS Signals .....	1-62
Table 1-3.	DSP Firmware Assembly Signals .....	1-69
Table 1-4.	Internal I/O Firmware Assembly Signals.....	1-76
Table 1-5.	TDMA 10.7 MHz Receiver PC Board Assembly Signals .....	1-80
Table 1-6.	RF Modem PC Board Assembly Signals .....	1-84
Table 1-7.	Baseband Mux PC Board Assembly Signals .....	1-87



## CHAPTER 1 INTRODUCTION

---

### **SECTION 1**

### **SECTION 2 GENERAL INFORMATION**

#### 1-1-1 SCOPE

- a. Type of Manual. General Support Maintenance Manual.
- b. Equipment Name and Model Number. IFR-1900CSA.
- c. Purpose of Equipment. The IFR-1900CSA is a general-purpose communications test set for testing radios and related equipment.

#### 1-1-2 NOMENCLATURE CROSS-REFERENCE LIST

Common Name	Official Nomenclature
Test Set	IFR-1900CSA

### **SECTION 3 EQUIPMENT DESCRIPTION AND DATA**

#### 1-2-1 EQUIPMENT CHARACTERISTICS, CAPABILITIES, AND FEATURES

Refer to IFR-1900CSA Operation Manual for this information.

#### 1-2-2 EQUIPMENT DATA

Refer to IFR-1900CSA Operation Manual for this information.

#### 1-2-3 SAFETY, CARE AND HANDLING

Observe all WARNINGS, CAUTIONS and NOTES in this manual. This equipment can be extremely dangerous if these instructions are not followed.

### **SECTION 4 PRINCIPLES OF OPERATION**

#### 1-3-1 GENERAL FUNCTIONAL DESCRIPTION

Refer to IFR-1900CSA Operation Manual for this information.

### 1-3-2 DETAILED FUNCTIONAL DESCRIPTION.

The Test Set Functional Block Diagram (fig. FO-1) shows the relationship of all assemblies. The following is a detailed description of the Test Set assemblies.

a. 34A5A22 POWER SUPPLY (fig. 1-1). The Power Supply has a built-in FAN, and when ac power is applied, it is passed to the PWR APPLIED CIRCUIT where it is regulated to form the PWR APPLIED LED Signal to activate the POWER APPLIED Indicator.

When dc power is applied, it is passed to the +15 V REG (Regulator). The 15 V Regulator provides +15 V to the PWR APPLIED CIRCUIT to generate the POWER APPLIED LED Signal to activate the POWER APPLIED Indicator.

Once the POWER Switch is pressed, the PWR ON SW Signal is sent to the PWR ON CIRCUIT. This Circuit activates the POWER ON LED Signal to illuminate the POWER ON Indicator.

If ac power is used, the POWER ON CIRCUIT also passes a signal to the RELAY DRIVER to activate the RELAY DRIVER, closing the AC IN RELAY. The ac voltage is passed to the LINE RECTIFIER & VOLTAGE DOUBLER. The LINE RECTIFIER & VOLTAGE DOUBLER provides approximately +300 Vdc to the POWER MOSFET Switcher.

If dc power is used, pressing the POWER Switch activates the DC/DC CONVERTOR CIRCUIT, which generates approximately +300 Vdc to the POWER MOSFET Switcher.

The POWER MOSFET Switcher passes a 300 Vp-p square wave to the TRANSFORMER & RECTIFIER Circuit. The TRANSFORMER & RECTIFIER Circuit has +15 V, +5 V and -15 V as outputs.

Current and voltage requirements are passed from the TRANSFORMER AND RECTIFIER CIRCUIT to the POWER MOSFET through the OPTO-COUPLER and the PULSE WIDTH MODULATOR (PWM). When a high current condition is detected by the OPTO- COUPLER and PULSE WIDTH MODULATOR, the POWER MOSFET shuts down, turning off the voltage output of the A22 Power Supply.

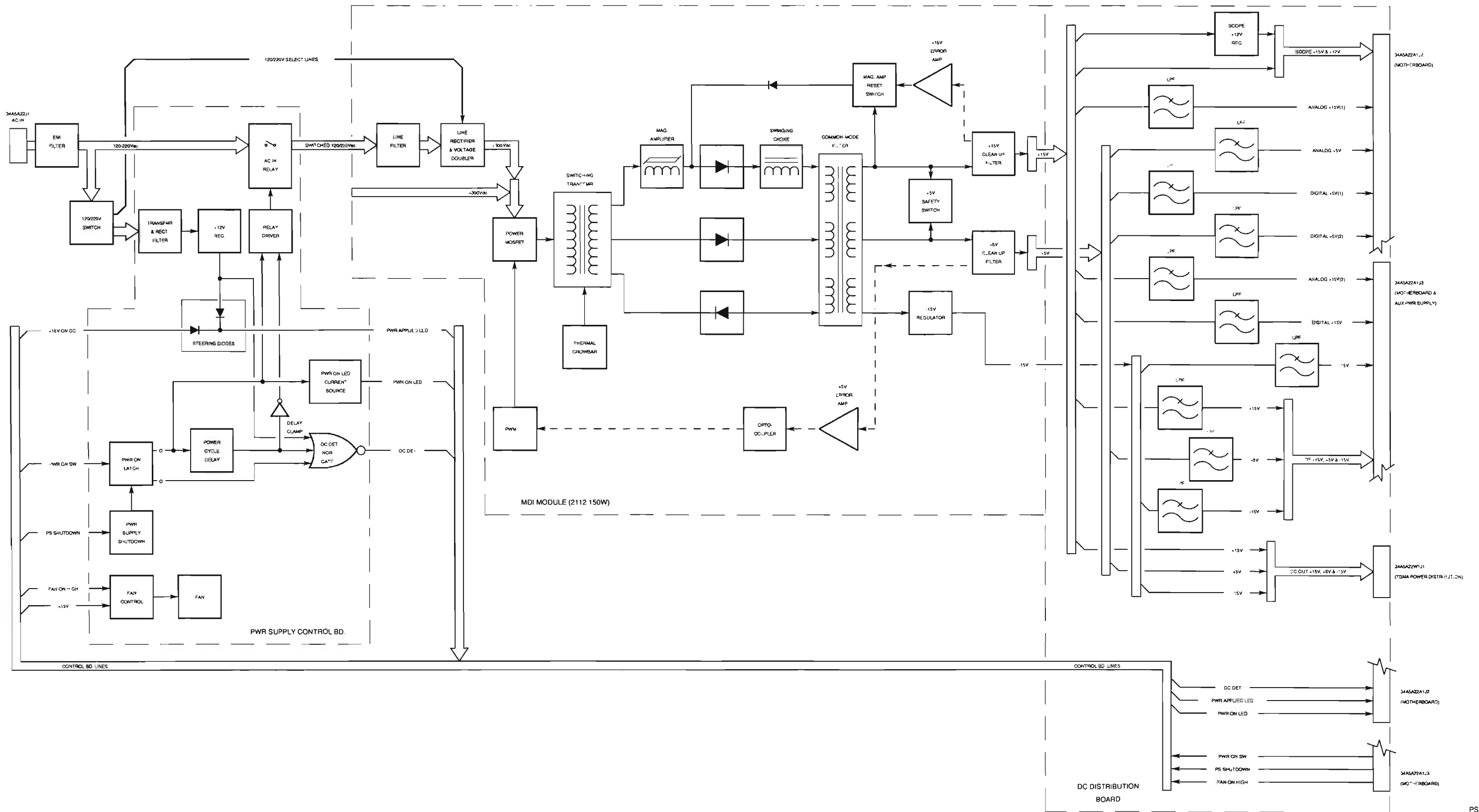

Figure 1-1. A22 Power Supply Functional Block Diagram.



THIS PAGE INTENTIONALLY LEFT BLANK.

## CHAPTER 1 INTRODUCTION

---

b. 34A5A26 PROCESSOR (INSTRUMENT) (fig. 1-2). The A26 Processor (Instrument) provides the overall control for the system. The CPU is an 80376 embedded microcontroller. The 80376 is a 32 bit processor with a 24 bit address bus and 16 bit data bus. To speed up the system, an 82370 Integrated System Peripheral Device is attached to provide supervision for DMA and Interrupt Requests and Acknowledges. Additional controller circuits include the following:

MAX 690 Supervisory Circuit controls power-up RESET and Nonmaskable Interrupt actions. RESET affects the 80376, the 82370 and other I/O Devices. The RESET signal from the MAX 690 becomes the RESDRV signal on the NAT-BUS.

Memory Select Circuit controls what section of memory is being used.

Wait State Circuit inserts 1 to 16 wait states into I/O processing, as needed.

Real-time clock containing time-of-day clock, alarm, 100 year calendar, programmable interrupt, square wave generator and 50 bytes of memory. A lithium power source is included in the package to keep the clock updated when power is not applied.

Memory available on the A26 Processor (Instrument) includes 128kX8 ROM and 64kX8 RAM. The ROM is used for part of the system code. The RAM is used for storing program global parameters.

The AT Compatible I/O Channel (NAT-BUS) contains:

- 16 bit bidirectional data bus
- 24 bit address line bus
- 9 levels of interrupt
- Memory and I/O Read/Write lines
- Clock and timing lines
- 5 channels of DMA control lines
- 7 memory refresh timing control lines

Data in and out of the NAT-BUS is controlled by the NAT-BUS Buffer.

The RS-232 INTERFACE is attached directly to the RS-232 Connector. The RS-232 INTERFACE translates both directions between the microprocessor and the device attached to the RS-232 connector.

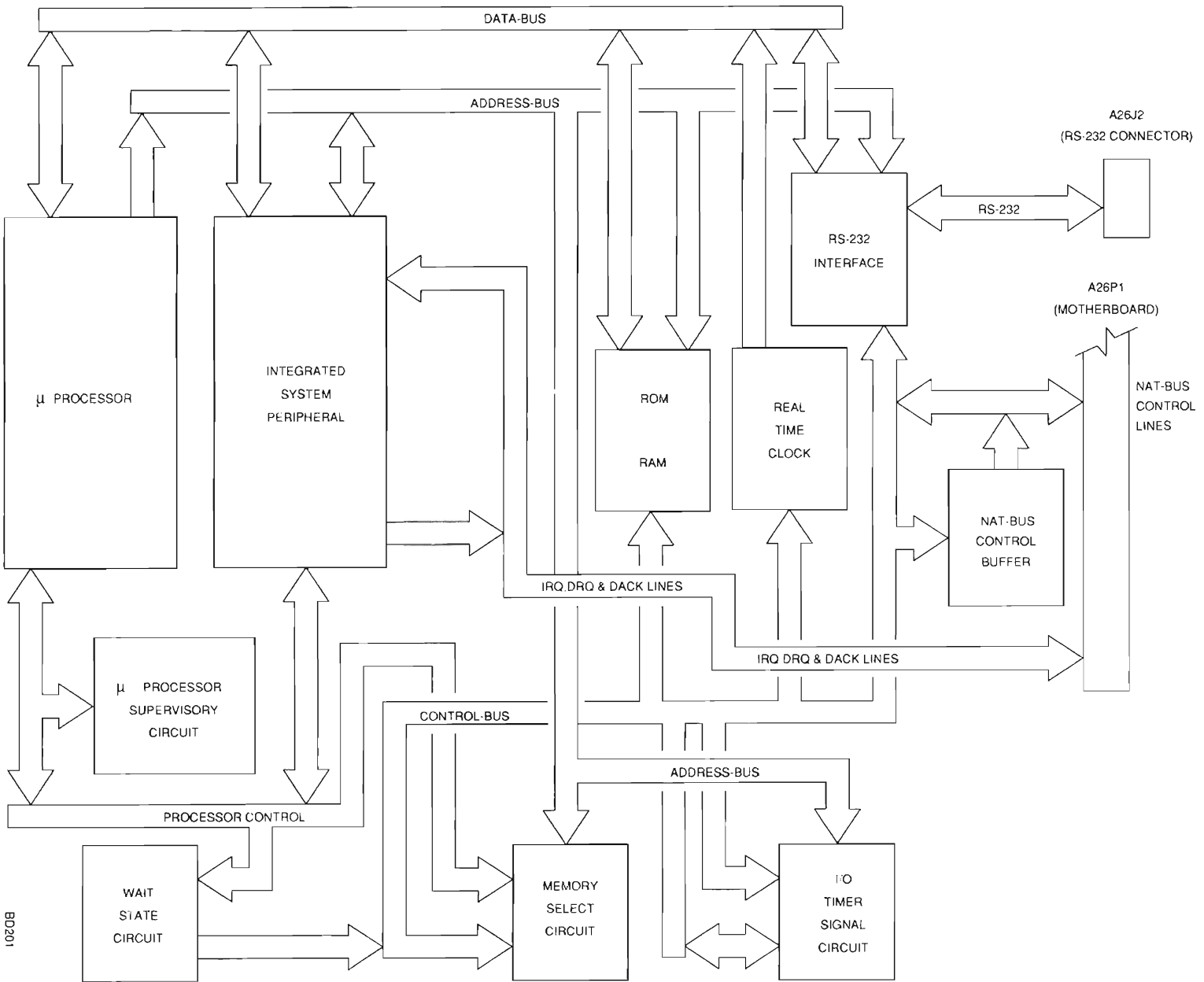

## CHAPTER 1 INTRODUCTION

---

c. 34A5A31 FUNCTION GENERATOR (fig. 1-3). The A31 Function Generator synthesizes the audio signals and serial data that the TEST SET generates. The A31 Function Generator is a microprocessor controlled with an interface to the A26 Processor (Instrument). The microprocessor, a Zilog Super 8, serves as slave processor to the A26 Processor (Instrument). The A31 Function Generator processes the following signals:

- GEN1 Output
- GEN2 Output
- Serial Data
- EXT MOD IN Connector input
- MIC/ACC Connector input
- DTMF

The two audio generators use a procedure that encompasses both analog and digital processes. The A26 Processor (Instrument) passes requirements to the Super 8 Microprocessor. The Super 8 Microprocessor passes information to the XILINX concerning wave shape, frequency and required synthesizer for generating audio tones. The XILINX instructs the proper PROM (one for each audio generator) which wave shape to write and provides the clock for the selected frequency. The output from the PROM is processed by a D/A Converter as the first step of the analog process. The resulting signal is then filtered by a Wave Shaping Filter selected by the Super 8 Microprocessor. The signal level is 5 Vp-p. The Generator Attenuator attenuates the signal to the required output level. The final output location for this signal is selected by the Audio Switching Matrix.

Both EXT MOD IN Connector signals and MIC/ACC Connector signals are imported and passed through an attenuator for setting the signal level. The resulting signals are passed to the Audio Switching Matrix for output selection.

Data signals can be generated by either the Super 8 Microprocessor or the SERIAL COMMUNICATION CONTROLLER. The resulting signal can be passed as raw data or filtered and attenuated. The filtered signal is sent to the Audio Switching Matrix. The unaltered signal is available directly for output. Level changing to bipolar ( $\pm 6$  V) and TTL levels is also available at the same time filtering is done. The Filter available is a 300 Hz Low-Pass Filter for use in signalling formats.

The Audio Switching Matrix is presented with five different inputs and selects three different outputs for each. For each input, only one output can be selected, however, all five inputs can be active simultaneously. The three outputs available include: FM MOD OUT, AM MOD OUT and FUNCTION GENERATOR AUDIO OUT to the AUDIO OUT Connector (A23J6). The FM MOD OUT and AM MOD OUT signals are available directly to the A41 90 MHz Generator from the Audio Switching Matrix. The FUNCTION GENERATOR AUDIO OUT is processed by another attenuator, giving a wider dynamic range and then filtered by a 60 kHz Low-Pass Filter. This signal is then presented to the AUDIO OUT Connector (A23J6). Selections for the Audio Switching Matrix are passed from A26 Processor (Instrument) to the Super 8 Microprocessor for processing.

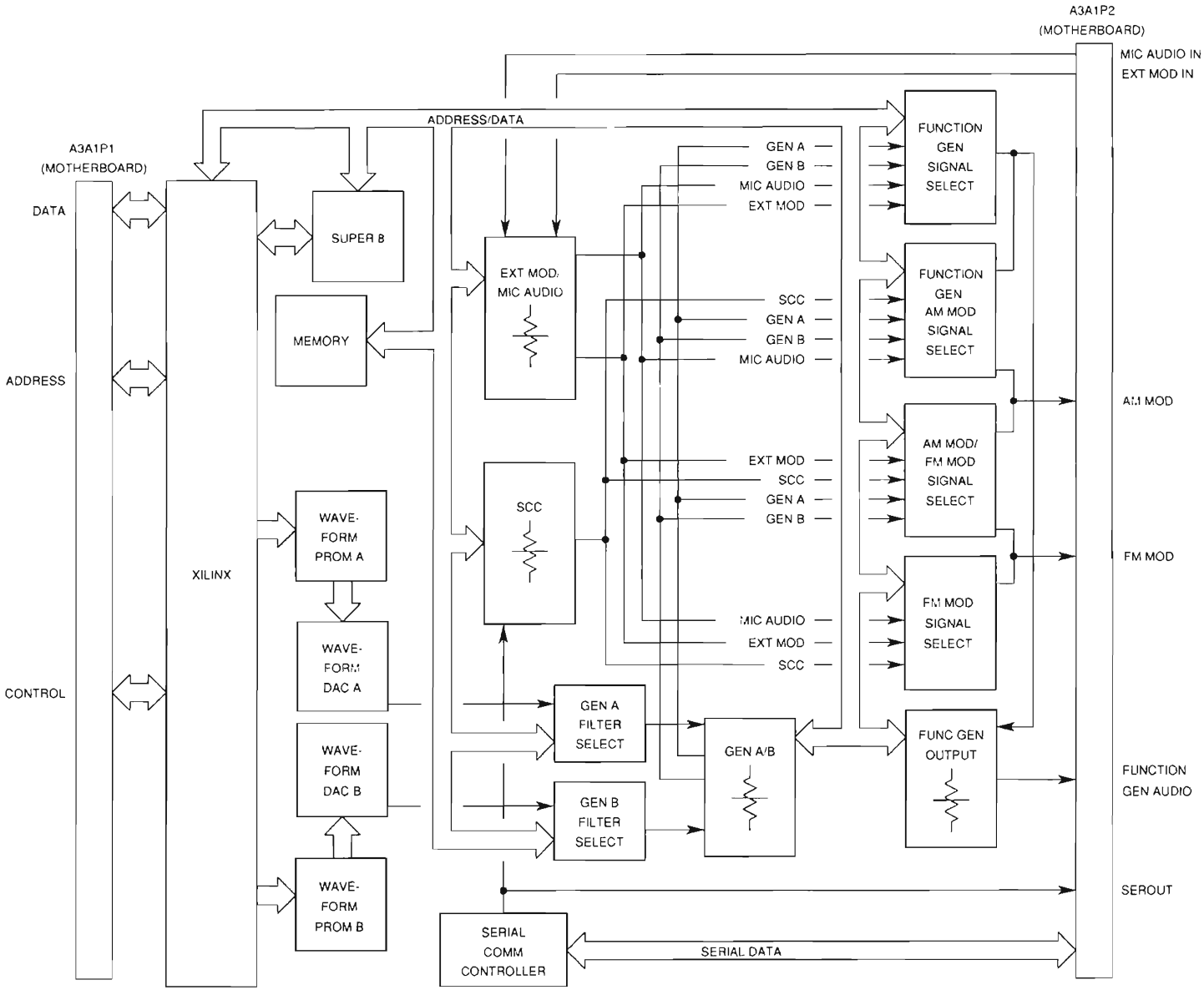

Figure 1-3. A31 Function Generator Functional Block Diagram.

BD204



## CHAPTER 1 INTRODUCTION

---

d. 34A5A28 VIDEO CONTROLLER (fig. 1-4). The A28 Video Controller drives the LCD Interface. The A28 Video Controller is composed of the following sections:

- Video Graphics Array
- Display RAM (256k x 16)
- LCD Interface
- Display Interface
- Monitor Interface
- Video Setup Circuitry

The controller of the A28 Video Controller is the Video Graphics Array. Upon power-up, the Video Setup Circuitry initializes the Video Graphics Array. The A28 Video Controller interprets data and passes the appropriate signals to the Front Panel through the LCD Interface.

Clocking for the Video Graphics Array is provide by a 14.318 MHz Clock.

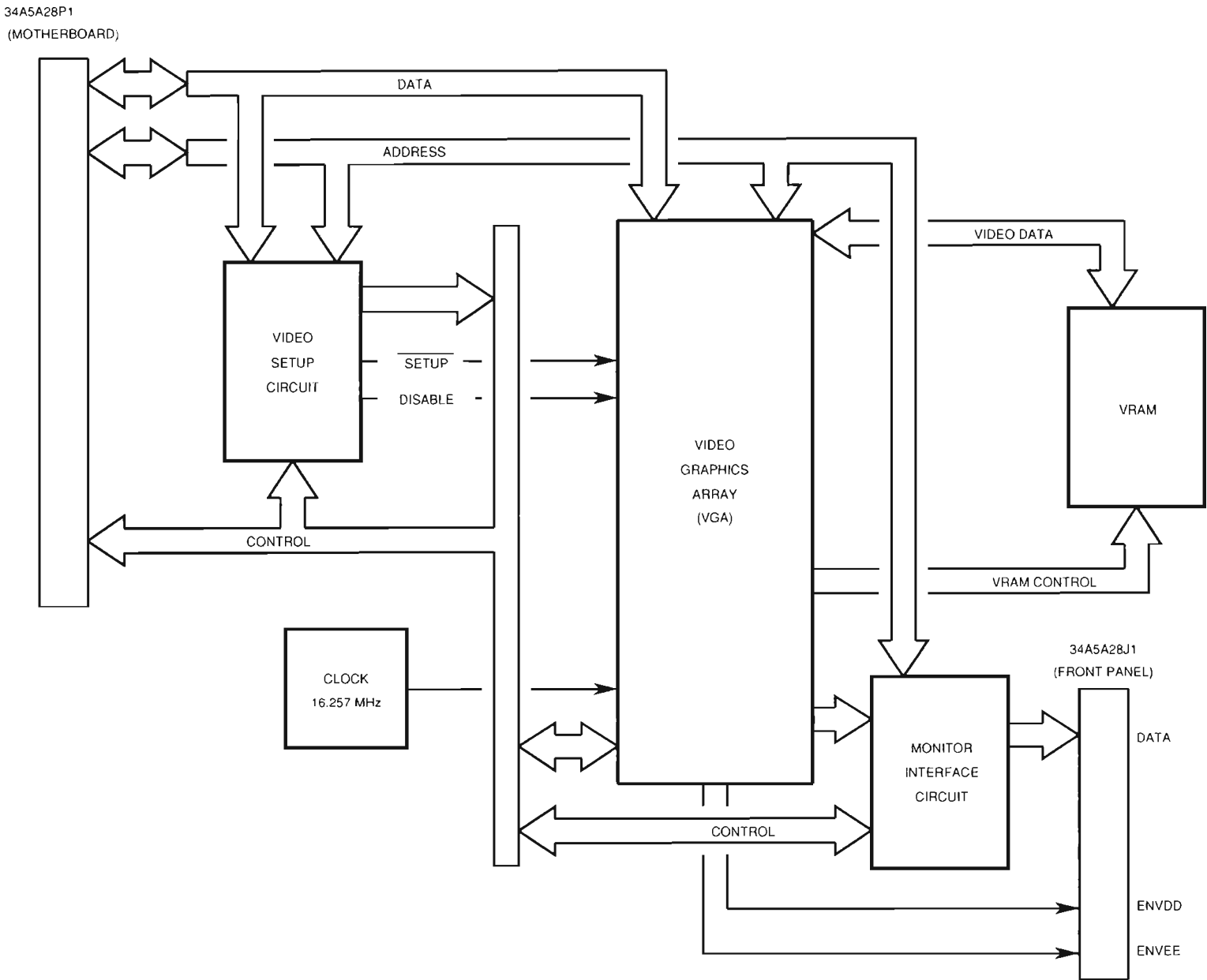

Figure 1-4. A28 Video Controller Functional Block Diagram.

## CHAPTER 1 INTRODUCTION

e. 34A5A33 MONITOR CONTROL (fig. 1-4). The A33 Monitor Control is the controller for the A6 Monitor. It provides control signals and clocking signals for the A6 Monitor. Additionally, the A33 Monitor Control contains the DVM (Digital Voltmeter), which measures the input selected in the A6 Monitor. Other functions contained in the A33 Monitor Control include a Serial Communication Controller for converting serial data to parallel and a DTMF Transceiver for decoding and encoding DTMF Signals. The A33 Monitor Control is controlled by the A26 Processor (Instrument).

Communication between the A26 Processor (Instrument) and the A33 Monitor Control is through the NAT-BUS. Information passed between the assemblies is either data or control and address signals. Information is bidirectional through the Data Lines (SD0-SD7). Data is conditioned by circuitry internal to the A33 Monitor Control depending on the information type. Raw data is passed through the DATA INTERFACE. Requests for data to and from the A33 Monitor Control pass through the DATA REQUEST LOGIC. Status Signals are returned to the A26 Processor (Instrument) after passing through the STATUS BUFFER. The DTMF XCVR (Transceiver) is also tied to the Data Lines and processes both data in and out. DTMF signals coming in are from the A6 Monitor. DTMF Signals generated are also passed to the A6 Monitor.

Control for these circuits and the Super 8 Processor is provided by the MONITOR DECODER CONTROL PAL. The inputs for THE MONITOR DECODER CONTROL PAL are passed from the NAT-BUS through the ADDRESS And CONTROL BUFFER.

As previously stated, the primary responsibility of the A33 Monitor Control is to control the A6 Monitor. The A26 Processor (Instrument) passes the requirements to the A33 Monitor Control. The Super 8 Processor then sets the required controls. Subordinate elements for the Super 8 Processor include RAM and EPROM Memory, MEMORY MAP DECODER PALS, SERIAL COMMUNICATION CONTROLLER and a Filter Clock Generator. The areas that the A33 Monitor Control controls include the following:

- DEMODO CONTROL (select demodulation type)
- VOL & SQ CONTROL (control volume level and squelch on/off)
- SQUELCH LEVEL CONTROL
- DVM CONTROL (select DVM input)
- CROSSPOINT CONTROL (control settings of crosspoint switches)

Another action performed in the A33 Monitor Control is that performed by the DVM (Digital Voltmeter). The DVM measures the dc voltage of the signal passed by the A6 Monitor and passes the measurement data to the Super 8 Processor. Control signals for the DVM are Memory Mapped and decoded by the MEMORY MAP DECODER PALS. Data is passed from the DVM through the Address/Data Bus. Address lines (A0-A2), from the Super 8 Processor, are used to calibrate the DVM.

The filters used on the A6 Monitor require clocks to function properly. The FILTER CLK GENERATOR provides the clocks required for the filters on the A6 Monitor.

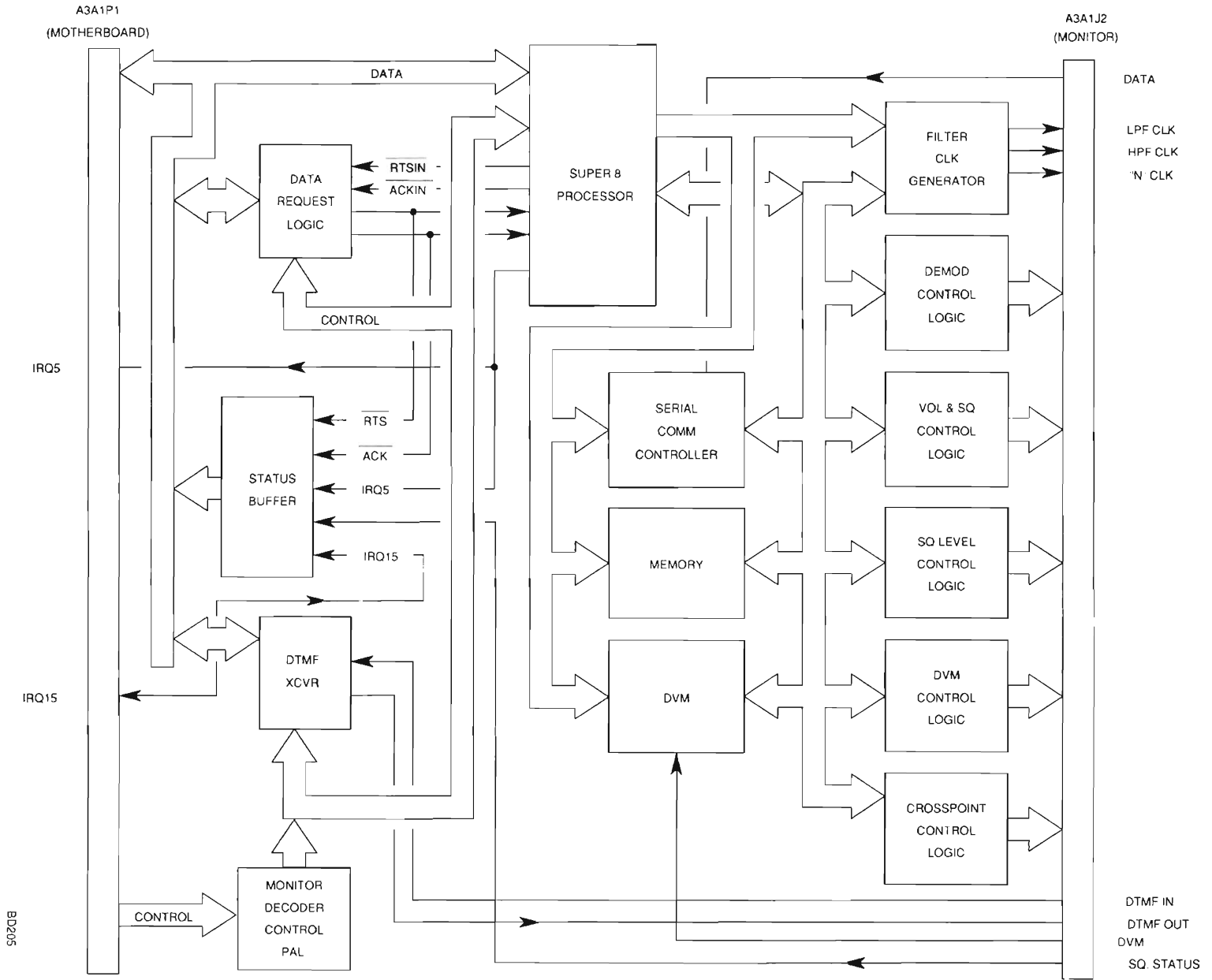

Figure 1-5. A33 Monitor Control Functional Block Diagram.

BD205

## CHAPTER 1 INTRODUCTION

---

- f. 34A5A30 COUNTER (fig. 1-5). The A30 Counter performs the following functions:
- Counts Audio and IF Frequencies
  - Monitors and Controls the A11 DMM
  - Monitors DATA ENTRY Keypad and DATA SCROLL Spinner and provides data to A26 Processor (Instrument)

The A30 Counter acts as a slave controller to the A26 Processor (Instrument). It performs the above functions on command and interrupts the A26 Processor (Instrument) as needed with Keyboard/Spinner information.

The CPU CONTROL SECTION controls the actions of all other major sections of the A30 Counter. The CPU CONTROL SECTION consists of the Zilog Super 8 Microprocessor, ROM, SRAM and a decoder for translating address and data signals into control signals for the various sections of the A30 Counter. The NAT-BUS INTERFACE provides the connection between the A26 Processor (Instrument) (through the NAT-BUS) and the CPU CONTROL SECTION.

The COUNTER FUNCTION INTERFACE counts the frequency of the Audio and the 425 kHz IF Signals. Counting the 425 kHz IF Signal provides the RF Error from the frequency of the A1 Receiver. The COUNTER FUNCTION uses the 1 MHz Reference Signal from the A15 2nd LO as the frequency time base for counting frequency. Control signals are passed to the COUNTER FUNCTION INTERFACE by the CPU CONTROL SECTION through the CONTROL BUS. Data from the COUNTER FUNCTION INTERFACE is returned through the DATA BUS to the CPU CONTROL SECTION, which passes the data through the NAT-BUS to the A26 Processor (Instrument).

The A30 Counter both reads and writes to the A11 DMM. Communication with the A11 DMM is conducted through the DMM INTERFACE. Data to and from the A11 DMM is in serial format, therefore a clock and latch system is required as well as a data line in and a data line out.

The A30 Counter also reads the DATA ENTRY Keypad and the DATA SCROLL Spinner. Reading Spinner counts requires SPINA and SPINB signals from the DATA SCROLL Spinner and a 2 MHz clock derived from the 8 MHz Clock on the NAT-BUS. Use of a key on the DATA ENTRY Keypad or the DATA SCROLL Spinner causes an interrupt in the CPU CONTROL SECTION Control. This Interrupt alerts the A26 Processor (Instrument) that new data has been entered. Enable signals for reading the DATA ENTRY Keypad are provided by the CPU CONTROL SECTION to the KEYBOARD INTERFACE. Enable signals for reading the DATA SCROLL Spinner are provided by the CPU CONTROL SECTION to the SPINNER INTERFACE. Data resulting from reading either the DATA SCROLL Spinner or the DATA ENTRY Keypad is returned to the CPU CONTROL SECTION through the DATA BUS.

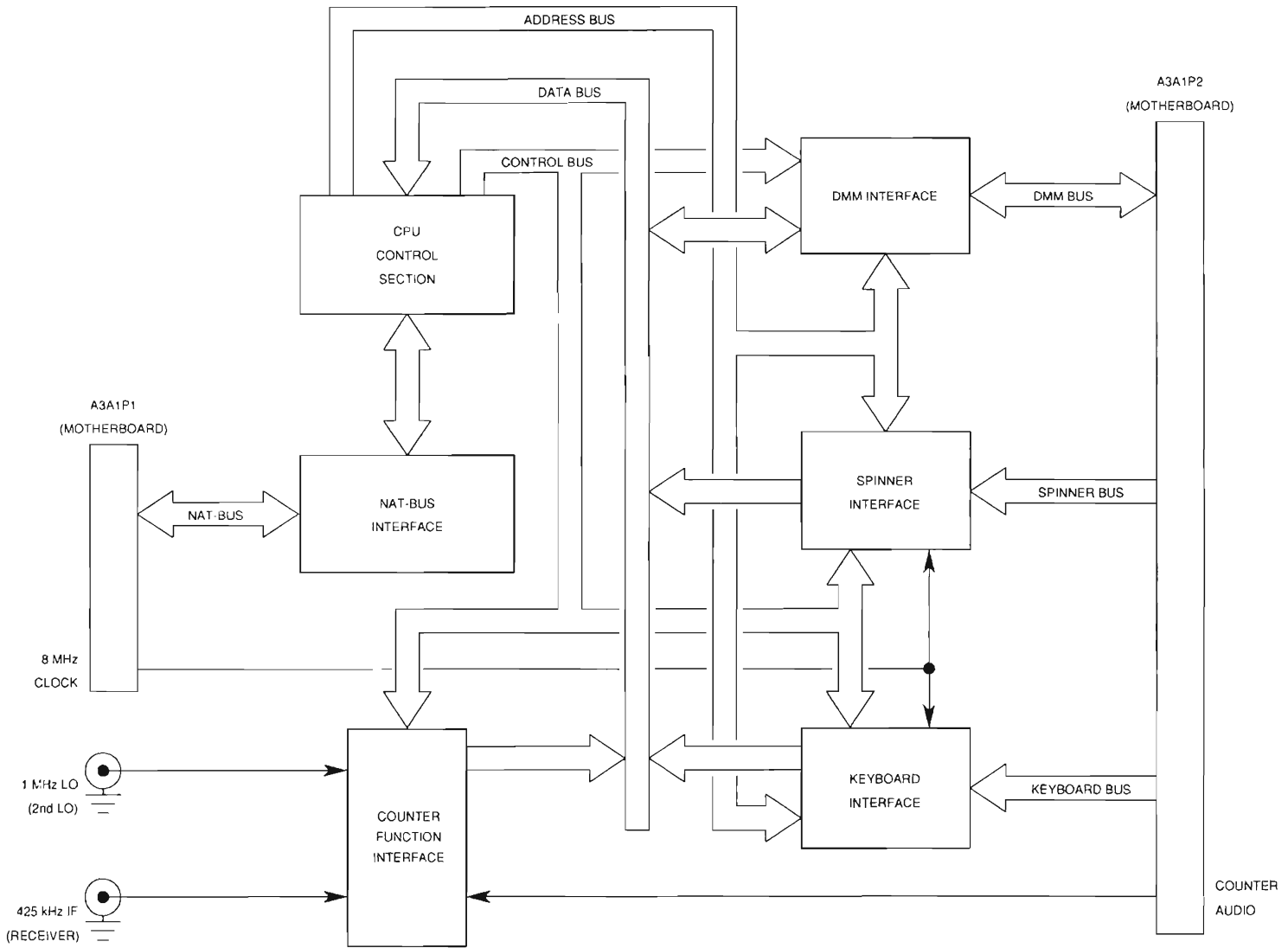

Figure 1-6. A30 Counter Functional Block Diagram.

BD215

## CHAPTER 1 INTRODUCTION

---

g. 34A5A23 FRONT PANEL (fig. 1-6). The A30 Front Panel provides the interface between the operator and the Test Set and provides the RF and Audio/Data link between the UUT and Test Set.

The A23A2A1 Function Keyboard is composed of the Soft Function Keys, the APPLIED and ON Indicators and the Power Switch. Soft Function Keys are mechanical momentary switches that are normally open. Switch closure connects a Row and Column signal. Each Switch connects a Row and Column signal to provide a signature signal to the A30 Counter.

Additional Components on the A23A2A1 Function Keyboard include the APPLIED and ON Indicators and the POWER Switch. The APPLIED Indicator is lit whenever power is applied to the Test Set. The signal that lights this LED is provided by the A22 Power Supply. The POWER Switch applies power to the Test Set when depressed. The POWER Switch grounds the POWER Switch signal, activating the Power On circuitry in the A22 Power Supply. The ON Indicator is activated by the Power On circuitry of the A22 Power Supply.

The A23A2 Keyboard is composed of all other keys and the DATA SCROLL Spinner. The Front Panel keys are mechanical momentary switches that are normally open. Switch closure connects a Row and Column signal. Each Switch connects a Row and Column signal to provide a signature signal to the A30 Counter.

The DATA SCROLL Spinner provides an increment and decrement function for editing data. The two signals generated, SPIN A and SPIN B, provide the A30 Counter with data change and direction information.

The A23A1 Connector provides the audio interface between the Test Set and the UUT. Connections available are EXT MOD IN Connector, SINAD BER IN Connector, AUDIO OUT Connector, DEMOD OUT Connector and MIC/ACC IN/OUT Connector.

The MIC/ACC IN/OUT Connector allows connection of a microphone or other peripheral device.

The DUPLEX OUT Connector is a BNC type connector providing an RF path for the signal generated during duplex operation. This connector is the alternative for generating out the T/R Connector during Duplex Operation. The DUPLEX OUT Connector is connected to the A36 Power Termination.

The ANTENNA IN Connector provides RF path for receiving signals during Receive and Duplex Operation. The ANTENNA IN Connector is connected to the Receive IF Assembly. During Duplex Operation, the alternative connector for receiving RF is the T/R Connector.

The SCOPE IN Connector provides direct access to the Oscilloscope Function, bypassing all other routings and filters. The SCOPE IN Connector is a BNC Connector.

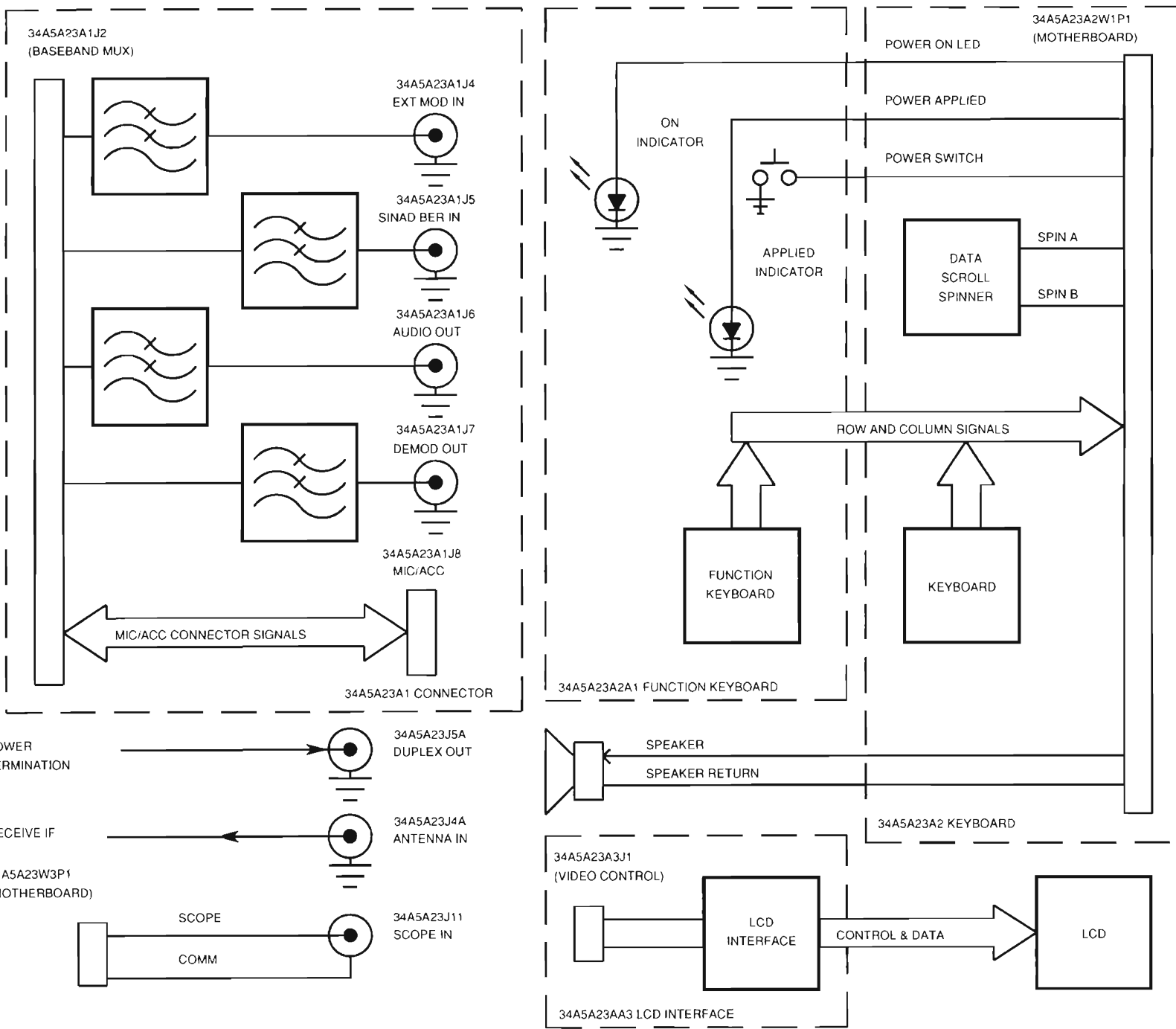

Figure 1-7. A23 Front Panel Functional Block Diagram.



## CHAPTER 1 INTRODUCTION

h. 34A5A21 POWER TERMINATION (fig. 1-8). The primary purpose of the A36 Power Termination is to isolate the signal coming into the T/R Connector (W2J1) from the rest of the TEST SET. Additionally the A36 Power Termination is used to pass the RF Signal from the A36 Attenuator out through either the T/R Connector (W2J1) or the DUPLEX OUT Connector (A21J2A). Switching between the DUPLEX OUT Connector (A30J2A) and the T/R Connector (W2J1) for Duplex Operation is performed in the A36 Power Termination.

If the T/R Connector (W2J1) is selected for input, then the signal is processed by the A21 Power Termination before being passed to the A16 Receive IF. The signal from the T/R Connector (W2J1) is attenuated by a 10 dB Pad. The attenuated signal is then either processed by a switchable 20 dB Pad or passed on without attenuation. Selection is provided by the 20 dB PAD Signal from the A36 Attenuator. The Signal then passes through a 30 dB Pad. This attenuated signal is passed to the A16 Receive IF for processing.

Additionally, when the signal passes through the 10 dB Pad, the input is split and passed through a 7 dB Pad to the LEVEL DETECTOR. The LEVEL DETECTOR passes the signal as a dc voltage to both the LOW PWR AMP and the HIGH PWR AMP. The selection of the path used is determined by the level of the signal. The LOW PWR AMP is used for signals  $\leq 2$  W. The level is sensed by the COMPARATOR that follows the LOW POWER AMP. If a level exceeding 2 W is sensed, the COMPARATOR passes a low voltage signal to the A22 RF I/O which causes the A22 RF I/O to send a RANGE SELECT Signal that selects the HIGH PWR AMP Path. Additionally, if the 20 dB PAD is bypassed in the routing from the T/R Connector (W2J1) to the A16 Receive IF, it is switched in to attenuate the signal and protect the circuitry internal to the TEST SET. The output of the switch is passed to the A6 Monitor for measuring RF Power of the incoming signal.

The A21 Power Termination is also where the output signal is connected to the appropriate connector for Duplex Operation. For Generate Operation, the T/R Connector (W2J1) is the only selection. The DUPLEX Signal sets the Switch to route the source from the A36 Attenuator to the DUPLEX OUT Connector (A30J2A) and routes the T/R Connector (W2J1) to a 50  $\Omega$  Termination. This signal is also sampled by a LEVEL DETECTOR, which converts the signal to a dc voltage. This dc voltage is passed to a COMPARATOR to determine if the signal exceeds 0.25 W. If the signal exceeds 0.25 W, the COMPARATOR outputs a voltage level that disconnects the input from the A36 Attenuator and the 3 dB Pad becomes the load for the DUPLEX OUT Connector (A30J2A). Additionally, the voltage is passed as an ALARM Signal, to let the A26 Processor (Instrument) know that the power level exceeded limitations. The A26 Processor (Instrument) generates an error message to alert the operator. The 3 dB Pad between the Switch and the DUPLEX OUT Connector (A30J2A) is present for VSWR matching and input protection.

Because of the heat generated when high level signals are attenuated by the various attenuators in the A21 Power Termination, a TEMP (Temperature) SENSOR monitors the temperature within the A21 Power Termination. The sensed temperature is passed to the A6 Monitor in the form of a dc voltage. If the temperature exceeds certain limitations, the unit will provide operator warnings.

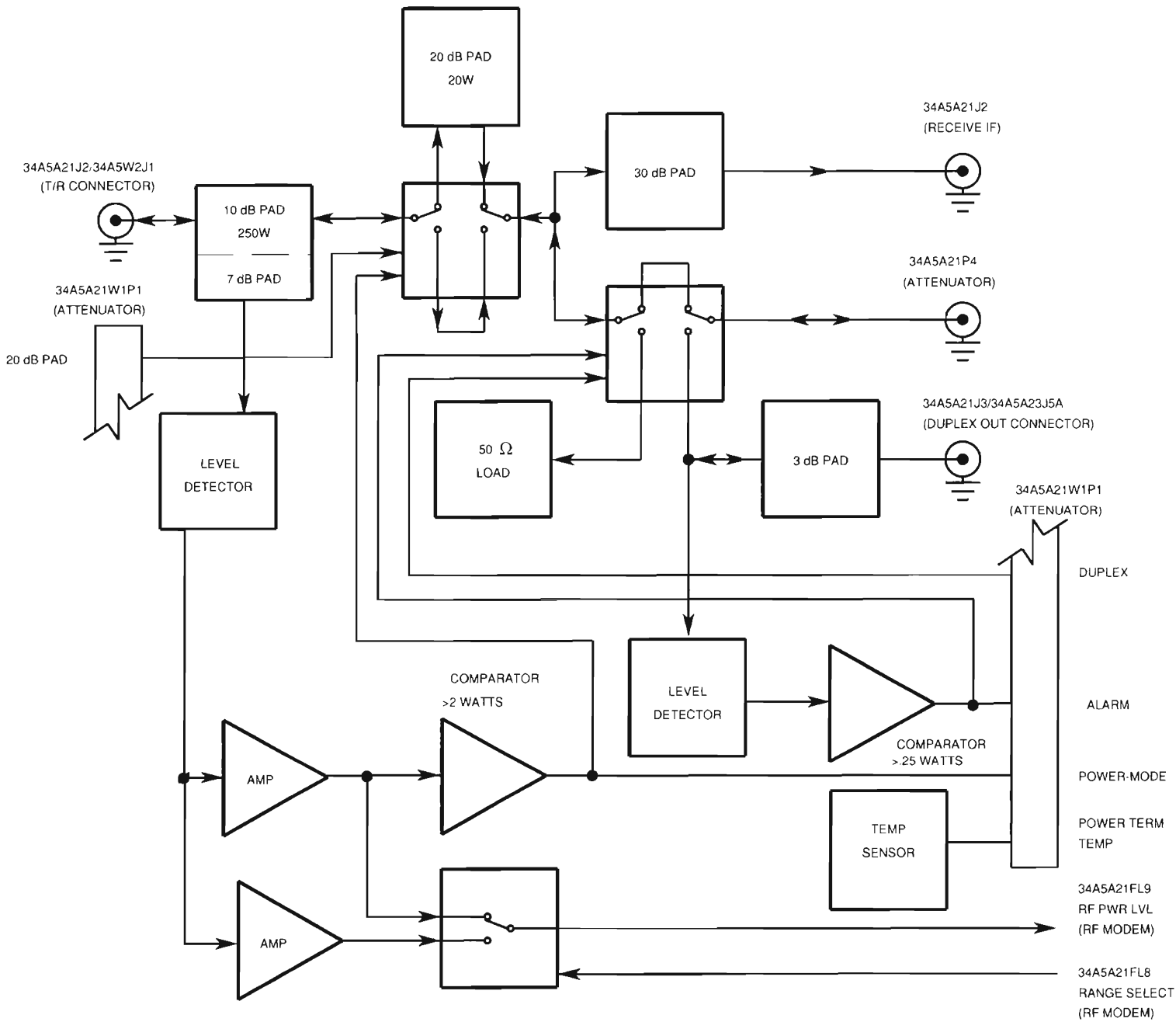

Figure 1-8. A21 Power Termination Functional Block Diagram.

PTBD01

## CHAPTER 1 INTRODUCTION

---

i. 34A5A16 RECEIVER IF (fig. 1-8). Signals can be received into the TEST SET through two connectors, the ANTENNA IN Connector (A23J1A) and the T/R Connector (W2J1). These signals are processed differently until they reach the A16 Receive IF where the two channels merge into one. Signals received through the ANTENNA IN Connector (A23J1A) are passed directly to the A16 Receive IF where the incoming signal is attenuated by a 3 dB pad, primarily for impedance matching. The signal passing through the T/R Connector (W2J1) is processed by the A36 Power Termination. From the A36 Power Termination, the signal passes to the A16 Receive IF where the two Receive Channels merge.

Selection of the connector to be used starts in the A26 Processor (Instrument). The data is passed to the A22 RF I/O to place on the RF I/O BUS. The data passes through the A37 Auxiliary Power Supply to the A36 Attenuator. The serial data is converted to control signals and become the Antenna/(T/R) SEL Signal. If the switch is set for the ANTENNA IN Connector (A30J1A) and the signal is too high in level, the switch automatically changes to select the T/R Connector (W2J1) and return an ALARM Signal to the A26 Processor (Instrument) through the path described in reverse order.

In the A16 Receive IF, the RF Signal is attenuated as selected by the operator. Attenuation is set using two 20 dB attenuators. The amount of attenuation selected is passed to the A16 Receive IF in the same manner as described for the ANTENNA/(T/R) SELECT Signal. These switchable attenuators are used to reduce signal level above -30 dBm.

The attenuated signal is presented to the 1st Mixer. The 1st Mixer transforms the RF signal into a 1300 MHz IF signal. The LO signal is from the A13 1st LO (1300-2298 MHz). For RF signals below 10 MHz, the 1st LO signal is 1300-1310 MHz. To remove leakage to the IF output, a null circuit splits, attenuates and phase shifts the LO signal to place in the IF signal path. This null signal cancels out the LO input from the A13 1st LO.

The 1300 MHz IF Signal from the 1st Mixer is passed to the 2nd Mixer. The 2nd Mixer transforms the 1300 MHz IF Signal into a 88-90 MHz IF Signal. This signal is amplified and passed to the A8 Analyzer RF and the 3rd Mixer of the A16 Receive IF. The LO Signal for the 2nd Mixer is generated by the A15 2nd LO at a frequency of 1210 MHz.

The 3rd Mixer mixes the 88-90 MHz IF Signal with the 77.3-79.3 MHz LO Signal from the A40 3rd LO to form the final 10.7 MHz IF Signal. This signal is then passed to the A1 Receiver.

THIS PAGE INTENTIONALLY LEFT BLANK.

CHAPTER 1 INTRODUCTION

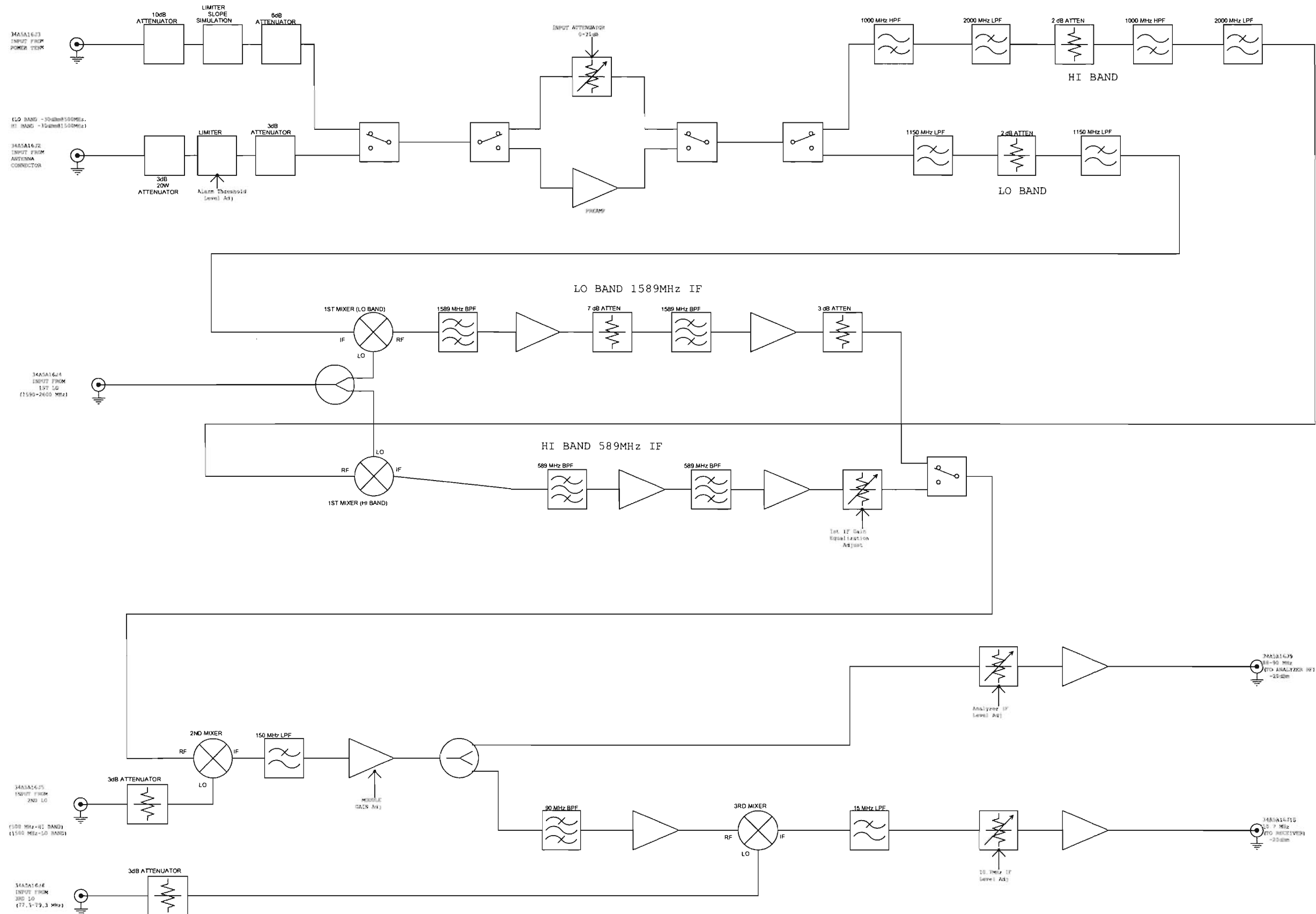

Figure 1-9. A16 Receive IF Functional Block Diagram.

THIS PAGE INTENTIONALLY LEFT BLANK

## CHAPTER 1 INTRODUCTION

---

j. 34A5A13 1st LO (fig. 1-9). The A13 1st LO is passed the frequency information from the A22 RF I/O through the A37 Auxiliary Power Supply. The data signals originate in the A26 Processor (Instrument) and are passed to the A22 RF I/O through the NAT-BUS. The A22 RF I/O converts the parallel format data to serial format and passes the data to the appropriate section of the A13 1st LO. The received data is converted back to parallel format in the SERIAL DATA INTERFACE. In the parallel format, this data represents the frequency of the required LO Signal and is used to set the DIGITAL PLL DIVIDER & COMPARATOR and the DIGITAL PLL LOOP FILTER frequencies.

The LO signal is based on a VCO which is tuned by DC TUNE and AC TUNE Signals. The DC TUNE Signal provides the coarse tune, while the AC TUNE Signal is used to fine tune the VCO. The data from the A26 Processor (Instrument) presets the DIGITAL PLL DIVIDER & COMPARATOR to a frequency that is close to the required frequency. The Reference for the DIGITAL PLL DIVIDER & COMPARATOR is a 1 MHz signal derived from the 10 MHz Standard Signal. The 10 MHz Signal passes through a  $\div 10$  Divider to form a 1 MHz Signal. This 1 MHz Signal is phase shifted as needed to correct phase shift error. The signal generated by the DIGITAL PLL DIVIDER & COMPARATOR passes through the DIGITAL PLL LOOP FILTER at high gain. From the DIGITAL PLL LOOP FILTER, the signal is presented as the DC TUNE Signal to the VCO. Once the VCO has locked on to the Operating Frequency, the DIGITAL PLL LOOP FILTER switches to low gain operation, to reduce conflict with the AC TUNE Signal. Additionally, a 1ST STATUS Signal (one for Receive and one for Generate) is generated to the A37 Auxiliary Power Supply.

Feedback is routed to two areas within the A13 1st LO to establish a phase-lock condition. The first signal is the VCO TO DIVIDER Signal. The VCO TO DIVIDER Signal is passed through a  $\div 256/\div 272$  Prescaler before being presented to the DIGITAL PLL DIVIDER & COMPARATOR. The MOD (Modulus) CONTROL Signal determines the prescale value used. Using the 1 MHz Reference, the DIGITAL PLL DIVIDER & COMPARATOR adjusts the output to correct the final output signal.

After a period of time, the second signal, the VCO TO SAMPLER Signal, is amplified and passed through the sampler, which is clocked by the PULSE GENERATOR. The PULSE GENERATOR uses the 2 MHz signal from the REFERENCE DIVIDER as a reference. The sampled signal is then amplified by the SAMPLER ERROR AMPLIFIER. The signal is then amplified by the SAMPLER LOOP GAIN Amplifier. The GAIN BAND CONTROL Signal sets the Amplifier according to the frequency of the required signal. This signal is the AC TUNE SIGNAL. The signal from the SAMPLER LOOP GAIN Amplifier is also passed through the PHASE ERROR DETECT Circuitry which controls the Reference Phase Shift. The Reference Phase Shift adjusts the phase of the 1 MHz Reference to match the phase of the AC TUNE Signal and the DC TUNE Signal.

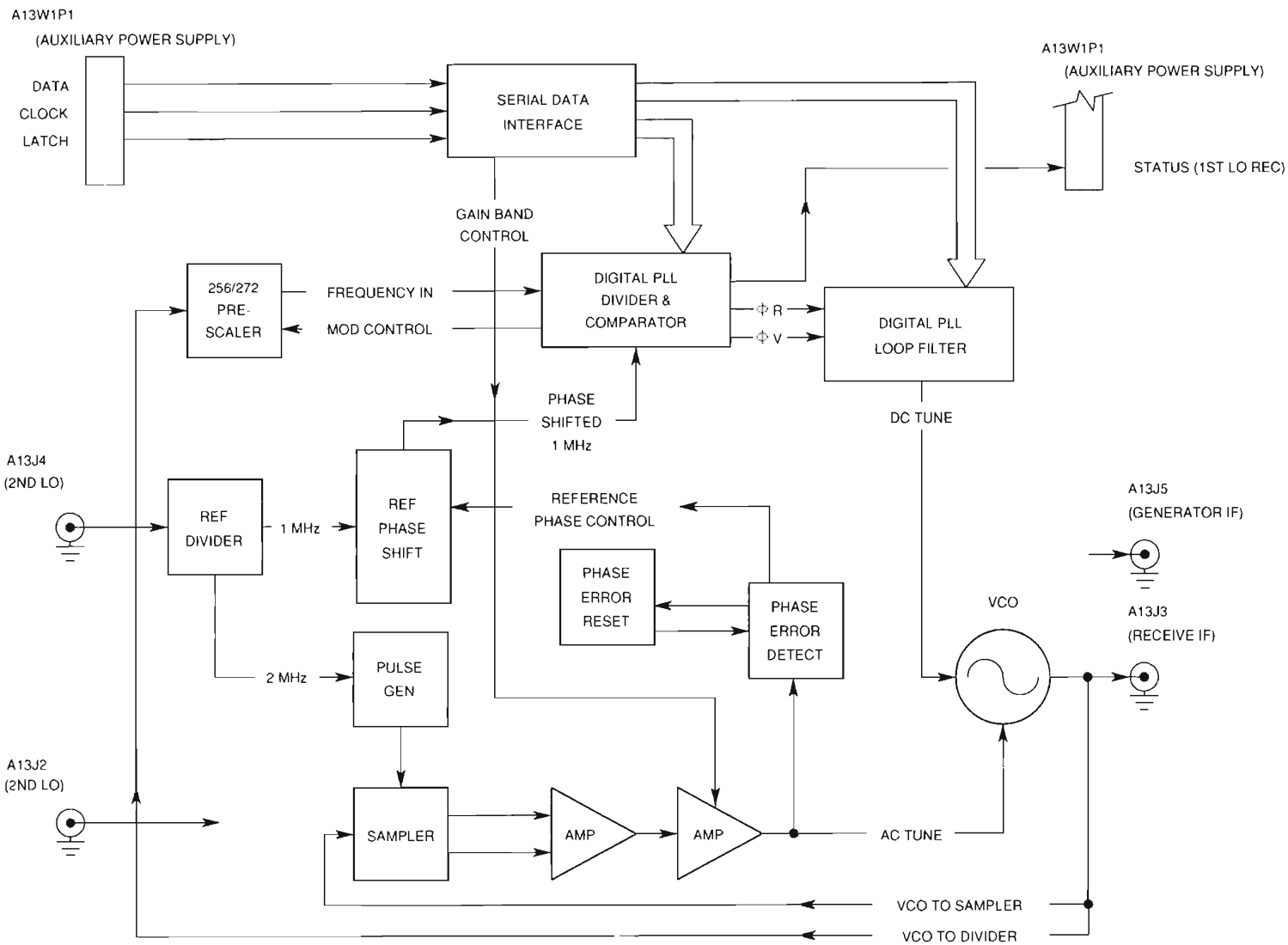

Figure 1-10. A13 1st LO Functional Block Diagram.

80207



## CHAPTER 1 INTRODUCTION

---

k. 34A5A15 2nd LO (fig. 1-10). The A15 2nd LO is used to generate the 1210 MHz signal used by the A16 Receive IF and A20 Generator IF. The A15 2nd LO is passed a 10 MHz signal for a reference signal. The A15 2nd LO has a possibility of two sources for that 10 MHz signal. The default is the TCXO (G1) contained in the unit. The second choice is an external 10 MHz Reference. If the A15 2nd LO detects the presence of an external standard, it switches to this signal and disables TCXO Power.

The 10 MHz signal is amplified and passed through a x11 Multiplier to generate a 110 MHz signal. The 110 MHz signal is then multiplied by a x11 Multiplier to generate a 1210 MHz signal. The resulting signal (1210 MHz LO) is amplified and used by both the A16 Receive IF and the A20 Generator IF.

The signal from the 10 MHz Standard is also used by the A13 1st LO. After the signal is amplified for the first x11 Multiplier, it is amplified, again, and split into three 10 MHz Signals. Two signals pass through a 10 MHz Bandpass Filter and are sent to the A13 1st LO, one signal for the Receive function and one for the Generate function.

The Third 10 MHz Signal is passed through a ÷10 Frequency Divider to create a 1 MHz Reference signal. This 1 MHz Reference signal is applied to five Buffers to create five 1 MHz Reference signals. The 1 MHz Reference signals are used by the following:

- A30 Counter
- A8 Analyzer RF
- A40 3rd LO
- A41 90 MHz Generator
- A1 Receiver

In addition to the generated signals mentioned, the A15 2nd LO passes the TCXO PWR Signal to the TCXO and to the A37 Auxiliary Power Supply. This is an analog signal that enables the TCXO output and also is used as a status signal to pass back to the A26 Processor (Instrument).

THIS PAGE INTENTIONALLY LEFT BLANK.

CHAPTER 1 INTRODUCTION

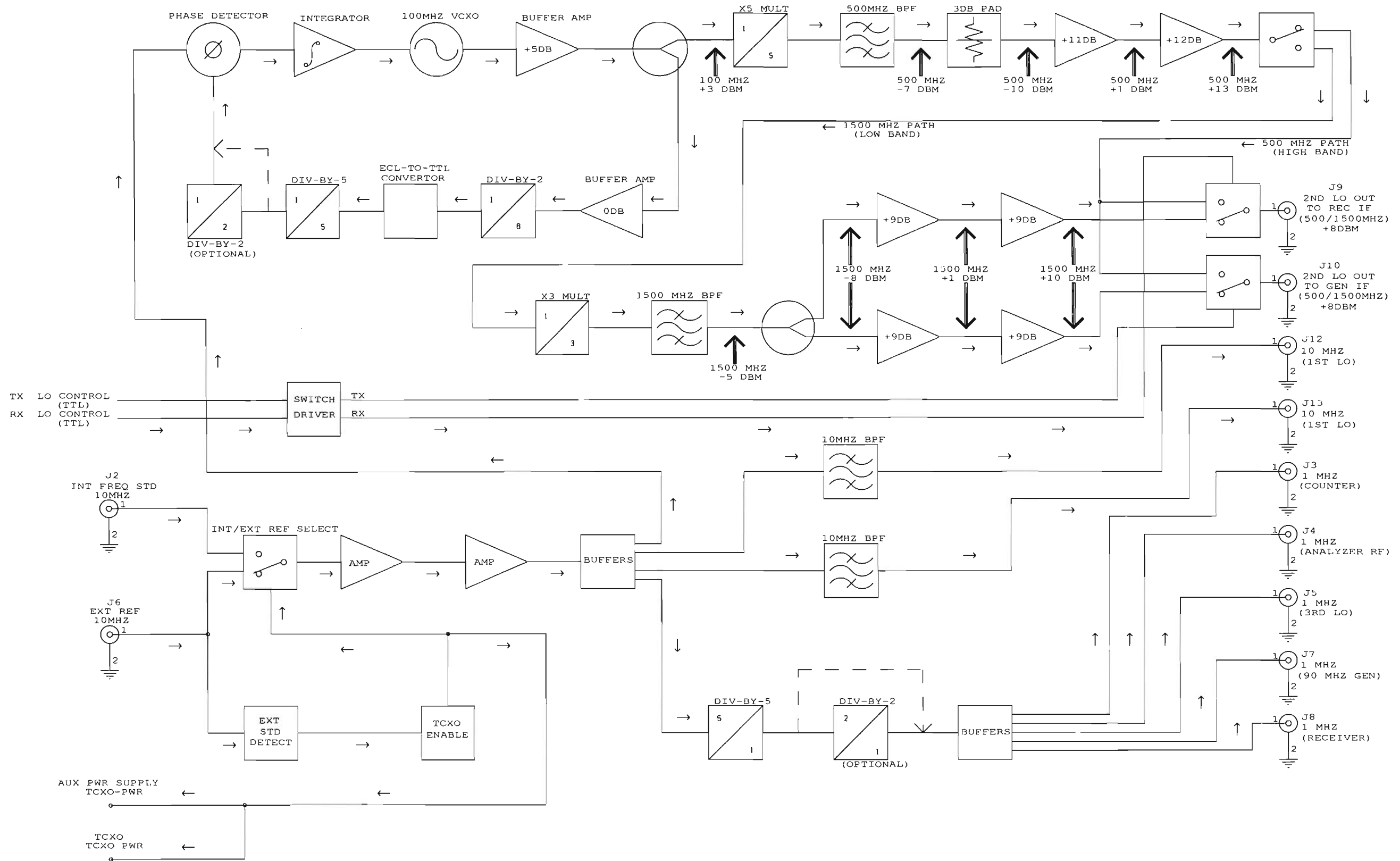

Figure 1-11. A15 2nd LO Functional Block Diagram.

THIS PAGE INTENTIONALLY LEFT BLANK

## CHAPTER 1 INTRODUCTION

I. 34A5A40 3rd LO (fig. 1-11). The output for the A40 3rd LO is a 77.3-79.3 MHz Signal to the A16 Receive IF and A8 Analyzer RF. The inputs for the A40 3rd LO include the 1 MHz Standard from the A15 2nd LO and frequency data from the A22 RF I/O. The data from the A22 RF I/O is initiated in the A26 Processor (Instrument). The A22 RF I/O receives the data from the A26 Processor (Instrument) through the NAT-BUS and converts the data from parallel format to serial format and passes the data to the A40 3rd LO. The internal mechanism of the A40 3rd LO consists of three major loops.

The first loop is the 780.125-800 MHz Coarse Loop. The 780-800 MHz VCO is pretuned by the data passed by the A22 RF I/O. This data is converted by a D/A Converter to an analog voltage and passed to the 780-800 MHz VCO. The same analog voltage is used to pre-position the 77.3-79.3 MHz VCO in the Summation Loop. The signal generated by the 780-800 MHz VCO takes two paths. First, the signal is passed back through a  $\pm 64/\pm 65$  Divider and compared to a Phase Lock Loop 125 kHz Reference which uses the 1 MHz Reference as a clock. The comparison initiates a Phase Lock Loop after proper adjustment of the VCO frequency. The PLL comparator outputs a LOCK DETECT signal to the Lock Detect Circuit once the Phase Lock Loop condition exists.

The second path for the 780-800 MHz signal is through a  $\pm 10$  Divider for an effective range of 78.0125-80 MHz with an increment of 12.5 kHz. This signal is mixed with the output of the Summation Loop creating a 700-712.4 kHz signal which is presented to a Phase Detector. The phase detector compares the output of this signal with the signal presented by the 350-356.2 MHz Fine Loop.

The 350-356.2 MHz Fine Loop Operates similar to the 780-800 MHz Coarse Loop. The 350 MHz VCO is pretuned by the data passed by the A22 RF I/O after it is passed through a D/A Converter. The analog voltage created is used to pretune the 350 MHz VCO. The signal generated by the 350 MHz VCO takes two paths. First, the signal is passed back through a  $\pm 64/\pm 65$  Divider and compared to a Phase Lock Loop 50 kHz Reference which uses the 1 MHz Reference as a clock. The comparison initiates a Phase Lock Loop after proper adjustment of the VCO frequency. The PLL comparator outputs a LOCK DETECT signal to the Lock Detect Circuit once the Phase Lock Loop condition exists.

The other path for the output of the 350 MHz VCO is through a  $\pm 5$  Divider and a  $\pm 100$  Divider to divide the 350-356.2 VCO signal by 500. The resulting signal (700-712.4 kHz) is passed to the PHASE DETECTOR.

The output of the Summation VCO is mixed with the output of the Coarse Loop to form a 700-712.4 kHz signal for input to the Phase Detector. This signal is compared against the output of the Fine Loop. This Phase Detect/Charge Pump output tunes the Summation VCO to the correct frequency. If the Summation VCO frequency exceeds the Coarse Loop frequency, the Summation VCO is railed low by a comparator. The Summation VCO is then freed and the system is allowed to function normally. Once the Summation VCO is properly tuned and phase lock is achieved, the Phase Detector outputs a Summation Loop Lock Detect signal to the Lock Detect Circuit.

Once all three loops are phase locked and Lock Detect signals are available, the Lock Detect Circuit outputs a 3rd LO Status Signal and extinguishes the Lock LED.

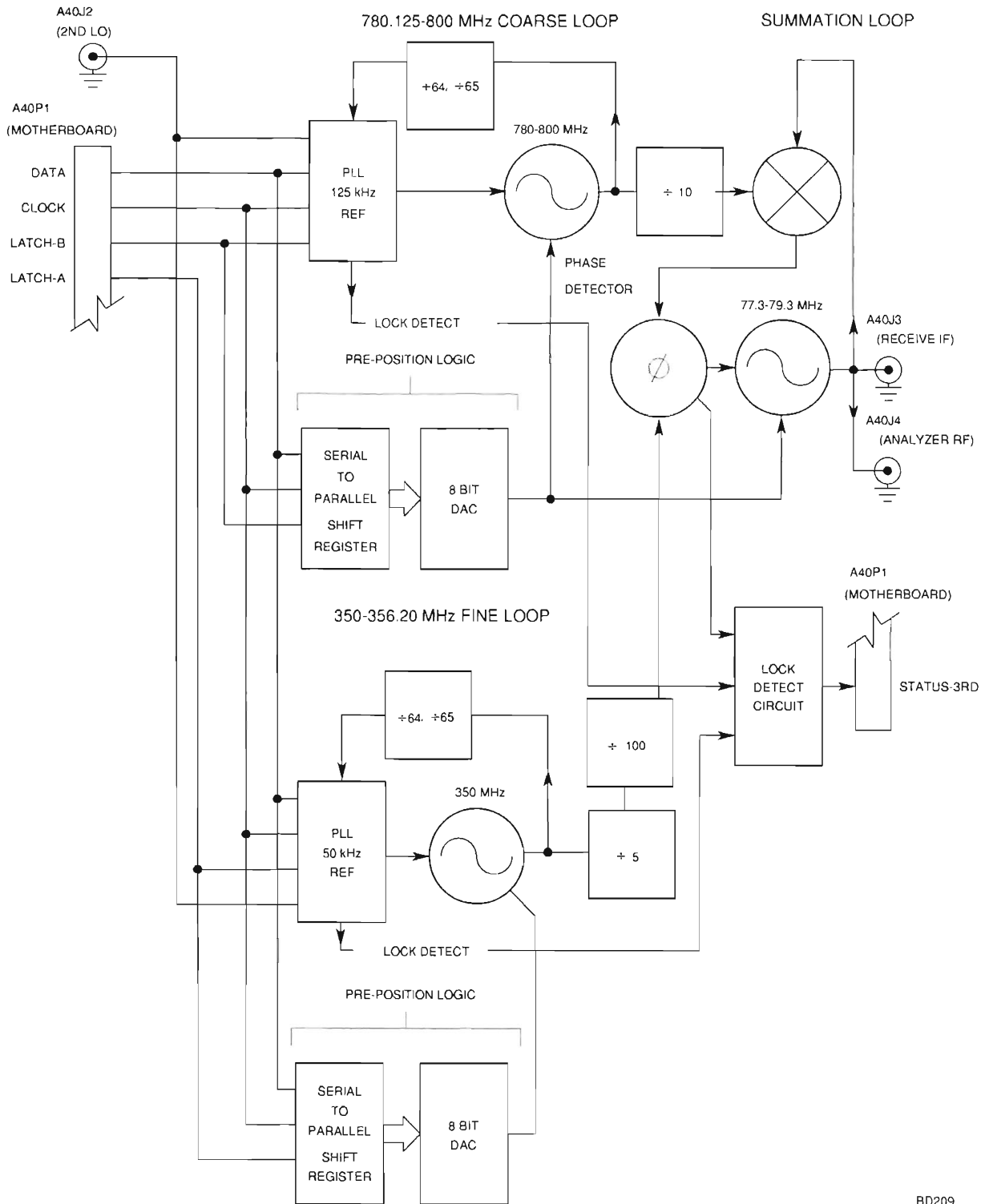

BD209

Figure 1-12. A40 3rd LO Functional Block Diagram.

## CHAPTER 1 INTRODUCTION

---

m. 34A5A9 RECEIVER (fig. 1-12). The 10.7 MHz IF Signal, passed to the A1 Receiver from the A16 Receive IF, is initially filtered by an IF Bandpass Filter. The filter is selected by control signals from the A22 RF I/O that are enabled by the A26 Processor (Instrument). If no filter selection signal is active, the 10.7 MHz Signal passes through a 500 kHz Bandwidth Bandpass Filter. The control signals select either a 30 kHz Bandwidth Bandpass filter with the 30 kHz BANDWIDTH CONTROL Signal or a 3 kHz Bandwidth Bandpass Filter with the 3 kHz BANDWIDTH CONTROL Signal.

Once filtered, the 10.7 MHz IF Signal then sent to a Mixer and mixed with an 11.125 MHz Phase Locked Oscillator to obtain a 425 kHz IF Signal.

The 425 kHz signal is passed to the A32 Digitizer and A30 Counter as well as Demodulation Circuitry. The Demodulation Circuitry produces the following signals:

- AM Demod
- FM Demod
- SSB Demod
- FM Data Demod
- Signal Strength Signal

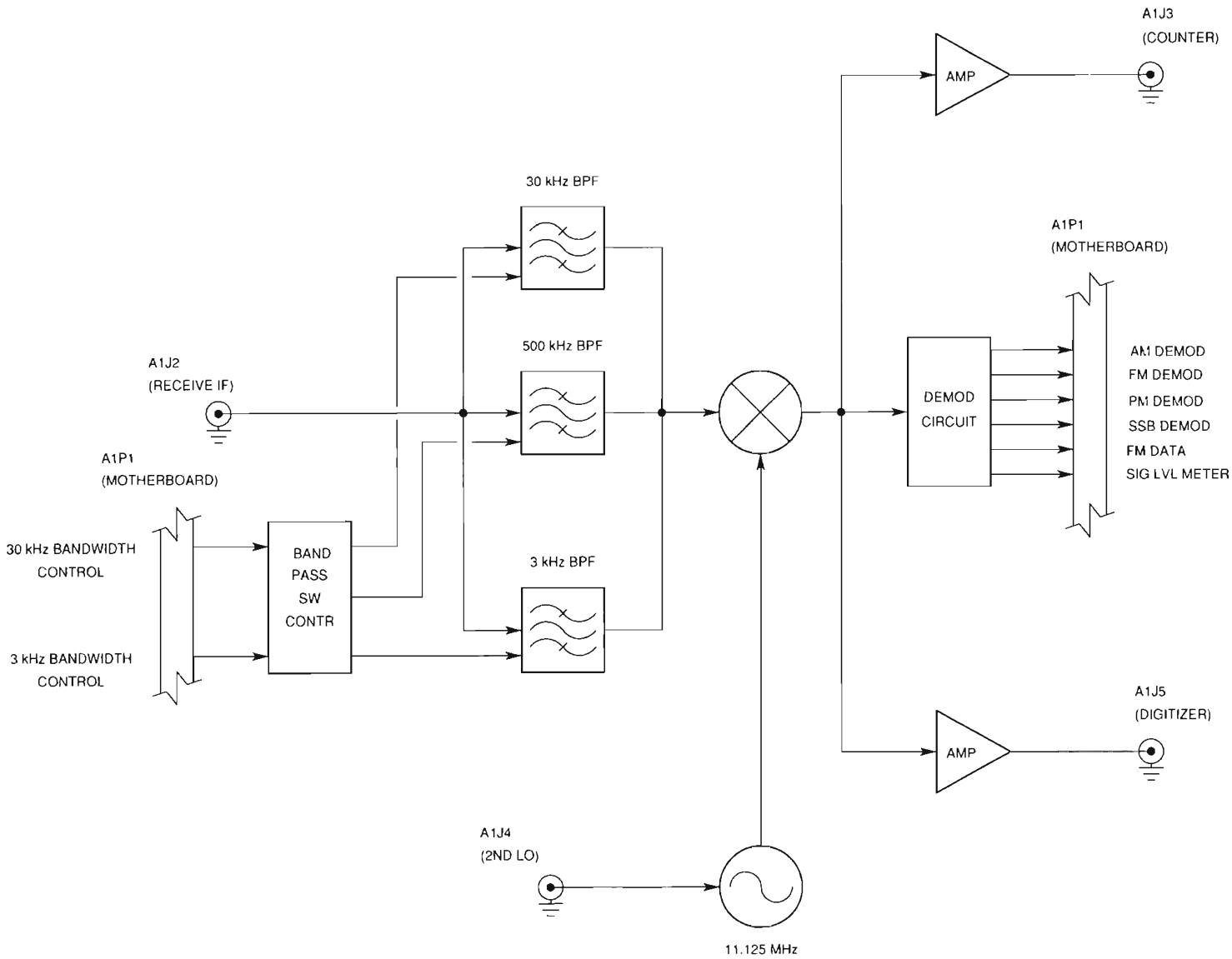

Figure 1-13. A9 Receiver Functional Block Diagram.

BD210



## CHAPTER 1 INTRODUCTION

n. 34A5A6 MONITOR (fig. 1-13). The A6 Monitor acts as a switching network to switch audio and analog signals through selected filters to desired outputs. The A33 Monitor Control provides control of the A6 Monitor in selecting the required path. Input Signals accepted by the A6 Monitor include:

- AM DEMOD
- FM DEMOD
- PM DEMOD
- SSB DEMOD
- FM DATA
- RF PWR LVL
- SINAD/BER IN Connector
- Function Generator Audio
- EXT MOD IN Connector
- DTMF IN
- Analog Signals

After filtering, amplifying and/or attenuating, the input signal is switched to the selected output. Outputs available include:

- DVM (Digital Voltmeter on A33 Monitor Control)
- DATA (A33 Monitor Control)
- DTMF OUT (A33 Monitor Control)
- SPEAKER
- DEMOD AUDIO OUT (DEMOD OUT Connector [A30J7])
- SCOPE AUDIO (A32 Digitizer)
- COUNTER AUDIO (A32 Digitizer)
- AUDIO OUT (AUDIO OUT Connector [A30J6])

The switching within the A6 Monitor is done with Crosspoint Switches which form a SWITCH MATRIX. The SWITCH MATRIX sets routings that pass signals straight to outputs listed above or through one or more of the following:

- "+" PEAK DETECTOR
- "-" PEAK DETECTOR
- C MSG BPF (C-Message Weighted Bandpass Filter)
- NBF (Notch Band Filter)
- LPF (Low-Pass Filter)
- HPF (High-Pass Filter)

The DVM Selector chooses the DVM input signal. Sole output is to the DVM on the A33 Monitor Control. DVM Selector inputs include:

"+" PEAK LEVEL	Analog Signals
"-" PEAK LEVEL	RMS (converted to DC)

Analog Signals include:

- RF PWR LVL
- Unit Ambient Temperature (A33 Monitor Control)
- SIG LVL MTR (A1 Receiver)
- Power Term Temperature (A36 Power Termination)
- +15V (A22 Power Supply)
- +5V (A22 Power Supply)
- 15V (A22 Power Supply)

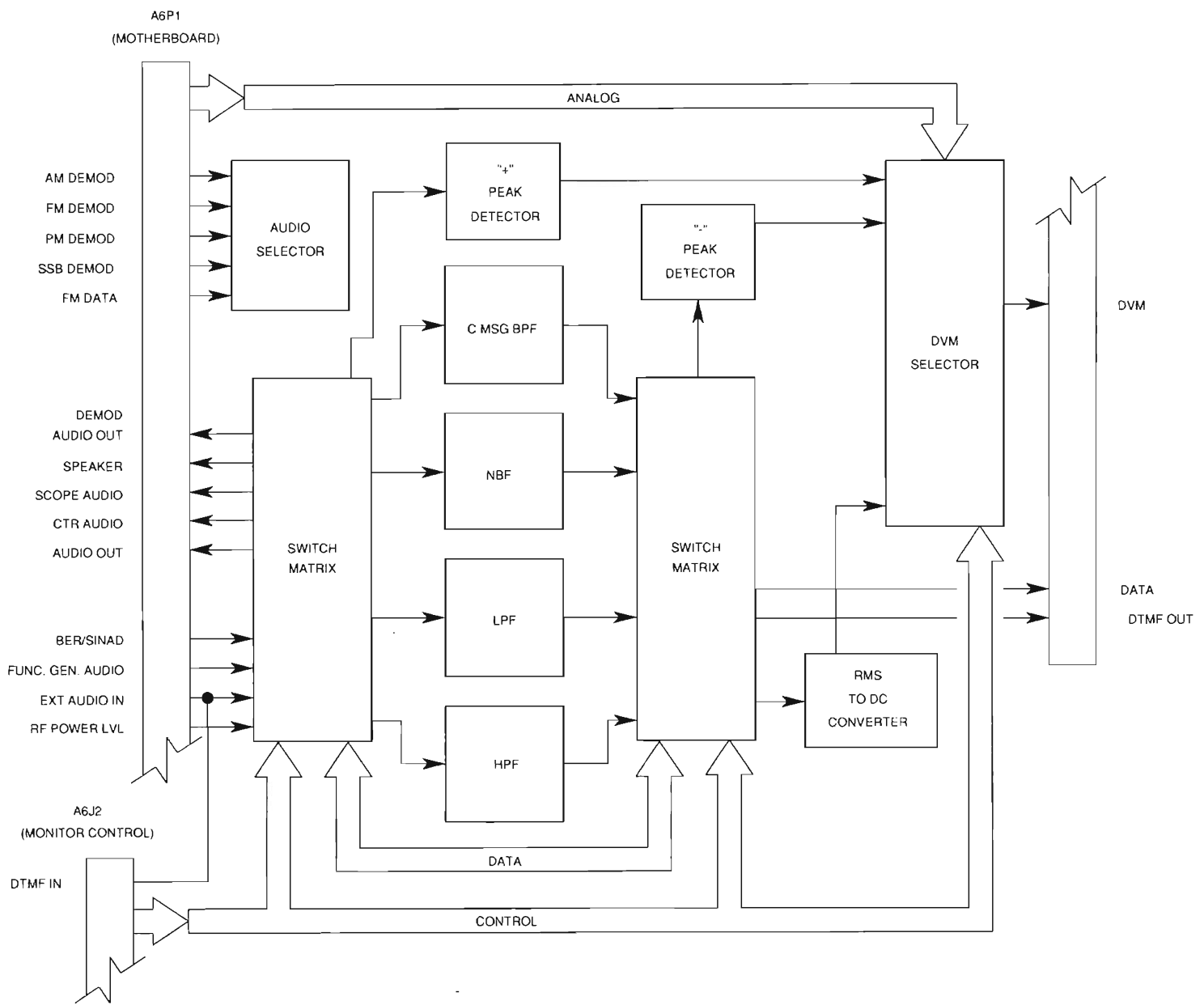

Figure 1-14. A6 Monitor Functional Block Diagram.

## CHAPTER 1 INTRODUCTION

---

o. 34A5A8 ANALYZER RF (fig. 1-14). In the A8 Analyzer RF, the 89 MHz IF Wideband Signal is converted to a 10.7 MHz IF Signal for the A7 Analyzer Log/IF. Input signals used for conversion include a 77.3-79.3 MHz Signal from the A40 3rd LO and 1 MHz Reference Signal from the A15 2nd LO. Signals generated in the A32 Digitizer are used to sweep and phase lock the Sweep VCO. Signals from the A32 Digitizer include ANLZR BLANK and ANLZR SWEEP.

The 89 MHz IF Wideband Signal is presented to the A8 Analyzer RF by the A16 Receive IF. The incoming signal is passed to the 1st Mixer, where it is mixed with the signal from the Sweep VCO to form the 33.3 MHz IF Signal. The signal is then passed to the 2nd Mixer. The 2nd Mixer converts the 33.3 MHz IF Signal to a 10.7 MHz IF Signal using the signal generated by the 44 MHz VCO. The 10.7 MHz IF Signal is then passed to the A7 Analyzer Log/IF.

The Sweep VCO Signal is also passed to the 3rd Mixer as the first stage of the phase lock system for the Sweep VCO. Using the 77.3-79.3 LO Signal from the A40 3rd LO, the 3rd Mixer converts the Sweep VCO Signal to a 44 MHz Signal.

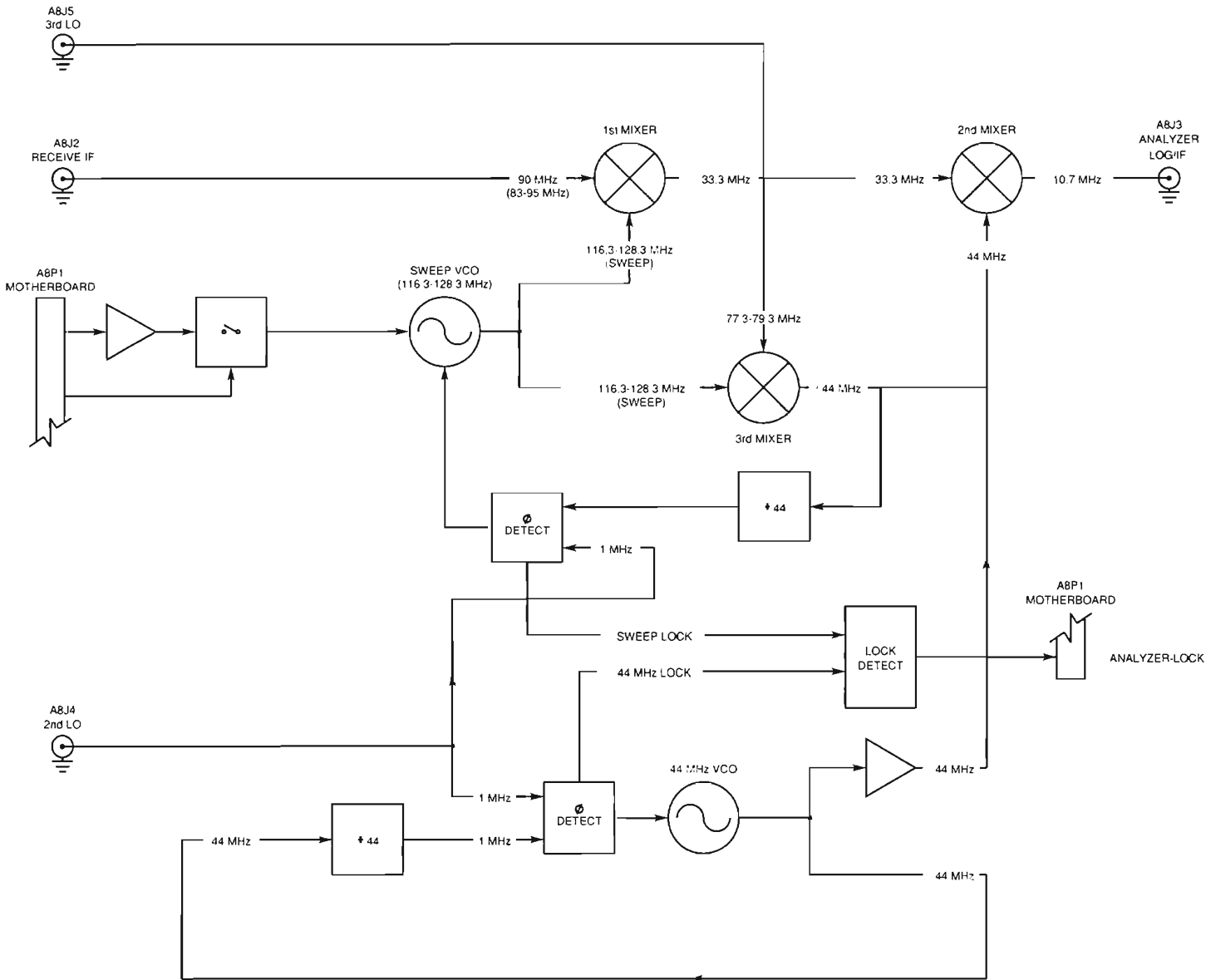

Figure 1-15. A8 Analyzer RF Functional Block Diagram.

BD237

## CHAPTER 1 INTRODUCTION

---

p. 34A5A7 ANALYZER LOG/IF (fig. 1-15). The 10.7 MHz IF Signal is sent to the A7 Analyzer Log/IF from the A8 Analyzer RF. The A26 Processor (Instrument) sends information on Resolution Bandwidth through the NAT-BUS to the A22 RF I/O where the data is converted to serial format. The A22 RF I/O passes the serial data to the A7 Analyzer Log/IF where the information is decoded in the Bandwidth Select Area into signals for setting the Pin Diode Switches to proper settings. Select lines are sent to the specified filter, attenuator or amplifier which generates the conditions to set the Pin Diode Switches to proper settings. The first switch selects the input path for the second switch. Selections include:

- Wide Band Attenuator
- 300 kHz Bandpass Filter
- 30 kHz Bandpass Filter

The output of the second switch is the input of the third switch which selects the input path for the fourth switch. Selections include:

- 3 kHz Bandpass Filter
- 300 Hz Bandpass Filter
- Broadband Amplifier

Once the signal passes through the last Pin Diode Switch, it goes to a Logarithmic Amplifier. The amplified signal then passes to an AM Detector. The AM Detector converts the 10.7 MHz IF to a voltage level. This voltage is amplified and passed to the A32 Digitizer as the ANLZR VIDEO Signal.

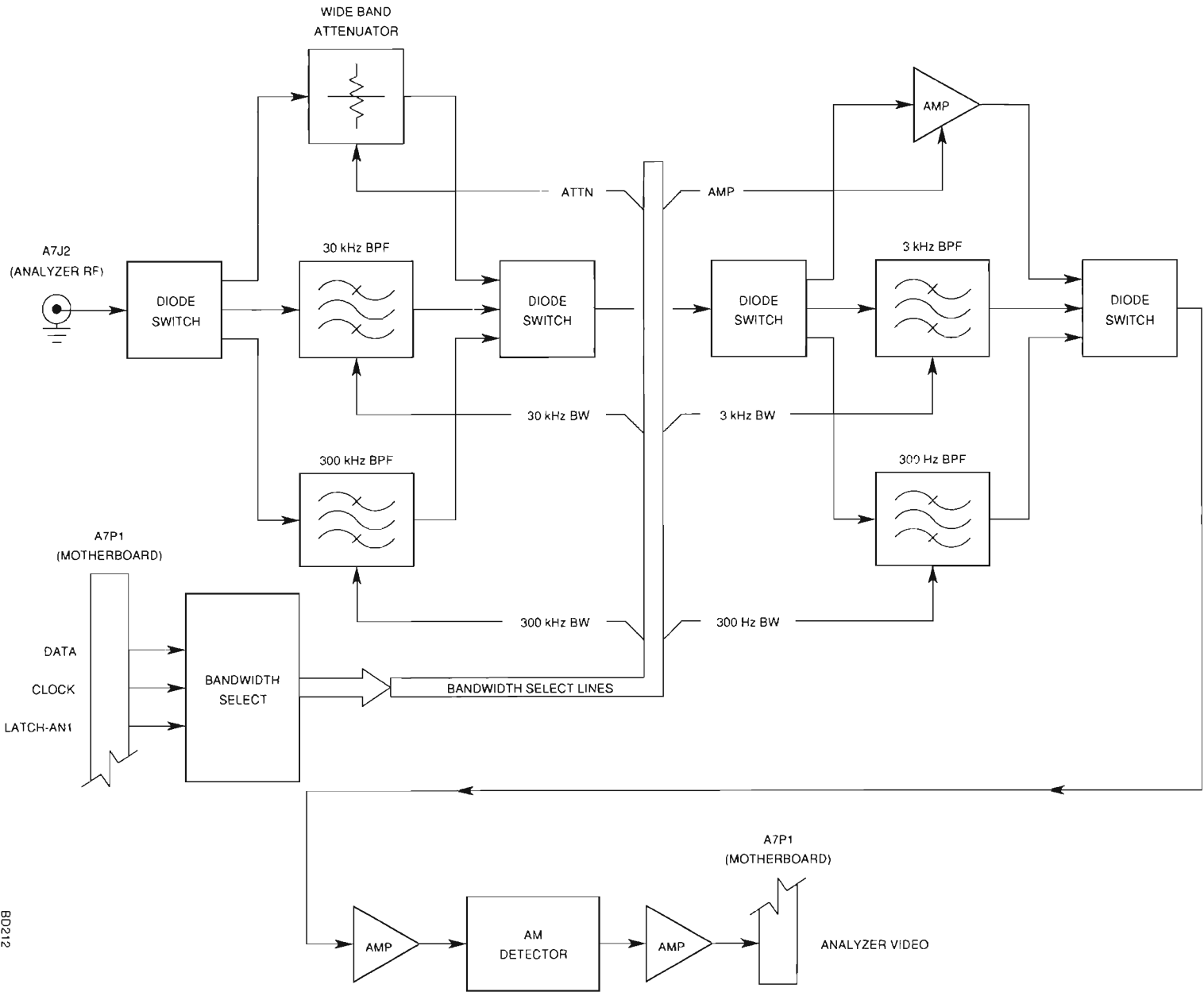

Figure 1-16. A7 Analyzer Log/IF Functional Block Diagram.

BD212

## CHAPTER 1 INTRODUCTION

---

q. 34A5A32 DIGITIZER (fig. 1-16). The primary operation of the A32 Digitizer is the conversion of analog data into digital data to be passed to the A26 Processor (Instrument). Additionally the A32 Digitizer generates the ANLZR SWEEP Signal and ANLZR BLANK Signal used by the A8 Analyzer RF to sweep the 89 MHz IF Signal. Inputs for the Digitizer are:

- SCOPE IN Connector
- Receive IF (425 kHz)
- Analyzer Video
- Scope Audio

Input signals are processed differently, but once processed, follow the same basic path. The signal, once selected, is scaled by the  $\pm 1/\pm 2/\pm 5$  Scaling Circuit, amplified and converted to digital data in a Flash A/D Converter. The digital data is then stored in on-board RAM until it is passed to the A26 Processor (Instrument) through the NAT-BUS.

Scope Audio, Analyzer Video and Receiver IF Input Signals are selections for the SCOPE/IF/ANALYZER Selector. The selected signal is routed to the SCOPE/INTERNAL SELECTOR. The signal, once selected, is scaled by the  $\pm 1/\pm 2/\pm 5$  Scaling Circuit as required, amplified and converted to digital data in a FLASH A/D CONVERTER. The digital data is then stored in on-board SRAM until it is passed to the A26 Processor (Instrument) through the NAT-BUS. If an offset of vertical position of signal is desired, an offset voltage is applied to the Amplifier before being passed to the FLASH A/D CONVERTER.

The other selection of the SCOPE/INTERNAL SELECTOR is the processed SCOPE IN Connector. The SCOPE IN Connector Signal can be AC, DC or GND (Ground) coupled. The Coupled signal can be sent through a SCOPE PREAMP if 1 mV/Div sensitivity is required. The signal then goes through a  $\pm 1/\pm 10/\pm 100/\pm 1000$  Scaling Attenuator. The signal then is passed to the SCOPE/INTERNAL SELECTOR. The signal is processed as described for the internal signals.

The ANLZR SWEEP Signal is generated by the SWEEP RAMP GENERATOR. The SWEEP COUNTER counts up the value for the SWEEP RAMP GENERATOR which builds the ANALYZER SWEEP Signal. The SWEEP COUNTER is disabled by the ANALYZER BLANKING Signal.

The ANALYZER BLANKING Signal is generated by the COUNTER/TIMER. The ANALYZER BLANKING Signal is used both internally to reset the SWEEP COUNTER and passed to the A8 Analyzer RF for use in sweeping the 89 MHz IF Signal.

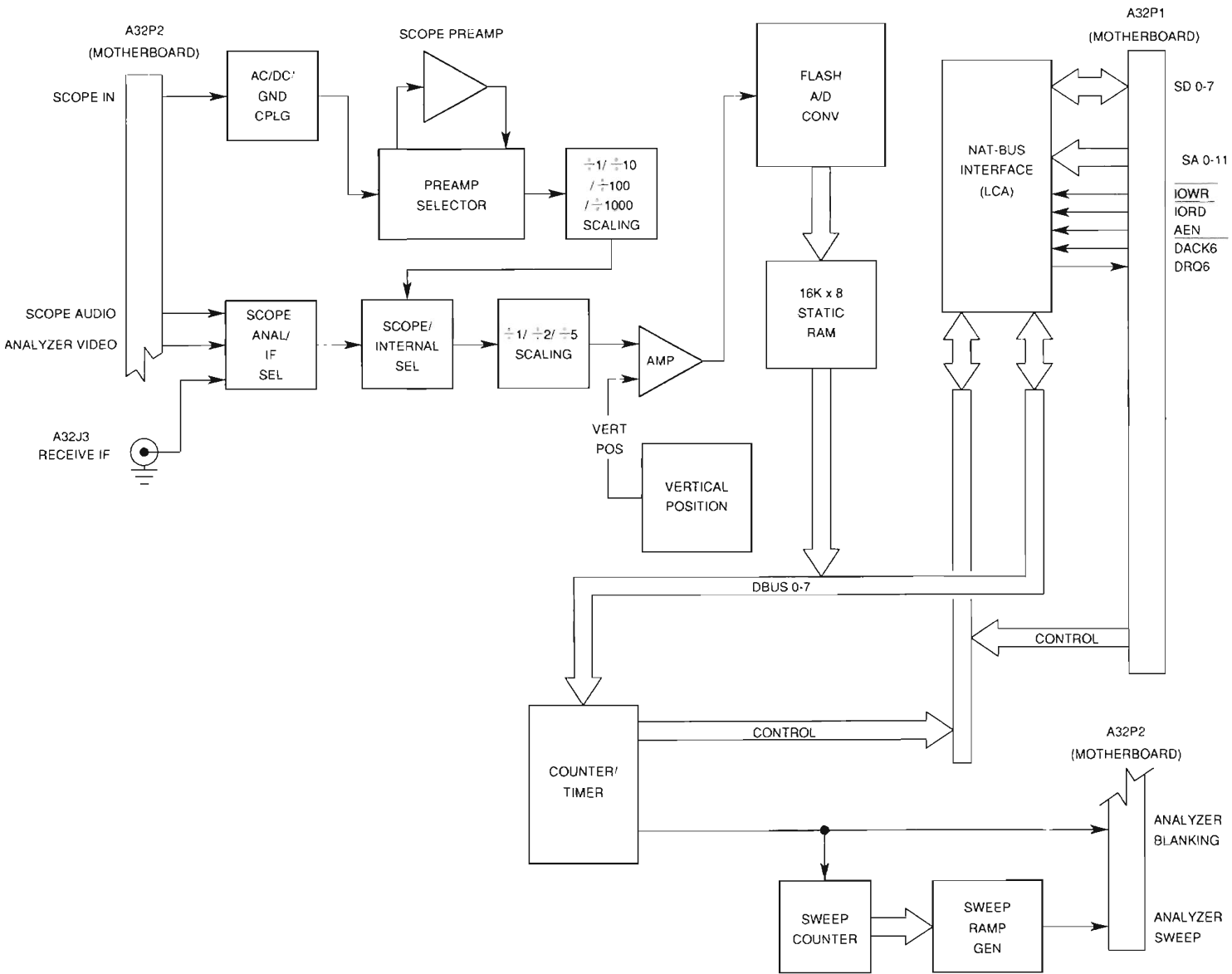

Figure 1-17. A32 Digitizer Functional Block Diagram.

BD213



## CHAPTER 1 INTRODUCTION

r. 34A5A41 90 MHz GENERATOR (fig. 1-17). The A41 90 MHz Generator provides an 88.0001-90 MHz Modulated IF signal to the A20 Generator IF. The A41 90 MHz Generator consists of two loops, of which the outputs are summed to make a final signal. This signal is attenuated and filtered before being provided to the A20 Generator IF. In the process, modulation is added to the signal. The location where modulation is added is dependent on modulation type.

The Coarse Loop is passed data by the A29 RF I/O from data generated in the A26 Processor (Instrument). The LATCH GEN B Signal is used to identify the Coarse Loop PLL FREQ Synthesizer. This data is integrated and used to tune a 780-800 MHz VCO. The VCO output is fed back to the Coarse Loop PLL FREQ Synthesizer, through a  $\div 64/\div 65$  Divider, to establish a phase lock condition. Once the VCO is phase locked, the Coarse Loop PLL FREQ Synthesizer passes a signal to the LOCK DETECT Circuit. The output of the 780-800 MHz VCO is passed through a  $\div 10$  Divider and sent to a mixer for mixing with the output of the Fine Loop. For speed, a preposition system is in place for initializing the 780-800 MHz VCO close to the required frequency. Data used is the same data used by the Coarse Loop PLL FREQ Synthesizer.

The Fine Loop is passed data by the A29 RF I/O from data generated in the A26 Processor (Instrument). The LATCH GEN A Signal is used to identify the Fine Loop PLL FREQ Synthesizer. This data is integrated and used to tune a 10 MHz VCO. The VCO output is fed back to the Fine Loop PLL FREQ Synthesizer, through a  $\div 128/\div 129$  Divider, to establish a phase lock condition. Once the VCO is phase locked, the Fine Loop PLL FREQ Synthesizer passes a signal to the LOCK DETECT Circuit. An additional signal added to the 10 MHz VCO is either the FM Modulation or Phase Modulation signal. FM Modulation from the Function Generator is differentiated to produce a Phase Modulation signal. Data from the A29 RF I/O selects between the two. This signal is added to the 10 MHz VCO signal to produce a 10 MHz IF Signal. The final product is mixed with the output from the 78-80 MHz LO produced in the Coarse Loop. This 88-90 MHz IF Signal is passed to the Attenuator.

The Attenuator is digitally controlled by the signals passed by the A29 RF I/O. The LATCH GEN C Signal is used to identify the data as being for the Digital Controlled Attenuator. AM Modulation from the A31 Function Generator is also summed with the Attenuator. The GEN LVL DET Signal is fed back from the A20 Generator IF to maintain the proper RF Output Level. The final product is passed through a 90 MHz Low-pass Filter and to the A20 Generator IF.

Once both the Fine Loop and the Coarse Loop are phase locked, both loops pass signals to the LOCK DETECT Circuit. When both signal are present, the LOCK DETECT generates a STATUS-GEN Signal, signifying that the A41 90 MHz Generator is in a phase locked condition.

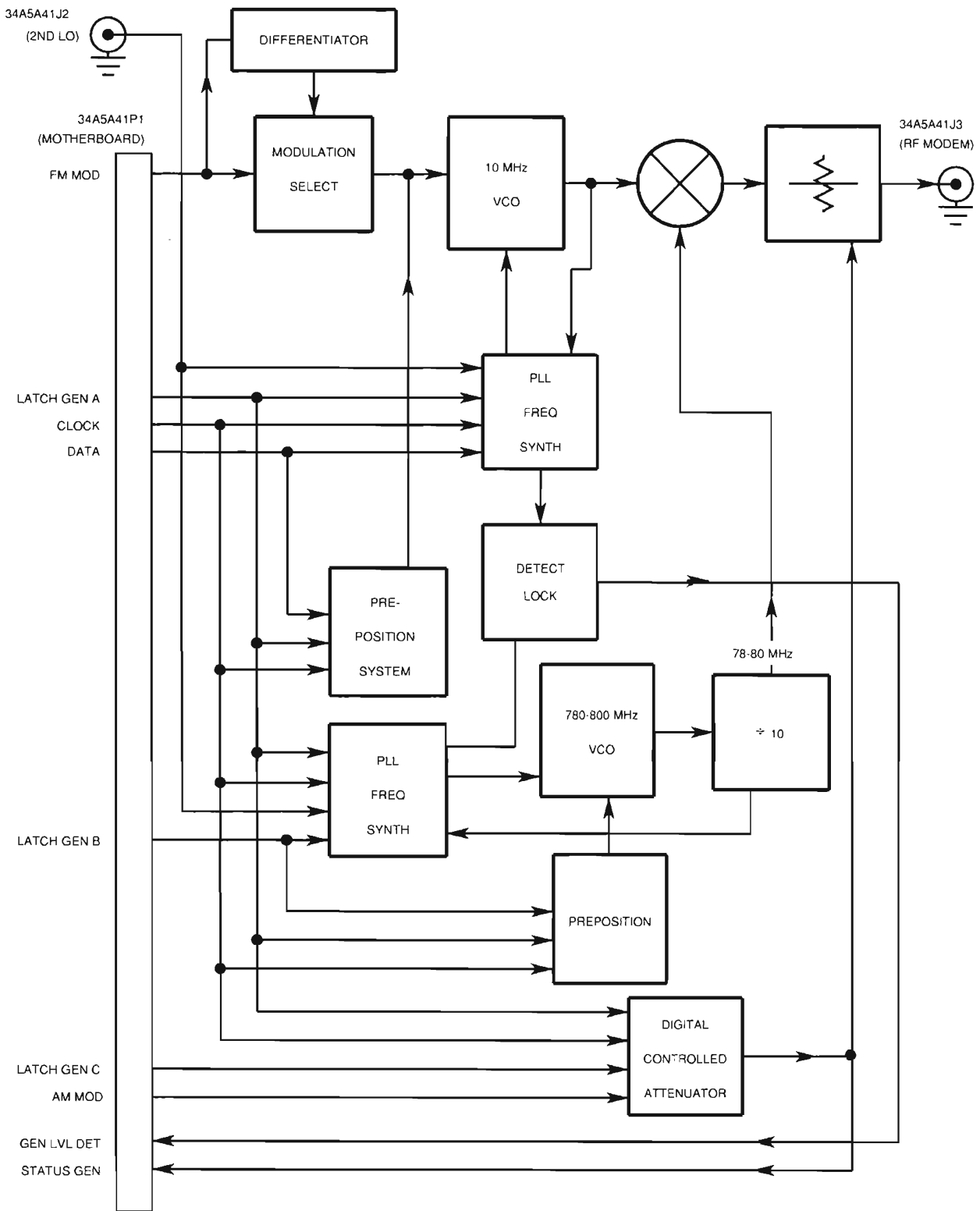

90MBD01

Figure 1-18. A41 90 MHz Generator Functional Block Diagram.

## CHAPTER 1 INTRODUCTION

---

s. 34A5A20 GENERATOR IF (fig. 1-18). The A20 Generator IF is responsible for taking the 88-90 MHz IF Signal from the A41 90 MHz Generator and transforming it into the final RF Signal. Signals from the A13 1st LO (1.3-2.298 GHz LO) and the A15 2nd LO (1210 MHz LO) are used to transform the signal.

The 88-90 MHz IF Signal passed from the A41 90 MHz Generator is presented to the GEN IF 1st Mixer. The GEN IF 1st Mixer adds the 1210 MHz LO Signal (A15 2nd LO) with this signal to produce a 1300-2298 MHz IF signal. The 1298-1300 MHz IF Signal is passed to the second mixer where it is combined with a 1300-2298 MHz LO (A13 1st LO). This mixer converts the signal to the final output frequency (0.250-1000 MHz). The RF Signal is amplified for +10-+20 dBm level required and passed to the A36 Attenuator.

The RF Signal also passes through a coupler where the output level is detected. This circuit produces the GEN LVL DET Signal and is routed through channels to the A41 90 MHz Generator where it is used for setting the Attenuator.

THIS PAGE INTENTIONALLY LEFT BLANK

CHAPTER 1 INTRODUCTION

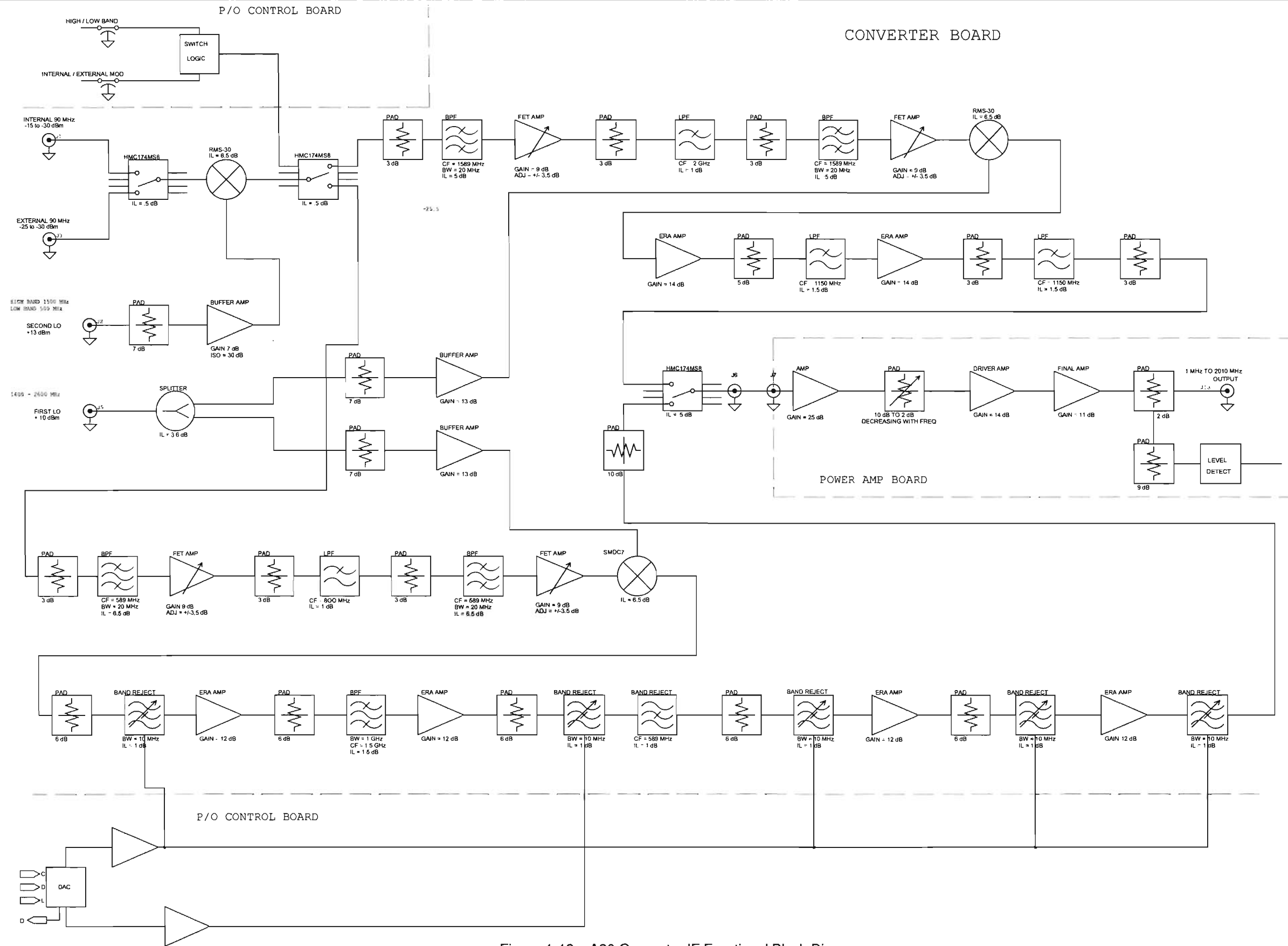

Figure 1-19. A20 Generator IF Functional Block Diagram.

THIS PAGE INTENTIONALLY LEFT BLANK

## CHAPTER 1 INTRODUCTION

t. 34A5A36 ATTENUATOR (fig. 1-19). The A36 Attenuator distributes  $\pm 15$  and  $+5$  Vdc from the A37 Auxiliary Power Supply to the A20 Generator IF, A16 Receive IF and A36 Power Termination.

Control signals for the A36 Attenuator originate in the A26 Processor (Instrument). The A22 RF I/O converts the data into a serial format and passes the data to the A36 Attenuator through the A37 Auxiliary Power Supply. The data is accepted by the A36 Attenuator when the appropriate Latching signal (LATCH-ATTEN) is generated. The serial data is converted to parallel format and split into control signals. Decoder #1 passes control signals to the A36 Power Termination and A16 Receive IF. It also passes the control signal for the 1 dB setting of Attenuator. Decoder #2 is used to control the remainder of the Attenuator settings. The A36 Attenuator both passes control signals and accepts status signals for the A36 Power Termination. The A36 Attenuator decodes the following control lines for the A36 Power Termination:

DUPLEX (sets DUPLEX OUT Connector (A23J5A) as output connector)  
 RANGE SELECT (sets switch selecting signal for RF PWR LVL Signal)  
 20dB PAD (activates 20 dB attenuator in signal path from T/R Connector (W2J1))

The status signals accepted from the A21 Power Termination include:

ALARM (T/R Connector [W1J1] Overload).	POWER-MODE
POWER TERM TEMP.	RF POWER LEVEL.

Status signals are also accepted from the A16 Receive IF and A20 Generator IF. The A20 Generator IF passes the GEN LEVEL DET Signal for eventual use by the A41 90 MHz Generator. ANTENNA OVERLOAD STATUS is provided for the A26 Processor (Instrument) by the A16 Receive IF.

Control signals provided to the A16 Receive IF include:

ANTENNA $\overline{T/R}$ SEL.	20 dB PAD #1 SEL.	20 dB PAD #2 SEL.
-------------------------------	-------------------	-------------------

The A36 Attenuator is responsible for attenuating the RF signal from the A20 Generator IF before entering the A21 Power Termination. Attenuation settings are 0-127 dB.

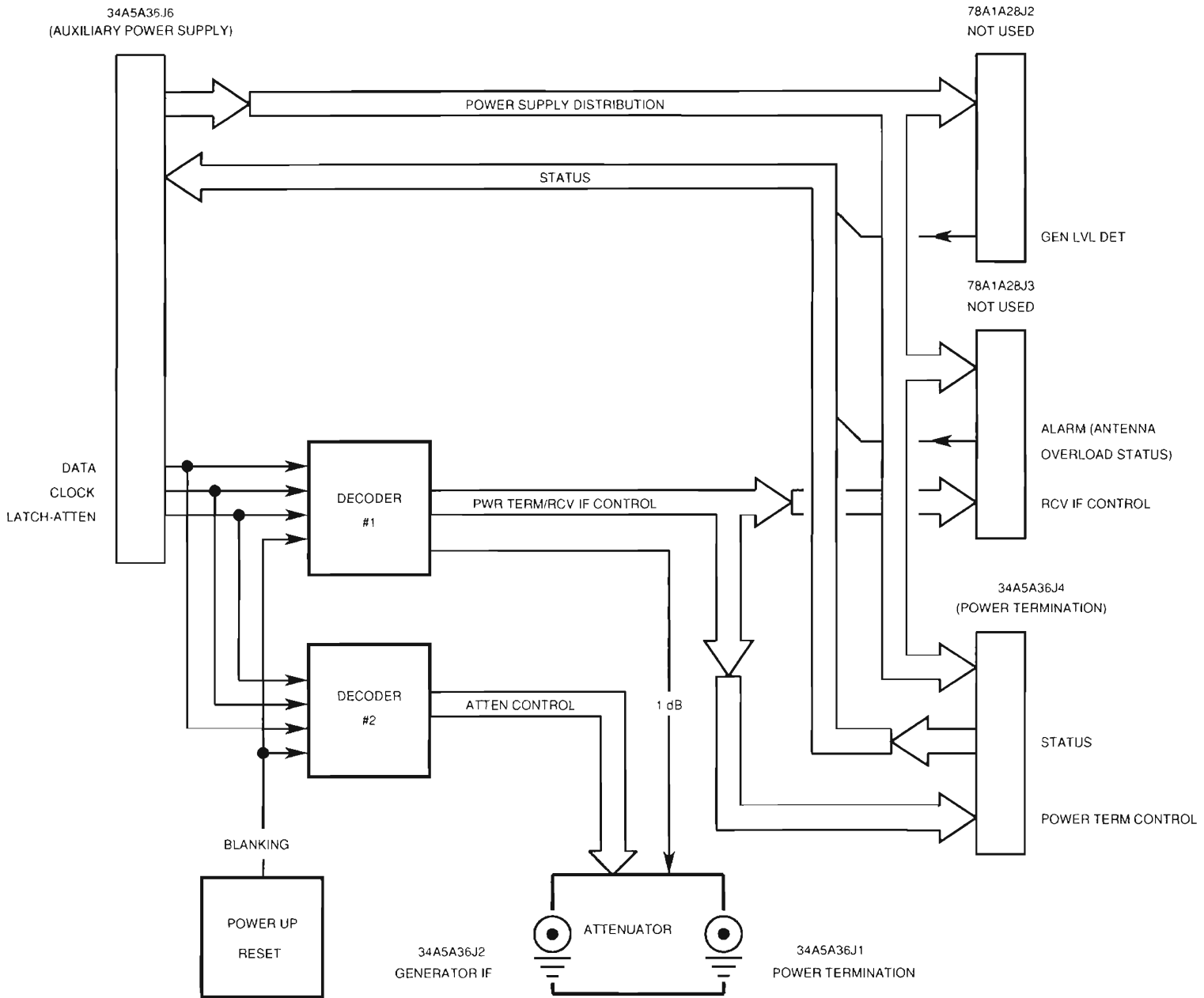

Figure 1-20. A36 Attenuator Functional Block Diagram.



## CHAPTER 1 INTRODUCTION

u. 34A5A29 RF I/O (fig. 1-20). The A22 RF I/O performs one primary function and several secondary functions. The primary function is to convert the data presented by the A26 Processor (Instrument) from parallel to serial format, using the Parallel-To-Serial Converter, for the modules attached to the RF I/O BUS. Included in that function are clock and latch functions for the transmission of serial data. Clock and Data Signals are presented to all attached assemblies simultaneously, however, Latch Signals are unique to each assembly. Selection of a latch line by the A26 Processor (Instrument) Data attaches the Serial Data Bus to the specific assembly. The Latch Decoder is used to decode the upper byte (D8-D15) of data from the processor to determine the specified I/O device. The Parallel-To-Serial Converter passes the serial data to the Latch Decoder to place on the RF I/O Bus.

The second function of the A29 RF I/O is to provide a return path to the A26 Processor (Instrument) from the assemblies attached to the RF I/O BUS. Status signals provided to the A29 RF I/O through the RF I/O BUS by the separate assemblies are assembled and latched to the NAT-BUS as a 16 bit word. Status lines returned to the A29 RF I/O include:

- STATUS-1stA (1st LO Receive)
- STATUS-1stB (1st LO Generate)
- STATUS-3rd (3rd LO)
- STATUS-2nd
- STATUS-GEN
- ANLZR-LOCK (Analyzer Phase Lock)
- ALARM POWERMODE
- SPR DC DET (A22 Power Supply)
- MIC-SW
- ACC-1
- ACC-2

The A29 RF I/O receives inputs from both the NAT-BUS and the RF I/O BUS. The signals provided by the NAT-BUS that are used by the A29 RF I/O include:

- Address Lines (SA0-SA15)
- Data Lines (SD0-SD15)
- I/O Read ( $\overline{\text{IORD}}$ )
- Upper Byte Enable ( $\overline{\text{SHBE}}$ )
- Address Latch Enable (BALE)
- I/O Write ( $\overline{\text{IOWR}}$ )

The EXTERNAL AGC D/A Converter creates the EXT AGC signal for the A1 Receiver. The VCXO D/A Converter provides the digital information needed to create the analog VCXO Signal. The FAN OPTO-COUPLER provides the FAN ON HIGH Signal. The PS SHUTDOWN OPTO-COUPLER provides the PS SHUTDOWN Signal.

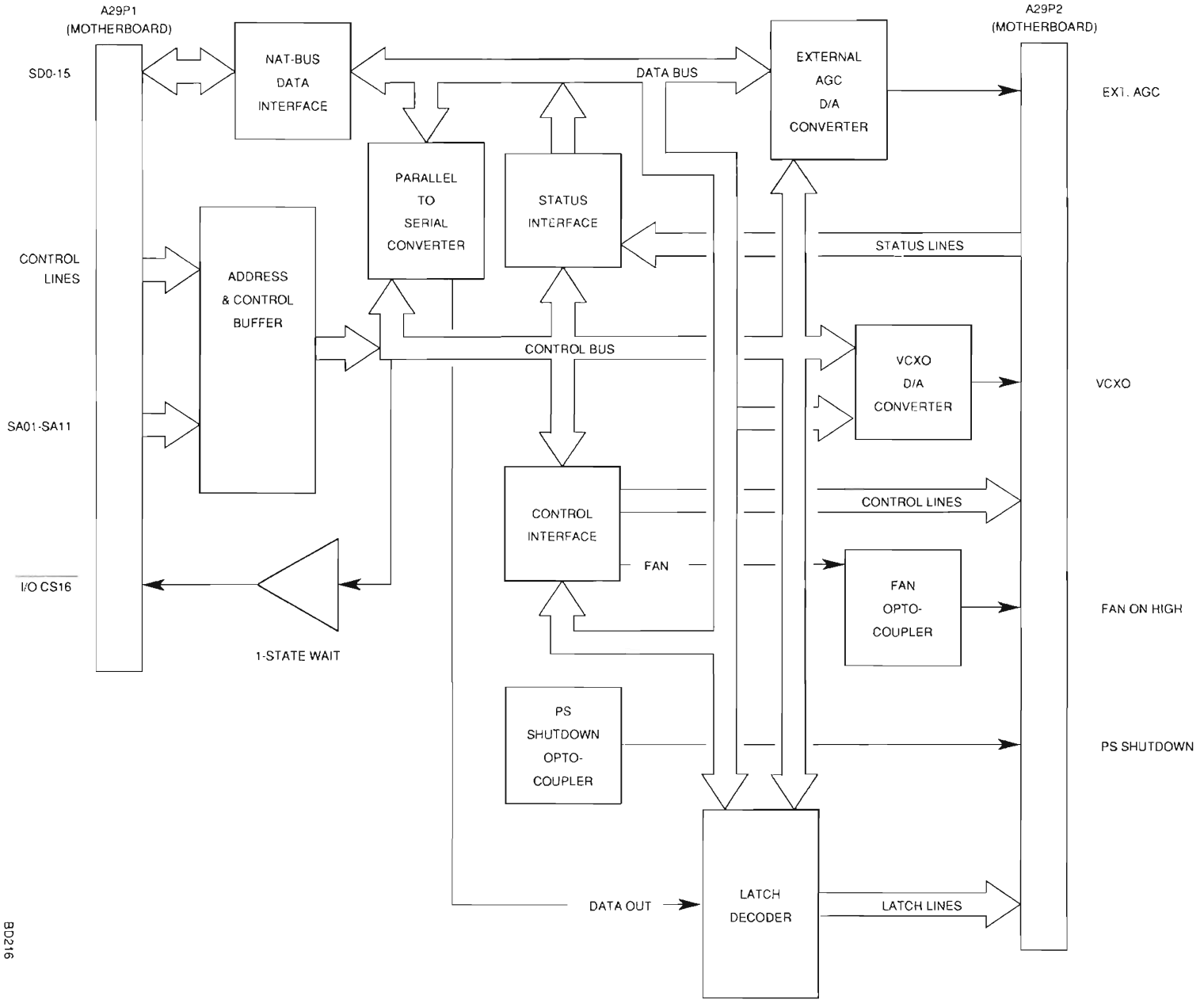

Figure 1-21. A29 RF I/O Functional Block Diagram.

BD216

## CHAPTER 1 INTRODUCTION

---

v. 34A5A37 AUXILIARY POWER SUPPLY (fig. 1-21). The A37 Auxiliary Power Supply performs four functions:

Provides interface from A13 1st LO, A15 2nd LO and A36 Attenuator to the A29 RF I/O.

Disperses +5 and  $\pm 15$  Vdc from the A22 Power Supply to the A13 1st LO, A15 2nd LO and A36 Attenuator.

Provides 34 Vdc to A13 1st LO.

Takes TCXO-PWR line from A15 2nd LO and generates an appropriate signal for STATUS-2ND (2nd LO status line).

The A37 Auxiliary Power Supply provides a feedthru interface for the A13 1st LO and A36 Attenuator to and from the A22 RF I/O through the RF I/O BUS. Information passed from the RF I/O BUS includes latch, clock and serial data signals. Information passed to the RF I/O BUS are status signals from the A13 1st LO and A36 Attenuator.

The A37 Auxiliary Power Supply also passes +5 and  $\pm 15$  V to the A13 1st LO, A15 2nd LO and A36 Attenuator. The A13 1st LO also requires a +34 V source. This is generated in the A37 Auxiliary Power Supply and is not used by any other assembly.

The A15 2nd LO passes TCXO-PWR Signal to the A37 Auxiliary Power Supply which passes the signal to the RF I/O BUS and also sets the appropriate signal for a status signal for the A15 2nd LO. If the TCXO-PWR Signal is high, the STATUS-2ND Line is high.

THIS PAGE INTENTIONALLY LEFT BLANK

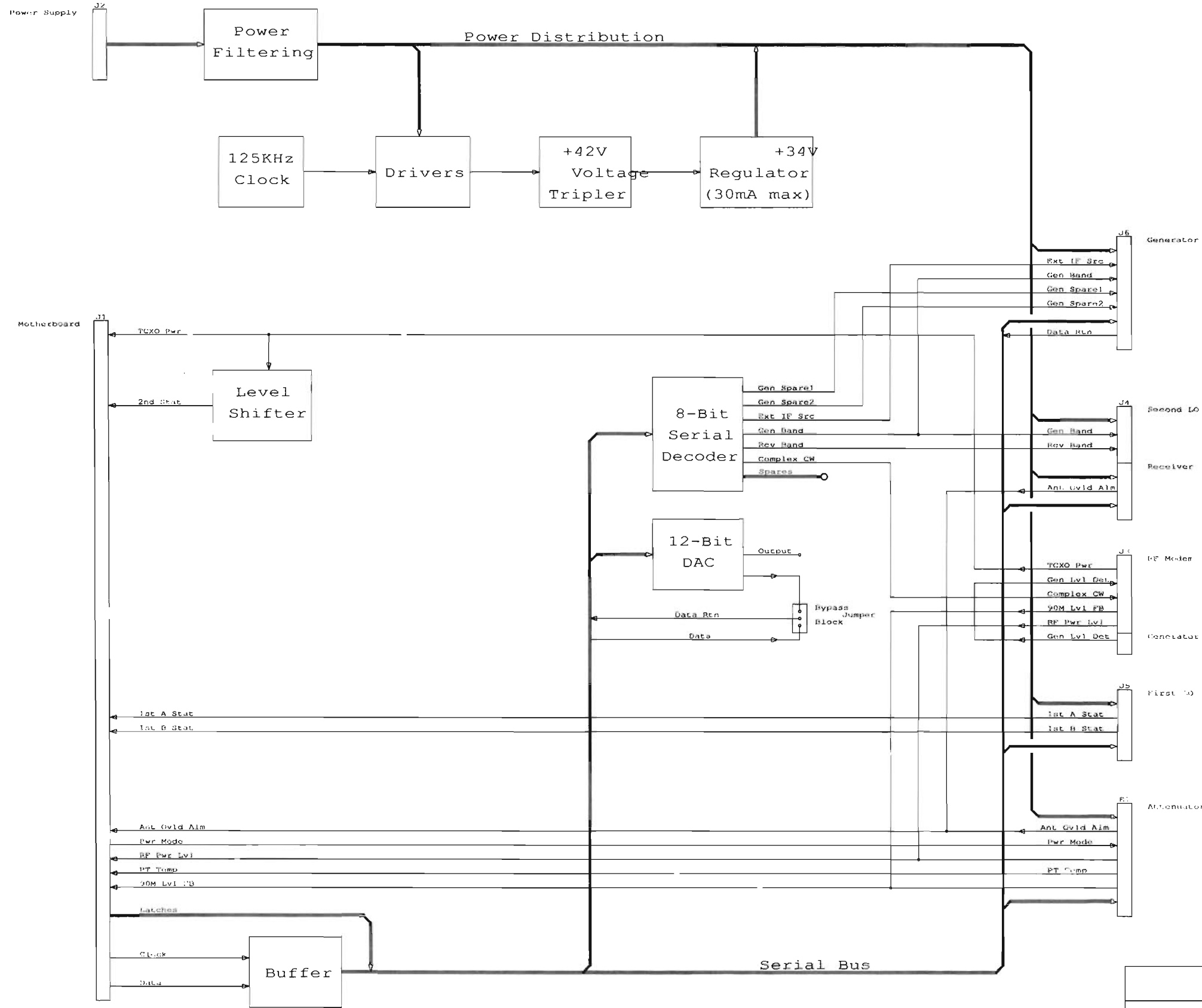

Figure 1-22. A37 Auxiliary Power Supply Functional Block Diagram.

THIS PAGE INTENTIONALLY LEFT BLANK

## CHAPTER 1 INTRODUCTION

---

w. 34A5A35 EXTERNAL I/O (fig. 1-22). The A35 External I/O provides the bidirectional communication link between the A26 Processor (Instrument) and the GPIB and SCSI Connectors. Data and Control signals are passed to the A35 External I/O through the NAT-BUS. Signals are returned to the A26 Processor (Instrument) from the A35 External I/O in the same manner. Control signals select which connector will be active and which controlling circuitry to use. The control and data signals are translated and passed through the appropriate connector. Return data takes the same path in reverse.

The GPIB Connector uses the GPIB CONTROLLER as the controlling device for remote operation. Use of this connector is in accordance with IEEE-488. The GPIB CONTROLLER accepts and passes data through the GPIB DATA TRANSCEIVER. Likewise, control signals pass through the GPIB CONTROL TRANSCEIVER. Clock signals for the GPIB CONTROLLER are provided by a clock within the assembly. Interrupt and DMA requests for GPIB are passed through the NAT-BUS INTERFACE to the NAT-BUS. DMA Acknowledge signals are returned along the same path in reverse.

The SCSI Connector uses the SCSI PROCESSOR as the controlling device for remote operation.

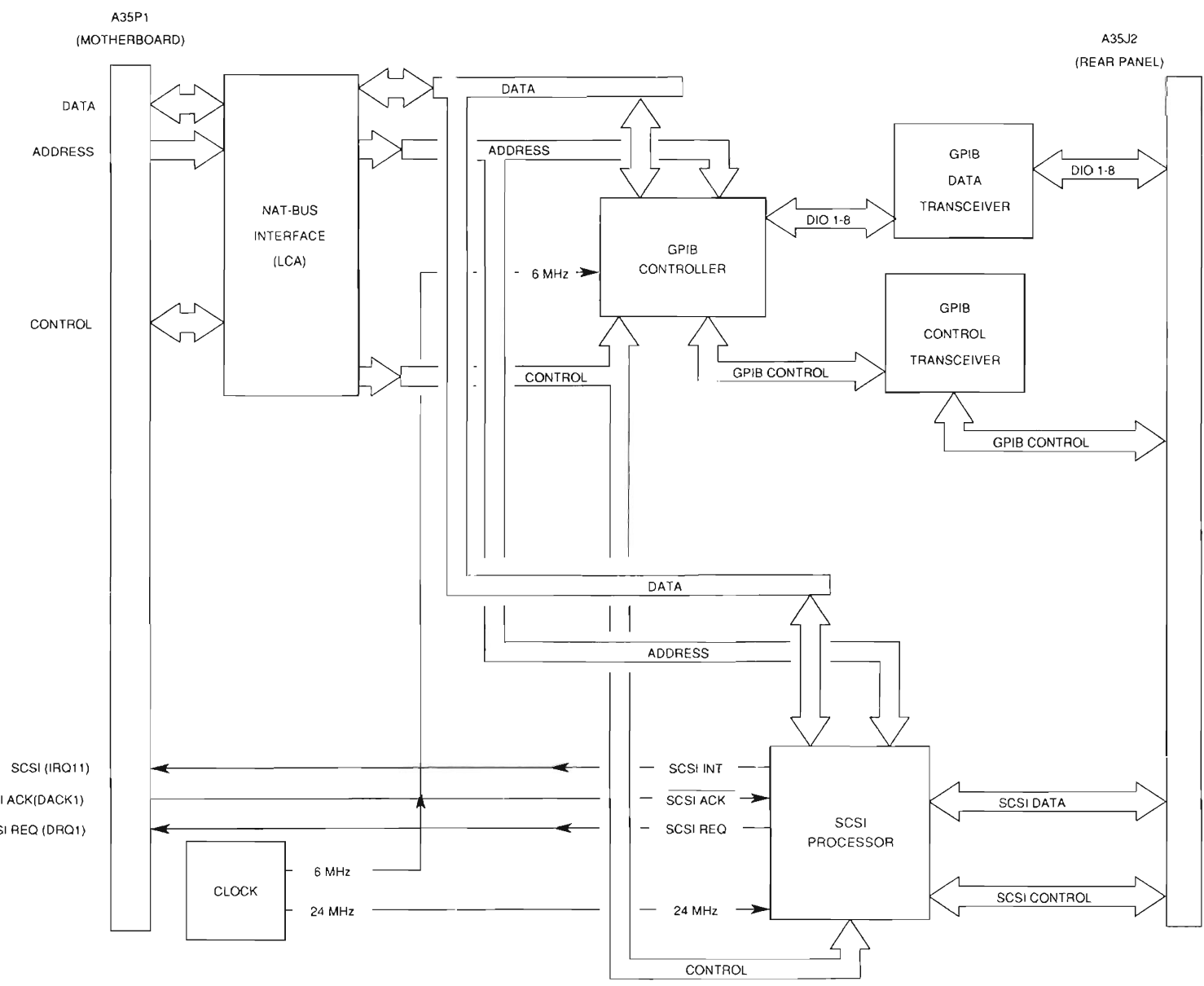

Figure 1-23. A35 External I/O Functional Block Diagram.

BD218



## CHAPTER 1 INTRODUCTION

x. 34A5A11 DMM (fig. 1-23). The A11 DMM converts current, voltage or resistance into digital data for the A30 Counter. The A30 Counter interprets the data and passes the measurement to the A26 Processor (Instrument). Resolution of the A11 DMM is 3 1/2 digits. Control data from the A30 Counter is passed to the A11 DMM in serial format. Required signals are DMM CLOCK Signal, DMM/INEN Signal (Enable) and DATA TO DMM Signal. This data is passed to the Serial To Parallel Relay Driver and the Serial To Parallel Converter. Both sets of circuitry convert the serial data into parallel format. This data is used to control:

- CURRENT RANGE SELECT Switch
- (V/OHMS)/AMPS SELECT Switch
- VOLTS/OHMS SELECT Switch
- OHMS/OHMS SELECT Switch
- VOLTAGE RANGE SELECT Switch
- OHMS TO VOLTAGE CONVERTER
- AC/DC SELECT Switch
- VOLTS/OHMS SELECT Switch
- 1V/.1V REF SELECT Switch

The path taken by the signal to be measured is dependent on the SELECT Switches. Different paths are taken based on whether the measurement is voltage, current or resistance. The path for measuring current starts at the DMM AMP Connector. Signals then pass through the CURRENT RANGE SELECT circuitry where the current signal is passed through a fixed resistance and a voltage level is extracted. The (V/OHMS)/AMPS SELECT Switch passes the analog voltage. The analog voltage then has two paths available. If the measurement to be made is for ac current measurement, the RMS voltage passes through the RMS TO DC CONVERTER, converting the RMS voltage to a dc voltage. If the analog voltage is already a dc voltage (dc current measurement is required), then the RMS TO DC CONVERTER is bypassed. The AC/DC SELECT Switch passes the required analog signal. This analog signal is routed to the VOLTS/OHMS SELECT Switch where the signal is passed to the A/D Converter and the dc voltage level is converted to digital data. This digital data is converted from parallel to serial format and passed to the A30 Counter.

Voltage signals enter from the DMM V $\Omega$  Connector and are switched to the Voltage Range Select by the Volts/ohms Select Switch. The VOLTAGE Range Select produces an analog signal based on the incoming voltage being referenced to ground through a load that is dependent on the range selected for the measurement. If the measurement to be made is for ac current measurement, the RMS voltage passes through the RMS To DC Converter, converting the RMS voltage to a dc voltage. If the analog voltage is already a dc voltage (dc current measurement is required), then the RMS To DC Converter is bypassed. The AC/DC SELECT Device passes the required analog signal. This analog signal is routed to the VOLTS/OHMS Select Device where the signal is passed to the A/D Converter where the dc voltage level is converted to digital data. This digital data is converted from parallel to serial format and passed to the A30 Counter.

Resistance is measured between the DMM V $\Omega$  Connector and the DMM COM Connector. A small current is passed out the DMM V $\Omega$  Connector and back in the DMM COM Connector. The resulting voltage between the two connectors is read by the Ohms To Voltage Converter and switched to the A/D Converter. The parallel format digital data is converted to serial data and passed to the A30 Counter.

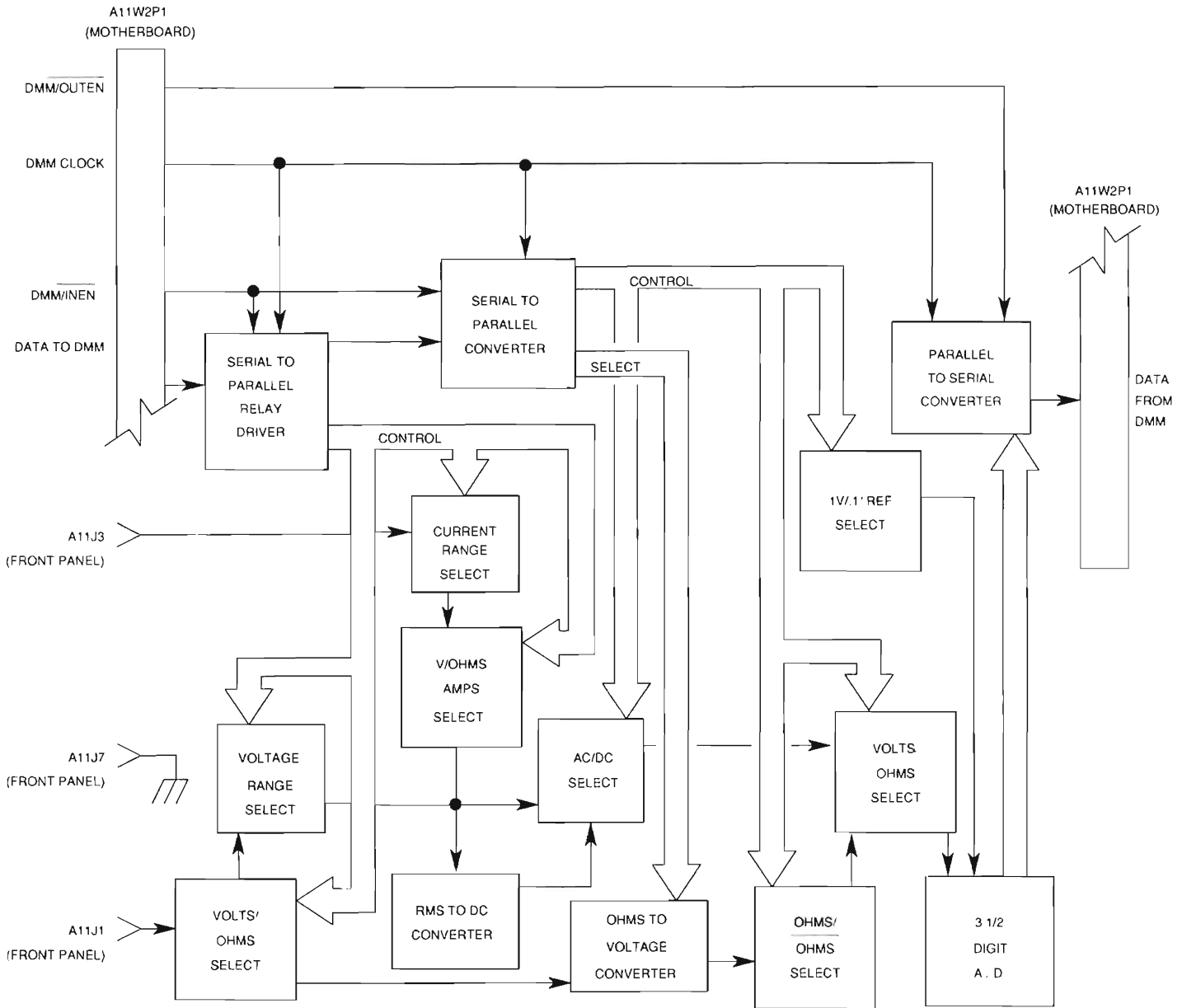
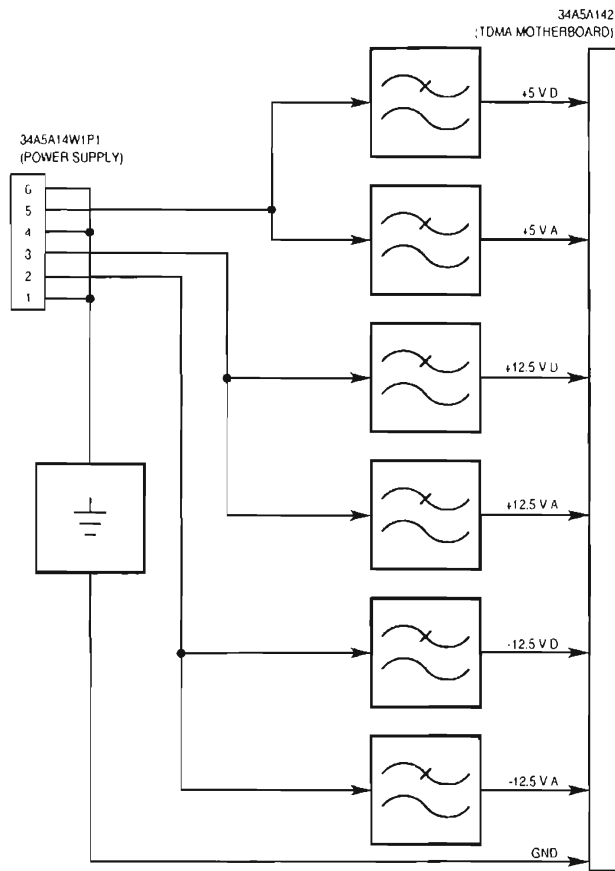

Figure 1-24. A11 DMM Functional Block Diagram.

BD219

# CHAPTER 1 INTRODUCTION

y. 34A5A14 TDMA POWER DISTRIBUTION (Fig 1-24). The TDMA Power Distribution PC Board Assembly filters and distributes the dc voltages from the Power Supply Assembly through the TDMA Motherboard PC Board Assembly to the other TDMA assemblies. The output filters attenuate output noise and ripple. The filters also isolate the digital voltages from the analog voltages. Refer to Figure 1-24 for the TDMA Power Distribution PC Board Assembly block diagram and Table 1-1 for list of signals.



TPDBD01

Figure 1-25. A14 TDMA Power Distribution PC Board Assembly Block Diagram

## CHAPTER 1 INTRODUCTION

SIGNAL (LOCATION) SOURCE OR DESTINATION	I/O	A/D	PARAMETER	RANGE
(34A5A3A24W1) Power Supply Assy	I		Operating Voltages	-15.0, +5 and +15.0 Vdc
+15.0 V A (34A5A3A24P2-B3, C3) TDMA Motherboard PC Board Assy	O		Analog Voltage	12.25 to 12.75 Vdc
			Analog dc Current	0 to 4 A (0.78 A nominal)
			Noise and Ripple per BW	<5 mV <sub>p-p</sub> (2 Hz to 1 kHz)
<20 mV <sub>p-p</sub> (1 kHz to 100 MHz)				
-15.0 V A (34A5A3A24P2-B4, C4) TDMA Motherboard PC Board Assy	O		Analog Voltage	-12.25 to -12.75 Vdc
			Analog dc Current	0 to 4 A (0.1 A nominal)
			Noise and Ripple per BW	<5 mV <sub>p-p</sub> (2 Hz to 1 kHz)
<20 mV <sub>p-p</sub> (1 kHz to 100 MHz)				
+5 V A (34A5A3A24P2-B5, C5) TDMA Motherboard PC Board Assy	O		Analog Voltage	5.0 to 5.2 Vdc
			Analog dc Current	0 to 10 A (0.21 A nominal)
			Noise and Ripple per BW	<5 mV <sub>p-p</sub> (2 Hz to 1 kHz)
<20 mV <sub>p-p</sub> (1 kHz to 100 MHz)				
+15.0 V D (34A5A3A24P2-B8, C8) TDMA Motherboard PC Board Assy	O		Analog Voltage	12.25 to 12.75 Vdc
			Analog dc Current	0.1 to 2 A (0.36 A nominal)
			Noise and Ripple per BW	<50 mV <sub>p-p</sub> (2 Hz to 100 MHz)
-15.0 V D (34A5A3A24P2-B9, C9) TDMA Motherboard PC Board Assy	O		Analog Voltage	-12.25 to -12.75 Vdc
			Analog dc Current	0.1 to 2 A (0.08 A nominal)
			Noise and Ripple per BW	<50 mV <sub>p-p</sub> (2 Hz to 100 MHz)
+5 V D (34A5A3A24P2-B11 to B15, C11 to C15) TDMA Motherboard PC Board Assy	O		Analog Voltage	5.0 to 5.2 Vdc
			Analog dc Current	1 to 10 A (3.32 A nominal)
			Noise and Ripple per BW	<50 mV <sub>p-p</sub> (2 Hz to 100 MHz)

Table 1-1. TDMA Power Distribution PC Board Assembly Signals

z. 34A5A24 TDMA PROCESSOR FIRMWARE ASSEMBLY. The TDMA Processor Firmware Assembly controls the TDMA portion of the system. The NAT-BUS supplies the normal +15.0 V D (34A5A3A2X11-A9) and +5 V D (34A5A3A2X11-A3 and A29) operating power. Refer to Figure 1-25 for the Processor Firmware (TDMA) Assembly block diagram and Table 1-2 for a listing of NAT-BUS signals.

The CPU is an 80376 embedded microcontroller. The 80376 is a 32-bit processor with a 24-bit address bus and 16-bit data bus. An attached 82370 Integrated System Peripheral Device supervises Interrupt Requests, speeding up the system. Other controller circuits are as follows:

- Supervisory Circuit controls power-up RESET and Nonmaskable Interrupt actions. RESET affects the 80376, the 82370 and other I/O Devices. The RESET signal from the Supervisory Circuit becomes the RESET DRV signal on the NAT-BUS.
- Memory Select Circuit controls what section of memory is being used.
- Wait State Circuit inserts 1 to 16 wait states into I/O processing, as needed.
- Real-time clock containing time-of-day clock, alarm, 100 year calendar, programmable interrupt, square wave generator and 50 bytes of memory. A lithium power source, included in the package, keeps the clock updated when power is not applied.

Memory available on the Processor Firmware (TDMA) Assembly includes 128k X 8 ROM and 64k X 8 RAM. The ROM stores part of the system code. The RAM stores program global parameters.

The AT Compatible I/O Channel (NAT-BUS) contains:

- 16 bit bi-directional data bus
- 24 bit address line bus
- Three levels of interrupt
- Memory and I/O Read/Write lines
- Clock and timing lines
- Memory refresh timing control lines

The TDMA NAT-BUS Buffer sends out the signals controlling data in and out of the TDMA NAT-BUS.

The RS-232 Interface provides the CSA serial interface with the user through the OPT. RS-232 Connector on the rear panel. The RS-232 Interface provides all of the RS-232 and Modem control signals for CSA remote operation or connecting to a modem. The baud rate of data transfer cannot exceed 20000. The RS-232 Interface generates an interrupt (IRQ3) to the  $\mu$ processor when attention is needed.

SIGNAL/LOCATION	I/O	DESCRIPTION
RESET DRV 34A5A24P1-A2	O	Resets system logic at power-up or low voltage. Active high on falling edge of clock.
$\overline{\text{MEMW}}$ 34A5A24P1-A11	O	Memory Write Command. Active low signal instructs memory to store data on data bus.
$\overline{\text{MEMR}}$ 34A5A24P1-A12	O	Memory Read Command. Active low signal instructs memory to put data on data bus.
$\overline{\text{IOWR}}$ 34A5A24P1-A13	O	I/O Write Command. Active low signal instructs I/O device to read data from data bus.
$\overline{\text{IORD}}$ 34A5A24P1-A14	O	I/O Read Command. Active low signal instructs I/O device to put data on data bus.
$\overline{\text{REFRESH}}$ 34A5A24P1-A19	O	Refreshes system dynamic memory.
IRQ7 34A5A24P1-A21	I	Interrupt Request Line. Active high signal informs CPU, the Parallel Printer Port on the Internal I/O Firmware Assembly requires attention.
BALE 34A5A24P1-A28	O	Buffered Address Latch Enable. Generated to latch memory addresses.
SPKDATA 34A5A24P1-B1	O	5 V logic level pulse signal ( $\leq 2$ kHz) for audio feedback when pressing Front Panel Assembly keys or for alarms, errors and warnings
$\overline{\text{SBHE}}$ 34A5A24P1-B2	I/O	System Bus High Enable. Indicates transfer of data on high byte of data bus, SD8 to SD15.
$\overline{\text{MEM CS16}}$ 34A5A24P1-B3	I	Memory Cycle Select 16-bits. Indicates a 16-bit memory cycle may be executed for the current memory transfer.
LA17-LA23 34A5A24P1-B15, B13, B12, B10, B8, B6, B4	O	Unlatched address of system memory. Provides 16 megabytes of address capability. Signals are only valid when BALE is high.
IRQ12 34A5A24P1-B11	I	Interrupt Request Line. Active high signal informs CPU, the Floating Point Dual Port RAM on the DSP Firmware Assembly requires attention.
IRQ15 34A5A24P1-B19	I	Interrupt Request Line. Active high signal informs CPU, the Fixed Point Dual Port RAM on the DSP Firmware Assembly requires attention.
SD0-SD15 34A5A24P1-C2 to 9, B21 to 26, B28, B30	I/O	System Data bits 0 to 15. SD0 is the least significant bit (LSB) and SD15 is the most significant bit (MSB).
IOCHRDY 34A5A24P1-C10	I	I/O Channel Ready. Pulled low (not ready) by I/O device to lengthen I/O cycle. Allows slower devices to attach to I/O channel. User devices set IOCHRDY line low upon detecting valid address and read or write command.
AEN 34A5A24P1-C11	O	Address Enable. Used in I/O address decoding to distinguish between DMA cycles (low) and regular I/O cycles (high).
SA0-SA19 34A5A24P1-C12 to 31 (in reverse sequence)	O	System Address bits 0 to 19. Active high address lines address memory and I/O devices. Lines are gated when BALE is high and latched on falling edge. SA0 is the least significant bit (LSB) and SA19 is the most significant bit (MSB).

Table 1-2. TDMA NAT-BUS Signals

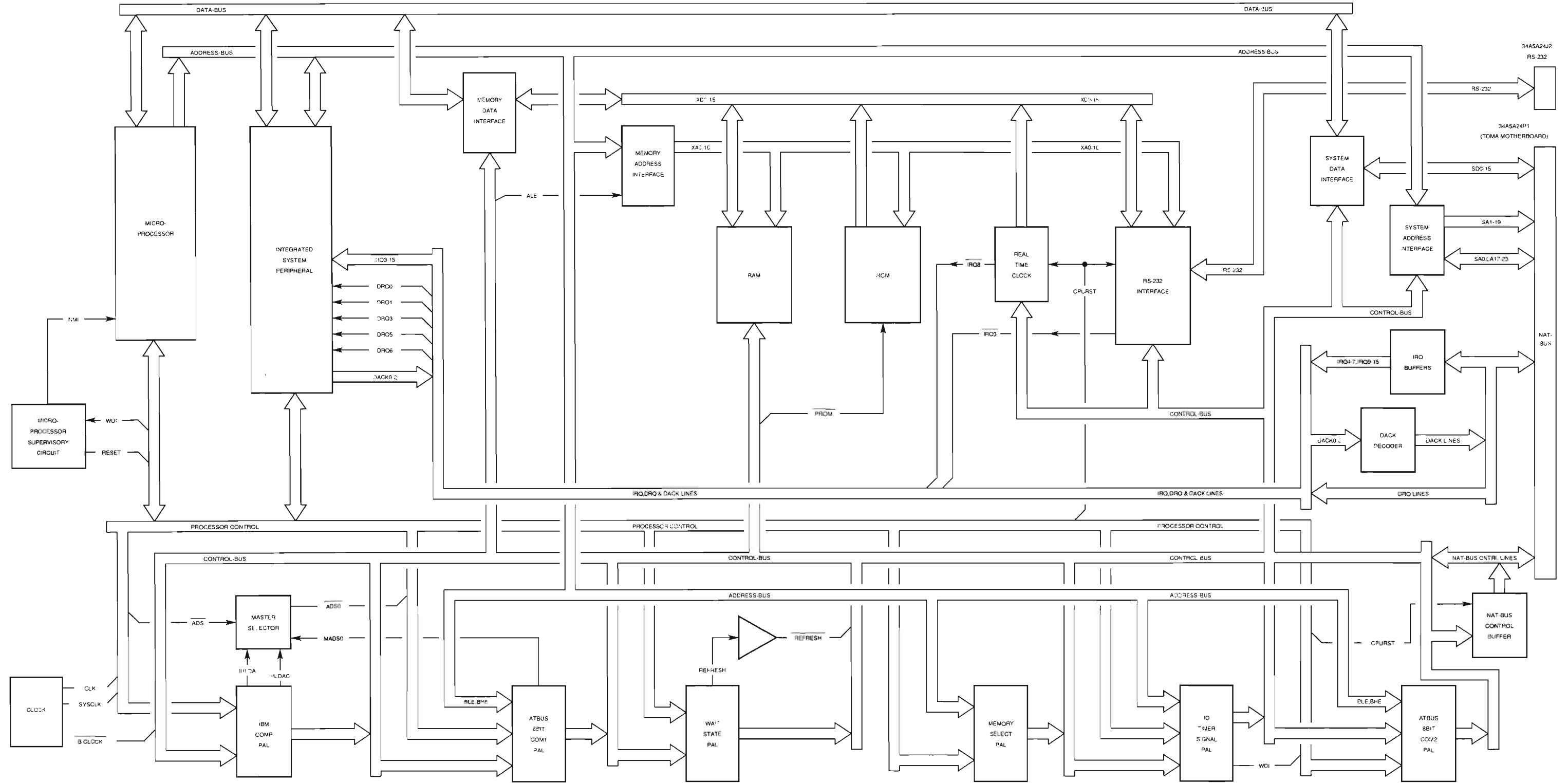

Figure 1-26. A24 TDMA Processor Firmware Assembly Block Diagram

THIS PAGE INTENTIONALLY LEFT BLANK.



aa. 34A5A25 FLASH MEMORY. The Flash Memory (TDMA) PC Board Assembly appears to the Processor Firmware (TDMA) Assembly as a large block of memory, both volatile and non-volatile, with a control system located in I/O space. Static RAM provides 768 kbytes of volatile memory and 256 kbytes of non-volatile memory (having on-board battery back-up). The Flash Memory PC Board Assembly also contains four megabytes of non-volatile Flash memory (ROM). The +15.0 V D (34A5A3A2X11-A9) and +5 V D (34A5A3A2X11-A3 and A29) provide normal operating power.

The memory interface consists of data, address and control buffers. The decode logic circuit selects the memory devices according to the input from the  $\mu$ processor on the Processor Firmware (TDMA) Assembly (LA17 to LA23 and BALE lines). Control signals used for memory transfers are  $\overline{\text{SBHE}}$ ,  $\overline{\text{MEMCS16}}$ ,  $\overline{\text{MEMW}}$ ,  $\overline{\text{MEMR}}$ , BALE and  $\overline{\text{REFRESH}}$ .

34A5A25P1  
(TDMA MOTHERBOARD)

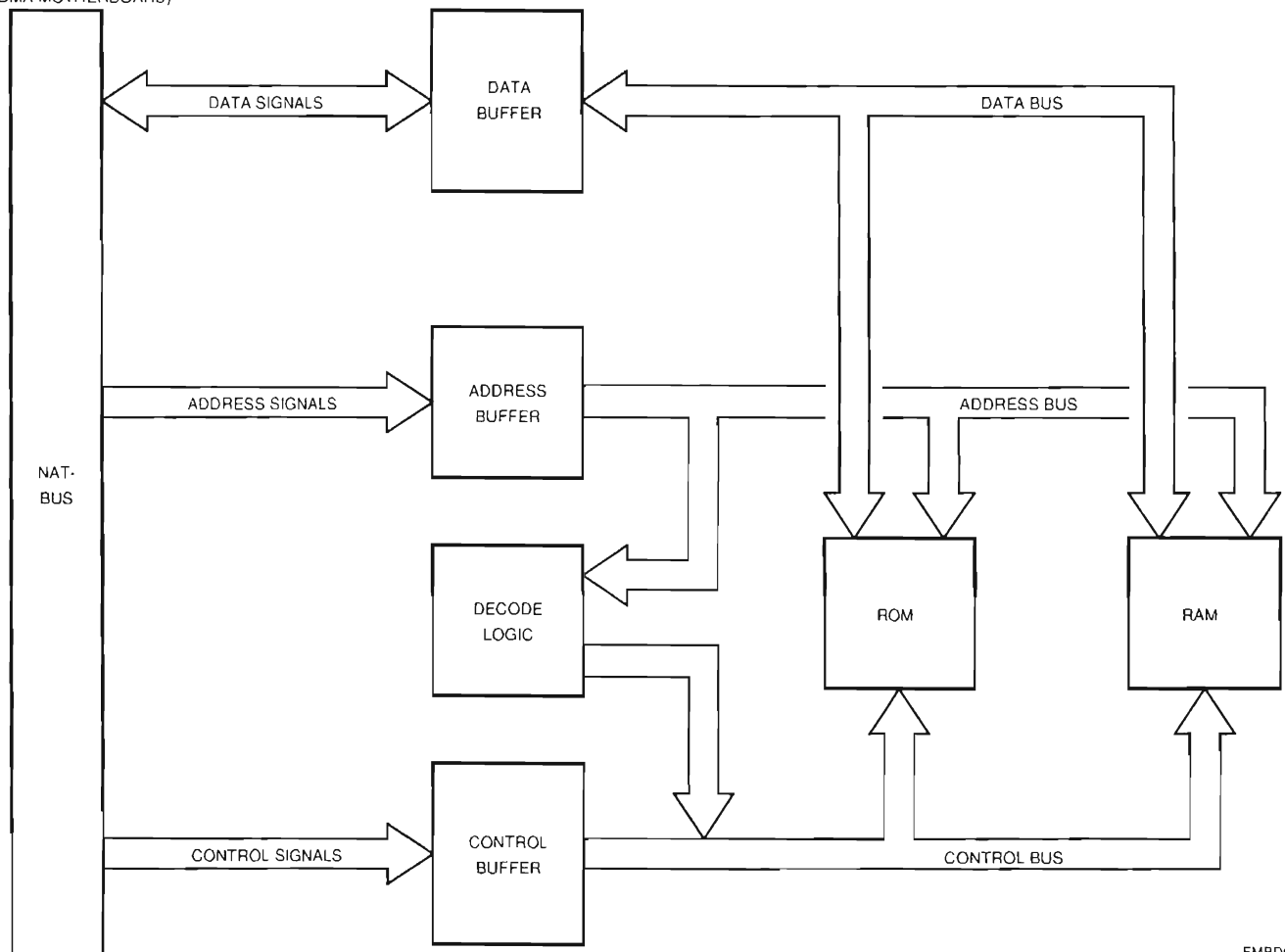

FMBD01

Figure 1-27. A25 Flash Memory PC Board Assembly Block Diagram

The microprocessor on the Processor Firmware (TDMA) Assembly maintains the control system on the Flash Memory PC Board Assembly. The control system, a control and status register, allows voltage control and signal observation, critical to programming and verifying Flash memory. The  $\overline{\text{IORD}}$ ,  $\overline{\text{IOWR}}$  and AEN lines control the I/O interface.

Refer to Table 1-2 for TDMA NAT-BUS signals sent to and from the Processor Firmware (TDMA) Assembly.

bb. 34A5A19 DSP FIRMWARE ASSEMBLY. The DSP Firmware Assembly contains two Digital Signal Processors (DSPs) for generating, receiving and measuring cellular data. The DSPs are organized in a bi-directional pipeline fashion for transmitting and receiving data. A floating point DSP at one end of the chain interfaces to the Coder/Decoder (CODEC) for audio input/output. A fixed point DSP at the other end interfaces to the IQ DACs for sending a baseband signal to the Baseband Mux PC Board Assembly for transmission. Both DSPs access the 10-Bit Receive ADC for decoding received data and signal measurements. Both DSPs communicate with the  $\mu$ processor on the Processor Firmware (TDMA) Assembly (hereafter referred to only as  $\mu$ processor) through the Dual Port RAMs and with each other over a 16-bit bi-directional data path. The -15.0 V D (34A5A3A2X13-A7), +15.0 V D (34A5A3A2X13-A9) and +5 V D (34A5A3A2X13-A3 and A29) provide normal operating power. Refer to Figure for the DSP Firmware Assembly block diagram and Table for a list of signals.

- NAT-BUS INTERFACE

The DSP Firmware Assembly has an Industry Standard Architecture (ISA) Bus compatible interface. The ISA Bus has access to 8-bit and 16-bit memory devices and 8-bit I/O devices. The  $\mu$ processor and each DSP share 8-bit Dual Port RAMs. The  $\mu$ processor and the Fixed Point DSP also share access to the fixed point program SRAM. Three control registers and a status register provide the 8-bit I/O devices. The  $\mu$ processor controls the DSPs, CODEC and Clock Control Logic through the three control registers. The DSP Firmware Assembly generates two interrupts to the  $\mu$ processor. The floating point Dual Port RAM initiates one interrupt, IRQ12, and the fixed point Dual Port RAM generates the other, IRQ15. Refer to Table 2-4 for NAT-BUS signals sent from and to the Processor Firmware (TDMA) Assembly.

- CLOCK CONTROL LOGIC

The Clock Control Logic circuit provides two clocks, transmit and receive. The DSPs control the independently selectable transmit and receive clocks. Frequency may or may not be different with each clock. The clocks are synchronous and in phase with each other when providing the same frequency. The Clock Control Logic circuit uses the following clock inputs: 97.2 kHz and 8 MHz from the RF Modem PC Board Assembly and 7.3728 MHz from the Internal I/O Firmware Assembly.

The Floating Point DSP controls the receive clock. The receive clock clocks the 10-Bit Receive ADC, latches data into the A/D Latches and generates interrupts for both DSPs. Possible receive clock frequencies are: 97.2 kHz, 160 kHz, 153.6 kHz or 1 MHz.

The Fixed Point DSP controls the transmit clock. The transmit clock latches data into the I and Q DACs and generates an interrupt to the Fixed Point DSP. Possible transmit clock frequencies are: 97.2, 160, 153.6, 250 or 500 kHz.

- FIXED POINT DSP

The Fixed Point DSP section digitizes, demodulates and decodes received IF signals. The Fixed Point DSP section also generates the baseband transmit signal. The Fixed Point DSP section consists of the DSP, program memory (SRAM), Dual Port RAM, IQ DACs, 10-Bit Receive ADC Interface and Floating Point DSP Interface.

The DSP shares 32k X 16 of program memory (SRAM) and 1k X 16 of Dual Port RAM with the  $\mu$ processor on the Processor Firmware (TDMA) Assembly. A 40 MHz Oscillator provides for a 25 ns instruction cycle time.

Due to the short bus cycle times, two address and data busses are associated with the DSP (local bus and I/O bus). The program memory and two sets of isolation buffers reside on the local bus. The isolation buffers provide access to the NAT-BUS and Processor Firmware (TDMA) Assembly or only the I/O bus. The Fixed Point DSP controls the Dual Port RAM, IQ DACs and various latches over the I/O bus.

The Fixed Point DSP executes program code out of the SRAM. The  $\mu$ processor downloads program code from the Flash Memory PC Board Assembly at power-up or when the task for the DSP changes. When operating, the DSP has complete control of the SRAM. When the  $\mu$ processor has control, the DSP shuts down. To gain access, the  $\mu$ processor sets a hold pin low through the NAT-BUS Interface to tri-state the DSP data and control lines. When tri-stated, the Fixed Point DSP sends out the hold acknowledgment in the status register, giving control to the  $\mu$ processor.

The Dual Port RAM, used for data storage and control information, sends an interrupt to the DSP when the  $\mu$ processor writes to location D97FCh or to the  $\mu$ processor (IRQ5) when the DSP writes to location FFFFh.

An interrupt to the DSP clears when the DSP reads from location FFFEh. An interrupt to the  $\mu$ processor clears when the  $\mu$ processor reads from location D97FEh. The Dual Port RAM generates a busy signal if the  $\mu$ processor or DSP attempts to access a memory location already accessed by the other. For the  $\mu$ processor, a busy signal causes the IOCHRDY line (NAT-BUS) to go low.

The 10-bit Receive ADC digitizes the RCVR IF signal and provides the digital data to the Fixed Point DSP for decoding.

The Fixed Point DSP transmits baseband data to the Baseband Mux PC Board Assembly using two 12-bit DACs. These DACs, called the IQ DACs, provide the AMPS and NAMPS modulation on the FM MOD line and the TDMA modulation on the I MOD and Q MOD lines. IQ DAC outputs go to 0.0000 V when reset. Low-pass filters eliminate switching noise from the DACs and prevent inter-symbol interference. The filters provide an output of  $\leq \pm 1.12 V_P$ .

Interface between the DSPs consists of 16-bit transmit and receive latches and buffers. The Floating Point DSP sends transmit data to the Fixed Point DSP through a latch controlled by the Floating Point DSP and a buffer controlled by the Fixed Point DSP. The Fixed Point DSP sends demodulated receive data to the Floating Point DSP through a latch controlled by the Fixed Point DSP and a buffer controlled by the Floating Point DSP.

A control register provided for the Fixed Point DSP controls the transmit clock (refer to -4-7B), output lines from the IQ DACs, DIAG OUT Connector output and TDMA Timeslot synchronization. For AMPS and NAMPS (analog formats), the control register sets the I DAC output to FM MOD. For TDMA (digital formats) the control register sets the IQ DACs to I MOD and Q MOD. For the DIAG OUT Connector on the Rear Panel Assembly output, the control register sends a high SYNC pulse when the IFR-1900 transmits TDMA Timeslot data to a mobile unit. When operating in the AMPS or NAMPS formats, the control register sends a TTL level, demodulated output of the received signal, out the DIAG OUT Connector. The DSP Firmware Assembly synchronizes the TDMA Timeslot data from the control register with the 97.2 kHz clock and transmits the TIMESLOT result to the Receiver PC Board Assembly.

- **FLOATING POINT DSP**

The Floating Point DSP performs signal parameter measurements, controls the CODEC and sets the receive gain on the Receiver PC Board Assembly. The Floating Point DSP section consists of the DSP, program memory (SRAM), Dual Port RAM, Audio CODEC Interface, 10-Bit Receive ADC Interface, Control Outputs and Fixed Point DSP Interface. Refer to 2-4-7C for the description of the interface between the DSPs.

The DSP uses 128k X 32 of program memory (SRAM) and shares 1k X 8 of Dual Port RAM with the  $\mu$ processor on the Processor Firmware (TDMA) Assembly. A 40 MHz Oscillator divided by two provides for a 50 ns instruction cycle time. The DSP measures SINAD, VSWR, power and modulation accuracy.

The Floating Point DSP executes program code out of the SRAM. The  $\mu$ processor downloads program code from the Flash Memory PC Board Assembly at power-up or when the task for the DSP changes. The  $\mu$ processor downloads program code through the Dual Port RAM.

The Dual Port RAM, used for data storage and control information, sends an interrupt to the DSP when the  $\mu$ processor writes to location D83FEh or to the  $\mu$ processor (IRQ12) when the DSP writes to location 4003FFh. An interrupt to the DSP clears when the DSP reads from location 4003FEh. An interrupt to the  $\mu$ processor clears when the  $\mu$ processor reads from location D83FFh. The Dual Port RAM generates a busy signal if the  $\mu$ processor or DSP attempts to access a memory location already accessed by the other. For the  $\mu$ processor, a busy signal causes the IOCHRDY line (NAT-BUS) to go low.

The CODEC handles the audio in and out of the IFR-1900. The CODEC circuit has an analog input AUDIO IN (typically a handset) from the AUDIO Connector on the Rear Panel Assembly and two analog outputs AUDIO OUT and DSP AUDIO. The AUDIO IN is set up to interface with an electret microphone providing an impedance of  $\approx 1 k\Omega$ . The line carries a +2 Vdc for biasing the microphone and is ac coupled into the CODEC. The CODEC sums the audio input with the output to provide the sidetone to the handset speaker. The ac coupled output, AUDIO OUT drives the handset speaker through the AUDIO Connector on the Rear Panel Assembly. The CODEC sends the buffered DSP AUDIO output with a dc offset to the Front Panel Assembly.

The 10-bit Receive ADC digitizes the RCVR IF and RF PWR METER signals for the Floating Point DSP to take measurements.

A 16-bit control register provided for the Floating Point DSP controls the receive clock (refer to 2-4-7B), measurement control lines, and receive gain. One output selects the 10-bit Receive ADC input, RCVR IF for decoding and taking other measurements or RF PWR METER for power measurements. The PINC/PREF CONTROL line for the VSWR test goes high to measure incident power or low to measure reflected power.

The VSWR/REC CONTROL line selects normal receive mode, when low, or VSWR test mode, when high. The RF GEN CONVERT line, also for the VSWR test, goes low to test forward channels or high to test reverse channels. The control register also sets receive gain through an 8-bit DAC to the Receiver PC Board Assembly (RX GAIN). The control line, INT/EXT AGC goes low for the DSP Firmware Assembly (8-bit DAC) to control the receive gain. INT/EXT AGC goes high for the Receiver PC Board Assembly to control the receive gain. The RX GAIN output has a range of 0 to  $\leq 10$  V.

SIGNAL (LOCATION) SOURCE OR DESTINATION	I/O	A/D	PARAMETER	RANGE
TDMA Power (34A5A19J1) RF Modem PC Board Assy	I	A	Input Voltage	0 to +5 V
			Input Impedance	100 k $\Omega$
TDMA 10.7 MHz RCVR IF (34A5A19J2) Receiver PC Board Assy	I	A	Input Voltage	- 2.5 to +2.5 V
			Input Impedance	ac coupled, biased to 2.5 V
I MOD (34A5A19P1-A5) Q MOD (34A5A19P1-A9) FM MOD (34A5A19P1-C7) Baseband Mux PC Board Assy	O	A	Output Voltage ( $\geq 600 \Omega$ load)	-1.2 to +1.2 VP 1.15 VP nominal
			Source Impedance	<10 $\Omega$
SYNC (34A5A19P1-A18) SYNC OUT Connector Rear Panel Assy	O	D	Voh	$\geq 3.8$ V (4.4 V nominal)
			Vol	$\leq 0.33$ V (0.1 V nominal)
PULSE (34A5A19P1-A20) RF Modem PC Board Assy	O	D	Voh	$\geq 3.8$ V (4.4 V nominal)
			Vol	$\leq 0.33$ V (0.1 V nominal)
<i>TIMESLOT</i> (34A5A19P1-A21) TDMA 10.7 MHz Receiver PC Board Assy	O	D	Voh	$\geq 3.86$ V
			Vol	$\leq 0.40$ V
8 MHz (34A5A19P1-A30) RF Modem PC Board Assy	I	D	Vih	$\geq 2$ V
			Vil	$\leq 0.8$ V
ENV INIT (34A5A19P1-B19) RF Modem PC Board Assy	O	D	Voh	$\geq 3.0$ V
			Vol	$\geq 0.55$ V
AUDIO IN (34A5A19P1-C1) AUDIO Out (GEN) Baseband Mux PC Board Assy	I	A	Input Voltage	0 to $\leq +5$ Vdc 300 mVP-P (typical)
AUDIO OUT (34A5A19P1-C2) AUDIO Connector Rear Panel Assy	O	A	Output Voltage	$\leq 7$ VP-P ( $\geq 5$ k $\Omega$ load)
			Nominal Speaker Load	40 $\Omega$
INT/EXT AGC (34A5A19P1-C22) TDMA 10.7 MHz Receiver PC Board Assy	O	D	Voh	$\geq 3.0$ V
			Vol	$\leq 0.55$ V
RX GAIN (34A5A19P1-C25) TDMA 10.7 MHz Receiver PC Board Assy	O	A	Output Voltage	0 to $\leq 10$ VP ( $\geq 5$ k $\Omega$ Load)
97.2 kHz (34A5A19P1-C30) RF Modem PC Board Assy	I	D	Vih	$\geq 2$ V
			Vil	$\leq 0.8$ V
7.3728 MHz (34A5A19P1-C32) Internal I/O Firmware Assy	I	D	Vih	$\geq 2$ V
			Vil	$\leq 0.8$ V

Table 1-3. DSP Firmware Assembly Signals

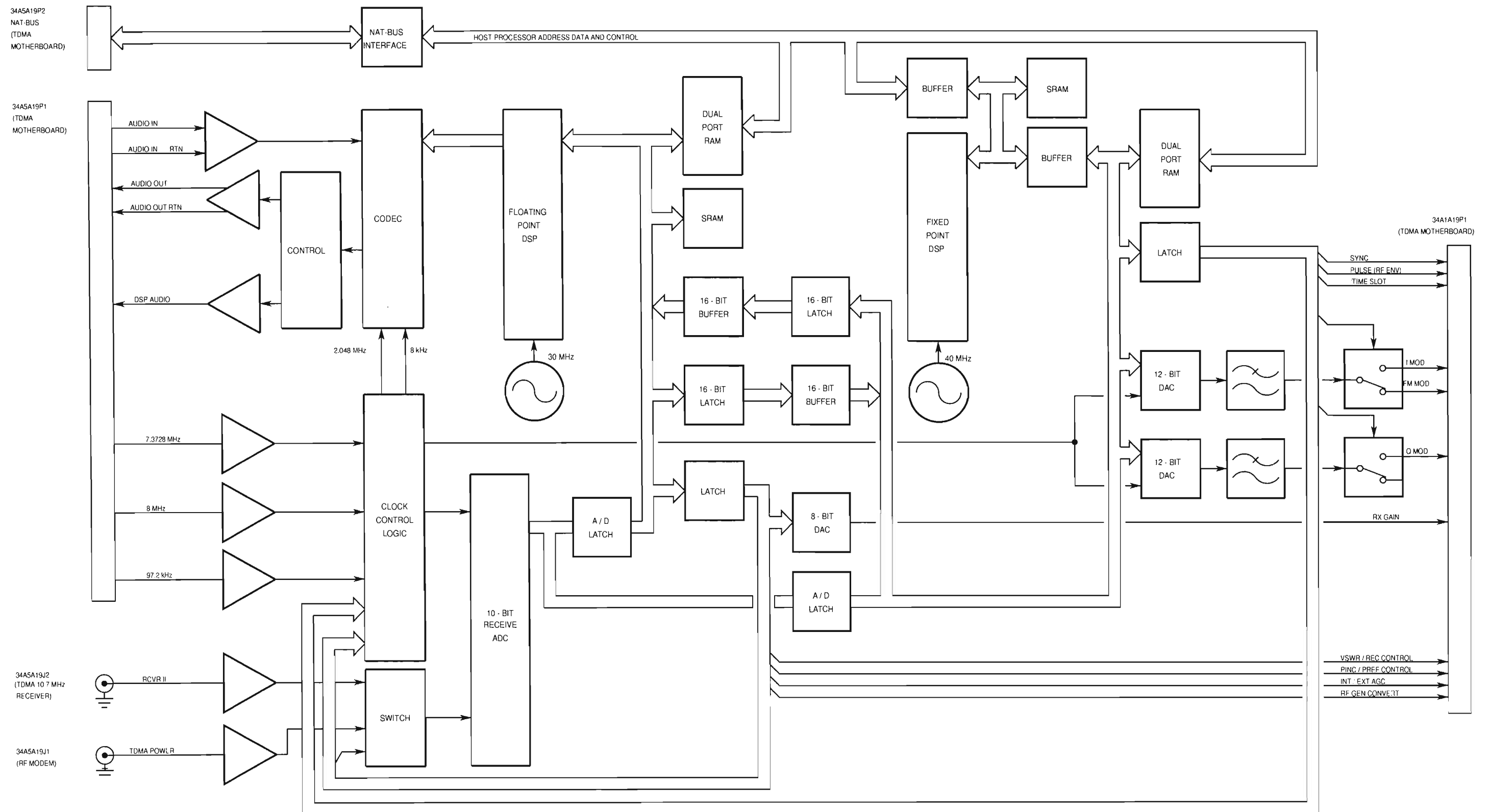

DSPBD01

Figure 1-28. A19 DSP Firmware Assembly Block Diagram

cc. 34A5A34 TDMA External I/O FIRMWARE ASSEMBLY. The A34 External I/O provides the bidirectional communication link between the A24 TDMA Processor and the GPIB and SCSI Connectors. Data and Control signals are passed to the A34 External I/O through the TDMA NAT-BUS. Signals are returned to the A24 TDMA Processor from the A34 External I/O in the same manner. Control signals select which connector will be active and which controlling circuitry to use. The control and data signals are translated and passed through the appropriate connector. Return data takes the same path in reverse.

The GPIB Connector uses the GPIB CONTROLLER as the controlling device for remote operation. Use of this connector is in accordance with IEEE-488. The GPIB CONTROLLER accepts and passes data through the GPIB DATA TRANSCEIVER. Likewise, control signals pass through the GPIB CONTROL TRANSCEIVER. Clock signals for the GPIB CONTROLLER are provided by a clock within the assembly. Interrupt and DMA requests for GPIB are passed through the NAT-BUS INTERFACE to the TDMA NAT-BUS. DMA Acknowledge signals are returned along the same path in reverse.

The SCSI Connector uses the SCSI PROCESSOR as the controlling device for remote operation.

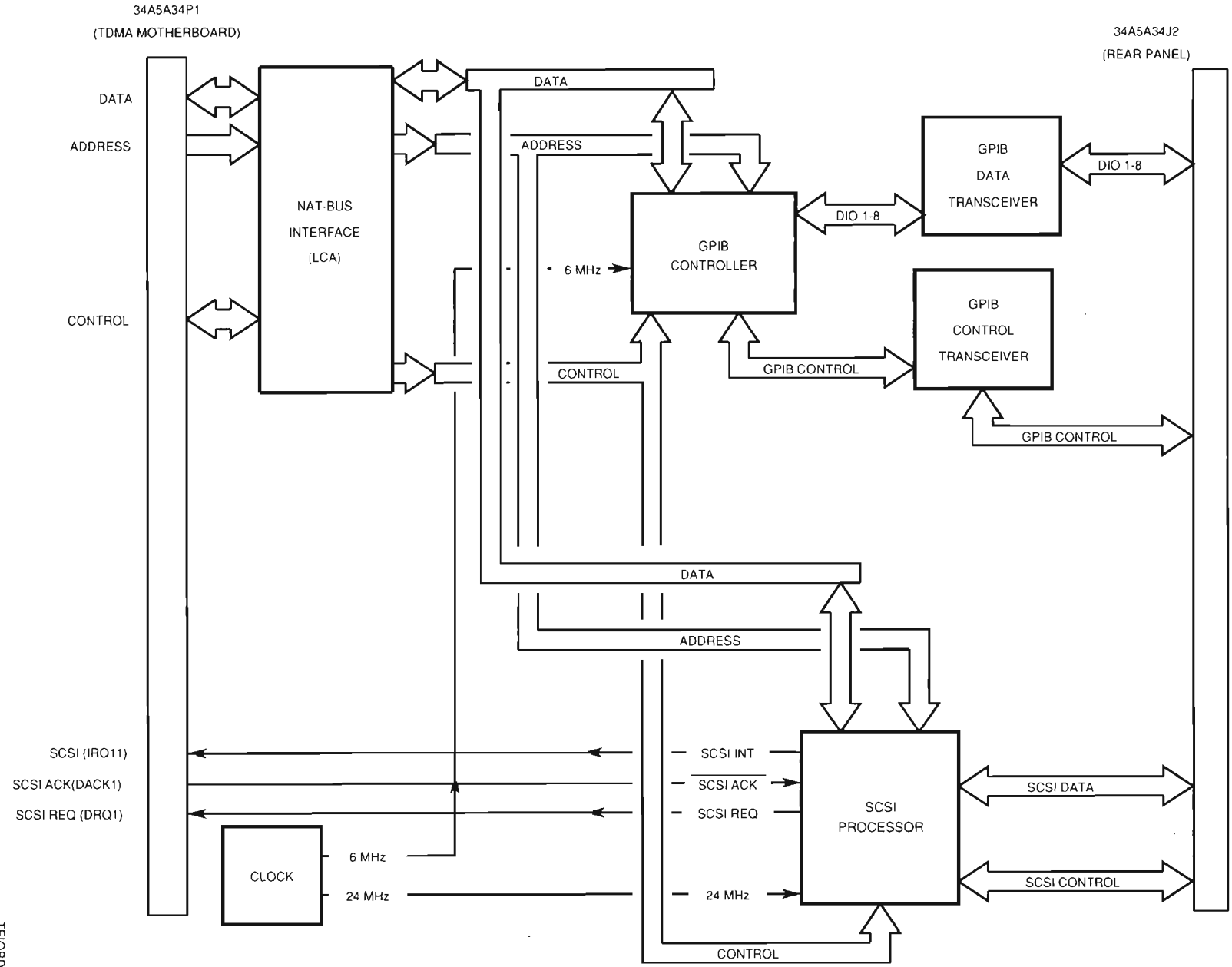

Figure 1-29. A34 TDMA External I/O Firmware Assembly Block Diagram

TEIOBD01



dd. 34A5A2 INTERNAL I/O FIRMWARE ASSEMBLY (fig 1-30). The Internal I/O Firmware Assembly provides the main interface between the  $\mu$ processor (hereafter referred to only as  $\mu$ processor) on the Processor Firmware Assembly and the operator. The I/O Board Firmware Assembly consists of a NAT-BUS Interface, Control Registers, Status Registers, Serial Bus, Keyboard Controller, LCD Control, RS-232 Port, Parallel Printer Port and DACs for signal control. The -15.0 V D (95A5A1X14-A7), +15.0 V D (95A5A1X14-A9) and +5 V D (95A5A1X14-A3 and A29) provide normal operating power. Refer to Figure 2-7 for the I/O Board Firmware Assembly block diagram and Table 2-6 for a list of signals.

- **NAT-BUS INTERFACE**

The I/O Board Firmware Assembly has an ISA Bus compatible interface. The ISA Bus has access to a 16-bit memory device (LCD DRAM) and various 8-bit I/O devices (registers, controllers, ports and DACs). The I/O Board Firmware Assembly generates three interrupts to the  $\mu$ processor. The RS-232 Port initiates an interrupt (IRQ4), the Parallel Printer Port sends out an interrupt (IRQ7) and the Keyboard Controller transmits an interrupt (IRQ10). Refer to Table 2-4 for NAT-BUS signals sent from and to the Processor Firmware Assembly.

- **REGISTERS**

Three registers control the RF, power supply, LCD backlight inverter and on board peripherals. The  $\mu$ processor sets all control register outputs low on power-up/reset. The IF BW SELECT A and B lines select the operating IF bandwidth on the Receiver PC Board Assembly as follows:

IF BW SELECT A	IF BW SELECT B	BANDWIDTH MODE
Low	Low	10 kHz (NAMPS)
High	Low	30 kHz (AMPS/TDMA)
Low	High	200 kHz (Modulation Accuracy)
High	High	300 kHz (Wideband)

A high MODE SELECT line sets the Receiver PC Board Assembly to AMPS/NAMPS mode. A low sets the Receiver PC Board Assembly to TDMA mode. The SWITCH I and II CONTROL lines select the operational modes on the Front End Assembly as follows:

SWITCH I CONTROL	SWITCH II CONTROL	MODE
Low	Low	AMPS/NAMPS/TDMA
Low	High	Selftest/VSWR
High	High (DSP reference) Low (measurement)	Cable Loss

The MIXER ENABLE line goes high to set the Generator frequency to the Receiver frequency for performing Selftest and the Cable Loss test. For normal operation, the MIXER ENABLE line stays low. The POWER METER RANGE A and B lines select the operating range of the Power Meter on the Front End Assembly as follows:

POWER METER RANGE A	POWER METER RANGE B	POWER METER RANGE
Low	High	-20 to 0 dBm (Low)
High	Low	0 to +20 dBm (Medium)
Low	Low	+20 to +40 dBm (High)
High	High	Meter Disconnect (Off)

The 30 dB and 60 dB ATTENUATION INSERT lines provide the software control of the receive line attenuation on the Front End Assembly. The 30 dB ATTENUATION INSERT goes low to insert a 30 dB attenuator. The 60 dB ATTENUATION INSERT goes low to add another 30 dB attenuator while keeping the first 30 dB attenuator inserted regardless of the 30 dB ATTENUATION INSERT setting. Both lines are normally kept high to allow the Front End hardware to adjust the receive line attenuation. The INCREMENT

BAND1 and BAND2 lines select one of three RF Modem frequency bands that determines the transmit frequency of the IFR-1900 as follows:

INCREMENT BAND1	INCREMENT BAND2	TRANSMIT FREQUENCY
Low	Low	869 to 875.73 MHz
High	Low	875.73 to 884 MHz
Low	High	884 to 894 MHz

The PWR UP line selects the bandwidth for a low-pass filter on the Baseband Mux PC Board Assembly. On power-up, the line goes high to maintain ≈10 seconds of 100 Hz bandwidth for power-up acquisition. The line is low for a 0.7 Hz bandwidth (low frequency FM capability) during normal operation. The  $\mu$ processor sets the control register BKLT ON line low to turn the LCD backlight on (inverter off) or high to turn the LCD backlight off (inverter on). The Control Registers provide two outputs to serially configure the EEPROMs on the Front End and Front Panel Assemblies. EE CLOCK1 provides the clock and EE DATA1 provides the data. Both outputs go through the NAT-BUS. The Control Registers also enable or disable the Parallel Printer Port output and the Configuration EEPROM interface data output. (A PWR OFF line to the TDMA Power Distribution PC Board Assembly shuts system power off when set high. For normal operation, this line remains low.)

Two status registers provide the current condition of several signals to the  $\mu$ processor. The ATTENUATION INDICATOR A and B lines show the status of the Front End Assembly receive attenuation as follows:

ATTENUATION INDICATOR A	ATTENUATION INDICATOR B	ATTENUATION INSERTED
Low	High	30 dB
Low	Low	60 dB
High	Low	0 dB
High	High	0 dB

The LOCK lines provide status of various frequency loops in the IFR-1900. A high indicates the applicable loop is locked or a low indicates the applicable loop is unlocked. The STEP LOCK line indicates the status of the Step Loop on the RF Modem PC Board Assembly. The INCREMENT LOCK line indicates the status of the Increment Loop on the RF Modem PC Board Assembly. The SUM LOCK line indicates the status of the Sum Loop on the RF Modem PC Board Assembly. The MOD LO LOCK line indicates the status of the Mod LO Loop on the Baseband Mux PC Board Assembly. The RF DETECT line provides status of the AGC circuit on the Baseband Mux PC Board Assembly. A high indicates normal operation or a low indicates an open loop. The RCVR LOCK line indicates the status of the receiver oscillators on the Receiver PC Board Assembly. A high indicates locked oscillators or a low indicates one or both oscillators are unlocked. The EXT REF ON line indicates frequency reference. A high indicates the IFR-1900 is locked to an external reference or low indicates operation from the internal reference oscillator.

- **SERIAL BUS**

The Serial Bus serially downloads data to set the step attenuator on the Front End Assembly, the increment synthesizer on the RF Modem PC Board Assembly and the oscillators on the Receiver PC Board Assembly. The  $\mu$ processor configures these devices at power-up and for channel and level changes. ATT LATCH latches the CLOCK and DATA output to the step attenuator on the Front End Assembly. INCREMENT LATCH latches the CLOCK and DATA output to the increment synthesizer on the Synthesizer/Reference PC Board Assembly. LATCH1 latches the CLOCK and DATA output to the 10.8215 MHz oscillator on the Receiver PC Board Assembly. LATCH2 latches the CLOCK and DATA output to the 81.7 MHz oscillator on the Receiver PC Board Assembly.

- **KEYBOARD CONTROLLER**

The Keyboard Controller interfaces with the keypad on the Front Panel Assembly. Refer to the Front Panel Assembly block diagram, Figure for row and column assignments. Row and column inputs are low when no keys are pressed. Pressing a key causes the corresponding row and column to go high. The Keyboard

Controller debounces the row and column inputs and generates an interrupt (IRQ10) to the  $\mu$ processor. The  $\mu$ processor reads the row and column data to determine the keyboard state and action.

The Keyboard Controller also has an ADC. The Keyboard Controller converts three analog signals to digital data for the  $\mu$ processor. The RSSI line provides the received RF signal level from the Receiver PC Board Assembly. The TEMPERATURE line provides an analog input indicating the temperature of the Front End Assembly.

- **LCD CONTROLLER**

The LCD Controller generates all the control and data lines necessary for driving the LCD on the Front Panel Assembly. The LCD Controller contains a display controller, 256 k X 16 DRAM and LCD drive/contrast control circuit. The  $\mu$ processor controls the LCD Controller through the NAT-BUS. The LCD drive/contrast voltage on the VEE line ranges from -11 to -24 V, as set by the CONTRAST line input. The LCD has stringent power up/down requirements. The LCD drive voltage cannot be turned on unless the logic signals are present. The LP (Latch Pulse, equivalent of horizontal sync) gates the LCD drive voltage on and off. A toggling LP enables the LCD drive voltage at a negative voltage. An inactive LP sets the LCD drive voltage to +0.4 V.

- **PORTS**

The Parallel Printer Port provides a parallel interface to an external Centronics compatible printer through the PARALLEL Port on the Rear Panel Assembly. The Parallel Printer Port generates an interrupt (IRQ7) to the  $\mu$ processor when interface signals are present.

- **DACS**

A 12-bit DAC provides the TX LEVEL output voltage (0 to +10.0 Vdc) for controlling the transmit signal level on the Baseband Mux PC Board Assembly. An 8-bit DAC provides the REF TUNE output voltage (0 to +10.0 V) for adjusting the internal reference oscillator on the RF Modem PC Board Assembly.

SIGNAL (LOCATION) SOURCE OR DESTINATION	I/O	A/D	PARAMETER	RANGE
PARALLEL Port Inputs (34A5A25J3-1 to 9, 11, 13, 15, 17, 19, 21, 23, 24) Rear Panel Assy	I	D	V <sub>ih</sub>	≥2.0 V
			V <sub>il</sub>	≤0.8 V
PARALLEL Port Outputs (34A5A25J3-1 to 3, 5 to 9, 11, 13, 15, 17) Rear Panel Assy	O	D	V <sub>oh</sub>	≥2.4 V
			V <sub>ol</sub>	≤0.4 V
RSSI (34A5A25P1-A1) TDMA 10.7 MHz Receiver PC Board Assy	I	A	Input Voltage	0 to ≤+5 V
			Input Current	2 μA
LATCH 1 and 2 (34A5A25P1-A6) TDMA 10.7 MHz Receiver PC Board Assy	O	D	V <sub>oh</sub>	≥3.8 V (4.4 V nominal)
			V <sub>ol</sub>	≤0.33 V (0.1 V nominal)
INCREMENT LATCH (34A5A25P1-A8) RF Modem PC Board Assy	O	D	V <sub>oh</sub>	≥3.8 V (4.4 V nominal)
			V <sub>ol</sub>	≤0.33 V (0.1 V nominal)
INCREMENT SUM LOCKS (34A5A25P2, B9, B11) RF Modem PC Board Assy	I	D	V <sub>ih</sub>	≥2 V
			V <sub>il</sub>	≤0.8 V
IF BW SELECT A and B (34A5A25P2-A17, A18) TDMA 10.7 MHz Receiver PC Board Assy	O	D	V <sub>oh</sub>	≥3.8 V (4.4 V nominal)
			V <sub>ol</sub>	≤0.33 V (0.1 V nominal)
MODE SELECT (34A5A25P2-A19)	O	D	V <sub>oh</sub>	≥3.8 V (4.4 V nominal)
Power Term Range (34A5A2P2-A13) RF Modem PC Board Assy TDMA 10.7 MHz Receiver PC Board Assy	I	D	V <sub>ih</sub>	≥2 V
			V <sub>il</sub>	≤0.8 V
7.3728 MHz (34A5A25P1-A23) DSP Firmware Assy	O	D	V <sub>oh</sub>	≥2 V
			V <sub>ol</sub>	≤0.8 V
ATT LATCH (34A5A25P1-B7) Baseband Mux PC Board Assy	O	D	V <sub>oh</sub>	≥3.8 V (4.4 V nominal)
			V <sub>ol</sub>	≤0.33 V (0.1 V nominal)
MOD LO LOCK (34A5A25P1-B12) Baseband Mux PC Board Assy	I	D	V <sub>ih</sub>	≥2 V
			V <sub>il</sub>	≤0.8 V
RF DETECT (34A5A25P1-B14) Baseband Mux PC Board Assy	I	D	V <sub>ih</sub>	≥2 V
			V <sub>il</sub>	≤0.8 V
REF TUNE (34A5A25P1-C1) RF Modem PC Board Assy	O	A	Output Voltage	0 to ≤10.0 V <sub>P</sub> (≥5 kΩ Load)
TX LEVEL (34A5A25P1-C2) Baseband Mux PC Board Assy	O	A	Output Voltage	0 to ≤10.0 V <sub>P</sub> (≥5 kΩ Load)
			Source Impedance	<0.05 Ω (typical)

Table 1-4. Internal I/O Firmware Assembly Signals

SIGNAL (LOCATION) SOURCE OR DESTINATION	I/O	A/D	PARAMETER	RANGE
CLOCK, DATA (34A5A25P1-C6, C8) TDMA 10.7 MHz Receiver PC Board Assy, RF Modem PC Board Assy, Baseband Mux PC Board Assy	O	D	Voh	≥3.8 V (4.4 V nominal)
			Vol	≤0.33 V (0.1 V nominal)
RCVR LOCK (34A5A25P1-C9) TDMA 10.7 MHz Receiver PC Board Assy	I	D	Vih	≥2 V
			Vil	≤0.8 V
EXT REF ON (34A5A25P1-C11) RF Modem PC Board Assy	I	D	Vih	≥2 V
			Vil	≤0.8 V
INCREMENT BAND1 and BAND2 (34A5A25P1-C16, C17) RF Modem PC Board Assy	O	D	Voh	≥3.8 V (4.4 V nominal)
			Vol	≤0.33 V (0.1 V nominal)
PWR UP (34A5A25P1-C18) Baseband Mux PC Board Assy	O	D	Voh	≥3.8 V (4.4 V nominal)
			Vol	≤0.33 V (0.1 V nominal)

Table 1-4. Internal I/O Firmware Assembly Signals (cont)

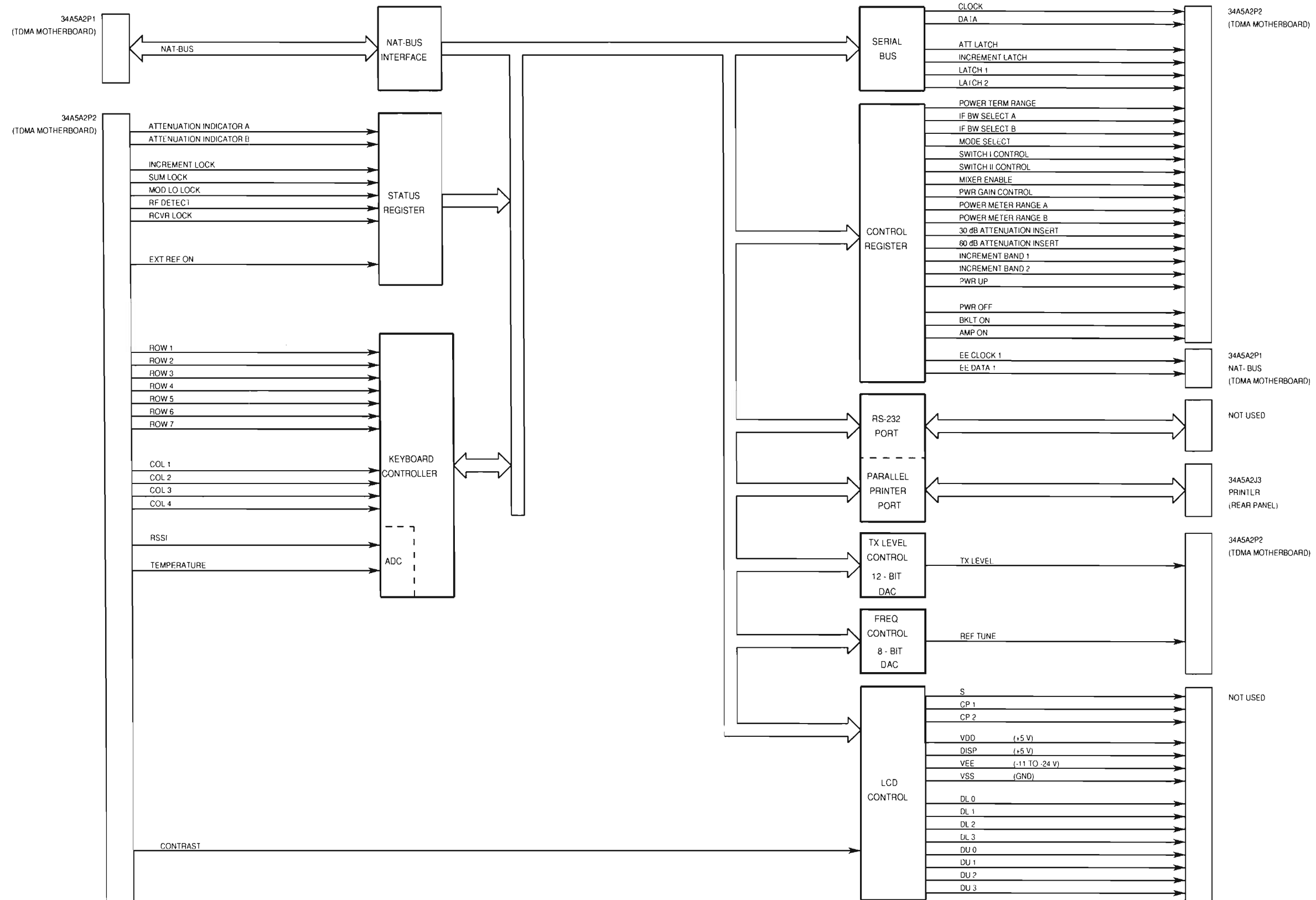

Figure 1-30. A2 Internal I/O Firmware Assembly Block Diagram

ee. 34A5A1 TDMA 10.7 MHz RECEIVER PC BOARD ASSEMBLY. The TDMA 10.7 MHz Receiver PC Board Assembly amplifies, filters and converts down the receive signal to provide the 121.5 kHz RCVR IF signal for the DSP Firmware Assembly. The TDMA 10.7 MHz Receiver PC Board Assembly uses four frequency stages (High Frequency Input, 71.0 MHz IF, 10.7 MHz IF and 121.5 kHz) to reach the final output frequency. The -15.0 V A (34A5A3A2X2-B3), +15.0 V A (34A5A3A2X2-B2) and +5 V A (34A5A3A2X2-B1) provide normal operating power. Refer to Figure 1- for the TDMA 10.7 MHz Receiver PC Board Assembly block diagram and Table 1-6 for a list of signals.

- **HIGH FREQUENCY INPUT**  
Depending on the selected operating mode, the Receiver PC Board Assembly receives one of two signals. When the  $\overline{\text{VSWR/REC}}$  line is low, the Receiver PC Board Assembly receives the normal RX SIGNAL from the Front End Assembly. When the  $\overline{\text{VSWR/REC}}$  line is high, the Receiver PC Board Assembly receives the VSWR signal from the Front End Assembly. Either signal has a frequency range of 824 to 849 MHz. Both signals pass through bandpass filters. The Receiver PC Board Assembly amplifies the RX SIGNAL to improve signal to noise ratio. The received signal mixes with the 753 to 778 MHz RCVR REF signal from the RF Modem PC Board Assembly to obtain the 71.0 MHz IF signal.
- **71.0 MHz IF**  
A low-pass filter removes the high frequency signals and the second IF (RF + LO). Two low noise, high dynamic range amplifiers improve receiver sensitivity. A 71 MHz Surface Caustic Wave (SAW) bandpass filter acts as the first element of the receiver IF selectivity filter chain. The amplified 71 MHz IF signal mixes with the 81.7 MHz local oscillator signal, phase locked to the IFR-1900 reference frequency (MAIN RCVR), to obtain the 10.7 MHz IF signal.
- **10.7 MHz IF**  
After amplification, the signal passes through a bandpass selectivity filter, selected according to the IF BW SELECT A and B lines. A high IF BW SELECT A and a low IF BW SELECT B selects the 30 kHz filter for receiving off the air AMPS and TDMA signals. A low IF BW SELECT A and IF BW SELECT B selects the 10 kHz filter for receiving off the air NAMPS signals. A low IF BW SELECT A and a high IF BW SELECT B selects the 200 kHz filter for receiving all direct connect (T/R Port) signals and measurements. A high IF BW SELECT A and IF BW SELECT B selects the attenuator for wideband (having only the SAW filter) for enhanced accuracy measurements and decoding all direct connect (T/R Port) signals. The filtered 10.7 MHz IF signal mixes with the 10.8215 MHz local oscillator signal, phase locked to the IFR-1900 reference frequency (MAIN RCVR), to obtain the 121.5 kHz IF signal.
- **121.5 kHz IF**  
After more filtering and amplification, the signal enters the AGC amplifier system. The system, developed to obtain accurate TDMA information from the timeslot pulses, consists of two paths having the same characteristics. The Slave AGC Amplifier finds the level of the receive signal and adjusts the gain accordingly. Through switches, the corrected gain voltage becomes the constant AGC voltage for the Master Amplifier during the next timeslot pulse. Having the same AGC characteristics effectively means the current gain setting for the Master Amplifier is based on the adjusted gain setting from the previous burst. The two path system allows correct gain adjustment (by the Slave Amplifier) without changing the received signal envelope (Master Amplifier stays constant during the pulse).

The Slave Amplifier also provides the corrected AGC voltage on the RSSI line. Because the AGC voltage is inversely proportional to the input level, the 2959 uses the RSSI line to measure the input signal level. The Master AGC Amplifier output provides the RCVR IF signal to the DSP Firmware Assembly. The internal AGC provides two modes of operation.

For FM analog (AMPS and NAMPS), all three sample switches are closed (set by a high on the MODE SELECT line). The AGC loop continuously sets the Slave Amplifier gain. The Master Amplifier continuously tracks the Slave Amplifier gain to maintain signal linearity and avoid clipping the received signal envelope.

For the TDMA digital mode, the Receiver PC Board Assembly transmits the signal in a burst mode, with each burst synchronized to the system synchronization clock (97.2 kHz signal). The AGC timing control circuit generates three timing pulses based on the system synchronization clock and the time slot synchronization pulse (TIMESLOT signal). The Sample I pulse closes the Slave AGC loop. The duration of the Sample 1

pulse allows the Slave Amplifier gain to get settled. After the gain is settled, Sample II pulse closes the switch that samples and preserves the Slave Amplifier AGC voltage. The Sample I pulse ends to open the Slave AGC loop and set the gain back to the 0 dB starting point. After the received burst ends, Sample III pulse closes the switch for the Master Amplifier to sample the preserved Slave Amplifier AGC voltage. That becomes the gain setting for the next burst. The current gain setting of the Master Amplifier is based on the gain setting for the previous burst. This process allows the Receiver PC Board Assembly to correctly adjust receiver gain without changing the received signal envelope.

The DSP Firmware Assembly controls the receiver gain by setting the INT/EXT AGC line low and sending out the RX GAIN voltage.

SIGNAL (LOCATION) SOURCE OR DESTINATION	I/O	A/D	PARAMETER	RANGE
10.7 MHz IF (34A5A1J1) RF Modem	I	A	Frequency	10.7 MHz
			Level	
RCVR IF (34A5A28J4) DSP Firmware Assy	O	A	Frequency	121.5 kHz
			Level	3 V <sub>P-P</sub>
2 MHz RCVR (34A5A28J5) RF Modem PC Board Assy	I	A	Frequency	2 MHz
			Level	0 to 5 V <sub>P-P</sub>
IF BW SELECT A and B (34A5A28P1-A1-2) Internal I/O Firmware Assy	I	D	Voh	≥3.8 V (4.4 V nominal)
			Vol	≤0.33 V (0.1 V nominal)
RX GAIN (34A5A28P1-A3) DSP Firmware Assy	I	A	Input Voltage	0 to ≤10 V <sub>P</sub> (≥5 kΩ Load)
INT/EXT AGC (34A5A28P1-A4) DSP Firmware Assy	I	D	Voh	≥3.0 V
			Vol	≤0.55 V
TIME SLOT (34A5A28P1-A5) DSP Firmware Assy	I	D	Voh	≥3.86 V
			Vol	≤0.40 V
97.2 kHz (34A5A28P1-A6) RF Modem PC Board Assy	I	D	Vih	≥2 V
			Vil	≤0.8 V
MODE SELECT (34A5A28P1-A7) Internal I/O Firmware Assy	I	D	Voh	≥3.8 V (4.4 V nominal)
			Vol	≤0.33 V (0.1 V nominal)
RSSI (34A5A28P1-A9) Internal I/O Firmware Assy	O	A	Output Voltage	0 to ≤+5 V
			Output Current	2 μA
CLOCK, DATA (34A5A28P1-B4, B5) Internal I/O Firmware Assy	I	D	Voh	≥3.8 V (4.4 V nominal)
			Vol	≤0.33 V (0.1 V nominal)
LATCH1, LATCH2 (34A5A28P1-B6) Internal I/O Firmware Assy	I	D	Voh	≥3.8 V (4.4 V nominal)
			Vol	≤0.33 V (0.1 V nominal)
RCVR LOCK (34A5A28P1-B8) Internal I/O Firmware Assy	O	D	Vih	≥2 V
			Vil	≤0.8 V

Table 1-5. TDMA 10.7 MHz Receiver PC Board Assembly Signals



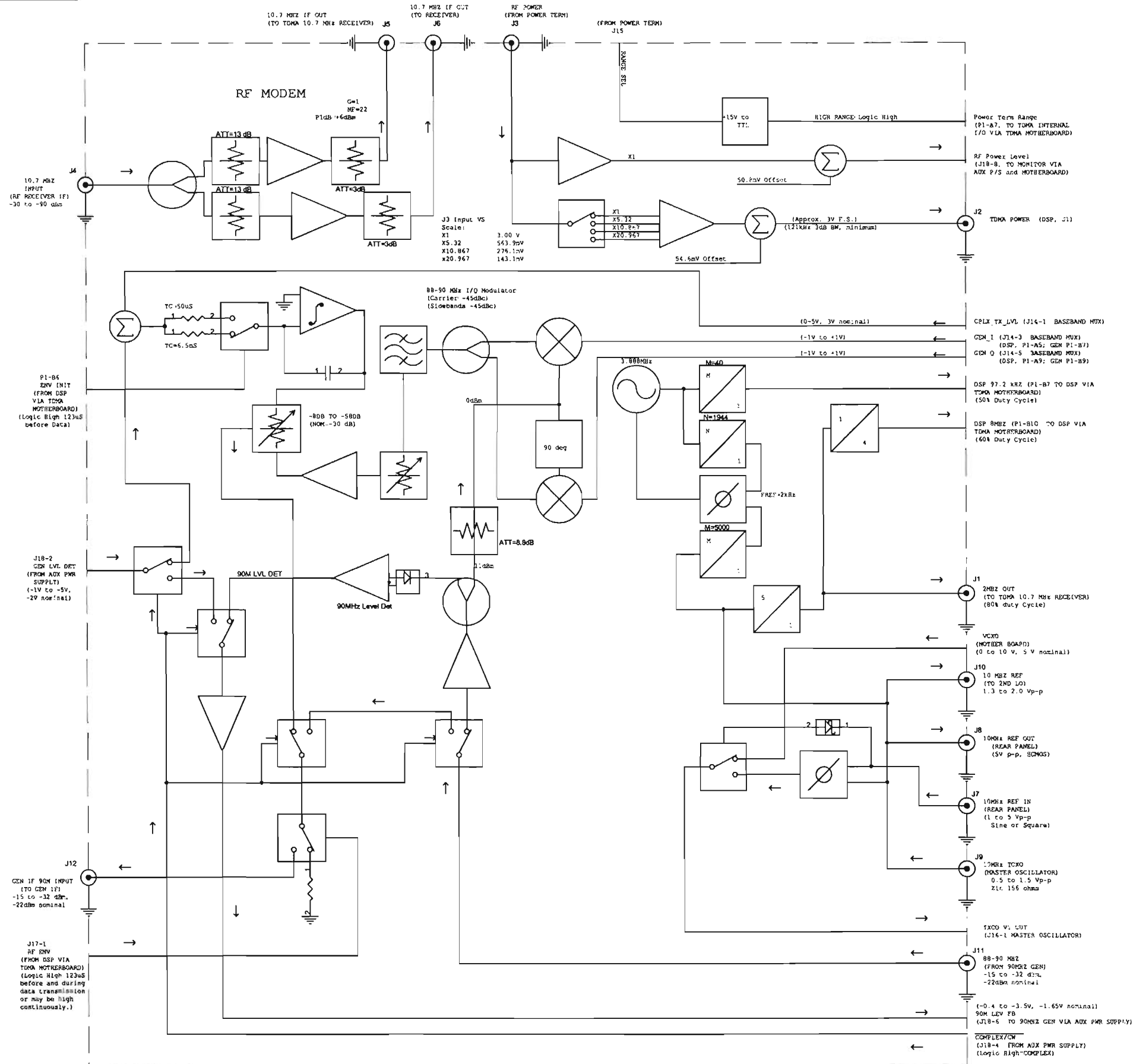

Figure 1-31. A1 TDMA 10.7 MHz Receiver PC Board Assembly Block Diagram



THIS PAGE INTENTIONALLY LEFT BLANK

ff. 34A5A18 RF MODEM PC BOARD ASSEMBLY. The RF Modem Assembly provides the reference and clock signals used by the IFR-1900 and generates the main LO (753 to 778 MHz) for the Generator and Receiver Assemblies. The -15.0 V A (34A5A3A2X4-B4), +15.0 V A (34A5A3A2X4-A4) and +5 V A (34A5A3A2X4-A5) provide normal operating power. Refer to Figure ?-? for the RF Modem PC Board Assembly block diagram and Table 1-6 for a list of signals.

- **REFERENCE**

The external reference circuit locks the internal or external reference, depending on the input. Connecting a 10 MHz external reference, having a 0.25 to 6.0 V<sub>P-P</sub> signal level, to the 10 MHz REF IN Connector on the Rear Panel Assembly causes the switch to select the external reference and the EXT REF ON line to go high. With no external reference, the switch selects the REF TUNE line and EXT REF ON line goes low. The reference processor divides the 10 MHz signal by 5 for the 2 MHz signal or divides by 2 for the 5 MHz signal.

- **MAIN SYNTHESIZER**

The main synthesizer has a triple loop design to reduce inband phase noise. The Step Loop offsets the main output to provide the Sum Loop referenced to the Increment Loop output.

The Internal I/O Firmware Assembly programs the increment synthesizer through the Serial Bus (CLOCK, DATA and INCREMENT LATCH). The Increment Loop uses a 40 kHz reference obtained by dividing the 10 MHz by 250. A locked Increment Loop sends a high out on the INCREMENT LOCK line. The Increment Loop output runs from 132 to 232 MHz in three bands, set by the INCREMENT BAND control lines as follows:

INCREMENT BAND1	INCREMENT BAND2	INCREMENT LOOP OUTPUT	REFERENCE OUTPUT	TRANSMIT FREQUENCY
Low	Low	132 to 158.92 MHz	753 to 759.73 MHz	869 to 875.73 MHz
High	Low	158.92 to 192 MHz	759.73 to 768 MHz	875.73 to 884 MHz
Low	High	192 to 232 MHz	768 to 778 MHz	884 to 894 MHz

The RF Modem PC Board Assembly divides the output by 256 to provide the required frequency for the Sum Loop phased detector.

The Sum Loop detects the Increment Loop output to set the final reference output frequency signals to the Generator and Receiver Assemblies. For the return loop, the final output mixes with the Step Loop output to provide a 33 to 58 MHz return frequency, divided by 64 for the detector. A locked Sum Loop sends a high out on the SUM LOCK line.

The Step Loop provides the Sum Loop LO (720 MHz). The Step Loop uses a 625 kHz reference obtained by dividing the 5 MHz signal by eight.

- **97.2 kHz CLOCK**

The 97.2 kHz clock initially divides the 2 MHz signal by 1000 for a 2 kHz reference. The passive loop filter has a  $\approx 65$  Hz bandwidth. The VCO provides a 3.888 MHz output, divided by 40, to provide the 97.2 kHz clock used in TDMA timeslot data timing.

- **8 MHz CLOCK**

The circuit multiplies the 2 MHz input by four to provide the desired 8 MHz. The RF Modem Assembly filters and buffers the output.

SIGNAL (LOCATION) SOURCE OR DESTINATION	I/O	A/D	PARAMETER	RANGE
2 MHz (34A5A18J1) TDMA 10.7 MHz Receiver PC Board Assy	O	A	Frequency	2 MHz
			Level	0.1 to 5 V <sub>P-P</sub>
TDMA POWER (34A5A18J2) DSP Firmware Assembly	O	A	Output Voltage	0 to +5 V
RF POWER (34A5A18J3) Power Term Assembly	O	A	Frequency	
			Level	143.1 mV to 3.00 V
10.7 MHz INPUT (34A5A18J4) RF Receiver IF Assembly	I	A	Frequency	10.7 MHz
			Level	-90 to -30 dBm
10.7 MHz IF (34A5A18J5) TDMA 10.7 MHz Receiver PC Board Assy	O	A	Frequency	10.7 MHz
			Level	
10.7 MHz IF (34A5A18J6) Receiver Assembly	O	A	Frequency	10.7 MHz
			Level	
10 MHz REF IN (34A5A18J7) Rear Panel Assembly	I	A	Frequency	10 MHz
			Level	1 to 5 V <sub>P-P</sub> Sine or Square
10 MHz REF OUT (34A5A18J8) Rear Panel Assembly	O	A	Frequency	10 MHz
			Level	5 V <sub>P-P</sub> HCMOS
10 MHz TCXO (34A5A18J9) Master Oscillator PC Board Assy	I	A	Frequency/Level	10 MHz/0.5 to 1.5 V <sub>P-P</sub>
			Input Impedance	156 Ω
10 MHz REF (34A5A18J10) 2 <sup>nd</sup> LO Assembly	O	A	Frequency	10 MHz
			Level	1.3 to 2.0 V <sub>P-P</sub>
90 MHz (34A5A18J11) 90 MHz Gen Assembly	I	A	Frequency	88 to 90 MHz
			Level	-32 to -15 dBm (-22 dBm nominal)
GEN IF (34A5A18J12) Generator IF Assembly	O	A	Frequency	88 to 90 MHz
			Level	-32 to -15 dBm (-22 dBm nominal)
TX LEVEL (34A5A17J4-1) Baseband Mux PC Board Assy	I	A	Input Voltage	0 to ≤10 Vdc (6 V nominal)
I MOD (GEN I) (34A5A17J4-3) Baseband Mux PC Board Assy	I	A	Input Voltage	≤±2.2 V <sub>P-P</sub>
			Deviation	≤1 kHz
Q MOD (GEN Q) (34A5A17J4-5) Baseband Mux PC Board Assy	I	A	Input Voltage	≤±2.2 V <sub>P-P</sub>
			Deviation	≤1 kHz
RANGE SEL (34A5A18J15-4) Power Term Assembly	O		Level	TTL to +15 V
TCXO VT OUT (34A5A18J16-1) Master Oscillator PC Board Assy	O	A	Frequency	10 MHz
			Level	

Table 1-6. RF Modem PC Board Assembly Signals

SIGNAL (LOCATION) SOURCE OR DESTINATION	I/O	A/D	PARAMETER	RANGE
TCXO TUNE LINE (34A5A18J16-4) RF O/O PC Board Assembly	I	A		
PULSE (RF ENV) (34A5A18J17-1) DSP Firmware Assembly	I	D	Vih	≥3.8 V (4.4 V nominal)
			Vil	≤0.33 V (0.1 V nominal)
GEN LEVEL DET (34A5A18J18-2) Aux Power Supply PC Board Assembly	I	A	Frequency	
			Level	-1 to -5 V (-2 V nominal)
COMPLEX/ CW (34A5A18J18-4) Aux Power Supply PC Board Assembly	I	D		
90 M LEVEL FB (34A5A18J18-6) 90 MHz Gen Assembly	O	A	Frequency	88 to 90 MHz
			Level	-3.5 to -0.4 V (-1.65 V nominal)
RF POWER LEVEL (34A5A18J18-8) Monitor Assembly	O	A	Frequency	
			Level	
CLOCK, DATA (34A5A18P1-A1, A2) Internal I/O Firmware Assembly	I	D	Vih	≥3.8 V (4.4 V nominal)
			Vil	≤0.33 V (0.1 V nominal)
POWER TERM RANGE (34A5A18P1-A7) Internal I/O Firmware Assembly	I	D	Vih	≥2 V
			Vil	≤0.8 V
INCREMENT LATCH (34A5A18P1-B1) Internal I/O Firmware Assembly	I	D	Voh	≥3.8 V (4.4 V nominal)
			Vol	≤0.33 V (0.1 V nominal)
97.2 kHz (34A5A18P1-B7) TDMA 10.7 MHz Receiver PC Board Assy and DSP Firmware Assembly	O	D	Voh	≥2 V
			Vol	≤0.8 V
8 MHz (34A5A18P1-B10) DSP Firmware Assembly	O	D	Voh	≥2 V
			Vol	≤0.8 V

Table 1-6. RF Modem PC Board Assembly Signals (cont)

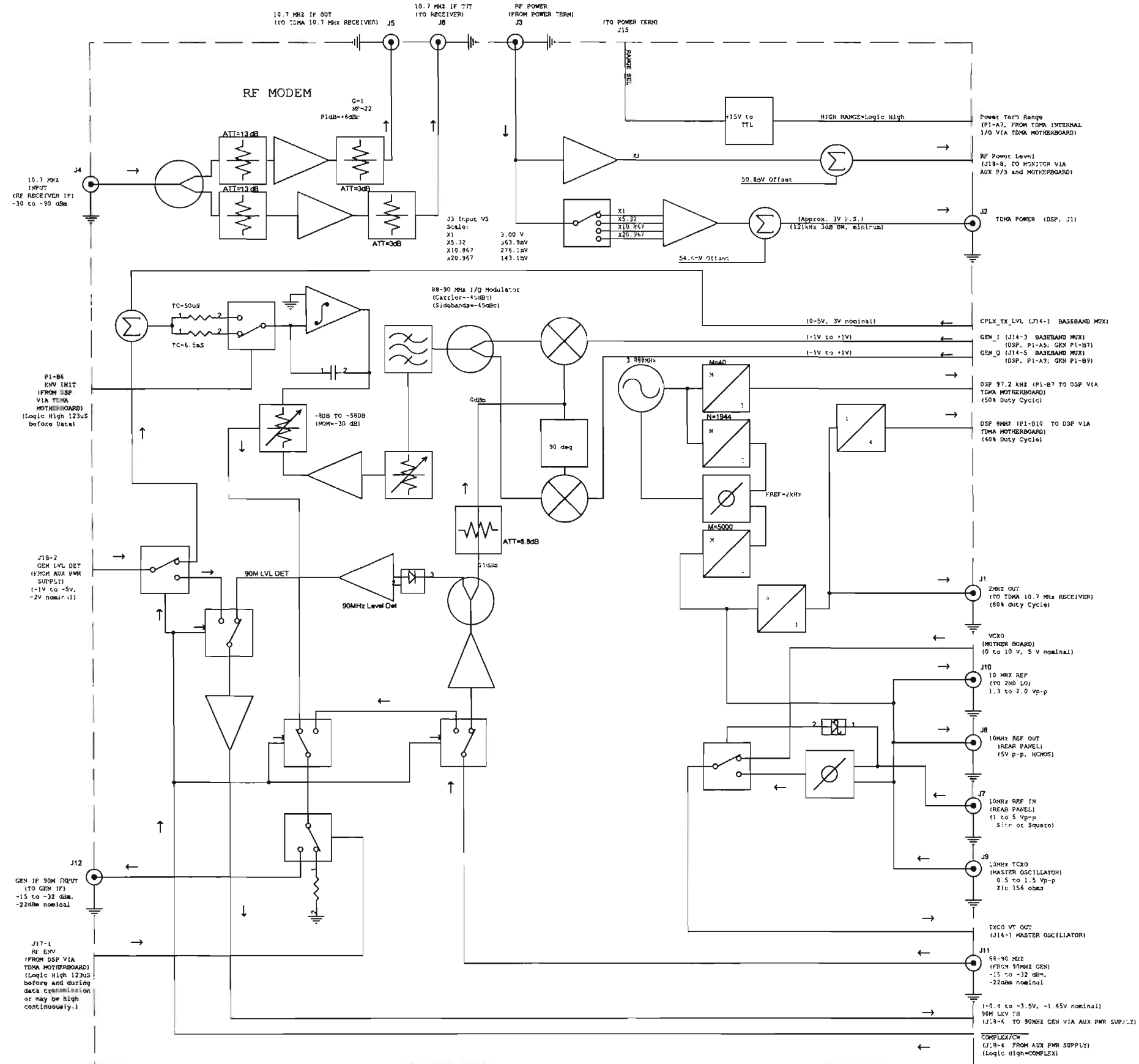

Figure 1-32. A18 RF Modem PC Board Assembly Block Diagram

gg. 34A5A17 BASEBAND MUX PC BOARD ASSEMBLY. The Baseband Mux PC Board Assembly provides the FM and complex modulation capability at 116 MHz and converts up to the cellular band with a leveled output. The Baseband Mux PC Board Assembly also provides the fine attenuation (<5 dB steps) for the transmit signal. The -15.0 V A (34A5A3A2X3-A8), +15.0 V A (34A5A3A2X3-A6) and +5 V A (34A5A3A2X3-B2) provide normal operating power. Refer to Figure 1- for the Baseband Mux PC Board Assembly block diagram and Table 1- for a list of signals.

SIGNAL (LOCATION) SOURCE OR DESTINATION	I/O	A/D	PARAMETER	RANGE
Mic (34A5A17J1-8) Front Panel Assy	I	A	Frequency	AF
			Level	
Ext Mod (34A5A17J1-14) Front Panel Assy	I	A	Frequency	AF
			Level	
BER/Sinad (34A5A17J1-16) Front Panel Assy	I	A	Frequency	
			Level	
Audio (34A5A17J1-18) Front Panel Assy	I	A	Frequency	AF
			Level	
Demod (34A5A17J1-20) Front Panel Assy	I	A	Frequency	AF
			Level	
Mic (Audio In) (34A5A17J2-6) Function Generator Firmware Assy	O	A	Frequency	AF
			Level	
Ext Mod/Audio In (34A5A17J2-14) Monitor Assy	O	A	Frequency	AF
			Level	
BER/Sinad (34A5A17J2-16) Monitor Assy	O	A	Frequency	
			Level	
Audio (Out) (34A5A17J2-18) Function Generator Firmware Assy	O	A	Frequency	AF
			Level	
Demod (Audio Out) (34A5A17J2-20) Monitor Assy	O	A	Frequency	AF
			Level	
AUDIO IN (34A5A17J3-1) DSP Firmware Assy	O	A	Output Voltage	0 to $\leq$ +5 Vdc 300 mV <sub>p-p</sub> (typical)
AUDIO OUT (34A5A17J3-2) DSP Firmware Assy	I	A	Input Voltage	$\leq$ 7 V <sub>p-p</sub> ( $\geq$ 5 k $\Omega$ load)
TX LEVEL (34A5A17J4-1) RF Modem PC Board Assy	O	A	Output Voltage	0 to $\leq$ 10 Vdc (6 V nominal)
I MOD (GEN I) (34A5A17J4-3) RF Modem PC Board Assy	O	A	Output Voltage	$\leq$ $\pm$ 2.2 V <sub>p-p</sub>
			Deviation	$\leq$ 1 kHz
Q MOD (GEN Q) (34A5A17J4-5) RF Modem PC Board Assy	O	A	Output Voltage	$\leq$ $\pm$ 2.2 V <sub>p-p</sub>
			Deviation	$\leq$ 1 kHz
CLOCK, DATA (34A5A17J5-1,3) Internal I/O Firmware Assy	I	D	Voh	$\geq$ 3.8 V (4.4 V nominal)
			Vol	$\leq$ 0.33 V (0.1 V nominal)
ATT LATCH (34A5A17-5) Internal I/O Firmware Assy	I	D	Voh	$\geq$ 3.8 V (4.4 V nominal)
			Vol	$\leq$ 0.33 V (0.1 V nominal)

Table 1-7. Baseband Mux PC Board Assembly Signals

SIGNAL (LOCATION) SOURCE OR DESTINATION	I/O	A/D	PARAMETER	RANGE
Buf I (I OUT) (34A5A17J6) Rear Panel Assy	O	A	Output Voltage	$\leq \pm 2.2 V_{P,P}$
			Deviation	$\leq 1$ kHz
Buf Q (Q OUT) (34A5A17J7) Rear Panel Assy	O	A	Output Voltage	$\leq \pm 2.2 V_{P,P}$
			Deviation	$\leq 1$ kHz
TX LEVEL (34A5A17P1-A1) Internal I/O Firmware Assy	I	A	Input Voltage	0 to $\leq 10$ Vdc (6 V nominal)
PWR UP (34A5A17P1-A3) Internal I/O Firmware Assy	I	D	Vih	$\geq 3.8$ V (4.4 V nominal)
			Vil	$\leq 0.33$ V (0.1 V nominal)
MOD LO LOCK (34A5A17P1-A4) Internal I/O Firmware Assy	O	D	Voh	$\geq 2$ V
			Vol	$\leq 0.8$ V
RF DETECT (34A5A17P1-B3) Internal I/O Firmware Assy	O	D	Voh	$\geq 2$ V
			Vol	$\leq 0.8$ V
FM MOD (34A5A17P1-B5) DSP Firmware Assy	I	A	Input Voltage	$\leq \pm 2.2 V_{P,P}$
			Deviation	$\approx 4$ kHz/V
I MOD (34A5A17P1-B7) DSP Firmware Assy	I	A	Input Voltage	$\leq \pm 2.2 V_{P,P}$
			Deviation	$\leq 1$ kHz
Q MOD (34A5A17P1-B9) DSP Firmware Assy	I	A	Input Voltage	$\leq \pm 2.2 V_{P,P}$
			Deviation	$\leq 1$ kHz

Table 1-7. Baseband Mux PC Board Assembly Signals (cont)



THIS PAGE INTENTIONALLY LEFT BLANK.

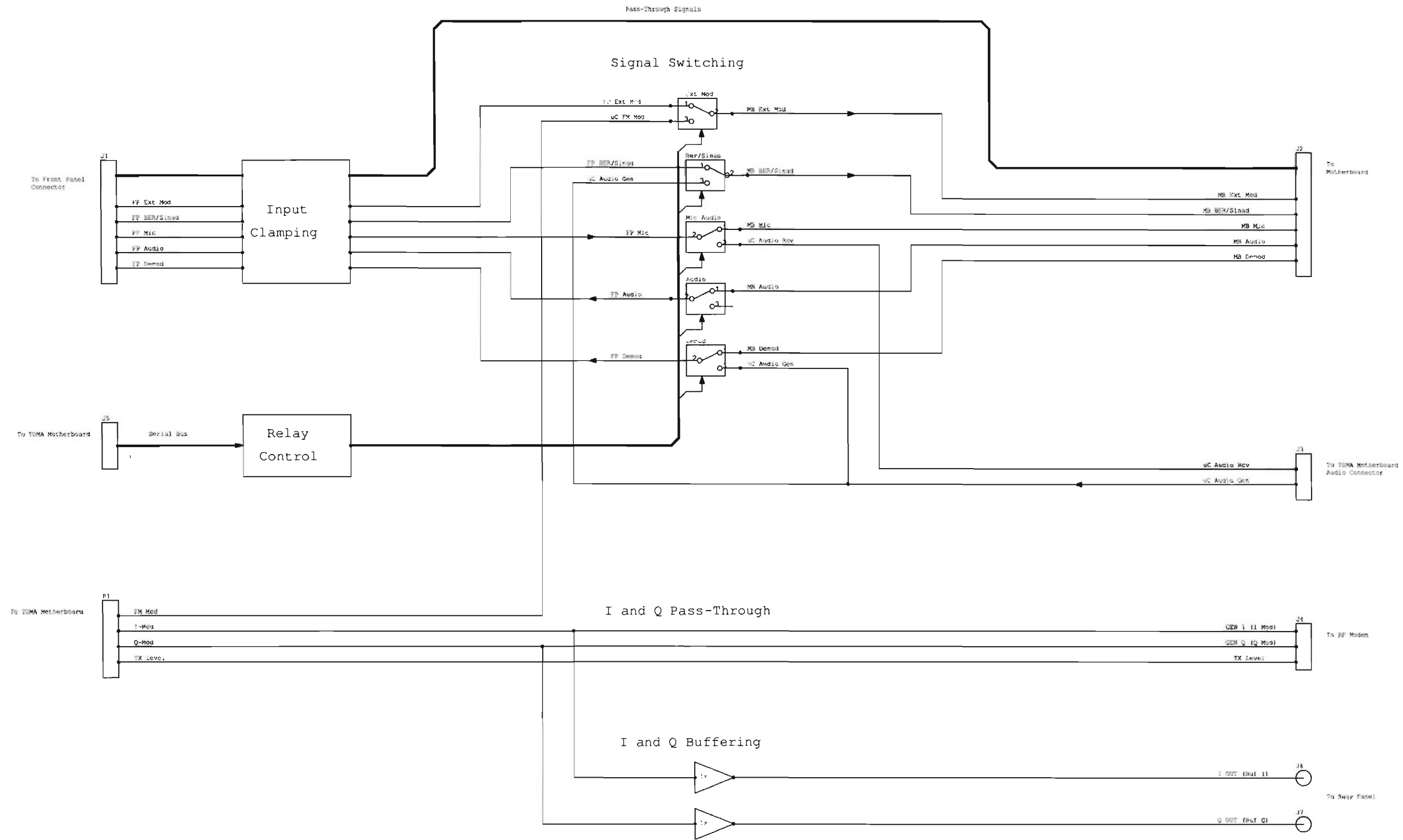

Figure 1-33. A17 Baseband Mux PC Board Assembly Block Diagram

## CHAPTER 2 MAINTENANCE INSTRUCTIONS

### CHAPTER TABLE OF CONTENTS

SECTION 1	SERVICE UPON RECEIPT.....	2-2
2-1-1	SERVICE UPON RECEIPT OF MATERIAL.....	2-2
2-1-2	PRELIMINARY SERVICING AND ADJUSTMENT OF EQUIPMENT.....	2-2
2-1-3	TROUBLESHOOTING SYMPTOM INDEX .....	2-3
2-1-4	TROUBLESHOOTING GUIDELINES.....	2-4
2-1-5	EQUIPMENT INSPECTION. ....	2-4
2-1-6	TROUBLESHOOTING TABLE .....	2-5
SECTION 2	TROUBLESHOOTING TESTS.....	2-22
2-2-1	Power Faults Test.....	2-22
2-2-2	BEEP SEQUENCE TEST .....	2-25
2-2-3	LCD ABNORMALITY TEST.....	2-27
2-2-4	KEYBOARD KEY TEST. ....	2-28
2-2-5	SELF TEST FAILURE TEST. ....	2-30
2-2-6	DMM TEST .....	2-44
2-2-7	PERFORMANCE TEST.....	2-47
2-2-8	FREQUENCY AGILITY TEST .....	2-68

## CHAPTER 2 MAINTENANCE INSTRUCTIONS

---

### SECTION 1 SERVICE UPON RECEIPT

#### 2-1-1 SERVICE UPON RECEIPT OF MATERIAL.

Unpacking. Special-design packing material inside this shipping carton provides maximum protection for Test Set. Avoid damaging carton and packing material during equipment unpacking. Use following steps for unpacking Test Set.

- Cut and remove sealing tape on carton top and open carton.
- Grasp Test Set firmly while restraining shipping carton and lift equipment and packing vertically.

#### **CAUTION**

Two people are required to lift and/or carry Test Set.

- Place Test Set and end cap packing on a suitable flat, clean and dry surface.
  - Remove protective plastic bag from Test Set. Place desiccant bags back inside protective plastic bag.
  - Place protective plastic bag and end cap packing material inside shipping carton.
  - Return shipping carton to supply system.
- a. Checking Unpacked Equipment.
- Inspect the equipment for damage incurred during shipment. If equipment has been damaged.
  - Check equipment against packing slip to see if shipment is complete.
  - Check to see whether equipment has been modified.

#### 2-1-2 PRELIMINARY SERVICING AND ADJUSTMENT OF EQUIPMENT.

Refer to IFR-1900CSA Operation Manual for this information.

## CHAPTER 2 MAINTENANCE INSTRUCTIONS

---

### 2-1-3 TROUBLESHOOTING SYMPTOM INDEX

Symptom	Page
1. APPLIED Indicator does not light .....	6
2. ON Indicator does not light .....	6
3. Fan does not work .....	6
4. Beep Sequence does not occur .....	7
5. Blows Fuses .....	7
6. LCD is blank or display abnormality exists .....	7
7. LCD Error Messages are displayed .....	7
8. Keyboard Keys Inoperable .....	8
9. DATA SCROLL Spinner Inoperable .....	8
10. Speaker Inoperable .....	9
11. Self Test Failure .....	9
12. Squelch Inoperable/Squelch Failure .....	9
13. AF GEN 1 Frequency and Level Accuracy Failure .....	10
14. AF GEN 1 Distortion Threshold Failure .....	10
15. AF GEN 2 Frequency and Level Accuracy Failure .....	10
16. AF GEN 2 Distortion Threshold Failure .....	11
17. External Modulation Failure .....	11
18. MIC/ACC IN/OUT Connector Modulation Failure .....	11
19. RF GEN Level Flatness Failure .....	12
19. RF GEN Level Flatness Failure. - Continued .....	13
20. RF GEN Frequency Accuracy Failure .....	13
21. RF GEN Level Accuracy Failure .....	13
22. RF GEN Residual FM Failure .....	14
23. RF GEN AM Failure .....	14
25. RF GEN Harmonic/Non-Harmonic Level Failure .....	16
26. Frequency/Frequency Error Meter Failure .....	16
27. AGC Failure .....	16
28. Receiver Sensitivity Failure .....	17
30. ANTENNA IN or DUPLEX OUT Connector Overload Protection Failure .....	18
31. BER Meter Failure .....	18
32. DUPLEX OUT Connector Level Failure .....	19
33. DTMF Failure .....	19
34. DMM Failure .....	20
35. Power Meter High Power Failure .....	21
36. Oscilloscope Vertical Accuracy Failure .....	21
37. Frequency Agility Procedure Failure .....	21

## CHAPTER 2 MAINTENANCE INSTRUCTIONS

---

### 2-1-4 TROUBLESHOOTING GUIDELINES.

Following is a list of aids to be used when troubleshooting Test Sets.

- a. Test Set has built-in self tests used in troubleshooting. Procedures for self-tests are specified in troubleshooting procedures.
- b. Refer to principles of operation, Chapter 1, Section III as required. This provides circuit theory of each section with references to functional block diagrams. Test Set Functional Block Diagram is located on figure FO-1. Test Set Assembly and Cable Locator Diagram is located on figure FO-2. Assembly component locators are located on figures FO-3 through FO-33.
- c. Many problems on Test Sets in service are caused by corrosion. Sometimes removing and reseating affected cable or circuit card will correct malfunction. Cleaning connector and/or switch contacts with alcohol will repair many types of digital and analog circuit malfunctions.
- d. When the A6 Monitor or A33 Monitor Control is installed on an extender board in the troubleshooting procedures, the Monitor/Monitor Control Extended Ribbon Cable (Appendix A) needs to be fabricated and used.
- e. Perform Turn-On Procedure (IFR-1900CSA Operation Manual), Self Test (para 2-4-5) and Performance Test (para 2-4-7) in order to troubleshoot Test Set.
- f. To eliminate the possibility of replacing good assemblies, refer to para 3-2-1 and perform required adjustment procedures to determine whether assembly is maladjusted or faulty.

### 2-1-5 EQUIPMENT INSPECTION.

The following inspection procedures are used to locate obvious malfunctions with Test Set.

- a. Inspect all external surfaces of Test Set for physical damage, breakage, loose or dirty contacts and missing components.

#### **WARNING**

Dangerous voltages are present with covers removed.

- b. Remove 34A3 Case Top (para 3-1-1) and 34A2 Case Bottom (para 3-1-2) on Test Set to access components.

#### **CAUTION**

Do not disconnect or remove any board assemblies in Radio Test Set unless instrument is unplugged. Some assemblies contain devices that can be damaged if board is removed when power is on. Several components, including MOS devices, can be damaged by electrostatic discharge. Use conductive foam and grounding straps when servicing is required around sensitive components. Use care when unplugging ICs from high-grip sockets.

- c. Inspect printed circuit board surfaces for discoloration, cracks, breaks and warping and printed circuit board conductors for breaks, cracks, cuts, erosion or looseness.
- d. Inspect all assemblies for burnt or loose components.
- e. Inspect all chassis-mounted components for looseness, breakage, loose contacts or conductors.
- f. Inspect all motherboard connectors for missing, broken or corroded contacts.
- g. Inspect Test Set for disconnected, broken, cut, loose or frayed cables or wires.

## CHAPTER 2 MAINTENANCE INSTRUCTIONS

---

### 2-1-6 TROUBLESHOOTING TABLE

Table 2-1 lists common malfunctions found during normal operation or maintenance of Test Set or components. Perform tests or inspections and corrective actions in order listed.

#### NOTE

- Voltage readings referenced to analog ground unless otherwise specified.
- See figure FO-2 for assembly and cable location diagram.

## CHAPTER 2 MAINTENANCE INSTRUCTIONS

Table 2-1. Troubleshooting

MALFUNCTION	TEST OR INSPECTION	CORRECTIVE ACTION						
<b>1. APPLIED Indicator does not light.</b>								
Step 1.	Locate A3A1W5 (fig. FO-2) and verify 8.5 Vdc ( $\pm 1.5$ Vdc) at A3A1W5P1, Pin 4 (fig. FO-5, Sheet 2 of 4).	<ul style="list-style-type: none"><li>Replace A22 Power Supply (para 3-1-18)</li></ul>						
Step 2.	Verify continuity between A23A2 Keyboard and A22 Power Supply (fig. FO-5).	<ul style="list-style-type: none"><li>If incorrect, replace A3A1 Motherboard (para 3-1-31).</li><li>If correct, replace A23 Front Panel (para 3-1-19).</li></ul>						
<b>2. ON Indicator does not light.</b>								
Step 1.	Verify ON indicator lights or lights momentarily when POWER Switch is pressed.	<ul style="list-style-type: none"><li>Perform Steps 3-4.</li></ul>						
Step 2.	Locate A22 Power Supply (fig. FO-2). Press POWER Switch and verify voltages with DMM at A22J4 (fig. FO-20) with DMM.	<table><tbody><tr><td>A22J4, Pin 1</td><td>+5 Vdc (<math>\pm 0.5</math> Vdc)</td></tr><tr><td>A22J4, Pin 3</td><td>+15 Vdc (<math>\pm 2</math> Vdc)</td></tr><tr><td>A22J4, Pin 5</td><td>-15 Vdc (<math>\pm 2</math> Vdc)</td></tr></tbody></table> <ul style="list-style-type: none"><li>If any voltage is incorrect, perform Power Faults Test (para 2-6).</li></ul>	A22J4, Pin 1	+5 Vdc ( $\pm 0.5$ Vdc)	A22J4, Pin 3	+15 Vdc ( $\pm 2$ Vdc)	A22J4, Pin 5	-15 Vdc ( $\pm 2$ Vdc)
A22J4, Pin 1	+5 Vdc ( $\pm 0.5$ Vdc)							
A22J4, Pin 3	+15 Vdc ( $\pm 2$ Vdc)							
A22J4, Pin 5	-15 Vdc ( $\pm 2$ Vdc)							
Step 3.	Locate A3A1W5 (fig. FO-2) and verify 8.5 Vdc ( $\pm 1.5$ Vdc) at A3A1W5P1, Pin 3 (fig. FO-5, Sheet 2 of 4).	<ul style="list-style-type: none"><li>Perform Step 5.</li></ul>						
Step 4.	Verify continuity between A23A2 Keyboard and A22 Power Supply (fig. FO-5).	<ul style="list-style-type: none"><li>If incorrect, replace A3A1 Motherboard (para 3-1-31).</li><li>If correct, replace A23 Front Panel (para 3-1-19).</li></ul>						
Step 5.	Disconnect power source from Test Set. Locate A23 Front Panel (fig. FO-2) and verify $<100 \Omega$ resistance with DMM between A23A2A1E1, Pin 13 (fig. FO-21) and Chassis Ground when POWER Switch is pressed.	<ul style="list-style-type: none"><li>If incorrect, replace A23 Front Panel (para 3-1-19).</li><li>If correct, replace A22 Power Supply (para 3-1-18).</li></ul>						
<b>3. Fan does not work.</b>								
Step 1.	Check Fan for obstructions.	<ul style="list-style-type: none"><li>If obstructions are present, remove obstructions.</li><li>If obstructions are not present, replace A22 Power Supply (para 3-1-18)</li></ul>						



## CHAPTER 2 MAINTENANCE INSTRUCTIONS

Table 2-1. Troubleshooting

MALFUNCTION	TEST OR INSPECTION	CORRECTIVE ACTION
<b>4. Beep Sequence does not occur.</b>		
Step 1.	Verify Logo Screen is displayed on LCD.	<ul style="list-style-type: none"> <li>• If incorrect, perform Beep Sequence Test (para 2-4-2).</li> <li>• If correct, perform Malfunction 11 – Speaker Inoperable.</li> </ul>
<b>5. Blows Fuses.</b>		
Step 1.	Fuses blows when Radio Test Set is connected to external power source.	<ul style="list-style-type: none"> <li>• Replace A22 Power Supply (para 3-1-18)</li> </ul>
Step 2.	Fuse blows when POWER Switch is pressed.	
<b>6. LCD is blank or display abnormality exists.</b>		
Step 1.	Perform LCD Abnormality Test (para ??)	<ul style="list-style-type: none"> <li>• Replace faulty assembly.</li> </ul>
<b>7. LCD Error Messages are displayed.</b>		
<b>Inactive Func Gen Board</b>		
		<ul style="list-style-type: none"> <li>• Replace A31 Function Generator (para 3-1-12).</li> </ul>
<b>Inactive RF-I/O Board</b>		
		<ul style="list-style-type: none"> <li>• Replace A29 RF I/O (para 3-1-13).</li> </ul>
<b>Inactive Counter Board</b>		
		<ul style="list-style-type: none"> <li>• Replace A30 Counter (para 3-1-4).</li> </ul>
<b>Inactive Monitor Control Board</b>		
		<ul style="list-style-type: none"> <li>• Replace A33 Monitor Control (para 3-1-11).</li> </ul>
<b>Inactive SCSI Interface</b>		
		<ul style="list-style-type: none"> <li>• Replace A35 External I/O (para 3-1-17).</li> </ul>
<b>Input or Overload on Ant or Duplex Port</b>		
	Locate A21W1 (fig. FO-2), disconnect A21W1P1 (fig. FO-19), press POWER Switch and verify error message.	
		<ul style="list-style-type: none"> <li>• If incorrect, replace A21 Power Termination (para 3-1-29).</li> <li>• If correct, replace A16 Receive IF (para 3-1-26).</li> </ul>

## CHAPTER 2 MAINTENANCE INSTRUCTIONS

Table 2-1. Troubleshooting

MALFUNCTION	TEST OR INSPECTION	CORRECTIVE ACTION
<b>Overload on T/R Port</b>		
Locate A21W1 (fig. FO-2), disconnect A21W1P1 (FO-33), press POWER Switch and verify error message.		
<ul style="list-style-type: none"><li>• If incorrect, replace A21 Power Termination (para 3-1-29).</li><li>• If correct, replace A6 Monitor (para 3-1-10).</li></ul>		
<b>Power Term Overload</b>		
<ul style="list-style-type: none"><li>• Remove A33 Monitor Control (para 3-1-11) and install on PC Board Assembly Extender in Test Set. Install Monitor/Monitor Control Extended Ribbon Cable in place of Monitor/Monitor Control Ribbon Cable (W49). Verify &gt;1.5 V with DMM at W49P1, Pin 47 (fig. FO-29,).</li><li>• If incorrect, replace A33 Monitor Control (para 3-1-11).</li></ul>		
If correct, replace A6 Monitor (para 3-1-10).		
<b>8. Keyboard Keys Inoperable.</b>		
Perform Keyboard Key Test (para 2-9).		
<ul style="list-style-type: none"><li>• Replace faulty assembly.</li></ul>		
<b>9. DATA SCROLL Spinner Inoperable.</b>		
Step 1.	Remove A30 Counter (para 3-1-4) and install on PC Board Assembly Extender in Test Set.	
Step 2.	Verify level alternates between 0 Vdc and +5 Vdc with Oscilloscope at A30P2, Pin 8B and 8C (fig. FO-26) when DATA SCROLL Spinner is rotated.	<ul style="list-style-type: none"><li>• If incorrect, perform Steps 3-4.</li><li>• If correct, replace A30 Counter (para 3-1-4).</li></ul>
Step 3.	Verify reading fluctuates between a short and an open with DMM between A30P2, Pin 8B and Ground (fig. FO-26).	
Step 4.	Verify reading fluctuates between a short and an open with DMM between A30P2, Pin 8C and Ground (fig. FO-26).	<ul style="list-style-type: none"><li>• If incorrect, replace A23 Front Panel (para 3-1-19).</li><li>• If correct, replace A30 Counter (para 3-1-4).</li></ul>

## CHAPTER 2 MAINTENANCE INSTRUCTIONS

Table 2-1. Troubleshooting

MALFUNCTION	TEST OR INSPECTION	CORRECTIVE ACTION
<b>10. Speaker Inoperable.</b>		
Step 1.	Remove A6 Monitor (para 3-1-10) and install on PC Board Assembly Extender in Test Set. Install Monitor/Monitor Control Extended Ribbon Cable in place of Monitor/Monitor Control Ribbon Cable (W49).	
Step 2.	Press AF GEN MODE Key.	
Step 3.	Use FIELD SELECT Keys to move cursor to GEN 1. Press ENTER Key to select On.	
Step 4.	Locate W49 (fig. FO-2) and verify +4 Vdc ( $\pm 1$ Vdc) logic switching with Oscilloscope at W49P2, Pins 1, 2 and 4 (fig. FO-7) when VOL CONTROL Keys are pressed.	<ul style="list-style-type: none"> <li>• If any voltage is incorrect, replace A33 Monitor Control (para 3-1-11).</li> </ul>
Step 5.	Verify 1 kHz sine wave with Oscilloscope at A6P1, Pin 16B.	<ul style="list-style-type: none"> <li>• If incorrect, replace A6 Monitor (para 3-1-10).</li> <li>• If correct, replace A23 Front Panel (para 3-1-19).</li> </ul>
<b>11. Self Test Failure.</b>		
Step 1.	Verify "Test Running" was displayed in lower left corner of LCD.	<ul style="list-style-type: none"> <li>• Perform para 2-9 for keys: "AUX" F6, 4 and ENTER.</li> </ul>
Step 2.	Verify Self Test completed all tests in <3 minutes.	<ul style="list-style-type: none"> <li>• Replace A32 Digitizer (para 3-1-3).</li> </ul>
Step 3.	Verify Self Test displays "P" for all tests.	<ul style="list-style-type: none"> <li>• Perform Self Test Failure Test (para 2-4-5).</li> </ul>
<b>12. Squelch Inoperable/Squelch Failure.</b>		
Step 1.	Remove A33 Monitor Control (para 3-1-11) and install on PC Board Assembly Extender in Test Set. Install Monitor/Monitor Control Extended Ribbon Cable in place of Monitor/Monitor Control Ribbon Cable (W49).	
Step 2.	Verify negative pulse from 0 to -5 Vdc with Oscilloscope at A33J2, Pin 3 (fig. FO-29) when DATA SCROLL Spinner is rotated.	<ul style="list-style-type: none"> <li>• Replace A33 Monitor Control (para 3-1-11).</li> </ul>
Step 3.	Verify 0-5 V logic switching with Oscilloscope at A33J2, Pin 33 when DATA SCROLL Spinner is rotated.	<ul style="list-style-type: none"> <li>• If incorrect, replace A6 Monitor (para 3-1-10).</li> <li>• If correct, replace A33 Monitor Control (para 3-1-11).</li> </ul>

## CHAPTER 2 MAINTENANCE INSTRUCTIONS

Table 2-1. Troubleshooting

MALFUNCTION	TEST OR INSPECTION	CORRECTIVE ACTION
<b>13. AF GEN 1 Frequency and Level Accuracy Failure.</b>		
Step 1.	Remove A31 Function Generator (para 3-1-12) and install on PC Board Assembly Extender in Test Set.	
Step 2.	Verify 1 kHz ( $\pm 1$ Hz) with Frequency Counter at A31P2, Pin 2B (fig. FO-27).	<ul style="list-style-type: none"><li>• Replace A31 Function Generator (para 3-1-12).</li></ul>
Step 3.	Verify 0.707 VRMS ( $\pm 0.5\%$ ) with DMM at A31P2, Pin 2B.	<ul style="list-style-type: none"><li>• Replace A31 Function Generator (para 3-1-12).</li></ul>
Step 4.	Install A31 Function Generator (para 3-1-12). Remove A6 Monitor (para 3-1-10) and install on PC Board Assembly Extender in Test Set. Install Monitor/Monitor Control Extended Ribbon Cable in place of Monitor/Monitor Control Ribbon Cable (W49).	
Step 5.	Verify 0.707 VRMS ( $\pm 0.5\%$ ) with DMM at A6P1, Pin 1A (fig. FO-7).	<ul style="list-style-type: none"><li>• If incorrect, replace A6 Monitor (para 3-1-10).</li><li>• If correct, replace A23 Front Panel (para 3-1-19).</li></ul>
<b>14. AF GEN 1 Distortion Threshold Failure.</b>		
Step 1.	Remove A6 Monitor (para 3-1-10) and install on PC Board Assembly Extender in Test Set. Install Monitor/Monitor Control Extended Ribbon Cable in place of Monitor/Monitor Control Ribbon Cable (W49).	
Step 2.	Connect Oscilloscope Probe to Distortion Analyzer input. Verify $<0.5\%$ distortion with Distortion Analyzer at A6P1, Pin 3A (fig. FO-7).	<ul style="list-style-type: none"><li>• Replace A31 Function Generator (para 3-1-12).</li></ul>
Step 3.	Connect Oscilloscope Probe to Distortion Analyzer input. Verify $<0.5\%$ distortion with Distortion Analyzer at A6P1, Pin 1A (fig. FO-7).	<ul style="list-style-type: none"><li>• If incorrect, replace A6 Monitor (para 3-1-10).</li><li>• If correct, replace A23 Front Panel (para 3-1-19).</li></ul>
<b>15. AF GEN 2 Frequency and Level Accuracy Failure.</b>		
Step 1.	Remove A31 Function Generator (para 3-1-12) and install on PC Board Extender in Test Set.	
Step 2.	Verify 1 kHz ( $\pm 1$ Hz) with Frequency Counter at A31P2, Pin 2B (fig. FO-27).	<ul style="list-style-type: none"><li>• Replace A31 Function Generator (para 3-1-12).</li></ul>
Step 3.	Verify 0.707 VRMS ( $\pm 0.5\%$ ) with DMM at A31P2, Pin 2B.	<ul style="list-style-type: none"><li>• If incorrect, replace A31 Function Generator (para 3-1-12).</li><li>• If correct, replace A23 Front Panel (para 3-1-19).</li></ul>

## CHAPTER 2 MAINTENANCE INSTRUCTIONS

Table 2-1. Troubleshooting

MALFUNCTION	TEST OR INSPECTION	CORRECTIVE ACTION
<b>16. AF GEN 2 Distortion Threshold Failure.</b>		
Step 1.	Remove A6 Monitor (para 3-1-10) and install on PC Board Assembly Extender in Test Set. Install Monitor/Monitor Control Extended Ribbon Cable in place of Monitor/Monitor Control Ribbon Cable (W49).	
Step 2.	Connect Oscilloscope Probe to Distortion Analyzer input. Verify <0.5% distortion with Distortion Analyzer at A6P1, Pin 3A (fig. FO-7).	<ul style="list-style-type: none"> <li>• Replace A31 Function Generator (para 3-1-12).</li> </ul>
Step 3.	Connect Oscilloscope Probe to Distortion Analyzer input. Verify <0.5% distortion with Distortion Analyzer at A6P1, Pin 1A (fig. FO-7).	<ul style="list-style-type: none"> <li>• If incorrect, replace A6 Monitor (para 3-1-10).</li> <li>• If correct, replace A23 Front Panel (para 3-1-19).</li> </ul>
<b>17. External Modulation Failure.</b>		
Step 1.	Remove A31 Function Generator (para 3-1-12) and install on PC Board Assembly Extender in Test Set.	
Step 2.	Verify 3.3 VRMS ( $\pm 0.3$ V) with DMM at A31P2, Pin 1B (fig. FO-27).	<ul style="list-style-type: none"> <li>• If incorrect, replace A23 Front Panel (para 3-1-19).</li> <li>• If correct, replace A31 Function Generator (para 3-1-12).</li> </ul>
<b>18. MIC/ACC IN/OUT Connector Modulation Failure.</b>		
Step 1.	Remove A31 Function Generator (para 3-1-12) and install on PC Board Assembly Extender in Test Set.	
Step 2.	Verify deflection of Oscilloscope trace coincident with tapping on Microphone at A31P2, Pin 1A (fig. FO-27).	<ul style="list-style-type: none"> <li>• If incorrect, replace A23 Front Panel (para 3-1-19).</li> <li>• If correct, replace A31 Function Generator (para 3-1-12).</li> </ul>

## CHAPTER 2 MAINTENANCE INSTRUCTIONS

Table 2-1. Troubleshooting

MALFUNCTION	TEST OR INSPECTION	CORRECTIVE ACTION
<b>19. RF GEN Level Flatness Failure.</b>		
Step 1.	Locate A36 Attenuator (fig. FO-2). Verify signals switch high and low with Oscilloscope at A36AT1, Pin 1 (fig. FO-31) when Test Set attenuation is varied from 1 to 0 dB.	<ul style="list-style-type: none"><li>• If constant low, replace A36 Attenuator (para 3-1-28).</li><li>• If constant high, replace A36 Attenuator (para 3-1-28).</li></ul>
Step 2.	Verify signals switch high and low with Oscilloscope at A36AT1, Pin 2 (fig. FO-31) when Test Set attenuation is varied from 2 to 1 dB.	<ul style="list-style-type: none"><li>• If constant low, replace A36 Attenuator (para 3-1-28).</li><li>• If constant high, replace A36 Attenuator (para 3-1-28).</li></ul>
Step 3.	Verify signals switch high and low with Oscilloscope at A36AT1, Pin 4 (fig. FO-31) when Test Set attenuation is varied from 4 to 3 dB.	<ul style="list-style-type: none"><li>• If constant low, replace A36 Attenuator (para 3-1-28).</li><li>• If constant high, replace A36 Attenuator (para 3-1-28).</li></ul>
Step 4.	Verify signals switch high and low with Oscilloscope at A36AT1, Pin 8 (fig. FO-31) when Test Set attenuation is varied from 8 to 7 dB.	<ul style="list-style-type: none"><li>• If constant low, replace A36 Attenuator (para 3-1-28).</li><li>• If constant high, replace A36 Attenuator (para 3-1-28).</li></ul>
Step 5.	Verify signals switch high and low with Oscilloscope at A36AT1, Pin 16 (fig. FO-31) when Test Set attenuation is varied from 16 to 15 dB.	<ul style="list-style-type: none"><li>• If constant low, replace A36 Attenuator (para 3-1-28).</li><li>• If constant high, replace A36 Attenuator (para 3-1-28).</li></ul>
Step 6.	Set Test Set to generate 100 MHz at 0 dBm.	
Step 7.	Disconnect W20 (fig. FO-2) from A41 90 MHz Generator (fig. FO-25), connect Oscilloscope to W20 (fig. FO-2) and verify 0-4 V square wave at 1 MHz (slightly distorted).	<ul style="list-style-type: none"><li>• Replace A15 2nd LO (para 3-1-23).</li></ul>
Step 8.	Reconnect W20. Disconnect W14 from A13 1st LO (fig. FO-2), connect Power Meter to W14 (fig. FO-2) and verify 7 dBm ( $\pm 2$ dB).	<ul style="list-style-type: none"><li>• Replace A15 2nd LO (para 3-1-23).</li></ul>
Step 9.	Reconnect W14. Disconnect W11 from A20 Generator IF (fig. FO-2), connect Power Meter to W11 (fig. FO-2) and verify $\geq 0$ dBm.	<ul style="list-style-type: none"><li>• Replace A15 2nd LO (para 3-1-23).</li></ul>

## CHAPTER 2 MAINTENANCE INSTRUCTIONS

Table 2-1. Troubleshooting

MALFUNCTION	TEST OR INSPECTION	CORRECTIVE ACTION										
<b>19. RF GEN Level Flatness Failure. - Continued</b>												
Step 10.	Reconnect W11. Disconnect W12 from A20 Generator IF (fig. FO-2), connect Power Meter to W12 (fig. FO-2) and verify $\geq 7$ dBm.											
Step 11.	Locate A20 Generator IF (fig. FO-2) and verify 11.5 dBm ( $\pm 3$ dB) with Power Meter at A20P6 (fig. FO-18).	<ul style="list-style-type: none"> <li>• Replace A20 Generator IF (para 3-1-27).</li> <li>• Reconnect W13 (fig. FO-2). Locate A21 Power Termination (fig. FO-2) and disconnect A21P4 (fig. FO-19). Remove A36 Attenuator (para 3-1-28). Reconnect A36J1, A36J2, A36J3 and A36J4 (fig. FO-31).</li> </ul>										
Step 12.	Locate A20 Generator IF (fig. FO-2) and verify 11.5 dBm ( $\pm 3$ dB) with Power Meter at A20P6 (fig. FO-18).	<ul style="list-style-type: none"> <li>• Replace A20 Generator IF (para 3-1-27).</li> </ul>										
Step 13.	Connect 50 $\Omega$ Load to A20P6 (fig. FO-18).											
Step 14.	Connect Signal Generator to A36J5 (fig. FO-31). Set Signal Generator for 100 MHz, +7 dBm. Record reference level.											
Step 15.	Verify insertion loss is 3 dB maximum (+0, -3 dB) with Power Meter at A36J6.	<ul style="list-style-type: none"> <li>• If incorrect, replace A36 Attenuator (para 3-1-28).</li> <li>• If correct, replace A21 Power Termination (para 3-1-29).</li> </ul>										
<b>20. RF GEN Frequency Accuracy Failure.</b>												
Step 1.	Disconnect W12 (fig. FO-2) from A20 Generator IF (fig. FO-2) and connect Frequency Counter to W12 (fig. FO-2). Enter frequencies in Test Set RF Field and verify readings on Frequency Counter.	<table style="margin-left: 40px; border: none;"> <tbody> <tr> <td style="padding-right: 40px;">50 MHz</td> <td>1350 MHz (<math>\pm 50</math> Hz)</td> </tr> <tr> <td>200 MHz</td> <td>1500 MHz (<math>\pm 200</math> Hz)</td> </tr> <tr> <td>400 MHz</td> <td>1700 MHz (<math>\pm 400</math>Hz)</td> </tr> <tr> <td>600 MHz</td> <td>1900 MHz (<math>\pm 600</math> Hz)</td> </tr> <tr> <td>800 MHz</td> <td>2100 MHz (<math>\pm 800</math> Hz)</td> </tr> </tbody> </table> <ul style="list-style-type: none"> <li>• Replace A13 1<sup>st</sup> LO (para 3-1-24).</li> </ul>	50 MHz	1350 MHz ( $\pm 50$ Hz)	200 MHz	1500 MHz ( $\pm 200$ Hz)	400 MHz	1700 MHz ( $\pm 400$ Hz)	600 MHz	1900 MHz ( $\pm 600$ Hz)	800 MHz	2100 MHz ( $\pm 800$ Hz)
50 MHz	1350 MHz ( $\pm 50$ Hz)											
200 MHz	1500 MHz ( $\pm 200$ Hz)											
400 MHz	1700 MHz ( $\pm 400$ Hz)											
600 MHz	1900 MHz ( $\pm 600$ Hz)											
800 MHz	2100 MHz ( $\pm 800$ Hz)											
Step 2.	Reconnect W12. Disconnect W13 from A18 RF Modem (fig. FO-2) and connect Frequency Counter to W13 (fig. FO-2). Verify 88.0001 MHz ( $\pm 88$ Hz).	<ul style="list-style-type: none"> <li>• If incorrect, replace A41 90 MHz Generator (para 3-1-8).</li> <li>• If correct, replace A15 2<sup>nd</sup> LO (para 3-1-23).</li> </ul>										
<b>21. RF GEN Level Accuracy Failure.</b>												
		<ul style="list-style-type: none"> <li>• Replace A36 Attenuator (para 3-1-28).</li> </ul>										

## CHAPTER 2 MAINTENANCE INSTRUCTIONS

Table 2-1. Troubleshooting

MALFUNCTION	TEST OR INSPECTION	CORRECTIVE ACTION
<b>22. RF GEN Residual FM Failure.</b>		
Step 1.	Disconnect W12 (fig. FO-2) from A20 Generator IF (fig. FO-2) and connect Measuring Receiver to W12 (fig. FO-2).	
Step 2.	Use FIELD SELECT Keys to move cursor to RF. Press ENTER Key. Use DATA ENTRY Keypad to enter 500 kHz. Press ENTER Key.	
Step 3.	Verify <70 Hz RMS on Measuring Receiver.	<ul style="list-style-type: none"><li>• Replace A13 1st LO (para 3-1-24).</li></ul>
Step 4.	Reconnect W12. Disconnect W11 from A20 Generator IF (fig. FO-2) and connect Measuring Receiver to W11 (fig. FO-2).	
Step 5.	Verify <70 Hz RMS on Measuring Receiver.	<ul style="list-style-type: none"><li>• If incorrect, replace A15 2nd LO (para 3-1-23).</li><li>• If correct, replace A41 90 MHz Generator (para 3-1-8).</li></ul>
<b>23. RF GEN AM Failure.</b>		
Step 1.	Remove A31 Function Generator (para 3-1-12) and install on PC Board Assembly Extender in Test Set.	
Step 2.	Set Test Set for 1 kHz with 90% modulation tone.	
Step 3.	Verify 0 Vdc ( $\pm 10$ mVdc) with DMM at A31P2, Pin 4A (fig. FO-27).	
Step 4.	Verify 1 kHz ( $\pm 10$ Hz) with <0.5% distortion with Frequency Counter and Distortion Analyzer at A31P2, Pin 2B.	
Step 5.	Replace A31 Function Generator (para 3-1-12). Disconnect W13 (fig. FO-2) from A41 90 MHz Generator (fig. FO-2), connect T-Connector between W13 (fig. FO-2) and A71J3 (fig. FO-10) and connect Measuring Receiver to T-Connector.	
Step 6.	Set Measuring Receiver Low-Pass Filter to 15 kHz and High-Pass Filter to 300 Hz.	
Step 7.	Set Test Set for 1 kHz with 90% modulation tone.	
Step 8.	Verify 1 kHz ( $\pm 10$ Hz) at 90% ( $\pm 4.5\%$ ) modulation with Measuring Receiver.	<ul style="list-style-type: none"><li>• If incorrect, replace A41 90 MHz Generator (para 3-1-8).</li><li>• If correct, replace A18 RF Modem.</li></ul>



## CHAPTER 2 MAINTENANCE INSTRUCTIONS

Table 2-1. Troubleshooting

MALFUNCTION	TEST OR INSPECTION	CORRECTIVE ACTION
<b>24. RF GEN FM Failure.</b>		
Step 1.	Remove A31 Function Generator (para 3-1-12) and install on PC Board Assembly Extender in Test Set.	
Step 2.	Use FIELD SELECT Keys to move cursor to AF FREQ. Press ENTER Key. Use DATA ENTRY Keypad to enter 1000.0 Hz. Press ENTER Key.	
Step 3.	Use FIELD SELECT Keys to move cursor to DEVIATION. Press ENTER Key. Use DATA ENTRY Keypad to enter 5.0 kHz. Press ENTER Key.	
Step 4.	Set Test Set for 1 kHz with 5 kHz deviation.	
Step 5.	Verify 0.67 VAC ( $\pm 0.03$ VAC) with DMM at A31P2, Pin 3B (fig. FO-27). <ul style="list-style-type: none"> <li>• Replace A31 Function Generator (para 3-1-12).</li> </ul>	
Step 6.	Verify 1 kHz ( $\pm 10$ Hz) with $<0.5\%$ distortion with Frequency Counter and Distortion Analyzer at A31P2, Pin 3B. <ul style="list-style-type: none"> <li>• Replace A31 Function Generator (para 3-1-12).</li> </ul>	
Step 7.	Disconnect W13 (fig. FO-2) from A41 90 MHz Generator (fig. FO-2), connect T-Connector between W13 (fig. FO-2) and A71J3 (fig. FO-10) and connect Measuring Receiver to T-Connector.	
Step 8.	Set Measuring Receiver Low-Pass Filter to 15 kHz and High-Pass Filter to 300 Hz. <ul style="list-style-type: none"> <li>• Use FIELD SELECT Keys to move cursor to AF FREQ. Press ENTER Key. Use DATA ENTRY Keypad to enter 100.00 Hz. Press ENTER Key.</li> </ul>	
Step 9.	Use FIELD SELECT Keys to move cursor to DEVIATION. Press ENTER Key. Use DATA ENTRY Keypad to enter 5.0 kHz. Press ENTER Key.	
Step 10.	Verify 1 kHz ( $\pm 10$ Hz) at 5 kHz ( $\pm 10\%$ ) modulation with Measuring Receiver. <ul style="list-style-type: none"> <li>• Replace A41 90 MHz Generator (para 3-1-8).</li> </ul>	
Step 11.	Disconnect W12 (fig. FO-2) from A20 Generator IF (fig. FO-2) and connect Measuring Receiver to W12 (fig. FO-2).	
Step 12.	Use FIELD SELECT Keys to move cursor to RF. Press ENTER Key. Use DATA ENTRY Keypad to enter 0.2500 MHz. Press ENTER Key.	
Step 13.	Set Measuring Receiver to measure RMS FM Deviation and verify $<100$ Hz RMS FM Deviation.	
Step 14.	Disconnect W11 from A20 Generator IF (fig. FO-2), connect Measuring Receiver to W11 (fig. FO-2) and verify $<100$ Hz RMS FM Deviation. <ul style="list-style-type: none"> <li>• If incorrect, replace A15 2nd LO (para 3-1-23).</li> <li>• If correct, replace A20 Generator IF (para 3-1-27).</li> </ul>	

## CHAPTER 2 MAINTENANCE INSTRUCTIONS

Table 2-1. Troubleshooting

MALFUNCTION	TEST OR INSPECTION	CORRECTIVE ACTION
<b>25. RF GEN Harmonic/Non-Harmonic Level Failure.</b>		
Step 1.	Disconnect W12 (fig. FO-2) from A20 Generator IF (fig. FO-2) and connect Spectrum Analyzer to W12 (fig. FO-2).	
Step 2.	Set Spectrum Analyzer to 1922 MHz and Full Span.	
Step 3.	Verify Harmonics are <-26 dBc and Non-Harmonics are <-50 dBc.	<ul style="list-style-type: none"><li>• If incorrect, replace A13 1st LO (para 3-1-24).</li><li>• If correct, replace A20 Generator IF (para 3-1-27).</li></ul>
<b>26. Frequency/Frequency Error Meter Failure.</b>		
Step 1.	Disconnect W24 (fig. FO-2) from A30 Counter(fig. FO-2, Sheet 1 of 3) and connect Frequency Counter to W24 (fig. FO-2).	
Step 2.	Set Frequency to 800 MHz on Signal Generator.	
Step 3.	Use FIELD SELECT Keys to move cursor to RF. Press ENTER Key. Use DATA ENTRY Keypad to enter 800.0000 MHz. Press ENTER Key.	
Step 4.	Verify 425 kHz ( $\pm 200$ Hz).	<ul style="list-style-type: none"><li>• If incorrect, replace A9 Receiver (para 3-1-9).</li><li>• If correct, replace A30 Counter (para 3-1-4).</li></ul>
<b>27. AGC Failure.</b>		
Step 1.	Remove A29 RF I/O (para 3-1-13) and install on PC Board Assembly Extender in Test Set.	
Step 2.	Press RCVR MODE Key.	
Step 3.	Verify 5 Vdc ( $\pm 0.5$ Vdc) with DMM at A29P2, Pin 1C (fig. FO-25).	<ul style="list-style-type: none"><li>• If incorrect, replace A29 RF I/O (para 3-1-13).</li><li>• If correct, replace A9 Receiver (para 3-1-9).</li></ul>

## CHAPTER 2 MAINTENANCE INSTRUCTIONS

Table 2-1. Troubleshooting

MALFUNCTION	TEST OR INSPECTION	CORRECTIVE ACTION
<b>28. Receiver Sensitivity Failure.</b>		
Step 1.	Set Signal Generator for -36 dBm FM with no modulation.	
Step 2.	Set Test Set to Receive mode.	
Step 3.	Set Spectrum Analyzer to 10.7 MHz.	
Step 4.	Disconnect W8 (fig. FO-2) from A18 RF Modem (fig. FO-2, Sheet 1 of 3), connect Spectrum Analyzer to W8 (fig. FO-2) and verify -36 dBm ( $\pm 5$ dB).	<ul style="list-style-type: none"> <li>• If incorrect, perform Steps 5-6.</li> <li>• If correct, replace A18 RF Modem (para 3-1-9).</li> </ul>
Step 5.	Set frequency on Spectrum Analyzer to 79.3 MHz.	
Step 6.	Disconnect W10 from A40 3rd LO (fig. FO-2), connect Spectrum Analyzer to A40J3 (fig. FO-8) and verify +10 dBm ( $\pm 3$ dB).	<ul style="list-style-type: none"> <li>• If incorrect, replace A40 3rd LO (para 3-1-7).</li> <li>• If correct, replace A16 Receive IF (para 3-1-26).</li> </ul>
<b>29. Receiver Selectivity Failure.</b>		
Step 1.	Remove A29 RF I/O (para 3-1-13) and install on PC Board Assembly Extender in Test Set.	
Step 2.	Set Signal Generator for 80 MHz signal at -60 dBm with no modulation.	
Step 3.	Use FIELD SELECT Keys to move cursor to RF. Press ENTER Key. Use DATA ENTRY Keypad to enter 80.0000 MHz. Press ENTER Key.	
Step 4.	Use FIELD SELECT Keys to move cursor to MOD. Press ENTER Key. Use DATA SCROLL Keys to select FM4. Press ENTER Key.	
Step 5.	Use FIELD SELECT Keys to cursor to Deviation Meter. Press ENTER Key. Use FIELD SELECT Keys to move cursor to RANGE. Press ENTER Key. Use DATA SCROLL Keys to select 200 kHz. Press ENTER Key.	
Step 6.	Press "Ret" F6.	
Step 7.	Use FIELD SELECT Keys to move cursor to Attn. Press ENTER Key. Use DATA SCROLL Keys to select 20 dB. Press ENTER Key.	

## CHAPTER 2 MAINTENANCE INSTRUCTIONS

Table 2-1. Troubleshooting

MALFUNCTION	TEST OR INSPECTION	CORRECTIVE ACTION
<b>29. Receiver Selectivity Failure. - Continued</b>		
Step 8.	Adjust UUT Squelch Controls for lowest setting where signal from Signal Generator breaks squelch.	
Step 9.	Set Signal Generator to 80.1 MHz at -57 dBm. Verify Receiver breaks squelch.	<ul style="list-style-type: none"><li>• If incorrect, perform Step 10.</li><li>• If correct, replace A9 Receiver (para 3-1-9).</li></ul>
Step 10.	Verify 0 Vdc ( $\pm 0.5$ Vdc) with DMM at A29P2, Pin 15A and Pin 16A (fig. FO-25).	<ul style="list-style-type: none"><li>• If incorrect, replace A29 RF I/O (para 3-1-13).</li><li>• If correct, replace A9 Receiver (para 3-1-9).</li></ul>
<b>30. ANTENNA IN or DUPLEX OUT Connector Overload Protection Failure.</b>		
Step 1.	Connect coaxial cable between AUDIO OUT Connector and ANTENNA IN Connector, then AUDIO OUT Connector and DUPLEX OUT Connector, and verify warning tone sounds and input overload message is displayed.	<ul style="list-style-type: none"><li>• If warning tone sounds and input overload message is displayed only for AUDIO OUT Connector – ANTENNA IN Connector, replace A16 Receive IF (para 3-1-26).</li><li>• If warning tone sounds and input overload message is displayed only for AUDIO OUT Connector - DUPLEX OUT Connector, replace A21 Power Termination (para 3-1-29).</li><li>• If warning tone does not sound and input overload message is not displayed for AUDIO OUT Connector – ANTENNA IN Connector and AUDIO OUT Connector - DUPLEX OUT Connector, replace A29 RF I/O (para 3-1-13).</li></ul>
<b>31. BER Meter Failure.</b>		
Step 2.	Remove A31 Function Generator (para 3-1-12) and install on PC Board Assembly Extender in Test Set.	
Step 1.	Press MTRS MODE Key.	
Step 2.	Use FIELD SELECT Keys to move cursor to "9. Bit Error Rate (BER) Func.". Press ENTER Key.	
Step 3.	Press "Run" F5.	

## CHAPTER 2 MAINTENANCE INSTRUCTIONS

Table 2-1. Troubleshooting

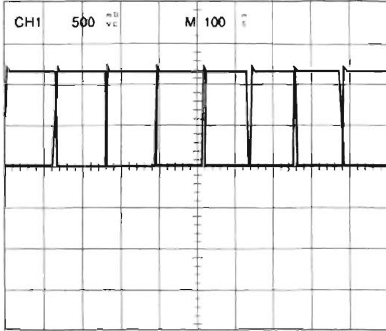
MALFUNCTION	TEST OR INSPECTION	CORRECTIVE ACTION
<b>31. BER Meter Failure. - Continued</b>		
	Step 4.	Verify series of pulses at 5 Vdc ( $\pm 0.5$ Vdc) with Oscilloscope at A31P2, Pin 10A (fig. FO-27) as shown.
		
		<ul style="list-style-type: none"> <li>• If incorrect, replace A31 Function Generator (para 3-1-12).</li> <li>• If correct, replace A6 Monitor (para 3-1-10).</li> </ul>
<b>32. DUPLEX OUT Connector Level Failure.</b>		
	Step 1.	Remove A36 Attenuator (para 3-1-28).
	Step 2.	Connect Signal Generator output to Measuring Receiver. Set Signal Generator for 100 MHz. Set Measuring Receiver to RF Level. Adjust Signal Generator output for -110 dBm on Measuring Receiver.
	Step 3.	Locate A21 Power Termination (fig. FO-2). Connect Signal Generator to A21P4 (fig. FO-19).
	Step 4.	Disconnect W3 (fig. FO-2) from A21 Power Termination (fig. FO-2) and connect Measuring Receiver to W3 (fig. FO-2).
	Step 5.	Verify -100 dBm ( $\pm 1.7$ dBm) on Measuring Receiver. <ul style="list-style-type: none"> <li>• If incorrect, replace A21 Power Termination (para 3-1-29).</li> <li>• If correct, replace A23 Front Panel (para 3-1-19).</li> </ul>
<b>33. DTMF Failure.</b>		
	Step 1.	Press "More" F6 until "RX" F2 appears. Press "RX" F2.
	Step 2.	Use FIELD SELECT Keys to move cursor to 123456789*0#. Press ENTER Key. Press and hold "1" Key on DATA ENTRY Keypad.
	Step 3.	Locate A33 Monitor Control (fig. FO-2). Verify 0.50 VAC ( $\pm 0.05$ VAC) with DMM at A33J2, Pin 44 (fig. FO-29).
	Step 4.	Replace A33 Monitor Control (para 3-1-11).

CE2FO245

## CHAPTER 2 MAINTENANCE INSTRUCTIONS

Table 2-1. Troubleshooting

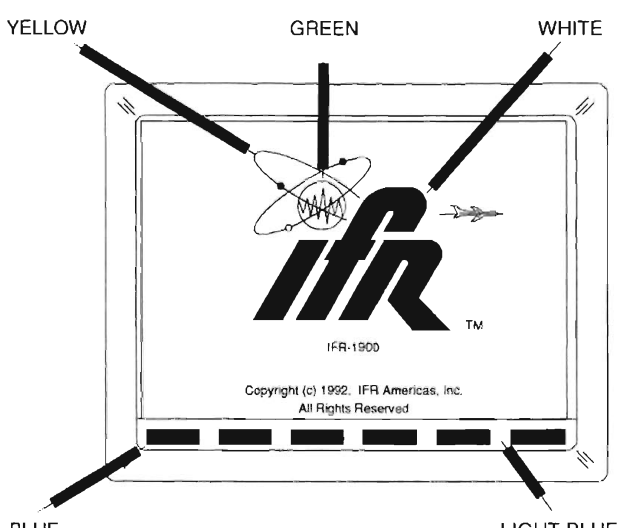
MALFUNCTION	TEST OR INSPECTION	CORRECTIVE ACTION														
<b>33. DTMF Failure. - Continued</b>																
Step 5.	Release "1" Key on DATA ENTRY Keypad. Use DATA ENTRY Keypad to enter "1111111111". Press ENTER Key.															
Step 6.	Press "More" F6 until "TX" F2 appears. Press "TX" F2.															
Step 7.	Press "More" F6 until "Decode" F2 appears. Press "Decode" F2.															
Step 8.	Press GO Key.															
Step 9.	Set Oscilloscope controls.	<table style="width: 100%; border: none;"> <tr> <td style="padding-left: 20px;">Channel 1 Scale</td> <td style="padding-left: 20px;">1 V (100 mV with x10 Probe)</td> </tr> <tr> <td style="padding-left: 20px;">Channel 1 Coupling</td> <td style="padding-left: 20px;">DC</td> </tr> <tr> <td style="padding-left: 20px;">Channel 2 Scale</td> <td style="padding-left: 20px;">1 V (100 mV with x10 Probe)</td> </tr> <tr> <td style="padding-left: 20px;">Channel 2 Coupling</td> <td style="padding-left: 20px;">DC</td> </tr> <tr> <td style="padding-left: 20px;">Sweep</td> <td style="padding-left: 20px;">500 <math>\mu</math>s</td> </tr> <tr> <td style="padding-left: 20px;">Trigger Source</td> <td style="padding-left: 20px;">Channel 1</td> </tr> <tr> <td style="padding-left: 20px;">Trigger Mode</td> <td style="padding-left: 20px;">Auto</td> </tr> </table>	Channel 1 Scale	1 V (100 mV with x10 Probe)	Channel 1 Coupling	DC	Channel 2 Scale	1 V (100 mV with x10 Probe)	Channel 2 Coupling	DC	Sweep	500 $\mu$ s	Trigger Source	Channel 1	Trigger Mode	Auto
Channel 1 Scale	1 V (100 mV with x10 Probe)															
Channel 1 Coupling	DC															
Channel 2 Scale	1 V (100 mV with x10 Probe)															
Channel 2 Coupling	DC															
Sweep	500 $\mu$ s															
Trigger Source	Channel 1															
Trigger Mode	Auto															
Step 10.	Connect Oscilloscope Channel 1 to A33J2, Pin 43. Connect Oscilloscope Channel 2 to A33J2, Pin 44.															
Step 11.	Verify Channel 1 and Channel 2 waveforms are identical and are similar to waveforms as shown.															
																
		<ul style="list-style-type: none"> <li>• If incorrect, replace A6 Monitor (para 3-1-10).</li> <li>• If correct, replace A33 Monitor Control (para 3-1-11).</li> </ul>														

CE2FO176

### 34. DMM Failure.

Perform DMM Test (para 2-11).

- Repair faulty assembly.

## CHAPTER 2 MAINTENANCE INSTRUCTIONS

Table 2-1. Troubleshooting

MALFUNCTION	TEST OR INSPECTION	CORRECTIVE ACTION
<b>35. Power Meter High Power Failure.</b>		
	Locate A21 Power Termination (fig FO-2) and verify 0.5 Vdc ( $\pm 0.5$ Vdc) with DMM at A21FL8 (fig. FO-19).	<ul style="list-style-type: none"> <li>• If incorrect, replace A36 Attenuator (para 3-1-28).</li> </ul>
<b>36. Oscilloscope Vertical Accuracy Failure.</b>		
Step 1.	Remove A32 Digitizer (para 3-1-3) and install on PC Board Assembly Extender in Test Set.	
Step 2.	Verify 2 Vdc ( $\pm 0.4$ Vdc) with DMM at A32P2, Pin 1B (fig. FO-28).	<ul style="list-style-type: none"> <li>• If incorrect, replace A23 Front Panel (para 3-1-19).</li> <li>• If correct, replace A32 Digitizer (para 3-1-3).</li> </ul>
<b>37. Frequency Agility Procedure Failure.</b>		
Step 1.	If A40 3rd LO was replaced assembly, replace A70 3rd LO (para 3-1-7).	
Step 2.	If A41 90 MHz Generator was replaced assembly, replace A41 90 MHz Generator (para 3-1-8).	
Step 3.	If A13 1st LO was replaced assembly, replace A13 1st LO (para 3-1-24).	

## CHAPTER 2 MAINTENANCE INSTRUCTIONS

### SECTION 2 TROUBLESHOOTING TESTS

#### 2-2-1 POWER FAULTS TEST

##### DESCRIPTION

This test determines whether a power fault is contained This test determines whether a power fault is contained within the A22 Power Supply or outside of the A22 Power Supply. If the power fault is outside of the A22 Power Supply, the test determines the assembly causing the fault.

##### NOTE

Perform this test only when instructed from table 2-1 or another troubleshooting test. Do not perform this troubleshooting test as a separate procedure unless otherwise instructed. Certain conditions have been established and/or tested prior to performing this test.

1. Disconnect A3A1W5 and A3A1W4 (fig. FO-2)
2. Verify readings and with DMM at following locations (fig. FO-5, Sheet 2 of 4) with DMM.

Location	Reading	If incorrect
A3A1W5P1, Pins 14 (+) and 13 (-)	>10 kΩ	Perform Step 5
A3A1W5P1, Pins 10 (+) and 13 (-)	>400 kΩ	Perform Steps 13-14
A3A1W5P1, Pins 16 (+) and 15 (-)	>200 kΩ	Perform Step 7
A3A1W5P1, Pins 12 (+) and 15 (-)	>20 kΩ	Perform Step 8
A3A1W4P1, Pins 9 (+) and 10 (-)	>20 Ω	Perform Step 3
A3A1W4P1, Pins 11 (+) and 12 (-)	>10 kΩ	Perform Step 4
A3A1W4P1, Pins 13 (+) and 15 (-)	>15 Ω	Perform Step 9
A3A1W4P1, Pins 7 (+) and 14 (-)	>5 kΩ	Perform Step 12
A3A1W4P1, Pins 14 (+) and 6 (-)	>5 kΩ	Perform Step 10
A3A1W4P1, Pins 1 (+) and 8 (-)	>500 Ω	Perform Step 11
A3A1W4P1, Pins 10 (+) and 13 (-)	>500 Ω	Perform Step 6

- If correct, replace A22 Power Supply (para 3-1-18).
3. Verify >20 Ω at A3A1W4P1, Pins 9 (+) and 10 (-) with DMM when assembly is pulled. Reinstall assembly if reading is correct.

Remove	If incorrect, replace
A31 Function Generator (para 3-1-12)	A31 Function Generator (para 3-1-12)
A6 Monitor (para 3-1-10)	A6 Monitor (para 3-1-10)
A9 Receiver (para 3-1-9)	A9 Receiver (para 3-1-9)
A41 90 MHz Generator (para 3-1-8)	A41 90 MHz Generator (para 3-1-8)
A29 RF I/O (para 3-1-13)	A29 RF I/O (para 3-1-13)

4. Verify >1 Ω at A3A1W4P1, Pins 11 (+) and 12 (-) with DMM when assembly is pulled. Reinstall assembly if reading is correct.

Remove	If incorrect, replace
A33 Monitor Control (para 3-1-11)	A33 Monitor Control (para 3-1-11)
A6 Monitor (para 3-1-10)	A6 Monitor (para 3-1-10)



## CHAPTER 2 MAINTENANCE INSTRUCTIONS

### 2-2-1 Power Faults Test - Continued

5. Verify  $>1\text{ k}\Omega$  at A3A1W5P1, Pins 14 (+) and 13 (-) with DMM when assembly is pulled. Reinstall assembly if reading is correct.

Remove	If incorrect, replace
A32 Digitizer (para 3-1-3) A8 Analyzer RF (para 3-1-6) A40 3rd LO (para 3-1-7) A7 Analyzer Log/IF (para 3-1-5)	A32 Digitizer (para 3-1-3) A8 Analyzer RF (para 3-1-6) A40 3rd LO (para 3-1-7) A7 Analyzer Log/IF (para 3-1-5)
Locate/Disconnect	If incorrect, replace
Locate A11 DMM (fig. FO-2, Sheet 3 of 7) and Disconnect A11W2P1 (fig. FO-9)	A11 DMM (para 3-1-22)

6. Verify  $>100\ \Omega$  at A3A1W4P1, Pins 10 (+) and 13 (-) with DMM when assembly is pulled or disconnected. Reinstall assembly or connection if reading is correct.

Remove	If incorrect, replace
A31 Function Generator (para 3-1-12) A6 Monitor (para 3-1-10) A9 Receiver (para 3-1-9) A41 90 MHz Generator (para 3-1-8) A29 RF I/O (para 3-1-13) A32 Digitizer (para 3-1-3) A8 Analyzer RF (para 3-1-6) A40 3rd LO (para 3-1-7) A7 Analyzer Log/IF (para 3-1-5)	A31 Function Generator (para 3-1-12) A6 Monitor (para 3-1-10) A9 Receiver (para 3-1-9) A41 90 MHz Generator (para 3-1-8) A29 RF I/O (para 3-1-13) A32 Digitizer (para 3-1-3) A8 Analyzer RF (para 3-1-6) A40 3rd LO (para 3-1-7) A7 Analyzer Log/IF (para 3-1-5)
Locate/Disconnect	If incorrect, replace
Locate A11 DMM (fig. FO-2, Sheet 1 of 3) and Disconnect A11W2P1 (fig. FO-9)	A11 DMM (para 3-1-22)

7. Verify  $>100\ \Omega$  at A3A1W5P1, Pins 16 (+) and 15 (-) with DMM when assembly is pulled. Reinstall assembly if reading is correct.

Remove	If incorrect, replace
A32 Digitizer (para 3-1-3) A30 Counter (para 3-1-4) A33 Monitor Control (para 3-1-11) A31 Function Generator (para 3-1-12) A29 RF I/O (para 3-1-13)	A32 Digitizer (para 3-1-3) A30 Counter (para 3-1-4) A33 Monitor Control (para 3-1-11) A31 Function Generator (para 3-1-12) A29 RF I/O (para 3-1-13)

8. Verify  $>15\ \Omega$  at A3A1W5P1, Pins 12 (+) and 15 (-) with DMM when assembly is pulled. Reinstall assembly if reading is correct.

Remove	If incorrect, replace
A28 Video Controller (para 3-1-16) A35 External I/O (para 3-1-17) A27 Flash Memory (para 3-1-14) A26 Processor (para 3-1-15)	A28 Video Controller (para 3-1-16) A35 External I/O (para 3-1-17) A27 Flash Memory (para 3-1-14) A26 Processor (para 3-1-15)

## CHAPTER 2 MAINTENANCE INSTRUCTIONS

### 2-2-1 Power Faults Test - Continued

9. Verify  $>15 \Omega$  at A3A1W4P1, Pins 13 (+) and 14 (-) with DMM when assembly is disconnected. Reinstall connection if reading is correct.

Locate/Disconnect	If incorrect, replace
Disconnect A20W1 (fig. FO-2, Sheet 2 of 3) from A36 Attenuator (fig. FO-2, Sheet 1 of 3)	A20 Generator IF (para 3-1-27)
Disconnect A16W1 (fig. FO-2, Sheet 2 of 3) from A36 Attenuator (fig. FO-2, Sheet 1 of 3)	A16 Receive IF (para 3-1-26)
Disconnect A21W1 (fig. FO-2, Sheet 2 of 3) from A36 Attenuator (fig. FO-2, Sheet 1 of 3)	A21 Power Termination (para 3-1-29)
Disconnect A15W1 (fig. FO-2, Sheet 2 of 3) from A37 Auxiliary Power Supply (fig. FO-2)	A15 2nd LO (para 3-1-23)
Locate A20 Generator IF and Disconnect A20P6 (fig. FO-18)	A13 1st LO (para 3-1-24)

10. Verify  $>1 \text{ k}\Omega$  at A3A1W4P1, Pins 14 (+) and 6 (-) with DMM when assembly is disconnected. Reinstall connection if reading is correct.

Disconnect	If incorrect, replace
Disconnect A20W1 (fig. FO-2, Sheet 2 of 3) from A36 Attenuator (fig. FO-2, Sheet 1 of 3)	A20 Generator IF (para 3-1-27)
Disconnect A21W1 (fig. FO-2, Sheet 2 of 3) from A36 Attenuator (fig. FO-2, Sheet 1 of 3)	A21 Power Termination (para 3-1-29)
Disconnect A20W1 (fig. FO-2, Sheet 2 of 3) from A37 Auxiliary Power Supply (fig. FO-2, Sheet 1 of 3)	A13 1st LO (para 3-1-24)
Disconnect A15W1 (fig. FO-2, Sheet 2 of 3) from A37 Auxiliary Power Supply (fig. FO-2, Sheet 1 of 3)	A15 2nd LO (para 3-1-23)

11. Verify  $>500 \Omega$  at A3A1W4P1, Pins 1 (+) and 8 (-) with DMM when assembly is pulled. Reinstall assembly if reading is correct.

Disconnect	If incorrect, replace
A6 Monitor (para 3-1-10) A29 RF I/O (para 3-1-13) A7 Analyzer Log/IF (para 3-1-5) A40 3rd LO (para 3-1-7) A41 90 MHz Generator (para 3-1-8) A32 Digitizer (para 3-1-3) A9 Receiver (para 3-1-9)	A6 Monitor (para 3-1-10) A29 RF I/O (para 3-1-13) A7 Analyzer Log/IF (para 3-1-5) A40 3rd LO (para 3-1-7) A41 90 MHz Generator (para 3-1-8) A32 Digitizer (para 3-1-3) A9 Receiver (para 3-1-9)

12. Verify  $>1 \text{ k}\Omega$  at A3A1W4P1, Pins 7 (+) and 14 (-) with DMM when A21W1 (fig. FO-2) is disconnected from A36 Attenuator (fig. FO-2).

- If incorrect, replace A21 Power Termination (para 3-1-29).

## CHAPTER 2 MAINTENANCE INSTRUCTIONS

### 2-2-2 BEEP SEQUENCE TEST

#### DESCRIPTION

This test isolates the fault depending upon the Beep Sequence heard at Power-Up.

#### NOTE

Perform this test only when instructed from table 2-1 or another troubleshooting test. Do not perform this troubleshooting test as a separate procedure unless otherwise instructed. Certain conditions have been established and/or tested prior to performing this test.

#### 0 BEEPS

Locate A28 Video Controller (fig. FO-2). Pull up A28 Video Controller, press POWER Switch and verify 1 Beep.

- If incorrect, replace A26 Processor (para 3-1-15).
- If correct, replace A28 Video Controller (para 3-1-16).

#### 0 BEEPS - ON INDICATOR LIGHTS - NO FAN

Locate A29 RF I/O (fig. FO-2). Pull up A29 RF I/O, press POWER Switch and verify 1 Beep.

If incorrect, replace A29 RF I/O (para 3-1-13).

If correct, replace A22 Power Supply (para 3-1-18).

#### 1 BEEP

Locate A22 Power Supply (fig. FO-20). Press POWER Switch and verify voltages with DMM at A22J4 (fig. FO-20).

A22J4, Pin 1 +5 Vdc ( $\pm 0.5$  Vdc)  
 A22J4, Pin 3 +15 Vdc ( $\pm 2$  Vdc)  
 A22J4, Pin 5 -15 Vdc ( $\pm 2$  Vdc)

- If any reading is incorrect, replace A22 Power Supply (para 3-1-18).
- If all readings are correct, perform Power Faults Test (para 2-6).

#### 1 BEEP - CONTINUOUSLY LOOPING

1. Pull up following assemblies (fig. FO-2). Install assemblies one at a time, press POWER Switch and verify 1 Beep - Continuously looping. Remove assembly if 1 Beep - Continuously looping is not present.

Assembly	If 1 Beep - Continuously looping, replace
A27 Memory	A27 Memory (para 3-1-14)
A30 Counter	A30 Counter (para 3-1-4)
A29 RF I/O	A29 RF I/O (para 3-1-13)
A32 Digitizer	A32 Digitizer (para 3-1-3)
A31 Function Generator	A31 Function Generator (para 3-1-12)
A33 Monitor Control	A33 Monitor Control (para 3-1-11)
A35 External I/O	A35 External I/O (para 3-1-17)

2. Install assemblies in groups and fault isolate 1 Beep - Continuously looping. Replace faulty assemblies.

## CHAPTER 2 MAINTENANCE INSTRUCTIONS

### 2-2-2 BEEP SEQUENCE TEST - Continued

#### 2 BEEPS

1. Pull up following assemblies (fig. FO-2). Install assemblies one at a time, press POWER Switch and verify 2 Beeps. Remove assembly if 2 Beeps is not present.

Assembly	If 2 Beeps, replace
A30 Counter	A30 Counter (para 3-1-4)
A29 RF I/O	A29 RF I/O (para 3-1-13)
A32 Digitizer	A32 Digitizer (para 3-1-3)
A31 Function Generator	A31 Function Generator (para 3-1-12)
A33 Monitor Control	A33 Monitor Control (para 3-1-11)
A35 External I/O	A35 External I/O (para 3-1-17)

2. Install assemblies in groups and fault isolate 2 Beeps. Replace faulty assemblies.

#### 2 BEEPS - CONTINUOUSLY LOOPING

Locate A28 Video Controller (fig. FO-2). Pull up A28 Video Controller, press POWER Switch and verify 1 Beep.

- If incorrect, replace A26 Processor (para 3-1-15).
- If correct, replace A28 Video Controller (para 3-1-16).

## CHAPTER 2 MAINTENANCE INSTRUCTIONS

### 2-2-3 LCD ABNORMALITY TEST

#### DESCRIPTION

This test checks for proper pulse trains from the A28 Video Controller to the A23A5 LCD and that +12 Vdc is present from the A22 Power Supply to the A23A5 LCD.

#### NOTE

Perform this test only when instructed from table 2-1 or another troubleshooting test. Do not perform this troubleshooting test as a separate procedure unless otherwise instructed. Certain conditions have been established and/or tested prior to performing this test.

1. Press POWER Switch, and verify LCD as shown.

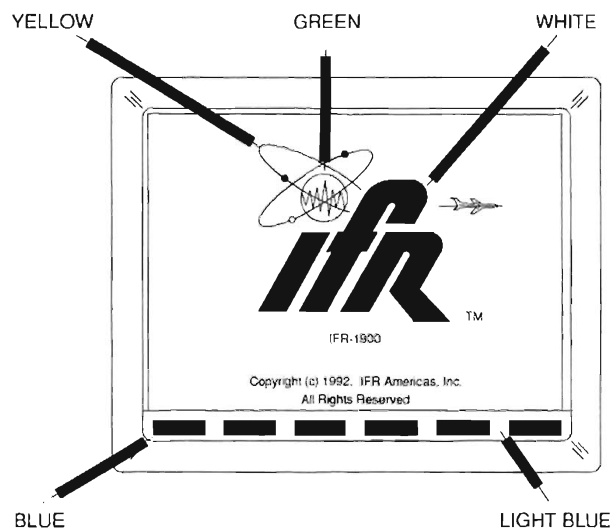

CE2FO176

- If LCD Display is dim, follow step 2.
  - If LCD display is blank (no display), follow step 3.
2. Locate External Video Connector. Connect external monitor through VGA port on rear panel.
    - If incorrect, replace A28 Video Controller Board (para 3-1-15).
    - If correct, replace A23 Front Panel (para 3-1-18).
  3. Ship unit to nearest service center for diagnostic and repair.

## CHAPTER 2 MAINTENANCE INSTRUCTIONS

### 2-2-4 KEYBOARD KEY TEST.

#### DESCRIPTION

This test checks the status of each key on the A23A2 Keyboard through the A30 Counter connection (A30P2) on the A3A1 Motherboard.

#### NOTE

Perform this test only when instructed from table 2-1 or another troubleshooting test. Do not perform this troubleshooting test as a separate procedure unless otherwise instructed. Certain conditions have been established and/or tested prior to performing this test.

1. Remove A30 Counter (para 3-1-4) and install on PC Board Assembly Extender in Test Set. KEYBOARD KEY TEST – Continued
2. Verify >10 k $\Omega$  (open) initially and <100  $\Omega$  between pins with DMM at following locations (fig. FO-27) when keys are pressed.

Location	Key	Location	Key
A30P2, Pins 14B and 9C	F1	A30P2, Pins 14B and 14C	8
A30P2, Pins 13B and 9C	F2	A30P2, Pins 13B and 14C	5
A30P2, Pins 12B and 9C	F3	A30P2, Pins 12B and 14C	2
A30P2, Pins 11B and 9C	F4,	A30P2, Pins 11B and 14C	0
A30P2, Pins 10B and 9C	F5	A30P2, Pins 10B and 14C	CE
A30P2, Pins 9B and 9C	F6	A30P2, Pins 9B and 14C	DEL
A30P2, Pins 14B and 10C	RF GEN	A30P2, Pins 14B and 15C	9
A30P2, Pins 13B and 10C	RCVR	A30P2, Pins 13B and 15C	6
A30P2, Pins 12B and 10C	DPLX	A30P2, Pins 12B and 15C	3
A30P2, Pins 11B and 10C	AF GEN	A30P2, Pins 11B and 15C	#
A30P2, Pins 10B and 10C	SCOPE/ANLZ	A30P2, Pins 10B and 15C	↑ (SQLCH)
A30P2, Pins 9B and 10C	MTRS	A30P2, Pins 9B and 15C	↓ (SQLCH)
A30P2, Pins 14B and 11C	AUTO	A30P2, Pins 14B and 16C	+/-
A30P2, Pins 13B and 11C	SGL STEP	A30P2, Pins 13B and 16C	M/□
A30P2, Pins 12B and 11C	GO	A30P2, Pins 12B and 16C	K/m
A30P2, Pins 11B and 11C	STOP	A30P2, Pins 11B and 16C	ENTER
A30P2, Pins 10B and 11C	PRINT SCRN	A30P2, Pins 10B and 16C	↑ (VOL)
A30P2, Pins 9B and 11C	HOLD SCRN	A30P2, Pins 9B and 16C	↓ (VOL)
A30P2, Pins 11B and 12C	□	A30P2, Pins 16C and 15B	↑ (FIELD SELECT)
A30P2, Pins 10B and 12C	SETUP	A30P2, Pins 15C and 15B	→ (FIELD SELECT)
A30P2, Pins 9B and 12C	STORE	A30P2, Pins 14C and 15B	→ (DATA SCROLL)
A30P2, Pins 14B and 13C	7	A30P2, Pins 13C and 15B,	← (DATA SCROLL)

## CHAPTER 2 MAINTENANCE INSTRUCTIONS

A30P2, Pins 13B and 13C	4	A30P2, Pins 16C and 16B,	← (FIELD SELECT)
A30P2, Pins 12B and 13C	1	A30P2, Pins 15C and 16B,	↓ (FIELD SELECT)
A30P2, Pins 11B and 13C	*	A30P2, Pins 14C and 16B	↓ (DATA SCROLL)
A30P2, Pins 10B and 13C	SHIFT	A30P2, Pins 13C and 16B	↑ (DATA SCROLL)
A30P2, Pins 9B and 13C	RCL		

- If any reading is incorrect, replace A23 Front Panel (para 3-1-19).
- If all readings are correct, replace A30 Counter (para 3-1-4).

# CHAPTER 2 MAINTENANCE INSTRUCTIONS

## 2-2-5 SELF TEST FAILURE TEST.

### DESCRIPTION

This test isolates faults based upon failures in Self Test.

### NOTE

Perform this test only when instructed from Table 2-1 or another troubleshooting test. Do not perform this troubleshooting test as a separate procedure unless otherwise instructed. Certain conditions have been established and/or tested prior to performing this test.

	Page
2. TIME OF DAY CLOCK.....	30
7. VOLTAGE .....	31
8. TEMPERATURE .....	32
9. AUDIO SINAD.....	32
10. SCOPE PERIOD AND LEVEL.....	33
11. AF COUNTER.....	34
12. LP FILTER .....	35
13. CWT FILTER .....	35
14. HP FILTER.....	36
15. PHASELOCK LOOPS.....	36
16. POWER METER.....	37
17. ANALYZER LEVEL .....	39
18. AM MODULATION.....	40
19. SYNTHESIZER RESPONSE.....	41
20. RF COUNTER .....	41
21. FM DEVIATION .....	41
22. ANALYZER DISPERSION.....	42
23. RECEIVER SELECTIVITY.....	43

### 2. TIME OF DAY CLOCK

Replace A26 Processor (para 3-1-15).

### NOTE

Failure Indications (F) for Self Tests 3 through 6 do not appear on the Self Test Menu. Failures for Self Tests 3 through 6 are catastrophic failures which are detected during the Power-Up (Beep) Sequence.



## CHAPTER 2 MAINTENANCE INSTRUCTIONS

### 2-2-5 SELF TEST FAILURE TEST. - Continued

#### 7. VOLTAGE

1. Run Self Test 7 in Extended Mode until failure is detected.
2. Locate A33 Monitor Control (fig. FO-2) and verify 3.3 Vdc ( $\pm 0.1$  Vdc) with DMM at A33J2, Pin 47 (fig. FO-29).
  - If incorrect, perform Steps 3-6.
  - If correct, replace A33 Monitor Control (para 3-1-11).
3. Remove A33 Monitor Control (para 3-1-11) and install on PC Board Assembly Extender in Test Set. Install Monitor/Monitor Control Extended Ribbon Cable in place of Monitor/Monitor Control Ribbon Cable (W49).
4. Verify voltages with DMM at A33J2 for failed test.

#### 5 VOLTS TEST FAILURE

A33J2, Pin 18 0 Vdc ( $\pm 0.5$  Vdc)  
 A33J2, Pin 19 5 Vdc ( $\pm 0.5$  Vdc)  
 A33J2, Pin 20 0 Vdc ( $\pm 0.5$  Vdc)  
 A33J2, Pin 21 5 Vdc ( $\pm 0.5$  Vdc)  
 A33J2, Pin 22 5 Vdc ( $\pm 0.5$  Vdc)

#### 15 VOLTS TEST FAILURE

A33J2, Pin 18 0 Vdc ( $\pm 0.5$  Vdc)  
 A33J2, Pin 19 0 Vdc ( $\pm 0.5$  Vdc)  
 A33J2, Pin 20 0 Vdc ( $\pm 0.5$  Vdc)  
 A33J2, Pin 21 5 Vdc ( $\pm 0.5$  Vdc)  
 A33J2, Pin 22 5 Vdc ( $\pm 0.5$  Vdc)

#### -15 VOLTS TEST FAILURE

A33J2, Pin 18 5 Vdc ( $\pm 0.5$  Vdc)  
 A33J2, Pin 19 0 Vdc ( $\pm 0.5$  Vdc)  
 A33J2, Pin 20 0 Vdc ( $\pm 0.5$  Vdc)  
 A33J2, Pin 21 5 Vdc ( $\pm 0.5$  Vdc)  
 A33J2, Pin 22 5 Vdc ( $\pm 0.5$  Vdc)

- If any voltage is incorrect, replace A33 Monitor Control (para 3-1-11).
5. Install A33 Monitor Control (para 3-1-11). Remove A6 Monitor (para 3-1-10) and install on PC Board Assembly Extender in Test Set. Install Monitor/Monitor Control Extended Ribbon Cable in place of Monitor/Monitor Control Ribbon Cable (W49).
  6. Verify voltages with DMM at A6P1 (fig. FO-7).

A6P1, Pin 5A +15 Vdc ( $\pm 1.0$  Vdc)  
 A6P1, Pin 7A +5 Vdc ( $\pm 0.5$  Vdc)  
 A6P1, Pin 4B -15 Vdc ( $\pm 1.0$  Vdc)

- If any voltage is incorrect, replace A22 Power Supply (para 3-1-18).
- If all voltages are correct, replace A6 Monitor (para 3-1-10).

## CHAPTER 2 MAINTENANCE INSTRUCTIONS

### 2-2-5 SELF TEST FAILURE TEST. - Continued

#### 8. TEMPERATURE

1. Run Self Test 8 in Extended Mode and verify 8.1 Ambient Test displays <100.
  - If incorrect, perform Steps 2-4.
  - If correct, perform Steps 5-6.
2. Locate A33 Monitor Control (fig. FO-2) and verify 3.0 Vdc ( $\pm 0.5$  Vdc) with DMM at A33J2, Pin 34 (fig. FO-29).
  - If incorrect, replace A33 Monitor Control (para 3-1-11).
3. Verify 2.5 Vdc ( $\pm 0.5$  Vdc) with DMM at A33J2, Pin 47.
  - If incorrect, perform Step 4.
  - If correct, replace A33 Monitor Control (para 3-1-11).
4. Verify voltages with DMM at A33J2.
  - A33J2, Pin 18 5 Vdc ( $\pm 0.5$  Vdc)
  - A33J2, Pin 19 0 Vdc ( $\pm 0.5$  Vdc)
  - A33J2, Pin 20 0 Vdc ( $\pm 0.5$  Vdc)
  - A33J2, Pin 21 0 Vdc ( $\pm 0.5$  Vdc)
  - If any voltage is incorrect, replace A33 Monitor Control (para 3-1-11).
  - If all voltages are correct, replace A6 Monitor (para 3-1-10).
5. Run Extended Self Test 8.2 (RF Test).
6. Locate A33 Monitor Control (fig. FO-2) and verify 0.250 Vdc ( $\pm 0.05$  Vdc) with DMM at A33J2, Pin 47 (fig. FO-29).
  - If incorrect, perform Steps 7-8.
  - If correct, replace A33 Monitor Control (para 3-1-11).
7. Locate A21 Power Termination (fig. FO-2) and verify 0.300 Vdc ( $\pm 0.05$  Vdc) with DMM at A21FL1 (fig. FO-19).
  - If incorrect, replace A21 Power Termination (para 3-1-29).
8. Locate A33 Monitor Control (fig. FO-2) and verify voltages with DMM at A33J2 (fig. FO-29).
  - A33J2, Pin 18 0 Vdc ( $\pm 0.5$  Vdc)
  - A33J2, Pin 19 5 Vdc ( $\pm 0.5$  Vdc)
  - A33J2, Pin 20 0 Vdc ( $\pm 0.5$  Vdc)
  - A33J2, Pin 21 0 Vdc ( $\pm 0.5$  Vdc)
  - If any voltage is incorrect, replace A33 Monitor Control (para 3-1-11).
  - If all voltages are correct, replace A6 Monitor (para 3-1-10).

#### 9. AUDIO SINAD

1. Locate A33 Monitor Control (fig. FO-2). Run Self Test 9 in Extended Mode and verify 1 Vdc ( $\pm 0.1$  Vdc) with DMM at A33J2, Pin 47 (fig. FO-29).
  - If incorrect, perform Steps 2-5.
  - If correct, replace A33 Monitor Control (para 3-1-11).

## CHAPTER 2 MAINTENANCE INSTRUCTIONS

### 2-2-5 SELF TEST FAILURE TEST. - Continued

#### 9. AUDIO SINAD (cont)

2. Connect Distortion Analyzer to AUDIO OUT Connector. Set Distortion Analyzer to measure SINAD.
3. Verify 10 dB ( $\pm 1$  dB) with Distortion Analyzer.

- If incorrect, replace A31 Function Generator (para 3-1-12).

4. Verify voltages with DMM at A33J2.

A33J2, Pin 18	0 Vdc ( $\pm 0.5$ Vdc)
A33J2, Pin 19	0 Vdc ( $\pm 0.5$ Vdc)
A33J2, Pin 20	5 Vdc ( $\pm 0.5$ Vdc)
A33J2, Pin 21	5 Vdc ( $\pm 0.5$ Vdc)

- If any voltage is incorrect, replace A33 Monitor Control (para 3-1-11).

5. Loop Self Test 9 and verify signals with Oscilloscope are not stuck at -7.5 Vdc or 7.5 Vdc at A33J2.

A33J2, Pin 8	A33J2, Pin 9	A33J2, Pin 10
A33J2, Pin 11	A33J2, Pin 12	A33J2, Pin 13
A33J2, Pin 14	A33J2, Pin 15	A33J2, Pin 16
A33J2, Pin 17		

- If any signal is incorrect, replace A33 Monitor Control (para 3-1-11).
- If all signals are correct, replace A6 Monitor (para 3-1-10).

#### 10. SCOPE PERIOD AND LEVEL

1. Remove A6 Monitor (para 3-1-10) and install on PC Board Assembly Extender in Test Set. Install Monitor/Monitor Control Extended Ribbon Cable in place of Monitor/Monitor Control Ribbon Cable (W49).
2. Run Self Test 10 and verify 2 kHz ( $\pm 20$  Hz) square wave at 6 Vp-p ( $\pm 0.6$  V) with Oscilloscope at A6P1, Pin 3A (fig. FO-7) as shown.

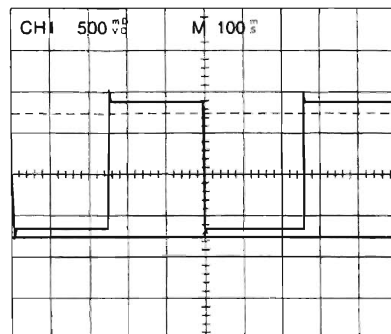

CE2FO244

- If incorrect, replace A31 Function Generator (para 3-1-12).
3. Verify 2 kHz ( $\pm 20$  Hz) square wave at 6 Vp-p ( $\pm 0.6$  V) with Oscilloscope at A6P1, Pin 2B.
    - If incorrect, perform Steps 4-5.
    - If correct, replace A32 Digitizer (para 3-1-3).
  4. Install A6 Monitor (para 3-1-10). Remove A33 Monitor Control (para 3-1-11) and install on PC Board Assembly Extender in Test Set. Install Monitor/Monitor Control Extended Ribbon Cable in place of Monitor/Monitor Control Ribbon Cable (W49).

## CHAPTER 2 MAINTENANCE INSTRUCTIONS

### 2-2-5 SELF TEST FAILURE TEST. - Continued

#### 10. SCOPE PERIOD AND LEVEL (cont)

5. Loop Self Test 10 and verify signals with Oscilloscope are not stuck at -7.5 Vdc or 7.5 Vdc at A33J2 (fig. FO-29).

A33J2, Pin 8	A33J2, Pin 9	A33J2, Pin 10
A33J2, Pin 11	A33J2, Pin 12	A33J2, Pin 13
A33J2, Pin 14	A33J2, Pin 15	A33J2, Pin 16
A33J2, Pin 17		

- If any signal is incorrect, replace A33 Monitor Control (para 3-1-11).
- If all signals are correct, replace A6 Monitor (para 3-1-10).

#### 11. AF COUNTER

1. Remove A6 Monitor (para 3-1-10) and install on PC Board Assembly Extender in Test Set. Install Monitor/Monitor Control Extended Ribbon Cable in place of Monitor/Monitor Control Ribbon Cable (W49).
2. Run Self Test 11.
3. Verify 37.890 kHz ( $\pm 40$  Hz) signal with Frequency Counter at A6P1, Pin 3A (fig. FO-7).
  - If incorrect, replace A31 Function Generator (para 3-1-12).
4. Verify 37.890 kHz ( $\pm 40$  Hz) signal with Frequency Counter at A6P1, Pin 3B.
  - If incorrect, perform Steps 5-6.
  - If correct, replace A30 Counter (para 3-1-4).
5. Install A6 Monitor (para 3-1-10). Remove A33 Monitor Control (para 3-1-11) and install on PC Board Assembly Extender in Test Set. Install Monitor/Monitor Control Extended Ribbon Cable in place of Monitor/Monitor Control Ribbon Cable (W49).
6. Loop Self Test 11 and verify signals with Oscilloscope are not stuck at -7.5 Vdc or 7.5 Vdc at A33J2 (fig. FO-29).

A33J2, Pin 8	A33J2, Pin 9	A33J2, Pin 10
A33J2, Pin 11	A33J2, Pin 12	A33J2, Pin 13
A33J2, Pin 14	A33J2, Pin 15	A33J2, Pin 16
A33J2, Pin 17		

- If any signal is incorrect, replace A33 Monitor Control (para 3-1-11).
- If all signals are correct, replace A6 Monitor (para 3-1-10).

## CHAPTER 2 MAINTENANCE INSTRUCTIONS

### 2-2-5 SELF TEST FAILURE TEST. - Continued

#### 12. LP FILTER

1. Locate A33 Monitor Control (fig. FO-2). Run Self Test 12 and verify signal with Oscilloscope and x10 Probe at A33J2, Pin 47 (fig. FO-29) as shown.

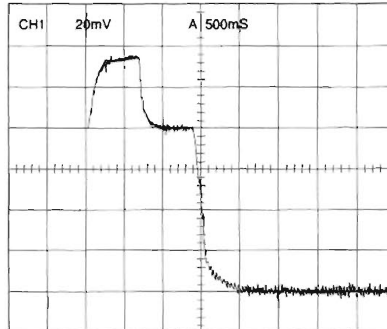

CE2FO242

2. Verify level of Region 1 is 1 Vdc ( $\pm 0.2$  V).

If incorrect, perform Step 5.

#### 12. LP FILTER - Continued

3. Verify level of Region 2 is 50% to 90% of level in Region 1.

- If incorrect, perform Step 5.

4. Verify level of Region 3 is  $< 10\%$  of Region 1.

- If incorrect, perform Step 5.
- If correct, replace A33 Monitor Control (para 3-1-11).

5. Verify voltages with DMM at A33J2.

A33J2, Pin 18 0 Vdc ( $\pm 0.5$  Vdc)  
 A33J2, Pin 19 0 Vdc ( $\pm 0.5$  Vdc)  
 A33J2, Pin 20 5 Vdc ( $\pm 0.5$  Vdc)  
 A33J2, Pin 21 5 Vdc ( $\pm 0.5$  Vdc)  
 A33J2, Pin 31 0 Vdc ( $\pm 0.5$  Vdc)

- If any voltage is incorrect, replace A33 Monitor Control (para 3-1-11).

6. Loop Self Test 12 and verify signals with Oscilloscope are not stuck at -7.5 Vdc or 7.5 Vdc at A33J2.

A33J2, Pin 8	A33J2, Pin 9	A33J2, Pin 10
A33J2, Pin 11	A33J2, Pin 12	A33J2, Pin 13
A33J2, Pin 14	A33J2, Pin 15	A33J2, Pin 16
A33J2, Pin 17		

- If any signal is incorrect, replace A33 Monitor Control (para 3-1-11).
- If all signals are correct, replace A6 Monitor (para 3-1-10).

#### 13. CWT FILTER

#### NOTE

Failures for Self Test 13 are detected as multiple failures. Failures for Self Test 13 are indicated and cleared on previous Self Test procedures.

## CHAPTER 2 MAINTENANCE INSTRUCTIONS

### 2-2-5 SELF TEST FAILURE TEST. - Continued

#### 14. HP FILTER

1. Locate A33 Monitor Control (fig. FO-2). Run Self Test 14 and verify signal with Oscilloscope and x10 Probe at A33J2, Pin 47 (fig. FO-29) as shown.

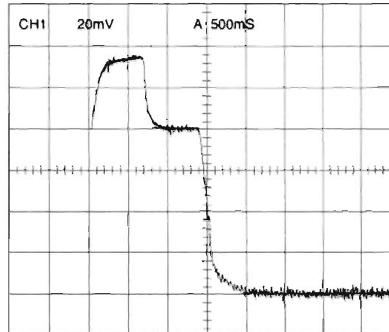

CE2FO242

2. Verify level of Region 1 is 1 Vdc ( $\pm 0.2$  V).
  - If incorrect, perform Step 5.
3. Verify level of Region 2 is 50% to 90% of level in Region 1.
  - If incorrect, perform Step 5.
4. Verify level of Region 3 is  $< 10\%$  of Region 1.
  - If incorrect, perform Step 5.
  - If correct, replace A33 Monitor Control (para 3-1-11).
5. Verify voltages with DMM at A33J2.
  - A33J2, Pin 18 0 Vdc ( $\pm 0.5$  Vdc)
  - A33J2, Pin 19 0 Vdc ( $\pm 0.5$  Vdc)
  - A33J2, Pin 20 5 Vdc ( $\pm 0.5$  Vdc)
  - A33J2, Pin 21 5 Vdc ( $\pm 0.5$  Vdc)
  - If any voltage is incorrect, replace A33 Monitor Control (para 3-1-11).
6. Loop Self Test 12 and verify signals with Oscilloscope are not stuck at -7.5 Vdc or 7.5 Vdc at A33J2.

A33J2, Pin 8	A33J2, Pin 9	A33J2, Pin 10
A33J2, Pin 11	A33J2, Pin 12	A33J2, Pin 13
A33J2, Pin 14	A33J2, Pin 15	A33J2, Pin 16
A33J2, Pin 17		

  - If any signal is incorrect, replace A33 Monitor Control (para 3-1-11).
7. Verify frequency is 300 kHz ( $\pm 5$  kHz) with Frequency Counter at A33J2, Pin 6.
  - If incorrect, replace A33 Monitor Control (para 3-1-11).
  - If correct, replace A6 Monitor (para 3-1-10).

#### 15. PHASELOCK LOOPS

1. Remove A29 RF I/O (para 3-1-13) and install on PC Board Assembly Extender in Test Set.
2. Run Self Test 15 in Extended Mode until failure is detected.

## CHAPTER 2 MAINTENANCE INSTRUCTIONS

### 2-2-5 SELF TEST FAILURE TEST. - Continued

#### 15. PHASELOCK LOOPS (cont)

3. Verify voltage for failed test with DMM at A29P2 (fig. FO-27).

Failed Test	Location	Voltage	If incorrect, perform
15.1	A29P2, Pin 11B	5 Vdc ( $\pm 0.5$ Vdc)	Step 4
15.2	A29P2, Pin 2C	5 Vdc ( $\pm 0.5$ Vdc)	Step 5
15.3	A29P2, Pin 3C	5 Vdc ( $\pm 0.5$ Vdc)	Step 6
15.4	A29P2, Pin 12C	5 Vdc ( $\pm 0.5$ Vdc)	Step 7
15.5	A29P2, Pin 14C	<0.4 Vdc	Step 8

- If correct, replace A29 RF I/O (para 3-1-13).
4. Disconnect W20 (fig. FO-2) from A41 90 MHz Generator (fig. FO-2), connect Frequency Counter to W20 (fig. FO-2) and verify 1 MHz ( $\pm 0.5$  Hz).
- If incorrect, perform Step 9.
  - If correct, replace A41 90 MHz Generator (para 3-1-8).
5. Disconnect W14 (fig. FO-2) from A13 1st LO (fig. FO-2), connect Frequency Counter to W14 (fig. FO-2) and verify 10 MHz ( $\pm 5$  Hz).
- If incorrect, perform Step 9.
  - If correct, replace A13 1st LO (para 3-1-24).
6. Disconnect W15 (fig. FO-2) from A13 1st LO (fig. FO-2), connect Frequency Counter to W15 (fig. FO-2) and verify 10 MHz ( $\pm 5$  Hz).
- If incorrect, perform Step 9.
  - If correct, replace A13 1st LO (para 3-1-24).
7. Disconnect W19 (fig. FO-2) from A40 3rd LO (fig. FO-2), connect Frequency Counter to W19 (fig. FO-2) and verify 1 MHz ( $\pm 0.5$  Hz).
- If incorrect, perform Step 9.
  - If correct, replace A40 3rd LO (para 3-1-7).
8. Disconnect W18 (fig. FO-2) from A8 Analyzer RF (fig. FO-2), connect Frequency Counter to W18 (fig. FO-2) and verify 1 MHz ( $\pm 0.5$  Hz).
- If incorrect, perform Step 9.
  - If correct, replace A8 Analyzer RF (para 3-1-6).
9. Reconnect coaxial cable. Disconnect W16 from A18 RF Modem (fig. FO-2), connect Frequency Counter to W16 (fig. FO-2) and verify 10 MHz ( $\pm 5$  Hz).
- If incorrect, replace A39 Master Oscillator (para 3-1-30).
  - If correct, replace A18 RF Modem.

#### 16. POWER METER

1. Run Self Test 16.
2. Connect Measuring Receiver to T/R Connector. Set Measuring Receiver to measure RF Power.
3. Verify 0 dBm ( $\pm 2$  dB) with Measuring Receiver.

## CHAPTER 2 MAINTENANCE INSTRUCTIONS

### 2-2-5 SELF TEST FAILURE TEST. - Continued

#### 16. POWER METER (cont)

- If incorrect, perform Steps 7-16.
4. Locate A21 Power Termination (fig. FO-2) and verify 0.25 Vdc ( $\pm 0.05$  Vdc) with DMM at A21FL9 (fig. FO-19).
    - If incorrect, replace A21 Power Termination (para 3-1-29).
  5. Locate A33 Monitor Control (fig. FO-2) and verify 0.21 Vdc ( $\pm 0.05$  Vdc) with DMM at A33J2, Pin 47 (fig. FO-29).
    - If incorrect, perform Step 6.
    - If correct, replace A33 Monitor Control (para 3-1-11).
  6. Verify voltages with DMM at A33J2.
    - A33J2, Pin 18 5 Vdc ( $\pm 0.5$  Vdc)
    - A33J2, Pin 19 0 Vdc ( $\pm 0.5$  Vdc)
    - A33J2, Pin 20 5 Vdc ( $\pm 0.5$  Vdc)
    - A33J2, Pin 21 5 Vdc ( $\pm 0.5$  Vdc)
    - If any voltage is incorrect, replace A33 Monitor Control (para 3-1-11).
    - If all voltages are correct, replace A6 Monitor (para 3-1-10).
  7. Locate A20 Generator IF (fig. FO-2) and verify -2.5 Vdc ( $\pm 1$  Vdc) with DMM at A20W1P1, Pin 4 (fig. FO-18).
    - If incorrect, perform Steps 17-19.
  8. Disconnect W13 (fig. FO-2) from A18 RF Modem (fig. FO-2), connect Measuring Receiver to W13 (fig. FO-2) and verify  $> -20$  dBm.
    - If incorrect, replace A41 90 MHz Generator (para 3-1-8).
  9. Reconnect W13. Disconnect W12 (fig. FO-2) from A20 Generator IF (fig. FO-2), connect Measuring Receiver to W12 (fig. FO-2) and verify  $> 5$  dBm.
    - If incorrect, replace A13 1st LO (para 3-1-24).
  10. Reconnect W12. Disconnect W11 (fig. FO-2) from A20 Generator IF (fig. FO-2), connect Measuring Receiver to W11 (fig. FO-2) and verify  $> -4$  dBm.
    - If incorrect, replace A15 2nd LO (para 3-1-23).
  11. Locate A36 Attenuator (fig. FO-2) and verify 0 Vdc ( $\pm 0.5$  Vdc) with DMM at A36AT1, Pins 1, 2, 4, 8, 16, 32, 32a and 32b (fig. FO-31).
    - Replace A36 Attenuator (para 3-1-28)
  12. Locate A21 Power Termination (fig. FO-2) and verify 13.5 Vdc ( $\pm 1$  Vdc) with DMM at A21FL2 (fig. FO-19).
    - If incorrect, replace A29 RF I/O (para 3-1-13).
  13. Remove A36 Attenuator (para 3-1-28). Reconnect A36J1, A36J2, A36J3 and A36J4 (fig. FO-31).
  14. Locate A20 Generator IF (fig. FO-2) and verify level is +11.5 dBm ( $\pm 2$  dB) with Measuring Receiver at A20P6 (fig. FO-18).
    - If incorrect, replace A20 Generator IF (para 3-1-27).



## CHAPTER 2 MAINTENANCE INSTRUCTIONS

### 2-2-5 SELF TEST FAILURE TEST. - Continued

#### 16. POWER METER (cont)

15. Connect coaxial cable between A20P6 and A36J5 (fig. FO-31).
16. Verify level is +8 to +11 dBm with Measuring Receiver at A36J6.
  - If incorrect, remove A36 Attenuator (para 3-1-28) and replace A36AT1.
  - If correct, replace A21 Power Termination (para 3-1-29).
17. Disconnect W13 (fig. FO-2) from A18 RF Modem (fig. FO-2), connect Measuring Receiver to W13 (fig. FO-2) and verify >-20 dBm.
  - If incorrect, replace A41 90 MHz Generator (para 3-1-8).
18. Reconnect W13. Disconnect W12 (fig. FO-2) from A20 Generator IF (fig. FO-2, Sheet 1 of 3), connect Measuring Receiver to W12 (fig. FO-2) and verify >5 dBm.
  - If incorrect, replace A13 1st LO (para 3-1-24).
19. Reconnect W12. Disconnect W11 (fig. FO-2) from A20 Generator IF (fig. FO-2, Sheet 1 of 3), connect Measuring Receiver to W11 (fig. FO-2) and verify >-4 dBm.
  - If incorrect, replace A15 2nd LO (para 3-1-23).
  - If correct, replace A20 Generator IF (para 3-1-27).

#### 17. ANALYZER LEVEL

1. Disconnect W4 (fig. FO-2) from A16 Receive IF (fig. FO-2) and connect Spectrum Analyzer to W4 (fig. FO-2).
2. Set Spectrum Analyzer Frequency to 10 MHz.
3. Run Self Test 17 in Extended Mode and verify level is -20 dBm ( $\pm 3$  dB).
  - If incorrect, replace A21 Power Termination (para 3-1-29).
4. Reconnect W4. Disconnect W9 from A8 Analyzer RF (fig. FO-2), connect Spectrum Analyzer to W9 (fig. FO-2) and verify -37 dBm ( $\pm 10$  dB) RF Power and Frequency for failed test.
 

10 MHz	90 MHz ( $\pm 45$ Hz)
64 MHz	90 MHz ( $\pm 45$ Hz)
578 MHz	88.0001 MHz ( $\pm 45$ Hz)
918 MHz	89.9875 MHz ( $\pm 45$ Hz)

  - If any frequency is incorrect, perform Step 17.
5. Reconnect W9.
6. Press MTRS MODE Key, "AUX" F6 and RCL Key.
7. Use Field Select Keys to move cursor to "10. Factory Defaults" and press ENTER Key twice.
8. Press SCOPE/ANLZ MODE Key to access Analyzer Operation Screen.
9. Use FIELD SELECT Keys to move cursor to RF. Press ENTER Key. Use DATA ENTRY Keypad to enter 500.0000 MHz. Press ENTER Key.
10. Use FIELD SELECT Keys to move cursor to Scan. Press ENTER Key. Use DATA SCROLL Keys to select 0 kHz. Press ENTER Key.
11. Set Signal Generator for 500 MHz signal at -40 dBm with no modulation. Connect Signal Generator to ANTENNA IN Connector.

## CHAPTER 2 MAINTENANCE INSTRUCTIONS

### 2-2-5 SELF TEST FAILURE TEST. - Continued

#### 17. ANALYZER LEVEL (cont)

12. Disconnect W25 from A7 Analyzer Log/IF (fig. FO-2) and connect Spectrum Analyzer to W25 (fig. FO-2). Set Spectrum Analyzer for 10.7 MHz.
13. Verify level is -27 dBm ( $\pm 5$  dB) at 10.7 MHz ( $\pm 1$  Hz).
  - If incorrect, perform Step 18.
14. Reconnect W25. Remove A32 Digitizer (para 3-1-3) and install on PC Board Assembly Extender in Test Set.
15. Locate A32 Digitizer (fig. FO-2) and verify 1.4 Vdc ( $\pm 0.1$  Vdc) with DMM at A32P2, Pin 8B (fig. FO-28).
  - If incorrect, replace A7 Analyzer Log/IF (para 3-1-5).
  - If correct, replace A32 Digitizer (para 3-1-3).
16. Reconnect W9. Disconnect W6 (fig. FO-2) from A16 Receive IF (fig. FO-2), connect Spectrum Analyzer to W6 (fig. FO-2) and verify >5 dBm RF Power and Frequency for failed test.

10 MHz	1310 MHz ( $\pm 655$ Hz)
64 MHz	1364 MHz ( $\pm 682$ Hz)
578 MHz	1876 MHz ( $\pm 938$ Hz)
918 MHz	2218 MHz ( $\pm 1109$ Hz)

- If any frequency is incorrect, replace A13 1st LO (para 3-1-24).
  - If all frequencies are correct, replace A16 Receive IF (para 3-1-26).
17. Reconnect W25. Disconnect W26 from A8 Analyzer RF (fig. FO-2), connect Spectrum Analyzer to W26 (fig. FO-2) and verify >3 dBm RF Power and Frequency for failed test.

10 MHz	79.3000 MHz ( $\pm 40$ Hz)
64 MHz	79.3000 MHz ( $\pm 40$ Hz)
578 MHz	77.3001 MHz ( $\pm 40$ Hz)
918 MHz	79.2875 MHz ( $\pm 40$ Hz)

- If any frequency is incorrect, replace A40 3rd LO (para 3-1-7).
- If all frequencies are correct, replace A8 Analyzer RF (para 3-1-6).

#### 18. AM MODULATION

1. Connect Measuring Receiver to T/R Connector. Select AM Detector on Measuring Receiver.
2. Run Self Test 18 and verify 100 MHz ( $\pm 100$  Hz) at -10 dBm ( $\pm 2$  dB) with 30% ( $\pm 5$ %) AM and 1 kHz Audio tone with Measuring Receiver.
  - If incorrect, perform Steps 7-10.
3. Remove A6 Monitor (para 3-1-10) and install on PC Board Assembly Extender in Test Set. Install Monitor/Monitor Control Extended Ribbon Cable in place of Monitor/Monitor Control Ribbon Cable (W49).
4. Run Self Test 18 and verify 1 kHz sine wave at 1 Vp-p ( $\pm 0.1$  V) with Oscilloscope at A6P1, Pin 8A (fig. FO-7).
  - If incorrect, replace A9 Receiver (para 3-1-9).
5. Install A6 Monitor (para 3-1-10). Remove A33 Monitor Control (para 3-1-11) and install on PC Board Assembly Extender in Test Set. Install Monitor/Monitor Control Extended Ribbon Cable in place of Monitor/Monitor Control Ribbon Cable (W49).

## CHAPTER 2 MAINTENANCE INSTRUCTIONS

### 2-2-5 SELF TEST FAILURE TEST. - Continued

#### 18. AM MODULATION (cont)

6. Verify 5.0 Vdc ( $\pm 0.5$  Vdc) with DMM at A33J2, Pin 23 (fig. FO-29).
  - If incorrect, replace A33 Monitor Control (para 3-1-11).
  - If correct, replace A6 Monitor (para 3-1-10).
7. Remove A41 90 MHz Generator (para 3-1-8) and install on PC Board Assembly Extender in Test Set.
8. Verify 0.8 VAC ( $\pm 0.04$  VAC) with DMM at A71P1, Pin 1A (fig. FO-10).
  - If incorrect, replace A31 Function Generator (para 3-1-12).
9. Disconnect W13 (fig. FO-2) from A41 90 MHz Generator (fig. FO-2) and connect Signal Generator to W13 (fig. FO-2). Set Signal Generator for 90 MHz at -25 dBm with 30% AM.
10. Verify -2.5 Vdc ( $\pm 1$  Vdc) with DMM at A71P1, Pin 2B (fig. FO-10).
  - If incorrect, replace A18 RF Modem.
  - If correct, replace A41 90 MHz Generator (para 3-1-8).

#### 19. SYNTHESIZER RESPONSE

#### NOTE

Failures for Self Test 19 are detected as multiple failures. Failures for Self Test 19 are indicated and cleared on previous Self Test procedures.

#### 20. RF COUNTER

1. Disconnect W24 (fig. FO-2) from A30 Counter (fig. FO-2) and connect Frequency Counter to W24 (fig. FO-2).
2. Run Self Test 20 and verify 425 kHz ( $\pm 50$  Hz).
  - If incorrect, replace A9 Receiver (para 3-1-9).
  - If correct, replace A30 Counter (para 3-1-4).

#### 21. FM DEVIATION

1. Connect Measuring Receiver to T/R Connector. Set Low-Pass Filter to 15 kHz and select FM Detector on Measuring Receiver.
2. Run Self Test 21 and verify 100 MHz ( $\pm 100$  Hz) at 0 dBm ( $\pm 2$  dB) with 5 kHz ( $\pm 1$  kHz) Deviation and 1 kHz Audio tone with Measuring Receiver.
  - If incorrect, perform Steps 6-13.
3. Remove A6 Monitor (para 3-1-10) and install on PC Board Assembly Extender in Test Set. Install Monitor/Monitor Control Extended Ribbon Cable in place of Monitor/Monitor Control Ribbon Cable (W49).
4. Run Self Test 21 and verify 1 kHz sine wave at 1 Vp-p ( $\pm 0.1$  V) with Oscilloscope at A6P1, Pin 8B (fig. FO-7).
  - If incorrect, replace A9 Receiver (para 3-1-9).
5. Install A6 Monitor (para 3-1-10). Remove A33 Monitor Control (para 3-1-11) and install on PC Board Assembly Extender in Test Set. Install Monitor/Monitor Control Extended Ribbon Cable in place of Monitor/Monitor Control Ribbon Cable (W49).
6. Verify 5.0 Vdc ( $\pm 0.5$  Vdc) with DMM at A33J2, Pin 24 (fig. FO-29).

## CHAPTER 2 MAINTENANCE INSTRUCTIONS

### 2-2-5 SELF TEST FAILURE TEST. - Continued

#### 21. FM DEVIATION (cont)

- If incorrect, replace A33 Monitor Control (para 3-1-11).
  - If correct, replace A6 Monitor (para 3-1-10).
7. Remove A41 90 MHz Generator (para 3-1-8) and install on PC Board Assembly Extender in Test Set.
  8. Verify 0.67 VAC ( $\pm 0.035$  VAC) with DMM at A71P1, Pin 2A (fig. FO-10).
    - If incorrect, replace A31 Function Generator (para 3-1-12).
  9. Disconnect W13 (fig. FO-2) from A41 90 MHz Generator (fig. FO-2), connect Measuring Receiver to A41J3 (fig. FO-10) and verify 90 MHz with 5 kHz ( $\pm 1$  kHz) deviation.
    - If incorrect, replace A41 90 MHz Generator (para 3-1-8).
  10. Reconnect W13 (fig. FO-2). Disconnect W12 from A20 Generator IF (fig. FO-2, Sheet 1 of 3) and connect Measuring Receiver to W12 (fig. FO-2). Set Measuring Receiver for FM Measurement, High-Pass Filter to 50 Hz, Low-Pass Filter to 15 kHz and RMS measurement.
  11. Press RF GEN MODE Key.
  12. Use Field Select Keys to move cursor to RF. Press ENTER Key. Use DATA ENTRY Keypad to enter 0.2500 MHz. Press ENTER Key.
  13. Verify reading of <100 Hz RMS.
    - If incorrect, replace A13 1st LO (para 3-1-24).
  14. Reconnect W12. Disconnect W11 from A20 Generator IF (fig. FO-2), connect Measuring Receiver to W11 (fig. FO-2) and verify reading of <100 Hz RMS.
    - If incorrect, replace A15 2nd LO (para 3-1-23).
    - If correct, replace A20 Generator IF (para 3-1-27).

#### 22. ANALYZER DISPERSION

1. Remove A32 Digitizer (para 3-1-3) and install on PC Board Assembly Extender in Test Set.
2. Press SCOPE/ANLZ MODE Key to access Analyzer Operation Screen.
3. Press "More" F6 until "Scan" F3 appears. Press "Scan" F3. Enter Scan Rates and verify Region 1 Duration is 64 ms ( $\pm 3.2$  ms) and Region 2 Duration is 10 ms ( $\pm 5$  ms) as shown. Verify Region 1 Level with Oscilloscope at A32P2, Pin 9B (fig. FO-28) as shown.

SCAN RATE	REGION 1 LEVEL
100 kHz	-5 to +5 V ( $\pm 10\%$ )
200 kHz	-1 to +1 V ( $\pm 10\%$ )
500 kHz	-2.5 to +2.5 V ( $\pm 10\%$ )

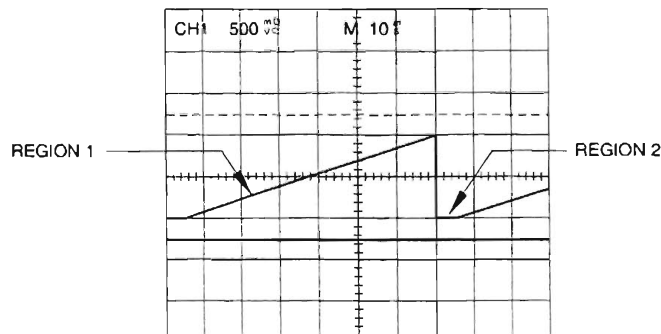

CE2FO243

## CHAPTER 2 MAINTENANCE INSTRUCTIONS

---

### 2-2-5 SELF TEST FAILURE TEST. - Continued

#### 22. ANALYZER DISPERSION (cont)

- If any output is incorrect, replace A32 Digitizer (para 3-1-3).
- If all outputs are correct, replace A8 Analyzer RF (para 3-1-6).

#### 23. RECEIVER SELECTIVITY

1. Remove A29 RF I/O (para 3-1-13) and install on PC Board Assembly Extender in Test Set.
2. Run Self Test 23 and verify voltage with DMM at A29P2 (fig. FO-27).

A29P2, Pin 15A 0 Vdc ( $\pm 0.5$  Vdc)

A29P2, Pin 16A 5 Vdc ( $\pm 0.5$  Vdc)

- If any voltage is incorrect, replace A29 RF I/O (para 3-1-13).
- If all voltages are correct, replace A9 Receiver (para 3-1-9).

## CHAPTER 2 MAINTENANCE INSTRUCTIONS

### 2-2-6 DMM TEST

#### DESCRIPTION

This test determines fault in the A11 DMM by measuring the response to known voltage, current and resistive loads.

#### NOTE

Perform this test only when instructed from table 2-1 or another troubleshooting test. Do not perform this troubleshooting test as a separate procedure unless otherwise instructed. Certain conditions have been established and/or tested prior to performing this test.

1. Connect external test equipment as shown.

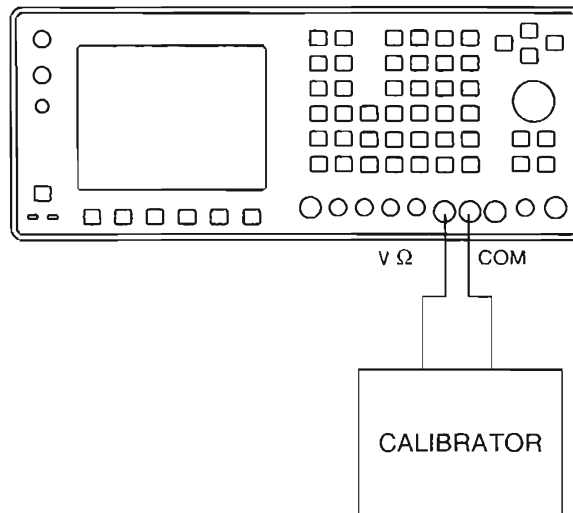

CE2FO170

2. Press MTRS MODE Key.
3. Use FIELD SELECT Keys to move cursor to "10. Digital Multimeter (DMM)." Press ENTER Key.
4. Use FIELD SELECT Keys to move cursor to MULTIMETER. Press ENTER Key. Use DATA SCROLL Keys to select DCV. Press ENTER Key.
5. Use FIELD SELECT Keys to move cursor to RANGE. Press ENTER Key. Select DCV ranges and verify values on DMM.

Range	Calibrator	DMM Value	If incorrect, replace/perform
200 mV	150 mVdc	150 mVdc ( $\pm 2.1$ mVdc)	Perform Steps 15-16
2 V	1.5 Vdc	1.5 Vdc ( $\pm 21$ mVdc)	A11 DMM (para 3-1-22)
20 V	15 Vdc	15 Vdc ( $\pm 0.21$ Vdc)	A11 DMM (para 3-1-22)
200 V	150 Vdc	150 Vdc ( $\pm 2.1$ Vdc)	A11 DMM (para 3-1-22)
2000 V	500 Vdc	500 Vdc ( $\pm 21$ Vdc)	A11 DMM (para 3-1-22)

## CHAPTER 2 MAINTENANCE INSTRUCTIONS

### 2-2-6 DMM TEST - Continued

6. Use FIELD SELECT Keys to move cursor to MULTIMETER. Press ENTER Key. Use DATA SCROLL Keys to select ACV. Press ENTER Key.
7. Use FIELD SELECT Keys to move cursor to RANGE. Press ENTER Key. Select ACV ranges and verify values on DMM. (When Multimeter readout exceeds 500 VAC, Test Set beeps and displays Multimeter Readout Bar in red.)

Range	Calibrator	DMM Value	If incorrect, replace/perform
200 mV	150 mVAC at 100 Hz	150 mVAC ( $\pm 10.1$ mVAC)	A11 DMM (para 3-1-22)
2.0 V	1.5 VAC at 100 Hz	1.5 VAC ( $\pm 101$ mVAC)	A11 DMM (para 3-1-22)
20 V	15 VAC at 100 Hz	15 VAC ( $\pm 1.01$ VAC)	A11 DMM (para 3-1-22)
200 V	150 VAC at 100 Hz	150 VAC ( $\pm 10.1$ VAC)	A11 DMM (para 3-1-22)
2000 V	500 VAC at 100 Hz	500 VAC ( $\pm 101$ VAC)	A11 DMM (para 3-1-22)

8. Use FIELD SELECT Keys to move cursor to MULTIMETER. Press ENTER Key. Use DATA SCROLL Keys to select Ohm. Press ENTER Key.
9. Use FIELD SELECT Keys to move cursor to RANGE. Press ENTER Key. Select Ohm ranges and verify values on DMM.

Range	Calibrator	DMM Value	If incorrect, replace/perform
200 OHM	100 $\Omega$	100 $\Omega$ ( $\pm 10\Omega$ )	A11 DMM (para 3-1-22)
2 K OHM	1000 $\Omega$	1000 $\Omega$ ( $\pm 100\Omega$ )	A11 DMM (para 3-1-22)
20 K OHM	10 K $\Omega$	10 K $\Omega$ ( $\pm 1$ K $\Omega$ )	A11 DMM (para 3-1-22)
200 K OHM	100 K $\Omega$	100 K $\Omega$ ( $\pm 10$ K $\Omega$ )	A11 DMM (para 3-1-22)
2 M OHM	1 M $\Omega$	1 M $\Omega$ ( $\pm 100$ K $\Omega$ )	A11 DMM (para 3-1-22)
20 M OHM	10 M $\Omega$	10 M $\Omega$ ( $\pm 1$ M $\Omega$ )	A11 DMM (para 3-1-22)

10. Connect external test equipment as shown.

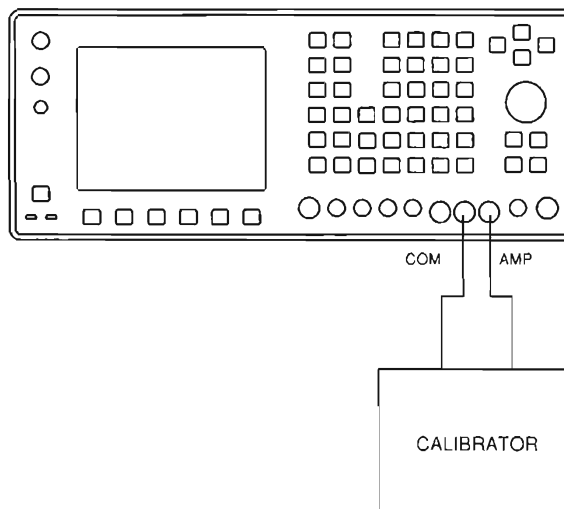

CE2FO171

11. Use FIELD SELECT Keys to move cursor to MULTIMETER. Press ENTER Key. Use DATA SCROLL Keys to select DCC. Press ENTER Key.

## CHAPTER 2 MAINTENANCE INSTRUCTIONS

### 2-2-6 DMM TEST - Continued

12. Use FIELD SELECT Keys to move cursor to RANGE. Press ENTER Key. Select DCC ranges and verify values on DMM.

Range	Calibrator	DMM Value	If incorrect, replace/perform
20 mA	15 mA	15 mA ( $\pm 1.01$ mA)	A11 DMM (para 3-1-22)
200 mA	150 mA	150 mA ( $\pm 10.1$ mA)	A11 DMM (para 3-1-22)
2 A	1.5 A	1.5 A ( $\pm 101$ mA)	A11 DMM (para 3-1-22)

13. Use FIELD SELECT Keys to move cursor to MULTIMETER. Press ENTER Key. Use DATA SCROLL Keys to select ACC. Press ENTER Key.
14. Use FIELD SELECT Keys to move cursor to RANGE. Press ENTER Key. Select ACC ranges and verify values on DMM.

Range	Calibrator	DMM Value	If incorrect, replace/perform
20 mA	15 mA at 100 Hz	15 mA ( $\pm 1.01$ mA)	A11 DMM (para 3-1-22)
200 mA	150 mA at 100 Hz	150 mA ( $\pm 10.1$ mA)	A11 DMM (para 3-1-22)
2 A	1.5 A at 100 Hz	1.5 A ( $\pm 101$ mA)	A11 DMM (para 3-1-22)

15. Use FIELD SELECT Keys to move cursor to MULTIMETER. Press ENTER Key. Use DATA SCROLL Keys to select Ohm. Press ENTER Key
16. Use FIELD SELECT Keys to move cursor to RANGE. Press ENTER Key. Select 200 OHM range. Set Calibrator to 100  $\Omega$  and verify 100  $\Omega$  ( $\pm 10 \Omega$ ) on DMM.
- If incorrect, perform Steps 17-19.
  - If correct, replace A11 DMM (para 3-1-22).
17. Remove A30 Counter (para 3-1-4) and install on PC Board Assembly Extender in Test Set.
18. Enter RANGE Field values and verify TTL pulses or pulse trains are present with Oscilloscope at A30P2 (fig. FO-27) when cycling through ranges, pressing ENTER Key at each range.
- |               |               |               |
|---------------|---------------|---------------|
| A30P2, Pin 1C | A30P2, Pin 2C | A30P2, Pin 3C |
| A30P2, Pin 4C |               |               |
- If any reading is incorrect, replace A30 Counter (para 3-1-4).
19. Enter RANGE Field values and verify TTL pulses or pulse trains are present with Oscilloscope at A30P2, Pin 1B when cycling through ranges, pressing ENTER Key at each range.
- If incorrect, replace A11 DMM (para 3-1-22).
  - If correct, replace A30 Counter (para 3-1-4)



## CHAPTER 2 MAINTENANCE INSTRUCTIONS

---

### 2-2-7 PERFORMANCE TEST

#### DESCRIPTION

This procedure covers:

- Intensity/Contrast
- Keyboard
- Data Scroll Spinner
- Squelch
- AF Gen 1 Frequency and Level Accuracy
- AF Gen 1 Distortion Threshold
- Speaker/Speaker Control
- AF Gen 2 Frequency And Level Accuracy
- AF Gen 2 Distortion Threshold
- External Modulation
- MIC/ACC IN/OUT Connector Modulation
- RF Gen Level Flatness
- RF Gen Frequency Accuracy
- RF Gen Level Accuracy
- RF Gen Residual FM
- RF Gen AM
- RF Gen FM
- RF Gen Harmonic/Non-Harmonic Level
- Frequency/Frequency Error Meter
- AGC
- Receiver Sensitivity
- Receiver Selectivity
- Antenna In Connector Overload Protection
- Duplex Out Connector Overload Protection
- BER Meter
- Duplex Out Connector Level
- DTMF
- DMM
- Power Meter High Power
- Oscilloscope Vertical Accuracy
- DC Power

#### NOTE

- Performance Test must be performed in order shown.
- Allow 30 minute warm-up period for Radio Test Set prior to performing the Performance Test.

## CHAPTER 2 MAINTENANCE INSTRUCTIONS

---

### 2-2-7 PERFORMANCE TEST - Continued

#### INITIALIZED SETUP

1. Perform Turn-On Procedure (FM/AM-1600 Operation Manual).
2. Perform Self Test (FM/AM-1600 Operation Manual).

#### INTENSITY/CONTRAST

---

1. Turn LCD INTENSITY/Contrast cw and ccw through full range of control and verify LCD Intensity changes with control movement from a dim display to full brightness.

#### KEYBOARD

---

1. Press MODE Keys and verify Screens appears.

RF GEN	RF Generator Screen
RCVR	Receiver Screen
DPLX	Duplex Screen
AF GEN	AF Generator Screen
SCOPE/ANLZ	Oscilloscope or Spectrum Analyzer Screen
MTRS	Meters Screen
2. Press "AUX" F6 and verify Auxiliary Functions Menu appears.
3. Use FIELD SELECT Keys to move cursor to "5. External I/O". Press ENTER Key and verify Configure Menu appears.
4. Use FIELD SELECT Keys to move cursor to "1. RS-232 port". Press ENTER Key and verify Configure RS-232 Menu appears.
5. Use FIELD SELECT Keys to move cursor to "7. Echo". Press ENTER Key to select On.
6. Press "TERM" F5 and verify RS-232 Monitor Screen appears.
7. Press SHIFT Key and verify "S" appears between F1 and F2 definitions.
8. Press Alphabetic Keys in sequence and verify each letter appears on RS-232 Monitor Screen.
9. Press "?" F1, "/" F2, "+" F3, "=" F4 and "," F5 and verify special characters appear on RS-232 Monitor Screen.
10. Press RF GEN MODE Key.
11. Press each FIELD SELECT Key and verify cursor moves with each key pressed.
12. Use FIELD SELECT Keys to move cursor to RF. Press ENTER Key. Use DATA ENTRY Keypad to enter 500 MHz. Press ENTER Key.
13. Press each DATA SCROLL Keys and verify cursor moves with each key pressed. Press ENTER Key.
14. Press SCOPE/ANLZ MODE Key to access Oscilloscope Screen.
15. Press HOLD SCRN Key and verify Trace stops all motion and "HOLD" Window appears over F3 and F4 definitions.
16. Press MTRS MODE Key and "AUX" F6.
17. Press STORE Key and verify Store Parameters Menu appears.
18. Press "AUX" F5.

## CHAPTER 2 MAINTENANCE INSTRUCTIONS

---

### 2-2-7 PERFORMANCE TEST - Continued

#### KEYBOARD - Continued

19. Press RCL Key and verify Recall Parameters Menu appears.
20. Use FIELD SELECT Keys to move cursor to "10. Factory Defaults." Press ENTER Key and verify "10. Factory Defaults Recall?" prompt appears.
21. Press ENTER Key and "AUX" F5.

#### DATA SCROLL SPINNER

---

1. Press RF GEN MODE Key.
2. Use FIELD SELECT Keys to move cursor to RF. Press ENTER Key. Use DATA ENTRY Keypad to enter 500.0000 MHz. Press ENTER Key.
3. Rotate DATA SCROLL Spinner cw and ccw and verify value increases and decreases.

#### SQUELCH

---

1. Press MTRS MODE Key, "AUX" F6 and RCL Key.
2. Use FIELD SELECT Keys to move cursor to "10. Factory Defaults" and press ENTER Key twice.
3. Connect Signal Generator to ANTENNA IN Connector.
4. Set Signal Generator for 80 MHz signal at -40 dBm with FM Modulation (1 kHz tone, 2.5 Khz deviation).
5. Press RCVR MODE Key.
6. Use FIELD SELECT Keys to move cursor to RF. Press ENTER Key. Use DATA ENTRY Keypad to enter 80.0000 MHz. Press ENTER Key.
7. Use FIELD SELECT Keys to move cursor to 0dB. Press ENTER Key. Use DATA SCROLL Keys to select 40 dB. Press ENTER Key.
8. Press SQLCH Key and verify Squelch Indicator Bar appears with white inner bar indicating amount of rejection.
9. Turn DATA SCROLL Spinner ccw until white bar disappears and verify readings are present for Receiver Operation Screen.
10. Turn DATA SCROLL Spinner cw until white bar extends from limit to limit and verify readings are replaced by "---".
11. Turn DATA SCROLL Spinner ccw until white bar disappears. Press ENTER Key.
12. Disconnect external test equipment.

#### AF GEN 1 FREQUENCY AND LEVEL ACCURACY

---

1. Press MTRS MODE Key, "AUX" F6 and RCL Key.
2. Use FIELD SELECT Keys to move cursor to "10. Factory Defaults" and press ENTER Key twice.
3. Press AF GEN MODE Key.
4. Use FIELD SELECT Keys to move cursor to GEN 1. Press ENTER Key to select On.
5. Use FIELD SELECT Keys to move cursor to LEVEL. Press ENTER Key. Use DATA ENTRY Keypad to enter 0.7070 V. Press ENTER Key.

## CHAPTER 2 MAINTENANCE INSTRUCTIONS

### 2-2-7 PERFORMANCE TEST - Continued

#### AF GEN 1 FREQUENCY AND LEVEL ACCURACY - Continued

6. Connect external test equipment as shown.

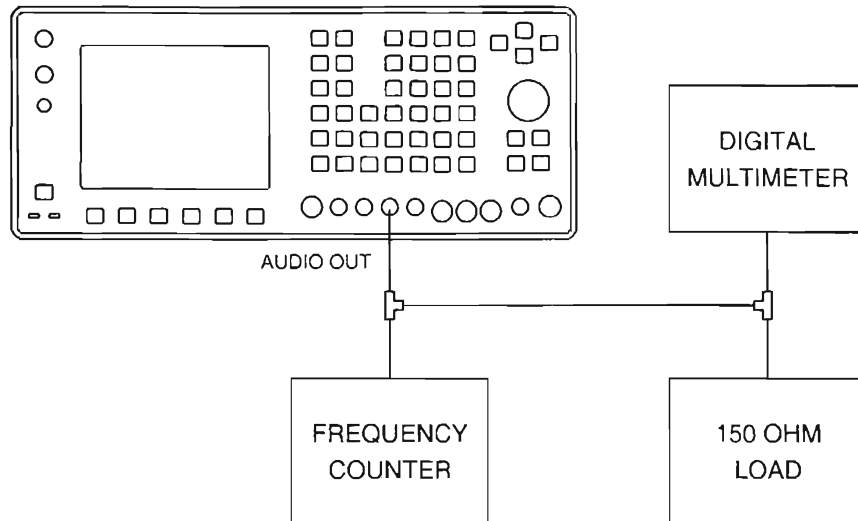

CE2FO163

7. Verify 1000.0 Hz ( $\pm 1$  Hz) on Frequency Counter and 0.707 VRMS (Nominal) on DMM.
8. Use FIELD SELECT Keys to move cursor to Scale. Press ENTER Key. Use DATA SCROLL Keys to select 500 mV. Press ENTER Key.
9. Use FIELD SELECT Keys to move cursor to Sweep. Press ENTER Key. Use DATA SCROLL Keys to select 100  $\mu$ s. Press ENTER Key. Verify sine wave on Oscilloscope.
10. Disconnect external test equipment.

#### AF GEN 1 DISTORTION THRESHOLD

1. Press MTRS MODE Key, "AUX" F6 and RCL Key.
2. Use FIELD SELECT Keys to move cursor to "10. Factory Defaults" and press ENTER Key twice.
3. Connect Distortion Analyzer to AUDIO OUT Connector.
4. Press AF GEN MODE Key.
5. Use FIELD SELECT Keys to move cursor to GEN 1. Press ENTER Key to select On.
6. Use FIELD SELECT Keys to move cursor to LEVEL. Press ENTER Key. Use DATA ENTRY Keypad to enter 1.0000 V. Press ENTER Key.
7. Verify <2% is displayed on Distortion Analyzer.
8. Disconnect external test equipment.

#### SPEAKER/SPEAKER CONTROL

1. Press MTRS MODE Key, "AUX" F6 and RCL Key.
2. Use FIELD SELECT Keys to move cursor to "10. Factory Defaults" and press ENTER Key twice.
3. Press AF GEN MODE Key.

## CHAPTER 2 MAINTENANCE INSTRUCTIONS

### 2-2-7 PERFORMANCE TEST - Continued

4. Use FIELD SELECT Keys to move cursor to GEN 1. Press ENTER Key to select On.
5. Use FIELD SELECT Keys to move cursor to LEVEL. Press ENTER Key. Use DATA ENTRY Keypad to enter 1.0000 V. Press ENTER Key.
6. Press SETUP Key.
7. Use FIELD SELECT Keys to move cursor to "5. AF Output Setup". Press ENTER Key. Use FIELD SELECT Keys to move cursor to "2. To Speaker". Press ENTER Key to select On.
8. Press "Ret" F5.
9. Press  $\uparrow$  VOL Control Key until Volume Bar appears and audible tone is present.
10. Press each VOL Control Keys and verify speaker volume increases and decreases.
11. Press SETUP Key.
12. Use FIELD SELECT Keys to move cursor to "5. AF Output Setup". Press ENTER Key. Use FIELD SELECT Keys to move cursor to "2. To Speaker". Press ENTER Key to select Off.
13. Press "Ret" F5.

### AF GEN 2 FREQUENCY AND LEVEL ACCURACY

1. Press MTRS MODE Key, "AUX" F6 and RCL Key.
2. Use FIELD SELECT Keys to move cursor to "10. Factory Defaults" and press ENTER Key twice.
3. Press AF GEN MODE Key.
4. Use FIELD SELECT Keys to move cursor to GEN 2. Press ENTER Key to select On.
5. Use FIELD SELECT Keys to move cursor to LEVEL. Press ENTER Key. Use DATA ENTRY Keypad to enter 0.7070 V. Press ENTER Key.
6. Connect external test equipment as shown.

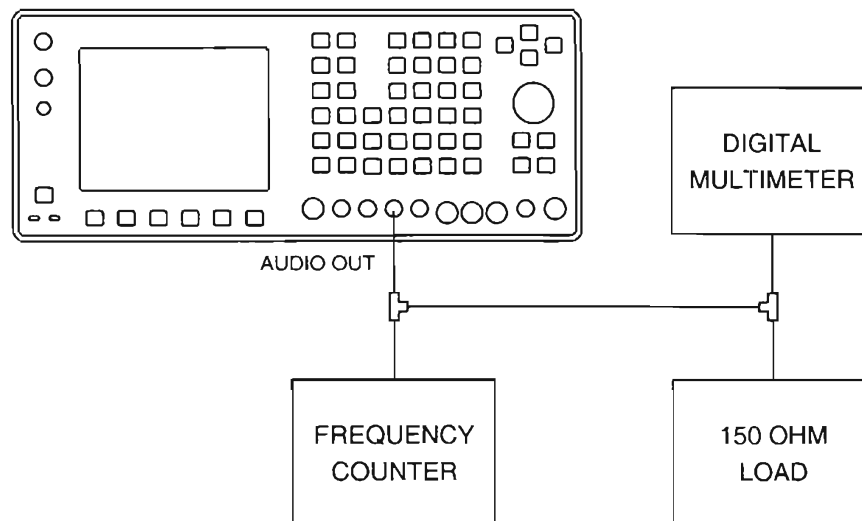

CE2FO163

7. Verify 1000.0 Hz ( $\pm 1$  Hz) on Frequency Counter and 0.707 VRMS (Nominal) on DMM.
8. Use FIELD SELECT Keys to move cursor to Scale. Press ENTER Key. Use DATA SCROLL Keys to select 500 mV. Press ENTER Key.

## CHAPTER 2 MAINTENANCE INSTRUCTIONS

### 2-2-7 PERFORMANCE TEST - Continued

#### AF GEN 2 FREQUENCY AND LEVEL ACCURACY -Continued

9. Use FIELD SELECT Keys to move cursor to Sweep. Press ENTER Key. Use DATA SCROLL Keys to select 100  $\mu$ s. Press ENTER Key. Verify Test Set Oscilloscope displays sine wave.
10. Disconnect external test equipment.

#### AF GEN 2 DISTORTION THRESHOLD

1. Press MTRS MODE Key, "AUX" F6 and RCL Key.
2. Use FIELD SELECT Keys to move cursor to "10. Factory Defaults" and press ENTER Key twice.
3. Connect Distortion Analyzer to AUDIO OUT Connector.
4. Press AF GEN MODE Key.
5. Use FIELD SELECT Keys to move cursor to GEN 2. Press ENTER Key to select On.
6. Use FIELD SELECT Keys to move cursor to LEVEL. Press ENTER Key. Use DATA ENTRY Keypad to enter 1.0000 V. Press ENTER Key.
7. Verify <0.5% is displayed on Distortion Analyzer.
8. Disconnect external test equipment.

#### EXTERNAL MODULATION

1. Press MTRS MODE Key, "AUX" F6 and RCL Key.
2. Use FIELD SELECT Keys to move cursor to "10. Factory Defaults" and press ENTER Key twice.
3. Connect external test equipment as shown.

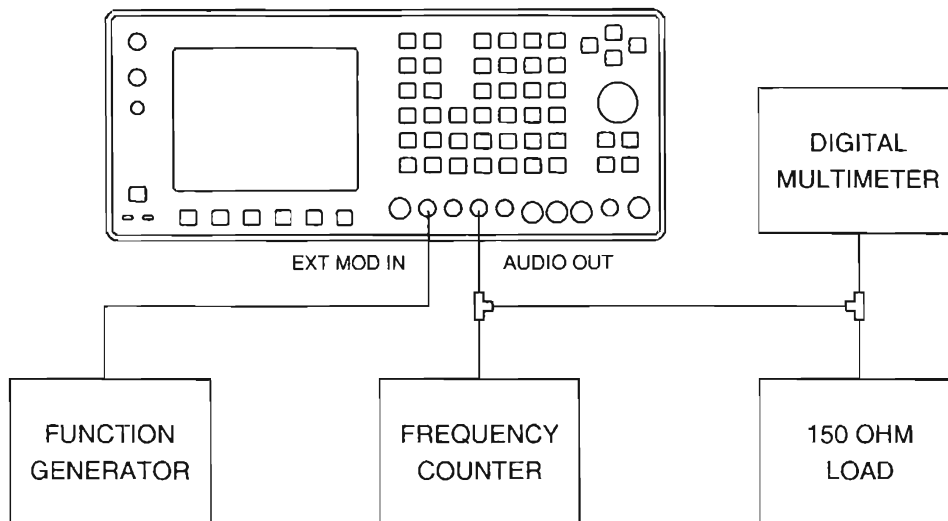

CE2FO164

4. Set Function Generator for 1 kHz sine wave at 3.5 VRMS.
5. Press AF GEN MODE Key.
6. Use FIELD SELECT Keys to move cursor to EXT. Press ENTER Key to select On.
7. Use FIELD SELECT Keys to move cursor to LEVEL. Press ENTER Key. Use DATA ENTRY Keypad to enter 1.0000 V. Press ENTER Key.

## CHAPTER 2 MAINTENANCE INSTRUCTIONS

---

### 2-2-7 PERFORMANCE TEST - Continued

#### EXTERNAL MODULATION - Continued

8. Verify Function Generator frequency on Frequency Counter. Note level on DMM.
9. Use FIELD SELECT Keys to move cursor to LEVEL. Press ENTER Key. Use DATA ENTRY Keypad to enter 2.0000 V. Press ENTER Key.
10. Verify change in level on DMM.
11. Disconnect external test equipment.

#### MIC/ACC IN/OUT CONNECTOR MODULATION

---

1. Press MTRS MODE Key, "AUX" F6 and RCL Key.
2. Use FIELD SELECT Keys to move cursor to "10. Factory Defaults" and press ENTER Key twice.
3. Connect Microphone to MIC/ACC IN/OUT Connector.
4. Press AF GEN MODE Key.
5. Use FIELD SELECT Keys to move cursor to MIC. Press ENTER Key to select On.
6. Use FIELD SELECT Keys to move cursor to LEVEL. Press ENTER Key. Use DATA ENTRY Keypad to enter 3.1000 V. Press ENTER Key.
7. Key Microphone, tap on Microphone Grill and verify deflection of Oscilloscope Trace coincident with tapping.
8. Disconnect external test equipment.

#### RF GEN LEVEL FLATNESS

---

1. Press MTRS MODE Key, "AUX" F6 and RCL Key.
2. Use FIELD SELECT Keys to move cursor to "10. Factory Defaults" and press ENTER Key twice.
3. Connect Measuring Receiver to T/R Connector.
4. Press RF GEN MODE Key.
5. Use FIELD SELECT Keys to move cursor to LEVEL. Press ENTER Key. Use DATA ENTRY Keypad to enter -10.0 dBm. Press ENTER Key.
6. Enter selected frequency on Measuring Receiver.
7. Enter frequencies in RF Field and verify -10 dBm ( $\pm 1.5$  dB) on Measuring Receiver.

250 kHz	499 kHz	500 kHz
999 kHz	1 MHz	49 MHz
50 MHz	124 MHz	125 MHz
199 MHz	200 MHz	399 MHz
400 MHz	599 MHz	600 MHz
799 MHz	800 MHz	999 MHz

8. Disconnect external test equipment.

#### RF GEN FREQUENCY ACCURACY

---

1. Press MTRS MODE Key, "AUX" F6 and RCL Key.
2. Use FIELD SELECT Keys to move cursor to "10. Factory Defaults" and press ENTER Key twice.

## CHAPTER 2 MAINTENANCE INSTRUCTIONS

### 2-2-7 PERFORMANCE TEST - Continued

#### RF GEN FREQUENCY ACCURACY - Continued

3. Connect Frequency Counter to T/R Connector.
4. Press RF GEN MODE Key.
5. Use FIELD SELECT Keys to move cursor to RF. Press ENTER Key. Enter frequencies and verify readings on Frequency Counter.

50 MHz	50 MHz ( $\pm 50$ Hz)
200 MHz	200 MHz ( $\pm 200$ Hz)
400 MHz	400 MHz ( $\pm 400$ Hz)
600 MHz	600 MHz ( $\pm 600$ Hz)
800 MHz	800 MHz ( $\pm 800$ Hz)

6. Disconnect external test equipment.

#### RF GEN LEVEL ACCURACY

1. Press MTRS MODE Key, "AUX" F6 and RCL Key.
2. Use FIELD SELECT Keys to move cursor to "10. Factory Defaults" and press ENTER Key twice.
3. Connect Measuring Receiver to T/R Connector.
4. Press RF GEN MODE Key.
5. Use FIELD SELECT Keys to move cursor to RF. Press ENTER Key. Use DATA ENTRY Keypad to enter 100.0000 MHz. Press ENTER Key.
6. Use FIELD SELECT Keys to move cursor to LEVEL. Press ENTER Key. Use DATA ENTRY Keypad to enter 0.0 dBm. Press ENTER Key.
7. Enter Frequency of 100 MHz on Measuring Receiver. Press TUNED RF and RATIO Keys on Measuring Receiver.
8. Enter levels and verify levels on Measuring Receiver.

0 dBm	0 dBm ( $\pm 1.5$ dB)	-111 dBm	-111 dBm ( $\pm 2.5$ dB)
-1 dBm	-1 dBm ( $\pm 1.5$ dB)	-112 dBm	-112 dBm ( $\pm 2.5$ dB)
-2 dBm	-2 dBm ( $\pm 1.5$ dB)	-113 dBm	-113 dBm ( $\pm 2.5$ dB)
-3 dBm	-3 dBm ( $\pm 1.5$ dB)	-114 dBm	-114 dBm ( $\pm 2.5$ dB)
-4 dBm	-4 dBm ( $\pm 1.5$ dB)	-115 dBm	-115 dBm ( $\pm 2.5$ dB)
-5 dBm	-5 dBm ( $\pm 1.5$ dB)	-116 dBm	-116 dBm ( $\pm 2.5$ dB)
-6 dBm	-6 dBm ( $\pm 1.5$ dB)	-117 dBm	-117 dBm ( $\pm 2.5$ dB)
-7 dBm	-7 dBm ( $\pm 1.5$ dB)	-118 dBm	-118 dBm ( $\pm 2.5$ dB)
-8 dBm	-8 dBm ( $\pm 1.5$ dB)	-119 dBm	-119 dBm ( $\pm 2.5$ dB)
-9 dBm	-9 dBm ( $\pm 1.5$ dB)	-120 dBm	-120 dBm ( $\pm 2.5$ dB)
16 dBm	16 dBm ( $\pm 1.5$ dB)	-121 dBm	-121 dBm ( $\pm 2.5$ dB)
-32 dBm	-32 dBm ( $\pm 1.5$ dB)	-122 dBm	-122 dBm ( $\pm 2.5$ dB)
-40 dBm	-40 dBm ( $\pm 1.5$ dB)	-123 dBm	-123 dBm ( $\pm 2.5$ dB)
-64 dBm	-64 dBm ( $\pm 1.5$ dB)	-124 dBm	-124 dBm ( $\pm 2.5$ dB)
-80 dBm	-80 dBm ( $\pm 1.5$ dB)	-125 dBm	-125 dBm ( $\pm 2.5$ dB)
-90 dBm	-90 dBm ( $\pm 1.5$ dB)	-126 dBm	-126 dBm ( $\pm 2.5$ dB)
-110 dBm	-110 dBm ( $\pm 2.5$ dB)	-127 dBm	-127 dBm ( $\pm 2.5$ dB)

9. Set Measuring Receiver to measure 800 MHz at RF Level down to -122 dBm.



## CHAPTER 2 MAINTENANCE INSTRUCTIONS

---

### 2-2-7 PERFORMANCE TEST - Continued

#### RF GEN LEVEL ACCURACY - Continued

10. Use FIELD SELECT Keys to move cursor to RF. Press ENTER Key. Use DATA ENTRY Keypad to enter 800.0000 MHz. Press ENTER Key.
11. Verify output of -110 dBm ( $\pm 1.0$  dB) on Measuring Receiver.
12. Disconnect external test equipment.

#### RF GEN RESIDUAL FM

---

1. Press MTRS MODE Key, "AUX" F6 and RCL Key.
2. Use FIELD SELECT Keys to move cursor to "10. Factory Defaults" and press ENTER Key twice.
3. Connect Measuring Receiver to T/R Connector.
4. Set Measuring Receiver to measure FM Deviation.
5. Press RF GEN MODE Key.
6. Use FIELD SELECT Keys to move cursor to LEVEL. Press ENTER Key. Use DATA ENTRY Keypad to enter -10.0 dBm. Press ENTER Key.
7. Use FIELD SELECT Keys to move cursor to LEVEL. Press ENTER Key. Use DATA ENTRY Keypad to enter -10.0 dBm. Press ENTER Key.
 

80 MHz	<45 Hz RMS
500 MHz	<140 Hz RMS
500 MHz	<140 Hz RMS
8. Disconnect external test equipment.

#### RF GEN AM

---

1. Press MTRS MODE Key, "AUX" F6 and RCL Key.
2. Use FIELD SELECT Keys to move cursor to "10. Factory Defaults" and press ENTER Key twice.
3. Connect Measuring Receiver to T/R Connector.
4. Set Measuring Receiver to measure AM on Positive Peak and activate 15 kHz Low-Pass Filter.
5. Press RF GEN MODE Key.
6. Use FIELD SELECT Keys to move cursor to LEVEL. Press ENTER Key. Use DATA ENTRY Keypad to enter 0.0 dBm. Press ENTER Key.
7. Use FIELD SELECT Keys to move cursor to SOURCE. Press ENTER Key. Use DATA SCROLL Keys to select AM. Press ENTER Key.
8. Use FIELD SELECT Keys to move cursor to MODULATION. Press ENTER Key. Use DATA ENTRY Keypad to enter 90%. Press ENTER Key.
9. Use FIELD SELECT Keys to move cursor to RF. Press ENTER Key. Enter 80 MHz and 500 kHz frequencies and verify 90% ( $\pm 4.5\%$ ) AM Modulation on Measuring Receiver.
10. Disconnect external test equipment.

## CHAPTER 2 MAINTENANCE INSTRUCTIONS

---

### 2-2-7 PERFORMANCE TEST - Continued

#### RF GEN FM

---

1. Press MTRS MODE Key, "AUX" F6 and RCL Key.
2. Use FIELD SELECT Keys to move cursor to "10. Factory Defaults" and press ENTER Key twice.
3. Connect Measuring Receiver to T/R Connector.
4. Set Measuring Receiver to measure FM on the Positive Peak and activate 3 kHz Low-Pass Filter.
5. Press RF GEN MODE Key.
6. Use FIELD SELECT Keys to move cursor to LEVEL. Press ENTER Key. Use DATA ENTRY Keypad to enter 0.0 dBm. Press ENTER Key.
7. Use FIELD SELECT Keys to move cursor to SOURCE. Press ENTER Key. Use DATA SCROLL Keys to select FM. Press ENTER Key.
8. Use FIELD SELECT Keys to move cursor to DEVIATION. Press ENTER Key. Enter frequencies and verify readings on Measuring Receiver.

5 kHz	5 kHz (250 Hz)
20 kHz	20 kHz ( $\pm 1$ kHz)
9. Disconnect external test equipment.

#### RF GEN HARMONIC/NON-HARMONIC LEVEL

---

1. Press MTRS MODE Key, "AUX" F6 and RCL Key.
2. Use FIELD SELECT Keys to move cursor to "10. Factory Defaults" and press ENTER Key twice.
3. Connect Spectrum Analyzer to T/R Connector.
4. Set Spectrum Analyzer Center Frequency to 500 MHz and Span Width to 100 MHz/Div..
5. Press RF GEN MODE Key.
6. Use FIELD SELECT Keys to move cursor to RF. Press ENTER Key. Use DATA ENTRY Keypad to enter 100.0000 MHz. Press ENTER Key.
7. Verify Harmonics are  $< -26$  dBc and Non-Harmonics are  $< -50$  dBc.
8. Disconnect external test equipment.

#### FREQUENCY/FREQUENCY ERROR METER

---

1. Press MTRS MODE Key, "AUX" F6 and RCL Key.
2. Use FIELD SELECT Keys to move cursor to "10. Factory Defaults" and press ENTER Key twice.
3. Press RCVR MODE Key.
4. Use FIELD SELECT Keys to move cursor to ANT. Press ENTER Key to select T/R.
5. Use FIELD SELECT Keys to move cursor to RF. Press ENTER Key. Use DATA ENTRY Keypad to enter 50.0000 MHz. Press ENTER Key.

## CHAPTER 2 MAINTENANCE INSTRUCTIONS

### 2-2-7 PERFORMANCE TEST - Continued

#### FREQUENCY/FREQUENCY ERROR METER - Continued

6. Connect external test equipment as shown.

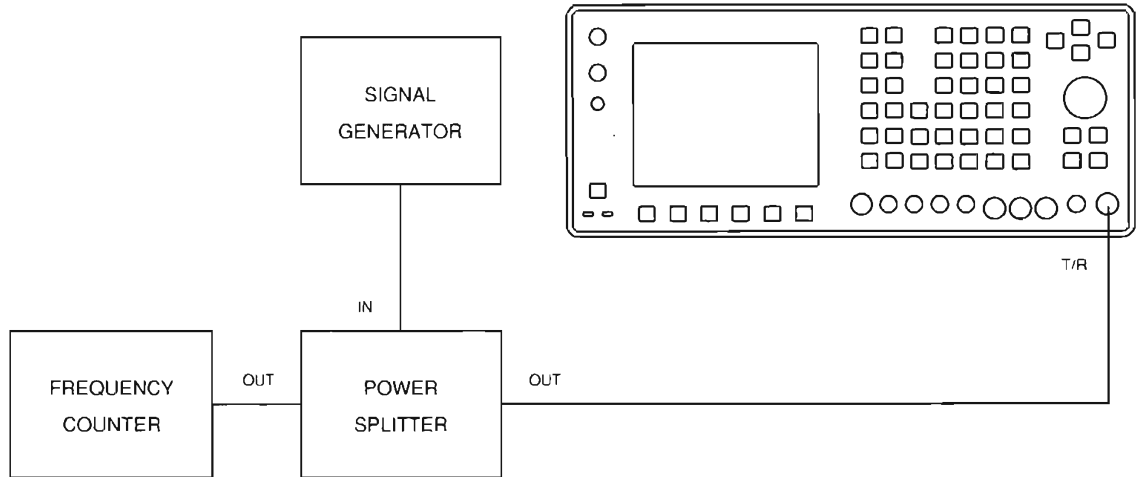

CE2FO165

7. Set Signal Generator and Radio Test Set for following signals and verify readings match Frequency Counter readings.

Signal Generator for	Radio Test Set for	Matches Frequency Counter Reading
50 MHz signal at 0 dB (with no modulation)	50 MHz signal at 0 dB (with no modulation)	Frequency Count Readout ( $\pm 50$ Hz)
200 MHz signal at 0 dB (with no modulation)	200 MHz signal at 0 dB (with no modulation)	Frequency Count Readout ( $\pm 200$ Hz)
400 MHz signal at 0 dB (with no modulation)	400 MHz signal at 0 dB (with no modulation)	Frequency Count Readout ( $\pm 400$ Hz)
600 MHz signal at 0 dB (with no modulation)	600 MHz signal at 0 dB (with no modulation)	Frequency Count Readout ( $\pm 600$ Hz)
800 MHz signal at 0 dB (with no modulation)	800 MHz signal at 0 dB (with no modulation)	Frequency Count Readout ( $\pm 800$ Hz)

8. Disconnect external test equipment.

## CHAPTER 2 MAINTENANCE INSTRUCTIONS

### 2-2-7 PERFORMANCE TEST - Continued

#### AGC

1. Press MTRS MODE Key, "AUX" F6 and RCL Key.
2. Use FIELD SELECT Keys to move cursor to "10. Factory Defaults" and press ENTER Key twice.
3. Connect external test equipment as shown.

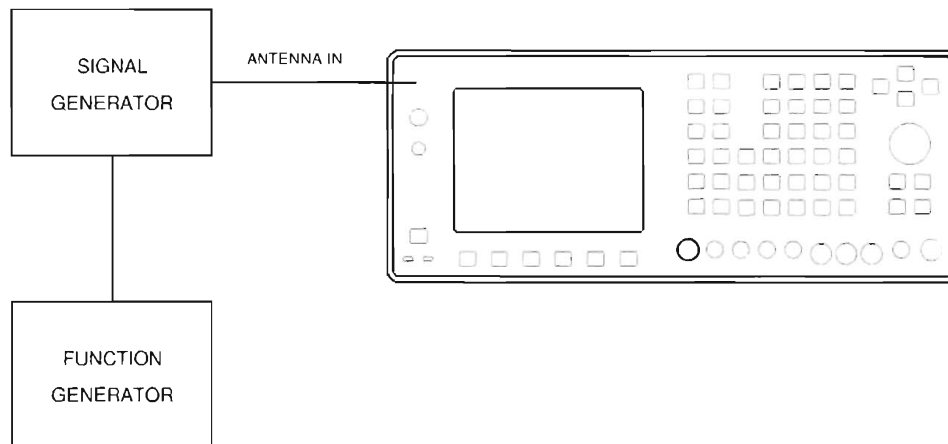

CE2FO166

4. Set Signal Generator for 100 MHz signal at -30 dBm. Select External AM Modulation at 50%.
5. Set Function Generator for 1 kHz square wave.
6. Press RCVR MODE Key.
7. Use FIELD SELECT Keys to move cursor to RF. Press ENTER Key. Use DATA ENTRY Keypad to enter 100.0000 MHz. Press ENTER Key.
8. Use FIELD SELECT Keys to move cursor to MOD. Press ENTER Key. Use DATA SCROLL Keys to select AM2. Press ENTER Key.
9. Press "MORE" F6 until "DISP" F1 appears. Press "DISP" F1.
10. Use FIELD SELECT Keys to move cursor to "4. Full Scope". Press ENTER Key.
11. Press "Input" F3. Use DATA SCROLL Keys to select Rcvr IF. Press ENTER Key.
12. Press SETUP Key.
13. Use FIELD SELECT Keys to move cursor to "5. Select AGC Type". Press ENTER Key. Use FIELD SELECT Keys to move cursor to "2. Manual". Press ENTER Key. Use DATA ENTRY Keypad to enter 1. Press ENTER Key.
14. Press "Ret" F5.
15. Verify flat line on Oscilloscope.
16. Press "More" F6 until "AGC" F5 appears.
17. Press "AGC" F5.

## CHAPTER 2 MAINTENANCE INSTRUCTIONS

### 2-2-7 PERFORMANCE TEST - Continued

#### AGC – Continued

18. Rotate DATA SCROLL Spinner cw and verify waveform as shown.

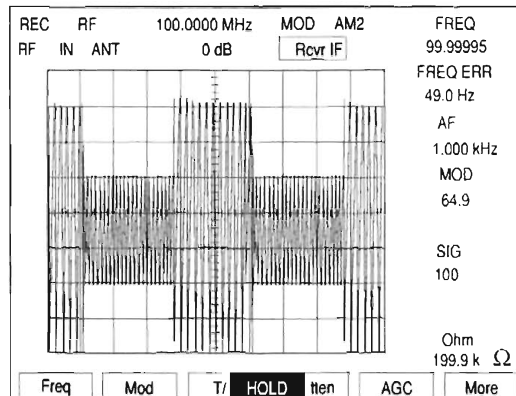

CE2FO179

19. Rotate DATA SCROLL Spinner cw and verify waveform.

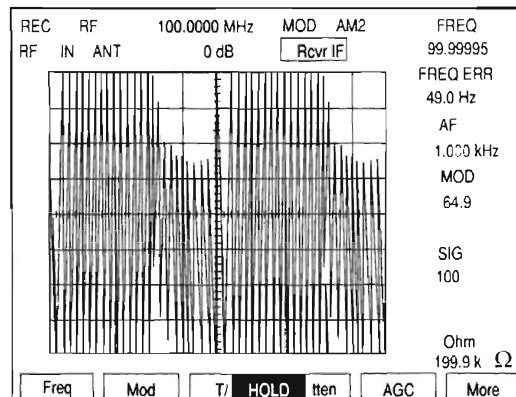

CE2FO178

20. Press ENTER Key.

21. Disconnect external test equipment.

### RECEIVER SENSITIVITY

1. Press MTRS MODE Key, "AUX" F6 and RCL Key.
2. Use FIELD SELECT Keys to move cursor to "10. Factory Defaults" and press ENTER Key twice.
3. Connect Signal Generator to ANTENNA IN Connector.
4. Set Signal Generator for 80 MHz signal at 5  $\mu$ V with FM Modulation (1 kHz tone, 6 kHz Deviation).
5. Press RCVR MODE Key.
6. Use SQLCH CONTROL Keys and VOL CONTROL Keys to set Squelch to minimum rejection and Volume to audible.
7. Use FIELD SELECT Keys to move cursor to RF. Press ENTER Key. Use DATA ENTRY Keypad to enter 80.0000 MHz. Press ENTER Key.

## CHAPTER 2 MAINTENANCE INSTRUCTIONS

---

### 2-2-7 PERFORMANCE TEST - Continued

#### RECEIVER SENSITIVITY - Continued

8. Press "More" F6 until "Meters" F4 appears. Press "Meters" F4.
9. Use FIELD SELECT Keys to move cursor to "2. SINAD". Press ENTER Key.
10. Verify SINAD Meter reads  $\geq 10$  dB.
11. Disconnect external test equipment.

#### RECEIVER SELECTIVITY

---

1. Press MTRS MODE Key, "AUX" F6 and RCL Key.
2. Use FIELD SELECT Keys to move cursor to "10. Factory Defaults" and press ENTER Key twice.
3. Set Signal Generator for 80 MHz signal at -60 dBm with no modulation. Connect Signal Generator to ANTENNA IN Connector.
4. Press RCVR MODE Key.
5. Use FIELD SELECT Keys to move cursor to RF. Press ENTER Key. Use DATA ENTRY Keypad to enter 80.0000 MHz. Press ENTER Key.
6. Use FIELD SELECT Keys to move cursor to MOD. Press ENTER Key. Use DATA SCROLL Keys to select FM4. Press ENTER Key.
7. Use FIELD SELECT Keys to move cursor to Deviation Meter. Press ENTER Key. Use FIELD SELECT Keys to move cursor to RANGE. Press ENTER Key. Use DATA SCROLL Keys to select 100 kHz. Press ENTER Key.
8. Press "Ret" F6.
9. Use FIELD SELECT Keys to move cursor to 0dB. Press ENTER Key. Use DATA SCROLL Keys to select 20 dB. Press ENTER Key.
10. Adjust SQLCH Control Keys for maximum squelch setting on Squelch Level Indicator. Use SQLCH Control Keys to decrease squelch until values appear on the meters.
11. Set Signal Generator to 80.1 MHz at -57 dBm. Verify numeric values are displayed on Receiver Meters.
12. Set Signal Generator to 80.485 MHz. Increase Signal Generator level until Squelch Indicator appears and verify Signal Generator level is -30 dBm or greater.
13. Set Signal Generator for 80 MHz signal at -60 dBm with no modulation.
14. Use FIELD SELECT Keys to move cursor to MOD. Press ENTER Key. Use DATA SCROLL Keys to select FM2. Press ENTER Key.
15. Adjust SQLCH Control Keys for maximum squelch setting on Squelch Level Indicator. Use SQLCH Control Keys to decrease squelch until values appear on the meters.
16. Set Signal Generator to 80.052 MHz. Increase Signal Generator level until Squelch Indicator appears and verify Signal Generator level is -30 dBm or greater.
17. Disconnect external test equipment.

## CHAPTER 2 MAINTENANCE INSTRUCTIONS

---

### 2-2-7 PERFORMANCE TEST - Continued

#### ANTENNA IN CONNECTOR OVERLOAD PROTECTION

---

1. Press MTRS MODE Key, "AUX" F6 and RCL Key.  
Use FIELD SELECT Keys to move cursor to "10. Factory Defaults" and press ENTER Key twice.
2. Press AF GEN MODE Key.
3. Use FIELD SELECT Keys to move cursor to GEN 1. Press ENTER Key to select On.
4. Use FIELD SELECT Keys to move cursor to GEN 1 AF. Press ENTER Key. Use DATA ENTRY Keypad to enter 25000.0 Hz. Press ENTER Key.
5. Use FIELD SELECT Keys to move cursor to LEVEL. Press ENTER Key. Use DATA ENTRY Keypad to enter 3.1000 V. Press ENTER Key.
6. Press RF GEN MODE Key.
7. Connect coaxial cable from AUDIO OUT Connector to ANTENNA IN Connector and verify warning tone and input overload message appears.
8. Disconnect coaxial cable.

#### DUPLEX OUT CONNECTOR OVERLOAD PROTECTION

---

1. Press MTRS MODE Key, "AUX" F6 and RCL Key.
2. Use FIELD SELECT Keys to move cursor to "10. Factory Defaults" and press ENTER Key twice.
3. Press AF GEN MODE Key.
4. Use FIELD SELECT Keys to move cursor to GEN 1. Press ENTER Key to select On.
5. Use FIELD SELECT Keys to move cursor to GEN 1 AF. Press ENTER Key. Use DATA ENTRY Keypad to enter 25000.0 Hz. Press ENTER Key.
6. Use FIELD SELECT Keys to move cursor to LEVEL. Press ENTER Key. Use DATA ENTRY Keypad to enter 3.1000 V. Press ENTER Key.
7. Press RF GEN MODE Key.
8. Connect coaxial cable from AUDIO OUT Connector to DUPLEX OUT Connector and verify warning tone and input overload message is displayed.
9. Disconnect coaxial cable.

#### BER METER

---

1. Press MTRS MODE Key, "AUX" F6 and RCL Key.
2. Use FIELD SELECT Keys to move cursor to "10. Factory Defaults" and press ENTER Key twice.
3. Connect AUDIO OUT Connector to SINAD/BER IN Connector using coaxial cable.
4. Press MTRS MODE Key.
5. Use FIELD SELECT Keys to move cursor to "9. Bit Error Rate (BER) Func". Press ENTER Key.
6. Use FIELD SELECT Keys to move cursor to BER TYPE. Press ENTER Key. Use FIELD SELECT Keys to move cursor to "3. Baseband". Press ENTER Key.

## CHAPTER 2 MAINTENANCE INSTRUCTIONS

---

### 2-2-7 PERFORMANCE TEST - Continued

#### BER METER - Continued

7. Use FIELD SELECT Keys to move cursor to DATA RATE. Press ENTER Key. Use FIELD SELECT Keys to move cursor to "8. 16 kbps". Press ENTER Key.
8. Use FIELD SELECT Keys to move cursor to DATA PATTERN SIZE. Press ENTER Key. Use DATA ENTRY Keypad to enter 10000 bits. Press ENTER Key.
9. Use FIELD SELECT Keys to move cursor to DATA POLARITY. Press ENTER Key. Use DATA SCROLL Keys to select Neg. SINAD/BER. Press ENTER Key.
10. Use FIELD SELECT Keys to move cursor to DATA PATTERN TYPE. Press ENTER Key. Use FIELD SELECT Keys to move cursor to "2. Fixed". Press ENTER Key.
11. Press "Run" F5 and verify BER Meter completes 100 passes with maximum error count of 1.
12. Press "Stop" F5.
13. Disconnect coaxial cable.

#### DUPLEX OUT CONNECTOR LEVEL

---

1. Press MTRS MODE Key, "AUX" F6 and RCL Key.
2. Use FIELD SELECT Keys to move cursor to "10. Factory Defaults" and press ENTER Key twice.
3. Connect Measuring Receiver to DUPLEX OUT Connector.
4. Set Measuring Receiver to measure dBm.
5. Press DPLX MODE Key and "RX" F2.
6. Use FIELD SELECT Keys to move cursor to RX. Press ENTER Key. Use DATA ENTRY Keypad to enter 500.0000 MHz frequency. Press ENTER Key.
7. Use FIELD SELECT Keys to move cursor to T/R. Press ENTER Key to select DPL.
8. Press TUNED RF Key on Measuring Receiver.
9. Use FIELD SELECT Keys to move cursor to dBm. Press ENTER Key. Use DATA ENTRY Keypad to enter 0.0 dBm. Press ENTER Key.
10. Verify 0 dBm ( $\pm 1.7$  dB) on Measuring Receiver.
11. Set Measuring Receiver to measure -40 dBm.
12. Press ENTER Key. Use DATA ENTRY Keypad to enter -40.0 dBm. Press ENTER Key.
13. Set Measuring Receiver to measure -80 dBm.
14. Press ENTER Key. Use DATA ENTRY Keypad to enter -80.0 dBm. Press ENTER Key.
15. Press ENTER Key. Use DATA ENTRY Keypad to enter -100.0 dBm. Press ENTER Key.
16. Verify -100 dBm ( $\pm 2.5$  dB) on Measuring Receiver.
17. Disconnect external test equipment.



## CHAPTER 2 MAINTENANCE INSTRUCTIONS

### 2-2-7 PERFORMANCE TEST - Continued

#### DTMF

1. Press MTRS MODE Key, "AUX" F6 and RCL Key.
2. Use FIELD SELECT Keys to move cursor to "10. Factory Defaults" and press ENTER Key twice.
3. Press DPLX MODE Key.
4. Use FIELD SELECT Keys to move cursor to OUT. Press ENTER Key to select T/R.
5. Use FIELD SELECT Keys to move cursor to SOURCE. Press ENTER Key. Use DATA SCROLL Keys to move cursor to 3. Use DATA SCROLL Keys to select FM. Press ENTER Key.
6. Use FIELD SELECT Keys to move cursor to DEV. Press ENTER Key. Use DATA ENTRY Keypad to enter 5.0 kHz. Press ENTER Key.
7. Use FIELD SELECT Keys to move cursor to PROGRAM # or DIRECT ENTRY. Press ENTER Key to select DIRECT ENTRY. Use FIELD SELECT Keys to move cursor down one line. Press ENTER Key. Use DATA ENTRY Keypad to enter "123456789\*0#". Press ENTER Key.
8. Press "TX" F1.
9. Use FIELD SELECT Keys to move cursor to ANT. Press ENTER Key to select T/R.
10. Press "More" F6 until "Decode" F2 appears. Press "Decode" F2.
11. Press GO Key.
12. Verify "123456789\*0#" appears on screen and repeats.
13. Press STOP Key.

#### DMM

1. Press MTRS MODE Key, "AUX" F6 and RCL Key.
2. Use FIELD SELECT Keys to move cursor to "10. Factory Defaults" and press ENTER Key twice.
3. Connect external test equipment as shown.

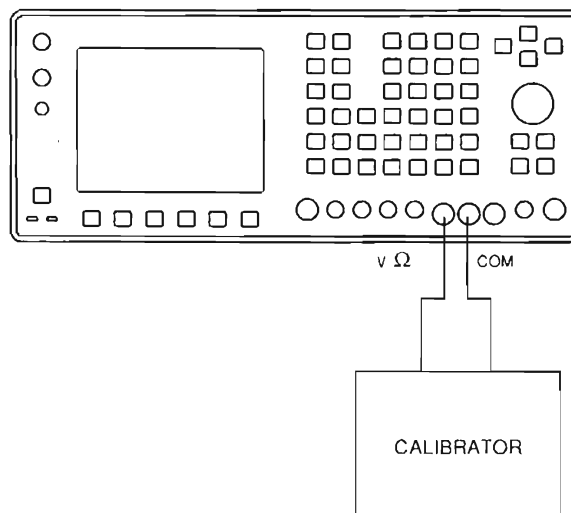

CE2FO170

4. Press MTRS MODE Key.

## CHAPTER 2 MAINTENANCE INSTRUCTIONS

### 2-2-7 PERFORMANCE TEST - Continued

#### DMM - Continued

5. Use FIELD SELECT Keys to move cursor to "10. Digital Multimeter (DMM)." Press ENTER Key.
6. Use FIELD SELECT Keys to move cursor to MULTIMETER. Press ENTER Key. Use DATA SCROLL Keys to select DCV. Press ENTER Key.
7. Use FIELD SELECT Keys to move cursor to RANGE. Press ENTER Key. Select DCV ranges and verify values on DMM.

Set Range to	Set Calibrator for	DMM displays
200 mV	150 mVdc	150 mVdc ( $\pm 2.1$ mVdc)
2 V	1.5 Vdc	1.5 Vdc ( $\pm 21$ mVdc)
20 V	15 Vdc	15 Vdc ( $\pm 0.21$ Vdc)
200 V	150 Vdc	150 Vdc ( $\pm 2.1$ Vdc)
2000 V	500 Vdc	500 Vdc ( $\pm 21$ Vdc)

8. Use FIELD SELECT Keys to move cursor to MULTIMETER. Press ENTER Key. Use DATA SCROLL Keys to select ACV. Press ENTER Key.
9. Use FIELD SELECT Keys to move cursor to RANGE. Press ENTER Key. Select ACV ranges and verify values on DMM. (When Multimeter readout exceeds 500 VAC, Radio Test Set beeps and displays Multimeter Readout Bar in red.)

Set Range to	Set Calibrator for	DMM displays
200 mV	150 mVAC at 100 Hz	150 mVAC ( $\pm 10.1$ mVAC)
2 V	1.5 VAC at 100 Hz	1.5 VAC ( $\pm 101$ mVAC)
20 V	15 VAC at 100 Hz	15 VAC ( $\pm 1.01$ VAC)
200 V	150 VAC at 100 Hz	150 VAC ( $\pm 10.1$ VAC)
2000 V	500 VAC at 100 Hz	500 VAC ( $\pm 101$ VAC)

10. Use FIELD SELECT Keys to move cursor to MULTIMETER. Press ENTER Key. Use DATA SCROLL Keys to select Ohm. Press ENTER Key.
11. Use FIELD SELECT Keys to move cursor to RANGE. Press ENTER Key. Select Ohm ranges and verify values on DMM.

Set Range to	Set Calibrator for	DMM displays
200 OHM	100 $\square$	100 $\square$ ( $\pm 10$ $\square$ )
2 K OHM	1000 $\square$	1000 $\square$ ( $\pm 100$ $\square$ )
20 K OHM	10 K $\square$	10 K $\square$ ( $\pm 1$ K $\square$ )
200 K OHM	100 K $\square$	100 K $\square$ ( $\pm 10$ K $\square$ )
2 M OHM	1 M $\square$	1 M $\square$ ( $\pm 100$ K $\square$ )
20 M OHM	10 M $\square$	10 M $\square$ ( $\pm 1$ M $\square$ )

## CHAPTER 2 MAINTENANCE INSTRUCTIONS

### 2-2-7 PERFORMANCE TEST - Continued

#### DMM - Continued

12. Connect external test equipment as shown.

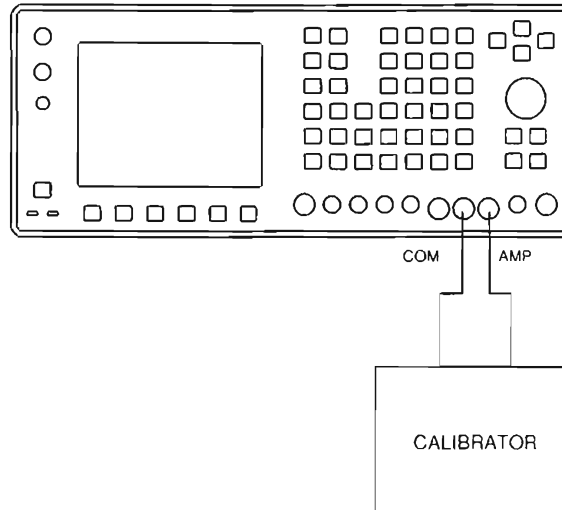

CE2FO171

13. Use FIELD SELECT Keys to move cursor to MULTIMETER. Press ENTER Key. Use DATA SCROLL Keys to select DCC. Press ENTER Key.
14. Use FIELD SELECT Keys to move cursor to RANGE. Press ENTER Key. Select DCC ranges and verify values on DMM.

Set Range to	Set Calibrator for	DMM displays
20 mA	15 mA	15 mA ( $\pm 1.01$ mA)
200 mA	150 mA	150 mA ( $\pm 10.1$ mA)
2 A	1.5 A	1.5 A ( $\pm 101$ mA)

15. Use FIELD SELECT Keys to move cursor to MULTIMETER. Press ENTER Key. Use DATA SCROLL Keys to select ACC. Press ENTER Key.
16. Use FIELD SELECT Keys to move cursor to RANGE. Press ENTER Key. Select ACC ranges and verify values on DMM.

Set Range to	Set Calibrator for	DMM displays
20 mA	15 mA at 100 Hz	15 mA ( $\pm 1.01$ mA)
200 mA	150 mA at 100 Hz	150 mA ( $\pm 10.1$ mA)
2 A	1.5 A at 100 Hz	1.5 A ( $\pm 101$ mA)

17. Disconnect external test equipment.

## CHAPTER 2 MAINTENANCE INSTRUCTIONS

### 2-2-7 PERFORMANCE TEST - Continued

#### POWER METER HIGH POWER

1. Press MTRS MODE Key, "AUX" F6 and RCL Key.
2. Use FIELD SELECT Keys to move cursor to "10. Factory Defaults" and press ENTER Key twice.
3. Connect external test equipment as shown.

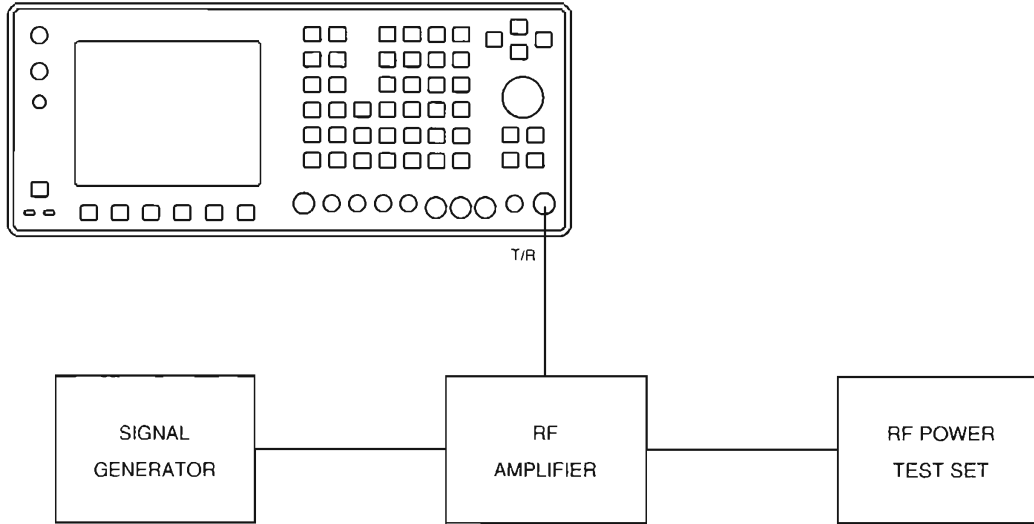

CE2FO174

4. Press MTRS MODE Key.
5. Use FIELD SELECT Keys to move cursor to "3. Pwr Meter (Pulse/CW)". Press ENTER Key.
6. Use FIELD SELECT Keys to move cursor to RANGE. Press ENTER Key. Use DATA SCROLL Keys to select 20 W. Press ENTER Key.
7. Set Signal Generator and RF Amplifier for 100 MHz signal at 10 W with no modulation using RF Power Test Set for reference.
8. Verify Test Set Power Meter reading matches Power Meter reading ( $\pm 20\%$ ).
9. Disconnect external test equipment.

## CHAPTER 2 MAINTENANCE INSTRUCTIONS

### 2-2-7 PERFORMANCE TEST - Continued

#### OSCILLOSCOPE VERTICAL ACCURACY

1. Press MTRS MODE Key, "AUX" F6 and RCL Key.
2. Use FIELD SELECT Keys to move cursor to "10. Factory Defaults" and press ENTER Key twice.
3. Connect external test equipment as shown.

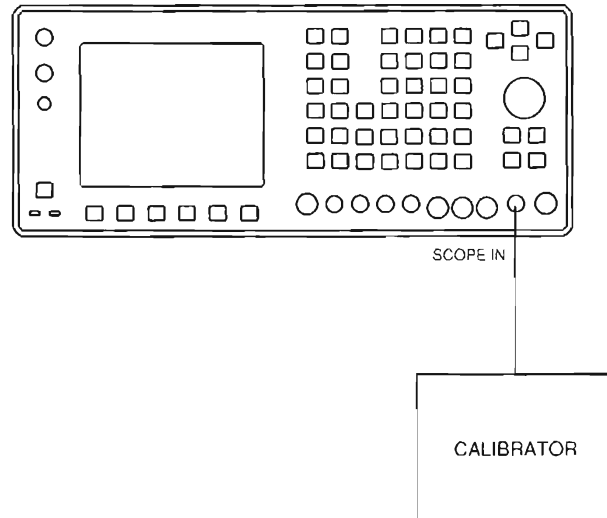

CE2FO175

4. Press AF GEN MODE Key.
5. Use FIELD SELECT Keys to move cursor to GEN 1. Press ENTER Key to select On.
6. Use FIELD SELECT Keys to move cursor to LEVEL. Press ENTER Key. Use DATA ENTRY Keypad to enter 1.0000 V. Press ENTER Key.
7. Press SCOPE/ANLZ MODE Key to access Oscilloscope Operation Screen.
8. Use FIELD SELECT Keys to move cursor to INPUT. Press ENTER Key. Use FIELD SELECT Keys to move cursor to "9. GND". Press ENTER Key.
9. Press "More" F6 until "Scale" F1 appears. Press "Scale" F1. Use DATA SCROLL Keys to select 2 V. Press ENTER Key.
10. Use FIELD SELECT Keys to move cursor to VERT. Press ENTER Key. Use DATA SCROLL Keys to center trace. Press ENTER Key.
11. Set Calibrator for 4 Vdc reading.
12. Use FIELD SELECT Keys to move cursor to INPUT. Press ENTER Key. Use FIELD SELECT Keys to move cursor to "8. DC". Press ENTER Key.
13. Verify trace is on second major division above center ( $\pm 2$  minor divisions).
14. Disconnect external test equipment.

## CHAPTER 2 MAINTENANCE INSTRUCTIONS

### 2-2-8 FREQUENCY AGILITY TEST

#### DESCRIPTION

This procedure is used to verify the Radio Test Set synthesizer response is in specification after A40 3rd LO A41 90 MHz Generator or A13 1st LO has been replaced.

1. Connect external test equipment as shown.

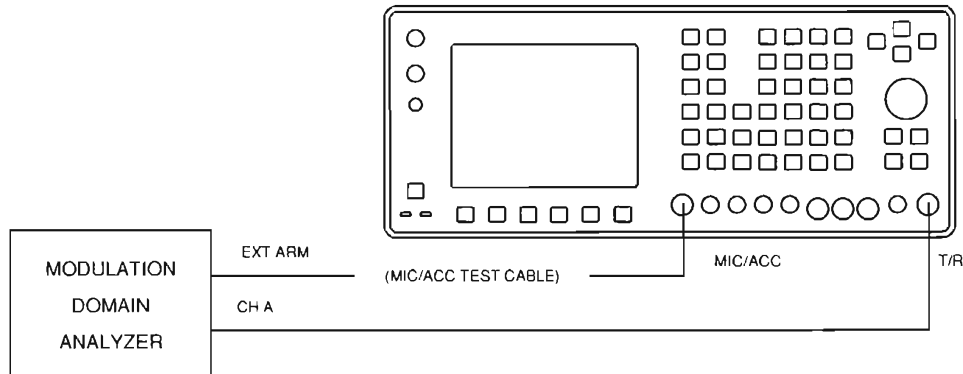

CE2FO260

2. Set Modulation Domain Analyzer controls.

Function	Frequency Channel A
Vertical	Center/Span
Center	87 MHz
Span	2 kHz
Trigger	Ext Edge, Arm Only, Rising Edge
Time Base	300 $\mu$ s
Reference	Left
Delay	0 s
Panorama	Off
Display	vs Time, Axes
Connect Real Time	On
Persistence	Single
Histogram Accumulate	Off
Time Markers	Off
Freq Markers	Off
vs Time Histogram Accumulate	Off
Sampling	Auto
Interval at Ctr	Auto
Clicker	On

3. Press MTRS MODE Key, "AUX" F6 and RCL Key.
4. Use Field Select Keys to move cursor to "10. Factory Defaults" and press ENTER Key twice.
5. Press RCVR MODE Key and SETUP Key.
6. Use FIELD SELECT Keys to move cursor to "1. Set Rcvr Freq." Press ENTER Key. Use DATA ENTRY Keys to enter 87.0000 MHz. Press ENTER Key.

## CHAPTER 2 MAINTENANCE INSTRUCTIONS

### 2-2-8 FREQUENCY AGILITY TEST – Continued

7. Use FIELD SELECT Keys to move cursor "2. Select Mod. Press ENTER Key. Use FIELD SELECT Keys to move cursor to "11. User Defined". Press ENTER Key. Use FIELD SELECT Keys to move cursor to "2. IF Filters". Press ENTER Key. Use FIELD SELECT Keys to move cursor to "3. 300 kHz". Press ENTER Key.
8. Press "ESC" F6.
9. Use FIELD SELECT Keys to move cursor to "5. Select AGC Type". Press ENTER Key. Use FIELD SELECT Keys to move cursor to "2. Manual". Press ENTER Key. Use DATA ENTRY Keypad to enter 255. Press ENTER Key.
10. Use FIELD SELECT KEYS to move cursor to "6. Rcvr Out Speaker". Press ENTER Key to select Off.
11. Press RF GEN MODE Key and SETUP Key.
12. Use FIELD SELECT Keys to move cursor to "5. RF Gen Setup". Press ENTER Key. Use FIELD SELECT Keys to move cursor to "1. RF Gen Freq". Press ENTER Key. Use DATA ENTRY Keypad to enter 30.0000 MHz. Press ENTER Key.
13. Use FIELD SELECT Keys to move cursor to 2. RF Gen Level. Press ENTER Key. Use DATA ENTRY Keypad to enter 0.0 dBm. Press ENTER Key.
14. Press "ESC" F6, "AUX" F6 and "S.R." F1.
15. Verify signal is within 1 kHz of 87 MHz in  $\ll 1.5$  ms from Trigger with Modulation Domain Analyzer as shown.

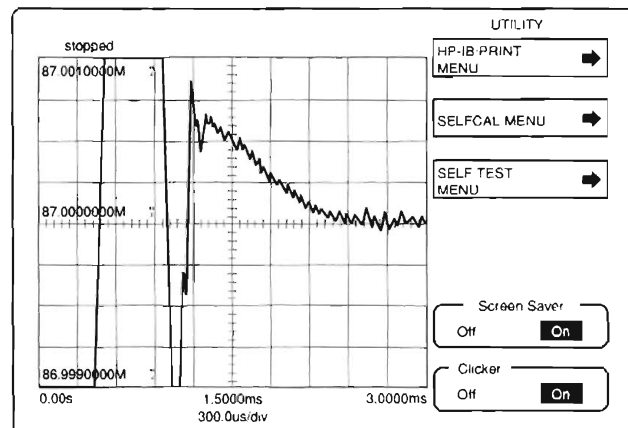

CE2FO259

16. Press "@" F1.
17. Disconnect external test equipment.

## CHAPTER 2 MAINTENANCE INSTRUCTIONS

### 2-2-8 FREQUENCY AGILITY TEST – Continued

18. Connect external test equipment as shown.

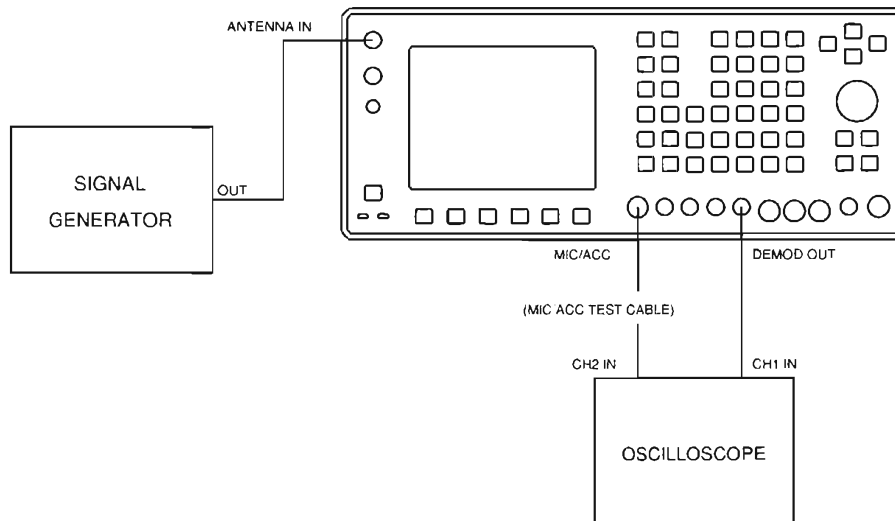

CE2FO261

19. Set Signal Generator for 30.000 MHz signal at -30 dBm with 4 kHz deviation and 1 kHz tone.

20. Set Oscilloscope controls.

Channel 1 Vertical Scale	5 V/Div
Channel 2 Vertical Scale	5 V/Div
Horizontal Sweep	2 ms/Div
Trigger	Channel 2
Trigger Type	Normal
Trigger Slope	Negative
Trigger Coupling	AC
Channel 1 Coupling	DC
Channel 2 Coupling	DC
Bandwidth	20 MHz

21. Press RF GEN MODE Key and SETUP Key.

22. Use FIELD SELECT Keys to move cursor to "5. RF Gen Setup". Press ENTER Key. Use FIELD SELECT Keys to move cursor to "1. RF Gen Freq". Press ENTER Key. Use DATA ENTRY Keypad to enter 87.0000 MHz. Press ENTER Key. Use FIELD SELECT Keys to move cursor to "2. RF Gen Level". Press ENTER Key. Use DATA ENTRY Keypad to enter -30.0 dBm. Press ENTER Key.

23. Press "ESC" F6.

24. Press RCVR MODE Key and SETUP Key.

25. Use FIELD SELECT Keys to move cursor to "1. Set Rcvr Freq". Press ENTER Key. Use DATA ENTRY Keypad to enter 30.0000 MHz. Press ENTER Key.

26. Press "Ret" F5.

27. Press SETUP Key, "AUX" F6 and "S.R." F1.

28. Select Channel 2 only for Oscilloscope Display. Adjust trigger level until Oscilloscope is triggered by clock pulse.



## CHAPTER 2 MAINTENANCE INSTRUCTIONS

### 2-2-8 FREQUENCY AGILITY TEST – Continued

29. Set Oscilloscope to view both Channel 1 and 2 as shown.

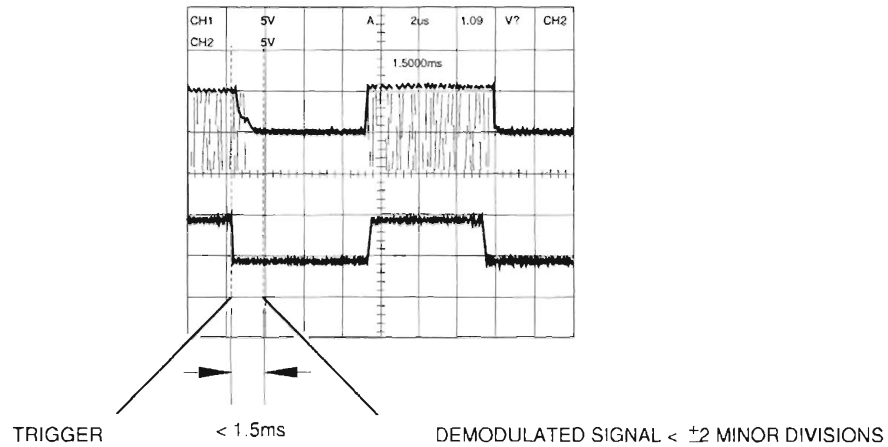

CE2FO262

30. Verify demodulated signal level varies <math>\lt; \pm 2 \text{ Minor Divisions}</math> within 1.5 ms of trigger.

31. Press ">U<" F1.

32. Disconnect external test equipment.

## CHAPTER 2 MAINTENANCE INSTRUCTIONS

---

THIS PAGE INTENTIONALLY LEFT BLANK.

## CHAPTER 3 REPLACEMENTS/ADJUSTMENTS

### CHAPTER TABLE OF CONTENTS

SECTION 1	REPLACEMENTS.....	3
3-1-1	REPLACE 34A3 TOP CASE .....	3
3-1-2	REPLACE 34A2 BOTTOM CASE .....	4
3-1-3	REPLACE 34A5A32 DIGITIZER .....	5
3-1-4	REPLACE 34A5A30 COUNTER .....	6
3-1-5	REPLACE 34A5A7 ANALYZER LOG/IF .....	7
3-1-6	REPLACE 34A5A8 ANALYZER RF .....	8
3-1-7	REPLACE 34A5A40 3rd LO .....	9
3-1-8	REPLACE 34A5A41 90 MHz GENERATOR.....	10
3-1-9	REPLACE 34A5A9 RECEIVER.....	11
3-1-10	REPLACE 34A5A6 MONITOR .....	12
3-1-11	REPLACE 34A5A33 MONITOR CONTROL.....	13
3-1-12	REPLACE 34A5A31 FUNCTION GENERATOR.....	14
3-1-13	REPLACE 34A5A29 RF I/O .....	15
3-1-14	REPLACE 34A5A27 FLASH MEMORY (INSTRUMENT) .....	16
3-1-15	REPLACE 34A5A26 PROCESSOR .....	17
3-1-16	REPLACE 34A5A28 VIDEO CONTROLLER .....	18
3-1-17	REPLACE 34A5A35 EXTERNAL I/O .....	19
3-1-18	REPLACE 34A5A22 POWER SUPPLY .....	20
3-1-19	REPLACE 34A5A23 FRONT PANEL .....	22
3-1-20	REPLACE 34A5A38 REAR PANEL CONNECTOR .....	23
3-1-21	REPLACE 34A5A5 REAR PANEL.....	24
3-1-22	REPLACE 34A5A11 DMM.....	25
3-1-23	REPLACE 34A5A15 2nd LO.....	26
3-1-24	REPLACE 34A5A13 1st LO.....	27
3-1-25	REPLACE 34A5A37 AUXILIARY POWER SUPPLY.....	28
3-1-26	REPLACE 34A5A16 RF RECEIVE IF .....	29
3-1-27	REPLACE 34A5A20 GENERATOR IF .....	30
3-1-28	REPLACE 34A5A36 ATTENUATOR.....	31
3-1-29	REPLACE 34A5A21 POWER TERMINATION.....	32
3-1-30	REPLACE 34A5A39 MASTER OSCILLATOR .....	33
3-1-31	UPLOAD INTERFACE SOFTWARE PROCEDURE .....	35
SECTION 2	ADJUSTMENTS.....	36
3-2-1	POWER SUPPLY ADJUSTMENT.....	40

## CHAPTER 3 REPLACEMENTS/ADJUSTMENTS

3-2-2	METERING DVM ADJUSTMENT .....	41
3-2-3	FUNC GEN LEVEL AND VRMS METER ADJUSTMENT .....	41
3-2-4	GEN OUTPUT LEVEL ADJUSTMENT .....	43
3-2-5	RF NULL ADJUSTMENT .....	44
3-2-6	SIGNAL METER ADJUSTMENT .....	44
3-2-7	FM ADJUSTMENT .....	45
3-2-8	DEVIATION METER ADJUSTMENT .....	46
3-2-8	MODULATION METER ADJUSTMENT .....	48
3-2-9	PHASE METER ADJUSTMENT .....	48
3-2-10	DISTORTION METER ADJUSTMENT .....	50
3-2-11	SINAD METER ADJUSTMENT .....	51
3-2-12	GEN MODULATION ADJUSTMENT .....	52
3-2-13	SCOPE ADJUSTMENT .....	55
3-2-14	SPECTRUM ANALYZER ADJUSTMENT .....	56
3-2-15	POWER METER ADJUSTMENT .....	58
SECTION 3	PREPARATION FOR STORAGE OR SHIPMENT .....	60
3-3-1	PACKAGING .....	60
3-3-2	ENVIRONMENT .....	60

## CHAPTER 3 REPLACEMENTS/ADJUSTMENTS

### SECTION 1 REPLACEMENTS

#### 3-1-1 REPLACE 34A3 TOP CASE

##### DESCRIPTION

This procedure covers: Remove. Install.

##### INITIAL SETUP

##### WARNING

Dangerous voltages are present with case assemblies removed.

##### CAUTION

Do not disconnect or remove any assemblies in Radio Test Set unless instrument is unplugged.

##### NOTE

After any screw or nut is loosened or removed 5 times, the use of Torque Seal is required.

##### PRELIMINARY PROCEDURES

- Perform required Adjustments (para 3-2-1).

##### REMOVE

1. Loosen 5 captive screws (1).
2. Slide 34A5A5 Rear Panel (2) toward rear.
3. Remove 34A3 Top Case (3).

##### INSTALL

1. Install 34A3 Top Case (3).
2. Slide 34A5A5 Rear Panel (2) toward front.
3. Tighten 5 captive screws (1).

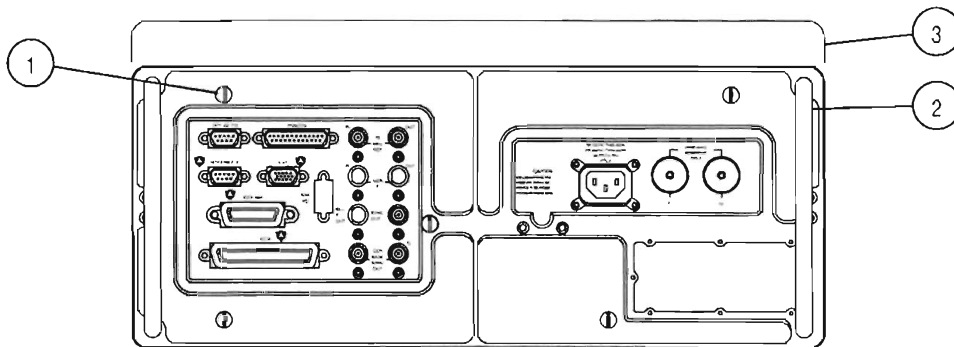

TCRE01

END OF TASK

## CHAPTER 3 REPLACEMENTS/ADJUSTMENTS

### 3-1-2 REPLACE 34A2 BOTTOM CASE

#### DESCRIPTION

This procedure covers: Remove. Install.

#### INITIAL SETUP

#### WARNING

Dangerous voltages are present with case assemblies removed.

#### NOTE

After any screw or nut is loosened or removed 5 times, the use of Torque Seal is required.

#### REMOVE

1. Loosen 5 captive screws (1).
2. Slide 34A5A5 Rear Panel (2) toward rear.
3. Remove 34A2 Bottom Case (3).

#### INSTALL

1. Install 34A2 Bottom Case (3).
2. Slide 34A5A5 Rear Panel (2) toward front.
3. Tighten 5 captive screws (1).

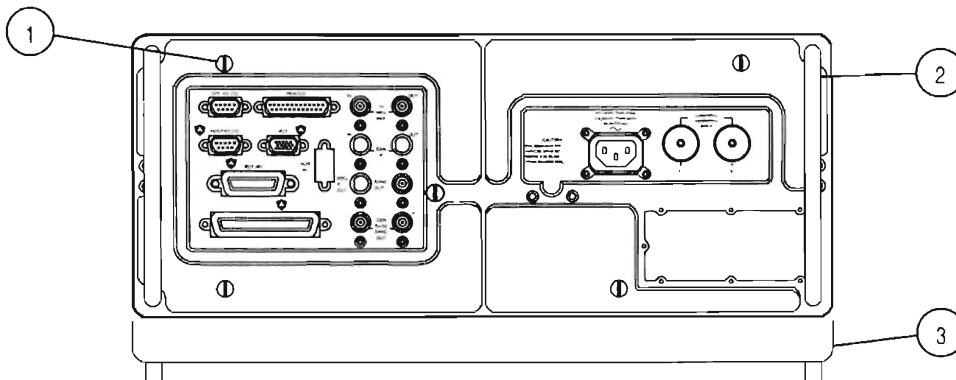

BCRE01

END OF TASK

## CHAPTER 3 REPLACEMENTS/ADJUSTMENTS

### 3-1-3 REPLACE 34A5A32 DIGITIZER

#### DESCRIPTION

This procedure covers: Remove. Install.

#### INITIAL SETUP

#### PRELIMINARY PROCEDURES:

- Remove 34A3 Top Case (para 3-1-1).

#### REMOVE

1. Disconnect coaxial cable (1).
2. Raise card ejectors and remove 34A5A32 Digitizer (2).

#### INSTALL

1. Install 34A5A32 Digitizer (2) in guides and close card ejectors.
2. Reconnect coaxial cable (1).

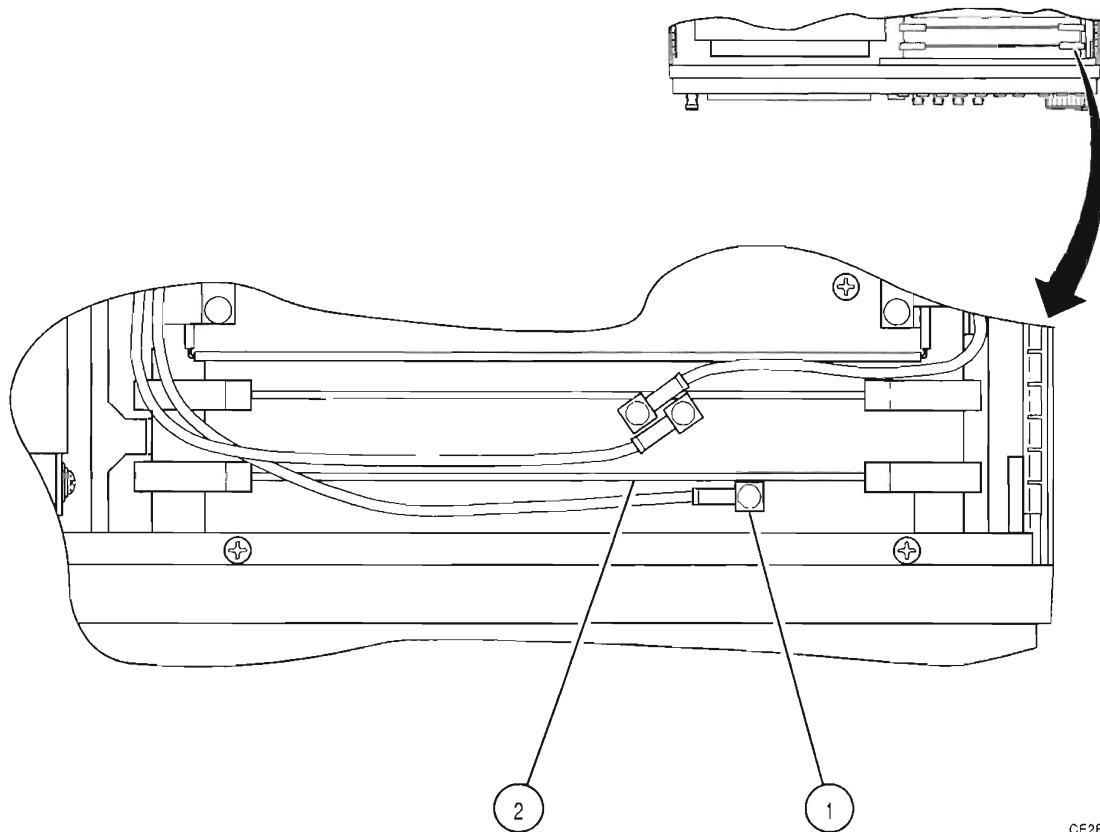

CE2F0017

#### FOLLOW-ON MAINTENANCE:

- Perform Adjustments (para 3-2-1).
- Install 34A3 Top Case (para 3-1-1).

#### END OF TASK

## CHAPTER 3 REPLACEMENTS/ADJUSTMENTS

### 3-1-4 REPLACE 34A5A30 COUNTER

#### DESCRIPTION

This procedure covers: Remove. Install.

#### INITIAL SETUP

##### PRELIMINARY PROCEDURES:

- Remove 34A3 Top Case (para 3-1-1).

#### REMOVE

1. Disconnect 3 coaxial cables (1).
2. Raise card ejectors and remove 34A5A30 Counter (2).

#### INSTALL

1. Install 34A5A30 Counter (2) in guides and close card ejectors.
2. Reconnect 3 coaxial cables (1).

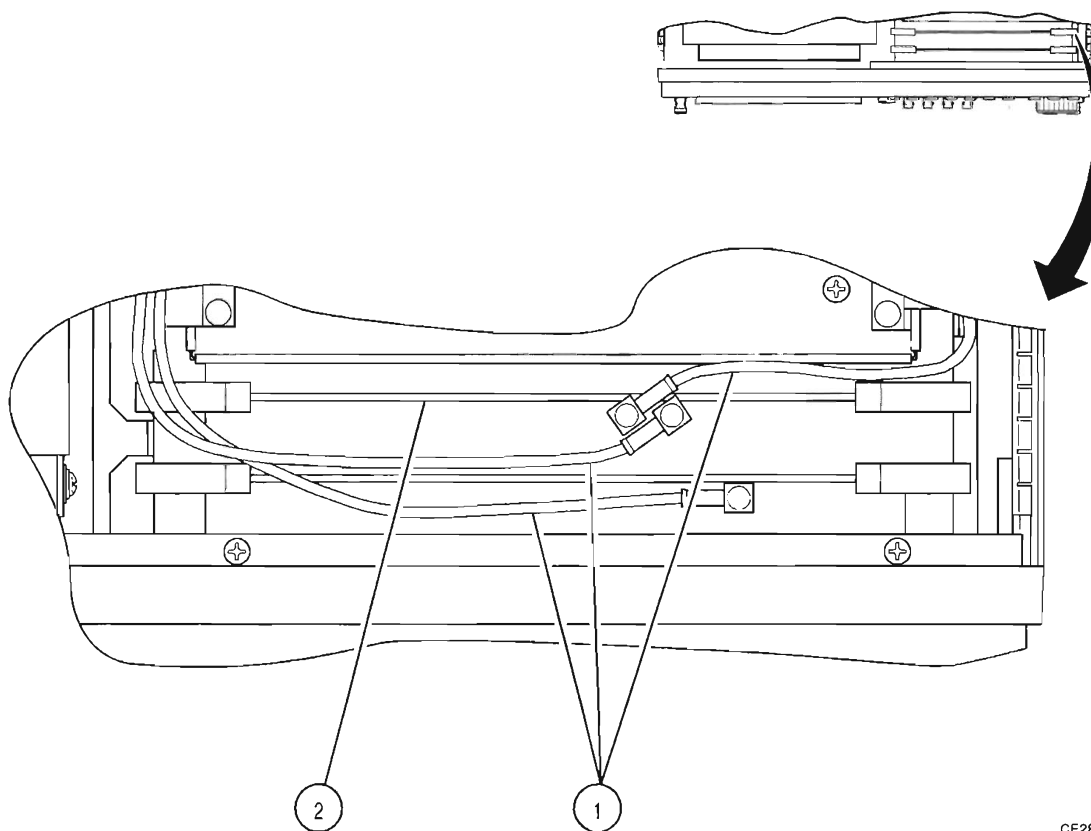

CE2FO018

##### FOLLOW-ON MAINTENANCE:

- Install 34A3 Top Case (para 3-1-1).

#### END OF TASK



## CHAPTER 3 REPLACEMENTS/ADJUSTMENTS

### 3-1-5 REPLACE 34A5A7 ANALYZER LOG/IF

#### DESCRIPTION

This procedure covers: Remove. Install.

#### INITIAL SETUP

#### PRELIMINARY PROCEDURES:

- Remove 34A3 Top Case (para 3-1-1).
- Remove 34A5A8 Analyzer RF (para 3-1-6).

#### REMOVE

1. Disconnect 3 coaxial cables (1).
2. Loosen 2 captive screws (2).
3. Remove 34A5A7 Analyzer Log/IF (3).

#### INSTALL

1. Install 34A5A7 Analyzer Log/IF (3)
2. Tighten 2 captive screws (2).
3. Reconnect 3 coaxial cables (1).

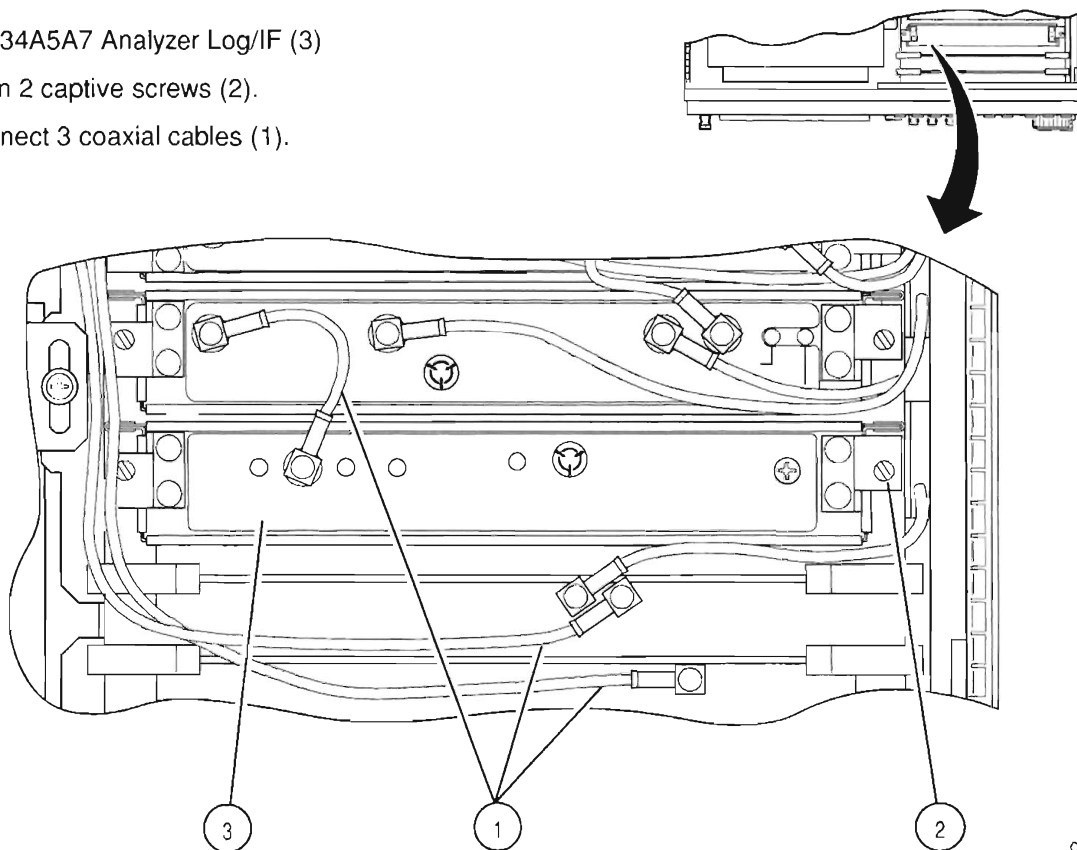

CE2FO019

#### FOLLOW-ON MAINTENANCE:

- Install 34A5A8 Analyzer RF (para 3-1-6).
- Perform Adjustments (para 3-2-1).
- Install 34A3 Top Case (para 3-1-1).

#### END OF TASK

## CHAPTER 3 REPLACEMENTS/ADJUSTMENTS

### 3-1-6 REPLACE 34A5A8 ANALYZER RF

#### DESCRIPTION

This procedure covers: Remove. Install.

#### INITIAL SETUP

#### PRELIMINARY PROCEDURES:

- Remove 34A3 Top Case (para 3-1-1).

#### REMOVE

1. Disconnect 6 coaxial cables (1).
2. Loosen 2 captive screws (2).
3. Remove 34A5A8 Analyzer RF (3).

#### INSTALL

1. Install 34A5A8 Analyzer RF (3)
2. Tighten 2 captive screws (2).
3. Reconnect 6 coaxial cables (1).

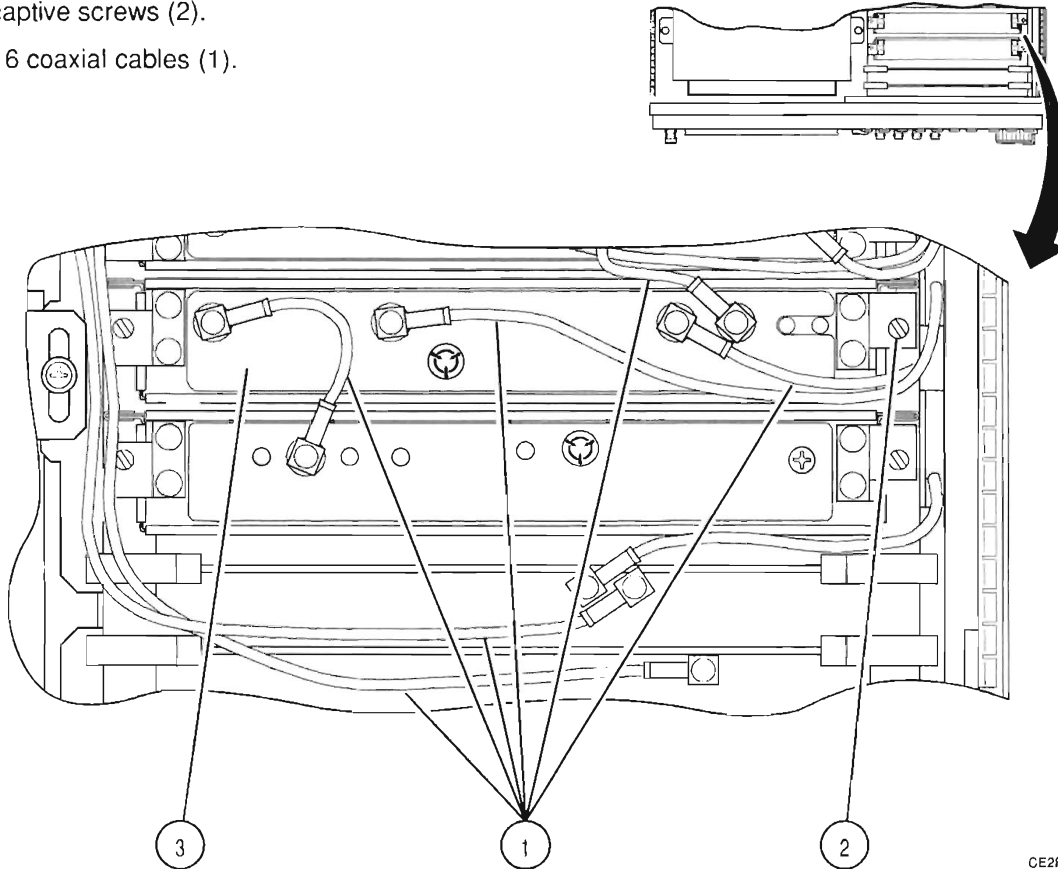

CE2FO020

#### FOLLOW-ON MAINTENANCE:

- Perform Adjustments (para 3-2-1).
- Install 34A3 Top Case (para 3-1-1).

#### END OF TASK

## CHAPTER 3 REPLACEMENTS/ADJUSTMENTS

### 3-1-7 REPLACE 34A5A40 3rd LO

#### DESCRIPTION

This procedure covers: Remove. Install.

#### INITIAL SETUP

#### PRELIMINARY PROCEDURES:

- Remove 34A3 Top Case (para 3-1-1).
- Remove 34A5A8 Analyzer RF (para 3-1-6).

#### REMOVE

1. Disconnect 5 coaxial cables (1).
2. Loosen 2 captive screws (2).
3. Remove 34A5A40 3rd LO (3).

#### INSTALL

1. Install 34A5A40 3rd LO (3).
2. Tighten 2 captive screws (2).
3. Reconnect 5 coaxial cables (1).

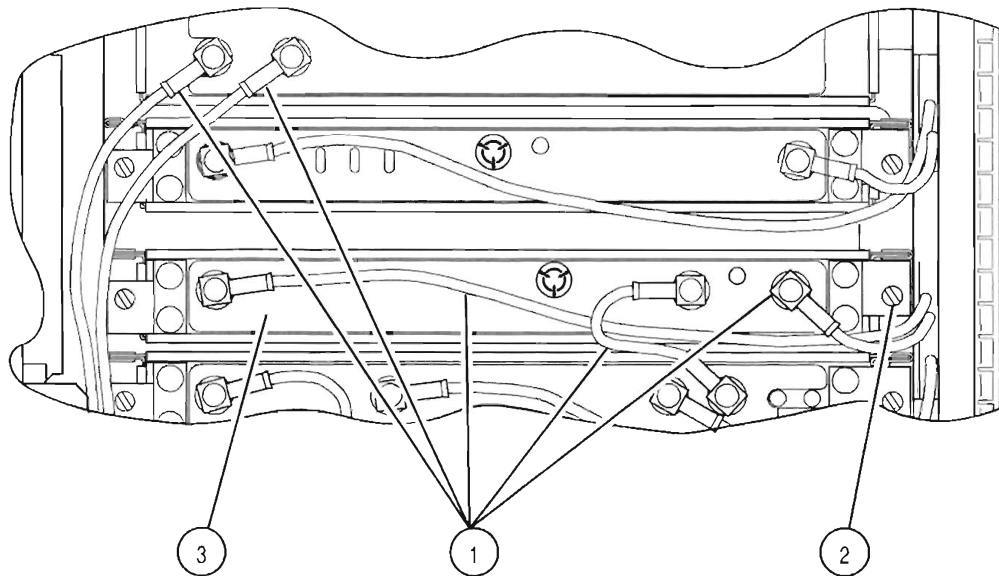
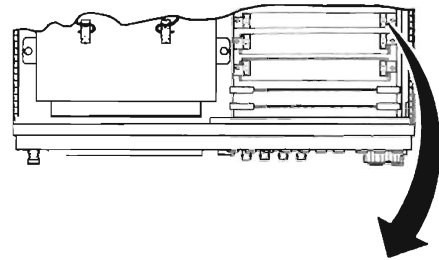

CE2FO021

#### FOLLOW-ON MAINTENANCE:

- Install 34A5A8 Analyzer RF (para 3-1-6).
- Perform Adjustments (para 3-2-1).
- Perform Frequency Agility Test (para 2-4-8).
- Install 34A3 Top Case (para 3-1-1).

#### END OF TASK

## CHAPTER 3 REPLACEMENTS/ADJUSTMENTS

### 3-1-8 REPLACE 34A5A41 90 MHz GENERATOR

#### DESCRIPTION

This procedure covers: Remove. Install.

#### INITIAL SETUP

##### PRELIMINARY PROCEDURES:

- Remove 34A3 Top Case (para 3-1-1).

#### REMOVE

1. Disconnect 4 coaxial cables (1).
2. Loosen 2 captive screws (2).
3. Remove 34A5A41 90 MHz Generator (3).

#### INSTALL

1. Install 34A5A41 90 MHz Generator (3).
2. Tighten 2 captive screws (2).
3. Reconnect 4 coaxial cables (1).

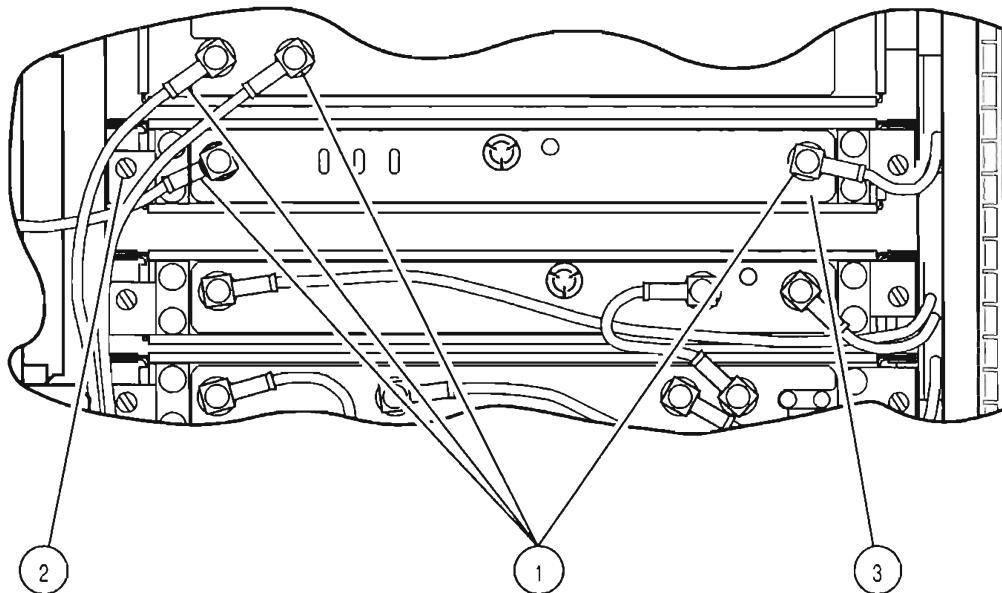
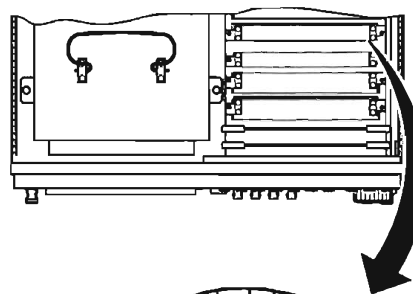

90MRE01

##### FOLLOW-ON MAINTENANCE:

- Perform Adjustments (para 3-2-1).
- Perform Frequency Agility Test (para 2-4-8).
- Install 34A3 Top Case (para 3-1-1).

#### END OF TASK

## CHAPTER 3 REPLACEMENTS/ADJUSTMENTS

### 3-1-9 REPLACE 34A5A9 RECEIVER

#### DESCRIPTION

This procedure covers: Remove. Install.

#### INITIAL SETUP

#### PRELIMINARY PROCEDURES:

- Remove 34A3 Top Case (para 3-1-1).

#### REMOVE

1. Disconnect 4 coaxial cables (1).
2. Loosen 2 captive screws (2).
3. Remove 34A5A9 Receiver (3).

#### INSTALL

1. Install 34A5A9 Receiver (3).
2. Tighten 2 captive screws (2).
3. Reconnect 4 coaxial cables (1).

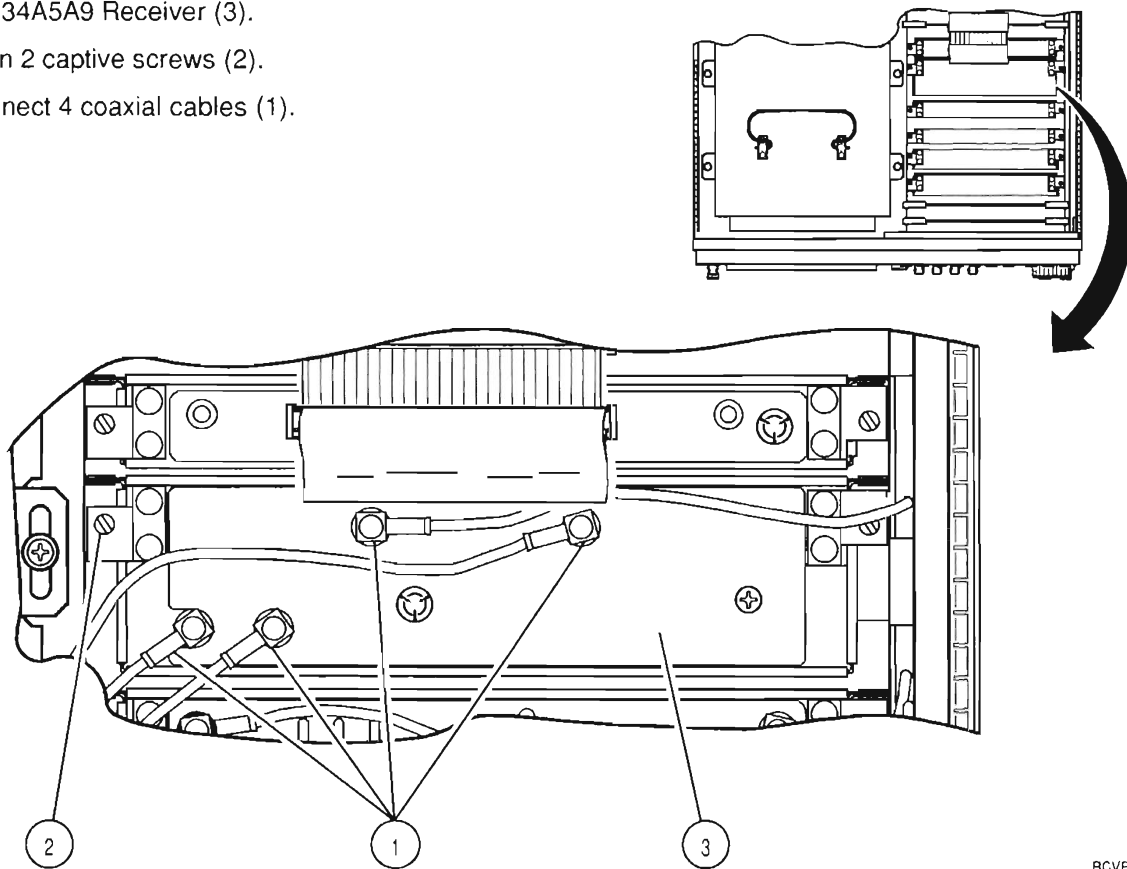

RCVARE01

#### FOLLOW-ON MAINTENANCE:

- Perform Adjustments (para 3-2-1).
- Install 34A3 Top Case (para 3-1-1).

#### END OF TASK

## CHAPTER 3 REPLACEMENTS/ADJUSTMENTS

### 3-1-10 REPLACE 34A5A6 MONITOR

#### DESCRIPTION

This procedure covers: Remove. Install.

#### INITIAL SETUP

##### PRELIMINARY PROCEDURES:

- Remove 34A3 Top Case (para 3-1-1).

#### REMOVE

1. Disconnect ribbon cable connector (1).
2. Loosen 2 captive screws (2).
3. Remove 34A5A6 Monitor (3).

#### INSTALL

1. Install 34A5A6 Monitor (3).
2. Tighten 2 captive screws (2).
3. Reconnect ribbon cable connector (1).

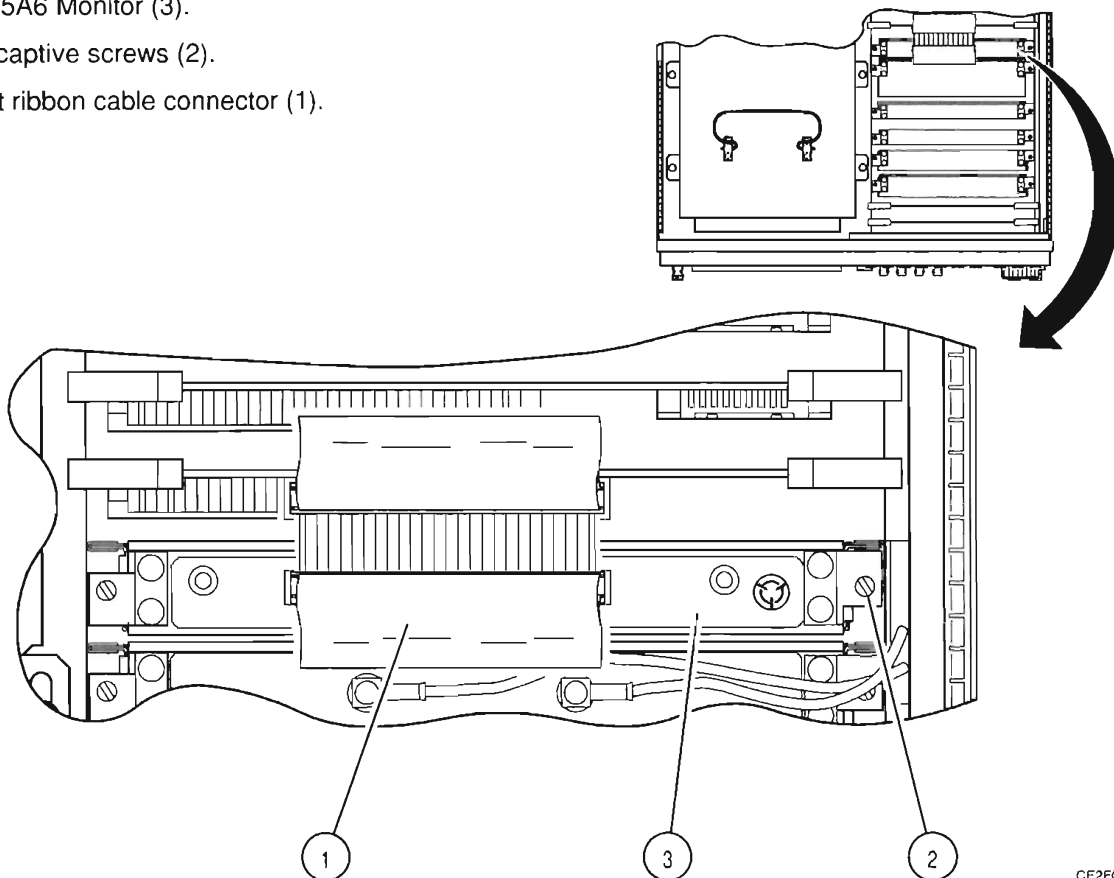

CE2FO024

##### FOLLOW-ON MAINTENANCE:

- Perform Adjustments (para 3-2-1).
- Install 34A3 Top Case (para 3-1-1).

#### END OF TASK

## CHAPTER 3 REPLACEMENTS/ADJUSTMENTS

### 3-1-11 REPLACE 34A5A33 MONITOR CONTROL

#### DESCRIPTION

This procedure covers: Remove. Install.

#### INITIAL SETUP

#### PRELIMINARY PROCEDURES:

- Remove 34A3 Top Case (para 3-1-1).

#### REMOVE

1. Disconnect ribbon cable connector (1).
2. Raise card ejectors and remove 34A5A33 Monitor Control (2).

#### INSTALL

1. Install 34A5A33 Monitor Control (2) in guides and close card ejectors.
2. Reconnect ribbon cable connector (1).

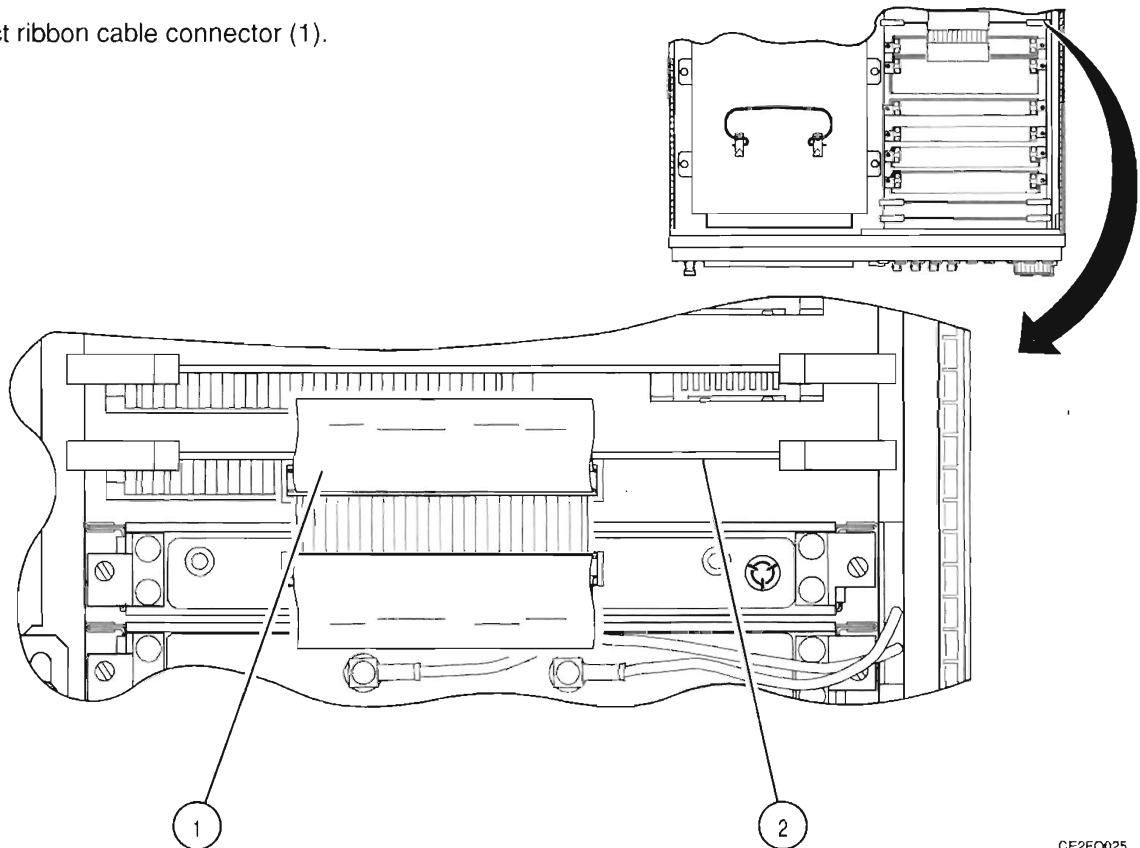

CE2FO025

#### FOLLOW-ON MAINTENANCE:

- Perform Adjustments (para 3-2-1).
- Install 34A3 Top Case (para 3-1-1).

#### END OF TASK

## CHAPTER 3 REPLACEMENTS/ADJUSTMENTS

### 3-1-12 REPLACE 34A5A31 FUNCTION GENERATOR

#### DESCRIPTION

This procedure covers: Remove, Install.

#### INITIAL SETUP

##### PRELIMINARY PROCEDURES:

- Remove 34A3 Top Case (para 3-1-1).

#### REMOVE

1. Raise card ejectors and remove 34A5A31 Function Generator (1).

#### INSTALL

1. Install 34A5A31 Function Generator (1) in guides and close card ejectors.

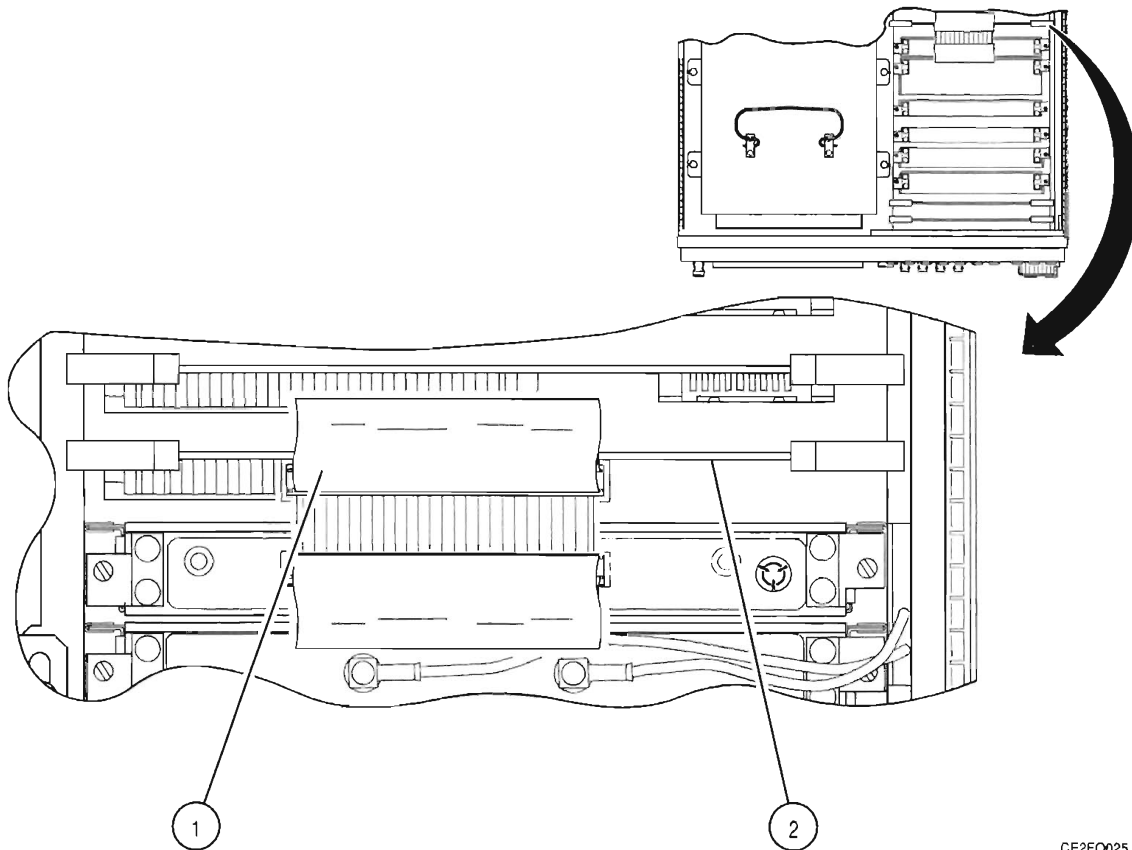

CE2FO025

##### FOLLOW-ON MAINTENANCE:

- Perform Adjustments (para 3-2-1).
- Install 34A3 Top Case (para 3-1-1).

#### END OF TASK



## CHAPTER 3 REPLACEMENTS/ADJUSTMENTS

### 3-1-13 REPLACE 34A5A29 RF I/O

#### DESCRIPTION

This procedure covers: Remove. Install.

#### INITIAL SETUP

#### PRELIMINARY PROCEDURES:

- Remove 34A3 Top Case (para 3-1-1).

#### REMOVE

1. Raise card ejectors and remove 34A5A29 RF I/O (1).

#### INSTALL

1. Install 34A5A29 RF I/O (1) in guides and close card ejectors.

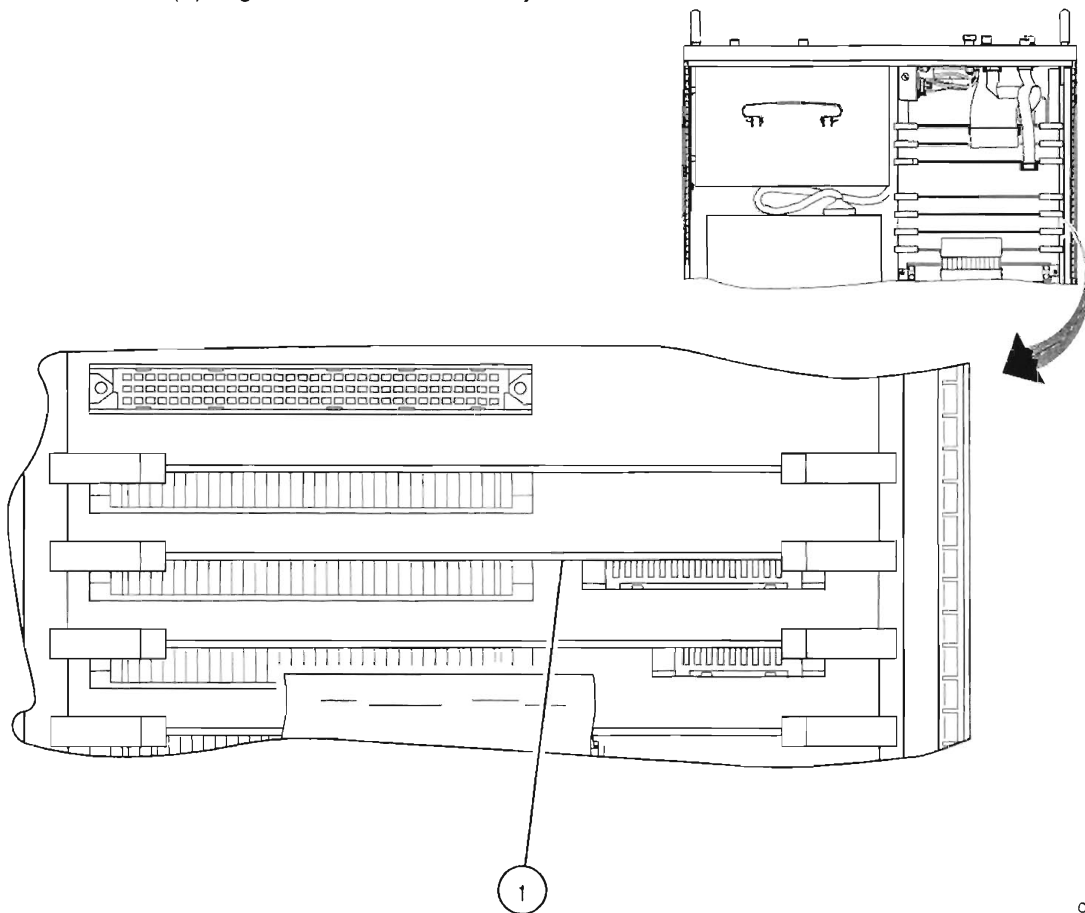

CE2FO027

#### FOLLOW-ON MAINTENANCE:

- Perform Adjustments (para 3-2-1).
- Install 34A3 Top Case (para 3-1-1).

#### END OF TASK

## CHAPTER 3 REPLACEMENTS/ADJUSTMENTS

### 3-1-14 REPLACE 34A5A27 FLASH MEMORY (INSTRUMENT)

#### DESCRIPTION

This procedure covers: Remove. Install.

#### INITIAL SETUP

##### PRELIMINARY PROCEDURES:

- Remove 34A3 Top Case (para 3-1-1).

#### REMOVE

2. Raise card ejectors and remove 34A5A27 Flash Memory (1).

#### INSTALL

3. Install 34A5A27 Flash Memory (1) in guides and close card ejectors.

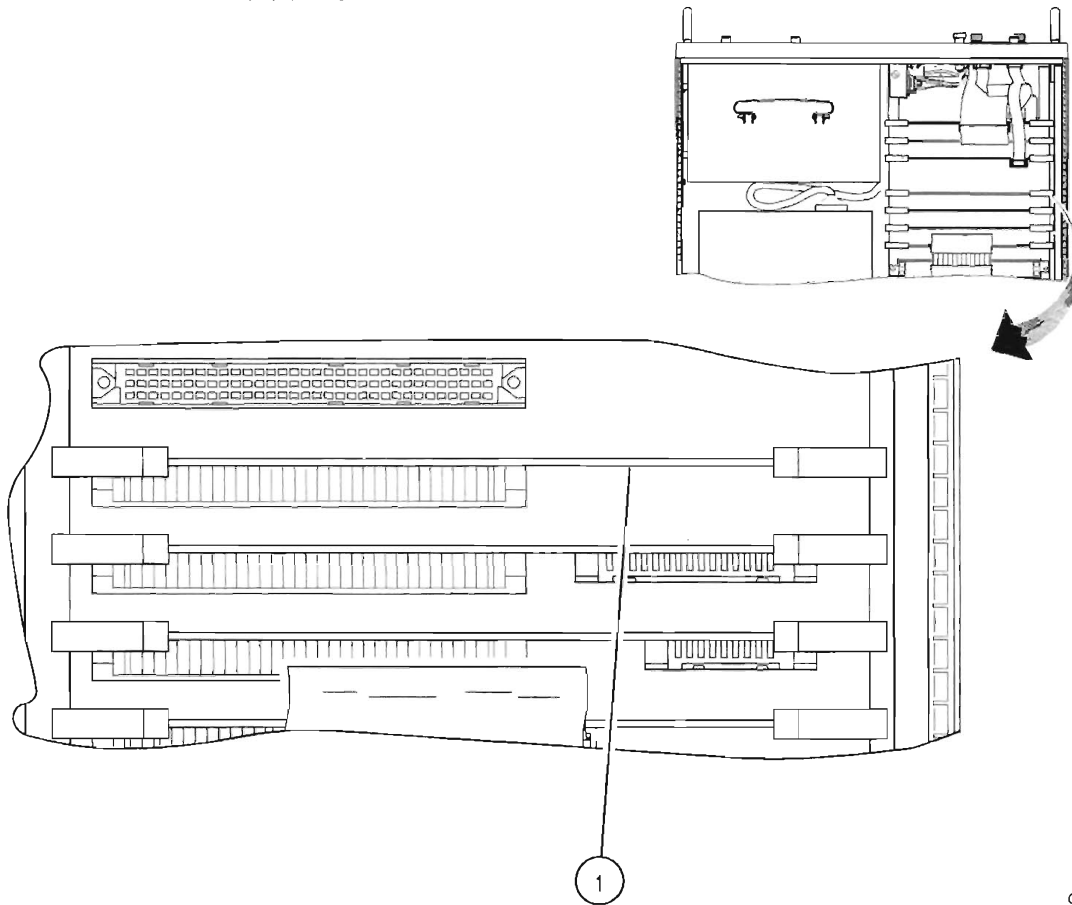

CE2FO028

##### FOLLOW-ON MAINTENANCE:

- Install 34A3 Top Case (para 3-1-1).

#### END OF TASK

## CHAPTER 3 REPLACEMENTS/ADJUSTMENTS

### 3-1-15 REPLACE 34A5A26 PROCESSOR

#### DESCRIPTION

This procedure covers: Remove. Install.

#### INITIAL SETUP

#### PRELIMINARY PROCEDURES:

- Remove 34A3 Top Case (para 3-1-1).

#### REMOVE

1. Disconnect ribbon cable connector (1).
2. Raise card ejectors and remove 34A5A26 Processor (2).

#### INSTALL

1. Install 34A5A26 Processor (2) in guides and close card ejectors.
2. Reconnect ribbon cable connector (1).

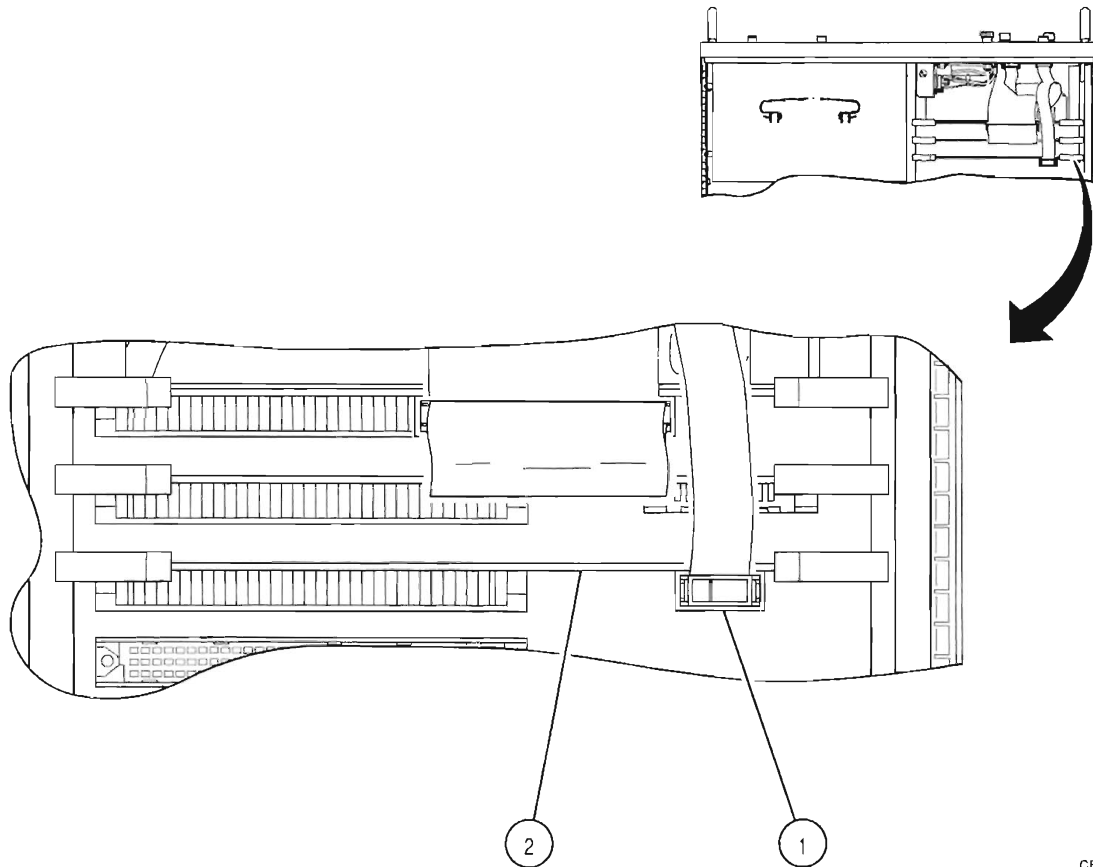

CE2FO029

#### FOLLOW-ON MAINTENANCE:

- Install 34A3 Top Case (para 3-1-1).

#### END OF TASK

## CHAPTER 3 REPLACEMENTS/ADJUSTMENTS

### 3-1-16 REPLACE 34A5A28 VIDEO CONTROLLER

#### DESCRIPTION

This procedure covers: Remove. Install.

#### INITIAL SETUP

##### PRELIMINARY PROCEDURES:

- Remove 34A3 Top Case (para 3-1-1).

#### REMOVE

1. Disconnect ribbon cable connector (1).
2. Raise card ejectors and remove 34A5A28 Video Controller (2).

#### INSTALL

1. Install 34A5A28 Video Controller (2) in guides and close card ejectors.
2. Reconnect ribbon cable connector (1).

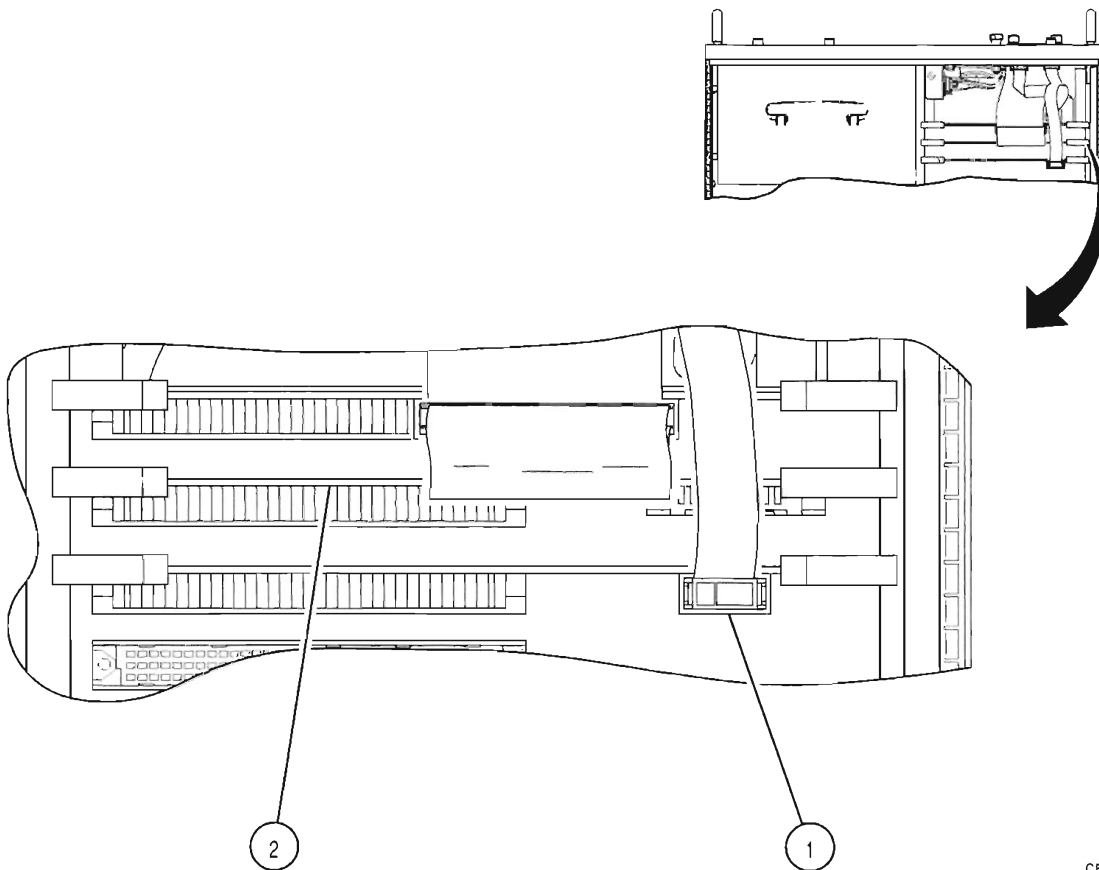

CE2FO030

##### FOLLOW-ON MAINTENANCE:

- Install 34A3 Top Case (para 3-1-1).

#### END OF TASK

## CHAPTER 3 REPLACEMENTS/ADJUSTMENTS

### 3-1-17 REPLACE 34A5A35 EXTERNAL I/O

#### DESCRIPTION

This procedure covers: Remove. Install.

#### INITIAL SETUP

#### PRELIMINARY PROCEDURES:

- Remove 34A3 Top Case (para 3-1-1).

#### REMOVE

1. Disconnect 2 ribbon cable connectors (1).
2. Raise card ejectors and remove 34A5A35 External I/O (2).

#### INSTALL

1. Install 34A5A35 External I/O (2) in guides and close card ejectors.
2. Reconnect 2 ribbon cable connectors (1).

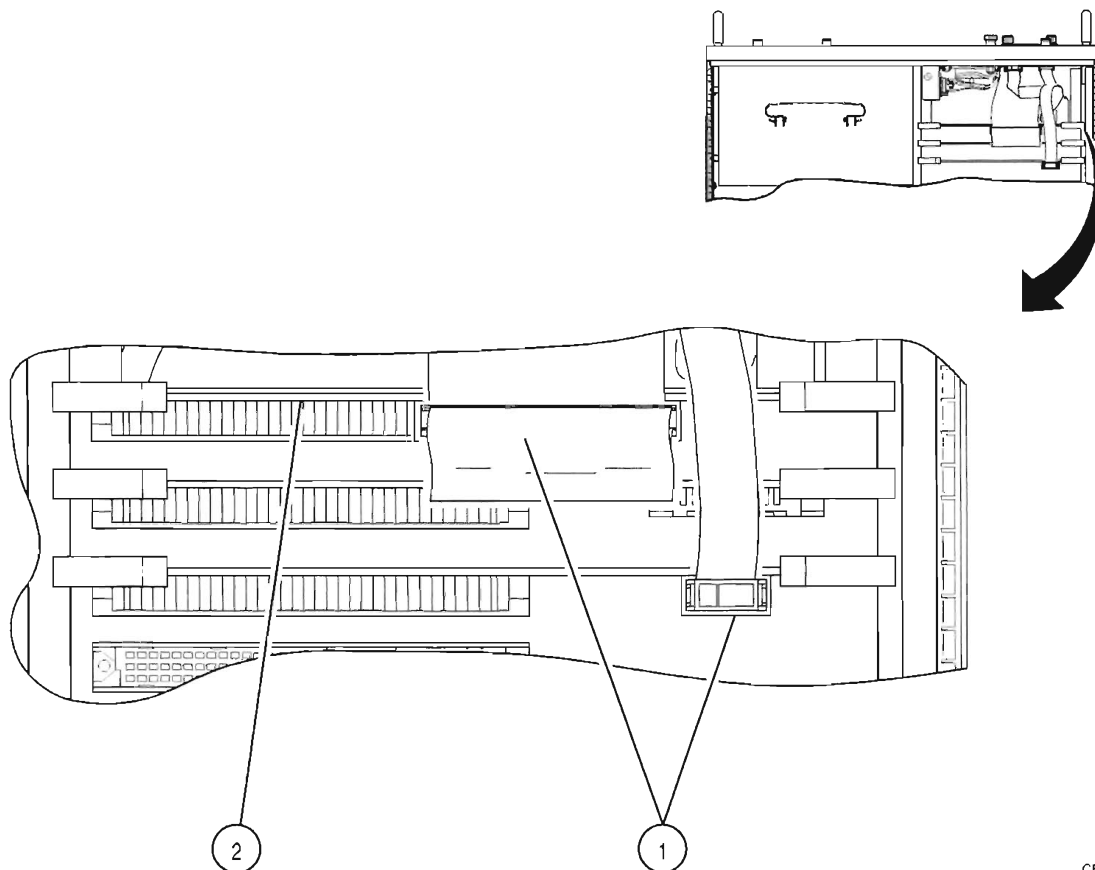

CE2FO031

#### FOLLOW-ON MAINTENANCE:

- Install 34A3 Top Case (para 3-1-1).

#### END OF TASK

## CHAPTER 3 REPLACEMENTS/ADJUSTMENTS

### 3-1-18 REPLACE 34A5A22 POWER SUPPLY

---

#### DESCRIPTION

This procedure covers: Remove. Install.

---

#### INITIAL SETUP

##### PRELIMINARY PROCEDURES:

- Remove 34A3 Top Case (para 3-1-1).
  - Remove 34A2 Bottom Case (para 3-1-2).
- 

#### REMOVE

1. Disconnect 2 wire cable connectors (1).
2. Disconnect wire cable connector (3).
3. Remove 2 screws and 4 washers (4).
4. Remove 2 covers (5).
5. Slide 34A5A22 Power Supply (6) toward front.
6. Raise handle (7) and remove 34A5A22 Power Supply (6).

#### INSTALL

1. Install 34A5A22 Power Supply (6).
2. Slide 34A5A22 Power Supply (6) toward rear.
3. Install 2 covers (5).
4. Install 2 screws and washers (4).
5. Reconnect wire cable connector (3).
6. Reconnect 2 wire cable connectors (1).

## CHAPTER 3 REPLACEMENTS/ADJUSTMENTS

### 3-1-18 REPLACE 34A5A22 POWER SUPPLY - Continued

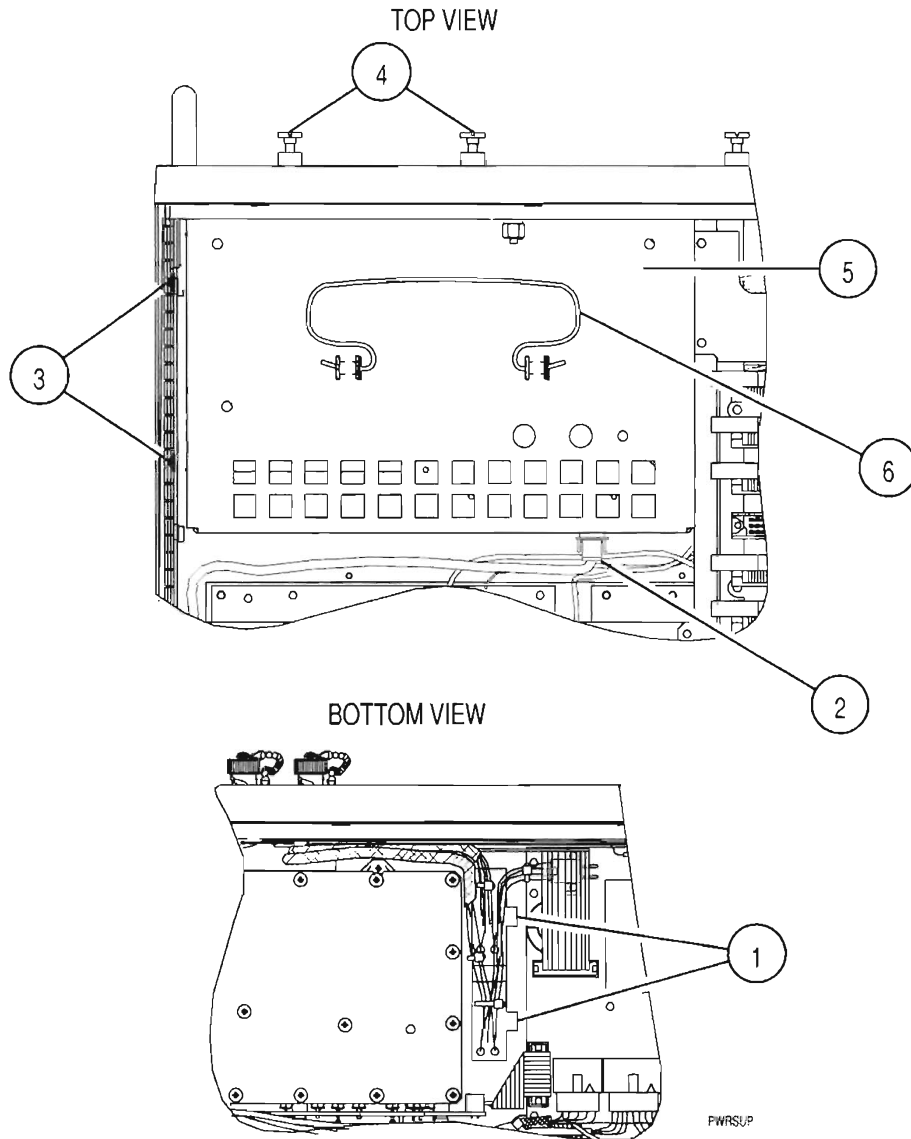

#### FOLLOW-ON MAINTENANCE:

- Perform Adjustments (para 3-2-1).
- Install 34A2 Bottom Case (para 3-1-2).
- Install 34A3 Top Case (para 3-1-1).

**END OF TASK**

## CHAPTER 3 REPLACEMENTS/ADJUSTMENTS

### 3-1-19 REPLACE 34A5A23 FRONT PANEL

#### DESCRIPTION

This procedure covers: Remove. Install.

#### INITIAL SETUP

##### PRELIMINARY PROCEDURES:

- Remove 34A3 Top Case (para 3-1-1).
- Remove 34A2 Bottom Case (para 3-1-2).

#### REMOVE

1. Remove nut (1).
2. Disconnect wire cable connector (2).
3. Remove 8 screws (3).
4. Lift 34A5A23 Front Panel (4) and disconnect 3 ribbon cable connectors (6) and 2 coaxial cable connectors (7).

#### INSTALL

1. Hold 34A5A23 Front Panel (4) and reconnect 3 ribbon cable connectors (6) and 2 coaxial cable connectors (7).
2. Install 34A5A23 Front Panel (4) on 34A5A1 Chassis (5).
3. Install 8 screws (3).
4. Reconnect wire cable connector (2).
5. Install nut (1). Torque to 120 in/lbs.

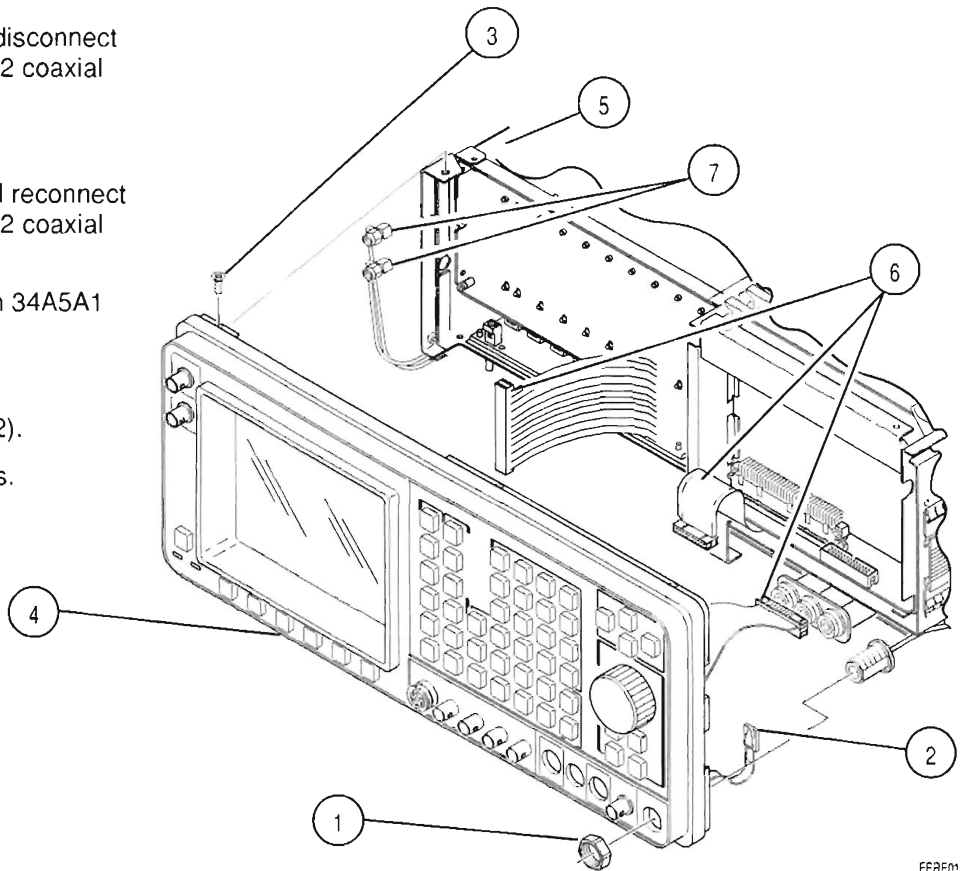

FFRE01

##### FOLLOW-ON MAINTENANCE:

- Install 34A2 Bottom Case (para 3-1-2).
- Install 34A3 Top Case (para 3-1-1).

#### END OF TASK



## CHAPTER 3 REPLACEMENTS/ADJUSTMENTS

### 3-1-20 REPLACE 34A5A38 REAR PANEL CONNECTOR

#### DESCRIPTION

This procedure covers: Remove. Install.

#### INITIAL SETUP

##### PRELIMINARY PROCEDURES:

- Remove 34A3 Top Case (para 3-1-1).
- Remove 34A5A26 Processor (para 3-1-15).
- Remove 34A5A28 Video Controller (para 3-1-16).
- Remove 34A5A35 External I/O (para 3-1-17).

#### REMOVE

1. Remove ESD Covers from connectors.
2. Remove 8 shell nuts (1).
3. Remove 34A5A38 Rear Panel Connector (2).
4. Disconnect 2 ribbon cable connectors (4).

#### INSTALL

1. Reconnect 2 ribbon cable connectors (4).
2. Install 34A5A38 Rear Panel Connector (2) on 34A5A5 Rear Panel (3).
3. Install 8 shell nuts (1) with Loctite 290.
4. Install ESD Covers on connectors.

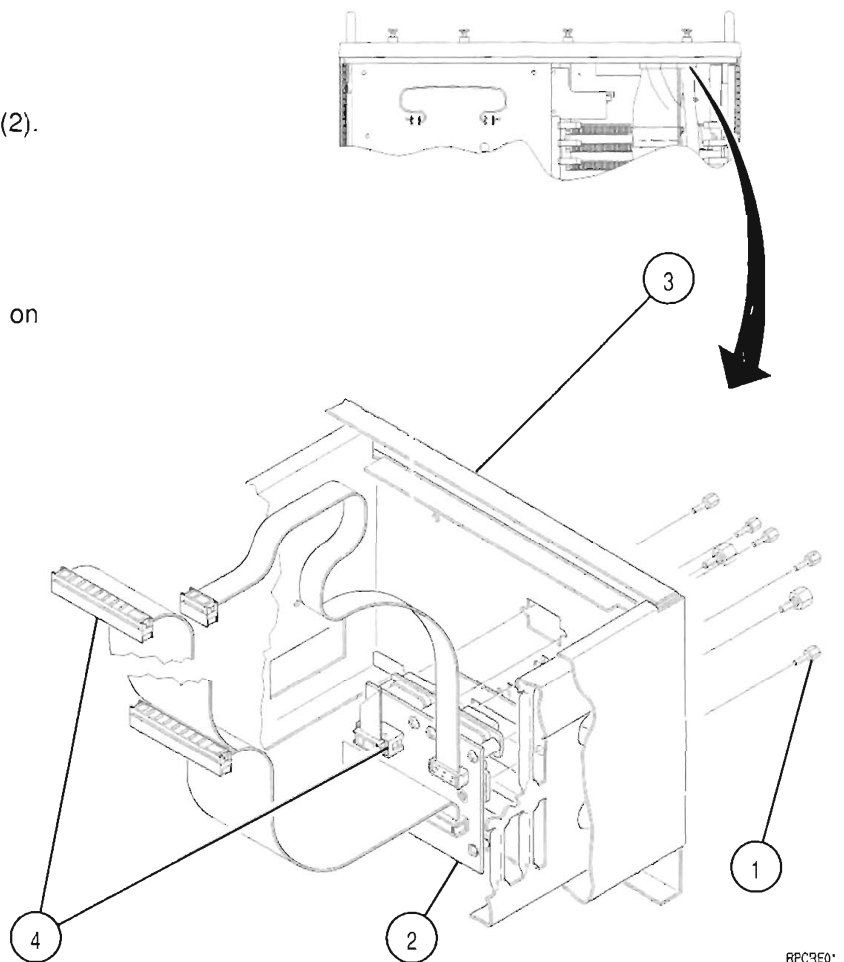

##### FOLLOW-ON MAINTENANCE:

- Install 34A5A35 External I/O (para 3-1-17).
- Install 34A5A28 Video Controller (para 3-1-16).
- Install 34A5A26 Processor (para 3-1-15).
- Install 34A3 Top Case (para 3-1-1).

#### END OF TASK

## CHAPTER 3 REPLACEMENTS/ADJUSTMENTS

### 3-1-21 REPLACE 34A5A5 REAR PANEL

#### DESCRIPTION

This procedure covers: Remove. Install.

#### INITIAL SETUP

##### PRELIMINARY PROCEDURES:

- Remove 34A3 Top Case (para 3-1-1).
- Remove 34A2 Bottom Case (para 3-1-2).

#### REMOVE

1. Remove 4 screws (1).
2. Loosen 5 captive screws (2).
3. Remove 34A5A5 Rear Panel (3).

#### INSTALL

1. Install 34A5A5 Rear Panel (3).
2. Tighten 5 captive screws (2).
3. Install 4 screws (1).

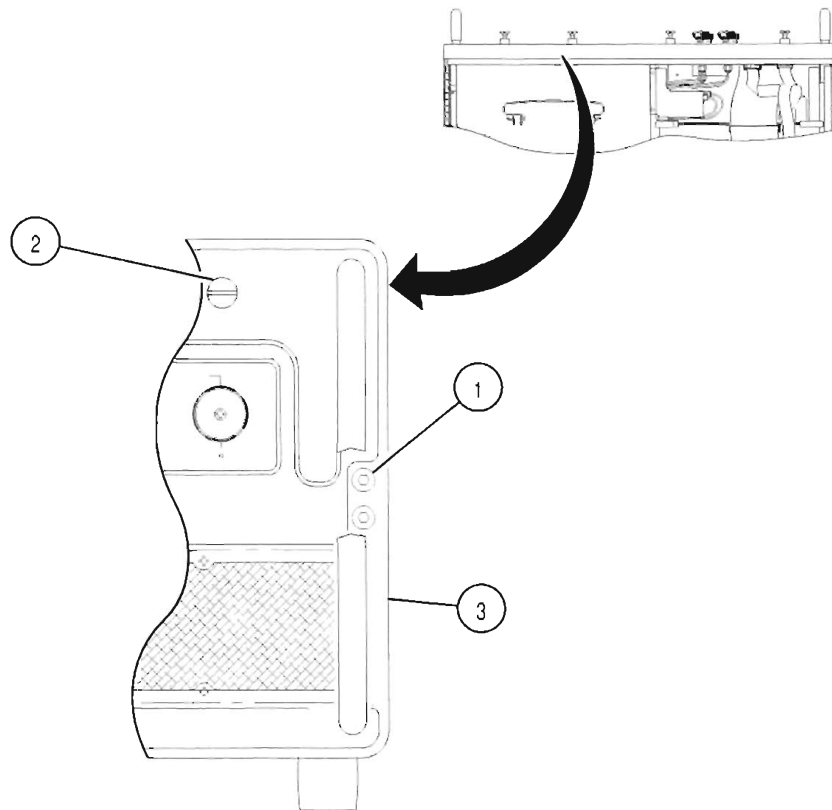

RPRE01

##### FOLLOW-ON MAINTENANCE:

- Install 34A2 Bottom Case (para 3-1-2).
- Install 34A3 Top Case (para 3-1-1).

#### END OF TASK

## CHAPTER 3 REPLACEMENTS/ADJUSTMENTS

### 3-1-22 REPLACE 34A5A11 DMM

#### DESCRIPTION

This procedure covers: Remove. Install.

#### INITIAL SETUP

#### PRELIMINARY PROCEDURES:

- Remove 34A2 Bottom Case (para 3-1-2).

#### REMOVE

1. Disconnect wire cable connector (1).
2. Remove 2 spacer nuts and 2 washers (2).
3. Slide 34A5A11 DMM (3) to rear and remove.

#### INSTALL

1. Install 34A5A11 DMM (3) and slide forward until tight against 34A5A23 Front Panel.
2. Reconnect wire cable connector (1).
3. Install 2 spacer nuts and 2 washers (2).

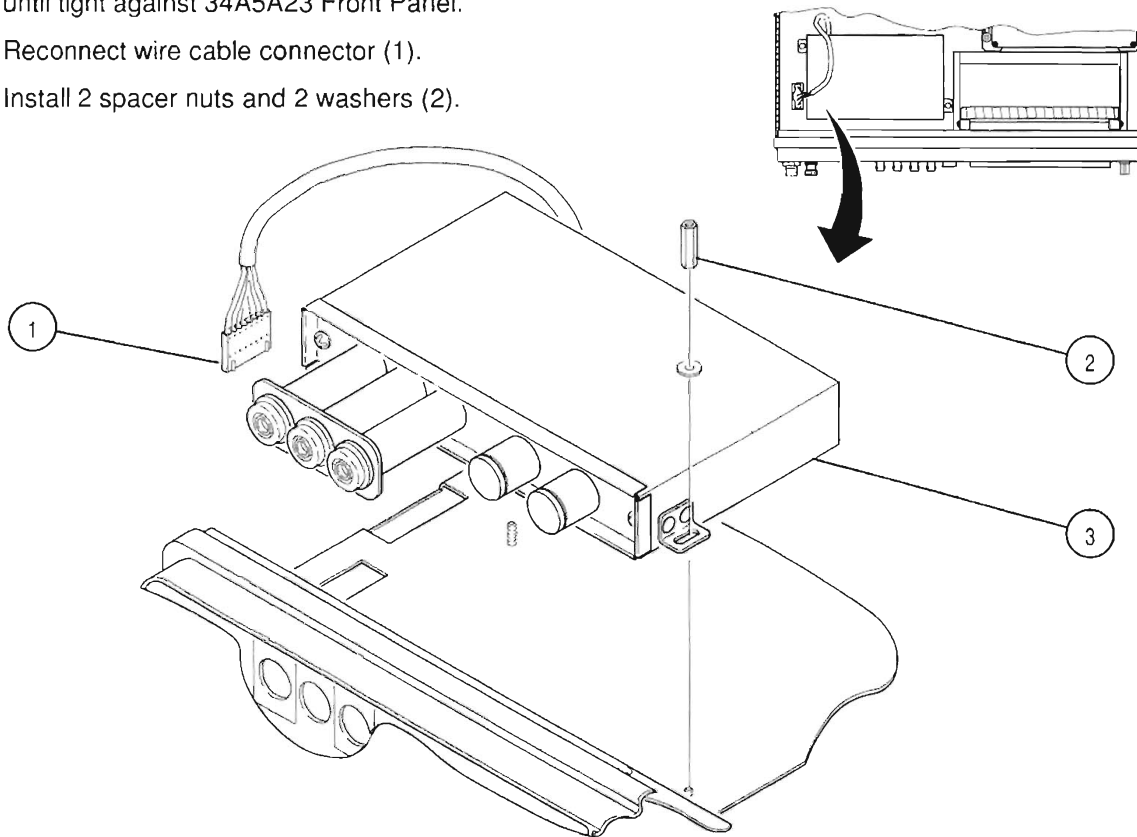

CE2FO040

#### FOLLOW-ON MAINTENANCE:

- Perform Adjustments (para 3-2-1).
- Install 34A2 Bottom Case (para 3-1-2).

#### END OF TASK

## CHAPTER 3 REPLACEMENTS/ADJUSTMENTS

### 3-1-23 REPLACE 34A5A15 2nd LO

#### DESCRIPTION

This procedure covers: Remove. Install.

#### INITIAL SETUP

##### PRELIMINARY PROCEDURES:

- Remove 34A2 Bottom Case (para 3-1-2).

#### REMOVE

1. Disconnect 10 coaxial connectors (1).
2. Disconnect 1 wire cable connectors (2).
3. Loosen 4 captive screws (3).
4. Remove 34A5A15 2nd LO (4).

#### INSTALL

1. Install 34A5A15 2nd LO (4).
2. Tighten 4 captive screws (3).
3. Reconnect 1 wire cable connectors (2).
4. Reconnect 10 coaxial connectors (1).

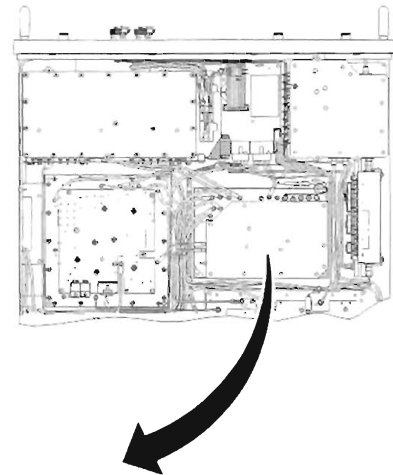
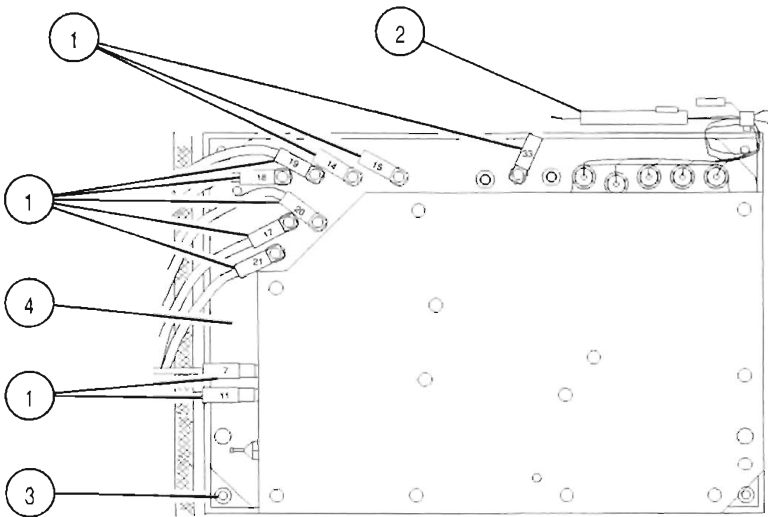

2LORE01

##### FOLLOW-ON MAINTENANCE:

- Perform Adjustments (para 3-2-1).
- Install 34A2 Bottom Case (para 3-1-2).

#### END OF TASK

## CHAPTER 3 REPLACEMENTS/ADJUSTMENTS

### 3-1-24 REPLACE 34A5A13 1st LO

#### DESCRIPTION

This procedure covers: Remove. Install.

#### INITIAL SETUP

#### PRELIMINARY PROCEDURES:

- Remove 34A2 Bottom Case (para 3-1-2).

#### REMOVE

1. Disconnect 4 coaxial cable connectors (1).
2. Remove ribbon cable retainer (5).
3. Disconnect ribbon cable connector (2).
4. Loosen 3 captive screws (3).
5. Remove 34A5A13 1st LO (4).

#### INSTALL

1. Install 34A5A13 1st LO (4).
2. Tighten 3 captive screws (3).
3. Reconnect ribbon cable connector (2).
4. Install ribbon cable retainer (5).
5. Reconnect 4 coaxial cable connectors (1).

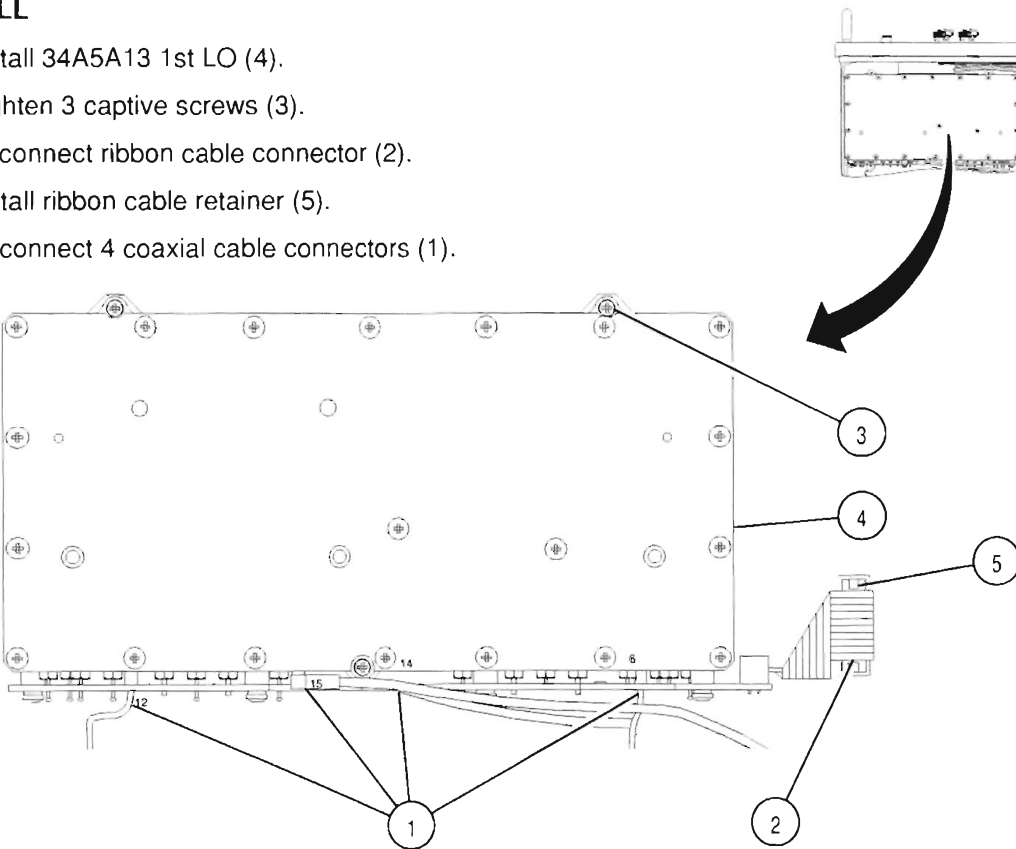

1LORE01

#### FOLLOW-ON MAINTENANCE:

- Perform Adjustments (para 3-2-1).
- Perform Frequency Agility Test (para 2-13).
- Install 34A2 Bottom Case (para 3-1-2).

#### END OF TASK

## CHAPTER 3 REPLACEMENTS/ADJUSTMENTS

### 3-1-25 REPLACE 34A5A37 AUXILIARY POWER SUPPLY

#### DESCRIPTION

This procedure covers: Remove. Install.

#### INITIAL SETUP

##### PRELIMINARY PROCEDURES:

- Remove 34A2 Bottom Case (para 3-1-2).

#### REMOVE

1. Remove 4 ribbon cable retainers (2).
2. Disconnect 4 ribbon cable connectors (3).
3. Disconnect 3 wire cable connectors (1).
4. Remove 4 screws (4).
5. Remove 34A5A37 Auxiliary Power Supply (5).

#### INSTALL

1. Install 34A5A37 Auxiliary Power Supply (5).
2. Install 4 screws (4).
3. Reconnect 5 wire cable connectors (1).
4. Reconnect 4 ribbon cable connectors (3).
5. Install 4 ribbon cable retainers (2).

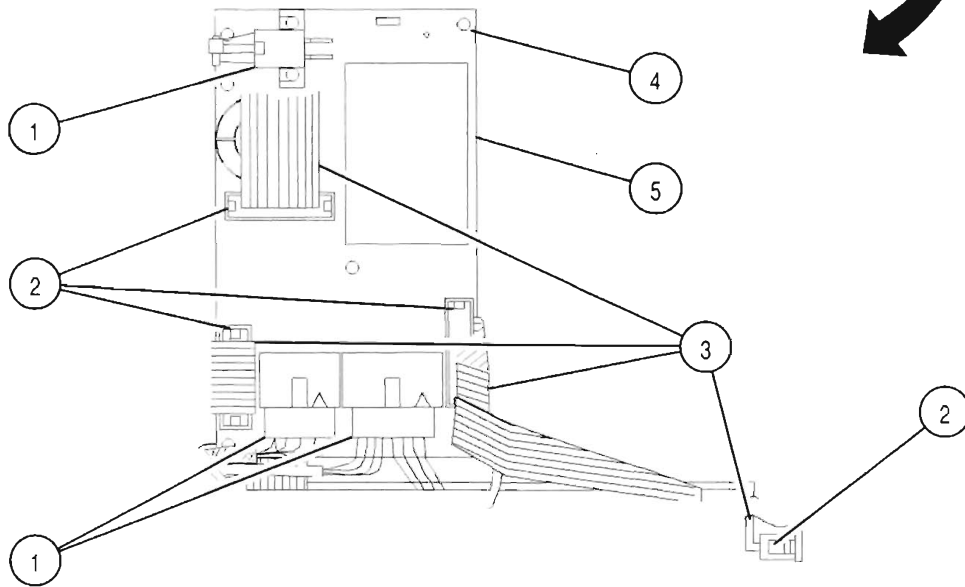

APSRE01

##### FOLLOW-ON MAINTENANCE:

- Perform Adjustments (para 3-2-1).
- Install 34A2 Bottom Case (para 3-1-2).

#### END OF TASK

## CHAPTER 3 REPLACEMENTS/ADJUSTMENTS

### 3-1-26 REPLACE 34A5A16 RF RECEIVE IF

#### DESCRIPTION

This procedure covers: Remove. Install.

#### INITIAL SETUP

#### PRELIMINARY PROCEDURES:

- Remove 34A2 Bottom Case (para 3-1-2).

#### REMOVE

1. Disconnect 7 coaxial cable connectors (1).
2. Disconnect wire cable connector (2).
3. Remove 4 captive screws (3).
4. Remove 34A5A16 RF Receive IF (4).

#### INSTALL

1. Install 34A5A16 RF Receive IF (4).
2. Install 4 captive screws (3).
3. Reconnect wire cable connector (2).
4. Reconnect 7 coaxial cable connectors (1).

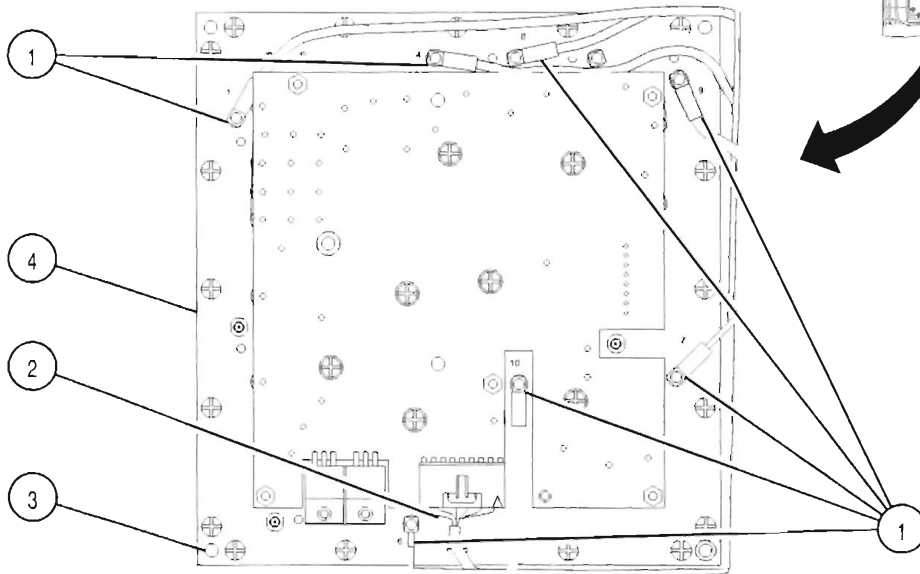

RIFRE01

#### FOLLOW-ON MAINTENANCE:

- Perform Adjustments (para 3-2-1).
- Install 34A2 Bottom Case (para 3-1-2).

#### END OF TASK

## CHAPTER 3 REPLACEMENTS/ADJUSTMENTS

### 3-1-27 REPLACE 34A5A20 GENERATOR IF

#### DESCRIPTION

This procedure covers: Remove. Install.

#### INITIAL SETUP

##### PRELIMINARY PROCEDURES:

- Remove 34A2 Bottom Case (para 3-1-2).

#### REMOVE

1. Disconnect wire cable connector (1).
2. Loosen connector (2).
3. Disconnect 4 coaxial cable connectors (3).
4. Remove ribbon cable retainer (4).
5. Disconnect ribbon cable connector (5).
6. Remove 4 screws (6).
7. Remove 34A5A20 Generator IF (7).

#### INSTALL

1. Install 34A5A20 Generator IF (7).
2. Install 4 screws (6).
3. Reconnect ribbon cable connector (5).
4. Install ribbon cable retainer (4).
5. Reconnect 4 coaxial cable connectors (3).
6. Tighten connector (2) to Torque of 10 in/lbs.
7. Reconnect wire cable connector (1).

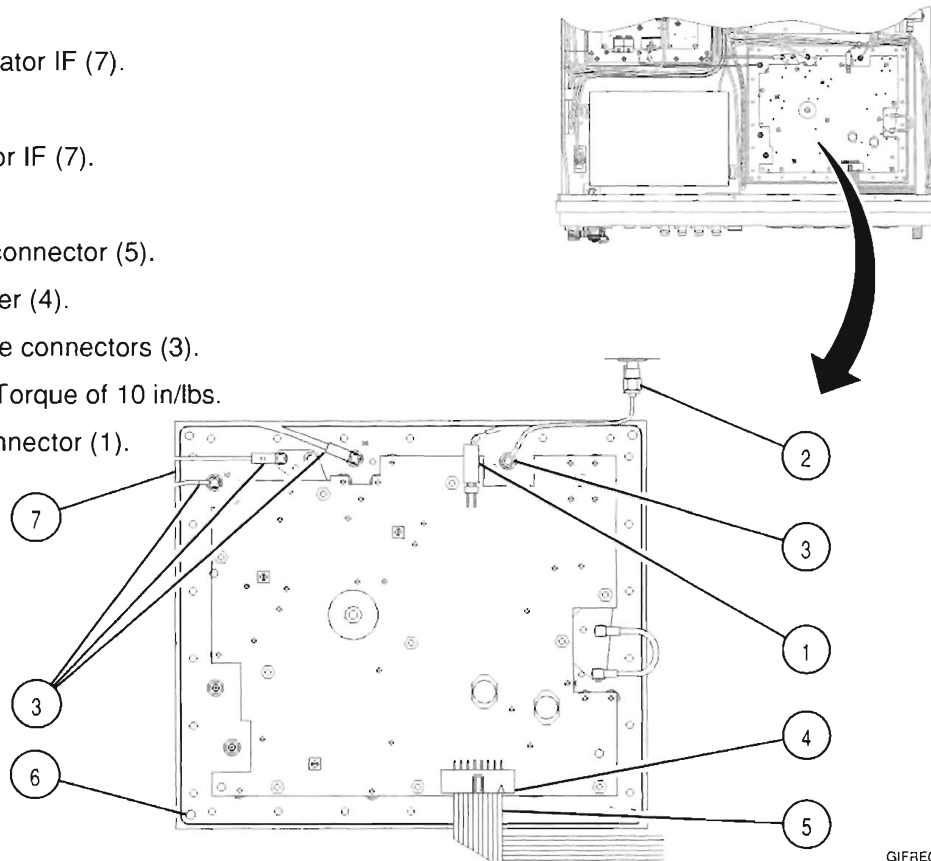

GIFRE01

##### FOLLOW-ON MAINTENANCE:

- Perform Adjustments (para 3-2-1).
- Install 34A2 Bottom Case (para 3-1-2).

#### END OF TASK



## CHAPTER 3 REPLACEMENTS/ADJUSTMENTS

### 3-1-28 REPLACE 34A5A36 ATTENUATOR

#### DESCRIPTION

This procedure covers: Remove. Install.

#### INITIAL SETUP

#### PRELIMINARY PROCEDURES:

- Remove 34A2 Bottom Case (para 3-1-2).

#### REMOVE

1. Disconnect 1 wire cable connectors (1).
2. Disconnect 2 coaxial cable connectors (4).
3. Remove 2 screws and 2 washers (5).
4. Disconnect retainer and ribbon cable connector (2).
5. Remove 34A5A36 Attenuator (3).

#### INSTALL

1. Install 34A5A36 Attenuator (3).
2. Reconnect retainer and ribbon cable connector (2).
3. Install 2 screws and 2 washers (5).
4. Reconnect 2 coaxial cable connectors (4).
5. Reconnect 1 wire cable connectors (1).

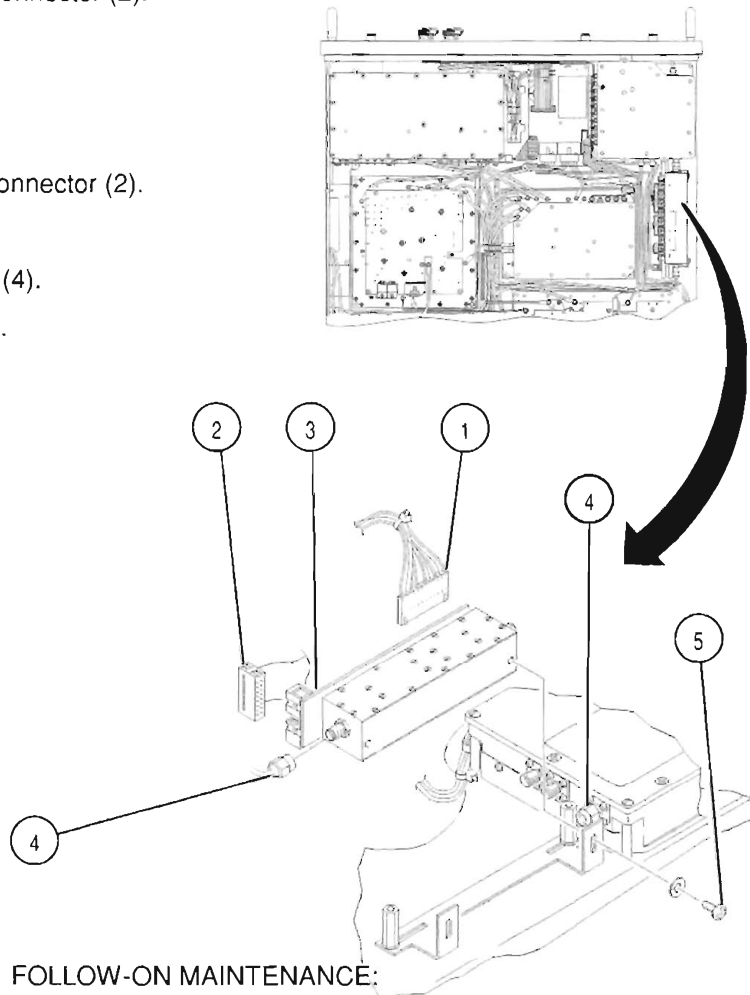

#### FOLLOW-ON MAINTENANCE:

- Perform Adjustments (para 3-2-1).
- Install 34A2 Bottom Case (para 3-1-2).

ARE01

#### END OF TASK

## CHAPTER 3 REPLACEMENTS/ADJUSTMENTS

### 3-1-29 REPLACE 34A5A21 POWER TERMINATION

#### DESCRIPTION

This procedure covers: Remove. Install.

#### INITIAL SETUP

#### PRELIMINARY PROCEDURES:

- Remove 34A2 Bottom Case (para 3-1-2).

#### REMOVE

1. Remove wire cable connector (1).
2. Disconnect 3 coaxial cable connectors (2).
3. Loosen 2 spacer nuts (3).
4. Disconnect coaxial cable connector (5).
5. Slide 34A5A36 Attenuator corner to front (4).
6. Remove 4 screws (6).
7. Remove 34A5A21 Power Termination (7).
8. Remove screw (8) and ground lug.
9. Desolder and remove coaxial cable from feed-thru (9).
10. Desolder and remove yellow-white wire from feed-thru (10).

#### INSTALL

1. Connect and solder yellow-white wire to feed-thru (10).
2. Connect and solder coaxial cable to feed-thru (9).
3. Install screw (8) and ground lug.
4. Install 34A5A21 Power Termination (7).
5. Install 4 captive screws (6).
6. Slide 34A5A36 Attenuator to rear.
7. Reconnect coaxial cable connector (5).
8. Tighten 2 spacer nuts (3).
9. Reconnect 3 coaxial cable connectors (2).
10. Reconnect wire cable connector (1).

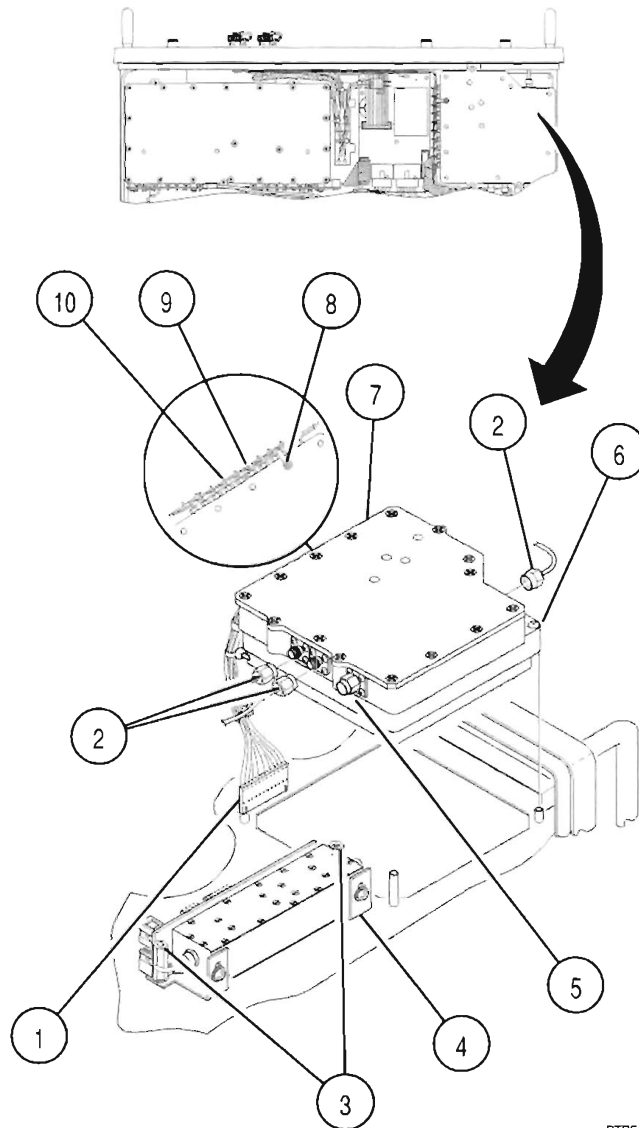

PTRE01

#### FOLLOW-ON MAINTENANCE:

- Perform Adjustments (para 3-2-1).
- Install 34A2 Bottom Case (para 3-1-2).

#### END OF TASK

## CHAPTER 3 REPLACEMENTS/ADJUSTMENTS

---

### 3-1-30 REPLACE 34A5A39 MASTER OSCILLATOR

---

#### DESCRIPTION

This procedure covers: Remove. Install.

---

#### INITIAL SETUP

##### PRELIMINARY PROCEDURES:

- Remove 34A3 Top Case (para 3-1-1).
  - Remove 34A2 Bottom Case (para 3-1-2).
  - Remove 34A5A5 Rear Panel (para 3-1-22).
- 

#### REMOVE

1. Remove 2 nuts and 2 washers (1).
2. Disconnect wire cable connector (2).
3. Remove bracket (3) attached to Master Oscillator (5).
4. Remove 3 screws (4).
5. Remove bracket (3) from 34A5A39 Master Oscillator(5).

#### INSTALL

1. Install bracket (3) on 34A5A39 Master Oscillator(5).
2. Install 2 nuts and 2 washers (7).
3. Install 34A5A39 Master Oscillator(5).
4. Install 2 nuts and 2 washers (1).
5. Reconnect wire cable connector (2).

## CHAPTER 3 REPLACEMENTS/ADJUSTMENTS

### 3-1-30 REPLACE 34A5A39 MASTER OSCILLATOR- Continued

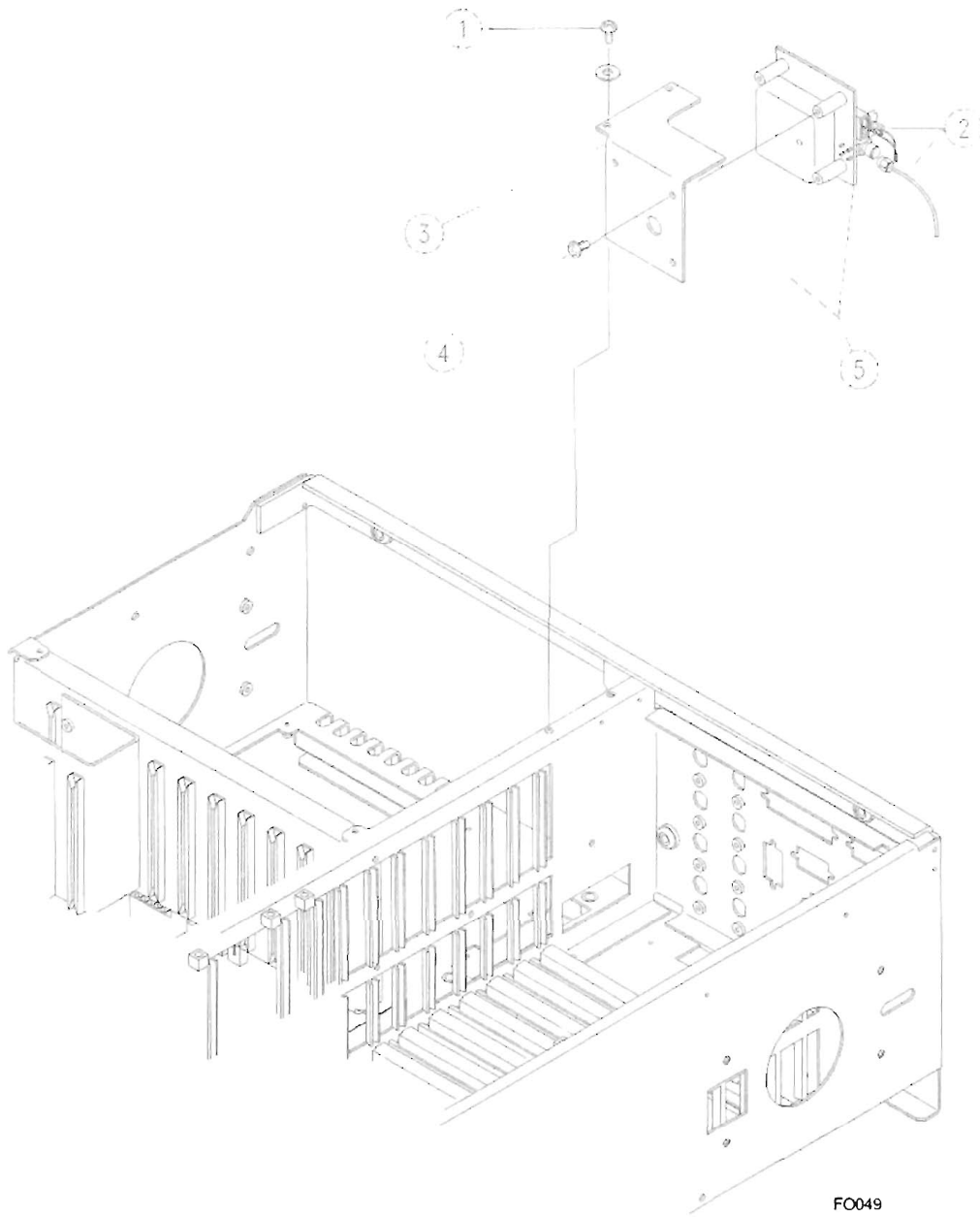

#### FOLLOW-ON MAINTENANCE:

- Perform Adjustments (para 3-2-1).
- Install 34A5A5 Rear Panel (para 3-1-22).
- Install 34A2 Bottom Case (para 3-1-2).
- Install 34A3 Top Case (para 3-1-1).

**END OF TASK**

## CHAPTER 3 REPLACEMENTS/ADJUSTMENTS

### 3-1-31 UPLOAD INTERFACE SOFTWARE PROCEDURE

#### DESCRIPTION

This procedure is used, after replacement of 34A5A27 Flash Memory, to automatically upload system software. After completion of the following steps, the Computer begins execution of Upload Interface Software. The User is kept informed of the status of the program and of the actions required through a series of menus that appear during program execution.

1. Press Computer Power Switch to ON.
2. Insert Upload Interface Software Disk into PC Disk Drive A. At operating prompt, type A:\INSTALL, press ENTER Key and follow instructions on Computer Display.
3. Disconnect external test equipment.

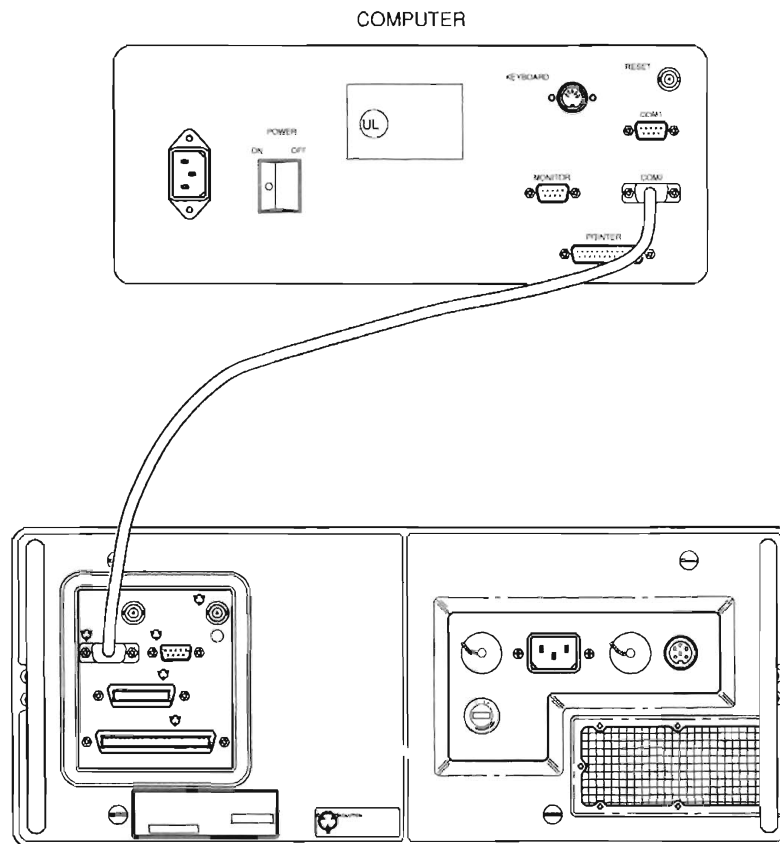

CE2F.M500

## CHAPTER 3 REPLACEMENTS/ADJUSTMENTS

### SECTION 2 ADJUSTMENTS.

#### DESCRIPTION

This procedure is used to adjust the Radio Test Set before and after an assembly is replaced. These adjustment procedures cover:

- Power Supply Adjustment (para 3-2-2)
- VCXO Adjustment (para 3-2-3)
- Metering DVM Adjustment (para 3-2-4)
- Func Gen Level And VRMS Meter Adjustment (para 3-2-5)
- Gen Output Level Adjustment (para 3-2-6)
- RF Null Adjustment (para 3-2-7)
- Signal Meter Adjustment (para 3-2-8)
- FM Adjustment (para 3-2-9)
- Deviation Meter Adjustment (para 3-2-10)
- Modulation Meter Adjustment (para 3-2-11)
- Phase Meter Adjustment (para 3-2-12)
- Distortion Meter Adjustment (para 3-2-13)
- Sinad Meter Adjustment (para 3-2-14)
- Gen Modulation Adjustment (para 3-2-15)
- Scope Adjustment (para 3-2-16)
- Spectrum Analyzer Adjustment (para 3-2-16)
- Digital Multimeter Adjustment (para 3-2-17)
- Power Meter Adjustment (para 3-2-18)

#### WARNING

Dangerous voltages are present with covers removed.

#### CAUTION

Do not disconnect or remove any board assemblies in Radio Test Set unless instrument is unplugged.

#### NOTE

- The adjustments required after repair/replacement of specific assemblies are shown in Table 2-2.
- Do not adjust components unless instructed to do so in the procedures.
- All indications and waveforms are referenced to chassis ground unless otherwise noted.
- If internal cal factors change when performing the Radio Test Set Adjustment Procedure, a "Backup Cal Data" Submenu appears. A key sequence reply (Y=Yes, N=No) must be initiated in order to proceed with the procedure.

## CHAPTER 3 REPLACEMENTS/ADJUSTMENTS

**Table 3-2-1. Post Repair/Replace Adjustments**

REPAIRED/REPLACED ASSEMBLIES	ADJUSTMENT
34A5A39 Master Oscillator	Gen Output Level Adjustment (para 3-2-6) RF Null Adjustment (para 3-2-7) Signal Meter Adjustment (para 3-2-8) FM Adjustment (para 3-2-9) Deviation Meter Adjustment (para 3-2-10) Modulation Meter Adjustment (para 3-2-11) Phase Meter Adjustment (para 3-2-12) Distortion Meter Adjustment (para 3-2-13) Sinad Meter Adjustment (para 3-2-14) Gen Modulation Adjustment (para 3-2-15) Scope Adjustment (para 3-2-16) Spectrum Analyzer Adjustment (para 3-2-16) Power Meter Adjustment (para 3-2-18)
34A5A5 Rear Panel	None
34A5A6 Monitor	Func Gen Level and VRMS Meter Adjustment (para 3-2-5) Signal Meter Adjustment (para 3-2-8) FM Adjustment (para 3-2-9) Deviation Meter Adjustment (para 3-2-10) Modulation Meter Adjustment (para 3-2-11) Phase Meter Adjustment (para 3-2-12) Distortion Meter Adjustment (para 3-2-13) Sinad Meter Adjustment (para 3-2-14) Power Meter Adjustment (para 3-2-18)
34A5A7 Analyzer Log/IF	Spectrum Analyzer Adjustment (para 3-2-16)
34A5A8 Analyzer RF	Spectrum Analyzer Adjustment (para 3-2-16)
34A5A1 TMDA 10.7 MHz RECEIVER	Signal Meter Adjustment (para 3-2-8) FM Adjustment (para 3-2-9) Deviation Meter Adjustment (para 3-2-10) Modulation Meter Adjustment (para 3-2-11) Phase Meter Adjustment (para 3-2-12)
34A5A40 3rd LO	Signal Meter Adjustment (para 3-2-8) FM Adjustment (para 3-2-9) Deviation Meter Adjustment (para 3-2-10) Modulation Meter Adjustment (para 3-2-11) Phase Meter Adjustment (para 3-2-12)
34A5A11 DMM	None
34A5A41 90 MHz Generator	Gen Output Level Adjustment (para 3-2-6) Gen Modulation Adjustment (para 3-2-15)
34A5A13 1st LO	Gen Output Level Adjustment (para 3-2-6) RF Null Adjustment (para 3-2-7) Signal Meter Adjustment (para 3-2-8) Gen Modulation Adjustment (para 3-2-15)
34A5A15 2nd LO	VCXO Adjustment (para 3-2-3) Gen Output Level Adjustment (para 3-2-6) Gen Modulation Adjustment (para 3-2-15)

## CHAPTER 3 REPLACEMENTS/ADJUSTMENTS

**Table 3-2-1. Post Repair/Replace Adjustments**

34A5A16 RF Receive IF	RF Null Adjustment (para 3-2-7) Signal Meter Adjustment (para 3-2-8) FM Adjustment (para 3-2-9) Deviation Meter Adjustment (para 3-2-10) Modulation Meter Adjustment (para 3-2-11) Phase Meter Adjustment (para 3-2-12) Spectrum Analyzer Adjustment (para 3-2-16)
34A5A20 Generator IF	Gen Output Level Adjustment (para 3-2-6) Gen Modulation Adjustment (para 3-2-15)
34A5A21 Power Termination	Gen Output Level Adjustment (para 3-2-6) Power Meter Adjustment (para 3-2-18)
34A5A22 Power Supply	Power Supply Adjustment (para 3-2-2) VCXO Adjustment (para 3-2-3) Metering DVM Adjustment (para 3-2-4) Func Gen Level and VRMS Meter Adjustment (para 3-2-5) Gen Output Level Adjustment (para 3-2-6) RF Null Adjustment (para 3-2-7) Signal Meter Adjustment (para 3-2-8) FM Adjustment (para 3-2-9) Deviation Meter Adjustment (para 3-2-10) Modulation Meter Adjustment (para 3-2-11) Phase Meter Adjustment (para 3-2-12) Distortion Meter Adjustment (para 3-2-13) Sinad Meter Adjustment (para 3-2-14) Gen Modulation Adjustment (para 3-2-15) Scope Adjustment (para 3-2-16) Spectrum Analyzer Adjustment (para 3-2-16) Digital Multimeter Adjustment (para 3-2-17) Power Meter Adjustment (para 3-2-18)
34A5A23 Front Panel	None
34A5A26 Processor	None
34A5A28 Video Controller	None
34A5A29 RF I/O	VCXO Adjustment (para 3-2-3)
34A5A30 Counter	None
34A5A31 Function Generator	Func Gen Level and VRMS Meter Adjustment (para 3-2-5) Gen Modulation Adjustment (para 3-2-15)
34A5A32 Digitizer	Scope Adjustment (para 3-2-16) Spectrum Analyzer Adjustment (para 3-2-16)
34A5A33 Monitor Control	Metering DVM Adjustment (para 3-2-4) Func Gen Level and VRMS Meter Adjustment (para 3-2-5) Signal Meter Adjustment (para 3-2-8) FM Adjustment (para 3-2-9) Deviation Meter Adjustment (para 3-2-10) Modulation Meter Adjustment (para 3-2-11) Phase Meter Adjustment (para 3-2-12) Distortion Meter Adjustment (para 3-2-13) Sinad Meter Adjustment (para 3-2-14)



**CHAPTER 3 REPLACEMENTS/ADJUSTMENTS****Table 3-2-1. Post Repair/Replace Adjustments**

	Power Meter Adjustment (para 3-2-18)
34A5A35 External I/O	None
34A5A36 Attenuator	Gen Output Level Adjustment (para 3-2-6)
34A5A37 Auxiliary Power Supply	Power Supply Adjustment (para 3-2-2)
34A5A38 Rear Panel Connector	None

## CHAPTER 3 REPLACEMENTS/ADJUSTMENTS

### 3-2-1 POWER SUPPLY ADJUSTMENT

---

#### DESCRIPTION

This procedure is used to adjust the +5 Vdc and +15 Vdc supplies.

1. Press POWER Switch to On and allow 20 minute warm-up period.
2. Press MTRS MODE Key, "AUX" F6 and RCL Key.
3. Use Field Select Keys to move cursor to "10. Factory Defaults" and press ENTER Key twice.
4. Locate A33 Processor (fig. FO-2, Sheet 1 of 3) and verify +5.05 Vdc ( $\pm 0.05$  Vdc) with DMM positive lead at A33RN2, Pin 1 (fig. FO-15, Sheet 1 of 3) and ground lead at chassis ground. Locate A22 Power Supply (fig. FO-2, Sheet 1 of 3) and adjust A22A2R37 (+5 Vdc ADJUST) (fig. FO-13) as required.
5. Locate A15 2nd LO (fig. FO-2, Sheet 1 of 3) and verify +15.05 Vdc ( $\pm 0.05$  Vdc) with DMM positive lead at A15FL1 (Red Wire) (fig. FO-8) and negative lead at A15GL1 (Black Wire). Locate A22 Power Supply (fig. FO-2, Sheet 1 of 3) and adjust A22A2R25 (+15 Vdc ADJUST) (fig. FO-13) as required.
6. Disconnect test equipment.

### VCXO ADJUSTMENT

---

#### DESCRIPTION

This procedure is used to adjust the VCXO used as the 10 MHz reference for the Test Set.

1. Press POWER Switch to On and allow 20 minute warm-up period.
2. Press MTRS MODE Key, "AUX" F6 and RCL Key.
3. Use Field Select Keys to move cursor to "10. Factory Defaults" and press ENTER Key twice.
4. Connect Frequency Counter to T/R Connector.
5. Press RF GEN MODE Key.
6. Use FIELD SELECT Keys to move cursor to RF. Press ENTER Key. Use DATA ENTRY Keypad to enter 900.0000 MHz. Press ENTER Key.
7. Use FIELD SELECT Keys to move cursor to LEVEL. Press ENTER Key. Use DATA ENTRY Keypad to enter 0.0 dBm. Press ENTER Key.
8. Verify 900 MHz ( $\pm 225$  Hz) with Frequency Counter.
  - If incorrect, perform Steps 9-15.
  - If correct, perform Step 15.
9. Press SETUP Key and "AUX" F6.
10. Press ENTER Key to access Calibration Menu.
11. Use FIELD SELECT Keys to move cursor to "12. VCXO Calibration". Press ENTER Key.
12. Use DATA SCROLL Keys to move cursor to least significant digit.
13. Use DATA SCROLL Keys to adjust for 900 MHz on Frequency Counter. Press ENTER Key.
14. Press "AUX" F6.
15. Disconnect test equipment.

## CHAPTER 3 REPLACEMENTS/ADJUSTMENTS

### 3-2-2 METERING DVM ADJUSTMENT

#### DESCRIPTION

This procedure is used to adjust the parameters for the internal DVM.

1. Press POWER Switch to On and allow 20 minute warm-up period.
2. Press MTRS MODE Key, "AUX" F6 and RCL Key.
3. Use Field Select Keys to move cursor to "10. Factory Defaults" and press ENTER Key twice.
4. Locate A33 Monitor Control (fig. FO-2, Sheet 1 of 3) and verify 4.0960 Vdc ( $\pm 0.002$  Vdc) with DMM negative lead at A33TP3 (fig. FO-15, Sheet 3 of 3) and positive lead at A33TP2. Adjust A33R18 as required.
5. Disconnect test equipment.

### 3-2-3 FUNC GEN LEVEL AND VRMS METER ADJUSTMENT

#### DESCRIPTION

This procedure is used to adjust the output of the Audio Function Generators and the VRMS Meter on the Audio Function Generator screen.

1. Remove A31 Function Generator (para 3-1-12) and install on PC Board Assembly Extender in Test Set.
2. Press POWER Switch to On and allow 20 minute warm-up period.
3. Press MTRS MODE Key, "AUX" F6 and RCL Key.
4. Use Field Select Keys to move cursor to "10. Factory Defaults" and press ENTER Key twice.
5. Press AF GEN MODE Key and SETUP Key.
6. Use FIELD SELECT Keys to move cursor to "5. AF Output Setup". Press ENTER Key. Use FIELD SELECT Keys to move cursor to "2. To Speaker". Press ENTER Key to select On. Press "ESC" F6.
7. Press AF GEN MODE Key.
8. Connect external test equipment as shown.

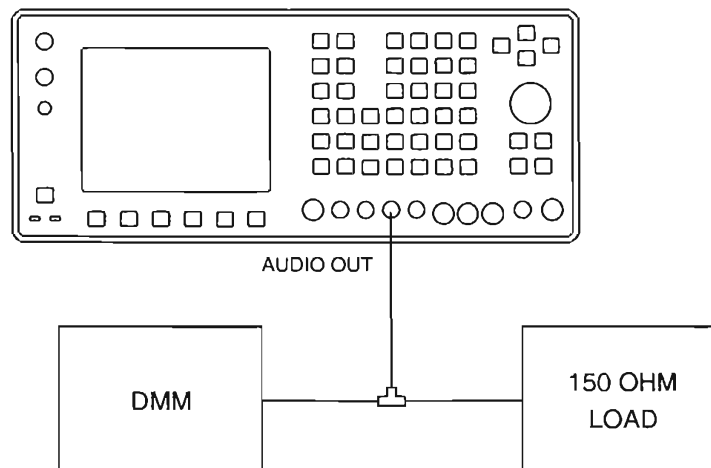

CE2FO252

9. Set DMM to VAC.
10. Use FIELD SELECT Keys to move cursor to GEN 1. Press ENTER Key to select On.

## CHAPTER 3 REPLACEMENTS/ADJUSTMENTS

### 3-2-3 FUNC GEN LEVEL AND VRMS METER ADJUSTMENT - Continued

11. Use FIELD SELECT Keys to move cursor to LEVEL. Press ENTER Key. Use DATA ENTRY Keypad to enter 2.5000 V. Press ENTER Key.
12. Verify 2.5 VRMS ( $\pm 0.5$  mVRMS).
  - If correct, perform Step 34.
13. Press SETUP Key and "AUX" F6.
14. Press ENTER Key to access Calibration Menu.
15. Use FIELD SELECT Keys to move cursor to "15. Func Gen Level". Press ENTER Key.
16. Use FIELD SELECT Keys to move cursor to "1. 199.9 mV". Press ENTER Key.
17. Use DATA SCROLL Keys to edit value until DMM equals 199.9 mVAC ( $\pm 0.03$  mVAC). Press ENTER Key.
  - If unable to adjust, perform Steps 20-33.
18. Use FIELD SELECT Keys to move cursor to "2. 2.5 V". Press ENTER Key.
19. Use DATA SCROLL Keys to edit value until DMM equals 2.500 VAC ( $\pm 0.5$  mVAC). Press ENTER Key.
  - If unable to adjust, perform Steps 20-33.
  - If able to adjust, perform Step 34.
20. Press "ESC" F6, "AUX" F6, AF GEN MODE Key and SETUP Key.
21. Use FIELD SELECT Keys to move cursor to "1. AF Gen #1 Setup". Press ENTER Key.
22. Use FIELD SELECT Keys to move cursor to "3. Wave Form". Press ENTER Key. Use FIELD SELECT Keys to move cursor to "7. 0 Lvl". Press ENTER Key. Press "ESC" F6.
23. Use FIELD SELECT Keys to move cursor to "2. AF Gen #2 Setup". Press ENTER Key.
24. Use FIELD SELECT Keys to move cursor to "1. Func Gen 2". Press ENTER Key to select On. Use FIELD SELECT Keys to move cursor to "3. Waveform". Press ENTER Key. Use FIELD SELECT Keys to move cursor to "7. 0 Lvl". Press ENTER Key. Press "ESC" F6.
25. Press AF GEN MODE Key.
26. Connect DMM positive lead to A31P2, Pin 2B (fig. FO-15, Sheet 2 of 3) and DMM negative lead to A31P2, Pin 6B.
27. Set DMM to Vdc.
28. Use FIELD SELECT Keys to move cursor to LEVEL. Press ENTER Key. Use DATA ENTRY Keypad to enter 3.100 V. Press ENTER Key.
29. Verify 0.000 Vdc with DMM. Adjust A31R22 as required.
30. Use FIELD SELECT Keys to move cursor to GEN 2. Press ENTER Key to select Off.
31. Use FIELD SELECT Keys to move cursor to GEN 1. Press ENTER Key to select Off.
32. Verify 0.000 Vdc with DMM. Adjust A31R23 as required.
33. Use FIELD SELECT Keys to move cursor to WAVE (GEN 1). Press ENTER Key. Use DATA SCROLL Keys to select "Sine". Use FIELD SELECT Keys to move cursor to WAVE (GEN 2). Press ENTER Key. Use DATA SCROLL Keys to select "Sine". Repeat Steps 9 through 19.

## CHAPTER 3 REPLACEMENTS/ADJUSTMENTS

### 3-2-3 FUNC GEN LEVEL AND VRMS METER ADJUSTMENT - Continued

34. Press AF GEN MODE Key. Verify VRMS Meter matches ( $\pm 10\%$ ) DMM.
  - If incorrect, perform Steps 35-39.
  - If correct, perform Step 39.
35. Press SETUP Key and "AUX" F6.
36. Press ENTER Key to access Calibration Menu.
37. Use FIELD SELECT Keys to move cursor to "8. VRMS Meter". Press ENTER Key twice. Use DATA ENTRY Keypad to enter DMM VRMS reading. Press ENTER Key.
38. Press "AUX" F6.
39. Disconnect test equipment and install A31 Function Generator (para 3-1-12).

### 3-2-4 GEN OUTPUT LEVEL ADJUSTMENT

#### DESCRIPTION

This procedure is used to adjust the output of the RF Generator.

1. Press POWER Switch to On and allow 20 minute warm-up period.
2. Press MTRS MODE Key, "AUX" F6 and RCL Key.
3. Use Field Select Keys to move cursor to "10. Factory Defaults" and press ENTER Key twice.
4. Connect Measuring Receiver to T/R Connector.
5. Press RF GEN MODE Key.
6. Use FIELD SELECT Keys to move cursor to LEVEL. Press ENTER Key. Use DATA ENTRY Keypad to enter 0.0 dBm. Press ENTER Key.
7. Press SETUP Key and "AUX" F6.
8. Press ENTER Key to access Calibration Menu.
9. Use FIELD SELECT Keys to move cursor to "14. Gen Output Level". Press ENTER Key.
10. Perform Steps 11-16 for following ranges.

RANGE	LOW FREQUENCY	HIGH FREQUENCY
1	250 kHz	499 kHz
2	500 kHz	999 kHz
3	1 MHz	49 MHz
4	50 MHz	124 MHz
5	125 MHz	199 MHz
6	200 MHz	399 MHz
7	400 MHz	599 MHz
8	600 MHz	799 MHz
9	800 MHz	999 MHz

11. Use FIELD SELECT Keys to move cursor to Low Frequency Range. Verify Low Frequency and note output level in dBm using Measuring Receiver.
12. Press "High" F1. Verify High Frequency and note output level in dBm using Measuring Receiver. Press "Low" F1.

## CHAPTER 3 REPLACEMENTS/ADJUSTMENTS

### 3-2-4 GEN OUTPUT LEVEL ADJUSTMENT - Continued

13. Verify Step 11 output is above 0.0 dBm and Step 12 output is below 0.0 dBm. If Step 11 output plus Step 12 output is  $\pm 0.30$  dBm, continue with next Range.
14. Press ENTER Key.
15. Use DATA SCROLL Keys to move cursor to least significant digit in data field and edit data. While monitoring Measuring Receiver, adjust level until value is within tolerance.
16. Repeat Steps 12 through 15 until levels match as closely as Radio Test Set allows. Continue with next Range.
17. Press "ESC" F6 and "AUX" F6.
18. Disconnect test equipment.

### 3-2-5 RF NULL ADJUSTMENT

---

#### DESCRIPTION

This procedure is used to adjust the mixer null for the Spectrum Analyzer.

---

1. Press POWER Switch to On and allow 20 minute warm-up period.
2. Press MTRS MODE Key, "AUX" F6 and RCL Key.
3. Use Field Select Keys to move cursor to "10. Factory Defaults" and press ENTER Key twice.
4. Press SCOPE/ANLZ MODE Key to access Analyzer Operation Screen.
5. Use FIELD SELECT Keys to move cursor to RF. Press ENTER Key. Use DATA ENTRY Keypad to enter 0.2500 MHz. Press ENTER Key.
6. Use FIELD SELECT Keys to move cursor to RF ATTEN. Press ENTER Key. Use DATA SCROLL Keys to select 40 dB. Press ENTER Key.
7. Use FIELD SELECT Keys to move cursor to 1 kHz. Press ENTER Key. Use DATA SCROLL Keys to select 1 MHz. Press ENTER Key.

#### NOTE

A22A7R2 and A22A7R3 are interactive and adjustment is extremely sensitive.

8. Verify Null signal is  $< -30$  dBm. Locate A22 Receive IF (fig. FO-2, Sheet 1 of 3) and alternately adjust A22A7R2 (fig. FO-9) and A22A7R3 as required.

### 3-2-6 SIGNAL METER ADJUSTMENT

---

#### DESCRIPTION

This procedure is used to adjust the Signal Meter on the RF Receive screen.

---

1. Press POWER Switch to On and allow 20 minute warm-up period.
2. Press MTRS MODE Key, "AUX" F6 and RCL Key.
3. Use Field Select Keys to move cursor to "10. Factory Defaults" and press ENTER Key twice.
4. Press RCVR MODE Key.
5. Use FIELD SELECT Keys to move cursor to RF. Press ENTER Key. Use DATA ENTRY Keypad to enter 121.1000 MHz. Press ENTER Key.
6. Connect Signal Generator to ANTENNA IN Connector. Set Signal Generator output for 121.100000 MHz at -30 dB.

## CHAPTER 3 REPLACEMENTS/ADJUSTMENTS

---

### 3-2-6 SIGNAL METER ADJUSTMENT - Continued

7. Verify Signal Strength Meter displays 100.
  - If incorrect, perform Steps 8-12.
  - If correct, perform Step 12.
8. Press SETUP Key and "AUX" F6.
9. Press ENTER Key to access Calibration Menu.
10. Use FIELD SELECT Keys to move cursor to "7. Signal Meter". Press ENTER Key twice. Use DATA ENTRY Keypad to enter 100. Press ENTER Key.
11. Press "Ret" F5 and "AUX" F6.
12. Disconnect test equipment.

### 3-2-7 FM ADJUSTMENT

#### DESCRIPTION

This procedure is used to adjust the FM demodulation circuit.

1. Press POWER Switch to On and allow 20 minute warm-up period.
2. Press MTRS MODE Key, "AUX" F6 and RCL Key.
3. Use Field Select Keys to move cursor to "10. Factory Defaults" and press ENTER Key twice.
4. Connect external test equipment as shown.
5. Set RF Signal Generator output for 121.100000 MHz at -30 dBm.
6. Set Oscilloscope Trigger to Auto, Sweep to 500  $\mu$ s, Coupling to DC and V/Div to 20 mV.
7. Press RCVR MODE Key.
8. Use FIELD SELECT Keys to move cursor to RF. Press ENTER Key. Use DATA ENTRY Keypad to enter 121.1000 MHz. Press ENTER Key.
9. Press SETUP Key.
10. Use FIELD SELECT Keys to move cursor to "5. Select AGC Type". Press ENTER Key. Use FIELD SELECT Keys to move cursor to "1. User Defined". Press ENTER Key. Use FIELD SELECT Keys to move cursor to "1. Measurement". Press ENTER Key.
11. Press RCVR MODE Key.
12. Verify FREQ ERR is  $\leq \pm 10$  Hz. Adjust Signal Generator frequency as required.
13. Press SETUP Key and "AUX" F6.
14. Press ENTER Key to access Calibration Menu.
15. Use FIELD SELECT Keys to move cursor to "11. FM Calibration". Press ENTER Key.
16. Use DATA SCROLL Keys to move cursor to least significant digit.
17. Use DATA SCROLL Keys to adjust Frequency Offset for 0 Vdc ( $\pm 40$  mVdc) on Oscilloscope. Press ENTER Key.
18. Press "AUX" F6.FM ADJUSTMENT - Continued
19. Disconnect test equipment.

## CHAPTER 3 REPLACEMENTS/ADJUSTMENTS

### 3-2-8 DEVIATION METER ADJUSTMENT

#### DESCRIPTION

This procedure is used to adjust the Deviation Meter for the Receive function.

1. Press POWER Switch to On and allow 20 minute warm-up period.
2. Press MTRS MODE Key, "AUX" F6 and RCL Key.
3. Use Field Select Keys to move cursor to "10. Factory Defaults" and press ENTER Key twice.
4. Connect external test equipment as shown.

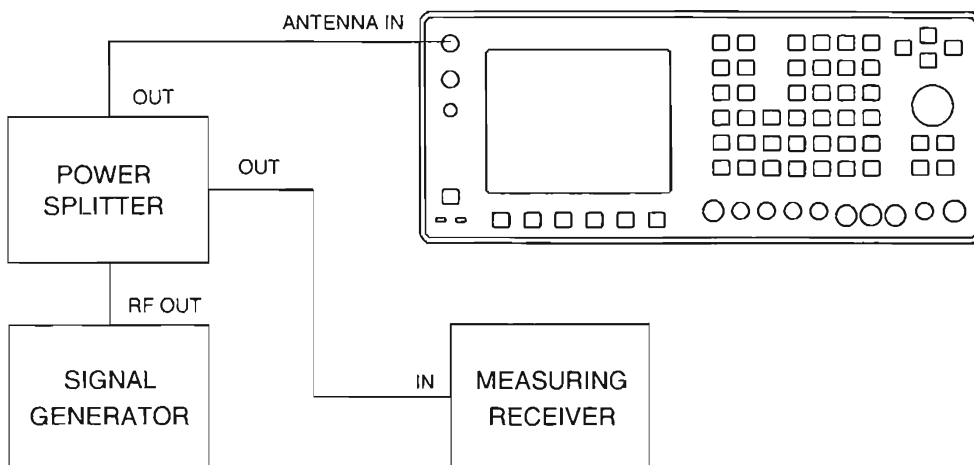

CE2FO254

5. Set Signal Generator output for 121.100000 MHz at 0 dBm with no modulation.
6. Set Measuring Receiver Measurement to FM, Detector to Peak+ and Low-Pass Filter to 3 kHz.
7. Adjust Signal Generator for FREQ ERR reading of  $\leq \pm 10$  Hz.
8. Press RCVR MODE Key.
9. Use FIELD SELECT Keys to move cursor to RF. Press ENTER Key. Use DATA ENTRY Keypad to enter 121.1000 MHz. Press ENTER Key.
10. Use FIELD SELECT Keys to move cursor to 0dB. Press ENTER Key. Use DATA SCROLL Keys to select 40 dB. Press ENTER Key.
11. Press SETUP Key.
12. Use FIELD SELECT Keys to move cursor to "2. Select Mod". Press ENTER Key. Use FIELD SELECT Keys to move cursor to "11. User Defined". Press ENTER Key. Use FIELD SELECT Keys to move cursor to "2. IF Filters". Press ENTER Key. Use FIELD SELECT Keys to move cursor to "3. 300 kHz". Press ENTER Key. Use FIELD SELECT Keys to move cursor to "3. Post Detection". Press ENTER Key. Use FIELD SELECT Keys to move cursor to "2. Low Pass". Press ENTER Key. Use DATA ENTRY Keypad to enter 3.000 kHz. Press ENTER Key.
13. Press RCVR MODE Key.



## CHAPTER 3 REPLACEMENTS/ADJUSTMENTS

---

### 3-2-7 DEVIATION METER ADJUSTMENT - Continued

14. Verify plus (+) and minus (-) deviation is within 200 Hz.
  - If deviation error is >200 Hz, remove external test equipment and perform FM Adjustment (para 3-2-9).
15. Press SETUP Key and "AUX" F6.
16. Press ENTER Key to access Calibration Menu.
17. Use FIELD SELECT Keys to move cursor to "2. Dev Meter (Peak)". Press ENTER Key.
18. Set Signal Generator output to 8 kHz deviation.
19. Press "Range" F1 until +10 kHz Range is displayed with AR (Auto Range) Off. Press ENTER Key.
20. Use DATA ENTRY Keypad to enter value from Measuring Receiver. Press ENTER Key.
21. Set Measuring Receiver Detector to Peak-.
22. Use DATA ENTRY Keypad to enter value from Measuring Receiver. Press +/- Key and ENTER Key.
23. Press "Range" F1 to set Range to 20 kHz.
24. Set Signal Generator output for 16 kHz deviation.
25. Set Measuring Receiver Detector to Peak+.
26. Press ENTER Key. Use DATA ENTRY Keypad to enter value from Measuring Receiver. Press ENTER Key.
27. Set Measuring Receiver Detector to Peak-.
28. Use DATA ENTRY Keypad to enter value from Measuring Receiver. Press +/- Key and ENTER Key.
29. Press "Range" F1 to set Range to 50 kHz.
30. Set Signal Generator output for 40 kHz deviation.
31. Set Measuring Receiver Detector to Peak+.
32. Press ENTER Key. Use DATA ENTRY Keypad to enter value from Measuring Receiver. Press ENTER Key.
33. Set Measuring Receiver Detector to Peak-.
34. Use DATA ENTRY Keypad to enter value from Measuring Receiver. Press +/- Key and ENTER Key.
35. Press "Range" F1 to set Range to 100 kHz.
36. Set Signal Generator output for 80 kHz deviation.
37. Set Measuring Receiver Detector to Peak+.
38. Press ENTER Key. Use DATA ENTRY Keypad to enter value from Measuring Receiver. Press ENTER Key.
39. Set Measuring Receiver Detector to Peak-.
40. Use DATA ENTRY Keypad to enter value from Measuring Receiver. Press +/- Key and ENTER Key.
41. Press "Ret" F5 and "AUX" F6.
42. Set Signal Generator output for 11 kHz deviation.
43. Set Measuring Receiver Detector to RMS.
44. Press MTRS MODE Key.

## CHAPTER 3 REPLACEMENTS/ADJUSTMENTS

---

### 3-2-7 DEVIATION METER ADJUSTMENT - Continued

45. Use FIELD SELECT Keys to move cursor to "12. Dev Meter (RMS)". Press ENTER Key.
46. Use FIELD SELECT Keys to move cursor to RANGE. Press ENTER Key. Use DATA SCROLL Keys to select 10 kHz. Press ENTER Key.
47. Verify Deviation Meter (RMS) matches Measuring Receiver ( $\pm 10\% \pm 1$  count).
  - If out of tolerance, perform Steps 48-52.
  - If in tolerance, perform Modulation Meter Adjustment (para 3-2-11).
48. Press SETUP Key and "AUX" F6.
49. Press ENTER Key to access Calibration Menu.
50. Use FIELD SELECT Keys to move cursor to "3. Dev Meter (RMS)". Press ENTER Key.
51. Press ENTER Key. Use DATA ENTRY Keypad to enter value from Measuring Receiver. Press ENTER Key.
52. Press "Ret" F5 and "AUX" F6.

### 3-2-8 MODULATION METER ADJUSTMENT

---

#### DESCRIPTION

This procedure is used to adjust the Modulation Meter for the Receive function.

---

1. Set Signal Generator output for 121.100000 MHz at 0 dBm with 80% AM modulation and 1 kHz tone.
2. Set Measuring Receiver Detector to Peak+, Low-Pass Filter to 15 kHz and Detector to AM.
3. Press RCVR MODE Key.
4. Use FIELD SELECT Keys to move cursor to MOD. Press ENTER Key. Use DATA SCROLL Keys to select AM2. Press ENTER Key.
5. Use FIELD SELECT Keys to move cursor to MOD Meter. Press ENTER Key.
6. Use FIELD SELECT Keys to move cursor to RANGE. Press ENTER Key. Use DATA SCROLL Keys to select 100%. Press ENTER Key.
7. Press SETUP Key and "AUX" F6.
8. Press ENTER Key to access Calibration Menu.
9. Use FIELD SELECT Keys to move cursor to "4. Modulation Meter". Press ENTER Key.
10. Press ENTER Key. Use DATA ENTRY Keypad to enter value from Measuring Receiver. Press ENTER Key.
11. Press "Ret" F5 and "AUX" F6.

### 3-2-9 PHASE METER ADJUSTMENT

---

#### DESCRIPTION

This procedure is used to adjust the Phase Meter for the Receive function.

---

1. Set Signal Generator output for 121.100000 MHz at 0 dBm with 6 kHz of deviation and 1 kHz rate.
2. Set Measuring Receiver Measurement to  $\phi$ M (Phase).
3. Press RCVR MODE Key.

## CHAPTER 3 REPLACEMENTS/ADJUSTMENTS

---

### 3-2-9 PHASE METER ADJUSTMENT - Continued

4. Use FIELD SELECT Keys to move cursor to MOD. Press ENTER Key. Use DATA SCROLL Keys to select PM. Press ENTER Key.
5. Verify phase reading is within 3% ( $\pm 1$  Count) of reading on Measuring Receiver.
  - If out of tolerance, perform Steps 6-15.
  - If in tolerance, perform Steps 11-15.
6. Press SETUP Key and "AUX" F6.
7. Press ENTER Key to access Calibration Menu.
8. Use FIELD SELECT Keys to move cursor to "9. Phase Meter". Press ENTER Key.
9. Press ENTER Key. Use DATA ENTRY Keypad to enter value from Measuring Receiver. Press ENTER Key.
10. Press "Ret" F5 and "AUX" F6.
11. Set Signal Generator output for 8.5 kHz deviation.
12. Set Measuring Receiver Detector to RMS.
13. Press MTRS MODE Key.
14. Use FIELD SELECT Keys to move cursor to "13. Phase Meter (RMS)". Press ENTER Key.
15. Verify Phase Meter (RMS) matches Measuring Receiver ( $\pm 10 \pm 1$  count).
  - If out of tolerance, perform Steps 16-21.
  - If in tolerance, perform Step 21.
16. Press SETUP Key and "AUX" F6.
17. Press ENTER Key to access Calibration Menu.
18. Use FIELD SELECT Keys to move cursor to "10 Phase Meter (RMS)". Press ENTER Key.
19. Press ENTER Key. Use DATA ENTRY Keypad to enter value from Measuring Receiver. Press ENTER Key.
20. Press "Ret" F5 and "AUX" F6.
21. Disconnect test equipment.

## CHAPTER 3 REPLACEMENTS/ADJUSTMENTS

### 3-2-10 DISTORTION METER ADJUSTMENT

#### DESCRIPTION

This procedure is used to adjust the Distortion Meter for the Receive function.

1. Connect external test equipment.

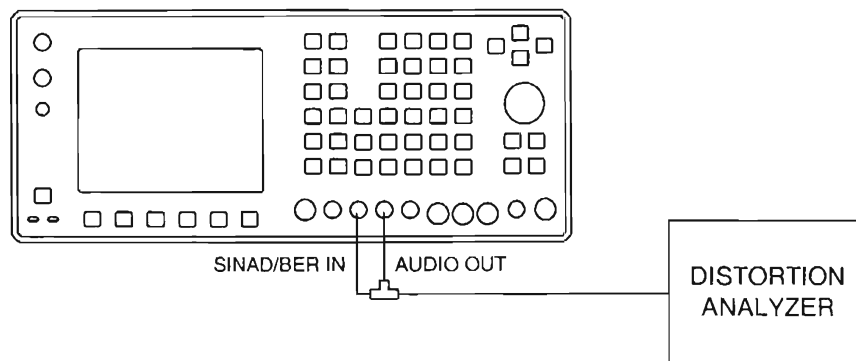

CE2FO255

2. Set Distortion Analyzer to DIST and Low-Pass Filter to 80 kHz.
3. Press POWER Switch to On and allow 20 minute warm-up period.
4. Press MTRS MODE Key, "AUX" F6 and RCL Key.
5. Use Field Select Keys to move cursor to "10. Factory Defaults" and press ENTER Key twice.
6. Press AF GEN MODE Key.
7. Press SETUP Key.
8. Use FIELD SELECT Keys to move cursor to "5. AF Output Setup". Press ENTER Key. Use FIELD SELECT Keys to move cursor to "5. Proportional Output". Press ENTER Key to select On.
9. Press AF GEN MODE Key.
10. Use FIELD SELECT Keys to move cursor to GEN 1. Press ENTER Key. Use DATA ENTRY Keypad to enter 100%. Press ENTER Key.
11. Use FIELD SELECT Keys to move cursor to GEN 2. Press ENTER Key. Use DATA ENTRY Keypad to enter 10%. Press ENTER Key.
12. Use FIELD SELECT Keys to move cursor to GEN 2 AF. Press ENTER Key. Use DATA ENTRY Keypad to enter 2400.0 Hz. Press ENTER Key.
13. Use FIELD SELECT Keys to move cursor to LEVEL. Press ENTER Key. Use DATA ENTRY Keypad to enter 1.0000 V. Press ENTER Key.

#### NOTE

To center waveform on CRT, select "Vert" F3 and use DATA SCROLL Spinner.

14. Press MTRS MODE Key.
15. Use FIELD SELECT Keys to move cursor to "6. Dist Meter". Press ENTER Key.

## CHAPTER 3 REPLACEMENTS/ADJUSTMENTS

---

### 3-2-10 DISTORTION METER ADJUSTMENT - Continued

16. Use FIELD SELECT Keys to move cursor to INPUT. Press ENTER Key. Use DATA SCROLL Keys to select SINAD/BER. Press ENTER Key.
17. Use FIELD SELECT Keys to move cursor to NOTCH FREQ. Press ENTER Key. Use DATA ENTRY Keys to enter 1000 Hz. Press ENTER Key.
18. Press SETUP Key.
19. Use FIELD SELECT Keys to move cursor to "10. Filter Select". Press ENTER Key. Use DATA ENTRY Keypad to enter 4.000 kHz. Press ENTER Key.
20. Press "Ret" F5.
21. Verify distortion reading is within  $\pm 0.5\%$  ( $\pm 1$  Count) of Distortion Analyzer.
  - If out of tolerance, perform Steps 22-26.
  - If in tolerance, perform SINAD Meter Adjustment.
22. Press SETUP Key and "AUX" F6.
23. Press ENTER Key to access Calibration Menu.
24. Use FIELD SELECT Keys to move cursor to "5. Distortion Meter". Press ENTER Key.
25. Press ENTER Key. Use DATA ENTRY Keypad to enter value from Distortion Analyzer. Press ENTER Key.
26. Press "Ret" F5 and "AUX" F6.

### 3-2-11 SINAD METER ADJUSTMENT

#### DESCRIPTION

This procedure is used to adjust the Sinad Meter for the Receive function.

1. Set Distortion Analyzer Measurement to SINAD.
2. Press AF GEN MODE Key.
3. Use FIELD SELECT Keys to move cursor to GEN 2. Press ENTER Key. Use DATA ENTRY Keypad to enter 32%. Press ENTER Key.
4. Press MTRS MODE Key.
5. Use FIELD SELECT Keys to move cursor to "7. SINAD Meter". Press ENTER Key.
6. Press SETUP Key.
7. Use FIELD SELECT Keys to move cursor to "10. Readout Res.". Press ENTER Key to select .1 dB. Press "Ret" F5.
8. Use FIELD SELECT Keys to move cursor to INPUT. Press ENTER Key. Use DATA SCROLL Keys to select SINAD/BER. Press ENTER Key.
9. Press SETUP Key.
10. Use FIELD SELECT Keys to move cursor to "9. Filter Select". Press ENTER Key. Use DATA ENTRY Keypad to enter 4.000 kHz. Press ENTER Key.
11. Press "Ret" F5.

## CHAPTER 3 REPLACEMENTS/ADJUSTMENTS

### 3-2-11 SINAD METER ADJUSTMENT - Continued

12. Verify SINAD reading is within  $\pm 1$  dB ( $\pm 1$  Digit) of Distortion Analyzer.
  - If out of tolerance, perform Steps 14-18.
  - If in tolerance, perform Step 18.
13. Press SETUP Key and "AUX" F6.
14. Press ENTER Key to access Calibration Menu.
15. Use FIELD SELECT Keys to move cursor to "6. SINAD Meter". Press ENTER Key.
16. Press ENTER Key. Use DATA ENTRY Keypad to enter value from Distortion Analyzer. Press ENTER Key.
17. Press "Ret" F5 and "AUX" F6.
18. Disconnect test equipment.

### 3-2-12 GEN MODULATION ADJUSTMENT

#### DESCRIPTION

This procedure is used to adjust the RF Generator modulation levels.

1. Connect Measuring Receiver to T/R Connector.
2. Set Measuring Receiver Measurement to AM, Low-Pass Filter to 15 kHz and Detector to Peak+.
3. Press POWER Switch to On and allow 20 minute warm-up period.
4. Press MTRS MODE Key, "AUX" F6 and RCL Key.
5. Use Field Select Keys to move cursor to "10. Factory Defaults" and press ENTER Key twice.
6. Press RF GEN MODE Key.
7. Press "More" F6 until "Disp" F1 is displayed. Press "Disp" F1.
8. Use FIELD SELECT Keys to move cursor to "2. Full Anlz". Press ENTER Key.
9. Use FIELD SELECT Keys to move cursor to RF. Press ENTER Key. Use DATA ENTRY Keypad to enter 121.1000 MHz. Press ENTER Key.
10. Record Peak Residual AM on Measuring Receiver.
11. Use FIELD SELECT Keys to move cursor to SOURCE. Press ENTER Key. Use DATA SCROLL Keys to select AM in MOD field 1. Press ENTER Key.
12. Use FIELD SELECT Keys to move cursor to MODULATION. Press ENTER Key. Use DATA ENTRY Keypad to enter 90%. Press ENTER Key.
13. Verify AM Modulation reading on Measuring Receiver is within  $\pm 5\%$  of Test Set setting less Peak Residual AM.
  - If out of tolerance, perform Steps 14-27.
  - If in tolerance, perform Steps 21-27.
14. Press SETUP Key and "AUX" F6.
15. Press ENTER Key to access Calibration Menu.
16. Use FIELD SELECT Keys to move cursor to "13. Gen Modulation". Press ENTER Key.

## CHAPTER 3 REPLACEMENTS/ADJUSTMENTS

### 3-2-12 GEN MODULATION ADJUSTMENT - Continued

17. Use FIELD SELECT Keys to move cursor to "1. AM Modulation (90%)". Press ENTER Key. Use DATA SCROLL Keys to set modulation reading on Measuring Receiver to "90%" plus Peak Residual AM reading recorded in Step 10.
  - If AM Modulation setting is out of tolerance and adjustment range is <175 or >180, perform Steps 18-27.
  - If AM Modulation setting is in tolerance, perform Steps 20-27.
18. Press ENTER Key. Use DATA ENTRY Keypad to enter 180. Press ENTER Key.
19. Locate A41 90 MHz Generator (fig. FO-2, Sheet 1 of 3) and adjust AM MOD ADJ (fig. FO-6) to set modulation reading on Measuring Receiver to 90% plus Residual AM recorded in Step 10.
20. Press RF GEN MODE Key.
21. Set Measuring Receiver to measure FM and set Low-Pass Filter to 3 kHz.
22. Use FIELD SELECT Keys to move cursor to SOURCE. Press ENTER Key. Use DATA SCROLL Keys to select OFF in MOD 1. Press ENTER Key.
23. Record Peak Residual FM on Measuring Receiver.
24. Press ENTER Key. Use DATA SCROLL Keys to select FM in MOD 1. Press ENTER Key.
25. Use FIELD SELECT Keys to move cursor to DEVIATION. Press ENTER Key. Use DATA ENTRY Keypad to enter 5.0 kHz. Press ENTER Key.
26. Use FIELD SELECT Keys to move cursor to AF FREQ. Press ENTER Key. Use DATA ENTRY Keypad to enter 905.8 Hz. Press ENTER Key.
27. Verify 5 kHz deviation reading on Measuring Receiver is within 5% of deviation setting less Peak Residual FM.
  - If deviation is not in tolerance, perform Steps 28-32.
  - If deviation is in tolerance, perform Steps 41-46.
28. Press SETUP Key and "AUX" F6.
29. Press ENTER Key to access Calibration Menu.
30. Use FIELD SELECT Keys to move cursor to "13. Gen Modulation". Press ENTER Key.
31. Use FIELD SELECT Keys to move cursor to "2. FM Deviation (20 kHz)". Press ENTER Key.
32. Use DATA SCROLL Keys to set FM Deviation on Measuring Receiver to 20 kHz plus Peak Residual FM reading recorded in Step 23. Press ENTER Key.
  - If FM Modulation setting is out of tolerance and adjustment range is <195 or >205, perform Steps 33-46.
  - If FM Modulation setting is in tolerance, perform Steps 35-46.
33. Press ENTER Key. Use DATA ENTRY Keypad to enter 200. Press ENTER Key.

## CHAPTER 3 REPLACEMENTS/ADJUSTMENTS

### 3-2-12 GEN MODULATION ADJUSTMENT - Continued

34. Press RF GEN MODE Key. Adjust FM MOD ADJ for minimum amplitude of carrier (<-35 dBc on Analyzer Display) as shown.

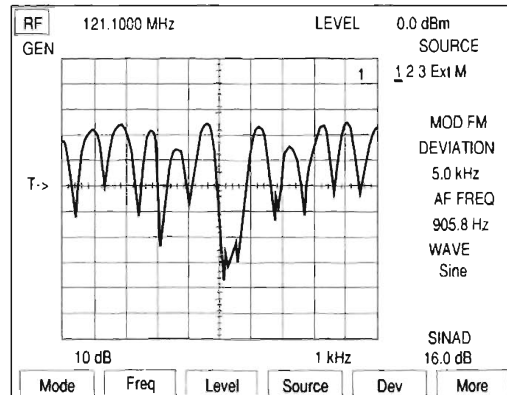

CE2FO258

35. Press SETUP Key and "AUX" F6.
36. Press ENTER Key to access Calibration Menu.
37. Use FIELD SELECT Keys to move cursor to "13. Gen Modulation". Press ENTER Key.
38. Use FIELD SELECT Keys to move cursor to "3. FM Deviation (80 kHz)". Press ENTER Key.
39. Use DATA SCROLL Keys to set FM Deviation on Measuring Receiver to 80 kHz plus Peak Residual FM reading recorded in Step 23. Press ENTER Key.
40. Press RF GEN MODE Key.
41. Set Measuring Receiver Measurement to PM and High-Pass Filter to 300 Hz.
42. Use FIELD SELECT Keys to move cursor to SOURCE. Press ENTER Key. Use DATA SCROLL Keys to select OFF in MOD 1. Press ENTER Key.
43. Record Residual PM on Measuring Receiver.
44. Press ENTER Key. Use DATA SCROLL Keys to select PM in MOD 1. Press ENTER Key.
45. Use FIELD SELECT Keys to move cursor to MODULATION. Press ENTER Key. Use DATA ENTRY Keypad to enter 6.0 Rad. Press ENTER Key.
46. Verify 6 Rad reading on Measuring Receiver is within 5% of Rad setting less Residual PM reading from Step 43.
- If not in tolerance, perform Steps 47-53.
  - If in tolerance, perform Step 53.
47. Press SETUP Key. Press "AUX" F6.
48. Press ENTER Key to access Calibration Menu.
49. Use DATA SCROLL Keys to move cursor to "13. Gen Modulation". Press ENTER Key.
50. Use FIELD SELECT Keys to move cursor to "4. Phase Modulation (6 Rad)". Press ENTER Key.
51. Use DATA SCROLL Keys to adjust data value until Phase Modulation on Measuring Receiver is 6 Rad plus Residual PM recorded in Step 43. Press ENTER Key.
52. Press "ESC" F6 and "AUX" F6.
53. Disconnect test equipment.



## CHAPTER 3 REPLACEMENTS/ADJUSTMENTS

### 3-2-13 SCOPE ADJUSTMENT

#### DESCRIPTION

This procedure is used to adjust the Oscilloscope for external signals at the SCOPE IN Connector.

1. Remove A32 Digitizer (para 3-1-3) and install on PC Board Assembly Extender in Test Set.
2. Press POWER Switch to On and allow 20 minute warm-up period.
3. Press MTRS MODE Key, "AUX" F6 and RCL Key.
4. Use Field Select Keys to move cursor to "10. Factory Defaults" and press ENTER Key twice.
5. Press SCOPE/ANLZ MODE Key to access Oscilloscope Operation Screen.
6. Connect DMM positive lead to A32TP4 (fig. FO-15, Sheet 3 of 3) and DMM negative lead to A32TP16.
7. Use FIELD SELECT Keys to move cursor to INPUT. Press ENTER Key. Use FIELD SELECT Keys to move cursor to "9. GND". Press ENTER Key.
8. Use FIELD SELECT Keys to move cursor to Scale. Press ENTER Key. Use DATA SCROLL Keys to select 10 mV. Press ENTER Key.
9. Adjust A32R44 for 0.000 Vdc ( $\pm 0.01$  Vdc) on DMM.
10. Press ENTER Key. Use DATA SCROLL Keys to select 2 mV. Press ENTER Key.
11. Adjust A32R39 for 0.000 Vdc ( $\pm 0.01$  Vdc) on DMM.
12. Disconnect external test equipment. Install A32 Digitizer (para 3-1-3).
13. Connect external test equipment as shown.

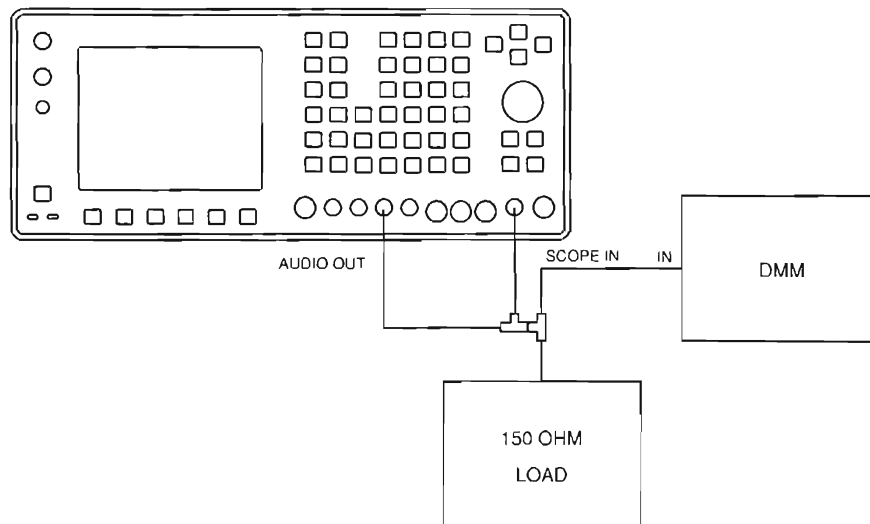

CE2FO256

14. Press AF GEN MODE Key.
15. Use FIELD SELECT Keys to move cursor to GEN 1. Press ENTER Key to select On.
16. Use FIELD SELECT Keys to move cursor to LEVEL. Press ENTER Key. Use DATA ENTRY Keypad to enter 0.0424 V. Press ENTER Key.
17. Press ENTER Key. Use DATA SCROLL Keys to move cursor to least significant digit.
18. Use DATA SCROLL Keys to adjust output for 42.43 mVRMS ( $\pm 0.12$  mVRMS) on DMM. Press ENTER Key.

## CHAPTER 3 REPLACEMENTS/ADJUSTMENTS

---

### 3-2-13 SCOPE ADJUSTMENT - Continued

19. Press SCOPE/ANLZ MODE Key.
20. Press "More" F6 until "Scale" F1 appears. Press "Scale" F1. Use DATA SCROLL Keys to select 20 mV. Press ENTER Key.
21. Use FIELD SELECT Keys to move cursor to INPUT. Press ENTER Key. Use FIELD SELECT Keys to move cursor to "7. AC". Press ENTER Key.
22. Press "Sweep" F3. Use DATA SCROLL Keys to select 100  $\mu$ s. Press ENTER Key.
23. Use FIELD SELECT Keys to move cursor to VERT. Press ENTER Key. Use DATA SCROLL Keys to center waveform. Press ENTER Key.
24. Use FIELD SELECT Keys to move cursor to TRIG LVL. Press ENTER Key. Use DATA SCROLL Keys to position trace start on center graticule.
25. Verify one cycle is displayed. Press ENTER Key.
26. Press "More" F6 until "Mkr 1" F3 appears. Press "Mkr 1" F3.
27. Use FIELD SELECT Keys to move cursor to MARKER. Press ENTER Key. Use DATA ENTRY Keypad to enter 250.000. Press ENTER Key.
28. Press "Mkr 2" F4.
29. Press ENTER Key. Use DATA ENTRY Keypad to enter 750.000. Press ENTER Key.
30. Verify DELTA is 500  $\mu$ s and 120 mV ( $\pm 8$  mV) . Adjust A32R25 as required.
31. Disconnect test equipment.

### 3-2-14 SPECTRUM ANALYZER ADJUSTMENT

---

#### DESCRIPTION

This procedure is used to adjust the parameters of the Spectrum Analyzer.

---

1. Press POWER Switch to On and allow 20 minute warm-up period.
2. Press MTRS MODE Key, "AUX" F6 and RCL Key.
3. Use Field Select Keys to move cursor to "10. Factory Defaults" and press ENTER Key twice.
4. Press SCOPE/ANLZ MODE Key to access Analyzer Operation Screen.
5. Connect Signal Generator to ANTENNA IN Connector. Set Signal Generator output frequency to 121.1 MHz at -40 dBm with no modulation.
6. Press SETUP Key.
7. Use FIELD SELECT Keys to move cursor to "2. Analyzer". Press ENTER Key to select On.
8. Use FIELD SELECT Keys to move cursor to "4. Setup Analyzer". Press ENTER Key.
9. Use FIELD SELECT Keys to move cursor to "2. Frequency". Press ENTER Key. Use DATA ENTRY Keypad to enter 121.1 MHz. Press ENTER Key.
10. Use FIELD SELECT Keys to move cursor to "6. Scan Width". Press ENTER Key. Use FIELD SELECT Keys to move cursor to 20 kHz. Press ENTER Key.
11. Press SCOPE/ANLZ MODE Key.
12. Locate A8 Analyzer RF (fig. FO-2, Sheet 1 of 3) and adjust ANLZR CENTER (fig. FO-4) to center trace on Analyzer Operation Screen.

## CHAPTER 3 REPLACEMENTS/ADJUSTMENTS

### 3-2-14 SPECTRUM ANALYZER ADJUSTMENT - Continued

13. Press "More" F6 until "Scan" F3 appears. Press "Scan" F3. Use DATA SCROLL Keys to alternate Scan Width between 20 kHz and 200 kHz, making adjustments to ANLZR CENTER to minimize centering error.
14. Use DATA SCROLL Keys to set Scan Width to 1 kHz. Press ENTER Key.
15. Verify trace is centered on center graticule ( $\pm 1$  Minor Division).
  - If trace out of tolerance, perform Steps 16-19.
  - If trace in tolerance, perform Steps 20-27.
16. Press SETUP Key. Press "AUX" F6.
17. Press ENTER Key to access Calibration Menu.
18. Use FIELD SELECT Keys to move cursor to "16. Anlz Horz Offset". Press ENTER Key. Use DATA ENTRY Keypad to increase or decrease value by 1. Press ENTER Key.
19. Press SCOPE/ANLZ MODE Key and perform Step 15.
20. Set Signal Generator for 5 kHz deviation with 1 kHz audio rate.
21. Verify signal peaks are over vertical Major Divisions. Adjust A8R28 (DISP ADJ) as required.
22. Use FIELD SELECT Keys to move cursor to RF. Press ENTER Key. Use DATA ENTRY Keypad to enter 500 MHz. Press ENTER Key.
23. Press "Scan" F3. Use DATA SCROLL Keys to select 200 kHz. Press ENTER Key.
24. Set Signal generator to 500 MHz at -40 dBm with no modulation.
25. Verify center frequency peak is -40 dBm on CRT. Locate A7 Analyzer Log/IF (fig. FO-2, Sheet 1 of 3) and adjust A7R5 (fig. FO-4) as required.
26. Press "Scan" F3. Use DATA SCROLL Keys to step through the following Scan Width settings and verify center frequency peak level, between all ranges, varies <2 dB. If individual Scan Width is not within tolerance, adjust Resolution Bandwidth Adjustment on A7 Analyzer Log/IF.

SCAN WIDTH	RESOLUTION BANDWIDTH ADJUSTMENT
1 MHz	A7R24 (300 kHz)
20 kHz	A7R57 (3 kHz)
10 kHz	A7R57 (3 kHz)
5 kHz	A7R57 (3 kHz)
2 kHz	A7R96 (300 Hz)
1 kHz	A7R96 (300 Hz)

27. Perform Step 26 until no further adjustments are required.
28. Disconnect test equipment.

## CHAPTER 3 REPLACEMENTS/ADJUSTMENTS

### 3-2-15 POWER METER ADJUSTMENT

#### DESCRIPTION

This procedure is used to adjust the parameters of the Power Meter.

1. Press POWER Switch to On and allow 20 minute warm-up period.
2. Press MTRS MODE Key, "AUX" F6 and RCL Key.
3. Use Field Select Keys to move cursor to "10. Factory Defaults" and press ENTER Key twice.
4. Locate A36 Power Termination (fig. FO-2, Sheet 1 of 3) and connect DMM positive lead to A36FL9 (fig. FO-11) and DMM negative lead to A36GL1.
5. Set Signal Generator RF output to 150 MHz.
6. Connect external test equipment as shown.

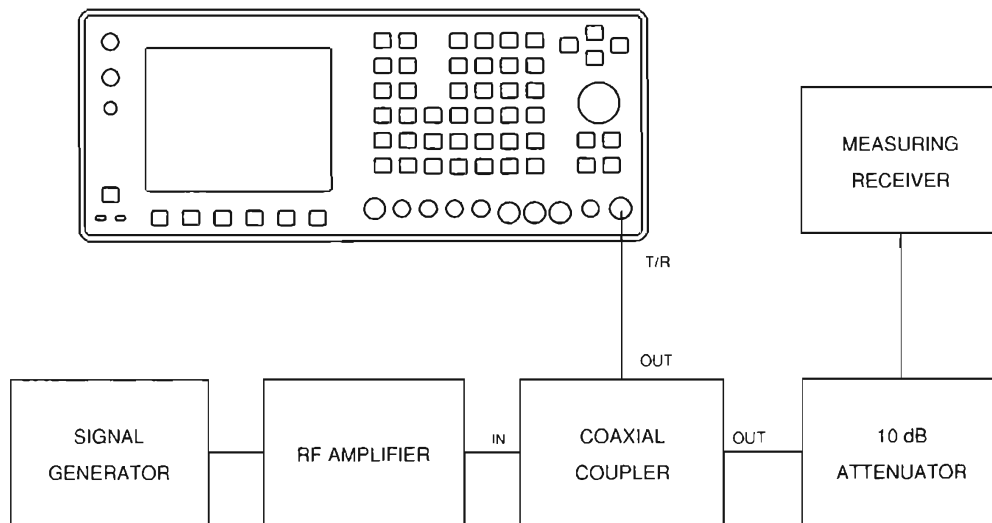

7. Use following formula to calculate and record power level at 0.2, 1400, 2000 and 10000 mW:  
$$\text{Log (milliwatts)} \times 10 - (\text{Coupler Attenuation}) = \text{dBm (Power Level)}$$
8. Reference Measuring Receiver RF Power reading to TRUE attenuation of 10 dB Attenuator.
9. Set Signal Generator RF output to OFF.
10. Press RF GEN MODE Key.
11. Use FIELD SELECT Keys to move cursor to LEVEL. Press ENTER Key. Use DATA ENTRY Keypad to enter -137 dBm. Press ENTER Key.
12. Press RCVR MODE Key.
13. Use FIELD SELECT Keys to move cursor to RF. Press ENTER Key. Use DATA ENTRY Keypad to enter 150.0000 MHz. Press ENTER Key.
14. Use FIELD SELECT Keys to move cursor to ANT. Press ENTER Key to select T/R.
15. Use FIELD SELECT Keys to move cursor to PWR. Press ENTER Key. Use FIELD SELECT Keys to move cursor to RANGE. Press ENTER Key. Use DATA SCROLL Keys to select 20 mW. Press ENTER Key.

## CHAPTER 3 REPLACEMENTS/ADJUSTMENTS

### 3-2-15 POWER METER ADJUSTMENT - Continued

16. Verify 0 V ( $\pm 1$  mV) DMM. Remove aluminum tape from A36 Power Termination and adjust A36A1R21 as required.
17. Press ENTER Key. Use DATA SCROLL Keys to select 20 W. Press ENTER Key.
18. Verify 0 V ( $\pm 1$  mV) with DMM. Adjust A36A1R18 as required.
19. Press ENTER Key. Use DATA SCROLL Keys to select 2 W. Press ENTER Key.
20. Set Signal Generator RF output to ON. Adjust Signal Generator RF output level until reading on Measuring Receiver is equal to calculated power level in Step 7 for 2000 mW.
21. Verify 4.025 V ( $\pm 0.025$  V) with DMM and 2.0 W ( $\pm 0.2$  W) on CRT. Adjust A36A1R58 as required.
22. Press ENTER Key. Use DATA SCROLL Keys to select 20 W. Press ENTER Key.
23. Adjust Signal Generator RF output level until reading on Measuring Receiver is equal to calculated power level in Step 7 for 10000 mW.
24. Verify 10 W ( $\pm 1$  W) on CRT. Adjust A36A1R46 as required.
25. Perform Steps 15-24 until no further adjustments are required.
26. Press SETUP Key and "AUX" F6.
27. Press ENTER Key to access Calibration Menu.
28. Use FIELD SELECT Keys to move cursor to "1. Power Meter". Press ENTER Key.
29. Press "Range" F1 to select 20 mW with AR Off.
30. Set Signal Generator RF output to OFF, press "Zero" F2 and verify Power Meter Zero raw data Zero value is momentarily displayed.
31. Press "Range" F1 to select 20 W.
32. Press "Zero" F2 and verify Power Meter Zero raw data Zero value is momentarily displayed.
33. Press "Range" F1 to select 2 W.
34. Adjust Signal Generator RF output level until reading on Measuring Receiver is equal to calculated power level in Step 7 for 1400 mW.
35. Press ENTER Key. Use DATA ENTRY Keypad to enter 1.40 W. Press ENTER Key.
36. Adjust Signal Generator RF output level until reading on Measuring Receiver is equal to calculated power level in Step 7 for 0.2 mW.
37. Press "Range" F1 to select 20 mW.
38. Press ENTER Key. Use DATA ENTRY Keypad to enter 0.2 mW. Press ENTER Key.
39. Verify 0.2 mW ( $\pm 0.1$  mW) on Power Meter.
40. Perform Steps 28 through 38 until no further adjustments are required.
41. Press "Ret" F5 and "AUX" F6.
42. Disconnect test equipment. Install aluminum tape on A36 Power Termination.

### SECTION 3 PREPARATION FOR STORAGE OR SHIPMENT

#### 3-3-1 PACKAGING

Package Radio Test Set in original shipping container. When using packing materials other than original, use following guidelines:

- Wrap Test Set in plastic packing material.
- Use double-wall cardboard shipping container.
- Protect all sides with shock-absorbing material to prevent Test Set movement within container.
- Seal shipping container with approved sealing tape.
- Mark "FRAGILE" on all sides, top and bottom of shipping container.

#### 3-3-2 ENVIRONMENT

The Test Set should be stored in a clean, dry environment. In high humidity environments, protect Radio Test Set from temperature variations that could cause internal condensation. The following environmental conditions apply to both shipping and storage:

Temperature .....	-40° to +158° F (-40° to +70° C)
Relative Humidity .....	0% to 95%
Altitude .....	0 to 40,000 ft (0 to 12,192 m)
Vibration .....	<2.0 g
Shock .....	<40 g

**CHAPTER TABLE OF CONTENTS**

SECTION 1	GENERAL .....	4-2
4-1-1	COMPOSITE ASSEMBLY.....	4-2
4-1-2	CASE ASSEMBLY.....	4-5
4-1-3	LID ASSEMBLY.....	4-6
4-1-4	FRONT PANEL ASSEMBLY .....	4-7
4-1-5	REAR PANEL ASSEMBLY.....	4-9
4-1-6	COAX KIT ASSEMBLY.....	4-10
4-1-7	WIRE HARNESS & RBN CABLE.....	4-12

## SECTION 4 – PARTS LIST

### SECTION 1 GENERAL

This section contains the part numbers and descriptions for replaceable parts in IFR 1900 CSA-4.

Prefix all reference designators with 34A5.

#### 4-1-1 COMPOSITE ASSEMBLY

REFERENCE DESIGNATOR	PART NUMBER	DESCRIPTION
1	2845-0000-017	FINGERSTOCK, BRIGHT TIN PLATED
2	2506-7877-200	HANDLE MOUNTING PLATE
3	2803-0188-003	SCREW, 440 X 3/16 PFHM
4	1409-7861-500	GUIDE, REAR PANEL 1600
5	1402-3461-800	RAIL, SIDE 1900 CSA
6	2803-0250-003	SCREW, 440 X 1/4 PFHM
7	2850-7866-200	NUT, 5/824, NTYPE CONNECTOR
8	2850-7866-300	STANDOFF, HEX, MALEFEMALE
9	2118-0000-003	MTG, SCREW, AMP
10	2403-1352-100	OVERLAY, REAR PANEL
11	2289-0001-002	CAP, BNC MALE W/CHAIN
12	2803-0188-006	SCREW, 440 X 3/16 PPHM
13	2805-0188-002	SCREW, 832 SHCS, BLACK
14	2803-0313-000	SCREW 440 X 5/16 PFHMS
16	1400-3453-800	BRACKET, OVEN IFR1900
17	2803-0250-000	SCREW, 440 X 1/4 PPHM
18	2840-0000-000	WASHER, LOCK, INT TOOTH, 4
19	2840-0000-000	WASHER, FLAT, 4, AN960C4
20	1407-0000-101	HANDLE, MOLDED GRIP 17.375
21	2805-0500-002	SCREW, 832 1/2 SHCS BLACK
22	2402-0017-100	PUSHBUTTON, TILT BAIL HANDLE
23	2106-0000-012	CMPRSN SPR.36 OD*.50 FREE LGTH
24	2805-1000-006	SCREW, 832 X 1 PPHM
25	2840-0000-014	WASHER, FLAT, 8
26	1407-0000-200	SIDE LEG, 9.5" TILT BAIL
27	2808-7270-200	DISC, HANDLE INDEXING
28	2510-7270-100	HUB, TILT BAIL HANDLE INNER
29	2850-7867-000	NUT, .188HEX, .625LG, 440
30	2803-0438-006	SCREW, 440 X 7/16 PPHM



## SECTION 4 – PARTS LIST

REFERENCE DESIGNATOR	PART NUMBER	DESCRIPTION
31	2800-7600-168	SPACER, AL, .25HEX, 440ID, .75 LG
32	2803-1250-003	SCREW, 440 X 1 1/4 PFHM
33	2803-0625-006	SCREW, 440 X 5/8 PPHM
34	4503-0002-016	RETAINER CLIP, 16P RIBBON CONN
35	3107-3453-100	INSULATOR, I/O
36	2519-3452-200	SHIELD, CONNECTOR
37	6004-6005-400	TYRAP, 4.0 LG
38	1050-0000-289	ADHESIVE, THREADLOC, LOCTITE271*
39	1050-0000-047	LOCTITE
40	1050-0000-288	PRIMER, ADHESIVE, LOCTITE N
45	2850-7882-600	SPCR, FOAM, .2 5"X.75"X 1.25"
46	4503-0002-026	RETAINER CLIP, 26P RIBBON CONN
A1	7010-3433-000	PCB ASSY, TDMA 10.7 MHz RECEIVER
A2	7011-3432-200	FIRMWARE ASSY, INTERNAL I/O
A3	7005-3445-400	MECH ASSY, CHASSIS
A5	7005-3440-200	MECH ASSY, REAR PANEL
A6	7005-7846-000	MECH ASSY, 1600 MONITOR
A7	7005-7840-300	MECH ASSY, ANALYZER LOGIF
A8	7005-7840-200	MECH ASSY, ANALYZER RF
A9	7005-7846-300	MECH ASSY, RECEIVER
A11	7005-7846-800	MECH ASSY, DMM
A13	7005-3447-900	MECH ASSY, 1ST LO 1900
A14	7010-3433-200	PCB ASSY, TDMA PWR DISTRIBUTION
A15	7005-3448-000	MECH ASSY, 2ND LO
A16	7005-3442-000	MECH ASSY, RF RECEIVER IF
A17	7010-3431-500	PCB ASSY, BASEBAND MUX
A18	7010-3435-300	PCB ASSY, RF MODEM
A19	7011-3438-500	DSP FIRMWARE ASSY
A20	7005-3444-200	MECH ASSY, GEN IF
A21	7005-3443-600	MECH ASSY, POWER TERM
A22	7005-3441-600	MECH ASSY, POWER SUPPLY
A23	7005-3445-500	MECH ASSY, FRONT PANEL
A24	7011-3432-800	FIRMWARE ASSY, PROCESSOR
A25	7011-3438-400	FIRMWARE ASSY, FLASH CSA19004
A26	7011-3432-800	FIRMWARE ASSY, PROCESSOR

## SECTION 4 – PARTS LIST

REFERENCE DESIGNATOR	PART NUMBER	DESCRIPTION
A27	7011-3438-300	FIRMWARE ASSY, FLASH P1900 4
A28	7010-1331-400	PCB ASSY, VIDEO CONTROL
A29	7010-7835-400	PCB ASSY, RF I/O
A30	7011-8644-500	FIRMWARE ASSY, COUNTER
A31	7011-8649-600	FIRMWARE ASSY FUNCTION GEN
A32	7011-8645-700	FIRMWARE ASSY DIGITIZER
A33	7011-8641-100	FIRMWARE ASSY, MONITOR CONTROL
A34	7011-3444-500	FIRM ASSY, TDMA EXTERNAL I/O
A35	7011-8645-900	FIRMWARE ASSY EXTERNAL I/O
A36	7010-3433-700	PCB ASSY, ATTENUATOR
A37	7010-3432-500	PCB ASSY, AUX POWER SUPPLY
A38	7010-3433-800	PCB ASSY, REAR PANEL CONNECTOR
A39	7010-3435-100	PCB ASSY, MASTER OSC (PIEZO)
A39	7010-3436-600	PCB ASSY, MASTER OSC (BLILEY)
A40	7005-3446-200	MECH ASSY, 3RD LO
A41	7005-3446-100	MECH ASSY, 90 MHZ GEN
J1	2200-0410-100	CONN, ADAPT, F BNC/F SMASTR BHD*
J2	2200-0410-100	CONN, ADAPT, F BNC/F SMASTR BHD*
J3	2200-0410-100	CONN, ADAPT, F BNC/F SMASTR BHD*
J4	2200-0410-100	CONN, ADAPT, F BNC/F SMASTR BHD*
J5	2200-0410-100	CONN, ADAPT, F BNC/F SMASTR BHD*
	1100-1005-200	EQUIPMENT HISTORY EVELOPE
	7009-3447-700	KIT, WIRE HARNESS & RBN CABLE
	7009-3448-600	COAX KIT, CSA-4

**SECTION 4 – PARTS LIST****4-1-2 CASE ASSEMBLY**

Prefix all reference designators with 34A3.

**CASE TOP**

REFERENCE DESIGNATOR	PART NUMBER	DESCRIPTION
1	1414-7850-400	COVER CASE TOP
2	2850-7867-200	SPCR,FOAM,.25"X.75"X 3.00"
4	2400-7865-000	LABEL FRONT OF UNIT
5	2850-7867-100	SPCR,FOAM,.25"X.75"X 6.00"
8	2850-7882-600	SPCR,FOAM,.25"X.75"X 1.25"

Prefix all reference designators with 34A2.

**CASE BOTTOM**

REFERENCE DESIGNATOR	PART NUMBER	DESCRIPTION
1	1414-7896-600	CASE BOTTOM
3	2400-7865-000	LABEL FRONT OF UNIT
4	1421-0000-500	FT, CONICAL, 80OD,.15ID,.58LG
5	2804-0375-006	SCREW, 6-32 X 3/8 PPHM

## SECTION 4 – PARTS LIST

### 4-1-3 LID ASSEMBLY

Prefix all reference designators with 34A4.

REFERENCE DESIGNATOR	PART NUMBER	DESCRIPTION
1	2503-7862-200	LID, PLASTIC
2	1412-7883-700	ACCESS POUCH, FRONT PNL COVER
3	1201-0909-900	ANTENNA
4	6041-0001-001	CORD, AC, NEMA515,IEC320C13,RA
5	2113-0000-013	CONN, ADAPT, M2F BNC, RT.ANGLE
6	5106-0000-023	FUSE, 4.0AMP, 250V, FAST, 1.25GL
7	2128-7801-100	PROBE, SET DMM
8	2200-0410-700	CONN, ADAPT BNC JACK - TNC PLUG

**SECTION 4 – PARTS LIST**

## 4-1-4 FRONT PANEL ASSEMBLY

Prefix all reference designators with 34A5A23.

REFERENCE DESIGNATOR	PART NUMBER	DESCRIPTION
1	1405-3456-900	PANEL, FRONT
2	2400-7856-800	LABEL, ESD
3	2525-0017-000	GSKT, ORIENTED WIRE, TINNED, .045
4	2525-9560-700	GASKET, FOAM, LCD LENS
5	3900-3452-500	LENS, IFR190
6	1400-7859-200	BRACKET, SPEAKER BASE
7	1400-1352-000	BRACKET, LENS
8	4503-0003-100	RETAINTER, 3" ROUND SPEAKER
9	2101-3457-400	CUSHION, FUNCTION KEYBOARD
10	2403-3457-200	OVERLAY, FRONT PANEL
11	2525-0006-000	GASKET ROPE
12	2845-0000-015	FINGERSTOCK, W/COND ADH TAPE
13	2506-3457-500	PLATE, KEY RETAINER FUNCT KEY
14	3107-2057-700	INSULATOR, LCD INTF
15	7067-7850-600	KEY CAP KIT 1600
16	2506-2058-200	PLATE, MTG, LCD SHIELD
17	2506-7857-400	PLATE, KEY RETAINER MAIN KEYB
18	2101-7857-100	CUSHION, MAIN KEYBOARD
19	2508-2056-400	SHIELD, LCD
20	2818-2056-500	STANDOFF, 3/16 HEX, .375L
22	2801-0250-006	SCREW, 256 X 1/4 PPH
23	2402-7854-200	KNOB, 1.50 DIA X .86 L
24	2840-0000-004	WASHER, LOCK, INT TOOTH, 2
25	2850-0000-012	NUT, HEX, SMALL PAT, 256
26	2850-0000-008	NUT, HEX, REG PAT, 44
27	2840-0000-008	WASHER, FLAT, 4, AN960C4
28	2803-0313-006	SCREW, 440 X 5/16 PPHM
29	2803-0375-003	SCREW, 440 X 3/8 PFHM
30	2803-0188-006	SCREW, 440 X 3/16 PPH
31	2803-0625-006	SCREW, 440 X 5/8 PPHM
32	2508-3457-600	SHIELD, TOP, LCD INTERFACE

## SECTION 4 – PARTS LIST

REFERENCE DESIGNATOR	PART NUMBER	DESCRIPTION
33	6012-0186-110	TUBING, CLEA
34	2803-0250-006	SCREW, 440 X 1/4 PPH
35	2803-0188-003	SCREW, 440 X 3/16 PFHM
36	2289-7895-400	BNC CAP, MALE, .375 RING
37	2845-0000-008	FINGERSTOCK, 97061117
38	2845-0000-018	FINGERSTOCK, BECU, WALL CLIPON
39	6004-6005-400	TYRAP, 4.0 LG
A1	7010-3431-300	PCB ASSY, FRONT PANEL CONNECTOR
A2	7010-3436-300	PCB ASSY, KEYBOARD
A3	7010-3435-500	PCB ASSY, LCD INTERFACE
A4	0002-0000-000	REF DESIG NOT USED
A5	7110-2042-400	DISPLAY, LCD COLOR, 640X480 6.4
GL1	2850-1180-100	LUG, GROUND, IT, 3/8, ZIERICK 814
J4	2200-0410-500	CONN, F TNC BHD / F SMA ADAPT
J5	2200-0410-500	CONN, F TNC BHD / F SMA ADAP
J11	2113-0000-018	CONN UG1094A/U
LS1	5950-0000-003	SPEAKER, FERRITE, 3 RND, 8 OHM
RE1	4795-0000-002	ENCODER, ROTARY CONTACT 25PIR
W1	6008-1000-001	UL 1213, 26GA, 7X34, BL
W2	6008-1000-003	UL 1213, 26GA, 7X34, RED
W3	6041-7883-900	CABLE ASSY, FP.PNL CONNECTOR
W4	1050-0000-075	WIRE, BUS, TINNED COPPER, 26GA
W5	1050-0000-075	WIRE, BUS, TINNED COPPER, 26G
W6	1050-0000-075	WIRE, BUS, TINNED COPPER, 26GA
W7	6045-2081-100	CABLE ASSY, LCD/INTF

**4-1-5 REAR PANEL ASSEMBLY**

Prefix all reference designators with 34A5A5.

<b>REFERENCE DESIGNATOR</b>	<b>PART NUMBER</b>	<b>DESCRIPTION</b>
1	1405-1350-100	PANEL, REAR
2	1400-7850-200	BRACKET, SCREEN
3	2602-7864-700	SCREEN, FAN EXHAUST
4	1407-7808-100	HANDLE, REAR PANEL
5	2803-0250-003	SCREW, 440 X 1/4 PFH
6	2845-0000-010	FINGERSTOCK 97054017
7	2805-0500-003	SCREW, 832 X 1/2 PFHMS
10	2525-0006-000	GASKET ROPE
11	2400-7856-700	LABEL, ESD CAUTIO
12	2845-0000-008	FINGERSTOCK, 97061117
13	1051-0100-200	ADHESIVE, LOCTITE 290-21

## SECTION 4 – PARTS LIST

### 4-1-6 COAX KIT ASSEMBLY

Prefix all reference designators with 34A5.

REFERENCE DESIGNATOR	PART NUMBER	DESCRIPTION
W1	6010-0250-200	TUBING,HS, 1/4 ID,BLACK
W2	6044-1653-000	COAX C SL M SMA R-M MMCX R 180
W3	6044-1911-900	COAX C S M SMA RA - M SMA ST
W4	6044-1562-000	COAX CON SL M SMA ST-M MMCX RA
W5	0002-0000-000	REF DESIG NOT USED
W6	6044-1633-000	COAX C S M MMCX RA-M MMCX RA
W7	6044-1602-200	COAX C S M SMB R-M MMCX R
W8	6044-1601-400	COAX C S M SMB R-M MMCX R
W9	6044-1600-400	COAX C S M SMB RA - M MMCX RA
W10	6044-1670-550	COAX C S M MMCX R-M MMCX R 90
W11	6044-1670-700	COAX C S M MMCX R-M MMCX R 90
W12	6044-1562-200	COAX C S M SMA S-M MMCX R
W13	6044-1602-500	COAX C S M SMB R-M MMCX R
W14	6044-1602-700	COAX C S M SMB R-M MMCX R
W15	6044-1602-700	COAX C S M SMB R-M MMCX R
W16	6044-1602-200	COAX C S M SMB R-M MMCX R
W17	6044-1602-500	COAX C S M SMB R-M MMCX R
W18	6044-1562-000	COAX CON SL M SMA ST-M MMCX RA
W19	6044-1431-000	COAX C S M SMB RA - M SMB RA
W20	6044-1430-920	COAX C S M SMB RA - M SMB RA
W21	6044-1430-425	COAX C S M SMB RA - M SMB RA
W22	6044-1430-425	COAX C S M SMB RA - M SMB RA
W23	0002-0000-000	REF DESIG NOT USED
W24	0002-0000-000	REF DESIG NOT USED
W25	0002-0000-000	REF DESIG NOT USED
W26	6044-1930-700	COAX C S M SMB R-M MMCX R 180
W27	6044-1600-800	COAX C S M SMB RA - M MMCX RA
W28	6044-1633-300	COAX C S M MMCX RA - M MMCX RA
W29	6044-1562-000	COAX CON SL M SMA ST-M MMCX RA
W30	6044-1700-700	COAX C S M SMB R-M MMCX R 90
W31	6044-1632-200	COAX C S M MMCX RA - M MMCX RA



**SECTION 4 – PARTS LIST**

<b>REFERENCE DESIGNATOR</b>	<b>PART NUMBER</b>	<b>DESCRIPTION</b>
W32	6044-1461-000	COAX C S M SMB RA-M SMB RA 180
W33	6044-1942-975	COAX C S M MMCX- G LUG OPEN
W34	6044-1951-000	COAX C S M SMB R-M MMCX R 270
W35	0002-0000-000	REF DESIG NOT USED
W36	6044-1562-400	COAX C S M SMA ST - M MMCX RA
W37	6044-1562-400	COAX C S M SMA ST - M MMCX RA
W38	6044-1942-975	COAX C S M MMCX- G LUG OPEN
W39	6044-1951-000	COAX C S M SMB R-M MMCX R 270
W41	6044-1562-400	COAX C S M SMA ST - M MMCX RA
W42	6044-1562-400	COAX C S M SMA ST - M MMCX RA

## SECTION 4 – PARTS LIST

### 4-1-7 WIRE HARNESS & RBN CABLE

Prefix all reference designators with 34A5.

REFERENCE DESIGNATOR	PART NUMBER	DESCRIPTION
W2	6042-1380-400	COAX ASSY,SR.141 N ST-M SMA ST
W6	6042-3483-400	COAX .086 M MMCX ST-M MMCX RA
W7	6042-3485-600	COAX .086 M MMCX ST-M MMCX RA
W11	6042-3485-500	COAX .086 M MMCX ST-M MMCX RA
W12	6042-3483-500	COAX .086 M MMCX ST-M MMCX RA
W30	6042-3483-600	COAX SR.086 M SMA ST-M MMCX RA
W43	6045-3481-400	RBN CA, VIDEO - REAR PNL
W44	6045-3481-500	RBN CA, VIDEO - FT PNL
W45	0002-0000-000	REF DESIG NOT USED
W46	6045-3481-700	RBN CA, MUX - FT PNL
W47	6045-3481-800	RBN CA,TDMA PROCESSOR,REAR PNL
W48	6045-3482-400	RBN CA, I/O - REAR PANEL
W49	6045-7881-600	RBN CA ASSY MONITOR/MONT CNTRL
W50	0002-0000-000	REF DESIG NOT USED
W51	7007-3482-500	WIRE HARN, MODEM - MUX
W52	0002-0000-000	REF DESIG NOT USED
W53	7007-3480-900	WIRE HARN,MOTHBD - MUX - MODEM
W54	7007-3481-100	WIRE HARN, MUX, TDMA MOTHERBD
W55	0002-0000-000	REF DESIG NOT USED
W56	7007-3482-200	WIRE HARN, RF MODEM - PWR TERM
W57	7007-3482-300	WIRE HARN,TDMA MOTHDB,REAR PNL
W58	7007-3483-200	WIRE HARN,MODEM,MOTHBD/MAST OC
W59	7007-3483-300	WIRE HARN,MODEM,AUX PWR,GEN
W60	7007-3485-300	WIRE HARN, AUX, 2ND LO, RECV
W61	6045-3483-900	RBN CA, AUX PWR / GEN

**CHAPTER TABLE OF CONTENTS**

Figure FO-1 Test Set Functional Block Diagram.....	FP-2
Figure FO-2 Test Set (34A5) Assembly, Cable Locator and Interconnect Diagram .....	FP-5
Figure FO-3 34A5A1 Assembly Component Locator Diagram.....	FP-12
Figure FO-4 34A5A2 Assembly Component Locator Diagram.....	FP-13
Figure FO-5 34A5A3A1 Motherboard Assembly Component Locator and Wiring Diagram .....	FP-14
Figure FO-6 34A5A3A2 TDMA Motherboard Assembly Component Locator and Wiring Diagram .....	FP-18
Figure FO-7 34A5A6, 34A5A7 and 34A5A8 Assemblies Component Locator Diagrams .....	FP-22
Figure FO-8 34A5A9 and 34A5A40 Assemblies Component Locator Diagrams .....	FP-23
Figure FO-9 34A5A11 DMM Assembly Component Locator Diagram.....	FP-24
Figure FO-10 34A5A41 Assembly Component Locator Diagram.....	FP-25
Figure FO-11 34A5A13 1 <sup>st</sup> LO Assembly Component Locator and Wiring Diagram .....	FP-26
Figure FO-12 34A5A14 PC Board Assembly Component Locator Diagram.....	FP-27
Figure FO-13 34A5A15 2 <sup>nd</sup> LO Assembly Component Locator and Wiring Diagram.....	FP-28
Figure FO-14 34A5A16 Receive IF Assembly Component Locator Diagram .....	FP-29
Figure FO-15 34A5A17 PC Board Assembly Component Locator Diagram.....	FP-30
Figure FO-16 34A5A18 PC Board Assembly Component Locator Diagram.....	FP-31
Figure FO-17 34A5A19 Firmware Assembly Component Locator Diagram .....	FP-32
Figure FO-18 34A5A20 Generator IF Assembly Component Locator Diagram.....	FP-33
Figure FO-19 34A5A21 Power Termination Assembly Component Locator and Wiring Diagram.....	FP-34
Figure FO-20 34A5A22 Power Supply Assembly Component Locator Diagram .....	FP-35
Figure FO-21 34A5A23 Front Panel Assembly Component Locator Diagram.....	FP-36
Figure FO-22 34A5A24/34A5A26 PC Board Assembly Component Locator Diagram .....	FP-37
Figure FO-23 34A5A25/34A5A27 PC Board Assembly Component Locator Diagram .....	FP-38
Figure FO-24 34A5A28 PC Board Assembly Component Locator Diagram.....	FP-39
Figure FO-25 34A5A29 PC Board Assembly Component Locator Diagram.....	FP-40
Figure FO-26 34A5A30 PC Board Assembly Component Locator Diagram.....	FP-41
Figure FO-27 34A5A31 PC Board Assembly Component Locator Diagram.....	FP-42
Figure FO-28 34A5A32 PC Board Assembly Component Locator Diagram.....	FP-43
Figure FO-29 34A5A33 PC Board Assembly Component Locator Diagram.....	FP-44
Figure FO-30 34A5A34/34A5A35 PC Board Assembly Component Locator Diagram .....	FP-45
Figure FO-31 34A5A36 Attenuator Assembly Component Locator Diagram.....	FP-46
Figure FO-32 34A5A37 Auxiliary Power Supply Assembly Component Locator and Schematic Diagram .....	FP-48
Figure FO-33 34A5A38 Rear Panel Connector PC Board Assembly Wiring Diagram.....	FP-50

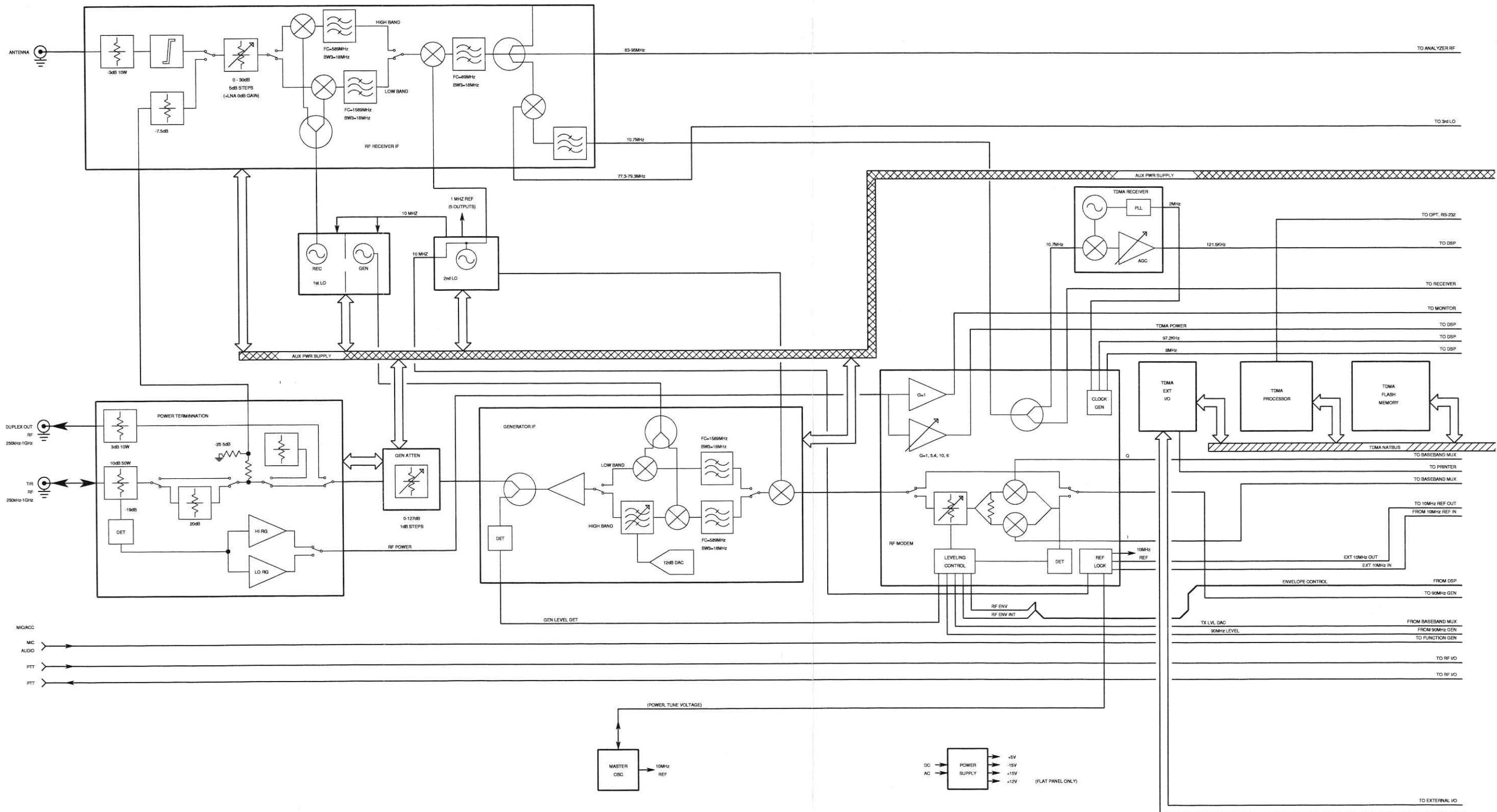

SBD01

Figure FO-1 Test Set Functional Block Diagram (Sheet 1 of 2)

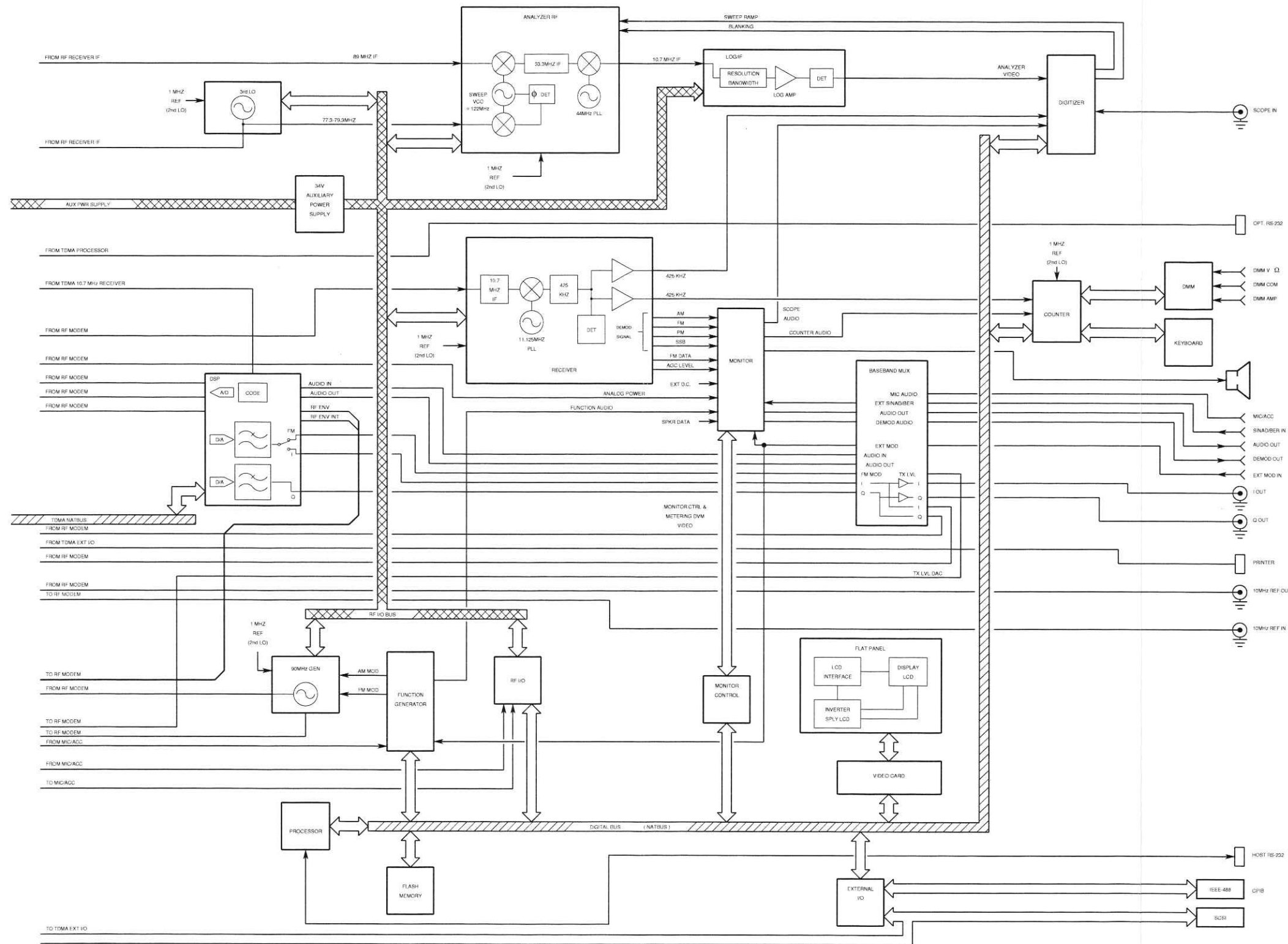

Figure FO-1 Test Set Functional Block Diagram (Sheet 2 of 2)

SBD02

THIS PAGE INTENTIONALLY LEFT BLANK.

CHAPTER 5 - MECHANICAL ASSEMBLIES, PC BOARDS AND SCHEMATICS

WIRE RUNNING LIST				
DESG	FROM	TO	COLOR	AWG
W1	A23J4B	A16J2		
W2	W2J1	A21J1		
W3	A21J3	A23J5B		
W4	A21J2	A16J3		
W6	A13J3	A16J4		
W7	A15J9	A16J5		
W8	A16J0	A18J4		
W9	A16J9	A8J2		
W10	A10J3	A16J6		
W11	A15J10	A20J2		
W12	A13J5	A20J5		
W13	A41J3	A18J11		
W14	A15J12	A13J2		
W15	A15J13	A13J4		
W16	A39J1	A18J9		
W17	A15J3	A30J3		
W18	A15J4	A8J4		
W19	A15J5	A40J2		
W20	A15J7	A41J2		
W21	A15J8	A9J4		
W22	J3B	A18J7		
W23	A9J5	A32J3		
W24	A9J3	A30J4		
W25	A8J3	A7J2		
W26	A40J4	A8J5		
W30	A20J13	A36J2		
W31	A18J5	A1J1		
W32	A18J6	A9J2		
W33	A18J10	A15J2		
W34	A18J8	J4B		
W35	A18J1	A1J5		
W36	A18J12	A20J1		
W37	A1J4	A19J2		
W38	A21FL9	A18J3		
W39	A18J2	A19J1		
W41	A17J6	J2B		
W42	A17J7	J1B		
W43	A28J2	A38J1		
W44	A23A3J1	A28J1		
W46	A23A1J2	A17J1		
W47	A24J2	RS232		
W48	A2J2	PRINTER		
W49	A6J2	A33J2		
W51	A18J14	A17J4		
W53	W53P3	A18J17		
W53	W53P2	A17J5		
W53	W53P1	A3A2J5		
W54	A3A2J2	A17J3		
W56	A21FL8	A18J15		
W57	A3A2J1	J5B		
W58	W58J1	A3A1W1P1		
W58	W58P2	A39J1		
W58	W58P1	A18J16		
W59	W59P1	A37J3		
W59	W59P2	A18J18		
W59	W59P3	A20A3J2		
W60	W60P2	A16A2J1		
W60	W60P1	A37J4		
W60	W60J1	A15W1P1		
W61	A20A3J1	A37J6		
	A23W3P1	A3A1J1		
	A23A2W1P1	A3A1J3		
	A11A1W2P1	A3A1J2		
	A3A1W6P1	A37J1		
	A3A1W4P1	A22A1J3		
	A3A1W4P2	A37J2		
	A3A1W7P1	A17J2		
	A3A1W5P1	A22A1J2		
	A14W1P1	A22W1J1		
	A38W1P1	A35J2		
	A38W1P2	A34J2		
	A38W2P1	A26J2		
	A13A3W1P1	A37J5		
	A21W1P1	A36J4		
	A37W1P1	A36J6		
	A21P4	A36J1		

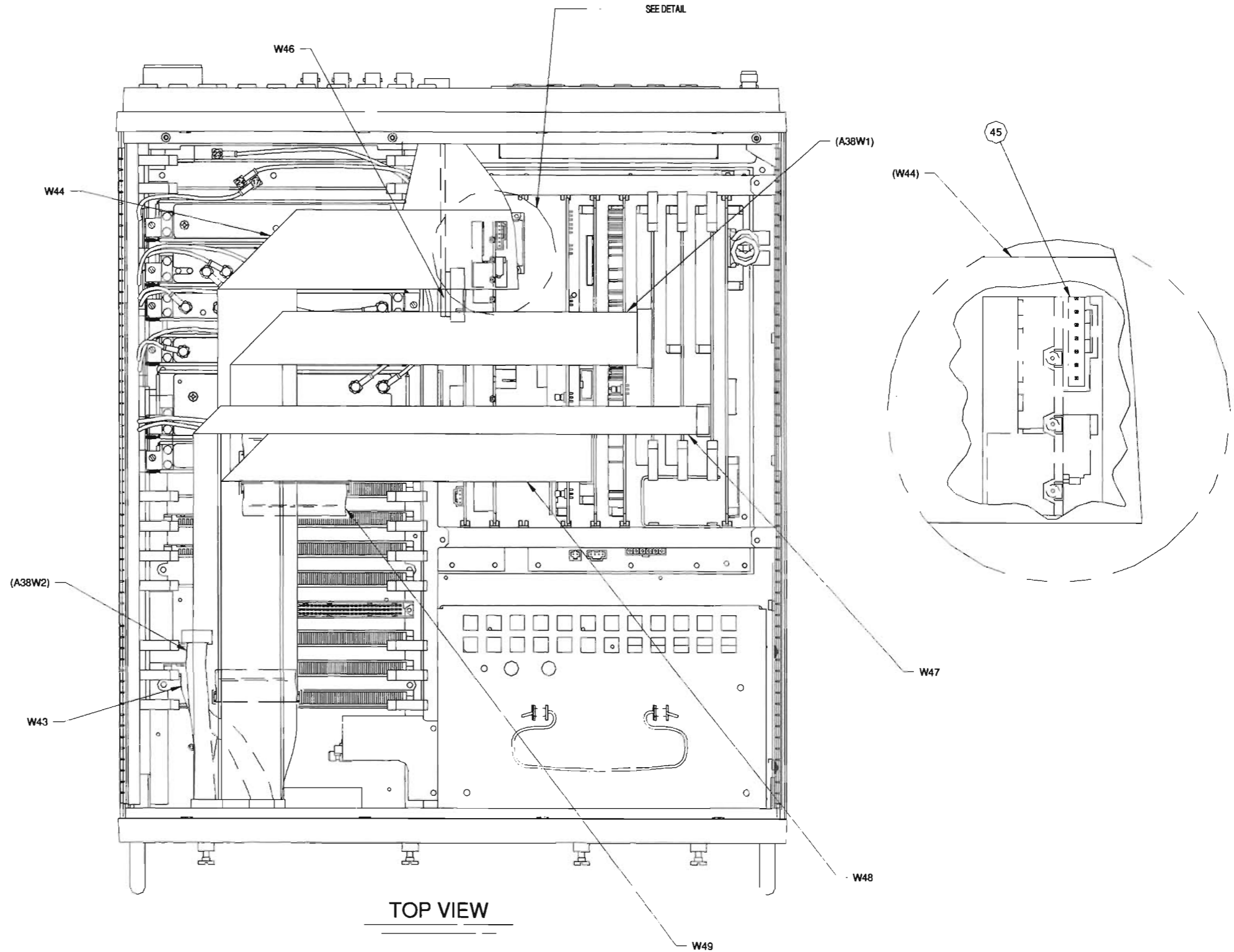

FOCA001

Figure FO-2 Test Set (34A5) Assembly, Cable Locator and Interconnect Diagram (Sheet 1 of 7)

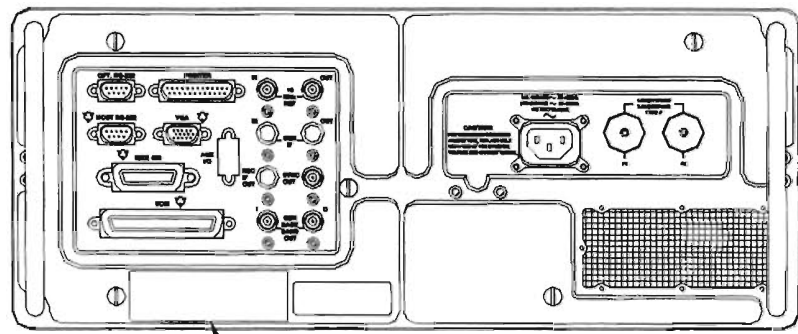

VIEW "A-A"

(41) 9

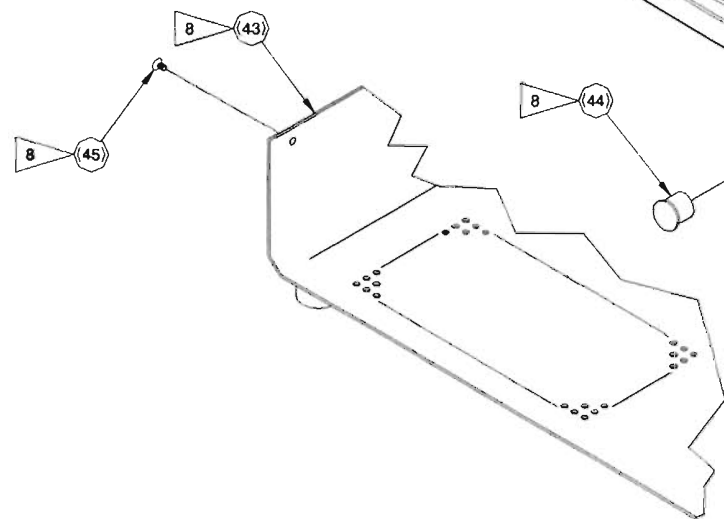
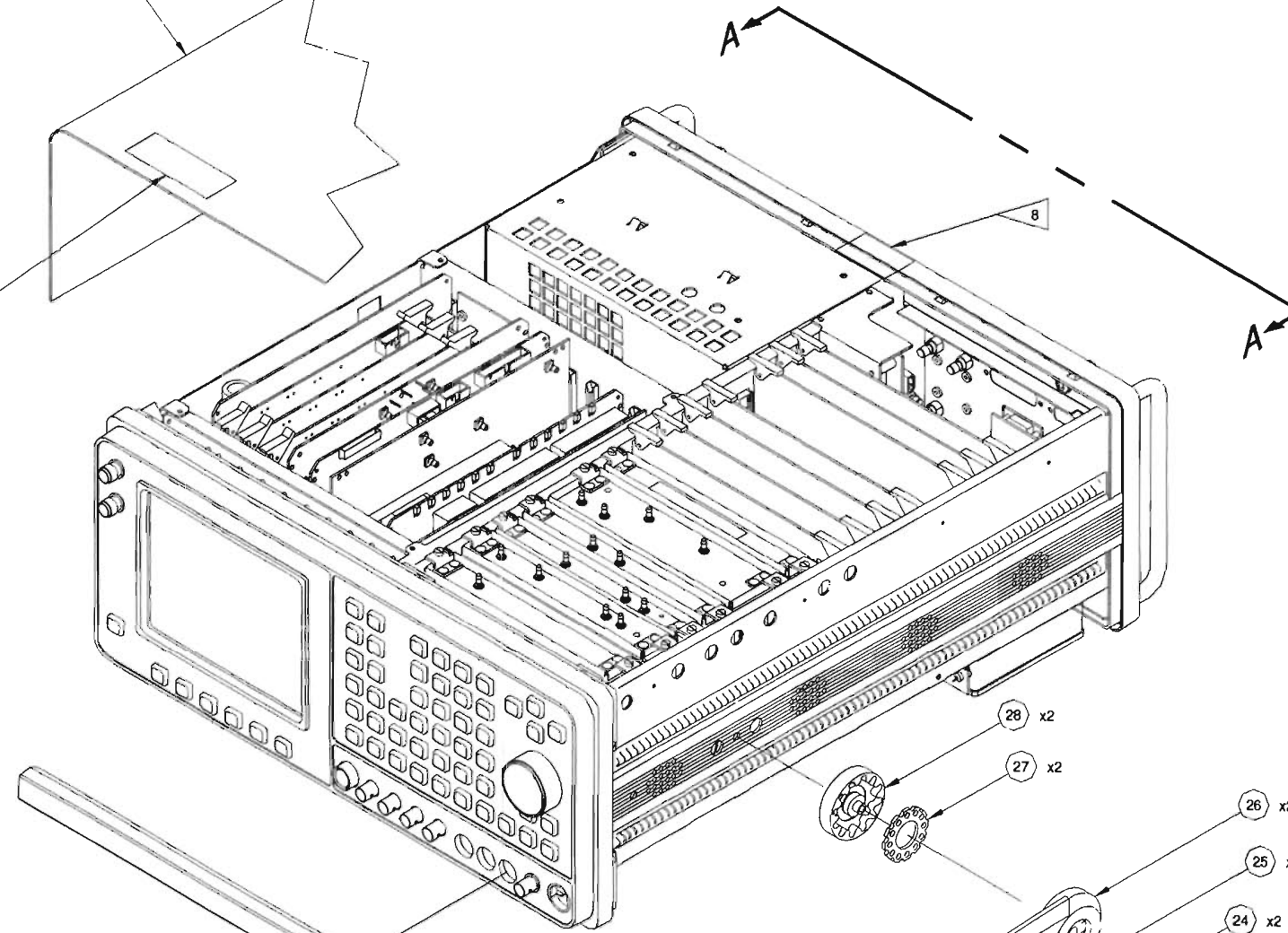
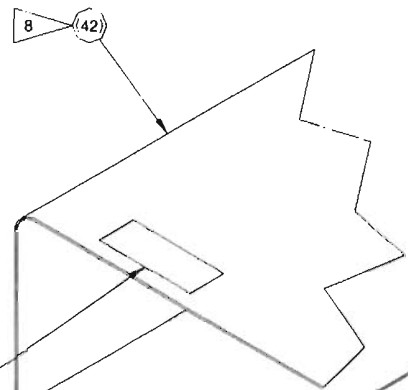

20

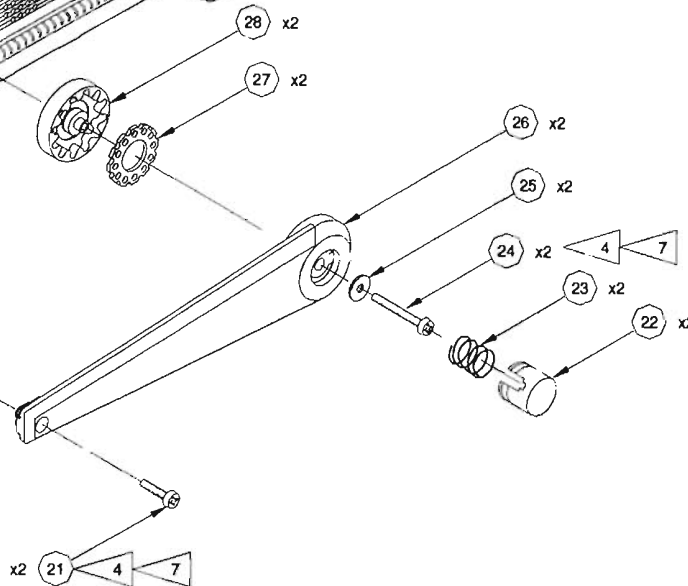

FOCA002

Figure FO-2 Test Set (34A5) Assembly, Cable Locator and Interconnect Diagram (Sheet 2 of 7)



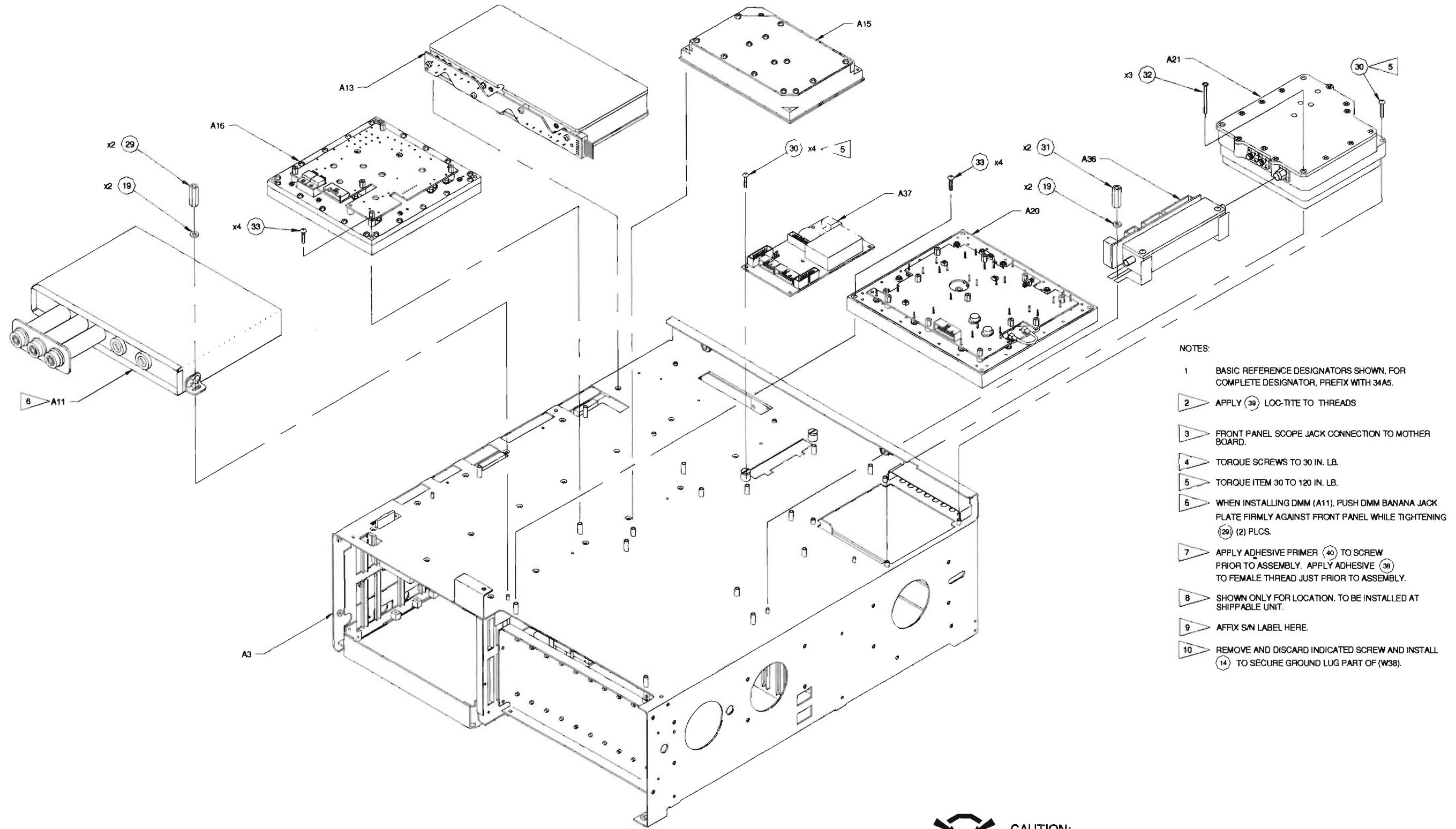

- NOTES:
1. BASIC REFERENCE DESIGNATORS SHOWN. FOR COMPLETE DESIGNATOR, PREFIX WITH 34A5.
  2. APPLY (38) LOC-TITE TO THREADS
  3. FRONT PANEL SCOPE JACK CONNECTION TO MOTHER BOARD.
  4. TORQUE SCREWS TO 30 IN. LB.
  5. TORQUE ITEM 30 TO 120 IN. LB.
  6. WHEN INSTALLING DMM (A11), PUSH DMM BANANA JACK PLATE FIRMLY AGAINST FRONT PANEL WHILE TIGHTENING (29) (2) PLCS.
  7. APPLY ADHESIVE PRIMER (40) TO SCREW PRIOR TO ASSEMBLY. APPLY ADHESIVE (38) TO FEMALE THREAD JUST PRIOR TO ASSEMBLY.
  8. SHOWN ONLY FOR LOCATION. TO BE INSTALLED AT SHIPPABLE UNIT.
  9. AFFIX S/N LABEL HERE.
  10. REMOVE AND DISCARD INDICATED SCREW AND INSTALL (14) TO SECURE GROUND LUG PART OF (W38).

 CAUTION:  
CONTAINS PARTS AND ASSEMBLIES  
SUSCEPTIBLE TO DAMAGE BY  
ELECTROSTATIC DISCHARGE (ESD).

FOCA003  
Figure FO-2 Test Set (34A5) Assembly, Cable Locator and Interconnect Diagram (Sheet 3 of 7)

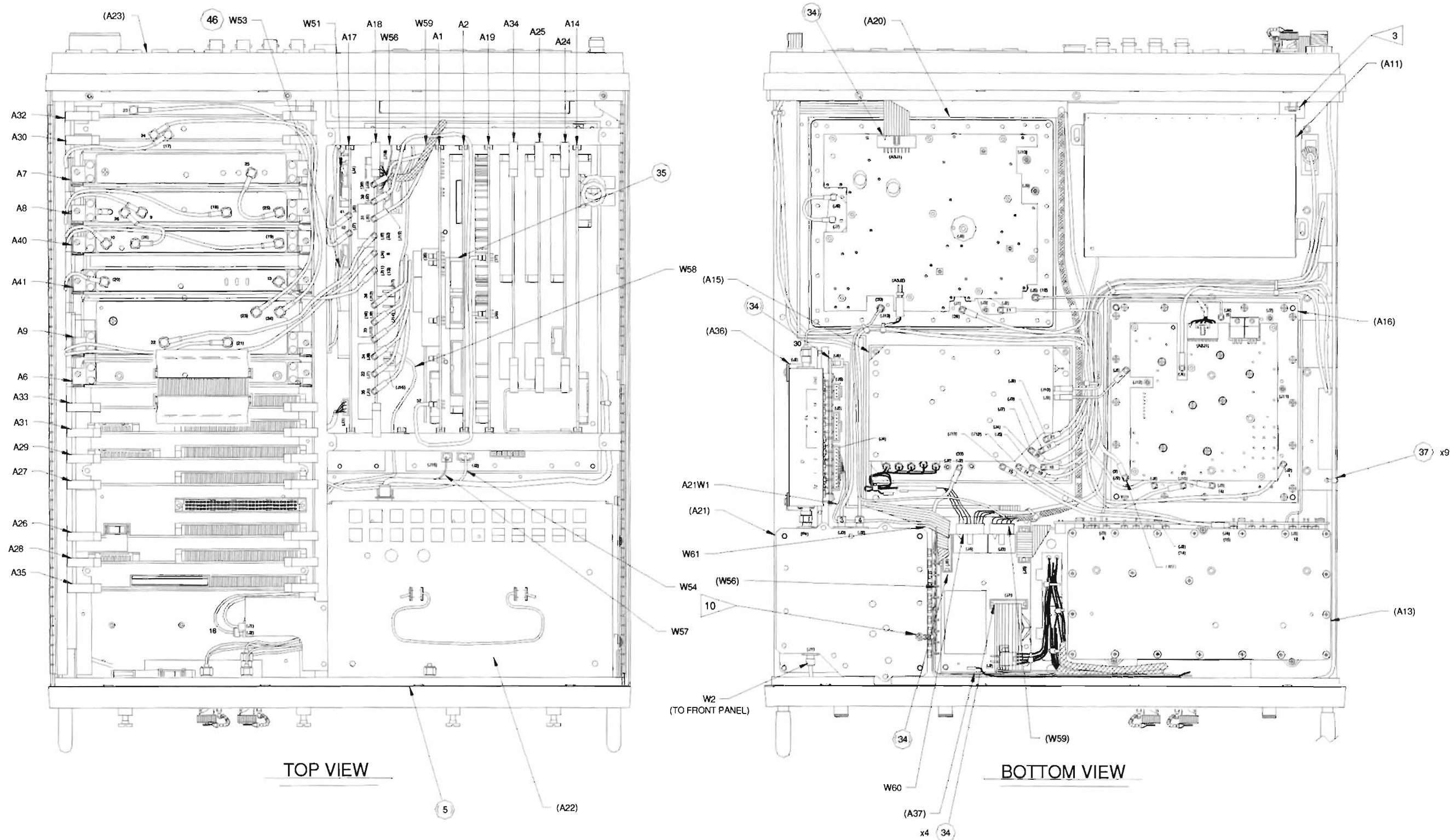

FOCA004

Figure FO-2 Test Set (34A5) Assembly, Cable Locator and Interconnect Diagram (Sheet 4 of 7)

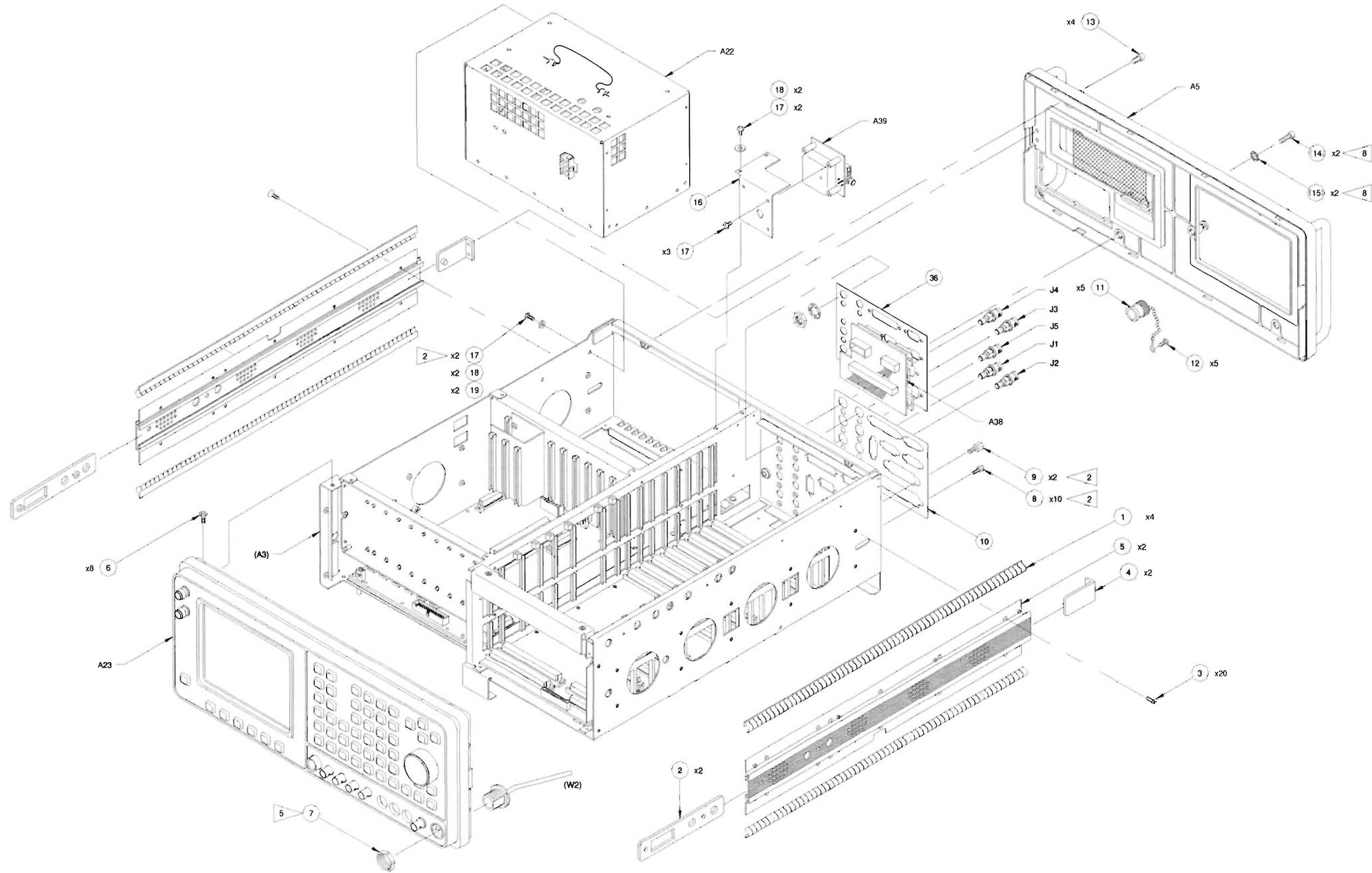

FOCA005

Figure FO-2 Test Set (34A5) Assembly, Cable Locator and Interconnect Diagram (Sheet 5 of 7)

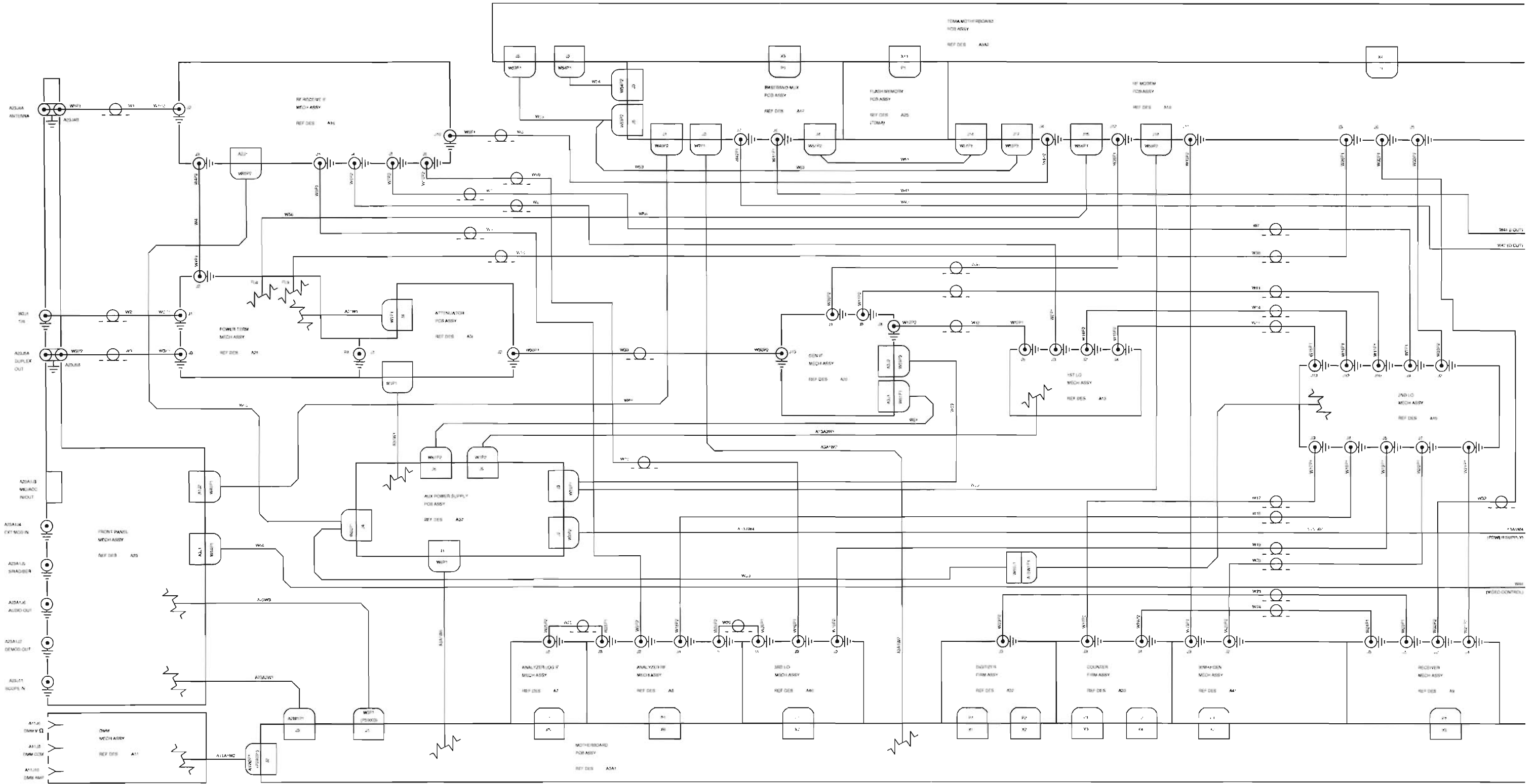

CA101  
**Figure FO-2 Test Set (34A5) Assembly, Cable  
 Locator and Interconnect Diagram (Sheet 6 of 7)**

CHAPTER 5 - MECHANICAL ASSEMBLIES, PC BOARDS AND SCHEMATICS

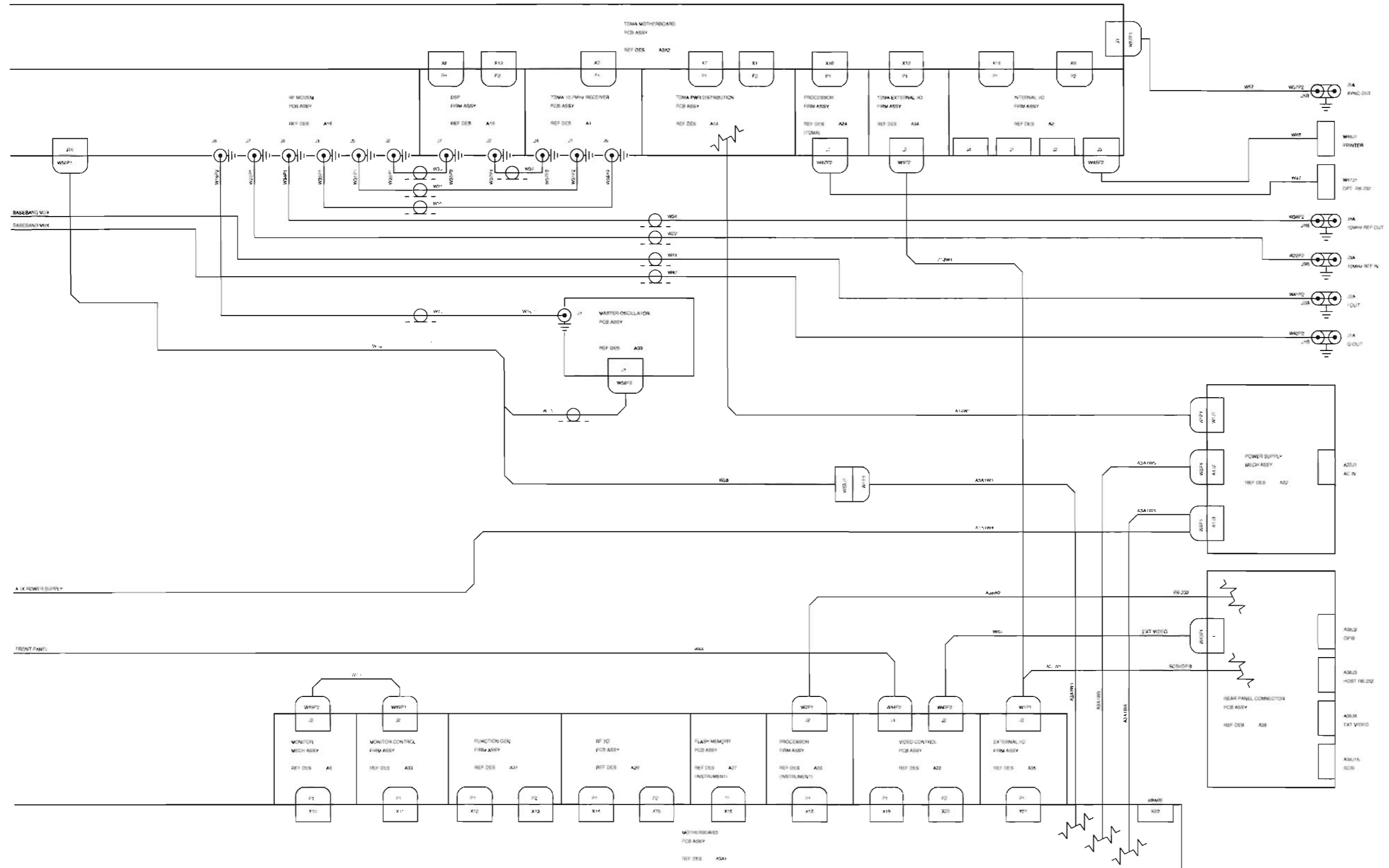

NOTES:  
(UNLESS OTHERWISE SPECIFIED)

1. BASIC REFERENCE DESIGNATORS SHOWN. FOR COMPLETE DESIGNATOR, PREFIX WITH 34A5.

Figure FO-2 Test Set (34A5) Assembly, Cable Locator and Interconnect Diagram (Sheet 7 of 7)



**CAUTION:**  
CONTAINS PARTS AND ASSEMBLIES  
SUSCEPTIBLE TO DAMAGE BY  
ELECTROSTATIC DISCHARGE (ESD).

### A1 TDMA 10.7 MHz Receiver

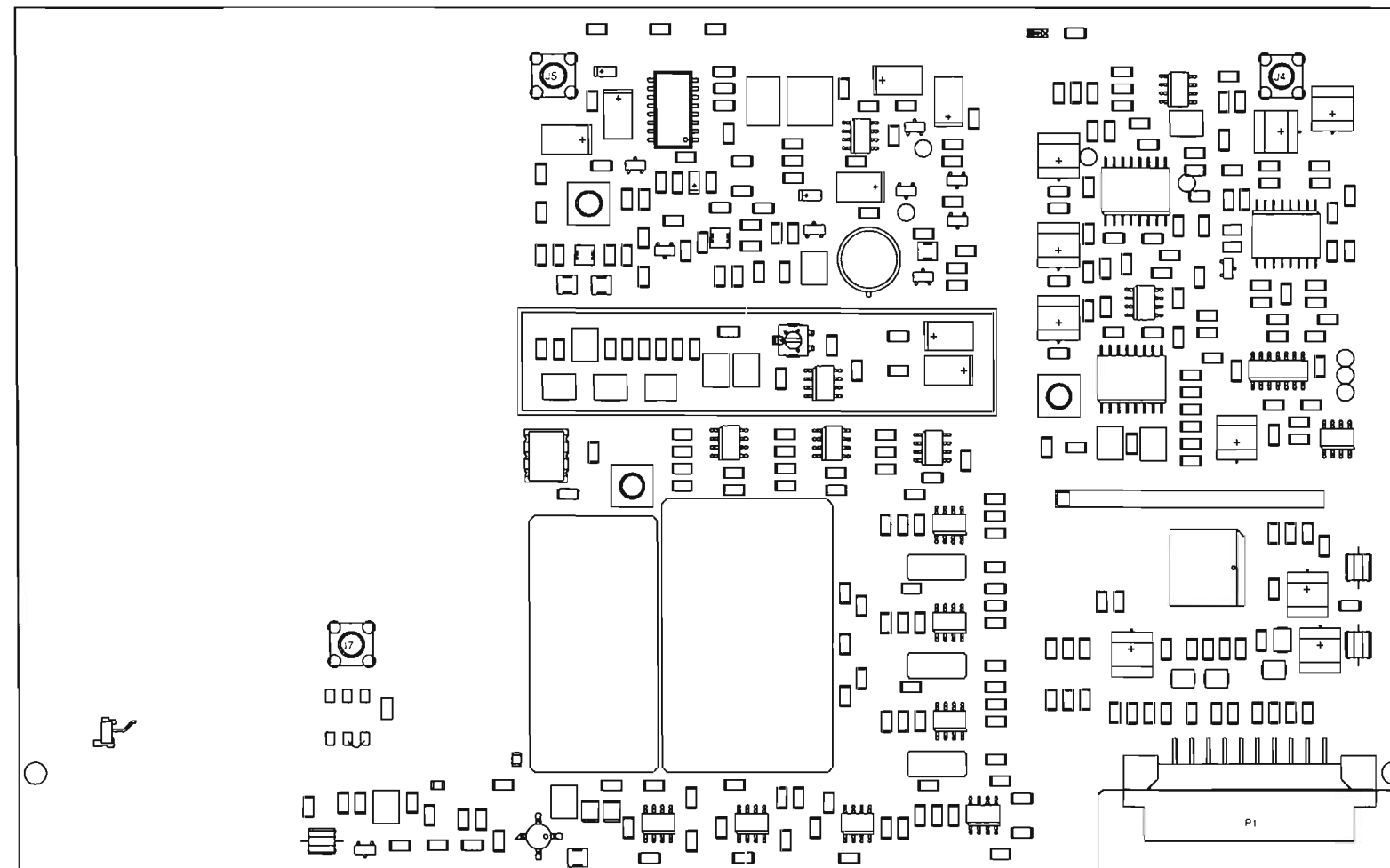

PREFIX ALL REFERENCE DESIGNATORS WITH 34A5A1.

TR01

**Figure FO-3 34A5A1 Assembly  
Component Locator Diagram**



**CAUTION:**  
CONTAINS PARTS AND ASSEMBLIES  
SUSCEPTIBLE TO DAMAGE BY  
ELECTROSTATIC DISCHARGE (ESD).

A2 Internal I/O

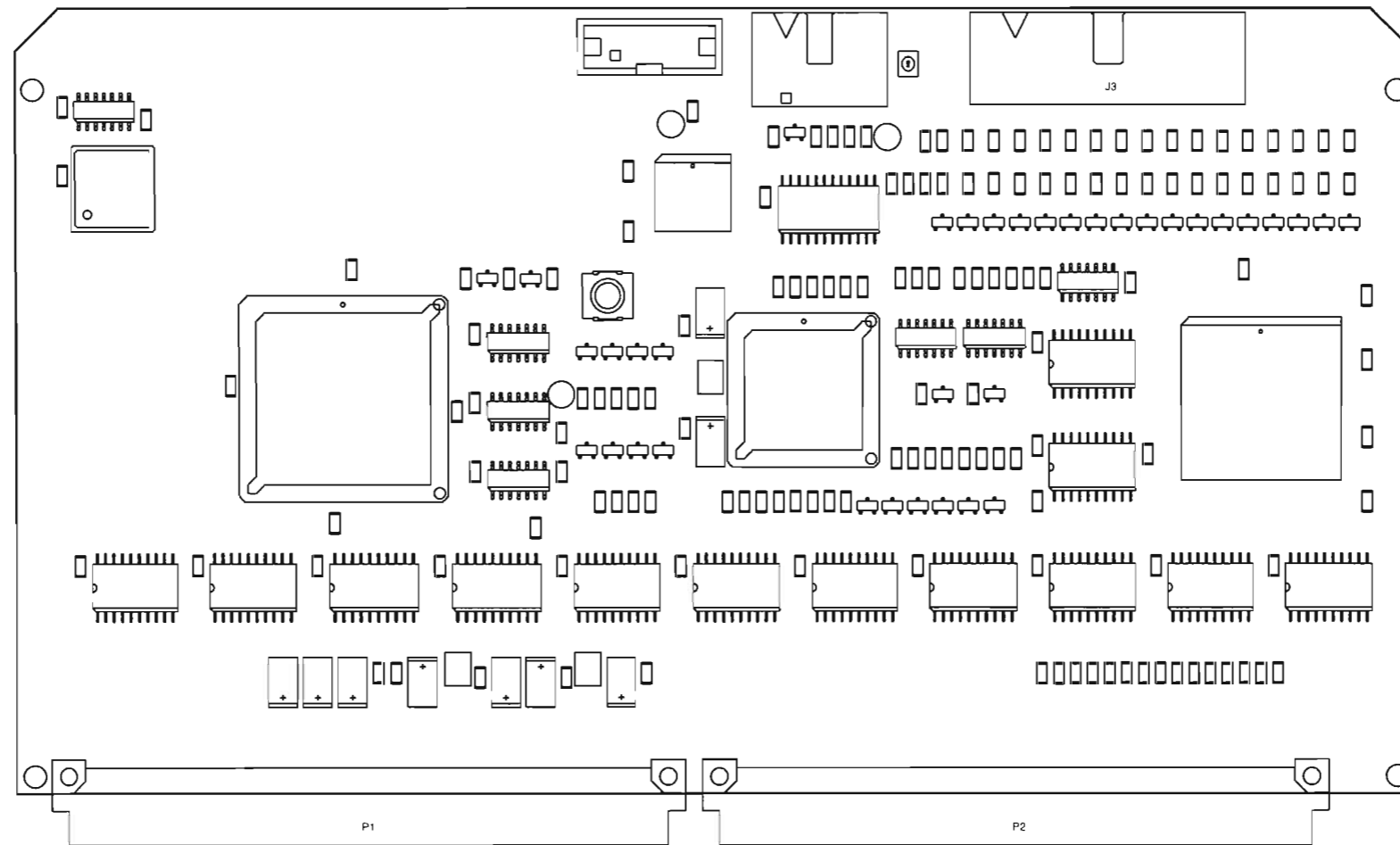

PREFIX ALL REFERENCE DESIGNATORS WITH 34A5A2.

11001

Figure FO-4 34A5A2 Assembly  
Component Locator Diagram

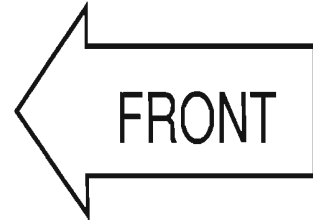

**CAUTION:**  
CONTAINS PARTS AND ASSEMBLIES  
SUSCEPTIBLE TO DAMAGE BY  
ELECTROSTATIC DISCHARGE (ESD).

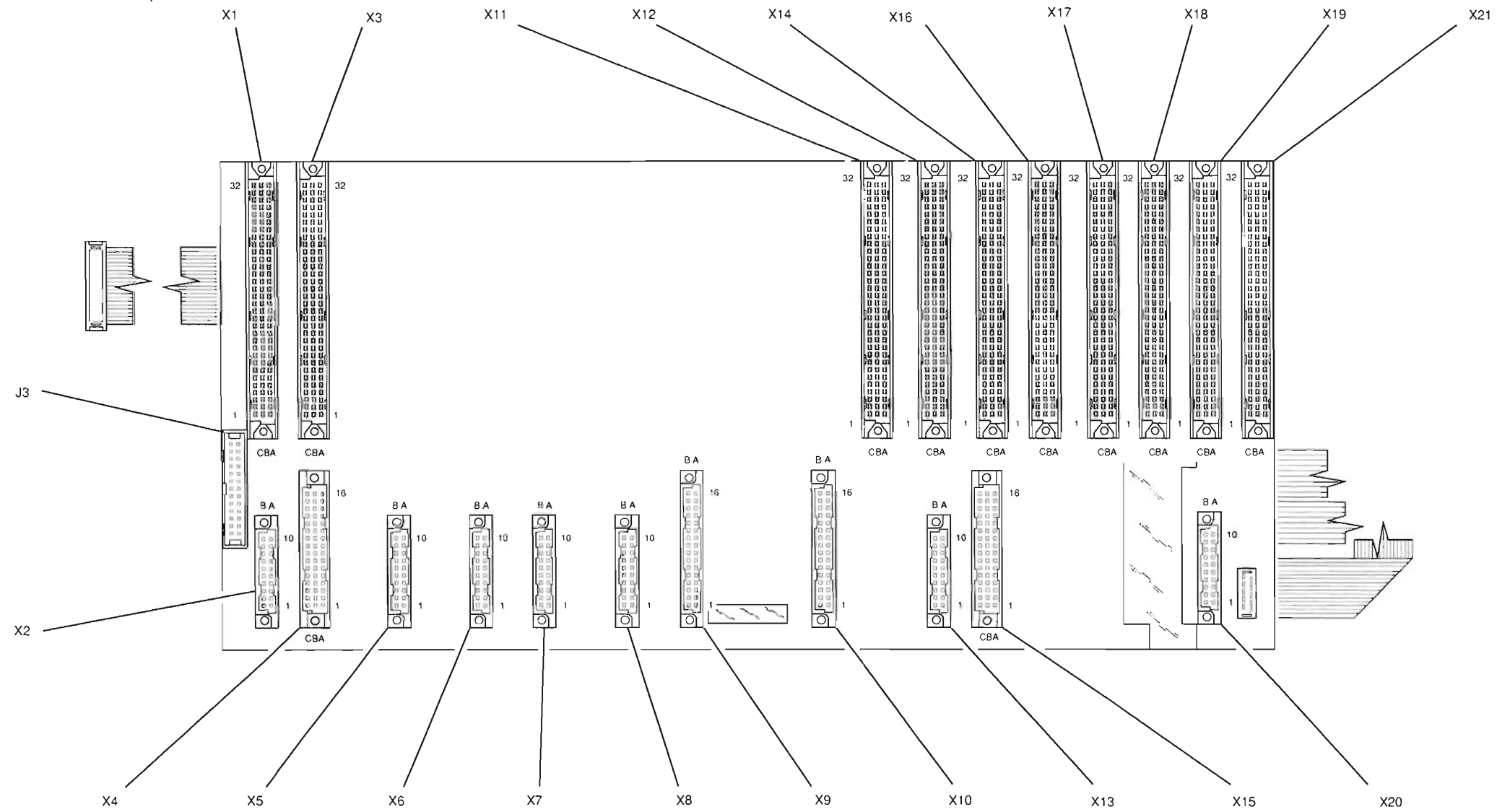

PREFIX ALL REFERENCE DESIGNATORS WITH 34A5A3A1.

MB01

Figure FO-5 34A5A3A1 Motherboard Assembly Component Locator and Wiring Diagram (Sheet 1 of 4)



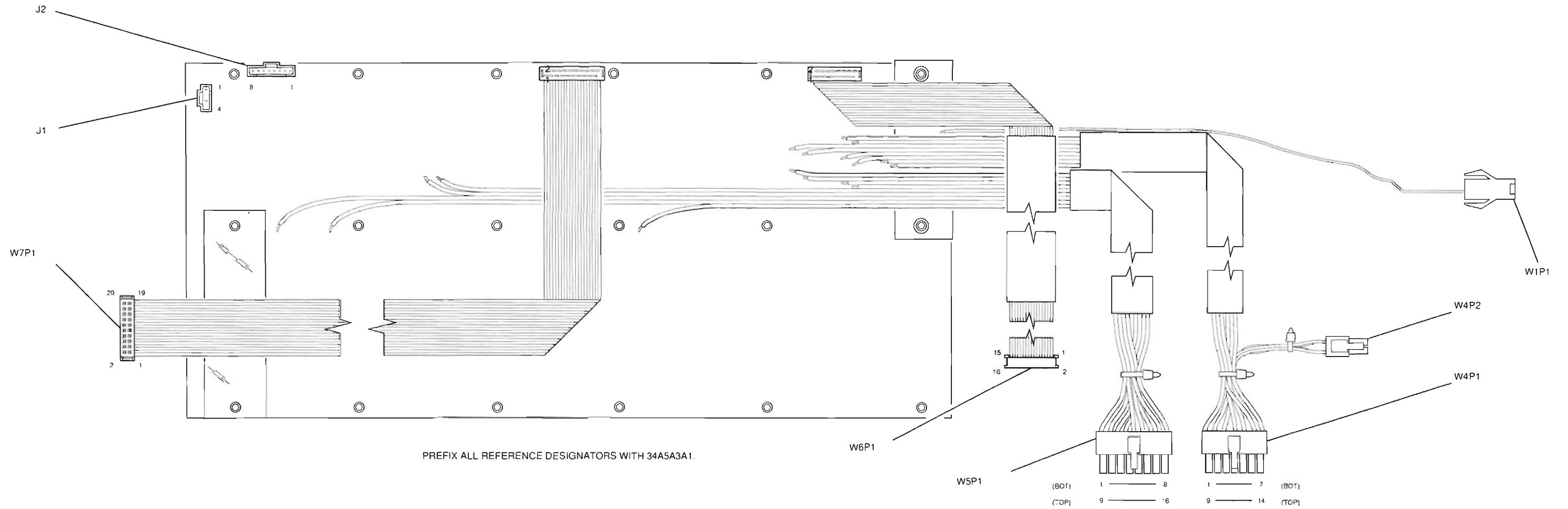
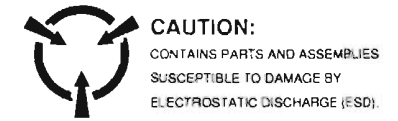
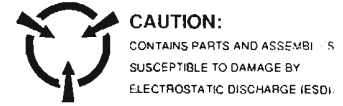
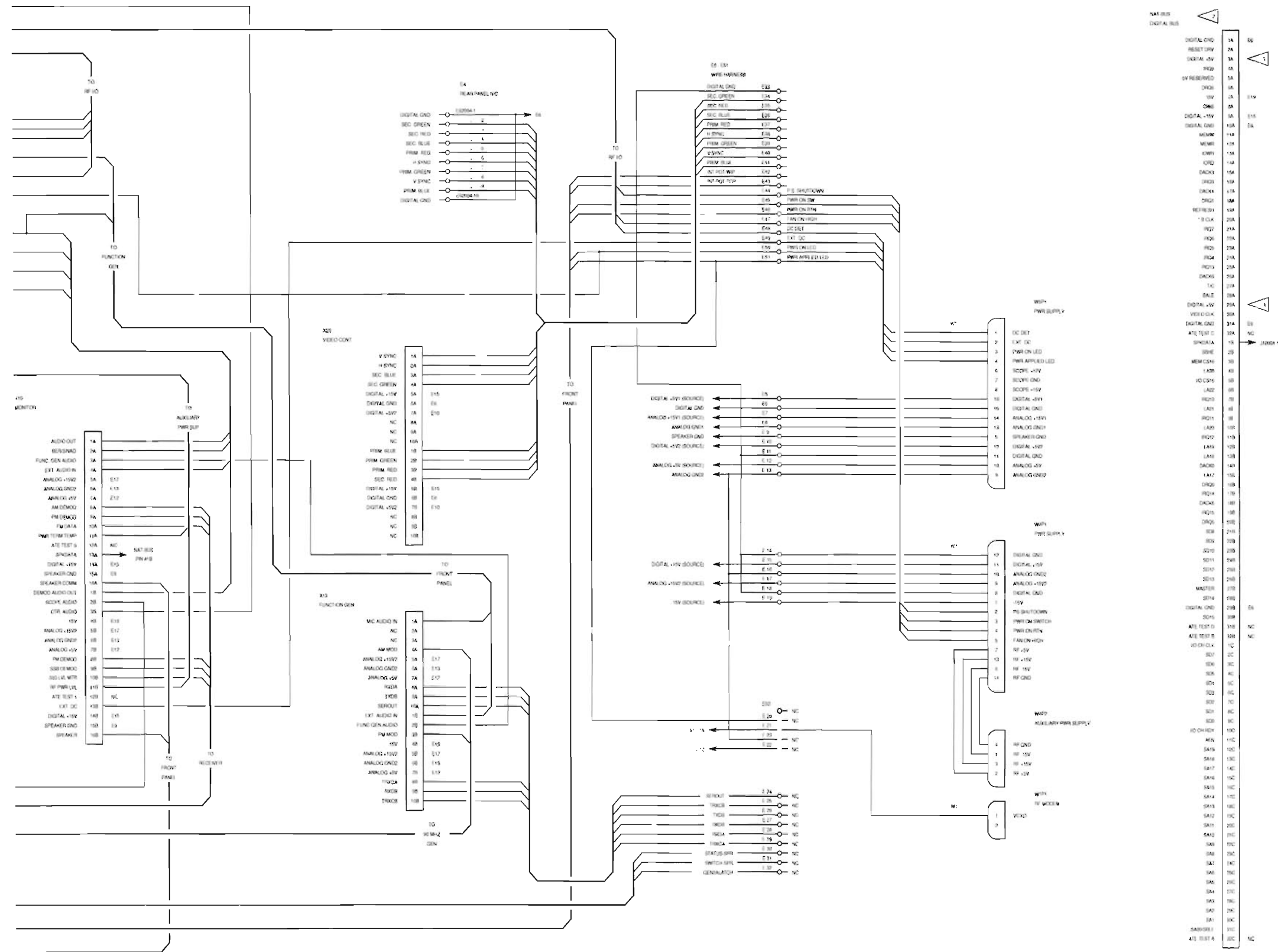

Figure FO-5 34A5A3A1 Motherboard Assembly Component Locator and Wiring Diagram (Sheet 2 of 4)



# CHAPTER 5 - MECHANICAL ASSEMBLIES, PC BOARDS AND SCHEMATICS



**CAUTION:**  
CONTAINS PARTS AND ASSEMBLIES  
SUSCEPTIBLE TO DAMAGE BY  
ELECTROSTATIC DISCHARGE (ESD).

- NOTES:  
(UNLESS OTHERWISE SPECIFIED)
- ALL REFERENCE NUMBERS CARRY AN ASSIGNLU DESIGNATOR SERIES THIS ASSEMBLY CARRIES SERIES: A, A3A1 (e.g. J1 IS A3A1J1)
  - "NAT.BUS" REPRESENTS THE PIN OUT OF THE DIGITAL BUS FOR THE FOLLOWING ASSFMBLES:
 

A32 DIGITIZER	=	(A3A1X1)
A30 COUNTER	=	(A3A1X3)
A33 MONITOR CONTROL	=	(A3A1X11)
A31 FUNCTION GENERATOR	=	(A3A1X12)
A29 RF I/O	=	(A3A1X14)
A27 FLASH MEMORY	=	(A3A1X16)
A26 PROCESSOR	=	(A3A1X18)
A28 VIDEO CONTROL	=	(A3A1X19)
A35 EXTERNAL I/O	=	(A3A1X22)
NAT-BUS SPARE	=	(A3A1X17)

- ALL PINS ARE COMMON TO THESE CONNECTORS (e.g. A32J1, PIN 1A IS CONNECTED TO ALL OTHER PINS 1A, EXCEPTIONS ARE LISTED IN FLAG NO 1/E 3)
- THE DIGITAL +5V SUPPLY IS DIVIDED INTO 2 SEPERATE LINES.
 

DIGITAL +5V 1
DIGITAL +5V 2

 DIGITAL +5V ISROUTED TO:
 

A32 DIGITIZER
A30 COUNTER
A33 MONITOR CONTROL
A31 FUNCTION GENERATOR
A29 RF I/O

 DIGITAL +5V ISROUTED TO:
 

A27 FLASH MEMORY
A26 PROCESSOR
A28 VIDEO CONTROL
A35 EXTERNAL I/O
NAT-BUS SPARE
  - PREFIX ALL REFERENCE DESIGNATORS WITH 34A5

Figure FO-5 34A5A3A1 Motherboard Assembly Component Locator and Wiring Diagram (Sheet 4 of 4)

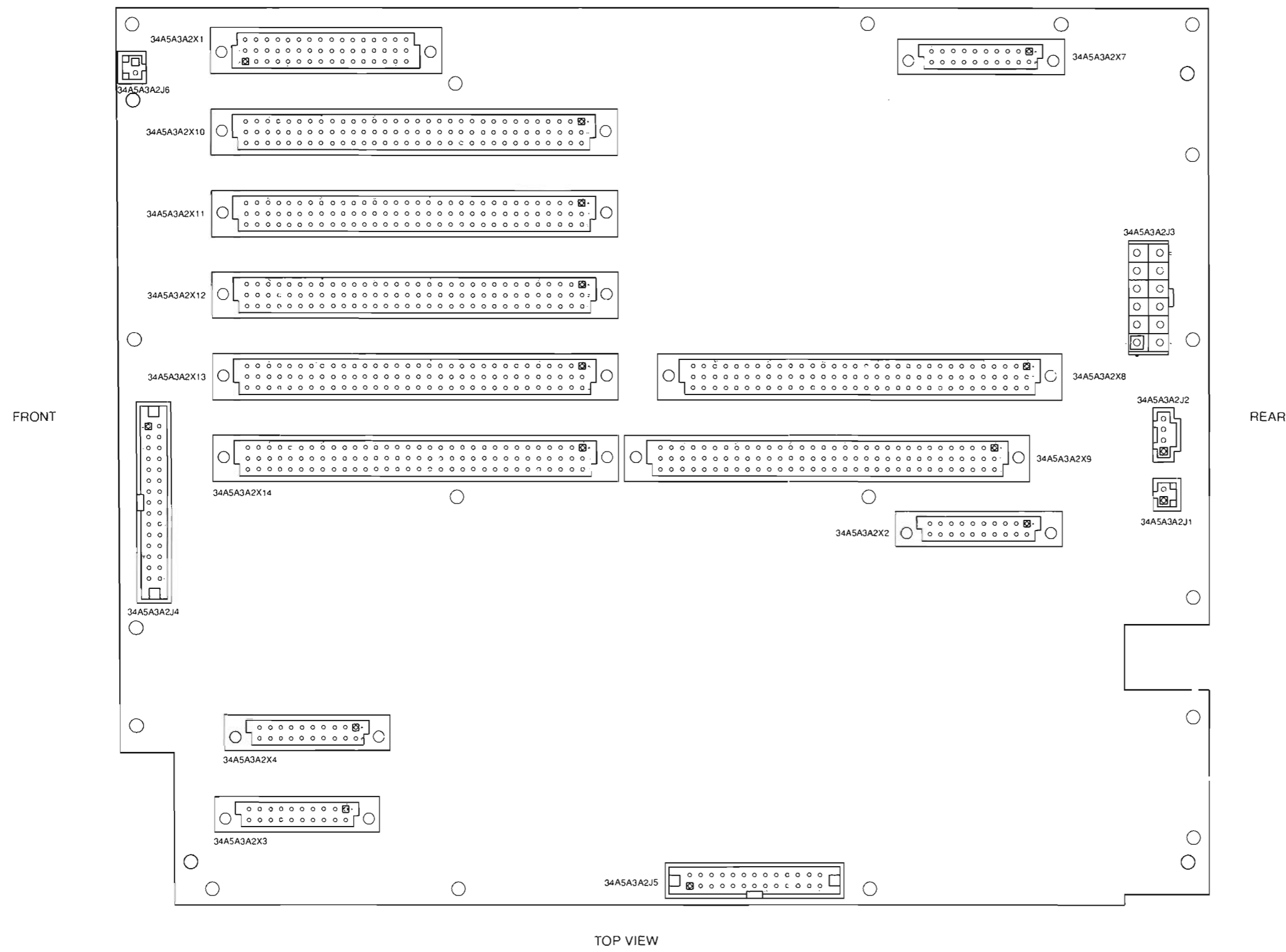

Figure FO-6 34A5A3A2 TDMA Motherboard Assembly Component Locator and Wiring Diagram (Sheet 1 of 4)

Tmb01

CHAPTER 5 - MECHANICAL ASSEMBLIES, PC BOARDS AND SCHEMATICS

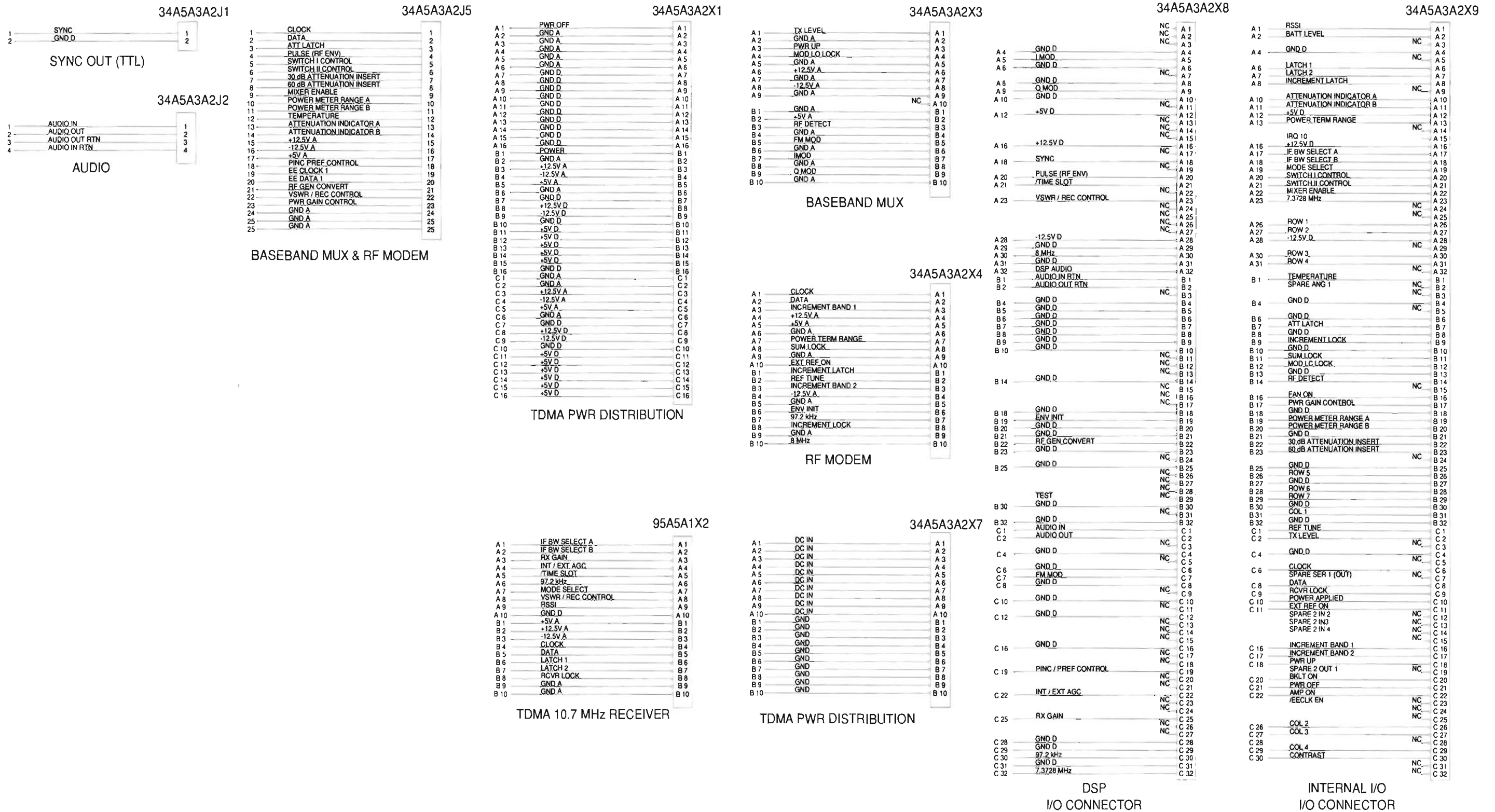

Figure FO-6 34A5A3A2 TDMA Motherboard Assembly Component Locator and Wiring Diagram (Sheet 2 of 4)

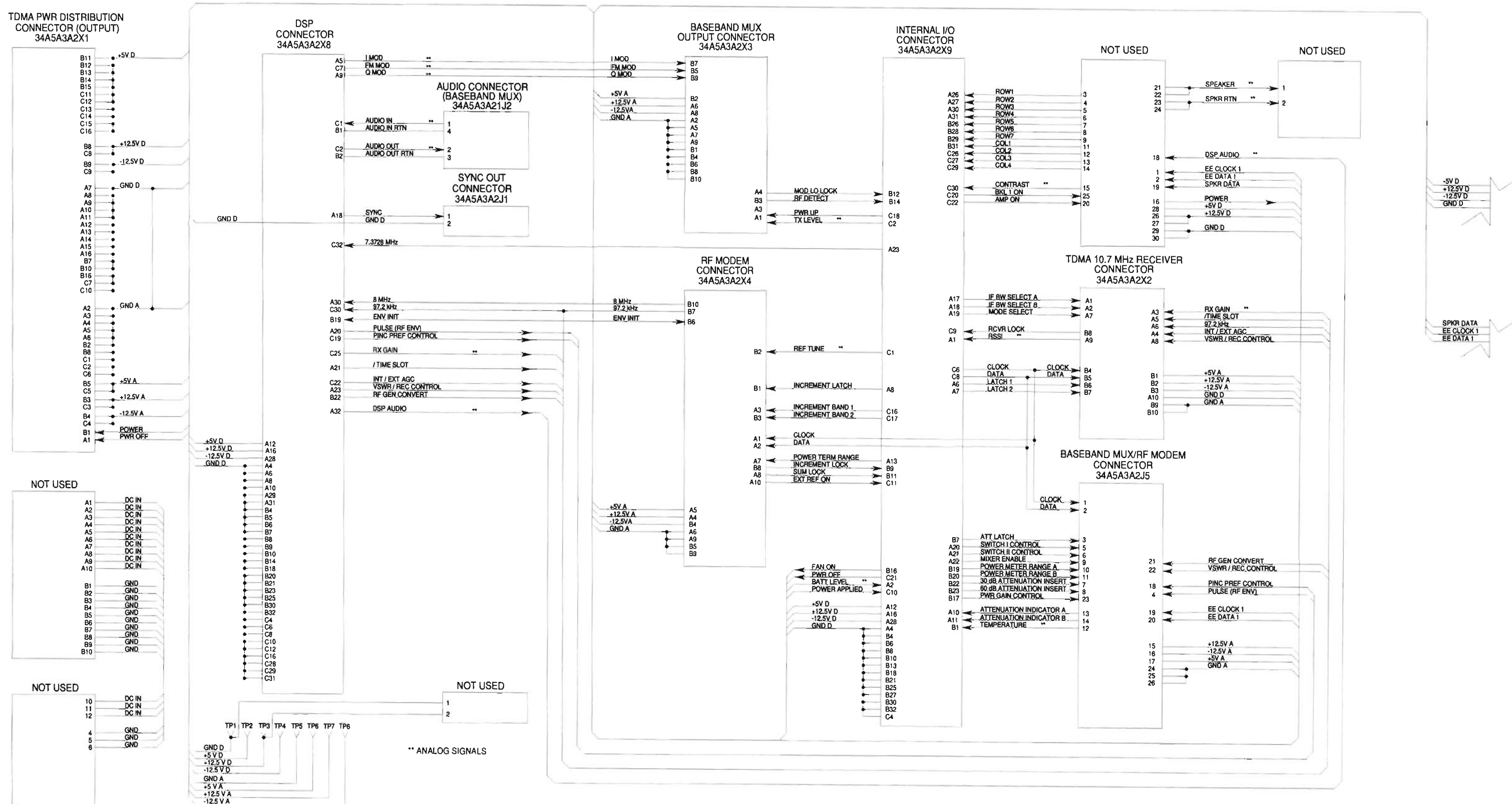
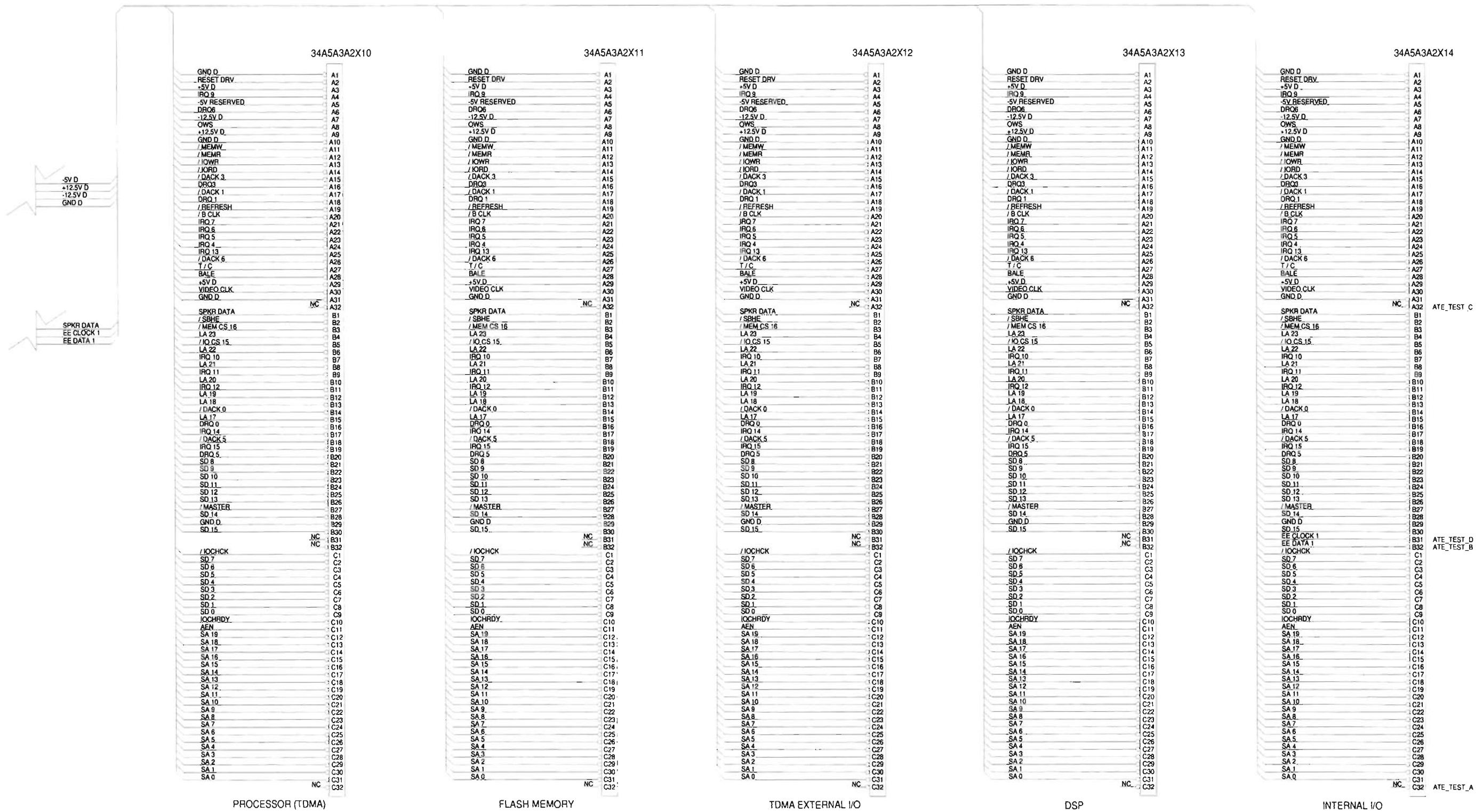

Figure FO-6 34A5A3A2 TDMA Motherboard Assembly Component Locator and Wiring Diagram (Sheet 3 of 4)

TMB001



TMB002

Figure FO-6 34A5A3A2 TDMA Motherboard Assembly Component Locator and Wiring Diagram (Sheet 4 of 4)



**CAUTION:**  
CONTAINS PARTS AND ASSEMBLIES  
SUSCEPTIBLE TO DAMAGE BY  
ELECTROSTATIC DISCHARGE (ESD).

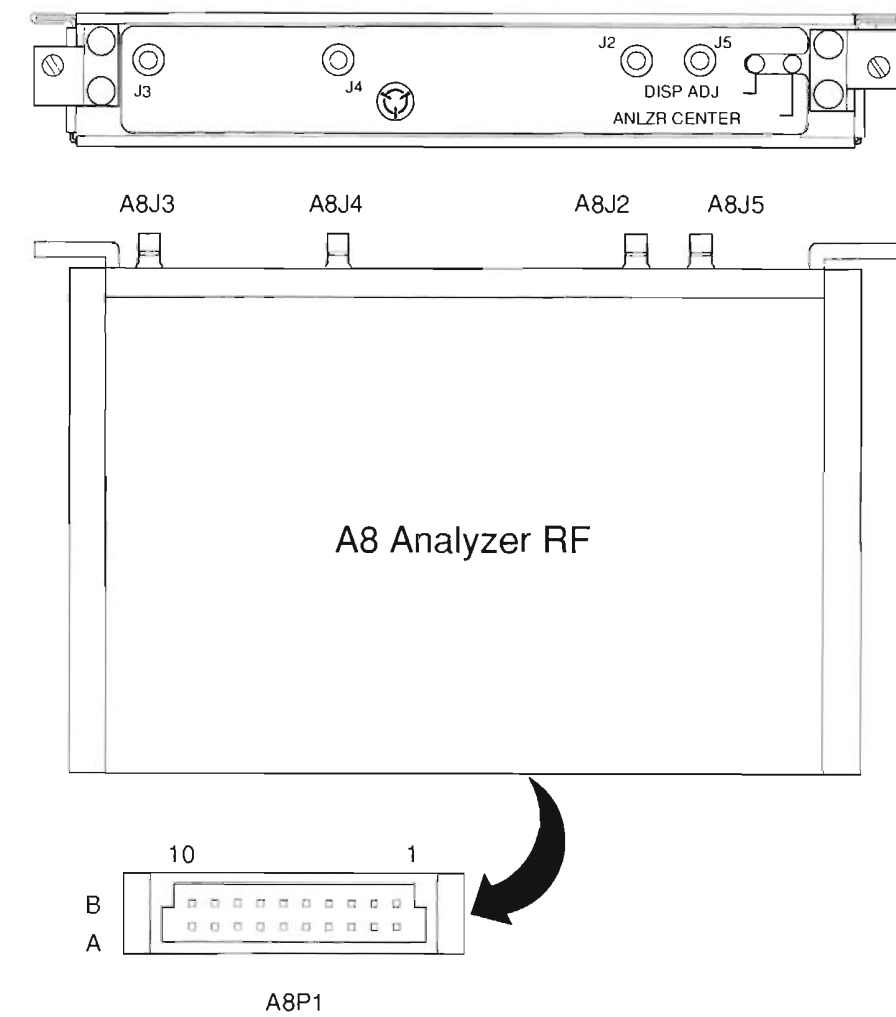
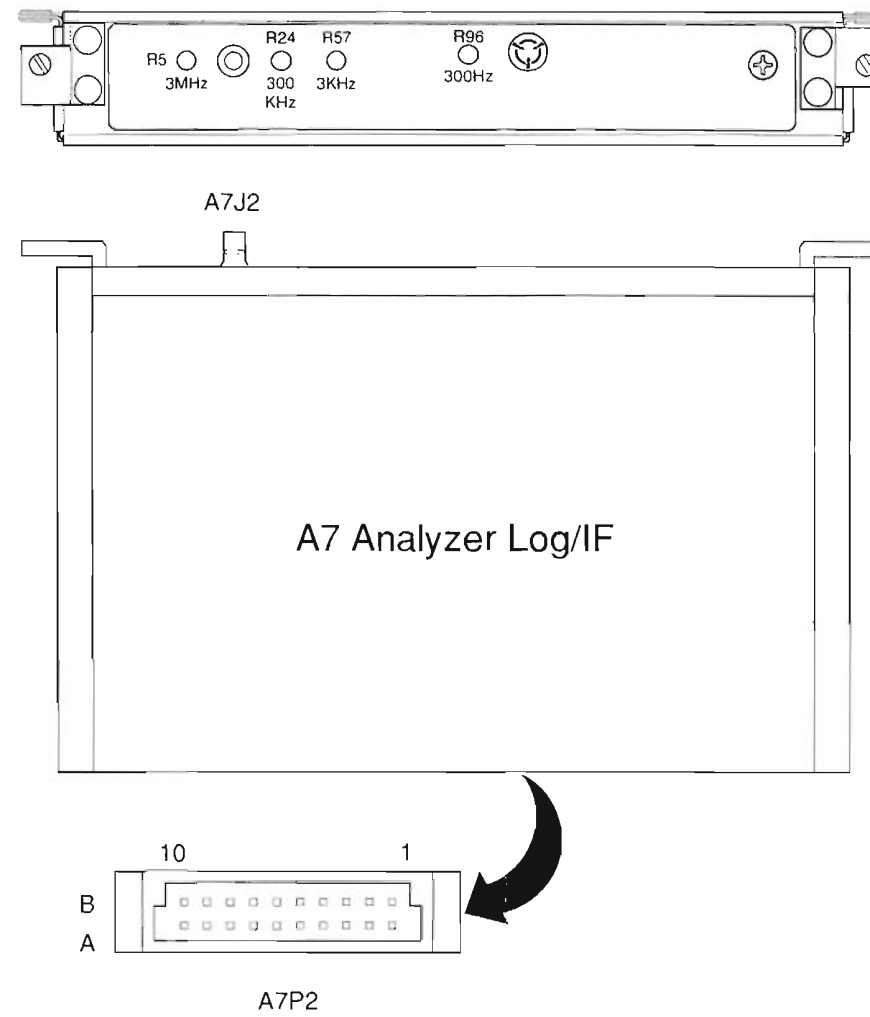
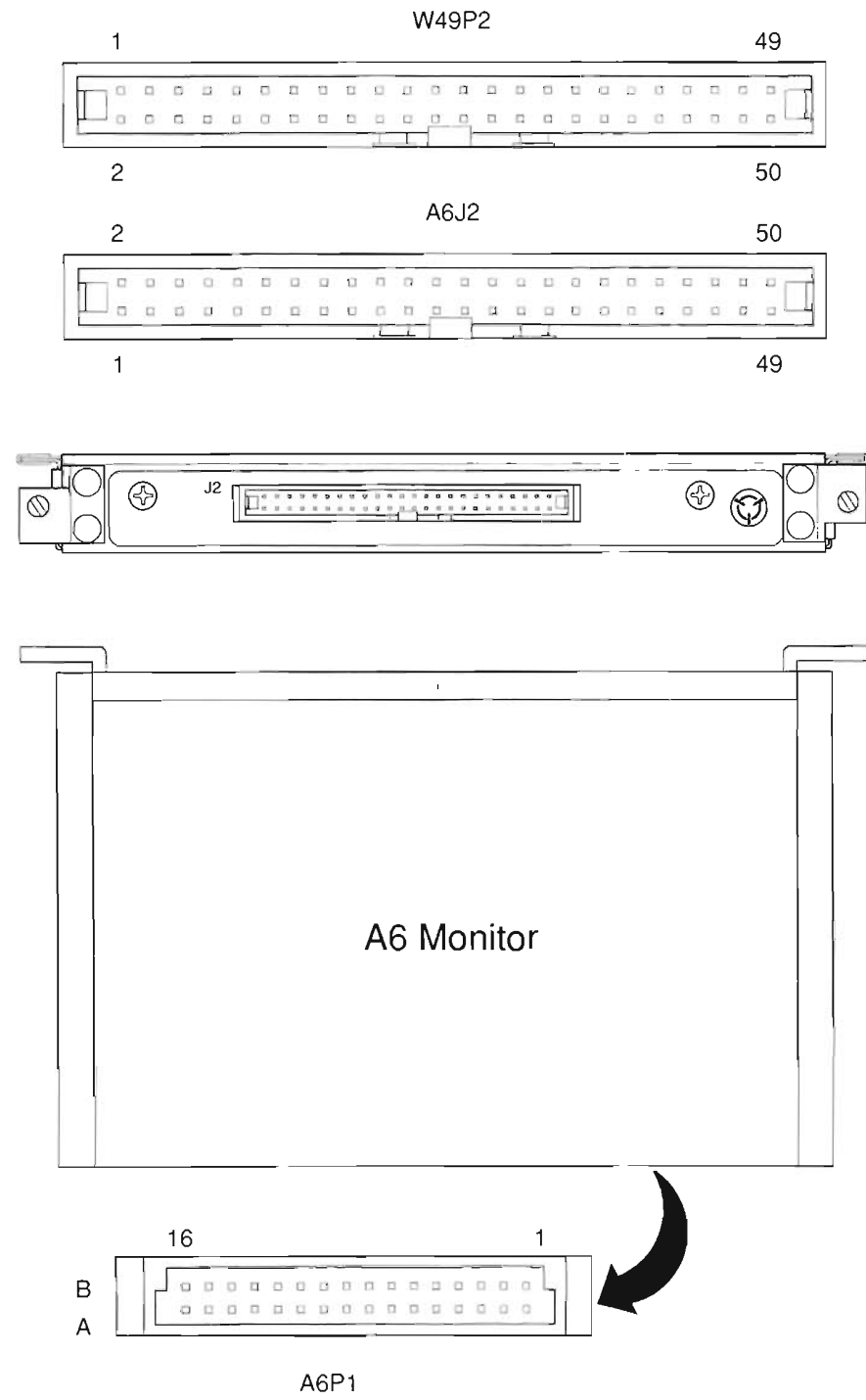

PREFIX ALL REFERENCE DESIGNATORS WITH 34A5.

FO073A  
**Figure FO-7 34A5A6, 34A5A7 and 34A5A8  
Assemblies Component Locator Diagrams**



 **CAUTION:**  
CONTAINS PARTS AND ASSEMBLIES  
SUSCEPTIBLE TO DAMAGE BY  
ELECTROSTATIC DISCHARGE (ESD).

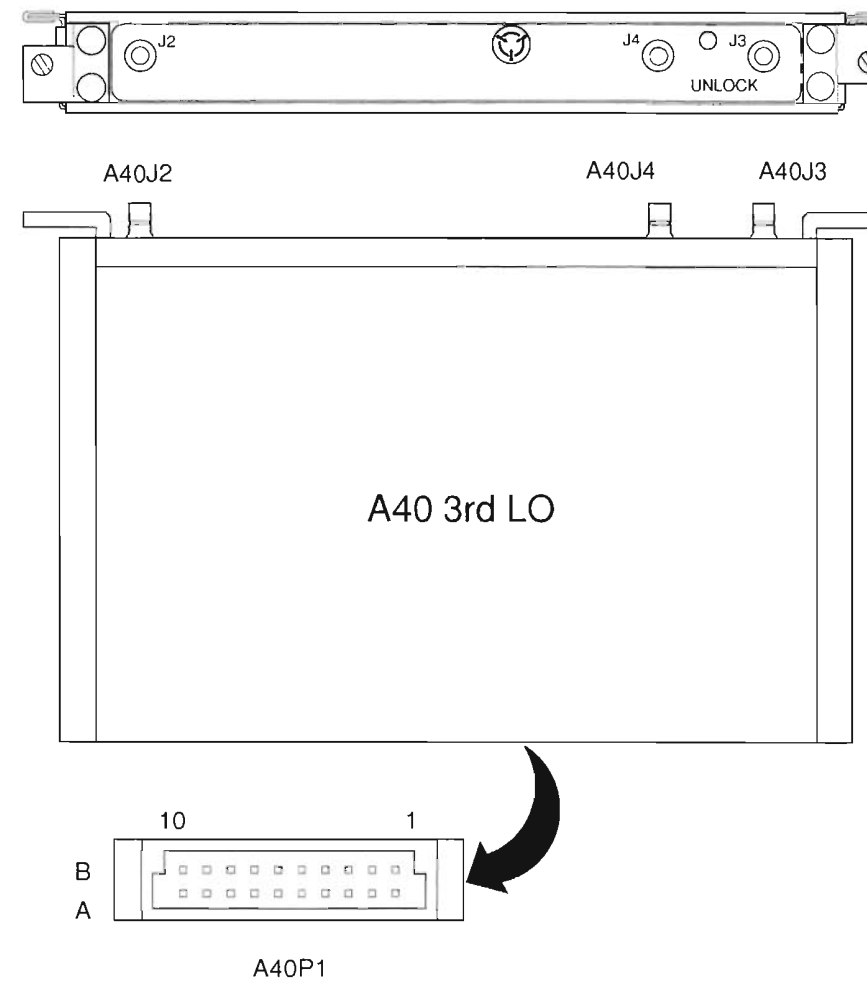
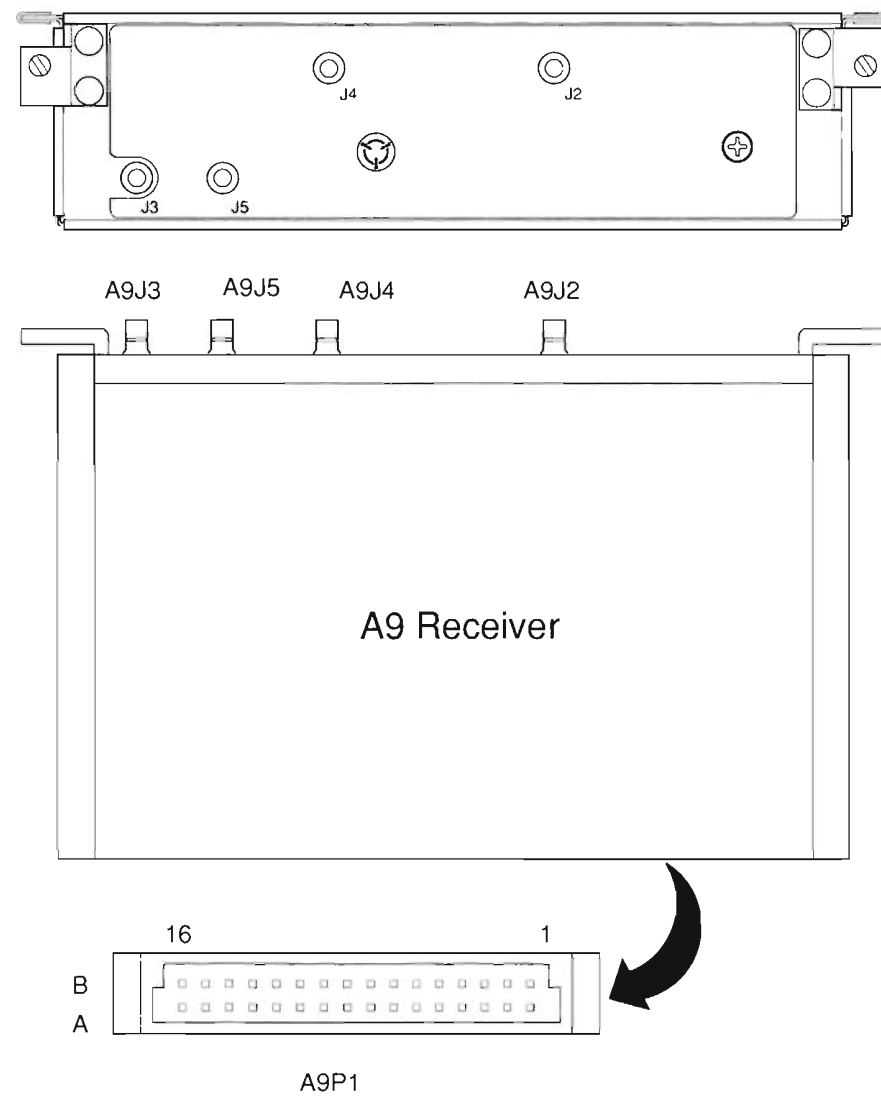

PREFIX ALL REFERENCE DESIGNATORS WITH 34A5.

FO073B  
Figure FO-8 34A5A9 and 34A5A40 Assemblies  
Component Locator Diagrams



**CAUTION:**  
CONTAINS PARTS AND ASSEMBLIES  
SUSCEPTIBLE TO DAMAGE BY  
ELECTROSTATIC DISCHARGE (ESD).

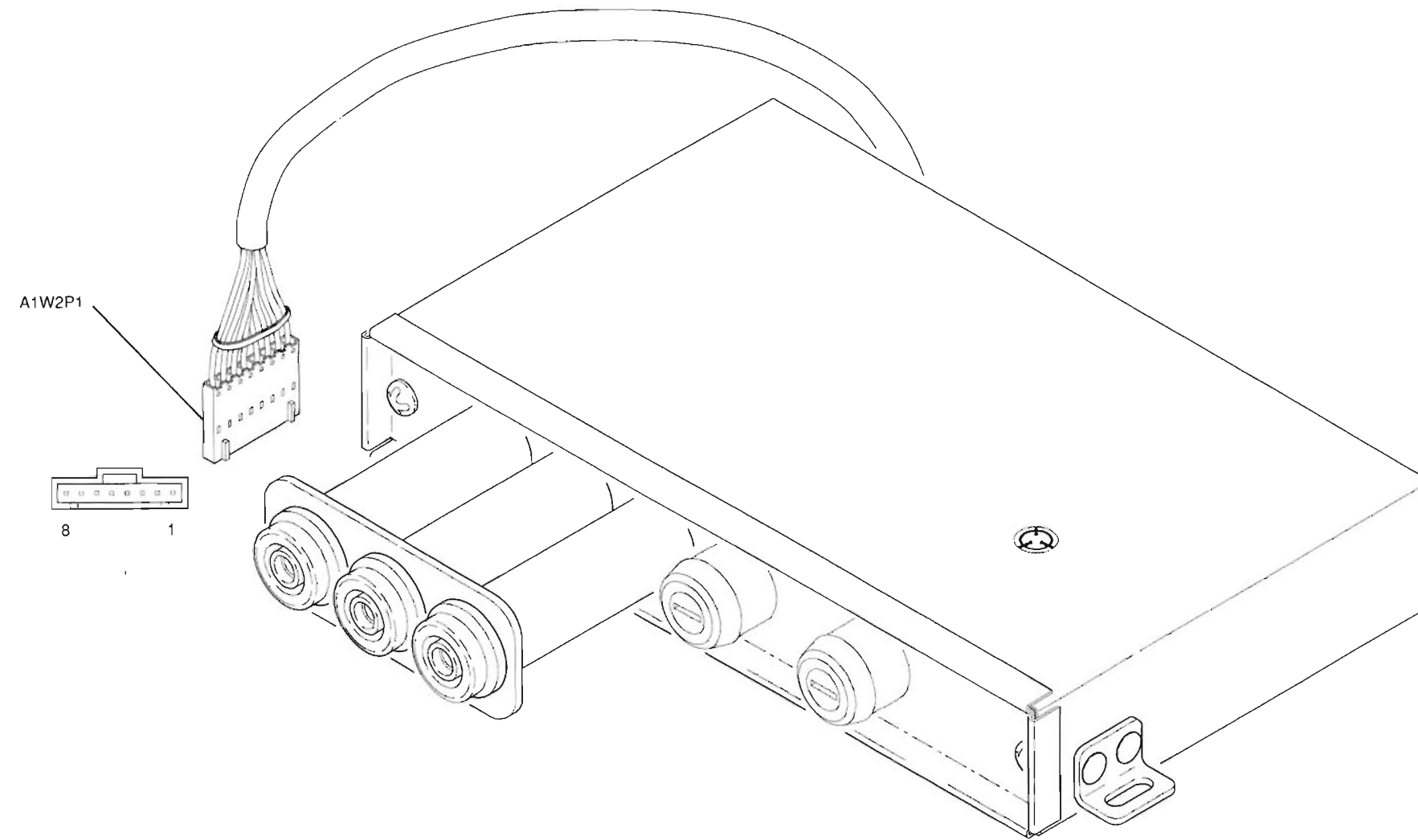

PREFIX ALL REFERENCE DESIGNATORS WITH 34A5A11.

DMM01

**Figure FO-9 34A5A11 DMM Assembly  
Component Locator Diagram**

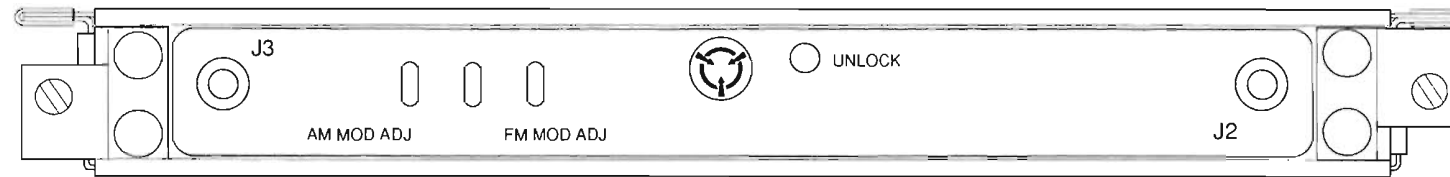

**CAUTION:**  
CONTAINS PARTS AND ASSEMBLIES  
SUSCEPTIBLE TO DAMAGE BY  
ELECTROSTATIC DISCHARGE (ESD).

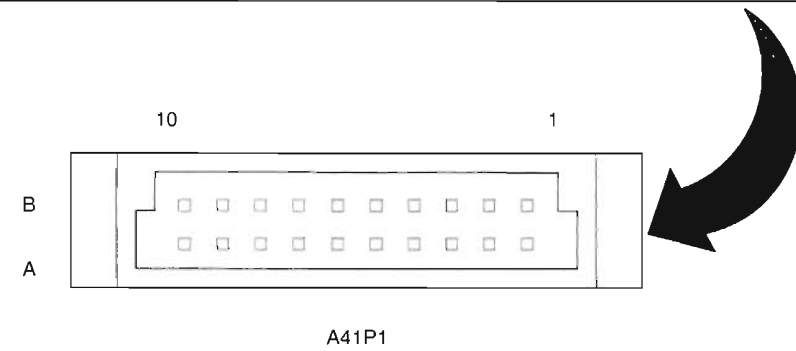
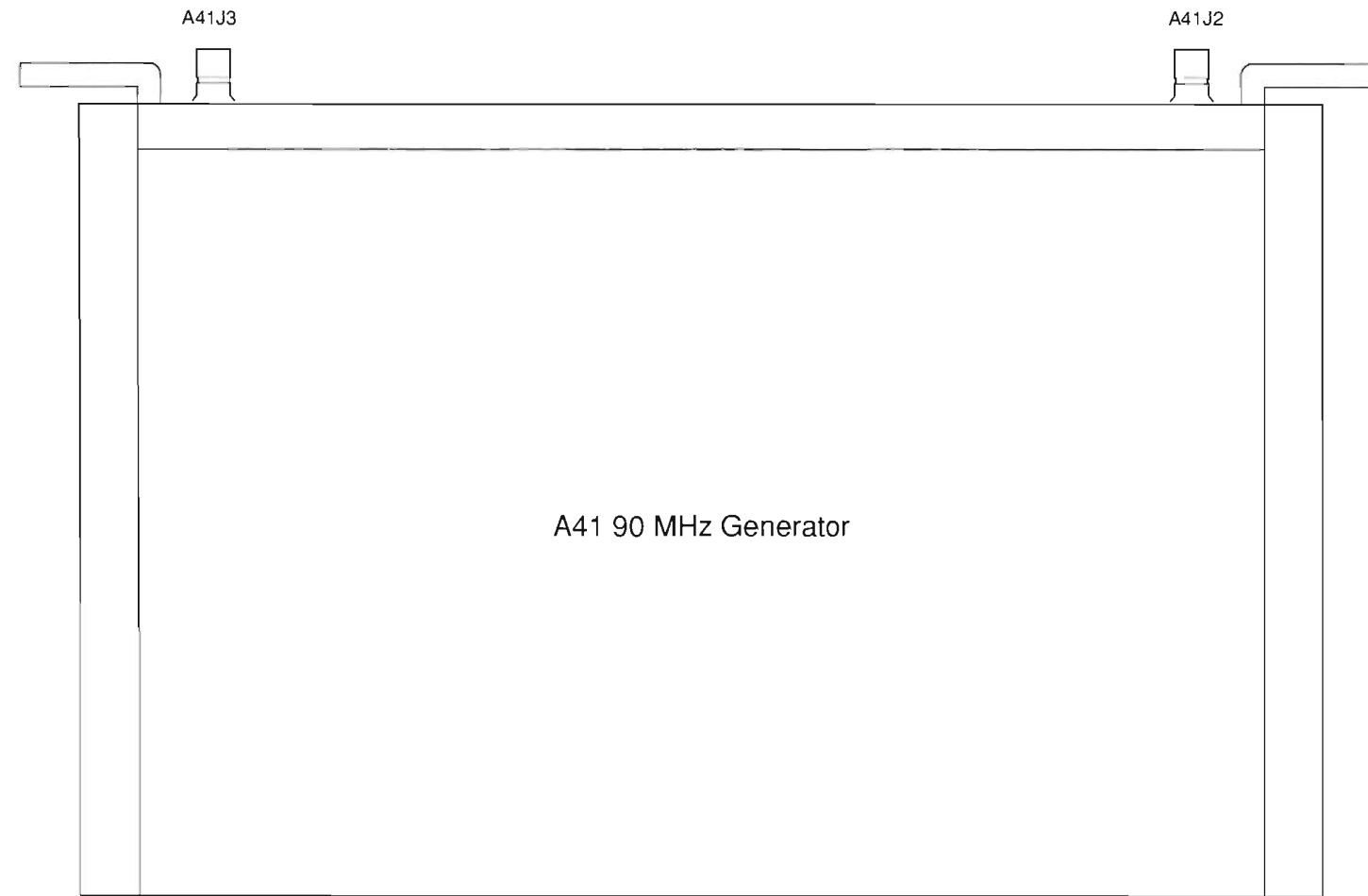

PREFIX ALL REFERENCE DESIGNATORS WITH 34A5.

90MG01  
Figure FO-10 34A5A41 Assembly  
Component Locator Diagram

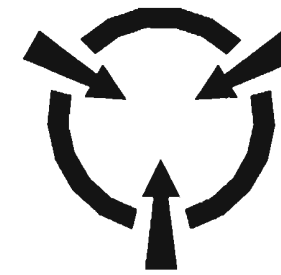
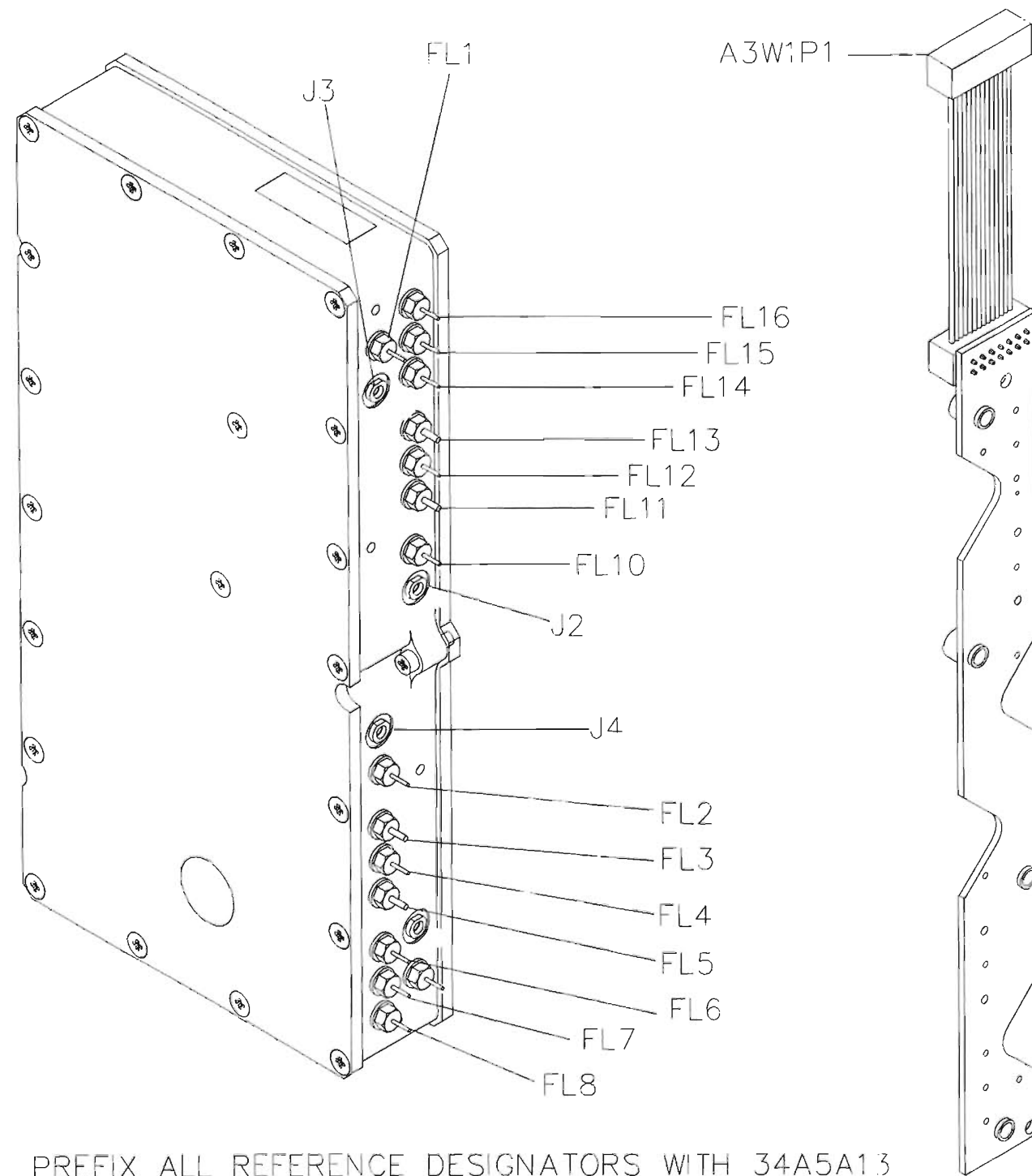

**CAUTION:**  
CONTAINS PARTS AND ASSEMBLIES  
SUSCEPTIBLE TO DAMAGE BY  
ELECTROSTATIC DISCHARGE (ESD).

CONNECTION	FUNCTION	DESTINATION
FL1 (REC)	15 V	W1P1, PIN 5
FL2 (REC)	STATUS A	W1P1, PIN 10
FL3	DATA	W1P1, PIN 12
FL4 (REC)	LATCH 1ST A	W1P1, PIN 9
FL5	CLOCK	W1P1, PIN 11
FL6 (REC)	15 V	W1P1, PIN 5
FL7	-15 V	W1P1, PIN 3
FL8	34 V	W1P1, PIN 1
FL9 (GEN)	15 V	W1P1, PIN 6
FL10 (GEN)	STATUS B	W1P1, PIN 7
FL11	DATA	W1P1, PIN 12
FL12 (GEN)	LATCH 1ST B	W1P1, PIN 8
FL13	CLOCK	W1P1, PIN 11
FL14 (GEN)	15 V	W1P1, PIN 6
FL15	-15 V	W1P1, PIN 3
FL16	34 V	W1P1, PIN 1
GL1	GND	W1P1, PIN 2
GL2	GND	W1P1, PIN 4

**Figure FO-11 34A5A13 1<sup>st</sup> LO Assembly  
Component Locator and Wiring Diagram**



**CAUTION:**  
CONTAINS PARTS AND ASSEMBLIES  
SUSCEPTIBLE TO DAMAGE BY  
ELECTROSTATIC DISCHARGE (ESD).

A14 TDMA Power Distribution

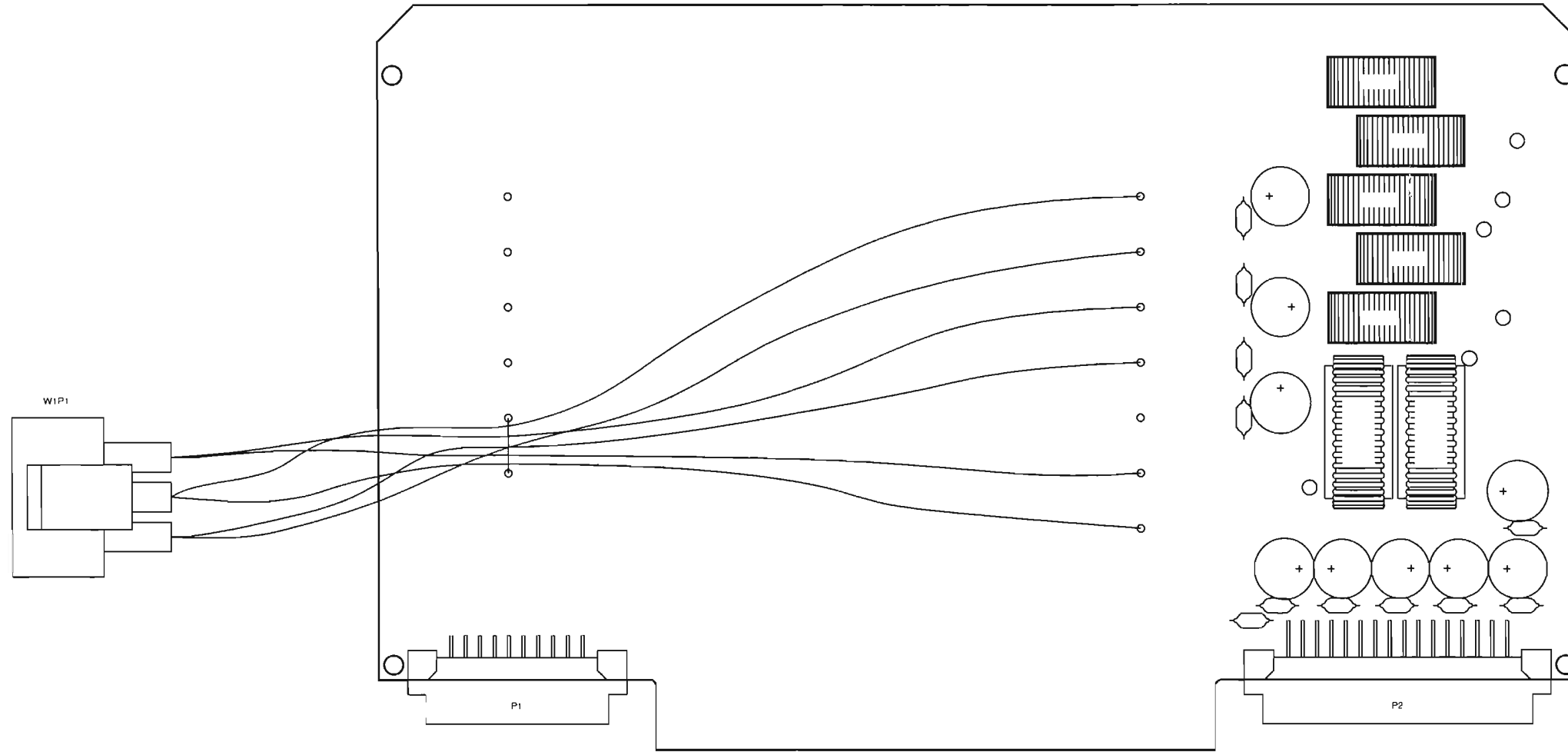

PREFIX ALL REFERENCE DESIGNATORS WITH 34A5A14.

TPD01

Figure FO-12 34A5A14 PC Board  
Assembly Component Locator Diagram

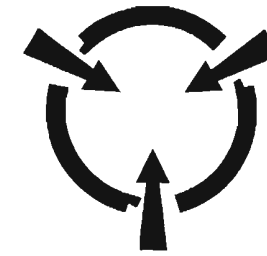
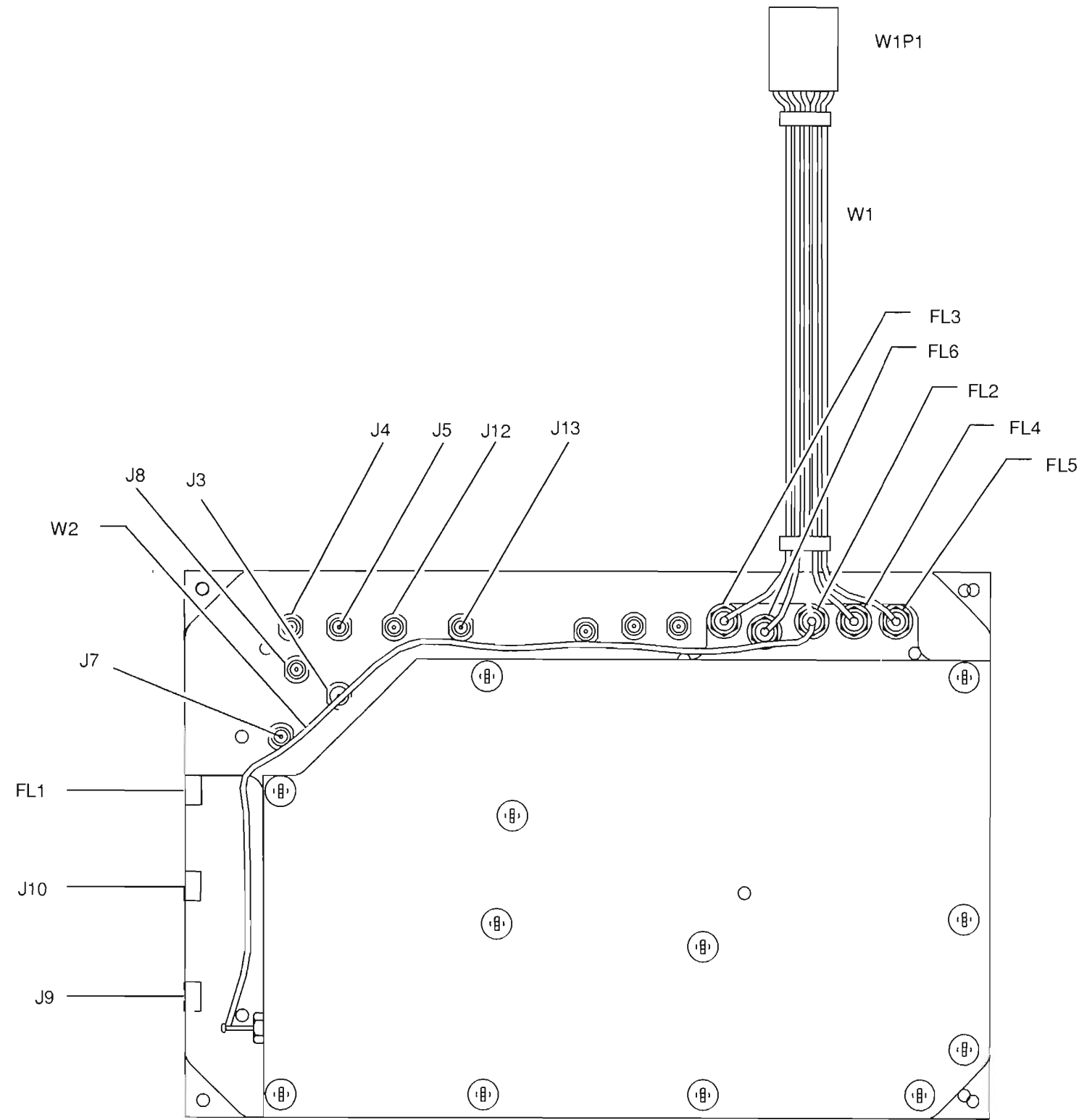

**CAUTION:**  
CONTAINS PARTS AND ASSEMBLIES  
SUSCEPTIBLE TO DAMAGE BY  
ELECTROSTATIC DISCHARGE (ESD).

CONNECTION	FUNCTION	DESTINATION
FL1	15 V	W1P1, PIN2
FL2	15 V	FL1
FL3	-15 V	W1P1, PIN3
FL4	TCXO PWR	W1P1, PIN1
FL4	CONDUCTOR	W2J1

PREFIX ALL REFERENCE DESIGNATORS WITH 34A5A15

2 LO  
**Figure FO-13 34A5A15 2<sup>nd</sup> LO Assembly  
Component Locator and Wiring Diagram**

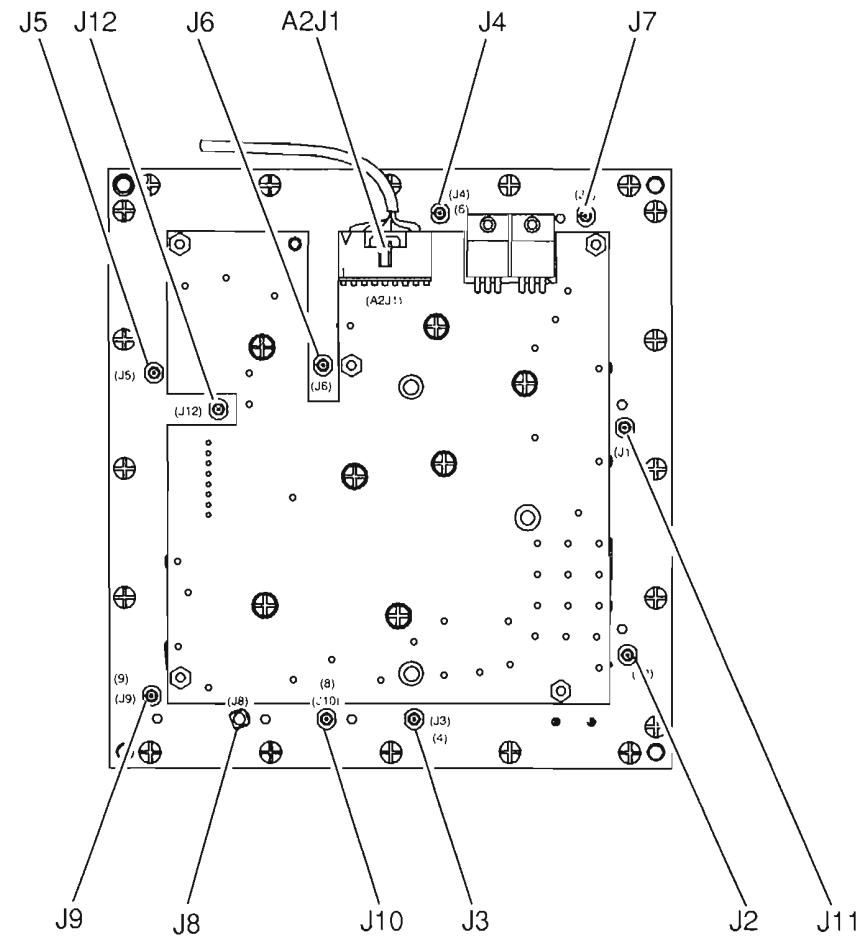

PREFIX ALL REFERENCE DESIGNATORS WITH 34A5A16.

Figure FO-14 34A5A16 Receive IF  
Assembly Component Locator Diagram

 **CAUTION:**  
CONTAINS PARTS AND ASSEMBLIES  
SUSCEPTIBLE TO DAMAGE BY  
ELECTROSTATIC DISCHARGE (ESD).

### A17 Baseband Mux

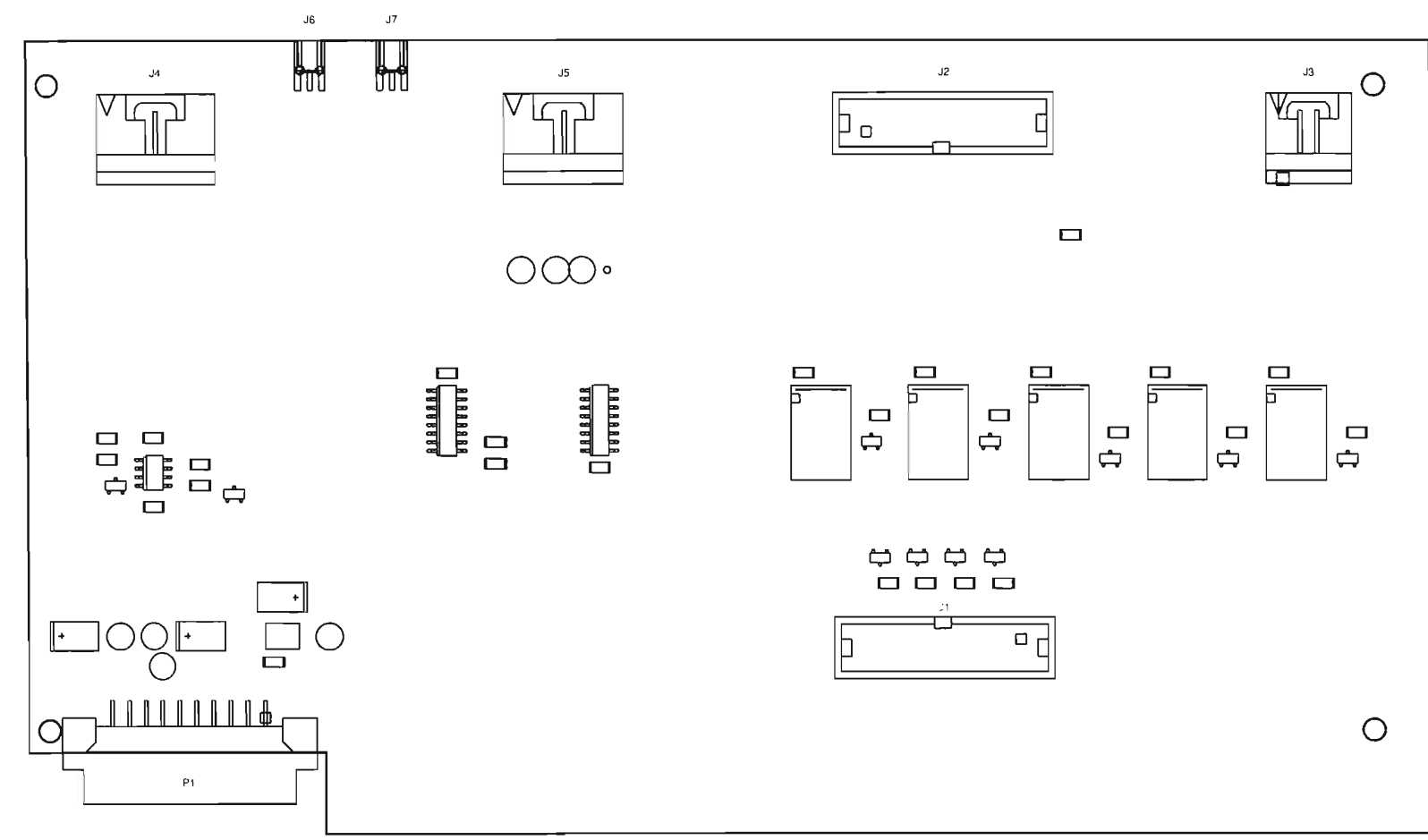

PREFIX ALL REFERENCE DESIGNATORS WITH 34A5A17.

BM01  
**Figure FO-15 34A5A17 PC Board  
Assembly Component Locator Diagram**



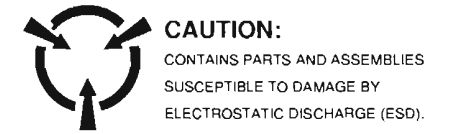

A18 RF Modem

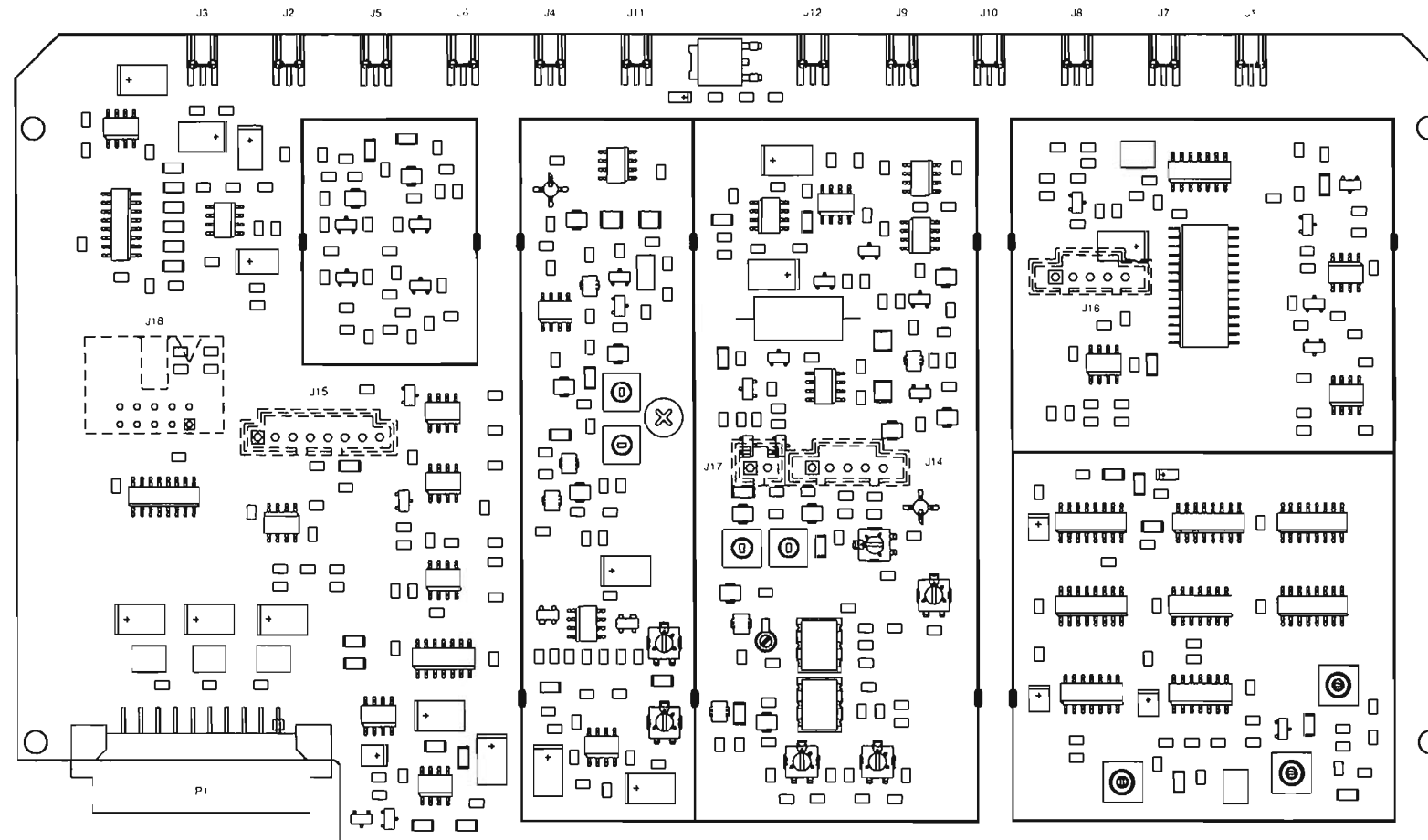

PREFIX ALL REFERENCE DESIGNATORS WITH 34A5A18.

RFM01  
Figure FO-16 34A5A18 PC Board  
Assembly Component Locator Diagram

 **CAUTION:**  
CONTAINS PARTS AND ASSEMBLIES  
SUSCEPTIBLE TO DAMAGE BY  
ELECTROSTATIC DISCHARGE (ESD).

A19 DSP

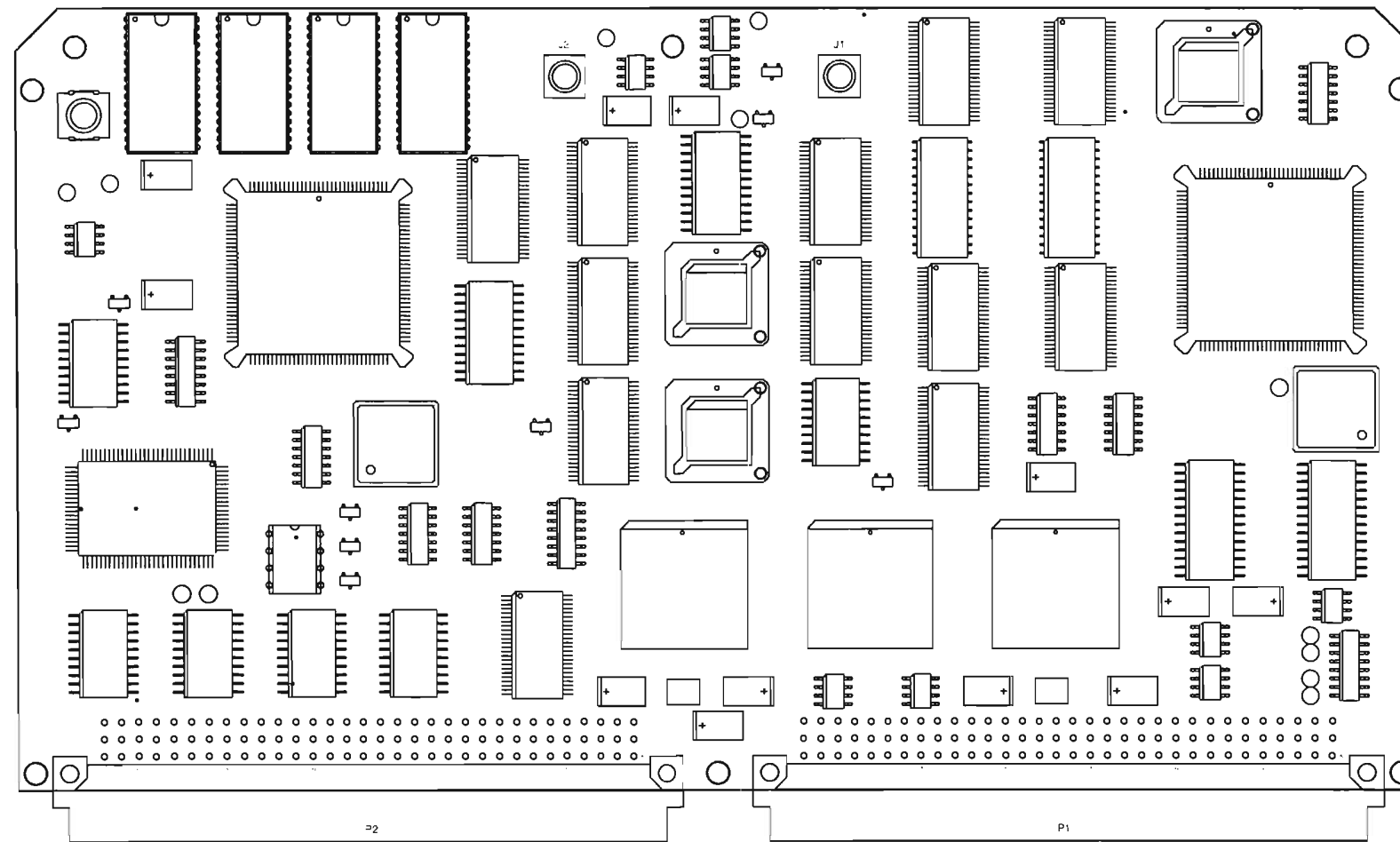

PREFIX ALL REFERENCE DESIGNATORS WITH 34A5A19.

DSP01

**Figure FO-17 34A5A19 Firmware  
Assembly Component Locator Diagram**

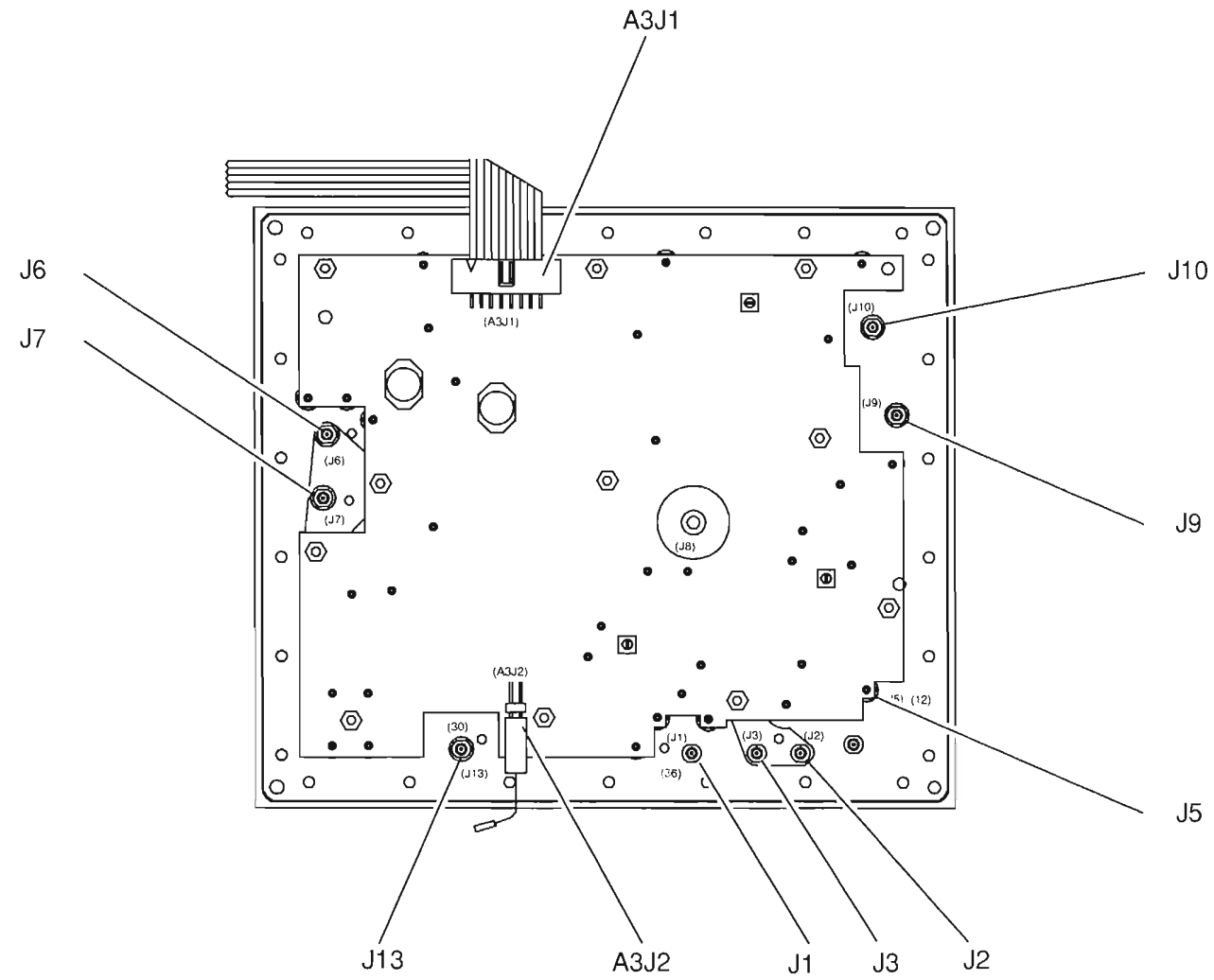

PREFIX ALL REFERENCE DESIGNATORS WITH 34A5A20.

Figure FO-18 34A5A20 Generator IF Assembly Component Locator Diagram

**CAUTION:**  
CONTAINS PARTS AND ASSEMBLIES  
SUSCEPTIBLE TO DAMAGE BY  
ELECTROSTATIC DISCHARGE (ESD).

CONNECTION	WIRE COLOR	FUNCTION	DESTINATION
FL1	BLUE/WHITE	PWR TERM TEMP	W1P1, PIN 5
FL2	VIOLET/WHITE	20 dB PAD	W1P1, PIN 8
FL3	YELLOW/WHITE	DUPLEX	W1P1, PIN 11
FL4	ORANGE	5 V	W1P1, PIN 3
FL5	RED	15 V	W1P1, PIN 2
FL6	YELLOW	-15 V	W1P1, PIN 12
FL7	BLACK/WHITE	PWR MODE	W1P1, PIN 4
FL8	GRAY/WHITE	RANGE SEL	W1P1, PIN 9
FL8	YELLOW/WHITE	RANGE SEL	W56P1
FL9	(COAXIAL CABLE)	RF PWR LVL	W38P1
FL10	ORANGE/WHITE	ALARM	W1P1, PIN 10
GL1	BLACK	GND	W1P1, PIN 1

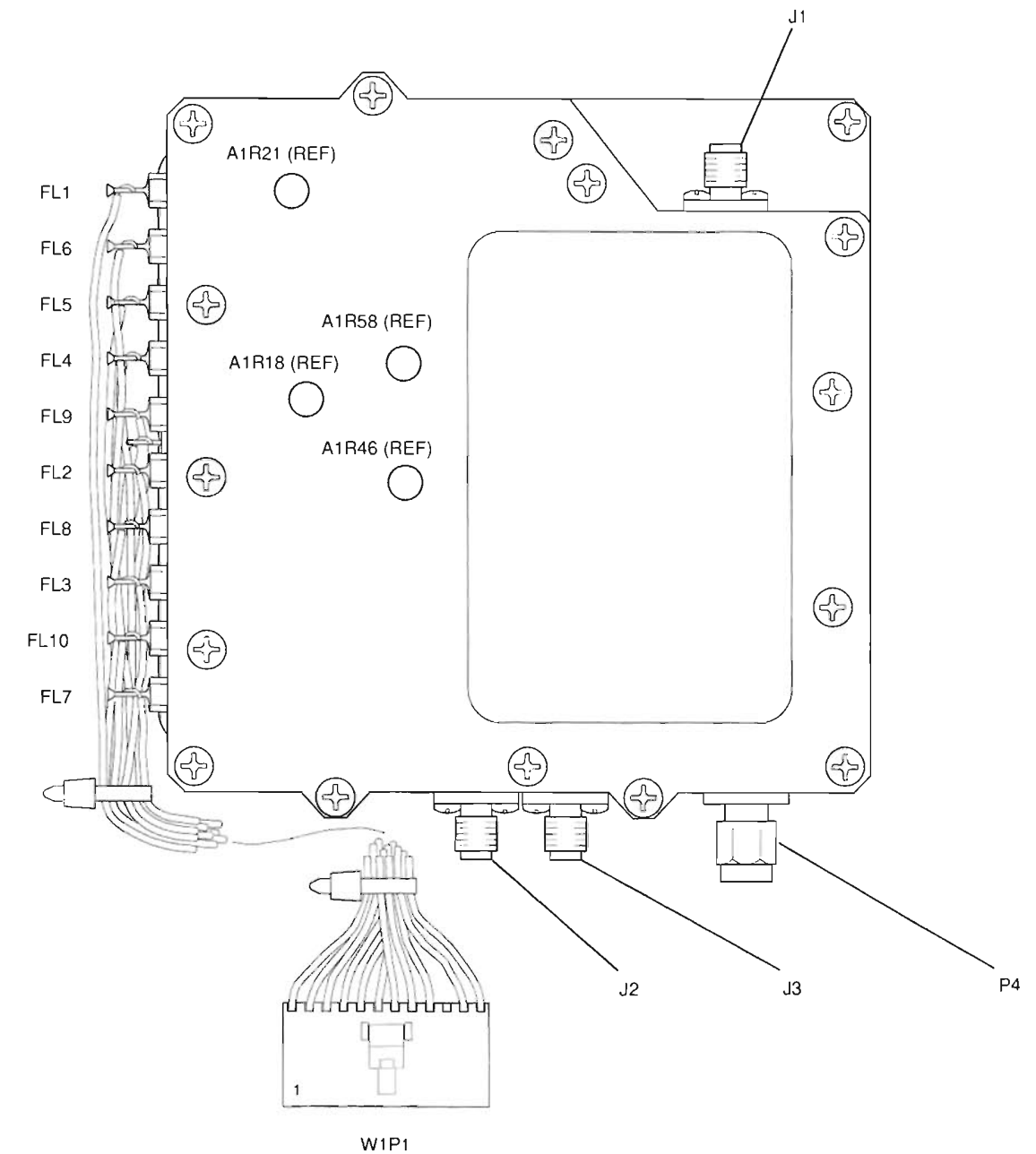

PREFIX ALL REFERENCE DESIGNATORS WITH 34A5A21.

PT01

Figure FO-19 34A5A21 Power Termination Assembly  
Component Locator and Wiring Diagram

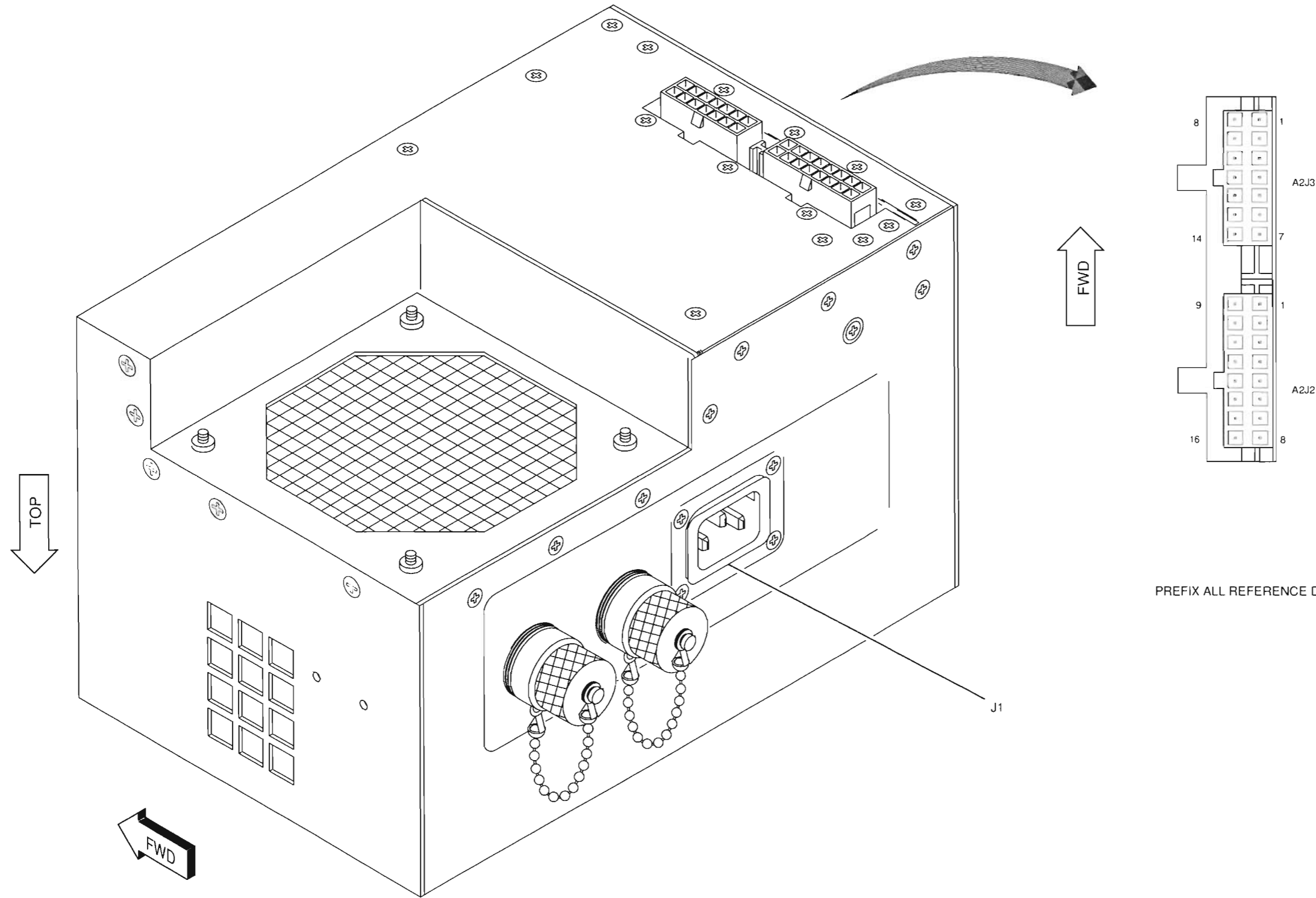

PREFIX ALL REFERENCE DESIGNATORS WITH 34A5A22.

PS01  
Figure FO-20 34A5A22 Power Supply Assembly  
Component Locator Diagram

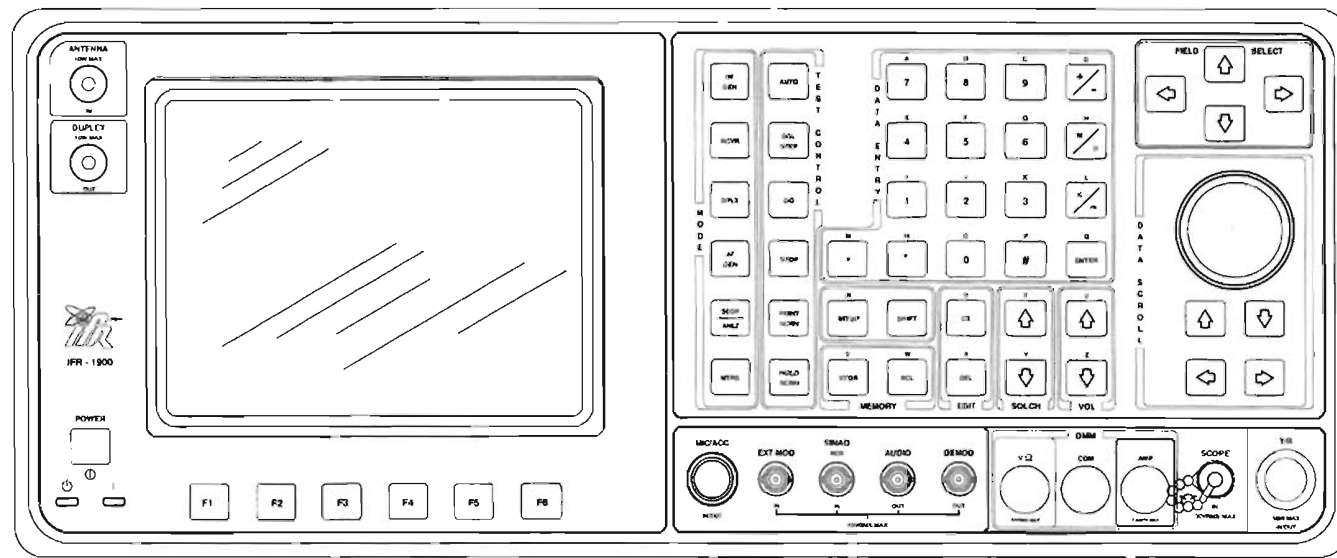

**CAUTION:**  
CONTAINS PARTS AND ASSEMBLIES  
SUSCEPTIBLE TO DAMAGE BY  
ELECTROSTATIC DISCHARGE (ESD).

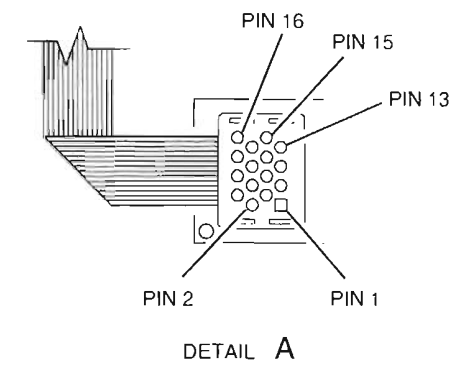
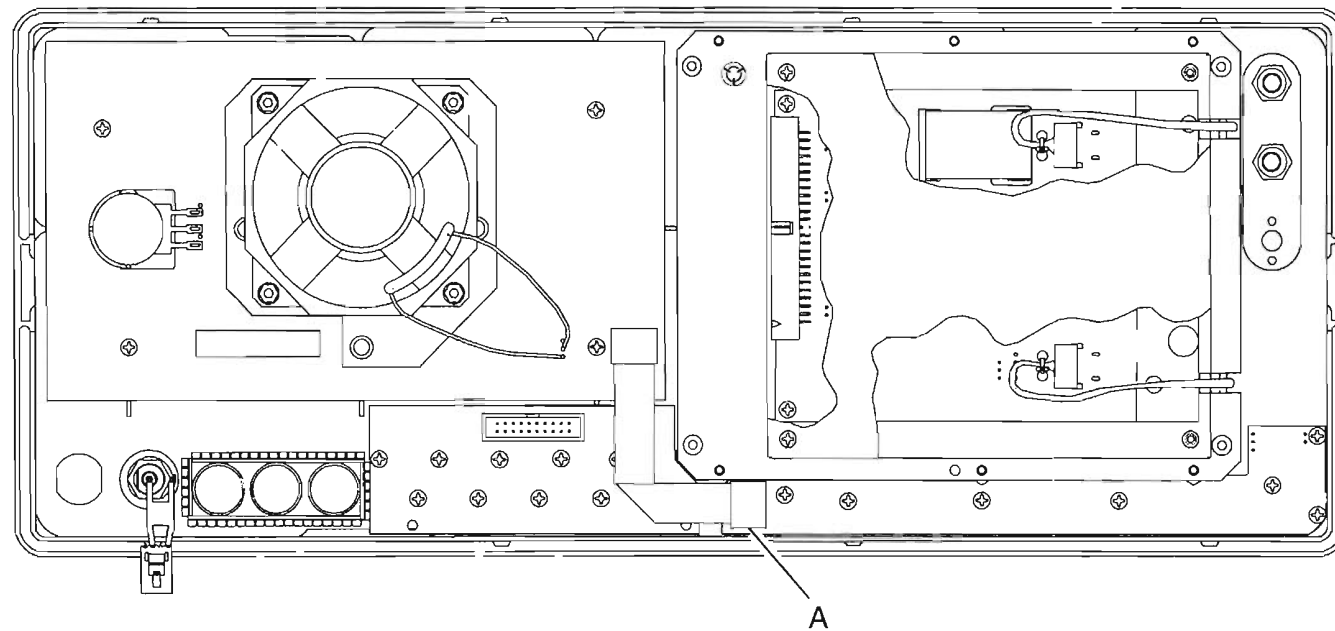

PREFIX ALL REFERENCE DESIGNATORS WITH 34A5A23.

FP01  
Figure FO-21 34A5A23 Front Panel Assembly  
Component Locator Diagram

PREFIX ALL REFERENCE DESIGNATORS WITH 34A5A24 (TDMA) OR 34A5A26 (INSTRUMENT).

**A24 Processor (TDMA) or A26 Processor (Instrument)**



**CAUTION:**  
 CONTAINS PARTS AND ASSEMBLIES  
 SUSCEPTIBLE TO DAMAGE BY  
 ELECTROSTATIC DISCHARGE (ESD).

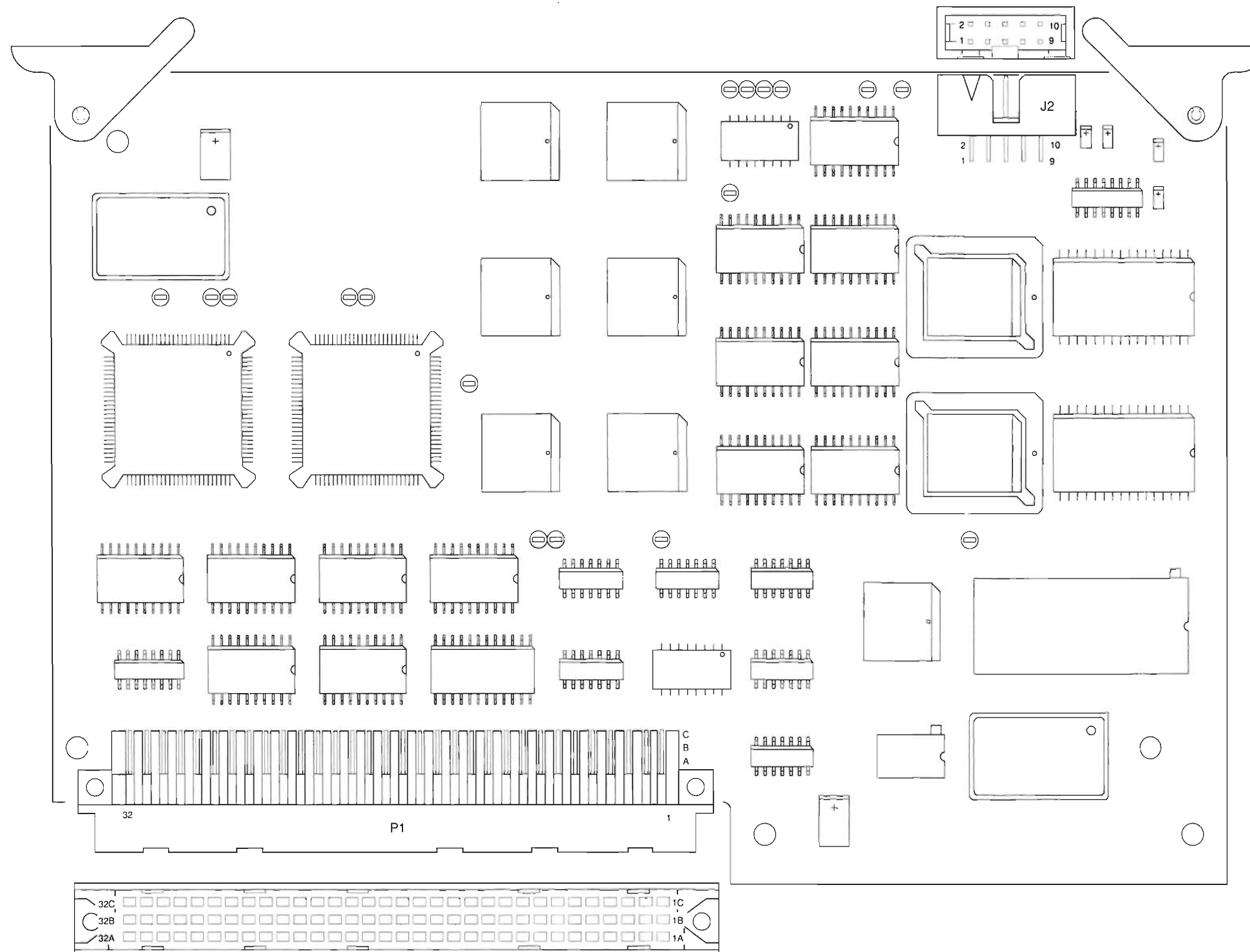

P01  
**Figure FO-22 34A5A24/34A5A26 PC Board  
 Assembly Component Locator Diagram**

PREFIX ALL REFERENCE DESIGNATORS WITH 34A5A25 (TDMA) OR 34A5A27 (INSTRUMENT).

### A25 Flash Memory (TDMA) or A27 Flash Memory (Instrument)

**CAUTION:**  
CONTAINS PARTS AND ASSEMBLIES  
SUSCEPTIBLE TO DAMAGE BY  
ELECTROSTATIC DISCHARGE (ESD).

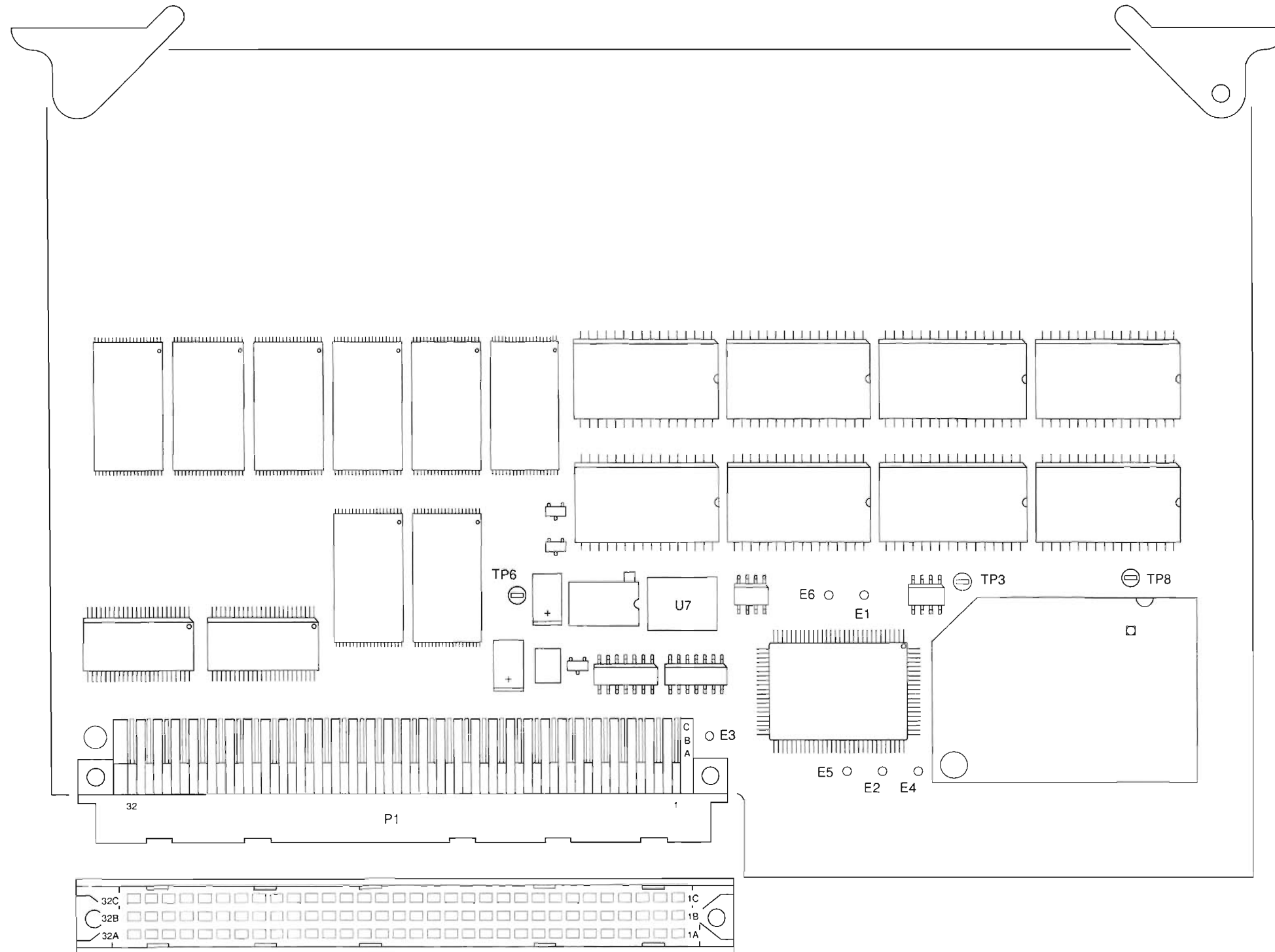

FM01  
Figure FO-23 34A5A25/34A5A27 PC Board  
Assembly Component Locator Diagram



PREFIX ALL REFERENCE DESIGNATORS WITH 34A5A28.

A28 Video Control



**CAUTION:**  
CONTAINS PARTS AND ASSEMBLIES  
SUSCEPTIBLE TO DAMAGE BY  
ELECTROSTATIC DISCHARGE (ESD).

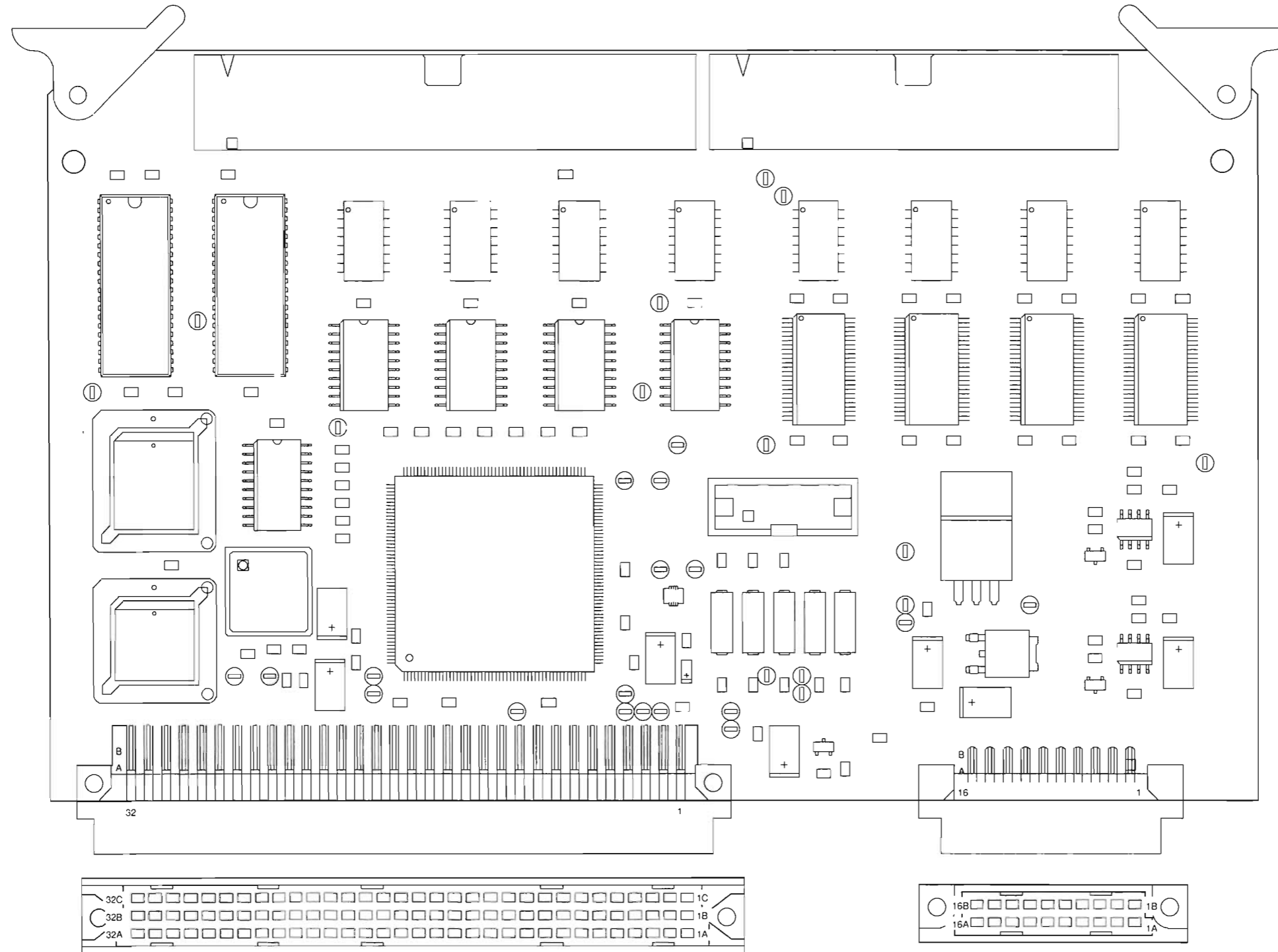

VC01  
**Figure FO-24 34A5A28 PC Board  
Assembly Component Locator Diagram**

PREFIX ALL REFERENCE DESIGNATORS WITH 34A5A29.

A29 RF I/O

 **CAUTION:**  
CONTAINS PARTS AND ASSEMBLIES  
SUSCEPTIBLE TO DAMAGE BY  
ELECTROSTATIC DISCHARGE (ESD).

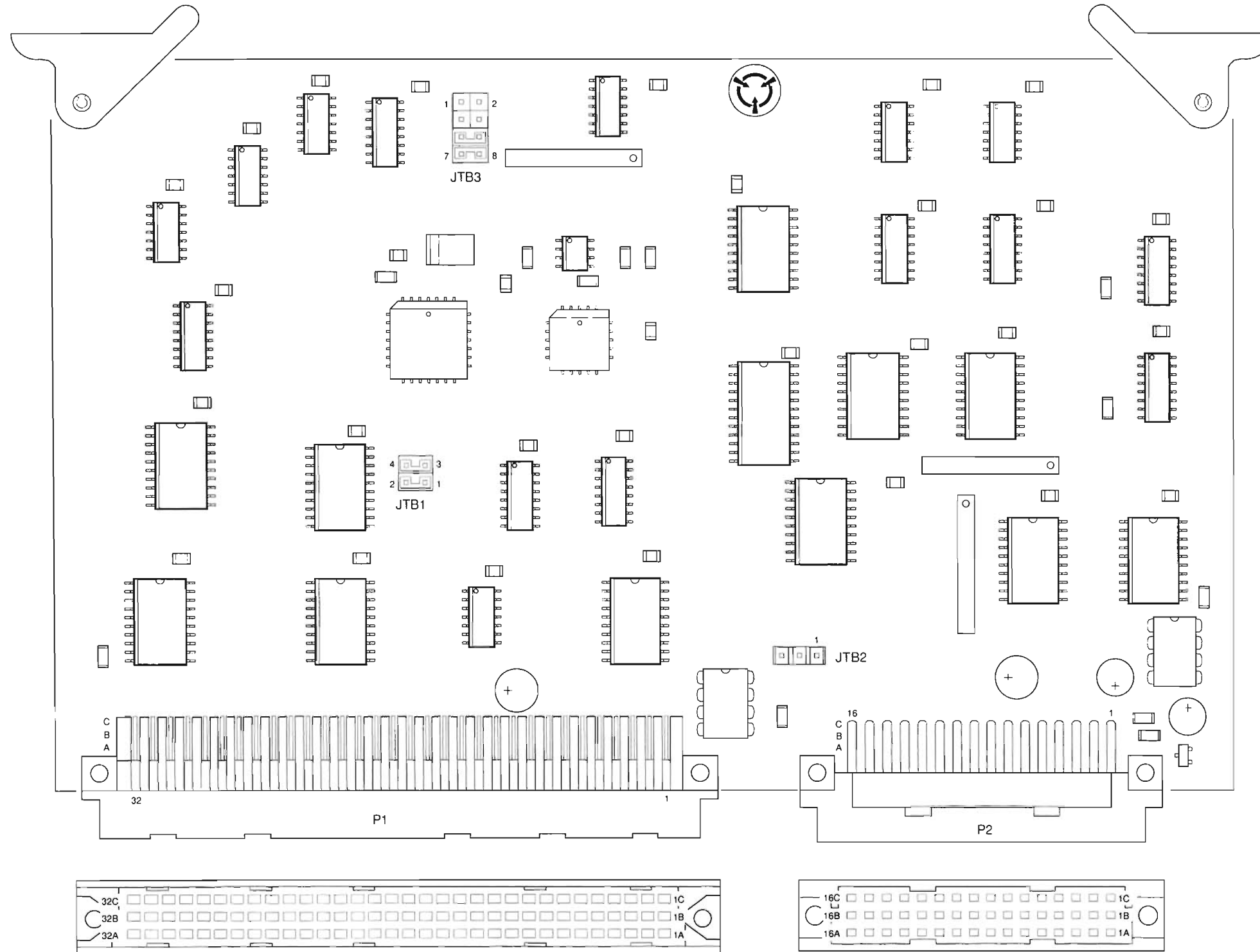

RFIO01  
Figure FO-25 34A5A29 PC Board  
Assembly Component Locator Diagram

PREFIX ALL REFERENCE DESIGNATORS WITH 34A5A30.

A30 Counter



**CAUTION:**  
CONTAINS PARTS AND ASSEMBLIES  
SUSCEPTIBLE TO DAMAGE BY  
ELECTROSTATIC DISCHARGE (ESD).

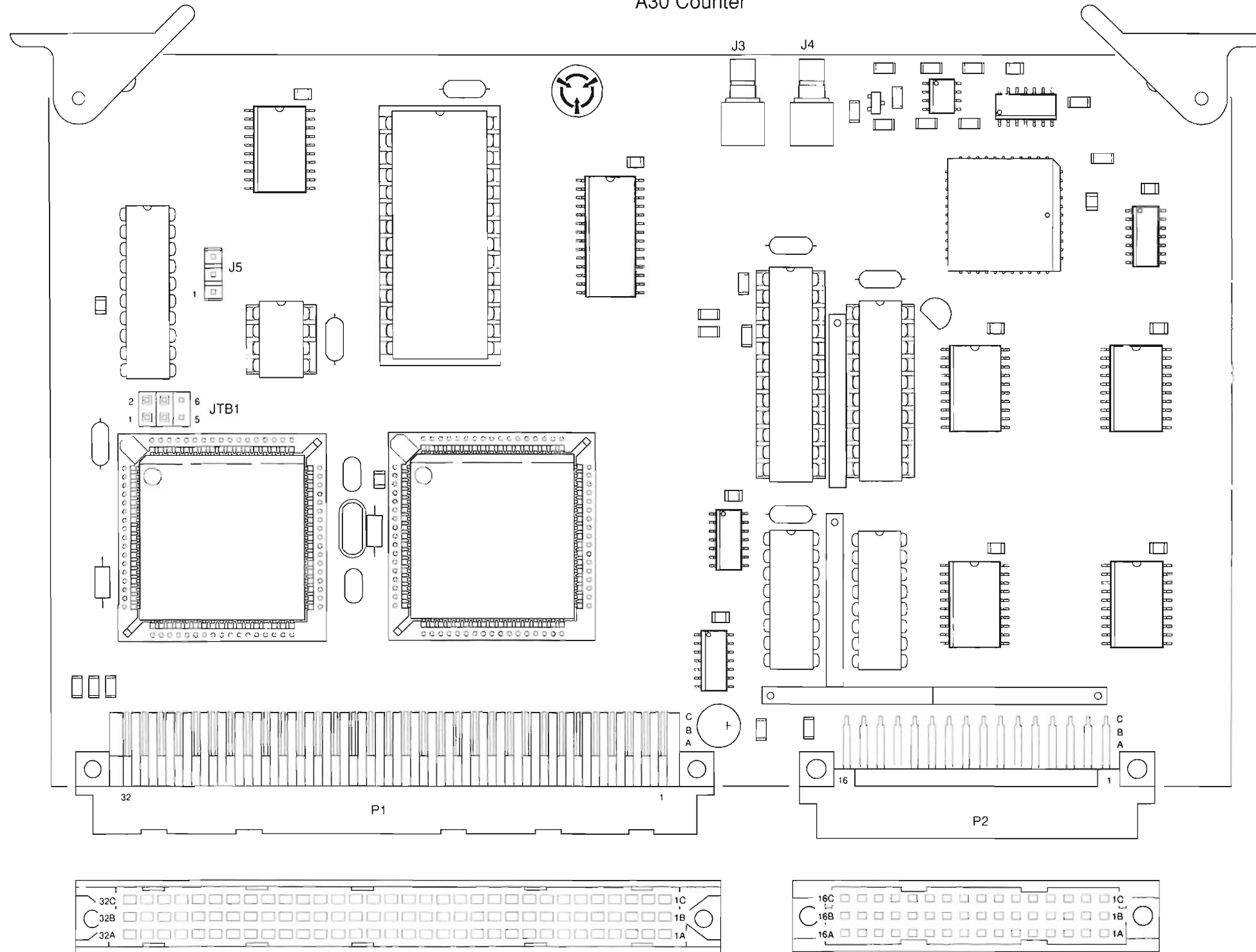

Figure FO-26 34A5A30 PC Board  
Assembly Component Locator Diagram

C01

PREFIX ALL REFERENCE DESIGNATORS WITH 34A5A31.

### A31 Function Generator



**CAUTION:**  
CONTAINS PARTS AND ASSEMBLIES  
SUSCEPTIBLE TO DAMAGE BY  
ELECTROSTATIC DISCHARGE (ESD).

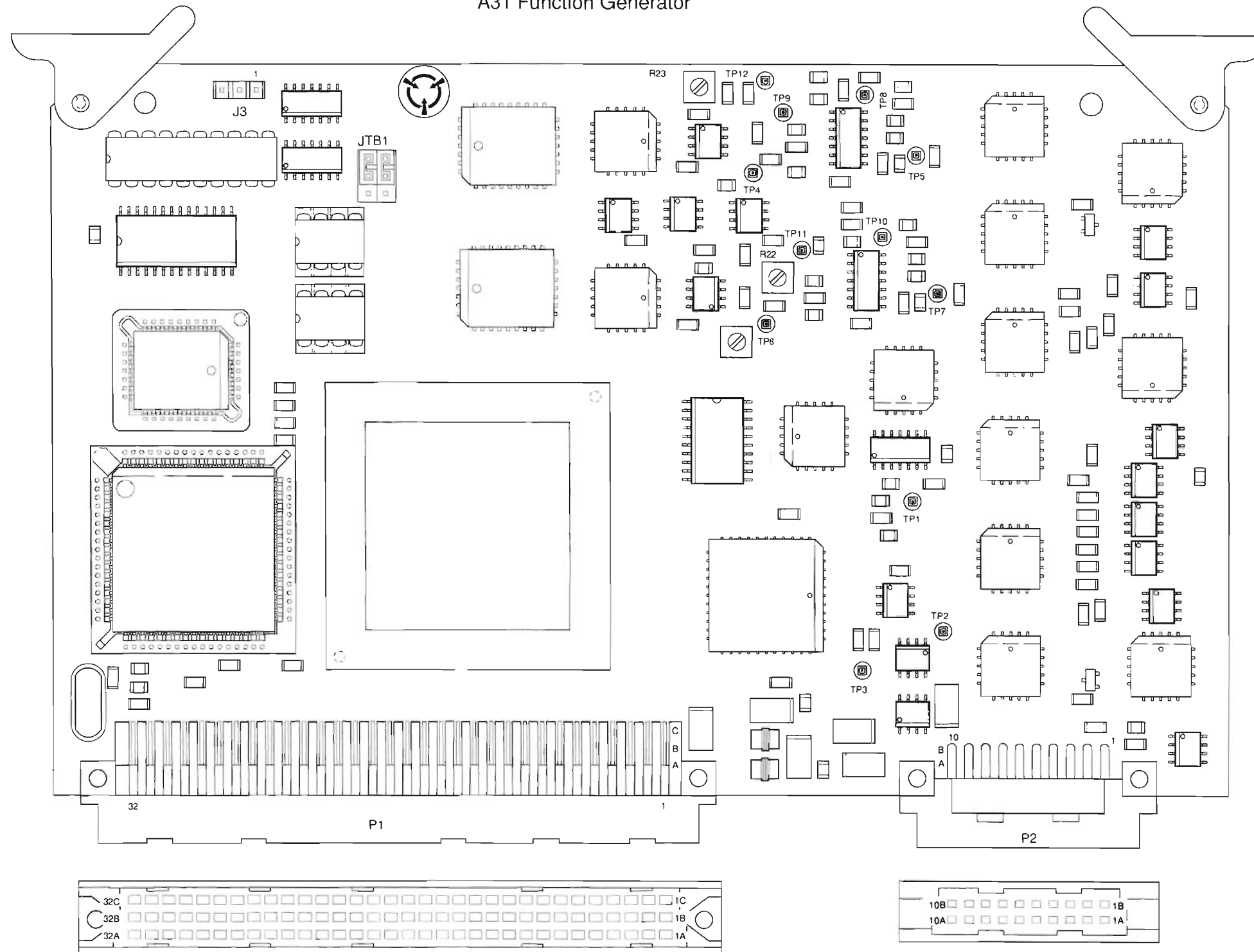

FG01

Figure FO-27 34A5A31 PC Board  
Assembly Component Locator Diagram

PREFIX ALL REFERENCE DESIGNATORS WITH 34A5A32.

A32 Digitizer

 **CAUTION:**  
CONTAINS PARTS AND ASSEMBLIES  
SUSCEPTIBLE TO DAMAGE BY  
ELECTROSTATIC DISCHARGE (ESD).

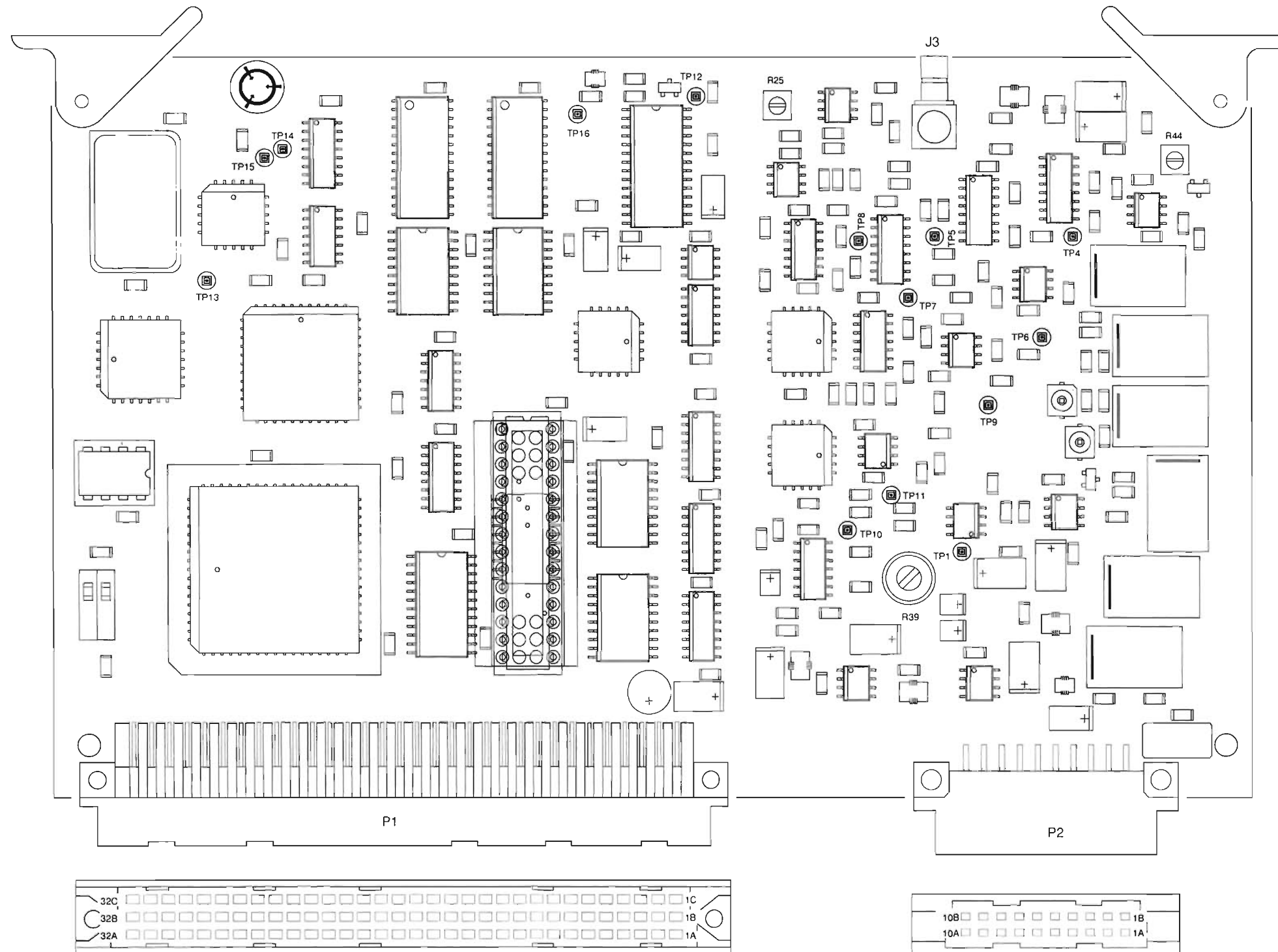

D01  
Figure FO-28 34A5A32 PC Board  
Assembly Component Locator Diagram

PREFIX ALL REFERENCE DESIGNATORS WITH 34A5A33.

### A33 Monitor Control

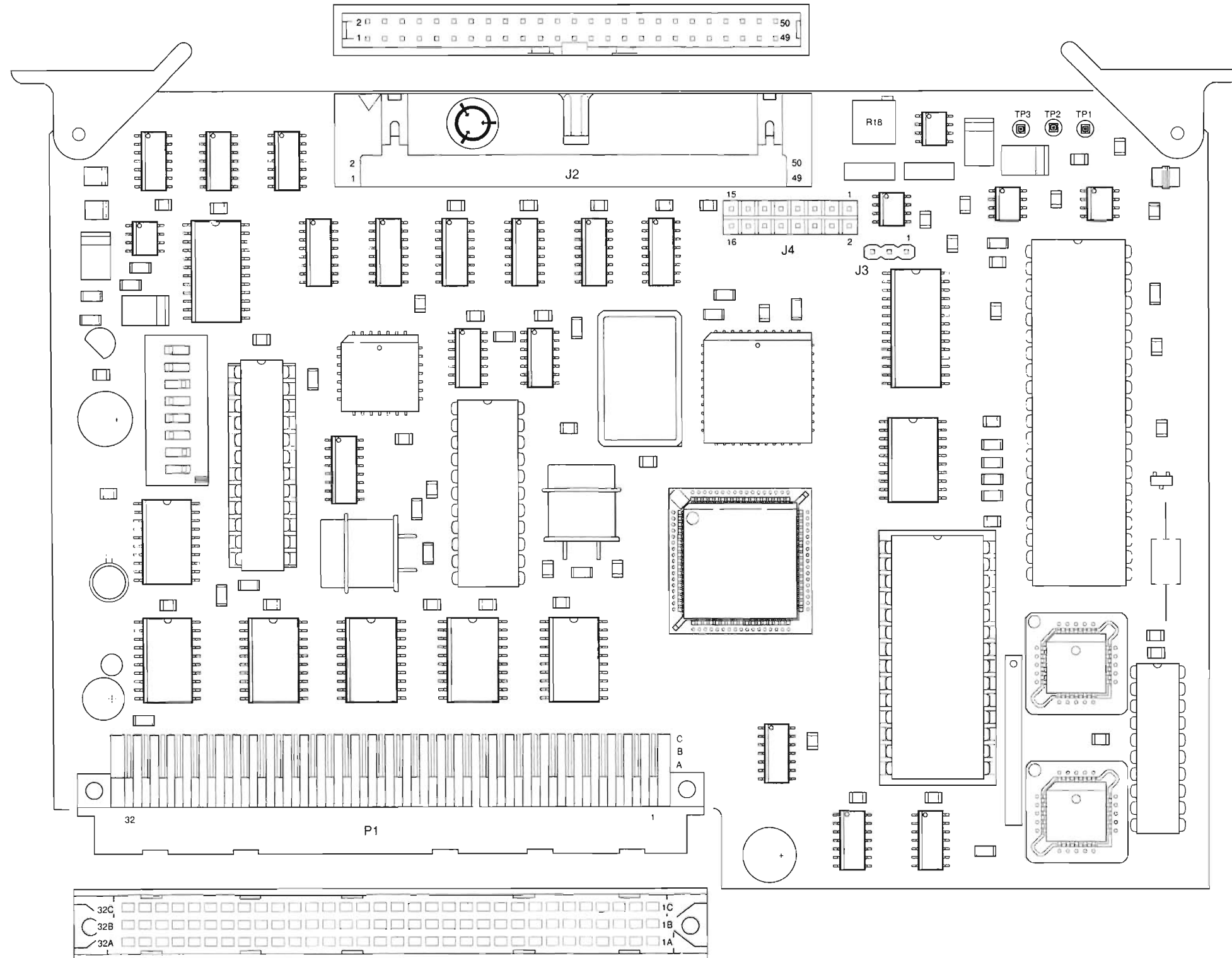

**CAUTION:**  
CONTAINS PARTS AND ASSEMBLIES  
SUSCEPTIBLE TO DAMAGE BY  
ELECTROSTATIC DISCHARGE (ESD).

MC01

Figure FO-29 34A5A33 PC Board  
Assembly Component Locator Diagram

A34 TDMA External I/O or A35 External I/O



CAUTION:  
CONTAINS PARTS AND ASSEMBLIES  
SUSCEPTIBLE TO DAMAGE BY  
ELECTROSTATIC DISCHARGE (ESD).

PREFIX ALL REFERENCE DESIGNATORS WITH 34A5A34 (TDMA) or 34A5A35.

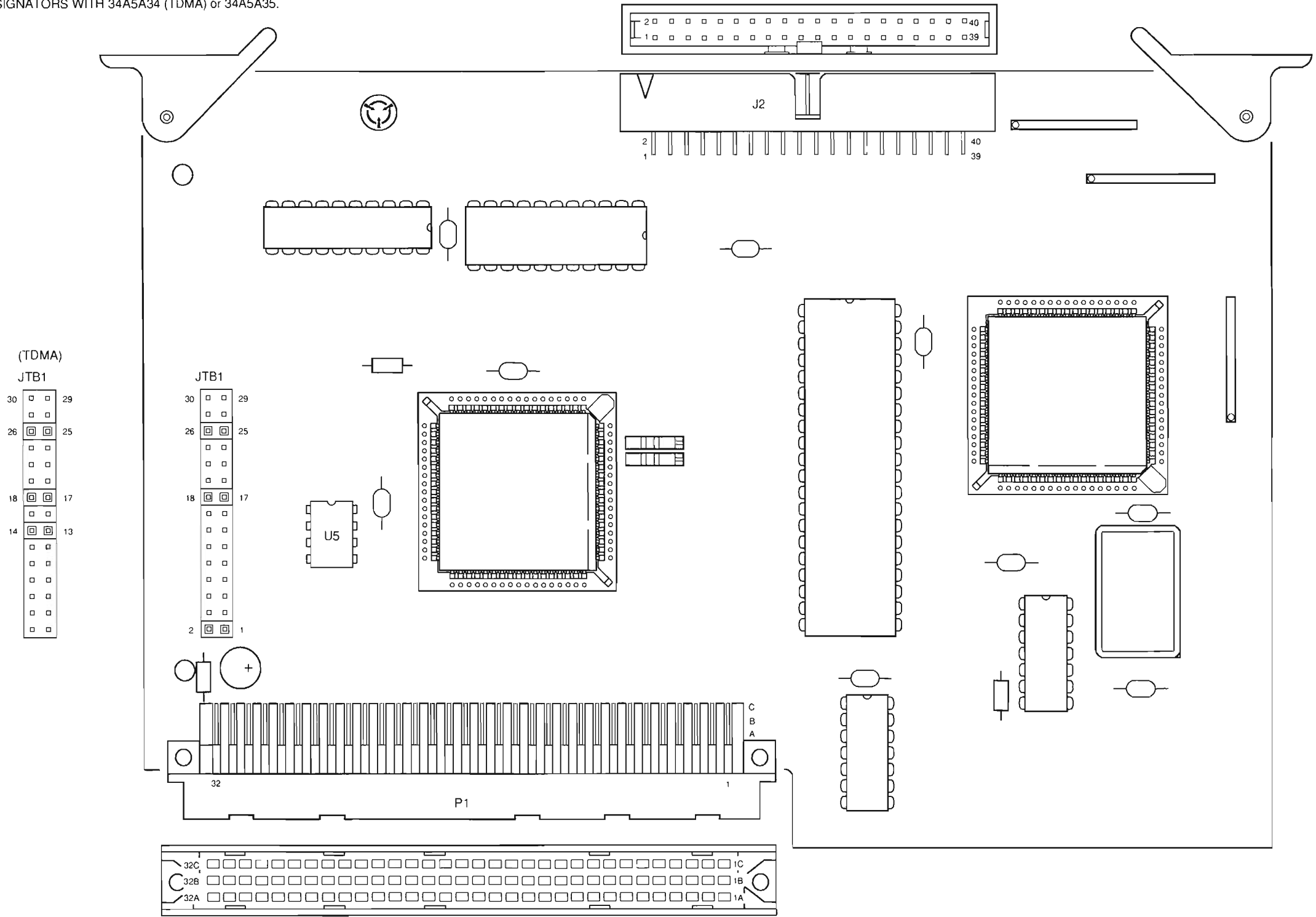
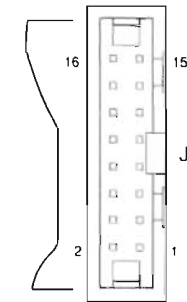
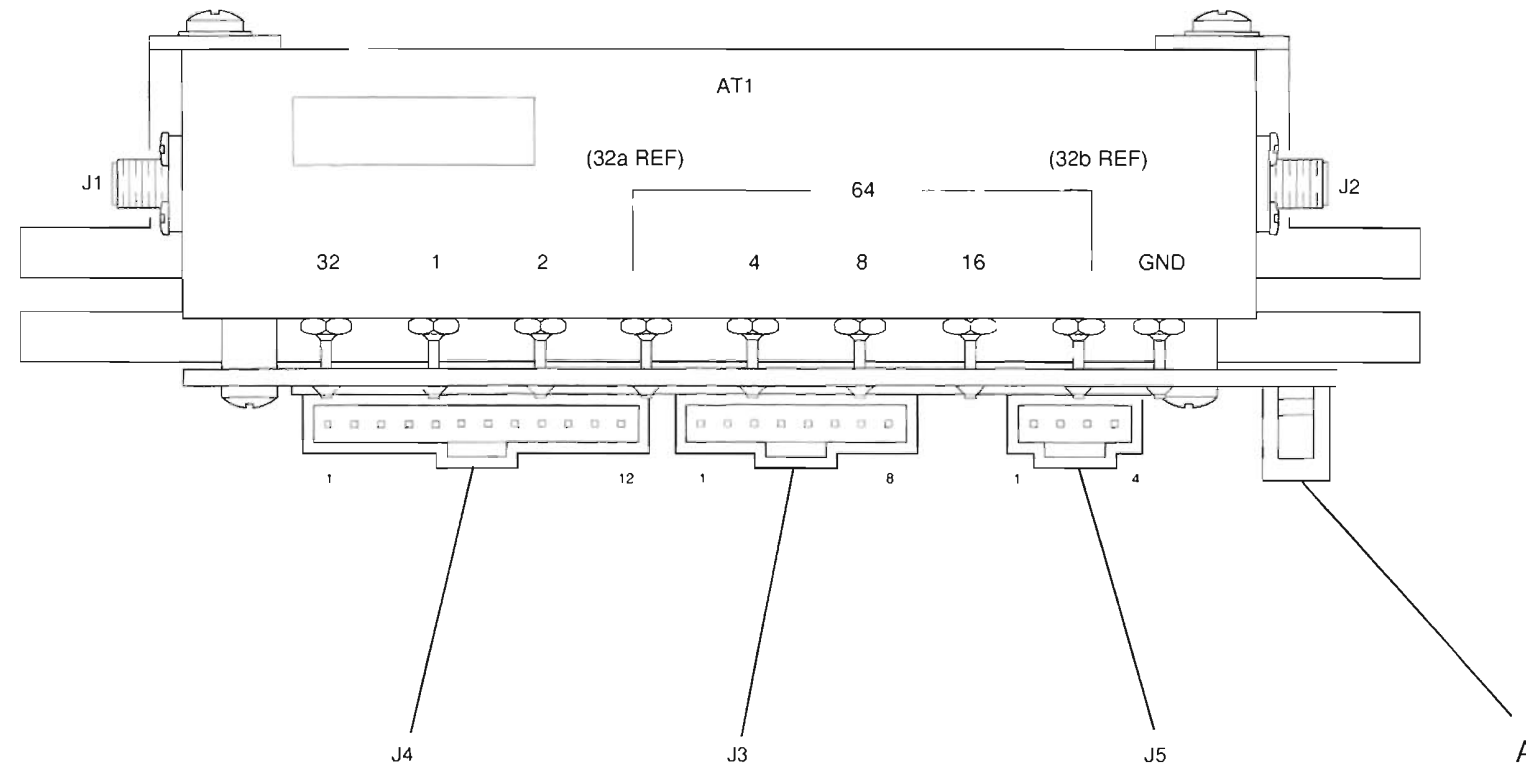

Figure FO-30 34A5A34/34A5A35 PC Board Assembly Component Locator Diagram

EIO01



**CAUTION:**  
CONTAINS PARTS AND ASSEMBLIES  
SUSCEPTIBLE TO DAMAGE BY  
ELECTROSTATIC DISCHARGE (ESD).



DETAIL A

PREFIX ALL REFERENCE DESIGNATORS WITH 34A5A36.

AA01  
Figure FO-31 34A5A36 Attenuator Assembly  
Component Locator Diagram



THIS PAGE INTENTIONALLY LEFT BLANK.



**CAUTION:**  
CONTAINS PARTS AND ASSEMBLIES  
SUSCEPTIBLE TO DAMAGE BY  
ELECTROSTATIC DISCHARGE (ESD).

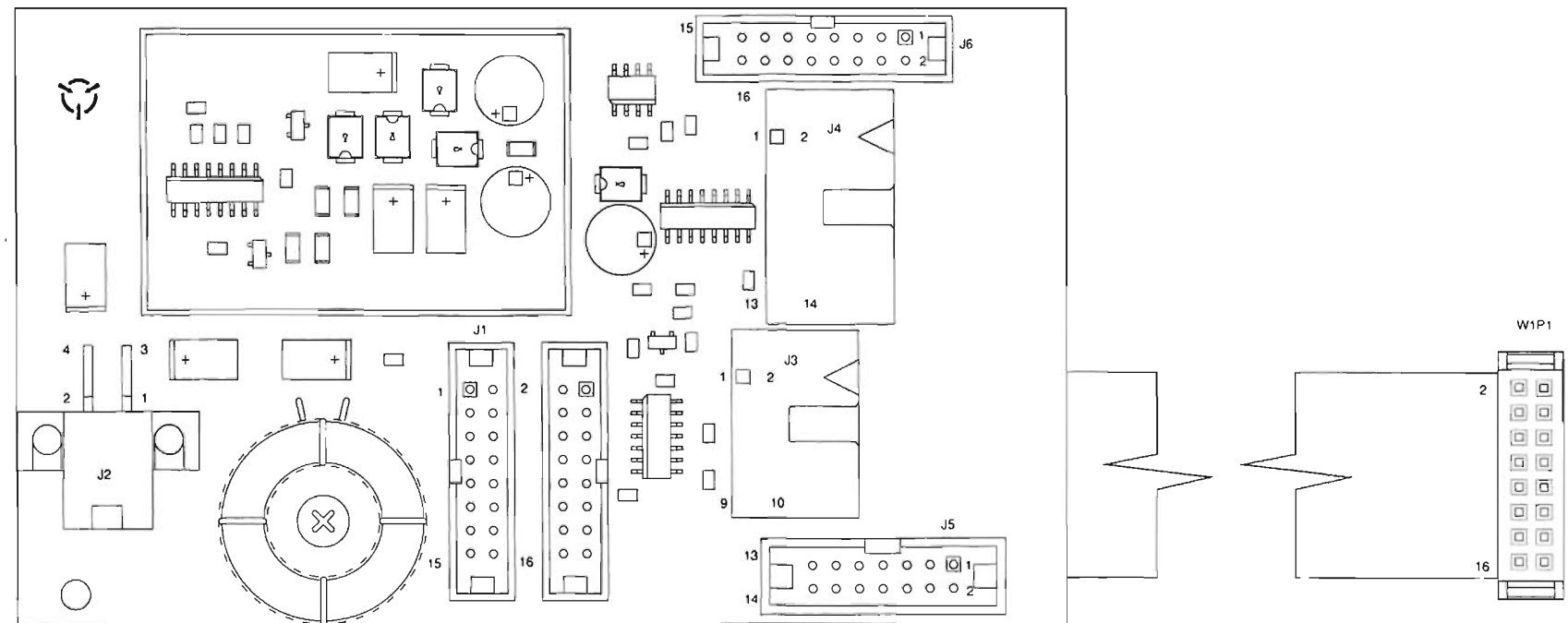

PREFIX ALL REFERENCE DESIGNATORS WITH 34A5A37.

APS01

**Figure FO-32 34A5A37 Auxiliary Power Supply Assembly  
Component Locator and Schematic Diagram (Sheet 1 of 2)**

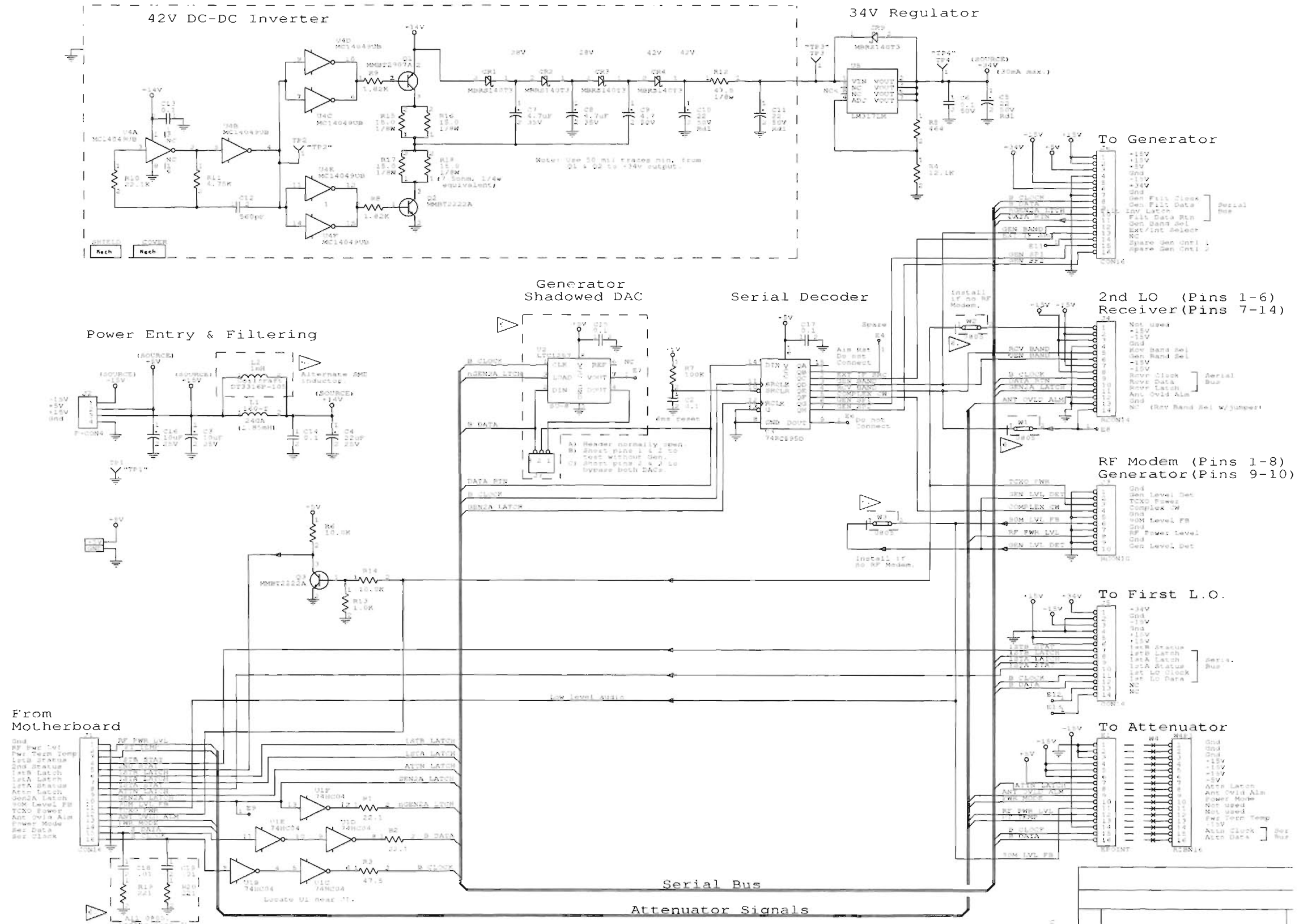
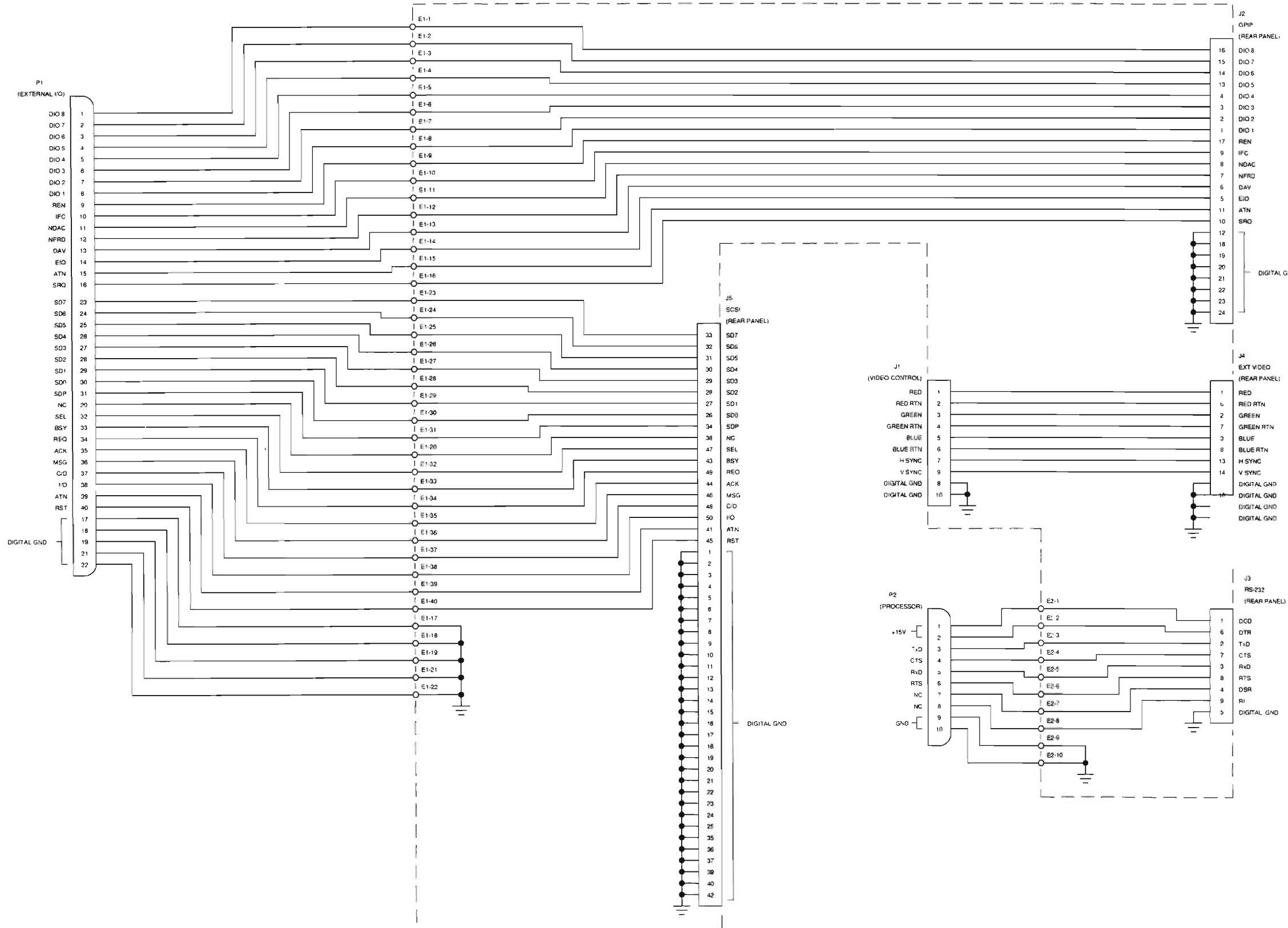

Figure FO-32 34A5A37 Auxiliary Power Supply Assembly Component Locator and Schematic Diagram (Sheet 2 of 2)



**CAUTION:**  
CONTAINS PARTS AND ASSEMBLIES  
SUSCEPTIBLE TO DAMAGE BY  
ELECTROSTATIC DISCHARGE (ESD).

- NOTES:  
(UNLESS OTHERWISE SPECIFIED)
1. ALL REFERENCE NUMBERS CARRY AN ASSIGNED DESIGNATOR SERIES. THIS ASSEMBLY CARRIES SERIES: A. A38 (e.g. E1 IS A38E1)
  2. PREFIX ALL REFERENCE DESIGNATORS WITH 34A5.

RPCS01

Figure FO-33 34A5A38 Rear Panel Connector  
PC Board Assembly Wiring Diagram

*Artekmedia => 2012*

**APPENDIX A**  
**COAXIAL SIGNALS, USER I/O CONNECTORS AND PIN-OUT TABLES**

***APPENDIX TABLE OF CONTENTS***

***TABLES***

Table A-1.	Coaxial Signals .....	A-2
Table A-2.	User I/O Connectors .....	A-4
Table A-3.	Pin-Outs for MIC/ACC Connector .....	A-5
Table A-4.	Pin-Outs for SERIAL Connector .....	A-6
Table A-5.	Pin-Outs for External Video Connector .....	A-7

***FIGURES***

Figure A-1.	MIC/ACC Connector Pin Identification .....	A-5
Figure A-2.	Serial Connector Pin Identification .....	A-6
Figure A-3.	External Video Connector Pin Identification .....	A-7

# APPENDIX A

## COAXIAL SIGNALS, USER I/O CONNECTORS AND PIN-OUT TABLES

Table A-1. Coaxial Signals

CABLE	SIGNAL SOURCE (SCE)	SCE CONN	SIGNAL LOAD	LOAD CONN	FREQ	SIGNAL LEVEL	SCE IMPD	LOAD IMPD
W1	Front Panel ANTENNA	A23J4B	RF Receiver IF	A16J2	10 - 2010 MHz	-100 - 0 dBm	50 Ω	50 Ω
W2	Front Panel T/R	W2J1	Power Term	A21J1	10 - 2010 MHz	0 - +47 dBm In -127 - 0 dBm Out	50 Ω	50 Ω
W3	Power Term	A21J3	Front Panel DUPLEX OUT	A23J5B	10 - 2010 MHz	-120 - +12 dBm	50 Ω	50 Ω
W4	Power Term	A21J2	RF Receiver IF	A16J3	10 - 2010 MHz	-30 - +17 dBm	50 Ω	50 Ω
W6	1 <sup>st</sup> LO	A13J3	RF Receiver IF	A16J4	1590 - 2600 MHz (2 MHz steps)	+12 (±1.2) dBm	50 Ω	50 Ω
W7	2 <sup>nd</sup> LO	A15J9	RF Receiver IF	A16J5	500/1500 MHz Fixed	+14 (±1.5) dBm	50 Ω	50 Ω
W8	RF Receiver IF	A16J10	RF Modem	A18J4	10 (±2) MHz	-100 - -20 dBm	50 Ω	50 Ω
W9	RF Receiver IF	A16J9	Analyzer RF	A8J2	83 - 95 MHz	-110 - -20 dBm	50 Ω	50 Ω
W10	3 <sup>rd</sup> LO	A40J3	RF Receiver IF	A16J6	79.3 - 77.001 MHz (100 Hz steps)	+7 dBm	50 Ω	50 Ω
W11	2 <sup>nd</sup> LO	A15J10	Gen IF	A20J2	500/1500 MHz Fixed	+14 (±1.5) dBm	50 Ω	50 Ω
W12	1 <sup>st</sup> LO	A13J5	Gen IF	A20J5	1590 - 2600 MHz (2 MHz steps)	+12 (±1.2) dBm	50 Ω	50 Ω
W13	90 MHz Gen	A41J3	RF Modem	A18J11	88.0001 - 90 MHz (100 Hz steps)	-27 - -15 dBm	50 Ω	50 Ω
W14	2 <sup>nd</sup> LO	A15J12	1 <sup>st</sup> LO	A13J2	10 MHz	2.8 V <sub>P-P</sub> Open Ckt	400 Ω	
W15	2 <sup>nd</sup> LO	A15J13	1 <sup>st</sup> LO	A13J4	10 MHz	2.8 V <sub>P-P</sub> Open Ckt	400 Ω	
W16	Master Oscillator	A39J1	RF Modem	A18J9	10 MHz	2.8 V <sub>P-P</sub> Open Ckt	100 Ω	160 Ω
W17	2 <sup>nd</sup> LO	A15J3	Counter	A30J3	1 MHz	HC TTL	22 Ω	
W18	2 <sup>nd</sup> LO	A15J4	Analyzer RF	A8J4	1 MHz	HC TTL	22 Ω	
W19	2 <sup>nd</sup> LO	A15J5	3 <sup>rd</sup> LO	A40J2	1 MHz	HC TTL	22 Ω	
W20	2 <sup>nd</sup> LO	A15J7	90 MHz Gen	A41J2	1 MHz	HC TTL	22 Ω	
W21	2 <sup>nd</sup> LO	A15J8	Receiver	A9J4	1 MHz	HC TTL	22 Ω	
W22	Rear Panel 10 MHz REF IN	J3B	RF Modem	A18J7	10 MHz	HC TTL	22 Ω	
W23	Receiver	A9J5	Digitizer	A32J3	425 kHz	-20 dBm	22 Ω	
W24	Receiver	A9J3	Counter	A30J4	425 kHz	-10 dBm	50 Ω	50 Ω
W25	Analyzer RF	A8J3	Analyzer Log IF	A7J2	10.7 MHz	-20 dBm	50 Ω	50 Ω
W26	3 <sup>rd</sup> LO	A40J4	Analyzer RF	A8J5	79.3 - 77.3001 MHz (100 Hz steps)	+7 dBm	50 Ω	50 Ω
W30	Gen IF	A20J13	Attenuator	A36J2	10 - 2010 MHz	+10 - +15 dBm	50 Ω	50 Ω
W31	RF Modem	A18J5	TDMA 10.7 MHz Receiver	A1J1	10.7 MHz	-100 - -20 dBm	50 Ω	50 Ω

## COAXIAL SIGNALS, USER I/O CONNECTORS AND PIN-OUT TABLES

Table A-1. Coaxial Signals

W32	RF Modem	A18J6	Receiver	A9J2	10 MHz	-100 - -20 dBm	50 $\Omega$	50 $\Omega$
W33	RF Modem	A18J10	2 <sup>nd</sup> LO	A15J2	10 MHz	1.5 V <sub>P.P</sub>	50 $\Omega$	50 $\Omega$
W34	RF Modem	A18J8	Rear Panel 10 MHz REF OUT	J4B	10 MHz	HC TTL	22 $\Omega$	
W35	RF Modem	A18J1	TDMA 10.7 MHz Receiver	A1J5	2 MHz	HC TTL	22 $\Omega$	
W36	RF Modem	A18J12	Gen IF	A20J1	88.0001 - 90 MHz	-22 dBm nominal (-30 - -15 dBm)	22 $\Omega$	
W37	TDMA 10.7 MHz Receiver	A1J4	DSP	A19J2				
W38	Power Term	A21FL9	RF Modem	A18J3	dc-24.3 kHz	0.050-+3 V		
W39	RF Modem	A18J2	DSP	A19J1	dc-24.3 kHz	0.1-+3 V		
W41	Baseband Mux	A17J6	Rear Panel I OUT	J2B	dc-24.3 kHz	-1.0-+1.0 V		
W42	Baseband Mux	A17J7	Rear Panel Q OUT	J1B	dc-24.3 kHz	-1.0-+1.0 V		

# APPENDIX A

## COAXIAL SIGNALS, USER I/O CONNECTORS AND PIN-OUT TABLES

Table A-2. User I/O Connectors

CONNECTOR NAME	CONNECTOR TYPE	SIGNAL IN/OUT	SIGNAL TYPE
T/R	"N" TYPE	IN/OUT	RF
SCOPE IN	BNC	IN	Analog
DMM AMP	Banana Jack	IN	AC/DC
DMM COM	Banana Jack	IN	GND
DMM V $\Omega$	Banana Jack	IN	AC/DC
DEMODO OUT	BNC	OUT	Audio
AUDIO OUT	BNC	OUT	Audio
SINAD/BER IN	BNC	IN	Analog - SINAD Digital - BER
EXT MOD IN	BNC	IN	Audio
MIC/ACC	8 Pin DIN	IN/OUT	See Pin-Out (A-2)
DUPLEX OUT	TNC	OUT	RF
ANTENNA IN	TNC	IN	RF
AC LINE IN	AC Power	IN	105-130, 210-260 VAC Auto-switching 115/230 V
SCSI	50 Pin Champ	IN/OUT	See Pin-Out (A-3)
GPIO (IEEE-488)	24 Pin Champ	IN/OUT	See Pin-Out (A-4)
AUXILIARY I/O	Reserved for Future Use		
HOST RS-232	9 Pin, D	IN/OUT	See Pin-Out (A-5)
EXTERNAL VIDEO	9 Pin, D	OUT	Video, VGA Format, See Pin-Out (A-6)
10 MHz REFERENCE IN	BNC	IN	10 MHz, Sine/Square
10 MHz REFERENCE OUT	BNC	OUT	10 MHz, TTL, driven by internal Master Oscillator
PRINTER	25 Pin, D	OUT	Centronics-compatible. See Pin-Out (A-7)
GENERATOR IF IN	Reserved for Future Use		
GENERATOR IF OUT			
RECEIVER IF			
CONNECTOR NAME	CONNECTOR TYPE	SIGNAL IN/OUT	SIGNAL TYPE
OPTIONAL RS-232	See 1900 Operation Manual		
SYNC OUT			
I (GENERATOR BASEBAND OUT)			
Q (GENERATOR BASEBAND OUT)			



COAXIAL SIGNALS, USER I/O CONNECTORS AND PIN-OUT TABLES

Table A-3. Pin-Outs for MIC/ACC Connector

PIN NUMBER	SIGNAL NAME	SIGNAL TYPE	I/O
1	PTT-Out	TTL	Programmable Out
2	Mic Audio	Audio	In
3	Demod Audio	Audio	Out
4	ACC-2	TTL	Programmable In
5	+15 Vdc	10-15 Vdc, 1 mA	Out
6	ACC-1	TTL	Programmable In
7	Mic Switch	TTL	Programmable In
8	GND		

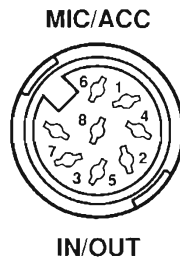

Figure A-1. MIC/ACC Connector Pin Identification

8618013

# APPENDIX A

## COAXIAL SIGNALS, USER I/O CONNECTORS AND PIN-OUT TABLES

PIN NUMBER	ASSIGNMENT
1	4.7 k $\Omega$ , + 15Vdc
2	TX DATA
3	RX DATA
4	N/C
5	Digital GND
6	4.7 k $\Omega$ , + 15Vdc
7	CTS
8	RTS
9	N/C

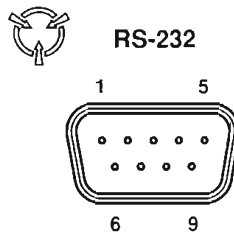

Figure A-2. Serial Connector Pin Identification

8618017

COAXIAL SIGNALS, USER I/O CONNECTORS AND PIN-OUT TABLES

Table A-5. Pin-Outs for External Video Connector			
PIN NUMBER	ASSIGNMENT	PIN NUMBER	ASSIGNMENT
1	Red	9	Not Used
2	Green	10	Digital GND
3	Blue	11	Digital GND
4	Not Used	12	Digital GND
5	Digital GND	13	Horizontal Sync
6	Red Return	14	Vertical Sync
7	Green Return	15	Not Used
8	Blue Return		

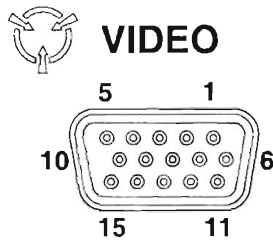

Figure A-3. External Video Connector Pin Identification

03418003

THIS PAGE INTENTIONALLY LEFT BLANK.

## INDEX

34A5A1 TDMA 10.7 MHz RECEIVER PC BOARD ASSEMBLY		34A5A19 DSP FIRMWARE	
DESCRIPTION .....	1-79	ASSEMBLY DESCRIPTION .....	1-66
A1 TDMA 10.7 MHz Receiver PC Board Assembly		A19 DSP Firmware Assembly Block Diagram .....	1-70
Block Diagram .....	1-82	34A5A19 Firmware Assembly Component	
34A5A1 Assembly Component Locator		Locator Diagram .....	FP-32
Diagram .....	FP-12		
34A5A2 INTERNAL I/O FIRMWARE		34A5A20 GENERATOR IF DESCRIPTION .....	1-43
ASSEMBLY DESCRIPTION .....	1-73	A20 Generator IF Functional Block Diagram .....	1-45
A2 Internal I/O Firmware Assembly Block		34A5A20 Generator IF Assembly Component	
Diagram .....	1-78	Locator Diagram .....	FP-33
34A5A2 Assembly Component Locator			
Diagram .....	FP-13	34A5A21 POWER TERMINATION DESCRIPTION .....	1-17
34A5A6 MONITOR DESCRIPTION .....	1-33	A21 Power Termination Functional	
A6 Monitor Functional Block Diagram .....	1-34	Block Diagram .....	1-18
34A5A6 Assemblies Component Locator		34A5A21 Power Termination Assembly Component Locator and	
Diagrams .....	FP-22	Wiring Diagram .....	FP-34
34A5A7 ANALYZER LOG/IF DESCRIPTION .....	1-37		
A7 Analyzer Log/IF Functional Block Diagram .....	1-38	34A5A22 POWER SUPPLY DESCRIPTION .....	1-1
34A5A7 Assemblies Component Locator		A22 Power Supply Functional Block Diagram .....	1-3
Diagrams .....	FP-22	34A5A22 Power Supply Assembly Component	
34A5A8 ANALYZER RF DESCRIPTION .....	1-35	Locator Diagram .....	FP-35
A8 Analyzer RF Functional Block Diagram .....	1-36		
34A5A9 RECEIVER DESCRIPTION .....	1-31	34A5A23 FRONT PANEL DESCRIPTION .....	1-15
A9 Receiver Functional Block Diagram .....	1-32	A23 Front Panel Functional Block Diagram .....	1-16
34A5A9 Assemblies Component Locator Diagrams .....	FP-23	34A5A23 Front Panel Assembly Component	
34A5A11 DMM DESCRIPTION .....	1-57	Locator Diagram .....	FP-36
A11 DMM Functional Block Diagram .....	1-58		
34A5A11 DMM Assembly Component Locator Diagram .....	FP-24	34A5A24 TDMA PROCESSOR FIRMWARE ASSEMBLY	
34A5A13 1st LO DESCRIPTION .....	1-23	DESCRIPTION .....	1-61
A13 1st LO Functional Block Diagram .....	1-24	A24 TDMA Processor Firmware Assembly Block Diagram .....	1-63
34A5A13 1st LO Assembly Component Locator and Wiring		34A5A24 PC Board Assembly Component	
Diagram .....	FP-26	Locator Diagram .....	FP-37
34A5A14 TDMA POWER			
DISTRIBUTION DESCRIPTION .....	1-59	34A5A25 FLASH MEMORY DESCRIPTION .....	1-65
A14 TDMA Power Distribution PC Board Assembly Block		A25 Flash Memory PC Board Assembly Block Diagram .....	1-65
Diagram .....	1-59	34A5A25 PC Board Assembly Component	
34A5A14 PC Board Assembly Component		Locator Diagram .....	FP-38
Locator Diagram .....	FP-27		
34A5A15 2nd LO DESCRIPTION .....	1-25	34A5A26 PROCESSOR (INSTRUMENT) DESCRIPTION .....	1-5
A15 2nd LO Functional Block Diagram .....	1-27	A26 Processor (Instrument) Functional Block Diagram .....	1-6
34A5A15 2nd LO Assembly Component Locator and Wiring		34A5A26 PC Board Assembly Component	
Diagram .....	FP-28	Locator Diagram .....	FP-37
34A5A16 RECEIVER IF DESCRIPTION .....	1-19		
A16 Receive IF Functional Block Diagram .....	1-21	34A5A28 VIDEO CONTROLLER DESCRIPTION .....	1-9
34A5A15 2nd LO Assembly Component Locator and Wiring		A28 Video Controller Functional Block Diagram .....	1-10
Diagram .....	FP-28	34A5A28 PC Board Assembly Component	
34A5A17 BASEBAND MUX PC BOARD		Locator Diagram .....	FP-39
ASSEMBLY DESCRIPTION .....	1-88		
A17 Baseband Mux PC Board Assembly Block Diagram .....	1-91	34A5A29 RF I/O DESCRIPTION .....	1-49
34A5A17 PC Board Assembly Component		A29 RF I/O Functional Block Diagram .....	1-50
Locator Diagram .....	FP-30	34A5A29 PC Board Assembly Component	
34A5A18 RF MODEM PC BOARD		Locator Diagram .....	FP-40
ASSEMBLY DESCRIPTION .....	1-84		
A18 RF Modem PC Board Assembly Block Diagram .....	1-87	34A5A30 COUNTER DESCRIPTION .....	1-13
34A5A18 PC Board Assembly Component		A30 Counter Functional Block Diagram .....	1-14
Locator Diagram .....	FP-31	34A5A30 PC Board Assembly Component	
		Locator Diagram .....	FP-41
		34A5A31 FUNCTION	
		GENERATOR DESCRIPTION .....	1-7
		A31 Function Generator Functional Block Diagram .....	1-8
		34A5A31 PC Board Assembly Component	
		Locator Diagram .....	FP-42
		34A5A32 DIGITIZER DESCRIPTION .....	1-39
		A32 Digitizer Functional Block Diagram .....	1-40
		34A5A32 PC Board Assembly Component	
		Locator Diagram .....	FP-43
		34A5A33 MONITOR CONTROL DESCRIPTION .....	1-11
		A33 Monitor Control Functional Block Diagram .....	1-12
		34A5A33 PC Board Assembly Component	
		Locator Diagram .....	FP-44

# INDEX

34A5A34 TDMA External I/O FIRMWARE		34A5A37 AUXILIARY POWER SUPPLY DESCRIPTION .....	1-51
ASSEMBLY DESCRIPTION .....	1-71	A37 Auxiliary Power Supply Functional Block Diagram .....	1-53
A34 TDMA External I/O Firmware Assembly		34A5A37 Auxiliary Power Supply Assembly Component Locator	
Block Diagram .....	1-72	and Schematic Diagram .....	FP-48
34A5A34 PC Board Assembly Component			
Locator Diagram .....	FP-45		
34A5A35 EXTERNAL I/O DESCRIPTION .....	1-55	34A5A40 3rd LO DESCRIPTION .....	1-29
A35 External I/O Functional Block Diagram .....	1-56	A40 3rd LO Functional Block Diagram .....	1-30
34A5A35 PC Board Assembly Component		34A5A40 Assemblies Component Locator	
Locator Diagram .....	FP-45	Diagrams .....	FP-23
34A5A36 ATTENUATOR DESCRIPTION .....	1-47	34A5A41 90 MHz GENERATOR DESCRIPTION .....	1-41
A36 Attenuator Functional Block Diagram .....	1-48	A41 90 MHz Generator Functional	
34A5A36 Attenuator Assembly Component		Block Diagram .....	1-42
Locator Diagram .....	FP-46	34A5A41 Assembly Component Locator	
		Diagram .....	FP-25

## INDEX

<b>A</b>	
<b>ADJUSTMENTS</b>	
Power Supply Adjustment.....	3-40
Metering DVM Adjustment.....	3-41
Function Generator Level and VRMS Meter Adjustment.....	3-41
Gen Output Level Adjustment.....	3-43
RF Null Adjustment.....	3-44
Signal Meter Adjustment.....	3-44
Fm Adjustment.....	3-45
Modulation Meter Adjustment.....	3-48
Phase Meter Adjustment.....	3-48
Distortion Meter Adjustment.....	3-50
SINAD Meter Adjustment.....	3-51
Gen Modulation Adjustment.....	3-52
Scope Adjustment.....	3-55
Spectrum Analyzer Adjustment.....	3-56
Power Meter Adjustment.....	3-58
<b>B</b>	
Beep Sequence Test.....	2-25
<b>D</b>	
Detailed Functional Description.....	1-2
DMM Test.....	2-44
<b>E</b>	
Equipment Characteristics, Capabilities, And Features.....	1-1
Equipment Data.....	1-1
Equipment Inspection.....	2-4
<b>F</b>	
Frequency Agility Test.....	2-68
<b>G</b>	
General Functional Description.....	1-1
<b>L</b>	
LCD abnormality test.....	2-27

<b>P</b>	
Performance Test.....	2-47
Power Faults Test.....	2-22
Preliminary Servicing And Adjustment Of Equipment.....	2-2
<b>R</b>	
<b>REPLACEMENTS</b>	
Replace 34A3 Top Case.....	3-3
Replace 34A2 Bottom Case.....	3-4
Replace 34A5A32 Digitizer.....	3-5
Replace 34A5A30 Counter.....	3-6
Replace 34A5A7 Analyzer Log/If.....	3-7
Replace 34A5A8 Analyzer Rf.....	3-8
Replace 34A5A40 3rd Lo.....	3-9
Replace 34A5A41 90 Mhz Generator.....	3-10
Replace 34A5A9 Receiver.....	3-11
Replace 34A5A6 Monitor.....	3-12
Replace 34A5A33 Monitor Control.....	3-13
Replace 34A5A31 Function Generator.....	3-14
Replace 34A5A29 Rf I/O.....	3-15
Replace 34A5A27 Flash Memory (Instrument).....	3-16
Replace 34A5A26 Processor.....	3-17
Replace 34A5A28 Video Controller.....	3-18
Replace 34A5A35 External I/O.....	3-19
Replace 34A5A22 Power Supply.....	3-20
Replace 34A5A23 Front Panel.....	3-22
Replace 34A5A38 Rear Panel Connector.....	3-23
Replace 34A5A5 Rear Panel.....	3-24
Replace 34A5A11 Dmm.....	3-25
Replace 34A5A15 2nd Lo.....	3-26
Replace 34A5A13 1st Lo.....	3-27
Replace 34A5A37 Auxiliary Power Supply.....	3-28
Replace 34A5A16 Rf Receive If.....	3-29
Replace 34A5A20 Generator If.....	3-30
Replace 34A5A36 Attenuator.....	3-31
Replace 34A5A21 Power Termination.....	3-32
Replace 34A5A39 Master Oscillator.....	3-33
<b>S</b>	
Safety, Care And Handling.....	1-1
Self Test Failure Test.....	2-30
Service Upon Receipt Of Material.....	2-2
<b>T</b>	
Troubleshooting Guidelines.....	2-4
Troubleshooting Symptom Index.....	2-3
Troubleshooting Table.....	2-5
<b>U</b>	
Upload Interface Software Procedure.....	3-35