

TECHNICAL MANUAL
CALIBRATION PROCEDURE
FOR
AM/FM SIGNAL GENERATOR
2023B

(AEROFLEX)

This publication replaces T.O. 33K3-4-3560-1 dated 30 January 2008.



Distribution Statement C - Distribution authorized to U. S. Government agencies and their contractors for official use or for administrative or operational purposes only, 30 July 2007. Requests for this document shall be referred to AFMETCAL, 813 Irving-Wick Dr W, Heath, OH 43056-1199.

Destruction Notice - For unclassified, limited documents, destroy by any method that will prevent disclosure of the contents or reconstruction of the document.

T.O. 33K3-4-3560-1

LIST OF EFFECTIVE PAGES

INSERT LATEST CHANGED PAGES. DESTROY SUPERSEDED PAGES.

NOTE: The portion of the text and illustrations affected by the changes is indicated by a vertical line in the outer margins of the page.

Date of issue for original and changed pages are:

Original.....030 August 2015

TOTAL NUMBER OF PAGES IN THIS PUBLICATION IS 38, CONSISTING OF THE FOLLOWING:

| Page No. | * Change No. | Page No. | * Change No. | Page No. | * Change No. |
|-----------------|--------------|----------|--------------|----------|--------------|
| Title | 0 | | | | |
| A | 0 | | | | |
| 1 - 33 | 0 | | | | |
| 34 Blank | 0 | | | | |
| A-1 | 0 | | | | |
| A-2 Blank | 0 | | | | |

*Zero in this column indicates an original page

AM/FM SIGNAL GENERATOR

2023B

(AEROFLEX)

1 CALIBRATION DESCRIPTION:*Table 1.*

| Test Instrument (TI) Characteristics | Performance Specifications | Test Method |
|---|---|--|
| Frequency Accuracy | Reference Oscillator Range: (STD) 10 MHz Accuracy: (TCXO) Accuracy: $\pm 1 \times 10^{-6}$; * ¹ Aging/year: $< \pm 1 \times 10^{-6}$; Temperature: $< \pm 7 \times 10^{-7}$ (0 to 55 °C) * ² Range: (2023B OPT 4) 10 MHz Accuracy: (OCXO) Accuracy: $\pm 2.5 \times 10^{-7}$; * ¹ Aging/year: $< \pm 2.5 \times 10^{-7}$; Aging/day: $< \pm 5 \times 10^{-9}$ after 2 months continuous use; Temperature: $< \pm 5 \times 10^{-8}$ (0 to 50 °C) * ² | Compared to a Frequency Standard |
| Display | Range: (2023B) 9 kHz to 2.05 GHz; (2025 OPT 11) 9 kHz to 2.51 GHz Accuracy: ± 1 count of LSD | Compared to an Universal Counter |
| RF Output | Range: (2023B and 2023B OPT 7) * ³ , * ⁴ 9 kHz to 2.05 GHz, -140 to +13 dBm Accuracy: * ⁵ 9 kHz to 1.2 GHz, > -127 to +13 dBm, ± 0.8 dB; 1.2 to 2.05 GHz, > -127 to ≤ -100 dBm, ± 1.4 dB; > -100 to +13 dBm, ± 1.2 dB | Measured with a Digital Multimeter, Power Meter, Power Sensor and Microwave Measurement System |

 See footnotes at end of Table.

Table 1. (Cont.)

| Test Instrument (TI) Characteristics | Performance Specifications | Test Method |
|---|---|---|
| RF Output (<i>Cont.</i>) | <p>Range: (2023B OPT 3 and 2023B OPT 11) 9 kHz to 2.05 GHz, -140 to +25 dBm *⁴</p> <p>Accuracy: *⁵, *⁶, *⁷, *⁸ 9 kHz to 1.2 GHz, >-127 to ≤+7 dBm, ±0.8 dB; >+7 to <+23 dBm, ±1 dB; ≥+23 to <+25 dBm, ±1.5 dB; 1.2 to 2.05 GHz, >-127 to ≤-100 dBm, ±1.4 dB; >-100 to ≤+7 dBm, ±1.2 dB; >+7 dBm to ≤+19 dBm, ±2 dB</p> <p>Range: (2025 OPT 11) *⁴ 9 kHz to 2.51 GHz, -140 to +25 dBm</p> <p>Accuracy: *⁵, *⁶, *⁸, *¹⁰ 9 kHz to 1.2 GHz, >-127 to ≤+7 dBm, ±0.8 dB; >+7 to <+23 dBm, ±1 dB; ≥+23 to <+25 dBm, ±1.5 dB; 1.2 to 2.05 GHz, >-127 to ≤-100 dBm, ±1.4 dB; >-100 to ≤+7 dBm, ±1.2 dB; >+7 dBm to ≤+19 dBm, ±2 dB; 2.05 to 2.51 GHz, >-127 to ≤+7 dBm, ±1.6 dB; 2.05 to 2.4 GHz, >+7 dBm to ≤+19 dBm, ±2 dB; 2.4 to 2.51 GHz, >+7 dBm to ≤+14 dBm, ±2 dB</p> | <p>Measured with a Digital Multimeter, Power Meter, Power Sensor and Microwave Measurement System</p> |
| Nonharmonics | <p>Range: 9 kHz to 2.05 GHz, ≤+7 dBm</p> <p>Accuracy: (Offsets >3 kHz) <-70 dBc, 9 kHz to 1 GHz; <-64 dBc, 1 to 2.05 GHz</p> <p>Range: (2025 OPT 11) 9 kHz to 2.51 GHz, ≤+7 dBm</p> <p>Accuracy: (Offsets >3 kHz) <-70 dBc, 9 kHz to 1 GHz; <-64 dBc, 1 to 2.05 GHz; <-60 dBc, 2.05 to 2.51 GHz</p> | <p>Measured with a Phase Noise Measurement System</p> |

See footnotes at end of Table.

Table 1. (Cont.)

| Test Instrument (TI) Characteristics | Performance Specifications | Test Method |
|---|--|---------------------------------------|
| Single Sideband Phase Noise | Range: (2023B) 9 kHz to 2.05 GHz, $\leq +7$ dBm; (2025 OPT 11) 9 kHz to 2.51 GHz, $\leq +7$ dBm Accuracy: <-124 dBc/Hz at 20 kHz offset from a 470 MHz carrier | |
| Residual FM | Range: (2023B) 9 kHz to 2.05 GHz, $\leq +7$ dBm; (2025 OPT 11) 9 kHz to 2.51 GHz, $\leq +7$ dBm Accuracy: <4.5 Hz rms in a 300 Hz to 3.4 kHz unweighted bandwidth at 1 GHz | |
| Amplitude Modulation | | |
| Depth | Range: <500 MHz, 0 to 99.9% Accuracy: (1 kHz rate) $\pm 5.0\%$ of set depth | Measured with a Measuring Receiver |
| Distortion | Range: <500 MHz, 0 to 99.9% Accuracy: (1 kHz rate) <1.5% THD for modulation depths up to 30% AM; <2.5% THD for modulation depths up to 80% AM | Measured with an Audio Analyzer |
| Frequency Modulation | | |
| Deviation | Range: <u>Carrier (Hz)</u> <u>Max Deviation (kHz)</u> 9 k to 18.75 M 100 18.75 to 37.5 M 200 37.5 to 75 M 400 75 to 150 M 800 150 to 300 M 1600 300 to 600 M 3200 600 M to 1.2 G 6400 1.2 to 2.05 G 12800 2.05 to 2.51 G 12800 (2025 OPT 11) | Measured with a Measuring Receiver |
| | Accuracy: (1 kHz rate) * ⁹ $\pm 4\%$ of set deviation | |

See footnotes at end of Table.

Table 1. (Cont.)

| Test Instrument (TI) Characteristics | Performance Specifications | Test Method |
|---|---|---------------------------------------|
| Frequency Modulation (<i>Cont.</i>) | | |
| Distortion | Range: <u>Carrier (Hz)</u> <u>Max Deviation (kHz)</u> 9 k to 18.75 M 100 18.75 to 37.5 M 200 37.5 to 75 M 400 75 to 150 M 800 150 to 300 M 1600 300 to 600 M 3200 600 M to 1.2 G 6400 1.2 to 2.05 G 12800 2.05 to 2.51 G 12800 (2025 OPT 11) Accuracy: * ⁹ (1 kHz rate, up to 20% of Max Deviation) <1% THD | Measured with an Audio Analyzer |
| Phase Modulation | | |
| Deviation | Range: (2023B) 9 kHz to 2.05 GHz; (2025 OPT 11) 9 kHz to 2.51 GHz, 0 to 10 rad Accuracy: (1 kHz rate) ±4% of set deviation excluding residual phase modulation | Measured with a Measuring Receiver |
| Distortion | Range: (2023B) 9 kHz to 2.05 GHz; (2025 OPT 11) 9 kHz to 2.51 GHz, 0 to 10 rad Accuracy: (1 kHz rate, at 10 rad) <3% THD | Measured with an Audio Analyzer |

See footnotes at end of Table.

Table 1. (Cont.)

| Test Instrument (TI) Characteristics | Performance Specifications | Test Method |
|---|--|--------------------------------------|
| Pulse Modulation | | |
| On/Off Ratio | Range: (2023B) * ³ 32 MHz to 2.05 GHz | Measured with a Spectrum Analyzer |
| | Accuracy: <1.2 GHz, >45 dB; >1.2 GHz, >40 dB | |
| | Range: (2023B OPT 7 and 2023B OPT 11) * ³ , * ⁷ , * ⁸ 100 kHz to 2.05 GHz | |
| | Accuracy: <1.2 GHz, >80 dBc; ≥1.2 to 2.05 GHz, >70 dBc | |
| | Range: (2025 OPT 11) * ³ , * ⁸ 100 kHz to 2.51 GHz | |
| | Accuracy: <1.2 GHz, >80 dBc; ≥1.2 to 2.05 GHz, >70 dBc; >2.05 to 2.51 GHz, >65 dBc | |
| Rise Time and Fall Time | Range: (2023B) * ³ 32 MHz to 2.05 GHz | Measured with an Oscilloscope |
| | Accuracy: <10 μs | |
| | Range: (2023B OPT 7 and 2023B OPT 11) * ³ , * ⁷ , * ⁸ 100 kHz to 2.05 GHz | |
| | Accuracy: <20 ns | |
| | Range: (2025 OPT 11) * ³ , * ⁸ 100 kHz to 2.51 GHz | |
| | Accuracy: <20 ns | |

See footnotes at end of Table.

Table 1. (Cont.)

| Test Instrument (TI) Characteristics | Performance Specifications | Test Method |
|---|--|---|
| Internal LF Generator | | |
| Frequency | Range: 0.01 Hz to 20 kHz, Sinewave; 0.01 Hz to 3 kHz, Trianglewave and Squarewave Accuracy: Same as Reference Oscillator | Implicitly verified during Reference Oscillator Calibration |
| Distortion | Range: 0.01 Hz to 20 kHz Accuracy: (At 1 kHz) <0.1% THD | Measured with an Audio Analyzer |

- *¹ The accuracy is the manufacturers calculated specification after one year. The accuracy specification is found by multiplying the longest term aging rate by the appropriate time interval to obtain one year.
- *² Typical or operational specification, not calibrated.
- *³ Maximum guaranteed RF Output is +8 dBm when Pulse Modulation is selected (+20 dBm or +14 dBm with high power option).
- *⁴ When AM is selected, the Maximum RF Output decreases linearly with increasing AM depth to +7 dBm at 99.9% depth.
- *⁵ When Pulse Modulation is enabled, add ±0.5 dB to the RF Output Accuracy.
- *⁶ Output power above +19 dBm is not a warranted specification for carrier frequencies above 1.2 GHz.
- *⁷ For 2023B OPT 3 only, Maximum RF Output is reduced by 5 dB when Pulse Modulation is selected and up to 6 dB dependent upon set AM depth.
- *⁸ For 2023B OPT 11 and 2025 OPT 11 only, Maximum RF Output is reduced by 3 dB when Pulse Modulation is selected.
- *⁹ See step 3.7.
- *¹⁰ Output power above +14 dBm is not a warranted specification for carrier frequencies above 2.4 GHz.

2 EQUIPMENT REQUIREMENTS:

| Noun | Minimum Use Specifications | Calibration Equipment | Sub-Item |
|------------------------|---|------------------------------|-----------------|
| 2.1 FREQUENCY STANDARD | Range: 10 MHz Accuracy: <6.25 X 10 ⁻⁸ | Arbiter 1083B | |

| Noun | Minimum Use Specifications | Calibration Equipment | Sub-Item |
|-----------------------------|--|----------------------------------|----------|
| 2.2 UNIVERSAL COUNTER | Range: 9.9 MHz to 2 GHz Accuracy: ± 1 count of LSD | Agilent 53132A OPT 124 | |
| 2.3 DIGITAL MULTIMETER | Range: 0.2 to 4.3 V rms, 9 to 99 kHz Accuracy: $\pm 2.2\%$ of ind | Hewlett-Packard 3458A | |
| 2.4 POWER METER | Range: -0.8 to +15 dBm Accuracy: * ¹ | Agilent E4418B | |
| 2.5 POWER SENSOR | Range: 100 kHz to 2.51 GHz Accuracy: (% of charted value) * ² $\pm 2.5\%$, 100 to 200 kHz; $\pm 2.4\%$, 200 to 300 kHz; $\pm 2.1\%$, 300 kHz to 1 MHz; $\pm 2.0\%$, 1 to 10 MHz; $\pm 2.7\%$, 10 to 50 MHz; $\pm 2.5\%$, 50 MHz to 2 GHz; $\pm 2.6\%$, 2 to 2.51 GHz | Hewlett-Packard 8482A | |
| 2.6 ATTENUATOR | Range: 10 dB, 10.1 MHz to 2.51 GHz Accuracy: Chorted * ³ | Hewlett-Packard 8491A OPT 010 | |
| 2.7 FEEDTHROUGH TERMINATION | Range: 50 Ω , 9 kHz to 10 MHz Accuracy: (At DC) $\pm 0.2\%$ of nominal | Hewlett-Packard 11048C | |
| 2.8 FEEDTHROUGH TERMINATION | Range: 600 Ω , 20 Hz to 20 kHz Accuracy: N/A | Hewlett-Packard 11095A | |
| 2.9 SPECTRUM ANALYZER | Range: 9 kHz to 8.2 GHz, 0 to 80 dB Accuracy: (Scale Fidelity) ± 1.6 dB | Hewlett-Packard 8563E | |

See footnotes at end of Equipment Requirements

| Noun | Minimum Use Specifications | Calibration Equipment | Sub-Item |
|-----------------------------------|---|---------------------------|----------|
| 2.10 MICROWAVE MEASUREMENT SYSTEM | <p>Range: (Tuned RF Level) -120 to 0 dB, 10.1 MHz to 2.51 GHz</p> <p>Accuracy: *² -80 to 0 dB, $\pm(0.02$ dB + 0.01 dB/10 dB + 1 digit); -110 to -80 dB, $\pm(0.02$ dB + 0.02 dB/10 dB + 1 digit); -110 to -120 dB, $\pm(0.02$ dB + 0.05 dB/10 dB + 1 digit)</p> <p>Range: (Amplitude Modulation) 10.1 MHz to 450 MHz, 23 to 95%, 1 kHz rate</p> <p>Accuracy: $\pm 1.25\%$ of indication</p> <p>Range: (Frequency Modulation) 10.1 MHz to 2.51 GHz, 9 to 396 kHz, 1 kHz rate</p> <p>Accuracy: $\pm 1\%$ of indication</p> <p>Range: (Phase Modulation) 10.1 MHz to 2.51 GHz, 0.9 to 10.4 rad, 1 kHz rate</p> <p>Accuracy: $\pm 2.75\%$ of ind</p> <p>TAR 1.5:1</p> | Hewlett-Packard 8902MS | |
| 2.11 AUDIO ANALYZER | <p>Range: 1 kHz, 0 to 100% THD</p> <p>Accuracy: ± 2 dB</p> | Hewlett-Packard 8903B | |
| 2.12 OSCILLOSCOPE | <p>Range: DC to 70 MHz</p> <p>Accuracy: <5 ns Rise Time and Fall Time</p> | Tektronix TDS5104B-AF | |

See footnotes at end of Equipment Requirements

| Noun | Minimum Use Specifications | Calibration Equipment | Sub-Item |
|-------------------------------------|---|--------------------------|----------|
| 2.13 PHASE NOISE MEASUREMENT SYSTEM | Range: 470 MHz to 1 GHz Accuracy: (Phase Noise) ±2 dB, 20 kHz offset; (Residual FM) ±2 dB TAR (worst case, Residual FM) 3.9:1 | Agilent E5504B | |
| 2.14 SYNTHESIZED FUNCTION GENERATOR | Range: 10 kHz Squarewave, 0 to 5 Vp; 0 to +5 VDC Accuracy: N/A | Hewlett-Packard 3325B | |
| 2.15 CRYSTAL DETECTOR | Range: 1 GHz Accuracy: N/A | Hewlett-Packard 8470B | |
| 2.16 BNC SHORT | Range: N/A Accuracy: N/A | As Available | |

*¹ Power Meter Accuracy is included in Power Sensor Accuracy.

*² The TAR is the RSS (Root Sum Square) result of the Power Sensor and Microwave Measurement System accuracies. The worst case TAR for TI RF Output for levels <0 dBm is 3.1:1.

*³ See step 3.6.

3 PRELIMINARY OPERATIONS:

3.1 Review and become familiar with the entire procedure before beginning the Calibration Process.



Unless otherwise designated, and prior to beginning the Calibration Process, ensure that all test equipment voltage and/or current outputs are set to zero (0) or turned off, where applicable. Ensure that all equipment switches are set to the proper position before making connections or applying power. If not strictly observed, could result in injury to, or death of, personnel or long term health hazards.

3.2 Connect test equipment to appropriate power source. Set all POWER switches to ON and allow warm-up as required by the manufacturer.

3.3 Connect TI to appropriate power source. Set the TI SUPPLY to On and allow a 30 minutes warm-up period except as noted below:

NOTE

The TI must have a 24 hour warm-up if it has been disconnected from the power source for less than 24 hours. If TI has been disconnected from the power source for 24 hours or more, the TI technically should be warmed up for 60 days. This may not be practical. Experience has shown that about 85% of new units and 95% of older units will be within specifications after a 24 hour warm-up. If TI fails the Frequency Accuracy and Display Calibration, the TI may be checked at 24 hour intervals up to the manufacturers stated warm-up time. If the TI passes the Frequency Accuracy and Display Calibration at any of these intermediate warm-up times, commence with the calibration. If the TI fails all intermediate intervals and after the manufacturers stated warm-up time, then perform the applicable maintenance actions for failure.

3.4 The following options are included in the procedure:

2023B

OPT 3 - High Power option.

OPT 4 - High Stability Oscillator option.

OPT 5 - Rear panel connectors. RF output, modulation input and LF out connectors are transferred to the rear panel. The TI specifications are unaltered.

OPT 7 -Fast Pulse Modulation option.

OPT 11 - Fast Pulse Modulation and High Power option.

2025

OPT 11 - Fast Pulse Modulation and High Power option.

3.5 Throughout the Calibration Process, the TI hardkeys will be in bold and upper case.

3.6 For TIs 2023B OPT 3 and 2023B OPT 11 only, chart the Attenuator at 10.1 and 500.1 MHz, 1.19, 1.21, 1.5 and 2.04 GHz (and 2025 OPT 11 only 2.06, 2.39, 2.41 and 2.51 GHz) with the Microwave Measurement System using T.O. 33K4-4-25-1 as a guide. Ensure that T.O. 33K4-4-25-1 still meets the requirement.

3.7 Due to the lack of standards, TI FM Deviation and Distortion is not calibrated above 380 kHz. Annotate and attach a Limited Certification Label accordingly.

3.8 Perform only those portions of the Calibration Process that pertain to the TI being calibrated.

4 CALIBRATION PROCESS:

NOTE

Unless otherwise specified, verify the results of each test and take corrective action whenever the test requirement is not met, before proceeding.

4.1 FREQUENCY ACCURACY AND DISPLAY CALIBRATION:

NOTE

Adjustment of the Time Base Oscillator is normal due to the Aging Rate of the crystal. This is common to all Quartz Oscillators. The adjustment actions taken during this calibration will ensure the greatest reliability of the TI by adjusting the time base reference frequency to the nominal value each time it is calibrated.

4.1.1 Connect Frequency Standard 10 MHz REF OUT to the Universal Counter Ref In. Set the Universal Counter for an external reference.

4.1.2 Connect TI FREQ STD IN-OUT (rear panel) to the Universal Counter CHANNEL 1 input. Set Universal Counter for a frequency measurement, resolution to 0.1 Hz and input impedance to 50 Ω .

4.1.3 Press TI **MENU** key and using the **NEXT** key select *Frequency/Sweep* then press **SELECT** key. Using the **NEXT** key, select *Frequency Standard* then press **SELECT** key. Press the **4** key then the **ENTER** key to select the *Internal 10MHz out*.

NOTE

The values in the following step are derived from multiplication of the Aging Rate to determine the offset at one year. Use these calculated twelve month values regardless of the length of the calibration interval for this TI in T.O. 33K-1-100-1/2.

4.1.4 Verify the Universal Counter indication is 9 999 990.0 to 10 000 010.0 Hz (9 999 997.5 to 10 000 002.5 Hz for TIs with OPT 4).

4.1.5 Disconnect test setup.

4.1.6 Connect equipment as shown in Figure 1. Set the Universal Counter resolution to 1 Hz.

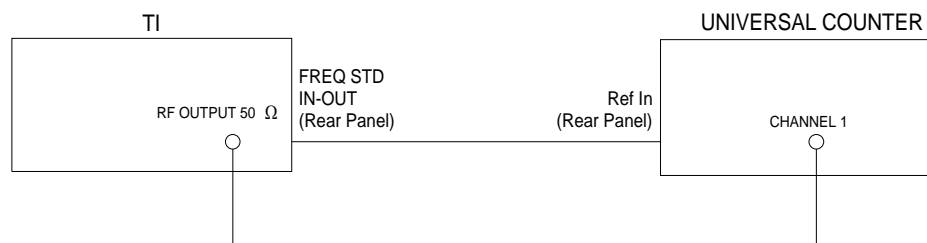

Figure 1.

4.1.7 Press the TI **RF LEVEL** key and using the numeric key pad set to 0.0 dBm.

4.1.8 Press TI **CARR FREQ** key and using the numeric key pad set to the first value listed in the Applied column of Table 2.

4.1.9 Verify the Universal Counter indication is within the values listed in the Limits column of Table 2.

4.1.10 Repeat steps 4.1.8 and 4.1.9 for the remaining corresponding values listed in Table 2.

Table 2.

| Applied (Hz) | Limits (Hz) |
|---------------------|----------------------------------|
| 111.111 111 M | 111.111 110 to 111.111 112 M |
| 222.222 222 M | 222.222 221 to 222.222 223 M |
| 333.333 333 M * | 333.333 332 to 333.333 334 M |
| 444.444 444 M | 444.444 443 to 444.444 445 M |
| 555.555 555 M | 555.555 554 to 555.555 556 M |
| 666.666 666 M | 666.666 665 to 666.666 667 M |
| 777.777 777 M | 777.777 776 to 777.777 778 M |
| 888.888 888 M | 888.888 887 to 888.888 889 M |
| 999.999 999 M | 999.999 998 M to 1.000 000 000 G |
| 1.000 000 000 G | 999.999 999 M to 1.000 000 001 G |
| 2.000 000 000 G | 1.999 999 999 to 2.000 000 001 G |

* Connect the TI RF OUTPUT 50 Ω to the Universal Counter CHANNEL 3 input.

4.1.11 Press the TI **CARR ON/OFF** key to set output level to OFF and disconnect test setup.

4.1.12 To ensure reliability of the TI, the following action will be taken: If TI passed the above steps, perform the applicable adjustment steps in Appendix A, and enter the applicable code into the Maintenance Data Collection System. If TI failed, perform the applicable steps listed in Appendix A and enter the applicable code into the Maintenance Data Collection System.

4.2 RF OUTPUT CALIBRATION:

4.2.1 Press the TI **RCL** key and using the numeric key pad enter **9, 9, 9** then press **ENTER** key.

4.2.2 Connect the TI RF OUTPUT 50 Ω through the Feedthrough Termination (2.7) to the Digital Multimeter input.

4.2.3 Set the Digital Multimeter as required for a VAC measurement.

4.2.4 Press the TI **CARR FREQ** key and using the numeric key pad set to the first value listed in the Applied Frequency column of Table 3 (Table 4 for TIs with OPT 3 or OPT 11).

4.2.5 Press the TI **RF LEVEL** key and using the numeric key pad set to the first value listed in the Applied Level column of Table 3 (Table 4 for TIs with OPT 3 or OPT 11).

4.2.6 Verify the Digital Multimeter indicates within the corresponding values listed in the Limits column of Table 3 (Table 4 for TIs with OPT 3 or OPT 11).

4.2.7 Repeat steps 4.2.4 through 4.2.6, as required, for the remaining corresponding values listed in Table 3 (Table 4 for TIs with OPT 3 or OPT 11).

Table 3.

| Frequency (Hz) | Applied Level (dBm) | Limits (V rms) |
|-----------------------|----------------------------|-----------------------|
| 9 k | +13 | 0.910930 to 1.095179 |
| | +10 | 0.644889 to 0.775327 |
| | +5 | 0.362648 to 0.435999 |
| | 0 | 0.203932 to 0.245180 |
| 50 k | +13 | 0.910930 to 1.095179 |
| | +10 | 0.644889 to 0.775327 |
| | +5 | 0.362648 to 0.435999 |
| | 0 | 0.203932 to 0.245180 |
| 99 k | +13 | 0.910930 to 1.095179 |
| | +10 | 0.644889 to 0.775327 |
| | +5 | 0.362648 to 0.435999 |
| | 0 | 0.203932 to 0.245180 |

Table 4.

| Frequency (Hz) | Applied Level (dBm) | Limits (V rms) |
|-----------------------|----------------------------|-----------------------|
| 9 k | +24 | 2.981845 to 4.211967 |
| | +20 | 1.992898 to 2.508910 |
| | +15 | 1.120689 to 1.410864 |
| | +10 | 0.630210 to 0.793387 |

Table 4. Cont.)

| Frequency (Hz) | Applied Level (dBm) | Limits (V rms) |
|----------------|---------------------|----------------------|
| 9 k | +5 | 0.362648 to 0.435999 |
| | 0 | 0.203932 to 0.245180 |
| 50 k | +24 | 2.981845 to 4.211967 |
| | +20 | 1.992898 to 2.508910 |
| | +15 | 1.120689 to 1.410864 |
| | +10 | 0.630210 to 0.793387 |
| | +5 | 0.362648 to 0.435999 |
| | 0 | 0.203932 to 0.245180 |
| 99 k | +24 | 2.981845 to 4.211967 |
| | +20 | 1.992898 to 2.508910 |
| | +15 | 1.120689 to 1.410864 |
| | +10 | 0.630210 to 0.793387 |
| | +5 | 0.362648 to 0.435999 |
| | 0 | 0.203932 to 0.245180 |

4.2.8 Press the TI **CARR ON/OFF** to set output level to OFF and disconnect test setup.

4.2.9 Standardize Power Meter and Power Sensor. Set the Power Meter for a Power measurement in the dBm mode.

4.2.10 Connect Power Sensor to the TI RF OUTPUT 50 Ω connector.

4.2.11 For TIs with OPT 3 or OPT 11 only, connect the Attenuator between the TI RF OUTPUT 50 Ω and the Power Sensor for output power levels of >+15 dBm.

4.2.12 Press the TI **CARR FREQ** key and using the numeric key pad set to the first value listed in the Applied Frequency column of Table 5 (Table 6 for TIs with OPT 3 or OPT 11).

4.2.13 Press the TI **RF LEVEL** key and using the numeric key pad set to the first value listed in the Applied Level column of Table 5 (Table 6 for TIs with OPT 3 or OPT 11). Press the TI **CARR ON/OFF** key to set output level to ON.

4.2.14 Verify the Power Meter indicates within the corresponding values listed in the Limits column of Table 5 (Table 6 for TIs with OPT 3 or OPT 11). For TIs with OPT 3 or 11, take into account the charted value of the Attenuator for output power levels >+15 dBm.

4.2.15 Repeat steps 4.2.11 through 4.2.14, as required, for the remaining corresponding values listed in Table 5 (Table 6 for TIs with OPT 3 or OPT 11). Record the Power Meter indication at 10.1 and 500.1 MHz, 1.19, 1.21, 1.5 and 2.04 GHz at 0 dBm.

Table 5.

| Frequency (Hz) | Applied Level (dBm) | Limits (dBm) |
|-----------------------|----------------------------|---------------------|
| 10.1 M | +13 | +12.2 to +13.8 |
| | +10 | +9.2 to +10.8 |
| | +5 | +4.2 to +5.8 |
| | 0 * ¹ | -0.8 to +0.8 |
| 500.1 M | +13 | +12.2 to +13.8 |
| | +10 | +9.2 to +10.8 |
| | +5 | +4.2 to +5.8 |
| | 0 * ¹ | -0.8 to +0.8 |
| 1.19 G | +13 | +12.2 to +13.8 |
| | +10 | +9.2 to +10.8 |
| | +5 | +4.2 to +5.8 |
| | 0 * ¹ | -0.8 to +0.8 |
| 1.21 G | +13 | +11.8 to +14.2 |
| | +10 | +8.8 to +11.2 |
| | +5 | +3.8 to +6.2 |
| | 0 * ¹ | -1.2 to +1.2 |
| 1.5 G | +13 | +11.8 to +14.2 |
| | +10 | +8.8 to +11.2 |
| | +5 | +3.8 to +6.2 |
| | 0 * ¹ | -1.2 to +1.2 |

See footnotes at end of table.

Table 5. (Cont.)

| Frequency (Hz) | Applied Level (dBm) | Limits (dBm) |
|-----------------------|----------------------------|---------------------|
| 2.04 G | +13 | +11.8 to +14.2 |
| | +10 | +8.8 to +11.2 |
| | +5 | +3.8 to +6.2 |
| | 0 * ¹ | -1.2 to +1.2 |

*¹ Record Power Meter indication.

Table 6.

| Frequency (Hz) | Applied Level (dBm) | Limits (dBm) |
|-----------------------|----------------------------|---------------------|
| 10.1 M | +24 | +22.5 to +25.5 |
| | +20 | +19.0 to +21.0 |
| | +15 * ² | +14.0 to +16.0 |
| | +10 | +9.0 to +11.0 |
| | +5 | +4.2 to +5.8 |
| | 0 * ¹ | -0.8 to +0.8 |
| 500.1 M | +24 | +22.5 to +25.5 |
| | +20 | +19.0 to +21.0 |
| | +15 * ² | +14.0 to +16.0 |
| | +10 | +9.0 to +11.0 |
| | +5 | +4.2 to +5.8 |
| | 0 * ¹ | -0.8 to +0.8 |
| 1.19 G | +24 | +22.5 to +25.5 |
| | +20 | +19.0 to +21.0 |
| | +15 * ² | +14.0 to +16.0 |

See footnotes at end of table.

Table 6. (Cont.)

| Frequency (Hz) | Applied Level (dBm) | Limits (dBm) |
|-----------------------|----------------------------|---------------------|
| 1.19 G | +10 | +9.0 to +11.0 |
| | +5 | +4.2 to +5.8 |
| | 0 * ¹ | -0.8 to +0.8 |
| 1.21 G | +19 | +17.0 to +21.0 |
| | +15 * ² | +13.0 to +17.0 |
| | +10 | +8.0 to +12.0 |
| | +5 | +3.8 to +6.2 |
| | 0 * ¹ | -1.2 to +1.2 |
| 1.5 G | +19 | +17.0 to +21.0 |
| | +15 * ² | +13.0 to +17.0 |
| | +10 | +8.0 to +12.0 |
| | +5 | +3.8 to +6.2 |
| | 0 * ¹ | -1.2 to +1.2 |
| 2.04 G | +19 | +17.0 to +21.0 |
| | +15 * ² | +13.0 to +17.0 |
| | +10 | +8.0 to +12.0 |
| | +5 | +3.8 to +6.2 |
| | 0 * ¹ | -1.2 to +1.2 |
| 2.06 G * ³ | +19 | +17.0 to +21.0 |
| | +15 * ² | +13.0 to +17.0 |
| | +10 | +8.0 to +12.0 |
| | +5 | +3.4 to +6.6 |
| | 0 * ¹ | -1.6 to +1.6 |

See footnotes at end of table.

Table 6. (Cont.)

| Frequency (Hz) | Applied Level (dBm) | Limits (dBm) |
|-----------------------|---------------------|----------------|
| 2.39 G * ³ | +19 | +17.0 to +21.0 |
| | +15 * ² | +13.0 to +17.0 |
| | +10 | +8.0 to +12.0 |
| | +5 | +3.4 to +6.6 |
| | 0 * ¹ | -1.6 to +1.6 |
| 2.41 G * ³ | +14 * ² | +12.0 to +16.0 |
| | +10 | +8.0 to +12.0 |
| | +5 | +3.4 to +6.6 |
| | 0 * ¹ | -1.6 to +1.6 |
| 2.51 G * ³ | +14 * ² | +12.0 to +16.0 |
| | +10 | +8.0 to +12.0 |
| | +5 | +3.4 to +6.6 |
| | 0 * ¹ | -1.6 to 1.6 |

*¹ Record Power Meter indication.

*² Press the TI **CARR ON/OFF** key to set output level to OFF and remove the Attenuator from the test setup. Press the **CARR ON/OFF** key to set output level to ON.

*³ For 2025 OPT 11 Only.

4.2.16 Press the TI **CARR ON/OFF** key to set output level to OFF and disconnect test setup.

4.2.17 Connect equipment as shown in Figure 2.

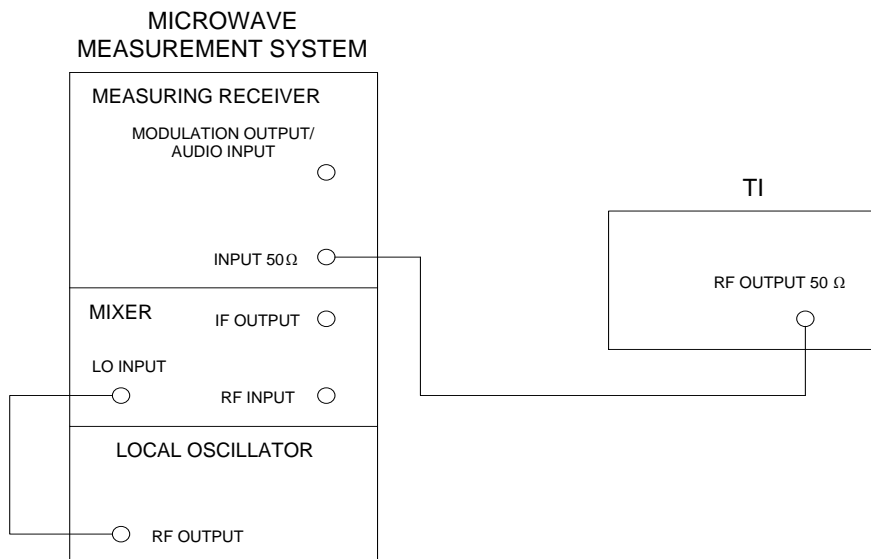

Figure 2.

4.2.18 Press the TI **CARR FREQ** key and using the numeric key pad set to 10.1 MHz.

4.2.19 Press the TI **RF LEVEL** key and using the numeric key pad set to the first value listed in the Applied column of Table 7. Press the TI **CARR ON/OFF** key to set output level to ON.

4.2.20 Press the Measuring Receiver (p/o Microwave Measurement System) Blue (Shift) key and INSTR PRESET.

4.2.21 Set the Measuring Receiver for a Tuned RF Level measurement at 10.1 MHz. Set Microwave Measurement System for a Tuned RF Level Measurement in the Frequency Offset Mode for frequencies >1.3 GHz.

4.2.22 Set a reference on the Measuring Receiver by pressing the Blue (Shift) key and SET REF. Verify the Measuring Receiver indicates 0.00 ± 0.02 dB.

4.2.23 Press the TI **RF LEVEL** key and set to the next value listed in the Applied column of Table 7 for the TI being verified.

4.2.24 Algebraically add the value recorded in step 4.2.15 to the Measuring Receiver indication.

4.2.25 Verify the result is within the corresponding values listed in the limits column of Table 7 for the TI model and frequency being verified.

4.2.26 Repeat steps 4.2.23 through 4.2.25 for the remaining values listed in Table 7.

Table 7.

| Applied (dBm) | Limits (dBm) | | |
|---------------|----------------------|------------------|------------------|
| | 10.1 MHz to 1.19 GHz | 1.21 to 2.04 GHz | 2.06 to 2.51 GHz |
| 0.0 | Reference | Reference | Reference |
| -10.0 | -10.8 to -9.2 | -11.2 to -8.8 | -11.6 to -8.4 |

Table 7. (Cont.)

| Applied (dBm) | Limits (dBm) | | |
|---------------|----------------------|------------------|------------------|
| | 10.1 MHz to 1.19 GHz | 1.21 to 2.04 GHz | 2.06 to 2.51 GHz |
| -20.0 | -20.8 to -19.2 | -21.2 to -18.8 | -21.6 to -18.4 |
| -30.0 | -30.8 to -29.2 | -31.2 to -28.8 | -31.6 to -28.4 |
| -40.0 | -40.8 to -39.2 | -41.2 to -38.8 | -41.6 to -38.4 |
| -50.0 | -50.8 to -49.2 | -51.2 to -48.8 | -51.6 to -48.4 |
| -60.0 | -60.8 to -59.2 | -61.2 to -58.8 | -61.6 to -58.4 |
| -70.0 | -70.8 to -69.2 | -71.2 to -68.8 | -71.6 to -68.4 |
| -80.0 | -80.8 to -79.2 | -81.2 to -78.8 | -81.6 to -78.4 |
| -90.0 | -90.8 to -89.2 | -91.2 to -88.8 | -91.6 to -88.4 |
| -100.0 | -100.8 to -99.2 | -101.4 to -98.6 | -101.6 to -98.4 |
| -110.0 | -110.8 to -109.2 | -111.4 to -108.6 | -111.6 to -108.4 |
| -120.0 | -120.8 to -119.2 | -121.4 to -118.6 | -121.6 to -118.4 |

4.2.27 Press the TI **CARR FREQ** key and using the numeric key pad set to 500.1 MHz.

4.2.28 Press the TI **RF LEVEL** key and using the numeric key pad set to 0.0 dBm.

4.2.29 Repeat steps 4.2.20 through 4.2.26 at 500.1 MHz.

4.2.30 Press the TI **CARR FREQ** key and using the numeric key pad set to 1.19 GHz.

4.2.31 Press the TI **RF LEVEL** key and using the numeric key pad set to 0.0 dBm.

4.2.32 Repeat steps 4.2.20 through 4.2.26 at 1.19 GHz.

4.2.33 Press the TI **CARR FREQ** key and using the numeric key pad set to 1.21 GHz.

4.2.34 Press the TI **RF LEVEL** key and using the numeric key pad set to 0.0 dBm.

4.2.35 Repeat steps 4.2.20 through 4.2.26 at 1.21 GHz.

4.2.36 Press the TI **CARR FREQ** key and using the numeric key pad set to 1.5 GHz.

4.2.37 Press the TI **RF LEVEL** key and using the numeric key pad set to 0.0 dBm.

4.2.38 Repeat steps 4.2.20 through 4.2.26 at 1.5 GHz.

4.2.39 Press the TI **CARR FREQ** key and using the numeric key pad set to 2.04 GHz.

- 4.2.40 Press the TI **RF LEVEL** key and using the numeric key pad set to 0.0 dBm.
- 4.2.41 Repeat steps 4.2.20 through 4.2.26 at 2.04 GHz.
- 4.2.42 For TI 2025 OPT 11, continue with step 4.2.43; all other models proceed to step 4.2.55.
- 4.2.43 Press the TI **CARR FREQ** key and using the numeric key pad set to 2.06 GHz.
- 4.2.44 Press the TI **RF LEVEL** key and using the numeric key pad set to 0.0 dBm.
- 4.2.45 Repeat steps 4.2.20 through 4.2.26 at 2.06 GHz.
- 4.2.46 Press the TI **CARR FREQ** key and using the numeric key pad set to 2.39 GHz.
- 4.2.47 Press the TI **RF LEVEL** key and using the numeric key pad set to 0.0 dBm.
- 4.2.48 Repeat steps 4.2.20 through 4.2.26 at 2.39 GHz.
- 4.2.49 Press the TI **CARR FREQ** key and using the numeric key pad set to 2.41 GHz.
- 4.2.50 Press the TI **RF LEVEL** key and using the numeric key pad set to 0.0 dBm.
- 4.2.51 Repeat steps 4.2.20 through 4.2.26 at 2.41 GHz.
- 4.2.52 Press the TI **CARR FREQ** key and using the numeric key pad set to 2.51 GHz.
- 4.2.53 Press the TI **RF LEVEL** key and using the numeric key pad set to 0.0 dBm.
- 4.2.54 Repeat steps 4.2.20 through 4.2.26 at 2.51 GHz.
- 4.2.55 Press the **TI CARR ON/OFF** key to set output level to OFF and disconnect test setup.

4.3 NONHARMONICS CALIBRATION:

- 4.3.1 Connect the TI RF OUTPUT 50 Ω through the Attenuator to the Spectrum Analyzer INPUT 50 Ω .
- 4.3.2 Press the TI **RCL** key and using the numeric key pad enter **9, 9, 9** then press **ENTER** key.
- 4.3.3 Press the TI **CARR FREQ** key and using the numeric key pad set to the first value listed in the Applied column of Table 8.
- 4.3.4 Press the TI **RF LEVEL** key and using the numeric key pad set to +7.0 dBm.
- 4.3.5 Set the Spectrum Analyzer controls to view the carrier. Set the Spectrum Analyzer controls to place the peak of the carrier at a convenient reference level.
- 4.3.6 Set the Spectrum Analyzer controls as required to view any Nonharmonic signal >3 kHz offset from carrier.
- 4.3.7 Verify the amplitude of any Nonharmonic signal is within the value listed in the Limits column of Table 8.
- 4.3.8 Press the TI **CARR FREQ** key and using the numeric key pad set to the next value listed in the Applied column of Table 8.
- 4.3.9 Repeat steps 4.3.5 through 4.3.7.

4.3.10 Repeat steps 4.3.8 and 4.3.9 for the remaining values listed in Table 8.

Table 8.

| Applied (Hz) | Limits (dBc) |
|---------------------|---------------------|
| 9 k | <-70 |
| 500 M | <-70 |
| 990 M | <-70 |
| 1.1 G | <-64 |
| 1.5 G | <-64 |
| 2.05 G | <-64 |
| 2.2 G * | <-60 |
| 2.51 G * | <-60 |

* For 2025 OPT 11 Only.

4.3.11 Press the **TI CARR ON/OFF** key to set output level to OFF and disconnect test setup.

4.4 SINGLE SIDEBAND PHASE NOISE AND RESIDUAL FM CALIBRATION:

CAUTION

Do not connect outputs of Phase Noise Measurement System Reference Source or TI to the Inputs of the Phase Noise Measurement System until connect diagram appears on screen. Damage to the Phase Noise Measurement System can result if Reference Source or TI output power is applied to the system before the connect diagram is shown. If not strictly observed, could result in damage to, or destruction of, equipment or loss of mission effectiveness.

4.4.1 Press the **TI RCL** key and using the numeric key pad enter **9, 9, 9** then press **ENTER** key.

4.4.2 Press the **TI CARR FREQ** key and using the numeric key pad set to 470 MHz.

4.4.3 Press the **TI RF LEVEL** key and using the numeric key pad set to +7.0 dBm. Ensure the **TI CARR ON/OFF** is set to OFF.

4.4.4 Verify the Phase Noise Measurement System is using the current Software Package CPIN 88M-E5504B/NOISE-F001-00A (Windows NT Systems), or 88M-E5504B/NOISE-F001-01A (Windows 2000 Systems), with the latest revision, as per ACPINS. The Desktop should be present on the screen when the computer is turned on.

4.4.5 Access the Phase Noise Calibration Program.

4.4.6 Select Define, then select Measurement.

4.4.7 On Phase Noise Measurement System select Preset. Select Yes. Set Offset Frequency Range Start Offset to 10 Hz and Stop Offset to 100 E+6.

4.4.8 On Phase Noise Measurement System select Sources. Select Preset. Select Yes. Set the following:

| | |
|-----------------------|-----------|
| Carrier Source | |
| Frequency | 470E+6 Hz |
| Power | 7 dBm |
| Reference Source | |
| Power | 16 dBm |
| VCO Tuning Parameters | |
| Nominal Tune Constant | 10E+3 |
| Tune Range +/- | 5 Volts |
| Input Resistance | 600 Ohms |

4.4.9 On Phase Noise Measurement System select Cal. Select Preset. Select Yes. Select VCO Tune Constant Calculate from expected VCO tune constant using tune port resistance. De-select Verify calculated phase locked loop suppression.

4.4.10 On Phase Noise Measurement System select Block Diagram. Select Preset. Select Yes. Select Downconverter None. Select VCO Tune Mode DC FM and Reference Source Agilent/HP 8664A.

4.4.11 On Phase Noise Measurement System select Test Set. Select Preset. Select Yes. Set LNA Low Pass Filter to 200 kHz and de-select Auto.

4.4.12 On Phase Noise Measurement System select Graph. Select Preset. Select Yes. Enter graph title as appropriate for the setup. Set X Scale Minimum to 10 Hz. Select Close.

4.4.13 On Phase Noise Measurement System select Measure. Select New Measurement. Select Yes when prompted to perform a new calibration and measurement.

CAUTION

PC Digitizer (P/O Phase Noise Measurement System) INPUT and OUTPUT connectors are fragile. Damage can occur to the PC Digitizer INPUT and OUTPUT connectors and cables while connected if tension is applied. If not strictly observed, could result in damage to, or destruction of, equipment or loss of mission effectiveness.

4.4.14 Connect equipment as shown in Figure 3. Press the TI **CARR ON/OFF** key to set output level to ON.

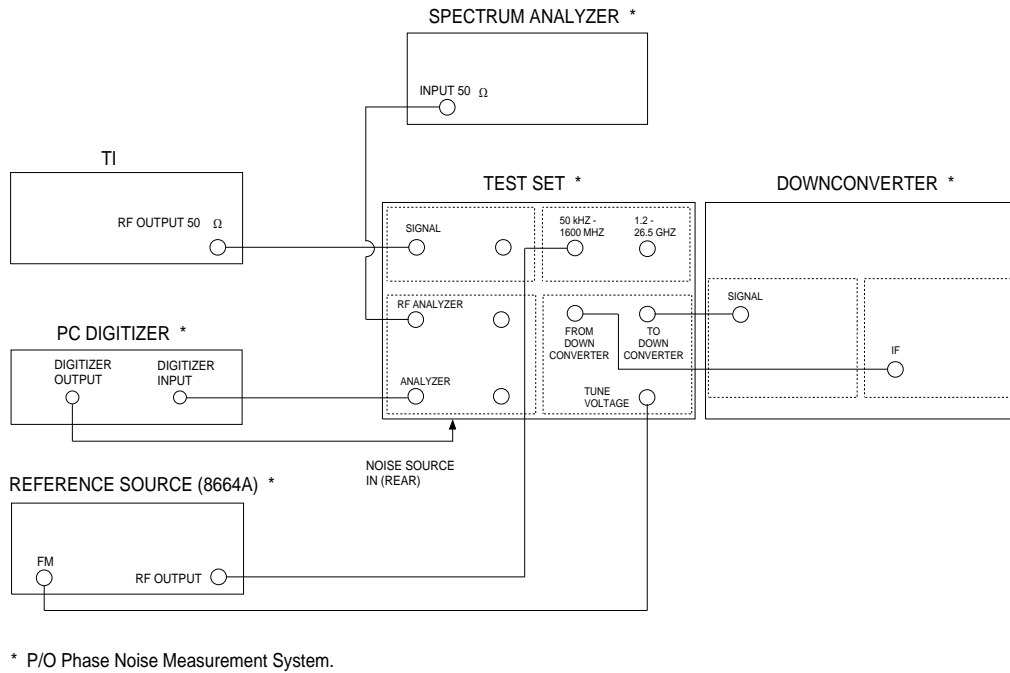

Figure 3.

4.4.15 When Verify Connections diagram appears on screen, ignore on-screen diagram and select Continue.

4.4.16 The Phase Noise Plot at 20 kHz offset must be <-124 dBc/Hz for Single Sideband Phase Noise. If desired, the Marker icon may be used to obtain specific offset frequencies and corresponding phase noise measurements on the graph. Press the TI **CARR ON/OFF** key to set output level to OFF.

4.4.17 On Phase Noise Measurement System select Define, then select Measurement.

4.4.18 On Phase Noise Measurement System select Sources to change Carrier Source Frequency to 1E+9.

4.4.19 Press the TI **CARR FREQ** key and using the numeric key pad set to 1 GHz.

4.4.20 Repeat steps 4.4.12 through 4.4.15 for 1 GHz.

4.4.21 On Phase Noise Measurement System select Analyze, then select Trace Integration.

4.4.22 From the Trace Integration screen, set the Start Offset to 300 Hz and Stop Offset to 3.4E+3. Set Data Type to Snu(f) (Spectral density of frequency fluctuations). Select Integrate.

4.4.23 Verify the Value of Definite Integral is <4.5 Hz/rms. Select Close.

4.4.24 Press the TI **CARR ON/OFF** key to set output level to OFF and disconnect test setup.

4.5 AMPLITUDE MODULATION CALIBRATION:

4.5.1 Connect equipment as shown in Figure 4.

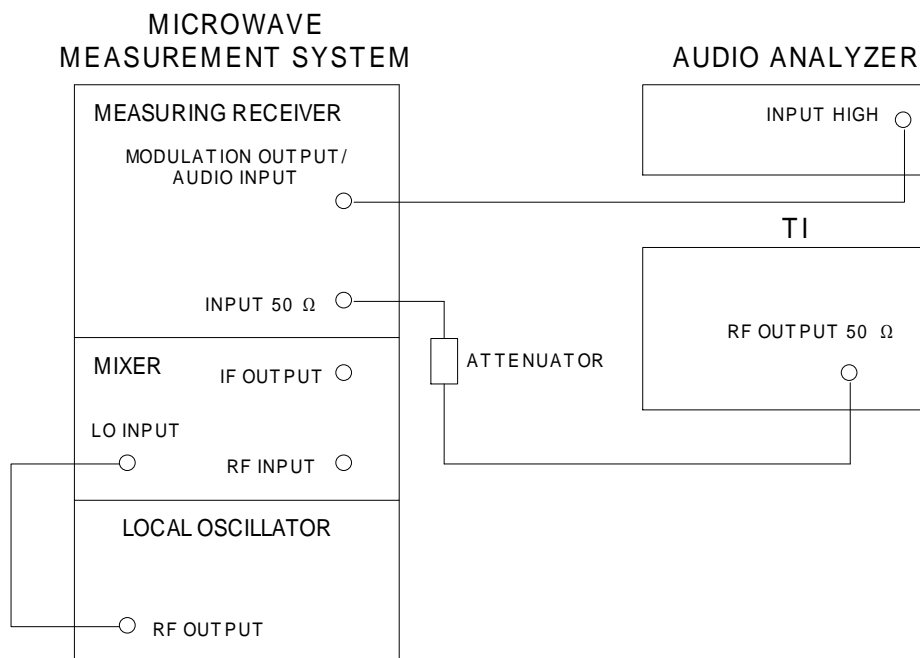

Figure 4.

4.5.2 Press the TI **RCL** key and using the numeric key pad enter **9, 9, 9** then press **ENTER** key.

4.5.3 Press the TI **CARR FREQ** key and using the numeric key pad enter the first value listed in the Applied Frequency column of Table 9.

4.5.4 Press the TI **RF LEVEL** key and using the numeric key pad set to 0.0 dBm.

4.5.5 Press the TI **MENU** key, **2, 0**, then the **ENTER** key to enter the Modulation Mode (Normal) screen.

4.5.6 Using the TI **PREV** and **NEXT** keys, highlight *AM Int* then press the **SELECT** key. Press the **MOD SOURCE** key to set MODF to $\hat{\sim}$ and using the numeric key pad set to 1 kHz.

4.5.7 Press the TI **MOD** key and using the numeric key pad enter the first value listed in the Applied Depth column of Table 9.

4.5.8 Press the TI **SOURCE ON/OFF** key to ON to enable the modulation source.

4.5.9 Press the TI **MOD ON/OFF** key to ON to enable the modulation.

4.5.10 Press the Measuring Receiver Blue (Shift) key and INSTR PRESET. Set the Measuring Receiver for an AM measurement. Set the HP FILTER to 300 Hz and LP FILTER to 3 kHz.

4.5.11 Verify the Measuring Receiver indicates within the values listed in the Limits Depth column of Table 9.

4.5.12 Set the Measuring Receiver HP FILTER and LP FILTER to off.

4.5.13 Set the Audio Analyzer controls for a distortion measurement. Verify the Audio Analyzer indicates within the values listed in the Limits Distortion column of Table 9.

4.5.14 Press the TI **MOD** key and using the numeric key pad enter the next value listed in the Applied Depth column of Table 9.

4.5.15 Set the Measuring Receiver HP FILTER to 300 Hz and LP FILTER to 3 kHz. Repeat steps 4.5.11 through 4.5.13.

4.5.16 Repeat steps 4.5.14 and 4.5.15 for the remaining corresponding values listed in Table 9 for the frequency being verified.

4.5.17 Press the TI **CARR FREQ** key and using the numeric key pad enter the next value listed in the Applied Frequency column of Table 9.

4.5.18 Press the TI **MOD** key and using the numeric key pad enter the first value listed in the Applied Depth column of Table 9 for the frequency being verified.

4.5.19 Repeat steps 4.5.10 through 4.5.16.

4.5.20 Repeat steps 4.5.17 through 4.5.19, as required, for the remaining corresponding values listed in Table 9.

Table 9.

| Frequency (Hz) | Applied | Limits | Distortion (%) |
|----------------|-----------|----------------|----------------|
| | Depth (%) | | |
| 10.1 M | 25.0 | 23.75 to 26.25 | <1.5 |
| | 50.0 | 47.5 to 52.5 | <2.5 |
| | 90.0 | 85.5 to 94.5 | N/A |
| 100 M | 25.0 | 23.75 to 26.25 | <1.5 |
| | 50.0 | 47.5 to 52.5 | <2.5 |
| | 90.0 | 85.5 to 94.5 | N/A |
| 450 M | 25.0 | 23.75 to 26.25 | <1.5 |
| | 50.0 | 47.5 to 52.5 | <2.5 |
| | 90.0 | 85.5 to 94.5 | N/A |

4.5.21 Press the TI **CARR ON/OFF** key to set output level to OFF and leave test setup connected.

4.6 FREQUENCY MODULATION CALIBRATION:

- 4.6.1 Press the TI **RCL** key and using the numeric key pad enter **9, 9, 9** then press **ENTER** key.
- 4.6.2 Press the TI **CARR FREQ** key and using the numeric key pad set to the first value listed in the Applied Frequency column of Table 10.
- 4.6.3 Press the TI **RF LEVEL** key and using the numeric key pad set to 0.0 dBm.
- 4.6.4 Press the TI **MENU** key, **2, 0**, then the **ENTER** key to enter the Modulation Mode (Normal) screen.
- 4.6.5 Using the TI **PREV** and **NEXT** keys, highlight *FM Int* then press the **SELECT** key. Press the **MOD SOURCE** key to set MODF to $\sqrt{\quad}$ and using the numeric key pad set to 1 kHz.
- 4.6.6 Press the TI **MOD** key and using the numeric key pad enter the first value listed in the Applied Deviation column of Table 10.
- 4.6.7 Press the TI **SOURCE ON/OFF** key to ON to enable the modulation source.
- 4.6.8 Press the TI **MOD ON/OFF** key to ON to enable the modulation.
- 4.6.9 Press the Measuring Receiver Blue (Shift) key and INSTR PRESET. Set the Measuring Receiver for an FM measurement. Set Microwave Measurement System for an FM Measurement in the Frequency Offset Mode for frequencies >1.3 GHz. Set the HP FILTER to 300 Hz and LP FILTER to 3 kHz.
- 4.6.10 Verify the Measuring Receiver indicates within the values listed in the Limits Deviation column of Table 10.
- 4.6.11 Set the Measuring Receiver HP FILTER and LP FILTER to off.
- 4.6.12 Set the Audio Analyzer controls for a distortion measurement. Set the Audio Analyzer LP FILTER to 30 kHz. Verify the Audio Analyzer indicates within the values listed in the Limits Distortion column of Table 10.
- 4.6.13 Press the TI **MOD** key and using the numeric key pad set to the next value listed in the Applied Deviation column of Table 10.
- 4.6.14 Set the Measuring Receiver HP FILTER to 300 Hz and LP FILTER to 3 kHz. Repeat steps 4.6.10 through 4.6.12, as applicable.
- 4.6.15 Repeat steps 4.6.13 and 4.6.14 for the remaining corresponding values listed in Table 10 for the frequency being verified.
- 4.6.16 Press the TI **CARR FREQ** key and using the numeric key pad enter the next value listed in the Applied Frequency column of Table 10.
- 4.6.17 Press the TI **MOD** key and using the numeric key pad enter the first value listed in the Applied Deviation column of Table 10 for the frequency being verified.
- 4.6.18 Repeat steps 4.6.9 through 4.6.15.
- 4.6.19 Repeat steps 4.6.16 through 4.6.18, as required, for the remaining corresponding values listed in Table 10.

Table 10.

| Frequency (Hz) | Applied | Limits | |
|----------------|-----------------|-----------------|----------------|
| | Deviation (kHz) | Deviation (kHz) | Distortion (%) |
| 10.1 M | 10.0 | 9.60 to 10.40 | <1 |
| | 100.0 | 96.0 to 104.0 | N/A |
| 35 M | 10.0 | 9.60 to 10.40 | <1 |
| | 100.0 | 96.0 to 104.0 | N/A |
| | 200.0 | 192.0 to 208.0 | N/A |
| 50 M | 10.0 | 9.60 to 10.40 | <1 |
| | 100.0 | 96.0 to 104.0 | N/A |
| | 380.0 | 364.8 to 395.2 | N/A |
| 100 M | 10.0 | 9.60 to 10.40 | <1 |
| | 100.0 | 96.0 to 104.0 | <1 |
| | 380.0 | 364.8 to 395.2 | N/A |
| 250 M | 10.0 | 9.60 to 10.40 | <1 |
| | 100.0 | 96.0 to 104.0 | <1 |
| | 380.0 | 364.8 to 395.2 | N/A |
| 500 M | 10.0 | 9.60 to 10.40 | <1 |
| | 100.0 | 96.0 to 104.0 | <1 |
| | 380.0 | 364.8 to 395.2 | <1 |
| 1.0 G | 10.0 | 9.60 to 10.40 | <1 |
| | 100.0 | 96.0 to 104.0 | <1 |
| | 380.0 | 364.8 to 395.2 | <1 |
| 1.5 G | 10.0 | 9.60 to 10.4 | <1 |
| | 100.0 | 96.0 to 104.0 | <1 |
| | 380.0 | 364.8 to 395.2 | <1 |
| 2.05 G | 10.0 | 9.60 to 10.40 | <1 |

Table 10. (Cont.)

| Frequency (Hz) | Applied | Limits | |
|----------------|-----------------|-----------------|----------------|
| | Deviation (kHz) | Deviation (kHz) | Distortion (%) |
| 2.05 G | 100.0 | 96.0 to 104.0 | <1 |
| | 380.0 | 364.8 to 395.2 | <1 |
| 2.2 G * | 10.0 | 9.60 to 10.40 | <1 |
| | 100.0 | 96.0 to 104.0 | <1 |
| | 380.0 | 364.8 to 395.2 | <1 |
| 2.51 G * | 10.0 | 9.60 to 10.40 | <1 |
| | 1000 | 96.0 to 104.0 | <1 |
| | 380.0 | 364.8 to 395.2 | <1 |

* For 2025 OPT 11 Only.

4.6.20 Press the TI **CARR ON/OFF** key to set output level to OFF and leave test setup connected.

4.7 PHASE MODULATION CALIBRATION:

4.7.1 Press the TI **RCL** key and using the numeric key pad enter **9, 9, 9** then press **ENTER** key.

4.7.2 Press the TI **CARR FREQ** key and using the numeric key pad enter the first value listed in the Applied Frequency column of Table 11.

4.7.3 Press the TI **RF LEVEL** key and using the numeric key pad set to 0.0 dBm.

4.7.4 Press the TI **MENU** key, **2, 0**, then the **ENTER** key to enter the Modulation Mode (Normal) screen.

4.7.5 Using the TI **PREV** and **NEXT** keys, highlight $\phi M Int$ then press the **SELECT** key. Press the **MOD SOURCE** key to set MODF to $\sqrt{\quad}$ and using the numeric key pad set to 1 kHz.

4.7.6 Press the TI **MOD** key and using the numeric key pad enter the first value listed in the Applied Deviation column of Table 11.

4.7.7 Press the TI **SOURCE ON/OFF** key to ON to enable the modulation source.

4.7.8 Press the TI **MOD ON/OFF** key to ON to enable the modulation.

4.7.9 Press the Measuring Receiver Blue (Shift) key and INSTR PRESET. Set the Measuring Receiver for a ϕM measurement. Set the HP FILTER to 300 Hz and LP FILTER to 3 kHz.

4.7.10 Verify the Measuring Receiver indicates within the values listed in the Limits Deviation column of Table 11.

4.7.11 As applicable, set the Audio Analyzer controls for a distortion measurement.

4.7.12 Verify the Audio Analyzer indicates within the values listed in the Limits Distortion column of Table 11.

4.7.13 Press the TI **MOD** key and using the numeric key pad enter the next value listed in the Applied Deviation column of Table 11.

4.7.14 Repeat steps 4.7.10 through 4.7.12, as applicable.

4.7.15 Repeat steps 4.7.13 and 4.7.14 for the remaining corresponding value listed in Table 11 for the frequency being verified.

4.7.16 Press the TI **CARR FREQ** key and using the numeric key pad set to the next value listed in the Applied Frequency column of Table 11.

4.7.17 Press the TI **MOD** key and using the numeric key pad set to the first value listed in the Applied Deviation column of Table 11 for the frequency being verified.

4.7.18 Repeat steps 4.7.9 through 4.7.15, as applicable.

4.7.19 Repeat steps 4.7.16 through 4.7.18, as required, for the remaining corresponding values listed in Table 11.

Table 11.

| Frequency (Hz) | Applied | | Limits | |
|----------------|-----------------|-----------------|-----------------|----------------|
| | Deviation (rad) | Deviation (rad) | Deviation (rad) | Distortion (%) |
| 10.1 M | 1.0 | 0.96 to 1.04 | N/A | |
| | 5.0 | 4.80 to 5.20 | N/A | |
| | 10.0 | 9.60 to 10.40 | <3 | |
| 100 M | 1.0 | 0.96 to 1.04 | N/A | |
| | 5.0 | 4.80 to 5.20 | N/A | |
| | 10.0 | 9.60 to 10.40 | <3 | |
| 500 M | 1.0 | 0.96 to 1.04 | N/A | |
| | 5.0 | 4.80 to 5.20 | N/A | |
| | 10.0 | 9.60 to 10.40 | <3 | |
| 1.0 G | 1.0 | 0.96 to 1.04 | N/A | |
| | 5.0 | 4.80 to 5.20 | N/A | |
| | 10.0 | 9.60 to 10.40 | <3 | |
| 1.5 G | 1.0 | 0.96 to 1.04 | N/A | |

Table 11. (Cont.)

| Frequency (Hz) | Applied | Limits | |
|----------------|-----------------|-----------------|----------------|
| | Deviation (rad) | Deviation (rad) | Distortion (%) |
| 1.5 G | 5.0 | 4.80 to 5.20 | N/A |
| | 10.0 | 9.60 to 10.40 | <3 |
| 2.05 | 1.0 | 0.96 to 1.04 | N/A |
| | 5.0 | 4.80 to 5.20 | N/A |
| | 10.0 | 9.60 to 10.40 | <3 |
| 2.2 G * | 1.0 | 0.96 to 1.04 | N/A |
| | 5.0 | 4.80 to 5.20 | N/A |
| | 10.0 | 9.60 to 10.40 | <3 |
| 2.51 G * | 1.0 | 0.96 to 1.04 | N/A |
| | 5.0 | 4.80 to 5.20 | N/A |
| | 10.0 | 9.60 to 10.40 | <3 |

* For 2025 OPT 11 Only.

4.7.20 Press the TI **CARR ON/OFF** key to set output level to OFF and disconnect the test setup.

4.8 PULSE MODULATION CALIBRATION:

4.8.1 Connect the TI RF OUTPUT 50 Ω to the Spectrum Analyzer INPUT 50 Ω . Connect the Synthesized Function Generator MAIN SIGNAL to the TI rear panel PULSE I/P (front panel PULSE INPUT for OPT 7 or OPT 11).

4.8.2 Press the TI **RCL** key and using the numeric key pad enter **9, 9, 9** then press **ENTER** key.

4.8.3 Press the TI **CARR FREQ** key and using the numeric key pad set to 1.0 GHz.

4.8.4 Press the TI **RF LEVEL** key and using the numeric key pad set to 0.0 dBm.

4.8.5 Press the TI **MENU** key, **2, 2**, then the **ENTER** key to enter the Pulse Modulation screen.

4.8.6 On the TI numeric key pad, press **1**, then the **ENTER** key.

4.8.7 Press the TI **MOD** key, **MOD** key again, then **MOD** key again to select the Pulse Mode.

4.8.8 Press the TI **SOURCE ON/OFF** key to ON to enable the modulation source.

4.8.9 Press the TI **MOD ON/OFF** key to ON to enable the modulation.

4.8.10 Set the Synthesized Function Generator for +5 VDC.

4.8.11 Set Spectrum Analyzer center frequency to 1 GHz and maximum sensitivity. Set the Reference Level to place the signal at the top graticule line of the CRT.

4.8.12 Disconnect the Synthesized Function Generator from the TI rear panel PULSE I/P (front panel PULSE INPUT for OPT 7 or OPT 11).

4.8.13 Connect the BNC Short to the TI rear panel PULSE I/P (front panel PULSE INPUT for OPT 7 or OPT 11).

4.8.14 Verify the signal amplitude decreases >45 dB (>80 dB for TIs with OPT 7 or OPT 11) from the top graticule on the CRT.

4.8.15 Press the TI **MOD ON/OFF** key to OFF to disable the modulation.

4.8.16 Remove the BNC Short from TI rear panel PULSE I/P (front panel PULSE INPUT for OPT 7 or OPT 11).

4.8.17 Connect the Synthesized Function Generator MAIN SIGNAL to the TI rear panel PULSE I/P (front panel PULSE INPUT for OPT 7 or OPT 11).

4.8.18 Press the TI **CARR FREQ** key and using the numeric key pad set to 2.0 GHz.

4.8.19 Set the Spectrum Analyzer center frequency set to 2 GHz and maximum sensitivity. Set the Reference Level to place the signal at the top graticule line of the CRT.

4.8.20 Press the TI **MOD ON/OFF** key to ON to enable the modulation.

4.8.21 Repeat steps 4.8.12 and 4.8.13.

4.8.22 Verify the signal amplitude decreases >40 dB (>70 dB for TIs with OPT 7 or OPT 11) from the top graticule on the CRT.

4.8.23 Press the TI **CARR ON/OFF** key to set output level to OFF and disconnect the test setup.

4.8.24 Connect the TI RF OUTPUT 50 Ω through the Crystal Detector and Feedthrough Termination (2.7) to the Oscilloscope CH 1 input. Connect the Synthesized Function Generator MAIN SIGNAL to the TI rear panel PULSE I/P (front panel PULSE INPUT for OPT 7 or OPT 11).

4.8.25 Press the TI **CARR FREQ** key and using the numeric key pad set to 1 GHz.

4.8.26 Press the TI **CARR ON/OFF** key to set output level to ON.

4.8.27 Set the Synthesized Function Generator for a 10 kHz squarewave at 0 to +5 V.

4.8.28 Set the Oscilloscope CH1 controls to view the TI output pulse. Set the controls as required to measure the Rise Time of the displayed pulse.

4.8.29 Verify the Rise Time of the displayed pulse is <10 μ s (<20 ns for TIs with OPT 7 or OPT 11) between the 10 and 90% points.

4.8.30 Set the Oscilloscope controls as required to measure the Fall Time of the displayed pulse.

4.8.31 Verify the Fall Time of the displayed pulse is <10 μ s (<20 ns for TIs with OPT 7 or OPT 11) between the 90 and 10% points.

4.8.32 Press the TI **CARR ON/OFF** key to set output level to OFF and disconnect the test setup.

4.9 INTERNAL LF GENERATOR CALIBRATION:

4.9.1 Connect the TI LF OUTPUT (MOD I/O for OPT 7 or OPT 11) through the Feedthrough Termination (2.8) to the Audio Analyzer INPUT HIGH. ■

4.9.2 Press the TI **RCL** key and using the numeric key pad enter **9, 9, 9** then press **ENTER** key.

4.9.3 Press the TI **SOURCE ON/OFF** key to ON to enable the modulation source.

4.9.4 Press the TI **MOD ON/OFF** key to ON to enable the modulation.

4.9.5 Press the TI **MOD SOURCE** key using the numeric key pad set to 1 kHz.

4.9.6 Set the Audio Analyzer for a distortion measurement.

4.9.7 Verify the Audio Analyzer indicates <0.1%.

4.9.8 Press the TI **CARR ON/OFF** key to set output level to OFF.

4.9.9 Set all **POWER** switches to **STBY** or **OFF**. Disconnect and secure all equipment.

4.9.10 Annotate and attach a Limited Certification Label per step 3.7.

CALIBRATION PERFORMANCE TABLE

Not Required

APPENDIX A**A-1 TIME BASE ADJUSTMENT:**

A-1.1 Connect the Frequency Standard 10 MHz REF OUT to the Universal Counter Ref In connector.

A-1.2 Connect the TI **FREQ STD** IN-OUT to the Universal Counter CHANNEL 1 input. Set the Universal Counter for 50 Ω input coupling and a display resolution of 0.1 Hz.

A-1.3 Press the TI **MENU** key, **8, 0** then the **ENTER** key to enter the Protection Lock/Unlock menu.

A-1.4 Press the TI **NEXT** key highlight *Level 2*. Using the numeric key pad enter **1, 2, 3, 4, 5, 6** (default password) and press the **ENTER** key. The display should now be unlocked.

A-1.5 Press the TI **MENU** key, **1, 0, 2** then the **ENTER** key to enter the Cal Frequency Standard screen.

A-1.6 Using the TI **NEXT** key highlight *Coarse DAC* and *Fine DAC* as required, and adjust for a Universal Counter indication as close as possible to 10 MHz.

A-1.7 After the adjustment, the TI must be Locked and Saved, as follows:

A-1.7.1 Using the TI **NEXT** key highlight *EXIT* then press the **SELECT** key. *SAVE CAL DATA AND QUIT* will be displayed on the TI. Press the **SELECT** key.

A-1.7.2 Press the TI **MENU** key, **8, 0** then the **ENTER** key. Press the **NEXT** key to highlight *Level 1*. Using the numeric key pad, enter **0, 1, 2, 3** (default password) and press the **ENTER** key. The display should indicate both *Level 1* and *Level 2* locked.

A-1.7.3 Press the TI **RCL** key and using the key pad enter **9, 9, 9** then press the **ENTER** key.

A-1.8 Disconnect the test setup and continue with para 4.2.