

TECHNICAL MANUAL
CALIBRATION PROCEDURE
FOR
COMMUNICATION SERVICE MONITOR
2945A, 2945B

(IFR)



Distribution Statement C - Distribution authorized to U. S. Government agencies and their contractors for official use or for administrative or operational purposes only, 30 May 2001. Requests for this document shall be referred to 562 CBSG/MLLW, 813 Irving-Wick Dr W, Heath, OH 43056-1199.

Destruction Notice - For unclassified, limited documents, destroy by any method that will prevent disclosure of the contents or reconstruction of the document.

Published under Authority of the Secretary of the Air Force

30 OCTOBER 2002
CHANGE 5 - 30 JUNE 2006

INSERT LATEST CHANGED PAGES. DESTROY SUPERSEDED PAGES.

LIST OF EFFECTIVE PAGES

NOTE: The portion of the text and illustrations affected by the changes is indicated by a vertical line in the outer margins of the page.

Date of issue for original and changed pages are:

Original.....0 30 October 2002
 Change.....130 March 2004
 Change.....230 March 2005
 Change.....3 30 July 2005
 Change.....430 January 2006
 Change.....530 June 2006

TOTAL NUMBER OF PAGES IN THIS PUBLICATION IS 50, CONSISTING OF THE FOLLOWING:

Page No.	* Change No.	Page No.	* Change No.	Page No.	* Change No.
Title	5				
A	5				
1	3				
2 - 4.....	0				
5	3				
6.....	0				
7 - 15.....	2				
16 - 33.....	0				
34.....	2				
35.....	5				
36.....	0				
37.....	1				
38 - 46.....	0				
A-1	0				
A-2 Blank	0				

*Zero in this column indicates an original page

COMMUNICATION SERVICE MONITOR

2945A, 2945B

(IFR)

1 CALIBRATION DESCRIPTION:*Table 1.*

Test Instrument (TI) Characteristics	Performance Specifications	Test Method
Frequency Accuracy		
Reference Oscillator	Range: 10 MHz Accuracy: (STD TI) $\pm 1 \times 10^{-6}$; * ¹ Aging/year: $< 1 \times 10^{-6}$; Temperature: $< 0.5 \times 10^{-6}$ (0 to 50 °C) * ² Accuracy: (OPT 03) $\pm 1 \times 10^{-7}$; * ¹ Aging/year: $< 1 \times 10^{-7}$ (after 1 month of continuous usage); Temperature: $< 5 \times 10^{-8}$ (5 to 55 °C) * ²	Verified with a Frequency Standard
Display	Range: 400 kHz to 1.05 GHz Accuracy: ± 1 count of LSD	Verified with a Frequency Counter
RF Signal Generator		
Frequency	Range: 400 kHz to 1.05 GHz Accuracy: Same as Frequency Accuracy	Verified during Frequency Accuracy Calibration
Output Level	Range: -141 to -21 dBm, N-Type connector; -115 to +5 dBm, BNC connector Accuracy: ± 2 dB, for levels > -127 dBm, to 1 GHz on N-Type connector	Verified with Microwave Measurement System and Power Meter and Power Sensor
Spectral Purity		
Residual FM	Range: 400 kHz to 1.05 GHz Accuracy: < 15 Hz rms (0.3 to 3.4 kHz) up to 500 MHz; < 20 Hz rms (0.3 to 3.4 kHz) up to 1 GHz	Verified with Microwave Measurement System

See footnotes at end of Table.

Table 1. (Cont.)

Test Instrument (TI) Characteristics	Performance Specifications	Test Method
RF Signal Generator <i>(Cont.)</i>		
Spectral Purity <i>(Cont.)</i>		
Harmonics	Range: 400 kHz to 1.05 GHz Accuracy: <-20 dBc	Verified with Spectrum Analyzer
Spurious Signals	Range: 400 kHz to 1.05 GHz Accuracy: <-30 dBc (± 10 kHz to 1.5 MHz offset from carrier frequency for over range 600 to 700 MHz); <-40 dBc from 400 kHz to 1 GHz	Verified with Spectrum Analyzer
Single-Sideband Phase Noise	Range: 400 kHz to 1.05 GHz, 20 kHz offset Accuracy: <-95 dBc/Hz up to 1 GHz	Verified with Phase Noise Measurement System
Amplitude Modulation (Internal)	Range: 400 kHz to 1.05 GHz, 0 to 99% depth Accuracy: $\pm(7\%$ of setting + 1 digit) for mod freq of 1 kHz, CW 1.5 to 400 MHz; $\pm(10\%$ of setting + 1 digit) for mod freq of 50 Hz to 5 kHz, CW 1.5 to 400 MHz; $\pm(15\%$ of setting + 1 digit) for mod freq of 50 Hz to 15 kHz, CW 1.5 to 400 MHz	Verified with Microwave Measurement System
Amplitude Modulation Distortion	Range: 400 kHz to 1.05 GHz, 0 to 99% depth, 20 Hz to 20 kHz mod freq Accuracy: (at 1 kHz for 30%, CCITT Weighted) <2% THD	Verified with Microwave Measurement System and Audio Analyzer
Frequency Modulation (Internal)	Range: 400 kHz to 1.05 GHz, 0 to 75 kHz deviation, 20 Hz to 25 kHz mod freq Accuracy: $\pm(5\%$ of setting + 10 Hz), at 1 kHz mod freq; $\pm 10\%$ of setting, 50 Hz to 15 kHz mod freq * ³	Verified with Microwave Measurement System
Frequency Modulation Distortion	Range: 400 kHz to 1.05 GHz, 0 to 75 kHz deviation, 20 Hz to 25 kHz mod freq Accuracy: (at 1 kHz for deviation of 5 kHz, CCITT Weighted) <1% THD	Verified with Microwave Measurement System and Audio Analyzer

See footnotes at end of Table.

Table 1. (Cont.)

Test Instrument (TI) Characteristics	Performance Specifications	Test Method
Audio Analyzer		
Audio Voltmeter	<p>Range: 0 to 100 mV to 0 to 100 V rms in a 1, 3 and 10 sequence, DC and 20 Hz to 50 kHz, AC only: 20 Hz to 50 kHz, Polarized DC (below 1 Hz)</p> <p>Accuracy: ($\pm 3\%$ of rdg + 3 mV + resolution) (Resolution is 1 mV or 1% of rdg, whichever is greater)</p>	Verified with Meter Calibrator
Audio Oscilloscope Voltage	<p>Range: Frequency: DC to 50 kHz, 3 Hz to 50 kHz, AC coupled Voltage: 10 mV to 20 V/div in a 1, 2 and 5 sequence</p> <p>Accuracy: $\pm 5\%$ FS</p>	
Audio Frequency Meter	<p>Range: 20 Hz to 20 kHz</p> <p>Accuracy: Same as Frequency Accuracy ± 1 digit \pm resolution (Resolution is 0.1 Hz at <10 kHz and 1 Hz at ≥ 10 kHz)</p>	Verified during Frequency Accuracy Calibration
Audio SINAD Meter	<p>Range: 1 kHz, 0 to 18 dB and 0 to 50 dB</p> <p>Accuracy: ± 1 dB</p>	Verified internally with two signals applied
Audio Distortion Meter	<p>Range: 1 kHz, 0 to 10%, 0 to 30% and 0 to 100%</p> <p>Accuracy: $\pm (5\%$ of rdg + 0.5% of distortion)</p>	
Audio S/N Meter	<p>Range: 0 to 30 dB and 0 to 100 dB</p> <p>Accuracy: ± 1 dB</p>	Verified during Distortion Meter and SINAD Meter Calibration
Transmitter		
RF Freq Meter	<p>Range: 100 kHz to 1.05 GHz</p> <p>Accuracy: Same as Frequency Accuracy \pm resolution (Resolution is 1 or 10 Hz, selectable)</p>	Verified during Frequency Accuracy Calibration

Table 1. (Cont.)

Test Instrument (TI) Characteristics	Performance Specifications	Test Method
Transmitter (<i>Cont.</i>)		
RF Power Meter (Broadband)	Range: 200 kHz to 1.05 GHz, 5 mW to 150 W N-Type connector; 0.05 to 250 mW BNC connector (antenna port) Accuracy: $\pm(10\%$ of rdg + resolution) N-Type connector (Resolution is 0.1 dB)	Verified with Microwave Measurement System and High Power High Frequency RF Amplifier System
Amplitude Modulation Depth	Range: 100 kHz to 1.05 GHz, 10 Hz to 15 kHz mod freq AM Depth: 0 to 99% (manually tuned); 0 to 90% below 100 MHz; 0 to 80% from 100 to 400 MHz Accuracy: $\pm(5\%$ of setting + 1 digit) at 1 kHz mod freq; $\pm(8.5\%$ of setting + 1 digit) from 50 Hz to 10 kHz mod freq * ³	Verified with Signal Generator and Microwave Measurement System
Frequency Modulation Deviation	Range: 100 kHz to 1.05 GHz, 10 Hz to 15 kHz mod freq, 0 to 75 kHz deviation Accuracy: $\pm(5\%$ of setting + resolution) at 1 kHz mod freq; $\pm(7.5\%$ of setting + resolution) for mod freq from 50 Hz to 10 kHz (Resolution is 10 Hz <2 kHz deviation, 1% >2 kHz deviation) * ³	
Frequency Modulation Demodulation Distortion	Range: 100 kHz to 1.05 GHz, 10 Hz to 15 kHz mod freq Accuracy: (at 1 kHz mod freq and 5 kHz FM deviation (CCITT weighted)) <2% THD	Verified with an AM/FM Test Source
Frequency Modulation Residual FM	Range: 100 kHz to 1.05 GHz Accuracy: <30 Hz (0.3 to 3.4 kHz)	

See footnotes at end of Table.

Table 1. (Cont.)

Test Instrument (TI) Characteristics	Performance Specifications	Test Method
<i>Transmitter (Cont.)</i>		
Amplitude Modulation Demodulation Distortion	Range: 100 kHz to 1.05 GHz, 10 Hz to 15 kHz mod freq Accuracy: (at 1 kHz mod freq with 30% AM (CCITT weighted)) <2% THD * ³	Verified with an AM/FM Test Source and Audio Analyzer
Amplitude Modulation Residual AM	Range: 100 kHz to 1.05 GHz Accuracy: <1% (0.3 to 3.4 kHz)	Verified with an AM/FM Test Source
<i>RF Spectrum Analyzer</i>		
Level Flatness	Range: 100 kHz to 1.0 GHz, -50 to + 52 dBm Accuracy: $\pm(1 \text{ dB} + \text{resolution})$ over 50 MHz span (Resolution is 0.1 dB on 2 dB/div and 0.5 dB on 10 dB/div)	Verified with Signal Generator and Microwave Measurement System
Intermodulation Distortion	Range: 100 kHz to 1.0 GHz, -50 to +52 dBm Accuracy: >-70 dB for two signals at -30 dBm into first mixer	Verified internally with two signals applied
<i>Audio Generator</i>		
Frequency	Range: 10 Hz to 25 kHz; 10 Hz to 30 kHz (2945B) Accuracy: 0.01 Hz \pm Frequency Accuracy <180 Hz; 0.1 Hz \pm Frequency Accuracy >180 Hz	Verified during Frequency Accuracy Calibration
Level	Range: 0.1 mV to 4 V rms Accuracy: $\pm(5\% \text{ of setting} + \text{resolution})$ (50 Hz to 15 kHz) (Resolution is 0.1 mV <409 mV, 1 mV >409 mV)	Verified with Digital Multimeter
Level Distortion	Range: 0.1 mV to 4 V rms Accuracy: <0.5% THD at 1 kHz, <1% THD from 50 Hz to 15 kHz	Verified with Audio Analyzer

See footnotes at end of Table.

Table 1. (Cont.)

Test Instrument (TI) Characteristics	Performance Specifications	Test Method
Audio Generator (OPT 01)		
Output Circuit		
Level	Range: 1 kHz, 600 Ω Accuracy: ±2% of setting	Verified with Digital Multimeter
Frequency Response	Range: 100 Hz to 20 kHz, 600 Ω Accuracy: ±0.5 dB, 200 Hz to 5 kHz; ±2 dB, 100 Hz to 20 kHz	Verified with a Thermal Voltage Converter and Digital Multimeter
Input Circuit		
Frequency Response	Range: 100 Hz to 20 kHz, 600 Ω Accuracy: ±0.5 dB, 200 Hz to 5 kHz; ±2 dB, 100 Hz to 20 kHz	Verified with an AC Measurement Standard

*¹ The accuracy is the manufacturers calculated specification after one year. The accuracy specification is found by multiplying the longest term aging rate by the appropriate time interval to obtain one year.

*² Typical or Operational specification. Not calibrated.

*³ At low modulation levels the Residual AM/FM may become significant.

2 EQUIPMENT REQUIREMENTS:

Noun	Minimum Use Specifications	Calibration Equipment	Sub-Item
2.1 FREQUENCY STANDARD	Range: 10 MHz Accuracy: <2.5 X 10 ⁻⁸	Austron 2100F	
2.2 FREQUENCY COUNTER	Range: 400 kHz to 1.05 GHz Accuracy: ±1 count of LSD	Hewlett-Packard 5343A	

Noun	Minimum Use Specifications	Calibration Equipment	Sub-Item
2.3 POWER METER	Range: -23 to -19 dBm Accuracy: ±1.2% of indication	Agilent E4418B	
2.4 POWER SENSOR	Range: 10 MHz to 1 GHz Accuracy: (all of Charted Cal Factor) ±2.0%, 10 to ≤30 MHz; ±2.4%, >30 MHz to 1 GHz	Agilent E4412A	
2.5 MICROWAVE MEASUREMENT SYSTEM	Range: (Tuned RF Level) 400 kHz to 1.05 GHz, -127 to 0 dBm Accuracy: ±0.4 dB Range: (Power) -9 to -3 dBm Accuracy: ±2% of indication Range: (AM Depth) 26 to 93% depth at 50 Hz to 15 kHz Accuracy: ±1.75% of rdg Range: (FM deviation) 4.7 to 79 kHz Accuracy: ±1.25% of rdg Range: (Audio Filters) 50 Hz to >20 kHz Accuracy: 50 Hz High-Pass Filter, <1% at rates ≥200 Hz; 300 Hz High-Pass Filter, <1% at rates ≥1 kHz; 3 kHz Low-Pass Filter, <1% at rates ≤1 kHz; 15 kHz Low-Pass Filter, <1% at rates ≤10 kHz; >20 kHz Low-Pass Filter, <1% at rates ≤10 kHz	Hewlett-Packard 8902MS	

Noun	Minimum Use Specifications	Calibration Equipment	Sub-Item
2.5.1 SENSOR MODULE	Range: 400 kHz to 1.05 GHz Accuracy: ±2.5% of charted value, 400 kHz to 10 MHz; ±3.2% of charted value, 10 to 100 MHz; ±2.6% of charted value, 100 MHz to 1.05 GHz	Hewlett-Packard 11722A	
2.6 SPECTRUM ANALYZER	Range: 400 kHz to 4.0 GHz Accuracy: ±1.6 dB	Hewlett-Packard 8563E	
2.7 PHASE NOISE MEASUREMENT SYSTEM	Range: Limited to the Absolute Phase Noise of the 8662A/8663A Reference Source Accuracy: (Offset) 20 kHz, ±2 dB	Hewlett-Packard 3048MS	
2.8 METER CALIBRATOR	Range: DC, 0 to 40 V; AC, 30 mV to 30 V rms, 50 Hz to 50 kHz Accuracy: ±0.75% of setting	Fluke 5700A	
2.9 SIGNAL GENERATOR	Range: 400 kHz to 1.05 GHz, -20 to +15 dBm Accuracy: Frequency, ±2.5% of setting Range: (AM Depth) 30 to 90% at 50 Hz to 15 kHz Accuracy: N/A Range: (FM deviation) 1 to 75 kHz Accuracy: N/A	Hewlett-Packard 8663A	

Noun	Minimum Use Specifications	Calibration Equipment	Sub-Item
2.10 DIGITAL MULTIMETER	Range: 0 to 4 V rms, 50 Hz to 15 kHz; 0 to 1 VDC Accuracy: AC, $\pm 1.25\%$ of rdg; DC, $\pm 0.25\%$ of indication	Hewlett-Packard 3458A	
2.11 AUDIO ANALYZER	Range: 50 Hz to 15 kHz, CCITT filter, -80 dBm Accuracy: ± 1 dB	Hewlett-Packard 8903B Opt 011 or 051	
2.12 POWER SPLITTER	Range: 10 MHz to 1 GHz Accuracy: (Tracking) ± 0.15 dB	Hewlett-Packard 11667A	
2.13 SYNTHESIZED SIGNAL GENERATOR	Range: +20 dBm, 10 MHz to 1 GHz Accuracy: N/A	Hewlett-Packard 8642B	
2.14 RF POWER MEASUREMENT SET	Range: 10 to 1000 MHz, 0 to 100 W Accuracy: $\pm 4.0\%$ of rdg TAR: 2.5:1	Bird 4421A300	
2.15 HIGH POWER HIGH FREQUENCY RF AMPLIFIER SYSTEM	Range: 10 to 1000 MHz, 0 to 100 W Accuracy: N/A	PST Corp BHED1719-1000/4006	
2.16 AM/FM TEST SOURCE	Range: (AM distortion) Accuracy: $< 0.5\%$ THD Range (Residual FM) Accuracy: < 7.5 Hz rms	Hewlett-Packard 11715A	
2.17 DIRECTIONAL BRIDGE	Range: 49 to 51 MHz Accuracy: N/A	Hewlett-Packard 8721A	

Noun	Minimum Use Specifications	Calibration Equipment	Sub-Item
2.18 FEEDTHROUGH TERMINATION	Range: 600 Ω , 100 Hz to 20 kHz Accuracy: $\pm 1\%$ of nominal	Hewlett-Packard 11095A	
2.19 THERMAL VOLTAGE CONVERTER	Range: 3 V, 600 Ω Accuracy: Air Force Calibrated, See accompanying Calibration Certificate	Ballantine 1395A3MOD600	
2.20 AC MEASUREMENT STANDARD	Range: 100 Hz to 20 kHz, 0.79 to 1.3 V rms Accuracy: $\pm 1.4\%$ of indication	Fluke 5790A	

3 PRELIMINARY OPERATIONS:

3.1 Review and become familiar with the entire procedure before beginning the Calibration Process.



Unless otherwise designated, and prior to beginning the Calibration Process, ensure that all test equipment voltage and/or current outputs are set to zero (0) or turned off, where applicable. Ensure that all equipment switches are set to the proper position before making connections or applying power.

3.2 Connect TI to the appropriate power source. Set TI CHARGE/OFF/ON (rear panel) switch to ON and allow a 30 minute warm-up.

3.3 Connect all test equipment to the appropriate power source. Set all POWER switches to ON and allow a warm-up time as required by manufacturer.

3.4 The TI Hardkeys are shown in uppercase in this procedure, all Softkeys and Menu keys are in lower case with Initial Caps.

3.5 The TI FREQ and LEVEL setting controls utilize a numerical key pad or an incremental/variable data entry, either can be used to enter the values desired.

3.6 To minimize the number of key presses to obtain the correct instrument setting, each section assumes the TI is being configured from the TI factory default power on state. To ensure this occurs, initially press the following keys:

3.6.1 Press HELP/SETUP, Setup and Setup page 2.

3.6.2 Toggle the Power Up From menu key until Preset Store 1 is shown highlighted in inverse video.

3.6.3 Set the TI CHARGE/OFF/ON (rear panel) switch to OFF. Set the TI CHARGE/OFF/ON (rear panel) switch to ON. The TI should now be in the factory default power on state.

3.7 Perform TI Self Test by pressing the following keys:

3.7.1 Press HELP/SETUP, Self Test and Go.

NOTE

The legend ACTIVE is displayed against each test as it is carried out, which changes to PASS or FAIL as each test is completed.

If a particular test fails, the reason is given alongside the FAIL legend, together with the measurement.

3.7.2 Verify the TI passes all self test. If a particular test fails, refer to the appropriate commercial data.

WARNING

Take care when touching the RF Input N Type connector after the application of high levels of continuous power. If 50 W is exceeded for a prolonged period, the temperature of the connector can become excessive.

CAUTION

A power overload condition is indicated by an audible and visual warning. Should this condition be indicated, immediately reduce the level of RF power from the transmitter into the TI.

Do not stop the warning by switching off the TI, as this will silence the warning but will leave the excessive RF power connected to the internal load.

Do not attempt to stop the warning by disconnecting the RF connector, as this can damage the transmitter and may cause electric shock or skin burns.

3.8 Make a copy of Table 21 for use during the calibration process.

4 CALIBRATION PROCESS:

NOTE

Unless otherwise specified, verify the results of each test and take corrective action whenever the test requirement is not met, before proceeding.

4.1 FREQUENCY ACCURACY AND DISPLAY CALIBRATION:

NOTE

Adjustment of the Time Base Oscillator is normal due to the Aging Rate of the crystal. This is common to all Quartz Oscillators. The adjustment actions taken during this calibration will ensure the greatest reliability of the TI by adjusting the time base reference to the nominal value each time it is calibrated.

4.1.1 Connect Frequency Standard 10 MHz REF OUT to Frequency Counter EXT FREQ STD input (10 MHz). Set the Frequency Counter INT/EXT switch to EXT.

4.1.2 Connect TI BNC output to the Frequency Counter 10 Hz - 500 MHz input. Set the Frequency Counter 50Ω/1MΩ switch to 50Ω.

4.1.3 On the TI, press the RF IN/OUT SELECT to select the BNC output.

4.1.4 On the TI, press Rx TEST. Press RF Gen and set the controls as follows:

GEN FREQ	10 MHz
LEVEL	-10 dBm

NOTE

Ensure the TI Modulation Generators MOD1 and MOD2 are off.

4.1.5 Adjust the Frequency Counter controls as required for a stable display indication and then push RESET.

NOTE

The values in the following step are derived from multiplication of the Aging Rate to determine the offset at one year. Use these calculated one year values regardless of the length of the calibration interval for this TI in T.O. 33K-1-100-1/2. The longest aging rate specification not to exceed one year has been used to calculate the limits.

4.1.6 Verify the Frequency Counter indicates within 9 999 990 to 10 000 010 Hz ±1 count of LSD for STD TI or 9 999 999 to 10 000 001 Hz ±1 count of LSD for TI OPT 03.

4.1.7 Set the TI output to minimum.

4.1.8 Disconnect the Frequency Standard 10 MHz REF OUT from the Frequency Counter EXT FREQ STD input and set Frequency Counter INT/EXT switch to INT.

4.1.9 Connect equipment as shown in Figure 1. Set the Frequency Counter for a 10 Hz display resolution.

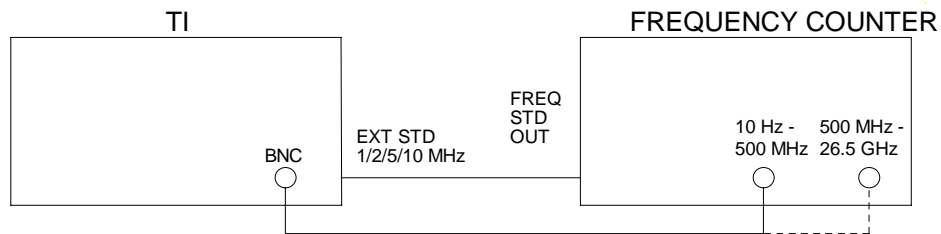

Figure 1.

4.1.10 Press TI RF Gen and set GEN FREQ to the first value listed in Freq column of Table 2. Set TI LEVEL to -10 dBm.

4.1.11 Verify the Frequency Counter indicates within the values listed in the Limits column of Table 2.

4.1.12 Repeat steps 4.1.10 and 4.1.11 for the remaining values listed in Table 2. Use the appropriate Frequency Counter input for the TI frequency being measured.

Table 2.

Freq (MHz)	Frequency Counter Display Limits
0.400	399 99 to 400 01
111.11111	111 111 10 to 111 111 12
122.22222	122 222 21 to 122 222 23
133.33333	133 333 32 to 133 333 34
144.44444	144 444 43 to 144 444 45
155.55555	155 555 54 to 155 555 56
166.66666	166 666 65 to 166 666 67
177.77777	177 777 76 to 177 777 78
188.88888	188 888 87 to 188 888 89
500.00000	499 999 99 to 500 000 01
1050.00000	1049 999 99 to 1050 000 01

4.1.13 Set the TI output to minimum and disconnect the test setup.

4.1.14 To ensure reliability of the TI, the following action will be taken: If TI passed the above steps, perform the applicable adjustment steps in Appendix A, and enter NO ADJUSTMENT ACTION into the Maintenance Data Collection System. If TI failed, perform the applicable steps listed in Appendix A and enter appropriate ADJUSTMENT ACTION into the Maintenance Data Collection System.

4.2 RF SIGNAL GENERATOR CALIBRATION:

4.2.1 OUTPUT LEVEL CALIBRATION:

4.2.1.1 Standardize Power Meter and Power Sensor. Set the Power Meter controls for a dBm measurement. Connect the Power Sensor to the TI N-Type output.

4.2.1.2 On the TI, press the RF IN/OUT SELECT to select the N-Type output/ANTENNA input.

4.2.1.3 On the TI, press Rx TEST. Press the RF Gen and set the controls as follows:

GEN FREQ	first value listed in the TI Freq column of Table 3
LEVEL	-21 dBm

NOTE

All modulation and noise measurements must be switched off.

- 4.2.1.4 Set the Power Meter CAL FACTOR switch to the appropriate value for the frequency being verified.
- 4.2.1.5 Verify the Power Meter indicates within values listed in the Limits column of Table 3. Record the Power Meter indication.
- 4.2.1.6 On the TI, press the RF IN/OUT SELECT to select the N-Type output/N-Type input.
- 4.2.1.7 Verify the Power Meter indicates within values listed in the Limits column of Table 3.
- 4.2.1.8 On the TI, press the RF IN/OUT SELECT to select the N-Type output/ANTENNA input.
- 4.2.1.9 Set TI GEN FREQ control to the next value listed in the TI Freq column of Table 3 and repeat steps 4.2.1.4 through 4.2.1.8.
- 4.2.1.10 Repeat step 4.2.1.9 for the remaining corresponding values listed in Table 3.

Table 3.

TI Freq (MHz)	Limits (dBm)
10	-23 to -19
100	-23 to -19
500	-23 to -19
1000	-23 to -19

- 4.2.1.11 Set the TI LEVEL to minimum and disconnect the Power Meter and Power Sensor from the TI N-Type output.
- 4.2.1.12 Connect the TI N-Type output to the Measuring Receiver INPUT 50 Ω.
- 4.2.1.13 Set TI GEN FREQ to 10 MHz and LEVEL to -21 dBm.
- 4.2.1.14 Press the Measuring Receiver INSTR PRESET. Press the Measuring Receiver Gold S key and TUNED RF LEVEL keys. Press the Measuring Receiver Blue Shift and SET REF keys. Verify the Measuring Receiver indicates 0.00 ±0.02 dB.
- 4.2.1.15 Set the TI LEVEL to the first value listed in the Level column of Table 4.
- 4.2.1.16 Algebraically add the value recorded in step 4.2.1.5 to the Measuring Receiver indication. Verify the results are within the values listed in the Limits column of Table 4.
- 4.2.1.17 Repeat steps 4.2.1.15 and 4.2.1.16 for the remaining corresponding values listed in Table 4.

Table 4.

Level (dBm)	Limits (dBm)
-22	-24 to -20
-23	-25 to -21
-24	-26 to -22
-25	-27 to -23
-26	-28 to -24
-27	-29 to -25
-28	-30 to -26
-29	-31 to -27
-30	-32 to -28
-40	-42 to -38
-50	-52 to -48
-60	-62 to -58
-70	-72 to -68
-80	-82 to -78
-90	-92 to -88
-100	-102 to -98
-110	-112 to -108
-120	-122 to -118
-125	-127 to -123

4.2.1.18 Repeat steps 4.2.1.13 through 4.2.1.17 for test frequencies of 100, 500 and 1000 MHz. ■

4.2.1.19 Set the TI output to minimum and disconnect the test setup.

4.2.2 SPECTRAL PURITY CALIBRATION:

4.2.2.1 RESIDUAL FM CALIBRATION:

4.2.2.1.1 Connect the TI BNC output to the Measuring Receiver INPUT 50Ω. (Connect TI directly to the Measuring Receiver, do not use the Sensor Module.)

4.2.2.1.2 On the TI, press RF IN/OUT SELECT to select the BNC output.

4.2.2.1.3 On the TI, press Rx TEST, press RF Gen and set the controls as follows:

GEN FREQ	990 MHz
LEVEL	0 dBm

NOTE

All modulation and noise measurements should be switched off.

4.2.2.1.4 Press the Measuring Receiver INSTR PRESET, FM, blue (shift) and then the RMS keys. Set the HP FILTER to 300 Hz and the LP FILTER to 3 kHz.

4.2.2.1.5 Verify the Measuring Receiver indication is within the values listed in the Limits column of Table 5.

4.2.2.1.6 Repeat steps 4.2.2.1.3 through 4.2.2.1.5 for the remaining corresponding values listed in the TI Freq column of Table 5.

Table 5.

TI Freq (MHz)	Limits (Hz rms)
990	<20
400	<15
100	<15

4.2.2.1.7 Set TI output to minimum and disconnect test setup.

4.2.2.2 HARMONICS AND SPURIOUS SIGNALS CALIBRATION:

4.2.2.2.1 Connect TI BNC output to the Spectrum Analyzer INPUT 50Ω.

4.2.2.2.2 On the TI, press RF IN/OUT SELECT to select the BNC output.

4.2.2.2.3 On the TI, press Rx TEST and RF Gen and set the controls as follows:

GEN FREQ	First value listed in the TI Freq column of Table 6
LEVEL	0 dBm

NOTE

All modulation and noise measurements must be switched off.

4.2.2.2.4 Set the Spectrum Analyzer controls, as required, to view the carrier and at least four harmonics. Set the Spectrum Analyzer controls, as required, to establish a reference level for the carrier.

4.2.2.2.5 Verify the amplitude of the Harmonics are within the values listed in the Harmonics Limits column of Table 6.

4.2.2.2.6 Set the Spectrum Analyzer controls, as required, to view any Spurious Signals.

4.2.2.2.7 Verify any Spurious Signal amplitude is within the values listed in the Spurious Signal Limits column of Table 6.

4.2.2.2.8 Set the TI GEN FREQ to the next value listed in the TI Freq column of Table 6. Repeat steps 4.2.2.2.4 through 4.2.2.2.7.

4.2.2.2.9 Repeat step 4.2.2.2.8 for the remaining corresponding values listed in Table 6.

Table 6.

TI Freq (MHz)	Harmonics Limits (dBc)	Spurious Signal Limits (dBc)
0.4	<-20	<-40
100.0	<-20	<-40
300.0	<-20	<-40
500.0	<-20	<-40
650.0	<-20	<-30 *
700.0	<-20	<-30 *
900.0	<-20	<-40
1000.0	<-20	<-40

* Verify the Spurious Signals from $\pm(10 \text{ kHz to } 1.5 \text{ MHz})$ offset from the carrier.

4.2.2.2.10 Set TI output to minimum and disconnect the test setup.

4.2.2.3 SINGLE-SIDEBAND PHASE NOISE CALIBRATION:

4.2.2.3.1 Connect TI BNC output to the 5 MHz to 1.6 GHz R Phase Detector input of the Phase Noise System.

4.2.2.3.2 On the TI, press Rx TEST, RF Gen and set the controls as follows:

GEN FREQ	1000 MHz
LEVEL	0 dBm

4.2.2.3.3 Verify the Phase Noise Measurement System is using the Software Package, CPIN 88M-3048MS/NOISE-F001-00A, with the correct revision, as per COMPENDIUM 80-1-88 or Q016.-110-WK-G01 for calibration of Single-Sideband Phase Noise. The Main Menu should be present on the screen when the computer is turned on.

4.2.2.3.4 From the Main Menu select Type/Range of Measurement to obtain the Measurement Type and Frequency Range Specifications. Select Phase Noise Using Phase Lock Loop Measurement type. Set Start Frequency to 10 Hz, Stop Frequency to 100 kHz, and Average to 4. Press ESC to return to Main Menu.

4.2.2.3.5 From the Main Menu select Parameters to obtain the Source and Interface Entry Menu. Select Low Freq Phase Detector (5 MHz to 1600 MHz). Select the following:

Carrier Frequency	1.E+09 Hz
Detector Input Frequency	1.E+09 Hz
VCO Tune Constant	5.0 Hz/Volt
Center Voltage of VCO Tune Curve	0 Volts
Tuning Range of VCO	10 Volts
VCO Tune Port Input Resistance	1.E+06 Ohms

Press ESC to return to Main Menu when done with selections.

NOTE

The VCO Tune Constant is obtained by the following formula:

$$VCO\ Tune\ Constant = 5\ E-9\ X\ Carrier\ Frequency$$

Example: $1000.0\ E+6\ X\ 5\ E-9 = 5.0\ Hz/Volts$

4.2.2.3.6 From the Main Menu select Calibration Technique. Press F2 to Select VCO Tune Constant Method. Select (Highlight) Measure the Tune Constant. Press ESC to return to the Main Menu when done with selection.

4.2.2.3.7 From the Main Menu select Instrument Control to obtain the source control for Measurement Using a Phase Lock Loop Menu. Select UUT USER'S SRCE MANUAL CTRL and REF SOURCE 8663A SYSTEM CTRL. Select REF SOURCE 8663A under EFC control. Press ESC to return to the Main Menu.

4.2.2.3.8 From the Main Menu select Define Graph. Enter graph title as appropriate for your setup. Enter in the proper blocks the following data:

Minimum X coordinate	10
Maximum X coordinate	100.E+03
Maximum Y coordinate	-50
Minimum Y coordinate	-140

Select Single-Sideband Phase Noise (dBc/Hz) for Graph Type. Press ESC.

4.2.2.3.9 From the Main Menu, select New Measurement and press Y. Connect equipment as shown on the CRT. Verify a Beat Note below the value on the screen is present on the Signal Analyzer and press F1 to proceed.

4.2.2.3.10 If REF #11 appears on the screen press P to proceed. The Phase Noise Measurement System should proceed without error and the Phase Noise Plot should appear on the display screen.

4.2.2.3.11 Verify the Phase Noise Plot at a 20 kHz offset is within the value listed in the Limits column of Table 7. If desired, the Marker function may be used to obtain specific offset frequencies and phase noise measurements on the graph. Press M to obtain the Marker function and use the arrow keys to obtain an offset frequency.

4.2.2.3.12 To print the TI Phase Noise Plot and the pertinent measurement parameters on Phase Noise Measurement System press SHIFT and F4 keys.

4.2.2.3.13 After printing the Phase Noise Plot, press ESC to return to the Main Menu.

4.2.2.3.14 Set TI GEN FREQ to the next value listed in the Applied column of Table 7.

4.2.2.3.15 From the Main Menu select Parameters and set the Carrier Frequency, Detector Input Frequency and VCO Tune Constant appropriately and repeat steps 4.2.2.3.9 through 4.2.2.3.13.

4.2.2.3.16 Repeat steps 4.2.2.3.14 and 4.2.2.3.15 for the remaining corresponding values listed in Table 7.

Table 7.

Applied (MHz)	Limits (dBc/Hz)
1000	<-95
750	<-95
500	<-95
250	<-95
100	<-95

4.2.2.3.17 Set TI output to minimum and disconnect the test setup.

4.2.3 AMPLITUDE MODULATION CALIBRATION:

4.2.3.1 Connect the TI BNC output to the Measuring Receiver INPUT 50Ω. (Connect TI directly to the Measuring Receiver, do not use the Sensor Module.)

4.2.3.2 Connect the Measuring Receiver MODULATION INPUT/OUTPUT to the Audio Analyzer HIGH input.

4.2.3.3 On the TI, press Rx TEST, RF Gen and set the controls as follows:

GEN FREQ	First value listed in the TI Freq column of Table 8
LEVEL	-15 dBm

4.2.3.4 Press the Measuring Receiver INSTR PRESET. Press the AM key.

4.2.3.5 Set the Measuring Receiver HP and LP FILTERS to the first values listed in the Measuring Receiver HP and LP FILTERS columns of Table 8.

4.2.3.6 On the TI, press TI Mod Gen and set controls as follows:

GEN 1/GEN 2	Gen 2
FREQ column of Table 8	First value listed in the Gen 2 Freq
LEVEL column of Table 8	First value listed in the Gen 2 Level

4.2.3.7 Verify the Measuring Receiver indication is within the values listed in the Limits column of Table 8.

4.2.3.8 Repeat steps 4.2.3.3 through 4.2.3.7 for the next values listed in Table 8.

4.2.3.9 Repeat step 4.2.3.8 for the remaining corresponding values of Table 8.

Table 8.

TI Freq (MHz)	Gen 2 Freq (kHz)	Gen 2 Level (%)	Measuring Receiver Filters		Limits (%)
			HP (Hz)	LP (Hz)	
10	0.05	30	none	3k	26 to 34
10	0.05	50	none	3k	44 to 56
10	0.05	80	none	3k	71 to 89
10	1	30	300	3k	26.9 to 33.1
10	1	50	300	3k	45.5 to 54.5
10	1	80	300	3k	73.4 to 86.6

Table 8. (Cont.)

TI Freq (MHz)	Gen 2 Freq (kHz)	Gen 2 Level (%)	Measuring Receiver Filters		Limits (%)
			HP (Hz)	LP (Hz)	
10	5	30	300	15k	26 to 34
10	5	50	300	15k	44 to 56
10	5	80	300	15k	71 to 89
10	15	30	300	>20k	24.5 to 35.5
10	15	50	300	>20k	41.5 to 58.5
10	15	80	300	>20k	67 to 93
350	0.05	30	none	3k	26 to 34
350	0.05	50	none	3k	44 to 56
350	0.05	80	none	3k	71 to 89
350	1	30	300	3k	26.9 to 33.1
350	1	50	300	3k	45.5 to 54.5
350	1	80	300	3k	73.4 to 86.6
350	5	30	300	15k	26 to 34
350	5	50	300	15k	44 to 56
350	5	80	300	15k	71 to 89
350	15	30	300	>20k	24.5 to 35.5
350	15	50	300	>20k	41.5 to 58.5
350	15	80	300	>20k	67 to 93

4.2.3.10 Set TI output to minimum and leave equipment connected.

4.2.4 AMPLITUDE MODULATION DISTORTION CALIBRATION:

4.2.4.1 Press the Audio Analyzer DISTN and CCITT WEIGHTING keys.

4.2.4.2 Press the Measuring Receiver INSTR PRESET. Press the AM key. Set the HP and LP FILTERS to off.

4.2.4.3 On the TI, press Rx TEST, RF Gen and set the controls as follows:

GEN FREQ	First value listed in the TI Freq column of Table 9
LEVEL	-15 dBm

4.2.4.4 On the TI, press TI Mod Gen and set controls as follows:

GEN 1/GEN 2	Gen 2
FREQ	1 kHz
LEVEL	30%

4.2.4.5 Verify the Audio Analyzer indicates within the value listed in the Limits column of Table 9.

4.2.4.6 On the TI, set the TI GEN FREQ to the next value listed in the TI Freq column of Table 9 and repeat step 4.2.4.5.

4.2.4.7 Repeat step 4.2.4.6 for the remaining corresponding values listed in Table 9.

Table 9.

TI Freq (MHz)	Limits (%)
0.5	<2
100	<2
500	<2
1000	<2

4.2.4.8 Set TI output to minimum and leave equipment connected.

4.2.5 FREQUENCY MODULATION CALIBRATION:

4.2.5.1 Press the Measuring Receiver INSTR PRESET. Press the FM key, then press Peak+ and Peak- simultaneously. Set the Measuring Receiver HP FILTER to 300 Hz and LP FILTER to 3 kHz.

4.2.5.2 On the TI, press Rx TEST, RF Gen and set the controls as follows:

GEN FREQ	First value listed in the TI Freq column of Table 10
LEVEL	0 dBm

4.2.5.3 On the TI, press TI Mod Gen and set the controls as follows:

GEN 1/GEN 2	Gen 2
FREQ	1 kHz
LEVEL	10 kHz

4.2.5.4 Verify the Measuring Receiver indicates within the values listed in the Limits column of Table 10.

4.2.5.5 Repeat steps 4.2.5.2 through 4.2.5.4 for the remaining corresponding values listed in Table 10.

Table 10.

TI Freq (MHz)	Limits (kHz)
10	9.49 to 10.51
100	9.49 to 10.51
500	9.49 to 10.51
1000	9.49 to 10.51

4.2.5.6 On the TI, press Rx TEST, RF Gen and set the controls as follows:

GEN FREQ	600 MHz
----------	---------

4.2.5.7 On the TI, press TI Mod Gen and set the controls as follows:

GEN 1/GEN 2	Gen 2
LEVEL	First value listed in the TI Gen 2 Level column of Table 11
FREQ	First value listed in the TI Gen 2 Freq column of Table 11

4.2.5.8 Press the Measuring Receiver INSTR PRESET. Press the FM key, then press Peak+ and Peak- simultaneously. Set the Measuring Receiver HP and LP Filters to the first settings listed in the applicable Measuring Receiver Filter columns of Table 11.

4.2.5.9 Verify the Measuring Receiver indicates within the values listed in the Limits column of Table 11.

4.2.5.10 Repeat steps 4.2.5.7 through 4.2.5.9 for the remaining corresponding values listed in Table 11.

Table 11.

TI Gen 2 Level (kHz)	TI Gen 2 Freq (kHz)	Measuring Receiver Filters		Limits (kHz)
		HP (Hz)	LP (Hz)	
75	0.05	none	3k	67.5 to 82.5
50	0.05	none	3k	45.0 to 55.0
25	0.05	none	3k	22.50 to 27.50
5	0.05	none	3k	4.50 to 5.50
75	1	300	3k	71.2 to 78.8
50	1	300	3k	47.5 to 52.5
25	1	300	3k	23.74 to 26.26
5	1	300	3k	4.74 to 5.26
75	15	300	>20k	67.5 to 82.5
50	15	300	>20k	45.0 to 55.0
25	15	300	>20k	22.50 to 27.50
5	15	300	>20k	4.50 to 5.50

4.2.5.11 Set TI output to minimum and leave equipment connected.

4.2.6 FREQUENCY MODULATION DISTORTION CALIBRATION:

4.2.6.1 Press the Audio Analyzer DISTN and CCITT WEIGHTING keys.

4.2.6.2 Press the Measuring Receiver INSTR PRESET. Press the FM keys, then the Peak+ key. Set the Measuring Receiver HP and LP FILTER to off (the 15 kHz LP FILTER will be automatically set at frequencies below 10 MHz).

4.2.6.3 On the TI, press Rx TEST, RF Gen and set the controls as follows:

GEN FREQ	First value listed in the TI Freq column of Table 12
LEVEL	0 dBm

4.2.6.4 On the TI, press TI Mod Gen and set the controls as follows:

GEN 1/GEN 2	Gen 2
FREQ	1 kHz
LEVEL	5 kHz

4.2.6.5 Verify the Audio Analyzer indicates within the value listed in the Limits column of Table 12.

4.2.6.6 Repeat steps 4.2.6.3 through 4.2.6.5 for the remaining corresponding values listed in Table 12.

Table 12.

TI Freq (MHz)	Limits (%)
0.5	<1
100	<1
500	<1
1000	<1

4.2.6.7 Set TI output to minimum and disconnect test setup.

4.3 AUDIO ANALYZER CALIBRATION:

4.3.1 AUDIO VOLTMETER CALIBRATION:

4.3.1.1 Set the TI CHARGE/OFF/ON (rear panel) switch to OFF. Set the TI CHARGE/OFF/ON (rear panel) switch to ON.

4.3.1.2 Connect TI AF INPUT to the Meter Calibrator OUTPUT HI and LO jacks.

4.3.1.3 On the TI, press AF TEST and set the controls as follows:

AF FILTER	50 kHz LP
AC/DC	DC

4.3.1.4 Set Meter Calibrator to the first value listed in the Applied column of Table 13. Set Meter Calibrator OPR/STBY switch to OPR.

4.3.1.5 Verify the TI indicates within the values listed in the Limits column of Table 13.

4.3.1.6 Set Meter Calibrator OPR/STBY to STBY.

4.3.1.7 Repeat steps 4.3.1.4 through 4.3.1.6 for the remaining corresponding values listed in Table 13.

Table 13.

Applied (VDC)	Limits (mV DC)
5	4797 to 5203
10 *	±9597 to 10403
20	19197 to 20803
40	38397 to 41603
60	57597 to 62403
80	76797 to 83203

* Check with both (+) and (-) voltage applied.

4.3.1.8 On the TI, press AC/DC coupling until AC coupled is displayed.

4.3.1.9 Set Meter Calibrator to the first value listed in the Applied Voltage and Frequency columns of Table 14.

4.3.1.10 Set Meter Calibrator OPR/STBY to OPR.

4.3.1.11 Verify the TI indicates within the values listed in the Limits column of Table 14.

4.3.1.12 Set the Meter Calibrator OPR/STBY to STBY.

4.3.1.13 Repeat steps 4.3.1.9 through 4.3.1.12 for the remaining corresponding values listed in Table 14.

Table 14.

Voltage (V)	Applied	Frequency (Hz)	Limits (mV AC)
30 m		1 k	25.1 to 34.9
200 m		1 k	189 to 211
1		1 k	957 to 1043
1		50	957 to 1043
1		100	957 to 1043
1		10 k	957 to 1043
1		30 k	957 to 1043
1		50 k	957 to 1043

Table 14. (Cont.)

Voltage (V)	Applied	Frequency (Hz)	Limits (mV AC)
2		1 k	1917 to 2083
5		1 k	4797 to 5203
10		1 k	9597 to 10403
30		1 k	28797 to 31203

4.3.1.14 Set Meter Calibrator OPR/STBY switch to STBY and leave equipment connected.

4.3.2 AUDIO OSCILLOSCOPE VOLTAGE CALIBRATION:

4.3.2.1 On the TI, press AF TEST and set controls as follows:

SCOPE/BAR	Scope
AC/DC	DC

4.3.2.2 Set TI Time/div control to 200 μ s/div.

4.3.2.3 Set TI Volts/div to the first value listed in the TI Range column of Table 15.

4.3.2.4 Set Meter Calibrator output for 0.00 VDC.

4.3.2.5 Set Meter Calibrator OPR/STBY switch to OPR.

4.3.2.6 Adjust TI SCOPE knob to place trace 2 div below center horizontal graticule line.

4.3.2.7 Set Meter Calibrator OPR/STBY switch to STBY.

4.3.2.8 Set Meter Calibrator to the first value listed in the Applied column of Table 15.

4.3.2.9 Set Meter Calibrator OPR/STBY switch to OPR.

4.3.2.10 Adjust Meter Calibrator output controls for a deflection 2 div above the center horizontal graticule.

4.3.2.11 Verify the Meter Calibrator indicates within the values listed in the Limits column of Table 15.

4.3.2.12 Set Meter Calibrator OPR/STBY switch to STBY.

4.3.2.13 Repeat steps 4.3.2.2 through 4.3.2.12 for the remaining corresponding listed values in Table 15.

Table 15.

TI Range (V/div)	Applied (VDC)	Limits (VDC)
10 m	40 m	37 to 43 m
20 m	80 m	74 to 86 m
50 m	200 m	185 to 215 m
100 m	400 m	370 to 430 m
200 m	800 m	740 to 860 m
500 m	2.00	1.85 to 2.15
1	4.00	3.7 to 4.3
2	8.00	7.4 to 8.6
5	20.00	18.5 to 21.5
10	40.00	37.0 to 43.0
20	80.00	74.0 to 86.0

4.3.2.14 Disconnect test setup.

4.3.3 AUDIO SINAD METER, DISTORTION METER AND S/N METER CALIBRATION:

4.3.3.1 Connect TI AF GEN OUT to TI AF INPUT and Digital Multimeter.

4.3.3.2 Set Digital Multimeter for a VAC measurement.

4.3.3.3 On the TI, press AF TEST and Audio Gen. Set AF1 LEVEL to 1 V as monitored on Digital Multimeter.

4.3.3.4 Press the TI ON/OFF to set AF1 to OFF.

4.3.3.5 On the TI, press GEN 1/GEN 2 to select GEN 2. Set AF2 FREQ to 400 Hz and AF2 LEVEL to 20 mV as monitored on Digital Multimeter.

NOTE

This will set AF1 to 1 VAC output at 1 kHz and AF2 to 20 mVAC at 400 Hz.

4.3.3.6 On the TI, press GEN 1/GEN 2 to select GEN 1.

4.3.3.7 Press the TI ON/OFF to set AF1 ON.

4.3.3.8 On the TI, press Return, DIST/S-N and DIST'N.

4.3.3.9 Verify the TI Distortion Meter indicates within 1.4 to 2.6% distortion.

4.3.3.10 On the TI, press the TI ON/OFF to set AF1 OFF.

4.3.3.11 On the TI, press GEN 1/GEN 2 to select AF2. Set the TI AF2 LEVEL to 250 mV as monitored on Digital Multimeter.

4.3.3.12 On the TI, press GEN 1/GEN 2 to select AF1. Press the TI ON/OFF to set AF1 ON.

4.3.3.13 On the TI, press Return, DIST/S-N and DIST*N.

4.3.3.14 Verify the TI Distortion Meter indicates within 23.2 to 26.8% distortion.

4.3.3.15 On the TI, press Return, DIST/S-N and SINAD.

4.3.3.16 Verify the TI SINAD Meter indicates within 11 to 13 dB.

4.3.3.17 Set all output levels to minimum and disconnect test setup.

4.4 TRANSMITTER CALIBRATION:

4.4.1 RF POWER METER CALIBRATION:

4.4.1.1 On the TI, set the CHARGE/OFF/ON (rear panel) switch to OFF. Set the TI CHARGE/OFF/ON (rear panel) switch to ON.

4.4.1.2 Press the Measuring Receiver INSTR PRESET. Standardize the Measuring Receiver and Sensor Module.

4.4.1.3 Connect the Synthesized Signal Generator through a low loss cable to the Sensor Module input.

4.4.1.4 On the Measuring Receiver, press RF POWER and LOG/LIN for a dBm indication.

4.4.1.5 Set the Synthesized Signal Generator output for the first value listed in the Signal Generator Level and Frequency columns of Table 16 as indicated on the Measuring Receiver.

4.4.1.6 Set the Synthesized Signal Generator RF OFF/ON to OFF.

4.4.1.7 Disconnect the Sensor Module from the low loss cable.

4.4.1.8 Connect the Synthesized Signal Generator through the same low loss cable used in step 4.4.1.3 to the TI N-type connector.

4.4.1.9 On the TI, press TX TEST, then press RF IN/OUT SELECT to select the N-Type output/N-Type input.

4.4.1.10 Set the Synthesized Signal Generator RF OFF/ON to ON.

4.4.1.11 Verify the TI indicates within the values listed in the Limits column of Table 16.

4.4.1.12 Set the Synthesized Signal Generator RF OFF/ON to OFF and disconnect from TI.

4.4.1.13 Repeat steps 4.4.1.3 through 4.4.1.12 for the remaining corresponding values listed in Table 16.

Table 16.

Signal Generator		
Level (dBm)	Frequency (MHz)	TI Limits (dBm)
+15.0	10	+14.4 to 15.5
+15.0	100	+14.4 to 15.5
+15.0	250	+14.4 to 15.5
+15.0	500	+14.4 to 15.5
+15.0	750	+14.4 to 15.5
+15.0	1000	+14.4 to 15.5

4.4.1.14 Disconnect the test setup.

4.4.1.15 Connect equipment as shown in Figure 2.



Take care when touching the RF Input N Type connector after the application of high levels of continuous power. If 50 W is exceeded for a prolonged period, the temperature of the connector can become excessive.



A power overload condition is indicated by an audible and visual warning. Should this condition be indicated, immediately reduce the level of RF power from the transmitter into the TI.

Do not stop the warning by switching off the TI, as this will silence the warning but will leave the excessive RF power connected to the internal load.

Do not attempt to stop the warning by disconnecting the RF connector, as this can damage the transmitter and may cause electric shock or skin burns.

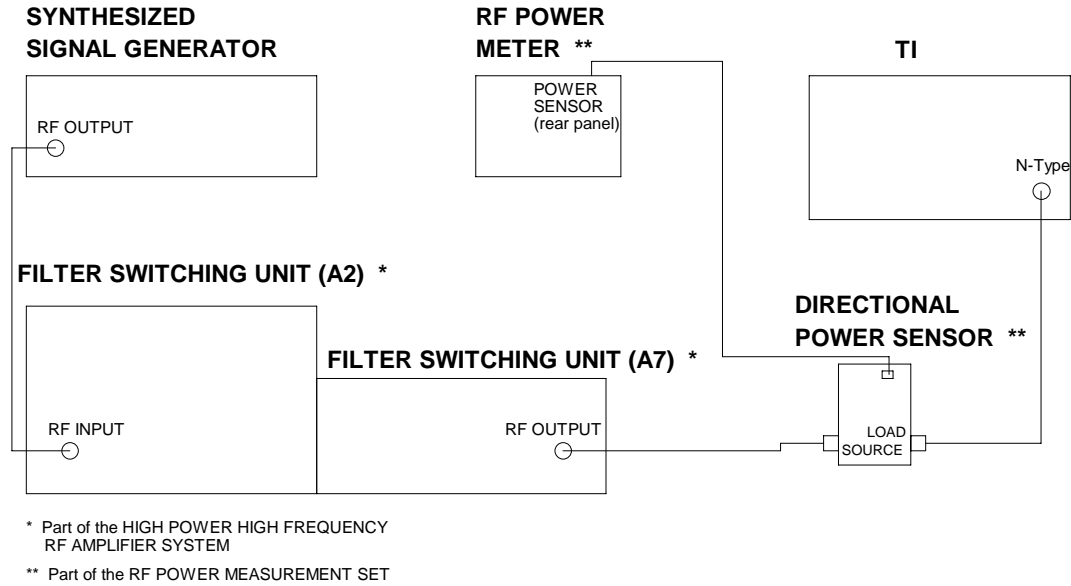

Figure 2.

NOTE

Use the applicable Directional Power Sensor, as required, for the frequency being tested.

4.4.1.16 Set the RF Power Meter, as required, to measure Watts.

4.4.1.17 On the Filter Switching Unit (A2), select the Band, as required, for the Test Frequency being tested.

4.4.1.18 On the Filter Switching Unit (A2), set the RF OUTPUT LEVEL CONTROL fully CCW and press the OPER/STBY key until the OPERATE lamp illuminates.

NOTE

Ensure the RF Power Meter FWD lamp is illuminated. If not, press the RF PWR key.

4.4.1.19 Set the Synthesized Signal Generator, as required, to 0.0 dBm at the first frequency listed in the Frequency column of Table 17.

4.4.1.20 Set the Filter Switching Unit (A2) RF OUTPUT LEVEL CONTROL for a RF Power Meter indication of the first value listed in the Applied column of Table 17.

NOTE

It may not be possible to set the Filter Switching Unit (A2) RF OUTPUT LEVEL CONTROL for an exact indication of the value listed in the TI WATTS meter indication column of Table 17. If it is not, set the RF OUTPUT LEVEL CONTROL as close as possible and calculate the limits from the TI WATTS meter displayed value.

4.4.1.21 Verify the TI indicates within the values listed in the Limits column of Table 17.

4.4.1.22 Set the Filter Switching Unit (A2) RF OUTPUT LEVEL CONTROL fully CCW.

4.4.1.23 Repeat steps 4.4.1.17 through 4.4.1.22 for the remaining corresponding values listed in Table 17. Use the applicable Directional Power Sensor, as required, for the frequency being tested.

Table 17.

Frequency (MHz)	Applied (meter indication)	Limits (W)
10.0000	15	13.2 to 16.9
10.0000	50	44.0 to 56.3
10.0000	100	88.0 to 113
100.0000	15	13.2 to 16.9
100.0000	50	44.0 to 56.3
100.0000	100	88.0 to 113
500.0000	15	13.2 to 16.9
500.0000	50	44.0 to 56.3
500.0000	100	88.0 to 113
1000.0000	15	13.2 to 16.9
1000.0000	50	44.0 to 56.3
1000.0000	100	88.0 to 113

4.4.1.24 Set Synthesized Signal Generator output to minimum. Disconnect the test setup.

4.4.2 AMPLITUDE MODULATION DEPTH CALIBRATION:

4.4.2.1 Connect equipment as shown in Figure 3.

4.4.2.2 On the TI, press Tx TEST, Mod Meter. Press the AM/FM/SSB to select AM. Press RF IN/OUT SELECT to select the BNC/ANTENNA input.

NOTE

From the power up default, the TI should already have an IF FILTER of 30 kHz and AF FILTER of 0.3 to 3.4 kHz selected. Verify this is the case and select if necessary.

NOTE

It may be necessary to change the TI Tx FREQ (or reselect AUTOTUNE) if the displayed Tx FREQ does not agree with the Signal Generator output frequency.

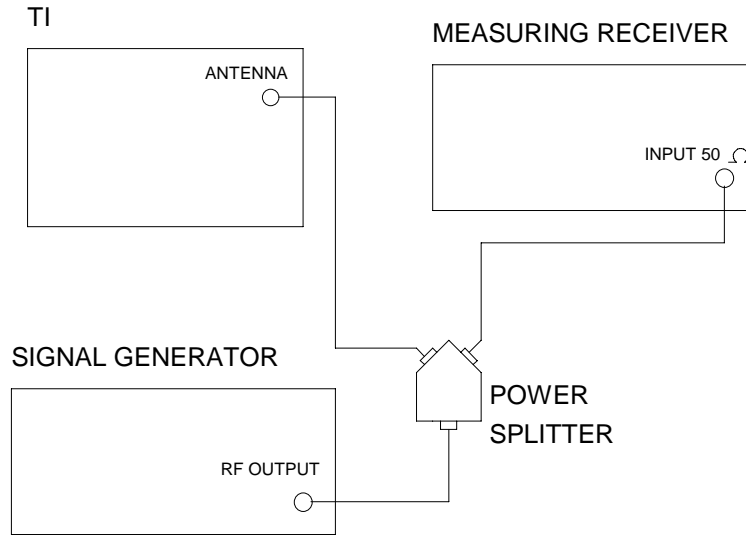

Figure 3.

4.4.2.3 Set the Signal Generator to -10 dBm and to the first frequency listed in the Signal Generator Frequency column of Table 18. Record TI AM indication.

4.4.2.4 Set the Signal Generator Modulation to AM and Modulation Frequency to the first value in the Modulation Frequency column of Table 18. Set the Modulation to on.

4.4.2.5 Press the Measuring Receiver INSTR PRESET. Press the AM mode key. Set the Measuring Receiver HP and LP Filters to the first settings listed in the applicable Measuring Receiver Filter columns of Table 18.

4.4.2.6 Set the Signal Generator to the first value in the AM Depth column of Table 18 as indicated on the Measuring Receiver.

4.4.2.7 Subtract the value recorded in step 4.4.2.3 from the TI indication. The result must indicate within the values listed in the Limits column of Table 18.

4.4.2.8 Repeat steps 4.4.2.3 through 4.4.2.7 for the remaining corresponding values listed in Table 18.

Table 18.

Modulation Frequency (kHz)	Signal Generator Frequency (MHz)	Measuring Receiver Filters		AM Depth (%)	Limits (%)
		HP	LP		
1	10	300	3k	30	27 to 33
1	10	300	3k	50	46 to 54
1	10	300	3k	90	84 to 96
1	100	300	3k	50	46 to 54
1	250	300	3k	50	46 to 54

Table 18. (Cont.)

Modulation Frequency (kHz)	Signal Generator Frequency (MHz)	Measuring Receiver Filters		AM Depth (%)	Limits (%)
		HP	LP		
1	500	300	3k	50	46 to 54
1	750	300	3k	50	46 to 54
1	1000	300	3k	50	46 to 54
0.05 *	10	none	3k	30	26 to 34
0.05	10	none	3k	50	45 to 55
0.05	10	none	3k	90	81 to 99
0.05	100	none	3k	50	45 to 55
0.05	250	none	3k	50	45 to 55
0.05	500	none	3k	50	45 to 55
0.05	750	none	3k	50	45 to 55
0.05	1000	none	3k	50	45 to 55
10 **	10	300	15k	30	26 to 34
10	10	300	15k	50	45 to 55
10	10	300	15k	90	81 to 99
10	100	300	15k	50	45 to 55
10	250	300	15k	50	45 to 55
10	500	300	15k	50	45 to 55
10	750	300	15k	50	45 to 55
10	1000	300	15k	50	45 to 55

* Set the TI AF FILTER to 3 kHz LP for 50 Hz modulation frequency.

** Set the TI AF FILTER to 15 kHz LP and IF FILTER to 300 kHz for 10 kHz modulation frequency.

4.4.2.9 Set the Signal Generator output to minimum and leave equipment connected.

4.4.3 FREQUENCY MODULATION DEVIATION CALIBRATION:

4.4.3.1 On the TI, press Tx TEST, Mod Meter. Set the controls as follows:

AM/FM/SSB	FM
Tx FREQ	First value listed in the Signal Generator Frequency column of Table 20

NOTE

It may be necessary to change the TI Tx FREQ (or reselect AUTOTUNE) if the displayed Tx FREQ does not agree with the Signal Generator output frequency.

4.4.3.2 Set the Signal Generator to -10 dBm and to the first frequency listed in the Signal Generator Frequency column of Table 20.

4.4.3.3 Set the Signal Generator Modulation to FM and Modulation Frequency to the first value listed in the Modulation Frequency column of Table 20. Set the Modulation to on.

4.4.3.4 Press the Measuring Receiver INSTR PRESET. Press FM mode key.

4.4.3.5 Set the Measuring Receiver HP and LP FILTERS and TI AF FILTERS to the corresponding settings listed in Table 19. Set TI IF FILTER to 30 kHz.

4.4.3.6 Set the Signal Generator Modulation controls to the first value listed in the Deviation column of Table 20 as indicated on the Measuring Receiver.

4.4.3.7 Verify the TI indicates within the values listed in the Limits column of Table 20.

4.4.3.8 Repeat steps 4.4.3.1 through 4.4.3.7 for the remaining corresponding values listed in Table 20. For Deviation Frequencies ≥ 50 kHz set the TI IF FILTER to 300 kHz.

Table 19.

Modulation Frequency (kHz)	Measuring Receiver Filters		TI AF Filters
	HP (Hz)	LP (Hz)	LP (Hz)
0.05	none	3k	3k
1.0	300	3k	3k
10	300	15k	15k

Table 20.

Signal Generator Frequency (MHz)	Deviation (kHz)	Modulation Frequency (kHz)	Limits (kHz)
500	1	0.05	0.91 to 1.09
1000	1	0.05	0.91 to 1.09
10	50	0.05	45.8 to 54.3
500	50	0.05	45.8 to 54.3
1000	50	0.05	45.8 to 54.3
10	75	0.05	68.6 to 81.4
500	75	0.05	68.6 to 81.4
1000	75	0.05	68.6 to 81.4
10	1	1.0	0.94 to 1.06
500	1	1.0	0.94 to 1.06
1000	1	1.0	0.94 to 1.06
10	50	1.0	47.0 to 53.0
500	50	1.0	47.0 to 53.0
1000	50	1.0	47.0 to 53.0
10	75	1.0	70.5 to 79.5
500	75	1.0	70.5 to 79.5
1000	75	1.0	70.5 to 79.5
10	1	10.0	0.91 to 1.09
500	1	10.0	0.91 to 1.09
1000	1	10.0	0.91 to 1.09
10	50	10.0	45.8 to 54.3
500	50	10.0	45.8 to 54.3
1000	50	10.0	45.8 to 54.3

Table 20. (Cont.)

Signal Generator Frequency (MHz)	Deviation (kHz)	Frequency Modulation (kHz)	Limits (kHz)
10	75	10.0	68.6 to 81.4
500	75	10.0	68.6 to 81.4
1000	75	10.0	68.6 to 81.4

4.4.3.9 Set the Signal Generator output to minimum and disconnect test setup.

4.4.4 FREQUENCY MODULATION DEMODULATION DISTORTION AND RESIDUAL FM CALIBRATION:

4.4.4.1 On the TI, set the CHARGE/OFF/ON (rear panel) switch to OFF, then set the TI CHARGE/OFF/ON (rear panel) switch to ON.

4.4.4.2 Connect AM/FM Test Source FM OUTPUT to the TI ANTENNA input. Connect the Audio Analyzer HIGH output to the AM/FM Test Source AUDIO INPUT.

4.4.4.3 On the TI, press the RF IN/OUT SELECT to select the ANTENNA input.

4.4.4.4 Set the controls as follows:

Tx FREQ	Auto Tune
Return	
Mod Meter	
AM/FM/SSB	FM

4.4.4.5 Set the AM/FM Test Source TEST MODE to FM. Set the AM/FM Test Source CARRIER FREQUENCY TUNE for a TI TX FREQ indication of about 400 MHz.

4.4.4.6 Set the Audio Analyzer frequency to 1 kHz and amplitude for 5 kHz Deviation as displayed on TI.

4.4.4.7 On the TI, press the AF FILTER and set to 0.3 to 3.4 kHz. Press the TI IF FILTER and set to 30 kHz. Press the TI DIST/S-N and set to DIST N.

4.4.4.8 Verify the TI distortion meter indicates <2%.

4.4.4.9 Set the Audio Analyzer amplitude to minimum and disconnect test setup.

4.4.4.10 Connect the AM/FM Test Source LOW RESIDUAL OUTPUT to the TI ANTENNA input.

4.4.4.11 Set the AM/FM Test Source TEST MODE to RESIDUAL FM.

4.4.4.12 Ensure the TI TX FREQ indicates about 560 MHz. Press the TI IF FILTER and set to 3 kHz.

4.4.4.13 Verify the TI FM LEVEL indicates <30 Hz.

4.4.4.14 Disconnect test setup.

4.4.5 AMPLITUDE MODULATION DEMODULATION DISTORTION AND RESIDUAL AM CALIBRATION:

4.4.5.1 On the TI, set the CHARGE/OFF/ON (rear panel) switch to OFF, then set the CHARGE/OFF/ON (rear panel) switch to ON.

4.4.5.2 Connect the AM/FM Test Source AM FM ÷32 OUTPUT to the TI ANTENNA input. Connect the Audio Analyzer HIGH output to the AM/FM Test Source AUDIO INPUT.

4.4.5.3 On the TI, press the RF IN/OUT SELECT to select the ANTENNA input.

4.4.5.4 Set the controls as follows:

Tx FREQ	Auto Tune
Return	
Mod Meter	
AM/FM/SSB	AM

4.4.5.5 Set the AM/FM Test Source TEST MODE to AM. Set the AM/FM Test Source CARRIER FREQUENCY TUNE for a TI TX FREQ indication of about 12.5 MHz.

4.4.5.6 Set the Audio Analyzer frequency to 1 kHz and amplitude for 30% depth as displayed on TI.

4.4.5.7 On the TI, press the AF FILTER and select the 0.3 to 3.4 kHz filter. Press the TI IF FILTER and set to 30 kHz. Press the TI DIST/S-N and set to DIST'N.

4.4.5.8 Verify the TI distortion meter indicates <2%.

4.4.5.9 Set the Audio Analyzer amplitude to minimum and disconnect from AM/FM Test Source AUDIO INPUT.

4.4.5.10 Verify the TI MOD LEVEL indicates <1%.

4.4.5.11 Disconnect test setup.

4.5 RF SPECTRUM ANALYZER CALIBRATION:

4.5.1 LEVEL FLATNESS CALIBRATION:

4.5.1.1 Standardize the Measuring Receiver and Sensor Module.

4.5.1.2 Connect the Signal Generator output to the Power Splitter input. Connect one leg of the Power Splitter to the Measuring Receiver and Sensor Module. Connect the other leg to the TI ANTENNA input.

4.5.1.3 Set the Measuring Receiver for a Power measurement.

4.5.1.4 On the TI, press the RF IN/OUT SELECT to select the Antenna input.

4.5.1.5 Set the TI to SPEC ANA. Set the VERT SCALE to 2 dB/div and SPAN to 52 MHz.

4.5.1.6 Set the Signal Generator Frequency to the first value listed in the Frequency column of Table 21. Set the Signal Generator Output Level for -6 dBm as monitored on the Measuring Receiver.

4.5.1.7 Set the Signal Generator Output Level to set the displayed signal on the TI center graticule line.

4.5.1.8 Record the Measuring Receiver indication, as the reference, in the Measuring Receiver indication column in a copy of Table 21.

4.5.1.9 Set the Signal Generator Frequency to the next value listed in the Frequency column of Table 21.

4.5.1.10 Set the Signal Generator Output Level to set the displayed signal on the TI center graticule line.

4.5.1.11 Record the Measuring Receiver indication in a copy of Table 21.

4.5.1.12 Repeat steps 4.5.1.10 and 4.5.1.11 for the remaining corresponding values listed in Table 21.

Table 21.

Frequency (MHz)	Measuring Receiver indication (dBm)
100	_____ (Reference)
75	_____
88	_____
112	_____
125	_____

4.5.1.13 Subtract each value recorded in the Measuring Receiver indication column of Table 21 from the Reference value (100 MHz Measuring Receiver indication). Record the results.

4.5.1.14 Determine the most positive and most negative values from the values recorded in step 4.5.1.13.

4.5.1.15 Algebraically add the values determined in step 4.5.1.14. Verify the result is ≤ 2.2 dB.

4.5.1.16 Set the Signal Generator Output Level to minimum and disconnect test setup.

4.5.2 INTERMODULATION DISTORTION CALIBRATION:

4.5.2.1 Standardize the Measuring Receiver and Sensor Module for a Power Measurement.

4.5.2.2 Connect the equipment as shown in Figure 4 with the Power Sensor connected to the Directional Bridge (TI is not connected at this time).

4.5.2.3 Set the Signal Generator to 50 MHz at -10 dBm as monitored on the Measuring Receiver.

4.5.2.4 Press the Signal Generator AMPLITUDE and FCTN OFF keys.

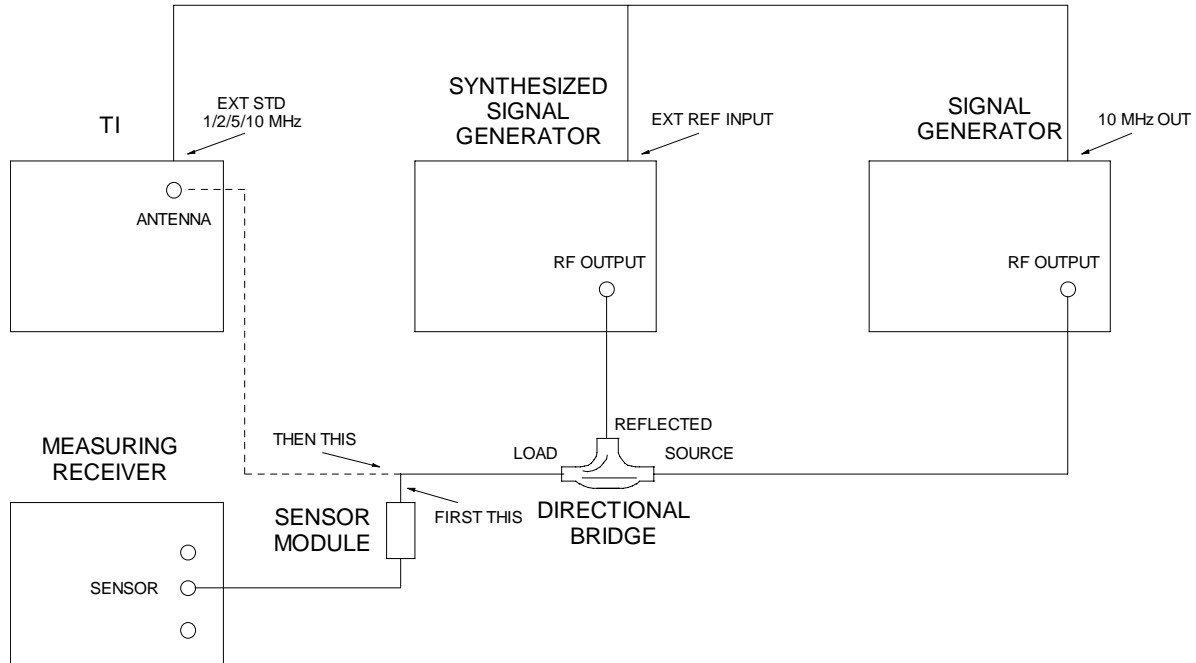

Figure 4.

4.5.2.5 On the TI, press the RF IN/OUT SELECT to select the Antenna input. Press SPEC ANA and set the controls as follows:

Attn	20 dB
Res BW	300 Hz
Ref Level	-10 dBm
Vert Scale	10 dB/div
Centre Freq	50.02 MHz
Span	200 kHz

4.5.2.6 Disconnect the Sensor Module from the LOAD of the Direction Bridge and connect Directional Bridge to TI ANTENNA input.

4.5.2.7 Press the Signal Generator AMPLITUDE key to turn on the output level.

4.5.2.8 On the TI, press the Marker to Ref.

4.5.2.9 Press the Signal Generator AMPLITUDE and FCTN OFF keys.

4.5.2.10 Set the Synthesized Signal Generator to 50.04 MHz and adjust Synthesized Signal Generator output level to the Marker to Ref level established in step 4.5.2.8.

4.5.2.11 Press the Signal Generator AMPLITUDE key to turn on the output level.

4.5.2.12 Verify the Third Intermodulation Distortion Products that are +40 kHz and -40 kHz of the center vertical graticule line are <-70 dBc.

4.5.2.13 Set the Signal Generator and Synthesized Signal Generator outputs to minimum and disconnect test setup.

4.5.2.14 If TI has OPT 01 proceed to para 4.7; otherwise proceed to para 4.6.

4.6 AUDIO GENERATOR CALIBRATION:

4.6.1 LEVEL CALIBRATION:

4.6.1.1 Connect the TI AF GEN OUT connector to the Digital Multimeter Input.

4.6.1.2 Set the Digital Multimeter for a VAC measurement.

4.6.1.3 On the TI, press AF TEST, Audio Gen and set the controls as follows:

Gen 1/Gen 2	Gen 1
FREQ Frequency column of Table 22	First value in the TI Audio
LEVEL	1 V

NOTE

Verify that TI AF GEN 2 is not activated.

4.6.1.4 Verify the Digital Multimeter indicates within the values listed in the Limits column of Table 22.

4.6.1.5 Repeat steps 4.6.1.3 and 4.6.1.4 for the remaining corresponding values listed in Table 22.

Table 22.

TI Audio Level (V)	TI Audio Frequency (Hz)	Limits (V)
1	50	0.949 to 1.051
1	500	0.949 to 1.051
1	5 k	0.949 to 1.051
1	10 k	0.949 to 1.051
1	20 k	0.949 to 1.051
2	50	1.899 to 2.101
2	20 k	1.899 to 2.101
4	50	3.799 to 4.201

Table 22. (Cont.)

TI Audio Level (V)	TI Audio Frequency (Hz)	Limits (V)
4	20 k	3.799 to 4.201
20 m	50	18.9 to 21.1 m
20 m	20 k	18.9 to 21.1 m
400 m	50	379.9 to 420.1 m
400 m	20 k	379.9 to 420.1 m

4.6.1.6 Set TI Audio Gen, Gen 1 Level to minimum.

4.6.1.7 Repeat steps 4.6.1.3 through 4.6.1.6 substituting GEN 2 for GEN 1.

4.6.1.8 Set TI Audio Gen, Gen 2 Level to minimum and disconnect the test setup.

4.6.2 LEVEL DISTORTION CALIBRATION:

4.6.2.1 Connect the TI AF GEN OUT connector to the Audio Analyzer HIGH input.

4.6.2.2 On the TI, press AF TEST, Audio Gen and set the controls as follows:

Gen 1/Gen 2	Gen 1
FREQ	First value listed in the TI Audio Frequency column of Table 23
LEVEL	1 V

NOTE

Verify that TI AF GEN 2 is not activated.

4.6.2.3 Set the Audio Analyzer as required to measure distortion at 1 kHz.

4.6.2.4 Verify the Audio Analyzer indicates within the values listed in the Limits column of Table 23.

4.6.2.5 Repeat steps 4.6.2.2 through 4.6.2.4 for the remaining corresponding values listed in Table 23.

Table 23.

TI Audio Level (V)	TI Audio Frequency (Hz)	Limits (%)
1	1 k	<0.5
1	50	<1.0
1	5 k	<1.0
1	10 k	<1.0
1	15 k	<1.0

4.6.2.6 Set TI AF GEN 1 Level to minimum.

4.6.2.7 Repeat steps 4.6.2.3 through 4.6.2.6 substituting GEN 2 for GEN 1.

4.6.2.8 Set TI Audio Gen, Gen 2 Level to minimum and disconnect the test setup.

4.6.2.9 Set all POWER switches to OFF. Disconnect and secure all equipment.

4.7 AUDIO GENERATOR CALIBRATION: (Opt 01 Only)

4.7.1 OUTPUT CIRCUIT LEVEL CALIBRATION:

4.7.1.1 Connect the TI AF GEN OUT connector through the Feedthrough Termination to the Digital Multimeter Input.

4.7.1.2 Set the Digital Multimeter for a VAC measurement.

4.7.1.3 On the TI, press HELP/SETUP, SETUP, then SETUP PAGE 2.

4.7.1.4 Set the TI AUDIO INPUT IMPEDANCE HIGH/600 Ω BAL to 600 Ω BAL. Set the TI AUDIO OUTPUT IMPEDANCE LOW/600 Ω BAL to 600 Ω BAL.

4.7.1.5 On the TI, press AF TEST, Audio Gen and set the controls as follows:

Gen 1/Gen 2	AF 1
AF 1 FREQ	1 kHz
Sin LEVEL	First value listed in the Applied column of Table 24
AF 1	on

NOTE

Verify that TI AF 2 is not activated.

4.7.1.6 Verify the Digital Multimeter indicates within the values listed in the Limits column of Table 24.

4.7.1.7 Repeat steps 4.7.1.5 and 4.7.1.6 for the remaining corresponding values listed in Table 24.

Table 24.

Applied (V rms)	Limits (V rms)
1 m	0.98 to 1.02 m
10 m	9.80 to 10.20 m
100 m	98 to 102 m
500 m	490 to 510 m
1	0.98 to 1.02
2.5	2.45 to 2.55

4.7.1.8 Set TI AF 1 Level to minimum. Press the TI ON/OFF to set AF 1 to off.

4.7.1.9 Press TI Gen 1/Gen 2 to select AF 2. Press the TI ON/OFF to set AF 2 to on.

4.7.1.10 Repeat steps 4.7.1.5 through 4.7.1.7 substituting AF 2 for AF 1.

4.7.1.11 Set TI AF 2 Level to minimum. Press the TI ON/OFF to set AF 2 to off.

4.7.1.12 Disconnect test setup.

4.7.2 OUTPUT CIRCUIT FREQUENCY RESPONSE CALIBRATION:

CAUTION

Set Audio Generator Level to minimum before making or removing connections from the Thermal Converter. Take several seconds to increase Audio Generator to desired level and several seconds to decrease Audio Generator level to minimum.

4.7.2.1 Connect the Meter Calibrator directly to the Thermal Converter Input. Connect the Thermal Converter Output to the Digital Multimeter Input. Set the Digital Multimeter for a VDC measurement.

4.7.2.2 Set the Meter Calibrator to each of the following values in the Applied column, recording the Digital Multimeter indication at each setting.

Applied (VDC)	Tolerance	Digital Multimeter
2.7696	+2 dB	_____
2.3304	+0.5 dB	_____
2.2000	Reference	_____
2.0769	-0.5 dB	_____
1.7475	-2 dB	_____

4.7.2.3 Set the Meter Calibrator to minimum and disconnect from the Thermal Converter.

4.7.2.4 Connect the TI AF GEN OUT directly to the Thermal Converter Input.

4.7.2.5 On the TI, press AF TEST, Audio Gen and set the controls as follows:

Gen 1/Gen 2	AF 1
AF 1 FREQ	1 kHz
AF 1	on

NOTE

Verify that TI AF 2 is not activated.

4.7.2.6 On the TI, press LEVEL and, using the rotary knob, adjust TI AF1 Sin Level for a Digital Multimeter indication of the value equivalent to 2.2000 V Reference recorded in step 4.7.2.2.

4.7.2.7 On the TI, press FREQ. Slowly vary the TI AF 1 FREQ over the range of 200 Hz to 5 kHz. Verify the Digital Multimeter indicates within the values recorded in step 4.7.2.2 for 2.0769 (-0.5 dB) and 2.3304 (+0.5 dB).

4.7.2.8 Slowly vary the TI AF 1 FREQ over the range of 100 Hz to 20 kHz. Verify the Digital Multimeter indicates within the values recorded in step 4.7.2.2 for 1.7475 (-2 dB) and 2.7696 (+2 dB).

4.7.2.9 Set TI AF 1 Level to minimum. Press the TI ON/OFF to set AF 1 to off.

4.7.2.10 Press TI Gen 1/Gen 2 to select AF 2. Press the TI ON/OFF to set AF 2 to on.

4.7.2.11 Repeat steps 4.7.2.5 through 4.7.2.8 substituting AF 2 for AF 1.

4.7.2.12 Set TI AF 2 Level to minimum. Press the TI ON/OFF to set AF 2 to off.

4.7.2.13 Disconnect test setup.

4.7.3 INPUT CIRCUIT FREQUENCY RESPONSE CALIBRATION:

4.7.3.1 Connect the Meter Calibrator OUTPUT HI and LO to the TI AF INPUT connector. Connect the AC Measurement Standard INPUT 2 HI and LO to the TI AF INPUT connector (this will monitor the Meter Calibrator at the TI AF INPUT).

4.7.3.2 On the TI, press AF TEST.

4.7.3.3 On the TI, press the TI AC/DC key to set TI Coupling to DC. On the TI, press the TI AF FILTER , then the 50 kHz LP Filter.

4.7.3.4 Set the Meter Calibrator to 1 kHz and for a TI indication of 1.000 V rms. Record the AC Measurement Standard indication.

4.7.3.5 Set the Meter Calibrator frequency to the first value listed in the Applied column of Table 25.

4.7.3.6 Set the Meter Calibrator amplitude for an AC Measurement Standard indication of the value recorded in step 4.7.3.4.

4.7.3.7 Verify the TI indicates within the values listed in the Limits column of Table 25.

4.7.3.8 Repeat steps 4.7.3.5 through 4.7.3.7 for the remaining corresponding values listed in Table 25.

Table 25.

Applied (Hz)	Limits (V rms)
100	0.794 to 1.259
201	0.944 to 1.059
500	0.944 to 1.059
1 k	0.944 to 1.059
2 k	0.944 to 1.059
4.99 k	0.944 to 1.059
5.01 k	0.794 to 1.259
10 k	0.794 to 1.259
15k	0.794 to 1.259
20 k	0.794 to 1.259

4.7.3.9 Set the Meter Calibrator output to minimum.

4.7.3.10 Set all POWER switches to OFF. Disconnect and secure all equipment.

CALIBRATION PERFORMANCE TABLE

Not Required

APPENDIX A**A-1 TIME BASE ADJUSTMENT:**

A-1.1 On the TI, press HELP SETUP, then Calibrate.

A-1.2 If the Calibrate key is locked, the message ENTRY CODE will appear.

A-1.2.1 Key in the code: 2, 9, 4 and 5, then press dBm/ENTER. If the procedure has been carried out correctly the LOCKED message will be removed, and the Calibrate key will now be active.

A-1.3 On the TI, press Freq Std to enter the FREQ STANDARD CAL display.

A-1.4 Connect Frequency Standard 10 MHz REF OUT to the Signal Generator EXT STD INPUT (rear panel). Set Signal Generator for EXT input.

A-1.5 Set Signal Generator for 1000 MHz, 0 dBm output. Connect Signal Generator output to TI N-Type RF connector.

A-1.6 The offset reading at the bottom of the TI display will now indicate the TI reading error at 1000 MHz.

A-1.7 Use the front panel variable control to alter the calibration value displayed, until the offset reading is as close to 0 Hz as possible. (The ↑ and ↓ keys switch between coarse and fine adjustments.)

A-1.8 When the offset indication has been set to as close to 0 Hz as practical, press Return, Store, Cal.

A-1.9 Disconnect equipment from TI and continue with para 4.2.