

TECHNICAL MANUAL
CALIBRATION PROCEDURE
FOR
COMMUNICATIONS SERVICE MONITOR
2947
(MARCONI)
2947, 2947A
(IFR)

This publication replaces T.O. 33K3-4-3213-1 dated 30 December 2015.



Distribution Statement C - Distribution authorized to U. S. Government agencies and their contractors for official use or for administrative or operational purposes only, 30 December 1998. Requests for this document shall be referred to AFMETCAL, 813 Irving-Wick Dr W, Heath, OH 43056-1199.

Destruction Notice - For unclassified, limited documents, destroy by any method that will prevent disclosure of the contents or reconstruction of the document.

T.O. 33K3-4-3213-1

LIST OF EFFECTIVE PAGES

INSERT LATEST CHANGED PAGES. DESTROY SUPERSEDED PAGES.

NOTE: The portion of the text and illustrations affected by the changes is indicated by a vertical line in the outer margins of the page.

Date of issue for original and changed pages are:

Original.....030 June 2016

TOTAL NUMBER OF PAGES IN THIS PUBLICATION IS 40, CONSISTING OF THE FOLLOWING:

Page No.	* Change No.	Page No.	* Change No.	Page No.	* Change No.
Title	0				
A	0				
1 - 35.....	0				
36 Blank.....	0				
A-1	0				
A-2 Blank	0				

*Zero in this column indicates an original page

COMMUNICATIONS SERVICE MONITOR

2947

(MARCONI)

2947, 2947A

(IFR)

1 CALIBRATION DESCRIPTION:*Table 1.*

Test Instrument (TI) Characteristics	Performance Specifications	Test Method
Frequency Standard	Range: 10 MHz Accuracy: (OCXO): Aging/year: $<1 \times 10^{-7}$; Temperature: $<5 \times 10^{-8}$ (0 to +55 °C) *	Verified with a Frequency Standard and Electronic Counter
Display	Range: 400 kHz to 1.05 GHz Accuracy: ± 1 count of LSD	Verified during Frequency Standard Calibration
RF Signal Generator		
Frequency	Range: 400 kHz to 1.05 GHz Accuracy: Same as Frequency Standard	Verified during Frequency Standard Calibration
Output Level	Range: -141 to -21 dBm, N-type connector; -115 to +5 dBm, BNC connector Accuracy: ± 2 dB, for levels > -127 dBm, to 1 GHz on N-type connector	Measured with a Power Meter and Power Sensor and Microwave Measurement Receiver
Spectral Purity		
Residual FM	Range: 400 kHz to 1.05 GHz Accuracy: < 12 Hz rms, 0.3 to 3.4 kHz Bandwidth	Measured with Microwave Measurement System
Harmonics	Range: 400 kHz to 1.05 GHz Accuracy: < -25 dBc	Measured with Spectrum Analyzer
Spurious Signals	Range: 400 kHz to 1.05 GHz Accuracy: < -50 dBc	Measured with Spectrum Analyzer

 See footnote at end of Table.

Table 1. (Cont.)

Test Instrument (TI) Characteristics	Performance Specifications	Test Method
<i>RF Signal Generator (Cont.)</i>		
Single Sideband Phase Noise	Range: 400 kHz to 1.05 GHz Accuracy: (2947) <-108 dBc/Hz at 20 kHz offset; (2947A) <-108 dBc/Hz at 20 kHz offset, to 1 GHz	Measured with MMR Spectrum Analyzer
Amplitude Modulation (Internal)	Range: 1.5 MHz to 1.0 GHz, 0 to 99% depth at 20 Hz to 20 kHz modulation frequency Accuracy: (2947) $\pm 5\% \pm 1$ digit, for modulation frequency of 1 kHz, at 50% depth; (2947A) $\pm 5\% \pm 1$ digit, for modulation frequency of 1 kHz, at 50% depth, CW <400 MHz; $\pm 7\% \pm 1$ digit, for modulation frequency of 1 kHz, at 50% depth, CW >400 MHz	Measured with Microwave Measurement System
Frequency Modulation (Internal)	Range: (2947) 400 kHz to 1.05 GHz, 75 kHz maximum deviation at 20 Hz to 20 kHz modulation frequency; (2947A) 400 kHz to 1.05 GHz, 75 kHz maximum deviation at 20 Hz to 25 kHz modulation frequency Accuracy: (2947) $\pm 7\% \pm 10$ Hz at 1 kHz modulation frequency; (2947A) $\pm 7\%$ at 1 kHz modulation frequency; $\pm 10\%$ at modulating frequencies from 50 Hz to 15 kHz	Measured with Microwave Measurement System

Table 1. (Cont.)

Test Instrument (TI) Characteristics	Performance Specifications	Test Method
Audio Analyzer		
Audio Voltmeter	<p>Range: 0 to 100 mV to 0 to 100 V rms in a 1, 3 and 10 sequence, DC and 50 Hz to 50 kHz, AC only: 50 Hz to 50 kHz</p> <p>Accuracy: DC: $\pm 1\% \pm 50 \text{ mV} \pm \text{resolution}$ up to 40 V, (Resolution is 1 mV or 1% of reading)</p> <p>AC: $\pm 3\% \pm 3 \text{ mV} \pm \text{resolution}$ up to 30 V rms, (Resolution is 1 mV or 1% of reading)</p>	Verified with a Meter Calibrator
Audio Frequency Meter	<p>Range: 20 Hz to 50 kHz</p> <p>Accuracy: Same as Frequency Standard $\pm 1 \text{ digit} \pm \text{resolution}$, (Resolution is 0.1 Hz at <10 kHz and 1 Hz at $\geq 10 \text{ kHz}$)</p>	Verified during Frequency Standard Calibration
Audio Distortion Meter	<p>Range: (2947) 1 kHz, 0 to 30%; (2947A) 1 kHz, 0 to 10 and 0 to 30%</p> <p>Accuracy $\pm 5\%$ of reading $\pm 0.5\%$ distortion</p>	Measured internal with two signals applied
Audio Sinad Meter	<p>Range: (2947) 1 kHz, 0 to 50 dB; (2947A) 1 kHz, 0 to 18 and 0 to 50 dB</p> <p>Accuracy: $\pm 1 \text{ dB}$</p>	Measured internal with two signals applied
Audio S/N Meter	<p>Range: 0 to 30 dB and 0 to 100 dB</p> <p>Accuracy: $\pm 1 \text{ dB}$</p>	Verified as part of the Distortion and Sinad Meter calibration
Audio Frequency Meter Sensitivity (2947A Only)	<p>Range: 50 Hz to 50 kHz</p> <p>Accuracy: TI must track signal input frequency across range $\leq 50 \text{ mV rms}$</p>	Verified with a Function Synthesizer
Transmitter		
RF Frequency Meter	<p>Range: 400 kHz to 1.05 GHz</p> <p>Accuracy: As Frequency Standard $\pm \text{resolution}$ (Resolution is 1 Hz or 10 Hz, selectable)</p>	Verified during Frequency Standard Calibration

Table 1. (Cont.)

Test Instrument (TI) Characteristics	Performance Specifications	Test Method
<i>Transmitter (Cont.)</i>		
RF Power Meter	Range: (2947) 5 mW to 150 W (N-type) for frequencies 200 kHz to 1.05 GHz, 0.05 to 250 mW (BNC antenna); * (2947A) 5 mW to 150 W (N-type) for frequencies 400 kHz to 1.05 GHz, 0.05 to 250 mW (BNC antenna) * Accuracy: (2947) $\pm 10\% \pm$ resolution, (N-type), (Resolution is 0.1 dB); (2947A) $\pm 10\% \pm$ resolution, (N-type), (Resolution is 0.1 dB), to 1 GHz	Verified with a Synthesized Signal Generator and Microwave Measurement System and High Power High Frequency RF Amplifier System
Amplitude Modulation	Range: 400 kHz to 1.05 GHz, 10 Hz to 15 kHz modulation frequency	
AM Depth	Range: (2947) 0 to 99%; (2947A) 0 to 99% (manually tuned); 0 to 90%, <100 MHz; 0 to 80%, 100 to 400 MHz Accuracy: (2947) $\pm 8\%$ FS ± 1 digit; (2947A) $\pm 5\%$ of setting ± 1 digit at 1 kHz; $\pm 8.5\%$ of setting ± 1 digit 50 Hz to 10 kHz	Verified with Microwave Measurement System
Residual AM	Range: 400 kHz to 1.05 GHz Accuracy: <1%, 300 Hz to 3.4 kHz Bandwidth	Not Calibrated
Frequency Modulation	Range: 400 kHz to 1.05 GHz, 10 Hz to 15 kHz modulation frequency	
Deviation	Range: 0 to 75 kHz Accuracy: (2947) $\pm 5\% \pm$ resolution, at 1 kHz modulation frequency (Resolution is 10 Hz <2 kHz deviation, and 1% >2 kHz deviation); (2947A) $\pm 5\% \pm$ resolution, at 1 kHz modulation frequency; $\pm 7.5\% \pm$ resolution, 50 Hz to 10 kHz modulation frequency (Resolution is 10 Hz <2 kHz deviation, and 1% >2 kHz deviation)	Verified with Microwave Measurement System

See footnote at end of Table.

Table 1. (Cont.)

Test Instrument (TI) Characteristics	Performance Specifications	Test Method
Residual FM	Range: 400 kHz to 1.05 GHz Accuracy: <30 Hz, 300 Hz to 3.4 kHz Bandwidth	Not Calibrated
RF Spectrum Analyzer	Range: (2947) 100 kHz to 1.05 GHz, -50 to + 52 dBm; (2947A) 400 kHz to 1.05 GHz, -50 to + 52 dBm	
Level	Range: 80 dB Accuracy: (Level) (2947) ± 2 dB \pm resolution; (2947A) ± 2 dB \pm resolution (10 dB/div), (Resolution is 0.1 dB on 2 dB/division or 0.5 dB on 10 dB/division)	Measured with a Signal Generator and Microwave Measurement System
Audio Generator		
Frequency	Range: 10 Hz to 20 kHz Accuracy: 0.01 Hz \pm Frequency Standard, at < 180 Hz; 0.1 Hz \pm Frequency Standard, at > 180 Hz	Verified during Frequency Standard Calibration
Level	Range: (2947) 4 V rms; (2947A) 0.1 mV to 4 V rms Accuracy: $\pm 5\%$ \pm resolution, 50 Hz to 15 kHz, (Resolution is 0.1 mV at <409 mV or 1 mV at >409 mV)	Measured with Digital Multimeter
Level Distortion	Range: (2947) 4 V rms; (2947A) 0.1 mV to 4 V rms Accuracy: <0.5% at 1 kHz; <1% at 50 Hz to 15 kHz	Measured with Audio Analyzer

* Typical or Operational Specification. Not calibrated.

2 EQUIPMENT REQUIREMENTS:

	Noun	Minimum Use Specifications	Calibration Equipment	Sub-Item
2.1	ELECTRONIC COUNTER	Range: 10 Hz to 10 MHz Accuracy: ±1 count of LSD	Hewlett-Packard 5345A	As Available
2.2	FREQUENCY STANDARD	Range: 10 MHz Accuracy: <2.5 X 10 ⁻⁸	Austron 2100F	Arbiter Systems 1083B
2.3	FREQUENCY COUNTER	Range: 400 kHz to 1 GHz Accuracy: ±1 count of LSD	Hewlett-Packard 5343A	Spectracom CNT-91R
2.4	MICROWAVE MEASUREMENT SYSTEM	Range: (AM depth) 50% depth at 1 kHz Accuracy: ±1.25% Range: (FM deviation) 0.1 to 75 kHz Accuracy: ±1.50% Range: (Audio Filters) 50 Hz to >20 kHz Accuracy: 50 Hz High-Pass Filter, <1% at rates ≥200 Hz; 300 Hz High-Pass Filter, <1% at rates ≥1 kHz; 3 kHz Low-Pass Filter, <1% at rates ≤1 kHz; 15 kHz Low-Pass Filter, <1% at rates ≤10 kHz; >20 kHz Low-Pass Filter, <1% at rates ≤10 kHz	Hewlett Packard 8902MS * ¹	Agilent N5530SE26
2.5	SENSOR MODULE (P/O 8902MS)	Range: 400 kHz to 999.999 MHz Accuracy: * ¹ ±2.5% 400 kHz to 10 MHz ±3.2% 10 to 100 MHz ±2.6% 100 MHz to 999.999 MHz	Hewlett-Packard 11722A	Agilent N5532A-504

See footnotes at end of Equipment Requirements.

	Noun	Minimum Use Specifications	Calibration Equipment	Sub-Item
2.6	SPECTRUM ANALYZER	Range: 400 kHz to 5 GHz Accuracy: ± 1.6 dB	Hewlett-Packard 8563E	Agilent E4440A
2.7	METER CALIBRATOR	Range: DC, 0 to 40 V; AC, 30 mV to 30 V rms, 20 Hz to 50 kHz Accuracy: DC, $\pm 0.25\%$; AC, $\pm 0.75\%$	Fluke 5700AOPT03	Fluke 5720A
2.8	SIGNAL GENERATOR	Range: 400 kHz to 999.999 MHz, at -20 to +10 dBm Accuracy: $\pm 2.5\%$	Hewlett-Packard 8662A	Agilent E8257D
2.9	DIGITAL MULTIMETER	Range: 0 to 4 V rms, 50 Hz to 15 kHz Accuracy: $\pm 1.25\%$	Hewlett-Packard 3458A	
2.10	AUDIO ANALYZER	Range: 50 Hz to 15 kHz Accuracy: ± 1 dB	Hewlett-Packard 8903B	
2.11	POWER SPLITTER	Range: 10 MHz Accuracy: N/A	Hewlett-Packard 11667A	
2.12	FUNCTION SYNTHESIZER	Range: -60 to +13.01 dBm, 20 Hz to 50 kHz Accuracy: ± 0.625 dB	Hewlett-Packard 3325B	Agilent 33250A
2.13	RF REFERENCE SOURCE	Range: -60 to +10 dBm, 10.05 MHz Accuracy: ± 0.625 dB	Fluke 9610A/AF	
2.14	SYNTHESIZED SIGNAL GENERATOR	Range: +15 dBm, 10 to 999.999 MHz Accuracy: N/A	Hewlett-Packard 8642B	Anritsu MG3642A
2.15	SYNTHESIZED LEVEL GENERATOR	Range: 400 Hz, -21 to +1 dBm Accuracy: N/A	Hewlett-Packard 3335A	

	Noun	Minimum Use Specifications	Calibration Equipment	Sub-Item
2.16	POWER DIVIDER	Range: 1 to 2 kHz Accuracy: N/A	Weinschel 1506A	
2.17	FEEDTHROUGH TERMINATION	Range: 50 Ω Accuracy: N/A	As Available	
2.18	MICROWAVE MEASUREMENT RECEIVER (MMR)	Range: -125 to -21 dBm, 10.1 to 999.999 MHz Accuracy: *2 Relative Tuned RF Level: Residual Noise to Max power, ±(0.015 dB + 0.005 dB/10 dB); Minimum Power to Residual Noise Threshold, ±(Cumulative Error + 0.0012 X (Input Power - Residual Noise Threshold Power) ²); Range 2, ±0.031 dB; *3 Range 3, ±0.031 dB *4	Agilent N5530SE26	
2.18.1	SPECTRUM ANALYZER	Range: (Noise Sidebands) 100 MHz to 999.999 MHz Accuracy: (20 kHz offset) ≤-114 dBc/Hz	Agilent E4440A	
2.19	POWER METER	Range: -21 to 0 dBm Accuracy: *5	Hewlett-Packard E4418B	
2.20	POWER SENSOR	Range: 10.1 to 999.999 MHz Accuracy: (all % are of charted value) *5 ±2.0%, 10.1 to ≤30 MHz; ±2.4%, >30 to ≤999.999 MHz	Hewlett-Packard E4412A	
2.21	RF POWER MEASUREMENT SET	Range: 10 to 999.999 MHz, 0 to 100 W Accuracy: ±3.0% of rdg	Bird 4421A300	
2.22	HIGH POWER HIGH FREQUENCY RF AMPLIFIER SYSTEM	Range: 10 to 999.999 MHz, 0 to 100 W Accuracy: N/A	PST Corp BHED1719- 1000/4006	MPD Wireless Inc SSPA0240- 226140 *6

- *¹ A worst case TAR of 3.4:1 is the result of the Root Sum Square (RSS) value of the Measuring Receiver and the Sensor Module when performing the TI RF Power Meter Calibration.
- *² A worst case TAR of 3.7:1 is the result of the Root Sum Square (RSS) value of the MMR and the Power Sensor when performing the TI RF Signal Generator Output Level Calibration for levels <-124 dBm.
- *³ This specification applies when the MMR enters Range 2. Range 2 is entered when the Range 1 Signal to Noise Ratio (SNR) falls between 50 and 28 dB. The SNR value is tuning dependent. Range 2 will be displayed on the MMR when the range is entered.
- *⁴ This specification, in addition to the Range 2 error, applies when the MMR enters Range 3. Range 3 is entered when the Range 2 SNR falls between 50 and 28 dB. The SNR value is tuning dependent. Range 3 will be displayed on the MMR when the range is entered.
- *⁵ Power Meter Accuracy included in Power Sensor Accuracy.
- *⁶ See step 3.11.

3 PRELIMINARY OPERATIONS:

3.1 Review and become familiar with the entire procedure before beginning Calibration Process.



Unless otherwise designated, and prior to beginning the Calibration Process, ensure that all test equipment voltage and/or current outputs are set to zero (0) or turned off, where applicable. Ensure that all equipment switches are set to the proper position before making connections or applying power. If not strictly observed, could result in injury to, or death of, personnel or long term health hazards.

3.2 Connect TI and test equipment to the required power sources.

3.3 Set all Test Equipment POWER switches to ON. Allow the required warm-up time for the test equipment as per the manufacturer.

3.4 The TI Hardkeys are shown in uppercase in this procedure, all Softkeys and Menu keys are in lower case with Initial Caps.

3.5 Multiple firmware versions may exist for TIs covered by this Calibration Procedure. This may require variations of softkeys, menus, keystrokes, pathways, steps or etc. to achieve setting of the TI to the required state/configuration. These variations are permitted provided the required state/configuration is maintained. Technicians may need to consult the commercial data and become familiar with the softkeys, menus, keystrokes, pathways, steps or etc. to activate the exact TI state/configuration required by each respective step in the Calibration Procedure prior to performing the Calibration Process. These variations do not constitute changes required to the Calibration Procedure.

3.6 Perform only those sections applicable to TI under tests.

3.7 To eliminate the number of key presses that the user needs to make to obtain the correct instrument settings, each section assumes that the instrument is being configured from the TI factory default power on state. To ensure this occurs, initially press the following keys:

3.7.1 Set TI POWER switch to ON. Press HELP/SETUP.

3.7.2 Press Setup.

3.7.3 Press Setup page 2.

3.7.4 Toggle the Power Up From menu key until Preset Store 1 is shown highlighted in inverse video.

3.7.5 Set the TI POWER switch to OFF. Set the TI POWER switch to ON and allow a 30 minute warm-up time. The TI should now be in the factory default power on state.

3.8 The TI RF Input Residual AM and Residual FM will not be calibrated. Because the Residual FM is not calibrated, the RF Input FM Deviation is not calibrated <1 kHz deviation. Annotate and attach a Limited Certification Label stating RF Input Residual AM and Residual FM not cal'd. RF Input FM Deviation not cal'd <1 kHz deviation.

3.9 When entering keystrokes and changing functions with the MMR, allow sufficient time for the unit to register the entries.

NOTE

Whenever a measurement is made with MMR at a carrier frequency of <20 MHz, the RF coupling must be set to DC. The 50 GHz MMR RF coupling is always DC. The 26.5 GHz MMR RF coupling must be set to DC.

3.10 Set the MMR for the Factory Preset. Preset the MMR. Perform Align All Now.

NOTE

The 50 Ω Leveling Head (p/o RF Reference Source) is an integral part of the RF Reference Source. All connections are to be made through the 50 Ω Leveling Head.

3.11 If using SSPA0240-226140 for TI RF Power Meter Calibration performed at 400 MHz, annotate and attach a Limited Certification Label stating not cal'd >406 MHz. 406 MHz is a user requirement that is inherently calibrated at 400 MHz.

3.12 On TI, press HELP/SETUP. Press Self Test. Ensure all parameters show PASS.

4 CALIBRATION PROCESS:

NOTE

Unless otherwise specified, verify the results of each test and take corrective action whenever the test requirement is not met, before proceeding.

4.1 FREQUENCY STANDARD CALIBRATION:

NOTE

Adjustment of the Time Base Oscillator is normal due to the Aging Rate of the crystal. This is common to all Quartz Oscillators. The adjustment actions taken during this calibration will ensure the greatest reliability of the TI by adjusting the time base reference to the nominal value each time it is calibrated.

4.1.1 Connect the Frequency Standard 10 MHz REF OUT to Electronic Counter EXT FREQ STD input (1-10 MHz) on the rear panel of the Electronic Counter.

4.1.2 Connect the TI BNC Output to Electronic Counter CHANNEL A input connector and set the Electronic Counter Impedance switch to 50 Ω . On the TI, press the RF IN/OUT SELECT to select the BNC output.

4.1.3 On the TI, press Rx TEST. Press RF Gen and set the controls as follows:

Freq	10 MHz
Level	-10 dBm

NOTE

The values in the following step are derived from multiplication of the Aging Rate to determine the offset at one year. Use these calculated twelve month values regardless of the length of the calibration interval for this TI in T.O. 33K-1-100-1/2.

NOTE

Ensure the TI Modulation Generators MOD1 and MOD2 are off.

4.1.4 Adjust the Electronic Counter controls as required for a stable display indication and then push RESET. Verify the Electronic Counter indication is 9 999 999 to 10 000 001 Hz \pm 1 count of LSD.

4.1.5 To ensure reliability of the TI, the following action will be taken: If TI passed the above steps, perform the applicable adjustment steps in Appendix A and enter the applicable code into the Maintenance Data Collection System. If TI failed, perform the applicable steps listed in Appendix A and enter the applicable code into the Maintenance Data Collection System.

4.1.6 Set TI output to minimum and disconnect the test set-up.

4.1.7 Connect the Frequency Counter FREQ STD OUT to the TI EXT. STD 1/2/5/10 MHz input (rear panel).

4.1.8 Connect the TI BNC Output to Frequency Counter 10 Hz - 500 MHz input connector. Set the Frequency Counter Frequency Input switch to 10 Hz - 500 MHz and the Impedance switch to 50 Ω .

4.1.9 On the TI, press the RF IN/OUT SELECT to select the BNC output.

4.1.10 Press Rx TEST. Press RF Gen and set the controls as follows:

Freq	400 kHz
Level	-10 dBm

4.1.11 Set the Frequency Counter RESOLUTION to 1 Hz.

4.1.12 The Frequency Counter must indicate within 399 999 to 400 001 Hz.

4.1.13 Repeat steps 4.1.10 through 4.1.12 for the remaining values listed in Table 2. Use the appropriate Frequency Counter input for the TI frequency being measured.

Table 2.

TI Freq (MHz)	Frequency Counter Limits (Hz)
0.400	399 999 to 400 001
111.11111	111 111 109 to 111 111 111
122.22222	122 222 219 to 122 222 221
133.33333	133 333 329 to 133 333 331
144.44444	144 444 439 to 144 444 441
155.55555	155 555 549 to 155 555 551
166.66666	166 666 659 to 166 666 661
177.77777	177 777 769 to 177 777 771
188.88888	188 888 879 to 188 888 881
500.00000	499 999 999 to 500 000 001
999.99999	999 999 989 to 999 999 991

4.1.14 Set the TI output to minimum and disconnect the test setup.

4.2 RF SIGNAL GENERATOR CALIBRATION:

4.2.1 OUTPUT LEVEL CALIBRATION:

4.2.1.1 Connect the MMR 10 MHz OUT (SWITCHED) to the TI EXT. STD 1/2/5/10 MHz input (rear panel).

4.2.1.2 Set the MMR controls, as required, to provide a 10 MHz timebase output.

4.2.1.3 Standardize Power Meter and Power Sensor. Set the Power Meter measurement in the dBm mode.

NOTE

Ensure the Power Sensor Calibration Factors have been programmed into the Power Meter memory. Select the appropriate Power Sensor file throughout the Calibration Process.

4.2.1.4 Connect the TI N-type Output Connector to the Power Sensor input. On the TI, press the RF IN/OUT SELECT to select the N-type output/antenna input mode.

4.2.1.5 On the TI, press Rx TEST. Press RF Gen and set the controls as follows:

Freq	10.1 MHz
Level	-21 dBm

NOTE

All modulation and noise measurements should be switched off.

4.2.1.6 Verify the Power Meter indication is within the corresponding values listed in the Limits column of Table 3. Record the Power Meter indication.

4.2.1.7 Set TI output to minimum and disconnect the Power Sensor from the test setup.

4.2.1.8 Connect the TI N-type Output Connector to the MMR RF INPUT 50 Ω .

4.2.1.9 Press TI Level, then set to the first value listed in the TI Level column of Table 3.

4.2.1.10 Set the MMR frequency to the TI frequency.

NOTE

For Tuned RF Level measurements do not change the signal level during the Range 2 Switch Level Cal Factor and Range 3 Switch Level Cal Factor calibration. Wait for the red calibrating message to disappear before continuing. Use this method throughout the Calibration Process when making Tuned RF Level measurements.

4.2.1.11 Set the MMR to make a Tuned RF Level measurement in High Accuracy mode.

4.2.1.12 Set the MMR to Set Ref.

4.2.1.13 Allow the MMR Tuned RF Level indication to settle.

4.2.1.14 Set the MMR Ext RF Atten to the value recorded, in dB, in step 4.2.1.6 for the frequency being verified.

4.2.1.15 Press TI Level, then set to the next value listed in the TI Level column of Table 3.

4.2.1.16 Allow the MMR Tuned RF Level indication to settle. Verify the MMR Tuned RF Level indication is within the corresponding values listed in the Limits column of Table 3.

4.2.1.17 Repeat steps 4.2.1.15 and 4.2.1.16 for the remaining values listed in the Level column of Table 3 for the frequency being verified.

Table 3.

TI Freq (MHz)	TI Level (dBm)	Limits (dB)
10.1	-21	-23 to -19
10.1	-25	-27 to -23
10.1	-30	-32 to -28
10.1	-40	-42 to -38
10.1	-50	-52 to -48

Table 3. (Cont.)

TI Freq (MHz)	TI Level (dBm)	Limits (dB)
10.1	-60	-62 to -58
10.1	-70	-72 to -68
10.1	-80	-82 to -78
10.1	-90	-92 to -88
10.1	-100	-102 to -98
10.1	-110	-112 to -108
10.1	-120	-122 to -118
10.1	-125	-127 to -123
500	-21	-23 to -19
500	-25	-27 to -23
500	-30	-32 to -28
500	-40	-42 to -38
500	-50	-52 to -48
500	-60	-62 to -58
500	-70	-72 to -68
500	-80	-82 to -78
500	-90	-92 to -88
500	-100	-102 to -98
500	-110	-112 to -108
500	-120	-122 to -118
500	-125	-127 to -123
999.999	-21	-23 to -19
999.999	-25	-27 to -23
999.999	-30	-32 to -28

Table 3. (Cont.)

TI Freq (MHz)	TI Level (dBm)	Limits (dB)
999.999	-40	-42 to -38
999.999	-50	-52 to -48
999.999	-60	-62 to -58
999.999	-70	-72 to -68
999.999	-80	-82 to -78
999.999	-90	-92 to -88
999.999	-100	-102 to -98
999.999	-110	-112 to -108
999.999	-120	-122 to -118
999.999	-125	-127 to -123

4.2.1.18 Disconnect the TI N-type Output Connector from the MMR RF INPUT 50 Ω . Set the MMR Ext RF Atten to 0 dB.

4.2.1.19 Repeat steps 4.2.1.4 through 4.2.1.18 for TI Freq 500 MHz and 999.999 MHz.

4.2.1.20 Set TI output to minimum and disconnect the test setup.

4.2.2 SPECTRAL PURITY CALIBRATION:

4.2.2.1 RESIDUAL FM CALIBRATION:

4.2.2.1.1 Connect the TI BNC Output connector to the Measuring Receiver INPUT 50 Ω (Connect TI directly, do not use the Sensor Module.). On the TI, press RF IN/OUT SELECT to select the BNC output.

4.2.2.1.2 Press the Measuring Receiver INSTR PRESET, FM, Blue (Shift) and then RMS keys. Set the HP FILTER to 300 Hz and the LP FILTER 3 kHz.

4.2.2.1.3 On the TI, press Rx TEST. Press RF Gen and set the controls as follows:

Freq	999.999 MHz
Level	0 dBm

NOTE

All modulation and noise measurements should be switched off.

4.2.2.1.4 The Measuring Receiver FM deviation indication must be <12 Hz rms.

4.2.2.1.5 Repeat steps 4.2.2.1.3 and 4.2.2.1.4 for the remaining values listed in Table 4.

Table 4.

TI Freq (MHz)	Limits (Hz rms)
999.999	<12
750	<12
500	<12
250	<12
10	<12

4.2.2.1.6 Set the TI output to minimum and disconnect the test setup.

4.2.2.2 HARMONICS AND SPURIOUS SIGNALS CALIBRATION:

4.2.2.2.1 Connect TI BNC Output Connector to the Spectrum Analyzer (2.6) RF INPUT 50 Ω connector.

4.2.2.2.2 On the TI, press Rx TEST and then press RF Gen and set the controls as follows:

Freq	0.4 MHz
Level	0 dBm

NOTE

All modulation and noise measurements should be switched off.

4.2.2.2.3 Set the Spectrum Analyzer (2.6) as required to measure the carrier and at least 4 harmonics.

4.2.2.2.4 Verify the level of the Harmonics are within the values listed in the Harmonics Limits column of Table 5.

4.2.2.2.5 Set the Spectrum Analyzer (2.6) controls as necessary to measure the Spurious Signals.

4.2.2.2.6 Verify the level of the Spurious Signals are within the limits listed in the Spurious Signals Limits column of Table 5.

4.2.2.2.7 Repeat steps 4.2.2.2.2 through 4.2.2.2.6 for the remaining values listed in Table 5.

Table 5.

TI Freq (MHz)	Harmonics (dBc)	Limits
		Spurious Signals (dBc)
0.4	<-25	<-50
1.0	<-25	<-50
10	<-25	<-50
100	<-25	<-50
250	<-25	<-50
500	<-25	<-50
750	<-25	<-50
999.999	<-25	<-50

4.2.2.2.8 Set TI output to minimum and disconnect the test setup.

4.2.2.3 SINGLE SIDEBAND PHASE NOISE CALIBRATION:

4.2.2.3.1 Connect the TI BNC Output connector to the MMR RF INPUT 50 Ω .

4.2.2.3.2 On the TI, press Rx TEST, RF Gen and set the controls as follows:

Freq	999.999 MHz
Level	0 dBm

NOTE

All modulation and noise measurements should be switched off.

4.2.2.3.3 Ensure the MMR Spectrum Analyzer is set to Spectrum Analysis Mode. Set the Center Frequency to the TI frequency, Span to 50 kHz and RBW to 300 Hz. Set the reference level as required to set the peak at a convenient level.

4.2.2.3.4 Set the MMR Spectrum Analyzer to do a peak search, set the Marker Delta to 20 kHz and set the Marker Noise to On.

4.2.2.3.5 Verify the MMR Spectrum Analyzer Δ Mkr Noise Level is within the corresponding value listed in the Limits column in Table 6.

NOTE

The MMR Spectrum Analyzer will display the indication in dB/Hz vs dBc/Hz.

4.2.2.3.6 Set the MMR Spectrum Analyzer Markers to Off.

4.2.2.3.7 Press the TI Rx TEST, RF Gen and set to the next value listed in the Applied column of Table 6.

4.2.2.3.8 Repeat step 4.2.2.3.3 through 4.2.2.3.7, as required, for remaining frequencies listed in the Applied column of Table 6.

Table 6.

Applied (MHz)	Limits (dBc/Hz)
999.999	<-108
750	<-108
500	<-108
250	<-108
100	<-108

4.2.2.3.9 Set TI output to minimum and disconnect the test setup.

4.2.3 AMPLITUDE MODULATION CALIBRATION:

4.2.3.1 Connect the TI BNC Output connector to the Measuring Receiver INPUT 50 Ω. (Connect TI directly, do not use the Sensor Module.)

4.2.3.2 Set the Measuring Receiver as follows: Press INSTR PRESET (resets the Measuring Receiver). Select AM measurement, press 300 Hz HP filter, 3 kHz LP filters and the PEAK+ and PEAK- detector keys simultaneously (selects PEAK±/2).

4.2.3.3 On the TI, press Rx TEST and then RF Gen and set the controls as follows:

Freq	10 MHz
Level	0 dBm

4.2.3.4 For TI modulation, press TI Mod Gen and set controls as follows:

Gen 1/Gen 2	Gen 2
Freq	1 kHz
Level	50%

NOTE

Gen 2 modulation must be switched on to continue.

4.2.3.5 Verify the Measuring Receiver indicates within 47.4 to 52.6%.

4.2.3.6 Repeat steps 4.2.3.3 through 4.2.3.5 for the remaining values listed in Table 7.

Table 7.

TI Freq (MHz)	Limits (%)	
	2947	2947A
10	47.4 to 52.6	47.4 to 52.6
50	47.4 to 52.6	47.4 to 52.6
250	47.4 to 52.6	47.4 to 52.6
500	47.4 to 52.6	46.4 to 53.6
750	47.4 to 52.6	46.4 to 53.6
999.999	47.4 to 52.6	46.4 to 53.6

4.2.3.7 Set TI output to minimum. Do not disconnect TI from the Measuring Receiver.

4.2.4 FREQUENCY MODULATION CALIBRATION:

4.2.4.1 Set the Measuring Receiver as follows: Press INSTR PRESET. Select and press the 50 Hz HP and 15 kHz LP filters, FM mode.

4.2.4.2 On the TI, press Rx TEST and then RF Gen, and set the controls as follows:

Freq	0.5 MHz
Level	0 dBm

4.2.4.3 For TI modulation, press TI Mod Gen and set the controls as follows:

Gen 1/Gen 2	Gen 2
Freq	1 kHz
Level	10 kHz

4.2.4.4 Verify the Measuring Receiver indicates within Limits column of Table 8.

4.2.4.5 Repeat steps 4.2.4.2 through 4.2.4.4 for the remaining values listed in Table 8.

Table 8.

TI Freq (MHz)	TI Mod LEVEL (kHz)	Limits (kHz)	
		2947	2947A
0.5	10	9.290 to 10.710	9.300 to 10.700
10	20	18.590 to 21.410	18.600 to 21.400
10	50	46.490 to 53.510	46.500 to 53.500
10	70	65.090 to 74.910	65.100 74.900
10	10	9.290 to 10.710	9.300 to 10.700
100	10	9.290 to 10.710	9.300 to 10.700
500	10	9.290 to 10.710	9.300 to 10.700
750	10	9.290 to 10.710	9.300 to 10.700
999.999	10	9.290 to 10.710	9.300 to 10.700

4.2.4.6 For 2947, proceed to step 4.2.4.11; otherwise, continue with step 4.2.4.7.

4.2.4.7 Select and press Measuring Receiver HP filter to off and LP filter to 3 kHz.

4.2.4.8 Repeat steps 4.2.4.2 through 4.2.4.5 using Table 9, except in step 4.2.4.3 set the TI Mod Gen Freq to 100 Hz.

4.2.4.9 Select and press Measuring Receiver HP filter to 300 Hz and LP filter to 15 kHz.

4.2.4.10 Repeat steps 4.2.4.2 through 4.2.4.5 using Table 9, except in step 4.2.4.3 set the TI Mod Gen Freq to 10 kHz.

Table 9.

TI Freq (MHz)	TI Mod LEVEL (kHz)	Limits (kHz)
0.5	10	9.000 to 11.000
10	20	18.000 to 22.000
10	50	45.000 to 55.000
10	70	63.000 to 77.000
10	10	9.000 to 11.000

Table 9. (Cont.)

TI Freq (MHz)	TI Mod LEVEL (kHz)	Limits (kHz)
100	10	9.000 to 11.000
500	10	9.000 to 11.000
750	10	9.000 to 11.000
999.999	10	9.000 to 11.000

4.2.4.11 Set TI output to minimum and disconnect test setup.

4.3 AUDIO ANALYZER CALIBRATION:

4.3.1 AUDIO VOLTMETER CALIBRATION:

4.3.1.1 Connect TI AF INPUT to the Meter Calibrator OUTPUT HI and LO jacks.

4.3.1.2 On the TI press AF TEST then press AF Filter and set the controls as follows:

Filter	50 kHz LP
AC/DC	DC coupled is displayed

4.3.1.3 Set the Meter Calibrator to +5 VDC. Set Meter Calibrator OPR/STBY switch to OPR.

4.3.1.4 The TI must indicate between 4.85 to 5.15 VDC.

4.3.1.5 Set Meter Calibrator OPR/STBY to STBY.

4.3.1.6 Repeat steps 4.3.1.3 through 4.3.1.5 for the remaining values listed in Table 10.

Table 10.

Applied (VDC)	TI Limits (VDC)
5	4.85 to 5.15
10	9.75 to 10.25
20	19.55 to 20.45
40	39.15 to 40.85

4.3.1.7 On the TI, press AC/DC coupling until AC coupled is displayed.

4.3.1.8 Set Meter Calibrator output to 30 mV at 1 kHz.

4.3.1.9 Set Meter Calibrator OPR/STBY to OPR.

4.3.1.10 The TI must indicate within 25.1 to 34.9 mV

4.3.1.11 Set the Meter Calibrator OPR/STBY to STBY.

4.3.1.12 Repeat steps 4.3.1.8 through 4.3.1.11 for the remaining values listed in Table 11.

Table 11.

Meter Calibrator		
Voltage (V)	Frequency (Hz)	Limits (VAC)
30 m	1 k	25.1 to 34.9 m
200 m	1 k	189 to 211 m
1	1 k	0.957 to 1.043
1	50	0.957 to 1.043
1	100	0.957 to 1.043
1	10 k	0.957 to 1.043
1	30 k	0.957 to 1.043
1	50 k	0.957 to 1.043
2	1 k	1.917 to 2.083
5	1 k	4.797 to 5.203
10	1 k	9.597 to 10.403
30	1 k	28.797 to 31.203

4.3.1.13 Set Meter Calibrator OPR/STBY switch to STBY.

4.3.1.14 Disconnect TI from Meter Calibrator.

4.3.2 AUDIO SINAD, DISTORTION AND S/N METER CALIBRATION:

4.3.2.1 Connect equipment as shown in Figure 1 with the Power Divider input connected to the Digital Multimeter input.

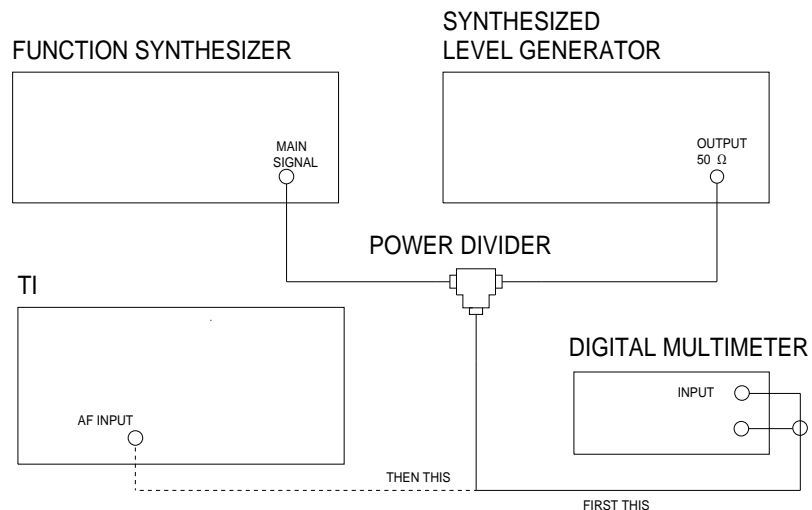

Figure 1.

4.3.2.2 Set the Digital Multimeter for ACV measurement.

4.3.2.3 Set the Function Synthesizer frequency to 1 kHz and output level for 1.000 V rms, as monitored on the Digital Multimeter.

4.3.2.4 Record the Function Synthesizer indication. Set the Function Synthesizer to minimum.

4.3.2.5 Set the Synthesized Level Generator frequency to 400 Hz and output level for 20.0 mV rms as monitored on the Digital Multimeter.

4.3.2.6 Set the Function Synthesizer to the value recorded in step 4.3.2.4.

4.3.2.7 Disconnect the Power Divider Input from the Digital Multimeter.

4.3.2.8 Connect the Power Divider Input to the TI AF INPUT.

4.3.2.9 On the TI press AF TEST, Dist/S-N and then Dist'N.

4.3.2.10 The TI distortion meter must indicate within 1.4 and 2.6%.

4.3.2.11 On the TI, press Dist/S-N and then Sinad.

4.3.2.12 The TI Sinad meter must indicate within 33 to 35 dB.

4.3.2.13 Set all outputs to minimum. Connect equipment as shown in Figure 1 with the Power Divider input connected to the Digital Multimeter input.

4.3.2.14 Set the Function Synthesizer frequency to 1 kHz and output level for 1.000 V rms, as monitored on the Digital Multimeter.

4.3.2.15 Record the Function Synthesizer indication. Set the Function Synthesizer to minimum.

4.3.2.16 Set the Synthesized Level Generator frequency to 400 Hz and output level for 259.0 mV rms as monitored on the Digital Multimeter.

4.3.2.17 Set the Function Synthesizer to the value recorded in step 4.3.2.15.

4.3.2.18 Disconnect the Power Divider Input from the Digital Multimeter.

4.3.2.19 Connect the Power Divider Input to the TI AF INPUT.

4.3.2.20 The TI Sinad meter must indicate within 11 to 13 dB.

4.3.2.21 On the TI, press Dist/S-N and then Dist'N.

4.3.2.22 The TI distortion meter must indicate within 23.2 to 26.8%.

4.3.2.23 Set all output levels to minimum and disconnect test setup.

4.3.3 AUDIO FREQUENCY METER SENSITIVITY CALIBRATION: (2947A Only)

NOTE

The input sensitivity of the TI is checked to verify that the TI will operate across the required frequency range at a minimum voltage level. TI controls may be adjusted as required to verify these parameters. Input Sensitivity does not directly affect the accuracy of frequency measurements. Therefore, failure to pass this test indicates a need for a repair action, not an out of tolerance condition for calibration accuracy.

4.3.3.1 Connect the Function Synthesizer 50 Ω OUTPUT through the Feedthrough Termination to the TI AF INPUT.

4.3.3.2 On the TI press AF TEST then press AF Filter and set the controls as follows:

Filter	50 kHz LP
AC/DC	DC coupled is displayed

4.3.3.3 Set the Function Synthesizer to 50 mV rms at 50 Hz.

4.3.3.4 Verify a stable frequency indication on the TI.

4.3.3.5 Slowly increase the Function Synthesizer frequency from 50 Hz to 50 kHz and ensure the TI counts properly across the entire 50 Hz to 50 kHz frequency range at = 50 mV rms.

4.3.3.6 Set the Function Synthesizer output to minimum and disconnect test setup.

4.4 TRANSMITTER CALIBRATION:**4.4.1 RF POWER METER CALIBRATION:**

4.4.1.1 On the TI, set the POWER switch to OFF. Set the POWER switch to ON and allow 5 minutes for the TI to stabilize. Press Tx TEST.

NOTE

Cycling the TI POWER switch allows the TI to reset to the default settings.

4.4.1.2 Connect the Synthesized Signal Generator through a low loss cable to the Sensor Module input.

4.4.1.3 On the Measuring Receiver, press INSTR PRESET and RF POWER. Enter the Sensor Module RF Cal Factor for 10 MHz and press % CAL FACTOR.

4.4.1.4 Set the Synthesized Signal Generator output for 10 MHz at +15.0 dBm as indicated on the Measuring Receiver.

4.4.1.5 Set the Synthesized Signal Generator RF OFF/ON switch to OFF.

4.4.1.6 Disconnect the Sensor Module from the low loss cable.

4.4.1.7 Connect the TI N-type connector to the Synthesized Signal Generator through the same low loss cable as in the above steps.

4.4.1.8 Set the Synthesized Signal Generator RF OFF/ON switch to ON.

4.4.1.9 The TI broadband power meter must indicate within +14.4 to +15.5 dBm.

4.4.1.10 Set the Synthesized Signal Generator RF OFF/ON switch to OFF.

4.4.1.11 Repeat steps 4.4.1.2 through 4.4.1.10 for the remaining values listed in Table 12.

Table 12.

Signal Generator Level (dBm)	Frequency (MHz)	TI Limits (dBm)
+15.0	10	+14.4 to +15.5
+15.0	100	+14.4 to +15.5
+15.0	250	+14.4 to +15.5
+15.0	500	+14.4 to +15.5
+15.0	750	+14.4 to +15.5
+15.0	999.999	+14.4 to +15.5

4.4.1.12 Set the Synthesized Signal Generator output to minimum and disconnect the test setup.

4.4.1.13 Connect equipment as shown in Figure 2.

WARNING

Take care when touching the TI RF Input N Type connector after the application of high levels of continuous power. If 50 W is exceeded for a prolonged period, the temperature of the connector can become excessive. If not strictly observed, could result in injury to, or death of, personnel or long term health hazards.

WARNING

A power overload condition is indicated by an audible and visual warning. Do not attempt to stop the warning by disconnecting the TI RF Input N Type connector, as this can damage the transmitter and may cause electric shock or skin burns. If not strictly observed, could result in injury to, or death of, personnel or long term health hazards.

CAUTION

If a power overload condition is indicated, immediately reduce the level of RF power from the transmitter into the TI. Do not stop the warning by switching off the TI, as this will silence the warning but will leave the excessive RF power connected to the internal load. If not strictly observed, could result in damage to, or destruction of, equipment or loss of mission effectiveness.

CAUTION

Reverse Power Protection N-Type: 50 W for 10 minutes, normal operation.
150 W for 1 minute at 20 °C. Overload indicated by audible and visual warning. If not strictly observed, could result in damage to, or destruction of, equipment or loss of mission effectiveness.

CAUTION

When applying power to TI, technician must follow the On/Off Duty Cycle:
Continuous; >10 to 50 W, On: Max of 3 minutes, Off: Min of 2 minutes;
>50 W to 100 W, On: Max of 30 seconds, Off: Min of 2 minutes. If not strictly observed, could result in damage to, or destruction of, equipment or loss of mission effectiveness.

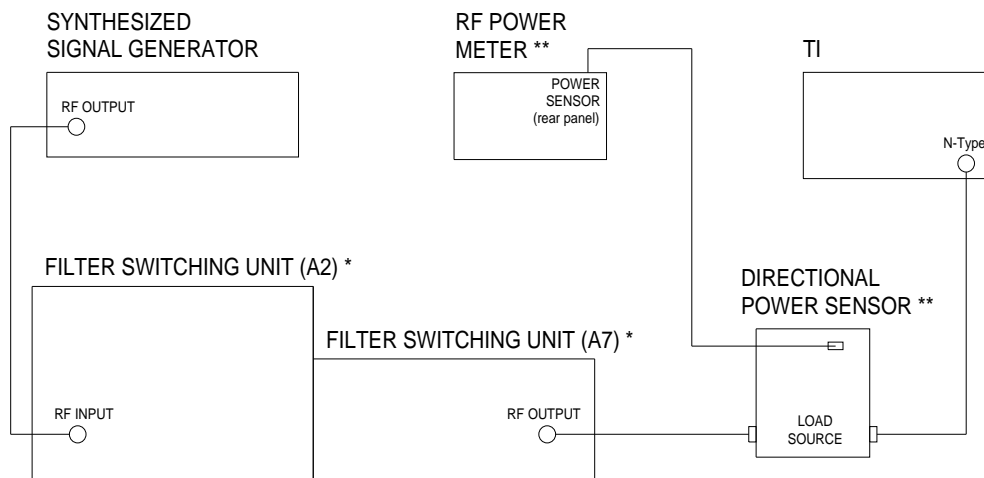

* Part of the HIGH POWER HIGH FREQUENCY RF AMPLIFIER SYSTEM.

** Part of the RF POWER MEASUREMENT SET.

Figure 2.

NOTE

Use the applicable Directional Power Sensor, as required, for the frequency being tested.

4.4.1.14 Set the RF Power Meter, as required, to measure Watts.

4.4.1.15 On TI, press HELP/SETUP, Setup and RF setup. Toggle the RF level measured in: key until Watts is highlighted. This changes the TI RF power reading to Watts for Table 13.

4.4.1.16 On the Filter Switching Unit (A2), select the Band, as required, for the Test Frequency being tested.

4.4.1.17 On the Filter Switching Unit (A2), set the RF OUTPUT LEVEL CONTROL fully CCW and press the OPER/STBY key until the OPERATE lamp illuminates.

NOTE

Ensure the RF Power Meter FWD lamp is illuminated. If not, press the RF PWR key.

4.4.1.18 Set the Synthesized Signal Generator, as required, to 0.0 dBm at the first frequency listed in the Frequency column of Table 13.

4.4.1.19 Set the Filter Switching Unit (A2) RF OUTPUT LEVEL CONTROL for a RF Power Meter indication of the first value listed in the Applied column of Table 13.

NOTE

It may not be possible to set the Filter Switching Unit (A2) RF OUTPUT LEVEL CONTROL for an exact indication of the value listed in the TI WATTS meter indication column of Table 13. If it is not, set the RF OUTPUT LEVEL CONTROL as close as possible and calculate the limits from the TI WATTS meter displayed value.

4.4.1.20 Verify the TI indicates within the values listed in the Limits column of Table 13.

4.4.1.21 Set the Filter Switching Unit (A2) RF OUTPUT LEVEL CONTROL fully CCW.

4.4.1.22 Repeat steps 4.4.1.16 through 4.4.1.21 for the remaining corresponding values listed in Table 13. Use the applicable Directional Power Sensor, as required, for the frequency being tested.

Table 13.

Frequency (MHz)	Applied (W) (meter indication)	Limits (W)
10.0000	15	13.2 to 16.9
10.0000	50	44.0 to 56.3
10.0000	100	88.0 to 113
100.0000	15	13.2 to 16.9
100.0000	50	44.0 to 56.3
100.0000	100	88.0 to 113
500.0000	15	13.2 to 16.9
500.0000	50	44.0 to 56.3
500.0000	100	88.0 to 113
999.999	15	13.2 to 16.9
999.999	50	44.0 to 56.3
999.999	100	88.0 to 113

4.4.1.23 On TI, press HELP/SETUP, Setup and RF setup. Toggle the RF level measured in: key until dBm is highlighted. This changes the TI RF power reading back to dBm.

4.4.1.24 Set Synthesized Signal Generator output to minimum. Disconnect the test setup.

4.4.2 AMPLITUDE MODULATION DEPTH CALIBRATION:

4.4.2.1 Connect equipment as shown in Figure 3 Press Tx TEST, press SELECT and select the ANTENNA input.

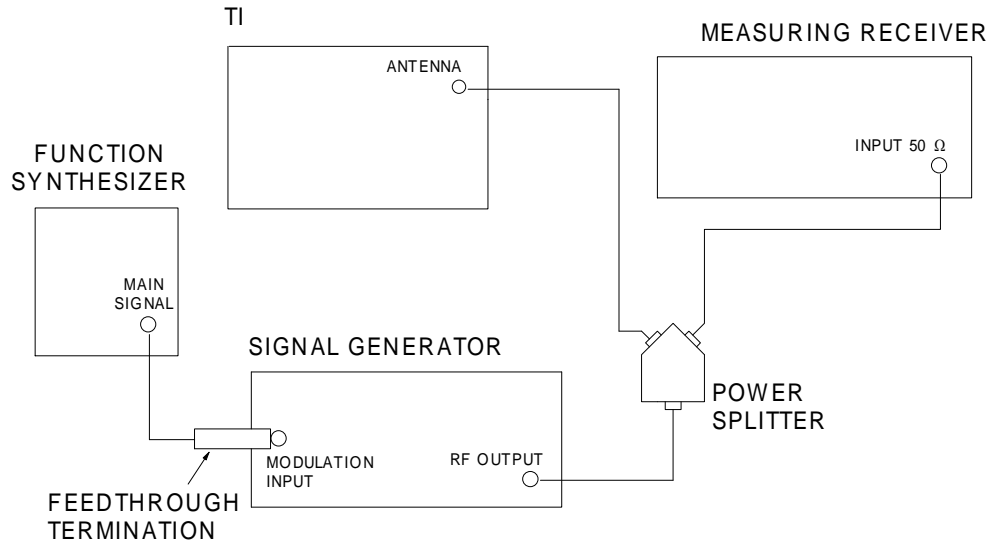

Figure 3.

4.4.2.2 Set the Measuring Receiver as follows: Press INSTR PRESET (resets the Measuring Receiver). Select AM measurement, press 300 Hz HP filter, 3 kHz LP filters and the PEAK+ and PEAK- detector keys simultaneously (selects PEAK \pm /2).

4.4.2.3 On the TI press Tx TEST and then press Mod Meter. Press the AM/FM/SSB to select AM.

NOTE

From the power up default, the TI should already have an IF filter of 30 kHz and AF filter of 0.3 to 3.4 kHz selected. To verify this is the case press Tx TEST, MOD METER, IF FILTER or AF FILTER then select correct filter if necessary.

NOTE

It may be necessary to change the TI Tx FREQ (or reselect AUTOTUNE) if the displayed Tx FREQ does not agree with the Signal Generator output frequency.

4.4.2.4 Set the Signal Generator to -10 dBm at 10 MHz. Set the modulation to AM and EXT DC. Set the modulation on.

4.4.2.5 Set the Function Synthesizer to 0.707 V rms at 1 kHz.

4.4.2.6 Adjust the Signal Generator AM modulation for the first value listed in the AM Depth column of Table 14 as indicated on the Measuring Receiver.

4.4.2.7 The TI must indicate within the value listed in the Limits column of Table 14.

4.4.2.8 Set the Signal Generator AMPLITUDE to OFF.

4.4.2.9 Repeat steps 4.4.2.4 through 4.4.2.8 for the remaining values listed in Table 14.

Table 14.

Level (dBm)	Signal Generator Frequency (MHz)	AM Depth (%)	Limits (%)	
			2947	2947A
-10	10	30	21 to 39	27 to 33
-10	10	50	41 to 59	46 to 54
-10	10	90	81 to 99	84 to 96
-10	100	50	41 to 59	46 to 54
-10	250	50	41 to 59	46 to 54
-10	500	50	41 to 59	46 to 54
-10	750	50	41 to 59	46 to 54
-10	999.999	50	41 to 59	46 to 54

4.4.2.10 Set the Measuring Receiver as follows: Press INSTR PRESET. Select AM measurement, 3 kHz LP filter and the PEAK+ and PEAK- detector keys simultaneously (selects PEAK±/2).

4.4.2.11 Repeat steps 4.4.2.4 through 4.4.2.9 using Table 15, except in step 4.4.2.5 set the Function Synthesizer to 0.707 V rms at 100 Hz. Set TI AF filter to 3 kHz LP.

4.4.2.12 Set the Measuring Receiver as follows: Press INSTR PRESET. Select AM measurement, press 300 Hz HP filter, 15 kHz LP filter and the PEAK+ and PEAK- detector keys simultaneously (selects PEAK±/2).

4.4.2.13 Repeat steps 4.4.2.4 through 4.4.2.9 using Table 15, except in step 4.4.2.5 set the Function Synthesizer to 0.707 V rms at 10 kHz. Set TI AF filter to 15 kHz LP and IF filter to 300 kHz.

Table 15.

Level (dBm)	Signal Generator Frequency (MHz)	AM Depth (%)	Limits (%)	
			2947	2947A
-10	10	30	21 to 39	26 to 34
-10	10	50	41 to 59	45 to 55
-10	10	90	81 to 99	81 to 99
-10	100	50	41 to 59	45 to 55

Table 15. (Cont.)

Level (dBm)	Signal Generator Frequency (MHz)	AM Depth (%)	Limits (%)	
			2947	2947A
-10	250	50	41 to 59	45 to 55
-10	500	50	41 to 59	45 to 55
-10	750	50	41 to 59	45 to 55
-10	1000	50	41 to 59	45 to 55

4.4.2.14 Set the Signal Generator output to minimum.

4.4.3 FREQUENCY MODULATION DEVIATION CALIBRATION:

4.4.3.1 Set the Measuring Receiver as follows: Press INSTR PRESET. Select and press 300 Hz HP and 3 kHz LP filters and FM mode keys.

4.4.3.2 On the TI, press Tx TEST and then Mod Meter. Set the controls as follows:

AM/FM/SSB	FM
Tx FREQ	100 MHz

NOTE

From the power up default, the TI should already have an IF filter of 30 kHz and AF filter of 0.3 to 3.4 kHz selected. Verify this is the case and select if necessary.

NOTE

It may be necessary to change the TI Tx FREQ (or reselect AUTOTUNE) if the displayed Tx FREQ does not agree with the Signal Generator output frequency.

4.4.3.3 Set the Signal Generator to 0.0 dBm at 100 MHz. Set the Modulation to FM and EXT DC. Set the AMPLITUDE to ON. Set the modulation to on.

4.4.3.4 Set the Function Synthesizer to 0.707 V rms at 1 kHz.

4.4.3.5 Adjust the Signal Generator FM modulation controls for the first value listed in the FM Deviation column of Table 16, as indicated on the Measuring Receiver.

4.4.3.6 The TI must indicate within the value listed in the Limits column of Table 16.

4.4.3.7 Set the Signal Generator AMPLITUDE to OFF.

4.4.3.8 Repeat steps 4.4.3.3 through 4.4.3.7 for the remaining values listed in Table 16.

Table 16.

Level (dBm)	Signal Generator		TI Limits (kHz)
	Frequency (MHz)	FM Deviation (kHz)	
0.0	100	20	18.8 to 21.2
0.0	500	20	18.8 to 21.2
0.0	999.999	20	18.8 to 21.2
0.0	100	50	47.0 to 53.0
0.0	100	75	70.5 to 79.5
0.0	100	1.00	0.94 to 1.06

4.4.3.9 For 2947, proceed to step 4.4.3.14; otherwise, continue with step 4.4.3.10.

4.4.3.10 Set the Measuring Receiver as follows: Press INSTR PRESET. Select and press HP filter to off, LP filter to 3 kHz and FM mode keys.

4.4.3.11 Repeat steps 4.4.3.3 through 4.4.3.8 using Table 17, except in step 4.4.3.4 set the Function Synthesizer to 0.707 V rms at 100 Hz. Set TI AF filter to 3 kHz LP and IF filter to 300 kHz.

4.4.3.12 Set the Measuring Receiver as follows: Press INSTR PRESET. Select and press 300 Hz HP and 15 kHz LP filters and FM mode keys.

4.4.3.13 Repeat steps 4.4.3.3 through 4.4.3.8 using Table 17, except in step 4.4.3.4 set the Function Synthesizer to 0.707 V rms at 10 kHz. Set TI AF filter to 15 kHz LP and IF filter to 300 kHz.

Table 17.

Level (dBm)	Signal Generator		TI Limits (kHz)
	Frequency (MHz)	FM Deviation (kHz)	
0.0	100	20	18.2 to 21.8
0.0	500	20	18.2 to 21.8
0.0	999.999	20	18.2 to 21.8
0.0	100	50	45.5 to 54.5
0.0	100	60	54.6 to 65.6
0.0	100	1.00	0.91 to 1.09

4.4.3.14 Set all output levels to minimum and disconnect test setup.

4.5 RF SPECTRUM ANALYZER CALIBRATION:**4.5.1 LEVEL CALIBRATION:**

4.5.1.1 Connect the TI BNC antenna connector to the RF Reference Source 50 Ω OUTPUT. Press the TI RF IN/OUT SELECT to select the BNC antenna input.

4.5.1.2 Set the RF Reference Source to 0.0 dBm at 10.05 MHz.

4.5.1.3 Set the TI to SPEC ANA. Set the TI Center Freq to 10.05 MHz. Set the Vert Scale to 10 dB/div and SPAN to 20 kHz. Set the Ref Level (if necessary) to place the signal to the top graticule line on the TI display.

4.5.1.4 Adjust the RF Reference Source level slightly, as necessary, to place the signal on the TI display exactly on the top graticule.

4.5.1.5 Record the exact level of the RF Reference Source.

4.5.1.6 Adjust the RF Reference Source level until the TI display moves to the next graticule line below the reference line. Record the level of the RF Reference Source.

4.5.1.7 Algebraically subtract the reading recorded in step 4.5.1.5 from the RF Reference Source level in step 4.5.1.6. The result must indicate within the values listed in the Limits column of Table 18.

4.5.1.8 Repeat steps 4.5.1.6 and 4.5.1.7 for the remaining values listed in Table 18.

Table 18.

Division below 0 dB Reference	Limits (dB)
1st	-12.5 to -7.5
2nd	-22.5 to -17.5
3rd	-32.5 to -27.5
4th	-42.5 to -37.5
5th	-52.5 to -47.5

4.5.1.9 Set the RF Reference Source output to minimum and disconnect the test setup.

4.6 AUDIO GENERATOR CALIBRATION:**4.6.1 LEVEL CALIBRATION:**

4.6.1.1 Connect the TI AF GEN OUT connector to the Digital Multimeter Input.

4.6.1.2 Set the Digital Multimeter to measure ACV.

4.6.1.3 On the TI, press AF TEST and then Audio Gen and set the controls as follows:

Gen 1/Gen 2	Gen 1
Freq	50 Hz
Level	1 V

NOTE

Verify that TI Gen 2 is not activated.

4.6.1.4 The Digital Multimeter must indicate within 0.949 to 1.051 V.

4.6.1.5 Repeat steps 4.6.1.3 and 4.6.1.4 for the remaining values listed in Table 19.

Table 19.

TI Audio Level (V)	TI Audio Frequency (Hz)	Limits (V)
1	50	0.949 to 1.051
1	500	0.949 to 1.051
1	5 k	0.949 to 1.051
1	10 k	0.949 to 1.051
1	15 k	0.949 to 1.051
2	50	1.899 to 2.101
2	15 k	1.899 to 2.101
4	50	3.799 to 4.201
4	15 k	3.799 to 4.201
20 m	50	18.9 to 21.1 m
20 m	15 k	18.9 to 21.1 m
400 m	50	379.9 to 420.1 m
400 m	15 k	379.9 to 420.1 m

4.6.1.6 Set TI Audio Gen, Gen 1 Level to minimum and disconnect the test setup.

4.6.2 LEVEL DISTORTION CALIBRATION:

4.6.2.1 Connect the TI AF GEN OUT connector to the Audio Analyzer input.

4.6.2.2 On the TI, press AF TEST and then Audio Gen and set the controls as follows:

Gen 1/Gen 2	Gen 1
Freq	1 kHz
Level	1 V

NOTE

Verify that TI Gen 2 is not activated.

4.6.2.3 Set the Audio Analyzer as required to measure distortion at 1 kHz.

4.6.2.4 The Audio Analyzer must indicate <0.5%.

4.6.2.5 Repeat steps 4.6.2.2 through 4.6.2.4 for the remaining values listed in Table 20.

Table 20.

TI Audio Level (V)	TI Audio Frequency (Hz)	Limits (%)
1	1 k	<0.5
1	50	<1.0
1	5 k	<1.0
1	10 k	<1.0
1	15 k	<1.0

4.6.2.6 Set TI AF Audio Test Gen 1 Level to minimum and disconnect the test setup.

4.6.2.7 Set all POWER switches to OFF. Disconnect and secure all equipment.

4.6.2.8 Annotate and attach a Limited Certification Label per step 3.8 or 3.11 as applicable. ■

CALIBRATION PERFORMANCE TABLE

Not Required

APPENDIX A**A.1 TIME BASE ADJUSTMENT:**

A.1.1 Connect Frequency Standard 10 MHz REF OUT to the Signal Generator EXT FREQ STD INPUT.

A.1.2 Connect the Signal Generator output to TI N-type connector. On the TI, press RF IN/OUT SELECT to select the N-type input.

A.1.3 On the TI, press HELP/SETUP, Setup, then Calibrate.

NOTE

Key in code 2, 9, 4, 5 to unlock the TI calibration and diagnostics menus.

A.1.4 On the TI, press Freq Std.

A.1.5 Set the Signal Generator to 1000 MHz at 0.0 dBm.

A.1.6 The offset reading at the bottom of the TI display now indicates the TI reading error at 1000 MHz.

A.1.7 Using the front panel variable control, adjust the calibration value displayed until the offset is as close to 0 Hz as possible.

NOTE

The ↑ and ↓ keys switch between coarse and fine adjustment for the calibration value.

A.1.8 When the offset indication is as close as practical to 0 Hz, press Return and then press Store Cal.

A.1.9 Press Return until the TI display is at the main menu.

A.1.10 Set the Signal Generator output to minimum. Disconnect the test setup. Cycle TI Power OFF, then back ON to relock TI calibration and diagnostics menus