



MAINTENANCE/OVERHAUL MANUAL

MODEL '429EX' ARINC 429 TX/RX

MANUAL NUMBER: 06-5006-00

REVISION: 0

DATE: OCTOBER 28, 1988

REVISION HISTORY

PAGE NO	REV LEV	DATE	DRAWING NO	REV LEV
1-1	0	10/28/88	40-1001-05	0
1-2	0	10/28/88		
			01-1001-05	0
2-1	0	10/28/88	25-1001-05	0
2-2	0	10/28/88	02-1001-05	0
3-1	0	10/28/88	20-5114-05	0
3-2	0	10/28/88	25-5114-05	0
3-3	0	10/28/88	02-5114-00	1
3-4	0	10/28/88		
3-5	0	10/28/88	20-5115-05	0
3-6	0	10/28/88	25-5115-00	3
3-7	0	10/28/88	02-5115-00	4
3-8	0	10/28/88		
3-9	0	10/28/88	20-5037-02	1
3-10	0	10/28/88	25-5037-02	5
3-11	0	10/28/88	02-5037-02	5
3-12	0	10/28/88		
3-13	0	10/28/88		
3-14	0	10/28/88		
3-15	0	10/28/88		
3-16	0	10/28/88		
4-1	0	10/28/88		
4-2	0	10/28/88		
4-3	0	10/28/88		
4-4	0	10/28/88		
5-1	0	10/28/88		
5-2	0	10/28/88		
5-3	0	10/28/88		
5-4	0	10/28/88		
5-5	0	10/28/88		
5-6	0	10/28/88		
5-7	0	10/28/88		
5-8	0	10/28/88		

TABLE OF CONTENTS

SECTION I GENERAL INFORMATION

Paragraph		Page
1.1	INTRODUCTION	1-1
1.2	TECHNICAL DESCRIPTION	1-1
1.3	TECHNICAL CHARACTERISTICS	1-1
1.4	UNITS AND ACCESSORIES SUPPLIED	1-2

SECTION II INSTALLATION

2.1	GENERAL INFORMATION	2-1
2.2	UNPACKING AND INSPECTION	2-1
2.3	EQUIPMENT INSTALLATION	2-1
2.3.1	Battery Charging	2-1
2.3.2	Connection to User Equipment	2-1
2.4	POST INSTALLATION CHECK	2-1
2.4.1	Unit Self Test	2-1

SECTION III OPERATION

3.1	GENERAL OPERATING DESCRIPTION	3-1
3.2	CONTROL FUNCTIONS	3-4
3.2.1	429EX Controls and Indicators	3-4
3.3	OPERATING EXAMPLES	3-10
3.3.1	Transmitter Functions	3-10
3.3.1.1	Entering Transmit Labels and Protecting Data	3-10
3.3.2	Receiver Functions	3-12
3.3.2.1	Using the Receiver Functions	3-12
3.3.3	Using the Receiver Trap Functions	3-13
3.3.3.1	General Trap Mode	3-13
3.3.3.2	Data Trap Mode	3-13
3.3.3.3	Filter Trap Mode	3-14
3.3.3.4	Trapping Using the Data Mode	3-14
3.3.3.5	Trapping Using the Trigger Mode	3-15
3.4	Changing Equipment ID Codes	3-16

SECTION IV GENERAL CIRCUIT THEORY

4.1	GENERAL CIRCUIT THEORY	4-1
4.1.1	Display Board	4-1
4.1.2	Digital Board	4-1
4.1.3	Analog Board	4-2

**SECTION V
MAINTENANCE**

5.1	INTRODUCTION	5-1
5.2	TEST and ALIGNMENT	5-1
5.2.1	Test Equipment Required	5-1
5.2.2	Alignment and Calibration Procedures	5-1
5.2.3	Test Procedures	5-1
5.2.3.1	Initial Test Setup	5-1
5.2.3.2	Power Supply Tests	5-1
5.2.3.3	Keyboard Tests	5-3
5.2.3.4	Receiver/Transmitter Tests	5-3
5.2.3.5	Signal Integrity Tests	5-5
5.2.3.6	General Check-Out	5-6
5.2.3.7	Final Check and Adjustment	5-7
5.3	BILLS OF MATERIAL ASSEMBLY DRAWINGS SCHEMATICS	5-8

SECTION I GENERAL INFORMATION

1.1 INTRODUCTION

This manual provides operational procedures, calibration procedures and maintenance information for the JcAir Model 429EX - ARINC 429 Transmitter/Receiver.

1.2 EQUIPMENT DESCRIPTION

The JcAIR 429EX Transmitter/Receiver provides avionics technicians and line maintenance personnel with an easy method for troubleshooting ARINC 429 avionics systems. The 429EX can transmit up to 10 independent ARINC 429 labels simultaneously and can receive and store up to 255 labels. A special 'Trigger Trap' feature allows selective trapping of block data protocols and alpha-numeric messages. The unit has a non-volatile memory and automatic scrolling to enable the user to store and review the trapped labels at his or her discretion. Internal batteries are provided for portable operation of the 429EX and the unit is housed in a rugged, compact case. Selection of the data, transmitted or received, can be in either hexadecimal or engineering formats. A more detailed description of the units capability can be found in Section 3 of this manual.

1.3 TECHNICAL CHARACTERISTICS

Specification

Characteristic

WEIGHT:

3 lbs (1.36 kgs)

DIMENSIONS:

Height:

7.25 in (18.42 cm)

Width:

4.5 in (11.43 cm)

Depth:

2.5 in (6.35 cm)

POWER REQUIREMENTS:

Six (6) internally mounted AA size rechargeable NiCad batteries.

OPERATING TEMPERATURE:

-10 to +60 degrees C

429 TRANSMITTER:

Bit Rate: 12.5 or 100 kbps +/- 0.5%
(selectable)

Pulse Rise Time: Low Speed -10 +/- 0.5 usec
High Speed -1.5 +/- 0.5 usec

Pulse Amplitude: HI = +10 +/- 1.0VDC
(Line A to B)
LO = -10 +/- 1.0VDC
(Line A to B)
NULL = 0 +/- 0.5VDC
(Line A to B)

Output Impedance: 75 +/- 50ohms (Line A to B)

Word Rate: 4 to 59998 msec

Parity: ODD or EVEN (selectable)

429 RECEIVER:

Bit Rate: Low Speed = 8 to 20 kbps
High Speed = 80 to 125 kbps

Word Rate: +/- 2 msec. average

Input Impedance: 12K ohms minimum (balanced)

1.4 UNITS AND ACCESSORIES SUPPLIED:

- A. JcAIR Model 429EX ARINC 429 Transmitter Receiver
JPN 001-1001-05
- B. STANDARD Accessory: 110V/60Hz to 9VDC Battery Charger
JPN 015-0009-00
- C. OPTIONAL Accessory: 220V/60Hz to 9VDC Battery Charger
JPN 015-0009-01

SECTION II INSTALLATION

2.1 GENERAL INFORMATION

This section contains information relating to the unpacking and inspection of the unit. Also included is information concerning charging of the internal batteries and an explanation of the Unit Self Test routine.

2.2 UNPACKING AND INSPECTING EQUIPMENT

Carefully remove the JcAIR 429EX and battery charger from the packing box. Visually inspect the units for any damage incurred during shipment. Should there be damage, save the packing box to show the shipping company when submitting your claim. It is generally a good idea to save the packing box should it become necessary to store or ship the unit.

2.3 EQUIPMENT INSTALLATION

2.3.1 BATTERY CHARGING

The batteries were fully charged when the unit was shipped from the factory. However, if the unit has been stored for an extended period of time, the batteries may have become discharged. Plug the charger into an appropriate voltage outlet (U.S. as well as international voltage chargers are available). A 4 to 5 hour charge should refresh the batteries. The 429EX may be operated while charging or with the charger disconnected. With fully charged batteries, the unit will operate for approximately four to six hours.

2.3.2 CONNECTION TO USER EQUIPMENT

Connect the JcAIR 429EX output (TX jack) to the input of the UUT and the JcAIR 429EX input (RX jack) to the output of the UUT using standard 1/4 inch stereo phone jacks.

2.4 POST INSTALLATION CHECK

2.4.1 UNIT SELF TEST

The JcAIR 429EX performs a self test routine on initial power up. The following tests are performed:

1. The message **EX VERSION *.*** is displayed. (*.* = software revision). Red LED's on the front of the unit will be lit for approximately 0.5 seconds each in the following order: EVEN and ODD Parity, TX and RX. For the remainder of the self test, unless an error condition exists, the LED's are extinguished. If one of the LED's fails to light, the unit should still function properly, but the LED should be replaced at the earliest opportunity.

If all LED's fail to illuminate and the display is blank or display's random data, then a catastrophic unit failure has occurred or the batteries are completely discharged.

2. The EPROM is checked by summing all the memory locations and comparing the result to the known checksum. If the checksums do not match, the unit will signal a checksum error by flashing the RX LED and will attempt to write "CHECKSUM ERROR" to the display. (If the entire EPROM has failed, however, or if one of the locations in the checksum subroutine is bad, the program will not be able to execute properly.)
3. The 429EX has RAM in two independent IC's. The unit tests each RAM section separately for data retention and address integrity. It begins by writing the lower 8 bits of the location address to the location. It completely writes all locations of the section. It will then read each location and check its value. If all is OK, it will repeat this sequence with the exception that it will write the complement of the lower 8 bits of the location address to the location. It performs this sequence for each RAM section.

If the first IC fails this test, the unit will flash the EVEN parity LED and attempt to write "NSC RAM ERR" to the display. This indicates that U5 has failed its test. If the second IC fails this test, the unit will flash and the ODD parity LED will attempt to write "6116 RAM ERR" to the display. This indicates that U3 has failed its test. The unit will then loop indefinitely reading from the failed location.

4. The 429EX has a loop back feature on the digital board to completely test the digital portion of the transmit and receive circuitry. The unit will turn on the loop back circuitry and transmit a word with a label of 0 and a data pattern of AA55AA. after a brief pause, the unit will read it's receive buffer and check the data against the transmitted data. If the data is not what is expected, the unit will flash the TX LED and attempt to write "LOOP BACK FAILED" to the display. No further operations will be possible until the cause of the failure is corrected.

The Loop test and Ram tests are not performed if the unit Trap mode is active.

If all tests have been successfully completed, the unit will display "**SELF TEST OK**" for approximately 2 seconds and will then enter the operational transmit mode and display the number of different labels currently being transmitted.

SECTION III OPERATION

3.1 GENERAL OPERATION DESCRIPTION

The JCAIR 429EX is a single channel ARINC 429 transmitter and receiver. It can receive and display all ARINC 429 labels. It can simultaneously output up to ten 429 words. Data can be displayed and entered in hexadecimal or engineering formats. The HEX mode has two types of data entry and display. The first type allows display and entry of bits 32 - 9 in hexadecimal format, reading left to right as 32 - 9. The label will be displayed in octal. The SDI (bits 10 - 9) is then displayed in binary. Bits 32 - 9 of the word are then displayed in HEX. On the far right of the display will be the SSM bits (31 - 30) of the word. The second type in HEX mode allows display and entry of bits 31 - 9 in binary format. The SDI bits (10 - 9) and SSM bits (31 - 30) each have their own screen. The remaining bits (29 - 11) each have their own individual screen. Word rate for the word is also available on a dedicated screen in the HEX mode. ENG (Engineering) mode allows data entry and display in engineering unit formats (Feet, Knots, MHZ, etc.). The label definition will determine the number of screens required for display of the possible fields of the word. Label definition may be changed by entering a new 'EQID' (Equipment Identifier). If the new ID is valid (per ARINC 429-11, attachment 2) for the currently selected label then the label will be decoded and displayed according to that definition. If the ID is invalid for the label, a default definition will be used. The last ID entered will remain active until changed or until the unit is turned off (unless in Trap or Protect mode). Some labels have definitions that don't have an assigned ID and are not the default definition. These have been arbitrarily assigned Equipment IDs of 'FF'. (NOTE: BITE Status Word has been assigned the same ID as the BITE Command Word (7E) and will be displayed in engineering format. However, due to the many variations of data types for the word, it must be entered in HEX format.)

There are two distinct modes of system operation. The RX mode is the receiver mode of operation. The TX mode is the transmit mode of operation. Selection of these modes and all other display operations are accomplished by keypad or slide switch entry. These are described in the following section:

The transmitter is capable of outputting up to ten 32 bit words in ARINC 429 or 419 bipolar RZ (Return-to-Zero) format. The word rate for each of the ten can be set independently. The word rate can be as low as 4 msec or as long as 59998 msec, or left to the default value as defined as the minimum word rate in the ARINC 429-11 specs. The transmitter automatically insures at least a 4 bit time (Low Speed) separation between adjacent words. The transmitter section may be placed into a 'PROTECTED' mode of operation. This mode protects the user entered parameters from changing when the unit is powered off.

When power is restored to the unit it will resume operation where it was at power down. If this mode is off then the unit will clear the transmitter section on power up. The unit will stay in the selected mode until changed by the user, even if the unit power is cycled.

The data for most labels with engineering definitions can be 'SLEWED'. This means that the data will dynamically change value according to user defined parameters. There will be 4 slew screens in the data mode for any label with slew capability. The first screen is a 'SLEW' screen that defines the amount of change in data. When this parameter is set to '0' (default) then no slewing will occur. The second screen is the 'MAX' screen which defines the upper limit that the data is allowed to slew to. The third screen is the 'MIN' screen which defines the lower limit that the data is allowed to slew to. Either parameter may be positive or negative (dependent on ARINC definition for the label) but the 'MAX' parameter MUST be larger than the 'MIN' parameter. Note that only bits 28 - 17 of the limits will be used in the limit check. All other bits are ignored and will be truncated upon user entry of new limit values. The fourth screen turns the 'ALT' (Alternate) mode on and off. If this mode is on, the data will slew to the limit in the direction it is going. When the limit is reached, the data will reverse direction and then slew to the opposite limit. When this limit is reached, the data will again reverse itself. If 'ALT' is off, the data will slew in the direction entered in the 'SLEW' parameter (positive or negative) to the limit and then reset to the value defined for the opposite limit (data wraps around).

The receiver has the capability of receiving and storing up to 255 (511 in 'DATA ONLY' mode) high or low speed 32 bit words in ARINC 429 or 419 RZ format. There are three mutually exclusive receiver modes of operation. Each mode has a screen that shows the count of words received, the label and description, or the data field currently selected. Normal mode (default) is a dynamic mode that displays all unique labels received. In this mode the screen is updated 4 times per second with the latest data received. 'FILTER' mode is identical to normal mode with the exception that words received may be filtered. Words may be filtered in 1 of 4 combinations: All Labels/All SDI, Specific Label/All SDI, All Labels/Specific SDI, and Specific Label/ Specific SDI. Any words that do not meet the filter parameters will be discarded. The third and most powerful mode is the 'TRAP' mode. This is a static mode of operation which captures and stores the data for detailed analysis. Words are received and stored in the trap buffer in their order of occurrence. They will remain in the buffer until the trap mode is turned off, even if the unit power is turned off. In normal trap mode up to 255 unique words may be stored. In this mode the time that has elapsed since the previous word is stored as the rate. In 'DATA ONLY' trap mode up to 511 words (must be the same label) are stored. The rate is invalid in this mode of operation.

The trap has user definable trigger and filter parameters. A trigger may be set up so that trapping will not occur until the trigger specs are met. Triggering specs may be set in 1 of 4 combinations: Don't Care Label/Don't Care Data (No Trigger), Specific Label/Don't Care Data, Don't Care Label/Specific Data Pattern, Specific Label/ Specific Data Pattern. Filtering specs may be set to filter the data in 1 of 4 combinations: All Labels/All Data, Specific Label/ All Data, All Labels/ Specific Data Pattern, and Specific Label/Specific Data pattern. The data pattern for each spec can be from 1 to 24 bits. If a data pattern is entered for either spec the the user will be prompted for a 'CARES' mask. If a bit is set in this mask, the corresponding bit in the received data will be checked against the same bit in the desired data pattern. The user may simply press the enter key if the prompted parameter is a don't care to the user. Data and care patterns must be entered in hexadecimal (up to 6 chars) if used. As an example, if a DATA pattern of 000001 and a CARES pattern of 000003 (default) is used then only the SDI bits (10 - 9) will be checked for an SDI of 01. The status of a bit in the DATA pattern is irrelevant if the corresponding bit in the CARES pattern is not set. The data stored in the trap buffer may be printed out on an IBM compatible parallel printer through the optional 25 pin female DSUB connector on the side of the 429EX.

The transmitter and receiver can operate at either 100kbps (High Speed) or 12.5 kbps (Low Speed). Each mode's speed can be set independently of the other. The parity of the words being transmitted can be set for either ODD or EVEN parity. An LED indicator will show the parity selected for transmitted words if in the TX mode or the parity of the currently displayed word if in the RX mode.

To minimize battery drain, the 429EX has the capability to sense there has been no activity (keypad, TX, or RX) for at least 5 minutes. When this happens, the 429EX will shut down some of it's circuitry and go to 'Sleep'. In this state, the 429EX is fully functional, but it is in a low current drain wait state. The LCD screen will be blank, but either the TX or RX LED will be lit. Any keypad or RX activity will reawaken the 429EX to it's normal operation mode.

3.2 CONTROL FUNCTIONS

3.2.1 429EX CONTROLS AND INDICATORS (Refer to Figure 3-1)

- (1) TRAP Mode Key
- IN RX MODE:
On/Off control for the TRAP mode. Pressing 'ENT' key for any of the prompted parameters will cause a don't care to be used for that parameter. Data is automatically protected if unit is powered off when TRAP is on.
- IN TX MODE:
On/Off key for TX data PROTECT mode. If Protect is on the Transmit parameters will be protected when the 429EX is powered off.
- (2) AUTO Mode Key
- IN RX MODE:
On/Off key for 'AUTO' scrolling mode. Allows the operator to scroll through labels that have been received by TRAP mode. AUTO mode steps 'Automatically' through the word buffer and displays the number of trapped words as well as the engineering name of the label, if it is in the 'Label' mode. If in the 'Data' mode, the AUTO mode steps to the same data menu for the next trapped word. Scroll keys will allow scanning direction to be selected.
- IN EDIT MODE:
While in the EDIT mode, this key allows the hexadecimal value 'C' to be entered.
- (3) TX Parity Switch
- Allows operator to select ODD or EVEN transmission parity.
- (4) TX SPEED Switch
- Allows operator to select HI (100 kbps) or LO (12.5 kbps) transmission rate.
- (5) TX Output Port
- Allows access to transmitter port using standard 3-conductor, 1/4" phone plug.
- (6) RX Input Port
- Provides input to receiver port using standard 3-conductor, 1/4" phone plug.

- (7) SCROLL Keys Allows operator to scroll through display menus (10 transmitter slots, up to 511 receiver slots, or data menus). Allows selection of the scanning direction in AUTO mode. If editing data of an ISO Alpha label (356 or 357), the SCROLL keys will allow selection of the Alpha character to be entered (SCROLL to the desired character and press 'ENT' to select a character).
- (8) TX/RX Indicator LED indicates that the system is in either the transmitter or receiver mode of operation for display and entry of data.
- (9) PARITY Indicator IN RX MODE:
LED Indicates parity (ODD or EVEN) of word presently displayed.
- IN TX MODE:
LED Indicates selected transmit parity.
- (10) HEX/ENG Switch Allows operator to select hexadecimal or engineering unit display and entry of data.
- (11) TX/RX Key Allows operator to select whether the system is in transmit or receive mode of operation for display and entry of data. After selection of the TX/RX key, initial display indicates the number of labels being transmitted, received, trapped, or filtered. SCROLL keys should then be used for manual stepping through transmitter or receiver slots. TX/RX LED indicators above display will indicate current mode of operation.
- (12) RX SPEED Switch Allows operator to select HI (100 kbps) or LO (12.5 kbps) receiver speed.

(13) DATA ENTRY Keys

Allows operator to enter various data in hexadecimal or engineering formats. Keys 0 - 9 and the '.' and '-' keys are valid while in ENG mode. Keys 0 - F are valid while in HEX mode. (Hex mode will be forced regardless of switch position if the label is currently undefined by ARINC specs. or is a label not supported in ENG mode. (Discrete data, Maintenance Data, etc.). Keys 0 - 7 are valid for LABEL entry since all labels are entered in octal format. The '0' and '1' keys allow clearing and setting, respectively, bits of discrete bit screens (SDI, SSM, RF management labels, frequency discretets and individual bit screens, etc.) and turning various modes on and off (e.g. slew ALTERNATE).

(14) LAB/DAT Key

Allows operator to select either LABEL mode or DATA mode of display. LABEL mode displays octal number and engineering definition of labels being transmitted or received. DATA mode allows viewing of data of the currently selected label being transmitted or received.

(15) EDIT/DEL Key

Allows operator access to the data entry mode. If in the data entry mode, the DEL keys allows correction of errors during data entry.

(16) ON/OFF Key

Turns unit ON and OFF

(17) ENT Key

This key has several functions, dependent on which mode the unit is in.

DATA Entry Mode:

Completes an entry sequence. Until the ENT key is pressed, an entry may be edited with the DEL key. If an entry is not allowed for some reason (out of range, illegal key), the old data will be retained.

(cont)

TX MODE:

Resets the TX timer counters of each active slot to their initial value. This allows the TX labels to be synchronized in their output order if all have the same word rate. They will be sent out in descending TX block order (10 through 1), e.g.: The user wants to simulate a DME LRU that transmits 6 labels in bursts 100 msec. apart. The user would enter the first label in the group in the TX slot 10 with a word rate of 100. The second label would go in the TX slot 9 with a word rate of 100. This would continue for the remaining labels with the last label of the group being entered in TX slot 5. Once all the data has been entered correctly and the user is ready to synchronize the labels, he(she) should press the ENT key. There will be no visible indication that anything has occurred, but the words have been synchronized and are being transmitted in bursts of 6, 100 msec apart. If any data is changed later, the ENT key should be pressed again to resynchronize the words.

IN RX MODE:

If in trap mode and the current screen is the word trapped count screen and there are valid words trapped, pressing the ENT key will initiate a printer dump sequence. If a printer is not connected to the 429EX or is off-line the 429EX will indicate this for 2 seconds and abort the print sequence. (NOTE: The LED's will act 'Erratically' and the keypad will be disabled during the print dump. This is normal and should be ignored.) To abort a print sequence just turn the unit off since the data will still be valid on restoration of power.

- (18) Battery Charging Jack Allows the internal batteries to be charged by connecting to the battery charger furnished with the 429EX.

- (19) Parallel Printer
Output Port
(Optional) . Allows connection to an IBM compatible parallel printer using a standard IBM/CENTRONICS parallel interface cable.
- (20) D.O. Key
IN EDIT MODE:
While in the EDIT mode, this key allows the hexadecimal value 'D' to be entered. IN RX MODE: Pressing this key when trap mode is first activated (before entering the Trap Label) will activate the DATA ONLY trap mode. This mode expands the trap capacity to 511 words, however, no label or rate information is stored. This means that the user must enter a trap label when prompted. This mode will be cleared when trap mode is turned off.
- (21) EQID Key
IN EDIT MODE:
While in the EDIT mode, this key allows the hexadecimal value 'E' to be entered. NON EDIT MODE: While in any mode other than edit mode pressing this key will 'Pop Up' the 'EQPMT ID' (Equipment Identifier) screen. This may then be edited using the normal edit procedure. Up to 2 hex characters may be entered. Pressing this key again or any other mode control key will clear this screen. The Equipment Identifier is used by the 429EX to determine which ARINC definition to use for the received and transmitted labels when displaying and entering data.
- (22) FILT Key
IN EDIT MODE:
While in the EDIT mode, this key allows the hexadecimal value 'F' to be entered. IN RX MODE: On/Off control for the FILTER mode. Pressing 'ENT' key for any of the prompted parameters will cause a don't care to be used for that parameter.

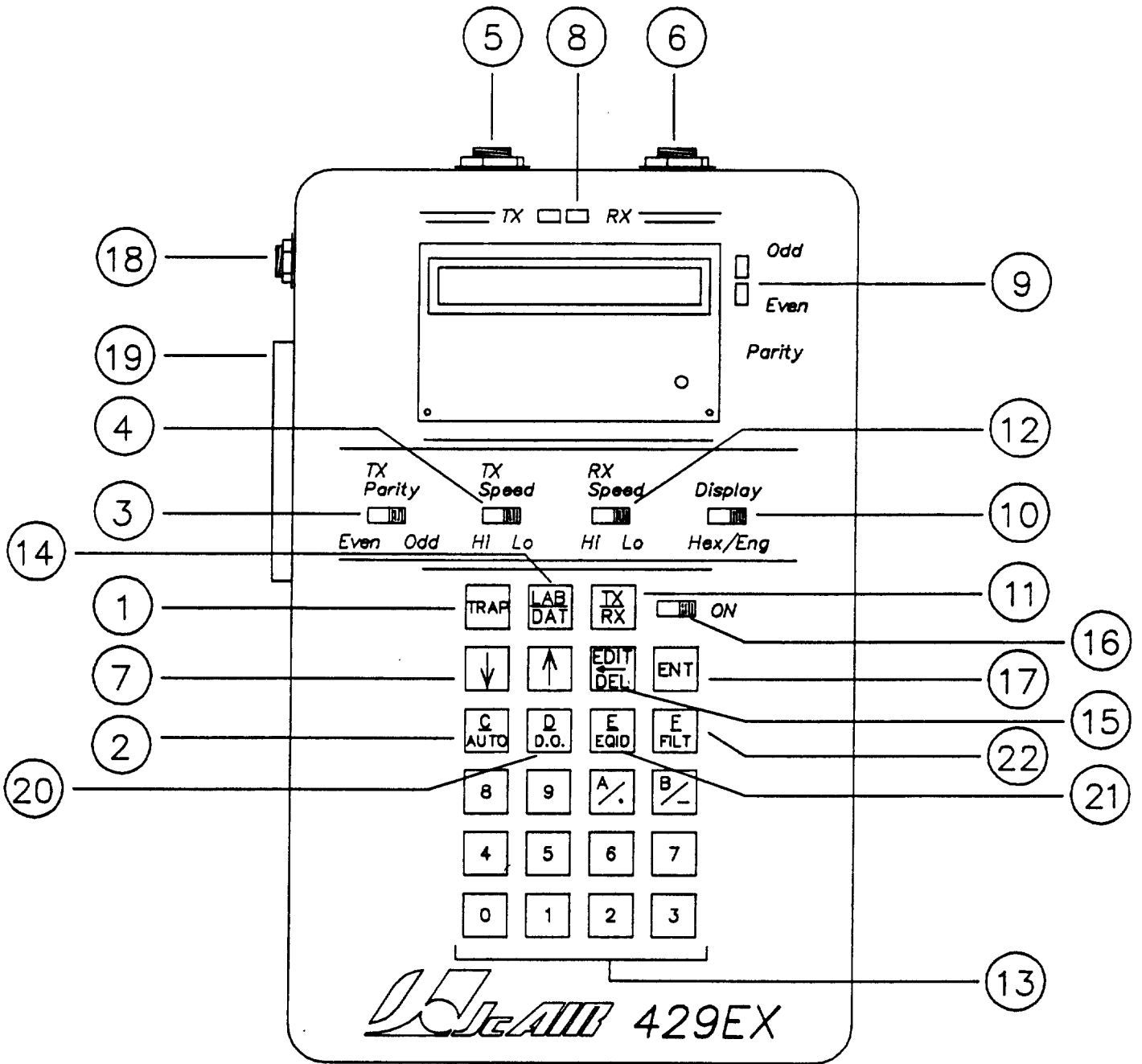

Figure 3-1
Controls and Indications

3.3 OPERATING EXAMPLE

The following section is a series of instructions designed to guide the user through some of the features of the 429EX.

NOTE: For these instructions we will use four ARINC labels throughout for the sake of consistency. The user is free to configure additional labels if desired. These labels are as follows:

033 ILS FREQUENCY
034 VOR FREQUENCY
035 DME FREQUENCY
102 SEL ALTITUDE

The 429EX hand held, transmitter/receiver features are designed to allow the user greater flexibility when working with ARINC 429 data buses. These features are outlined below.

1. Expanded screen displays of data and information.
2. User definable Equipment ID codes.
3. Labels defined to ARINC 429-11 Air Transport specifications.
4. Data slewing or ramping capabilities.
5. Positive or negative slewing.
6. Non-volatile memory that stores previously entered information when protection feature is turned on.
7. Additional, expanded selective trap capabilities.
8. Dynamic display of slewed and ramped data.
9. Individual display and control of bits 11 to 29.
10. Separate screens for SDI and SSM.
11. Non-volatile memory for RX and TRAP mode.

3.3.1 TRANSMITTER FUNCTIONS

3.3.1.1 Entering Transmit Labels and Protecting Data

1. Turn on the 429EX (unit will self test and go to the transmit mode). To clear the transmitter if it contains labels, depress the trap key displaying NOT PROTECTED and turn unit off for 5 seconds then back on.
2. Depress the TRAP key for PROTECTED or NOT PROTECTED data mode. When data is NOT PROTECTED it will not be retained in the units memory when it is turned off. Set unit to PROTECTED.
3. Depress scroll up arrow to access transmitter #1 which will display TX 1 INACTIVE.

Note: Arrow keys are scroll up/down keys.

4. Depress the EDIT/DEL key and LABEL ? will appear. Enter the first label: LABEL ?. Enter 033 and depress ENT key. Unit now displays 033 ILS FREQ and you can view the default data for this label by depressing the LAB/DAT key. To scroll through the data use the UP/DOWN arrows. This step is the same for all future labels to be entered. To correct an incorrect label, simply edit over it and enter correct label. To clear a transmitter and show the TX INACTIVE, edit and enter 0.
5. Depress the LAB/DAT key and return to label 033. use the scroll up key to access TX 2 INACTIVE. Depress EDIT/DEL and enter label 034 VOR FREQ. Repeat this procedure and enter LABEL 035.
6. Scroll to TX 4 and enter Label 102 SEL ALTITUDE. The following sequence is to slew and ramp the data within a selected non-RF label. For demonstration purposes we will limit this to label 102.

Note: For all data entry that follows it will be necessary for the user to follow the previous sequence of depressing the appropriate keys such as EDIT/DEL and ENT as well as the scroll keys to access all of the data displays for editing.

- A) Depress LAB/DAT key. Depress the up arrow key as required until SLEW appears.
- B) SLEW defines the value that our data will change by. Enter 100 ft. (EDIT - 100 - ENT).
- C) Scroll to MAX=65520. This is the default limit in the ARINC specification truncated to 12 bits. Enter 10000 ft.
- D) Scroll to MIN=00000 and enter 9000 ft. The display will now announce 08992 instead of 9000. This is due to the program using only the first 12 bits of significant data (bits 28 to 17). Other bits are truncated and this results in a resolution of 8 ft for limit checking for this label.
- E) Scroll to SLEW ALT OFF. To turn this feature on simply depress EDIT and enter 1. (1 turns ALT ON and 0 turns ALT OFF). When SLEW ALTERNATING is on, slewing will continuously occur bi-directional reversing itself when upper and lower limits are reached. When this feature is off, slewing will occur in only one direction, up/down, positive/negative.
- F) Scroll to the next screen and there will be a dynamic display of the slewing from 9000 ft to 10000 ft up and down in increments of 100 feet.

- G) Scroll to the rate screen and RATE = 100 MS. Enter 500 MS to slow the updating speed down for additional visibility.
- H) Scroll to the SDI screen which will display 00. Edit as required.
- I) Scroll to the SSM screen which will display 11 / NORM which is the ARINC default norm for this label. Enter 00 and watch the display change to 00 / FAIL. Re-enter 11 and SSM returns to normal.
- J) Scroll once more to return to SLEW then depress LAB/DAT key to return to the label.
- K) Depress TX/RX key to go to the receiver mode.

NOTE: When entering data, it is possible to view and turn on or off individual bits 11 to 29. To access this feature depress the LAB/DAT key to go to the data mode and move the display switch from Eng to Hex then scroll till the desired bit is reached. Edit each bit individually with 0 for off and 1 for on.

3.3.2 RECEIVER FUNCTIONS

3.3.2.1 Using the Receiver Functions

1. To use the receiver port it is necessary to loop the unit to itself by connecting the transmitter port to the receiver port. In this manner you will see displayed the four labels entered previously on the transmitter side.

Note: If there are any labels trapped in the memory of the 429EX they will annunciate on the screen. To clear the memory depress the TRAP key; or the F/FILT key if XX FILTERED WORDS appears.

2. Once this is accomplished the receiver will display 4 RX LABELS.
3. To view the labels, simply depress the scroll/arrow key in the direction you wish to scroll. You will see displayed the four labels entered; 033, 034, 035, and 102.
4. To view data, depress the LAB/DAT key. For this exercise we will view label 102.
5. Label 102 will display data that is being slewed at the rate of 100ft every 500 MS as was previously programmed.
6. Scrolling through the data will sequentially display RATE, SDI and SSM.

7. By switching the unit from the ENG mode to the HEX mode it is possible to scroll through the data mode and individually view bits 11 through 29. These bits can also be viewed and edited individually on the transmitter side.

3.3.3 USING THE RECEIVER TRAP FUNCTIONS

3.3.3.1 General Trap Mode

1. To trap the first 255 labels received , depress the TRAP key. Unit will display TRAP LABEL, depress ENT, unit will display DATA ?, depress ENT, unit will display TRIG LABEL, depress ENT, unit will display DATA ?, depress ENT and unit will begin trapping. It is necessary to depress ENT for the unit to default to the general trap mode. No data needs to be entered.
2. To view the trapped labels, depress the appropriate scroll key. To auto-scroll, depress the C/AUTO key and display will automatically display one label approximately every second. You can reverse the scroll direction by using the opposite scroll key. The display will show the number of the trapped word. To stop autoscroll, depress the C/AUTO key again.
3. By holding down either scroll keys, it is possible to speed up the sequence to reach a specific label more quickly.
4. To clear the trap memory, depress the TRAP key and the unit will return to receiving 4 labels only.

3.3.3.2 Data Trap Mode

1. Depress the TRAP key Then the D/D.O. key and watch the display which will flash DATA ONLY. The unit will now trap one word 511 times. Enter TRAP LABEL 102 and depress the ENT key until unit starts to trap. The unit is trapping label 102, 511 times and the label is transmitted at the rate of 500 MS. It is possible to start viewing individual labels while the unit is still trapping by scrolling to the first few labels trapped. This does not interfere with the unit which will continue to trap incoming labels.
2. Once the unit is finished trapping it is possible to scroll through each label trapped and view them individually. By depressing the LAB/DAT key and then the C/AUTO key you can view label 102 which was trapped as it slewed from 9000 ft to 10000 ft. It is also possible to view all data on each individual label trapped including bits 11 to 29, SDI, SSM, etc.

3. To clear the trap memory depress TRAP.

NOTE: When trapping using the DATA ONLY mode, it is necessary to enter a label as this mode traps off of the label it is searching for.

3.3.3.3 Filter Trap Mode

1. Depress the F/FILT key. Enter label 035, SDI is optional. Unit will now trap label 035 if it is being received. This mode strips all irrelevant words from the received data for the sought after combination.
2. This label and its data can now be viewed as in the other trap modes.
3. To clear the filter mode depress the F/FILT key.

3.3.3.4 Trapping Using the Data Mode

1. To trap when only data is known, depress the TRAP key. Depress the ENT key until DATA ? is displayed.
2. Enter the data you wish trapped. (For our purposes, we will use 627100 which represents 10000 ft in label 102 which we are transmitting and simultaneously slewing from 9000 ft to 10000ft.)
3. The next screen will ask CARES ?. It is now necessary to enter 7FFFFFF which is to mask parity off to allow the unit to search for specific data. Depress ENT (it is necessary to depress ENT three times) until the unit begins to trap.

Cares is a 24 bit hex mask to determine if a bit in the data word will be checked for status. This function is particularly useful for trapping block data protocols. For example the Williamsburg Protocol, Bite Memory Transfer and Alpha-numeric messages. It is also useful for monitoring a bus for a specific flag such as an autopilot armed flag, where a specific bit in a specific word arms an autopilot and it is necessary to determine when this event occurs.

In the example we have used, we are searching for a specific data field and the cares function is masked by the entry of 7FFFFFF. Some useful cares patterns follow:

7FFFFFF = Masks parity off and allows for checking all bits in the data field.

000003 = Default bit which means only the SDI bits 9 & 10 will be checked.

600003 = SSM and SDI bits only checked, (bits 31 & 32 and 9 & 10).

Other bit parameters may be set as desired.

When viewing the 429EX screen the display in the hex mode shows the following information:

XXX	XX	XXXXXX	XX
LABEL	SDI	DATA	SSM

The SSM is in binary, the DATA in hex, the SDI in binary and the LABEL in octal.

4. The unit will now look for only this data and trap those words it receives with this data. It may take a few moments for the first word to be received. As soon as the first word is received it is possible to view the word by scrolling to it and viewing the data. The word should be 102 at an altitude of 10000 ft. By selecting HEX on the switch, you can view the data which is 627100.

5. To turn off the trap mode depress the TRAP key.

3.3.3.5 Trapping Using the Trigger Trap Mode

1. To trap a string of data triggering from either a label and/or from data the trigger must be armed. Depress the TRAP key depress ENT twice, then enter the data in label 102 for 10000ft which is 627100 and for CARES turn off the parity mask using 7FFFFFF.

2. When the information is entered the screen will display TRIGGER IS ARMED and the unit will wait till it receives this data. As soon as the data is received, the unit will go into the normal trap mode and it will trap the first label immediately following the data that was in the trigger. This should be label 035 which has the fastest time out at a rate of 100 MS.

3. This can then be viewed in the normal manner by scrolling through the labels. The first label trapped will be 035 DME FREQ as it is transmitted at the fastest rate which is 100 MS and it is followed by 034 and 033. Label 102 will only be caught in the string very sparingly as its rate was set earlier at 500 MS.
4. When trapping using the data only mode, note that it is necessary to enter the label first as this mode traps only the label it is looking for. To trap label 102 starting when it reaches 10,000ft depress TRAP then the D key. Enter label 102, scroll TRIGGER DATA and enter 627100 then mask parity in cares with 7FFFFFF. The first label 102 trapped by the unit will be 102 at 10,000 ft (data 627100).

3.4 CHANGING EQUIPMENT ID CODES

The 429EX has the capability to change equipment ID codes to any Air Transport Equipment Identifier Specification codes defined in ARINC 429-11. To change these codes, the following procedure is used.

1. When the unit is in the TX mode scroll to label 035 that was entered previously and it will display 035 DME FREQ.
2. Depress the E key and the unit will display EQPMT ID =00.
3. Depress the EDIT/DEL key and unit will display EQPMT ID ?. Enter 06 and depress the ENT key (06 is the ID code found in the ARINC specification that identifies labels used for Air Data Systems.)
4. The 429EX will now display 035 BARO (IN) which is inches of mercury used for air data testing. Note that label 034 has also been changed and it now displays 034 BARO (MB).
5. To return to the original ID simply use the same steps to enter 00 which is the original ID to which the unit will default. The display will again show 035 DME FREQ.

The 429EX changes the definition of all labels that are defined in the ARINC 429 Air Transport specification with the same ID. In the above example, the definitions identified with an ID of 06 would be desirable when working with Air Data Systems. It is also possible to change the ID codes while in the receiver mode by following the same sequence.

Note: Some ARINC labels do not have designated ID codes. To access these labels JCAIR has assigned a special ID code of FF. Using FF will allow access to these labels such as label 77.

SECTION IV

THEORY OF OPERATION

4.1 GENERAL CIRCUIT THEORY

The JcAIR Model 429EX, JPN 01-1001-10, ARINC 429 single channel transmitter and receiver consists of three board level sub assemblies and a battery pack. The three boards are :

- 1) Display Board (JPN 20-5114-00)
- 2) Digital Board (JPN 20-5115-00)
- 3) Analog Board (JPN 20-5037-00)

4.1.1 DISPLAY BOARD

The Display board performs the human interface function for the 429EX. It has three major sections of circuitry:

- 1) Display circuits
- 2) Keypad circuits
- 3) Slide Switch circuits

The Display circuits output data in visual form. The display circuit consists of the liquid crystal display (DS1). The Keypad switches allow data to be input to the unit. The keypad circuits consist of 23 momentary contact switches (S1 - S23). The switches are arranged in an X/Y matrix and are decoded by the firmware on the digital board. The slide switches allow various I/O information (Parity, TX Baud, etc.) to be changed and to turn the unit on and off. The slide switch circuits consist of 5 SPST slide switches (S24 - S28) and various discrete components (resistors, transistors and capacitors).

4.1.2 DIGITAL BOARD

The Digital board contains the digital circuitry for the 429EX. This circuitry has three major sections:

- 1) Control circuits
- 2) 429 Receive Buffer
- 3) 429 Generator

The Control circuits are the 'Heart' of the system that controls and monitors all other circuits in the system. The control circuits consist of the following components

- 1) Microcontroller (U1)
- 2) Firmware EPROM (U2)
- 3) RAM (U3)
- 4) Address Latch (U4)
- 5) RAM IO (U5)

The control circuits monitor the number of 'bits' received and upon completion, will read the receive buffer.

The 429 Receive buffer stores the 429 bit stream data (Converted to TTL levels by the Analog board). The following components make up the 429 receive buffer.

- 1) Bit Latch (1/2 U8)
- 2) Serial Register (1/2 U6)
- 3) Mux (U14)

The 429 Generator circuits send TTL level bit stream data to the Analog board, where it is converted to the correct levels for output. The Generator is loaded and started by the Control circuits. The Generator consists of the following components:

- 1) Digital drivers (U9)
- 2) Serial Register (1/2 U6)
- 3) Baud Clock/Bit Counter (U5)
- 4) Driver Enable (1/2 U8)

4.1.3 ANALOG BOARD

The Analog board contains the analog circuitry for the 429EX. This circuitry has three major sections:

- 1) Power Circuits
- 2) 429 Receiver
- 3) 429 Driver

The Power circuits supply power to the system from one of two sources. If the battery charger is disconnected, the circuits supply power to the system from the battery pack. The battery voltage is monitored by the power circuits. Should the voltage drop to an insufficient level it is the power circuits that will indicate this to the Control circuits. An indication of low power will be seen on the display board should the afore mentioned conditions exist. If the charger is connected, the power circuits will supply power to the system from the charger and will also trickle charge the NiCad batteries. The power circuits consist of the following components:

- 1) Low Drop Out Regulator (U5)
- 2) Voltage converter (U6)
- 3) Monitor (U7)

The 429 Receiver circuits convert ARINC 429 RZ transmitted signals form 10V levels (between A & B) to TTL level signals for use by the 429 Receiver Buffer on the Digital board. The 429 receiver circuits consist of a Comparator and a number of discrete components. The 429 driver circuits convert the TTL level signal from the digital board into 10V (between A and B) ARINC 429 compatible signal levels.

The 429 Driver circuits consist of the following components:

- 1) "1" Driver (U2, Q1, Q2)
- 2) "0" Driver (U3, Q3, Q4)
- 3) Speed Switch (U1)

The battery Pack supplies power to the system and consists of the following components:

- 1) Battery Holder
- 2) Six (6) 'AA' NiCad rechargeable batteries.

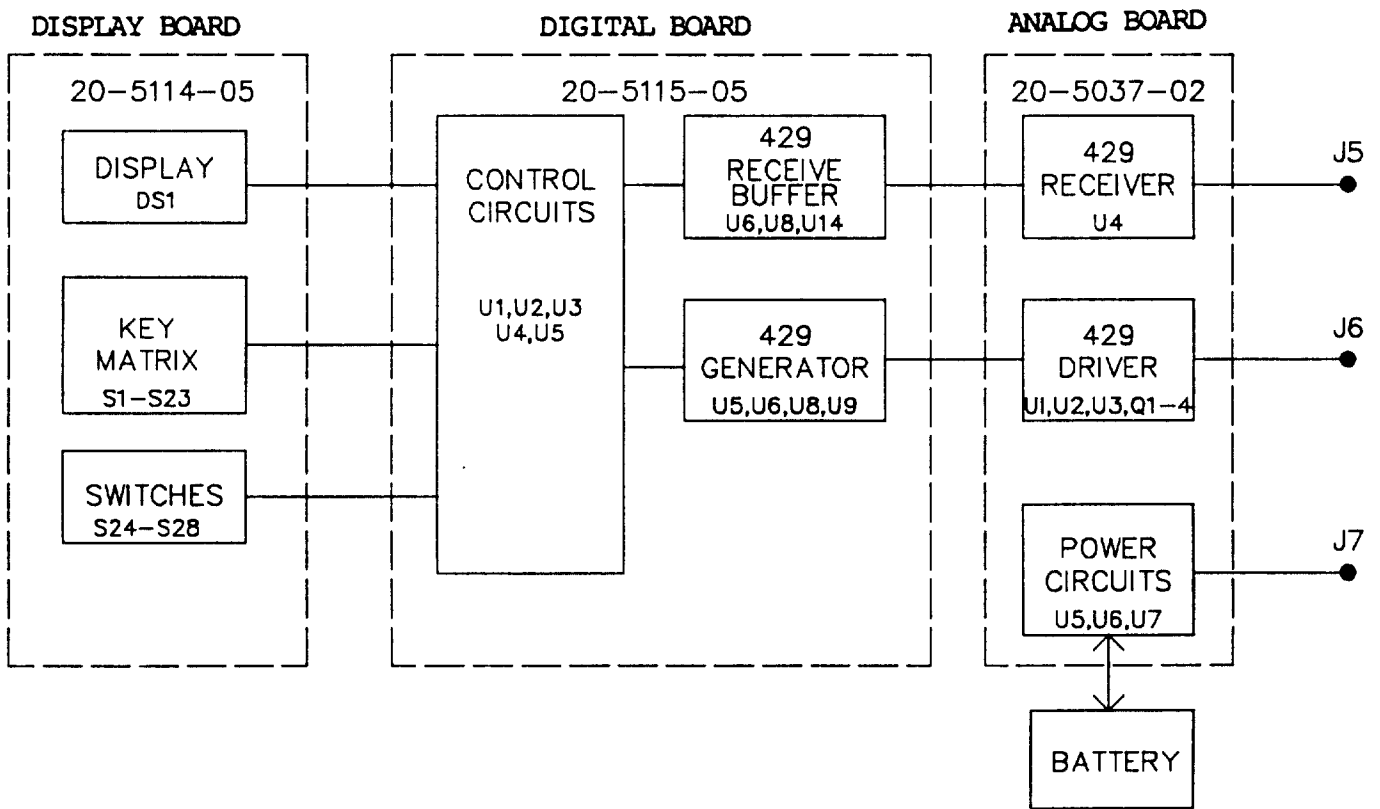

Figure 4-1 429EX Block Diagram
(Dwg. NO. 40-1001-05)

SECTION V MAINTENANCE

5.1 INTRODUCTION

The maintenance section contains test and alignment procedures for a JCAIR 429EX ARINC 429 Transmitter/Receiver. Also included are bills of material, assembly drawings and schematics to assist in troubleshooting.

5.2 TEST AND ALIGNMENT

5.2.1 TEST EQUIPMENT REQUIRED

DVM.....Fluke 8050A or equivalent
Power Supply.....Heathkit IP-27 or equivalent
Scope.....Tektronics 465 or equivalent

5.2.2 ALIGNMENT AND CALIBRATION PROCEDURES

No alignment or calibration required

5.2.3 TEST PROCEDURES

This specification defines the procedure to be used for the complete testing of the JCAIR Model 429EX. This procedure provides an orderly sequence of tests to insure a completely tested unit.

5.2.3.1 Initial Test Setup

1. Set slide switches to the following positions:

ON/OFF.....OFF
TX PARITY.....ODD
TX SPEED.....LO
RX SPEED.....LO
DISPLAY.....HEX

2. If necessary, install a fresh set of batteries into the unit and plug the charger into the unit. Allow the unit to charge at least 15 hours with the unit turned on before finishing test procedure.

5.2.3.2 Power Supply Tests

1. With the unit OFF and the charger unplugged measure the battery voltage at E7 & E8 and verify that it is greater than 8.1 VDC.

2. Remove the "+" battery lead from E7 on the P.C. board. Install a mA meter between the battery lead and the cathode of CR1 and verify the following:
 - a) With the unit ON, the 429EX shall draw less than 125mA.
 - b) With the unit ON, allow the unit to set idle (no keystrokes) for at least 5 minutes. The 429EX shall now draw 20 to 40mA less than the current measured in the previous step.
 - c) With the unit ON and the charger plugged in, the batteries shall be charging between 0 and 25mA.
 - d) With the unit OFF and the charger plugged in, the batteries shall be charging less than 75mA.
3. Turn the unit OFF and remove charger and ammeter. Hook up an external power supply set for 10VDC to the following points: on the Analog board "+" lead to the cathode of CR1 and "-" lead to ground. Turn the 429EX ON and verify the following conditions:
 - a) With the unit ON and the supply voltage set for 5.15 +/- .05 VDC the display shall flash "LOW BATTERY" every 7-12 seconds.
 - b) When the supply voltage is brought up to 5.75 +/- .05 VDC the 429EX shall cease displaying "LOW BATTERY".
4. Turn the unit OFF, remove external supply and install battery lead back to E7 on Analog board. Turn the unit ON and verify the following:
 - a) The display shall read "EX VERSION *.*" (*.* = software version).
 - b) Each LED is lit in sequence for approx. .5 seconds each.
 - c) The display shall read "SELF TEST OK" for approximately 2 seconds.
 - d) The display shall then read "~~TX~~ TX LABELS".
 - e) The 'TX' LED shall be lit.
 - f) The 'ODD' LED shall be lit.
 - g) The voltage measured across C1 on the Display board is between 4.75 and 5.50 VDC.
 - h) The voltage measured across R16 of the Analog board is between -6.30 and -7.20 VDC.

5.2.3.3 Keyboard Tests

1. Enter the following information using the following keystrokes and verify the corresponding displayed messages:

<u>KEYSTROKES</u>	<u>DISPLAYED MESSAGE</u>
UP ARROW	TX 1 INACTIVE
EDIT/DEL	Blank display w/blinking cursor
012 ENT	012 GROUND SPEED
LAB/DAT	012 00 800000 00
EDIT/DEL	Blank display w/blinking cursor
345678 ENT	012 00 345678 01
UP ARROW	RATE = 250 MS
EDIT/DEL	Blank display w/blinking cursor
90 ENT	RATE = 90 MS
DOWN ARROW	012 00 345678 01
TRAP	PROTECTED
TRAP	NOT PROTECTED
TRAP	PROTECTED

2. Verify the following:

- a) The 'TX' LED is lit.
- b) The 'ODD' LED is lit.

5.2.3.4 Receiver/Transmitter Tests

1. Verify the proper operation of the 429EX by jumpering the transmitter to the receiver and perform the following:
2. Press the 'TX/RX' key and verify the following:
 - a) The display indicates "1 RX LABELS".
 - b) The 'RX' LED is lit.
 - c) Both 'Parity' LEDs are off.
3. Enter the following information using the following keystrokes and verify the corresponding displayed messages:

<u>KEYSTROKES</u>	<u>DISPLAYED MESSAGE</u>
UP ARROW	012 GROUND SPEED
LAB/DAT	012 00 345678 01
UP ARROW	RATE = 90 MS

4. Switch the 'TX Parity' switch to 'Even' and verify the 'Even' parity LED is lit.
5. Press the 'DOWN ARROW' key and verify the display indicates "012 00 B45678 01".

6. Enter the following information using the following keystrokes and verify the corresponding displayed messages:

<u>KEYSTROKES</u>	<u>DISPLAYED MESSAGE</u>
TRAP	TRAP LABEL? XXX
012 ENT	DATA ? XXXXXX
000001 ENT	CARES ? 000003
ENT	TRIG LABEL? XXX
ENT	DATA ? XXXXXX
ENT	0 TRAP WORDS

7. Enter the following information using the following keystrokes and verify the corresponding displayed messages:

<u>KEYSTROKES</u>	<u>DISPLAYED MESSAGE</u>
TRAP	1 RX LABELS
TRAP	TRAP LABEL? XXX
ENT	DATA ? XXXXXX
ENT	TRIG LABEL? XXX
ENT	DATA ? XXXXXX

8. Press the "ENT" key and verify that the display is counting up the number of trap words until it indicates "255 TRAP WORDS".
9. Press the 'UP ARROW' key and verify the display blinks the current word position (1), then indicates "012 GROUND SPEED".
10. Press the 'DOWN ARROW' key twice and verify the display blinks the current word position (255), then indicates "012 GROUND SPEED".
11. Turn unit off then back on. Press the "TX/RX" key, and repeat steps 4.8 and 4.9.
12. Press the 'TRAP' key and verify the display indicates "1 RX LABEL".
13. Press the 'TX/RX' key and verify the display indicates "1 TX LABELS".
14. Press the 'UP ARROW' key and verify the display indicates "012 GROUND SPEED".

15. Enter the following information using the following keystrokes and verify the corresponding displayed message:

<u>KEYSTROKES</u>	<u>DISPLAYED MESSAGE</u>
EDIT/DEL	LABEL ? w/blinking cursor
377 ENT	377 EQUIPMENT ID
LAB/DAT	377 00 000000 00
EDIT/DEL	Blank display w/blinking cursor
ABCDEF ENT	377 11 2BCDEF 01
UP ARROW	RATE = 200 MS
EDIT/DEL	Blank display w/blinking cursor
10 ENT	RATE = 10 MS

16. Press the 'TX/RX' key and verify the display indicates "1 RX LABEL".

5.2.3.5 Signal Integrity Tests

1. Connect a scope between ground and one of the transmitter outputs and verify the following:
 - a) The output is TRI-STATE.
 - b) The amplitude is +/- 5 +/- .5 V peak to peak.
 - c) The period of the data word is 2.5 +/- .1mS
 - d) The time between data words is 10 +/- 2mS.
 - e) The other output has the same levels and is inverted.
 - f) The rise time of a bit pulse is between 5 and 10uS from a 0 to 4 V level.
2. Set 'RX Speed' switch to 'Hi' and verify that within 3 seconds the unit displays "0 RX LABELS".
3. Set the 'TX Speed' switch to 'Hi' and verify the display indicates "1 RX LABEL".
4. Press the 'UP ARROW' key and verify the display indicates "377 EQUIPMENT ID".
5. Verify the following parameters using the scope:
 - a) The output is TRI-STATE.
 - b) The rise time of a bit pulse is between .75 and 1.5uS from a 0 to 4 V level.
 - c) The time between data words is 10 +/- 2mS.
 - d) The period of the data word is 315 +/- 10uS.

5.2.3.6 General Check-Out

1. Enter the following information using the following keystrokes and verify the corresponding displayed messages:

<u>KEYSTROKES</u>	<u>DISPLAYED MESSAGE</u>
TX/RX	1 TX LABELS
UP ARROW	377 EQUIPMENT ID
UP ARROW	TX 2 INACTIVE
EDIT/DEL	LABEL ? w/blinking cursor
072 ENT	072 STAT VAN ANG
UP ARROW	TX 3 INACTIVE
EDIT/DEL	LABEL ? w/blinking cursor
115 ENT	115 WAYPOINT BRG
UP ARROW	TX 4 INACTIVE
EDIT/DEL	LABEL ? w/blinking cursor
116 ENT	116 X TRACK DIST
UP ARROW	TX 5 INACTIVE
EDIT/DEL	LABEL ? w/blinking cursor
121 ENT	121 HZ CMD SIGN
UP ARROW	TX 6 INACTIVE
EDIT/DEL	LABEL ? w/blinking cursor
151 ENT	151 LOC BRG TRU
UP ARROW	TX 7 INACTIVE
EDIT/DEL	LABEL ? w/blinking cursor
257 ENT	257 FUEL QTY
UP ARROW	TX 8 INACTIVE
EDIT/DEL	LABEL ? w/blinking cursor
357 ENT	357 ISO ALPHA #5
UP ARROW	TX 9 INACTIVE
EDIT/DEL	LABEL ? w/blinking cursor
366 ENT	366 N-S VELOCITY
UP ARROW	TX 10 INACTIVE
EDIT/DEL	LABEL ? w/blinking cursor
346 ENT	346 N1 ACTUAL

2. Press the 'LAB/DAT' key and verify the display indicates "346 00 800000 00"
3. Press the 'EDIT/DEL' key and enter the following: 123456 ENT. Verify the display indicates "346 10 123456 00".
4. Set the 'Display' switch to 'Eng' and verify the display indicates "-220.734 % RPM".
5. Press the 'TX/RX' key and verify the display indicates "10 RX LABELS."

6. Enter the following information using the following keystrokes and verify the corresponding displayed messages:

<u>KEYSTROKES</u>	<u>DISPLAYED MESSAGE</u>
UP ARROW	072 STAT VAN ANG
UP ARROW	115 WAYPOINT BRG
UP ARROW	116 X TRACK DIST
UP ARROW	121 HZ CMD SIGN
UP ARROW	151 LOC BRG TRU
UP ARROW	257 FUEL QTY #2
UP ARROW	346 N1 ACTUAL
UP ARROW	357 LABEL
UP ARROW	366 N-S VELOCITY
UP ARROW	377 EQUIPMENT ID

7. With the unit ON and the charger plugged in, monitor the charge current and verify that when the charge plug is wiggled in the jack the charge current does not vary.

5.2.3.7 Final Check and Adjustment

1. Install cover and verify that the push buttons and slide switches operate smoothly without binding or catching on the case.
2. Adjust the display contrast by looking at the display at a 45 degree viewing angle and adjusting the contrast pot such that the display is barely readable.

5.3 BILLS OF MATERIAL, ASSEMBLY DRAWINGS AND SCHEMATICS

To assist in the maintenance of the 429EX, bills of material, assembly drawings and schematics are included. They are arranged as follows.

<u>DRAWING NO</u>	<u>DESCRIPTION</u>
01-1001-05	FINAL ASSEMBLY B/M
25-1001-05	FINAL ASSEMBLY
02-1001-05	FINAL ASSEMBLY SCHEMATIC
20-5114-05	DISPLAY BOARD B/M
25-5114-05	DISPLAY BOARD ASSEMBLY
02-5114-00	DISPLAY BOARD SCHEMATIC
20-5115-05	DIGITAL BOARD B/M
25-5115-00	DIGITAL BOARD ASSEMBLY
02-5115-00	DIGITAL BOARD SCHEMATIC
20-5037-02	ANALOG BOARD B/M
25-5037-02	ANALOG BOARD ASSEMBLY
02-5037-02	ANALOG BOARD SCHEMATIC

JCAIR INC.

NAME: FINAL ASSY 429EX

ASSY NO: 01-1001-05

REVISION: 00

DATE: 10/18/88

ITEM/ SYMBOL	JCAIR PART NO.	DESCRIPTION	U/M	QTY
1	15-0009-00	BATTERY CHARGER 110V/60HZ TO 9VDC	EA	1.00
2	20-5037-02	ANALOG BOARD	EA	1.00
3	20-5114-05	DISPLAY BD 429EX	EA	1.00
4	20-5115-05	DIGITAL BD 429EX	EA	1.00
5	24-6028-14	WIRE RIBBON CABLE 28 AWG 14 COND	FT	1.00
6	24-6028-50	WIRE RIBBON CABLE 28 AWG 50 COND	FT	1.00
7	30-2100-50	CONN RIBBON RCPTL 50 POS	EA	2.00
8	30-3027-14	CONN CRIMP RIBBON DIP 14 POS	EA	2.00
9	33-1008-00	PHONE JACK 3 COND DBL OPEN CIRCUIT	EA	2.00
10	33-1012-02	PHONE JACK MIN TRANSFER CIRCUIT	EA	1.00
11	33-1032-00	PHONE PLUG 3 CONDUCTOR	EA	2.00
12	43-0001-00	BATTERY NICAD 1.2V AA	EA	6.00
13	47-0035-05	COVER MODIFIED	EA	1.00
14	47-0036-02	CHASSIS MODIFIED	EA	1.00
15	47-0038-00	BATTERY BRACKET	EA	1.00
16	51-0002-03	TUBING SHRINK CLEAR .125 OD	IN	7.00
17	57-1001-05	SERIAL TAG 429EX	EA	1.00
18	89-0044-00	WASHER FLAT #4 FIBRE	EA	8.00
19	89-0104-00	WASHER FLAT #4 SM PAT	EA	4.00
20	89-0904-00	WASHER LOCK #4	EA	4.00
21	89-2104-04	SCREW PHP #4-40 X .250	EA	4.00
22	89-3104-04	SCREW FHP #4-40 X .250	EA	6.00
23	90-0004-00	RUBBER FEET SELF-STICK	EA	4.00
24	90-0452-01	BATTERY HOLDER AA MODIFIED	EA	1.00
25	92-0113-10	SPACER F/F #4-40 X .625	EA	1.00
26	92-1113-10	SPACER F/F #4-40 X .625	EA	3.00
27	92-1113-12	SPACER F/F #4-40 X .750	EA	4.00
28	94-1113-02	SPACER M/M #4-40 X .125	EA	4.00
29	98-1101-04	RIVET POP FH .125 X .250	EA	2.00
REF1	01-1001-05	FINAL ASSY 429EX	EA	-
REF2	02-1001-05	SCHEMATIC 429EX	EA	-
REF3	04-1001-05	TEST PROCEDURE 429EX	EA	-
REF4	25-1001-05	ASSY DWG 429EX	EA	-
REF5	40-1001-05	BLOCK DIAGRAM 429EX	EA	-

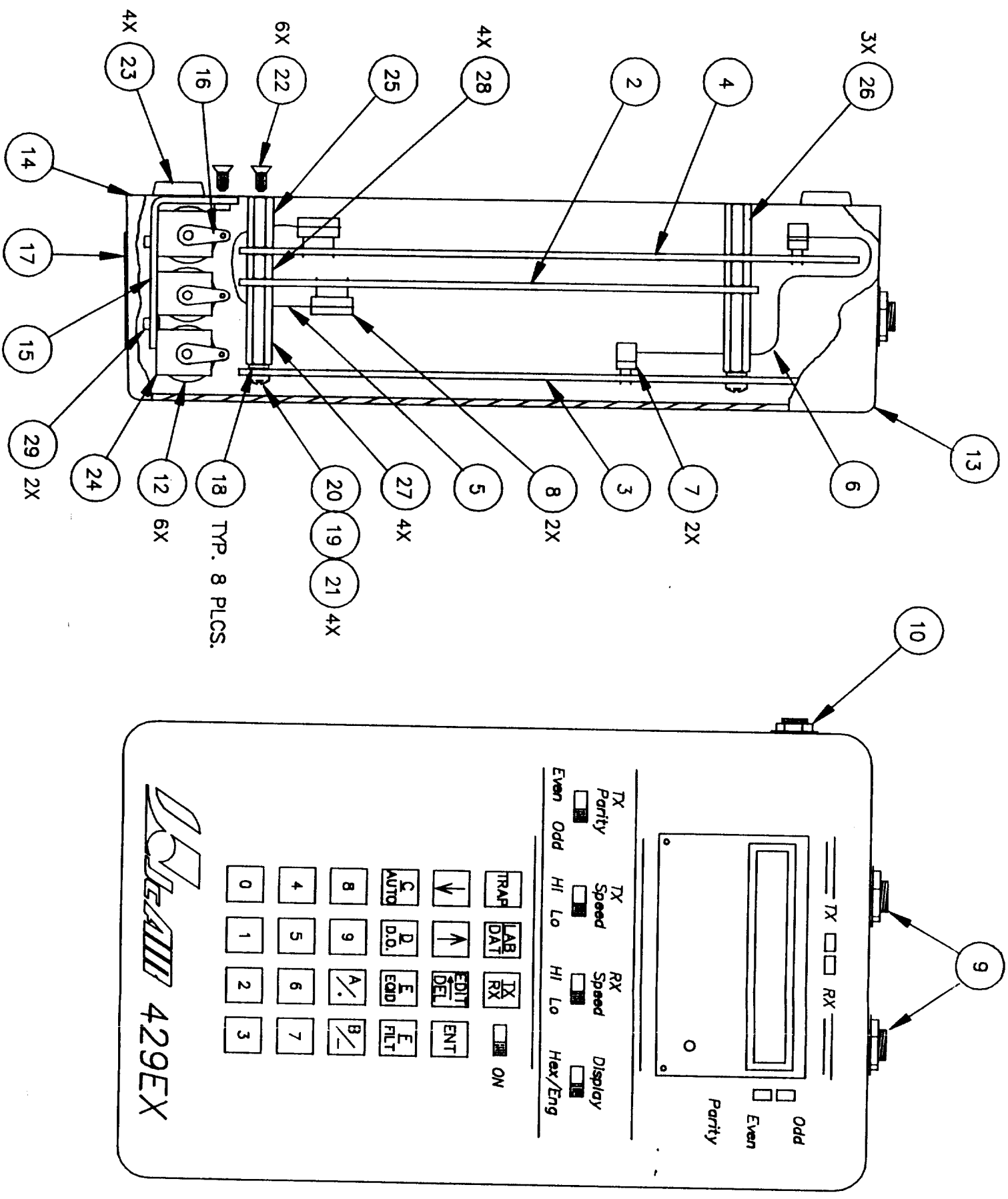

NOTES:
 1. ITEMS 1 (BATTERY CHARGER) AND 11 (PHONE PLUG) NOT SHOWN.

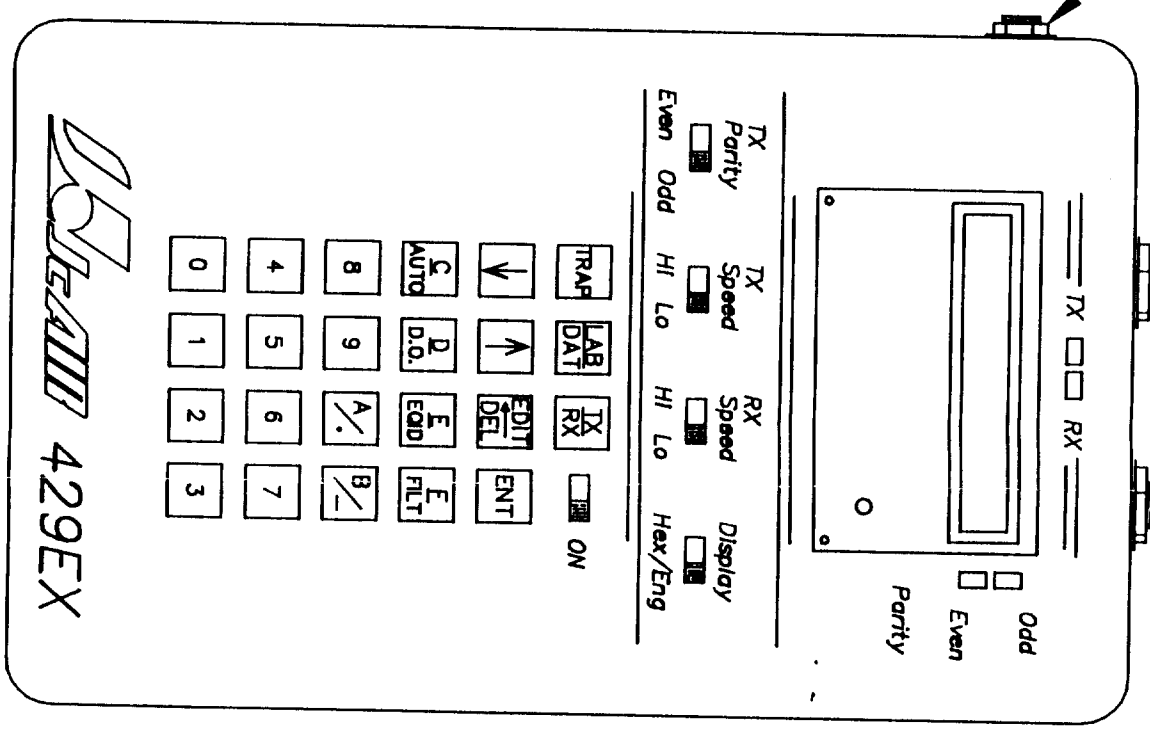

429EX	01-1001-05	QTY	PART NO.	DESCRIPTION	ITEM
UNIT	NEXT ASSY.				
DIMENSIONS ARE IN INCHES		CONTRACT NO.		400 INDUSTRIAL PARK,	
TOLERANCES ARE:		APPROVALS		ROCKWELL, ANDERSON,	
FRACTIONAL DECIMAL ANGLES		DATE		KANSAS CITY	
DRAWN BY		10/78			
CHECKED BY					
MATERIAL CODE					
NOT TO SCALE					
SCALE		25-1001-05		SHT 1 OF 1	
REV		B		0	
FINAL ASSEMBLY 429EX					

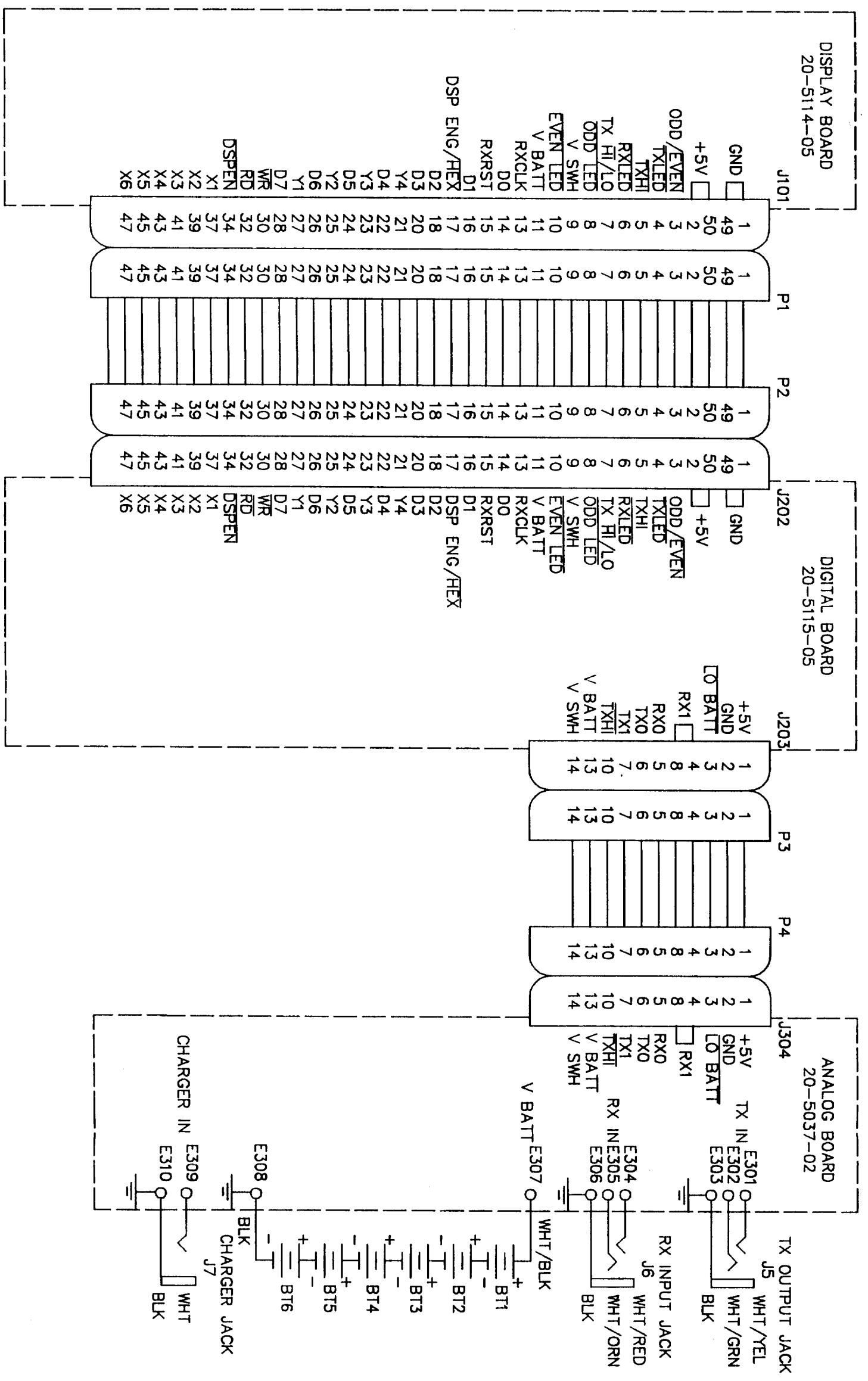

429EX	10-1001-05	QTY	PART NO.	DESCRIPTION	ITEM
UNIT	NEXT ASSY.				
DIMENSIONS ARE IN INCHES					
TOLERANCES ARE:					
FRACT	DECIMAL	ANGLES			
± .012	± .010	± .010			
± .005					
APPROVALS	DATE				
DESIGNED BY: BLP	10/98				
SCHEMATIC 429EX					
REV	DATE				
B	02-1001-05	SHEET NO. 1 OF 1			

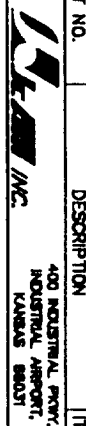

JCAIR INC.

NAME: DISPLAY BD 429EX

ASSY NO: 20-5114-05

REVISION: 00

DATE: 10/19/88

ITEM/ SYMBOL	JCAIR PART NO.	DESCRIPTION	U/M	QTY
-----	-----	-----	---	---
1	09-5114-00	PCB DISPLAY	EA	1.00
2	33-0028-00	SOCKET SINGLE MINI SPRING	EA	13.00
3	89-0004-00	WASHER FLAT #4	EA	2.00
4	89-2104-04	SCREW PHP #4-40 X .250	EA	2.00
C101	CE-0103-13	CAP DP .01UF 50V 10% X7R	EA	1.00
C102	CD-1102-40	CAP MP .001UF 50V 5%	EA	1.00
CR101	07-7006-00	LED RED	EA	4.00
CR102	07-7006-00	LED RED	EA	-
CR103	07-7006-00	LED RED	EA	-
CR104	07-7006-00	LED RED	EA	-
DS101	37-0001-00	DISPLAY LCD	EA	1.00
J101	30-2027-50	CONN POST HEADER DBL ROW 50 PIN	EA	1.00
Q101	07-0132-00	XSTR NPN 2N2222A	EA	1.00
R101	RB-0334-23	RES CF 330K QW 5%	EA	1.00
R102	RB-0223-23	RES CF 22K QW 5%	EA	1.00
R103	RB-0333-23	RES CF 33K QW 5%	EA	1.00
R104	RB-0474-23	RES CF 470K QW 5%	EA	2.00
R105	RB-0474-23	RES CF 470K QW 5%	EA	-
R106	RB-0104-23	RES CF 100K QW 5%	EA	2.00
R107	RB-0104-23	RES CF 100K QW 5%	EA	-
R108	RB-0102-23	RES CF 1K QW 5%	EA	4.00
R109	RB-0102-23	RES CF 1K QW 5%	EA	-
R110	RB-0102-23	RES CF 1K QW 5%	EA	-
R111	RB-0102-23	RES CF 1K QW 5%	EA	-
S101	31-5006-01	SWITCH PUSH BUTTON SPST "TRAP"	EA	1.00
S102	31-5006-02	SWITCH PUSH BUTTON SPST "LAB/DAT"	EA	1.00
S103	31-5006-03	SWITCH PUSH BUTTON SPST "TX/RX"	EA	1.00
S104	31-5006-04	SWITCH PUSH BUTTON SPST "ON ARROW"	EA	1.00
S105	31-5006-05	SWITCH PUSH BUTTON SPST "UP ARROW"	EA	1.00
S106	31-5006-06	SWITCH PUSH BUTTON SPST "EDIT/DEL"	EA	1.00
S107	31-5006-07	SWITCH PUSH BUTTON SPST "ENT"	EA	1.00
S108	31-5006-08	SWITCH PUSH BUTTON SPST "C/AUTO"	EA	1.00
S109	31-5006-24	SWITCH PUSH BUTTON SPST "D/D.O."	EA	1.00
S110	31-5006-25	SWITCH PUSH BUTTON SPST "E/EQID"	EA	1.00
S111	31-5006-26	SWITCH PUSH BUTTON SPST "F/FILT"	EA	1.00
S112	31-5006-12	SWITCH PUSH BUTTON SPST "8"	EA	1.00
S113	31-5006-13	SWITCH PUSH BUTTON SPST "9"	EA	1.00
S114	31-5006-14	SWITCH PUSH BUTTON SPST "A/."	EA	1.00
S115	31-5006-15	SWITCH PUSH BUTTON SPST "B/-"	EA	1.00
S116	31-5006-16	SWITCH PUSH BUTTON SPST "4"	EA	1.00
S117	31-5006-17	SWITCH PUSH BUTTON SPST "5"	EA	1.00
S118	31-5006-18	SWITCH PUSH BUTTON SPST "6"	EA	1.00
S119	31-5006-19	SWITCH PUSH BUTTON SPST "7"	EA	1.00
S120	31-5006-20	SWITCH PUSH BUTTON SPST "0"	EA	1.00
S121	31-5006-21	SWITCH PUSH BUTTON SPST "1"	EA	1.00
S122	31-5006-22	SWITCH PUSH BUTTON SPST "2"	EA	1.00
S123	31-5006-23	SWITCH PUSH BUTTON SPST "3"	EA	1.00
S124	31-0002-00	SWITCH SLIDE SPST PC MOUNT	EA	5.00
S125	31-0002-00	SWITCH SLIDE SPST PC MOUNT	EA	-
S126	31-0002-00	SWITCH SLIDE SPST PC MOUNT	EA	-

JCAIR INC.

NAME: DISPLAY BD 429EX

ASSY NO: 20-5114-05

REVISION: 00

DATE: 10/19/88

ITEM/ SYMBOL	JCAIR PART NO.	DESCRIPTION	U/M	QTY
S127	31-0002-00	SWITCH SLIDE SPST PC MOUNT	EA	-
S128	31-0002-00	SWITCH SLIDE SPST PC MOUNT	EA	-
REF1	02-5114-00	SCHEMATIC DISPLAY BOARD	EA	-
REF2	25-5114-05	ASSY DWG DISPLAY BD 429EX	EA	-

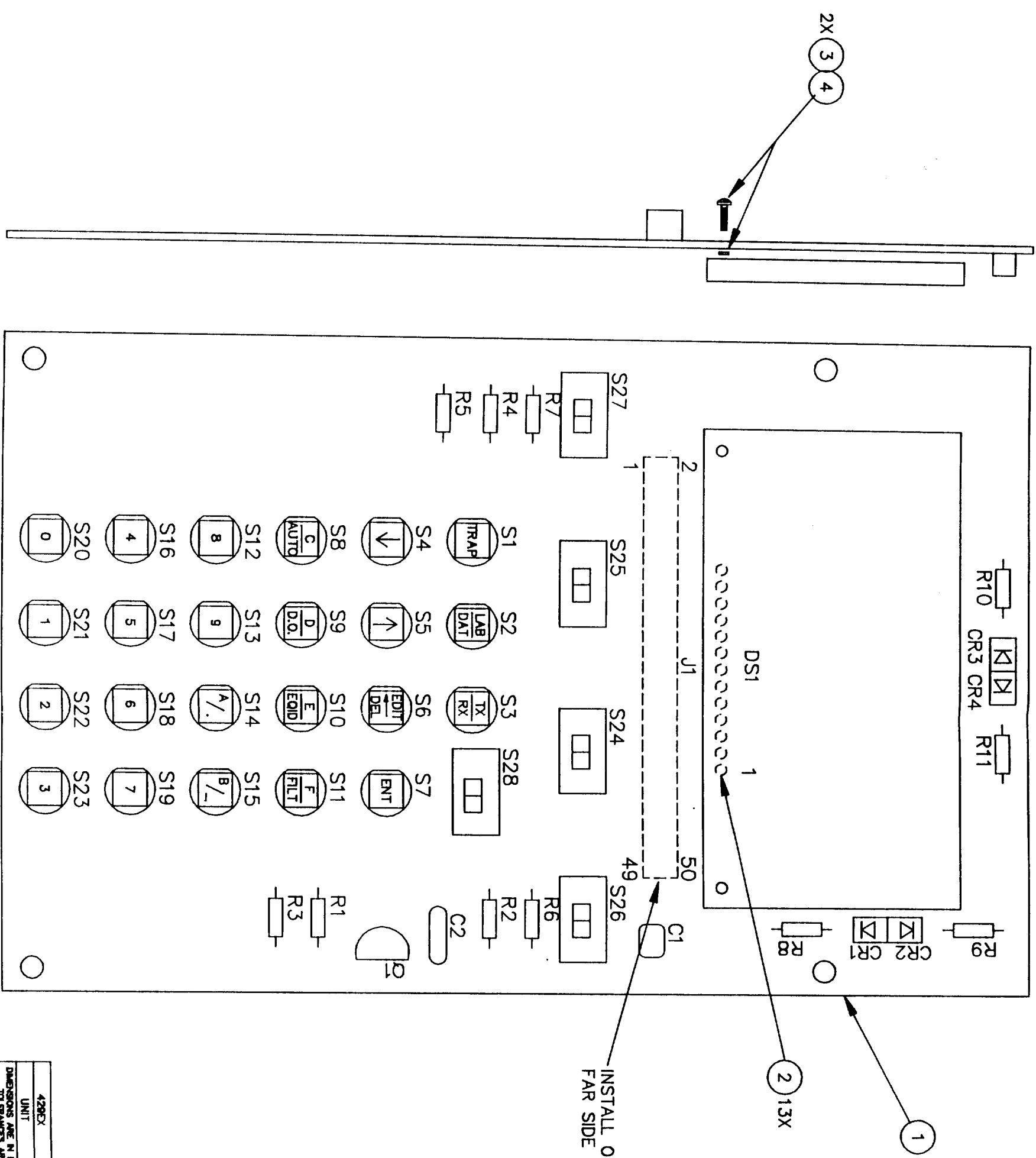

NOTES:
 1) ALL DESIGNATORS HAVE A 100 PREFIX.

428CX	01-1001-05	QTY	PART NO.	DESCRIPTION	ITEM
UNIT	NEXT ASSY.				
DIMENSIONS ARE IN INCHES					
TOLERANCES ARE:					
FRACT	DECIMAL	ANGLES			
±	±	±			
APPROVALS					
DATE	10/78				
ASSEMBLY DISPLAY BD					
400 INDUSTRIAL PARK, INDUSTRIAL AVENUE, KANSAS 66201					
REV B					
25-5114-05					
SHT 1 OF 1					
0					

REV	DESCRIPTION	DATE	APPR
1	CONVERT TO 8 DIGIT SYSTEM	10/04/88	B PAGE 1

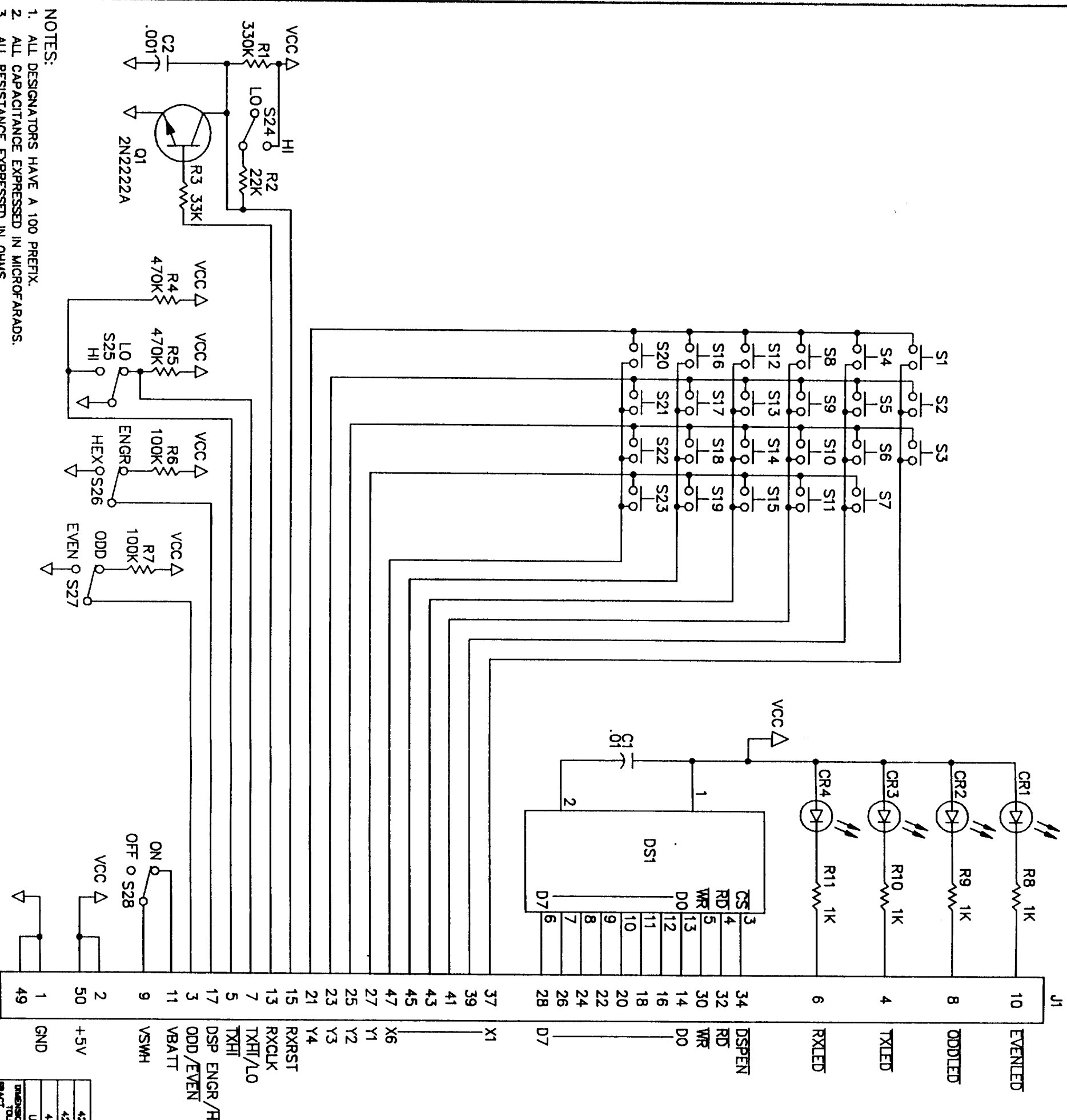

- NOTES:
1. ALL DESIGNATORS HAVE A 100 PREFIX.
 2. ALL CAPACITANCE EXPRESSED IN MICROFARADS.
 3. ALL RESISTANCE EXPRESSED IN OHMS.

REV	DESCRIPTION	DATE	APPR
1	CONVERT TO 8 DIGIT SYSTEM	10/04/88	B PAGE 1

4296CX	01-1001-05		
4296EB	01-1001-10		
429E	01-1001-00		

DATE	DESIGN	APPROVALS	DATE
10/88	DLB		

SCHEMATIC DISPLAY BD

400 INDUSTRIAL PARK
INDUSTRIAL AVENUE
KANSAS CITY, MO 64112

SIZE: 100%
B 02-5114-00 SH 1 of 1

JCAIR INC.

NAME: DIGITAL BD 429EX

ASSY NO: 20-5115-05

REVISION: 00

DATE: 10/19/88

ITEM/ SYMBOL	JCAIR PART NO.	DESCRIPTION	U/M	QTY
-----	-----	-----	---	---
1	09-5115-00	PCB DIGITAL	EA	1.00
2	16-0002-00	RTV CLEAR	AR	1.00
3	30-2026-06	CONN POST HEADER DBL ROW 6 PIN	EA	1.00
4	33-0008-25	SOCKET IC 24 PIN OPEN LADDER MCHND .6SP	EA	1.00
5	33-0008-28	SOCKET IC 28 PIN OPEN LADDER MACHINED	EA	1.00
6	90-0016-00	2 POSITION JUMPER	EA	1.00
C201	CB-0106-35	CAP TN 10UF 35V	EA	1.00
C202	CE-0103-13	CAP DP .01UF 50V 10% X7R	EA	14.00
C203	CE-0103-13	CAP DP .01UF 50V 10% X7R	EA	-
C204	CE-0103-13	CAP DP .01UF 50V 10% X7R	EA	-
C205	CE-0103-13	CAP DP .01UF 50V 10% X7R	EA	-
C206	CE-0103-13	CAP DP .01UF 50V 10% X7R	EA	-
C207	CE-0103-13	CAP DP .01UF 50V 10% X7R	EA	-
C208	CE-0103-13	CAP DP .01UF 50V 10% X7R	EA	-
C209	CE-0103-13	CAP DP .01UF 50V 10% X7R	EA	-
C210	CE-0103-13	CAP DP .01UF 50V 10% X7R	EA	-
C211	CE-0103-13	CAP DP .01UF 50V 10% X7R	EA	-
C212	CE-0103-13	CAP DP .01UF 50V 10% X7R	EA	-
C213	CE-0103-13	CAP DP .01UF 50V 10% X7R	EA	-
C214	CE-0103-13	CAP DP .01UF 50V 10% X7R	EA	-
C217	CH-0330-20	CAP CK 33PF 200V 10%	EA	2.00
C218	CH-0330-20	CAP CK 33PF 200V 10%	EA	-
C219	CE-0103-13	CAP DP .01UF 50V 10% X7R	EA	-
J202	30-2027-50	CONN POST HEADER DBL ROW 50 PIN	EA	1.00
J203	33-0005-14	SOCKET IC 14 PIN	EA	1.00
R201	RB-0103-23	RES CF 10K QW 5%	EA	5.00
R202	RB-0104-23	RES CF 100K QW 5%	EA	1.00
R203	RB-0103-23	RES CF 10K QW 5%	EA	-
R204	RB-0103-23	RES CF 10K QW 5%	EA	-
R205	RB-0822-23	RES CF 8.2K QW 5%	EA	1.00
R206	RH-4103-14	RES RN 10K X 7 2%	EA	1.00
R207	RB-0103-23	RES CF 10K QW 5%	EA	-
R208	RB-0471-23	RES CF 470 QW 5%	EA	2.00
R209	RB-0471-23	RES CF 470 QW 5%	EA	-
R210	RB-0103-23	RES CF 10K QW 5%	EA	-
U201	12-7548-00	IC P80C31BH-1 UPROCESSOR	EA	1.00
U202	60-0114-00	PROGRAMMED EPROM	EA	1.00
U203	12-7576-00	IC DS1220Y RAM	EA	1.00
U204	12-7531-00	IC 74HC573 3-STATE D-TYPE LATCH	EA	1.00
U205	12-7549-00	IC 810AN-4 RAM IO/TIMER	EA	1.00
U206	12-7443-00	IC 4517 DUAL 64-BIT SHIFT REG	EA	1.00
U207	12-7550-00	IC 74HC4066 QUAD ANALOG SWITCH	EA	1.00
U208	12-7181-00	IC 74HC74 DUAL D-TYPE FLIP/FLOP	EA	1.00
U209	12-7551-00	IC 74HC11 TRIPLE 3-INPUT AND	EA	1.00
U210	12-7552-00	IC 74HC08 QUAD 2-INPUT AND GATE	EA	1.00
U211	12-7553-00	IC 74HC32 QUAD 2-INPUT OR GATE	EA	1.00
U212	12-7264-00	IC 74HC04 HEX INVERTER	EA	2.00
U213	12-7264-00	IC 74HC04 HEX INVERTER	EA	-
U214	12-7555-00	IC 74HC157 QUAD 2 TO 1 MUX	EA	1.00
U215	12-7554-00	IC 74HC21 DUAL 4-INPUT AND	EA	1.00

JCAIR INC.

NAME: DIGITAL BD 429EX

ASSY NO: 20-5115-05

REVISION: 00

DATE: 10/19/88

ITEM/ SYMBOL	JCAIR PART NO.	DESCRIPTION	U/M	QTY
U216	12-7556-00	IC 74HC4520 DUAL 4-BIT COUNTER	EA	1.00
Y201	44-0018-04	XTAL 16.000 MHZ PARALLEL RES HC-18	EA	1.00
REF1	02-5115-00	SCHEMATIC DIGITAL BOARD	EA	-
REF2	25-5115-00	ASSY DWG DIGITAL BOARD	EA	-

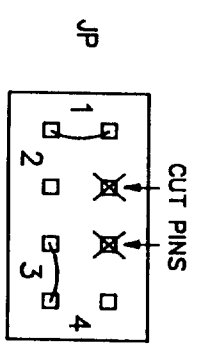
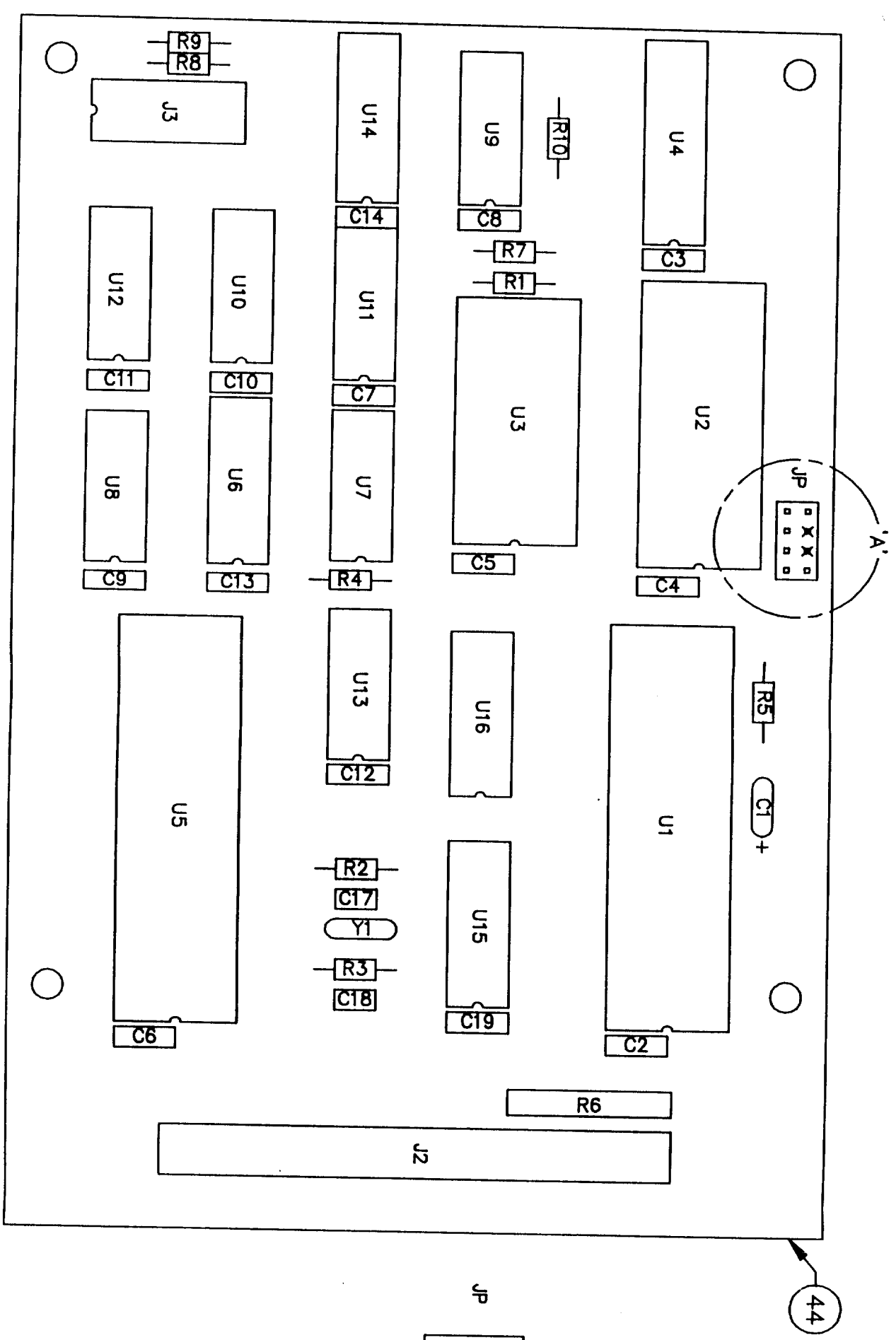

NOTES:
1) ALL DESIGNATORS HAVE A 200 PREFIX.

429EX	01-1001-05				
429EB	01-1001-10				
429E	01-1001-00				
UNIT	NEXT ASSTY.	QTY	PART NO.	DESCRIPTION	ITEM
DIMENSIONS ARE IN INCHES					
TOLERANCES ARE:					
FRACTION	DECIMAL	ANGLES			
±	±	±			
DRAWN: BLP					
DATE: 10/88					
APPROVALS:					
DESIGNER: BLP					
CHECKER:					
NOT TO SCALE					
SIZE	DWG. NO.	DESCRIPTION		ITEM	
B	25-5115-00	ASSEMBLY DIGITAL BD		3	
				SHT 1 OF 1	
				REV. 3	

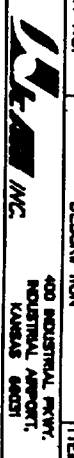

REV	DESCRIPTION	DATE	APPR.
3	CONVERT TO 8 DIGIT SYSTEM	7/86	B PAGE
4	CHANGE VALUE OF R208 AND 209	B/86	B PAGE

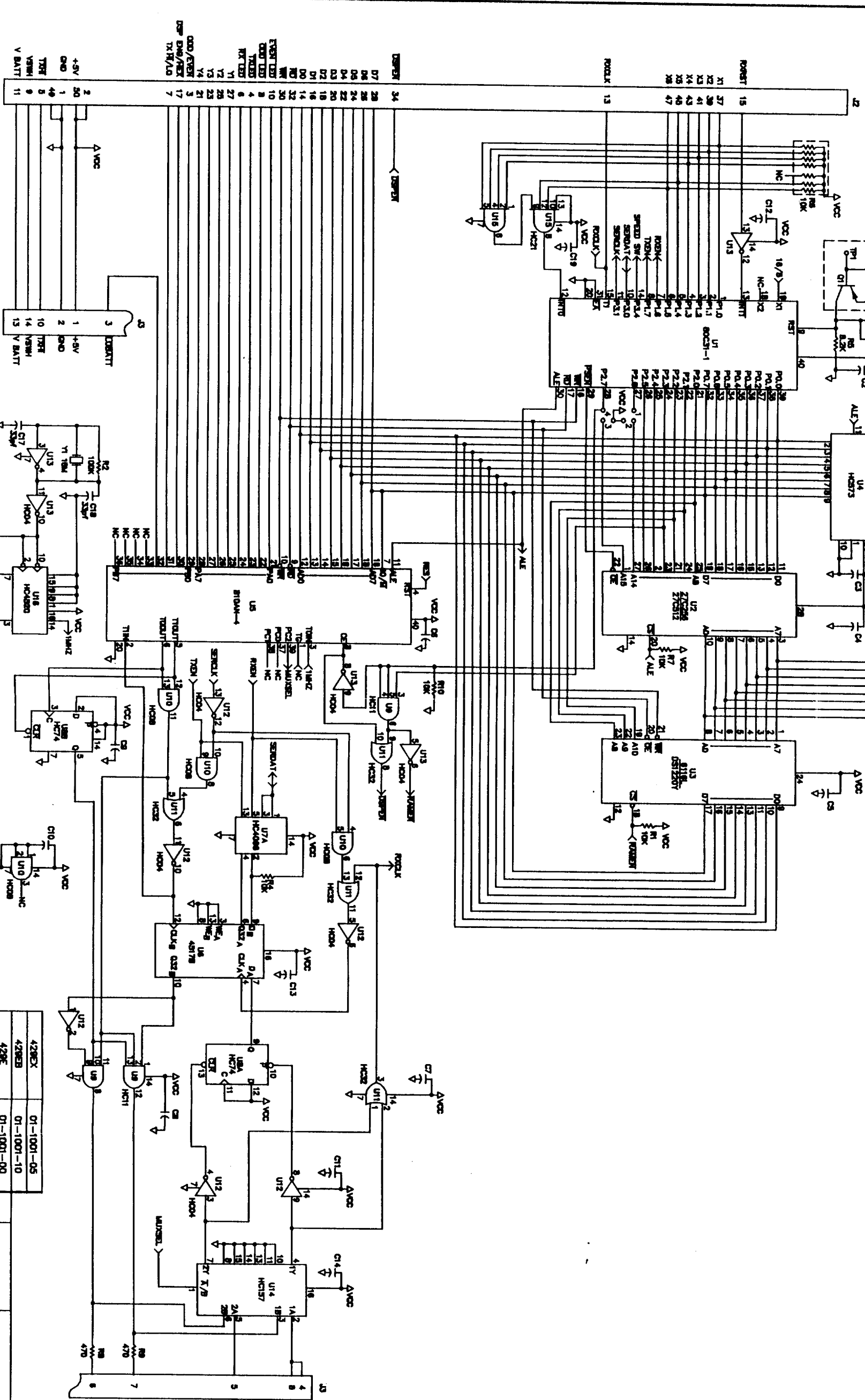

NOTES:

1. ALL DESIGNATORS HAVE A 200 PREFIX.
2. ALL RESISTORS ARE 5% UNLESS OTHERWISE SPECIFIED.
3. ALL CAPACITORS ARE .01UF UNLESS OTHERWISE SPECIFIED.

REV	DATE	APPR.
3	7/86	B PAGE
4	B/86	B PAGE

UNIT	DESCRIPTION	QTY	PART NO.
429EX	01-1001-05		
429EB	01-1001-10		
429E	01-1001-00		

APPROVALS	DATE
DIB	10/86

REV	DATE	APPR.
B	02-5115-00	SHR 1 OF 1

SCHEMATIC DIGITAL BD

JCAIR INC.

NAME: ANALOG BOARD

ASSY NO: 20-5037-02

REVISION: 01

DATE: 08/05/88

ITEM/ SYMBOL	JCAIR PART NO.	DESCRIPTION	U/M	QTY
1	09-5037-02	PCB ANALOG	EA	1.00
2	24-2224-00	WIRE TEFLON 24 AWG BLK	IN	32.00
3	24-2224-02	WIRE TEFLON 24 AWG RED	IN	16.00
4	24-2224-92	WIRE TEFLON 24 AWG WHT/RED	IN	8.00
5	24-2224-93	WIRE TEFLON 24 AWG WHT/ORG	IN	8.00
6	24-2224-94	WIRE TEFLON 24 AWG WHT/YEL	IN	8.00
7	24-2224-95	WIRE TEFLON 24 AWG WHT/GRN	IN	8.00
C301	CF-1471-51	CAP CD 470PF 500V 10% Y5P	EA	4.00
C302	CF-1471-51	CAP CD 470PF 500V 10% Y5P	EA	-
C303	CF-1101-51	CAP CD 100PF 500V 10% Y5P	EA	5.00
C304	CF-0472-33	CAP CD 4700 PF 100V +80-20% Z5U	EA	2.00
C305	CF-0472-33	CAP CD 4700 PF 100V +80-20% Z5U	EA	-
C306	CF-1101-51	CAP CD 100PF 500V 10% Y5P	EA	-
C307	CF-1470-51	CAP CD 47 PF 500V 10% Y5P	EA	3.00
C308	CF-1101-51	CAP CD 100PF 500V 10% Y5P	EA	-
C309	CF-1100-51	CAP CD 10 PF 500V 10% Y5P	EA	2.00
C310	CD-1104-40	CAP MP .1UF 50V 5%	EA	8.00
C311	CD-1104-40	CAP MP .1UF 50V 5%	EA	-
C312	CF-1471-51	CAP CD 470PF 500V 10% Y5P	EA	-
C313	CF-1101-51	CAP CD 100PF 500V 10% Y5P	EA	-
C314	CF-1470-51	CAP CD 47 PF 500V 10% Y5P	EA	-
C315	CF-1101-51	CAP CD 100PF 500V 10% Y5P	EA	-
C316	CF-1100-51	CAP CD 10 PF 500V 10% Y5P	EA	-
C317	CD-1104-40	CAP MP .1UF 50V 5%	EA	-
C318	CD-1104-40	CAP MP .1UF 50V 5%	EA	-
C319	CF-1471-51	CAP CD 470PF 500V 10% Y5P	EA	-
C320	CD-1104-40	CAP MP .1UF 50V 5%	EA	-
C321	CD-1104-40	CAP MP .1UF 50V 5%	EA	-
C322	CD-1104-40	CAP MP .1UF 50V 5%	EA	-
C323	CF-1470-51	CAP CD 47 PF 500V 10% Y5P	EA	-
C324	CA-1101-11	CAP AL 100UF 10V	EA	1.00
C325	CD-1104-40	CAP MP .1UF 50V 5%	EA	-
C326	CA-1100-13	CAP AL 10UF 25V	EA	2.00
C327	CA-1100-13	CAP AL 10UF 25V	EA	-
CR301	07-6016-00	DIODE SIL 1N4148	EA	3.00
CR302	07-6016-00	DIODE SIL 1N4148	EA	-
CR303	07-6016-00	DIODE SIL 1N4148	EA	-
CR304	07-5082-00	DIODE ZEN 1N4738A 8.2V 5%	EA	1.00
CR305	07-6013-00	DIODE SIL 1N5817	EA	1.00
J304	33-0005-14	SOCKET IC 14 PIN	EA	1.00
J305	33-1004-00	PHONE JACK STEREO SINGLE CLOSED CIRCUIT	EA	2.00
J306	33-1004-00	PHONE JACK STEREO SINGLE CLOSED CIRCUIT	EA	-
J307	33-1024-00	PHONE JACK 3 COND DBL CLOSED CIRCUIT	EA	1.00
Q301	07-0132-00	XSTR NPN 2N2222A	EA	2.00
Q302	07-0136-00	XSTR PNP 2N2907A	EA	3.00
Q303	07-0132-00	XSTR NPN 2N2222A	EA	-
Q304	07-0136-00	XSTR PNP 2N2907A	EA	-
Q305	07-0136-00	XSTR PNP 2N2907A	EA	-
R301	RB-0472-23	RES CF 4.7K QW 5%	EA	4.00
R302	RB-0472-23	RES CF 4.7K QW 5%	EA	-

JCAIR INC.

NAME: ANALOG BOARD

ASSY NO: 20-5037-02

REVISION: 01

DATE: 08/05/88

ITEM/ SYMBOL	JCAIR PART NO.	DESCRIPTION	U/M	QTY
R303	RB-0562-23	RES CF 5.6K QW 5%	EA	4.00
R304	RB-0562-23	RES CF 5.6K QW 5%	EA	-
R305	RB-0102-23	RES CF 1K QW 5%	EA	6.00
R306	RB-0471-23	RES CF 470 QW 5%	EA	2.00
R307	RB-0472-23	RES CF 4.7K QW 5%	EA	-
R308	RB-0472-23	RES CF 4.7K QW 5%	EA	-
R309	RB-0562-23	RES CF 5.6K QW 5%	EA	-
R310	RB-0562-23	RES CF 5.6K QW 5%	EA	-
R311	RB-0102-23	RES CF 1K QW 5%	EA	-
R312	RB-0471-23	RES CF 470 QW 5%	EA	-
R313	RB-0560-23	RES CF 56 QW 5%	EA	2.00
R314	RB-0390-23	RES CF 39 QW 5%	EA	2.00
R315	RB-0390-23	RES CF 39 QW 5%	EA	-
R316	RB-0560-23	RES CF 56 QW 5%	EA	-
R317	RB-0103-23	RES CF 10K QW 5%	EA	2.00
R318	RB-0120-23	RES CF 12 QW 5%	EA	2.00
R319	RB-0563-23	RES CF 56K QW 5%	EA	2.00
R320	RB-0183-23	RES CF 18K QW 5%	EA	2.00
R321	RB-0102-23	RES CF 1K QW 5%	EA	-
R322	RB-0102-23	RES CF 1K QW 5%	EA	-
R323	RB-0103-23	RES CF 10K QW 5%	EA	-
R324	RB-0563-23	RES CF 56K QW 5%	EA	-
R325	RB-0120-23	RES CF 12 QW 5%	EA	-
R326	RB-0102-23	RES CF 1K QW 5%	EA	-
R327	RB-0102-23	RES CF 1K QW 5%	EA	-
R328	RB-0183-23	RES CF 18K QW 5%	EA	-
R329	RB-0123-23	RES CF 12K QW 5%	EA	2.00
R330	RB-0681-23	RES CF 680 QW 5%	EA	3.00
R331	RB-0123-23	RES CF 12K QW 5%	EA	-
R332	RB-0681-23	RES CF 680 QW 5%	EA	-
R333	RB-0027-23	RES CF 2.7 QW 5%	EA	1.00
R334	RB-0220-23	RES CF 22 QW 5%	EA	1.00
R335	RB-0681-23	RES CF 680 QW 5%	EA	-
R336	RB-0047-23	RES CF 4.7 QW 5%	EA	1.00
R337	RC-4993-12	RES MF 499K EW 1%	EA	1.00
R338	RB-0106-23	RES CF 10M QW 5%	EA	1.00
R339	RC-1822-12	RES MF 18.2K EW 1%	EA	1.00
R340	RB-0150-23	RES CF 15 QW 5%	EA	1.00
U301	12-7138-00	IC 4016 QUAD ANALOG SWITCH	EA	1.00
U302	12-7315-00	IC 3130 BIMOS OP AMP	EA	2.00
U303	12-7315-00	IC 3130 BIMOS OP AMP	EA	-
U304	12-7225-00	IC LM393 DUAL VOLTAGE COMP	EA	1.00
U305	12-7491-00	IC LM2931T-5.0 5V REG LOW DROP	EA	1.00
U306	12-7492-00	IC 7660 VOLTAGE CONVERTER	EA	1.00
U307	12-7490-00	IC LM10CLN LOW VOLT DETECTOR	EA	1.00
REF1	02-5037-02	SCHEMATIC ANALOG BOARD	EA	-
REF2	25-5037-02	ASSY DWG ANALOG BOARD	EA	-
REF3	20-5037-02	ANALOG BOARD	EA	-

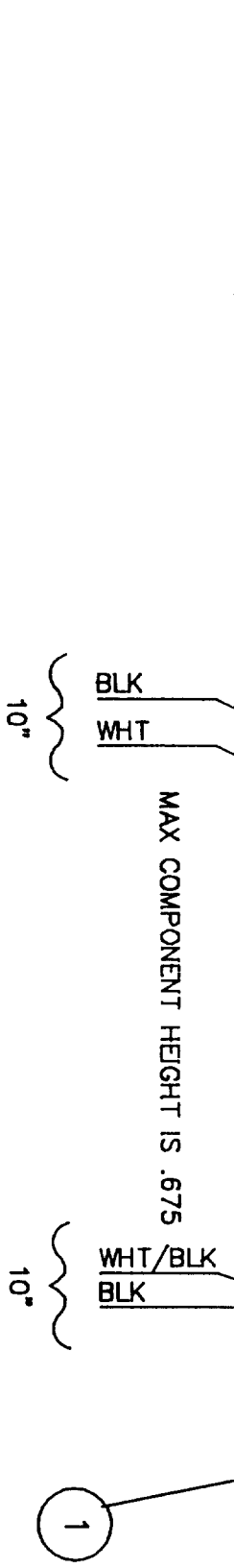
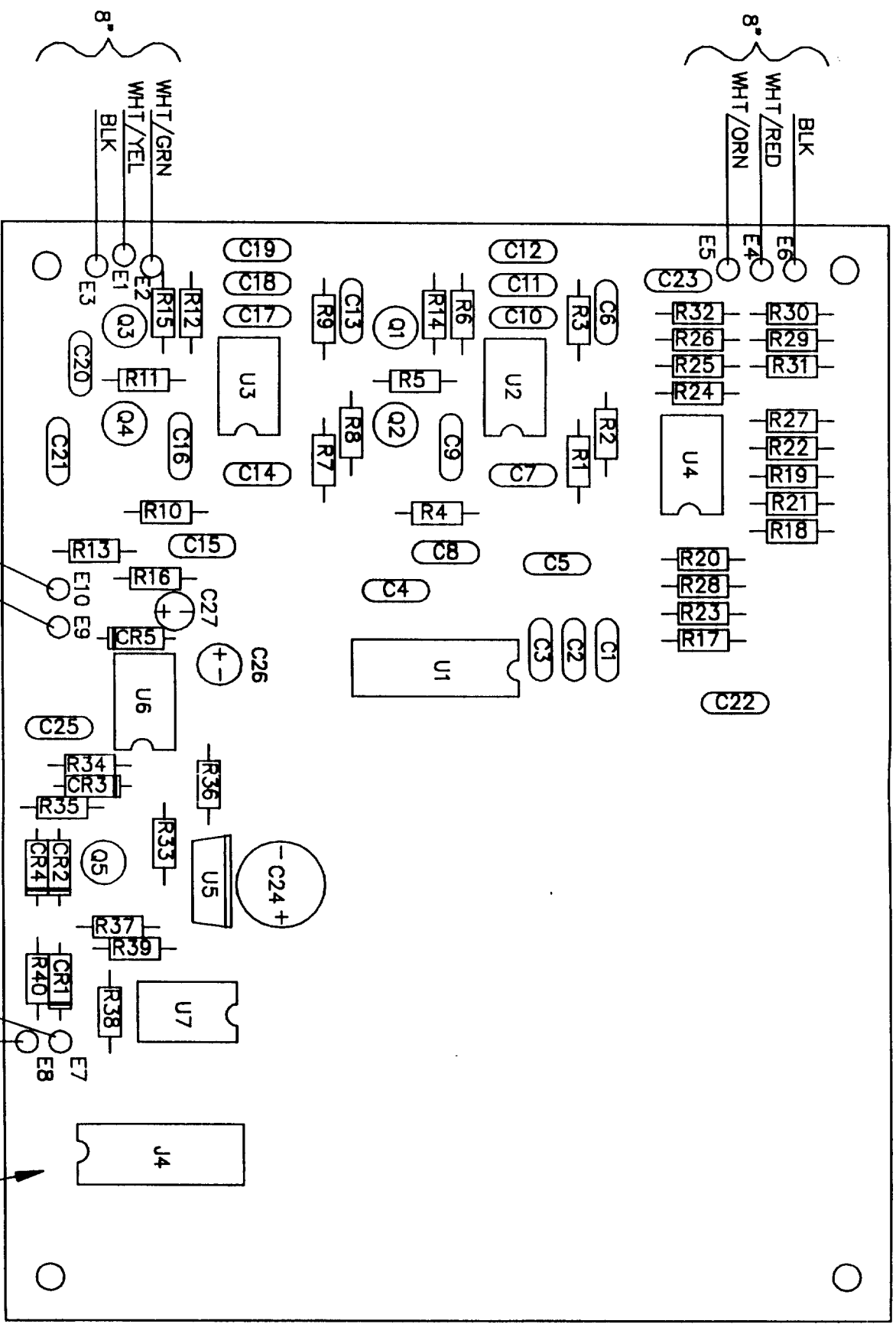

NOTES:
 1) ALL DESIGNATORS HAVE A 300 PREFIX

429EX	01-1001-05				
429EB	01-1001-10				
429E	01-1001-00				
429	01-0001-00				
UNIT	NEXT ASSY:	QTY	PART NO.	DESCRIPTION	ITEM
DIMENSIONS ARE IN INCHES TOLERANCES ARE: DIMENSIONS IN INCHES ANGLES DIMENSIONS IN MILLIMETERS ANGLES APPROVALS DATE 10/88 ASSEMBLY ANALOG BD 400 INDUSTRIAL PARK, INDUSTRIAL AVENUE, KANSAS CITY, MISSOURI 64111					
DATE	REV	REV	REV	REV	REV
10/88	1	2	3	4	5
DATE	REV	REV	REV	REV	REV
10/88	1	2	3	4	5
DATE	REV	REV	REV	REV	REV
10/88	1	2	3	4	5

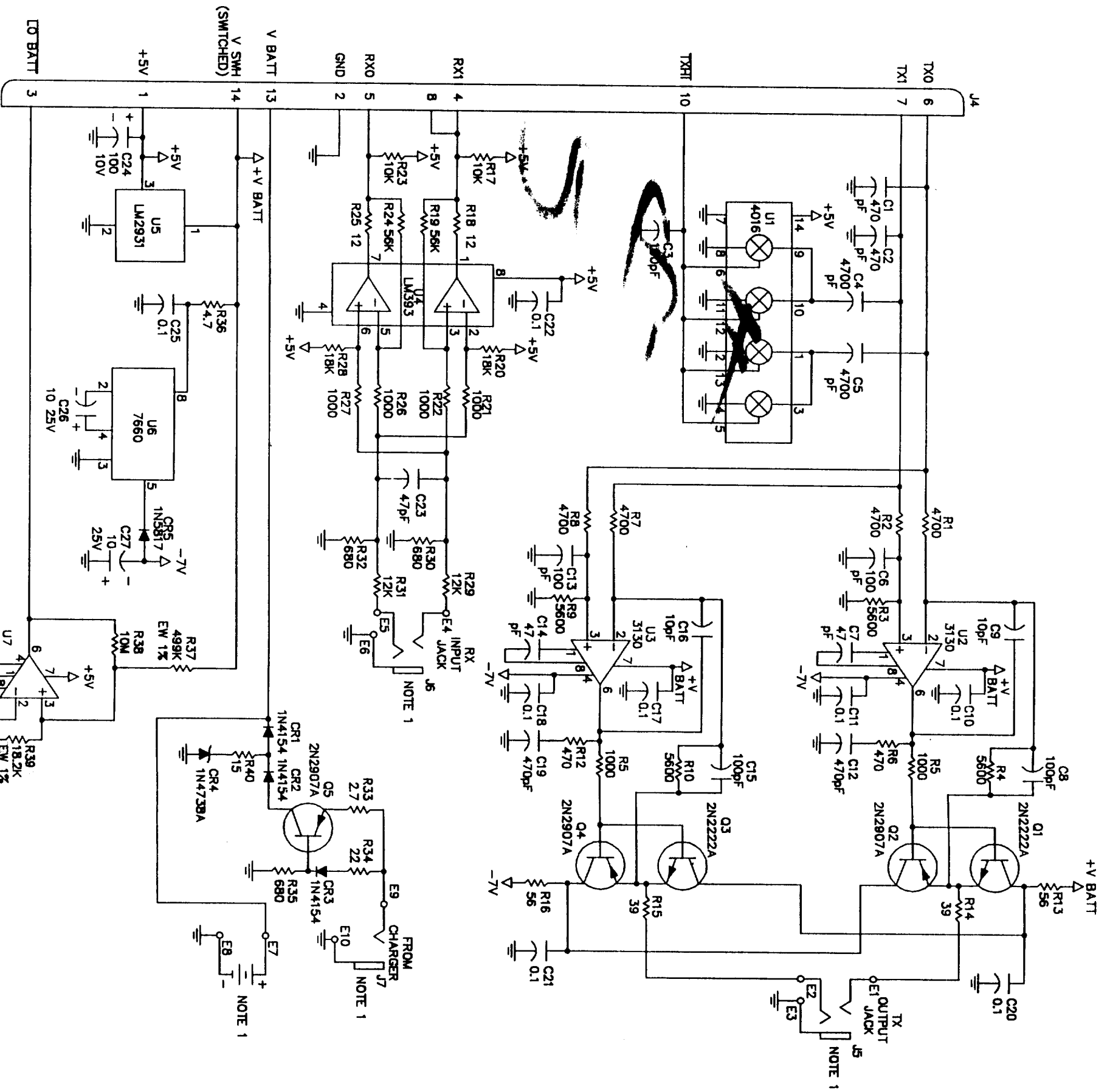

- NOTES:
1. PARTS ARE SHOWN FOR REFERENCE ONLY.
 2. ALL DESIGNATORS HAVE A 300 PREFIX.
 3. CAPACITANCE EXPRESSED IN uF UNLESS OTHERWISE SPECIFIED.
 4. RESISTORS ARE 5% UNLESS OTHERWISE SPECIFIED.

REV	DESCRIPTION	DATE	APPR
5	CONVERT TO 8 DIGIT SYSTEM	8/88	BLP

REV	DATE	DESCRIPTION
429EX	01-1001-05	
429EB	01-1001-10	
429E	01-1001-00	
429	01-0001-00	

UNIT	NEXT ASSY.	QTY	PART NO.	DESCRIPTION	ITEM

APPROVALS	DATE
DESIGNED	10/85
CHECKED	
DRWN	

SIZE	DWG. NO.	REV
B	02-5037-02	1 OF 1

SCHEMATIC ANALOG BD

400 INDUSTRIAL PARK,
 INDUSTRIAL AVENUE,
 KANSAS CITY, MO 64111