

3. Assemblies and Schematics

A. General

This section contains component layout drawings for all PC Board Assemblies, Interconnect Diagrams and Circuit Schematics within the ATC-600A-2.

NOTE: Bubble call-outs correspond to items in the Parts List in Section 4.

B. How To Use Schematics

To trace coaxial cable conductors from one schematic to another, follow the procedure outlined in para 2-2-3B(1) To trace conductors for multiple pin connectors, follow the procedure outlined in para 2-2-3B(2).

(1) Coaxial Cables

STEP	PROCEDURE
1.	Locate desired assembly or module on Interconnect Diagram.
2.	Locate desired coaxial cable on Interconnect Diagram. NOTE: Connectors are identified by reference designators.
3.	Follow coaxial cable on Interconnect Diagram to locate opposite end of conductor. Note coaxial cable reference designator and destination.
4.	Locate schematic of desired assembly or module.
5.	Locate reference designator of coaxial cable and continue tracing circuit.

(2) Multiple Pin Connectors

STEP	PROCEDURE
1.	Locate desired assembly or module on Interconnect Diagram.
2.	Locate desired multiple pin connector on Interconnect Diagram. NOTE: Connectors are identified by reference designators.
3.	Note reference designator of the mating connector. Note assembly, module or wire harness, connector is mounted on or grouped with.
4.	Locate schematic of desired assembly or module.
5.	Locate reference designator of multiple pin connector and corresponding pin number. Continue tracing circuit.



TITLE	PAGE
Final Assembly -----	5
Lid Assembly-----	6
Case Assembly -----	7
Composite Assembly	
Composite Assembly -----	8
Interconnect Diagram -----	13
Rear Panel Assembly-----	14
Front Panel Assembly	
Front Panel Assembly-----	15, 19
Front Panel Interface PC Board Assembly -----	17, 21
Front Panel Interface PC Board Assembly Circuit Schematic -----	18, 22
5 Volt Regulator PC Board Assembly	
5 Volt Regulator PC Board Assembly -----	23
5 Volt Regulator PC Board Assembly Circuit Schematic -----	24
Power Supply Assembly	
Power Supply Assembly -----	25
Power Supply Assembly Circuit Schematic -----	27
Oscillator Multiplier Assembly	
Oscillator Multiplier Assembly-----	28, 31
Oscillator Multiplier PC Board Assembly -----	29, 32
Oscillator Multiplier Assembly Circuit Schematic -----	30, 33
Oscillator Tuneline Assembly	
Oscillator Tuneline Assembly-----	34, 38
Oscillator Tuneline Assembly Circuit Schematic-----	35, 39
17X/18X Oscillator Amplifier PC Board Assembly -----	36, 40
17X/18X Oscillator Amplifier PC Board Assembly Circuit Schematic -----	37, 41
SLS and RF Leveler PC Board Assembly	
SLS and RF Leveler PC Board Assembly -----	42
SLS and RF Leveler PC Board Assembly Circuit Schematic-----	43
Altitude Register and Comparator PC Board Assembly	
Altitude Register and Comparator PC Board Assembly-----	44
Altitude Register and Comparator PC Board Assembly Circuit Schematic -----	45
DM8200 to 74LS85 PC Board Assembly-----	46
DM8200 to 74LS85 PC Board Assembly Circuit Schematic -----	47
DME Signal PC Board Assembly	
DME Signal PC Board Assembly -----	48
DME Signal PC Board Assembly Circuit Schematic -----	49
PC Cardcage Assembly	
PC Cardcage Assembly-----	50
Motherboard PC Board Assembly-----	51
Motherboard PC Board Assembly Circuit Schematic -----	52
Digital Display Assembly	
Digital Display Assembly -----	53, 59
Power Supply PC Board Assembly -----	54
Power Supply PC Board Assembly Circuit Schematic-----	55
Digital Display PC Board Assembly -----	56
Digital Readout PC Board Assembly -----	57, 60
Digital Display Assembly Circuit Schematic -----	58, 61
SLS Attenuator and RF Block Assembly -----	64
Diode Switch Block Assembly-----	65
RF Chassis Assembly	
RF Chassis Assembly-----	66
RF Chassis Assembly Circuit Schematic -----	67



TITLE	PAGE
Regulator/Timer PC Board Assembly	
Regulator/Timer PC Board Assembly -----	68
Regulator/Timer PC Board Assembly Circuit Schematic-----	69
Range Velocity PC Board Assembly	
Range Velocity PC Board Assembly-----	70
Range Velocity PC Board Assembly Circuit Schematic-----	71
XPDR Signal PC Board Assembly	
XPDR Signal PC Board Assembly -----	72
XPDR Signal PC Board Assembly Circuit Schematic-----	73



THIS PAGE INTENTIONALLY LEFT BLANK.

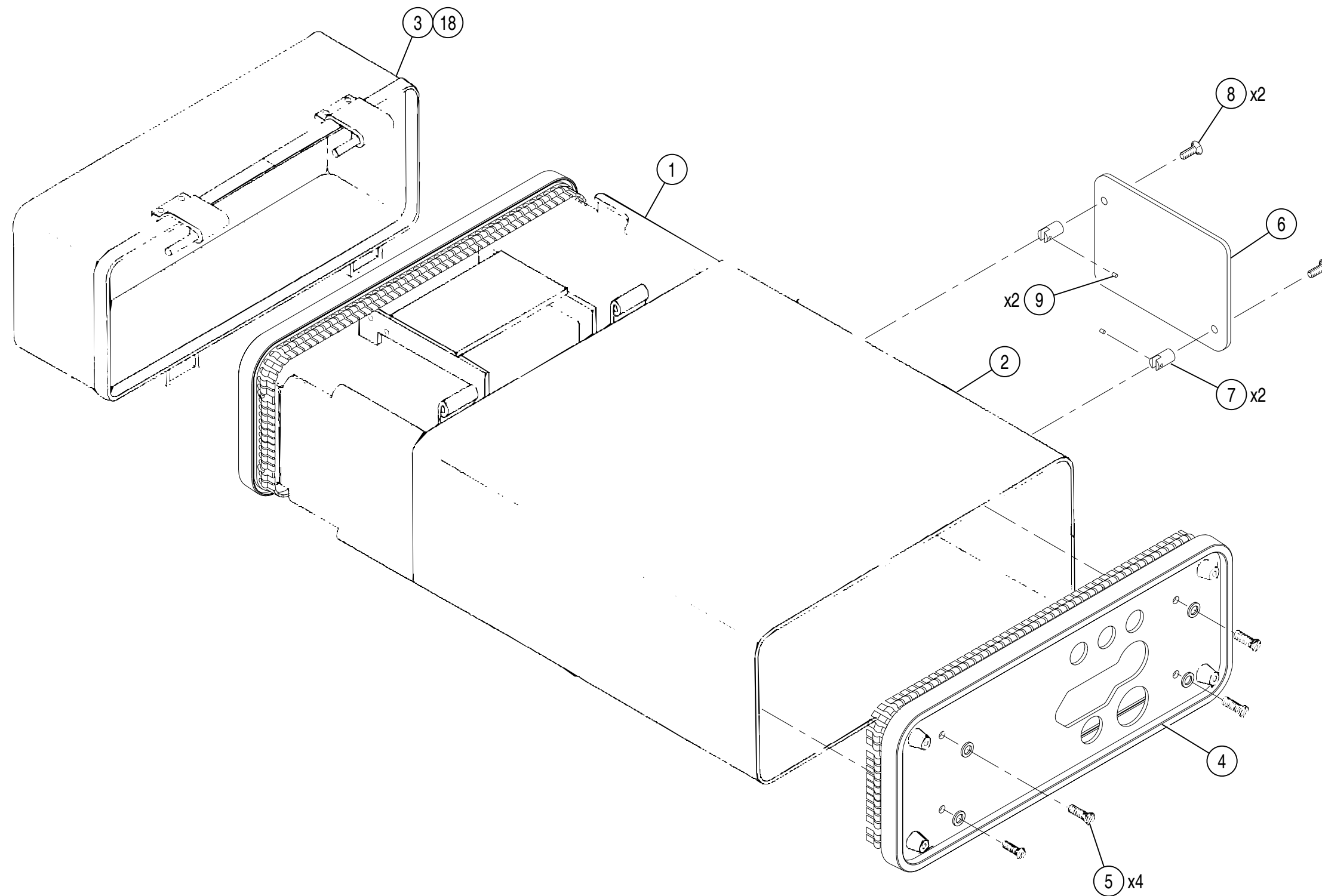

Final Assembly
(7002-0880-400-C)

Final Assembly
Figure 6

00820005

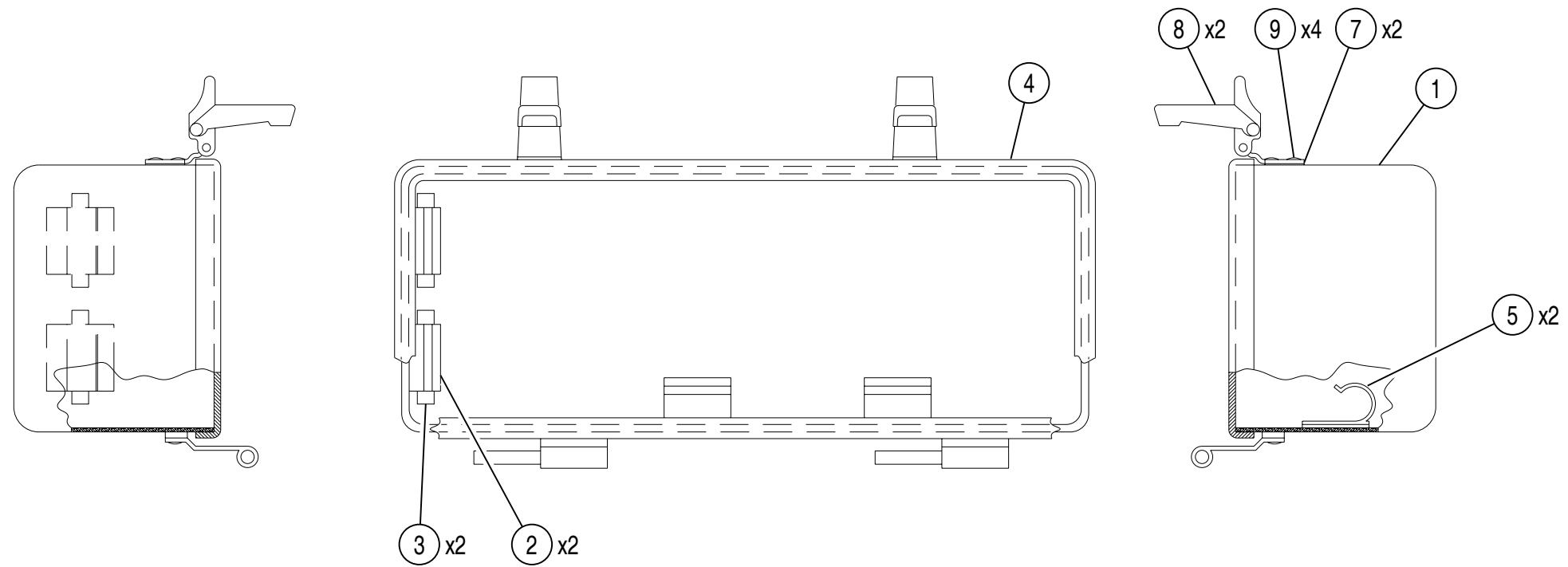

NOTES:

1. BASIC REFERENCE DESIGNATORS SHOWN, FOR COMPLETE DESIGNATOR PREFIXES REFER TO SYSTEM INTERCONNECT.

Lid Assembly
(7005-0846-100-A)

Lid Assembly
Figure 7

00820006

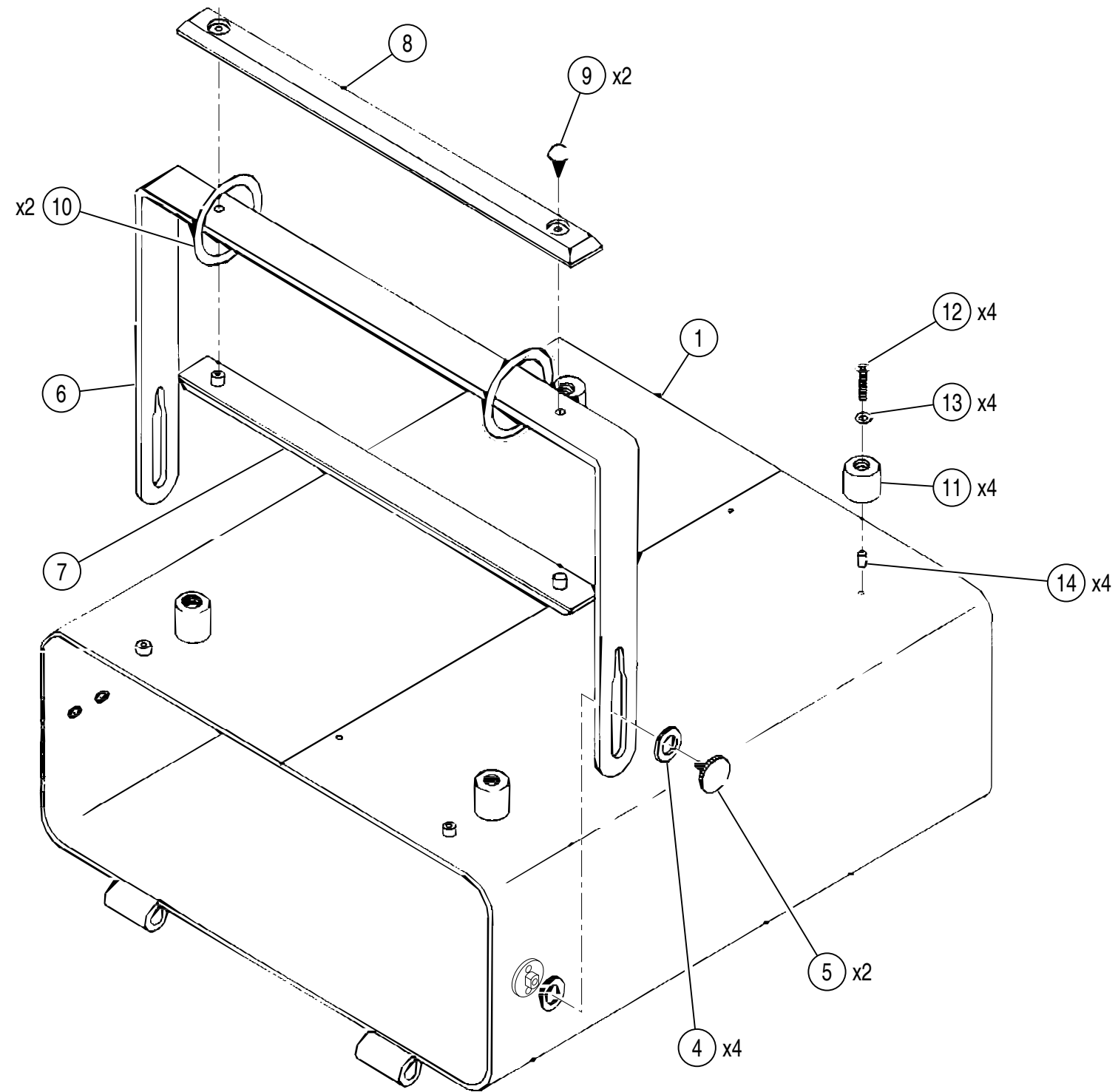

Case Assembly
(7005-0844-200-B)

Case Assembly
Figure 8

00820007

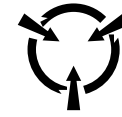

CAUTION:
CONTAINS PARTS AND ASSEMBLIES
SUSCEPTIBLE TO DAMAGE BY
ELECTROSTATIC DISCHARGE (ESD).

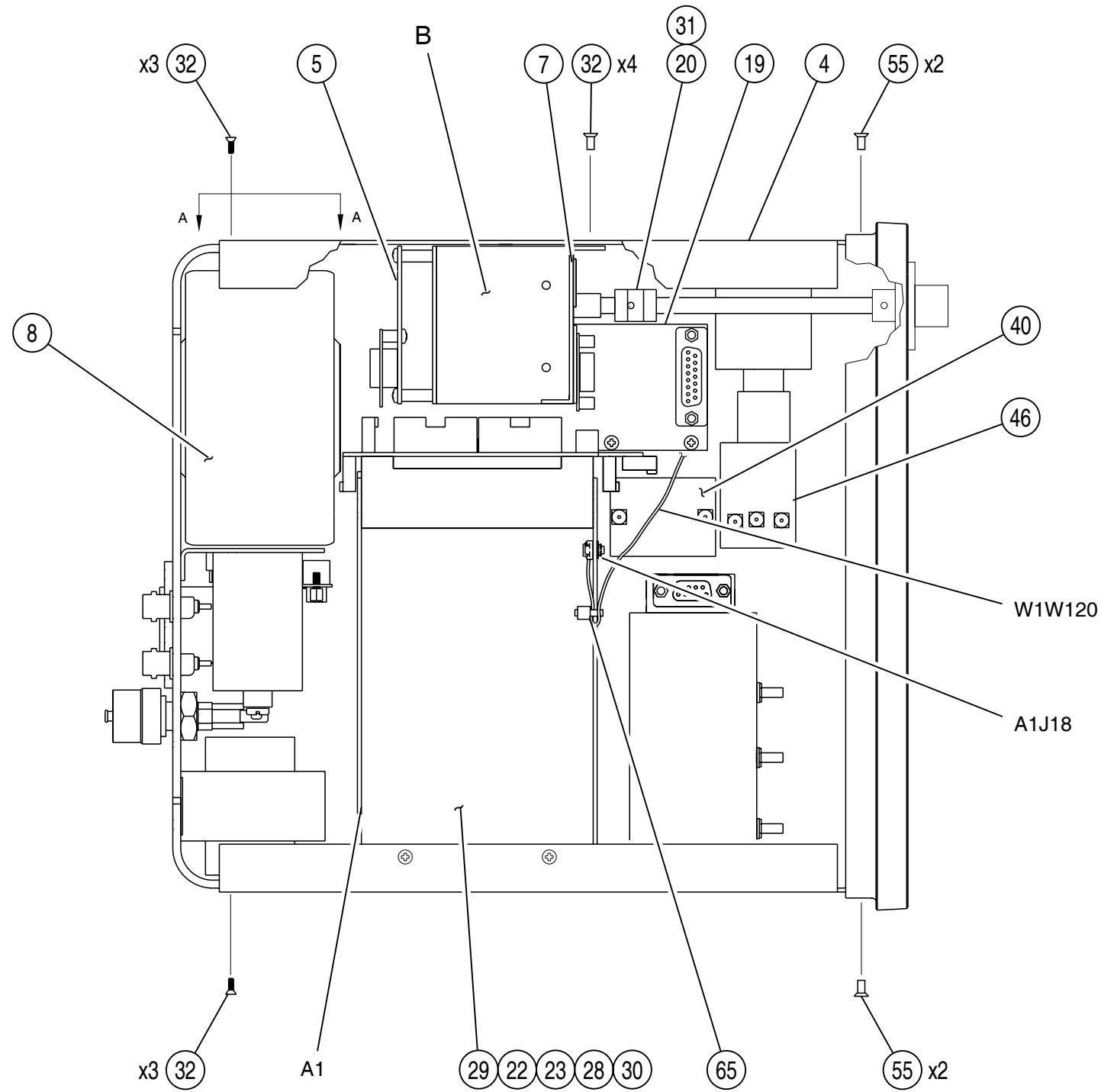

Composite Assembly
(7003-0845-200-E)

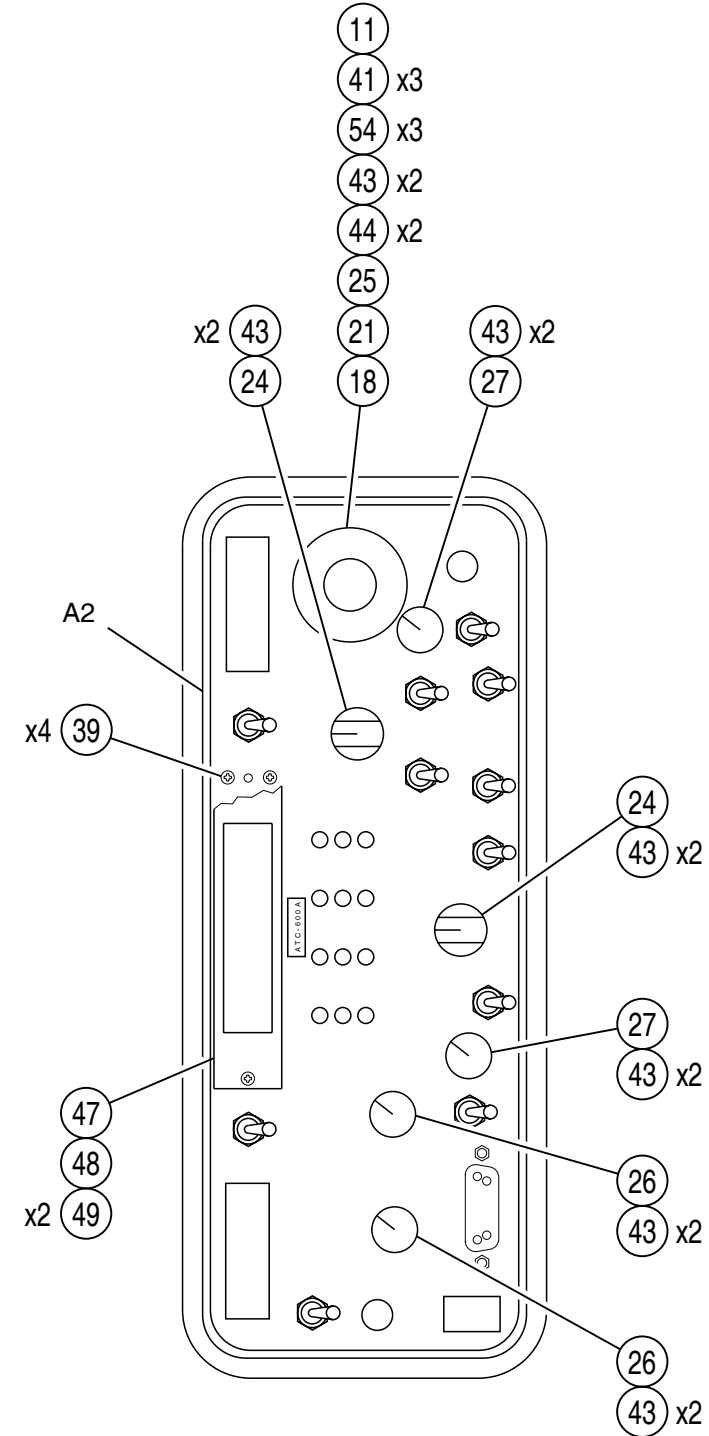

Composite Assembly (Sheet 1 of 6)
Figure 9



CAUTION:
CONTAINS PARTS AND ASSEMBLIES
SUSCEPTIBLE TO DAMAGE BY
ELECTROSTATIC DISCHARGE (ESD).

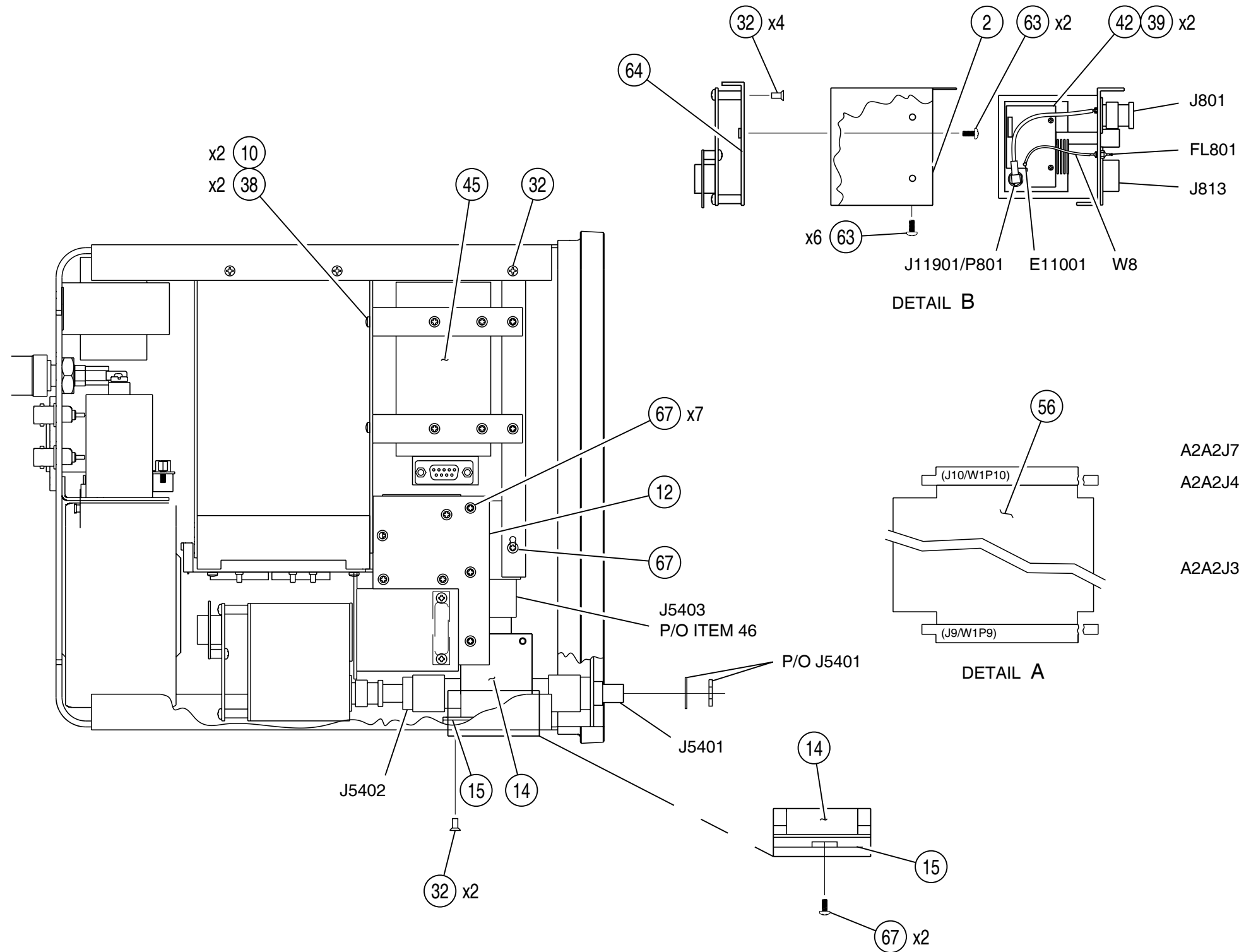

Composite Assembly (cont)
(7003-0845-200-E)

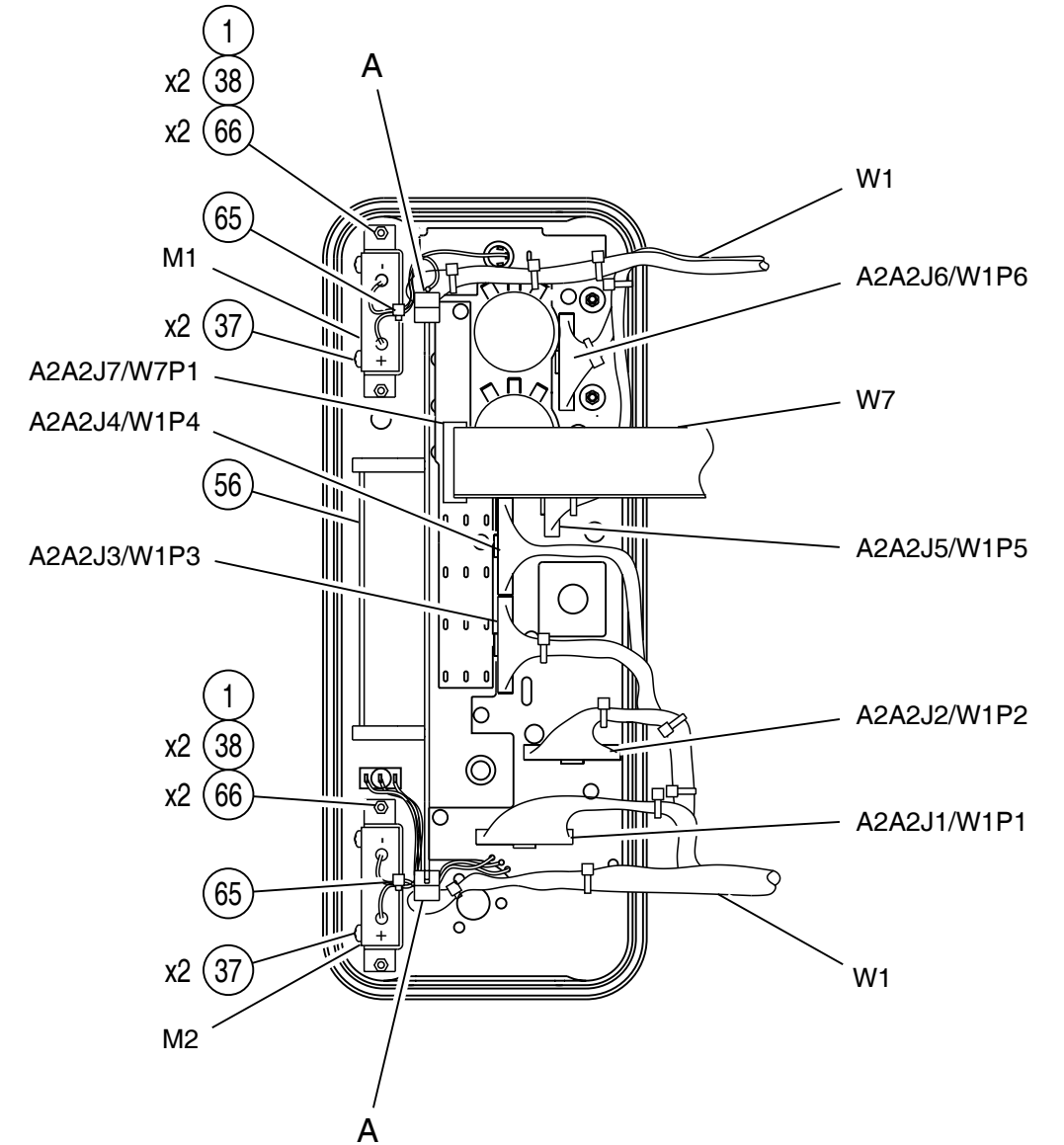

Composite Assembly (Sheet 2 of 6)
Figure 9



CAUTION:
CONTAINS PARTS AND ASSEMBLIES
SUSCEPTIBLE TO DAMAGE BY
ELECTROSTATIC DISCHARGE (ESD).

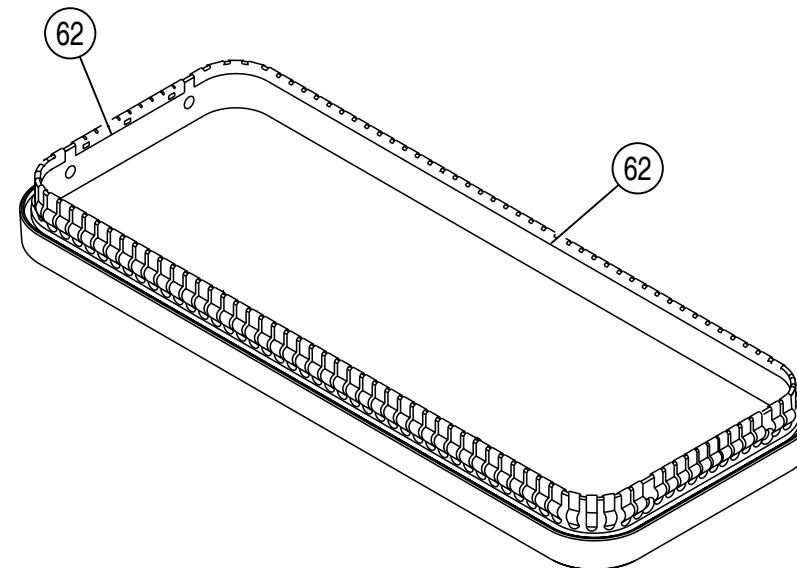
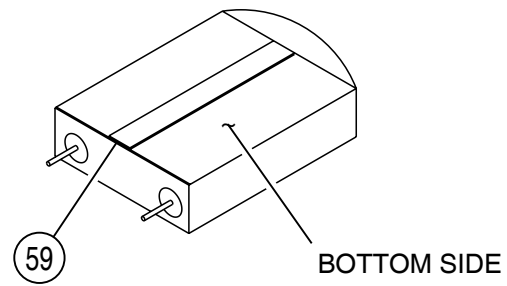
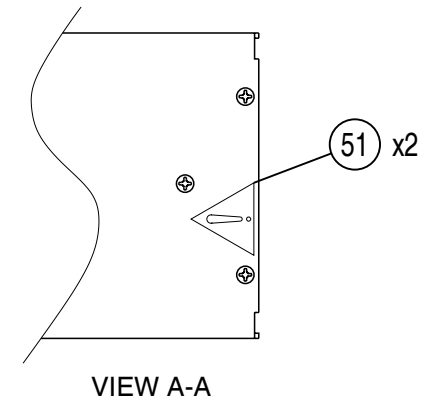
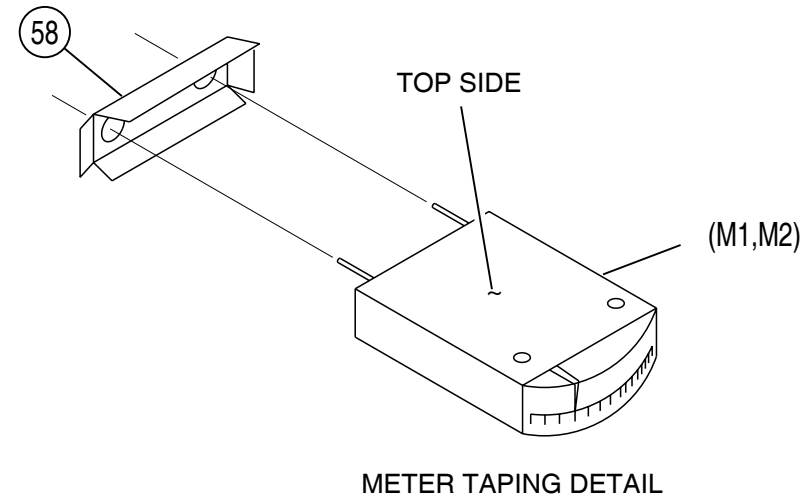

Composite Assembly (cont)
(7003-0845-200-E)

Composite Assembly (Sheet 3 of 6)
Figure 9

008M-018



CAUTION:
CONTAINS PARTS AND ASSEMBLIES
SUSCEPTIBLE TO DAMAGE BY
ELECTROSTATIC DISCHARGE (ESD).

WIRE RUNNING LIST				
DESG	FROM	TO	COLOR	AWG
	FPNL (A2)	M1+	VIO	
	FPNL (A2)	M1-	BLK	
	FPNL (A2)	M2+	WHT/VIO	
	FPNL (A2)	M2-	BLACK	
W2	J12202	J20301	COAX	
W3	J12201	J20303	COAX	
W6	J12203	J17601	COAX	
W5	J20302	J17602	COAX	
	W1P20	A1J15	COAX	
	W1P7	A1J16	COAX	
	W1P24	A1J17	COAX	
	W1P25	C17603	YEL	
	W1P26	C17602	BLUE	
	W1P27	C17601	WHT	
	W1P28	C812	VIO	
W8	E11001	FL801	RED	
	A1J18	W1W120	BLACK	
	FL801	W1W121	RED	

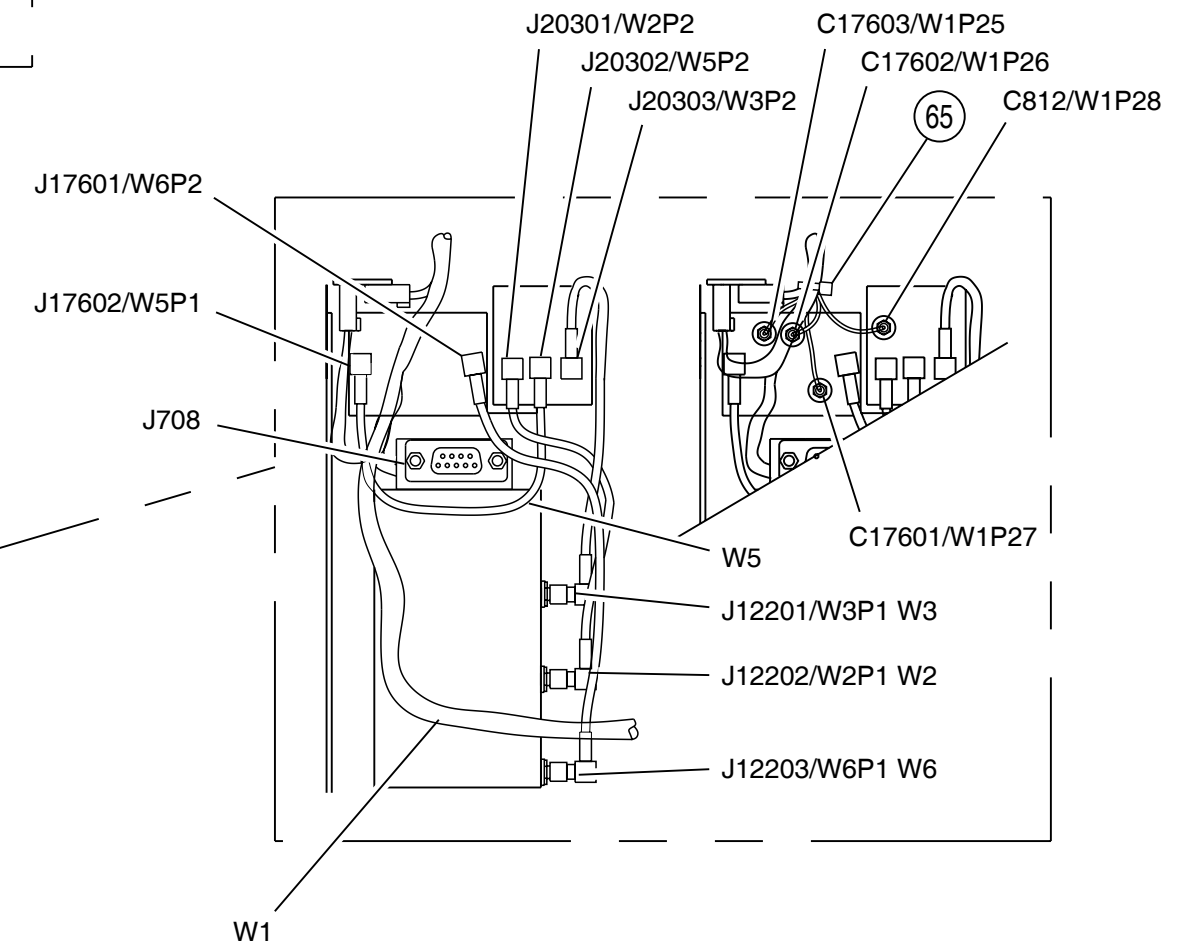
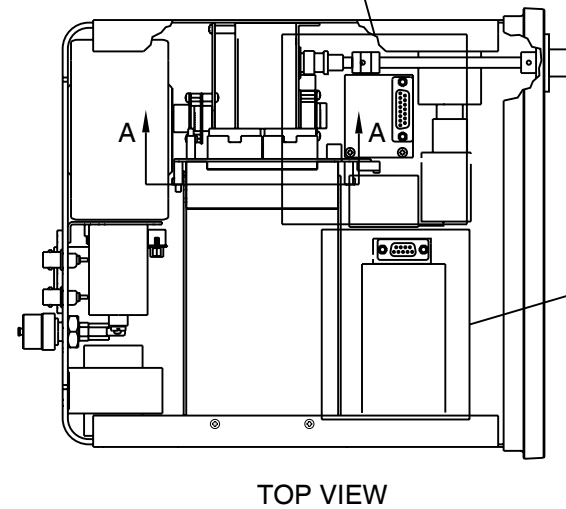
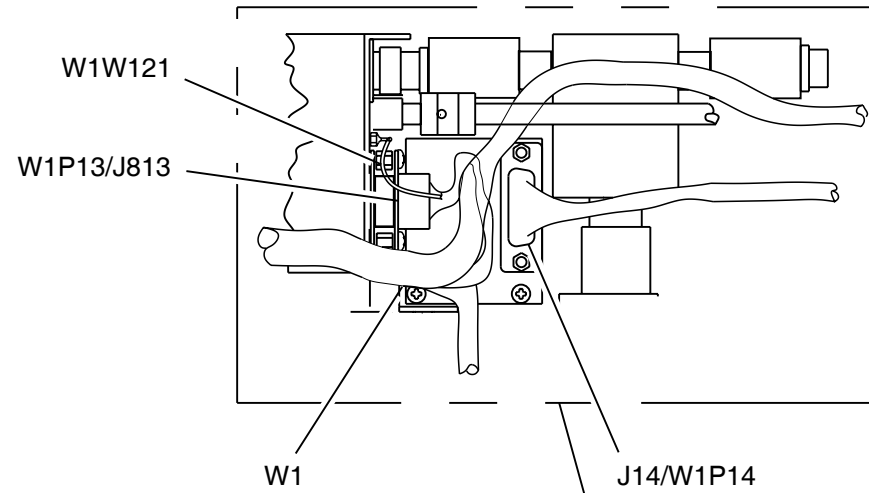
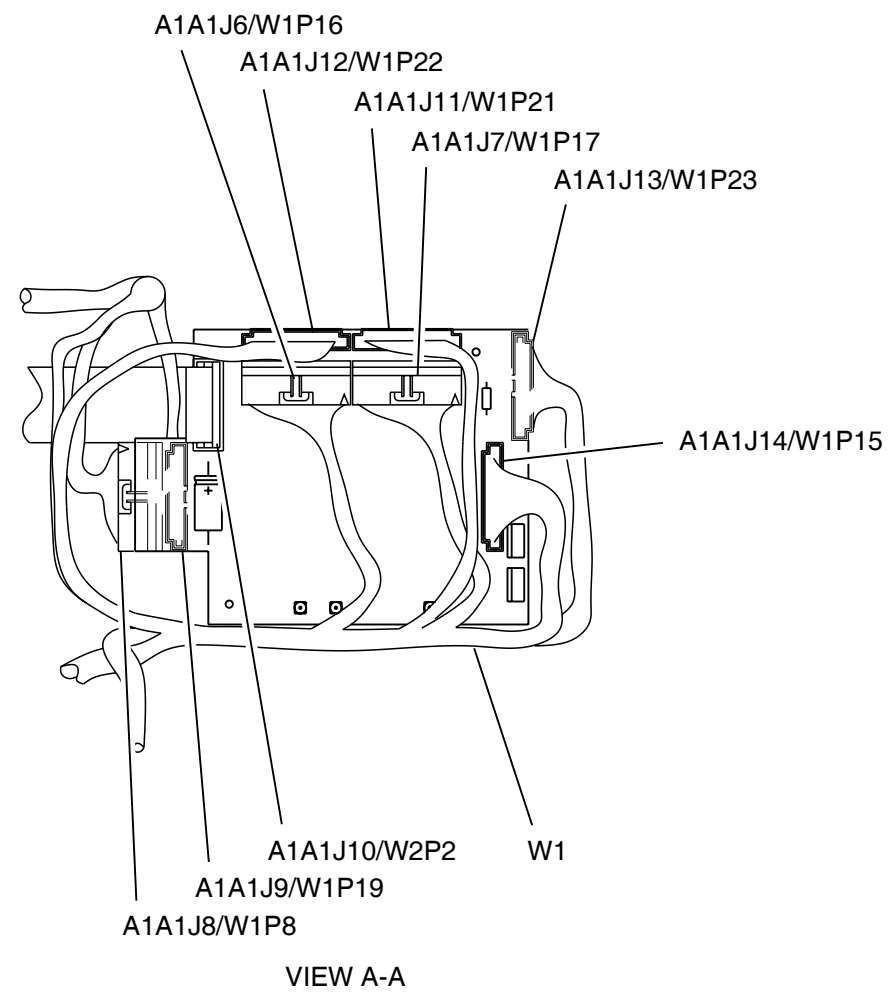

Composite Assembly (cont)
(7003-0845-200-E)

Composite Assembly (Sheet 4 of 6)
Figure 9

008M-019



CAUTION:
CONTAINS PARTS AND ASSEMBLIES
SUSCEPTIBLE TO DAMAGE BY
ELECTROSTATIC DISCHARGE (ESD).

BOTTOM VIEW

J1101/W1P12

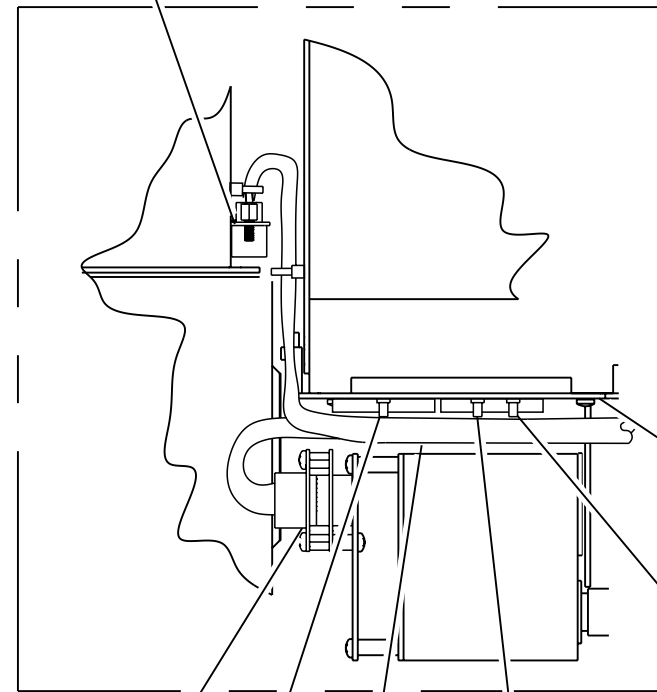

J1151/W1P11

A1J17

W1

A1J16

A1A1

A1J15

J708/W1P8

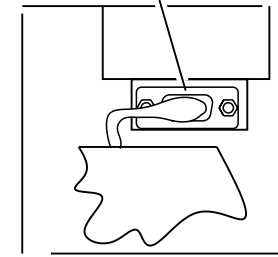

A1J16/W1P7

A1J15/W1P20

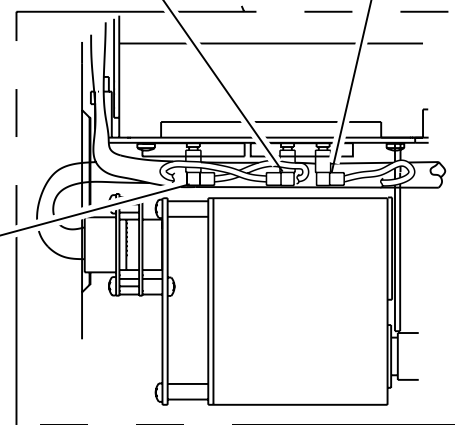

A1W17/W1P24

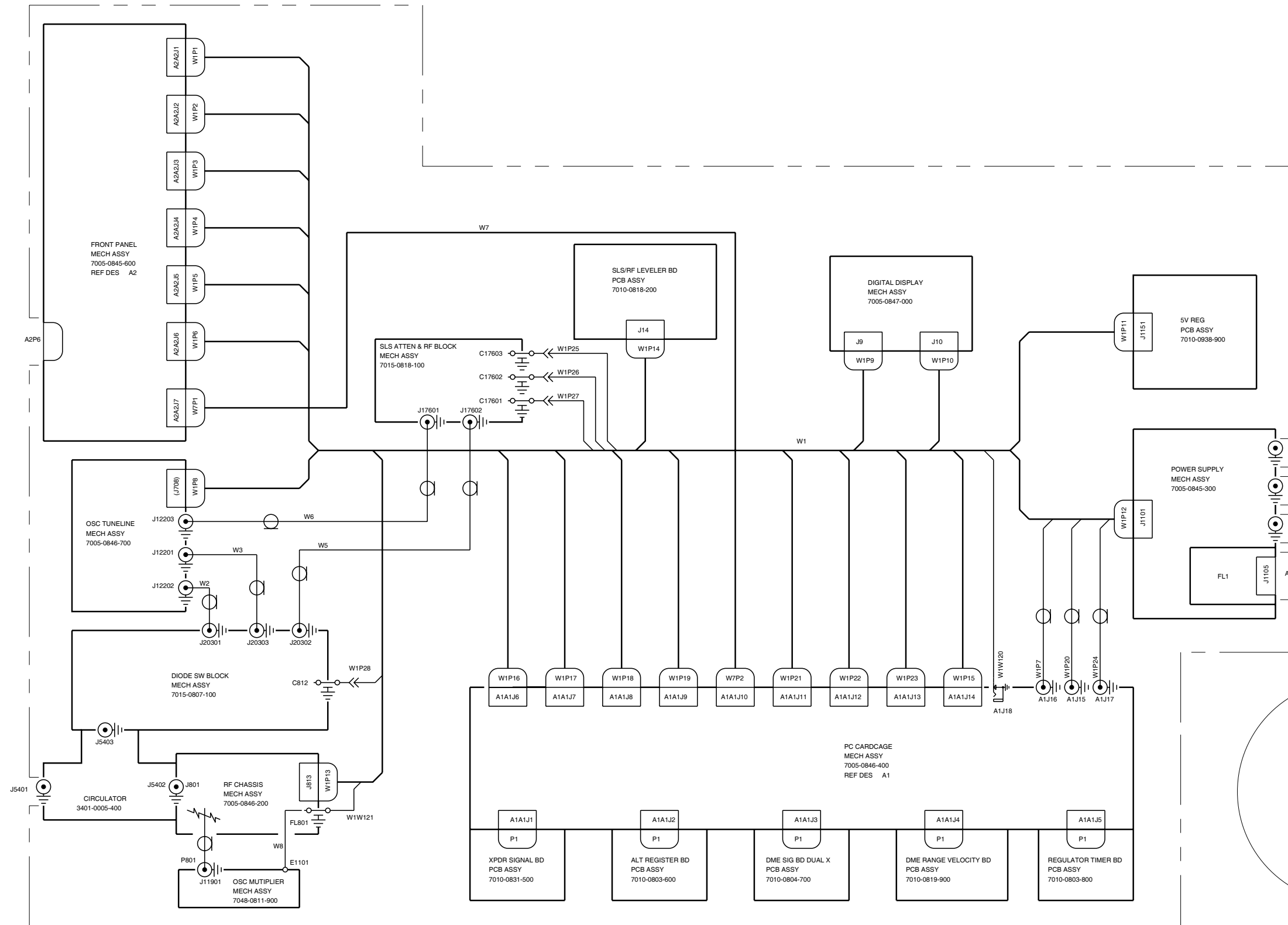

Interconnect Diagram
(0000-0845-200-C)

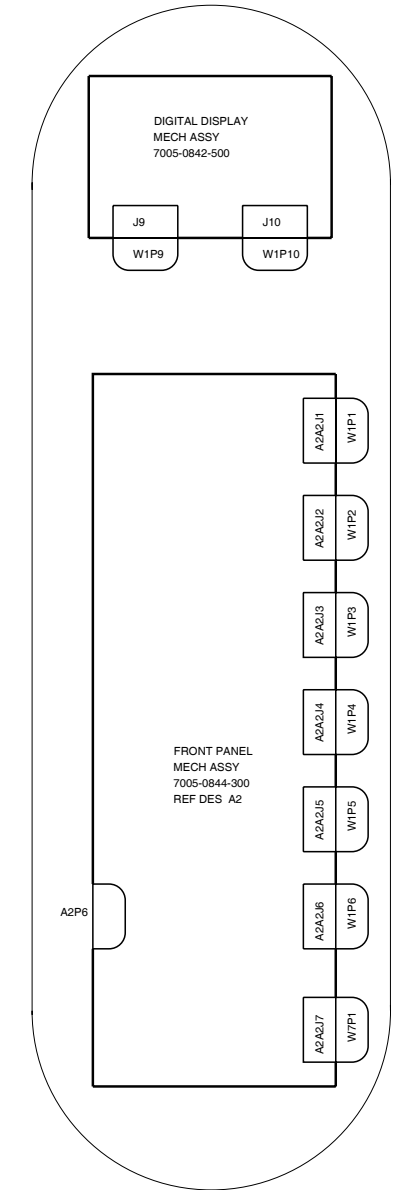

(REV A, B)

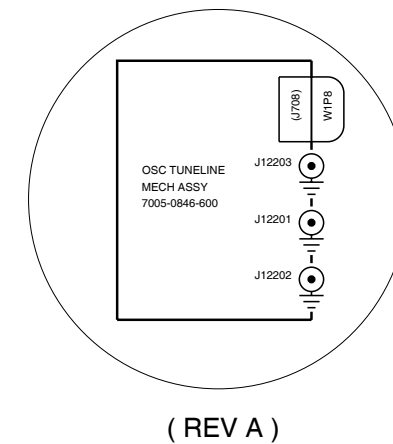

(REV A)

Composite Assembly (Sheet 6 of 6)
Figure 9

008M-015

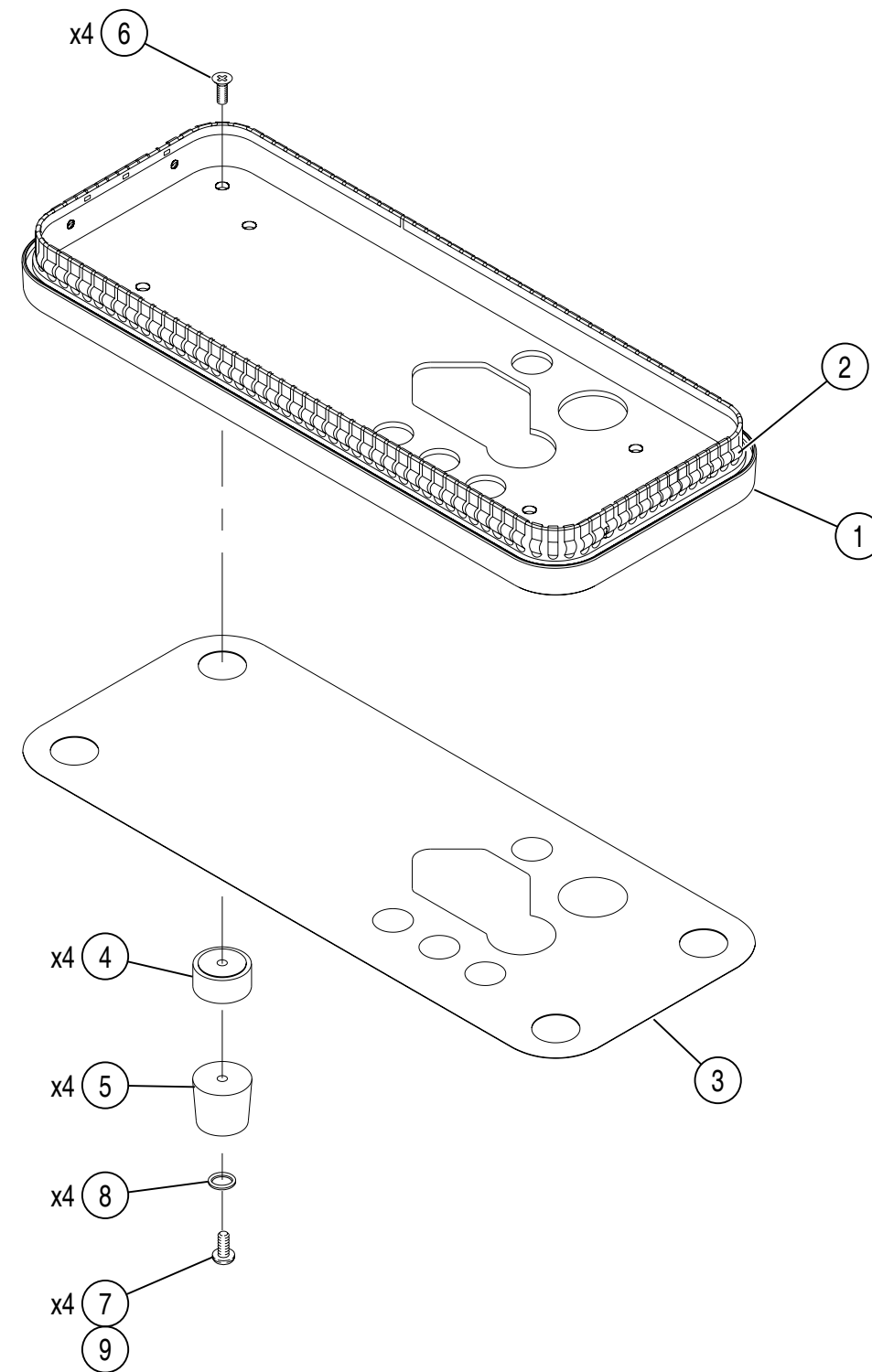

Rear Panel Assembly
(7005-0845-500-B)

00820013

Rear Panel Assembly
Figure 10

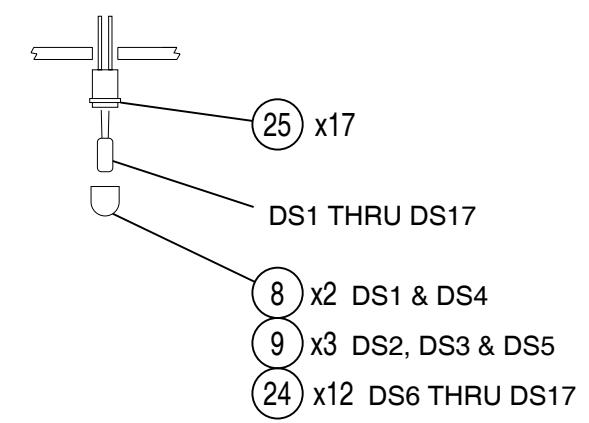
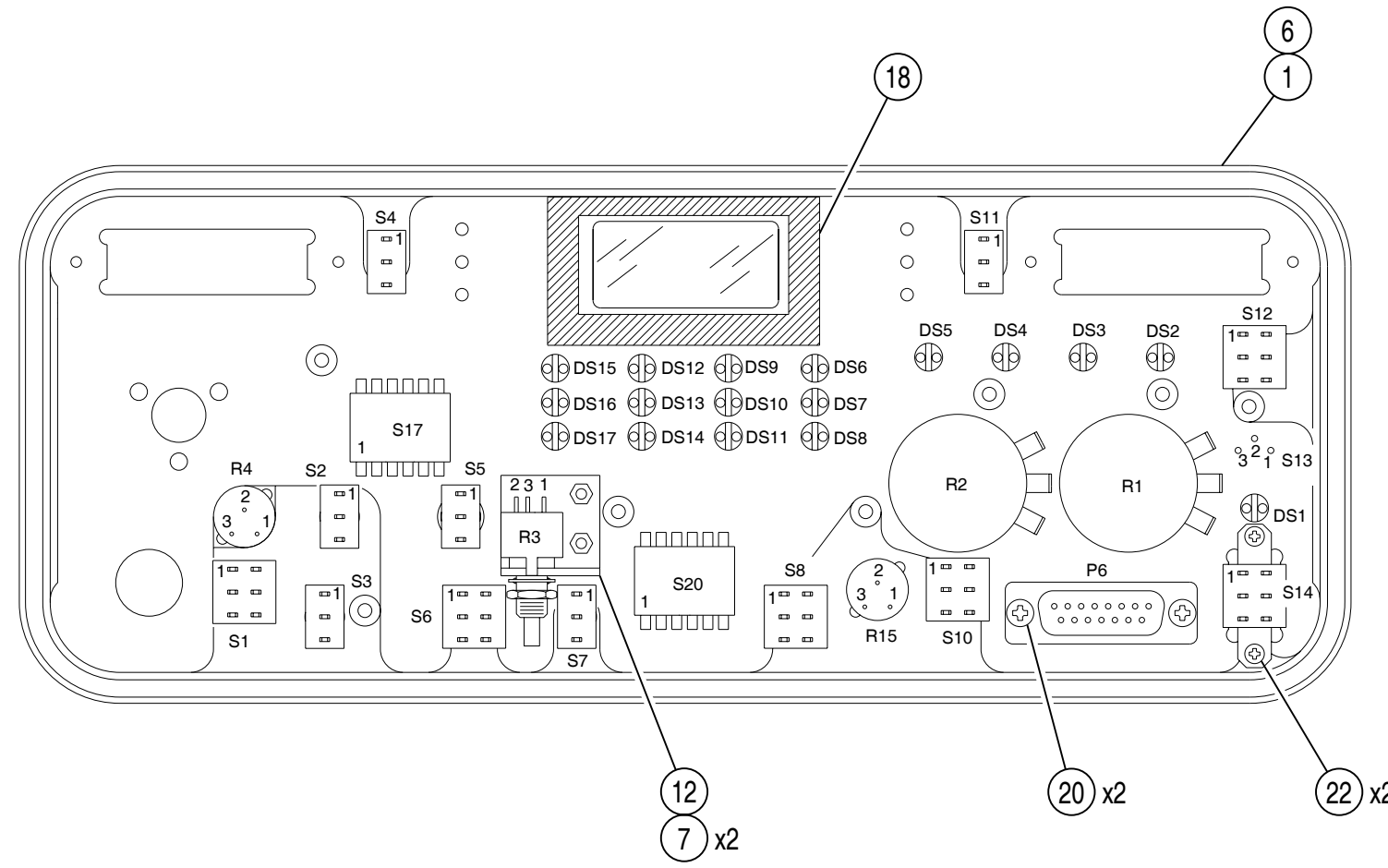

S1 THRU S8 & S10 THRU S12

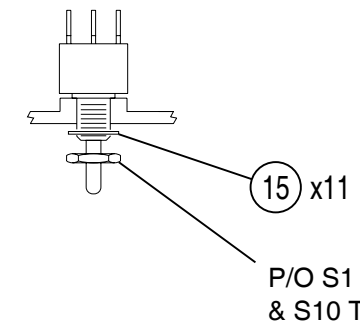

R4 & R15

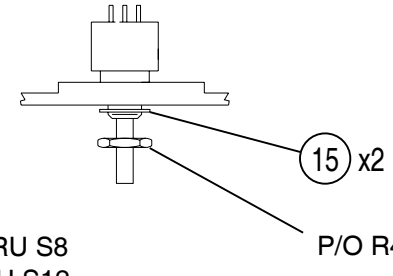

S13

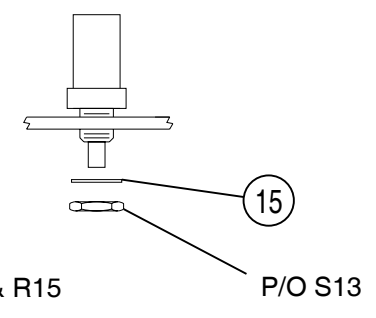

S17 & S20

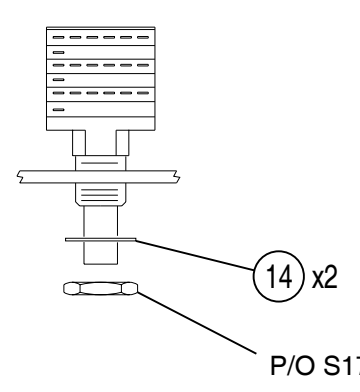

R1 & R2

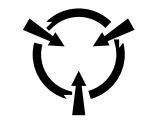
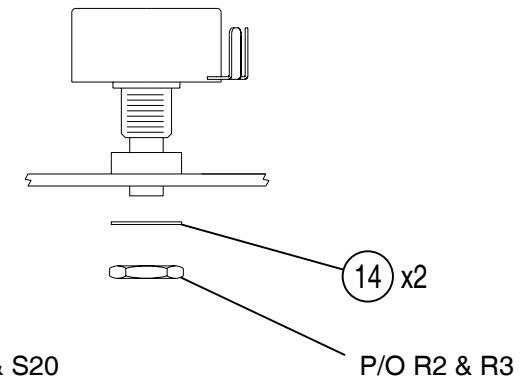

CAUTION:
CONTAINS PARTS AND ASSEMBLIES
SUSCEPTIBLE TO DAMAGE BY
ELECTROSTATIC DISCHARGE (ESD).

NOTES:

1. BASIC REFERENCE DESIGNATORS SHOWN, FOR COMPLETE DESIGNATOR PREFIXES REFER TO SYSTEM INTERCONNECT.

Front Panel Assembly
(7005-0844-300-B)

Front Panel Assembly (Sheet 1 of 8)
Figure 11

00820014

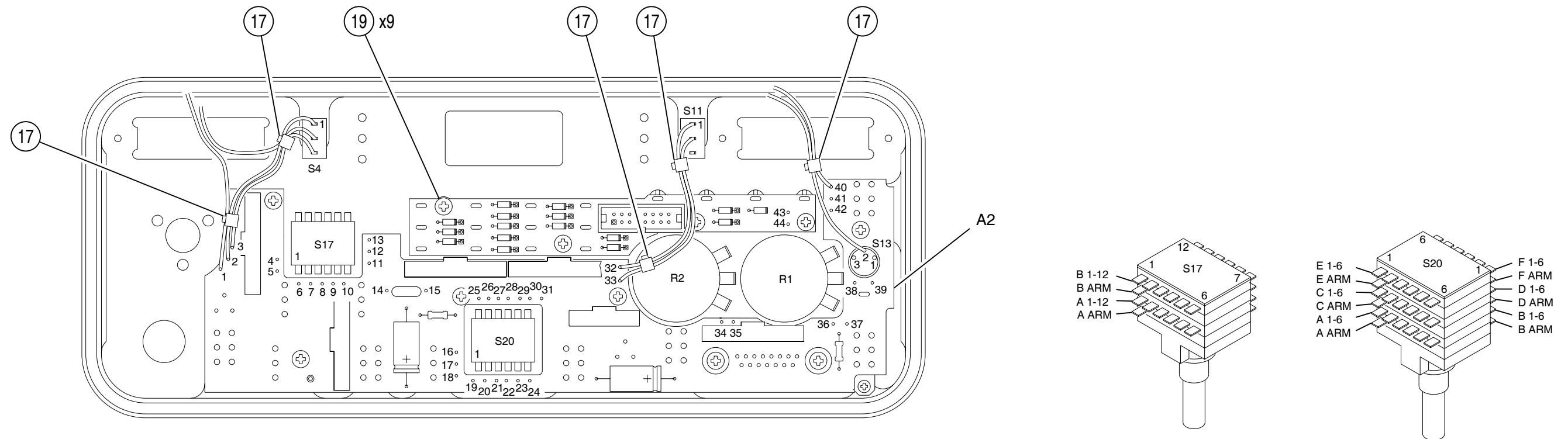

WIRE RUNNING LIST				
DESG	FROM	TO	COLOR	AWG
W1	E1	M1 -	BLK	26
W2	E2	S4-1	VIO	26
W3	E3	S4-3	WHT	26
W4	S4-2	M1 +	VIO	26
W5 *	E4	S17-1B	BUSS	26
W6 *	E5	S17-ARMB	BUSS	26
W7 *	E6	S17-ARMA	BUSS	26
W8 *	E7	S17-2A	BUSS	26
W9 *	E8	S17-3A	BUSS	26
W10 *	E9	S17-4A	BUSS	26
W11 *	E10	S17-5A	BUSS	26
W12 *	E11	S17-6A	BUSS	26
W13 *	E12	S17-7B	BUSS	26
W14 *	E13	S17-7A	BUSS	26
W15 *	E14	R3-2	BUSS	26
W16 *	E15	R3-1	BUSS	26
W17 *	E16	S20-ARME	BUSS	26
W18 *	E17	S20-1E	BUSS	26

WIRE RUNNING LIST				
DESG	FROM	TO	COLOR	AWG
W19 *	E18	S20-ARMA	BUSS	26
W20 *	E19	S20-1A	BUSS	26
W21 *	E20	S20-1C	BUSS	26
W22 *	E21	S20-ARMC	BUSS	26
W23 *	E22	S20-3E	BUSS	26
W24 *	E23	S20-3A	BUSS	26
W25 *	E24	S20-4C	BUSS	26
W26 *	E25	S20-4B	BUSS	26
W27 *	E26	S20-4D	BUSS	26
W28 *	E27	S20-3B	BUSS	26
W29 *	E28	S20-2D	BUSS	26
W30 *	E29	S20-1B	BUSS	26
W31 *	E30	S20-ARMB	BUSS	26
W32 *	E31	S20-ARMD	BUSS	26
W33	E32	S11-1	ORN	26
W34	E33	S11-2	BLK/WHT	26
W35 *	E34	R2-1	ORN	26
W36 *	E35	R2-3	GRN	26

WIRE RUNNING LIST				
DESG	FROM	TO	COLOR	AWG
W37 *	E36	R1-1	ORN	26
W38 *	E37	R1-3	WHT/VIO	26
W39	E38	S13-1	BLK/WHT	26
W40	E39	S13-3	BLK/WHT	26
W41	S13-2	M2 +	VIO/WHT	26
W42	E40	M2 -	BLK	26
W43 *	E41	E43	BLK	26
W44 *	E42	E44	ORN	26
W45	R3-2	R3-3	BUSS	26
W46	S20-1A	S20-2A	BUSS	26
W47	S20-2B	S20-3B	BUSS	26
W48	S20-1C	S20-2,3C	BUSS	26
W49	S20-1D	S20-2,3D	BUSS	26
W50 *	S20-1E	S20-4E	BUSS	26
W51	S17-2B	3,4,5,6,7B	BUSS	26
W52	R2-2	R2-3	BUSS	26
W53	R1-2	R1-3	BUSS	26

Front Panel Assembly (cont)
(7005-0844-300-B)

Front Panel Assembly (Sheet 2 of 8)
Figure 11

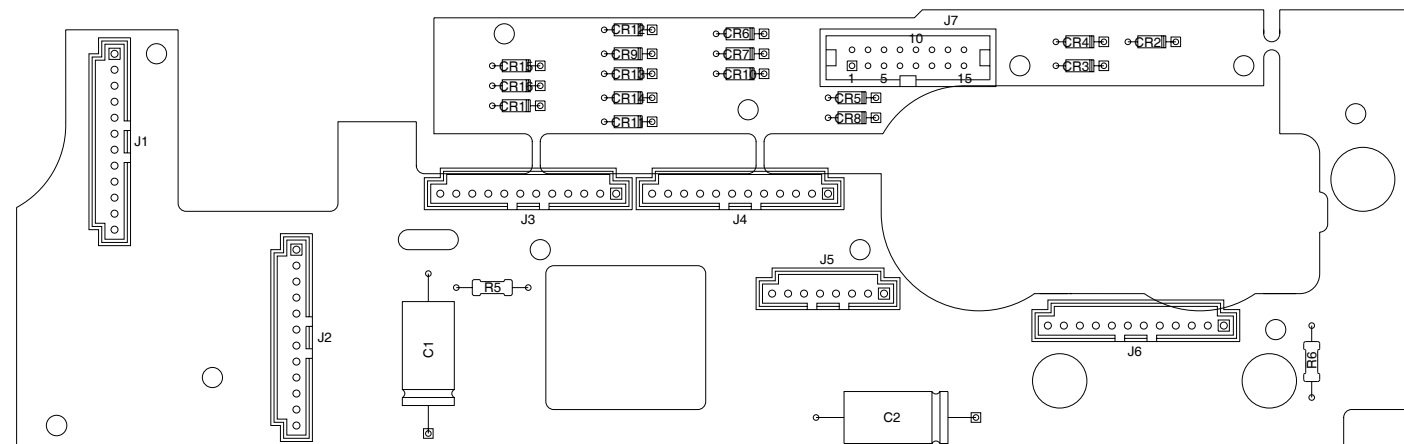

CAUTION:
CONTAINS PARTS AND ASSEMBLIES
SUSCEPTIBLE TO DAMAGE BY
ELECTROSTATIC DISCHARGE (ESD).

NOTES:

1. BASIC REFERENCE DESIGNATORS SHOWN, FOR COMPLETE DESIGNATOR PREFIXES REFER TO SYSTEM INTERCONNECT.

Front Panel Interface PC Board Assembly
(7010-0834-300-A)

Front Panel Assembly (Sheet 3 of 8)
Figure 11

00818006

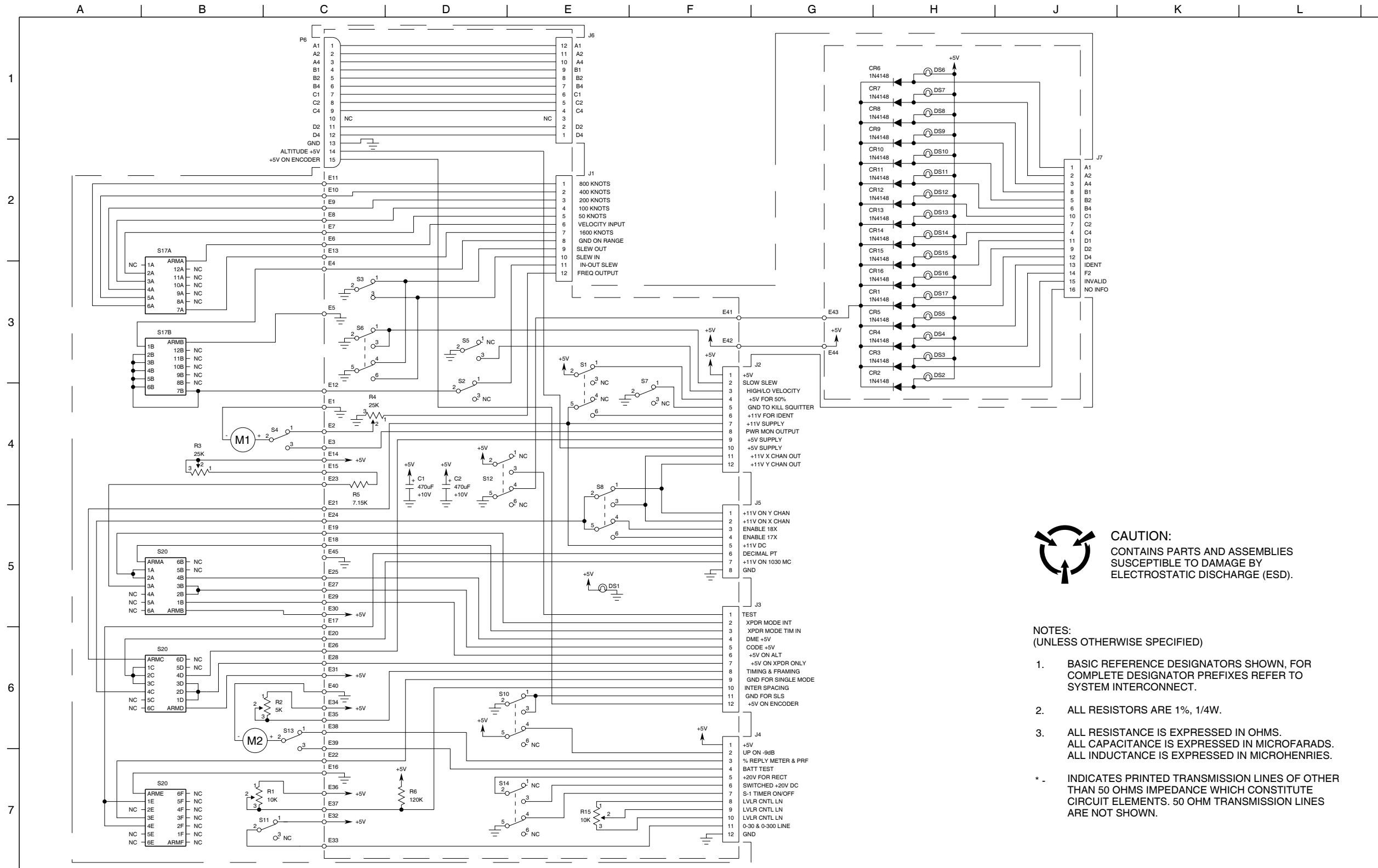

CAUTION:
CONTAINS PARTS AND ASSEMBLIES
SUSCEPTIBLE TO DAMAGE BY
ELECTROSTATIC DISCHARGE (ESD).

NOTES:

- (UNLESS OTHERWISE SPECIFIED)
1. BASIC REFERENCE DESIGNATORS SHOWN, FOR COMPLETE DESIGNATOR PREFIXES REFER TO SYSTEM INTERCONNECT.
 2. ALL RESISTORS ARE 1%, 1/4W.
 3. ALL RESISTANCE IS EXPRESSED IN OHMS. ALL CAPACITANCE IS EXPRESSED IN MICROFARADS. ALL INDUCTANCE IS EXPRESSED IN MICROHENRIES.
- * - INDICATES PRINTED TRANSMISSION LINES OF OTHER THAN 50 OHMS IMPEDANCE WHICH CONSTITUTE CIRCUIT ELEMENTS. 50 OHM TRANSMISSION LINES ARE NOT SHOWN.

Front Panel Interface PC Board Assembly Circuit Schematic
(0000-0834-300-A)

Front Panel Assembly (Sheet 4 of 8)
Figure 11



CAUTION:
CONTAINS PARTS AND ASSEMBLIES
SUSCEPTIBLE TO DAMAGE BY
ELECTROSTATIC DISCHARGE (ESD).

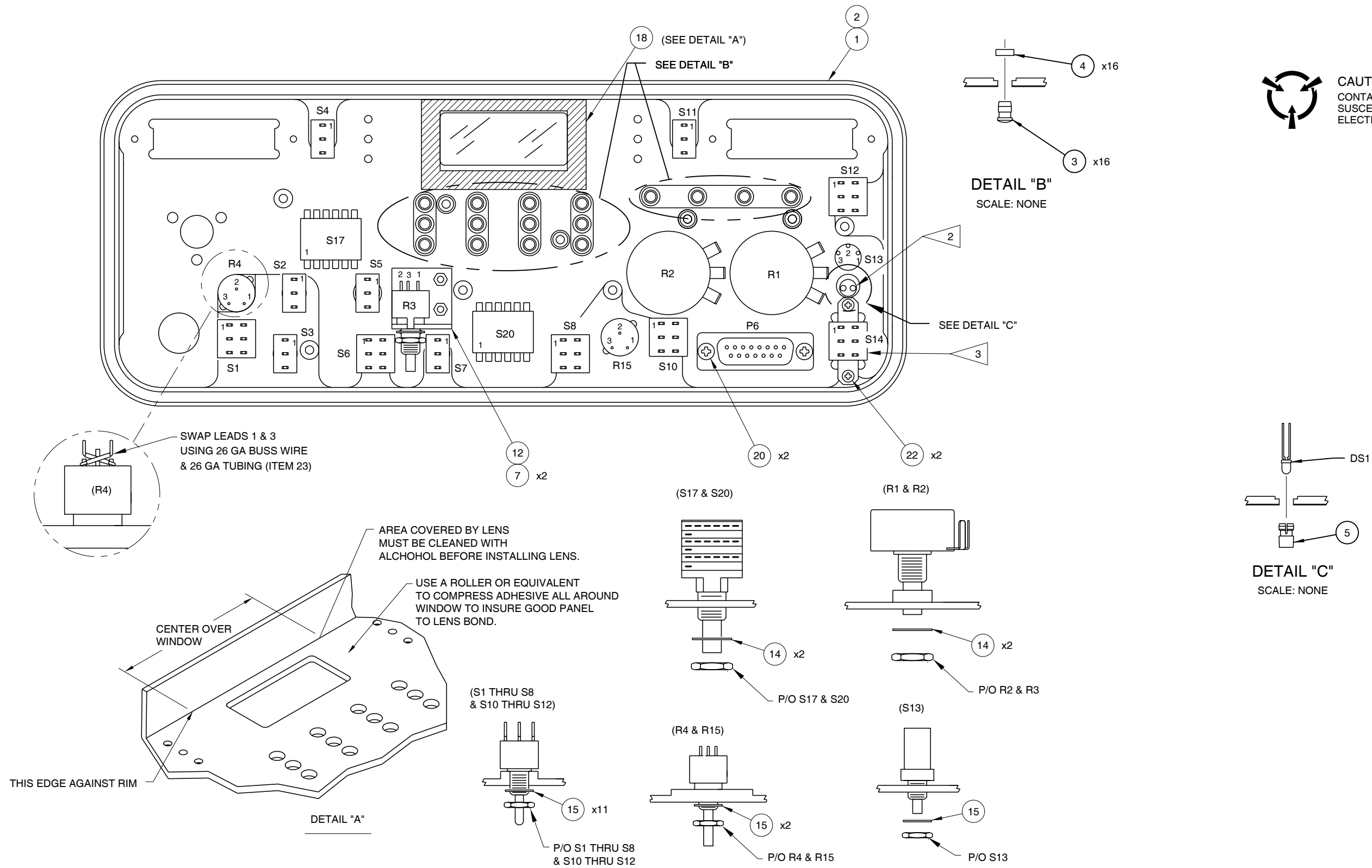

Front Panel Assembly
(7005-0845-600-B)

Front Panel Assembly (Sheet 5 of 8)
Figure 11

008M-003

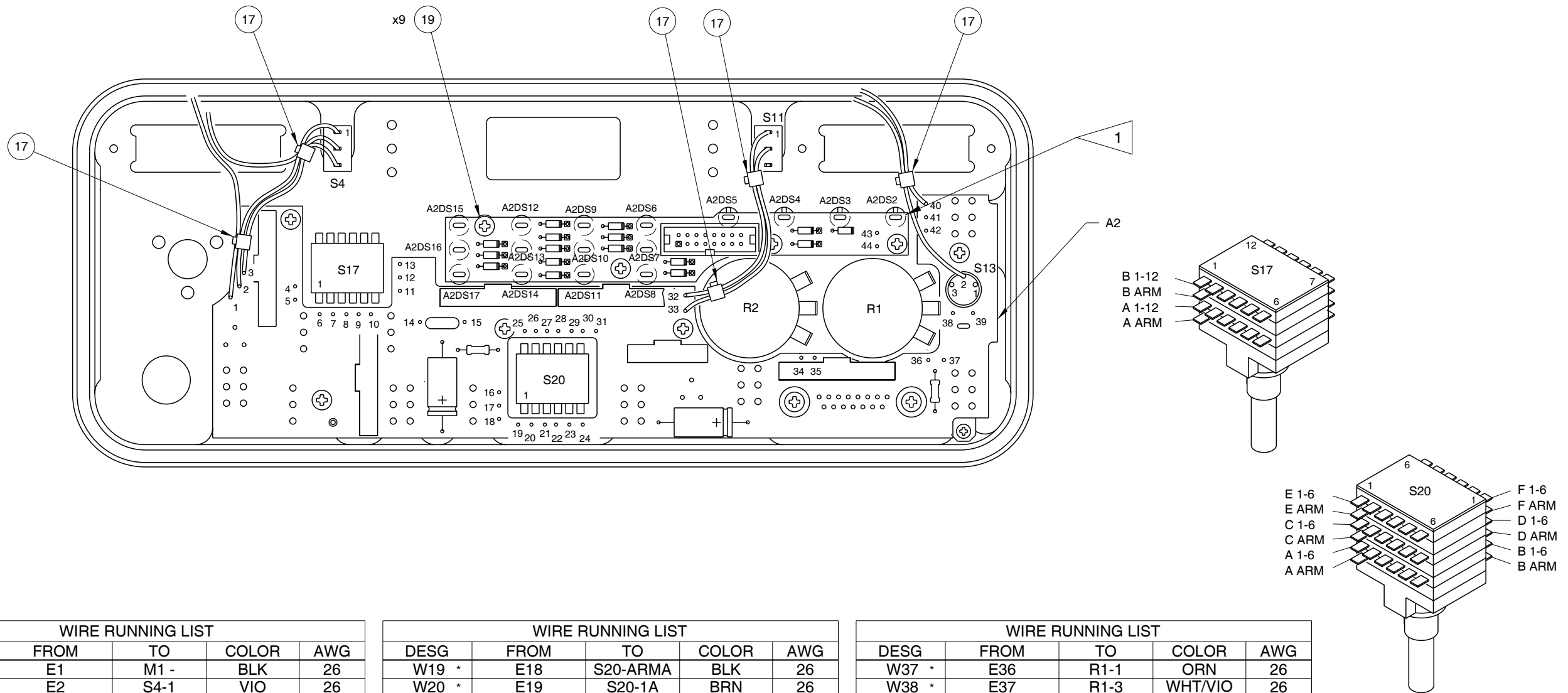

WIRE RUNNING LIST				
DESG	FROM	TO	COLOR	AWG
W1	E1	M1 -	BLK	26
W2	E2	S4-1	VIO	26
W3	E3	S4-3	WHT	26
W4	S4-2	M1 +	VIO	26
W5 *	E4	S17-1B	BLK	26
W6 *	E5	S17-ARMB	BRN	26
W7 *	E6	S17-ARMA	RED	26
W8 *	E7	S17-2A	ORN	26
W9 *	E8	S17-3A	YEL	26
W10 *	E9	S17-4A	GRN	26
W11 *	E10	S17-5A	BLU	26
W12 *	E11	S17-6A	VIO	26
W13 *	E12	S17-7B	GRY	26
W14 *	E13	S17-7A	WHT	26
W15 *	E14	R3-2	RED	26
W16 *	E15	R3-1	BLK	26
W17 *	E16	S20-ARME	YEL	26
W18 *	E17	S20-1E	GRN	26

WIRE RUNNING LIST				
DESG	FROM	TO	COLOR	AWG
W19 *	E18	S20-ARMA	BLK	26
W20 *	E19	S20-1A	BRN	26
W21 *	E20	S20-1C	RED	26
W22 *	E21	S20-ARMC	ORN	26
W23 *	E22	S20-3E	YEL	26
W24 *	E23	S20-3A	GRN	26
W25 *	E24	S20-4C	BLU	26
W26 *	E25	S20-4B	VIO	26
W27 *	E26	S20-4D	GRY	26
W28 *	E27	S20-3B	WHT	26
W29 *	E28	S20-2D	BLK	26
W30 *	E29	S20-1B	BRN	26
W31 *	E30	S20-ARMB	RED	26
W32 *	E31	S20-ARMD	ORN	26
W33	E32	S11-1	ORN	26
W34	E33	S11-2	BLK/WHT	26
W35 *	E34	R2-1	ORN	26
W36 *	E35	R2-3	GRN	26

WIRE RUNNING LIST				
DESG	FROM	TO	COLOR	AWG
W37 *	E36	R1-1	ORN	26
W38 *	E37	R1-3	WHT/VIO	26
W39	E38	S13-1	BLK/WHT	26
W40	E39	S13-3	BLK/WHT	26
W41	S13-2	M2 +	VIO/WHT	26
W42	E40	M2 -	BLK	26
W43 *	E41	E43	BLK	26
W44 *	E42	E44	ORN	26
W45	R3-2	R3-3	BUSS	26
W46	S20-1A	S20-2A	BUSS	26
W47	S20-2B	S20-3B	BUSS	26
W48	S20-1C	S20-2,3C	BUSS	26
W49	S20-1D	S20-2,3D	BUSS	26
W50 *	S20-1E	S20-4E	BUSS	26
W51	S17-2B	3,4,5,6,7B	BUSS	26
W52	R2-2	R2-3	BUSS	26
W53	R1-2	R1-3	BUSS	26

Front Panel Assembly (cont)
(7005-0845-600-B)

Front Panel Assembly (Sheet 6 of 8)
Figure 11

008M-004



CAUTION:
CONTAINS PARTS AND ASSEMBLIES
SUSCEPTIBLE TO DAMAGE BY
ELECTROSTATIC DISCHARGE (ESD).

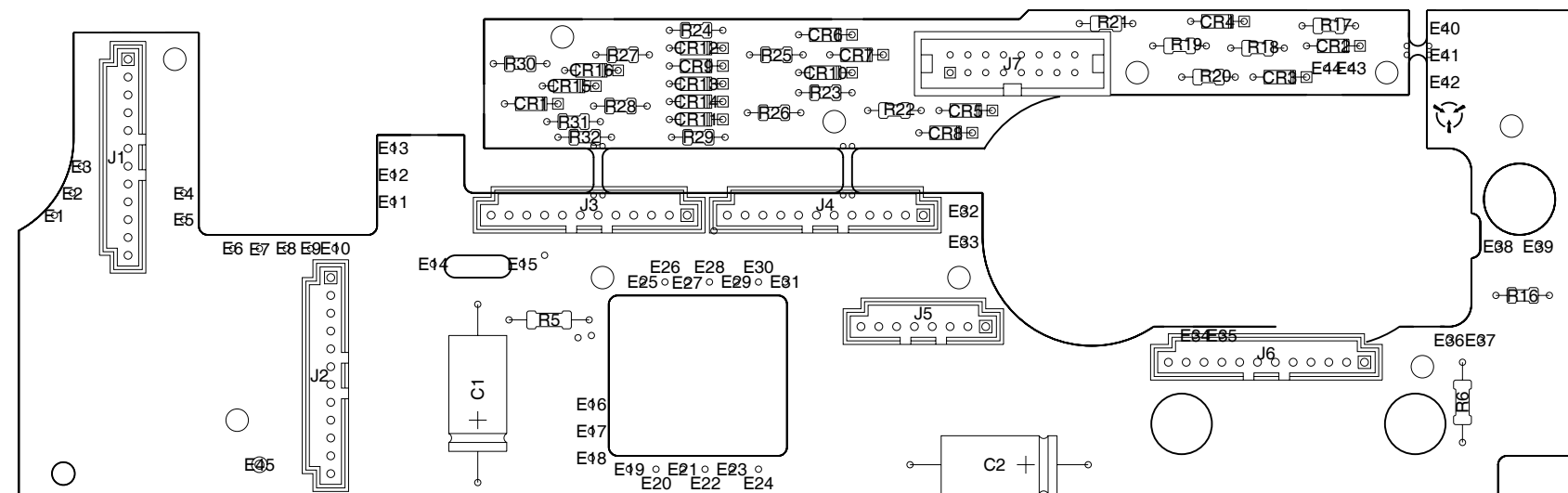

Front Panel Interface PC Board Assembly
(7010-0835-600-C)

008M-001
Front Panel Assembly (Sheet 7 of 8)
Figure 11

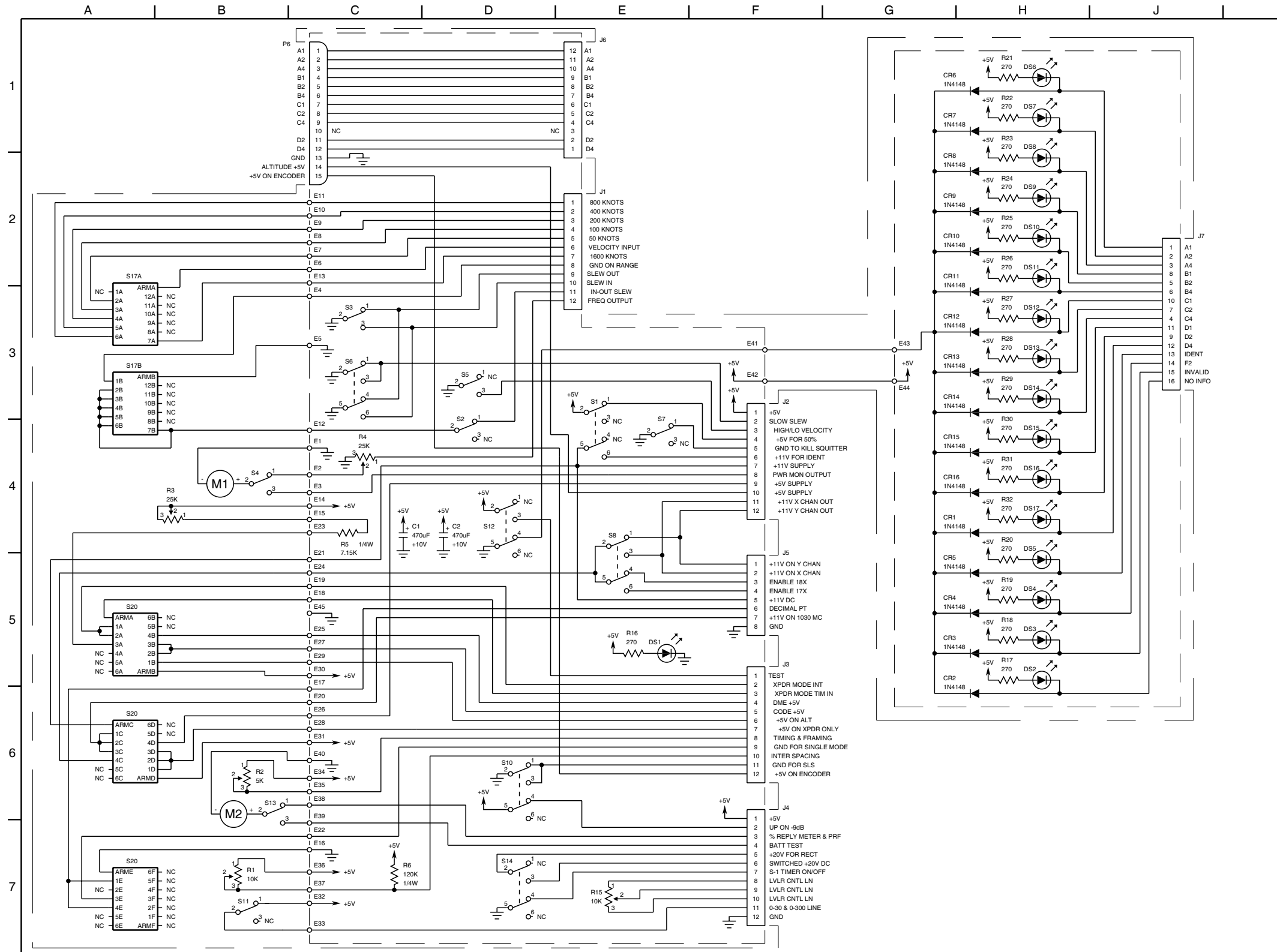

CAUTION:
CONTAINS PARTS AND ASSEMBLIES
SUSCEPTIBLE TO DAMAGE BY
ELECTROSTATIC DISCHARGE (ESD).

NOTES:
(UNLESS OTHERWISE SPECIFIED)

1. BASIC REFERENCE DESIGNATORS SHOWN, FOR COMPLETE DESIGNATOR PREFIXES REFER TO SYSTEM INTERCONNECT.
 2. ALL RESISTORS ARE 5%, 1/8 W.
 3. ALL RESISTANCE IS EXPRESSED IN OHMS. ALL CAPACITANCE IS EXPRESSED IN MICROFARADS. ALL INDUCTANCE IS EXPRESSED IN MICROHENRIES.
- * - INDICATES PRINTED TRANSMISSION LINES OF OTHER THAN 50 OHMS IMPEDANCE WHICH CONSTITUTE CIRCUIT ELEMENTS. 50 OHM TRANSMISSION LINES ARE NOT SHOWN.

Front Panel Interface PC Board Assembly Circuit Schematic
(0000-0835-600-A)

Front Panel Assembly (Sheet 8 of 8)
Figure 11

008M-002

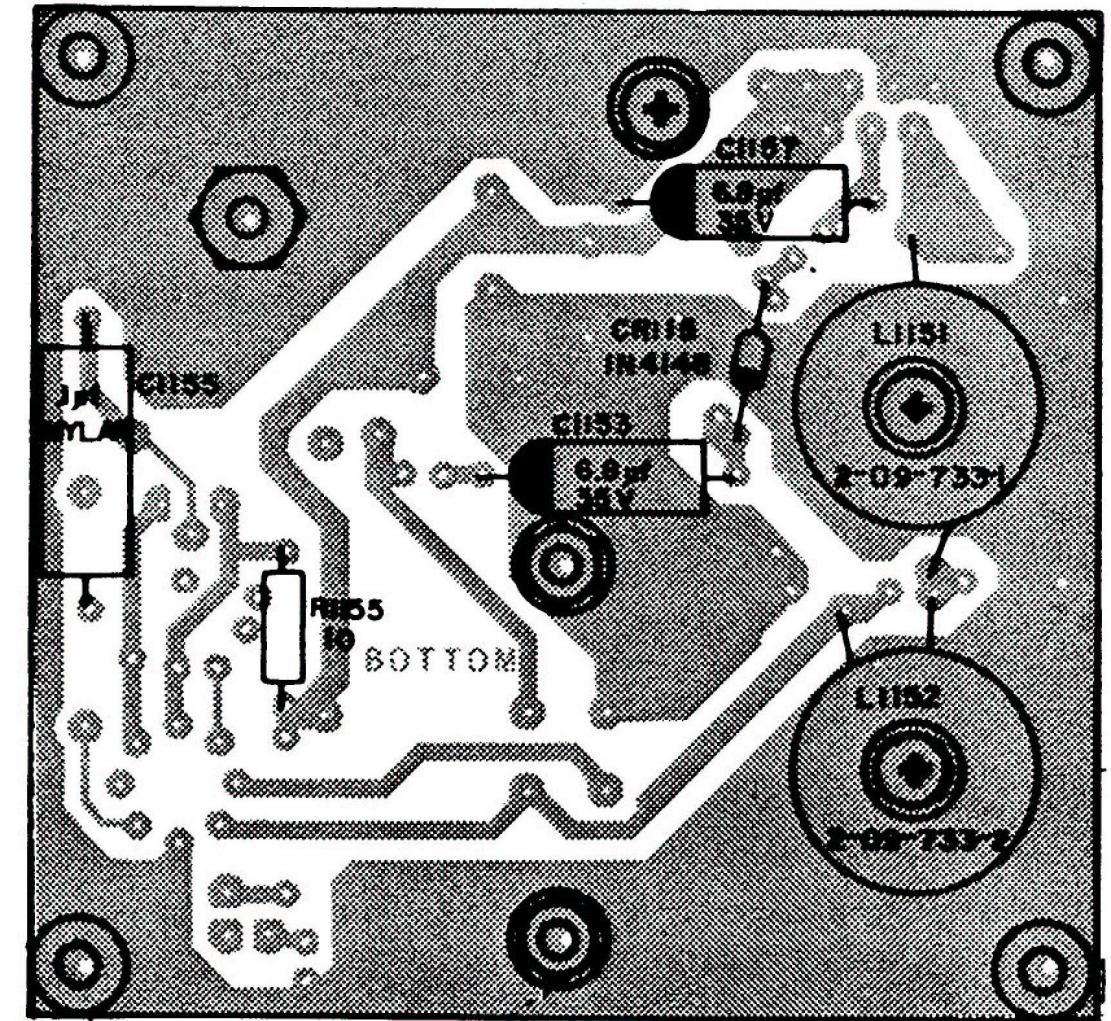
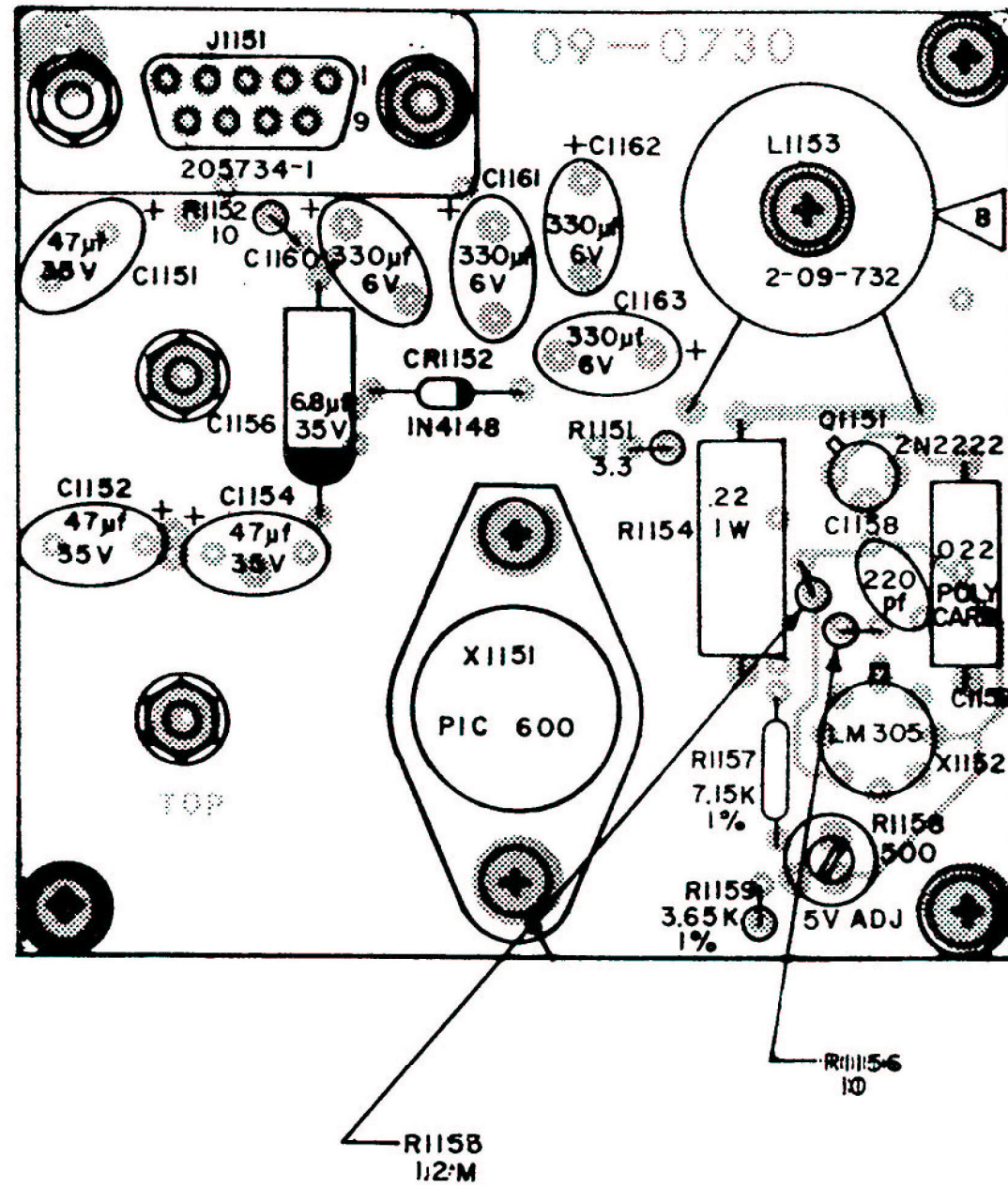

5 Volt Regulator PC Board Assembly
(7010-0938-900-B)

5 Volt Regulator PC Board Assembly
(Sheet 1 of 2)
Figure 12



CAUTION:
CONTAINS PARTS AND ASSEMBLIES
SUSCEPTIBLE TO DAMAGE BY
ELECTROSTATIC DISCHARGE (ESD).

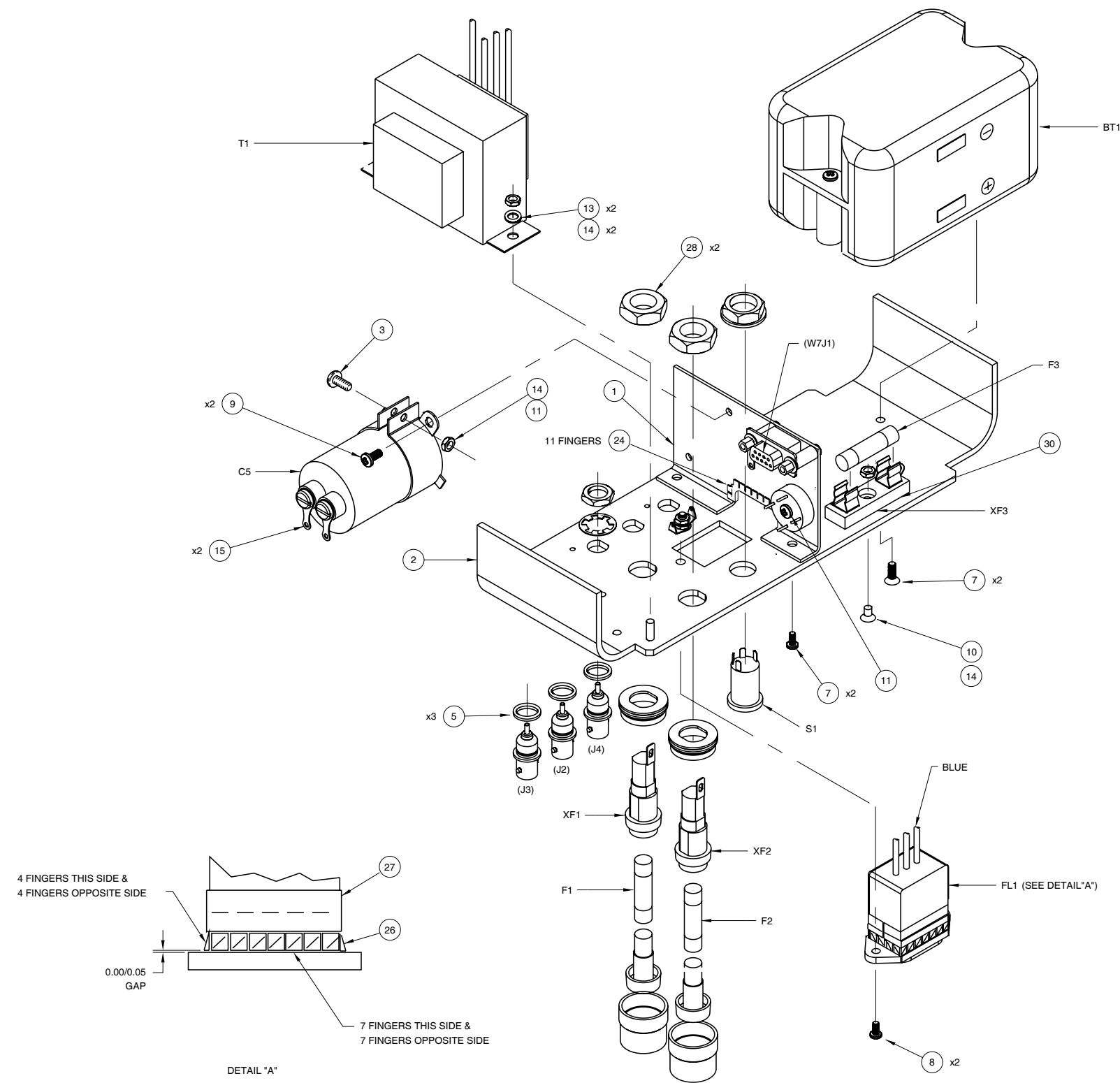

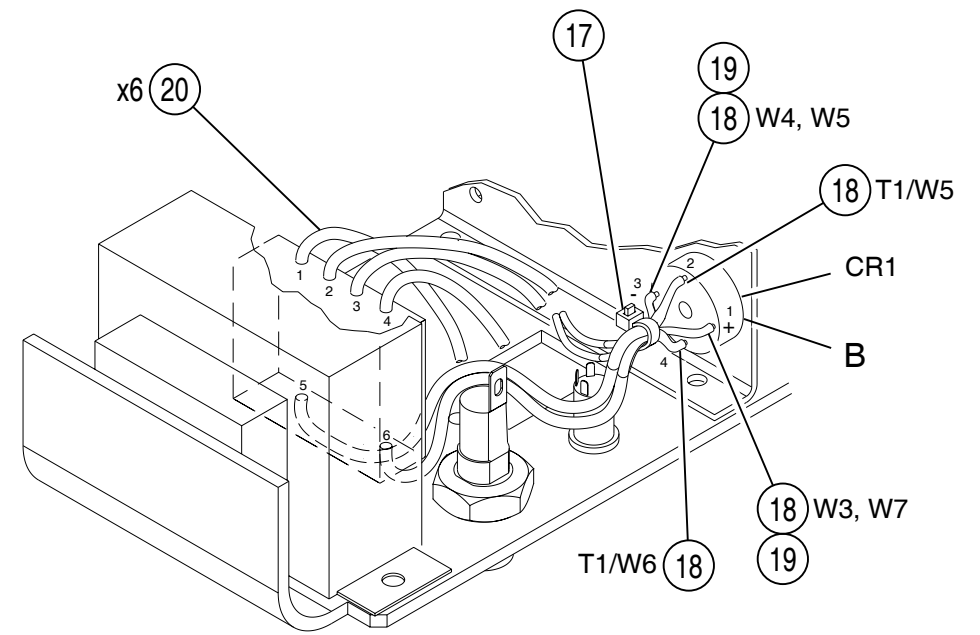
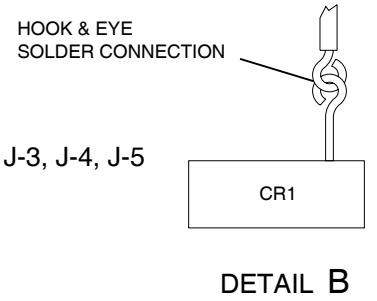
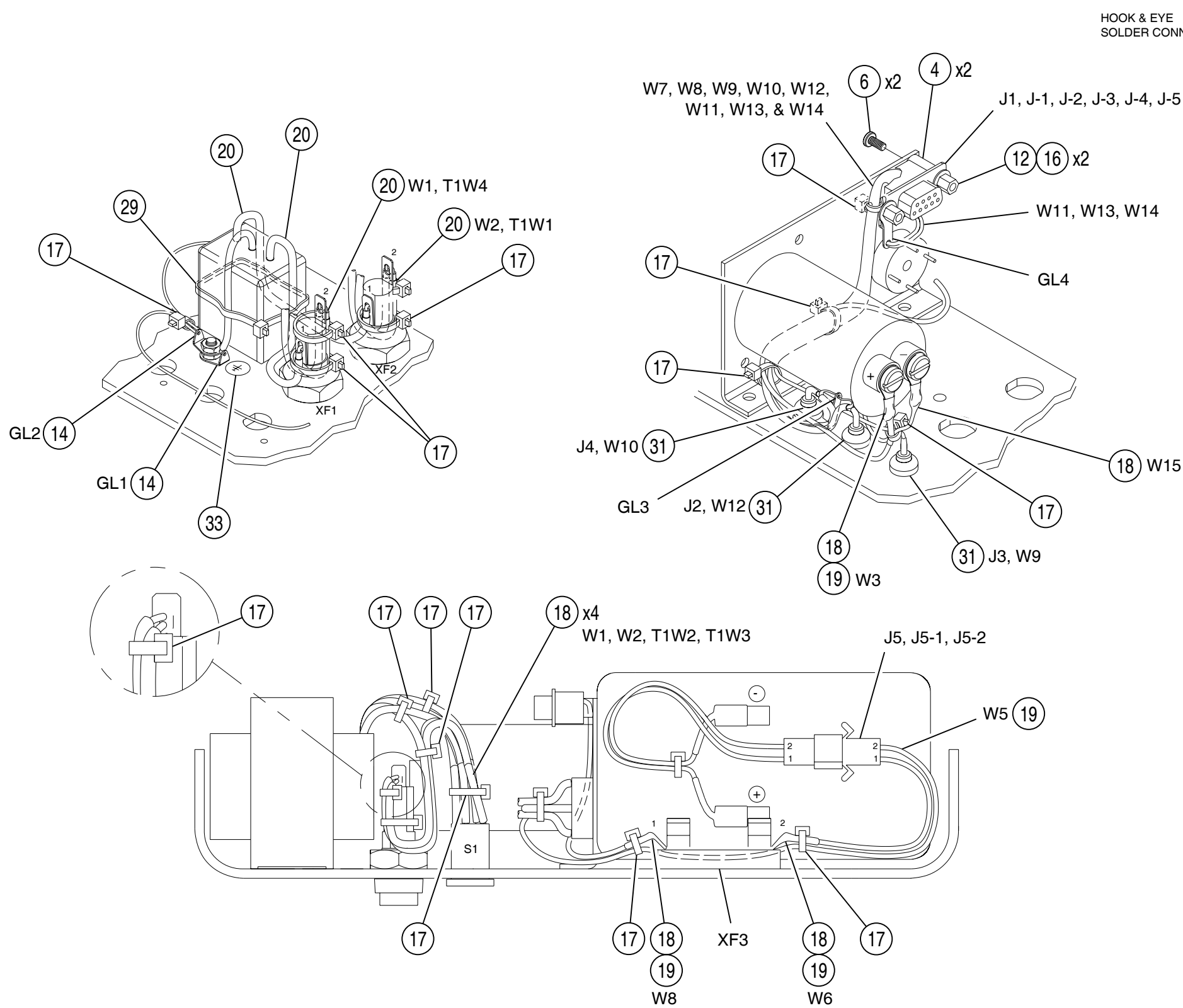

WIRE RUNNING LIST					LENGTH
DESIG	FROM	TO	COLOR	AWG	+/-0.25
	T1-4	XF2-2	BLU/WHT	18	3.90
	T1-3	S1-2	BLUE	18	3.40
	T1-2	S1-3	BLK/WHT	18	3.50
	T1-1	XF1-2	BLACK	18	4.10
	T1-5	CR1-2	GREEN	18	5.25
	T1-6	CR1-4	GREEN	18	4.50
	FL1	XF2-1	BLUE	18	4.40
	FL1	XF1-1	BROWN	18	3.40
	FL1	GL1	GRN/YEL	18	2.20
W1	XF1-2	S1-1	BROWN	18	4.60
W2	XF2-2	S1-4	BLUE	18	5.50
W3	CR1-1 (+)	C5 (+)	RED	22	7.00
W4	CR1-3 (-)	GL2	BLACK	22	3.70
W5	CR1-3 (-)	J5-2	BLACK	22	8.20
W6	XF3-2	J5-1	RED	22	3.00
W7	J1-1	CR1-1 (+)	RED	22	4.00
W8	J1-2	XF3-1	RED	22	3.50
W9	J1-3	J3	WHT/GRN	22	6.00
W10	J1-4	J4	COAX		6.50
W11	W10 GND	GL4	BLACK	22	2.00
W12	J1-5	J2	COAX		6.50
W13	W12 GND	GL4	BLACK	22	2.00
W14	J1-6	GL4	BLACK	22	1.50
W15	C5 (-)	GL2	BLACK	22	3.50

Power Supply Assembly (cont)
(7005-0845-300-F1)

Power Supply Assembly (Sheet 2 of 3)
Figure 13

00820017

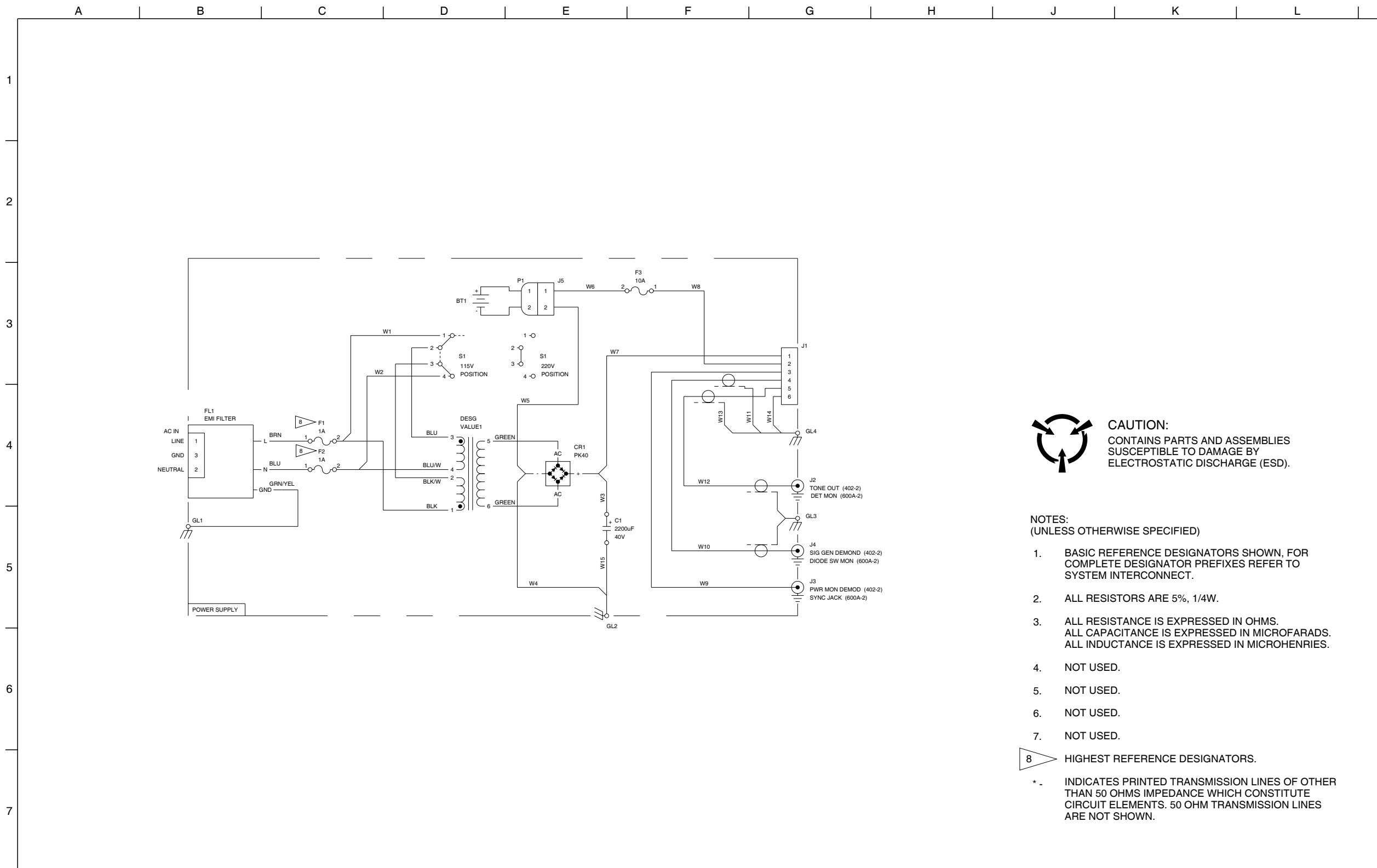

CAUTION:
CONTAINS PARTS AND ASSEMBLIES
SUSCEPTIBLE TO DAMAGE BY
ELECTROSTATIC DISCHARGE (ESD).

NOTES:
(UNLESS OTHERWISE SPECIFIED)

1. BASIC REFERENCE DESIGNATORS SHOWN. FOR COMPLETE DESIGNATOR PREFIXES REFER TO SYSTEM INTERCONNECT.
 2. ALL RESISTORS ARE 5%, 1/4W.
 3. ALL RESISTANCE IS EXPRESSED IN OHMS. ALL CAPACITANCE IS EXPRESSED IN MICROFARADS. ALL INDUCTANCE IS EXPRESSED IN MICROHENRIES.
 4. NOT USED.
 5. NOT USED.
 6. NOT USED.
 7. NOT USED.
8. HIGHEST REFERENCE DESIGNATORS.
- * - INDICATES PRINTED TRANSMISSION LINES OF OTHER THAN 50 OHMS IMPEDANCE WHICH CONSTITUTE CIRCUIT ELEMENTS. 50 OHM TRANSMISSION LINES ARE NOT SHOWN.

Power Supply Assembly Circuit Schematic
(0000-0845-300-B)

Power Supply Assembly (Sheet 3 of 3)
Figure 13

00818030

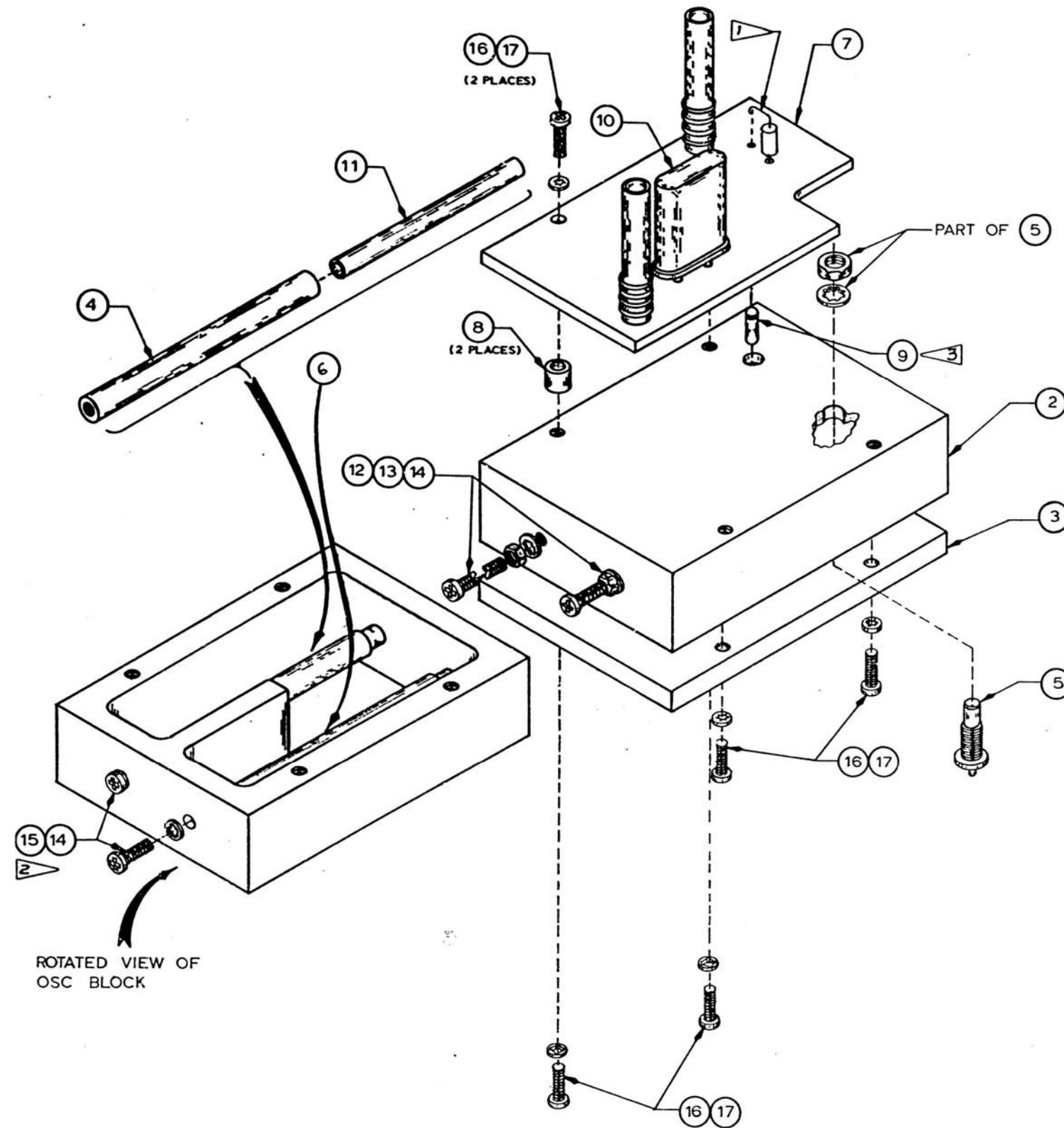

NOTES:

- 1. WHEN SOLDERING ITEM 9 TO R8, STAND R8 VERT TO PCB DD AND CUT LEADS OF ITEM 9 & R8 AS SHORT AS POSSIBLE.
- 2. TORQUE ITEM NO. 15 TO 6 IN. LB.
- 3. LEAD LENGTH BETWEEN ITEM NO. 9 (CRI) AND ITEM NO. 4 TO BE .050.

Oscillator Multiplier Assembly
(7048-0811-900-G2)

Oscillator Multiplier Assembly (Sheet 1 of 6)
Figure 14

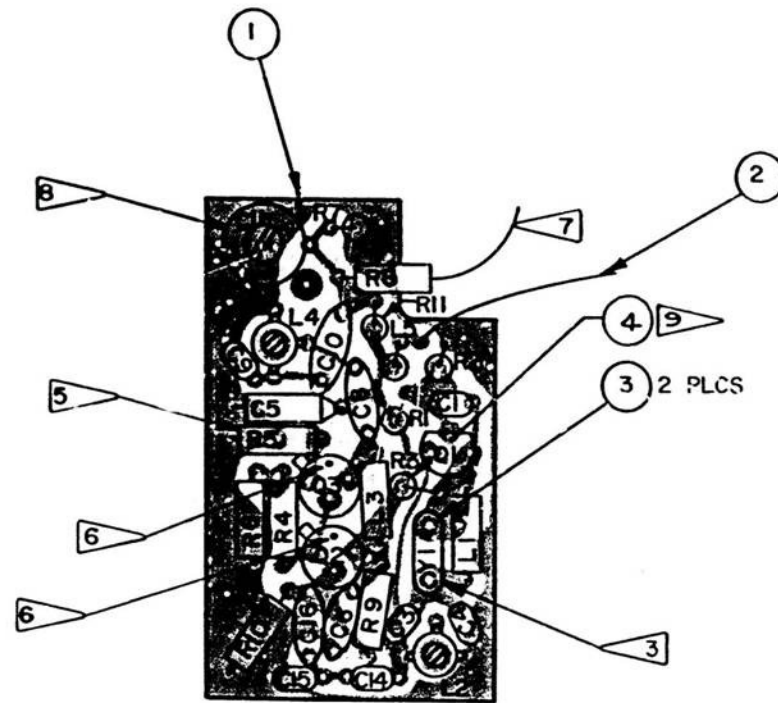

NOTES:

1. COMPONENT LEADS MAY EXTEND .04 TO .06 BEYOND BOTTOM OF BOARD AFTER SOLDERING.
2. MAXIMUM HEIGHT OF COMPONENTS TO BE .85.
3. FREQ DEPENDS UPON APPLICATION 97.8 MHz, 103.0 MHz, 106.55 MHz, 110.4 MHz.
4. SCHEMATIC C000-0812-200 AND 0000-0822-600
5. R5 IS SAT
RANGE: 68 Ω THRU 330 Ω
NOM. VALUE: 68 Ω
6. CUT LEG SHOWN, POSITION OF TAB IS CRITICAL.
7. R8 MUST LAY FLAT TO PC BD.
8. INSTALL CII WITH MARKED LEG TO GROUND.
9. TO PREVENT POSSIBLE SHORT, R3 TO BE INSTALLED WITH 226A SLEEVING

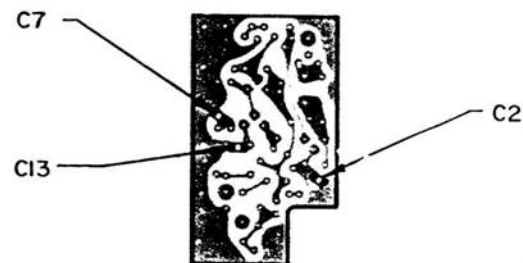

BOTTOM VIEW
SCALE 1:1

Oscillator Multiplier PC Board Assembly
(7010-0808-400-K8)

Oscillator Multiplier Assembly (Sheet 2 of 6)
Figure 14

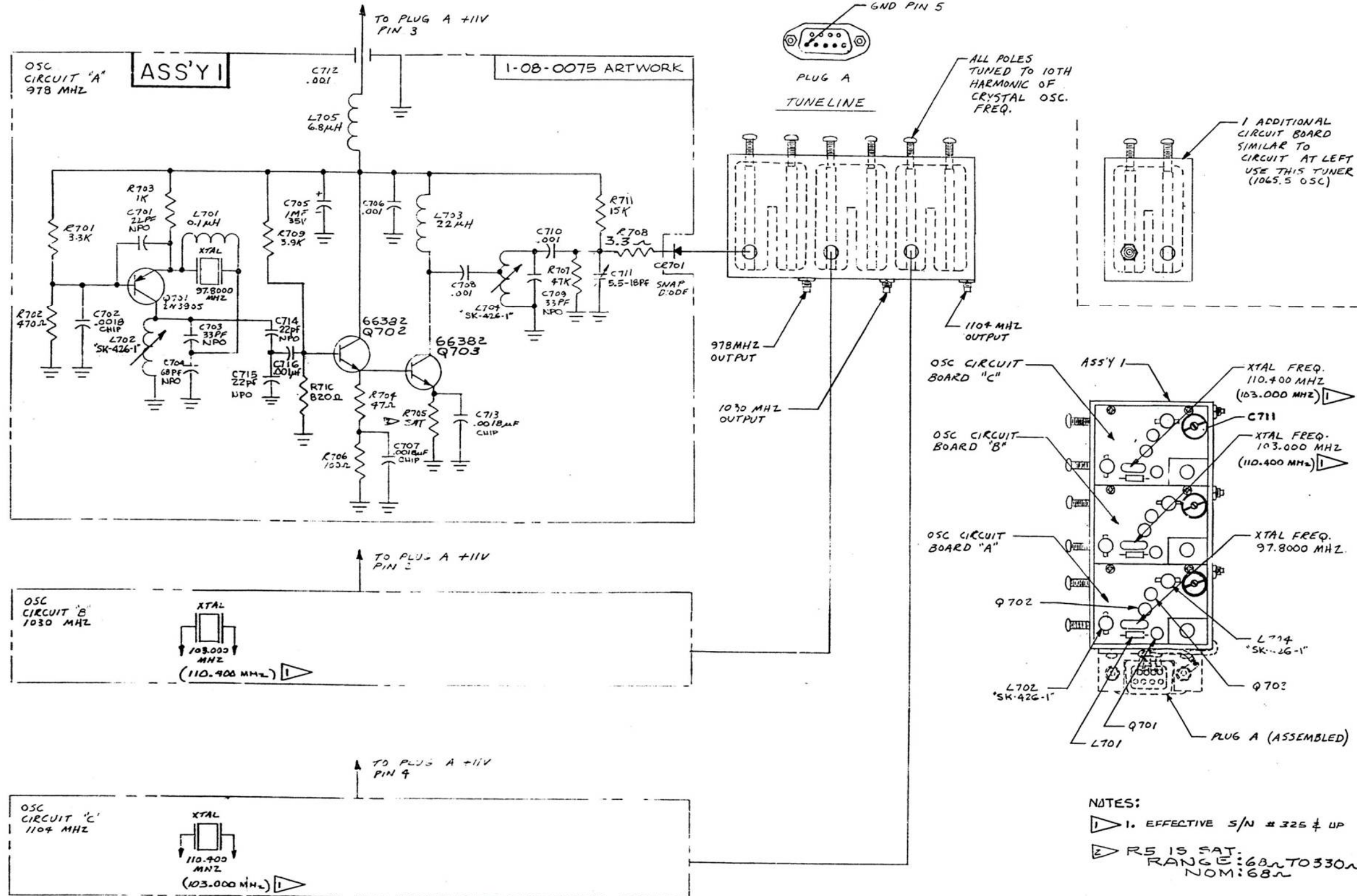

Oscillator Multiplier Assembly Circuit Schematic
(0000-0812-100-G3)

Oscillator Multiplier Assembly (Sheet 3 of 6)
Figure 14

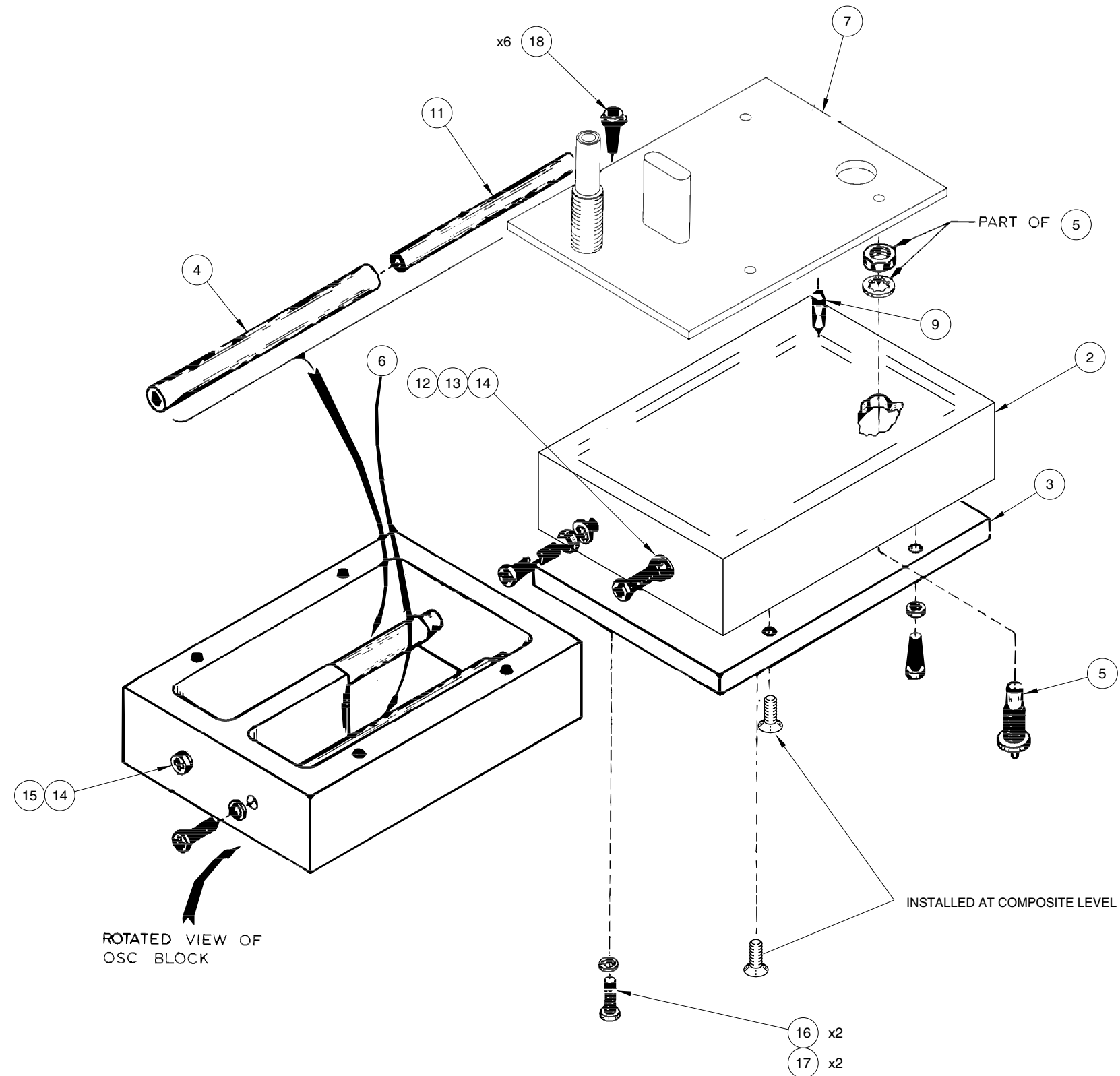

Oscillator Multiplier Assembly
(7048-0811-900-H)

Oscillator Multiplier Assembly (Sheet 4 of 6)
Figure 14

008M-013



CAUTION:

CONTAINS PARTS AND ASSEMBLIES
SUSCEPTIBLE TO DAMAGE BY
ELECTROSTATIC DISCHARGE (ESD).

NOTES:
(UNLESS OTHERWISE SPECIFIED)

1. BASIC REFERENCE DESIGNATORS SHOWN, FOR COMPLETE DESIGNATOR PREFIXES REFER TO PRODUCT STRUCTURE AND SYSTEM INTERCONNECT FOR APPLICATIONS WHERE USED.
2. ALL RESISTORS ARE 1%, 1/8W.
3. ALL RESISTANCE IS EXPRESSED IN OHMS. ALL CAPACITANCE IS EXPRESSED IN MICROFARADS. ALL INDUCTANCE IS EXPRESSED IN MICROHENRIES.
- *- INDICATES PRINTED TRANSMISSION LINES OF OTHER THAN 50 OHMS IMPEDANCE WHICH CONSTITUTE CIRCUIT ELEMENTS. 50 OHM TRANSMISSION LINES ARE NOT SHOWN.

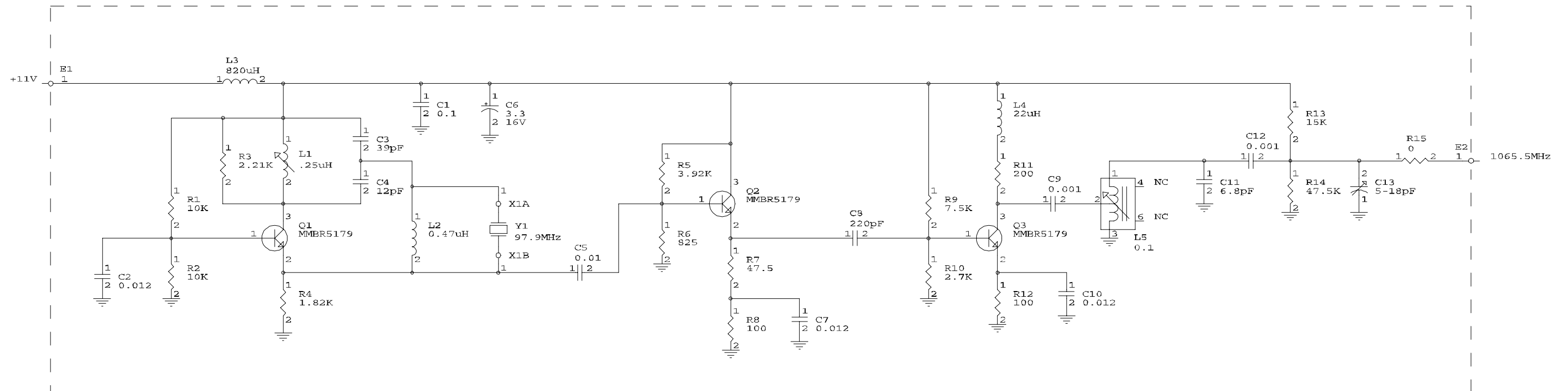

Oscillator Multiplier PC Board Assembly Circuit Schematic
(0000-0834-700-B)

Oscillator Multiplier Assembly (Sheet 6 of 6)
Figure 14

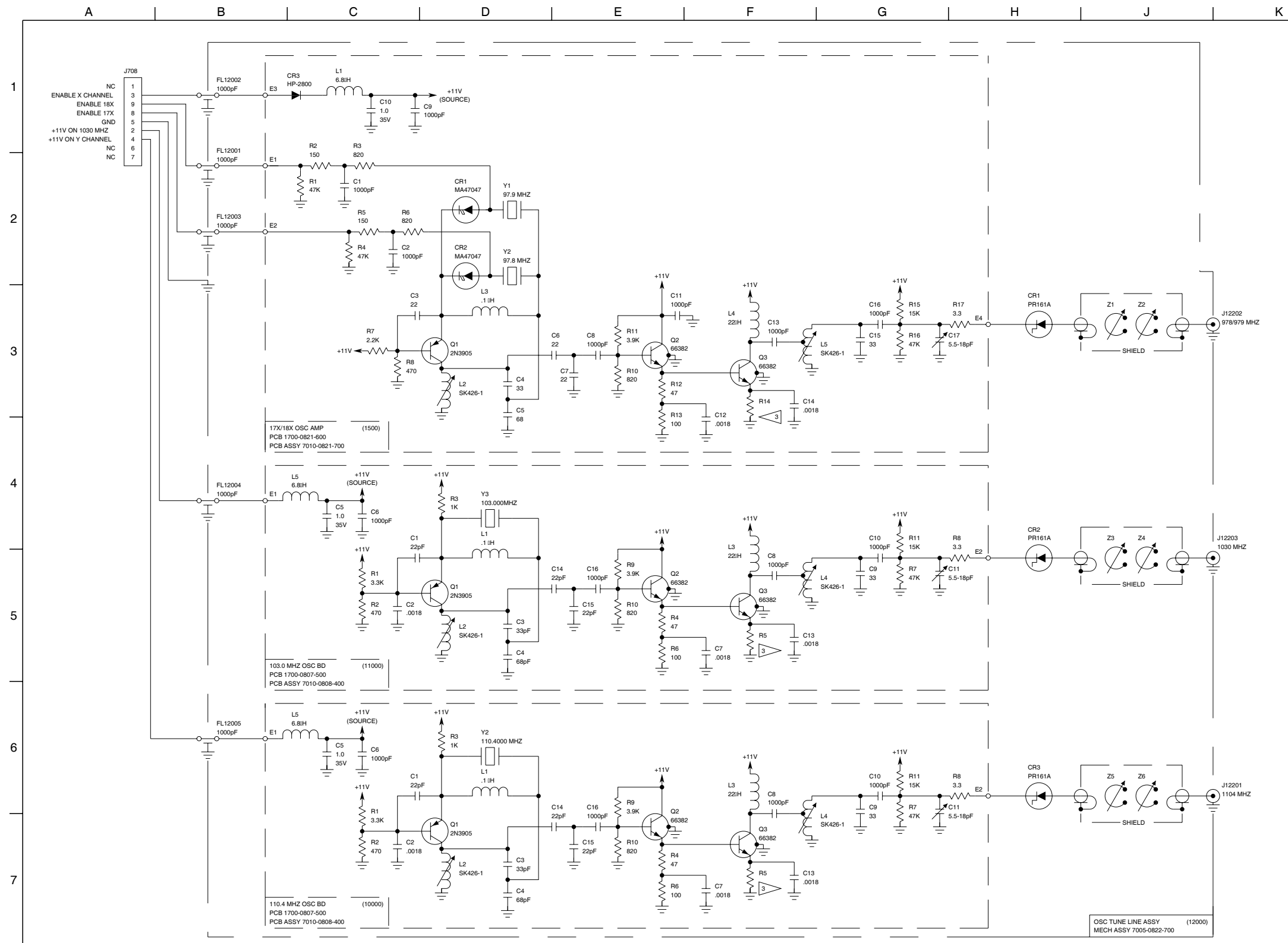

CAUTION:
CONTAINS PARTS AND ASSEMBLIES
SUSCEPTIBLE TO DAMAGE BY
ELECTROSTATIC DISCHARGE (ESD).

NOTES:
(UNLESS OTHERWISE NOTED)

- ALL REFERENCE NUMBERS CARRY AN ASSIGNED DESIGNATOR SERIES.
7005-0822-700 SERIES 12000 (OSC TUNE LINE ASSY)
7010-0808-400 SERIES 10000 (110.4 MHZ OSC)
7010-0808-400 SERIES 11000 (103.0 MHZ OSC)
7010-0821-700 SERIES 1500 (97.8/97.9 MHZ OSC)

- ALL RESISTORS ARE 1/4 W, 5% TOLERANCE.

3 R5 AND R14 ARE SELECT AT TEST.
NOMINAL VALUE IS 68 OHMS.
RANGE IS 68-330 OHMS.

- ALL RESISTANCE IS EXPRESSED IN OHMS.

- ALL CAPACITANCE IS EXPRESSED IN MICROFARADS.

Oscillator Tuneline Assembly Circuit Schematic
(0000-0822-600-B4)

Oscillator Tuneline Assembly (Sheet 2 of 8)
Figure 15

00818010

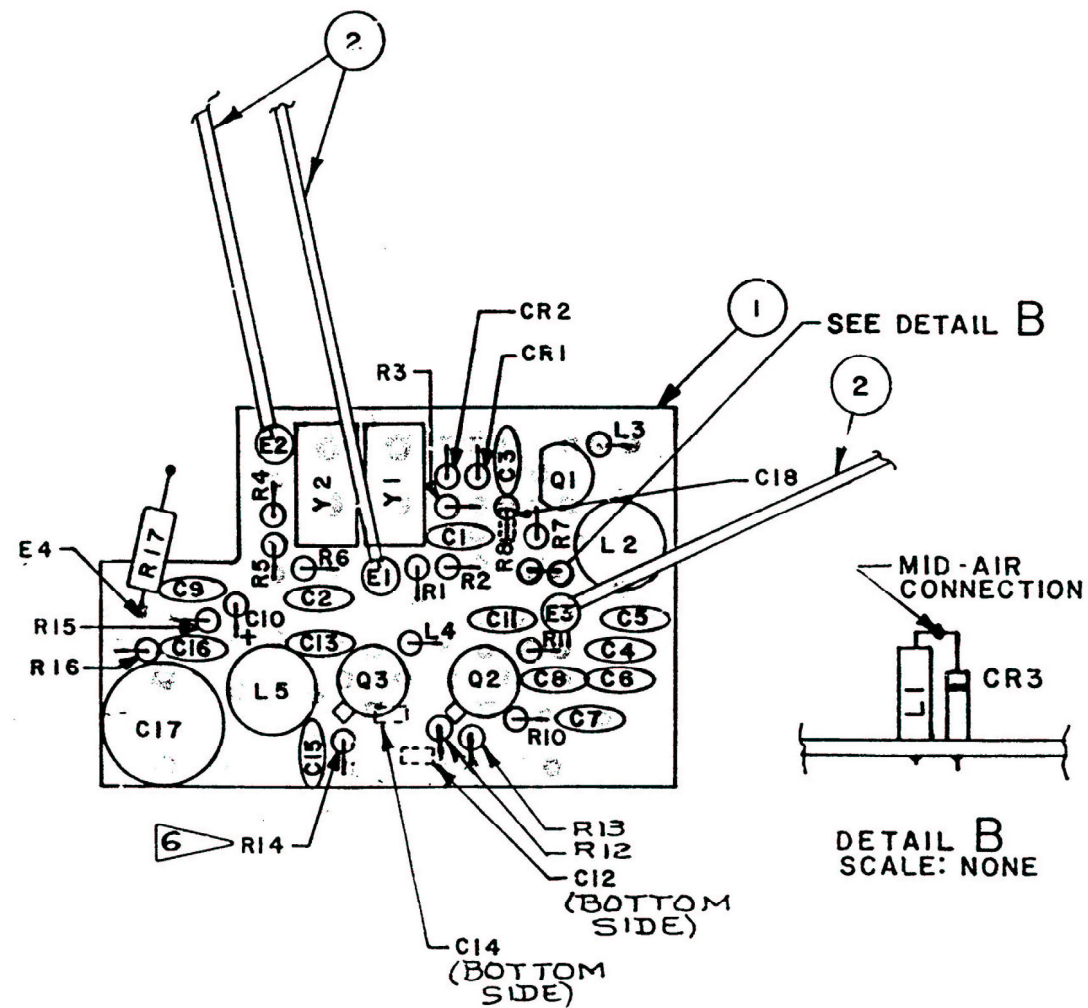

NOTES:

1. REF CIRCUIT SCHEMATIC 0000-0821-500 & 0000-0822-600
 2. ALL REF NO'S ARE 1500 SERIES. (I.E. R1 IS R1501)
 3. MOUNT CR1 AND CR2 AS SHOWN IN DETAIL A
 4. MOUNT C12, C14 & C18 ON BOTTOM SIDE OF BOARD.
5. PATHWORK AND GROUND PLANE ARE OMITTED FOR CLARITY. WHERE NO OTHER TERMINATION IS PROVIDED, COMPONENTS TERMINATE ON GROUND PLANE.
6. R14 IS SAT:
RANGE: 68Ω THRU 330 OHM
NOMINAL: 68Ω

7010-0821-700 (08-217-00) SHOWN.



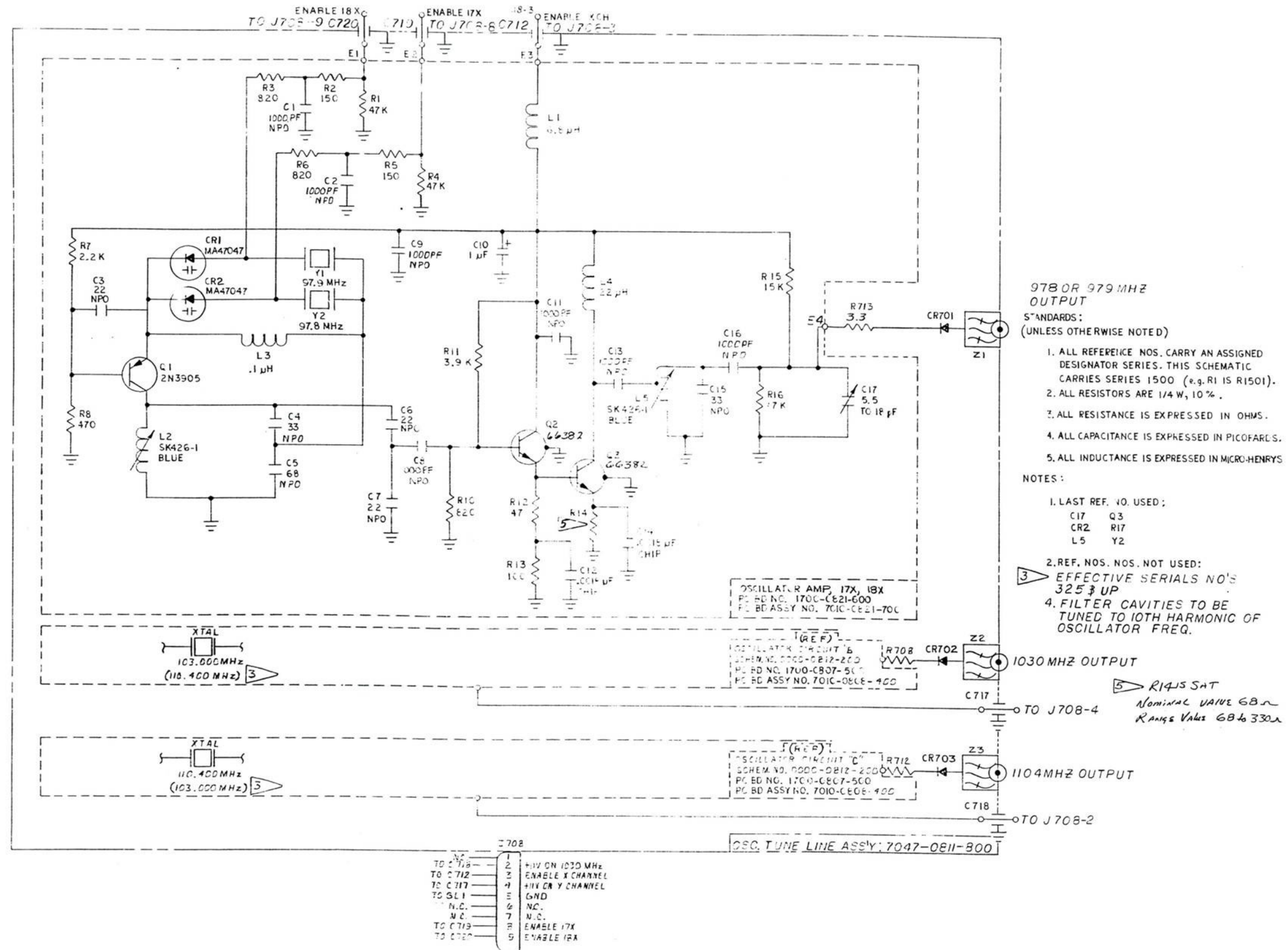

17X/18X Oscillator Amplifier PC Board Assembly Circuit Schematic
(0000-0821-500-A3)

Oscillator Tuneline Assembly (Sheet 4 of 8)
Figure 15

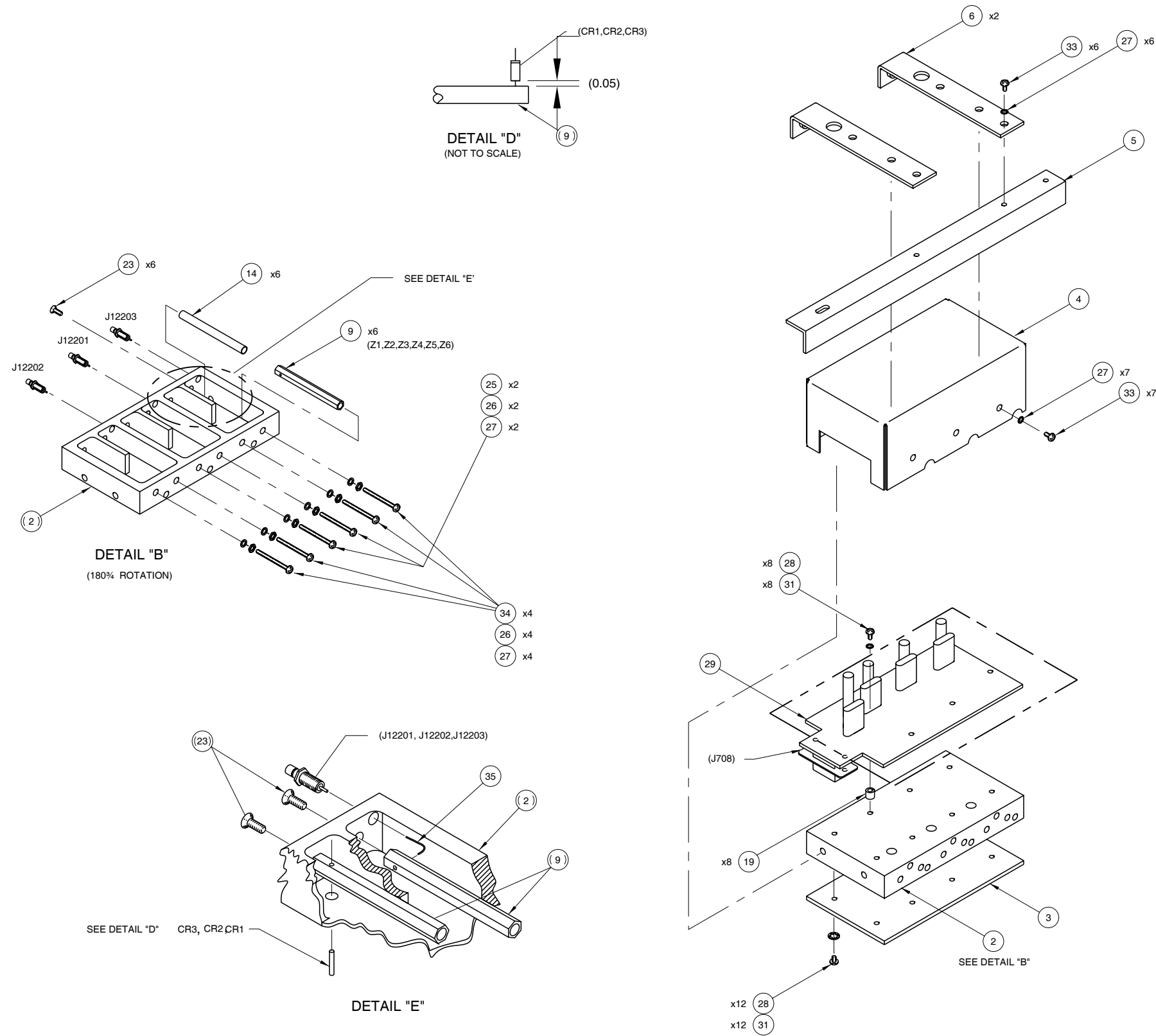

Oscillator Tuneline Assembly
(7005-0846-700-B)

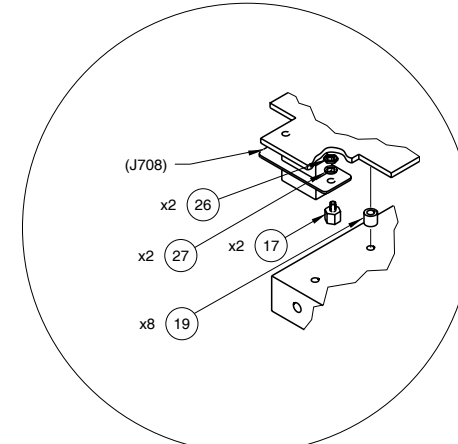
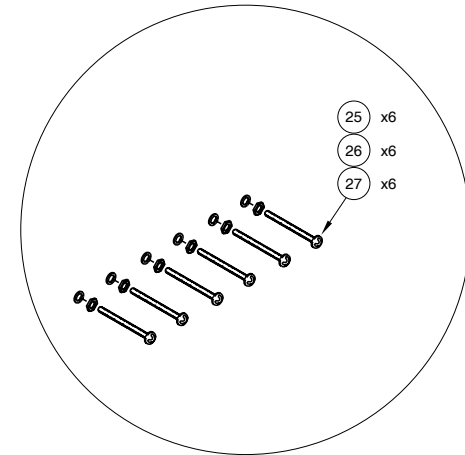

(REV A)

Oscillator Tuneline Assembly (Sheet 5 of 8)
Figure 15

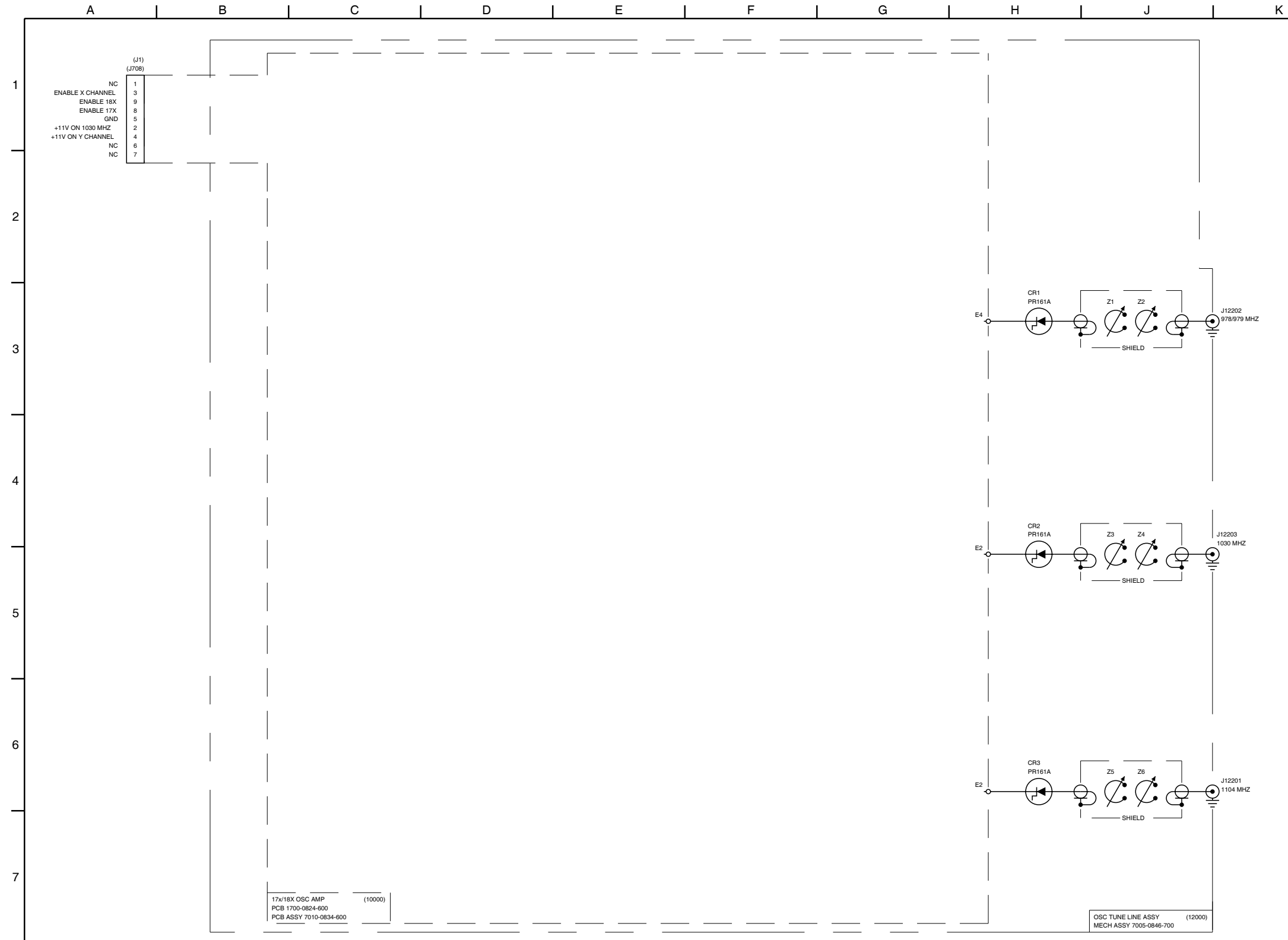

CAUTION:
CONTAINS PARTS AND ASSEMBLIES
SUSCEPTIBLE TO DAMAGE BY
ELECTROSTATIC DISCHARGE (ESD).

NOTES:
(UNLESS OTHERWISE NOTED)

1. ALL REFERENCE DESIGNATORS CARRY AN ASSIGNED DESIGNATOR SERIES.
7005-0846-700 SERIES 12000 (OSC TUNELINE ASSY)
2. ALL RESISTORS ARE 1/4 W, 5% TOLERANCE.
3. ALL RESISTANCE IS EXPRESSED IN OHMS.
4. ALL CAPACITANCE IS EXPRESSED IN MICROFARADS.

Oscillator Tuneline Assembly Circuit Schematic
(0000-0846-700-A)

Oscillator Tuneline Assembly (Sheet 6 of 8)
Figure 15

008M-006



CAUTION:
CONTAINS PARTS AND ASSEMBLIES
SUSCEPTIBLE TO DAMAGE BY
ELECTROSTATIC DISCHARGE (ESD).

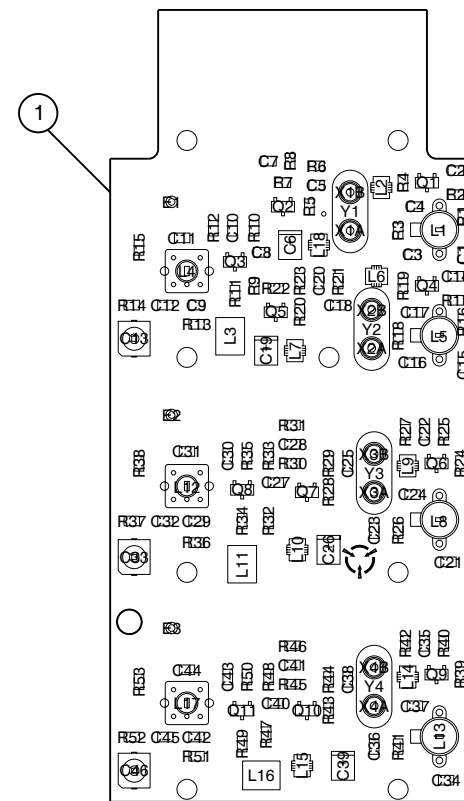

(TOP)

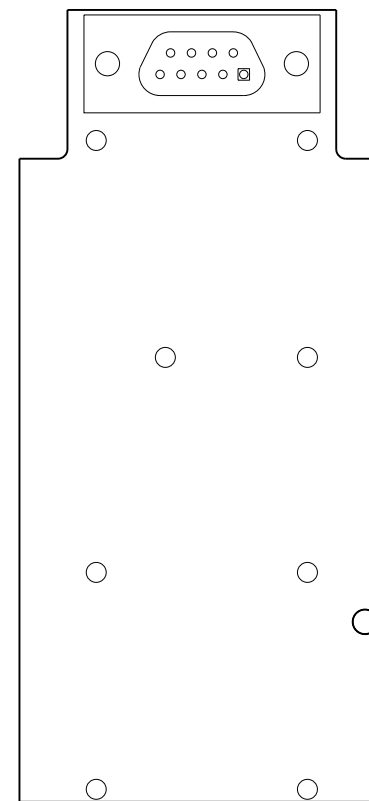

(BOTTOM)

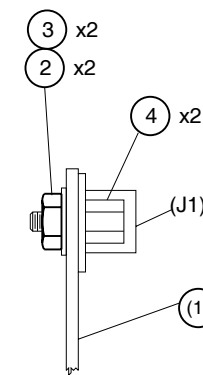

17X/18X Oscillator Amplifier PC Board Assembly
(7010-0834-600-B1)

Oscillator Tuneline Assembly (Sheet 7 of 8)
Figure 15



CAUTION:
CONTAINS PARTS AND ASSEMBLIES
SUSCEPTIBLE TO DAMAGE BY
ELECTROSTATIC DISCHARGE (ESD).

NOTES
(UNLESS OTHERWISE SPECIFIED)

1. BASIC REFERENCE DESIGNATORS SHOWN. FOR COMPLETE DESIGNATOR PREFIXES REFER TO PRODUCT STRUCTURE AND SYSTEM INTERCONNECT FOR APPLICATIONS WHERE USED.
2. ALL RESISTORS ARE 1%, 1/8W.
3. ALL RESISTANCE IS EXPRESSED IN OHMS. ALL CAPACITANCE IS EXPRESSED IN MICROFARADS. ALL INDUCTANCE IS EXPRESSED IN MICROHENRIES.
4. * INDICATES PRINTED TRANSMISSION LINES OF OTHER THAN 50 OHMS IMPEDANCE WHICH CONSTITUTE CIRCUIT ELEMENTS. 50 OHM TRANSMISSION LINES ARE NOT SHOWN.

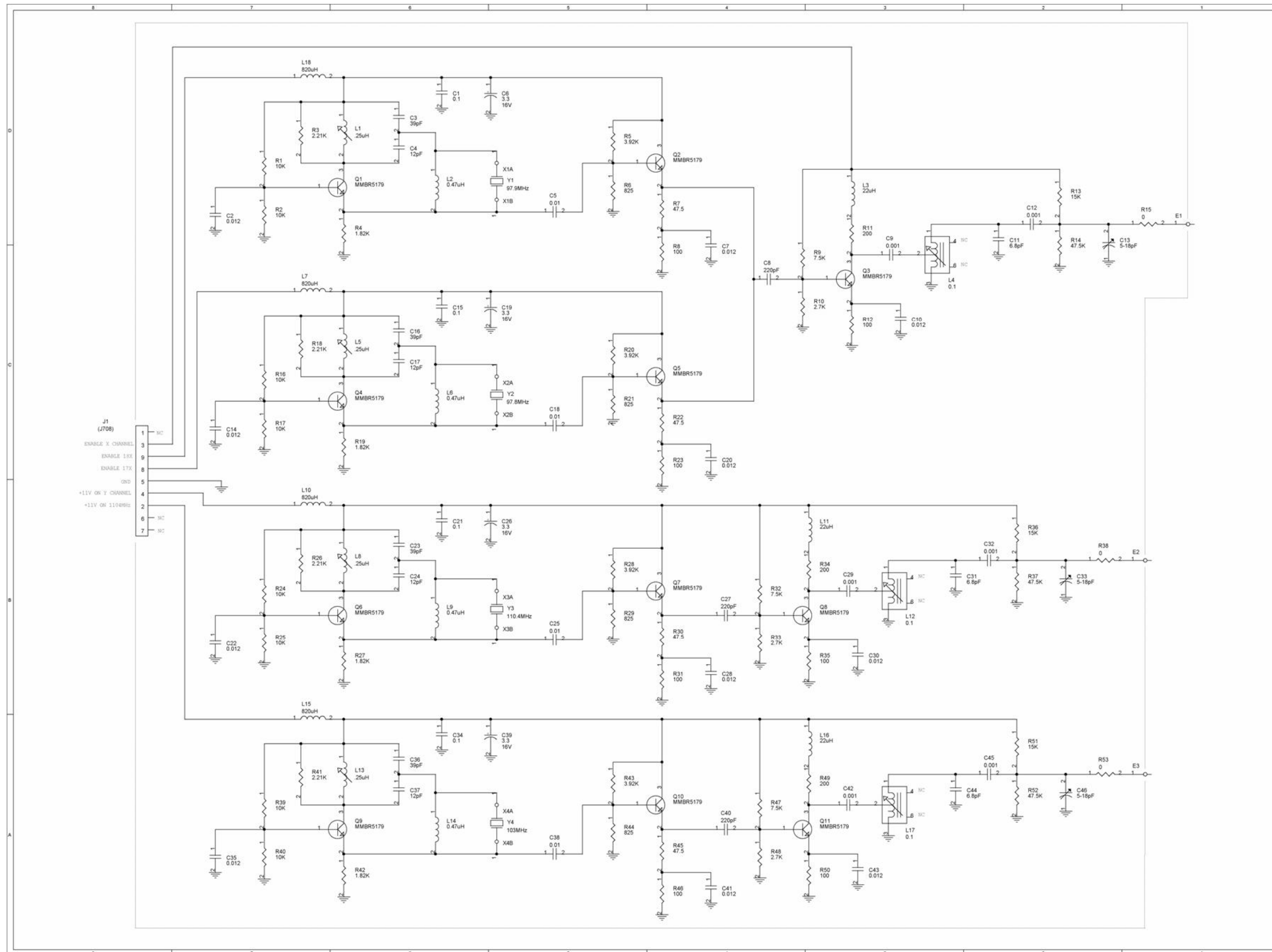

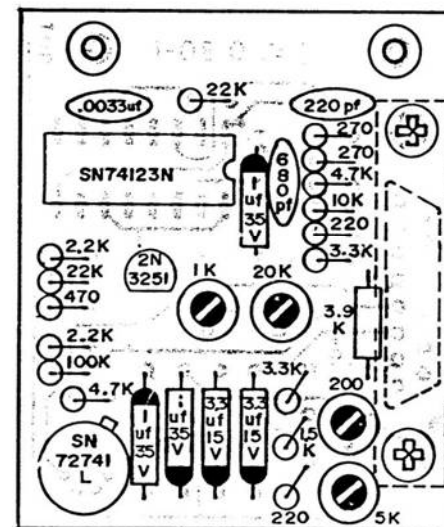
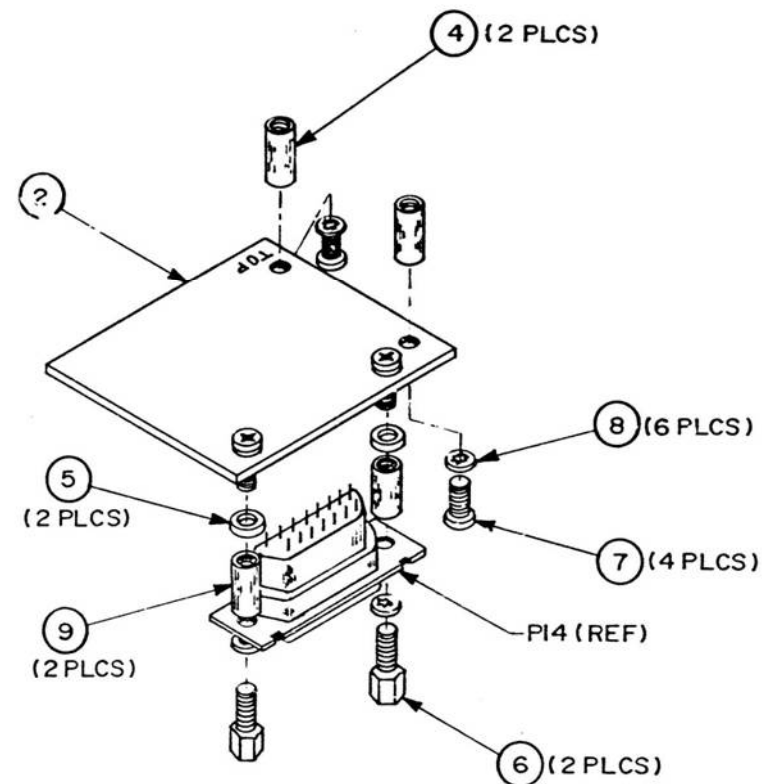
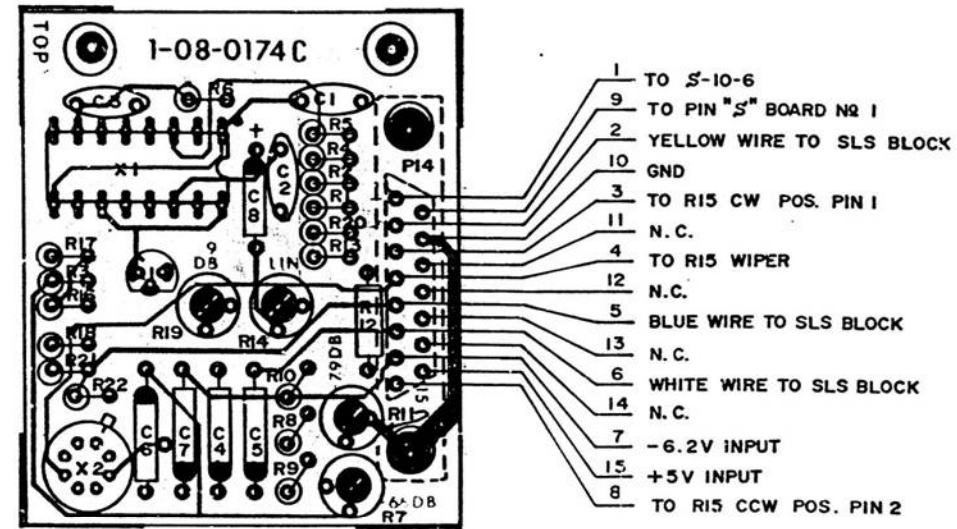

NOTES:

1. REF. SCHEMATIC: 0000-0817-500
2. CONN. TO EXTEND .75 MAX. BELOW BOARD.
3. COMPONENT LEADS MAY EXTEND .04 TO .06 BEYOND BOTTOM OF BD. AFTER SOLDERING.
4. MAX. HEIGHT OF COMPONENTS TO BE .35 FROM COMPONENT SIDE OF BD.

SLS and RF Leveler PC Board Assembly
(7010-0818-200-K5)

SLS and RF Leveler PC Board Assembly
(Sheet 1 of 2)
Figure 16

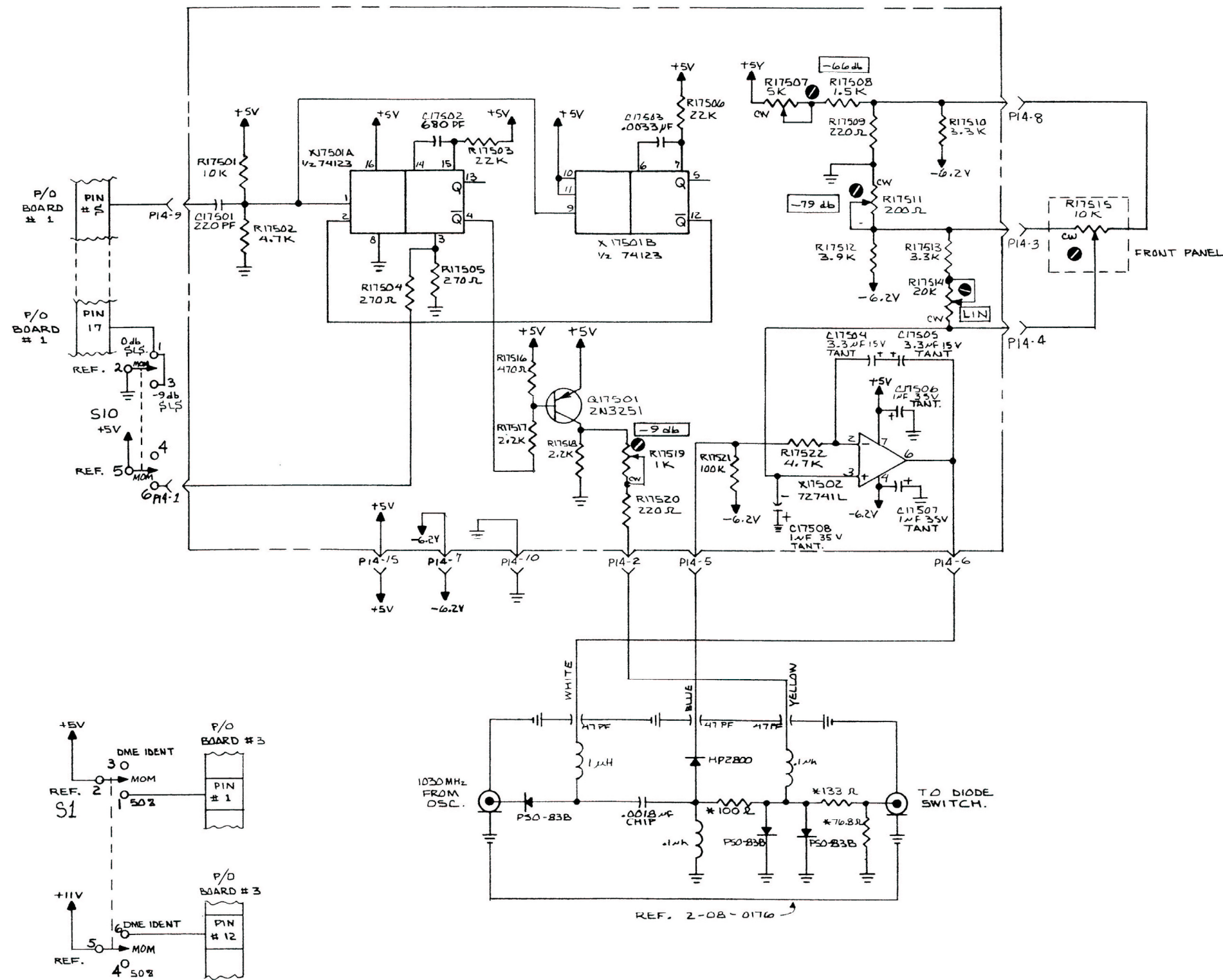

SLS and RF Leveler PC Board Assembly Circuit Schematic
(0000-0817-500-E)

SLS and RF Leveler PC Board Assembly
(Sheet 2 of 2)
Figure 16

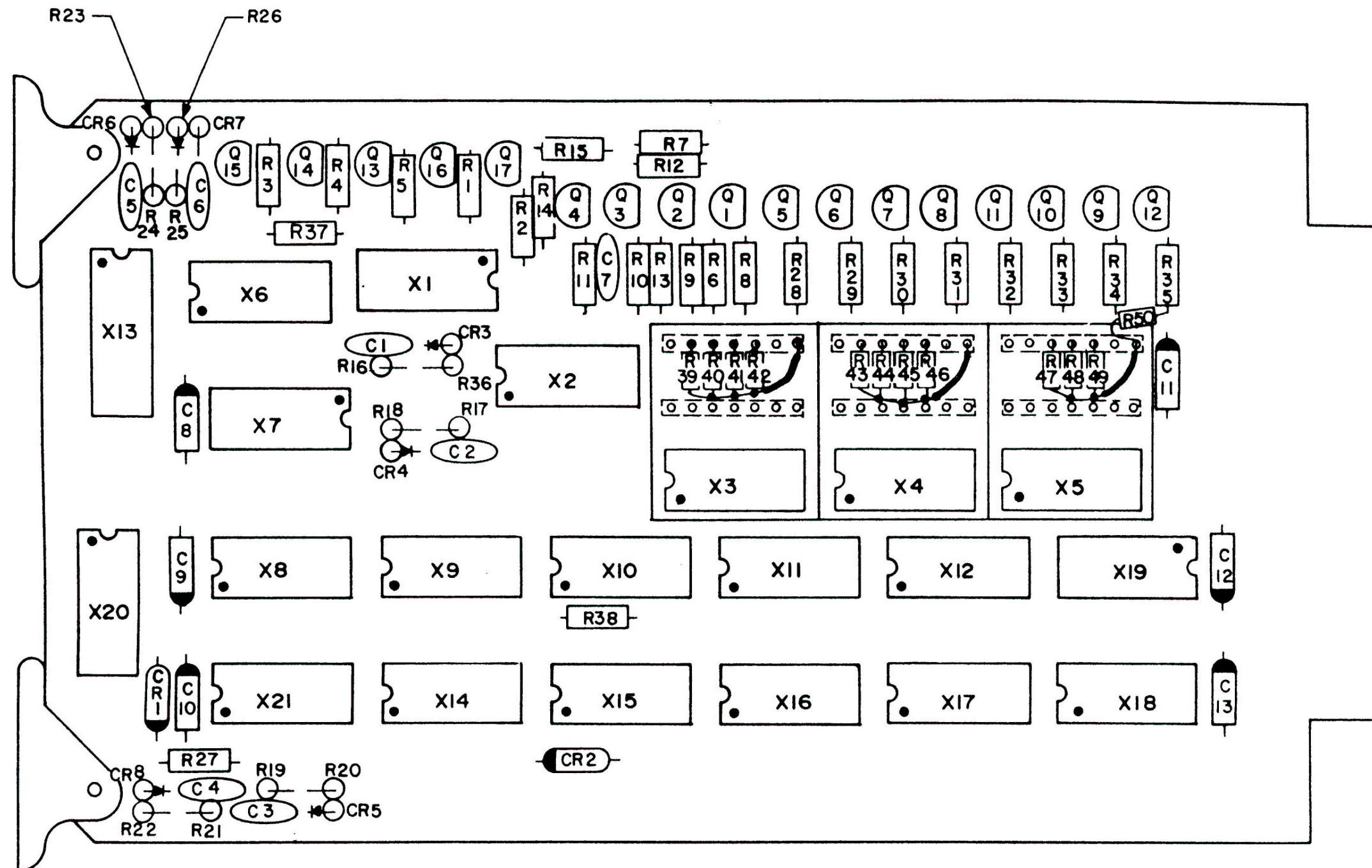

Altitude Register and Comparator PC Board Assembly
(7010-0803-600-L)

Altitude Register and Comparator PC Board
Assembly (Sheet 1 of 4)
Figure 17

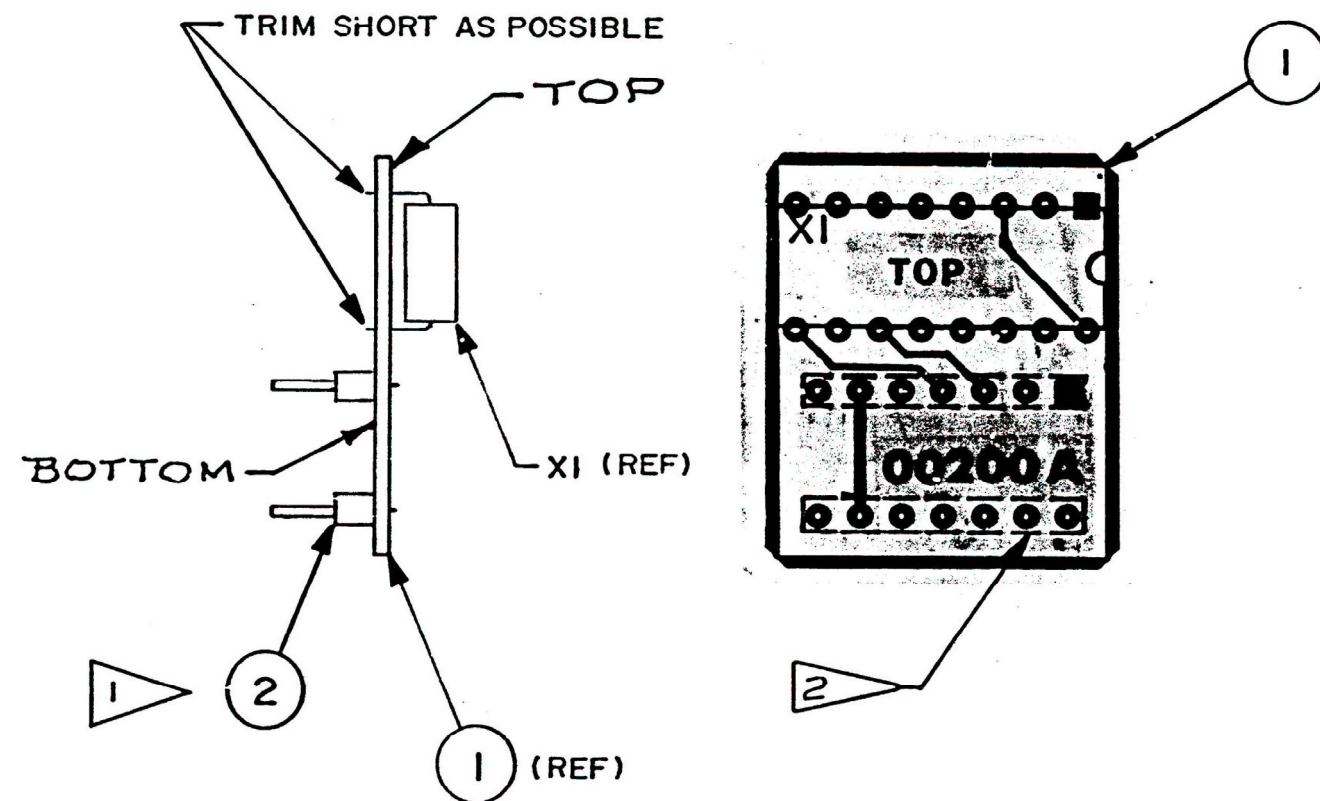

NOTE:

- 1 DIVIDE ITEM 2 INTO TWO PARTS OF 7 PINS EACH & INSTALL AS SHOWN.
- 2 DO NOT TRIM LEADS OF CONNECTOR

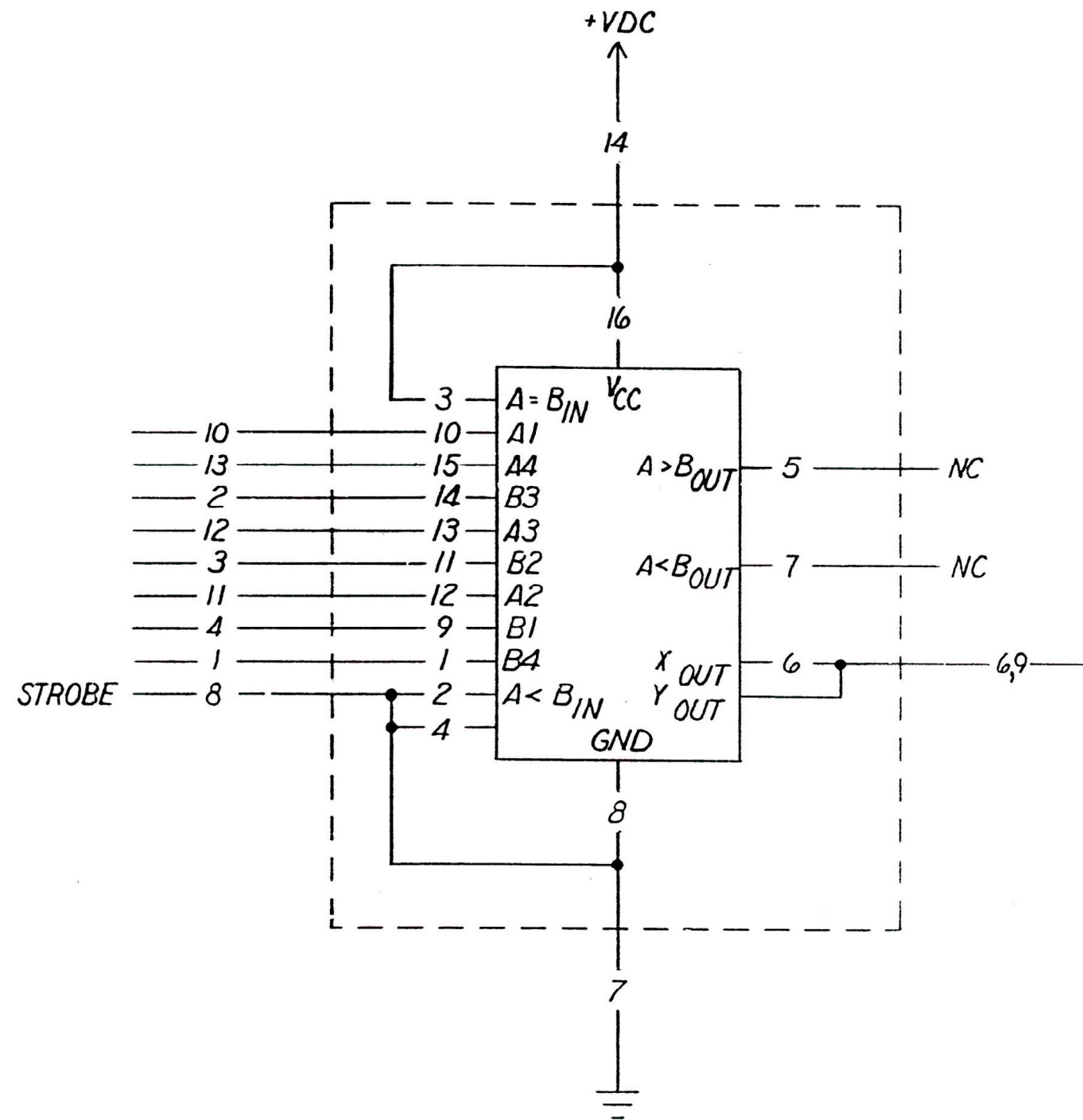

NOTE:

FOR PIN N^o's SHOWN INSIDE DASHED LINE,
REFER TO IC PIN N^o's.
FOR PIN N^o's SHOWN OUTSIDE DASHED LINE,
REFER TO ADAPTER B_D PIN N^o's.

DM8200 to 74LS85 PC Board Assembly Circuit Schematic
(0000-0010-000-A)

Altitude Register and Comparator PC Board
Assembly (Sheet 4 of 4)
Figure 17

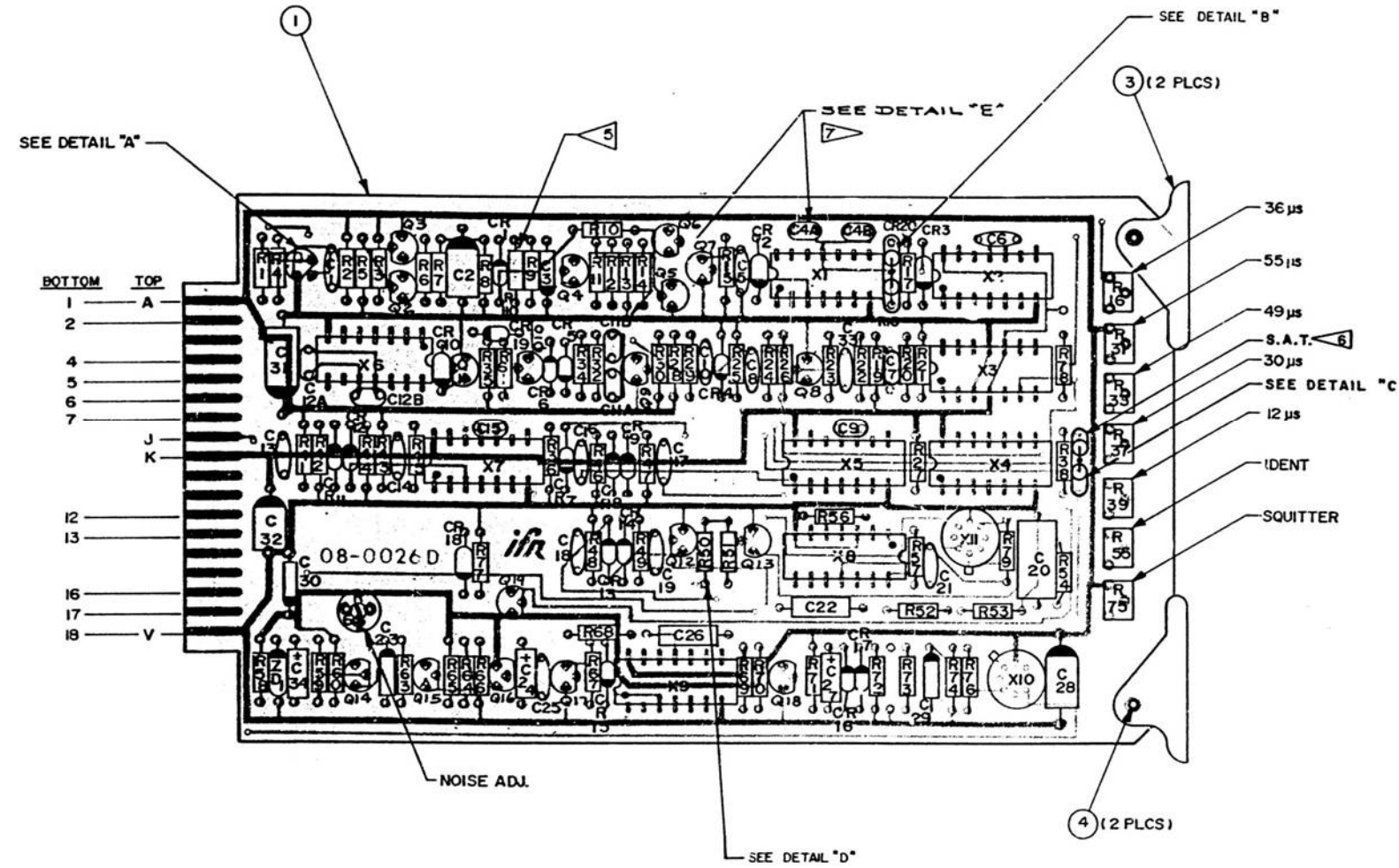

NOTES:

1. ALL REFERENCE DESIGNATORS CARRY AN ASSIGNED DESIGNATOR SERIES. THIS DWG CARRIES SERIES 300, EXCEPT AS NOTED (e.i. R1 IS R301).
2. REF SCHEMATIC: 0000-0804-700
REF PC BD: 1700-0802-600
3. COMPONENT LEADS MAY EXTEND .04 TO .06 BEYOND BOTTOM OF B; AFTER SOLDERING.
4. MAXIMUM HEIGHT OF COMPONENTS TO BE .35 FROM COMPONENT SIDE OF BD.
5. R110 CARRIES REF DES SERIES 100.
6. R340 IS SELECTED AT TEST (S.A.T.)
NOMINAL VALUE: 25.5 K
RANGE: 23.2K-28.0K
7. CRIMP LEADS ON C304A & B, C311A & B, SO CAPACITOR BODY DOES NOT CONTACT PC BOARD.

EDGE CONNECTOR CHART			
PIN NO	FUNCTION	PIN NO	FUNCTION
1	+5v FOR 50%	A	+11v SUPPLY
2	FROM RANGE BD	B	NOT USED
3	NOT USED	C	NOT USED
4	VIDEO INPUT	D	NOT USED
5	+11V FOR X CHANNEL DECODER	E	NOT USED
6	-6.2v SUPPLY	F	NOT USED
7	DECODER VIDEO OUT	H	NOT USED
8	NOT USED	J	PULSES OUT
9	NOT USED	K	+5v SUPPLY
10	NOT USED	L	NOT USED
11	NOT USED	M	NOT USED
12	+11v FOR IDENT	N	NOT USED
13	+11v FOR Y CHANNEL OUTPUT	P	NOT USED
14	NOT USED	R	NOT USED
15	NOT USED	S	NOT USED
16	+11V FOR X CHANNEL OUTPUT	T	NOT USED
17	GND TO KILL SQUITTER	U	NOT USED
18	-6.2v SUPPLY	V	GND

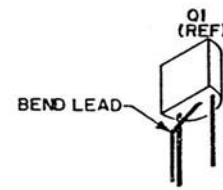

DETAIL "A"



DETAIL "E"
SCALE - NONE



DETAIL "B"



DETAIL "C"

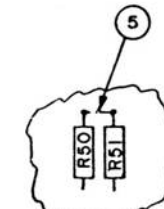

DETAIL "D"

DME Signal PC Board Assembly
(7010-0804-700-D)

DME Signal PC Board Assembly (Sheet 1 of 2)
Figure 18

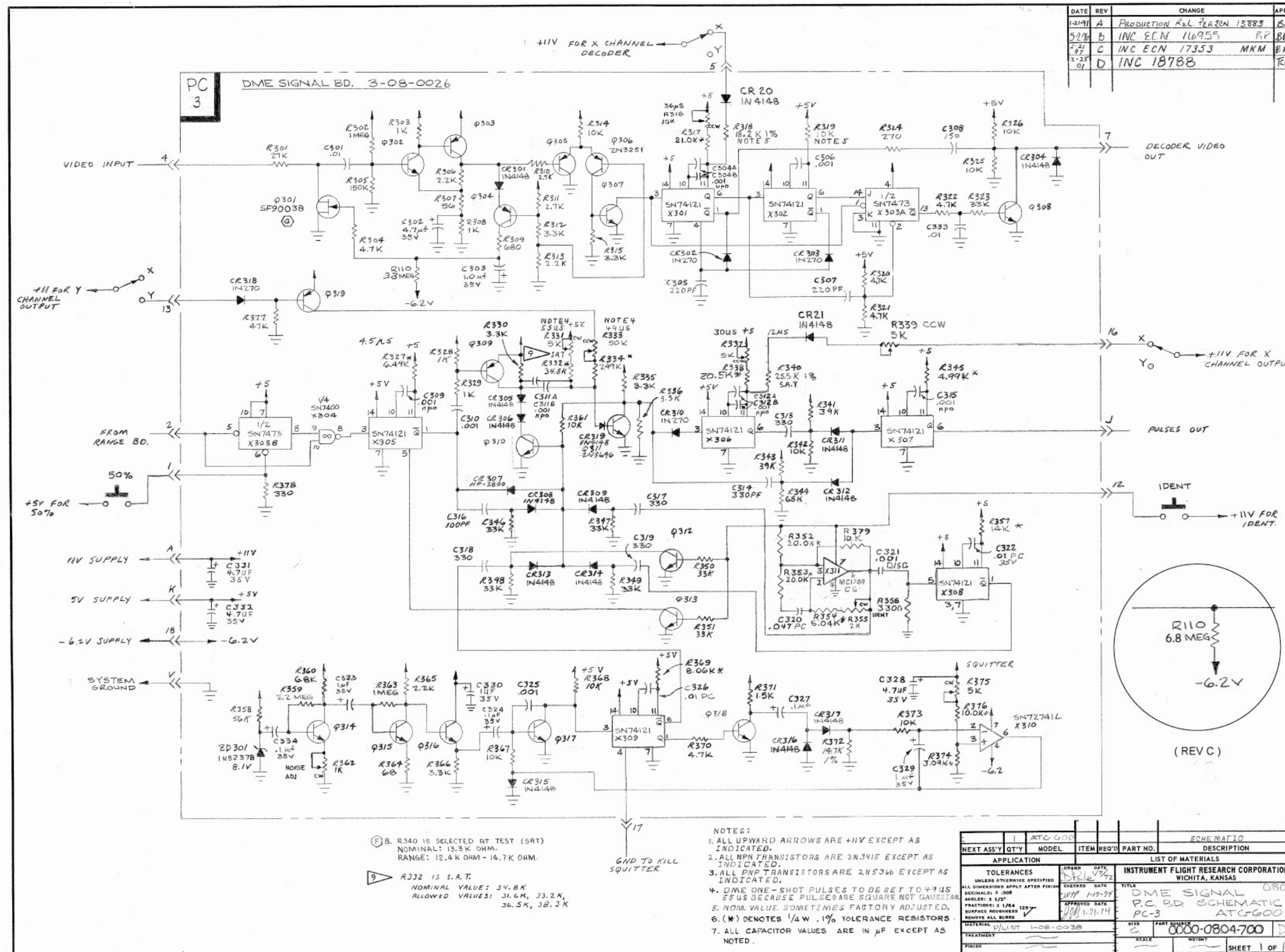

DME Signal PC Board Assembly Circuit Schematic
(0000-0804-700-D)

DME Signal PC Board Assembly (Sheet 2 of 2)
Figure 18

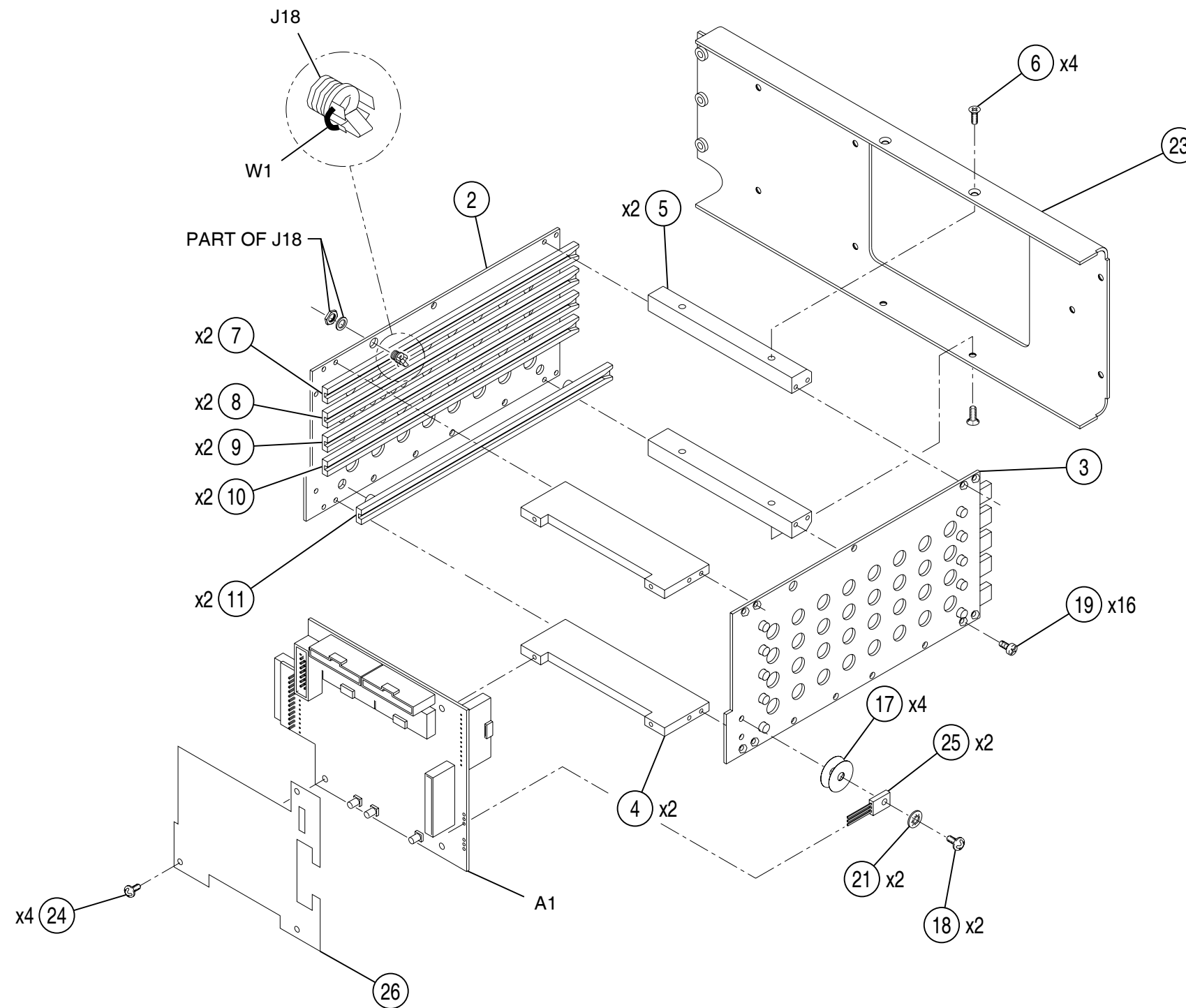

CAUTION:
CONTAINS PARTS AND ASSEMBLIES
SUSCEPTIBLE TO DAMAGE BY
ELECTROSTATIC DISCHARGE (ESD).

NOTES:

1. BASIC REFERENCE DESIGNATORS SHOWN. FOR COMPLETE DESIGNATOR PREFIXES REFER TO SYSTEM INTERCONNECT.

PC Cardcage Assembly
(7005-0846-400-B)

PC Cardcage Assembly (Sheet 1 of 3)
Figure 19

00820020



CAUTION:
CONTAINS PARTS AND ASSEMBLIES
SUSCEPTIBLE TO DAMAGE BY
ELECTROSTATIC DISCHARGE (ESD).

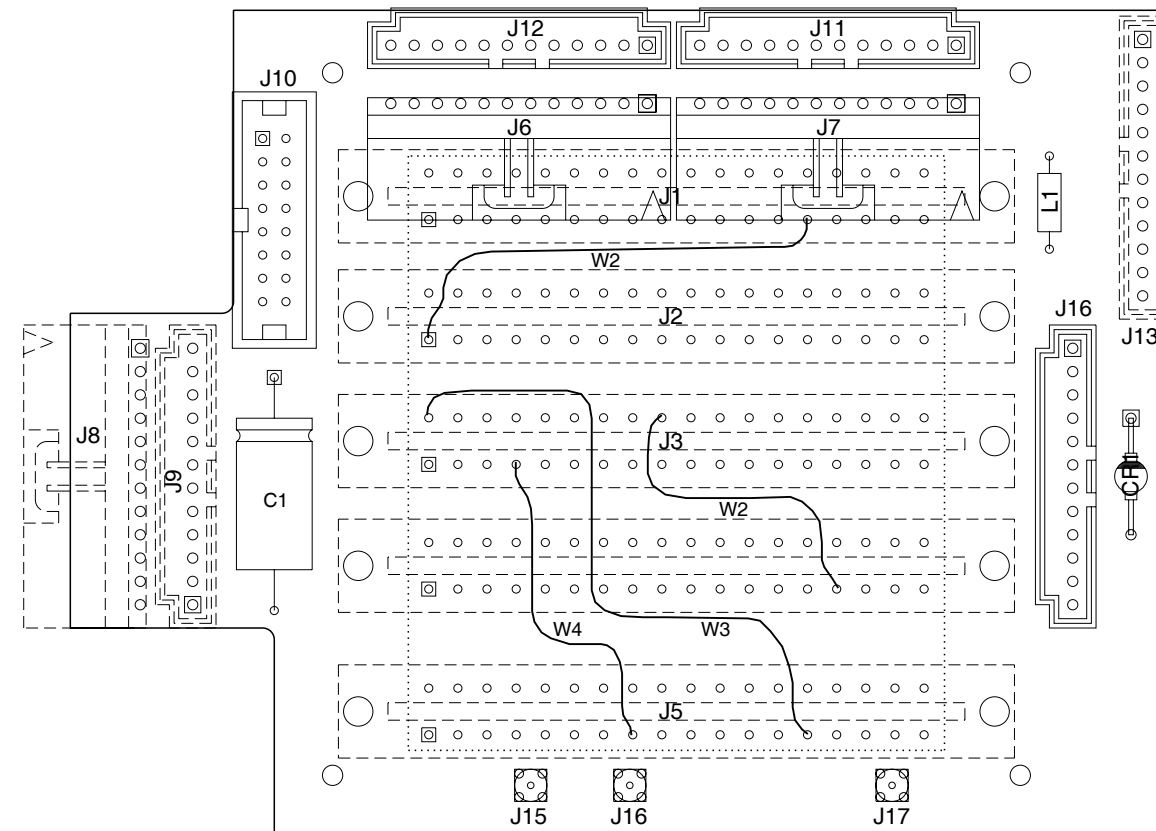

Motherboard PC Board Assembly
(7010-0834-400-C1)

PC Cardcage Assembly (Sheet 2 of 3)
Figure 19

008M-010

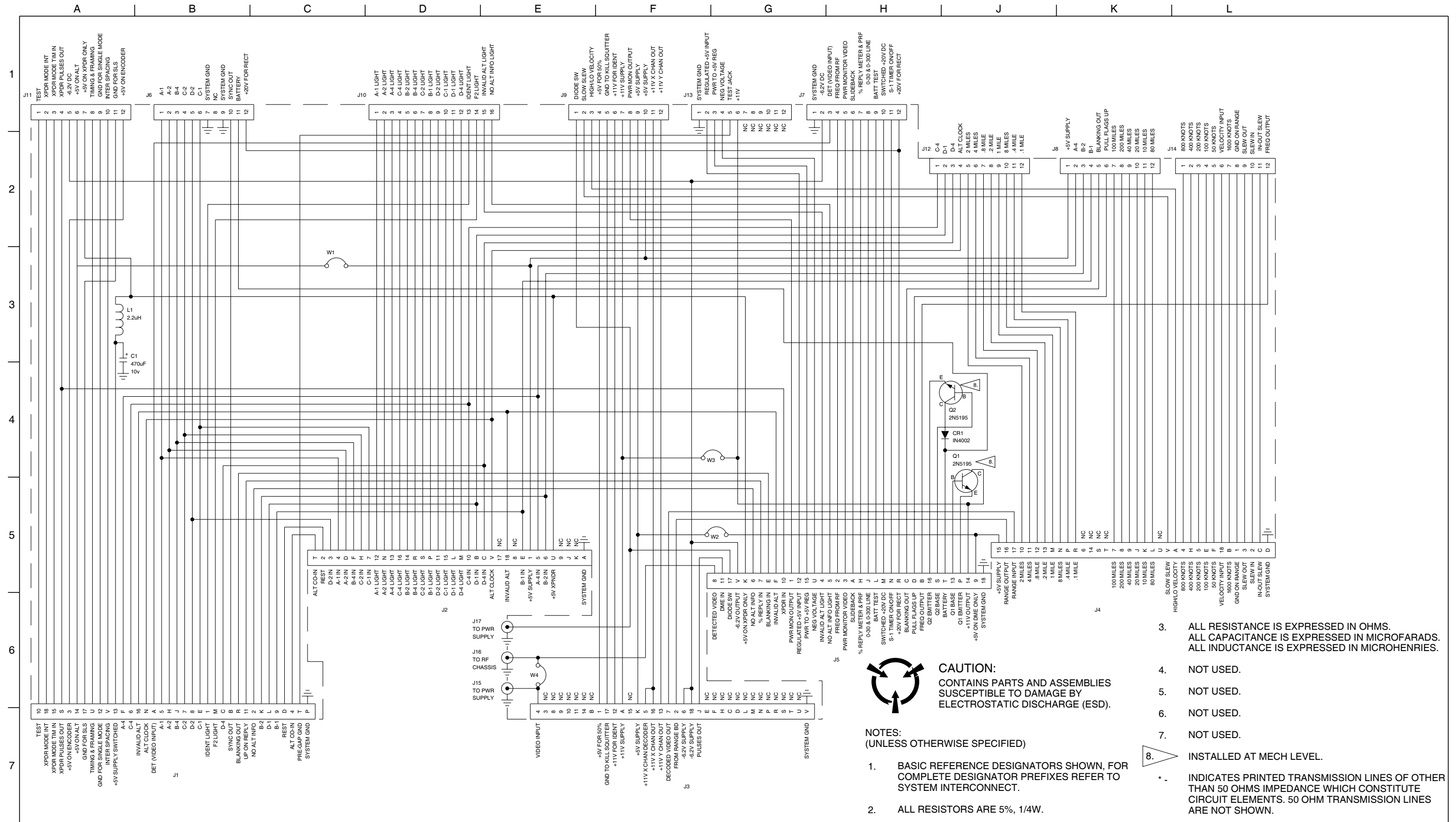

Motherboard PC Board Assembly Circuit Schematic
(0000-0834-400-A1)

PC Cardcage Assembly (Sheet 3 of 3)
Figure 19

00818032

WIRE RUNNING LIST				
DESG	FROM	TO	COLOR	AWG
W1	E3	E8	WHT/BLK	22
W2	E2	E27	WHT/BLK	22
W3	E7	E25	WHT/YEL	22
W4	E1	E26	WHT/YEL	22

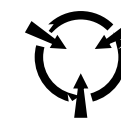
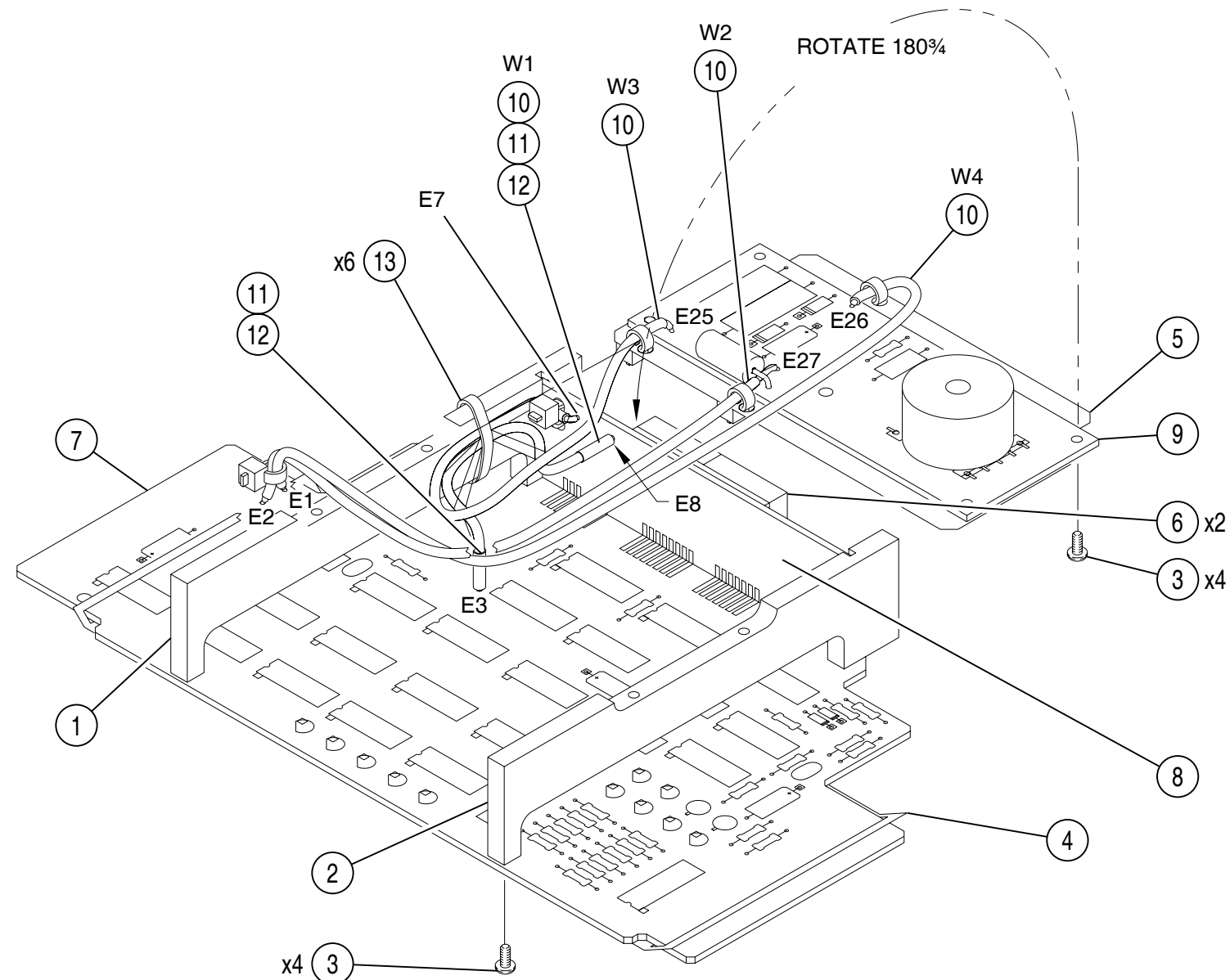

CAUTION:
CONTAINS PARTS AND ASSEMBLIES
SUSCEPTIBLE TO DAMAGE BY
ELECTROSTATIC DISCHARGE (ESD).

NOTES:

1. BASIC REFERENCE DESIGNATORS SHOWN, FOR COMPLETE DESIGNATOR PREFIXES REFER TO SYSTEM INTERCONNECT.

Digital Display Assembly
(7005-0842-500-A)

Digital Display Assembly (Sheet 1 of 11)
Figure 20

00820021

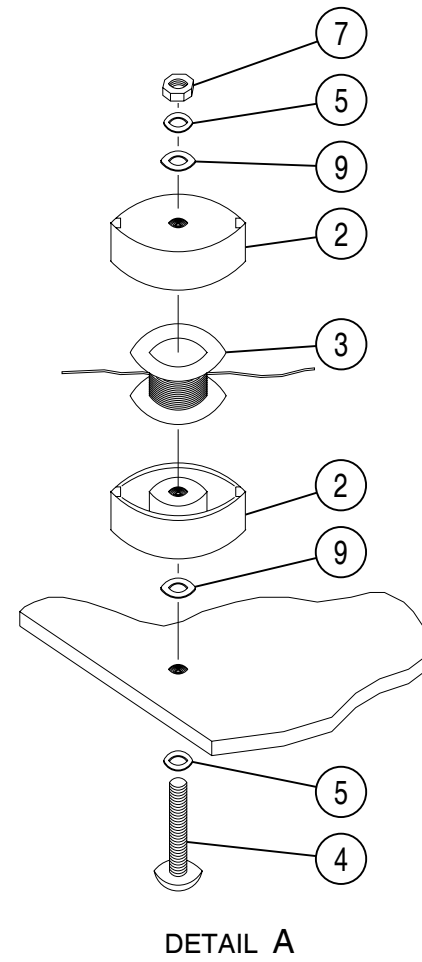
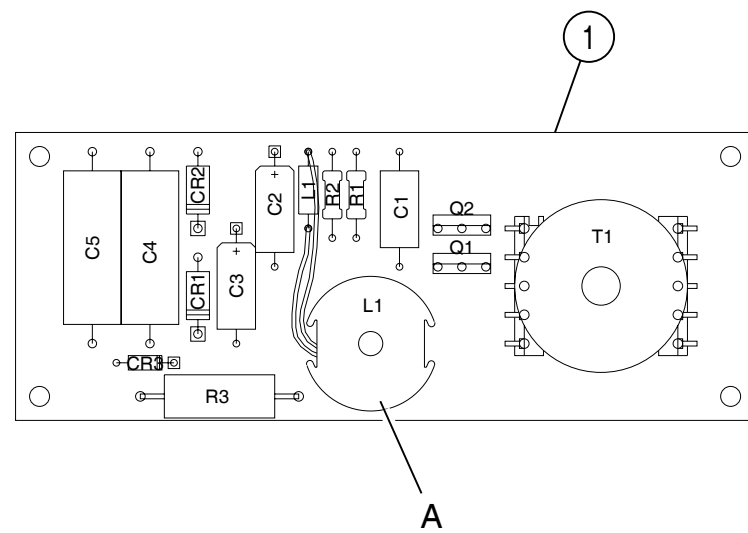

CAUTION:
CONTAINS PARTS AND ASSEMBLIES
SUSCEPTIBLE TO DAMAGE BY
ELECTROSTATIC DISCHARGE (ESD).

NOTES:

1. BASIC REFERENCE DESIGNATORS SHOWN, FOR COMPLETE DESIGNATOR PREFIXES REFER TO SYSTEM INTERCONNECT.

Power Supply PC Board Assembly
(7010-0933-000-A1)

Digital Display Assembly (Sheet 2 of 11)
Figure 20

00818021

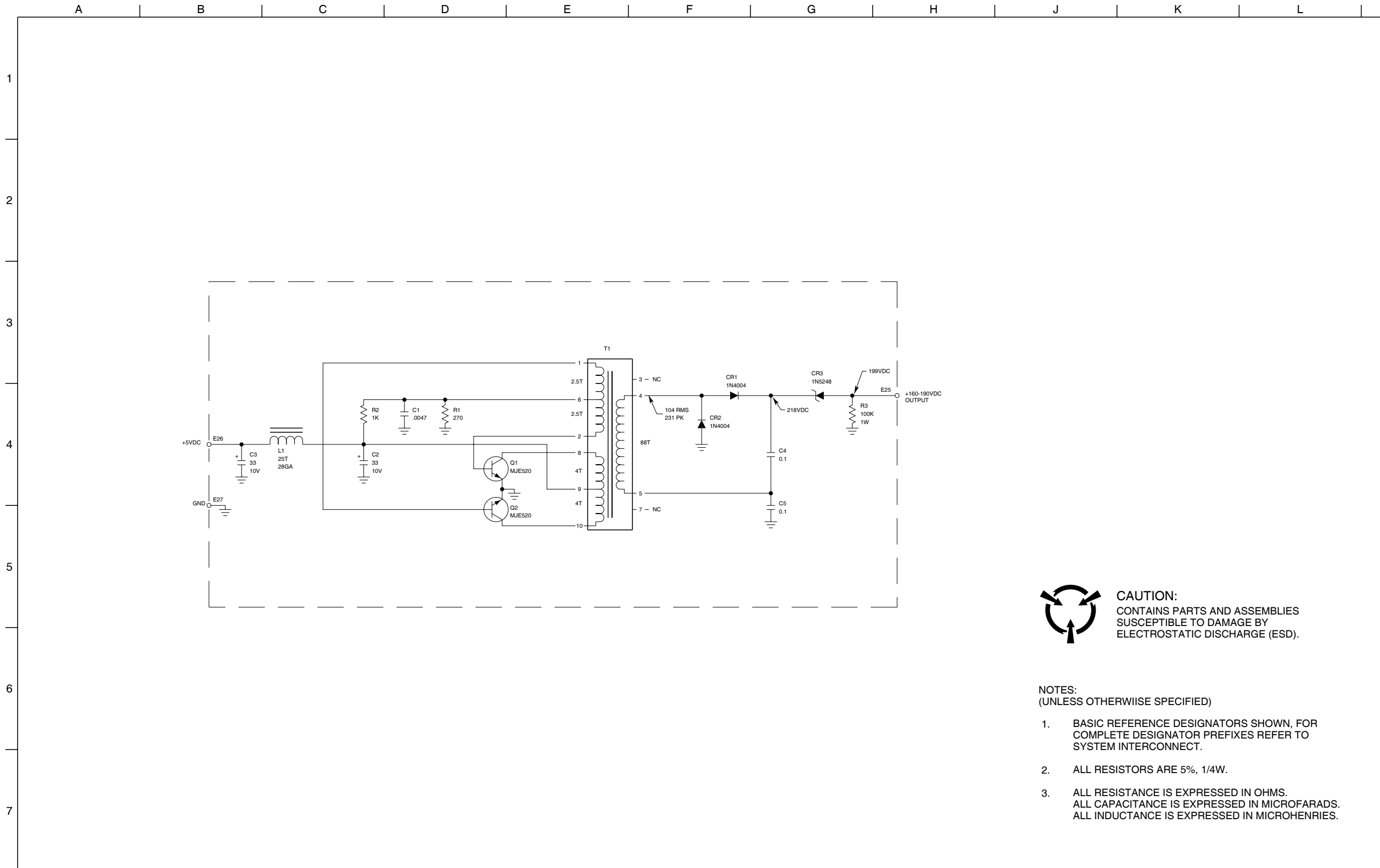

CAUTION:
CONTAINS PARTS AND ASSEMBLIES
SUSCEPTIBLE TO DAMAGE BY
ELECTROSTATIC DISCHARGE (ESD).

NOTES:
(UNLESS OTHERWISE SPECIFIED)

1. BASIC REFERENCE DESIGNATORS SHOWN, FOR COMPLETE DESIGNATOR PREFIXES REFER TO SYSTEM INTERCONNECT.
2. ALL RESISTORS ARE 5%, 1/4W.
3. ALL RESISTANCE IS EXPRESSED IN OHMS.
ALL CAPACITANCE IS EXPRESSED IN MICROFARADS.
ALL INDUCTANCE IS EXPRESSED IN MICROHENRIES.

Power Supply PC Board Assembly Circuit Schematic
(0000-0933-000-A)

Digital Display Assembly (Sheet 3 of 11)
Figure 20

00818033

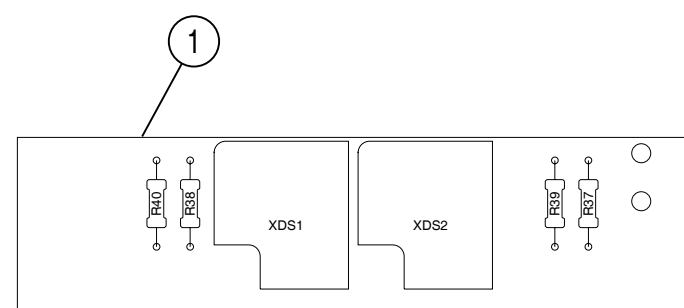

CAUTION:
CONTAINS PARTS AND ASSEMBLIES
SUSCEPTIBLE TO DAMAGE BY
ELECTROSTATIC DISCHARGE (ESD).

NOTES:

1. BASIC REFERENCE DESIGNATORS SHOWN, FOR COMPLETE DESIGNATOR PREFIXES REFER TO SYSTEM INTERCONNECT.

Digital Display PC Board Assembly
(7010-0832-500-A)

00818022

Digital Display Assembly (Sheet 4 of 11)
Figure 20

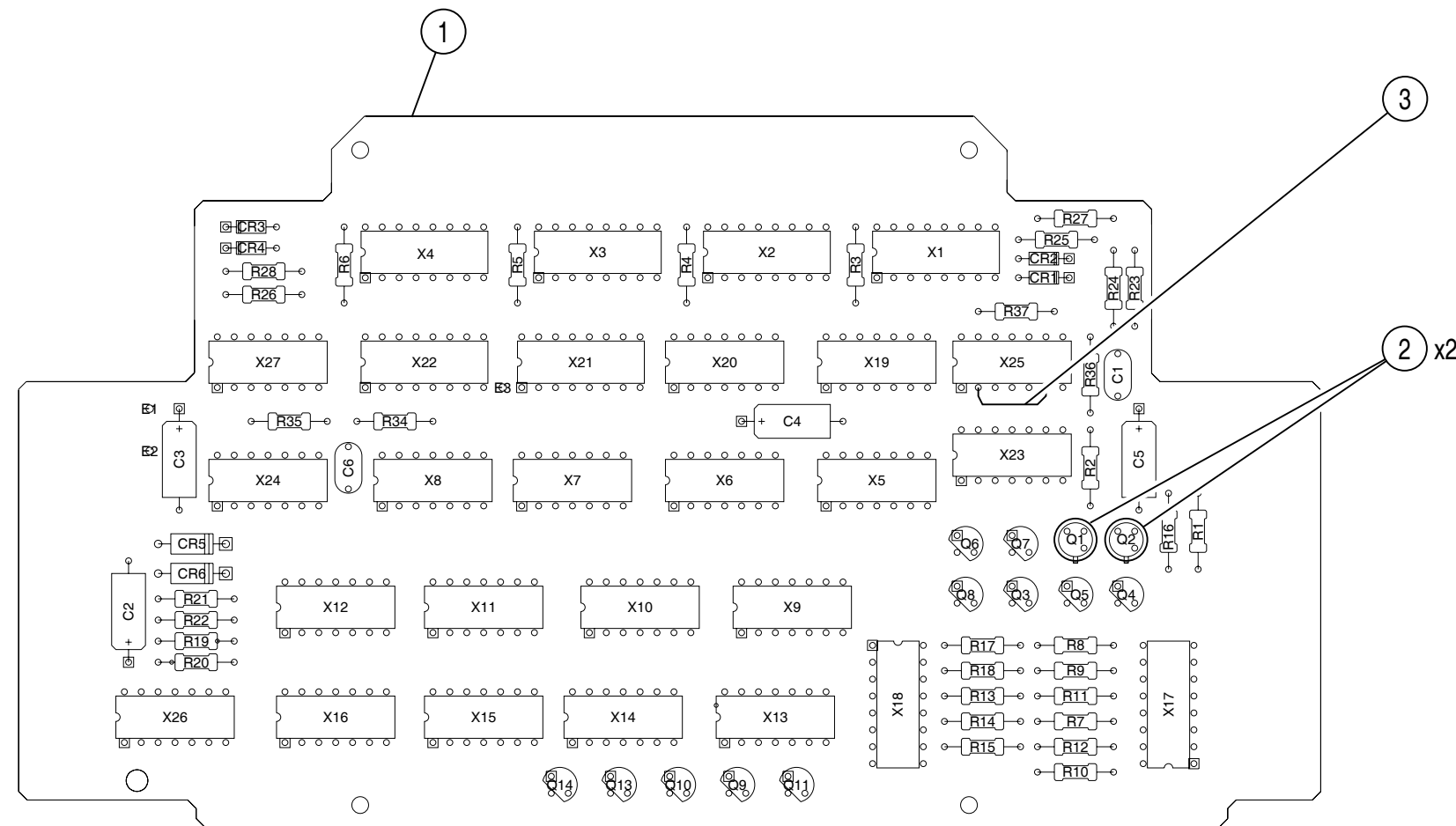

CAUTION:
CONTAINS PARTS AND ASSEMBLIES
SUSCEPTIBLE TO DAMAGE BY
ELECTROSTATIC DISCHARGE (ESD).

NOTES:

1. BASIC REFERENCE DESIGNATORS SHOWN, FOR COMPLETE DESIGNATOR PREFIXES REFER TO SYSTEM INTERCONNECT.

Digital Readout PC Board Assembly
(7010-0832-600-A1)

Digital Display Assembly (Sheet 5 of 11)
Figure 20

00818023

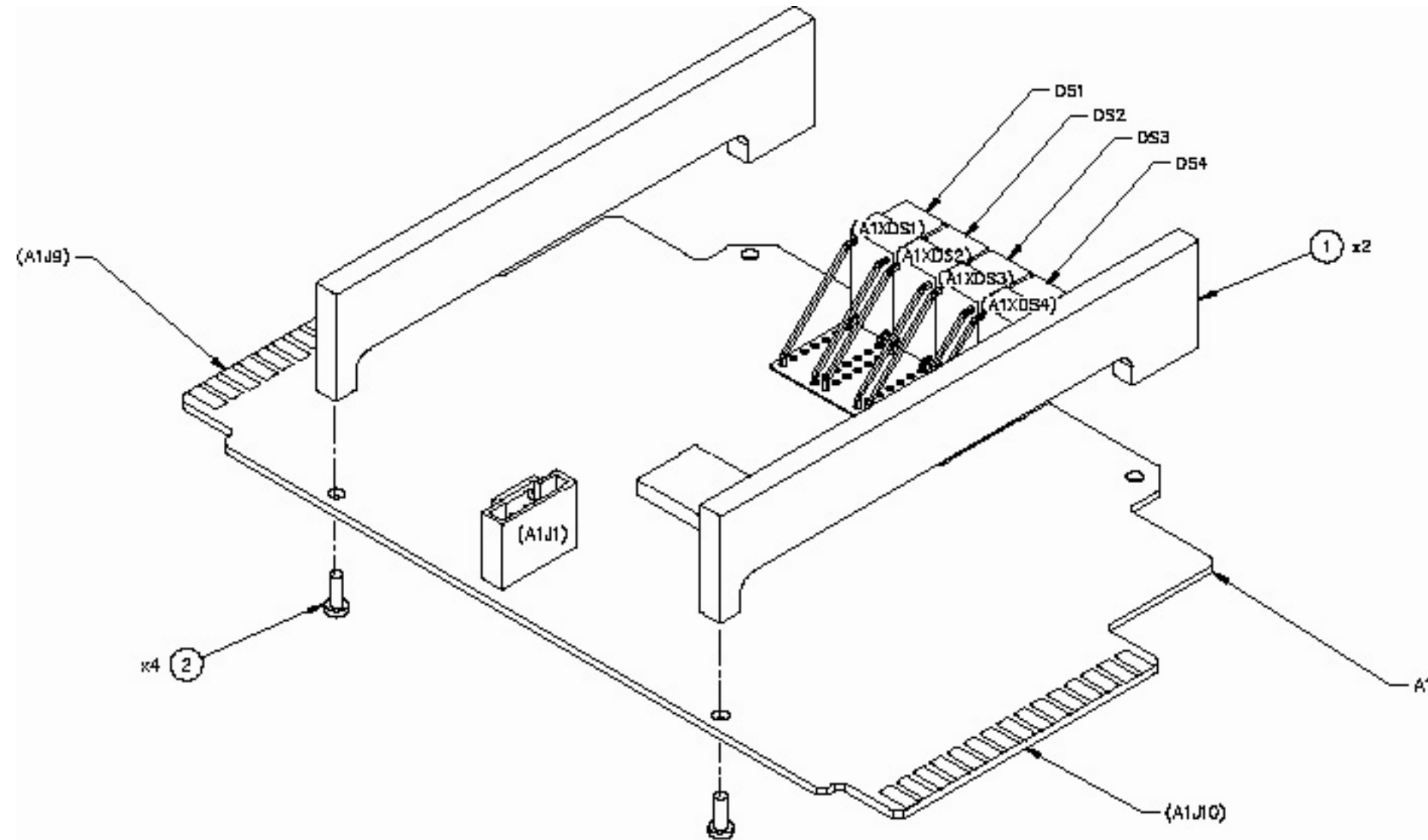

Digital Display Assembly
(7005-0847-000-A)

Digital Display Assembly (Sheet 7 of 11)
Figure 20



CAUTION:
CONTAINS PARTS AND ASSEMBLIES
SUSCEPTIBLE TO DAMAGE BY
ELECTROSTATIC DISCHARGE (ESD).

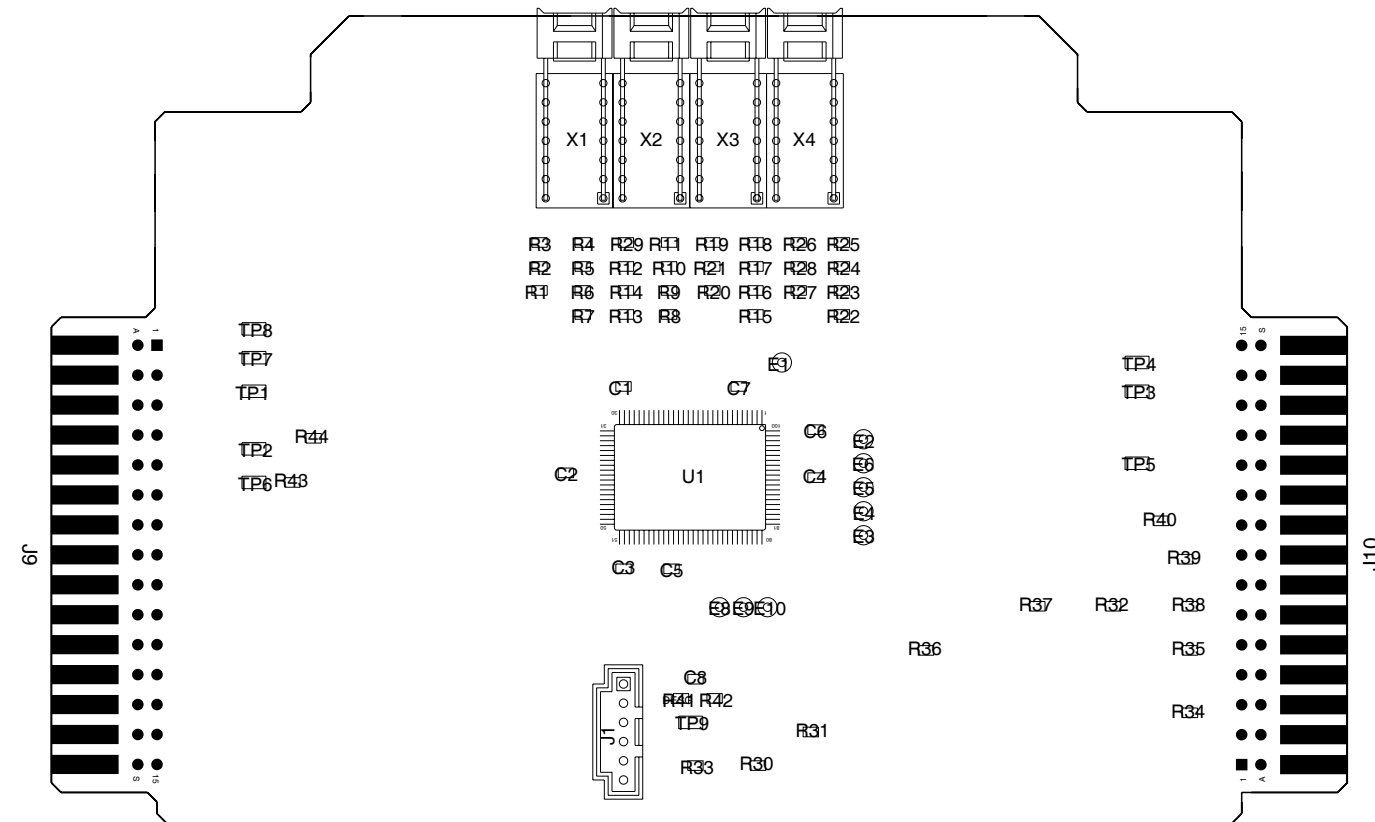

Digital Readout PC Board Assembly
(7010-0835-000-A)

Digital Display Assembly (Sheet 8 of 11)
Figure 20

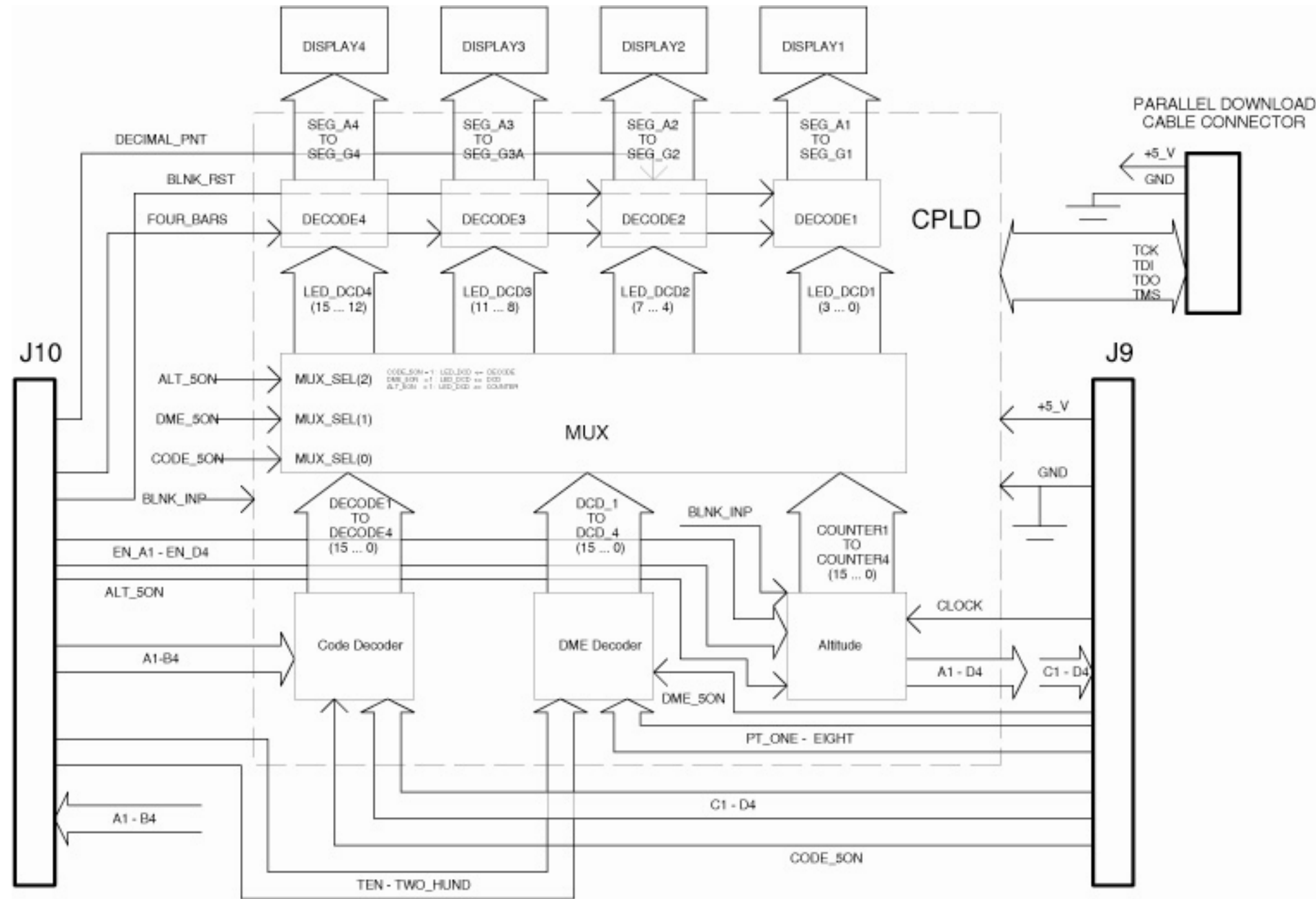

- NOTES:**
(UNLESS OTHERWISE SPECIFIED)
1. BASIC REFERENCE DESIGNATORS SHOWN, FOR COMPLETE DESIGNATOR PREFIXES REFER TO PRODUCT STRUCTURE AND SYSTEM INTERCONNECT.
 2. ALL RESISTORS ARE 1%, 1/10W.
 3. ALL RESISTANCE IS EXPRESSED IN OHMS
ALL CAPACITANCE IS EXPRESSED IN MICROFARADS.
ALL INDUCTANCE IS EXPRESSED IN MICROHENRIES.
 4. NOT USED
 5. NOT USED
 6. COMPONENT(S) NOT INSTALLED.
- CAUTION:**
CONTAINS PARTS AND ASSEMBLIES SUSCEPTIBLE TO DAMAGE BY ELECTROSTATIC DISCHARGE (ESD).

Digital Display Assembly Circuit Schematic
(0000-0835-000-B)

Digital Display Assembly (Sheet 9 of 11)
Figure 20

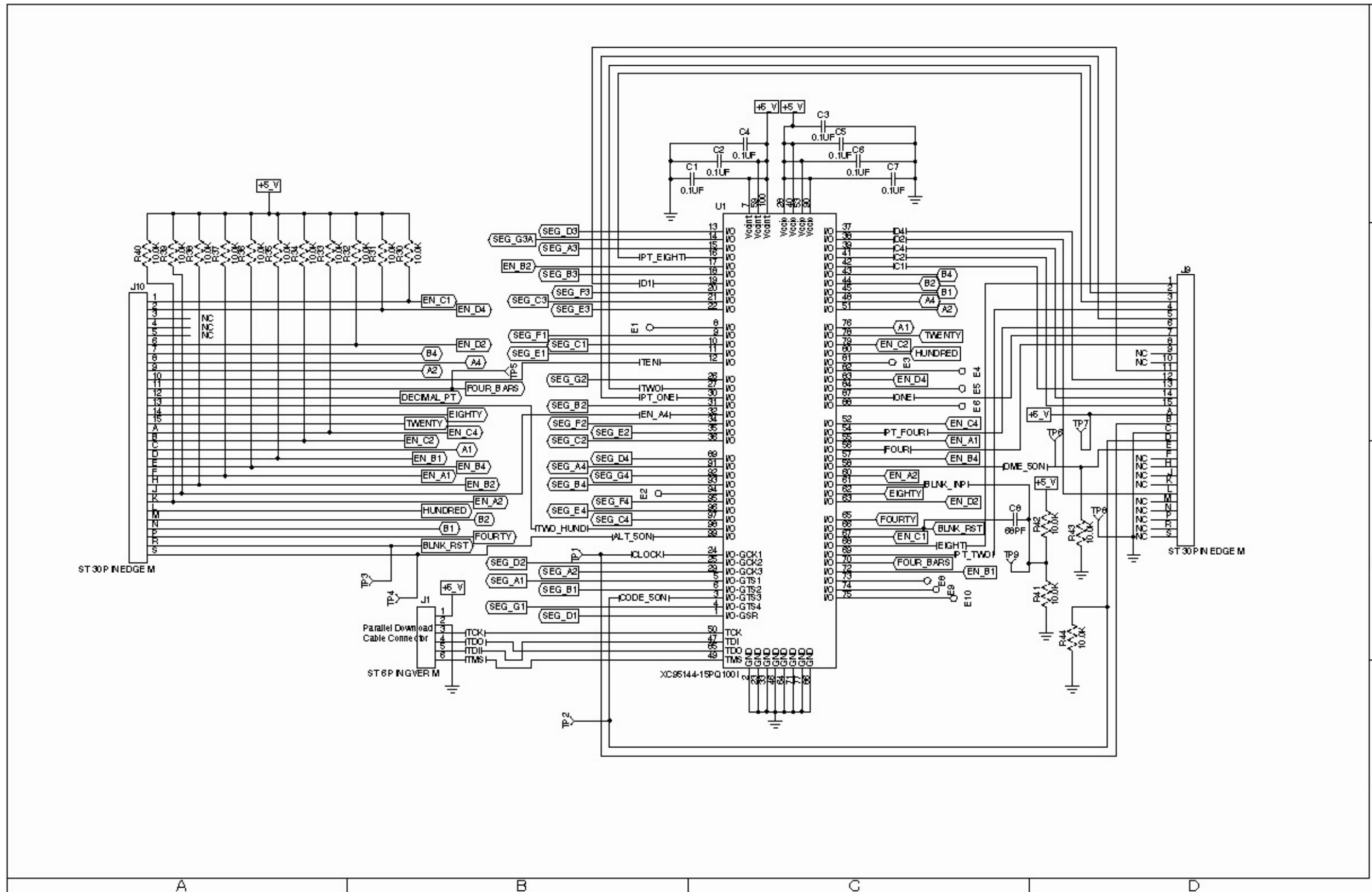

Digital Display Assembly Circuit Schematic (cont)
(0000-0835-000-B)

Digital Display Assembly (Sheet 10 of 11)
Figure 20

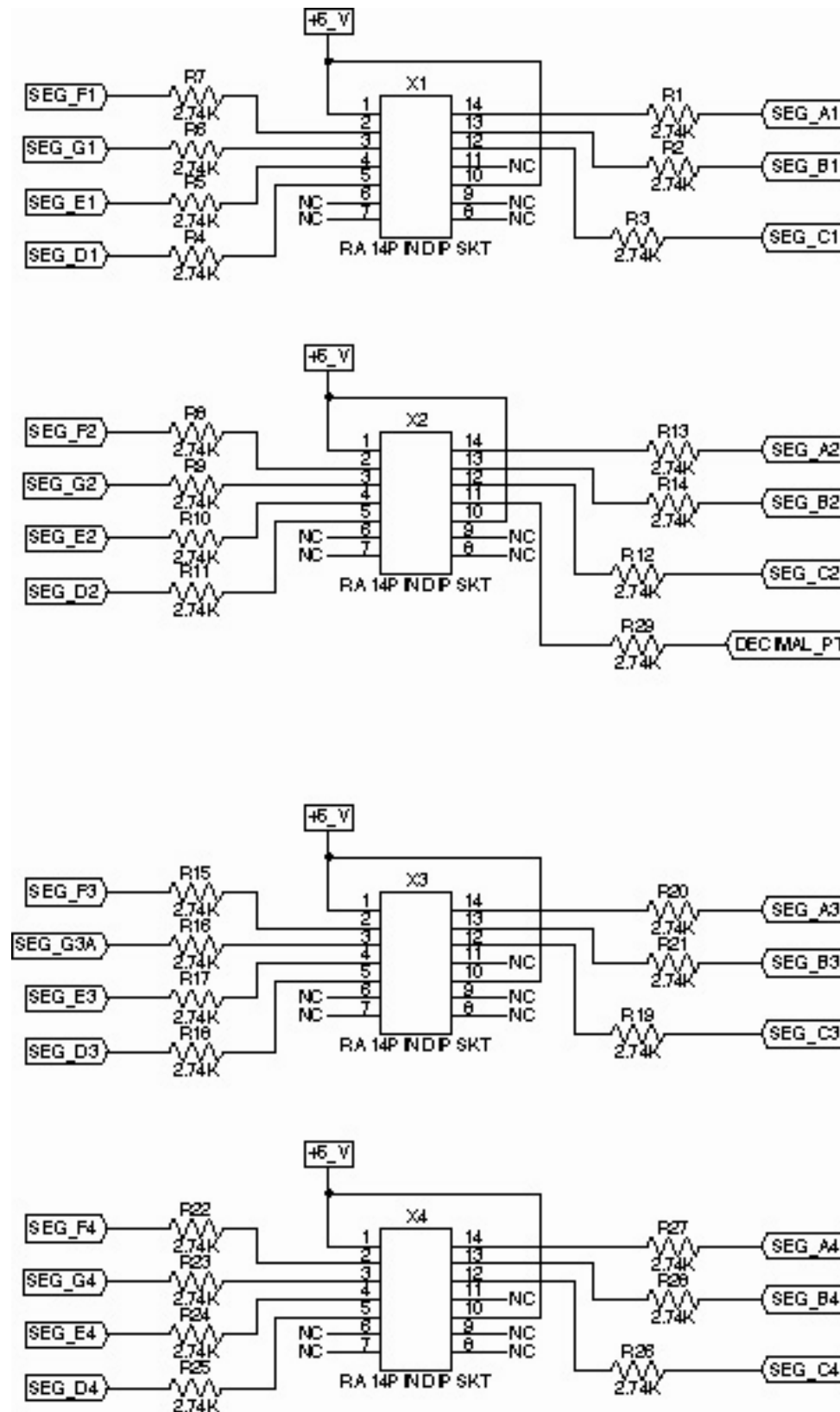

Digital Display Assembly Circuit Schematic (cont)
(0000-0835-000-B)

Digital Display Assembly (Sheet 11 of 11)
Figure 20

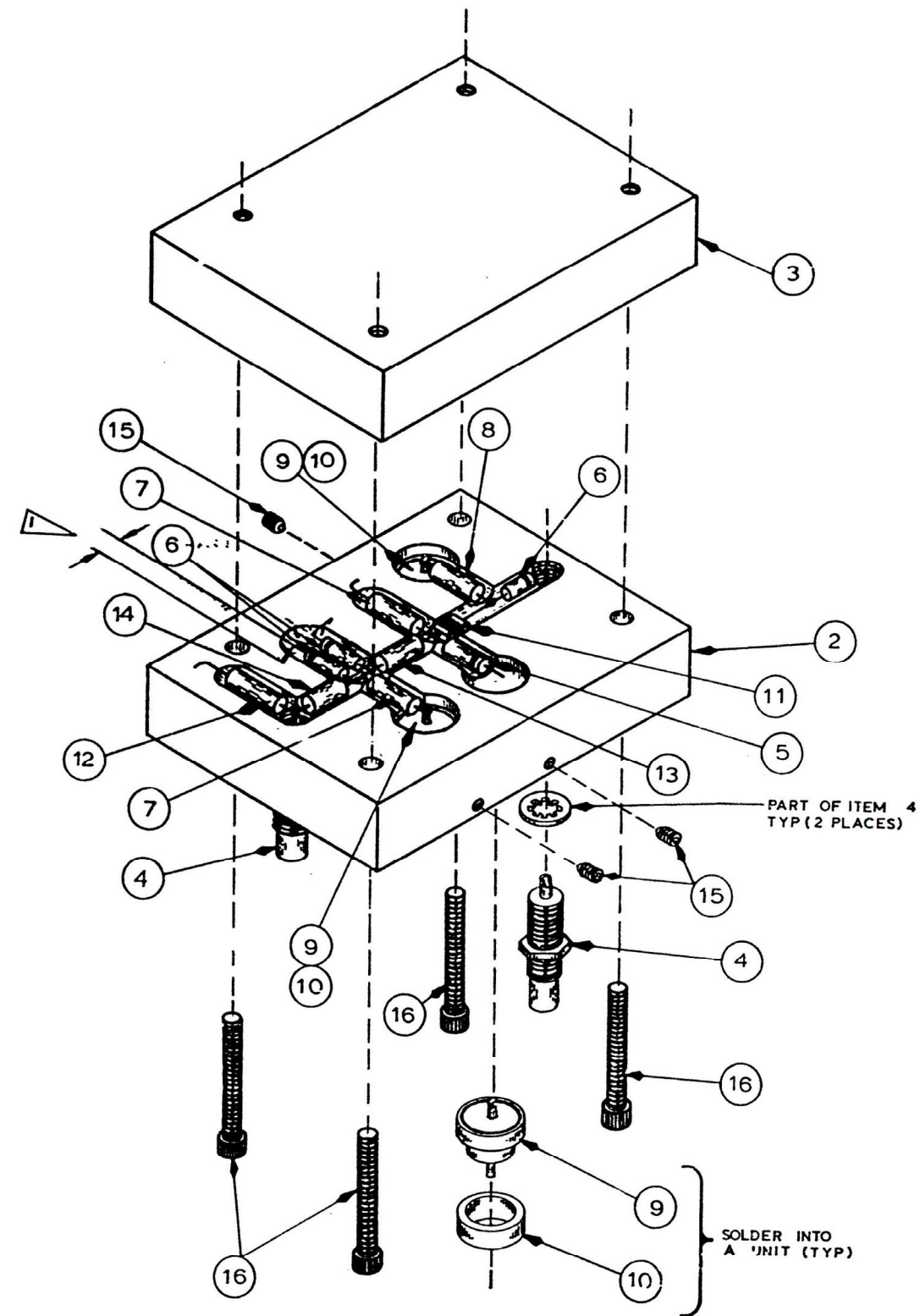

SLS Attenuator and RF Block Assembly
(7015-0818-100-J)

SLS Attenuator and RF Block Assembly
Figure 21

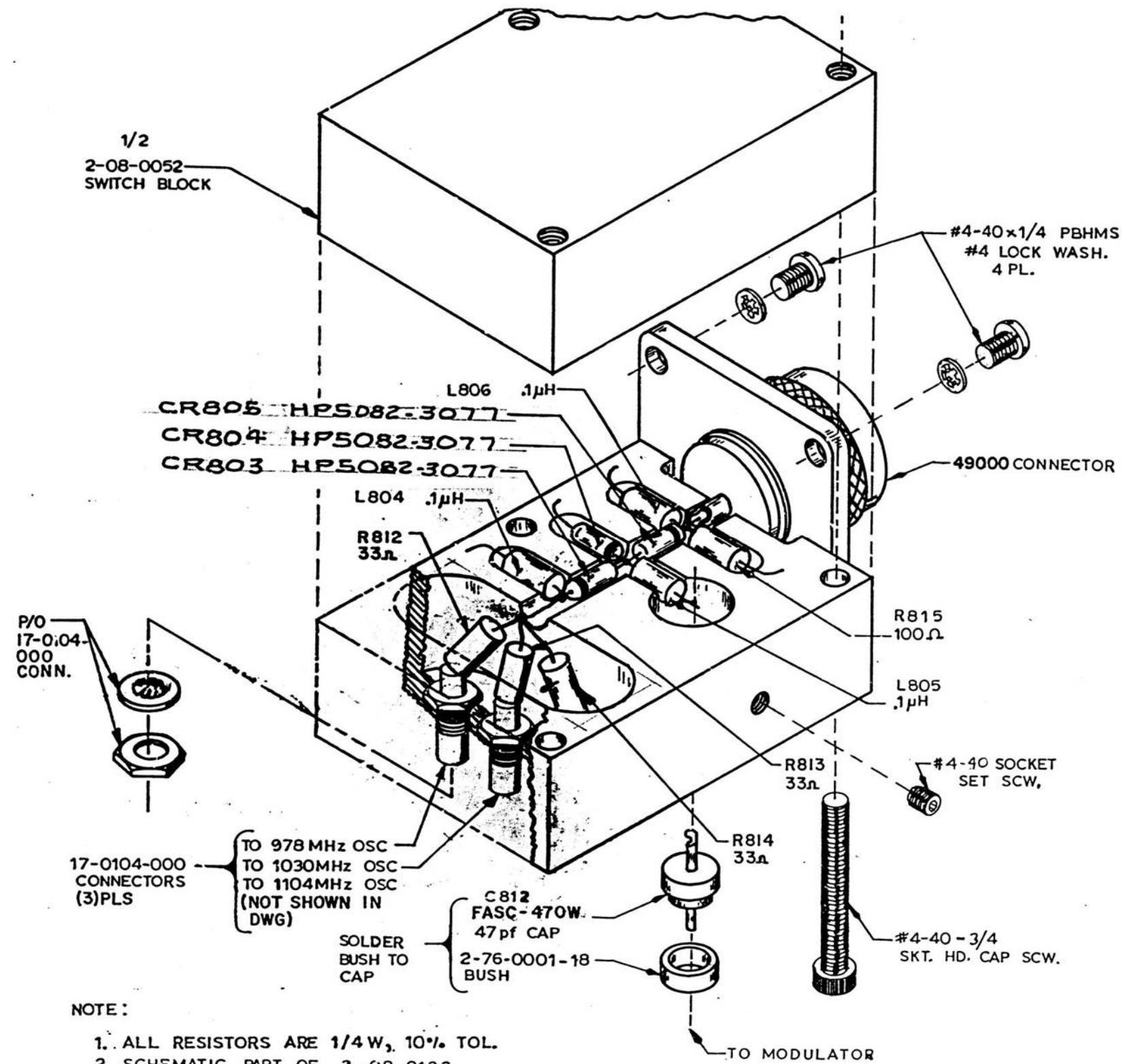

Diode Switch Block Assembly
(7015-0807-100-E3)

Diode Switch Block Assembly
Figure 22

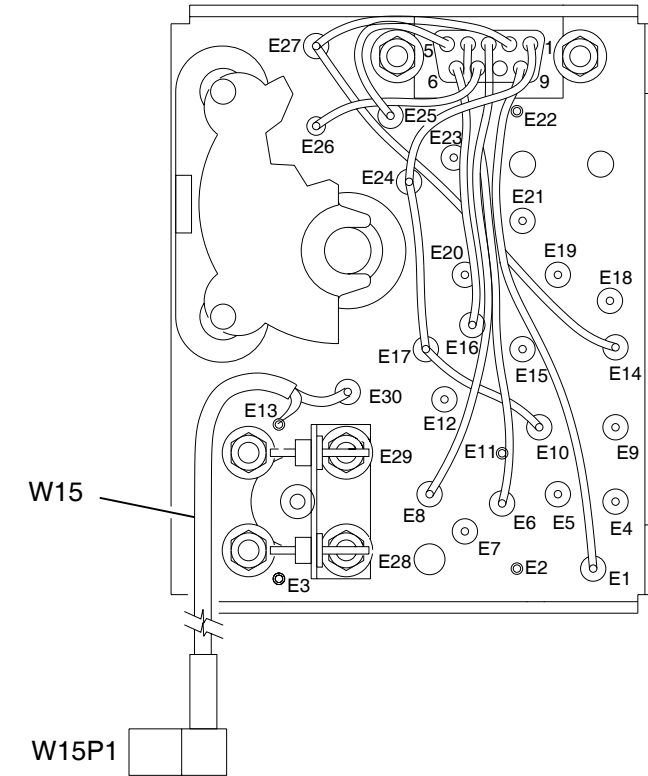
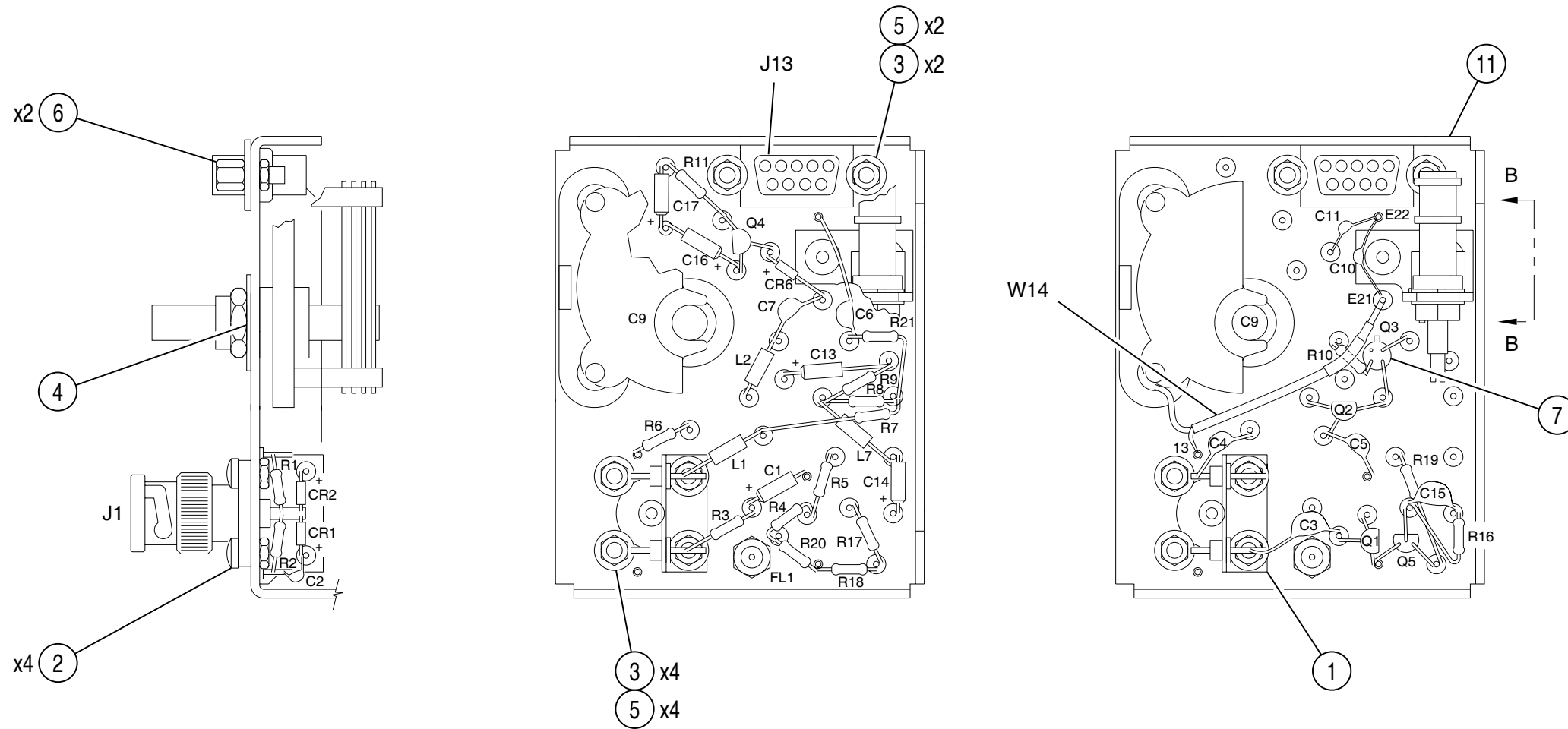

WIRE RUNNING LIST				
DESG	FROM	TO	COLOR	AWG
W1	J13-1	E24	RED	26
W2	J13-2	E27	YEL	26
W3	J13-3	E8	VIO	26
W4	J13-4	E6	BRN	26
W5	J13-5	E25	BLU	26
W6	J13-6	E16	GRN	26
W7	J13-7	E26	BLK	26
W8	J13-9	E1	WHT	26
W9	E24	E17	BUSS	26
W10	E17	E10	BUSS	26
W11	E27	E14	BUSS	26
W14	C9	E21	COND	COAX
(W14)	E13	N/C	SHLD	COAX
W15	(W15P1)	E30	COND	COAX
(W15)	(W15P1)	E13	SHLD	COAX
W19	E31	E21	BUSS	26
W17	L3-1	E31	BUSS	26
W18	L3-2	GL1	BUSS	26

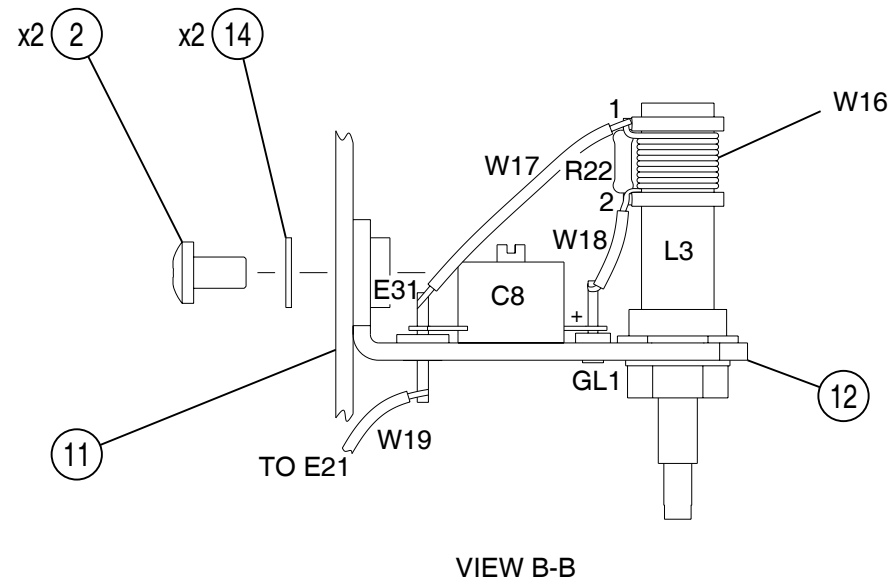

CAUTION:
CONTAINS PARTS AND ASSEMBLIES
SUSCEPTIBLE TO DAMAGE BY
ELECTROSTATIC DISCHARGE (ESD).

NOTES:

1. BASIC REFERENCE DESIGNATORS SHOWN, FOR COMPLETE DESIGNATOR PREFIXES REFER TO SYSTEM INTERCONNECT.

RF Chassis Assembly
(7005-0846-200-E)

RF Chassis Assembly (Sheet 1 of 2)
Figure 23

00820024

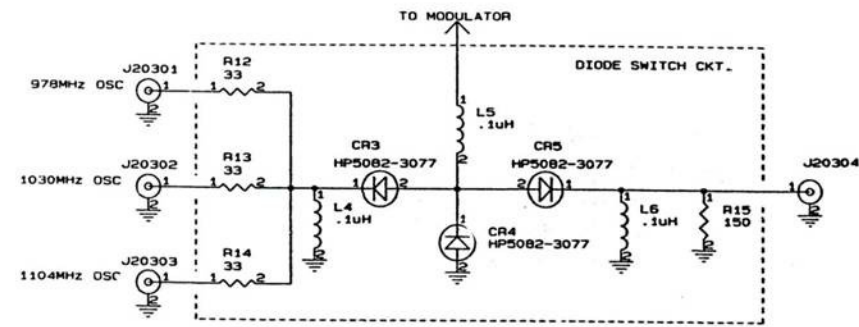

- NOTES:
(UNLESS OTHERWISE SPECIFIED)
1. BASIC REFERENCE DESIGNATORS SHOWN. FOR COMPLETE DESIGNATOR PREFIXES REFER TO PRODUCT STRUCTURE AND SYSTEM INTERCONNECT FOR APPLICATIONS WHERE USED.
 2. ALL RESISTORS ARE 1%, 1/8W.
 3. ALL RESISTANCE IS EXPRESSED IN OHMS. ALL CAPACITANCE IS EXPRESSED IN MICROFARADS. ALL INDUCTANCE IS EXPRESSED IN MICRONEARIES.
 4. HIGHEST REFERENCE DESIGNATIONS:
C17 C18 E30 J13 L7 O5 R22 W15 P1
 5. REFERENCE DESIGNATIONS NOT USED:
C12
 6. FOR INTERCONNECT/BLOCK DIAGRAM SEE APPLICATIONS WHERE USED.
 7. IC FUNCTIONS NOT USED: NONE

B. L3 - 11 TURNS #28 ENAMELED WIRE

*- INDICATES PRINTED TRANSMISSION LINES OF OTHER THAN 50 OHMS IMPEDANCE WHICH CONSTITUTE CIRCUIT ELEMENTS. 50 OHM TRANSMISSION LINES ARE NOT SHOWN.

CAUTION:
CONTAINS PARTS AND ASSEMBLIES SUSCEPTIBLE TO DAMAGE BY ELECTROSTATIC DISCHARGE (ESD).

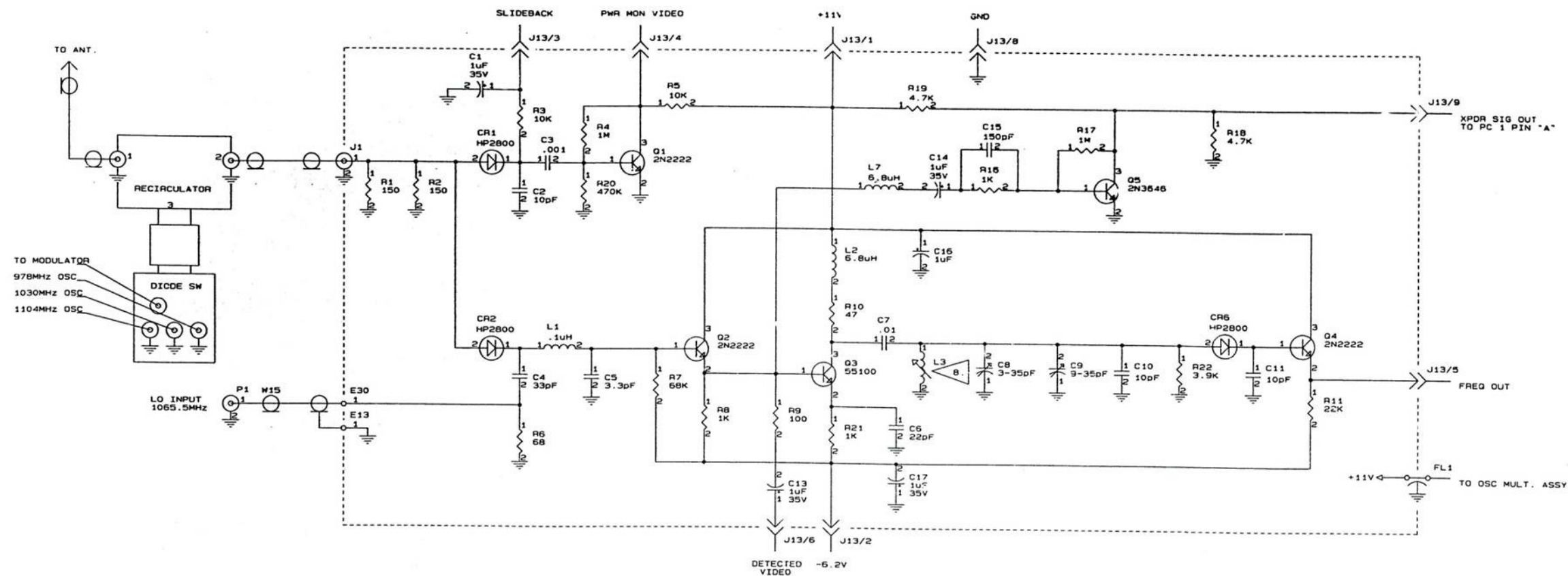

RF Chassis Assembly Circuit Schematic
(0000-0846-200-A)

RF Chassis Assembly (Sheet 2 of 2)
Figure 23

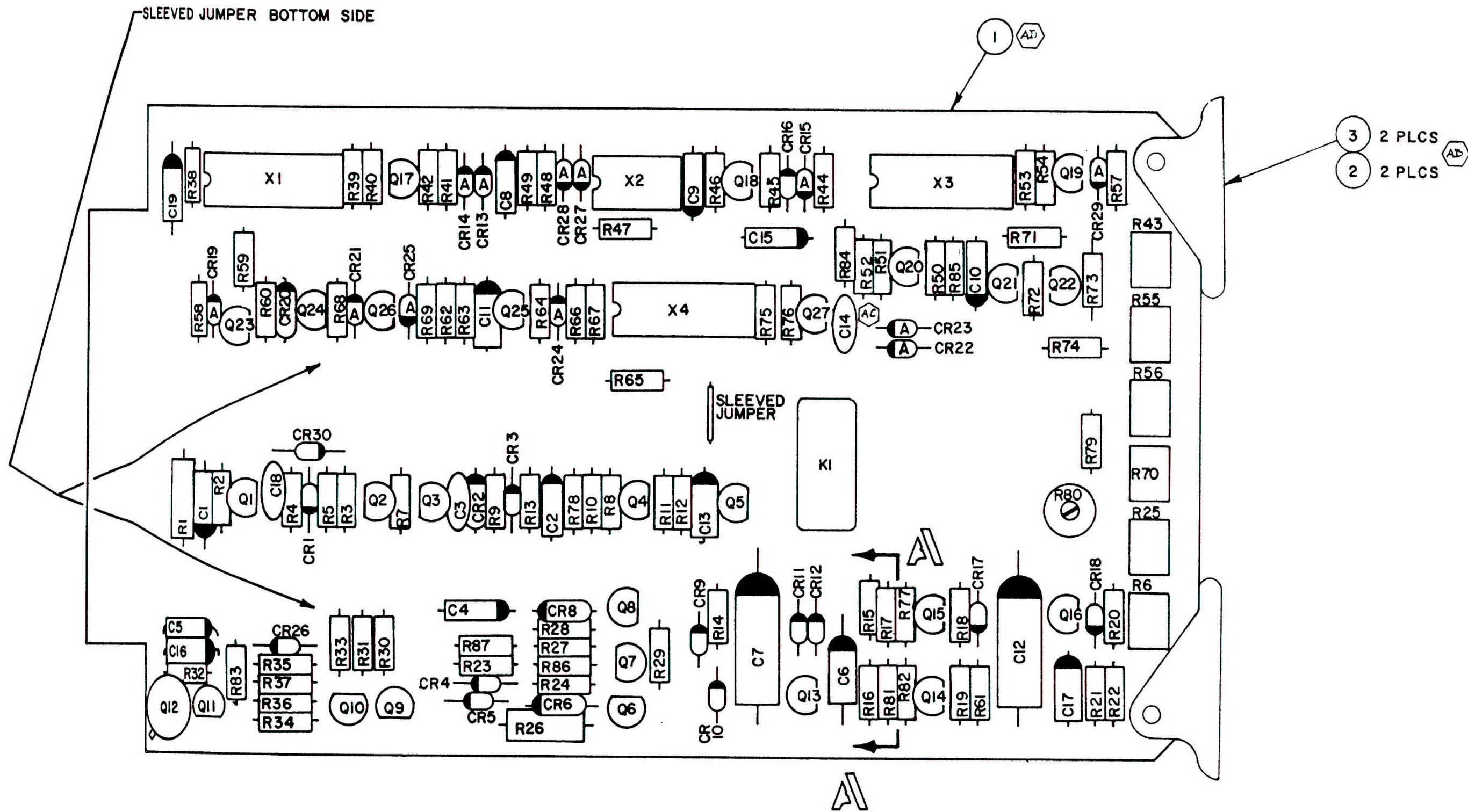

Regulator/Timer PC Board Assembly
(7010-0803-800-AE)

Regulator/Timer PC Board Assembly
(Sheet 1 of 2)
Figure 24

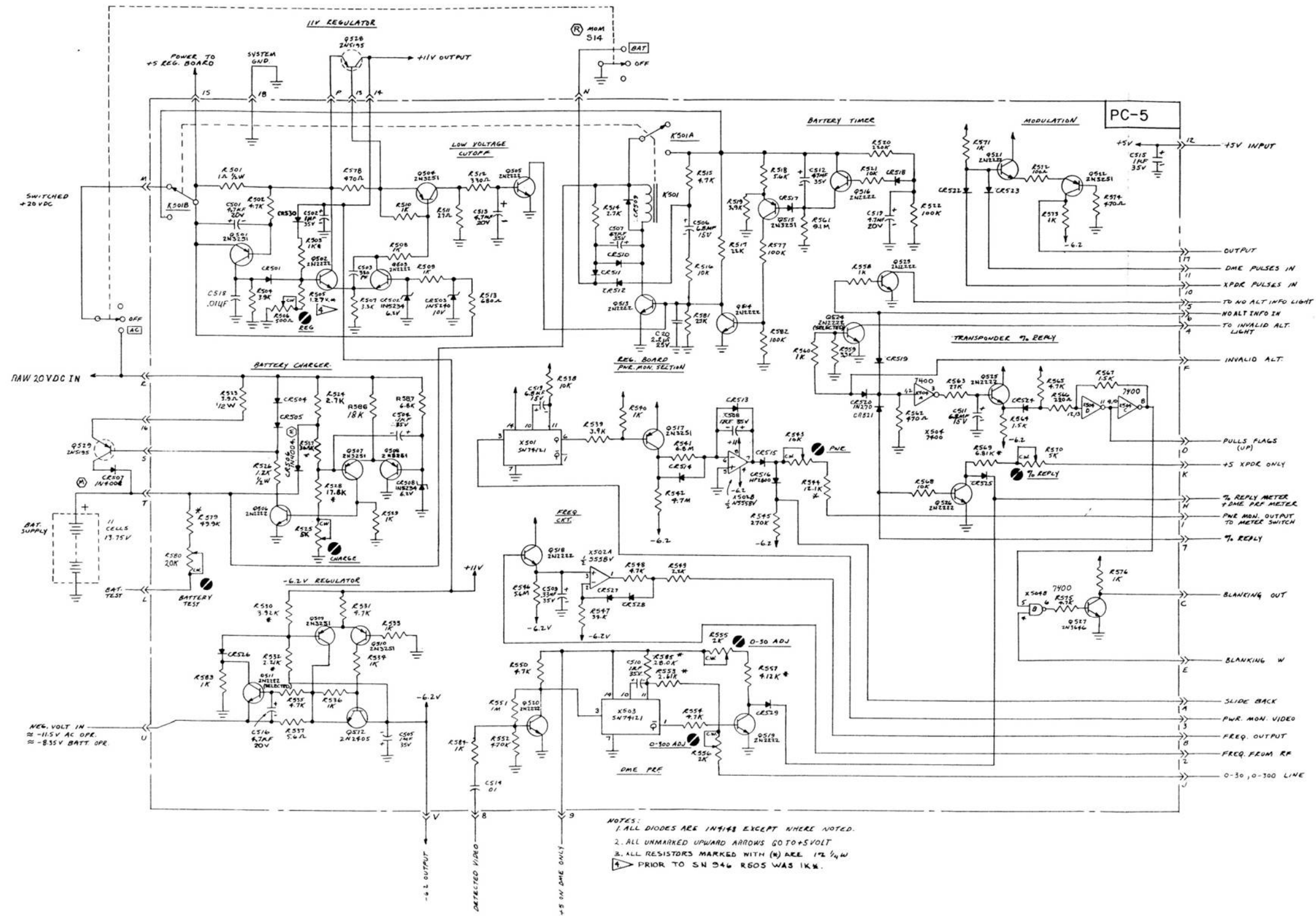

Regulator/Timer PC Board Assembly Circuit Schematic
(0000-0816-400-R)

Regulator/Timer PC Board Assembly
(Sheet 2 of 2)
Figure 24

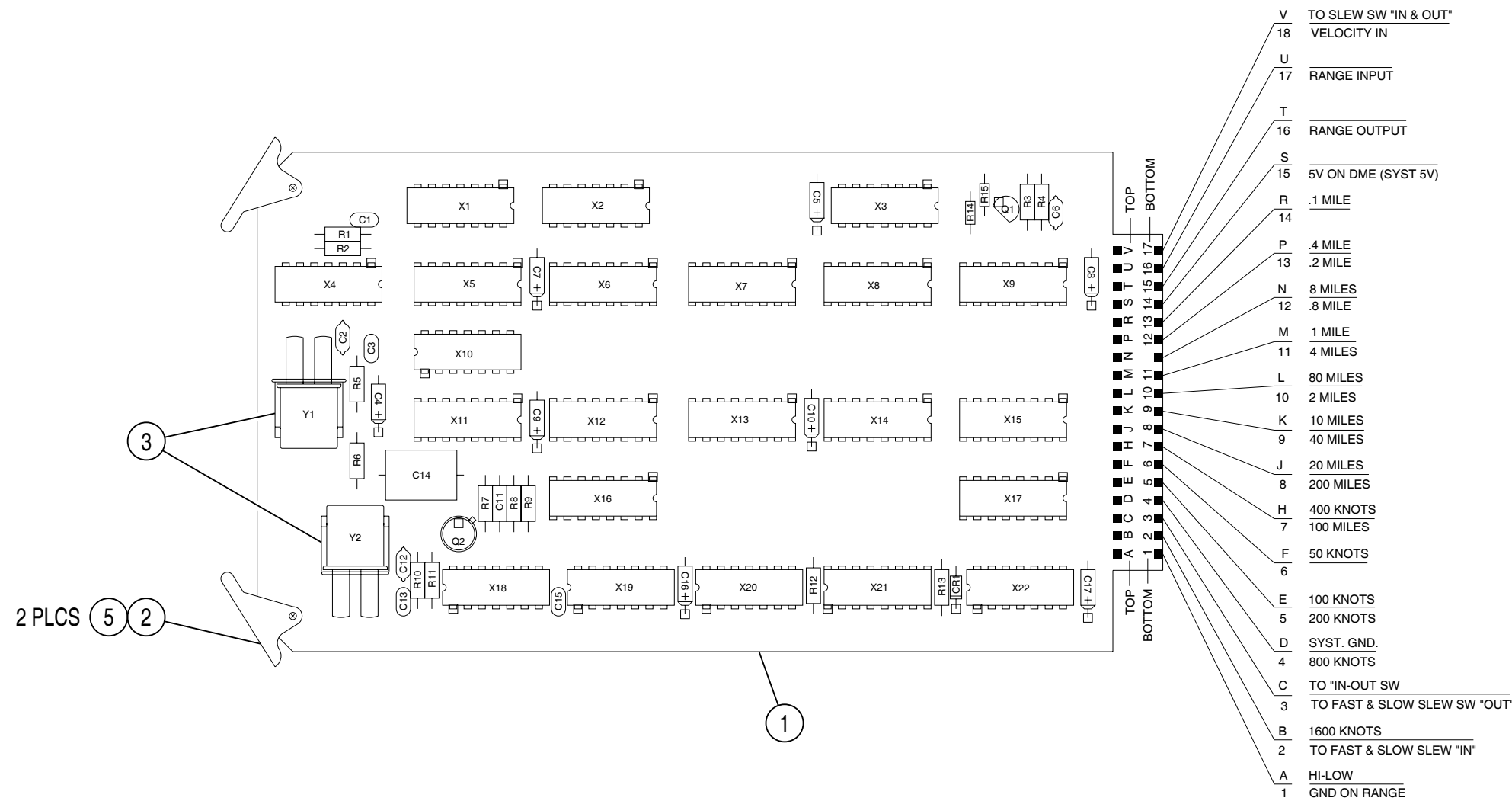

Range Velocity PC Board Assembly
(7010-0819-900-J)

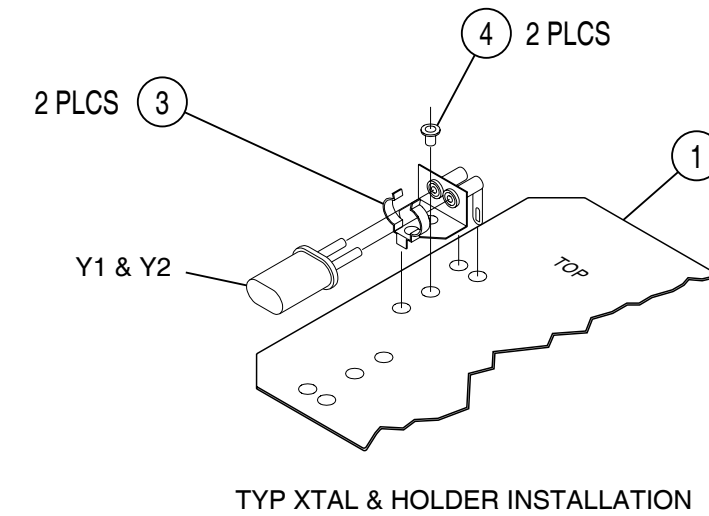

TYP XTAL & HOLDER INSTALLATION



CAUTION:
CONTAINS PARTS AND ASSEMBLIES
SUSCEPTIBLE TO DAMAGE BY
ELECTROSTATIC DISCHARGE (ESD).

NOTES:

1. BASIC REFERENCE DESIGNATORS SHOWN, FOR COMPLETE DESIGNATOR PREFIXES REFER TO SYSTEM INTERCONNECT.

00818025

Range Velocity PC Board Assembly
(Sheet 1 of 2)
Figure 25

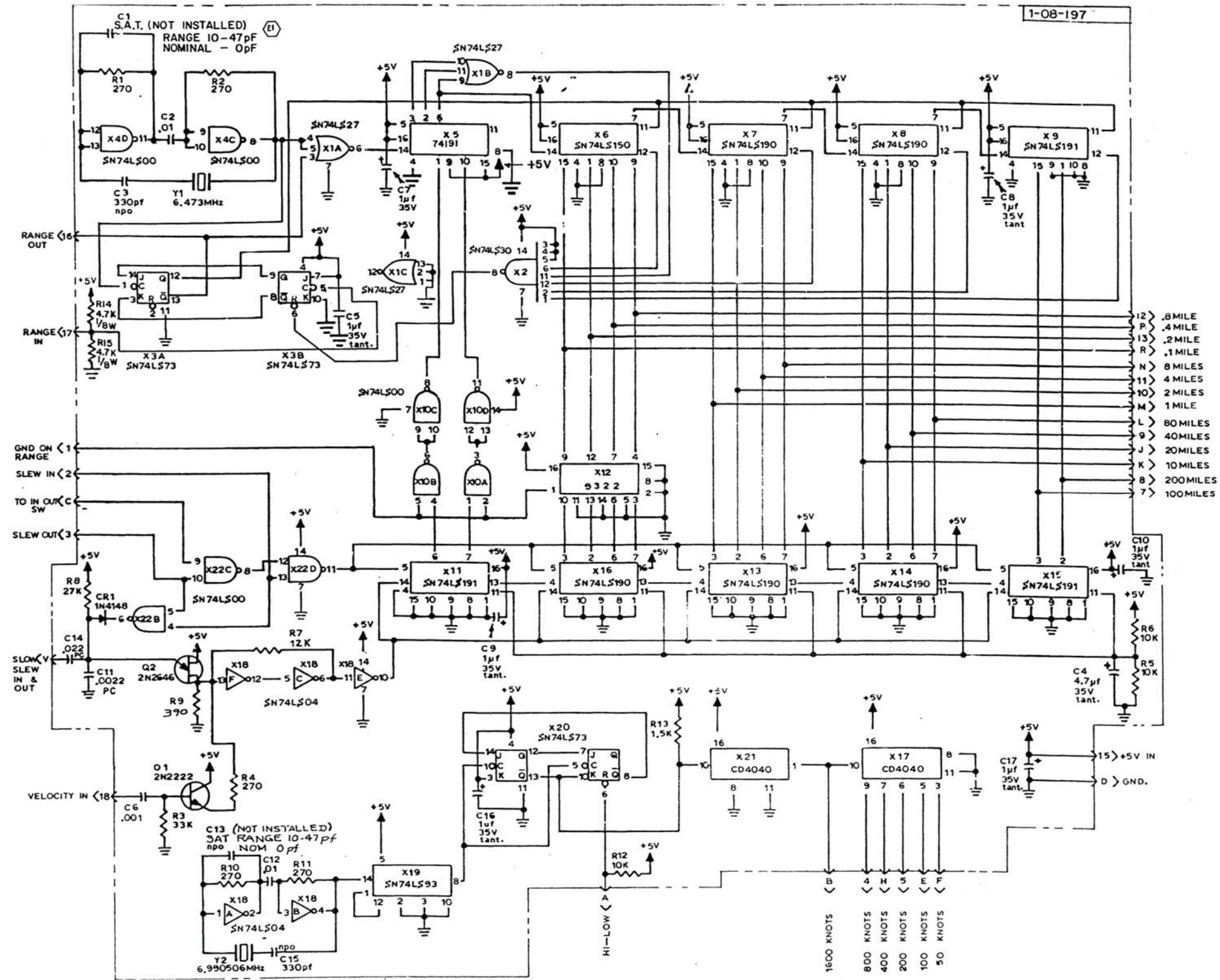

Range Velocity PC Board Assembly Circuit Schematic
(0000-0819-800-J)

Range Velocity PC Board Assembly
(Sheet 2 of 2)
Figure 25

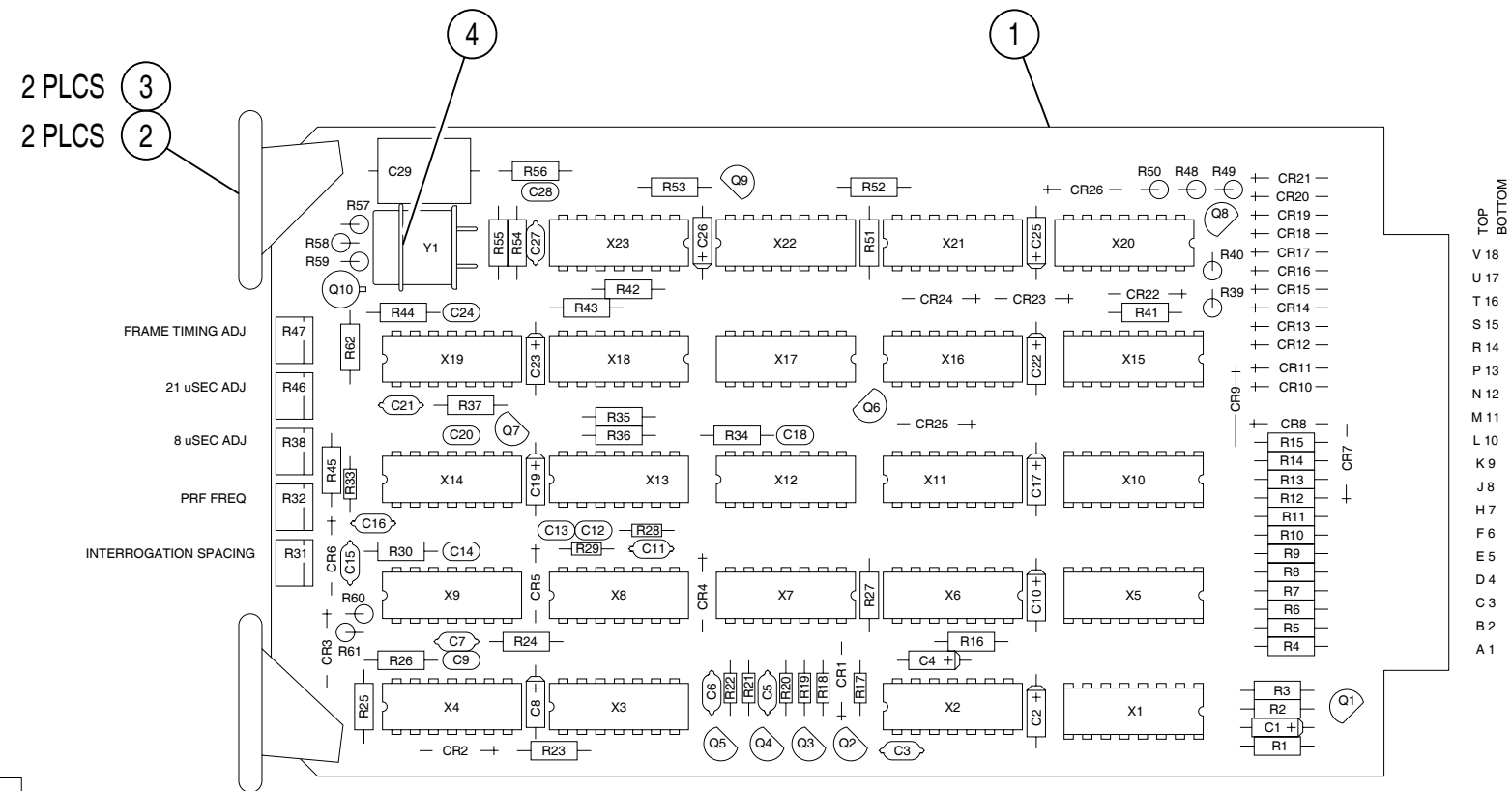

TOP
BOTTOM
V 18
U 17
T 16
S 15
R 14
P 13
N 12
M 11
L 10
K 9
J 8
H 7
F 6
E 5
D 4
C 3
B 2
A 1

PIN	SIGNAL	PIN	SIGNAL
1	IDENT LIGHT	A	DETECTED VIDEO
2	NO ALTITUDE INFO	B	SYNC OUT
3	+5V ON ENCODED	C	D4 PULSE POSITION
4	ALT COIN	D	RESET ALT REG
5	A1 PULSE POSITION	E	C1 PULSE POSITION
6	C4	F	A4
7	C2	H	A2
8	D2	J	B4
9	B1	K	B2
10	TEST	L	D1
11	UP ON NO REPLY	M	F2 FRAME LIGHT
12	SINGLE MODE GND	N	ALTITUDE CLOCK
13	+5v (SWITCHED)	P	SYS GND
14	+5V ON ALTITUDE	R	BLANKING OUT
15	XPNDR MODE TIME INTERN	S	XPNDR PULSE OUT
16	INVALID ALTITUDE	T	PRF GAP GND
17	SLS GND	U	FRAME TIMING POT
18	XPNDR MODE INTERNAL	V	INTER SPACING



CAUTION:
CONTAINS PARTS AND ASSEMBLIES
SUSCEPTIBLE TO DAMAGE BY
ELECTROSTATIC DISCHARGE (ESD).

NOTES:

1. BASIC REFERENCE DESIGNATORS SHOWN, FOR COMPLETE DESIGNATOR PREFIXES REFER TO SYSTEM INTERCONNECT.

XPDR Signal PC Board Assembly
(7010-0831-500-A)

XPDR Signal PC Board Assembly (Sheet 1 of 2)
Figure 26

00818027

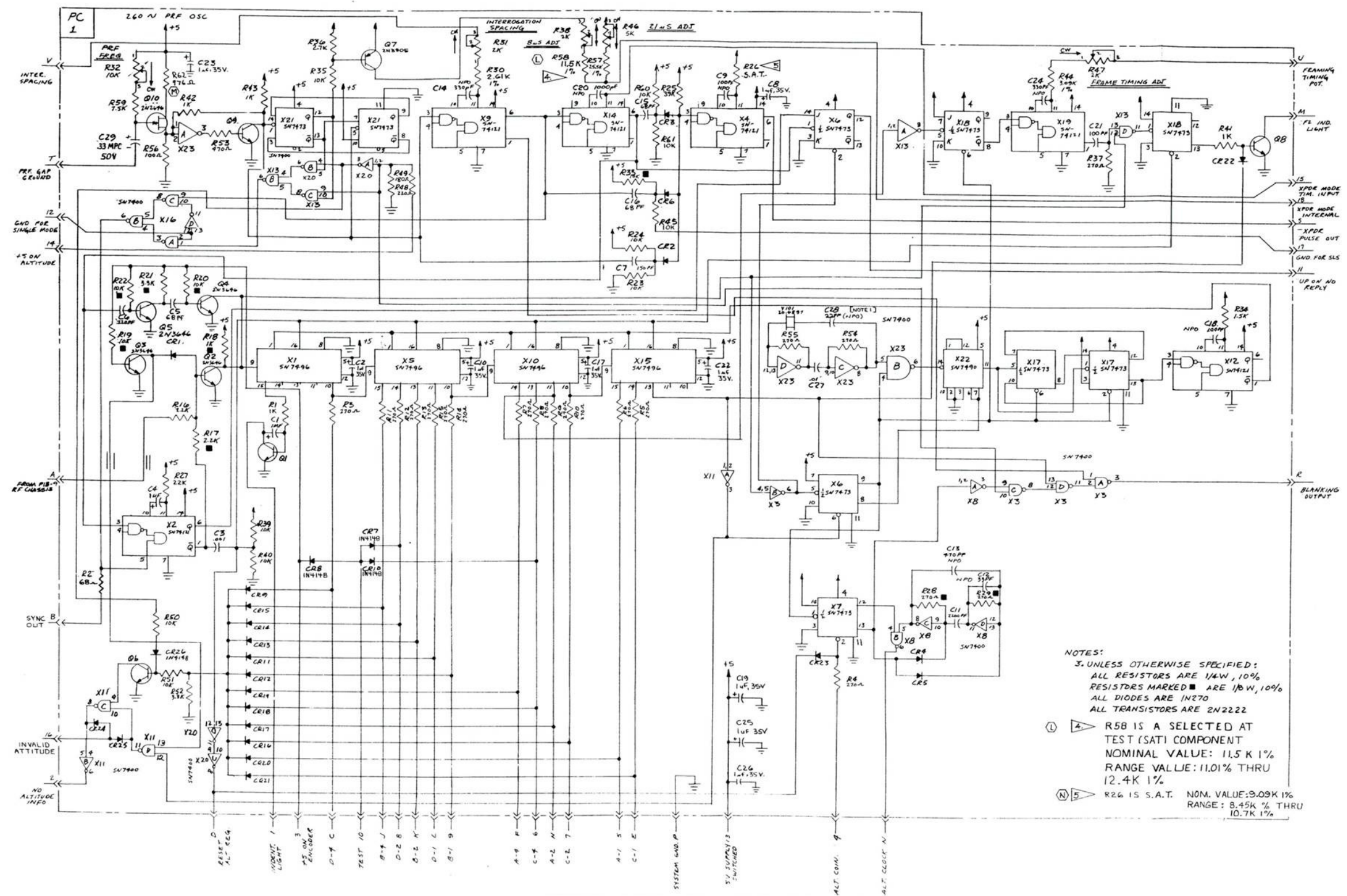

XPDR Signal PC Board Assembly Circuit Schematic
(0000-0831-500-N1)

XPDR Signal PC Board Assembly (Sheet 2 of 2)
Figure 26

THIS PAGE INTENTIONALLY LEFT BLANK.