

APPENDIX D - CONTROLS, CONNECTORS AND INDICATORS

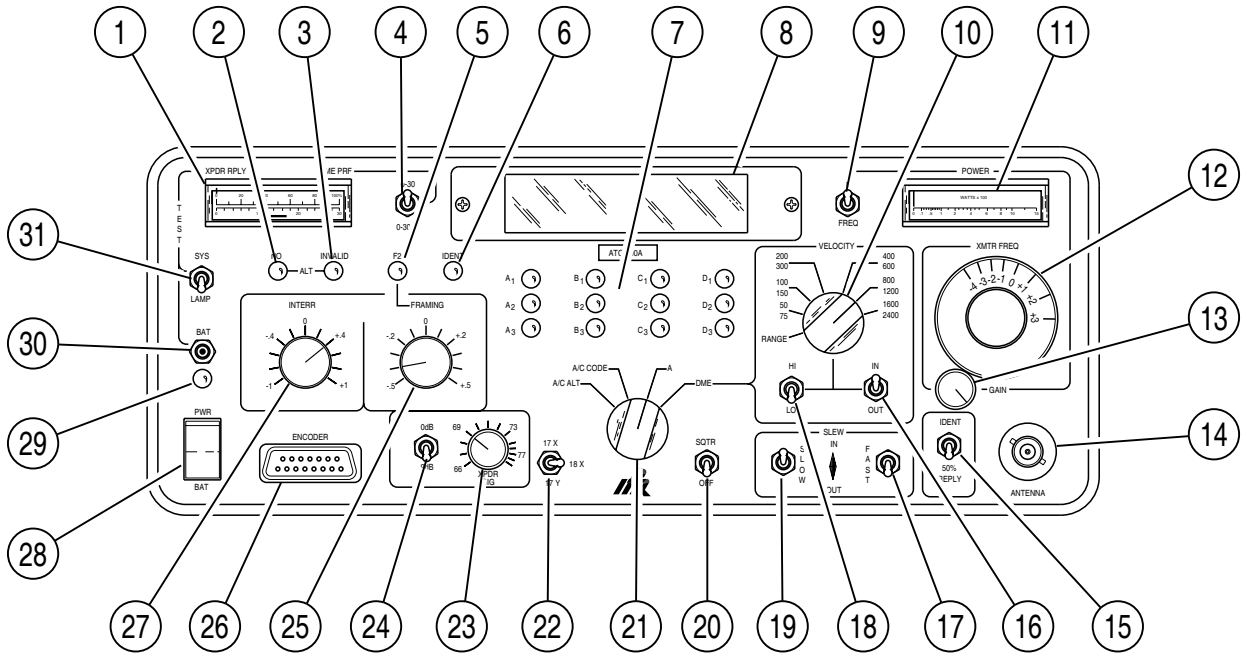

00807011

Front Panel
Figure 1

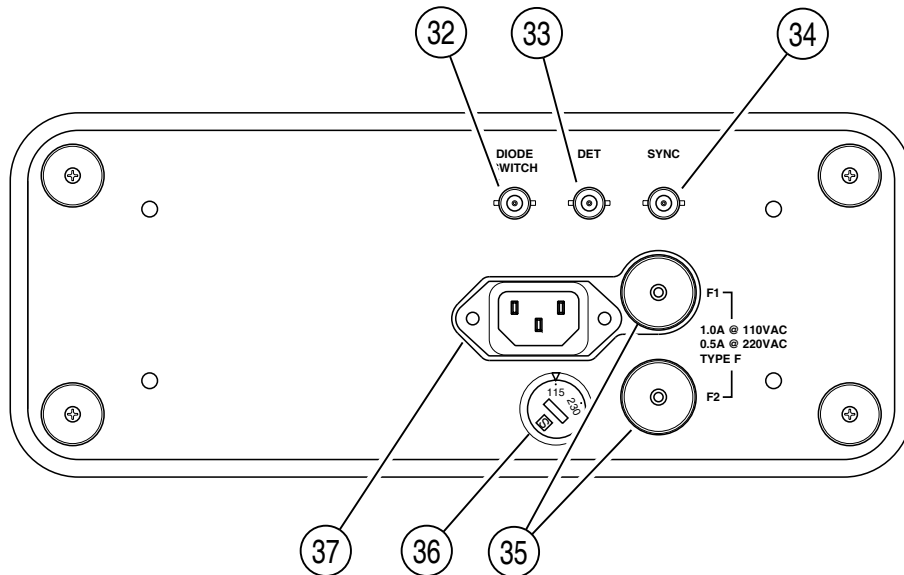

00807010

Rear Panel
Figure 2



CONTROLS, CONNECTORS AND INDICATORS IN NUMERIC ORDER		CONTROLS, CONNECTORS AND INDICATORS IN ALPHABETICAL ORDER	
XPDR % RPLY/DME PRF Meter	1	0/OFF/-9 dB SLS Switch	24
NO ALT Indicator	2	AC POWER Connector	37
INVALID ALT Indicator	3	ALTITUDE ENCODER INPUT Connector	26
DME PRF Switch	4	BAT TEST Switch	30
F ₂ PULSE SPACING Indicator	5	OCTAL READOUT Indicators	7
IDENT PULSE Indicator (SPI)	6	DETECTED RF VIDEO OUTPUT Connector	33
OCTAL READOUT Indicators	7	DIODE SWITCH INPUT Connector	32
NUMERICAL Readout	8	DME CHANNEL Switch	22
FREQ/PWR Switch	9	DME PRF Switch	4
DME RANGE/VELOCITY Switch	10	DME RANGE/VELOCITY Switch	10
FREQ/PWR Meter	11	F ₂ PULSE SPACING Indicator	5
XMTR FREQ Control	12	FAST SLEW Switch	17
FREQ GAIN Control	13	FRAMING PULSE SPACING Control	25
RF INPUT/OUTPUT Connector	14	FREQ GAIN Control	13
IDENT/50% RPLY Switch	15	FREQ/PWR Meter	11
VELOCITY IN/OUT Switch	16	FREQ/PWR Switch	9
FAST SLEW Switch	17	FUSES	35
VELOCITY HI/LO RANGE Switch	18	IDENT/50% RPLY Switch	15
SLOW SLEW Switch	19	IDENT PULSE Indicator (SPI)	6
SQUITTER ON/OFF Switch	20	INTERROGATION SPACING Control	27
MODE Switch	21	INVALID ALT Indicator	3
DME CHANNEL Switch	22	MODE Switch	21
XPDR SIGNAL LEVEL Control	23	NO ALT Indicator	2
0/OFF/-9 dB SLS Switch	24	NUMERICAL Readout	8
FRAMING PULSE SPACING Control	25	PWR/BAT Switch	28
ALTITUDE ENCODER INPUT Connector	26	PWR Indicator	29
INTERROGATION SPACING Control	27	RF INPUT/OUTPUT Connector	14
PWR/BAT Switch	28	SLOW SLEW Switch	19
PWR Indicator	29	SQUITTER ON/OFF Switch	20
BAT TEST Switch	30	SYNC OUTPUT Connector	34
SYS/LAMP TEST Switch	31	SYS/LAMP TEST Switch	31
DIODE SWITCH INPUT Connector	32	VELOCITY HI/LO RANGE Switch	18
DETECTED RF VIDEO OUTPUT Connector	33	VELOCITY IN/OUT Switch	16
SYNC OUTPUT Connector	34	VOLTAGE SELECT Switch	36
FUSES	35	XMTR FREQ Control	12
VOLTAGE SELECT Switch	36	XPDR % RPLY/DME PRF Meter	1
AC POWER Connector	37	XPDR SIGNAL LEVEL Control	23

1. Front Panel

Refer to Appendix D, Figure 1.

ITEM	DESCRIPTION
1. XPDR % RPLY/DME PRF Meter	<p>In Transponder Modes (A/C ALT, A/C CODE and A settings of MODE Switch), indicates the percent reply of the Transponder (in the operation mode selected).</p> <p>In DME Mode (DME setting of MODE Switch), indicates the Pulse Repetition Frequency (PRF) of the DME under test.</p>
2. NO ALT Indicator	<p>When lit, indicates No Altitude pulses are present between F1 and F2 of the Transponder's altitude reply.</p>
3. INVALID ALT Indicator	<p>When lit, indicates a received altitude code has an unassigned combination of codes.</p> <p>The conditions to VALID Altitude information are the presence of at least one of the C Pulses (C1, C2 or C4) and never C1 and C4 ON at the same time.</p>
4. DME PRF Switch	<p>Selects the full scale range (in PRF) of the XPDR % RPLY/DME PRF Meter:</p> <ul style="list-style-type: none"> ● 0-30 is used for track rates. ● 0-300 is used for search rates. <p>NOTE: The interrogation Pulse Repetition Frequency (PRF) is fixed at 235 pps. (Only in Transponder Mode.)</p>
5. F2 PULSE SPACING Indicator	<p>When lit, the FRAMING PULSE SPACING Control is positioned to a time when no part of the F2 pulse is present. If the FRAMING PULSE SPACING Control is at or near zero, and the F2 PULSE SPACING Indicator is lit, the 2nd framing pulse in the Transponder reply is improperly spaced, is too narrow for normal operation or is absent altogether.</p> <p>NOTE: If F2 is out of position, all other reply pulses between F1 and F2 may be skewed out of position.</p>
6. IDENT PULSE Indicator	<p>When lit, indicates the Ident Pulse (SPI) is present in the reply.</p> <p>When the Test Set is in A/C ALT Mode, the Ident Pulse is paired with the D4 pulse.</p> <p>NOTE: Active in Transponder Modes only.</p>
7. NUMERICAL Readout	<p>Displays pilot's code (as set into the Control Head) when the MODE Switch is set to A/C CODE.</p> <p>Displays altitude from -1.0 thousand to +126.7 thousand feet when the MODE Switch is set to A/C ALT.</p> <p>Displays altitude of Encoding Altimeter when an Encoding Altimeter is connected to the ALTITUDE ENCODER INPUT Connector.</p> <p>Displays range in nautical miles when the MODE Switch is set to DME.</p>

ITEM	DESCRIPTION
8. OCTAL READOUT Indicators	<p>Indicates which pulses are activating the NUMERICAL Readout when the MODE Switch is set to A/C ALT.</p> <p>NOTE: The altitude code is a Gray Daytex code.</p> <p>Indicates pilot's code (set in the Transponder Control Head) in binary form when MODE Switch is set to A/C CODE or A.</p> <p>NOTE: Active in Transponder Modes only.</p>
9. DME RANGE/VELOCITY Switch	<p>RANGE yields fixed range replies. (Starting range is set with the FAST SLEW Switch and/or SLOW SLEW Switch.)</p> <p>VELOCITY is divided into two crystal-controlled steps (50/75, 100/150, etc.). (The VELOCITY HI/LO RANGE Switch determines which of the two values to be selected in VELOCITY mode.) (Starting range is set with the FAST SLEW Switch and/or SLOW SLEW Switch.)</p> <p>NOTE: The FAST SLEW Switch and SLOW SLEW Switch operate in VELOCITY Mode in actual system range increments of approximately 0.025 NM. However, the velocity range is displayed on the NUMERICAL Readout in 0.1 NM steps only.</p>
10. FREQ/PWR Switch	<ul style="list-style-type: none"> ● FREQ switches FREQ/PWR Meter to display frequency deviation. ● PWR switches FREQ/PWR Meter to display peak power.
11. FREQ/PWR Meter	<p>When the FREQ/PWR Switch is set to PWR, FREQ/PWR Meter displays peak power from 0 to 1.5 kW (if test antenna spacing from the aircraft is correct or a 34 dB pad and coaxial cable are used).</p> <p>NOTE: The 34 dB pad and coaxial cable are not supplied with the unit.</p> <p>When the FREQ/PWR Switch is set to FREQ, FREQ/PWR Meter displays frequency deviation of the UUT from desired frequency.</p>
12. XMTR FREQ Control	<p>Used to tune the FREQ/PWR Meter needle for maximum deflection.</p> <p>In Transponder operation, frequency deviation (from 1090 MHz) of the UUT is read directly from the XMTR FREQ Control in MHz.</p> <p>In DME operation, frequency deviation (from 1041 MHz) of the UUT is read directly from the XMTR FREQ Control in MHz.</p> <p>NOTE: The Plus (+) and minus (-) signs on the XMTR FREQ Control are reversed in DME operation (positive values are left of zero and negative values are right of zero).</p>
13. FREQ GAIN Control	<p>Regulates amount of current to the FREQ/PWR Meter to enable all signals (weak and powerful) to display equally.</p>

ITEM	DESCRIPTION
14. RF INPUT/OUTPUT Connector	<p>Used to connect up a remote test antenna (ramp operation) or a 34 dB pad and coaxial cable (bench operation).</p> <p>NOTE: The 34 dB pad and coaxial cable are not supplied with the unit.</p>
15. IDENT/50% RPLY Switch	<ul style="list-style-type: none"> ● IDENT sends a 1350 Hz tone to the DME. ● 50% RPLY deletes 50% of the replies to a DME on a 50-50 basis.
16. VELOCITY IN/OUT Switch	<p>Selects the direction of the replied range in VELOCITY Mode:</p> <ul style="list-style-type: none"> ● IN - towards the ground station. ● OUT - away from the ground station. <p>NOTE: When the inbound range reaches 0.0 NM, the range instantly changes to 399.0 NM and continues inbound. When the outbound range reaches 399.0 NM, the range instantly changes to 0.0 NM and continues outbound.</p>
17. FAST SLEW Switch	<p>Sets DME replied distance or range approximately 10 times faster than the SLOW SLEW Switch. Range is slewed from 0.0 to 399.0 NM in approximately 10.0 NM steps (inbound or outbound).</p>
18. VELOCITY HI/LO RANGE Switch	<p>Determines which of the two crystal-controlled increments (50/75, 100/150, etc.) selected by the DME RANGE/VELOCITY Switch to implement:</p> <ul style="list-style-type: none"> ● HI selects the greater of the two values. ● LO selects the lesser of the two values.
19. SLOW SLEW Switch	<p>Sets DME replied distance or range approximately 10 times slower than the SLOW SLEW Switch. Range is slewed from 0.0 to 399.0 NM in 1.0 NM steps (inbound or outbound).</p>
20. SQUITTER ON/OFF Switch	<ul style="list-style-type: none"> ● SQTR turns squitter ON in DME Operation. ● OFF turns squitter OFF in DME Operation. <p>NOTE: Squitter is fixed to an average of 2700 PRF at a random rate.</p>
21. MODE Switch	<p>Determines which Transponder Mode (AC ALT, A/C CODE or A) or DME Mode is active.</p>

ITEM	DESCRIPTION
------	-------------

22. DME CHANNEL Switch

Selects one of three DME channels (**17X**, **17Y** or **18X**).

Refer to Appendix D, Table 1 for appropriate reply frequency and pulse spacing.

CHANNEL	VOR-PAIRED FREQUENCY
17X	108.00 MHz
18X	108.10 MHz
17Y	108.05 MHz

GROUND TO AIR		
CHANNEL	FREQUENCY	SPACING
17X	978 MHz	12 μ s
18X	979 MHz	12 μ s
17Y	1104 MHz	30 μ s

AIR TO GROUND		
CHANNEL	FREQUENCY	SPACING
17X	1041 MHz	12 μ s
18X	1042 MHz	12 μ s
17Y	1041 MHz	36 μ s

DME Frequency/Spacing Assignments
Table 1

23. XPDR SIGNAL LEVEL Control

Varies the Transponder output signal level at the receiver antenna from -66 to -79 dBm (± 1.5 dBm). (Valid with the remote test antenna or 34 dB pad and coaxial cable.)

NOTE: The 34 dB pad and coaxial cable are not supplied with the unit.

24. 0/OFF/-9 dB SLS Switch

- **OFF** - P1 and P3 of the Transponder interrogation are transmitted.
- **0dB** - P2 is added at the same level as P1.
- **-9dB** - P2 is added at -9 dB amplitude, relative to P1.

25. FRAMING PULSE SPACING Control

Used to calculate the position and width of the the F2 pulse by rotating cw or ccw until the F2 PULSE SPACING Indicator is lit (indicating the exact leading and trailing edges of the F2 pulse).

NOTE: The approximate width of the F2 pulse equals the difference between the lowest and highest FRAMING PULSE SPACING Control settings at which the F2 PULSE SPACING Indicator is lit.

ITEM	DESCRIPTION
26.	<p>ALTITUDE ENCODER INPUT Connector</p> <p>Used for direct connection of altimeter output for encoding altimeter testing. (MODE Switch must be set to A/C ALT for altimeter testing and input pulse must be per ARINC 532D [Appendix D, Figure 3].)</p> <p>NOTE: ALTITUDE ENCODER INPUT Connector Pin-Out is shown in Appendix A.</p>
27.	<p>INTERROGATION SPACING Control</p> <p>Used to adjust the interrogation spacing from P1 to P2 and P3 in Transponder operation.</p> <p>P1 and P3 interrogation spacing is set at 8 and 21 μs. P2 interrogation spacing is 2 μs.</p> <p>The INTERROGATION SPACING Control moves P2 and P3 $\pm 1.0 \mu$s relative to P1. P2 and P3 spacing remains constant. (Refer to Appendix D, Figure 3)</p>
28.	<p>PWR/BAT Switch</p> <p>Two position switch controls power to the Test Set:</p> <ul style="list-style-type: none"> ● PWR connects Test Set to ac line power connected to AC IN Connector. ● BAT connects or disconnects Test Set from internal Battery. Connecting the Test Set to the Battery activates an internal battery timer. Test Set operation disconnects from the internal Battery after reaching the internal battery timer limit (approximately 6 to 10 minutes) or by pressing the PWR/BAT Switch to BAT to disconnect.
29.	<p>PWR Indicator</p> <p>Is lit when applying ac or battery power to the Test Set.</p>
30.	<p>BAT TEST Switch</p> <p>When pressed, indicates battery voltage on XPDR % RPLY/DME PRF Meter. (Left edge of white band indicates 12.1 V.)</p>
31.	<p>SYS/LAMP TEST Switch</p> <ul style="list-style-type: none"> ● LAMP - all OCTAL READOUT Indicators are lit. ● SYS - F2 PULSE SPACING Indicator and the BINARY READOUT Indicators (C4 and D2) are lit; internal circuits are checked in Transponder Modes: <ul style="list-style-type: none"> ● AC ALT - NUMERICAL Readout displays 126.7 thousand feet. ● A/C CODE - NUMERICAL Readout displays 0042. <p>NOTE: Center position is OFF.</p>

2. Rear Panel

Refer to Appendix D, Figure 2.

ITEM	DESCRIPTION
32. DIODE SWITCH INPUT Connector	Used with an high impedance probe to monitor all modulator pulses sent to the internal diode switch.
33. DETECTED RF VIDEO OUTPUT Connector	Used with an high impedance probe to monitor detected RF Video from the UUT.
34. SYNC OUTPUT Connector	Used with an high impedance probe to monitor the positive going TTL level pulse (present during Transponder operation). NOTE: Pulse should be coincident with the leading edge of P1 of the Transponder interrogation. Used, with a coaxial cable connected to an external Oscilloscope Sync/Trigger Connector, for viewing XPDR Interrogation and/or Reply Pulses. NOTE: The coaxial cable is not supplied with the unit.
35. FUSES	Fuses input power to the Test Set. Refer to 1-2-1, Table 1 in ATC-600A-2 Operation Manual for correct fuse size and type.
36. VOLTAGE SELECT Switch	Selects 115 or 230 VAC to match input ac power.
37. AC POWER Connector	Provides input for external ac power. Refer to Appendix C for Power Requirements.

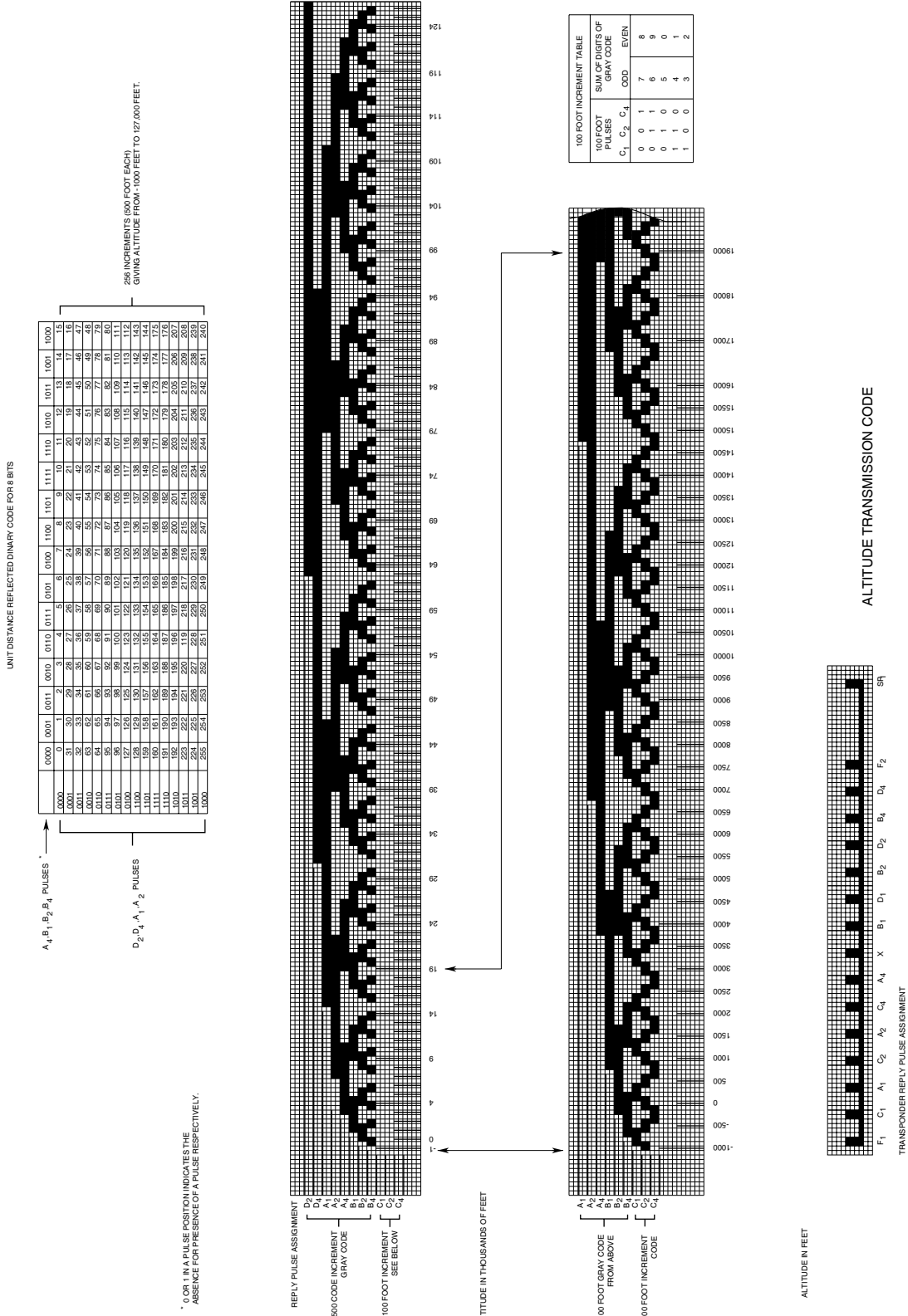

Altitude Pulse Position Assignment Chart (ARINC 532D)
Figure 3



THIS PAGE INTENTIONALLY LEFT BLANK.