

APPENDIX F - HETERODYNE MONITOR

The materials required to construct the Heterodyne Monitor used in the maintenance procedures contained in this manual are listed in Appendix F, Table 1. Appendix F, Figure 1 shows the circuit schematic for constructing the Heterodyne Monitor.

CAUTION: KEEP ALL LEADS TO COMPONENTS AS SHORT AS POSSIBLE TO REDUCE STRAY INDUCTANCE.

QUANTITY	DESCRIPTION
1	Shielded Enclosure
2	BNC Connector (Female)
1	BNC Connector (Male)
1	Mixer (ANZAC MD-113)
2	Inductor ($0.15 \mu\text{H}$)
1	Inductor ($0.33 \mu\text{H}$)
2	Capacitor (68 pF)
1	Capacitor (120 pF)
1	Resistor (5% , $1/4 \text{ W}$, 150Ω)

Heterodyne Monitor Components
Table 1

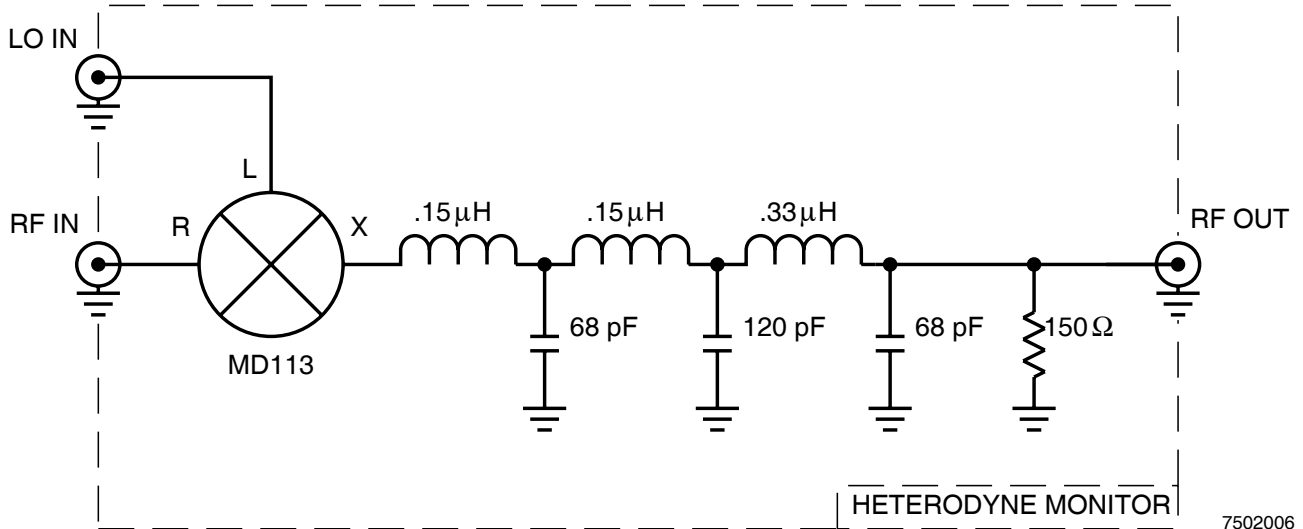

Heterodyne Monitor Circuit Schematic
Figure 1

7502006