

APPENDIX G - CONTROLS, CONNECTORS AND INDICATORS

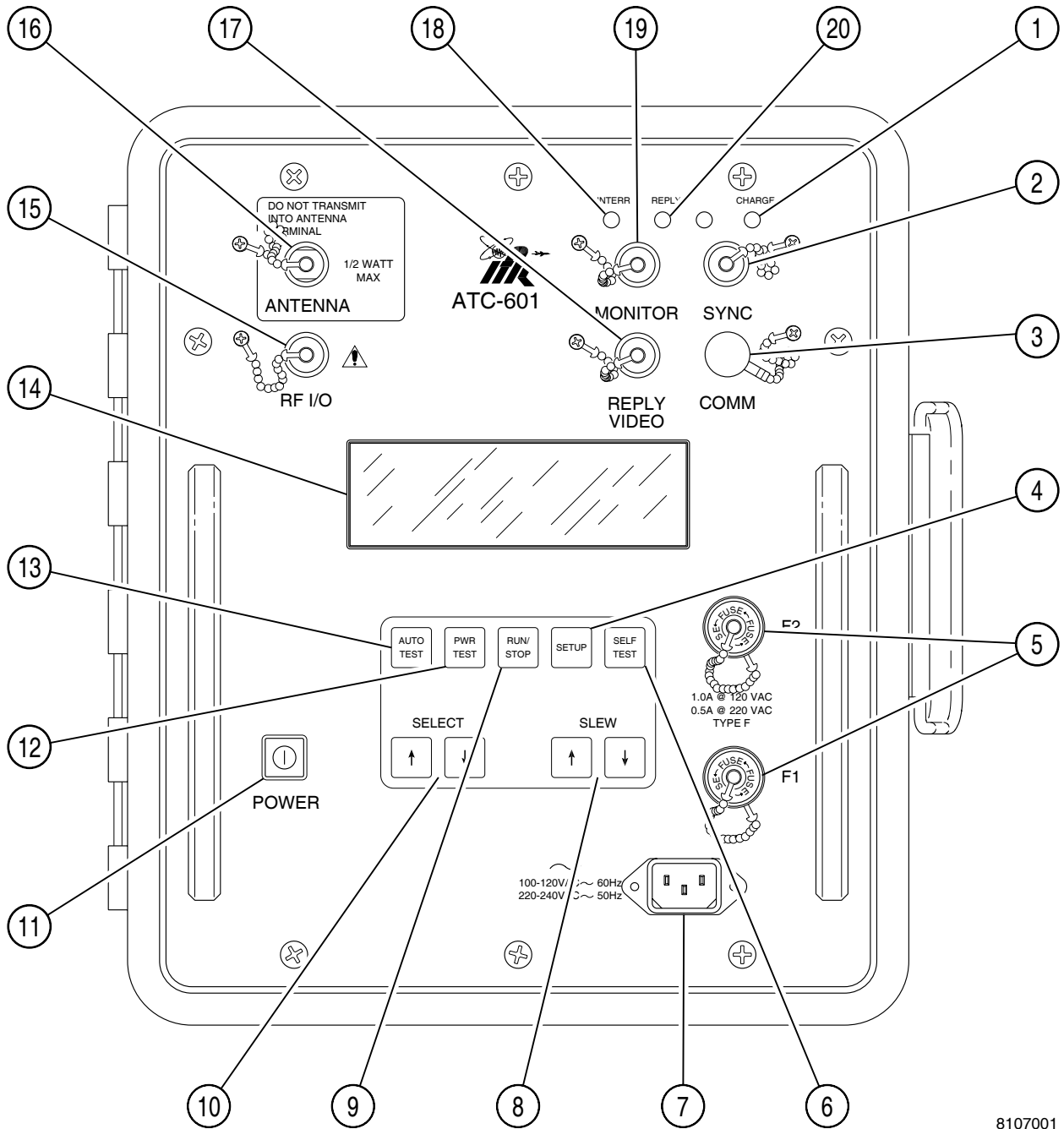



ATC-601-2 Front Panel
Figure 1

8107001

1. Front Panel

Refer to Appendix G, Figure 1.

ITEM	DESCRIPTION
1. CHARGE Indicator	LED indicates the charger is active (ac applied with Test Set Off). Red indicates when battery is charging and green indicates battery is more than 80% charged.
2. SYNC Connector (J10055)	BNC type connector provides Oscilloscope Sync. Long pulse goes from low to high before an interrogation and from high to low before an expected reply.
3. COMM Connector (J10053)	LEMO type connector provides for remote 4-line serial communication (with Option 1 installed) and includes the signals TRANSMIT, RECEIVE, DTR and CTS. The COMM Connector provides data dump output capability with or without Option 1 installed. Refer to COMM Connector Pin-Out Table in Appendix A.
4. SETUP Key	Enters Setup Menus onto the DISPLAY.
5. FUSES	Provide safe operation with ac input power applied to the ATC-601. Refer to Appendix F for correct fuse size and type.
6. SELF TEST Key	Enters Self Test screen onto the DISPLAY.
7. AC PWR Connector (J10050) 	Provides the input for an external ac power source (100 to 120 VAC at 60 Hz or 220 to 240 VAC at 50 Hz) for recharging the battery or operating the Test Set. The operating voltage range depends on the Line Supply Switch Setting, only serviceable by a qualified technician. Refer to Battery/Voltage Instructions in the ATC-601-2 Operation Manual.
8. SLEW Keys	<p>Used to:</p> <ul style="list-style-type: none"> ● Adjust values and parameters in Setup Menus. ● Select Signal Type in Diagnostics screen. ● Adjust values in Diagnostics screen. ● Select antenna to be tested in Power Test. <p>Variable slew rates are available, depending on item being edited. Keeping SLEW Key pressed provides greater rate of change, in most instances, than pressing and releasing.</p>
9. RUN/STOP Key	Starts or stops testing.

ITEM	DESCRIPTION
10. SELECT Keys	Used to select: <ul style="list-style-type: none"> ● Test to perform in Single Test. ● Items to edit in Setup Menus. ● Antenna to be tested in Power Test. ● Diagnostics screen menu from Self Test screen.
11. POWER Key 	Applies power to the Test Set; push On (I) or push Off (O). NOTE: When operating on battery power, an internal automatic time-out removes power from the Test Set following 15 minutes of no key activity.
12. PWR TEST Key	Enters Power Test screen onto the DISPLAY.
13. AUTO TEST Key	Enters Auto Test screen onto the DISPLAY.
14. DISPLAY	LCD readout displays various test screens.
15. RF I/O Connector (J10058) 	CAUTION: MAXIMUM INPUT POWER MUST NOT EXCEED +59 dBm (800 W). TNC type connector provides for RF input and output when directly connected with the UUT (Direct Connect).
16. ANTENNA Connector (J10057)	CAUTION: DO NOT TRANSMIT DIRECTLY INTO ANTENNA TERMINAL. MAXIMUM OVER-THE-AIR INPUT POWER MUST NOT EXCEED 1/2 W. BNC type connector is used with the Test Set Antenna (Flat Antenna or Flexible Antenna). Over-the-air testing of the UUT is accomplished through the ANTENNA connector. The connector cover, when attached, provides the 50 Ω load required when connecting the RF I/O Connector to the UUT (Direct Connect) or running the Self Test.
17. REPLY VIDEO Connector (J10054)	BNC type connector provides demodulated (detected) reply (only when direct connection with UUT is used) for use with an Oscilloscope.
18. INTERR Indicator	Illuminates when Test Set is generating an interrogation signal.
19. MONITOR Connector (J10056)	BNC type connector provides interrogation and reply pulses clipped at 50% amplitude point to preserve pulse shape.
20. REPLY Indicator	Illuminates when the Test Set receives a valid reply signal.

2. Flat Antenna

Refer to Appendix G, Figure 2.

ITEM	DESCRIPTION
21. ANTENNA PUSH BUTTON Switch	Starts or stops testing, same as the RUN/STOP Key.
22. FLAT ANTENNA Connector (J29001)	BNC type connector is used to connect Flat Antenna to ATC-601 Test Set.

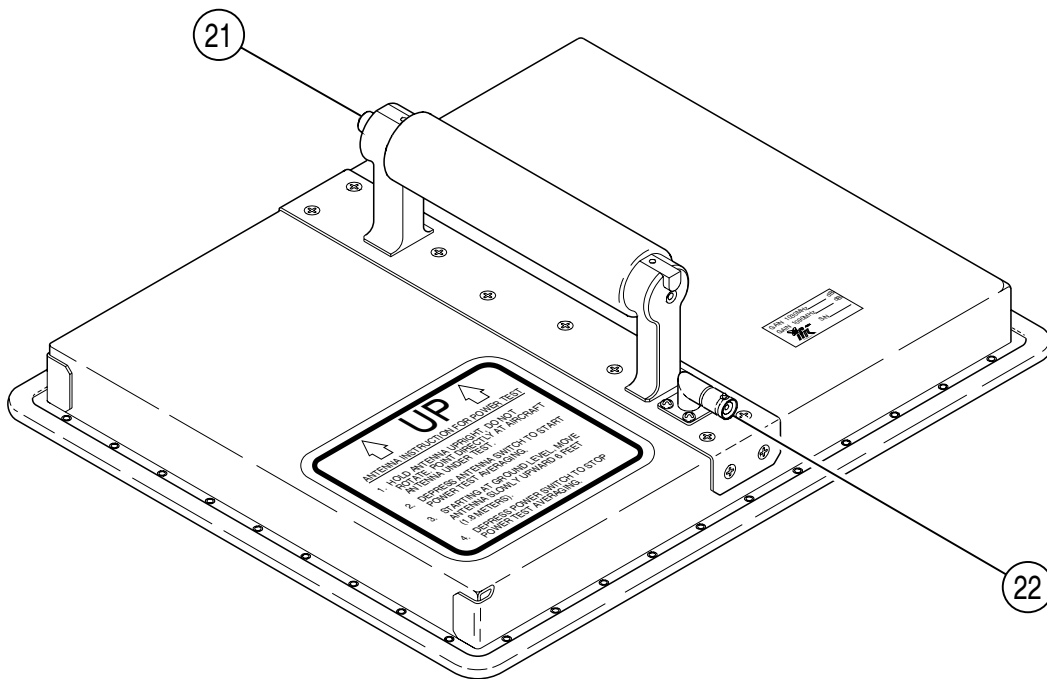

8507007

Flat Antenna
Figure 2