



2. Calibration/Verification

A. General

<u>VERIFICATION PROCEDURE</u>	<u>PAGE</u>
Signal Generator-----	7
Pulse Characteristics -----	9
UUT Measurements -----	13
Overall-----	25
<u>CALIBRATION PROCEDURE</u>	<u>PAGE</u>
Power Supply-----	33
RF Assembly-----	34
LO Source -----	34
Attenuator -----	35
Isolation Null-----	37
Generator Output Power -----	38
Generator Image -----	38
LO Null -----	38
Receive Image -----	39
Receive Power-----	39
Isolation Reset -----	40
Detector Pulse Width -----	40
Direct Connect Set-----	41
RF Bit Detector Set-----	42
Oscillator Compensation-----	42
System-----	44
Self Test -----	44
Receive Power System Recheck -----	44
Isolation System Recheck -----	44
Generator Power System Recheck-----	45
Mixer Nulls -----	45

(1) Calibration/Verification Schedule

The Calibration/Verification Procedures should be performed as a result of one or more of the following conditions:

- Failure to Meet Specifications

If, during the course of normal operation, the ATC-601-2 or any major function thereof fails to meet the performance specifications according to Appendix F, Calibration/Verification Procedures should be performed.

If any failure occurs during performance of Verification Procedures, pertinent Calibration Procedures should be performed according to 2-2-2, Table 15.

- Module/Assembly Replacement

If one or more ATC-601-2 assemblies are replaced, Calibration Procedures should be performed according to 2-2-2, Table 14.

- Annual Calibration/Verification

Aeroflex recommends an annual Calibration/Verification on the ATC-601-2 to maintain proper testing standards.

(2) Controls, Connectors and Indicators

Refer to Appendix G for location of external Controls, Connectors and Indicators.

(3) Test Record

Calibration and Verification Data Sheets are provided for recording the results obtained while performing the Calibration or Verification Procedures.

NOTE: It is recommended the technician reproduce copies of the Calibration and Verification Data Sheets, rather than use copies in this manual.

If this assembly is repaired or replaced, the following Calibration Procedures must be performed.		Analog IF Assembly	Attenuator PC Board Assembly	Battery	Detector Assembly	Digital IF PC Board Assembly	Driver PC Board Assembly	Front Panel Pulse PC Board Assembly	LO Source PC Board Assembly	Mixer PC Board Assembly	Power Supply Assembly
		Power Supply				●					
RF Assembly	LO Source						●	●	●		●
	Attenuator		●				●	●			●
	Isolation Null	●	●						●	●	●
	Generator Output Power	●	●						●	●	●
	Generator Image	●	●						●	●	●
	LO Null	●	●						●	●	●
	Receive Image	●	●						●	●	●
	Receive Power	●	●						●	●	●
	Isolation Reset	●	●						●	●	●
	Detector Pulse Width	●			●						●
	Direct Connect Set	●					●				●
	RF Bit Detector Set	●	●				●	●	●	●	●
	Oscillator Compensation	●									●
System	Self Test	●	●	●	●	●	●	●	●	●	●
	Receive Power System Recheck	●	●			●			●	●	●
	Isolation System Recheck	●	●			●			●	●	●
	Generator Power System Recheck	●	●						●	●	●
	Mixer Nulls	●	●						●	●	●

Assembly Replacement Calibration Requirements
Table 14

If this Verification Procedure has failed, the following Calibration Procedures must be performed.		Output Frequency	Output Level/UUT Receiver Sensitivity	Direct Connection	UUT Transmitter Frequency	UUT Transmitter Power
Power Supply						
RF Assembly	LO Source					
	Attenuator		●			●
	Isolation Null		●			●
	Generator Output Power		●			●
	Generator Image		●			●
	LO Null		●			●
	Receive Image		●			●
	Receive Power		●			●
	Isolation Reset					
	Detector Pulse Width					
	Direct Connect Set			●		
	RF Bit Detector Set		●			●
	Oscillator Compensation	●			●	
System	Self Test		●		●	
	Receive Power System Recheck		●		●	●
	Isolation System Recheck		●		●	●
	Generator Power System Recheck		●		●	●
	Mixer Nulls		●		●	●

Verification Failure Calibration Requirements
Table 15

B. Precautions

(1) Safety

- WARNING:** REMOVE ALL JEWELRY OR OTHER COSMETIC APPAREL BEFORE PERFORMING ANY CALIBRATION/VERIFICATION PROCEDURE INVOLVING LIVE CIRCUITS.
- WARNING:** WHEN WORKING WITH LIVE CIRCUITS OF HIGH POTENTIAL, KEEP ONE HAND IN POCKET OR BEHIND BACK TO AVOID SERIOUS SHOCK HAZARD.
- WARNING:** USE ONLY INSULATED TROUBLESHOOTING TOOLS WHEN WORKING WITH LIVE CIRCUITS.
- WARNING:** FOR ADDED INSULATION, PLACE RUBBER BENCH MAT UNDERNEATH ALL POWERED BENCH EQUIPMENT, AS WELL AS A RUBBER MAT UNDERNEATH TECHNICIAN'S CHAIR.
- WARNING:** HEED ALL WARNINGS AND CAUTIONS CONCERNING MAXIMUM VOLTAGES AND POWER INPUTS.

(2) ESD

- CAUTION:** THE POWER SUPPLY ASSEMBLY, DIGITAL IF PC BOARD ASSEMBLY, FRONT PANEL PULSE PC BOARD ASSEMBLY, RF ASSEMBLY, AND FRONT PANEL ASSEMBLY CONTAIN PARTS SENSITIVE TO DAMAGE BY ELECTROSTATIC DISCHARGE (ESD). ALL PERSONNEL PERFORMING CALIBRATION PROCEDURES SHOULD HAVE KNOWLEDGE OF ACCEPTED ESD PRACTICES AND/OR BE ESD CERTIFIED.

(3) EMC and Safety Compliance

All assemblies, cables, connectors, plastic fasteners, gaskets, fingerstock and miscellaneous hardware within the Test Set are configured to satisfy the safety and EMC compliance standards.

- CAUTION:** UPON COMPLETION OF ANY MAINTENANCE ACTION; ALL ASSEMBLIES, CABLES, CONNECTORS, PLASTIC FASTENERS, GASKETS, FINGERSTOCK AND MISCELLANEOUS HARDWARE MUST BE CONFIGURED AS INSTALLED AT THE FACTORY.

C. Requirements

(1) Performance

It is strongly recommended that personnel thoroughly read and understand all steps of the procedures to be performed and be familiar with the circuit under test. Knowledge of power, frequency and waveform to be expected at each test point is recommended.

NOTE: When one circuit provides the same pulse characteristic for different pulses, it is necessary to test the specifications for that characteristic only once.

(2) Test Equipment

Appendix B contains a list of test equipment suitable for performing any procedure contained in this manual. Other equipment meeting specifications listed in Appendix B may be substituted in place of recommended models.

NOTE: For certain procedures in this manual, the equipment listed in Appendix B may exceed minimum required specifications.

(3) Disassembly

No disassembly is required to perform Verification Procedures. The Chassis Assembly must be removed from Case Assembly to perform Calibration Procedures. For better access, the RF Assembly is removed from Chassis Assembly in Calibration Procedures.

(4) Environment

For best results, environmental conditions should be identical to the conditions at the normal operating location.

D. Verification Procedures

NOTE: Pulse spacings are measured from rising edge to rising edge at the 50% amplitude points. Pulse widths are measured from rising edge to falling edge at the 50% amplitude points.

(1) Signal Generator

TEST EQUIPMENT: 1 3 dB Fixed Attenuator
 1 Universal Timer/Counter
 1 Measuring Receiver
 1 Power Sensor

STEP	PROCEDURE
------	-----------

OUTPUT FREQUENCY

1. Connect Universal Timer/Counter through 3 dB Attenuator to ATC-601-2 ANTENNA Connector.
2. Set Universal Timer/Counter to measure 1030 MHz with 100 Hz resolution.
3. Press SELF TEST Key and either SELECT Key to enter Diagnostics screen.
4. Set ATC-601-2 Signal Type to **CW**, PRF to **235** and Attenuation to **0**.
5. Press RUN/STOP Key to initiate test.
6. Verify frequency is 1030 MHz (± 10.0 kHz). If not, perform Calibration Procedures according to 2-2-2, Table 15.
7. Press RUN/STOP Key to terminate test.
8. Disconnect Universal Timer/Counter from 3 dB Attenuator.

OUTPUT LEVEL

9. Connect Measuring Receiver through Power Sensor and 3 dB Attenuator to ATC-601-2 Antenna Connector.
10. Press RUN/STOP Key to initiate test.
11. Verify ATC-601-2 output is -7.6 dBm (± 2.0 dB), considering 3 dB Attenuator. Record output for reference level. If not, perform Calibration Procedures according to 2-2-2, Table 15.

STEP

PROCEDURE

12. Verify 2-2-2, Table 16; setting ATC-601-2 Attenuation accordingly. If ATC-601-2 output is incorrect, perform Calibration Procedures according to 2-2-2, Table 15.

SPECIFICATION	ATTENUATION	OUTPUT LEVEL
Output Level (-7 dBm) and Receiver Sensitivity (-69 dBm) (Antenna) MTL-A	0	-7.6 dBm (± 2 dB)
Receiver Sensitivity (-77 dBm) (Antenna) MTL-A	16	-15.6 dBm (± 2 dB)
Receiver Sensitivity (-67 dBm) (Direct) MTL-D	23	-19.15 dBm (± 2 dB)
Receiver Sensitivity (-79 dBm) (Direct) MTL-D	47	-31.15 dBm (± 2 dB)
Output Level (-57 dBm)	100	-57.6 dBm (± 2 dB)
<p>NOTE: UUT Receiver Sensitivity Specification Verification is based on the following three equations:</p> <p>Output Level = -7.6 - (ATTENUATION:)/2 MTL-A = Output Level - Cable Loss + Antenna Gain - Path Loss MTL-D = Output Level - 48.25</p>		

Output Level/UUT Receiver Sensitivity
 Table 16

13. Press RUN/STOP Key to terminate test.

DIRECT CONNECTION

14. Disconnect 3 dB Attenuator from ATC-601-2 ANTENNA Connector and reconnect to RF I/O Connector (BNC to TNC Adapter is required.)
15. Set ATC-601-2 Attenuation to **0**.
16. Press RUN/STOP Key to initiate test.
17. Verify output is reference from Step 11 minus 48.25 dB (± 0.5 dB). If not, perform Calibration Procedures according to 2-2-2, Table 15.
18. Press RUN/STOP Key to terminate test.
19. Disconnect test equipment.

(2) Pulse Characteristics

- TEST EQUIPMENT:
- 1 Heterodyne Monitor
 - 1 Frequency Counter
 - 2 Oscilloscopes
 - 1 RF Signal Generator
 - 1 Spectrum Analyzer

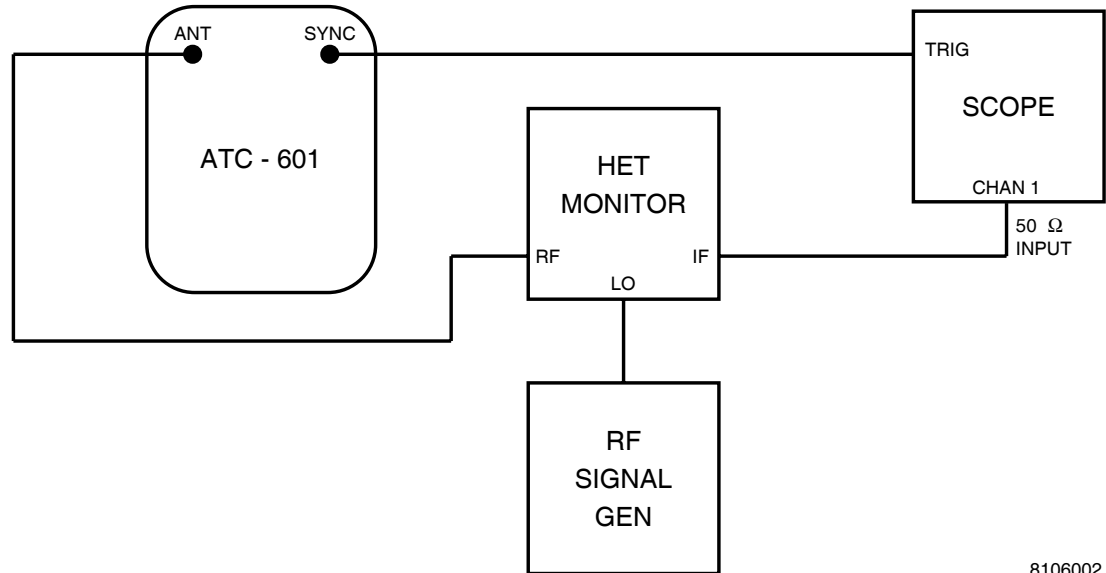

8106002

Pulse Characteristics Test Setup Diagram
Figure 18

STEP	PROCEDURE
1.	Connect test equipment according to 2-2-2, Figure 18.
2.	Set Oscilloscope to view Channel 1 with a 20 MHz bandwidth limit.
3.	Set RF Signal Generator for 1030 MHz at +5 dBm.
	SPACING
4.	Set ATC-601-2 Signal Type to ATC_A , PRF to 235 and Attenuation to 0 .
5.	Press RUN/STOP Key to initiate test.
6.	Verify P1 to P3 pulse spacing is 8.00 μs (±50 ns).
7.	Press RUN/STOP Key to terminate test.
8.	Set ATC-601-2 Signal Type to ATC_C .
9.	Press RUN/STOP Key to initiate test.
10.	Verify P1 to P3 pulse spacing is 21.00 μs (±50 ns).
11.	Press RUN/STOP Key to terminate test.
12.	Set ATC-601-2 Signal Type to FMT0 and PRF to 78 .
13.	Press RUN/STOP Key to initiate test.
14.	Verify P1 to P2 pulse spacing is 2.00 μs (±50 ns).

STEP PROCEDURE

15. Verify P₁ to P₆ pulse spacing is 3.50 μ s (\pm 50 ns).
16. Press RUN/STOP Key to terminate test.
17. Set ATC-601-2 Signal Type to **FMT4_SPR_ON**.
18. Press RUN/STOP Key to initiate test.
19. Verify P₁ to Synchronous Phase Reversal (SPR) spacing is 4.75 μ s (\pm 50 ns). Refer to 2-2-2, Figure 19.

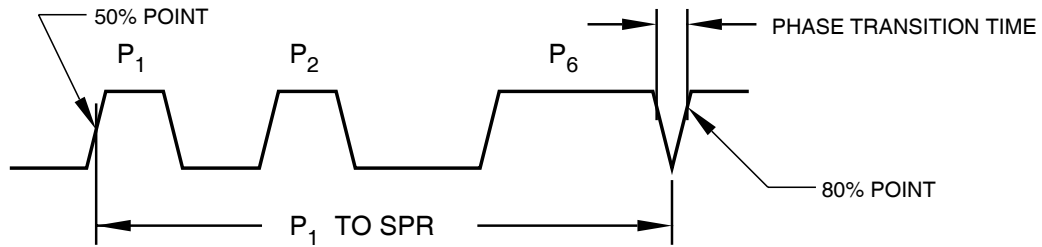

P₁ to SPR Spacing/Phase Transition Time
Figure 19

20. Press RUN/STOP Key to terminate test. Set ATC-601-2 Signal Type to **ITM_ATC_A**.
21. Press RUN/STOP Key to initiate test.
22. Verify P₁ to P₄ pulse spacing is 10.00 μ s (\pm 50 ns).
23. Press RUN/STOP Key to terminate test.
24. Set ATC-601-2 Signal Type to **ITM_MODES_C**.
25. Press RUN/STOP Key to initiate test.
26. Verify P₁ to P₄ pulse spacing is 23.00 μ s (\pm 50 ns).
27. Press RUN/STOP Key to terminate test.

WIDTHS

28. Set ATC-601-2 Signal Type to **ATC_A**, PRF to **235**.
29. Press RUN/STOP Key to initiate test.
30. Verify P₁ pulse width is 0.80 μ s (\pm 50 ns).
31. Press RUN/STOP Key to terminate test.
32. Set ATC-601-2 Signal Type to **ATC_C**.
33. Press RUN/STOP Key to initiate test.
34. Verify P₃ pulse width is 0.80 μ s (\pm 50 ns).
35. Press RUN/STOP Key to terminate test.
36. Set ATC-601-2 Signal Type to **FMT0** and PRF to **78**.
37. Press RUN/STOP Key to initiate test.
38. Verify P₂ pulse width is 0.80 μ s (\pm 50 ns).

STEP	PROCEDURE
------	-----------

39. Press RUN/STOP Key to terminate test.
40. Set ATC-601-2 Signal Type to **FMT4_SPR_ON**.
41. Press RUN/STOP Key to initiate test.
42. Verify P6 (short) pulse width is 16.25 μ s (\pm 50 ns).
43. Press RUN/STOP Key to terminate test.
44. Set ATC-601-2 Signal Type to **FMT16**.
45. Press RUN/STOP Key to initiate test.
46. Verify P6 (long) pulse width is 30.25 μ s (\pm 50 ns).
47. Press RUN/STOP Key to terminate test.
48. Set ATC-601-2 Signal Type to **ITM_ATC_A**.
49. Press RUN/STOP Key to initiate test.
50. Verify P4 (short) pulse width is 0.80 μ s (\pm 50 ns).
51. Press RUN/STOP Key to terminate test.
52. Set ATC-601-2 Signal Type to **ITM_MODES_C**.
53. Press RUN/STOP Key to initiate test.
54. Verify P4 (long) pulse width is 1.60 μ s (\pm 50 ns).
55. Press RUN/STOP Key to terminate test.

RISE AND FALL TIMES

56. Set ATC-601-2 Signal Type to **ATC_A**, PRF to **235**.
57. Press RUN/STOP Key to initiate test.
58. Verify P1 pulse rise time, from 10% amplitude point to 90% amplitude point on rising edge, is 50 to 100 ns.
59. Verify P1 pulse fall time, from 90% amplitude point to 10% amplitude point on falling edge, is 50 to 200 ns.
60. Press RUN/STOP Key to terminate test.

PHASE MODULATION: TRANSITION TIME

61. Set ATC-601-2 Signal Type to **FMT4_SPR_ON** and PRF to **78**.
62. Press RUN/STOP Key to initiate test.
63. Verify SPR transition time is between 80% points is \leq 80 ns.
64. Set Oscilloscope to view P6 and verify difference between highest and lowest transition amplitude peaks is $<$ 4 dB.
65. Press RUN/STOP Key to terminate test.

STEP

PROCEDURE

AMPLITUDE LEVELS

66. Connect Spectrum Analyzer Input to ATC-601-2 ANTENNA Connector.

67. Set Spectrum Analyzer as follows:

<u>CONTROL</u>	<u>SETTING</u>
Frequency Band	0.01 to 1.8 GHz
Center Frequency	1030 MHz
Frequency Span/Div	Max
Resolution Bandwidth	Max
Frequency Span Mode	200 kHz/Div
Sweep Source	Internal
Sweep Trigger	Free Run
Sweep Time/Div	Auto
Reference Level	0 dBm
Input Attenuation	10 dB
Log Scale	2 dB/Div

68. Set ATC-601-2 Signal Type to **CW_P4** and PRF to **235**.

69. Press RUN/STOP Key to initiate test.

70. Set and record reference point. Center signal on y axis with peak amplitude point resting on second major division above x axis.

71. Press RUN/STOP Key to terminate test.

72. Set ATC-601-2 Signal Type to **CW_M5**.

73. Press RUN/STOP Key to initiate test.

74. Verify difference in amplitude between reference point established in Step 70 and current signal position is -9 dB (± 1 dB).

75. Press RUN/STOP Key to terminate test.

76. Disconnect test equipment.

(3) UUT Measurements

- TEST EQUIPMENT:
- 1 3 dB Attenuator
 - 2 Function Generators
 - 1 Heterodyne Monitor
 - 1 Measuring Receiver
 - 1 Oscilloscope
 - 1 Power Sensor
 - 2 RF Signal Generators
 - 1 Spectrum Analyzer
 - 1 Waveform Generator

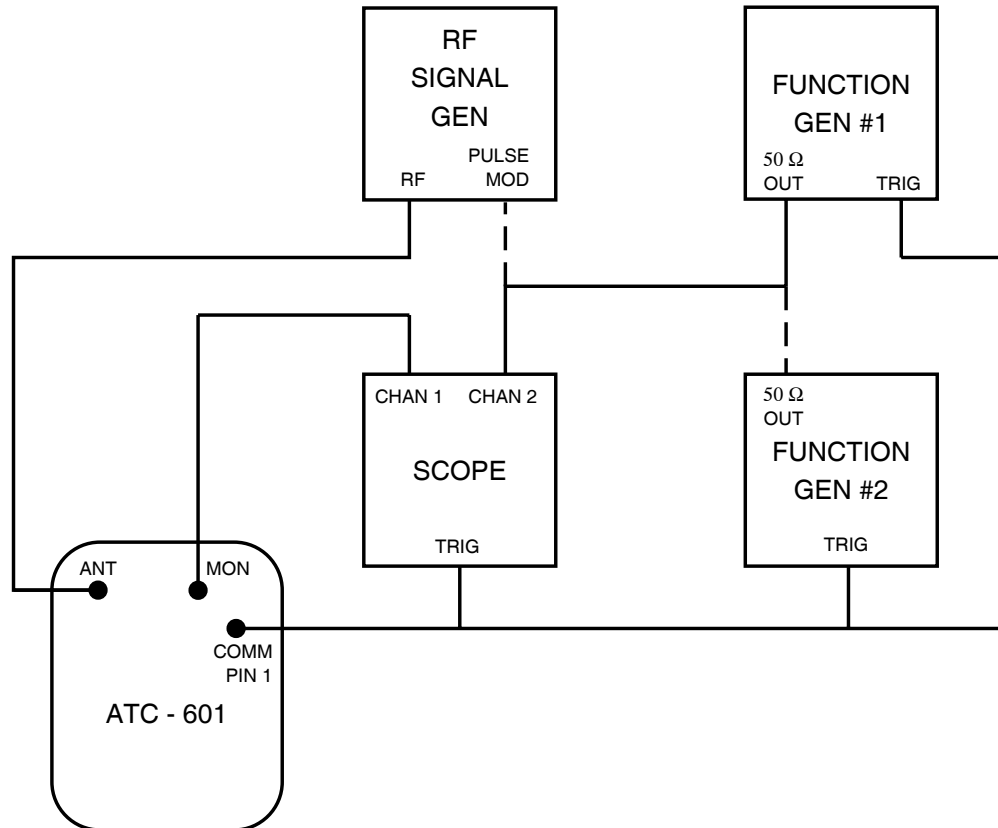

8106007

Frequency Measurement Test Setup Diagram
Figure 20

STEP	PROCEDURE
------	-----------

UUT TRANSMITTER FREQUENCY

1. Connect test equipment as shown in 2-2-2, Figure 20 with Function Generator #1 connected to Oscilloscope Channel 2.
2. Press AUTO TEST Key. Use SELECT Keys to enter Frequency Test screen.
3. Press RUN/STOP Key to initiate test.

STEP

PROCEDURE

4. Set Function Generator #1 as follows:
 - Function to pulse and PRF to 10 kHz.
 - Output for two 0.45 μs ($\pm 0.1 \mu\text{s}$) wide pulses, 20.3 μs ($\pm 0.1 \mu\text{s}$) apart (simulated Mode A reply, F1-F2). Set level to $\approx 1.5 \text{ Vdc}$ peak.
 - To be triggered off leading edge of sync pulse from ATC-601-2 COMM Connector, Pin 1.
 - For pulse pair to start 3 μs ($\pm 0.5 \mu\text{s}$) after leading edge of P3 (simulated Mode A reply delay).
 - Disconnect Function Generator #1 from Oscilloscope.
5. Connect Function Generator #2 to Oscilloscope Channel 2 and set Function Generator #2 as follows:
 - Output for 118 Hz ($\pm 10 \text{ Hz}$) square wave.
 - To be triggered off leading edge of sync pulse from ATC-601-2 COMM Connector, Pin 1.
 - Disconnect Function Generator #2 from Oscilloscope.
6. Connect Function Generator #1 and Function Generator #2 to Oscilloscope Channel 2 using BNC T-Connector. Adjust Function Generator #2 amplitude and dc offset so Function Generator #2 pulses on Function Generator #1 pulses are below zero volts (simulated 50% reply to keep attenuation at minimum level). Refer to 2-2-2, Figure 21.

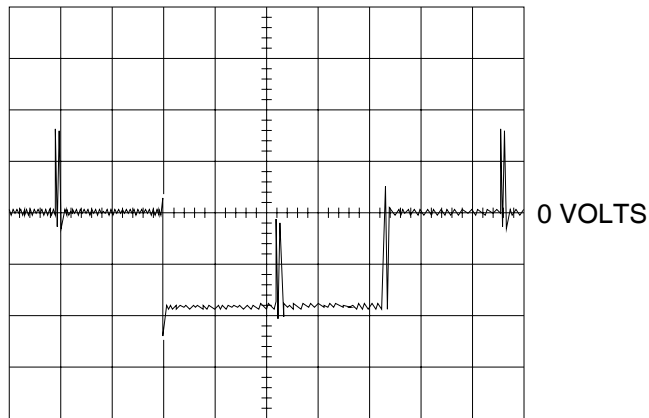

8116002

UUT Transmitter Frequency Modulation Signal
Figure 21

7. Disconnect Function Generators from Oscilloscope Channel 2. Connect Function Generators to RF Signal Generator pulse modulation input. Set RF Signal Generator output for 1087 MHz at -4.6 dBm with external pulse modulation.
8. Disconnect RF Signal Generator from ATC-601-2 ANTENNA Connector.

NOTE: Disconnecting RF Signal Generator when starting actual test, sets ATC-601-2 to maximum sensitivity.
9. Reconnect RF Signal Generator to ATC-601-2 ANTENNA Connector.
10. Verify frequency measurement ($\pm 50 \text{ kHz}$). If not, perform Calibration Procedures according to 2-2-2, Table 15.

STEP	PROCEDURE
------	-----------

11. Set RF Signal Generator to 1090 MHz.
12. Verify frequency measurement (± 50 kHz). If not, perform Calibration Procedures according to 2-2-2, Table 15.
13. Set RF Signal Generator to 1093 MHz.
14. Verify frequency measurement (± 50 kHz). If not, perform Calibration Procedures according to 2-2-2, Table 15.
15. Press RUN/STOP Key to terminate test.
16. Disconnect test equipment.

UUT TRANSMITTER POWER

17. Connect RF Signal Generator through 3 dB Attenuator to ATC-601-2 ANTENNA Connector.
18. Press SELF TEST Key. Press one of SELECT Keys to enter Diagnostics screen.
19. Set ATC-601-2 Signal Type to **DSP_MEASURE**, PRF to **118** and Attenuation **0**.
20. Set RF Signal Generator for ATC-601-2 input of 1090 MHz at -4.6 dBm, considering 3 dB Attenuator.
21. Press RUN/STOP Key to initiate test.
22. Verify **128** (Counts) is displayed in Diagnostics screen DATA: field. If not, perform Calibration Procedures according to 2-2-2, Table 15.
23. Verify 2-2-2, Table 17; setting ATC-601-2 Test Set and RF Signal Generator accordingly. If ATC-601-2 fails to display correct count number, perform Calibration Procedures according to 2-2-2, Table 15.
24. Press RUN/STOP Key to terminate test.
25. Disconnect test equipment.

SPECIFICATION	RF INPUT LEVEL	ATTENUATION	DATA: COUNT (± 1 dB)
+57 dBm (Antenna)	-4.6 dBm	0	128 (114 to 143)
+48.5 dBm (Antenna)	-12.9 dBm	0	049 (044 to 055)
+46.5 dBm (Direct)	-1.75 dBm	20	056 (050 to 063)
+59 dBm (Direct)	+10.75 dBm	40	075 (067 to 084)
<p>NOTE: UUT Transmitter Power Specification Verification is based on the following three equations:</p> <p>RF Input Level = $20 \cdot \log(\text{count}) + (\text{ATTENUATION})/2 - 46.74$ ERP = Input Level + Cable Loss - Antenna Gain + Path Loss Direct Connection Peak Pulse Power = RF Input Level + 48.25</p>			

Power Measurement Data
Table 17

UUT RECEIVER SENSITIVITY

NOTE: UUT receiver sensitivity level is directly related to output level. Both are verified in para 2-2-2F(1), Steps 9 through 13.

REPLY DELAY

26. Connect test equipment as shown in 2-2-2, Figure 22, initially connecting pulse modulated RF Signal Generator #2 to Function Generator and ATC-601-2 ANTENNA Connector. Connect LO source RF Signal Generator #1 to Heterodyne Monitor.
27. Press SETUP Key to enter Setup Menu.
28. Set RANGE and HEIGHT fields to \emptyset .
29. Press SELF TEST Key. Press one of SELECT Keys to enter Diagnostics screen.
30. Set ATC-601-2 Signal Type to **ATC_C**, PRF to **235** and Attenuation to \emptyset .
31. Press the RUN/STOP Key to initiate test.
32. Set RF Signal Generator #2 to 1090 MHz at -4.6 dBm.
33. Using Oscilloscope Channel 2, set Function Generator for two 0.45 μs ($\pm 0.1 \mu\text{s}$) wide pulses, spaced 20.3 μs ($\pm 0.1 \mu\text{s}$) apart (simulated Mode C reply, F_1-F_2) and triggered off leading edge of sync pulse from ATC-601-2 COMM Connector, Pin 1. Delay start of F_1 until 3 μs ($\pm 0.5 \mu\text{s}$) after leading edge of P3 of the interrogation.
34. Disconnect RF Signal Generator #2 from ANTENNA Connector. Connect Heterodyne Monitor to ATC-601-2 ANTENNA Connector.

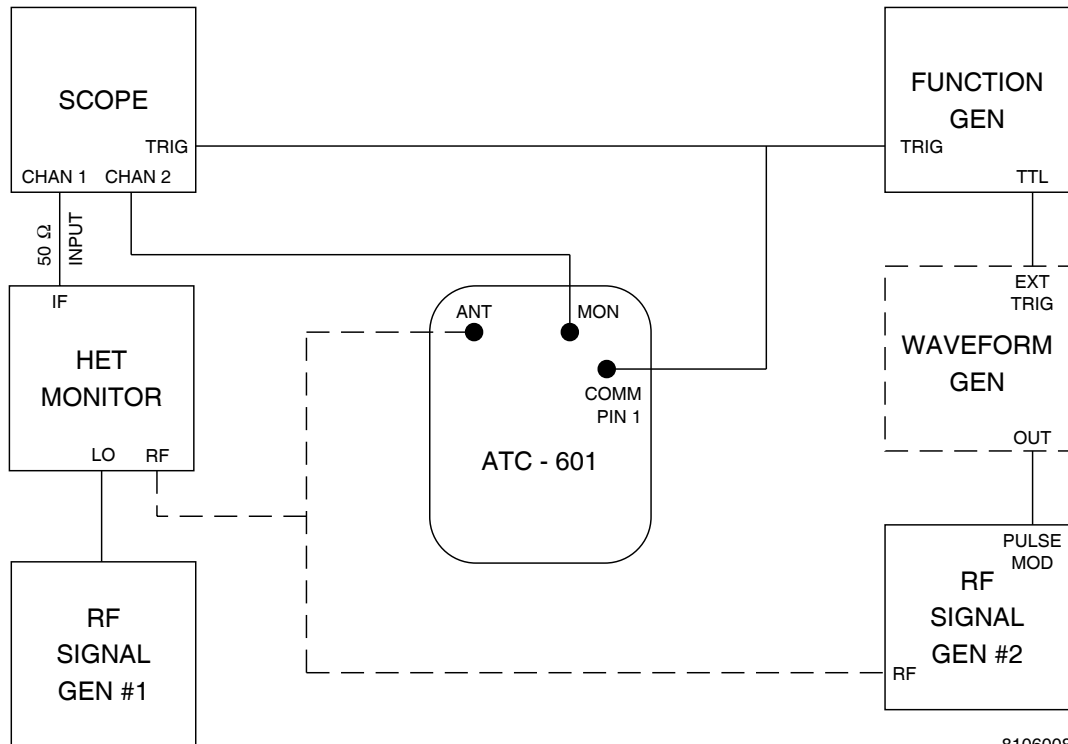

8106008

Reply Delay Test Setup Diagram
Figure 22

STEP	PROCEDURE
35.	Set LO source RF Signal Generator #1 to 1030 MHz at +5 dBm.
36.	Use Δ Time Start on Oscilloscope Channel 1 to reference rising edge of P ₃ in interrogation.
37.	Disconnect Heterodyne Monitor from ATC-601-2 ANTENNA Connector. Connect pulse modulated RF Signal Generator #2 to Heterodyne Monitor.
38.	Set LO source RF Signal Generator #1 to 1090 MHz.
39.	Use Δ Time Stop on Oscilloscope Channel 1 to reference rising edge of F ₁ in simulated reply.
40.	Record Δ Time measurement.
41.	Disconnect pulse modulated RF Signal Generator #2 from Heterodyne Monitor. Connect pulse modulated RF Signal Generator #2 to ATC-601-2 ANTENNA Connector.
43.	Press AUTO TEST Key and use SELECT Keys to enter Reply Delay Test screen.
44.	Press the RUN/STOP Key to initiate test.
45.	Verify Mode C Reply Delay shown on ATC-601-2 equals reference measurement recorded in Step 40 (± 100 ns).
46.	Press the RUN/STOP Key to terminate test.
47.	Press SELF TEST Key. Press one of SELECT Keys to enter Diagnostics screen.
48.	Set ATC-601-2 Signal Type to ITMATCS-C , PRF to 78 and Attenuation to 0 .
49.	Press the RUN/STOP Key to initiate test.
50.	Using Oscilloscope Channel 2, set Function Generator for 0.45 μ s single pulse, triggered off leading edge of sync pulse from ATC-601-2 COMM Connector, Pin 1. Delay start of pulse 128 μ s from leading edge of P ₄ .
51.	Using Mode S Reply Table, create required Mode S waveform on the Arbitrary Waveform Generator setup for 16,000 points and a frequency of 1 kHz (2-2-2, Table 18). Set the output amplitude on the Waveform Generator to the level needed to modulate RF Signal Generator #2. Connect TTL output from Function Generator to the Arbitrary Waveform Generator external trigger input. Connect Arbitrary Waveform Generator output to RF Signal Generator #2 pulse mod input.
52.	Disconnect RF Signal Generator #2 from ATC-601-2 ANTENNA Connector. Connect Heterodyne Monitor to ATC-601-2 ANTENNA Connector.
53.	Set LO source RF Signal Generator #1 to 1030 MHz.
54.	Use Δ Time Start on Oscilloscope Channel 1 to reference P ₄ in interrogation.
55.	Disconnect ATC-601-2 ANTENNA Connector from Heterodyne Monitor. Connect pulse modulated RF Signal Generator #2 to Heterodyne Monitor.
56.	Set LO source RF Signal Generator #1 to 1090 MHz.
57.	Use Δ Time Stop on Oscilloscope Channel 1 to reference rising edge of F ₁ in simulated reply.
58.	Record Δ Time measurement.
59.	Press the RUN/STOP Key to terminate test.

STEP

PROCEDURE

-
60. Disconnect pulse modulated RF Signal Generator from Heterodyne Monitor. Connect pulse modulated RF Signal Generator #2 to ATC-601-2 ANTENNA Connect.
 61. Press AUTO TEST Key. Use SELECT Keys to enter Reply Delay Test screen.
 62. Press the RUN/STOP Key to initiate test.
 63. Verify ITM C Reply Delay shown on ATC-601-2 equals reference measurement recorded in Step 58 (± 100 ns).
 64. Press the RUN/STOP Key to terminate test.

PULSE POSITION	START POINT	END POINT	SPACING (from P1)
P ₁ (PREAMBLE)	1	8	0.0
P ₂ (PREAMBLE)	17	24	1.0
P ₃ (PREAMBLE)	57	64	3.5
P ₄ (PREAMBLE)	73	80	4.5
P ₅ (ADDRESS BIT 16)	137	144	8.5
P ₆ (ADDRESS BIT 8)	144	152	9.0
P ₇ (ADDRESS BIT 4)	169	176	10.5
P ₈ (ADDRESS BIT 2)	176	184	11.0
P ₉ (ADDRESS BIT 1)	193	200	12.0
<i>DOWN LINK FORMAT 11 (8, 2, 1 AT HIGH POSITION)</i>			
P ₁₀ (DATA BIT 6)	217	224	13.5
P ₁₁ (DATA BIT 7)	233	240	14.5
P ₁₂ (DATA BIT 8)	249	256	15.5
P ₁₃ (DATA BIT 9)	265	272	16.5
P ₁₄ (DATA BIT 10)	281	288	17.5
P ₁₅ (DATA BIT 11)	297	304	18.5
P ₁₆ (DATA BIT 12)	313	320	19.5
P ₁₇ (DATA BIT 13)	329	336	20.5
P ₁₈ (DATA BIT 14)	345	352	21.5
P ₁₉ (DATA BIT 15)	361	368	22.5
P ₂₀ (DATA BIT 16)	377	384	23.5
P ₂₁ (DATA BIT 17)	393	400	24.5
P ₂₂ (DATA BIT 18)	409	416	25.5
P ₂₃ (DATA BIT 19)	425	432	26.5
P ₂₄ (DATA BIT 20)	441	448	27.5
P ₂₅ (DATA BIT 21)	457	464	28.5
P ₂₆ (DATA BIT 22)	473	480	29.5
P ₂₇ (DATA BIT 23)	489	496	30.5
P ₂₈ (DATA BIT 24)	505	512	31.5
P ₂₉ (DATA BIT 25)	521	528	32.5
P ₃₀ (DATA BIT 26)	537	544	33.5
P ₃₁ (DATA BIT 27)	553	560	34.5
P ₃₂ (DATA BIT 28)	569	576	35.5
P ₃₃ (DATA BIT 29)	585	592	36.5
P ₃₄ (DATA BIT 30)	601	608	37.5
P ₃₅ (DATA BIT 31)	617	624	38.5
P ₃₆ (DATA BIT 32)	633	640	39.5
P ₃₇ (DATA BIT 33)	640	648	40.0
P ₃₈ (DATA BIT 34)	657	664	41.0
P ₃₉ (DATA BIT 35)	673	680	42.0
P ₄₀ (DATA BIT 36)	689	696	43.0
P ₄₁ (DATA BIT 37)	705	712	44.0
P ₄₂ (DATA BIT 38)	721	728	45.0

Mode S Reply
Table 18

PULSE POSITION	START POINT	END POINT	SPACING (from P1)
P ₄₃ (DATA BIT 39)	737	744	46.0
P ₄₄ (DATA BIT 40)	761	768	47.5
P ₄₅ (DATA BIT 41)	768	776	48.0
P ₄₆ (DATA BIT 42)	785	792	49.0
P ₄₇ (DATA BIT 43)	809	816	50.5
P ₄₈ (DATA BIT 44)	816	824	51.0
P ₄₉ (DATA BIT 45)	833	840	52.0
P ₅₀ (DATA BIT 46)	849	856	53.0
P ₅₁ (DATA BIT 47)	873	880	54.5
P ₅₂ (DATA BIT 48)	889	896	55.5
P ₅₃ (DATA BIT 49)	896	904	56.0
P ₅₄ (DATA BIT 50)	921	928	57.5
P ₅₅ (DATA BIT 51)	928	936	58.0
P ₅₆ (DATA BIT 52)	945	952	59.0
P ₅₇ (DATA BIT 53)	969	976	60.5
P ₅₈ (DATA BIT 54)	985	992	61.5
P ₅₉ (DATA BIT 55)	992	1000	62.0
P ₆₀ (DATA BIT 56)	1009	1016	63.0

Mode S Reply (cont)
Table 18

REPLY JITTER

65. Connect test equipment as shown in 2-2-2, Figure 23.

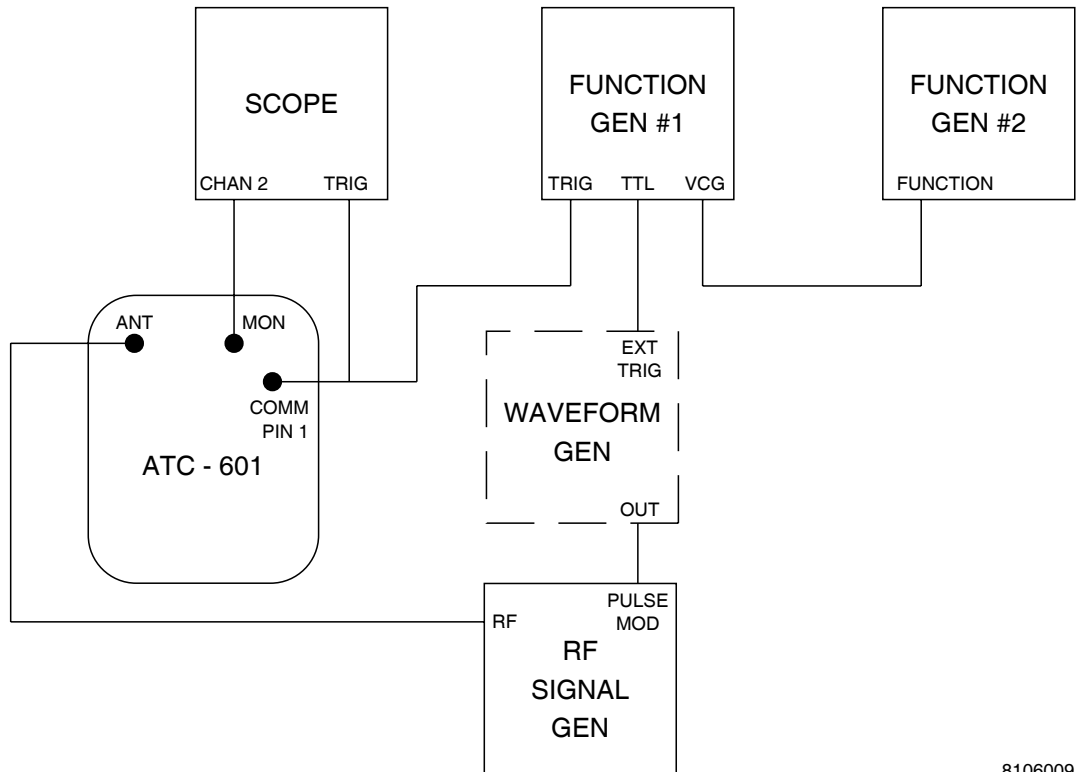

8106009

Reply Jitter Test Setup Diagram
Figure 23

66. Set Function Generator #1 for two $0.45 \mu\text{s}$ ($\pm 0.1 \mu\text{s}$) wide pulses, spaced $20.3 \mu\text{s}$ ($\pm 0.1 \mu\text{s}$) apart (simulated Mode C reply, F_1 - F_2) and triggered off leading edge of sync pulse from ATC-601-2 COMM Connector, Pin 1. Delay start of F_1 until $3 \mu\text{s}$ ($\pm 0.5 \mu\text{s}$) after leading edge of P_3 .
67. Set Function Generator #2 for square wave modulation to vary delay $0.05 \mu\text{s}$ at rate of 100 Hz.
68. Press SELF TEST Key. Press one of SELECT Keys to enter Diagnostics screen.
69. Set ATC-601-2 Signal Type to **ATC_C**, PRF to **235** and Attenuation to **0**.
70. Press the RUN/STOP Key to initiate test.
71. Use Oscilloscope Channel 2 to measure jitter on F_1 of simulated reply (time between minimum and maximum reply delays [P_3 to F_1]).
72. Press the RUN/STOP Key to terminate test.
73. Press AUTO TEST Key. Press one of SELECT Keys to enter Reply Jitter Test screen.
74. Press the RUN/STOP Key to initiate test.
75. Verify Mode C Reply Jitter shown on ATC-601-2 equals measured value from Step 71 ($\pm 50 \text{ ns}$).

STEP	PROCEDURE
------	-----------

76. Press the RUN/STOP Key to terminate test.
77. Press SELF TEST Key. Press one of SELECT Keys to enter Diagnostics screen.
78. Set ATC-601-2 Signal Type to **ITMATCS-C**, PRF to **78** and Attenuation to **0**.
79. Press the RUN/STOP Key to initiate test.
80. Using Oscilloscope Channel 1, set Function Generator for 0.45 μ s single pulse, triggered off leading edge of sync pulse from ATC-601-2 COMM Connector, Pin 1. Delay start of pulse 128 μ s from leading edge of P4.
81. Using Mode S Reply Table, create required Mode S waveform on the Arbitrary Waveform Generator setup for 16,000 points and a frequency of 1 kHz (2-2-2, Table 18). Set the output amplitude on the Waveform Generator to the level needed to modulate RF Signal Generator #2. Connect TTL output from Function Generator to the Arbitrary Waveform Generator external trigger input. Connect Arbitrary Waveform Generator output to RF Signal Generator #2 pulse mod input.
82. Set Function Generator #2 for square wave modulation to vary delay 0.05 μ s at rate of 100 Hz.
83. Use Oscilloscope Channel 2 to measure jitter on P1 of simulated reply (time between minimum and maximum reply delays [P4 to F1]).
84. Press the RUN/STOP Key to terminate test.
85. Press AUTO TEST Key. Press one of SELECT Keys to enter Reply Jitter Test screen.
86. Press the RUN/STOP Key to initiate test.
87. Verify ITM C Reply Jitter shown on ATC-601-2 equals measured value from Step 83 (± 50 ns).
88. Press the RUN/STOP Key to terminate test.

F1 TO F2 SPACING

89. Disconnect Function Generator #2 from Function Generator #1. Connect test equipment according to 2-2-2, Figure 22, with RF Signal Generator #2 connected to ATC-601-2 ANTENNA Connector.
90. Set Function Generator for two 0.45 μ s (± 0.1 μ s) wide pulses, spaced 20.3 μ s (± 0.1 μ s) apart (simulated Mode C reply, F1-F2) and triggered off leading edge of sync pulse from ATC-601-2 COMM Connector, Pin 1. Delay start of F1, until 3 μ s (± 0.5 μ s) after leading edge of P3.
91. Press SELF TEST Key. Press one of SELECT Keys to enter Diagnostics screen.
92. Set ATC-601-2 Signal Type to **ATC_C**, PRF to **235** and Attenuation to **0**.
93. Press the RUN/STOP Key to initiate test.
94. Measure F1 to F2 spacing on Oscilloscope.
95. Press the RUN/STOP Key to terminate test.
96. Press AUTO TEST Key. Use SELECT Keys to enter ATCRBS Reply Test screen.
97. Press the RUN/STOP Key to initiate test.

STEP	PROCEDURE
98.	Verify F1 to F2 spacing shown on ATC-601-2 equals measured value from Step 94 (± 50 ns).
99.	Press the RUN/STOP Key to terminate test.
100.	Disconnect pulse modulated RF Signal Generator #2 from ATC-601-2 ANTENNA Connector. Reconnect RF Signal Generator #2 to Heterodyne Monitor. Refer to 2-2-2, Figure 22.
101.	Set LO Source RF Signal Generator to 1090 MHz.
102.	Press SELF TEST Key. Press one of SELECT Keys to enter Diagnostics screen.
103.	Set ATC-601-2 Signal Type to ATC_C , PRF to 235 and Attenuation to Ø .
104.	Press the RUN/STOP Key to initiate test.
105.	Measure both F1 and F2 pulse widths on Oscilloscope.
106.	Press the RUN/STOP Key to terminate test.
107.	Disconnect pulse modulated RF Signal Generator #2 from Heterodyne Monitor. Connect RF Signal Generator #2 to ATC-601-2 ANTENNA Connector.
108.	Press AUTO TEST Key. Use SELECT Keys to enter ATCRBS Reply Test screen.
109.	Press the RUN/STOP Key to initiate test.
110.	Verify F1 and F2 pulse widths shown on ATC-601-2 equal respective measured values from Step 105 (± 50 ns).
111.	Press the RUN/STOP Key to terminate test.
SQUITTER PERIOD	
NOTE: Squitter Period uses same timer used for output of interrogations at maximum PRF. The ± 10 ms Squitter Period Accuracy is verified when timing of interrogations, output at maximum PRF, is ± 10 ms or less.	
112.	Disconnect test equipment except for Oscilloscope Channel 2 to ATC-601-2 MONITOR Connector.
113.	Press SELF TEST Key. Press one of SELECT Keys to enter Diagnostics screen.
114.	Set ATC-601-2 Signal Type to ATC_C , PRF to 235 and Attenuation to Ø .
115.	Press the RUN/STOP Key to initiate test.
116.	Verify time between interrogations is < 5.0 ms.
117.	Press the RUN/STOP Key to terminate test.
DIVERSITY ISOLATION	
118.	Connect RF Signal Generator, providing 1090 MHz at -4.6 dBm, to ATC-601-2 ANTENNA Connector.
119.	Set ATC-601-2 Signal Type to DSP_MEASURE , PRF to 235 and Attenuation to Ø .
120.	Press the RUN/STOP Key to initiate test.
121.	Record reading from ATC-601-2 Diagnostics screen DATA: field.
122.	Set RF Signal Generator for ATC-601-2 input of 1090 MHz at -24.6 dBm.

STEP

PROCEDURE

123. Record reading from ATC-601-2 Diagnostics screen DATA: field.

124. Press the RUN/STOP Key to terminate test.

125. Verify following equation:

$$20 \bullet \log(\text{Step 121 reading} \div \text{Step 123 reading}) \text{ dB} = 20 \text{ dB } (\pm 3 \text{ dB})$$

(4) Overall

STEP

PROCEDURE

1. Disconnect test equipment.
2. Initiate Self Test according to para 2-2-2G(3).

THIS PAGE INTENTIONALLY LEFT BLANK.



E. Verification Data Sheet

TECHNICIAN: _____ DATE: _____

ATC-601-2 S/N: _____

STEP	DATA	RESULT
(1)	Signal Generator	
	OUTPUT FREQUENCY	
6.	ATC-601-2 Transmit Frequency 1030 MHz (1029.090 to 1030.010 MHz)	-----
	OUTPUT LEVEL/RECEIVER SENSITIVITY	
11.	ATC-601-2 Transmit Power -7.6 dBm (-9.6 to -5.6 dBm)	-----
12.	ATC-601-2 Transmit Power/UUT Receiver Sensitivity	
	Ø Attenuation -7.6 dBm (-9.6 to -5.6 dBm)	-----
	16 Attenuation -15.6 dBm (-17.6 to -13.6 dBm)	-----
	23 Attenuation -19.15 dBm (-21.15 to -17.15 dBm)	-----
	47 Attenuation -31.15 dBm (-33.15 to -29.15 dBm)	-----
	DIRECT CONNECTION	
17.	Direct Connection Step 11 - 48.25 dB (±0.5 dB)	-----
(2)	Pulse Characteristics	
	SPACING	
6.	ATC (Mode A) P1 to P3 Pulse Spacing 8.00 µs (7.95 to 8.05 µs)	-----
10.	ATC (Mode C) P1 to P3 Pulse Spacing 21.00 µs (20.95 to 21.05 µs)	-----
14.	Mode S P1 to P2 Pulse Spacing 2.00 µs (1.95 to 2.05 µs)	-----
15.	Mode S P1 to P6 Pulse Spacing 3.50 µs (3.45 to 3.55 µs)	-----
19.	Mode S P1 to SPR Pulse Spacing 4.75 µs (4.70 to 4.80 µs)	-----
22.	ATCRBS Only All-Call (ITM A/short P4) P1 to P4 Pulse Spacing 10.00 µs (9.95 to 10.05 µs)	-----
26.	ATCRBS/Mode S All-Call (ITM C/long P4) P1 to P4 Pulse Spacing 23.00 µs (22.95 to 23.05 µs)	-----

STEP	DATA	RESULT
WIDTHS		
30.	P1 Pulse Width 0.80 μ s (0.75 to 0.85 μ s)	_____
34.	P3 Pulse Width 0.80 μ s (0.75 to 0.85 μ s)	_____
38.	P2 Pulse Width 0.80 μ s (0.75 to 0.85 μ s)	_____
42.	P6 (short) Pulse Width 16.25 μ s (16.2 to 16.3 μ s)	_____
46.	P6 (long) Pulse Width 30.25 μ s (30.2 to 30.3 μ s)	_____
50.	P4 (short) Pulse Width 0.80 μ s (0.75 to 0.85 μ s)	_____
54.	P4 (long) Pulse Width 1.60 μ s (1.55 to 1.65 μ s)	_____
RISE AND FALL TIMES		
58.	P1 Rise Time (50 to 100 ns)	_____
59.	P1 Fall Time (50 to 200 ns)	_____
PHASE MODULATION: TRANSMISSION TIME		
63.	SPR Transition Times \leq 80 ns	_____
64.	P6 even Transition Amplitude (<4 dB difference)	_____ (✓)
AMPLITUDE LEVELS		
70.	Reference Point (MTL+4 dB)	_____
74.	(MTL-5 dB) difference from Reference Point -9 dB (-10 to -8 dB)	_____
(3) UUT Measurements		
UUT TRANSMITTER FREQUENCY		
10.	Frequency 1087 MHz (1086.95 to 1087.05 MHz)	_____
12.	Frequency 1090 MHz (1089.95 to 1090.05 MHz)	_____
14.	Frequency 1092 MHz (1092.95 to 1093.05 MHz)	_____
UUT TRANSMITTER POWER		
22.	-4.6 dBm (128 Counts)	_____ (✓)
23.	-4.6 dBm 128 Counts (114 to 143 Counts)	_____
	-12.9 dBm 049 Counts (044 to 055 Counts)	_____
	-1.75 dBm 056 Counts (050 to 063 Counts)	_____
	+10.75 dBm 075 Counts (067 to 084 Counts)	_____

STEP	DATA	RESULT
REPLY DELAY		
40.	Mode C Reply Delay measured time reference (Δ Time)	-----
45.	Mode C Reply Delay ATC-601-2 reading = reference (± 100 ns)	-----
58.	Mode S Reply Delay measured time reference (Δ Time)	-----
63.	Mode S Reply Delay ATC-601-2 reading = reference (± 100 ns)	-----
REPLY JITTER		
71.	Mode C Reply Jitter measured time reference	-----
75.	Mode C Reply Jitter ATC-601-2 reading = reference (± 50 ns)	-----
83.	Mode S Reply Jitter measured time reference	-----
87.	Mode S Reply Jitter ATC-601-2 reading = reference (± 50 ns)	-----
F1 TO F2 SPACING		
94.	F1 to F2 Spacing measured time reference	-----
98.	F1 to F2 Spacing ATC-601-2 reading = reference (± 50 ns)	-----
F1 TO F2 PULSE WIDTH		
105.	F1 Pulse Width measured time reference	-----
	F2 Pulse Width measured time reference	-----
110.	F1 Pulse Width ATC-601-2 reading = reference (± 50 ns)	-----
	F2 Pulse Width ATC-601-2 reading = reference (± 50 ns)	-----
SQUITTER PERIOD		
116.	Squitter Period (time between interrogations is < 5.0 ms)	----- (\checkmark)
DIVERSITY ISOLATION		
121.	Diversity Isolation -4.6 dBm DATA: field reading	-----
123.	Diversity Isolation -24.6 dBm DATA: field reading	-----
125.	Diversity Isolation 20 dB (17 to 23 dB)	-----
(4)	Overall	
2.	Self Test All Modules/Assemblies Passed.	----- (\checkmark)

THIS PAGE INTENTIONALLY LEFT BLANK.

THIS PAGE INTENTIONALLY LEFT BLANK.

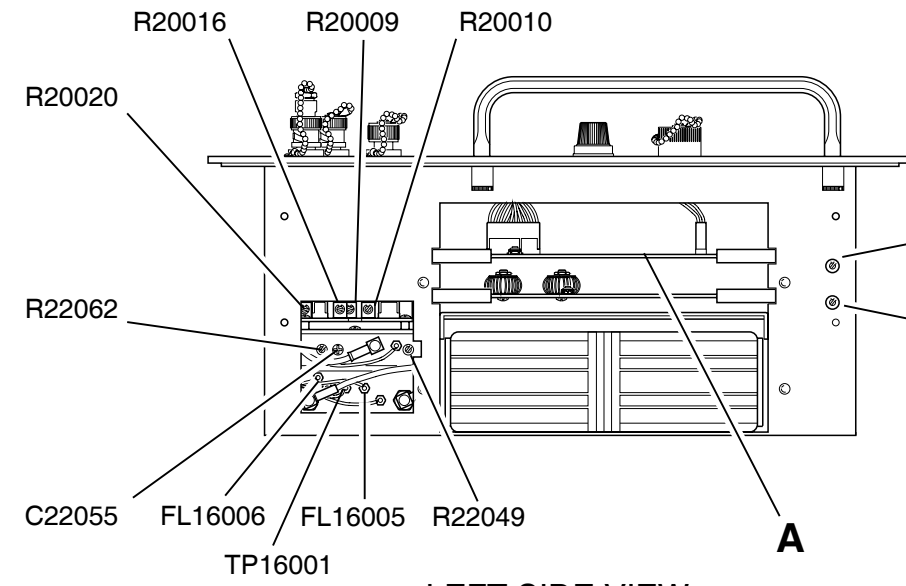

LEFT SIDE VIEW

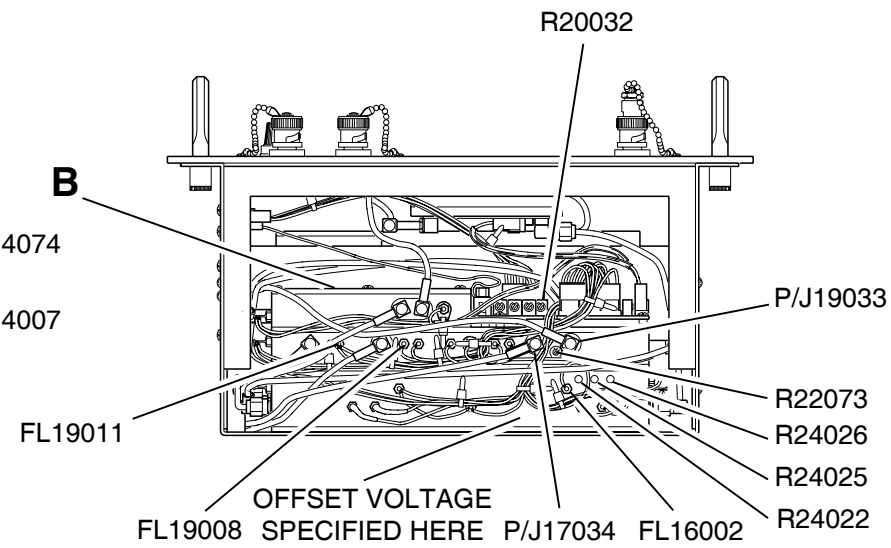

TOP VIEW

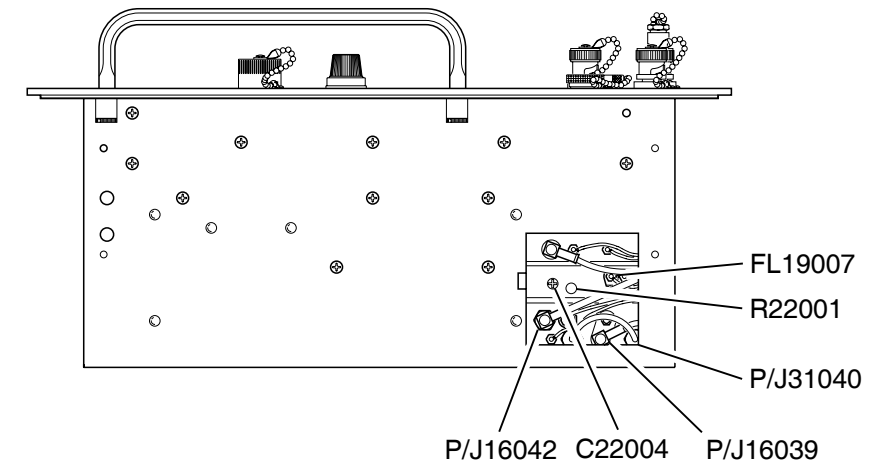

RIGHT SIDE VIEW

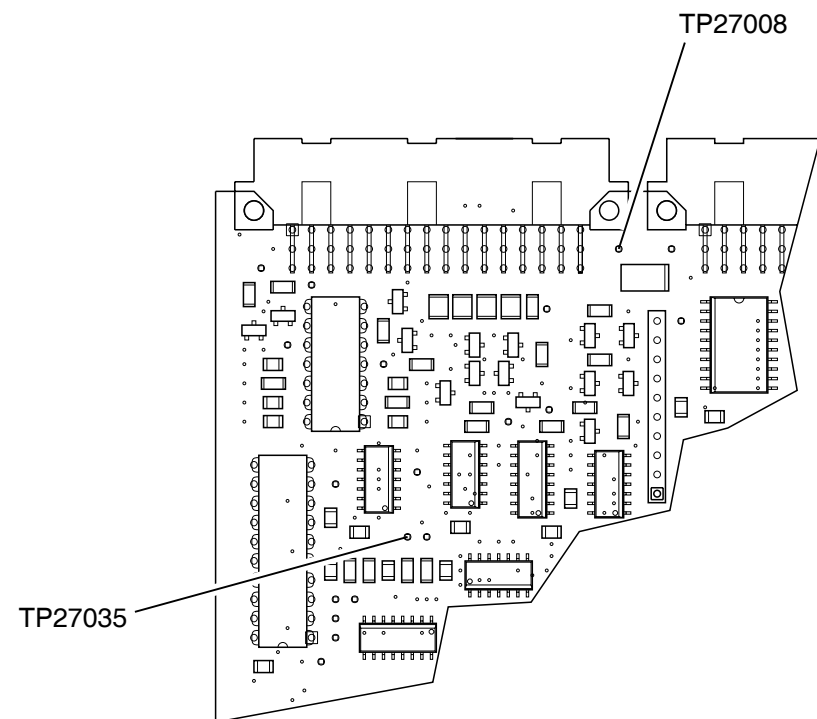

DETAIL A

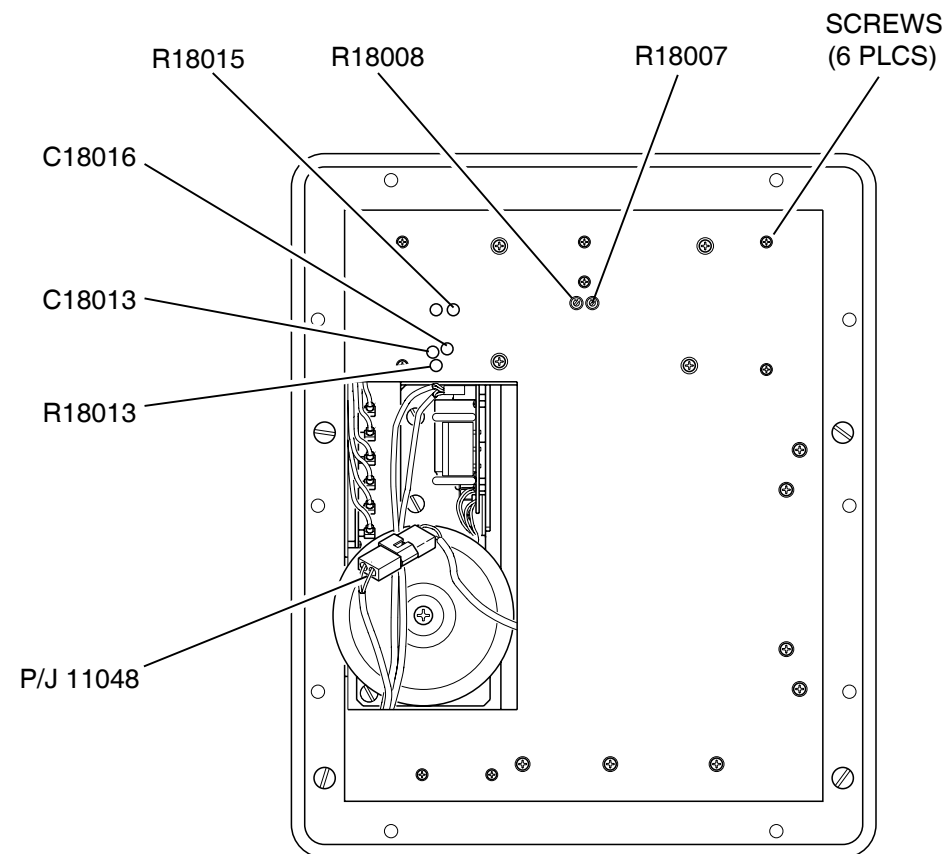

REAR VIEW

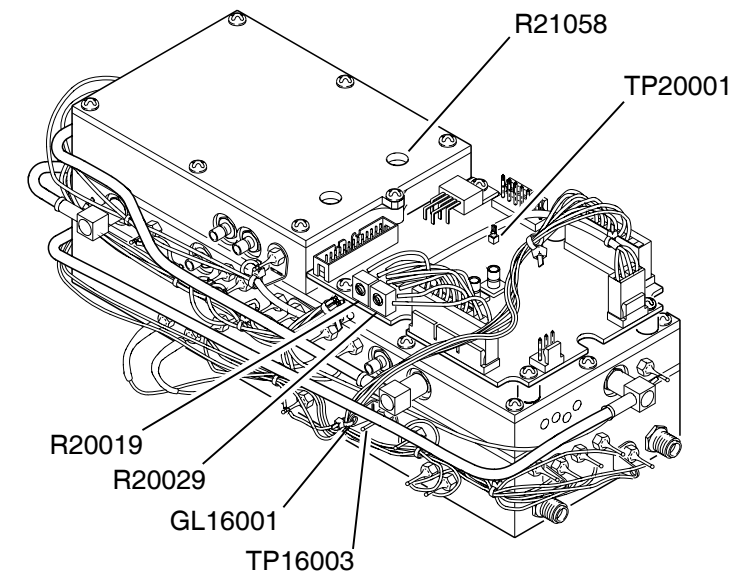

DETAIL B

F. Calibration

Refer to 2-2-2, Figure 24 for test points and adjustments.

(1) Power Supply

TEST EQUIPMENT: 1 Digital Multimeter

STEP	PROCEDURE
1.	Verify ATC-601-2 is Off and not connected to external power source.
2.	Remove 12 screws and lift Chassis Assembly from Case Assembly.
3.	Connect ac power cable to AC PWR Connector and verify CHARGE Indicator is green.
	NOTE: The CHARGE Indicator illuminates green when battery contains full charge.
4.	Connect Digital Multimeter to P/J11048 and verify 14.6 Vdc (± 0.1 V). Adjust R14007 as needed.
5.	Press POWER Key On.
6.	Use Digital Multimeter to verify +5.1 Vdc (± 0.05 V) between FL19008 and ground (GL16001). Adjust R14074 as needed.
7.	Use Digital Multimeter to verify +12 Vdc (± 0.3 V) between FL19011 and ground (GL16001).
8.	Use Digital Multimeter to verify -12 Vdc (± 0.3 V) between FL16002 and ground (GL16001).
9.	Use Digital Multimeter to verify +11 Vdc (± 0.25 V) between FL16005 and ground (GL16001). If not, remove RF Assembly according to Attenuator procedure, Steps 20 to 22 of para 2-2-2H(2). Refer to Driver PC Board Assembly (2-2-3, Figure 37) and adjust R16054.

(2) RF Assembly

PREREQUISITES: Power Supply (para 2-2-2F[1])

TEST EQUIPMENT: 1 3 dB Attenuator
 1 ATC-1400A Transponder/DME Test Set
 1 Digital Multimeter
 1 Universal Timer Counter
 1 Measuring Receiver
 1 Oscilloscope
 1 Power Meter
 2 Power Sensors
 1 RF Signal Generator
 1 Spectrum Analyzer
 1 Temperature Probe

STEP	PROCEDURE
------	-----------

LO SOURCE

1. Connect Digital Multimeter to TP16003.
2. Verify the DC Voltage is 0 mV (± 50 mV) on Digital Multimeter.

If reading is incorrect, Aeroflex recommends returning the unit to the factory for fault isolation and repair.

3. Connect Spectrum Analyzer to ATC-601-2 ANTENNA Connector.
4. Set Spectrum Analyzer controls as follows:

CONTROL	SETTING
Center Frequency	1030 MHz
Scan	1 MHz/Div
Bandwidth	300 kHz
Scale	10 dB

5. From the Self Test Menu, press \uparrow SEL or \downarrow SEL Key to display the Diagnostics Menu on the ATC-601-2.

6. Set IFF-701Ti as follows:

FIELD	SETTING
SIGNAL TYPE	CW
ATTENUATION	0

7. Press RUN/STOP Key on ATC-601-2 to start test.
8. Adjust R24022 cw then ccw and verify ± 4.5 MHz sweep on Spectrum Analyzer. If needed, adjust R24026 (tuning) and R24025 (width) for 1030 MHz (± 4.5 MHz) on Spectrum Analyzer.

If adjustment cannot be accomplished, Aeroflex recommends returning the unit to the factory for fault isolation and repair.

9. Adjust R24022 fully cw until the offset voltage rails on Digital Multimeter. Record.

STEP	PROCEDURE
------	-----------

10. Adjust R24022 fully ccw until the offset voltage rails on Digital Multimeter. Record.
11. Add Step 9 and 10, and then divide the result by 2. Adjust R24022 until the Digital Multimeter displays this value.
12. Verify phase lock at 1030 MHz at the offset voltage in Step 12 on the Digital Multimeter.

If adjustment cannot be accomplished, Aeroflex recommends returning the unit to the factory for fault isolation and repair.
13. Verify the offset voltage is 0 mV (± 50 mV) on the Digital Multimeter.

If adjustment cannot be accomplished, Aeroflex recommends returning the unit to the factory for fault isolation and repair.
14. Connect Digital Multimeter to TP16001.
15. Verify the tune voltage is 5.5 Vdc (± 0.5 Vdc) on the Digital Multimeter.

If adjustment cannot be accomplished, Aeroflex recommends returning the unit to the factory for fault isolation and repair.
16. Connect Digital Multimeter to FL16006.
17. Verify output voltage is 4.5 to 6 Vdc on the Digital Multimeter.

If adjustment cannot be accomplished, Aeroflex recommends returning the unit to the factory for fault isolation and repair.
18. Press RUN/STOP Key on ATC-601-2 to stop test.

ATTENUATOR

19. Press POWER Key. (ATC-601-2 power is Off.)
20. Refer to 2-2-2, Figure 24 and remove six screws from Chassis Assembly (Rear View).
21. Carefully lift out RF Assembly, applying only minimal stress on connecting cables.
22. Press POWER Key.
23. Set ATC-601-2 Signal Type to **DSP MEASURE =** and Attenuation to **80.0 dB**.
24. Press RUN/STOP Key to initiate test.
25. Adjust R20009 (ZERO VOLT ADJ) for 0 V at TP20001, using Digital Multimeter.

STEP

PROCEDURE

26. Remove P31040 from J31040 and connect test equipment as shown in 2-2-2, Figure 25.

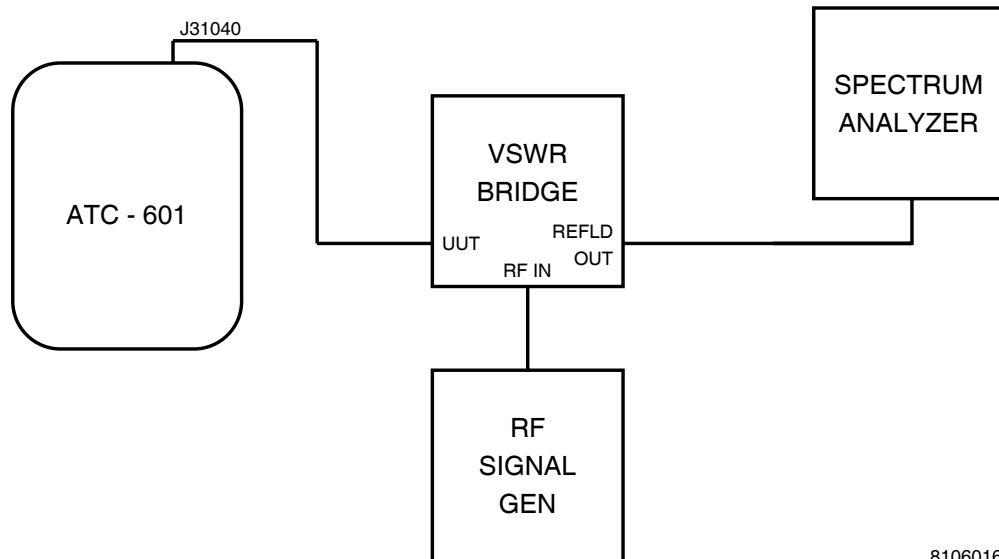

8106016

Attenuator VSWR Test Setup Diagram
Figure 25

27. Terminate ATC-601-2 ANTENNA Connector with Connector Cover providing 50 Ω load.
28. Set RF Signal Generator to 1060 MHz at 0 dBm.
29. Set Spectrum Analyzer to 1060 MHz center frequency and 10 MHz/Div scan width.
30. Adjust R20019 (VSWR 50 dB ADJ) for lowest signal level on Spectrum Analyzer.
31. Disconnect test equipment and reconnect P31040 to J31040.
32. Set ATC-601-2 Attenuation to \emptyset .

STEP PROCEDURE

33. Remove P16039 from J16039 and connect test equipment as shown in 2-2-2, Figure 26.

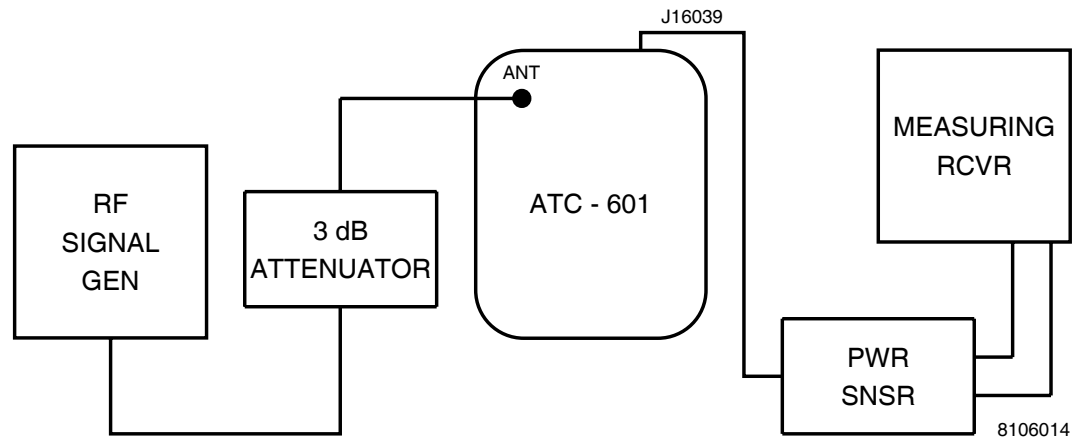

Attenuator Test Setup Diagram
Figure 26

34. Set RF Signal Generator for ATC-601-2 input of 1090 MHz at -4.6 dBm, considering 3 dB Attenuator.
35. Set Measuring Receiver to Tuned RF Level Mode and calibrate at 30 MHz. Record and set displayed level as zero reference on Measuring Receiver.
36. Set ATC-601-2 Attenuation to **80**.
37. Adjust R20010 (50 dB ADJ OFFSET) for -40 dBm on Measuring Receiver.
38. Set ATC-601-2 Attenuation to **20**.
39. Adjust R20016 (10 dB ADJ SLOPE) for -10 dBm on Measuring Receiver.
40. Set ATC-601-2 Attenuation to **0**.
41. Verify Measuring Receiver is at level recorded in Step 35.
42. Press RUN/STOP Key to terminate test.
43. Disconnect test equipment and reconnect P16039 to J16039.

ISOLATION NULL

44. Disconnect the 30 MHz Receive IF input (P17034) from J17034.
45. Connect 50 Ω termination cover to ATC-601-2 ANTENNA Connector.
46. Connect Spectrum Analyzer (center frequency at 30 MHz) to J17034.
47. Set ATC-601-2 Signal Type to **CW** and Attenuation to **0**.
48. Press RUN/STOP Key to initiate test.
49. Adjust R22062 (ISOLATION) and C22055 for maximum signal nullification at 30 MHz.
50. Adjust R22062 (ISOLATION) for -6 dBm signal level.
51. Press RUN/STOP Key to terminate test.

STEP PROCEDURE

- 52. Disconnect Spectrum Analyzer from J17034.
- 53. Reconnect P17034 to J17034.

GENERATOR OUTPUT POWER

- 54. Connect Measuring Receiver (set for 1030 MHz) through Power Sensor and 3 dB Attenuator to ATC-601-2 ANTENNA Connector.
- 55. Press RUN/STOP Key to initiate test.
- 56. Adjust R22049 (TX GAIN) for ATC-601-2 output of -7.6 dBm. Measuring Receiver displays -7.6 less attenuation provided by 3 dB Attenuator.
- 57. Press RUN/STOP Key to terminate test.

GENERATOR IMAGE

- 58. Disconnect Power Sensor from 3 dB Attenuator.
- 59. Connect Spectrum Analyzer through 3 dB Attenuator to ATC-601-2 ANTENNA Connector.
- 60. Set the Spectrum Analyzer as follows:

<u>CONTROL</u>	<u>SETTING</u>
Center Frequency	1060 MHz
Amp Scale	10 dB/Div
Scan Width	10 MHz/Div

- 61. Press RUN/STOP Key to initiate test.
- 62. Position peak amplitude point of 1030 MHz at top major graticule.
- 63. Verify 1090 MHz signal level is >30 dB below 1030 MHz signal level in Step 62. If not, adjust C18013 and C18016 (1090 MHz NULL PHASE ADJ) and either R18013 or R18015 (1090 MHz NULL AMPLITUDE ADJ).

NOTE: One resistor (R18013 or R18015) must remain fully cw for correct ATC-601-2 operation.

LO NULL

- 64. Adjust R18007 and R18008 (1060 MHz NULL ADJ) until 1060 MHz signal level is >40 dB below 1030 MHz signal level in Step 62.
- 65. Press RUN/STOP Key to terminate test.

RECEIVE IMAGE

66. Disconnect 30 MHz (P17034) from J17034 and connect test equipment according to 2-2-2, Figure 27.

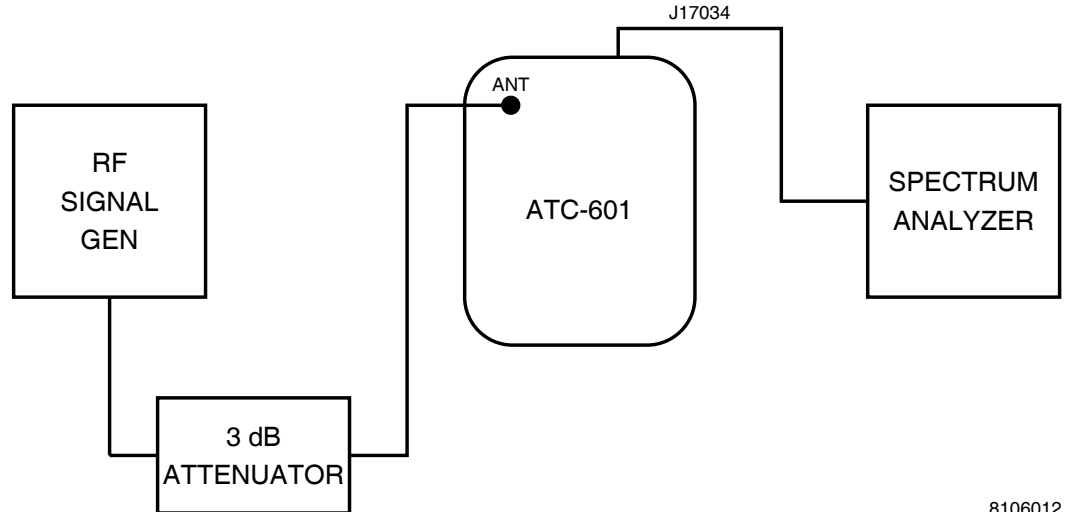

8106012

Receive Image Test Setup Diagram
Figure 27

67. Set ATC-601-2 Signal Type to **DSP_MEASURE=** and Attenuation to \emptyset .
68. Press RUN/STOP Key to initiate test.
69. Set RF Signal Generator for ATC-601-2 input of 1090 MHz at 0.0 dBm, considering 3 dB Attenuator.
70. Set peak amplitude level of 30 MHz signal as top reference on Spectrum Analyzer.
71. Set RF Signal Generator for a ATC-601-2 input of 1030 MHz at 0.0 dBm, considering 3 dB Attenuator.
72. Verify 30 MHz signal level on Spectrum Analyzer is >15 dB below reference level in Step 70. If not, return to Step 64 and repeat the LO Null adjustment; otherwise, continue to next step.
73. Press RUN/STOP Key to terminate test.

RECEIVE POWER

74. Set RF Signal Generator for ATC-601-2 input of 1090.06 MHz at -9.05 dBm, considering 3 dB Attenuator.
75. Press RUN/STOP Key to initiate test.
76. Adjust R22073 (RX GAIN) for 0.0 dBm output at J17034.
77. Press RUN/STOP Key to terminate test.

STEP

PROCEDURE

ISOLATION RESET

78. Disconnect Spectrum Analyzer from J17034.
79. Connect Measuring Receiver through Power Sensor to J17034.
80. Disconnect RF Signal Generator from ATC-601-2 ANTENNA Connector.
81. Terminate ATC-601-2 ANTENNA Connector with Connector Cover providing 50 Ω load.
82. Set ATC-601-2 Signal Type to **CW** and Attenuation to \emptyset .
83. Press RUN/STOP Key to initiate test.
84. Adjust R22062 (ISOLATION) for -6 dBm signal level on Measuring Receiver.
85. Press RUN/STOP Key to terminate test.
86. Disconnect test equipment.

DETECTOR PULSE WIDTH

87. Connect test equipment according to 2-2-2, Figure 28.

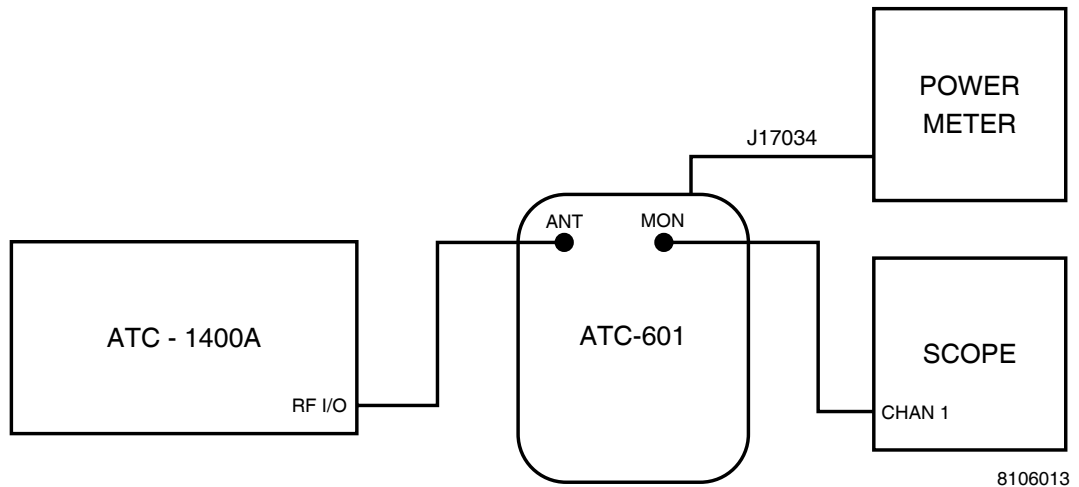

Detector Pulse Width Test Setup Diagram
Figure 28

88. Set ATC-1400A as follows:

CONTROL	SETTING
CW/NORM/OFF Switch	CW
TO/TAC/TD Switch	TO
PRF/SQTR Thumbwheels	3000
FREQ/FUNCTION SELECT Thumbwheels	1090 MHz XPDR
XPDR PULSE WIDTH Thumbwheels	0.45 μ s

89. Set ATC-601-2 Signal Type to **DSP_MEASURE=** and Attenuation to \emptyset .
90. Adjust ATC-1400A RF LEVEL Control to obtain Power Meter levels of +3, -12 and -27 dBm. Record ATC-1400A RF LEVEL -dBm Display reading for each level.
91. Disconnect Power Sensor from J17034.

STEP	PROCEDURE
------	-----------

92. Disconnect P19033 from J19033.
93. Connect P19033 to J17034.
94. Set ATC-1400A RF LEVEL Control to -12 dBm reference established in Step 90 and CW/NORM/OFF Switch to NORM setting.
95. Adjust R21058 (PULSE WIDTH) for 0.45 μ s detector pulse width on Oscilloscope.
96. Vary ATC-1400A RF LEVEL Control to +3 and -27 dBm reference levels established in Step 90. Verify pulse width changes <40 ns from 0.45 μ s.
97. Disconnect P19033 from J17034 and reconnect P19033 to J19033.
98. Disconnect test equipment.

DIRECT CONNECT SET

99. Connect test equipment according to 2-2-2, Figure 29 with 3 dB Attenuator initially connected to ATC-601-2 ANTENNA Connector.

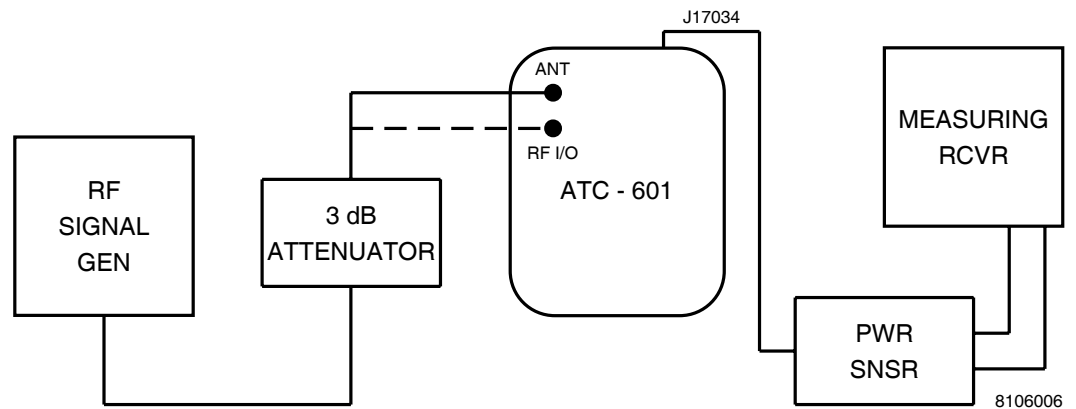

Direct Connect Set Test Setup Diagram
Figure 29

100. Set ATC-601-2 Signal Type to **DSP_MEASURE**, PRF to 235 and Attenuation to \emptyset .
101. Press RUN/STOP Key to initiate test.
102. Set RF Signal Generator for ATC-601-2 input of 1090.06 MHz at -14.6 dBm, considering 3 dB Attenuator.
103. Record and set displayed level as zero reference on Measuring Receiver.
104. Disconnect 3 dB Attenuator from ATC-601-2 ANTENNA Connector and connect 3 dB Attenuator to ATC-601-2 RF I/O Connector.
105. Terminate ATC-601-2 ANTENNA Connector with Connector Cover providing 50 Ω load.
106. Adjust R20020 (DIRECT CONNECT POWER ADJ) until Measuring Receiver indicates 48.25 dB below reference level set in Step 103.
107. Press RUN/STOP Key to terminate test.
108. Disconnect test equipment. Reconnect P17034 to J17034.

STEP	PROCEDURE
------	-----------

RF BIT DETECTOR SET

109. Press POWER Key. (ATC-601-2 power is Off.)
110. Remove Front Panel Pulse PC Board Assembly as needed to connect Digital Voltmeter (+) lead to TP27035 and (-) lead to TP27008 (ground).
111. Reinstall Front Panel Pulse PC Board Assembly.
112. Press POWER Key.
113. Set ATC-601-2 Signal Type to **CW_P4** and Attenuation to **Ø**.
114. Verify Digital Multimeter reads 10 to 50 mV (45 to 50 mV is nominal) with no RF (no signal activated). Adjust R20029 (ZERO ADJUST) as needed.
115. Press RUN/STOP Key to initiate test.
116. Verify Digital Multimeter indicates 2.80 V. Adjust R20032 (RF DET ADJ) as needed.
117. Repeat Steps 114 through 116 until no adjustment is needed.
118. Press RUN/STOP Key to terminate test.
119. Disconnect Digital Multimeter from test points.

OSCILLATOR COMPENSATION

120. Connect ATC-601-2 ANTENNA Connector to Universal Timer/Counter.
121. Set Universal Timer/Counter for 10 Hz resolution.
122. Set ATC-601-2 Signal Type to **CW** and Attenuation to **Ø**.
123. Press RUN/STOP Key to initiate test.

CAUTION: DO NOT SHORT TEMPERATURE PROBE TO ASSEMBLY WHILE MAKING CONTACT WITH COMPONENTS OR TRACES ON ANALOG IF PC BOARD.

124. Insert Temperature Probe (connected to Digital Multimeter) through R22001 adjustment hole and obtain CR22001 temperature reading.
125. Record FL19007 voltage required for temperature obtained in Step 124 as specified in 2-2-2, Table 19.
126. Connect Digital Voltmeter (+) lead to FL19007 and (-) lead to ground.
127. Verify FL19007 voltage equals voltage recorded in Step 125. Adjust R22001 as needed.
128. Verify frequency output is 1030 MHz (± 200 Hz). Adjust C22004 as needed.
129. Press RUN/STOP Key to terminate test.
130. Disconnect test equipment.

CR22001 (°C)	FL19007 (Vdc)	CR22001 (°C)	FL19007 (Vdc)
20	2.93	35	3.08
21	2.94	36	3.09
22	2.95	37	3.10
23	2.96	38	3.11
24	2.97	39	3.12
25	2.98	40	3.13
26	2.99	41	3.14
27	3.00	42	3.15
28	3.01	43	3.16
29	3.02	44	3.17
30	3.03	45	3.18
31	3.04	46	3.19
32	3.05	47	3.20
33	3.06	48	3.21
34	3.07	49	3.22

Oscillator Compensation
Table 19

(3) System

TEST EQUIPMENT: 1 3 dB Fixed Attenuator
 1 Digital Multimeter
 1 Measuring Receiver
 1 Oscilloscope
 1 Power Sensor
 1 RF Signal Generator
 1 Spectrum Analyzer

STEP	PROCEDURE
------	-----------

SELF TEST

1. Reinstall RF Assembly into Chassis Assembly and secure by tightening six screws on Chassis Assembly (Rear View).
2. Press SELF TEST Key and RUN/STOP Key to initiate Self Test.
3. Verify all modules/assemblies passed test. If not, refer to 1-2-3 in ATC-601-2 Operation Manual (Revision 1 or later).

RECEIVE POWER SYSTEM RECHECK

4. Disconnect P17034 from J17034 and connect test equipment as shown in 2-2-2, Figure 31 with 3 dB Attenuator connected to ATC-601-2 ANTENNA Connector.
5. Set ATC-601-2 Signal Type to **DSP_MEASURE**, PRF to **235** and Attenuation to **0**.
6. Set RF Signal Generator for ATC-601-2 input of 1090.06 MHz at -14.6 dBm, considering 3 dB Attenuator.
7. Press RUN/STOP Key to initiate test.
8. Record and set displayed level as zero reference on Measuring Receiver.
9. Set RF Signal Generator for ATC-601-2 input of 1090.06 MHz at -4.6 dBm, considering 3 dB Attenuator.
10. Subtract 10 dB from Measuring Receiver reading to obtain compression error.
11. Calculate correct count number using following equation:

$$\text{Counts} = 128 \bullet 10(\text{compression error}/20)$$
12. Disconnect Power Sensor from J17034.
13. Reconnect P17034 to J17034.
14. Verify ATC-601-2 Diagnostics screen **DATA:** field displays count number calculated in Step 11. Adjust R22073 (RX GAIN) as needed.
15. Press RUN/STOP Key to terminate test.

ISOLATION SYSTEM RECHECK

16. Adjust RF Signal Generator output level (at 1090 MHz) until ATC-601-2 **DATA:** field displays **64**.
17. Disconnect P17034 from J17034.
18. Connect Oscilloscope Channel 1 to J17034.
19. Adjust Oscilloscope for full screen view of signal. Record signal level as reference.

STEP	PROCEDURE
------	-----------

20. Disconnect RF Signal Generator.
21. Terminate ATC-601-2 ANTENNA Connector with Connector Cover providing 50 Ω load.
22. Set ATC-601-2 Signal Type to **CW**.
23. Press RUN/STOP Key to initiate test.
24. Verify signal level equals reference level in Step 19. Adjust R22062 (ISOLATION) as needed.
25. Press RUN/STOP Key to terminate test.
26. Disconnect Oscilloscope from J17034.
27. Reconnect P17034 to J17034.

GENERATOR POWER SYSTEM RECHECK

28. Connect Measuring Receiver through Power Sensor and 3 dB Attenuator to ATC-601-2 ANTENNA Connector.
29. Set ATC-601-2 Signal Type to **CW** and Attenuation to \emptyset .
30. Press RUN/STOP Key to initiate test.
31. Verify ATC-601-2 output is -7.6 dBm, considering 3 dB Attenuator. Adjust R22049 (TX GAIN) as needed.

NOTE: If output is >0.5 dB, resetting RF Bit Detector according to para 2-2-2H(2), Steps 110 to 120, is required.

32. Press RUN/STOP Key to terminate test.

MIXER NULLS

33. Disconnect Measuring Receiver and Power Sensor from 3 dB Attenuator.
34. Connect Spectrum Analyzer to 3 dB Attenuator.
35. Set ATC-601-2 Attenuation to \emptyset .
36. Press RUN/STOP Key to initiate test.
37. Center 1030 MHz signal on Spectrum Analyzer with peak amplitude referenced at top major graticule.
38. Center 1060 MHz signal on Spectrum Analyzer. Verify 1060 MHz signal amplitude is >40 dB less than 1030 MHz signal level. If not, adjust R18007 and R18008 (1060 MHz NULL ADJ) for lowest amplitude.
39. Press RUN/STOP Key to terminate test.
40. Disconnect test equipment.
41. Reinstall Chassis Assembly into Case Assembly and tighten 12 screws with 23 in/lbs (2.56 newton•meters) of torque.

NOTE: Replacing nylon washers is recommended to maintain water resistance capability.

THIS PAGE INTENTIONALLY LEFT BLANK.



G. Calibration Data Sheet

TECHNICIAN: _____ DATE: _____

ATC-601-2 S/N: _____

STEP	DATA	RESULT
(1) Power Supply		
3.	CHARGE Indicator illuminates green	_____ (✓)
4.	+14.6 Vdc (+14.5 to +14.7 Vdc)	_____
5.	+5.1 Vdc (+5.05 to +5.15 Vdc)	_____
6.	+12 Vdc (+11.7 to +12.3 Vdc)	_____
7.	-12 Vdc (-12.3 to -11.7 Vdc)	_____
9.	+11 Vdc (+10.75 to +11.25 Vdc)	_____
(2) RF Assembly		
LO SOURCE		
2.	DC Voltage is 0 mV (± 50 mV)	_____
8.	± 4.5 MHz sweep	_____ (✓)
	1030 MHz (± 4.5 MHz)	_____
9.	Fully cw - Record	_____
10.	Fully ccw - Record	_____
11.	Add Step 9 and 10, then divide by 2	_____
12.	Phase lock at 1030 MHz at the offset voltage in Step 11	_____ (✓)
13.	Offset voltage is 0 mV (± 50 mV)	_____
15.	Tune voltage is 5.5 Vdc (± 0.5 Vdc)	_____
17.	Output voltage is 4.5 to 6 Vdc	_____
ATTENUATOR		
25.	Attenuation Zero Volt adjustment	_____ (✓)
30.	Attenuation VSWR adjustment	_____ (✓)
35.	Receive Level at 0 dB Attenuation	_____
37.	40 dB Attenuation adjustment	_____ (✓)
39.	10 dB Attenuation adjustment	_____ (✓)
41.	Receive Level at 0 dB Attenuation (Step 36 level)	_____

STEP	DATA	RESULT
ISOLATION NULL		
49.	30 MHz Signal Nullification	_____ (√)
50.	30 MHz Signal Level -6 dBm	_____
GENERATOR OUTPUT POWER		
56.	Generator Output Power -7.6 dBm	_____
GENERATOR IMAGE		
63.	1090 MHz Signal Level >30 dB below 1030 MHz Signal Level	_____ (√)
LO NULL		
64.	1060 MHz Signal Level >40 dB below 1030 MHz Signal Level	_____ (√)
RECEIVE IMAGE		
72.	1030 MHz Receive Signal Level >15 dB below 1030 MHz Signal Level	_____ (√)
RECEIVE POWER		
76.	Receive Power 0.0 dBm	_____ (√)
ISOLATION RESET		
84.	30 MHz Signal Level -6 dBm	_____ (√)
DETECTOR PULSE WIDTH		
90.	RF Level Indication +3 dBm -12 dBm -27 dBm	_____ _____ _____
95.	Detector Pulse Width 0.45 μs	_____ (√)
96.	Detector Pulse Width varies <40 ns	_____ (√)
DIRECT CONNECT SET		
103.	RF Level (ANTENNA Connector) -14.6 dBm	_____
106.	RF Level (RF I/O Connector) Step 104 - 48.25 dB	_____ (√)
RF BIT DETECTOR SET		
114.	Bit Detector Zero Voltage 10 to 50 mV	_____
116.	Bit Detector Active Voltage 2.80 V	_____
OSCILLATOR COMPENSATION		
124.	Oscillator Compensation Diode Temperature	_____
125.	Oscillator Voltage required for Diode Temperature	_____
127.	Oscillator Voltage (Step 126 voltage)	_____
128.	Frequency Output 1030 MHz (1029.0008 to 1030.0002 MHz)	_____

STEP	DATA	RESULT
(3) System		
	SELF TEST	
3.	Self Test All Modules/Assemblies Passed.	_____ (√)
	RECEIVE POWER SYSTEM RECHECK	
8.	RF Signal Level -14.6 dBm	_____
10.	Receive Power Compression Error	_____
11.	Calculated Counts 128 • 10(compression error/20)	_____
14.	Receive Power Counts (Step 11 counts)	_____
	ISOLATION SYSTEM RECHECK	
19.	30 MHz Signal Level (Receive)	_____
24.	30 MHz Signal Level (Transmit) Step 19 Level	_____
	GENERATOR SYSTEM RECHECK	
31.	Generator Power -7.6 dBm	_____
	MIXER NULLS	
38.	1060 MHz Signal Level >40 dB below 1030 MHz Signal Level	_____ (√)

THIS PAGE INTENTIONALLY LEFT BLANK.