

### SECTION 3 - DISASSEMBLY/REASSEMBLY

#### 1. Disassembly

##### A. General

Contains instructions necessary to remove and disassemble assemblies within the ATC-601-2.

PROCEDURE	PAGE
Storage Compartment and Chassis Assembly -----	4
Battery -----	7
Line Supply Assembly -----	7
Power Supply Assembly -----	9
Digital IF PC Board Assembly -----	11
Front Panel Pulse PC Board Assembly -----	11
RF Assembly -----	13
Front Panel Assembly -----	21
Flat Antenna Assembly -----	28
Motherboard PC Board Assembly -----	30

##### B. Preliminary Considerations

###### (1) Tools Required

TOOL	SIZE	DESCRIPTION
SCREWDRIVER	#2 #4 #6	PHILLIPS
SCREWDRIVER	#2	SLOTTED
WRENCH	1/4 in 3/16 in	SOCKET
WRENCH	3/32 in 0.05 in	HEX-HEAD
WRENCH	3/8 in 1/4 in 3/16 in 5/8 in	OPEN
SOLDERING IRON	N/A	PIN-TYPE

Disassembly Tools  
Table 1

###### (2) Disassembly Precautions

- CAUTION:** TAG EACH WIRE AND CABLE PRIOR TO REMOVAL.
- CAUTION:** AVOID BENDING OR TWISTING SEMI-RIGID COAXIAL CABLES.
- CAUTION:** AVOID PLACING UNDUE STRAIN ON ANY WIRE OR CABLE.
- CAUTION:** AVOID DISCARDING LOOSE ITEMS (NUTS, SCREWS, WASHERS, ETC.).
- CAUTION:** AVOID EXPOSING COMPONENTS TO EXCESSIVE HEAT WHEN REMOVING SOLDER.

## (3) ESD

**CAUTION:** THE POWER SUPPLY PC BOARD ASSEMBLY, DIGITAL IF PC BOARD ASSEMBLY, FRONT PANEL PULSE PC BOARD ASSEMBLY, RF ASSEMBLY AND FRONT PANEL ASSEMBLY CONTAIN PARTS SENSITIVE TO DAMAGE BY ELECTROSTATIC DISCHARGE (ESD). ALL PERSONNEL PERFORMING DISASSEMBLY SHOULD HAVE KNOWLEDGE OF ACCEPTED ESD PRACTICES.

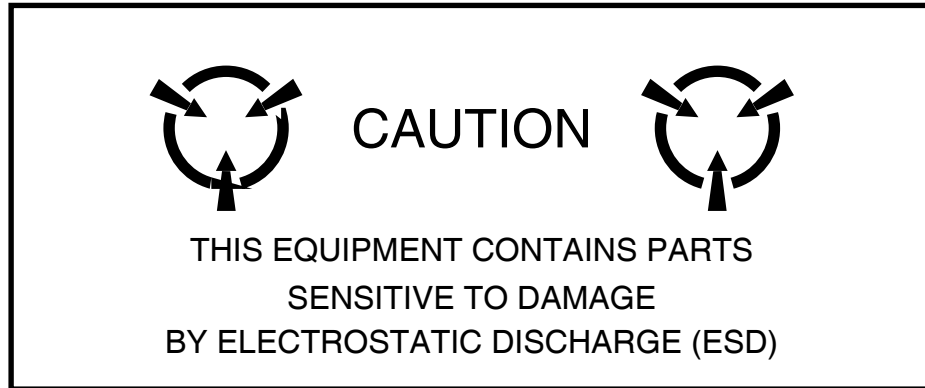

## (4) EMC and Safety Compliance

All assemblies, cables, connectors, plastic fasteners, gaskets, fingerstock and miscellaneous hardware within the Test Set are configured to satisfy the safety and EMC compliance standards.

**CAUTION:** UPON COMPLETION OF ANY MAINTENANCE ACTION; ALL ASSEMBLIES, CABLES, CONNECTORS, PLASTIC FASTENERS, GASKETS, FINGERSTOCK AND MISCELLANEOUS HARDWARE MUST BE CONFIGURED AS INSTALLED AT THE FACTORY.



THIS PAGE INTENTIONALLY LEFT BLANK.

## C. Procedures

## (1) Storage Compartment and Chassis Assembly

**NOTE:** Item numbers refer to 2-3-1, Figure 1.

STEP	PROCEDURE
1.	Unlock fasteners (18) securing Storage Compartment (17) to Case Assembly (19).
2.	Remove Storage Compartment (17) from Case Assembly (19).
3.	Remove twelve screws (1) and nylon washers (2) from Front Panel Assembly (3).
4.	Lift Chassis Assembly (7) from Case Assembly (19).

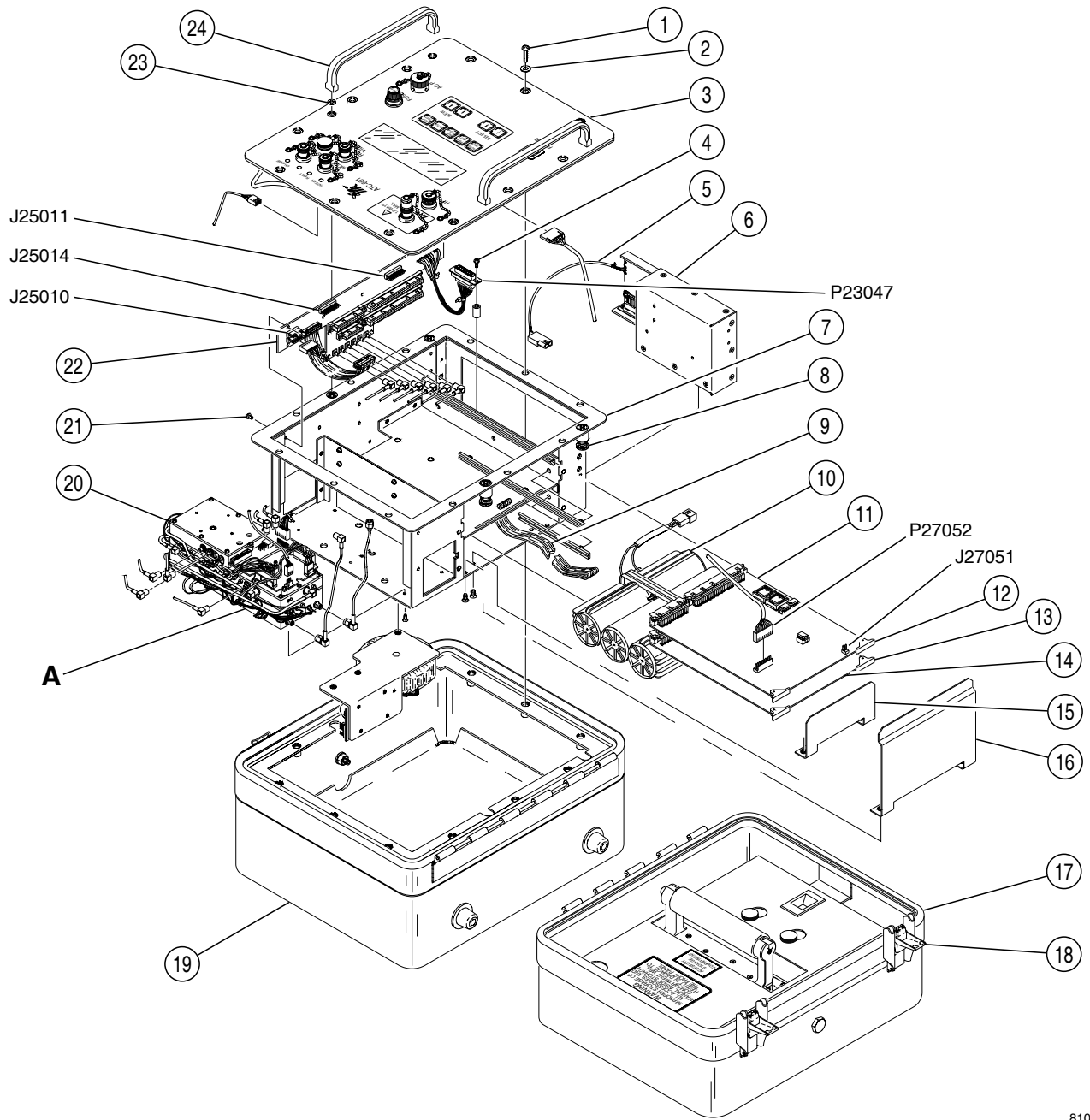

8107031

ATC-601-2 Chassis and Storage Compartment Disassembly  
Figure 1

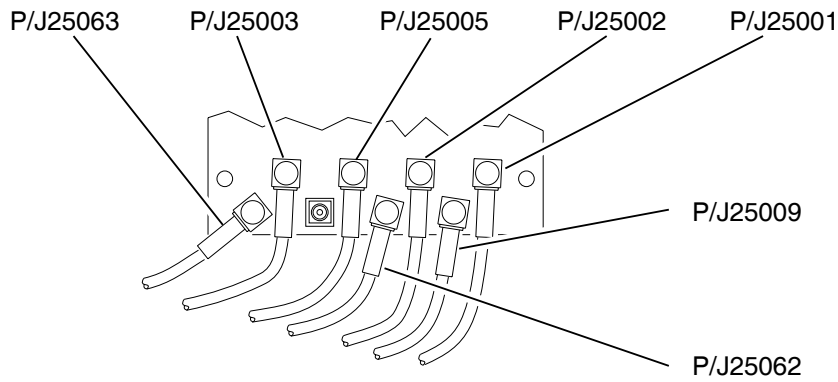
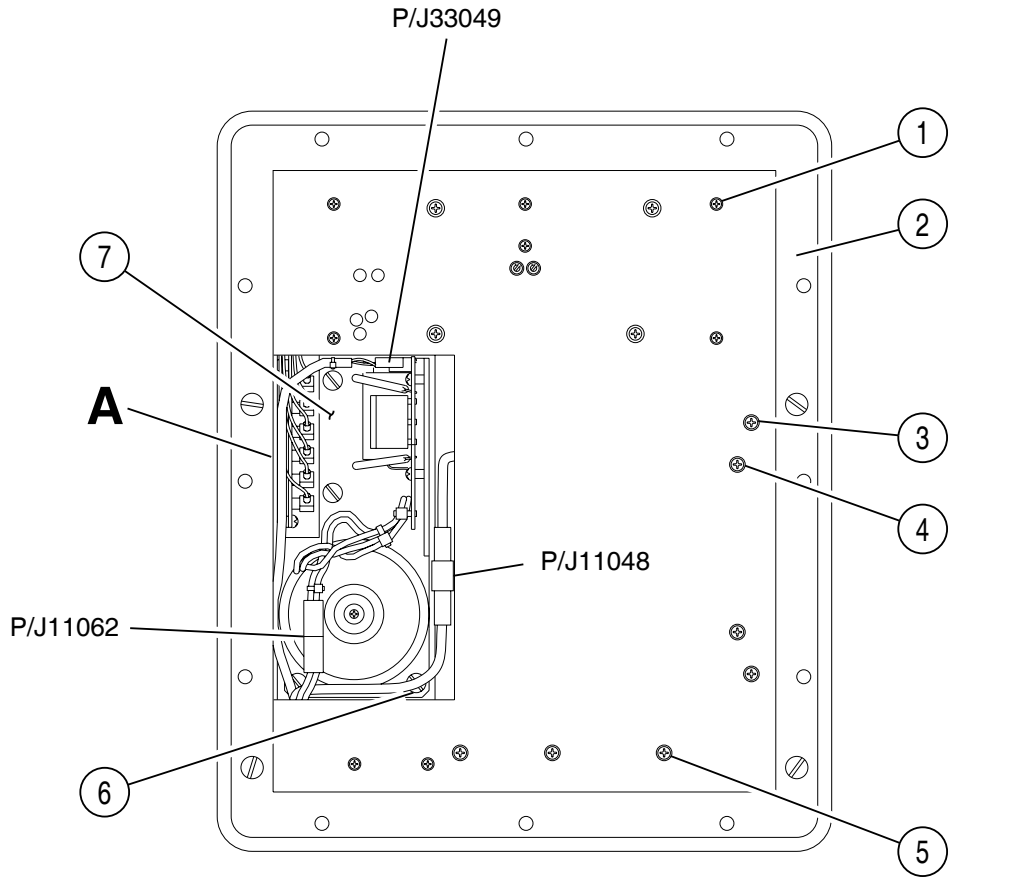

ATC-601-2 Test Set - Rear View  
Figure 2

8507028

(2) Battery

**NOTE:** Item numbers refer to 2-3-1, Figure 2 unless otherwise noted.

STEP	PROCEDURE
1.	Remove Storage Compartment and Chassis Assembly according to para 2-3-1C(1).
2.	Disconnect battery connector (P/J11048).
3.	Remove two screws (3) from bottom of Chassis Assembly (2) and remove PC board retainer (16) (2-3-1, Figure 1).
4.	Remove two screws (4) from bottom of Chassis Assembly (2) and remove battery cover (15) (2-3-1, Figure 1).
5.	Refer to 2-3-1, Figure 1, and pull ejector strap (9) to remove battery (10) from Chassis Assembly (7).

(3) Line Supply Assembly

STEP	PROCEDURE
1.	Remove Storage Compartment and Chassis Assembly according to para 2-3-1C(1).
	<b>NOTE:</b> For Steps 2 through 4, item numbers refer to 2-3-1, Figure 2.
2.	Disconnect P/J33049.
3.	Disconnect P/J11062.
4.	Loosen three captive screws (6) securing Line Supply Assembly (7) to Chassis Assembly (2).
5.	Remove Line Supply Assembly (7) from Chassis Assembly (2).
	<b>NOTE:</b> For Steps 6 through 9, item numbers refer to 2-3-1, Figure 3.
6.	Remove four screws (3) securing Line Supply PC Board Assembly (2) to bracket assembly (1).
7.	Remove one screw (4) securing bridge rectifier (5) to bracket assembly (1).
8.	Remove one screw (9) securing transformer (6) to bracket assembly (1).
9.	Remove transformer (6), conical washer (8), two insulators (7), bridge rectifier (5) and Line Supply PC Board Assembly (2) from bracket assembly (1).

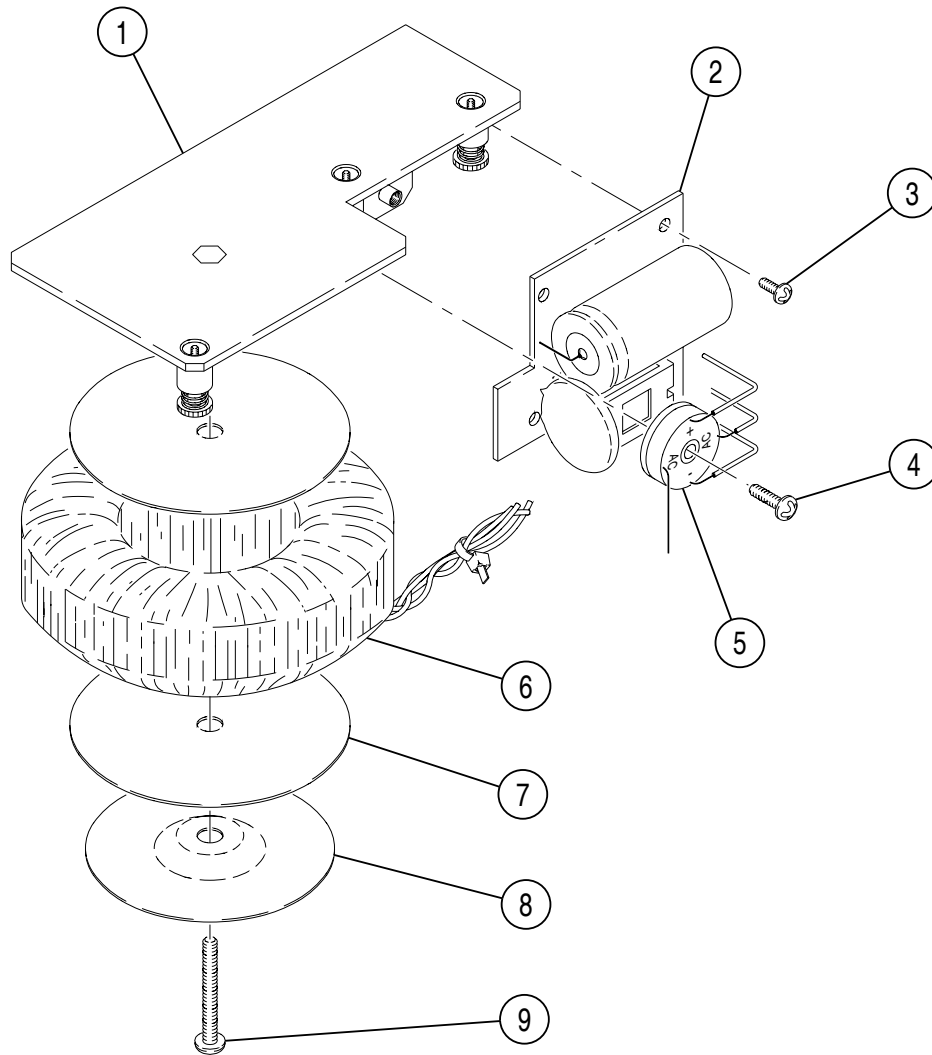

8507027

Line Supply Disassembly  
Figure 3



(4) Power Supply Assembly

STEP	PROCEDURE
1.	Remove Storage Compartment and Chassis Assembly according to para 2-3-1C(1).
	<b>NOTE:</b> For Steps 2 and 3, item numbers refer to 2-3-1, Figure 2.
2.	Disconnect battery connector (P/J11048).
3.	Remove three screws (5) securing Power Supply Assembly to Chassis Assembly.
	<b>NOTE:</b> For Steps 4 and 5, item numbers refer to 2-3-1, Figure 1.
4.	Lift Power Supply Assembly (6) and disconnect J23047 from P23047.
5.	Remove Power Supply Assembly (6) from Chassis Assembly (7). Carefully guide battery cable (5) out from middle of Chassis Assembly cavity and through Power Supply Assembly cavity.
	<b>POWER SUPPLY PC BOARD ASSEMBLY</b>
	<b>NOTE:</b> For Steps 6 through 11, item numbers refer to 2-3-1, Figure 4.
6.	Remove nine screws (1) from Power Supply Assembly.
7.	Remove cover (2) from Power Supply Assembly.
8.	Remove four screws (8), four nuts (3), four flat washers (4) and four shoulder washers (5) securing regulators (9), FETs (7) and insulators (6) to enclosure (11).
9.	Remove two hex nut screws (10) securing J23047 to enclosure (11).
10.	Remove nine screws (12) securing Power Supply PC Board Assembly (13) to enclosure (11).
11.	Remove Power Supply PC Board Assembly (13) from enclosure (11).

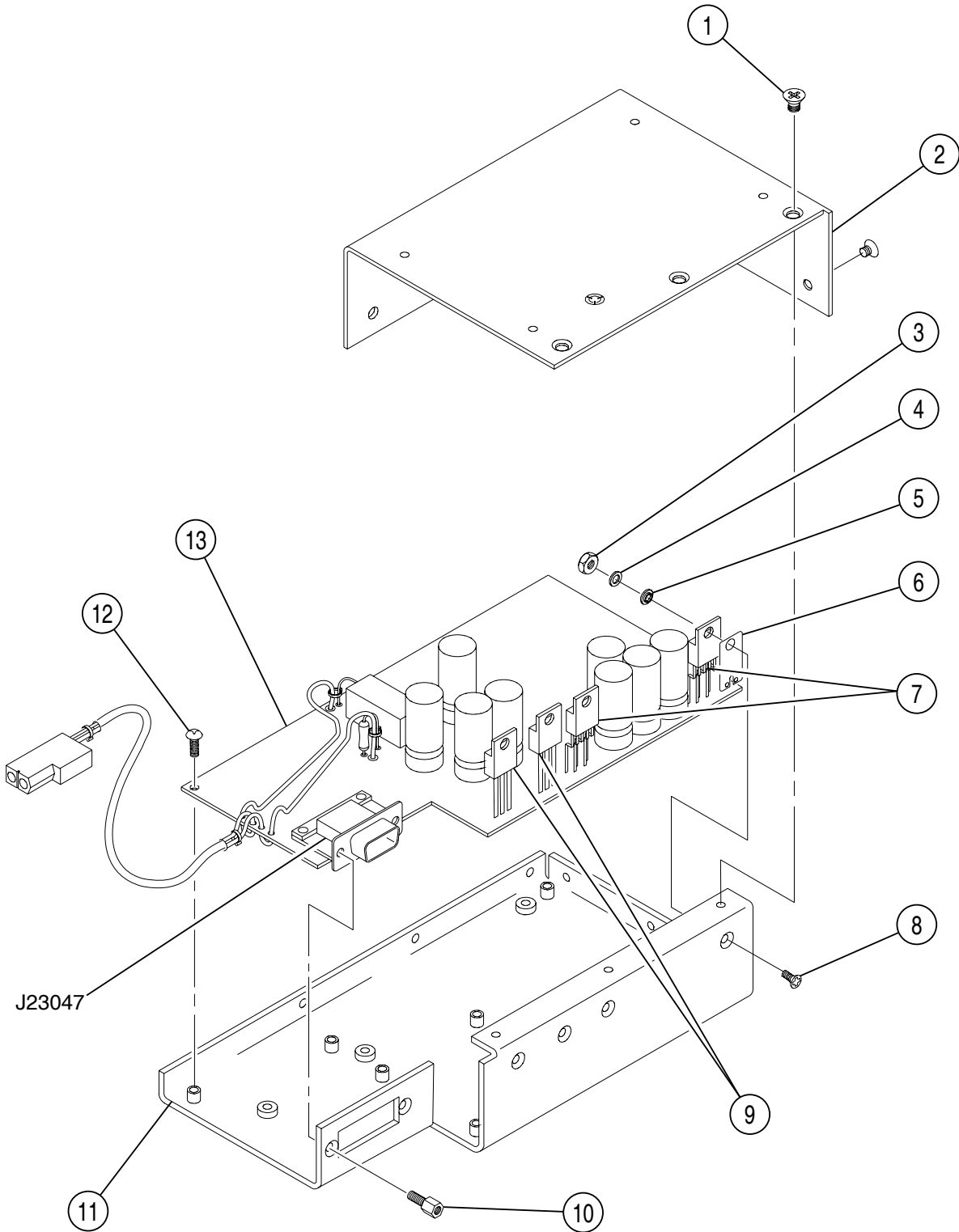

8507031

Power Supply Disassembly  
Figure 4

## (5) Digital IF PC Board Assembly

**NOTE:** Item numbers refer to 2-3-1, Figure 1 unless otherwise noted.

STEP	PROCEDURE
------	-----------

1. Remove Storage Compartment and Chassis Assembly according to para 2-3-1C(1).
2. Remove two screws (4) (2-3-1, Figure 2) securing PC board retainer (6) to Chassis Assembly (7).
3. Pull card ejector (13) and remove Digital IF PC Board Assembly (14) from Chassis Assembly (7).

## (6) Front Panel Pulse PC Board Assembly

**NOTE:** Item numbers refer to 2-3-1, Figure 1 unless otherwise noted.

STEP	PROCEDURE
------	-----------

1. Remove Storage Compartment and Chassis Assembly according to para 2-3-1C(1).
2. Remove two screws (4) (2-3-1, Figure 2) securing PC board retainer (16) to Chassis Assembly (7).
3. Disconnect P27051 and P27052 from Front Panel Pulse PC Board Assembly (11).
4. Pull card ejector (12) and remove Front Panel Pulse PC Board Assembly (11) from Chassis Assembly (7).

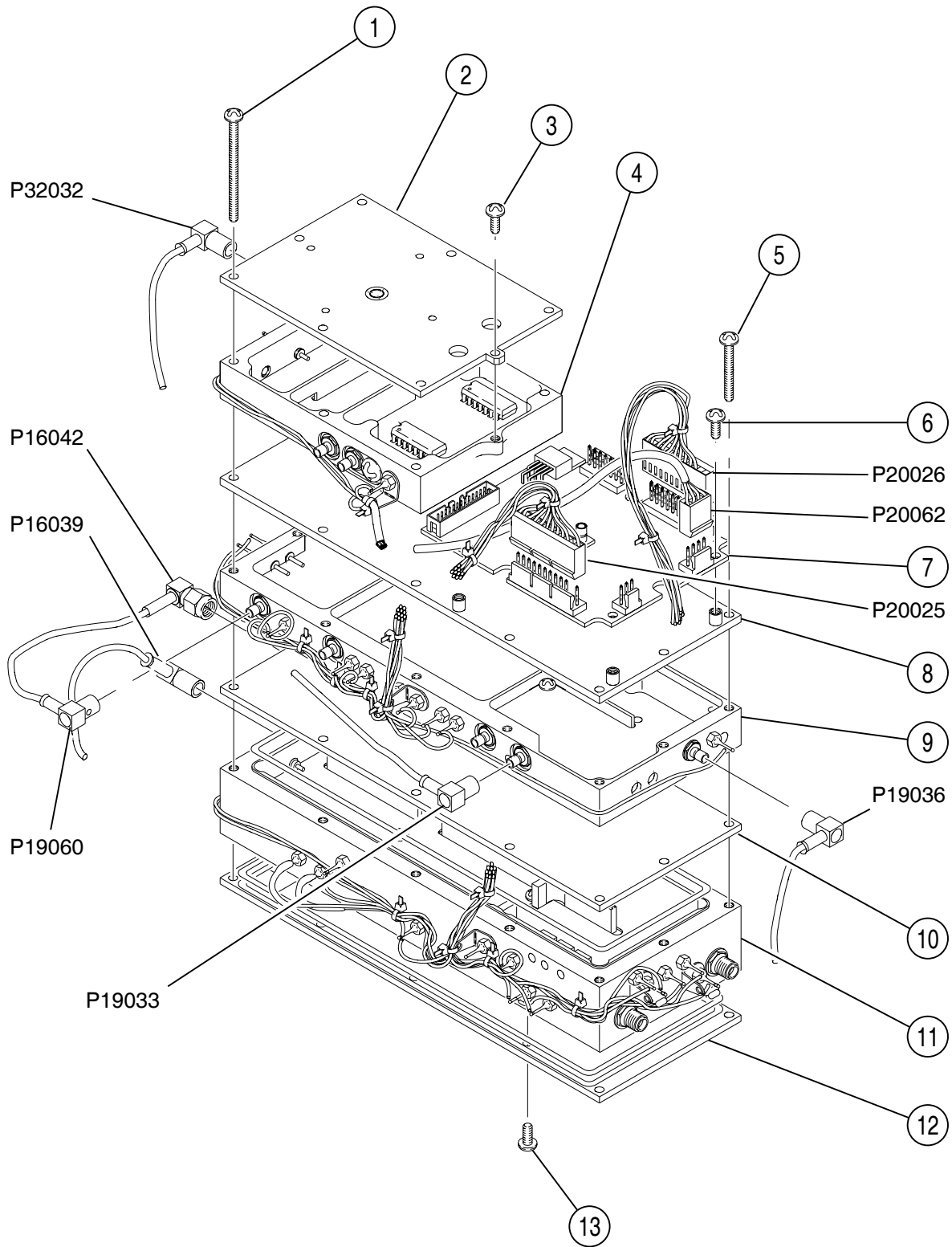

8107023

RF Disassembly  
Figure 5

(7) RF Assembly

**NOTE:** Item numbers refer to 2-3-1, Figure 1 unless otherwise noted.

STEP	PROCEDURE
1.	Remove Storage Compartment and Chassis Assembly according to para 2-3-1C(1).
2.	Refer to 2-3-1, Figure 2 and remove six screws (1) securing RF Assembly to Chassis Assembly (2).
3.	Carefully lift RF Assembly (20) up and out of Chassis Assembly (7), applying minimal stress on connecting cables.
4.	Disconnect cables: <ul style="list-style-type: none"> <li>P17037 (Front Panel Assembly) from J17037 (RF Assembly)</li> <li>P17038 (Front Panel Assembly) from J17038 (RF Assembly)</li> <li>P17027 (Front Panel Assembly) from J17027 (RF Assembly)</li> <li>P17022 (Motherboard PC Board Assembly) from J17022 (RF Assembly)</li> <li>P17023 (Motherboard PC Board Assembly) from J17023 (RF Assembly)</li> <li>P17024 (Motherboard PC Board Assembly) from J17024 (RF Assembly)</li> <li>P17021 (Motherboard PC Board Assembly) from J17021 (RF Assembly)</li> <li>P17034 (Motherboard PC Board Assembly) from J17034 (RF Assembly)</li> <li>P17035 (Motherboard PC Board Assembly) from J17035 (RF Assembly)</li> <li>P17031 (Motherboard PC Board Assembly) from J17031 (RF Assembly)</li> <li>P17030 (Front Panel Assembly) from J17030 (RF Assembly)</li> </ul>
5.	Remove RF Assembly (20) from Chassis Assembly (7).

(a) Driver PC Board Assembly

**NOTE:** Item numbers refer to 2-3-1, Figure 5 unless otherwise noted.

STEP	PROCEDURE
1.	Remove RF Assembly according to para 2-3-1C(7).
2.	Disconnect cables: <ul style="list-style-type: none"> <li>P20062 (Detector Assembly) from J20062 (Driver PC Board Assembly)</li> <li>P20025 (Analog IF Assembly) from J20025 (Driver PC Board Assembly)</li> <li>P20026 (SSB Assembly) from J20026 (Driver PC Board Assembly)</li> </ul>
3.	Remove four screws (6) securing Driver PC Board Assembly (7) to Analog IF cover (8).
4.	Remove Driver PC Board Assembly (7) from RF Assembly.

(b) Detector Assembly

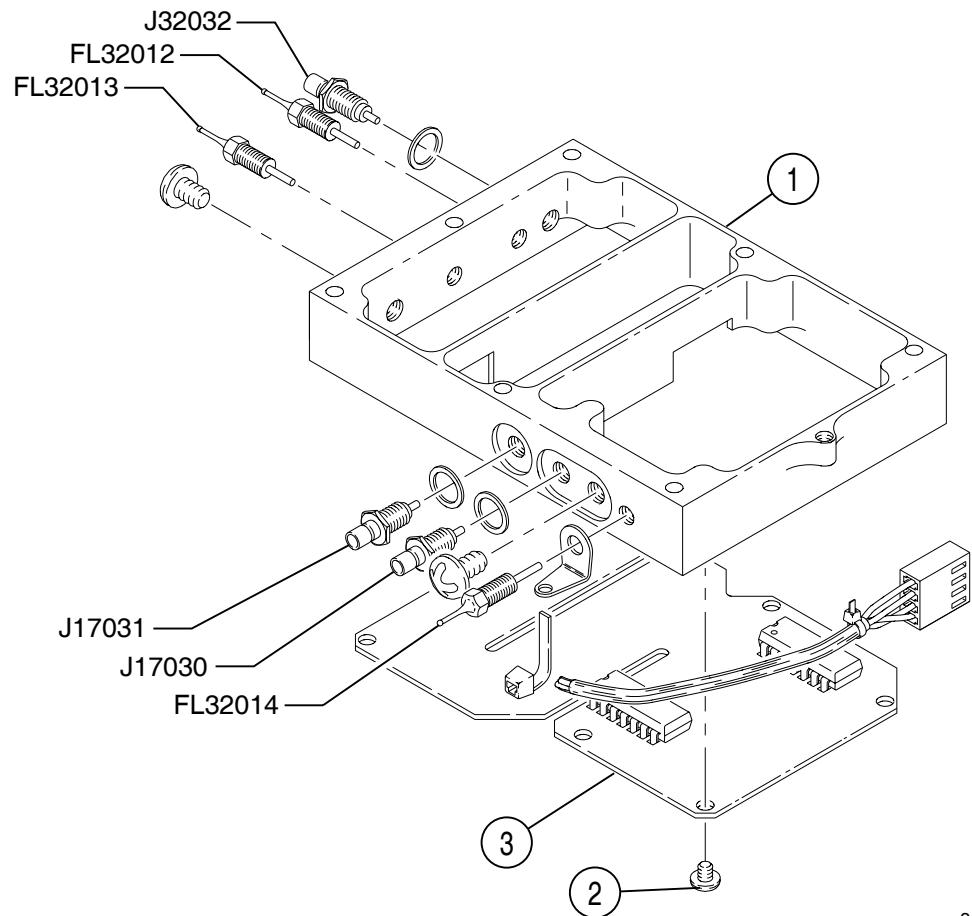

8107021

Detector Disassembly  
Figure 6

STEP	PROCEDURE
------	-----------

**NOTE:** For Steps 1 through 5, item numbers refer to 2-3-1, Figure 5.

1. Remove RF Assembly according to para 2-3-1C(7).
2. Disconnect cables:
  - P20062 (Detector Assembly) from J20062 (Driver PC Board Assembly)
  - P32032 (Analog IF Assembly) from J32032 (Detector Assembly)
3. Remove seven screws (1) securing Detector Assembly (4) to SSB Assembly (11).
4. Remove Detector Assembly (4) from RF Assembly.

**DETECTOR PC BOARD ASSEMBLY**

5. Loosen screw (3) and rotate Detector cover (2).

**NOTE:** For Steps 6 through 8, item numbers refer to 2-3-1, Figure 6.

STEP	PROCEDURE
------	-----------

6. Remove solder from Detector PC Board Assembly (3) at filter and connector junctions as follows:
  - FL32012
  - FL32013
  - FL32014
  - J17030
  - J17031
  - J32032
7. Remove seven screws (2) securing Detector PC Board Assembly (3) to Detector Assembly (1).
8. Remove Detector PC Board Assembly (3) from Detector Assembly (1).

(c) Analog IF Assembly

STEP	PROCEDURE
------	-----------

**NOTE:** For Steps 1 through 4, item numbers refer to 2-3-1, Figure 5.

1. Remove Detector Assembly according to para 2-3-1C(7)(b).
2. Disconnect cables as follows:
  - P19036 (SSB Assembly) from J19036 (Analog IF Assembly)
  - P20025 (Analog IF Assembly) from J20025 (Driver PC Board Assembly)
  - P19033 (Detector Assembly) from J19033 (Analog IF Assembly)
  - P19060 (SSB Assembly) from J19060 (Analog IF Assembly)
3. Remove five screws (5) securing Analog IF Assembly (9) to SSB Assembly (11).
4. Remove Analog IF cover (8) and Analog IF Assembly (9) from RF Assembly.

**ANALOG IF PC BOARD ASSEMBLY**

**NOTE:** For Steps 5 through 7, item numbers refer to 2-3-1, Figure 7.

5. Remove solder from Analog IF PC Board Assembly (1) at filter and connector junctions as follows:
 

FL19010	FL19002	J19036
FL19008	J19033	J17035
J17034	FL19011	FL19006
J19060	FL19005	FL19001
FL19004	FL19007	FL19003
6. Remove fourteen screws (2) securing Analog IF PC Board Assembly (1) to Analog IF Assembly (3).
7. Remove Analog IF PC Board Assembly (1) from Analog IF Assembly (3).

THIS PAGE INTENTIONALLY LEFT BLANK.



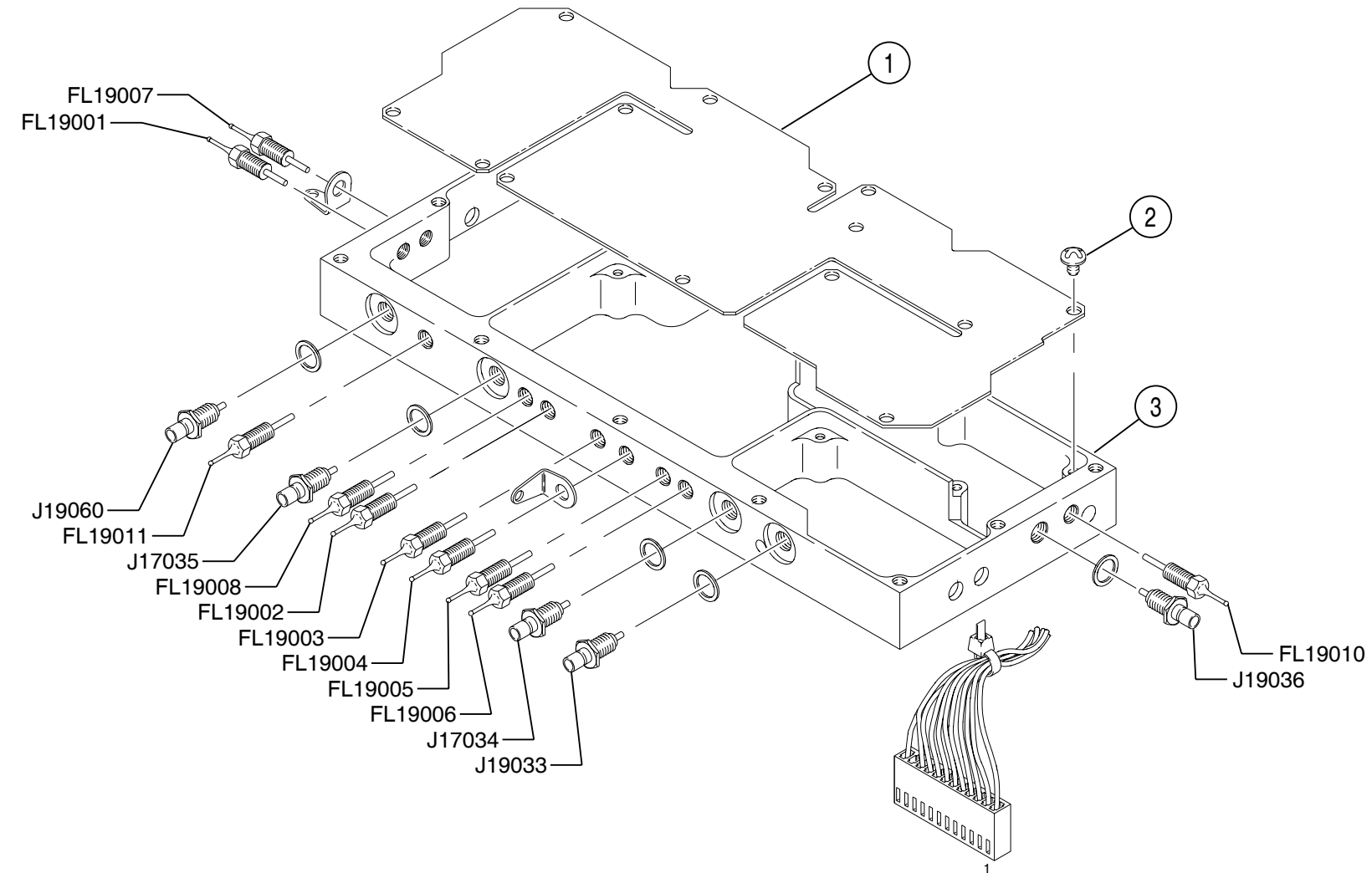

8107020

Analog IF Disassembly  
Figure 7

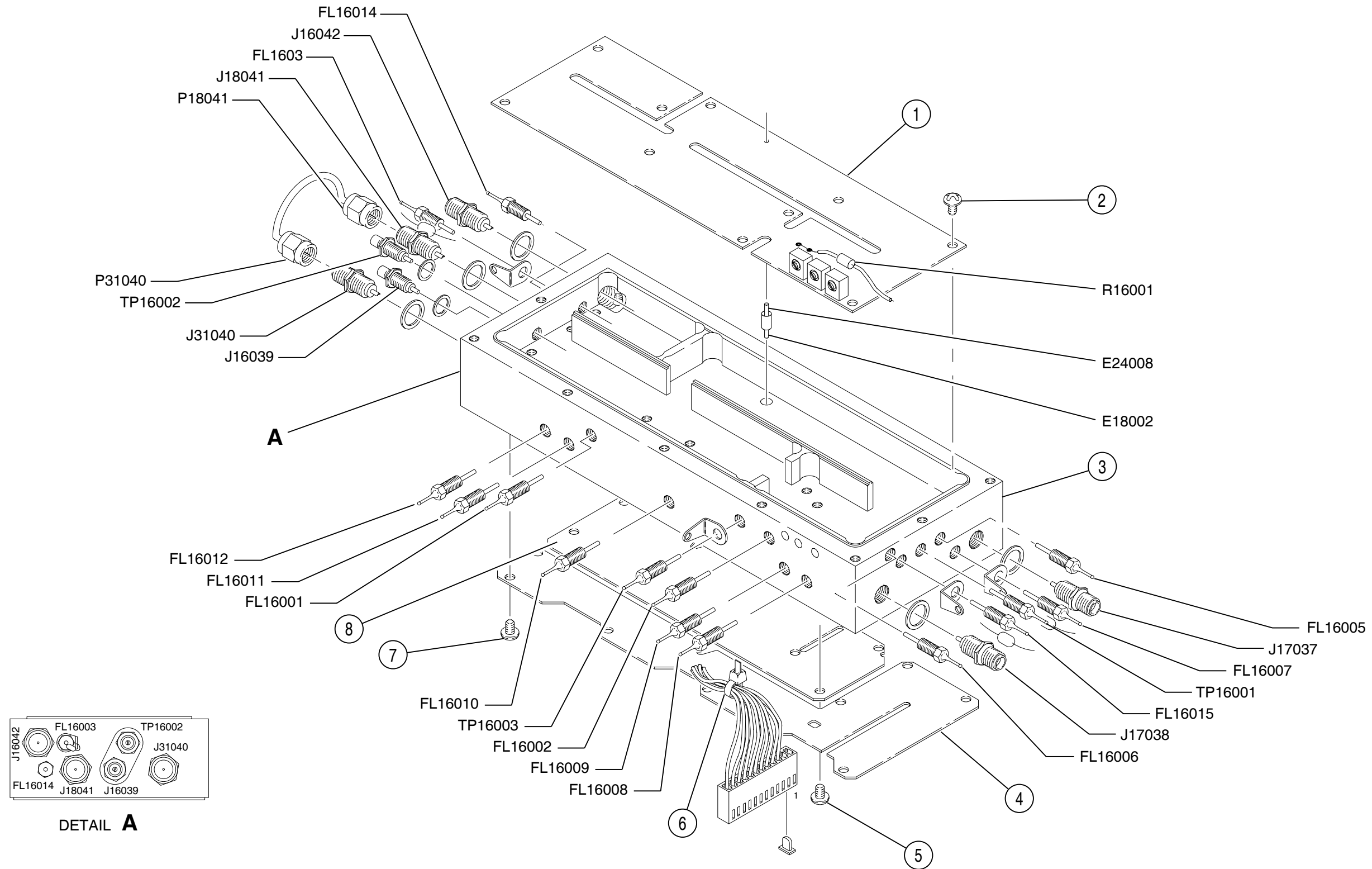

(d) SSB Assembly

**NOTE:** Item numbers refer to 2-3-1, Figure 8 unless otherwise noted.

STEP	PROCEDURE
------	-----------

1. Remove RF Assembly according to para 2-3-1C(7).

**MIXER PC BOARD ASSEMBLY**

2. Disconnect cables as follows:
  - P18041 from J18041 and P31040 from J31040 (Attenuator PC Board Assembly to Mixer PC Board Assembly).
  - P16039 (Analog IF Assembly) from J16039 (SSB Assembly). Refer to 2-3-1, Figure 5.
3. Refer to 2-3-1, Figure 5 and remove four screws (13) securing Mixer cover (12) to SSB Assembly (11).
4. Remove solder from Mixer PC Board Assembly (8) at filter and connector junctions as follows:

J16039	J18041
FL16014	E18002

5. Remove J16039, FL16014 and J18041 from SSB Assembly (3).
6. Remove five screws (5) securing Mixer PC Board Assembly (8) to SSB Assembly (3).
7. Remove Mixer PC Board Assembly (8) from SSB Assembly (3).

**ATTENUATOR PC BOARD ASSEMBLY**

8. Remove solder from Attenuator PC Board Assembly (4) at filter and connector junctions as follows:

J31040	FL16008
FL16012	J17038
FL16011	FL16007
FL16010	J17037
FL16009	

9. Remove J31040, FL16012, FL16011, FL16010, FL16009, FL16008, J17038, FL16007 and J17037 from SSB Assembly (3).
10. Remove nine screws (7) securing Attenuator PC Board Assembly (4) to SSB Assembly (3).
11. Remove Attenuator PC Board Assembly (4) from SSB Assembly (3).

**LO SOURCE PC BOARD ASSEMBLY**

12. Remove Analog Assembly according to 2-3-1C(7)(c).
13. Refer to 2-3-1, Figure 5 and remove LO Source cover (10) from SSB Assembly (11).
14. Remove P16042 (Analog IF Assembly) from J16042 (SSB Assembly).

STEP	PROCEDURE
------	-----------

---

15. Remove solder from LO Source PC Board Assembly (1) at filter, test point and connector junctions as follows:

FL16005	FL16001
TP16001	TP16002
FL16015	FL16003
FL16006 from R16001	J16042
FL16002	E24008
TP16003	

16. Remove FL16005, TP16001, FL16015, FL16006, FL16002, TP16003, FL16001, TP16002, FL16003 and J16042 from SSB Assembly (3).
17. Remove ten screws (2) securing LO Source PC Board Assembly (1) to SSB Assembly (3).
18. Remove LO Source PC Board Assembly (1) from SSB Assembly (3).

(8) Front Panel Assembly

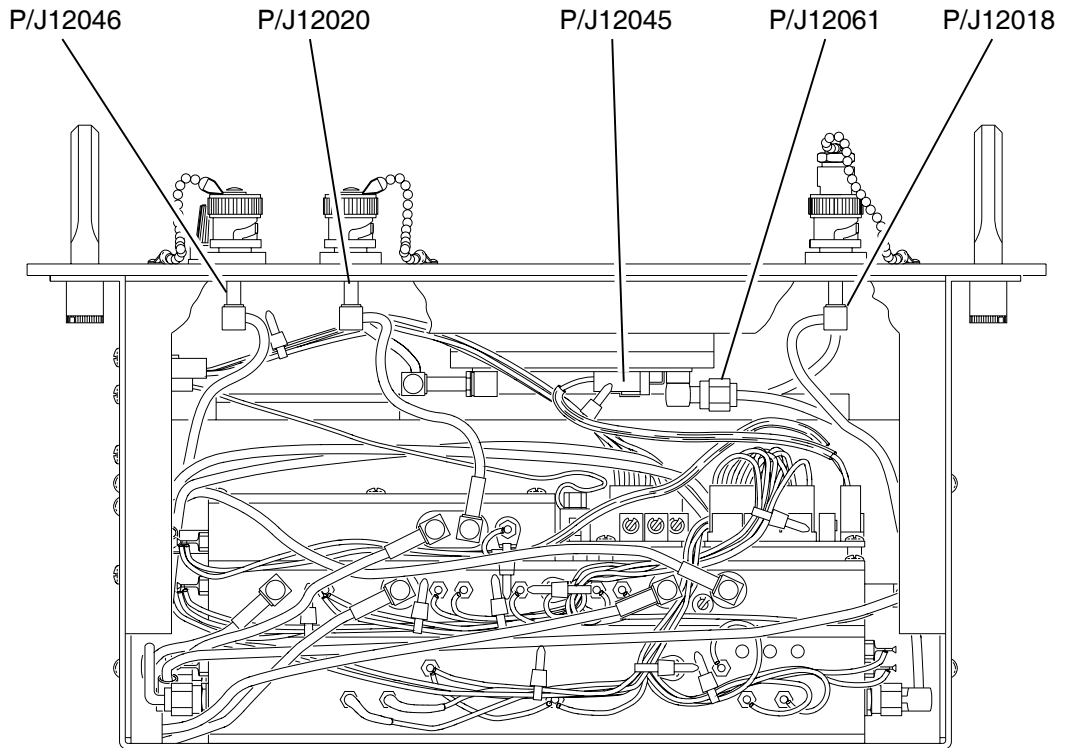

8107027

ATC-601-2 Test Set Top View  
Figure 9

**STEP**

**PROCEDURE**

1. Remove Storage Compartment and Chassis Assembly according to para 2-3-1C(1).
2. Refer to 2-3-1, Figure 2 and disconnect P11062 (Front Panel Assembly) from J11062 (Line Supply Assembly).
3. Refer to 2-3-1, Figure 9 and disconnect cables:
  - P12018 (RF Assembly) from J12018 (Front Panel Assembly).
  - P12061 (RF Assembly) from J12061 (Front Panel Assembly).
  - P12045 (RF Assembly) from J12045 (Front Panel Assembly).
  - P12020 (RF Assembly) from J12020 (Front Panel Assembly).
  - P12046 (Motherboard PC Board Assembly) from J12020 (Front Panel Assembly).
- NOTE:** For Steps 4 through 9, item numbers refer to 2-3-1, Figure 1.
4. Loosen four captive screws (8).
5. Remove two handles (24) and four washers (23) from Front Panel Assembly (3).

- | STEP | PROCEDURE                                                                                                                                                                                                                                                                                                                                                                                                                            |
|------|--------------------------------------------------------------------------------------------------------------------------------------------------------------------------------------------------------------------------------------------------------------------------------------------------------------------------------------------------------------------------------------------------------------------------------------|
| 6.   | <p>Tilt left side of Front Panel Assembly (3) up approximately 30° and disconnect cables as follows:</p> <ul style="list-style-type: none"> <li>● P27052 (Front Panel Assembly) from J27052 (Front Panel Pulse PC Board Assembly).</li> <li>● P27051 (Front Panel Assembly) from J27051 (Front Panel Pulse PC Board Assembly).</li> </ul> <p><b>NOTE:</b> Left side of Chassis Assembly (7) has access to PC boards and battery.</p> |
| 7.   | <p>Set left side of Front Panel Assembly (3) on Chassis Assembly (7) and tilt right side of Front Panel Assembly (3) up approximately 30°.</p> <p><b>NOTE:</b> The Keypad ribbon cable is taped to the Front Panel Assembly (3) and should be carefully untaped to achieve better access to connecting cables.</p>                                                                                                                   |
| 8.   | <p>Disconnect cables as follows:</p> <ul style="list-style-type: none"> <li>● P25011 (Front Panel Assembly) from J25011 (Motherboard PC Board Assembly).</li> <li>● P25010 (Front Panel Assembly) from J25010 (Motherboard PC Board Assembly).</li> <li>● P25014 (Front Panel Assembly) from J25014 (Motherboard PC Board Assembly).</li> </ul>                                                                                      |
| 9.   | <p>Carefully guide connecting cables and remove Front Panel Assembly (3) from Chassis Assembly (7).</p>                                                                                                                                                                                                                                                                                                                              |
| (a)  | Video Detector PC Board Assembly                                                                                                                                                                                                                                                                                                                                                                                                     |
|      | <p><b>NOTE:</b> Item numbers refer to 2-3-1, Figure 10 unless otherwise noted.</p>                                                                                                                                                                                                                                                                                                                                                   |

- | STEP | PROCEDURE                                                                                                                                                                                                                                                              |
|------|------------------------------------------------------------------------------------------------------------------------------------------------------------------------------------------------------------------------------------------------------------------------|
| 1.   | Remove Front Panel Assembly according to para 2-3-1C(7).                                                                                                                                                                                                               |
| 2.   | <p>Disconnect cables as follows:</p> <ul style="list-style-type: none"> <li>● P30043 (Power Termination Assembly) from J30043 (Video Detector PC Board Assembly).</li> <li>● P30044 (REPLY VIDEO Connector) from J30043 (Video Detector PC Board Assembly).</li> </ul> |
| 3.   | Remove seven screws (8) and two screws (10) securing Video Detector PC Board Assembly (7) to Power Termination cover (6).                                                                                                                                              |
| 4.   | Remove Video Detector PC Board Assembly (7) from Front Panel Assembly (1).                                                                                                                                                                                             |

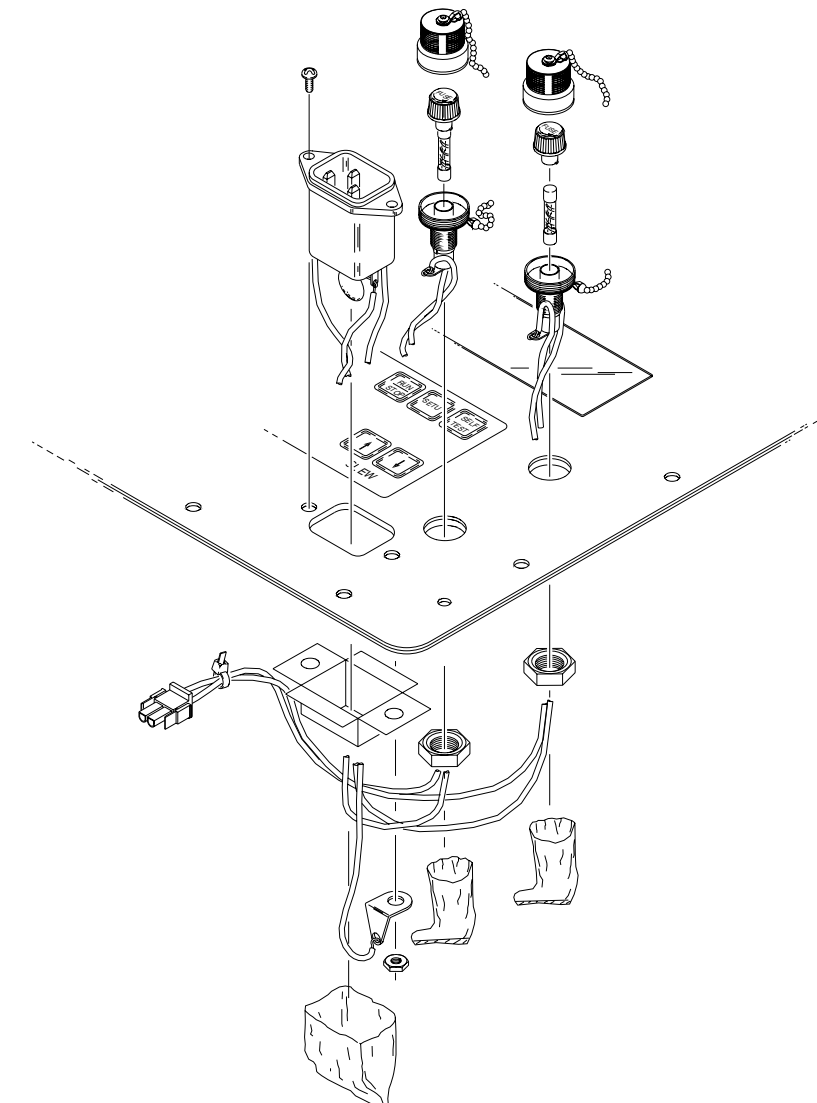
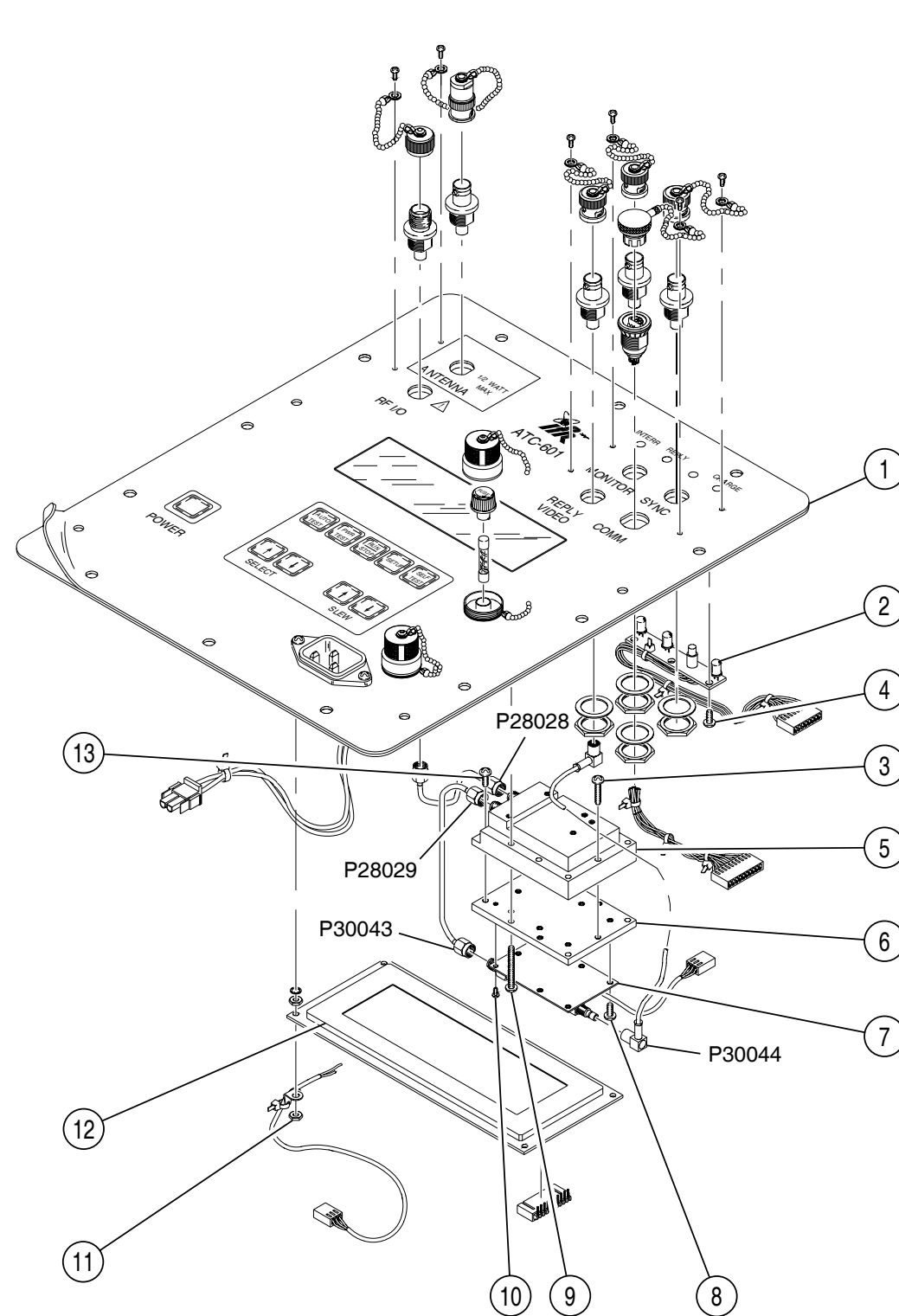

DETAIL A

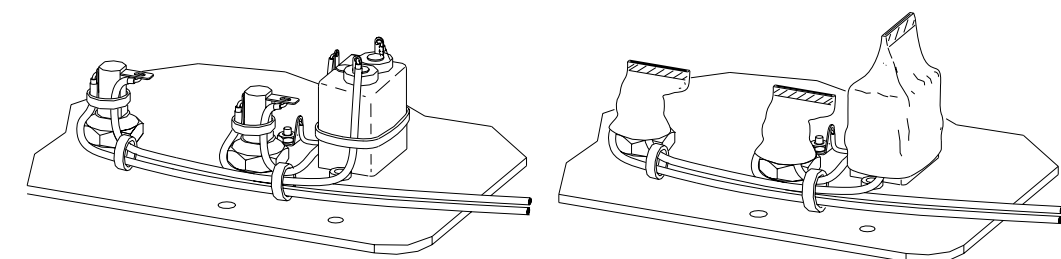

VIEW A-A

8107032

Front Panel Disassembly (Sheet 1 of 2)  
Figure 10

(7005-8144-200)

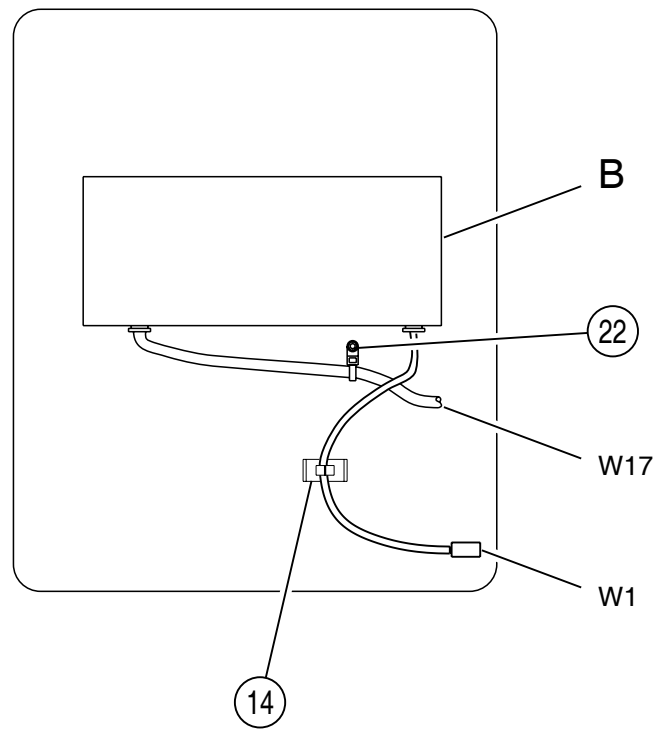

(7005-8142-900)

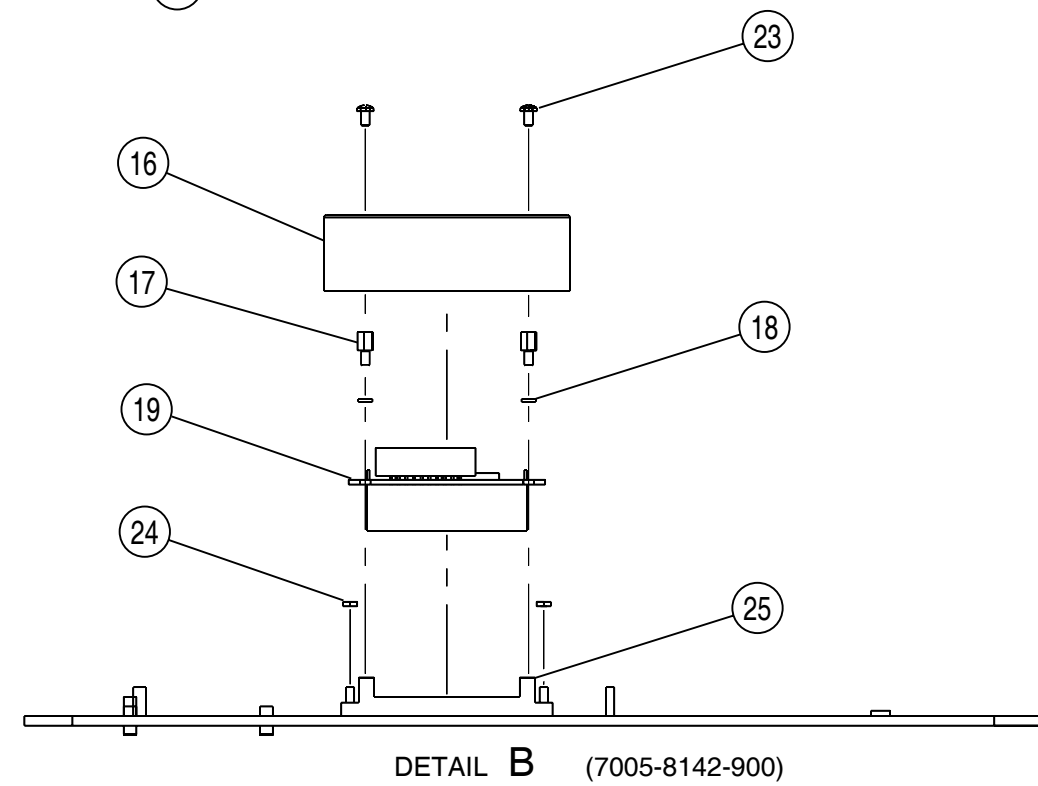
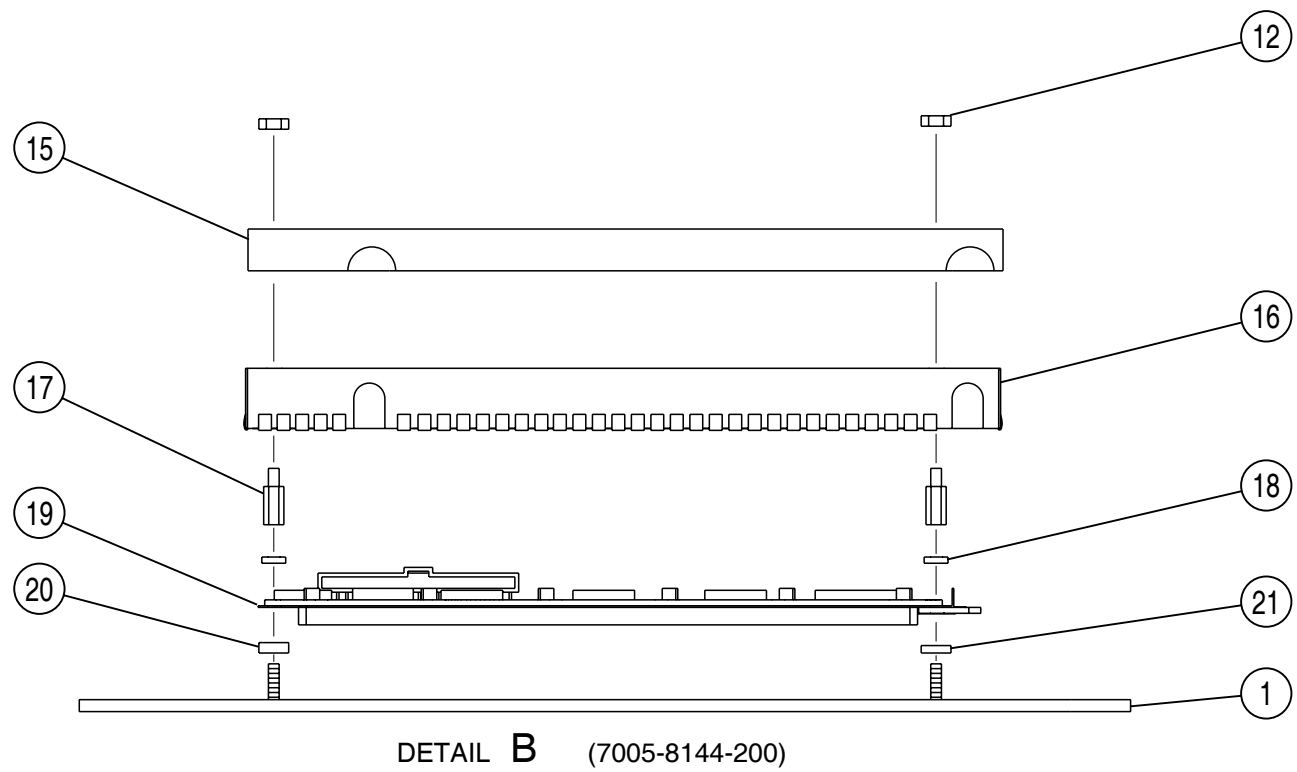
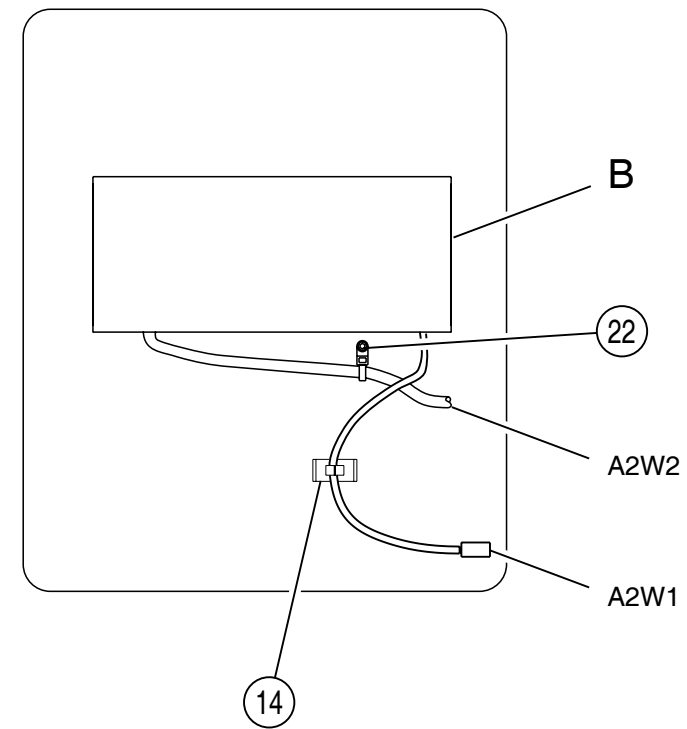

DETAIL B (7005-8144-200)

DETAIL B (7005-8142-900)

Front Panel Disassembly (Sheet 2 of 2)  
Figure 11

8507034A



(b) Power Termination Assembly

STEP	PROCEDURE
1.	Remove Front Panel Assembly according to para 2-3-1C(7).
	<b>NOTE:</b> For Steps 2 through 5, item numbers refer to 2-3-1, Figure 10.
2.	Disconnect cables as follows:
	● P28028 (RF I/O Connector) from J28028 (Power Termination Assembly).
	● P28029 (Video Detector PC Board Assembly) from J28029 (Power Termination Assembly).
	● P30044 (REPLY VIDEO Connector) from J30044 (Video Detector PC Board Assembly).
3.	Remove four screws (9) securing Power Termination Assembly (5) to Front Panel Assembly (1).
4.	Remove three screws (4) and two screws (13) securing Power Termination cover (6).
5.	Remove Power Termination cover (6) from Power Termination Assembly (5).
	<b>NOTE:</b> For Steps 6 through 13, item numbers refer to 2-3-1, Figure 11.
	<b>RESISTOR R28002</b>
6.	Remove two socket head screws (1) securing R28002 (3) to Power Termination Assembly (4).
7.	Remove solder from connection between R28002 (3) and Power Termination PC Board (2).
8.	Remove R28002 (3) from Power Termination Assembly (4).
	<b>CONNECTORS J28028 AND J28029</b>
9.	Remove four screws (5) securing J28028 or J28029 to Power Termination Assembly (4).
10.	Remove solder between connector and Power Termination PC Board (2).
11.	Remove connector from Power Termination Assembly (4).
	<b>POWER TERMINATION PC BOARD</b>
12.	Remove three screws (6) securing Power Termination PC Board (2) to Power Termination Assembly (4).
13.	Remove Power Termination PC Board (2) and Power Termination Assembly (4).

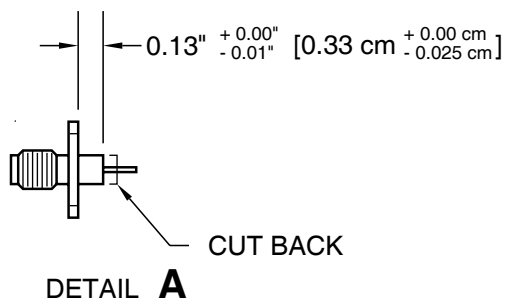
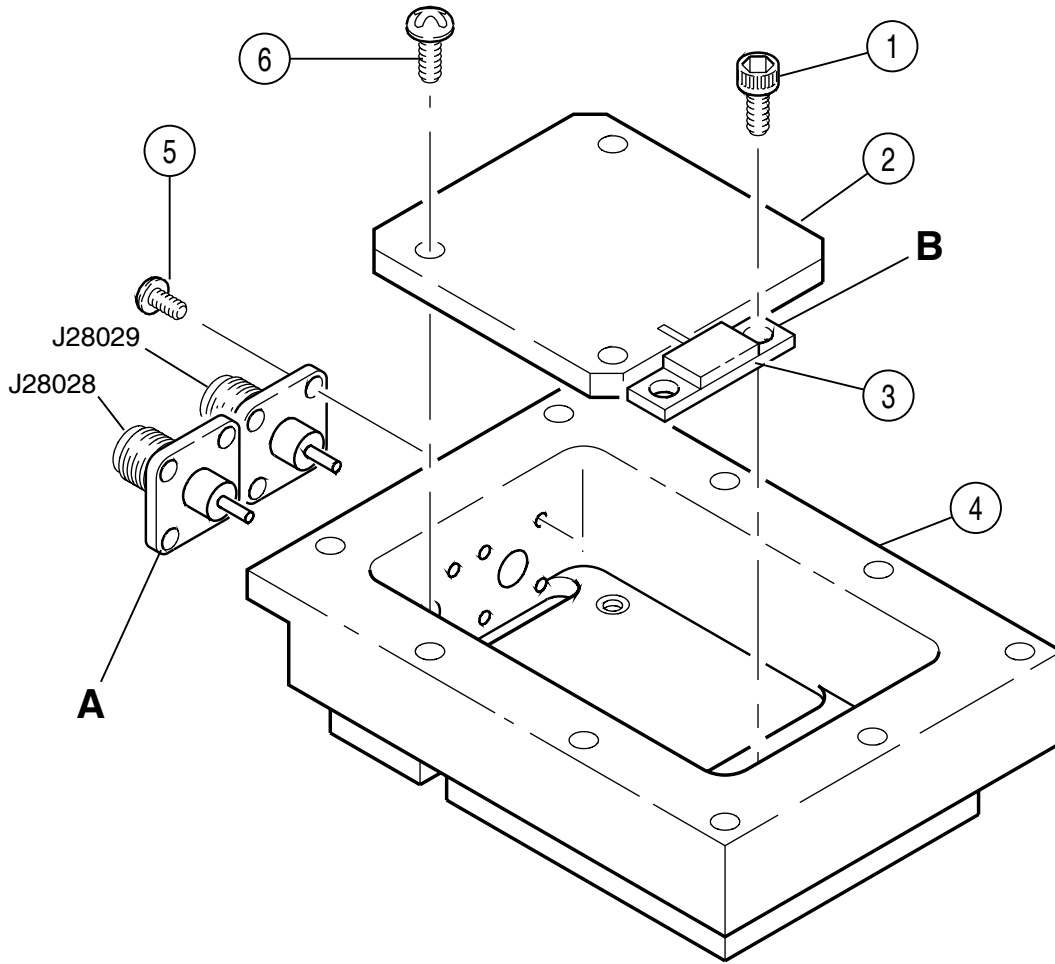

(J28028 & J28029)

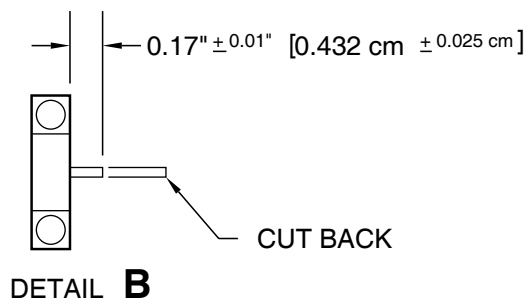

Power Termination Disassembly  
Figure 11

8507011

(c) Front Panel LED PC Board Assembly

**NOTE:** Item numbers refer to 2-3-1, Figure 10.

STEP	PROCEDURE
1.	Remove Front Panel Assembly according to para 2-3-1C(7).
2.	Remove three screws (3) securing Front Panel LED PC Board Assembly (2) to Front Panel Assembly (1).
3.	Remove Front Panel LED PC Board Assembly (2) from Front Panel Assembly (1).

(d) Modified LCD Display PC Board Assembly

**NOTE:** Item numbers refer to 2-3-1, Figure 10.

STEP	PROCEDURE
1.	Remove Front Panel Assembly according to para 2-3-1C(7).
2.	<u>(7005-8144-200)</u> Remove four nuts (11) securing LCD (12) to Front Panel Assy (1).  <u>(7005-8142-900)</u> Remove four screws (23) (7005-8540-100) securing LCD (12) to Front Panel Assy (1).
3.	<u>(7005-8144-200)</u> Remove wire harness restraining nut (22) and remove wire harness (W1) from adhesive clip (14).  <u>(7005-8142-900)</u> Remove wire harness restraining nut (22) and remove wire harness (A2W1) from adhesive clip (14).
4.	Remove shield support bracket (15) and slide back grommets from display shield (16). (7005-8144-200 only)
5.	Carefully remove display shield (16).
6.	Remove four standoffs (17) and four spacers (18).
7.	Remove LCD Display PCB Assy (Modified) (19) from Front Panel Assy (1).
8.	<u>(7005-8144-200)</u> Note locations of different size washers (20) and (21). Remove four washers (20) and (21).  <u>(7005-8142-900)</u> Remove four nuts (24) and display support bracket (25) from Front Panel Assy (1).
9.	<u>(7005-8144-200)</u> Disconnect W17P1 from J12059 on LCD Display PCB Assy (Modified) (19).  <u>(7005-8142-900)</u> Disconnect A2W2P1 from J27052 on Front Panel Pulse PCB Assy (11) (2-3-1, Figure 1).

(9) Flat Antenna Assembly

**NOTE:** Item numbers refer to 2-3-1, Figure 12 unless otherwise noted.

STEP	PROCEDURE
1.	Remove two screws (13) and cover plate (12) from Flat Antenna Assembly (14).
2.	Refer to Detail A in 2-3-1, Figure 12. Remove solder from connections between Antenna PC Board (21) and Splitter PC Board (16).
3.	Refer to Detail A in 2-3-1, Figure 12 and remove two screws (20).
4.	Remove ten screws (19) securing handle assembly to Flat Antenna Assembly (14).
5.	Remove handle assembly from Flat Antenna Assembly (14).
<b>FLAT ANTENNA CONNECTOR (J29001)</b>	
6.	Remove six screws (10) securing right plate (11) to left plate (15).
7.	Remove two screws (8) securing J29001 to left plate (15).
8.	Remove two screws (6) and left plate (15) from back plate (18).
9.	Remove solder from connection between J29001 and Antenna Splitter PC Board (16).
10.	Remove two screws (8) securing J29001 to right plate (11).
11.	Remove J29001 from back plate (18).
<b>ANTENNA SPLITTER PC BOARD</b>	
12.	Remove two screws (7) and right plate (11) from back plate (18).
13.	Remove solder from switch wire (5) connections on Antenna Splitter PC Board (16).
14.	Remove Antenna Splitter PC Board (16) from handle assembly.
<b>ANTENNA PUSH BUTTON SWITCH (S29001)</b>	
15.	Remove ring nut (1) from push button switch (4).
16.	Remove two screws (19) securing top handle bracket (3).
17.	Loosen socket head screw (2) in top handle bracket (3).
18.	Remove top handle bracket (3) from handle (9) and back plate (18).
19.	Remove push button switch (4) from top handle bracket (3).

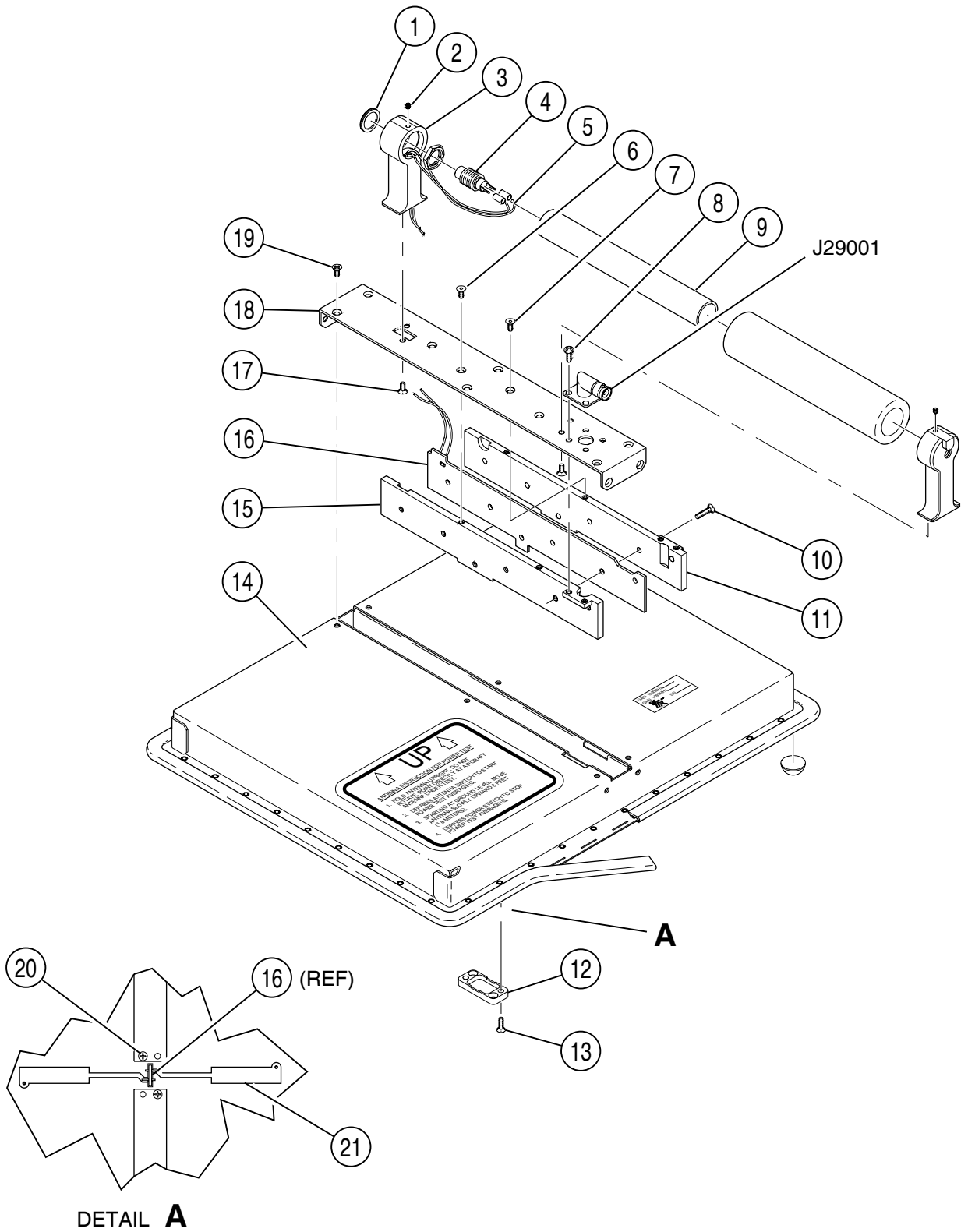

Flat Antenna Disassembly  
Figure 12

8507023

(10) Motherboard PC Board Assembly

**NOTE:** Item numbers refer to 2-3-1, Figure 1 unless otherwise noted.

STEP	PROCEDURE
1.	Remove Power Supply Assembly according to para 2-3-1C(4).
2.	Remove Digital IF PC Board Assembly according to para 2-3-1C(5).
3.	Remove Front Panel Pulse PC Board Assembly according to para 2-3-1C(6).
4.	Remove Front Panel Assembly according to para 2-3-1C(8).
5.	Remove two screws (4) securing P23047 to the Chassis Assembly (7).
6.	Refer to 2-3-1, Figure 2 and disconnect cables as follows: <ul style="list-style-type: none"> <li data-bbox="354 630 1393 657">● P33049B (Power Supply Assembly) from J33049A/B (Line Supply Assembly)</li> <li data-bbox="354 678 1338 705">● P25001 (RF Assembly) from J25001 (Motherboard PC Board Assembly).</li> <li data-bbox="354 726 1300 783">● P25009 (Front Panel Assembly) from J25009 (Motherboard PC Board Assembly).</li> <li data-bbox="354 804 1338 831">● P25002 (RF Assembly) from J25002 (Motherboard PC Board Assembly).</li> <li data-bbox="354 852 1338 879">● P25005 (RF Assembly) from J25005 (Motherboard PC Board Assembly).</li> <li data-bbox="354 900 1338 928">● P25004 (RF Assembly) from J25004 (Motherboard PC Board Assembly).</li> <li data-bbox="354 949 1338 976">● P25003 (RF Assembly) from J25003 (Motherboard PC Board Assembly).</li> </ul>
7.	Remove twelve screws (21) securing Motherboard PC Board (22) to Chassis Assembly (7).
8.	Remove Motherboard PC Board Assembly (22) from Chassis Assembly (7).

2. Reassembly

A. General

Reassembly depends upon extent of disassembly and should be performed with normal repair and/or cleaning. Perform reassembly in reverse sequence of disassembly procedures. Incorporate Special Reassembly Procedures in para 2-3-2C as required.

<u>PROCEDURE</u>	<u>PAGE</u>
Storage Compartment and Chassis Assembly -----	2
Battery-----	2
Line Supply Assembly -----	3
Power Supply Assembly -----	3
Digital IF PC Board Assembly -----	3
Front Panel Pulse PC Board Assembly -----	3
RF Assembly-----	3
Front Panel Assembly-----	4
Flat Antenna Assembly -----	6
Motherboard PC Board Assembly-----	6

B. Preliminary Considerations

(1) Tools Required

Reassembly and disassembly require the same tools. Refer to 2-3-1, Table 1.

(2) Reassembly Precautions

**CAUTION:** INSURE ALL COAXIAL CONNECTIONS ARE PROPERLY MATED.

**CAUTION:** AVOID BENDING OR TWISTING SEMI-RIGID COAXIAL CABLES.

**CAUTION:** PLACE ALL RIBBON CABLES TO LAY FLAT AND NEATLY FOLDED.

**CAUTION:** AVOID PLACING UNDUE STRAIN ON ANY WIRE OR CABLE.

**CAUTION:** AVOID OVERTIGHTENING SCREWS AND NUTS INCLUDING COAXIAL CONNECTORS.

**CAUTION:** REPLACE EACH REMOVED PLASTIC FASTENER IN SAME LOCATION AS MARKED AND CONFIGURED PRIOR TO REMOVAL.

**CAUTION:** AVOID EXPOSING COMPONENTS TO EXCESSIVE HEAT WHEN SOLDERING.

**CAUTION:** REPLACE WORN SHOULDER WASHERS AND INSULATORS. CAREFULLY REINSTALL SHOULDER WASHERS AND INSULATORS IN CORRECT POSITIONS. FAILURE TO INSTALL SHOULDER WASHERS AND INSULATORS CORRECTLY COULD RESULT IN A SHORT CIRCUIT.

(3) ESD

**CAUTION:** THE POWER SUPPLY PC BOARD ASSEMBLY, DIGITAL IF PC BOARD ASSEMBLY, FRONT PANEL PULSE PC BOARD ASSEMBLY, RF ASSEMBLY AND FRONT PANEL ASSEMBLY CONTAIN PARTS SENSITIVE TO DAMAGE BY ELECTROSTATIC DISCHARGE (ESD). ALL PERSONNEL PERFORMING REASSEMBLY SHOULD HAVE KNOWLEDGE OF ACCEPTED ESD PRACTICES.



(4) EMC and Safety Compliance

All assemblies, cables, connectors, plastic fasteners, gaskets, fingerstock and miscellaneous hardware within the Test Set are configured to satisfy the safety and EMC compliance standards.

**CAUTION:** UPON COMPLETION OF ANY MAINTENANCE ACTION; ALL ASSEMBLIES, CABLES, CONNECTORS, PLASTIC FASTENERS, GASKETS, FINGERSTOCK AND MISCELLANEOUS HARDWARE MUST BE CONFIGURED AS INSTALLED AT THE FACTORY.

C. Special Reassembly Procedures

Most procedures only apply if the particular item(s) mentioned was/were removed.

(1) Storage Compartment and Chassis Assembly

**NOTE:** Instrument Case Top (2503-8153-600) and Bottom (1412-8153-500) are a matched set and should not be separated.

- Replace the twelve nylon washers (2840-8110-000) to maintain water resistance capability.
- Tighten twelve screws securing Chassis Assembly to Case Assembly with 23 inch•pounds (2.56 newton•meters) of torque.

(2) Battery

Ensure Battery Ejector Strap (1410-7452-300) is installed with doubled-over side facing out.

(3) Line Supply Assembly

**NOTE:** Mounting hardware (1 metal washer [on top] and 2 rubber washers [1 washer on bottom, 1 washer on top] is supplied with transformer, when installed new.

- Hand clean with solvent only. Do not submerge in solvent.
- Apply Loctite 222 (1050-0000-047) to first 1/4 in of threads of screw (2809-1000-006) securing transformer, T33001, to PC Board Assembly. Torque screw to 24 inch•pounds (2.71 newton•meters).
- Wires W00001 and W00002, E1 through E4 are to be soldered from top side only.



**LINE SUPPLY PC BOARD ASSEMBLY**

- Add switch, S15001, last. Do not submerge switch in solvent, brush clean only.
- Trim leads to 0.070 in maximum.

## (4) Power Supply Assembly

Use thermal compound (1050-0000-019) on both sides of mica insulators (4835-0000-103) (4 places).

**POWER SUPPLY PC BOARD ASSEMBLY**

- Add transformers, T14001 and T14002, last. Do not submerge transformers in solvent, brush clean only.
- Remove thick gold wire with identification labels 5 and 6 from transformers, T14001 and T14002, when installed new.

## (5) Digital IF PC Board Assembly

Apply Loctite 222 (1050-0000-047) to nuts on L26009, L26010 and Q26005.

## (6) Front Panel Pulse PC Board Assembly

**NOTE:** Metallic top of U27044 is connected to +5 Vdc.

Add switch S27001 and IC U27044 last. Do not submerge switch and IC in solvent.

## (7) RF Assembly

No special reassembly procedures required at the assembly level.

## (a) Driver PC Board Assembly

No special reassembly procedures required.

## (b) Detector Assembly

No special reassembly procedures required.

**DETECTOR PC BOARD ASSEMBLY**

No special reassembly procedures required.

## (c) Analog IF Assembly

No special reassembly procedures required.

**ANALOG IF PC BOARD ASSEMBLY**

- Add crystal, Y22001, last. Do not submerge crystal in solvent.
- TAK PAK end of L22027, Inductor Assembly, to PC Board.
- See Analog IF PC Board Assembly Circuit Schematic (2-4-1, Figure 41, Sheet 16) for Select At Test (SAT) values for C22080, C22082 and R22065.

## (d) SSB Assembly

No special reassembly procedures required.

**MIXER PC BOARD ASSEMBLY**

See 2-3-2, Figure 14 for special reassembly procedures.

**ATTENUATOR PC BOARD ASSEMBLY**

No special reassembly procedures required.

**LO SOURCE PC BOARD ASSEMBLY**

No special reassembly procedures required.

**SOURCE MODULE VCO PC BOARD ASSEMBLY**

No special reassembly procedures required.

## (8) Front Panel Assembly

- Discard nut and washer supplied with XF0001 and XF0002, when installing new.
- Apply adhesive (1050-0000-288) to threads and seating face of both fuse holders nuts (2850-7894-800). Apply adhesive (1050-0000-289) to Fuse Holders and nut sealing areas of enclosure. Torque Fuse Holder nuts (2850-7894-800) to 7 inch•pounds (0.79 newton•meters).
- Apply adhesive (1050-0000-140) to backside of six screws (2803-0188-006) securing the chains attached to the connector caps to the Front Panel after screws are installed.
- Before applying Overlay (2403-8553-500) to Front Panel (1405-8158-200), center Lens (3900-8157-100) with conductive side down over opening of Front Panel (1405-8158-200).
- After installing W00001, Backlight Wire Harness Assembly, spot coat E1-1 and E1-2 on top side of the Modified LCD Display PC Board Assembly (7010-8138-400) with conformal coat. Refer to 2-3-2, Figure 14 for location of E1-1 and E1-2.

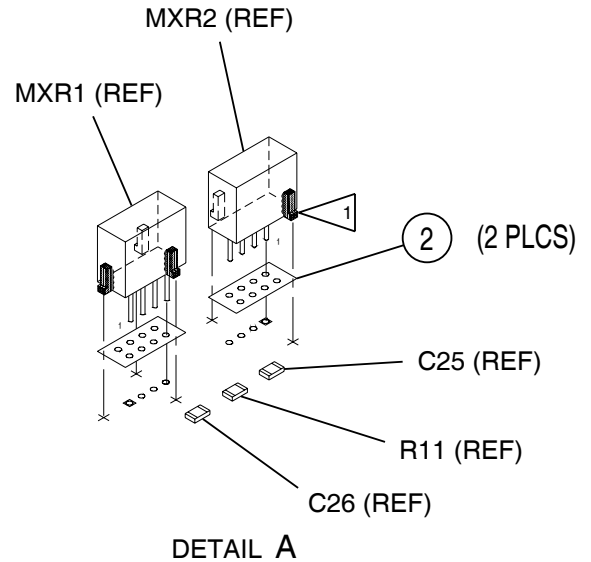
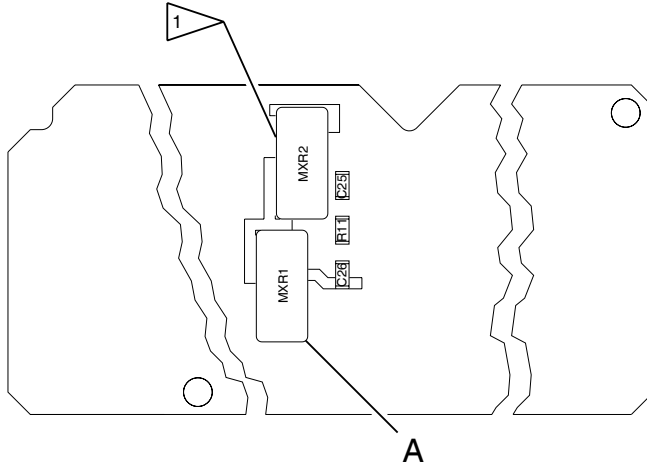

### SPECIAL REASSEMBLY PROCEDURES

**1** MXR1 & MXR2 MUST BE INSTALLED IN STEPS. WHEN PLACING SOLDER WICK (DPN 1050-0000-207) USE ONLY ESD CERTIFIED, QUICK-RECOVERY SOLDERING STATION WITH 3/32" 30 DEG. CHISEL TIP (TEMPERATURE:  $\leq 775^{\circ}\text{F}$  [ $405^{\circ}\text{C}$ ]).

**CAUTION:** EXCESSIVE HEAT DESTROYS MIXERS.

**STEP 1:** SOLDER SOLDER WICK TO SIDES OF MXR1 & MXR2, IN LOCATIONS SHOWN (5 PLCS). SEE DETAIL A.

**STEP 2:** AFTER SOLDERING SOLDER WICK TO BOTH MIXERS, VERIFY THAT SOLDER HAS NOT BRIDGED TO ANY LEADS.

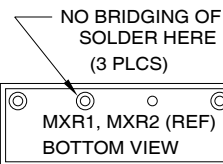

**STEP 3:** SOLDER MXR1 & MXR2 IN PLACE, THEN TACK SOLDER SOLDER WICK TO GROUND.

**CAUTION:** DO NOT USE EXCESSIVE HEAT OR SOLDER WHEN SOLDERING TO GROUND.

8530801P

Mixer PC Board Assembly  
Figure 14

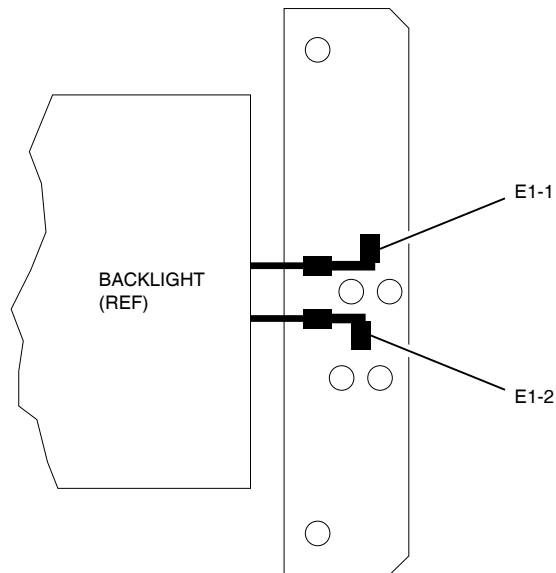

853400P

Solder Points for Backlight Wire Harness  
Figure 15

- (a) Video Detector PC Board Assembly  
No special reassembly procedures required.
- (b) Power Termination Assembly
  - Trim Termination Resistor (R28002) lead to 0.17 in ( $\pm 0.01$  in) before reinstalling.
  - Position PC Board and Termination Resistor (R28002) to maintain equal gap at both ends of PC Board (approximately 0.05 in).
  - Spot coat E1 and E2 after reassembly. Avoid over-spray of conformal coat on block flange.
- (c) Front Panel LED PC Board Assembly  
No special reassembly procedures required.
- (d) Modified LCD Display PC Board Assembly  
No special reassembly procedures required.
- (9) Flat Antenna Assembly  
See 2-3-2, Figure 15 for special reassembly procedures.
- (10) Motherboard PC Board Assembly  
No special reassembly procedures required.

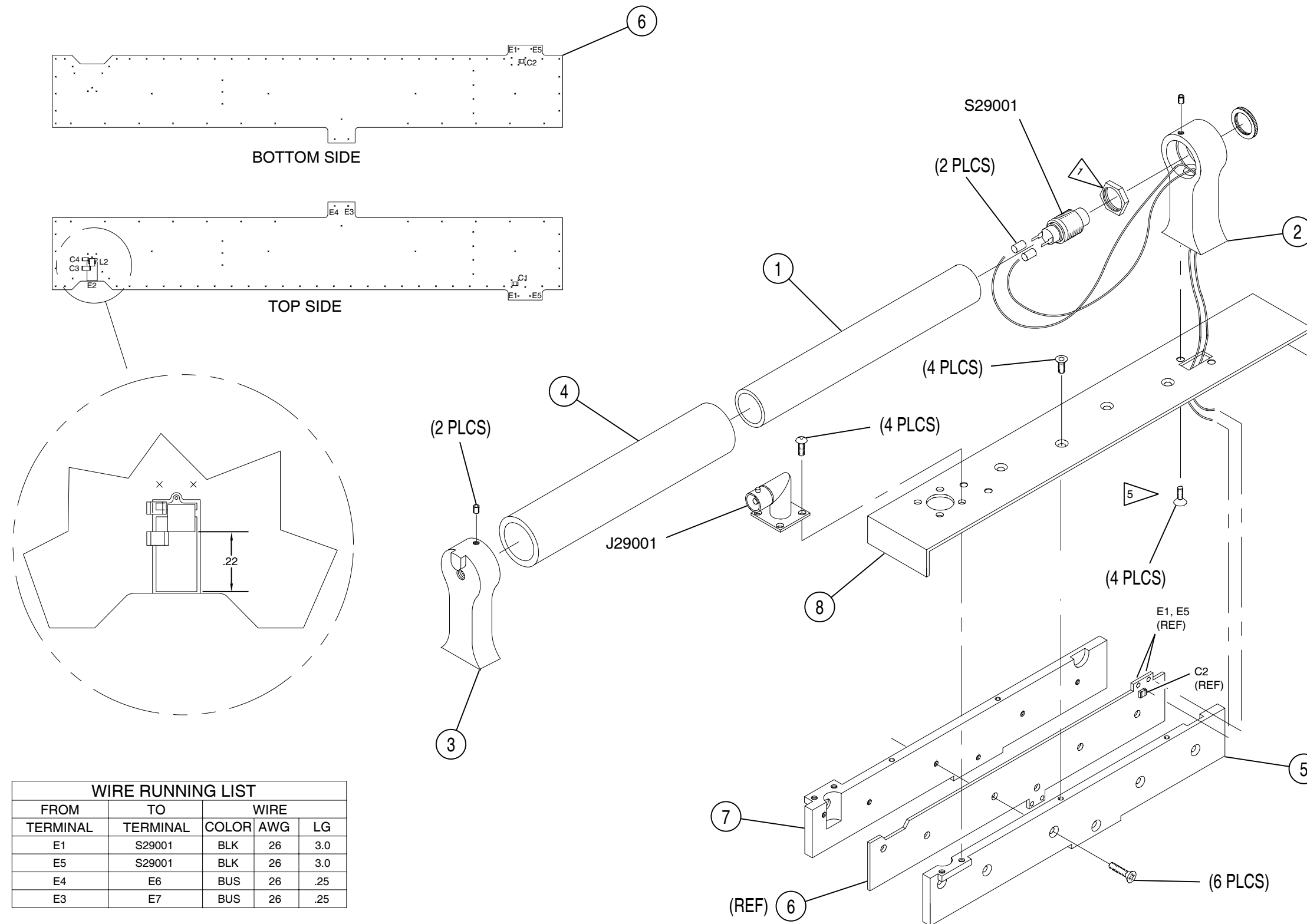

SPECIAL REASSEMBLY PROCEDURES:

1. SCREW NUT ONTO S29001 (FINGER TIGHT).
2. ALL PARTS ON SHT 1 MUST BE ASSEMBLED IN SEQUENCE. SEE STEPS BELOW:
  - a. MOUNT ITEMS 1, 2, 3 & 4 PRIOR TO INSTALLING SPLITTER BD ASSEMBLY.
  - b. ASSEMBLE ITEMS 5, 6, & 7. DO NOT TIGHTEN SCREWS AT THIS TIME.
  - c. SOLDER WIRES TO ITEM 6 AS SHOWN.
  - d. MOUNT ITEMS 5, 6, & 7 TO ITEM 8. MAKE SURE THAT ITEM 6 IS CENTERED BETWEEN ITEMS 5 & 7, THEN TIGHTEN ALL SCREWS.
  - e. INSTALL J29001 TIGHT AGAINST ITEM 6. TIGHTEN SCREWS.
3. USE ACCESS HOLE TO SOLDER J29001 TO E2.
4. INSTALL ITEM 9 PRIOR TO INSTALLING ITEM 10 AND ITEM 11.
5. TORQUE SCREWS TO 8 in. lb. APPLY LOCTITE 290-21 TO THREADS PRIOR TO ASSEMBLY.

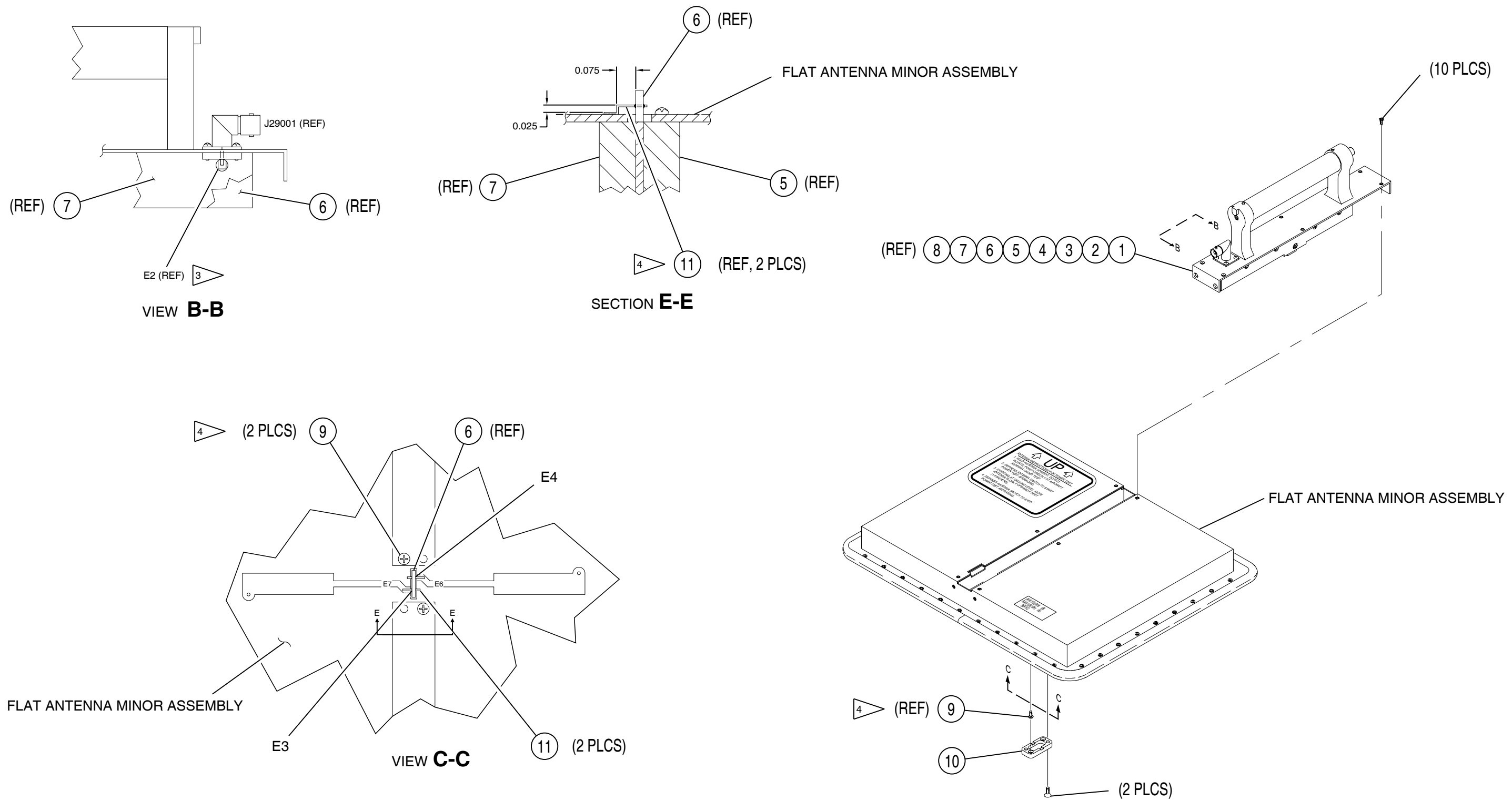

Flat Antenna Assembly (Sheet 2 of 2)  
Figure 17

8545602M