

7730300P

Interface PC Board Assembly
(7010-7730-300-D1)

ADDRESS	S T A T U S	DATA BITS							
		7	6	5	4	3	2	1	0
C000	W	DUPLEX GENERATOR	DUPLEX CLOCK	DUPLEX DATA	DUPLEX LATCH	RF: 800 M	RF: 400 M	RF: 200 M	RF: 100 M
C001	W	RF: 80 M	RF: 40 M	RF: 20 M	RF: 10 M	RF: 8 M	RF: 4 M	RF: 2 M	RF: 1 M
C002	W	RF: 800 K	RF: 400 K	RF: 200 K	RF: 100 K	RF: 80 K	RF: 40 K	RF: 20 K	RF: 10 K
	R	FREQ METER SWITCH A	FREQ METER SWITCH B	FREQ METER SWITCH C	FREQ METER SWITCH D	DCS NEG DEV	DCS POS DEV	SPARE	SPARE
C003	W	RF: 8 K	RF: 4 K	RF: 2 K	RF: 1 K	RF: 800 Hz	RF: 400 Hz	RF: 200 Hz	RF: 100 Hz
	R	MOD METER SWITCH A	MOD METER SWITCH B	MOD METER SWITCH C	MOD METER SWITCH D	+12V ON RCV	SQUELCH GATE	MODE SWITCH A	MODE SWITCH B
C004	W	TONE GEN 52424.8 Hz	TONE GEN 26212.4 Hz	TONE GEN 13106.2 Hz	TONE GEN 6553.6 Hz	TONE GEN 3276.8 Hz	TONE GEN 1638.4 Hz	TONE GEN 819.2 Hz	TONE GEN 409.6 Hz
C005	W	TONE GEN 204.8 Hz	TONE GEN 102.4 Hz	TONE GEN 51.2 Hz	TONE GEN 25.6 Hz	TONE GEN 12.8 Hz	TONE GEN 6.4 Hz	TONE GEN 3.2 Hz	TONE GEN 1.6 Hz
C006	W	TONE GEN 0.8 Hz	TONE GEN 0.4 Hz	TONE GEN 0.2 Hz	TONE GEN 0.1 Hz	TONE GEN CTL 3	TONE GEN CTL 2	TONE GEN CTL 1	TONE GEN CTL 0
C007	W	MOD METER A	MOD METER B	MOD METER C	MOD METER D	MOD METER AVG/PEAK	MOD METER 2ND FREQ	REC (1) GEN (0)	DUP ENABLE (0)
C008	W	SPARE	SPARE	FREQ ERROR XTB	FREQ ERROR X1/X3	FREQ ERROR YTB	FREQ ERROR AUDIO/RF	TONE CTL 4	SPARE
C010	W	MODULATION 6 K	MODULATION 15 K	MODULATION 200 K	MODULATION FM WIDE	MODULATION SSB	MODULATION AM		METER SFLECT
	R		METERS STATUS	METERS POLARITY	METERS OVERRANGE	METERS B12	METERS B11	METERS B10	METERS B9
C011	R	METERS B8	METERS B7	METERS B6	METERS B5	METERS B4	METERS B3	METERS B2	METERS B1
C012	R			MODULATION 6 K	MODULATION 15 K	MODULATION 200 K	MODULATION FM WIDE	MODULATION SSB	MODULATION AM
C013	W	DTMF RESET							
	R	DTMF READY	DTMF INSTALLED				WRITE - DTMF LATCH		

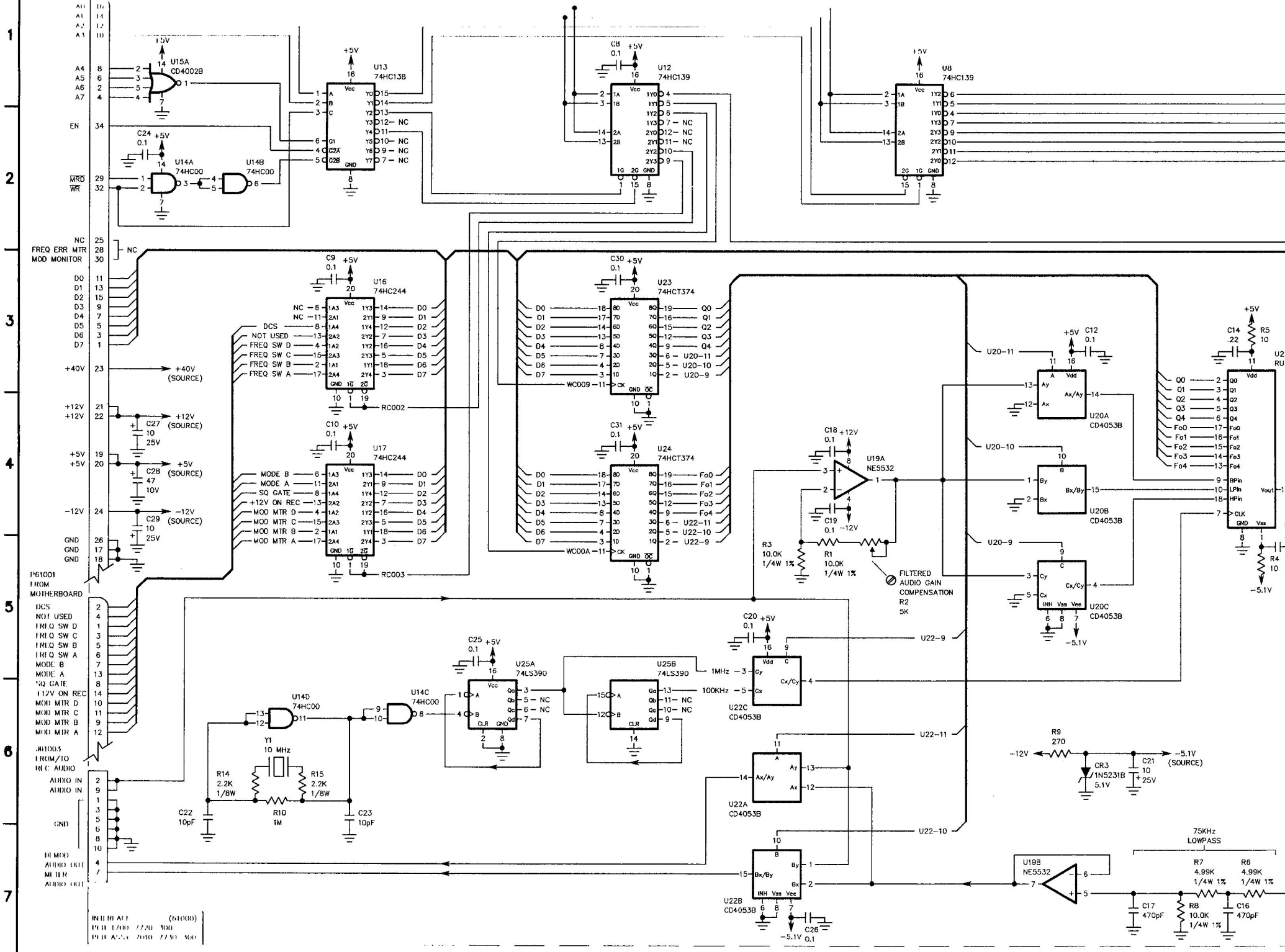

1
2
3
4
5
6
7

A0 16
 A1 14
 A2 12
 A3 10
 A4 8
 A5 6
 A6 5
 A7 4
 EN 34
 WR 29
 WR 32
 NC 25
 FREQ ERR MTR 28
 MOD MONITOR 30
 D0 11
 D1 13
 D2 15
 D3 9
 D4 7
 D5 5
 D6 3
 D7 1
 +40V 23
 +12V 21
 +12V 22
 +5V 19
 +5V 20
 -12V 24
 GND 26
 GND 17
 GND 18
 PG1001 FROM MOTHERBOARD
 DCS 2
 NOT USED 4
 FREQ SW D 1
 FREQ SW C 1
 FREQ SW B 5
 FREQ SW A 6
 MODE B 7
 MODE A 13
 SQ GATE 8
 +12V ON REC 14
 MOD MTR D 10
 MOD MTR C 11
 MOD MTR B 9
 MOD MTR A 12
 J1003 FROM I/O HC C AUDIO
 AUDIO IN 2
 AUDIO IN 9
 1
 3
 5
 6
 8
 10
 GND
 DI MOD
 AUDIO OUT 4
 MI II R
 AUDIO OUT 7
 IN I I AC 1 (1000)
 IN I 1 200 7720 300
 IN I A 2 2010 7730 300

