

MAINTENANCE MANUAL

FM/AM-500/A

COMMUNICATIONS SERVICE MONITORS

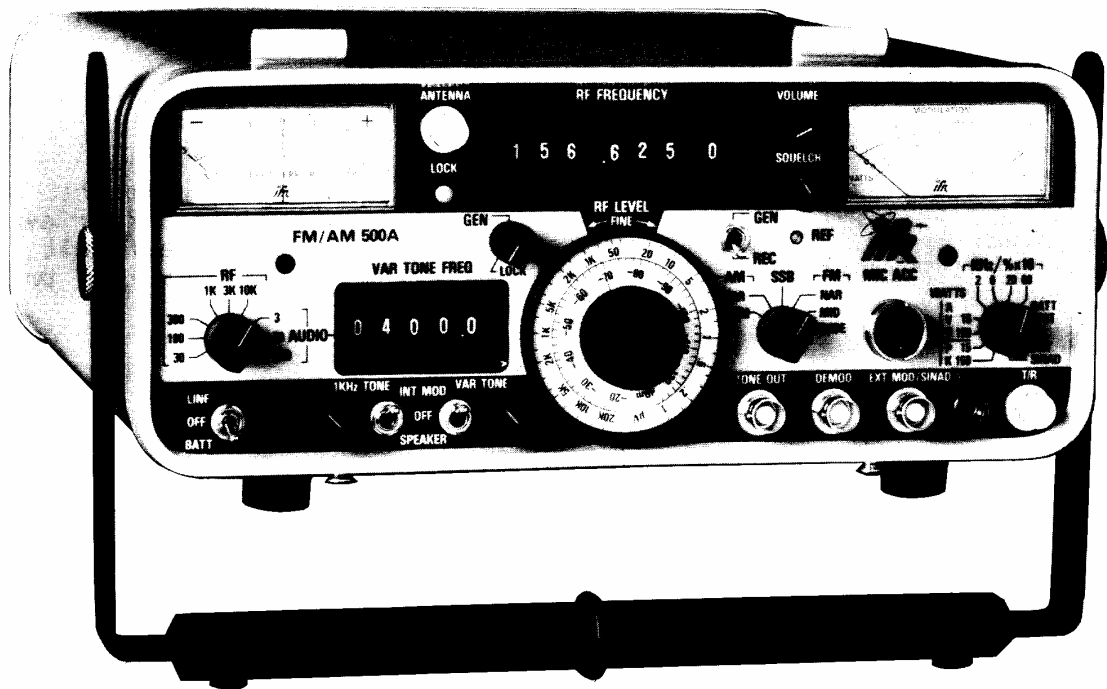

10200 West York Street/Wichita, Kansas 67215 U.S.A./ (316) 522-4981/TWX 910-741-6952

1002-5201-100

LIST OF EFFECTIVE PAGES

The manual pages listed below which are affected by a current change or revision, are so identified by a revision number and an asterisk.

Date of issue for original and changed pages are:

Original.....0.....August 1, 1984
 Revision.....1.....August 1, 1985
 Revision.....2.....April 1, 1986
 Revision.....3.....September 9, 1987

TOTAL NUMBER OF PAGES IN THIS MANUAL IS 328 CONSISTING OF FOLLOWING:

Pg. No.	Change No.	Pg. No.	Change No.
Title Page.....	0	3-17.....	0
*Copyright Page.....	3	3-18 Blank.....	0
Warning Page.....	2	3-19 thru 3-20.....	0
Caution Page.....	0	3-21.....	0
*A.....	3	3-22 thru 3-23.....	0
*B.....	3	3-24 thru 3-25.....	2
i thru vi.....	0	3-26 Blank.....	0
*vii.....	3	3-27 thru 3-29.....	0
viii thru ix.....	0	3-30 Blank.....	0
*x thru xvi.....	3	3-31.....	0
1-1 thru 1-3.....	0	3-32 thru 3-35.....	0
1-4 Blank.....	0	3-36 thru 3-37.....	0
1-5 thru 1-6.....	0	3-38 Blank.....	0
2-1 thru 2-11.....	0	3-39.....	2
2-12 Blank.....	0	3-40 thru 3-42.....	0
3-1 thru 3-3.....	0	4-1 thru 4-3.....	0
3-4 Blank.....	0	4-4 Blank.....	0
3-5.....	0	4-5.....	0
3-6 Blank.....	0	4-6.....	1
3-7.....	0	4-7.....	0
3-8 Blank.....	0	4-8 Blank.....	0
3-9.....	0	4-9 thru 4-13.....	0
3-10.....	2	4-14 Blank.....	0
3-11 thru 3-14.....	2	4-15 thru 4-21.....	0
3-15 thru 3-16.....	0	4-22 Blank.....	0

LIST OF EFFECTIVE PAGES

Pg. No.	Change No.	Pg. No.	Change No.
4-23.....	2	8-1 thru 8-2.....	0
4-24 thru 4-25.....	0	*9-1 thru 9-4.....	3
4-26 Blank.....	0	9-5.....	1
4-27 thru 4-30.....	0	*9-6 thru 9-8.....	3
5-1 thru 5-3.....	0	9-9.....	1
5-4 Blank.....	0	*9-9a thru 9-9b.....	3
5-5 thru 5-7.....	0	*9-10 thru 9-12.....	3
5-8 Blank.....	0	9-13.....	1
5-9 thru 5-11.....	0	9-14.....	2
5-12 Blank.....	0	9-15 thru 9-16.....	1
5-13 thru 5-17.....	0	*9-17 thru 9-18.....	3
5-18 Blank.....	0	*10-1 thru 10-2.....	3
5-19 thru 5-25.....	0	10-3.....	1
5-26 Blank.....	0	10-4 thru 10-5.....	2
5-27 thru 5-29.....	0	*10-6.....	3
5-30 Blank.....	0	10-7.....	1
5-31 thru 5-43.....	0	*10-8 thru 10-10.....	3
5-44 Blank.....	0	10-11.....	1
6-1 thru 6-9.....	0	*10-12.....	3
*6-10 thru 6-11.....	3	*10-12a.....	3
*6-11a thru 6-11b.....	3	*10-12b Blank.....	3
*6-12 thru 6-13.....	3	*10-13 thru 10-14.....	3
6-14.....	1	10-15.....	1
6-15 thru 6-24.....	0	*10-16.....	3
*6-25.....	3	*10-16a thru 10-16b..	3
6-26 thru 6-28.....	0	*10-17.....	3
7-1 thru 7-3.....	0	10-18.....	1
7-4 Blank.....	0	*10-19 thru 10-22....	3
7-5 thru 7-9.....	0	10-23.....	0
7-10 Blank.....	0	*10-24.....	3
7-11 thru 7-15.....	0	10-25.....	1
7-16 Blank.....	0	*10-26 thru 10-28....	3
7-17 thru 7-45.....	0	10-29 thru 10-31....	1
7-46 Blank.....	0	*10-32.....	3
7-47 thru 7-74.....	0	A-1 thru A-2.....	0
*7-75 thru 7-78.....	3	*A-3.....	3
*7-78a.....	3	A-4.....	0
*7-78b Blank.....	3	C-1 thru C-2.....	0
7-79 thru 7-83.....	0	D-1 thru D-2.....	0
7-84 Blank.....	0	E-1 thru E-2.....	0
7-85 thru 7-86.....	0		

PREFACE

SCOPE

This manual contains maintenance instructions for the FM/AM-500 and the FM/AM-500A Communications Service Monitor. The information in this manual will enable the technician to:

1. Service, test, repair or replace any major assembly or module within the test set.
2. Maintain the operating condition of the set to expected performance standards.
3. Understand the principles of operation as they relate to the overall operation of the set, as well as to individual circuits.

APPLICABILITY

The designation "FM/AM-500A" is used throughout this manual when the discussion applies to both, the FM/AM-500 and the FM/AM-500A.

However, when information is applicable to only one model, it is identified as "FM/AM-500 only" or "FM/AM-500A only".

ORGANIZATION

The contents of this manual are divided into eleven major sections:

SECTION 1 - INTRODUCTION

Provides a brief description of the electrical and mechanical configuration of the FM/AM-500A, intended to familiarize the technician with the overall structure of the set.

SECTION 2 - THEORY OF OPERATION

Describes the FM/AM-500A circuit theory on a simplified level, based on accompanying block diagrams.

SECTION 3 - PERFORMANCE EVALUATION

Contains "covers on" functional checkout procedures for evaluating the performance of the FM/AM-500A in generate and receive operation.

SECTION 4 - CALIBRATION

Contains step-by-step calibration procedures for use during normal calibration intervals or when replacement parts are installed in the FM/AM-500A.

SECTION 5 - TROUBLESHOOTING

Contains step-by-step troubleshooting recommendations, in the form of logical tabular procedures, for use in isolating fault conditions within the major electrical circuits.

SECTION 6 - DISASSEMBLY/REASSEMBLY PROCEDURES

Provides detailed instructions for removing and/or disassembling the various modules within the FM/AM-500A, for purposes of repair or replacement. Contains mechanical assembly drawings of all modules within the FM/AM-500A.

SECTION 7 - MODULE TESTING

Contains detailed theory of operation, troubleshooting and testing recommendations for all modules within the FM/AM-500A deemed to be field repairable. |

SECTION 8 - PREVENTIVE MAINTENANCE

Contains routine instructions for cleaning and inspection of the FM/AM-500A.

SECTION 9 - PC BOARD ASSEMBLIES

Contains component layout drawings for all PC Board assemblies within the FM/AM-500A.

SECTION 10 - CIRCUIT SCHEMATICS

Contains FM/AM-500A circuit schematics for all modules.

APPENDICES

Contain useful supplementary maintenance and operational data.

TABLE OF CONTENTS

Paragraph	Title	Page
Preface		i
Table of Contents		iii
List of Illustrations		xiii
List of Tables		xvii

SECTION 1 - INTRODUCTION

1-1	General	1-1
1-2	FM/AM-500A Electrical Description	1-1
1-2-1	Frequency Selectors	1-1
1-2-2	Meters	1-1
1-2-3	Mode/Bandwidth Control	1-1
1-2-4	RF Output Level Control	1-2
1-3	FM/AM-500A Power Requirements	1-2
1-4	Frequency Standards	1-2
1-5	FM/AM-500A Mechanical Description	1-2
1-6	Reference Designators	1-2
1-7	Corrective Maintenance Procedures	1-3

SECTION 2 - THEORY OF OPERATION

2-1	Introduction	2-1
2-1-1	Simplified Theory of Operation	2-1
2-1-2	Intermodule Systems Theory of Operation	2-1

Paragraph	Title	Page
2-2	General	2-1
2-2-1	Open PC Boards	2-1
2-2-2	Enclosed PC Boards	2-2
2-2-3	Block Modules	2-2
2-3	Simplified Theory of Operation	2-2
2-3-1	Operation as a Receiver	2-2
2-3-2	Operation as a Generator	2-4
2-4	Intermodule Systems Theory of Operations	2-5
2-4-1	Reference Frequencies	2-5
2-4-2	Frequency Conversion Modules	2-5
2-4-3	Audio System	2-6
2-4-4	Frequency Error Display	2-8
2-4-5	Phase Lock Indicator Circuit	2-10

SECTION 3 - PERFORMANCE EVALUATION

3-1	General	3-1
3-1-1	Test Equipment Requirements	3-2
3-2	Mobile Performance Evaluation Procedures	3-3
3-2-1	1 kHz Tone Generator	3-5
3-2-2	Variable Tone Generator	3-7
3-2-3	Receiver	3-9
3-2-4	RF Frequency Error Meter	3-11
3-2-5	Audio Frequency Error Meter	3-13
3-2-6	Generate Mode and Modulation Meter	3-15

Paragraph	Title	Page
3-3	Laboratory Performance Evaluation Procedures	3-17
3-3-1	1 kHz Tone Generator	3-19
3-3-2	Variable Tone Generator	3-21
3-3-3	Receiver	3-23
3-3-4	Generate System	3-27
3-3-5	Frequency Error Meter - RF & SSB	3-31
3-3-6	Frequency Error Meter - Audio	3-33
3-3-7	Modulation and Power Meter	3-35
3-3-8	SINAD Meter	3-39
3-3-9	Power Meter	3-41

SECTION 4 - CALIBRATION

4-1	General	4-1
4-1-1	Safety Precautions	4-1
4-1-2	Disassembly Requirements	4-2
4-1-3	Recommended Calibration Sequence	4-2
4-1-4	Test Equipment Requirements	4-3
4-1-5	Controls and Calibration Points	4-3
4-2	Calibration Procedures	4-7
4-2-1	Mechanical Zeroing of Modulation and Frequency Error Meters	4-7
4-2-2	Power Supply	4-9
4-2-3	10 MHz Oscillator	4-11
4-2-4	Variable Tone Generator	4-15
4-2-5	Frequency Error Meter	4-17

Paragraph	Title	Page
4-2-6	Modulation Meter	4-19
4-2-7	SINAD Meter	4-23
4-2-8	Power Meter	4-27
4-2-9	Generate Output Level	4-29

SECTION 5 - TROUBLESHOOTING

5-1	General	5-1
5-1-1	How to Use Tabular Flowcharts	5-1
5-1-2	Troubleshooting Hints	5-1
5-1-3	Safety Precautions	5-2
5-1-4	Test Equipment Requirements	5-2
5-1-5	Disassembly/Reassembly Requirements	5-3
5-1-6	Index of Troubleshooting Flowcharts	5-3
5-2	Troubleshooting Power Supply	5-5
5-2-1	Incorrect Output Voltages	5-5
5-2-2	Incorrect Battery Charging Rate	5-9
5-3	Troubleshooting Receiver	5-11
5-3-1	Sensitivity Low at Certain Frequencies	5-11
5-3-2	Sensitivity Low at All Frequencies	5-13
5-3-3	Improper Demodulation	5-15
5-4	Troubleshooting Generator	5-19
5-4-1	Incorrect Carrier Amplitude	5-19
5-4-2	Incorrect Carrier Frequency	5-27
5-4-3	Inadequate Response to Variable Generator Control	5-31

Paragraph	Title	Page
5-5	Troubleshooting Phase Lock System	5-33
5-5-1	Lock Light Indicates System Is Not Phase Locked	5-33
5-5-2	High Loop Does Not Phase Lock	5-37
5-5-3	Low Loop Does Not Phase Lock	5-41

SECTION 6 - DISASSEMBLY/REASSEMBLY PROCEDURES

6-1	Disassembly/Reassembly Procedures	6-1
6-1-1	General	6-1
6-1-2	Preliminary Considerations	6-1
6-1-3	Index Of Module Disassembly and Reassembly Procedures	6-2
6-2	Removal and Disassembly	6-3
6-2-1	Case	6-3
6-2-2	Battery	6-5
6-2-3	Oven Oscillator	6-5
6-2-4	Frequency Standard PC Board	6-5
6-2-5	Power Supply PC Board	6-5
6-2-6	1120 MHz Low Pass Filter	6-6
6-2-7	Speaker	6-6
6-2-8	Motherboard	6-6
6-2-9	Audio PC Boards	6-7
6-2-10	Enclosed Modules	6-9
6-2-11	Output Amplifier (SN 1001 thru 3224)	6-11
6-2-11(a)	Output Amplifier (SN 3225 On)	6-11b
6-2-12	IF Module	6-13
6-2-13	Dual VCO	6-15
6-2-14	Rear Panel	6-16

Paragraph	Title	Page
6-2-15	Front Panel	6-19
6-2-16	Generate Amplifier	6-25
6-3	Assembly	6-26
6-3-1	RF Level Attenuator	6-26

SECTION 7 - MODULE TESTING

7-1	General	7-1
7-1-1	Modules Recommended for Factory Repair	7-1
7-1-2	Disassembly Requirements	7-1
7-1-3	Test Equipment Requirements	7-1
7-1-4	Safety Precautions	7-2
7-1-5	Index of Module Testing Procedures	7-3
7-2	Power Supply	7-5
7-2-1	Theory of Operation	7-5
7-2-2	Preparation for Testing	7-7
7-2-3	Testing	7-8
7-2-4	Reassembly	7-9
7-3	IF Module	7-11
7-3-1	Theory of Operation	7-11
7-3-2	Preparation for Testing	7-13
7-3-3	Testing	7-14
7-3-4	Reassembly	7-15
7-4	Dual VCO	7-17
7-4-1	Theory of Operation	7-17

Paragraph	Title	Page
7-4-2	Preparation for Testing.....	7-19
7-4-3	Testing.....	7-20
7-4-4	Reassembly.....	7-22
7-5	High Loop Synthesizer Module.....	7-23
7-5-1	Theory of Operation.....	7-23
7-5-2	Preparation for Testing.....	7-29
7-5-3	Testing.....	7-29
7-5-4	Reassembly.....	7-32
7-6	Low Loop Synthesizer.....	7-33
7-6-1	Theory of Operation.....	7-33
7-6-2	Preparation for Testing.....	7-35
7-6-3	Testing.....	7-35
7-6-4	Reassembly.....	7-36
7-7	Receiver/Generator.....	7-37
7-7-1	Theory of Operation.....	7-37
7-7-2	Preparation for Testing.....	7-40
7-7-3	Testing.....	7-41
7-7-4	Reassembly.....	7-42
7-8	Frequency Standard.....	7-43
7-8-1	Theory of Operation.....	7-43
7-8-2	Preparation for Testing.....	7-44
7-8-3	Testing.....	7-45
7-8-4	Reassembly.....	7-45

Paragraph	Title	Page
7-9	Digital Module	7-47
7-9-1	Theory of Oepration	7-47
7-9-2	Preparation for Testing	7-51
7-9-3	Testing	7-52
7-9-4	Reassembly	7-56
7-10	Receive Audio Module	7-57
7-10-1	Theory of Operation	7-57
7-10-2	Preparation for Testing	7-62
7-10-3	Testing	7-63
7-10-4	Reassembly	7-66
7-11	Generate Audio Module	7-67
7-11-1	Theory of Operation	7-67
7-11-2	Preparation for Testing	7-70
7-11-3	Testing	7-71
7-11-4	Reassembly	7-74
7-12	Output Amplifier	7-75
7-12-1	Theory of Operation (Thru S/N 3224)	7-75
7-12-2	Theory of Operation (S/N 3225 On)	7-76
7-12-3	Preparation for Testing	7-78
7-12-4	Testing	7-78a
7-12-5	Reassembly	7-78a
7-13	Variable Tone Generator	7-79
7-13-1	Theory of Operation	7-79
7-13-2	Preparation for Testing	7-81
7-13-3	Testing	7-82

Paragraph	Title	Page
7-13-4	Reassembly	7-83
7-14	Optional Generate Amplifier	7-85
7-14-1	Theory of Operation	7-85
7-14-2	Preparation for Testing	7-86
7-14-3	Testing	7-86
7-14-4	Reassembly	7-86

SECTION 8 - PREVENTIVE MAINTENANCE

8-1	Preventive Maintenance	8-1
8-1-1	External Cleaning	8-1
8-1-2	Internal Cleaning	8-1
8-1-3	Visual Inspection	8-1

SECTION 9 - PC BOARD ASSEMBLIES

9-1	General	9-1
9-2	Index of PC Board Assembly Drawings	9-1

SECTION 10 - CIRCUIT SCHEMATICS

10-1	General	10-1
10-2	Index of Schematics	10-1

APPENDICES

A	Specifications	A-1
B	Test Equipment	B-1
C	Special Test Equipment	C-1
D	Abbreviations and Symbols	D-1
E	Repacking for Shipment	E-1

LIST OF ILLUSTRATIONS

Figure	Title	Page
1-1	Corrective Maintenance Flow Chart	1-5
1-2	Controls, Indicators & Connectors	1-6
2-1	FM/AM-500A Module Identifier	2-3
2-2	Simplified Block Diagram	2-4
2-3	Reference Frequencies Block Diagram.....	2-5
2-4	Frequency Conversion Modules Block Diagram	2-7
2-5	Audio System Block Diagram	2-9
2-6	Frequency Error Indicator Block Diagram	2-10
2-7	Phase Lock Indicator Circuit Block Diagram	2-11
3-1	1 kHz Tone Generator Lab Test Set-up	3-19
3-2	Variable Tone Generator Lab Test Set-up	3-21
3-3	Receiver Lab Test Set-up	3-23
3-4	Frequency Error Meter Lab Test Set-up - RF & SSB ...	3-31
3-5	Frequency Error Meter Lab Test Set-up - Audio	3-33
3-6	Modulation Meter Lab Test Set-up	3-35
4-1	Calibration Points	4-6
4-2	Modulation Meter Calibration Set-up	4-19
6-1	FM/AM-500A Case Removal	6-3
6-2	FM/AM-500A Composite Assembly	6-4
6-3	Enclosed Module Assemblies	6-8
6-4	Output Amplifier Assembly (Thru S/N 3224)	6-10
6-4a	Output Amplifier Assembly (S/N 3225 On)	6-11a
6-5	IF Module Assembly	6-12

Figure	Title	Page
6-7	Rear Panel Assembly	6-16
6-8	Front Panel Assembly	6-20
6-9	Generate Amplifier Assembly	6-25
6-10	Attenuator Control Alignment	6-26
7-1	Power Supply Block Diagram	7-6
7-2	IF Module Block Diagram	7-12
7-3	Dual VCO Block Diagram	7-17
7-4	Dual VCO Test Connections	7-20
7-5	High Loop Synthesizer Block Diagram	7-24
7-6	Low Loop Synthesizer Block Diagram	7-33
7-7	Low Loop Synthesizer Test Set-up	7-35
7-8	Receiver/Generator Block Diagram	7-38
7-9	Frequency Standard Block Diagram	7-44
7-10	Digital Module Block Diagram	7-49
7-11	Digital Module Input Signals	7-53
7-12	Receive Audio Module Block Diagram	7-59
7-13	Generate Audio Module Block Diagram	7-68
7-14	Output Amplifier Module Block Diagram (SN 1001 thru 3224)	7-75
7-14a	Output Amplifier Module Block Diagram (SN 3225 & On)	7-77
7-15	Variable Tone Generator Block Diagram	7-80
7-16	Generate Amplifier Block Diagram	7-85
9-1	Motherboard PC Board	9-3
9-2	Modulation Meter Switch PC Board (FM/AM-500A)	9-4
9-3	RF Thumbwheel Switch PC Board	9-4
9-4	Variable Tone Thumbwheel Switch PC Board	9-4
9-5	Power Supply PC Board	9-5

Figure	Title	Page
9-6	Frequency Standard PC Board.....	9-6
9-7	Output Amplifier PC Board (SN 1001 thru 3224).....	9-7
9-7a	Output Amplifier PC Board (SN 3225 On)	9-7
9-8	1300 MHz Amplifier PC Board.....	9-8
9-9	IF Amplifier PC Board.....	9-8
9-10	IF Mixer PC Board.....	9-8
9-11	High Loop Analog PC Board.....	9-9
9-12	High Loop Divider PC Board.....	9-10
9-13	Low Loop PC Board.....	9-11
9-14	Receiver/Generator PC Board.....	9-12
9-15	Receive Audio PC Board (FM/AM-500).....	9-13
9-16	Receive Audio PC Board (FM/AM-500A).....	9-13
9-17	Generate Audio PC Board.....	9-14
9-18	Variable Tone Generator PC Board.....	9-15
9-19	Digital Reference PC Board.....	9-16
9-20	Digital Counter PC Board.....	9-16
9-21	Generate Amplifier PC Board.....	9-17
9-22	Dual VCO Module.....	9-18
10-1	Coax Interconnect.....	10-3
10-2	Electrical Interconnect (Prior to SN 2501).....	10-4
10-3	Electrical Interconnect (SN 2501 and on).....	10-5
10-4	Motherboard Schematic.....	10-6
10-5	Power Supply Schematic.....	10-8
10-6	Frequency Standard Schematic.....	10-9
10-7	Front Panel Schematic (FM/AM-500).....	10-10
10-8	Front Panel Schematic (FM/AM-500A).....	10-10

Figure	Title	Page
10-9	Modulation Switch Schematic (FM/AM-500A)	10-11
10-10	RF Thumbwheel Switch Schematic	10-11
10-11	Variable Tone Thumbwheel Switch Schematic	10-11
10-12	Output Amplifier Schematic (SN 1001 thru 3224)	10-12
10-12a	Output Amplifier Schematic (SN 3225 On)	10-12a
10-13	IF Module Schematic	10-13
10-14	High Loop Schematic	10-14
10-15	Dual VCO Schematic	10-17
10-16	Low Loop Schematic	10-18
10-17	Receiver/Generator Schematic	10-20
10-18	Receive Audio Schematic (FM/AM-500)	10-22
10-19	Receive Audio Schematic (FM/AM-500A)	10-24
10-20	Generate Audio Schematic	10-26
10-21	Variable Tone Generator Schematic	10-27
10-22	Digital Module Schematic	10-28
10-23	Generate Amplifier Schematic	10-32
C-1	Circuit Schematic and Diagram of Battery Load Simulator	C-1
C-2	Attenuator Knob Spacer.....	C-2
E-1	Repacking for Shipment	E-2

LIST OF TABLES

Table Number	Title	Page
4-1	Recommended Calibration Sequence	4-3
4-2	Module Replacement and Alignment Requirements	4-5
4-3	Frequency Error Meter Calibration	4-18
7-1	Power Supply Output Voltages	7-9
7-2	RF Frequency BCD Logic Values	7-30
7-3	RF Frequency Error Testing	7-55
7-4	Audio Frequency Error Testing	7-55
7-5	MIC/ACC Jack Functions	7-73

SECTION 1 - INTRODUCTION

1-1 GENERAL

The FM/AM-500A is a small, lightweight test instrument capable of generating both RF and audio frequencies for external application and/or internal references for evaluating and analyzing various communications systems.

1-2 FM/AM-500A ELECTRICAL DESCRIPTION

Front panel controls allow the technician to establish a variety of analytical parameters and accurately measure the resultant performance of a unit under test. Major controls and indicators are described below.

1-2-1 FREQUENCY SELECTORS

A fixed 1 kHz audio tone generator is standard with the FM/AM-500A. A selector switch controls its use for internal modulation or speaker. A variable tone generator (optional on the FM/AM-500) is similarly controlled. In addition, a thumbwheel switch selects its operating frequencies between 10 Hz and 9999.9 Hz in 0.1 Hz increments. The RF frequency selector also utilizes a thumbwheel switch to select frequencies between 100 kHz and 999.9999 MHz in 100 Hz increments. In the GEN Mode, a rotary control locks the RF frequency on the frequency selected by the thumbwheels or can vary it more than 10 kHz above or below the selected frequency.

1-2-2 METERS

Two analog dc milliammeters provide visual references for analysis. The mode and sensitivity of each meter is controlled by its own rotary selector switch. The Frequency Error Meter reflects the difference between the frequency of a monitored signal and the frequency produced by either the internally generated RF, the 1 kHz tone, or the variable tone generator, as selected by related control switches. The meter control switch provides three ranges of resolution in each mode, RF and audio. In addition, the FM/AM-500 with the optional oven oscillator, and all FM/AM-500A have three additional high resolution ranges in the RF mode. The Modulation Meter displays modulation of a received or generated signal as a percent of total signal strength for AM or deviation from center frequency for FM, and reflects the level of battery charge and the relative strength of a received signal. On the FM/AM-500A only, it also displays SINAD, distortion and power when selected.

1-2-3 MODE/BANDWIDTH CONTROL

The operating mode, whether FM, AM, or SSB, and the bandwidth within the modes, are selected by a single rotary switch. Two AM and three FM bandwidths are provided.

1-2-4 RF OUTPUT LEVEL CONTROL

The RF output level is controlled by an attenuator with steps in 10 dB increments and a vernier which adjusts from 0 to 11 dB above the position of the step attenuator. The step attenuator dial is marked in both dB and millivolt scales. The vernier cursor overlays the step attenuator dial to allow direct reading of the power level.

1-3 FM/AM-500A POWER REQUIREMENTS

The FM/AM-500A normally operates on 105-130/210-260 VAC, 50-400 Hz or 12-14 VDC. An internal 12 volt rechargeable battery is optional. When the Power Switch is in the LINE position, the AC source is applied. An internal switch allows the operator to select between high and low AC voltages. In the BATT position, the DC source is applied. External DC of 12 volts or greater will override the internal battery. A timer automatically interrupts DC operation (external or battery) after approximately 10½ minutes, except when the optional oven oscillator is installed. The Power Switch must be turned OFF and returned to BATT to resume operation. An integral battery charger recharges the battery when the set is connected to an AC source. This takes approximately 8 hours when the Power Switch is OFF or 12 hours with the switch in the LINE position. An external DC source of approximately 13.5-14 volts will also recharge the battery.

1-4 FREQUENCY STANDARDS

A temperature-compensated crystal oscillator (TCXO) generates a 10 MHz reference signal for frequency control. The TCXO can be calibrated to WWV or a frequency counter. An optional oven oscillator is available, but if it is selected, the optional battery cannot be installed. If desired, an external frequency standard can be connected and used for reference. The FM/AM-500A will automatically switch from the TCXO to the external standard when a signal is applied.

1-5 FM/AM-500A MECHANICAL DESIGN

The FM/AM-500A's modular electronic design allows the electronic circuits to be isolated within mechanical module assemblies. This allows adequate shielding where required within minimum space requirements while facilitating access for maintenance procedures. The stamped sheet metal chassis forms PC Board guides and provides mounting points for enclosed modules. Figure 2-1 identifies the various mechanical modules composing the FM/AM-500A.

1-6 REFERENCE DESIGNATORS

Electrical components are identified by reference designators according to the type of component, its location on the circuit schematic, and the PC Board or mechanical assembly where it is installed. The reference designator consists of a group of one to three letters signifying the type of component (see Appendix D), followed by one or two series designators identifying the board or assembly, then two more component

numbers identifying the specific component on the schematic and assembly drawing. Listed below are the series designators.

Number	Assembly
100	Front Panel
200	RF Frequency Thumbwheel Switch
300	Variable Tone Frequency Thumbwheel Switch
1900	VCO Mixer Assembly
2000	1210 MHz VCO PC Board
2100	1300-2298 MHz VCO PC Board
2200	IF Block & Amplifier PC Board
2300	IF Mixer PC Board
2400	1300 MHz Amplifier PC Board
2500	Frequency Standard PC Board
3000	Mother Board
3100	Variable Tone Generator PC Board
3200	Generate Audio PC Board
3300	Receive Audio PC Board
3400	Receive Audio PC Board
4000	High Loop Analog PC Board
4100	High Loop Divider PC Board
4200	Low Loop PC Board
4300	Receiver/Generator PC Board
4400	Digital Counter PC Board
4500	Digital Reference PC Board
5000	Chassis Wire Harness
5100	Output Amplifier PC Board
5200	Power Supply PC Board
6400	1120 MHz Low Pass Filter
9000	Generate Amplifier PC Board

1-7 CORRECTIVE MAINTENANCE PROCEDURES

In the event a failure is confirmed within the FM/AM-500A, the technician should take appropriate corrective maintenance action to return the set to its normal operating condition. The "CORRECTIVE MAINTENANCE FLOWCHART" shown in Figure 1-1 is intended to serve as a guide in directing the technician through the troubleshooting/maintenance process. By observing this general sequence, the technician will be able to use the maintenance/troubleshooting recommendations contained within this and other sections of this manual, to return the FM/AM-500A to normal operation.

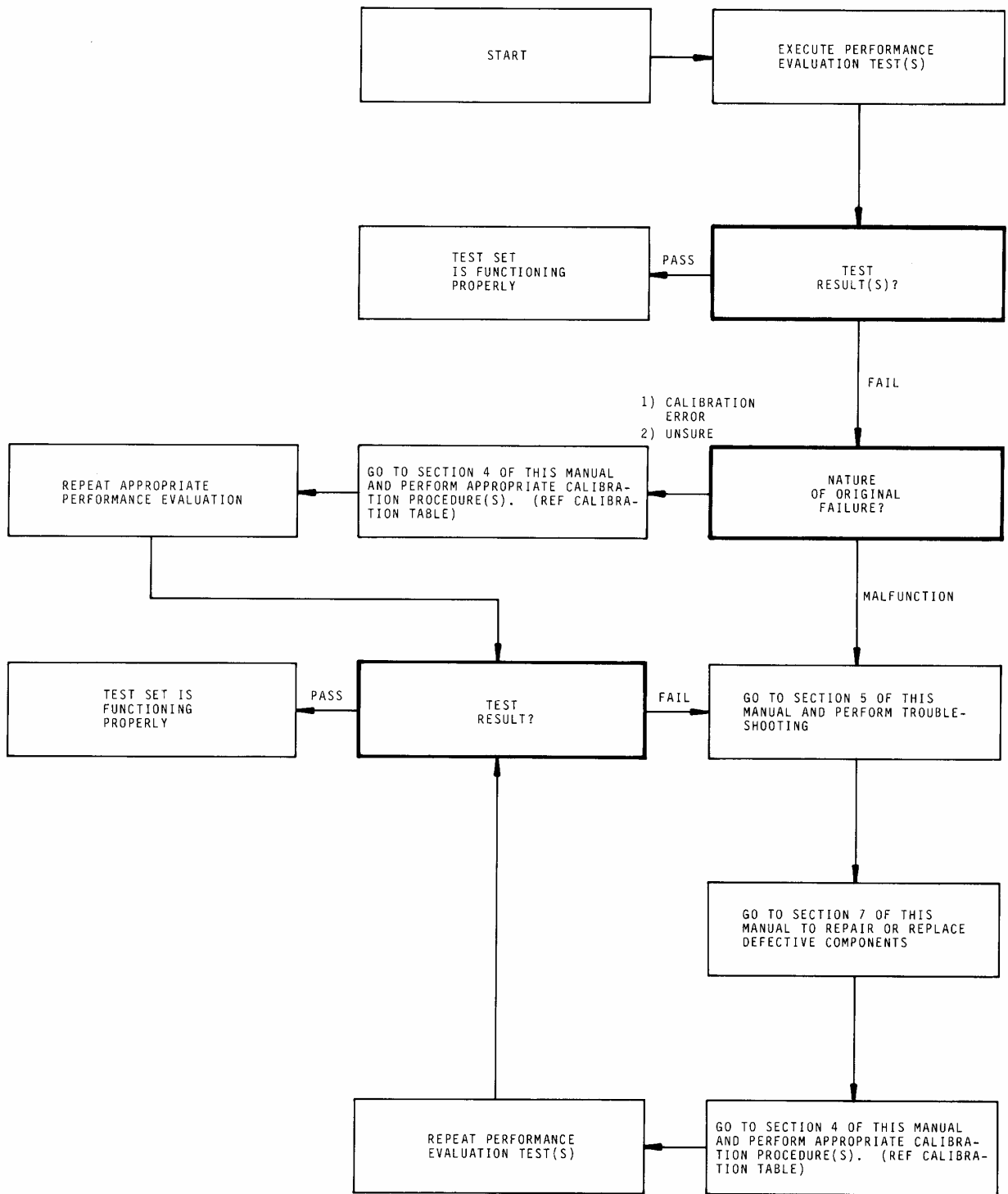

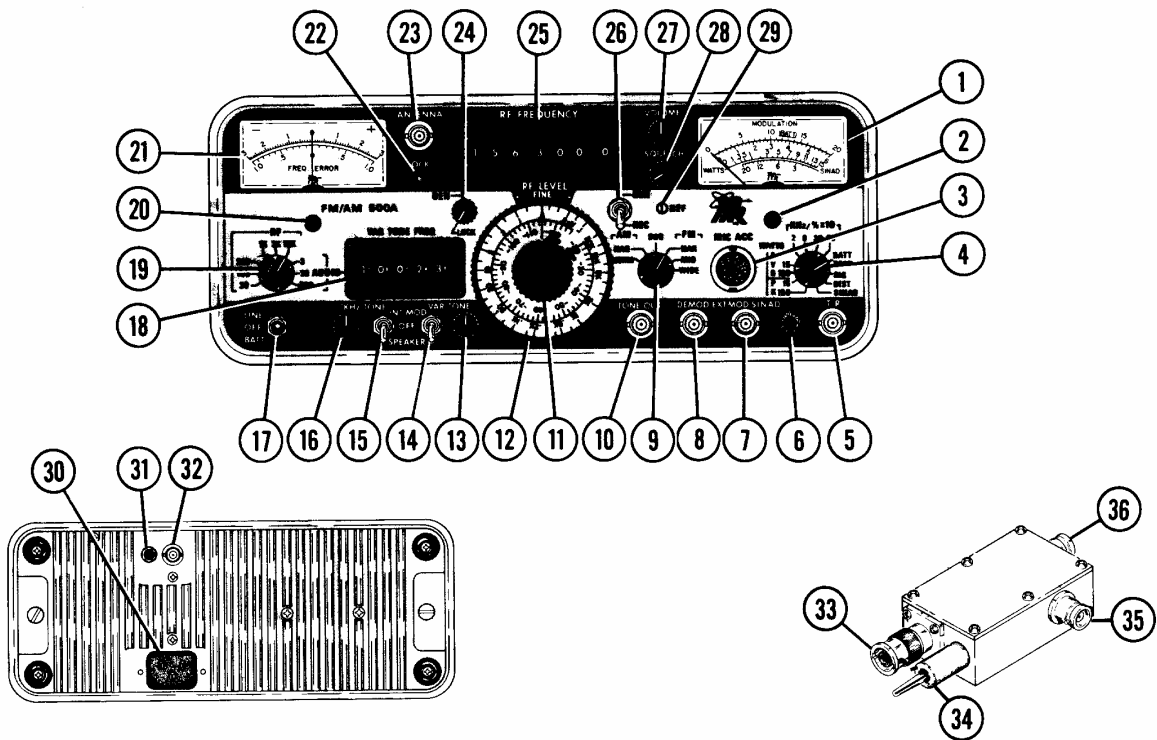

KEY	ITEM	KEY	ITEM
1	MODULATION Meter	19	FREQ ERROR Meter Range Switch
2	Modulation Meter Zero Adjustment	20	Freq Error Meter Zero Adjustment
3	MIC/ACC Connector	21	FREQ ERROR Meter
4	Modulation Meter Range Switch	22	RF Frequency LOCK Lamp
5	T/R (Trans/Rec) Connector	23	ANTENNA Connector
6	Optional Generate Amplifier Connector	24	GEN/LOCK Control
7	EXT MOD/SINAD Connector	25	RF FREQUENCY Thumbwheels
8	DEMODO Connector	26	GEN/REC Mode Switch
9	Modulation Mode Selector Switch	27	VOLUME Control
10	TONE OUT Connector	28	SQUELCH Control
11	RF LEVEL Attenuator Control	29	REF Frequency Adjustment
12	RF LEVEL FINE Adjust Control	30	AC Power Connector
13	VAR TONE Level Control	31	DC Power Connector
14	VAR TONE Selector Switch	32	Frequency Standard Connector
15	1 kHz TONE Selector Switch	33	Monitor T/R (Connects to 5)
16	1 kHz TONE Level Control	34	Monitor Power (Connects to 6)
17	Power Switch	35	Monitor Antenna (Connects to 23)
18	VAR TONE FREQ Thumbwheels	36	UUT T/R Test (Connects to UUT)

SECTION 2 - THEORY OF OPERATION

2-1 INTRODUCTION

This section provides a functional description of the circuitry contained in the FM/AM-500A Communications Service Monitor on the following levels. Detailed module level theory of operation is contained in Section 7.

2-1-1 SIMPLIFIED THEORY OF OPERATION

Paragraph 2-3 provides a simplified description of the signal flow through the appropriate modules within the FM/AM-500A according to the operating mode. This description is based on the FM/AM-500A Simplified Block Diagram shown in Figure 2-2.

2-1-2 INTERMODULE SYSTEMS THEORY OF OPERATION

Paragraph 2-4 provides system-oriented theory of operation for functions involving two or more modules. Block diagrams accompany each discussion to depict the interactivity of the several circuits utilized.

2-2 GENERAL

The FM/AM-500A's modular design allows electronic circuits to be isolated within the mechanical assemblies for ample shielding and ease of maintenance accessibility, yet minimizing space and interconnection requirements. Except for AC and DC power connectors and a 10 MHz RF connector on the Rear Panel, all controls, indicators and connectors are mounted on the Front Panel. The main power transformer, AC voltage select switch and power fuses are also mounted on the Rear Panel. All other components are contained within the modules listed below according to mechanical characteristics, not functional relationships, one with another. Figure 2-1 identifies these modules.

2-2-1 OPEN PC BOARDS

1. Power Supply - Provides regulated +12 VDC, -12 VDC, +5 VDC, and unregulated +43 VDC for set operation and current-regulated +15 VDC for battery charging.
2. Frequency Standard - Provides precise reference frequencies for various modules.
3. Receive Audio Board - Controls squelch level and bandwidth of demodulated audio signals and directs the signal to subsequent monitoring and analysis functions.
4. Generate Audio Board - Converts audio frequency into a modulation voltage.

5. Variable Tone Generator (Optional on FM/AM-500) - Generates audio frequency selected by Front Panel Thumbwheels.

2-2-2 ENCLOSED PC BOARDS

1. High Loop Synthesizer - Produces tuning voltages for first and second local oscillators in Dual VCO Module to maintain the correct difference between the two oscillators.
2. Low Loop Synthesizer - Generates the mixing frequency for the IF Module to produce the final received IF frequency.
3. Receiver/Generator - Demodulates received IF signals and generates and modulates IF signals for transmission.
4. Digital Module - Produces tuning voltage for carrier VCO and 1 kHz audio frequency. Determines frequency difference of received RF or Audio frequency from selected frequency and produces error signal for Frequency Error Meter.

2-2-3 BLOCK MODULES

1. IF Module - Mixes local oscillator frequencies with RF frequency to produce the required IF frequency and vice versa.
2. Dual VCO - Produces first and second mixing frequencies for the IF module.
3. Output Amplifier - Amplifies generated RF signals and attenuates received RF signals coupled through the T/R jack on the Front Panel.
4. Generate Amplifier (Optional) - A plug-in accessory which amplifies a generated RF signal by 30 dBm.

2-3 SIMPLIFIED THEORY OF OPERATION (Reference Figure 2-2)

2-3-1 OPERATION AS A RECEIVER

When a signal is received, it first enters the IF Module, where it is filtered, amplified, and mixed with signals from frequency-synthesized local oscillators to produce an output frequency of approximately 10.7 MHz. The RF FREQUENCY Thumbwheel Switches control the oscillator frequencies, and thus select the frequency of the signal to be received. The Receiver/Generator Module amplifies and filters the 10.7 MHz IF signal into a bandwidth of 200 kHz, 15 kHz, or 6 kHz, then demodulates it into FM and AM audio. A BFO signal, injected just ahead of the AM demodulator, allows reception of SSB and CW signals. The demodulated AM and FM audio signals are fed to the Receive Audio Module, which furnishes an AGC signal to the Receiver/Generator and a bandwidth-filtered audio signal to the Speaker, Modulation Meter, audio counter in the Digital Module, and DEMOD jack.

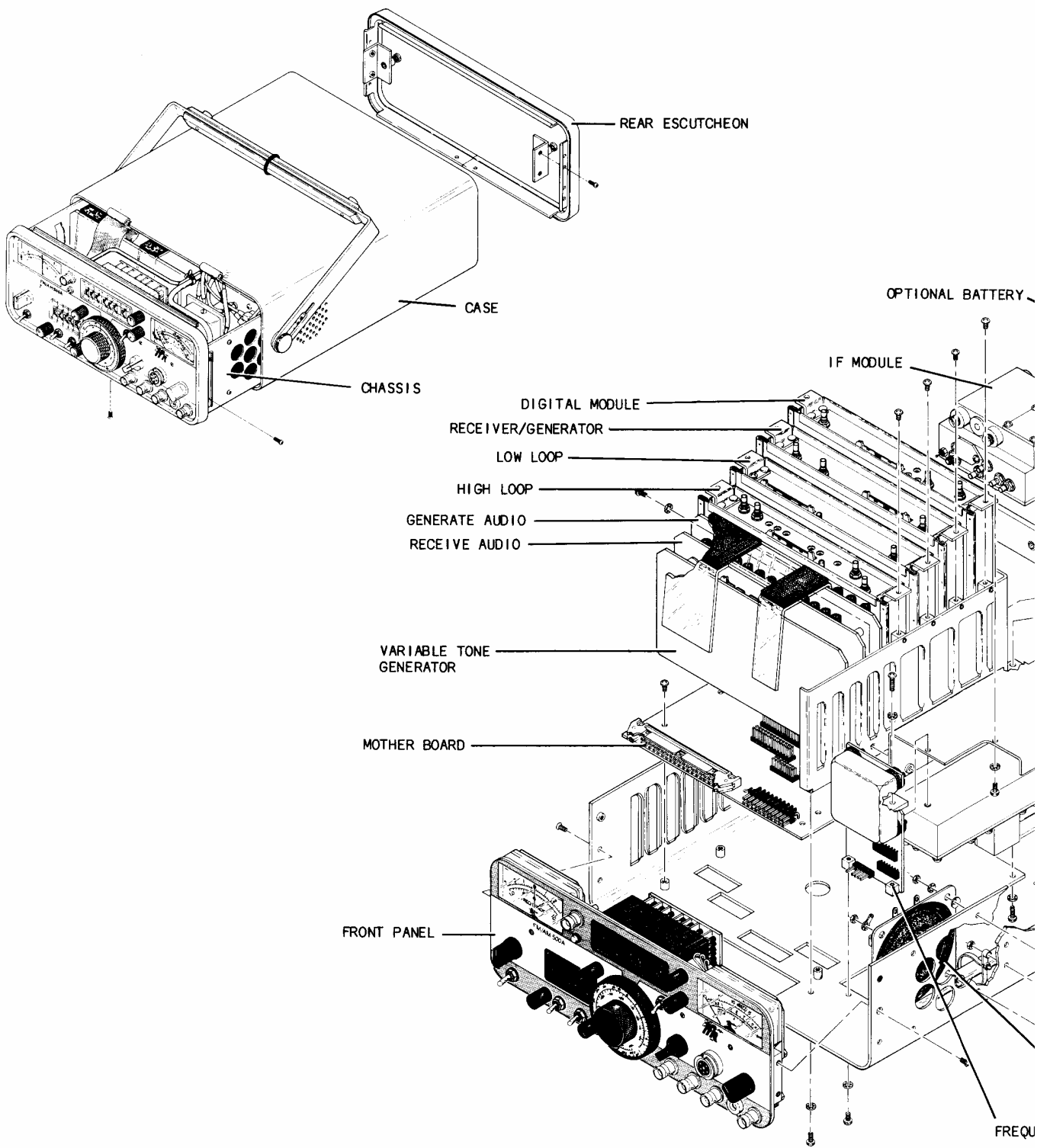

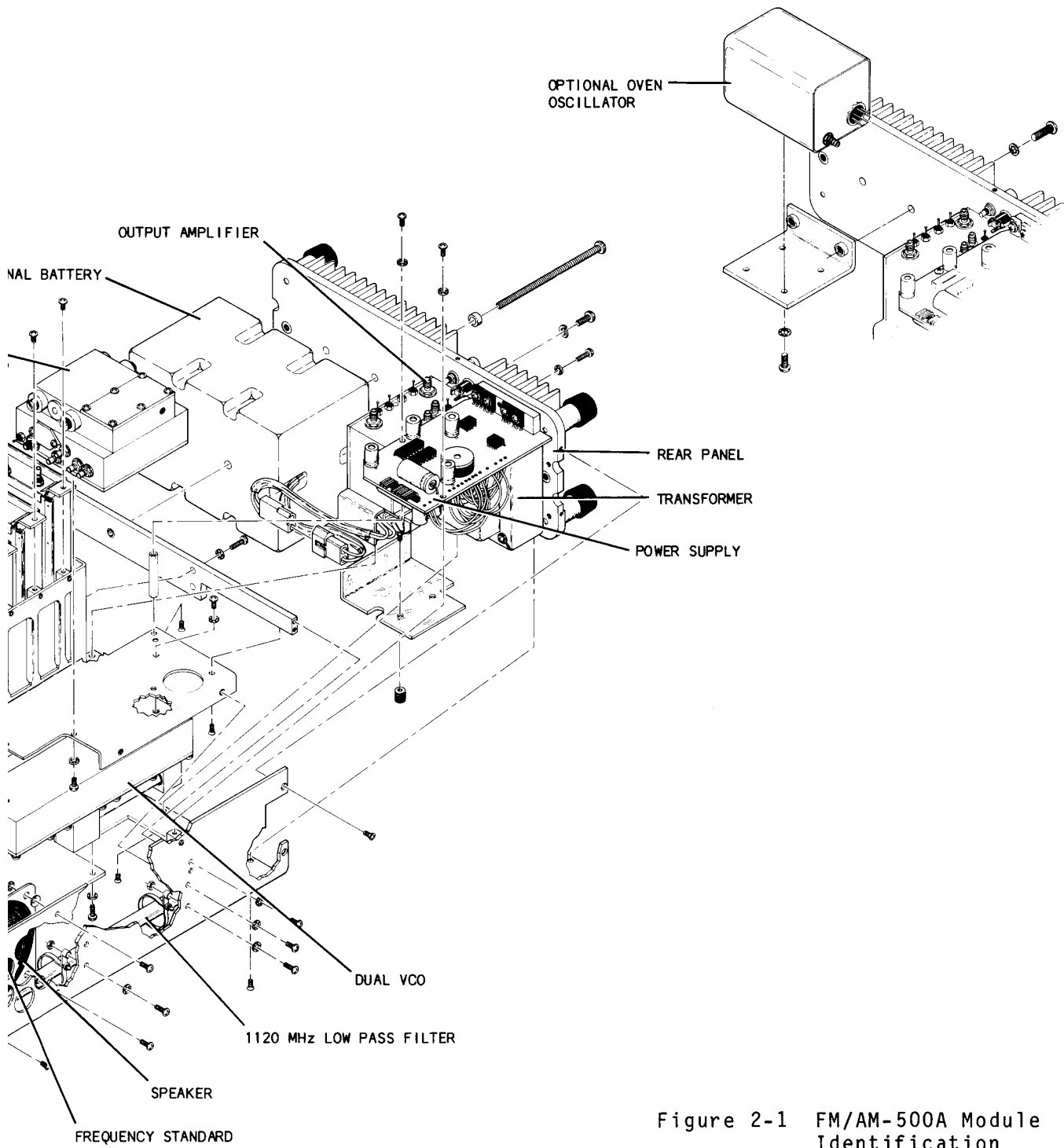

Figure 2-1 FM/AM-500A Module Identification

2-3-2 OPERATION AS A GENERATOR

An oscillator circuit in the Receiver/Generator Module produces the modulated IF signal. The Digital Module phase-locks the oscillator to a standard frequency. The Generate Audio Module furnishes the modulation either by a VCO control voltage fluctuation for FM, or by varying the control voltage to the leveling attenuator in the oscillator circuit for AM. The leveler circuit also controls the amplitude of the oscillator output signal. The RF LEVEL FINE Control allows adjustment of the output level over an 11 dB range.

The IF Module mixes the signal from the Receiver/Generator Module with the output from the frequency-synthesized local oscillators, amplifies it, filters it to the frequency established on the RF FREQUENCY thumbwheel switches, and sends it to the Output Amplifier. The Output Amplifier routes the signal through the 0 to -100 (in 10 dB steps) RF LEVEL attenuator, providing a -127 dBm to -20 dBm signal at the 50 ohm T/R jack. A power detector in the Output Amplifier provides a signal to a power monitor in the Receive Audio Module, corresponding to the RF output level. Feedback from the power monitor to the leveler circuit in the Generate Audio Module allows the leveler to compare the detected RF level with the combined selected AM signal and RF LEVEL FINE DC voltage. The leveler circuit then applies the error signal to the Leveler/AM Modulator Attenuator in the Receiver/Generator.

The FM/AM-500A has four sources of audio signals for modulation: the 1 kHz tone, the variable tone, the microphone, and an external source.

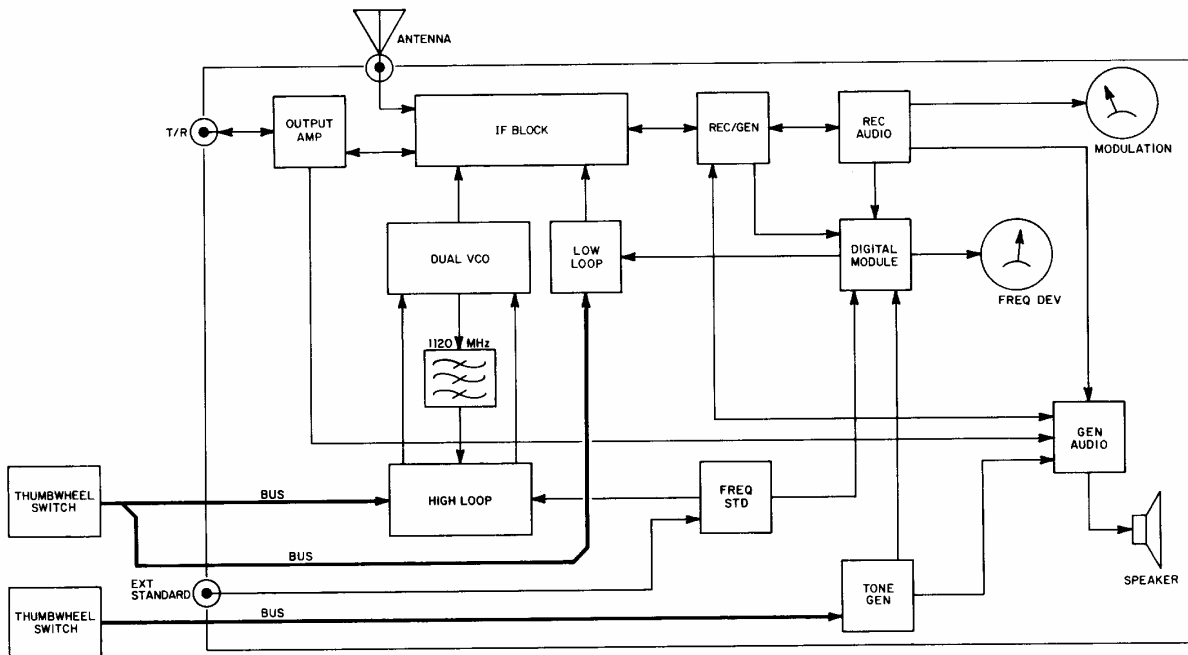

Figure 2-2 Simplified Block Diagram

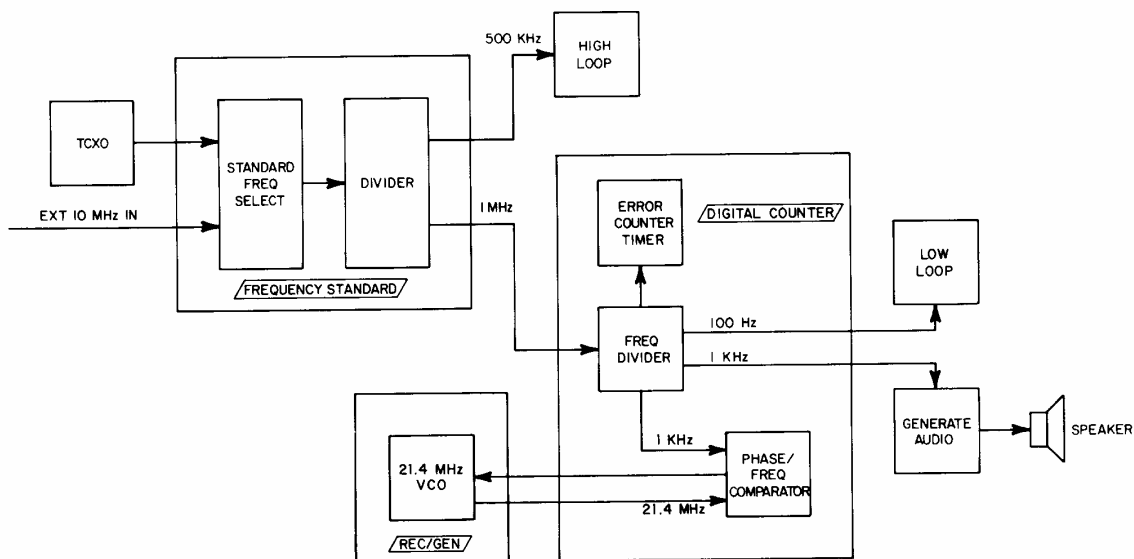

Figure 2-3 Reference Frequencies Block Diagram

2-4 INTERMODULE SYSTEMS THEORY OF OPERATIONS

2-4-1 REFERENCE FREQUENCIES (Figure 2-3)

The FM/AM-500A uses 10 MHz as the primary standard frequency. A Temperature Compensated Crystal Oscillator (TCXO) in the Frequency Standard Module generally produces this frequency; however, an oven oscillator, installed in the battery well, is optional. An external signal can also be used in place of the TCXO when desired. The Frequency Standard Module divides the 10 MHz to 500 kHz as a reference for the High Loop Synthesizer Module and to 1 MHz for the Digital Module. The 1 MHz is then divided into frequencies of 10 Hz, 100 Hz, 1 kHz, and 10 kHz to operate the counter timing circuit. The 100 Hz is also fed to the Low Loop Synthesizer Module as its reference. The 1 kHz is used as a reference for the 21.4 MHz VCO in the Receiver/Generator and by the Generate Audio Module to produce the fixed 1 kHz audio tone.

2-4-2 FREQUENCY CONVERSION MODULES (Figure 2-4)

The frequency conversion modules interact to convert a received RF signal of from 100 kHz to 999.9999 MHz to an IF of 10.7 MHz. The interactive modules performing this function are: IF, Dual VCO, High Loop Synthesizer, Low Loop Synthesizer and Receiver/Generator Modules, and the RF FREQUENCY Thumbwheels.

Each thumbwheel is a Binary Coded Decimal (BCD) switch, all of which set counters in the High and Low Loop Synthesizers. As shown in Figure 2-4, the two left hand thumbwheels (100 MHz and 10 MHz) set

counters only in the High Loop; the four right hand thumbwheels (100 kHz, 10 kHz, 1 kHz, and 100 Hz) set counters only in the Low Loop. Coding from the 1 MHz thumbwheel, though, is divided between both these modules.

Three VCOs govern the RF frequency selection. The High Loop Synthesizer controls the frequency of the first two VCOs, located in the Dual VCO Module. The third VCO is part of the Low Loop Synthesizer. The minimum frequency of the first VCO is 1300 MHz. The three left hand thumbwheels (100 MHz, 10 MHz, and 1 MHz) increase the VCO frequency in increments equal to the thumbwheel setting in excess of 000 MHz, except that the 1 MHz thumbwheel increases the frequency only in even integer positions (0, 2, 4, 6, and 8). This produces a frequency increase of up to 998 MHz, providing a VCO frequency of from 1300 MHz to 2298 MHz. The second VCO is preset to 1210 MHz, and is not affected by the thumbwheel settings. The maximum frequency of the third VCO is 79.3 MHz. As the four right hand thumbwheels (100 kHz, 10 kHz, 1 kHz, and 100 Hz) are rotated upward from 0000, the VCO frequency is decreased in corresponding increments. Rotation of the 1 MHz thumbwheel to any odd integer (1, 3, 5, 7, or 9) decreases the VCO frequency 1 MHz. The combined effect of these five thumbwheels is to reduce the third VCO frequency a maximum of 1.9999 MHz, or to a minimum frequency of 77.3001 MHz. The difference frequency of all three VCOs, then, is 10.7 MHz, or the IF frequency.

An RF signal received from the antenna or through the T/R jack, enters the IF Module, where it passes through a 1000 MHz low pass filter. It is then mixed with a selected frequency from the first VCO. A 1300 MHz bandpass filter allows only a difference frequency of 1298-1300 MHz to pass, thus rejecting all RF frequencies other than any within the 2 MHz span which will produce the correct difference. This difference, or IF, signal is mixed with the 1210 MHz from the second VCO and bandpass-filtered again to pass the second IF of 88-90 MHz. The second IF is mixed with the selected frequency from the third VCO to produce the third IF of 10.7 MHz. In the Receiver/Generator, three 10.7 MHz filters (of 200 kHz, 15 kHz, and 6 kHz bandwidths) limit the 10.7 MHz IF to be demodulated.

When generating RF signals, the modulated 10.7 MHz IF signal is fed into the third mixer, through the IF Module in the reverse order of a received signal, but goes to an Output Amplifier Module rather than to the antenna.

2-4-3 AUDIO SYSTEM (Figure 2-5)

In the Receive mode, demodulated AM and FM audio from the Receiver/Generator Module is bandwidth-filtered by the Receive Audio Module. It is then furnished to the DEMOD jack on the Front Panel, and to the Speaker through an audio amplifier in the Generate Audio Module. The signal is also available to the Modulation Meter for monitoring modulation. When the frequency of a received audio signal is being determined, the Digital Module compares a sample of the received signal with a signal from the Variable Tone Generator, using an up/down counter

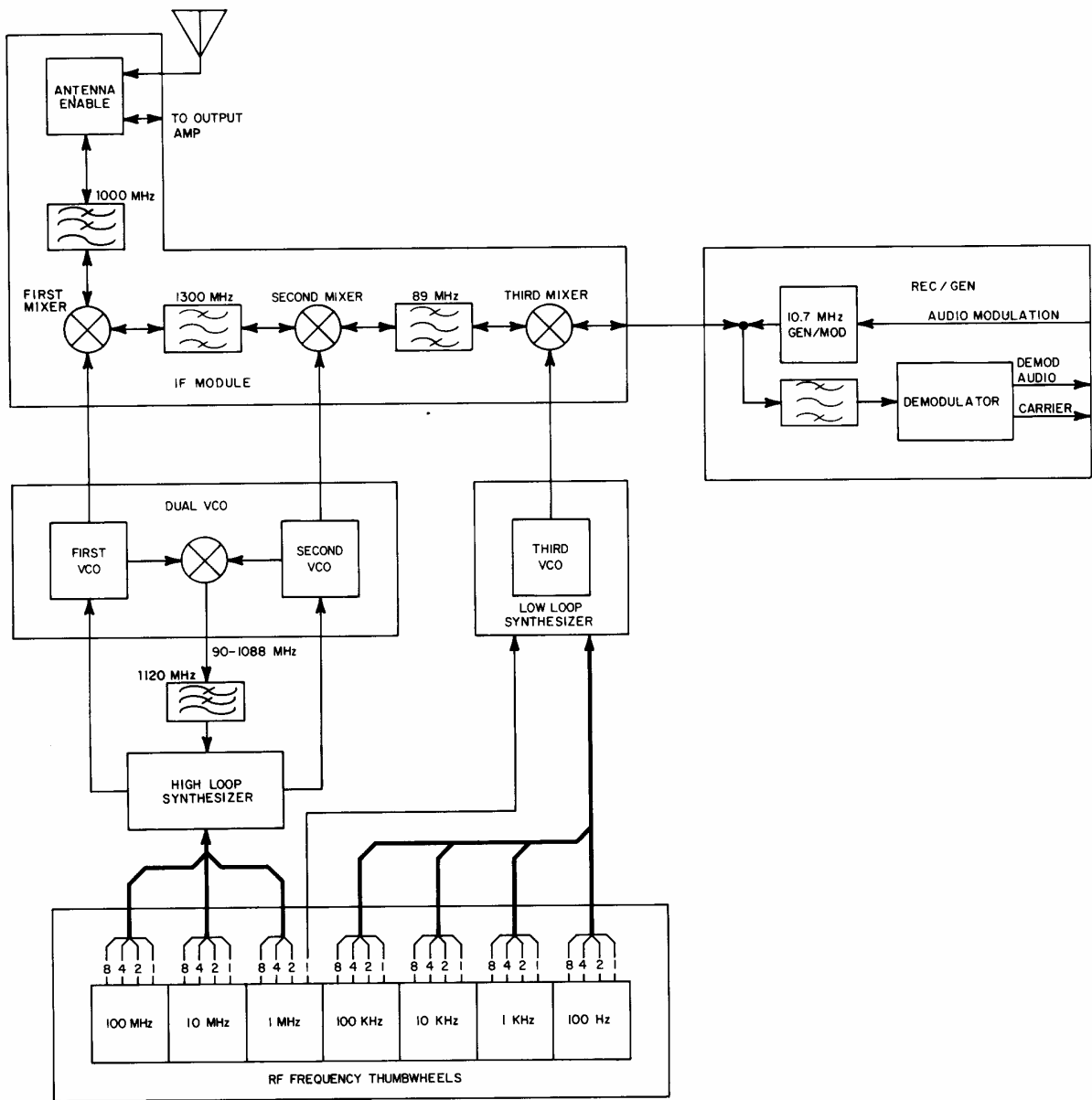

Figure 2-4 Frequency Conversion Modules Block Diagram

system, and displays the difference from the selected Variable Tone frequency on the Frequency Error Meter.

In the Generate mode, audio signals to be modulated onto the carrier can come from any or all of four different sources. A 1kHz signal from the Digital Module and a variable tone from the Variable Tone Generator can be coupled directly to the speaker amplifier or to the modulation amplifier, both in the Generate Audio Module, as desired. Signals from the microphone jack and EXT MOD jack can also be applied directly to the modulation amplifier. The amplifier combines all signals present and supplies the combined signal to the TONE OUT jack and to the AM/FM selector in the Generate Audio.

For FM modulation, the signal is coupled to the control voltage of the carrier-producing VCO in the Receiver/Generator. The VCO then converts the low frequency amplitude variations into frequency variations around the 21.4 MHz center frequency. For AM modulation, the signal is coupled to an attenuator in the Receiver/Generator. The attenuator, driven by the low frequency amplitude variations from the modulation amplifier, varies the amplitude of the carrier after it has been reduced to the IF frequency of 10.7 MHz.

2-4-4 FREQUENCY ERROR DISPLAY (Figure 2-6)

When in use, the Frequency Error Meter displays the difference between the frequency of a received signal (audio or RF carrier) and the setting of the RF FREQUENCY or VAR TONE FREQ Thumbwheels. When the frequency of the received signal differs from the thumbwheel setting, a Digital-to-Analog Converter (DAC) in the Digital Module produces a more- or a less- positive voltage. This voltage deflects the meter needle right (+) or left (-) from center ("0" error). The thumbwheel setting plus (+ indication) or minus (- indication) the meter reading equals the received frequency. Accuracy depends upon the sensitivity established on the Frequency Error Range Switch.

A. RF CARRIER FREQUENCY

If the RF carrier frequency received differs from the RF FREQUENCY Thumbwheel setting, the IF output frequency of the IF Module will differ from 10.7 MHz by an equal amount. After being demodulated in the Receiver/Generator, the IF signal is coupled to the counter system of the Digital Module. The Frequency Error Range Switch selects a time-base frequency to establish the time duration for sampling the signal, and preloads the counter system with a starting count. The number of cycles counted during the sampling period is added to the starting count. When the ending count is 128, the DAC output is null. A total above or below 128 results in a more- or less- positive voltage respectively, which produces a corresponding deflection of the meter needle.

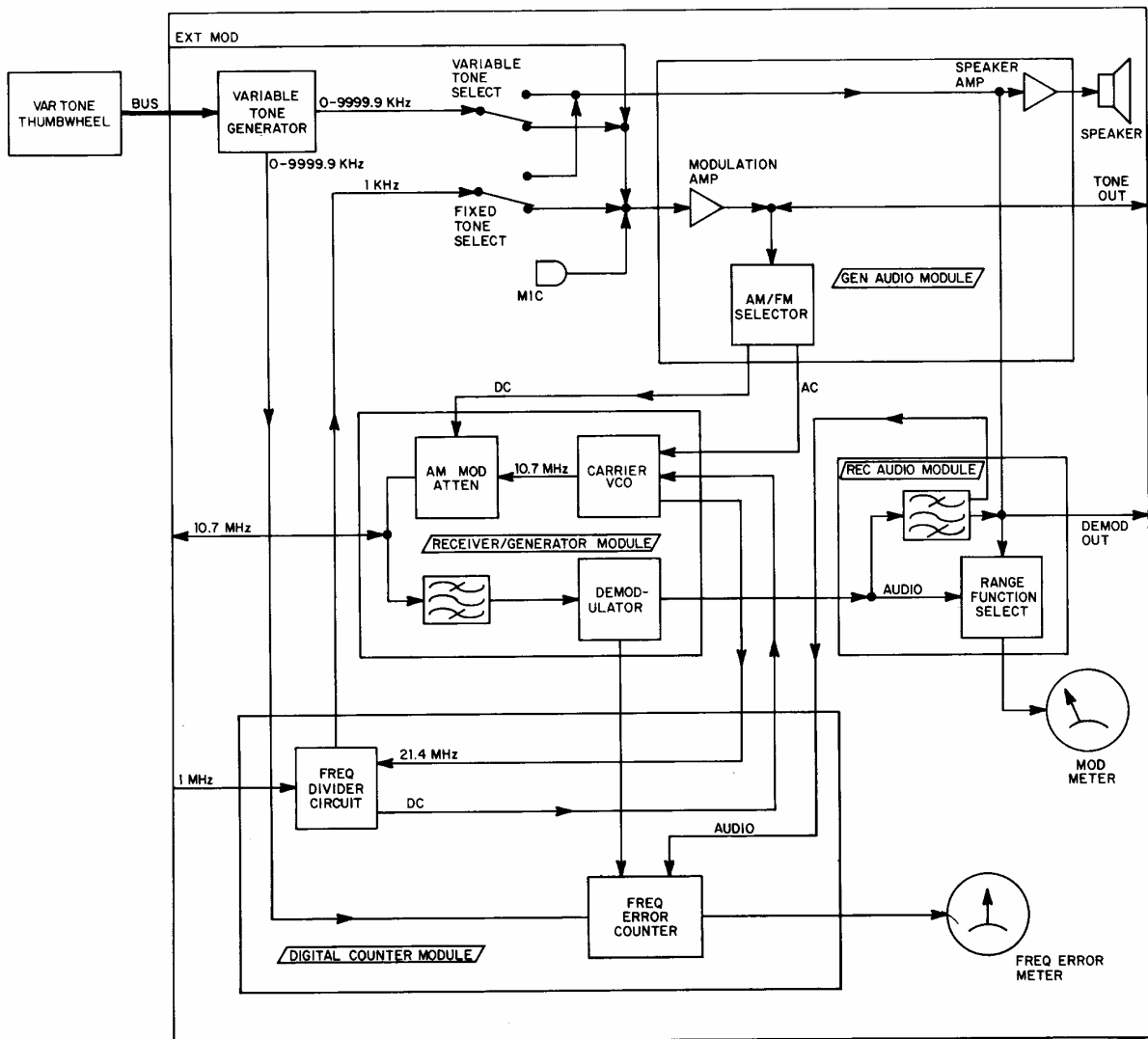

Figure 2-5 Audio System Block Diagram

B. AUDIO FREQUENCY

When measuring an audio frequency, the counter system is pre-loaded with a count of 128, which causes the DAC to produce a null voltage and the meter to read "0". The timing circuit of the Digital Module couples the unknown audio frequency to the counter system, which counts upward for a time period established by the Frequency Error Range Switch. Next, the timing circuit couples the reference frequency established on the Variable Tone Generator to the counter system and allows it to count downward for the next time period. If the unknown fre-

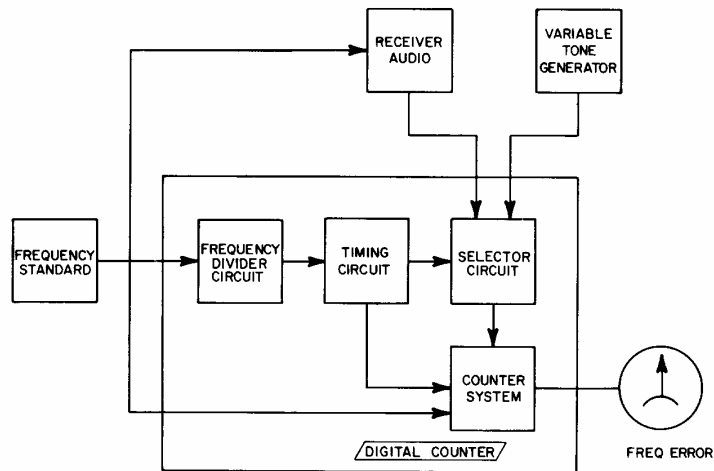

Figure 2-6 Frequency Error Indicator Block Diagram

quency is above or below the reference frequency, the ending count will be above or below the preloaded count of 128 respectively. The DAC converts this ending count to the corresponding positive or negative analog voltage to operate the meter.

C. ERROR INDICATION

The counter system contains five counters; the first two feed the DAC and the remaining three receive overflow and feed an over/under range detector. The Frequency Error Range Switch, through a logic network, establishes a starting count for each counter. The DAC operates on a count of from 0 to 255. From a maximum negative voltage at 0, its output decreases linearly to zero volts at 128, then swings positive linearly to 255. When the count exceeds 255, the overflow is passed on to the first overflow counter and the two DAC counters are reset. The overflow is added to the starting count set on the overflow counters and their ending value is interpreted by the over/under range detector. When an over- or under-range count is detected, a positive or negative voltage pegs the meter in the corresponding direction. To provide the "on scale" reading produced by the DAC, the DAC counters must overflow enough times during the sampling period for the overflow count plus the preset count to bring all outputs of the overflow counters to zero.

2-4-5 PHASE LOCK INDICATOR CIRCUIT (Figure 2-7)

The Phase Lock Indicator Circuit provides a steady illumination of the LED on the Front Panel when the Frequency Conversion local oscillators are phase-locked to the related reference frequencies. If phase lock is not achieved, the LED flashes and another LED mounted on the

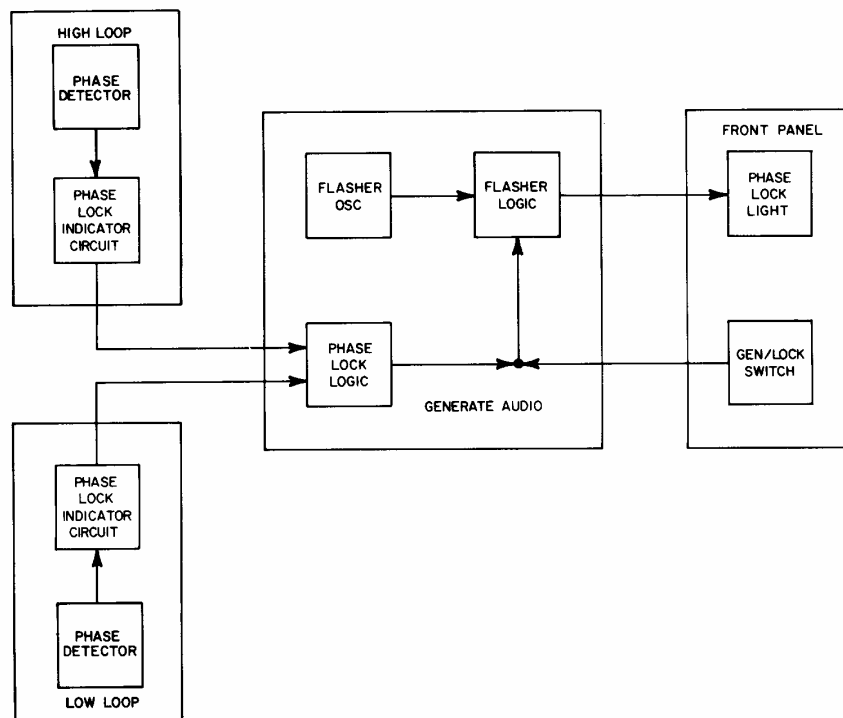

Figure 2-7 Phase Lock Indicator Circuit Block Diagram

unlocked module (High Loop or Low Loop Synthesizer) is illuminated. Components of the Phase Lock Indicator Circuit are installed in the High Loop Synthesizer, Low Loop Synthesizer, and Generate Audio Modules and on the Front Panel.

A positive voltage is normally applied to each input of the phase lock logic, causing its output to the flasher logic to be low. If the phase detector of either synthesizer senses its related VCO and reference frequencies are out of phase, it furnishes a signal to the corresponding grounding logic. The grounding logic then grounds that input to the phase lock logic, which also grounds that module's LED and allows it to illuminate. With either or both inputs low, the phase lock logic supplies a high signal to the flasher logic.

The flasher oscillator provides a continually pulsing signal to one input of the flasher logic at approximately two pulses per second. The second input is from the phase lock logic or the GEN/LOCK switch on the Front Panel. When either input is low, the flasher logic applies a positive voltage to the Front Panel LED. Thus, with both synthesizers locked and the GEN/LOCK Switch in LOCK, one input to the flasher logic is constantly low, and the LED is steady. However, with a high input from the phase lock logic or the GEN/LOCK Switch, the flasher logic receives only the pulsing low input from the flasher. It then produces only a pulsing high output to the Front Panel LED, causing the LED to flash at approximately two flashes per second.

SECTION 3 - PERFORMANCE EVALUATION

3-1 GENERAL

This section contains step-by-step test procedures for assessing the performance of the FM/AM-500A. These procedures should be used as a quick check if a malfunction with the set is suspected, and as the first step in the troubleshooting/maintenance process when the operating condition of the set is in question. They should also be performed after repair, but before recalibrating to be sure the suspected fault has been corrected. All procedures contained in this section are performed using the FM/AM-500A Front Panel controls and do not require removing the exterior case. These procedures are divided into the following subsections:

A. MOBILE PERFORMANCE CHECKS

These procedures are quick, qualitative checks designed to assess the performance of the FM/AM-500A in a mobile situation. Any of these checks can be conducted within 5 to 10 minutes, while the set is operating on its own battery power if the optional battery is installed. Only a two foot length of 50 ohm coaxial cable (with BNC connectors on each end) is required to perform these checks.

B. LABORATORY (OR BENCH) PERFORMANCE CHECKS

These procedures are intended for use in a laboratory or bench environment, where each test can be supported and verified by using additional test equipment. These procedures are more detailed than those described above, and will, therefore, enable the technician to make a more precise and conclusive evaluation of the set's overall performance.

NOTE

If one or more of the mobile checks indicate the FM/AM-500A is not performing properly, the operator/technician should also perform the corresponding laboratory checks before commencing any corrective maintenance action.

Each test procedure, in both the mobile and laboratory test subsections, contains several common headings which are defined as follows:

3-2-1 Test procedure number.

TEST PROCEDURE: Name of test procedure to be performed.

SPECIAL ACCESSORY

EQUIPMENT REQ'D: List of any special accessory test equipment required to complete the test procedure.

TEST SET-UP

DIAGRAM: A diagrammatic aid for making connections between FM/AM-500A and any special accessory equipment.

INITIAL FM/AM-500A

CONTROL SETTINGS: Initial FM/AM-500A Front Panel control settings required to begin the procedure (See Figure 1-2 for Front Panel control identification.)

3-1-1 TEST EQUIPMENT REQUIREMENTS

Appendix B at the back of this manual contains a comprehensive list of test equipment suitable for performing any of the procedures in this manual. Any other equipment meeting the specifications listed in the appendix may be substituted for the recommended models.

NOTE

For certain procedures in this manual, the equipment listed in Appendix B may exceed the minimum required specifications. For this reason, minimum use specifications appear at the beginning of all individual test procedures where accessory test equipment is required.

3-2 MOBILE PERFORMANCE EVALUATION PROCEDURES

Para.	Procedure	Page
3-2-1	1 kHz Tone Generator Performance Evaluation	3-5
3-2-2	Variable Tone Generator Performance Evaluation	3-7
3-2-3	Receiver Performance Evaluation	3-9
3-2-4	RF Frequency Error Meter Performance Evaluation	3-11
3-2-5	Audio Frequency Error Meter Performance Evaluation	3-13
3-2-6	Generate Mode and Modulation Meter Performance Evaluation	3-15

3-3/3-4 Blank

3-2-1

PERFORMANCE
EVALUATION: 1 kHz TONE GENERATOR

SPECIAL ACCESSORY
EQUIPMENT REQ'D: None

TEST SET-UP
DIAGRAM: None

INITIAL FM/AM-500A
CONTROL SETTINGS: Reference Figure 1-2

KEY	CONTROL	SETTING
15	1 kHz TONE Selector Switch	"SPEAKER"
16	1 kHz TONE Level Control	Fully ccw
17	Power Switch	"OFF"
25	VAR TONE Selector Switch	"OFF"
27	VOLUME Control	Fully ccw

STEP

PROCEDURE

NOTE

If any of the following test procedures fails to produce the proper results, refer to Corrective Maintenance Flowchart in Section 1 for appropriate corrective action.

1. Set Power Switch (17) in "LINE" position if AC power is available, or in "BATT" position if external DC or optional battery power is to be used.
2. Slowly rotate 1 kHz TONE Level Control (16) cw until a tone is audible.
3. Set 1 kHz TONE Selector Switch (15) in "OFF" position. Verify tone ceases.

3-2-2

PERFORMANCE

EVALUATION: VARIABLE TONE GENERATOR

SPECIAL ACCESSORY

EQUIPMENT REQ'D: None

TEST SET-UP

DIAGRAM: None

INITIAL FM/AM-500A

CONTROL SETTINGS: Reference Figure 1-2

KEY	CONTROL	SETTING
13	VAR TONE Level Control	Fully ccw
14	VAR TONE Selector Switch	"SPEAKER"
15	1 kHz TONE Selector Switch	"OFF"
17	Power Switch	"OFF"
18	VAR TONE FREQ Thumbwheels	"1000.0"
27	VOLUME Control	Fully ccw

STEP

PROCEDURE

NOTE

If any of the following test procedures fails to produce the proper results, refer to Corrective Maintenance Flowchart in Section 1 for appropriate corrective action.

1. Set Power Switch (17) in "LINE" or "BATT" position as applicable.
2. Slowly rotate VAR TONE Level Control (13) cw until a tone is audible.
3. Rotate the first digit (1000 Hz) of the VAR TONE FREQ Thumbwheels (18) through all ten positions. Verify a change in tone occurs with each increment.

NOTE

Due to the frequency response of the FM/AM-500A speaker, the VAR TONE Level Control (13) may require additional cw rotation before higher frequencies will be audible.

4. Set VAR TONE Selector Switch (14) in "OFF" position. Verify tone ceases.

3-7/3-8 Blank

3-2-3

PERFORMANCE
EVALUATION: RECEIVER

SPECIAL ACCESSORY
EQUIPMENT REQ'D: Antenna
| 1 50 Ω Coax Cable, BNC Connectors

TEST SET-UP
DIAGRAM: None

INITIAL FM/AM-500A
CONTROL SETTINGS: Reference Figure 1-2

KEY	CONTROL	SETTING
4	Modulation Meter Mode Switch	"SIG"
9	Modulation Mode Selector Switch	"FM MID"
14	VAR TONE Selector Switch	"OFF"
15	1 kHz TONE Selector Switch	"OFF"
17	Power Switch	"OFF"
24	GEN/LOCK Control	"LOCK"
25	RF FREQUENCY Thumbwheels	Set to local FM Broadcast Station
26	GEN/REC Mode Switch	"REC"
27	VOLUME Control	Fully ccw
28	SQUELCH Control	Fully ccw

STEP

PROCEDURE

NOTE

If any of the following test procedures fails to produce the proper results, refer to Corrective Maintenance Flowchart in Section 1 for appropriate corrective action.

1. Connect accessory antenna to ANTENNA jack (23).
2. Set Power Switch (17) in "LINE" or "BATT" position as applicable.
3. Slowly rotate VOLUME Control (27) cw until broadcast is audible.
4. Rotate SQUELCH Control (28) fully cw. Verify broadcast audio is muted.

STEP

PROCEDURE

5. Rotate SQUELCH Control (28) back fully ccw.
6. Rotate Modulation Mode Selector Switch (9) to "FM NAR" position. Verify audio is noisy and severely distorted.
7. Rotate RF FREQUENCY Thumbwheels (25) to local AM broadcast station.
8. Rotate Modulation Mode Selector Switch (9) to "AM NORM" position. Adjust the VOLUME Control (27) as required to verify broadcast is audible.

NOTE

Steps 9 through 14 apply to the FM/AM-500A only.

9. Connect coax cable between TONE OUT (10) and EXT MOD/SINAD (7) jacks.
10. Set 1 kHz TONE Selector Switch (15) in "INT MOD" position.
11. Rotate level control fully ccw.
12. Rotate Modulation Meter Range Switch (4) to "DIST". Modulation Meter (1) should read less than 3 on the top scale.
13. Rotate VAR TONE Thumbwheels (18) to 2400 and set VAR Tone Selector Switch (14) to "INT MOD".
14. Rotate level control CW until 10 is red on top scale.
15. Rotate Modulation Meter Range Switch (4) to "SINAD" position and read 20 on SINAD Scale.

3-2-4

PERFORMANCE
EVALUATION: RF FREQUENCY ERROR METER

SPECIAL ACCESSORY
EQUIPMENT REQ'D: 1 50Ω Ohm Coax Cable, BNC/BNC

TEST SET-UP
DIAGRAM: None

INITIAL FM/AM-500A
CONTROL SETTINGS: Reference Figure 1-2

KEY	CONTROL	SETTING
9	Modulation Mode Selector Switch	"SSB"
14	VAR TONE Selector Switch	"OFF"
15	1 kHz TONE Selector Switch	"OFF"
17	Power Switch	"OFF"
19	Frequency Error Meter Range Switch	"RF 1K"
24	GEN/LOCK Control	"LOCK"
25	RF FREQUENCY Thumbwheels	"010 000 0"
26	GEN/REC Mode Switch	"REC"
27	VOLUME Control	Fully ccw
28	SQUELCH Control	Fully ccw

STEP

PROCEDURE

NOTE

If any of the following test procedures fails to produce the proper results, refer to Corrective Maintenance Flowchart in Section 1 for appropriate corrective action.

1. Connect coax cable to 10 MHz REF and ANTENNA jacks.
2. Set Power Switch (17) in "LINE" or "BATT" position as applicable. Verify LOCK lamp (22) illumination is steady.
3. Verify FREQ ERROR Meter (21) indicates 0 Hz (± 30 Hz).
4. Rotate RF FREQUENCY Thumbwheels (25) to "010 001 0". Verify FREQ ERROR Meter (21) indicates -1000 Hz (± 30 Hz).
5. Rotate VOLUME Control (27) sufficiently to verify a 1 kHz tone is audible.

STEP	PROCEDURE
6.	Rotate RF FREQUENCY Thumbwheels (25) to "009 999 0". Verify FREQ ERROR Meter (21) indicates +1000 Hz (± 30 Hz).
7.	Rotate Frequency Error Meter Range Switch (19) to "RF 3K".
8.	Rotate RF FREQUENCY Thumbwheels (25) to "009 997 0". Verify FREQ ERROR Meter (21) indicates +3000 Hz (± 150 Hz).
9.	Rotate RF FREQUENCY Thumbwheels (25) to "010 003 0". Verify FREQ ERROR Meter (21) indicates -3000 Hz (± 150 Hz).
10.	Rotate Frequency Error Meter Range Switch (17) to "RF 10K".
11.	Rotate RF FREQUENCY Thumbwheels (25) to "010 010 0". Verify FREQ ERROR Meter (21) indicates -10 kHz (± 300 Hz).
12.	Rotate RF FREQUENCY Thumbwheels (25) to "009 990 0". Verify FREQ ERROR Meter (21) indicates +10 kHz (± 300 Hz).

3-2-5

PERFORMANCE
EVALUATION: AUDIO FREQUENCY ERROR METER

SPECIAL ACCESSORY
EQUIPMENT REQ'D: None

TEST SET-UP
DIAGRAM: None

INITIAL FM/AM-500A
CONTROL SETTINGS: Reference Figure 1-2

KEY	CONTROL	SETTING
4	Modulation Meter Range Switch	"20"
9	Modulation Mode Selector Switch	"FM MID"
14	VAR TONE Selector Switch	"OFF"
15	1 kHz TONE Selector Switch	"INT MOD"
16	1 kHz TONE Level Control	Fully ccw
17	Power Switch	"OFF"
18	VAR TONE FREQ Thumbwheels	"1000.0"
19	Frequency Error Meter Range Switch	"AUDIO 3"
24	GEN/LOCK Control	"LOCK"
25	RF FREQUENCY Thumbwheels	"001 000 0"
26	GEN/REC Mode Switch	"GEN"
27	VOLUME Control	Fully ccw
28	SQUELCH Control	Fully ccw

STEP

PROCEDURE

NOTE

If any of the following test procedures fails to produce the proper results, refer to Corrective Maintenance Flowchart in Section 1 for appropriate corrective action.

1. Set Power Switch (17) in "LINE" or "BATT" position as applicable. Verify LOCK Lamp (22) illumination is steady.
2. Rotate 1 kHz TONE Level Control (16) cw until MODULATION Meter (1) indicates 20 kHz. Verify FREQ ERROR Meter (21) indicates 0 Hz (± 0.18 Hz).
3. Rotate VAR TONE FREQ Thumbwheels (18) to "1003.0". Verify FREQ ERROR Meter (21) indicates -3 Hz (± 0.18 Hz).

STEP

PROCEDURE

4. Rotate VAR TONE FREQ Thumbwheels (18) to "0997.0". Verify FREQ ERROR Meter (21) indicates +3 Hz (± 0.18 Hz).
5. Rotate Frequency Error Meter Range Switch (19) to "AUDIO 30".
6. Rotate VAR TONE FREQ Thumbwheels (18) to "0970.0". Verify FREQ ERROR Meter (21) indicates +30 Hz (± 1.8 Hz).
7. Rotate VAR TONE FREQ Thumbwheels (18) to "1030.0". Verify FREQ ERROR Meter (21) indicates -30 Hz (± 1.8 Hz).
8. Rotate Frequency Error Meter Range Switch (19) to "AUDIO 300".
9. Rotate VAR TONE FREQ Thumbwheels (18) to "1300.0". Verify FREQ ERROR Meter (21) indicates -300 Hz (± 18 Hz).
10. Rotate VAR TONE FREQ Thumbwheels (18) to "0700.0". Verify FREQ ERROR Meter (21) indicates +300 Hz (± 18 Hz).

STEP

PROCEDURE

5. Slowly rotate 1 kHz TONE Level Control (16) cw until MODULATION Meter (1) indicates 2 kHz deviation.
6. Rotate Modulation Meter Range Switch (4) to "6". Verify MODULATION Meter (1) indicates 2 kHz (± 180 Hz).
7. Rotate 1 kHz TONE Level Control (16) cw until MODULATION Meter (1) indicates 6 kHz.
8. Rotate Modulation Meter Range Switch (4) to "20". Verify MODULATION Meter (1) indicates 6 kHz (± 600 Hz).
9. Rotate VOLUME Control (27) cw sufficiently to verify a 1 kHz tone is audible.
10. Set GEN/REC Mode Switch (26) in "REC".
11. Connect microphone to MIC/ACC Jack (3) and key microphone. Verify 1 kHz tone is audible through Speaker. Disconnect microphone.
12. Set GEN/REC Mode Switch (26) in "GEN".
13. Rotate VOLUME Control (27) fully ccw.
14. Rotate 1 kHz TONE Level Control (16) fully cw. Verify MODULATION Meter (1) indicates deviation greater than 20 kHz.
15. Rotate 1 kHz TONE Level Control (16) fully ccw.
16. Rotate Modulation Meter Range Switch (4) to "2". Verify MODULATION Meter (1) indicates deviation less than 100 Hz.
17. Rotate Modulation Mode Selector Switch (9) to "AM NORM".
18. Rotate 1 kHz TONE Level Control (16) cw until MODULATION Meter (1) indicates 20% modulation.
19. Rotate Modulation Meter Range Switch (4) to "6". Verify MODULATION Meter (1) indicates 20% ($\pm 3\%$) modulation.
20. Rotate 1 kHz TONE Level Control (16) cw until MODULATION Meter (1) indicates 60% modulation.
21. Rotate Modulation Meter Range Switch (4) to "20". Verify MODULATION Meter (1) indicates 60% ($\pm 10\%$) modulation.
22. Rotate VOLUME Control (27) cw to verify 1 kHz tone is audible.
23. Rotate VOLUME Control (27) fully ccw.
24. Rotate 1 kHz TONE Level Control (16) fully cw. Verify MODULATION Meter (1) indicates modulation greater than 150%.

3-3 LABORATORY PERFORMANCE EVALUATION PROCEDURES

Para.	Procedure	Page
3-3-1	1 kHz Tone Generator Performance Evaluation	3-19
3-3-2	Variable Tone Generator Performance Evaluation	3-21
3-3-3	Receiver Performance Evaluation	3-23
3-3-4	Generate System Performance Evaluation	3-27
3-3-5	Frequency Error Meter Performance Evaluation - RF and SSB	3-31
3-3-6	Frequency Error Meter Performance Evaluation - Audio	3-33
3-3-7	Modulation and Power Meter Performance Evaluation	3-35
3-3-8	SINAD Meter Performance Evaluation	3-39
3-3-9	Power Meter Performance Evaluation	3-41

3-3-1

PERFORMANCE
EVALUATION: 1 kHz TONE GENERATOR

SPECIAL ACCESSORY
EQUIPMENT REQ'D: 1 Digital Multimeter (DMM), 3½ Digit, 100 KΩ/V sensitivity, with thru RMS
1 Frequency Counter, 0.1 Resolution, 4½ Digit
1 Distortion Analyzer Capable of ±0.5% @ 1 kHz
1 Coax "T" Connector, BNC
1 50Ω Coax Cable, BNC/BNC
1 Resistor, 150Ω, 5%, 1/8 W

TEST SET-UP
DIAGRAM:

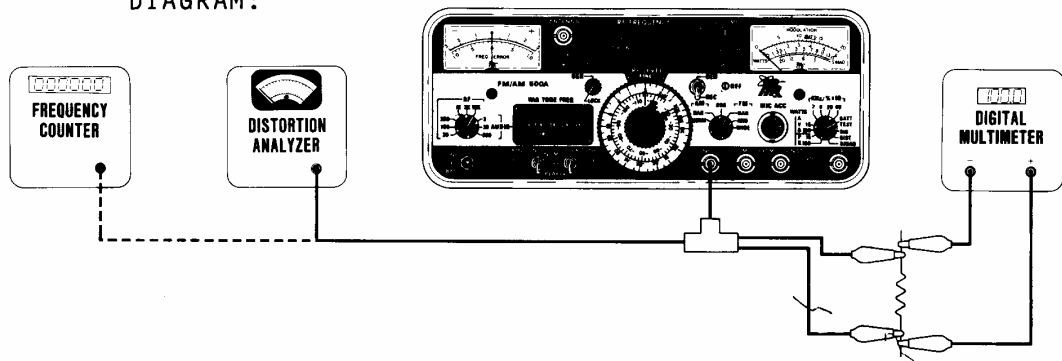

Figure 3-1 1 kHz Tone Generator Lab Test Set-Up

INITIAL FM/AM-500A
CONTROL SETTINGS: Reference Figure 1-2

KEY	CONTROL	SETTING
14	VAR TONE Selector Switch	"OFF"
15	1 kHz TONE Selector Switch	"INT MOD"
16	1 kHz TONE Level Control	Fully cw
17	Power Switch	"OFF"

STEP PROCEDURE

NOTE

If any of the following test procedures fails to produce the proper results, refer to Corrective Maintenance Flowchart in Section 1 for appropriate corrective action.

STEP

PROCEDURE

1. Connect FM/AM-500A to accessory test equipment as shown in Figure 3-1.
2. Set Power Switch (17) in "LINE" position. Verify LOCK Lamp illumination is steady.
3. Verify DMM indicates 2.50 VRMS or more.
4. Rotate 1 kHz TONE Level Control (16) ccw until DMM indicates 2.50 VRMS.
5. Using Distortion Analyzer, verify distortion is less than 0.5%.
6. Disconnect coax cable from Distortion Analyzer and connect it to the Frequency Counter.
7. Verify Frequency Counter indicates 1 kHz (± 0.1 Hz).

3-3-2

PERFORMANCE
EVALUATION: VARIABLE TONE GENERATOR

SPECIAL ACCESSORY
EQUIPMENT REQ'D: 1 Digital Multimeter (DMM), 3½ Digit, 100 K Ω /V
sensitivity, with true RMS
1 Frequency Counter, 0.1 Resolution, 4½ Digit
1 Distortion Analyzer Capable of $\pm 0.5\%$ @ 1 kHz
1 Coax "T" Connector, BNC
1 50 Ω Coax Cable, BNC/BNC
1 50 Ω Coax Cable, BNC/Alligator Clip
1 Resistor, 150 Ω , 5%, 1/8 W

TEST SET-UP
DIAGRAM:

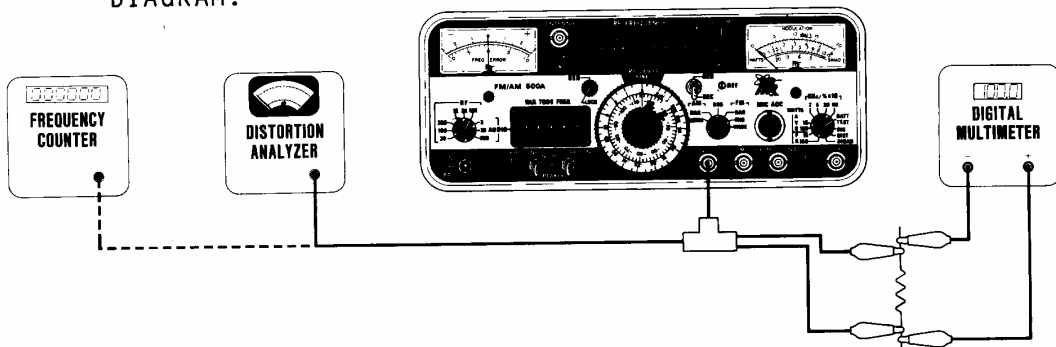

Figure 3-2 Variable Tone Generator Lab Test Set-Up

INITIAL FM/AM-500A
CONTROL SETTINGS: Reference Figure 1-2

KEY	CONTROL	SETTING
13	VAR TONE Level Control	Fully cw
14	VAR TONE Selector Switch	"INT MOD"
15	1 kHz TONE Selector Switch	"OFF"
17	Power Switch	"OFF"
18	VAR TONE FREQ Thumbwheels	"1000.0"

STEP

PROCEDURE

NOTE

If any of the following test procedures fails to produce the proper results, refer to Corrective Maintenance Flowchart in Section 1 for appropriate corrective action.

1. Connect FM/AM-500A to accessory test equipment as shown in Figure 3-2.
2. Set Power Switch (17) in "LINE" position. Verify LOCK Lamp illumination is steady.
3. Verify DMM indicates 2.50 VRMS or more.
4. Rotate VAR TONE Level Control (13) ccw until DMM indicates 2.50 VRMS.
5. Using Distortion Analyzer, verify distortion is less than 0.5%.
6. Rotate VAR TONE FREQ Thumbwheels (18) to "0010.0". Verify distortion is less than 1.5%.
7. Rotate VAR TONE FREQ Thumbwheels (18) to "9999.9". Verify distortion is less than 1.5%.
8. Disconnect coax cable from Distortion Analyzer and connect it to the Frequency Counter. Verify Frequency Counter displays 9999.9 Hz (± 1 Hz).
9. Rotate VAR TONE FREQ Thumbwheels (18) in each of the settings below and verify Frequency Counter displays that frequency within the corresponding tolerances:

FREQUENCY	TOLERANCE	FREQUENCY	TOLERANCE
8888.8 Hz	± 0.9 Hz	3333.3 Hz	± 0.4 Hz
7777.7 Hz	± 0.8 Hz	2222.2 Hz	± 0.3 Hz
6666.6 Hz	± 0.7 Hz	1111.1 Hz	± 0.2 Hz
5555.5 Hz	± 0.6 Hz	0000.0 Hz	± 0.1 Hz
4444.4 Hz	± 0.5 Hz		

3-3-3

PERFORMANCE
EVALUATION: RECEIVER

SPECIAL ACCESSORY
EQUIPMENT REQ'D:

- 1 Signal Generator Modulation Capabilities:
Freq. Range 1.0-1000 MHz, Ampl. Range -110 dBm
to -50 dBm, Freq. Accuracy $\pm 0.005\%$ or with
10 MHz phase lock reference input or output
available
- 1 Distortion Analyzer, Measures less than 0.5%
distortion at 1 kHz
- 1 Digital Multimeter (DMM), 100 K Ω /V sensitivity
3 $\frac{1}{2}$ Digit, True RMS
- 3 50 Ω Coax Cables, BNC/BNC
- 1 50 Ω Coax Cable, BNC/Alligator Clips
- 1 "T" Coax Connector, BNC

TEST SET-UP
DIAGRAM:

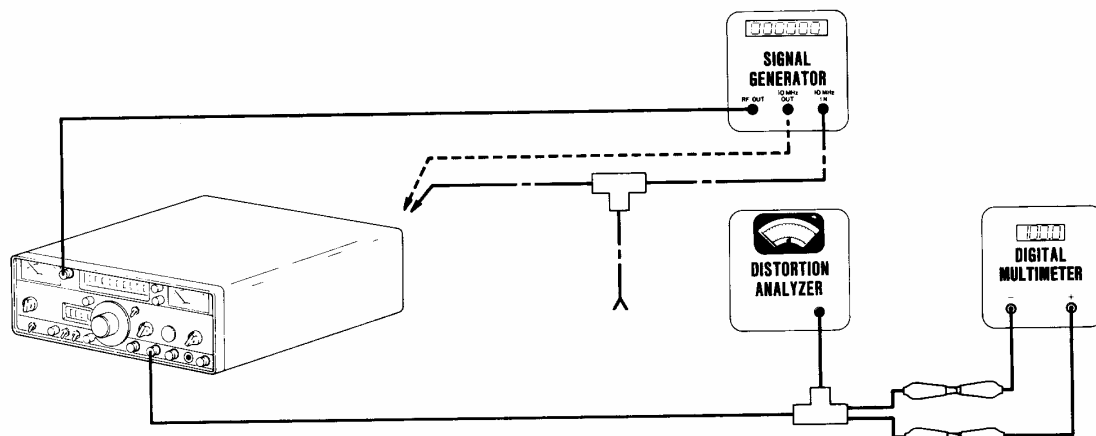

Figure 3-3 Receiver Lab Test Set-Up

INITIAL FM/AM-500A

CONTROL SETTINGS: Reference Figure 1-2

KEY	CONTROL	SETTING
4	Modulation Meter Range Switch	"SIG"
9	Modulation Mode Selector Switch	"FM NAR"
14	VAR TONE Selector Switch	"OFF"
15	1 kHz TONE Selector Switch	"OFF"
16	1 kHz TONE Level Control	Fully ccw
17	Power Switch	"OFF"
19	Frequency Error Meter Range Switch	"RF 1K"
24	GEN/LOCK Control	"LOCK"
25	RF FREQUENCY Thumbwheels	"150.2 MHz"
26	GEN/REC Mode Selector Switch	"REC"
27	VOLUME Control	Fully ccw
28	SQUELCH Control	Fully ccw

STEP PROCEDURE

NOTE

If any of the following test procedures fails to produce the proper results, refer to Corrective Maintenance Flowchart in Section 1 for appropriate corrective action.

1. Connect FM/AM-500A to accessory test equipment as shown in Figure 3-3.
2. Adjust Signal Generator to produce a 150.2 MHz CW signal at -110 dBm.
3. Set Power Switch (17) in "LINE" position.
4. Slowly increase output level of Signal Generator until FREQUENCY ERROR Meter (21) indicates 0 Hz (± 100 Hz). Verify Signal Generator output is less than -100 dBm ($2 \mu\text{V}$ into 50Ω).
5. Set Signal Generator to produce a 500.00 MHz FM signal at -50 dBm with a modulation frequency of 1000 Hz at 5.0 kHz deviation. Verify Distortion Analyzer indicates less than 3% distortion and DMM indicates 300 mV (± 100 mV).
6. Rotate Modulation Mode Selector Switch (9) to "FM MID".

STEP

PROCEDURE

7. Set deviation on Signal Generator to 50 kHz. Verify Distortion Analyzer indicates less than 3% distortion and DMM indicates 3.0 VRMS (± 1.0 VRMS).
8. Rotate VOLUME Control (27) cw to verify tone is audible.
9. Rotate SQUELCH Control (28) fully cw to verify tone ceases.
10. Rotate VOLUME Control (27) and SQUELCH Control (9) fully ccw.
11. Rotate Modulation Mode Selector Switch (9) to "AM NORM".
12. Set Signal Generator to produce a 1 kHz, 80% AM signal on a 500.0000 MHz carrier at -50 dBm. Verify DMM indicates 400 mV (± 100 mV).
13. Set Signal Generator to produce a 500.0000 MHz CW signal at -50 dBm.
14. Place Modulation Mode Selector Switch (9) in SSB position.
15. Set RF FREQUENCY Thumbwheels (25) to "500 001 0".
16. Rotate VOLUME Control (27) cw to verify tone becomes audible.

3-3-4

PERFORMANCE
EVALUATION: GENERATE SYSTEM

SPECIAL ACCESSORY
EQUIPMENT REQ'D: 1 Frequency Counter Capable of Counting to 200 MHz
with resolution of 0.1 Hz

1 Spectrum Analyzer, 100 kHz to 1 GHz

1 Modulation Meter

1 Audio Generator

2 50 Ω Coax Cables, BNC/BNC

TEST SET-UP
DIAGRAM: None

INITIAL FM/AM-500A
CONTROL SETTINGS: Reference Figure 1-2

KEY	CONTROL	SETTING
4	Modulation Meter Range Switch	"20"
9	Modulation Mode Selector Switch	"FM MID"
11	RF LEVEL Attenuator Control	"-20 dBm"
12	RF LEVEL FINE Adjust Control	Fully ccw
14	VAR TONE Selector Switch	"OFF"
15	1 kHz TONE Selector Switch	"OFF"
16	1 kHz TONE Level Control	Fully ccw
17	Power Switch	"LINE"
19	Frequency Error Meter Range	"RF 10K"
24	GEN/LOCK Control	"LOCK"
25	RF FREQUENCY Thumbwheels	"010.000 0"
26	GEN/REC Mode Switch	"GEN"
27	VOLUME Control	Fully ccw
28	SQUELCH Control	Fully ccw

STEP

PROCEDURE

NOTE

If any of the following test procedures fails to produce the proper results, refer to Corrective Maintenance Flowchart in Section 1 for appropriate corrective action.

STEP

PROCEDURE

1. Connect Frequency Counter to EXT STD Jack (32) and verify the output frequency is 10 MHz (\pm Master Oscillator tolerance).
2. Connect Frequency Counter to T/R Jack (5) and verify output frequency is the same as in Step 1.
3. Rotate GEN/LOCK Control (24) cw just out of detent. LOCK Lamp (22) should now be flashing and frequency should be at least 10 kHz lower than in Step 1.
4. Rotate GEN/LOCK Control (24) fully cw. Frequency should now be at least 10 kHz above Step 1.
5. Rotate GEN/LOCK Control (24) fully ccw into LOCK detent.
6. Rotate RF FREQUENCY Thumbwheels (25) to each of the following positions and verify the corresponding frequencies are within the tolerances given:

<u>SETTING</u>	<u>TOLERANCE</u>
a. 011.1111	± 1.1 Hz
b. 012.2222	± 1.2 Hz
c. 013.3333	± 1.3 Hz
d. 014.4444	± 1.4 Hz
e. 015.5555	± 1.6 Hz
f. 016.6666	± 1.7 Hz
g. 017.7777	± 1.8 Hz
h. 018.8888	± 1.9 Hz
i. 019.9999	± 2.0 Hz
j. 010.0000	± 1.0 Hz

7. Disconnect Frequency Counter and connect Spectrum Analyzer.
8. Verify output level is -20 dBm (± 3 dB). Note the output level.
9. Rotate RF LEVEL FINE Adjust Control (12) fully cw. Verify Spectrum Analyzer display is at least 11 dB below that in Step 8. Return RF LEVEL FINE Adjust Control fully ccw.

STEP	PROCEDURE
10.	Rotate RF LEVEL Attenuator Control (11) through detents to "-100 dBm". Verify at each detent that Spectrum Analyzer displays a corresponding level (± 3 dBm).
11.	Rotate RF LEVEL Attenuator Control (11) to -20 dBm.
12.	Rotate RF FREQUENCY Thumbwheels (25) to "001" MHz, then in 10 MHz increments from "010" to "990" MHz and finally to "999" MHz. At each position, verify actual frequency corresponds to the Thumbwheel setting and that the output level remains at -20 dBm (± 3 dB) across the spectrum.
13.	Disconnect Spectrum Analyzer and connect Modulation Meter to T/R Jack (5).
14.	Rotate RF FREQUENCY Thumbwheel (25) to "120 000 0".
15.	Set 1 kHz TONE Selector Switch (15) in "INT MOD".
16.	Rotate 1 kHz TONE Level Control (16) cw to verify a deviation capability of 20 kHz or greater.
17.	Rotate Modulation Mode Selector Switch (9) to "AM NORM".
18.	Rotate 1 kHz TONE Level Control (16) ccw or cw as required to verify a modulation capability at 100% or greater.
19.	Rotate 1 kHz TONE Level Control (16) as required to obtain 50% modulation.
20.	Rotate RF LEVEL FINE Adjust Control (12) fully cw then back fully ccw. Modulation should not change more than 5%.
21.	Set 1 kHz TONE Selector Switch (15) in "OFF" position.
22.	Rotate Modulation Mode Selector Switch (9) to "FM MID".
23.	Connect Audio Generator to EXT MOD/SINAD Jack (7).
24.	Adjust Audio Generator to produce a 1.6 VRMS sinewave at 1 kHz. Verify Modulation Meter shows approximately 20 kHz deviation.
25.	Rotate Modulation Mode Selector Switch (9) to "AM NORM". Verify Modulation Meter displays greater than 100% modulation.

3-3-5

PERFORMANCE
EVALUATION: FREQUENCY ERROR METER - RF AND SSB

SPECIAL ACCESSORY
EQUIPMENT REQ'D: 1 Signal Generator, Modulation Capabilities:
Freq. Range 1.0-1000 MHz, Ampl. Range -110 dBm
to -50 dBm, Freq. Accuracy $\pm 0.005\%$ or with
10 MHz phase lock reference input or output
available

3 50 Ω Coax Cables, BNC/BNC

1 "T" Coax Connector, BNC

TEST SET-UP
DIAGRAM:

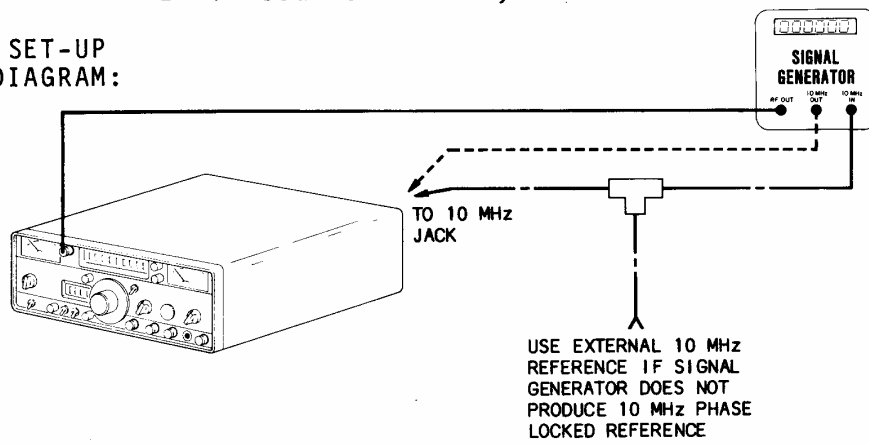

Figure 3-4 Frequency Error Meter Lab
Test Set-Up - RF and SSB

INITIAL FM/AM-500A
CONTROL SETTINGS: Reference Figure 1-2

KEY	CONTROL	SETTING
9	Modulation Mode Selector Switch	"FM NAR"
15	1 kHz TONE Selector Switch	"OFF"
16	1 kHz TONE Level Control	Fully ccw
17	Power Switch	"OFF"
19	Frequency Error Meter Range	"RF 10K"
24	GEN/LOCK Control	"LOCK"
25	RF FREQUENCY Thumbwheels	"500 010 0"
26	GEN/REC Mode Switch	"REC"
27	VOLUME Control	Fully ccw
28	SQUELCH Control	Fully ccw

STEP

PROCEDURE

NOTE

If any of the following test procedures fails to produce the proper results, refer to Corrective Maintenance Flowchart in Section 1 for appropriate corrective action.

1. Connect FM/AM-500A to accessory test equipment as shown in Figure 3-4.
2. Verify FREQ ERROR Meter (21) indicates 0 Hz (± 0 Hz).
3. Set Signal Generator to produce a 500.0000 MHz CW at -50 dBm.
4. Set Power Switch (17) in "LINE" position. Verify LOCK Lamp (22) illumination is steady and that FREQ ERROR Meter (21) indicates -10 kHz (± 300 Hz).
5. Rotate Frequency Error Meter Range Switch (19) to "RF 3K".
6. Rotate RF FREQUENCY Thumbwheels (25) to "500 003 0". Verify FREQ ERROR Meter (21) indicates -3 kHz (± 300 Hz).
7. Rotate Frequency Error Meter Range Switch (19) to "RF 1K".
8. Rotate RF FREQUENCY Thumbwheels (25) to "500 001 0". Verify FREQ ERROR Meter (21) indicates -1 kHz (± 90 Hz).
9. Rotate RF FREQUENCY Thumbwheels (25) to "500 000 0". Verify FREQ ERROR Meter (21) indicates 0 Hz (± 30 Hz).
10. Rotate RF FREQUENCY Thumbwheels (25) to "499 999 0". Verify FREQ ERROR Meter (21) indicates +1 kHz (± 30 Hz).
11. Rotate Frequency Error Meter Range Switch (19) to "RF 3K".
12. Rotate RF FREQUENCY Thumbwheels (25) to "499 997 0". Verify FREQ ERROR Meter (21) indicates +3 kHz (± 30 Hz).
13. Rotate Frequency Error Meter Range Switch (19) to "RF 10K".
14. Rotate RF FREQUENCY Thumbwheels (25) to "499 990 0". Verify FREQ ERROR Meter (21) indicates +10 kHz (± 90 Hz).

3-3-6

PERFORMANCE
EVALUATION: FREQUENCY ERROR METER - AUDIO

SPECIAL ACCESSORY
EQUIPMENT REQ'D: 1 Signal Generator, Modulation Capabilities:
Freq. Range 1.0-1000 MHz, Ampl. Range -110 dBm
to -50 dBm, Freq. Accuracy $\pm 0.005\%$ or with
10 MHz phase lock reference input or output
available

3 50 Ω Coax Cables, BNC/BNC

1 Coax "T" Connector, BNC

TEST SET-UP
DIAGRAM:

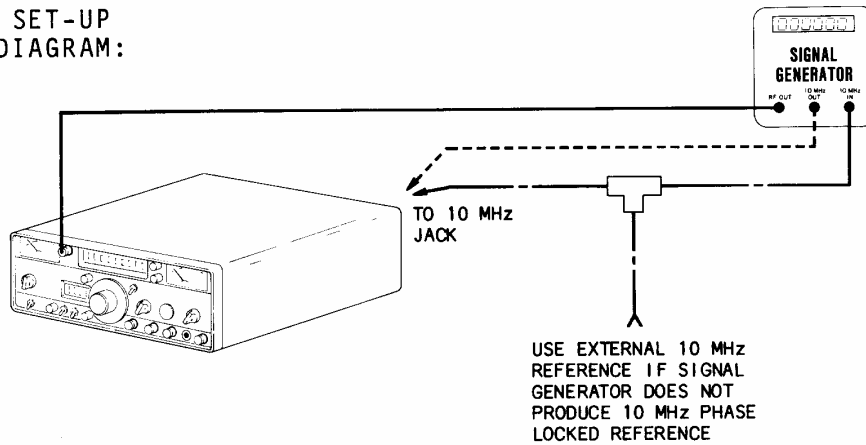

Figure 3-5 Frequency Error Meter Lab
Test Set-Up - Audio

INITIAL FM/AM-500A
CONTROL SETTINGS: Reference Figure 1-2

KEY	CONTROL	SETTING
9	Modulation Mode Selector Switch	"FM NAR"
13	VAR TONE Level Control	Fully ccw
14	VAR TONE Selector Switch	"OFF"
15	1 kHz TONE Selector Switch	"OFF"
17	Power Switch	"OFF"
18	VAR TONE FREQ Thumbwheels	"1300.0"
24	GEN/LOCK Control	"LOCK"
25	RF FREQUENCY Thumbwheels	"500 010 0"
26	GEN/REC Mode Switch	"REC"
27	VOLUME Control	Fully ccw
28	SQUELCH Control	Fully ccw
19	FREQ ERROR Meter Range Switch	AUDIO 300

3-33

02

STEP

PROCEDURE

NOTE

If any of the following test procedures fails to produce the proper results, refer to Corrective Maintenance Flowchart in Section 1 for appropriate corrective action.

1. Connect FM/AM-500A to accessory test equipment as shown in Figure 3-5.
2. Verify FREQ ERROR Meter (21) indicates 0 Hz (± 0 Hz).
3. Set Signal Generator to produce a 1000 Hz FM carrier of 500.0000 MHz at -50 dBm with dispersion of 5 kHz.
4. Set Power Switch (17) in "LINE" position. Verify FREQ ERROR Meter (21) indicates -300 Hz (± 18 Hz).
5. Rotate VAR TONE FREQ Thumbwheels (18) to "1030.0".
6. Rotate Frequency Error Meter Range Switch (19) to "AUDIO 30". Verify FREQ ERROR Meter (21) indicates -30 Hz (± 1.8 Hz).
7. Rotate VAR TONE FREQ Thumbwheels (18) to "1003.0".
8. Rotate Frequency Error Meter Range Switch (19) to "AUDIO 3". Verify FREQ ERROR Meter (21) indicates -3 Hz (± 0.18 Hz).
9. Rotate VAR TONE FREQ Thumbwheels (18) to "1000.0". Verify FREQ ERROR Meter (21) indicates 0 Hz (± 0.18 Hz).
10. Rotate VAR TONE FREQ Thumbwheels (18) to "0997.0". Verify FREQ ERROR Meter (21) indicates +3 Hz (± 0.18 Hz).
11. Rotate VAR TONE FREQ Thumbwheels (18) to "0970.0".
12. Rotate Frequency Error Meter Range Switch (19) to "AUDIO 30". Verify FREQ ERROR Meter (21) indicates +30 Hz (± 1.8 Hz).
13. Rotate VAR TONE FREQ Thumbwheels (18) to "0700.0".
14. Rotate Frequency Error Meter Range Switch (19) to "AUDIO 300". Verify FREQ ERROR Meter (21) indicates +300 Hz (± 18 Hz).

3-3-7

PERFORMANCE
EVALUATION: MODULATION AND POWER METER

SPECIAL ACCESSORY
EQUIPMENT REQ'D: 1 Signal Generator, Modulation Capabilities:
Freq. Range 1.0-1000 MHz, Ampl. Range -110 dBm
to -50 dBm, Freq. Accuracy $\pm 0.005\%$ or with
10 MHz phase lock reference input or output
available

3 50 Ω Coax Cables, BNC/BNC

TEST SET-UP
DIAGRAM:

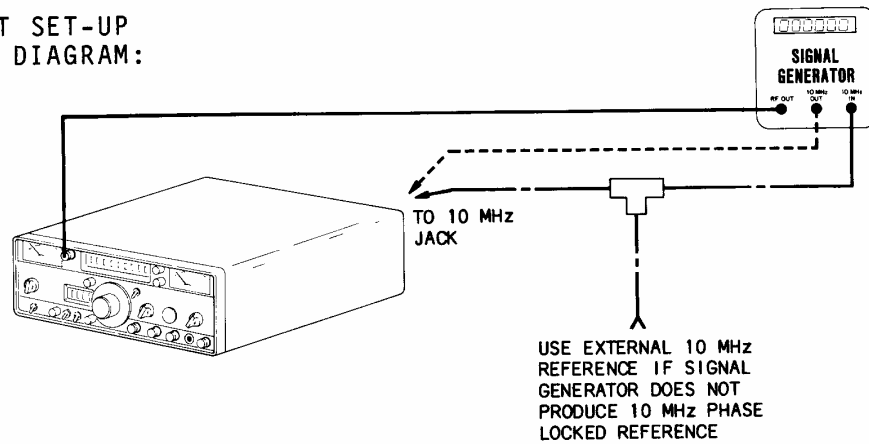

Figure 3-6 Modulation Meter Lab Test Set-Up

INITIAL FM/AM-500A
CONTROL SETTINGS: Reference Figure 1-2

KEY	CONTROL	SETTING
4	Modulation Meter Range Switch	"2"
9	Modulation Mode Selector Switch	"FM NAR"
15	1 kHz TONE Selector Switch	"OFF"
17	Power Switch	"OFF"
18	VAR TONE Selector Switch	"OFF"
24	GEN/LOCK Control	"LOCK"
25	RF FREQUENCY Thumbwheels	"500 000 0"
26	GEN/REC Mode Switch	"REC"
27	VOLUME Control	Fully ccw
28	SQUELCH Control	Fully ccw
19	FREQ ERROR Meter Range Switch	RF 10K

3-35

02

STEP

PROCEDURE

NOTE

If any of the following test procedures fails to produce the proper results, refer to Corrective Maintenance Flowchart in Section 1 for appropriate corrective action.

1. Connect FM/AM-500A to accessory test equipment as shown in Figure 3-6.
2. Verify MODULATION Meter (1) indicates 0.
3. Set Power Switch (17) in "LINE" position. Verify LOCK Lamp (22) illumination is steady.
4. Set Signal Generator to produce a 500.0000 MHz CW carrier at -50 dBm. Verify MODULATION Meter (1) indicates less than 100 Hz deviation.
5. Apply 1000 Hz FM signal at 2 kHz deviation to the output of the Signal Generator. Verify MODULATION Meter (1) indicates 2 kHz deviation.
6. Rotate Modulation Meter Range Switch (4) to "6". Verify MODULATION Meter (1) indicates 2 kHz (± 240 Hz) deviation.
7. Set deviation on Signal Generator to 5 kHz. Verify MODULATION Meter (1) indicates 5 kHz (± 430 Hz).
8. Rotate Modulation Mode Switch (9) to "FM MID".
9. Rotate Modulation Meter Range Switch (4) to "20". Verify MODULATION Meter (1) indicates 5 kHz (± 850 Hz).
10. Set deviation on Signal Generator to 20 kHz. Verify MODULATION Meter (1) indicates 20 kHz (± 1.6 kHz).
11. Apply 1000 Hz AM signal at 80% modulation to the output of the Signal Generator.
12. Rotate Modulation Mode Selector Switch (9) to "AM NAR". Verify MODULATION Meter (1) indicates 80% ($\pm 10\%$) modulation.
13. Reduce modulation level to 60%. Verify MODULATION Meter (1) indicates 60% ($\pm 9\%$).
14. Rotate Modulation Meter Range Switch (4) to "6". Verify MODULATION Meter (1) indicates 60% ($\pm 5\%$).
15. Reduce modulation level to 20%. Verify MODULATION Meter (1) indicates 20% ($\pm 2.5\%$).

STEP

PROCEDURE

16. Rotate Modulation Meter Range Switch (4) to "2". Verify MODULATION Meter (1) indicates 20% ($\pm 1.6\%$).

3-3-8

PERFORMANCE
EVALUATION: SINAD METER

SPECIAL ACCESSORY
EQUIPMENT REQ'D: 1 Distortion Analyzer or Oscilloscope
2 50 Ω Coax Cables
1 Coax "T" Connector

TEST SET-UP
DIAGRAM: None

INITIAL FM/AM-500A
CONTROL SETTINGS: Reference Figure 1-2

KEY	CONTROL	SETTING	
		Method A	Method B
4	Modulation Meter Range Switch	"SINAD"	"SINAD"
14	VAR TONE Selector Switch	"OFF"	"INT MOD"
15	1 kHz TONE Selector Switch	"INT MOD"	"INT MOD"
17	Power Switch	"LINE"	"LINE"
18	VAR TONE FREQ Thumbwheels	"2400.0"	"2400.0"

STEP PROCEDURE

NOTE

If any of the following test procedures fails to produce the proper results, refer to Corrective Maintenance Flowchart in Section 1 for appropriate corrective action.

A. USING DISTORTION ANALYZER

1. Connect coax "Tee" to TONE OUT jack (10).
2. Connect one coax between "Tee" and Distortion Analyzer and second coax between "Tee" and EXT MOD/SINAD jack (7).
3. Adjust 1 kHz TONE Level Control (16) to approximately 1.4 VRMS as shown on Distortion Analyzer.
4. Set VAR TONE Selector Switch (13) in "INT MOD" position.
5. Adjust VAR TONE Level Control (14) for 25% distortion on Distortion Analyzer. Verify Modulation Meter (1) reads 12 dB on the SINAD scale.

3-39

02

STEP

PROCEDURE

6. Adjust VAR TONE Level Control (13) for 10% distortion on Distortion Analyzer.
7. Rotate Modulation Meter Range Switch (4) to "DIST". Verify Modulation Meter (1) reads approximately 10%.

B. USING OSCILLOSCOPE

1. Connect coax "Tee" to TONE OUT jack (10).
2. Connect one coax between "Tee" and Oscilloscope and second coax between "Tee" and EXT MOD/SINAD jack (7).
3. Adjust 1 kHz TONE Level Control (16) for a 4 Vp-p sinewave display on Oscilloscope.
4. Adjust VAR TONE Level Control (13) for a 1 Vp-p sinewave display on Oscilloscope.
5. Verify Modulation Meter (1) reads 12 dB on the SINAD scale.
6. Adjust VAR TONE Level Control (13) for a 0.4 Vp-p sinewave display on Oscilloscope.
7. Rotate Modulation Meter Range Switch (4) to "DIST". Verify Modulation Meter (1) indicates approximately 10% on top scale.

3-3-9

PERFORMANCE
EVALUATION: POWER METER

SPECIAL ACCESSORY
EQUIPMENT REQ'D: 1 AM Transmitter, 4 W at 27 MHz
1 Transmitter, 5-10 W at 150-170 MHz and
800-950 MHz
1 Transmitter, 50-100 W at 150-170 MHz and
800-950 MHz
1 Power Meter, Thru-line
2 50 Ω Coax Cables, BNC/BNC

TEST SET-UP
DIAGRAM: None

INITIAL FM/AM-500A
CONTROL SETTINGS: Reference Figure 1-2

KEY	CONTROL	SETTING
4	Modulation Meter Range Switch	"15 WATTS AVG"
17	Power Switch	"LINE"
26	GEN/REC Switch	"REC"

STEP PROCEDURE

NOTE

If any of the following test procedures fails to produce the proper results, refer to Corrective Maintenance Flowchart in Section 1 for appropriate corrective action.

1. Connect 5-10 W Transmitter RF OUT jack to Power Meter IN jack with coax.
2. Connect Power Meter OUT jack to FM/AM-500A T/R jack (5) with coax.
3. Transmit a 150-170 MHz unmodulated CW and verify Modulation Meter (1) WATTS scale reading agrees with the Power Meter.
4. Read the reflected power on the Power Meter. Reflected power should be less than 5% of applied power.
5. Transmit an 800-950 MHz unmodulated CW and verify Modulation Meter (1) WATTS scale reading agrees with the Power Meter.

STEP

PROCEDURE

6. Rotate Modulation Meter Range Switch (4) to "150 WATTS AVG".
7. Connect 50-100 W Transmitter in place to the 5-10 W Transmitter.
8. Transmit a 150-170 MHz unmodulated CW (preferably at 50 W) and verify Modulation Meter (1) WATTS scale reading agrees with the Power Meter.

CAUTION

DO NOT EXCEED POWER LIMITATIONS OF:

100 W - 1½ minutes ON, 4 minutes OFF
50 W - 2 minutes ON, 2 minutes OFF

9. Transmit an 800-950 MHz unmodulated CW and verify Modulation Meter (1) WATTS scale reading agrees with Power Meter.
10. Rotate Modulation Meter Range Switch (4) to "15 WATTS AVG".
11. Connect AM Transmitter in place of 50-100 W Transmitter.
12. Transmit an unmodulated CW and record the power applied on the Modulation Meter (1).
13. Transmit a modulated signal. Modulation Meter (1) should read approximately the same as in Step 12.
14. Rotate Modulation Meter Range Switch (4) to "15 WATTS PK".
15. Transmit an unmodulated CW. Modulation Meter (1) should read the same as recorded in Step 12.
16. Transmit a modulated signal. Modulation Meter (1) should read approximately four times that recorded in Step 12.

SECTION 4 - CALIBRATION

4-1 GENERAL

This section contains calibration procedures for the following FM/AM-500A Front Panel indicators and internal modules:

Para.	Calibration Procedure	Page
4-2-1	Mechanical Zeroing of Modulation and Frequency Error Meters	4-7
4-2-2	Power Supply	4-9
4-2-3	10 MHz Oscillator	4-11
4-2-4	Variable Tone Generator	4-15
4-2-5	Frequency Error Meter	4-17
4-2-6	Modulation Meter	4-19
4-2-7	SINAD Meter	4-23
4-2-8	Power Meter	4-27
4-2-9	Generate Output Level	4-29

These procedures should be performed as a result of one or more of the following conditions:

1. If, during the course of normal operation, the FM/AM-500A fails to meet the performance specifications as provided in "SECTION 3 - PERFORMANCE EVALUATION".
2. If a module is found to be defective and requires replacement.
3. If the recommended annual calibration is due.

4-1-1 SAFETY PRECAUTIONS

As with any piece of electronic equipment, extreme caution should be taken when troubleshooting "live" circuits. When performing the calibration procedures in this section, be sure to observe the following precautions:

WARNING

THE REAR PANEL TRANSFORMER CARRIES 120 OR 240 VAC AT INPUT LEADS AS LONG AS AC POWER CORD IS CONNECTED TO FM/AM-500A AND TO EXTERNAL POWER SOURCE. DO NOT CONTACT THESE OR ANY ASSOCIATED COMPONENTS DURING TROUBLESHOOTING OR CALIBRATION.

AS LONG AS THE BATTERY IS INSTALLED OR EXTERNAL AC OR DC POWER IS APPLIED, A 12 VDC POTENTIAL EXISTS AT VARIOUS POINTS ON REAR PANEL, REGARDLESS OF THE FRONT PANEL POWER SWITCH POSITION.

WARNING

WHEN THE FM/AM-500A IS OPERATING ON INTERNAL BATTERY OR EXTERNAL DC, A 115 OR 230 VAC POTENTIAL EXISTS IN THE TRANSFORMER PRIMARY CIRCUIT. DO NOT OPERATE ON "BATT" (INCLUDING EXTERNAL DC) WITH THE AC POWER CORD INSTALLED TO AVOID AN UNPROTECTED LINE VOLTAGE POTENTIAL ON THE POWER CORD PLUG.

WHEN WORKING WITH "LIVE" CIRCUITS OF HIGH POTENTIAL, KEEP ONE HAND IN POCKET OR BEHIND YOUR BACK TO AVOID SERIOUS SHOCK HAZARD.

REMOVE ALL JEWELRY OR OTHER COSMETIC APPAREL BEFORE TROUBLESHOOTING AND/OR REPAIRING LIVE CIRCUITS.

FOR ADDED INSULATION, PLACE RUBBER BENCH MAT UNDER ALL POWERED BENCH EQUIPMENT, AS WELL AS A RUBBER FLOOR MAT BENEATH TECHNICIAN'S CHAIR.

HEED ALL WARNINGS AND CAUTIONS CONCERNING MAXIMUM VOLTAGES AND POWER INPUTS.

4-1-2 DISASSEMBLY REQUIREMENTS

To perform any of the calibration procedures contained in this section (with the exception of procedure 4-2-1), the exterior case must be removed from the FM/AM-500A.

4-1-3 RECOMMENDED CALIBRATION SEQUENCE

Before making any calibration adjustments, always observe the signal measurement. If the measurement is within tolerances given, do not proceed with that specific adjustment. The only time an adjustment is required for an in-tolerance measurement is when a subsequent interactive adjustment is not sufficient for end results and the procedure explicitly requires repeating earlier calibration steps.

Although most of the calibration procedures within this section can be performed in a random sequence, certain modules within the FM/AM-500A should be calibrated in a prescribed order. These particular modules are considered interactive, in that the improper calibration of one may adversely affect the calibration of another. Table 4-1 defines the recommended sequence of calibration for those interactive modules.

NOTE

The following recommendations are based on the assumption that all other circuits and/or modules within the FM/AM-500A are in proper working order.

4-1-4 TEST EQUIPMENT REQUIREMENTS

Minimum test equipment requirements are listed on each calibration procedure.

4-1-5 CONTROLS AND CALIBRATION POINTS

The various controls, meters and connectors specified in the calibration procedures are followed by an item number. Figure 1-2 shows the location of each of these items. Calibration points are identified in Figure 4-1.

WHEN CALIBRATING THE MODULE LISTED BELOW:	FIRST MAKE SURE THE FOLLOWING MODULES ARE IN PROPER CALIBRATION:
10 MHz OSCILLATOR	1. POWER SUPPLY
VARIABLE TONE GENERATOR	1. POWER SUPPLY
FREQUENCY ERROR METER	1. MECHANICAL ZEROING OF FREQUENCY ERROR METER 2. POWER SUPPLY 3. 10 MHz OSCILLATOR
MODULATION METER	1. MECHANICAL ZEROING OF MODULATION METER 2. POWER SUPPLY 3. 10 MHz OSCILLATOR
SINAD METER	1. MECHANICAL ZEROING OF MODULATION METER 2. POWER SUPPLY 3. 10 MHz OSCILLATOR
POWER METER	1. MECHANICAL ZEROING OF MODULATION METER 2. POWER SUPPLY
GEN OUTPUT LVL	1. POWER SUPPLY 2. 10 MHz OSCILLATOR 3. (DESIRABLE) MODULATION METER

Table 4-1 Recommended Calibration Sequence

<p>THEN THE FOLLOWING CALIBRATION STEPS MUST BE PERFORMED</p> <p>IF THIS MODULE IS BEING REPAIRED OR REPLACED</p>	POWER SUPPLY	10 MHz OSCILLATOR	VARIABLE TONE GENERATOR	FREQUENCY ERROR METER	MODULATION METER	SIN. MET
POWER SUPPLY	●					
IF MODULE						
DUAL VCO						
HIGH LOOP						
LOW LOOP						
RECEIVER / GENERATOR						
FREQUENCY STANDARD		●				
DIGITAL MODULE				●		
RECEIVE AUDIO					●	●
GENERATE AUDIO						
OUTPUT AMPLIFIER						
VARIABLE TONE GENERATOR			●			

FUNCTION	SINAD METER	POWER METER	GENERATE OUTPUT LEVEL	IF MODULE (SECTION 7)	HIGH LOOP MODULE (SECTION 7)	LOW LOOP MODULE (SECTION 7)	RECEIVER / GENERATOR MODULE (SECTION 7)
				●			
					●		
					●		
						●	
							●
	●	●					
			●				
		●	●				

Table 4-2 Module Replacement and Alignment Requirements

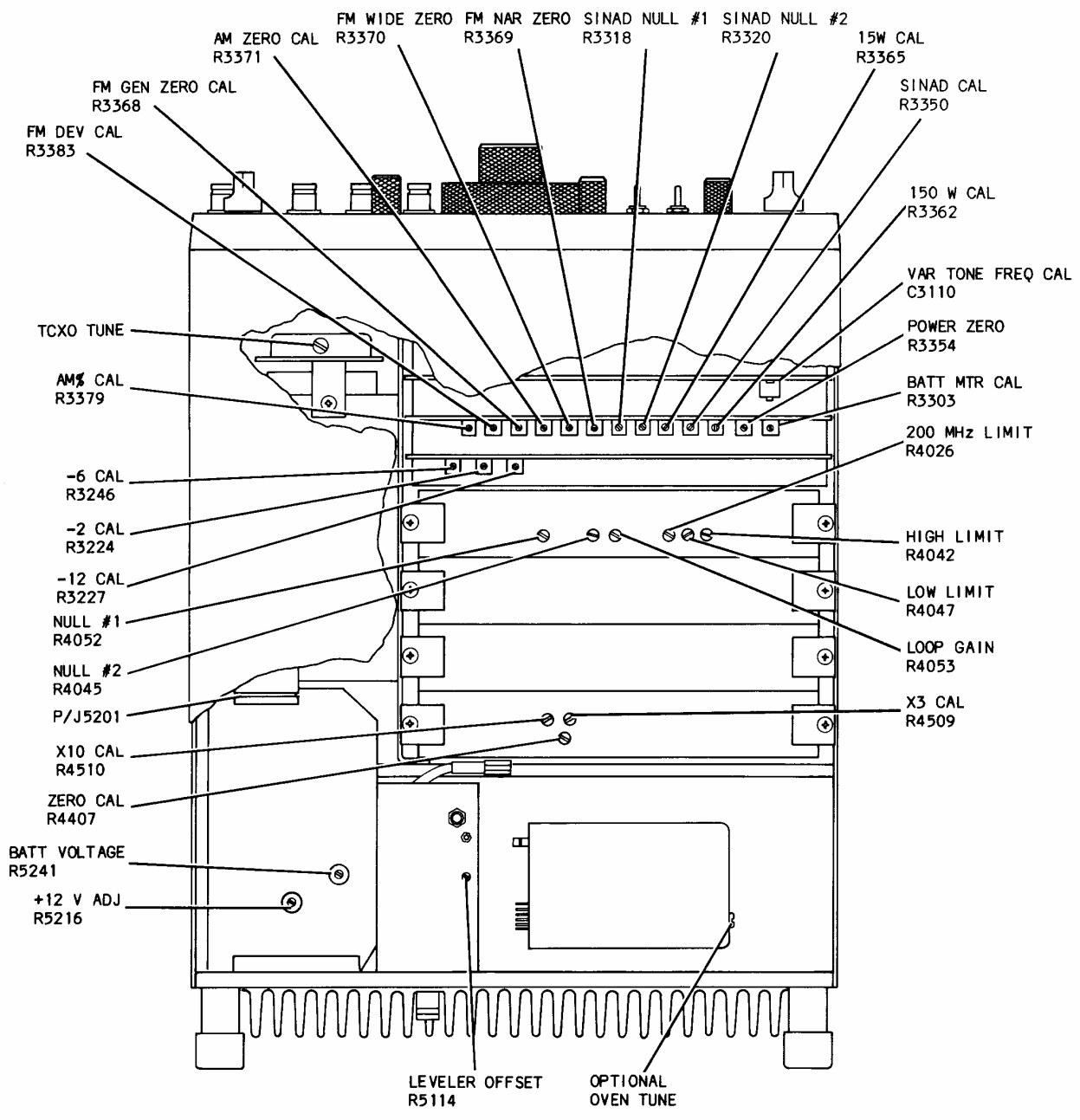

CAL

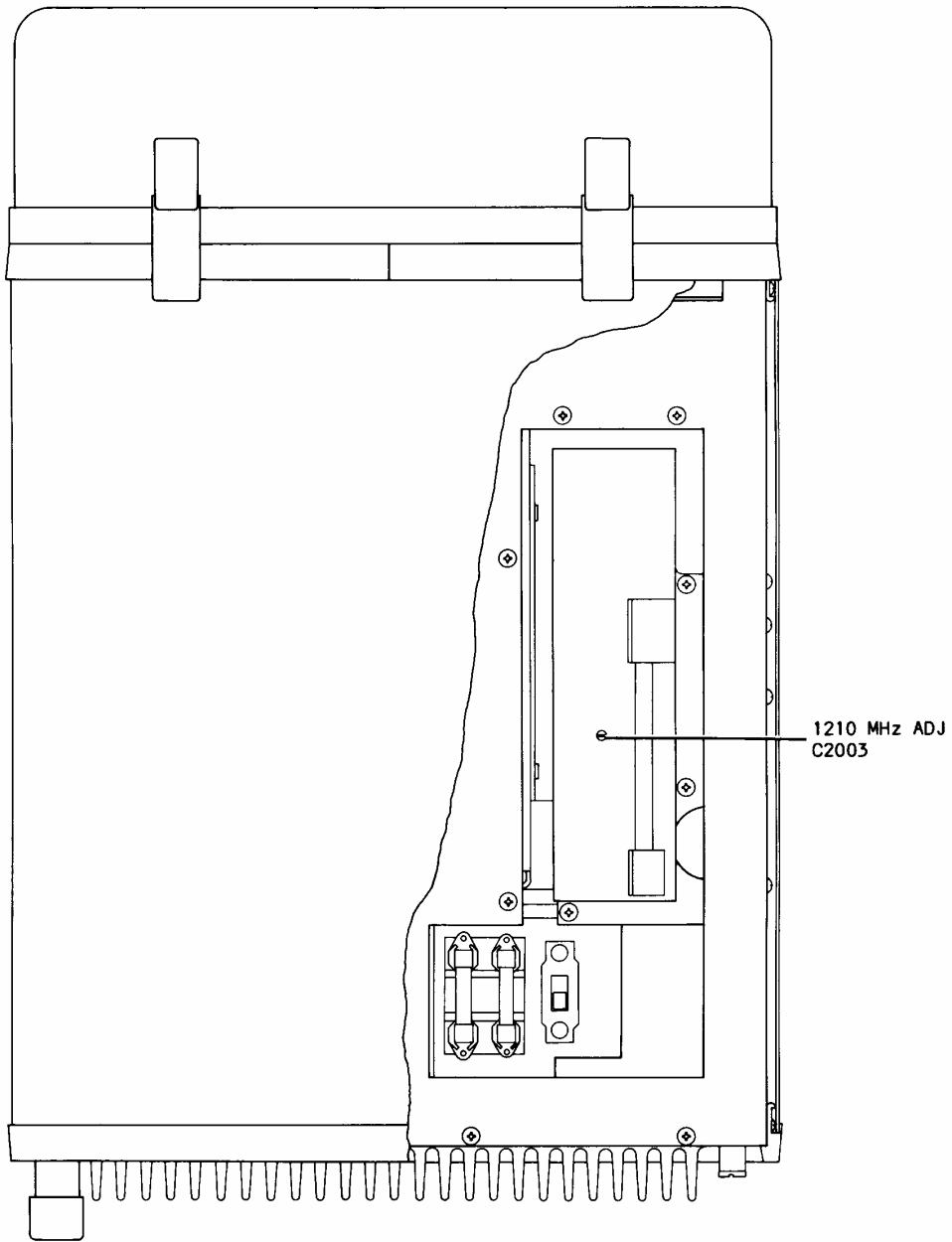

Figure 4-1 Calibration Points

4-2 CALIBRATION PROCEDURES

4-2-1

CALIBRATION
PROCEDURE: MECHANICAL ZEROING OF MODULATION AND FREQUENCY
ERROR METERS

PREREQUISITES: None

SPECIAL ACCESSORY
EQUIPMENT REQ'D: 1 Small Slotted Screwdriver

TEST SET-UP
DIAGRAM: None

CALIBRATION
POINTS: See Figure 4-1

STEP PROCEDURE

NOTE

If any of the following calibration procedures fails to produce the proper results, refer to Corrective Maintenance Flowchart in Section 1 for appropriate corrective action.

1. Place Power Switch (17) in "OFF" position.
2. Adjust the appropriate Meter Zero Adjust screw (2, 20) until the Meter (1, 21) indicates 0 (± 0).

4-2-2

CALIBRATION
PROCEDURE: POWER SUPPLY CALIBRATION PROCEDURE

PREREQUISITES: None

SPECIAL ACCESSORY
EQUIPMENT REQ'D: 1 Battery Load Simulator IFR P/N 7003-9801-600
(Appendix C)
1 Digital Voltmeter (DVM) 100 K Ω /V, 3½ Digit

TEST SET-UP
DIAGRAM: None

CALIBRATION
POINTS: See Figure 4-1

STEP PROCEDURE

NOTE

If any of the following calibration procedures fails to produce the proper results, refer to Corrective Maintenance Flowchart in Section 1 for appropriate corrective action.

A. BATTERY CHARGER CIRCUIT

1. With Power Switch (17) in "OFF" position, disconnect Battery and connect Battery Load Simulator to P5004.

CAUTION

DISCONNECT ALL EXTERNAL POWER CORDS BEFORE DISCONNECTING BATTERY CONNECTOR P/J5004.

2. Rotate Battery Load Simulator's Load Control Pot to center of its mechanical travel (approximately 50 Ω load).
3. Connect External AC power cord to power source and FM/AM-500A.
4. Connect DVM between pin 1 of J5201 and ground.
5. Adjust R5241 for an indication of 14.4 VDC (± 0.1 V) on DVM.
6. Set Meter Switch on Battery Load Simulator to read current.
7. Adjust Battery Load Simulator fully cw (0 Ω load). Verify current is limited to approximately 1.4 Amps.

STEP

PROCEDURE

B. OPTIONAL SIMULCAST (OVEN OSCILLATOR) POWER SUPPLY

1. Connect DVM between pin 1 of J5201 and ground.
2. Adjust R5241 for a DVM indication as close to 12.0 VDC as possible (not to exceed 14.0 VAC).

C. DISTRIBUTED VOLTAGES

1. Set Power Switch (17) in "LINE" position. Verify current shown on Battery Load Simulator Meter is approximately 0.9 Amps.
2. Connect DVM to J5201 pin 8.
3. Adjust R5216 until DVM indicates 12.0 VDC (± 0.2 VDC).
4. Measure voltages on following pins of J5201 and verify they are within tolerances. Repeat Steps 9 through 11 as necessary to obtain tolerances on pins 3, 8, and 10.

J5201 Pin	Voltage DC	Tolerance
3	-12.0 V	± 0.2 V
9	+43.0 V Nom	± 5.0 V
10	+5.0 V	± 0.2 V

5. Set Power Switch (17) in "OFF" position, then disconnect AC power cord.
6. Disconnect P5004 from Battery Load Simulator and reconnect to J5004 from Battery.
7. Connect DVM to pin 1 of P5201.
8. Rotate Modulation Meter Range Switch (4) to "BATT TEST".
9. Set Power Switch (17) in "BATT" position.
10. Adjust R3303 (on Receive Audio PC Board) until Battery Voltage shown on MODULATION Meter (1) (top scale) agrees with DVM.
11. Measure voltages on following pins of J5201 and verify they are within tolerances.

J5201 Pin	Voltage DC	Tolerance
3	-12.0 V	± 0.2 V
8	+12.0 V	± 0.2 V
9	+43.0 V Nom	± 5.0 V
10	+5.0 V	± 0.2 V

4-2-3

CALIBRATION
PROCEDURE: 10 MHz OSCILLATOR CALIBRATION PROCEDURE

PREREQUISITES: Power Supply Calibration

SPECIAL ACCESSORY
EQUIPMENT REQ'D:

- 1 Frequency Counter
10 MHz Capacity, 1 Hz resolution; 0.1 Hz
Resolution if used for fine calibration.
Counter Time Base accuracy:
 - .1 ppm for standard oscillator
 - .05 ppm for optional oscillator
 - .01 ppm for optional oven oscillator
- 1 Coax Cable, BNC/BNC

TEST SET-UP
DIAGRAM: None

CALIBRATION
POINTS: See Figure 4-1

STEP PROCEDURE

NOTE

If any of the following calibration procedures fails to produce the proper results, refer to Corrective Maintenance Flowchart in Section 1 for appropriate corrective action.

A. COARSE CALIBRATION

NOTE

Coarse calibration should be performed only if the REF Frequency Adjustment (29) has insufficient range to accurately calibrate the 10 MHz frequency standard.

1. Connect Frequency Counter to 10 MHz Connector (32) in Rear Panel.
2. Set Power Switch (17) in "LINE" position and allow a 10 minute warm-up period.
3. Position REF Frequency Adjustment (29) in the center of its mechanical travel.
4. Remove access plug on 10 MHz oscillator cover.

STEP PROCEDURE

4. (Cont'd)

NOTE

The 10 MHz oscillator is located on Frequency Standard PC Board for models with standard and optional TCXOs. If the oven oscillator option is installed, the oscillator is installed on the Rear Panel, in the battery well.

5. Rotate adjustment screw inside oscillator enclosure until Frequency Counter indicates 10 MHz (± 2 Hz). Replace access plug.

NOTE

After coarse calibration is completed, or if coarse calibration is not required, proceed with one of the two fine calibration procedures.

B. FINE CALIBRATION TO WWV

1. Connect antenna to ANTENNA Connector (23).
2. Connect unshielded test lead to 10 MHz REF Connector (32) on Rear Panel.
3. Set Front Panel controls as follows (see Figure 1-2):

KEY	CONTROL	SETTING
9	Modulation Mode Selector Switch	"AM NORM" or "AM NAR"
24	GEN/LOCK Control	"LOCK"
25	RF FREQUENCY Thumbwheels	"010.0000"
26	GEN/REC Mode Switch	"REC"
27	VOLUME Control	As required for audible tone
28	SQUELCH Control	As required

4. Position test lead near antenna to produce best beat note.
5. Rotate REF Frequency Adjustment (29) as required to obtain minimum beat frequency.

C. FINE CALIBRATION TO EXTERNAL COUNTER

1. Connect Frequency Counter to 10 MHz Connector (32) on Rear Panel.

STEP

PROCEDURE

2. Rotate REF Frequency Adjustment (29) on Front Panel as required to obtain 10 MHz within:
 - a. ± 1 Hz with standard oscillator
 - b. ± 0.5 Hz with optional oscillator
 - c. ± 0.1 Hz with optional oven oscillator

4-2-4

CALIBRATION
PROCEDURE: VARIABLE TONE GENERATOR CALIBRATION PROCEDURE

PREREQUISITES: Power Supply Calibration

SPECIAL ACCESSORY
EQUIPMENT REQ'D: 1 Frequency Counter
Preferred (with probe): 2.5 MHz capability
with 1 Hz Resolution

Alternate: 5 kHz capability with .1 Hz Resolu-
tion

1 50Ω Coax Cable, BNC/BNC

1 Extender Cable

TEST SET-UP
DIAGRAM: None

INITIAL FM/AM-500
CONTROL SETTINGS: Reference Figure 1-2

KEY	CONTROL	SETTING
13	VAR TONE Level Control	Fully clockwise
14	VAR TONE Selector Switch	"INT MOD"
17	Power Switch	"OFF"
18	VAR TONE FREQ Thumbwheels	"5000.0" Hz

CALIBRATION
POINTS: See Figure 4-1

STEP PROCEDURE

NOTE

If any of the following calibration procedures fails to produce the proper results, refer to Corrective Maintenance Flowchart in Section 1 for appropriate corrective action.

1. Remove Variable Tone Generator PC Board and connect extender cable between J3102 on the Mother Board and P3102 on Variable Tone Generator PC Board.
2. Set Power Switch (17) in "LINE" position. Allow a 5 minute warm-up period.
3. Connect Frequency Counter to pin 1 of U3102. (Refer to Variable Tone Generator PC Board drawing in Section 9.)

STEP

PROCEDURE

4. Adjust C3110 until Frequency Counter indicates 2048 kHz \pm 1 Hz.

NOTE

If preferred Frequency Counter is not available and alternate equipment is used, connect Frequency Counter to TONE OUT Jack (10) and adjust C3110 until counter indicates 5000.0 Hz.

4-2-5

CALIBRATION
PROCEDURE: FREQUENCY ERROR METER CALIBRATION PROCEDURE

PREREQUISITES: 10 MHz Oscillator Calibration, Mechanical Zeroing
of Frequency Error Meter

SPECIAL ACCESSORY
EQUIPMENT REQ'D: 1 50Ω Coax Cable, BNC/BNC

TEST SET-UP
DIAGRAM: None

INITIAL FM/AM-500
CONTROL SETTINGS: Reference Figure 1-2

KEY	CONTROL	SETTING
9	Modulation Mode Selector	"FM NAR"
14	VAR TONE Selector Switch	"OFF"
15	1 kHz TONE Selector Switch	"OFF"
17	Power Switch	"OFF"
19	Frequency Error Meter Range Switch	"RF 10K"
23	GEN/LOCK Control	"LOCK"
25	RF FREQUENCY Thumbwheels	"010 000 0"
26	GEN/REC Mode Switch	"REC"
27	VOLUME Control	Fully counterclockwise
28	SQUELCH Control	Fully counterclockwise

CALIBRATION
POINTS: See Figure 4-1

STEP PROCEDURE

NOTE

If any of the following calibration procedures fails to produce the proper results, refer to Corrective Maintenance Flowchart in Section 1 for appropriate corrective action.

1. Connect coax cable between ANTENNA Connector (23) on Front Panel and 10 MHz Connector (32) on Rear Panel.
2. Set Power Switch (17) in "LINE" position.
3. Refer to Table 4-3. Make the control settings in Steps 1, 2 and 3 of the table and adjust the corresponding trimpots to obtain the correct meter readings. Then proceed with Steps 4 through 14 to verify correct readings in the remaining positions.

STEP

PROCEDURE

3. (Cont'd)

Step	RF FREQUENCY Thumbwheels	Frequency Error Meter Range Switch	FREQ ERROR Meter Reading	Adjustment Trimpot
1	010 000 0	RF10K	0	R4507
2	010 010 0	RF10K	-1.0	R4510
3	010 003 0	RF3K	-3	R4509
4	010 001 0	RF1K	-1.0	-
5	010 000 3	RF300	-3	-
6	010 000 1	RF100	-1.0	-
7	010 000 1	RF30	Pegged (-)	-
8	010 000 0	RF30	0	-
9	009 999 9	RF30	Pegged (+)	-
10	009 999 9	RF100	+1.0	-
11	009 999 7	RF300	+3	-
12	009 999 0	RF1K	+1.0	-
13	009 997 0	RF3K	+3	-
14	009 990 0	RF10K	+1.0	-

Table 4-3 Frequency Error Meter Calibration

4-2-6

**CALIBRATION
PROCEDURE: MODULATION METER CALIBRATION PROCEDURE**

**PREREQUISITES: Mechanical Zeroing of Modulation Meter, Power
Supply Calibration**

- SPECIAL ACCESSORY
EQUIPMENT REQ'D:**
- 1 Modulation Meter Capable of 0-50% Modulation (AM) and 0-15 kHz Deviation (FM)
 - 1 Signal Generator Capable of Producing 120 MHz at 0 dBm with 0-50% Modulation (AM) and 0-15 kHz Deviation (FM)
 - 3 50 Ω Coax Cables, BNC/BNC
 - 1 Directional Coupler, 50 Ω , -20 dBm
or
1 30 dB pad

**TEST SET-UP
DIAGRAM:**

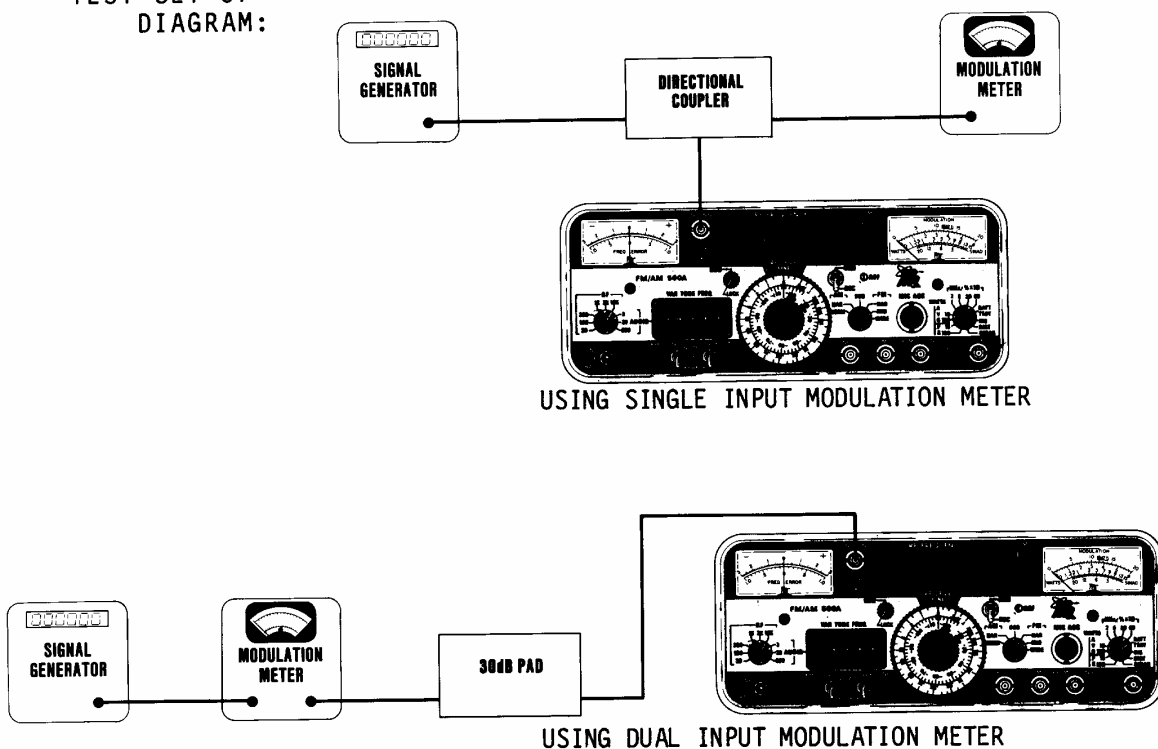

Figure 4-2 Modulation Meter Calibration Set-Up

INITIAL FM/AM-500

CONTROL SETTINGS: See Figure 1-2

KEY	CONTROL	SETTING
4	Modulation Meter Range Switch	"2 kHz/%x10"
9	Modulation Mode Selector	"FM NAR"
11	RF LEVEL Control	Fully clockwise
12	RF LEVEL FINE Adjust Control	Fully clockwise
14	VAR TONE Selector Switch	"OFF"
15	1 kHz TONE Selector Switch	"OFF"
17	Power Switch	"OFF"
24	GEN/LOCK Control	"LOCK"
25	RF FREQUENCY Thumbwheels	"120 000 0"
26	GEN/REC Mode Switch	"GEN"
27	VOLUME Control	Fully counterclockwise
28	SQUELCH Control	Fully counterclockwise

CALIBRATION

POINTS: Reference Figure 4-1

STEP

PROCEDURE

NOTE

If any of the following calibration procedures fails to produce the proper results, refer to Corrective Maintenance Flowchart in Section 1 for appropriate corrective action.

1. Connect Test Equipment as follows (see Figure 4-2):
 - a. For single input Modulation Meter, connect both, Modulation Meter and Signal Generator to Directional Coupler and connect Directional Coupler to ANTENNA Jack (23) on Front Panel.
 - b. For dual input Modulation Meter, connect Modulation Meter to Signal Generator and to 30 dB Pad. Connect 30 dB pad to ANTENNA Jack (23) on Front Panel.
2. Set Power Switch (17) in "LINE" position. Allow a 5 minute warm-up period.
3. Adjust R3368 as necessary until MODULATION Meter (1) indicates 0 (± 0.1).
4. Set Signal Generator to produce a 120 MHz cw carrier at 0 dBm.
5. Set GEN/REC Mode Switch (26) in "REC" position.

STEP

PROCEDURE

6. Adjust R3369 as necessary until MODULATION Meter (1) indicates 0 (± 0.1).
7. Rotate Modulation Mode Selector (9) to "FM WIDE".
8. Adjust R3370 as necessary until MODULATION Meter (1) indicates 0 (± 0.1).
9. Rotate Modulation Meter Range Switch (4) to "6".
10. Rotate Modulation Mode Selector (9) to "FM NAR".
11. Set Signal Generator for 1 kHz modulation frequency at 5 kHz deviation as indicated on accessory Modulation Meter.
12. Adjust R3383 as necessary until MODULATION Meter (1) indicates 5 kHz (± 0.43 kHz).
13. Repeat Steps 4 through 12 until the correct level is attained in all three settings.
14. Set Signal Generator to produce a 120 MHz CW carrier at 0 dBm.
15. Rotate Modulation Meter Range Switch (4) to "2".
16. Rotate Modulation Mode Selector (9) to "AM NORM".
17. Adjust R3371 as necessary until MODULATION Meter (1) indicates 0 (± 0.1).
18. Rotate Modulation Meter Range Switch (4) to "6".
19. Set Signal Generator to produce AM modulation at 50% as indicated on accessory Modulation Meter.
20. Adjust R3379 as necessary until MODULATION Meter (1) indicates 50% ($\pm 2.5\%$).
21. Repeat Steps 14 through 20 until correct level is attained in both settings.

4-2-7

CALIBRATION
PROCEDURE: SINAD METER CALIBRATION (FM/AM-500A ONLY)

PREREQUISITES: Power Supply Calibration, 10 MHz Oscillator Calibration, Mechanical Zeroing of Modulation Meter

SPECIAL ACCESSORY
EQUIPMENT REQ'D: 1 Distortion Analyzer or Oscilloscope
2 50Ω Coax Cables, BNC/BNC
1 Coax "Tee"

TEST SET-UP
DIAGRAM: None

INITIAL FM/AM-500
CONTROL SETTINGS: Reference Figure 1-2

KEY	CONTROL	SETTING	
		Method A	Method B
4	Modulation Meter Range Switch	"SINAD"	"SINAD"
14	VAR TONE Selector Switch	"OFF"	"INT MOD"
15	1 kHz TONE Selector Switch	"INT MOD"	"INT MOD"
17	Power Switch	"LINE"	"LINE"
18	VAR TONE FREQ Thumbwheels	"2400.0"	"2400.0"

CALIBRATION
POINTS: See Figure 4-1

STEP PROCEDURE

NOTE

If any of the following calibration procedures fails to produce the proper results, refer to Corrective Maintenance Flowchart in Section 1 for appropriate corrective action.

A. USING DISTORTION ANALYZER

1. Connect coax to TONE OUT Jack (10).
2. Connect one coax between "Tee" and Distortion Analyzer and second coax between "Tee" and EXT MOD/SINAD jack (7).
3. Alternately adjust SINAD Null trimpots R3318 and R3320 to obtain a null indication on Modulation Meter (1).

4-23

02

STEP

PROCEDURE

4. Rotate Modulation Meter Range Switch (4) to "DIST" and again alternately adjust trimpots R3318 and R3320 to a null indication on Modulation Meter (1).
5. Adjust 1 kHz TONE Level Control (16) approximately to 1.4 VRMS in Distortion Analyzer Meter.
6. Set VAR TONE Selector Switch (14) to "INT MOD" and adjust VAR TONE Level Control (15) for 25% distortion on Distortion Analyzer.
7. Adjust SINAD Cal trimpot R3350 to obtain a 12 dB indication on Modulation Meter (1).
8. Rotate VAR TONE Level Control to obtain 10% distortion as shown on Distortion Analyzer.
9. Rotate Modulation Meter Range Switch (4) to "DIST". Modulation Meter (1) should indicate approximately 10% distortion.
10. Repeat Steps 1 and 3 thru 10, changing the null trimpots slightly each time, until approximately 10% distortion is achieved in Step 10.

B. USING OSCILLOSCOPE

1. Connect coax "Tee" to TONE OUT jack (10).
2. Connect one coax between "Tee" and Oscilloscope and second coax between "Tee" and EXT MOD/SINAD jack (7).
3. Adjust VAR TONE Level Control (13) for a 1 Vp-p sinewave on the Oscilloscope.
4. Set VAR TONE Selector Switch (14) in "OFF" position.
5. Adjust 1 kHz TONE Level Control (16) for a 4 Vp-p sinewave on the Oscilloscope.
6. Alternately adjust SINAD Null trimpots R3318 and R3320 to obtain a null indication on the SINAD scale of the Modulation Meter (1).
7. Set VAR TONE Selector Switch (14) in "INT MOD" position.
8. Adjust SINAD Cal trimpot R3350 for a reading of 12 dB on Modulation Meter (1).
9. Set 1 kHz TONE Selector Switch (15) in "OFF" position.
10. Adjust VAR TONE Level Control (13) to produce a 0.4 Vp-p sinewave on the Oscilloscope.

STEP

PROCEDURE

11. Set 1 kHz TONE Selector Switch in "INT MOD" position and rotate Modulation Meter Selector Switch to "DIST". Modulation Meter (1) should indicate approximately 10%.
12. Repeat Steps 1 through 11, changing the null trimpots slightly each time, until approximately 10% distortion is achieved in Step 11.

4-2-8

CALIBRATION
PROCEDURE: POWER METER CALIBRATION (FM/AM-500A ONLY)

PREREQUISITES: Power Supply Calibration, Zero Meter Adjust

SPECIAL ACCESSORY
EQUIPMENT REQ'D: 1 Transmitter, 5-10 W at 150-170 MHz and
800-950 MHz
1 Transmitter, 50-100 W at 150-170 MHz and
800-950 MHz
1 Power Meter, Thru-line
2 50 Ω Coax Cables, BNC/BNC

TEST SET-UP
DIAGRAM: None

INITIAL FM/AM-500
CONTROL SETTINGS: Reference Figure 1-2

KEY	CONTROL	SETTING
4	Modulation Meter Range Switch	"15 WATTS AVG"
17	Power Switch	"LINE"
26	GEN/REC Switch	"REC"

CALIBRATION
POINTS: See Figure 4-1

STEP PROCEDURE

NOTE

If any of the following calibration procedures fails to produce the proper results, refer to Corrective Maintenance Flowchart in Section 1 for appropriate corrective action.

1. Adjust Power Zero trimpot R3354 to zero the Modulation Meter (1) on the WATTS Scale.
2. Connect 5-10 W Transmitter RF OUT jack to Power Meter IN jack with coax.
3. Connect Power Meter OUT jack to FM/AM-500A's T/R jack with coax.

STEP

PROCEDURE

4. Transmit a 150-170 MHz unmodulated CW. Note reading on Power Meter and adjust 15 W trimpot R3365 until Modulation Meter (1) WATTS Scale reading agrees with the Power Meter.
5. Read the reflected power on the Power Meter. Reflected power should be less than 5% of applied power.
6. Transmit an 800-950 MHz unmodulated CW. Power Meter and Modulation Meter (1) WATTS Scale readings should agree. Repeat Steps 4 and 6 as required, changing R3365 slightly each time, to obtain correct readings at both frequencies.
7. Rotate Modulation Meter Range Switch (4) to "150 WATTS AVG".
8. Connect 50-100 W Transmitter in place of the 5-10 W Transmitter.
9. Transmit a 150-170 MHz unmodulated CW (preferably at 50 W). Note reading on Power Meter and adjust 150 W trimpot R3362 until Modulation Meter (1) WATTS Scale reading agrees with Power Meter.

CAUTION

DO NOT EXCEED POWER LIMITATIONS OF:

100 W - 1½ minutes ON, 4 minutes OFF
50 W - 2 minutes ON, 2 minutes OFF.

10. Transmit an 800-950 MHz unmodulated CW. Power Meter and Modulation Meter (1) WATTS Scale readings should agree. Repeat Steps 9 and 10 as required, changing R3362 slightly each time, to obtain correct readings at both frequencies.

4-2-9

CALIBRATION
PROCEDURE: GENERATE OUTPUT LEVEL CALIBRATION PROCEDURE

PREREQUISITES: Power Supply Calibration

SPECIAL ACCESSORY
EQUIPMENT REQ'D: 1 Power Meter, 0.1 dB Resolution

TEST SET-UP
DIAGRAM: None

INITIAL FM/AM-500
CONTROL SETTINGS: Reference Figure 1-2

KEY	CONTROL	SETTING
9	Modulation Mode Selector	"FM NAR"
11	RF LEVEL Control	"-30 dBm"
12	RF LEVEL FINE Adjust Control	"-30 dBm"
14	VAR TONE Selector Switch	"OFF"
15	1 kHz TONE Selector Switch	"OFF"
17	Power Switch	"OFF"
24	GEN/LOCK Control	"LOCK"
25	RF FREQUENCY Thumbwheels	"120.0000" MHz
26	GEN/REC Mode Switch	"GEN"
27	VOLUME Control	Fully counterclockwise
28	SQUELCH Control	Fully counterclockwise

CALIBRATION
POINTS: See Figure 4-1

STEP PROCEDURE

NOTE

If any of the following calibration procedures fails to produce the proper results, refer to Corrective Maintenance Flowchart in Section 1 for appropriate corrective action.

1. Connect Power Meter to T/R Jack (5) on Front Panel.
2. Connect DVM to cathode of CR3313 and ground.
3. Adjust R3354 to 0.0 VDC.
4. Disconnect P5101 from Output Amplifier.
5. Connect DVM between FL5104 and ground.

STEP

PROCEDURE

6. Set Power Switch (17) in "LINE" position.
7. Adjust R5114 as required to obtain the minimum DVM reading (zero, if possible).
8. Place Power Switch (17) in "OFF" position.
9. Connect P5101 to J5101 on Output Amplifier.
10. Set Power Switch (17) in "LINE" position.
11. Rotate RF LEVEL FINE Adjust Control (12) to "-31 dBm".
12. Adjust R3224 as necessary for Power Meter to indicate -31 dBm.
13. Rotate RF LEVEL FINE Adjust Control (12) to "-42 dBm".

NOTE

Do NOT alter setting of RF LEVEL Attenuator Control (11).

14. Adjust R3246 as necessary for Power Meter to indicate -42 dBm.
15. Rotate RF LEVEL FINE Adjust Control (12) to "-37 dBm".
16. Adjust R3227 as necessary for Power Meter to indicate -37 dBm.
17. Repeat Steps 10 through 15 until the correct level is attained in all three settings.

SECTION 5 - TROUBLESHOOTING

5-1 GENERAL

This section contains tabular flowcharts designed to aid the technician in troubleshooting the FM/AM-500A. These flowcharts will enable the technician to isolate a given malfunction down to an individual module or PC board assembly. Typically, the technician will refer to the flowcharts in this section to isolate a trouble symptom which may have been detected during normal operation or while performing the Performance Evaluation Procedures in Section 3 or Calibration Procedures in Section 4.

5-1-1 HOW TO USE TABULAR FLOWCHARTS

Each of the flowcharts in this section is designed to isolate a specific trouble symptom down to a repairable/replaceable module or PC board. Once a trouble symptom has been identified, the technician should locate the proper troubleshooting flowchart and proceed, beginning with Step 1. Each step has a YES and NO block and the numbers in these blocks indicate the next step the technician must perform. The technician should continue compliance with the flowchart until the faulty module or PC board is identified, then proceed with the recommended repair/replacement procedures.

5-1-2 TROUBLESHOOTING HINTS

Before proceeding with extensive troubleshooting, it is advisable that the technician first make a few simple checks which may eliminate many of the possible causes of the malfunction. These checks may save the technician many hours of labor which might needlessly be spent on extensive troubleshooting.

A. FRONT PANEL CONTROL SETTINGS

Improper control settings on the FM/MA-500A or any associated test equipment may produce false troubleshooting symptoms.

B. VISUAL INSPECTION

Visually inspect any components within the FM/AM-500A which may have a relationship to the malfunction. In many instances, a malfunction may be caused by loose connections, broken wires, unsoldered connections, damaged components, bent connector pins, etc. Also, look for signs of excessive heat as evidenced by burned or charred components.

C. PERFORMANCE EVALUATION

Before attempting any troubleshooting, make sure all appropriate performance evaluation procedures in Section 3 have been performed. In many cases, using these procedures, a technician can isolate a trouble symptom to a particular module, thereby making any subsequent troubleshooting easier or unnecessary.

D. CALIBRATION

Make sure the FM/AM-500A is properly calibrated. One or more maladjusted calibration potentiometers may be the cause of the trouble symptom(s) and the apparent malfunction.

5-1-3 SAFETY PRECAUTIONS

As with any piece of electronic equipment, extreme caution should be taken when troubleshooting "live" circuits. Certain circuits and/or components within the FM/AM-500A contain high voltage potentials, CAPABLE OF CAUSING SERIOUS BODILY INJURY OR DEATH (see WARNINGS below)! When troubleshooting the FM/AM-500A, be sure to observe the following precautions:

WARNING

THE REAR PANEL CORCOM CONNECTOR AND POWER SUPPLY MODULE CARRIES 120 OR 240 VAC AS LONG AS POWER CORD IS CONNECTED TO THE FM/AM-500A AND EXTERNAL AC POWER SOURCE. DO NOT CONTACT THESE OR ANY ASSOCIATED COMPONENTS DURING TROUBLESHOOTING OR CALIBRATION.

REMOVE ALL JEWELRY OR OTHER COSMETIC APPAREL BEFORE PERFORMING ANY CALIBRATION PROCEDURES INVOLVING "LIVE" CIRCUITS.

WHEN WORKING WITH "LIVE" CIRCUITS OF HIGH POTENTIAL, KEEP ONE HAND IN POCKET OR BEHIND BACK, TO AVOID SERIOUS SHOCK HAZARD.

USE ONLY INSULATED TROUBLESHOOTING TOOLS WHEN WORKING WITH "LIVE" CIRCUITS.

FOR ADDED INSULATION, PLACE RUBBER BENCH MAT BENEATH ALL POWERED BENCH EQUIPMENT, AS WELL AS A RUBBER MAT UNDER THE TECHNICIAN'S CHAIR.

HEED ALL WARNINGS AND CAUTIONS CONCERNING MAXIMUM VOLTAGES AND POWER INPUTS.

CAUTION

DO NOT REMOVE OR REPLACE ANY MODULE OR COMPONENT WHILE FM/AM-500A IS POWERED!

5-1-4 TEST EQUIPMENT REQUIREMENTS

Appendix B, at the rear of this manual, contains a comprehensive list of test equipment suitable for performing any of the troubleshooting procedures in this section. Any other test equipment meeting the specifications listed in Appendix B may be substituted for recommended models.

5-1-5 DISASSEMBLY/REASSEMBLY REQUIREMENTS

To use the troubleshooting flowcharts in this section, the case must be removed from the FM/AM-500A.

Refer to Section 6 for case removal, module or PC board removal and/or module disassembly/reassembly instructions.

5-1-6 INDEX OF TROUBLESHOOTING FLOWCHARTS

Paragraph	Flowchart	Page
5-2	Troubleshooting Power Supply	5-5
5-2-1	Incorrect Output Voltages	5-5
5-2-2	Incorrect Battery Charging Rate	5-9
5-3	Troubleshooting Receiver	5-11
5-3-1	Sensitivity Low at Certain Frequencies	5-11
5-3-2	Sensitivity Low at All Frequencies	5-13
5-3-3	Improper Demodulation	5-15
5-4	Troubleshooting Generator	5-19
5-4-1	Incorrect Carrier Amplitude	5-19
5-4-2	Incorrect Carrier Frequency	5-27
5-4-3	Inadequate Response to Variable Generator Control .	5-31
5-5	Troubleshooting Phase Lock System	5-33
5-5-1	Lock Light Indicates System is Not Phase Locked ...	5-33
5-5-2	High Loop Does Not Phase Lock	5-37
5-5-3	Low Loop Does Not Phase Lock	5-41

5-2 TROUBLESHOOTING POWER SUPPLY

5-2-1

TRUBLESHOOTING
PROCEDURE: INCORRECT OUTPUT VOLTAGES

SPECIAL ACCESSORY
EQUIPMENT REQ'D: Digital Multimeter - 100 K Ω /V 3½ Digit

STEP	DIRECTIONS	DECISION	YES	NO
1.	Set Power Switch in "LINE" position.		2	
2.	Measure voltage between J5201, pin 2 (ground) and pin 9.	Is voltage +43 VDC (± 5 V)?	3	12
3.	Measure voltage between J5201, pin 2 and pin 8.	Is voltage +12 VDC (± 0.2 V)?	4	10
		NOTE		
		If voltage is not correct, do not proceed with Steps 4 through 9 until the +12 V fault is corrected.		
4.	Measure voltage between J5201, pin 2 and pin 3.	Is voltage -12 VDC (± 0.2 V)?	5	9
5.	Measure voltage between J5201, pin 2 and pin 10.	Is voltage +5 VDC (± 0.2 V)?	6	7
6.	Power Supply outputs do not test faulty.		17	
7.	Measure voltage across E5212/E5213 and across E5214/E5213.	Is each voltage approximately 8 VAC?	8	15

STEP	DIRECTIONS	DECISION	YES	NO
8.	Test the +5 V regulator circuit on Power Supply PC Board. Repair or replace as required. Refer to Power Supply paragraph in Section 7.		17	
9.	Test the -12 V regulator circuit on Power Supply PC Board. Repair or replace as required. Refer to Power Supply paragraph in Section 7.		17	
10.	Measure voltage across E5215/E5217 and E5219/E5217.	Is each voltage approximately 15 VAC?	11	12
11.	Test the +12 V regulator circuit on Power Supply PC Board. Repair or replace as required. Refer to Power Supply paragraph in Section 7.		17	
12.	Measure voltage across E5210/E5211.	Is voltage 43 VAC (± 5 V)?	13	14
13.	Test +40 V rectifier circuit on Power Supply PC Board. Repair or replace as required. Refer to Power Supply paragraph in Section 7.		17	
14.	Measure voltage across Transformer black and white leads and across the brown and yellow leads.	Is each voltage approximately 115 VAC?	15	16
15.	Replace Transformer. Refer to Rear Panel Removal and Disassembly paragraph in Section 6.		17	

STEP	DIRECTIONS	DECISION	YES	NO
16.	Trace circuitry back to power source to locate open. Repair or replace as required. Refer to Section 6 for appropriate removal and disassembly procedures.		17	
17.	End of procedure. Repeat as necessary.			

5-2-2

TROUBLESHOOTING
PROCEDURE: INCORRECT BATTERY CHARGING RATE

SPECIAL ACCESSORY
EQUIPMENT REQ'D: Battery Load Simulator - (Appendix C)
Digital Multimeter - 100 K Ω /V, 3½ Digit

STEP	DIRECTIONS	DECISION	YES	NO
1.	Set Power Switch in "OFF" position.		2	
2.	Disconnect P/J5004 and connect Battery Load Simulator to P5004.		3	
3.	With Battery Load Simulator set at 0.3 A load, use Digital Voltmeter to measure voltage at E5202/E5203.	Is voltage 14.4 VDC (± 0.1 V)?	4	8
4.	Slowly increase simulated battery load past the point of maximum current. CAUTION IN NO EVENT SHOULD THE CURRENT EXCEED 1.7 AMPS OR DAMAGE TO THE POWER SUPPLY PC BOARD MAY RESULT.	Is maximum current between 1.2 A and 1.4 A?	5	7
5.	Set Power Switch in "LINE" position.	Does current drop to between 0.7 A and 0.8 A?	6	7
6.	Replace Battery. Refer to Battery Removal paragraph in Section 6.		9	

STEP	DIRECTIONS	DECISION	YES	NO
7.	Test the battery charger current limiter circuit on the Power Supply PC Board. Repair or replace as required. Refer to Power Supply paragraph in Section 7.		9	
8.	Test the battery charger voltage regulator circuit on the Power Supply PC Board. Repair or replace as required. Refer to Power Supply paragraph in Section 7.		9	
9.	End of procedure. Repeat as necessary.			

5-3 TROUBLESHOOTING RECEIVER

5-3-1

TRUBLESHOOTING
PROCEDURE: SENSITIVITY LOW AT CERTAIN FREQUENCIES

SPECIAL ACCESSORY
EQUIPMENT REQ'D: Spectrum Analyzer - 1300 MHz to 2300 MHz

STEP	DIRECTIONS	DECISION	YES	NO
1.	Set RF FREQUENCY Thumb-wheels to a frequency with faulty sensitivity.		2	
2.	Connect Spectrum Analyzer to J2103 and set center frequency at 1300 MHz plus the RF FREQUENCY Thumb-wheel setting to observe the 1st VCO output level.	Is output level +8 dBm (± 4 dB)?	3	4
3.	Test the IF Module. Repair or replace as required. Refer to IF Module paragraph in Section 7.		5	
4.	Troubleshoot the 1st VCO in the Dual VCO Module. Refer to paragraph 5-5-2.		5	
5.	End of procedure. Repeat as necessary.			

5-3-2

TROUBLESHOOTING
PROCEDURE: SENSITIVITY LOW AT ALL FREQUENCIES

SPECIAL ACCESSORY
EQUIPMENT REQ'D: Spectrum Analyzer - 10.7 MHz to 1500 MHz
Signal Generator - 120 MHz at -30 dBm

STEP	DIRECTIONS	DECISION	YES	NO
1.	Set FM/AM-500/A Controls as follows: RF FREQUENCY Thumbwheels "120.0000" GEN/REC Switch "REC" VOLUME Control Fully ccw SQUELCH Control Fully ccw		2	
2.	Connect Spectrum Analyzer to P4302 and set center frequency at 10.7 MHz.		3	
3.	Connect Signal Generator to ANTENNA Jack and inject a 120 MHz signal at -30 dBm.	Does Spectrum Analyzer display a 10.7 MHz signal between -25 dBm and -35 dBm in amplitude?	4	5
4.	Test the Receiver/Generator Module. Repair or replace as required. Refer to Receiver/Generator Module paragraph in Section 7.		12	
5.	Connect Spectrum Analyzer to J4202.	Is 79.3 MHz signal level +7 dBm (± 4 dB)?	6	11
6.	Connect Spectrum Analyzer to J2003.	Is 1210 MHz signal level +8 dBm (± 4 dB)?	7	10
7.	Connect Spectrum Analyzer to J2103.	Is 1420 MHz signal level +8 dBm (± 4 dB)?	8	9

STEP	DIRECTIONS	DECISION	YES	NO
8.	Test IF Module. Repair or replace as required. Refer to IF Module paragraph in Section 7.		12	
9.	Test output amplifier circuit of 1st VCO in Dual VCO Module. Repair or replace as required. Refer to Dual VCO Module paragraph in Section 7.		12	
10.	Test output amplifier circuit of 2nd VCO in Dual VCO Module. Repair or replace as required. Refer to Dual VCO Module paragraph in Section 7.		12	
11.	Test output amplifier circuit of VCO in Low Loop Module. Repair or replace as required. Refer to Low Loop Synthesizer Module paragraph in Section 7.		12	
12.	End of procedure. Repeat as necessary.			

5-3-3

TROUBLESHOOTING
PROCEDURE: IMPROPER DEMODULATION

SPECIAL ACCESSORY
EQUIPMENT REQ'D: Signal Generator - 120 MHz at -50 dBm
Oscilloscope - 10 MHz Bandwidth

STEP	DIRECTIONS	DECISION	YES	NO
1.	Connect Signal Generator to ANTENNA Jack of FM/AM-500A.		2	
2.	Set FM/AM-500A controls as follows: Modulation Meter Range Switch "IG" VAR TONE Selector Switch "OFF" 1 kHz TONE Selector Switch "OFF" RF FREQUENCY Thumbwheels "120 000 0" GEN/REC Switch "REC" VOLUME Control Fully ccw SQUELCH Control Fully ccw	Which of the following conditions applies? a. Have FM but not AM demodulation? b. Have AM but not FM demodulation? c. Have no demodulation?	11 6 3	
3.	Inject a 120 MHz signal at approximately -50 dBm.	Does Modulation Meter indicate approximately mid-scale or higher?	4	5
4.	Test the Receive Audio PC Board. Repair or replace as required. Refer to Receive Audio Module paragraph in Section 7.		17	
5.	Troubleshoot Receiver Sensitivity. Refer to paragraph 5-3-1 and 5-3-2.		17	
6.	Rotate Modulation Mode Selector Switch to "FM NAR" position.		7	

STEP	DIRECTIONS	DECISION	YES	NO
7.	Inject a 120 MHz signal with 1 kHz modulation and 4 kHz deviation, at approximately -50 dBm.		8	
8.	With Oscilloscope Probe, sample the FM Audio signal at J4301, pin 17.	Does Oscilloscope display a 1 kHz audio signal?	9	10
9.	Test Receive Audio PC Board. Repair or replace as required. Refer to Receive Audio Module paragraph in Section 7.		17	
10.	Test FM demodulator circuit of Receiver/Generator Module. Repair or replace as required. Refer to Receiver/Generator Module paragraph in Section 7.		17	
11.	Rotate Modulation Mode Selector Switch to "AM NORM".		12	
12.	Inject a 120 MHz signal at approximately -50 dBm, with AM modulation of 1 kHz at 30%.		13	
13.	With Oscilloscope Probe, sample the AM audio signal at J4301, pin 19.	Is audio signal: a. Approximately 0.6 VAC p-p with approximately 1 VDC offset? b. Approximately 0 VDC and Modulation Meter approximately <u>1.</u> full scale? <u>2.</u> zero? c. Approximately 4 VDC and Modulation Meter approximately <u>1.</u> full scale? <u>2.</u> zero?	16 14 15 15 14	

STEP	DIRECTIONS	DECISION	YES	NO
14.	Test AGC circuit on Receive Audio PC Board. Repair or replace as required. Refer to Receive Audio Module paragraph in Section 7.		17	
15.	Test AGC circuit in Receiver/Generator Module. Repair or replace as required. Refer to Receiver/Generator Module paragraph in Section 7.		17	
16.	Test AM Detector circuit on Receive Audio PC Board. Repair or replace as required. Refer to Receive Audio Module paragraph in Section 7.		17	
17.	End of procedure. Repeat as necessary.			

5-4 TROUBLESHOOTING GENERATOR

5-4-1

TRUBLESHOOTING
PROCEDURE: INCORRECT CARRIER AMPLITUDE

SPECIAL ACCESSORY
EQUIPMENT REQ'D: Digital Multimeter - 100 K Ω /V, 3½ Digital
Spectrum Analyzer - 10 MHz to 1500 MHz
Signal Generator - 120 MHz at -30 dBm
Extender Cable

STEP	DIRECTIONS	DECISION	YES	NO
1.	Set FM/AM-500A Controls as follows: RF LEVEL Control "-20 dBm" RF LEVEL FINE Control Fully ccw VAR TONE Selector Switch "OFF" 1 kHz TONE Selector Switch "OFF" Power Switch "LINE" GEN/LOCK Control "LOCK" RF FREQUENCY Thumbwheels "010.0000" GEN/REC Switch "GEN"		2	
2.	Connect Spectrum Analyzer to T/R Jack and observe output level.	Is signal level: a. -20 dBm (3 dB)? b. Greater than -17 dBm? c. Less than -23 dBm? d. Non-existent?	4 1 3 3	
3.	Remove Generate Audio PC Board and measure voltage at J3201, pin 32 on Mother Board. Re-install the PC Board.	Is voltage level greater than 0 V?	4	5

STEP	DIRECTIONS	DECISION	YES	NO
4.	Using DMM, test GEN/REC Switch and associated circuitry through Mother Bd. for a short to a voltage source. Repair or replace as required. Refer to Section 6 for Mother Board and Front Panel removal and disassembly procedures.		5	
5.	Measure voltage at each of the following locations: FL5101; FL2210; J4301, pin 15; J3007, pin 16.	Is +12 V present at: a. All locations? b. Some locations? c. No location?	8 7 6	
6.	Test Generate/Receive Mode Power Circuit on Generate Audio PC Board. Repair or replace as required. Refer to Generate Audio Module paragraph in Section 7.		49	
7.	Test for an open in the Mother Board and/or wire harness for the circuit without power. Repair or replace as required. Refer to Section 6 for Mother Board removal procedures.		49	
8.	Set GEN/REC Switch in "REC" and the Modulation Mode Selector Switch in "FM NAR".		9	
9.	Connect Signal Generator to ANTENNA jack on FM/AM-500A and test receiver sensitivity. Return GEN/REC Switch to "GEN".	Is receiver sensitivity 2 μ V or less?	10	25
10.	Set Modulation Meter Range Switch in "SIG".	Is Meter deflection approximately full scale?	11	16

STEP	DIRECTIONS	DECISION	YES	NO
11.	Connect Spectrum Analyzer to J4302.	Is 10.7 MHz signal level less than -10 dBm?	12	16
12.	Test Receiver/Generator Module. Repair or replace as required. Refer to Receiver/Generator Module paragraph in Section 7.		49	
13.	Connect Spectrum Analyzer to P5101.	Is 10 MHz signal level less than -25 dBm?	14	15
14.	Test IF Module. Repair or replace as required. Refer to IF Module paragraph in Section 7.		49	
15.	Test amplifier circuit of Output Amplifier. Repair or replace as required. Refer to Output Amplifier Module paragraph in Section 7.		49	
16.	Measure voltage at FL5104.	Is voltage less than .3 V?	17	20
17.	Measure voltage at J4301, pin 1.	Is voltage greater than 8 V?	18	19
18.	Test Receiver/Generator. Repair or replace as required. Refer to Receiver/Generator paragraph in Section 7.		49	
19.	Test AM Modulator/Leveler circuit on Generate Audio PC Board and RF LEVEL FINE Adjust Control on Front Panel. Repair or replace as required. Refer to Generate Audio Module paragraph in Section 7.		49	

STEP	DIRECTIONS	DECISION	YES	NO
20.	Connect Spectrum Analyzer to J5103.	Is 10 MHz signal level approximately 0 dBm?	21	24
21.	Connect Spectrum Analyzer to P5102.	Is 10 MHz signal level approximately 0 dBm?	22	23
22.	Test terminator pad in Output Amplifier. Repair or replace as required. Refer to Output Amplifier Module paragraph in Section 7.		49	
23.	Replace Step Attenuator. Refer to Section 6 for Front Panel removal and reassembly procedures.		49	
24.	Test amplifier circuit of Output Amplifier. Repair or replace as required. Refer to Output Amplifier Module paragraph in Section 7.		49	
25.	Connect Spectrum Analyzer to J4302.	Is signal frequency 10.7 MHz?	26	33
26.		Is signal level greater than -10 dBm?	27	17
27.	Connect Spectrum Analyzer to J4202.	Is 79.8 MHz signal level +7 dBm (± 4 dB)?	27	31
28.	Connect Spectrum Analyzer to J2003.	Is 1210 MHz signal level +8 dBm (± 4 dB)?	28	30
29.	Connect Spectrum Analyzer to J2002.	Is 1310 MHz signal level +8 dBm (± 4 dB)?	29	30

STEP	DIRECTIONS	DECISION	YES	NO
30.	Test IF Module. Repair or replace as required. Refer to IF Module paragraph in Section 7.		49	
31.	Troubleshoot High Loop and Dual VCO Modules. Refer to paragraph 5-5-2.		49	
32.	Troubleshoot Low Loop Module. Refer to paragraph 5-5-3.		49	
33.	Test Phase Lock Circuit of Digital Module. Repair or replace as required. Refer to Digital Module paragraph in Section 7.		49	
34.	Measure voltage at FL5104.	Is voltage negative or less than +.2 V?	35	36
35.	Test Level Detector Circuit of Output Amplifier. Repair or replace as required. Refer to Output Amplifier Module paragraph in Section 7.		49	
36.	Measure voltage at J3002, pin 33.	Is voltage greater than +1 V?	37	38
37.	Test AM Modulator/Leveler circuit on Generate Audio PC Board and RF LEVEL FINE Adjust Control on Front Panel. Repair or replace as required. Refer to Generate Audio Module paragraph in Section 7.		49	
38.	Measure voltage at J4301, pin 1.	Is voltage greater than 8 V?	39	40

STEP	DIRECTIONS	DECISION	YES	NO
39.	Test AM Modulator/Leveler circuit on Generate Audio PC Board. Repair or replace as required. Refer to Generate Audio Module paragraph in Section 7.		49	
40.	Test Attenuator circuit in Receiver/Generator Module. Repair or replace as required. Refer to Receiver/Generator Module paragraph in Section 7.		49	
41.	Rotate RF LEVEL Step Attenuator cw and observe signal level at each detent. Return attenuator to -20 dBm.	Does signal level at each detent equal the attenuator marking ± 3 dB?	42	46
42.	Slowly rotate RF LEVEL FINE Adjust Control fully cw, then fully ccw while observing output level on Spectrum Analyzer.	Does level follow the dial, then return to its beginning level in direct relationship to the control movement?	43	44
43.	This test indicates proper level of the carrier generator system.		49	
44.	Calibrate the RF LEVEL FINE Adjust Control in accordance with Generate Output Level Calibration Procedure in Section 4.	Was calibration procedure successful?	43	45
45.	Test RF LEVEL FINE Adjust Control on Front Panel and AM Modulator/Leveler Circuit on Generate Audio PC Board. Repair or replace as required. Refer to Generate Audio Module paragraph in Section 7.		49	

STEP	DIRECTIONS	DECISION	YES	NO
46.	Connect Spectrum Analyzer to P5102. Rotate Step Attenuator cw and observe signal level at each detent. Return attenuator to -20 dBm.	At each detent, is signal level 20 dB (± 3 dB) above the attenuator marking?	47	48
47.	Test the Output Amplifier for RF leakage. Repair or replace as required. Refer to Output Amplifier Module in Section 7.		49	
48.	Replace RF LEVEL Step Attenuator. Refer to Section 6 for removal and installation procedures.		49	
49.	End of procedure. Repeat as necessary.			

5-4-2

TROUBLESHOOTING
PROCEDURE: INCORRECT CARRIER FREQUENCY

SPECIAL ACCESSORY
EQUIPMENT REQ'D: Digital Multimeter - 100 K Ω /V, 3½ Digit
Frequency Counter - 10 MHz to 1000 MHz with
10 Hz Resolution

STEP	DIRECTIONS	DECISION	YES	NO
1.	Set FM/AM-500A Controls as follows: RF LEVEL Control "-20 dBm" RF LEVEL FINE Control Fully ccw VAR TONE Selector Switch "OFF" 1 kHz TONE Selector Switch "OFF" Power Switch "LINE" GEN/LOCK Control "LOCK" RF FREQUENCY Thumbwheels "010.0000" GEN/REC Switch "GEN"		2	
2.	Connect Frequency Counter to EXT STD Jack on Rear Panel.		3	
3.	Calibrate FM/AM-500A Frequency standard to Frequency Counter. Refer to Section 4.		4	
4.	Connect Frequency Counter to T/R Jack.	Is frequency 10 MHz?	5	10

STEP	DIRECTIONS	DECISION	YES	NO
5.	Rotate RF FREQUENCY Thumb-wheels to the following frequencies and observe Frequency Counter: 011.1111 011.2222 011.3333 011.4444 011.5555 011.6666 011.7777 011.8888 011.9999 010.0000	Are frequencies correct?	6	9
6.	Rotate RF FREQUENCY Thumb-wheels to 001 MHz, then in 10 MHz increments, from 010 MHz through 990 MHz, and finally to 999 MHz. Observe Frequency Counter at each increment.	Are all frequencies correct?	7	8
7.	Carrier frequencies do not test faulty.		19	
8.	Troubleshoot High Loop and Dual VCO. Refer to paragraph 5-5-2.		19	
9.	Troubleshoot Low Loop. Refer to paragraph 5-5-3.		19	
10.	Connect Frequency Counter to J4302.	Is frequency 10.7 MHz?	11	12
11.	Reconnect P/J4302 and connect Frequency Counter to T/R Jack.		5	
12.	Measure voltage at J4301, pin 16.	Is voltage 0 V?	13	18

STEP	DIRECTIONS	DECISION	YES	NO
13.	Smoothly rotate GEN/LOCK Control fully ccw and observe Frequency Counter for appropriate change.	Does frequency respond to GEN/LOCK Control movement?	14	15
14.	Test Timebase Divider Circuit of Digital Module. Repair or replace as required. Refer to Digital Module paragraph in Section 7.		19	
15.	Measure voltage at J4301, pin 18 while rotating GEN/LOCK Control.	Does voltage vary directly with rotation of control?	16	17
16.	Test VCO Circuit in Receiver/Generator. Repair or replace as required. Refer to Receiver/Generator Module paragraph in Section 7.		19	
17.	Test GEN/LOCK Control Circuit and Timebase Divider Circuit in Digital Module. Repair or replace as required. Refer to Digital Module paragraph in Section 7.		19	
18.	Test FM Modulation Circuit on Generate Audio PC Board. Repair or replace as required. Refer to Generate Audio Module paragraph in Section 7.		19	
19.	End of procedure. Repeat as required.			

5-4-3

TROUBLESHOOTING
 PROCEDURE: INADEQUATE RESPONSE TO VARIABLE GENERATOR
 CONTROL

SPECIAL ACCESSORY
 EQUIPMENT REQ'D: Digital Multimeter - 100 K Ω /V, 3½ Digit

STEP	DIRECTIONS	DECISION	YES	NO
1.	Rotate GEN/LOCK Control cw out of detent and set Power Switch in "LINE" position.		2	
2.	Measure voltage at J4501, pin 3.	Is voltage greater than +3.5 VDC (nominally +5 VDC)?	3	6
3.	Measure voltage at J4501, pin 4, while rotating GEN/LOCK Control from full ccw (short of detent) to full cw.	Does voltage vary with control rotation from approximately 0 VDC to approximately +12 VDC?	4	5
4.	Test VCO tuning voltage select circuit in Digital Module. Repair or replace as required. Refer to Digital Module paragraph in Section 7.		9	
5.	Measure voltage at J3002, pin 38, while rotating GEN/LOCK Control from fully cw to fully ccw just short of detent.	Does voltage vary with control rotation from approximately +12 VDC to approximately 0 VDC?	7	8
6.	Measure voltage at J3002, pin 37.	Is voltage greater than +3.5 VDC (nominally +5 VDC)?	7	8
7.	Test Mother Board and Wire Harness. Repair or replace as required. Refer to Section 6 for Mother Board removal procedures.		9	

STEP	DIRECTIONS	DECISION	YES	NO
8.	Test GEN/LOCK Control on Front Panel. Repair or replace as required. Refer to Section 6 for Front Panel removal and disassembly.		9	
9.	End of procedure. Repeat as necessary.			

5-5 TROUBLESHOOTING PHASE LOCK SYSTEM

5-5-1

TRUBLESHOOTING
PROCEDURE: LOCK LIGHT INDICATOR SYSTEM IS NOT PHASE LOCKED

SPECIAL ACCESSORY
EQUIPMENT REQ'D: Digital Multimeter - 100 K Ω /V, 3½ Digit
Extender Cable

STEP	DIRECTIONS	DECISION	YES	NO
1.	With GEN/LOCK Control in "LOCK" detent and RF FREQUENCY Thumbwheels set for 999.9999 MHz, set Power Switch in "LINE" position and observe Phase Lock Indicator Light on Front Panel.	Is illumination: a. Out? b. Steady? c. Flashing?	18 11 2	
2.	Observe Phase Lock Indicator lights on High Loop and Low Loop Modules.	Which condition exists: a. High Loop only is illuminated? b. Low Loop only is illuminated? c. Both are illuminated? d. Neither is illuminated?	10 9 6 3	
3.	Measure voltages at J4102, pin 4 and J4201, pin 8.	Are both voltages approximately +11 VDC?	4	5
4.	Test Phase Lock Indicator Circuit on Generate Audio PC Board. Repair or replace as required. Refer to Generate Audio Module paragraph in Section 7.		25	
5.	Troubleshoot module(s) with low voltage. Refer to paragraphs 5-5-2 and 5-5-3.		25	

STEP	DIRECTIONS	DECISION	YES	NO
6.	Set 1 kHz TONE Selector Switch in "SPKR" position and rotate 1 kHz TONE Level Control cw as required for audible tone.	Is 1 kHz fixed tone audible?	7	8
7.	Troubleshoot High Loop and Low Loop Systems separately. Refer to paragraphs 5-5-2 and 5-5-3.		25	
8.	Test Frequency Standard. Repair or replace as required. Refer to Frequency Standard Module paragraph in Section 7.		25	
9.	Troubleshoot Low Loop. Refer to paragraph 5-5-3.		25	
10.	Troubleshoot High Loop and Dual VCO. Refer to paragraph 5-5-2.		25	
11.	Rotate 100 MHz Thumbwheel quickly from 9 through 0 to 1.	Does light now flash regularly?	12	15
12.	Rotate 100 MHz Thumbwheel to 2, then back to 1.	Is light now steady?	13	14
13.	Test 200 MHz limit circuit in High Loop. Repair or replace as required. Refer to High Loop Synthesizer Module paragraph in Section 7.		25	
14.	Test Phase Lock in High Loop. Repair or replace as required. Refer to High Loop Synthesizer Module paragraph in Section 7.		25	

STEP	DIRECTIONS	DECISION	YES	NO
15.	Allow set to fully warm up.	Does Lock Light flash when set is hot?	16	17
16.	Test High Loop Divider Circuit under high temperature conditions. Repair or replace as required. Refer to High Loop Synthesizer Module paragraph in Section 7.		25	
17.	Test Phase Lock Circuit in High Loop. Repair or replace as required. Refer to High Loop Synthesizer Module paragraph in Section 7.		25	
18.	Measure voltage at junction of Phase Lock Indicator LED lead and green wire.	Is voltage +5 V (± 0.2 V)?	19	22
19.	Turn Power Switch to "OFF" and test continuity between junction of LED lead and J5201, pin 2 (ground).	Is circuit open?	20	21
20.	Test Wire Harness and Mother Board. Repair or replace as required. Refer to Section 6 for Mother Board removal procedure.		25	
21.	Replace LED. Refer to Front Panel Disassembly paragraph in Section 6 for LED removal procedure.		25	
22.	Install Generate Audio PC Board on extender and measure voltage at J3201, pin 9.	Is voltage +5 V (± 0.2 V)?	23	24

STEP	DIRECTIONS	DECISION	YES	NO
23.	Test Wire Harness and Mother Board. Repair or replace as required. Refer to Section 6 for Mother Board removal procedure.		25	
24.	Test Phase Lock Indicator Circuit on Generate Audio PC Board. Repair or replace as required. Refer to Generate Audio Module paragraph in Section 7.		25	
25.	End of procedure. Repeat as required.			

5-5-2

TROUBLESHOOTING

PROCEDURE: HIGH LOOP DOES NOT PHASE LOCK

SPECIAL ACCESSORY

EQUIPMENT REQ'D: Digital Multimeter - 100 K Ω /V, 3½ Digit
 Spectrum Analyzer - 90 MHz to 2300 MHz
 Frequency Counter - 10 MHz to 1000 MHz with
 10 Hz Resolution
 Power Supply - 0-40 VDC

STEP	DIRECTIONS	DECISION	YES	NO
1.	Select 999 MHz on RF FREQUENCY Thumbwheels and observe Phase Lock Light on High Loop.	Is light illuminated on High Loop Module?	2	25
2.	Connect Frequency Counter to P4001 and read Frequency. Reconnect P/J4001.	Is 500 kHz reference frequency available?	3	21
3.	Connect Spectrum Analyzer to P4101.			
4.	Connect 0-40 VDC Power Supply to P4003.			
5.	Smoothly vary voltage between 0 and 40 V and observe frequency response on Spectrum Analyzer.	Does Dual VCO mixed output vary smoothly from less than 90 MHz to more than 1088 MHz at approximately -30 to -35 dBm?	6	20
6.	Reconnect P/J4003. Connect Spectrum Analyzer to P2205 and DVM to P2101.			
7.	Again, smoothly vary voltage between 0 and 40 V. Observe frequency response on Spectrum Analyzer and voltage response on DVM.	Does frequency vary smoothly from less than 1300 MHz to more than 2298 MHz at +8 dBm (± 4 dB)?	8	19

STEP	DIRECTIONS	DECISION	YES	NO
8.		Does voltage vary smoothly and correspond with voltage from variable Power Supply?	9	18
9.	Connect P/J2101 and connect Frequency Counter to P2205.			
10.	Step RF FREQUENCY Thumbwheels from "000" MHz through "999" MHz in 10 MHz increments and observe Frequency Counter.	Does frequency begin at 1300 MHz and increase in 10 MHz increments throughout its range to 2298 MHz corresponding to thumbwheel steps?	11	14
11.	Connect Spectrum Analyzer to P2207.	Is 1210 MHz signal level +8 dBm (± 4 dB)?	12	13
12.	High Loop and Dual VCO do not test faulty.		27	
13.	Test amplifier in second VCO. Repair or replace as required. Refer to Dual VCO Module paragraph in Section 7.		27	
14.	Set RF FREQUENCY Thumbwheels at "111" MHz and measure voltages at J4101, pins 1, 3, 5, 7, 9, 13, 17, 19 and 20.	Are all voltages approximately +11 V?	15	17
15.	Rotate RF FREQUENCY Thumbwheels to "222" MHz and measure voltages at J4101, pins 11 and 15.	Are both voltages approximately +11 V?	16	17
16.	Test Thumbwheel Switches. Repair or replace as required. Refer to High Loop Synthesizer Module paragraph in Section 7.		26	

STEP	DIRECTIONS	DECISION	YES	NO
17.	Test frequency select network of High Loop. Repair or replace as required. Refer to High Loop Synthesizer Module paragraph in Section 7.		26	
18.	Test High Loop Module. Repair or replace as required. Refer to High Loop Synthesizer Module paragraph in Section 7.		27	
19.	Test amplifier of 1st VCO. Repair or replace as required. Refer to Dual VCO Module paragraph in Section 7.		27	
20.	Test Dual VCO Module. Repair or replace as required. Refer to Dual VCO Module paragraph in Section 7.		27	
21.	Set 1 kHz TONE Selector Switch in "SPEAKER" position and rotate Level Control cw until tone is audible.	Does 1 kHz tone become audible?	22	23
22.	Test divider circuit of Frequency Standard. Repair or replace as required. Refer to Frequency Standard Module paragraph Section 7.		27	
23.	Connect Frequency Counter to EXT STD Jack on Rear Panel.	Is 10 MHz frequency available at EXT STD Jack?	22	24

STEP	DIRECTIONS	DECISION	YES	NO
24.	Test TCX0 Circuit on Frequency Standard PC Board (or oven oscillator if installed). Repair or replace as required. Refer to Frequency Standard Module paragraph in Section 7.		27	
25.	Disconnect P/J4001. Observe light on High Loop Module, then reconnect P/J4001.	Does light illuminate with P/J4001 disconnected?	2	26
26.	Test Phase Lock and Phase Lock Indicator circuit on High Loop. Repair or replace as required. Refer to High Loop Synthesizer Module paragraph in Section 7.		27	
27.	End of procedure. Repeat as required.			

5-5-3

TROUBLESHOOTING
PROCEDURE: LOW LOOP DOES NOT PHASE LOCK

SPECIAL ACCESSORY
EQUIPMENT REQ'D: Digital Multimeter - 100 K Ω /V, 3½ Digit
Frequency Counter - 100 Hz to 80 MHz with 1 Hz Resolution

STEP	DIRECTIONS	DECISION	YES	NO																				
1.	Select "0.0000" MHz on RF FREQUENCY Thumbwheels (settings of 100 and 10 MHz thumbwheels are irrelevant).	Is light illuminated on Low Loop Module?	2	16																				
2.	Connect Frequency Counter to J4201, pin 6.	Is 100 Hz reference frequency available?	3	11																				
3.	Connect Frequency Counter to J4202 and observe frequency.	Is Frequency 79.3 MHz?	4	9																				
4.	Rotate RF FREQUENCY Thumbwheels through the following positions and observe for corresponding frequencies at J4202:	Are all frequencies correct?	5	6																				
	<table border="0"> <thead> <tr> <th>THUMBWHEEL (MHz)</th> <th>FREQUENCY (MHz)</th> </tr> </thead> <tbody> <tr><td>1.1111</td><td>78.1889</td></tr> <tr><td>2.2222</td><td>79.0778</td></tr> <tr><td>3.3333</td><td>77.9667</td></tr> <tr><td>4.4444</td><td>78.8556</td></tr> <tr><td>5.5555</td><td>77.7445</td></tr> <tr><td>6.6666</td><td>78.6334</td></tr> <tr><td>7.7777</td><td>77.5223</td></tr> <tr><td>8.8888</td><td>78.4112</td></tr> <tr><td>9.9999</td><td>77.3331</td></tr> </tbody> </table>	THUMBWHEEL (MHz)	FREQUENCY (MHz)	1.1111	78.1889	2.2222	79.0778	3.3333	77.9667	4.4444	78.8556	5.5555	77.7445	6.6666	78.6334	7.7777	77.5223	8.8888	78.4112	9.9999	77.3331			
THUMBWHEEL (MHz)	FREQUENCY (MHz)																							
1.1111	78.1889																							
2.2222	79.0778																							
3.3333	77.9667																							
4.4444	78.8556																							
5.5555	77.7445																							
6.6666	78.6334																							
7.7777	77.5223																							
8.8888	78.4112																							
9.9999	77.3331																							

STEP	DIRECTIONS	DECISION	YES	NO
5.	Test Phase Lock Indicator Circuit in Low Loop. Repair or replace as required. Refer to Low Loop Synthesizer Module paragraph in Section 7.		18	
6.	Rotate RF FREQUENCY Thumbwheels to "1.1111" MHz and measure voltages at J4201, pins 2, 3, 4, 5, 9, 11, 13, 15, 17, 21, 25 and 26.	Are all voltages approximately +11 V?	7	9
7.	Rotate RF FREQUENCY Thumbwheels to "2.2222" MHz and measure voltages at J4201, pins 1, 7, 19, 23 and 24.	Are all voltages approximately +11 V?	8	9
8.	Test Thumbwheel Switches. Repair or replace as required. Refer to RF Frequency Thumbwheels BCD Logic Table in Section 6.		18	
9.	Test frequency select network of Low Loop. Repair or replace as required. Refer to Low Loop Synthesizer Module paragraph in Section 7.		18	
10.	Test Low Loop Module. Repair or replace as required. Refer to Low Loop Synthesizer Module paragraph in Section 7.		18	
11.	Connect Frequency Counter to P4503.	Is Frequency 1 MHz?	11	13

STEP	DIRECTIONS	DECISION	YES	NO
12.	Test Time Base Divider Circuit on Digital Module. Repair or replace as required. Refer to Digital Module paragraph in Section 7.		18	
13.	Connect Frequency Counter to EXT STD Jack on Rear Panel.	Is Frequency 10 MHz?	14	15
14.	Test divider circuit on Frequency Standard. Repair or replace as required. Refer to Frequency Standard Module paragraph in Section 7.		18	
15.	Test TCXO circuit on Frequency Standard PC Board (and oven oscillator if installed). Repair or replace as required. Refer to Frequency Standard Module paragraph in Section 7.		18	
16.	Disconnect P/J4503. Observe light on Low Loop Module, then reconnect P/J4503.	With P/J4503 disconnected, is light illuminated?	17	2
17.	Test Phase Lock and Phase Lock Indicator Circuits on Low Loop. Repair or replace as required. Refer to Low Loop Synthesizer Module paragraph in Section 7.		18	
18.	End of procedure. Repeat as required.			

SECTION 6 - DISASSEMBLY/REASSEMBLY PROCEDURES

6-1 DISASSEMBLY/REASSEMBLY PROCEDURES

6-1-1 GENERAL

This section contains instructions that are necessary to remove and disassemble modules within the FM/AM-500A. Case removal (para. 6-2-1) is a prerequisite for all module removals. Most module removals are reflected in Figure 6-2, Composite Disassembly. However, due to the complexity of the composite, further details of module disassembly are shown on individual disassembly drawings for specific modules.

Reassembly of modules is in the reverse sequence of removal and disassembly procedures. The only specific reassembly instruction is for the RF LEVEL attenuators. To assist in locating, routing and connecting coaxial cables, refer to Coaxial Cable Interconnect drawing in Section 10.

6-1-2 PRELIMINARY CONSIDERATIONS

A. Tools required for Disassembly/Reassembly

- | | |
|--------------------------------------|---------------------------------|
| 1. #1 & #2 Phillips Screwdrivers | 5. .050 Allen Wrench |
| 2. 3/16" Spade (Slotted) Screwdriver | 6. Digital Ohmmeter |
| 3. 1/4" and 5/16" Open End Wrenches | 7. Soldering Iron |
| 4. 1/4", 5/16" & 3/8" Nut Drivers | 8. Brass Shimstock (Appendix C) |

CAUTION

TAG EACH WIRE AND CABLE PRIOR TO REMOVAL.

BE SURE ALL COAX CONNECTORS ARE PROPERLY MATED.

DO NOT BEND NOR TWIST SEMI-RIGID COAX CABLES.

ALL RIBBON CABLES MUST LIE FLAT AND BE NEATLY FOLDED.

DO NOT PLACE UNDUE STRAIN ON ANY WIRE OR CABLE.

DO NOT DISCARD LOOSE ITEMS (NUTS, SCREWS, WASHERS, ETC).

6-1-3 INDEX OF MODULE DISASSEMBLY AND REASSEMBLY PROCEDURES

Paragraph	Title	Page
6-2	Disassembly	6-3
6-2-1	Case	6-3
6-2-2	Battery	6-5
6-2-3	Oven Oscillator	6-5
6-2-4	Frequency Standard	6-5
6-2-5	Power Supply	6-5
6-2-6	1100 MHz Low Pass Filter	6-6
6-2-7	Speaker	6-6
6-2-8	Mother Board	6-6
6-2-9	Audio PC Boards	6-7
6-2-10	Enclosed Modules	6-9
6-2-11	Output Amplifier	6-11
6-2-12	IF Module	6-13
6-2-13	Dual VCO	6-15
6-2-14	Rear Panel	6-16
6-2-15	Front Panel	6-19
6-2-16	Generate Amplifier	6-25
6-3	Reassembly	6-26
6-3-1	RF Level Attenuator	6-26

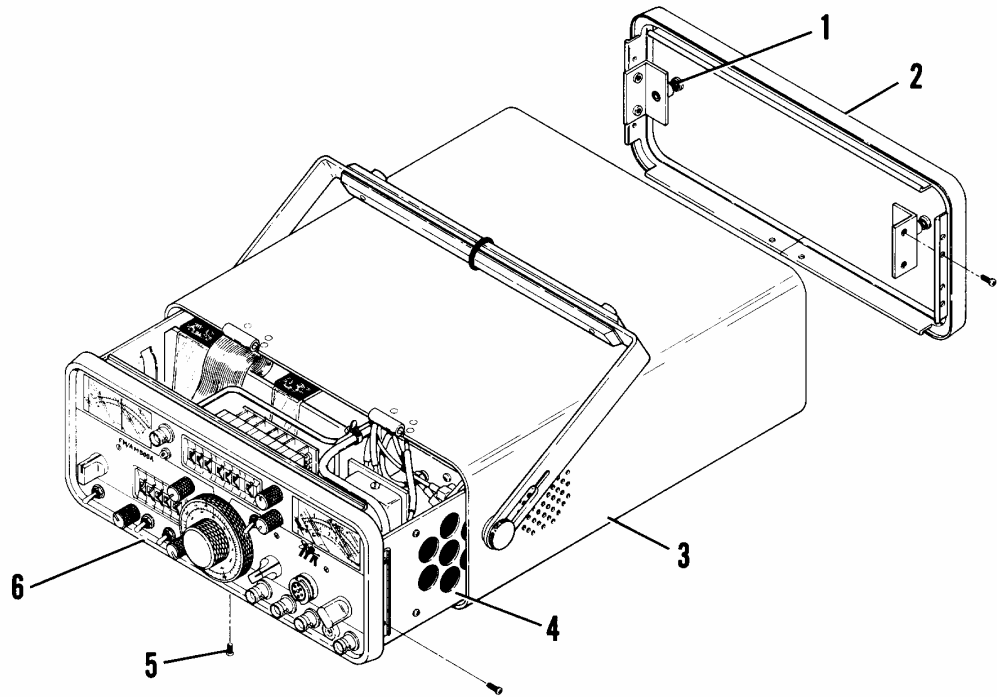

Figure 6-1 FM/AM-500A Case Removal

6-2 REMOVAL AND DISASSEMBLY

6-2-1 CASE

A. Removal (Figure 6-1)

1. Loosen two captive screws (1) on rear escutcheon (2) and remove escutcheon.
2. Carefully slide chassis (4) out of case (3).

NOTE

During installation, case must engage in groove in front and rear escutcheons.

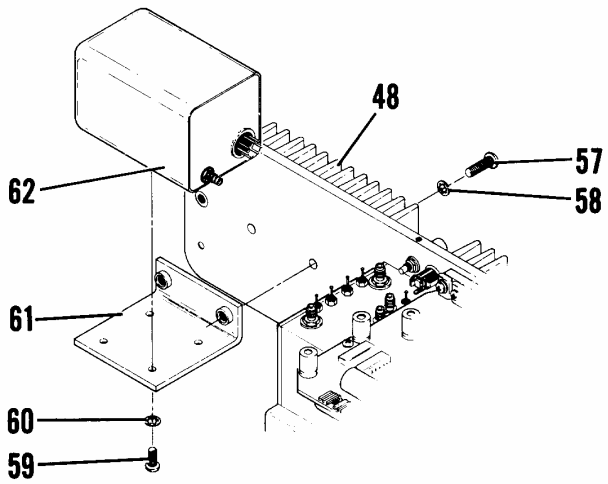

DETAIL **A**

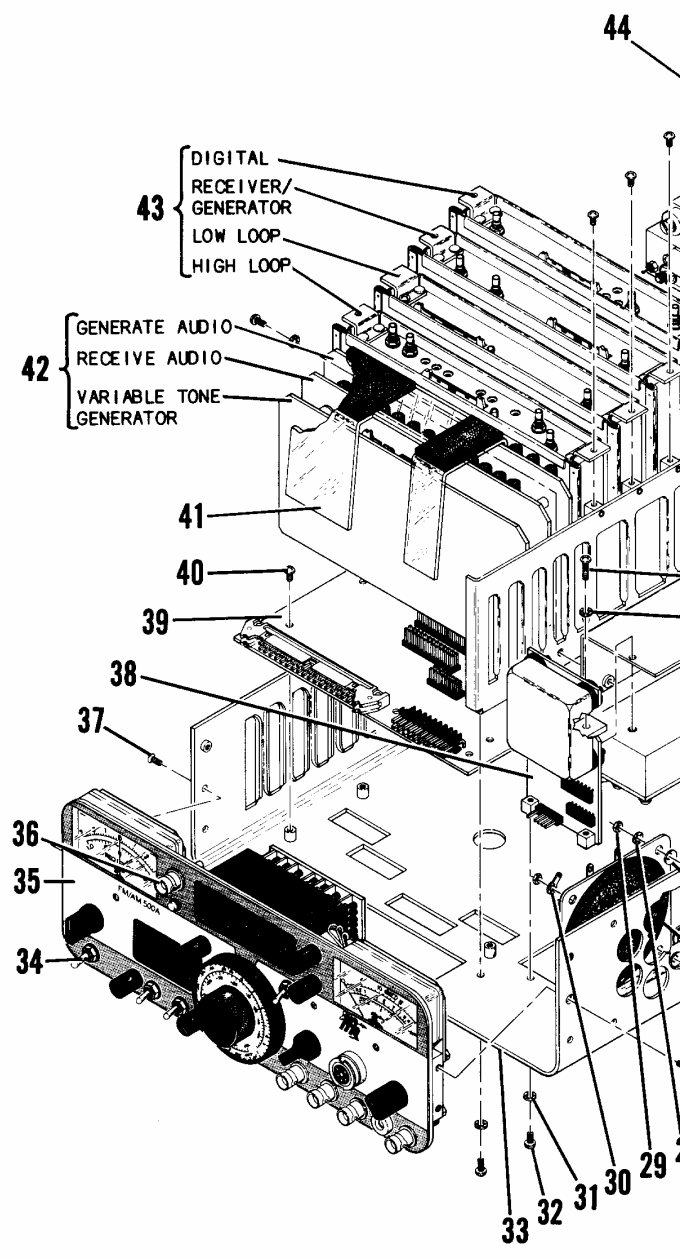

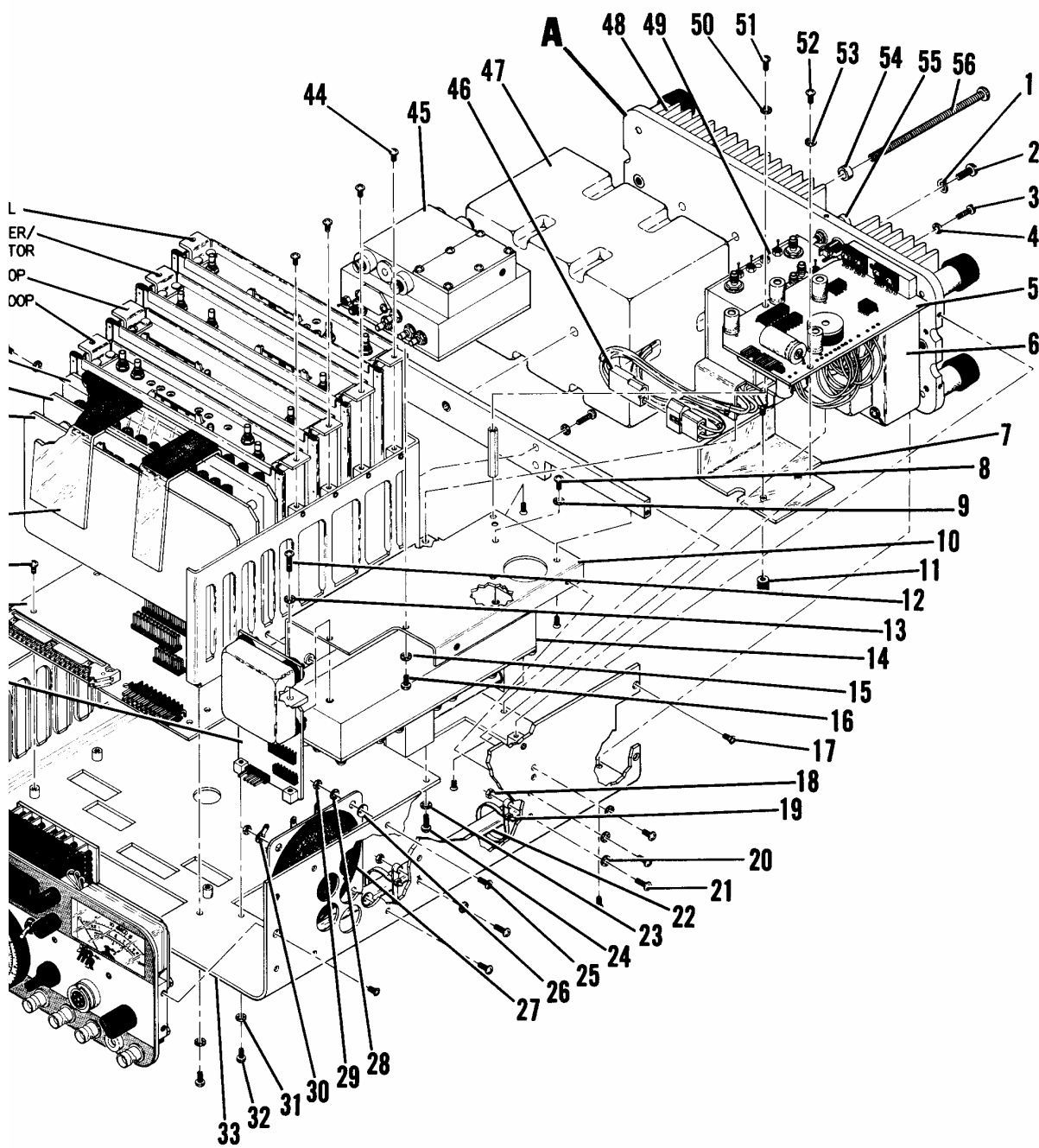

Figure 6-2 FM/AM-500A Composite Assembly

6-2-2 BATTERY (47) (OPTIONAL)

A. Removal (Figure 6-2)

CAUTION

ALL EXTERNAL POWER CORDS MUST BE DISCONNECTED
BEFORE REMOVING THE BATTERY.

1. Disengage battery wire harness connector (46).
2. On some FM/AM-500 only, remove two screws (56) and spacers (54) through Rear Panel (48) and Battery (47).
3. Lift Battery (47) from compartment.

6-2-3 OVEN OSCILLATOR (62) (OPTIONAL)

A. Removal (Figure 6-2, Detail A)

1. Disconnect Wire Harness Connector and coax connector from oven oscillator (62).
2. On test sets which have the oscillator (62) mounted on a bracket (61), remove two screws (57) and lock washers (58), withdraw the oscillator and bracket from the compartment, then remove four screws (59) and lock washers (60).
3. On test sets which have the oscillator (62) mounted directly on the chassis (33), remove four screws (59) and lock washers (60), then remove the oscillator.

6-2-4 FREQUENCY STANDARD PC BOARD (38)

A. Removal (Figure 6-2)

1. Remove two screws (32) and lock washers (31) attaching PC board assembly (38) to bottom of chassis (33).
2. Remove screw (12) and lock washer (13) attaching PC board assembly (38) to inner mounting bracket (10).
3. Withdraw PC board assembly (38) from chassis (33) and disengage wire harness plug from PC board.
4. Three flexible coax cables are permanently attached to the Frequency Standard (38). Disconnect these from High Loop Synthesizer and Digital Modules (43), and the External Standard jack (55).

6-2-5 POWER SUPPLY PC BOARD (5)

A. Removal (Figure 6-2)

1. Remove screw (3) and lock washer (4) attaching PC board assembly (5) to Rear Panel (48).
2. Remove two screws (51 and 52) and lock washers (50 and 53) attaching PC board assembly (5) to chassis (33).
3. Disengage wire harness connector from PC board (5).
4. Tag and unsolder all wires from transformer (6), fuseholder (Figure 6-7, Item 25) and switch (Figure 6-7, Item 20) attached to PC board assembly (5).

6-2-6 1120 MHz LOW PASS FILTER (22)

A. Removal (Figure 6-2)

1. Remove Dual VCO (14) (paragraph 6-2-13).
2. Remove screw (21), lock washer (20) and nut (18) attaching wire tie(s) (19) mounting Filter (22) to chassis (33).
3. Disconnect flexible coax cables from each end of Filter (22) and withdraw filter from chassis (33).

6-2-7 SPEAKER (27)

A. Removal (Figure 6-2)

1. Remove Dual VCO (14) (paragraph 6-2-13).
2. Remove 1120 MHz Low Pass Filter (22) (paragraph 6-2-6).
3. Tag and unsolder wires from two terminals on Speaker (27).
4. Remove four nuts (29), three lock washers (28), one terminal lug (30), four compression washers (26) and four screws (25) attaching Speaker (27) to chassis (33). Lift Speaker from chassis.

6-2-8 MOTHER BOARD (39) (Figure 6-2)

1. Remove Audio PC boards (42) (paragraph 6-2-9).
2. Remove Enclosed Modules (43) (paragraph 6-2-10).
3. Remove Front Panel (35) (paragraph 6-2-15).
4. Tag and unsolder wires in wire harness (not ribbon cables) from Mother Board (39).
5. Remove four screws (40) attaching Mother Board (39) to chassis (33).

6-2-9 AUDIO PC BOARDS (42)

A. Removal (Figure 6-2)

1. Disconnect ribbon cable connector from Variable Tone Generator PC Board (42).
2. Lift PC Board Retainer (41) from over the PC boards.
3. Pull straight up on PC board (42) to disengage connector from Mother Board (39) and lift from chassis (33).

NOTE

Sheet metal of chassis is formed into PC board guides.

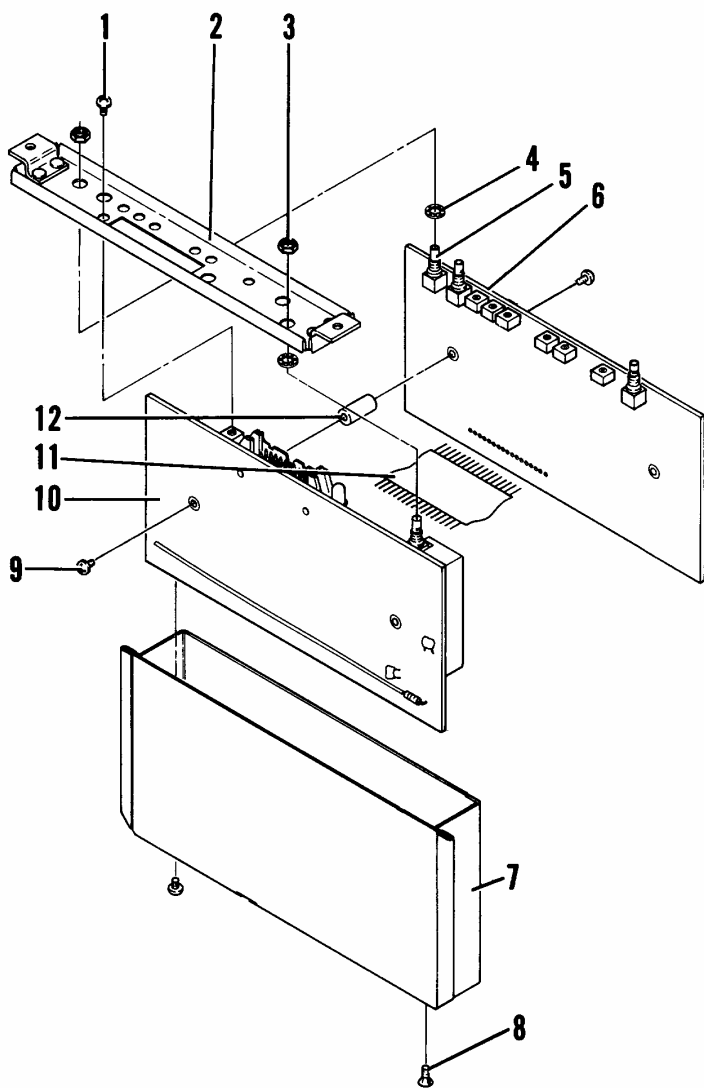

HIGH LOOP SYNTHESIZER

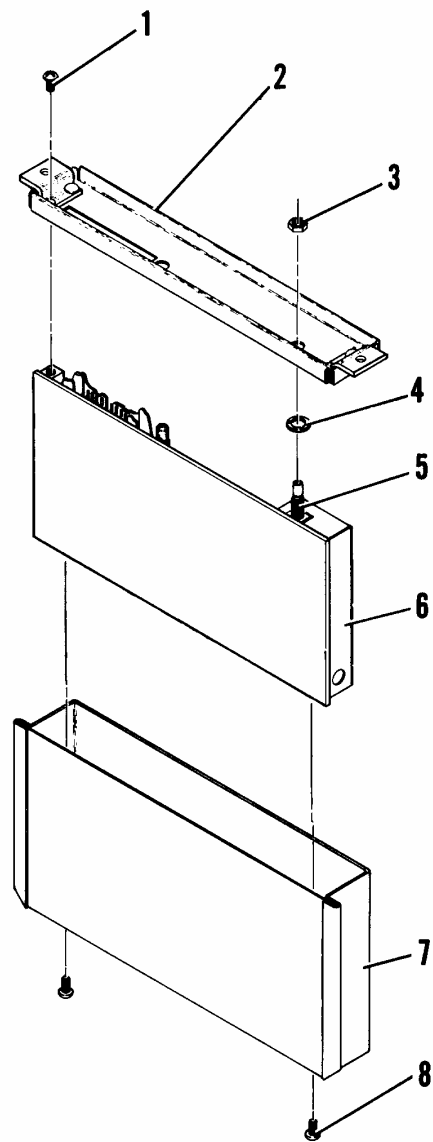

LOW LOOP SYNTHESIZER

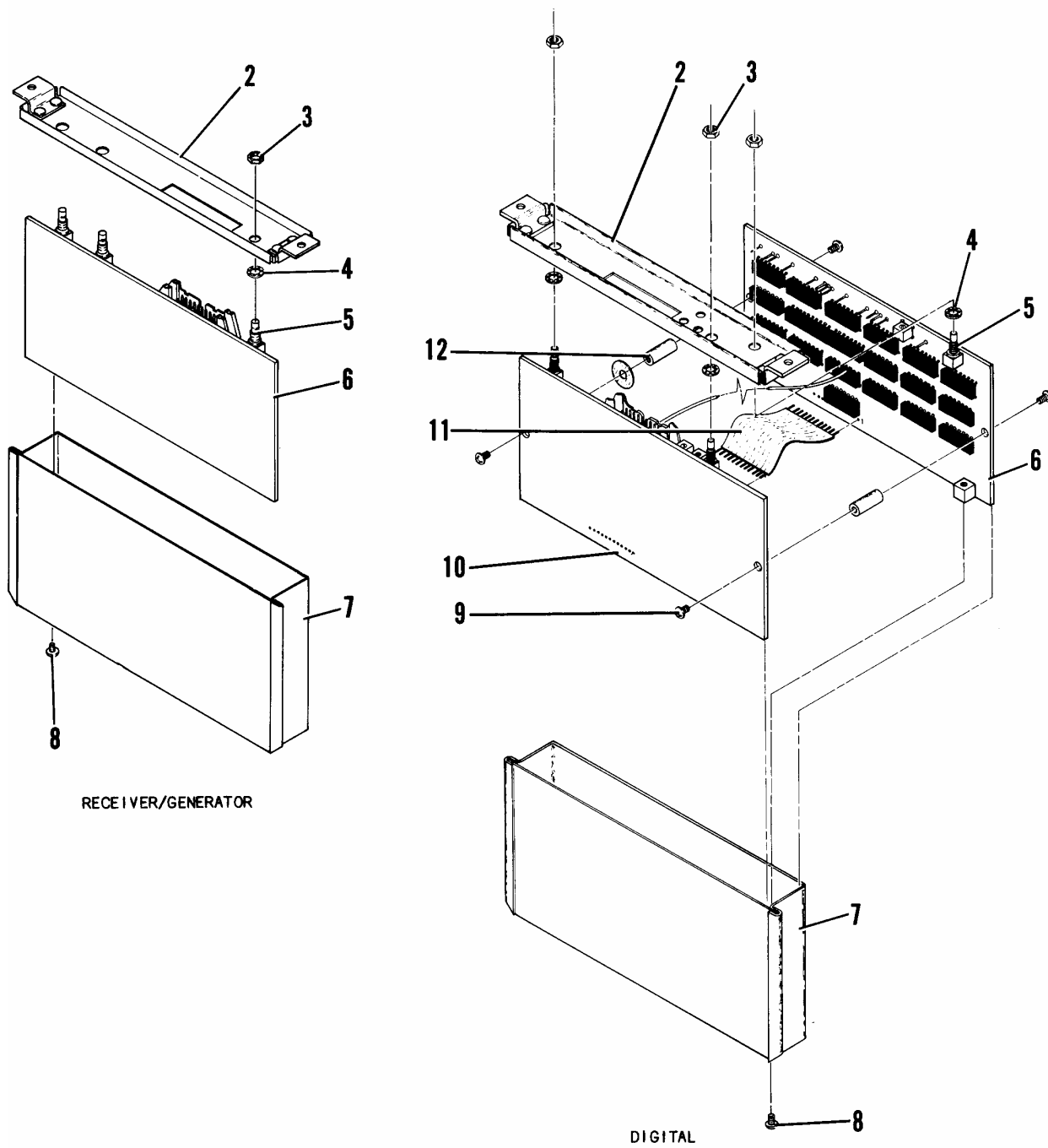

Figure 6-3 Enclosed Module Assemblies

6-2-10 ENCLOSED MODULES (43)

A. Removal (Figure 6-2)

1. Disengage all ribbon cables necessary to allow module removal.
2. Tag and disconnect flexible coax cables from module being removed.
3. Remove two screws (44) securing module (43) to chassis (33).
4. Lift module (43) from chassis (33).

NOTE

Sheet metal of chassis is formed into module guides.

B. Disassembly (Figure 6-3)

1. Remove nut (3) securing each coax connector (5) to top panel (2).
2. Remove all screws (1) securing top panel (2) to PC board assembly (6). Lift top panel from canister (7) and remove lock washers (4) from coax connectors (5).
3. Remove two screws (8) securing PC board assembly (6) to bottom of canister (7). Lift PC board assembly from canister.
4. To separate the paired PC boards of the High Loop Synthesizer and Digital Modules, remove two screws (9) securing PC boards (6, 10) to spacers (12), then unsolder flex strip (11) from each board.

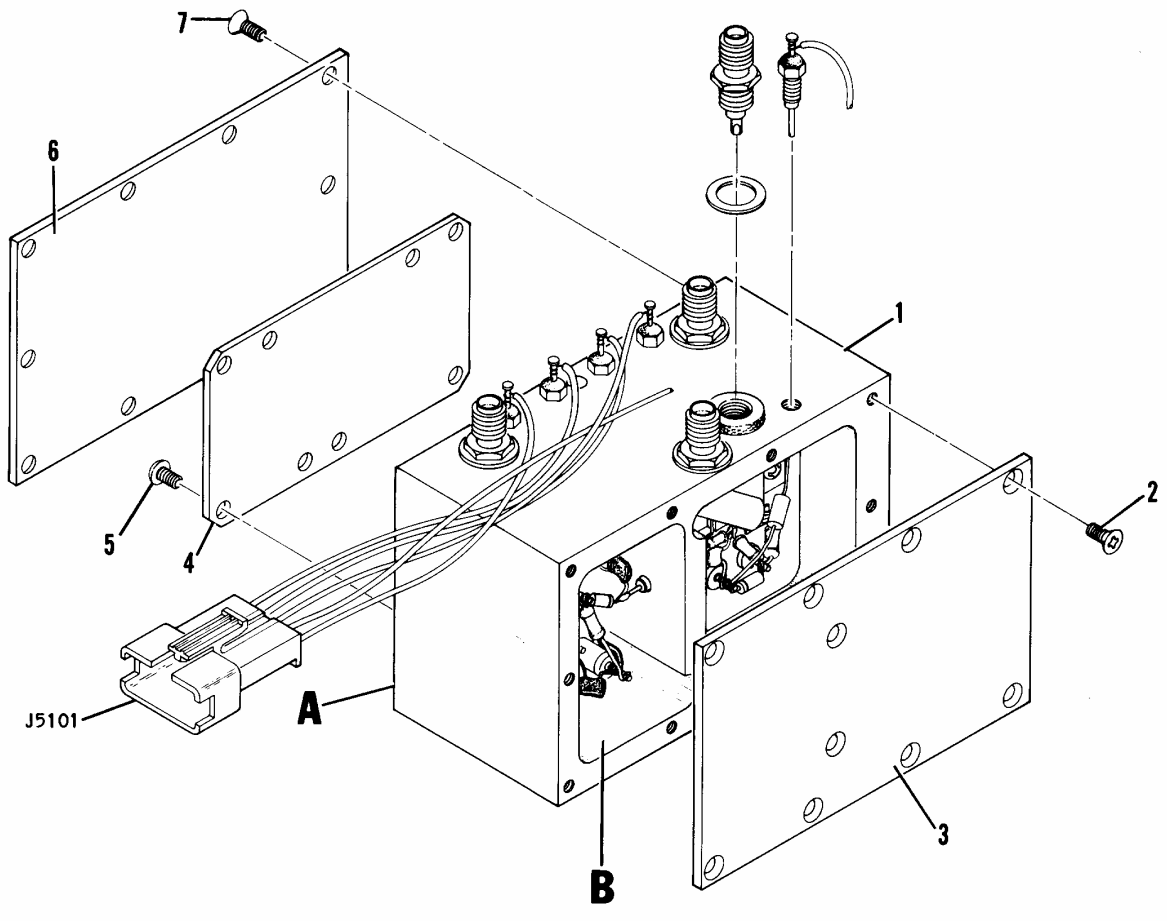

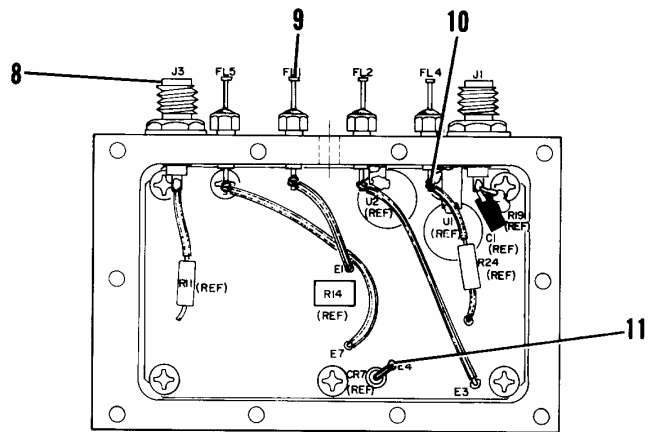

DETAIL A

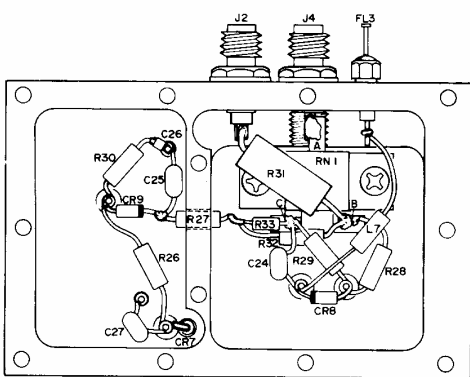

FM/AM-500 ONLY

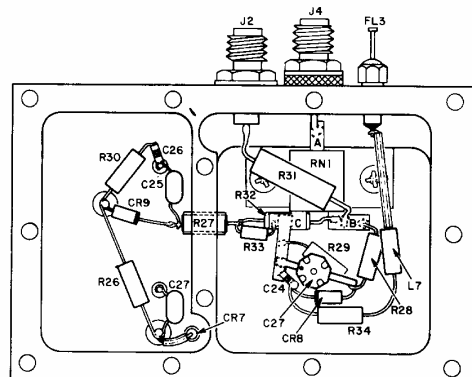

FM/AM-500A ONLY

DETAIL B

Figure 6-4 Output Amplifier Assembly (SN 1001 thru SN 3224)

6-2-11 OUTPUT AMPLIFIER (49) (S/N 1001 THRU 3224)

A. Removal (Figure 6-2)

1. Remove Battery (47) (paragraph 6-2-2), if installed.
2. Disconnect four semi-rigid coax connectors from Output Amplifier (49).
3. Disconnect J5101 on Output Amplifier (49) from P5101.
4. Remove two screws (2) and lock washers (1) attaching Output Amplifier (49) to Rear Panel (48).
5. Slide Output Amplifier (49) into battery well and lift from chassis (33).

NOTE

Before reinstalling Output Amplifier (49), apply a thin coat of Thermal Joint Compound (Wakefield Engineering, Inc. Type 120 or equivalent) to surface of enclosure block which contacts Rear Panel.

B. Disassembly (Figure 6-4)

1. Remove twelve screws (2) attaching cover (3) to enclosure block (1).
2. Remove ten screws (7) attaching cover (6) to enclosure block (1).
3. Unsolder leads from two coax connectors (8) and four feed-thru filters (9) at PC board (4). Remove connectors and filters.
4. Unsolder grounding strap (10) from enclosure block (1) and PC board (4).
5. Unsolder feedthru diode lead (11) from PC board (4).
6. Remove seven screws (5) attaching PC board (4) to enclosure block (1) and remove PC board.

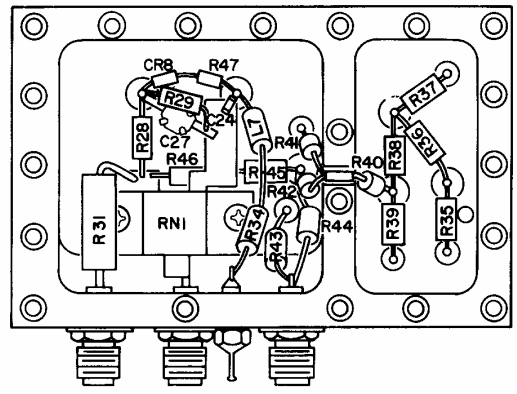
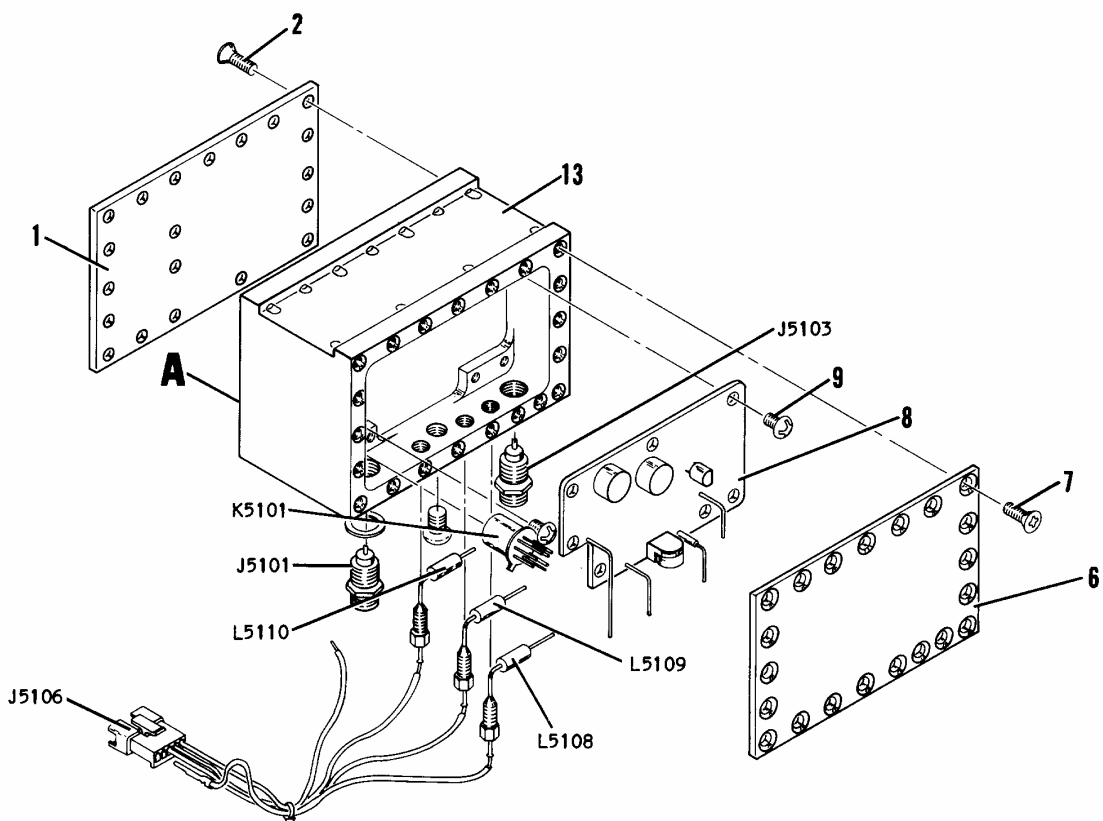

DETAIL **A**

Figure 6-4a Output Amplifier Assembly
(SN 3225 & On)

6-2-11a OUTPUT AMPLIFIER (49) (S/N 3225 ON)

A. Removal (Figure 6-2)

1. Remove Battery (47) (paragraph 6-2-2), if installed.
2. Disconnect four semi-rigid coax connectors from Output Amplifier (49).
3. Disconnect J5106 on Output Amplifier (49) from P5106.
4. Remove two screws (2) and lock washers (1) attaching Output Amplifier (49) to Rear Panel (48).
5. Slide Output Amplifier (49) into battery well and lift from chassis (33).

NOTE

Before reinstalling Output Amplifier (49), apply a thin coat of Thermal Joint Compound (Wakefield Engineering, Inc., Type 120 or equivalent) to surface of enclosure block which contacts Rear Panel.

B. Disassembly (Figure 6-4a)

1. Remove twenty screws (2) attaching cover (1) to enclosure block (13).
2. Remove twenty-one screws (7) attaching cover (6) to enclosure block (13).
3. Unsolder leads from two coax connectors (5101 and 5103) and three feed-thru filters (L5110, L5109 and L5108) at PC board (8). Remove connectors and filters.
4. Unsolder lead between E5108 and Relay K5101.
5. Unsolder grounding strap between PC board (8) and enclosure block (13).
6. Remove seven screws (9) attaching PC board (8) to enclosure block and remove PC board.

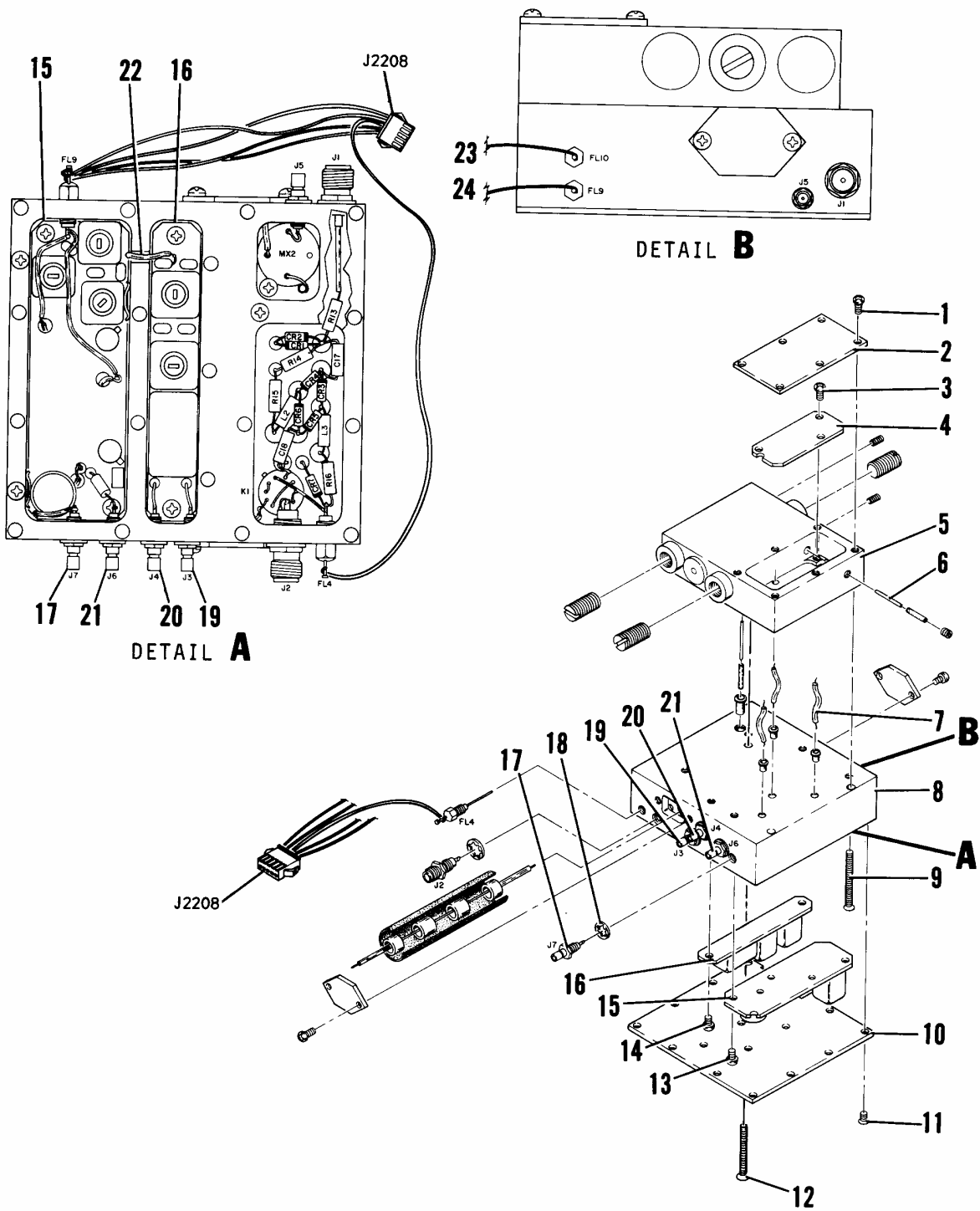

Figure 6-5 IF Module Assembly

6-2-12 IF Module (45)

A. Removal (Figure 6-2)

1. Remove Power Supply PC Board (5) (paragraph 6-2-5).
2. Disconnect four flexible coax cables from IF Block (45).
3. Disconnect two semi-rigid coax connectors from IF Block (45).
4. Remove two screws (16) and lock washers (15) attaching IF Block (45) to inner mounting bracket (10).
5. Lift IF Block (45) from chassis (33) and disconnect connector J2208.

B. Disassembly (Figure 6-5)

1. Remove six screws (1) attaching cover (2) to enclosure block (5).
2. Remove 1300 MHz Amplifier PC Board (4).
 - a. Unsolder diodes and capacitor leads from feed-thru (6).
 - b. Unsolder three feed-thru leads (7) from PC Board (4).
 - c. Remove three screws (3) attaching PC board (4) to enclosure block (5).
3. Remove sixteen short screws (11) and one long screw (12) attaching large cover (10) to enclosure block (8).
4. Remove IF Amplifier PC Board (15).
 - a. Unsolder and remove two feed-thru filters (Detail "B", Items 23, 24) and two coax jacks (17, 21) and lock washers (18).
 - b. Unsolder three leads (7) which feed through enclosure blocks (6, 8) from PC Board (15) to PC Board (4).
 - c. Unsolder jumper (22) from PC Board (Detail "A", Item 15).
 - d. Remove two screws (13) attaching PC Board (15) to enclosure block (8) and lift PC board from its compartment.
5. Remove IF Mixer PC Board (16).
 - a. Unsolder leads to two coax jacks (19, 20).
 - b. Unsolder jumper (22) from PC Board (16).
 - c. Remove two screws (14) attaching PC Board (16) to enclosure block (8) and lift PC board from its compartment.

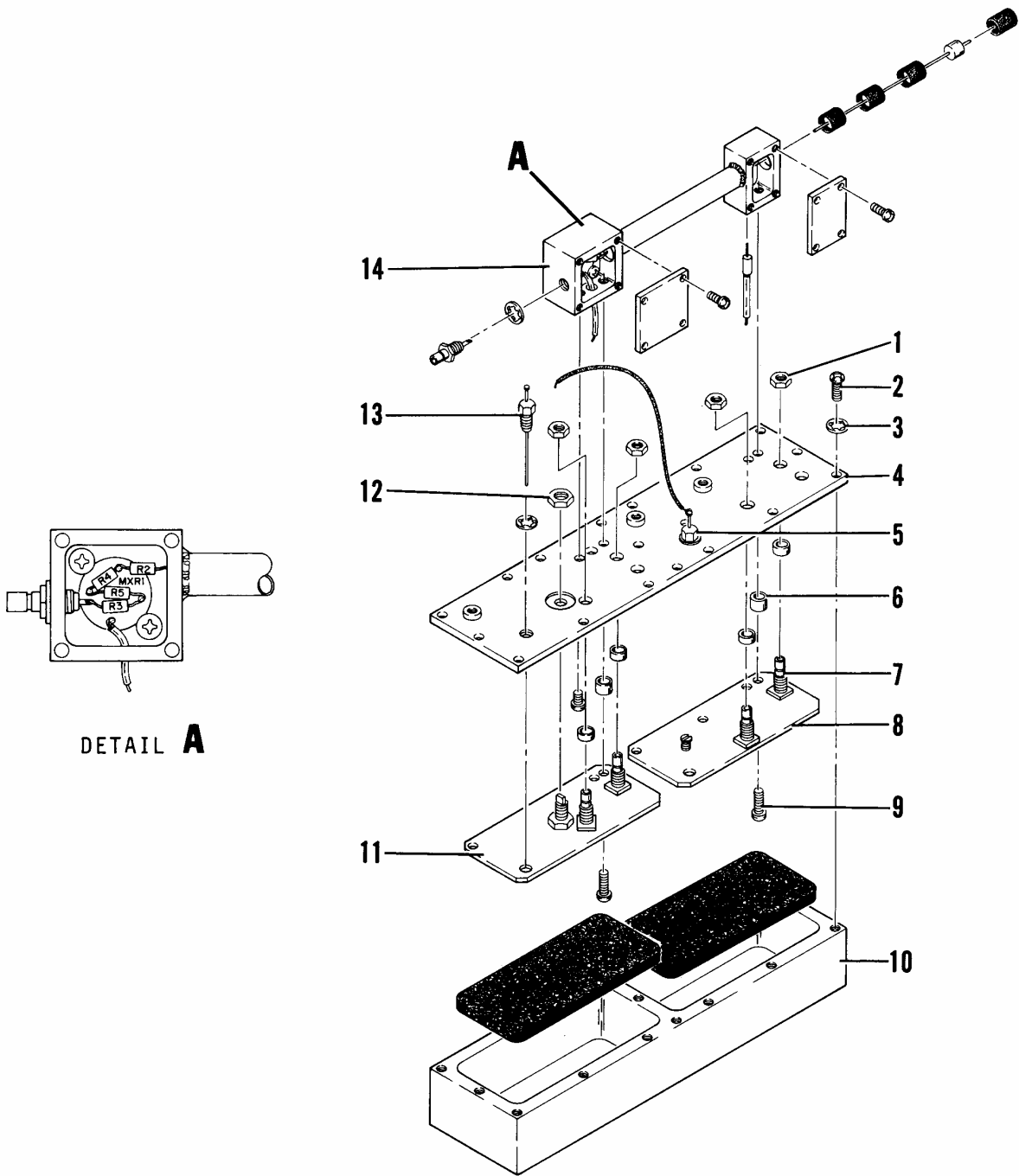

Figure 6-6 Dual VCO Assembly

6-2-13 DUAL VCO (14)

A. Removal (Figure 6-2)

1. Disconnect five flexible coax cables from Dual VCO (14).
2. Unsolder harness wire from feedthru filter on Dual VCO (14).
3. Remove two screws (8 and 12) and lock washers (9 and 13) attaching Dual VCO (14) to inner mounting bracket (10), and withdraw module from chassis.

B. Disassembly (Figure 6-6)

NOTE

Field repair of the Dual VCO is not recommended due to difficult realignment procedures requiring use of high performance test equipment and extensive trial and error adjustments.

1. Remove seventeen screws (2) and lock washers (3) attaching cover plate assembly (4) to enclosure block (10).

CAUTION

DO NOT ALTER POSITIONS OF COMPONENTS ON PC BOARDS OR OPERATING CHARACTERISTICS MAY BE SIGNIFICANTLY CHANGED.

2. Unsolder feedthru filters (5, 13) from PC boards (8, 11).
3. Unsolder lead from each PC board (8, 11) to mixer/bandpass filter assembly (14).
4. Remove nut (12) securing power transistor heat sink of 1300-2298 MHz VCO PC Board (11) to cover plate (4).
5. Remove nut (1) securing each of four coax connectors to cover plate (4).
6. Remove two (or three) screws (9) and spacers (6) attaching PC boards (8, 11) to cover plate (4) and remove PC boards.

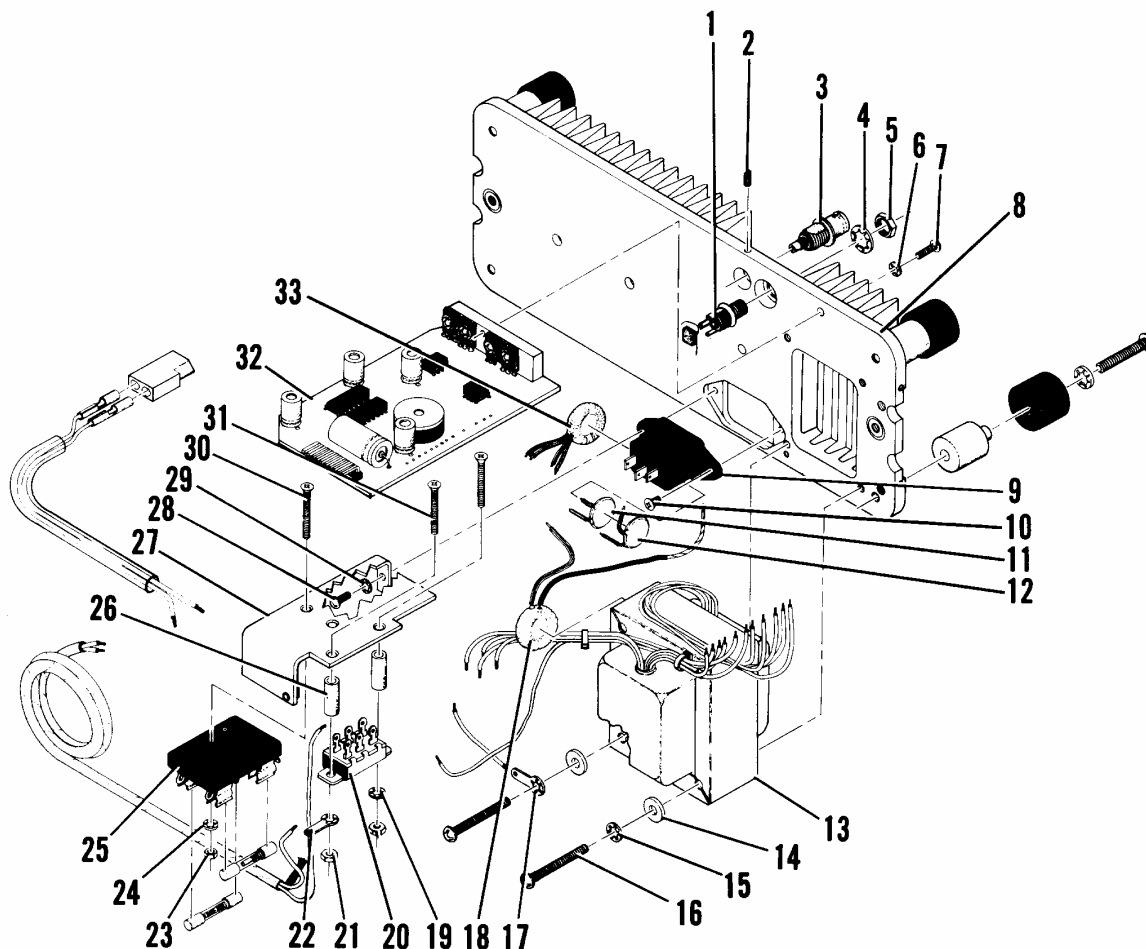

Figure 6-7 Rear Panel Assembly

6-2-14 REAR PANEL (48)

A. Removal (Figure 6-2)

1. Remove Battery (47), if so equipped. (Paragraph 6-2-2.)
2. Disconnect coax cable from External 10 MHz connector (55).
3. Remove two screws (1) and lock washers (2) attaching Output Amplifier (49) to Rear Panel (48).
4. Remove two screws (51 and 52) and lock washers (50 and 53) attaching Power Supply PC Board (5) to chassis (33).

5. Remove screw (24) and lock washer (23) attaching mounting bracket (Figure 6-7, Item 27) to chassis (33).
 6. Remove eight screws (17) attaching Rear Panel (48) to chassis (33).
 7. Remove two thumbnuts (11) securing fuse protector (7) and remove fuse protector.
 8. Withdraw Rear Panel Assembly (48) from chassis (33).
 9. Disconnect wire harness connector from Power Supply PC Board (5).
 10. Unsolder black wire from fuseholder (Figure 6-7, Item 25).
 11. Remove nut (Figure 6-7, Item 21) and terminal lug (Figure 6-7, Item 22) attaching white wire to voltage select switch (Figure 6-7, Item 20).
- B. Disassembly (Figure 6-7)
1. Remove Transformer (13).
 - a. Remove screw (7) and lock washer (6) attaching Power Supply PC Board (32) to Rear Panel (8).
 - b. Tag and unsolder all wires from transformer (13) to Power Supply PC Board (32).
 - c. Tag and unsolder three wires from transformer (13) to voltage select switch (20).
 - d. Unsolder wire from External DC Power jack (1) to torroid coil (18).
 - e. Remove four screws (16), three lock washers (15), four flat washers (14) and grounding lug (17) mounting transformer (13) on rear panel (8).
 2. Remove power source control components.
 - a. Tag and unsolder all wires from voltage select switch (20).
 - b. Tag and unsolder all wires and capacitor lead from fuseholder (25).
 - c. Remove two nuts (21), lock washer (19), terminal lug (22), if installed, and screws (30) attaching fuseholder (25) to mounting bracket (27).
 - d. Identify and unsolder torroid (33) and capacitor (11, 12) leads from AC connector (9).

- e. Remove two screws (10, 28) and one lock washer (29) attaching mounting bracket (27) and AC connector (9) to rear panel (8).
3. Remove 10 MHz coax connector (3).
 - a. Loosen set screw (2).
 - b. Unscrew coax connector (3) from Rear Panel (8).
 4. Remove external DC Power Supply Connector (1).
 - a. Tag and unsolder two wires from external DC Power Supply Connector (1) if not already disconnected in disassembly procedure.
 - b. Remove nut (5) and lockwasher (4) and withdraw connector (1) from Rear Panel (8).

6-2-15 FRONT PANEL

A. Removal (Figure 6-2)

1. Disconnect semi-rigid coax from ANTENNA connector (36) on Front Panel (35).
2. Remove six screws (Figure 6-1, Item 5) attaching front escutcheon (Figure 6-1, Item 6) to Front Panel (35). Remove escutcheon.
3. Remove one screw (37) securing each side of chassis to Front Panel (35).
4. Slide Front Panel (35) out of chassis (33) and disengage ribbon cable connectors from Mother Board (39).
5. Disconnect semi-rigid coaxes from T/R connector (Figure 6-8, Item 26) and step attenuator (Figure 6-8, Item 7).
6. Identify and unsolder two wires (in wrapped two-wire bundle running to chassis) from Power Switch (34).

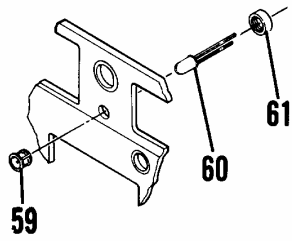

DETAIL **A**

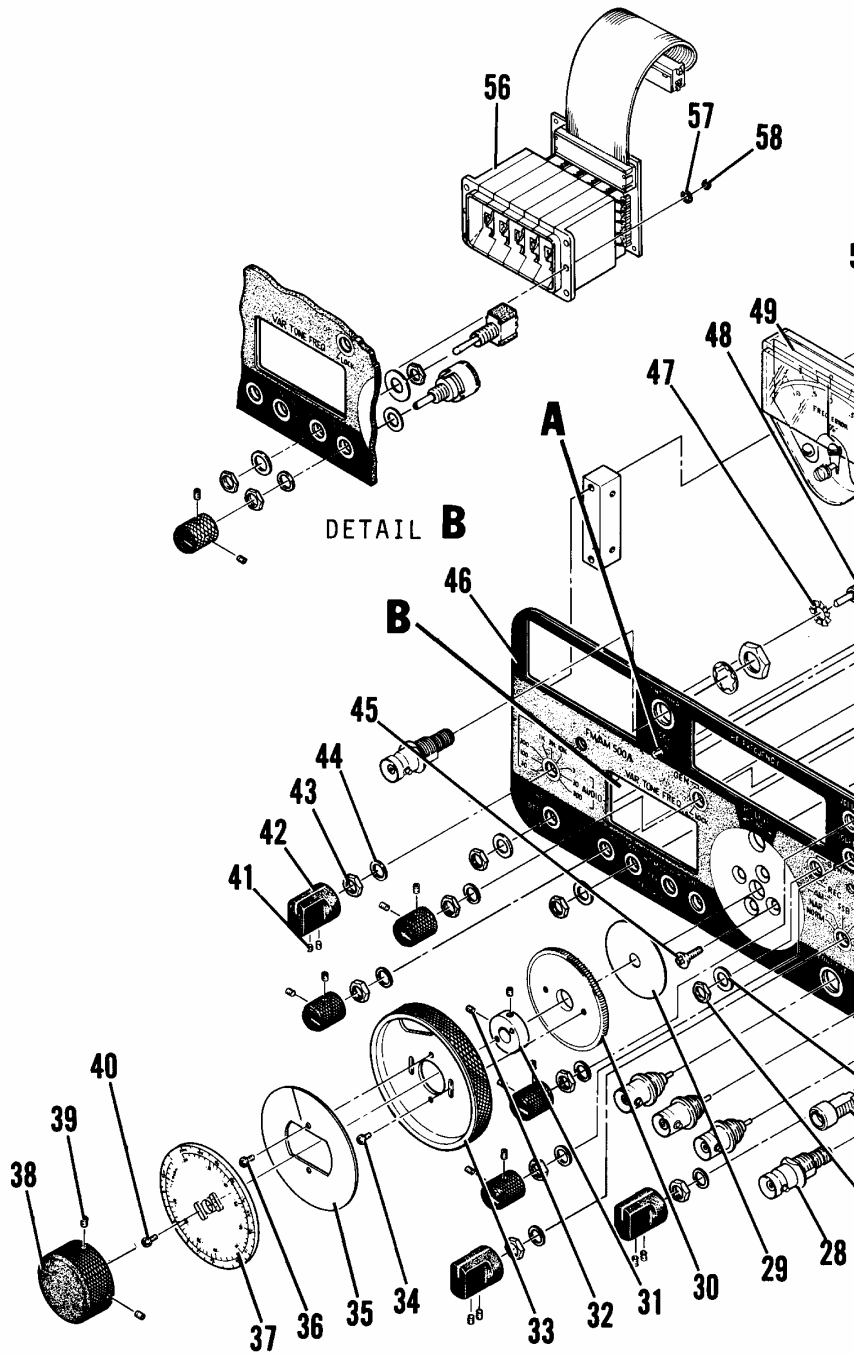

DETAIL **B**

A

B

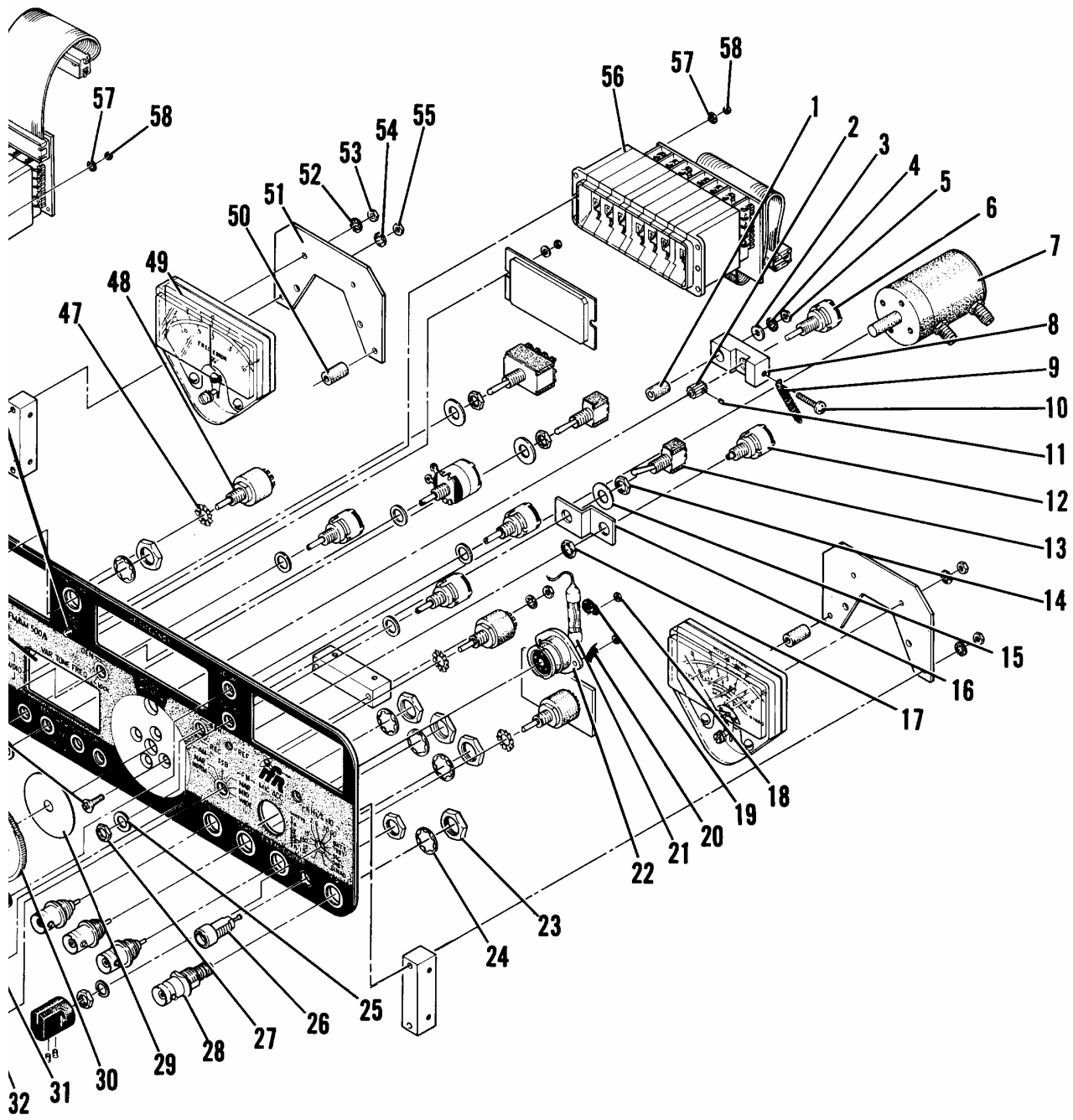

Figure 6-8 Front Panel Assembly

B. Disassembly (Figure 6-8)

1. Remove MIC/ACC Connector (22).
 - a. On FM/AM-500A only, unsolder fuse (21) from MIC/ACC Connector (22).
 - b. Tag and unsolder leads to connector (22).
 - c. Remove two nuts (18), one terminal lug (19) and one lock washer (20), then withdraw connector (22) from Front Panel (46).
2. Remove BNC (28) and Generate Amplifier power (26) connectors.
 - a. Remove heat shrink tubing and unsolder wires from connectors (26, 28).

NOTE

T/R and ANTENNA Connectors are screw-on coax connectors and have already been disconnected.

- b. Remove nut (23) and lock washer (24) (if installed), then withdraw connector (26, 28) from Front Panel (46).

NOTE

Generate Amplifier power connector (26) does not have lock washer (24).

3. Remove GEN/REC Switch (13) and REF Adjust Potentiometer (12).

- a. Tag and unsolder all leads.
- b. Remove nut (27) and flat washer (25) attaching GEN/REC Switch (13) to Front Panel (46). Withdraw switch (13) with nut (14), and flat washer (15), and remove REF Potentiometer (12) Assembly.

NOTE

During installation, be sure potentiometer shaft is centered in its hole in the Front Panel before securely tightening GEN/REC Switch mounting nut (27).

- c. Remove nut (17) and withdraw REF Potentiometer (12) from mounting bracket (16).

NOTE

On earlier Test Sets, the REF Potentiometer (12) screws into the mounting bracket (16) and no nut (17) is installed.

4. Remove Thumbwheel Switches (56).
 - a. Remove two nuts (58) and lock washers (57) attaching Thumbwheel Switch (56) to Front Panel (46).
 - b. Withdraw switch (56) from Front Panel (46).
5. Remove Meters (49).
 - a. Remove heat shrink tubing, identify and unsolder wires from meter (49) terminals.

NOTE

Ribbon cable is secured to FREQ ERROR Meter with wire tie.

- b. Remove two nuts (55) and lock washers (54) attaching meter mounting bracket (51) to Front Panel (46). Withdraw meter assembly and spacer (50) from Front Panel.
 - c. Remove two nuts (53) and lock washers (52) attaching mounting bracket (51) to meter (49), and remove bracket.
6. Remove RF Level Attenuator (7).
 - a. Remove RF FREQUENCY Thumbwheel Switch (Step B-4 of this paragraph).
 - b. Loosen two set screws (39) and remove knob (38).
 - c. Remove two screws (40) and dial (37).
 - d. Remove two screws (36) and FINE Adjust cursor (35).
 - e. Remove two screws (34) and FINE Adjust knob (33).
 - f. Loosen two set screws (32) and remove hub (31).
 - g. Lift FINE Adjust drive gear (30) and nylon washer (29) from attenuator (7) shaft.
 - h. Remove four screws (45) and withdraw attenuator (7) from Front Panel (46).
 - i. Tag and unsolder three wires from FINE Adjust Potentiometer (6).
 - j. Unhook spring (9) from stud on Front Panel (46).
 - k. Remove nut (5), lock washer (4), flat washer (3) and spacer (1) mounting FINE Adjust pivot block (8) to Front Panel (46).

- l. Loosen set screw (11) and remove potentiometer drive gear (2).
 - m. Remove set screw (10) and spring (9).
 - n. Unscrew potentiometer (6) from pivot block (8).
7. Remove Phase LOCK Indicator LED (60) (Detail A).
 - a. Tag and unsolder wires from LED (60) leads.
 - b. Using small screwdriver, carefully pry retainer (61) from grommet (59).
 - c. Using needle-nosed pliers, grasp both leads to LED (60) and pull LED from grommet (59).
 - d. Press grommet (59) from Front Panel (46).

NOTE

During reassembly, retainer (61) must be pressed onto grommet (59) securely to prevent rotation of LED (60). If rotation cannot be prevented in this manner, apply a small amount of adhesive, such as Lock-Tite Tack Pak or fingernail polish to retainer (61) and Front Panel (46).

8. Remove all other controls and switches. (Typical for all remaining potentiometers and switches.)
 - a. Loosen two set screws (41) and remove knobs (42) as required.
 - b. Tag and unsolder wires from controls and switches (48) being removed.
 - c. Remove nut (43) and flat washer (44) and withdraw control or switch (48) and washer (47) from Front Panel (46).

NOTE

Front Panel is drilled for positioning lugs for some controls and switches. During installation, be sure these lugs are engaged in the holes.

When installing the three rotary switches, rotate shaft fully clockwise. Secure switch in the position so when the knob is installed, it will align with the corresponding index line on Front Panel. All three switches have wires secured with wire ties.

NOTE

Rotate GEN/LOCK Control fully counterclockwise into detent, then align knob with LOCK index mark.

Rotate VOLUME and SQUELCH Controls fully counterclockwise and position knob with index at 7:00 o'clock.

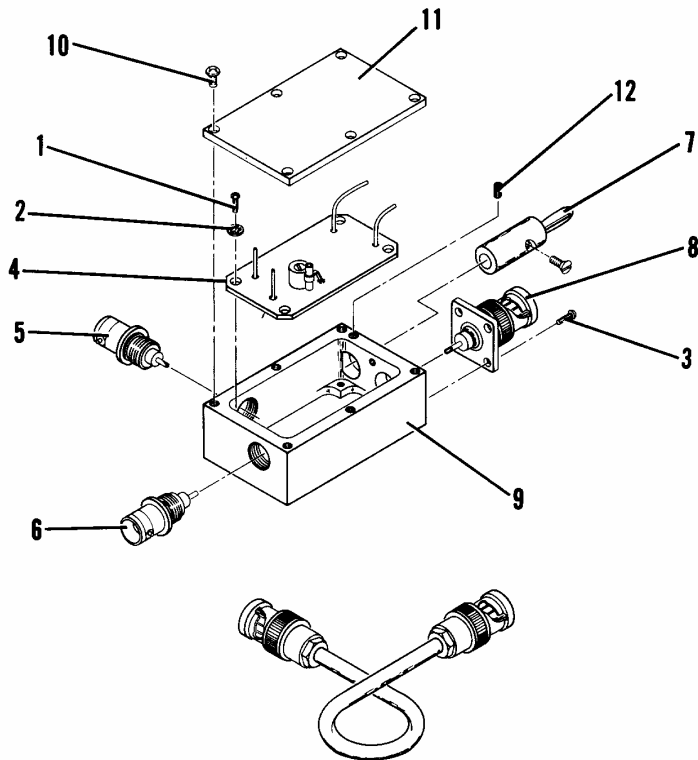

Figure 6-9 Generate Amplifier Assembly

6-2-16 GENERATE AMPLIFIER

A. Removal

The optional Generate Amplifier is an external plug-in module with no locking restraints. To remove, pull module straight away from Front Panel.

B. Disassembly (Figure 6-9)

1. Remove six screws (10) attaching cover (11) to enclosure block (9).
2. Unsolder leads to BNC connectors (5, 6 and 8). Unscrew and remove male connectors (5) and (6).
3. Unsolder lead to connector (7). Loosen set screw (12).
4. Remove four screws (3) attaching BNC connector (8) to enclosure block (9).
5. Remove four screws (1) and lock washers (2) attaching PC board (4) to enclosure block (9).

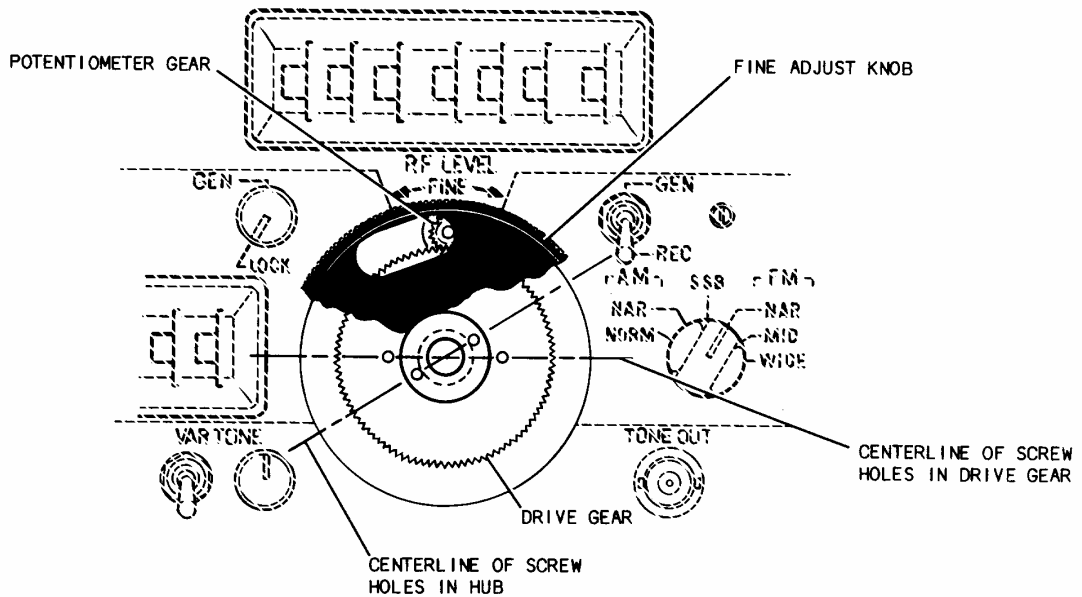

Figure 6-10 Attenuator Control Alignment

6-3 ASSEMBLY

6-3-1 RF LEVEL ATTENUATOR (Figure 6-8)

1. Position attenuator (7) on Front Panel (46) and install four flat head screws (45).
2. Screw FINE Adjust Potentiometer (6) fully into pivot block (8).
3. Insert set screw (10) through spring (9) and install in pivot block (8) to secure potentiometer (6).
4. Place potentiometer drive gear (2) on potentiometer (6) shaft and tighten set screw (10).
5. Place pivot block (8) assembly on stud of Front Panel (46) and install spacer (1), flat washer (3), lock washer (4), and nut (5).
6. Hook spring (9) over stud on Front Panel (46) and seal with an adhesive such as Lock-Tite Tack Pack (Item No. 12292).
7. Identify and solder three wires to potentiometer (6) terminals.
8. Rotate attenuator (7) and potentiometer (6) shafts fully cw.

9. Connect ohmmeter to common and minimum resistance terminals of potentiometer (6). Ohmmeter should read "0" resistance.
10. Adjust potentiometer (6) to 130 ohms (± 120 ohms).
11. Place nylon washer (29), gear (30), and hub (31) on shaft of attenuator (7). Tighten two set screws (32) in hub. Monitor ohmmeter to prevent inadvertent change in potentiometer setting.

NOTE

Screw holes in gear must be aligned horizontally. Holes in hub must be aligned just above center line of VAR TONE Volume knob or the plug in the Front Panel (see Figure 6-10).

12. Place FINE Adjust knob (33) in position, with machined slot over gear (2). Insert 0.005 inch shimstock (Appendix C) between knob (33) and hub (31). Rotate knob fully ccw so end of slot contacts gear and install two flat head screws (34) (Figure 6-10). Monitor ohmmeter to prevent accidental change in potentiometer setting. Remove shimstock.

NOTE

Spacing with shimstock is essential to prevent excessive drag of knob (33) on hub (31).

13. Rotate FINE Adjust knob (33) fully cw and back ccw. Ohmmeter should return to its original reading of between 10 and 250 ohms.
14. Position cursor (35) on FINE Adjust knob (33) and install two flat head screws (36).
15. To install dial (37), proceed as follows:
 - a. Install knob (38) on attenuator (7) shaft and tighten set screws (39).
 - b. Rotate attenuator knob (38) ccw one detent. Loosen set screws (39) and remove knob.

NOTE

The attenuator must be free to stop itself, centered in the detent. Rotating the shaft with pliers could overrun the detent center and cause misalignment of the dial.

- c. Position dial (37) with -30 dB index directly over cursor (35) index. Install two round head screws (40).

SECTION 7 - MODULE TESTING

7-1 GENERAL

This section contains detailed testing procedures for the modules and PC Boards which make up the FM/AM-500A. These procedures are intended to aid the technician in determining whether the module, identified during troubleshooting procedures, is actually faulty. Failure to obtain a specified test result normally indicates one or more of the components in that portion of the circuit may be defective. However, do not rule out the possibility that another circuit or module may cause the improper test result.

Each test procedure in this section provides the following information for the module under test:

1. Theory of module operation with functional block diagram;
2. Preparations required to commence test procedures;
3. Step-by-step test procedures.

During testing, refer to Section 6 for mechanical assembly drawings. PC Board layout drawings are in Section 9, and circuit schematics are in Section 10.

After repairing or replacing a module, it is essential to conduct appropriate Calibration Procedures before returning the FM/AM-500A to service.

7-1-1 MODULES RECOMMENDED FOR FACTORY REPAIR

The Dual VCO Module and the 88-90 MHz bandpass filter poles in the IF Module are not field repairable and should, therefore, be returned to the IFR Factory for repair.

7-1-2 DISASSEMBLY REQUIREMENTS

Removal of the exterior case from the FM/AM-500A is a primary requirement for performing the test procedures in this section. In addition, most of the procedures also require that the module under test be removed from the set to allow access to test points, internal components, etc. The technician should refer to "SECTION 6 - DISASSEMBLY/ REASSEMBLY PROCEDURES" for instruction for removing and disassembling individual modules.

7-1-3 TEST EQUIPMENT REQUIREMENTS

Appendix B at the back of this manual contains a comprehensive list of test equipment suitable for performing any of the procedures in this manual. Any other equipment meeting the specifications listed in the appendix or specific test procedure may be substituted in place of the recommended models.

NOTE

For certain procedures in this manual, the equipment listed in Appendix B may exceed the minimum required specifications. For this reason, minimum use specifications appear within all module test procedures where accessory equipment is required.

7-1-4 SAFETY PRECAUTIONS

As with any piece of electronic equipment, extreme caution should be taken when troubleshooting "live" circuits. When troubleshooting the FM/AM-500A, be sure to observe the following precautions:

WARNING

THE REAR PANEL TRANSFORMER CARRIES 120 OR 240 VAC AT INPUT LEADS AS LONG AS AC POWER CORD IS CONNECTED TO FM/AM-500A AND TO EXTERNAL POWER SOURCE. DO NOT CONTACT THESE OR ANY ASSOCIATED COMPONENTS DURING TROUBLESHOOTING OR CALIBRATION.

AS LONG AS THE BATTERY IS INSTALLED OR EXTERNAL AC OR DC POWER IS APPLIED, A 12 VDC POTENTIAL EXISTS AT VARIOUS POINTS ON REAR PANEL, REGARDLESS OF THE FRONT PANEL POWER SWITCH POSITION.

AS LONG AS THE FM/AM-500A IS OPERATING ON INTERNAL BATTERY OR EXTERNAL DC, A 115 OR 230 VAC POTENTIAL EXISTS AT THE AC POWER CONNECTOR. DO NOT OPERATE ON "BATT" (INCLUDING EXTERNAL DC) WITH THE AC POWER CORD INSTALLED.

WHEN WORKING WITH "LIVE" CIRCUITS OF HIGH POTENTIAL, KEEP ONE HAND IN POCKET OR BEHIND YOUR BACK TO AVOID SERIOUS SHOCK HAZARD.

REMOVE ALL JEWELRY OR OTHER COSMETIC APPAREL BEFORE TROUBLESHOOTING AND/OR REPAIRING LIVE CIRCUITS.

FOR ADDED INSULATION, PLACE RUBBER BENCH MAT UNDER ALL POWERED BENCH EQUIPMENT, AS WELL AS A RUBBER FLOOR MAT BENEATH TECHNICIAN'S CHAIR.

HEED ALL WARNINGS AND CAUTIONS CONCERNING MAXIMUM VOLTAGES AND POWER INPUTS.

7-1-5 INDEX OF MODULE TESTING PROCEDURES

Paragraph	Title	Page
7-2	Power Supply	7-5
7-3	IF Module	7-11
7-4	Dual VCO	7-17
7-5	High Loop Synthesizer	7-23
7-6	Low Loop Synthesizer	7-33
7-7	Receiver/Generator	7-37
7-8	Frequency Standard	7-43
7-9	Digital Module	7-47
7-10	Receive Audio	7-57
7-11	Generator Audio	7-67
7-12	Output Amplifier	7-75
7-13	Variable Tone Generator	7-79
7-14	Optional Generate Amplifier	7-85

7-2 POWER SUPPLY

7-2-1 THEORY OF OPERATION (Refer to Figure 7-1 and Power Supply Circuit Schematic in Section 10)

A. GENERAL

The Power Supply consists of a transformer and associated rectifier, regulator, battery charger, and timer-interrupt circuits. The transformer has two primary windings which are switched in parallel for 120 VAC operation or in series for 240 VAC operation. The three secondary windings (40 V, 16 VCT and 30 VCT) are rectified to supply +40 VDC, +8 VDC, +15 VDC, and -15 VDC. The +15 VDC is regulated to +12 VDC, with tracking regulators regulating the +8 VDC and -15 VDC to +5 VDC and -12 VDC respectively. The 30 VCT secondary winding also has 24 V taps which are used during DC/Battery operation.

The battery and the +12 VDC external power jack are connected in parallel to the transformer driver circuit, which consists of a 400 Hz oscillator, two oscillator control transistors, two driver transistors, and two power transistors. When the Power Switch is in the BATT position, the source with the higher DC potential (either battery or external power) activates the circuit. The multivibrator drives the driver transistors, which in turn drive two power transistors with a 400 Hz squarewave, and subsequently, the two 24 V taps of the transformer's 30 VCT secondary winding. Acting as an autotransformer, this winding then furnishes the +15 VDC and the -15 VDC to the +12 VDC and -12 VDC regulators. It also induces a current in the primary and other two secondary windings of the transformer.

A timer counts the pulses from the 400 Hz oscillator and, after approximately 10½ minutes of DC operation, shuts off the oscillator. This keeps power to the transformer inoperative until the Power Switch is turned OFF. Battery or external DC operation can then be resumed by returning the Power Switch to the BATT position.

The Power Switch, when in the OFF position, removes the forward bias on a diode in the +12 VDC regulator circuit, which subsequently shuts off the three voltage regulators, transformer driver circuit, and DC timer. It does not interrupt AC power to the transformer, the +40 VDC, or the +15 VDC to the battery charger. With the Power Switch in the LINE position, +12 VDC is applied to the battery charger regulator, which reduces the charge rate to prevent excessive power consumption. Only when the Power Switch is in the BATT position is the AC power connector disconnected from the transformer.

B. VOLTAGE SUPPLY CIRCUIT

The operating power source is selected by switch SW104 on the Front Panel. Voltage select switch SW5001 connects the trans-

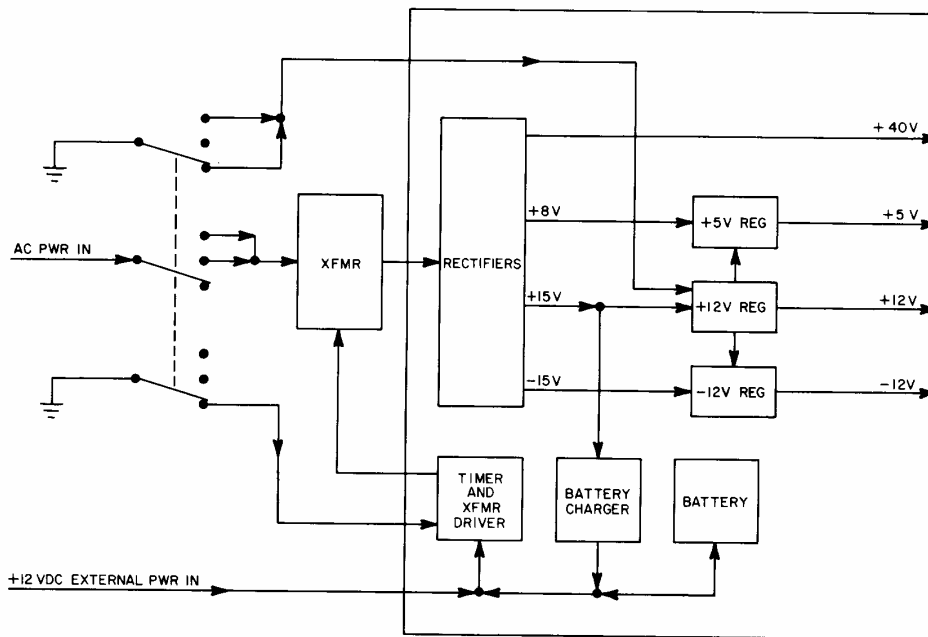

Figure 7-1 Power Supply Block Diagram

former's two primary windings in parallel or series to accommodate 115 VAC or 230 VAC. The unregulated +40 VDC supply uses diodes CR5212 through CR5215 as a bridge rectifier. Capacitors C5201 and C5202, with resistors R5201 and R5244, filter the output of the +40 V secondary winding. The regulated +5 VDC supply utilizes the 16 VCT winding. The regulated +5 VDC supply utilizes the 16 VCT winding with diodes CR5201 through CR5204 forming a full wave rectifier. Op amp U5201B and transistors Q5201 and Q5202 make up the regulator. Capacitors C5203, C5205 and C5217 and toroid inductor L5201 filter the output. Op Amp U5201B is connected to the output of the +12 VDC regulator, which provides the +5 VDC regulator with a reference point. Zener diode CR5205 limits the output to +6.2 VDC for overvoltage protection.

The +12 VDC uses bridge rectifier BR5201 from the 30 VCT winding of the transformer. Op amp U5201A and transistors Q5203 and Q5204 form the regulator, with trimpot R5216 used for calibration. Zener diode CR5207 establishes a reference level for regulator operation. Filtering is accomplished by capacitors C5206, C5207, C5213, C5215 and C5218. When the Power Switch is in the OFF position, R5208 pulls the non-inverting input of op amp U5201A above 6.9 V. This stops the operation of the +12 VDC regulator, and subsequently, the +5 VDC and -12 VDC regulators, which track the +12 VDC regulator output.

Transistor Q5205 and op amp U5202B provide regulation of the -12 VDC supply, which comes from bridge rectifier BR5201. One input to the op amp is from the regulated +12 VDC, which allows the -12 VDC to track the +12 VDC. Capacitors C5208 and C5209 filter the supply.

C. BATTERY CHARGER CIRCUIT

Op amp U5202A and transistors Q5212 and Q5215 form the battery charger voltage regulator. Trimpot R5241 allows adjustment of the voltage. Transistor Q5213 limits the current. When the +12 VDC regulator is operating (Power Switch in LINE position), +12 VDC is applied to the base of transistor Q5214, which reduces voltage on the base of transistor Q5213. This drops the charging rate from 1.4 amps to .9 amp. With the switch in BATT, op amp U5202A is disabled, shutting down the battery charger circuit. However, an external DC source can be used to charge the battery directly.

D. TRANSFORMER DRIVER CIRCUIT

Multivibrator U5203 and its timing capacitor C5240 and resistor R5230 produce a 400 Hz squarewave to drive transistors Q5210 and Q5211. These two transistors drive power transistors Q5207 and Q5208 respectively, each of which feeds one leg of the 24 V tap of the 30 VCT secondary winding of the transformer. The emitters of driver transistors Q5210 and Q5211 are returned to the +5 V supply to reduce heat dissipation in resistors R5224 and R5225 and to increase the efficiency of the power supply. Transistor Q5206 supplies power to counter U5204, which counts output pulses from multivibrator U5203 and to the base and emitter of transistor Q5209. The counter normally grounds the base of Q5209, allowing it to conduct. After approximately 10½ minutes, the counter output to Q5209 goes high, turning the transistor off, and shutting down the multivibrator. Since transistor Q5206 continues to conduct, counter U5204 is not reset until the Power Switch is turned "OFF". As long as transistor Q5209 is conducting, it supplies power to op amp U5202 in the battery charger circuit, which shuts down the battery charger to conserve battery power.

7-2-2 PREPARATION FOR TESTING

A. REMOVAL AND DISASSEMBLY

Remove Battery from within the FM/AM-500A chassis. If repair or replacement is required, refer to Rear Panel Removal and Disassembly paragraphs in Section 6 for procedures.

B. REQUIRED TEST EQUIPMENT

- 1 - DC Voltmeter 100 K Ω /V
- 1 - Battery Load Simulator IFR P/N 7003-9801-600
(Appendix C)
- 1 - DC Power Supply +12 V @ 4 A
- 1 - Stopwatch 30 minute capacity (minimum),
with 1 second resolution

C. PREPARATION (Refer to Controls, Indicators and Connectors Drawing in Section 1)

- 1. Disconnect Battery Connector P/J5004.
- 2. Connect Battery Load Simulator to Battery disconnect plug P5004.
- 3. Place the following switches in the corresponding initial positions:

KEY	CONTROL	SETTING
14	VAR TONE Selector Switch (if applicable)	"INT MOD"
15	1 kHz TONE Selector Switch	"INT MOD"
17	Power Switch	"OFF"
26	GEN/REC Mode Switch	"GEN"

7-2-3 TESTING (Refer to Power Supply PC Board Drawing in Section 9 and Power Supply Circuit Schematic in Section 10)

- 1. Connect AC power cord to FM/AM-500A and to power source.

CAUTION

WHEN AC POWER IS APPLIED, THE BATTERY CHARGER CIRCUIT IS ACTIVE. USE CARE WHEN HANDLING THIS LIVE CIRCUIT.

- 2. Adjust Battery Load Simulator to obtain charging current of 300 mA.
- 3. Measure voltage across Battery Load Simulator. Adjust potentiometer R5241 to obtain +14.4 VDC (± 0.1 V).
- 4. Adjust Battery Load Simulator until voltmeter displays +13.0 VDC. Verify charging current is 1.4 A (± 0.3 A).
- 5. Set Power Switch in LINE position. Verify charging current drops to 0.9 A (± 0.3 A).

6. Measure Power Supply output voltages in accordance with Table 7-1. Refer to Section 4 for calibration procedures.

TEST POINT	VOLTAGE	TOLERANCE
J5201, Pin 8	+12.0 V	±0.2 V
J5201, Pin 3	-12.0 V	±0.2 V
J5201, Pin 10	+ 5.0 V	±0.2 V
J5201, Pin 9	*+43.0 V	±5.0 V
* +43 V output is unregulated		

Table 7-1 Power Supply Output Voltages

7. Set Power Switch in "OFF" position, then remove AC power cord.
8. Connect DC power cord between +12 VDC bench power supply and External DC connector of FM/AM-500A, and apply +12.0 VDC.
9. Simultaneously, start the stopwatch and place Power Switch in "BATT" position.
10. While stopwatch is running, measure Power Supply output voltages in accordance with Table 7-1.
11. Verify FM/AM-500A automatically shuts off after 10 minutes, 54 seconds (±1 minute).
12. Set Power Switch in "OFF" position and back to BATT. Verify FM/AM-500A is once more operating.

7-2-4 REASSEMBLY

With all power "OFF", disconnect test equipment. Replace Battery and any components removed for repair or replacement in reverse order of removal procedure outlined in Section 6.

7-3 IF MODULE

7-3-1 THEORY OF OPERATION (Refer to Figure 7-2 and to IF Module Circuit Schematic in Section 10)

A. GENERAL

An RF signal from the antenna first passes through a static protector to an antenna enable relay. Anytime the set is operating in the Receive mode, the relay is energized by the Mode Power Circuit in the Generate Audio Module and couples the signal to the IF network. When in the Generate mode, or if a 100 mW or greater signal is received at the T/R jack, the relay is de-energized. The relay then switches the signal path through the Output Amplifier to the T/R jack and, at the same time, opens the antenna circuit.

From the antenna enable relay, the received RF signal passes through a 1000 MHz lowpass filter to the first mixer. The first mixer combines the received RF signal with the signal (which is between 1300 and 2298 MHz) from the first VCO in the Dual VCO Module. A 1300 MHz bandpass filter allows only a difference (first IF) frequency of 1298-1300 MHz, which contains the modulation characteristics of the received RF signal, to pass. The first IF signal is amplified, then mixed with the 1210 MHz, constant frequency from the second VCO in the Dual VCO module. A second bandpass filter allows only the difference (second IF) signal of 88-90 MHz to pass. After further amplification, the second IF is mixed with the signal (which is between 79.3 and 77.3 MHz) from the third VCO in the Low Loop Synthesizer Module. This third, or final IF, when the RF thumbwheels are set to the actual RF frequency received, is the 10.7 MHz IF frequency used by the Receiver/Generator Module.

When the set is operating in the Generate mode, the IF module functions basically in reverse of the Receive mode. However, different interstage amplifiers are used. In the Receive mode, the Generate Audio Module furnishes a REC command (+12 VDC) to enable the receive amplifiers in the IF Module; in the Generate Mode, a GEN command (+12 VDC) is applied to the generate amplifiers.

B. STATIC PROTECT/ANTENNA ENABLE CIRCUIT

Resistors R2213 and R2214 and diodes CR2201 and CR2202 shunt to ground any static charge developing in the antenna and its connecting coax. Diodes CR2203 through CR2206 form a diode switch which, when forward biased by the REC command signal, conducts the received frequency through antenna enable relay K2201 to the 1000 MHz lowpass filter. Inductors L2202 and L2203, in the diode switch control line, prevent the RF of a received signal from entering the DC control circuitry. The relay, which is energized by the ANT ENABLE command signal, normally shunts any

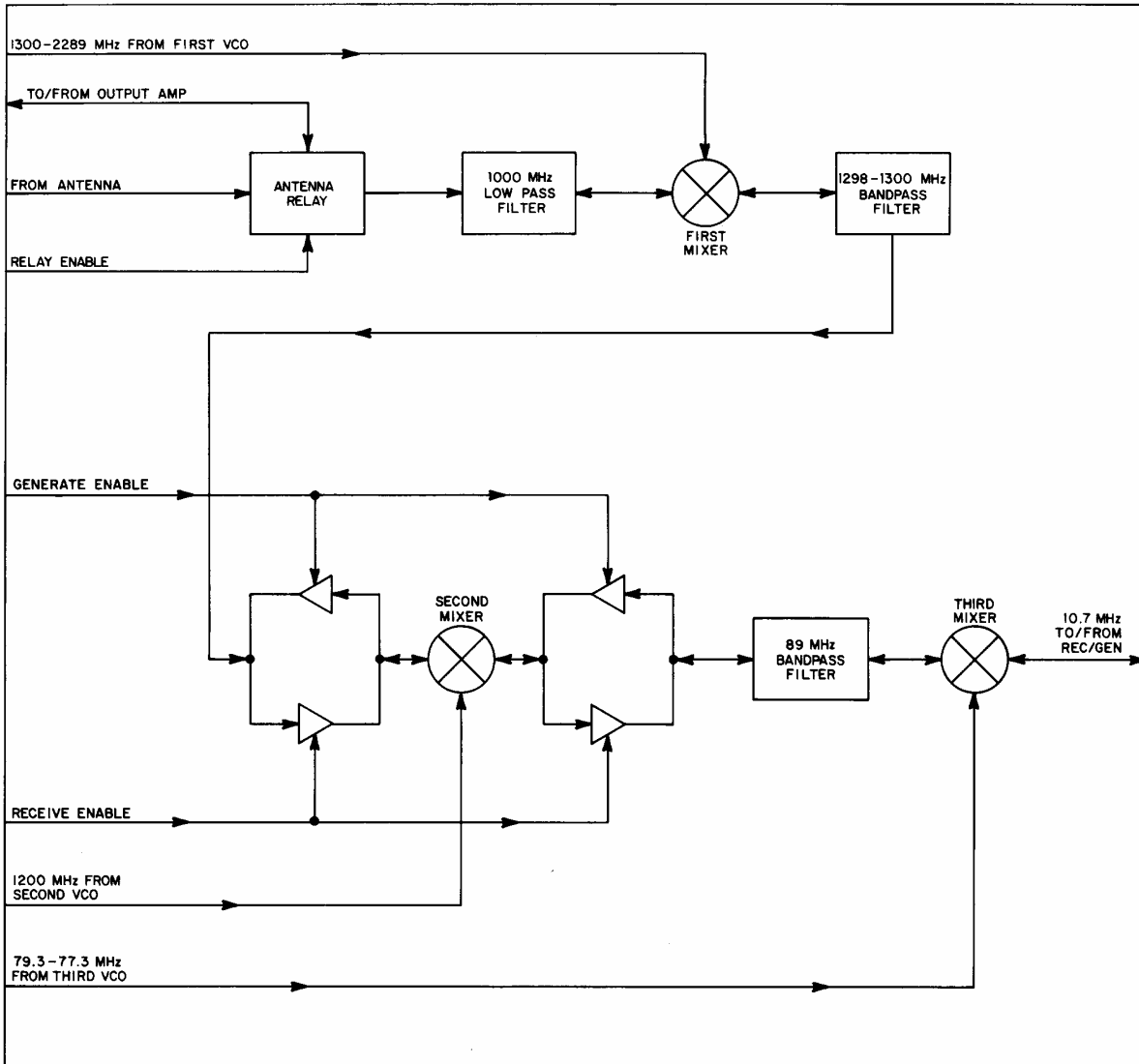

Figure 7-2 IF Module Block Diagram

static leakage through the switch, to ground. When the relay is not energized, the T/R jack on the Front Panel is coupled through the Output Amplifier to the Monitor/Generate (M/G) jack of the IF Module to the lowpass filter.

C. FIRST MIXER/AMPLIFIER CIRCUIT

Inductors L2204 through L2209 and capacitors C2219 through C2222 form the 1000 MHz lowpass filter. Filters FL2205, FL2206 and FL2207 form a 1300 MHz bandpass filter. Mixer MXR2202, which is between the two filters, mixes the signal it receives with the first VCO frequency to produce either the final RF frequency of less than 1000 MHz in the Generate mode, or the first IF frequency of between 1298 and 1300 MHz in the Receive mode. Transistors Q2401 and Q2402, with associated circuitry, form a two-stage amplifier. The REC command signal turns on these two transistors to allow a received signal to pass. Transistor Q2403 and its associated circuitry form a single-stage amplifier, which operates when the transistor is forward-biased by the GEN command signal (when in the Generate mode).

D. SECOND MIXER/AMPLIFIER CIRCUIT

In the Receive mode, the 1300 MHz IF is mixed with the 1210 MHz frequency from the second VCO in mixer MXR2201. The output signal is amplified by a two-stage amplifier consisting of transistors Q2203 and Q2204 and associated circuitry, then coupled to the 88-90 MHz bandpass filter consisting of filters FL2301, FL2302, FL2201, FL2202, FL2203 and capacitors C2301 through C2304 and C2202 through C2206. Transistors Q2201 and Q2202 and associated circuitry form a two-stage 1210 MHz amplifier which is enabled by the GEN command signal. In the Generate mode, a signal passing through this bandpass filter and amplifier is then mixed in mixer MXR2201 with the 1210 MHz from the second VCO, and sent to the 1300 MHz generate amplifier.

E. THIRD MIXER

In the Receive mode, the second IF frequency is mixed in mixer MXR2301 with the output of the third VCO in the Low Loop Synthesizer, and produces the 10.7 MHz IF output signal to the Receiver/Generator. In the Generate mode, the 10.7 MHz IF, which is produced by the Receiver/Generator, is mixed with the output of the third VCO, and passed through the 88-90 MHz bandpass filter to the 1210 MHz mixer/amplifier circuit.

7-3-2 PREPARATION FOR TESTING

A. REMOVAL AND DISASSEMBLY

For testing, remove the IF Module as outlined in Section 6. Disassemble only if required for repair.

B. REQUIRED TEST EQUIPMENT

- 1 - DC Power Supply +12 VDC @ 250 mA
- 1 - Tracking Generator 60-1500 MHz Range

- 1 - Signal Generator Capable of generating 1389 MHz at +7dBm
- 1 - Resistor 1.0 K Ω , 10%, $\frac{1}{4}$ W
- 4 - 50 Ohm Coax Cables BNC/SMB
- 1 - 50 Ohm "T" Coax Connector ... BNC

C. PREPARATION (Refer to IF Module Component Location Drawing in Section 9)

- 1. Connect Power Supply common terminal to ground on IF Module.
- 2. Connect Power Supply +12 VDC terminal to FL2209
- 3. Connect 1 K Ω resistor between Power Supply +12 VDC terminal and center conductor of J2202.

NOTE

This resistor will cause the first mixer to conduct RF in both directions between the first VCO and 1300 MHz bandpass filter without changing the applied frequency. This arrangement is used for test purposes only.

- 4. Connect Tracking Generator output to J2205 and its input to J2206.

7-3-3 TESTING (Refer to IF Module Component Location Drawing in Section 9 and IF Module Circuit Schematic in Section 10)

- 1. Apply power to Power Supply, then set Tracking Generator controls as follows:
 - a. Center frequency 1300 MHz
 - b. Output level -30 dBm
 - c. Dispersion 20 MHz span (2 MHz/Div)
- 2. Adjust FL2205, FL2206, and FL2207 for a bandwidth of 2 MHz centered at 1300 MHz at a level of -35 dBm (± 2 dB).
- 3. Disconnect Power Supply lead from FL2209 and connect to FL2210.
- 4. Reverse leads to Tracking Generator (output now to J2206 and input to J2205). Verify level displayed is -45 dBm (± 2 dB) at 1300 MHz.
- 5. Disconnect Power supply lead from FL2210 and reconnect to FL2209.
- 6. Disconnect resistor from J2202 and connect it to J2204.

6. (Cont'd)

NOTE

The resistor now causes the third mixer to conduct between the third VCO and the 89 MHz band-pass filter ports without changing the applied frequency. This arrangement is used for test purposes only.

7. Using "T" coax connector, connect output of Signal Generator to J2205 and J2207.
8. Adjust Signal Generator output to 1389 MHz at +7 dBm.
9. Connect Tracking Generator output to J2202 and input to J2203.
10. Set Tracking Generator controls as follows:
 - a. Center frequency 89 MHz.
 - b. Output level -30 dBm.
 - c. Dispersion 5 MHz span (500 kHz/Div)
11. Adjust FL2301, FL2302, FL2201, FL2202, and FL2203 for the following characteristics as seen on the Tracking Generator:
 - a. Center frequency, 89 MHz.
 - b. Bandwidth, ± 1 MHz at 1 dB.
 - c. Rejection at 79 MHz is 80 dB or greater.
 - d. Gain, 0 dB ± 4 dB.
12. Connect Power Supply to FL2204. Do not disconnect from FL2209 at this time.
13. Connect Tracking Generator output to J2201 and verify level displayed is -30 dBm (± 4 dB).
14. Disconnect Power Supply from FL2204 and FL2209.
15. Connect Tracking Generator input to J2202 and its output to J2203. Verify level displayed is -47.5 dBm (± 2.5 dB).

7-3-4 REASSEMBLY

With all power "OFF", disconnect all test equipment from IF Module. Reassemble and/or reinstall in reverse order of removal and disassembly procedure outlined in Section 6.

7-4 DUAL VCO

7-4-1 THEORY OF OPERATION (Refer to Figure 7-3 and Dual VCO Circuit Schematic in Section 10)

A. GENERAL

The Dual VCO furnishes the first and second local oscillator signals to the IF Module. The frequency of the first oscillator is controlled by the High Loop Synthesizer to between 1300 and 2298 MHz, depending upon the setting of the RF FREQUENCY Thumbwheels. This provides the first mixer in the IF Module with the frequency required for selection of the RF frequency. The second oscillator frequency is fixed at 1210 MHz, and furnishes the second mixer in the IF Module with the frequency required to produce the second stage IF frequency.

The Dual VCO Module consists of two similar VCO circuits, a 1400 MHz lowpass filter, and a mixer. An 1120 MHz Lowpass Filter is not a physical part of the module, but is required to allow only the difference frequency from the mixer to reach the High Loop.

The High Loop Synthesizer generates an error voltage which controls the frequencies of the two VCOs. To do this, a sample of each VCO frequency is mixed, then filtered by the 1120 MHz Lowpass Filter to allow the High Loop Synthesizer to compare only the difference frequency with the selected RF frequency. The High Loop then generates an error voltage when this difference frequency does not equal the selected RF frequency plus 90 MHz. The DC and low frequency components of the error voltage

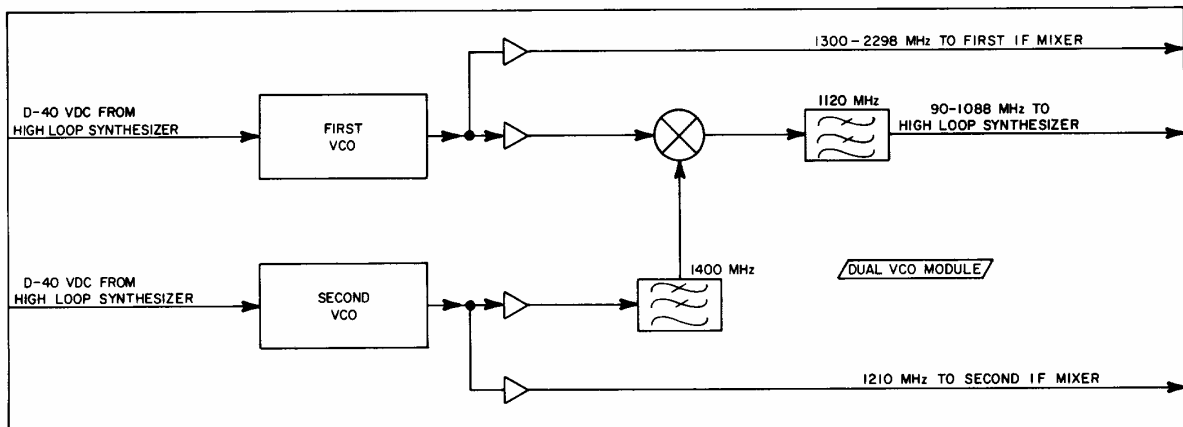

Figure 7-3 Dual VCO Block Diagram

(primarily the frequency error) are used to tune the first VCO to 1300 MHz plus the selected RF frequency. The high frequency components (primarily noise) of the error voltage tunes the second VCO. The result is that while the first VCO may vary slightly around its established frequency, the difference between the first and second VCO frequencies is held constant, producing a stable 90 MHz IF product.

B. FIRST (1300-2298 MHz) VCO CIRCUIT

Inductor L2102, varactor CR2101 and chip capacitors C2104 and C2106, with transistor Q2102, inductor L2103 and resistor R2108 forming a regenerative feedback circuit, comprise the basic oscillator. Capacitor C2122, resistors R2104, R2105, R2109 and R2110, and inductors L2105 and L2106 provide a bias network for transistor Q2102. Inductor L2101 and capacitor C2101 form a lowpass L-type DC filter, and transistor Q2101, resistors R2101 and R2102, and capacitor C2102 make a voltage regulator. Tuning voltage enters through J2101 and is filtered by resistors R2102, R2106 and R2107, capacitors C2103, C2105 and C2123, and inductor L2104. Exposed leads of varactor CR2101 and chip capacitors C2104 and C2106 form an inductor, coupling the oscillator output to inductor L2108, which feeds the buffer amplifiers.

C. FIRST VCO BUFFER AMPLIFIER CIRCUITS

The first VCO output is inductance-coupled through inductor L2108 to two identical two-stage buffers. One buffer feeds the first IF mixer through J2103, and the other goes to the mixer furnishing VCO feedback to the High Loop Synthesizer. Since both buffers are identical except for reference designators, the buffer feeding the first IF mixer will be discussed in detail. The first stage amplifier uses a common emitter, self-biased, class B amplifier Q2105, with resistor R2118 establishing proper bias and feedback. Inductor L2110 and capacitor C2109 form a lowpass LC filter, and resistor R2115 is a load resistor. The second stage is identical to the first. Capacitors C2110, C2114 and C2120 isolate the two stages, the input, and the output of the amplifier.

D. SECOND (1210 MHz) VCO CIRCUIT

Transistor Q2002 functions as an oscillator with varactor CR2001 controlling the frequency in response to the applied voltage level. Capacitor C2004 and inductor L2005, which is formed from one lead of the capacitor, establish the tuned circuit. Inductors L2002, L2003 and L2004 are isolation inductors. Trimmer capacitor C2003 allows calibration of the output frequency. Power is supplied through a lowpass LC filter comprised of inductor, L2001 and capacitor C2002. Transistor Q2001 and the associated resistors R2001 and R2002, and capacitor C2002 regulate the voltage. VCO output coupling is through inductor L2006. Phase shift voltage enters through J2001.

E. SECOND VCO BUFFER AMPLIFIER CIRCUIT

The second VCO output is inductance-coupled through inductor L2006 to two identical two-stage buffers. One buffer feeds the second IF mixer through J2003 and the other goes through the 1400 MHz lowpass filter to the mixer. The difference frequency is then used as feedback to the High Loop Synthesizer. These buffers are identical to the first VCO buffers described above except for resistor values and the use of an RC filter rather than an LC filter.

7-4-2 PREPARATION FOR TESTING

CAUTION

THE DUAL VCO MODULE IS NOT FIELD REPAIRABLE DUE TO CRITICAL LENGTHS AND SENSITIVE ALIGNMENTS. IF THE DUAL VCO IS FAULTY, IT SHOULD BE RETURNED TO THE IFR, INC. FACTORY FOR REPAIR. IF THE FOLLOWING TEST IS PERFORMED, BE EXTREMELY CAREFUL NOT TO DISTURB ANY COMPONENT.

A. REMOVAL AND DISASSEMBLY

Remove and disassemble the Dual VCO Module for testing as described in Section 6. Do not remove the PC boards from the cover plate assembly.

B. REQUIRED TEST EQUIPMENT

- 1 - Power Supply +12 VDC @ 250 mA
- 1 - Power Supply +40 VDC @ 100 mA
- 1 - Spectrum Analyzer 90-2500 MHz
- 1 - Frequency Counter Capable of 1.3 GHz
- 1 - Oscilloscope 10 MHz Bandwidth
- 1 - Digital Voltmeter 3½ Digit
- 1 - Inductor 22 μ H
- 1 - Capacitor 1.0 μ F, 50V
- 1 - Capacitor001 μ F
- 1 - Potentiometer 10 K Ω , 10 turns
- 1 - 50 Ohm Coax Cable BNC/Alligator Clips

C. PREPARATION (Refer to Figure 7-4, Dual VCO Assembly Drawing in Section 6 and Dual VCO Module Drawing in Section 9)

1. Disconnect jumper between FL2101 and FL2102.
2. Connect +12 VDC terminal of Power Supply to FL2101 and FL2102 (refer to Dual VCO Assembly Drawing in Section 6).
3. Connect common lead of Power Supply to chassis ground on Dual VCO Module.
4. Rotate adjustment screw on capacitor C2003 cw against the stop (refer to Dual VCO Assembly Drawing in Section 9).

CAUTION

DO NOT FORCE ROTATION OF C2003 PAST THE STOP.

5. Connect 10 K Ω potentiometer, 1.0 μ F capacitor and 22 μ H inductor to J2101 as shown in Figure 7-4.
6. Connect coax cable to Signal Generator.
7. Connect alligator clips to .001 μ F capacitor and to VCO PC Board ground as shown in Figure 7-4.
8. Solder .001 μ F capacitor to junction of R2106 and C2103 on first VCO PC Board as shown in Figure 7-4.

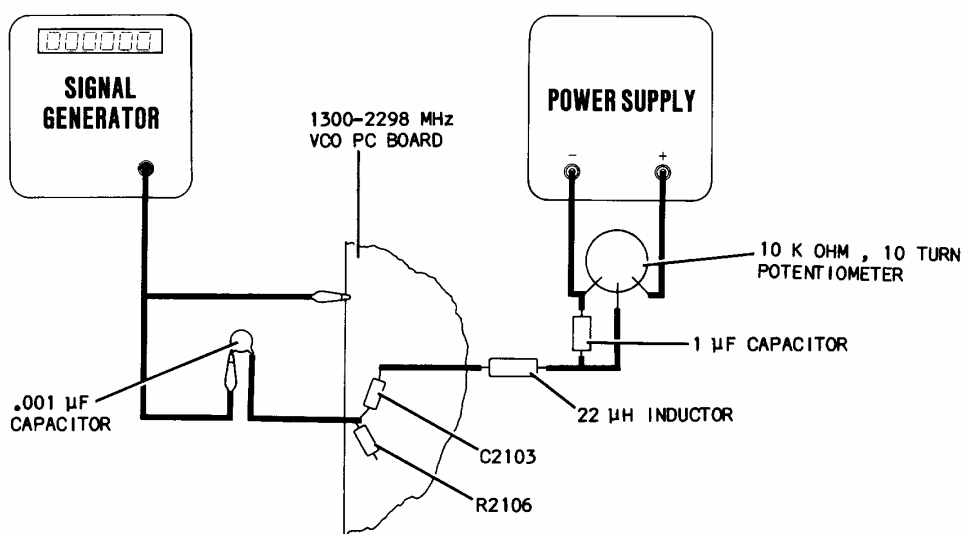

Figure 7-4 Dual VCO Test Connections

7-4-3 TESTING (Refer to Dual VCO Module Drawing in Section 9 and Circuit Schematic in Section 10)

A. FIRST (1300-2298 MHz) VCO

1. Apply power to +12 VDC Power Supply.
2. Using DVM, measure voltage at emitter of Q2101. Voltage should be approximately +11 VDC.
3. Connect Spectrum Analyzer input to J2103 and set at 2300 MHz.
4. Adjust 10 K Ω potentiometer as required to establish VCO at 2300 MHz. Spectrum Analyzer should show signal strength of +8 dBm (± 4 dB).
5. Using DVM, measure voltage at J2101. Voltage should be +26 VDC to +31 VDC. Record reading.
6. Adjust Spectrum Analyzer to 1300 MHz.
7. Adjust 10 K Ω potentiometer to establish VCO at 1300 MHz. Spectrum Analyzer should show signal strength of +8 dBm (± 4 dB).
8. Using DVM, measure voltage at J2101. Voltage should be +1 VDC (± 0.5 VDC). Record voltage.

B. SECOND (1210 MHz) VCO

1. Using DVM, measure voltage at emitter of Q2001. Voltage should be approximately +11 VDC.
2. Connect Frequency Counter to J2003.
3. Adjust C2003 until Frequency Counter displays 1210 MHz ± 1 MHz.
4. Connect Spectrum Analyzer to J2001. Verify output is +8 dBm (± 4 dB) at 1210 MHz.

C. MIXER OUTPUT

1. Connect 1120 MHz Lowpass Filter to J1901.
2. Connect output of 1120 MHz Lowpass Filter to Spectrum Analyzer.
3. Connect DVM to J2101.
4. Adjust 10 K Ω potentiometer from level in Step A.8. smoothly to level in Step A.5. Observe signal on Spectrum Analyzer. Signal should vary smoothly from 90 MHz to 1098 MHz at -30 dBm to -35 dBm.

5. Connect Spectrum Analyzer to J1901.
6. While adjusting 10 K Ω potentiometer from level in Step A.5. smoothly to level in step A.8, observe 2420 MHz harmonic mixing with first VCO signal producing 1120 to 129 MHz signal. This unwanted signal must be 40 dB or more below mixer output signal, especially at crossing point of 605 MHz.

7-4-4 REASSEMBLY

With all power "OFF", disconnect all test equipment from Dual VCO Module. Reassemble and replace module in reverse order of removal and disassembly procedures described in Section 6.

7-5 HIGH LOOP SYNTHESIZER MODULE

7-5-1 THEORY OF OPERATION (Refer to Figure 7-5 and High Loop Analog and High Loop Divider Circuit Schematics in Section 10)

A. GENERAL

The High Loop Synthesizer receives the difference frequency of 90-1088 MHz resulting from mixing the first and second local oscillators in the Dual VCO Module. This signal is amplified and the frequency divided by a $\div 4$ prescaler, then divided again by a $\div N$ programmable divider to 500 kHz. The programmable divider consists of a network of counters, flip-flops, gates, and a prescaler, and is set by the three left hand (MHz) RF FREQUENCY thumbwheels to divide by a number from 45 to 544. (This is the thumbwheel setting divided by 2 MHz, dropping any fraction of a MHz, then adding 45.)

The 500 kHz signal from the divider network is applied to a frequency detector network, which also receives a 500 kHz reference from the Frequency Standard. This network consists of an input amplifier for each signal and a phase/frequency detector in parallel with two phase sampler circuits. When a difference exists between the two frequencies, the detector sends an error signal to an integrator circuit, which varies the DC voltage driving the first (1300-2298 MHz) VCO in the Dual VCO Module. As the first VCO frequency changes, the VCO difference frequency to the High Loop Synthesizer changes accordingly, which changes the output frequency of the divider network. When the two frequencies (divider output and reference frequency) are approximately equal, the output becomes quiet.

In the first phase sampler, the leading edge of the divider output (approximately 500 kHz squarewave) triggers a switch which provides +11 VDC pulses. Through gating, the divider output and the corresponding 500 kHz pulses produce spikes of very short duration, which enable a second switch. The 500 kHz reference, which is also a square wave, is the input to the second switch; the output is a pulse whose level is that of the reference signal at the time and for the duration the switch is enabled. If the divider output frequency differs from the reference, the pulses will alternate between high and low amplitude. If the frequencies are equal but not in phase, the output will be either high or low. When the frequencies are equal and in phase, the switch will conduct a sample of the leading edge ramp. This output sample goes to a two-stage amplifier, then sends the signal to the second sampler.

The output from the programmable divider, in addition to its other uses, goes to a pulse generator in the phase detector circuit. These pulses enable the second sampler to conduct the DC offset signal from the first sampler at its level at the time and for the duration of the pulse. Second sampler output

pulses are nulled, the signal is amplified, then sent to the integrator circuit for the first VCO and to a gain control and digital-to-analog circuit for the second VCO.

One amplifier in the integrator circuit varies the voltage controlling the first VCO frequency. Two comparators limit this voltage to preset low and high levels, restricting the VCO to between 1275 MHz and 2330 MHz. A third comparator is enabled when the RF FREQUENCY Thumbwheels are set at less than 200 MHz. This ensures that the VCO frequency slews sufficiently to be within the range of the frequency detector circuit when making extreme frequency changes on the thumbwheels.

A quad-bilateral switch, controlled by the BCD signal from the 100 MHz RF FREQUENCY Thumbwheel, adjusts the gain of the second VCO error signal from the phase detector. The AC components of the error signal pass through the selected switch or switches and corresponding paralleled resistors to an amplifier. A choke smooths the amplifier output, which then goes to the second VCO to effect a phase shift.

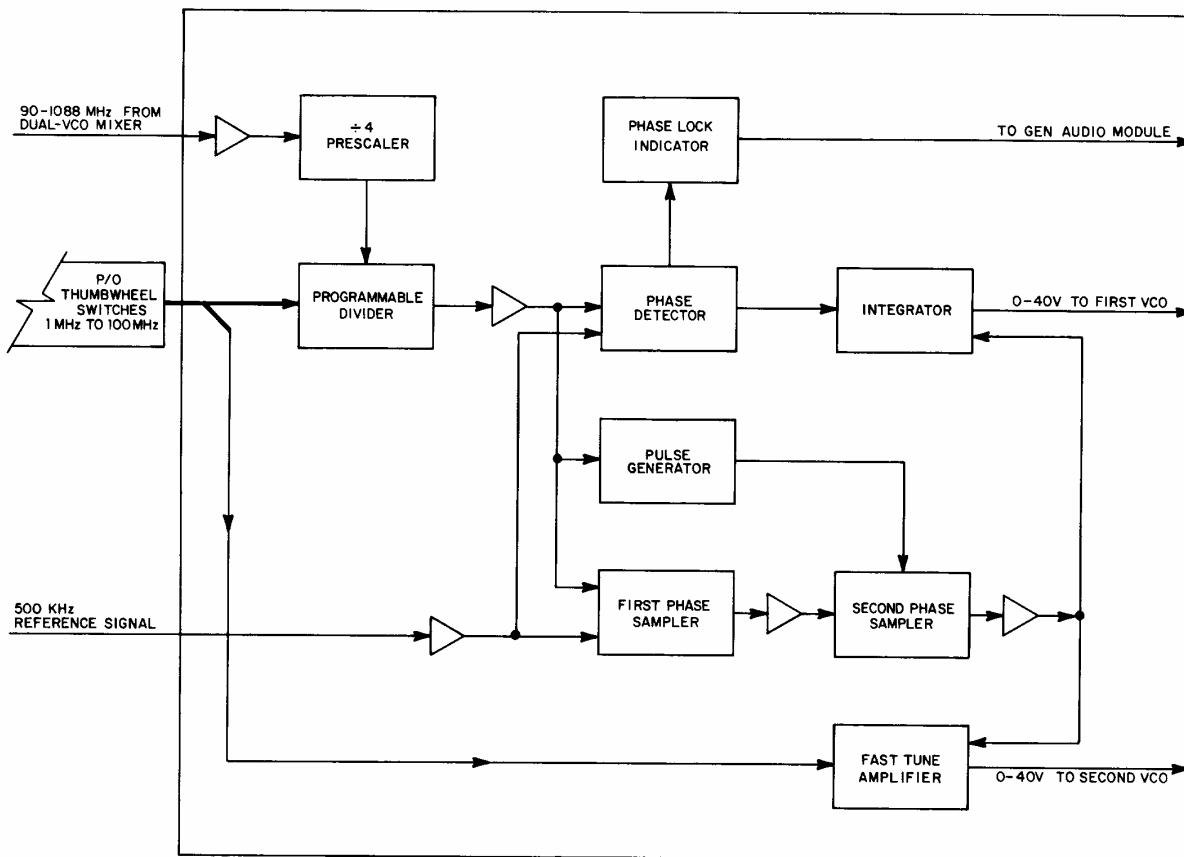

Figure 7-5 High Loop Synthesizer Block Diagram

A second output of the frequency detector operates in the phase lock indicator circuit. When the phase of the divider network output differs from the phase of the reference signal, an LED on the High Loop is illuminated and a logic voltage from the Generate Audio Module is grounded, allowing that logic circuit to produce a 2 Hz signal to the LOCK light on the Front Panel rather than the normal steady DC. This causes the Front Panel LED to flash at approximately half-second intervals.

B. RF FEEDBACK AMPLIFIER CIRCUIT (On Divider PC Board)

The 90-1088 MHz feedback signal from the Dual VCO goes through a four-stage amplifier consisting of amplifiers U4101, U4102 and U4103, and RF transistor Q4101. The output of the amplifier is split, with one part going through a level-shaping network consisting of choke L4105, resistor R4148 and capacitor C4158, to the ÷4 prescaler U4104. The second part goes to an AGC circuit which feeds back to diode CR4110 between amplifiers U4102 and U4103, thus decreasing the signal level to amplifier U4103 as the forward-bias decreases. Diode CR4111 and capacitor C4154 form a level detector, while potentiometer R4145 allows adjustment of the AGC level. The output of op amp U4111, thus, is positive when the signal is relatively weak, which turns on diode CR4110 and allows the input to amplifier U4103 to increase. This results in a stronger signal to op amp U4111. When the signal strength is greater than the non-inverting input, the output becomes more negative, which would increase the signal flow at CR4110. However, capacitor C4155, which is parallel with the op amp, prevents abrupt changes in the feedback signal and allows the op amp to adjust the signal level to equilibrium with the reference voltage on the non-inverting input to the op amp.

C. FEEDBACK FREQUENCY DIVIDER (On Divider PC Board)

Prescaler U4104 (÷4) divides the signal from the RF amplifier, then sends it to prescaler U4107 (÷5/÷6). Counter U4105 furnishes the signal to gate U4108B, which sets U4107 to divide by six for a selected number of pulses, then by five until the end of count is reached. Counter U4105 furnishes the signal which sets U4107 to divide by six. Decade counters U4105, U4106 and U4109 count the output pulses from U4107, starting with the numbers set on the three left-most (1's, 10's and 100's MHz) RF FREQUENCY Thumbwheels. When the end-of-count is reached, gates U4108A and U4108C clock flip-flop U4110B, which resets the counters and flip-flop U4110A. U4110A then provides the signals to the ECL-to-TTL translator in prescaler U4107, which, in turn, produces a squarewave at approximately 500 kHz.

D. SECOND FEEDBACK AMPLIFIER (On Analog PC Board)

The second feedback amplifier utilizes transistors Q4003 and Q4004. When the feedback signal is high, Q4004 conducts,

grounding the amplifier output. When the signal is low, Q4003 conducts, which brings the output high. One output of the second amplifier goes to the first phase sampler circuit; another is to the pulse generator.

E. PULSE GENERATOR CIRCUIT (On Analog PC Board)

Initially, capacitor C4006 is charged through resistor R4006, and transistor Q4006 conducts a capacitor-charging voltage to ground. As the output of the second feedback amplifier goes low, C4006 discharges, causing Q4006 to stop conducting and the voltage it controls to go high. C4006 then recharges, Q4006 resumes conducting, and its controlled voltage again drops. As this voltage drops, capacitor C4007, which is charged through resistor R4011, discharges and causes transistor Q4008 to stop conducting until C4007 recharges. The voltage normally grounded by Q4008 then produces a spike which simultaneously charges capacitor C4009, thus turning on FET transistor Q4010 for the duration of the spike, and stops transistor Q4009 from conducting. During the time Q4009 is not conducting, capacitor C4010 discharges to cancel noise produced by C4009 and Q4010.

F. REFERENCE SIGNAL AMPLIFIER (On Analog PC Board)

The reference signal amplifier is very similar to the second feedback amplifier discussed above. When the incoming signal is high, transistor Q4002 conducts, grounding the amplifier output. When the signal is low, Q4001 conducts, which brings the output high.

G. FIRST PHASE SAMPLER (On Divider PC Board)

The first phase sampler receives a 500 kHz signal from the second feedback amplifier and the reference signal amplifier. The feedback signal is applied to one input of NOR gate U4113D, and to the clock of bilateral switch U4114D. When the signal is high, U4114D couples +11 VDC to NOR gate U4113C. Capacitor C4144 and resistor R4136 delay the rise of the output from gate U4113C after the feedback pulse drops. With the output from U4113C coupled to the second input of U4113D, this holds both inputs to U4113D low for the time constant of C4144 and R4136, causing a short duration pulse as the output of U4113D. The pulse enables bilateral switch U4114A to conduct the reference signal's instantaneous level to the first sampler amplifier. This output is a constant level DC when the system is phase locked.

H. FIRST SAMPLER ISOLATION AMPLIFIER (On Analog PC Board)

Capacitor C4005 holds the DC signal from U4114A at the sampled level until U4114A makes the next sample. At that time, C4005

is recharged. Transistors Q4005 and Q4007 are emitter-followers which buffer the DC output, providing two diode gaps of amplification to the second sampler.

I. SECOND PHASE SAMPLER (On Analog PC Board)

The output from the first sampler isolation amplifier is applied to the drain of FET Q4010. When gated by the spike from the pulse generator through capacitor C4009, the output of Q4010 is the instantaneous level of the signal at the drain. When the system is phase locked, this level is constant. Capacitor C4011 holds the output level, being recharged each time Q4010 is gated. At the same time Q4010 is gated, capacitor C4010 is discharged to reduce output noise.

J. SECOND SAMPLER AMPLIFIER (On Analog PC Board)

The output from the second sampler is combined with an adjustable bias voltage through potentiometer R4045 and applied to the base of transistor Q4012. Q4012 applies a voltage to the base of transistor Q4011, whose output is divided, with one branch connected to the first (1300-2298 MHz) VCO integrator circuit and the second branch being fed to the second (1210 MHz) VCO integrator circuit.

K. PHASE DETECTOR CIRCUIT (On Divider PC Board)

The 500 kHz reference signal from the reference signal amplifier and the 500 kHz feedback signal from the second feedback amplifier are fed through inverters U4113B and U4113A respectively, to phase-locked loop U4112. U4112 has two outputs; one is to transistor Q4103 in the phase lock indicator circuit; the other is a correction signal to the first (1300-2298 MHz) VCO integrator. The level of this signal, which is approximately 5.2 VDC when the system is phase locked, is limited to a minimum of approximately 2.7 VDC and a maximum of approximately 8.1 VDC by a voltage limiting circuit consisting of zeners CR4106 and CR4107, diodes CR4105 and CR4108, resistors R4126 and R4127 and capacitor C4133.

L. FIRST VCO INTEGRATOR CIRCUIT (On Analog PC Board)

The +40 VDC from the Power Supply provides the voltage to operate the first (1300-2298 MHz) VCO in the Dual VCO Module. The first VCO integrator circuit controls this voltage, adjusting it as necessary to operate the VCO at the desired frequency. The output from the second sampler amplifier feeds into integrator U4004A. As its input level increases, the integrator's output decreases, pulling down on the VCO voltage through transistor Q4013 at a gain equal to the ratio of resistor R4039 and resistors R4030 and R4031. Op amps U4005A and U4005B, with potentiometers R4042 and R4047, establish high and low limits respectively. A third limiter prevents the output to the VCO

from becoming too high when the RF FREQUENCY Thumbwheels are set for less than 200 MHz. To accomplish this, binary signals for 200, 400 and 800 MHz are coupled to NOR gate U4003B. If any of these signals is high, the gate output is low, pulling down the non-inverting input to op amp U4004B. U4004B then has no effect on the integrator circuit. However, when all binary signals to U4003B are low, the output is high and any tuning voltage applied to the non-inverting input of U4004B exceeding the voltage on the inverting input, causes a high feedback to the integrator which, in turn, pulls down on the VCO control voltage. The voltage to the inverting input of U4004B is established by potentiometer R4024.

M. SECOND VCO TUNING AMPLIFIER (On Analog PC Board)

The second output of the second sampler amplifier and the VCO correction signal from the phase detector circuit are gain-controlled through a parallel resistor network. Resistor combinations are selected by a quad-bilateral switch, controlled by binary codes from the 100 MHz thumbwheel. The output of the resistor network is coupled through capacitor C4012 to op amp U4002A. The gain of U4002A is set by potentiometer R4053 in the amplifier hysteresis loop. A changing input signal level affects the amplifier output, but when the input level is steady, its output returns slowly to its preset level. The output of the amplifier changes quickly in response to small input level changes in order to cause a fast response in the second VCO frequency. However, when the input stops changing, the VCO returns to its output frequency of 1210 MHz output, and the feedback changes frequency accordingly. This gives the first VCO integrator time to respond to the phase correction signal.

N. PHASE LOCK INDICATOR CIRCUIT (On Divider PC Board)

One input DC signal to the phase lock indicator circuit in the Generate Audio Module is coupled to the High Loop Synthesizer phase detector circuit for control. When this signal is grounded, the LOCK Lamp on the Front Panel flashes. This also grounds LED CR4013 on the High Loop Synthesizer, allowing it to glow continuously. Transistor Q4104 conducts this signal to ground when a high input to its base exists. Transistor Q4103 supplies the base voltage to Q4104 when the phase comparator signal from the phase-locked loop U4112 is low, indicating an unlocked condition.

O. VOLTAGE REGULATOR (On Divider PC Board)

Transistor Q4102, with associated resistors R4131 and R4132 and capacitors C4142 and C4143, provide the +11 VDC required by various circuits in the High Loop Synthesizer.

7-5-2 PREPARATION FOR TESTING

A. REMOVAL AND DISASSEMBLY

Remove the High Loop Synthesizer as outlined in Section 6. Disassemble if repair is required.

B. REQUIRED TEST EQUIPMENT

- 1 - Digital Multimeter 100 K Ω /V
- 1 - Oscilloscope 10 MHz Bandwidth
- 1 - Frequency Counter Capable of 2.56 GHz
- 1 - Spectrum Analyzer 1.0 - 2.5 GHz
- 1 - Potentiometer 10 K Ω , 10 turns
- 1 - 500 Ohm Coax Cable BNC/BNC

C. PREPARATION (Refer to High Loop Analog and Divider PC Board Drawings in Section 9 and Circuit Schematics in Section 10)

1. Perform the tests prescribed in paragraph 7-4, Dual VCO, prior to testing the High Loop.
2. Uncouple connectors P/J4002, P/J4003 and P/J4102.
3. Connect the 10 K potentiometer as follows:

Terminal 1	Chassis ground
Terminal 2 (wiper)	P4003 Center Conductor
Terminal 3	J5201 pin 9 (Power Supply)
4. Connect Frequency Counter to J2103 on Dual VCO.
5. Connect Spectrum Analyzer to J2003 on Dual VCO.

7-5-3 TESTING (Refer to Controls, Indicators and Connector Drawings in Section 1, High Loop Analog and Divider PC Board Drawings in Section 9 and High Loop Analog and Divider Circuit Schematics in Section 10)

1. Set Power Switch in "LINE" position.

2. Using DMM, verify the voltages on the following pins of P4102 are within tolerances given below:

Pin No.	Voltage	Tolerance
2	+5 V	±0.2 V
12	-12 V	±0.2 V
14	+12 V	±0.2 V
16	+43 V	±6.0 V

NOTE

If all the required voltages are not present, troubleshoot the Power Supply and Distribution Circuit.

RF FREQUENCY Thumb-wheel Settings	BCD at J4102 Pin No.										
	1	3	5	7	9	11	13	15	17	19	20
000 000 0 111 000 0	0 0	0 0	0 0	0 0	0 0	0 1	0 0	0 1	0 0	0 0	0 0
222 000 0 333 000 0	1 1	0 0	0 0	0 0	0 0	0 1	1 1	0 1	0 0	1 1	0 0
444 000 0 555 000 0	0 0	1 1	1 1	0 0	0 0	0 1	0 0	0 1	0 0	0 0	1 1
666 000 0 777 000 0	1 1	1 1	1 1	0 0	0 0	0 1	1 1	0 1	0 0	1 1	1 1
888 000 0 999 000 0	0 0	0 0	0 0	1 1	1 1	0 1	0 0	0 1	1 1	0 0	0 0
BCD 0 = <5Ω 1 = >2 MΩ											

Table 7-2 RF FREQUENCY BCD Logic Values

3. Using DMM, verify the logic states of the RF FREQUENCY switches according to Table 7-2.

NOTE

If the logic is not correct, test the RF FREQUENCY switches and the Mother Board.

4. Set Power Switch in "OFF" position and connect P/J4102.
5. Set Power Switch in "LINE" position and verify a steady illumination of the phase lock LED on the High Loop Module.

6. Set RF FREQUENCY Thumbwheels to "299 000 0".
7. Connect DVM between wiper of 10K pot and ground.
8. Adjust the 10 K pot to obtain each of the following frequencies and record the corresponding voltage:
 - a. 1250 MHz
 - b. 1550 MHz
 - c. 2330 MHz

NOTE

If the VCO requires more than 34 volts to produce 2330 MHz, test the VCO as described in paragraph 7-4 before proceeding with this procedure.

9. Connect DVM between center conductor of J4003 and ground.
10. Adjust the 10 K pot to obtain a frequency of 1700 MHz.
11. Adjust Low Limit trimpot R4047 to obtain a voltage equal to that recorded in Step 8a.
12. Adjust the 10 K pot to obtain a frequency of 1500 MHz.
13. Adjust High Limit trimpot R4042 to obtain a voltage equal to that recorded in Step 8c.
14. Rotate RF FREQUENCY Thumbwheels to "199 000 0".
15. Adjust the 10 K pot to obtain a frequency of 1400 MHz.
16. Adjust 200 MHz Limit trimpot R4024 to obtain a voltage equal to that recorded in Step 8b.
17. Disconnect the DVM and 10 K pot and recouple P/J4002 and P/J4003.
18. Rotate RF FREQUENCY Thumbwheels to "999 000 0". Verify the High Loop phase lock indicator LED is not illuminated.
19. Verify the Spectrum Analyzer displays 1210 MHz at +8 dBm (± 4 dB).
20. Adjust the following trimpots for the minimum spurs at 500 kHz and 1 MHz as displayed on the Spectrum Analyzer.
 - a. R4045 (Null #2)
 - b. R4052 (Null #1)

21. Connect the Spectrum Analyzer to the T/R jack.
22. Rotate RF FREQUENCY Thumbwheels to "150 000 0".
23. Adjust trimpot R4053 to obtain the lowest overall noise.
24. Connect the Spectrum Analyzer to J2103 on the Dual VCO Module.
25. For each of the RF FREQUENCY Thumbwheel settings listed below, verify the Spectrum Analyzer displays a signal at the corresponding frequency at +8 dBm (± 4 dB).

Thumbwheel Setting	1st VCO Output Frequency (MHz)
999 000 0	2298
888 000 0	2188
777 000 0	2076
666 000 0	1966
555 000 0	1854
444 000 0	1744
333 000 0	1632
222 000 0	1522
111 000 0	1410
000 000 0	1300

26. Rotate the RF FREQUENCY Thumbwheels to "900 000 0" and verify the Front Panel phase lock indicator quickly achieves steady illumination.
27. Rotate the RF FREQUENCY Thumbwheels back to "000 000 0". Again verify the Front Panel phase lock indicator quickly achieves a steady illumination.

7-5-4 REASSEMBLY

With all power "OFF", disconnect all test equipment. Reassemble and reinstall in reverse order of removal and disassembly procedures outlined in Section 6.

7-6 LOW LOOP SYNTHESIZER

7-6-1 THEORY OF OPERATION (Refer to Figure 7-6 and Low Loop Circuit Schematic in Section 10)

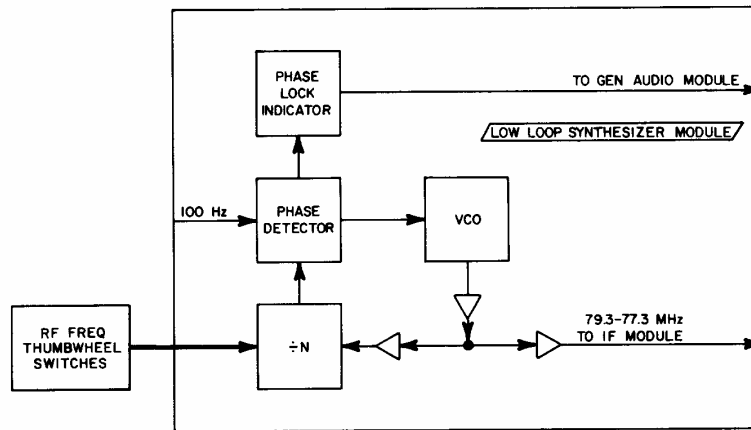

Figure 7-6 Low Loop Synthesizer Block Diagram

A. GENERAL

A VCO in the Low Loop Synthesizer produces the 79.3 to 77.3 MHz frequency required by the third mixer in the IF Module. The VCO output is buffered, then split, with one branch being buffered further and fed into the third mixer. The second branch is buffered and fed into a $\div N$ divider which is controlled by the RF FREQUENCY Thumbwheels. This divider divides by a factor of between 793,000 and 773,001.

The output of the divider network, when phase-locked, is a 100 Hz pulse furnished to a phase comparator. The comparator compares this signal with a 100 Hz reference signal from the Digital Counter. Any difference between the signals causes corresponding changes in the detector's output voltage. This output voltage is integrated and then fed to the VCO to vary its frequency. Thus, if the divider output frequency is not 100 Hz, the phase comparator steers the VCO frequency to obtain the 100 Hz divider output frequency.

A second output of the phase comparator operates in the phase lock indicator circuit. When the phase of the VCO output differs from the phase of the reference signal, the cathode of the

LED on the Low Loop is grounded, allowing a continuous forward bias to illuminate the LED. The grounding of the LED also enables a 2 Hz oscillator in the Generate Audio Module, causing the LED on the Front Panel to flash at approximately half-second intervals.

B. VCO.CIRCUIT

The Low Loop output of 79.3 to 77.3 MHz is produced by voltage controlled oscillator Q4206. Variable inductor L4203 provides calibration adjustment. Inductor L4202 and capacitor C4212 decouple the oscillator from the power supply circuitry. Oscillator tuning bandwidth is established by capacitors C4213, C4214 and C4217, inductor L4203, and diode CR4203. Diode CR4202, resistor R4217, and capacitor C4215 control the amplitude.

C. BUFFER AMPLIFIERS

The VCO output is buffered by transistor Q4205, then split and applied to two independent buffers. One second stage buffer, consisting of transistors Q4203 and Q4204, feeds the third mixer of the IF Module. The other second stage buffer, which uses transistors Q4201 and Q4202, furnishes feedback to the programmable divider network.

D. PROGRAMMABLE DIVIDER NETWORK

The divider network consists of a $\div 10/\div 11$ prescaler and chained dividers U4201, U4203, U4204, U4205, U4207 and U4208, which are programmed by the X.XXXX RF FREQUENCY thumbwheel switches. The network divides the VCO output frequency by a number equal to 793000 minus the setting of the .XXXX thumbwheels (minus 10,000 when the X. thumbwheel setting is an odd integer). The output of the divider network goes to the phase detector circuit.

E. PHASE DETECTOR CIRCUIT

Dual flip-flop U4212 compares the programmable divider network output frequency with the 100 Hz reference signal from the Digital Counter Module. NAND gate U4213D allows the Q outputs of U4212 to reset the flip-flops. Diodes CR4204 and CR4205 allow the flip-flops to charge or discharge capacitor C4224 when a phase error exists. This provides a ripple DC to drive op amp U4214B. U4214B and capacitor C4215 function as an integrator, furnishing analog DC to the VCO circuit to steer the VCO frequency as required to correspond with the reference signal. The \bar{Q} outputs of U4212 are applied to NAND gate U4213C. When the two \bar{Q} signals are not in phase, U4213C causes transistor Q4207 to conduct, grounding LED CR4207, causing it to illuminate.

7-6-2 PREPARATION FOR TESTING

A. REMOVAL AND DISASSEMBLY

Remove and disassemble the Low Loop Synthesizer as outlined in Section 6.

B. REQUIRED TEST EQUIPMENT

- 1 - Spectrum Analyzer 60-1700 MHz
- 1 - Oscilloscope 10 MHz Bandwidth (minimum)
- 1 - Frequency Counter Capable of counting to 80 MHz
with 10 Hz resolution
- 1 - 50 Ohm Coax Cable BNC/SMB

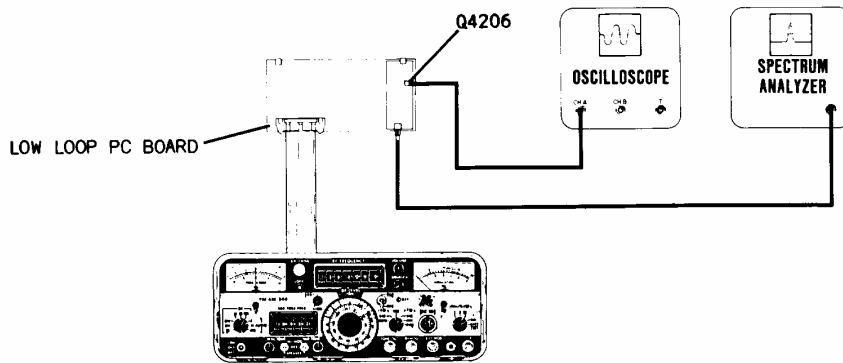

Figure 7-7 Low Loop Synthesizer Test Set-up

C. PREPARATION (Refer to Figure 7-7 and Low Loop PC Board Drawing in Section 9)

1. Connect ribbon cable connector P4201 to J4201.
2. Connect spectrum analyzer to J4202.
3. Connect oscilloscope to Q4206 pin 3.
4. Set RF FREQUENCY Thumbwheels to 001 999 9.

7-6-3 TESTING (Refer to Low Loop PC Board Drawing in Section 9 and Circuit Schematic in Section 10)

1. Set Power Switch in "LINE" position.
2. Verify oscilloscope displays a smooth DC level of -3 V (± 1 V).

3. Verify phase lock LED on Low Loop Synthesizer Module is not illuminated.
4. Connect oscilloscope to TP4201. Verify oscilloscope displays a smooth DC level of 2.75 V (± 0.25 V).
5. Verify spectrum analyzer displays a level of +7 dBm (± 4 dB) at 77.3 MHz.
6. Rotate RF FREQUENCY Thumbwheels to "000 000 0".
7. Verify phase lock LED on Low Loop Synthesizer Module is not illuminated.
8. Verify Oscilloscope displays a smooth DC level of 7 V (± 1 V).
9. Verify Spectrum Analyzer displays an amplitude of +7 dBm (± 4 dB) at 79.3 MHz.
10. Verify harmonics above 1000 MHz are at a level of -70 dBm or less.
11. Connect Frequency Counter to J4202. Verify frequency displayed is 79.300000 MHz (± 20 Hz).
12. Rotate RF FREQUENCY Thumbwheels to "001 999 9". Verify Frequency Counter displays 77.30010 MHz (± 20 Hz).

NOTE

Limit RF FREQUENCY Thumbwheel (5) selections to between "000 000 0" and "001 999 9" for this test. Output frequency is always 79.3000 MHz minus the setting of the RF FREQUENCY Thumbwheels (5).

7-6-4 REASSEMBLY

With all power "OFF", disconnect test equipment from Low Loop Synthesizer. Reassemble in reverse order of removal and disassembly procedures outlined in Section 6.

7-7 RECEIVER/GENERATOR

7-7-1 THEORY OF OPERATION (Refer to Figure 7-8 and Receiver/Generator Circuit Schematic in Section 10)

A. GENERATE MODE

In the Generate mode, the Receiver/Generator utilizes a VCO tuned to 21.4 MHz to provide the carrier for RF signal generation and SSB reception. The output of the VCO is sampled by the Digital Module, which returns an analog tuning voltage to maintain the frequency at 21.4 MHz. When FM modulation is required, an audio modulation voltage from the Generate Audio Module is combined with the tuning voltage to produce the frequency modulated VCO output signal. A flip-flop divides the VCO output signal in half to produce the IF 10.7 MHz AM carrier or the FM signal. This signal passes through an attenuator which, in the Generate AM mode, modulates the carrier with the audio modulation voltage from the Generator Audio Module. The signal is then sent to the third mixer in the IF Module. The Generate Audio Module also supplies the GEN command signal (+12 VDC) which enables the flip-flop and, through an inverter, opens the receive enable circuit, preventing the generated signal from entering the receiver circuit at full strength. This attenuated signal is fed into the receiver circuit to allow the Receive Audio Module to monitor and display the signal on the Modulation and Frequency Error Meters.

B. RECEIVE MODE

In the Receive mode, the modulated 10.7 MHz signal from the IF Module passes through the receive enable circuit, two AGC amplifiers, and one of three bandpass filters. These filters have a center frequency of 10.7 MHz with bandwidths of 200 kHz (FM Wide and Mid), 15 kHz (FM Narrow and AM Norm) and 6 kHz (AM Narrow and SSB). The signal is amplified again by a third AGC amplifier, then demodulated, with the AM and FM audio going to the Receive Audio Module and the 10.7 MHz carrier going to the Digital Module. When in the Receive SSB mode, a flip-flop divides the 21.4 MHz output of the VCO to 10.7 MHz and, through a BFO level potentiometer, injects the beat frequency into the modulated signal just ahead of the AM demodulator.

C. RECEIVED SIGNAL AMPLIFIER CIRCUITS

The 10.7 MHz IF signal from the IF Module first enters the Receive Enable circuit. This circuit consists of diode CR4301, resistor R4384 and capacitors C4336 and C4348. When forward biased by transistor Q4307, diode CR4301 conducts, coupling the RF signal through coupling transformer FL4301 to the first amplifier circuit. When the mode power circuit in the Generate Audio Module applies the GEN command, the +12 VDC command voltage is applied to transistor Q4307, which shuts off diode

CR4301. Capacitor C4348 allows an attenuated sample of the generator signal to enter the receiver circuit.

The first amplifier is dual-stage, consisting of field-effect transistors Q4301 and Q4302, filter FL4302, inductors L4302, L4303, L4304 and L4307, and related resistors and capacitors. The amplified signal is then connected by coupling transformer FL4303 to the bandpass filters. After bandwidth filtering, the signal is connected by coupling transformer FL4304, for isolation, to the second amplifier consisting of field-effect transistor Q4311, coupling transformer FL4305, inductor L4306 and related capacitors and resistors. An AGC, using transistors Q4304 and Q4305, controls the gain through Q4301, Q4302 and Q4311.

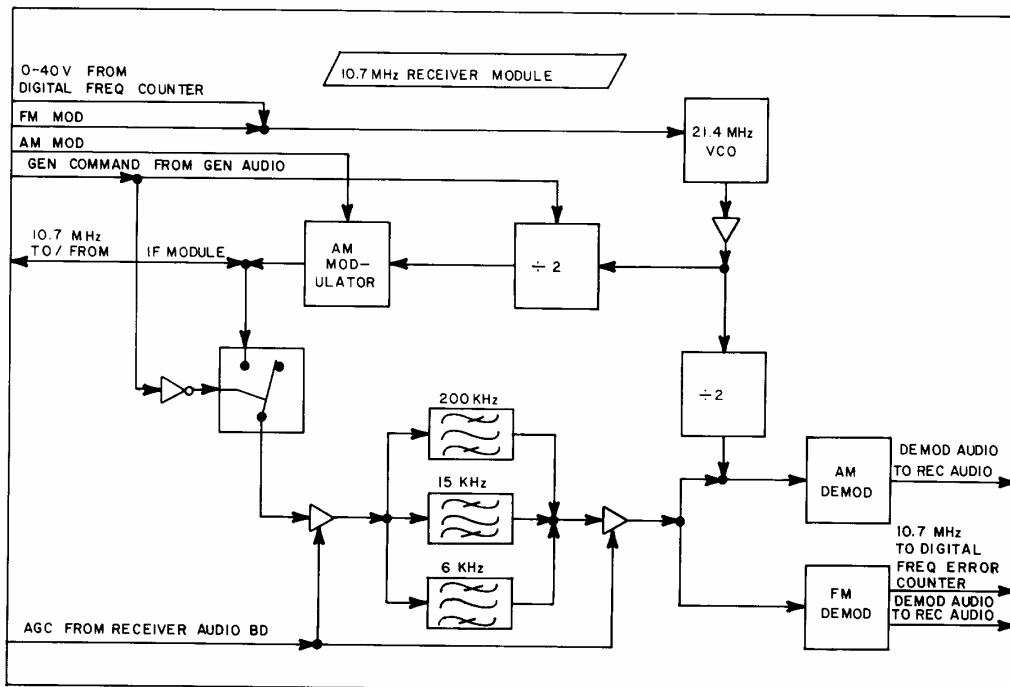

Figure 7-8 Receiver/Generator Block Diagram

D. BANDPASS FILTERS

The three bandpass filter circuits each utilize an RF transistor, two crystal filters, and two isolation diodes. The three circuits are identical except for resistor values and the bandwidths of the crystal filters. When a bandwidth is selected on the Modulation Mode Selector Switch on the Front Panel (i.e., AM NAR), a +12 VDC command is applied to the appropriate filter

circuit, which forward-biases the isolation diodes and allows the filter to function.

E. AM DEMODULATOR CIRCUIT

When operating in the Receive AM or Receive SSB mode, the modulated 10.7 MHz IF from the final amplifier coupler transformer FL4305 is applied to the base of RF transistor Q4312, which drives tuned filter FL4307. Diode CR4304 and capacitor C4327 form a high level AM detector. Resistor R4374, capacitor C4330 and diode CR4315 provide bias for the detector, which is buffered by op amp U4303B. The signal is then filtered by inductor L4305 and capacitor C4344 to remove any RF which may have passed diode CR4304, then is fed to the Receiver Audio Module as a signal varying only in voltage. When in SSB mode, a 10.7 MHz BFO, taken from the 21.4 MHz VCO, is added to the received signal at the base of transistor Q4312.

F. FM DEMODULATOR CIRCUIT

In the Receive FM mode, the 10.7 MHz IF from the secondary winding of final amplifier coupler transformer FL4305 is applied to RF transistor Q4313. This transistor and associated circuitry form a limiter amplifier which strips off any AM and amplifies the remaining carrier and FM slightly. Diodes CR4317 and CR4318 limit the output. U4302 is an IF amplifier with quadrature detector. Choke L4320, resistor R4378 and capacitors C4341, C4342 and C4380 form a tuned circuit for the detector. One output of the detector is a hard-limited 10.7 MHz signal fed to the Digital Module. The other output is a varying DC, which is the demodulated FM audio signal. This is amplified by op amp U4303A and filtered by inductor L4311 and capacitor C4343 to remove any residual RF, then is fed to the Receiver Audio Module.

G. 21.4 MHz VCO CIRCUIT

Field-effect transistor Q4305 and associated components comprise the basic oscillator circuit. Zener diode CR4316 regulates the supply voltage to +12 VDC, with decoupling from the power supply accomplished by inductor L4317 and capacitor C4354. A tuned circuit, consisting of diode CR4309, capacitors C4360, C4362 and C4374, and inductor L4312, determines the oscillator frequency. An FM modulation voltage, supplied by the Generate Audio Module, is combined with the tuning voltage through varactor CR4309 to produce a frequency-modulated signal centered on 21.4 MHz. Transistor Q4306 amplifies the signal. The signal is then split, with one branch going to the Digital Module at 21.4 MHz. Another branch is divided to 10.7 MHz by flip-flop U4301A to be used in the AM demodulator as a beat frequency for SSB reception. A third branch is divided to 10.7 MHz by flip-flop U4301B, and becomes the IF signal. This signal, which contains the frequency modulation originating in the Generate Audio Module, passes through the AM modulator circuit.

H. AM MODULATOR CIRCUIT

Inductor L4314 and capacitors C4368 and C4369 filter the square wave from flip-flop U4301B into a sinewave. Diodes CR4313 and CR4314 and associated circuitry form a voltage-controlled attenuator which is driven by an AM control voltage supplied by the modulator/leveler in the Generate Audio Module.

7-7-2 PREPARATION FOR TESTING

A. REMOVAL AND DISASSEMBLY

Remove and disassemble the Receiver/Generator Module as described in Section 6 for Enclosed Modules.

B. REQUIRED TEST EQUIPMENT

- 1 - Signal Generator 10.7 MHz @ 0 dBm
 - 1 - Spectrum Analyzer Capable of 10.7 MHz
 - 1 - Frequency Counter Capable of 25 MHz with 1 kHz resolution
 - 1 - Audio Distortion Meter Resolution of 0.1% @ 1 kHz
 - 1 - Oscilloscope 1 MHz with X-Y capabilities
 - 1 - Digital Voltmeter (DVM) 3½ Digit
 - 1 - 50 Ohm Coax Cable BNC/SNB Connectors
 - 1 - 26 Gauge Shorting Strap Alligator Clips both ends
- C. PREPARATION (Refer to Receiver/Generator PC Board Drawing in Section 9)
- 1. With Receiver/Generator PC Board insulated from FM/AM-500A chassis, connect P/J4301, P/J4303 and P/J4304.

CAUTION

DO NOT APPLY POWER TO POWER SUPPLY DURING PREPARATION PROCEDURES.

- 2. Connect Signal Generator output to J4302.
- 3. Using DC coupling, connect J4301 pin 19 to Oscilloscope input.
- 4. Connect shorting strap to either end of R4339 and to ground.

5. Set FM/AM-500A controls as follows:
 - a. Modulation Mode Selector Switch "FM VAR"
 - b. VAR TONE Selector Switch "OFF"
 - c. 1 kHz TONE Selector Switch "OFF"

7-7-3 TESTING (Refer to Receiver/Generator PC Board Drawing in Section 9 and Circuit Schematic in Section 10)

1. Apply power to test equipment.
2. Set Signal Generator to 10.7 MHz and adjust output level to obtain approximately +1 VDC level as viewed on Oscilloscope.

CAUTION

DO NOT EXCEED 0 dBm. IF DC LEVEL OF +1 VDC CANNOT BE OBTAINED, SET SIGNAL GENERATOR LEVEL TO 0 dBm.

3. Adjust FL4301, FL4302, FL4303, FL4304, FL4305 and FL4037 for maximum DC level as shown on Oscilloscope.
4. Reduce Signal Generator output level until amplitude of Oscilloscope display is approximately 1 major graticule division, then repeat Step 3. Repeat this procedure until a minimum level of +2 VDC is obtained at an input of 1.0 μ V.

NOTE

If +2 VDC is not obtained, adjust R4385 as required.

5. Rotate Modulation Mode Selector Switch to FM Wide position.
6. Modulate Signal Generator with 1 kHz audio. Select FM modulation with 50 kHz deviation.
7. Connect Oscilloscope to DEMOD jack and adjust L4320 for maximum output level.
8. Connect Modulation Meter to DEMOD jack and adjust L4320 slightly for distortion less than 2%.
9. Adjust Signal Generator for 5 kHz deviation and rotate Modulation Mode Selector Switch to "FM NAR". Distortion should be less than 3%. If not, slightly adjust FL4303 and FL4304.
10. Adjust Signal Generator for 90% AM modulation at 1 kHz and rotate Modulation Mode Selector Switch to "AM NORM".

11. Verify distortion is less than 5%. If not, test Q4301, Q4302 and Q4311.

NOTE

If one of these transistors is bad, replace it with one from the same manufacturer or replace all three with transistors from any one manufacturer.

12. Observe Distortion Meter while slowly increasing Signal Generator output to 30 mV. Verify distortion remains less than 2% for entire range of -50 dBm to -80 dBm.
13. Disconnect Signal Generator and reconnect P/J4302.
14. Set GEN/REC Switch in "GEN" position, rotate RF FREQUENCY Thumbwheels to "010.0000" MHz, and rotate RF LEVEL Attenuator to -20 dBm.
15. Connect Frequency Counter to T/R jack.
16. Rotate GEN/LOCK Control fully cw.
17. Adjust L4312 to obtain at least 10.010000 MHz (typically 10.020000 MHz) as measured on Frequency Counter.
18. Rotate GEN/LOCK Control fully ccw, just out of detent. Frequency Counter should display less than 9.990000 MHz (typically 9.980000 MHz). If necessary, readjust L4312 slightly.
19. Connect Oscilloscope to DEMOD jack and adjust R4351 to obtain maximum amplitude of display.
20. Rotate GEN/LOCK Control ccw into detent.
21. Connect Spectrum Analyzer input to J4302. Display should be -30 dBm or more.
22. Set GEN/REC Switch in "REC" and verify Spectrum Analyzer displays a level of -70 dBm or less.

7-7-4 REASSEMBLY

With all power "OFF", disconnect all test equipment from Receiver/Generator. Reassemble in reverse order of Enclosed Module removal procedures in Section 6.

7-8 FREQUENCY STANDARD MODULE

7-8-1 THEORY OF OPERATION (Refer to Figure 7-9 and Frequency Standard Circuit Schematic in Section 10)

A. GENERAL

The Frequency Standard uses a Voltage Controlled Temperature Compensated Crystal Oscillator (TCXO) to furnish a constant, internally-produced 10 MHz reference frequency. When desired, an external 10 MHz signal can be used by connecting the signal source to the EXT STD jack on the Rear Panel of the set. A dual decade ripple counter divides the 10 MHz to a 500 kHz signal which goes to the High Loop Synthesizer, and to a 1 MHz signal, which goes to the Digital Module. The 1 MHz is further divided in the Digital Module to produce the additional required reference frequencies.

A level detector circuit determines when an external signal is present on the external jack and responds by deactivating the TCXO and activating gates which simultaneously isolate the TCXO and couple the external signal to the counter.

A resistor, which is installed parallel with the external signal gates, allows a low level signal produced by the TCXO to reach the external jack. This provides sufficient radiation capability for a beat signal which can be used during calibration, but is insufficient to trigger the level detector. The resistor prevents an external signal from bypassing the level detector and gates.

B. TCXO POWER CIRCUIT

The level detector in the reference signal selector circuit controls the base voltage to transistor Q2501, which, in turn, controls the operating power to the TCXO. Potentiometer R106 on the Front Panel allows adjustment of the operating power to calibrate the TCXO.

C. REFERENCE SIGNAL SELECTOR CIRCUIT

The 10 MHz output of the TCXO is fed through the reference switching logic gates U2502C and U2502B to a frequency divider circuit and to the EXT STD jack on the Rear Panel. When an external signal in excess of 1 Vp-p is present at the EXT STD jack, the signal is applied to logic gate U2502A and to the level detector, which consists of op amp U2501 and associated circuitry. The level detector output raises the base voltage on transistor Q2501, disabling the TCXO and enabling gates U2502A, U2502B, U2502C and U2502D to transfer the signal to the frequency divider.

D. FREQUENCY DIVIDER

The frequency divider consists of dual counter U2503, transistor Q2502 and associated resistors. The 10 MHz input is divided by 10 in the first counter and sent to isolation amplifier transistor Q2502 before being supplied through P2502 to the Digital Counter at 1 MHz. The counter also divides the 1 MHz further to 500 kHz and supplies that frequency to the High Loop Synthesizer through P2503.

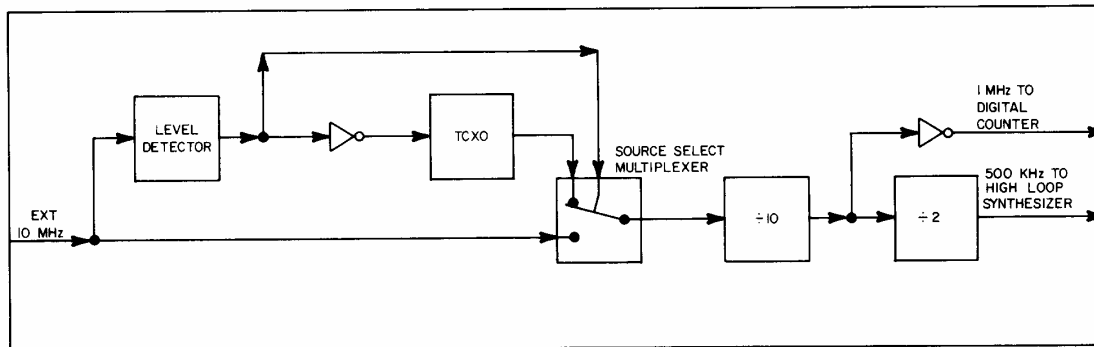

Figure 7-9 Frequency Standard Block Diagram

7-8-3 PREPARATION FOR TESTING

A. REMOVAL AND DISASSEMBLY

For testing the Frequency Standard, removal is not normally required. However, if repair is necessary, remove the PC Board assembly as outlined in Section 6. No module disassembly is required.

B. REQUIRED TEST EQUIPMENT

- 1 - Frequency Counter Capable of counting 10 MHz with 1 MHz resolution
- 1 - Signal Generator 10 MHz @ -25 dBm
- 2 - 50 Ohm Coax Cables BNC/SNB

C. PREPARATION

1. Connect Frequency Counter to P2501. (Refer to Frequency Standard PC Board Drawing in Section 9.)

2. Set REF potentiometer on Front Panel to center of its travel. (Refer to Controls, Indicators and Connectors Drawing in Section 1.)

7-8-3 TESTING (Refer to Frequency Standard PC Board Drawing in Section 9 and Circuit Schematic in Section 10)

1. Set Power Switch in "LINE" position.
2. Rotate REF potentiometer on Front Panel fully cw, then fully ccw. Verify Frequency Counter changes frequency accordingly.

NOTE

If correct frequency cannot be obtained using only the REF trimpot, adjust TCX0 coarse tuning adjustment (located on TCX0) for an indication of 10 MHz (± 2 Hz) on Frequency Counter, then repeat fine adjustment using the REF potentiometer.

3. Rotate REF potentiometer to obtain an indication of 10 MHz (± 1 Hz) on Frequency Counter.
4. Connect Frequency Counter to P2502. Verify displayed frequency is 1 MHz (± 1 Hz).
5. Connect Frequency Counter to P2503. Verify displayed frequency is 500 kHz (± 1 Hz).
6. Connect Signal Generator to P2501. Adjust Signal Generator to 10 MHz at -25 dBm (± 5 dBm). Verify Frequency Counter displays 500 kHz (± 3 Hz).
7. Adjust Signal Generator to 8 MHz. Verify Frequency Counter displays 400 kHz (± 3 Hz).

7-8-4 REASSEMBLY

With all power "OFF", disconnect test equipment from Frequency Standard and reconnect coax cables. If Frequency Standard PC Board was removed for repair or replacement, reassemble in reverse order of removal procedures outlined in Section 6.

7-9 DIGITAL MODULE

7-9-1 THEORY OF OPERATION (Refer to Figure 7-10 and Digital Counter and Digital Reference Circuit Schematics in Section 10)

A. GENERAL

As a signal source, the Digital Module divides the 1 MHz reference signal from the Frequency Standard into frequencies of 10 Hz, 100 Hz, 1 kHz and 10 kHz. According to the Frequency Error Range Switch position, one of these four frequencies is applied to the frequency error counter system. In addition, the 100 Hz signal is used as a reference signal by the Low Loop Synthesizer and the 1 kHz signal is used for the fixed audio tone and as a reference frequency for the 21.4 MHz VCO in the Receiver/Generator Module. A 21.4 MHz sample from the VCO is divided and compared with the 1 kHz by a phase comparator which supplies a tuning voltage to the VCO.

As an RF frequency counter, a counter system counts the incoming carrier signal digitally, and produces an analog voltage to drive the Frequency Error Meter according to its difference from a pre-set count. For audio frequency counting, the counter system digitally compares the demodulated audio frequency to the frequency set on the VAR TONE FREQ thumbwheels, and produces a corresponding analog voltage.

The Digital Module is divided, for discussion purposes, into three major circuits; the Frequency Divider Circuit, the Timing Circuit, and the Counter System.

B. FREQUENCY DIVIDER CIRCUIT (On Digital Reference PC Board)

The incoming 1 MHz reference signal is divided successively by BCD counters U4505, U4506 and U4507 to produce frequencies of 10 kHz, 1 kHz, 100 Hz and 10 Hz. These signals are all coupled to time-base multiplexer U4508. In addition, the 100 Hz frequency is fed to the Low Loop Synthesizer; the 1 kHz is the reference for the 21.4 MHz VCO phase detector, and also goes to a 1 kHz bandpass filter consisting of op amps U4514A, U4514B and U4515A and related circuitry. The bandpass filter changes the square wave into a sinewave for the 1 kHz fixed tone audio signal. The 21.4 MHz VCO sample is first amplified by transistor Q4501, then divided by counters U4501 and U4502 and NAND gate U4516 to produce a frequency of 1kHz. PLL (Phase Locked Loop) U4503 compares this frequency with the 1 kHz signal from the time-base divider circuit and produces a VCO tuning voltage. The potentiometer in the GEN/LOCK control on the Front Panel provides an alternative VCO tuning voltage. The GEN/LOCK Control Switch applies approximately +5 VDC when in the GEN position, enabling multiplexer U4504C to select between these two alternative tuning voltages.

C. TIMING AND SIGNAL SELECTOR CIRCUIT (On Digital Counter PC Board)

In the timing circuit, counter U4411 divides the time-base frequency by 10. Dual master-slave flip-flop U4412A and U4412B provide timed control signals. Triple multiplexer U4401A, U4401B and U4401C provides signal selection. Dual one-shot multivibrator U4413A and U4413B resets the system. A multiplier circuit (installed on the Digital Reference PC Board) multiplies the audio signal by a factor of 100 so it can be counted during the established time-base period. The multiplier circuit consists of demultiplexer U4509, PLL U4510 and counter U4511 for the reference signal and PLL U4512 and counter U4513 for the unknown audio frequency.

In the audio frequency multiplier circuit, demultiplexer U4509 (on Digital Reference PC Board) selects the capacitance required for timing the VCO in the PLL according to the setting of the VAR TONE FREQ Thumbwheels. The output frequency of the PLL VCO is sampled by the counter, and divided by 100. The PLL comparator compares the counter output frequency to the incoming audio frequency (reference or unknown), and produces a VCO tuning voltage which is used by the PLL VCO for its own tuning. The output from each PLL is coupled to one input of multiplexer U4401B.

The control signal for multiplexer U4401B is from the Q output of slaved flip-flop U4412B. When this signal is low, U4401B feeds the unknown audio frequency (multiplied by 100) to multiplexer U4401C. When the Q output is high, U4401B feeds the reference signal (also multiplied by 100) to U4401C. When the Frequency Error Range Switch on the Front Panel is in one of the RF positions, multiplexer U4401C couples the demodulated 10.7 MHz carrier signal to the counter system. With the switch in one of the AUDIO positions, the unknown and reference signals (multiplied by 100) are selected.

According to the setting of the Frequency Error Range Switch, the time-base selector U4508 feeds one of the four frequencies available to it to counter U4411 for division by 10. The counter's end-of-count signal clocks master flip-flop U4412A.

Starting with the condition of Q being high, when U4412A is clocked by U4411, Q goes low and \bar{Q} goes high. The \bar{Q} signal inhibits the counter system and is applied to multiplexer U4401A as a reset signal. Through inverter U4421, the corresponding low Q becomes high, clocking U4412B and resetting counter U4411 to a count of 9. The next time-base pulse then causes U4411 to again clock U4412A. Q goes low, \bar{Q} goes high, and the cycle repeats.

When the Q output from slaved flip-flop U4412B is low, the counter system counts upward and multiplexer U4401B couples the unknown audio signal to the signal selector multiplexer U4401C.

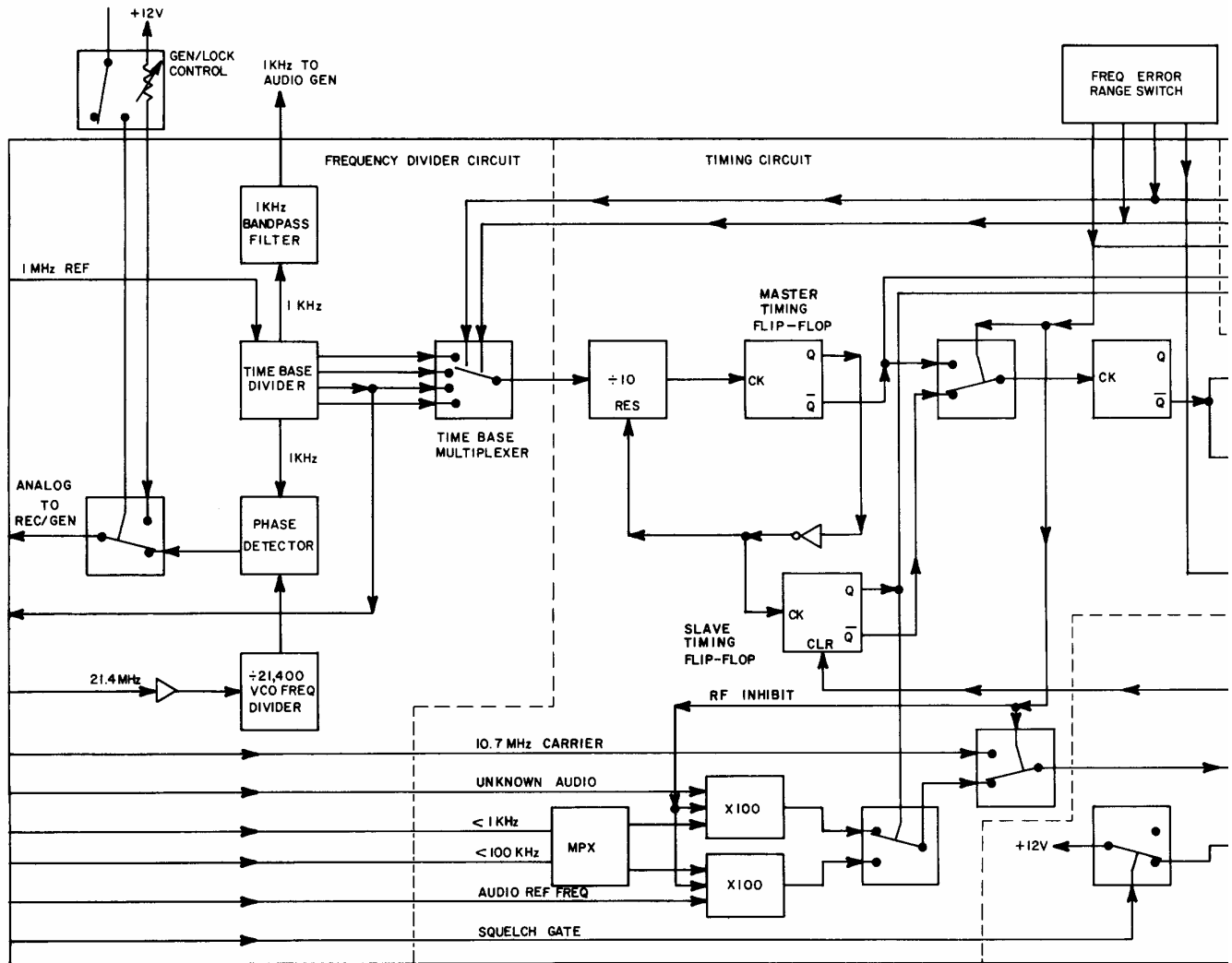

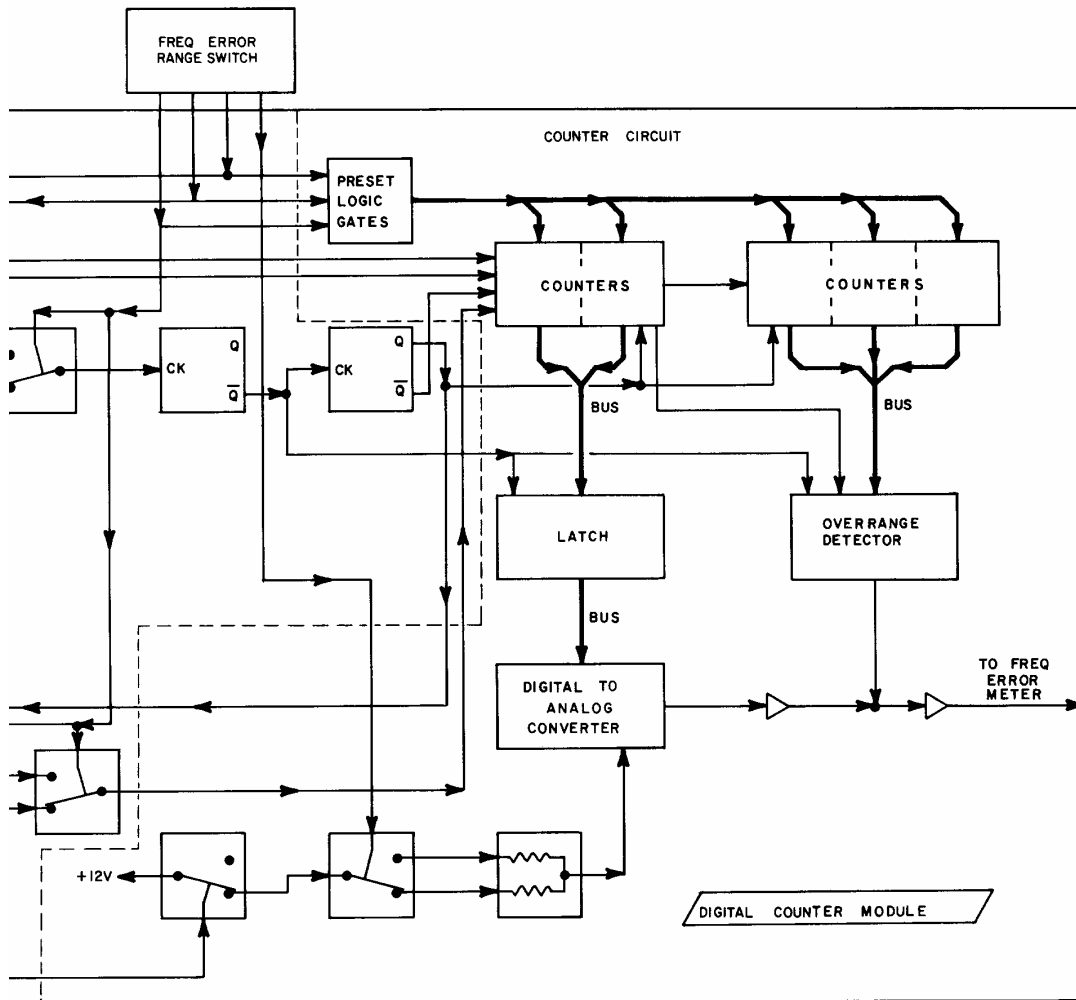

Figure 7-10 Digital Module Block Diagram

The corresponding high \bar{Q} is available at reset signal multiplexer U4401A. Upon receiving the clock pulse (U4412A low Q), U4412B Q goes high, switching U4401B to pass the reference frequency and setting the counter system to count downward. In the RF mode, after a 15 microsecond delay, the reset circuit resets U4412B to a low Q, high \bar{Q} condition. However, in the audio mode, reset does not occur for an additional 10 time-base pulses while U4412A completely recycles and clocks U4412B back to low Q, high \bar{Q} . Therefore, the reset signal to U4412B is functional only in the RF mode.

In the RF mode, multiplexer U4401A passes every high \bar{Q} signal from U4412A to the reset one-shot multivibrator U4413A. In the AUDIO mode, the \bar{Q} from U4412B is selected, which coincides with alternate high \bar{Q} signals from U4412A. When the reset master multivibrator U4413A is clocked, the \bar{Q} output produces a 15 microsecond low pulse to trigger the counter system. The leading edge of the following high clocks the slaved multivibrator U4413B. Simultaneous 15 microsecond pulse outputs (high from Q, low from \bar{Q}) reset the counter system and the slaved timing multivibrator U4412B.

D. COUNTER SYSTEM (On Digital Counter PC Board)

A logic network consisting of NOR gates U4414A, U4414B, U4414C and U4414D, NAND gates U4416B, U4416C and U4416D, and inverters U4417B, U4417D, U4417E and U4417F, is controlled by binary codes from the Frequency Error Range Switch. This network establishes the starting count for chained counters U4402 through U4406. Outputs from counters U4402 and U4403 are coupled to latch U4408. When triggered by reset multivibrator U4413A, latch U4408 transfers the count to DAC U4409. Outputs from counters U4404, U4405 and U4406 go to a logic network comprised of NOR gates U4410, U4415B, U4420C and U4420D, and inverter U4421D. If the overflow count from U4403, plus the starting count, at all three overflow counters is not zero, the over-range logic feeds a corresponding over- or under-range signal to dual flip-flop U4407A and U4407B. When triggered by reset multivibrator U4413A, latch U4408 transfers the count from U4402 and U4403 to DAC U4409 and any value from overrange flip-flop U4407A or U4407B to op amp U4419B.

The DAC supplies two differential signals to op amp U4419A (which is a current-to-voltage converter), which feed op amp U4419B. U4419B subsequently furnishes the signal to deflect the Frequency Error Meter needle. If an overrange count occurs, the output of either U4407A or U4407B will override the DAC circuit output and peg the needle either high or low according to the error direction.

7-9-2 PREPARATION FOR TESTING

A. REMOVAL AND DISASSEMBLY

If repair is required, remove and disassemble the Digital Module in accordance with instructions provided in Section 6 for Enclosed Module Removal.

B. REQUIRED TEST EQUIPMENT

- 1 - Oscilloscope 30 MHz Bandwidth
- 1 - Signal Generator 111.0 - 111.2 MHz at -40 dBm
- 1 - Frequency Counter 30 MHz capacity, 40 Hz Resolution
- 1 - Digital Voltmeter 100 K Ω /V
- 1 - 50 Ohm Coax "T" Connector ... SMB
- 1 - 50 Ohm Coax Cable BNC/BNC
- 1 - 50 Ohm Coax Cable BNC/SMB

C. PREPARATION

1. Make the following initial control settings (Refer to Controls, Indicators and Connectors Drawing in Section 1).

KEY	CONTROL	SETTING
4	Modulation Meter Range Switch	"20"
9	Modulation Mode Selector Switch	"FM WIDE"
11	RF LEVEL Attenuator Control	"-110 dBm"
13	VAR TONE Level Control	Fully ccw
14	VAR TONE Select Switch	"OFF"
15	1 kHz TONE Select Switch	"OFF"
16	1 kHz TONE Level Control	Fully ccw
17	Power Switch	"OFF"
18	VAR TONE FREQ Thumbwheels	"000.0"
19	Frequency Error Meter Range Switch	"AUDIO 300"
24	GEN/LOCK Control	Fully cw
25	RF FREQUENCY Thumbwheels	"111 100 0"
26	GEN/REC Switch	"GEN"
27	VOLUME Control	Fully ccw
28	SQUELCH Control	Fully ccw

2. Disconnect the following connectors: P/J4401, P/J4501, P/J4502 and P/J4503 (Refer to Digital Reference PC Board Drawings in Section 9).

7-9-3 TESTING (Refer to Digital Counter and Digital Reference PC Board Drawings in Section 9 and Circuit Schematics in Section 10)

1. Set Power Switch in "LINE" position.
2. Using DVM, verify the following pins of J4501 have the correct voltages:

Pin No.	Voltage	Tolerance
3	0	±0.3
4	+5.0	±0.3
7	+11.5	±0.7
14	-12.0	±0.3
16	+12.0	±0.3
18	+5.0	±0.3

3. Rotate the GEN/LOCK Control to "LOCK" and verify the following voltages are present on J4501:

Pin No.	Voltage	Tolerance
3	+12.0	±0.3
4	0	±0.3

NOTE

If all the voltages required in Steps 2 and 3 are not present, troubleshoot the Power Supply and the Distribution Circuit.

4. Using DVM, verify the voltage on each pin of J4501 is within ±0.3 V of that given below for each position of the Frequency Error Range Switch.

Switch Position	Pin 1	Pin 11	Pin 19	Pin 20
AUDIO 300	0	+5	+5	+5
AUDIO 30	0	+5	0	+5
AUDIO 3	0	+5	+5	0
RF 10 K	+5	0	0	+5
RF 3 K	0	0	0	+5
RF 1 K	+5	0	+5	0

5. Using DVM, verify the voltage on each pin of J4501 is within ± 0.3 V of that given below for each position of the VAR TONE FREQ Thumbwheels:

Thumbwheel Setting	Pin 13	Pin 15
0000.0	+12	+12
0100.0	0	+12
1000.0	+12	0
1100.0	0	0

6. Using the Oscilloscope, verify the signals shown in Figure 7-11 are present.

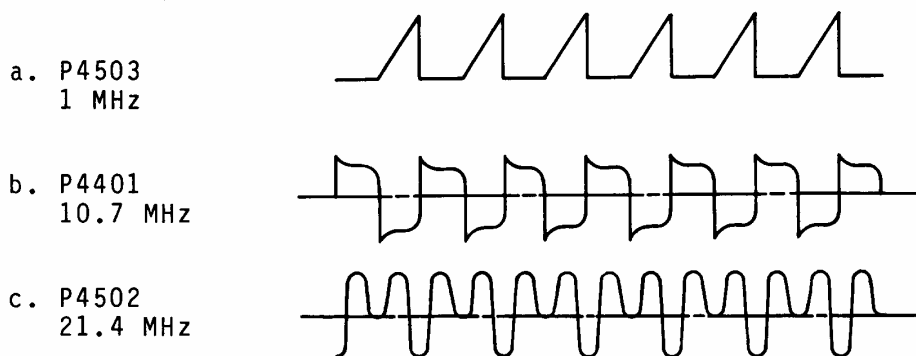

Figure 7-11 Digital Module Input Signals

7. Set Power Switch in "OFF" position and make the following connections:
 - a. P4401 to J4401
 - b. P4501 to J4501
 - c. P4503 to J4503
 - d. Coax SMB "T" connector to J4502
 - e. P4502 to coax SMB "T" connector
 - f. Frequency Counter to coax SMB "T" connector
8. Set Power Switch in "LINE" position and allow a five minute warm-up period.
9. Verify Frequency Counter displays 21.4 MHz (± 20 Hz).
10. Rotate GEN/LOCK Control just out of detent. Verify the Frequency Counter displays at least 21.45 MHz.
11. Rotate GEN/LOCK Control fully cw and verify the Frequency Counter displays 21.35 MHz or less.

12. Rotate GEN/LOCK Control to "LOCK".
13. Remove coax "T" connector and connect P4502 to J4502.
14. Set GEN/REC Switch in "REC" position.
15. Connect coax between EXT 10 MHz Connector and ANTENNA Connector.
16. Make the following control settings:

KEY	CONTROL	SETTING
9	Modulation Mode Selector Switch	"FM NAR"
19	Frequency Error Range Switch	"RF 1K"
25	RF FREQUENCY Thumbwheels	"010 000 0"
26	GEN/REC Switch	"GEN"

17. Adjust trimpot R4407 to obtain an indication of "0" on the FREQ ERROR Meter.
18. Rotate RF FREQUENCY Thumbwheels to "010 002 0".
19. Adjust trimpot R4509 to obtain an indication of "2 kHz" on the FREQ ERROR Meter.
20. Rotate RF FREQUENCY Thumbwheels to "010 010 0".
21. Adjust trimpot R4510 to obtain an indication of "10 kHz" on the FREQ ERROR Meter.
22. Connect the output of the Signal Generator to the ANTENNA Connector.

CAUTION

DO NOT EXCEED 0.25 WATT INPUT TO THE ANTENNA CONNECTOR.

NOTE

For best results, connect a common 10 MHz reference frequency to the Signal Generator and the FM/AM-500A.

23. For each of the Frequency Error Range Switch positions listed in Table 7-3, adjust the Signal Generator to produce the corresponding frequencies and verify the Frequency Error Meter provides the correct indication.

24. Rotate SQUELCH Control fully cw to verify squelch operation. Frequency Error Meter should indicate 0 ± 100 Hz. Return the SQUELCH Control fully ccw.
25. Modulate the Signal Generator with a 1 kHz tone from FM/AM-500A, at 15 kHz deviation.
26. For each of the Frequency Error Range Switch positions listed in Table 7-4, rotate the VAR TONE FREQ Thumbwheels to the corresponding frequencies and verify the Frequency Error Meter provides the correct indication.

FREQUENCY ERROR RANGE SWITCH POSITION	SIGNAL GENERATOR OUTPUT FREQUENCY MHz @ -40 dBm	FREQUENCY ERROR METER INDICATION Hz
RF 1 K	111.1000	0 ± 50
	111.1005	+500 ± 50
	111.0995	-500 ± 50
RF 3 K	111.0995	-500 ± 100
	111.0980	-2 K ± 100
	111.1020	+2 K ± 100
RF 10 K	111.1020	+2 K ± 500
	111.1050	+5 K ± 500
	111.0950	-5 K ± 500

Table 7-3 RF Frequency Error Testing

FREQUENCY ERROR RANGE SWITCH POSITION	VAR TONE FREQ THUMBWHEEL SWITCH SETTING	FREQUENCY ERROR METER INDICATION Hz
AUDIO 3	1000.0	0 ± 0.1
	1002.0	-2 ± 0.2
AUDIO 30	1020.0	-20 ± 2
AUDIO 300	1200.0	-200 ± 20
	0800.0	+200 ± 20
AUDIO 30	0980.0	+20 ± 2
AUDIO 3	0998.0	+2 ± 0.2

Table 7-4 Audio Frequency Error Testing

7-9-4 REASSEMBLY

With all power "OFF", disconnect test equipment. If module was disassembled for repair, reassemble in reverse order of removal and disassembly procedures outlined in Section 6.

7-10 RECEIVE AUDIO MODULE

7-10-1 THEORY OF OPERATION (Refer to Figure 7-12 and Receive Audio Circuit Schematic in Section 10)

A. GENERAL

Demodulated AM and FM audio signals from the Receiver/Generator are fed into a mode selector which is controlled by the Modulation Mode Selector Switch on the Front Panel. The squelch gate multiplexer, operated by the squelch level circuit, couples the selected signal to three lowpass filters (80 kHz, 8 kHz and 250 Hz). The signals from the 80 kHz and 8 kHz filters pass through a multiplexer, operated by the "FM WIDE" position of the Modulation Mode Selector Switch, to an amplifier whose output goes three places: (1) out of the module, through the VOLUME Control to the Generate Audio Module, to the Speaker; (2) out of the module to the DEMOD jack on the Front Panel; and (3) to a range control multiplexer in the Modulation Meter driver circuit. Signals from the 8 kHz and 250 Hz filters pass through a multiplexer controlled by the Variable Tone Generator, to a multiplexer in the Generate Audio Module. This multiplexer normally couples this signal to the AGC circuit in the Receive Audio Module and on to the Audio Counter Circuit in the Digital Module. However, when "SINAD" or "DIST" is selected on the Modulation Meter Range Switch, this multiplexer disables the received audio signal and couples a signal from the EXT MOD/SINAD jack to the AGC circuit in the Receive Audio Module.

The signal selected by the Modulation Meter range control multiplexer is rectified, then combined with a DC offset. The DC offset level is controlled by the Modulation Meter Range Switch, the Modulation Mode Selector Switch, and the operating mode circuit in the Generate Audio Module. It is then available for the function select multiplexer U3313 to couple to the Modulation Meter.

For sinad and distortion measurements, the output of the AGC passes through a 1 kHz notch filter (very narrow band-reject) and rectifier to the function select multiplexer U3313. A level detector samples the AGC control level and pegs the meter if the input signal is too low.

A branch of the demodulated AM signal is amplified and fed back to the Receiver/Generator for automatic gain control. After amplification, it also is applied to the function select multiplexer U3313 to provide an indication of received signal strength. This signal is also used by the squelch control.

The squelch control voltage and the demodulated and amplified AM audio signal are compared by an op amp. When the audio signal level exceeds the squelch voltage level, the amplifier enables the squelch gate, which conducts the audio signal to the bandpass filters.

A DC signal from the Power Detector Circuit in the Output Amplifier Module, which is representative of the signal level entering the T/R jack, passes through the Power Monitor Circuit. The Power Monitor Circuit sends two samples of the power detector signal, one of which is amplified for the low power level, to the function select multiplexer U3313 for Power Meter readings. Another sample from the Power Monitor Circuit goes to the Generate Audio Module for automatic change over when transmitter power is present at the T/R jack.

B. INCOMING SIGNAL SELECTION

Multiplexer U3301A selects between FM and AM audio signals according to the position of the Modulation Mode Selector Switch on the Front Panel. The squelch gate, multiplexer U3322B, conducts when the signal level received by squelch amplifier U3302B exceeds the level established by the SQUELCH Control on the Front Panel.

C. LOWPASS FILTERS

The three lowpass filters are identical circuits except for resistor and capacitor values. Each filter utilizes a dual op amp (U3319, U3320 and U3321) configured in two identical serial stages. The circuit with U3319 forms the 80 kHz filter. The one with U3320 makes the 8 kHz filter, while the 250 Hz filter uses U3321. Multiplexer U3322A selects the 250 Hz filter when a frequency of less than 400 Hz is selected on the optional Variable Tone Generator for audio frequency counting. If the Modulation Mode Selector Switch is in the "FM WIDE" position, multiplexer U3322C directs the signal from the 80 kHz filter to the Speaker and Modulation Meter circuits. When the control voltage to either or both of these multiplexers is low, the audio signal through the 8 kHz filter is fed into the corresponding circuits.

D. RECEIVE AGC CIRCUIT

The signal from the AM demodulator (in the Receiver/Generator Module), which represents the detected level of the received 10.7 MHz IF signal, is amplified, then used for feedback to the Receiver AGC circuit in the Receiver/Generator. Multiplexer U3301C changes the speed of integrator U3302A according to the position of the Modulation Mode Selector Switch. Also, when SSB is selected, multiplexer U3301B switches the integrator from average operation to peak operation by allowing fast charging of the integrator through resistor R3306 and diode CR3301, and slow discharging through resistor R3301. One output from integrator U3302A is to the Receiver/Generator AGC circuit. The other output is rectified by diode CR3302 and amplified by op amp U3303A. One output of U3303A is coupled to the Modulation Meter through the meter function select multiplexer U3313 to provide an indication of relative signal

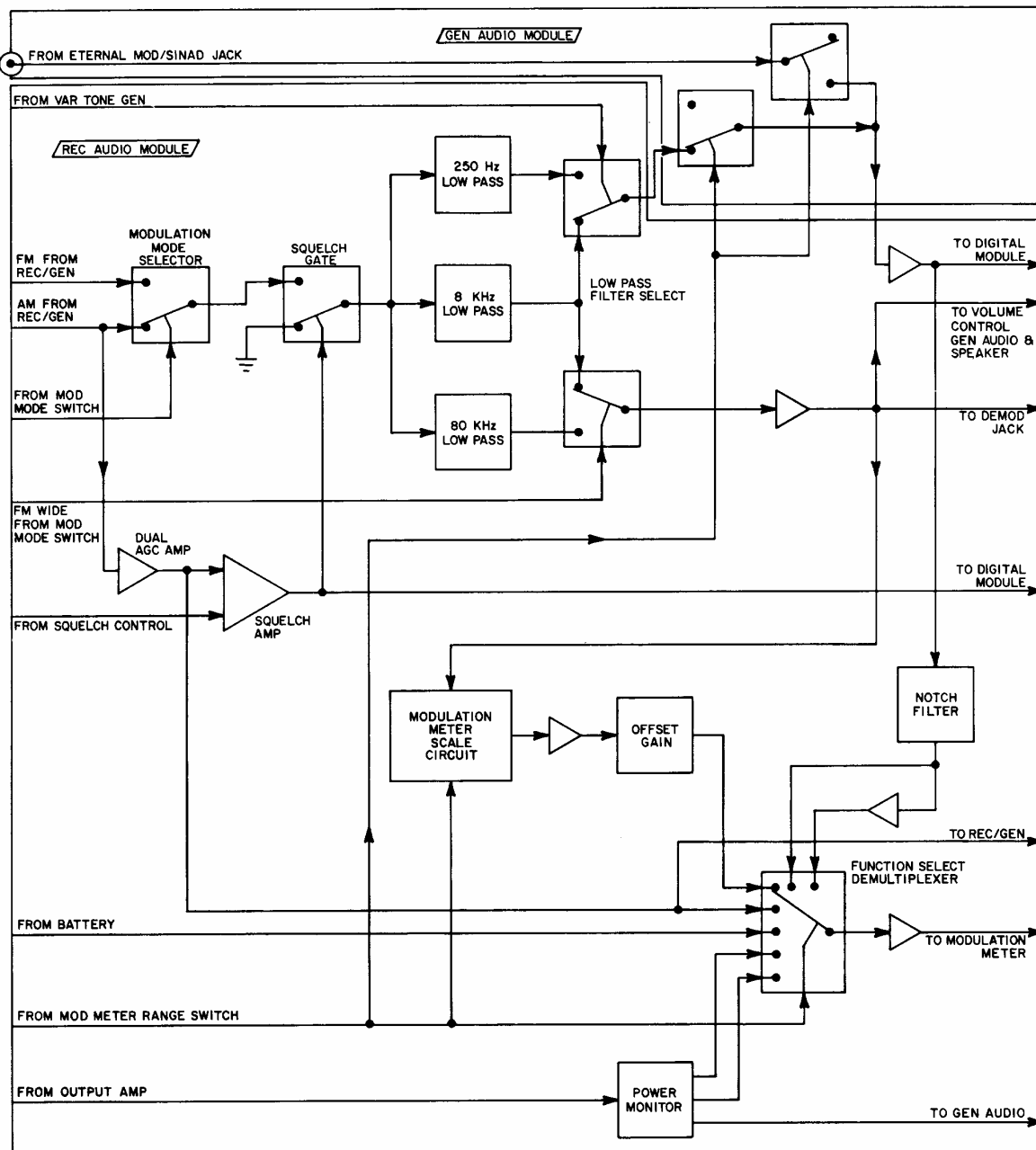

Figure 7-12 Receive Audio Module Block Diagram

strength. The other output is fed to op amp U3302B for comparison against the DC level established by the SQUELCH Control on the Front Panel.

The audio signal passing through either the 8 kHz or 80 kHz lowpass filter, as selected by multiplexer U3322C, is amplified by op amp U3318A. This signal is then connected to the DEMOD jack, and to the VOLUME Control (both on the Front Panel), to the speaker amplifier circuit in the Generate Audio Module. The output of U3318A also goes to multiplexer U3316 in the Modulation Meter driver circuit. On the FM/AM-500A only, multiplexer U3324C extends the meter range to add the X60 scale.

E. AUDIO AGC CIRCUIT

The audio signal passing through either the 250 Hz or 8 kHz band-pass filter, as selected by multiplexer U3322A, is available for frequency and noise and distortion analysis. From U3322A, the signal is routed to the Generate Audio Module. Multiplexers R3202A and U3202C (in the Generate Audio Module) couple either this audio signal or a signal applied to the EXT MOD/SINAD jack back to the Receiver Audio AGC circuit. The signal first passes through photoresistor U3304 to vary the gain of op amp U3305A, whose output is split three ways. One output goes to a precision full wave rectifier consisting of op amps U3309A and U3309B, diodes CR3307 and CR3308, and associated resistors R3334, R3336, R3339, R3340 and R3341, then to an integrator consisting of op amp U3305B, capacitor C3305 and diode CR3306. The integrator output then is fed to the LED in the photoresistor to achieve level control. The second output is converted to a square wave by op amp U3308, and fed to the Digital Module for frequency counting. The third output (on the FM/AM-500A only) goes to the SINAD circuit.

F. SINAD CIRCUIT (FM/AM-500A only)

The third output from op amp U3305A goes to a notch filter circuit consisting of op amp U3306B, capacitors C3306, C3307, C3327 and C3328, resistors R3317, R3319, R3321, R3322, and R3323, and trim pots R3318 and R3320. This circuit is tuned to reject only a frequency of 1000 Hz (1 Hz at -40 dB), and all other frequencies which then pass through the filter are considered noise and distortion. The signal is rectified by a precision full wave rectifier consisting of op amps U3307A and U3307B, diodes CR3310 and CR3311, and resistors R3328, R3329, R3330, R3332 and R3333. Trim pot R3350 allows calibration, then the signal passes to multiplexer U3324A, both directly and through op amp U3323A. When SINAD is selected, U3324A connects the unamplified signal directly to the function select multiplexer U3313. However, when DIST is selected, U3324A selects the amplified signal.

When the level of the signal received at the EXT MOD/SINAD jack is very low, and the AGC integrator U3305B output approaches

its upper limit, level detector U3306A output goes high to peg the meter and prevent erroneous meter readings resulting from insufficient signal level.

G. POWER MONITOR (FM/AM-500A only)

Resistor R3345 provides a negative voltage to bias the power detector in the Output Amplifier, which enables the power detector to provide feedback to the power monitor. The power monitor circuit consists of resistors R3346 and R3347, which form a voltage divider, and op amp U3312B. Potentiometer R3354 provides DC offset for the output of U3312B. One branch of the output from U3312B goes to the Generator Audio to drive the receive/generate logic. On the FM/AM-500A only, two more branches drive the Power Meter function. The first of these goes through a voltage divider consisting of trimpot R3362 and resistors R3360 and R3361 for 150 W calibration, then to the function select multiplexer U3313. The other branch is amplified by op amp U3312A, whose output is calibrated by trimpot R3365 and resistors R3366 and R3367 for 15 W operation, then goes to U3313.

H. MODULATION SCALE CIRCUIT

The audio signal selected by multiplexer U3322C is buffered by op amp U3318A. Its output goes to a voltage divider consisting of resistors R3398, R3399, R3400, R3401, R3404 and on the FM/AM-500A only, R3432. One tap goes to the DEMOD jack, the other taps go to multiplexer U3316. (On the FM/AM-500A only, two taps first go through multiplexer U3324C to provide the "X60" range on the Modulation Meter.) The output of U3316 is buffered by op amp U3314A, then rectified by a precision full wave rectifier consisting of op amps U3315A and R3315B, diodes CR3314 and CR3315, and resistors R3407 through R3411. The rectified signal is then sent to op amp U3323B. A DC offset, which is calibrated through FM and AM zero trim pots (R3368, R3369, R3370 or R3371) as selected by multiplexers U3310A, U3310B and U3310C, is applied to a voltage divider consisting of resistors R3421, through R3424. Multiplexer U3317 selects the appropriate tap from the voltage divider and applies it to U3323B. U3323B then sums the two inputs to provide the FM deviation or AM percent modulation signal to the Modulation Meter driver circuit.

I. METER DRIVER CIRCUIT

The meter driver circuit consists of multiplexer U3313, a peak detector comprised of op amp U3311 and associated components, a buffer using op amp U3314B and related resistors and, on the FM/AM-500A only, multiplexer U3324B.

On the FM/AM-500, the output of U3323B goes to the peak detector, then to multiplexer U3313. The input signal to U3313, which is selected by the Modulation Meter Range Switch, is coupled to the amplifier, whose output drives the meter.

On the FM/AM-500A, the output of U3323B is connected to multiplexer U3313. The input signal to U3313, which is selected by the Modulation Meter Range Switch, is then connected directly to multiplexer U3324B and, normally, through U3314B to the meter. However, when a peak power or modulation function is selected, U3324B couples the output of U3313 through the peak detector, then through U3314B and to the meter.

7-10-2 PREPARATION FOR TESTING

A. REMOVAL AND DISASSEMBLY

Remove the Receiver Audio PC Board as outlined in Section 6. No disassembly is required.

B. REQUIRED TEST EQUIPMENT

- 1 - Oscilloscope 10 MHz Bandwidth
- 1 - Digital Multimeter 100 K Ω /V
- 1 - Extender Cable 26 Pin M/F Connectors
- 1 - 12", 20 GA Lead E-Z Mini Hook

C. PREPARATION

1. Make the following initial control settings (Refer to Controls, Indicator and Connector Drawing in Section 1).

KEY	CONTROL	SETTING
4	Modulation Meter Range Switch	"BATT TEST"
9	Modulation Mode Select Switch	"FM WIDE"
11	RF LEVEL Attenuator Control	"-110 dBm"
12	RF LEVEL FINE Adjust Control	Fully ccw
13	VAR TONE Level Control	"OFF"
14	VAR TONE Select Switch	Fully cw
15	1 kHz TONE Select Switch	Fully cw
16	1 kHz TONE Level Control	"OFF"
17	Power Switch	"OFF"
18	VAR TONE FREQ Thumbwheels	"1300.0"
24	GEN/LOCK Control	"LOCK"
25	Frequency Error Meter Range Switch	"RF 10 K"
26	GEN/REC Switch	"GEN"
27	VOLUME Control	Fully ccw
28	SQUELCH Control	Fully cw

2. Install Extender Cable between connector J5 on the Mother Board and J3301 on the Receiver Audio PC Board (Refer to Mother Board and Receive Audio PC Board Drawings in Section 9).

7-10-3 TESTING (Refer to Controls, Indicators and Connectors Drawing in Section 1, Receive Audio PC Board Drawing in Section 9 and Circuit Schematic in Section 10)

1. Set Power Switch in "LINE" position.
2. Connect lead between J5201, pin 2 on the Power Supply and pin 14 of the male connector of the Extender Cable.
3. Using DMM, measure voltage at J3301, pin 22. Adjust trimpot R3354 to obtain a reading of 0 V (± 20 mV).
4. Using DMM, verify the following pins of the male connector of the Extender Cable have the correct voltages:

Pin No.	Voltage	Tolerance
3	0	± 0.3
5	+12.0	± 0.3
8	0	± 0.3
10	0.15	± 0.3
11	-12.0	
12	+12.0	± 0.3
13	+5.0	
15	+12.0	
* 26	+14.4	± 0.1

* Record this voltage for later reference.

NOTE

If any test in Steps 3 through 14 fails, the cause of that failure is not in the Receive Audio PC Board.

5. Make the following control settings:

KEY	CONTROL	SETTING
4	Modulation Mode Select Switch	"FM MID"
25	VAR TONE FREQ Thumbwheels	"0300.0"
28	SQUELCH Control	Fully ccw

6. Using DVM, confirm the voltage at pin 12 of extender cable male connector is 0 V (± 0.3 V).

7. Rotate the Modulation Mode Select Switch to "SSB" and confirm the following voltages on the extender cable male connector:

Pin No.	Voltage	Tolerance
3	+5.0 V	±0.3 V
5	0 V	±0.3 V
8	+11.5 V	±0.3 V
10	+12.0 V	±0.3 V
12	-3.5 V	±0.3 V

8. Rotate Modulation Mode Selector Switch to "FM WIDE".
9. Using DVM, confirm the voltages on the extender cable male connector are correct for each position of the Modulation Meter Range Switch as follows:

Switch Position	Pin 19	Pin 21	Pin 23	Tolerance
BATT TEST	+0.15 V	+0.15 V	+0.15 V	±0.3 V
SIG	+12.0 V	+0.15 V	+0.15 V	±0.3 V
20	+0.15 V	+12.0 V	+0.15 V	±0.3 V
6	+12.0 V	+12.0 V	+0.15 V	±0.3 V
2	+0.15 V	+0.15 V	+12.0 V	±0.3 V

10. Using Oscilloscope, verify positive and negative peaks of noise on pin 6 of extender cable male connector do not exceed +15 V and 0 V respectively.
11. Set Power Switch in "OFF" position.
12. Connect Receiver Audio Board to extender cable.
13. Set Power Switch in "LINE" position.
14. Confirm the following voltages at P3301:

Pin No.	Voltage	Tolerance
2	-2.3 V	±0.40 V
20	-0.2 V	±50 mV

15. Set 1 kHz TONE Select Switch in "INT MOD" position.
16. Using Oscilloscope, confirm a 1 kHz sinewave of 5 Vp-p minimum is present at P3301, pin 4.

NOTE

A failure of any test in Steps 15 through 19 is not necessarily the result of a fault in the Receive Audio Board.

17. Rotate Modulation Mode Select Switch to "AM NORM".

18. Using the Oscilloscope, rotate 1 kHz TONE Level Control to obtain a 1 kHz sinewave approximately 2 Vp-p at P3301, pin 6.
19. Using Oscilloscope, confirm a 1 kHz sinewave is present at P3301, pin 17. The amplitude of this sinewave is not critical because it is partially dependent upon the 1 kHz tone level.
20. Rotate Modulation Mode Select Switch to "FM WIDE".
21. Rotate 1 kHz TONE Level Control fully cw.
22. Using Oscilloscope, confirm a 1 kHz sinewave of approximately 7 Vp-p is present at P3301, pin 4.
23. Rotate Modulation Mode Select Switch to "FM MID".
24. Using Oscilloscope, confirm a 1 kHz sinewave of approximately 7 Vp-p is present at P3301, pin 25.
25. Using Oscilloscope, confirm the 1 kHz sinewave at P3301, pin 1 is less than 0.06 VRMS.
26. Rotate VAR TONE FREQ Thumbwheels to "1300.0" and confirm the sinewave at P3301, pin 1 increases in amplitude to approximately 2 Vp-p.
27. Rotate VAR TONE FREQ Thumbwheels to "0300.0".
28. Set 1 kHz TONE Selector Switch in "OFF" position.
29. Set VAR TONE Selector Switch in "INT MOD" position and confirm a 300 Hz sinewave of approximately 1.8 Vp-p is present at P3301, pins 1 and 18.
30. Verify a 300 Hz squarewave of approximately 12 Vp-p is present at P3301, pin 24.
31. Rotate Modulation Meter Range Switch to "20".
32. Set VAR TONE Selector Switch in "OFF" position.
33. Set 1 kHz TONE Selector Switch in "INT MOD" position.
34. Rotate 1 kHz TONE Level Control for a deviation of 5 kHz as shown on Modulation Meter.
35. Rotate Modulation Meter Range Switch to "6" and confirm the meter indicates 5 kHz \pm 250 Hz.
36. Adjust 1 kHz TONE Level Control for a deviation of 1 kHz as shown on Modulation Meter.

37. Rotate Modulation Meter Range Switch to "2" and confirm the meter indicates 1 kHz \pm 100 Hz.
38. Rotate Modulation Meter Range Switch to "BATT TEST" and adjust R3303 until the meter indication is within \pm 5% of the reading recorded in Step 3.
39. Set GEN/REC Switch in "REC" position.
40. Using DVM, verify voltage at P3301, pin 7 exceeds +11.0 V.
41. Rotate SQUELCH Control fully cw and verify voltage at P3301, pin 7 exceeds -10 V.

7-10-4 REASSEMBLY

With all power OFF, disconnect test equipment. Reinstall the Receive Audio PC Board in the reverse order of removal procedure outlined in Section 6.

7-11 GENERATE AUDIO MODULE

7-11-1 THEORY OF OPERATION (Refer to Figure 7-13 and Generate Audio Circuit Schematic in Section 10)

A. GENERAL

The Generate Audio Module receives audio signals from any or all of four sources: (1) 1 kHz fixed frequency from the Digital Module; (2) a variable frequency from the Variable Tone Generator; (3) through the microphone jack; or (4) through the EXT MOD jack on the Front Panel. These signals are combined and amplified, with a tap from the output going to the TONE OUT jack. For FM modulation, the signal is sent directly to the Receiver/Generator 21.4 MHz VCO tuning line by the Modulation Mode Selector Switch. For AM modulation, the signal is routed through an AM modulator/leveler, which consists of two amplifiers and the RF LEVEL FINE Adjust potentiometer, and then to the Receiver/Generator.

The 1 kHz fixed tone and the variable tone can be switched independently to modulate the generator or directly to the speaker amplifier (either Generate or Receive mode). In the Receive mode, the audio signal from the Receive Audio Module is routed to the speaker amplifier, then fed to the Speaker. The level of each of these signals is controlled by Front Panel potentiometers.

The operating mode (Generate or Receive) of other modules is determined by an operating mode circuit in the Generate Audio Module. In the Generate Mode, a GEN command (+12 VDC signal) performs the following functions: (1) it enables the generate amplifiers in the IF Module and Output Amplifier; (2) in the Receiver/Generator, it enables the frequency divider and inhibits the receive-enable multiplexer; and (3) in the Receive Audio Module, it enables the Modulation Meter multiplexer in the deviation/percent modulation mode. In the Receive mode, a REC command (+12 VDC signal) enables the receive amplifiers in the IF Module, and an ANT ENABLE command (+12 VDC signal) energizes the Antenna Enable Relay, coupling the signal between the T/R jack and the IF Module. If the set is operating in the Generate mode and a signal exceeding 100 mW is received at the T/R jack, it will automatically switch to the Receive mode, but the Antenna Enable Relay will not be energized. Also, with the set in the Receive mode, depressing the microphone Press-To-Talk Key automatically switches the set to the Generate mode and de-energizes the Antenna Enable Relay to route the generated signal through the Output Amplifier to the T/R jack.

The phase lock indicator circuit consists of four logic NAND gates (two of which function as a flasher oscillator), a transistor in the Generate Audio Module, related grounding circuits in the High Loop and Low Loop Synthesizers, and the GEN/LOCK

Control on the Front Panel. When the appropriate frequency in each Synthesizer is equal to and in phase with its reference, neither grounding circuit conducts and the voltages applied to the inputs of the first gate in the indicator logic circuit are high. When neither input to the gate is grounded, the transistor conducts power to the LED on the Front Panel, indicating a phase-locked condition. If one or both inputs to the gate is grounded, or the GEN/LOCK control is out of detent, other gates cause the LED to flash, indicating an unlocked condition.

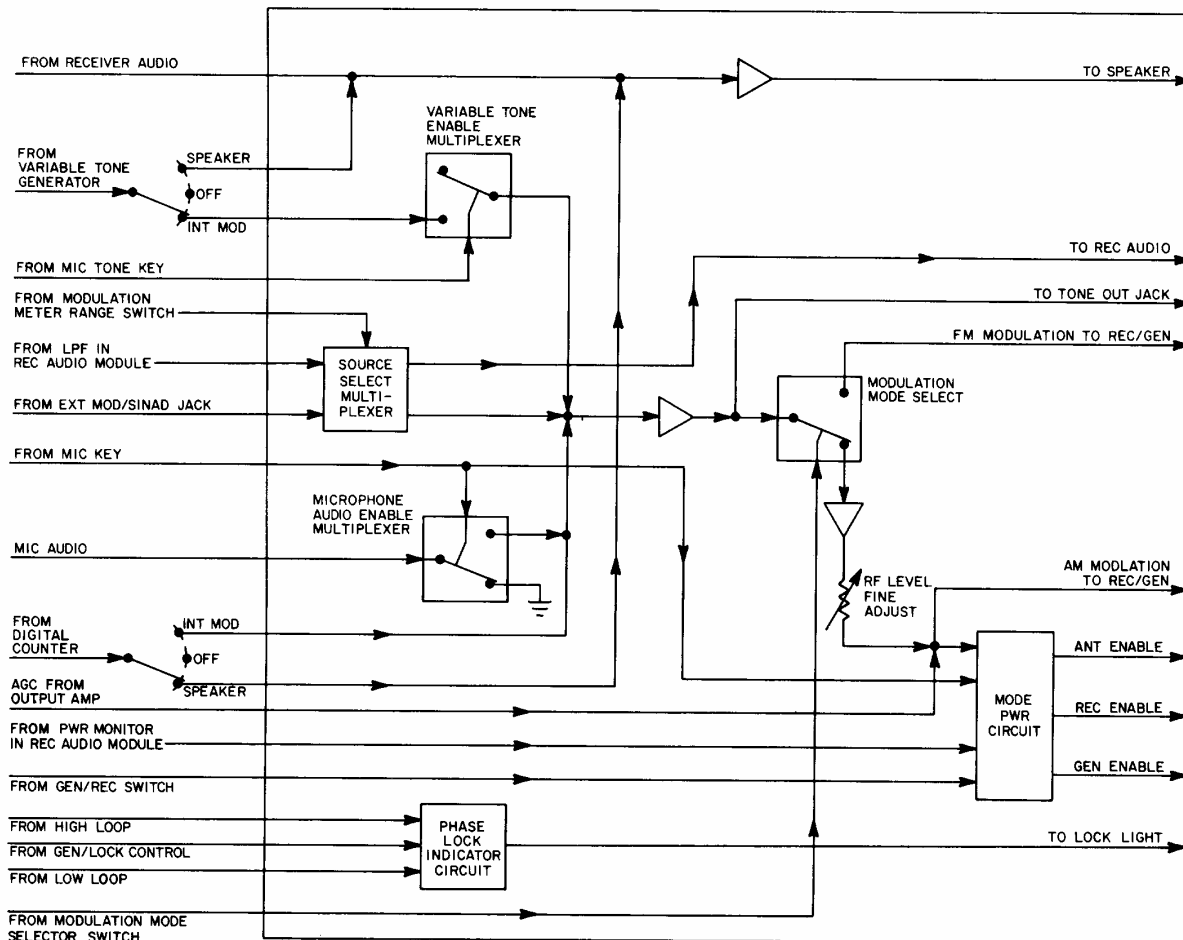

Figure 7-13 Generate Audio Module Block Diagram

B. SPEAKER AMPLIFIER

The demodulated audio from the Receive Audio Module, the 1 kHz fixed tone from the Digital Module, and the 10 Hz to 9999.9 Hz tone from the Variable Tone Generator are combined in the Generate Audio and fed to op amp U3201. U3201 amplifies the combined signal and furnishes it to the Speaker. The op amp and related resistors and capacitors are connected to an isolated ground.

C. SIGNAL SWITCHING

All audio signals supplied to the Generate Audio Module for modulation are combined and applied to the audio modulation amplifier, op amp U3203B. The 1 kHz fixed tone from the Digital Module and any signal applied through the EXT MOD/SINAD connector on the Front Panel go directly to the amplifier. Signals from the microphone and optional Variable Tone Generator first go through switching circuits. The microphone Press-To-Talk Key enables multiplexer U3205B to couple the microphone audio signal to the amplifier. The variable tone signal is applied to the amplifier except when the microphone is grounded to the FM/AM-500A case, which then disables multiplexer U3202B and opens the circuit to the amplifier. After the signal is amplified by op amp U3203B, it is split, with one branch going to the TONE OUT jack on the Front Panel, and the other going to demultiplexer U3205A to select either FM or AM. When the Modulation Mode Selector Switch on the Front Panel is in an AM or SSB position, U3205B is enabled and directs the signal into the AM modulator/leveler circuit. With the switch in an FM position, the audio signal is routed directly to the 21.4 MHz VCO tuning input in the Receiver/Generator.

The audio signal from the Low Pass filter circuit in the Receive Audio Module is routed through multiplexer U3202C in the Generate Audio Module, then back to the audio AGC circuit in the Receive Audio Module. A signal received at the EXT MOD/SINAD jack is routed through multiplexer U3202A to U3203B. On the FM/AM-500A, if either "SINAD" or "DIST" is selected on the Modulation Meter Range Switch, U3202C breaks the circuit in the audio signal, and U3202A couples the EXT MOD/SINAD signal to the audio AGC circuit in its place.

D. AM MODULATOR/LEVELER

When in the AM Generate mode, the audio signal from demultiplexer U3205A is summed with a DC voltage in op amp U3204B. This composite DC level and modulation signal is attenuated by the RF LEVEL FINE Adjust potentiometer on the Front Panel and is applied to error amplifier U3204A. U3204A adjusts its output (to the attenuator/modulator in the Receiver/Generator Module) to keep the signal from the potentiometer equal to the detected level of the output signal from the Output Amplifier Module.

In the Receive mode, +12 VDC through diode CR3207 overrides the detector signal and shuts off the modulator/leveler.

E. MODE POWER CIRCUIT

With the GEN/REC Mode switch on the Front Panel in the REC position, a control voltage enables multiplexer U3205C, grounding the base of transistor Q3202. This permits Q3202 to conduct,

applying the REC command (+12 VDC) to the receive circuits, while the voltage applied to the base of transistor Q3201 prevents it from conducting. Op amp U3207 applies a low voltage to the base of transistor Q3203, allowing it to conduct, pulling down the voltage to the base of transistor Q3204. Q3204 then conducts, applying +12 VDC to the antenna enable relay in the IF Module. The relay closes, coupling the ANTENNA jack to the IF Module. When the switch is in the GEN position, no voltage is supplied to multiplexer U3205C, allowing it to ground the base of transistor Q3201. Q3201 conducts and supplies the GEN command (+12 VDC) to the generate circuits and to the base of transistor Q3203. Q3203 stops conducting, allowing the base voltage to transistor Q3204 to rise. Q3204 subsequently stops conducting, so the antenna enable relay switches the IF Module from the ANTENNA jack to the Output Amplifier and grounds the ANTENNA jack. Also, the base voltage to Q3202 goes high, so it stops conducting the REC command.

1

F. PHASE LOCK INDICATOR LOGIC

As long as approximately +5 VDC is applied to both inputs of NAND gate U3206A, its output remains low. If either the High Loop or Low Loop is not phase-locked to the appropriate reference frequency, one of the inputs goes low, and the output of U3206A goes high. While the output of U3206A is low and the GEN/LOCK Control is in LOCK, the input to NAND gate U3206B on pin 6 is a constant low, and its output a constant high. When pin 6 is a constant high, the output of U3206B alternates between low and high according to the input at pin 5. A high output from U3206B to the base of transistor Q3205 causes the transistor to conduct, illuminating the phase lock indicator LED on the Front Panel. NAND gates U3206C and U3206D, with resistors R3242 and R3243 and capacitor C3218, form an oscillator circuit whose output is fed to pin 5 of U3206B. Thus, the pulsing signal on pin 5, when the input to pin 6 is high, causes the output of U3206B to go high and low inversely to the output of the oscillator. When both inputs to U3206B are low, the high output from pin 4 causes transistor Q3205 to conduct +5V to the phase lock indicator LED on the Front Panel.

7-11-2 PREPARATION FOR TESTING

A. REMOVAL AND DISASSEMBLY

Remove the Generator Audio Module as outlined in Section 6. No disassembly of the PC Board is required.

B. REQUIRED TEST EQUIPMENT

- 1 - Oscilloscope Single Trace, 1 MHz
- 1 - Digital Multimeter 100 K Ω /V
- 1 - Extender Cable 26 Pin M/F Connectors
- 1 - Shorting Strap 26 Gauge - Alligator clip
each end
- 1 - Shorting Strap 26 Gauge - Alligator clip/
.040 pin

C. PREPARATION FOR TESTING

1. Make the following initial control settings (Refer to Controls, Indicators and Connectors Drawing in Section 1)

KEY	CONTROL	SETTING
4	Modulation Meter Range Switch	"SIG"
9	Modulation Mode Select Switch	"AM NORM"
11	RF LEVEL Attenuator Control	"-20 dBm"
12	RF LEVEL FINE Adjust Control	Fully ccw
13	VAR TONE Level Control	Fully ccw
14	VAR TONE Selector Switch	"SPEAKER"
15	1 kHz TONE Selector Switch	"SPEAKER"
16	1 kHz TONE Level Control	Fully ccw
17	Power Switch	"OFF"
18	VAR TONE FREQ Thumbwheels	"1000.0"
24	GEN/LOCK Control	Fully cw
25	RF FREQUENCY Thumbwheels	"100 000 0"
26	GEN/REC Switch	"REC"
27	VOLUME Control	Fully ccw
28	SQUELCH Control	Fully ccw

2. Connect Extender Cable to connector J3009 on the Mother Board (Refer to Mother Board Drawing in Section 9).

7-11-3 TESTING (Refer to Generate Audio PC Board Drawing in Section 9 and Circuit Schematic in Section 10)

NOTE

If any test in Steps 1 through 9 fails, the cause of that failure is not with the Generator Audio PC Board.

- Using DVM, confirm the following resistances:

FROM EXTENDER CABLE CONNECTOR	TO	REQUIRED RESISTANCE
Pin 21	Ground	exceeds 100 K Ω
Pin 21	MIC/ACC Jack Pin 1	less than 10 Ω
Pin 31	Ground	exceeds 100 K Ω
Pin 31	MIC/ACC Jack Pin 3	less than 10 Ω

- Set Power Switch in "LINE" position.
- Using DMM, verify voltages at extender cable connector as follows:

PIN	VOLTAGE (VDC)	TOLERANCE (VDC)
1	+5.0	± 0.25
2	-12.0	± 0.5
6	+5.0	± 0.5
8	+5.0	± 0.5
10	+5.0	± 0.5
27	+11.5	± 0.6
32	+11.5	± 0.6
37	-12.0	± 0.2

- Connect Oscilloscope to extender cable connector.
- Rotate 1 kHz TONE Level Control cw until Oscilloscope displays a 1 kHz sinewave at 1 Vp-p.
- Connect Oscilloscope to extender cable connector pin 34.
- Rotate VAR TONE Level Control cw until Oscilloscope displays a 1 kHz sinewave at 1 Vp-p.
- Set 1 kHz TONE and VAR TONE Selector Switches in "INT MOD" position.
- Using Oscilloscope, verify 1 kHz sinewaves at 1 Vp-p are present at extender cable connector pins 5 and 7.
- Set Power Switch in "OFF" position.
- Connect extender cable connector to J3201 of Generate Audio PC Board.
- Set Power Switch in "LINE" position.
- Connect Oscilloscope to J3201, pin 9 and verify a flat trace at +2.0 VDC (± 0.5 V).

14. Rotate GEN/LOCK Control out of "LOCK" detent. Verify Oscilloscope displays a 2.0 V (± 0.5 V) squarewave at approximately 2 Hz.
15. Rotate GEN/LOCK Control into "LOCK" detent.
16. Disconnect P/J4101, verify Oscilloscope again displays a 2 Hz, 2.0 V squarewave, then reconnect P/J4101.
17. Disconnect P/J4503, verify Oscilloscope again displays a 2 Hz, 2.0 V squarewave, then reconnect P/J4503.
18. Using DMM, verify the voltages for each of the conditions given in Table 7-5.

GEN/REC SWITCH POSITION	SHORTING STRAP MIC/ACC JACK PIN 3 TO PIN 2 (GROUND)	SHORTING STRAP J3201 PIN 1 TO PIN 35	REQUIRED VOLTAGE (± 0.5 V) AT J3201 PIN NO.		
			25	29	33
REC	NO	NO	0	+11.5	+11.5
REC	YES	NO	+11.5	0	0
GEN	YES	YES	+11.5	0	0
GEN	NO	YES	0	+11.5	+11.5
GEN	NO	NO	+11.5	0	0

Table 7-5 MIC/ACC Jack Functions

19. Set 1 kHz TONE Selector Switch in "OFF" position.
20. Using Oscilloscope, verify a 1.8 V_{p-p}, 1 kHz sinewave is present at J3201, pins 19 and 23.
21. Using Oscilloscope, verify a flat trace at 0 V (± 0.1 V) on J3201, pin 19 appears when pins 1 and 2 of the MIC/ACC jack are shorted.
22. Connect Oscilloscope to J3201, pin 18 and verify a flat trace at +0.75 V (± 0.1 V).
23. Rotate RF LEVEL FINE Adjust Control fully cw and verify a flat trace at +0.5 V (± 0.1 V).
24. Rotate Modulation Mode Selector Switch to "AM NORM" and verify a 1 kHz sinewave of approximately 0.15 V_{p-p}.
25. Rotate RF LEVEL FINE Adjust Control fully ccw and verify a 1 kHz sinewave of approximately 0.3 V_{p-p}.
26. Set 1 kHz TONE Selector Switch in "SPKR" position and verify a 1 kHz sinewave of approximately 2 V_{p-p} at J3201, pin 36.

7-11-4 REASSEMBLY

With all power "OFF", disconnect all test equipment. Reinstall the Generate Audio PC Board in the reverse order of removal procedure outlined in Section 6.

7-12 OUTPUT AMPLIFIER MODULE

7-12-1 THEORY OF OPERATION (THRU S/N 3224)

Refer to Figure 7-14 and Output Amplifier Circuit Schematics in Section 10

A. GENERAL

In the Generate mode, the Output Amplifier receives the RF output signal from the IF Module. A four-stage signal amplifier, enabled by the GEN command (+12 VDC) from the mode power circuit in the Generator Audio Module, amplifies the signal. Detected RF from the amplifier allows the Generate Audio Module to adjust the 10.7 MHz signal from the Receiver/Generator to correct the signal level leaving the Output Amplifier. The Output Amplifier output goes to the RF LEVEL step attenuator on the Front Panel, then through a 50 ohm, 20 dB pad in the Output Amplifier, and to the T/R jack.

When transmitting into the T/R jack, the 50 ohm, 20 dB pad dissipates up to 150 Watts of RF power. A power detector senses the input power for automatic mode switching by the Generate Audio Module.

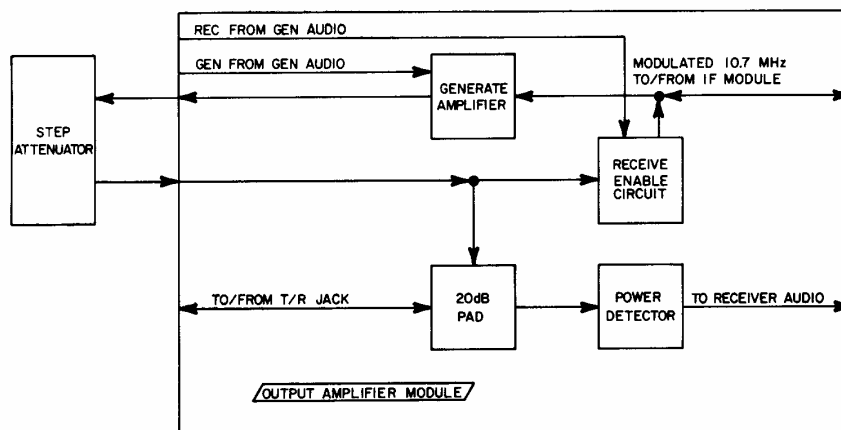

Figure 7-14 Output Amplifier Module Block Diagram (thru S/N 3324)

B. SIGNAL AMPLIFIER CIRCUIT

The four-stage signal amplifier circuit consists of two hybrid amplifiers (U5101 and U5102) and two RF power transistors (Q5101 and Q5103). Bias amplifier Q5102 adjusts the base current to transistor Q5103 to achieve a constant collector current in Q5103.

C. LEVEL DETECTOR CIRCUIT

The output level from the signal amplifier circuit is sensed by a level detector circuit to provide feedback to the modulator/leveler circuit in the Generate Audio Module. Diode CR5102 and capacitor C5116 form a level detector; and op amp U5103, with diode CR5106 and capacitors C5117 and C5118, functions as an amplifier. Potentiometer R5114 provides system adjustment.

D. RECEIVE ENABLE CIRCUIT

In the REC mode, the REC command turns on diodes CR5103, CR5104 and CR5107 to allow an attenuated sample of the transmitter power to be routed to the IF Module. In the GEN mode, the diodes are OFF, achieving isolation of the generated signal from the output.

E. POWER DETECTOR CIRCUIT AND 20 dB PAD

A generated signal leaving the signal amplifier circuit passes through the RF LEVEL Attenuator on the Front Panel, then through RN5101, which is a 20 dB pad in the Output Amplifier, before being connected to the T/R jack. A signal entering through the T/R jack passes through the 20 dB pad, then through the receive enable circuit to the IF Module. A power detector circuit monitors the incoming signal strength and provides feedback through the Receive Audio power level adjustment circuit, then to the Generate Audio mode power circuit to switch to the Receive mode automatically. Diode CR5108 and capacitor C5124 form the power detector.

7-12-2 THEORY OF OPERATION (S/N 3225 AND ON)

In the Receive mode, the output Amplifier Module couples any signal received at the T/R Connector through a 20 dB pad to the IF Module. In the Generate mode, it amplifies the signal received from the IF Module and routes it to the Step Attenuator on the Front Panel. This signal is then returned to the Output Amplifier for 20 dB additional attenuation and routed to the T/R Connector.

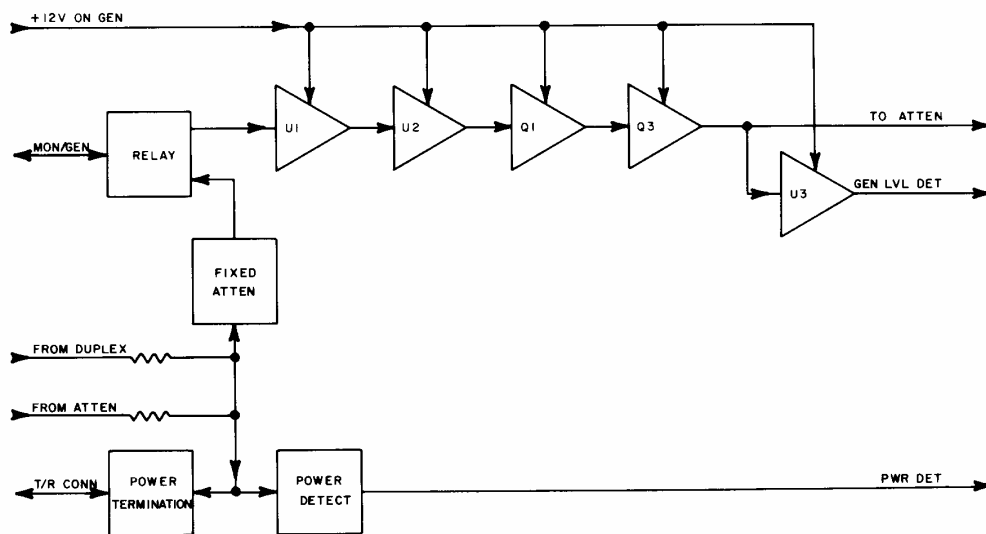

Figure 7-14a Output Amplifier Module Block Diagram
(S/N 3225 and On)

A. RECEIVE MODE

All signals received through the T/R Connector are attenuated 20 dB by RN5101. The signal is then split. One signal goes to the power detector circuit consisting of CR5108, C5124, trimcap C5127, L5107, R5128, R5129, R5134 and R5147, where it is converted to a DC voltage level proportional to the signal power, and supplied to the Receive Audio Module. The other signal is further attenuated by a series of voltage dividers, using R5135 through R5146, and coupled by relay K5101 through J5101 to the IF Module.

B. GENERATE MODE

In the Generate mode, +12V energizes mode relay K5101 and enables the generate amplifier and level detector circuits. The relay couples the RF signal from the IF Module to the output amplifier circuit in the Generate mode. Two amplifiers, U5101 and U5102, amplify the signal and apply it to the base of RF transistor Q5101 which, in turn, controls the base of RF transistor Q5103. Q5102 is a bias transistor to adjust the base current of Q5103 to achieve a constant collector current in Q5103. The signal level at this point is nominally 0 dB. From the collector of Q5103, the signal is coupled through J5103 to the GEN LEVEL Step Attenuator and through CR5102 to the GEN LEVEL Step Attenuator and through CR5102 to the generate level detector circuit.

The Step Attenuator, while not a physical part of the Output Amplifier Module, is electrically an integral component. It attenuates the generated signal from 0-100 dB in 10 dB steps, allowing operator control of the signal level. (Vernier control from +1 to -11 dB is achieved by varying the signal level in the

Gen/Audio Module.) From the Step Attenuator, the signal is returned to the Output Amplifier, where RN1501 attenuates it an additional 20 dB. The signal is then routed to the T/R Connector.

CR5102 and C5116 form a detector which senses the signal level from Q1503. Amplifier U5103 then sends an analog net signal to the Generate Audio PC Board. The AM modulation circuit uses this signal to adjust the modulator/leveler attenuator in the 10.7 MHz Gen/Rec Module, thereby affecting the level of the generated signal which is ultimately applied to the Output Amplifier. Trimpot R5114 allows adjustment of the output from U5103 as necessary, to obtain a level of 0 dB at J1503.

7-12-3 PREPARATION FOR TESTING

A. REMOVAL AND DISASSEMBLY

If repair or replacement is required, remove and disassemble the Output Amplifier as outlined in Section 6.

B. REQUIRED TEST EQUIPMENT

- 1 - RF Power Source 5 W @ 175 MHz
- 1 - Spectrum Analyzer with
Tracking Generator 1 MHz - 1 GHz
- 1 - Power Supply +12 V and -12 V @ 500 mA
- 1 - Digital Multimeter 100 K Ω /V
- 1 - 50 Ω Coax Cable SMA/SMA
- 2 - 50 Ω Coax Cables BNC/SMA

C. PREPARATION (Refer to Output Amplifier Module Drawing in Section 9)

1. Remove Output Amplifier Module from FM/AM-500A chassis.
2. Connect Tracking Generator output to J5104 and the Spectrum Analyzer input to J5101.
3. Connect Power Supply as follows: common lead to chassis of Output Amplifier; negative lead to FL5105; positive lead to FL5102.
4. Connect SMA/SMA coax cable between J5102 and J5103.

7-12-4 TESTING (Refer to Output Amplifier Module Drawing in Section 9 and Circuit Schematic in Section 10)

1. Apply power to Power Supply and adjust outputs to +12 VDC and -12 VDC.
2. Apply power to the Spectrum Analyzer and Tracking Generator and set the controls as follows:

EQUIPMENT	CONTROL	SETTING
Spectrum Analyzer	Center Frequency	"500 MHz"
	Dispersion	"100 MHz/DIV"
	Reference Level	"-10 dBm"
	Scale	"2 dB/DIV"
	Sweep Rate	"10 μ S/DIV"
	Resolution	"3 MHz"
Tracking Generator	Output Level	"0 dBm"

3. Verify Spectrum Analyzer display is flat within ± 4 dB at a level of -20 dBm (± 4 dB).
4. Connect +12 V Power Supply lead to FL5101.
5. Connect Tracking Generator output to J5101 and the Spectrum Analyzer input to J5104.
6. Adjust Test Equipment as follows and verify each display is flat within ± 6 dB at a level of -10 dBm (± 3 dB):

Tracking Generator	Output Level	-20 dBm
Spectrum Analyzer	Reference Level	0 dBm
	Scale	2 dB/DIV

7. Adjust Spectrum Analyzer Dispersion to "0".
8. Connect DMM between FL5104 and Output Amplifier chassis and verify voltage is approximately 1.8 V.
9. Disconnect Test Equipment from Output Amplifier.
10. Connect DMM between FL5103 and Output Amplifier chassis.
11. Connect RF Power Source to J5104 and adjust to 157 MHz CW @ 5W (± 1 W). Verify DMM indicates approximately 1.9 V.

7-12-5 REASSEMBLY

With all power "OFF", disconnect all test equipment. Reassemble in reverse order of removal and disassembly procedures outlined in Section 6.

7-13 VARIABLE TONE GENERATOR

7-13-1 THEORY OF OPERATION (Refer to Figure 7-15 and Variable Tone Generator Circuit Schematic in Section 10)

A. GENERAL

The Variable Tone Generator consists of an adder system, a crystal oscillator circuit, a ROM/DAC signal generator to produce the audio frequency sinewave, and an output amplifier/lowpass filter circuit.

The crystal oscillator circuit provides a 256 kHz frequency to clock the adder system, the ROM, and its latch. The VAR TONE FREQ Thumbwheels set a value for the adders (ten times the thumbwheel setting) which accumulate with every clock pulse. The ROM is programmed to produce a series of 128 binary-coded signals. Each time the adder system reaches or exceeds a count of 20,000, the ROM advances to the next sequential output code. Any amount in excess of 20,000 is added into the next accumulation. Thus, the higher the thumbwheel setting, the faster the adders accumulate to 20,000 and advance the ROM to the next code. With each low output from the oscillator, the latch stores the ROM output code, then transfers that code to the DAC when the oscillator output goes high. The DAC converts the binary code to an analog voltage which, as a result of the ROM programming, forms a sinewave at the frequency established on the thumbwheels.

After amplification, the output of the DAC passes through a 10 kHz lowpass filter. When the frequency selected is below 1 kHz, a 1 kHz lowpass filter is switched in series with the 10 kHz filter. The signal is further amplified before being fed to the Generate Audio Module.

Gates coupled to the frequency selection BCD signals (controlled by the thumbwheels) provide DC control voltages to the Digital Module - one when the selected frequency is below 1 kHz and another below 100 Hz. A third control voltage goes to the Receive Audio Module if the frequency is below 400 Hz. The adder system also furnishes a reference signal (at the frequency set on the thumbwheels), to the Digital Module for audio frequency comparison.

B. CRYSTAL OSCILLATOR CIRCUIT

Crystal oscillator Y3101 and associated timing capacitors produce a frequency of 2.048 MHz. NAND gates U3113A and U3113B and binary counter U3102A divide this frequency to 256 kHz to clock the latches in the adder system and the sine ROM latch U3116. NAND gates U3113C and U3113D enable ROM U3114 only during the required operating time to conserve power.

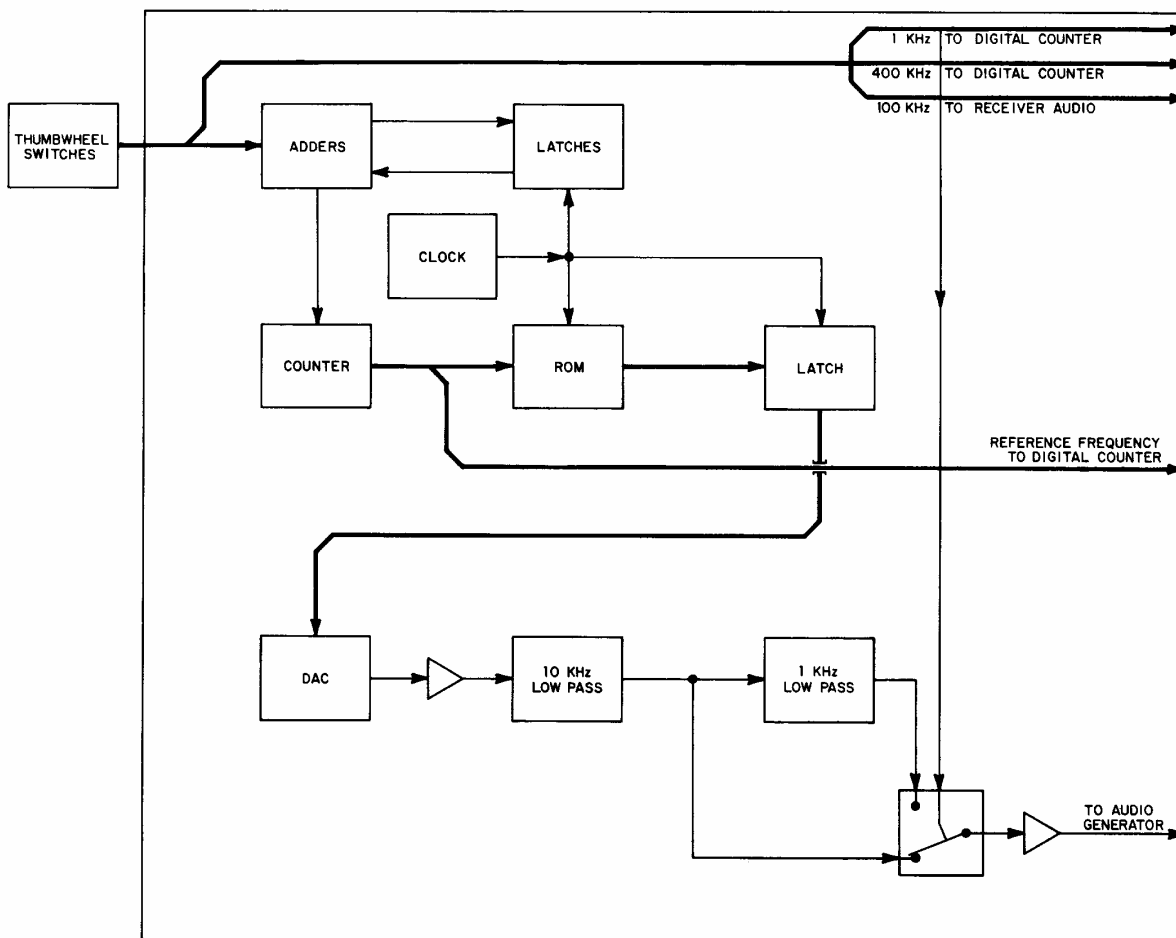

Figure 7-15 Variable Tone Generator Block Diagram

C. ADDER SYSTEM

The adder system uses five chained adders: U3103, U3105, U3107, U3108 and U3109. The BCD input power is supplied through resistor networks RN3101 and RN3102 and resistors R3104 and R3105 to four inputs of each adder and to the VAR TONE FREQ Thumbwheels. The thumbwheel switches ground the various code lines as required to establish the frequency coding. With each pulse from the crystal oscillator, latches U3104, U3106 and U3109 transfer the adder outputs back to their respective inputs to be added to the BCD frequency code. Latch U3104 also furnishes the three most significant codes to the ROM. Overflow count from adder U3103 goes to counter U3102B. Upon receiving the clock pulse from the crystal oscillator, the counter system sends its binary count to the ROM.

D. AUDIO SIGNAL GENERATOR

Buffers U3111A, U3111D, U3111E, U3111F, U3112A, U3112B and U3112C shift the binary count signals received from the adder system from a +12 VDC level to +5 VDC. Buffer U3111B shifts the ROM enable pulse and U3112F shifts the latch pulse levels similarly. Latch U3115 transfers the output from ROM U3114 to DAC U3116. Op amp U3117A converts the DAC output current to voltage.

E. LOWPASS FILTERS

The output from op amp U3117A is filtered to a smooth sinewave by op amps U3117B and U3118A and associated circuitry, which function as a 10 kHz lowpass filter. It is then coupled through multiplexer U3120 to output op amp U3119B. If a frequency of less than 1 kHz is selected, the lowpass multiplexer is enabled, routing the signal from the 10 kHz lowpass filter through a similar circuit utilizing op amps U3118B and U3119A and associated circuitry which function as a 1 kHz lowpass filter, then to the output amplifier U3119B.

F. FREQUENCY SELECTION DETECTORS

The 4-input NOR gate U3101A is connected to the four BCD lines to the 1-9 kHz thumbwheel switch. When all of these lines are low (less than 1 kHz is selected), a high output signal enables the lowpass multiplexer and is also fed to the Digital Module. NOR gate U3101B is similarly connected to the 100-900 Hz thumbwheel switch. When all inputs to U3101B are low, the high output is fed to the Digital Module. The 8-input NAND gate U3121 is connected to the 1-9 kHz thumbwheel switch and the 4 and 8 input of the 100-900 Hz thumbwheel switch. U3121D subsequently inverts the output of U3121. Thus, with any frequency less than 400 Hz, the output of U3121 is low; consequently, U3112D sends a high signal to the Receive Audio Module.

7-13-2 PREPARATION FOR TESTING

A. REMOVAL AND DISASSEMBLY

Remove the Variable Tone Generator Module according to instructions for Audio PC Board Removal in Section 6. No disassembly is required to test the Variable Tone Generator.

B. REQUIRED TEST EQUIPMENT

- 1 - Frequency Counter Capable of counting from
10 Hz to 300 kHz with 0.1 Hz
resolution
- 1 - Oscilloscope 10 MHz bandwidth, single trace
- 1 - Digital Voltmeter (DVM) 100 K Ω /V, 3½ digit
- 1 - Extender Cable 26 Pin M/F Connectors
- 2 - 50 Ohm Coax Cables BNC/SNB

C. PREPARATION (Refer to Controls, Indicators and Connectors Drawing in Section 1 and Variable Tone Generator PC Board Drawing in Section 9)

- 1. Connect extender cable between J3102 and P3102.
- 2. Connect P3101 to J3101.
- 3. Connect Frequency Counter to TP3103.
- 4. Connect Oscilloscope to J3102 Pin 9.
- 5. Connect DVM to J3102 Pin 5.
- 6. Rotate VAR TONE FREQ Thumbwheels to "9999.9" Hz.
- 7. Set VAR TONE Selector Switch to "SPKR".

7-13-3 TESTING (Refer to Variable Tone Generator PC Board Drawing in Section 9 and Circuit Schematic in Section 10)

- 1. Adjust capacitor C3110 to obtain a reading of 256.0000 kHz on Frequency Counter.
- 2. Verify DVM displays a voltage less than +0.5 VDC.
- 3. Verify Oscilloscope displays a clean sinewave approximately 6 Vp-p.
- 4. Connect Frequency Counter to J3102 Pin 9. Verify frequency displayed is 9999.9 Hz.
- 5. Rotate VAR TONE FREQ Thumbwheels to "0999.9" Hz. Verify frequency displayed on Frequency Counter is 999.9 Hz.
- 6. Verify DVM displays a voltage greater than +11.0 VDC.
- 7. Verify Oscilloscope displays a clean sinewave approximately 6 Vp-p.

7-13-4 REASSEMBLY

With all power "OFF", disconnect all test equipment. Replace the Variable Tone Generator in the reverse order of the removal procedure outlined in Section 6.

7-14 OPTIONAL GENERATE AMPLIFIER

7-14-1 THEORY OF OPERATION (Refer to Figure 7-16 and Generate Amplifier Circuit Schematic in Section 10)

A. GENERAL

The Generate Amplifier is a plug-in accessory which boosts the output signal level by 30 dBm. In the Generate mode, +12 VDC supplied at the accessory power jack enables a three-stage amplifier and energizes the transmit relay. The output signal is then coupled through the Unit Under Test (UUT) T/R jack of the Generate Amplifier, which may be connected directly to a UUT or to the accessory antenna. In the Receive mode, the +12 VDC power is discontinued, allowing the relay to switch the UUT T/R connection to the Antenna jack. Any signal received on the accessory antenna is then routed to the Antenna jack. An accessory coax cable is provided to couple this jack to the ANTENNA jack on the Front Panel of the FM/AM-500A.

CAUTION

NEVER TRANSMIT INTO THE UUT T/R JACK OF THE GENERATE AMPLIFIER. TO DO SO WILL DAMAGE EITHER THE GENERATE AMPLIFIER, THE FM/AM-500A, OR BOTH.

B. CIRCUIT DESCRIPTION

Hybrid amps U9001 and U9002 form the first two amplifier stages. Transistors Q9001 and Q9002 with inductors L9003 and L9004 and associated resistors and capacitors form the third stage. Inductor L9003 is created by cutting the lead of capacitor C9008 to a specific length of 0.2 inch. Inductors L9001, L9002 and L9005 inhibit stray RF from entering the FM/AM-500A +12 VDC power distribution circuit. Relay K9001 performs the signal switching function.

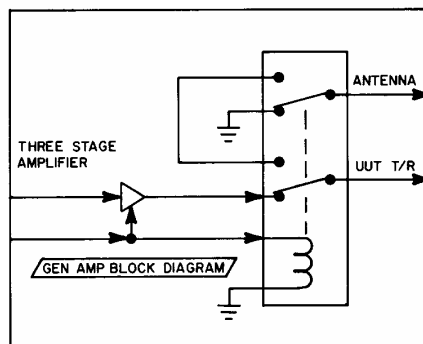

Figure 7-16 Generate Amplifier Block Diagram

7-14-2 PREPARATION FOR TESTING

A. REMOVAL AND DISASSEMBLY

If installed, unplug the Generate Amplifier from the accessory power and T/R jacks. Disassemble the Module per instructions in Section 6.

B. REQUIRED TEST EQUIPMENT

- 1 - Tracking Generator 10 kHz to 1 GHz span
- 1 - Power Supply +12 VDC, 250 mA
- 2 - 50 Ohm Coax Cables BNC/BNC Connectors
- 1 - 50 Ohm Coax Cable BNC/Type N Connectors

C. PREPARATION (Refer to Generate Amplifier Module Drawing in Section 9)

1. Connect Tracking Generator input to J9002 (UUT T/R Port).
2. Connect Tracking Generator output to J9003 (Antenna Port).

7-14-3 TESTING (Refer to Generate Amplifier Module Drawing in Section 9 and Circuit Schematic in Section 10)

1. Set Tracking Generator for 100 MHz/Division with center frequency of 500 MHz and output level of -25 dBm. Verify loss is less than 4 dB.
2. Connect Tracking Generator output to J9001.
3. Connect Power Supply common terminal to Generate Amplifier chassis.
4. Apply +12 VDC from Power Supply to J9004 (banana plug).
5. Verify Tracking Generator displays an output level between +7 and +10 dBm. Verify response curve is flat (within ± 3 dBm) from 10 kHz to 1 GHz.
6. Increase output level of Tracking Generator to -5 dBm. Verify output level displayed is between +10 dBm and +20 dBm.

7-14-4 REASSEMBLY

With all power "OFF", disconnect all test equipment. If module was disassembled for repair, reassemble in reverse order of disassembly procedure outlined in Section 6.

SECTION 8 - PREVENTIVE MAINTENANCE

8-1 PREVENTIVE MAINTENANCE (POWER "OFF")

This section contains routine maintenance instructions for cleaning and inspecting the FM/AM-500A Communication Service Monitor.

8-1-1 EXTERNAL CLEANING

1. Clean Front Panel, switches and meter covers with a soft, lint-free cloth. If dirt is difficult to remove, dampen cloth with water, using liquid detergent if necessary.

CAUTION

EXCESSIVE PRESSURE CAN DAMAGE METER COVERS.

2. Remove grease, fungus and ground-in dirt from surfaces with a soft, lint-free cloth dampened (not wet) with denatured alcohol.
3. Remove dust and dirt from connectors with a soft-bristled brush.
4. Clean cables with a soft lint-free cloth.
5. Touch up painted metal surfaces as necessary to avoid rust or corrosion.

8-1-2 INTERNAL CLEANING

1. Remove dust with hand-controlled dry air jet of 15 psi (1.054 kg/cm) and wipe internal chassis parts and frame with soft, lint-free cloth moistened with denatured alcohol.

CAUTION

AVOID MOVING (HOWEVER SLIGHTLY) DISCRETE COMPONENTS ON CIRCUIT BOARDS, ETC.

DO NOT OPEN COMPLEX INTERNAL MODULES SOLELY TO CLEAN AND INSPECT THEM.

8-1-3 VISUAL INSPECTION

1. Inspect chassis for:
 - a. Tightness of subassemblies and chassis-mounted connectors.
 - b. Corrosion or damage to metal surfaces.

2. Inspect capacitors for:
 - a. Loose mounting, deformities or obvious physical damage.
 - b. Leakage or corrosion around leads.
3. Inspect connectors for:
 - a. Loose or broken parts, cracked insulation and damaged contacts. DO NOT disassemble connectors solely for inspection and cleaning.
4. Inspect potentiometers for:
 - a. Free rotation. If rotation feels rough, refer to Section 7 for proper test procedure.
5. Inspect circuit boards for:
 - a. Corrosion or damage to connectors.
 - b. Damage to any mounted components, including crystals and IC's.
 - c. Freedom from all foreign materials.
6. Inspect resistors for:
 - a. Cracked, broken, charred or blistered bodies.
 - b. Loose or corroded soldered connections.
7. Inspect semiconductors for:
 - a. Cracked, broken, charred or discolored bodies.
 - b. Loose or damaged seals around leads.
8. Inspect switches for:
 - a. Loose levers, terminals and switch body contact to frame.
 - b. Bent or loose line switch contacts.
9. Inspect wiring for:
 - a. Broken or loose ends and connections.
 - b. Cuts in or charred insulation.
10. It is recommended that all connectors not in use be covered with a suitable dust cover to prevent tarnishing of connector contacts.

SECTION 9 - PC BOARD ASSEMBLIES

9-1 GENERAL

This section contains component layout drawings for all PC Boards contained within the FM/AM-500. These drawings provide the locations and identification of discrete components, connectors, test points, etc., which are referenced in other sections of this manual.

NOTE

The figure title for each PC Board is followed by a number enclosed within parentheses. This number represents the reference designator series number assigned to the PC Board shown in that figure (e.g., if a PC Board carries a designator series number 3200, then component R1 is R3201, Q5 is Q3205, etc.).

If a PC Board has components located on both sides of the board, both a top and bottom view of the PC Board is shown in the illustration. If, however, a PC Board has components only on one side, then only the component side is shown.

9-2 ALPHABETICAL INDEX OF PC BOARD ASSEMBLY DRAWINGS

Title	Figure	Page
Digital Counter PC Board (7010-5234-400 Rev. D)..	9-20	9-16
Digital Reference PC Board (7010-5234-500 Rev. F5).....	9-19	9-16
Frequency Standard PC Board (7010-5232-500 Rev. L).....	9-6	9-6
Generate Amplifier PC Board (Optional) (7010-5239-000 Rev. A4).....	9-21	9-17
Generate Audio PC Board (7010-5233-200 Rev. G)...	9-17	9-14
High Loop Analog PC Board (7010-5234-000 Rev. E1)	9-11	9-9
High Loop Divider PC Board (7010-5234-100 Rev H)	9-12	9-9B
High Loop Analog PC Board (7010-5134-000 Rev. D9)	9-11A	9-9A
High Loop Divider PC Board (7010-5134-100 Rev. E8)	9-12A	9-10
IF Amplifier PC Board (7010-5232-200 Rev. A1)....	9-9	9-8
IF Mixer PC Board (7010-5232-300 Rev. A4).....	9-10	9-8
IF 1300 MHz Amplifier PC Board (7010-5234-400 Rev. C).....	9-8	9-8
Low Loop PC Board (7010-5234-200 Rev. R6).....	9-13	9-11
Modulation Meter Switch PC Board (FM/AM-500A) (7010-5235-300 Rev. B).....	9-2	9-4

Title	Figure	Page
Motherboard (7010-5233-001 Rev. C).....	9-1	9-3
Output Amplifier PC Board (7010-5235-100 Rev. D).	9-7	9-7
Output Amplifier PC Board (7010-5131-500 Rev. C9)	9-7	9-7
Power Supply PC Board (7010-5235-200 Rev. F2)....	9-5	9-5
Receive Audio PC Board (FM/AM-500) (7010-5233-300 Rev. B)	9-15	9-13
Receive Audio PC Board (FM/AM-500A) (7010-5233-301 Rev. E6).....	9-16	9-13
Receiver/Generator PC Board (7010-5234-301 Rev. U4).....	9-14	9-12
RF Thumbwheel Switch PC Board (7010-5230-200 Rev. C1)		
Variable Tone Generator PC Board (7010-5230-100 Rev. F2).....	9-18	9-15
Variable Tone Thumbwheel Switch PC Board (7010-5230-300 Rev. C1).....	9-4	9-4
1210 MHz VCO PC Board (7010-5232-000 Rev. L1)....	9-22	9-18
1300-2300 MHz VCO PC Board (7010-5232-100 Rev. AF).....	9-22	9-18

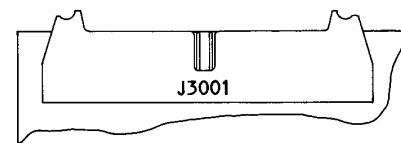
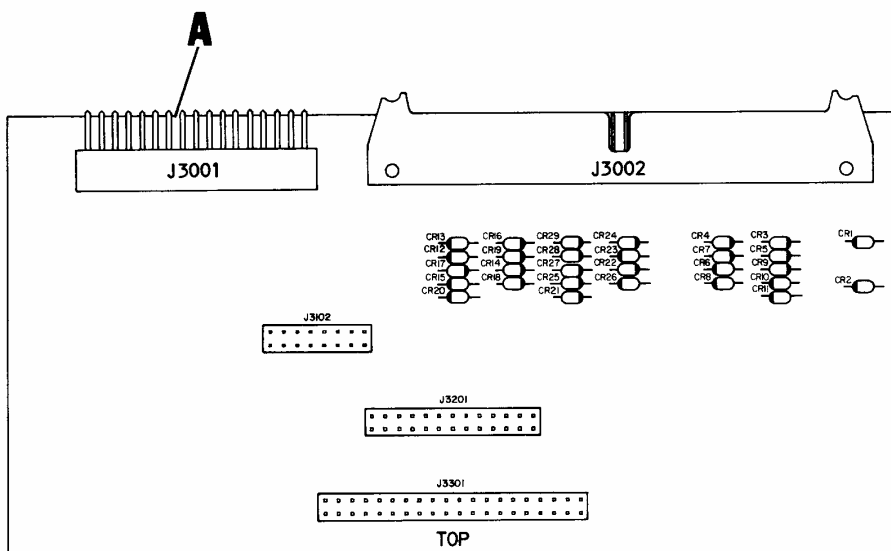

(EFF SN 1001 THRU SN 2177)

DETAIL A

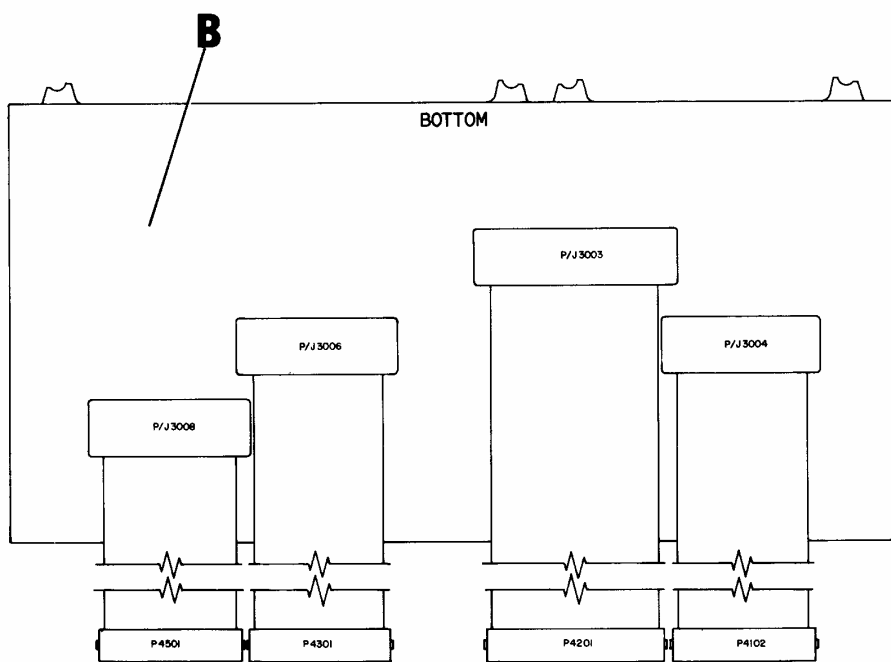

FM/AM-500

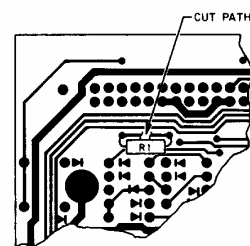

(EFF SN 2241 THRU SN 2390)

DETAIL B

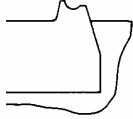

2177)

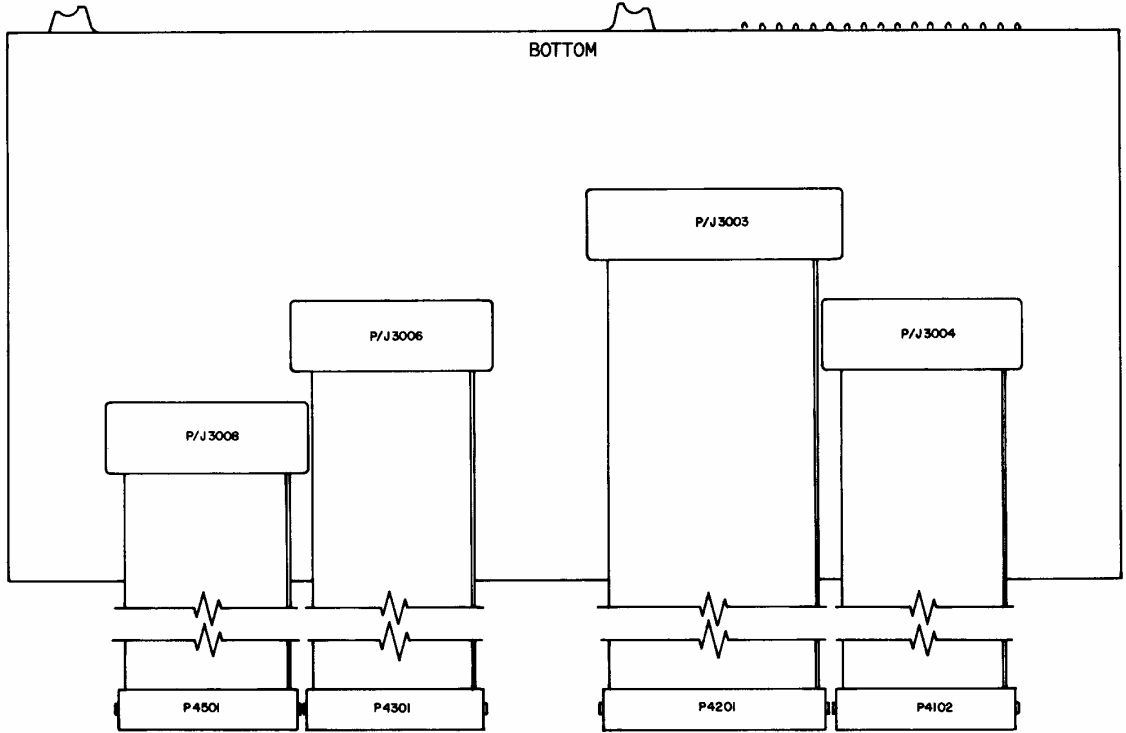
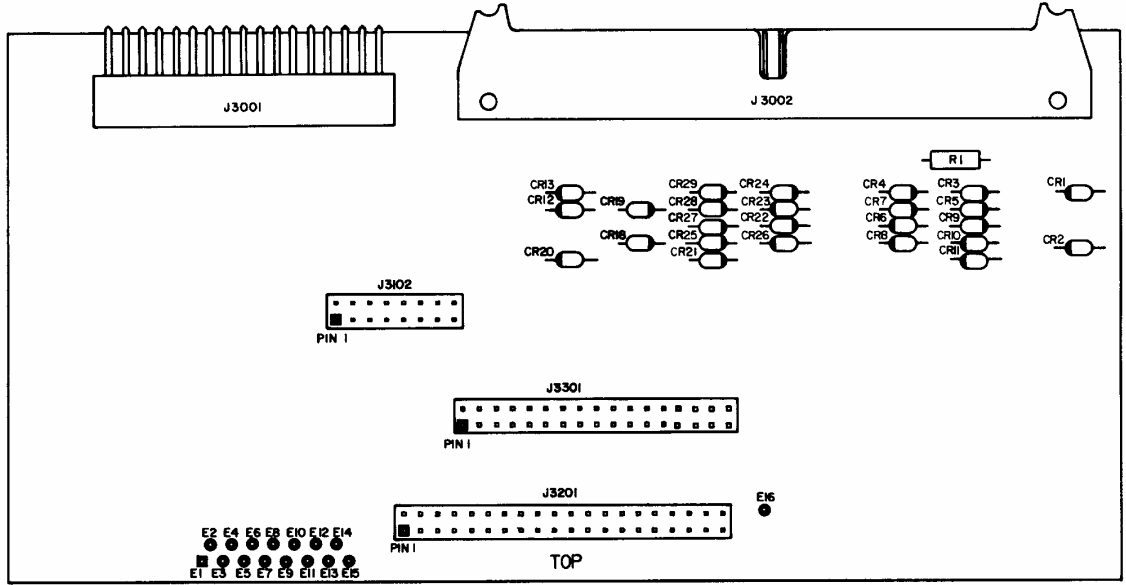

FM/AM-500A

Figure 9-1 Motherboard PC Board Assembly (3000)

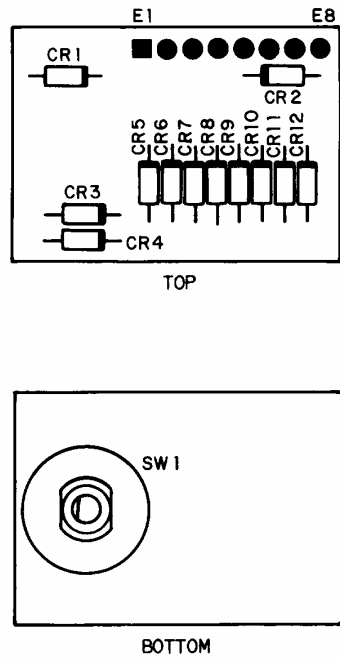

Figure 9-2 Modulation Meter Switch
PC Board Assembly (5300)
(FM/AM-500A)

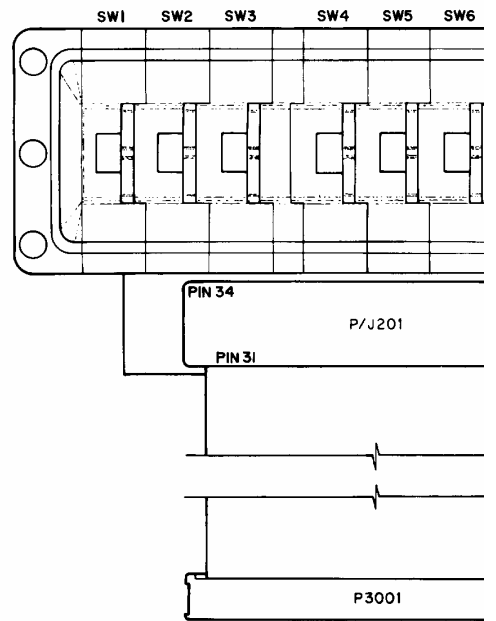
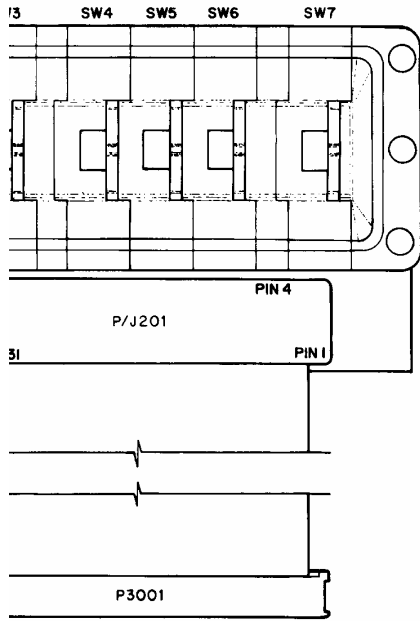

Figure 9-3 RF Thumbwheel Switch
PC Board Assembly



RF Thumbwheel Switch
PC Board Assembly (200)

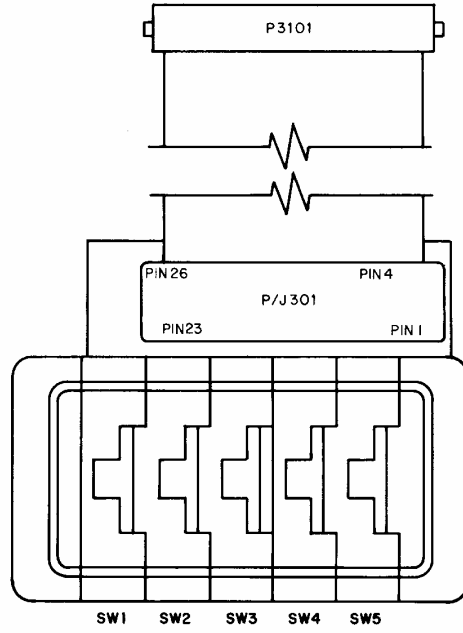

Figure 9-4 Variable Tone Thumbwheel
Switch PC Board Assembly
(300)

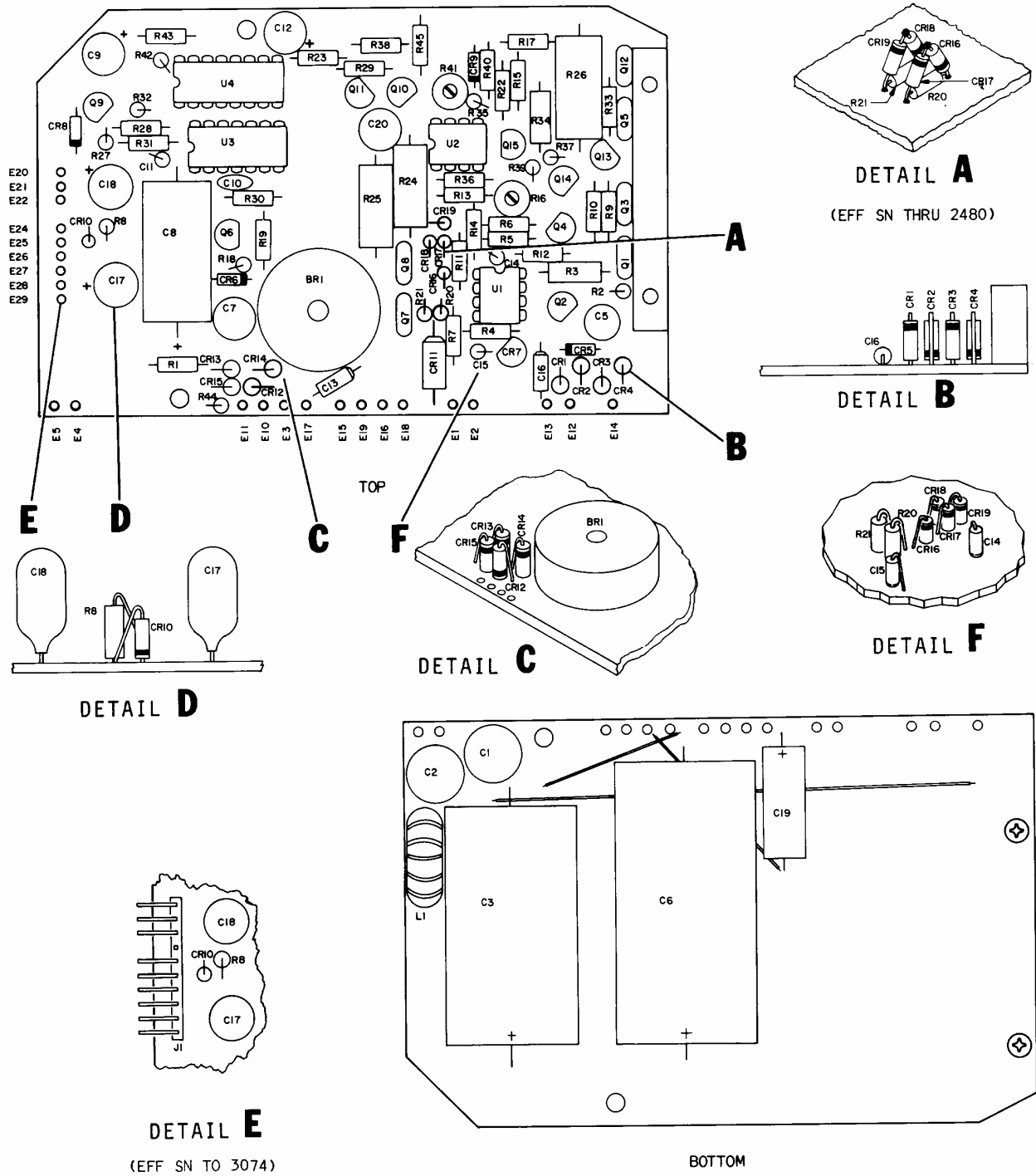
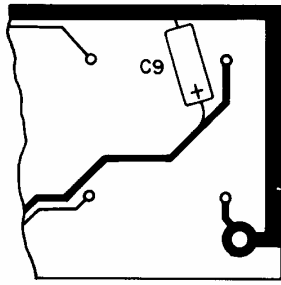
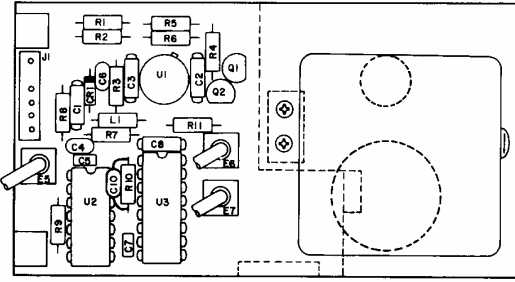

Figure 9-5 Power Supply PC Board Assembly (5200)
(EFF SN 3075 & ON)



BOTTOM



TOP

Standard TCXO - .5 PPM

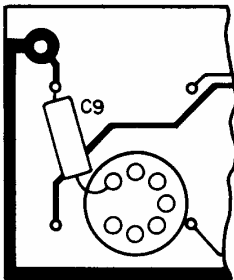

BOTTOM

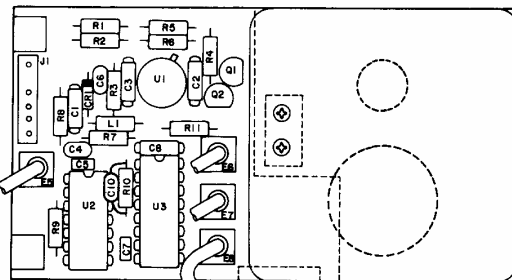

TOP

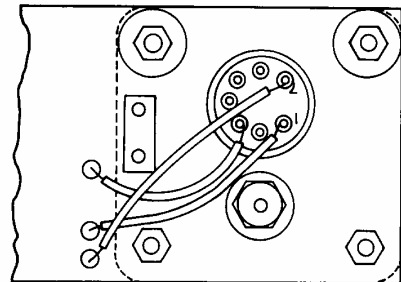

BOTTOM

Optional TCXO - .2 PPM

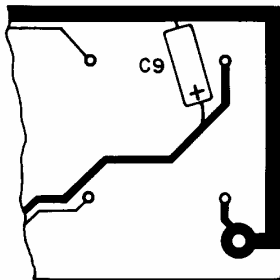

BOTTOM

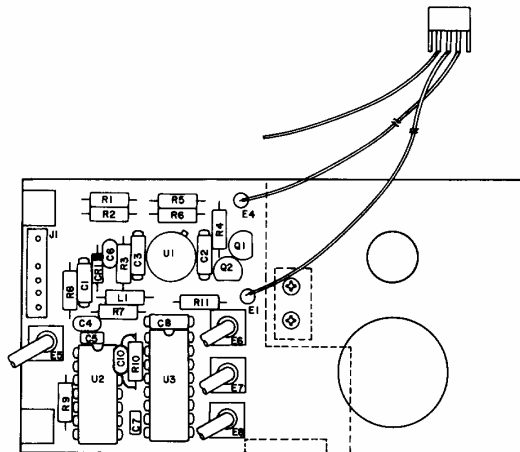

TOP

Optional Oven - .05 PPM

Figure 9-6 Frequency Standard PC Board Assembly (2500)

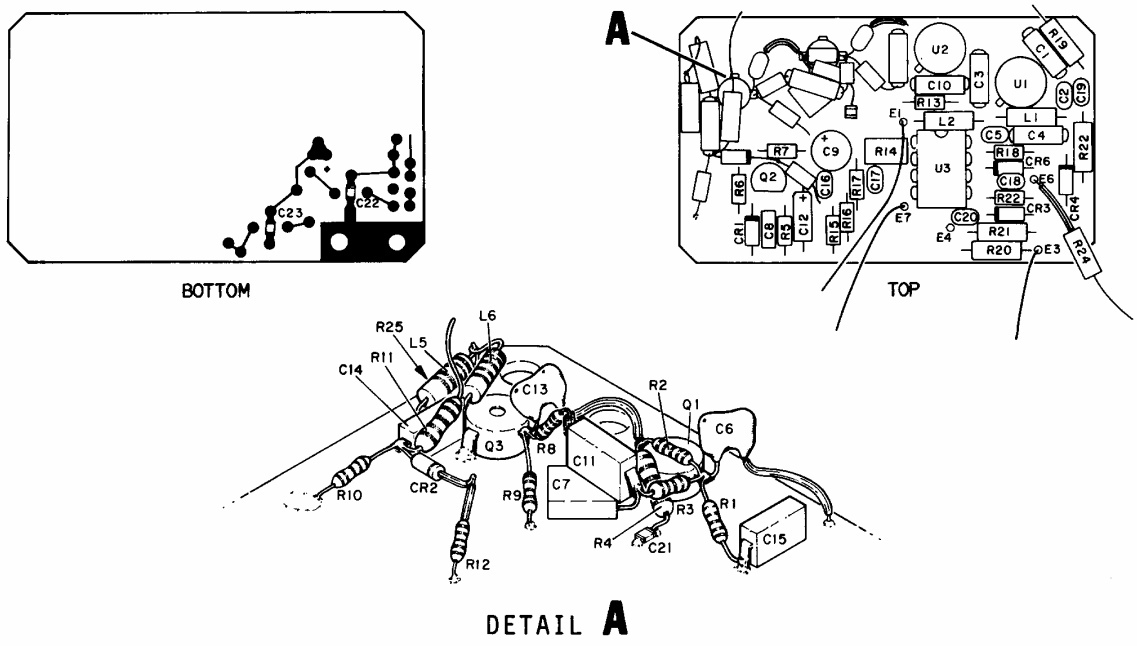

Figure 9-7 Output Amplifier PC Board Assembly (5100)
(EFF SN 1001 THRU SN 3234)

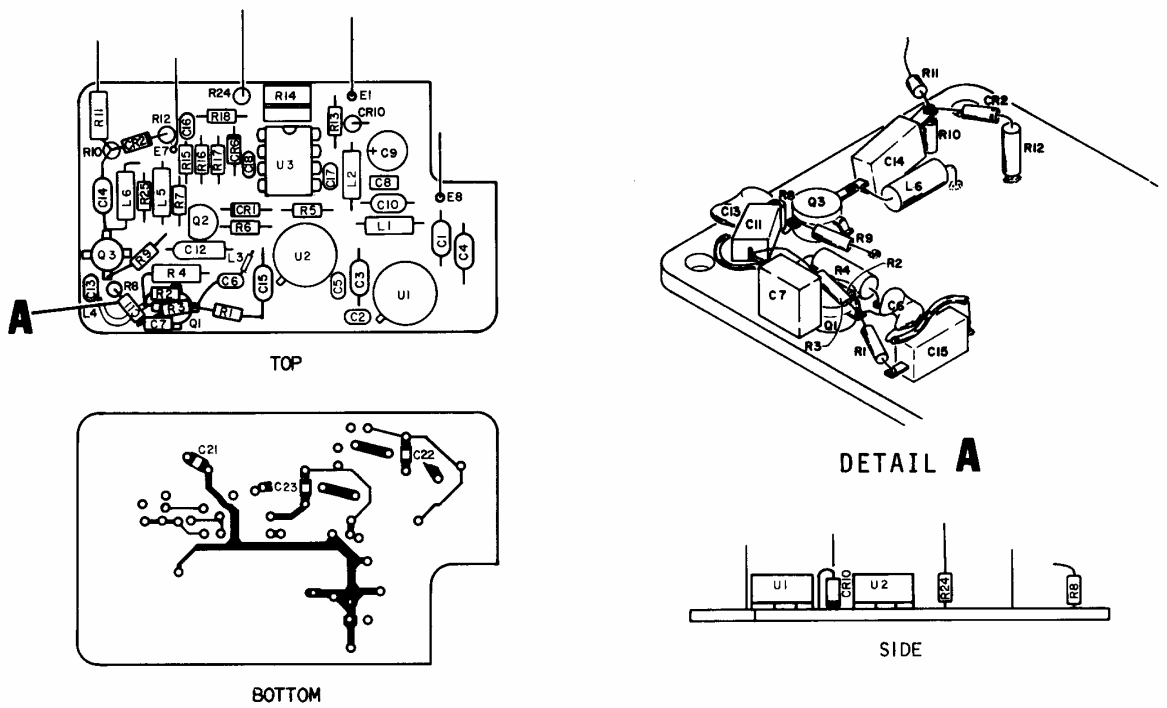

Figure 9-7a Output Amplifier PC Board Assembly (5100)
(EFF SN 3225 and On)

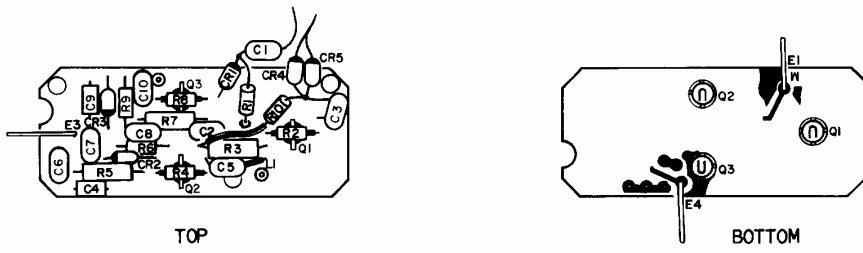

Figure 9-8 1300 MHz Amplifier PC Board Assembly (2400)

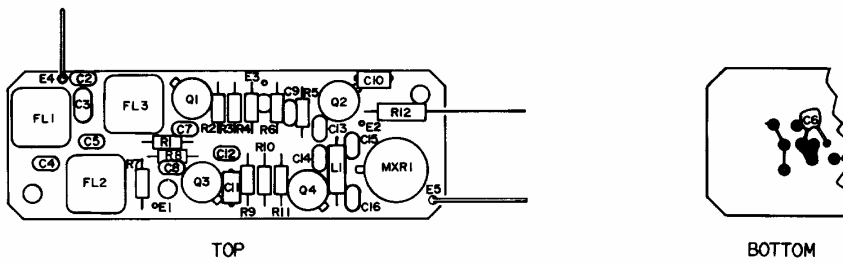

Figure 9-9 IF Amplifier PC Board Assembly (2200)

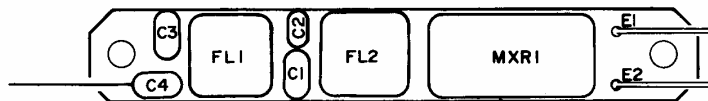
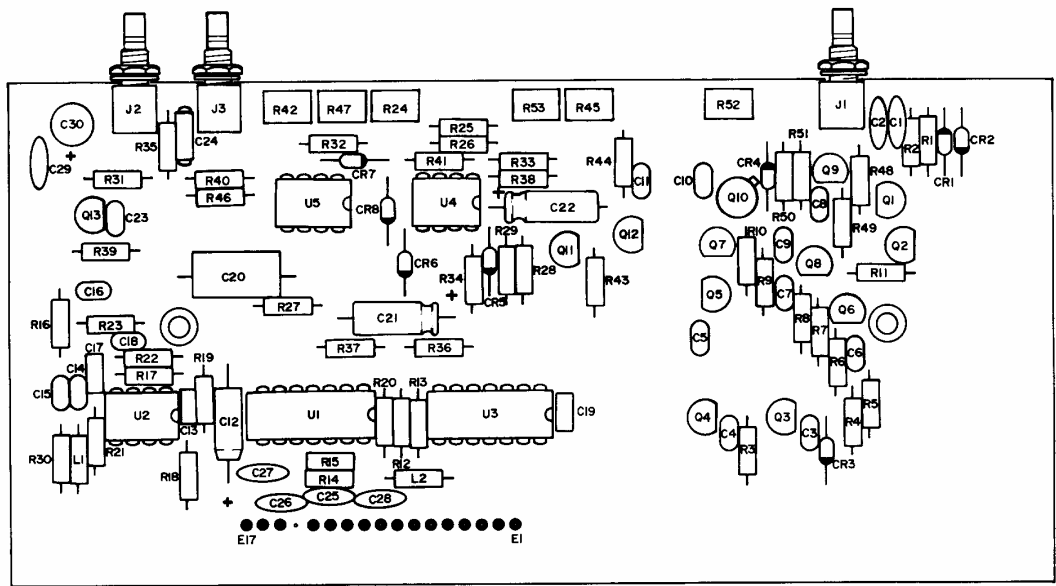
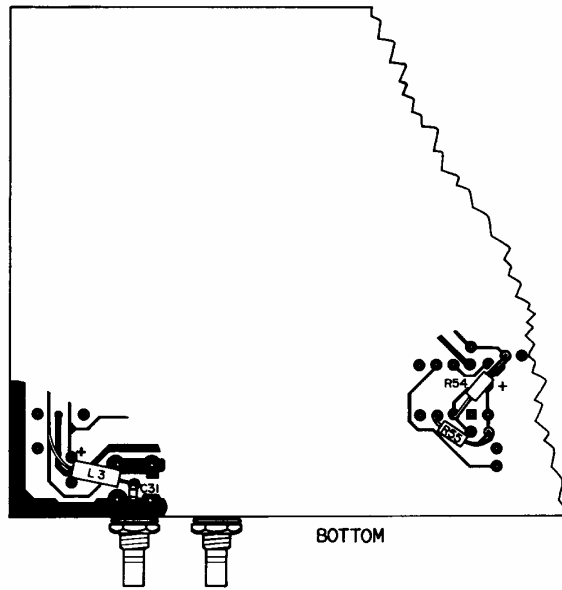

Figure 9-10 IF Mixer PC Board Assembly (2300)



TOP



BOTTOM

Figure 9-11 High Loop Analog
PC Bd Assembly (4000)
(EFF SN THRU 3074)

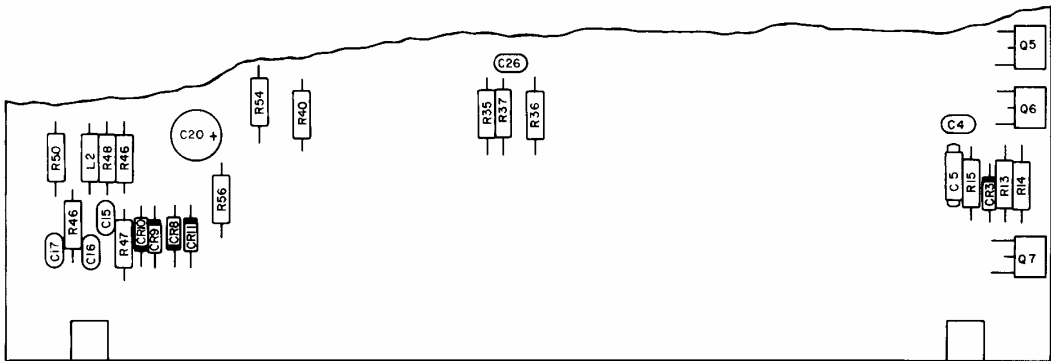

(EFF SN 3075 THRU SN 3488)

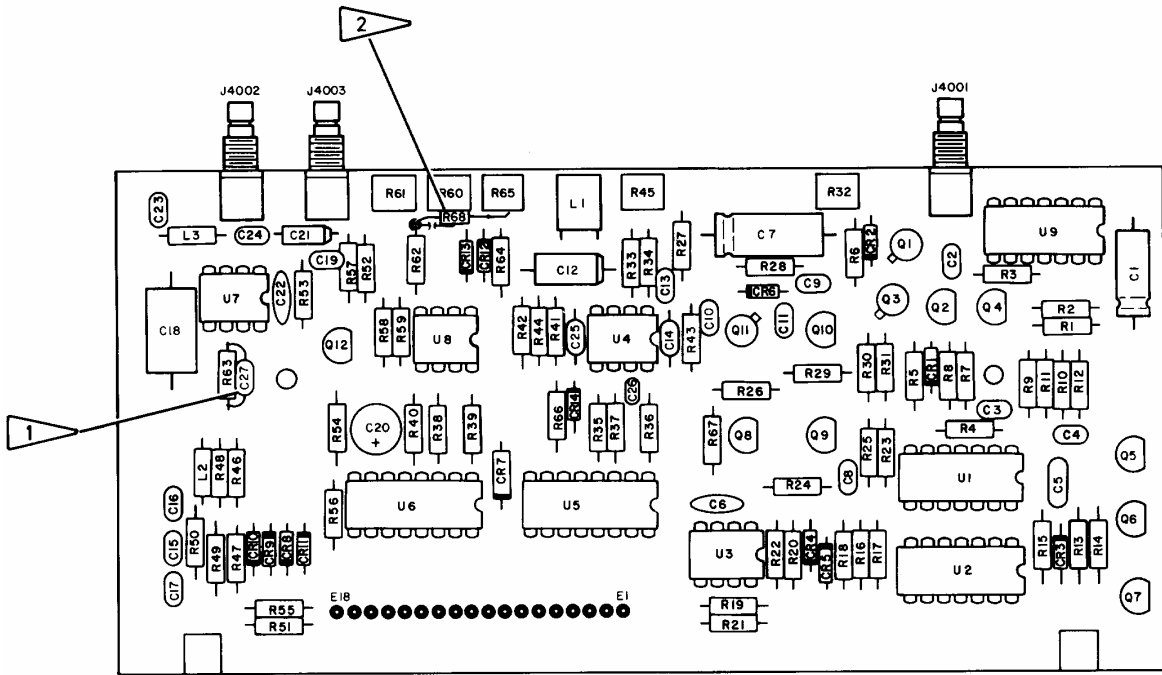

(EFF SN 3489 AND ON)

- 1 EFF SN 4235 AND ON
- 2 EFF SN 4273 AND ON

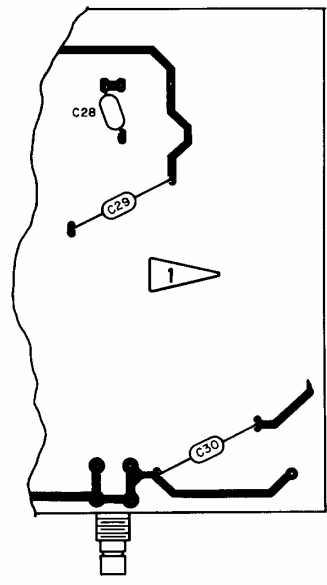
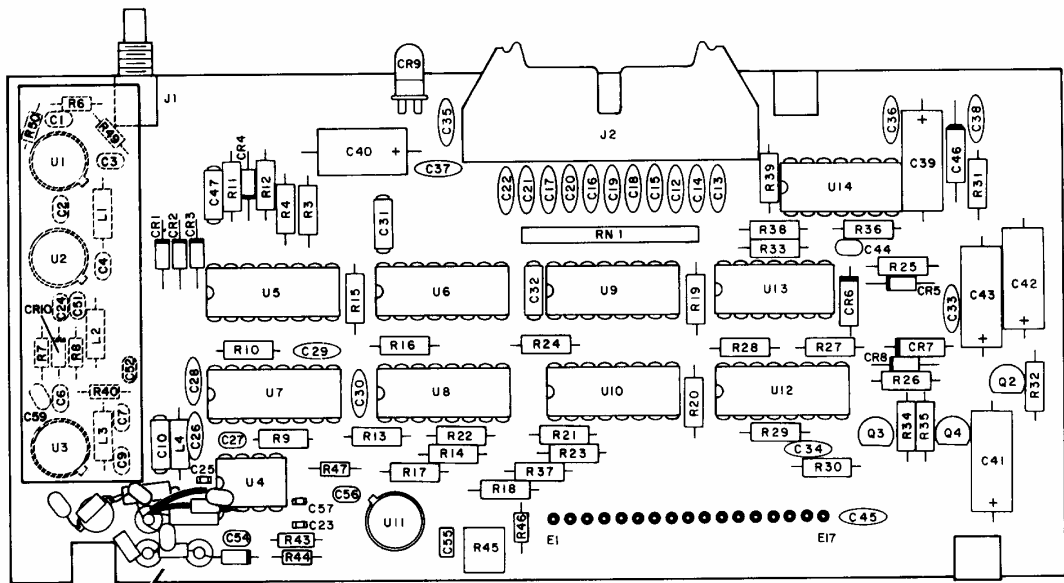
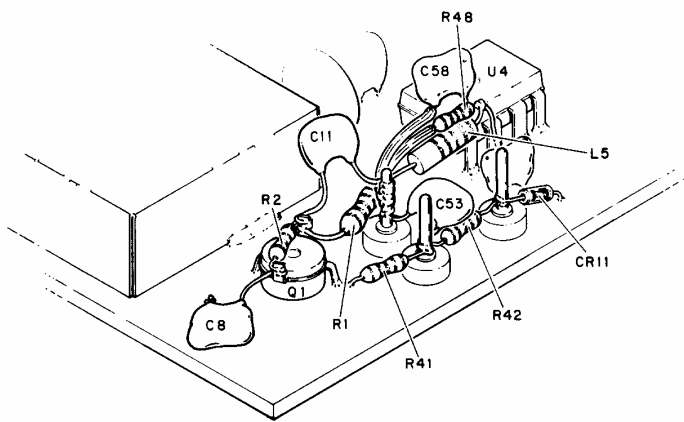

Figure 9-11a High Loop Analog PC Board Assembly (4000)



TOP

A



DETAIL A

C50

C49

C48

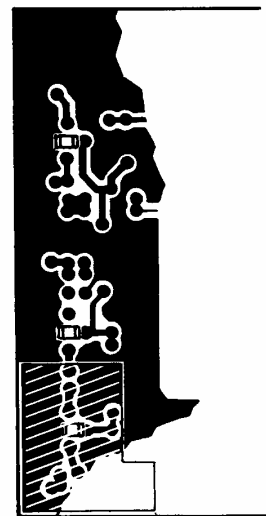

BOTTOM

Figure 9-12 High Loop Divider PC Board Assembly (4100)
(Thru SN 3074)

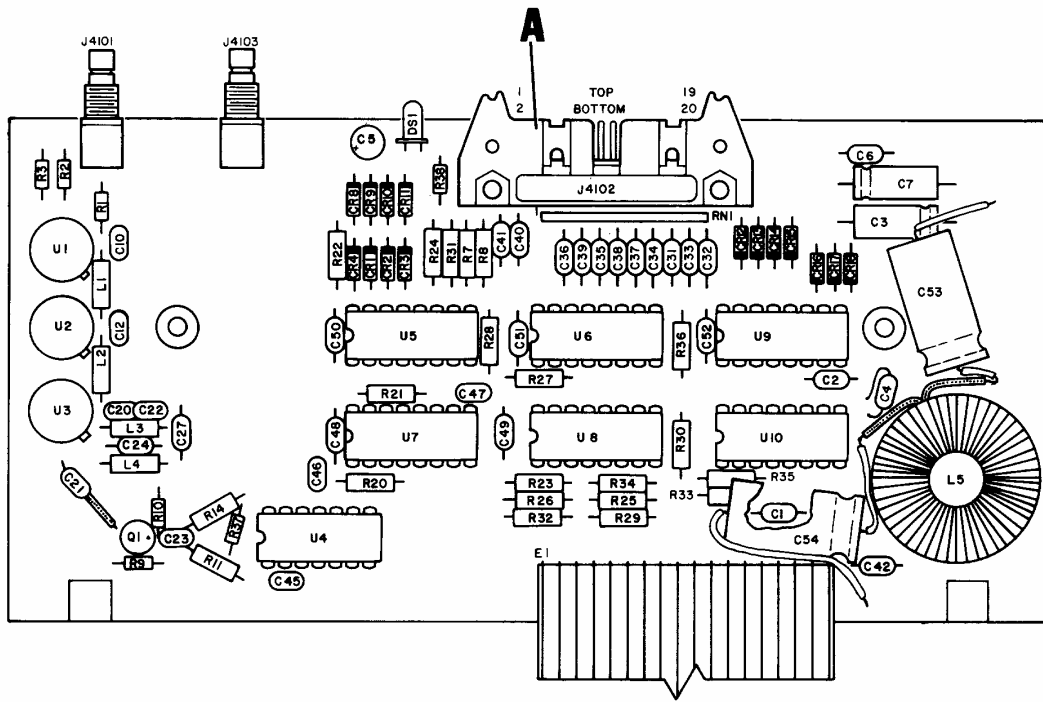

TOP
(EFF SN 3413 AND ON)

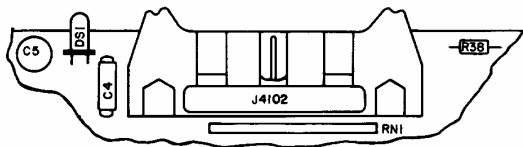

DETAIL **A**
(EFF SN 3075 THRU SN 3412)

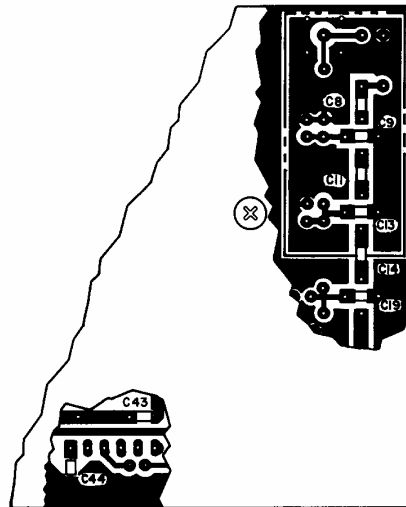

BOTTOM

Figure 9-11b High Loop Divider PC Board Assembly (4100)



(EFF THRU SN 2335)

DETAIL **A**

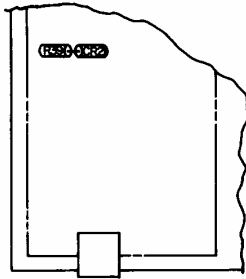

(EFF SN 2336 THRU SN 2844)

DETAIL **B**

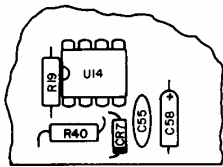

(EFF SN 2446 THRU SN 2845)

DETAIL **C**

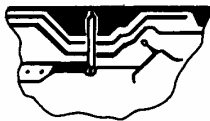

(EFF SN 4377 AND ON)

DETAIL **D**

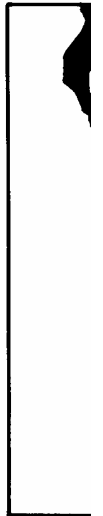
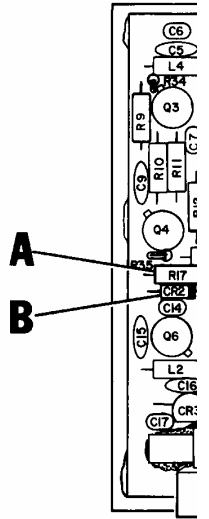
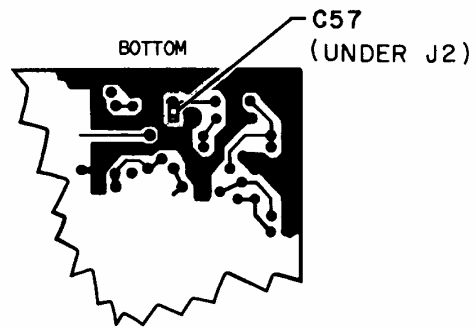

R J2)

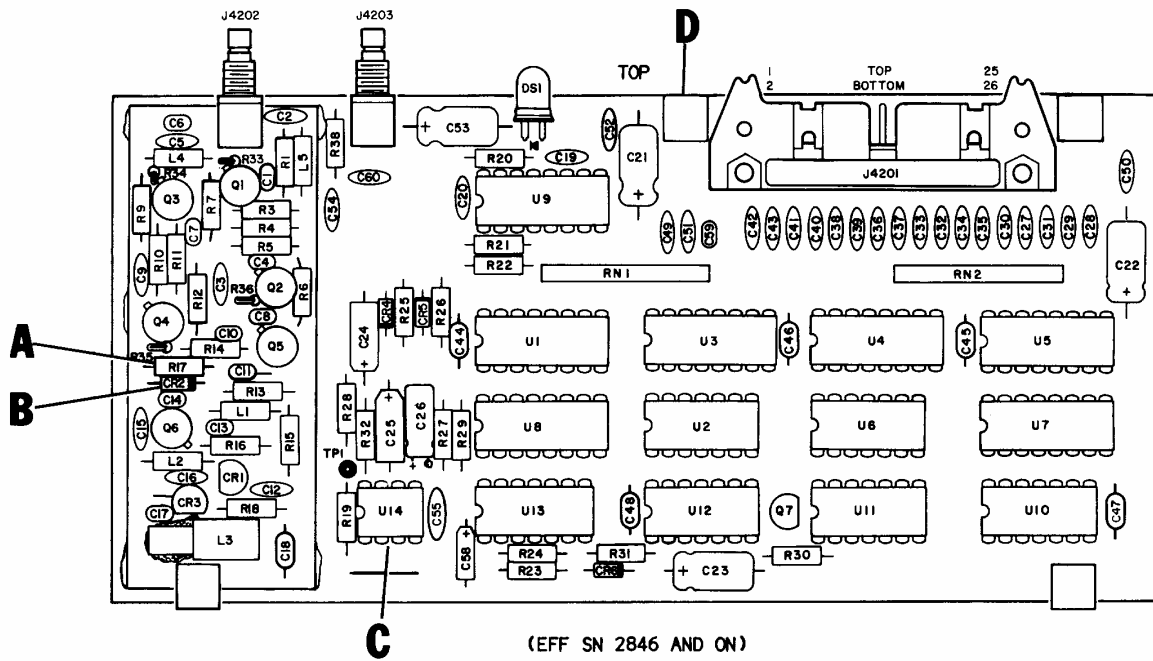

(EFF SN 2846 AND ON)

BOTTOM

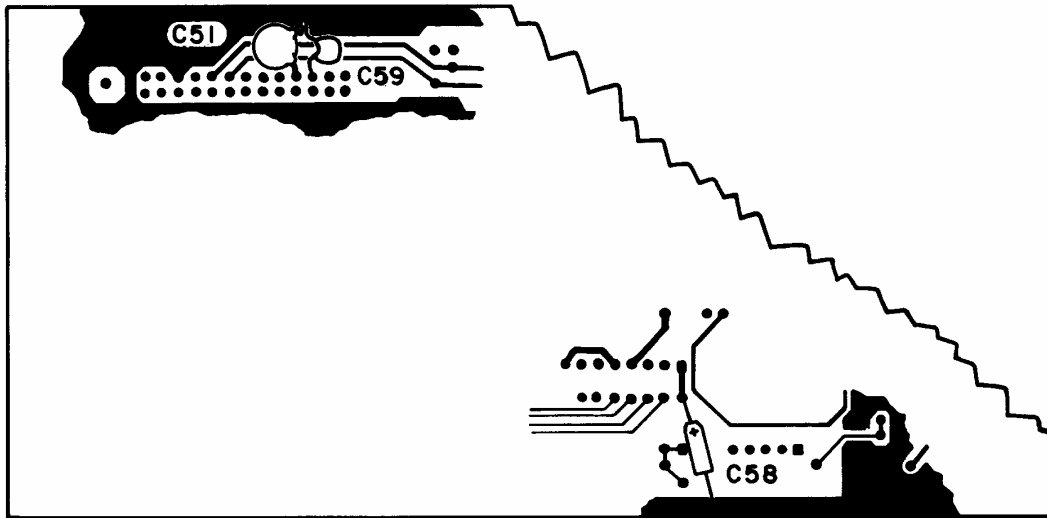

(EFF THRU SN 2445)

Figure 9-13 Low Loop PC Board Assembly (4200) (EFF SN 2846 & On)

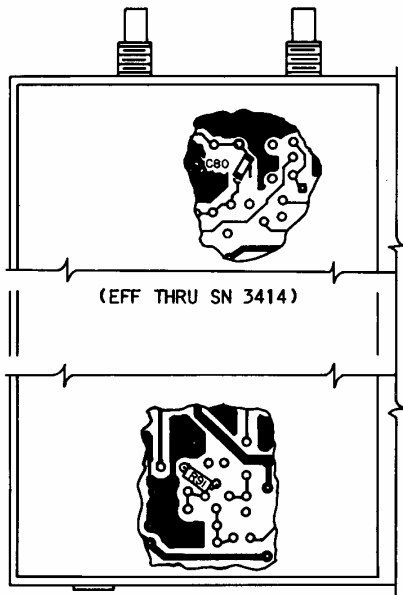

(EFF SN 2649 THRU SN 3414)

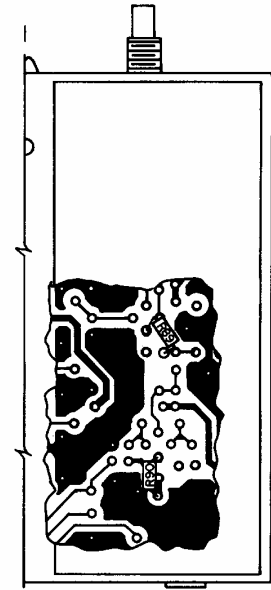

BOTTOM

(EFF SN 2649 THRU SN 3414)

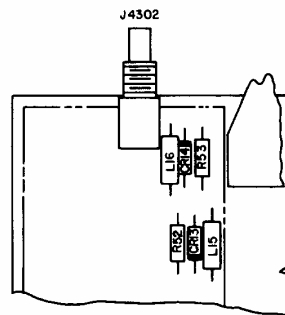

(EFF THRU SN 3564)

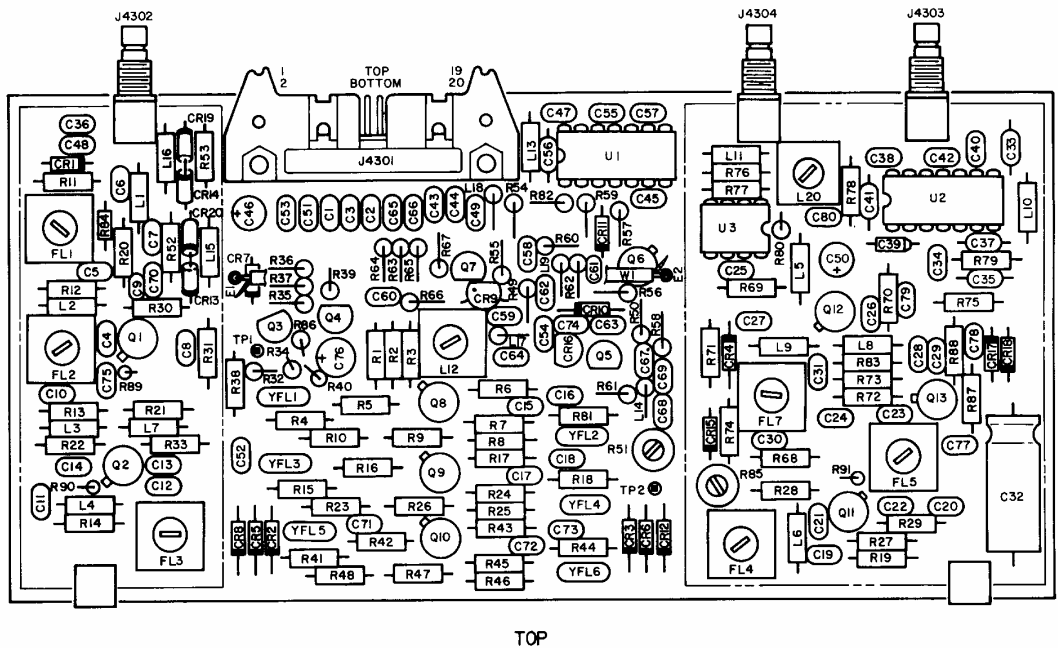

TOP

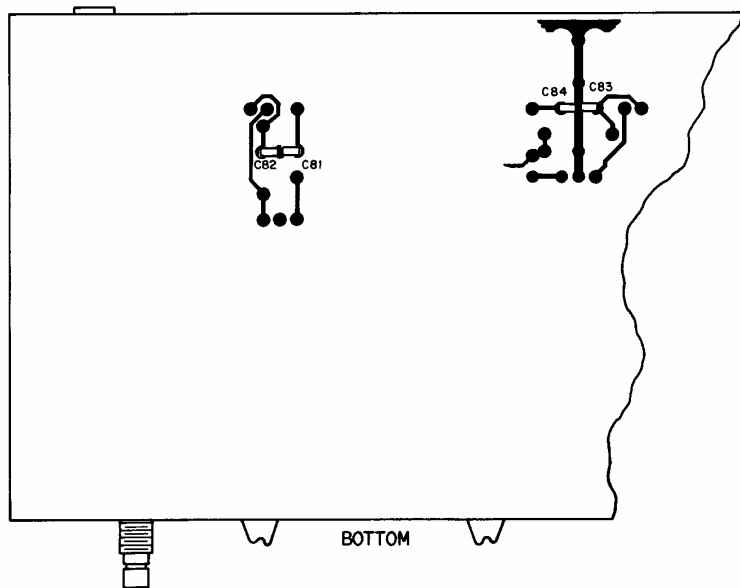

Figure 9-14 Receiver/Generator PC Board Assembly (4300)

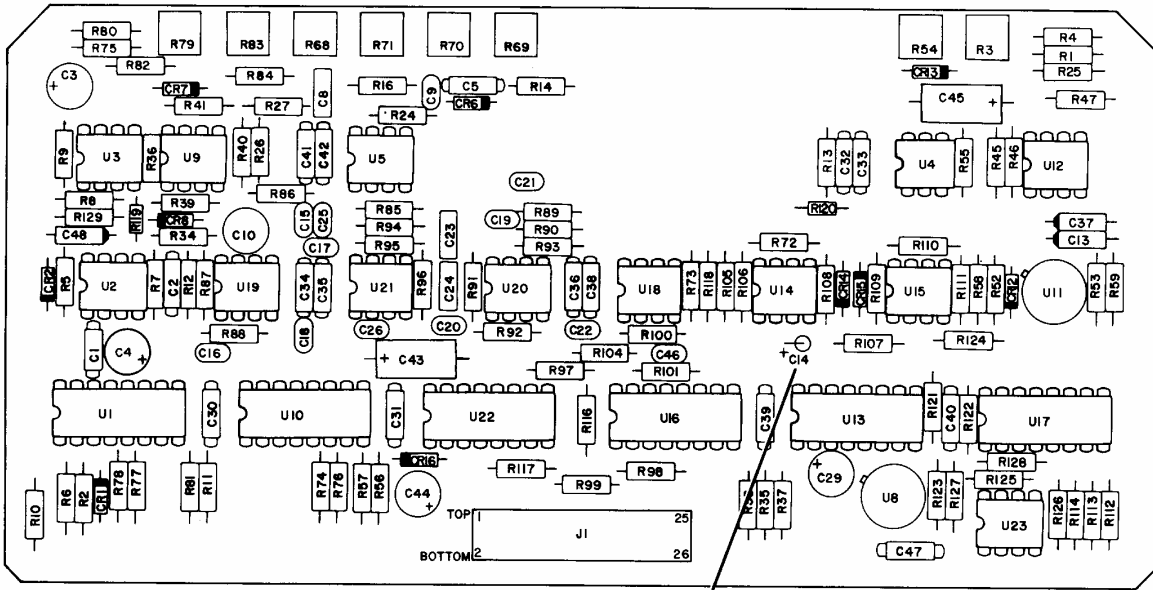
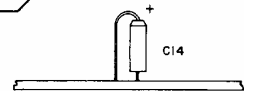

Figure 9-15 Receive Audio PC Board Assembly (3300, 3400)
(FM/AM-500)



DETAIL A

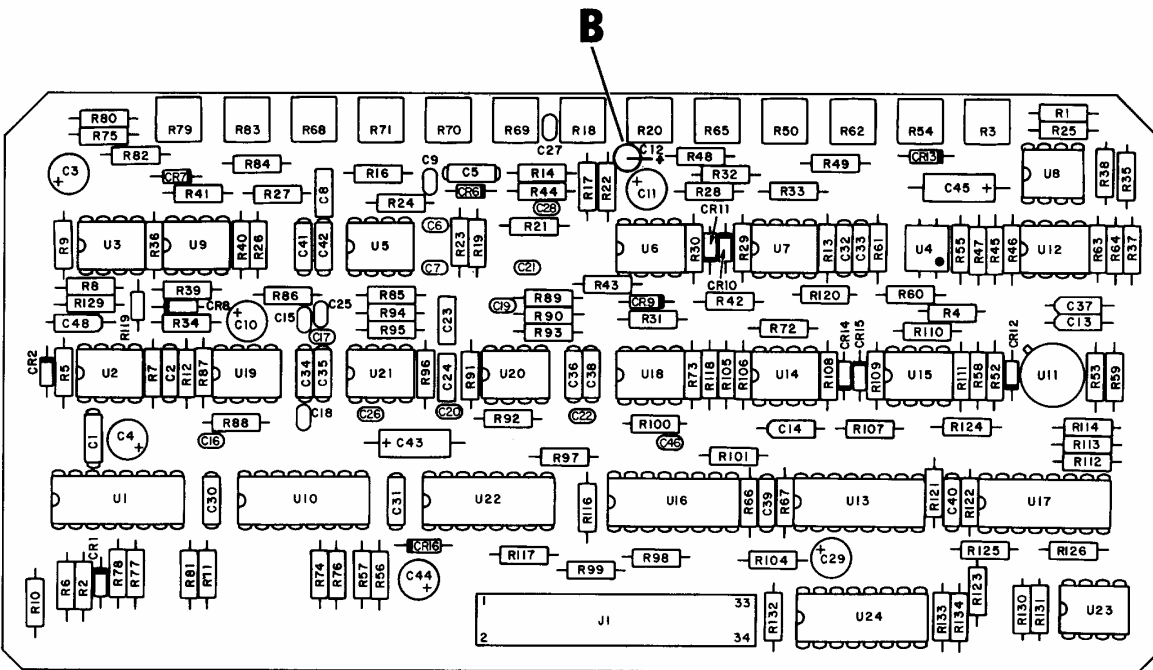
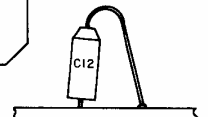

Figure 9-16 Receive Audio PC Board Assembly (3300, 3400)
(FM/AM-500A)



DETAIL B

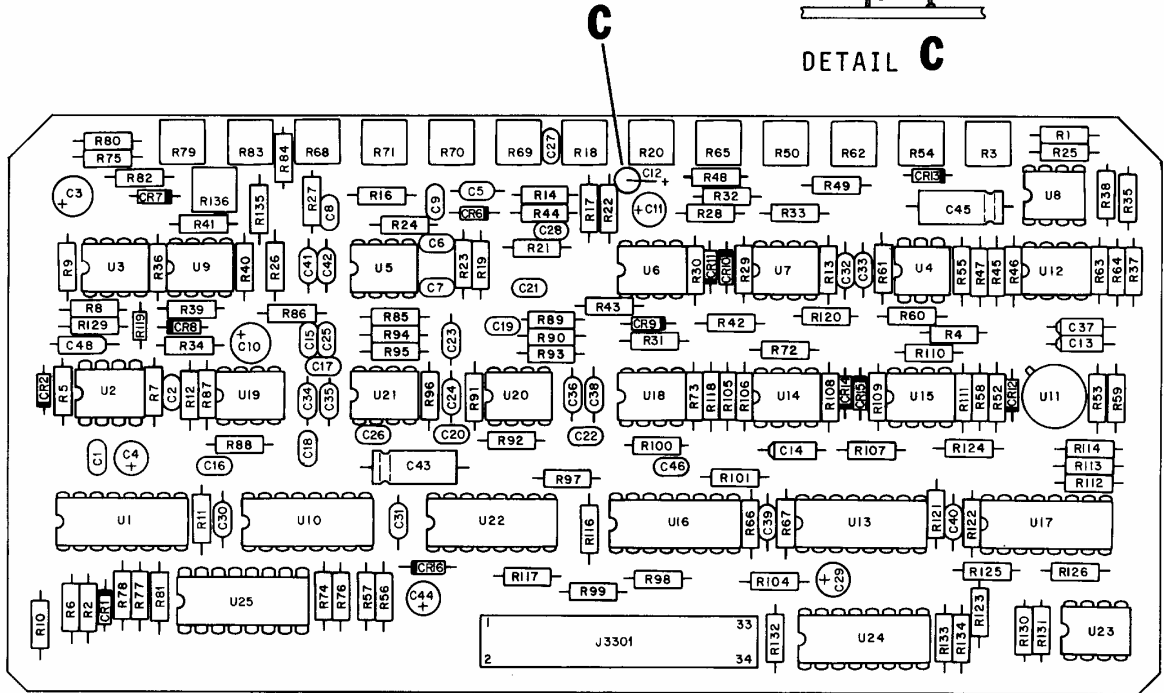
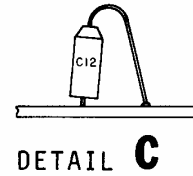
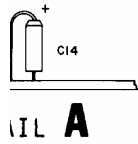
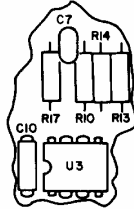

Figure 9-16A Receive Audio PC Board Assembly (3300, 3400) FM/AM-500A) (Eff. SN 3872 & On)



DETAIL A
(EFF SN THRU 3489)

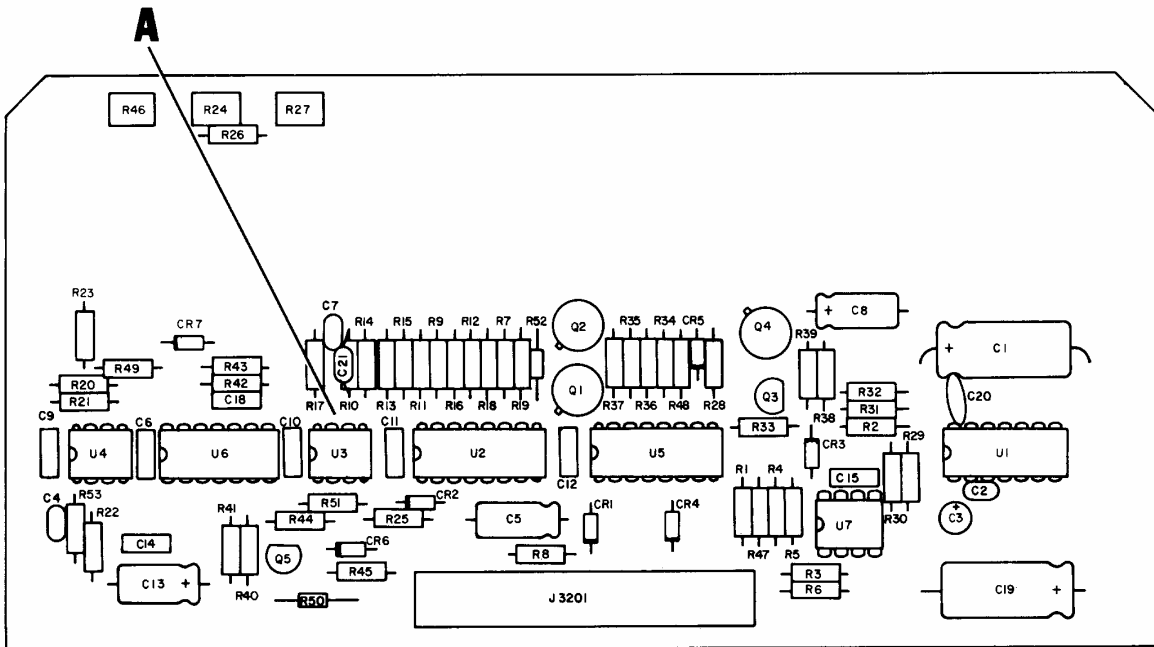
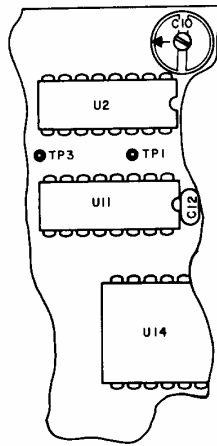

Figure 9-17 Generate Audio PC Board Assembly (3200)
(Eff SN 3490 & On)



DETAIL A
(EFF SN THRU 2649)

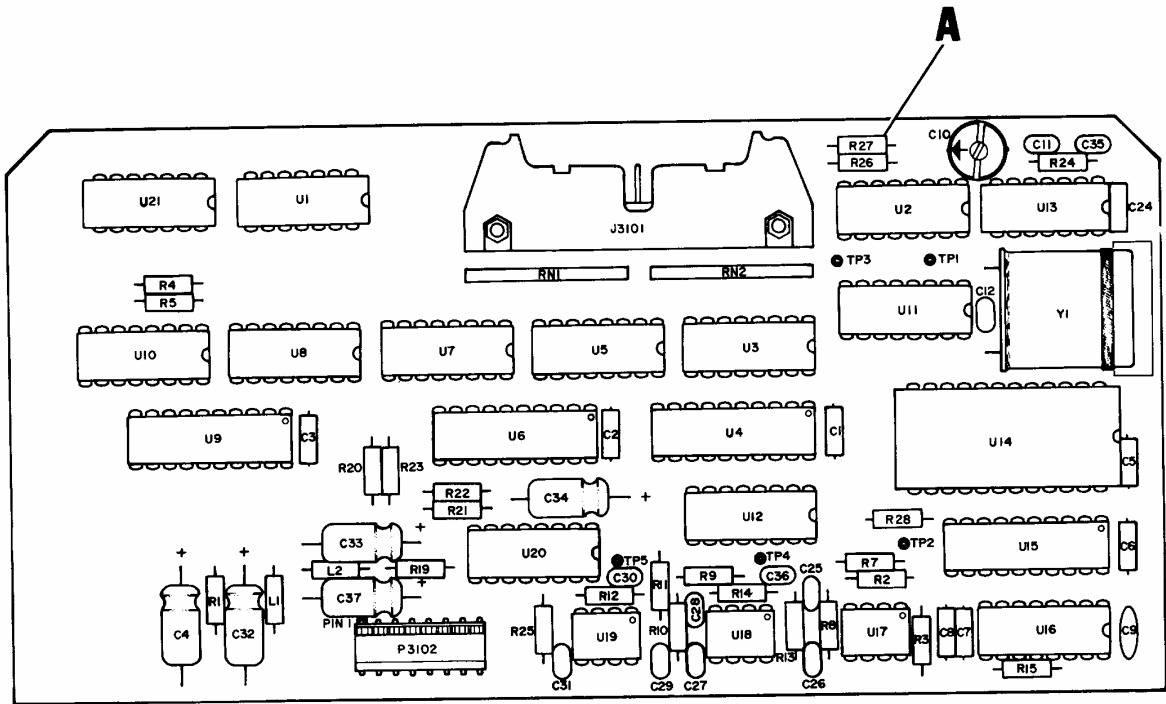

Figure 9-18 Variable Tone Generator PC Board Assembly (3100)
(EFF SN 2650 & ON)

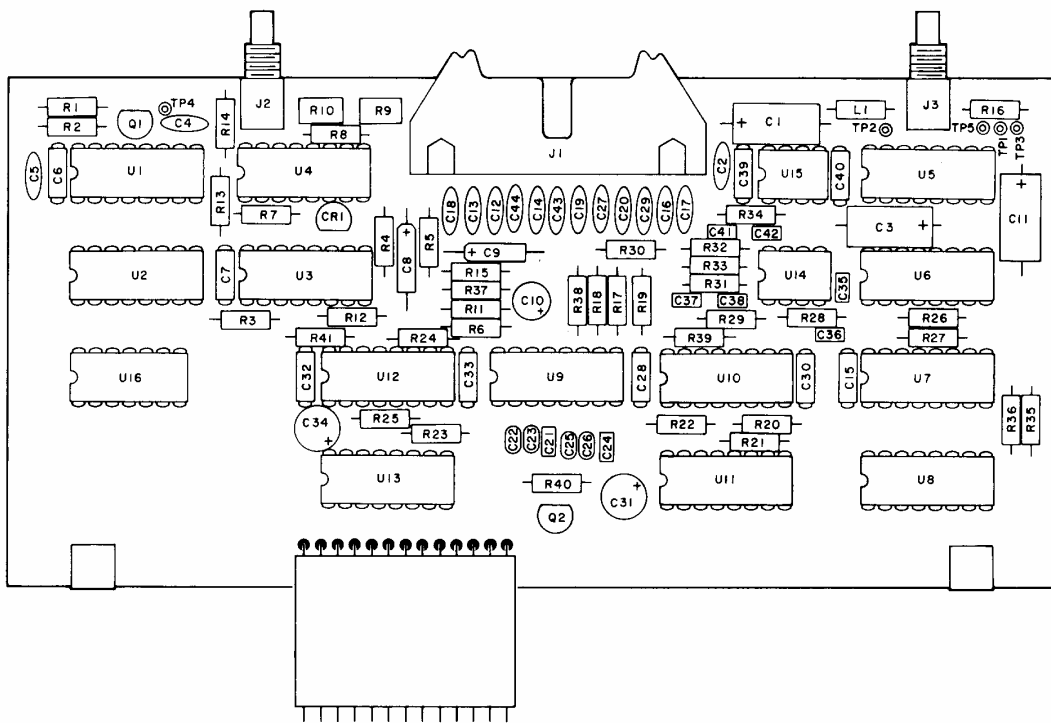

Figure 9-19 Digital Reference PC Board Assembly (4500)

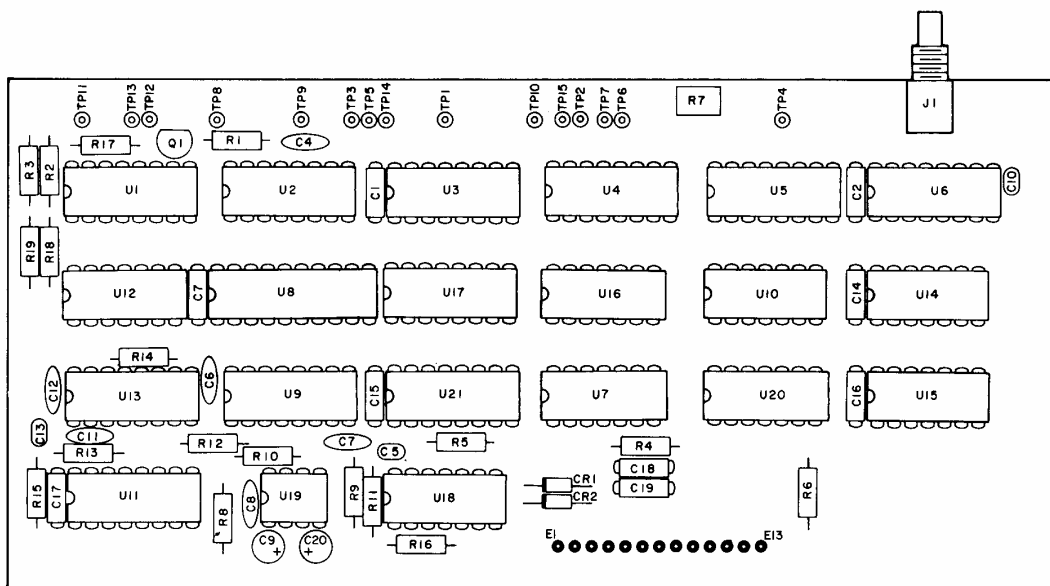
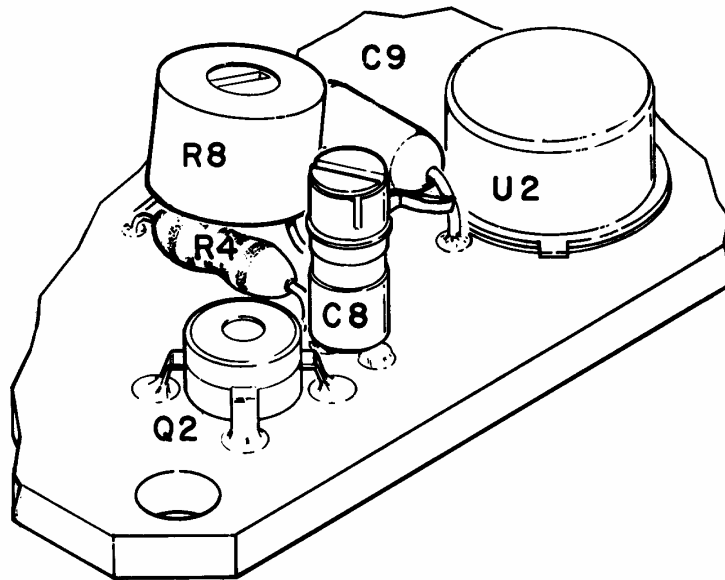
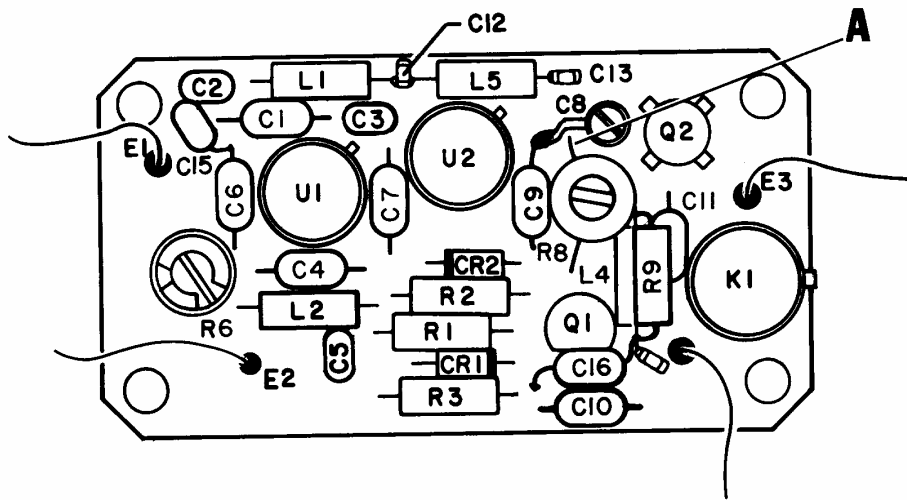
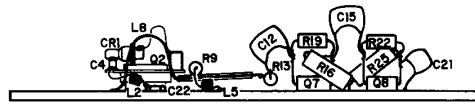
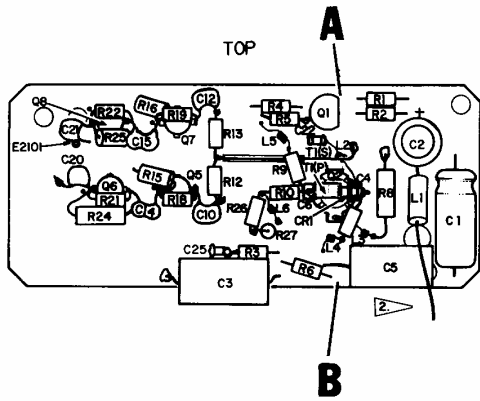

Figure 9-20 Digital Counter PC Board Assembly (4400)



DETAIL **A**

Figure 9-21 Generate Amplifier PC Board Assembly (9000)



DETAIL A

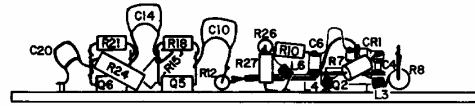

DETAIL B

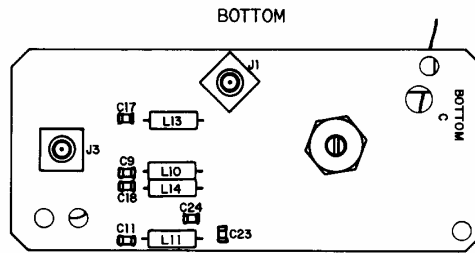

1300-2300 MHz VCO PC Board Assembly (2100)

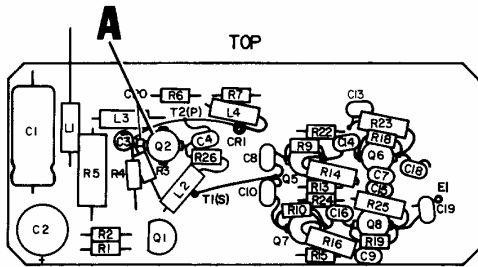

(EFF SN 3525 & ON)

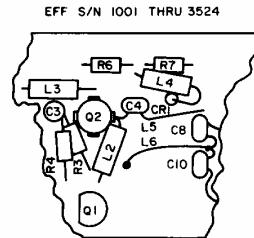

(EFF SN 1001 THRU SN 3524)

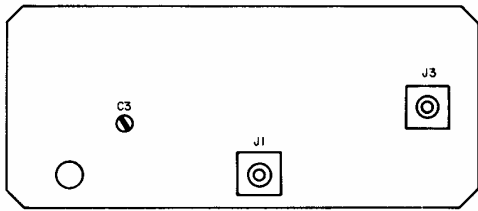

1210 MHz VCO PC Board Assembly (2000)

Figure 9-22 Dual VCO Module (1900)

SECTION 10 - CIRCUIT SCHEMATICS

10-1 GENERAL

This section contains module interconnect drawings and individual module circuit schematics. Except when specifically identified, the drawings apply to both, the FM/AM-500 and FM/AM-500A. Although some modules include multiple PC boards and/or components installed directly in an enclosure block or on the chassis, the entire circuit is shown in the related schematic.

NOTE

Reference designator series numbers assigned to the individual PC boards, the enclosure blocks, etc., are within the board and/or module identification block and in accompanying notes. While the text refers to a component by the complete designator number, such as R3201, the schematic shows the series in the identification block and notes only. R3201 would show 3200 as the series and the individual components as R1.

10-2 INDEX OF SCHEMATICS

Title	Figure	Page
Digital Module (0000-5214-500, Rev. D).....	10-22	10-28
Dual VCO Module (0000-5212-100 Rev L1, 0000-5212-000 Rev L1).....	10-15	10-17
Frequency Standard Module (0000-5212-500 Rev. D)..	10-6	10-9
Front Panel (FM/AM-500) (0000-5210-100 Rev. D)....	10-7	10-10
Front Panel (FM/AM-500A) (0000-5210-101, Rev. D)..	10-8	10-10
Generate Amplifier Module (Optional) (0000-5219-000 Rev. B2).....	10-23	10-32
Generate Audio Module (0000-5213-200 Rev. E).....	10-20	10-26
High Loop Module (0000-5214-100 Rev. E, 0000-5214-000 Rev. D1 (Eff S/N Thru 3074).....	10-14	10-14
High Loop Module (0000-5114-100 Rev. E4, 0000-5114-000 Rev. D9 (Eff S/N 3075 and On).....	10-14	10-14
IF Module (0000-5212-200 Rev. A).....	10-13	10-13
FM/AM-500 and 500A Coax Interconnect (0000-5219-100 Rev. A).....	10-1	10-3
FM/AM-500 and 500A Electrical Interconnect (0000-5219-100 Rev. A) (S/N 1001 Thru S/N 2500).	10-2	10-4
FM/AM-500 and 500A Electrical Interconnect (0000-5219-100 Rev. A) (S/N 2501 and On).....	10-3	10-5
Low Loop Module (0000-5214-200 Rev. R1).....	10-16	10-18
Modulation Meter Switch (FM/AM-500A) (0000-5215-300 Rev. B).....	10-9	10-11
Motherboard (0000-5213-001, Rev. B1).....	10-4	10-6

Title	Figure	Page
Output Amplifier Module (0000-5215-101 Rev. A2) (SN 1001 thru 3224).....	10-12	10-12
Output Amplifier Module (0000-5111-500 Rev. C5) (SN 3225 and On).....	10-12A	10-12A
Power Supply/Rear Panel (0000-5215-200 Rev. G)....	10-5	10-8
Receive Audio Module (FM/AM-500) (0000-5213-300 Rev. A1) (SN 1001 thru 2215).....	10-18	10-22
Receive Audio Module (FM/AM-500A) (SN 2216 and On) (0000-5213-301 Rev. E3)	10-19	10-24
Receiver/Generator Module (0000-5214-300 Rev. R5).....	10-17	10-20
RF Thumbwheel Switch (0000-5210-200 Rev. P1).....	10-10	10-11
Variable Tone Generator Module (0000-5213-100 Rev. B).....	10-21	10-27
Variable Tone Thumbwheel Switch (0000-5210-300 Rev. P1).....	10-11	10-11

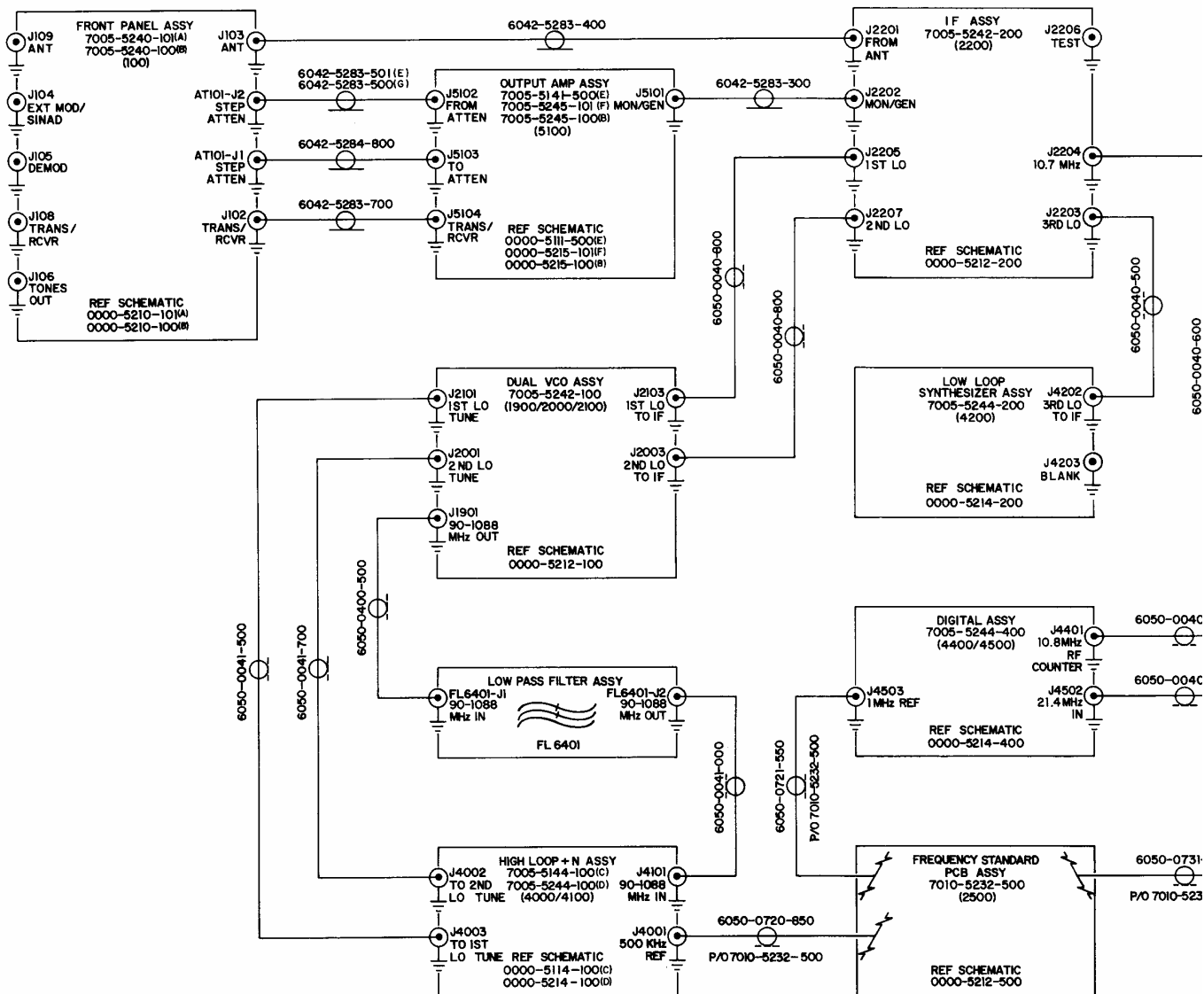

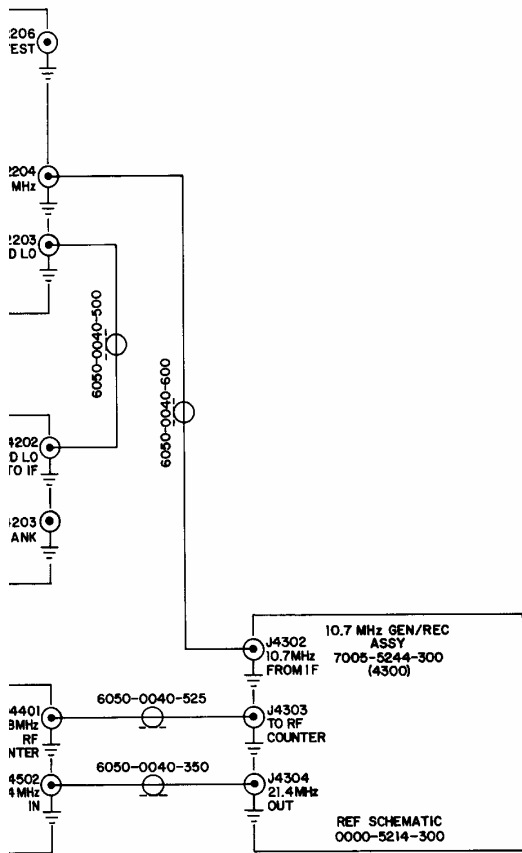

- (A)-FM/AM-500A...SN2181 & ON
- (B)-FM/AM-500...SN1001 THRU SN2180
- (C)-FM/AM-500A...SN3075 & ON
- (D)-FM/AM-500A...SN1001 THRU SN3074
- (E)-FM/AM-500A...SN3225 & ON
- (F)-FM/AM-500A...SN2180 THRU SN3224
- (G)-FM/AM-500A...SN1001 THRU SN3224

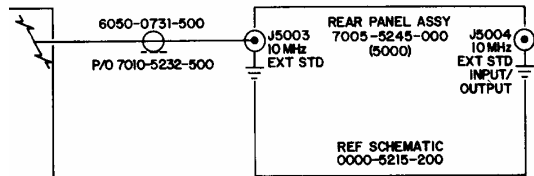

Figure 10-1 Coax Interconnect

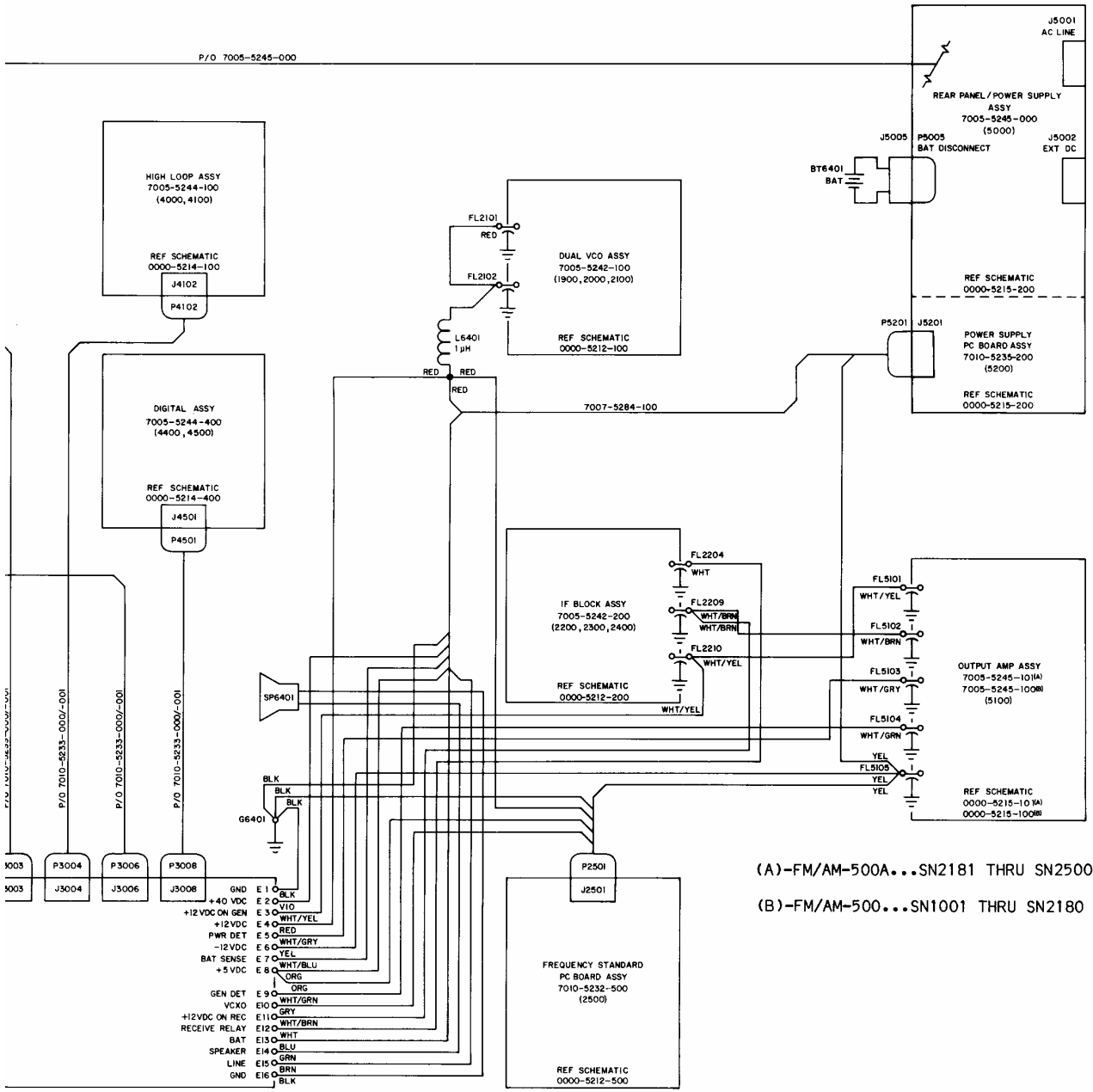
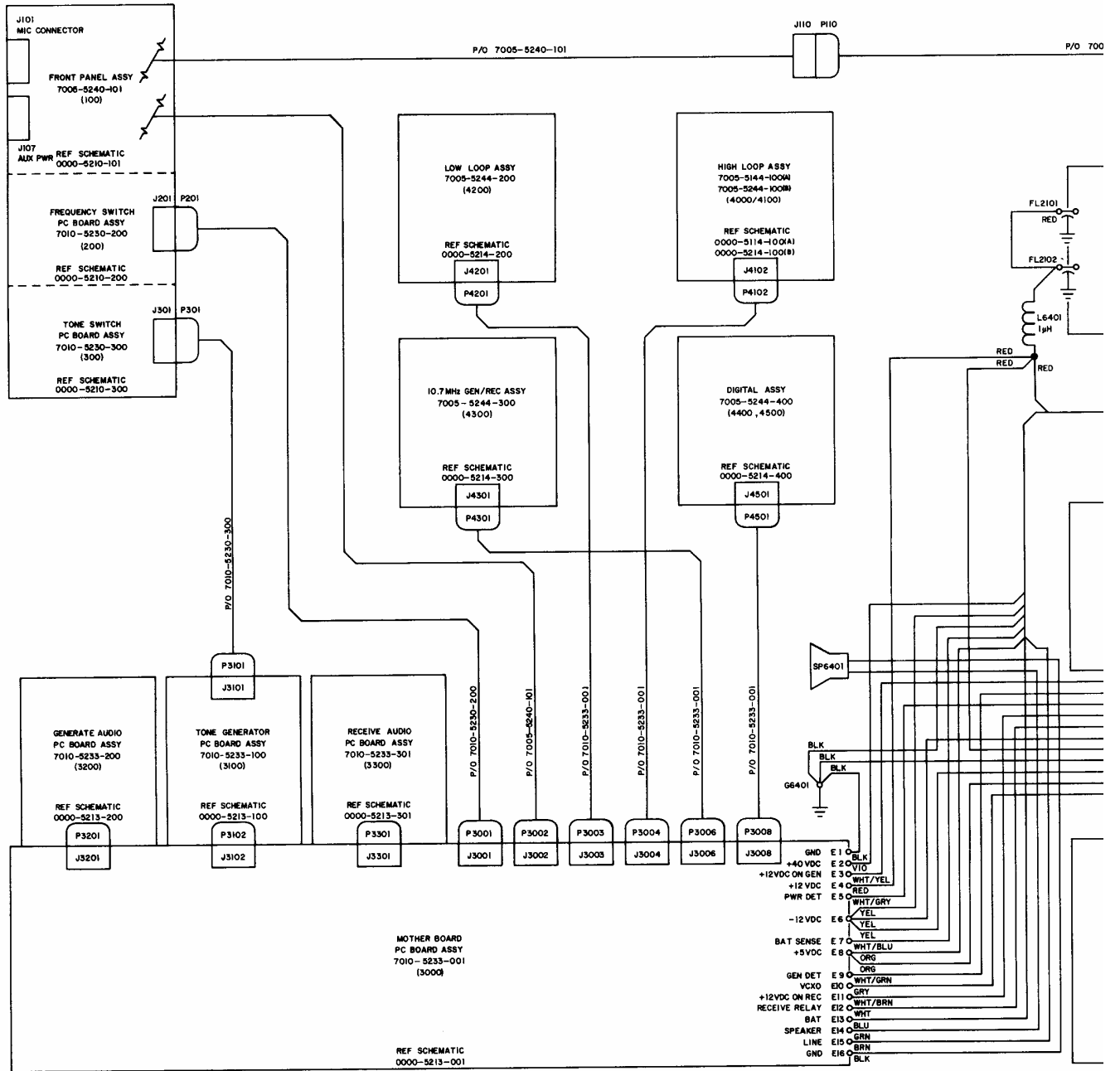
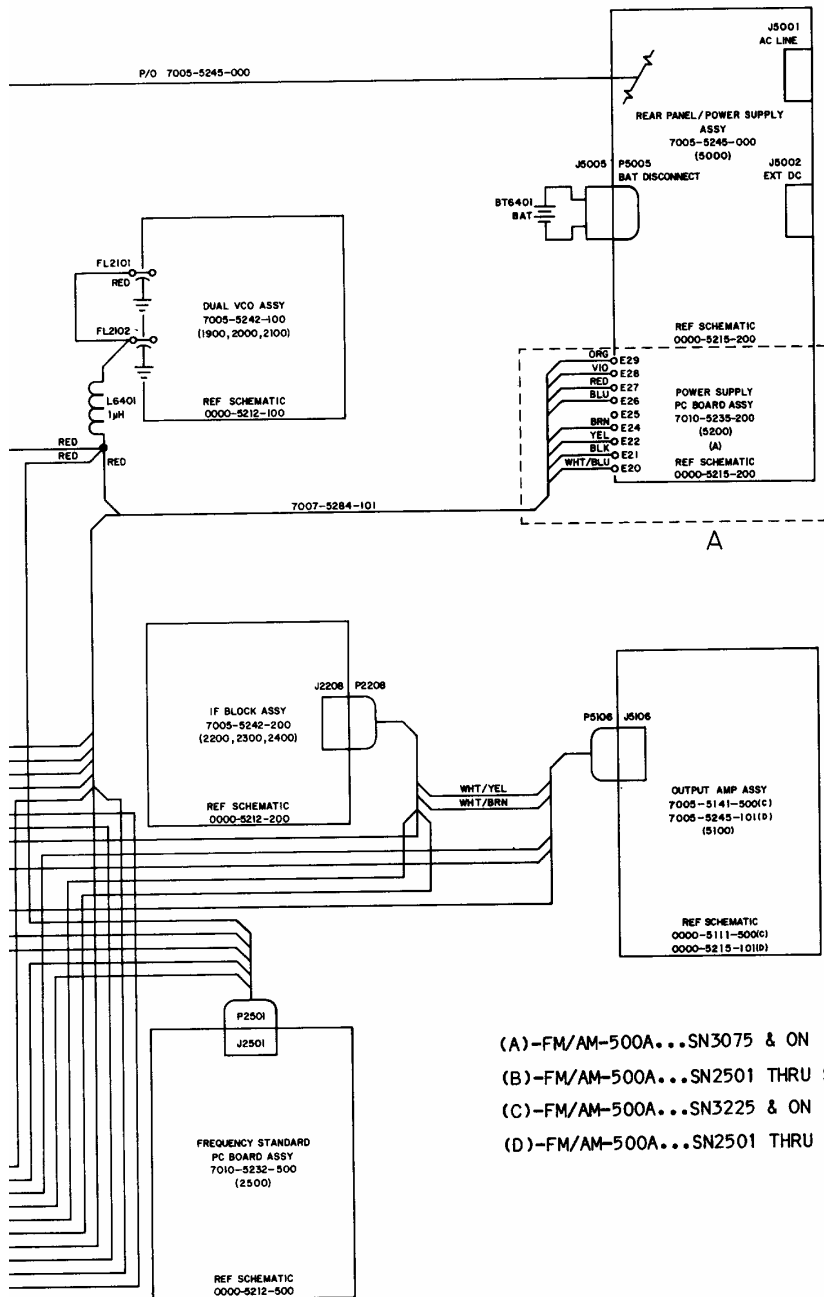

Figure 10-2 Electrical Interconnect (SN 1001 thru SN 2500)





- (A)-FM/AM-500A...SN3075 & ON
- (B)-FM/AM-500A...SN2501 THRU SN3074
- (C)-FM/AM-500A...SN3225 & ON
- (D)-FM/AM-500A...SN2501 THRU SN3224

Figure 10-3 Electrical Interconnect (SN 2501 and on)

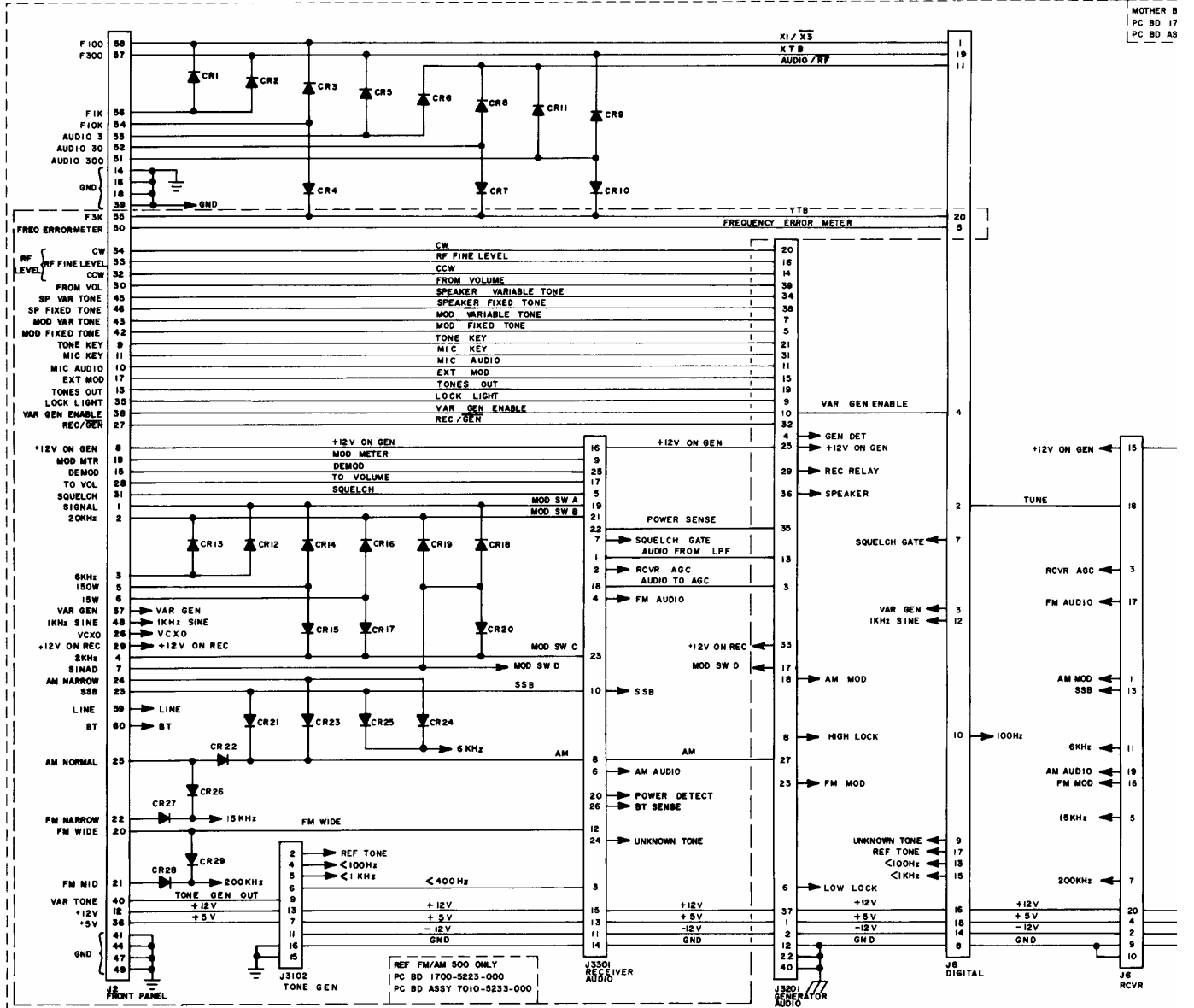

MOTHER BOARD (3000)
 PC BD 1700-5223-000/-001
 PC BD ASSY 7010-5233-000/-001

NOTES:

1. ALL REFERENCE NUMBERS CARRY AN ASSIGNED DESIGNATOR SERIES. THE SERIES FOR THIS SCHEMATIC IS 3000 (E.G., CR1 IS CR3001).
2.  R1 (1/4 W, 5%) EFF SN2241 AND ON.
3. ALL DIODES ARE 1N4148.

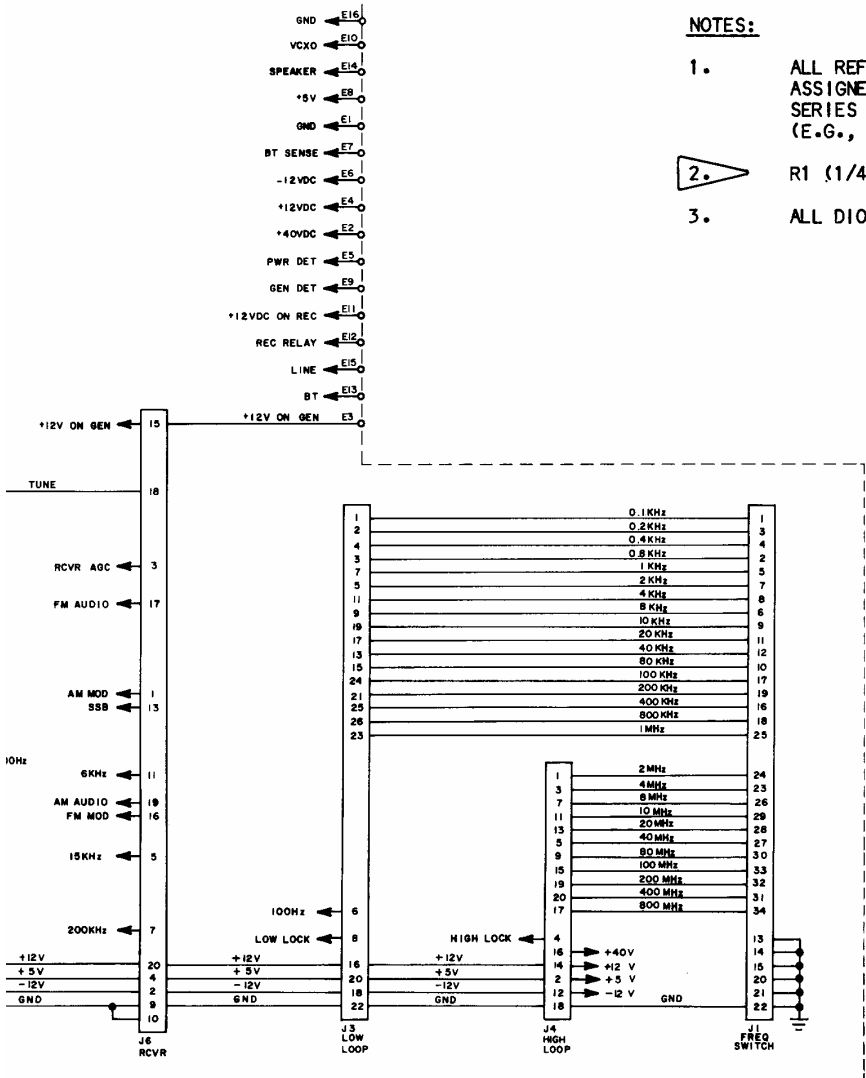

Figure 10-4 Motherboard Schematic (Sheet 1 of 2)

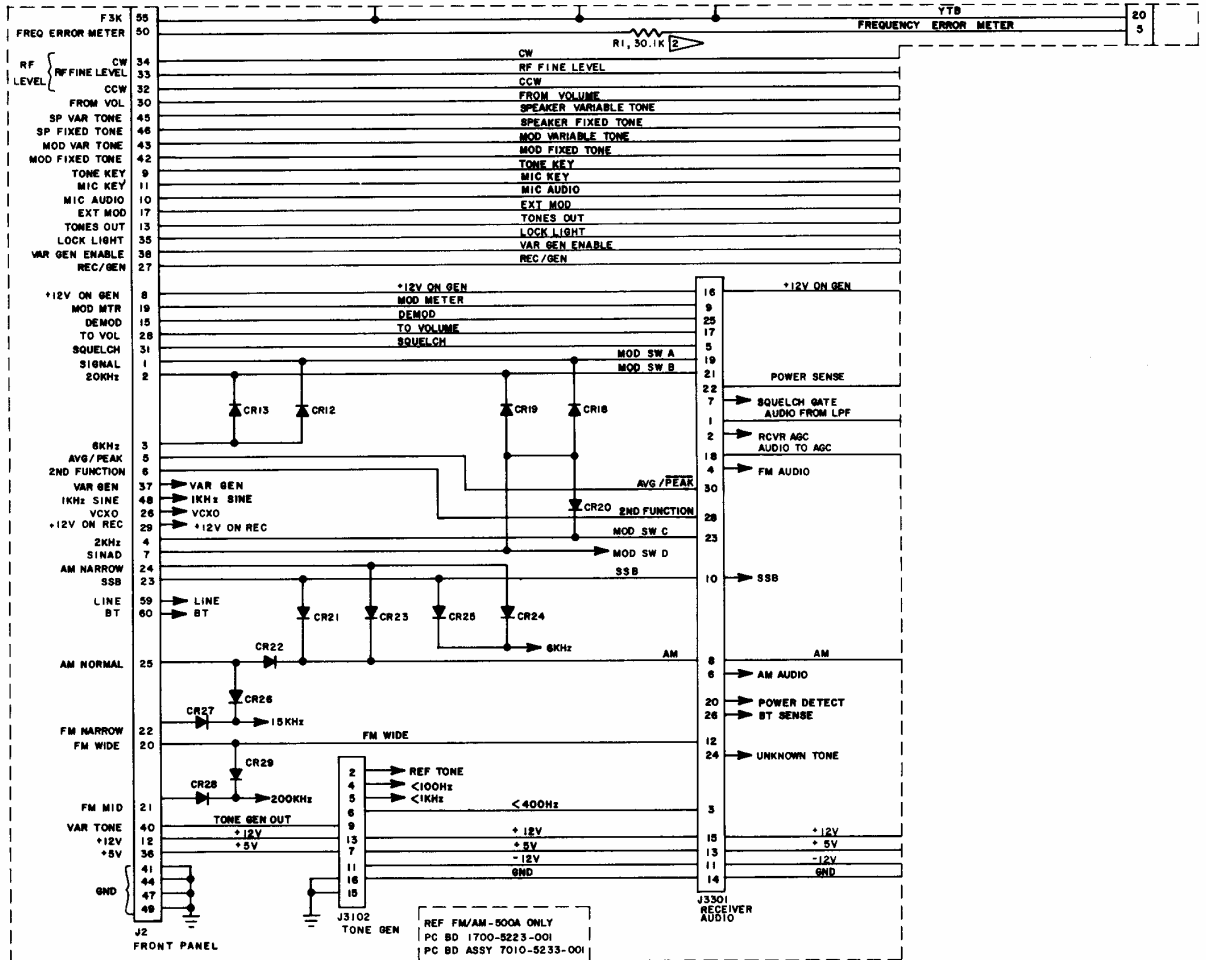
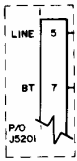

Figure 10-4 Motherboard Schematic
(Sheet 2 of 2)

10-7
01



DETAIL B

SN 1001 thru
SN 3074

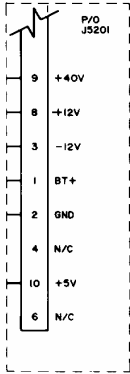

DETAIL C

SN 1001 thru
SN 3074

NOTES:

1. ALL REFERENCE NUMBERS CARRY AN ASSIGNED DESIGNATOR SERIES. THE SERIES FOR THIS SCHEMATIC IS 5200 AND 5000 (E.G., R1 IS R5201).
2. ALL RESISTORS ARE 1/4 W 5% TOLERANCE UNLESS OTHERWISE NOTED.
3. L1 IS FORMED BY 22 TURNS OF 18 AWG WIRE AROUND A TORROID CORE.
4. WHEN SIMULCAST OPTION IS INSTALLED DELETE CR8, CR9 AND R37; REPLACE R50 WITH 10 K RESISTOR; REMOVE Q9 AND JUMPER ACROSS EMITTER AND COLLECTOR PADS; E2 IS WIRED TO P2505 OF FREQUENCY STANDARD.
5. EFF S/N 4318, C51 AND C52 WERE REMOVED.
6. ALL RESISTANCE IS EXPRESSED IN OHMS UNLESS OTHERWISE NOTED.
7. ALL CAPACITANCE IS EXPRESSED IN MICRO-FARADS UNLESS OTHERWISE NOTED.

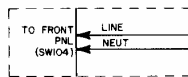
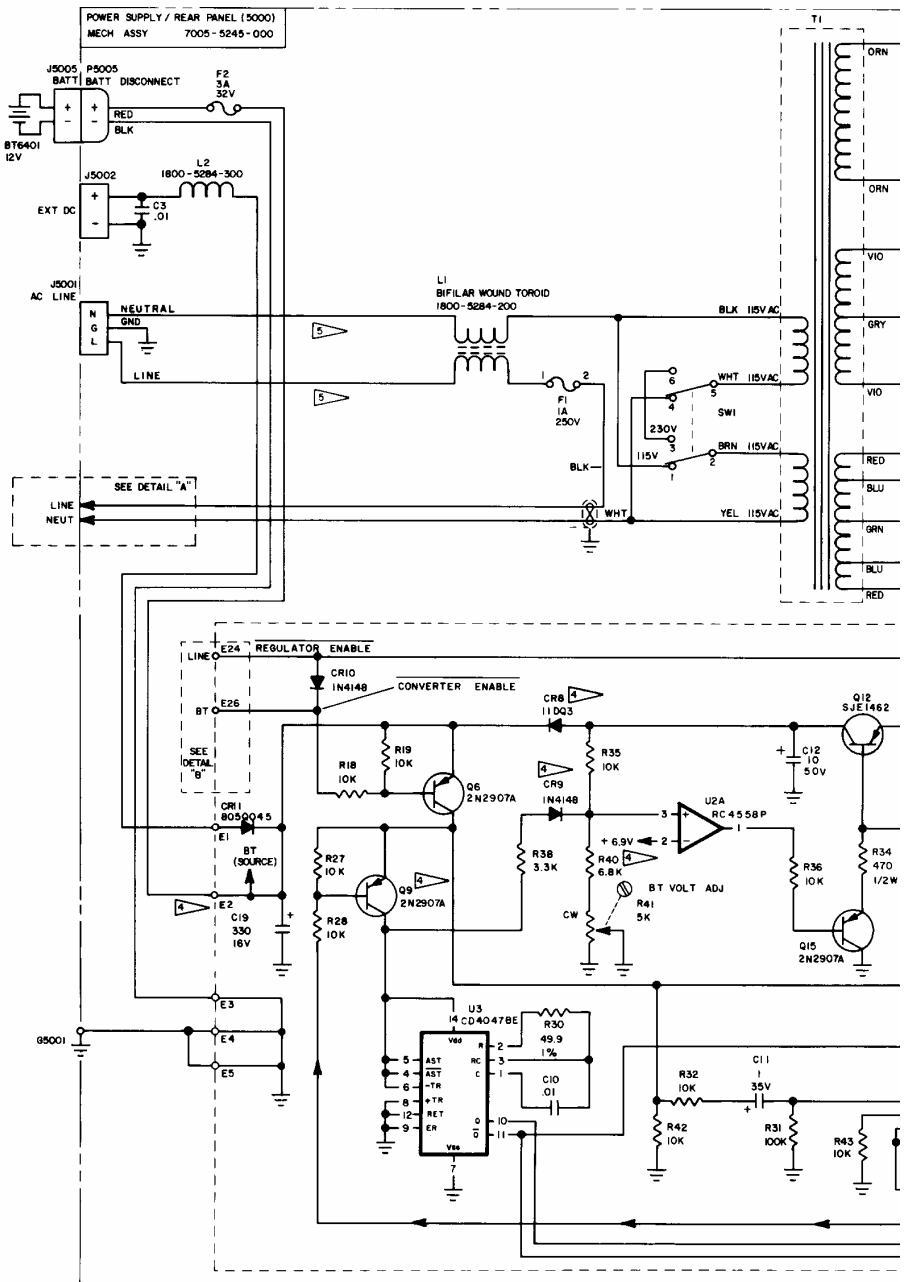

DETAIL A

SN 3446 & ON

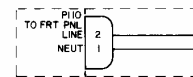

DETAIL A

SN 2501 THRU S/N 3445

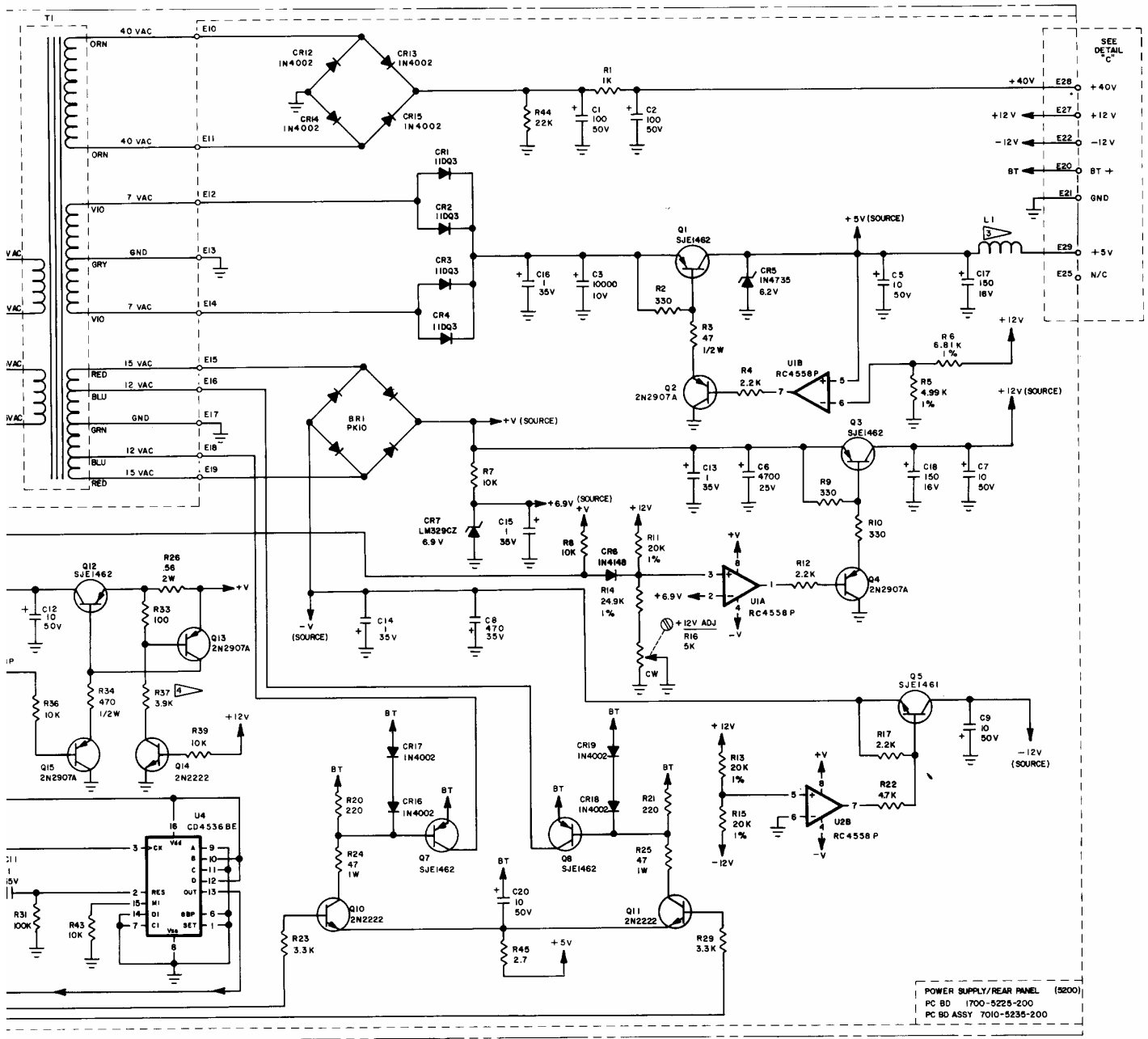
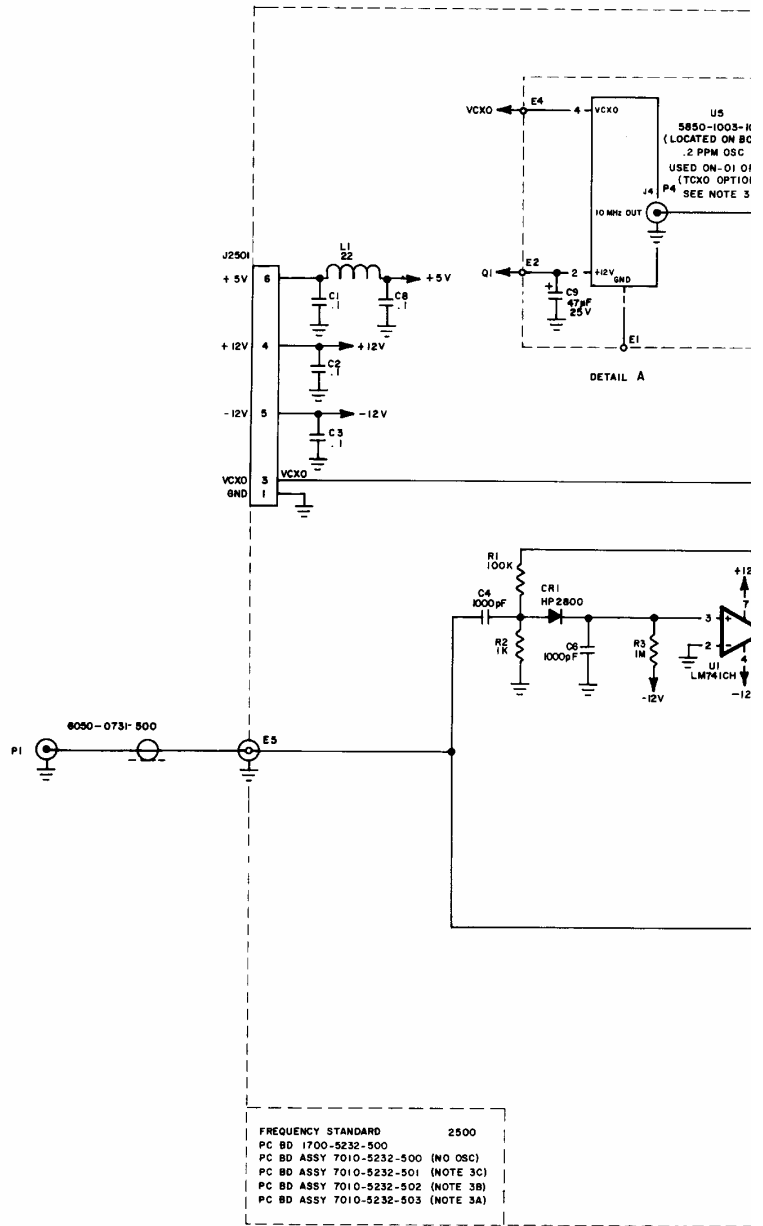

Figure 10-5 Power Supply/Rear Panel Circuit Schematic

NOTES:

1. ALL REFERENCE NUMBERS CARRY AN ASSIGNED DESIGNATOR SERIES. THE SERIES FOR THIS SCHEMATIC IS 2500 (E.G., R1 IS R2501).
2. ALL RESISTORS ARE 1/4 W 5% TOLERANCE.
3. ALL RESISTANCE IS EXPRESSED IN OHMS UNLESS OTHERWISE NOTED.
4. ALL CAPACITANCE IS EXPRESSED IN MICRO-FARADS UNLESS OTHERWISE NOTED.
5. ONLY ONE (1) OSCILLATOR IS INSTALLED PER ASSEMBLY.
 - A. INSTALLED WITH 0.05 PPM OSCILLATOR ONLY
 - B. INSTALLED WITH 0.2 PPM OSCILLATOR ONLY
 - C. INSTALLED WITH 0.5 OSCILLATOR ONLY
6. FOR 0.05 PPM OSCILLATOR (SIMULCAST OPTION), REFER TO POWER SUPPLY SCHEMATIC.
7. ALL INDUCTANCE IS EXPRESSED IN MICRO-HENRYS UNLESS OTHERWISE NOTED.



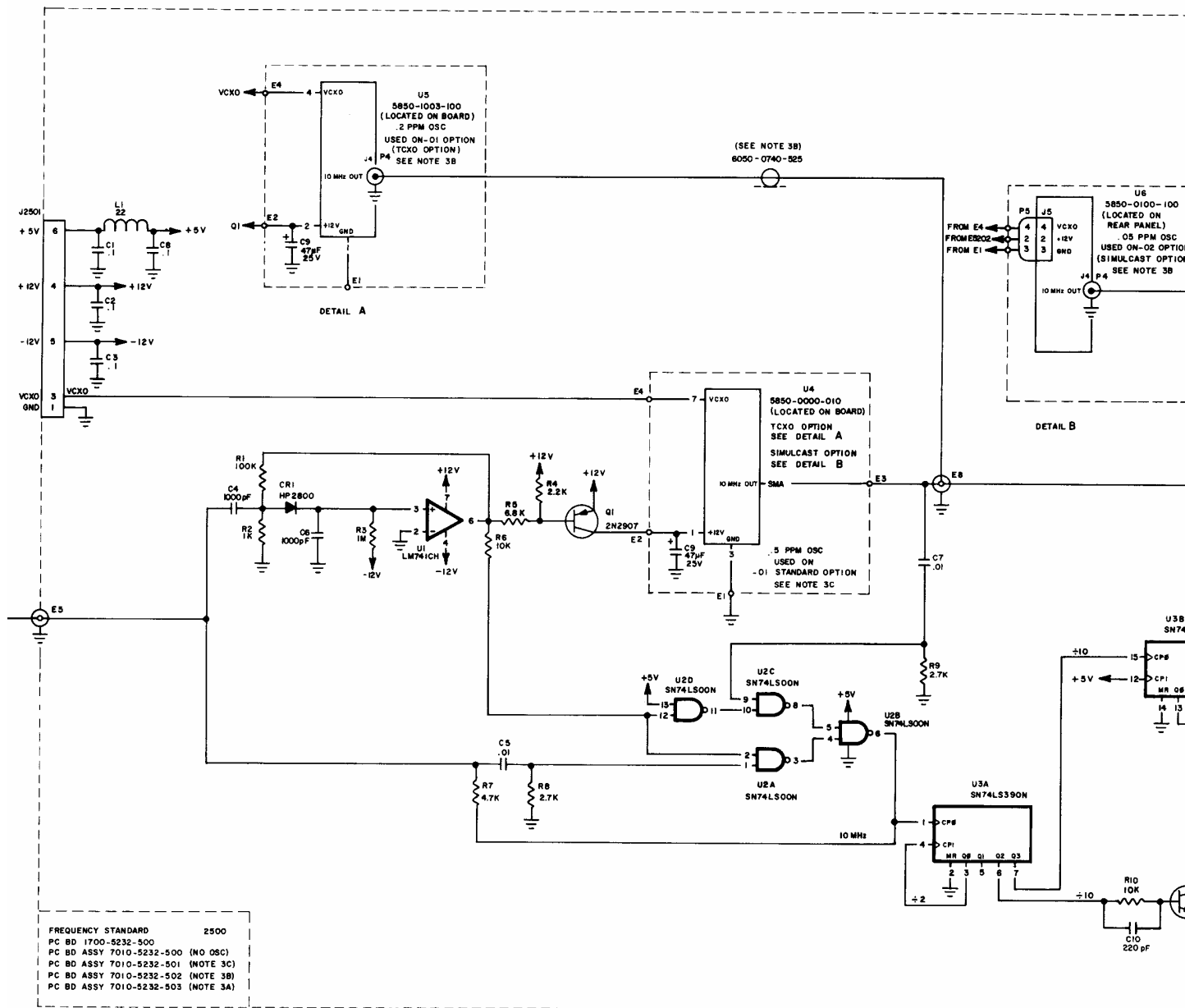

Figure 10-6

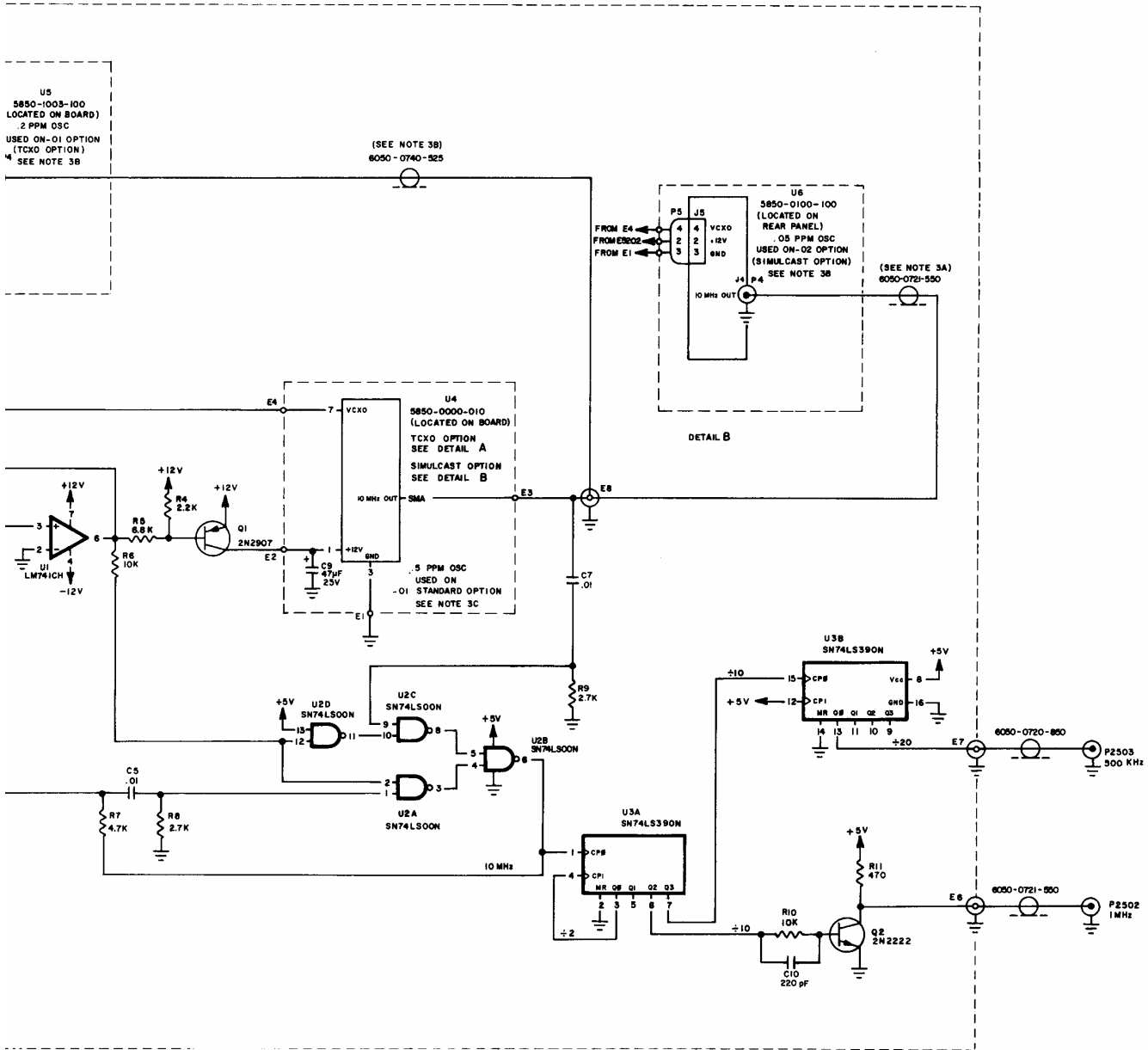

Figure 10-6 Frequency Standard Module Circuit Schematic

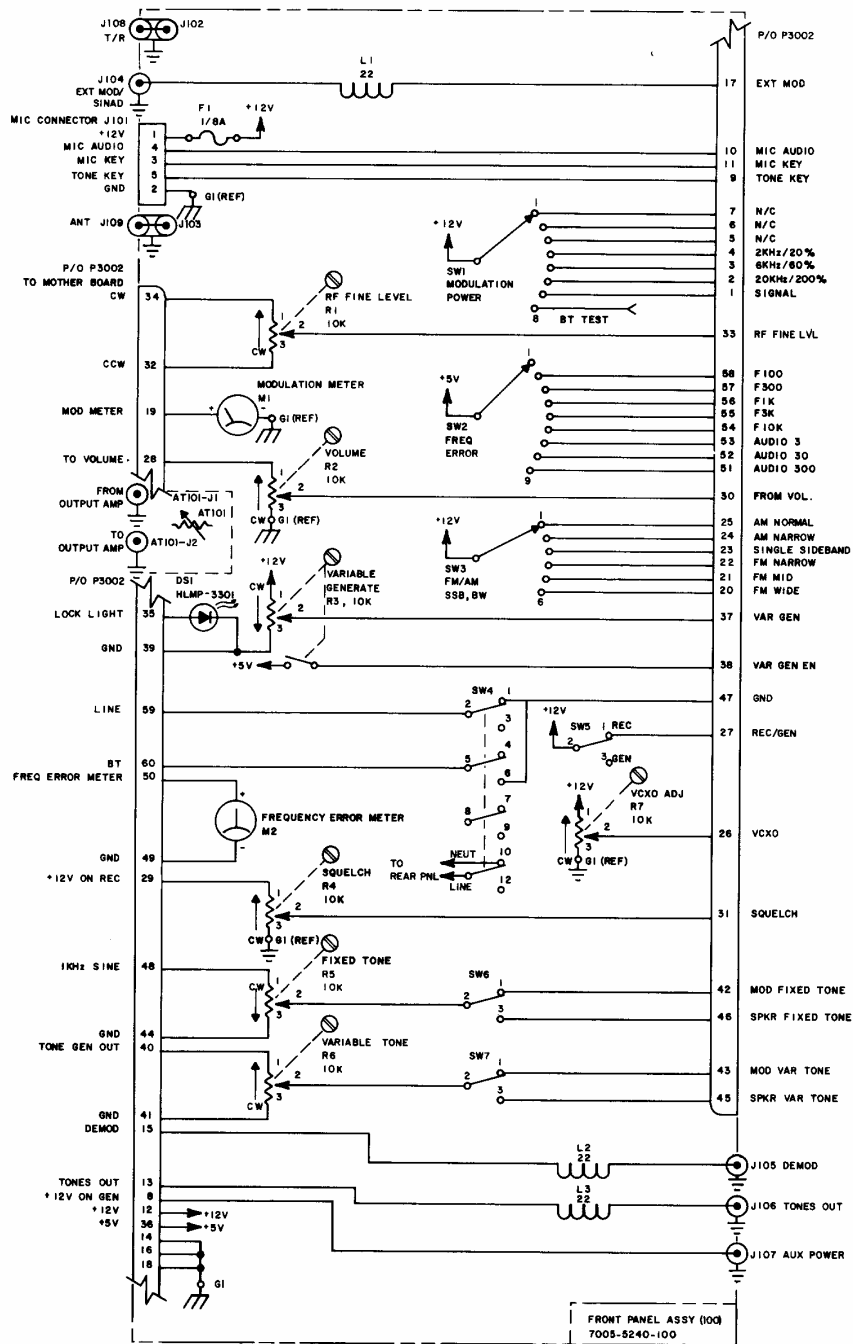

Figure 10-7 Front Panel Circuit Schematic (FM/AM-500)

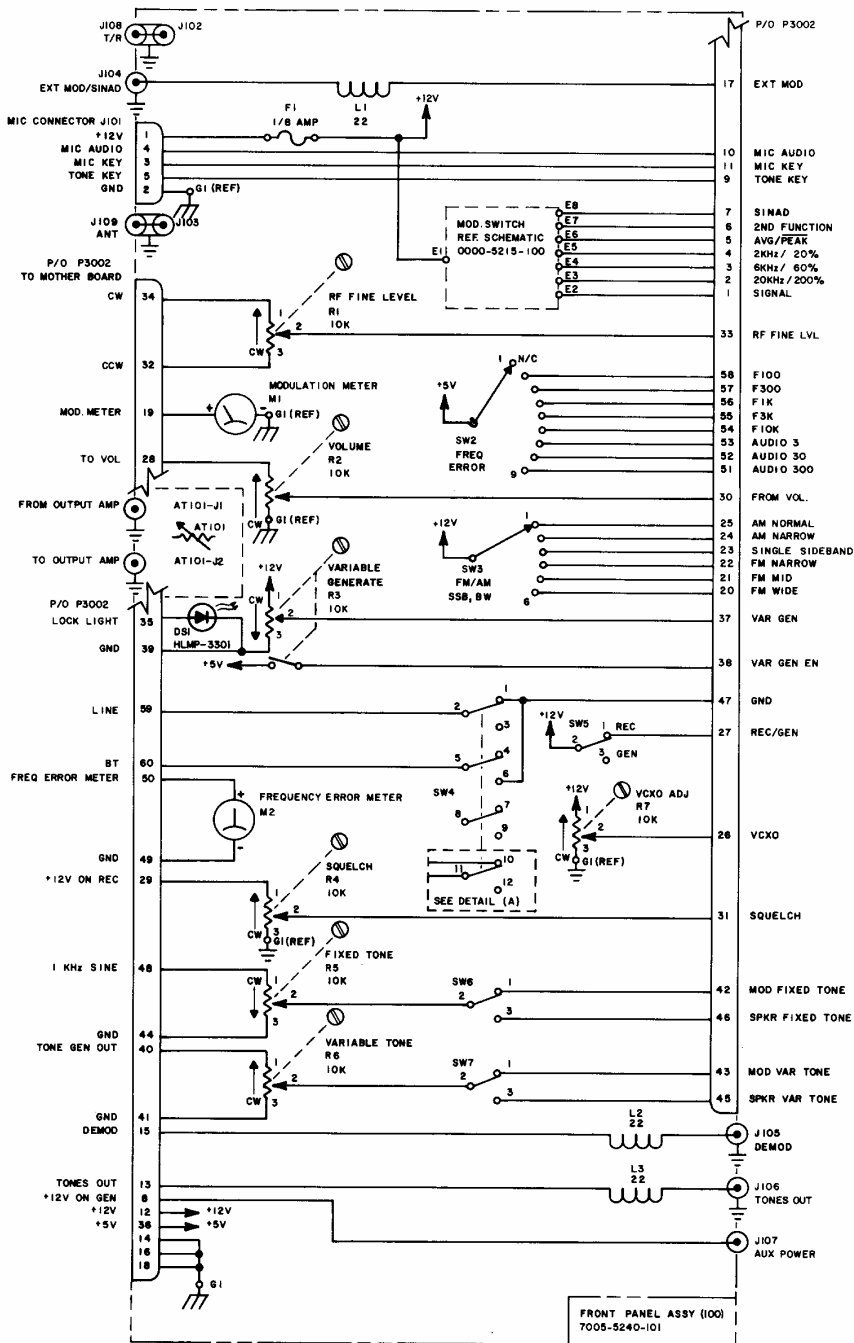
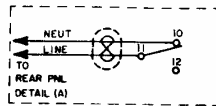

Figure 10-8 Front Panel Circuit Schematic (FM/AM-500A)

NOTES:

1. ALL REFERENCE NUMBERS CARRY AN ASSIGNED DESIGNATOR SERIES. THE SERIES FOR THIS SCHEMATIC IS 100 (E.G. R1 IS R101).
2. ALL RESISTORS ARE 1/4 W 5% TOLERANCE.
3. ALL RESISTANCE IS EXPRESSED IN OHMS.
4. ALL INDUCTANCE IS EXPRESSED IN MICROHENRYS.



DETAIL A

SN 3446 & ON

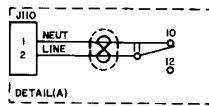

DETAIL A

SN 2501 THRU SN 3445

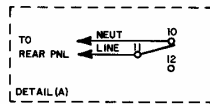

DETAIL A

SN 2216 THRU SN 2500

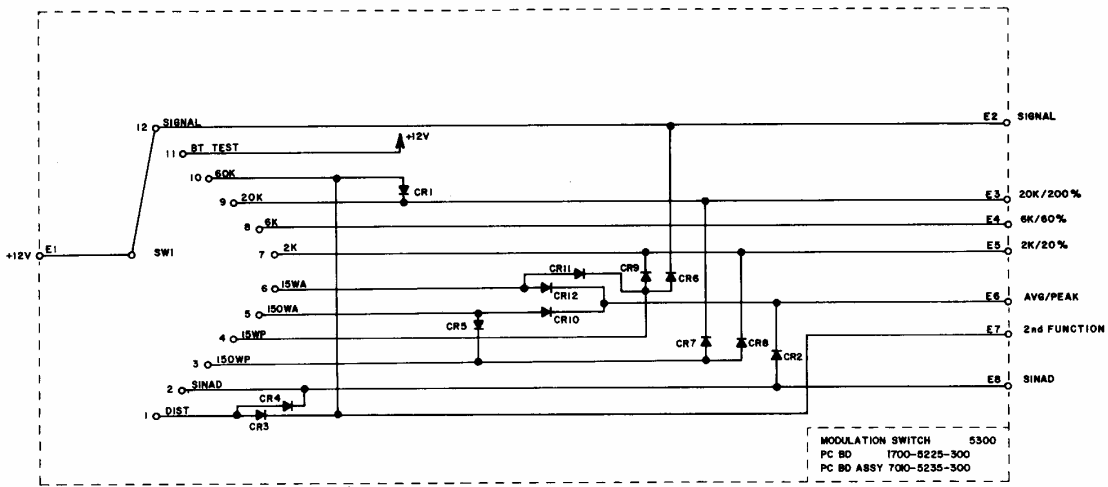

NOTES:

1. ALL REFERENCE NUMBERS CARRY AN ASSIGNED DESIGNATOR SERIES. THE SERIES FOR THIS SCHEMATIC IS 5300 (E.G. CR1 IS CR5301).
2. ALL DIODES ARE 1N4148.

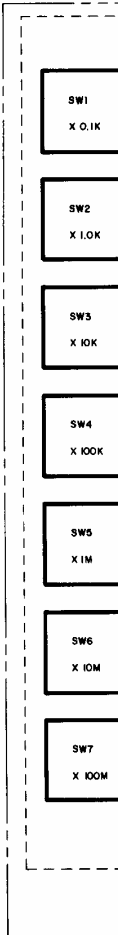

NOTES:

1. ALL REFERENCE NUMBERS CARRY AN ASSIGNED DESIGNATOR SERIES. THE SERIES FOR THIS SCHEMATIC IS 5300 (E.G. J1 IS J15301).

Figure 10-9 Modulation Meter Switch Circuit Schematic (FM/AM-500A)

Figure 10-10

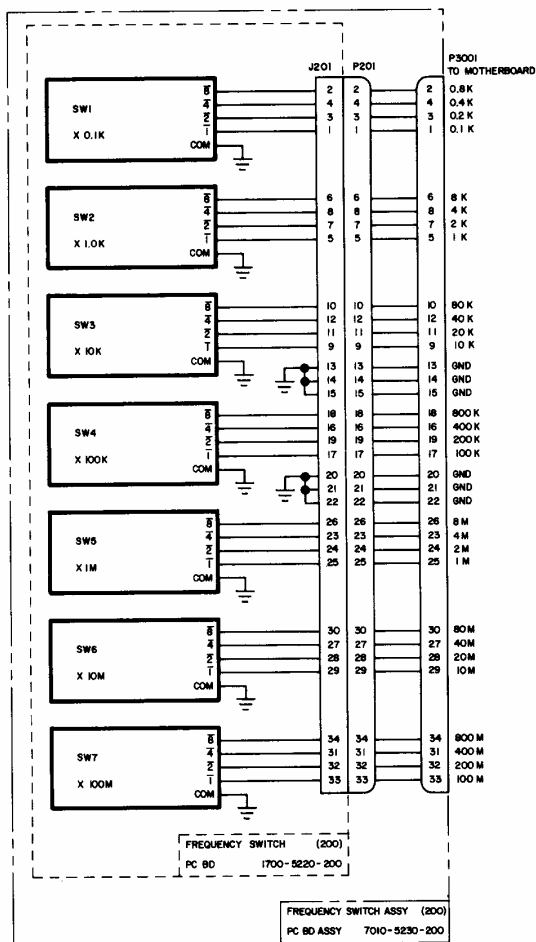
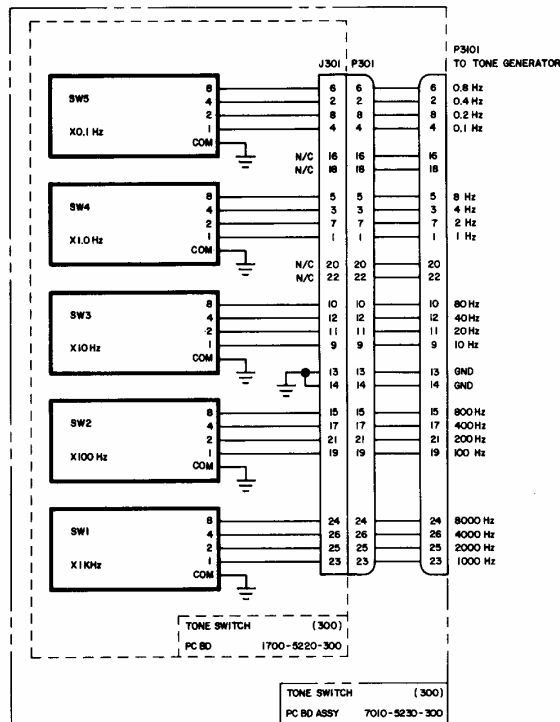

Figure 10-10 RF Thumbwheel Switch Circuit Schematic

ALL REFERENCE NUMBERS CARRY AN ASSIGNED DESIGNATOR SERIES. THE SERIES FOR THIS SCHEMATIC IS 200 (E.G. J1 IS J201).



NOTES:

1. ALL REFERENCE NUMBERS CARRY AN ASSIGNED DESIGNATOR SERIES. THE SERIES FOR THIS SCHEMATIC IS 300 (E.G. J1 IS J301).

Figure 10-11 Variable Tone Thumbwheel Switch Circuit Schematic

NOTES:

1. ALL REFERENCE NUMBERS CARRY AN ASSIGNED DESIGNATOR SERIES. THE SERIES FOR THIS SCHEMATIC IS 5100 (E.G., R1 IS R5101).
2. ALL RESISTORS ARE 1/4 W, 5% TOLERANCE UNLESS OTHERWISE NOTED.
3. L3 AND L4 ARE FORMED BY INDUCTANCE OF 0.4 IN LEADS OF C6 AND C13 RESPECTIVELY.
4. ALL RESISTANCE IS EXPRESSED IN OHMS UNLESS OTHERWISE NOTED.
5. J5106 IS NOT USED THRU SN 2500.
6. ALL CAPACITANCE IS EXPRESSED IN MICROFARADS UNLESS OTHERWISE NOTED.
7. ALL INDUCTANCE IS EXPRESSED IN MICROHENRYS UNLESS OTHERWISE NOTED.
8. SN 1001 THRU SN 2593; R8 VALUE IS 1.5 K, R14 VALUE IS 100 K.
9. SN 1001 THRU SN 2180 (FM/AM-500); R3221, R33, R34 AND C27 ARE NOT USED.
10. EFF S/N 1001 THRU 3224; REF SCHEMATIC 0000-5111-500 FOR S/N 3225 & ON.

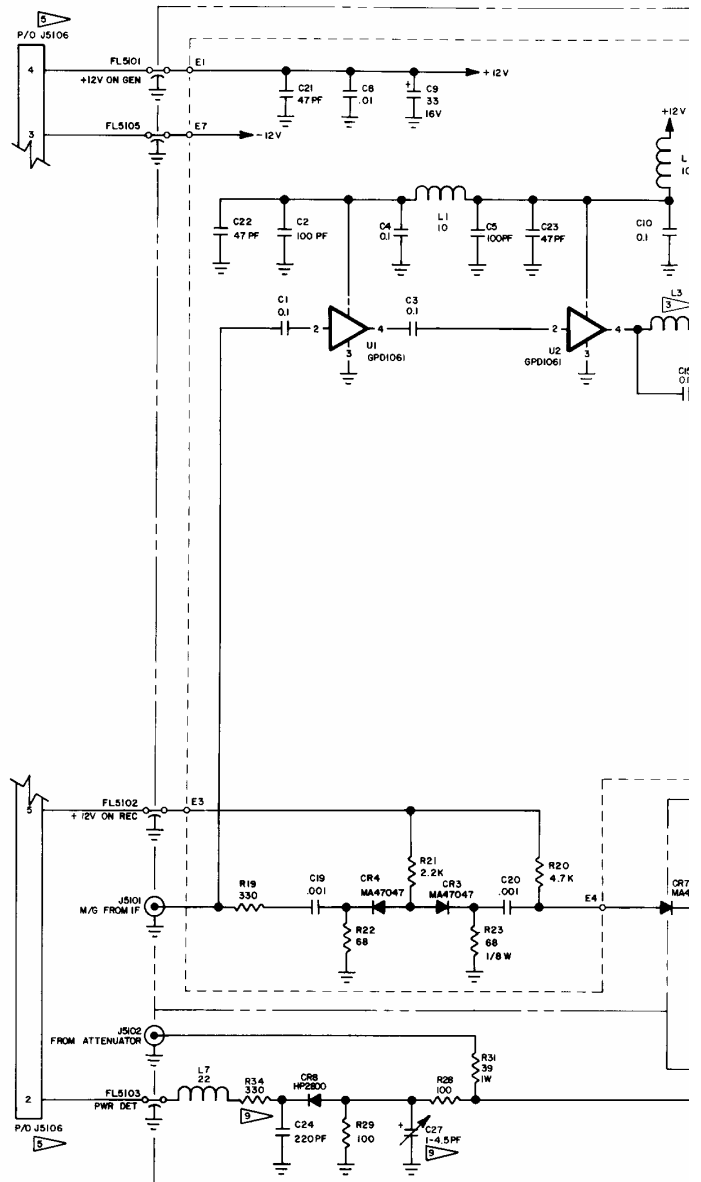

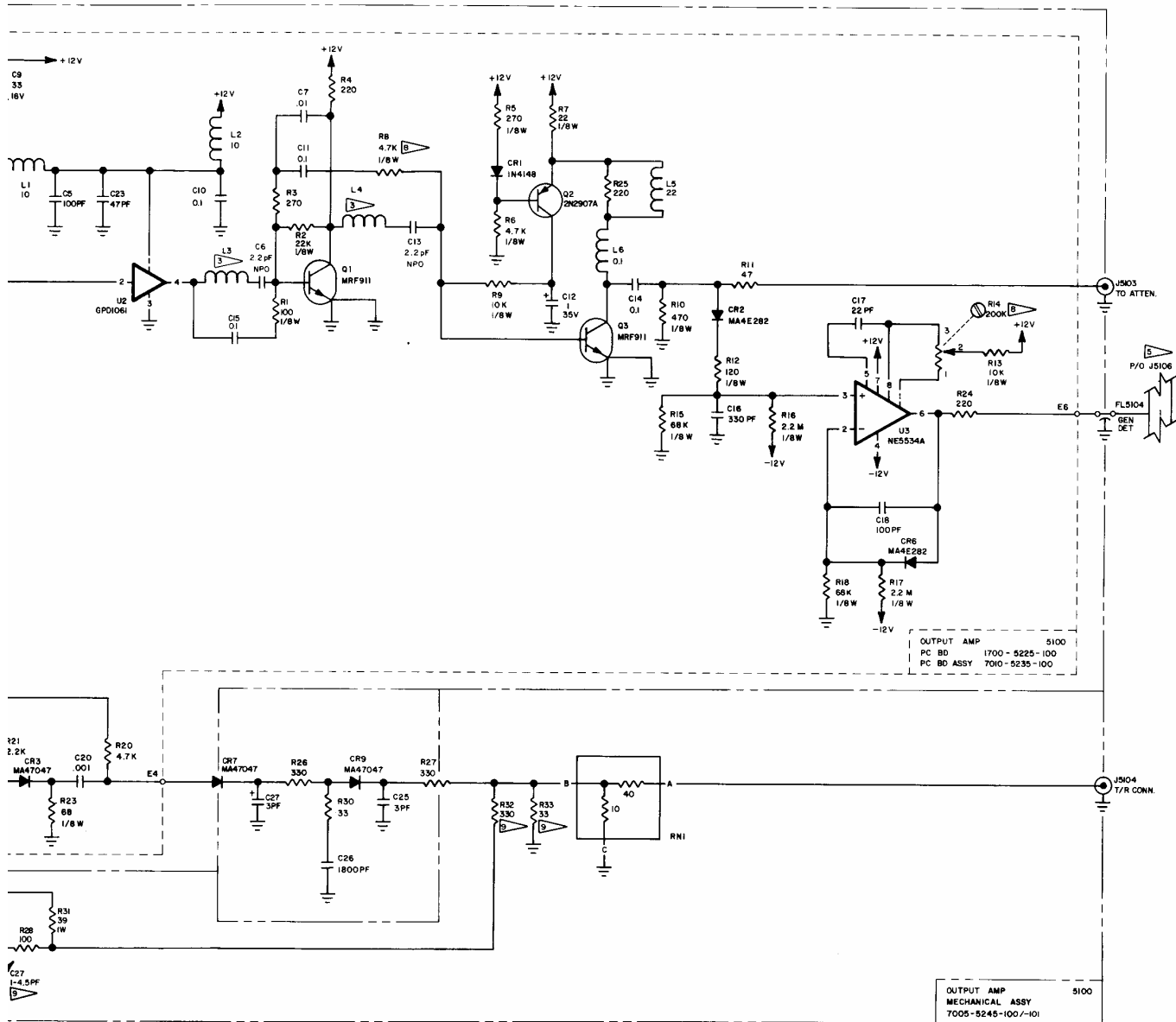
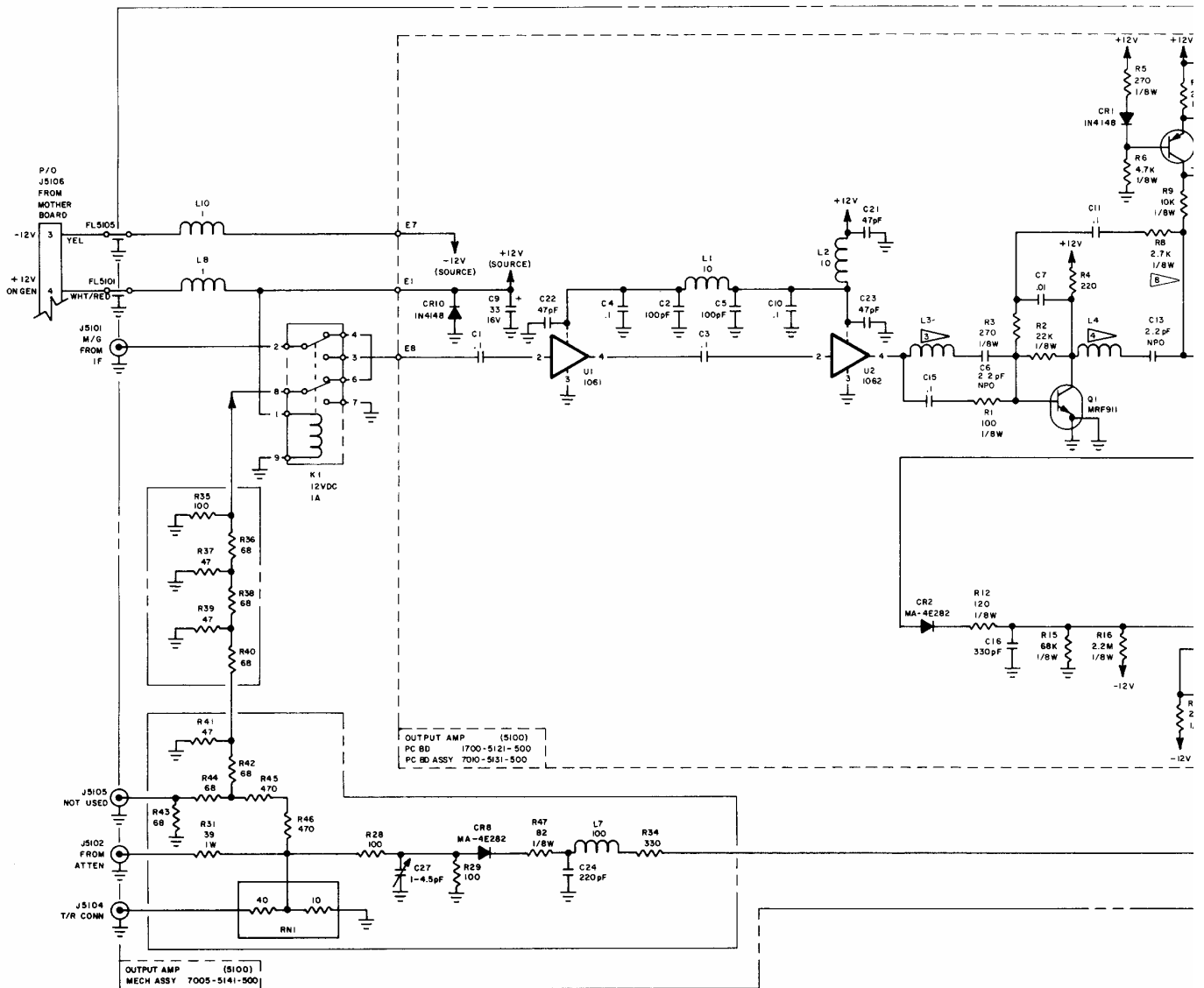
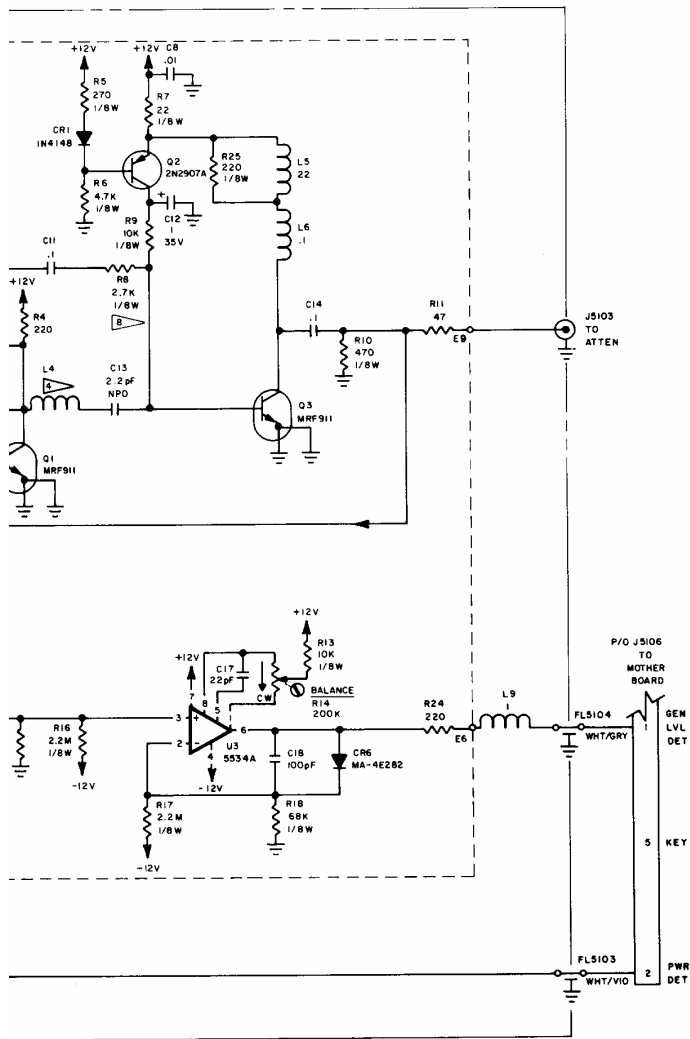

Figure 10-12 Output Amplifier Module Circuit Schematic





NOTES:

1. ALL REFERENCE NUMBERS CARRY ASSIGNED DESIGNATOR SERIES. THIS SCHEMATIC CARRIES SERIES 5100 (E.G., R1 IS R5101).
2. ALL RESISTORS ARE 1/4 W 5% TOLERANCE UNLESS OTHERWISE NOTED.
3. L3 IS FORMED BY THE LEAD OF C516 CUT TO A LENGTH OF .4 INCHES.
4. L4 IS FORMED BY THE LEAD OF C5106 CUT TO A LENGTH OF .4 INCHES.
5. ALL RESISTANCE IS EXPRESSED IN OHMS UNLESS OTHERWISE NOTED.
6. ALL CAPACITANCE IS EXPRESSED IN MICRO-FARADS UNLESS OTHERWISE NOTED.
7. ALL INDUCTANCE IS EXPRESSED IN MICRO-HENRY'S UNLESS OTHERWISE NOTED.
8. R8 IS SELECTED AT TEST (S.A.T.).
NOMINAL VALUE = 2.7 K
RANGE VALUE = 1.8 K - 4.7 K
EFF SN 4078 & ON

Figure 10-12a Output Amplifier Module Circuit Schematic (SN 3225 and On)

10-12a/10-12b Blank

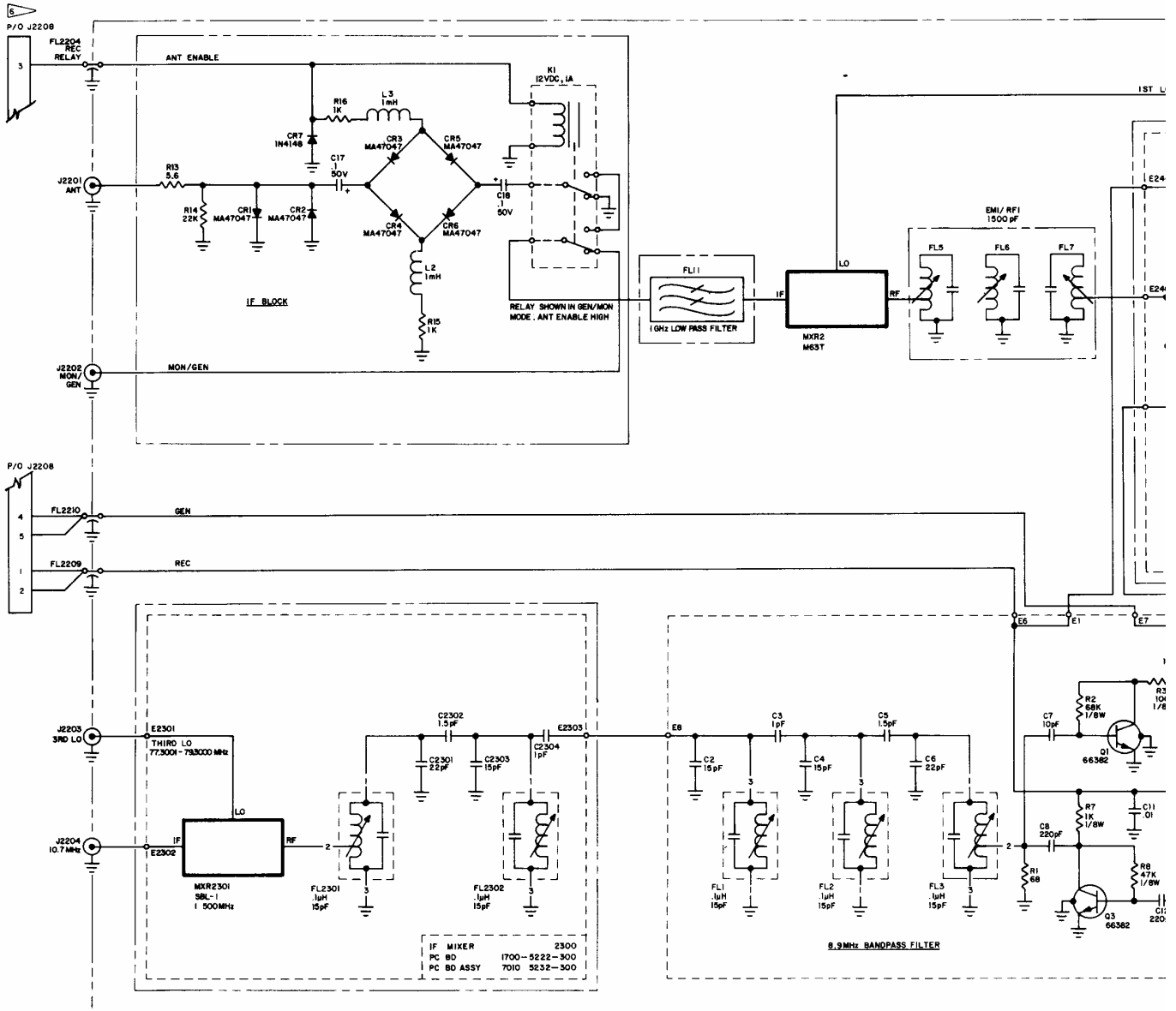

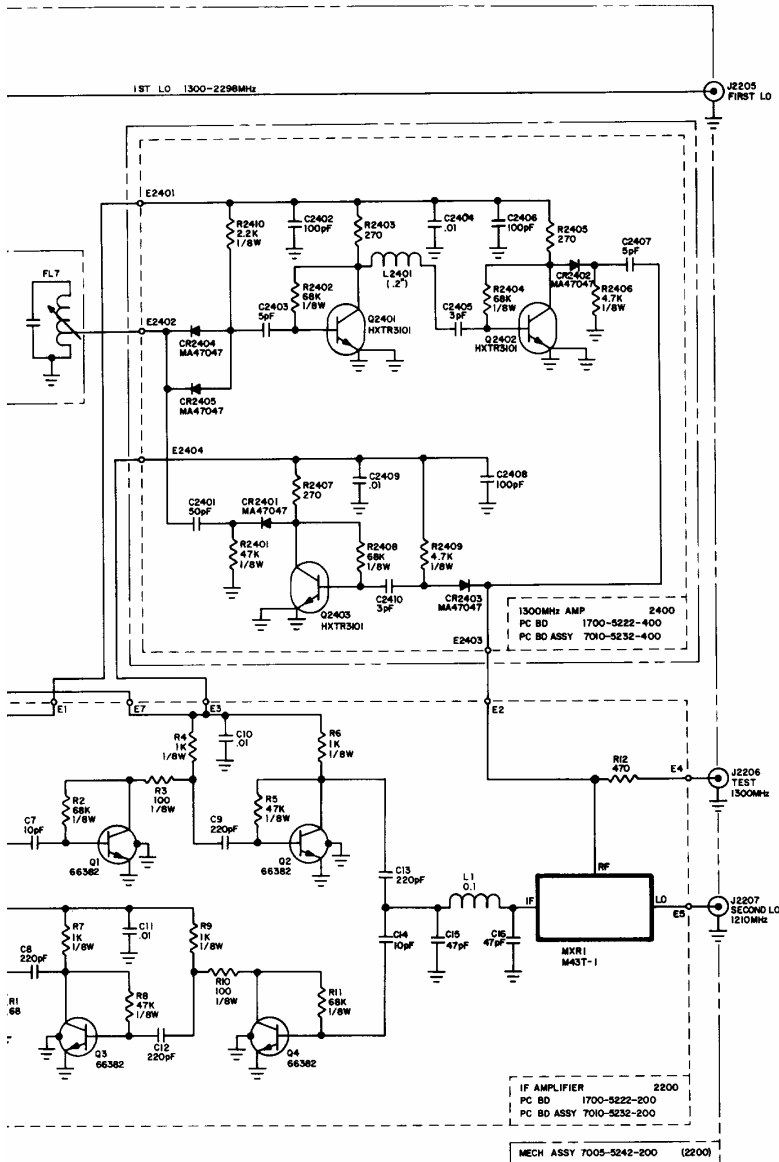

NOTES:

1. ALL REFERENCE NUMBERS CARRY AN ASSIGNED DESIGNATOR SERIES. THE SERIES FOR THESE SCHEMATICS ARE:
 - A. MECHANICAL ASSY - 2200
 - B. IF AMPLIFIER BD - 2200
 - C. IF MIXER BD - 2300
 - D. 1300 MHz AMP BD - 2400 (EG., R1 IS R2201)
2. ALL RESISTORS ARE 1/4 W 5% TOLERANCE UNLESS OTHERWISE NOTED.
3. ALL RESISTANCE IS EXPRESSED IN OHMS UNLESS OTHERWISE NOTED.
4. ALL CAPACITANCE IS EXPRESSED IN MICRO-FARADS UNLESS OTHERWISE NOTED.
5. ALL INDUCTANCE IS EXPRESSED IN MICRO-HENRYS UNLESS OTHERWISE NOTED.

6. EFF SN 2501 & ON

Figure 10-13 IF Module Circuit Schematic

NOTES:

1. ALL REFERENCE NUMBERS CARRY AN ASSIGNED DESIGNATOR SERIES. THE SERIES FOR THIS SCHEMATIC ARE:
 - A. ANALOG BD - 4000 (E.G. R1 IS R4001).
 - B. DIVIDER BD - 4100 (E.G. R1 IS R4101).
2. ALL RESISTORS ARE 1/4 W 5% TOLERANCE.
3. ALL RESISTANCE IS EXPRESSED IN OHMS UNLESS OTHERWISE NOTED.
4. ALL CAPACITANCE IS EXPRESSED IN MICROFARADS UNLESS OTHERWISE NOTED.
5. ALL INDUCTANCE IS EXPRESSED IN MICROHENRYS.
6. EFF SN1001 THRU 3074.

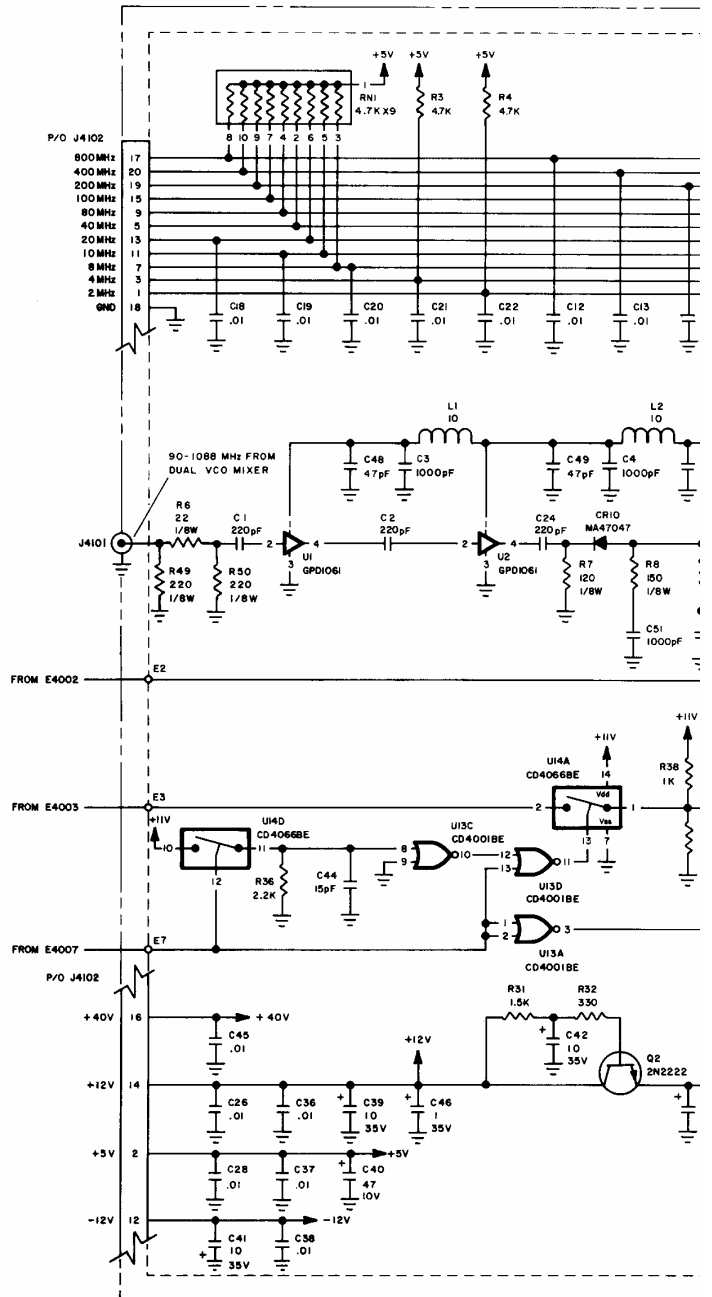

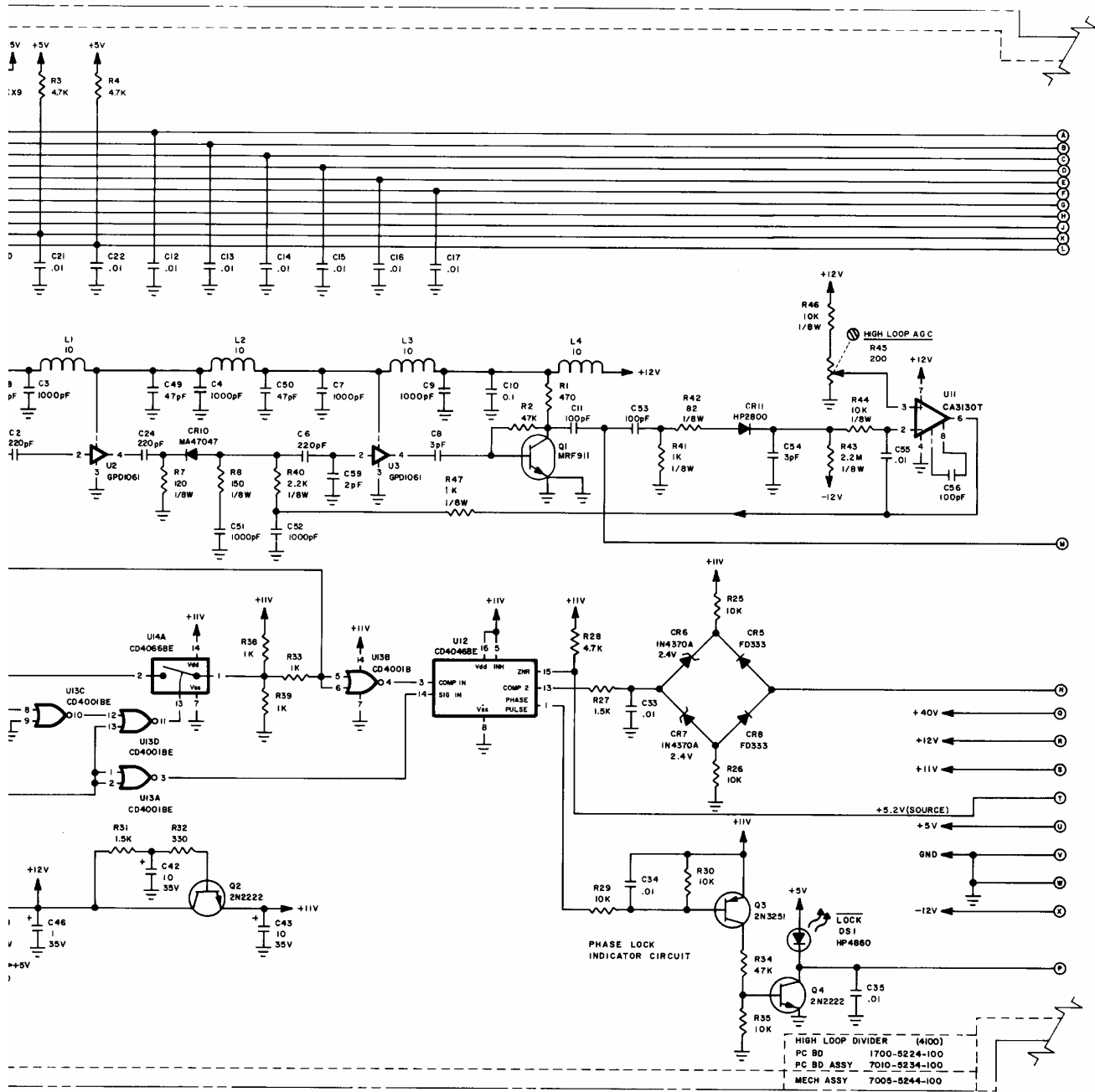
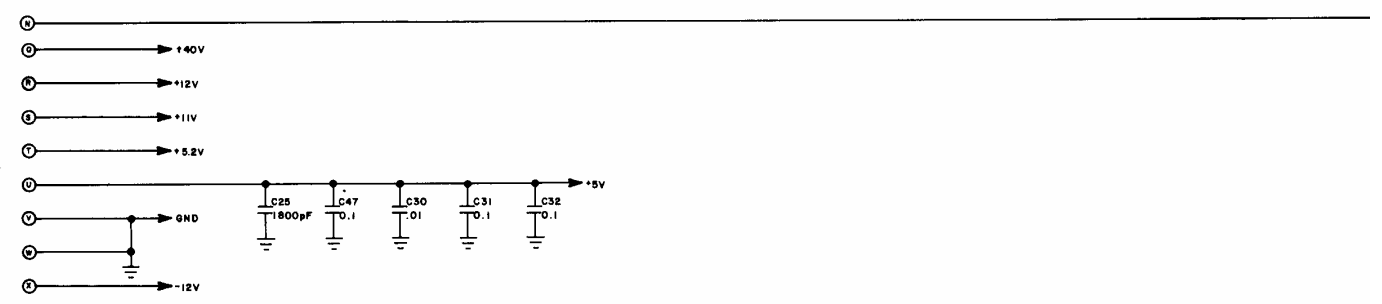
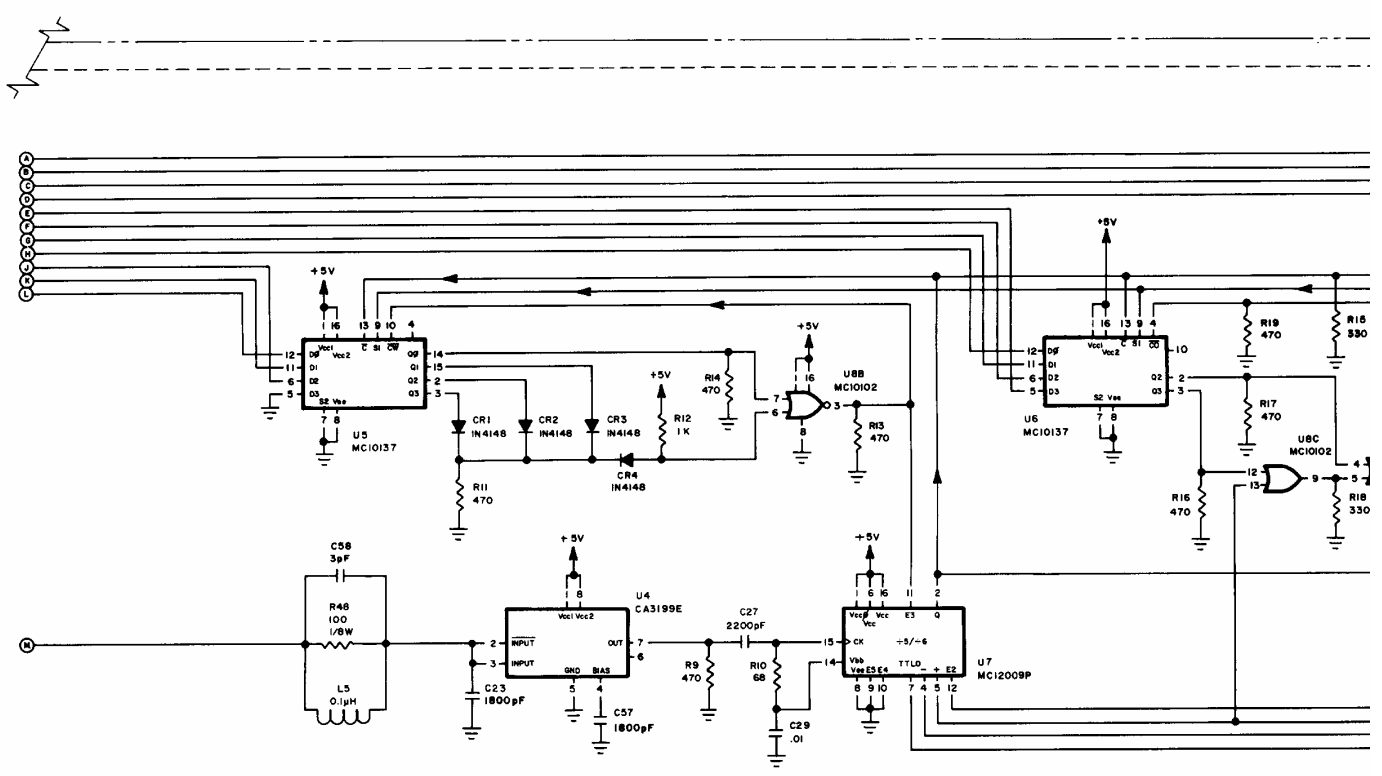

Figure 10-14 High Loop Module Circuit Schematic (Sheet 1 of 3)



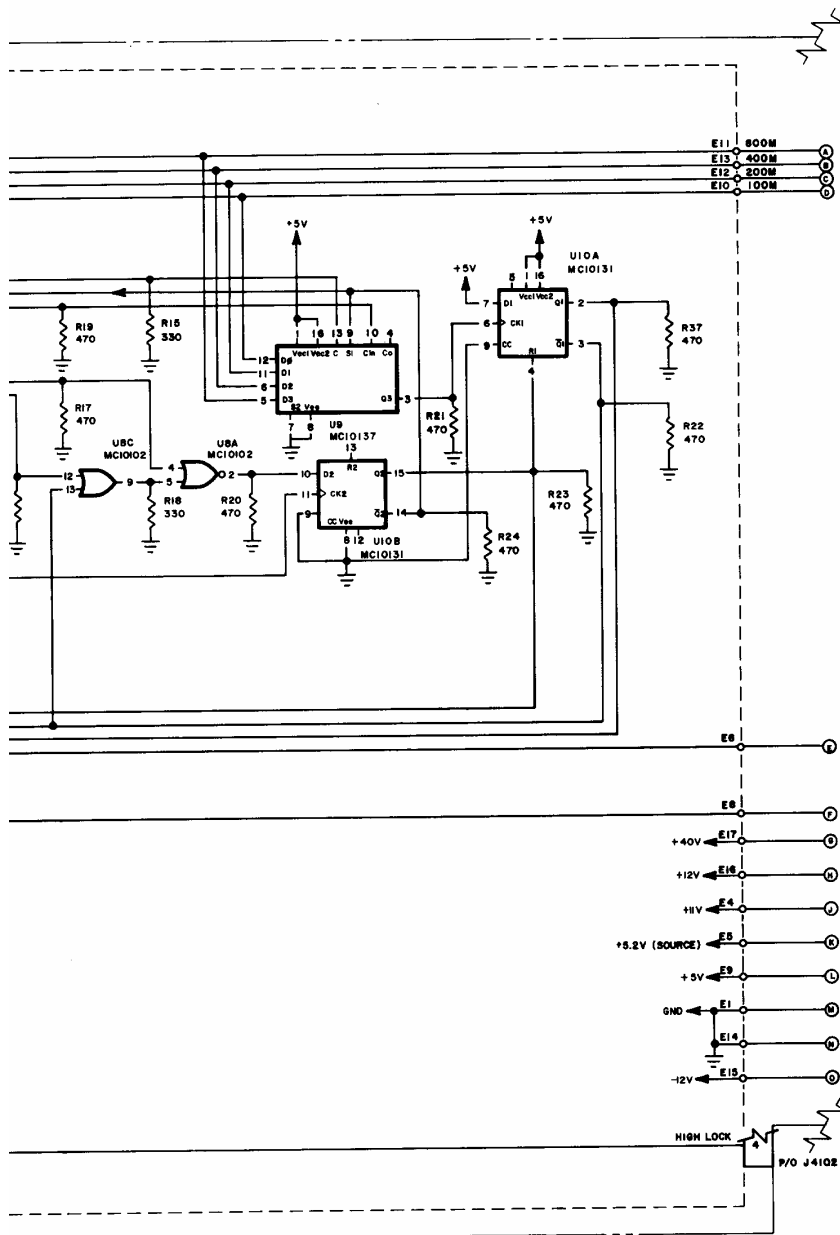
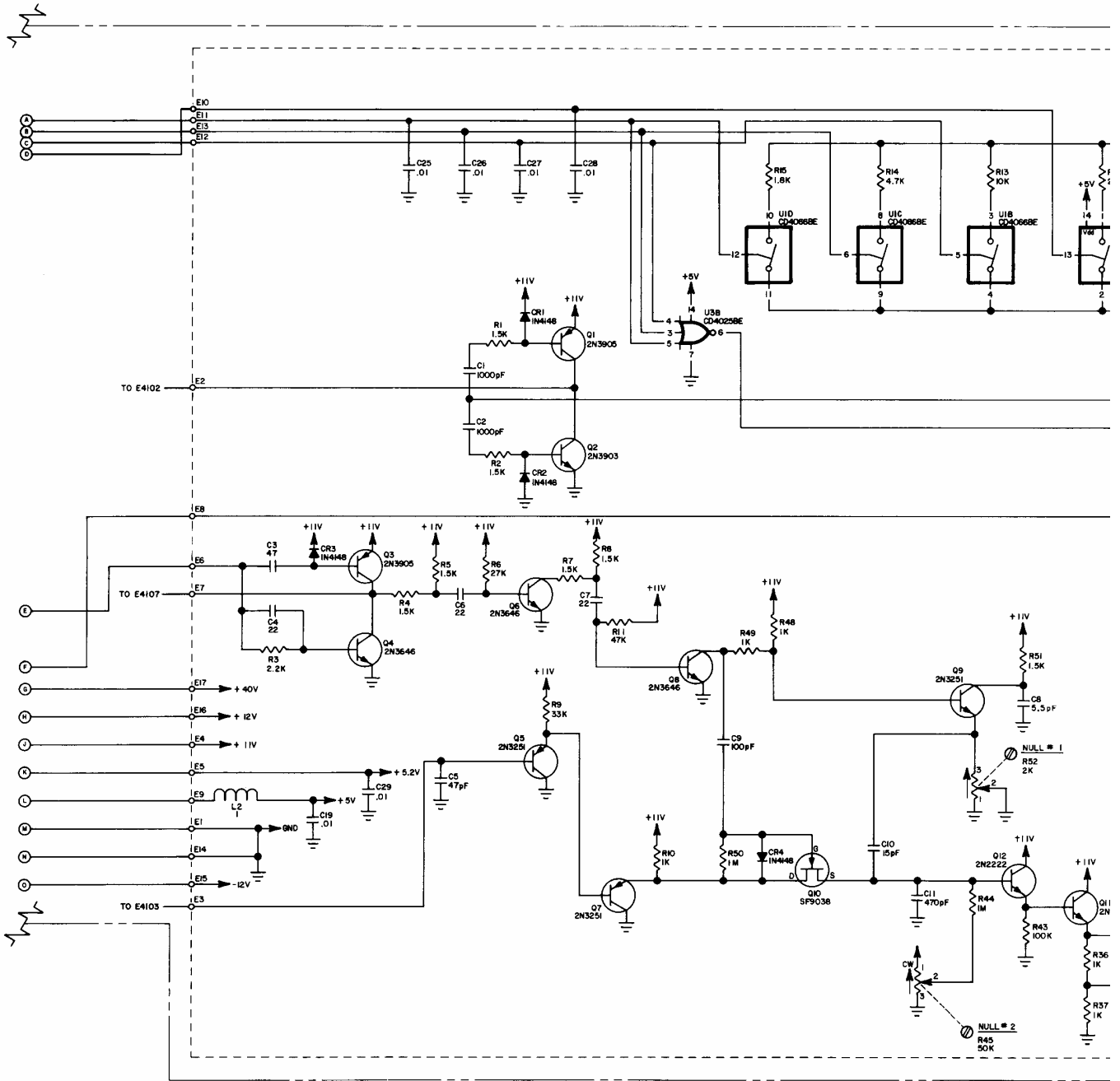

Figure 10-14 High Loop Module
Circuit Schematic
(Sheet 2 of 3)



Fi

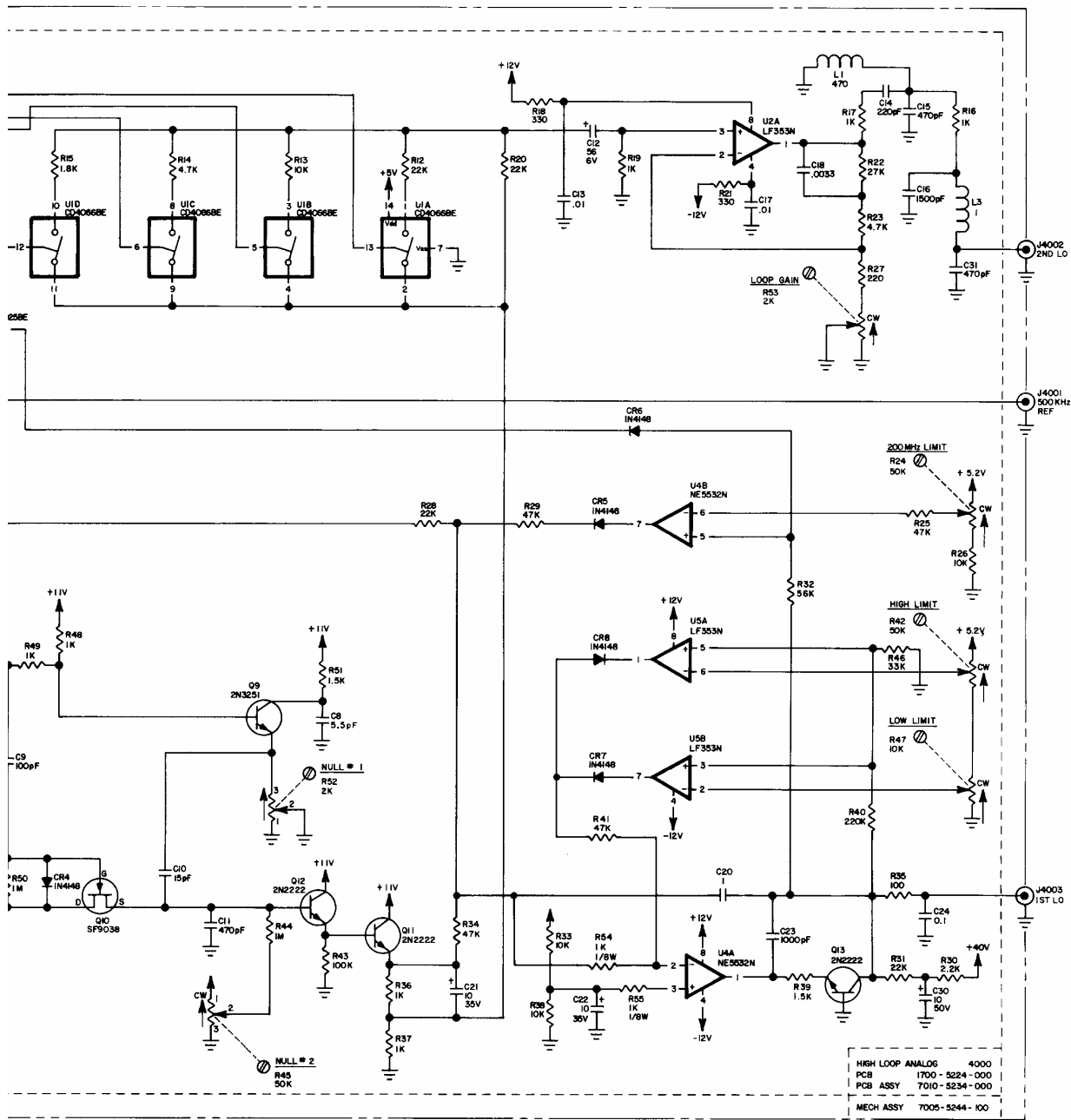
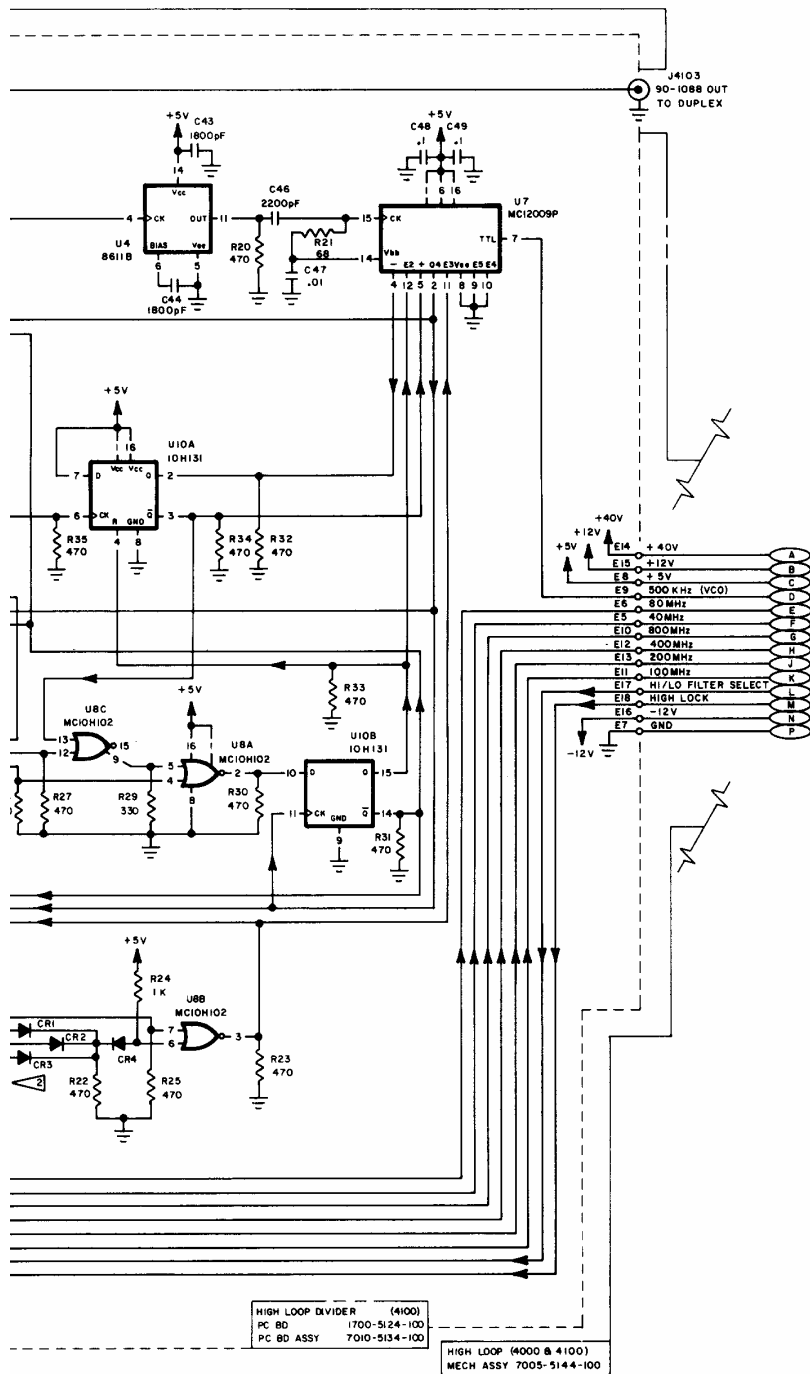

Figure 10-14 High Loop Module Circuit Schematic (Sheet 3 of 3)



NOTES:

1. \blacktriangle R37 IS S.A.T. NOMINAL VALUE 33Ω , RANGE: 22-56 Ω .
2. ALL DIODES ARE 1N4148.
3. ALL RESISTORS ARE 1/4 W, 5% TOLERANCE.
4. ALL CAPACITANCE IS EXPRESSED IN MICRO-FARADS.
5. ALL INDUCTANCE IS EXPRESSED IN MICRO-HENRYS.
6. EFF SN 3075 AND ON.
7. \blacktriangle SN 3075 THRU SN 3643 C21 VALUE IS 0.1 μ F.
8. \blacktriangle C4027 IS SELECTED AT TEST (S.A.T). NOMINAL VALUE = 22 pF RANGE VALUE = 10 pF - 47 pF EFF S/N 4235 & ON
9. \blacktriangle EFF S/N 4235 & ON
10. \blacktriangle EFF S/N 4273 & ON R4065 WAS 20 K.

Figure 10-14a High Loop Module Circuit Schematic (Sheet 1 of 2)

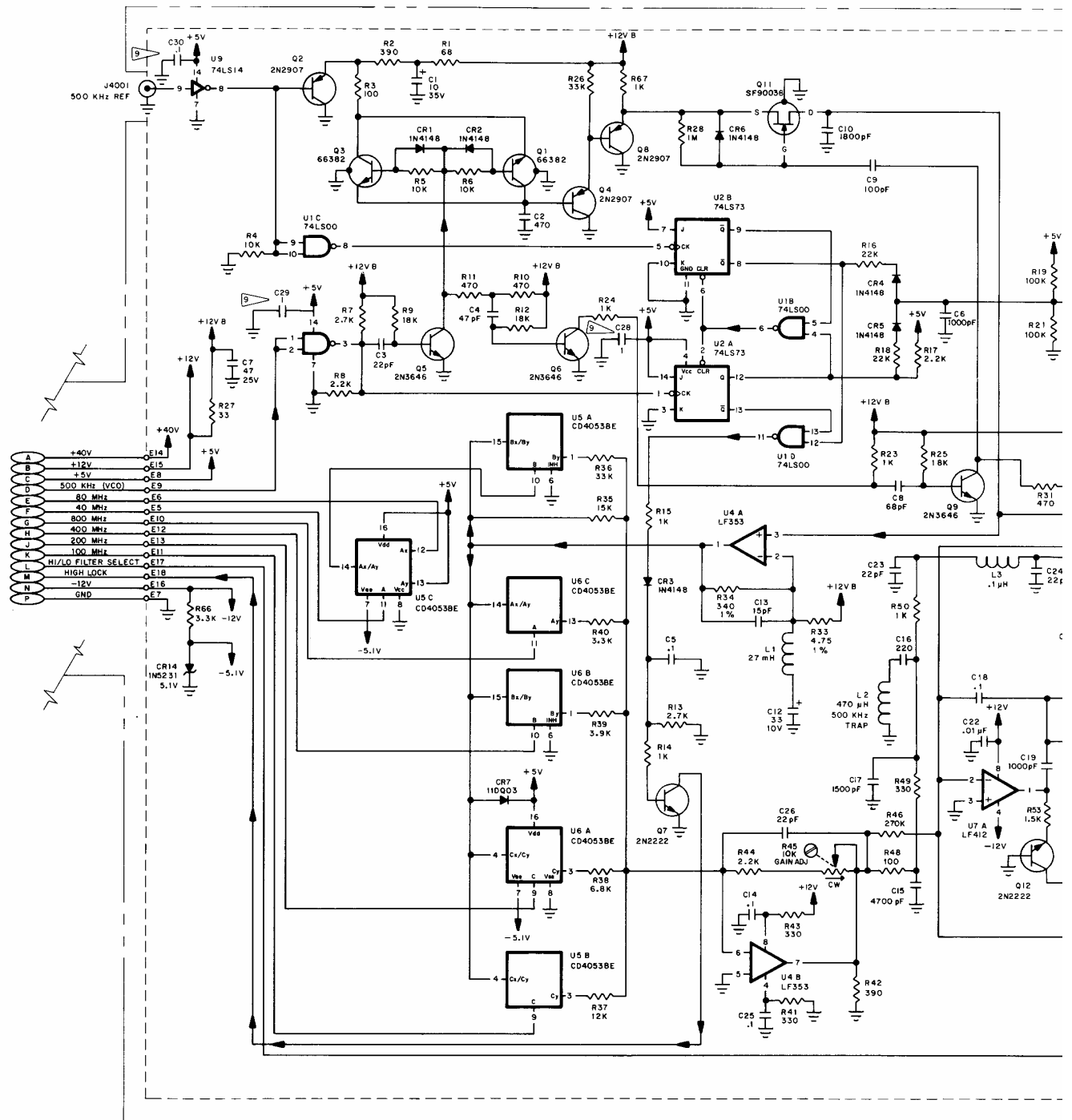

Figure 10

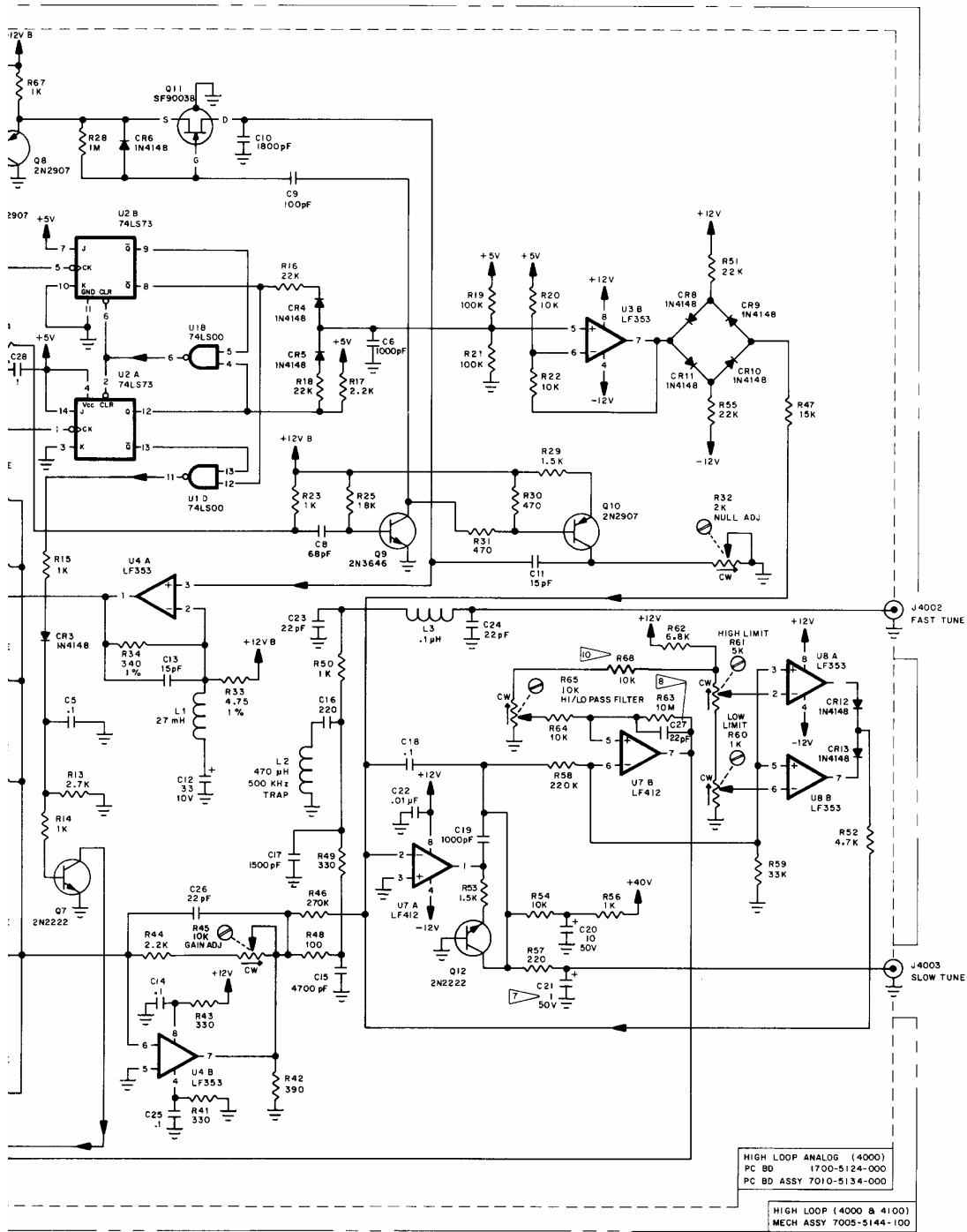
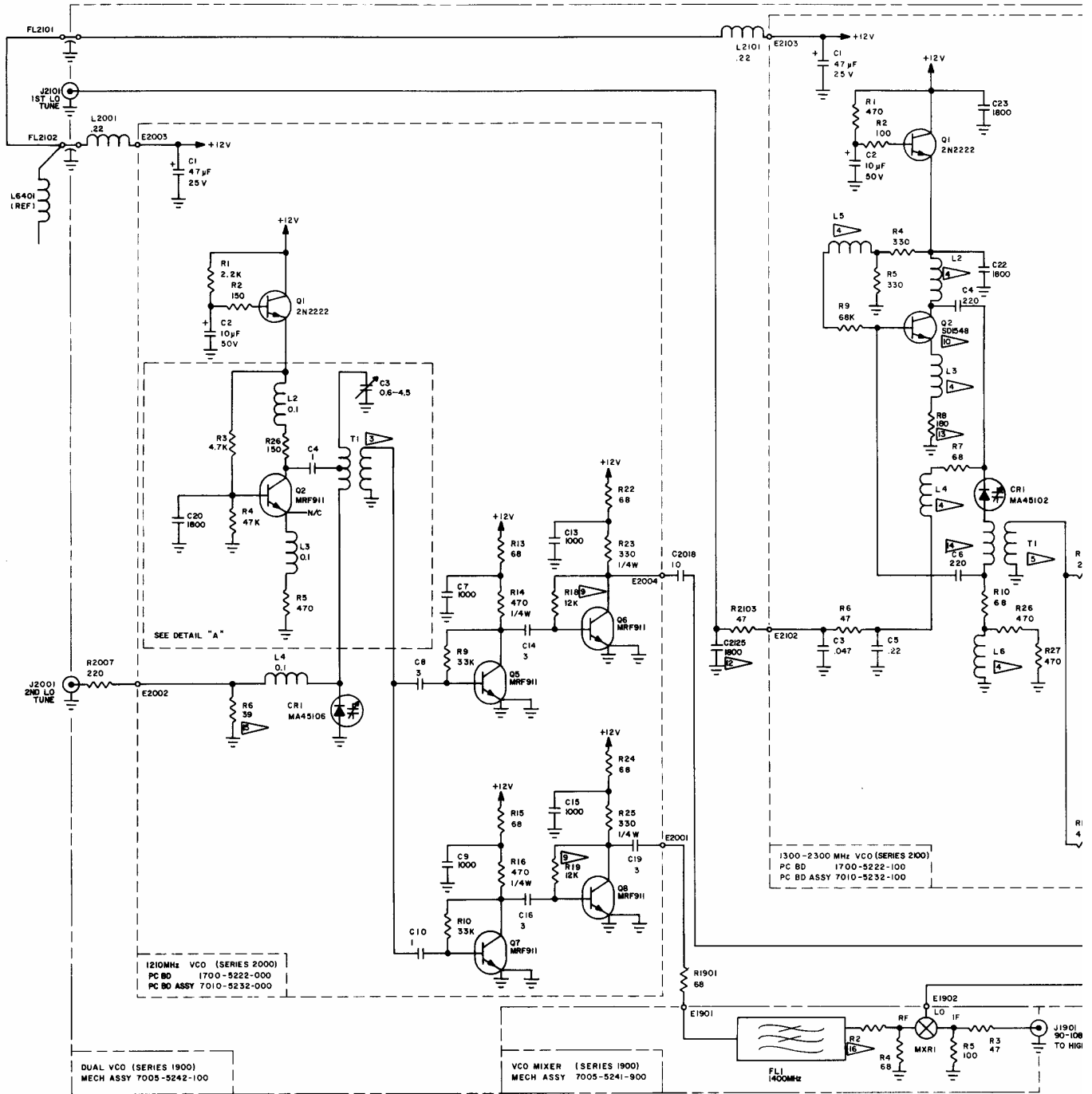

Figure 10-14a High Loop Module Circuit Schematic (Sheet 2 of 2)

10-16b
 03



NOTES:

1. ALL REFERENCE NUMBERS CARRY AN ASSIGNED DESIGNATOR SERIES. THE SERIES FOR THIS SCHEMATIC ARE:
 - A. VCO MIXER - 1900 (E.G., R1 IS R1901)
 - B. 1210 MHz VCO - 2000 (E.G., R1 IS R2001)
 - C. 1300-2300 MHz VCO - 2100 (E.G., R1 IS R2101)
2. ALL RESISTORS ARE 1/8 W, 5% TOLERANCE UNLESS OTHERWISE NOTED.
3. PRIMARY OF T2001 IS FORMED BY 18 GA BUS WIRE, .9 IN. LONG, WITH LEAD OF C2004 SOLDERED TO APPROX. CTR OF WIRE. (EXACT LOCATION OF C2004 ON WIRE IS SELECTED AT TEST). SECONDARY OF T2001 IS FORMED BY 22 GA BUS WIRE, .8 IN. LONG.
4. 10 TURNS 38 GA WIRE. 0.04 IN. DIA.
5. PRIMARY FORMED BY LEAD OF C6 SOLDERED TO CR1. LENGTH, S.A.T. (SELECTED AT TEST). SECONDARY FORMED BY 22 GA WIRE BENT DOWN WITHIN 0.4" OF BOARD SURFACE, THEN BACK UP TO WITHIN 0.2" OF PRIMARY.
6. ALL RESISTANCE IS EXPRESSED IN OHMS UNLESS OTHERWISE NOTED.
7. ALL CAPACITANCE IS EXPRESSED IN PICO FARADS UNLESS OTHERWISE NOTED.
8. ALL INDUCTANCE IS EXPRESSED IN MICROHENRYS UNLESS OTHERWISE NOTED.
9. SN1001 THRU SN1349, R18 AND R19 VALUE IS 22K.
10. SN1001 THRU SN2120, TRANSISTOR USED IS CD1857.
11. SN1001 THRU SN2000, R21 AND R22 VALUE IS 22K.
12. SN1001 THRU SN2555, C25 NOT USED.
13. R2108 IS SELECTED AT TEST (SAT). RANGE IS 180Ω. RANGE IS 47Ω THRU 220Ω.
14. SN1001 THRU SN3219, C6 VALUE IS 1200 pF.
15. SN1001 THRU SN3524, R6 VALUE IS 56.
16. SN10012 THRU SN3524

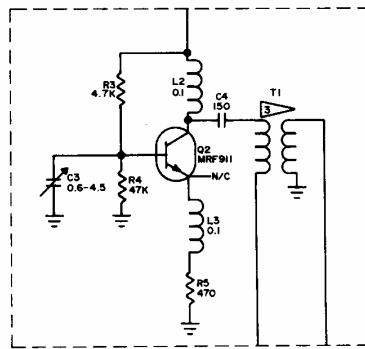
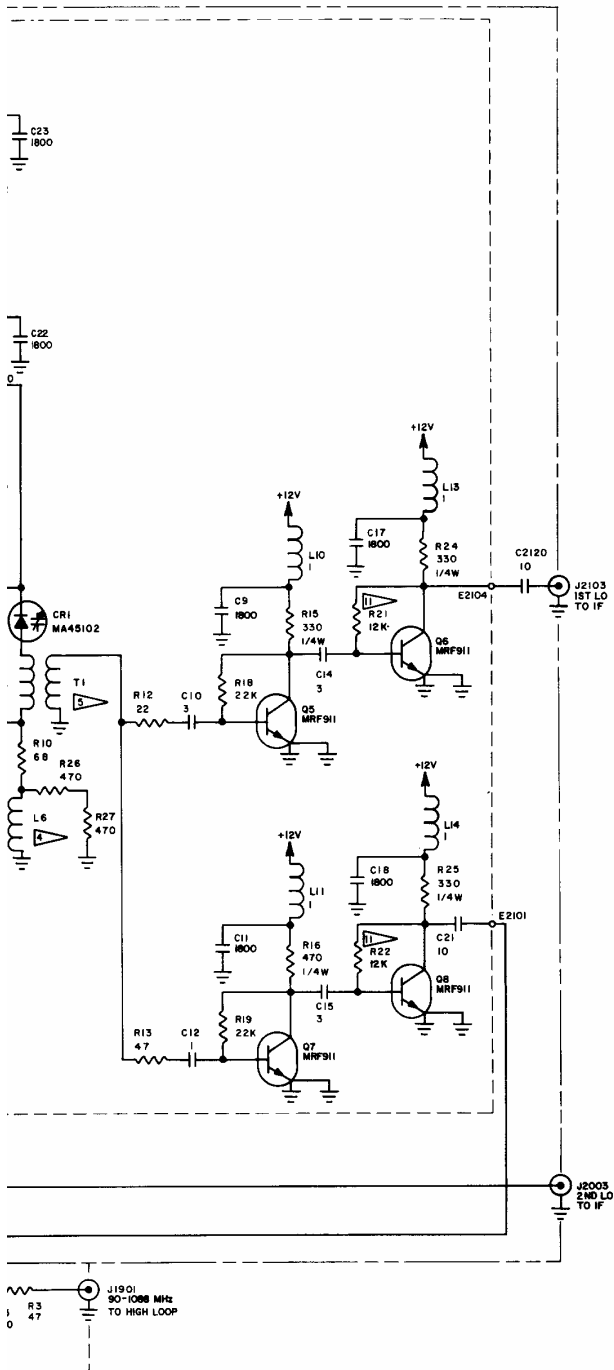

DETAIL A
(EFF SN 1001 THRU SN 3524)

Figure 10-15 Dual VCO Module Circuit Schematic

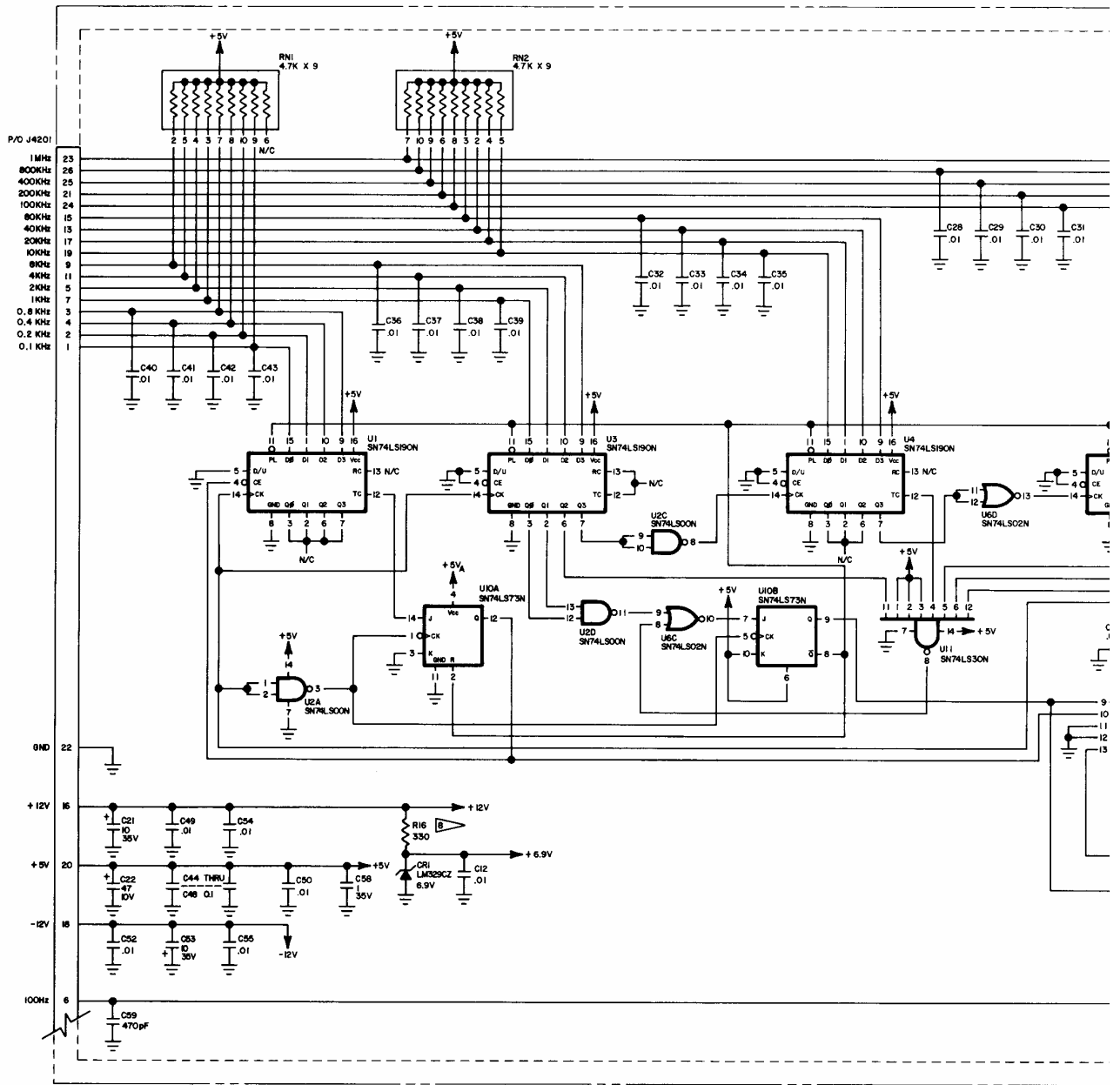

Figure 1

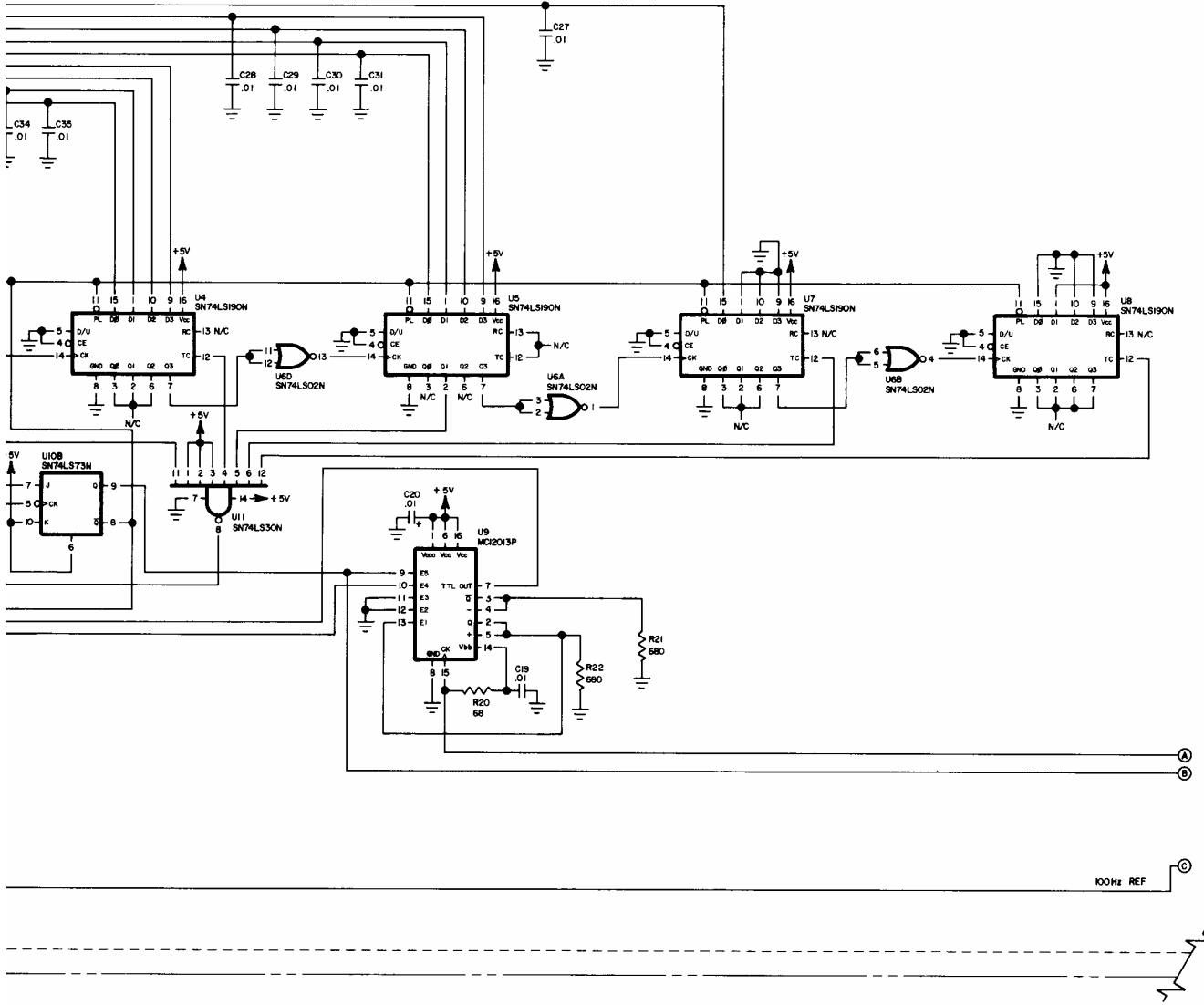
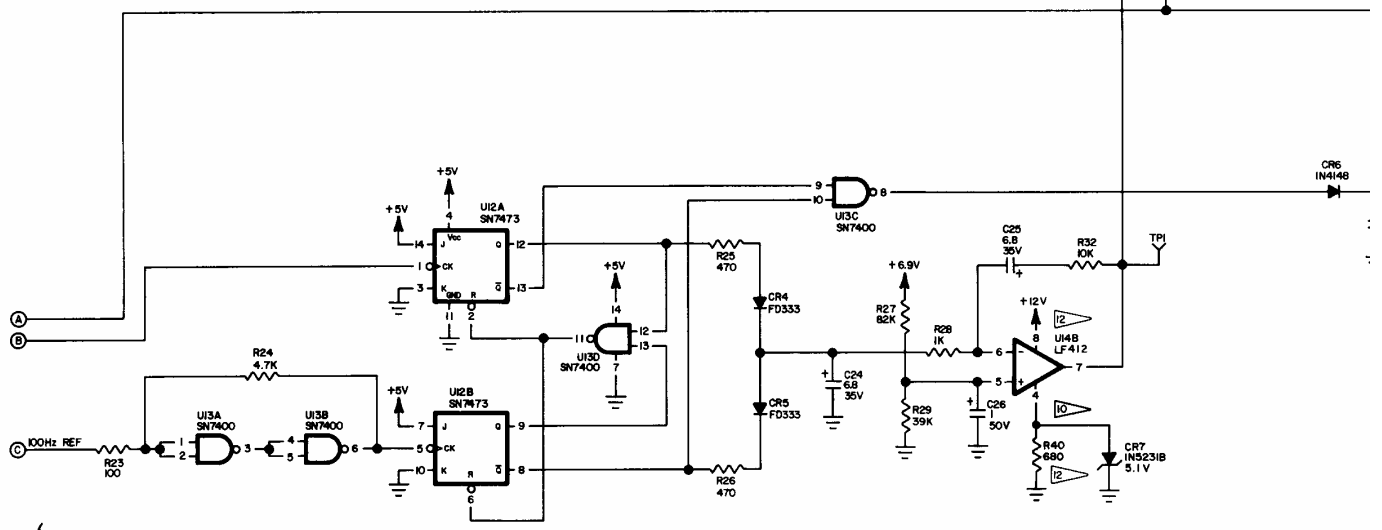
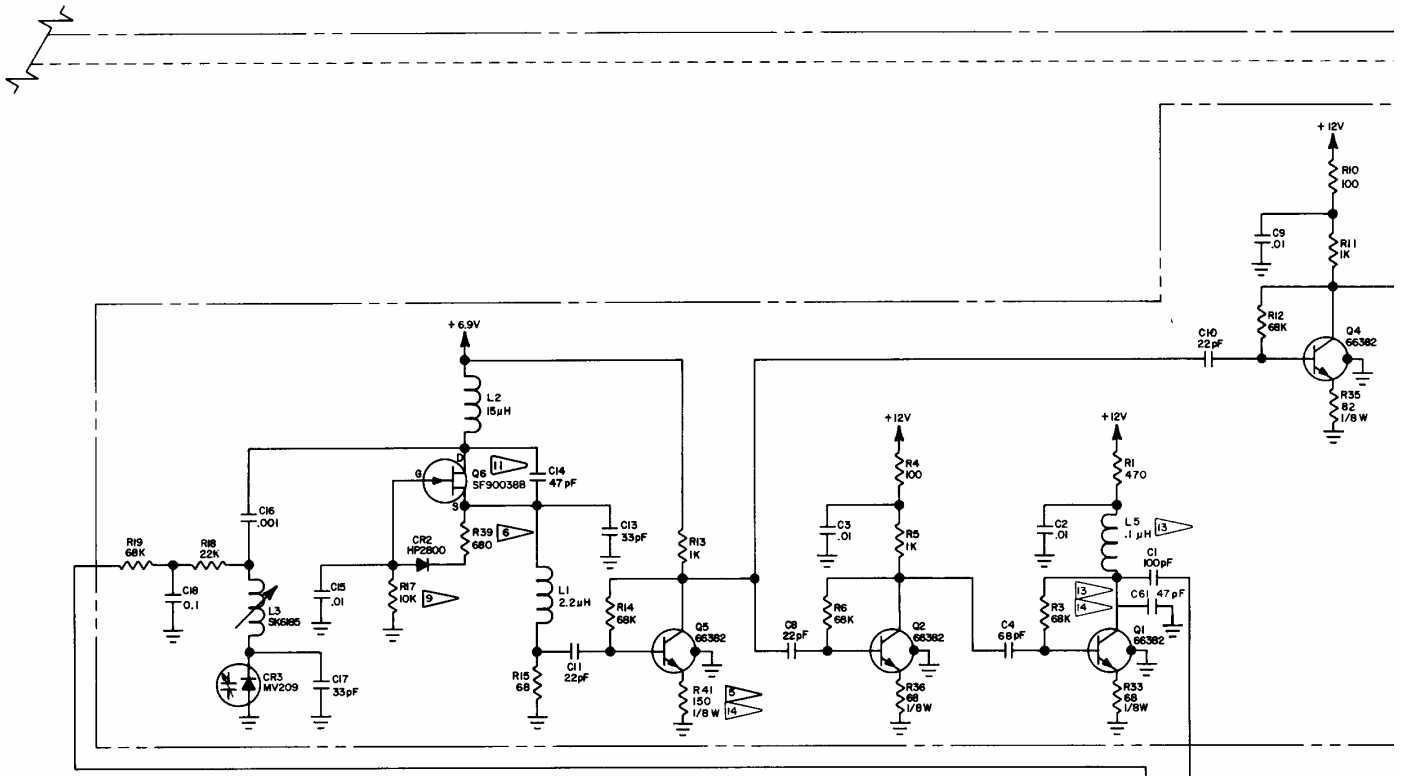
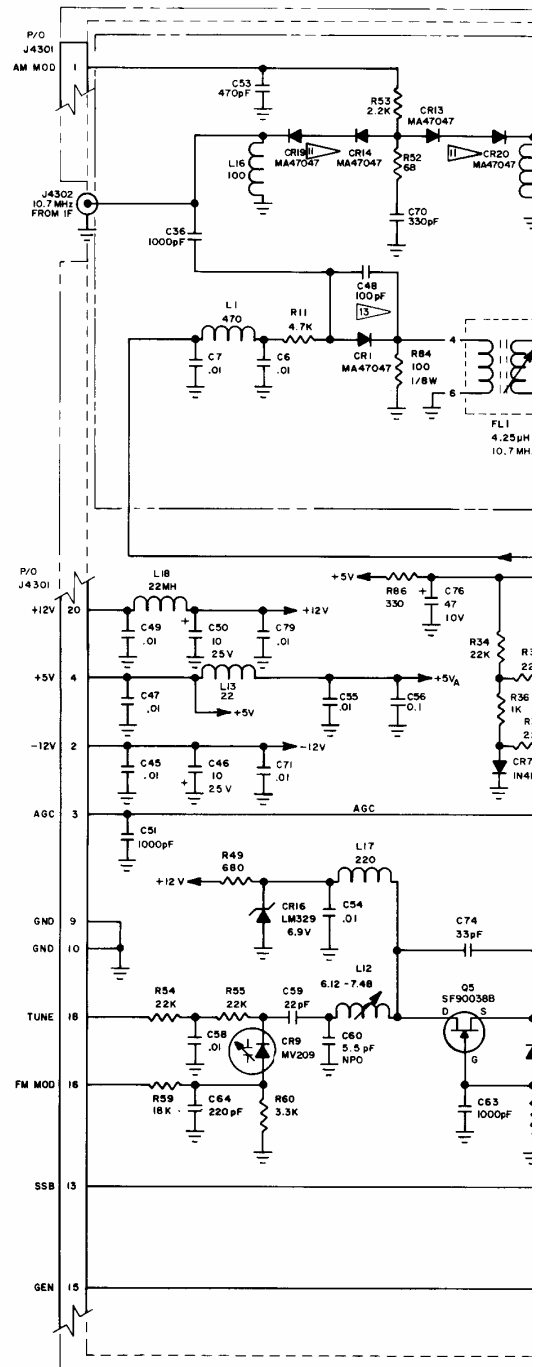

Figure 10-16 Low Loop Module Circuit Schematic (Sheet 1 of 2)



NOTES:

1. ALL REFERENCE NUMBERS CARRY AN ASSIGNED DESIGNATOR SERIES. THE SERIES FOR THIS SCHEMATIC IS 4300 (E.G. R1 IS R4301).
2. ALL RESISTORS ARE 1/4 W, 5% TOLERANCE.
3. ALL RESISTANCE IS EXPRESSED IN OHMS UNLESS OTHERWISE NOTED.
4. ALL CAPACITANCE IS EXPRESSED IN MICRO-FARADS UNLESS OTHERWISE NOTED.
5. ALL INDUCTANCE IS EXPRESSED IN MICRO-HENRYS UNLESS OTHERWISE NOTED.
6. FL1 THRU FL7 ARE 76-251 TOKO COILS.
7. SN 1001 THRU SN 2181, R56 VALUE IS 10K.
8. SN 1001 THRU 2647, R89, R90 AND R91, (VALUE OF 68 OHM 1/8 W), ARE NOT USED.
9. SN 1001 THRU SN 2648, C33 VALUE IS 1 μ F, 35 V
10. SN 1001 THRU SN 2555, R80 VALUE IS 150 K.
11. SN 1001 THRU SN 3564, CR19 AND CR20 WERE NOT USED.
12. R38 IS SELECTED AT TEST (S.A.T.) NOMINAL VALUE 6.8 K TO 15 K; ANY RESISTOR MAY BE USED.
13. C48 IS SELECTED AT TEST (S.A.T.). NOMINAL VALUE IS 100 pF. RANGE IS 10 pF TO 100 pF.
14. EFF SN 4153 AND ON, C81, C82, C83 AND C84 ARE INSTALLED IN PCB.



Figure

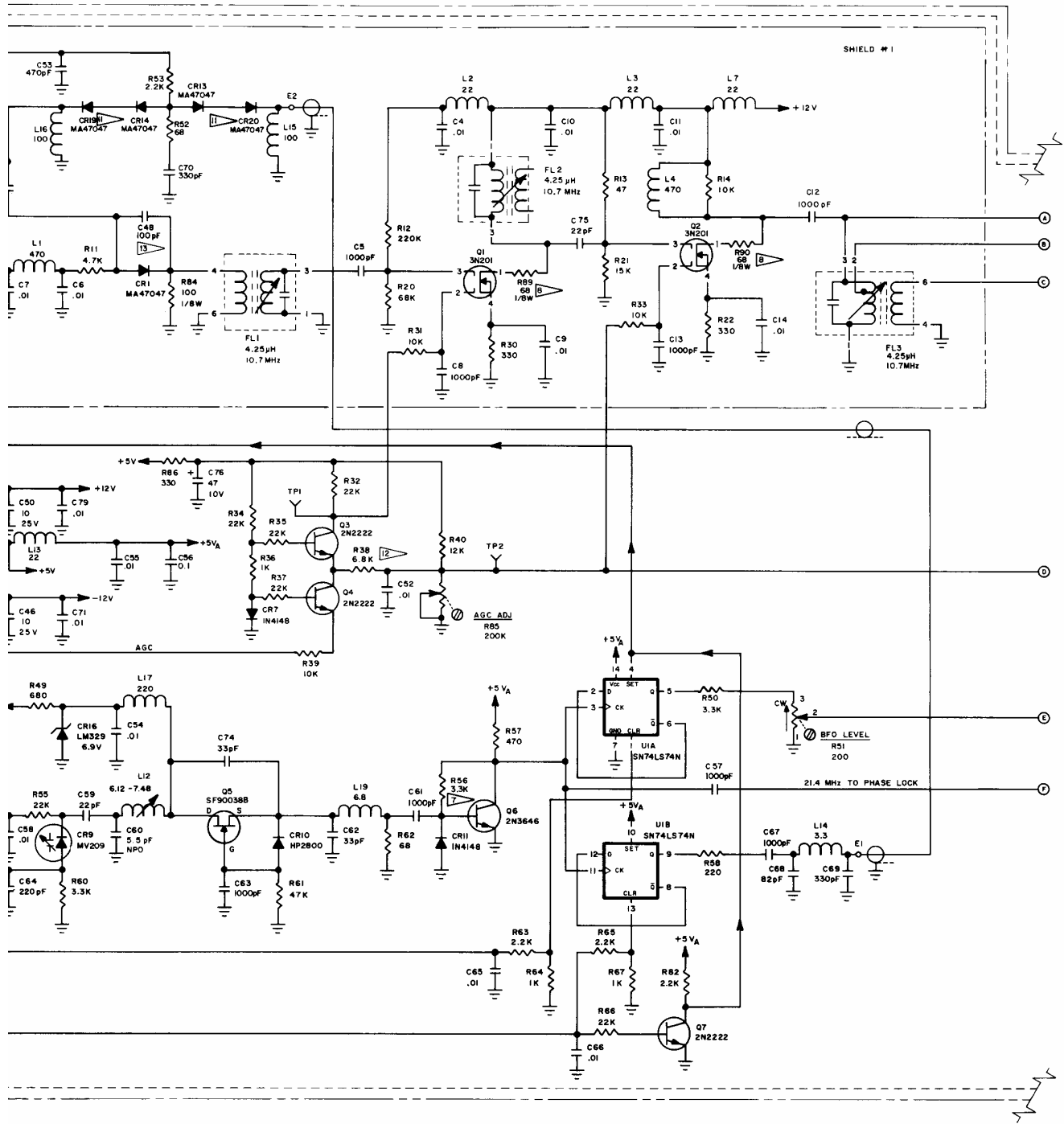
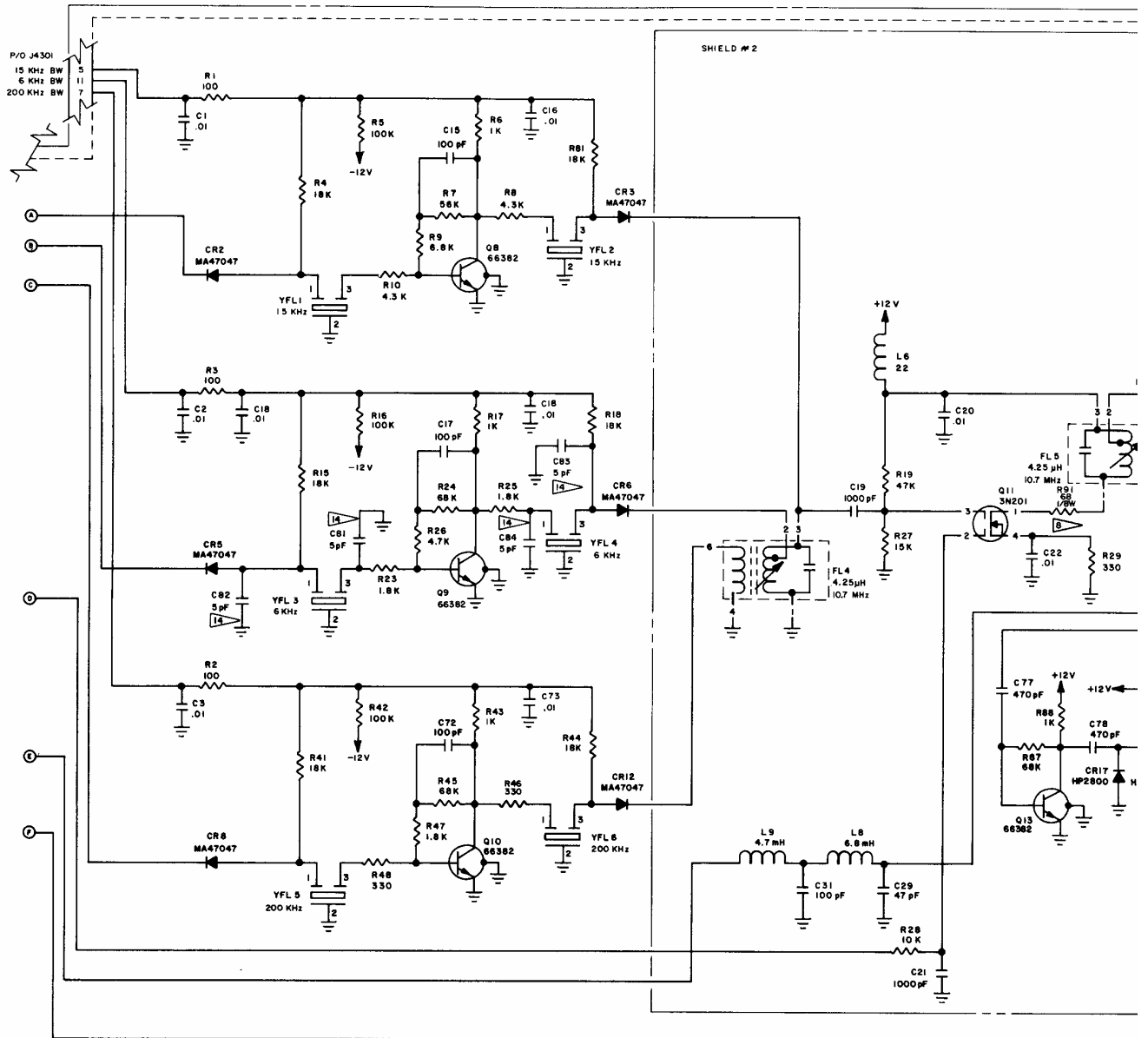

Figure 10-17 Receiver/Generator Module Circuit Schematic (Sheet 1 of 2)



IO.7 MHz RECEIVER (4300)	
PC BD	1700-5224-300
PC BD ASSY	7010-5234-301
MECH ASSY	7005-5244-300

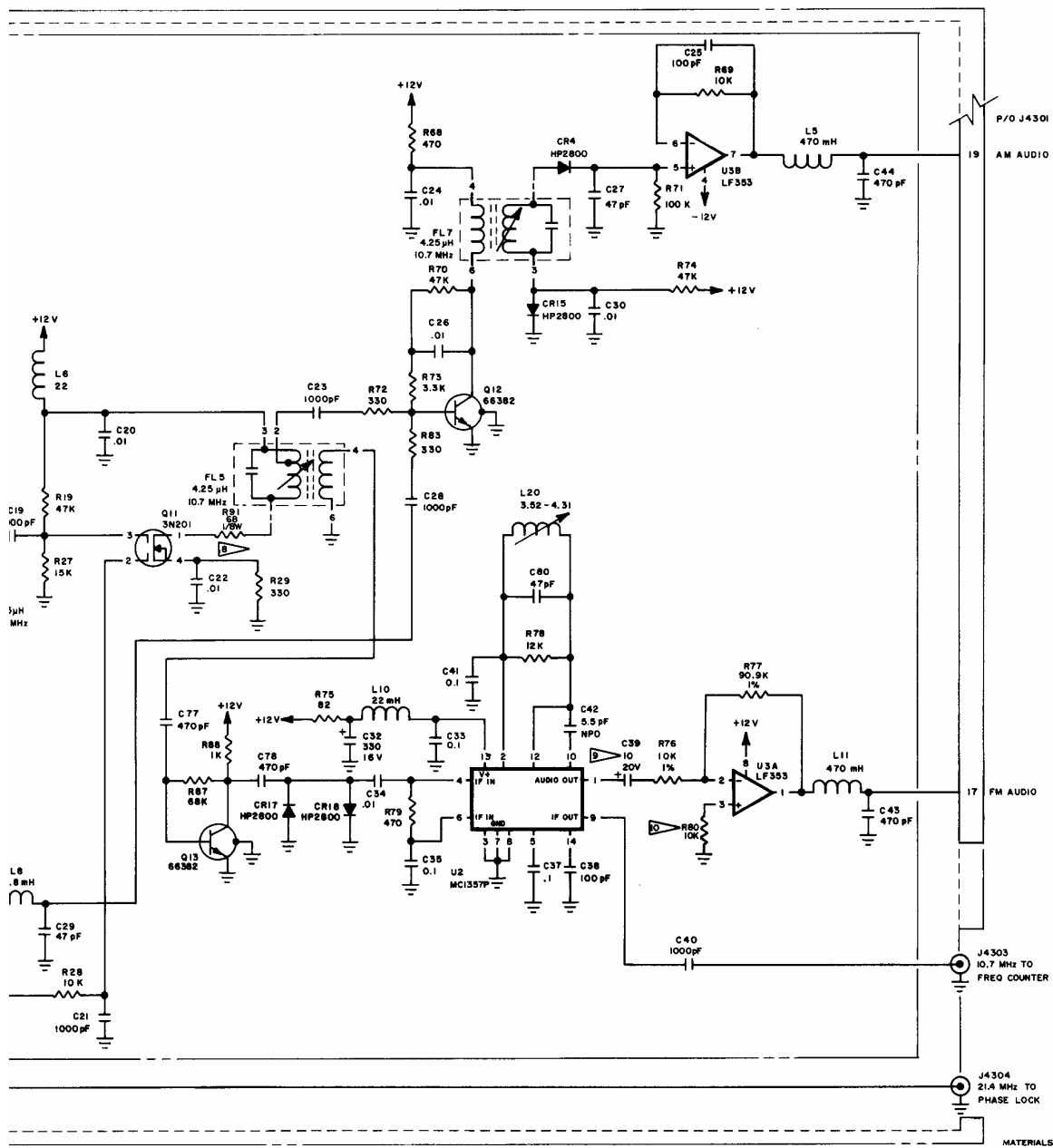
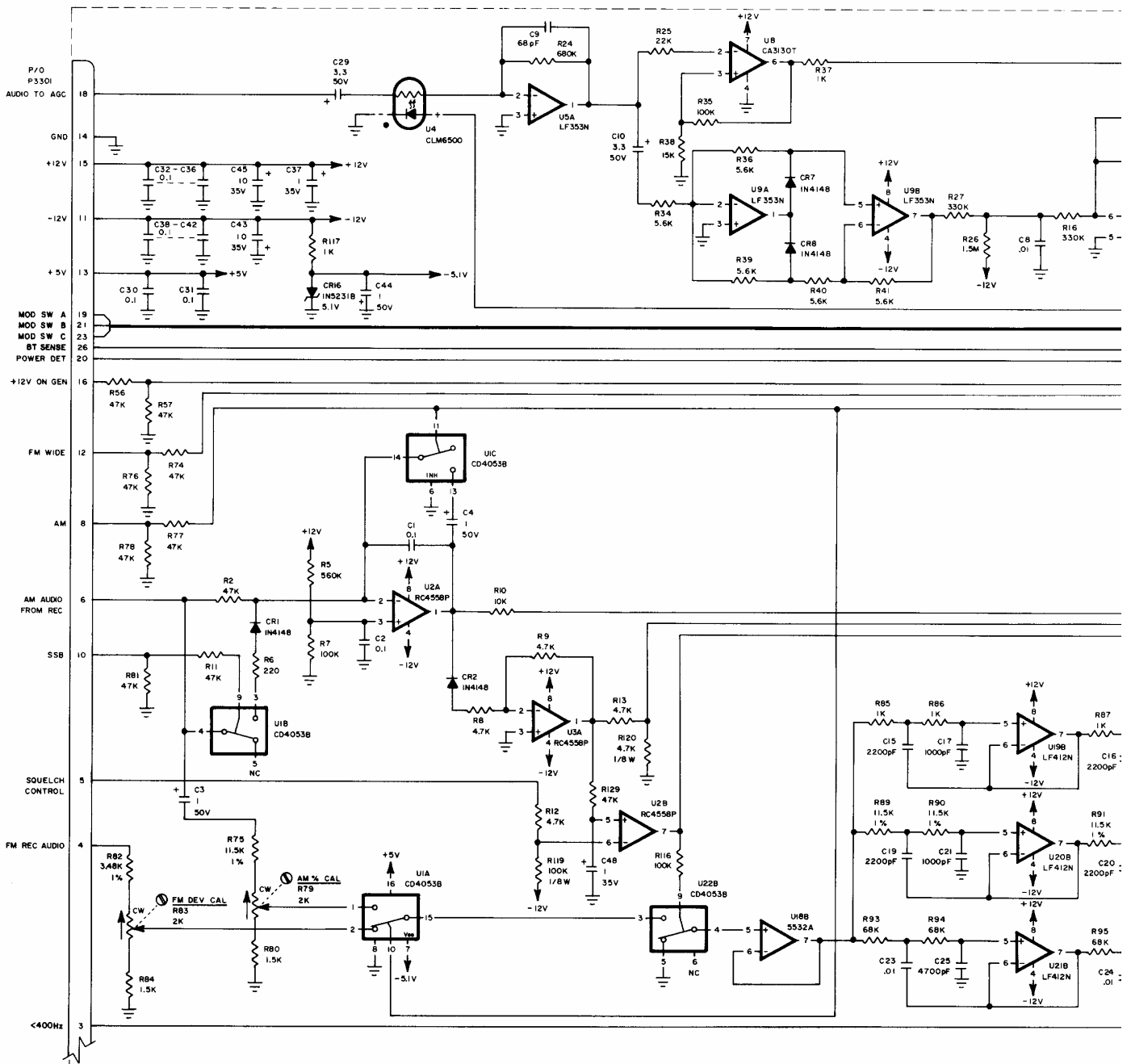
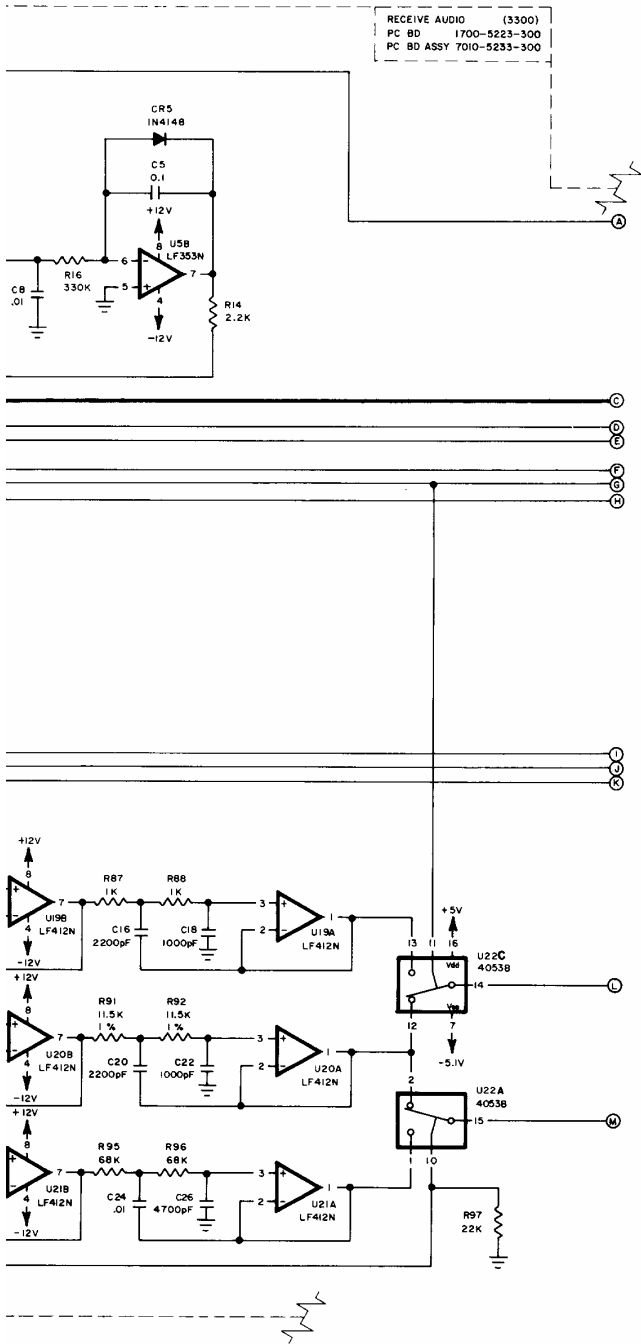

Figure 10-17 Receiver/Generator Module Circuit Schematic (Sheet 2 of 2)





NOTES:

1. ALL REFERENCE NUMBERS CARRY AN ASSIGNED DESIGNATOR SERIES. THE SERIES FOR THIS SCHEMATIC ARE 3300 AND 3400 (E.G. R1 IS 3301 AND R101 IS 3401).
2. ALL RESISTORS ARE 1/4 W 5% TOLERANCE.
3. ALL RESISTANCE IS EXPRESSED IN OHMS UNLESS OTHERWISE NOTED.
4. ALL CAPACITANCE IS EXPRESSED IN MICROFARADS UNLESS OTHERWISE NOTED.

Figure 10-18 Receive Audio Module Circuit Schematic (FM/AM-500)
 (Sheet 1 of 2)

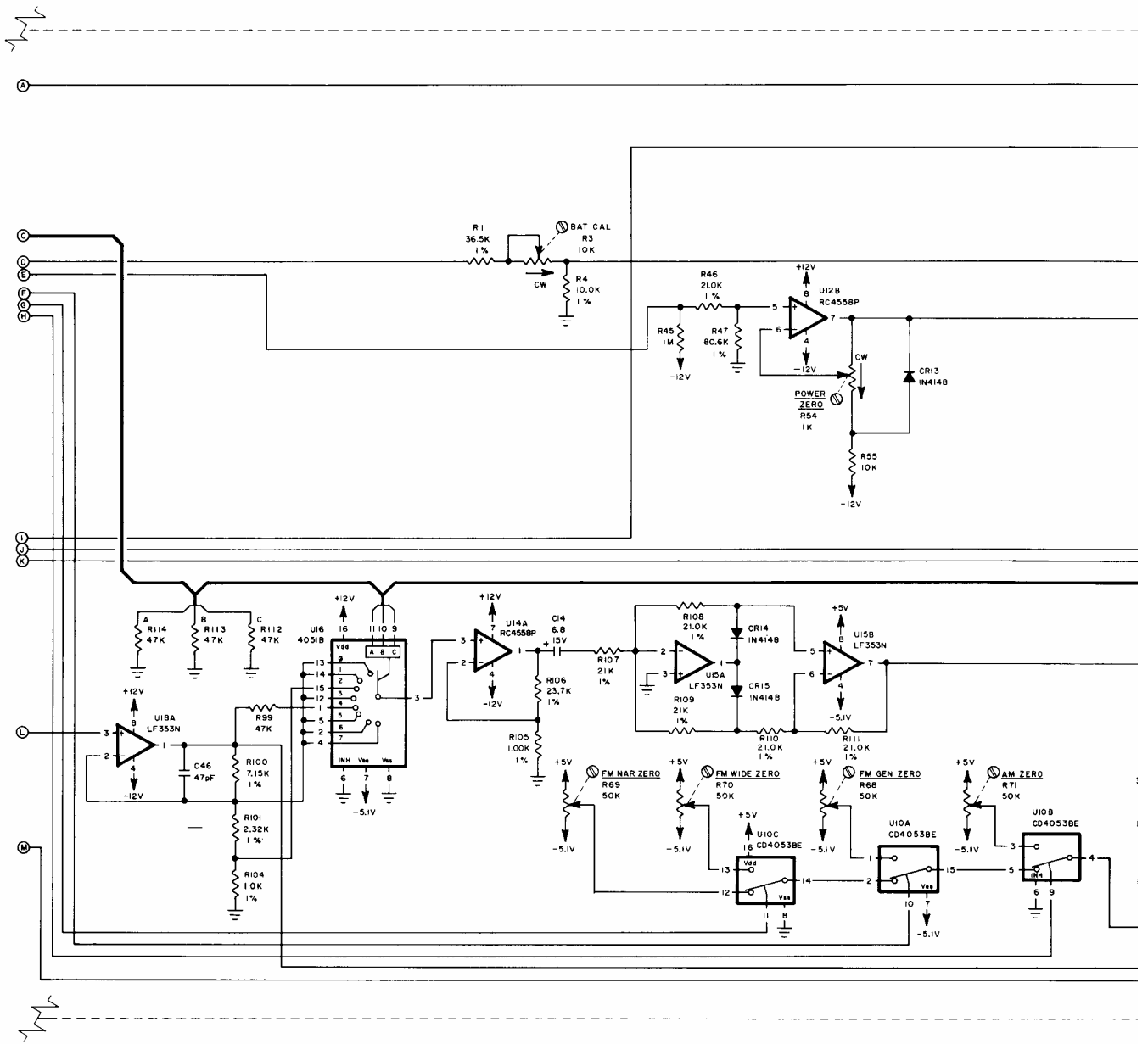

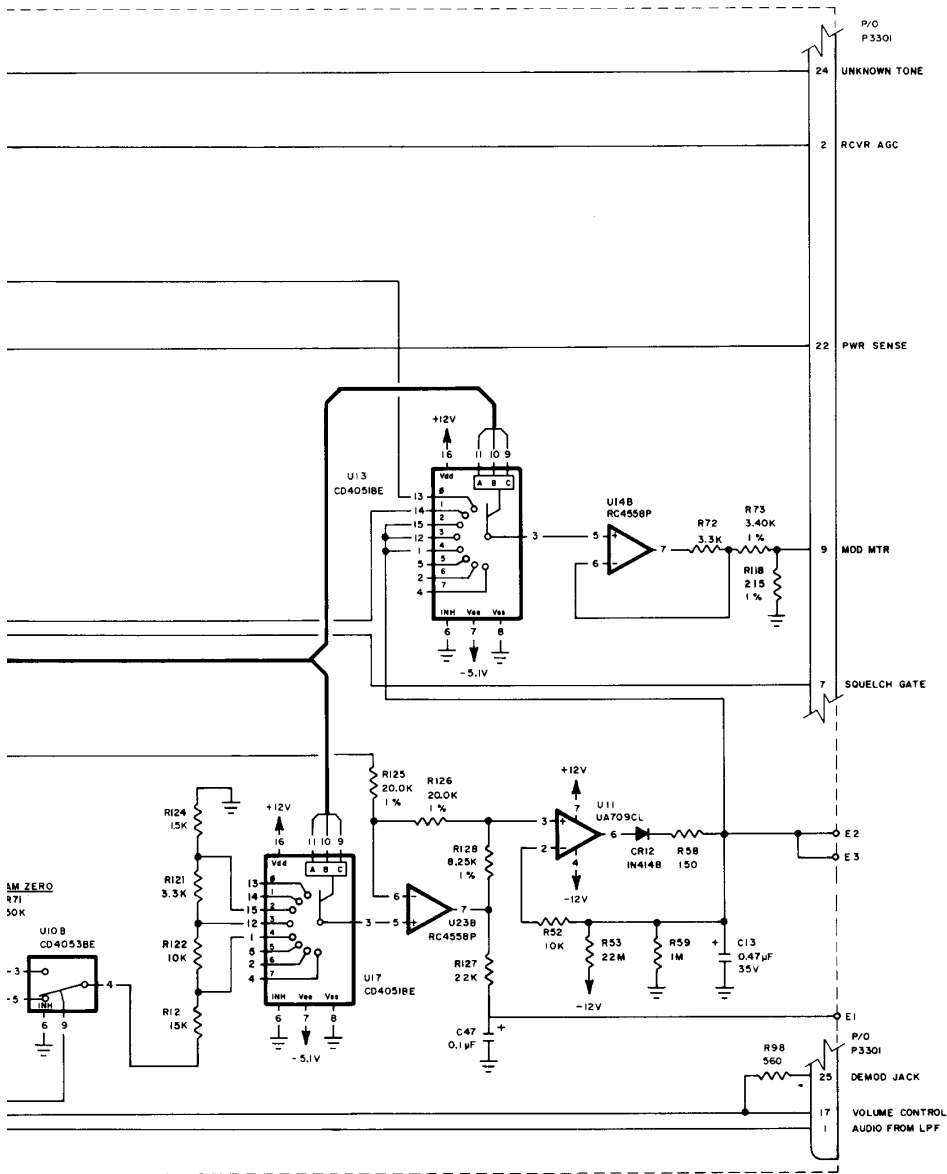
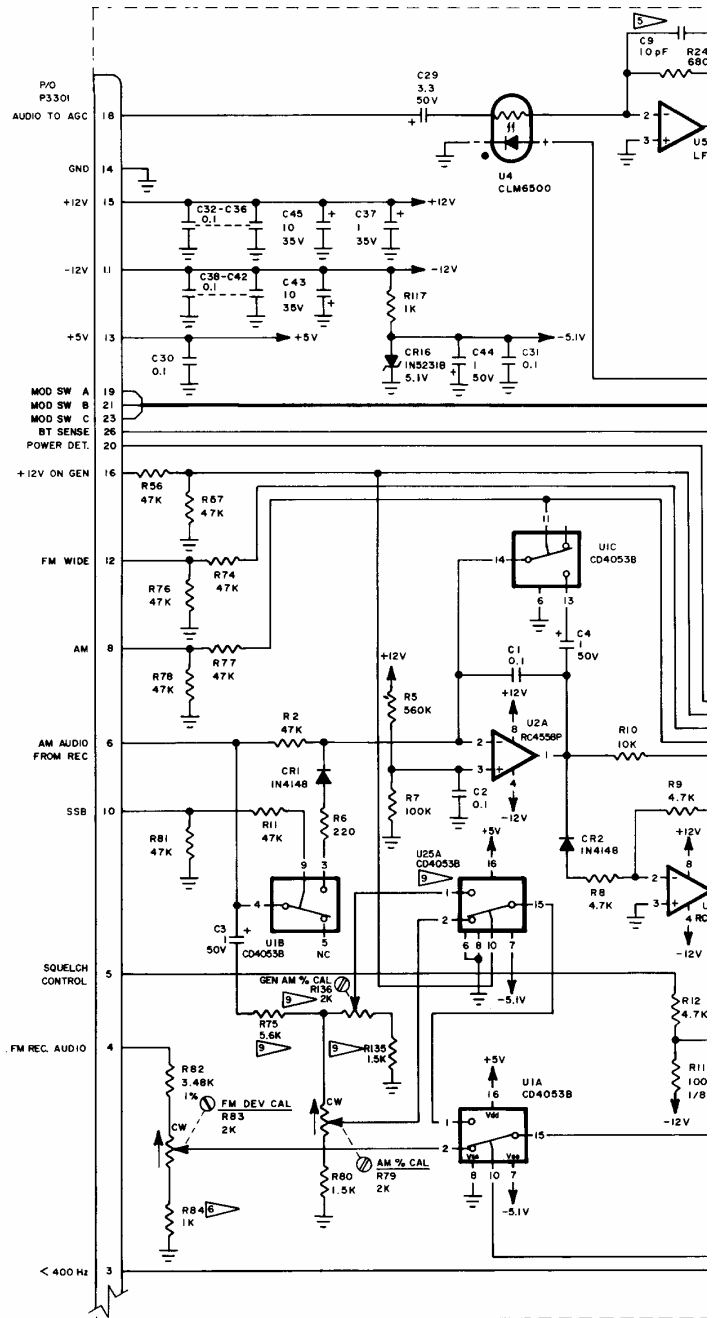

Figure 10-18 Receive Audio Module Circuit Schematic (FM/AM-500) (Sheet 2 of 2)

NOTES:

1. ALL REFERENCE NUMBERS CARRY AN ASSIGNED DESIGNATOR SERIES. THE SERIES FOR THIS SCHEMATIC ARE 3300 AND 3400 (E.G., R1 IS 3301 AND R101 IS 3400).
2. ALL RESISTORS ARE 1/4 W, 5% TOLERANCE UNLESS OTHERWISE NOTED.
3. ALL RESISTANCE IS EXPRESSED IN OHMS UNLESS OTHERWISE NOTED.
4. ALL CAPACITANCE IS EXPRESSED IN MICRO-FARADS UNLESS OTHERWISE NOTED.
5. SN2181 THRU SN2240;
C7 VALUE IS 68 pF.
R18 VALUE IS 5 K.
R19 VALUE IS 26.7 K.
R28 VALUE IS 3.3 K.
R121 VALUE 2.7 K.
R124 VALUE IS 1.5 K.
R131 VALUE IS 20 K.
6. SN2181 THRU SN2555, R84 VALUE IS 1.5 K.
7. SN2181 THRU SN2555, R22 VALUE IS 10Ω, 1%.
8. SN2181 THRU SN2863, C12 VALUE IS .01.
9. SN 2181 THRU SN 3871, R75 VALUE IS 11.5 K, 1%. R135, R136 AND U25 ARE NOT USED, PIN 1 OF U1A IS CONNECTED DIRECTLY TO WIPER OF R79.



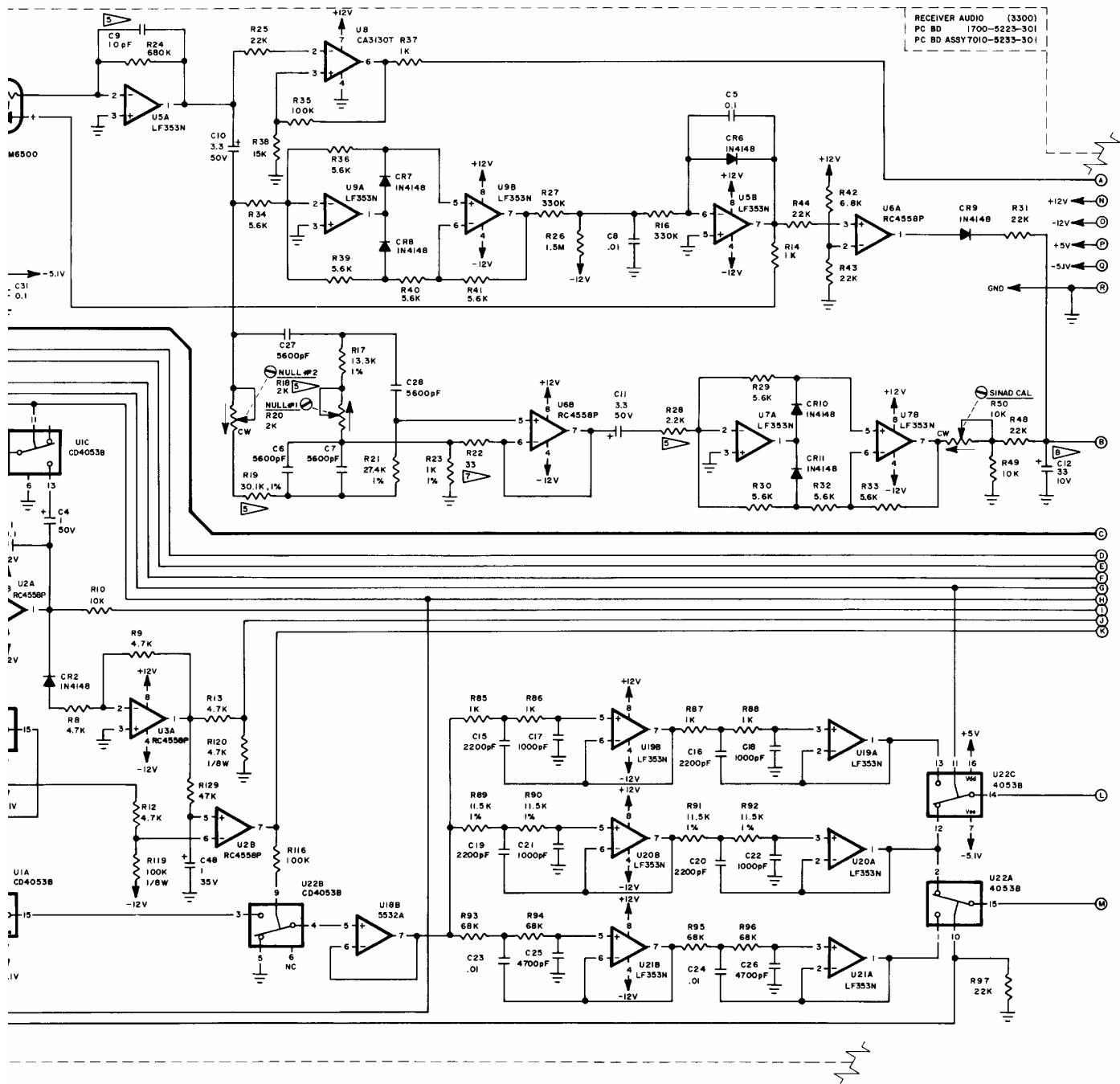
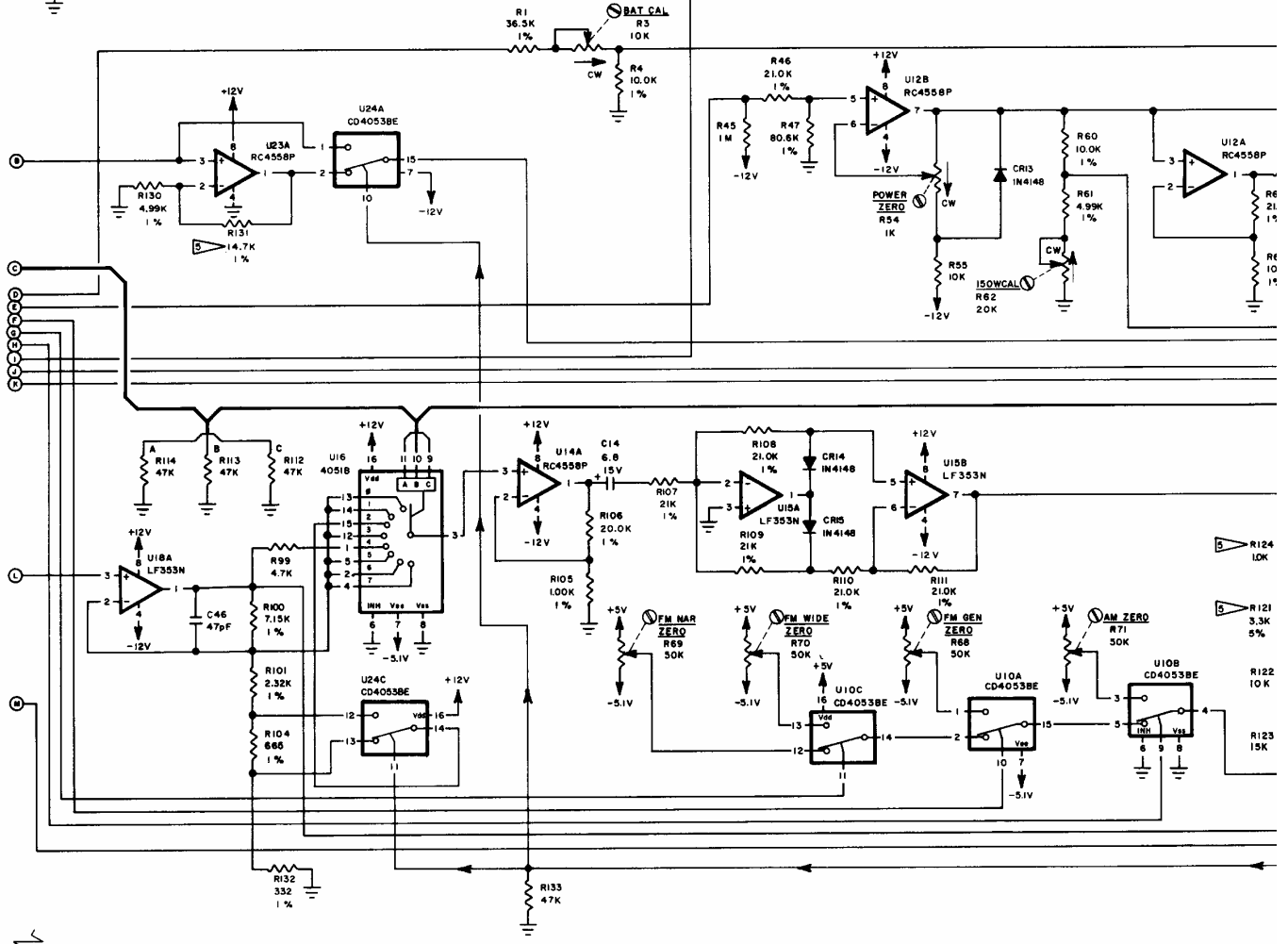
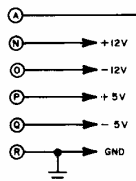

Figure 10-19 Receive Audio Module Circuit Schematic (FM/AM-500A)
(Sheet 1 of 2)



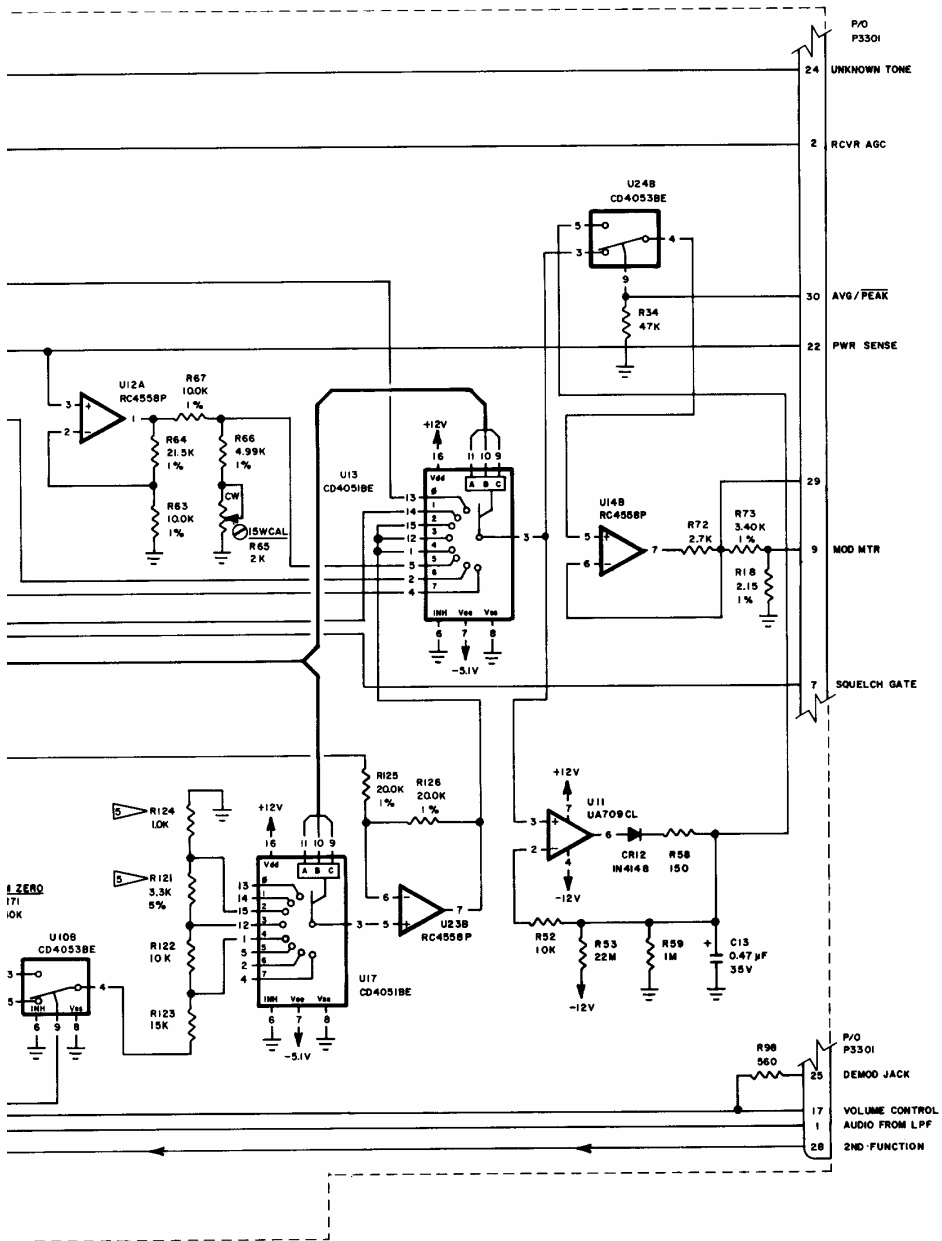

Figure 10-19 Receive Audio Module Circuit Schematic (FM/AM-500A) (Sheet 2 of 2)

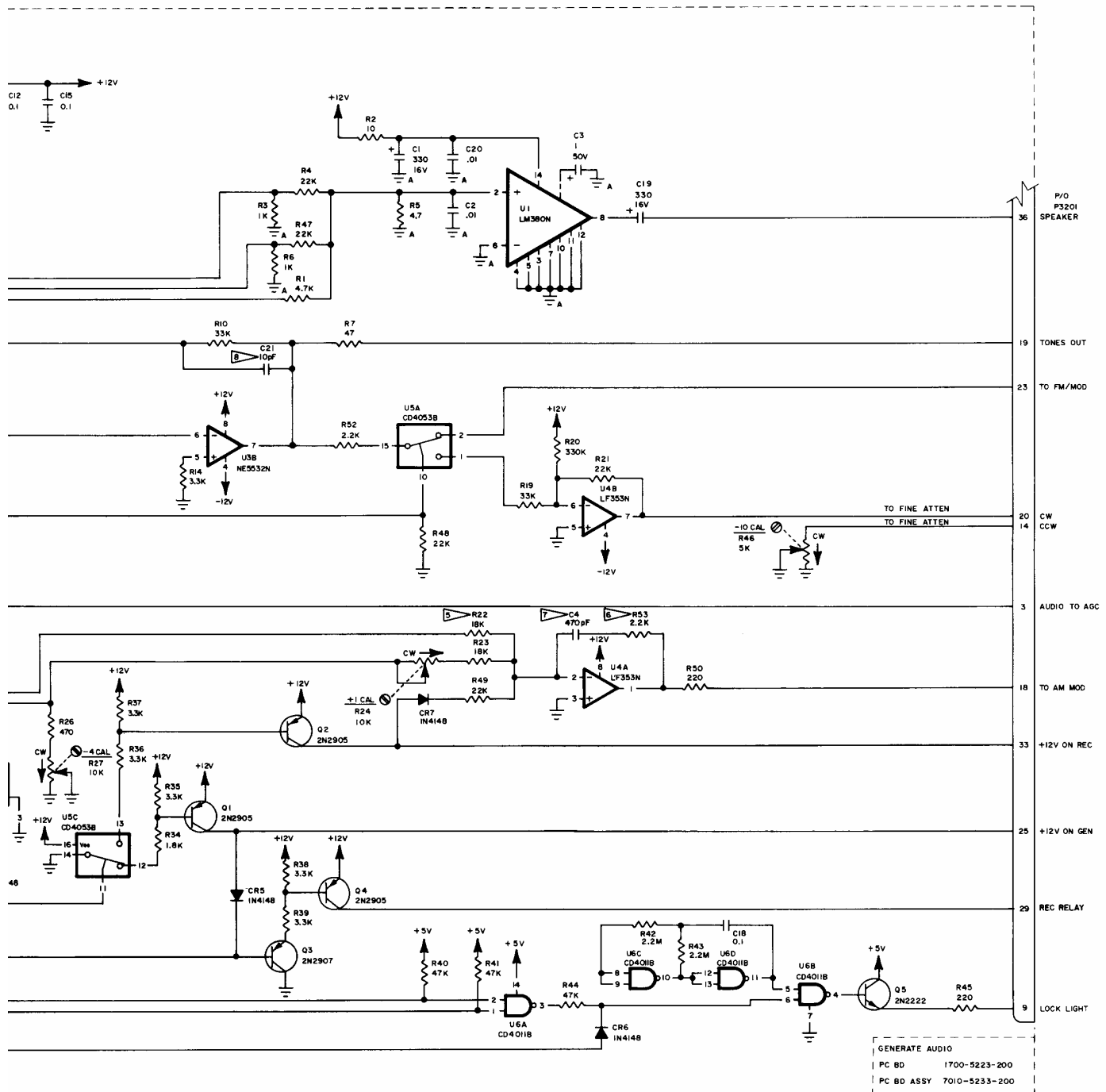
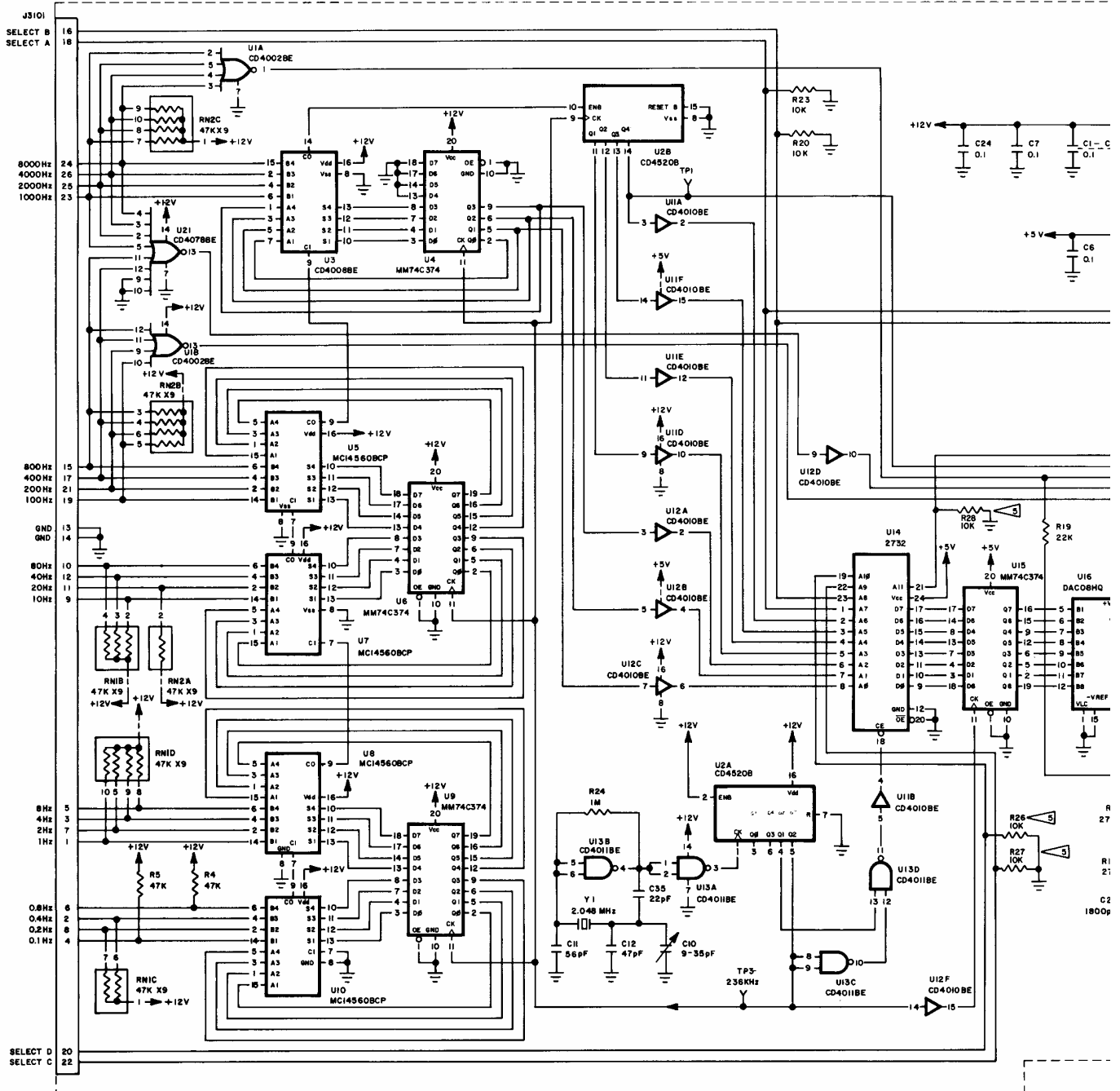

Figure 10-20 Generate Audio Module Circuit Schematic



J3101
 SELECT B
 SELECT A
 16
 18
 24
 26
 25
 23
 8000Hz
 4000Hz
 2000Hz
 1000Hz
 800Hz
 400Hz
 200Hz
 100Hz
 GND
 GND
 80Hz
 40Hz
 20Hz
 10Hz
 8Hz
 4Hz
 2Hz
 1Hz
 0.8Hz
 0.4Hz
 0.2Hz
 0.1Hz
 SELECT D
 SELECT C
 20
 22

+12V
 C24 0.1
 C7 0.1
 C1-C 0.1
 +5V
 C6 0.1
 R23 10K
 R20 10K
 R28 10K
 R19 22K
 R27 10K
 R26 10K
 R1 21
 C2 1800p
 R 27
 R1 21
 C2 1800p

NOTES:

1. ALL REFERENCE NUMBERS CARRY AN ASSIGNED DESIGNATOR SERIES. THE SERIES FOR THIS SCHEMATIC IS 3100 (E.G. R1 IS R3101).
2. ALL RESISTORS ARE 1/4 W 5% TOLERANCE.
3. ALL RESISTANCE IS EXPRESSED IN OHMS UNLESS OTHERWISE NOTED.
4. ALL CAPACITANCE IS EXPRESSED IN MICROFARADS UNLESS OTHERWISE NOTED.

5.  R26, R27 AND R28 EFF SN2650 AND ON.

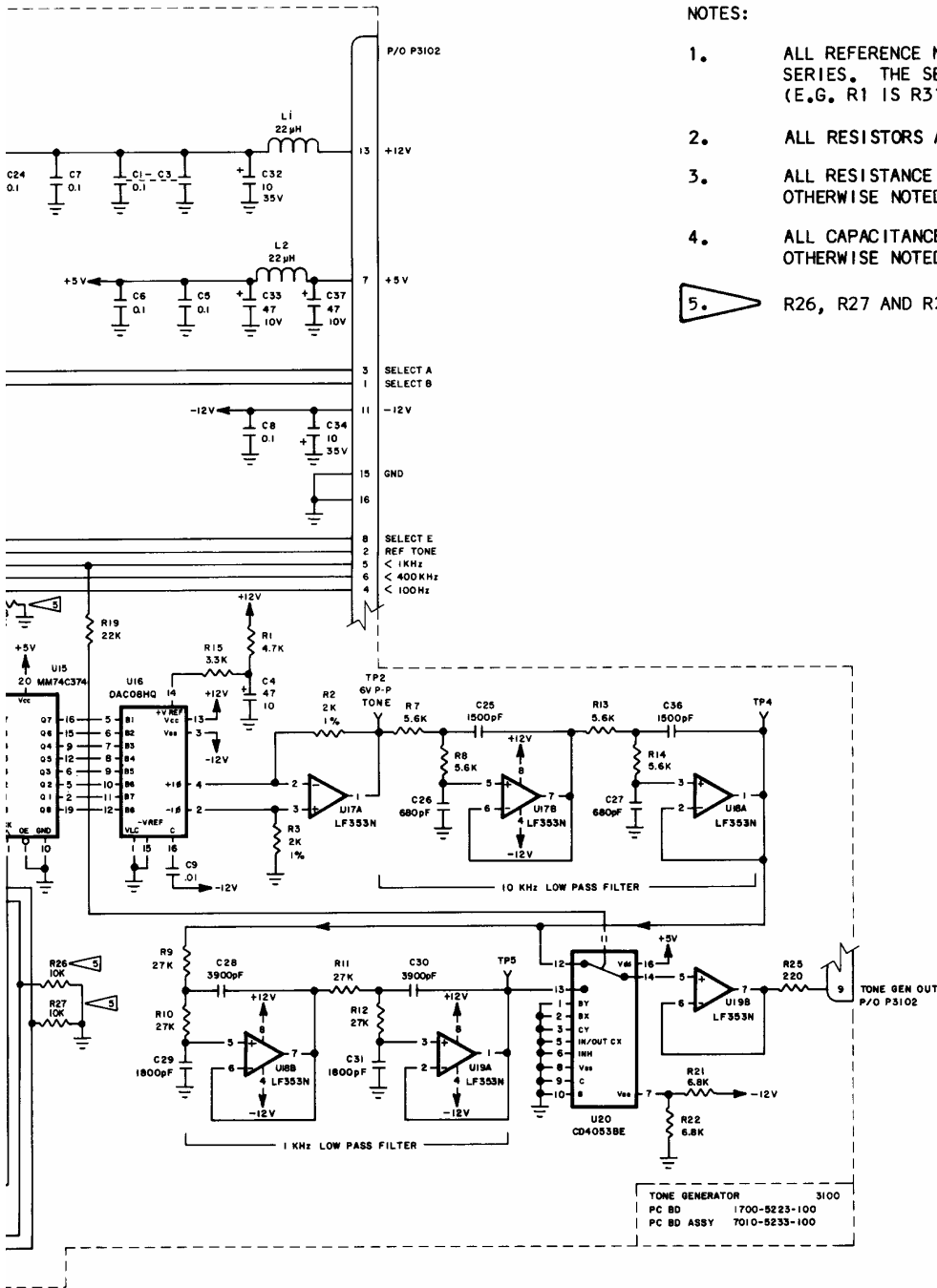
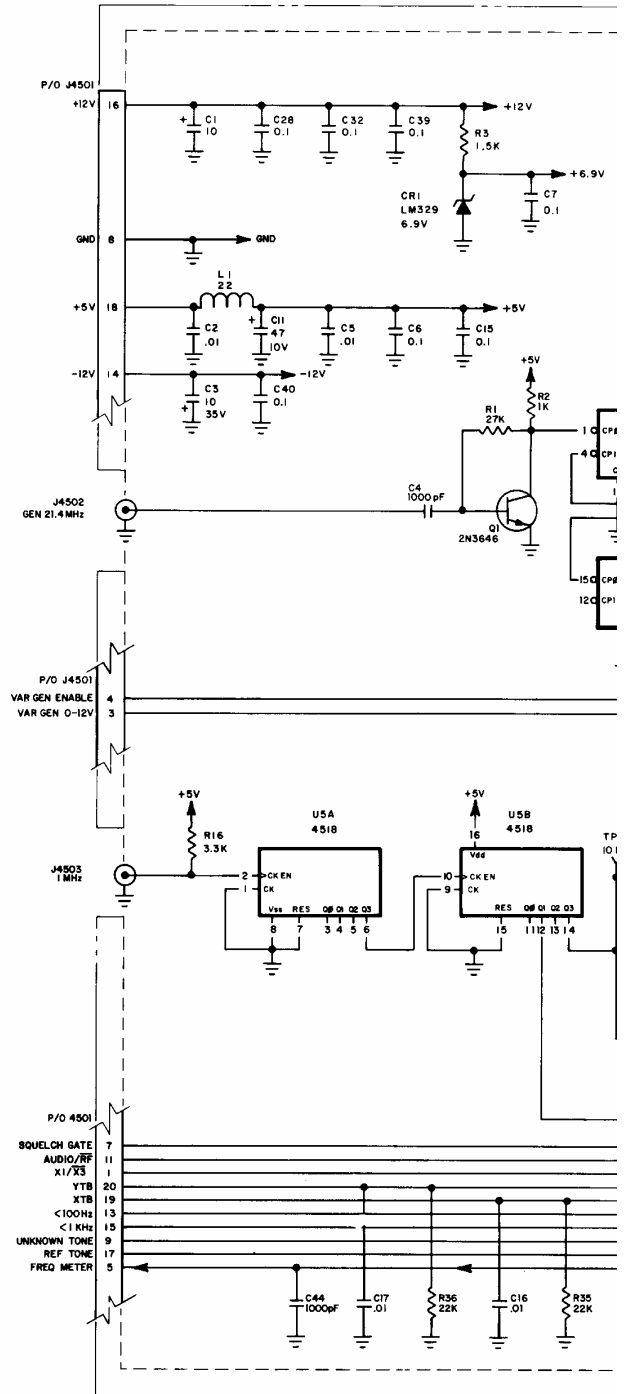

Figure 10-21 Variable Tone Generator Module Circuit Schematic

NOTES:

1. ALL REFERENCE NUMBERS CARRY AN ASSIGNED DESIGNATOR SERIES. THE SERIES FOR THESE SCHEMATICS ARE:
 - A. COUNTER BOARD - 4400 (E.G., R1 IS 4401)
 - B. REFERENCE BOARD - 4500 (E.G., R1 IS R4501)
2. ALL RESISTORS ARE 1/4 W 5% TOLERANCE UNLESS OTHERWISE NOTED.
3. ALL RESISTANCE IS EXPRESSED IN OHMS UNLESS OTHERWISE NOTED.
4. ALL CAPACITANCE IS EXPRESSED IN MICRO-FARADS UNLESS OTHERWISE NOTED.
5. ALL INDUCTANCE IS EXPRESSED IN MICRO-HENRYS.
6. 6. SN 1001 THRU SN 2390 R4416 IS 30.1 K, 1%.



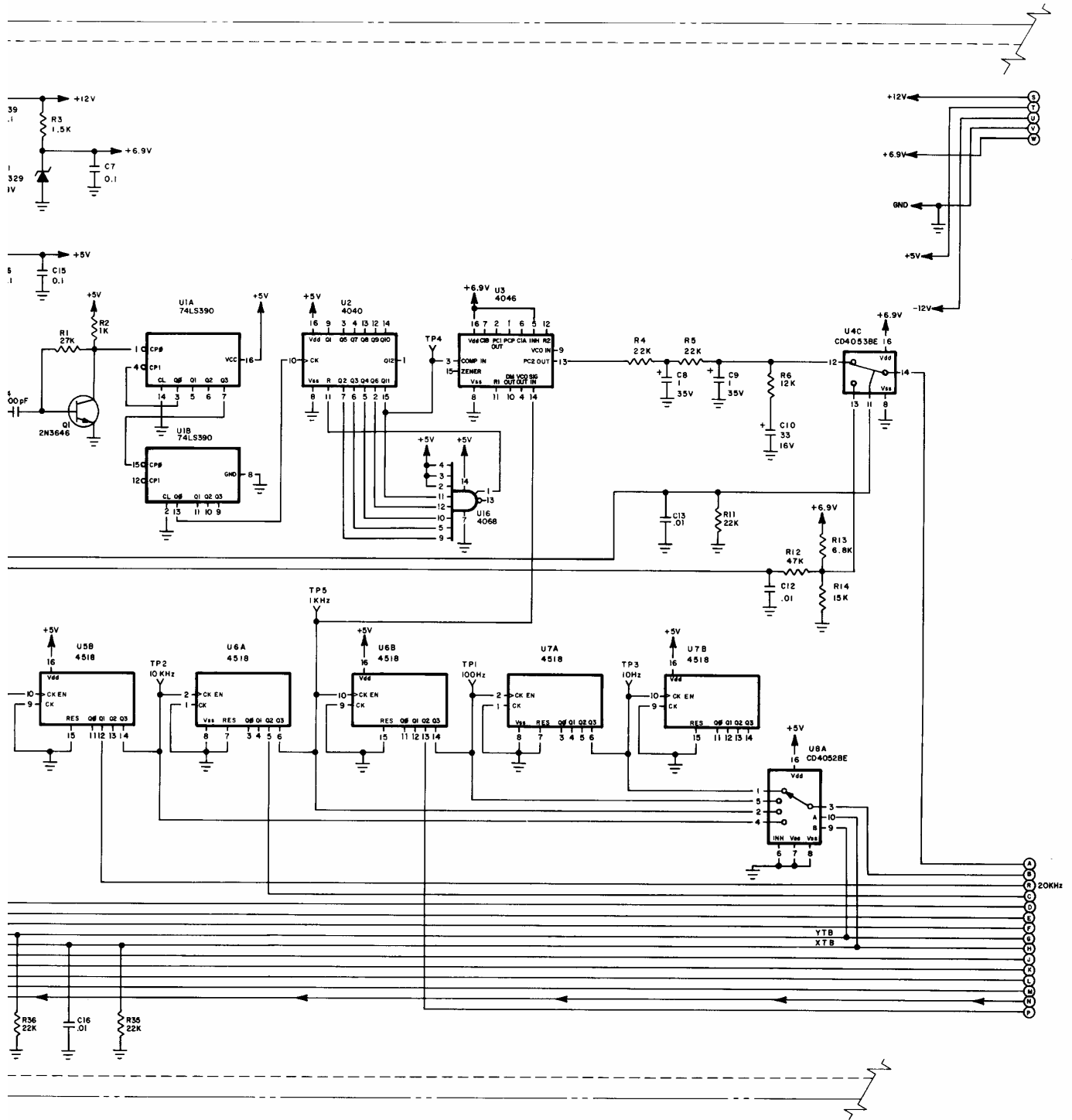
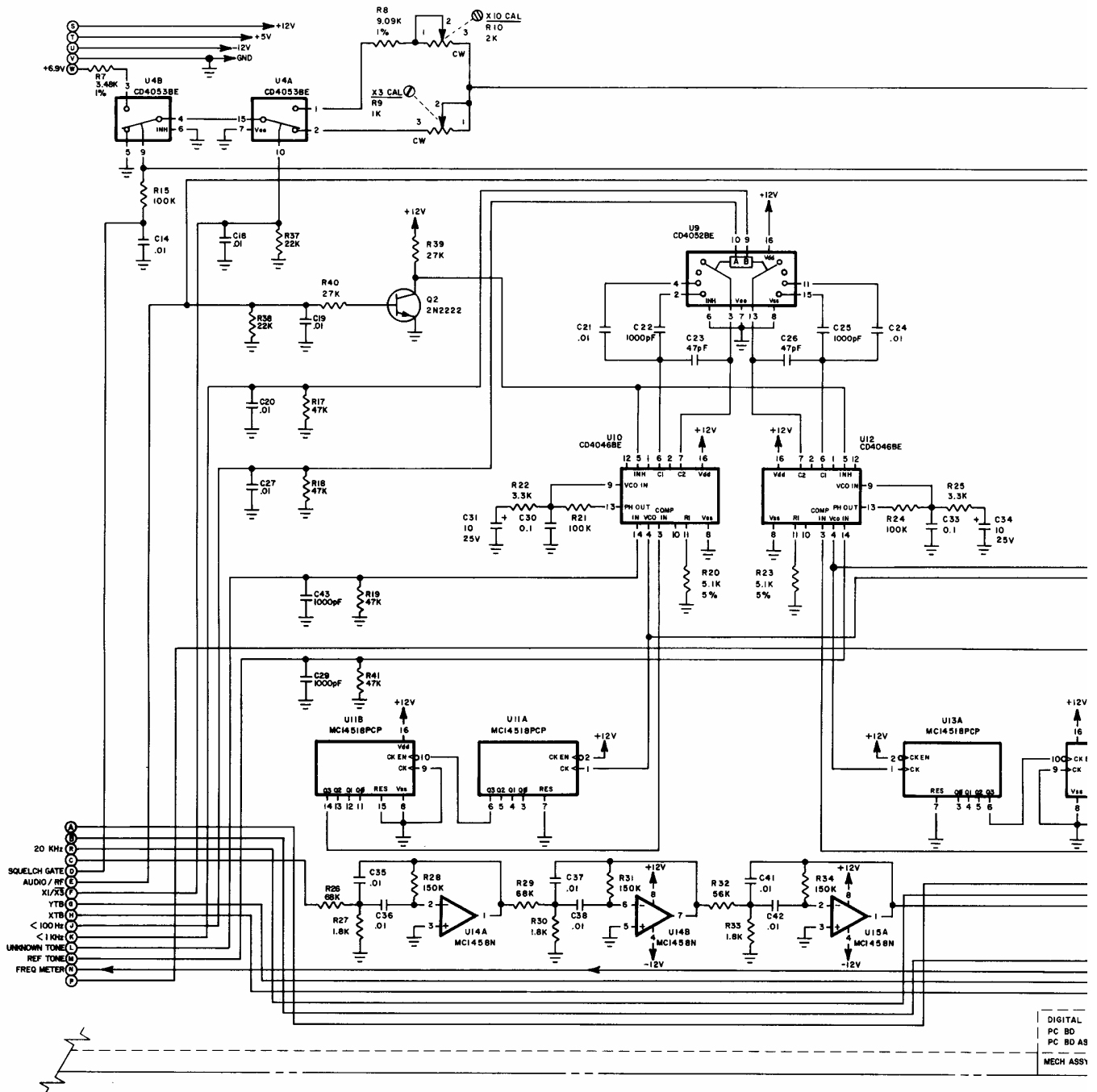

Figure 10-22 Digital Module Circuit Schematic (Sheet 1 of 4)



DIGITAL
 PC BD
 PC BD AS
 MECH ASSY

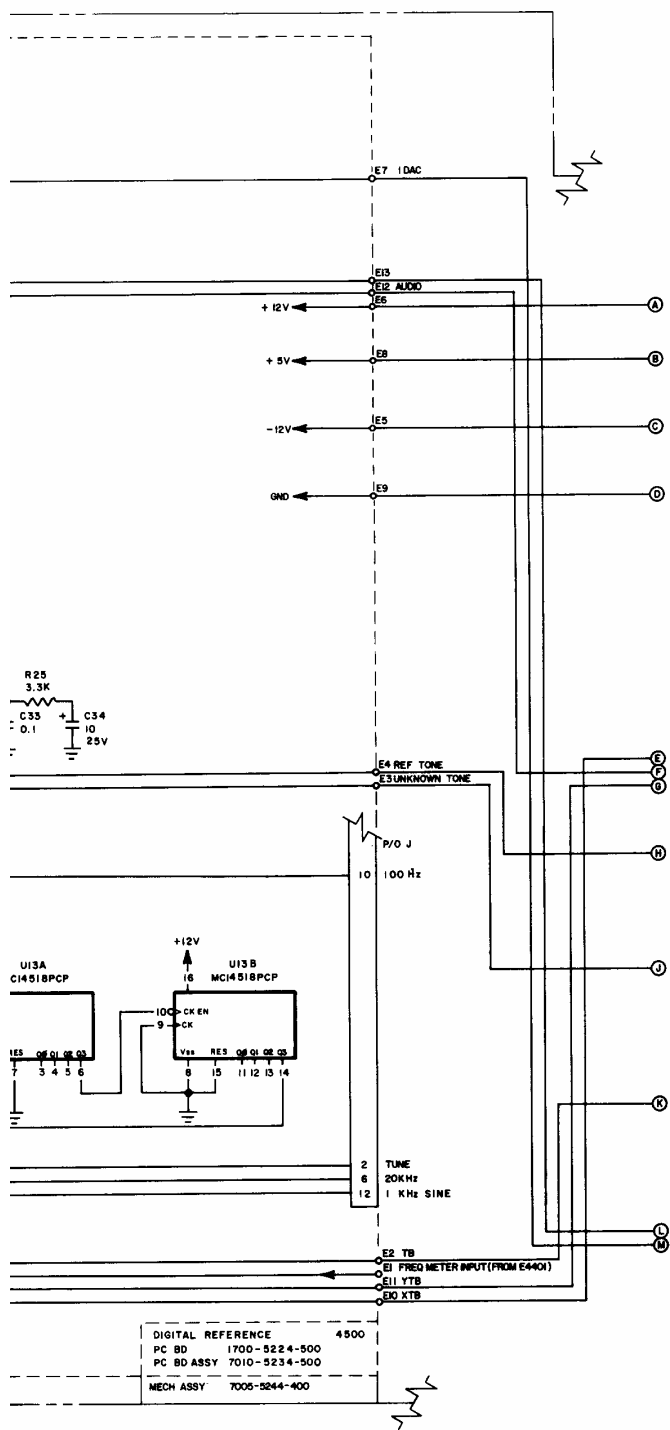

Figure 10-22 Digital Module Circuit Schematic (Sheet 2 of 4)

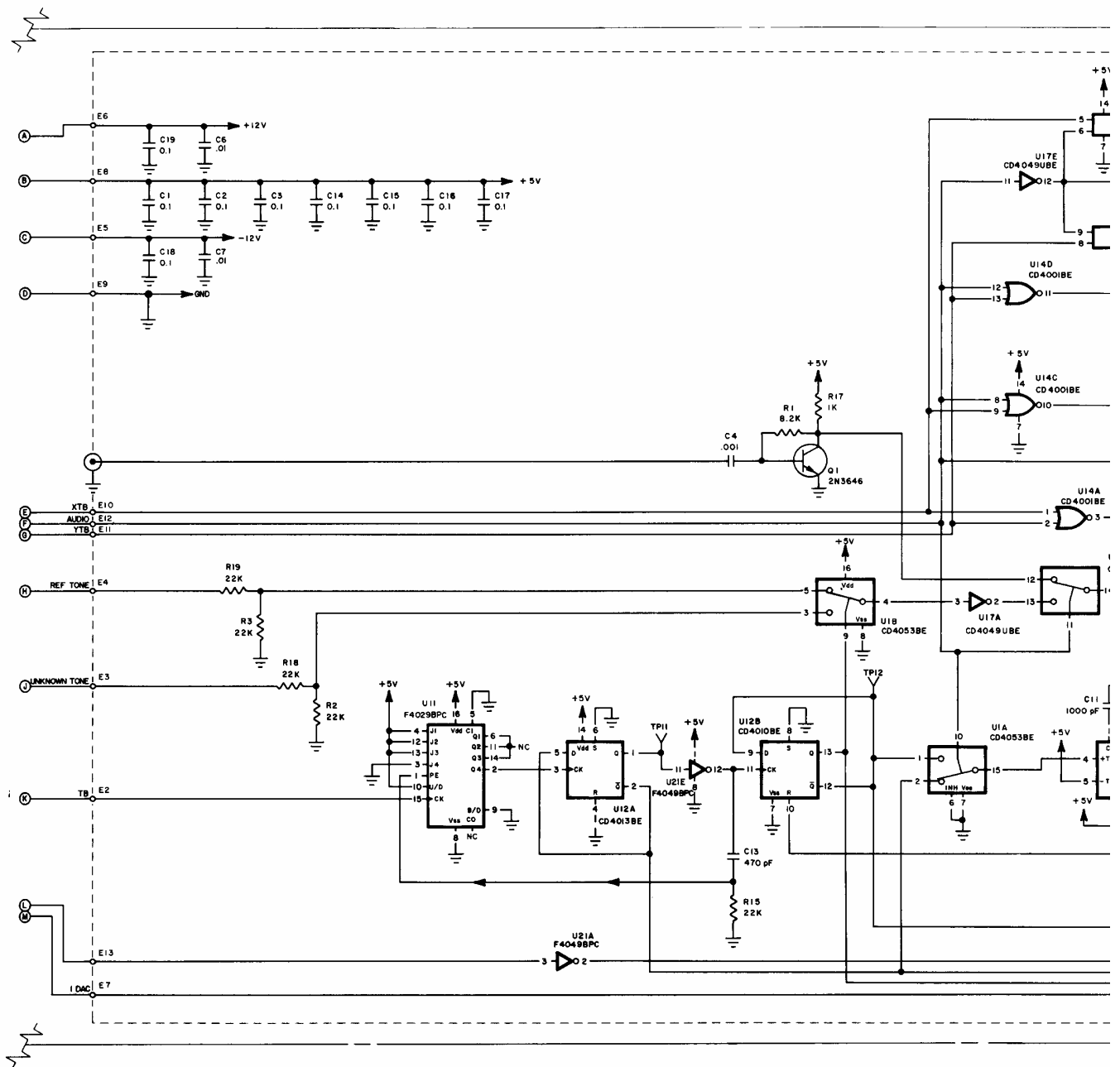

Figure 10-22 Digit
(Sheet 1)

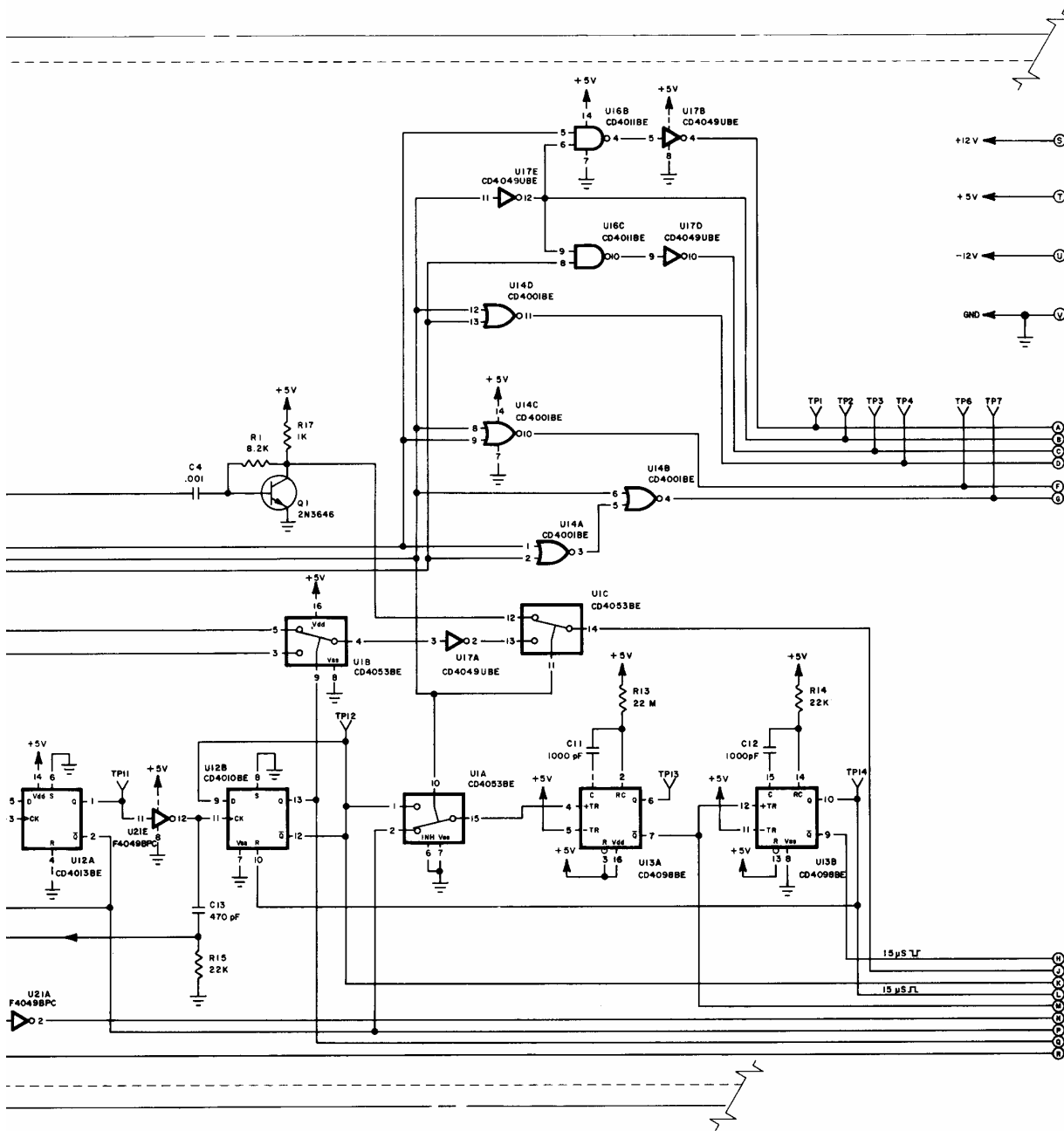

Figure 10-22 Digital Module Circuit Schematic (Sheet 3 of 4)

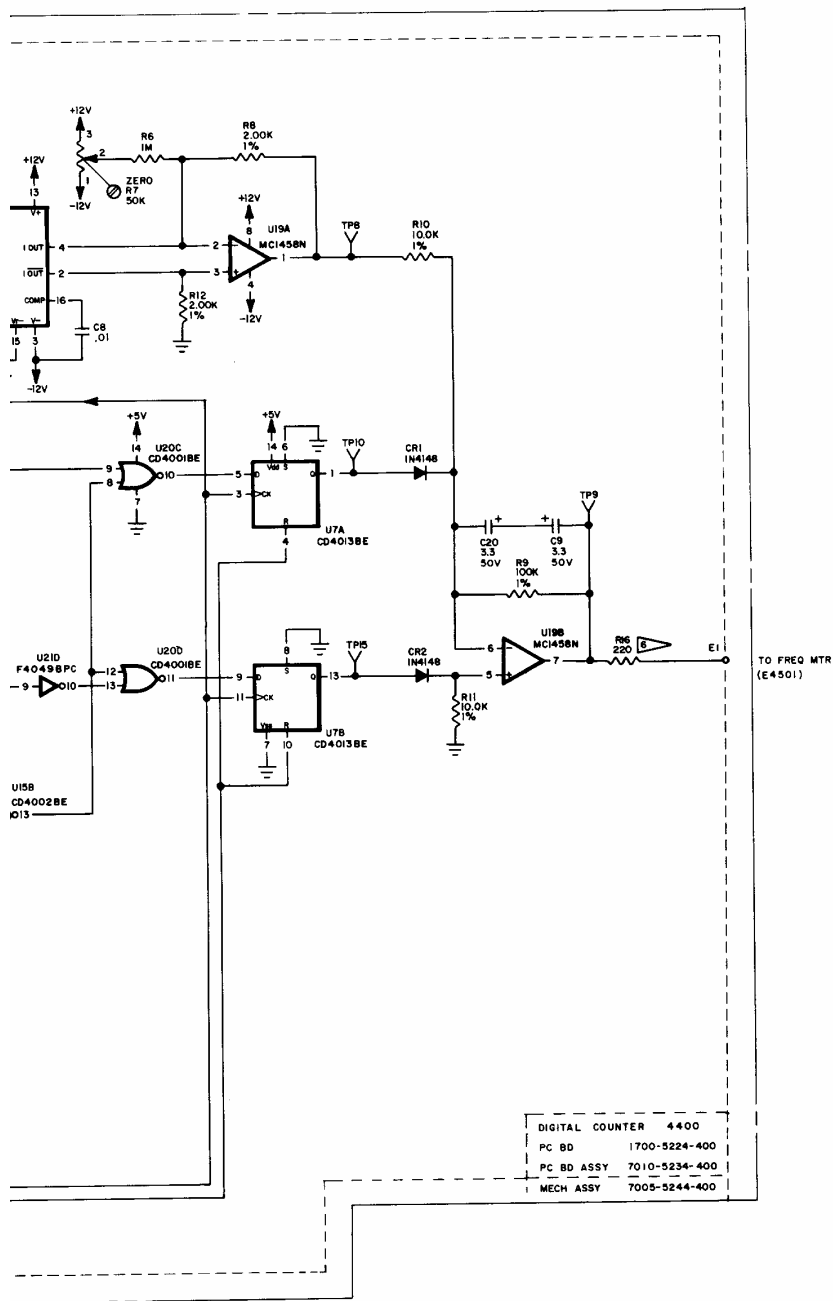
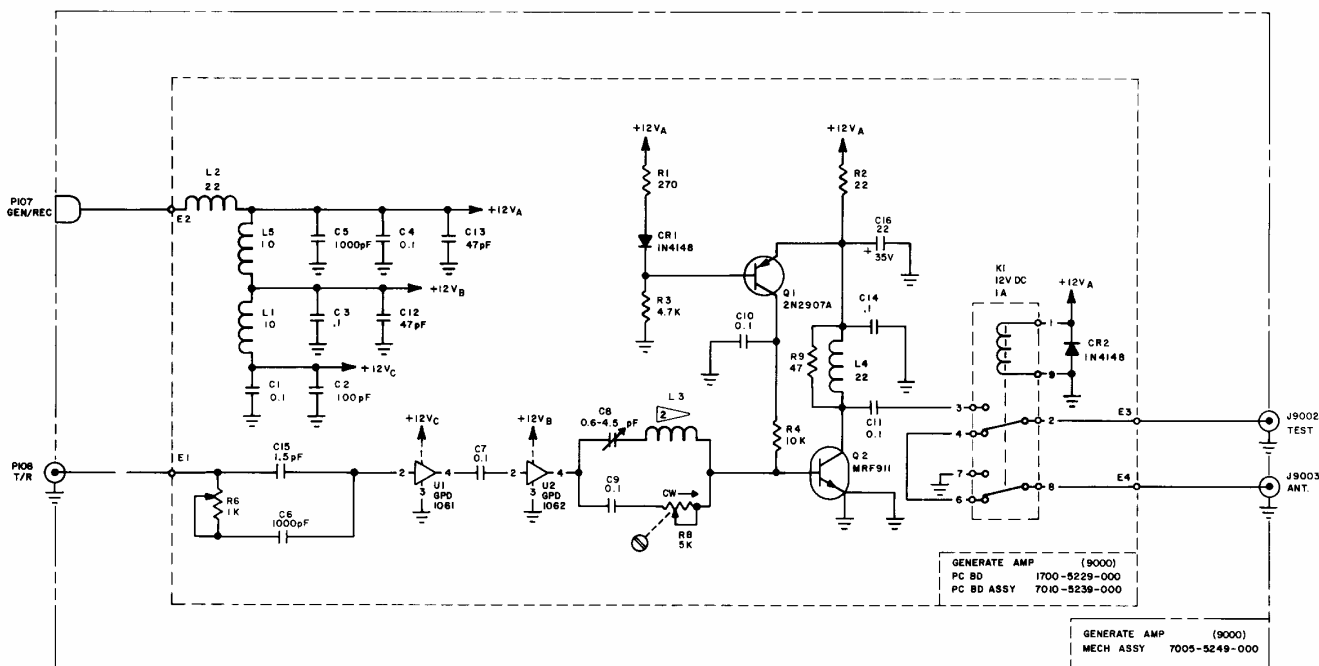

Figure 10-22 Digital Module
Circuit Schematic
(Sheet 4 of 4)



NOTES:

1. ALL REFERENCE NUMBERS CARRY AN ASSIGNED DESIGNATOR SERIES. THE SERIES FOR THIS SCHEMATIC IS 9000 (E.G. R1 IS R9001).
2. L3 IS FORMED FROM LEAD OF C8 CUT TO A LENGTH OF 0.2 IN.
3. ALL RESISTORS ARE 1/4 W 5% TOLERANCE.
4. ALL RESISTANCE IS EXPRESSED IN OHMS UNLESS OTHERWISE NOTED.
5. ALL CAPACITANCE IS EXPRESSED IN MICROFARADS UNLESS OTHERWISE NOTED.
6. ALL INDUCTANCE IS EXPRESSED IN MICROHENRYS UNLESS OTHERWISE NOTED.

Figure 10-23 Generate Amplifier Circuit Schematic

APPENDICES

APPENDIX A: SPECIFICATIONS OF FM/AM-500A

A-1 RF SIGNAL GENERATOR

Frequency Range: 250 kHz to 999.9999 MHz in 100 Hz increments

Frequency Accuracy: Same as Master Oscillator

Variable Generate: Continuous tuning ± 10 kHz from selected frequency

Residual FM: < 100 Hz peak, 300 Hz to 3 kHz bandwidth

RF Output Power: -127 dBm to -20 dBm (10 dB steps with 11 dB range continuous vernier)

RF Output Accuracy: ± 3 dB

Output Impedance: 50 Ohms Nominal

Output Protection: Fully protected, 25 Watts continuous, 150 Watts for 60 seconds. Auto changeover from generate to monitor will occur at a nominal 100 mW level.

Internal Modulation: See Audio Generator

External Modulation:

Frequency Response: FM: 2 Hz to 30 kHz (DC when in variable generate)
AM: 10 Hz to 10 kHz (30% maximum modulation above 5 kHz)

Modulation Sensitivity: FM: 0.08 VRMS/kHz
AM: 0.01 VRMS/%

Distortion (1 kHz tone): FM: $< 1\%$ to 20 kHz deviation
AM: $< 10\%$ to 60% modulation

Input Impedance: Greater than 10 K Ohms

A-2 AUDIO GENERATOR*

Operating Modes:

Internal: Modulation/Tone Out level controlled by 1 kHz or Variable Tone Control

Speaker: Tone applied directly to speaker with volume controlled by 1 kHz or Variable Tone Control

External Plus Internal: External modulation input is summed directly with tones and applied to modulator

Tone Accuracy:

Fixed: Same as Master Oscillator
Variable: ±0.01%

Tone Distortion (at 2.5 VRMS Output):

Fixed: <0.5%
Variable: <0.5% at 1 kHz, <1.5% 10 Hz to 9999.9 Hz

Tone Output Level: 0 to 2.5 VRMS minimum either tone into 150 Ohm load

Frequency Range

(Variable): 10 Hz to 9999.9 Hz in 0.1 Hz increments

* Variable Tone Generator is optional on FM/AM-500, standard on FM/AM-500A

A-3 GENERATE AMPLIFIER (Optional)

Gain: 30 ±2 dB typical, 100 kHz to 1000 MHz

Test Set Output
with Amplifier
Installed:

Variable to +10 dBm, FM CW
Variable to +4 dBm, AM (nominal)

A-4 RECEIVER/MONITOR

Frequency Range: 100 kHz to 999.9999 MHz in 100 Hz increments

Sensitivity: 2 µV (1 MHz to 1000 MHz, FM Narrow)

Selectivity:

Mode	RCVR Bandwidth	Audio Bandwidth
FM WIDE	200 kHz	80 kHz
FM MID	200 kHz	8 kHz
FM NAR	15 kHz	8 kHz
SSB	6 kHz	8 kHz
AM NAR	6 kHz	8 kHz
AM NORM	15 kHz	8 kHz

Adjacent Channel
Rejection:

RCVR Bandwidth	-40 dB at
200 kHz	±300 kHz
15 kHz	±27 kHz
6 kHz	±12 kHz

Demodulation Output:

Output Impedance: 600 Ohms

Output Level (Measured into an open circuit):

FM: 60 mVRMS/±1 kHz
AM: 5 mVRMS/%

Receiver Antenna Input
Protection: 0.25 Watts maximum without damage

A-5 MASTER OSCILLATOR

Standard TCXO:
Stability: 0.5 PPM (0-50°C)
Aging: 3 PPM first year, 1 PPM thereafter

Optional TCXO:
Stability: 0.2 PPM (0-50°C)
Aging: 3 PPM first year, 1 PPM thereafter

Optional Oven (Prohibits internal battery installation):
Accuracy: 0.05 PPM (0-50°C)
Aging: 1 PPM per year

A-6 FREQUENCY ERROR METER

RF Counter:
Accuracy: ±Master Oscillator ±3% of full scale

Ranges:
FM/AM-500 ±10 kHz, ±3 kHz, ±1 kHz full scale
High Resolution Option:
(±300 Hz, ±100 Hz, ±30 Hz full scale)

FM/AM-500A ±10 kHz, ±3 kHz, ±1 kHz, ±300 Hz,
±100 Hz, ±30 Hz full scale

Audio Counter:
FM/AM-500 (with variable tone generator option only)
FM/AM-500A
Accuracy: ±0.01% of frequency ±6% of full scale
Ranges: ±300 Hz, ±30 Hz, ±3 Hz full scale

A-7 MODULATION METER (Monitor Mode)

Type: Maximum of positive or negative peak (AM and FM)

FM Deviation:
Accuracy: ±5% of reading ±3% of full scale
Ranges: 2 kHz, 6 kHz, 20 kHz, 60 kHz full scale

AM% Modulation:
Accuracy: ±5% of reading ±3% of full scale
Ranges: 60%, 200% full scale

A-8 SINAD/DISTORTION METER (FM/AM-500A Only)

SINAD:
Accuracy: ±1 dB at 12 dB
Range: 3 to 20 dB at 1 kHz
Input Level: 0.25 VRMS to 10 VRMS

APPENDIX B: TEST EQUIPMENT REQUIREMENTS

B-1 GENERAL

This appendix contains a list of test equipment suitable for performing all of the maintenance procedures contained in this manual. Any other equipment meeting the specifications listed in this appendix may be substituted in place of the recommended models. It should be noted that the equipment listed in this appendix may exceed the minimum required specifications for some of the procedures contained in this manual.

B-2 RECOMMENDED TEST EQUIPMENT

TYPE	MANUFACTURER & MODEL	SPECIFICATIONS
Oscilloscope	Tektronix 2215	DC to 60 MHz 10 mV/div vertical trace 5 nS/div sweep rate Dual Trace
Spectrum Analyzer	Tektronix 7613 Frame Tektronix 7L13/U Spectrum Analyzer	Variable Persistence Storage Oscilloscope Frequency Range: 1 kHz to 2.5 GHz Resolution: 1 kHz Bandwidth: 30 Hz to 3 MHz
Tracking Generator	Tektronix TM503 Frame Tektronix TR502 Tracking Generator	Three-wide Mainframe Frequency Range: 100 kHz to 1.8 GHz Output Level: 0 dBm, ± 0.5 dB Power Range: 0 to -59 dBm in 10 and 1 dB steps
Frequency Counter	Fluke Model 7220A	Frequency Range: 5 Hz to 1300 MHz
Digital Multimeter	Fluke Model 8010A	3½ digit, 100 K Ω /V $\pm 0.1\%$ basic DC accuracy
Distortion Analyzer	Sound Technology Model 1700B	Frequency Range: 10 Hz to 110 kHz Accuracy: .002% distortion AC Voltage Accuracy: 2%

TYPE	MANUFACTURER & MODEL	SPECIFICATIONS
Signal Generator	Wavetek 3000	Frequency Range: 1 to 520 MHz Resolution: 1 kHz Accuracy: 0.001% RF Output: +13 to -137 dBm
Sweep Signal Generator	Wavetek 2002A	Frequency Range: 1 to 1389 MHz Calibrated RF Output: +13 to -77 dBm
Wattmeter	Sierra 174A-1	Frequency Range: 25 to 1000 MHz VSWR: 25-512 MHz: 1.10 max 512-1000 MHz: 1.20 max Accuracy Incident Power: 25-512 MHz: $\pm 5\%$ of full scale 512-1000 MHz: $\pm 7\%$ of full scale
FM/AM Modulation Meter	Boonton Model 82AD	Frequency Range: 10 MHz to 1.2 GHz Accuracy: FM: $\pm 2\%$ of reading from 30 Hz to 100 kHz Accuracy: AM: $\pm 2\%$ of reading from 10% to 90% AM and 5% of reading below 10% and above 90%; from 30 Hz to 100 kHz Resolution: 0.1% of full scale for FM and AM
RF Power Source	MCL 15122 Main Frame 6048 Oscillator Module	Frequency Range: 50 to 200 MHz Power Range: 0 to 65 W

TYPE	MANUFACTURER & MODEL	SPECIFICATIONS
RF Power Meter with Power Detector	Boonton RF Microwatt-meter Model 42 BD	Frequency Range: 200 kHz to 18 GHz Power Range: 1.0 nW to 10 mW Accuracy: $\pm 0.25\%$ fs ± 0.15 dB >10 nW
	Boonton Power Sensor Model 41-4A	Frequency Range: 200 kHz to 7 GHz Power Range: 1 nW to 10 mW Accuracy: ± 0.3 dB >10 nW
Triple Output Power Supply	LAMBDA LPT-7202-FM	Regulation: 0.1% Ripple: 5 mV Voltage Ranges: 0-7 VDC @ 5.0 A 0-20 VDC @ 1.5 A 0-20 VDC @ 1.5 A
Power Supply	B & K 1601	Regulation: .1% or 1 mV Ripple: 5 mV Voltage Range: 0-50 VDC @ 0-2 A

APPENDIX C: SPECIAL TEST EQUIPMENT

C-1 BATTERY LOAD SIMULATOR

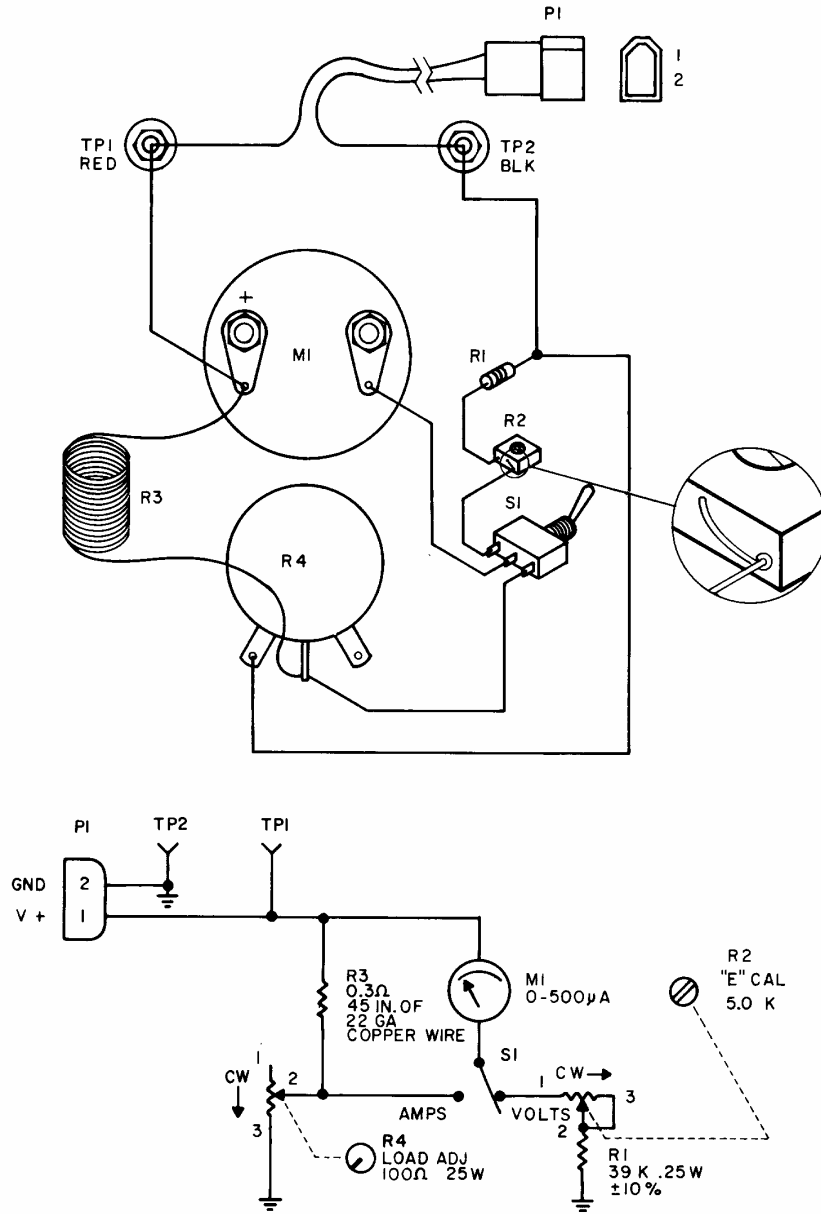

Figure C-1 Circuit Schematic and Diagram of Battery Load Simulator

C-2 ATTENUATOR KNOB SPACER

Material: .005 Brass Shimstock
1.850 \pm .1 X .375 \pm .1

Fabrication: Cut material to size and form into arc as shown in Figure C-2.

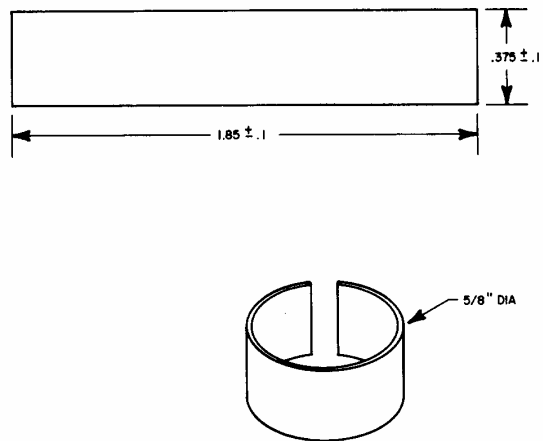

Figure C-2 Attenuator Knob Spacer

APPENDIX D: ABBREVIATIONS & SYMBOLS

D-1 GENERAL

Defined below are various abbreviations and symbols which are commonly used throughout the FM/AM-500A Maintenance Manual Text.

D-2 GENERAL ABBREVIATIONS

AC	- Alternating Current
adj	- adjustment
AGC	- Automatic Gain Control
ALC	- Automatic Leveling Control
AM	- Amplitude Modulation
ANT	- Antenna
Assy	- Assembly
BCD	- Binary-Coded Data
°C	- Degrees Celsius
CW	- Continuous Wave
cw	- clockwise
ccw	- counter clockwise
DAC	- Digital to Analog Converter
dB	- decibel
dBm	- decibel referred to one milliwatt
DC	- Direct Current
DMM	- Digital Multimeter
DVM	- Digital Voltmeter
EXT V/DIV	- External Volts per Division
°F	- Degrees Fahrenheit
FREQ	- Frequency
GEN	- Generator
GHz	- Gigahertz
Hz	- Hertz
IC	- Integrated Circuit
IF	- Intermediate Frequency
IPC	- Illustrated Parts Catalog
kg/cm ²	- Kilogram per square centimeter
kHz	- Kiloherzt
LED	- Light-Emitting Diode
mA	- milliamperes
MHz	- Megahertz
ms or mSec	- millisecond
mW	- milliwatt
μS	- microsecond
μV	- microvolt
ns	- nanosecond
Ω	- ohm
op amp	- operational amplifier
P	- Plug
para	- paragraph
PC	- Printed Circuit
pot	- potentiometer

psi	- pounds per square inch
%	- percent
REF	- Reference
RF	- Radio Frequency
ROM	- Read Only Memory
SW	- Switch
TP	- Test Point
trimcap	- trimming capacitor
trimpot	- trimming potentiometer
TTL	- Transistor-Transistor Logic
UUT	- Unit Under Test
V	- Volt
Vp	- Volts peak
Vp-p	- Volts peak to peak
VAC	- Voltage Alternating Current
VCO	- Voltage Controlled Oscillator
VDC	- Voltage Direct Current
VRMS	- Volts Root Mean Square
VSWR	- Vertical Standing Wave Ratio
W	- Watt
XMTR	- Transmitter

D-3 ABBREVIATIONS FOR REFERENCE DESIGNATORS

BR	- Bridge Rectifier
C	- Capacitor
CR	- Diode
E	- Terminal
FL	- Filter
G	- Ground
J	- Connector (Fixed)
K	- Relay
L	- Inductor
M	- Meter
MX or MXR	- Mixer
P	- Connector (Movable)
Q	- Transistor
R	- Resistor
SW	- Switch
T	- Transformer
TU	- Tuning Pole
U	- Inseparable Circuit, (e.g. Opto-isolator)
VR	- Voltage Regulator
X	- Integrated Circuit
Y	- Crystal
YFL	- Crystal Filter

APPENDIX E: REPACKING FOR SHIPMENT

E-1 SHIPPING INFORMATION

IFR test sets returned to factory for calibration, service or repair must be repackaged and shipped subject to the following conditions:

Do not return any products to factory without first receiving authorization from IFR Customer Service Department.

CONTACT:

Customer Service Dept.
IFR, Inc.
10200 West York Street
Wichita, Kansas 67215

Telephone: (800)-835-2350
TWX: 910-741-6952

All test sets must be tagged with:

- a. Owner's identification and address.
- b. Nature of service or repair required.
- c. Model No.
- d. Serial No.

Sets must be repackaged in original shipping containers using IFR packing materials. If original shipping containers and materials are not available, contact IFR Customer Service Dept. for shipping instructions.

All freight costs on non-warranty shipments are assumed by customer. (See "Warranty Packet" for freight charge policy on warranty claims.)

E-2 REPACKING PROCEDURE (Reference Figure E-1)

1. Make sure bottom packing mold is seated on floor of shipping container.
2. Carefully wrap test set with polyethylene sheeting to protect finish.
3. Place test set into shipping container, making sure set is securely seated in bottom packing mold.
4. Place top packing mold over top of set and press down until mold rests solidly on bottom packing mold.
5. Close shipping container lids and seal with shipping tape or an industrial stapler. Tie all sides of container with break resistant rope, twine or equivalent.

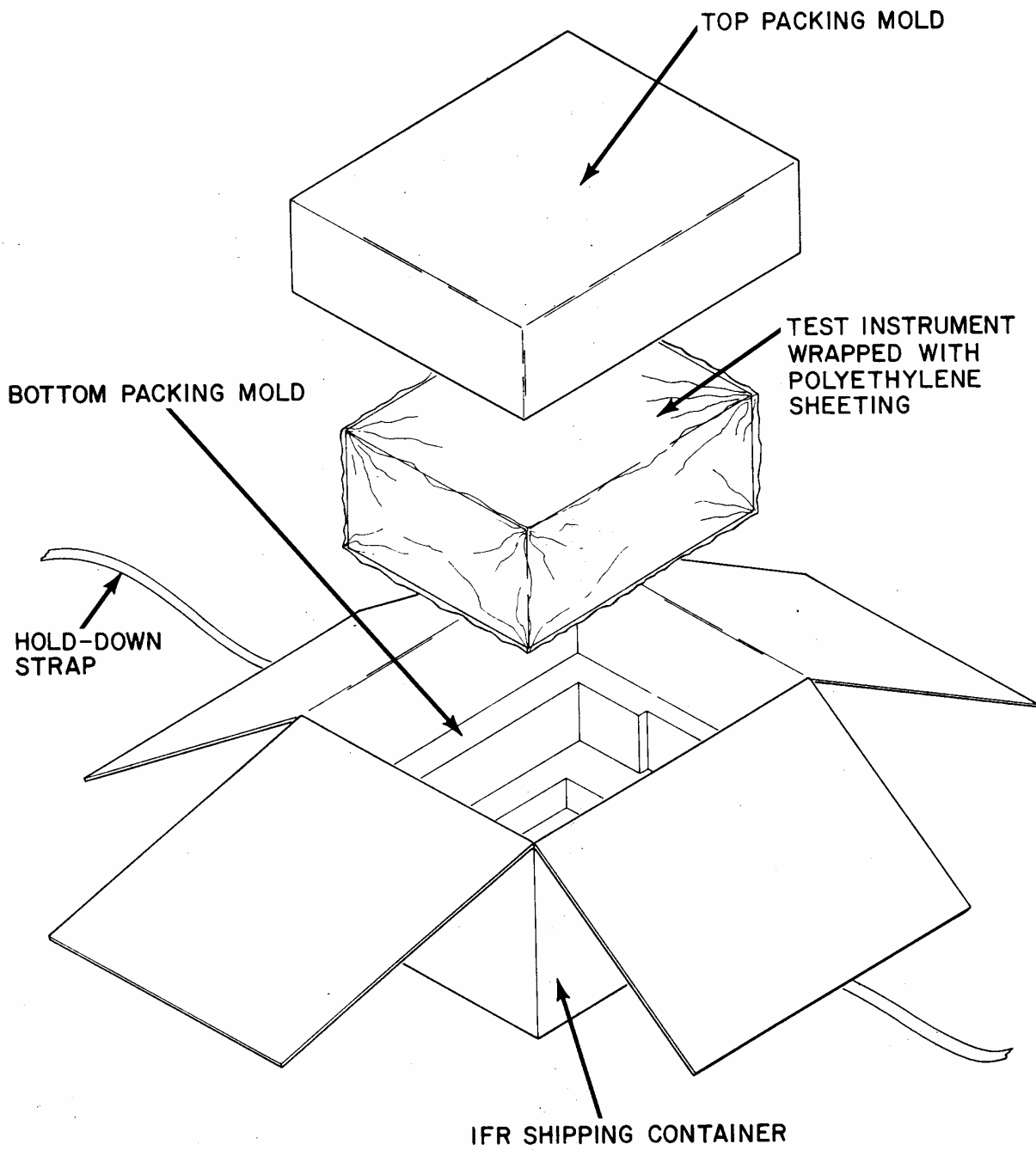

Figure E-1 Repacking for Shipment