



Radar Test Set RD-301A

Maintenance Manual

1002-9001-300

Issue-5

EXPORT CONTROL WARNING: This document contains controlled technology or technical data under the jurisdiction of the Export Administration Regulations (EAR), 15 CFR 730-774. It cannot be transferred to any foreign third party without the specific prior approval of the U.S. Department of Commerce Bureau of Industry and Security (BIS). Violations of these regulations are punishable by fine, imprisonment, or both.

MAINTENANCE MANUAL

RADAR TEST SET

RD-301A

PUBLISHED BY
Aeroflex

COPYRIGHT © Aeroflex 2008

All rights reserved. No part of this publication may be reproduced, stored in a retrieval system, or transmitted in any form or by any means, electronic, mechanical, photocopying, recording or otherwise without the prior permission of the publisher.

Original Printing	Jun 92
Issue-2	Feb 04
Issue-3	Oct 04
Issue-4	Feb 07
Issue-5	Aug 08

10200 West York / Wichita, Kansas 67215 U.S.A. / (316) 522-4981 / FAX (316) 524-2623

Subject to Export Control, see Cover Page for details.

Subject to Export Control, see Cover Page for details.

WARNING:

HIGH VOLTAGE EQUIPMENT

THIS EQUIPMENT CONTAINS CERTAIN CIRCUITS AND/OR COMPONENTS OF EXTREMELY HIGH VOLTAGE POTENTIALS, CAPABLE OF CAUSING SERIOUS BODILY INJURY OR DEATH. WHEN PERFORMING ANY OF THE PROCEDURES CONTAINED IN THIS MANUAL, HEED ALL APPLICABLE SAFETY PRECAUTIONS.

SAFETY FIRST: TO ALL OPERATIONS AND SERVICE PERSONNEL

REFER ALL SERVICING OF UNIT TO QUALIFIED TECHNICAL PERSONNEL.

WARNING: USING THIS EQUIPMENT IN A MANNER NOT SPECIFIED BY THE ACCOMPANYING DOCUMENTATION MAY IMPAIR THE SAFETY PROTECTION PROVIDED BY THE EQUIPMENT.

CASE, COVER OR PANEL REMOVAL

Removing protective covers, casings or panels from this Test Set exposes the technician to electrical hazards that can result in electrical shock or equipment damage.

SAFETY IDENTIFICATION IN TECHNICAL MANUAL

This manual uses the following terms to draw attention to possible safety hazards, that may exist when operating or servicing this equipment.

CAUTION: THIS TERM IDENTIFIES CONDITIONS OR ACTIVITIES THAT, IF IGNORED, CAN RESULT IN EQUIPMENT OR PROPERTY DAMAGE (E.G., FIRE).

WARNING: THIS TERM IDENTIFIES CONDITIONS OR ACTIVITIES THAT, IF IGNORED, CAN RESULT IN PERSONAL INJURY OR DEATH.

SAFETY SYMBOLS IN MANUALS AND ON UNITS



CAUTION: Refer to accompanying documents. (This symbol refers to specific CAUTIONS represented on the unit and clarified in the text.)



AC OR DC TERMINAL: Terminal that may supply or be supplied with ac or dc voltage.



DC TERMINAL: Terminal that may supply or be supplied with dc voltage.



AC TERMINAL: Terminal that may supply or be supplied with ac or alternating voltage.



SWITCH OFF: AC line power to the device is OFF.



SWITCH ON: AC line power to the device is ON.

EQUIPMENT GROUNDING PRECAUTION

Improper grounding of equipment can result in electrical shock.

USE OF PROBES

Check specifications for the maximum voltage, current and power ratings of any connector on the Test Set before connecting it with a probe from a terminal device. Be sure the terminal device performs within these specifications before using it for measurement, to prevent electrical shock or damage to the equipment.

POWER CORDS

Power cords must not be frayed, broken nor expose bare wiring when operating this equipment.

USE RECOMMENDED FUSES ONLY

Use only fuses specifically recommended for the equipment at the specified current and voltage ratings.

CAUTION: INTEGRATED CIRCUITS AND SOLID STATE DEVICES SUCH AS MOS FETS, ESPECIALLY CMOS TYPES, ARE SUSCEPTIBLE TO DAMAGE BY ELECTROSTATIC DISCHARGES RECEIVED FROM IMPROPER HANDLING, THE USE OF UNGROUNDED TOOLS AND IMPROPER STORAGE AND PACKAGING. ANY MAINTENANCE TO THIS UNIT MUST BE PERFORMED WITH THE FOLLOWING PRECAUTIONS:

- BEFORE USE IN A CIRCUIT, KEEP ALL LEADS SHORTED TOGETHER EITHER BY THE USE OF VENDOR-SUPPLIED SHORTING SPRINGS OR BY INSERTING LEADS INTO A CONDUCTIVE MATERIAL.
- WHEN REMOVING DEVICES FROM THEIR CONTAINERS, GROUND THE HAND BEING USED WITH A CONDUCTIVE WRISTBAND.
- TIPS OF SOLDERING IRONS AND/OR ANY TOOLS USED MUST BE GROUNDED.
- DEVICES MUST NEVER BE INSERTED INTO NOR REMOVED FROM CIRCUITS WITH POWER ON.
- PC BOARDS, WHEN TAKEN OUT OF THE SET, MUST BE LAID ON A GROUNDED CONDUCTIVE MAT OR STORED IN A CONDUCTIVE STORAGE BAG. REMOVE ANY BUILT-IN POWER SOURCE, SUCH AS A BATTERY, BEFORE LAYING PC BOARDS ON A CONDUCTIVE MAT OR STORING IN A CONDUCTIVE BAG.
- PC BOARDS, IF BEING SHIPPED TO THE FACTORY FOR REPAIR, MUST BE PACKAGED IN A CONDUCTIVE BAG AND PLACED IN A WELL-CUSHIONED SHIPPING CONTAINER.

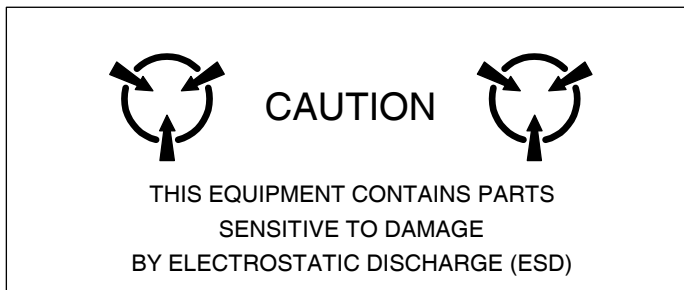

CAUTION: SIGNAL GENERATORS CAN BE A SOURCE OF ELECTROMAGNETIC INTERFERENCE (EMI) TO COMMUNICATION RECEIVERS. SOME TRANSMITTED SIGNALS CAN CAUSE DISRUPTION AND INTERFERENCE TO COMMUNICATION SERVICES OUT TO A DISTANCE OF SEVERAL MILES. USERS OF THIS EQUIPMENT SHOULD SCRUTINIZE ANY OPERATION THAT RESULTS IN RADIATION OF A SIGNAL (DIRECTLY OR INDIRECTLY) AND ENSURE COMPLIANCE WITH INSTRUCTIONS IN FAA CIRCULAR AC 170-6C, DATED FEBRUARY 19, 1981.

CAUTION: KEEP ALL VENT OPENINGS CLEAR AND UNOBSTRUCTED FOR PROPER EQUIPMENT COOLING AND CONTINUED RELIABILITY. WHEN OPERATING THE EQUIPMENT IN THE NORMAL HORIZONTAL POSITION, MAINTAIN AT LEAST TWO INCHES (APPROX. FIVE CENTIMETERS) OF CLEARANCE BETWEEN THE REAR PANEL AND OBJECTS OR WALLS.



TABLE OF CONTENTS

<u>Title</u>	<u>Chapter/Section</u>
Title/Copyright Page	
Warning/Cautions Pages	
Table of Contents	
Introduction	
Chapter 2	
Section 1 - Servicing	2-1
Section 2 - Troubleshooting	2-2
Section 3 - RD-301A Parts List	2-3
Appendix A - Connector Pin-Out Tables	
Appendix B - R1, R2 AUTO Threshold Adjustment	
Appendix C - Test Equipment Requirements	
Appendix D - Test Equipment Construction	
Appendix E - Metric/British Imperial Conversion Table with Nautical Distance Conversions	
Appendix F - Controls, Connectors and Indicators	
Appendix G - Specifications	
Appendix H - Abbreviations	
Index	



THIS PAGE INTENTIONALLY LEFT BLANK.



INTRODUCTION

This manual contains the information necessary to perform calibrate/verification on the RD-301A Radar Test Set. Assembly diagrams and circuit schematics are provided to assist the technician in repairing the unit.

It is strongly recommended that personnel be thoroughly familiar with the RD-301A and the contents of this manual before attempting to service this equipment.

Only qualified personnel should perform maintenance on this equipment.

ORGANIZATION

This manual is divided into the following sections:

CHAPTER 2 - MAINTENANCE

Section 1 - SERVICING (preventive maintenance)

Section 2 - TROUBLESHOOTING (calibration/verification; and assemblies and schematics)

Section 3 - RD-301A PARTS LIST



THIS PAGE INTENTIONALLY LEFT BLANK.



CHAPTER TWO
RD-301A RADAR TEST SET
MAINTENANCE MANUAL
TABLE OF CONTENTS

<u>Title</u>	<u>Chapter/Section/Subject</u>	<u>Page</u>
SECTION 1 - SERVICING	2-1	
1. Preventive Maintenance Procedures	2-1-1	1
A. External Cleaning	2-1-1	1
B. Internal Cleaning	2-1-1	1
C. Visual Inspection	2-1-1	2
SECTION 2 - TROUBLESHOOTING	2-2	
2. Calibration/Verification	2-2-2	1
A. General	2-2-2	1
(1) Calibration/Verification Schedule	2-2-2	1
(2) Controls, Connectors and Indicators	2-2-2	1
(3) Test Record	2-2-2	1
B. Precautions	2-2-2	1
(1) Safety	2-2-2	1
(2) ESD	2-2-2	2
C. Requirements	2-2-2	2
(1) Performance	2-2-2	2
(2) Test Equipment	2-2-2	2
(3) Disassembly	2-2-2	2
(4) Environment	2-2-2	2
D. Verification Procedures	2-2-2	5
(1) RF Signal Generator	2-2-2	5
(2) IF Signal Generator	2-2-2	21
(3) INTL Modulation/PRF Counter	2-2-2	27
(4) Range	2-2-2	28
(5) Power Meter	2-2-2	31
(6) XMTR DSCRM 0.1V/MHz Connector	2-2-2	33
(7) Inputs	2-2-2	35
E. Verification Data Sheet	2-2-2	37
F. Calibration Procedures	2-2-2	47
(1) Power Supply	2-2-2	47
(2) 100 MHz Clock	2-2-2	48
(3) 8.25 GHz LO	2-2-2	51
(4) RF Display Limits	2-2-2	53
(5) Marker Oscillator	2-2-2	54
(6) IF Oscillator	2-2-2	56
(7) IF Generator Power Amplifier	2-2-2	59
(8) External AM	2-2-2	61
(9) Levelers	2-2-2	62
(10) Internal PRF	2-2-2	68
(11) Pulse Width	2-2-2	69
(12) Range Delay	2-2-2	73
(13) Power Meter	2-2-2	75
(14) Discriminator	2-2-2	77
G. Calibration Data Sheet	2-2-2	80



<u>Title</u>	<u>Chapter/Section/Subject</u>	<u>Page</u>
3. Assemblies and Schematics	2-2-3	1
SECTION 3 - RD-301A PARTS LIST	2-3	



LIST OF ILLUSTRATIONS

<u>Title</u>	<u>Chapter/Section/Subject</u>	<u>Page</u>
Tracking Verification Setup	2-2-2	6
RD-301A Tracking Spectrum Analyzer Signals	2-2-2	8
RD-301A Heterodyne Monitor Tracking Output	2-2-2	8
RD-301A Heterodyne Monitor ΔF Output	2-2-2	12
Output Power Verification Setup	2-2-2	13
Pulse Width Verification Setup	2-2-2	16
Pulse Width Measurement Points	2-2-2	17
Range Delay Verification Setup	2-2-2	28
Power Meter Verification Setup	2-2-2	31
XMTR DSCRM 0.1V/MHz Connector Verification Setup	2-2-2	33
AM EXT INPUT Connector Verification Setup	2-2-2	35
EXT TRIG Connector Verification Setup	2-2-2	36
Floor Test Points and Adjustments	2-2-2	49
Card Frame (Top) Test Points and Adjustments	2-2-2	49
Card Frame (Bottom) Test Points and Adjustments	2-2-2	50
8.25 GHz LO Top Test Points and Adjustments	2-2-2	50
External AM Calibration Setup	2-2-2	60
Main Leveler Calibration Setup	2-2-2	61
R1 and R2 Signal Levels as Stored Traces	2-2-2	66
R1 and R2 Signal Levels	2-2-2	67
Pulse Width Calibration Setup	2-2-2	69
Pulse Width Calibration Measurement Points	2-2-2	70
Range Delay Calibration Setup	2-2-2	72
Power Meter Calibration Setup	2-2-2	73
Discriminator Calibration Setup	2-2-2	76

LIST OF TABLES

<u>Title</u>	<u>Chapter/Section/Subject</u>	<u>Page</u>
Verification Failure Calibration Requirements	2-2-2	3
Assembly Replacement Calibration Requirements	2-2-2	4
Range Reply Rings Verification	2-2-2	29
Test RF Levels for Power Meter Verification	2-2-2	32
Power Supply Terminal Bus Voltages	2-2-2	47
Test RF Levels for Power Meter Verification	2-2-2	74



THIS PAGE INTENTIONALLY LEFT BLANK.

SECTION 1 - SERVICING

1. Preventive Maintenance Procedures

Contains routine maintenance instructions for cleaning and inspecting the Test Set.

CAUTION: DISCONNECT POWER FROM TEST SET TO AVOID POSSIBLE DAMAGE TO ELECTRONIC CIRCUITS.

A. External Cleaning

STEP	PROCEDURE
1.	Clean front panel, switches and display face with soft lint-free cloth. If dirt is difficult to remove, dampen cloth with water and mild liquid detergent.
2.	Remove fan filter from rear panel and remove dust with dry air jet. (If dirt is difficult to remove, wash filter in warm soapy water and dry with dry air jet.)
3.	Remove grease, fungus and ground-in dirt from surfaces with soft lint-free cloth dampened (not wet) with isopropyl alcohol.
4.	Remove dust and dirt from connectors with soft-bristled brush.
5.	Cover connectors, not in use, with suitable dust cover to prevent tarnishing of connector contacts.
6.	Clean cables with soft lint-free cloth.
7.	Paint exposed metal surface to avoid corrosion.

B. Internal Cleaning

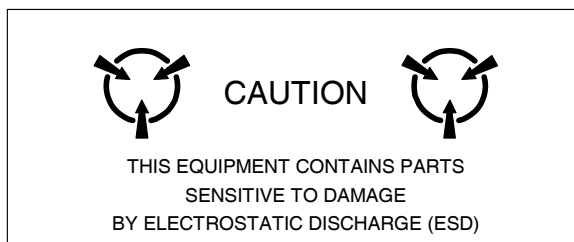

CAUTION: AVOID MOVING COMPONENTS ON CIRCUIT BOARDS OR DISASSEMBLING CONNECTORS NEEDLESSLY TO PREVENT POSSIBLE DAMAGE.

CAUTION: AVOID OPENING COMPLEX INTERNAL MODULES FOR SOLE PURPOSE OF CLEANING AND INSPECTION.

STEP	PROCEDURE
1.	Remove dust with hand-controlled dry air jet of 15 psi (1.054 kg/cm ²) and wipe internal chassis parts and frame with soft lint-free cloth moistened with isopropyl alcohol.
2.	Clean switches and controls with contact cleaner.

C. Visual Inspection

STEP	PROCEDURE
1. Inspect Chassis for:	<ul style="list-style-type: none"> ● Tightness of sub-assemblies and chassis mounted connectors. ● Corrosion or damage to metal surfaces.
2. Inspect Capacitors for:	<ul style="list-style-type: none"> ● Loose mounting, deformities or obvious physical damage. ● Leakage or corrosion around leads.
3. Inspect Connectors for loose or broken parts, cracked insulation and bad contacts.	
4. Inspect Thumbwheel Switches for selectability.	
5. Inspect Rotary Control Switches for ability to freely rotate.	
6. Inspect Circuit Boards for:	<ul style="list-style-type: none"> ● Corrosion or damage to connectors. ● Damage to mounted components including crystals and ICs. ● Freedom from foreign material.
7. Inspect Resistors for:	<ul style="list-style-type: none"> ● Cracked, broken, charred or blistered bodies. ● Loose or corroded soldering connections.
8. Inspect Semiconductors for:	<ul style="list-style-type: none"> ● Cracked, broken, charred or discolored bodies. ● Seals around leads being in place and in good condition.
9. Inspect Switches for:	<ul style="list-style-type: none"> ● Loose levers, terminals and switch body contact to frame. ● Bent or loose line switch contacts.
10. Inspect Wiring for:	<ul style="list-style-type: none"> ● Broken or loose ends and connections. ● Proper dress relative to other chassis parts. <p>NOTE: Verify laced wiring is tight with ends securely tied.</p>

2. Calibration/Verification

A. General

(1) Calibration/Verification Schedule

The Calibration/Verification Procedures should be performed as a result of one or more of the following conditions:

- Failure to Meet Specifications

If, during the course of normal operation, the RD-301A or any major function thereof fails to meet the performance specifications according to Appendix G, the Calibration/Verification Procedures should be performed.

If any failure occurs during performance of the Verification Procedures, pertinent Calibration Procedures should be performed according to 2-2-2, Table 1.

- Module/Assembly Replacement

If one or more of the RD-301A assemblies are replaced, the Calibration/Verification Procedures should be performed.

- Annual Calibration/Verification

Aeroflex recommends an annual Calibration/Verification on the RD-301A to maintain proper testing standards.

(2) Controls, Connectors and Indicators

Refer to Appendix F for location of the RD-301A Controls, Connectors and Indicators.

(3) Test Record

Calibration/Verification Data Sheets are provided for recording the results obtained while performing the Calibration/Verification Procedures.

NOTE: It is recommended the technician reproduce copies of the Calibration/Verification Data Sheets, rather than use copies in this manual.

B. Precautions

(1) Safety

Extreme caution should be taken when troubleshooting with live circuits. When performing the Calibration/Verification Procedures, be sure to observe the following precautions:

WARNING: REMOVE ALL JEWELRY OR OTHER COSMETIC APPAREL BEFORE PERFORMING ANY CALIBRATION/VERIFICATION PROCEDURE INVOLVING LIVE CIRCUITS.

WARNING: WHEN WORKING WITH LIVE CIRCUITS OF HIGH POTENTIAL, KEEP ONE HAND IN POCKET OR BEHIND BACK TO AVOID SERIOUS SHOCK HAZARD.

WARNING: USE ONLY INSULATED TROUBLESHOOTING TOOLS WHEN WORKING WITH LIVE CIRCUITS.

WARNING: FOR ADDED INSULATION, PLACE RUBBER BENCH MAT UNDERNEATH ALL POWERED BENCH EQUIPMENT, AS WELL AS A RUBBER MAT UNDERNEATH TECHNICIAN'S CHAIR.

WARNING: HEED ALL WARNINGS AND CAUTIONS CONCERNING MAXIMUM VOLTAGES AND POWER INPUTS.

(2) ESD



C. Requirements

(1) Performance

It is strongly recommended that personnel thoroughly read and understand all steps of the Calibration/Verification Procedures prior to performing the procedure. Knowledge of power, frequency and waveform to be expected at each test point is recommended. Knowledge of external test equipment connections and operation is also recommended.

- PANEL Meter

Before applying power to RD-301A, verify PANEL Meter (43) indicates zero on power scale. Adjust PANEL METER ZERO Control (45) as needed.

- Serialized Coaxial Cable and Waveguide Coupler

The RD-301A Radar Test Set includes the RD-301A, Serialized Coaxial Cable and Waveguide Coupler. All equipment must be available to verify and calibrate the system.

(2) Test Equipment

Appendix D contains a list of test equipment suitable for performing any procedure contained in this manual. Other equipment meeting specifications listed in Appendix D may be substituted in place of recommended models.

NOTE: For certain procedures in this manual, the equipment listed in Appendix D may exceed minimum required specifications.

NOTE: High quality RG58 BNC coaxial cables should be used to connect test equipment.

(3) Disassembly

No disassembly is required to perform the Verification Procedures. The top cover is removed when performing the Calibration Procedures. Other disassembly procedures are performed only as necessary.

(4) Environment

For best results, environmental conditions should be identical to the conditions at the normal operating location.

IF THIS VERIFICATION PROCEDURE FAILS		THE FOLLOWING CALIBRATION PROCEDURES MUST BE PERFORMED													
		POWER SUPPLY	100 MHz CLOCK	8.25 GHz LO	RF DISPLAY LIMITS	MARKER OSCILLATOR	IF OSCILLATOR	IF GENERATOR POWER AMPLIFIER	EXTERNAL AM	LEVELERS	INTERNAL PRF	PULSE WIDTH	RANGE DELAY	POWER METER	DISCRIMINATOR
RF SIGNAL GENERATOR	FREQUENCY AND RF COUNTER	●	●	●	●										
	TRACKING AND ΔF OFFSET	●	●	●							●			●	
	OUTPUT POWER AND INTERNAL AM AMPLITUDE									●					
	PULSE WIDTH	●	●	●							●				
	RF ON/OFF RATIO									●					
IF SIGNAL GENERATOR	FREQUENCY AND IF COUNTER	●	●	●			●								
	SWEEP WIDTH	●	●	●			●								
	MARKER FREQUENCY	●	●	●		●									
	POWER	●	●	●			●	●							
	PULSE WIDTH	●	●	●							●				
	IF ON/OFF RATIO	●	●	●			●	●		●					
INTL MODULATION/PRF COUNTER		●	●							●	●				
RANGE		●	●	●						●	●	●			
POWER METER													●		
XMTR DSCRM .1V/MHz CONNECTOR		●	●	●							●				●
INPUTS	AM EXT INPUT CONNECTOR								●						
	EXT TRIG CONNECTOR														

9002002

Verification Failure Calibration Requirements
Table 1

IF THIS ASSEMBLY IS REPAIRED OR REPLACED THE FOLLOWING CALIBRATION PROCEDURES MUST BE PERFORMED	POWER SUPPLY	100 MHz CLOCK	8.25 GHz LO	RF DISPLAY LIMITS	MARKER OSCILLATOR	IF OSCILLATOR	IF GENERATOR POWER AMPLIFIER	EXTERNAL AM	LEVELERS	INTERNAL PRF	PULSE WIDTH	RANGE DELAY	POWER METER	DISCRIMINATOR
8.25 GHz LO	●	●	●											
475/570-775 MHz FILTER ASSEMBLY	●	●	●								●			●
AGC PC BOARD ASSEMBLY	●	●	●	●	●	●	●	●	●					
COUPLER/SPLITTER ASSEMBLY	●	●	●								●			●
DELAY LINE ASSEMBLY	●	●	●								●			●
DISCRIMINATOR #1 PC BOARD ASSEMBLY	●	●	●								●			●
DISCRIMINATOR #2 PC BOARD ASSEMBLY	●	●	●								●			●
DISPLAY COUNTER ASSEMBLY	●	●	●	●		●								
FRONT PANEL ASSEMBLY	●	●	●						●	●	●	●	●	●
HETERODYNE ASSEMBLY														
IF GEN PWR AMPL PC BOARD ASSEMBLY	●	●	●			●	●							
IF MKR/OSC PC BOARD ASSEMBLY	●	●	●		●	●								
MAIN DIODE SWITCH ASSEMBLY	●								●					
POWER SUPPLY ASSEMBLY	●													
PRESCALER PC BOARD ASSEMBLY	●	●	●		●									
RANGE #1 PC BOARD ASSEMBLY	●	●										●		
RANGE #2 PC BOARD ASSEMBLY	●	●	●							●	●			
VCO #2 ASSEMBLY	●	●	●	●					●		●			●
VIDEO PC BOARD ASSEMBLY	●	●	●								●		●	●
X-BAND FRONT END	●	●	●						●		●		●	●

9002001

Assembly Replacement Calibration Requirements
Table 2

D. Verification Procedures

VERIFICATION PROCEDURE	PAGE
RF Signal Generator	5
IF Signal Generator	21
INTL Modulation/PRF Counter	27
Range	28
Power Meter	31
XMTR DSCRM 0.1V/MHz Connector	33
Inputs	35

(1) RF Signal Generator

(a) Frequency and RF Counter

TEST EQUIPMENT: Frequency Counter

STEP	PROCEDURE										
1.	Set RD-301A as follows:										
	<table border="1"> <thead> <tr> <th>CONTROL</th> <th>SETTING</th> </tr> </thead> <tbody> <tr> <td>(2) PRF/RF Switch</td> <td>RF</td> </tr> <tr> <td>(10) MNL FREQ Controls</td> <td>fully ccw</td> </tr> <tr> <td>(16) RF/IF MODE Pushbutton Switches</td> <td>RF MNL</td> </tr> <tr> <td>(29) MODULATION MODE Pushbutton Switches</td> <td>INTL</td> </tr> </tbody> </table>	CONTROL	SETTING	(2) PRF/RF Switch	RF	(10) MNL FREQ Controls	fully ccw	(16) RF/IF MODE Pushbutton Switches	RF MNL	(29) MODULATION MODE Pushbutton Switches	INTL
CONTROL	SETTING										
(2) PRF/RF Switch	RF										
(10) MNL FREQ Controls	fully ccw										
(16) RF/IF MODE Pushbutton Switches	RF MNL										
(29) MODULATION MODE Pushbutton Switches	INTL										
2.	Apply power to RD-301A and allow for 30 minute stabilization period.										
3.	Connect Frequency Counter high frequency input to X-BAND I/O Connector (18).										
4.	Verify ≤ 9295 MHz on Frequency Counter. Record reading.										
5.	Verify FREQUENCY Hz/MHz Digital Display (1) equals Frequency Counter reading from Step 4 (± 250 kHz).										
6.	Adjust MNL FREQ Controls (10) fully cw .										
7.	Verify ≥ 9500 MHz on Frequency Counter. Record reading.										
8.	Verify FREQUENCY Hz/MHz Digital Display (1) equals Frequency Counter reading from Step 7 (± 250 kHz).										
9.	If RD-301A fails any step, perform Calibration Procedures according to 2-2-2, Table 1.										
10.	Disconnect test equipment.										

(b) Tracking and ΔF Offset

TEST EQUIPMENT: 20 dB Coupler
Frequency Counter
Oscilloscope
Spectrum Analyzer
TWT Amplifier
X-Band Signal Generator

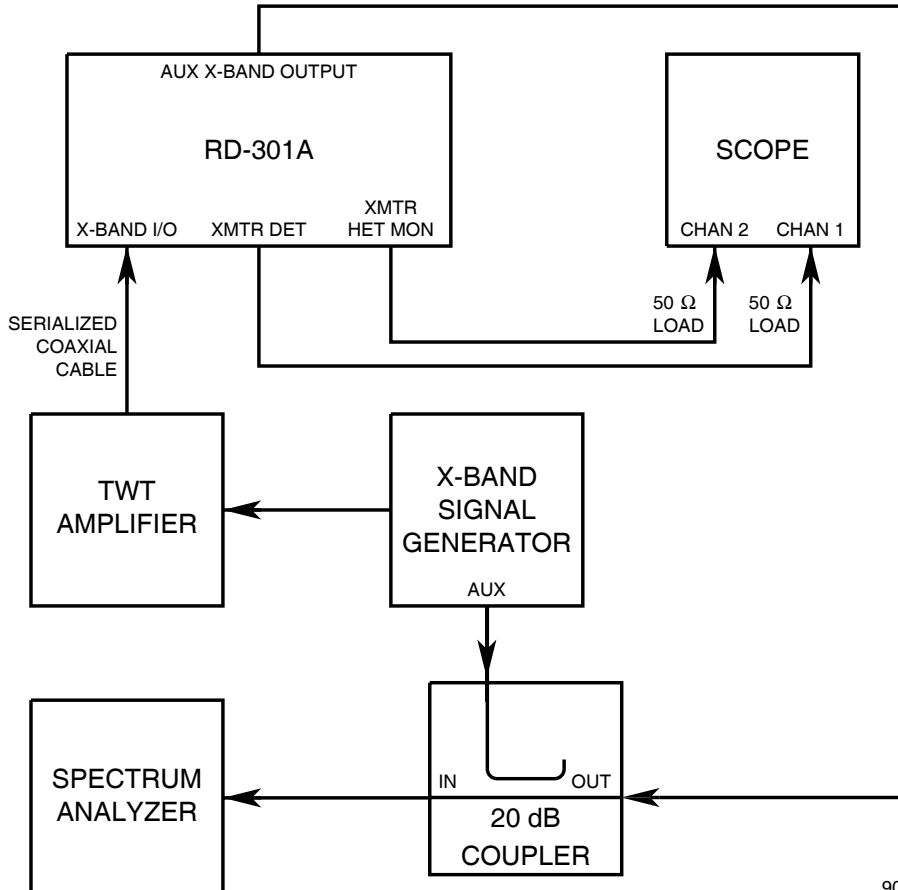

9006007

Tracking Verification Setup
Figure 1

STEP	PROCEDURE												
1.	Set RD-301A as follows:												
	<table border="1"> <thead> <tr> <th>CONTROL</th> <th>SETTING</th> </tr> </thead> <tbody> <tr> <td>(2) PRF/RF Switch</td> <td><i>RF</i></td> </tr> <tr> <td>(4) OUTPUT LEVEL FINE dBm Control</td> <td><i>0</i></td> </tr> <tr> <td>(9) OUTPUT LEVEL COARSE dBm Control</td> <td><i>-50</i></td> </tr> <tr> <td>(16) RF/IF MODE Pushbutton Switches</td> <td><i>RF TRACK</i></td> </tr> <tr> <td>(29) MODULATION MODE Pushbutton Switches</td> <td><i>CW</i></td> </tr> </tbody> </table>	CONTROL	SETTING	(2) PRF/RF Switch	<i>RF</i>	(4) OUTPUT LEVEL FINE dBm Control	<i>0</i>	(9) OUTPUT LEVEL COARSE dBm Control	<i>-50</i>	(16) RF/IF MODE Pushbutton Switches	<i>RF TRACK</i>	(29) MODULATION MODE Pushbutton Switches	<i>CW</i>
CONTROL	SETTING												
(2) PRF/RF Switch	<i>RF</i>												
(4) OUTPUT LEVEL FINE dBm Control	<i>0</i>												
(9) OUTPUT LEVEL COARSE dBm Control	<i>-50</i>												
(16) RF/IF MODE Pushbutton Switches	<i>RF TRACK</i>												
(29) MODULATION MODE Pushbutton Switches	<i>CW</i>												

STEP PROCEDURE

2. Apply power to RD-301A and allow for 30 minute stabilization period.

CAUTION: SOME TWT AMPLIFIERS PRODUCE LARGE OUTPUT POWER SPIKES ON POWER-UP. TEST TWT AMPLIFIER BEFORE CONNECTING TO RD-301A.

3. Connect test equipment as shown in 2-2-2, Figure 1.

NOTE: 20 dB Coupler is used in reverse direction to combine signals and provide greatest isolation.

4. Set TWT Amplifier power On and in Standby mode.

5. Set Oscilloscope with both channels dc coupled as follows:

CONTROL	SETTING
Sweep Speed	5 μ s/Div
Amplitude Scale	50 mV/Div
Trigger	Channel 1

6. Set Spectrum Analyzer as follows:

CONTROL	SETTING
Center Frequency	9295 MHz
Frequency Span	5 kHz/Div
Resolution Bandwidth	3 kHz
Amplitude Scale	10 dB/Div
Reference Level	-40 dBm

7. Set X-Band Signal Generator as follows:

CONTROL	SETTING
Frequency	9295 MHz
Pulse Width	30 μ s
PRF	500 Hz

CAUTION: CONNECTIONS TO TWT AMPLIFIER MUST BE CORRECT BEFORE SWITCHING TO OPERATE MODE.

8. Set TWT Amplifier to Operate mode.

9. Set X-Band Signal Generator output level for PANEL Meter (43) reading of **0.5 kW**.

TRACKING

10. Identify signals on Spectrum Analyzer and adjust attenuation so signals are similar in power level. Refer to 2-2-2, Figure 2.

NOTE: When both signals overlap, RD-301A tracking signal is identified by setting METER SELECT Switch (47) to ΔF and varying ΔF OFFSET/EFF PEAKING Control (48). Another identifying method is narrowing resolution bandwidth of Spectrum Analyzer or changing OUTPUT LEVEL COARSE dBm Control (9) and observing change in signal level.

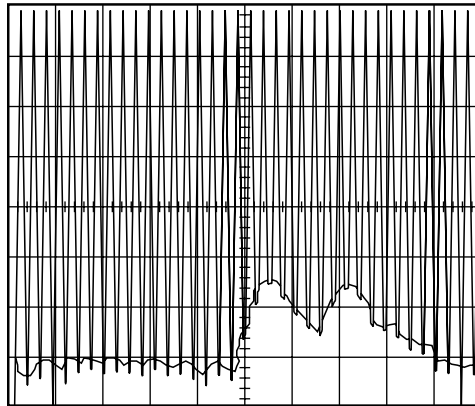

9016008

RD-301A Tracking Spectrum Analyzer Signals
Figure 2

11. Verify frequency difference between signals is ≤ 25 kHz.
12. Adjust Oscilloscope and verify XMTR HET MON Connector (11) output display on Channel 2 shows relatively parallel lines according to 2-2-2, Figure 3.

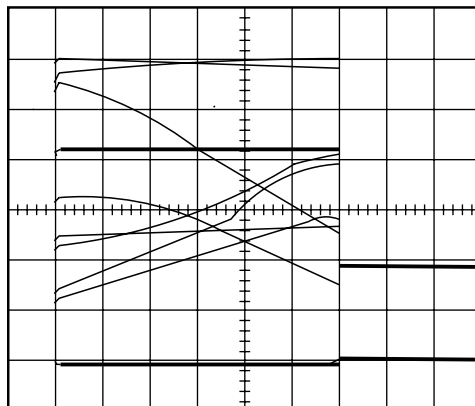

9016009

RD-301A Heterodyne Monitor Tracking Output
Figure 3

13. Set X-Band Signal Generator modulation pulse width to 2 μ s.

STEP	PROCEDURE
------	-----------

14. Verify frequency difference between signals is ≤ 25 kHz.
15. Set Oscilloscope sweep speed to 500 ns/Div and adjust to verify XMTR HET MON Connector (11) output display on Channel 2 shows relatively parallel lines according to 2-2-2, Figure 3.
16. Set Spectrum Analyzer frequency span to 10 kHz/Div.
17. Set X-Band Signal Generator modulation pulse width to 0.5 μ s.
18. Verify frequency difference between signals is ≤ 60 kHz.
19. Set Oscilloscope sweep speed to 100 ns/Div and adjust to verify XMTR HET MON Connector (11) output display on Channel 2 shows relatively parallel lines according to 2-2-2, Figure 3.
20. Set Spectrum Analyzer frequency span to 100 kHz/Div and resolution bandwidth to 1 kHz.
21. Set X-Band Signal Generator modulation pulse width to 0.1 μ s.
22. Verify frequency difference between signals is ≤ 600 kHz.
23. Set Oscilloscope sweep speed to 50 ns/Div and adjust to verify XMTR HET MON Connector (11) output display on Channel 2 shows relatively parallel lines according to 2-2-2, Figure 3.
24. Set Spectrum Analyzer frequency span to 250 kHz/Div.

CAUTION: NARROW WIDTH PULSES MAY INCREASE TWT AMPLIFIER POWER OUTPUT TO HIGH LEVELS THAT MAY DAMAGE EQUIPMENT. WIDEN NARROW PULSE WIDTH AS SOON AS POSSIBLE.

25. Set X-Band Signal Generator modulation pulse width to 0.05 μ s.
26. Verify frequency difference between signals is ≤ 2 MHz.
27. Adjust Oscilloscope and verify XMTR HET MON Connector (11) output display on Channel 2 shows relatively parallel lines according to 2-2-2, Figure 3.
28. Set X-Band Signal Generator modulation pulse width to 30 μ s and frequency to 9400 MHz.
29. Set Spectrum Analyzer as follows:

CONTROL	SETTING
Center Frequency	9400 MHz
Frequency Span	5 kHz/Div
Resolution Bandwidth	3 kHz

30. Set Oscilloscope sweep speed to 5 μ s/Div.
31. Repeat Steps 9 through 27.
32. Set X-Band Signal Generator modulation pulse width to 30 μ s and frequency to 9500 MHz.

 STEP PROCEDURE

33. Set Spectrum Analyzer as follows:

CONTROL	SETTING
Center Frequency	9500 MHz
Frequency Span	5 kHz/Div
Resolution Bandwidth	3 kHz

34. Set Oscilloscope sweep speed to 5 μ s/Div.

35. Repeat Steps 9 through 27.

36. Set X-Band Signal Generator modulation pulse width to 30 μ s and frequency to 9295 MHz.

37. Set Spectrum Analyzer as follows:

CONTROL	SETTING
Center Frequency	9295 MHz
Frequency Span	5 kHz/Div
Resolution Bandwidth	3 kHz
Reference Level	-20 dBm

38. Set Oscilloscope sweep speed to 5 μ s/Div.

39. Set X-Band Signal Generator output level for PANEL Meter (43) reading of **12 kW**.

40. Repeat Steps 10 through 35.

TRACK MODULATION PRF

41. Set X-Band Signal Generator as follows:

CONTROL	SETTING
Frequency	9295 MHz
Pulse Width	5 μ s
PRF	50 Hz

42. Set X-Band Signal Generator output level for PANEL Meter (43) reading of **0.5 kW**.

43. Set Spectrum Analyzer as follows:

CONTROL	SETTING
Center Frequency	9295 MHz
Frequency Span	5 kHz/Div
Resolution Bandwidth	3 kHz

44. Set PRF/RF Switch (2) to **PRF**.

45. Verify FREQUENCY Hz/MHz Digital Display (1) reads **50 Hz** (± 1 Hz).

46. Verify frequency difference between signals is ≤ 25 kHz.

47. Set Oscilloscope sweep speed to 5 μ s/Div and adjust to verify XMTR HET MON Connector (11) output display on Channel 2 shows relatively parallel lines according to 2-2-2, Figure 3.

48. Set X-Band Signal Generator PRF to 2 kHz.

49. Verify FREQUENCY Hz/MHz Digital Display (1) reads **2000 Hz** (± 1 Hz).

 STEP PROCEDURE

50. Verify frequency difference between signals is ≤ 25 kHz.
 51. Adjust Oscilloscope and verify XMTR HET MON Connector (11) output display on Channel 2 shows relatively parallel lines according to 2-2-2, Figure 3.
 52. Set X-Band Signal Generator PRF to 20 kHz.
- NOTE:** Spectrum Analyzer cannot be used effectively at 20 kHz PRF.
53. Verify FREQUENCY Hz/MHz Digital Display (1) reads **20000 Hz** (± 3 Hz).
 54. Adjust Oscilloscope and verify XMTR HET MON Connector (11) output display on Channel 2 shows relatively parallel lines according to 2-2-2, Figure 3.

55. Set X-Band Signal Generator as follows:

CONTROL	SETTING
Frequency	9400 MHz
Pulse Width	5 μ s
PRF	50 Hz

56. Set X-Band Signal Generator output level for PANEL Meter (43) reading of **0.5 kW**.
57. Set Spectrum Analyzer center frequency to 9400 MHz.
58. Repeat Steps 45 through 54.
59. Set X-Band Signal Generator as follows:

CONTROL	SETTING
Frequency	9500 MHz
Pulse Width	5 μ s
PRF	50 Hz

60. Set X-Band Signal Generator output level for PANEL Meter (43) reading of **0.5 kW**.
61. Set Spectrum Analyzer center frequency to 9500 MHz
62. Repeat Steps 45 through 54.

Δ F OFFSET

63. Set X-Band Signal Generator frequency to 9400 MHz.
64. Disconnect 20 dB Coupler from X-Band Signal Generator and AUX X-BAND OUTPUT Connector (54).
65. Connect AUX X-BAND OUTPUT Connector (54) to Frequency Counter.
66. Record Frequency Counter reading.
67. Set METER SELECT Switch (47) to Δ F.
68. Adjust Δ F OFFSET/EFF PEAKING Control (48) until PANEL Meter (43) reads **-0.75 MHz**.
69. Verify Frequency Counter reading equals reading from Step 63 minus 750 kHz (± 95 kHz).

STEP

PROCEDURE

70. Adjust Oscilloscope and verify XMTR HET MON Connector (11) output display on Channel 2 shows cross-hatching according to 2-2-2, Figure 4.

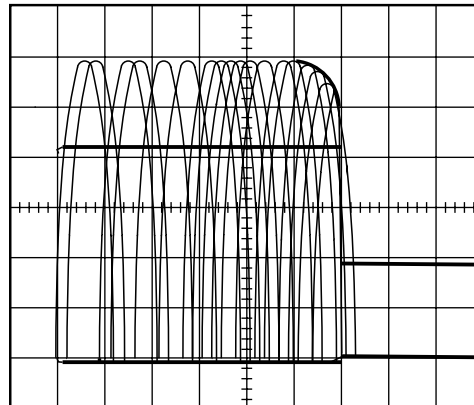

9016013

RD-301A Heterodyne Monitor ΔF Output
Figure 4

71. Adjust ΔF OFFSET/EFF PEAKING Control (48) until PANEL Meter (43) reads **+0.75 MHz**.
72. Verify Frequency Counter reading equals reading from Step 63 plus 750 kHz (± 95 kHz). If not, perform Calibration Procedures according to 2-2-2, Table 1.
73. Adjust Oscilloscope and verify XMTR HET MON Connector (11) output display on Channel 2 shows cross-hatching according to 2-2-2, Figure 4.
74. If RD-301A fails any step, perform Calibration Procedures according to 2-2-2, Table 1.
75. Slowly decrease TWT Amplifier power and set to Standby mode for ≥ 15 minutes.
76. Disconnect test equipment.

(c) Output Power and Internal AM Amplitude

TEST EQUIPMENT: 20 dB Coupler
L-Band Signal Generator
Pulse Generator
Spectrum Analyzer
X-Band Signal Generator

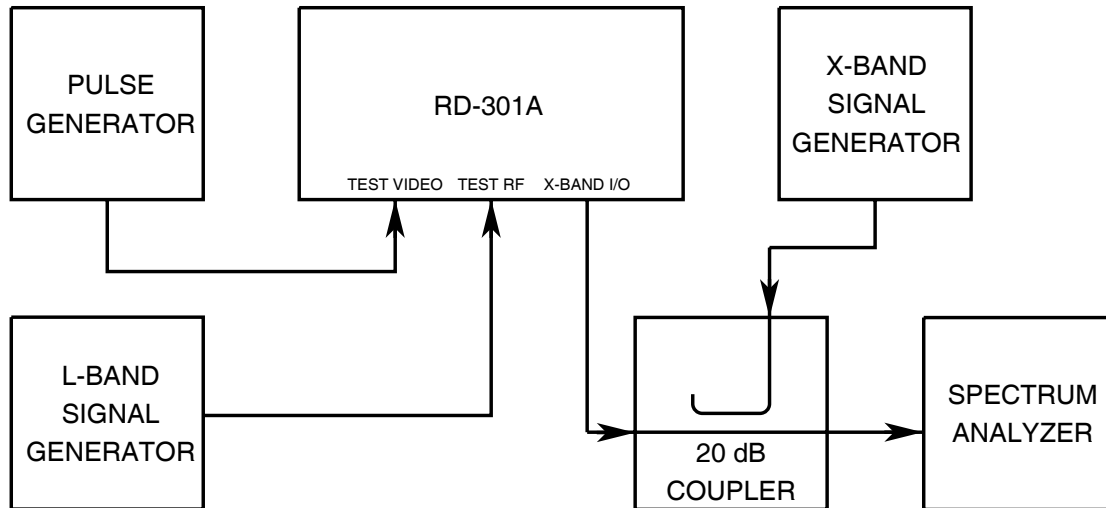

9006009

Output Power Verification Setup
Figure 5

STEP	PROCEDURE																		
1.	Set RD-301A as follows:																		
	<table border="1"> <thead> <tr> <th>CONTROL</th> <th>SETTING</th> </tr> </thead> <tbody> <tr> <td>(2) PRF/RF Switch</td> <td><i>RF</i></td> </tr> <tr> <td>(3) CONTOUR/R2/INTL AM dB BOOST/ATTEN Control</td> <td><i>00</i></td> </tr> <tr> <td>(4) OUTPUT LEVEL FINE dBm Control</td> <td><i>0</i></td> </tr> <tr> <td>(9) OUTPUT LEVEL COARSE dBm Control</td> <td><i>-50</i></td> </tr> <tr> <td>(10) MNL FREQ Controls</td> <td><i>9375 MHZ</i></td> </tr> <tr> <td>(16) RF/IF MODE Pushbutton Switches</td> <td><i>RF MNL</i></td> </tr> <tr> <td>(29) MODULATION MODE Pushbutton Switches</td> <td><i>CW</i></td> </tr> <tr> <td>(39) RANGE SEL Switch</td> <td><i>RINGS 1</i></td> </tr> </tbody> </table>	CONTROL	SETTING	(2) PRF/RF Switch	<i>RF</i>	(3) CONTOUR/R2/INTL AM dB BOOST/ATTEN Control	<i>00</i>	(4) OUTPUT LEVEL FINE dBm Control	<i>0</i>	(9) OUTPUT LEVEL COARSE dBm Control	<i>-50</i>	(10) MNL FREQ Controls	<i>9375 MHZ</i>	(16) RF/IF MODE Pushbutton Switches	<i>RF MNL</i>	(29) MODULATION MODE Pushbutton Switches	<i>CW</i>	(39) RANGE SEL Switch	<i>RINGS 1</i>
CONTROL	SETTING																		
(2) PRF/RF Switch	<i>RF</i>																		
(3) CONTOUR/R2/INTL AM dB BOOST/ATTEN Control	<i>00</i>																		
(4) OUTPUT LEVEL FINE dBm Control	<i>0</i>																		
(9) OUTPUT LEVEL COARSE dBm Control	<i>-50</i>																		
(10) MNL FREQ Controls	<i>9375 MHZ</i>																		
(16) RF/IF MODE Pushbutton Switches	<i>RF MNL</i>																		
(29) MODULATION MODE Pushbutton Switches	<i>CW</i>																		
(39) RANGE SEL Switch	<i>RINGS 1</i>																		
2.	Apply power to RD-301A and allow for 30 minute stabilization period.																		
3.	Connect test equipment as shown in 2-2-2, Figure 5.																		
4.	Set L-Band Signal Generator for 1125 MHz CW signal at +7 dBm.																		
5.	Set Pulse Generator for 5 μ s pulse at TTL level and 1 kHz PRF.																		

STEP PROCEDURE

6. Connect RD-301A X-Band I/O Connector (18) and X-Band Signal Generator to 20 dB Coupler with coupler intentionally reversed for maximum isolation. Set X-Band Signal Generator for 9374.95 MHz CW signal. Adjust X-Band Signal Generator output to same level as RD-301A (\approx -50 dBm).

NOTE: X-Band Signal Generator must have power levels characterized for frequencies used in this procedure. Characterization must be accurate to ± 0.1 dBm.

7. Set Spectrum Analyzer as follows:

CONTROL	SETTING
Center Frequency	9375 MHz
Frequency Span	50 kHz/Div
Resolution Bandwidth	1 kHz
Amplitude Scale	2 dB/Div
Reference Level	-50 dBm
Input Attenuation	0 dB

8. Set OUTPUT LEVEL FINE dBm Control (4) to each position from **-1** to **-10**. Decrease X-Band Signal Generator output level by 1 dB for each setting. Verify difference between RD-301A output level and X-Band Signal Generator output level is ≤ 0.5 dB at each position. Record differences.
9. Set OUTPUT LEVEL FINE dBm Control (4) to **0**.
10. Set OUTPUT LEVEL COARSE dBm Control (9) to each position from **-60** to **-100**. Decrease X-Band Signal Generator output level by 10 dB for each setting. Adjust Spectrum Analyzer reference level and verify difference between RD-301A output level and X-Band Signal Generator output level is ≤ 2 dB at each position. Record differences.
11. Set Spectrum Analyzer resolution bandwidth to 300 Hz and reference level to -105 dBm.
12. Set OUTPUT LEVEL COARSE dBm Control (9) to **-110**. Decrease X-Band Signal Generator output level by 10 dB from last setting in Step 10. Verify difference between RD-301A output level and X-Band Signal Generator output level is ≤ 2 dB. Record difference.
13. Set Spectrum Analyzer for 100 Hz Resolution Bandwidth and reference level to -115 dBm.
14. Set OUTPUT LEVEL COARSE dBm Control (9) to **-120**. Decrease X-Band Signal Generator output level by 10 dB from setting in Step 12. Verify difference between RD-301A output level and X-Band Signal Generator output level is ≤ 2 dB. Record difference.
15. Set OUTPUT LEVEL COARSE dBm Control (9) to **-80**.
16. Set Spectrum Analyzer as follows:

CONTROL	SETTING
Frequency Span	Zero
Resolution Bandwidth	3 MHz
Amplitude Scale	2 dB/Div
Reference Level	-82 dBm

17. Set X-Band Signal Generator output to same level as RD-301A.

CONTOUR BOOST and INTERNAL AM UP MODULATION

NOTE: Because the same level control circuit is used for Contour Boost and Internal AM Up Modulation, levels only need to be verified once.

18. Set RANGE SEL Switch (39) to CONTOUR/AM UP MOD. Verify difference between RD-301A output level and X-Band Signal Generator output level is ≤ 1 dB. Record difference.
19. Set CONTOUR/R2/INTL AM dB BOOST ATTEN Control (3) inner knob to each position from **01** to **09**. Increase X-Band Signal Generator output level by 1 dB for each setting. Verify difference between RD-301A output level and X-Band Signal Generator output level is ≤ 0.5 dB at each position. Record differences.
20. Set CONTOUR/R2/INTL AM dB BOOST ATTEN Control (3) to **10**. Increase X-Band Signal Generator Output Level by 1 dB from last setting in Step 19. Verify difference between RD-301A output level and X-Band Signal Generator output level is ≤ 1 dB. Record difference.
21. Set Spectrum Analyzer reference level to -70 dBm.
22. Set CONTOUR/R2/INTL AM dB BOOST ATTEN Control (3) to **20**. Increase X-Band Signal Generator Output Level by 10 dB. Verify difference between RD-301A output level and X-Band Signal Generator output level is ≤ 1 dB. Record difference.
23. Set CONTOUR/R2/INTL AM dB BOOST ATTEN Control (3) to **00**.

RANGE 2 ATTENUATION and INTERNAL AM DOWN MODULATION

NOTE: Because the same level control circuit is used for Range 2 Attenuation and Internal AM Down Modulation, levels only need to be verified once.

24. Set X-Band Signal Generator output to same level as RD-301A.
25. Set RANGE SEL Switch (39) to **R2 ON**. Verify difference between RD-301A output level and X-Band Signal Generator output level is ≤ 1.5 dB. Record difference.
26. Set CONTOUR/R2/INTL AM dB BOOST ATTEN Control (3) inner knob to each position from **01** to **09**. Decrease X-Band Signal Generator output level by 1 dB for each setting. Verify difference between RD-301A R2 output level and X-Band Signal Generator output level is ≤ 1.5 dB at each position. Record differences.
27. Set CONTOUR/R2/INTL AM dB BOOST ATTEN Control (3) outer knob to each position from **19** to **59**. Decrease X-Band Signal Generator output level by 10 dB for each setting. Verify difference between RD-301A R2 output level and X-Band Signal Generator output level is ≤ 1.5 dB at each position. Record differences.
28. Disconnect test equipment.

(d) Pulse Width

TEST EQUIPMENT: 6 dB Pad
Heterodyne Monitor
L-Band Signal Generator
Oscilloscope
X-Band to L-Band Down Converter

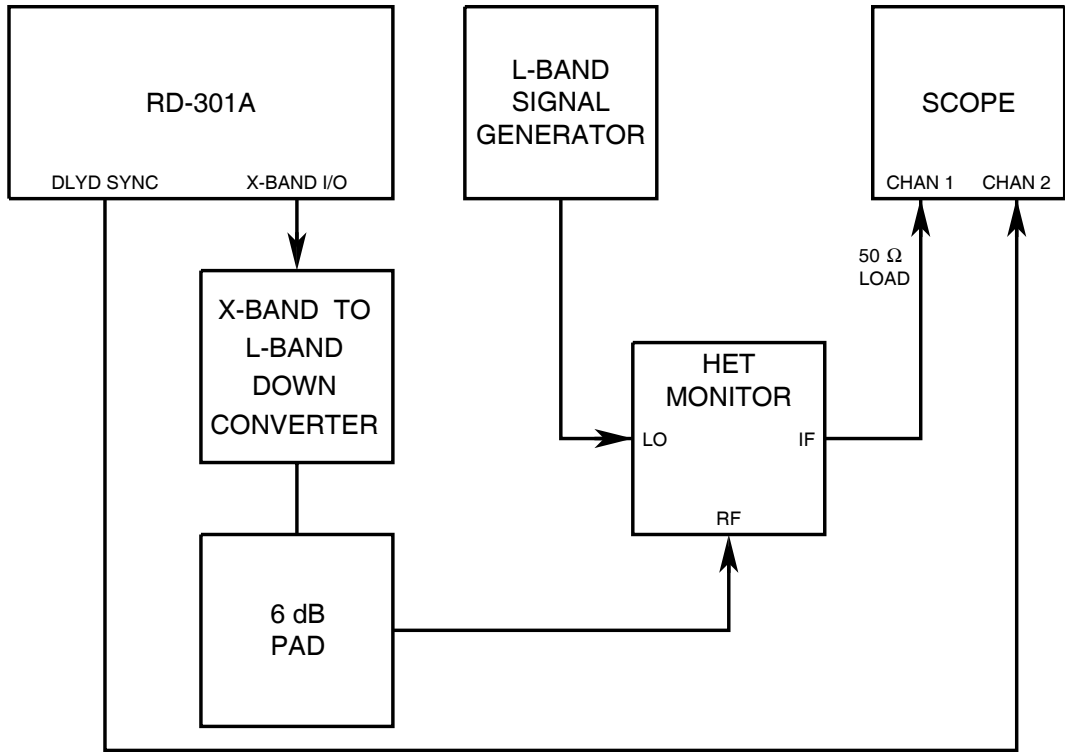

9006006

Pulse Width Verification Setup
Figure 6

STEP

PROCEDURE

1. Set RD-301A as follows:

CONTROL	SETTING
(2) PRF/RF Switch	RF
(4) OUTPUT LEVEL FINE dBm Control	0
(9) OUTPUT LEVEL COARSE dBm Control	-50
(10) MNL FREQ Controls	9375.0 MHz
(16) RF/IF MODE Pushbutton Switches	RF MNL
(29) MODULATION MODE Pushbutton Switches	INTL
(31) PULSE WIDTH μ S Control (RANGE 2)	0.5
(32) PULSE WIDTH μ S Control (RANGE 1)	0.5
(34) PULSE WIDTH MULTIPLIER Control (RANGE 1)	0.1
(35) PULSE WIDTH MULTIPLIER Control (RANGE 2)	0.1
(36) μ S/NM Switch	μS
(37) RANGE 1 DELAY Thumbwheels	000.3
(38) RANGE 2 DELAY Thumbwheels	900.0
(39) RANGE SEL Switch	RINGS 1
(42) X1/X10 INTL PRF/AM Switch	X10

2. Apply power to RD-301A and allow for 30 minute stabilization period.
3. Connect test equipment as shown in 2-2-2, Figure 6.

NOTE: Refer to Appendix D for X-Band to L-Band Down Converter.

4. Set L-Band Signal Generator for 1125 MHz CW signal at +5 dBm.
5. Set PRF/RF Switch (2) to **PRF**.
6. Adjust INTL PRF/AM Control (41) until 1000 Hz is shown on FREQUENCY Hz/MHz Digital Display (1).
7. Set PRF/RF Switch (2) to **RF**.
8. Set Oscilloscope to trigger on Channel 2 and sweep speed to 10 ns/Div.
9. Verify pulse width is 50 ns (± 5 ns). If not, perform Calibration Procedures according to 2-2-2, Table 1.

NOTE: All pulse widths are measured from 50% amplitude on rising edge to 50% amplitude on falling edge. Refer to 2-2-2, Figure 7.

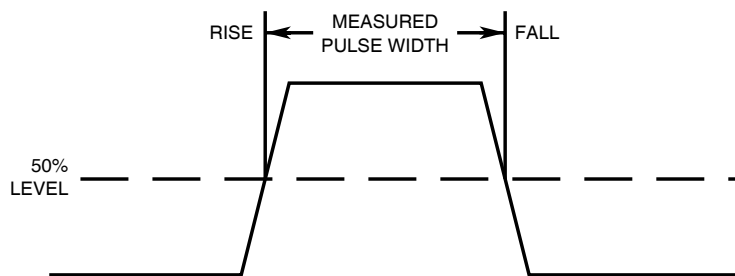

9016002

Pulse Width Measurement Points
Figure 7

10. Set PULSE WIDTH μ S Control (Range 1) (32) to **5**.
11. Set Oscilloscope sweep speed to 100 ns/Div.

STEP	PROCEDURE
12.	Verify pulse width is 500 ns (± 50 ns). If not, perform Calibration Procedures according to 2-2-2, Table 1.
13.	Set PULSE WIDTH MULTIPLIER Control (RANGE 1) (34) to 1 .
14.	Set Oscilloscope sweep speed to 1 μ s/Div.
15.	Verify pulse width is 5 μ s (± 0.5 μ s). If not, perform Calibration Procedures according to 2-2-2, Table 1.
16.	Set PULSE WIDTH MULTIPLIER Control (RANGE 1) (34) to 10 .
17.	Set Oscilloscope sweep speed to 10 μ s/Div.
18.	Verify pulse width is 50 μ s (± 5 μ s). If not, perform Calibration Procedures according to 2-2-2, Table 1.
19.	Set PULSE WIDTH MULTIPLIER Control (RANGE 1) (34) to 100 .
20.	Set PRF/RF Switch (2) to PRF .
21.	Adjust INTL PRF/AM Control (41) until 500 Hz is shown on FREQUENCY Hz/MHz Digital Display (1).
22.	Set PRF/RF Switch (2) to RF .
23.	Set Oscilloscope sweep speed to 100 μ s/Div.
24.	Verify pulse width is 500 μ s (± 50 μ s). If not, perform Calibration Procedures according to 2-2-2, Table 1.
25.	Set PRF/RF Switch (2) to PRF .
26.	Sets PULSE WIDTH μ s Control (RANGE 1) (32) to 0.5 μs .
27.	Set PULSE WIDTH MULTIPLIER Control (RANGE 1) (34) to X500 .
28.	Set X1/X10 INTL PRF Switch (34) to X1 .
29.	Adjust X1/X10 INTL PRF Switch (42) until 125 Hz is shown on FREQUENCY Hz/MHz Digital Display (1).
30.	Verify pulse width is 2.5 ms (2.0 to 3.0 ms).
31.	Set PRF/RF Switch (2) to PRF .
32.	Set RANGE 1 DELAY Thumbwheels (37) to 900.0 .
33.	Set RANGE 2 DELAY Thumbwheels (38) to 000.3 .
34.	Set RANGE SEL Switch (39) R2 ON .
35.	Adjust INTL PRF/AM Control (41) until 1000 kHz is shown on FREQUENCY Hz/MHz Digital Display (1).
36.	Set PRF/RF Switch (2) to RF .
37.	Set Oscilloscope sweep speed to 10 ns/Div.
38.	Verify pulse width is 50 ns (± 5 ns). If not, perform Calibration Procedures according to 2-2-2, Table 1.
39.	Set PULSE WIDTH μ S Control (RANGE 2) (31) to 5 .
40.	Set Oscilloscope sweep speed to 100 ns/Div.
41.	Verify pulse width is 500 ns (± 50 ns). If not, perform Calibration Procedures according to 2-2-2, Table 1.

STEP

PROCEDURE

-
42. Set PULSE WIDTH MULTIPLIER Control (RANGE 2) (35) to **1**.
 43. Set Oscilloscope sweep speed to 1 $\mu\text{s}/\text{Div}$.
 44. Verify pulse width is 5 μs ($\pm 0.5 \mu\text{s}$). If not, perform Calibration Procedures according to 2-2-2, Table 1.
 45. Set PULSE WIDTH MULTIPLIER Control (RANGE 2) (35) to **10**.
 46. Set Oscilloscope sweep speed to 10 $\mu\text{s}/\text{Div}$.
 47. Verify pulse width is 50 μs ($\pm 5 \mu\text{s}$). If not, perform Calibration Procedures according to 2-2-2, Table 1.
 48. Set PULSE WIDTH MULTIPLIER Control (RANGE 2) (35) to **100**.
 49. Set PRF/RF Switch (2) to **PRF**.
 50. Adjust INTL PRF/AM Control (41) until **500 Hz** is shown on FREQUENCY Hz/MHz Digital Display (1).
 51. Set PRF/RF Switch (2) to **RF**.
 52. Set Oscilloscope sweep speed to 100 $\mu\text{s}/\text{Div}$.
 53. Verify pulse width is 500 μs ($\pm 50 \mu\text{s}$). If not, perform Calibration Procedures according to 2-2-2, Table 1.
 54. Disconnect test equipment.

(e) RF ON/OFF Ratio

TEST EQUIPMENT: Spectrum Analyzer

STEP	PROCEDURE
------	-----------

1. Set RD-301A as follows:

CONTROL	SETTING
(2) PRF/RF Switch	RF
(4) OUTPUT LEVEL FINE dBm Control	0
(9) OUTPUT LEVEL COARSE dBm Control	-50
(10) MNL FREQ Controls	9375.00 MHz
(16) RF/IF MODE Pushbutton Switches	RF MNL
(29) MODULATION MODE Pushbutton Switches	CW
(39) RANGE SEL Switch	RINGS 1

2. Apply power to RD-301A and allow for 30 minute stabilization period.
3. Use Serialized Coaxial Cable to connect Spectrum Analyzer to X-BAND I/O Connector (18).
4. Set Spectrum Analyzer as follows:

CONTROL	SETTING
Center Frequency	9375 MHz
Scan Width	5 MHz/Div
Amplitude Scale	10 dB/Div
Reference Level	-40 dBm

5. Center (ON) signal on Spectrum Analyzer display and record level.
6. Set MODULATION MODE Pushbutton Switches (29) to **EXT (+)** without applying external trigger.
7. Verify (OFF) signal level on Spectrum Analyzer is ≥ 70 dB less than level recorded in Step 5. Record level and difference.
8. Disconnect test equipment.

- (2) IF Signal Generator
 - (a) Frequency and IF Counter

TEST EQUIPMENT: Frequency Counter

STEP	PROCEDURE												
1.	Set RD-301A as follows:												
	<table border="1" style="width: 100%; border-collapse: collapse;"> <thead> <tr> <th style="text-align: left;"><u>CONTROL</u></th> <th style="text-align: left;"><u>SETTING</u></th> </tr> </thead> <tbody> <tr> <td>(4) OUTPUT LEVEL FINE dBm Control</td> <td style="text-align: right;"><i>0</i></td> </tr> <tr> <td>(9) OUTPUT LEVEL COARSE dBm Control</td> <td style="text-align: right;"><i>0</i></td> </tr> <tr> <td>(10) MNL FREQ Controls</td> <td style="text-align: right;"><i>fully ccw</i></td> </tr> <tr> <td>(16) RF/IF MODE Pushbutton Switches</td> <td style="text-align: right;"><i>IF HI</i></td> </tr> <tr> <td>(29) MODULATION MODE Pushbutton Switches</td> <td style="text-align: right;"><i>CW</i></td> </tr> </tbody> </table>	<u>CONTROL</u>	<u>SETTING</u>	(4) OUTPUT LEVEL FINE dBm Control	<i>0</i>	(9) OUTPUT LEVEL COARSE dBm Control	<i>0</i>	(10) MNL FREQ Controls	<i>fully ccw</i>	(16) RF/IF MODE Pushbutton Switches	<i>IF HI</i>	(29) MODULATION MODE Pushbutton Switches	<i>CW</i>
<u>CONTROL</u>	<u>SETTING</u>												
(4) OUTPUT LEVEL FINE dBm Control	<i>0</i>												
(9) OUTPUT LEVEL COARSE dBm Control	<i>0</i>												
(10) MNL FREQ Controls	<i>fully ccw</i>												
(16) RF/IF MODE Pushbutton Switches	<i>IF HI</i>												
(29) MODULATION MODE Pushbutton Switches	<i>CW</i>												
2.	Apply power to RD-301A and allow for 30 minute stabilization period.												
3.	Connect Frequency Counter to IF OUT Connector (15).												
4.	Verify ≤ 20 MHz on Frequency Counter. Record reading.												
5.	Verify FREQUENCY Hz/MHz Digital Display (1) equals Frequency Counter reading from Step 4 (± 2 kHz).												
6.	Adjust MNL FREQ Controls (10) <i>fully cw</i> .												
7.	Verify ≥ 70 MHz on Frequency Counter. Record reading.												
8.	Verify FREQUENCY Hz/MHz Digital Display (1) equals Frequency Counter reading from Step 7 (± 7 kHz).												
9.	If RD-301A fails any step, perform Calibration Procedures according to 2-2-2, Table 1.												
10.	Disconnect test equipment.												

(b) Sweep Width

TEST EQUIPMENT: Spectrum Analyzer

STEP	PROCEDURE										
1.	Set RD-301A as follows:										
	<table border="1" style="width: 100%; border-collapse: collapse;"> <thead> <tr> <th style="text-align: left;">CONTROL</th> <th style="text-align: left;">SETTING</th> </tr> </thead> <tbody> <tr> <td>(4) OUTPUT LEVEL FINE dBm Control</td> <td style="text-align: right;">0</td> </tr> <tr> <td>(9) OUTPUT LEVEL COARSE dBm Control</td> <td style="text-align: right;">0</td> </tr> <tr> <td>(16) RF/IF MODE Pushbutton Switches</td> <td style="text-align: right;">IF HI</td> </tr> <tr> <td>(29) MODULATION MODE Pushbutton Switches</td> <td style="text-align: right;">CW</td> </tr> </tbody> </table>	CONTROL	SETTING	(4) OUTPUT LEVEL FINE dBm Control	0	(9) OUTPUT LEVEL COARSE dBm Control	0	(16) RF/IF MODE Pushbutton Switches	IF HI	(29) MODULATION MODE Pushbutton Switches	CW
CONTROL	SETTING										
(4) OUTPUT LEVEL FINE dBm Control	0										
(9) OUTPUT LEVEL COARSE dBm Control	0										
(16) RF/IF MODE Pushbutton Switches	IF HI										
(29) MODULATION MODE Pushbutton Switches	CW										
2.	Apply power to RD-301A and allow for 30 minute stabilization period.										
3.	Connect Spectrum Analyzer to IF OUT Connector (15).										
4.	Set Spectrum Analyzer as follows:										
	<table border="1" style="width: 100%; border-collapse: collapse;"> <thead> <tr> <th style="text-align: left;">CONTROL</th> <th style="text-align: left;">SETTING</th> </tr> </thead> <tbody> <tr> <td>Center Frequency</td> <td style="text-align: right;">30 MHz</td> </tr> <tr> <td>Scan Width</td> <td style="text-align: right;">0.5 kHz/Div</td> </tr> <tr> <td>Reference Level</td> <td style="text-align: right;">+20 dBm</td> </tr> <tr> <td>Sweep Speed</td> <td style="text-align: right;">50 ms/Div</td> </tr> </tbody> </table>	CONTROL	SETTING	Center Frequency	30 MHz	Scan Width	0.5 kHz/Div	Reference Level	+20 dBm	Sweep Speed	50 ms/Div
CONTROL	SETTING										
Center Frequency	30 MHz										
Scan Width	0.5 kHz/Div										
Reference Level	+20 dBm										
Sweep Speed	50 ms/Div										
5.	Adjust MNL FREQ Controls (10) for 30 MHz on FREQUENCY Hz/MHz Digital Display (1).										
6.	Adjust SWEEP WIDTH MHz Control (33) cw .										
7.	Verify carrier starts sweeping when SWEEP WIDTH MHz Control (33) passes 0 setting. If not, perform Calibration Procedures according to 2-2-2, Table 1.										
8.	Set SWEEP WIDTH MHz Control (33) to 4 .										
9.	Verify carrier sweep is displayed across 8.0 divisions (4 MHz sweep width) on Spectrum Analyzer. If not, perform Calibration Procedures according to 2-2-2, Table 1.										
10.	Set SWEEP WIDTH MHz Control (33) to OFF .										
11.	Disconnect test equipment.										

(c) Marker Frequency

TEST EQUIPMENT: None

STEP	PROCEDURE														
1.	Set RD-301A as follows:														
	<table border="1" style="width: 100%; border-collapse: collapse;"> <thead> <tr> <th style="text-align: left;">CONTROL</th> <th style="text-align: left;">SETTING</th> </tr> </thead> <tbody> <tr> <td>(2) PRF/RF Switch</td> <td><i>RF</i></td> </tr> <tr> <td>(4) OUTPUT LEVEL FINE dBm Control</td> <td><i>0</i></td> </tr> <tr> <td>(9) OUTPUT LEVEL COARSE dBm Control</td> <td><i>0</i></td> </tr> <tr> <td>(16) RF/IF MODE Pushbutton Switches</td> <td><i>IF HI</i></td> </tr> <tr> <td>(19) MKR FREQ Control</td> <td><i>fully ccw</i></td> </tr> <tr> <td>(29) MODULATION MODE Pushbutton Switches</td> <td><i>CW</i></td> </tr> </tbody> </table>	CONTROL	SETTING	(2) PRF/RF Switch	<i>RF</i>	(4) OUTPUT LEVEL FINE dBm Control	<i>0</i>	(9) OUTPUT LEVEL COARSE dBm Control	<i>0</i>	(16) RF/IF MODE Pushbutton Switches	<i>IF HI</i>	(19) MKR FREQ Control	<i>fully ccw</i>	(29) MODULATION MODE Pushbutton Switches	<i>CW</i>
CONTROL	SETTING														
(2) PRF/RF Switch	<i>RF</i>														
(4) OUTPUT LEVEL FINE dBm Control	<i>0</i>														
(9) OUTPUT LEVEL COARSE dBm Control	<i>0</i>														
(16) RF/IF MODE Pushbutton Switches	<i>IF HI</i>														
(19) MKR FREQ Control	<i>fully ccw</i>														
(29) MODULATION MODE Pushbutton Switches	<i>CW</i>														
2.	Apply power to RD-301A and allow for 30 minute stabilization period.														
3.	Press DISPLAY MKR Switch (21) and verify ≤ 20 MHz on FREQUENCY Hz/MHz Digital Display (1). Record reading.														
4.	Adjust MKR FREQ Control (19) <i>fully cw</i> .														
5.	Press DISPLAY MKR Switch (21) and verify ≥ 70 MHz on FREQUENCY Hz/MHz Digital Display (1). Record reading.														
6.	If RD-301A fails any step, perform Calibration Procedures according to 2-2-2, Table 1.														

(d) Power

TEST EQUIPMENT: Spectrum Analyzer

STEP	PROCEDURE												
1.	Set RD-301A as follows:												
	<table border="1"> <thead> <tr> <th>CONTROL</th> <th>SETTING</th> </tr> </thead> <tbody> <tr> <td>(4) OUTPUT LEVEL FINE dBm Control</td> <td>0</td> </tr> <tr> <td>(9) OUTPUT LEVEL COARSE dBm Control</td> <td>0</td> </tr> <tr> <td>(10) MNL FREQ Controls</td> <td>30 MHz</td> </tr> <tr> <td>(16) RF/IF MODE Pushbutton Switches</td> <td>IF HI</td> </tr> <tr> <td>(29) MODULATION MODE Pushbutton Switches</td> <td>CW</td> </tr> </tbody> </table>	CONTROL	SETTING	(4) OUTPUT LEVEL FINE dBm Control	0	(9) OUTPUT LEVEL COARSE dBm Control	0	(10) MNL FREQ Controls	30 MHz	(16) RF/IF MODE Pushbutton Switches	IF HI	(29) MODULATION MODE Pushbutton Switches	CW
CONTROL	SETTING												
(4) OUTPUT LEVEL FINE dBm Control	0												
(9) OUTPUT LEVEL COARSE dBm Control	0												
(10) MNL FREQ Controls	30 MHz												
(16) RF/IF MODE Pushbutton Switches	IF HI												
(29) MODULATION MODE Pushbutton Switches	CW												
2.	Apply power to RD-301A and allow for 30 minute stabilization period.												
3.	Connect Spectrum Analyzer to IF OUT Connector (15).												
4.	Set Spectrum Analyzer as follows:												
	<table border="1"> <thead> <tr> <th>CONTROL</th> <th>SETTING</th> </tr> </thead> <tbody> <tr> <td>Center Frequency</td> <td>30 MHz</td> </tr> <tr> <td>Scan Width</td> <td>5 MHz/Div</td> </tr> <tr> <td>Amplitude Scale</td> <td>2 dB/Div</td> </tr> <tr> <td>Reference Level</td> <td>-8 dBm</td> </tr> </tbody> </table>	CONTROL	SETTING	Center Frequency	30 MHz	Scan Width	5 MHz/Div	Amplitude Scale	2 dB/Div	Reference Level	-8 dBm		
CONTROL	SETTING												
Center Frequency	30 MHz												
Scan Width	5 MHz/Div												
Amplitude Scale	2 dB/Div												
Reference Level	-8 dBm												
5.	Adjust MNL FREQ Controls (10) for 30 MHz on FREQUENCY Hz/MHz Digital Display (1).												
6.	Verify signal level is 0 dBm (± 2.5 dB). If not, perform Calibration Procedures according to 2-2-2, Table 1.												
7.	Set Spectrum Analyzer reference level to +10 dBm.												
8.	Set OUTPUT LEVEL COARSE dBm Control (9) to +20 .												
9.	Verify signal level is +20 dBm (± 2.7 dB). If not, perform Calibration Procedures according to 2-2-2, Table 1.												
10.	Set RF/IF MODE Pushbutton Switches (16) to IF LO .												
11.	Set OUTPUT LEVEL COARSE dBm Control (9) to -120 .												
12.	Set OUTPUT LEVEL FINE dBm Control (4) to -10 .												
13.	Set Spectrum Analyzer reference level to -134 dBm.												
14.	Verify signal level is -130 dBm (± 3.8 dB). If not, perform Calibration Procedures according to 2-2-2, Table 1.												
15.	Disconnect test equipment.												

(e) Pulse Width

TEST EQUIPMENT: Oscilloscope

STEP	PROCEDURE
------	-----------

1. Set RD-301A as follows:

CONTROL	SETTING
(2) PRF/RF Switch	RF
(4) OUTPUT LEVEL FINE dBm Control	0
(9) OUTPUT LEVEL COARSE dBm Control	0
(10) MNL FREQ Controls	30 MHz
(16) RF/IF MODE Pushbutton Switches	IF HI
(29) MODULATION MODE Pushbutton Switches	INTL
(32) PULSE WIDTH μ S Control (RANGE 1)	0.5
(34) PULSE WIDTH MULTIPLIER Control (RANGE 1)	1
(36) μ S/NM Switch	μS
(39) RANGE SEL Switch	RINGS 1
(42) X1/X10 INTL PRF/AM Switch	X10

2. Apply power to RD-301A and allow for 30 minute stabilization period.
3. Connect Oscilloscope Channel 1 to IF OUT Connector (15) and Oscilloscope Trigger to DLYD SYNC Connector (24).
4. Set PRF/RF Switch (2) to **PRF**.
5. Adjust INTL PRF/AM Control (41) until **1000 Hz** is shown on FREQUENCY Hz/MHz Digital Display (1).
6. Set Oscilloscope sweep speed to 100 ns/Div.
7. Verify pulse width is 500 ns (± 50 ns). If not, perform Calibration Procedures according to 2-2-2, Table 1.

NOTE: All pulse widths are measured from 50% amplitude on rising edge to 50% amplitude on falling edge. Refer to 2-2-2, Figure 7.
8. Set PULSE WIDTH μ S Control (RANGE 1) (32) to **5**.
9. Set PULSE WIDTH MULTIPLIER Control (RANGE 1) (34) to **100**.
10. Adjust INTL PRF/AM Control (41) until **500 Hz** is shown on FREQUENCY Hz/MHz Digital Display (1).
11. Set Oscilloscope sweep speed to 100 μ s/Div.
12. Verify pulse width is 500 μ s (± 50 μ s). If not, perform Calibration Procedures according to 2-2-2, Table 1.
13. Disconnect test equipment.

(f) IF ON/OFF Ratio

TEST EQUIPMENT: Spectrum Analyzer

STEP	PROCEDURE														
1.	Set RD-301A as follows:														
	<table border="1"> <thead> <tr> <th>CONTROL</th> <th>SETTING</th> </tr> </thead> <tbody> <tr> <td>(2) PRF/RF Switch</td> <td>RF</td> </tr> <tr> <td>(4) OUTPUT LEVEL FINE dBm Control</td> <td>0</td> </tr> <tr> <td>(9) OUTPUT LEVEL COARSE dBm Control</td> <td>+20</td> </tr> <tr> <td>(10) MNL FREQ Controls</td> <td>30 MHz</td> </tr> <tr> <td>(16) RF/IF MODE Pushbutton Switches</td> <td>IF HI</td> </tr> <tr> <td>(29) MODULATION MODE Pushbutton Switches</td> <td>CW</td> </tr> </tbody> </table>	CONTROL	SETTING	(2) PRF/RF Switch	RF	(4) OUTPUT LEVEL FINE dBm Control	0	(9) OUTPUT LEVEL COARSE dBm Control	+20	(10) MNL FREQ Controls	30 MHz	(16) RF/IF MODE Pushbutton Switches	IF HI	(29) MODULATION MODE Pushbutton Switches	CW
CONTROL	SETTING														
(2) PRF/RF Switch	RF														
(4) OUTPUT LEVEL FINE dBm Control	0														
(9) OUTPUT LEVEL COARSE dBm Control	+20														
(10) MNL FREQ Controls	30 MHz														
(16) RF/IF MODE Pushbutton Switches	IF HI														
(29) MODULATION MODE Pushbutton Switches	CW														
2.	Apply power to RD-301A and allow for 30 minute stabilization period.														
3.	Connect Spectrum Analyzer to IF OUT Connector (15).														
4.	Set Spectrum Analyzer as follows:														
	<table border="1"> <thead> <tr> <th>CONTROL</th> <th>SETTING</th> </tr> </thead> <tbody> <tr> <td>Center Frequency</td> <td>30 MHz</td> </tr> <tr> <td>Scan Width</td> <td>5 MHz/Div</td> </tr> <tr> <td>Amplitude Scale</td> <td>10 dB/Div</td> </tr> <tr> <td>Reference Level</td> <td>+25 dBm</td> </tr> </tbody> </table>	CONTROL	SETTING	Center Frequency	30 MHz	Scan Width	5 MHz/Div	Amplitude Scale	10 dB/Div	Reference Level	+25 dBm				
CONTROL	SETTING														
Center Frequency	30 MHz														
Scan Width	5 MHz/Div														
Amplitude Scale	10 dB/Div														
Reference Level	+25 dBm														
5.	Center (ON) signal on Spectrum Analyzer display and record level.														
6.	Set MODULATION MODE Pushbutton Switches (29) to EXT (+) without applying external trigger.														
7.	Verify (OFF) signal level on Spectrum Analyzer is ≥ 48 dB less than level recorded in Step 5. Record level and difference.														
8.	Set MODULATION MODE Pushbutton Switches (29) to CW .														
9.	Set MNL FREQ Controls (10) for 60 MHz according to FREQUENCY Hz/MHz Digital Display (1).														
10.	Set Spectrum Analyzer center frequency to 60 MHz .														
11.	Center (ON) signal on Spectrum Analyzer display and record level.														
12.	Set MODULATION MODE Pushbutton Switches (29) to EXT (+) without applying external trigger.														
13.	Verify (OFF) signal level on Spectrum Analyzer is ≥ 48 dB less than level recorded in Step 11. Record level and difference.														
14.	Disconnect test equipment.														

(3) INTL Modulation/PRF Counter

TEST EQUIPMENT: Frequency Counter

STEP	PROCEDURE	SETTING
1.	Set RD-301A as follows:	
	CONTROL	
	(2) PRF/RF Switch	PRF
	(29) MODULATION MODE Pushbutton Switches	INTL
	(42) X1/X10 INTL PRF/AM Switch	X1
2.	Apply power to RD-301A and allow for 30 minute stabilization period.	
3.	Connect Frequency Counter to SYNC Connector (26).	
4.	Adjust INTL PRF/AM Control (41) for 50 Hz sync pulse frequency on Frequency Counter.	
5.	Verify INTL PRF/AM Control (41) setting is within marked area for 50 Hz . If not, perform Calibration Procedures according to 2-2-2, Table 1.	
6.	Verify FREQUENCY Hz/MHz Digital Display (1) reads 50 Hz (± 1 Hz). If not, perform Calibration Procedures according to 2-2-2, Table 1.	
7.	Adjust INTL PRF/AM Control (41) for 500 Hz sync pulse frequency on Frequency Counter.	
8.	Verify INTL PRF/AM Control (41) setting is within marked area for 500 Hz . If not, perform Calibration Procedures according to 2-2-2, Table 1.	
9.	Verify FREQUENCY Hz/MHz Digital Display (1) reads 500 Hz (± 1 Hz). If not, perform Calibration Procedures according to 2-2-2, Table 1.	
10.	Set X1/X10 INTL PRF/AM Switch (42) to X10 .	
11.	Adjust INTL PRF/AM Control (41) for 500 Hz sync pulse frequency on Frequency Counter.	
12.	Verify INTL PRF/AM Control (41) setting is within marked area for 50 Hz . If not, perform Calibration Procedures according to 2-2-2, Table 1.	
13.	Verify FREQUENCY Hz/MHz Digital Display (1) reads 500 Hz (± 1 Hz). If not, perform Calibration Procedures according to 2-2-2, Table 1.	
14.	Verify frequencies in Steps 9 and 10 overlap frequencies in Steps 12 and 13. If not, perform Calibration Procedures according to 2-2-2, Table 1.	
15.	Adjust INTL PRF/AM Control (41) for 5000 Hz sync pulse frequency on Frequency Counter.	
16.	Verify INTL PRF/AM Control (41) setting is within marked area for 500 Hz . If not, perform Calibration Procedures according to 2-2-2, Table 1.	
17.	Verify FREQUENCY Hz/MHz Digital Display (1) reads 5000 Hz (± 2 Hz). If not, perform Calibration Procedures according to 2-2-2, Table 1.	
18.	Disconnect test equipment.	

(4) Range

TEST EQUIPMENT: Pulse Generator
Oscilloscope
X-Band to L-Band Down Converter
L-Band Signal Generator

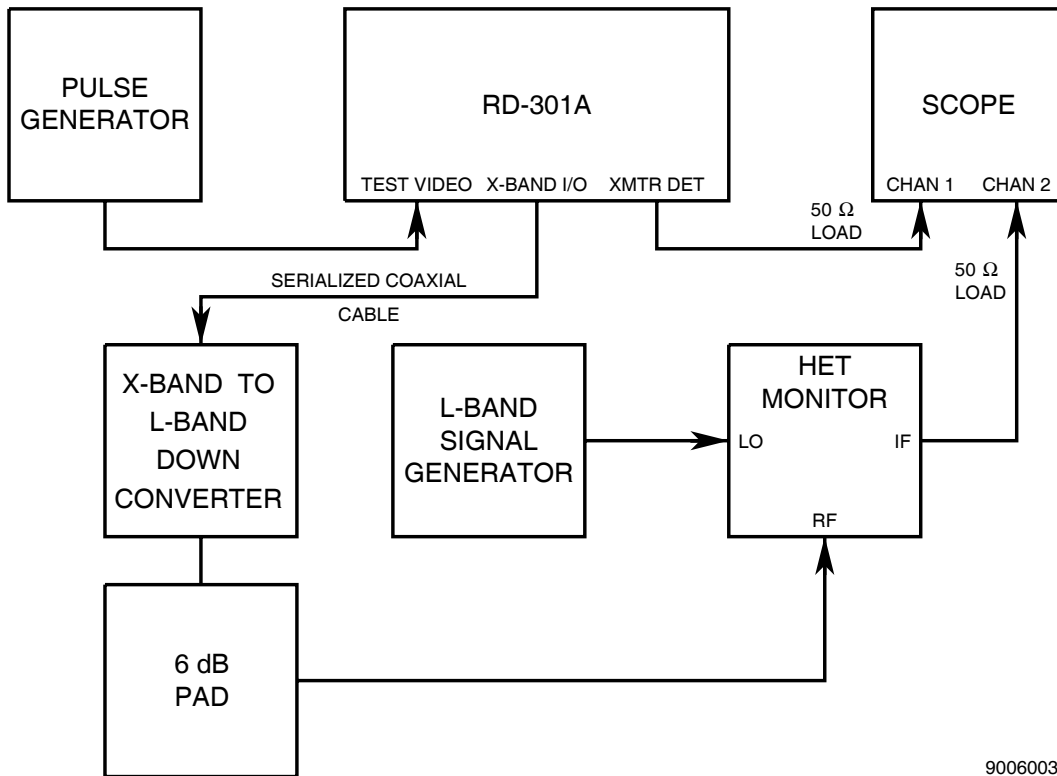

Range Delay Verification Setup
Figure 8

9006003

STEP	PROCEDURE
------	-----------

1. Set RD-301A as follows:

CONTROL	SETTING
(2) PRF/RF Switches	<i>RF</i>
(10) MNL FREQ Controls	<i>9375.0 MHz</i>
(16) RF/IF MODE Pushbutton Switches	<i>RF MNL</i>
(29) MODULATION MODE Pushbutton Switches	<i>TRACK</i>
(31) PULSE WIDTH μ S Control (RANGE 2)	<i>5</i>
(32) PULSE WIDTH μ S Control (RANGE 1)	<i>5</i>
(34) PULSE WIDTH MULTIPLIER Control (RANGE 1)	<i>1</i>
(35) PULSE WIDTH MULTIPLIER Control (RANGE 2)	<i>1</i>
(36) μ S/NM Switch	<i>μS</i>
(37) RANGE 1 DELAY Thumbwheels	<i>000.0</i>
(38) RANGE 2 DELAY Thumbwheels	<i>000.0</i>
(39) RANGE SEL Switch	<i>RINGS 1</i>

2. Apply power to RD-301A and allow for 30 minute stabilization period.
3. Connect test equipment as shown in 2-2-2, Figure 8.

STEP	PROCEDURE
------	-----------

4. Set Pulse Generator for 3 μ s pulse at TTL level and 1 kHz PRF.
5. Set L-Band Signal Generator for 1125 MHz CW signal at +7 dBm.
NOTE: Keep RD-301A and L-Band Signal Generator near same L-Band frequency (zero-beat) for minimum distortion.
6. Set Oscilloscope to display both channels.
NOTE: Insure both Oscilloscope channel delays are calibrated to match.

RANGE 1

7. Verify residual delay is 0.1 μ s ($\pm 0.1 \mu$ s). Record Range 1 residual delay.
NOTE: Measure range and residual delays from leading edge of XMTR DET Connector (13) transmitter pulse to leading edge of X-Band I/O Connector (18) reply pulse at 50% amplitude points.
NOTE: Refer to Appendix D. Subtract fixed delay through X-Band to L-Band Down Converter from RD-301A range delay measurement to obtain actual range delay.
8. Set RANGE 1 DELAY Thumbwheels (37) to **000.1**.
9. Verify range delay is 0.1 μ s + residual delay from Step 7.
10. Set μ S/NM Switch (36) to **NM**.
11. Verify range delay is 1.236 μ s + residual delay from Step 7.
12. Set μ S/NM Switch (36) to **μ S**.
13. Set RANGE 1 DELAY Thumbwheels (37) to **100.0**.
14. Verify range delay is 100 μ s + residual delay from Step 7 (± 10 ns).
15. Set RANGE SEL Switch (39) according to 2-2-2, Table 3 and verify results (leading edge to leading edge at 50% amplitude points).

SETTING	RESULT
RINGS 2	Two reply pulses are present. Ring 2 reply pulse occurs 100 μ s (± 10 ns) after Ring 1 reply pulse.
RINGS 3	Three reply pulses are present. Ring 3 reply pulse occurs 100 μ s (± 10 ns) after Ring 2 reply pulse.
RINGS 4	Four reply pulses are present. Ring 4 reply pulse occurs 100 μ s (± 10 ns) after Ring 3 reply pulse.
RINGS 5	Five reply pulses are present. Ring 5 reply pulse occurs 100 μ s (± 10 ns) after Ring 4 reply pulse.

Range Reply Rings Verification
Table 3

16. Set RANGE SEL Switch (39) to **RINGS 1**.
17. Set RANGE 1 DELAY Thumbwheels (37) to **999.9**.
18. Adjust Oscilloscope and use Δ time to verify range delay is 999.9 μ s + residual delay from Step 7 ($\pm 0.1 \mu$ s).

STEP PROCEDURE

19. Set μ S/NM Switch (36) to **NM**.
20. Verify range delay is 12.358 ms + residual delay from Step 7 ($\pm 1.2 \mu$ s).

RANGE 2

21. Reset RD-301A as follows:

CONTROL

SETTING

(36) μ S/NM Switch	μ S
(37) RANGE 1 DELAY Thumbwheels	100.0
(39) RANGE SEL Control	R2 ON

22. Verify residual delay is 0.4 μ s ($\pm 0.1 \mu$ s). Record Range 2 residual delay. If not, perform calibration procedures according to 2-2-2, Table 1.
23. Set RANGE 2 DELAY Thumbwheels (38) to **000.1**.
24. Verify range delay is 0.1 μ s + residual delay from Step 22. If not, perform calibration procedures according to 2-2-2, Table 1.
25. Set μ S/NM Switch (36) to **NM**.
26. Verify range delay is 1.236 μ s + residual delay from Step 22. If not, perform calibration procedures according to 2-2-2, Table 1.
27. Set μ S/NM Switch (36) to **μ S**.
28. Set RANGE 2 DELAY Thumbwheels (38) to **999.9**.
29. Adjust Oscilloscope and use Δ time to verify range delay to Range 2 reply pulse is 999.9 μ s + residual delay from Step 22 ($\pm 0.1 \mu$ s). If not, perform calibration procedures according to 2-2-2, Table 1.
30. Set μ S/NM Switch (36) to **NM**.
31. Verify range delay to Range 2 reply pulse is 12.358 ms + residual delay from Step 22 ($\pm 1.2 \mu$ s). If not, perform calibration procedures according to 2-2-2, Table 1.
32. Disconnect test equipment.

(5) Power Meter

TEST EQUIPMENT: Bandpass Filter
Power Meter Assembly
TWT Amplifier
X-Band Signal Generator

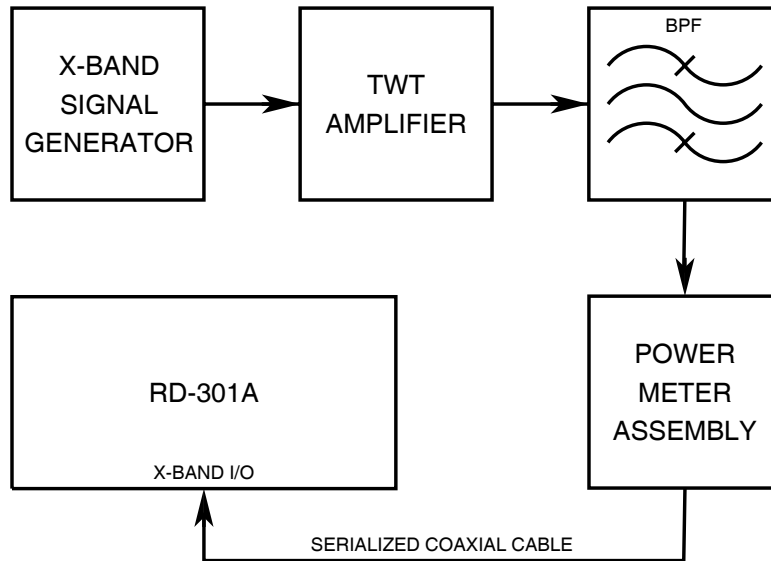

9006004

Power Meter Verification Setup
Figure 9

STEP	PROCEDURE
------	-----------

1. Apply power to RD-301A and allow for 30 minute stabilization period.
2. Set TWT Amplifier power On and in Standby mode.
3. Connect test equipment as shown in 2-2-2, Figure 9.
4. Set X-Band Signal Generator as follows:

CONTROL

SETTING

Frequency	9375 MHz
Pulse Width	3 μ s
PRF	1 kHz

5. Set METER SELECT Switch (47) to **PK POWER**.
6. Record coupling value of Waveguide Coupler used with RD-301A.

NOTE: The coupling value is marked (not tagged value) on Waveguide Coupler.

STEP

PROCEDURE

7. Record 1 kW and 12 kW Test RF Levels from 2-2-2, Table 4 according to Waveguide Coupler Value from Step 6.

WAVEGUIDE COUPLER VALUE	1 kW TEST RF LEVEL	12 kW TEST RF LEVEL
19.0 dB	12.589 W	151.071 W
19.1 dB	12.303 W	147.632 W
19.2 dB	12.023 W	144.272 W
19.3 dB	11.749 W	140.988 W
19.4 dB	11.482 W	137.778 W
19.5 dB	11.220 W	134.642 W
19.6 dB	10.965 W	131.577 W
19.7 dB	10.715 W	128.582 W
19.8 dB	10.471 W	125.655 W
19.9 dB	10.233 W	122.795 W
20.0 dB	10.000 W	120.000 W
20.1 dB	9.772 W	117.268 W
20.2 dB	9.550 W	114.599 W
20.3 dB	9.333 W	111.991 W
20.4 dB	9.120 W	109.441 W
20.5 dB	8.913 W	106.950 W
20.6 dB	8.710 W	104.516 W
20.7 dB	8.511 W	102.137 W
20.8 dB	8.318 W	99.812 W
20.9 dB	8.128 W	97.540 W
21.0 dB	7.943 W	95.319 W

Test RF Levels for Power Meter Verification
Table 4

CAUTION: CONNECTIONS TO TWT AMPLIFIER MUST BE CORRECT BEFORE SWITCHING TO OPERATE MODE.

8. Set TWT Amplifier to Operate mode.
9. Adjust X-Band Signal Generator level until Power Meter Assembly indicates characterized value for 1 kW Test RF Level from Step 7.
10. Verify PANEL Meter (43) indicates **1 kW** (± 148 W). If not, perform Calibration Procedures according to 2-2-2, Table 1.
11. Adjust X-Band Signal Generator level until Power Meter Assembly indicates characterized value for 12 kW Test RF Level from Step 7.
12. Verify PANEL Meter (43) indicates **12 kW** (± 1776 W). If not, perform Calibration Procedures according to 2-2-2, Table 1.
13. Slowly decrease TWT Amplifier power and set to Standby mode for ≥ 15 minutes.
14. Disconnect test equipment.

(6) XMTR DSCRM 0.1V/MHz Connector

TEST EQUIPMENT: Oscilloscope
TWT Amplifier
X-Band Signal Generator

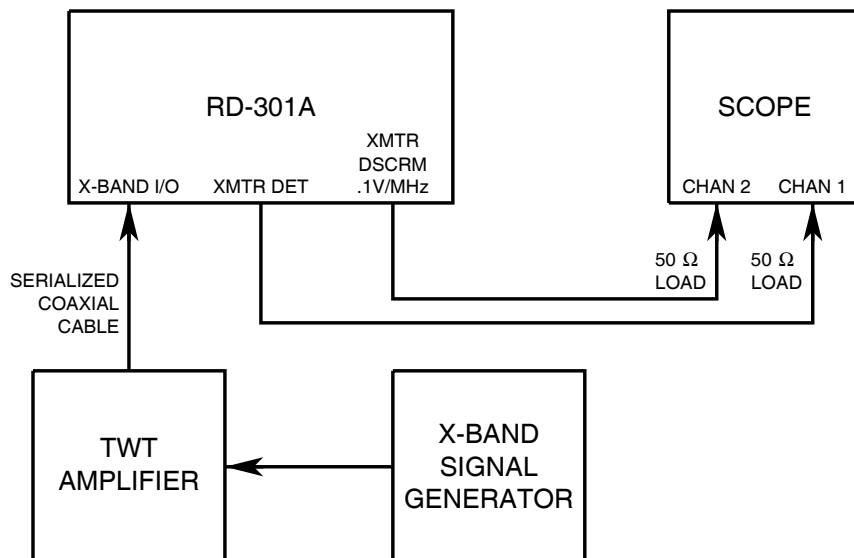

9006017

XMTR DSCRM 0.1V/MHz Connector Verification Setup
Figure 10

STEP	PROCEDURE
------	-----------

1. Set RD-301A as follows:

CONTROL	SETTING
(2) PRF/RF Switch	RF
(4) OUTPUT LEVEL FINE dBm Control	0
(9) OUTPUT LEVEL COARSE dBm Control	-50
(16) RF/IF MODE Pushbutton Switches	RF MNL
(29) MODULATION MODE Pushbutton Switches	TRACK

2. Apply power to RD-301A and allow for 30 minute stabilization period.
3. Connect test equipment as shown in 2-2-2, Figure 10.
4. Set TWT Amplifier power On and in Standby mode.
5. Set Oscilloscope with both channels dc coupled as follows:

CONTROL	SETTING
Sweep Speed	500 ns/Div
Amplitude Scale (Channel 1)	50 mV/Div
Amplitude Scale (Channel 2)	10 mV/Div
Trigger	Channel 1

STEP PROCEDURE

6. Set X-Band Signal Generator as follows:

CONTROL	SETTING
Frequency	9400 MHz
Pulse Width	5 μ s
PRF	500 Hz

CAUTION: CONNECTIONS TO TWT AMPLIFIER MUST BE CORRECT BEFORE SWITCHING TO OPERATE MODE.

7. Set TWT Amplifier to Operate mode.
8. Set X-Band Signal Generator output level for PANEL Meter (43) reading of **0.5 kW**.
9. Adjust MNL FREQ Controls (10) to align XMTR DSCRM .1V/MHz Connector (12) pulses with XMTR DET Connector (13) pulses.
10. Record FREQUENCY Hz/MHz Digital Display (1) readout as reference.
11. Set Oscilloscope to display only Channel 2 and center pulse level on first horizontal graticule below top of screen.
12. Adjust MNL FREQ Controls (10) for Step 10 reference minus 0.5 MHz as shown on FREQUENCY Hz/MHz Digital Display (1).
13. Verify pulse level on Oscilloscope decreases 50 mV (± 5 mV).
14. Adjust MNL FREQ Controls (10) for Step 10 reference.
15. Set Oscilloscope to center pulse level on second horizontal graticule above bottom of screen.
16. Adjust MNL FREQ Controls (10) for Step 10 reference plus 0.5 MHz as shown on FREQUENCY Hz/MHz Digital Display (1).
17. Verify pulse level on Oscilloscope increases 50 mV (± 5 mV).
18. Slowly decrease TWT Amplifier power and set to Standby mode for ≥ 15 minutes.
19. Disconnect test equipment.

(7) Inputs

(a) AM EXT INPUT Connector

TEST EQUIPMENT: Function Generator
Modulation Meter
X-Band to L-Band Down Converter

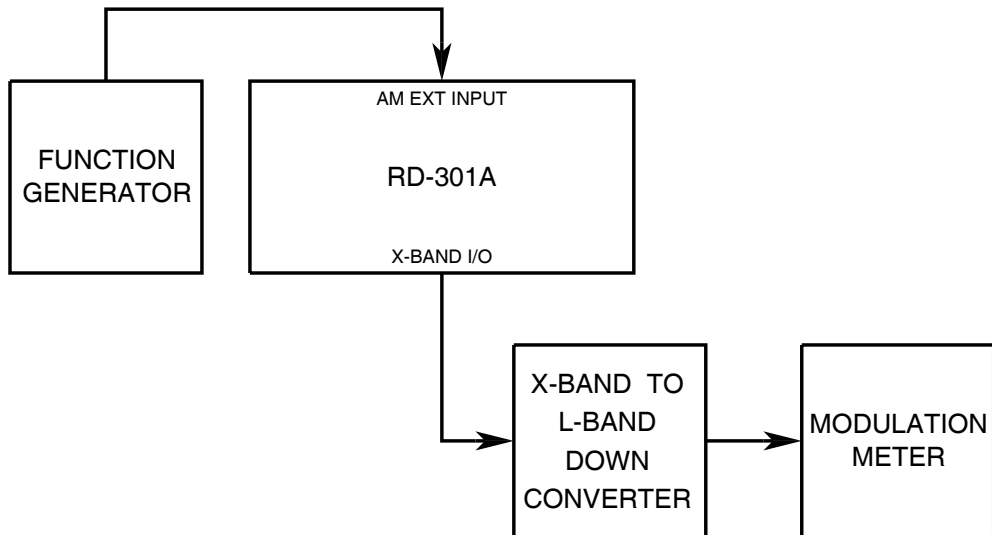

9006016

AM EXT INPUT Connector Verification Setup
Figure 11

STEP	PROCEDURE														
1.	Apply power to RD-301A and allow for 30 minute stabilization period.														
2.	Set RD-301A as follows:														
	<table border="1"> <thead> <tr> <th>CONTROL</th> <th>SETTING</th> </tr> </thead> <tbody> <tr> <td>(2) PRF/RF Switch</td> <td>RF</td> </tr> <tr> <td>(4) OUTPUT LEVEL FINE dBm Control</td> <td>0</td> </tr> <tr> <td>(9) OUTPUT LEVEL COARSE dBm Control</td> <td>-50</td> </tr> <tr> <td>(10) MNL FREQ Controls</td> <td>9375 MHz</td> </tr> <tr> <td>(16) RF/IF MODE Pushbutton Switches</td> <td>RF MNL</td> </tr> <tr> <td>(29) MODULATION MODE Pushbutton Switches</td> <td>CW</td> </tr> </tbody> </table>	CONTROL	SETTING	(2) PRF/RF Switch	RF	(4) OUTPUT LEVEL FINE dBm Control	0	(9) OUTPUT LEVEL COARSE dBm Control	-50	(10) MNL FREQ Controls	9375 MHz	(16) RF/IF MODE Pushbutton Switches	RF MNL	(29) MODULATION MODE Pushbutton Switches	CW
CONTROL	SETTING														
(2) PRF/RF Switch	RF														
(4) OUTPUT LEVEL FINE dBm Control	0														
(9) OUTPUT LEVEL COARSE dBm Control	-50														
(10) MNL FREQ Controls	9375 MHz														
(16) RF/IF MODE Pushbutton Switches	RF MNL														
(29) MODULATION MODE Pushbutton Switches	CW														
3.	Connect test equipment as shown in 2-2-2, Figure 11.														
4.	Set Function Generator for 1 kHz sine wave at 3 Vp-p.														
5.	Verify 30% ($\pm 2\%$) modulation on Modulation Meter. If not, perform Calibration Procedures according to 2-2-2, Table 1.														
6.	Disconnect test equipment.														

(b) EXT TRIG Connector

TEST EQUIPMENT: Oscilloscope
Pulse Generator

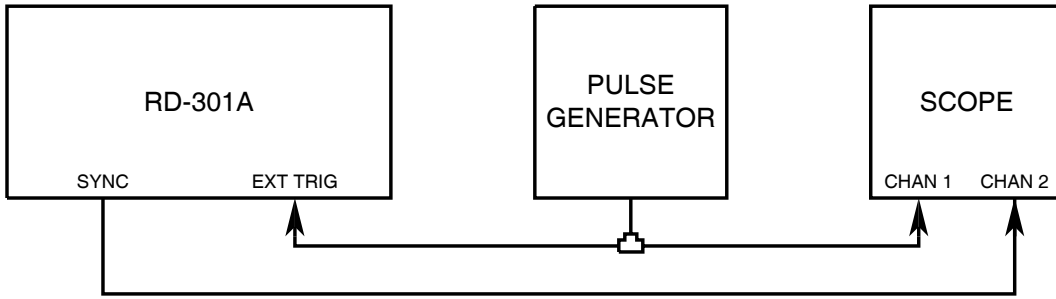

9006015

EXT TRIG Connector Verification Setup
Figure 12

STEP	PROCEDURE
------	-----------

1. Set RD-301A as follows:

CONTROL

SETTING

(2) PRF/RF Switch	PRF
(29) MODULATION MODE Pushbutton Switches	EXT (+)
(36) μ S/NM Switch	μS
(37) RANGE 1 DELAY Thumbwheels	000.3
(39) RANGE SEL Switch	RINGS 1

2. Apply power to RD-301A and allow for 30 minute stabilization period.
3. Connect test equipment as shown in 2-2-2, Figure 12.
4. Set Oscilloscope to trigger on positive edge of Channel 1 input.
5. Set Pulse Generator for 1 μ s wide positive pulse, 2 Vp-p at 1 kHz.
6. Adjust output level of Pulse Generator and verify sync pulse appears.
7. Set MODULATION MODE Pushbutton Switches (29) to **EXT (-)**.
8. Set Pulse Generator for 1 μ s wide negative pulse, 2 Vp-p at 1 kHz.
9. Set Oscilloscope to trigger on negative edge of Channel 1 input.
10. Adjust output level of Pulse Generator and verify sync pulse appears.
11. Disconnect test equipment.



G. Verification Data Sheet

RD-301A S/N: _____ DATE: _____

TECHNICIAN: _____

STEP	DATA	RESULT
(1)	RF Signal Generator	
(a)	Frequency and RF Counter	
	4. Frequency ≤ 9295 MHz	_____
	5. FREQUENCY Hz/MHz Digital Display (1) readout equals Step 4 reading (± 250 kHz)	_____
	7. Frequency ≥ 9500 MHz	_____
	8. FREQUENCY Hz/MHz Digital Display (1) readout equals Step 7 reading (± 250 kHz)	_____
(b)	Tracking and ΔF Offset	
	TRACKING	
	11. Frequency Difference (30 μ s wide pulse)	
	(9295 MHz at 0.5 kW) ≤ 25 kHz	_____
	(9400 MHz at 0.5 kW) ≤ 25 kHz	_____
	(9500 MHz at 0.5 kW) ≤ 25 kHz	_____
	(9295 MHz at 12 kW) ≤ 25 kHz	_____
	(9400 MHz at 12 kW) ≤ 25 kHz	_____
	(9500 MHz at 12 kW) ≤ 25 kHz	_____
	12. XMTR HET MON Connector (11) output	
	(9295 MHz at 0.5 kW)	_____ (✓)
	(9400 MHz at 0.5 kW)	_____ (✓)
	(9500 MHz at 0.5 kW)	_____ (✓)
	(9295 MHz at 12 kW)	_____ (✓)
	(9400 MHz at 12 kW)	_____ (✓)
	(9500 MHz at 12 kW)	_____ (✓)



STEP	DATA	RESULT
14.	Frequency Difference (2 μ s wide pulse)	
	(9295 MHz at 0.5 kW) \leq 25 kHz	-----
	(9400 MHz at 0.5 kW) \leq 25 kHz	-----
	(9500 MHz at 0.5 kW) \leq 25 kHz	-----
	(9295 MHz at 12 kW) \leq 25 kHz	-----
	(9400 MHz at 12 kW) \leq 25 kHz	-----
	(9500 MHz at 12 kW) \leq 25 kHz	-----
15.	XMTR HET MON Connector (11) output	
	(9295 MHz at 0.5 kW)	----- (✓)
	(9400 MHz at 0.5 kW)	----- (✓)
	(9500 MHz at 0.5 kW)	----- (✓)
	(9295 MHz at 12 kW)	----- (✓)
	(9400 MHz at 12 kW)	----- (✓)
	(9500 MHz at 12 kW)	----- (✓)
18.	Frequency Difference (0.5 μ s wide pulse)	
	(9295 MHz at 0.5 kW) \leq 60 kHz	-----
	(9400 MHz at 0.5 kW) \leq 60 kHz	-----
	(9500 MHz at 0.5 kW) \leq 60 kHz	-----
	(9295 MHz at 12 kW) \leq 60 kHz	-----
	(9400 MHz at 12 kW) \leq 60 kHz	-----
	(9500 MHz at 12 kW) \leq 60 kHz	-----
19.	XMTR HET MON Connector (11) output	
	(9295 MHz at 0.5 kW)	----- (✓)
	(9400 MHz at 0.5 kW)	----- (✓)
	(9500 MHz at 0.5 kW)	----- (✓)
	(9295 MHz at 12 kW)	----- (✓)
	(9400 MHz at 12 kW)	----- (✓)
	(9500 MHz at 12 kW)	----- (✓)

STEP	DATA	RESULT
22.	Frequency Difference (0.5 μ s wide pulse)	
	(9295 MHz at 0.5 kW) \leq 600 kHz	-----
	(9400 MHz at 0.5 kW) \leq 600 kHz	-----
	(9500 MHz at 0.5 kW) \leq 600 kHz	-----
	(9295 MHz at 12 kW) \leq 600 kHz	-----
	(9400 MHz at 12 kW) \leq 600 kHz	-----
	(9500 MHz at 12 kW) \leq 600 kHz	-----
23.	XMTR HET MON Connector (11) output	
	(9295 MHz at 0.5 kW)	----- (✓)
	(9400 MHz at 0.5 kW)	----- (✓)
	(9500 MHz at 0.5 kW)	----- (✓)
	(9295 MHz at 12 kW)	----- (✓)
	(9400 MHz at 12 kW)	----- (✓)
	(9500 MHz at 12 kW)	----- (✓)
26.	Frequency Difference (0.05 μ s wide pulse)	
	(9295 MHz at 0.5 kW) \leq 2 MHz	-----
	(9400 MHz at 0.5 kW) \leq 2 MHz	-----
	(9500 MHz at 0.5 kW) \leq 2 MHz	-----
	(9295 MHz at 12 kW) \leq 2 MHz	-----
	(9400 MHz at 12 kW) \leq 2 MHz	-----
	(9500 MHz at 12 kW) \leq 2 MHz	-----
27.	XMTR HET MON Connector (11) output	
	(9295 MHz at 0.5 kW)	----- (✓)
	(9400 MHz at 0.5 kW)	----- (✓)
	(9500 MHz at 0.5 kW)	----- (✓)
	(9295 MHz at 12 kW)	----- (✓)
	(9400 MHz at 12 kW)	----- (✓)
	(9500 MHz at 12 kW)	----- (✓)
TRACK MODULATION PRF		
45.	50 Hz PRF/9295 MHz 49 to 51 Hz	-----
	50 Hz PRF/9400 MHz 49 to 51 Hz	-----
	50 Hz PRF/9500 MHz 49 to 51 Hz	-----



STEP	DATA	RESULT
46.	50 Hz PRF/9295 MHz	
	Frequency difference ≤ 25 kHz	-----
	50 Hz PRF/9400 MHz	
	Frequency difference ≤ 25 kHz	-----
	50 Hz PRF/9500 MHz	
	Frequency difference ≤ 25 kHz	-----
47.	XMTR HET MON Connector (11) output	
	(50 Hz PRF/9500 MHz)	----- (✓)
	(50 Hz PRF/9500 MHz)	----- (✓)
	(50 Hz PRF/9500 MHz)	----- (✓)
49.	2 kHz PRF/9295 MHz 1999 to 2001 Hz	-----
	2 kHz PRF/9400 MHz 1999 to 2001 Hz	-----
	2 kHz PRF/9500 MHz 1999 to 2001 Hz	-----
50.	2 kHz PRF/9295 MHz	
	Frequency difference ≤ 25 kHz	-----
	2 kHz PRF/9400 MHz	
	Frequency difference ≤ 25 kHz	-----
	2 kHz PRF/9500 MHz	
	Frequency difference ≤ 25 kHz	-----
51.	XMTR HET MON Connector (11) output	
	(2 kHz PRF/9500 MHz)	----- (✓)
	(2 kHz PRF/9500 MHz)	----- (✓)
	(2 kHz PRF/9500 MHz)	----- (✓)
53.	20 kHz PRF/9295 MHz	
	Frequency difference ≤ 25 kHz	-----
	20 kHz PRF/9400 MHz	
	Frequency difference ≤ 25 kHz	-----
	20 kHz PRF/9500 MHz	
	Frequency difference ≤ 25 kHz	-----
54.	XMTR HET MON Connector (11) output	
	(20 kHz PRF/9500 MHz)	----- (✓)
	(20 kHz PRF/9500 MHz)	----- (✓)
	(20 kHz PRF/9500 MHz)	----- (✓)



STEP	DATA	RESULT
ΔF OFFSET		
63.	9400 MHz Frequency Counter reading	_____
66.	Offset -0.75 MHz Step 63 - 750 kHz (± 95 kHz)	_____
67.	XMTR HET MON Connector (11) output	_____ (✓)
69.	Offset +0.75 MHz Step 63 + 750 kHz (± 95 kHz)	_____
70.	XMTR HET MON Connector (11) output	_____ (✓)
(c)	Output Power and Internal AM Amplitude	
8.	Level difference between	
	1 dBm position and reference (≤ 0.5 dB)	_____
	2 dBm position and reference (≤ 0.5 dB)	_____
	3 dBm position and reference (≤ 0.5 dB)	_____
	4 dBm position and reference (≤ 0.5 dB)	_____
	5 dBm position and reference (≤ 0.5 dB)	_____
	6 dBm position and reference (≤ 0.5 dB)	_____
	7 dBm position and reference (≤ 0.5 dB)	_____
	8 dBm position and reference (≤ 0.5 dB)	_____
	9 dBm position and reference (≤ 0.5 dB)	_____
	10 dBm position and reference (≤ 0.5 dB)	_____
10.	Level difference between	
	-60 dBm position and reference (≤ 2 dB)	_____
	-70 dBm position and reference (≤ 2 dB)	_____
	-80 dBm position and reference (≤ 2 dB)	_____
	-90 dBm position and reference (≤ 2 dB)	_____
	-100 dBm position and reference (≤ 2 dB)	_____
12.	Level difference between	
	-110 dBm position and reference (≤ 2 dB)	_____
14.	Level difference between	
	-120 dBm position and reference (≤ 2 dB)	_____
CONTOUR BOOST and INTERNAL AM UP MODULATION		
18.	Level difference between	
	-80 dBm position and reference (≤ 1 dB)	_____



STEP	DATA	RESULT
19.	Level difference between	
	01 position and reference (≤ 0.5 dB)	-----
	02 position and reference (≤ 0.5 dB)	-----
	03 position and reference (≤ 0.5 dB)	-----
	04 position and reference (≤ 0.5 dB)	-----
	05 position and reference (≤ 0.5 dB)	-----
	06 position and reference (≤ 0.5 dB)	-----
	07 position and reference (≤ 0.5 dB)	-----
	08 position and reference (≤ 0.5 dB)	-----
	09 position and reference (≤ 0.5 dB)	-----
20.	Level difference between	
	10 position and reference (≤ 1 dB)	-----
22.	Level difference between	
	20 position and reference (≤ 1 dB)	-----
RANGE 2 ATTENUATION and INTERNAL AM DOWN MODULATION		
25.	Level difference between	
	-80 dBm position and reference (≤ 1.5 dB)	-----
26.	Level difference between	
	01 position and reference (≤ 1.5 dB)	-----
	02 position and reference (≤ 1.5 dB)	-----
	03 position and reference (≤ 1.5 dB)	-----
	04 position and reference (≤ 1.5 dB)	-----
	05 position and reference (≤ 1.5 dB)	-----
	06 position and reference (≤ 1.5 dB)	-----
	07 position and reference (≤ 1.5 dB)	-----
	08 position and reference (≤ 1.5 dB)	-----
	09 position and reference (≤ 1.5 dB)	-----
27.	Level difference between	
	19 position and reference (≤ 0.5 dB)	-----
	29 position and reference (≤ 0.5 dB)	-----
	39 position and reference (≤ 0.5 dB)	-----
	49 position and reference (≤ 0.5 dB)	-----
	59 position and reference (≤ 0.5 dB)	-----



STEP	DATA	RESULT
(d)	Pulse Width	
9.	Range 1 pulse 50 ns (45 to 55 ns)	-----
12.	Range 1 pulse 500 ns (450 to 550 ns)	-----
15.	Range 1 pulse 5 μ s (4.5 to 5.5 μ s)	-----
18.	Range 1 pulse 50 μ s (45 to 55 μ s)	-----
24.	Range 1 pulse 500 μ s (450 to 550 μ s)	-----
30.	Range 1 pulse 2.5 ms (2.0 to 3.0 ms)	-----
38.	Range 2 pulse 50 ns (45 to 55 ns)	-----
41.	Range 2 pulse 500 ns (450 to 550 ns)	-----
44.	Range 2 pulse 5 μ s (4.5 to 5.5 μ s)	-----
47.	Range 2 pulse 50 μ s (45 to 55 μ s)	-----
53.	Range 2 pulse 500 μ s (450 to 550 μ s)	-----
(e)	RF ON/OFF Ratio	
5.	ON signal level	-----
7.	OFF signal level	-----
	OFF signal level \geq 70 dB below ON signal level	-----
(2)	IF Signal Generator	
(a)	Frequency and IF Counter	
4.	Frequency \leq 20 MHz	-----
5.	FREQUENCY Hz/MHz Digital Display (1) readout equals Step 4 reading (\pm 2 kHz)	-----
7.	Frequency \geq 70 MHz	-----
8.	FREQUENCY Hz/MHz Digital Display (1) readout equals Step 7 reading (\pm 7 kHz)	-----
(b)	Sweep Width	
7.	Carrier starts sweeping past 0 setting	----- (\checkmark)
9.	4 MHz sweep width	----- (\checkmark)
(c)	Marker Frequency	
3.	FREQUENCY Hz/MHz Digital Display (1) readout \leq 20 MHz	-----
5.	FREQUENCY Hz/MHz Digital Display (1) readout \geq 70 MHz	-----
(d)	Power	
6.	Signal level 0 dBm (-2.5 to +2.5 dBm)	-----
9.	Signal level +20 dBm (+17.3 to +22.7 dBm)	-----
14.	Signal level -130 dBm (-133.8 to -126.2 dBm)	-----



STEP	DATA	RESULT
(e)	Pulse Width	
	7. 500 ns (450 to 550 ns)	-----
	12. 500 μ s (450 to 550 μ s)	-----
(f)	IF ON/OFF Ratio	
	5. 30 MHz ON signal level	-----
	7. 30 MHz OFF signal level	-----
	OFF signal level \geq 48 dB below ON signal level	-----
	11. 60 MHz ON signal level	-----
	13. 60 MHz OFF signal level	-----
	OFF signal level \geq 48 dB below ON signal level	-----
(3)	INTL Modulation/PRF Counter	
	5. INTL PRF/AM Control (41) is set to 50 Hz	----- (✓)
	6. FREQUENCY Hz/MHz Digital Display (1) readout is 50 Hz (49 to 51 Hz)	-----
	8. INTL PRF/AM Control (41) is set to 500 Hz	----- (✓)
	9. FREQUENCY Hz/MHz Digital Display (1) readout is 500 Hz (499 to 501 Hz)	-----
	12. INTL PRF/AM Control (41) is set to 50 Hz	----- (✓)
	13. FREQUENCY Hz/MHz Digital Display (1) readout is 500 Hz (499 to 501 Hz)	-----
	14. Frequencies in Steps 9 and 10 overlap frequencies in Steps 12 and 13	----- (✓)
	16. INTL PRF/AM Control (41) is set to 500 Hz	----- (✓)
	17. FREQUENCY Hz/MHz Digital Display (1) readout is 5000 Hz (4998 to 5002 Hz)	-----
(4)	Range	
	RANGE 1	
	7. Residual delay 0.1 μ s (0.0 to 0.2 μ s)	-----
	9. Delay 0.1 μ s + Step 7 residual delay	----- (✓)
	11. Delay 1.236 μ s + Step 7 residual delay	----- (✓)
	14. Delay 100 μ s + Step 7 residual delay (\pm 10 ns)	-----
	15. Ring 1 reply pulse to Ring 2 reply pulse is 100 μ s (99.99 to 100.09 μ s)	-----
	Ring 2 reply pulse to Ring 3 reply pulse is 100 μ s (99.99 to 100.09 μ s)	-----
	Ring 3 reply pulse to Ring 4 reply pulse is 100 μ s (99.99 to 100.09 μ s)	-----
	Ring 4 reply pulse to Ring 5 reply pulse is 100 μ s (99.99 to 100.09 μ s)	-----



STEP	DATA	RESULT
18.	Delay 999.9 μ s + Step 7 residual delay ($\pm 0.1 \mu$ s)	-----
20.	Delay 12.358 ms + Step 7 residual delay ($\pm 1.2 \mu$ s)	-----
RANGE 2		
22.	Residual delay 0.4 μ s (0.3 to 0.5 μ s)	-----
24.	Delay 0.1 μ s + Step 22 residual delay	----- (✓)
26.	Delay 1.236 μ s + Step 22 residual delay	----- (✓)
29.	Delay 999.9 μ s + Step 22 residual delay ($\pm 0.1 \mu$ s)	-----
31.	Delay 12.358 ms + Step 22 residual delay ($\pm 1.2 \mu$ s)	-----
(5)	Power Meter	
6.	Waveguide Coupler value	-----
7.	1 kW Test RF Level (2-2-2, Table 4)	-----
	12 kW Test RF Level (2-2-2, Table 4)	-----
10.	PANEL Meter (43) shows 1 kW (852 to 1148 W)	-----
12.	PANEL Meter (43) shows 12 kW (10224 to 13776 W)	-----
(6)	XMTR DSCRM 0.1V/MHz Connector	
10.	FREQUENCY Hz/MHz Digital Display (1) readout	-----
13.	Pulse level decreases 50 mV (45 to 55 mV)	-----
17.	Pulse level increases 50 mV (45 to 55 mV)	-----
(7)	Inputs	
(a)	AM EXT INPUT Connector	
5.	30% Modulation (28% to 32%)	-----
(b)	EXT TRIG Connector	
5.	EXT (+) Sync pulse appears	----- (✓)
9.	EXT (-) Sync pulse appears	----- (✓)



THIS PAGE INTENTIONALLY LEFT BLANK.

H. Calibration Procedures

CALIBRATION PROCEDURE	PAGE
Power Supply	47
100 MHz Clock	48
8.25 GHz LO	51
RF Display Limits.....	53
Marker Oscillator	54
IF Oscillator	56
IF Generator Power Amplifier	59
External AM	61
Levelers	62
Internal PRF.....	68
Pulse Width.....	69
Range Delay.....	73
Power Meter	75
Discriminator	77

(1) Power Supply

PREREQUISITES: None
TEST EQUIPMENT: Digital Multimeter (DMM)
 Oscilloscope
FIGURE REFERENCE: 2-2-2, Figure 13

STEP	PROCEDURE
1.	Press LINE Switch (30) to OFF .
2.	Remove four screws from top cover on RD-301A. Slide top cover to rear and remove from RD-301A.
3.	Press LINE Switch (30) to ON .
4.	Use DMM to verify voltages between Test Points listed in 2-2-2, Table 5 and ground at TP49001 Pin 5.

TEST POINT	VOLTAGE LIMITS	RIPPLE VOLTAGE
TB49001 Pin 3 (+5 V)	+4.7 to +5.3 Vdc	≤15 mVp-p
TB49001 Pin 2 (+12 V)	+11.4 to +12.6 Vdc	≤15 mVp-p
TB49001 Pin 4 (-12 V)	-11.4 to -12.6 Vdc	≤15 mVp-p
TB49001 Pin 1 (-24 V)	-22.0 to -25.2 Vdc	≤20 mVp-p

Power Supply Terminal Bus Voltages
Table 5

5. Use Oscilloscope to verify ripple voltages between Test Points listed in 2-2-2, Table 5 and ground at TB49001 Pin 5.
6. Disconnect test equipment and replace top cover on RD-301A.

(2) 100 MHz Clock

PREREQUISITES: Power Supply (para 2-2-2H[1])

TEST EQUIPMENT: Frequency Counter
10:1 Oscilloscope Probe

FIGURE REFERENCE: 2-2-2, Figure 14

STEP	PROCEDURE
1.	Apply power to RD-301A and allow for 30 minute stabilization period.
2.	Refer to para 2-2-2H(1), Step 2 and remove top cover from RD-301A.
3.	Set μ S/NM Switch (36) to μ S.
4.	Connect 10:1 Oscilloscope Probe from Frequency Counter to TP19001 on Range #1 PC Board Assembly.
5.	Verify frequency is 100 MHz (\pm 5 kHz). If not, adjust L19002 on Range #1 PC Board Assembly. Record frequency.
	NOTE: Adjusting L19002 also affects μ s Range Delay and FREQUENCY Hz/MHz Digital Display (1) counter (10 kHz time base).
6.	Set μ S/NM Switch (36) to NM .
7.	Verify frequency at TP19001 is 8.091269 MHz (\pm 400 Hz). If oscillator is not in tolerance after following proper stabilization procedures and insuring adequate Frequency Counter accuracy, change value of C19015 on Range #1 PC Board Assembly. Refer to Range #1 PC Board Assembly and Circuit Schematic drawings for component location and circuit understanding. Value for C19015 may range from 68 to 100 pF (type NPO). If C19015 is replaced, allow RD-301A to restabilize before retesting. Record frequency.
	NOTE: 100 MHz Clock calibration errors affect the representation of Radar transmitter and RD-301A frequencies shown on the FREQUENCY Hz/MHz Digital Display (1). Frequency Tracking accuracy is not affected by 100 MHz Clock calibration errors.
8.	Disconnect test equipment and replace top cover on RD-301A.

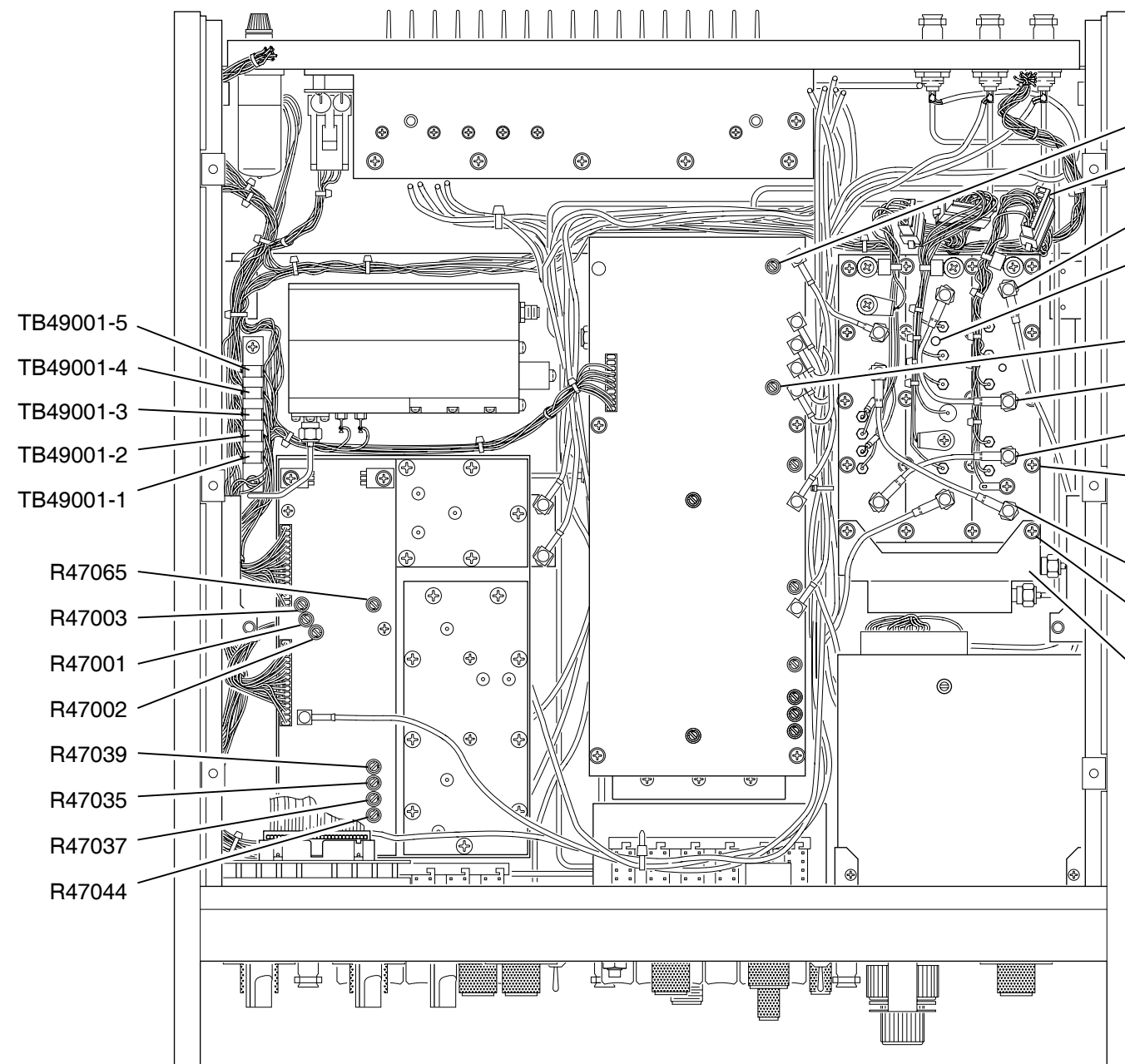

Floor Test Points and Adjustments
Figure 13

- R17128
- P/J33003
- P/J33001
- R36023
- TP19001
- R17143
- P/J33002
- P/J33004
- SCREW
(9 PLCS)
- L19002
- P/J33005
- SCREW
(2 PLCS)
- BRACKET
- R19047

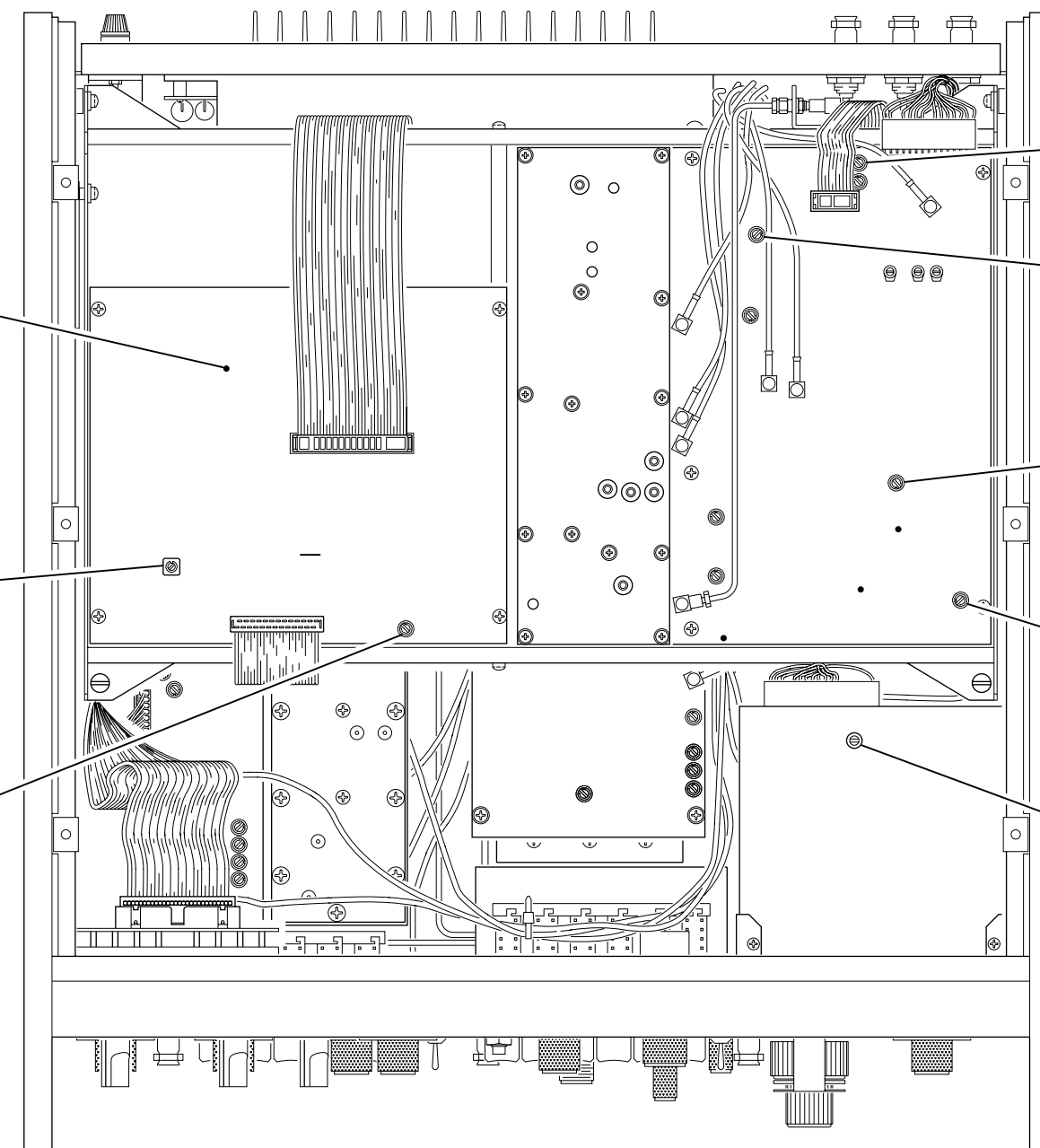

Card Frame (Top) Test Points and Adjustments
Figure 14

9019001

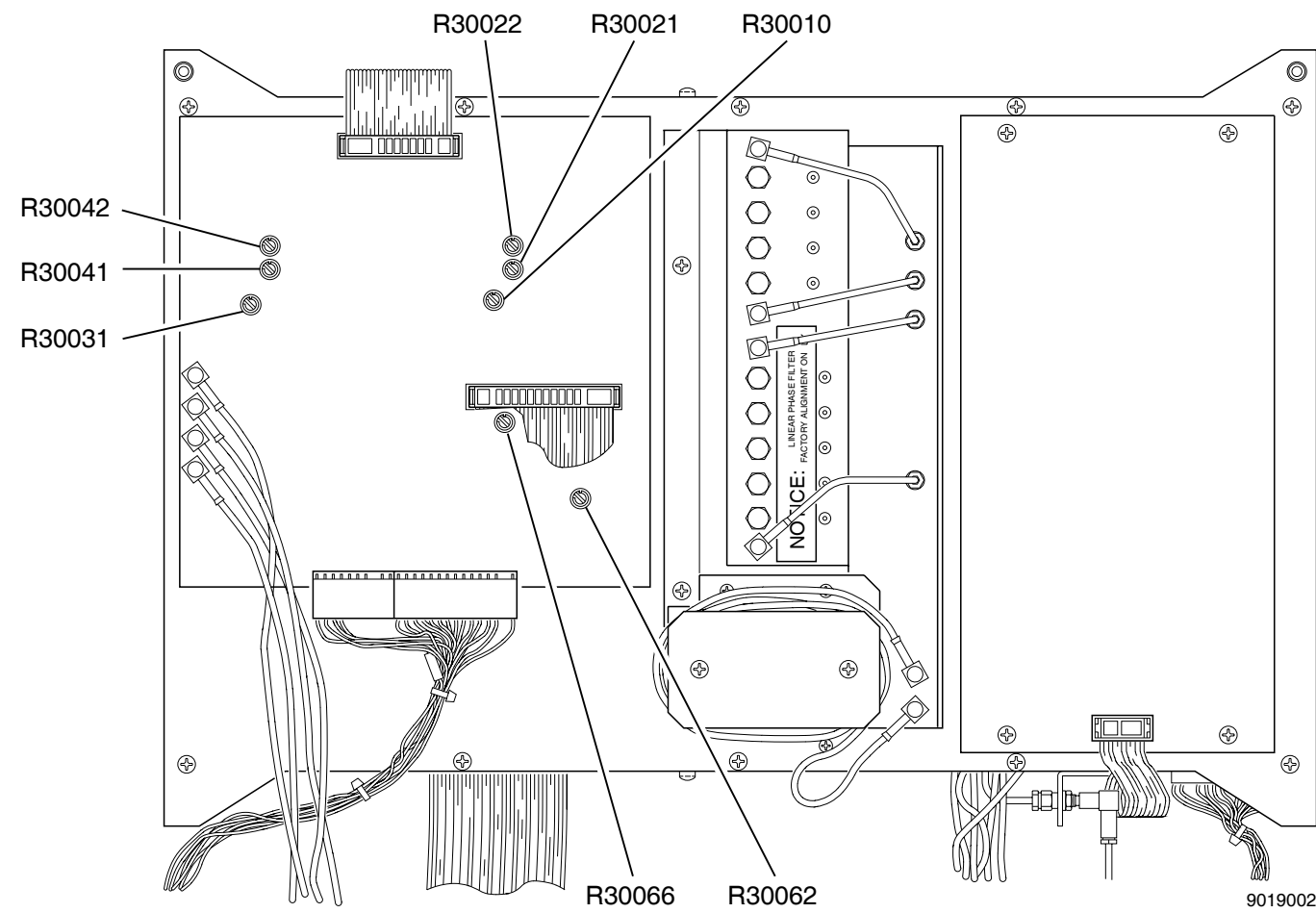

Card Frame (Bottom) Test Points and Adjustments
Figure 15

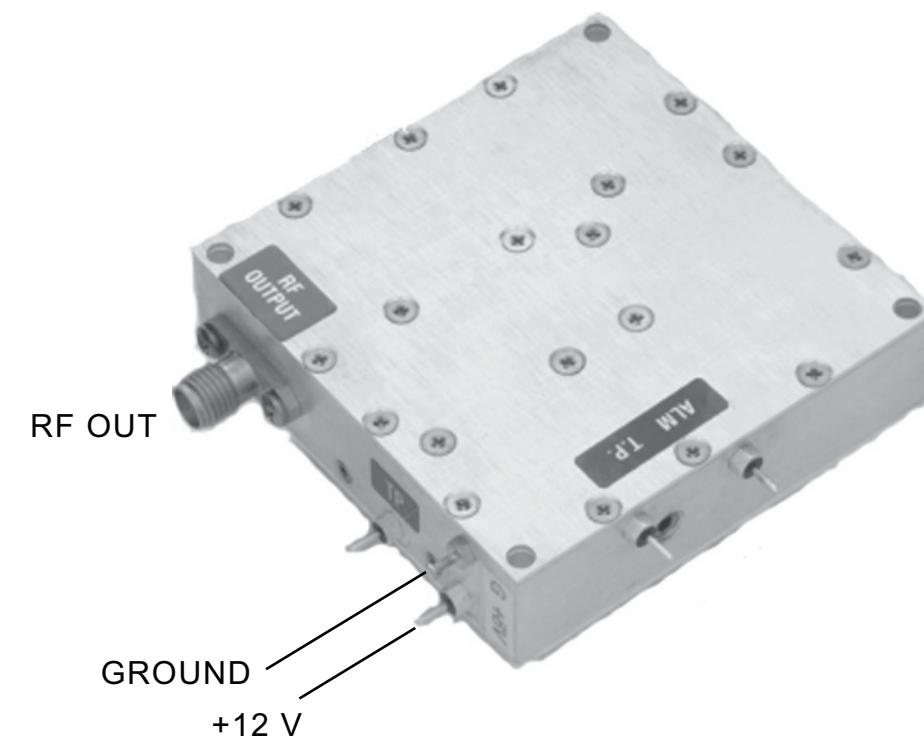

8.25 GHz LO Top Test Points and Adjustments
Figure 16

(3) 8.25 GHz LO

PREREQUISITES: 100 MHz Clock (para 2-2-2H[2])

TEST EQUIPMENT: Digital Multimeter (DMM)
Frequency Counter

FIGURE REFERENCE: 2-2-2, Figure 16

STEP	PROCEDURE
------	-----------

1. Apply power to RD-301A and allow for 30 minute stabilization period.
2. Set RD-301A as follows:

CONTROL	SETTING
(2) PRF/RF Switch	RF
(4) OUTPUT LEVEL FINE dBm Control	0
(9) OUTPUT LEVEL COARSE dBm Control	-50
(10) MNL FREQ Controls	9375 MHz
(16) RF/IF MODE Pushbutton Switches	MNL
(29) MODULATION MODE Pushbutton Switches	CW

3. Refer to para 2-2-2H(1), Step 2 and remove top cover from RD-301A.
4. Examine 8.25 GHz LO for +12 V or -24 V input. Module with +12 V input has red wire at the top of the module labeled +12 V.
5. If 8.25 GHz LO is +12 V input, proceed to Step 12. If 8.25 GHz LO is -24 V input proceed to next step.
6. Connect Frequency Counter to XTAL MON (Crystal Monitor) Connector on right side of 8.25 GHz LO.
7. Place top cover loosely on RD-301A, insuring cable is not damaged.
8. Monitor frequency 15 minutes to insure drift is stabilized.
9. After stabilization, verify frequency is 103.125 MHz (± 2.1 kHz). Adjust XTAL ADJ (Crystal Adjustment) on 8.25 GHz LO as needed. Allow time for restabilization after adjustment. Record adjusted frequency.
10. Use DMM to verify voltage between Φ LCK (Phase Lock) Voltage Terminal on 8.25 GHz LO and ground is -10 Vdc (± 5 Vdc). If voltage is out of tolerance, adjust FREQ ADJ Control for correct voltage.
11. Disconnect test equipment and secure top cover to RD-301A.
12. Connect Frequency Counter to output side of 8.25 GHz Oscillator pad.
13. Verify frequency on Frequency Counter reads 8.25 GHz (± 100 kHz). Record frequency.
14. Disconnect test equipment and secure top cover to the RD-301A.

STEP

PROCEDURE

15. Connect Frequency Counter to X-BAND I/O Connector (18). Verify FREQUENCY Hz/MHz Digital Display (1) matches Frequency Counter reading (± 250 kHz).

NOTE: FREQUENCY Hz/MHz Digital Display (1) accuracy depends on the frequency precision of the 8.25 GHz LO signal and 10 kHz Clock derived from the 100 MHz Oscillator on Range #1 PC Board Assembly. The frequency shown on the FREQUENCY Hz/MHz Digital Display (1) indirectly represents the signal frequency at the X-BAND I/O Connector (18). The FREQUENCY Hz/MHz Digital Display (1) shows the frequency count (10 kHz Clock base) of the prescaled L-Band signal added to a fixed 8250 MHz offset (8.25 GHz LO ideal frequency). The L-Band signal (1045-1250 MHz) generated by the VCO #2 Assembly is converted up by the 8.25 GHz LO signal to provide the X-Band signal at the X-BAND I/O Connector (18).

NOTE: 8.25 GHz LO calibration errors do not affect Frequency Tracking accuracy. The received Radar transmitter signal is converted down by the same 8.25 GHz LO signal the RD-301A L-Band signal is converted up by.

(4) RF Display Limits

PREREQUISITES: 8.25 GHz LO (para 2-2-2H[3])

TEST EQUIPMENT: None

FIGURE REFERENCE: 2-2-2, Figure 13

STEP	PROCEDURE												
1.	Apply power to RD-301A and allow for 30 minute stabilization period.												
2.	Set RD-301A as follows:												
	<table border="1"> <thead> <tr> <th style="text-align: left;">CONTROL</th> <th style="text-align: left;">SETTING</th> </tr> </thead> <tbody> <tr> <td>(2) PRF/RF Switch</td> <td>RF</td> </tr> <tr> <td>(4) OUTPUT LEVEL FINE dBm Control</td> <td>0</td> </tr> <tr> <td>(9) OUTPUT LEVEL COARSE dBm Control</td> <td>-50</td> </tr> <tr> <td>(16) RF/IF MODE Pushbutton Switches</td> <td>MNL</td> </tr> <tr> <td>(29) MODULATION MODE Pushbutton Switches</td> <td>CW</td> </tr> </tbody> </table>	CONTROL	SETTING	(2) PRF/RF Switch	RF	(4) OUTPUT LEVEL FINE dBm Control	0	(9) OUTPUT LEVEL COARSE dBm Control	-50	(16) RF/IF MODE Pushbutton Switches	MNL	(29) MODULATION MODE Pushbutton Switches	CW
CONTROL	SETTING												
(2) PRF/RF Switch	RF												
(4) OUTPUT LEVEL FINE dBm Control	0												
(9) OUTPUT LEVEL COARSE dBm Control	-50												
(16) RF/IF MODE Pushbutton Switches	MNL												
(29) MODULATION MODE Pushbutton Switches	CW												
3.	Rotate MNL FREQ Controls (10) fully cw .												
4.	Verify 9508 MHz (± 5.0 MHz) on FREQUENCY Hz/MHz Digital Display (1). If not in tolerance, refer to para 2-2-2H(1), Step 2 and remove top cover from RD-301A. Adjust R47035 on AGC PC Board Assembly until 9508 MHz is shown on FREQUENCY Hz/MHz Digital Display (1).												
5.	Rotate MNL FREQ Controls (8) fully ccw .												
6.	Verify 9287 MHz (± 5.0 MHz) on FREQUENCY Hz/MHz Digital Display (1). If not in tolerance, refer to para 2-2-2H(1), Step 2 and remove top cover from RD-301A. Adjust R47039 on AGC PC Board Assembly until 9287 MHz is shown on FREQUENCY Hz/MHz Digital Display (1).												
7.	Repeat Steps 3 through 6 until no more adjustments are required.												
8.	If removed, replace top cover on RD-301A and repeat Steps 3 through 6 with top cover on.												

(5) Marker Oscillator

PREREQUISITES: 8.25 GHz LO (para 2-2-2H[3])

TEST EQUIPMENT: Frequency Counter

FIGURE REFERENCE: 2-2-2, Figure 13

STEP	PROCEDURE
1.	Refer to para 2-2-2H(1), Step 2 and remove top cover from RD-301A.
2.	Disconnect following coaxial cables and connectors: <ul style="list-style-type: none"> ● P33001 (AGC PC Board Assembly) from J33001 (IF MKR/OSC PC Board Assembly) ● P33002 (IF GEN PWR AMPL PC Board Assembly) from J33002 (IF MKR/OSC PC Board Assembly) ● P33003 (Main Wire Harness Assembly) from J33003 (IF MKR/OSC PC Board Assembly) ● P33004 (Prescaler PC Board Assembly, P/J23003) from J33004 (IF MKR/OSC PC Board Assembly) ● P33005 (Prescaler PC Board Assembly, P/J23004) from J33005 (IF MKR/OSC PC Board Assembly)
3.	Remove two screws and move Bracket away from IF MKR/OSC PC Board Assembly.
4.	Remove nine screws and remove IF MKR/OSC PC Board Assembly from enclosure.
5.	Place IF MKR/OSC PC Board Assembly on insulated medium (thick cardboard recommended), close enough to reconnect coaxial cables and connectors.
6.	Carefully position IF MKR/OSC PC Board Assembly for access to C33034 and L33001. Refer to IF MKR/OSC PC Board Assembly drawing.
7.	Reconnect coaxial cables and connectors disconnected in Step 2 except P/J33005.
8.	Connect Frequency Counter to J33005.
9.	Apply power to RD-301A and allow for 30 minute stabilization period.
10.	Rotate MKR FREQ Control (19) fully ccw .
11.	Press DISPLAY MKR Switch (21).
12.	Verify ≤ 18.0 MHz is shown on Frequency Counter. If not, adjust C33034 on IF MKR/OSC PC Board Assembly.
13.	Rotate MKR FREQ Control (19) fully cw .
14.	Press DISPLAY MKR Switch (21).
15.	Verify Frequency Counter indicates ≥ 74 MHz.
	NOTE: Frequency drifts lower with assembly in enclosure and RD-301A at stabilized temperature.
16.	Replace IF MKR/OSC PC Board Assembly in enclosure. Replace and tighten all screws.
17.	Disconnect Frequency Counter from J33005.

STEP

PROCEDURE

18. Reconnect P33005 to J33005.
19. Replace top cover on RD-301A.
20. Set PRF/RF Switch (2) to **RF** and select **IF HI** on RF/IF MODE Pushbutton Switches (16).
21. Press DISPLAY MKR Switch (21).
22. Verify ≥ 70 MHz is shown on FREQUENCY Hz/MHz Digital Display (1). Record frequency.
23. Rotate MKR FREQ Control (19) **fully ccw**.
24. Press DISPLAY MKR Switch (21).
25. Verify ≤ 20 MHz is shown on FREQUENCY Hz/MHz Digital Display (1). Record frequency.

(6) IF Oscillator

PREREQUISITES: 8.25 GHz LO (para 2-2-2H[3])

TEST EQUIPMENT: Frequency Counter
 Digital Multimeter (DMM)
 Spectrum Analyzer

FIGURE REFERENCE: 2-2-2, Figure 13

STEP	PROCEDURE
1.	Apply power to RD-301A and allow for 30 minute stabilization period.
2.	Refer to para 2-2-2H(1), Step 2 and remove top cover from RD-301A.
3.	Set PRF/RF Switch (2) to RF and select IF HI on RF/IF MODE Pushbutton Switches (16).
4.	Rotate MNL FREQ Controls (10) fully cw .
5.	Verify FREQUENCY Hz/MHz Digital Display (1) indicates 77 MHz. If not, adjust R47037 on AGC PC Board Assembly.
6.	Rotate MNL FREQ Controls (10) fully cw .
7.	Verify FREQUENCY Hz/MHz Digital Display (1) indicates ≤ 18 MHz. If not, adjust R47044 on AGC PC Board Assembly.
8.	Rotate MNL FREQ Controls (10) fully cw .
9.	Verify FREQUENCY Hz/MHz Digital Display (1) indicates ≥ 74 MHz. If not, repeat Steps 5 through 9 until indications are correct. Record correct upper and lower frequency indications and proceed at Step 38. If unable to attain correct indications, proceed at Step 10.
	NOTE: Frequency drifts lower with assembly in enclosure and RD-301A at stabilized temperature.
10.	Press LINE Switch (30) to OFF .
11.	Disconnect following coaxial cables and connectors: <ul style="list-style-type: none"> ● P33001 (AGC PC Board Assembly) from J33001 (IF MKR/OSC PC Board Assembly) ● P33002 (IF GEN PWR AMPL PC Board Assembly) from J33002 (IF MKR/OSC PC Board Assembly) ● P33003 (Main Wire Harness Assembly) from J33003 (IF MKR/OSC PC Board Assembly) ● P33004 (Prescaler PC Board Assembly, P/J23003) from J33004 (IF MKR/OSC PC Board Assembly) ● P33005 (Prescaler PC Board Assembly, P/J23004) from J33005 (IF MKR/OSC PC Board Assembly)
12.	Remove two screws and move Bracket away from IF MKR/OSC PC Board Assembly.
13.	Remove nine screws and remove IF MKR/OSC PC Board Assembly from enclosure.
14.	Place IF MKR/OSC PC Board Assembly on insulated medium (thick cardboard recommended), close enough to reconnect coaxial cables and connectors.

STEP	PROCEDURE
------	-----------

15. Carefully position IF MKR/OSC PC Board Assembly for access to C33034 and L33001. Refer to IF MKR/OSC PC Board Assembly drawing.
16. Reconnect coaxial cables and connectors disconnected in Step 11 except P/J33004.
17. Connect Frequency Counter to J33004 with 50 Ω coaxial cable.
18. Connect DMM between ground at TB49001-5 and anode lead of CR47006 on AGC PC Board Assembly. Refer to AGC PC Board Assembly drawing.
19. Press LINE Switch (30) to **ON** and allow for five minute stabilization period.
20. Set R47044 on AGC PC Board Assembly to center position.
21. Adjust R47037 on AGC PC Board Assembly for -18.0 V on DMM.
22. Refer to IF MKR/OSC PC Board Assembly drawing and adjust L47001 on IF MKR/OSC PC Board Assembly for 77.0 MHz on Frequency Counter.
23. Rotate MNL FREQ Controls (10) **fully cw** and adjust R47044 for 17.0 MHz on Frequency Counter.
24. Verify tune line voltage on DMM is \approx -2.0 V.
25. Rotate MNL FREQ Controls (10) **fully cw** and verify 77 MHz on Frequency Counter.
26. Readjust R47037 and R47044 to achieve frequency range from 17.0 to 77.0 MHz.
27. Disconnect Frequency Counter from J33004.
28. Reconnect P33004 to J33004.

MIXER BALANCE ADJUSTMENT

29. Disconnect P33002 from J33002
30. Connect Spectrum Analyzer to J33002.
31. Set Spectrum Analyzer as follows:

CONTROL	SETTING
Center Frequency	50 MHz
Frequency Span	10 MHz/Div
Amplitude Scale	10 dB/Div
Input Attenuation	30 dB

32. Adjust MNL FREQ Controls (10) for **60 MHz** on FREQUENCY Hz/MHz Digital Display (1).
33. Refer to IF MKR/OSC PC Board Assembly drawing and adjust R33024 on IF MKR/OSC PC Board Assembly for maximum 60 MHz signal with minimum spurious signals.
34. Disconnect test equipment.
35. Replace IF MKR/OSC PC Board Assembly in enclosure. Replace and tighten all screws.
36. Reconnect P33002 to J33002.
37. Repeat Steps 3 through 9.

STEP PROCEDURE

SWEEP WIDTH

38. Connect Spectrum Analyzer to IF OUT Connector (15).
39. Set Spectrum Analyzer as follows:

CONTROL

SETTING

Center Frequency	30 MHz
Frequency Span	500 kHz/Div
Reference Level	+20 dBm
Sweep Speed	50 ms/Div

40. Adjust MNL FREQ Controls (10) for **30 MHz** on FREQUENCY Hz/MHz Digital Display (1).
41. Adjust SWEEP WIDTH MHz Control (33) **cw**.
42. Verify carrier starts sweeping when SWEEP WIDTH MHz Control (33) passes 0 setting. If not, reset SWEEP WIDTH MHz Control (33) as follows:
 - Remove two set screws and dial.
 - Rotate control shaft cw until carrier begins to sweep.
 - Rotate shaft control ccw until sweep stops.
 - Without rotating control, replace dial with index mark set to zero and tighten two set screws.
43. Set SWEEP WIDTH MHz Control (33) to **4**.
44. Verify carrier sweep is displayed across 8.0 divisions (4 MHz sweep width) on Spectrum Analyzer. If not, adjust R31007 on Counter Gating PC Board.
45. Set SWEEP WIDTH MHz Control (33) to **2**.
46. Verify carrier sweep (2 MHz wide) is displayed across 4.0 divisions (± 2 minor divisions) on Spectrum Analyzer. If not, adjust R31007 on Counter Gating PC Board.
47. If needed, adjust R31007 until carrier sweep at 2 and 4 MHz is within 10% of dial setting. Record sweep width at both settings.
48. Set SWEEP WIDTH MHz Control (33) to **OFF**.
49. Disconnect test equipment and replace top cover on RD-301A.

(7) IF Generator Power Amplifier

PREREQUISITES: IF Oscillator (para 2-2-2H[6])

TEST EQUIPMENT: Spectrum Analyzer
Power Meter
L-Band Signal Generator

FIGURE REFERENCE: 2-2-2, Figure 13

STEP	PROCEDURE												
1.	Apply power to RD-301A and allow for 30 minute stabilization period.												
2.	Set RD-301A as follows:												
	<table border="1" style="width: 100%; border-collapse: collapse;"> <thead> <tr> <th style="text-align: left;"><u>CONTROL</u></th> <th style="text-align: left;"><u>SETTING</u></th> </tr> </thead> <tbody> <tr> <td>(2) PRF/RF Switch</td> <td>RF</td> </tr> <tr> <td>(4) OUTPUT LEVEL FINE dBm Control</td> <td>0</td> </tr> <tr> <td>(9) OUTPUT LEVEL COARSE dBm Control</td> <td>-50</td> </tr> <tr> <td>(16) RF/IF MODE Pushbutton Switches</td> <td>IF HI</td> </tr> <tr> <td>(29) MODULATION MODE Pushbutton Switches</td> <td>CW</td> </tr> </tbody> </table>	<u>CONTROL</u>	<u>SETTING</u>	(2) PRF/RF Switch	RF	(4) OUTPUT LEVEL FINE dBm Control	0	(9) OUTPUT LEVEL COARSE dBm Control	-50	(16) RF/IF MODE Pushbutton Switches	IF HI	(29) MODULATION MODE Pushbutton Switches	CW
<u>CONTROL</u>	<u>SETTING</u>												
(2) PRF/RF Switch	RF												
(4) OUTPUT LEVEL FINE dBm Control	0												
(9) OUTPUT LEVEL COARSE dBm Control	-50												
(16) RF/IF MODE Pushbutton Switches	IF HI												
(29) MODULATION MODE Pushbutton Switches	CW												
3.	Refer to para 2-2-2H(1), Step 2 and remove top cover from RD-301A.												
4.	Set Spectrum Analyzer RF for 30 MHz signal at 0 dBm and Amplitude Scale to 2 dB/Div.												
5.	Connect L-Band Signal Generator to Spectrum Analyzer using high quality RG58 BNC coaxial cable.												
6.	Set L-Band Signal Generator for 30 MHz CW signal. Insure all harmonics and spurious signals are ≥ 30 dB below carrier for accurate power measurements.												
7.	Disconnect L-Band Signal Generator from Spectrum Analyzer.												
8.	Connect L-Band Signal Generator to Power Meter using same RG58 BNC coaxial cable.												
9.	Adjust L-Band Signal Generator for 0 dBm on Power Meter.												
10.	Reconnect L-Band Signal Generator to Spectrum Analyzer using same cable. Record reference level of 30 MHz CW signal at 0 dBm on Spectrum Analyzer screen with reference level accurate to ± 0.2 dB.												
11.	Disconnect L-Band Signal Generator from Spectrum Analyzer.												
12.	Connect IF OUT Connector (15) to Spectrum Analyzer using same cable used to set reference level.												
13.	Rotate MNL FREQ Controls (10) to indicate 30 MHz on FREQUENCY Hz/MHz Digital Display (1).												
14.	Adjust R36023 on IF GEN PWR AMPL PC Board Assembly to match signal amplitude on Spectrum Analyzer of 30 MHz reference level recorded in Step 10.												
15.	Disconnect Spectrum Analyzer from IF OUT Connector (15).												
16.	Set Spectrum Analyzer RF for a signal of 60 MHz at 0 dBm.												
17.	Connect L-Band Signal Generator to Spectrum Analyzer using same RG58 BNC coaxial cable.												
18.	Set L-Band Signal Generator for 60 MHz CW signal. Insure all harmonics and spurious signals are ≥ 30 dB below carrier for accurate power measurements.												

STEP

PROCEDURE

-
19. Disconnect L-Band Signal Generator from Spectrum Analyzer.
 20. Connect L-Band Signal Generator to Power Meter using same RG58 BNC coaxial cable.
 21. Adjust L-Band Signal Generator for 0 dBm on Power Meter.
 22. Reconnect L-Band Signal Generator to Spectrum Analyzer using same cable. Record reference level of 60 MHz CW signal at 0 dBm on Spectrum Analyzer screen with reference level accurate to ± 0.2 dB.
 23. Disconnect L-Band Signal Generator from Spectrum Analyzer.
 24. Connect IF OUT Connector (15) to Spectrum Analyzer using same cable used to set reference level.
 25. Rotate MNL FREQ Controls (10) to indicate **60 MHz** on FREQUENCY Hz/MHz Digital Display (1).
 26. Verify Spectrum Analyzer indicates 0 dBm (± 2.5 dB). If not, adjust R36023.
 27. If R36023 is adjusted in Step 26, repeat Steps 4 through 26 until 30 MHz and 60 MHz signals both indicate 0 dBm (± 2.5 dB) on Spectrum Analyzer.
 28. Disconnect test equipment and replace top cover on RD-301A.

(8) External AM

PREREQUISITES: 100 MHz Clock (para 2-2-2H[2])

TEST EQUIPMENT: Function Generator
Modulation Meter
X-Band to L-Band Down Converter

FIGURE REFERENCE: 2-2-2, Figure 13

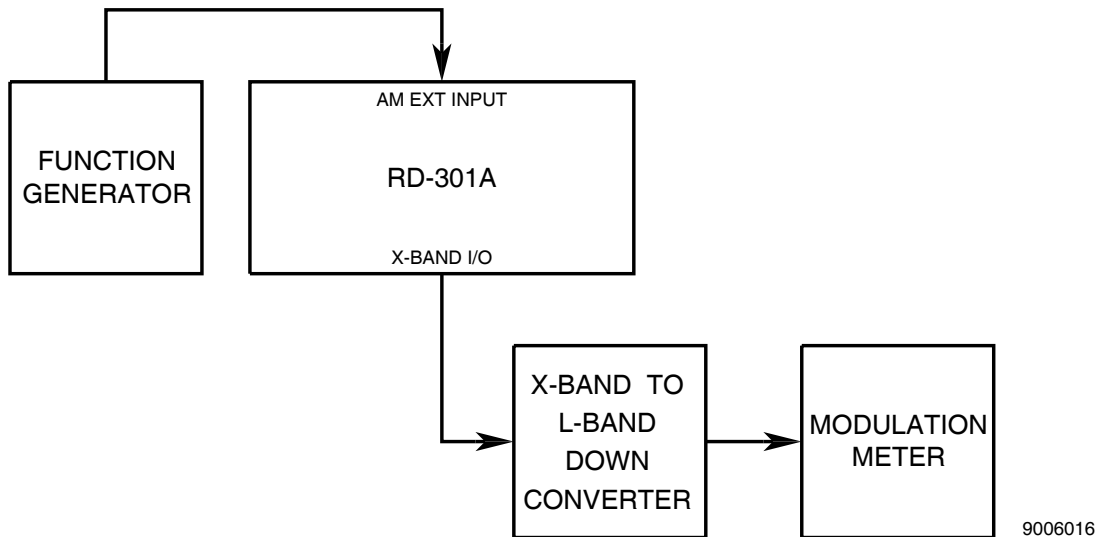

External AM Calibration Setup
Figure 17

STEP	PROCEDURE
------	-----------

1. Apply power to RD-301A and allow for 30 minute stabilization period.
2. Set RD-301A as follows:

CONTROL	SETTING
(2) PRF/RF Switch	RF
(9) OUTPUT LEVEL COARSE dBm Control	-50
(10) MNL FREQ Controls	9375 MHz
(16) RF/IF MODE Pushbutton Switches	RF MNL
(29) MODULATION MODE Pushbutton Switches	CW

3. Refer to para 2-2-2H(1), Step 2 and remove top cover from RD-301A.
4. Connect test equipment as shown in 2-2-2, Figure 17.
5. Set Function Generator for 1 kHz sine wave at 3 Vp-p.
6. Verify 30% ($\pm 2\%$) modulation on Modulation Meter. If not, adjust R47003 on AGC PC Board Assembly.
7. Disconnect test equipment and replace top cover on RD-301A.

(9) Levelers

PREREQUISITES: None

TEST EQUIPMENT: Function Generator
Power Meter
Spectrum Analyzer

FIGURE REFERENCE: 2-2-2, Figure 13

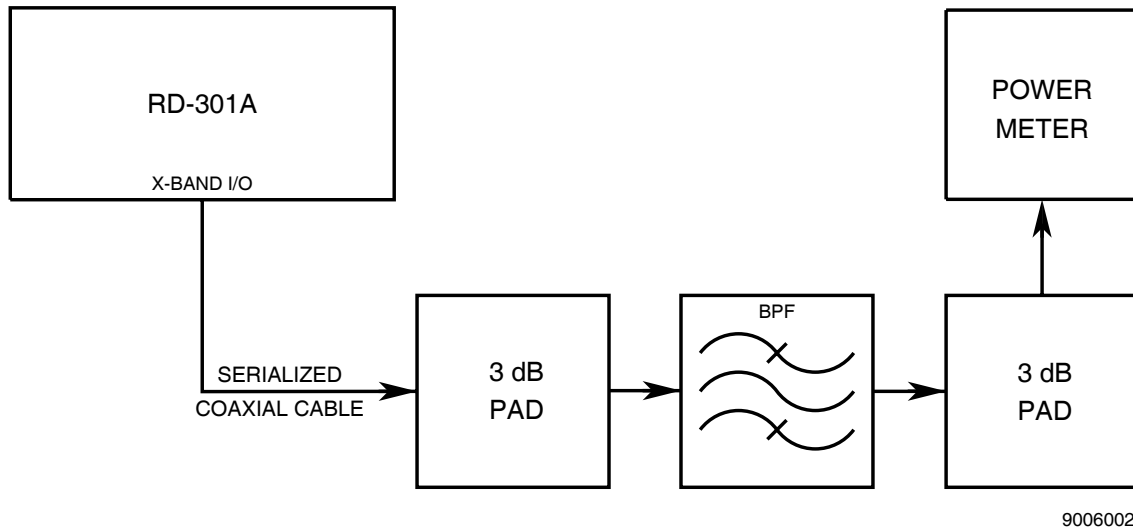

Main Leveler Calibration Setup
Figure 18

STEP	PROCEDURE
------	-----------

1. Apply power to RD-301A and allow for 30 minute stabilization period.
2. Set RD-301A as follows:

CONTROL	SETTING
(2) PRF/RF Switch	RF
(3) CONTOUR/R2/INTL AM dB BOOST/ATTEN Control	00
(4) OUTPUT LEVEL FINE dBm Control	-3
(9) OUTPUT LEVEL COARSE dBm Control	-50
(10) MNL FREQ Controls	9400 MHz
(16) RF/IF MODE Pushbutton Switches	RF MNL
(29) MODULATION MODE Pushbutton Switches	CW
(39) RANGE SEL Switch	RINGS 1

3. Connect test equipment as shown in 2-2-2, Figure 18.

NOTE: Assembled 3 dB Pads and Bandpass Filter require flatness of ± 0.1 dB from 9295 to 9500 MHz. Once loss and flatness of filter-pad assembly have been characterized, assembly should not be disassembled.

4. Move Serialized Coaxial Cable and observe Power Meter display. If display fluctuates more than 0.1 dB, replace Serialized Coaxial Cable.

STEP	PROCEDURE
------	-----------

5. Use Equation 1 to compute X-Band Output Power Level (A). Tolerance is X-Band Output Power Level (A) (± 2 dB).

EQUATION 1: $A = B + C + D$

Where:

A = Computed X-Band Output Power Level

B = RD-301A Output Level Settings (OUTPUT LEVEL FINE and COARSE dBm Controls [4] and [9])

C = Waveguide Coupler Value (attenuation) (marked on Waveguide Coupler)

D = Insertion loss of Bandpass Filter and 3 dB Pads

EXAMPLE: RD-301A Output Level Settings (B) = -53.0 dBm

Waveguide Coupler Value (C) = +20.2 dB

Insertion Loss of Bandpass Filter (D) = -7.17 dB

$A = -53.0 \text{ dBm} + +20.2 \text{ dB} + -7.17 \text{ dB}$

$A = -39.97 \text{ dBm}$

6. Compute X-Band Output Power Level upper limit (A + 2 dB).
7. Compute X-Band Output Power Level lower limit (A - 2 dB).
8. Adjust MNL FREQ Controls (10) from **9295 MHz** to **9500 MHz** and verify Power Meter reading stays between upper limit from Step 6 and lower limit from Step 7. If so, proceed at Step 14. If not, proceed at Step 9.
9. Adjust MNL FREQ Controls (10) from **9295 MHz** to **9500 MHz** and record highest and lowest amplitude values. Determine midpoint amplitude value between highest and lowest amplitude values.
10. Refer to para 2-2-2H(1), Step 2 and remove top cover from RD-301A.
11. Adjust MNL FREQ Controls (10) to frequency between **9295 MHz** to **9500 MHz** having power level closest to midpoint amplitude value from Step 9.
12. Adjust R47001 on AGC PC Board Assembly until selected frequency has same power output level as X-Band Output Power Level from Step 5.
13. Adjust MNL FREQ Controls (10) from **9295 MHz** to **9500 MHz** and verify Power Meter reading stays between upper limit from Step 6 and lower limit from Step 7. If so, proceed at Step 14. If not, repeat Steps 9 through 13.
14. Disconnect test equipment.

CONTOUR LEVELER

15. Use Serialized Coaxial Cable to connect Spectrum Analyzer to X-BAND I/O Connector (18).

STEP PROCEDURE

16. Set Spectrum Analyzer as follows:

CONTROL	SETTING
Center Frequency	9360 MHz
Frequency Span	20 MHz/Div
Resolution Bandwidth (uncoupled)	3 MHz
Amplitude Scale	2 dB/Div
Sweep Speed	10 ms/Div
Input Attenuation	10 dB

NOTE: For all leveler procedures, Spectrum Analyzer video filter can be used with caution, when displayed amplitude is not affected.

17. Set OUTPUT LEVEL FINE dBm Control (4) to **-5**.
 18. Set Spectrum Analyzer amplitude scale for 6 division reference level.

NOTE: Steps 19 through 34 use a dual trace, storage Spectrum Analyzer.
 Steps 35 through 40 use a non-storage Spectrum Analyzer.

CONTOUR LEVELER - STORAGE SPECTRUM ANALYZER

19. Set Spectrum Analyzer for Max Hold (Trace B).
 20. Slowly rotate MNL FREQ Controls (10) from 9295 MHz to 9410 MHz.
 21. Store reference trace (Trace B).
 22. Set RANGE SEL Switch (39) to **CONTOUR/AM UP MOD**.
 23. Set Spectrum Analyzer for Max Hold (Trace A).
 24. Slowly rotate MNL FREQ Controls (10) from **9295 MHz** to **9410 MHz**.

NOTE: Using Spectrum Analyzer, Normalizer displays a single trace to represent signal level difference of Trace A with respect to Trace B, referenced to a zero line.

25. Verify Trace A level equals Trace B reference level (± 1 dB) across specified band. If not, adjust R47002 on AGC PC Board Assembly.

NOTE: Difference in level between two signals (Main and Contour) is measured at all frequencies to verify unit meets specifications. Absolute level of two signals, shown by Spectrum Analyzer, is unimportant.

26. Set OUTPUT LEVEL COARSE dBm Control (9) to **-60** and CONTOUR/R2/INTL AM dB BOOST/ATTEN Control (3) to **10**.
 27. Set Spectrum Analyzer for Max Hold (Trace A).
 28. Slowly rotate MNL FREQ Controls (10) from **9295 MHz** to **9410 MHz**.
 29. Verify difference between Trace A level and Trace B reference level is ≤ 1 dB across specified band.
 30. Set OUTPUT LEVEL COARSE dBm Control (9) to **-70** and CONTOUR/R2/INTL AM dB BOOST/ATTEN Control (3) to **20**.
 31. Set Spectrum Analyzer for Max Hold (Trace A).
 32. Slowly rotate MNL FREQ Controls (10) from **9295 MHz** to **9410 MHz**.
 33. Verify difference between Trace A level and Trace B reference level is ≤ 1 dB across specified band.

 STEP PROCEDURE

34. Proceed at Step 41.

CONTOUR LEVELER - NON-STORAGE SPECTRUM ANALYZER

35. Slowly rotate MNL FREQ Controls (10) from **9295 MHz** to **9410 MHz**. While rotating MNL FREQ Controls (10), frequently switch RANGE SEL Switch (39) between **RINGS 1** and **CONTOUR/AM UP MOD**. Verify displayed levels of both modes are equal (± 1 dB). If not, adjust R47002 on AGC PC Board Assembly.
36. Set Spectrum Analyzer amplitude scale to 5 dB/Div.
37. Set OUTPUT LEVEL COARSE dBm Control (9) to **-60** and CONTOUR/R2/INTL AM dB BOOST/ATTEN Control (3) to **10**.
38. Slowly rotate MNL FREQ Controls (10) from **9295 MHz** to **9410 MHz**. While rotating MNL FREQ Controls (10), frequently switch RANGE SEL Switch (39) between **RINGS 1** and **CONTOUR/AM UP MOD**. Verify change from **RINGS 1** to **CONTOUR/AM UP MOD** increases output level by 10 dB (± 1 dB).
39. Set OUTPUT LEVEL COARSE dBm Control (9) to **-70** and CONTOUR/R2/INTL AM dB BOOST/ATTEN Control (3) to **20**.
40. Slowly rotate MNL FREQ Controls (10) from **9295 MHz** to **9410 MHz**. While rotating MNL FREQ Controls (10), frequently switch RANGE SEL Switch (39) between **RINGS 1** and **CONTOUR/AM UP MOD**. Verify change from **RINGS 1** to **CONTOUR/AM UP MOD** increases output level by 20 dB (± 1 dB).

R1/R2 LEVELER

41. Reset RD-301A controls as follows:

CONTROL	SETTING
(2) PRF/RF Switch	PRF
(3) CONTOUR/R2/INTL AM dB BOOST/ATTEN Control	06
(4) OUTPUT LEVEL FINE dBm Control	-5
(9) OUTPUT LEVEL COARSE dBm Control	-50
(29) MODULATION MODE Pushbutton Switches	INTL
(31) PULSE WIDTH μ S Control (RANGE 2)	5
(32) PULSE WIDTH μ S Control (RANGE 1)	5
(34) PULSE WIDTH MULTIPLIER Control (RANGE 1)	100
(36) μ S/NM Switch	μS
(37) RANGE 1 DELAY Thumbwheels	001.0
(38) RANGE 2 DELAY Thumbwheels	700.0
(39) RANGE SEL Switch	R2 ON
(42) X1/X10 INTL PRF/AM Switch	X10

42. Set INTL PRF/AM Control (41) for **700 Hz** on FREQUENCY Hz/MHz Digital Display (1).

43. Set PRF/RF Switch (2) to **RF**.

NOTE: Steps 44 through 52 use a dual trace, storage Spectrum Analyzer. Steps 53 through 55 use a non-storage Spectrum Analyzer.

R1/R2 LEVELER - STORAGE SPECTRUM ANALYZER

44. Set PULSE WIDTH MULTIPLIER Control (RANGE 2) (35) to **0.1**.
45. Set Spectrum Analyzer video filter to .01 and frequency span to 10 MHz/Div.
46. Set Spectrum Analyzer for Max Hold (Trace B).
47. Slowly rotate MNL FREQ Controls (10) from **9295 MHz** to **9410 MHz**.

STEP PROCEDURE

48. Store reference trace (Trace B) (Range 1 Reply Pulse amplitude level).
49. Set PULSE WIDTH MULTIPLIER Control (RANGE 1) (34) to **0.1** and PULSE WIDTH MULTIPLIER Control (RANGE 2) (35) to 100.
50. Set Spectrum Analyzer for Max Hold (Trace A).
51. Slowly rotate MNL FREQ Controls (10) from **9295 MHz** to **9410 MHz**.
52. Verify Trace A level is 6 dB (± 1 dB) below Trace B reference level across specified band. Refer to 2-2-2, Figure 19. If not, adjust R47065 on AGC PC Board Assembly.

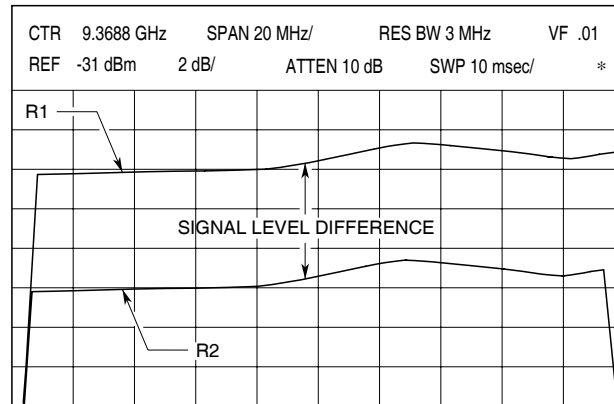

9016011

R1 and R2 Signal Levels as Stored Traces
Figure 19

53. Proceed at Step 57.

R1/R2 LEVELER - NON-STORAGE SPECTRUM ANALYZER

54. Set PULSE WIDTH MULTIPLIER Control (RANGE 2) (35) to **0.1**.
55. Set Spectrum Analyzer frequency span to 1 MHz/Div and sweep speed to 5 ms/Div.

STEP

PROCEDURE

56. Slowly rotate MNL FREQ Controls (10) from **9295 MHz** to **9410 MHz** while tuning Spectrum Analyzer frequency to track pulses. Refer to 2-2-2, Figure 20. Verify difference between R1 and R2 pulse peaks is 6 dB (± 1.5 dB) across specified band. If not, adjust R47065 on AGC PC Board Assembly.

NOTE: Connecting Spectrum Analyzer external trigger input to SYNC Connector (26) may help define pulse peaks.

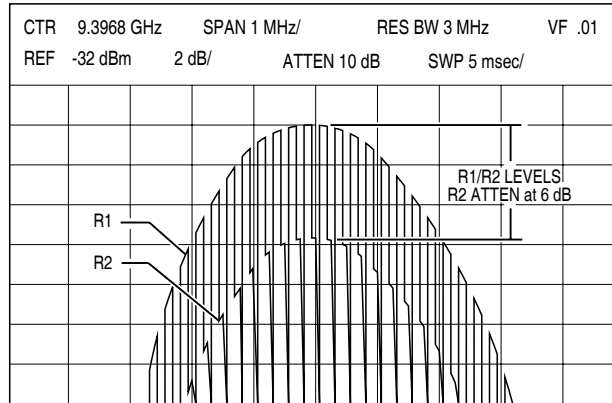

9016012

R1 and R2 Signal Levels
Figure 20

57. Disconnect test equipment and replace top cover on RD-301A.

(10) Internal PRF

PREREQUISITES: 100 MHz Clock (para 2-2-2H[2])

TEST EQUIPMENT: Oscilloscope

FIGURE REFERENCE: 2-2-2, Figure 15

STEP	PROCEDURE								
1.	Apply power to RD-301A and allow for 30 minute stabilization period.								
2.	Set RD-301A as follows:								
	<table border="1" style="width: 100%; border-collapse: collapse;"> <thead> <tr> <th style="text-align: left;"><u>CONTROL</u></th> <th style="text-align: left;"><u>SETTING</u></th> </tr> </thead> <tbody> <tr> <td>(2) PRF/RF Switch</td> <td>PRF</td> </tr> <tr> <td>(29) MODULATION MODE Pushbutton Switches</td> <td>INTL</td> </tr> <tr> <td>(42) X1/X2 INTL PRF/AM Switch</td> <td>X1</td> </tr> </tbody> </table>	<u>CONTROL</u>	<u>SETTING</u>	(2) PRF/RF Switch	PRF	(29) MODULATION MODE Pushbutton Switches	INTL	(42) X1/X2 INTL PRF/AM Switch	X1
<u>CONTROL</u>	<u>SETTING</u>								
(2) PRF/RF Switch	PRF								
(29) MODULATION MODE Pushbutton Switches	INTL								
(42) X1/X2 INTL PRF/AM Switch	X1								
3.	Connect Oscilloscope to SYNC Connector (26).								
4.	Adjust INTL PRF/AM Control (41) for FREQUENCY Hz/MHz Digital Display (1) reading of 50 Hz .								
5.	Verify INTL PRF/AM Control (41) is within area marked for 50 Hz . If not, reset INTL PRF/AM Control (41) as follows: <ul style="list-style-type: none"> ● Remove two set screws and dial. ● Reset dial onto shaft with INTL PRF/AM Control (41) set to 50. ● Tighten two set screws. 								
6.	Set Oscilloscope with sweep speed at 2 ms/Div to display SYNC Connector (26) output.								
7.	Refer to para 2-2-2H(1), Step 2 and remove top cover from RD-301A.								
8.	Verify sync pulse shown on Oscilloscope has 50% ($\pm 2.5\%$) duty cycle. (Positive excursion is same time as negative excursion $\pm \approx 1$ minor division.) If not, adjust R30062 on Range #2 PC Board Assembly.								
9.	Set INTL PRF/AM Control (41) to initial line marked for 500 Hz .								
10.	Verify FREQUENCY Hz/MHz Digital Display (1) reads 500 Hz (± 1 Hz). If not, adjust R30066 on Range #2 PC Board Assembly.								
11.	Set Oscilloscope sweep speed to 0.2 ms/Div.								
12.	Verify sync pulse shown on Oscilloscope has 50% ($\pm 2.5\%$) duty cycle. (Positive excursion is same time as negative excursion $\pm \approx 1$ minor division.) If not, repeat Steps 4 through 12 until all steps pass.								
13.	Perform INTL Modulation/PRF Counter Verification Procedure (para 2-2-2F[3]).								
14.	Disconnect equipment and replace top cover on RD-301A.								

(11) Pulse Width

- PREREQUISITES:** 8.25 GHz LO (para 2-2-2H[3])
- TEST EQUIPMENT:** 6 dB Pad
Heterodyne Monitor
L-Band Signal Generator
Oscilloscope
X-Band to L-Band Down Converter

FIGURE REFERENCE: 2-2-2, Figure 15

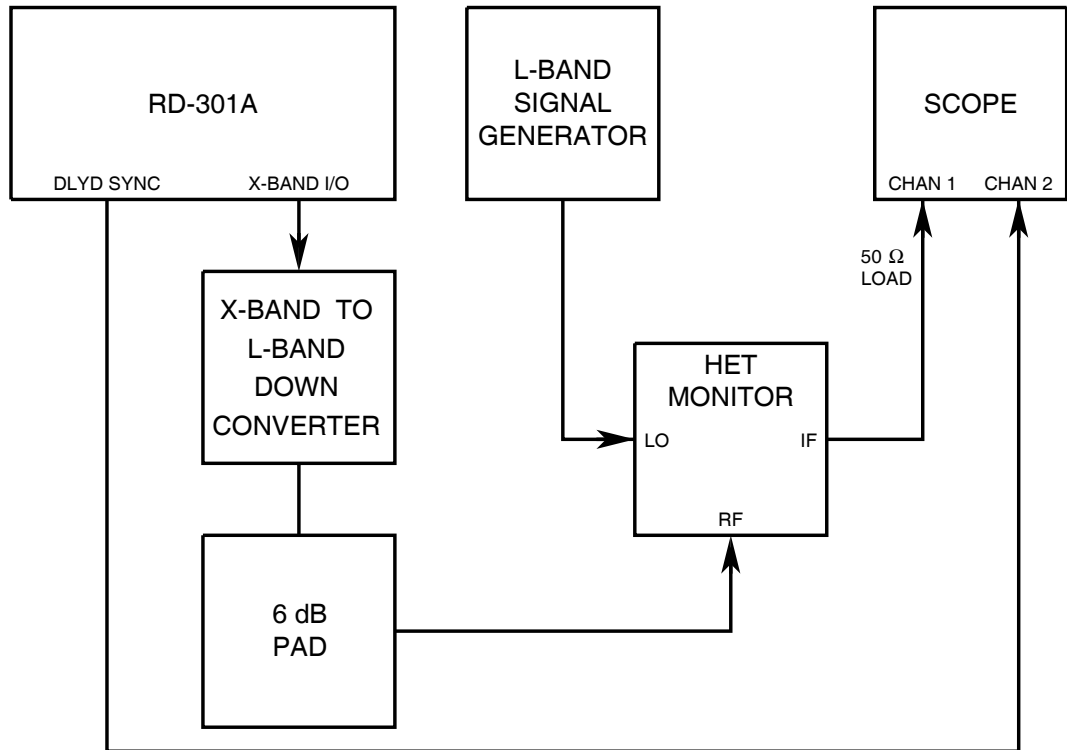

9006006

Pulse Width Calibration Setup
Figure 21

STEP

PROCEDURE

1. Apply power to RD-301A and allow for 30 minute stabilization period.

RANGE #1

2. Set RD-301A as follows:

CONTROL	SETTING
(2) PRF/RF Switch	RF
(4) OUTPUT LEVEL FINE dBm Control	0
(9) OUTPUT LEVEL COARSE dBm Control	-50
(10) MNL FREQ Controls	9375 MHz
(16) RF/IF MODE Pushbutton Switches	RF MNL
(29) MODULATION MODE Pushbutton Switches	INTL
(31) PULSE WIDTH μ S Control (RANGE 2)	0.5
(32) PULSE WIDTH μ S Control (RANGE 1)	0.5
(34) PULSE WIDTH MULTIPLIER Control (RANGE 1)	0.1
(35) PULSE WIDTH MULTIPLIER Control (RANGE 2)	0.1
(36) μ S/NM Switch	μS
(37) RANGE 1 DELAY Thumbwheels	000.3
(38) RANGE 2 DELAY Thumbwheels	900.0
(39) RANGE SEL Switch	RINGS 1
(42) X1/X10 INTL PRF/AM Switch	X10

3. Connect test equipment as shown in 2-2-2, Figure 21.
 4. Refer to para 2-2-2H(1), Step 2 and remove top cover from RD-301A.
 5. Set L-Band Signal Generator for 1125 MHz CW signal at +5 dBm.
 6. Set PRF/RF Switch (2) to **PRF**.
 7. Adjust INTL PRF/AM Control (41) until **1000 Hz** is shown on FREQUENCY Hz/MHz Digital Display (1).
 8. Set PRF/RF Switch (2) to **RF**.
 9. Set Oscilloscope to trigger on Channel 2 and sweep speed to 10 ns/Div.
 10. Verify pulse width is 50 ns (± 5 ns). If not, adjust R30022 on RANGE #2 PC Board Assembly.
- NOTE:** All pulse widths are measured from 50% amplitude on rising edge to 50% amplitude on falling edge. Refer to 2-2-2, Figure 22.

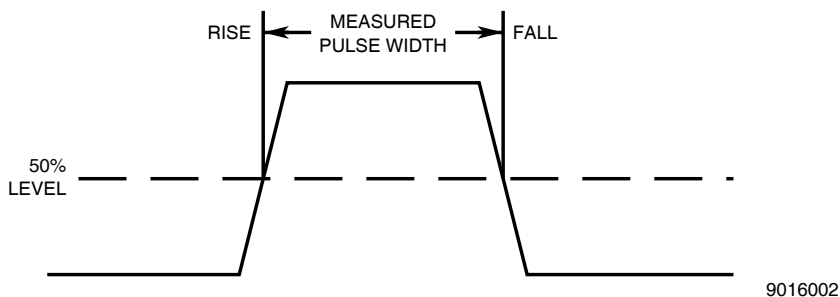

Pulse Width Calibration Measurement Points
Figure 22

11. Set PULSE WIDTH MULTIPLIER Control (RANGE 1) (34) to **1**.

STEP	PROCEDURE
------	-----------

12. Set Oscilloscope sweep speed to 100 ns/Div.
13. Verify pulse width is 500 ns (± 50 ns). If not, adjust R30021 on RANGE #2 PC Board Assembly.
14. Set PULSE WIDTH MULTIPLIER Control (RANGE 1) (34) to **100**.
15. Set PRF/RF Switch (2) to **PRF**.
16. Adjust INTL PRF/AM Control (41) until 500 Hz is shown on FREQUENCY Hz/MHz Digital Display (1).
17. Set PRF/RF Switch (2) to **RF**.
18. Set Oscilloscope sweep speed to 100 μ s/Div.
19. Verify pulse width is 500 μ s (± 50 μ s). If not, adjust R30010 on RANGE #2 PC Board Assembly.
20. Set pulse width to 0.5 μ s.
21. Set PULSE WIDTH MULTIPLIER Control (RANGE 1) (34) to **X500**.
23. Set PRF/RF Switch (2) to **PRF**.
24. Set X1/X10 INTL PRF/AM Switch (42) to **X1**.
25. Adjust X1/X10 INTL PRF/AM Switch (42) until 125 Hz is displayed on FREQUENCY Hz/MHz Digital Display (1).
26. Adjust R30088 on RANGE #2 PC Board Assembly until pulse width is 250.0 μ s.
27. Set Oscilloscope sweep speed to 500 μ s/div. Set pulse width to 5.0 μ s.
28. Verify pulse width is 2.5 ms (2.0 to 3.0 ms).
29. Repeat Steps 1 to 28 until 50 ns, 500 ns, 500 μ s and 2.5 ms pulse width measurements are stable and within specified tolerance ranges.

RANGE #2

30. Set RD-301A as follows:

<u>CONTROL</u>	<u>SETTING</u>
(2) PRF/RF Switch	PRF
(37) RANGE 1 DELAY Thumbwheels	900.0
(38) RANGE 2 DELAY Thumbwheels	000.3
(39) RANGE SEL Switch	R2 ON

31. Adjust INTL PRF/AM Control (41) until 1000 Hz is shown on FREQUENCY Hz/MHz Digital Display (1).
32. Set PRF/RF Switch (2) to **RF**.
33. Set Oscilloscope sweep speed to 10 ns/Div.
34. Verify pulse width is 50 ns (± 5 ns). If not, adjust R30042 on RANGE #2 PC Board Assembly.
35. Set PULSE WIDTH MULTIPLIER Control (RANGE 1) (34) to **1**.
36. Set Oscilloscope sweep speed to 100 ns/Div.
37. Verify pulse width is 500 ns (± 50 ns). If not, adjust R30041 on RANGE #2 PC Board Assembly.
38. Set PULSE WIDTH MULTIPLIER Control (RANGE 2) (35) to **100**.

STEP	PROCEDURE
------	-----------

39. Set PRF/RF Switch (2) to **PRF**.
40. Adjust INTL PRF/AM Control (41) until **500** (500 Hz) is shown on FREQUENCY Hz/MHz Digital Display (1).
41. Set PRF/RF Switch (2) to **RF**.
42. Set Oscilloscope sweep speed to 100 μ s/Div.
43. Verify pulse width is 500 μ s (\pm 50 μ s). If not, adjust R30031 on RANGE #2 PC Board Assembly.
44. Disconnect test equipment and replace top cover on RD-301A.

(12) Range Delay

PREREQUISITES: Pulse Width (para 2-2-2H[11])

TEST EQUIPMENT: Pulse Generator
Oscilloscope
X-Band to L-Band Down Converter
L-Band Signal Generator

FIGURE REFERENCE: 2-2-2, Figure 14

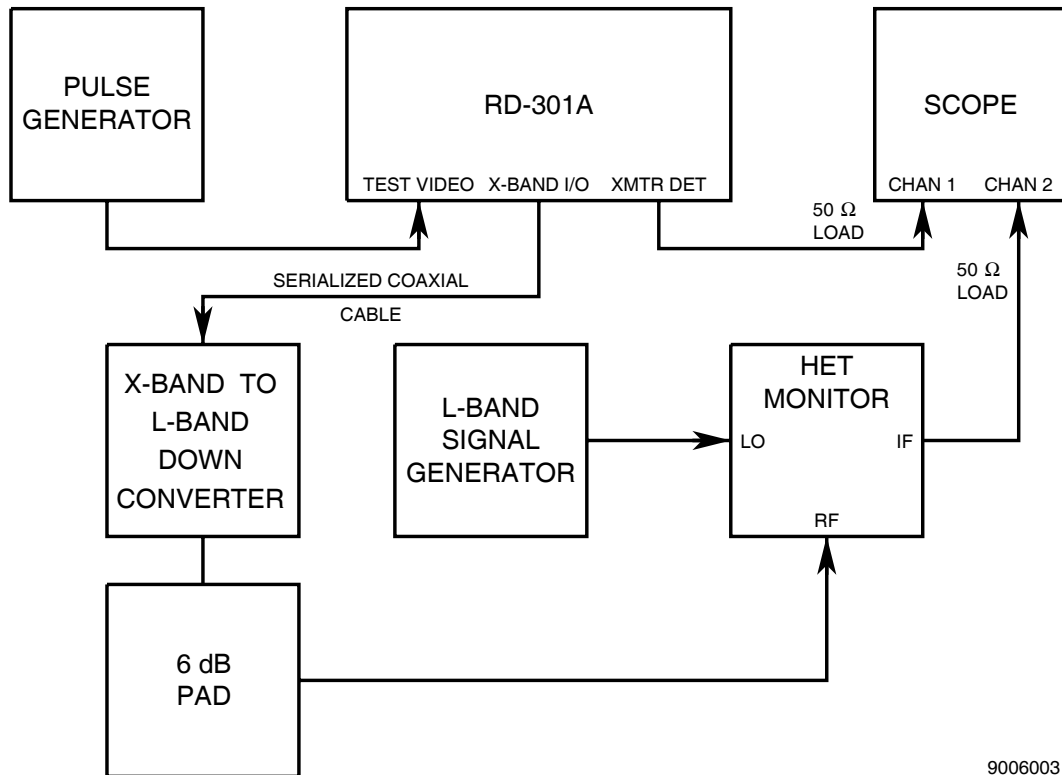

9006003

Range Delay Calibration Setup
Figure 23

STEP

PROCEDURE

1. Apply power to RD-301A and allow for 30 minute stabilization period.
2. Set RD-301A as follows:

CONTROL	SETTING
(2) PRF/RF Switch	RF
(10) MNL FREQ Controls	9375 MHz
(16) RF/IF MODE Pushbutton Switches	RF MNL
(29) MODULATION MODE Pushbutton Switches	TRACK
(31) PULSE WIDTH μ S Control (RANGE 2)	5
(32) PULSE WIDTH μ S Control (RANGE 1)	5
(34) PULSE WIDTH MULTIPLIER Control (RANGE 1)	1
(35) PULSE WIDTH MULTIPLIER Control (RANGE 2)	1
(36) μ S/NM Switch	μS
(37) RANGE 1 DELAY Thumbwheels	100.0
(38) RANGE 2 DELAY Thumbwheels	000.2
(39) RANGE SEL Switch	RINGS 1

3. Refer to para 2-2-2H(1) and remove top cover from RD-301A.
4. Connect test equipment as shown in 2-2-2, Figure 23.
5. Set Pulse Generator for 3 μ s pulse at TTL level and 1 kHz PRF.
6. Set L-Band Signal Generator for 1125 MHz CW signal at +7 dBm.

NOTE: Keep RD-301A and L-Band Signal Generator near same L-Band frequency (zero-beat) for minimum distortion.
7. Set Oscilloscope to display both channels.

NOTE: Insure both Oscilloscope channel delays are calibrated to match.
8. Verify range delay is 0.6 μ s (\pm 0.05 μ s). If not, adjust R19047 on Range #1 PC Board Assembly.

NOTE: Measure range delay from leading edge of transmitter pulse through XMTR DET Connector (13) to leading edge of reply pulse through X-Band I/O Connector (18) at 50% amplitude points.

NOTE: Refer to Appendix D. Subtract fixed delay through X-Band to L-Band Down Converter from RD-301A range delay measurement to obtain actual range delay.
9. Disconnect equipment and replace top cover on RD-301A.

(13) Power Meter

PREREQUISITES: Power Supply (para 2-2-2H[1])

TEST EQUIPMENT: Bandpass Filter
Power Meter Assembly
TWT Amplifier
X-Band Signal Generator

FIGURE REFERENCE: 2-2-2, Figure 13

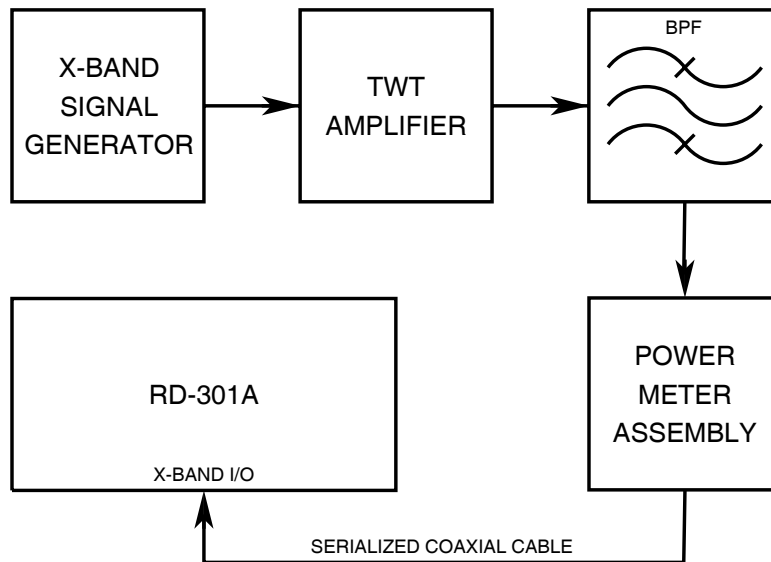

9006004

Power Meter Calibration Setup
Figure 24

STEP	PROCEDURE
------	-----------

1. Apply power to RD-301A and allow for 30 minute stabilization period.
2. Set TWT Amplifier power On and in Standby mode.
3. Connect test equipment as shown in 2-2-2, Figure 24.
4. Set X-Band Signal Generator as follows:

CONTROL	SETTING
Frequency	9375 MHz
Pulse Width	3 μ s
PRF	1 kHz

5. Set METER SELECT Switch (47) to **PK POWER**.

STEP PROCEDURE

6. Record coupling value of Waveguide Coupler used with RD-301A.

NOTE: The coupling value is marked (not tagged value) on Waveguide Coupler.

WAVEGUIDE COUPLER VALUE	2 kW TEST RF LEVEL	10 kW TEST RF LEVEL
19.0 dB	25.179 W	125.893 W
19.1 dB	24.605 W	123.027 W
19.2 dB	24.045 W	120.226 W
19.3 dB	23.498 W	117.490 W
19.4 dB	22.973 W	114.815 W
19.5 dB	22.440 W	112.202 W
19.6 dB	21.930 W	109.648 W
19.7 dB	21.430 W	107.152 W
19.8 dB	20.943 W	104.713 W
19.9 dB	20.466 W	102.329 W
20.0 dB	20.000 W	100.000 W
20.1 dB	19.545 W	97.724 W
20.2 dB	19.100 W	95.499 W
20.3 dB	18.665 W	93.325 W
20.4 dB	18.140 W	91.201 W
20.5 dB	17.825 W	89.125 W
20.6 dB	17.419 W	87.096 W
20.7 dB	17.023 W	85.114 W
20.8 dB	16.635 W	83.176 W
20.9 dB	16.257 W	81.283 W
21.0 dB	15.887 W	79.433 W

Test RF Levels for Power Meter Verification
Table 6

7. Record 2 kW and 10 kW Test RF Levels from 2-2-2, Table 6 according to Waveguide Coupler Value from Step 6.

8. Refer to para 2-2-2H(1), Step 2 and remove top cover from RD-301A.

CAUTION: CONNECTIONS TO TWT AMPLIFIER MUST BE CORRECT BEFORE SWITCHING TO OPERATE MODE.

9. Set TWT Amplifier to Operate mode.

10. Adjust X-Band Signal Generator level until Power Meter Assembly indicates 2 kW Test RF Level from Step 7.

11. Verify PANEL Meter (43) indicates **2 kW** (± 296 W). If not, adjust R17143 on Video PC Board Assembly.

12. Adjust X-Band Signal Generator level until Power Meter Assembly indicates 10 kW Test RF Level from Step 7.

13. Verify PANEL Meter (43) indicates **10 kW** (± 1480 W). If not, adjust R17128 on Video PC Board Assembly.

14. Repeat Steps 10 through 13 until no adjustments are required.

15. Perform Power Meter Verification Procedure (para 2-2-2F[5]).

16. Slowly decrease TWT Amplifier power and set to Standby mode for ≥ 15 minutes.

17. Disconnect test equipment and replace top cover on RD-301A.

(14) Discriminator

PREREQUISITES: Pulse Width (para 2-2-2H[11])

TEST EQUIPMENT: Oscilloscope
TWT Amplifier
X-Band Signal Generator

FIGURE REFERENCE: 2-2-2, Figure 14

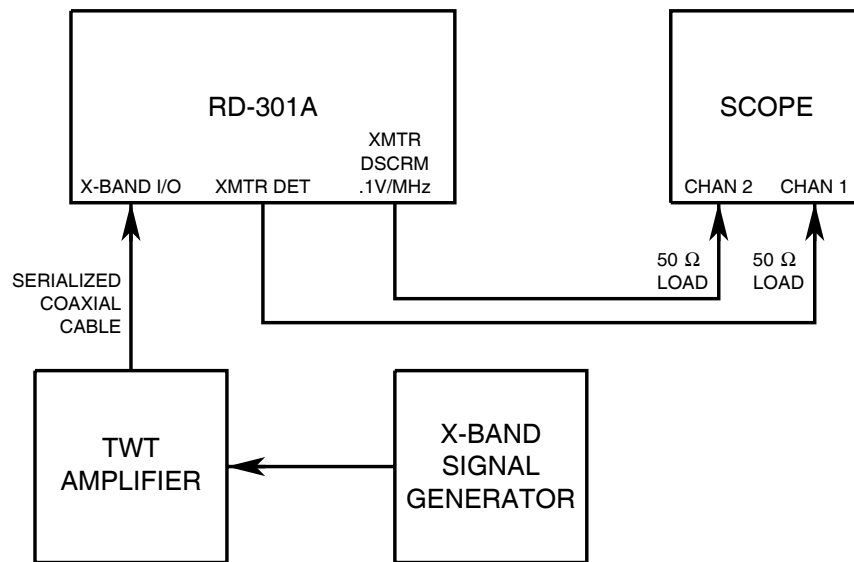

9006017

Discriminator Calibration Setup
Figure 25

STEP	PROCEDURE																
1.	Apply power to RD-301A and allow for 30 minute stabilization period.																
2.	Set RD-301A as follows:																
	<table border="1"> <thead> <tr> <th>CONTROL</th> <th>SETTING</th> </tr> </thead> <tbody> <tr> <td>(2) PRF/RF Switch</td> <td>RF</td> </tr> <tr> <td>(4) OUTPUT LEVEL FINE dBm Control</td> <td>0</td> </tr> <tr> <td>(9) OUTPUT LEVEL COARSE dBm Control</td> <td>-50</td> </tr> <tr> <td>(16) RF/IF MODE Pushbutton Switches</td> <td>RF MNL</td> </tr> <tr> <td>(29) MODULATION MODE Pushbutton Switches</td> <td>TRACK</td> </tr> <tr> <td>(47) METER SELECT Switch</td> <td>PK POWER</td> </tr> <tr> <td>(48) ΔF OFFSET/EFF PEAKING Control</td> <td>CAL</td> </tr> </tbody> </table>	CONTROL	SETTING	(2) PRF/RF Switch	RF	(4) OUTPUT LEVEL FINE dBm Control	0	(9) OUTPUT LEVEL COARSE dBm Control	-50	(16) RF/IF MODE Pushbutton Switches	RF MNL	(29) MODULATION MODE Pushbutton Switches	TRACK	(47) METER SELECT Switch	PK POWER	(48) ΔF OFFSET/EFF PEAKING Control	CAL
CONTROL	SETTING																
(2) PRF/RF Switch	RF																
(4) OUTPUT LEVEL FINE dBm Control	0																
(9) OUTPUT LEVEL COARSE dBm Control	-50																
(16) RF/IF MODE Pushbutton Switches	RF MNL																
(29) MODULATION MODE Pushbutton Switches	TRACK																
(47) METER SELECT Switch	PK POWER																
(48) ΔF OFFSET/EFF PEAKING Control	CAL																
3.	Connect test equipment as shown in 2-2-2, Figure 25.																
4.	Set TWT Amplifier power On and in Standby mode.																
5.	Set X-Band Signal Generator for 5 μs wide pulse at 500 Hz PRF.																
6.	Adjust X-Band Signal Generator frequency for 9350 MHz as shown on FREQUENCY Hz/MHz Digital Display (1).																
7.	Set X-Band Signal Generator output level for 0.5 kW as indicated on PANEL Meter (43).																

STEP

PROCEDURE

8. Refer to para 2-2-2H(1), Step 2 and remove top cover from RD-301A.
CAUTION: CONNECTIONS TO TWT AMPLIFIER MUST BE CORRECT BEFORE SWITCHING TO OPERATE MODE.
9. Set TWT Amplifier to Operate mode.
ΔF OFFSET
10. Set METER SELECT Switch (47) to ΔF.
11. Verify PANEL Meter (43) indicates **0.0 MHz** offset. If not, adjust R50069 on Discriminator #1 PC Board Assembly.
12. Remove ΔF OFFSET/EFF PEAKING Control (48) from CAL position and adjust for **9350 MHz** frequency as shown on FREQUENCY Hz/MHz Digital Display (1).
13. Verify PANEL Meter (43) indicates **0.0 MHz** offset. If not, adjust R50090 on Discriminator #1 PC Board Assembly.
14. If adjustments are made in Step 11 and/or Step 13, repeat Steps 10 through 13 until no adjustments are required.
15. Adjust ΔF OFFSET/EFF PEAKING Control (48) for **+0.5 MHz** on PANEL Meter (43).
16. Verify FREQUENCY Hz/MHz Digital Display (1) indicates **9350.50 MHz**. If not, adjust R50077 on Discriminator #1 PC Board Assembly.
17. If adjustment is made in Step 16, repeat Steps 15 and 16 until all indications are correct without adjustments.
18. Repeat Steps 10 through 14.
19. Adjust ΔF OFFSET/EFF PEAKING Control (48) for **-0.5 MHz** on PANEL Meter (43).
20. Verify FREQUENCY Hz/MHz Digital Display (1) indicates **9349.50 MHz** (±0.25 MHz).
21. Adjust ΔF OFFSET/EFF PEAKING Control (48) for **0.0 MHz** on PANEL Meter (43).
22. Verify FREQUENCY Hz/MHz Digital Display (1) indicates **9350 MHz** (±0.25 MHz).
23. Adjust ΔF OFFSET/EFF PEAKING Control (48) for **+0.75 MHz** on PANEL Meter (43).
24. Verify FREQUENCY Hz/MHz Digital Display (1) indicates **9350.75 MHz** (±0.25 MHz).
25. Adjust ΔF OFFSET/EFF PEAKING Control (48) for **-0.75 MHz** on PANEL Meter (43).
26. Verify FREQUENCY Hz/MHz Digital Display (1) indicates **9349.25 MHz** (±0.25 MHz).
27. If any step fails, repeat Steps 10 through 26.
28. Set ΔF OFFSET/EFF PEAKING Control (48) to **CAL**.
29. Set METER SELECT Switch (47) to **PK POWER**.

STEP

PROCEDURE

XMTR DSCRM .1V/MHz CONNECTOR

30. Set Oscilloscope with both channels dc coupled as follows:

CONTROL
SETTING

Sweep Speed	5 μ s/Div
Amplitude Scale (Both Channels)	10 mV/Div
Trigger	Channel 1

31. Adjust X-Band Signal Generator frequency for **9400 MHz** as shown on FREQUENCY Hz/MHz Digital Display (1).
32. Set RF/IF MODE Pushbutton Switches (16) to **RF MNL**.
33. Adjust MNL FREQ Controls (10) for **9400 MHz** as shown on FREQUENCY Hz/MHz Digital Display (1). Adjust Oscilloscope and verify XMTR DSCRM .1V/MHz Connector (12) pulse and XMTR DET Connector (13) pulse have same even amplitude.
34. Adjust MNL FREQ Controls (10) for **9400.50 MHz** as shown on FREQUENCY Hz/MHz Digital Display (1).
35. Verify XMTR DSCRM .1V/MHz Connector (12) pulse level increases to 50 mV (± 5 mV) above XMTR DET Connector (13) pulse level. If not, mark current position of R50182 on Discriminator #1 PC Board Assembly and adjust no more than 1/8th turn. Record correct voltage difference.
- NOTE:** If R50182 on Discriminator #1 PC Board Assembly requires more than 1/8th turn of adjustment, Discriminator #1 PC Board Assembly may need module level calibration. Contact Aeroflex Customer Service (800-835-2350) if assistance is needed.
36. Adjust MNL FREQ Controls (10) for **9399.50 MHz** as shown on FREQUENCY Hz/MHz Digital Display (1).
37. Verify XMTR DSCRM .1V/MHz Connector (12) pulse level decreases to 50 mV (± 5 mV) below XMTR DET Connector (13) pulse level. If not, repeat Steps 34 through 37 until all levels are within tolerance. Record correct voltage difference.
38. Slowly decrease TWT Amplifier power and set to Standby mode for ≥ 15 minutes.
39. Disconnect test equipment and replace top cover on RD-301A.



I. Calibration Data Sheet

RD-301A S/N: _____ DATE: _____

TECHNICIAN: _____

STEP	DATA	RESULT
(1)	Power Supply	
	4. +5 V (+4.7 to +5.3 Vdc)	-----
	+12 V (+11.4 to +12.6 Vdc)	-----
	-12 V (-11.4 to -12.6 Vdc)	-----
	-24 V (-22.0 to -25.2 Vdc)	-----
	5. +5 V Ripple Voltage ≤ 15 mVp-p	-----
	+12 V Ripple Voltage ≤ 15 mVp-p	-----
	-12 V Ripple Voltage ≤ 15 mVp-p	-----
	-24 V Ripple Voltage ≤ 20 mVp-p	-----
(2)	100 MHz Clock	
	5. 100 MHz (99.995 to 100.005 MHz)	-----
	7. 8.091269 MHz (8.091243 to 8.09430 MHz)	-----
(3)	8.25 GHz LO	
	9. 103.125 MHz (103.1229 to 103.1271 MHz)	-----
	10. -10 Vdc (-5 to -15 Vdc)	-----
	12. Frequency Counter reading 8.25 GHz (± 100 kHz)	-----
	15. FREQUENCY Hz/MHz Digital Display (1) readout ± 250 kHz	-----
(4)	RF Display Limits	
	4. 9504 MHz (9503 to 9505 MHz)	-----
	6. 9291 MHz (9290 to 9292 MHz)	-----
(5)	Marker Oscillator	
	12. ≤ 18.0 MHz	-----
	15. ≥ 74 MHz	-----
	22. FREQUENCY Hz/MHz Digital Display (1) readout ≥ 70 MHz	-----
	25. FREQUENCY Hz/MHz Digital Display (1) readout ≤ 20 MHz	-----



STEP	DATA	RESULT
(6)	IF Oscillator	
	5. FREQUENCY Hz/MHz Digital Display (1) readout 77 MHz	_____ (√)
	7. FREQUENCY Hz/MHz Digital Display (1) readout ≤18 MHz	_____
	9. FREQUENCY Hz/MHz Digital Display (1) readout ≥74 MHz	_____
	21. -18.0 V	_____ (√)
	22. 77.0 MHz	_____ (√)
	23. 17.0 MHz	_____ (√)
	24. ≈-2.0 V	_____ (√)
	25. 77 MHz	_____ (√)
	26. Frequency Range 17.0 to 77.0 MHz	_____ (√)
	MIXER BALANCE ADJUSTMENT	
	33. Maximum 60 MHz signal with minimum spurious signals	_____ (√)
	SWEEP WIDTH	
	42. Carrier starts sweeping past 0 setting.	_____ (√)
	44. 4 MHz sweep width	_____ (√)
	46. 2 MHz sweep width (1.8 to 2.2 MHz)	_____
(7)	IF Generator Power Amplifier	
	6. All harmonics and spurious signals are ≥30 dB below 30 MHz carrier	_____ (√)
	10. 30 MHz reference level 0 dBm (-0.2 to +0.2 dBm)	_____
	14. R36023 adjusted to Step 10 reference level	_____ (√)
	18. All harmonics and spurious signals are ≥30 dB below 60 MHz carrier	_____
	22. 60 MHz reference level 0 dBm (-0.2 to +0.2 dBm)	_____
	26. 0 dBm (-2.5 to +2.5 dBm)	_____
	27. 30 MHz and 60 MHz signal levels 0 dBm (-2.5 to +2.5 dBm)	_____ (√)
(8)	External AM	
	6. 30% modulation (28% to 32%)	_____
(9)	Levelers	
	MAIN LEVELER	
	5. Computed X-Band Output Power Level (A)	
	RD-301A Output Level Settings (B)	_____
	Waveguide Coupler Value (C)	_____
	Insertion Loss of Bandpass Filter and 3 dB Pads	_____
	B + C + D = A	_____
	6. X-Band Output Power Level upper limit (A + 2 dB)	_____



STEP	DATA	RESULT
	7. X-Band Output Power Level lower limit (A - 2 dB)	_____
	8. X-Band Output Power Level from 9295 to 9500 MHz stays between Step 6 and Step 7 limits	_____ (√)
	9. Midpoint amplitude value	_____
	12. Midpoint amplitude value = Step 5 X-Band Output Power Level	_____ (√)
	13. X-Band Output Power Level from 9295 to 9500 MHz stays between Step 6 and Step 7 limits	_____ (√)
	CONTOUR LEVELER - STORAGE SPECTRUM ANALYZER	
	25. -50, 00 settings Trace A level equals Trace B level (± 1 dB)	_____
	29. -60, 10 settings Trace A level equals Trace B level (± 1 dB)	_____
	33. -70, 20 settings Trace A level equals Trace B level (± 1 dB)	_____
	CONTOUR LEVELER - NON-STORAGE SPECTRUM ANALYZER	
	35. RINGS 1 and CONTOUR/AM UP MOD settings have equal levels (± 1 dB)	_____
	38. CONTOUR/AM UP MOD setting level is 10 dB above RINGS 1 setting level (9 to 11 dB)	_____
	40. CONTOUR/AM UP MOD setting level is 20 dB above RINGS 1 setting level (9 to 11 dB)	_____
	R1/R2 LEVELER - STORAGE SPECTRUM ANALYZER	
	52. Trace A level (R2) is 6 dB below Trace B level (R1) (5 to 7 dB)	_____ (√)
	R1/R2 LEVELER - NON-STORAGE SPECTRUM ANALYZER	
	56. R2 pulse peaks are 6 dB below R1 pulse peaks (5 to 7 dB)	_____ (√)
(10)	Internal PRF	
	5. INTL PRF/AM Control (41) is set to 50 Hz	_____ (√)
	8. Sync pulse has 50% (47.5% to 52.5 %) duty cycle	_____
	10. FREQUENCY Hz/MHz Digital Display (1) shows 500 Hz (499 to 501 Hz)	_____
	12. Sync pulse has 50% (47.5% to 52.5 %) duty cycle	_____
	13. RD-301A passes INTL Modification/PRF Counter Verification Procedure (para 2-2-2F[3])	_____ (√)
(11)	Pulse Width	
	RANGE 1	
	10. 50 ns (45 to 55 ns)	_____
	13. 500 ns (450 to 550 ns)	_____
	19. 500 μ s (450 to 550 μ s)	_____
	28. 2.5 ms (2.0 to 3.0 ms)	_____
	RANGE 2	
	34. 50 ns (45 to 55 ns)	_____
	37. 500 ns (450 to 550 ns)	_____
	43. 500 μ s (450 to 550 μ s)	_____



STEP	DATA	RESULT
(12)	Range Delay	
	8. 0.6 μ s (0.55 to 0.65 μ s)	-----
(13)	Power Meter	
	6. Waveguide Coupler value	-----
	7. 2 kW Test RF Level (2-2-2, Table 6)	-----
	10 kW Test RF Level (2-2-2, Table 6)	-----
	11. PANEL Meter (43) shows 2 kW (1704 to 2296 W)	-----
	13. PANEL Meter (43) shows 10 kW (8.52 to 11.48 kW)	-----
	15. RD-301A passes Power Meter Verification Procedure (para 2-2-2F[5])	----- (✓)
(14)	Discriminator	
	ΔF OFFSET	
	11. CAL PANEL Meter (43) indicates 0.0 MHz offset	----- (✓)
	13. Out of CAL PANEL Meter (43) indicates 0.0 MHz offset	----- (✓)
	16. Frequency Hz/MHz Digital Display (1) indicates 9350.50 MHz	----- (✓)
	20. Frequency Hz/MHz Digital Display (1) indicates 9349.50 MHz (9349.25 to 9349.75 MHz)	-----
	22. Frequency Hz/MHz Digital Display (1) indicates 9350.00 MHz (9349.75 to 9350.25 MHz)	-----
	24. Frequency Hz/MHz Digital Display (1) indicates 9350.75 MHz (9350.50 to 9351.00 MHz)	-----
	26. Frequency Hz/MHz Digital Display (1) indicates 9349.25 MHz (9349.00 to 9349.50 MHz)	-----
	XMTR DSCRM .1V/MHz CONNECTOR	
	33. XMTR DSCRM .1V/MHz Connector (12) and XMTR DET Connector (13) pulses are same level	----- (✓)
	35. XMTR DSCRM .1V/MHz Connector (12) pulse level is 50 mV above XMTR DET Connector (13) pulse level (45 to 55 mV)	-----
	37. XMTR DSCRM .1V/MHz Connector (12) pulse level is 50 mV below XMTR DET Connector (13) pulse level (45 to 55 mV)	-----



THIS PAGE INTENTIONALLY LEFT BLANK.



3. Assemblies and Schematics

TITLE	NUMBER/REVISION	PAGE
Product Structure	0000-9000-100-G	3
Composite Assy	7003-9047-000-B	4
Interconnect Diagram	0000-9040-000-E	8
Rear Panel Assy	7005-9040-900-A4	9
Rear Panel Assy Schematic	0000-9040-900-A1	10
Power Supply Assy	7005-9040-400-A3	11
Power Supply PCB Assy	7010-9030-400-E	12
Power Supply Assy Schematic	0000-9040-400-C2	14
Floor Assy	7005-9042-000-C	16
Floor Assy	7005-9042-000-C1	17
Floor Assy	7005-9042-000-D	19
Floor Assy Interconnect	0000-9042-000-B	21
Heterodyne Assy	7005-9040-200-C	23
Heterodyne PCB Assy	7010-9030-200-B	24
Heterodyne Assy Schematic	0000-9040-200-B2	25
Coupler/Splitter Assy	7005-9040-300-B1	27
Coupler/Splitter Assy Schematic	0000-9040-300-B1	28
Video PCB Assy	7010-9030-500-E	29
Video PCB Assy Schematic	0000-9030-500-D	30
Buffer Amp Assy	7010-9030-700-B1	33
Buffer Amp Assy Schematic	0000-9030-700-B	35
VCO #2 Assy	7005-9041-200-C1	36
VCO #2 Assy Schematic	0000-9041-200-A2	38
AGC PCB Assy	7010-4933-200-B	42
AGC PCB Assy Schematic	0000-4933-200-B1	43
Main Diode Switch Assy	7005-4940-900-K1	44
Main Diode Switch PCB Assy	7010-4930-000-E	45
Main Diode Switch Assy Schematic	0000-4910-000-E	46
X-Band Front End Assy	2517-2511-700-A	46
8.25 GHz LO Assy	5850-0000-067-B	50
8.25 GHz LO Assy	5850-0000-069-A	51
IF Marker/Oscillator PCB Assy	7010-4931-400-D1	52
IF Marker/Oscillator PCB Assy Schematic	0000-4911-400-C	53
IF Generator Power Amplifier PCB Assy	7010-4931-500-B	54
IF Generator Power Amplifier PCB Assy Schematic	0000-4911-500-A3	55
Front Panel Assy	7005-9047-100-A	56
Front Panel Assy Schematic	0000-9047-100-A	60
Modulation Mode Switch Assy	7010-4931-700-A2	61
Modulation Mode Switch Assy Schematic	0000-4911-700-A	62
RF Mode Switch PCB Assy	7010-4930-700-D1	63
RF Mode Switch PCB Assy Schematic	0000-4910-700-D	65
Range Discrete PCB Assy	7010-4930-900-E	66
Range Discrete PCB Assy Schematic	0000-4910-900-D	67
Range Digit PCB Assy	7010-4930-800-C2	68
Range Digit PCB Assy Schematic	0000-4910-800-C	69
Display Counter Assy	7005-9041-900-A	70
Display Counter PCB Assy	7010-9031-900-C	71
Display Counter Assy Schematic	0000-9041-900-C	72
475/570-775 MHz Filter Assy	7005-4943-000-F	75
475/570-775 MHz Filter Assy Schematic	0000-4913-000-C	76
Delay Line Assy	7005-9041-000-A	77
Card Frame Assy	7005-9041-800-A	78
Range #1 PCB Assy	7010-4930-300-H	80
Range #1 PCB Assy Schematic	0000-4910-300-H	81
Range #2 PCB Assy	7010-9031-800-B	84
Range #2 PCB Assy Schematic	0000-9031-800-B	85



TITLE	NUMBER/REVISION	PAGE
Discriminator #2 PCB Assy	7010-4931-300-B5	87
Discriminator #2 PCB Assy Schematic	0000-4911-300-B1	88
Discriminator #1 PCB Assy	7010-4932-800-K	90
Discriminator #1 PCB Assy Schematic	0000-4912-800-L	93

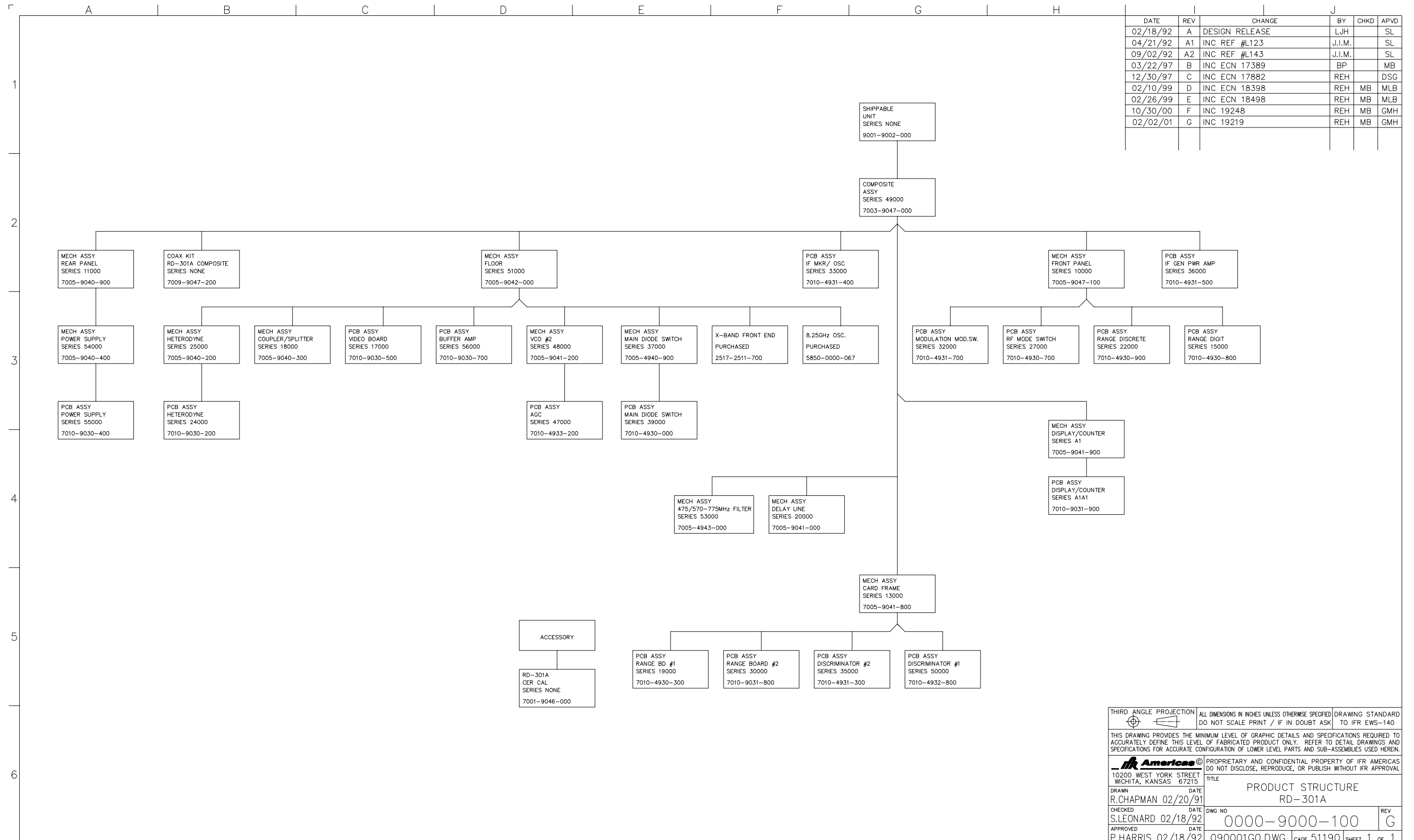

THIRD ANGLE PROJECTION	ALL DIMENSIONS IN INCHES UNLESS OTHERWISE SPECIFIED DO NOT SCALE PRINT / IF IN DOUBT ASK	DRAWING STANDARD TO IFR EWS-140
THIS DRAWING PROVIDES THE MINIMUM LEVEL OF GRAPHIC DETAILS AND SPECIFICATIONS REQUIRED TO ACCURATELY DEFINE THIS LEVEL OF FABRICATED PRODUCT ONLY. REFER TO DETAIL DRAWINGS AND SPECIFICATIONS FOR ACCURATE CONFIGURATION OF LOWER LEVEL PARTS AND SUB-ASSEMBLIES USED HEREIN.		
10200 WEST YORK STREET WICHITA, KANSAS 67215		PROPRIETARY AND CONFIDENTIAL PROPERTY OF IFR AMERICAS DO NOT DISCLOSE, REPRODUCE, OR PUBLISH WITHOUT IFR APPROVAL
DRAWN R.CHAPMAN	DATE 02/20/91	TITLE PRODUCT STRUCTURE RD-301A
CHECKED S.LEONARD	DATE 02/18/92	DWG NO 0000-9000-100
APPROVED P.HARRIS	DATE 02/18/92	REV G
090001G0.DWG		CAGE 51190 SHEET 1 of 1

DATE	REV	CHANGE	BY	CHKD	APVD
02/09/01	A	REL 19219	REH	MB	GMH
11/14/03	B	INC 19862	RLA	CL	GMH
3/16/05	B1	INC 19842	SCP	CJM	GMH

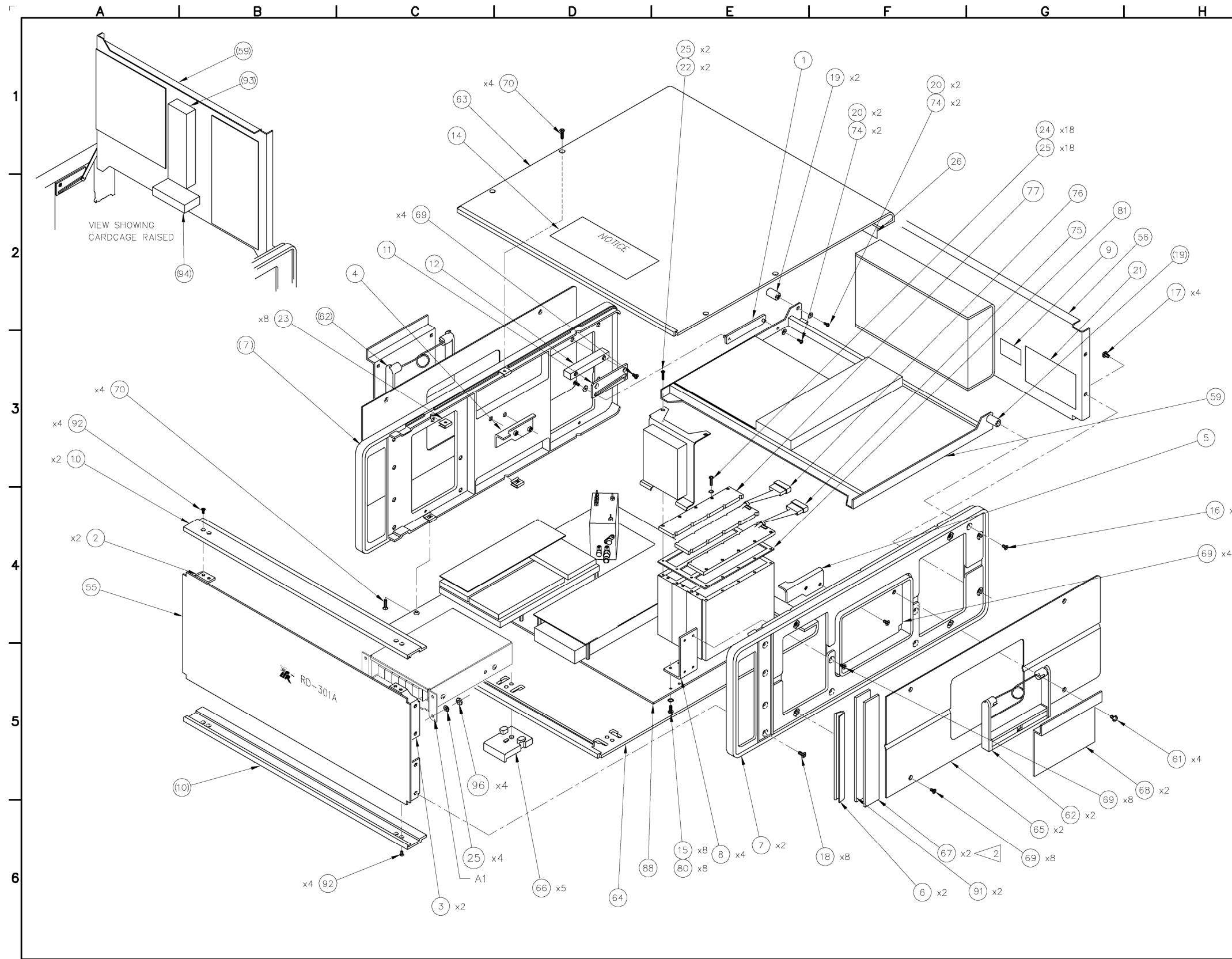

- NOTES:
1. BASIC REFERENCE DESIGNATORS SHOWN, FOR COMPLETE DESIGNATOR PREFIXES REFER TO PRODUCT STRUCTURE, AND SYSTEM INTERCONNECT FOR APPLICATIONS WHERE USED.
 2. MOUNT ITEM 67, DECAL TRIM STRIP, TO ITEM 7, SIDE FRAME, WITH ITEM 91, VINYL FOAM TAPE.



CAUTION:
CONTAINS PARTS AND ASSEMBLIES
SUSCEPTIBLE TO DAMAGE BY
ELECTROSTATIC DISCHARGE (ESD).

THIRD ANGLE PROJECTION	ALL DIMENSIONS IN INCHES UNLESS OTHERWISE SPECIFIED DO NOT SCALE PRINT / IF IN DOUBT ASK	DRAWING STANDARD TO IFR EWS-140
THIS DRAWING PROVIDES THE MINIMUM LEVEL OF GRAPHIC DETAILS AND SPECIFICATIONS REQUIRED TO ACCURATELY DEFINE THIS ITEM OF FABRICATED PRODUCT ONLY. REFER TO DETAIL DRAWINGS AND SPECIFICATIONS FOR ACCURATE CONFIGURATION OF LOWER LEVEL PARTS AND SUB-ASSEMBLIES USED HEREIN.		
AEROFLEX 10200 WEST YORK STREET WICHITA, KANSAS 67215		PROPRIETARY AND CONFIDENTIAL PROPERTY OF AEROFLEX WICHITA DO NOT DISCLOSE, REPRODUCE, OR PUBLISH WITHOUT AEROFLEX APPROVAL
DRAWN R.HARRIS 01/12/01		DATE 01/12/01
CHECKED M.BRUFFETT 01/19/01		DATE 01/19/01
APPROVED G.HILL 02/09/01		DATE 02/09/01
TITLE COMPOSITE ASSY, RD-301A		DWG NO 7003-9047-000
SHEET 1 OF 4		REV B1

Subject to Export Control, see Cover Page for details.

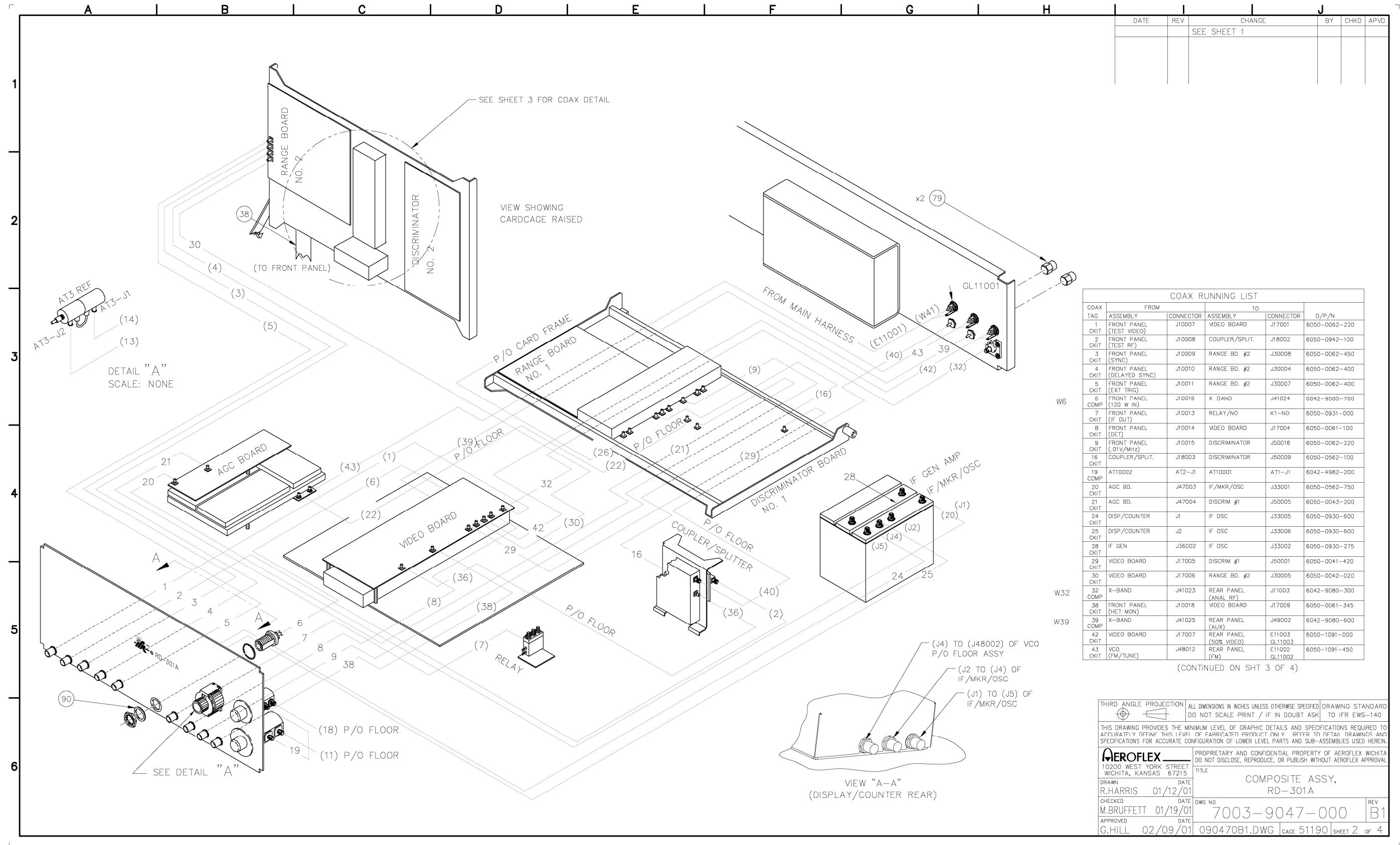

DATE	REV	CHANGE	BY	CHKD	APVD
		SEE SHEET 1			

COAX TAG	FROM ASSEMBLY	CONNECTOR	TO ASSEMBLY	CONNECTOR	D/P/N
1 CKIT	FRONT PANEL (TEST VIDEO)	J10007	VIDEO BOARD	J17001	6050-0062-220
2 CKIT	FRONT PANEL (TEST RF)	J10008	COUPLER/SPLIT.	J18002	6050-0942-100
3 CKIT	FRONT PANEL (SYNC)	J10009	RANGE BD. #2	J30008	6050-0062-450
4 CKIT	FRONT PANEL (DELAYED SYNC)	J10010	RANGE BD. #2	J30004	6050-0062-400
5 CKIT	FRONT PANEL (EXT TRIG)	J10011	RANGE BD. #2	J30007	6050-0062-400
6 CKIT	FRONT PANEL (120 W IN)	J10016	X DAND	J41024	6042-9080-700
7 CKIT	FRONT PANEL (IF OUT)	J10013	RELAY/NO	K1-NO	6050-0931-000
8 CKIT	FRONT PANEL (DET)	J10014	VIDEO BOARD	J17004	6050-0061-100
9 CKIT	FRONT PANEL (.01V/MHz)	J10015	DISCRIMINATOR	J50016	6050-0062-220
16 CKIT	COUPLER/SPLIT.	J18003	DISCRIMINATOR	J50009	6050-0562-100
19 COMP	AT10002	AT2-J1	AT10001	AT1-J1	6042-4982-200
20 CKIT	AGC BD.	J47003	IF/MKR/OSC	J33001	6050-0562-750
21 CKIT	AGC BD.	J47004	DISCRIM #1	J50005	6050-0043-200
24 CKIT	DISP/COUNTER	J1	IF OSC	J33005	6050-0930-600
25 CKIT	DISP/COUNTER	J2	IF OSC	J33006	6050-0930-600
28 CKIT	IF GEN	J36002	IF OSC	J33002	6050-0930-275
29 CKIT	VIDEO BOARD	J17005	DISCRIM #1	J50001	6050-0041-420
30 CKIT	VIDEO BOARD	J17006	RANGE BD. #2	J30005	6050-0042-020
32 COMP	X-BAND	J41023	REAR PANEL (ANAL RF)	J11003	6042-9080-300
38 CKIT	FRONT PANEL (HEI MON)	J10018	VIDEO BOARD	J17009	6050-0061-345
39 COMP	X-BAND	J41025	REAR PANEL (AUX)	J49002	6042-9080-600
42 CKIT	VIDEO BOARD	J17007	REAR PANEL (50% VIDEO)	E11003 GL11003	6050-1091-000
43 CKIT	VCO (FM/TUNE)	J48012	REAR PANEL (FM)	E11002 GL11002	6050-1091-450

(CONTINUED ON SHT 3 OF 4)

THIRD ANGLE PROJECTION	ALL DIMENSIONS IN INCHES UNLESS OTHERWISE SPECIFIED DO NOT SCALE PRINT / IF IN DOUBT ASK TO IFR EWS-140	DRAWING STANDARD
THIS DRAWING PROVIDES THE MINIMUM LEVEL OF GRAPHIC DETAILS AND SPECIFICATIONS REQUIRED TO ACCURATELY DEFINE THIS LEVEL OF FABRICATED PRODUCT ONLY. REFER TO DETAIL DRAWINGS AND SPECIFICATIONS FOR ACCURATE CONFIGURATION OF LOWER LEVEL PARTS AND SUB-ASSEMBLIES USED HEREIN.		
AEROFLEX 10200 WEST YORK STREET WICHITA, KANSAS 67215		PROPRIETARY AND CONFIDENTIAL PROPERTY OF AEROFLEX WICHITA DO NOT DISCLOSE, REPRODUCE, OR PUBLISH WITHOUT AEROFLEX APPROVAL.
DRAWN: R.HARRIS DATE: 01/12/01		TITLE: COMPOSITE ASSY, RD-301A
CHECKED: M.BRUFFETT DATE: 01/19/01		DWG NO: 7003-9047-000
APPROVED: G.HILL DATE: 02/09/01		REV: B1 090470B1.DWG (PAGE 51190) SHEET 2 OF 4

DATE	REV	CHANGE	BY	CHKD	APVD
		SEE SHEET 1			

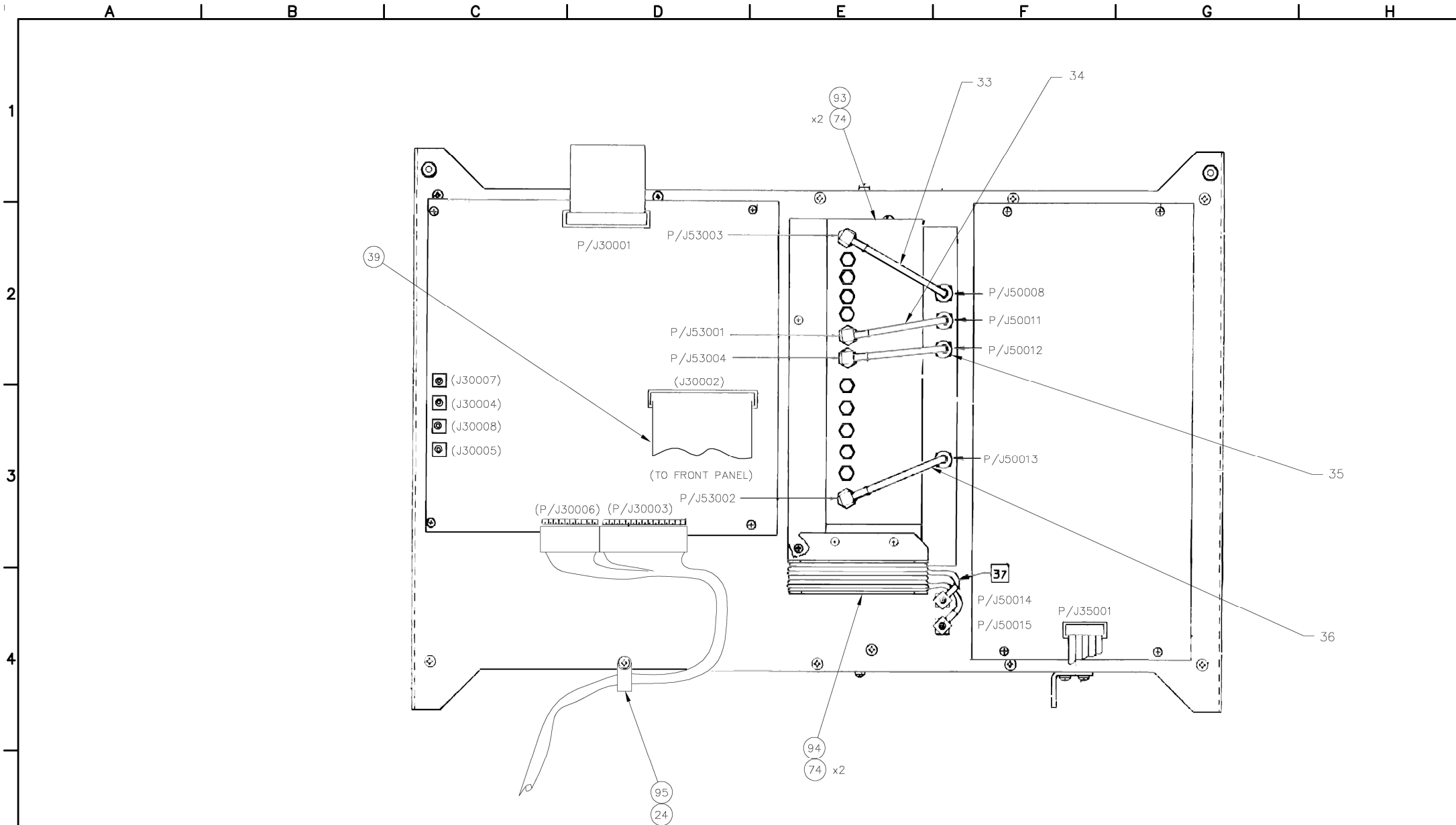

BOTTOM VIEW

COAX TAG	FROM ASSEMBLY	CONN	TO ASSEMBLY	CONN	ITEM	D/P/N
33	7010-4932-800	J50008	7005-4943-000	J53003		6043-1180-370
34	7010-4932-800	J50011	7005-4943-000	J53001		6043-1180-325
35	7010-4932-800	J50012	7005-4943-000	J53004		6043-1180-325
36	7010-4932-800	J50013	7005-4943-000	J53002		6043-1180-370

THIRD ANGLE PROJECTION

ALL DIMENSIONS IN INCHES UNLESS OTHERWISE SPECIFIED
DO NOT SCALE PRINT / IF IN DOUBT ASK TO IFR EWS-140

DRAWING STANDARD TO IFR EWS-140

THIS DRAWING PROVIDES THE MINIMUM LEVEL OF GRAPHIC DETAILS AND SPECIFICATIONS REQUIRED TO ACCURATELY DEFINE THIS LEVEL OF FABRICATED PRODUCT ONLY. REFER TO DETAIL DRAWINGS AND SPECIFICATIONS FOR ACCURATE CONFIGURATION OF LOWER LEVEL PARTS AND SUB-ASSEMBLIES USED HEREIN.

AEROFLEX
10200 WEST YORK STREET
WICHITA, KANSAS 67215

PROPRIETARY AND CONFIDENTIAL PROPERTY OF AEROFLEX WICHITA
DO NOT DISCLOSE, REPRODUCE, OR PUBLISH WITHOUT AEROFLEX APPROVAL

TITLE: COMPOSITE ASSY, RD-301A

DRAWN: R.HARRIS DATE: 01/12/01

CHECKED: M.BRUFFETT DATE: 01/19/01

APPROVED: G.HILL DATE: 02/09/01

DWG NO: 7003-9047-000

REV: B1

090470B1.DWG | CAGE 51190 | SHEET 3 OF 4

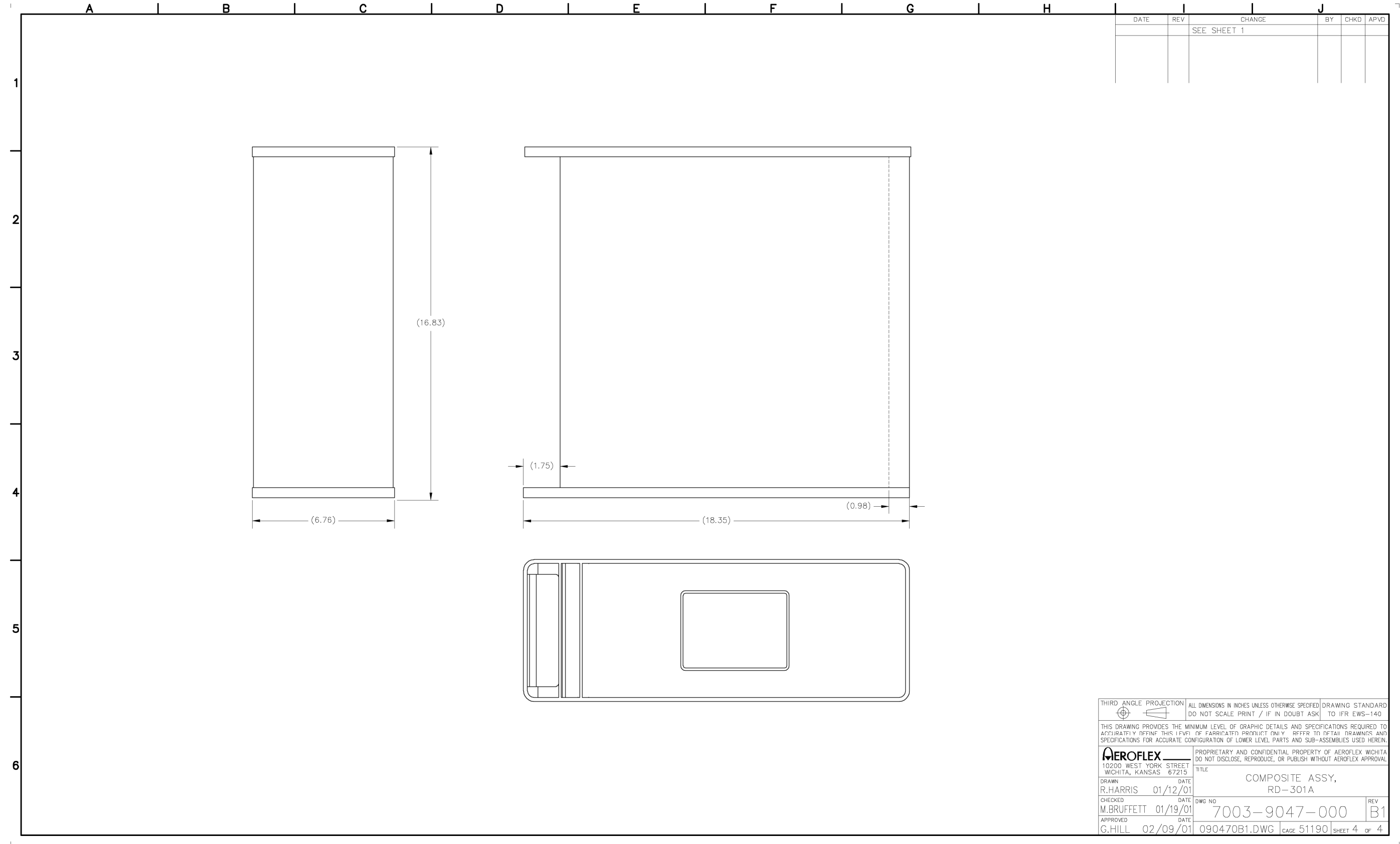

THIRD ANGLE PROJECTION	ALL DIMENSIONS IN INCHES UNLESS OTHERWISE SPECIFIED DO NOT SCALE PRINT / IF IN DOUBT ASK	DRAWING STANDARD TO IFR EWS-140
THIS DRAWING PROVIDES THE MINIMUM LEVEL OF GRAPHIC DETAILS AND SPECIFICATIONS REQUIRED TO ACCURATELY DEFINE THIS LEVEL OF FABRICATED PRODUCT ONLY. REFER TO DETAIL DRAWINGS AND SPECIFICATIONS FOR ACCURATE CONFIGURATION OF LOWER LEVEL PARTS AND SUB-ASSEMBLIES USED HEREIN.		
AEROFLEX 10200 WEST YORK STREET WICHITA, KANSAS 67215		PROPRIETARY AND CONFIDENTIAL PROPERTY OF AEROFLEX WICHITA DO NOT DISCLOSE, REPRODUCE, OR PUBLISH WITHOUT AEROFLEX APPROVAL.
DRAWN R.HARRIS	DATE 01/12/01	TITLE COMPOSITE ASSY, RD-301A
CHECKED M.BRUFFETT	DATE 01/19/01	DWG NO 7003-9047-000
APPROVED G.HILL	DATE 02/09/01	REV B1
090470B1.DWG CAGE 51190		SHEET 4 OF 4

Subject to Export Control, see Cover Page for details.

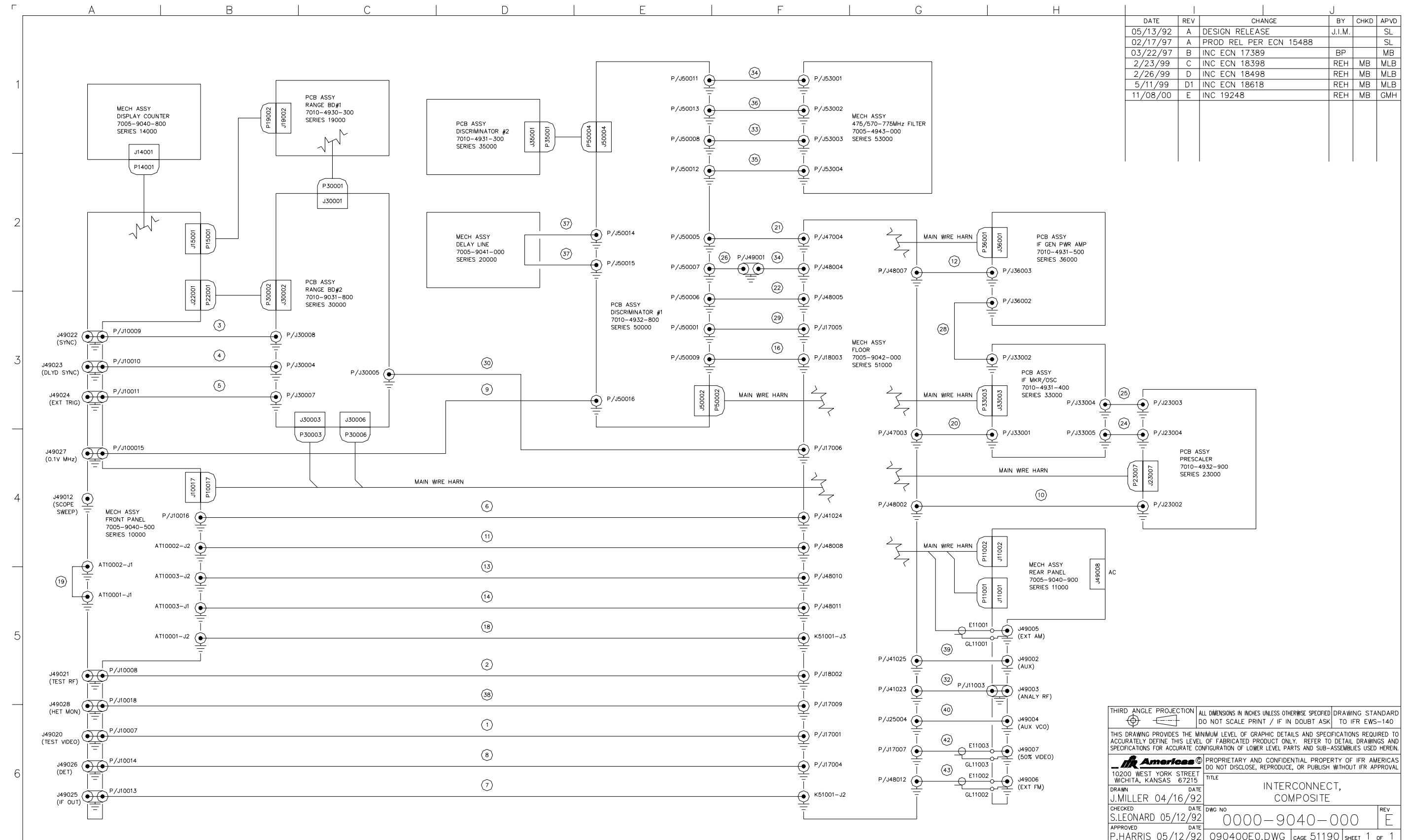

Subject to Export Control, see Cover Page for details.

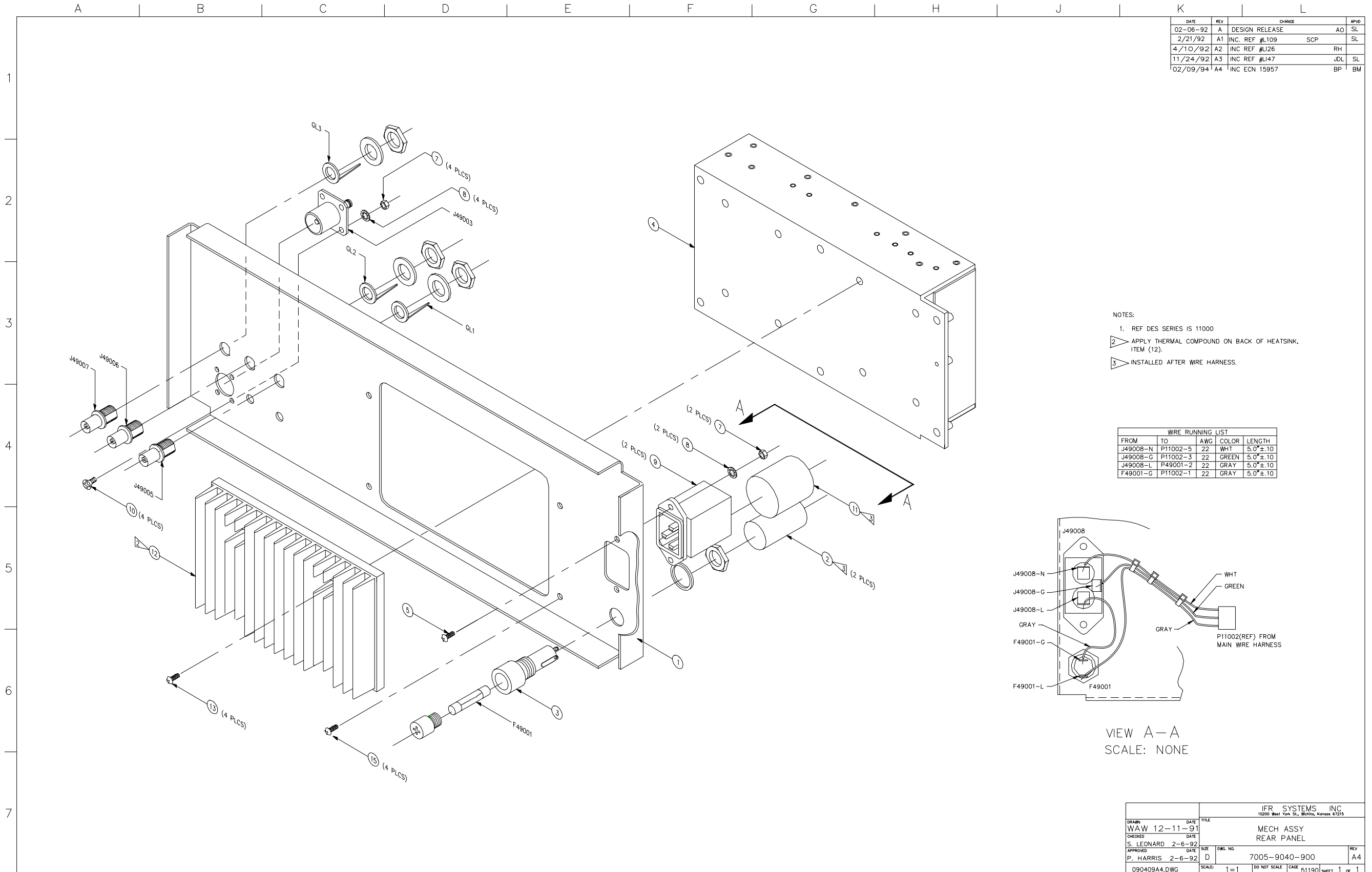

Subject to Export Control, see Cover Page for details.

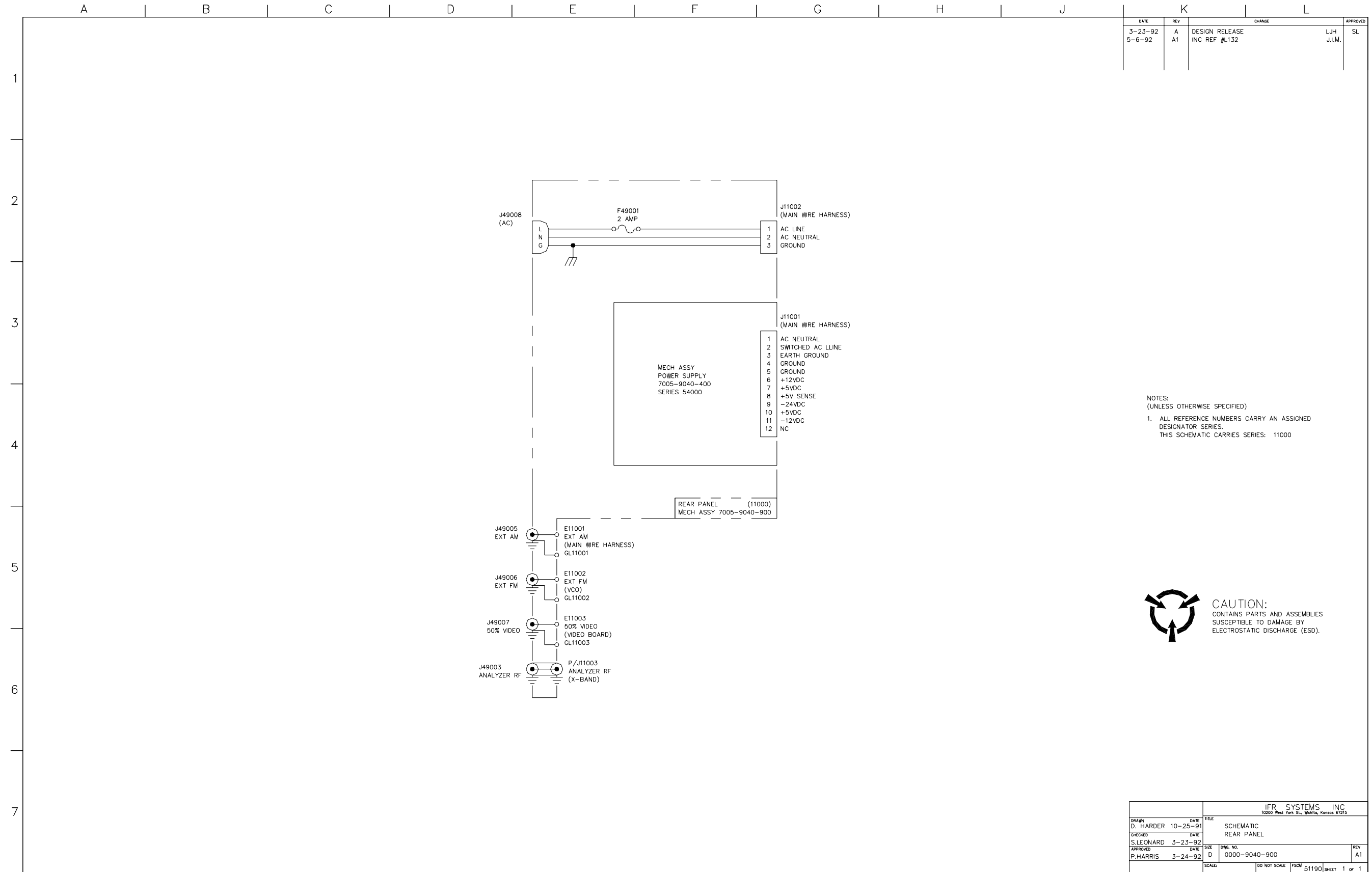

DATE	REV	CHANGE	APPROVED
3-23-92	A	DESIGN RELEASE	LJH
5-6-92	A1	INC REF #L132	J.I.M.

NOTES:
(UNLESS OTHERWISE SPECIFIED)
1. ALL REFERENCE NUMBERS CARRY AN ASSIGNED DESIGNATOR SERIES.
THIS SCHEMATIC CARRIES SERIES: 11000



DRAWN				CHECKED				APPROVED			
D. HARDER	10-25-91	S. LEONARD	3-23-92	P. HARRIS	3-24-92	IFR SYSTEMS INC 10200 West York St., Wichita, Kansas 67215					
DATE		DATE		DATE		TITLE		DWG. NO.		REV	
10-25-91		3-23-92		3-24-92		SCHEMATIC REAR PANEL		0000-9040-900		A1	
SCALE: DO NOT SCALE				PSON 51190 SHEET 1 OF 1							

DATE	REV	CHANGE	BY	CHKD	APVD
02/03/92	A	DESIGN RELEASE	REH		SL
02/21/92	A1	INC. REF# L110	SCP		SL
04/23/92	A2	INC. REF# L129	REH		SL
02/17/93	A2	PROD. REL. PER ECN 15488	REH		SL
12/14/98	A3	INC ECN 18442	REH	RLD	EM

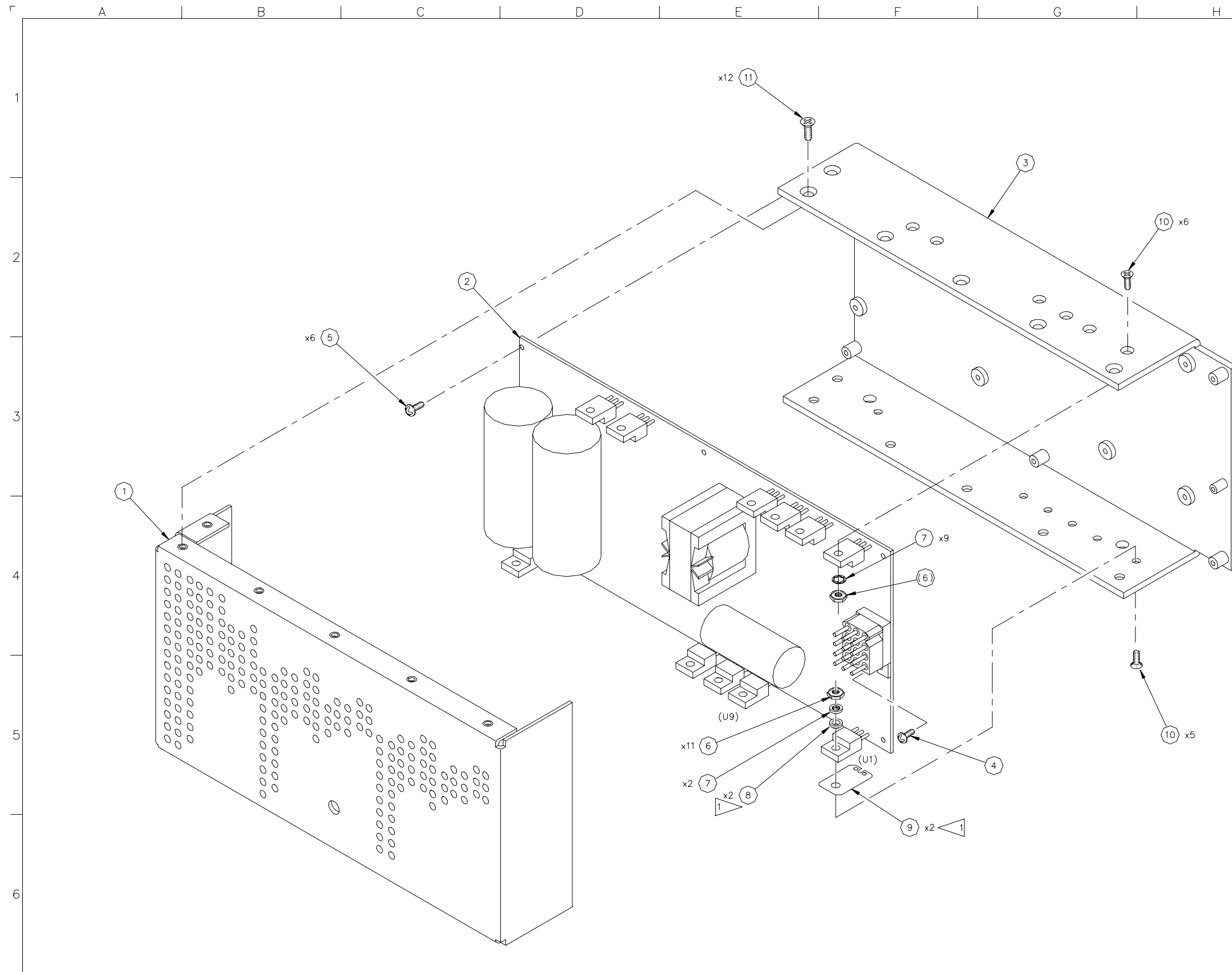

NOTES:

- 1. ITEM #8 AND #9 ARE USED ON U1 AND U9 ONLY.
- 2. REF SCHEMATIC: 0000-9040-400.
- 3. BASIC REFERENCE DESIGNATORS SHOWN, FOR COMPLETE DESIGNATOR PREFIXES REFER TO PRODUCT STRUCTURE, AND SYSTEM INTERCONNECT FOR APPLICATIONS WHERE USED.



CAUTION:
CONTAINS PARTS AND ASSEMBLIES
SUSCEPTIBLE TO DAMAGE BY
ELECTROSTATIC DISCHARGE (ESD).

THIRD ANGLE PROJECTION	ALL DIMENSIONS IN INCHES UNLESS OTHERWISE SPECIFIED DO NOT SCALE PRINT / IF IN DOUBT ASK	DRAWING STANDARD TO IFR EWS-140
THIS DRAWING PROVIDES THE MINIMUM LEVEL OF GRAPHIC DETAILS AND SPECIFICATIONS REQUIRED TO ACCURATELY DEFINE THIS LEVEL OF FABRICATED PRODUCT ONLY. REFER TO DETAIL DRAWINGS AND SPECIFICATIONS FOR ACCURATE CONFIGURATION OF LOWER LEVEL PARTS AND SUB-ASSEMBLIES USED HEREIN.		
PROPRIETARY AND CONFIDENTIAL PROPERTY OF IFR AMERICAS DO NOT DISCLOSE, REPRODUCE, OR PUBLISH WITHOUT IFR APPROVAL		
10200 WEST YORK STREET WICHITA, KANSAS 67215	TITLE MECH ASSY, PWR SUPPLY	
DRAWN R.HARRIS 01/31/92	DATE 01/31/92	
CHECKED S.LEONARD 02/03/92	DATE 02/03/92	DWG NO 7005-9040-400
APPROVED P.HARRIS 02/03/92	DATE 02/03/92	REV A3
090404A3.DWG		CAGE 51190 SHEET 1 OF 1

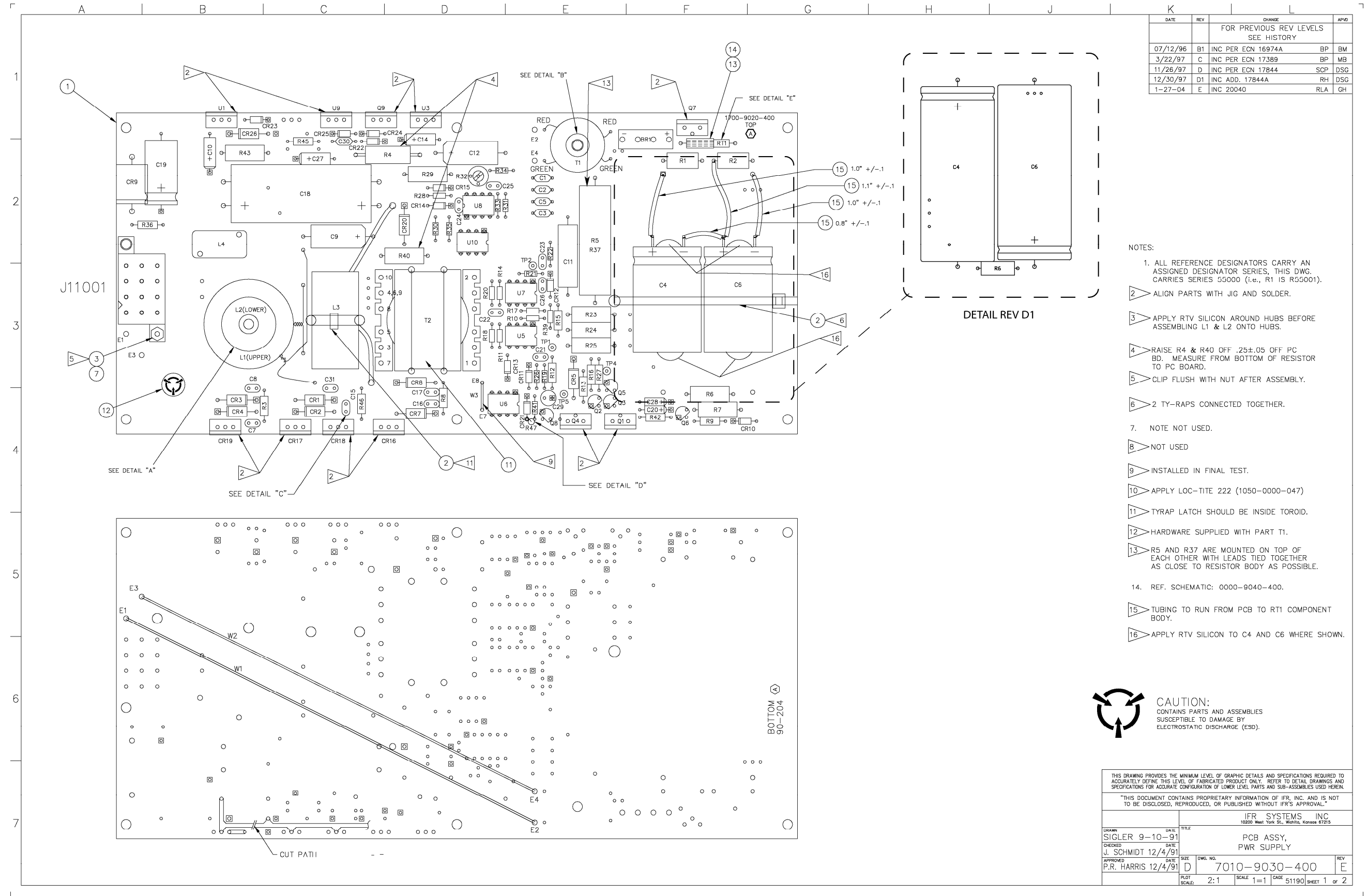

DATE	REV	CHANGE	APVD
FOR PREVIOUS REV LEVELS SEE HISTORY			
07/12/96	B1	INC PER ECN 16974A	BP BM
3/22/97	C	INC PER ECN 17389	BP MB
11/26/97	D	INC PER ECN 17844	SCP DSG
12/30/97	D1	INC ADD. 17844A	RH DSG
1-27-04	E	INC 20040	RLA GH

- NOTES:
- ALL REFERENCE DESIGNATORS CARRY AN ASSIGNED DESIGNATOR SERIES, THIS DWG. CARRIES SERIES 55000 (i.e., R1 IS R55001).
 - ALIGN PARTS WITH JIG AND SOLDER.
 - APPLY RTV SILICON AROUND HUBS BEFORE ASSEMBLING L1 & L2 ONTO HUBS.
 - RAISE R4 & R40 OFF .25±.05 OFF PC BD. MEASURE FROM BOTTOM OF RESISTOR TO PC BOARD.
 - CLIP FLUSH WITH NUT AFTER ASSEMBLY.
 - 2 TY-RAPS CONNECTED TOGETHER.
 - NOTE NOT USED.
 - NOT USED
 - INSTALLED IN FINAL TEST.
 - APPLY LOC-TITE 222 (1050-0000-047)
 - TYRAP LATCH SHOULD BE INSIDE TOROID.
 - HARDWARE SUPPLIED WITH PART T1.
 - R5 AND R37 ARE MOUNTED ON TOP OF EACH OTHER WITH LEADS TIED TOGETHER AS CLOSE TO RESISTOR BODY AS POSSIBLE.
 - REF. SCHEMATIC: 0000-9040-400.
 - TUBING TO RUN FROM PCB TO RT1 COMPONENT BODY.
 - APPLY RTV SILICON TO C4 AND C6 WHERE SHOWN.



CAUTION:
CONTAINS PARTS AND ASSEMBLIES
SUSCEPTIBLE TO DAMAGE BY
ELECTROSTATIC DISCHARGE (ESD).

THIS DRAWING PROVIDES THE MINIMUM LEVEL OF GRAPHIC DETAILS AND SPECIFICATIONS REQUIRED TO ACCURATELY DEFINE THIS LEVEL OF FABRICATED PRODUCT ONLY. REFER TO DETAIL DRAWINGS AND SPECIFICATIONS FOR ACCURATE CONFIGURATION OF LOWER LEVEL PARTS AND SUB-ASSEMBLIES USED HEREIN.

"THIS DOCUMENT CONTAINS PROPRIETARY INFORMATION OF IFR, INC. AND IS NOT TO BE DISCLOSED, REPRODUCED, OR PUBLISHED WITHOUT IFR'S APPROVAL."

DRAWN		DATE		TITLE	
SIGLER 9-10-91				IFR SYSTEMS, INC. 10200 West York St., Wichita, Kansas 67215	
CHECKED		DATE		PCB ASSY, PWR SUPPLY	
J. SCHMIDT 12/4/91					
APPROVED		DATE		SIZE	
P.R. HARRIS 12/4/91				D	
		DWG. NO.		REV	
		7010-9030-400		E	
PLOT SCALE:		SCALE		CASE	
2:1		1=1		51190	
				SHEET 1 OF 2	

DATE	REV	CHANGE	APVD
		SEE PAGE ONE	

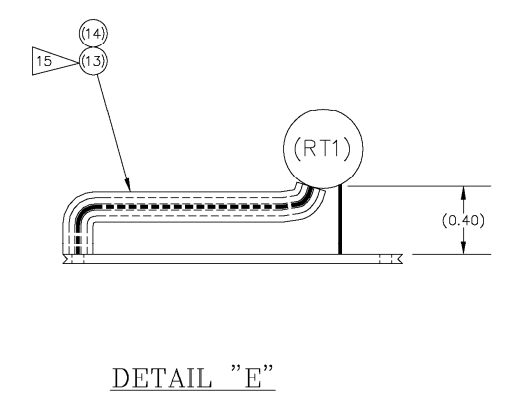
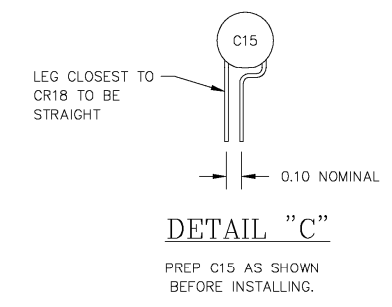
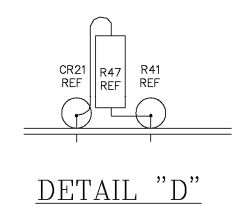
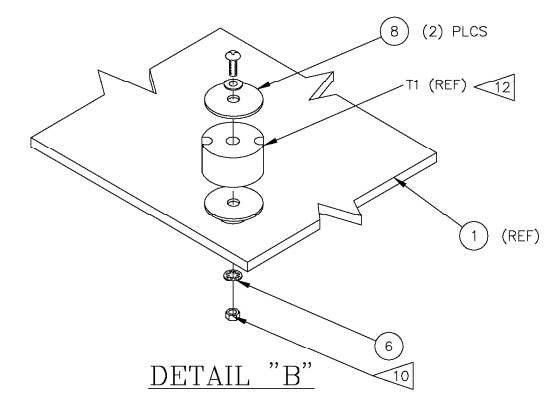
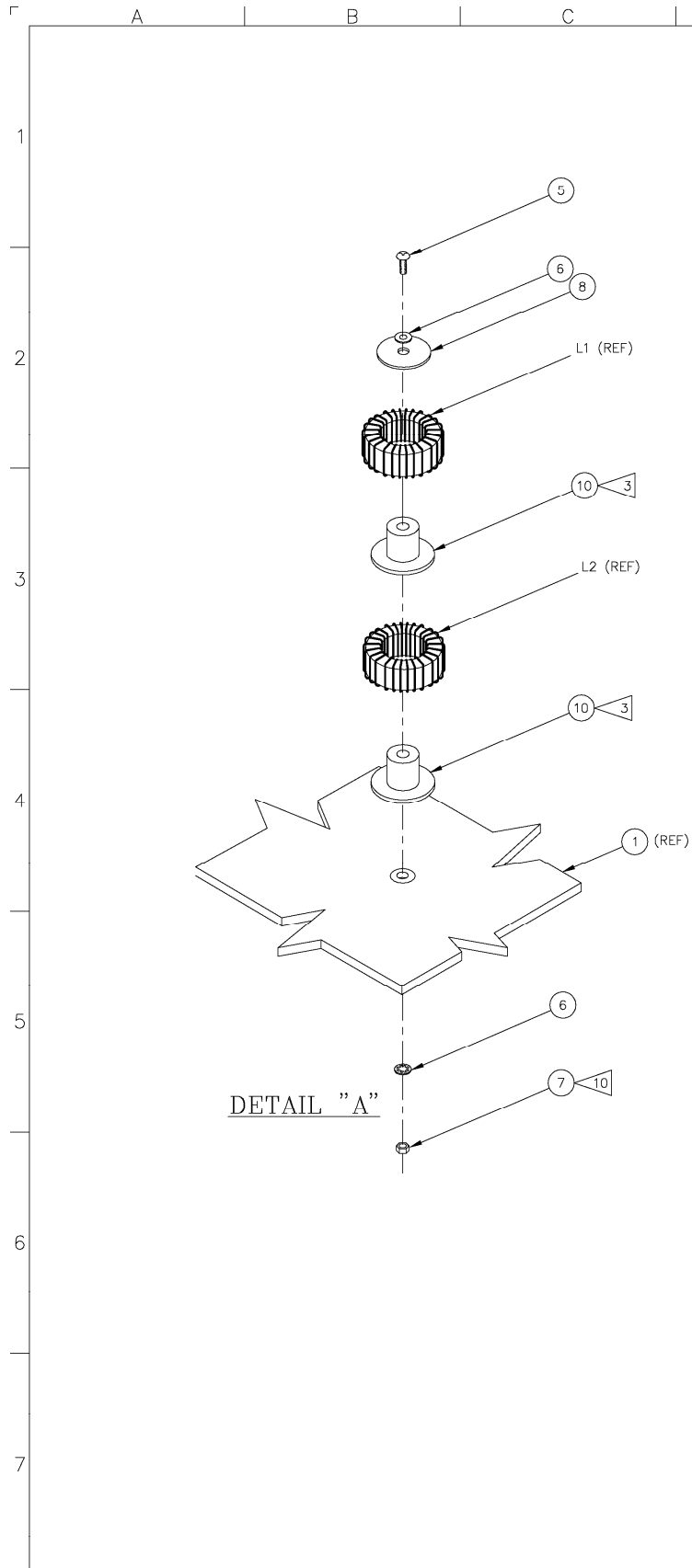

THIS DRAWING PROVIDES THE MINIMUM LEVEL OF GRAPHIC DETAILS AND SPECIFICATIONS REQUIRED TO ACCURATELY DEFINE THIS LEVEL OF FABRICATED PRODUCT ONLY. REFER TO DETAIL DRAWINGS AND SPECIFICATIONS FOR ACCURATE CONFIGURATION OF LOWER LEVEL PARTS AND SUB-ASSEMBLIES USED HEREIN.

"THIS DOCUMENT CONTAINS PROPRIETARY INFORMATION OF IFR, INC. AND IS NOT TO BE DISCLOSED, REPRODUCED, OR PUBLISHED WITHOUT IFR'S APPROVAL."

DRAWN		DATE		TITLE	
SIGLER		9-10-91		PCB ASSY, PWR SUPPLY	
CHECKED		DATE		REV	
J. SCHMIDT		12/4/91		E	
APPROVED		DATE		DWG. NO.	
P.R. HARRIS		12/4/91		7010-9030-400	
PLOT SCALE:		2:1		SCALE 1=1	
CAGE		51190		SHEET 2 of 2	

DATE	REV	CHANGE	BY	CHKD	APVD
11/12/92	A	DESIGN RELEASE	JIM		SL
02/17/93	A	PROD REL PER 15488	REH		SL
3/17/00	A1	INC ECN 15620	BP		BM
04/25/94	A2	INC ECN 16076	BP		BM
05/16/96	B	INC ECN 16974	RLA		BM
03/22/97	C	INC ECN 17389	BP		MB
12/14/98	C1	INC ECN 18442	REH		EM
03/20/00	C2	INC RC 18982	REH	SCP	TCN

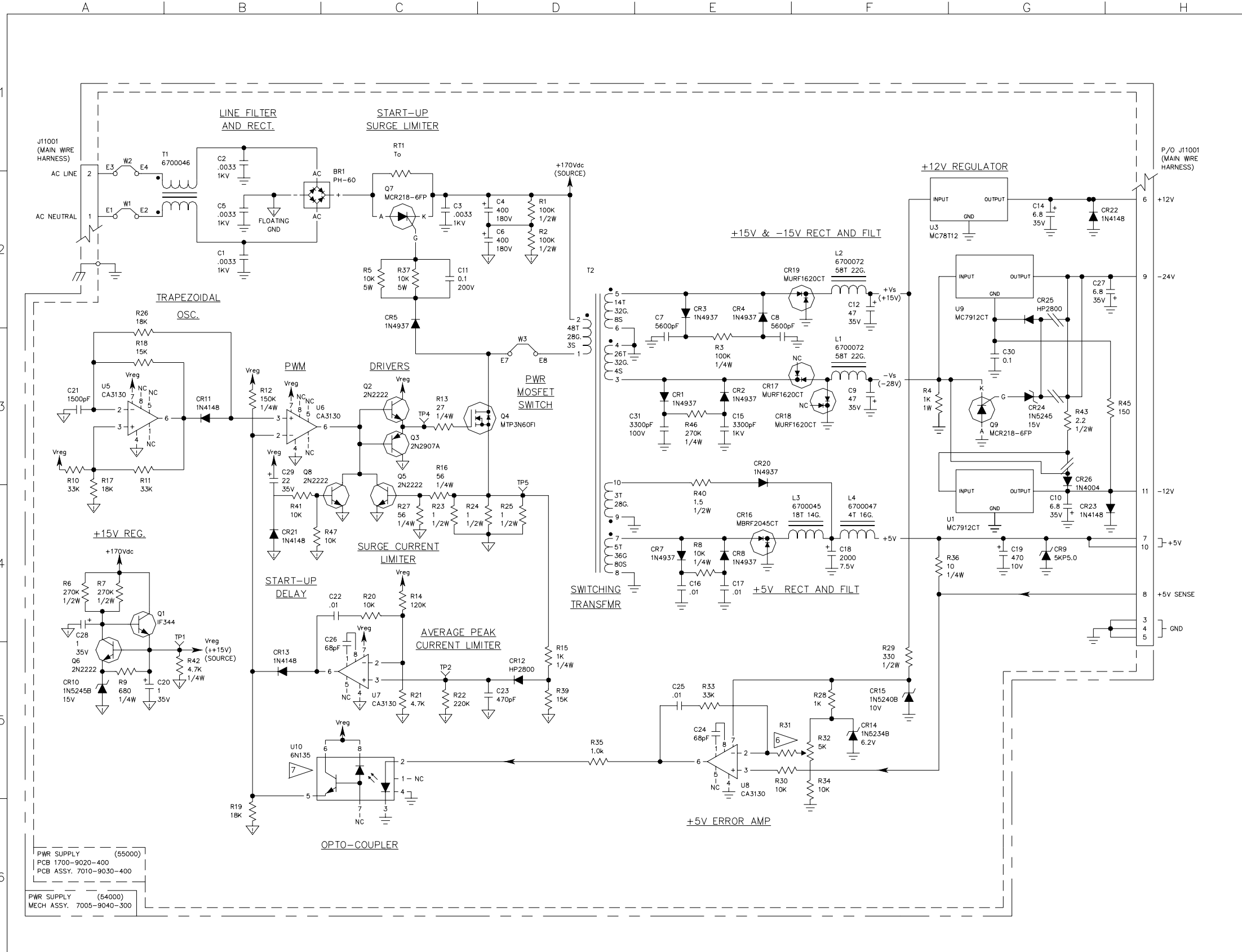

- NOTES:
(UNLESS OTHERWISE SPECIFIED)
- ALL REFERENCE NUMBERS CARRY AN ASSIGNED DESIGNATOR SERIES. THIS SCHEMATIC CARRIES SERIES: 7005-9040-400 54000 7010-9030-400 55000
 - ALL RESISTORS ARE 5% 1/8 W. ALL CAPACITANCE IS EXPRESSED IN MICROFARADS.
 - HIGHEST REFERENCE DESIGNATIONS. C31 R47 L4 CR26 Q9 U10 T2 BR1 W3 TP5
 - REFERENCE DESIGNATIONS NOT USED. C13, CR6, R44, TP3, U2, U4
- 6 R31 IS S.A.T. NOMINAL VALUE: 15K SELECT VALUE: 12K, 18K, 22K
- 7 U10 IS S.A.T. DEVICE C.T.R. = 15-22 VCE = 2 VOLTS

 CAUTION: CONTAINS PARTS AND ASSEMBLIES SUSCEPTIBLE TO DAMAGE BY ELECTROSTATIC DISCHARGE (ESD).

THIRD ANGLE PROJECTION	ALL DIMENSIONS IN INCHES UNLESS OTHERWISE SPECIFIED	DRAWING STANDARD TO IFR EWS-140
THIS DRAWING PROVIDES THE MINIMUM LEVEL OF GRAPHIC DETAILS AND SPECIFICATIONS REQUIRED TO ACCURATELY DEFINE THIS LEVEL OF FABRICATED PRODUCT ONLY. REFER TO DETAIL DRAWINGS AND SPECIFICATIONS FOR ACCURATE CONFIGURATION OF LOWER LEVEL PARTS AND SUB-ASSEMBLIES USED HEREIN.		
 PROPRIETARY AND CONFIDENTIAL PROPERTY OF IFR AMERICAS DO NOT DISCLOSE, REPRODUCE, OR PUBLISH WITHOUT IFR APPROVAL 10200 WEST YORK STREET WICHITA, KANSAS 67215 TITLE: SCHEMATIC, MECH PWR SUPPLY		
DRAWN: D.HARDER	DATE: 9/4/91	REV: C2
CHECKED: P.HARRIS	DATE: 01/14/92	DWG NO: 0000-9040-400
APPROVED: J.SCHMIDT	DATE: 12/4/91	090404C2.DWG
PAGE 51190		SHEET 1 OF 2

DATE	REV	CHANGE	BY	CHKD	APVD
		SEE SHEET 1			

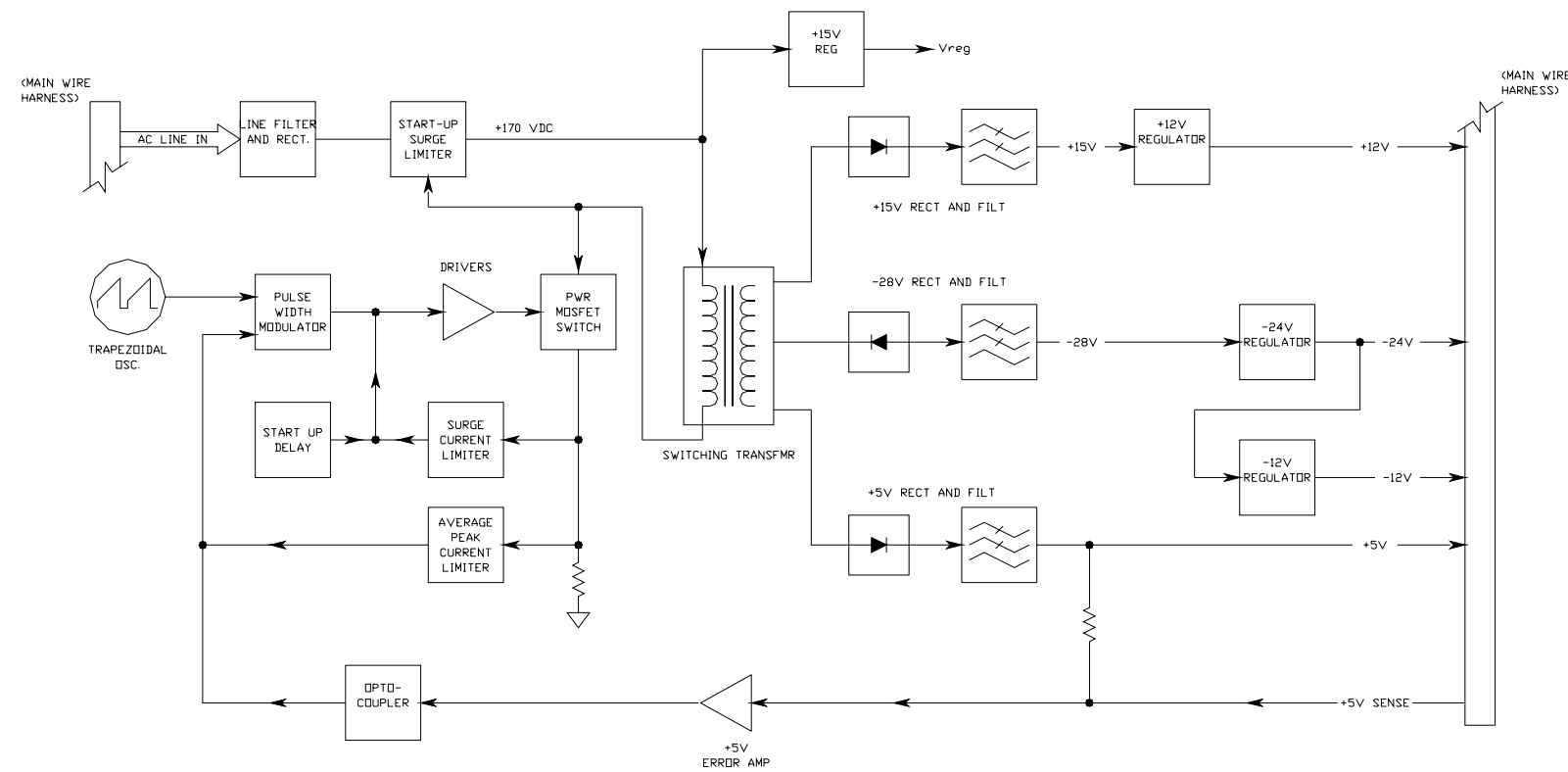

THIRD ANGLE PROJECTION	ALL DIMENSIONS IN INCHES UNLESS OTHERWISE SPECIFIED DO NOT SCALE PRINT / IF IN DOUBT ASK	DRAWING STANDARD TO IFR EWS-140
THIS DRAWING PROVIDES THE MINIMUM LEVEL OF GRAPHIC DETAILS AND SPECIFICATIONS REQUIRED TO ACCURATELY DEFINE THIS LEVEL OF FABRICATED PRODUCT ONLY. REFER TO DETAIL DRAWINGS AND SPECIFICATIONS FOR ACCURATE CONFIGURATION OF LOWER LEVEL PARTS AND SUB-ASSEMBLIES USED HEREIN.		
 10200 WEST YORK STREET WICHITA, KANSAS 67215		PROPRIETARY AND CONFIDENTIAL PROPERTY OF IFR AMERICAS DO NOT DISCLOSE, REPRODUCE, OR PUBLISH WITHOUT IFR APPROVAL TITLE
DRAWN D.HARDER 9/4/91	DATE 9/4/91	SCHEMATIC, MECH PWR SUPPLY
CHECKED P.HARRIS 01/14/92	DATE 01/14/92	DWG NO 0000-9040-400
APPROVED J.SCHMIDT 12/4/91	DATE 12/4/91	REV C2
090404C2.DWG		CAGE 51190 SHEET 2 OF 2

Subject to Export Control, see Cover Page for details.

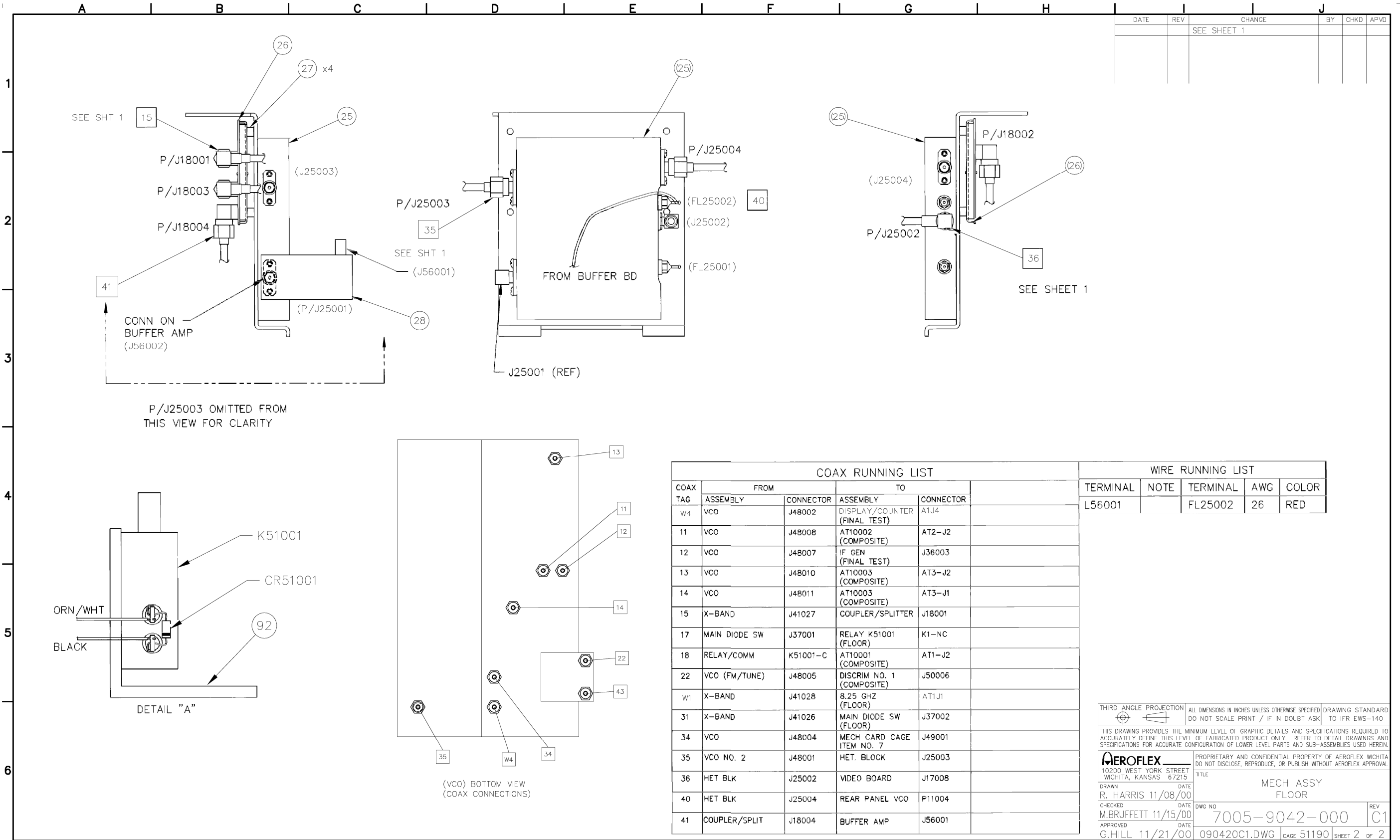

DATE	REV	CHANGE	BY	CHKD	APVD
		SEE SHEET 1			

P/J25003 OMITTED FROM THIS VIEW FOR CLARITY

DETAIL "A"

(VCO) BOTTOM VIEW (COAX CONNECTIONS)

COAX RUNNING LIST

COAX TAG	FROM		TO	
	ASSEMBLY	CONNECTOR	ASSEMBLY	CONNECTOR
W4	VCO	J48002	DISPLAY/COUNTER (FINAL TEST)	A1J4
11	VCO	J48008	AT10002 (COMPOSITE)	AT2-J2
12	VCO	J48007	IF GEN (FINAL TEST)	J36003
13	VCO	J48010	AT10003 (COMPOSITE)	AT3-J2
14	VCO	J48011	AT10003 (COMPOSITE)	AT3-J1
15	X-BAND	J41027	COUPLER/SPLITTER	J18001
17	MAIN DIODE SW	J37001	RELAY K51001 (FLOOR)	K1-NC
18	RELAY/COMM	K51001-C	AT10001 (COMPOSITE)	AT1-J2
22	VCO (FM/TUNE)	J48005	DISCRIM NO. 1 (COMPOSITE)	J50006
W1	X-BAND	J41028	8.25 GHZ (FLOOR)	AT1J1
31	X-BAND	J41026	MAIN DIODE SW (FLOOR)	J37002
34	VCO	J48004	MECH CARD CAGE ITEM NO. 7	J49001
35	VCO NO. 2	J48001	HET. BLOCK	J25003
36	HET BLK	J25002	VIDEO BOARD	J17008
40	HET BLK	J25004	REAR PANEL VCO	P11004
41	COUPLER/SPLIT	J18004	BUFFER AMP	J56001

WIRE RUNNING LIST

TERMINAL	NOTE	TERMINAL	AWG	COLOR
L56001		FL25002	26	RED

THIRD ANGLE PROJECTION

ALL DIMENSIONS IN INCHES UNLESS OTHERWISE SPECIFIED DRAWING STANDARD DO NOT SCALE PRINT / IF IN DOUBT ASK TO IFR EWS-140

THIS DRAWING PROVIDES THE MINIMUM LEVEL OF GRAPHIC DETAILS AND SPECIFICATIONS REQUIRED TO ACCURATELY DEFINE THIS LEVEL OF FABRICATED PRODUCT ONLY. REFER TO DETAIL DRAWINGS AND SPECIFICATIONS FOR ACCURATE CONFIGURATION OF LOWER LEVEL PARTS AND SUB-ASSEMBLIES USED HEREIN.

AEROFLEX
10200 WEST YORK STREET
WICHITA, KANSAS 67215

PROPRIETARY AND CONFIDENTIAL PROPERTY OF AEROFLEX WICHITA DO NOT DISCLOSE, REPRODUCE, OR PUBLISH WITHOUT AEROFLEX APPROVAL.

TITLE
MECH ASSY FLOOR

DRAWN: R. HARRIS DATE: 11/08/00
CHECKED: M. BRUFFETT DATE: 11/15/00
APPROVED: G. HILL DATE: 11/21/00

DWG NO: 7005-9042-000
CAGE 51190

REV: C1
SHEET 2 OF 2

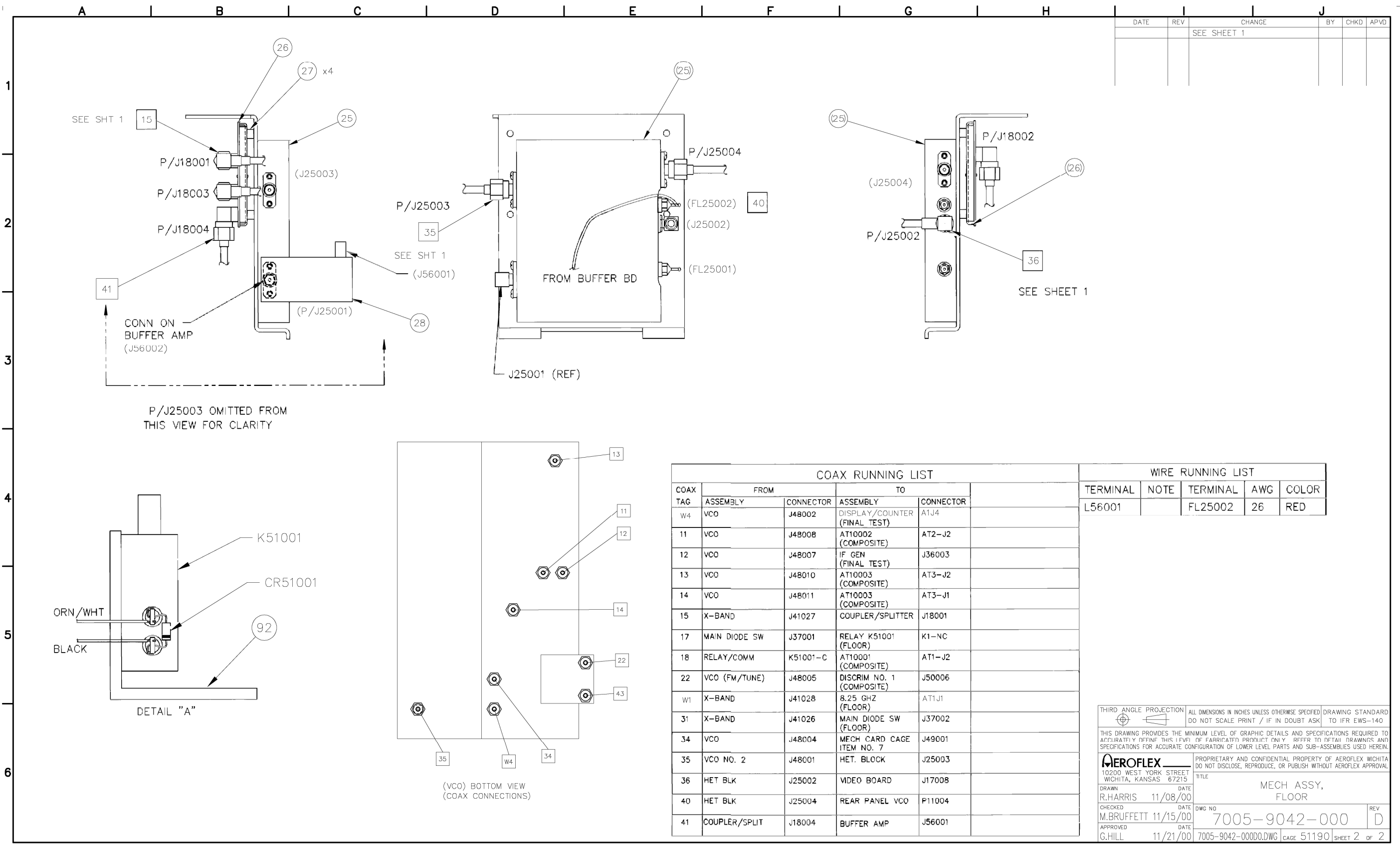

SEE SHT 1

CONN ON
BUFFER AMP
(J56002)

P/J25003 OMITTED FROM
THIS VIEW FOR CLARITY

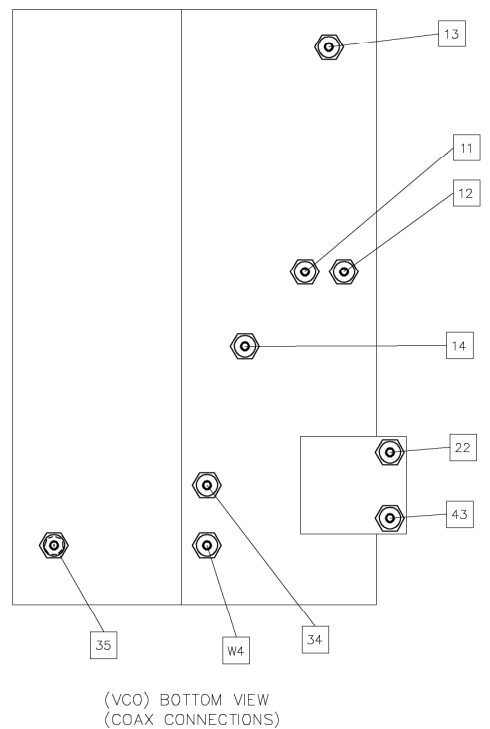
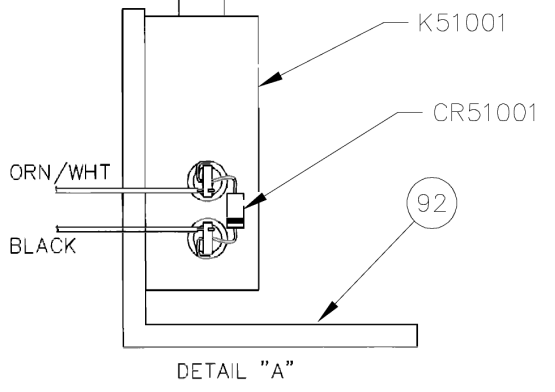

COAX RUNNING LIST				
COAX TAG	FROM		TO	
	ASSEMBLY	CONNECTOR	ASSEMBLY	CONNECTOR
W4	VCO	J48002	DISPLAY/COUNTER (FINAL TEST)	AT1J4
11	VCO	J48008	AT10002 (COMPOSITE)	AT2-J2
12	VCO	J48007	IF GEN (FINAL TEST)	J36003
13	VCO	J48010	AT10003 (COMPOSITE)	AT3-J2
14	VCO	J48011	AT10003 (COMPOSITE)	AT3-J1
15	X-BAND	J41027	COUPLER/SPLITTER	J18001
17	MAIN DIODE SW	J37001	RELAY K51001 (FLOOR)	K1-NC
18	RELAY/COMM	K51001-C	AT10001 (COMPOSITE)	AT1-J2
22	VCO (FM/TUNE)	J48005	DISCRIM NO. 1 (COMPOSITE)	J50006
W1	X-BAND	J41028	8.25 GHZ (FLOOR)	AT1J1
31	X-BAND	J41026	MAIN DIODE SW (FLOOR)	J37002
34	VCO	J48004	MECH CARD CAGE ITEM NO. 7	J49001
35	VCO NO. 2	J48001	HET. BLOCK	J25003
36	HET BLK	J25002	VIDEO BOARD	J17008
40	HET BLK	J25004	REAR PANEL VCO	P11004
41	COUPLER/SPLIT	J18004	BUFFER AMP	J56001

WIRE RUNNING LIST				
TERMINAL	NOTE	TERMINAL	AWG	COLOR
L56001		FL25002	26	RED

THIRD ANGLE PROJECTION

ALL DIMENSIONS IN INCHES UNLESS OTHERWISE SPECIFIED DO NOT SCALE PRINT / IF IN DOUBT ASK TO IFR EWS-140

DRAWING STANDARD TO IFR EWS-140

THIS DRAWING PROVIDES THE MINIMUM LEVEL OF GRAPHIC DETAILS AND SPECIFICATIONS REQUIRED TO ACCURATELY OFFER THIS LEVEL OF FABRICATED PRODUCT ONLY. REFER TO DETAIL DRAWINGS AND SPECIFICATIONS FOR ACCURATE CONFIGURATION OF LOWER LEVEL PARTS AND SUB-ASSEMBLIES USED HEREIN.

AEROFLEX
10200 WEST YORK STREET
WICHITA, KANSAS 67215

PROPRIETARY AND CONFIDENTIAL PROPERTY OF AEROFLEX WICHITA DO NOT DISCLOSE, REPRODUCE, OR PUBLISH WITHOUT AEROFLEX APPROVAL

TITLE: MECH ASSY, FLOOR

DRAWN: R.HARRIS DATE: 11/08/00

CHECKED: M.BRUFFETT DATE: 11/15/00

APPROVED: G.HILL DATE: 11/21/00

DWG NO: 7005-9042-000 REV: D

7005-9042-0000.DWG CAGE 51190 SHEET 2 OF 2

DATE	REV	CHANGE	BY	CHKD	APVD
11/28/00	A	REL 19248	REH	MB	GMH
01/09/01	B	REL 19219	REH	MB	GMH

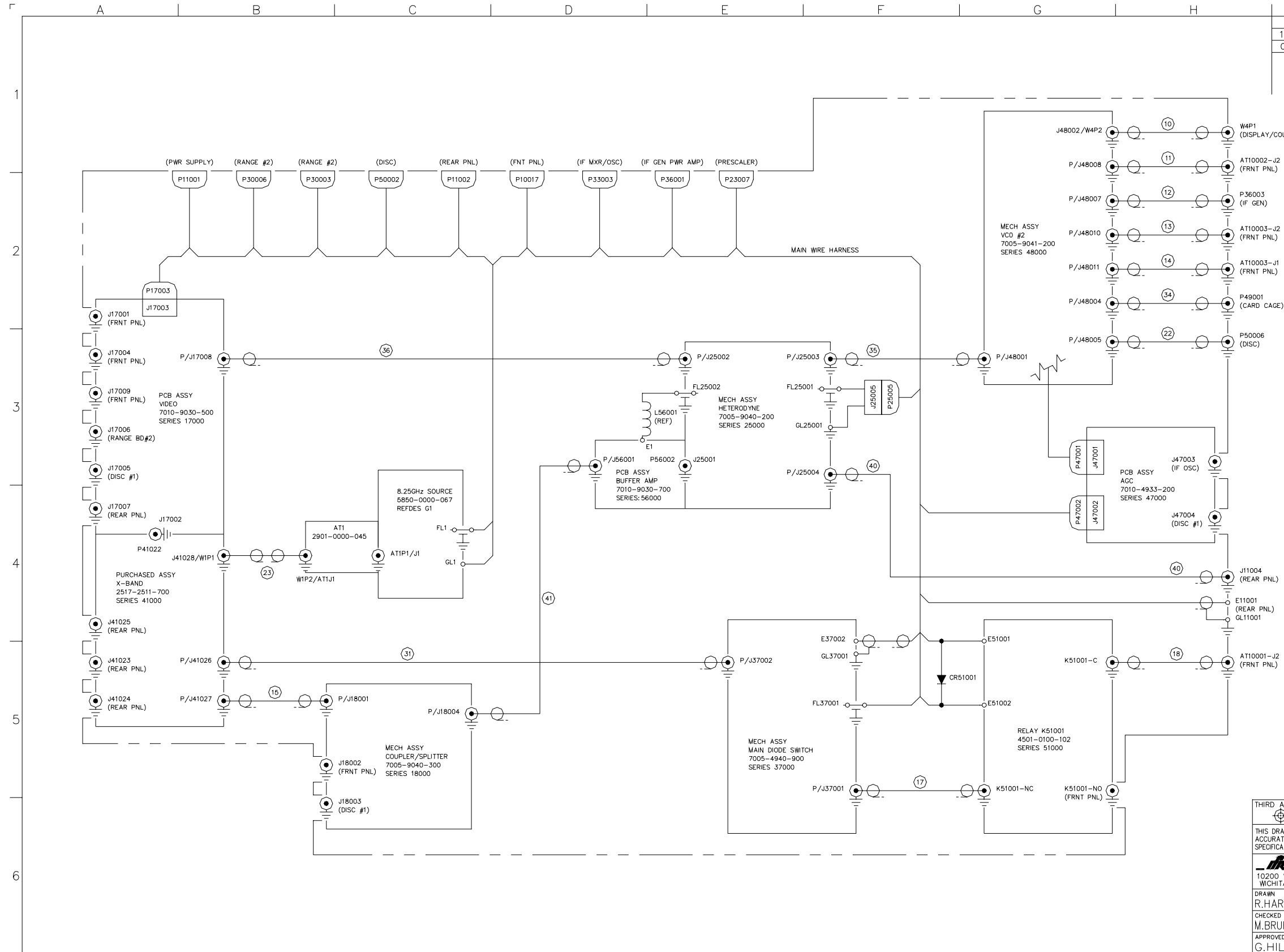

THIRD ANGLE PROJECTION		ALL DIMENSIONS IN INCHES UNLESS OTHERWISE SPECIFIED		DRAWING STANDARD TO IFR EWS-140	
DO NOT SCALE PRINT / IF IN DOUBT ASK					
THIS DRAWING PROVIDES THE MINIMUM LEVEL OF GRAPHIC DETAILS AND SPECIFICATIONS REQUIRED TO ACCURATELY DEFINE THIS LEVEL OF FABRICATED PRODUCT ONLY. REFER TO DETAIL DRAWINGS AND SPECIFICATIONS FOR ACCURATE CONFIGURATION OF LOWER LEVEL PARTS AND SUB-ASSEMBLIES USED HEREIN.					
		PROPRIETARY AND CONFIDENTIAL PROPERTY OF IFR AMERICAS DO NOT DISCLOSE, REPRODUCE, OR PUBLISH WITHOUT IFR APPROVAL			
10200 WEST YORK STREET WICHITA, KANSAS 67215		TITLE INTERCONNECT, FLOOR RD-301			
DRAWN R.HARRIS	DATE 11/08/00	DATE 11/10/00	DWG NO 0000-9042-000	REV B	
CHECKED M.BRUFFEIT	DATE 11/21/00	DATE 11/21/00	DWG NO 090420B0.DWG	PAGE 51190	SHEET 1 OF 2

Subject to Export Control, see Cover Page for details.

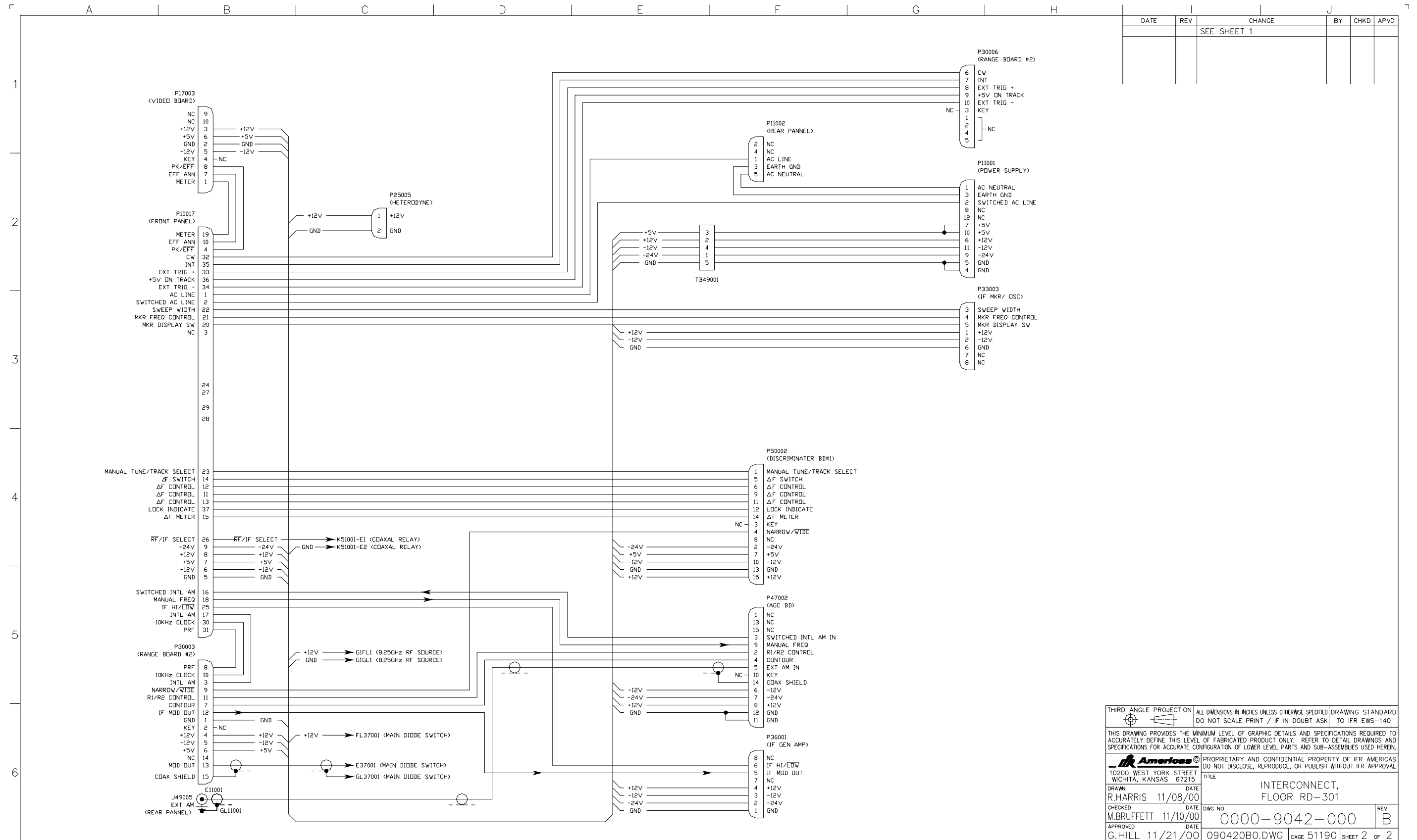

THIRD ANGLE PROJECTION	ALL DIMENSIONS IN INCHES UNLESS OTHERWISE SPECIFIED DO NOT SCALE PRINT / IF IN DOUBT ASK	DRAWING STANDARD TO IFR EWS-140
THIS DRAWING PROVIDES THE MINIMUM LEVEL OF GRAPHIC DETAILS AND SPECIFICATIONS REQUIRED TO ACCURATELY DEFINE THIS LEVEL OF FABRICATED PRODUCT ONLY. REFER TO DETAIL DRAWINGS AND SPECIFICATIONS FOR ACCURATE CONFIGURATION OF LOWER LEVEL PARTS AND SUB-ASSEMBLIES USED HEREIN.		
 AMERICAS 10200 WEST YORK STREET WICHITA, KANSAS 67215		PROPRIETARY AND CONFIDENTIAL PROPERTY OF IFR AMERICAS DO NOT DISCLOSE, REPRODUCE, OR PUBLISH WITHOUT IFR APPROVAL
DRAWN R.HARRIS	DATE 11/08/00	TITLE INTERCONNECT, FLOOR RD-301
CHECKED M.BRUFFETT	DATE 11/10/00	DWG NO 0000-9042-000
APPROVED G.HILL	DATE 11/21/00	REV B
090420B0.DWG		CAGE 51190 SHEET 2 OF 2

Subject to Export Control, see Cover Page for details.

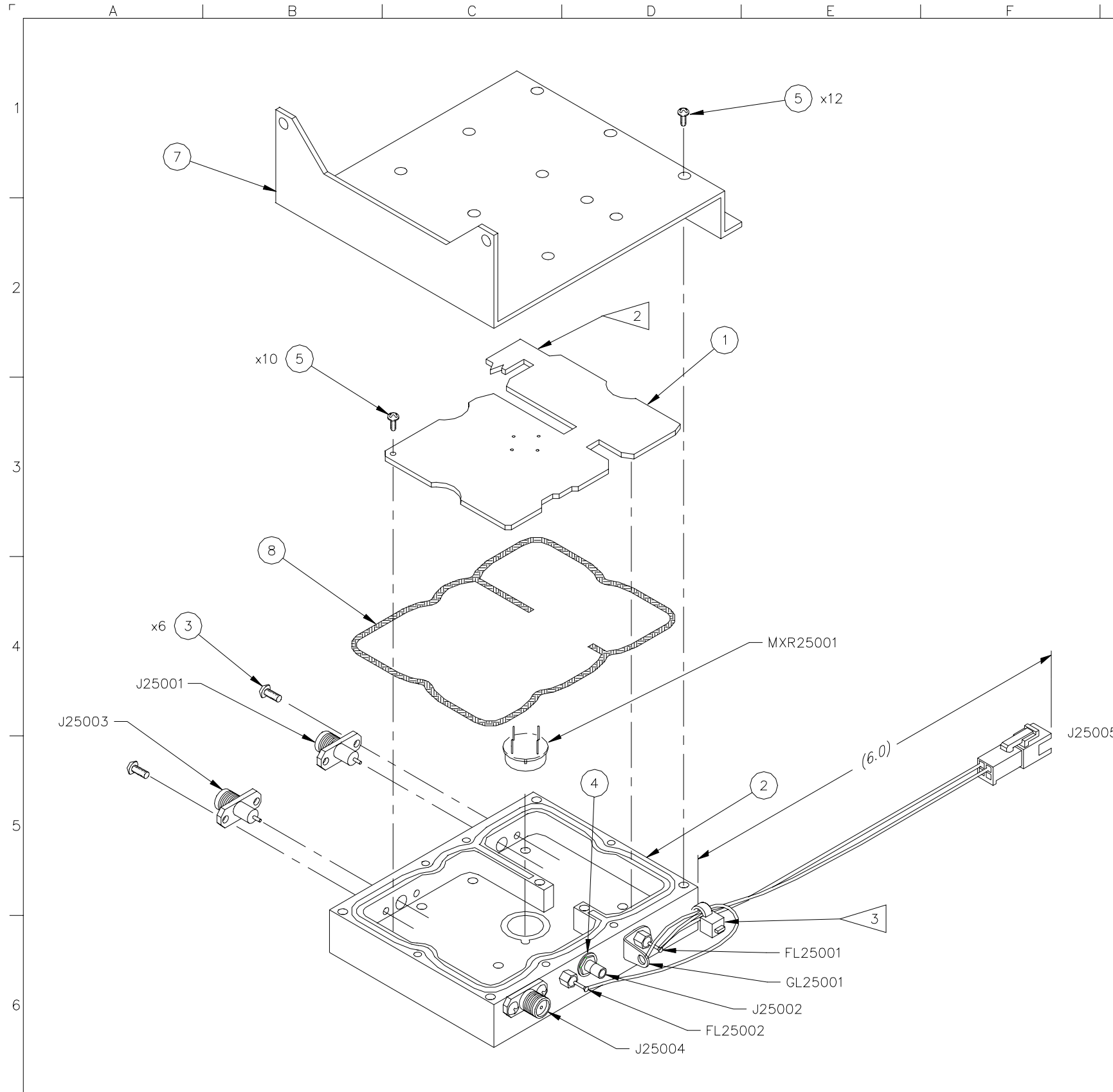

DATE	REV	CHANGE	APVD
1/12/92	A	DESIGN RELEASE	SL
3/23/92	A1	INC REF. #L121	SL
4/23/92	B	INC REF. #L128	RH SL
5/14/92	B1	INC REF. #L134	RH SL
9/2/92	B2	INC REF. #L143	AO SL
2/17/93	B2	PROD. REL. PER ECN 15488	SL
9/8/98	C	INC ECN 18295	RH MLB

NOTES:

1. BASIC REFERENCE DESIGNATORS SHOWN, FOR COMPLETE DESIGNATOR PREFIXES REFER TO PRODUCT STRUCTURE, AND SYSTEM INTERCONNECT FOR APPLICATIONS WHERE USED.
2. CUT AWAY BORDER AS INDICATED, 6 PLCS BEFORE INSTALLING PCB ASSY.
3. INSTALLED AT NEXT MECHANICAL LEVEL.

WIRE RUNNING LIST				
DESG	FROM	TO	COLOR	AWG
W1	FL25001	FL25002	RED	22
W2	J25005-1	J25001	RED	26
W3	J25005-2	GL25001	BLK	26

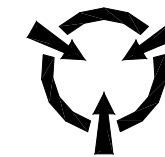

CAUTION:
CONTAINS PARTS AND ASSEMBLIES
SUSCEPTIBLE TO DAMAGE BY
ELECTROSTATIC DISCHARGE (ESD).

THIS DRAWING PROVIDES THE MINIMUM LEVEL OF GRAPHIC DETAILS AND SPECIFICATIONS REQUIRED TO ACCURATELY DEFINE THIS LEVEL OF FABRICATED PRODUCT ONLY. REFER TO DETAIL DRAWINGS AND SPECIFICATIONS FOR ACCURATE CONFIGURATION OF LOWER LEVEL PARTS AND SUB-ASSEMBLIES USED HEREIN.	
IFR SYSTEMS, INC. 10200 WEST YORK STREET WICHITA, KANSAS 67215	PROPRIETARY AND CONFIDENTIAL PROPERTY OF IFR SYSTEMS, INC. DO NOT DISCLOSE, REPRODUCE, OR PUBLISH WITHOUT IFR APPROVAL
DRAWN WAW 10/11/91	DATE 10/11/91
CHECKED J.SCHMIDT 12/20/91	DATE 12/20/91
APPROVED P.HARRIS 1/11/92	DATE 1/11/92
TITLE MECH ASSY, HETERODYNE BLOCK	
DWG NO 7005-9040-200	REV C
090402C0.DWG CAGE 51190 SHEET 1 OF 1	

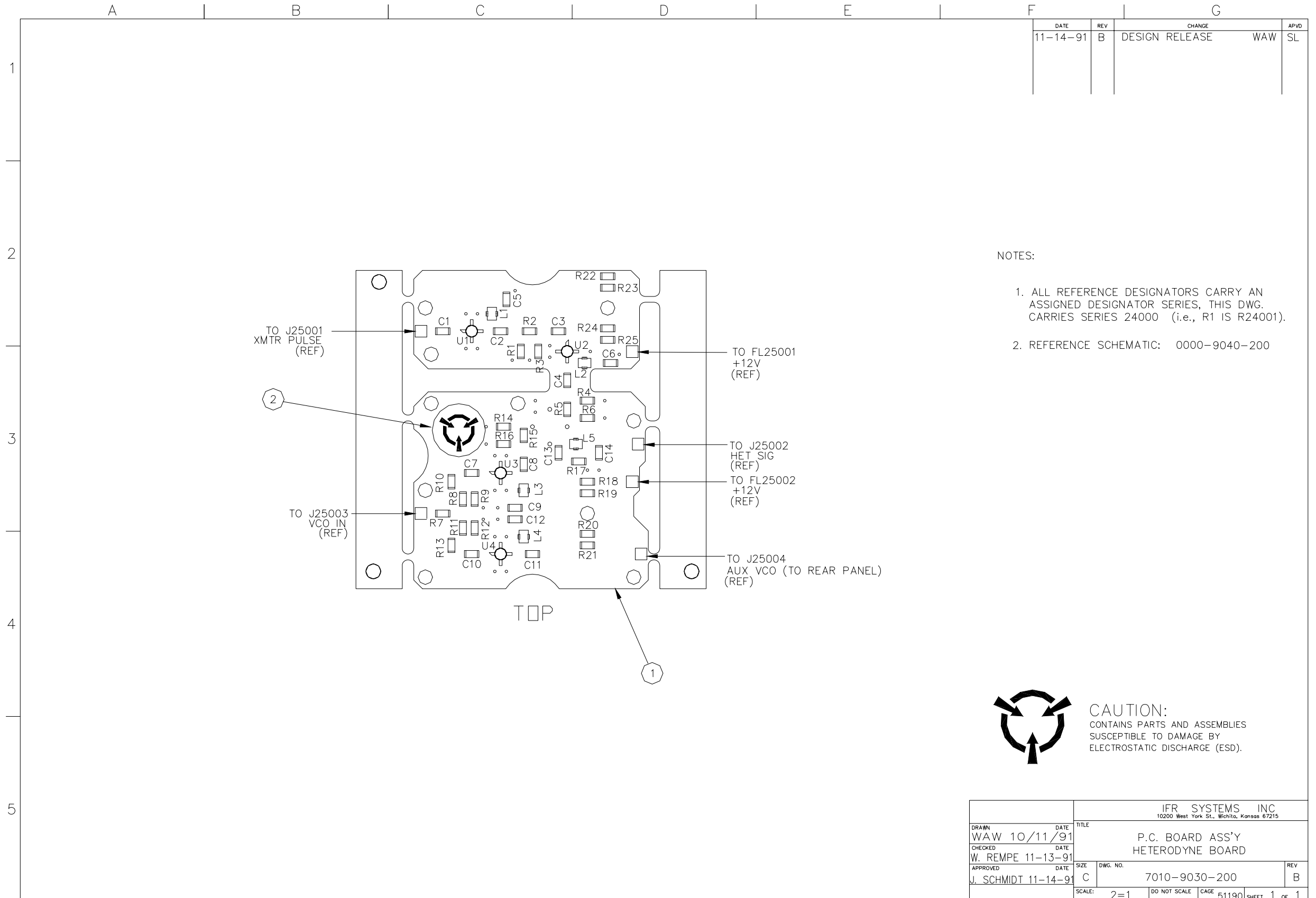

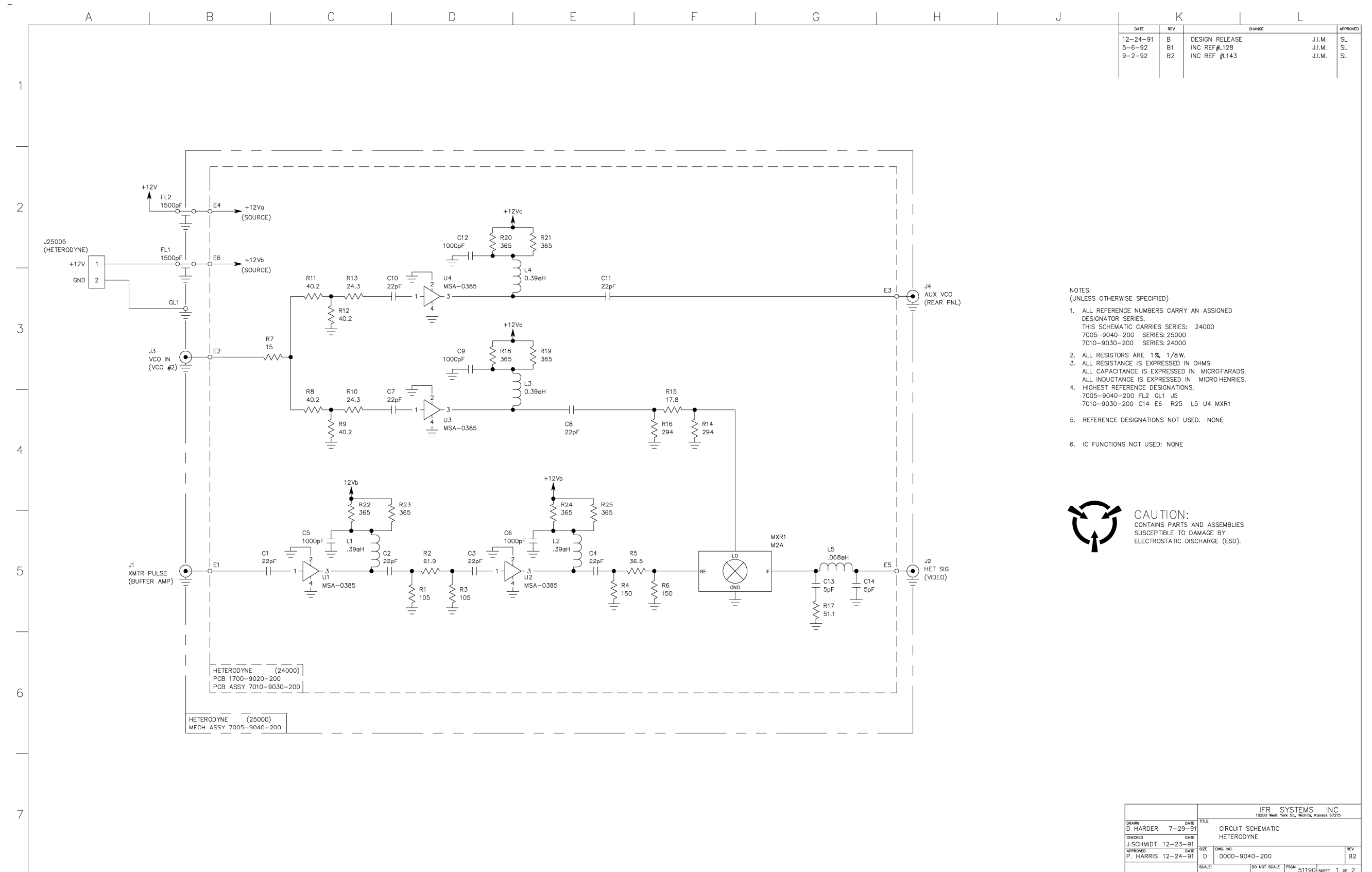

Subject to Export Control, see Cover Page for details.

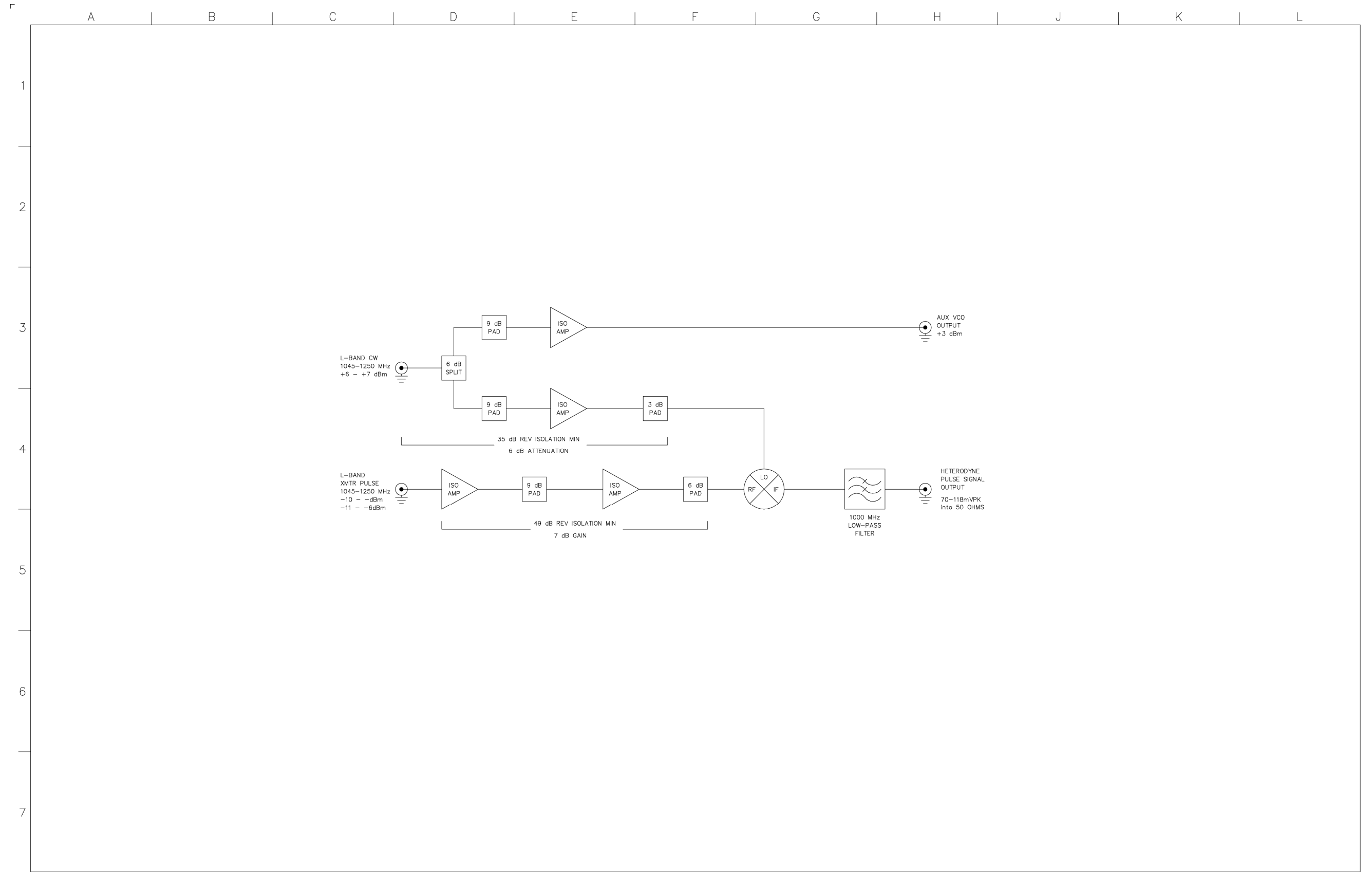

DATE	REV	CHANGE	APVD
1-11-92	B	DESIGN RELEASE	SL
7/22/92	B1	INC REF # L139	RH SL

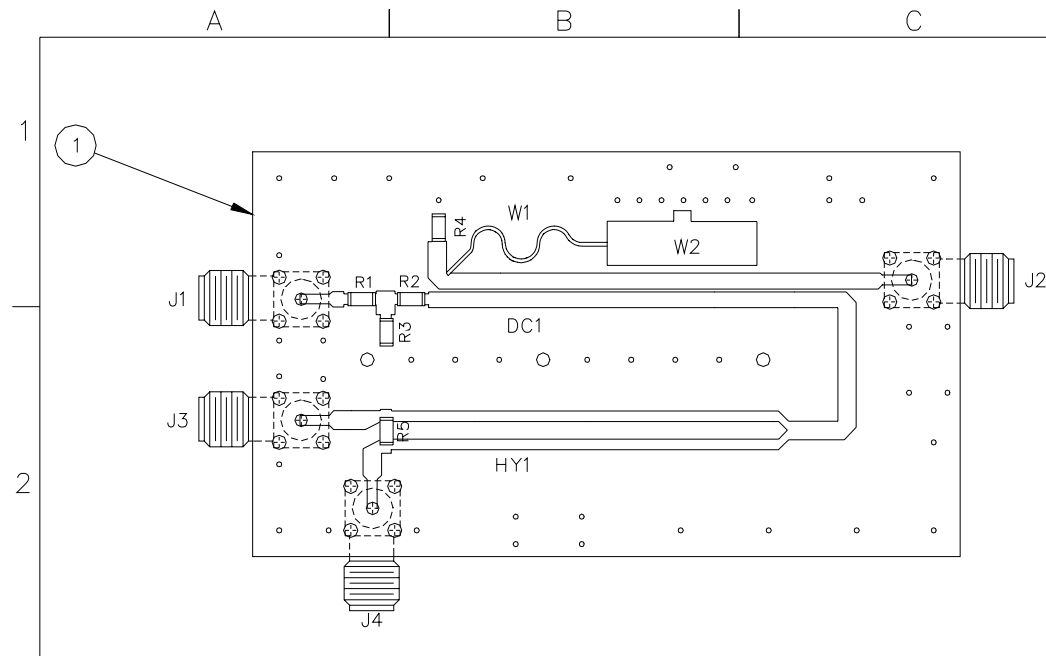

TOP SIDE

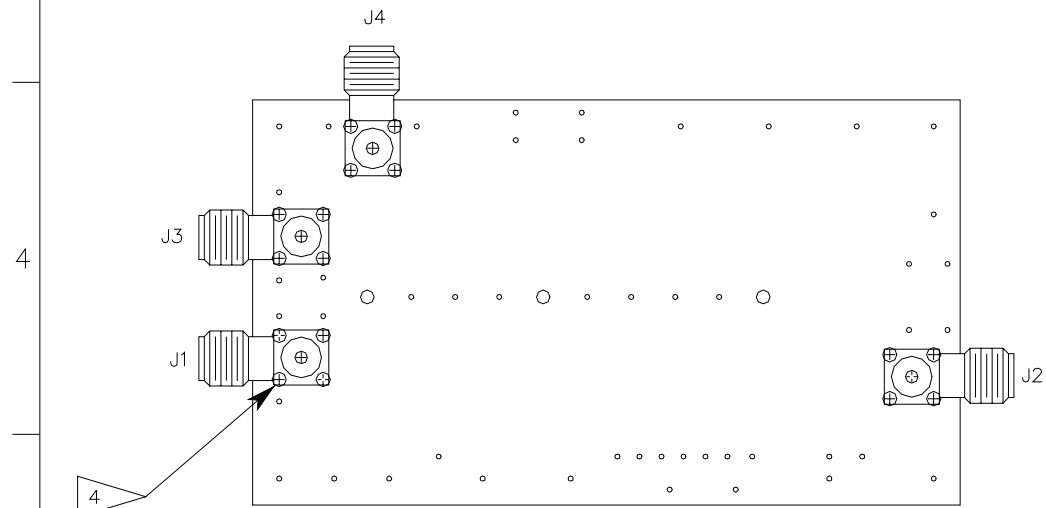

BOTTOM SIDE

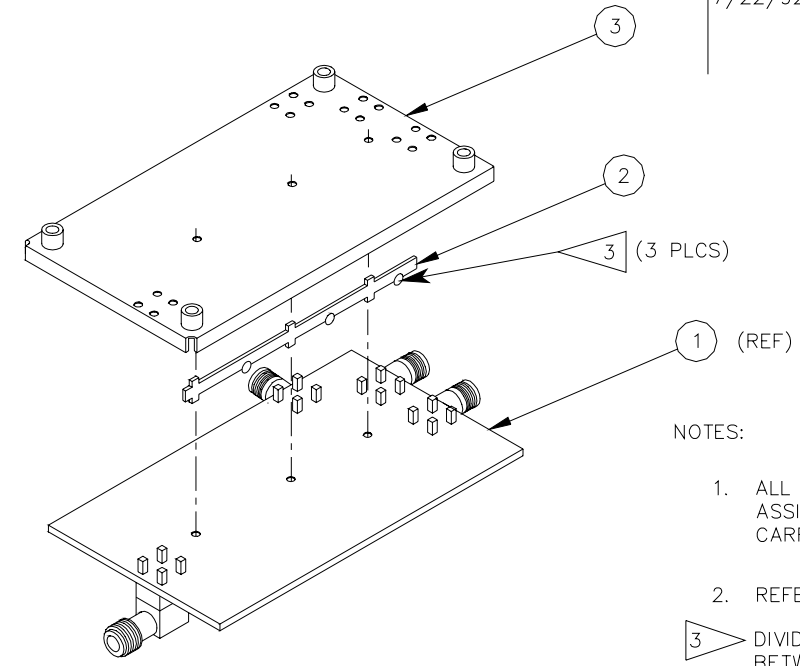

DETAIL "A"

NOTES:

1. ALL REFERENCE DESIGNATORS CARRY AN ASSIGNED DESIGNATOR SERIES. THIS DWG CARRIES SERIES 18000. (i.e. R1 IS 18001)
2. REFERENCE SCHEMATIC IS 0000-9040-300.
3. DIVIDER SHOULD BE TACKED 3 PLACES, BETWEEN EACH TAB ON PC BOARD.
4. SOLDER SHOULD FLOW THROUGH TO THE TOP SIDE OF CONNECTORS.

TOLERANCES: (UNLESS OTHERWISE SPECIFIED)		MATERIAL	
ALL DIMENSIONS APPLY AFTER FINISH		N/A	
SURFACE FINISH: REMOVE ALL BURRS		FINISH	
DECIMALS: .XXX = ±		N/A	
ANGLES: ± 1/2 DEG.			
IFR SYSTEMS, INC 10200 West York St., Wichita, Kansas 67215			
DRAWN WAW 10/7/91	DATE	TITLE	
CHECKED J. SCHMIDT 12-20-91	DATE	MECH ASS'Y COUPLER / SPLITTER	
APPROVED P. HARRIS 12-21-91	DATE	SIZE C	REV B1
DWG. NO. 7005-9040-300			
SCALE: 2=1		DO NOT SCALE	CAGE 51190 SHEET 1 OF 1

A | B | C | D | E | F | G | H

DATE	REV	CHANGE	APPROVED
12-6-91	B	DESIGN RELEASE	J.I.M. SL
DATE	REV	CHANGE	APPROVED
2-17-93	B1	PROD. REL. PER ECN #15488	J.I.M. SL

1
2
3
4
5

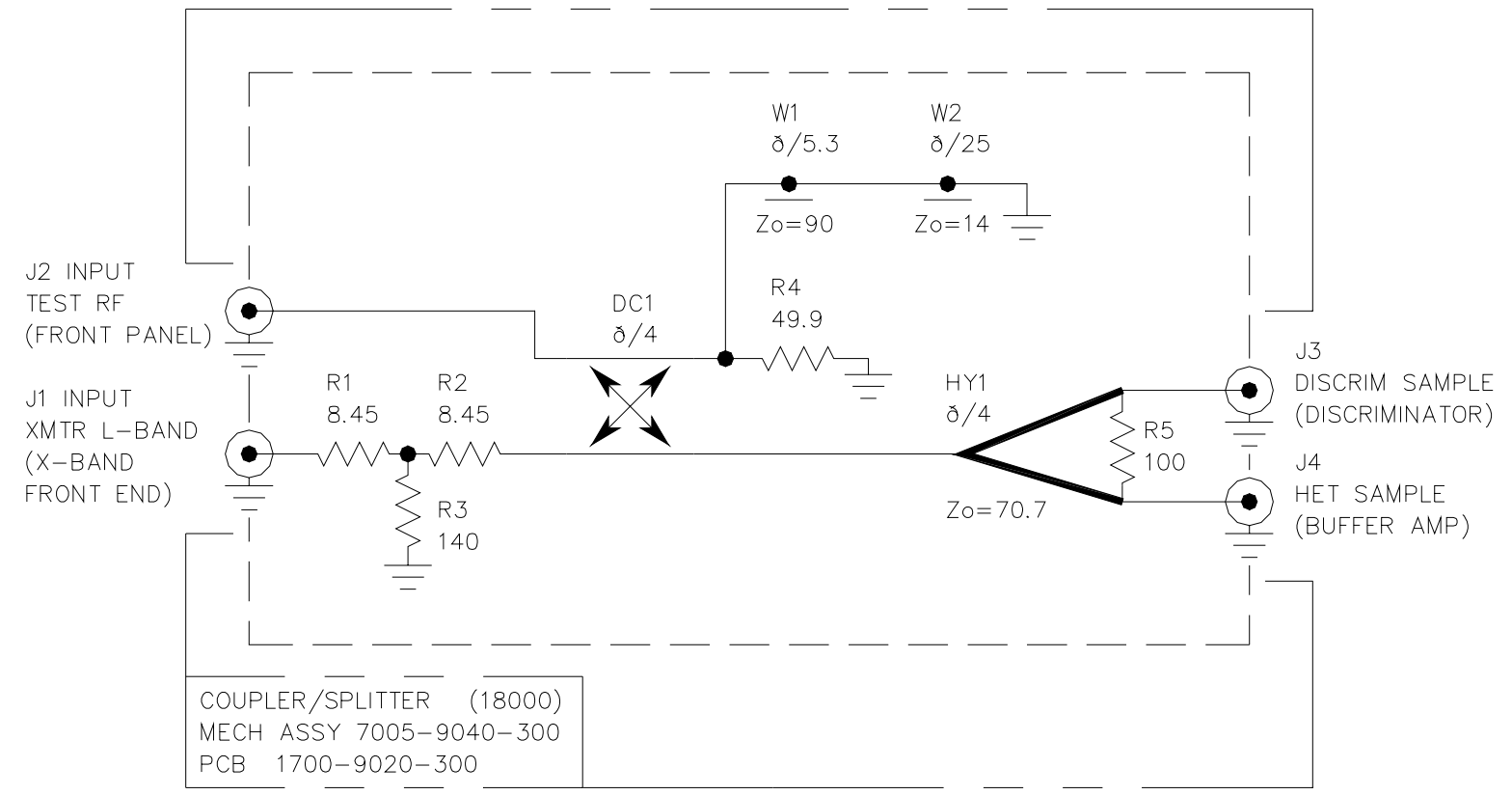

- NOTES:
(UNLESS OTHERWISE SPECIFIED)
1. ALL REFERENCE NUMBERS CARRY AN ASSIGNED DESIGNATOR SERIES.
THIS SCHEMATIC CARRIES SERIES: (18000)
 2. ALL RESISTORS ARE 1%, 1/8 W.
 3. ALL RESISTANCE IS EXPRESSED IN OHMS.
ALL CAPACITANCE IS EXPRESSED IN MICRO FARADS.
ALL INDUCTANCE IS EXPRESSED IN MICRO HENRIES.
 4. HIGHEST REFERENCE DESIGNATIONS.
DC1, R5, HY1, W2
 5. CENTER FREQUENCY FOR WAVELENGTH IS 1143 MHz.

DRAWN R.CHAPMAN		DATE 4-16-91	TITLE CIRCUIT SCHEMATIC COUPLER/SPLITTER	
CHECKED A.KRAUSKA		DATE 12-2-91	REV B1	
APPROVED P.R.HARRIS		DATE 12-2-91	SIZE B	DWG. NO. 0000-9040-300
SCALE:		DO NOT SCALE	FSCM 51190	SHEET 1 OF 1

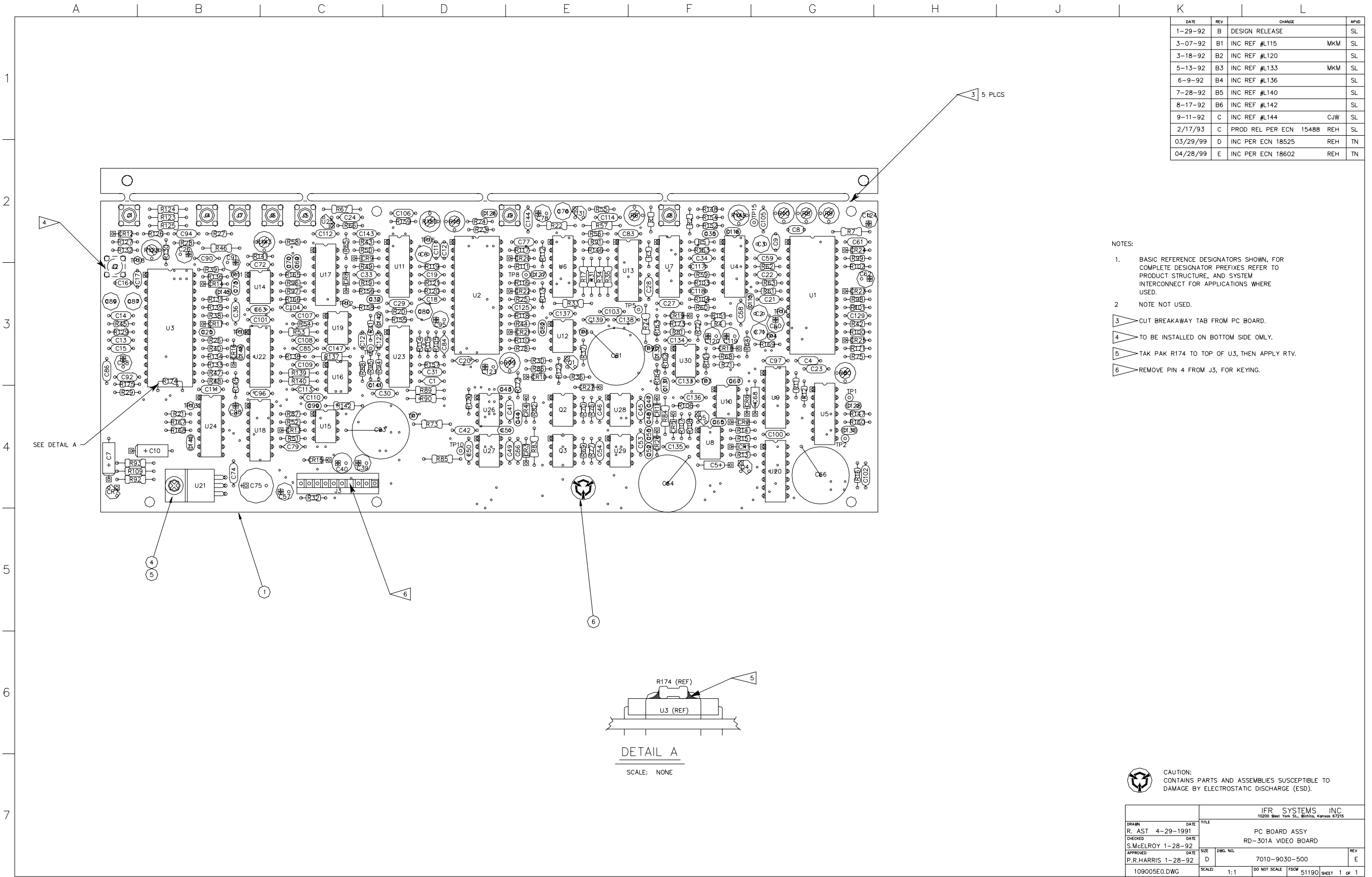

DATE	REV	CHANGE	APPROVED
1-29-92	B	DESIGN RELEASE	SL
3-07-92	B1	INC REF #1115	MkM SL
3-18-92	B2	INC REF #1120	SL
5-13-92	B3	INC REF #1133	MkM SL
6-9-92	B4	INC REF #1136	SL
7-28-92	B5	INC REF #1140	SL
8-17-92	B6	INC REF #1142	SL
9-11-92	C	INC REF #1144	CJW SL
2/17/93	C	PROD REL PER ECN 15488	REH SL
03/29/99	D	INC PER ECN 18525	REH TN
04/28/99	E	INC PER ECN 18602	REH TN

- NOTES:
- BASIC REFERENCE DESIGNATORS SHOWN. FOR COMPLETE DESIGNATOR PREFIXES REFER TO PRODUCT STRUCTURE, AND SYSTEM INTERCONNECT FOR APPLICATIONS WHERE USED.
 - NOTE NOT USED.
 - CUT BREAKAWAY TAB FROM PC BOARD.
 - TO BE INSTALLED ON BOTTOM SIDE OMLY.
 - TAK PAK R174 TO TOP OF U3, THEN APPLY RTV.
 - REMOVE PIN 4 FROM J3, FOR KEYING.

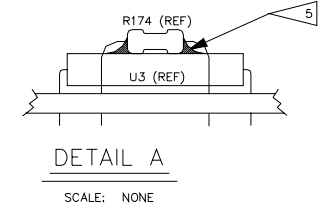

CAUTION:
CONTAINS PARTS AND ASSEMBLIES SUSCEPTIBLE TO
DAMAGE BY ELECTROSTATIC DISCHARGE (ESD).

DRAWN		DATE		TITLE	
R. AST	4-29-1991	IFR SYSTEMS, INC 10200 West York St., Wichita, Kansas 67215			
CHECKED		DATE		PC BOARD ASSY	
S. McELROY	1-28-92	RD-301A VIDEO BOARD			
APPROVED		SIZE	DWG. NO.	REV	
P. R. HARRIS	1-28-92	D	7010-9030-500	E	
109005E0.DWG	SCALE:	1:1	DO NOT SCALE	FSCM 51190	SHEET 1 of 1

Subject to Export Control, see Cover Page for details.

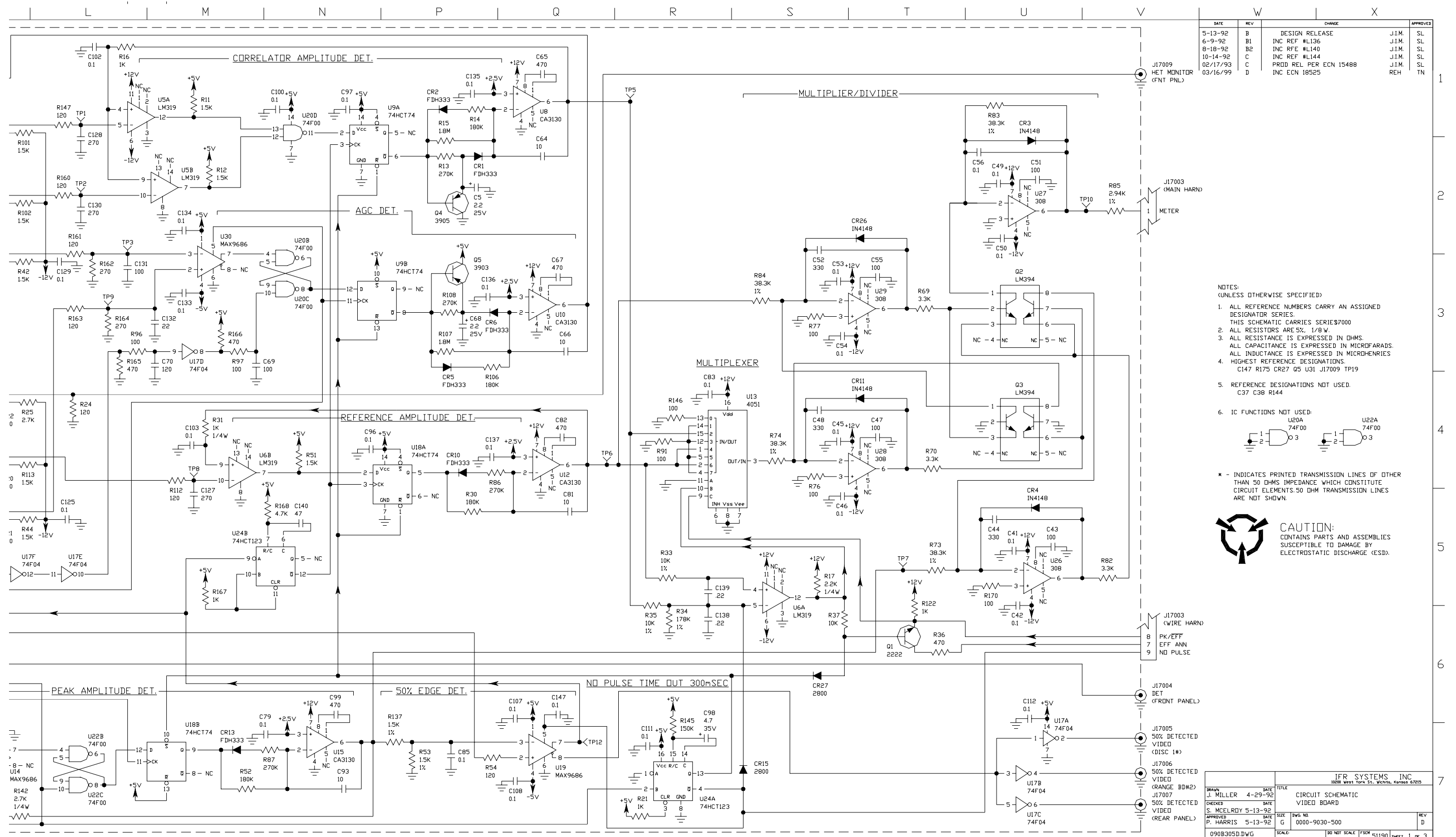

DATE	REV	CHANGE	APPROVED
5-13-92	B	DESIGN RELEASE	JIM SL
6-9-92	B1	INC REF #L136	JIM SL
8-18-92	B2	INC RFE #L140	JIM SL
10-14-92	C	INC REF #L144	JIM SL
02/17/93	C	PROD REL PER ECN 15488	JIM SL
03/16/99	D	INC ECN 18525	REH TN

- NOTES:
(UNLESS OTHERWISE SPECIFIED)
- ALL REFERENCE NUMBERS CARRY AN ASSIGNED DESIGNATOR SERIES. THIS SCHEMATIC CARRIES SERIES 7000
 - ALL RESISTORS ARE 5%, 1/8 W.
 - ALL RESISTANCE IS EXPRESSED IN OHMS. ALL CAPACITANCE IS EXPRESSED IN MICROFARADS. ALL INDUCTANCE IS EXPRESSED IN MICROHENRIES
 - HIGHEST REFERENCE DESIGNATIONS:
C147 R175 CR27 Q5 U31 J17009 TP19
 - REFERENCE DESIGNATIONS NOT USED:
C37 C38 R144
 - IC FUNCTIONS NOT USED:
U20A 74F00 U22A 74F00
- * - INDICATES PRINTED TRANSMISSION LINES OF OTHER THAN 50 OHMS IMPEDANCE WHICH CONSTITUTE CIRCUIT ELEMENTS. 50 OHM TRANSMISSION LINES ARE NOT SHOWN.



DATE	REV	CHANGE	APPROVED
5-13-92	B	DESIGN RELEASE	JIM SL
6-9-92	B1	INC REF #L136	JIM SL
8-18-92	B2	INC RFE #L140	JIM SL
10-14-92	C	INC REF #L144	JIM SL
02/17/93	C	PROD REL PER ECN 15488	JIM SL
03/16/99	D	INC ECN 18525	REH TN

DESIGNED BY	J. MILLER	DATE	4-29-92	TITLE	CIRCUIT SCHEMATIC
CHECKED BY	S. MCELROY	DATE	5-13-92	DWG NO.	0000-9030-500
APPROVED BY	P. HARRIS	DATE	5-13-92	REV	D
FILE NO.	090B305D.DWG	SCALE		DO NOT SCALE FROM	51190
					SHEET 1 OF 3

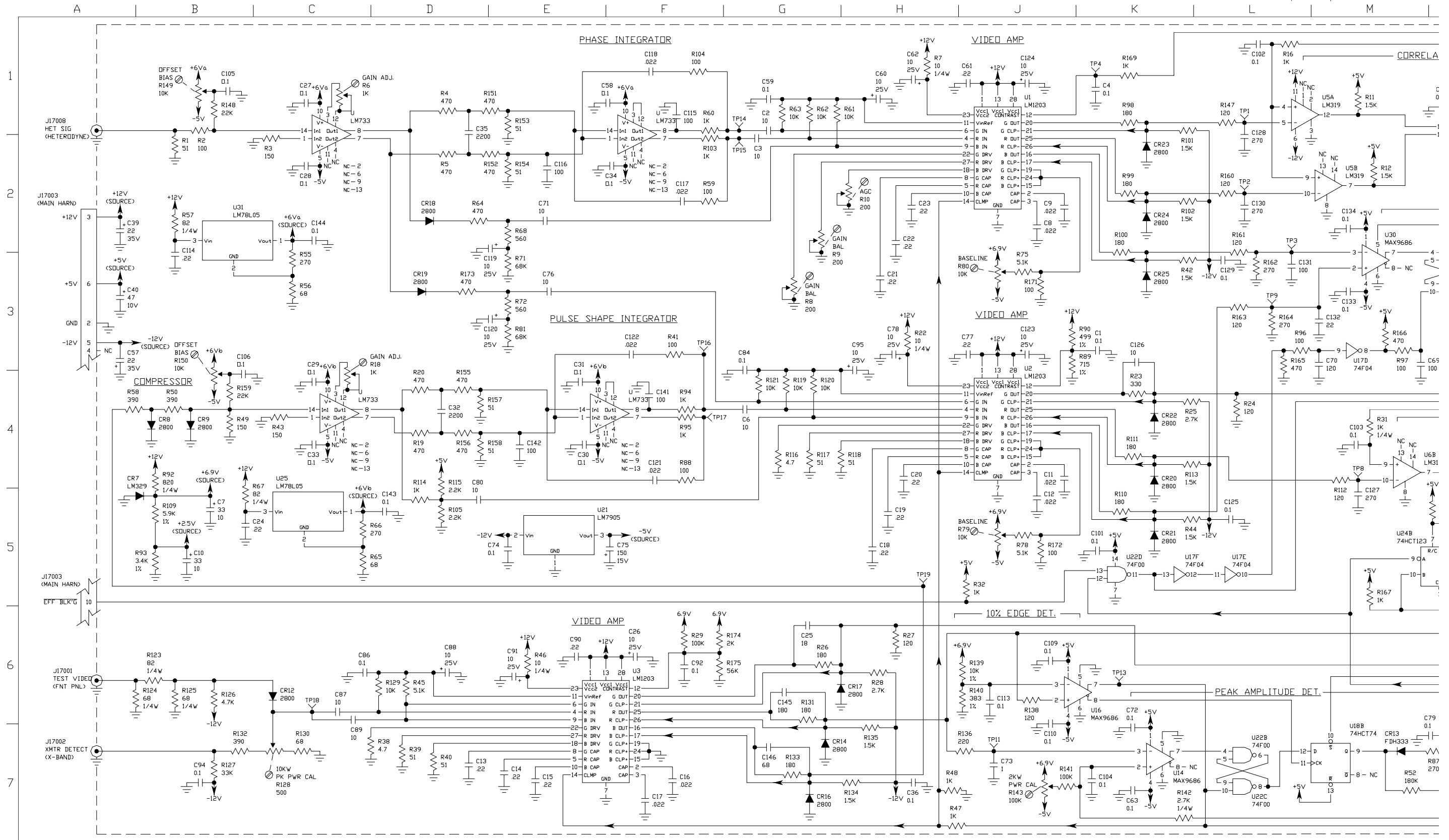

VIDEO BOARD 0000-9030-500 REV D SHEET 2 OF 3

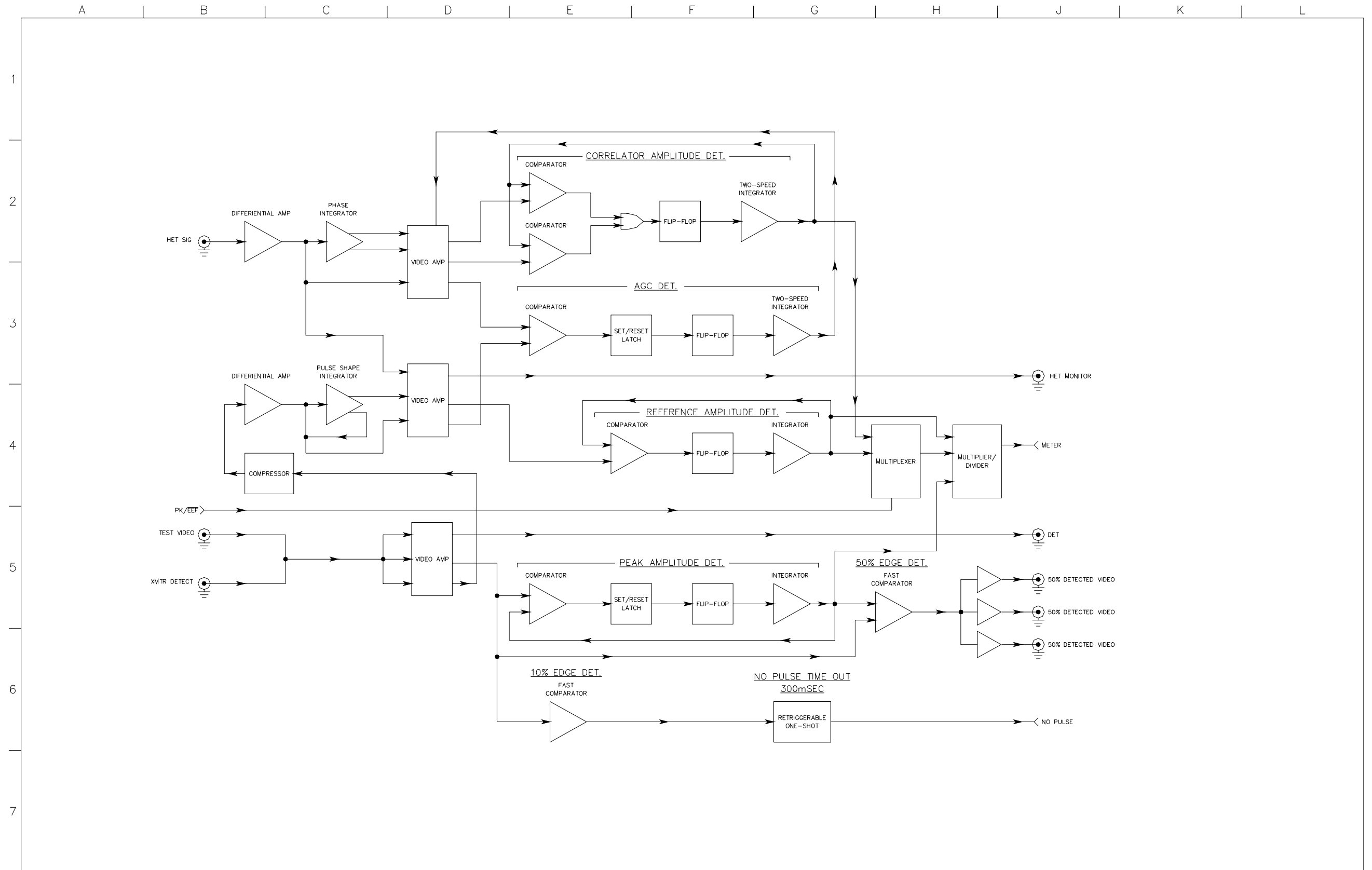

A | B | C | D | E | F | G

DATE	REV	CHANGE	APVD
02-19-93	A	PROD. REL. PER ECN 15488	RLA SL
01-11-94	B	INC ECN 15731	SL
01-18-94	B1	INC ECN 15731A	BP BM

1

2

3

4

5

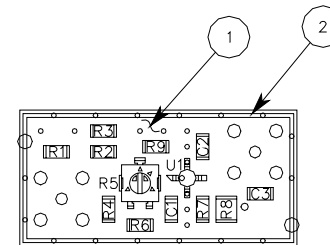

NOTES:

- 1 ALL REFERENCE DESIGNATORS CARRY AN ASSIGNED DESIGNATOR SERIES. THIS DWG CARRIES SERIES 56000. (i.e., R1 IS R56001).



CAUTION:
CONTAINS PARTS AND ASSEMBLIES SUSCEPTIBLE TO
DAMAGE BY ELECTROSTATIC DISCHARGE (ESD).

DRAWN		DATE		TITLE	
M.K.MOFFITT		8-25-92		ASSEMBLY DWG	
CHECKED		DATE		BUFFER AMP	
R. CRAWFORD		01-23-93			
APPROVED		SIZE	DWG. NO.	REV	
P. HARRIS		C	7010-9030-700	B1	
109007B1.PLT		SCALE:	N.T.S.	DO NOT SCALE	FSCM 51190 SHEET 1 of 2

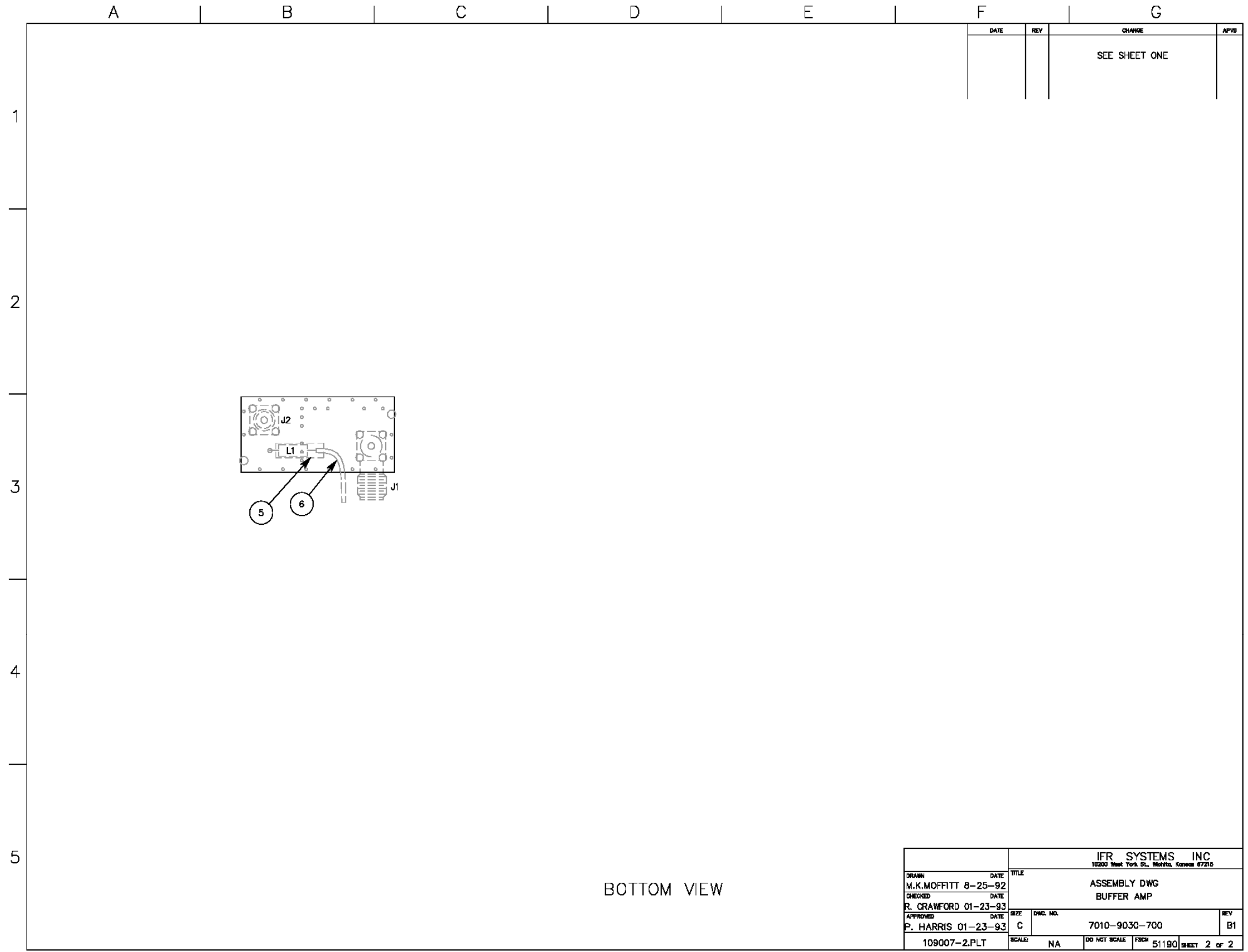

DATE	REV	CHANGE	APPROV
		SEE SHEET ONE	

BOTTOM VIEW

DRAWN		DATE		TITLE		IFR SYSTEMS INC	
M.K. MOFFITT		8-25-92		ASSEMBLY DWG		10200 West York St., Wichita, Kansas 67215	
CHECKED		DATE		BUFFER AMP			
R. CRAWFORD		01-23-93		SIZE	DWG. NO.	REV	
APPROVED		DATE		C	7010-9030-700	B1	
P. HARRIS		01-23-93		SCALE:	NA	DO NOT SCALE	FROM 51190 SHEET 2 of 2

DATE	REV	CHANGE	APPROVED
2-19-93	A	PROD. REL. PER ECN #15488	J.I.M.
01-14-94	B	INC ECN 15731	BP

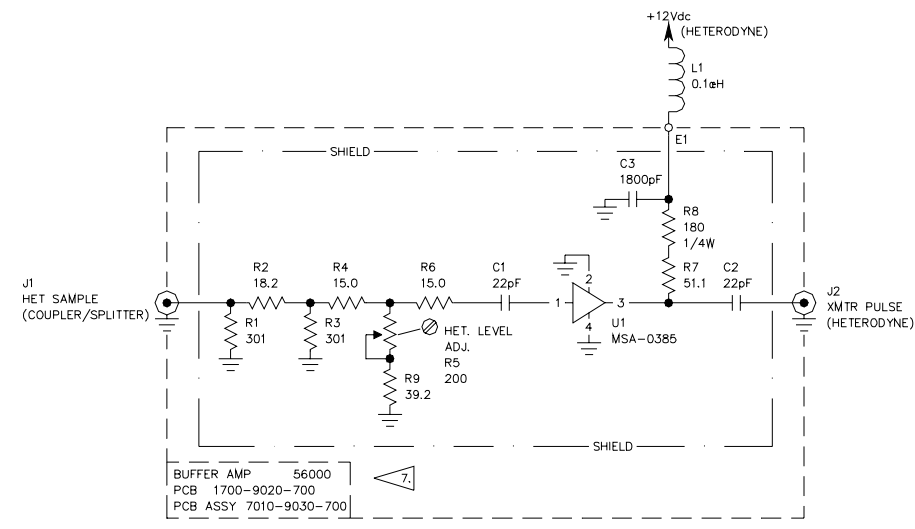

- NOTES:
(UNLESS OTHERWISE SPECIFIED)
- ALL REFERENCE NUMBERS CARRY AN ASSIGNED DESIGNATOR SERIES.
THIS SCHEMATIC CARRIES SERIES: 56000
 - ALL RESISTORS ARE 1%, 1/8W.
 - ALL RESISTANCE IS EXPRESSED IN OHMS.
ALL CAPACITANCE IS EXPRESSED IN MICROFARADS.
ALL INDUCTANCE IS EXPRESSED IN MICROHENRIES
 - HIGHEST REFERENCE DESIGNATIONS.
C3, E1, J2, L1, R9, U1.
 - REFERENCE DESIGNATIONS NOT USED.
NONE
 - IC FUNCTIONS NOT USED: NONE
 - AMP HAS APPROXIMATELY 0 TO 5dB GAIN, AND 24dB REVERSE ISOLATION FROM 1045 TO 1245MHz.
- * - INDICATES PRINTED TRANSMISSION LINES OF OTHER THAN 50 OHMS IMPEDANCE WHICH CONSTITUTE CIRCUIT ELEMENTS. 50 OHM TRANSMISSION LINES ARE NOT SHOWN.



CAUTION:
CONTAINS PARTS AND ASSEMBLIES
SUSCEPTIBLE TO DAMAGE BY
ELECTROSTATIC DISCHARGE (ESD).

BUFFER AMP 56000
PCB 1700-9020-700
PCB ASSY 7010-9030-700

DRAWN		DATE		TITLE	
J. MILLER	10-14-92	CIRCUIT SCHEMATIC BUFFER AMP			
CHECKED		DATE			
S. LEONARD	2-18-93				
APPROVED		DATE		REV	
R. CRAWFORD	2-18-93	D		B	
090B307A.DWG		SCALE		DO NOT SCALE	
		FSCM 51190		SHEET 1 of 1	

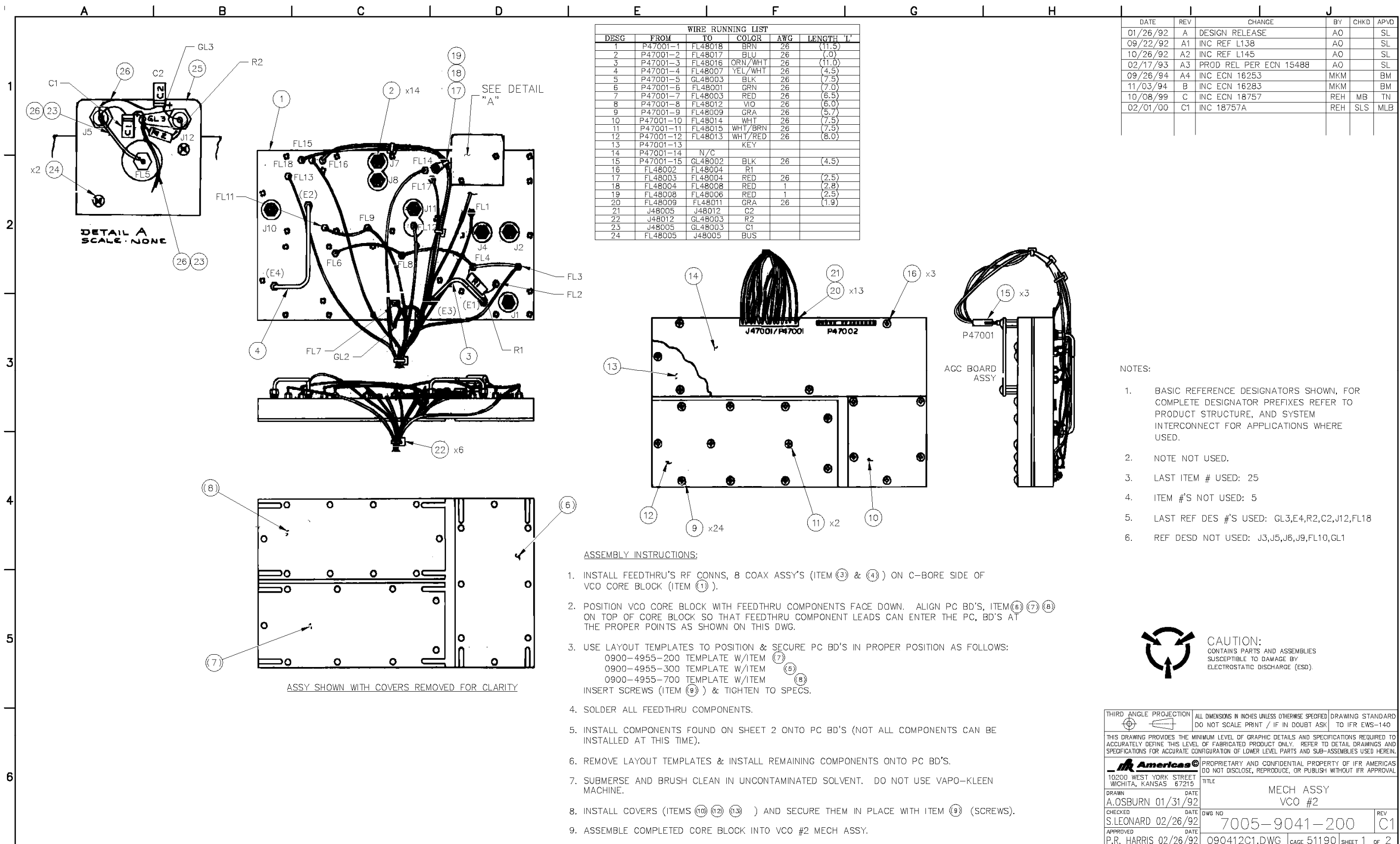

WIRE RUNNING LIST					
DESG	FROM	TO	COLOR	AWG	LENGTH 'L'
1	P47001-1	FL48018	BRN	26	(11.5)
2	P47001-2	FL48017	BLU	26	(.9)
3	P47001-3	FL48016	ORN/WHT	26	(11.0)
4	P47001-4	FL48007	YEL/WHT	26	(4.5)
5	P47001-5	GL48003	BLK	26	(7.5)
6	P47001-6	FL48001	GRN	26	(7.0)
7	P47001-7	FL48003	RED	26	(6.5)
8	P47001-8	FL48012	VIO	26	(6.0)
9	P47001-9	FL48009	GRA	26	(5.7)
10	P47001-10	FL48014	WHT	26	(7.5)
11	P47001-11	FL48015	WHT/BRN	26	(7.5)
12	P47001-12	FL48013	WHT/RED	26	(8.0)
13	P47001-13		KEY		
14	P47001-14	N/C			
15	P47001-15	GL48002	BLK	26	(4.5)
16	FL48002	FL48004	R1		
17	FL48003	FL48004	RED	26	(2.5)
18	FL48004	FL48008	RED	1	(2.8)
19	FL48008	FL48006	RED	1	(2.5)
20	FL48009	FL48011	GRA	26	(1.9)
21	J48005	J48012	C2		
22	J48012	GL48003	R2		
23	J48005	GL48003	C1		
24	FL48005	J48005	BUS		

DATE	REV	CHANGE	BY	CHKD	APVD
01/26/92	A	DESIGN RELEASE	AO		SL
09/22/92	A1	INC REF L138	AO		SL
10/26/92	A2	INC REF L145	AO		SL
02/17/93	A3	PROD REL PER ECN 15488	AO		SL
09/26/94	A4	INC ECN 16253	MKM		BM
11/03/94	B	INC ECN 16283	MKM		BM
10/08/99	C	INC ECN 18757	REH	MB	TN
02/01/00	C1	INC 18757A	REH	SLS	MLB

ASSEMBLY INSTRUCTIONS:

- INSTALL FEEDTHRU'S RF CONNS, 8 COAX ASSY'S (ITEM (3) & (4)) ON C-BORE SIDE OF VCO CORE BLOCK (ITEM (1)).
- POSITION VCO CORE BLOCK WITH FEEDTHRU COMPONENTS FACE DOWN. ALIGN PC BD'S, ITEM (6) (7) (8) ON TOP OF CORE BLOCK SO THAT FEEDTHRU COMPONENT LEADS CAN ENTER THE PC, BD'S AT THE PROPER POINTS AS SHOWN ON THIS DWG.
- USE LAYOUT TEMPLATES TO POSITION & SECURE PC BD'S IN PROPER POSITION AS FOLLOWS:
0900-4955-200 TEMPLATE W/ITEM (7)
0900-4955-300 TEMPLATE W/ITEM (9)
0900-4955-700 TEMPLATE W/ITEM (8)
INSERT SCREWS (ITEM (9)) & TIGHTEN TO SPECS.
- SOLDER ALL FEEDTHRU COMPONENTS.
- INSTALL COMPONENTS FOUND ON SHEET 2 ONTO PC BD'S (NOT ALL COMPONENTS CAN BE INSTALLED AT THIS TIME).
- REMOVE LAYOUT TEMPLATES & INSTALL REMAINING COMPONENTS ONTO PC BD'S.
- SUBMERSE AND BRUSH CLEAN IN UNCONTAMINATED SOLVENT. DO NOT USE VAPO-KLEEN MACHINE.
- INSTALL COVERS (ITEMS (10) (12) (13)) AND SECURE THEM IN PLACE WITH ITEM (9) (SCREWS).
- ASSEMBLE COMPLETED CORE BLOCK INTO VCO #2 MECH ASSY.

NOTES:

- BASIC REFERENCE DESIGNATORS SHOWN, FOR COMPLETE DESIGNATOR PREFIXES REFER TO PRODUCT STRUCTURE, AND SYSTEM INTERCONNECT FOR APPLICATIONS WHERE USED.
- NOTE NOT USED.
- LAST ITEM # USED: 25
- ITEM #'S NOT USED: 5
- LAST REF DES #'S USED: GL3,E4,R2,C2,J12,FL18
- REF DESD NOT USED: J3,J5,J6,J9,FL10,GL1



CAUTION:
CONTAINS PARTS AND ASSEMBLIES
SUSCEPTIBLE TO DAMAGE BY
ELECTROSTATIC DISCHARGE (ESD).

THIRD ANGLE PROJECTION	ALL DIMENSIONS IN INCHES UNLESS OTHERWISE SPECIFIED DO NOT SCALE PRINT / IF IN DOUBT ASK	DRAWING STANDARD TO IFR EWS-140
THIS DRAWING PROVIDES THE MINIMUM LEVEL OF GRAPHIC DETAILS AND SPECIFICATIONS REQUIRED TO ACCURATELY DEFINE THIS LEVEL OF FABRICATED PRODUCT ONLY. REFER TO DETAIL DRAWINGS AND SPECIFICATIONS FOR ACCURATE CONFIGURATION OF LOWER LEVEL PARTS AND SUB-ASSEMBLIES USED HEREIN.		
PROPRIETARY AND CONFIDENTIAL PROPERTY OF IFR AMERICAS DO NOT DISCLOSE, REPRODUCE, OR PUBLISH WITHOUT IFR APPROVAL		
10200 WEST YORK STREET WICHITA, KANSAS 67215		TITLE MECH ASSY VCO #2
DRAWN A.OSBURN	DATE 01/31/92	DWG NO 7005-9041-200
CHECKED S.LEONARD	DATE 02/26/92	REV C1
APPROVED P.R. HARRIS	DATE 02/26/92	090412C1.DWG CAGE 51190 SHEET 1 OF 2

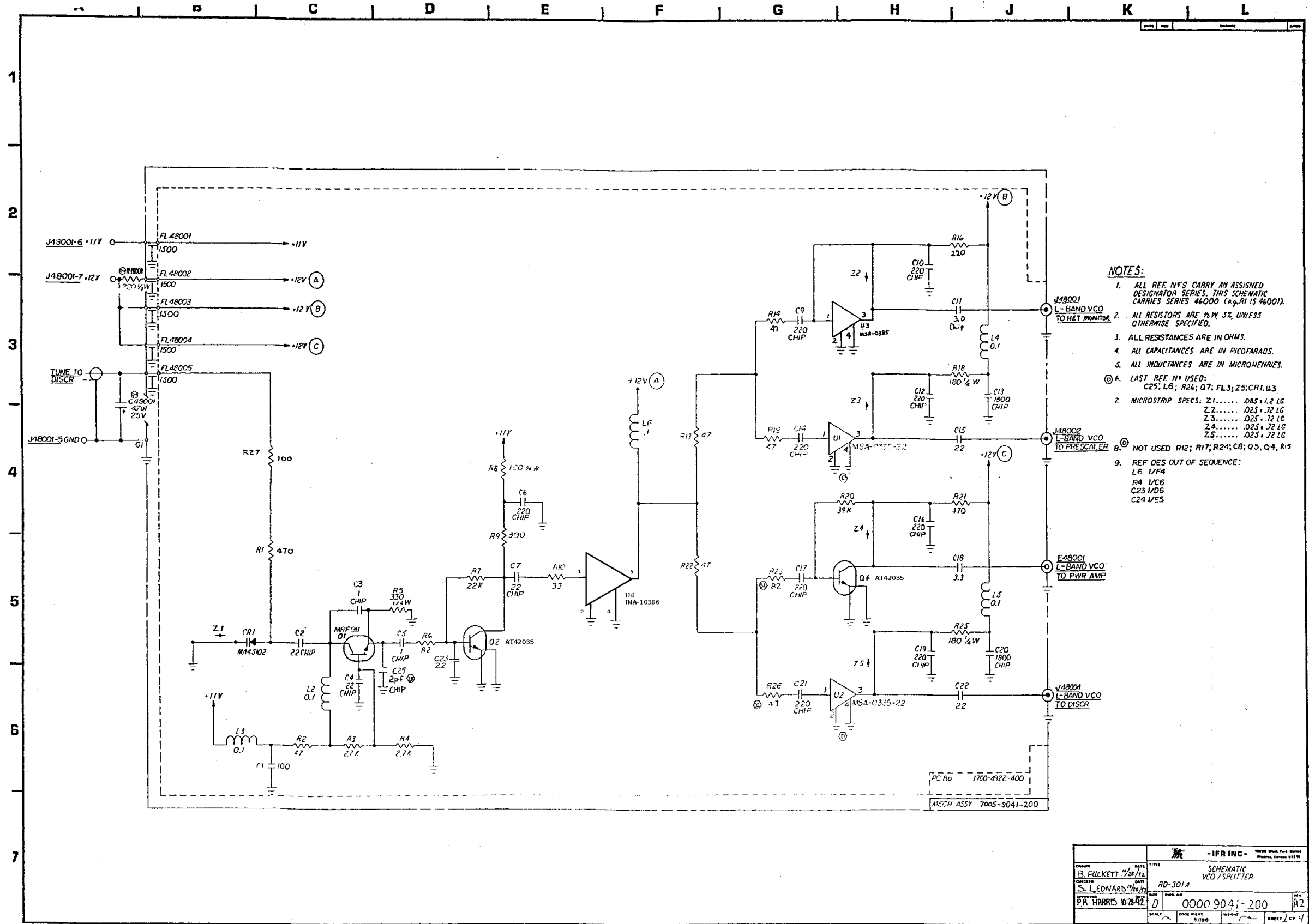

- NOTES:**
1. ALL REF. N°S CARRY AN ASSIGNED DESIGNATOR SERIES. THIS SCHEMATIC CARRIES SERIES 46000 (e.g. R1 IS 46001).
 2. ALL RESISTORS ARE 1/4W, 5%, UNLESS OTHERWISE SPECIFIED.
 3. ALL RESISTANCES ARE IN OHMS.
 4. ALL CAPACITANCES ARE IN PICOFARADS.
 5. ALL INDUCTANCES ARE IN MICROHENRIES.
 6. LAST REF. N° USED:
C25: L6; R26; Q7; FL3; Z5; C11; U3
 7. MICROSTRIP SPECS: Z1..... .085 x 1.2 LG
Z2..... .025 x .72 LG
Z3..... .025 x .72 LG
Z4..... .025 x .72 LG
Z5..... .025 x .72 LG
 8. NOT USED: R12; R17; R24; C8; Q5; Q4; R15
 9. REF DES OUT OF SEQUENCE:
L6 1/F4
R4 1/C6
C23 1/D6
C24 1/E5

-IFR INC-		DATE	
DESIGNED BY	B. RUCKETT	DATE	7/2/72
DESIGNED BY	S. LEONARD	DATE	7/2/72
APPROVED BY	P.A. HARRIS	DATE	10/2/72
TITLE		RD-301A	
SCHEMATIC		VCO/SPLITTER	
SCALE		0000 9041-200	
SHEET		2 OF 4	

Subject to Export Control, see Cover Page for details.

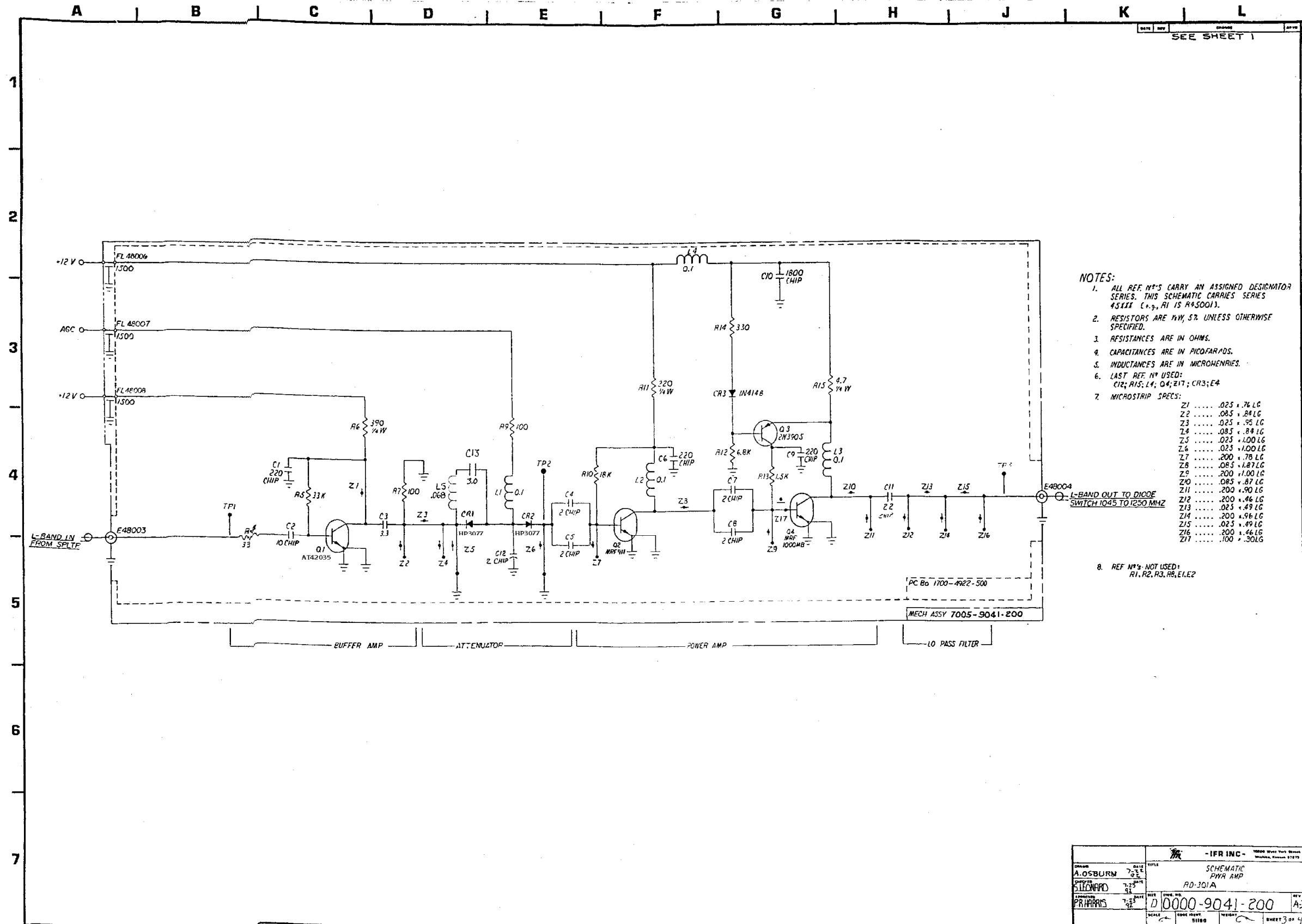

Subject to Export Control, see Cover Page for details.

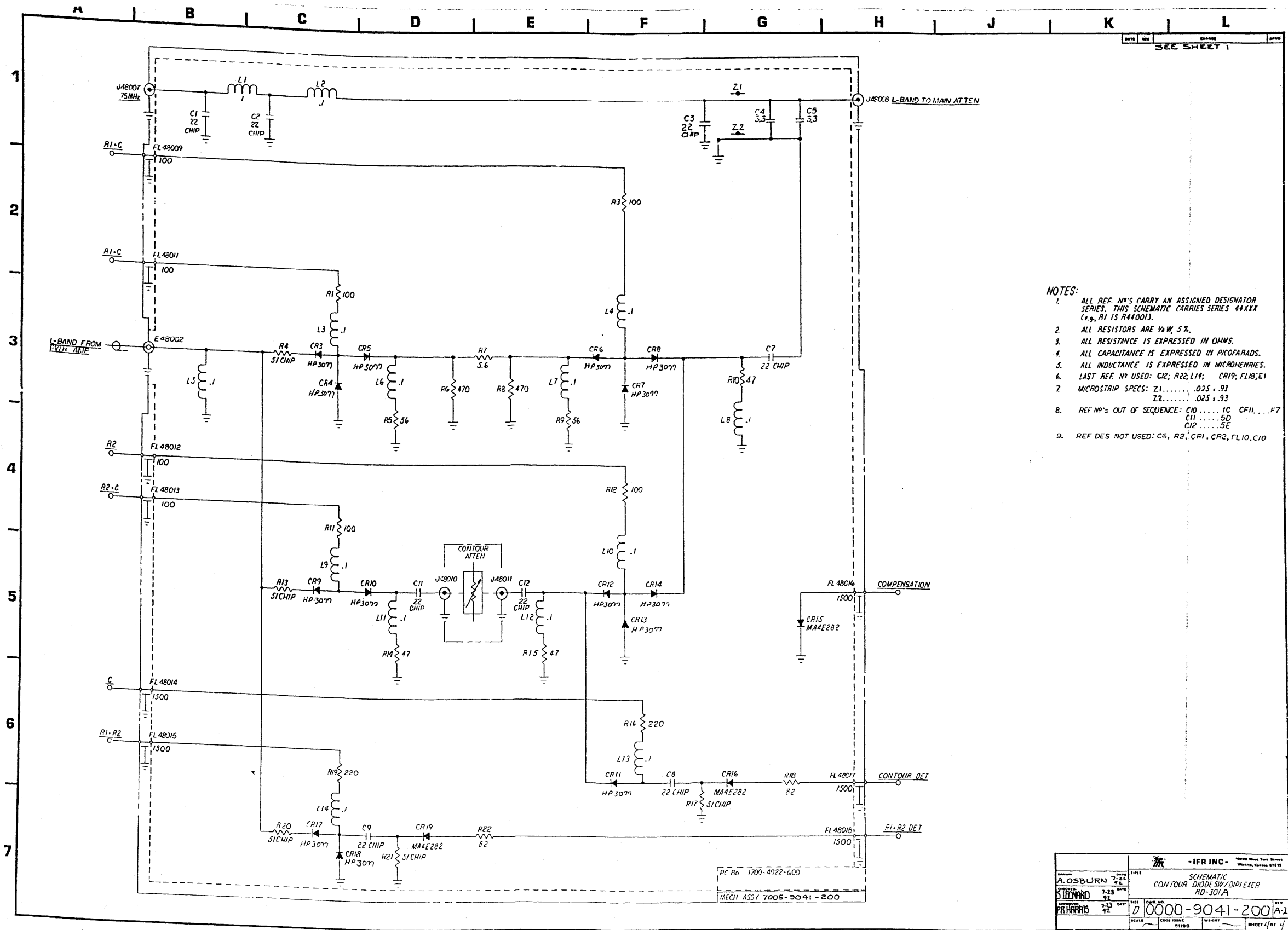

- NOTES:**
1. ALL REF. NOS. CARRY AN ASSIGNED DESIGNATOR SERIES. THIS SCHEMATIC CARRIES SERIES 44XX (e.g., R1 IS R44001).
 2. ALL RESISTORS ARE 1/4W, 5%.
 3. ALL RESISTANCE IS EXPRESSED IN OHMS.
 4. ALL CAPACITANCE IS EXPRESSED IN PICOFARADS.
 5. ALL INDUCTANCE IS EXPRESSED IN MICROHENRIES.
 6. LAST REF. NO. USED: CR2, R22, L14; CR19, FL18, E1
 7. MICROSTRIP SPECS: Z1..... 0.25 + .93
Z2..... 0.25 + .93
 8. REF. NOS. OUT OF SEQUENCE: C10..... 10 C11..... F7
C11..... 50
C12..... 5E
 9. REF. NOS. NOT USED: C6, R2, CR1, CR2, FL10, C10

AEROFLEX		- IFR INC -	
DATE	REV	TITLE	1700 West Park Street Waltham, Kansas 6719
A. OSBURN	7-23	SCHEMATIC	
STEWART	91	CONTOUR DIODE SW/DIPIEXER	
PHARRIS	92	RD-301A	
SCALE	CODE	WEIGHT	SHEET 4 of 4
D	0000-9041-200	A-2	

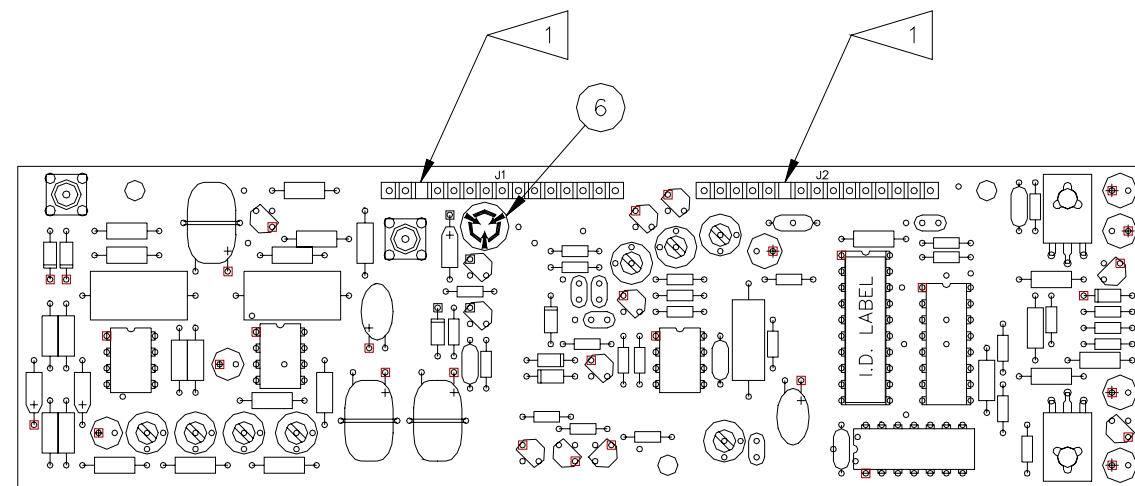

FINISH NOTES:

1 REMOVE PIN #13 OF J1 AND PIN #10 OF J2 BEFORE INSTALLING.



CAUTION:
CONTAINS PARTS AND ASSEMBLIES SUSCEPTIBLE TO
DAMAGE BY ELECTROSTATIC DISCHARGE (ESD).

IFR Systems Inc. Assembly Process Print	PROC. CHG BY:	Last ECN:	Prepared By: 12/23/98 R. BURNETT	Check By:	Description PCB ASS'Y, AGC	Assembly #  *7010-4933-200*	Revision  *B*	Operation 2 of 2 Sheet 1 of 1
--	---------------	-----------	-------------------------------------	-----------	-------------------------------	--	--	----------------------------------

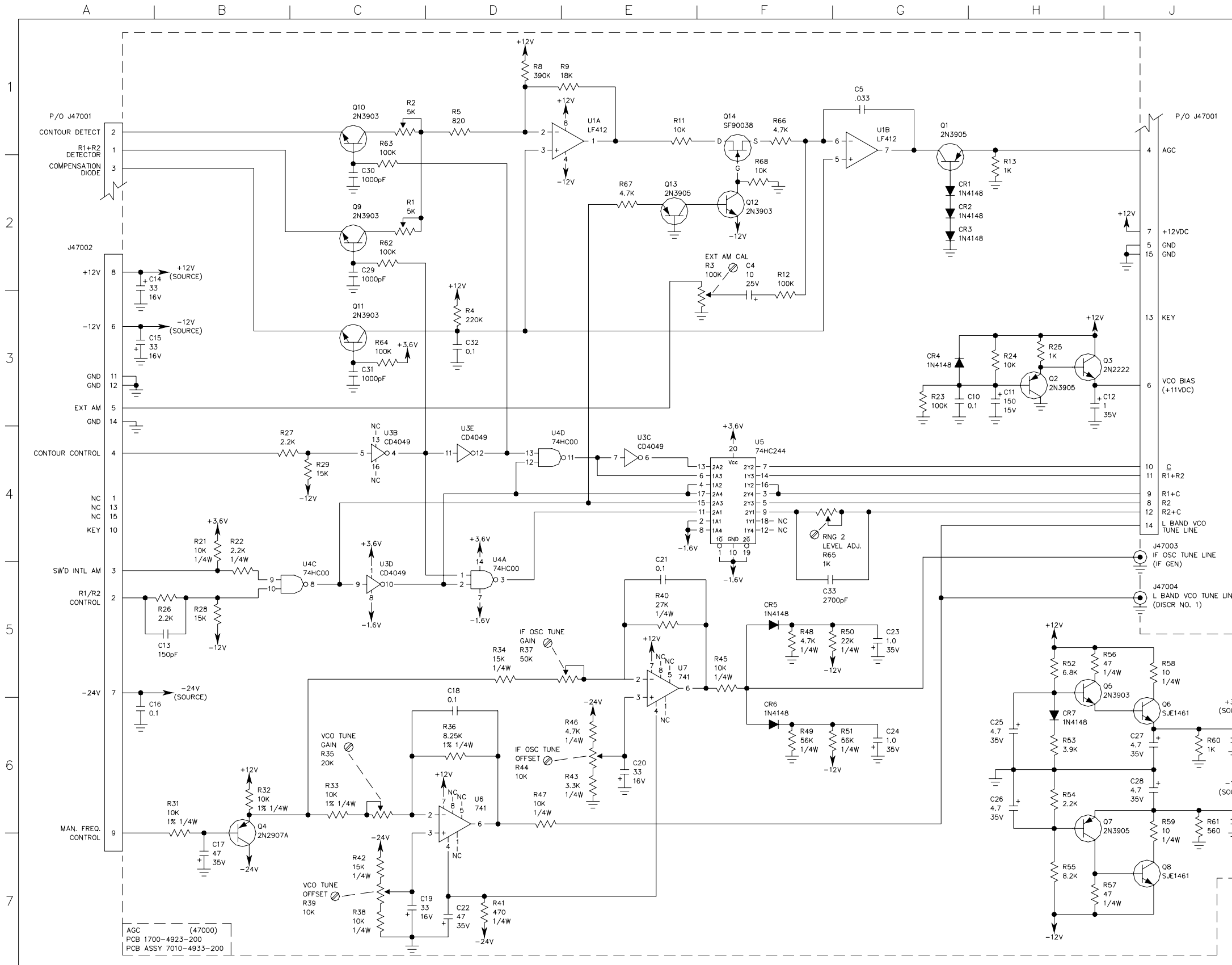

DATE	REV	CHANGE	ILLUS
4/11/90	A	FIRST GENERATION	DAH
7/3/90	B	DELETE C1, CHANGE R65	DAH
			APPROVED
1-28-91	B	DESIGN RELEASE	SL
			APPROVED
2-17-93	B1	PROD. REL. PER ECN #15488	J.I.M. SL

- NOTES:
(UNLESS OTHERWISE SPECIFIED)
1. ALL REFERENCE NUMBERS CARRY AN ASSIGNED DESIGNATOR SERIES.
THIS SCHEMATIC CARRIES SERIES: 47000
 2. ALL RESISTORS ARE 5% 1/8W.
 3. ALL RESISTANCE IS EXPRESSED IN OHMS.
ALL CAPACITANCE IS EXPRESSED IN MICRO FARADS.
 4. HIGHEST REFERENCE DESIGNATIONS.
C35, CR7, J47004, Q14, R68, U7.
 5. REFERENCE DESIGNATIONS NOT USED.
C1-C3, C6-C9, R6, R7, R10, R14-R20, R30, U2.
 6. IC FUNCTIONS NOT USED:

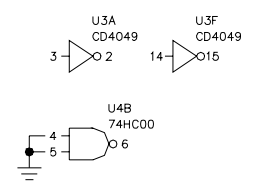

AGC (47000)
PCB 1700-4923-200
PCB ASSY 7010-4933-200

DRAWN		DATE		TITLE	
D.HAYNES	4-11-90	CIRCUIT SCHEMATIC			
L.GREENBANK	1-28-91	AGC			
J.SCHMIDT	1-28-91	SCALE:	DO NOT SCALE	FSCM 51190	SHEET 1 OF 1

Subject to Export Control, see Cover Page for details.

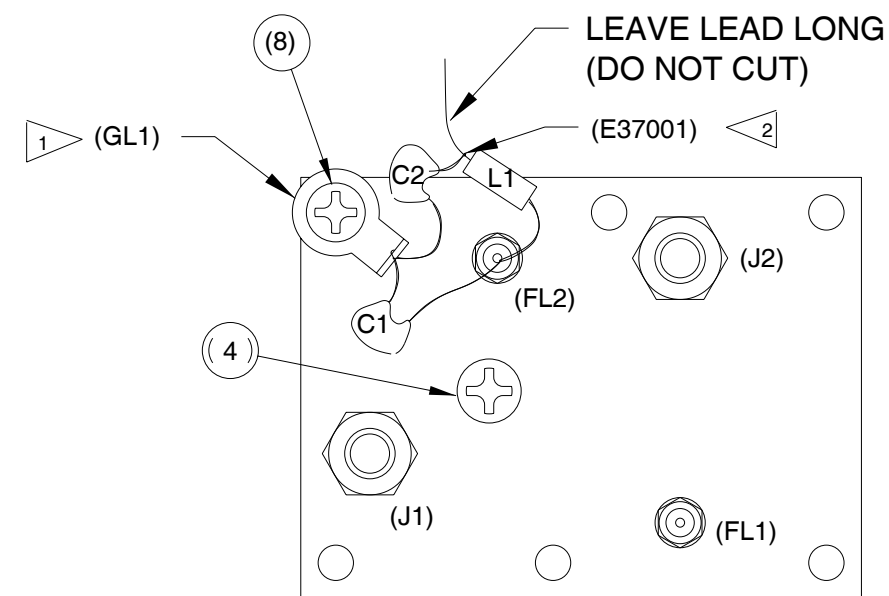
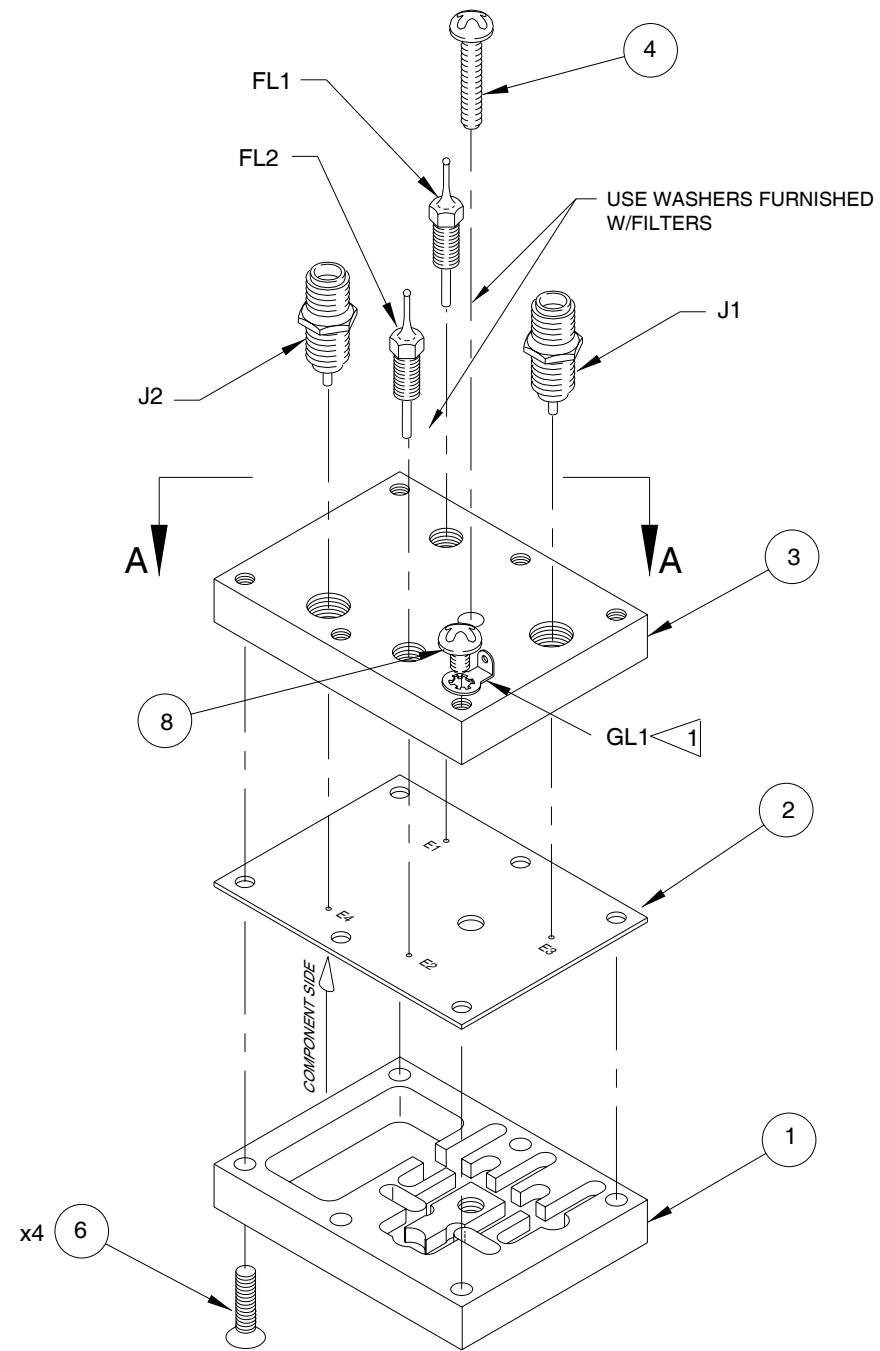

DETAIL A-A
ROTATED 180°

1 Rev. K reference designator was 7.
2 Added on Rev. K1

49409K1

MECH ASSY, MAIN DIODE SWITCH
7005-4940-900-K1

Subject to Export Control, see Cover Page for details.

DATE	REV	CHANGE	BY	CHKD	APVD
		REDRWN TO NEW FORMAT			
10/28/98	C9	INC RC 18350	REH	RLD	MLB
07/02/01	D	INC 19553	REH	CJM	TCN
7-22-04	E	INC 20245	RLA		RC

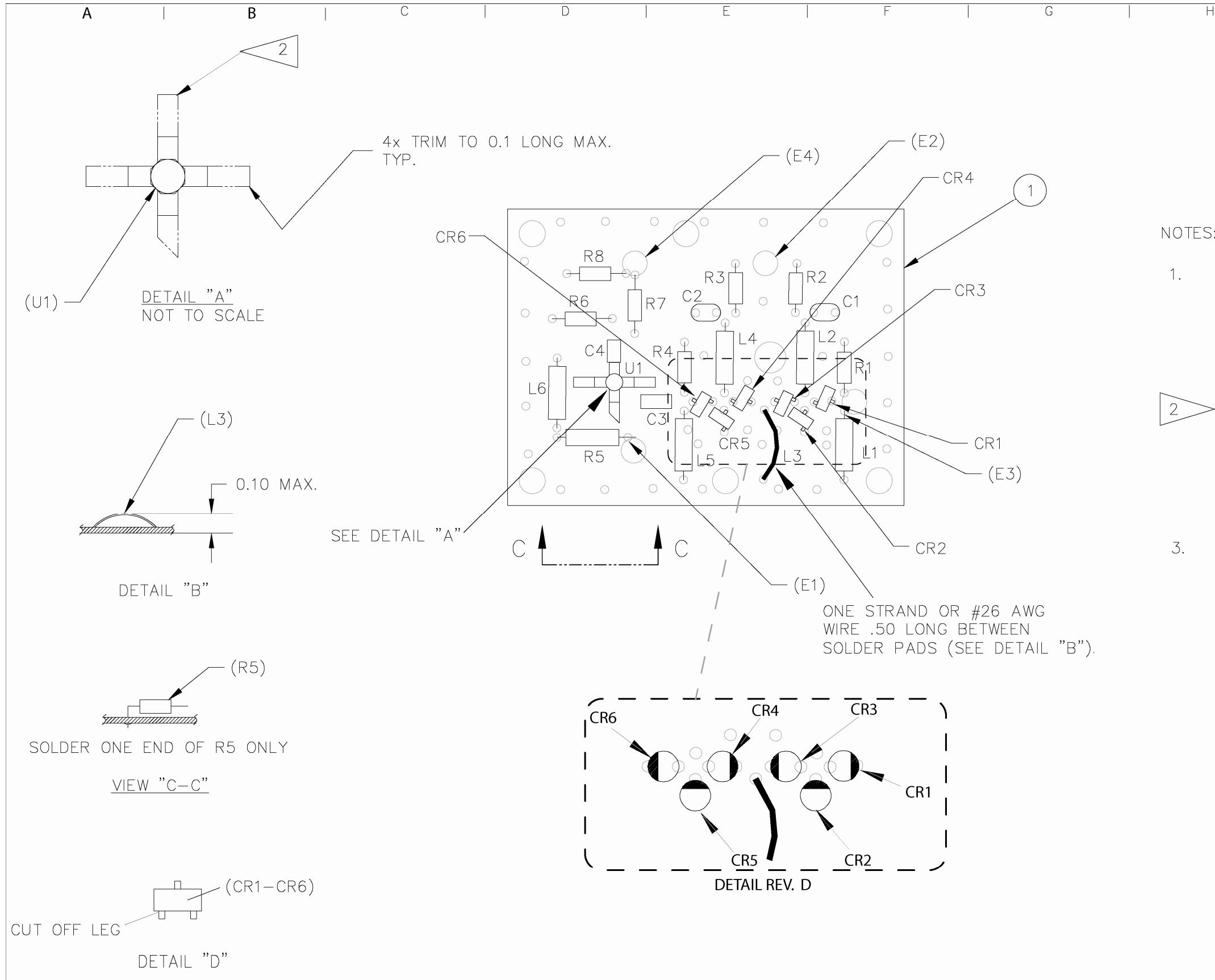

NOTES:

1. BASIC REFERENCE DESIGNATORS SHOWN, FOR COMPLETE DESIGNATOR PREFIXES REFER TO PRODUCT STRUCTURE, AND SYSTEM INTERCONNECT FOR APPLICATIONS WHERE USED.
2. REFER TO SPECIAL SOLDERING INSTRUCTIONS. THIS PART IS HEAT SENSITIVE. APPLY HEAT (250°C, 482°F) FOR LESS THAN 2 SECONDS PER LEAD TO AVOID DEGRADATION. SOLDER ENTIRE LEAD UP TO BODY OF PART.
3. CUT OFF ONE LEG OF CR1-CR6 AS SHOWN IN DETAIL "D". USE TF-1281 TO ALIGN AND INSTALL CR1-CR6.

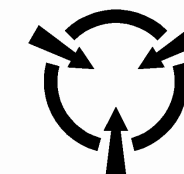

CAUTION:
CONTAINS PARTS AND ASSEMBLIES SUSCEPTIBLE TO DAMAGE BY ELECTROSTATIC DISCHARGE (ESD).

THIRD ANGLE PROJECTION	ALL DIMENSIONS IN INCHES UNLESS OTHERWISE SPECIFIED DO NOT SCALE PRINT / IF IN DOUBT ASK	DRAWING STANDARD TO IFR EWS-140
THIS DRAWING PROVIDES THE MINIMUM LEVEL OF GRAPHIC DETAILS AND SPECIFICATIONS REQUIRED TO ACCURATELY DEFINE THIS LEVEL OF FABRICATED PRODUCT ONLY. REFER TO DETAIL DRAWINGS AND SPECIFICATIONS FOR ACCURATE CONFIGURATION OF LOWER LEVEL PARTS AND SUB-ASSEMBLIES USED HEREIN.		
10200 WEST YORK STREET WICHITA, KANSAS 67215		PROPRIETARY AND CONFIDENTIAL PROPERTY OF IFR AMERICAS DO NOT DISCLOSE, REPRODUCE, OR PUBLISH WITHOUT IFR APPROVAL
DRAWN A. OSBURN	DATE 10/10/84	TITLE PC BOARD ASSY, MAIN DIODE SWITCH
CHECKED WB	DATE 10/12/84	DWG NO. 7010-4930-000
APPROVED B. YOUNG	DATE 10/18/84	REV. E
049300D0.DWG		CAGE 51190 SHEET 1 OF 1

DATE	REV	CHANGE	BY	CHKD	APVD
10 OCT. 84	B	PRODUCTION REL 6490			VH
2-8-85	C	INC ECN 6678	MTH		VH
10-1-85	C1	INC RC 7744	SLR		VH
10-29-85	C2	INC RC 7831	DAH		VH
12-19-85	C3	INC RC 8045	DAH		VH
1-4-86	C4	INC RC 8168	JS		DAH
1-4-86	C5	INC RC 8134	DAH		OJ
11-10-87	C6	INC ECN 10457A	RB		VLH
11-9-88	C7	INC ECN 11434	PL		BP
9-26-90	C8	INC RC 13661	BP		TE
7-13-01	D	INC 19553			TCN
7-22-04	E	INC 20245	RLA		RC

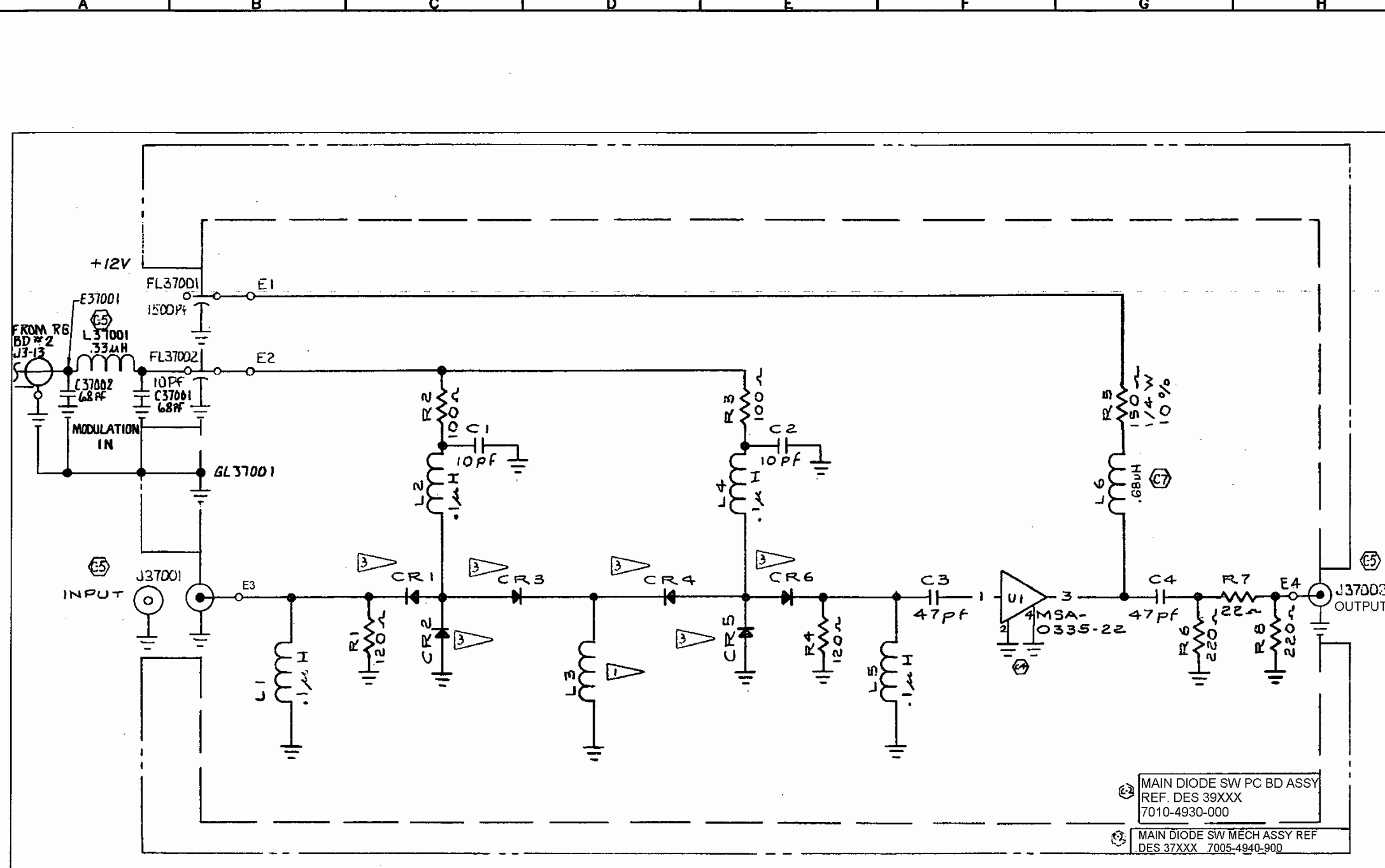

- STANDARDS:
- BASIC REFERENCE DESIGNATORS SHOWN, FOR COMPLETE DESIGNATOR PREFIXES REFER TO PRODUCT STRUCTURE, AND SYSTEM INTERCONNECT FOR APPLICATIONS WHERE USED.
- NOTES:
- L3 IS A SINGLE STRAND FROM A 26GA STRANDED WIRE, .50 LONG BETWEEN SOLDER JOINTS.
 - LAST REF DES USED:
C39004, J37002, R39008, CR39006, L39006, U39001, FL37002
 - CR1 THRU CR6 ARE SUBJECT TO DAMAGE DUE TO ELECTROSTATIC CHARGES. PROPER PRECAUTIONS MUST BE USED WHEN HANDLING.

MAIN DIODE SW PC BD ASSY
REF. DES 39XXX
7010-4930-000

MAIN DIODE SW MECH ASSY REF
DES 37XXX 7005-4940-900

THIRD ANGLE PROJECTION	ALL DIMENSIONS IN INCHES UNLESS OTHERWISE SPECIFIED DO NOT SCALE PRINT / IF IN DOUBT, ASK	DRAWING STANDARD TO IFR EWS-140
THIS DRAWING PROVIDES THE MINIMUM LEVEL OF GRAPHIC DETAILS AND SPECIFICATIONS REQUIRED TO ACCURATELY DEFINE THIS LEVEL OF FABRICATED PRODUCT ONLY. REFER TO DETAIL DRAWINGS AND SPECIFICATIONS FOR ACCURATE CONFIGURATION OF LOWER LEVEL PARTS AND SUB-ASSEMBLIES USED HEREIN.		
PROPRIETARY AND CONFIDENTIAL PROPERTY OF IFR SYSTEMS, INC. DO NOT DISCLOSE, REPRODUCE, OR PUBLISH WITHOUT IFR APPROVAL.		
10200 WEST YORK STREET WICHITA, KANSAS 67215		
TITLE CIRCUIT SCHEMATIC MAIN DIODE SWITCH		
DRAWN A.OSBURN	DATE 10 OCT. 84	DWG NO 0000-4910-000
CHECKED WB 10-12-84	DATE 10-12-84	REV E
APPROVED B.YOUNG 10-18-84	DATE 10-18-84	SHEET 1 OF 1

REVISIONS				
REV	DATE	DESCRIPTION	DRAWN BY	OK APPR/DATE
A	2-5-92	Production Rel. Per ECN 14369	B. Arnett	BP 2/5/92

CUSTOM ITEM DRAWING

OK & APPROV FOR REV A LEVEL		OK & APPROV REV A LEVEL		 IFR SYSTEMS, INC	
NAME	DATE	NAME	DATE		
DRAWN BY	DATE	SCDC	DATE		
MECH CK	DATE	APPROVED	DATE		
PURCH CK1	DATE	PURCH CK2	DATE		
ELEC CK				TITLE X BAND FRONT END	
Q A CK					
FSCM 51190		SCALE NONE	REV A	DRAWING NO 2517-2511-700	SHEET 1 OF 6

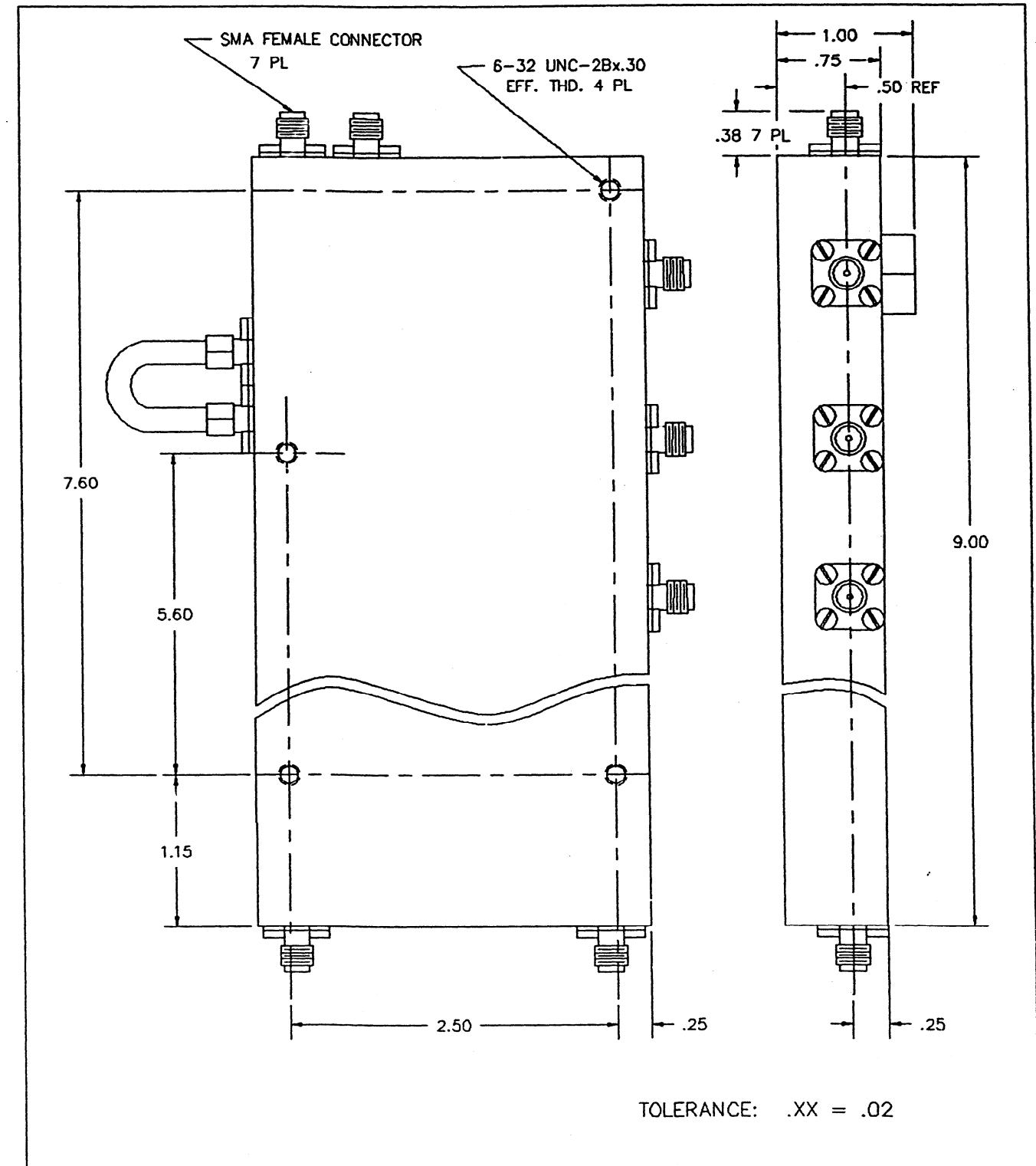

CUSTOM ITEM DRAWING

IFR SYSTEMS, INC	FSCM 51190	REV A	DRAWING NO 2517-2511-700	SHEET 2 OF 6
------------------	------------	----------	-----------------------------	-----------------

I. PORT 26			
SIGNAL GENERATOR INPUT			
A. PORT 26 - PORT 24 INSERTION LOSS		21.0 dB MAXIMUM	
B. PORT 26 - PORT 25 INSERTION LOSS		16.0 dB MAXIMUM	
C. FREQUENCY SENSITIVITY		SENSITIVITY	
L-BAND INPUT AT J-26 (MHz)	X-BAND OUTPUT AT J-24 (GHz)	_____ (dB) _____	
1045 - 1250	9.295 - 9.500	±.5	
II. PORT 27			
XMTR SAMPLE OUT			
A. SATURATED PEAK POWER AT PORT 27 DUE TO 5 W TO 120 W PEAK PULSES AT PORT 24		-9 dBm MINIMUM	
III. PORT 28			
LOCAL OSCILLATOR INPUT			
A. POWER		+7 dBm ±3 dB	
B. FREQUENCY		8.250 GHz	
C. PORT 28 VSWR		1.3:1 MAXIMUM	
IV. PORT 25			
AUXILIARY RF OUTPUT			
A. VSWR (9.295 - 9.500 GHz)		1.5:1 MAXIMUM	
B. RF INPUT POWER (AT PRF - 400 Hz, PULSE WIDTH = 3.5 μS)		250 W PEAK MAXIMUM WITH NO DAMAGE TO UNIT	
V. PORT 24			
A. RF INPUT POWER (AT PRF - 400 Hz, PULSE WIDTH = 3.5 μS)		250 W PEAK MAXIMUM WITH NO DAMAGE TO UNIT	
B. VSWR		1.4:1 MAXIMUM	
C. PORT 26 - PORT 24 1 dB COMPRESSION POINT		-24 dBm MINIMUM	
VI. PORT 23			
SPECTRUM ANALYZER OUTPUT			
A. INSERTION LOSS PORT 24 - PORT 23		62 ±6 dB	
B. PORT 23 TO DETECTOR REVERSE ISOLATION*		14 dB MINIMUM	
*NOTE: PORT WILL BE OPEN EXCEPT WHEN TEST SET OPERATOR IS USING A SPECTRUM ANALYZER. AN OPEN CIRCUIT SHOULD NOT INFLUENCE SIGNAL TO THE DETECTOR			
CUSTOM ITEM DRAWING			
IFR SYSTEMS, INC	FSCM 51190	REV A	DRAWING NO 2517-2511-700
		SHEET 5 OF 6	

V11. PORT 22			
DETECTOR OUTPUT			
A. PORT 24 - PORT 22 DETECTOR FLATNESS		FLAT WITHIN ±0.3 dB AT 9.295 - 9.500 GHz	
B. LINEARITY PORT 24 TO PORT 22 AT J 24		±0.3 dB FROM 10 W TO 120 W	
C. PORT 22 OUTPUT VOLTAGE		1.1 TO 2.5 V WITH 20 W AT J 24	
V111. MISCELLANEOUS			
A. L. O. FEEDTHRU AT J 24		-38 dBm MAXIMUM	
B. SPURIOUS OUTPUTS AT PORT 24 DUE TO -4 dBm SIGNAL AT PORT 26		-30 dBc MAXIMUM	
1. PASSBAND IS 9.295 - 9.500 GHz. STOPBAND IS SUFFICIENT TO ATTENUATE L.O. FEEDTHRU AND THE IMAGE FREQUENCIES (7.0 TO 7.205 GHz)			
C. L-BAND CIRCULATOR ISOLATION PORT 26 - PORT 27 (1045 - 1250 MHz)		12 dB MINIMUM	
D. CONNECTORS		SMA FEMALE	
E. TEMPERATURE RANGE		0°C TO 50°C	
F. L-BAND RFI ISOLATION, ANTENNA TO J24		-90 dBc	
NOTE: 1. MANUFACTURER TO PROVIDE A COPY OF THEIR TEST PROCEEDURE TO IFR. 2. MANUFACTURER TO INCLUDE A COPY OF THE PRODUCTION TEST ACCEPTANCE DATA WITH EACH UNIT			
CUSTOM ITEM DRAWING			
IFR SYSTEMS, INC	FSCM 51190	REV A	DRAWING NO 2517-2511-700
		SHEET 6 OF 6	

SPECIFICATIONS

Frequency:	8.25GHz
Frequency Stability:	±20ppm
Power Output:	+13dBm min.
Single Side Band Phase Noise:	
Offset	Level
10Hz	-48dBc/Hz
100Hz	-78dBc/Hz
1KHz	-98dBc/Hz
10KHz	-110dBc/Hz
100KHz	-110dBc/Hz
1MHz	-130dBc/Hz
Spurious:	<-80dBc
Harmonics:	<-55dBc
Source VSWR:	2.0:1 Max from 7 to 9.4 GHz
Load VSWR:	3.0:1 Max
Isolation from External Radiation:	90dB Min
D.C. Supply:	+12V @ 425mA
Operating Temperature range:	0° to 75° C
Physical Dimensions:	See attached drawing (option B)
Output Connector:	SMA Female, captivated connector
	Note: All SMA connectors must be captivated to support the Isolation requirement. The connector body must be electrically free from voids due to tooling holes, etc.

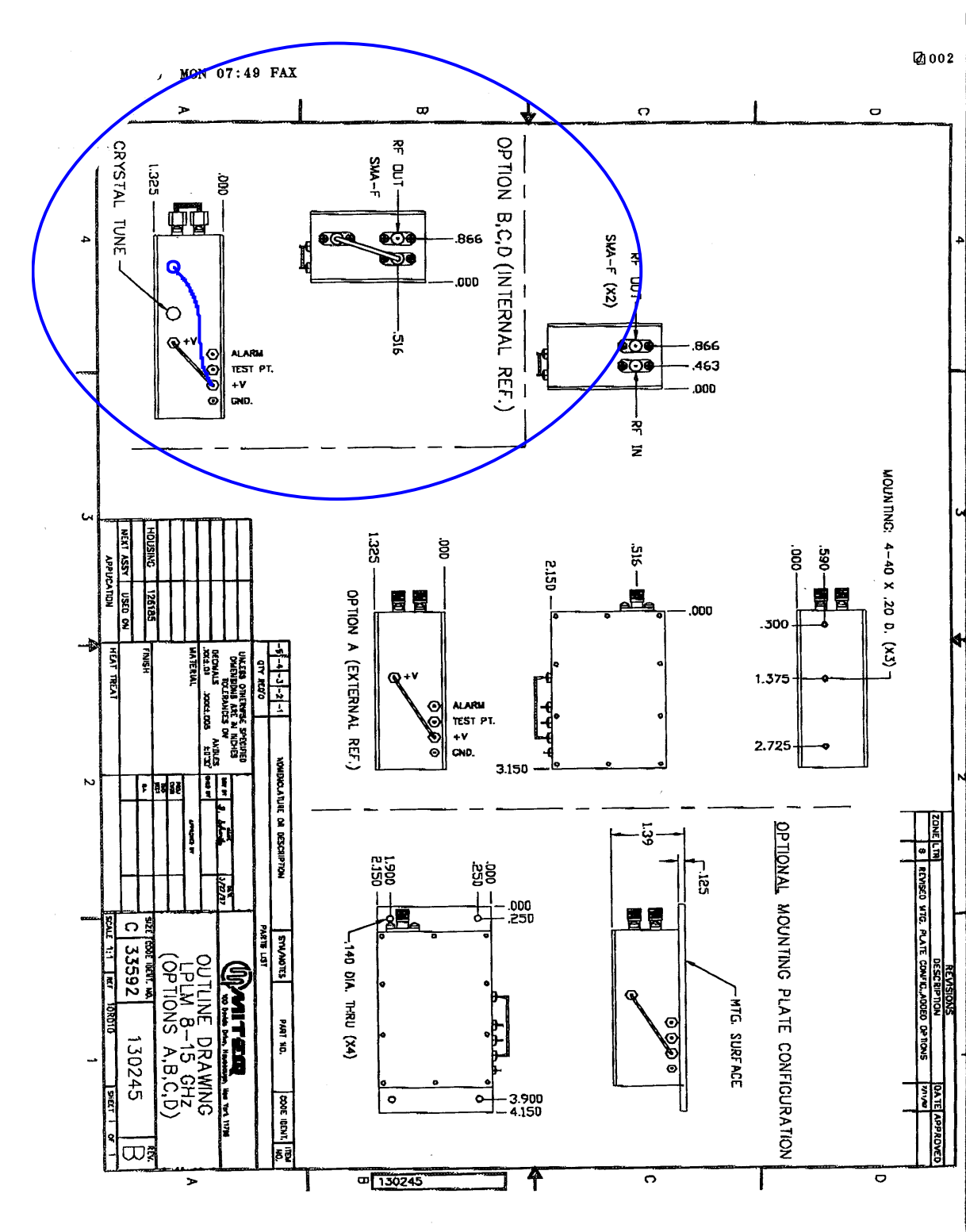

OSC, PL, 8.25GHZ, +12V, +13DBM

5850-0000-067

SPECIFICATIONS

Frequency:	8.25GHz
Frequency Stability:	±20ppm
Power Output:	+13dBm min.
Single Side Band Phase Noise:	
Offset	Level
10Hz	-65dBc/Hz
100Hz	-78dBc/Hz
1KHz	-108dBc/Hz
10KHz	-115dBc/Hz
100KHz	-115dBc/Hz
1MHz	-135dBc/Hz
Spurious:	<-70dBc
Harmonics:	<-50dBc
Load VSWR:	1.5:1 Max
D.C. Supply:	+12V @ 300mA
Operating Temperature range:	-10° to +60° C
Physical Dimensions:	See attached drawing
Output Connector:	SMA Female, captivated connector
	Note: All SMA connectors must be captivated to support the Isolation requirement. The connector body must be electrically free from voids due to tooling holes, etc.

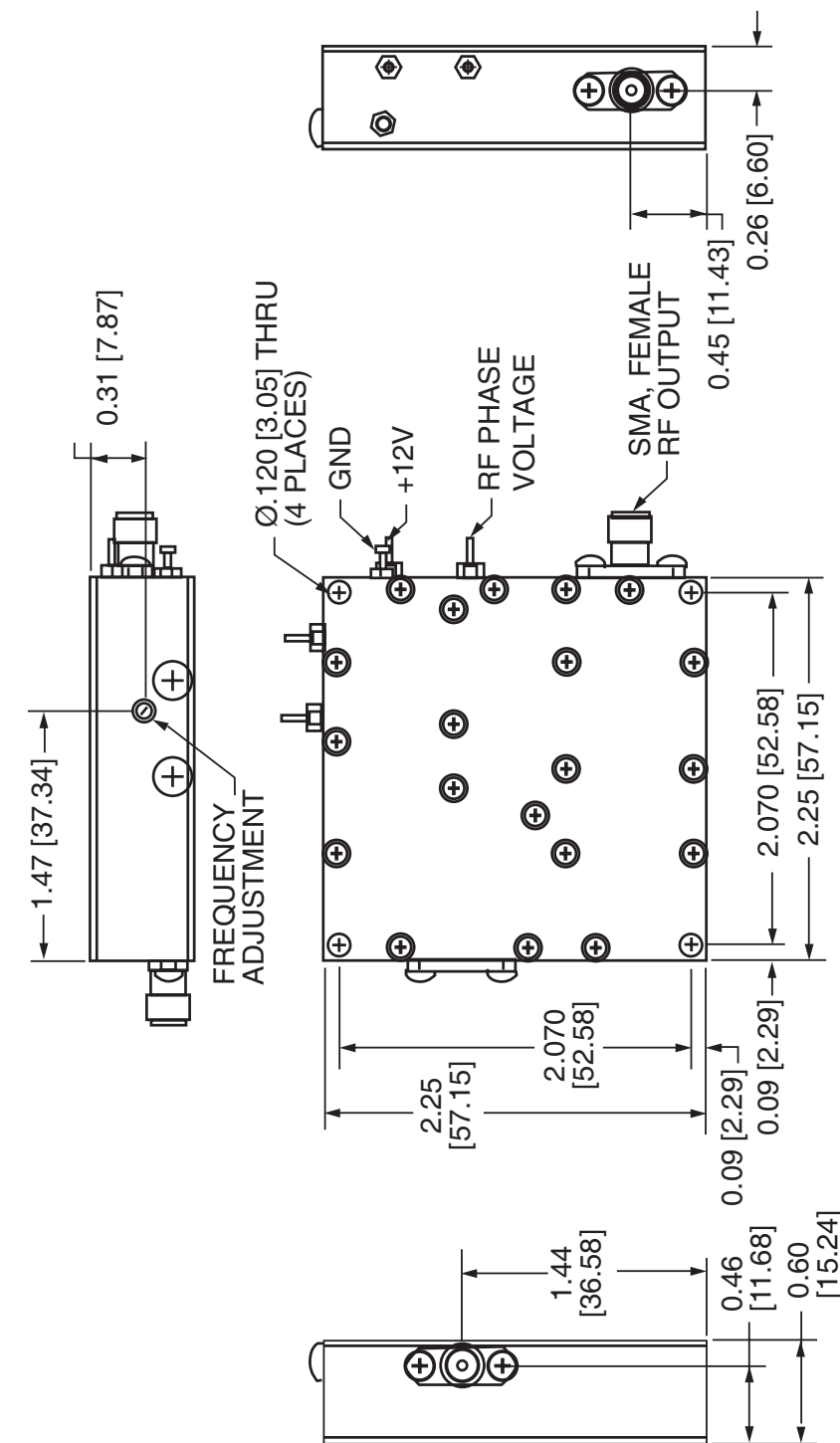

OSC, PL, 8.25GHZ, +12V

5850-0000-069

DATE	REV	CHANGE	J	BY	CHKD	APVD
		DRAWN TO NEW FORMAT				
		FOR PREV REV SEE HISTORY				
12/23/99	D	INC ECN 18659		REH	CJM	TCN
02/09/00	D1	INC RC 18928		REH	CJM	TCN

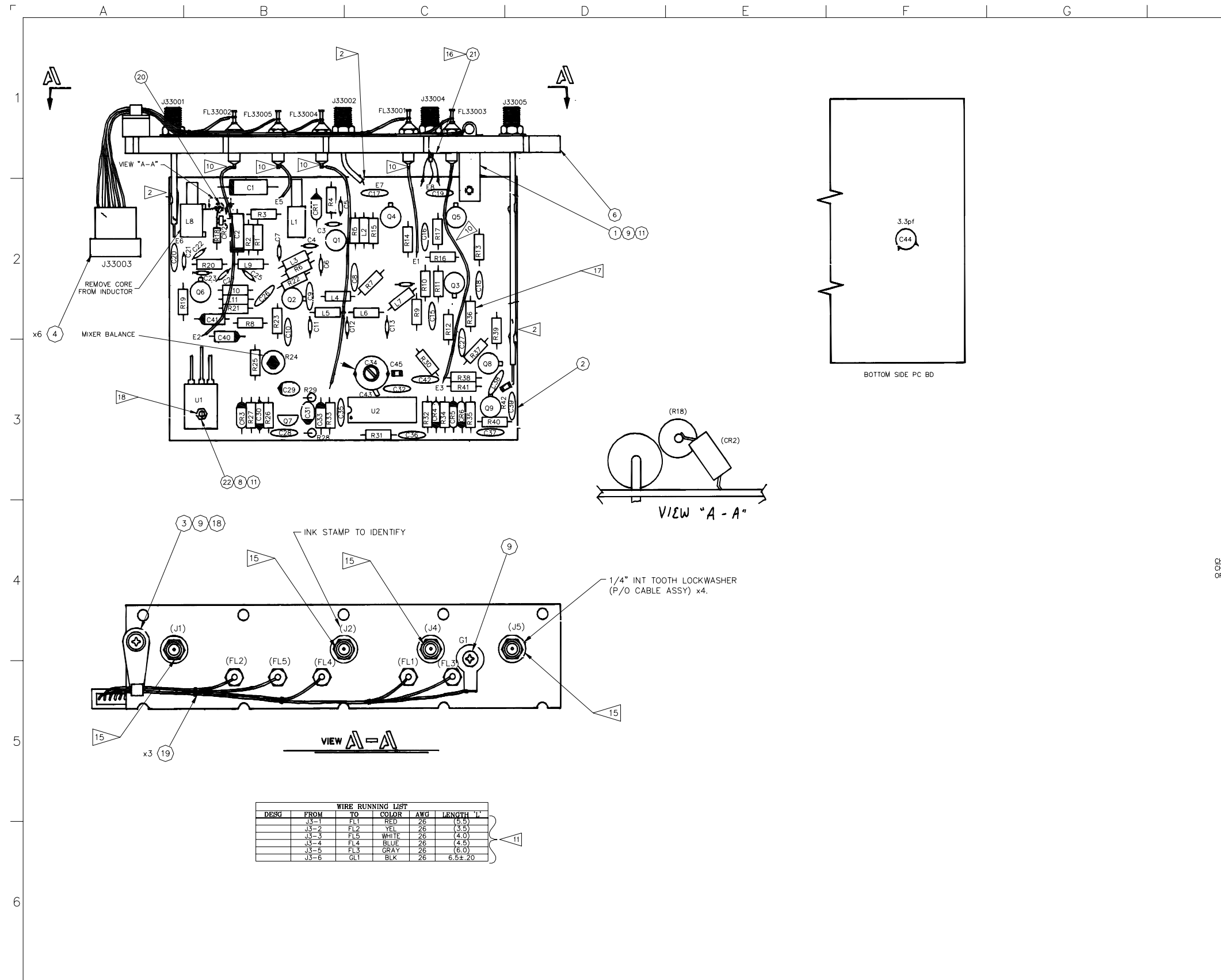

NOTES:

- NOTE NOT USED.
- ATTACH RIGID COAX ASS'YS TO PC BD AS FOLLOWS:
 - LIGHTLY SAND OUTER JACKET OF COAX WITH 400 GRIT SANDPAPER TO REMOVE OXIDATION AND OTHER CONTAMINATES.
 - SOLDER COAX JACKET TO PC BD USING NO MORE THAN ABOUT A 40W SOLDERING IRON AND HEAT COAX FOR AS SHORT A PERIOD OF TIME AS POSSIBLE. LIQUID FLUX MAY BE USED IF NECESSARY. (DO NOT USE SOLDERING PASTE.)
- ALL RESISTORS ARE 1/4W, 5% TOL., UNLESS OTHERWISE SPECIFIED.
- ALL CAPACITORS ARE IN μ UNLESS OTHERWISE SPECIFIED.
- COMPONENT LEADS MAY EXTEND .04-.06 BEYOND BOTTOM OF BOARD AFTER SOLDERING.
- MAX HT OF COMPONENTS TO BE .60 FROM COMPONENTS SIDE OF BOARD.
- NOTE NOT USED.
- NOTE NOT USED.
- BASIC REFERENCE DESIGNATORS SHOWN, FOR COMPLETE DESIGNATOR PREFIXES REFER TO PRODUCT STRUCTURE, AND SYSTEM INTERCONNECT FOR APPLICATIONS WHERE USED.
- ALL ANNOTATED WIRE LENGTHS TO BE 26 ω g.
- ALL ANNOTATED WIRE LENGTHS TO BE 26 ω g TEFLON COVERED WIRE.
- C43 CONNECTS FROM PIN 13 OF U2 TO GND.
- LAST REF # USED: J3305, C45, U2, L1, CR6, R42, Q9, FL5, GL1.
- TORQUE TO 15 INCH LBS., J1, J2, J4, J5.
- SHAPE GROUND STRAP FROM .6" 22GA. BUSS WIRE. DPN 1050-0000-073, ITEM #21 SOLDER 3 PLCS.
- R36 IS SELECTED AT TEST (SAT) NOMINAL VALUE 8.2K, RANGE VALUE 4.7K-12K.
- INSTALL ITEM 22 FROM BOTTOM OF BOARD.

CHECKOUT PROCEDURE

CHECK FOR PROPER COAX CONTINUITY AFTER COMPLETION OF THE BOARD AS FOLLOWS:

- USE A "MIDLAND" VOM MODEL 23-107 OR EQUIVALENT.
- SELECT THE "R X 1" SCALE SETTING ON THE METER & CHECK TO SEE THAT THE METER IS PROPERLY ZEROED AT BOTH ENDS.
- PLACE THE POSITIVE (RED) LEAD ON THE CENTER CONDUCTOR OF THE CONNECTOR & THE COMMON (BLACK) LEAD ON THE CENTER CONDUCTOR OF THE COAX WHERE IT ENTERS THE BOARD. THIS SHOULD OBTAIN A READING OF 0 OHMS ON BOTH COAX CABLES.
- PLACE THE POSITIVE (RED) LEAD ON THE CENTER CONDUCTOR OF THE CONNECTOR & THE COMMON (BLACK) LEAD ON THE LARGE COPPER AREA ON TOP OF THE BOARD (GROUND). THIS SHOULD OBTAIN NO READING AT ALL ON BOTH COAX CABLES.



CAUTION:
CONTAINS PARTS AND ASSEMBLIES
SUSCEPTIBLE TO DAMAGE BY
ELECTROSTATIC DISCHARGE (ESD).

THIRD ANGLE PROJECTION	ALL DIMENSIONS IN INCHES UNLESS OTHERWISE SPECIFIED	DRAWING STANDARD TO IFR EWS-140
THIS DRAWING PROVIDES THE MINIMUM LEVEL OF GRAPHIC DETAILS AND SPECIFICATIONS REQUIRED TO ACCURATELY DEFINE THIS LEVEL OF FABRICATED PRODUCT ONLY. REFER TO DETAIL DRAWINGS AND SPECIFICATIONS FOR ACCURATE CONFIGURATION OF LOWER LEVEL PARTS AND SUB-ASSEMBLIES USED HEREIN.		
PROPRIETARY AND CONFIDENTIAL PROPERTY OF IFR AMERICAS DO NOT DISCLOSE, REPRODUCE, OR PUBLISH WITHOUT IFR APPROVAL		
10200 WEST YORK STREET WICHITA, KANSAS 67215	TITLE PCB ASSY, IF MARKER/OSCILLATOR, RD-301	
DRAWN R.HARRIS	DATE 11/18/99	DWG NO 7010-4931-400
CHECKED WB	DATE 1/11/85	REV D1
APPROVED B.YOUNG	DATE 1/14/85	049314D1.DWG
	CAGE 51190	SHEET 1 OF 1

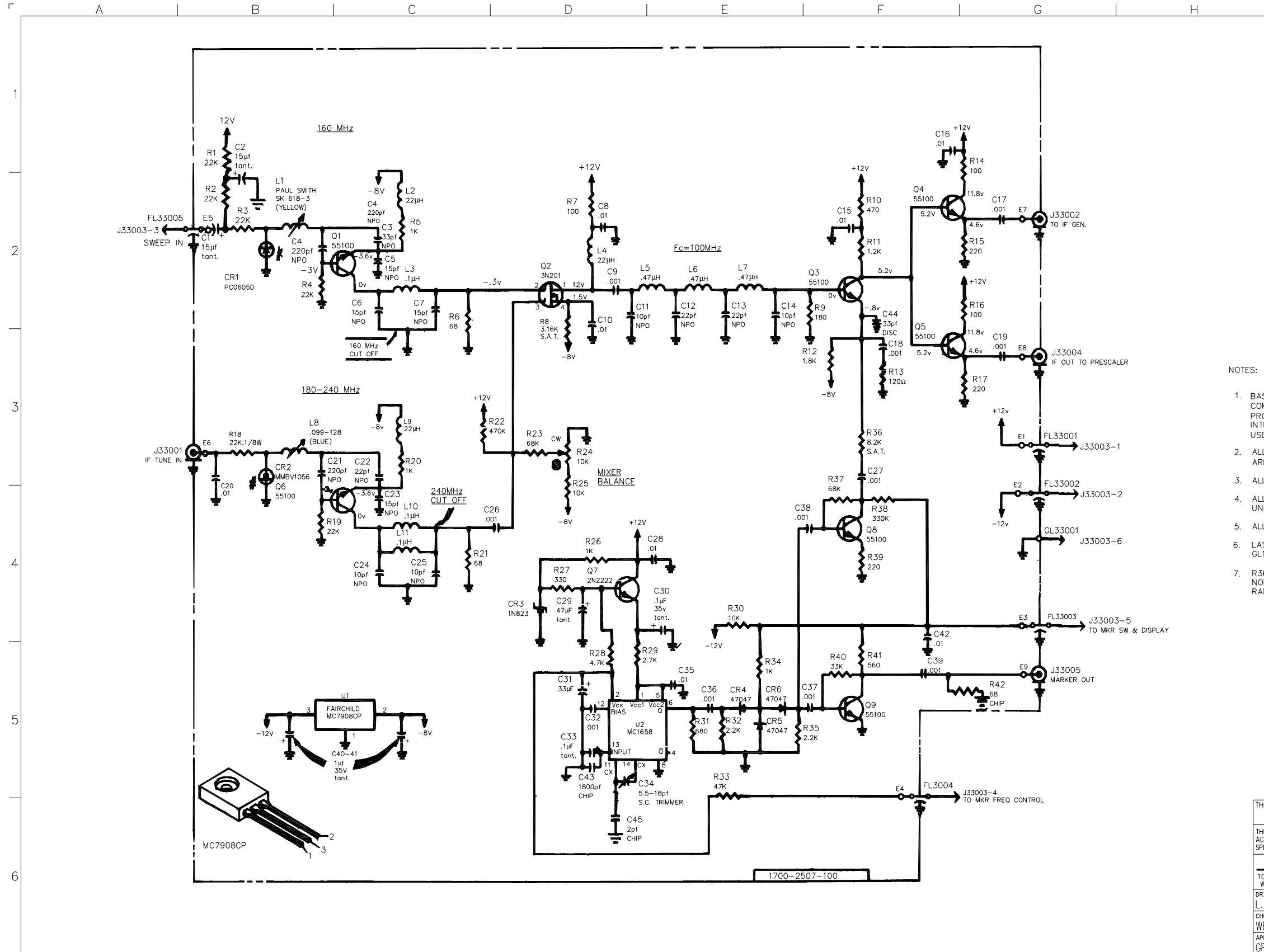

DATE	REV	CHANGE	BY	CHKD	APVD
02/01/85	A	PRODUCTION RELEASE	L.A.		VA
01/10/86	A1	INC RC 8097 & 8212	DAH		JS
04/01/86	A2	INC ECN 8464	DAH		VLH
02/19/90	A3	INC ECN 13134	AO		BP
09/13/90	A4	INC ECN 13637	AO		BP
04/03/96	B	INC ECN 16793	BP		BM
11/29/99	C	INC ECN 18659	REH	SCP	TN

NOTES:

1. BASIC REFERENCE DESIGNATORS SHOWN, FOR COMPLETE DESIGNATOR PREFIXES REFER TO PRODUCT STRUCTURE, AND SYSTEM INTERCONNECT FOR APPLICATIONS WHERE USED.
2. ALL RESISTORS ARE 1/4W, 5% PRECISION RESISTORS (1% ARE DESIGNATED BY AN ASTERISK (*)).
3. ALL RESISTANCE IS EXPRESSED IN OHMS.
4. ALL CAPACITANCE IS EXPRESSED IN MICROFARADS, UNLESS OTHERWISE SPECIFIED.
5. ALL INDUCTANCE IS EXPRESSED IN MICROHENRYS.
6. LAST REFERENCE NUMBER USED: Q9,U2,CR6,L11,R42,C45, GL1,FL5,J5.
7. R36 IS A SELECTED AT TEST (SAT) COMPONENT. NOMINAL VALUE IS 8.2K. RANGE VALUE IS 4.7K TO 12K.

THIRD ANGLE PROJECTION	ALL DIMENSIONS IN INCHES UNLESS OTHERWISE SPECIFIED	DRAWING STANDARD TO IFR EWS-140
------------------------	---	---------------------------------

THIS DRAWING PROVIDES THE MINIMUM LEVEL OF GRAPHIC DETAILS AND SPECIFICATIONS REQUIRED TO ACCURATELY DEFINE THIS LEVEL OF FABRICATED PRODUCT ONLY. REFER TO DETAIL DRAWINGS AND SPECIFICATIONS FOR ACCURATE CONFIGURATION OF LOWER LEVEL PARTS AND SUB-ASSEMBLIES USED HEREIN.

Americas PROPRIETARY AND CONFIDENTIAL PROPERTY OF IFR AMERICAS DO NOT DISCLOSE, REPRODUCE, OR PUBLISH WITHOUT IFR APPROVAL

10200 WEST YORK STREET
WICHITA, KANSAS 67215

TITLE: SCHEMATIC, IF MKR/OSC

DRAWN: L.A. MEIS 01/23/85
DATE: 01/23/85
CHECKED: WB 01/29/85
DATE: 01/29/85
APPROVED: GREENBANK 01/29/85

DWG NO: 0000-4911-400
REV: C
CAGE 51190 SHEET 1 OF 1

DATE	REV	CHANGE	BY	CHKD	APVD
		DRAWN TO NEW FORMAT			
		SEE HIST FOR PREV REV.			
3/15/00	B	INC ECN 18886	REH	SLS	TCN

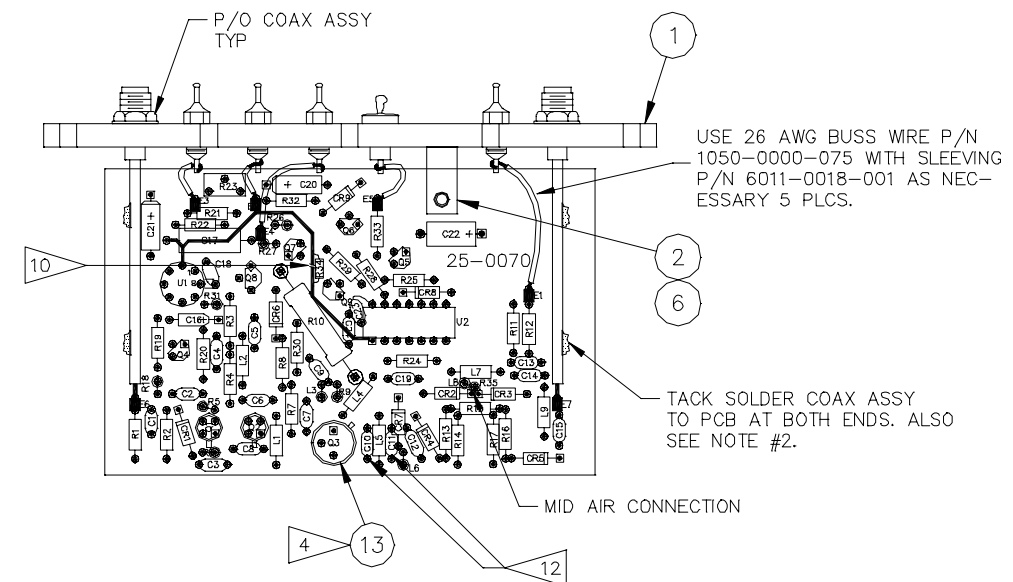
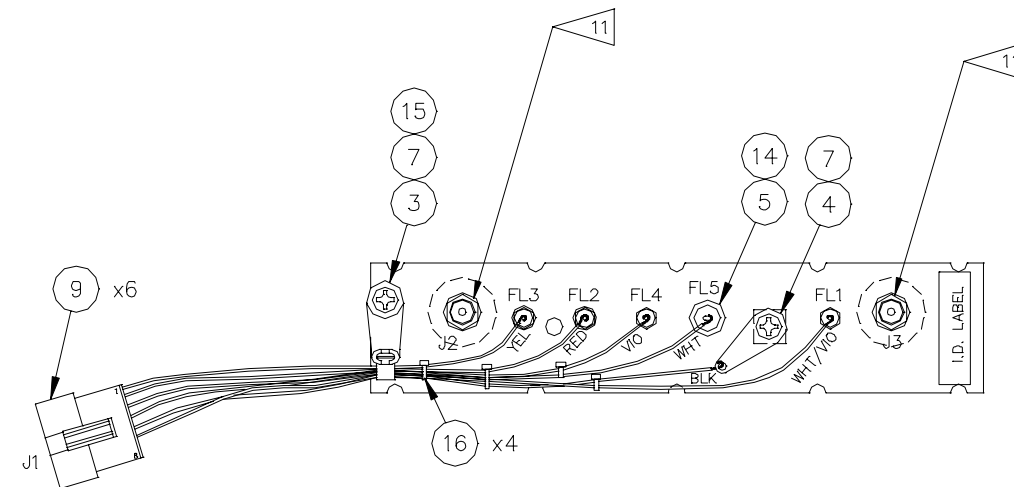

CHECKOUT PROCEDURE

CHECK FOR PROPER COAX CONTINUITY AFTER COMPLETION OF THE BOARDS AS FOLLOWS:

- USE A "MIDLAND" VOM MODEL 23-107 OR SIMILAR.
- SELECT THE "Rx1" SETTING ON THE METER & CHECK TO SEE THAT THE METER IS PROPERLY ZEROED ON BOTH ENDS OF THE SCALE.
- PLACE THE + (RED) LEAD ON THE CENTER CONDUCTOR OF THE CONNECTOR & THE COMMON (BLACK) LEAD ON THE COAX CENTER CONDUCTOR WHERE IT ENTERS THE PC BD. THIS SHOULD OBTAIN A READING OF 0Ω W/BOTH COAX CABLES.
- PLACE THE +(RED) LEAD ON THE CENTER CONDUCTOR OF THE CONNECTOR & THE COMMON (BLACK) LEAD ON THE LARGE COPPER AREA ON TOP OF THE BD (GND). WITH COAX "B", THIS SHOULD OBTAIN A READING OF $85-115\Omega$. WITH COAX "C", THIS SHOULD OBTAIN NO READING AT ALL.

USE 26 AWG BUSS WIRE P/N 1050-0000-075 WITH SLEEVING P/N 6011-0018-001 AS NECESSARY 5 PLCS.

TACK SOLDER COAX ASSY TO PCB AT BOTH ENDS. ALSO SEE NOTE #2.

WIRE RUNNING LIST				
FROM	TO	COLOR	AWG	LNTH
J1-1	GNDLUG	BLK	26	5.5"
J1-2	FL-4	VIO	26	4.5"
J1-3	FL-3	YEL	26	3.5"
J1-4	FL-2	RED	26	4.0"
J1-5	FL-5	WHT	26	5.0"
J1-6	FL-1	WHT/VIO	26	6.0"
J1-7	NC			
J1-8	NC			

NOTES:

- REFER TO ASSY PROCEDURE #1-34-0100-2 FOR PROPER RIGID COAX ASSY INSTRUCTIONS. INSPECT PER CHECKOUT PROCEDURE LISTED ELSEWHERE ON THIS DWG.
- ATTACH RIGID COAX ASSY'S TO PC BD AS FOLLOWS:
LIGHTLY SAND OUTER JACKET OF COAX W/400 GRIT SANDPAPER TO REMOVE OXIDATION & OTHER CONTAMINATES.

SOLDER COAX JACKET TO PC BD USING NO MORE THAN ABOUT A 40w SOLDERING IRON & HEAT COAX FOR AS SHORT A PERIOD OF TIME AS POSSIBLE. LIQUID FLUX MAY BE USED IF NECESSARY. DO NOT USE SOLDERING PASTE.

- 3 NOT USED
- 4 ANNOTATED PART TO HAVE HEAT SINK (ITEM 13).
- 5 NOT USED.
- 6 ALL RESISTORS ARE 1/4W, 5% UNLESS OTHERWISE NOTED.
- 7 ALL CAPACITOR VALUES ARE IN μF UNLESS OTHERWISE NOTED.
- 8 LEADS TO EXTEND .040 -.060 BEYOND BTM OF BD AFTER SOLDERING
- 9 MAX HT OF COMPONENTS TO BE .375 FROM COMPONENT SIDE OF BD.
- 10 CUT PATH THEN ADD R34, 10K 1/8W TO PATH.
- 11 TORQUE TO 15 INCH LBS., J2 & J3.
- 12 INVERT CAPS BEFORE INSTALLATION TO PREVENT SHORT TO GND PLANE.

THIRD ANGLE PROJECTION	ALL DIMENSIONS IN INCHES UNLESS OTHERWISE SPECIFIED DO NOT SCALE PRINT / IF IN DOUBT ASK	DRAWING STANDARD TO IFR EWS-140
THIS DRAWING PROVIDES THE MINIMUM LEVEL OF GRAPHIC DETAILS AND SPECIFICATIONS REQUIRED TO ACCURATELY DEFINE THIS LEVEL OF FABRICATED PRODUCT ONLY. REFER TO DETAIL DRAWINGS AND SPECIFICATIONS FOR ACCURATE CONFIGURATION OF LOWER LEVEL PARTS AND SUB-ASSEMBLIES USED HEREIN.		
10200 WEST YORK STREET WICHITA, KANSAS 67215		PROPRIETARY AND CONFIDENTIAL PROPERTY OF IFR AMERICAS DO NOT DISCLOSE, REPRODUCE, OR PUBLISH WITHOUT IFR APPROVAL
DRAWN RW&LM DATE 03/10/00	DATE 6/21/00	TITLE PCB ASSY, IF GEN PWR AMP
CHECKED VLH DATE 03/25/85	DATE 6/21/00	DWG NO 7010-4931-500
APPROVED T. EVERHART DATE 03/26/85	DATE 6/21/00	REV B
049315B0.DWG		CAGE 51190 SHEET 1 OF 1

DATE	REV	CHANGE	APPD
3-58	A	PRODUCTION RELEASE	VY
5-58	A-2	INC ECN 9450	AO
7-58	A-3	INC ECN 9616	TH

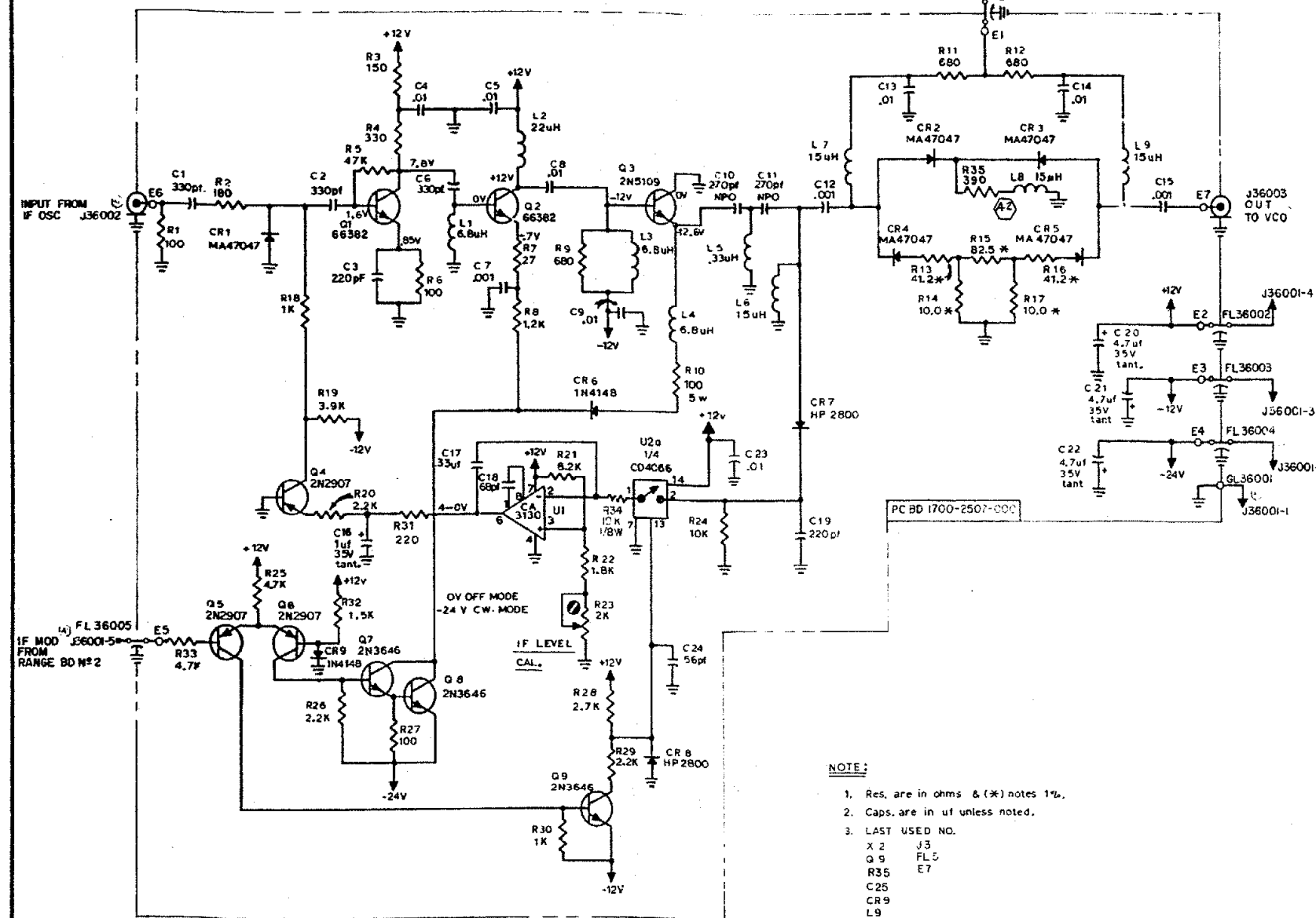

NOTE:

1. Res. are in ohms & (*) notes 1%.
2. Caps. are in uf unless noted.
3. LAST USED NO.
X 2 J3
Q 9 FL5
R35 E7
C25
CR9
L9
4. ALL COMPONENTS HAVE THE REFERENCE DESIGNATOR SERIES 36XXX (i.e. R1=R36001, C12=C36012, etc.).
5. ALL FEEDTHRU CAPACITORS ARE TO BE 1500pf UNLESS OTHERWISE SPECIFIED.
6. REF DES. NOT USED
C25

DRAWN: L. A. Meis, Jr.	DATE: 12-2-58	CR/Job:	TITLE: SCHEMATIC
CHECKED: VY	DATE: 12-2-58		IF GEN POWER AMP
APPROVED: [Signature]	DATE: 12-2-58		RD 301
RELEASED:	DATE:	PART NO. 0000-4911-500	
MODEL: RD 301	SCALE:	SHEET 1 OF 1	REV: A 3

Subject to Export Control, see Cover Page for details.

DATE	REV	CHANGE	BY	CHKD	APVD
02/09/01	A	REL 19219	REH	MB	GMH

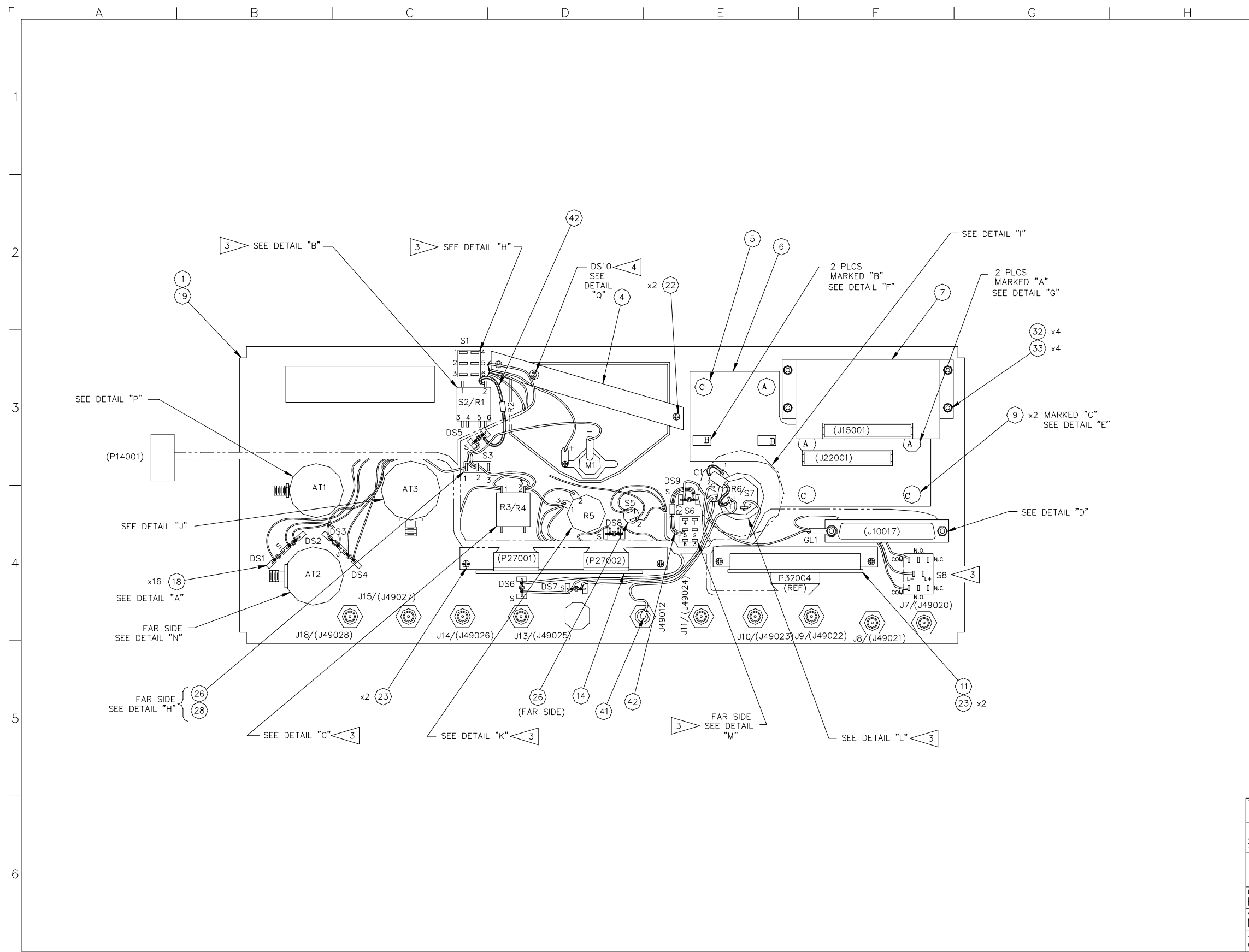

NOTES:

1. ALL REFERENCE DESIGNATORS CARRY AN ASSIGNED DESIGNATOR SERIES, THIS ASS'Y CARRIES SERIES 10000 (i.e., R1 IS R10001).
2. ITEM 20. (SPACER) MAY REQUIRE SELECTIVE "FITTING".
3. REFERENCE SHT 3 (WIRE RUNNING LIST) FOR CONNECTIONS.
4. BEFORE INSTALLING M10001 TO ITEM 1, MOUNT LED FLUSH WITH BACK SIDE OF METER AND ADHERE AS SHOWN (DETAIL "Q").
5. USE HARDWARE SUPPLIED AS FREE STOCK
6. TO CHECK DS1 THRU DS9 INSTALLATION, PLACE RED PROBE OF RINGER TO THE LEAD MARKED "S". PLACE BLACK PROBE OF RINGER TO THE OPPOSITE LEAD. IF THE LED IS INSTALLED CORRECTLY, IT WILL LIGHT UP AS PROBES ARE ATTACHED.
7. W# REFERENCE DESIGNATORS ARE USED TO FACILITATE THE BUILD PROCESS ONLY AND DO NOT TRACK BOM OR TO SCHEMATICS.

THIRD ANGLE PROJECTION	ALL DIMENSIONS IN INCHES UNLESS OTHERWISE SPECIFIED DO NOT SCALE PRINT / IF IN DOUBT ASK	DRAWING STANDARD TO IFR EWS-140
THIS DRAWING PROVIDES THE MINIMUM LEVEL OF GRAPHIC DETAILS AND SPECIFICATIONS REQUIRED TO ACCURATELY DEFINE THIS LEVEL OF FABRICATED PRODUCT ONLY. REFER TO DETAIL DRAWINGS AND SPECIFICATIONS FOR ACCURATE CONFIGURATION OF LOWER LEVEL PARTS AND SUB-ASSEMBLIES USED HEREIN.		
PROPRIETARY AND CONFIDENTIAL PROPERTY OF IFR AMERICAS DO NOT DISCLOSE, REPRODUCE, OR PUBLISH WITHOUT IFR APPROVAL		
DRAWN R.HARRIS DATE 01/09/01	DATE 01/09/01	TITLE MECH ASSY, FRONT PANEL
CHECKED M.BRUFFETT DATE 02/02/01	DATE 02/02/01	DWG NO 7005-9047-100
APPROVED G.HILL DATE 02/09/01	DATE 02/09/01	REV A
090471A0.DWG		CAGE 51190 SHEET 1 OF 4

Subject to Export Control, see Cover Page for details.

DATE	REV	CHANGE	BY	CHKD	APVD
		SEE SHEET 1			

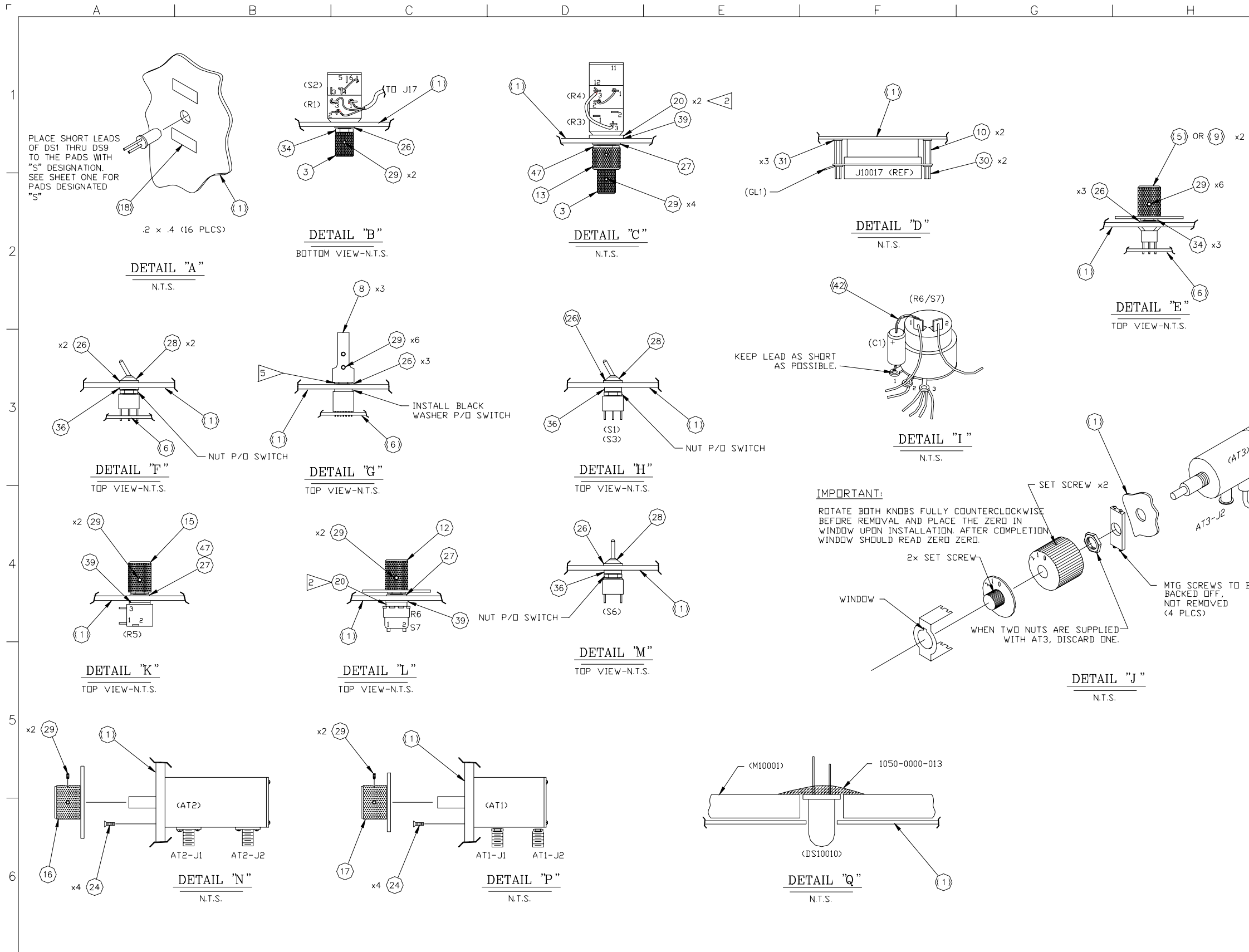

KEEP LEAD AS SHORT AS POSSIBLE.

IMPORTANT:
ROTATE BOTH KNOBS FULLY COUNTERCLOCKWISE BEFORE REMOVAL AND PLACE THE ZERO IN WINDOW UPON INSTALLATION. AFTER COMPLETION WINDOW SHOULD READ ZERO ZERO.

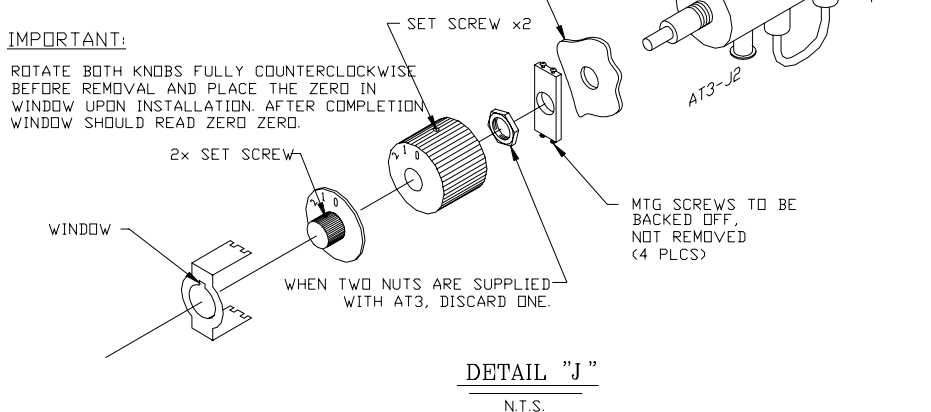

THIRD ANGLE PROJECTION	ALL DIMENSIONS IN INCHES UNLESS OTHERWISE SPECIFIED DO NOT SCALE PRINT / IF IN DOUBT ASK	DRAWING STANDARD TO IFR EWS-140
THIS DRAWING PROVIDES THE MINIMUM LEVEL OF GRAPHIC DETAILS AND SPECIFICATIONS REQUIRED TO ACCURATELY DEFINE THIS LEVEL OF FABRICATED PRODUCT ONLY. REFER TO DETAIL DRAWINGS AND SPECIFICATIONS FOR ACCURATE CONFIGURATION OF LOWER LEVEL PARTS AND SUB-ASSEMBLIES USED HEREIN.		
10200 WEST YORK STREET WICHITA, KANSAS 67215		
DRAWN R.HARRIS 01/09/01	DATE 01/09/01	TITLE MECH ASSY, FRONT PANEL
CHECKED M.BRUFFETT 02/02/01	DATE 02/02/01	DWG NO 7005-9047-100
APPROVED G.HILL 02/09/01	DATE 02/09/01	REV A
090471A0.DWG CAGE 51190		SHEET 2 OF 4

F A B C D E F G H I J

DATE	REV	CHANGE	BY	CHKD	APVD
		SEE SHEET 1			

WIRE RUNNING LIST

LINE No	FROM	TO	WIRE
	TERMINAL	TERMINAL	COLOR AWG DESG
1	DS10002-SHORT	DS10003-SHORT	BLK 26 (W1)
2	DS10004-SHORT	R10005-3 (3)	BLK 26 (W2)
3	DS10005-LONG	R10002 390 OHM	SLEEVE
4	DS10005-SHORT (2)	S10003-2 (3)	BLK 26 (W3)
5	DS10005-SHORT (2)	S10001-5	BLK 26 (W4)
6	DS10006-SHORT	DS10007-SHORT (2)	BLK 26 (W5)
7	DS10007-SHORT (2)	R10006-3 (4)	BLK 26 (W6)
8	DS10009-SHORT (2)	R10006-3 (4)	BLK 26 (W7)
9	DS10009-SHORT (2)	R10005-3 (3)	BLK 26 (W8)
10	DS10009-LONG	R10007 390 OHM	SLEEVE
11	R10007	S10006-5	
12	DS10010-LONG	S10002-6 (2)	RED 26 (W9)
13	M10001 +	S10001-2	WHT 26 (W10)
14	M10001 -	S10003-2 (3)	BLK 26 (W11)
15	S10001-4	NC	
16	S10002-2	R10002	SLEEVE
17	S10002-3	NC	
18	S10002-4 (3)	S10005-2 (3)	RED 26 (W12)
19	S10002-4 (3)	S10002-6 (2)	RED 26 (W13)
20	S10002-5	NC	
21	S10003-2 (3)	R10004-2 (3)	BLK 26 (W14)
22	S10003-3	NC	
23	S10005-2 (3)	S10006-6 (2)	RED 26 (W15)
24	S10006-1	NC	
25	S10006-4	NC	
26	S10007-1 (2)	C10001 + 33UF 20V	SLEEVE
27	S10007-1 (2)	J49012	WHT 26 (W16)
28	NOT USED		
29	NOT USED		
30	NOT USED		
31	S10008-2b	NC	
32	S10008-2	NC	
33	NOT USED		
34	R10003-1	R10005-1 (3)	VID 26 (W17)
35	R10003-3	R10004-3	WHT 26 (W18)
36	R10004-1 (2)	R10004-2 (3)	BLK 26 (W19)
37	R10004-2 (3)	R10005-3 (3)	BLK 26 (W20)
38	R10006-1	C10001 - 33UF 20V	
39	R10006-3 (4)	GL10001 (2)	BLK 26 (W21)
40	J10017-1	S10008-1b (TDP)	GRY 22 (W22)
41	J10017-2	S10008-1 (TDP)	WHT 22 (W23)
42	J10017-3	NC	
43	J10017-4	DS10010-SHORT	WHT/BLK 26 (W24)
44	J10017-5	GL10001 (2)	BLK 22 (W25)
45	J10017-6	P27001-8	YEL 26 (W26)
46	J10017-7	P32004-4 (2)	DRN 22 (W27)
47	J10017-8	+12V S10005-2 (3)	RED 26 (W28)
48	J10017-9	R10005-1 (3)	VID 26 (W29)
49	J10017-10	S10001-6	WHT/GRN 26 (W30)
50	J10017-11	R10001-3	WHT 26 (W31)
51	J10017-12	R10001-2	WHT/BLU 26 (W32)
52	J10017-13	R10001-1	WHT/GRY 26 (W33)
53	J10017-14	S10002-1	WHT/VID 26 (W34)
54	J10017-15	S10001-1	WHT/YEL 26 (W35)
55	J10017-16	S10006-3	WHT/RED 26 (W36)
56	J10017-17	S10006-2	WHT/GRN 26 (W37)
57	J10017-18	R10003-2	WHT/GRY 26 (W38)
58	J10017-19	S10001-3	WHT/DRN 26 (W39)
59	J10017-20	S10005-1 (2)	WHT/RED 26 (W40)
60	J10017-21	R10005-2	WHT/VID 26 (W41)
61	J10017-22	R10006-2	WHT/BLU 26 (W42)
62	J10017-23	P27001-1 (2)	WHT/BRN 26 (W43)
63	J10017-24		
64	J10017-25	P27001-10	WHT/VID 26 (W45)
65	J10017-26	P27001-5	WHT/DRN 26 (W46)
66	J10017-27		
67	J10017-28		
68	J10017-28		
69	J10017-29		
70	J10017-30	P14001-1	WHT/BRN 26 (W49)
71	J10017-31	P14001-3	WHT 26 (W50)
72	J10017-32	CW SEL P32004-8	WHT/BLK 26 (W51)
73	J10017-33	P32004-6	BRN 26 (W52)
74	J10017-34	EXT TRIG- P32004-5	WHT/BLU 26 (W53)
75	J10017-35	INT SEL P32004-12	GRN 26 (W54)

WIRE RUNNING LIST

LINE No	FROM	TO	WIRE
	TERMINAL	TERMINAL	COLOR AWG DESG
76	J10017-36	+5 DN TRACK P32004-13	WHT/GRY 26 (W55)
77	J10017-37	DS10008-LONG	WHT 26 (W56)
78	P14001-1	J10017-30	*
79	P14001-2	R10004-1 (2)	BLK 26 (W57)
80			
81	P14001-3	J10017-31	*
82	P14001-4	KEY	
83	P14001-5	S10003-1	GRN 26 (W59)
84	P14001-6	S10007-2	WHT/DRN 26 (W62)
85	P14001-7	S10005-1 (2)	WHT/RED 26 (W60)
86	P14001-8	+5V P32004-4 (2)	DRN 26 (W61)
87	P14001-9	P27001-6	WHT 26 (W63)
88	P14001-10	S10002-4 (3)	RED 26 (W64)
89			
90			
91			
92			
93			
94			
95			
96			
97	P27001-1	J10017-23	*
98	P27001-1 (2)	DS10008-SHORT	WHT/BLK 26 (W65)
99	P27001-2	KEY	
100	P27001-3	P27002-10 (2)	BLK 26 (W66)
101	P27001-4	NC	
102	P27001-5	J10017-26	*
103	P27001-6	P14001-11	*
104			
105	P27001-8	J10017-6	*
106	P27001-9	R10005-1 (3)	VID 26 (W67)
107	P27001-10	J10017-25	*
108	P27002-1	S10006-6 (2)	RED 26 (W68)
109	P27002-2	NC	
110	P27002-3	KEY	
111	P27002-4	DS10002-LONG	WHT/YEL 26 (W69)
112	P27002-5	DS10007-LONG	WHT 26 (W70)
113	P27002-6	DS10001-LONG	WHT/DRN 26 (W71)
114	P27002-7	DS10004-LONG	WHT/BRN 26 (W72)
115	P27002-8	DS10003-LONG	WHT/GRN 26 (W73)
116	P27002-9	DS10006-LONG	WHT/RED 26 (W74)
117	P27002-10 (2)	R10006-3 (4)	BLK 26 (W75)
118	P27002-10 (2)	P27001-3	*
119	P32004-1	NC	
120	P32004-2	NC	
121	P32004-3	KEY	
122	P32004-4	J10017-7	*
123	P32004-4	P14001-9	*
124	P32004-5	J10017-34	*
125	P32004-6	J10017-33	*
126	P32004-7	NC	
127	P32004-8	J10017-32	*
128	P32004-9	NC	
129	P32004-10	NC	
130	P32004-11	NC	
131	P32004-12	J10017-35	*
132	P32004-13	J10017-36	*
133	P32004-14	NC	
134	P32004-15	NC	
135	P32004-16	NC	
136	P32004-17	NC	
137	P32004-18	NC	

INDEX

TERMINAL	LINE NUMBERS
DS10001	113
DS10002	1, 111
DS10003	1, 115
DS10004	2, 114
DS10005	4, 5
DS10006	6, 116
DS10007	6, 7, 112
DS10008	77, 98
DS10009	8, 10
DS10010	12, 43
M10001	13, 14
S10001	5, 13, 15, 49, 54, 58
S10002	12, 16, 19, 20, 53, 90
S10003	4, 14, 21, 22, 83
S10005	18, 23, 47, 59, 85
S10006	11, 23, 25, 55, 56, 108
S10007	26, 27, 88
S10008	31, 32, 40
R10001	50 THRU 52
R10002	3, 16
R10003	34, 35
R10004	21, 35 THRU 37, 79
R10005	2, 9, 34, 37, 48, 60, 106
R10006	7, 8, 38, 39, 61, 117
R10007	10, 11
C10001	26, 38
GL10001	39, 44
J10012	27
J10017	40 THRU 78, 81, 84, 86, 102, 104, 105, 107, 122, 124, 125, 127, 131, 132
P27001	45, 62 THRU 65, 89, 97 THRU 107, 118
P27002	108 THRU 118
P32004	46, 72 THRU 76, 87, 119 THRU 137
P14001	66, 78 THRU 96, 103, 123

LEGEND:

ASTERISK (*) ----- WIRE RUN REPEATED, FOR REFERENCE ONLY
 (***) COAX SHIELDS JOINED FIRST W/167" OF BLK 26 AWG WIRE (COVER COAX SHIELD CONNECTIONS WITH HEATSHRINK TUBING A/R)
 NC ----- NO CONNECTION
 (N) ----- NUMBER (QTY) OF WIRES
 PGT ----- PIGTAIL
 SS(X) ----- SHIELDED SINGLE NO.X
 SP(X) ----- SHIELDED PAIR NO.X
 ST(X) ----- SHIELDED TRIPLE NO.X
 SQ(X) ----- SHIELDED QUAD (4) NO.X
 CX(X) ----- COAX NO.X (CENTER CONDUCTOR ONLY)
 S ----- SOLDER
 C(N) ----- CONNECTION SO INDICATED HAS MULTIPLE CONDUCTORS ATTACHED AND IS NOT COMPLETED AT THIS TIME
 M ----- MALE TERMINAL
 F ----- FEMALE TERMINAL
 T ----- TAG IDENTIFY BY TERMINAL DESIGNATION

THIRD ANGLE PROJECTION	ALL DIMENSIONS IN INCHES UNLESS OTHERWISE SPECIFIED DO NOT SCALE PRINT / IF IN DOUBT ASK	DRAWING STANDARD TO IFR EWS-140
THIS DRAWING PROVIDES THE MINIMUM LEVEL OF GRAPHIC DETAILS AND SPECIFICATIONS REQUIRED TO ACCURATELY DEFINE THIS LEVEL OF FABRICATED PRODUCT ONLY. REFER TO DETAIL DRAWINGS AND SPECIFICATIONS FOR ACCURATE CONFIGURATION OF LOWER LEVEL PARTS AND SUB-ASSEMBLIES USED HEREIN.		
		PROPRIETARY AND CONFIDENTIAL PROPERTY OF IFR AMERICAS DO NOT DISCLOSE, REPRODUCE, OR PUBLISH WITHOUT IFR APPROVAL
10200 WEST YORK STREET WICHITA, KANSAS 67215 TITLE MECH ASSY, FRONT PANEL		
DRAWN R.HARRIS	DATE 01/09/01	
CHECKED M.BRUFFETT	DATE 02/02/01	DWG NO 7005-9047-100
APPROVED G.HILL	DATE 02/09/01	REV A
090471A0.DWG		CAGE 51190 SHEET 3 OF 4

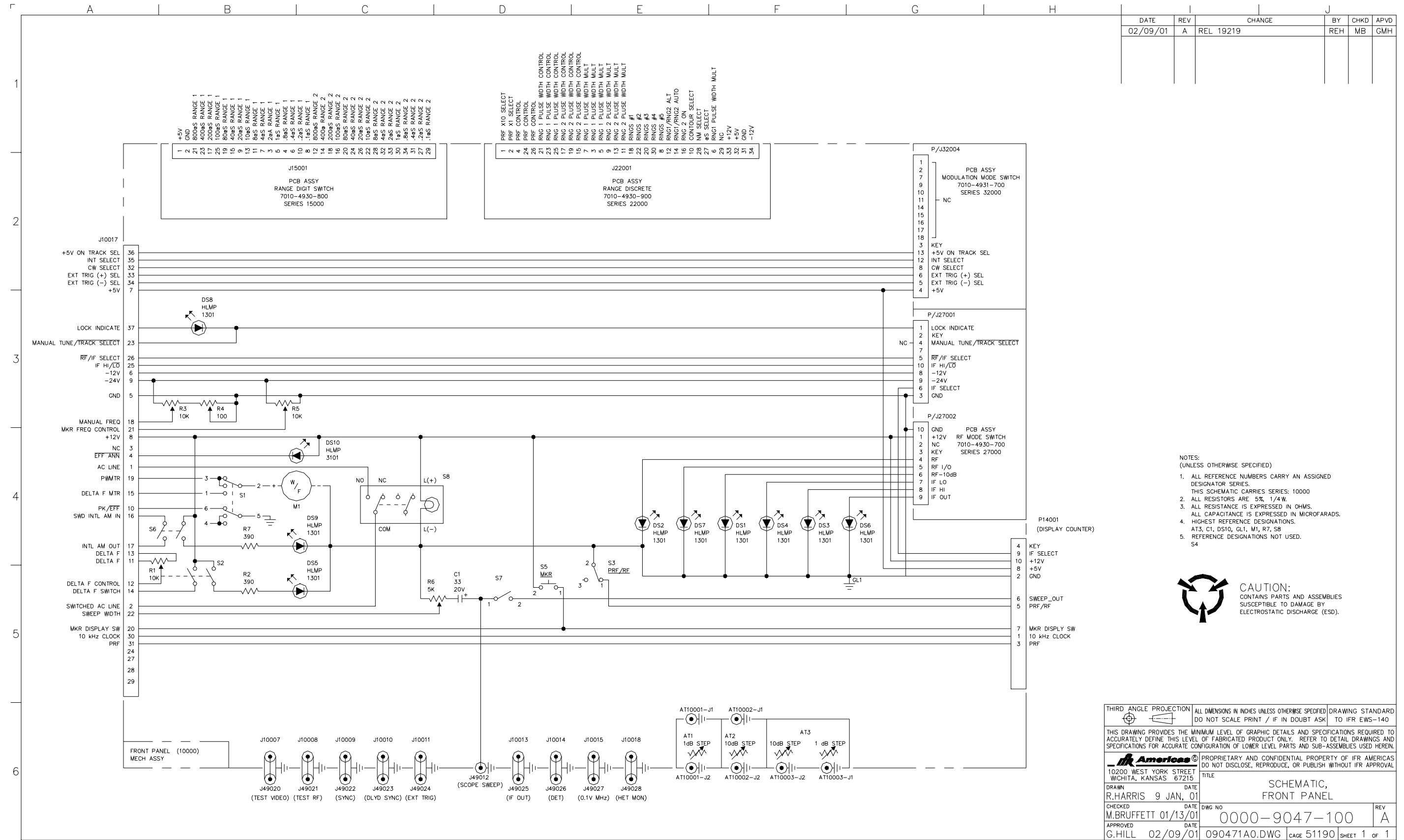

Subject to Export Control, see Cover Page for details.

DATE	REV	CHANGE	APP'D
3/20/85	A	PROD. RELEASE ECN 6490	VLH
4/1/85	A-1	INC RC 7698 SLR	VLH
6/13/86	A-2	INC RC 8696 WAW	VLH

NOTES:

- 1 TIGHTEN SCREWS TO \approx 5 IN LBS. APPLY A SMALL DROP OF "LOCTITE" #290. (DPC1051-0100-200) AROUND THE HEAD OF EACH SCREW AFTER TIGHTENING
- 2. SOLDER WITH "KESTER" 63/37 WIRE SOLDER WITH #25+ FLUX.
- 3. WASH WITH "ZEPRIDE" SOAP AND WATER.
- 4. DO NOT SUBMERGE SWITCH IN WATER.
- 5 PIN 3 REMOVED FOR KEYING PURPOSES
- A2 6 AFTER ITEM 2 IS INSTALLED ON SWITCH, CLIP SWITCH PINS ON OPPOSITE SIDE OF SWITCH BY AT LEAST .125 IN (APPROX HALF OF PIN). REMAINING PINS SHOULD NOT EXCEED .15 IN.

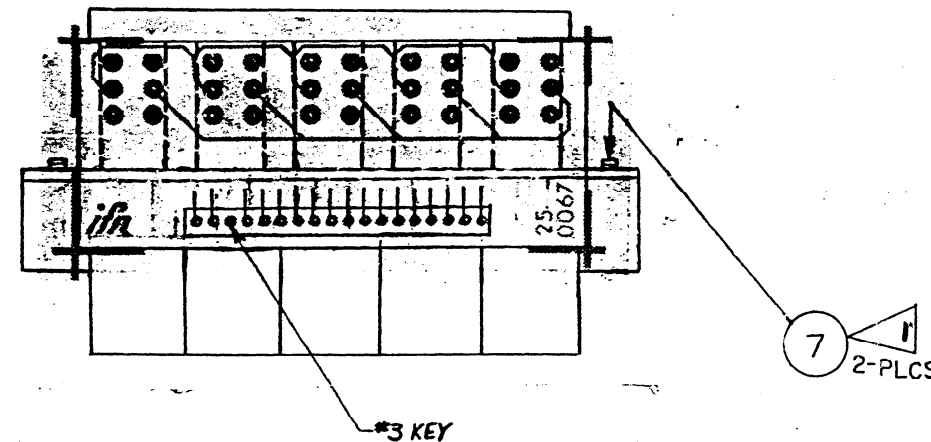
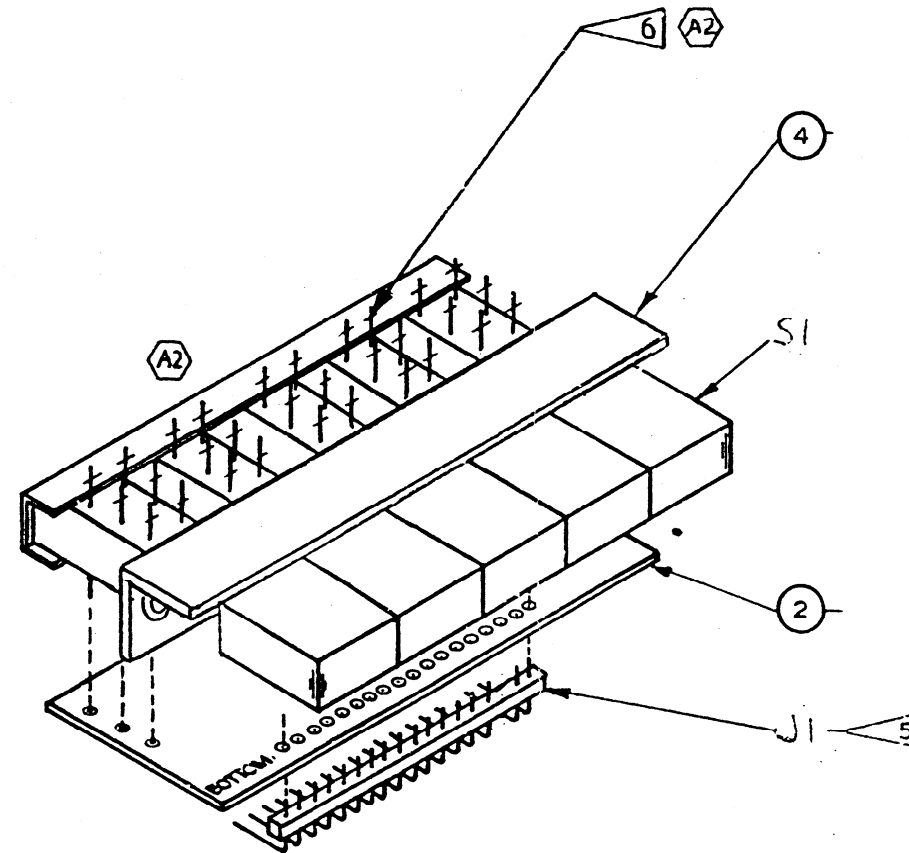

NOTE:

- 1. REF SCHEMATIC DWG N^o 0000-4911-700
- 2. REF DES SERIES ASSIGNED - 32XXX
- 3. ITEM N^o NOT USED.....1,6
- A-1 4. LAST REF DES USED... S1, J1
- A-1 5. LAST ITEM N^o USED... 7
- A-1 6. ITEM N^os NOT USED... 1,3,5,6

SEE SEPARATE B.O.M

ITEM	QTY	PART NO.	DESCRIPTION
7	2	A-40x3/16	PBHMS
5	1	22-05-2181	MOLEX (18) PIN CONN.
4	1	49-816	MTG. BRKT.
3	1	2B1170	CENTRALAB (5) SECT SWITCH
2	1	25-0067	P.C. BOARD
49-401	1	RD301	SWITCH ASS'Y. (MOD. MODE)

49-401	1	RD301	1	1	49-317	SWITCH ASS'Y. (MOD. MODE)
NEXT ASS'Y	QTY	MODEL	ITEM REQ'D	PART NO.	DESCRIPTION	
APPLICATION			LIST OF MATERIALS			
TOLERANCES UNLESS OTHERWISE SPECIFIED ALL DIMENSIONS APPLY AFTER FINISH			DRAWN DATE 12-24-85		INSTRUMENT FLIGHT RESEARCH CORPORATION WICHITA, KANSAS	
DECIMALS: \pm .005 ANGLES: \pm 1/2° FRACTIONS: \pm 1/64 SURFACE ROUGHNESS 125 REMOVE ALL BURRS			CHECKED DATE WB 2-11-85		TITLE MODULATION MODE SWITCH ASS'Y.	
MATERIAL NOTED			APPROVED DATE Greenbank 2/14/85		49-317	
TREATMENT			SIZE B		PART NUMBER 7010-4931-700	
FINISH			SCALE NONE		REV A2	
			WEIGHT		SHEET 1 OF 1	

A B C D E F G H

DATE	REV	CHANGE	APVD
3/20/85	A	PROD RELEASE ECN 10470	TE

1
2
3
4
5

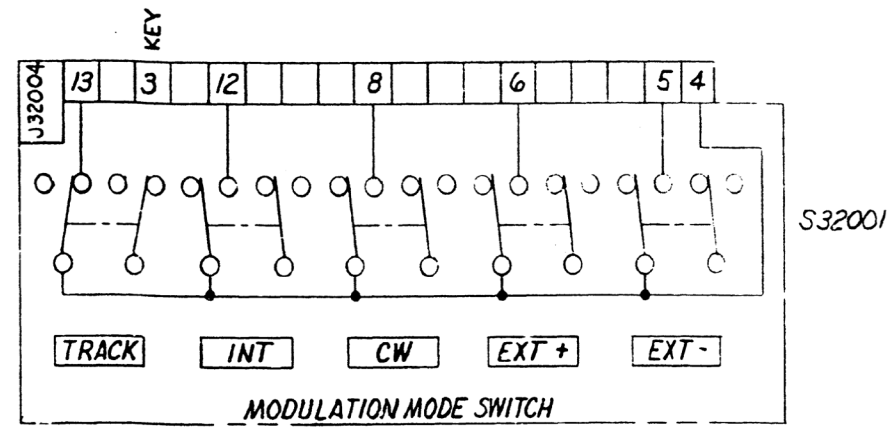

NOTE:

- ALL REF N^o's CARRY AN ASSIGNED DESIGNATOR SERIES. THIS SCHEMATIC CARRIES SERIES 32XXX
- LAST REF USED : J32004
S32001
- REF N^o's NOT USED : J32001
J32002
J32003
- SWITCH SHOWN IN TRACKING MODE POSITION.

UNLESS OTHERWISE SPECIFIED: ALL DIMENSIONS APPLY AFTER FINISH			
TOLERANCES: DECIMALS: .xx ± .1 .xxx ± .2 FRACTIONS: 1/16 ± .005 ANGLES: 1/2 SURFACE FINISH: <input checked="" type="checkbox"/> REMOVE ALL BURRS DO NOT SCALE THIS DRAWING			
MATERIAL			
FINISH			
DASH NO	REF DES SERIES	NEXT ASSY	MODEL
	32XXX	7010-4931-700	RD301
APPLICATION			
IFR INC - 10200 West York Street Wichita, Kansas 67215			
DRAWN	DATE	TITLE	
L.A. Meis, Jr.	01 FEB 85	SCHEMATIC MODULATION MODE SWITCH RD 301 (49-117)	
CHECKED	DATE	SIZE	DWG. NO.
	2-11-85	B	0000-4911-700
APPROVED	DATE	SCALE	REV
Greenbank	2-11-85		A
CODE IDENT.		WEIGHT	SHEET / OF /
51190			1 / 1

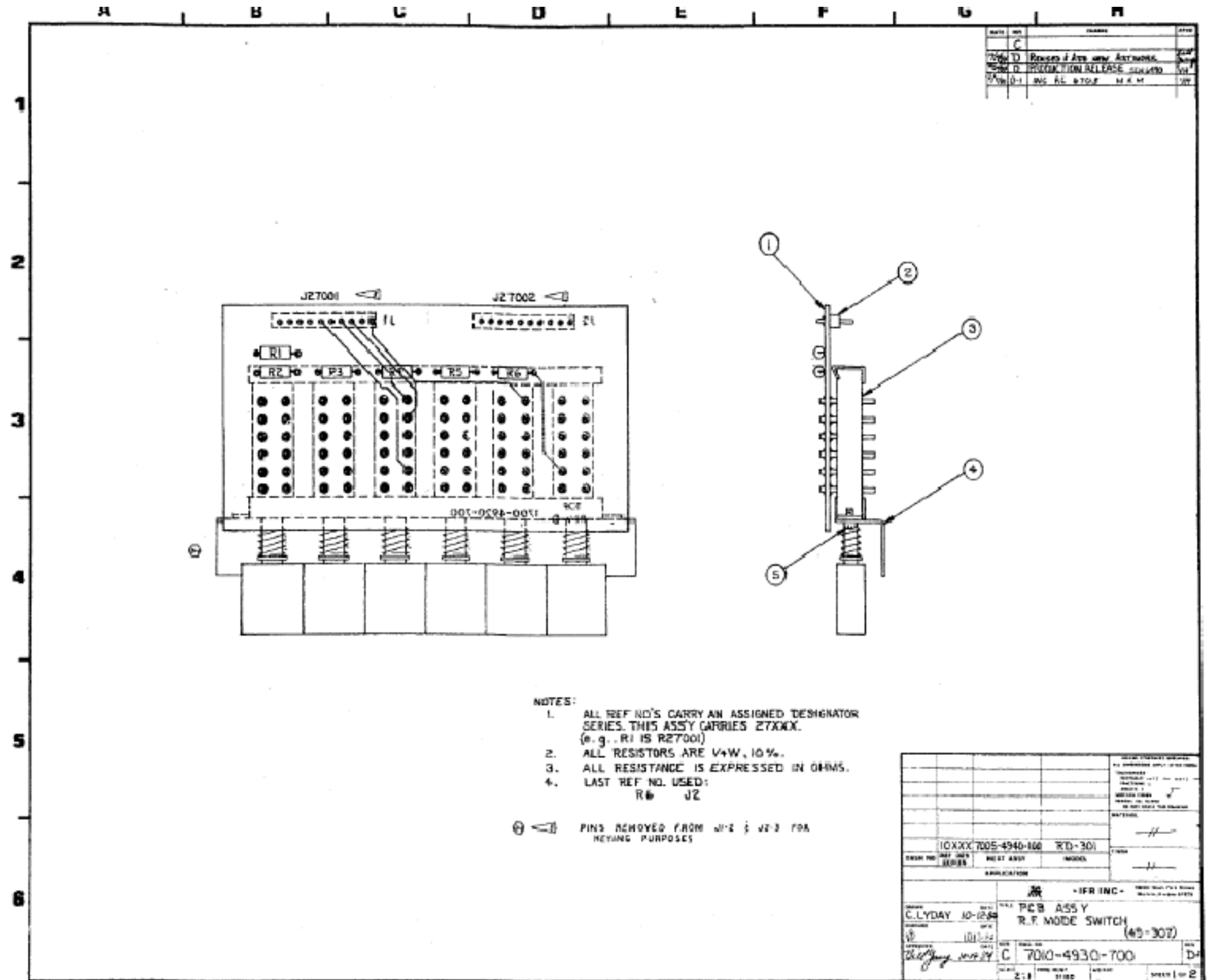

DATE	REV	CHANGE	BY
	C		
10/10/70	D	Revised to Add new Assembly	WJ
10/10/70	D	PRODUCTION RELEASE	WJ
10/10/70	D-1	INS. RL. STOLF	M. K. M.

- NOTES:
1. ALL REF NO'S CARRY AN ASSIGNED DESIGNATOR SERIES. THIS ASSY CARRIES Z7XX. (e.g., R1 IS R27001)
 2. ALL RESISTORS ARE V+W, 10%.
 3. ALL RESISTANCE IS EXPRESSED IN OHMS.
 4. LAST REF NO. USED:
R# J2

④ PINS REMOVED FROM WIRE & W/2 FOR KEYING PURPOSES

10XXX 7005-4940-800		RD-301
DATE	REV	BY
10/10/70	C	WJ
AEROFLEX INC.		
PCB ASSY		
R.F. MODE SWITCH		
(49-307)		
DATE	REV	BY
10/10/70	C	WJ
7010-4930-700		
DATE	REV	BY
10/10/70	2:8	WJ

DATE	REV	CHANGE	APPROV
	C		
	D	REMOVE JUMPER & ADD REV. ARTWORK	
	D	PRODUCTION RELEASE ECN 6490 VH	
		SEE SHEET 1	

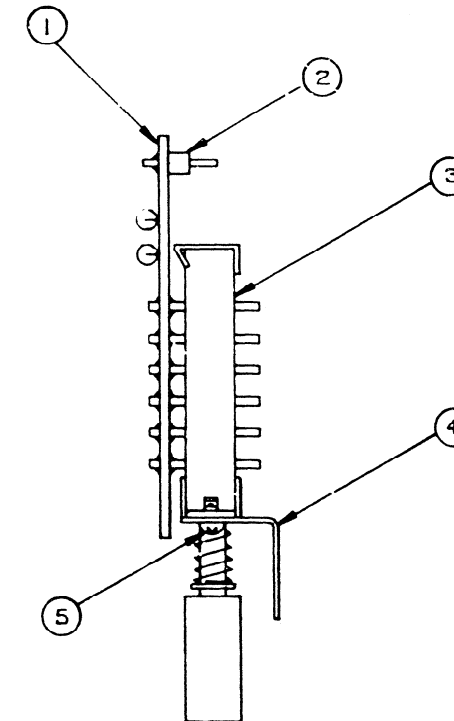
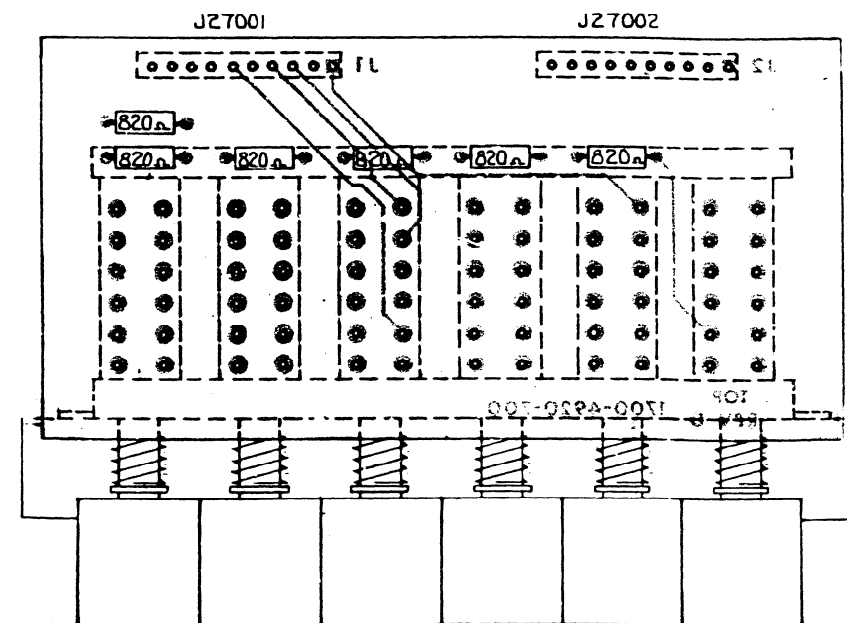

NOTES : SEE SHT 1 OF 2

DASH NO		REF DES		NEXT ASSY		MODEL		APPLICATION	
10XXX		7005-4940-100		RD-301					
<p>10000 West York Street Wichita Kan 67219</p> <p>IFR INC</p>									
DRAWN	DATE	TITLE							
C. LYDAY	10-12-84	PCB ASSY							
CHECKED	DATE	R.F. MODE SWITCH							
		(49-307)							
APPROVED	DATE	SIZE	DWG NO						
Bill Gray	10-11-84	C	7010-4930-700						
SCALE		CODE IDENT	WEIGHT	SHEET 2 OF 2					
2:1		51190							

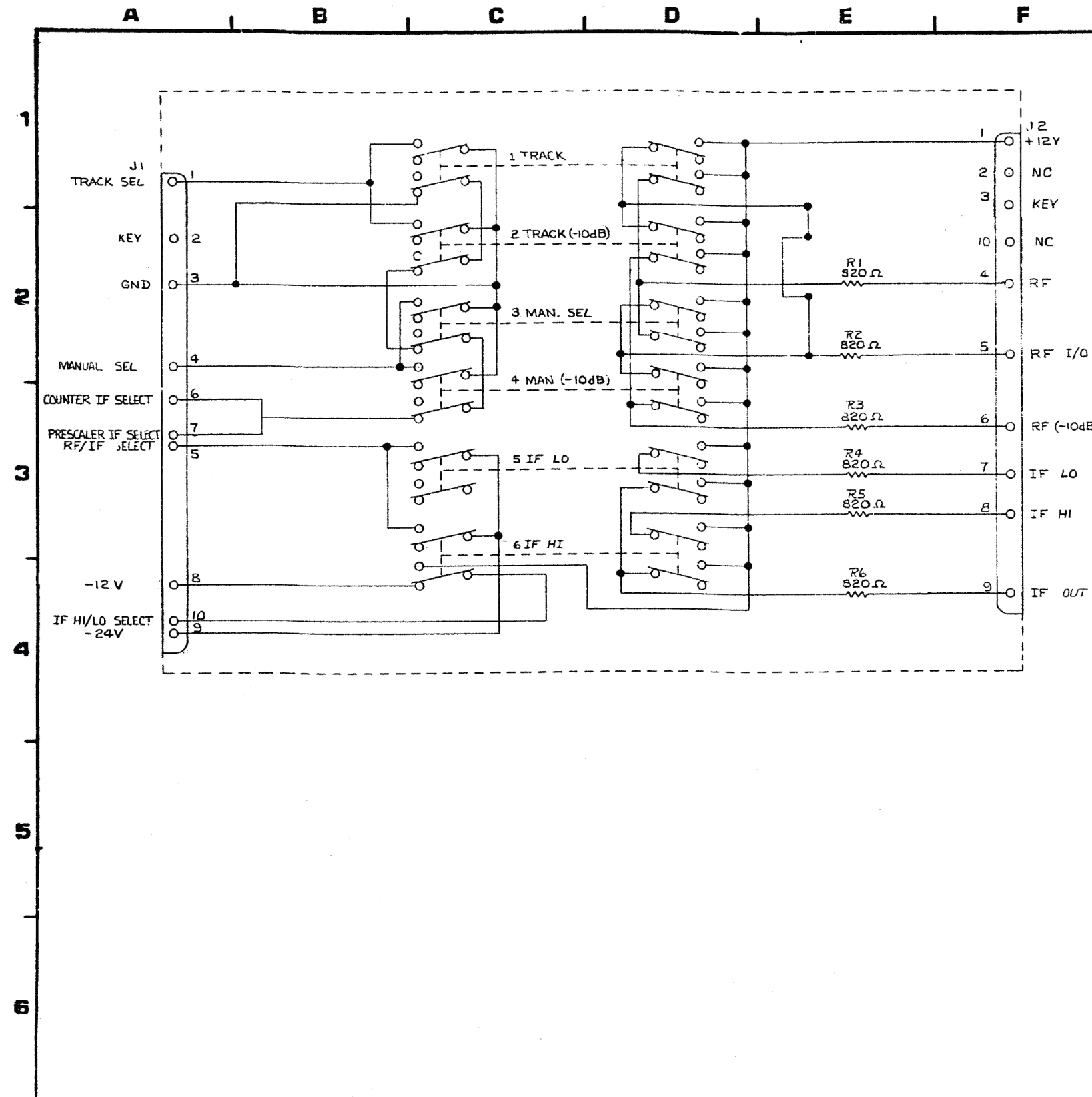

DATE	REV	CHANGE	APVD
11/14/84	C	SEE HISTORY FILE	
12/21/84	D	REVISED ADD KEY POSITIONS	
2/24/85	D	PRODUCTION RELEASE ECN 4495	VH

- NOTES
- ALL REF NO'S CARRY AN ASSIGNED DESIGNATOR SERIES. THIS SCHEMATIC CARRIES SERIES NO 27XXX. (e.g., R1 IS R27001)
 - ALL RESISTORS ARE 1/4 W. 10%.
 - ALL RESISTANCE EXPRESSED IN OHMS.
 - LAST REF NO USED:
R6 J2

DASH NO		27XXX	REF DES SERIES	1700-4920-700	NEXT ASSY	RD-301	MODEL	
APPLICATION								
DRAWN								C. LYDAY
DATE								6-4-84
CHECKED								
DATE								
APPROVED								
DATE								12-19-84
TITLE								RF MODE SW BD SCHEMATIC (49-107)
DWG. NO.								0000-4910-700
SCALE								
CODE IDENT								51180
WEIGHT								
SHEET								1 OF 1

A | B | C | D | E | F | G | H

DATE	REV	CHANGE	BY	CHKD	APVD
		DRAWN TO NEW FORMAT			
		SEE HISTORY FOR PREV REV			
04/27/99	E	INC ECN 18498	REH	MB	MLB

SWITCH STOP PIN POSITIONS					
GRAYHILL SWITCH			GRIGSBY STD SWITCH		
SW #	PIN #1	PIN #2	PIN #1	PIN #2	
SW1	1-12	9-10	2-3	11-12	
SW3	1-12	4-5	2-3	6-7	
SW5	1-12	5-6	2-3	6-7	

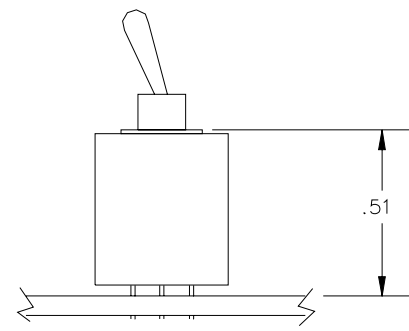

DETAIL "B"

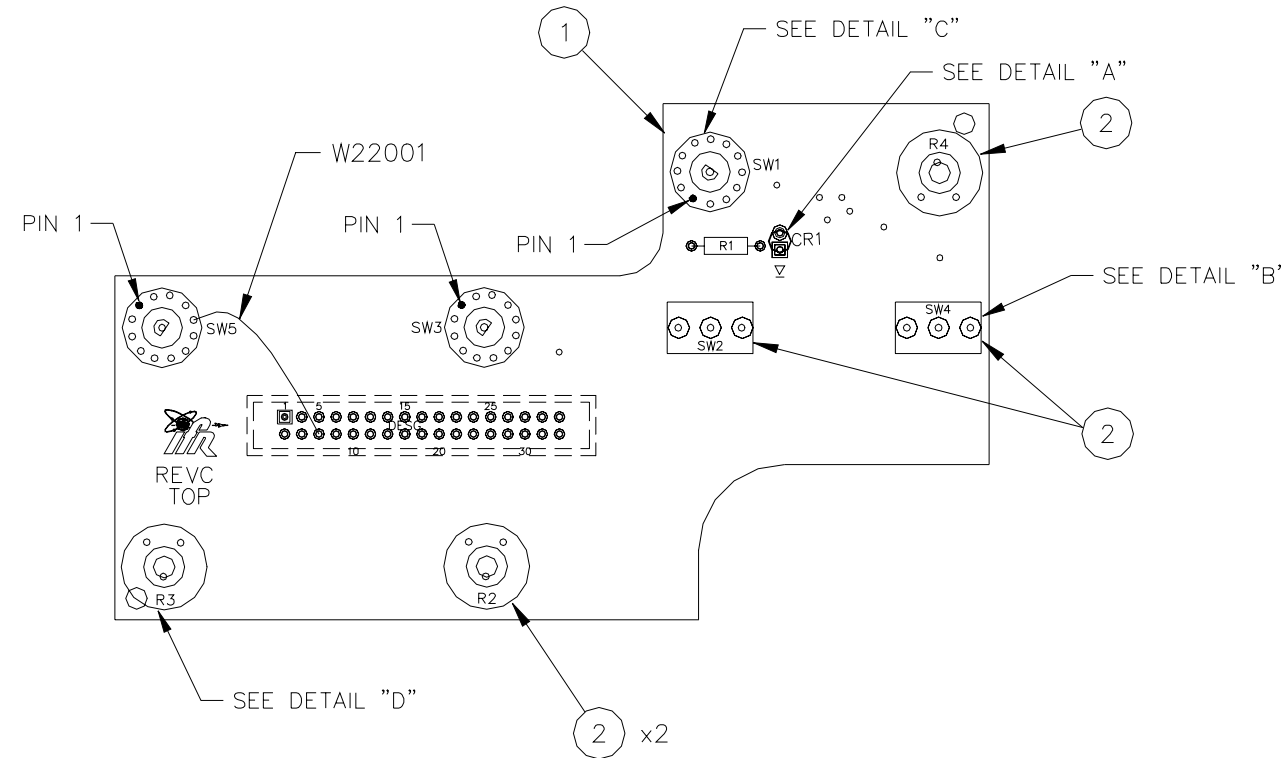

NOTES:

- BASIC REFERENCE DESIGNATORS SHOWN, FOR COMPLETE DESIGNATOR PREFIXES REFER TO PRODUCT STRUCTURE, AND SYSTEM INTERCONNECT FOR APPLICATIONS WHERE USED.
- JIG IS USED TO BUILD BOARD.

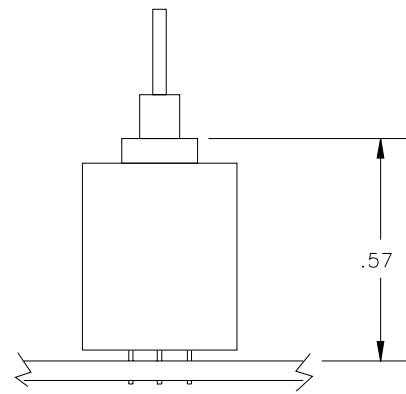

DETAIL "D"

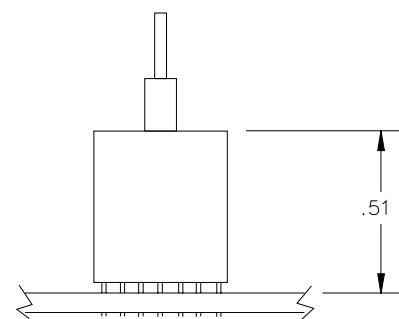

DETAIL "C"

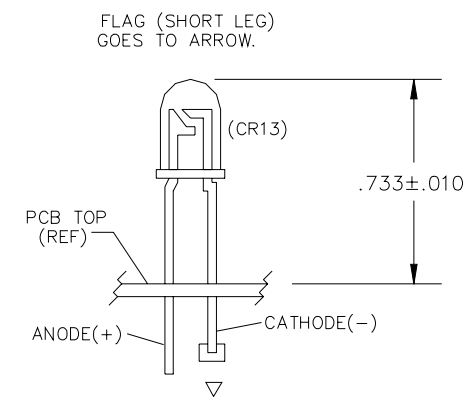

DETAIL A
NOT TO SCALE

THIRD ANGLE PROJECTION	ALL DIMENSIONS IN INCHES UNLESS OTHERWISE SPECIFIED DO NOT SCALE PRINT / IF IN DOUBT ASK	DRAWING STANDARD TO IFR EWS-140
THIS DRAWING PROVIDES THE MINIMUM LEVEL OF GRAPHIC DETAILS AND SPECIFICATIONS REQUIRED TO ACCURATELY DEFINE THIS LEVEL OF FABRICATED PRODUCT ONLY. REFER TO DETAIL DRAWINGS AND SPECIFICATIONS FOR ACCURATE CONFIGURATION OF LOWER LEVEL PARTS AND SUB-ASSEMBLIES USED HEREIN.		
10200 WEST YORK STREET WICHITA, KANSAS 67215		PROPRIETARY AND CONFIDENTIAL PROPERTY OF IFR AMERICAS DO NOT DISCLOSE, REPRODUCE, OR PUBLISH WITHOUT IFR APPROVAL
DRAWN A.OSBURN	DATE 09/18/84	TITLE PCB ASSY. RANGE DISCRETE
CHECKED WB	DATE 10/12/84	DWG NO 7010-4930-900
APPROVED B.YOUNG	DATE 10/12/84	REV E
049309E0.DWG		CAGE 51190 SHEET 1 OF 1

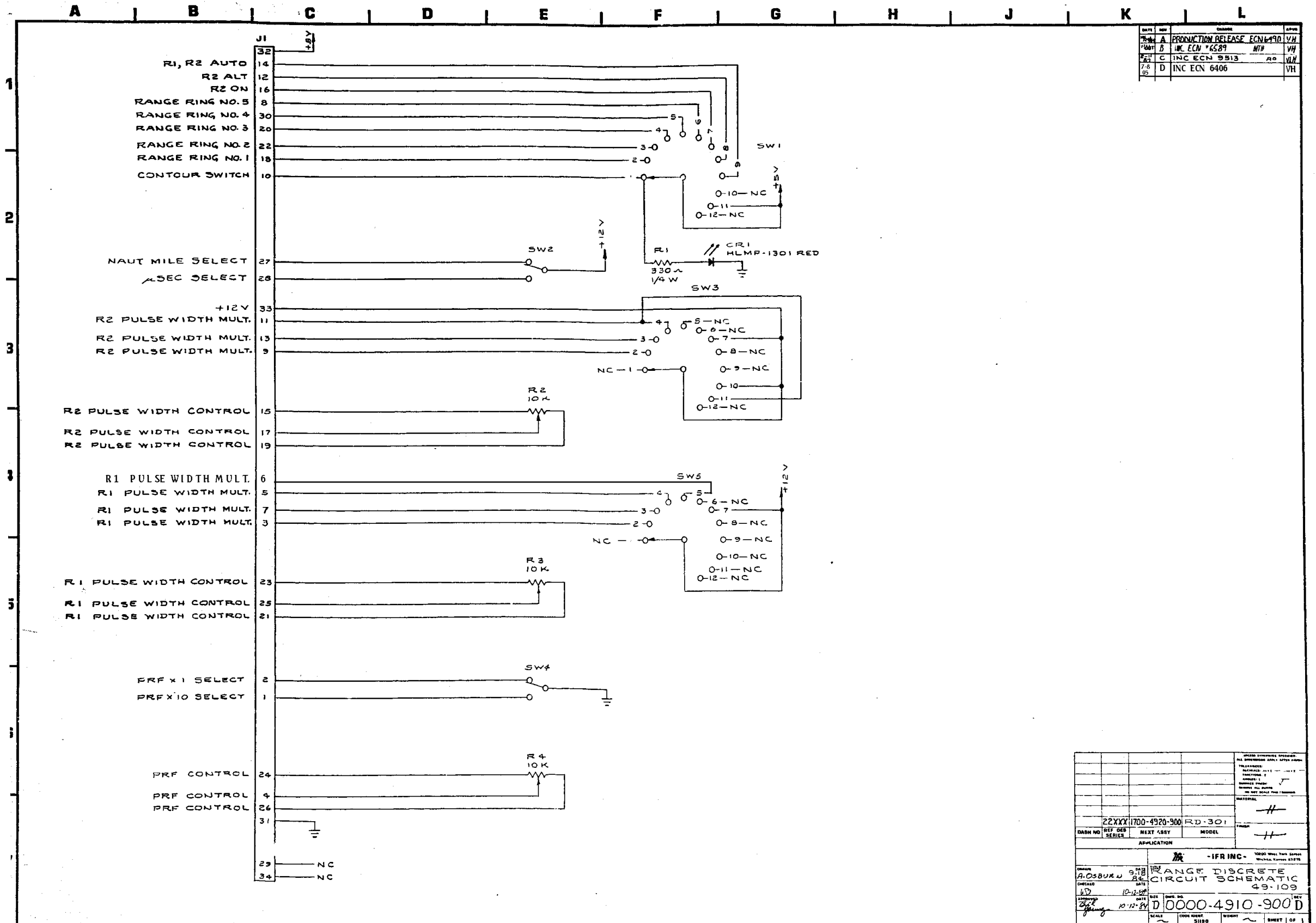

REV	DATE	DESCRIPTION	BY
74	02	PRODUCTION RELEASE ECN 6490	VH
74	02	INC ECN 6539	VH
74	02	INC ECN 9513	AO
74	02	INC ECN 6406	VH

22XX11700-4920-900		RD-301	
DASH NO	REF DES	MODEL	FRONT
SERIES			
APPLICATION			
-IFR INC-			
DRAWN A. OSBURN 9-18-84			
CHECKED DATE 10-12-84			
SIZE D 0000-4910-900 D			
SCALE	UNIT	SHEET	SHEET 1 OF 1

A B C D E F G H

DATE	REV	DESCRIPTION	APPR
	A	PROTOTYPE RELEASE	
	B	REVISED & REDRAWN	
	C	ADD NEW ARTWORK	
10-23-84	C	PRODUCTION RELEASE ECN 6490	VH
10-23-84	C-1	INC RC 6879 RW	VLH
10-23-84	C-2	INC RC 9078 DAH	VLH

1
2
3
4
5
6

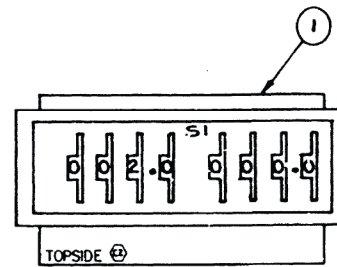

TOPSIDE ⊕

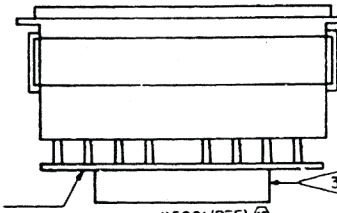

⊖ BOTTHSDE

J15001 (REF) ⊕

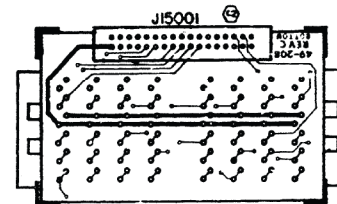

J15001 ⊕

NOTES

- ALL REF NO'S CARRY AN ASSIGNED DESIGNATOR SERIES. THIS ASSY CARRIES SERIES 15XXX. (e.g., R115 R15001)
- LAST REF NO USED
J1 S1

③ PIN 1 IS INDICATED BY SQUARE PAD.

DASH NO				REF DES				NEXT ASSY				MODEL			
10XXX				7005-4940-100				RD-301							
APPLICATION															
- IFR INC -															
DRAWN		DATE		TITLE		REV		DATE		SCALE		CODE		WEIGHT	
OSBURN		9-7		PC BOARD ASSY.		C		10-28-84		1:1		5190			
CHECKED		DATE		RANGE DIGIT SW BD		C		10-30-87		1:1		5190			
APPROVED		DATE		49-308		C		10-30-87		1:1		5190			
APPROVED		DATE		7010-4930-800		C		10-30-87		1:1		5190			
APPROVED		DATE		7010-4930-800		C		10-30-87		1:1		5190			

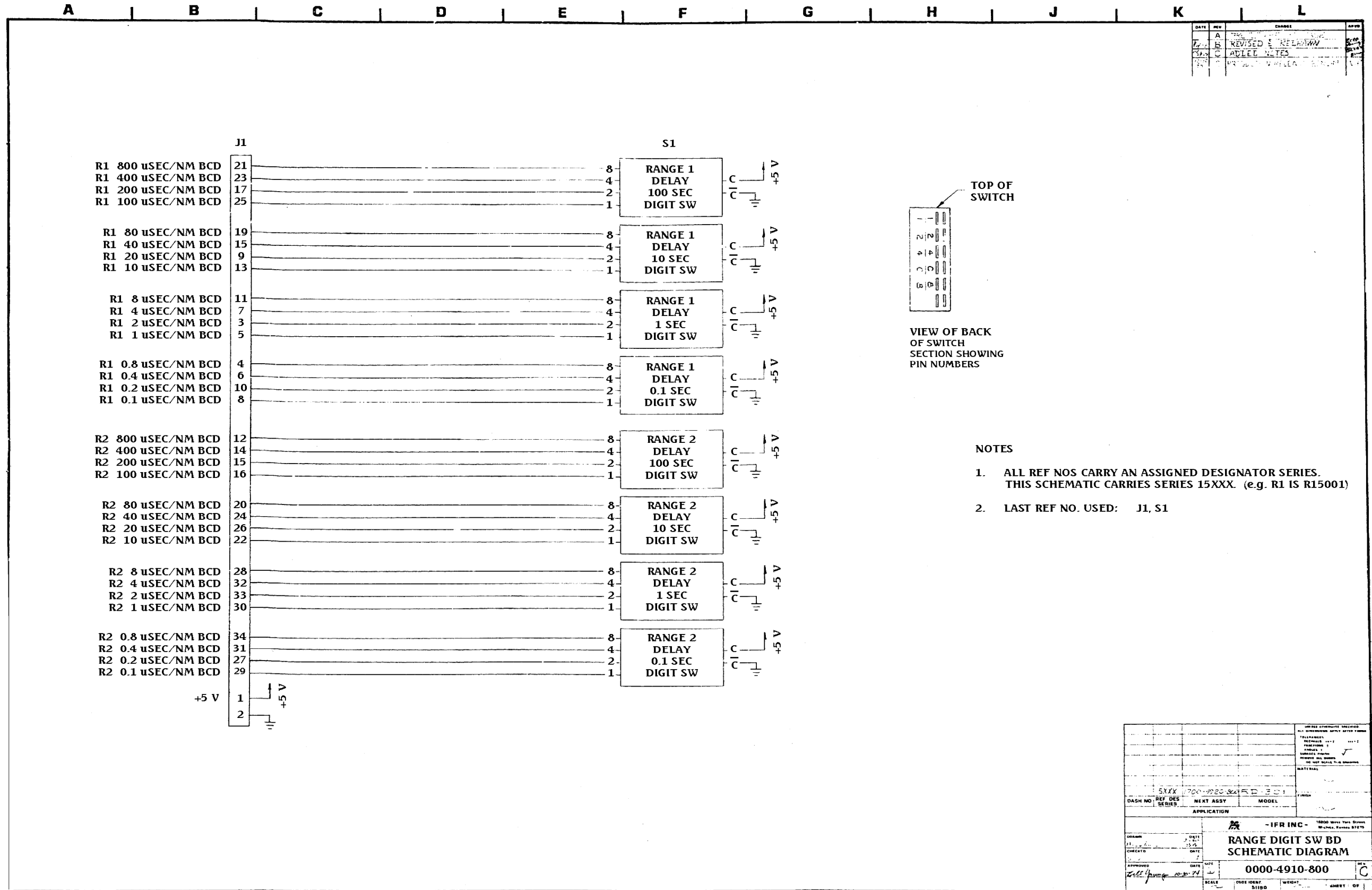

DASH NO: 15XXX		REF DES: 100-220-001	MODEL: RD-301A
APPLICATION: - IFR INC - 1800 West Park Drive, Wichita, Kansas 67279			
RANGE DIGIT SW BD SCHEMATIC DIAGRAM			
0000-4910-800			

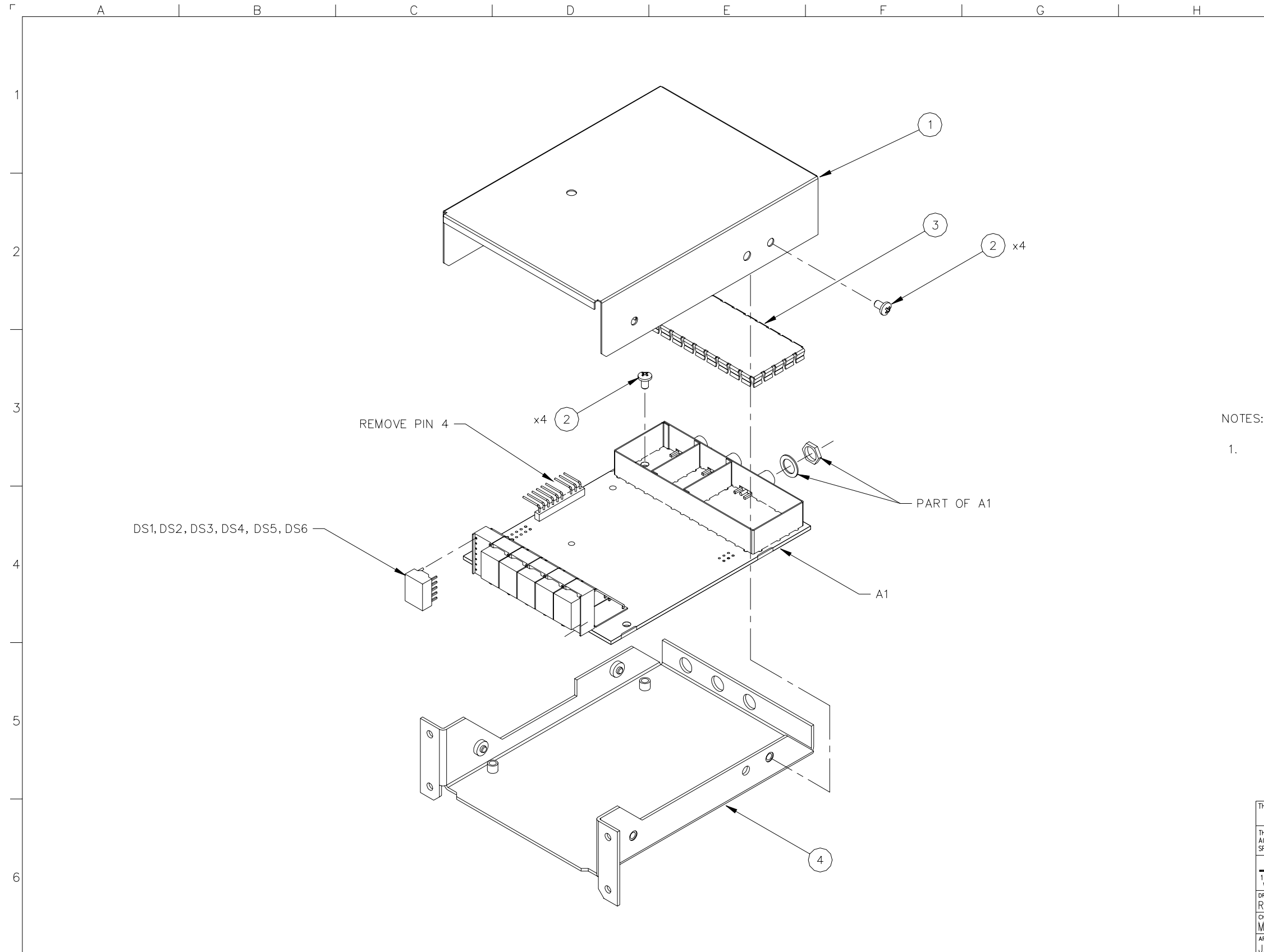

DATE	REV	CHANGE	BY	CHKD	APVD
02/20/01	A	REL 19219	REH	MB	GMH

NOTES:

1. BASIC REFERENCE DESIGNATORS SHOWN, FOR COMPLETE DESIGNATOR PREFIXES REFER TO PRODUCT STRUCTURE, AND SYSTEM INTERCONNECT FOR APPLICATIONS WHERE USED.

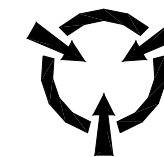

CAUTION:
CONTAINS PARTS AND ASSEMBLIES
SUSCEPTIBLE TO DAMAGE BY
ELECTROSTATIC DISCHARGE (ESD).

THIRD ANGLE PROJECTION	ALL DIMENSIONS IN INCHES UNLESS OTHERWISE SPECIFIED DO NOT SCALE PRINT / IF IN DOUBT ASK	DRAWING STANDARD TO IFR EWS-140
THIS DRAWING PROVIDES THE MINIMUM LEVEL OF GRAPHIC DETAILS AND SPECIFICATIONS REQUIRED TO ACCURATELY DEFINE THIS LEVEL OF FABRICATED PRODUCT ONLY. REFER TO DETAIL DRAWINGS AND SPECIFICATIONS FOR ACCURATE CONFIGURATION OF LOWER LEVEL PARTS AND SUB-ASSEMBLIES USED HEREIN.		
PROPRIETARY AND CONFIDENTIAL PROPERTY OF IFR AMERICAS DO NOT DISCLOSE, REPRODUCE, OR PUBLISH WITHOUT IFR APPROVAL		
10200 WEST YORK STREET WICHITA, KANSAS 67215		
DRAWN R.HARRIS	DATE 14 FEB, 01	TITLE MECH ASSY, DISPLAY/COUNTER
CHECKED M.BRUFFETT	DATE 02/09/01	DWG NO 7005-9041-900
APPROVED J.BISHOP	DATE 02/20/01	REV A
090419A0.DWG		CAGE 51190 SHEET 1 OF 1

DATE	REV	CHANGE	APVD
16 Oct. 00	A	NOT RELEASED	MKM GH
20 Dec. 00	B	RELEASE PER #19219	MKM GH
19 Nov '01	C	INC PER #19632	MKM GH

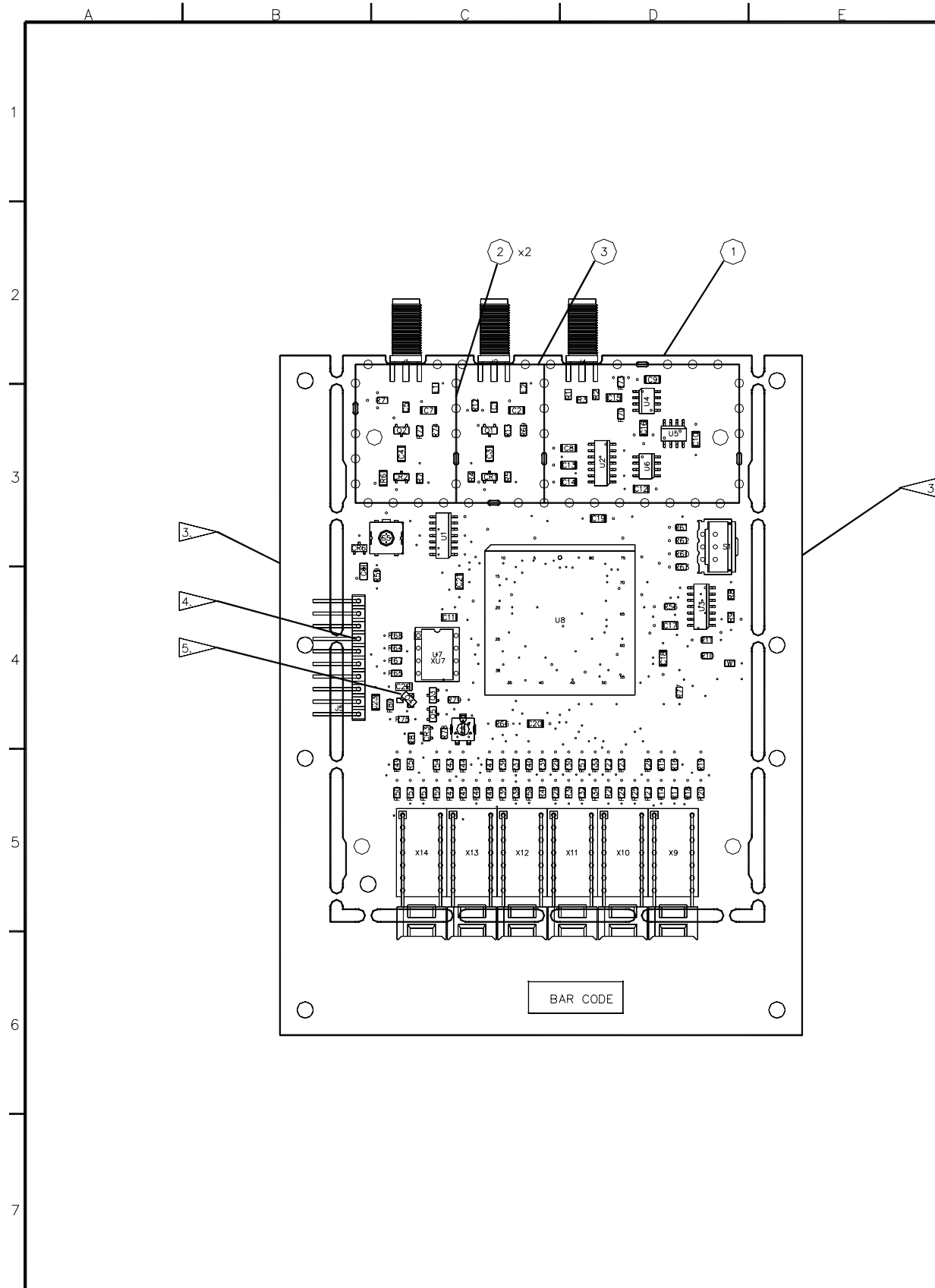

NOTES:

1. BASIC REFERENCE DESIGNATORS SHOWN, FOR COMPLETE DESIGNATOR PREFIXES REFER TO PRODUCT STRUCTURE, AND SYSTEM INTERCONNECT FOR APPLICATIONS WHERE USED.
2. HARDWARE THAT IS NOT PART OF BILL OF MATERIALS SHOULD NOT BE INSTALLED.
3. TO BE REMOVED PRIOR TO MECH. ASSY.
4. REMOVE PIN 4 FROM J5 FOR KEYING.
5. INSTALL Q4 UPSIDE DOWN AND ROTATED AS SHOWN.

CAUTION:
CONTAINS PARTS AND ASSEMBLIES SUSCEPTIBLE TO
DAMAGE BY ELECTROSTATIC DISCHARGE (ESD).

<p>"THIS DOCUMENT CONTAINS PROPRIETARY INFORMATION OF IFR SYSTEMS, INC. AND IS NOT TO BE DISCLOSED, REPRODUCED, OR PUBLISHED WITHOUT IFR'S APPROVAL."</p>			
<p>IFR SYSTEMS, INC. 10200 West York St., Wichita, Kansas 67215-8935</p>		<p>RF Division</p>	
<p>DRAWN M.Moffitt DATE 17 Oct, 00</p>	<p>CHECKED J.Bishop DATE 18 Oct, 00</p>	<p>TITLE PCB_ASSY, Display / Counter</p>	<p>REV C</p>
<p>APPROVED G.Hill DATE 18 Oct, 00</p>	<p>SIZE B</p>	<p>PART NO. 7010-9031-900</p>	<p>SCALE: DO NOT SCALE</p>
<p>109019C0.PLT</p>	<p>CAGE 51190</p>	<p>SHEET 1 OF 1</p>	

TOP VIEW

DATE	REV	CHANGE	APPRVD
03 Jan, 01	B	Release Per 19219 MKM	GH
19 Nov '01	C	INC Per 19632 MKM	GH

NOTES:
(UNLESS OTHERWISE SPECIFIED)

1. BASIC REFERENCE DESIGNATORS SHOWN, FOR COMPLETE DESIGNATOR PREFIXES REFER TO PRODUCT STRUCTURE AND SYSTEM INTERCONNECT.
2. ALL RESISTORS ARE 1%, 1/8W.
3. ALL RESISTANCE IS EXPRESSED IN OHMS
ALL CAPACITANCE IS EXPRESSED IN MICROFARADS.
ALL INDUCTANCE IS EXPRESSED IN MICROHENRIES.
4. HIGHEST REFERENCE DESIGNATIONS:
C23 CR6 J5 L2 Q5 R81 RA1
S5 U8 W2 X14 XU7
5. REFERENCE DESIGNATIONS NOT USED:
CR4 CR5 S2-S4 X1-X8 XU1-XU3 XU5 XU6

◀ 6. COMPONENT(S) NOT INSTALLED.

7. IC FUNCTIONS NOT USED:

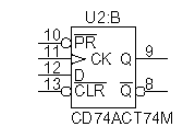

CAUTION:
CONTAINS PARTS AND ASSEMBLIES SUSCEPTIBLE TO DAMAGE BY ELECTROSTATIC DISCHARGE (ESD).

This document contains proprietary information of IFR Systems, INC. and is not to be disclosed, reproduced, or published without IFR's approval.		IFR SYSTEMS INC. 10200 WEST YORK STREET WICHITA, KANSAS 67215-8935		
Drawn J Bishop	Date 26 Oct, 00	Title Display/Counter		
Checked M. Moffitt	Date 26 Oct, 00	Size B	Number 0000-9041-900	Rev C
Approved G.Hill	Date 26 Oct, 00	Cage 51190	Print Date Mon Nov 19, 2001	Filename 090419c0.sch Sheet 1 of 3

A

B

C

D

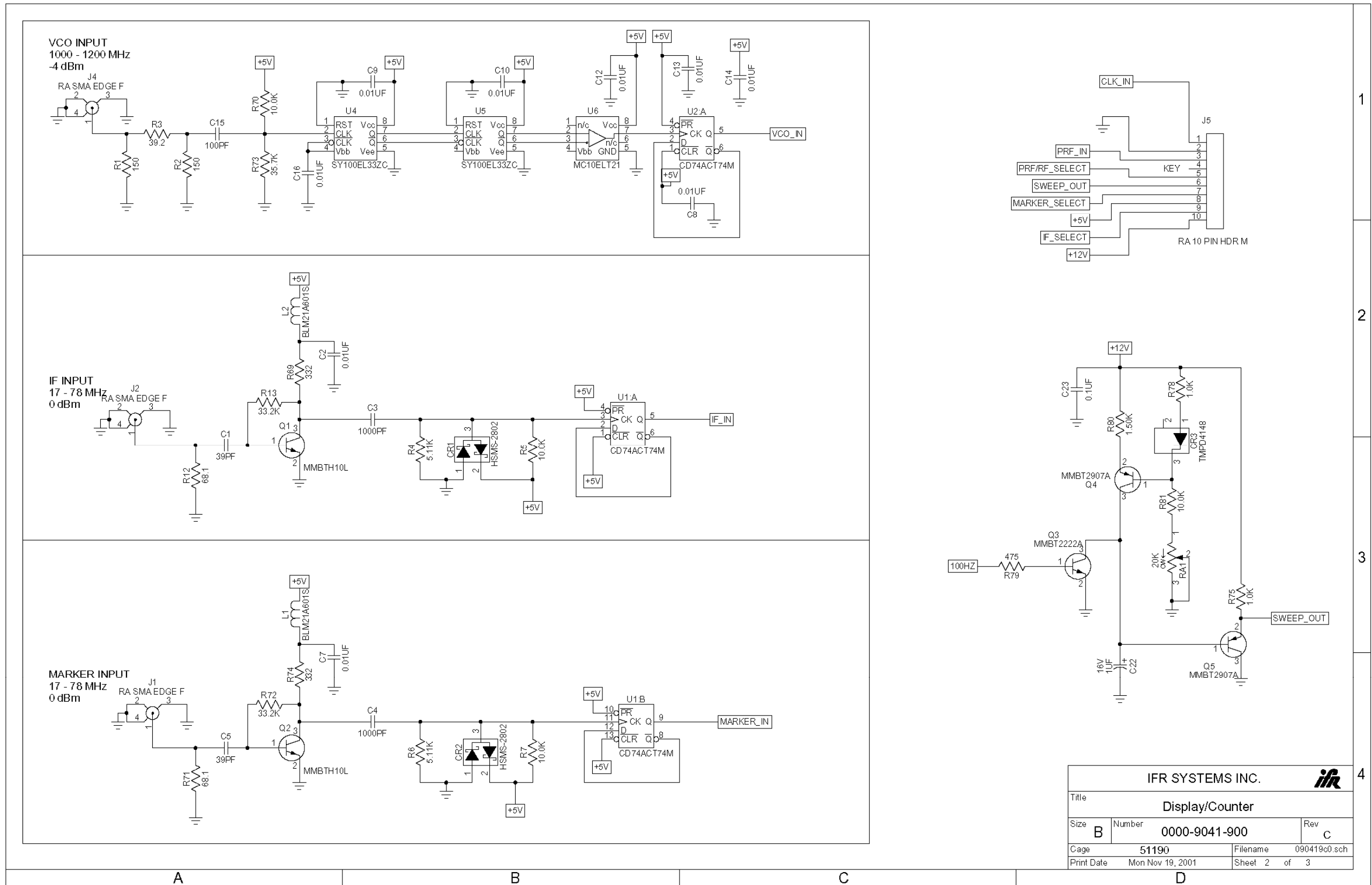

IFR SYSTEMS INC.		ifr
Title Display/Counter		
Size B	Number 0000-9041-900	Rev C
Cage 51190	Filename 090419c0.sch	
Print Date Mon Nov 19, 2001	Sheet 2 of 3	

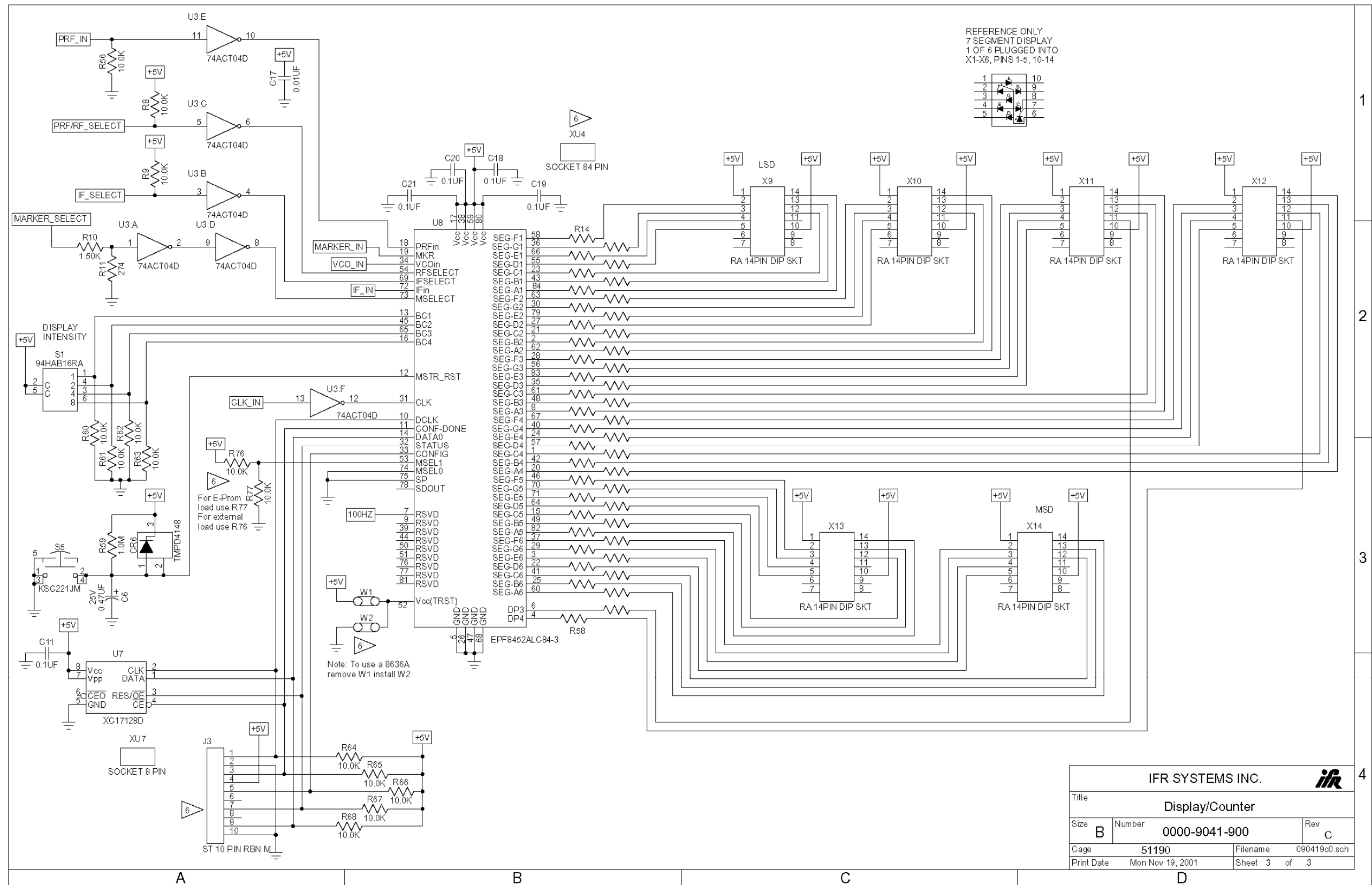

DATE	REV	CHANGE	BY	CHKD	APVD
		DRAWN TO NEW FORMAT SEE HISTORY FOR PREV REV			
01/11/99	D	INC ECN 18461	REH	MT	MLB
05/11/99	D1	INC ECN 18618	REH	MB	MLB
03/15/00	E	INC ECN 18945	REH	SLS	MLB
7-19-04	F	INC 20175	RLA		GH

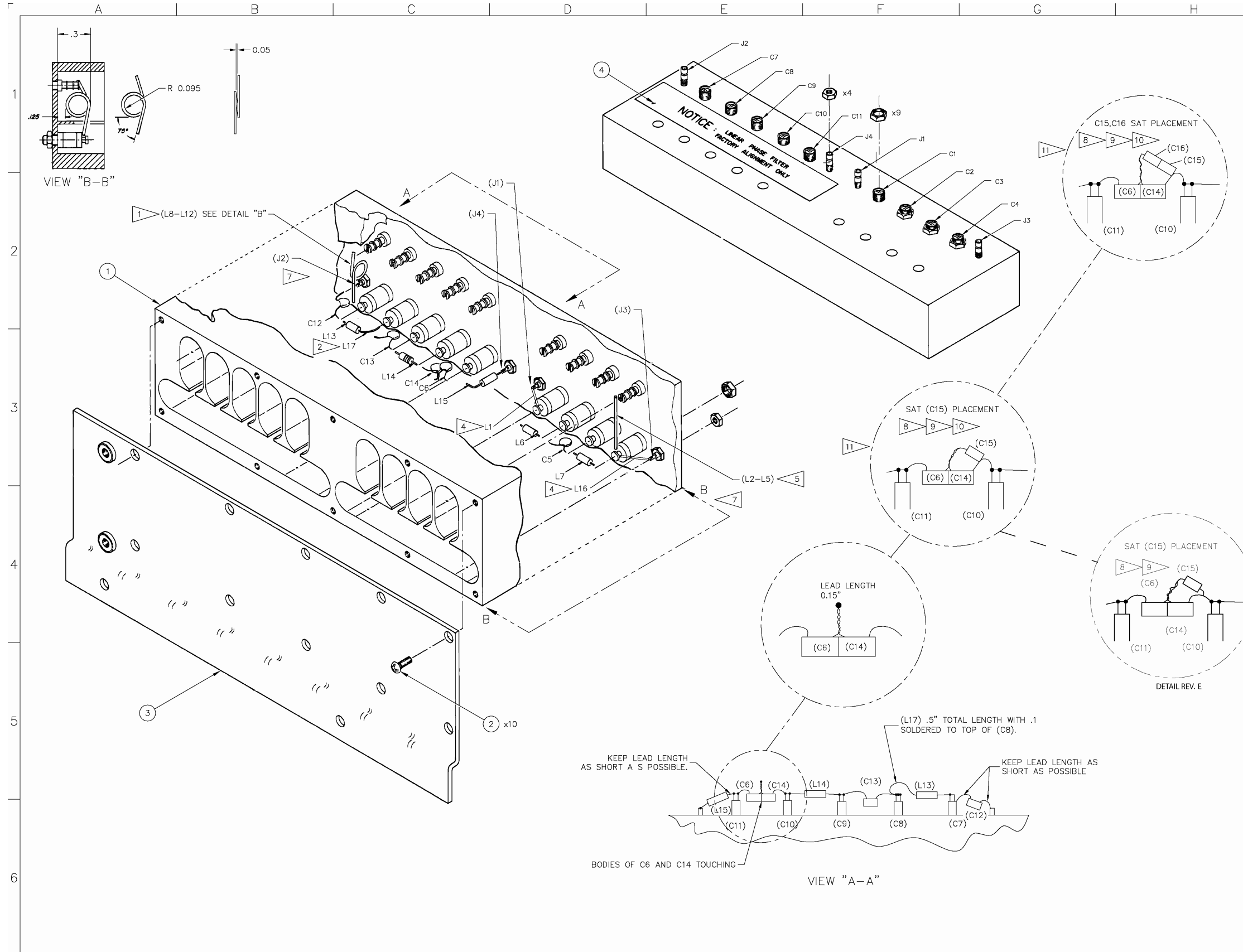

NOTES:

- 1 IND L8, L9, L11, L12 ARE FORMED BY 1.5" 18 GA WIRE.
- 2 IND L17 IS A .5" LEAD ON L13.
- 3 NOT USED.
- 4 IND L1, L16 ARE FORMED BY 22GA. WIRE LEAD AS SHORT AS POSSIBLE.
- 5 IND L2, L3, L4, L5 ARE FORMED BY .65" 18 GA. WIRE
- 6 BASIC REFERENCE DESIGNATORS SHOWN, FOR COMPLETE DESIGNATOR PREFIXES REFER TO PRODUCT STRUCTURE, AND SYSTEM INTERCONNECT FOR APPLICATIONS WHERE USED.
- 7 PART PLACEMENT AND LENGTHS ARE CRITICAL! SEE VIEW "A-A".
- 8 C15 IS S.A.T.
SAT VALUES 0pF, .4PF, .6PF (SEE DETAIL)
- 9 C16 IS S.A.T.
SAT VALUES 0pF, .4PF IN SERIES WITH C15
- 10 BEND THE 2 LEADS WHICH CONNECT C6 AND C14 OVER SUCH THAT THE SAT OR SAT VALUES CAN BE SOLDERED ACROSS C14.
- 11 IMPLEMENTED ON REV. F.



CAUTION:
CONTAINS PARTS AND ASSEMBLIES
SUSCEPTIBLE TO DAMAGE BY
ELECTROSTATIC DISCHARGE (ES)

THIRD ANGLE PROJECTION	ALL DIMENSIONS IN INCHES UNLESS OTHERWISE SPECIFIED DO NOT SCALE PRINT / IF IN DOUBT ASK	DRAWING STANDARD TO IFR EWS-140
THIS DRAWING PROVIDES THE MINIMUM LEVEL OF GRAPHIC DETAILS AND SPECIFICATIONS REQUIRED TO ACCURATELY DEFINE THIS LEVEL OF FABRICATED PRODUCT ONLY. REFER TO DETAIL DRAWINGS AND SPECIFICATIONS FOR ACCURATE CONFIGURATION OF LOWER LEVEL PARTS AND SUB-ASSEMBLIES USED HEREIN.		
10200 WEST YORK STREET WICHITA, KANSAS 67215		PROPRIETARY AND CONFIDENTIAL PROPERTY OF IFR AMERICAS DO NOT DISCLOSE, REPRODUCE, OR PUBLISH WITHOUT IFR APPROVAL
DRAWN HOA VU	DATE 06/01/88	TITLE 475/570-775 MHz FILTER RD-301
CHECKED J.SCHMIDT	DATE 07/07/88	DWG NO 7005-4943-000
APPROVED S.P.	DATE 07/14/88	REV F
O49430F0.DWG		CAGE 51190 SHEET 1 OF 1

DATE	REV	CHANGE	BY	CHKD	APVD
		DRAWN TO NEW FORMAT			
		SEE HISTORY FOR PREV REV			
01/11/99	B	INC ECN 18461	REH	MT	GB
02/18/00	C	INC ECN 18945	REH	MT	TCN

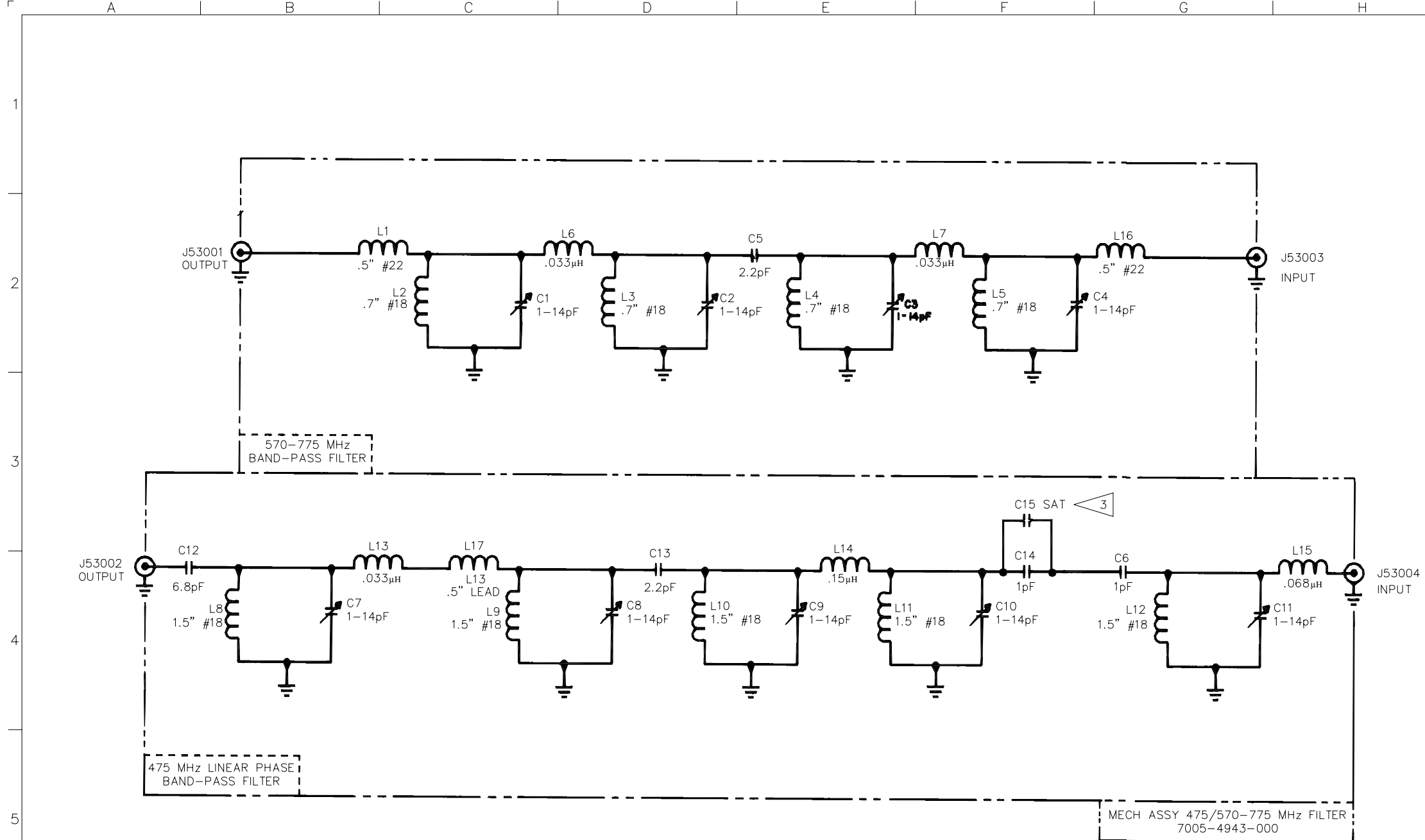

STANDARDS:

1. ALL REFERENCE DESIGNATORS CARRY AN ASSIGNED DESIGNATOR SERIES. THIS DRAWING CARRIES SERIES 5300.
2. ALL CAPACITANCE IS EXPRESSED IN PICO FARADS, UNLESS OTHERWISE NOTED.
3. ALL INDUCTANCE IS EXPRESSED IN MICRO HENRYS, UNLESS OTHERWISE NOTED.

NOTES:

1. LAST REFERENCE DESIGNATOR NUMBER USED:
L17, C15, J4
 2. REFERENCE DESIGNATORS NOT USED:
NONE
- 3 C15 IS S.A.T.:
NOMINAL VALUE: 0pF
SELECTED VALUES: .4 pF, .6pF.

THIRD ANGLE PROJECTION	ALL DIMENSIONS IN INCHES UNLESS OTHERWISE SPECIFIED DO NOT SCALE PRINT / IF IN DOUBT ASK	DRAWING STANDARD TO IFR EWS-140
THIS DRAWING PROVIDES THE MINIMUM LEVEL OF GRAPHIC DETAILS AND SPECIFICATIONS REQUIRED TO ACCURATELY DEFINE THIS LEVEL OF FABRICATED PRODUCT ONLY. REFER TO DETAIL DRAWINGS AND SPECIFICATIONS FOR ACCURATE CONFIGURATION OF LOWER LEVEL PARTS AND SUB-ASSEMBLIES USED HEREIN.		
PROPRIETARY AND CONFIDENTIAL PROPERTY OF IFR AMERICAS DO NOT DISCLOSE, REPRODUCE, OR PUBLISH WITHOUT IFR APPROVAL		
10200 WEST YORK STREET WICHITA, KANSAS 67215		
DRAWN	DATE	TITLE
HOA VU	06/27/88	SCHEMATIC
CHECKED	DATE	475/570-775 MHz FILTER, RD-301
J.SCHMIDT	07/14/88	DWG NO
APPROVED	DATE	0000-4913-000
S.P.	07/14/88	REV C
049130C0.DWG	CAGE 51190	SHEET 1 OF 1

* PARTS TO BE INSTALLED
APPEAR IN BLACK.

ASSEMBLY NOTES:

1 P50015 IS INSTALLED AT FINAL TEST.

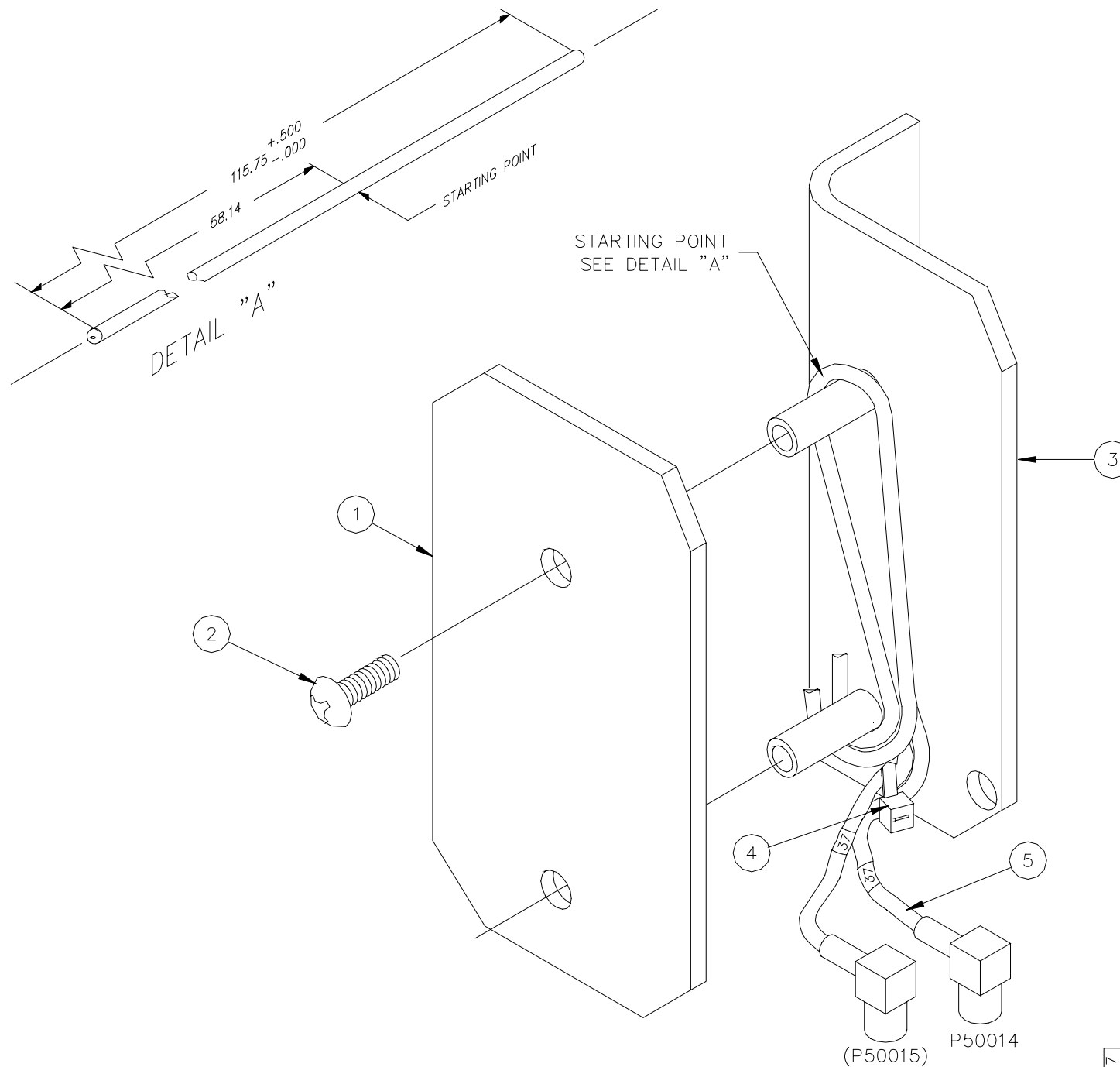

CAUTION:
CONTAINS PARTS AND ASSEMBLIES SUSCEPTIBLE TO
DAMAGE BY ELECTROSTATIC DISCHARGE (ESD).

Prepared By: 10/22/97 J. WRIGHT Checked By:	IFR Systems Inc. Assembly Process Print		
	Description:		Operation 1 of 1
	MECH. ASSY, DELAY LINE, RD-301A		Sheet 1 of 1
	Assembly #	Revision	Prod. Cont. #
7005-9041-000		*A*	*102297*

DATE	REV	CHANGE	BY	CHKD	APVD
03/18/99	A	RELEASE PER ECN 18498	REH	MB	MLB

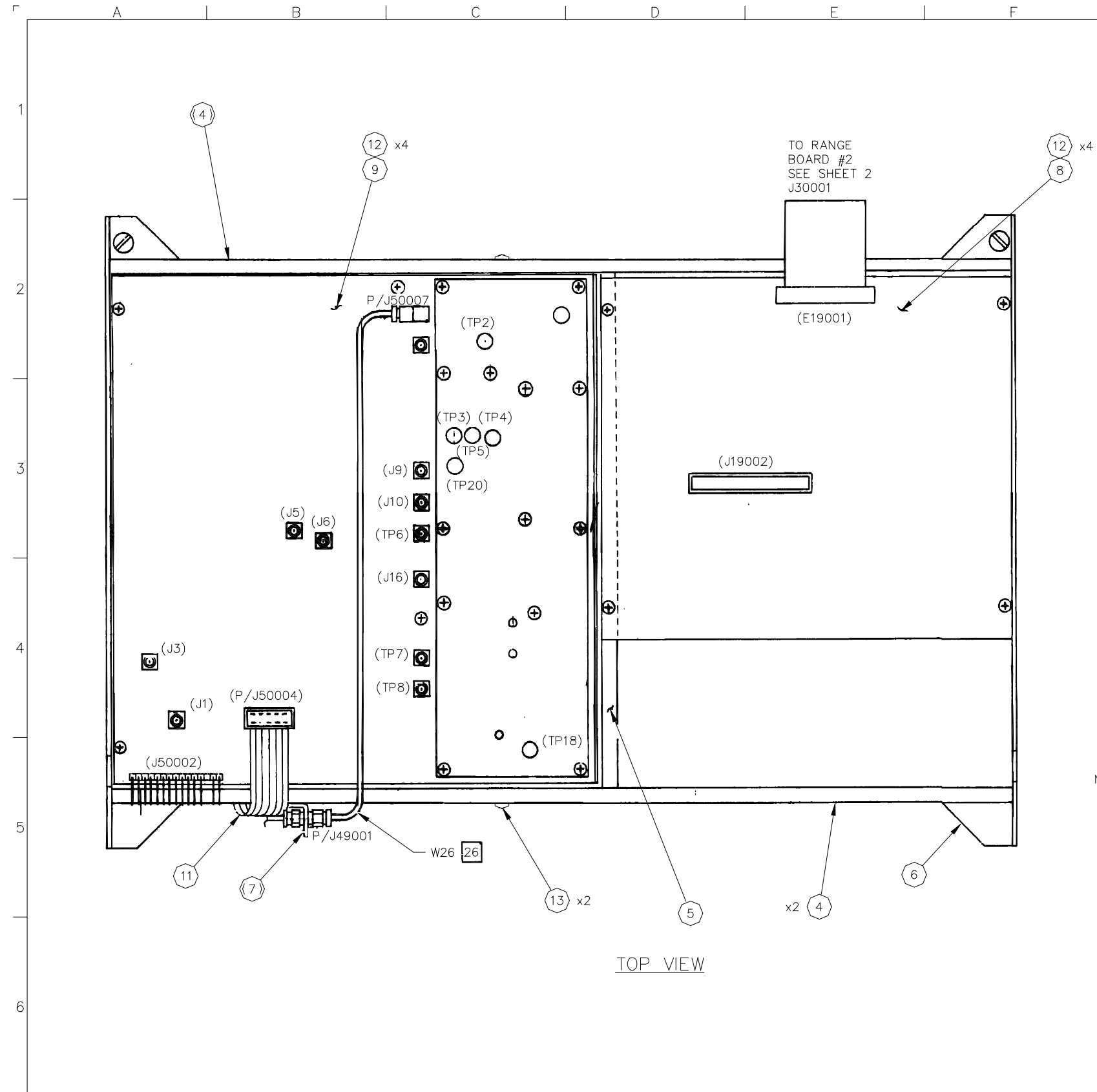

- NOTES:
- BASIC REFERENCE DESIGNATORS SHOWN, FOR COMPLETE DESIGNATOR PREFIXES REFER TO PRODUCT STRUCTURE, AND SYSTEM INTERCONNECT FOR APPLICATIONS WHERE USED.
 - XX INDICATES COAX TAG No.

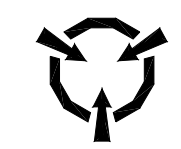

CAUTION:
CONTAINS PARTS AND ASSEMBLIES
SUSCEPTIBLE TO DAMAGE BY
ELECTROSTATIC DISCHARGE (ESD).

THIRD ANGLE PROJECTION	ALL DIMENSIONS IN INCHES UNLESS OTHERWISE SPECIFIED DO NOT SCALE PRINT / IF IN DOUBT ASK	DRAWING STANDARD TO IFR EWS-140
THIS DRAWING PROVIDES THE MINIMUM LEVEL OF GRAPHIC DETAILS AND SPECIFICATIONS REQUIRED TO ACCURATELY DEFINE THIS LEVEL OF FABRICATED PRODUCT ONLY. REFER TO DETAIL DRAWINGS AND SPECIFICATIONS FOR ACCURATE CONFIGURATION OF LOWER LEVEL PARTS AND SUB-ASSEMBLIES USED HEREIN.		
IFR Americas 10200 WEST YORK STREET WICHITA, KANSAS 67215		PROPRIETARY AND CONFIDENTIAL PROPERTY OF IFR AMERICAS DO NOT DISCLOSE, REPRODUCE, OR PUBLISH WITHOUT IFR APPROVAL TITLE MECH ASSY, CARD FRAME
DRAWN R.HARRIS	DATE 02/26/99	DWG NO 7005-9041-800
CHECKED M.BRUFFETT	DATE 03/18/99	REV A
APPROVED M.BACHMAN	DATE 03/18/99	090418A0.DWG CAGE 51190 SHEET 1 OF 2

DATE	REV	CHANGE	BY	CHKD	APVD
		SEE SHEET 1			

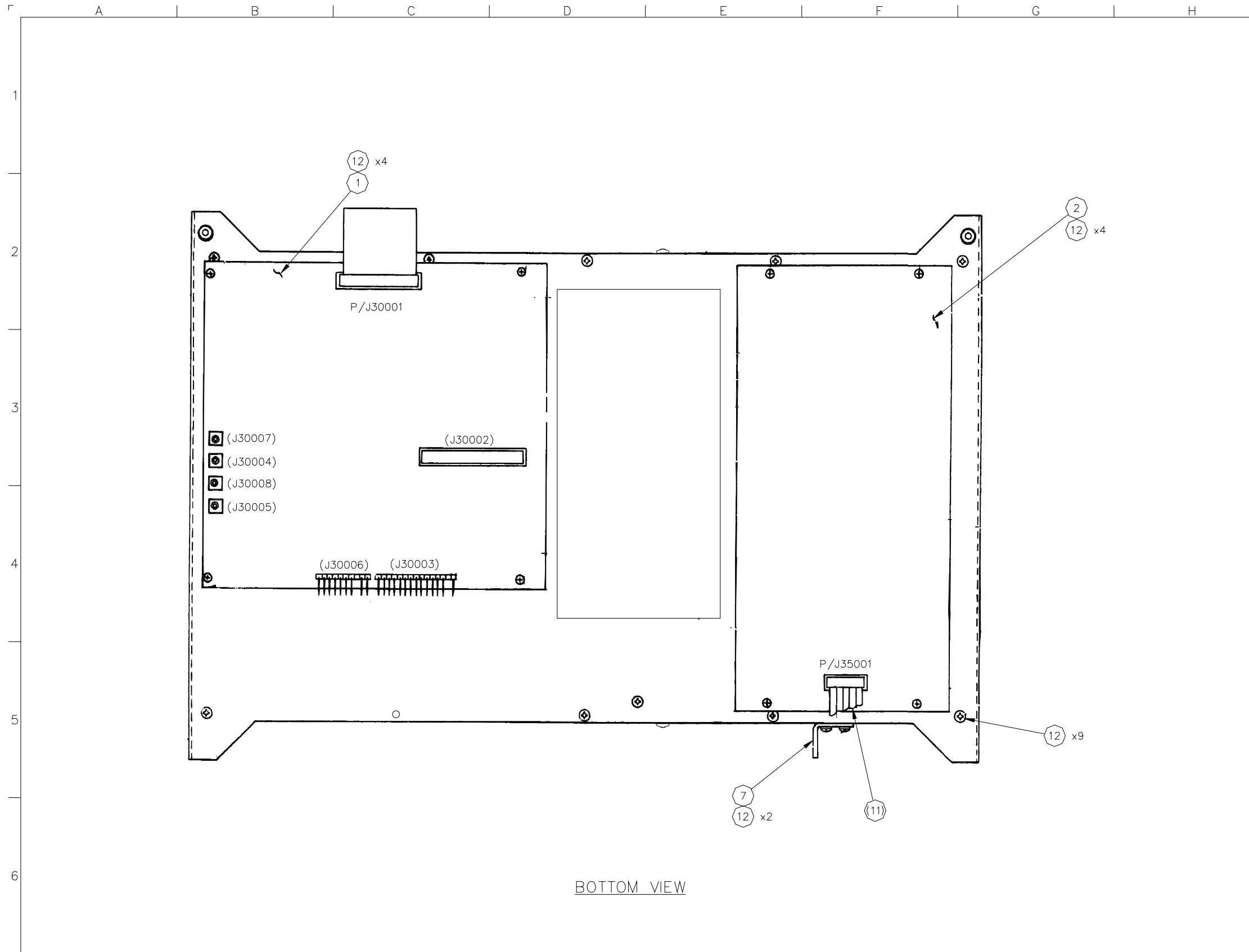

BOTTOM VIEW

THIRD ANGLE PROJECTION	ALL DIMENSIONS IN INCHES UNLESS OTHERWISE SPECIFIED DO NOT SCALE PRINT / IF IN DOUBT ASK	DRAWING STANDARD TO IFR EWS-140
THIS DRAWING PROVIDES THE MINIMUM LEVEL OF GRAPHIC DETAILS AND SPECIFICATIONS REQUIRED TO ACCURATELY DEFINE THIS LEVEL OF FABRICATED PRODUCT ONLY. REFER TO DETAIL DRAWINGS AND SPECIFICATIONS FOR ACCURATE CONFIGURATION OF LOWER LEVEL PARTS AND SUB-ASSEMBLIES USED HEREIN.		
		PROPRIETARY AND CONFIDENTIAL PROPERTY OF IFR AMERICAS DO NOT DISCLOSE, REPRODUCE, OR PUBLISH WITHOUT IFR APPROVAL
10200 WEST YORK STREET WICHITA, KANSAS 67215		TITLE MECH ASSY, CARD FRAME
DRAWN R.HARRIS	DATE 02/26/99	REV A
CHECKED M.BRUFFETT	DATE 03/18/99	DWG NO 7005-9041-800
APPROVED M.BACHMAN	DATE 03/18/99	090418A0.DWG CAGE 51190 SHEET 2 OF 2

Subject to Export Control, see Cover Page for details.

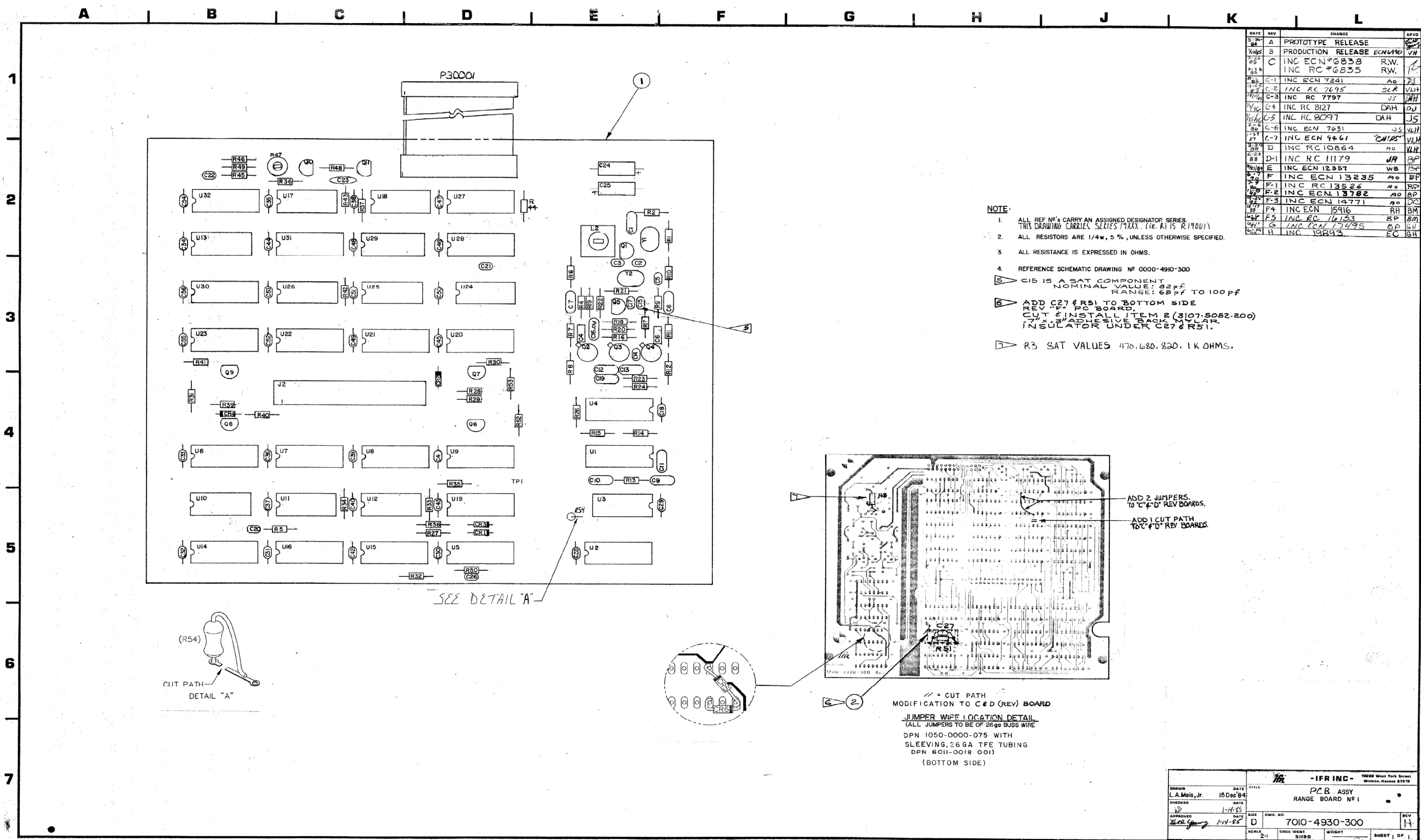

DATE	REV	CHANGE	APPROV
84	A	PROTOTYPE RELEASE	VH
84	B	PRODUCTION RELEASE ECN#490	VH
85	C	INC ECN#6838 R.W.	
85		INC RC #6835	
85	C-1	INC ECN 7241	AO JS
85	C-2	INC RC 7695	5CR VJH
85	C-3	INC RC 7797	JS VJH
85	C-4	INC RC 8127	DAH DU
85	C-5	INC RC 8097	DAH JS
85	C-6	INC ECN 7631	JS VJH
85	C-7	INC ECN 9441	CH125 VJH
85	D	INC RC 10864	AO VJH
88	D-1	INC RC 11179	JR BP
88	E	INC ECN 12357	WB JSF
88	F	INC ECN 13235	AO BP
88	F-1	INC RC 13526	AO BP
88	F-2	INC ECN 13782	AO BP
88	F-3	INC ECN 14771	AO BP
88	F-4	INC ECN 15916	RH BM
88	F-5	INC RC 16153	5P BM
88	G	INC ECN 17495	6P BH
88	H	INC 19893	EC BH

- NOTE:**
- ALL REF NOS CARRY AN ASSIGNED DESIGNATOR SERIES. THIS DRAWING CARRIES SERIES 71XXX. (IE. A1 IS R17001)
 - ALL RESISTORS ARE 1/4W, 5%, UNLESS OTHERWISE SPECIFIED.
 - ALL RESISTANCE IS EXPRESSED IN OHMS.
 - REFERENCE SCHEMATIC DRAWING NO 0000-4910-300
 - C15 IS A SAT COMPONENT
NOMINAL VALUE: 82pf
RANGE: 68pf TO 100pf
 - ADD C27 & R51 TO BOTTOM SIDE REV OF PCB BOARD.
CUT & INSTALL ITEM 2 (3107-5052-200) 7% EPOXY INSULATOR UNDER C27 & R51.
 - R3 SAT VALUES 470, 680, 820, 1K OHMS.

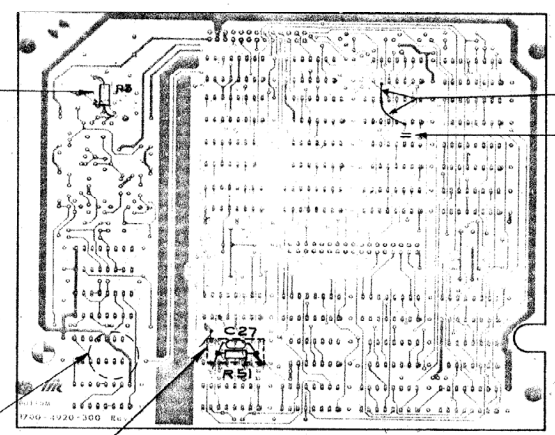

ADD 2 JUMPERS TO 'C' & 'D' REV BOARDS.
ADD 1 CUT PATH TO 'C' & 'D' REV BOARDS.

== CUT PATH
MODIFICATION TO C & D (REV) BOARD
JUMPER WIRE LOCATION DETAIL
(ALL JUMPERS TO BE OF 26ga BUSS WIRE
DPN 1050-0000-075 WITH
SLEEVING, 26 GA TFE TUBING
DPN 6011-0018 001)
(BOTTOM SIDE)

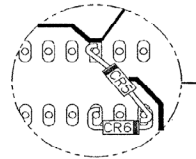
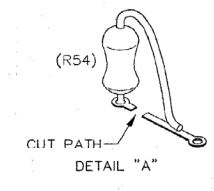

DRAWN		DATE		TITLE	
L.A. Melo, Jr.	15 Dec 84	PCB ASSY RANGE BOARD NO 1			
CHECKED	DATE				
APPROVED	DATE				
SCALE	CHECK IDENT	WEIGHT	SHEET 1 OF 1		

1
2
3
4
5
6
7

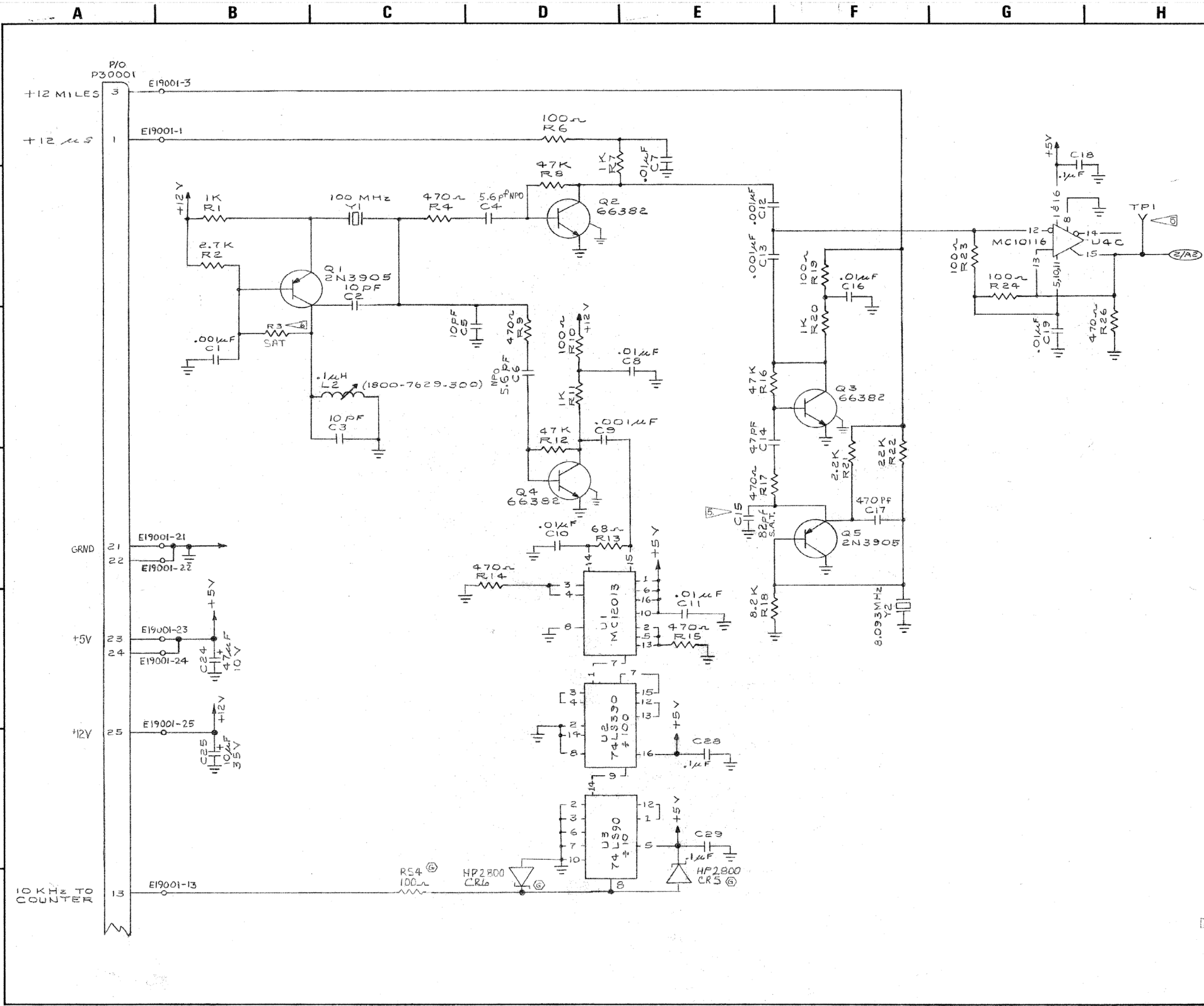

DATE	REV	CHANGE	APPD
1/2/81	B	UPDATED DWG. AS	WH
1/2/81	B	PRODUCTION RELEASE ENLARGED	WH
1/2/81	C	INC ECN # 6838 R.W.	JT
1/2/81	C1	INC ECN 7241	NO DS
1/2/81	C2	INC RC 7517	TR VJH
1/2/81	C3	INC RC 7797	JS DPH
1/2/81	C4	INC RC 8127	DAH OJ
1/2/81	C5	INC RC 8097	DAH JS
1/2/81	C6	INC ECN 7621	JS VJH
1/2/81	C7	INC RC 8465	WH VJH
1/2/81	D	INC RC 10864	NO VJH
1/2/81	E	REF ONLY ECN 12357	
1/2/81	F	PER ECN 13235 TO TRACK WITH FC; ALSO INC ECN 12762 RD	RD
1/2/81	F1	INC RC 13826	NO BS
1/2/81	F2	INC ECN 13782	AD BS
1/2/81	F3	INC ECN 15916	BH BM
1/2/81	G	INC ECN 17495	BP BH
1/2/81	H	INC 19893	EC GH

- STANDARDS:
(UNLESS OTHERWISE NOTED):
1. ALL REF DES CARRY AN ASSIGNED DESIGNATOR SERIES. THIS SCHEMATIC CARRIES SERIES 19XXX (E.G., R1 IS 19001).
 2. ALL RESISTORS ARE 1/4 W, 5%.
 3. ALL RESISTANCE IS EXPRESSED IN OHMS.
 4. ALL CAPACITANCE IS EXPRESSED IN MICROFARADS.

- NOTES:
1. LAST REF DES USED:
U1 MC10116 Q11 Y2
C15 82PF R11 E1
C19 4 U33 P30001

2. REF DES NOT USED:
L1 R25 J1

3. REF DES OUT OF SEQ:

0000000004	1/85	00044	3/86
0000000005	1/85	00045	3/86
0000000006	2/85	00046	3/86
0000000007	3/85	00047	3/86
0000000008	1/86	00048	3/86
0000000009	1/86	00049	3/86
0000000010	2/86	00050	3/86
0000000011	2/A6	00051	3/86
0000000012	2/C5	00052	3/86
0000000013	2/D5	00053	3/86
0000000014	2/D5	00054	3/86
0000000015	2/D7	00055	3/86
0000000016	2/E5	00056	3/86
0000000017	2/F5	00057	3/86
0000000018	2/F5	00058	3/86
0000000019	2/G5	00059	3/86
0000000020	2/H4	00060	3/86
0000000021	2/H4	00061	3/86
0000000022	2/H4	00062	3/86
0000000023	2/H4	00063	3/86
0000000024	2/H4	00064	3/86
0000000025	2/H4	00065	3/86
0000000026	2/H4	00066	3/86
0000000027	2/H4	00067	3/86
0000000028	2/H4	00068	3/86
0000000029	2/H4	00069	3/86
0000000030	2/H4	00070	3/86

4. FUNCTIONS NOT USED:
U4A
-4- 0-2-
-5- 3-
U4B
-9- 6-
-10- 7-

C15 (SAT.) TUNES OSCILLATOR 1 CIRCUIT TO 8.091269 MHz AT TPI; NOMINAL 82PF, RANGE: 68pf TO 100pf

R3 SAT VALUES 470, 680, 820, 1K OHMS

SEE SEPARATE BILL OF MATERIALS

REV	DATE	BY	CHKD	APPD

UNLESS OTHERWISE SPECIFIED
ALL DIMENSIONS ARE IN INCHES
DECIMALS ARE TO 0.010 UNLESS OTHERWISE SPECIFIED
ANGLES ARE TO 1/4
SURFACE FINISHES
REMOVE ALL BURRS
DRAWING NOT TO BE SCALED

FRG INC - WICHITA, KANSAS
SCHEMATIC RANGE 3D NO. 1 49-103
00004910-300H
SHEET 1 OF 3

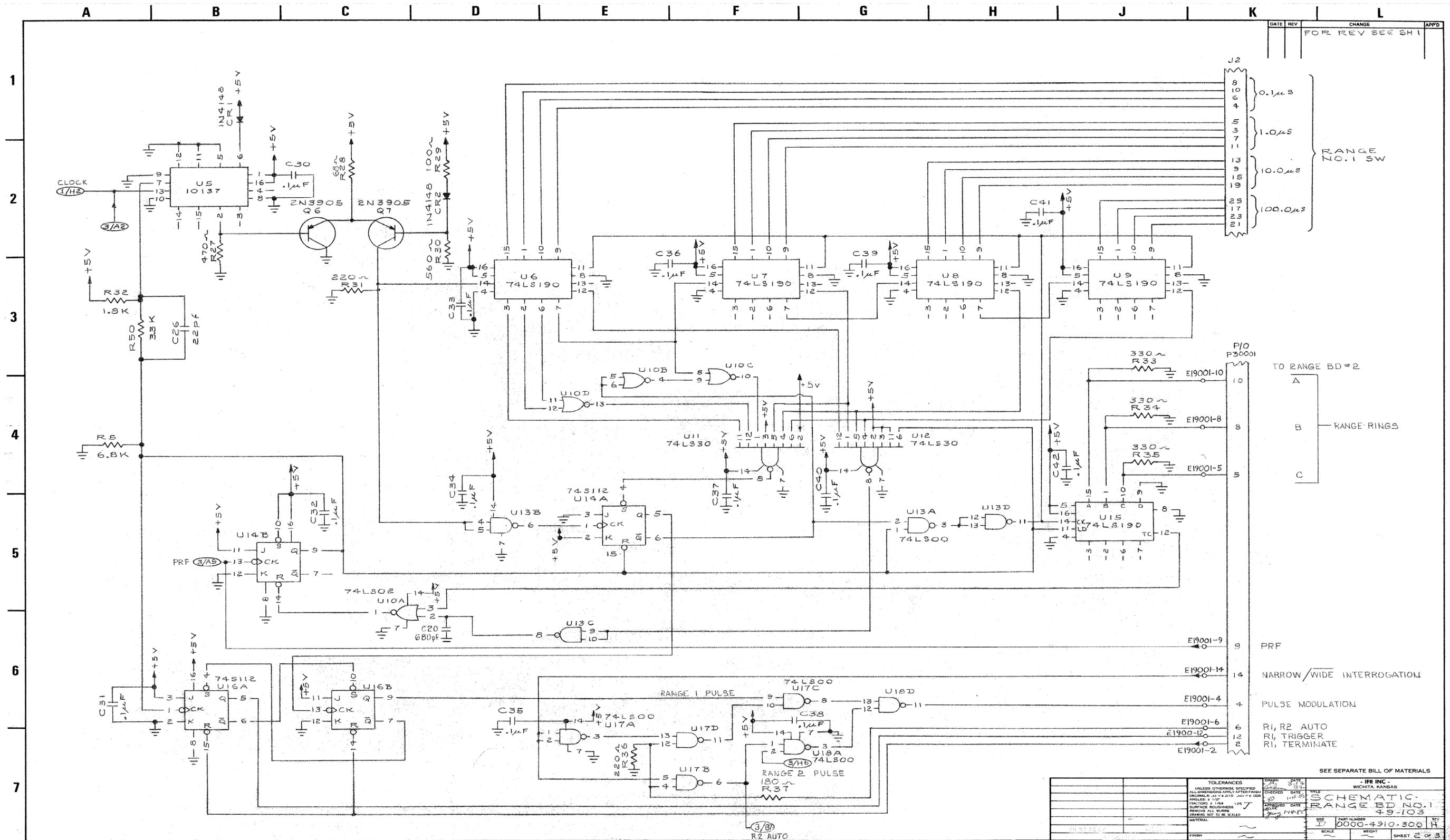

Subject to Export Control, see Cover Page for details.

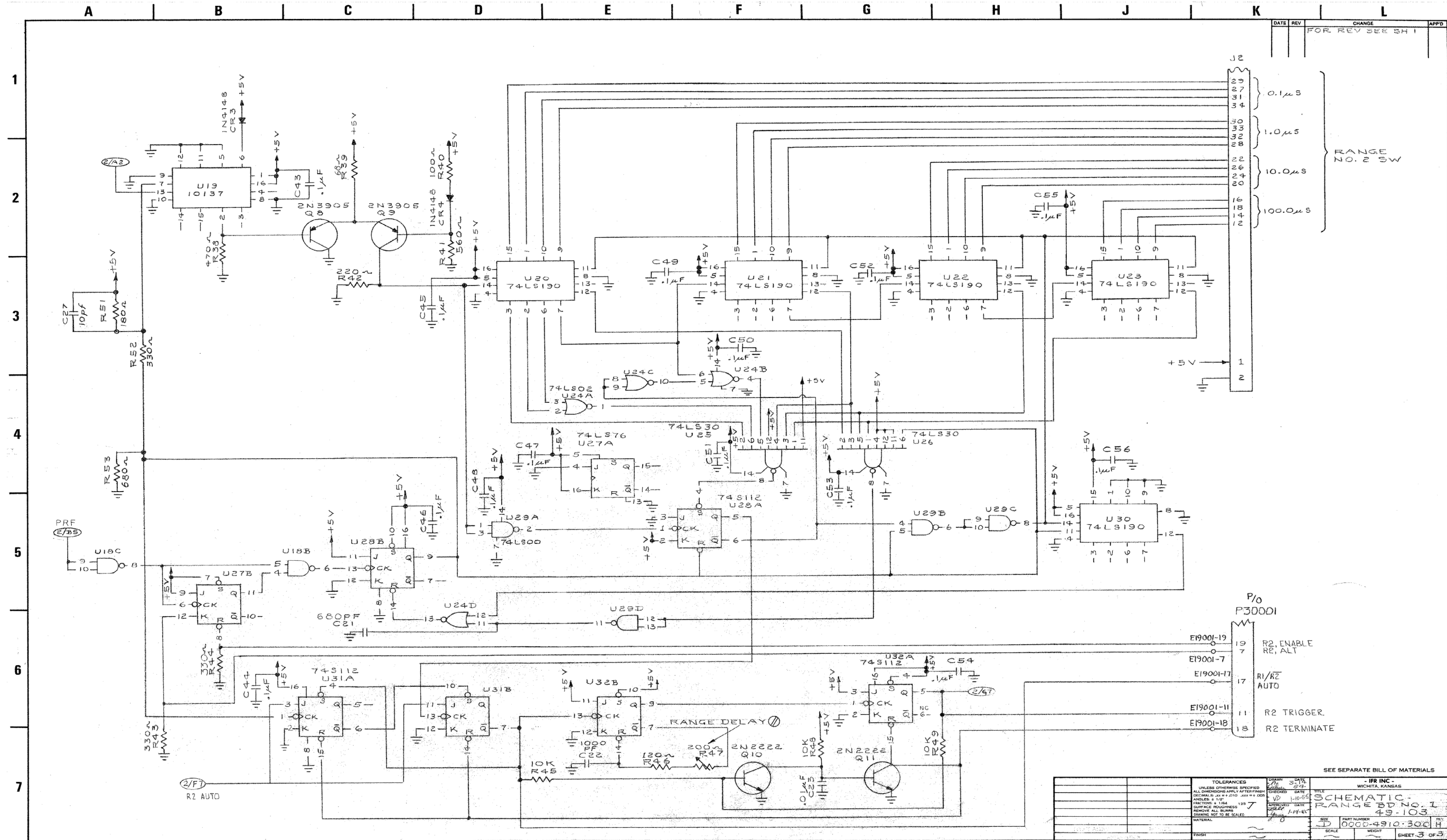

Subject to Export Control, see Cover Page for details.

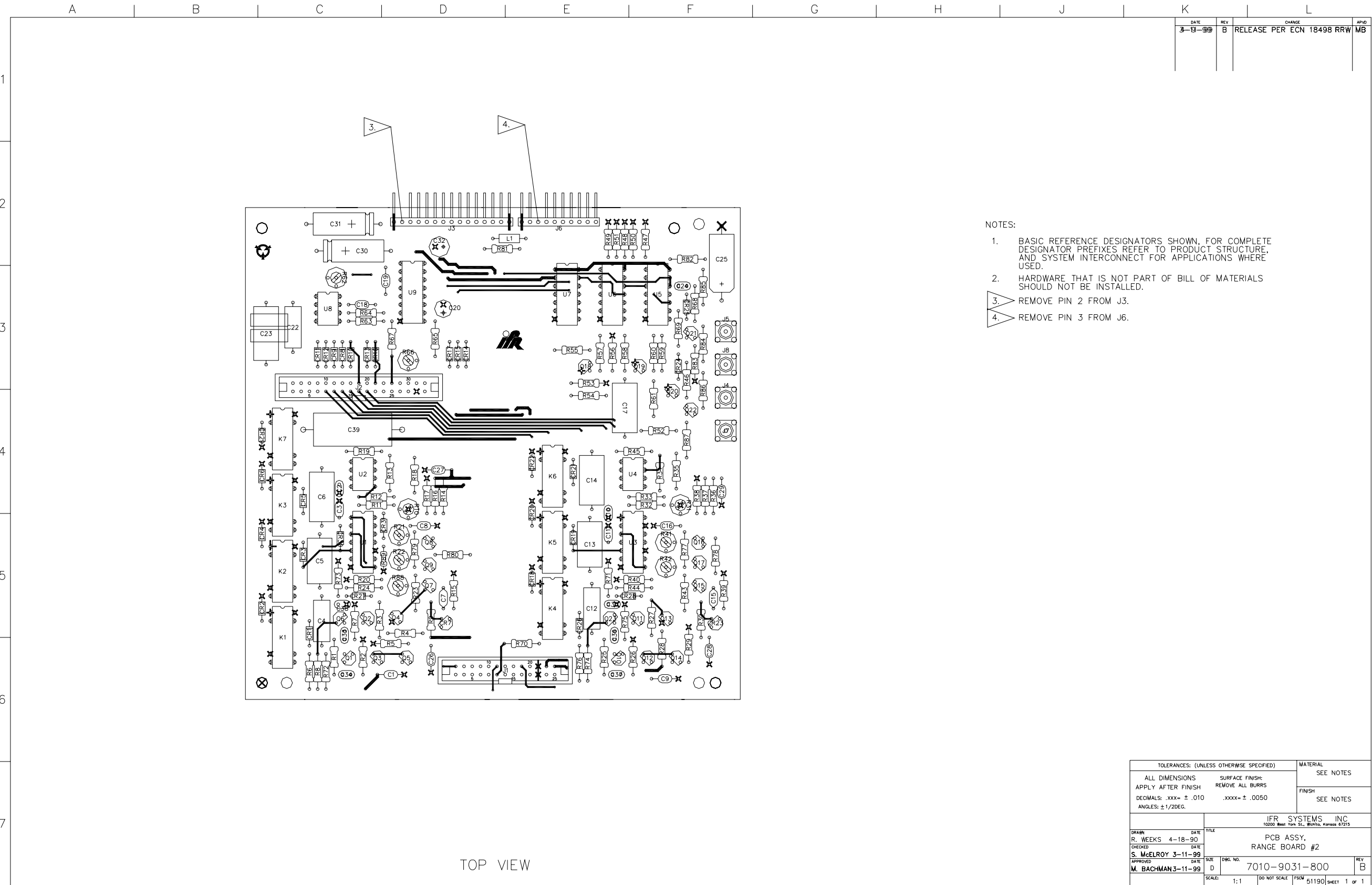

DATE	REV	CHANGE	APPROVED
3-13-99	B	RELEASE PER ECN 18498 RRW	MB

NOTES:

1. BASIC REFERENCE DESIGNATORS SHOWN. FOR COMPLETE DESIGNATOR PREFIXES REFER TO PRODUCT STRUCTURE, AND SYSTEM INTERCONNECT FOR APPLICATIONS WHERE USED.
2. HARDWARE THAT IS NOT PART OF BILL OF MATERIALS SHOULD NOT BE INSTALLED.
3. REMOVE PIN 2 FROM J3.
4. REMOVE PIN 3 FROM J6.

TOLERANCES: (UNLESS OTHERWISE SPECIFIED)		MATERIAL	
ALL DIMENSIONS	SURFACE FINISH:	SEE NOTES	
APPLY AFTER FINISH	REMOVE ALL BURRS	FINISH	
DECIMALS: .xxx = ± .010	.xxxx = ± .0050	SEE NOTES	
ANGLES: ± 1/2DEG.			
IFR SYSTEMS, INC. 10200 West York St., Wichita, Kansas 67215			
DRAWN R. WEEKS	DATE 4-18-90	TITLE PCB ASSY, RANGE BOARD #2	
CHECKED S. McELROY	DATE 3-11-99	SIZE D	REV B
APPROVED M. BACHMAN	DATE 3-11-99	DWG. NO. 7010-9031-800	
SCALE 1:1	DO NOT SCALE	FROM 51190	SHEET 1 OF 1

Subject to Export Control, see Cover Page for details.

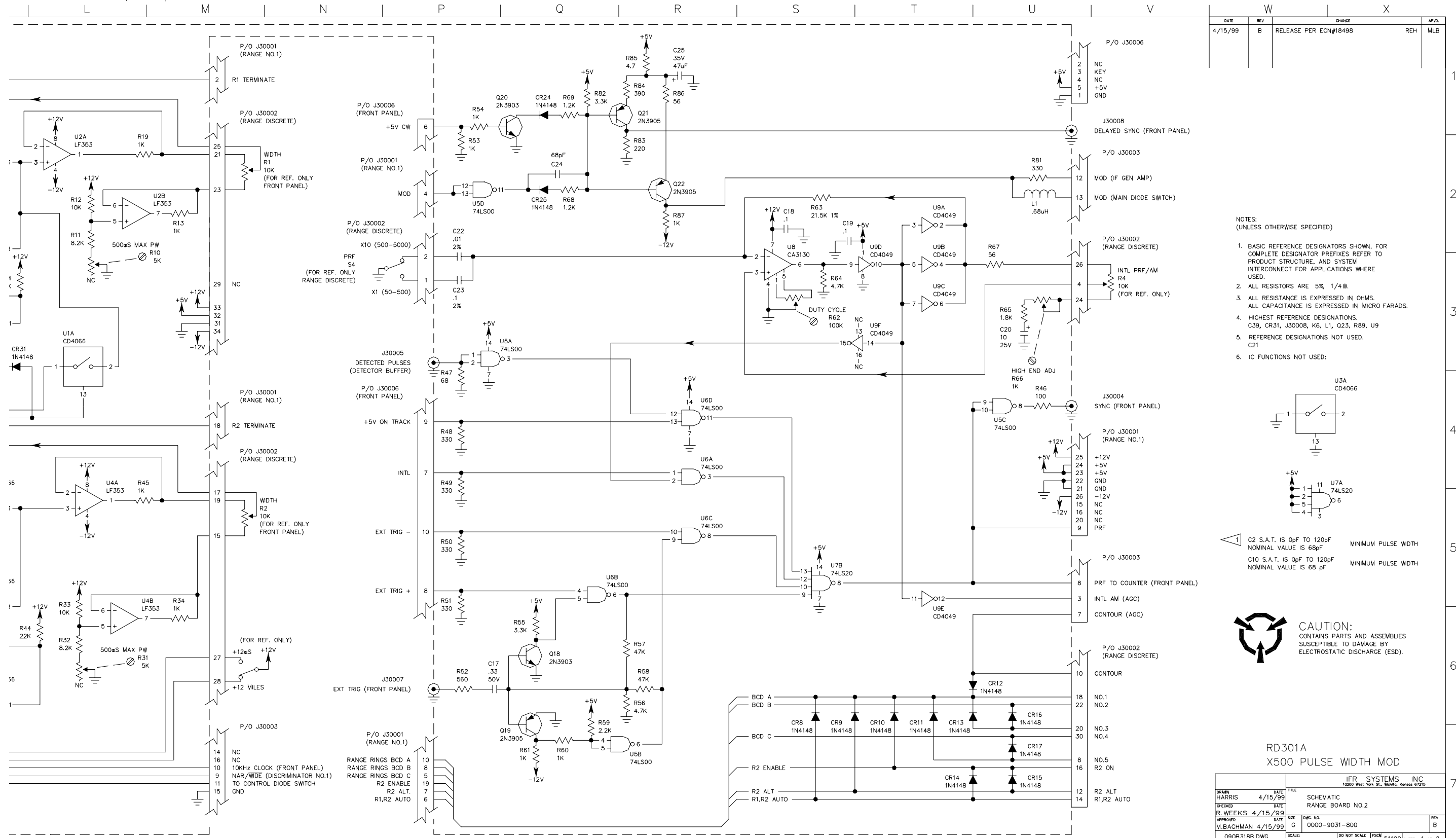

- NOTES:
(UNLESS OTHERWISE SPECIFIED)
1. BASIC REFERENCE DESIGNATORS SHOWN, FOR COMPLETE DESIGNATOR PREFIXES REFER TO PRODUCT STRUCTURE, AND SYSTEM INTERCONNECT FOR APPLICATIONS WHERE USED.
 2. ALL RESISTORS ARE 5%, 1/4W.
 3. ALL RESISTANCE IS EXPRESSED IN OHMS. ALL CAPACITANCE IS EXPRESSED IN MICRO FARADS.
 4. HIGHEST REFERENCE DESIGNATIONS. C39, CR31, J30008, K6, L1, Q23, R89, U9
 5. REFERENCE DESIGNATIONS NOT USED. C21
 6. IC FUNCTIONS NOT USED:

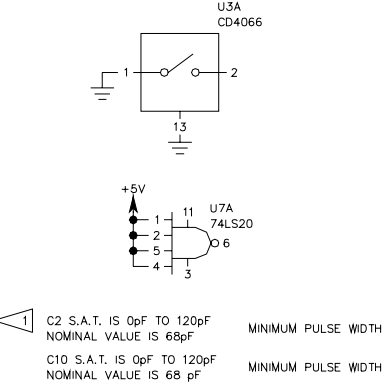

CAUTION:
CONTAINS PARTS AND ASSEMBLIES
SUSCEPTIBLE TO DAMAGE BY
ELECTROSTATIC DISCHARGE (ESD).

RD301A
X500 PULSE WIDTH MOD

DRAWN		DATE		TITLE	
HARRIS	4/15/99	SCHEMATIC RANGE BOARD NO.2			
CHECKED		DATE		SCALE	
R. WEEKS	4/15/99	DO NOT SCALE			
APPROVED		DATE		REV	
M. BACHMAN	4/15/99	G	0000-9031-800	B	
090B318B.DWG		SCALE		SHEET 1 OF 2	

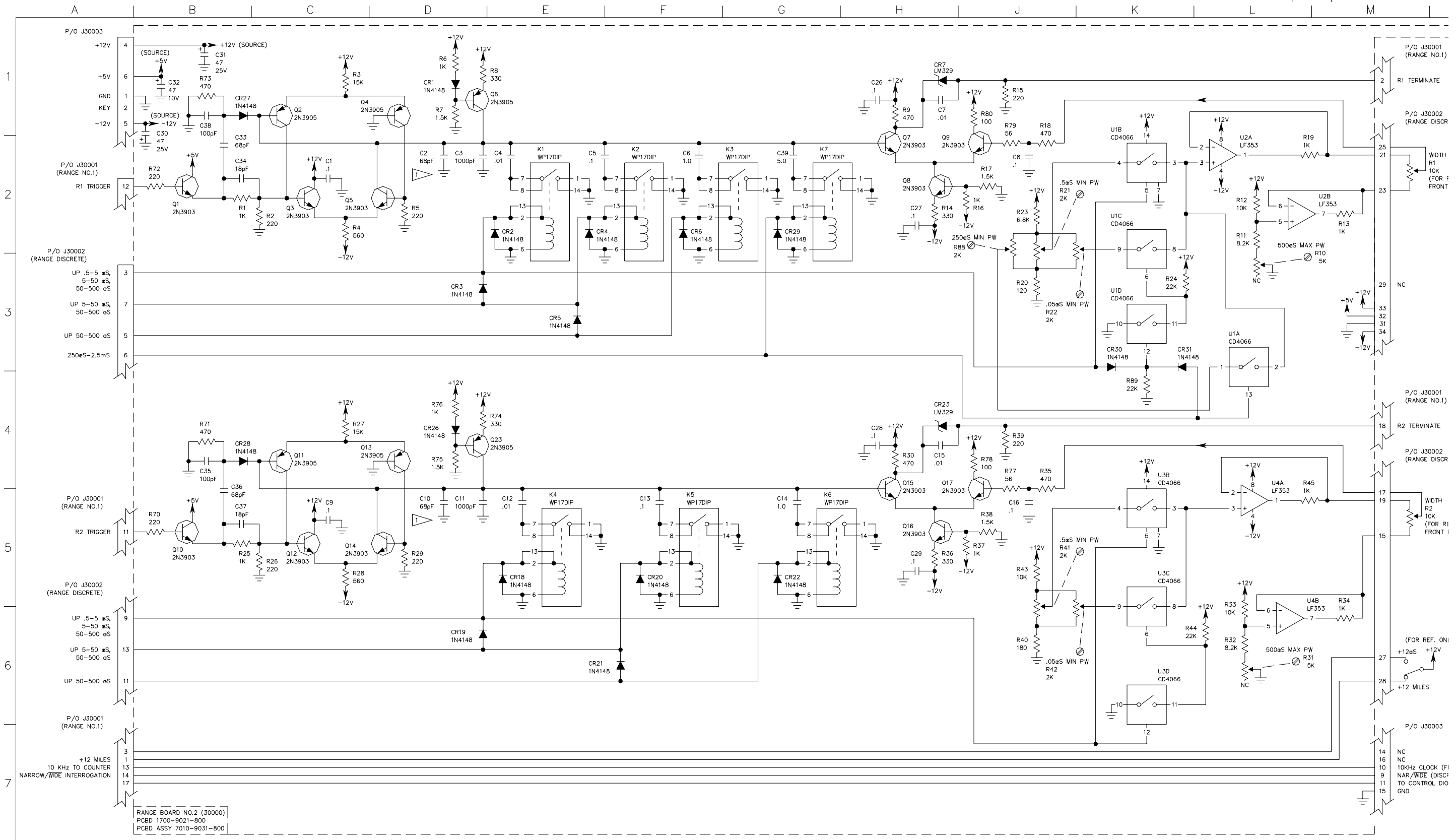

RD301A X500 PULSE WIDTH MOD. 090B318B.DWG RANGE BOARD NO.2 0000-9031-800 REV B SHEET 2 OF 2

Subject to Export Control, see Cover Page for details.

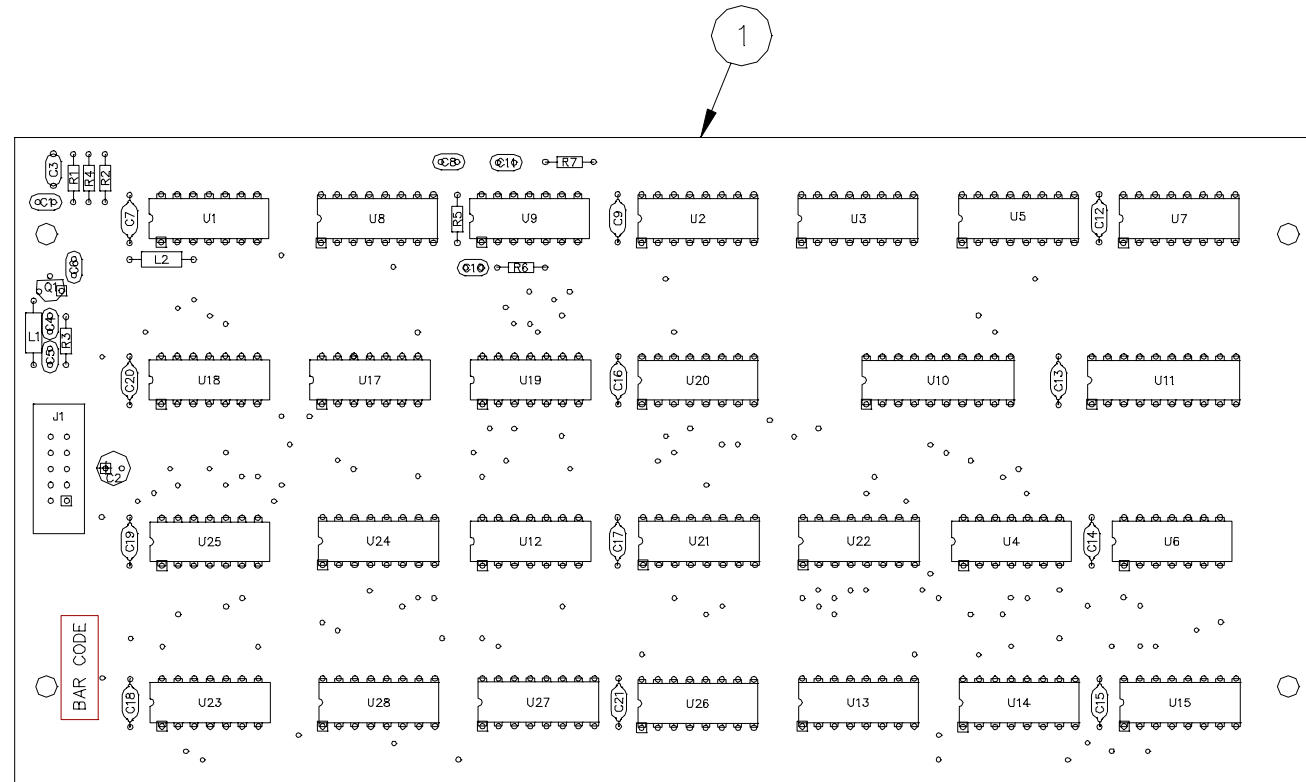

STUFF NOTES:

1. INSTALL ALL HIGHLIGHTED PARTS.



CAUTION:
CONTAINS PARTS AND ASSEMBLIES SUSCEPTIBLE TO
DAMAGE BY ELECTROSTATIC DISCHARGE (ESD).

IFR Systems Inc. Assembly Process Print	PROC. CHG BY: R.B. 03/Nov/03	Last ECN:	Prepared By: 03/Nov/03 R. BURNETT	Check By:	Description PCB ASSY, DISCRIMINATOR #2	Assembly # *7010-4931-300*	Revision *B5*	Operation 1 of 1 Sheet 1 of 1
--	---------------------------------	-----------	--------------------------------------	-----------	---	-------------------------------	------------------	----------------------------------

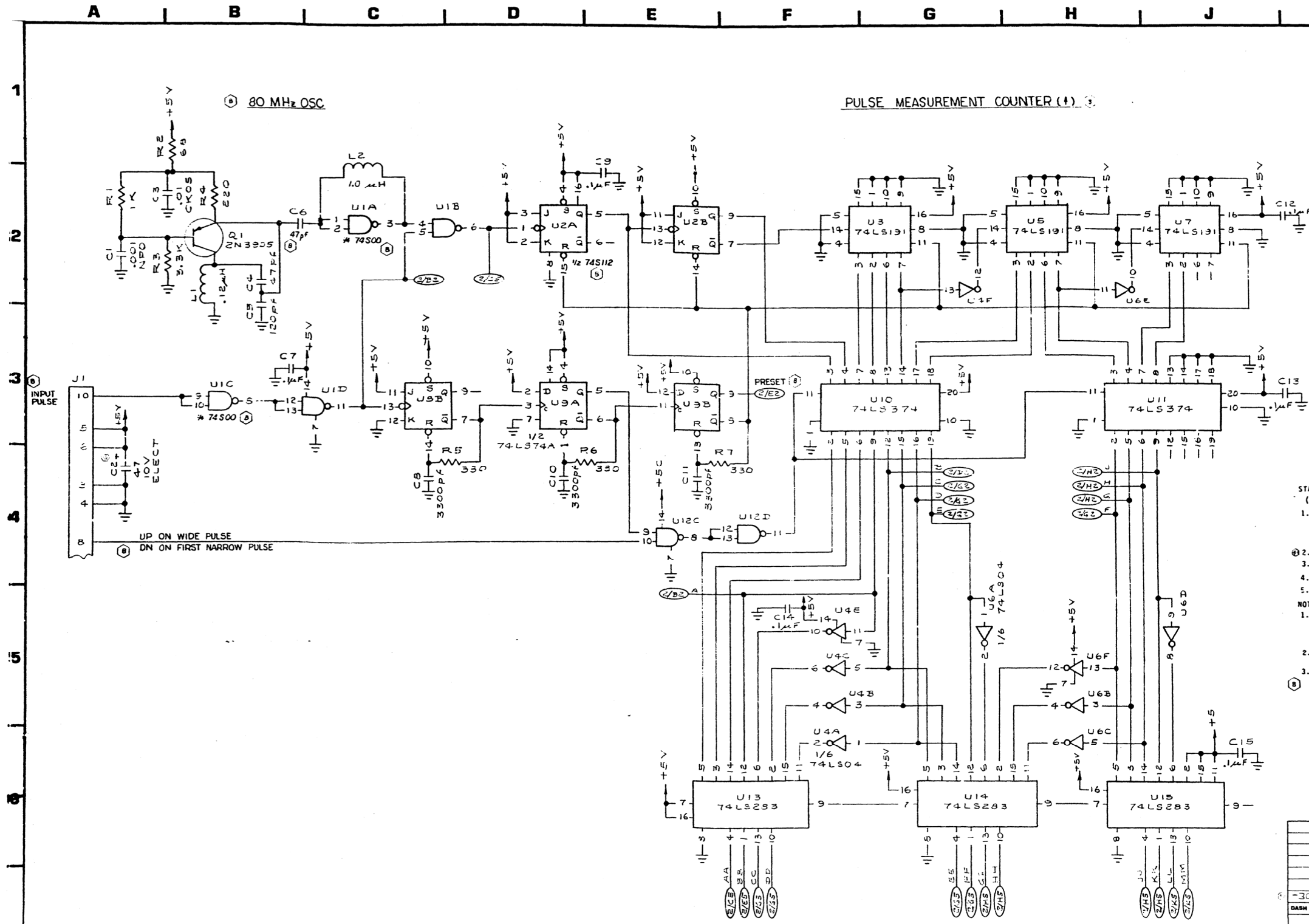

DATE	REV	CHANGE	BY	CHKD
12-2-84	1	Revised per mark up	EA	EA
12-2-84	2	PRODUCTION RELEASE ECN 4990	EA	EA
12-2-84	3	REVISED PER MARK UP	EA	EA

- STANDARDS:
(UNLESS OTHERWISE NOTED)
1. ALL REFERENCE NUMBERS CARRY AN ASSIGNED DESIGNATOR SERIES. THIS SCHEMATIC CARRIES SERIES 35XXX (E.G. R1 IS R35001).
 2. ALL RESISTORS ARE: 1/4w 5%
 3. ALL RESISTANCES ARE EXPRESSED IN OHMS.
 4. ALL CAPACITANCES ARE EXPRESSED IN MICROFARADS.
 5. ALL INDUCTANCES ARE EXPRESSED IN MICROHENRIES.
- NOTES:
1. LAST REF DES USED:
C21 RQ1
J1 RQ7
L2 U2B
 2. REF DES NOT USED:
U16
 3. FUNCTIONS NOT USED:
U17D

DASH NO	REF DES	NEXT ASSY	MODEL
-300	35XXX	7010-4931-300	RD-301
APPLICATION			
-IFR INC- 1000 West Park Street Woburn, Mass 01896			
DESIGNED	DATE	CHKD	DATE
EA	12-2-84	EA	12-2-84
CHECKED	DATE	DATE	DATE
EA	12-2-84		
APPROVED	DATE	DATE	DATE
EA	12-2-84		
SCALE		CODE IDENT	WEIGHT
		5110	
SHEET 1		OF 2	

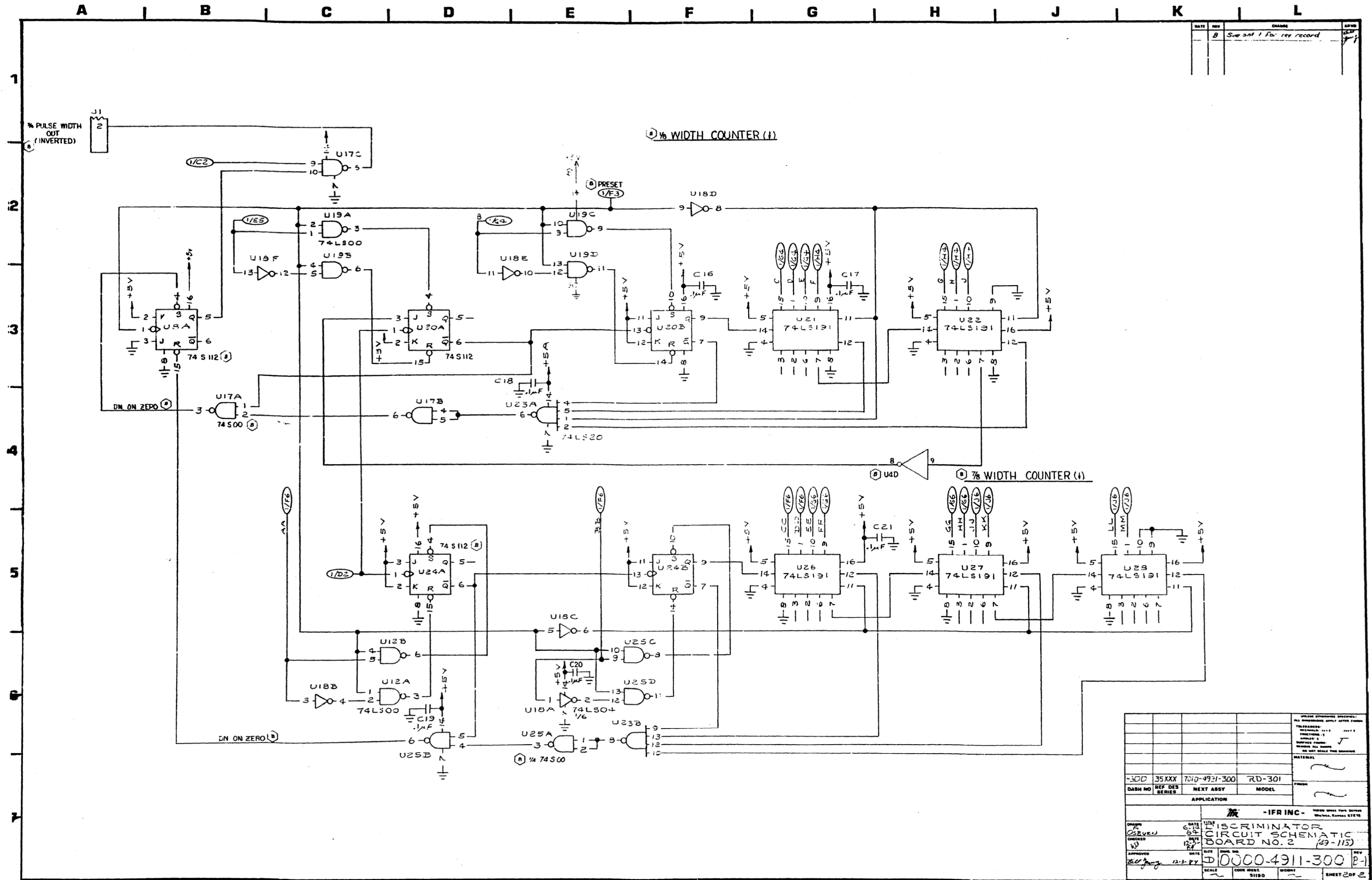

DASH NO				REF DES				NEXT ASSY				MODEL			
-300				35XX				7010-931-300				RD-301			
APPLICATION															
- IFR INC -															
DATE		DRAWN		DATE		CHECKED		DATE		DATE		DATE		DATE	
02/10/82		02/10/82		02/10/82		02/10/82		02/10/82		02/10/82		02/10/82		02/10/82	
DISCRIMINATOR CIRCUIT SCHEMATIC BOARD NO. 2 (49-115)															
SCALE				CODE				WEIGHT				SHEET 2 OF 2			
1:1				1110				1110				2			

DATE	REV	CHANGE	APPR	DATE	REV	CHANGE	APPR
1-27-77	J	INC ECN 17618	RH	DSG	A	PRODUCTION RELEASE ECN 8053	VAH
4-29-78	K	INC 19830	EC	GH	5-19-80	INC ECN 8521	JS
7-14-77					A-1	INC ECN 8234 ADDENDUM "CHIPS"	VAH
7-14-77					D-1	INC ECN 9972	JS
7-14-77					D-2	INC RC 10175	AO
7-14-77					E	INC RC 10161 "CHIPS"	VAH
7-14-77					E-1	INC ECN 11166	HV
7-14-77					E-2	INC RC 11441	AO
7-14-77					E-3	INC ECN 11474	AO
7-14-77					E-4	INC RC 11499	PL
7-14-77					E-5	INC RC 11871	PL
7-14-77					E-6	INC RC 11966	JR
7-14-77					E-7	INC RC 12365	AO
7-14-77					E-8	INC ECN 13230	AO
7-14-77					E-9	INC RC 13334	AO
7-14-77					F	INC RC 13387	AO
7-14-77					F-1	INC RC 13534	AO
7-14-77					F-2	INC RC 13490	AO
7-14-77					F-3	INC RC 13858	AO
7-14-77					G	INC ECN 14073	AO
7-14-77					G-1	INC ECN 15477	BP
7-14-77					G-2	INC ECN 15510	BP
7-14-77					G-3	INC ECN 16283	MRM

NOTES:

- ALL REF NO'S CARRY AN ASSIGNED DESIGNATOR SERIES. THIS DWG CARRIES SERIES 50XXX (e.g., R1 IS R50001).
- MOUNT MIXER 1 AND 2 FLAT AGAINST P.C. BOARD. TAC SOLDER CAN TO GND PLANE. USED M2A ONLY.
- NOTE NOT USED.
- NOT USED.
- NOT USED.
- NOTE NOT USED.
- NOTE NOT USED.
- NOTE NOT USED.
- NOTE NOT USED.
- NOTE NOT USED.
- L7 IS CONSTRUCTED FROM AN 18GA WIRE 1.8" LG. C60 IS ATTACHED 2" FROM GND PLANE. (SEE DETAIL P62 FOR CONSTRUCTION INFO).
- NOT USED.
- REMOVE OXIDE AND EXCESS SOLDER UNDER ENCLOSURE.
- NOT USED.
- LEAD ON SLEEVING
L61: C95 4" IF POSSIBLE, 3" MIN
L59: R120 5"
L58: R136 4"
- C155 LEADS TO SOLDER TO TRACE IN LINE WITH ADJACENT PLATED THRU HOLES
- O86 SEMI RIGID, 1.25" LG SOLDERED TO GND AT ENDS
- L62 IS FORMED BY 26GA, 11" LG, 2 TURNS. KEEP IT CLEAR OF THE COVER BLOCK
- NO CONNECTION TO PC BOARD
- NOT USED
- NOTE NOT USED

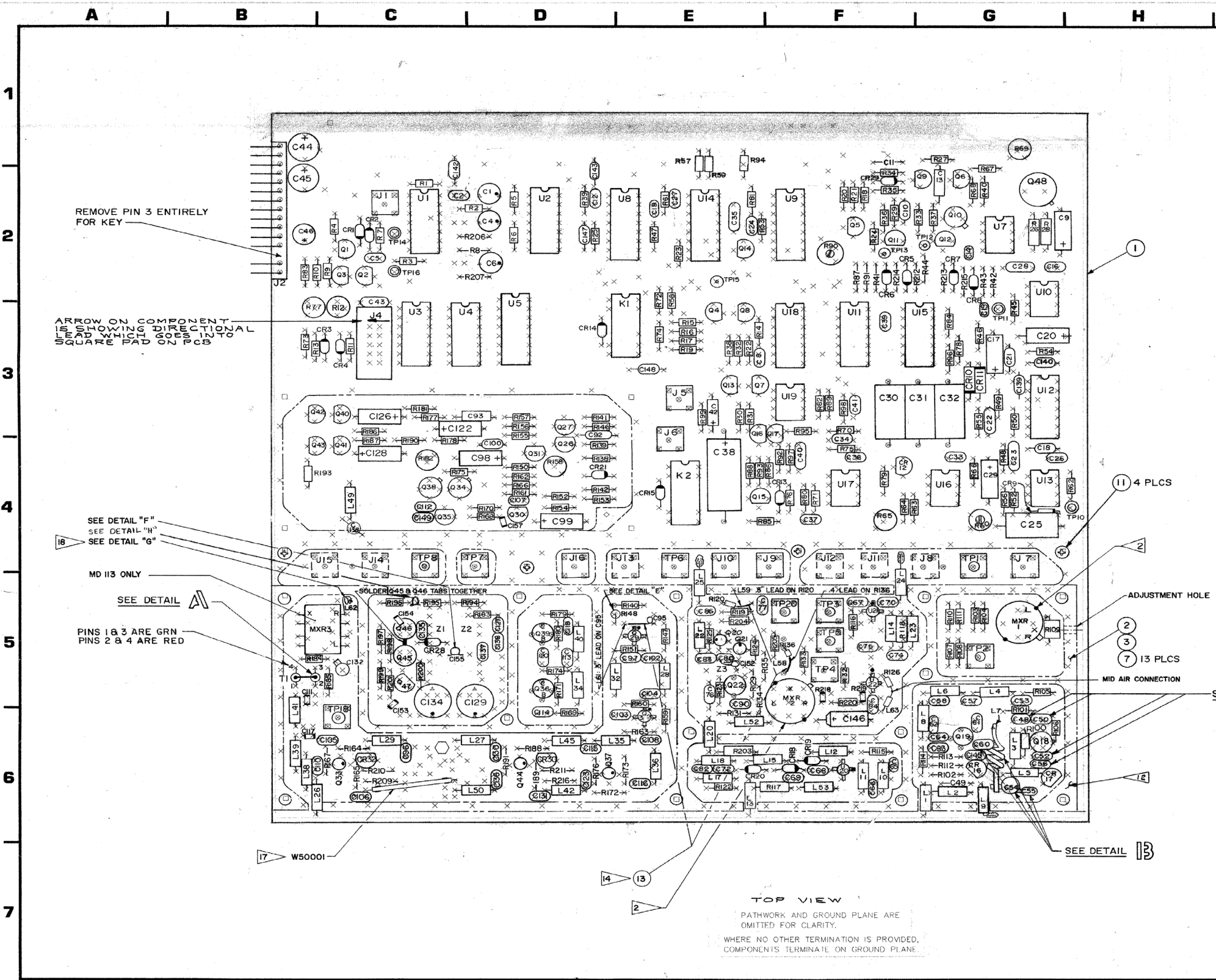

SEE SHEET 3 FOR DETAILS

DRAWN		DATE		TITLE	
J. SIGLER				P.C. BD ASS'Y	
CHECKED		DATE		DISCRIMINATOR BD NO. 1	
T. [Signature]		5/15/86		RD301 (49-328)	
APPROVED		DATE		DWG. NO.	
D				7010-4932-800	
SCALE		CODE IDENT		SHEET	
2:1		5110		1 OF 3	

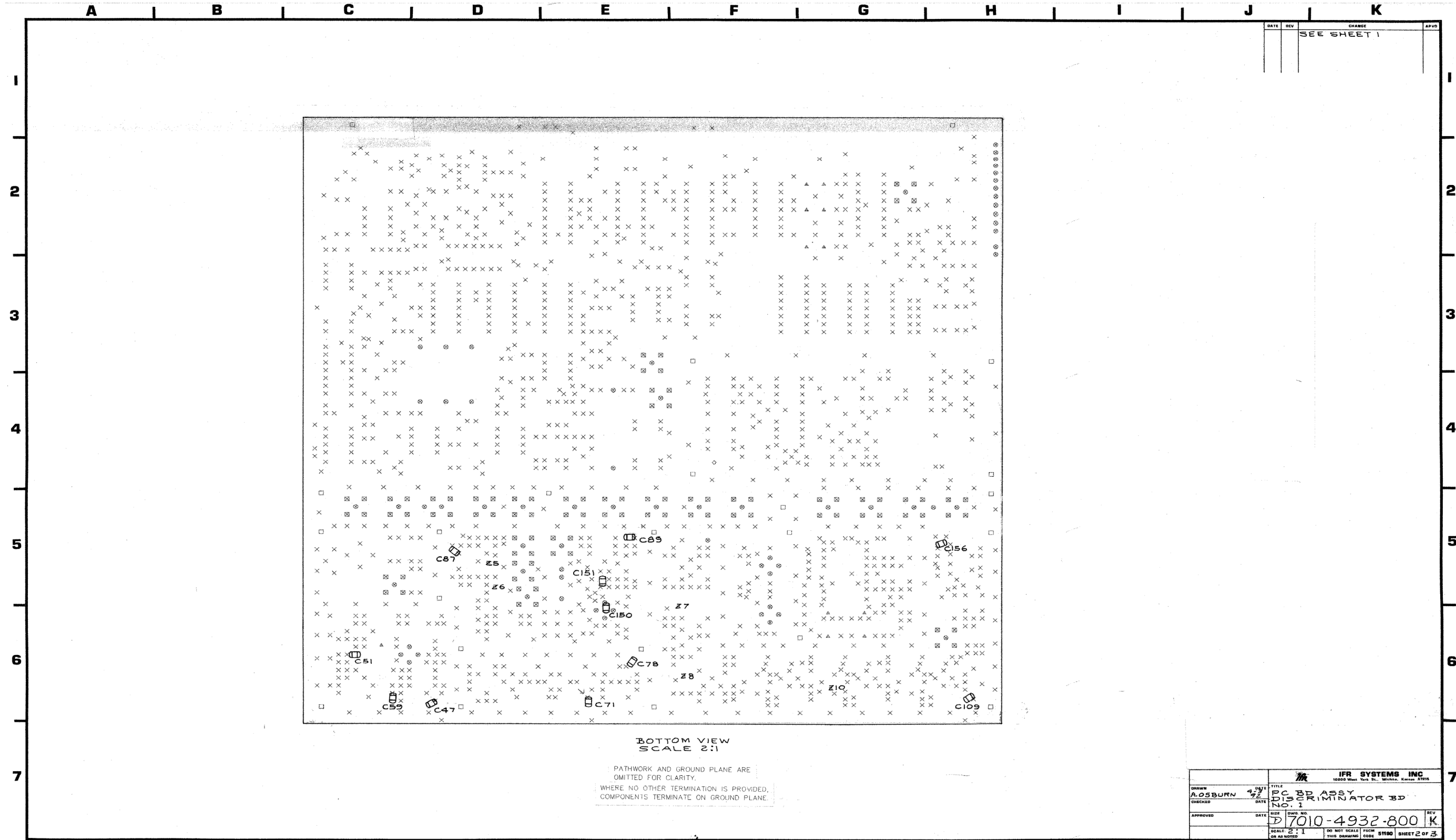

DATE	REV	CHANGE	APPROVED
		SEE SHEET 1	

IFR SYSTEMS INC 10800 Main York St., Wichita, Kansas 67218			
DRAWN A.OSBURN	DATE 4/27/72	TITLE PC BOARD ASSY DISCRIMINATOR 3D NO. 1	REV
CHECKED	DATE	SIZE D	REV K
APPROVED	DATE	QTY 1	REV
		SCALE 2:1	REV
		DO NOT SCALE OR ADJUST THIS DRAWING	FORM 5180 SHEET 2 OF 3

DATE	REV	CHANGE	APPROV
		SEE SHEET ONE	

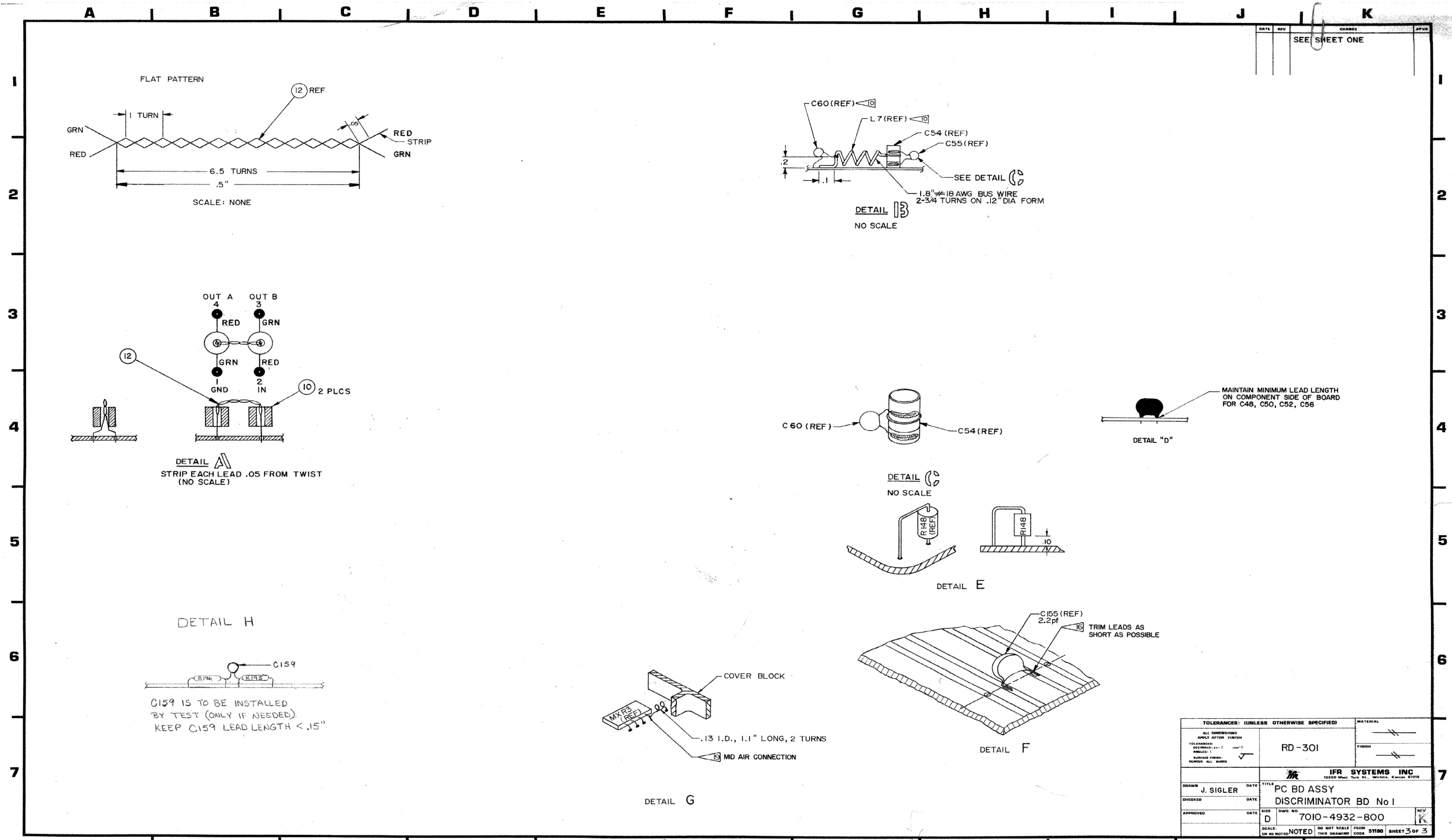

TOLERANCES: (UNLESS OTHERWISE SPECIFIED)		MATERIAL
ALL DIMENSIONS APPLY AFTER FINISH		
TOLERANCES: DECIMALS: .015" ± .001"	RD-301	FINISH
FRACTIONS: 1/16" ± .001"		
ANGLES: 1° ± .05°		
SURFACE FINISH: REMOVE ALL BURRS		
IFR SYSTEMS INC 10250 West York St., Wichita, Kansas 67225		
DRAWN: J. SIGLER	DATE:	TITLE: PC BD ASSY
CHECKED:	DATE:	DISCRIMINATOR BD No 1
APPROVED:	DATE:	SIZE: D
		DWG NO: 7010-4932-800
		SCALE: D
		DO NOT SCALE FROM THIS DRAWING
		OR AS NOTED
		FROM THIS DRAWING
		CODE: 5190
		SHEET 3 OF 3

A B C D E F G H J K L

1
2
3
4
5
6
7

DATE	REV	CHANGE	APPROV
	B	PROD. REL. & ADVANCED BOARD TO "B" REV. PER FIRST BUILD ECN 8053	VLH
5-15-80	B1	INC ECN 8521	JS VLH
4-14-81	D	INC ECN 9238 & ADDENDUM "CHIPS"	VLH
8-1-81	D-1	INC ECN 9972	JS VLH
7-8-81	E	INC RC 10161 "CHIPS"	VLH
7-8-81	E-1	INC ECN 11166	JR BP
7-8-81	F-1	INC ECN 13230	BP
7-8-81	E-3	INC ECN 13534	A0 BP
7-8-81	F	WAS NEVER RELEASED	
7-8-81	G	INC ECN 14073	BP
7-8-81	G1	INC ECN 15477	AD BP
7-8-81	H	INC ECN 16283	MRM BM
7-8-81	J	INC ECN 17618	MRM BSB
7-8-81	K	INC 19830	EC GH
7-8-81	L	INC 20600	EB RC

▷ R114 IS S.A.T. (SELECTED AT TEST)
NOMINAL VALUE: 50 OHM
ALLOWED VALUES: 39 OHM
82 OHM, 120 OHM, 150 OHM,
180 OHM

7. PRINTED INDUCTOR SPECS:
L10013 * .75 Lg
L19013 * .75 Lg
L31013 * .75 Lg
L33013 * .67 Lg
L37013 * 1.00 Lg
L43013 * .75 Lg
L51013 * .78 Lg
L54015 * .310 Lg
L55015 * .215 Lg

▷ C2, C3 & C7 ARE INSTALLED IN FINAL TEST, AS REQUIRED.
RANGE VALUE: C2 - NOM 27pf
RANGE 15-33pf
C3 RANGE 0-56pf
C7 RANGE 0-82pf

- ▷ SAT VALUES FOR R39 ARE 12K, 15K
- ▷ SAT VALUES FOR R47 ARE 18K, 22K
- ▷ SAT VALUES FOR R61 ARE 2.2K, 10K
- ▷ SAT VALUES FOR R81 ARE 330K, 390K
- ▷ SAT VALUES FOR C159 IS 100pf, NOMINAL IS Opt. IF INSTALLED KEEP LEAD LENGTH OF C159 < .15"

STANDARDS:
(UNLESS OTHERWISE NOTED)

1. ALL REF. N^o'S CARRY AN ASSIGNED DESIGNATOR SERIES. THIS SCHEMATIC CARRIES SERIES 50XXX, (e.g., R1 IS R.50001).
2. ALL RESISTORS ARE 1/4 W, 5%.
3. ALL RESISTANCE IS EXPRESSED IN OHMS.
4. ALL CAPACITANCE IS EXPRESSED IN MICROFARADS.
5. ALL INDUCTANCE IS EXPRESSED IN MICRO-HENRY'S.

NOTES:

1. LAST REF. DES. USED:
C159 MXR3 EI
CR32 Q48 TI
J16 TP20
K2 R220
L63 U22

3. REF. DES. NOT USED:
J3 T2 C125 R130 R202 L57 C94 L56 Q28
TP9 L47 C144 R133 R51 23 C101 R144
TP17 L48 C95 C91 R143 24 C136 R137 R149
L21 R142 R135 Q23 TP19 211 C3 R217 R208
C79 U5 R127 Q24 C88 C21 C7 R145 C73
C81 C124 R128 Q25 R21 C118 L50 CR31

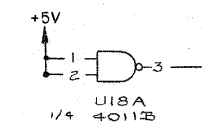
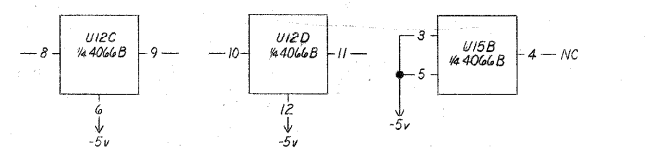
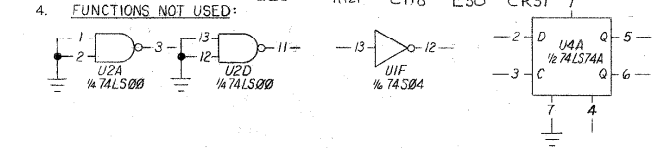

DRAWN		DATE		TITLE	
L.A. Meis, Jr.		12 NOV 75		SCHEMATIC	
CHECKED		DATE		DISCRIMINATOR Bd #1	
DATE		DATE		RD 301	
DATE		DATE		(49-128)	
DATE		DATE		REV	
DATE		DATE		L	
DATE		DATE		D	
DATE		DATE		0000-4912-800	
DATE		DATE		SCALE	
DATE		DATE		CODE IDENT	
DATE		DATE		WEIGHT	
DATE		DATE		SHEET / OF 5	

DATE	REV	CHANGE	APPROV
		FOR REV SEE SH1	

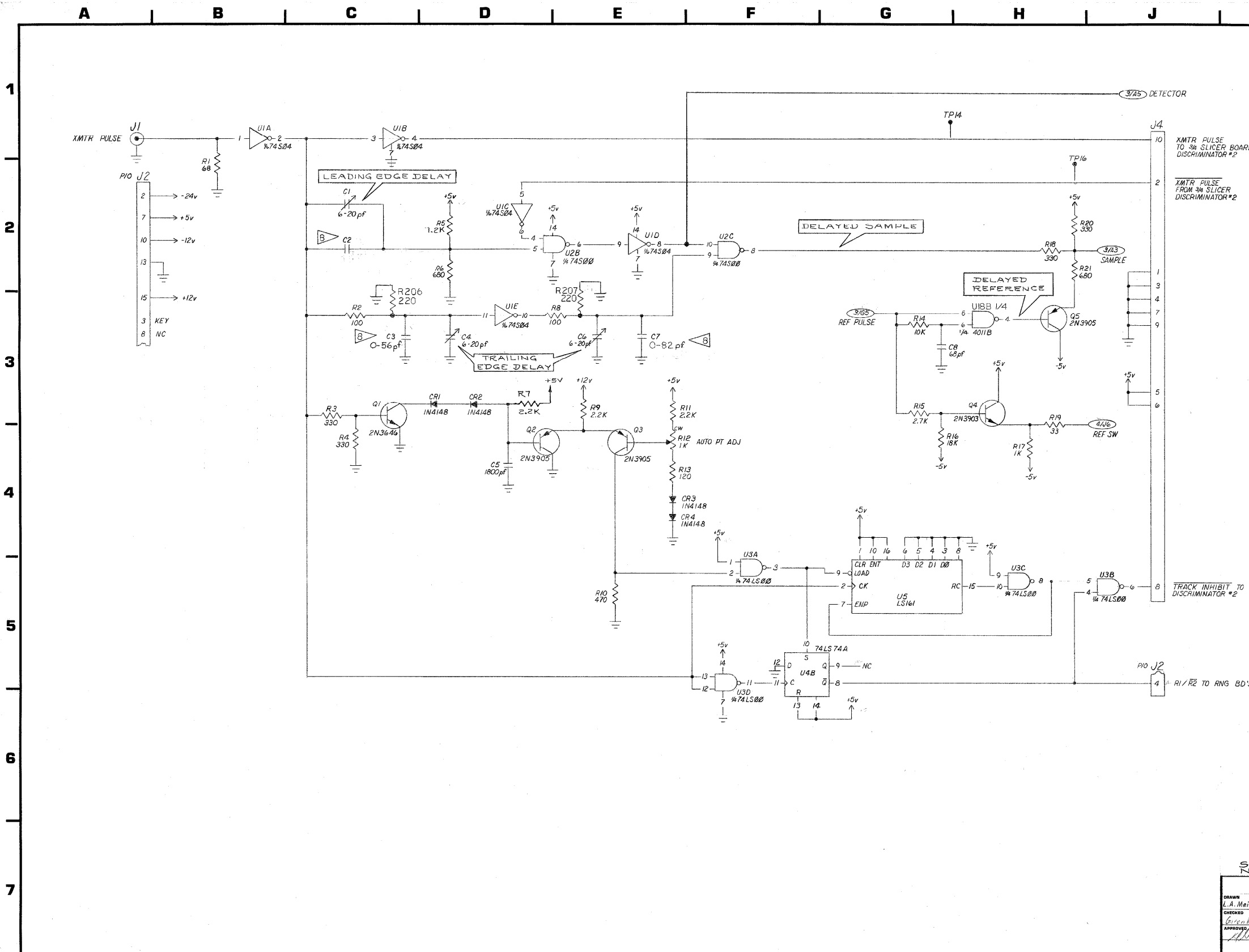

SEE SHEET 1 FOR NOTES & STANDARDS

DRAWN		DATE		TITLE	
L. A. Meis, Jr.		05 NOV 85		SCHEMATIC	
CHECKED		DATE		DISCRIMINATOR Bd N° 1	
APPROVED		DATE		RD-301 (49-128)	
SIZE	DWG. NO.	SCALE	CODE IDENT.	WEIGHT	SHEET 2 OF 5
D	0000-4912-800		S119D		

Subject to Export Control, see Cover Page for details.

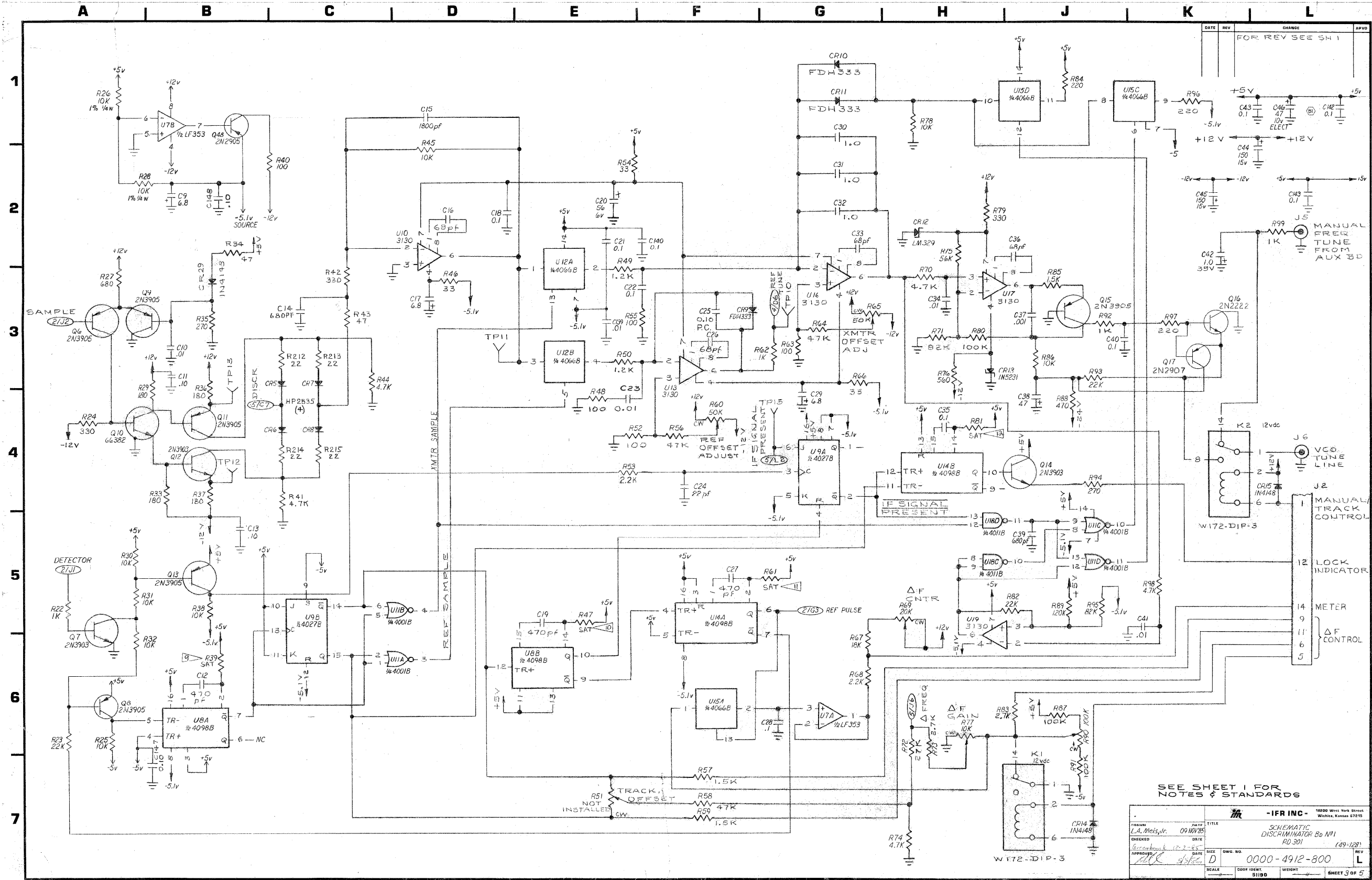

Subject to Export Control, see Cover Page for details.

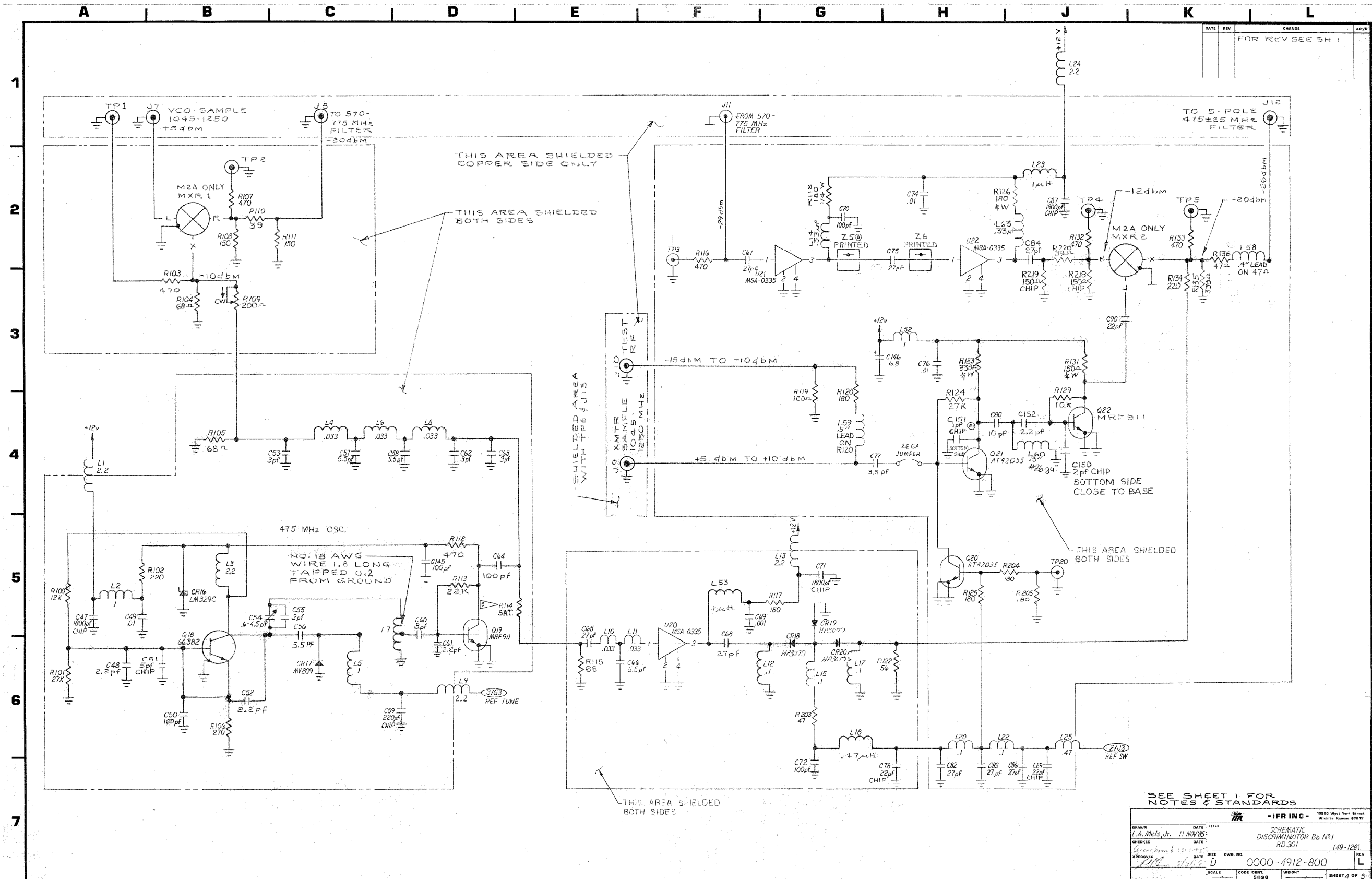

SEE SHEET 1 FOR NOTES & STANDARDS

DRAWN		DATE		TITLE	
L.A. Metz Jr.		11 NOV 75		SCHEMATIC	
CHECKED		DATE		DISCRIMINATOR Bo N#1	
R.L.C. S.L.P.				RD 301	
APPROVED		DATE		SIZE	
R.L.C. S.L.P.				D	
SCALE		CODE IDENT.		WEIGHT	
		S180		SHEET 2 OF 5	

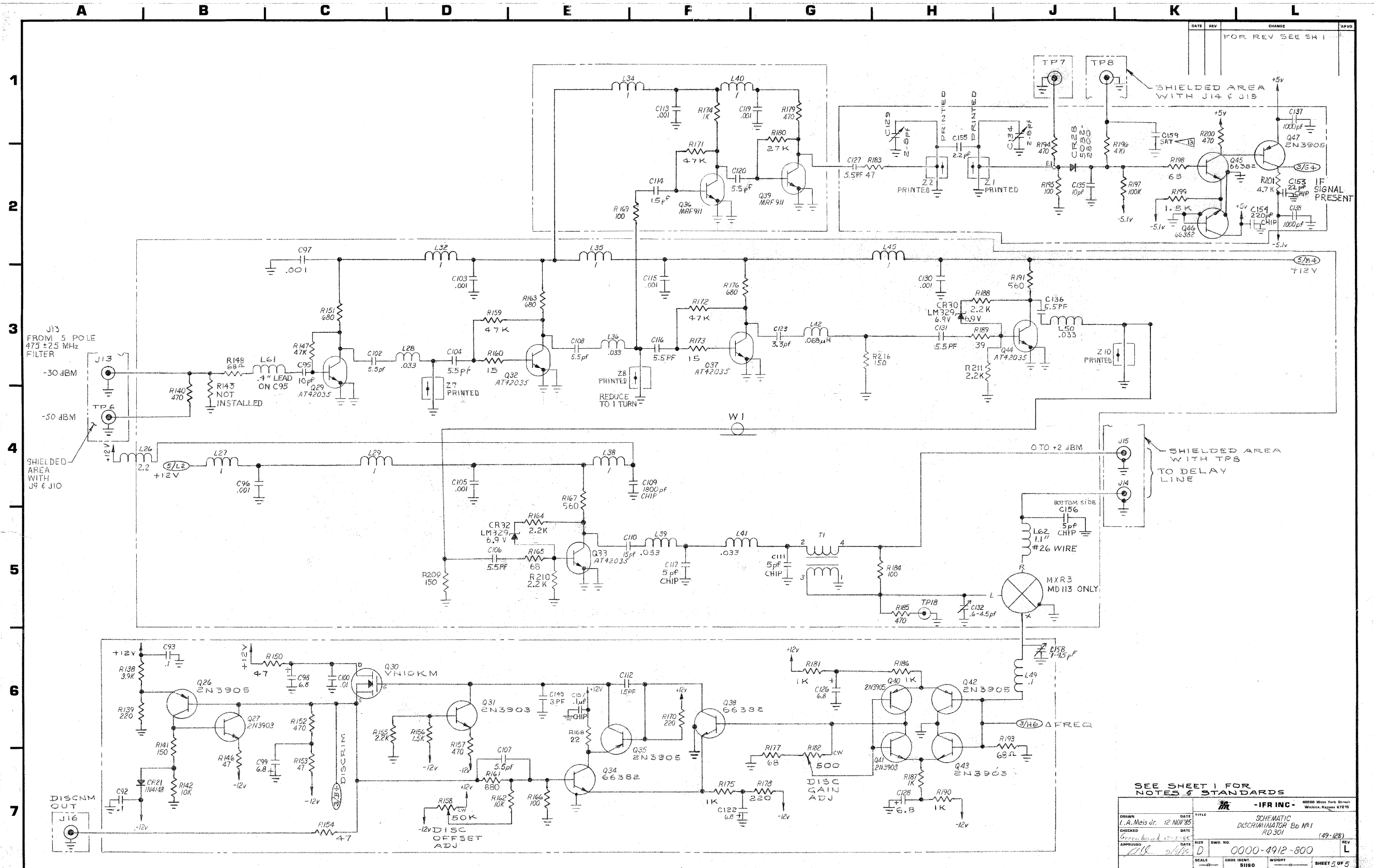

SEE SHEET 1 FOR NOTES & STANDARDS

DRAWN I. A. Meis Jr. 12 NOV 85		DATE		TITLE SCHEMATIC DISCRIMINATOR Bo #1 RD 301 (49-128)	
CHECKED George Bensch 12-2-85		DATE		DWG NO. 0000-4912-800	
APPROVED JLB 2/1/86		DATE		REV L	
SCALE		CODE IDENT. 5110		WEIGHT	
				SHEET 5 OF 5	

Subject to Export Control, see Cover Page for details.

THIS PAGE INTENTIONALLY LEFT BLANK.



SECTION 3 - RD-301A PARTS LIST

ASSEMBLY	PAGE
475/570-775 MHz FLTR Assy -----	54
AGC PCB Assy -----	32
Buffer Amp PCB Assy -----	26
Card Frame Assy -----	56
Composite Assy -----	3
Coupler/Splitter Assy -----	16
Delay Line Assy -----	55
Discriminator #1 PCB Assy -----	68
Discriminator #2 PCB Assy -----	66
Display/Counter Assy -----	50
Display/Counter PCB Assy -----	51
Floor Assy -----	12
Front Panel Assy -----	43
Heterodyne Assy -----	14
Heterodyne PCB Assy -----	15
IF GEN PWR AMP PCB Assy -----	40
IF MKR/OSC PCB Assy -----	37
Main Diode Switch Assy -----	35
Main Diode Switch PCB Assy -----	36
MOD Mode Switch PCB Assy -----	46
Power Supply Assy -----	7
Power Supply PCB Assy -----	8
Range Board #1 PCB Assy -----	57
Range Board #2 PCB Assy -----	61
Range Digit Switch PCB Assy -----	49
Range Discrete PCB Assy -----	48
RD-301A Coaxial Cable Kit -----	5
RD-301A Ship Unit -----	2
Rear Panel Assy -----	6
RF Mode Switch PCB Assy -----	47
VCO Assy -----	27
Video PCB Assy -----	17



9001-9002-000

SHIP UNIT, RD-301A

D

REFERENCE DESIGNATOR	PART NUMBER	DESCRIPTION
	1001-2529-200	WAVEGUIDE CONNECTING HARDWARE
	2400-7502-600	LABEL, RD-301 ACCESSORY S/N
	2400-8501-000	LABEL, RECEIVING/UNPACKING
	4100-7623-600	COUPLER 612-A79 MICROLAB
	5650-7623-500	TERMINATION WF-0055 MICROLAB
	6042-0000-012	COAX ASSY, 4' TYPE N--N ARMORED
	7003-9047-000	COMPOSITE ASSY, RD-301A



7003-9047-000

ASSY, COMPOSITE

B

REFERENCE DESIGNATOR	PART NUMBER	DESCRIPTION
1	1400-4953-300	BRACKET,LATCH GUIDE
2	1400-4980-100	BRKT,LEFT FRONT PANEL MOUNTING
3	1400-4980-101	BRKT,RIGHT FRONT PANEL MOUNT
4	1400-4985-300	BRKT,SUPT,CARD FRAME,RIGHT
5	1400-4985-301	BRKT,SUPT,CARD FRAME,LEFT
6	1407-7632-700	HANDLE EXTRUSION
7	1415-7627-500	SIDE FRAME
8	1421-1424-201	FOOT MOUNTING
9	2400-9933-000	LABEL,S/N,RD-301A
10	2410-4950-200	BAR,TRIM,FRONT PANEL
11	2506-4953-400	PLATE,CARD RACK LATCH GUIDE
12	2800-4954-200	SPACER,LATCH CARD FRAME
14	2400-7502-800	LABEL ACCESSORIES
15	2804-0375-006	SCREW,6-32 X 3/8 PPHM
16	2804-0313-003	SCREW 6-32 X 5/16 PFHMS
17	2805-0250-006	SCREW,8-32X1/4,PPHMSSS
18	2805-0375-003	SCREW 8-32 X 3/8 PFHMS
19	2832-2504-800	HINGE PIVOT
20	2840-0000-008	WASHER,FLAT,4,AN960-C4
21	2403-9051-500	OVERLAY,REAR PNL RD-301A
22	2803-0438-006	SCREW,4-40 X 7/16 PPHM
23	2850-0000-001	SPEED NUT TIMMERMAN C11351632
24	2803-0375-006	SCREW, 4-40 X 3/8 PPHM
25	2840-0000-003	WASHER,LOCK,INT TOOTH,4
26	2400-7501-900	LABEL,CAUTION,WIRED FOR 230VAC
38	6045-4981-200	RBN CA ASSY,RANGE--DIGIT SW
39	6045-4981-300	RBN CA ASSY,RANGE--DISCRETE SW
55	7005-9047-100	MECH ASSY,FRONT PANEL
56	7005-9040-900	MECH ASSY,REAR PANEL
59	7005-9041-800	MECH ASSY,CARD FRAME
61	2805-0375-006	SCREW 8-32X3/8 PHIL BIND HD
62	1407-7632-400	HANDLE ASSY
63	1414-7606-501	COVER,TOP
64	1414-7606-601	COVER,BOTTOM,7IN RACK MNT CASE
65	1414-7612-101	SIDE COVER
66	1421-7630-200	FOOT ASSY
67	2400-7607-001	DECAL TRIM STRIP
68	2506-7606-900	PLATE,HANDLE MTG,PAINTED
69	2804-0250-003	SCREW 6-32X1/4 PFHMS
70	2804-0500-003	SCREW,6-32 X 1/2 PFHM
74	2803-0250-006	SCREW,4-40 X 1/4 PPHM
75	7010-4931-400	PCB ASSY,IF MKR/OSC,RD-301
76	7010-4931-500	PCB ASSY,IF GEN PWR AMP,RD-301
77	2506-4953-500	PLATE,MOUNTING,PRESALER
79	5650-0010-200	TERMINATION,M SMA,50 OHM,1.15
80	2840-0000-001	WASHER,LOCK,INT TOOTH,6
81	2525-4952-000	GASKET,RF,FLOOR MODULES
88	7005-9042-000	MECH ASSY,FLOOR
90	2840-7600-214	WASHER,ALUM,.870D,.6301D,.030T
91	1050-0000-170	TAPE, VINYL FOAM 3/4" 2-SIDED
92	2803-0250-003	SCREW,4-40 X 1/4 PFHM



7003-9047-000

ASSY, COMPOSITE (cont)

B

REFERENCE DESIGNATOR	PART NUMBER	DESCRIPTION
93	7005-4943-000	MECH ASSY,475/570-775MHZ FLTR
94	7005-9041-000	MECH ASSY, DELAY LINE
95	2109-0000-007	CLAMP CABLE TYRAP TY34M.8
96	2850-0000-008	NUT,HEX,REG PAT,4-40
A01	7005-9041-900	MECH ASSY,DISPLAY COUNTER
TAG #01	6050-0062-220	COAX ASSY,316,RF SMB/S M SMA
TAG #02	6050-0942-100	COAX ASSY,316,R M SMA/S M SMA
TAG #03	6050-0062-450	COAX ASSY,316,R F SMB/S M SMA
TAG #04	6050-0062-400	COAX ASSY,316,R F SMB/S M SMA
TAG #05	6050-0062-400	COAX ASSY,316,R F SMB/S M SMA
TAG #06	6042-9080-700	COAX ASSY,SR.141 X-BAND-FT.PNL
TAG #07	6050-0931-000	COAX ASSY,316,R M SMA/R M SMA
TAG #08	6050-0061-150	COAX ASSY,316,RF SMB/SM SMA
TAG #09	6050-0062-220	COAX ASSY,316,RF SMB/S M SMA
TAG #16	6050-0562-100	COAX ASSY,316,R M SMA/R F SMB
TAG #19	6042-4982-200	COAX ASSY,SR.086,ATTEN*ATTEN
TAG #20	6050-0562-750	COAX ASSY,316,R M SMA/R F SMB
TAG #21	6050-0043-200	COAX ASSY,316,R F SMB/R F SMB
TAG #24	6050-0930-600	COAX ASSY,316,R M SMA/R M SMA
TAG #25	6050-0930-600	COAX ASSY,316,R M SMA/R M SMA
TAG #28	6050-0930-275	COAX ASSY,316,R M SMA/R M SMA
TAG #29	6050-0041-420	RG 316/U FLEX COAX ASSY
TAG #30	6050-0042-020	COAX ASSY,316,R F SMB/R F SMB
TAG #32	6042-9080-300	COAX ASSY,SR.086 X-BAND-R PNL
TAG #33	6043-1180-370	COAX ASSY,CONF,SMB RA-SMB STR
TAG #34	6043-1180-325	COAX ASSY,CONF,SMB RA-SMB STR
TAG #35	6043-1180-325	COAX ASSY,CONF,SMB RA-SMB STR
TAG #36	6043-1180-370	COAX ASSY,CONF,SMB RA-SMB STR
TAG #38	6050-0061-345	RG 316/U FLEX COAX ASSY
TAG #39	6042-9080-600	COAX ASSY,SR.086 XBND-RPNL AUX
TAG #42	6050-1091-000	COAX ASSY,316,R F SMB/ES-006
TAG #43	6050-1091-450	COAX ASSY,316,R F SMB/ES-006

7003-9047-000

ASSY, COMPOSITE

B1

Contains all parts found in Revision B.



7009-9047-200

COAXIAL CABLE KIT, RD-301A

A

REFERENCE DESIGNATOR	PART NUMBER	DESCRIPTION
TAG #1	6050-0062-220	COAX ASSY,316,RF SMB/S M SMA
TAG #2	6050-0942-100	COAX ASSY,316,R M SMA/S M SMA
TAG #3	6050-0062-450	COAX ASSY,316,R F SMB/S M SMA
TAG #4	6050-0062-400	COAX ASSY,316,R F SMB/S M SMA
TAG #5	6050-0062-400	COAX ASSY,316,R F SMB/S M SMA
TAG #7	6050-0931-000	COAX ASSY,316,R M SMA/R M SMA
TAG #8	6050-0061-150	COAX ASSY,316,RF SMB/SM SMA
TAG #9	6050-0062-220	COAX ASSY,316,RF SMB/S M SMA
TAG #16	6050-0562-100	COAX ASSY,316,R M SMA/R F SMB
TAG #20	6050-0562-750	COAX ASSY,316,R M SMA/R F SMB
TAG #21	6050-0043-200	COAX ASSY,316,R F SMB/R F SMB
TAG #24	6050-0930-600	COAX ASSY,316,R M SMA/R M SMA
TAG #25	6050-0930-600	COAX ASSY,316,R M SMA/R M SMA
TAG #28	6050-0930-275	COAX ASSY,316,R M SMA/R M SMA
TAG #29	6050-0041-420	RG 316/U FLEX COAX ASSY
TAG #30	6050-0042-020	COAX ASSY,316,R F SMB/R F SMB
TAG #33	6043-1180-370	COAX ASSY,CONF,SMB RA-SMB STR
TAG #34	6043-1180-325	COAX ASSY,CONF,SMB RA-SMB STR
TAG #35	6043-1180-325	COAX ASSY,CONF,SMB RA-SMB STR
TAG #36	6043-1180-370	COAX ASSY,CONF,SMB RA-SMB STR
TAG #38	6050-0061-345	RG 316/U FLEX COAX ASSY
TAG #42	6050-1091-000	COAX ASSY,316,R F SMB/ES-006
TAG #43	6050-1091-450	COAX ASSY,316,R F SMB/ES-006



7005-9040-900

ASSY, REAR PANEL

A4

REFERENCE DESIGNATOR	PART NUMBER	DESCRIPTION
1	1405-9050-500	PANEL, REAR RD-301A
2	6007-0000-001	CAP,S ID.375-RED 1 INCH
3	5106-0000-011	HOLDER,FUSE,BUSSMAN HKP
4	7005-9040-400	MECH ASSY,PWR SUPPLY
5	2803-0375-006	SCREW, 4-40 X 3/8 PPHM
7	2850-0000-008	NUT,HEX,REG PAT,4-40
8	2840-0000-003	WASHER,LOCK,INT TOOTH,4
10	2803-0313-003	SCREW 4-40 X 5/16 PFHMS
11	6007-0000-003	BOOT,LINE RCPT AC
12	5400-9051-700	HEATSINK,PWR SUPPLY
13	2805-0500-006	SCREW 8-32 X 1/2 PBHMS
14	2840-0000-002	WASHER,LOCK,INT TOOTH,8
15	2805-0313-006	SCREW 8-32X5/16 SLTD M/S SS
	6008-3000-009	WIRE,UL1213,22GA,7X30,GRY
F49001	5106-0000-017	FUSE,2.0AMP,250V,FAST,1.25GL
GL11001	2850-0000-025	GROUND LUG 31-759
GL11002	2850-0000-025	GROUND LUG 31-759
GL11003	2850-0000-025	GROUND LUG 31-759
J49003	2200-6950-100	CONN,F N/SMA F,STR BULKHEAD
J49005	2113-0000-020	CONN UG1094/U
J49006	2113-0000-020	CONN UG1094/U
J49007	2113-0000-020	CONN UG1094/U
J49008	2220-1021-100	CONN, PWR, FLTR AC, MALE RCPT

7005-9040-900

ASSY, REAR PANEL

B

Contains all parts in Revisions A4 plus the following:

REFERENCE DESIGNATOR	PART NUMBER	DESCRIPTION
P11002	2115-9002-005	CONN,RECT.098 PLUG 5-P,SMP05VB
P11002-1	2114-9002-001	CONTACT SKT26-22GA.SHF001T8SS
P11002-3	2114-9002-001	CONTACT SKT26-22GA.SHF001T8SS
P11002-5	2114-9002-001	CONTACT SKT26-22GA.SHF001T8SS
W11001	6008-3000-009	WIRE,UL1213,22GA,7X30,GRY
W11002	6008-3000-006	WIRE,UL1213,22GA,7X30,GRN
W11003	6008-3000-010	WIRE,UL1213,22GA,7X30,WHT
W11004	6008-3000-009	WIRE,UL1213,22GA,7X30,GRY



7005-9040-400

ASSY, PWR SUPPLY

A3

REFERENCE DESIGNATOR	PART NUMBER	DESCRIPTION
1	1414-9050-600	COVER, POWER SUPPLY
2	7010-9030-400	PCB ASSY,PWR SUPPLY
3	1415-9050-700	ENCLOSURE, POWER SUPPLY
4	2803-0438-006	SCREW,4-40 X 7/16 PPHM
5	2803-0375-006	SCREW, 4-40 X 3/8 PPHM
6	2850-0000-008	NUT,HEX,REG PAT,4-40
7	2840-0000-003	WASHER,LOCK,INT TOOTH,4
8	2840-6153-500	WASHER PPS SHOULDER
9	4835-0000-103	INSUL,MICA,TO-220 TRANS,DF103B
10	2803-0375-003	SCREW,4-40 X 3/8 PFHM
11	2804-0250-003	SCREW 6-32X1/4 PFHMS



7010-9030-400

PCB ASSY, PWR SUPPLY

D1

REFERENCE DESIGNATOR	PART NUMBER	DESCRIPTION
1	1700-9020-400	PC BD, PWR SUPPLY
2	6004-6005-550	TY-RAP,5.5 LG
3	2803-0500-051	SCREW 4-40 X 1/2 SPHM NYLON
5	2803-1500-006	SCREW 4-40 X 1 1/2 PBHMS
6	2840-0000-009	WASHER,FLAT,4,MS15795-803
7	2850-0000-020	NUT,HEX,SMALL PAT,4-40
8	2840-7600-216	WASHER,PHEN,.63OD,.140ID,.060T
10	2510-2327-102	HUB,MTG,INDUCTOR
11	2109-0000-010	MOUNTING CLAMP PWR SUP TRANS
12	2400-7856-800	LABEL,ESD
13	6011-0053-001	TUBING,TF,16 AWG,NATURAL,TW
14	6012-0085-100	TUBING,PVC-105,12 AWG,CLEAR
BR55001	4823-2010-600	RECT,PH60,BRIDGE, 600V, 5A
C55001	1501-0332-001	CAP,3300PF,1000V,20%,DISC
C55002	1501-0332-001	CAP,3300PF,1000V,20%,DISC
C55003	1501-0332-001	CAP,3300PF,1000V,20%,DISC
C55004	1580-4010-800	CAP,400UF,180V,ELE,100
C55005	1501-0332-001	CAP,3300PF,1000V,20%,DISC
C55006	1580-4010-800	CAP,400UF,180V,ELE,100
C55007	1506-0562-017	CAP,5600pF,100V,5%,NPO
C55008	1506-0562-017	CAP,5600pF,100V,5%,NPO
C55009	1507-0476-018	CAP,47UF,35V,20%,TANT
C55010	1507-0685-018	CAP,6.8UF,35V,20%,TANT
C55011	1503-0104-009	CAP,0.1UF,200V,5%,PE
C55012	1507-0476-018	CAP,47UF,35V,20%,TANT
C55014	1507-0685-018	CAP,6.8UF,35V,20%,TANT
C55015	1501-0332-001	CAP,3300PF,1000V,20%,DISC
C55016	1506-0103-017	CAP,0.01UF,100V,NPO
C55017	1506-0103-017	CAP,0.01UF,100V,NPO
C55018	1515-0202-075	CAP,2000UF,7V,ELE,4L
C55019	1515-0471-006	CAP,470UF,10V,ELE,10
C55020	1507-0105-018	CAP,1UF,35V,20%,TANT
C55021	1506-0152-017	CAP,1500pF,100V,NPO
C55022	1506-0103-017	CAP,0.01UF,100V,NPO
C55023	1506-0471-017	CAP,470pF,100V,5%,NPO
C55024	1506-0680-017	CAP,68pF,100V,5%,NPO
C55025	1506-0103-017	CAP,0.01UF,100V,NPO
C55026	1506-0680-017	CAP,68pF,100V,5%,NPO
C55027	1507-0685-018	CAP,6.8UF,35V,20%,TANT
C55028	1507-0105-018	CAP,1UF,35V,20%,TANT
C55029	1580-2202-420	CAP,22UF,35V,ELE,RDL
C55030	1521-0000-008	CAP,0.1UF,50V,DIP,Z5U
C55031	1506-0332-017	CAP,3000pF,100V,5%,NPO
CR55001	4901-4937-000	DIODE, IN4937, RECT, 600V,1A
CR55002	4901-4937-000	DIODE, IN4937, RECT, 600V,1A
CR55003	4901-4937-000	DIODE, IN4937, RECT, 600V,1A
CR55004	4901-4937-000	DIODE, IN4937, RECT, 600V,1A
CR55005	4901-4937-000	DIODE, IN4937, RECT, 600V,1A
CR55007	4901-4937-000	DIODE, IN4937, RECT, 600V,1A
CR55008	4901-4937-000	DIODE, IN4937, RECT, 600V,1A
CR55009	4945-0150-050	DIODE,5KP5.0 ,TZORB, 5V,5KW



7010-9030-400

PCB ASSY, PWR SUPPLY (cont)

D1

REFERENCE DESIGNATOR	PART NUMBER	DESCRIPTION
CR55010	4901-5245-200	DIODE, 1N5245B ,ZENER, 15V,.5W
CR55011	4815-0000-003	DIODE, 1N4148 ,SIGNAL, 75PRV
CR55012	4816-0000-001	DIODE,5082-2800,S BAR, 70VBR
CR55013	4815-0000-003	DIODE, 1N4148 ,SIGNAL, 75PRV
CR55014	4818-0000-004	DIODE, 1N5234B ,ZENER,6.2V,.5W
CR55015	4818-0000-001	DIODE, 1N5240B ,ZENER, 10V,.5W
CR55016	4822-0000-006	RECT, 45V 20A DUAL ISO TO-220*
CR55017	4822-0000-005	RECT,200V 8V DUAL ISO TO-220
CR55018	4822-0000-005	RECT,200V 8V DUAL ISO TO-220
CR55019	4822-0000-005	RECT,200V 8V DUAL ISO TO-220
CR55020	4901-4937-000	DIODE, IN4937, RECT, 600V,1A
CR55021	4815-0000-003	DIODE, 1N4148 ,SIGNAL, 75PRV
CR55022	4815-0000-003	DIODE, 1N4148 ,SIGNAL, 75PRV
CR55023	4815-0000-003	DIODE, 1N4148 ,SIGNAL, 75PRV
CR55024	4901-5245-200	DIODE, 1N5245B ,ZENER, 15V,.5W
CR55025	4816-0000-001	DIODE,5082-2800,S BAR, 70VBR
CR55026	4815-0000-002	DIODE, 1N4004 ,RECT, 400V, 1A
J11001	2115-8001-440	CONN,BURNDY SMS12RE-4-D70
L55001	1800-7626-000	INDUCTOR,TOROID,58T,22GA
L55002	1800-7626-000	INDUCTOR,TOROID,58T,22GA
L55003	1800-3881-900	INDUCTOR,TORROID,14GA,18T
L55004	1800-3882-000	INDUCTOR,TORROID,16GA, 4T
Q55001	5050-0344-000	TRANS,NPN,HIGH VOLTAGE
Q55002	4801-0000-001	TRANSISTOR NPN HS SW
Q55003	4805-0000-001	TRANS,2N2907A,PNP HS SW (3251)
Q55004	5050-2445-300	TRANS,N-CH 600V 2.5R ISO 220*
Q55005	4801-0000-001	TRANSISTOR NPN HS SW
Q55006	4801-0000-001	TRANSISTOR NPN HS SW
Q55007	4811-0000-009	TRANS,SCR 400V 8A ISO TO-220
Q55008	4801-0000-001	TRANSISTOR NPN HS SW
Q55009	4811-0000-009	TRANS,SCR 400V 8A ISO TO-220
R55001	4703-0104-003	RES,100K,1/2W,5%
R55002	4703-0104-003	RES,100K,1/2W,5%
R55003	4702-0104-003	RES,100K,1/4W,5%
R55004	4704-0102-003	RES,1.0K,1W,5%
R55005	4709-0103-004	RES,10K,7W,5%,WW
R55006	4703-0274-002	RES,270K,1/2W,5%
R55007	4703-0274-002	RES,270K,1/2W,5%
R55008	4702-0103-003	RES,10K,1/4W,5%
R55009	4702-0681-003	RES,680,1/4W,5%
R55010	4701-0333-003	RES,33K,1/8W,5%
R55011	4701-0333-003	RES,33K,1/8W,5%
R55012	4702-0154-003	RES,150K,1/4W,5%
R55013	4702-0270-003	RES,27,1/4W,5%
R55014	4701-0124-003	RES,120K,1/8W,5%
R55015	4702-0102-003	RES,1.0K,1/4W,5%
R55016	4702-0560-003	RES,56,1/4W,5%
R55017	4701-0183-003	RES,18K,1/8W,5%
R55018	4701-0153-003	RES,15K,1/8W,5%
R55019	4701-0183-003	RES,18K,1/8W,5%
R55020	4701-0103-003	RES,10K,1/8W,5%



7010-9030-400

PCB ASSY, PWR SUPPLY (cont)

D1

REFERENCE DESIGNATOR	PART NUMBER	DESCRIPTION
R55021	4701-0472-003	RES,4.7K,1/8W,5%
R55022	4701-0224-003	RES,220K,1/8W,5%
R55023	4703-0109-003	RES,1,1/2W,5%
R55024	4703-0109-003	RES,1,1/2W,5%
R55025	4703-0109-003	RES,1,1/2W,5%
R55026	4701-0183-003	RES,18K,1/8W,5%
R55027	4702-0560-003	RES,56,1/4W,5%
R55028	4701-0102-003	RES,1.0K,1/8W,5%
R55029	4703-0331-003	RES,330,1/2W,5%
R55030	4701-0103-003	RES,10K,1/8W,5%
R55031	4701-0153-003	RES,15K,1/8W,5%
R55031SAT	4701-0183-003	RES,18K,1/8W,5%
R55031SAT	4701-0123-003	RES,12K,1/8W,5%
R55031SAT	4701-0223-003	RES,22K,1/8W,5%
R55032	4752-0502-002	POT 5K OHM
R55033	4701-0333-003	RES,33K,1/8W,5%
R55034	4701-0103-003	RES,10K,1/8W,5%
R55035	4701-0102-003	RES,1.0K,1/8W,5%
R55036	4702-0100-003	RES,10,1/4W,5%
R55037	4709-0103-004	RES,10K,7W,5%,WW
R55039	4701-0153-003	RES,15K,1/8W,5%
R55040	4703-0159-003	RES,1.5,1/2W,5%
R55041	4701-0103-003	RES,10K,1/8W,5%
R55042	4702-0472-003	RES,4.7K,1/4W,5%
R55043	4703-0229-003	RES,2.2,1/2W,5%
R55045	4702-0151-003	RES,150,1/4W,5%
R55046	4702-0274-003	RES,270K,1/4W,5%
R55047	4701-0103-003	RES,10K,1/8W,5%
RT1	4800-0000-017	VRIS,LMTR CUR INRUSH 3 AMP
T55001	5604-3881-700	XFMR,INPUT FILTER,POWER SUPPLY
T55002	5604-9000-001	TRANSFORMER, PWR SUPPLY RD301A
TP55001	2114-0000-007	TEST POINT,LOOP PROFILE,WHITE*
TP55002	2114-0000-007	TEST POINT,LOOP PROFILE,WHITE*
TP55004	2114-0000-007	TEST POINT,LOOP PROFILE,WHITE*
TP55005	2114-0000-007	TEST POINT,LOOP PROFILE,WHITE*
U55001	3224-0079-121	IC,7912CT,1.5A -12V REGULATOR
U55003	3224-0078-121	IC,78T12,3A 12V 2% V REGULATOR
U55005	3133-0000-024	IC,3130,BIMOS OP AMP,PLAST DIP
U55006	3133-0000-024	IC,3130,BIMOS OP AMP,PLAST DIP
U55007	3133-0000-024	IC,3130,BIMOS OP AMP,PLAST DIP
U55008	3133-0000-024	IC,3130,BIMOS OP AMP,PLAST DIP
U55009	3224-0079-121	IC,7912CT,1.5A -12V REGULATOR
U55010	4819-0000-005	6N135 SCREENED CTR 15-22 VCE=2
W1	6008-4000-010	WIRE,UL1213,20GA,7X28,WHT
W2	6008-4000-001	WIRE,UL1213,20GA,7X28,BLK
W3	1050-0000-073	WIRE,BUS,TINNED COPPER,22GA



7010-9030-400

PCB ASSY, PWR SUPPLY (cont)

E

Contains all parts in Revision D1 plus the following:

REFERENCE DESIGNATOR	PART NUMBER	DESCRIPTION
15	6008-5009-007	WIRE,UL 600V 18GA,75,BLUE

The following part number has been changed:

REFERENCE DESIGNATOR	PART NUMBER	DESCRIPTION
C55004	1580-0471-020	CAP,470UF,200V,20%,ELE
C55006	1580-0471-020	CAP,470UF,200V,20%,ELE



7005-9042-000

ASSY, FLOOR

C

REFERENCE DESIGNATOR	PART NUMBER	DESCRIPTION
1	1406-9052-300	FLOOR,PLATE RD-301A
3	7010-9030-500	PCB ASSY,VIDEO
4	7005-4940-900	MECH ASSY,MAIN DIODE SWITCH
5	2517-2511-700	X-BAND FRONT END MICROWAVE
6	2803-0375-006	SCREW, 4-40 X 3/8 PPHM
7	7005-9041-200	MECH ASSY, VCO
8	2100-2515-900	BLOCK
9	2506-2516-000	PLATE END
10	2200-0110-400	CONN,ADAPT,M2M SMA,RIGHT ANGLE
11	2525-4952-000	GASKET,RF,FLOOR MODULES
12	2803-0250-006	SCREW,4-40 X 1/4 PPHM
13	2803-0313-006	SCREW,4-40 X 5/16 PPHM
16	2804-0375-006	SCREW,6-32 X 3/8 PPHM
18	2800-7600-187	SPACER,AL,.25HEX,4-40ID,1.17LG
19	2840-0000-003	WASHER,LOCK,INT TOOTH,4
20	2840-0000-001	WASHER,LOCK,INT TOOTH,6
21	7007-9083-000	WIRE HARNESS,MAIN,RD-301A
22	2803-0500-006	SCREW,4-40 X 1/2 PPHM
23	2109-0000-007	CLAMP CABLE TYRAP TY34M.8
25	7005-9040-200	MECH ASSY,HETERODYNE
26	7005-9040-300	MECH ASSY, COUPLER/SPLITTER
27	2801-0188-006	SCREW 2-56 X 3/16 PPHMS
28	7010-9030-700	PCB ASSY, BUFFER AMP
92	1400-9052-100	BRACKET, RELAY MTG.
AT1	2901-0000-045	ATTEN,6DB,2W,SMA,M/F,18GHZ
CR51001	4815-0000-003	DIODE, 1N4148,SIGNAL, 75PRV
G1	5850-0000-067	OSC,PL,8.25GHZ,+12V,+13DBM
K51001	4501-0100-102	RELAY,SMA COAXIAL,SPDT,28VDC
TAG#11	6042-4986-000	COAX ASSY - VCO TO MAIN ATTEN
TAG#12	6050-0931-650	COAX ASSY,316,R M SMA/R M SMA
TAG#13	6042-4985-800	COAX ASSY-VCO TO R2 ATTEN
TAG#14	6042-4985-900	COAX ASSY - R2 ATTEN TO VCO
TAG#15	6050-0930-850	COAX ASSY,316,R M SMA/R M SMA
TAG#17	6042-4986-700	COAX ASSY,SR.086,RLY--DIODE SW
TAG#18	6042-4986-800	COAX ASSY,SR.086, RELAY-ATTEN
TAG#22	6050-0042-050	COAX ASSY,316,R F SMB/R F SMB
TAG#31	6042-4980-500	COAX ASSY,SR.086,DIO SW*X-BAND
TAG#34	6042-9080-900	COAX ASSY,SR.086 VCO-DSCRM
TAG#35	6042-9080-400	COAX ASSY,SR.086 VCO-HET BLOCK
TAG#36	6050-0040-700	COAX ASSY,316,R F SMB/R F SMB
TAG#40	6042-9080-500	COAX ASSY,SR.086 HET-R PNL VCO
TAG#41	6050-0930-375	COAX ASSY,316,R M SMA/R M SMA
W1	6044-1150-270	COAX ASSY,8.25 GHZ TO X-BAND
W4	6044-1512-020	COAX ASSY,CONF.,RA SMA/RA SMA



W005-9042-000

ASSY, FLOOR

C1

Contains all parts in Revision C plus the following:

REFERENCE DESIGNATOR	PART NUMBER	DESCRIPTION
15	2803-0625-006	SCREW,4-40 X 5/8 PPHM

7005-9042-000

ASSY, FLOOR

D

Contains all parts in Revision C with changes to the following:

REFERENCE DESIGNATOR	PART NUMBER	DESCRIPTION
AT1	2901-0102-010	ATTEN,10DB,2W,SMA,12.4GHZ
G1	5850-0000-069	OSC,PL,8.25GHZ,+12V



7005-9040-200

ASSY, HETERODYNE

C

REFERENCE DESIGNATOR	PART NUMBER	DESCRIPTION
1	7010-9030-200	PCB ASSY,HETERODYNE
2	1415-9050-100	ENCLOSURE, HETERODYNE MODULE
3	2801-0250-006	SCREW,2-56 X 1/4 PPHM
4	2840-7600-229	WASHER,ALUM,.305D,.196ID,.038T
5	2803-0188-006	SCREW,4-40 X 3/16 PPHM
7	1400-9050-200	BRACKET, CPLR/SPLITTER-HET BLK
8	2525-7874-100	GASKET RF,.070 DIA (BLUE)
10	6004-6005-400	TY-RAP,4.0 LG
FL25001	5801-0000-006	PI FILTER,EMI/RFI 1500pF 8-32
FL25002	5801-0000-006	PI FILTER,EMI/RFI 1500pF 8-32
GL25001	2850-0000-100	LUG,GND,#8 RT.ANG NON-LOCKING
J25001	2200-1930-100	CONN,SMA,F,NARROW FLANGE
J25002	2123-0000-038	CONN,M SMB,W/TERM,STR BULKHD
J25003	2200-1930-100	CONN,SMA,F,NARROW FLANGE
J25004	2200-1930-100	CONN,SMA,F,NARROW FLANGE
J25005	2115-9001-002	CONN,RECT.098 RCPT 2-P
J25005-1	2114-9001-001	CONTACT PIN26-22GA.SYM001T0.6
J25005-2	2114-9001-001	CONTACT PIN26-22GA.SYM001T0.6
MXR25001	5250-0804-301	MIXER, 700-1500MHz TO-8
W25001	6008-3000-003	WIRE,UL1213,22GA,7X30,RED
W25002	6008-1000-003	WIRE,UL1213,26GA,7X34,RED
W25003	6008-1000-001	WIRE,UL1213,26GA,7X34,BLK

7005-9040-200

ASSY, HETERODYNE

C1

Contains all of the items in Rev. C.



7010-9030-200

PCB ASSY, HETERODYNE

B

REFERENCE DESIGNATOR	PART NUMBER	DESCRIPTION
1	1700-9020-200	PC BD, HETERODYNE
2	2400-7856-800	LABEL,ESD
C24001	1622-0220-001T	CAP,22PF,100V,5%,1206,NPO
C24002	1622-0220-001T	CAP,22PF,100V,5%,1206,NPO
C24003	1622-0220-001T	CAP,22PF,100V,5%,1206,NPO
C24004	1622-0220-001T	CAP,22PF,100V,5%,1206,NPO
C24005	1622-0102-001T	CAP,1000pF,50V,CHIP,NPO
C24006	1622-0102-001T	CAP,1000pF,50V,CHIP,NPO
C24007	1622-0220-001T	CAP,22PF,100V,5%,1206,NPO
C24008	1622-0220-001T	CAP,22PF,100V,5%,1206,NPO
C24009	1622-0102-001T	CAP,1000pF,50V,CHIP,NPO
C24010	1622-0220-001T	CAP,22PF,100V,5%,1206,NPO
C24011	1622-0220-001T	CAP,22PF,100V,5%,1206,NPO
C24012	1622-0102-001T	CAP,1000pF,50V,CHIP,NPO
C24013	1622-0050-001T	CAP,5pF,50V,CHIP
C24014	1622-0050-001T	CAP,5pF,50V,CHIP
L24001	1811-6391-001T	IND,SM .39UH 10% C 1008
L24002	1811-6391-001T	IND,SM .39UH 10% C 1008
L24003	1811-6391-001T	IND,SM .39UH 10% C 1008
L24004	1811-6391-001T	IND,SM .39UH 10% C 1008
L24005	1811-6680-001T	IND,SM .068UH 10% C 1008
R24001	4722-1050-001T	RES,105,1/8W,1%
R24002	4722-6199-001T	RES,61.9,1/8W,1%
R24003	4722-1050-001T	RES,105,1/8W,1%
R24004	4722-1500-001T	RES,150,1/8W,1%
R24005	4722-3659-001T	RES,36.5,1/8W,1%
R24006	4722-1500-001T	RES,150,1/8W,1%
R24007	4722-1509-001T	RES,15,1/8W,1%
R24008	4722-4029-001T	RES,40.2,1/8W,1%
R24009	4722-4029-001T	RES,40.2,1/8W,1%
R24010	4722-2439-001T	RES,24.3,1/8W,1%
R24011	4722-4029-001T	RES,40.2,1/8W,1%
R24012	4722-4029-001T	RES,40.2,1/8W,1%
R24013	4722-2439-001T	RES,24.3,1/8W,1%
R24014	4722-2940-001T	RES,294,1/8W,1%
R24015	4722-1789-001T	RES,17.8,1/8W,1%
R24016	4722-2940-001T	RES,294,1/8W,1%
R24017	4722-5119-001T	RES,51.1,1/8W,1%
R24018	4722-3650-001T	RES,365,1/8W,1%
R24019	4722-3650-001T	RES,365,1/8W,1%
R24020	4722-3650-001T	RES,365,1/8W,1%
R24021	4722-3650-001T	RES,365,1/8W,1%
R24022	4722-3650-001T	RES,365,1/8W,1%
R24023	4722-3650-001T	RES,365,1/8W,1%
R24024	4722-3650-001T	RES,365,1/8W,1%
R24025	4722-3650-001T	RES,365,1/8W,1%
U24001	5050-2501-300	IC,MSA-0385,AMPLIFIER
U24002	5050-2501-300	IC,MSA-0385,AMPLIFIER
U24003	5050-2501-300	IC,MSA-0385,AMPLIFIER
U24004	5050-2501-300	IC,MSA-0385,AMPLIFIER



7005-9040-300

ASSY, COUPLER/SPLITTER

B1

REFERENCE DESIGNATOR	PART NUMBER	DESCRIPTION
1	1700-9020-300	PC BD, COUPLER/SPLITTER
2	2506-9051-000	DIVIDER, COUPLER/SPLITTER
3	2508-9050-400	SHIELD, COUPLER/SPLITTER
J18001	2123-0000-054	CONN, RF SUB, SMA, PCB RTANG JACK
J18002	2123-0000-054	CONN, RF SUB, SMA, PCB RTANG JACK
J18003	2123-0000-054	CONN, RF SUB, SMA, PCB RTANG JACK
J18004	2123-0000-054	CONN, RF SUB, SMA, PCB RTANG JACK
R18001	4722-8458-001	RES, 8.45, 1/8W, 1%
R18002	4722-8458-001	RES, 8.45, 1/8W, 1%
R18003	4722-1400-001	RES, 140, 1/8W, 1%
R18004	4722-4999-001	RES, 49.9, 1/8W, 1%
R18005	4722-1000-001	RES, 100, 1/8W, 1%



7010-9030-500

PCB ASSY, VIDEO

E

REFERENCE DESIGNATOR	PART NUMBER	DESCRIPTION
1	1700-9020-500	PC BD, VIDEO
4	2850-0000-020	NUT,HEX,SMALL PAT,4-40
5	2803-0250-006	SCREW,4-40 X 1/4 PPHM
6	2400-7856-800	LABEL,ESD
C17001	1521-0000-008	CAP,0.1UF,50V,DIP,Z5U
C17002	1585-1000-016	CAP,10UF,16V,NON-POLAR,RDL
C17003	1585-1000-016	CAP,10UF,16V,NON-POLAR,RDL
C17004	1521-0000-008	CAP,0.1UF,50V,DIP,Z5U
C17005	1507-0225-019	CAP,2.2UF,25V,20%,TANT
C17006	1585-1000-016	CAP,10UF,16V,NON-POLAR,RDL
C17007	1507-0336-023	CAP,30UF,10V,20%,TANT
C17008	1625-2230-100	CAP,0.022UF,100V,5%,X7R
C17009	1625-2230-100	CAP,0.022UF,100V,5%,X7R
C17010	1507-0336-023	CAP,30UF,10V,20%,TANT
C17011	1625-2230-100	CAP,0.022UF,100V,5%,X7R
C17012	1625-2230-100	CAP,0.022UF,100V,5%,X7R
C17013	1627-2240-450	CAP,0.22UF,50V
C17014	1627-2240-450	CAP,0.22UF,50V
C17015	1627-2240-450	CAP,0.22UF,50V
C17016	1625-2230-100	CAP,0.022UF,100V,5%,X7R
C17017	1625-2230-100	CAP,0.022UF,100V,5%,X7R
C17018	1627-2240-450	CAP,0.22UF,50V
C17019	1627-2240-450	CAP,0.22UF,50V
C17020	1627-2240-450	CAP,0.22UF,50V
C17021	1627-2240-450	CAP,0.22UF,50V
C17022	1627-2240-450	CAP,0.22UF,50V
C17023	1627-2240-450	CAP,0.22UF,50V
C17024	1627-2240-450	CAP,0.22UF,50V
C17025	1506-0180-017	CAP,18pF,100V,5%,NPO
C17026	1580-1000-200	CAP,10UF,25V,ELE,RDL
C17027	1521-0000-008	CAP,0.1UF,50V,DIP,Z5U
C17028	1521-0000-008	CAP,0.1UF,50V,DIP,Z5U
C17029	1521-0000-008	CAP,0.1UF,50V,DIP,Z5U
C17030	1521-0000-008	CAP,0.1UF,50V,DIP,Z5U
C17031	1521-0000-008	CAP,0.1UF,50V,DIP,Z5U
C17032	1506-0222-017	CAP,2200pF,50V,NPO
C17033	1521-0000-008	CAP,0.1UF,50V,DIP,Z5U
C17034	1521-0000-008	CAP,0.1UF,50V,DIP,Z5U
C17035	1506-0222-017	CAP,2200pF,50V,NPO
C17036	1521-0000-008	CAP,0.1UF,50V,DIP,Z5U
C17039	1580-2202-420	CAP,22UF,35V,ELE,RDL
C17040	1580-4702-105	CAP,47UF,10V,ELE,RDL
C17041	1521-0000-008	CAP,0.1UF,50V,DIP,Z5U
C17042	1521-0000-008	CAP,0.1UF,50V,DIP,Z5U
C17043	1506-0101-017	CAP,100pF,100V,5%,NPO
C17044	1506-0331-017	CAP,330pF,100V,5%,NPO
C17045	1521-0000-008	CAP,0.1UF,50V,DIP,Z5U
C17046	1521-0000-008	CAP,0.1UF,50V,DIP,Z5U
C17047	1506-0101-017	CAP,100pF,100V,5%,NPO
C17048	1506-0331-017	CAP,330pF,100V,5%,NPO
C17049	1521-0000-008	CAP,0.1UF,50V,DIP,Z5U



7010-9030-500

PCB ASSY, VIDEO (cont)

E

REFERENCE DESIGNATOR	PART NUMBER	DESCRIPTION
C17050	1521-0000-008	CAP,0.1UF,50V,DIP,Z5U
C17051	1506-0101-017	CAP,100pF,100V,5%,NPO
C17052	1506-0331-017	CAP,330pF,100V,5%,NPO
C17053	1521-0000-008	CAP,0.1UF,50V,DIP,Z5U
C17054	1521-0000-008	CAP,0.1UF,50V,DIP,Z5U
C17055	1506-0101-017	CAP,100pF,100V,5%,NPO
C17056	1521-0000-008	CAP,0.1UF,50V,DIP,Z5U
C17057	1580-2202-420	CAP,22UF,35V,ELE,RDL
C17058	1521-0000-008	CAP,0.1UF,50V,DIP,Z5U
C17059	1521-0000-008	CAP,0.1UF,50V,DIP,Z5U
C17060	1580-1000-200	CAP,10UF,25V,ELE,RDL
C17061	1627-2240-450	CAP,0.22UF,50V
C17062	1580-1000-200	CAP,10UF,25V,ELE,RDL
C17063	1521-0000-008	CAP,0.1UF,50V,DIP,Z5U
C17064	1502-0106-012	CAP,10UF,50V,20%,MPC
C17065	1506-0471-017	CAP,470pF,100V,5%,NPO
C17066	1502-0106-012	CAP,10UF,50V,20%,MPC
C17067	1506-0471-017	CAP,470pF,100V,5%,NPO
C17068	1507-0225-019	CAP,2.2UF,25V,20%,TANT
C17069	1506-0101-017	CAP,100pF,100V,5%,NPO
C17070	1506-0121-017	CAP,120pF,100V,5%,NPO
C17071	1585-1000-016	CAP,10UF,16V,NON-POLAR,RDL
C17072	1521-0000-008	CAP,0.1UF,50V,DIP,Z5U
C17073	1506-0010-017	CAP,1pF,100V,MICA,50
C17074	1521-0000-008	CAP,0.1UF,50V,DIP,Z5U
C17075	1508-0157-020	CAP,150UF,15V,TANT,RDL
C17076	1585-1000-016	CAP,10UF,16V,NON-POLAR,RDL
C17077	1627-2240-450	CAP,0.22UF,50V
C17078	1580-1000-200	CAP,10UF,25V,ELE,RDL
C17079	1521-0000-008	CAP,0.1UF,50V,DIP,Z5U
C17080	1585-1000-016	CAP,10UF,16V,NON-POLAR,RDL
C17081	1502-0106-012	CAP,10UF,50V,20%,MPC
C17082	1506-0471-017	CAP,470pF,100V,5%,NPO
C17083	1521-0000-008	CAP,0.1UF,50V,DIP,Z5U
C17084	1521-0000-008	CAP,0.1UF,50V,DIP,Z5U
C17085	1521-0000-008	CAP,0.1UF,50V,DIP,Z5U
C17086	1521-0000-008	CAP,0.1UF,50V,DIP,Z5U
C17087	1585-1000-016	CAP,10UF,16V,NON-POLAR,RDL
C17088	1580-1000-200	CAP,10UF,25V,ELE,RDL
C17089	1585-1000-016	CAP,10UF,16V,NON-POLAR,RDL
C17090	1627-2240-450	CAP,0.22UF,50V
C17091	1580-1000-200	CAP,10UF,25V,ELE,RDL
C17092	1521-0000-008	CAP,0.1UF,50V,DIP,Z5U
C17093	1502-0106-012	CAP,10UF,50V,20%,MPC
C17094	1521-0000-008	CAP,0.1UF,50V,DIP,Z5U
C17095	1580-1000-200	CAP,10UF,25V,ELE,RDL
C17096	1521-0000-008	CAP,0.1UF,50V,DIP,Z5U
C17097	1521-0000-008	CAP,0.1UF,50V,DIP,Z5U
C17098	1580-4792-305	CAP,4.7UF,35V
C17099	1506-0471-017	CAP,470pF,100V,5%,NPO
C17100	1521-0000-008	CAP,0.1UF,50V,DIP,Z5U



7010-9030-500

PCB ASSY, VIDEO (cont)

E

REFERENCE DESIGNATOR	PART NUMBER	DESCRIPTION
C17101	1521-0000-008	CAP,0.1UF,50V,DIP,Z5U
C17102	1521-0000-008	CAP,0.1UF,50V,DIP,Z5U
C17103	1521-0000-008	CAP,0.1UF,50V,DIP,Z5U
C17104	1521-0000-008	CAP,0.1UF,50V,DIP,Z5U
C17105	1521-0000-008	CAP,0.1UF,50V,DIP,Z5U
C17106	1521-0000-008	CAP,0.1UF,50V,DIP,Z5U
C17107	1521-0000-008	CAP,0.1UF,50V,DIP,Z5U
C17108	1521-0000-008	CAP,0.1UF,50V,DIP,Z5U
C17109	1521-0000-008	CAP,0.1UF,50V,DIP,Z5U
C17110	1521-0000-008	CAP,0.1UF,50V,DIP,Z5U
C17111	1521-0000-008	CAP,0.1UF,50V,DIP,Z5U
C17112	1521-0000-008	CAP,0.1UF,50V,DIP,Z5U
C17113	1521-0000-008	CAP,0.1UF,50V,DIP,Z5U
C17114	1627-2240-450	CAP,0.22UF,50V
C17115	1506-0101-017	CAP,100pF,100V,5%,NPO
C17116	1506-0101-017	CAP,100pF,100V,5%,NPO
C17117	1625-2230-100	CAP,0.022UF,100V,5%,X7R
C17118	1625-2230-100	CAP,0.022UF,100V,5%,X7R
C17119	1580-1000-200	CAP,10UF,25V,ELE,RDL
C17120	1580-1000-200	CAP,10UF,25V,ELE,RDL
C17121	1625-2230-100	CAP,0.022UF,100V,5%,X7R
C17122	1625-2230-100	CAP,0.022UF,100V,5%,X7R
C17123	1580-1000-200	CAP,10UF,25V,ELE,RDL
C17124	1580-1000-200	CAP,10UF,25V,ELE,RDL
C17125	1521-0000-008	CAP,0.1UF,50V,DIP,Z5U
C17126	1506-0100-017	CAP,10pF,100V,5%,NPO
C17127	1506-0271-017	CAP,270pF,100V,5%,NPO
C17128	1506-0271-017	CAP,270pF,100V,5%,NPO
C17129	1521-0000-008	CAP,0.1UF,50V,DIP,Z5U
C17130	1506-0271-017	CAP,270pF,100V,5%,NPO
C17131	1506-0101-017	CAP,100pF,100V,5%,NPO
C17132	1506-0220-017	CAP,22PF,100V,5%,NPO
C17133	1521-0000-008	CAP,0.1UF,50V,DIP,Z5U
C17134	1521-0000-008	CAP,0.1UF,50V,DIP,Z5U
C17135	1521-0000-008	CAP,0.1UF,50V,DIP,Z5U
C17136	1521-0000-008	CAP,0.1UF,50V,DIP,Z5U
C17137	1521-0000-008	CAP,0.1UF,50V,DIP,Z5U
C17138	1627-2240-450	CAP,0.22UF,50V
C17139	1627-2240-450	CAP,0.22UF,50V
C17140	1506-0470-017	CAP,47pF,100V,NPO
C17141	1506-0101-017	CAP,100pF,100V,5%,NPO
C17142	1506-0101-017	CAP,100pF,100V,5%,NPO
C17143	1521-0000-008	CAP,0.1UF,50V,DIP,Z5U
C17144	1521-0000-008	CAP,0.1UF,50V,DIP,Z5U
C17145	1506-0181-017	CAP,180pF,100V,5%,NPO
C17146	1506-0680-017	CAP,68pF,100V,5%,NPO
C17147	1521-0000-008	CAP,0.1UF,50V,DIP,Z5U
CR17001	4831-0000-001	DIODE,FDH333 ,SIGNAL,HCLL
CR17002	4831-0000-001	DIODE,FDH333 ,SIGNAL,HCLL
CR17003	4815-0000-003	DIODE, 1N4148 ,SIGNAL, 75PRV
CR17004	4815-0000-003	DIODE, 1N4148 ,SIGNAL, 75PRV



7010-9030-500

PCB ASSY, VIDEO (cont)

E

REFERENCE DESIGNATOR	PART NUMBER	DESCRIPTION
CR17005	4831-0000-001	DIODE,FDH333 ,SIGNAL,HCLL
CR17006	4831-0000-001	DIODE,FDH333 ,SIGNAL,HCLL
CR17007	4818-0000-015	DIODE,LM329C,6.9V ZENER REF
CR17008	4816-0000-001	DIODE,5082-2800,S BAR, 70VBR
CR17009	4816-0000-001	DIODE,5082-2800,S BAR, 70VBR
CR17010	4831-0000-001	DIODE,FDH333 ,SIGNAL,HCLL
CR17011	4815-0000-003	DIODE, 1N4148 ,SIGNAL, 75PRV
CR17012	4816-0000-001	DIODE,5082-2800,S BAR, 70VBR
CR17013	4831-0000-001	DIODE,FDH333 ,SIGNAL,HCLL
CR17014	4816-0000-001	DIODE,5082-2800,S BAR, 70VBR
CR17015	4816-0000-001	DIODE,5082-2800,S BAR, 70VBR
CR17016	4816-0000-001	DIODE,5082-2800,S BAR, 70VBR
CR17017	4816-0000-001	DIODE,5082-2800,S BAR, 70VBR
CR17018	4816-0000-001	DIODE,5082-2800,S BAR, 70VBR
CR17019	4816-0000-001	DIODE,5082-2800,S BAR, 70VBR
CR17020	4816-0000-001	DIODE,5082-2800,S BAR, 70VBR
CR17021	4816-0000-001	DIODE,5082-2800,S BAR, 70VBR
CR17022	4816-0000-001	DIODE,5082-2800,S BAR, 70VBR
CR17023	4816-0000-001	DIODE,5082-2800,S BAR, 70VBR
CR17024	4816-0000-001	DIODE,5082-2800,S BAR, 70VBR
CR17025	4816-0000-001	DIODE,5082-2800,S BAR, 70VBR
CR17026	4815-0000-003	DIODE, 1N4148 ,SIGNAL, 75PRV
CR17027	4816-0000-001	DIODE,5082-2800,S BAR, 70VBR
J17001	2200-2010-400	CONN,M SMB,PC MTG,STR,.453LG
J17002	2200-1920-100	CONN,JACK SMA PCM STR
J17003	2115-0000-016	WAFER,PCB,.100C,STR,10-P
J17004	2200-2010-400	CONN,M SMB,PC MTG,STR,.453LG
J17005	2200-2010-400	CONN,M SMB,PC MTG,STR,.453LG
J17006	2200-2010-400	CONN,M SMB,PC MTG,STR,.453LG
J17007	2200-2010-400	CONN,M SMB,PC MTG,STR,.453LG
J17008	2200-2010-400	CONN,M SMB,PC MTG,STR,.453LG
J17009	2200-2010-400	CONN,M SMB,PC MTG,STR,.453LG
Q17001	4801-0000-001	TRANSISTOR NPN HS SW
Q17002	4809-0000-030	TRANS, LM394 NPN
Q17003	4809-0000-030	TRANS, LM394 NPN
Q17004	4807-0000-002	TRANS, 2N3905 ,PNP HS SW
Q17005	4807-0000-001	TRANS, 2N3903 ,NPN HS SW
R17001	4701-0510-003	RES,51,1/8W,5%
R17002	4701-0101-003	RES,100,1/8W,5%
R17003	4701-0151-003	RES,150,1/8W,5%
R17004	4701-0471-003	RES,470,1/8W,5%
R17005	4701-0471-003	RES,470,1/8W,5%
R17006	4752-0102-002	POT 1K OHM
R17007	4702-0100-003	RES,10,1/4W,5%
R17008	4752-0201-002	POT, 200 OHM
R17009	4752-0201-002	POT, 200 OHM
R17010	4752-0201-002	POT, 200 OHM
R17011	4701-0152-003	RES,1.5K,1/8W,5%
R17012	4701-0152-003	RES,1.5K,1/8W,5%
R17013	4701-0274-003	RES,270K,1/8W,5%
R17014	4701-0184-003	RES,180K,1/8W,5%



7010-9030-500

PCB ASSY, VIDEO (cont)

E

REFERENCE DESIGNATOR	PART NUMBER	DESCRIPTION
R17015	4701-0185-003	RES,1.8MEG,1/8W,5%
R17016	4701-0102-003	RES,1.0K,1/8W,5%
R17017	4702-0222-003	RES,2.2K,1/4W,5%
R17018	4752-0102-002	POT 1K OHM
R17019	4701-0471-003	RES,470,1/8W,5%
R17020	4701-0471-003	RES,470,1/8W,5%
R17021	4701-0102-003	RES,1.0K,1/8W,5%
R17022	4702-0100-003	RES,10,1/4W,5%
R17023	4701-0331-003	RES,330,1/8W,5%
R17024	4701-0121-003	RES,120,1/8W,5%
R17025	4701-0272-003	RES,2.7K,1/8W,5%
R17026	4701-0181-003	RES,180,1/8W,5%
R17027	4701-0121-003	RES,120,1/8W,5%
R17028	4701-0272-003	RES,2.7K,1/8W,5%
R17029	4701-0104-003	RES,100K,1/8W,5%
R17030	4701-0184-003	RES,180K,1/8W,5%
R17031	4702-0102-003	RES,1.0K,1/4W,5%
R17032	4701-0102-003	RES,1.0K,1/8W,5%
R17033	4706-1002-001	RES,10.0K,1/4W,1%
R17034	4706-1783-001	RES,178K,1/4W,1%
R17035	4706-1002-001	RES,10.0K,1/4W,1%
R17036	4701-0471-003	RES,470,1/8W,5%
R17037	4701-0103-003	RES,10K,1/8W,5%
R17038	4701-0479-003	RES,4.7,1/8W,5%
R17039	4701-0510-003	RES,51,1/8W,5%
R17040	4701-0510-003	RES,51,1/8W,5%
R17041	4701-0101-003	RES,100,1/8W,5%
R17042	4701-0152-003	RES,1.5K,1/8W,5%
R17043	4701-0151-003	RES,150,1/8W,5%
R17044	4701-0152-003	RES,1.5K,1/8W,5%
R17045	4701-0512-002	RES,5.1K,1/8W,5%
R17046	4702-0100-003	RES,10,1/4W,5%
R17047	4701-0102-003	RES,1.0K,1/8W,5%
R17048	4701-0102-003	RES,1.0K,1/8W,5%
R17049	4701-0151-003	RES,150,1/8W,5%
R17050	4701-0391-003	RES,390,1/8W,5%
R17051	4701-0152-003	RES,1.5K,1/8W,5%
R17052	4701-0184-003	RES,180K,1/8W,5%
R17053	4706-1501-001	RES,1.50K,1/4W,1%
R17054	4701-0121-003	RES,120,1/8W,5%
R17055	4701-0271-003	RES,270,1/8W,5%
R17056	4701-0680-003	RES,68,1/8W,5%
R17057	4702-0820-003	RES,82,1/4W,5%
R17058	4701-0391-003	RES,390,1/8W,5%
R17059	4701-0101-003	RES,100,1/8W,5%
R17060	4701-0102-003	RES,1.0K,1/8W,5%
R17061	4701-0103-003	RES,10K,1/8W,5%
R17062	4701-0103-003	RES,10K,1/8W,5%
R17063	4701-0103-003	RES,10K,1/8W,5%
R17064	4701-0471-003	RES,470,1/8W,5%
R17065	4701-0680-003	RES,68,1/8W,5%



7010-9030-500

PCB ASSY, VIDEO (cont)

E

REFERENCE DESIGNATOR	PART NUMBER	DESCRIPTION
R17066	4701-0271-003	RES,270,1/8W,5%
R17067	4702-0820-003	RES,82,1/4W,5%
R17068	4701-0561-003	RES,560,1/8W,5%
R17069	4701-0332-003	RES,3.3K,1/8W,5%
R17070	4701-0332-003	RES,3.3K,1/8W,5%
R17071	4701-0683-003	RES,68K,1/8W,5%
R17072	4701-0561-003	RES,560,1/8W,5%
R17073	4706-3832-001	RES,38.3K,1/4W,1%
R17074	4706-3832-001	RES,38.3K,1/4W,1%
R17075	4701-0512-002	RES,5.1K,1/8W,5%
R17076	4701-0101-003	RES,100,1/8W,5%
R17077	4701-0101-003	RES,100,1/8W,5%
R17078	4701-0512-002	RES,5.1K,1/8W,5%
R17079	4752-0103-002	POT 10K OHM
R17080	4752-0103-002	POT 10K OHM
R17081	4701-0683-003	RES,68K,1/8W,5%
R17082	4701-0332-003	RES,3.3K,1/8W,5%
R17083	4706-3832-001	RES,38.3K,1/4W,1%
R17084	4706-3832-001	RES,38.3K,1/4W,1%
R17085	4706-2941-001	RES,2.94K,1/4W,1%
R17086	4701-0274-003	RES,270K,1/8W,5%
R17087	4701-0274-003	RES,270K,1/8W,5%
R17088	4701-0101-003	RES,100,1/8W,5%
R17089	4706-7150-001	RES,715,1/4W,1%
R17090	4706-4990-001	RES,499,1/4W,1%
R17091	4701-0101-003	RES,100,1/8W,5%
R17092	4702-0821-003	RES,820,1/4W,5%
R17093	4706-3401-001	RES,3.40K,1/4W,1%
R17094	4701-0102-003	RES,1.0K,1/8W,5%
R17095	4701-0102-003	RES,1.0K,1/8W,5%
R17096	4701-0101-003	RES,100,1/8W,5%
R17097	4701-0101-003	RES,100,1/8W,5%
R17098	4701-0181-003	RES,180,1/8W,5%
R17099	4701-0181-003	RES,180,1/8W,5%
R17100	4701-0181-003	RES,180,1/8W,5%
R17101	4701-0152-003	RES,1.5K,1/8W,5%
R17102	4701-0152-003	RES,1.5K,1/8W,5%
R17103	4701-0102-003	RES,1.0K,1/8W,5%
R17104	4701-0101-003	RES,100,1/8W,5%
R17105	4701-0222-003	RES,2.2K,1/8W,5%
R17106	4701-0184-003	RES,180K,1/8W,5%
R17107	4701-0185-003	RES,1.8MEG,1/8W,5%
R17108	4701-0274-003	RES,270K,1/8W,5%
R17109	4706-5901-001	RES,5.90K,1/4W,1%
R17110	4701-0181-003	RES,180,1/8W,5%
R17111	4701-0181-003	RES,180,1/8W,5%
R17112	4701-0121-003	RES,120,1/8W,5%
R17113	4701-0152-003	RES,1.5K,1/8W,5%
R17114	4701-0102-003	RES,1.0K,1/8W,5%
R17115	4701-0222-003	RES,2.2K,1/8W,5%
R17116	4701-0479-003	RES,4.7,1/8W,5%



7010-9030-500

PCB ASSY, VIDEO (cont)

E

REFERENCE DESIGNATOR	PART NUMBER	DESCRIPTION
R17117	4701-0510-003	RES,51,1/8W,5%
R17118	4701-0510-003	RES,51,1/8W,5%
R17119	4701-0103-003	RES,10K,1/8W,5%
R17120	4701-0103-003	RES,10K,1/8W,5%
R17121	4701-0103-003	RES,10K,1/8W,5%
R17122	4701-0102-003	RES,1.0K,1/8W,5%
R17123	4702-0820-003	RES,82,1/4W,5%
R17124	4702-0680-003	RES,68,1/4W,5%
R17125	4702-0680-003	RES,68,1/4W,5%
R17126	4701-0472-003	RES,4.7K,1/8W,5%
R17127	4701-0333-003	RES,33K,1/8W,5%
R17128	4752-0501-002	POT, 500 OHM
R17129	4701-0103-003	RES,10K,1/8W,5%
R17130	4701-0680-003	RES,68,1/8W,5%
R17131	4701-0181-003	RES,180,1/8W,5%
R17132	4701-0391-003	RES,390,1/8W,5%
R17133	4701-0181-003	RES,180,1/8W,5%
R17134	4701-0152-003	RES,1.5K,1/8W,5%
R17135	4701-0152-003	RES,1.5K,1/8W,5%
R17136	4701-0221-003	RES,220,1/8W,5%
R17137	4706-1501-001	RES,1.50K,1/4W,1%
R17138	4701-0121-003	RES,120,1/8W,5%
R17139	4706-1002-001	RES,10.0K,1/4W,1%
R17140	4706-3830-001	RES,383,1/4W,1%
R17141	4701-0104-003	RES,100K,1/8W,5%
R17142	4702-0272-003	RES,2.7K,1/4W,5%
R17143	4752-0104-002	POT 100K OHM
R17145	4701-0154-003	RES,150K,1/8W,5%
R17146	4701-0101-003	RES,100,1/8W,5%
R17147	4701-0121-003	RES,120,1/8W,5%
R17148	4701-0223-003	RES,22K,1/8W,5%
R17149	4752-0103-002	POT 10K OHM
R17150	4752-0103-002	POT 10K OHM
R17151	4701-0471-003	RES,470,1/8W,5%
R17152	4701-0471-003	RES,470,1/8W,5%
R17153	4701-0510-003	RES,51,1/8W,5%
R17154	4701-0510-003	RES,51,1/8W,5%
R17155	4701-0471-003	RES,470,1/8W,5%
R17156	4701-0471-003	RES,470,1/8W,5%
R17157	4701-0510-003	RES,51,1/8W,5%
R17158	4701-0510-003	RES,51,1/8W,5%
R17159	4701-0223-003	RES,22K,1/8W,5%
R17160	4701-0121-003	RES,120,1/8W,5%
R17161	4701-0121-003	RES,120,1/8W,5%
R17162	4701-0271-003	RES,270,1/8W,5%
R17163	4701-0121-003	RES,120,1/8W,5%
R17164	4701-0271-003	RES,270,1/8W,5%
R17165	4701-0471-003	RES,470,1/8W,5%
R17166	4701-0471-003	RES,470,1/8W,5%
R17167	4701-0102-003	RES,1.0K,1/8W,5%
R17168	4701-0472-003	RES,4.7K,1/8W,5%



7010-9030-500

PCB ASSY, VIDEO (cont)

E

REFERENCE DESIGNATOR	PART NUMBER	DESCRIPTION
R17169	4701-0102-003	RES,1.0K,1/8W,5%
R17170	4701-0101-003	RES,100,1/8W,5%
R17171	4701-0101-003	RES,100,1/8W,5%
R17172	4701-0101-003	RES,100,1/8W,5%
R17173	4701-0471-003	RES,470,1/8W,5%
R17174	4800-0000-003	THERM,2KOHM,25/125=19.8,2H-202
R17175	4701-0563-003	RES,56K,1/8W,5%
TP17001	2114-0000-007	TEST POINT,LOOP PROFILE,WHITE*
TP17002	2114-0000-007	TEST POINT,LOOP PROFILE,WHITE*
TP17003	2114-0000-007	TEST POINT,LOOP PROFILE,WHITE*
TP17004	2114-0000-007	TEST POINT,LOOP PROFILE,WHITE*
TP17005	2114-0000-007	TEST POINT,LOOP PROFILE,WHITE*
TP17006	2114-0000-007	TEST POINT,LOOP PROFILE,WHITE*
TP17007	2114-0000-007	TEST POINT,LOOP PROFILE,WHITE*
TP17008	2114-0000-007	TEST POINT,LOOP PROFILE,WHITE*
TP17009	2114-0000-007	TEST POINT,LOOP PROFILE,WHITE*
TP17010	2114-0000-007	TEST POINT,LOOP PROFILE,WHITE*
TP17011	2114-0000-007	TEST POINT,LOOP PROFILE,WHITE*
TP17012	2114-0000-007	TEST POINT,LOOP PROFILE,WHITE*
TP17013	2114-0000-007	TEST POINT,LOOP PROFILE,WHITE*
TP17014	2114-0000-007	TEST POINT,LOOP PROFILE,WHITE*
TP17015	2114-0000-007	TEST POINT,LOOP PROFILE,WHITE*
TP17016	2114-0000-007	TEST POINT,LOOP PROFILE,WHITE*
TP17017	2114-0000-007	TEST POINT,LOOP PROFILE,WHITE*
TP17018	2114-0000-007	TEST POINT,LOOP PROFILE,WHITE*
TP17019	2114-0000-007	TEST POINT,LOOP PROFILE,WHITE*
U17001	3224-1203-000	IC,RGB VIDEO AMPLIFIER
U17002	3224-1203-000	IC,RGB VIDEO AMPLIFIER
U17003	3224-1203-000	IC,RGB VIDEO AMPLIFIER
U17004	3222-0733-000	IC,LM733 DIFF AMP 120MHZ BW
U17005	3223-0004-000	IC,319,HI SPEED DUAL VOLT COMP
U17006	3223-0004-000	IC,319,HI SPEED DUAL VOLT COMP
U17007	3222-0733-000	IC,LM733 DIFF AMP 120MHZ BW
U17008	3133-0000-024	IC,3130,BIMOS OP AMP,PLAST DIP
U17009	3214-9474-000	IC,74HCT74,DUAL D FLIP-FLOP
U17010	3133-0000-024	IC,3130,BIMOS OP AMP,PLAST DIP
U17011	3222-0733-000	IC,LM733 DIFF AMP 120MHZ BW
U17012	3133-0000-024	IC,3130,BIMOS OP AMP,PLAST DIP
U17013	3214-4051-100	IC,4051B,8-CH ANALOG MPLXR
U17014	3130-0000-037	IC,9686 TTL LATCH COMPARATOR
U17015	3133-0000-024	IC,3130,BIMOS OP AMP,PLAST DIP
U17016	3130-0000-037	IC,9686 TTL LATCH COMPARATOR
U17017	3215-0000-001	IC,74F04,FAST HEX INVERTER
U17018	3214-9474-000	IC,74HCT74,DUAL D FLIP-FLOP
U17019	3130-0000-037	IC,9686 TTL LATCH COMPARATOR
U17020	3215-0000-000	IC,74F00 QUAD 2-INPUT NAND
U17021	3224-0001-000	IC,7905C,1.5A -5V REGULATOR
U17022	3215-0000-000	IC,74F00 QUAD 2-INPUT NAND
U17023	3222-0733-000	IC,LM733 DIFF AMP 120MHZ BW
U17024	3214-9412-301	IC,74HCT123 DUAL RETRIG 1SHOT*
U17025	3224-0008-000	IC,5V 3-TERM REG TO-92



7010-9030-500

PCB ASSY, VIDEO (cont)

E

REFERENCE DESIGNATOR	PART NUMBER	DESCRIPTION
U17026	3223-0308-000	IC, PRECISION OP AMP
U17027	3223-0308-000	IC, PRECISION OP AMP
U17028	3223-0308-000	IC, PRECISION OP AMP
U17029	3223-0308-000	IC, PRECISION OP AMP
U17030	3130-0000-037	IC,9686 TTL LATCH COMPARATOR
U17031	3224-0008-000	IC,5V 3-TERM REG TO-92



7010-9030-700

PCB ASSY, BUFFER AMP

B1

REFERENCE DESIGNATOR	PART NUMBER	DESCRIPTION
1	1700-9020-700	PC BD, BUFFER AMP
2	2508-9052-000	SHEILD, BUFFER AMP
5	6010-0125-100	TUBING,HS, 1/8 ID,CLEAR
6	6008-3000-003	WIRE,UL1213,22GA,7X30,RED
C56001	1622-0220-001	CAP,22PF,100V,5%,1206,NPO
C56002	1622-0220-001	CAP,22PF,100V,5%,1206,NPO
C56003	1622-0182-001	CAP,1800pF,50V,CHIP
J56001	2123-0000-054	CONN,RF SUB,SMA,PCB RTANG JACK
J56002	2123-0000-072	CONN,PLUG SMA PCM STR
L56001	1801-0108-001	IND, .10UH,.08OHM,1025-94
R56001	4722-3010-001	RES,301,1/8W,1%
R56002	4722-1829-001	RES,18.2,1/8W,1%
R56003	4722-3010-001	RES,301,1/8W,1%
R56004	4722-1509-001	RES,15,1/8W,1%
R56005	4749-0201-005	POT,SMD, TOP ADJ 200 OHM
R56006	4722-1509-001	RES,15,1/8W,1%
R56007	4722-5119-001	RES,51.1,1/8W,1%
R56008	4721-0181-002	RES,180,1/4W,5%,CHIP
R56009	4722-3929-001	RES,39.2,1/8W,1%
U56001	5050-2501-300	IC,MSA-0385,AMPLIFIER



7005-9041-200

ASSY, VCO

C1

REFERENCE DESIGNATOR	PART NUMBER	DESCRIPTION
1	2100-4954-800	BLOCK,VCO BASE
2	2840-7600-208	WASHER,ALUM,.38OD,.250ID,.020T
3	6042-4986-100	COAX ASSY .086 SR SPLTR TO AMP
4	6042-4986-200	COAX ASSY.086 SR AMP DIODE SW
6	1700-4922-400	PC BD,VCO/SPLITTER
7	1700-4922-600	PC BD,CTR DIODE SW/DIPLEXER
8	1700-4922-500	PC BD,PWR AMP
9	2804-0625-006	SCREW,6-32 X 5/8 PPHM
10	1414-4955-000	COVER,VCO/SPLITTER
11	2803-0625-006	SCREW,4-40 X 5/8 PPHM
12	1414-4954-900	COVER,CONTOUR DIODE SWITCH
13	1414-4955-100	COVER,POWER AMP
14	7010-4933-200	PCB ASSY, AGC
15	2850-3851-600	SCREW,.300L4-40.19HH,6-32X.700
16	2803-0250-006	SCREW,4-40 X 1/4 PPHM
17	2109-0000-007	CLAMP CABLE TYRAP TY34M.8
18	2804-0313-006	SCREW 6-32X5/16 PHIL BIND HD
19	2840-0000-006	WASHER,FLAT,ID.160OD.306TK.039
20	2114-0000-022	CONTACT,DCANT,CRIMP,22-30,GOLD
21	2127-9900-100	KEY,POLARIZIN,MOLEX 15-04-9209
22	6004-6005-400	TY-RAP,4.0 LG
23	1050-0000-075	WIRE,BUS,TINNED COPPER,26GA
24	2804-0188-006	SCREW 6-32X3/16 PHIL BIND HD
25	1400-9051-800	BRACKET,FM/TUNE
26	6011-0018-001	TUBING,TF,26 AWG,NATURAL,TW
	2850-0000-106	SCREW,.875L6-32.25HH,6-32X.250
	6008-1000-001	WIRE,UL1213,26GA,7X34,BLK
	6008-1000-002	WIRE,UL1213,26GA,7X34,BRN
	6008-1000-003	WIRE,UL1213,26GA,7X34,RED
	6008-1000-006	WIRE,UL1213,26GA,7X34,GRN
	6008-1000-007	WIRE,UL1213,26GA,7X34,BLU
	6008-1000-008	WIRE,UL1213,26GA,7X34,VIO
	6008-1000-009	WIRE,UL1213,26GA,7X34,GRY
	6008-1000-010	WIRE,UL1213,26GA,7X34,WHT
	6008-1000-012	WIRE,UL1213,26GA,7X34,WHT/BRN
	6008-1000-013	WIRE,UL1213,26GA,7X34,WHT/RED
	6008-1000-014	WIRE,UL1213,26GA,7X34,WHT/ORN
	6008-1000-015	WIRE,UL1213,26GA,7X34,WHT/YEL
C44001	1620-2200-500	CAP,22pF,100V,CHIP,NPO
C44002	1620-2200-500	CAP,22pF,100V,CHIP,NPO
C44003	1620-2200-500	CAP,22pF,100V,CHIP,NPO
C44004	1506-0030-017	CAP,3.3pF,100V,MICA,17
C44005	1506-0030-017	CAP,3.3pF,100V,MICA,17
C44007	1620-2200-500	CAP,22pF,100V,CHIP,NPO
C44008	1620-2200-500	CAP,22pF,100V,CHIP,NPO
C44009	1620-2200-500	CAP,22pF,100V,CHIP,NPO
C44011	1620-2200-500	CAP,22pF,100V,CHIP,NPO
C44012	1620-2200-500	CAP,22pF,100V,CHIP,NPO
C45001	1620-2210-600	CAP,220pF,100V,CHIP,NPO
C45002	1523-0000-005	CAP,10pF,50V,NPO,CHIP
C45003	1506-0030-017	CAP,3.3pF,100V,MICA,17

7005-9041-200

ASSY, VCO (cont)

C1

REFERENCE DESIGNATOR	PART NUMBER	DESCRIPTION
C45004	1620-2090-510	CAP,2pF,200V,CHIP,NPO
C45005	1620-2090-510	CAP,2pF,200V,CHIP,NPO
C45006	1620-2210-600	CAP,220pF,100V,CHIP,NPO
C45007	1620-2090-510	CAP,2pF,200V,CHIP,NPO
C45008	1620-2090-510	CAP,2pF,200V,CHIP,NPO
C45009	1620-2210-600	CAP,220pF,100V,CHIP,NPO
C45010	1523-0000-002	CAP,1800pF,50V,X7R,CHIP
C45011	1620-2200-500	CAP,22pF,100V,CHIP,NPO
C45012	1620-2090-510	CAP,2pF,200V,CHIP,NPO
C45013	1622-0030-001	CAP,3pF,50V,CHIP
C46001	1506-0101-017	CAP,100pF,100V,5%,NPO
C46002	1620-2200-500	CAP,22pF,100V,CHIP,NPO
C46003	1620-1090-511	CAP,1pF,50V,CHIP
C46004	1620-2200-500	CAP,22pF,100V,CHIP,NPO
C46005	1620-1090-511	CAP,1pF,50V,CHIP
C46006	1620-2210-600	CAP,220pF,100V,CHIP,NPO
C46007	1620-2200-500	CAP,22pF,100V,CHIP,NPO
C46009	1620-2210-600	CAP,220pF,100V,CHIP,NPO
C46010	1620-2210-600	CAP,220pF,100V,CHIP,NPO
C46011	1622-0030-001	CAP,3pF,50V,CHIP
C46012	1620-2210-600	CAP,220pF,100V,CHIP,NPO
C46013	1523-0000-002	CAP,1800pF,50V,X7R,CHIP
C46014	1620-2210-600	CAP,220pF,100V,CHIP,NPO
C46015	1506-0220-017	CAP,22PF,100V,5%,NPO
C46016	1620-2210-600	CAP,220pF,100V,CHIP,NPO
C46017	1620-2210-600	CAP,220pF,100V,CHIP,NPO
C46018	1506-0030-017	CAP,3.3pF,100V,MICA,17
C46019	1620-2210-600	CAP,220pF,100V,CHIP,NPO
C46020	1523-0000-002	CAP,1800pF,50V,X7R,CHIP
C46021	1620-2210-600	CAP,220pF,100V,CHIP,NPO
C46022	1506-0220-017	CAP,22PF,100V,5%,NPO
C46023	1506-0020-017	CAP,2.2pF,100V,NPO,25
C46025	1620-2090-510	CAP,2pF,200V,CHIP,NPO
C48001	1580-4792-305	CAP,4.7UF,35V
C48002	1580-1000-200	CAP,10UF,25V,ELE,RDL
CR44003	4828-0000-002	DIODE,PIN,.3 PF,100 NS
CR44004	4828-0000-002	DIODE,PIN,.3 PF,100 NS
CR44005	4828-0000-002	DIODE,PIN,.3 PF,100 NS
CR44006	4828-0000-002	DIODE,PIN,.3 PF,100 NS
CR44007	4828-0000-002	DIODE,PIN,.3 PF,100 NS
CR44008	4828-0000-002	DIODE,PIN,.3 PF,100 NS
CR44009	4828-0000-002	DIODE,PIN,.3 PF,100 NS
CR44010	4828-0000-002	DIODE,PIN,.3 PF,100 NS
CR44011	4828-0000-002	DIODE,PIN,.3 PF,100 NS
CR44012	4828-0000-002	DIODE,PIN,.3 PF,100 NS
CR44013	4828-0000-002	DIODE,PIN,.3 PF,100 NS
CR44014	4828-0000-002	DIODE,PIN,.3 PF,100 NS
CR44015	4915-0500-100	DIODE,MA-4E282,S BAR 30VBR
CR44016	4915-0500-100	DIODE,MA-4E282,S BAR 30VBR
CR44017	4828-0000-002	DIODE,PIN,.3 PF,100 NS
CR44018	4828-0000-002	DIODE,PIN,.3 PF,100 NS



7005-9041-200

ASSY, VCO (cont)

C1

REFERENCE DESIGNATOR	PART NUMBER	DESCRIPTION
CR44019	4915-0500-100	DIODE,MA-4E282,S BAR 30VBR
CR45001	4828-0000-002	DIODE,PIN,.3 PF,100 NS
CR45002	4828-0000-002	DIODE,PIN,.3 PF,100 NS
CR45003	4815-0000-003	DIODE, 1N4148 ,SIGNAL, 75PRV
CR46001	4829-0000-001	DIODE,MA-45102 ,VARC,1.2PF/-4V
FL48001	5801-0000-006	PI FILTER,EMI/RFI 1500pF 8-32*
FL48002	5801-0000-006	PI FILTER,EMI/RFI 1500pF 8-32*
FL48003	5801-0000-006	PI FILTER,EMI/RFI 1500pF 8-32*
FL48004	5801-0000-006	PI FILTER,EMI/RFI 1500pF 8-32*
FL48005	5801-0000-006	PI FILTER,EMI/RFI 1500pF 8-32*
FL48006	5801-0000-006	PI FILTER,EMI/RFI 1500pF 8-32*
FL48007	5801-0000-006	PI FILTER,EMI/RFI 1500pF 8-32*
FL48008	5801-0000-006	PI FILTER,EMI/RFI 1500pF 8-32*
FL48009	1526-0000-006	CAP,100pF,200V,FEEDTHRU
FL48011	1526-0000-006	CAP,100pF,200V,FEEDTHRU
FL48012	1526-0000-006	CAP,100pF,200V,FEEDTHRU
FL48013	1526-0000-006	CAP,100pF,200V,FEEDTHRU
FL48014	5801-0000-006	PI FILTER,EMI/RFI 1500pF 8-32*
FL48015	5801-0000-006	PI FILTER,EMI/RFI 1500pF 8-32*
FL48016	5801-0000-006	PI FILTER,EMI/RFI 1500pF 8-32*
FL48017	5801-0000-006	PI FILTER,EMI/RFI 1500pF 8-32*
FL48018	5801-0000-006	PI FILTER,EMI/RFI 1500pF 8-32*
GL48002	2850-0000-041	LUG,GND,8
GL48003	2850-0000-010	LUG,GND,10
J48001	2123-0000-030	CONN,FSMA,W/TERM,STR BULKHEAD*
J48002	2123-0000-030	CONN,FSMA,W/TERM,STR BULKHEAD*
J48004	2123-0000-030	CONN,FSMA,W/TERM,STR BULKHEAD*
J48005	2123-0000-038	CONN,M SMB,W/TERM,STR BULKHD
J48007	2123-0000-030	CONN,FSMA,W/TERM,STR BULKHEAD*
J48008	2123-0000-030	CONN,FSMA,W/TERM,STR BULKHEAD*
J48010	2123-0000-030	CONN,FSMA,W/TERM,STR BULKHEAD*
J48011	2123-0000-030	CONN,FSMA,W/TERM,STR BULKHEAD*
J48012	2123-0000-038	CONN,M SMB,W/TERM,STR BULKHD
L44001	1806-0108-002	IND, .1 UH,.13OHM,0819-00
L44002	1806-0108-002	IND, .1 UH,.13OHM,0819-00
L44003	1806-0108-002	IND, .1 UH,.13OHM,0819-00
L44004	1806-0108-002	IND, .1 UH,.13OHM,0819-00
L44005	1806-0108-002	IND, .1 UH,.13OHM,0819-00
L44006	1806-0108-002	IND, .1 UH,.13OHM,0819-00
L44007	1806-0108-002	IND, .1 UH,.13OHM,0819-00
L44008	1806-0108-002	IND, .1 UH,.13OHM,0819-00
L44009	1806-0108-002	IND, .1 UH,.13OHM,0819-00
L44010	1806-0108-002	IND, .1 UH,.13OHM,0819-00
L44011	1806-0108-002	IND, .1 UH,.13OHM,0819-00
L44012	1806-0108-002	IND, .1 UH,.13OHM,0819-00
L44013	1806-0108-002	IND, .1 UH,.13OHM,0819-00
L44014	1806-0108-002	IND, .1 UH,.13OHM,0819-00
L45001	1806-0108-002	IND, .1 UH,.13OHM,0819-00
L45002	1806-0108-002	IND, .1 UH,.13OHM,0819-00
L45003	1806-0108-002	IND, .1 UH,.13OHM,0819-00
L45004	1806-0108-002	IND, .1 UH,.13OHM,0819-00



7005-9041-200

ASSY, VCO (cont)

C1

REFERENCE DESIGNATOR	PART NUMBER	DESCRIPTION
L45005	1801-0000-007	IND, .068 UH, .060 OHM
L46002	1806-0108-002	IND, .1 UH, .13OHM,0819-00
L46003	1806-0108-002	IND, .1 UH, .13OHM,0819-00
L46004	1806-0108-002	IND, .1 UH, .13OHM,0819-00
L46005	1806-0108-002	IND, .1 UH, .13OHM,0819-00
L46006	1806-0108-002	IND, .1 UH, .13OHM,0819-00
P47001	2115-0000-014	CONN PLASTIC MOLEX 22-01-2151
Q45001	5050-2502-005	TRANS, SI NPN,MED PWR L6GHZ
Q45002	4803-0000-004	TRANS,NPN,LP/VHF AMP
Q45003	4807-0000-002	TRANS, 2N3905 ,PNP HS SW
Q45004	5010-0503-000	TRANS,MRF1000MB,NPN PWR HF AMP
Q46001	4803-0000-008	TRANS,NPN MRF911
Q46002	5050-2502-005	TRANS, SI NPN,MED PWR L6GHZ
Q46006	5050-2502-005	TRANS, SI NPN,MED PWR L6GHZ
R44001	4701-0101-003	RES,100,1/8W,5%
R44003	4701-0101-003	RES,100,1/8W,5%
R44004	4722-5119-001	RES,51.1,1/8W,1%
R44005	4701-0560-003	RES,56,1/8W,5%
R44006	4701-0471-003	RES,470,1/8W,5%
R44007	4701-0569-002	RES,5.6,1/8W,5%
R44008	4701-0471-003	RES,470,1/8W,5%
R44009	4701-0560-003	RES,56,1/8W,5%
R44010	4701-0470-003	RES,47,1/8W,5%
R44011	4701-0101-003	RES,100,1/8W,5%
R44012	4701-0101-003	RES,100,1/8W,5%
R44013	4722-5119-001	RES,51.1,1/8W,1%
R44014	4701-0470-003	RES,47,1/8W,5%
R44015	4701-0470-003	RES,47,1/8W,5%
R44016	4701-0221-003	RES,220,1/8W,5%
R44017	4722-5119-001	RES,51.1,1/8W,1%
R44018	4701-0820-003	RES,82,1/8W,5%
R44019	4701-0221-003	RES,220,1/8W,5%
R44020	4722-5119-001	RES,51.1,1/8W,1%
R44021	4722-5119-001	RES,51.1,1/8W,1%
R44022	4701-0820-003	RES,82,1/8W,5%
R45004	4701-0330-003	RES,33,1/8W,5%
R45005	4701-0333-003	RES,33K,1/8W,5%
R45006	4702-0391-003	RES,390,1/4W,5%
R45007	4701-0101-003	RES,100,1/8W,5%
R45009	4701-0101-003	RES,100,1/8W,5%
R45010	4701-0183-003	RES,18K,1/8W,5%
R45011	4702-0221-003	RES,220,1/4W,5%
R45012	4701-0682-003	RES,6.8K,1/8W,5%
R45013	4701-0152-003	RES,1.5K,1/8W,5%
R45014	4701-0331-003	RES,330,1/8W,5%
R45015	4702-0479-003	RES,4.7,1/4W,5%
R46001	4701-0471-003	RES,470,1/8W,5%
R46002	4701-0470-003	RES,47,1/8W,5%
R46003	4701-0272-003	RES,2.7K,1/8W,5%
R46004	4701-0272-003	RES,2.7K,1/8W,5%
R46005	4702-0331-003	RES,330,1/4W,5%



7005-9041-200

ASSY, VCO (cont)

C1

REFERENCE DESIGNATOR	PART NUMBER	DESCRIPTION
R46006	4701-0820-003	RES,82,1/8W,5%
R46007	4701-0223-003	RES,22K,1/8W,5%
R46008	4706-1000-001	RES,100,1/4W,1%
R46009	4701-0391-003	RES,390,1/8W,5%
R46010	4701-0330-003	RES,33,1/8W,5%
R46013	4701-0470-003	RES,47,1/8W,5%
R46014	4701-0470-003	RES,47,1/8W,5%
R46016	4702-0221-003	RES,220,1/4W,5%
R46018	4702-0181-003	RES,180,1/4W,5%
R46019	4701-0470-003	RES,47,1/8W,5%
R46020	4701-0393-003	RES,39K,1/8W,5%
R46021	4701-0471-003	RES,470,1/8W,5%
R46022	4701-0470-003	RES,47,1/8W,5%
R46023	4701-0820-003	RES,82,1/8W,5%
R46025	4702-0181-003	RES,180,1/4W,5%
R46026	4701-0470-003	RES,47,1/8W,5%
R46027	4701-0101-003	RES,100,1/8W,5%
R48001	4702-0221-003	RES,220,1/4W,5%
R48002	4702-0510-002	RES,51,1/4W,5%
U46001	5050-2501-100	IC,MSA-0335-22,IC AMP
U46002	5050-2501-100	IC,MSA-0335-22,IC AMP
U46003	5050-2501-300	IC,MSA-0385,AMPLIFIER
U46004	5051-0000-200	IC, INA-10386 MMIC AMP



7010-4933-200

PCB ASSY, AGC

B

REFERENCE DESIGNATOR	PART NUMBER	DESCRIPTION
1	1700-4923-200	PC BD, AGC
2	2803-0313-006	SCREW,4-40 X 5/16 PPHM
3	2840-0000-009	WASHER,FLAT,4,MS15795-803
4	2850-0000-020	NUT,HEX,SMALL PAT,4-40
5	1050-0000-074	WIRE,BUS,TINNED COPPER,24GA
6	2400-7856-800	LABEL,ESD
C47004	1580-1000-200	CAP,10UF,25V,ELE,RDL
C47005	1502-0333-006	CAP,0.033UF,50V,5%,PC
C47010	1521-0000-008	CAP,0.1UF,50V,DIP,Z5U
C47011	1508-0157-020	CAP,150UF,15V,TANT,RDL
C47012	1507-0105-018	CAP,1UF,35V,20%,TANT
C47013	1506-0151-017	CAP,150pF,100V,5%,NPO
C47014	1605-3360-475	CAP,30UF,16V,TANT,RDL
C47015	1605-3360-475	CAP,30UF,16V,TANT,RDL
C47016	1521-0000-008	CAP,0.1UF,50V,DIP,Z5U
C47017	1508-0476-018	CAP,47UF,35V,TANT,RDL
C47018	1502-0104-010	CAP,0.1UF,50V,5%,PC
C47019	1605-3360-475	CAP,30UF,16V,TANT,RDL
C47020	1605-3360-475	CAP,30UF,16V,TANT,RDL
C47021	1502-0104-010	CAP,0.1UF,50V,5%,PC
C47022	1508-0476-018	CAP,47UF,35V,TANT,RDL
C47023	1507-0105-018	CAP,1UF,35V,20%,TANT
C47024	1507-0105-018	CAP,1UF,35V,20%,TANT
C47025	1580-4792-305	CAP,4.7UF,35V
C47026	1580-4792-305	CAP,4.7UF,35V
C47027	1580-4792-305	CAP,4.7UF,35V
C47028	1580-4792-305	CAP,4.7UF,35V
C47029	1506-0102-017	CAP,1000pF,100V,5%,NPO
C47032	1521-0000-008	CAP,0.1UF,50V,DIP,Z5U
C47033	1506-0272-017	CAP,2700pF,100V,NPO
C47034	1521-0000-008	CAP,0.1UF,50V,DIP,Z5U
C47035	1521-0000-008	CAP,0.1UF,50V,DIP,Z5U
C49030	1506-0102-017	CAP,1000pF,100V,5%,NPO
C49031	1506-0102-017	CAP,1000pF,100V,5%,NPO
CR47001	4815-0000-003	DIODE, 1N4148 ,SIGNAL, 75PRV
CR47002	4815-0000-003	DIODE, 1N4148 ,SIGNAL, 75PRV
CR47003	4815-0000-003	DIODE, 1N4148 ,SIGNAL, 75PRV
CR47004	4815-0000-003	DIODE, 1N4148 ,SIGNAL, 75PRV
CR47005	4815-0000-003	DIODE, 1N4148 ,SIGNAL, 75PRV
CR47006	4815-0000-003	DIODE, 1N4148 ,SIGNAL, 75PRV
CR47007	4815-0000-003	DIODE, 1N4148 ,SIGNAL, 75PRV
J47001	2115-0000-050	WAFER,PCB,.100C,STR,15-P
J47002	2115-0000-050	WAFER,PCB,.100C,STR,15-P
J47003	2200-2010-400	CONN,M SMB,PC MTG,STR,.453LG
J47004	2200-2010-400	CONN,M SMB,PC MTG,STR,.453LG
Q47001	4807-0000-002	TRANS, 2N3905 ,PNP HS SW
Q47002	4807-0000-002	TRANS, 2N3905 ,PNP HS SW
Q47003	4801-0000-001	TRANSISTOR NPN HS SW
Q47004	4805-0000-001	TRANS,2N2907A,PNP HS SW (3251)
Q47005	4807-0000-001	TRANS, 2N3903 ,NPN HS SW
Q47006	4811-0000-001	TRANS,SJE1461 ,NPN PWR AMP



7010-4933-200

PCB ASSY, AGC (cont)

B

REFERENCE DESIGNATOR	PART NUMBER	DESCRIPTION
Q47007	4807-0000-002	TRANS, 2N3905 ,PNP HS SW
Q47008	4811-0000-001	TRANS,SJE1461 ,NPN PWR AMP
Q47009	4807-0000-001	TRANS, 2N3903 ,NPN HS SW
Q47010	4807-0000-001	TRANS, 2N3903 ,NPN HS SW
Q47011	4807-0000-001	TRANS, 2N3903 ,NPN HS SW
Q47012	4807-0000-001	TRANS, 2N3903 ,NPN HS SW
Q47013	4807-0000-002	TRANS, 2N3905 ,PNP HS SW
Q47014	5050-2601-000	TRANS,SF-90038,FETSELECTED
R47001	4752-0502-002	POT 5K OHM
R47002	4752-0502-002	POT 5K OHM
R47003	4752-0104-002	POT 100K OHM
R47004	4701-0224-003	RES,220K,1/8W,5%
R47005	4701-0821-003	RES,820,1/8W,5%
R47008	4701-0394-003	RES,390K,1/8W,5%
R47009	4701-0183-003	RES,18K,1/8W,5%
R47011	4701-0103-003	RES,10K,1/8W,5%
R47012	4701-0104-003	RES,100K,1/8W,5%
R47013	4701-0102-003	RES,1.0K,1/8W,5%
R47021	4702-0103-003	RES,10K,1/4W,5%
R47022	4702-0222-003	RES,2.2K,1/4W,5%
R47023	4701-0104-003	RES,100K,1/8W,5%
R47024	4701-0103-003	RES,10K,1/8W,5%
R47025	4701-0102-003	RES,1.0K,1/8W,5%
R47026	4701-0222-003	RES,2.2K,1/8W,5%
R47027	4701-0222-003	RES,2.2K,1/8W,5%
R47028	4701-0153-003	RES,15K,1/8W,5%
R47029	4701-0153-003	RES,15K,1/8W,5%
R47031	4706-1002-001	RES,10.0K,1/4W,1%
R47032	4706-1002-001	RES,10.0K,1/4W,1%
R47033	4706-1002-001	RES,10.0K,1/4W,1%
R47034	4702-0153-003	RES,15K,1/4W,5%
R47035	4752-0203-002	POT 20K OHM
R47036	4706-8251-001	RES,8.25K,1/4W,1%
R47037	4752-0503-002	POT 50K OHM
R47038	4702-0103-003	RES,10K,1/4W,5%
R47039	4752-0103-002	POT 10K OHM
R47040	4702-0273-003	RES,27K,1/4W,5%
R47041	4702-0471-003	RES,470,1/4W,5%
R47042	4702-0153-003	RES,15K,1/4W,5%
R47043	4702-0332-003	RES,3.3K,1/4W,5%
R47044	4752-0103-002	POT 10K OHM
R47045	4702-0103-003	RES,10K,1/4W,5%
R47046	4702-0472-003	RES,4.7K,1/4W,5%
R47047	4702-0103-003	RES,10K,1/4W,5%
R47048	4702-0472-003	RES,4.7K,1/4W,5%
R47049	4702-0563-003	RES,56K,1/4W,5%
R47050	4702-0223-003	RES,22K,1/4W,5%
R47051	4702-0563-003	RES,56K,1/4W,5%
R47052	4701-0682-003	RES,6.8K,1/8W,5%
R47053	4701-0392-003	RES,3.9K,1/8W,5%
R47054	4701-0222-003	RES,2.2K,1/8W,5%



7010-4933-200

PCB ASSY, AGC (cont)

B

REFERENCE DESIGNATOR	PART NUMBER	DESCRIPTION
R47055	4701-0822-003	RES,8.2K,1/8W,5%
R47056	4702-0470-003	RES,47,1/4W,5%
R47057	4702-0470-003	RES,47,1/4W,5%
R47058	4702-0100-003	RES,10,1/4W,5%
R47059	4702-0100-003	RES,10,1/4W,5%
R47060	4701-0102-003	RES,1.0K,1/8W,5%
R47061	4701-0561-003	RES,560,1/8W,5%
R47062	4701-0104-003	RES,100K,1/8W,5%
R47063	4701-0104-003	RES,100K,1/8W,5%
R47064	4701-0104-003	RES,100K,1/8W,5%
R47065	4752-0102-002	POT 1K OHM
R47066	4701-0472-003	RES,4.7K,1/8W,5%
R47067	4701-0472-003	RES,4.7K,1/8W,5%
R47068	4701-0103-003	RES,10K,1/8W,5%
U47001	3135-0000-054	IC,412,DUAL J-FET OP AMP
U47003	3133-0000-006	IC,4049UB,HEX BUFFER/CONVERTER
U47004	3214-9000-000	IC,74HC00,HS CMOS,4*2-INP NAND
U47005	3214-9244-000	IC,74HC244,OCTAL BUF/DRVR/RCVR
U47006	3130-0000-034	IC 741C PLASTIC DIP OP-AMP
U47007	3130-0000-034	IC 741C PLASTIC DIP OP-AMP



7005-4940-900

ASSY, MAIN DIODE SWITCH

K

REFERENCE DESIGNATOR	PART NUMBER	DESCRIPTION
1	1414-4950-900	COVER,BOTTOM,MAIN DIODE SWITCH
2	7010-4930-000	PCB ASSY,MAIN DIODE SWITCH
3	1414-4950-800	COVER, TOP,MAIN DIODE SWITCH
4	2804-0625-006	SCREW,6-32 X 5/8 PPHM
6	2803-0438-003	SCREW 4-40 X 7/16 PFHMS
7	2850-0000-014	LUG,GND,4
8	2803-0188-006	SCREW,4-40 X 3/16 PPHM
C37001	1506-0680-017	CAP,68pF,100V,5%,NPO
C37002	1506-0680-017	CAP,68pF,100V,5%,NPO
FL37001	5801-0000-006	PI FILTER,EMI/RFI 1500pF 8-32*
FL37002	1526-0000-005	CAP,10pF,200V,FEEDTHRU
J37001	2123-0000-030	CONN,FSMA,W/TERM,STR BULKHEAD*
J37002	2123-0000-030	CONN,FSMA,W/TERM,STR BULKHEAD*
L37001	1801-0338-001	IND, .33UH,.2 OHM,1025-08

7005-4940-900

ASSY, MAIN DIODE SWITCH

K1

REFERENCE DESIGNATOR	PART NUMBER	DESCRIPTION
----------------------	-------------	-------------

Contains all of the items in Rev. K except the following:

7	2850-0000-014	LUG,GND,4
---	---------------	-----------

Contains all of the items in Rev. K plus the following:

GL37001	2850-0000-014	LUG,GND,4
---------	---------------	-----------



7010-4930-000

PCB ASSY, MAIN DIODE SWITCH

D

REFERENCE DESIGNATOR	PART NUMBER	DESCRIPTION
1	1700-4920-000	PC BD,MAIN DIODE SWITCH
C39001	1506-0100-017	CAP,10pF,100V,5%,NPO
C39002	1506-0100-017	CAP,10pF,100V,5%,NPO
C39003	1523-0000-004	CAP,47pF,50V,NPO,CHIP
C39004	1523-0000-004	CAP,47pF,50V,NPO,CHIP
CR39001	4915-0501-200	DIODE,S BAR,5082-2209
CR39002	4915-0501-200	DIODE,S BAR,5082-2209
CR39003	4915-0501-200	DIODE,S BAR,5082-2209
CR39004	4915-0501-200	DIODE,S BAR,5082-2209
CR39005	4915-0501-200	DIODE,S BAR,5082-2209
CR39006	4915-0501-200	DIODE,S BAR,5082-2209
L39001	1801-0108-001	IND, .10UH,.08OHM,1025-94
L39002	1801-0108-001	IND, .10UH,.08OHM,1025-94
L39004	1801-0108-001	IND, .10UH,.08OHM,1025-94
L39005	1801-0108-001	IND, .10UH,.08OHM,1025-94
L39006	1801-0688-001	IND, .68UH,.6 OHM,1025-16
R39001	4701-0121-003	RES,120,1/8W,5%
R39002	4701-0101-003	RES,100,1/8W,5%
R39003	4701-0101-003	RES,100,1/8W,5%
R39004	4701-0121-003	RES,120,1/8W,5%
R39005	4702-0151-003	RES,150,1/4W,5%
R39006	4701-0221-003	RES,220,1/8W,5%
R39007	4701-0220-003	RES,22,1/8W,5%
R39008	4701-0221-003	RES,220,1/8W,5%
U39001	5050-2501-100	IC,MSA-0335-22,IC AMP

7010-4930-000

PCB ASSY, MAIN DIODE SWITCH

E

The following part numbers have been changed:

REFERENCE DESIGNATOR	PART NUMBER	DESCRIPTION
CR39001	4816-0000-072	DIODE,S BAR,5082-2209
CR39002	4816-0000-072	DIODE,S BAR,5082-2209
CR39003	4816-0000-072	DIODE,S BAR,5082-2209
CR39004	4816-0000-072	DIODE,S BAR,5082-2209
CR39005	4816-0000-072	DIODE,S BAR,5082-2209
CR39006	4816-0000-072	DIODE,S BAR,5082-2209



7010-4931-400

PCB ASSY, IF MKR/OSC

D1

REFERENCE DESIGNATOR	PART NUMBER	DESCRIPTION
1	1400-2516-400	BRACKET MOUNTING
2	1700-2507-100	PC BD, IF MARKER OSCILLATOR
3	2109-0000-007	CLAMP CABLE TYRAP TY34M.8
4	2114-9001-001	CONTACT PIN26-22GA.SYM001T0.6*
6	2506-2515-600	PLATE MOUNTING
8	2850-0000-020	NUT,HEX,SMALL PAT,4-40
9	2803-0313-006	SCREW,4-40 X 5/16 PPHM
11	2840-0000-003	WASHER,LOCK,INT TOOTH,4
18	2840-0000-008	WASHER,FLAT,4,AN960-C4
19	6004-6005-400	TY-RAP,4.0 LG
20	2813-0000-005	TERM,INSUL,STANDOFF,.148DIA
22	2803-0250-006	SCREW,4-40 X 1/4 PPHM
	6008-1000-001	WIRE,UL1213,26GA,7X34,BLK
	6008-1000-003	WIRE,UL1213,26GA,7X34,RED
	6008-1000-005	WIRE,UL1213,26GA,7X34,YEL
	6008-1000-007	WIRE,UL1213,26GA,7X34,BLU
	6008-1000-009	WIRE,UL1213,26GA,7X34,GRY
	6008-1000-010	WIRE,UL1213,26GA,7X34,WHT
C33001	1507-0156-021	CAP,15UF,20V,20%,TANT
C33002	1507-0156-021	CAP,15UF,20V,20%,TANT
C33003	1506-0330-017	CAP,33pF,100V,5%,NPO
C33004	1506-0221-017	CAP,220pF,100V,5%,NPO
C33005	1506-0150-017	CAP,15pF,100V,5%,NPO
C33006	1506-0150-017	CAP,15pF,100V,5%,NPO
C33007	1506-0150-017	CAP,15pF,100V,5%,NPO
C33008	1501-0103-005	CAP,0.01UF,50V,20%,DISC
C33009	1501-0102-001	CAP,1000pF,500V,CERAMIC,DISC
C33010	1501-0103-005	CAP,0.01UF,50V,20%,DISC
C33011	1506-0100-017	CAP,10pF,100V,5%,NPO
C33012	1506-0220-017	CAP,22PF,100V,5%,NPO
C33013	1506-0220-017	CAP,22PF,100V,5%,NPO
C33014	1506-0100-017	CAP,10pF,100V,5%,NPO
C33015	1501-0103-005	CAP,0.01UF,50V,20%,DISC
C33016	1501-0103-005	CAP,0.01UF,50V,20%,DISC
C33017	1501-0102-001	CAP,1000pF,500V,CERAMIC,DISC
C33018	1501-0102-001	CAP,1000pF,500V,CERAMIC,DISC
C33019	1501-0102-001	CAP,1000pF,500V,CERAMIC,DISC
C33020	1501-0103-005	CAP,0.01UF,50V,20%,DISC
C33021	1506-0221-017	CAP,220pF,100V,5%,NPO
C33022	1506-0220-017	CAP,22PF,100V,5%,NPO
C33023	1506-0150-017	CAP,15pF,100V,5%,NPO
C33024	1506-0100-017	CAP,10pF,100V,5%,NPO
C33025	1506-0100-017	CAP,10pF,100V,5%,NPO
C33026	1501-0102-001	CAP,1000pF,500V,CERAMIC,DISC
C33027	1501-0102-001	CAP,1000pF,500V,CERAMIC,DISC
C33028	1501-0103-005	CAP,0.01UF,50V,20%,DISC
C33029	1508-0476-018	CAP,47UF,35V,TANT,RDL
C33030	1507-0104-018	CAP,0.1UF,35V,20%,TANT
C33031	1508-0336-023	CAP,30UF,10V,TANT,RDL
C33032	1501-0102-001	CAP,1000pF,500V,CERAMIC,DISC
C33033	1507-0104-018	CAP,0.1UF,35V,20%,TANT



7010-4931-400

PCB ASSY, IF MKR/OSC (cont)

D1

REFERENCE DESIGNATOR	PART NUMBER	DESCRIPTION
C33034	1521-0000-002	CAP VAR,5.5-18pF,350V,VPCM
C33035	1501-0103-005	CAP,0.01UF,50V,20%,DISC
C33036	1501-0102-001	CAP,1000pF,500V,CERAMIC,DISC
C33037	1501-0102-001	CAP,1000pF,500V,CERAMIC,DISC
C33038	1501-0102-001	CAP,1000pF,500V,CERAMIC,DISC
C33039	1501-0102-001	CAP,1000pF,500V,CERAMIC,DISC
C33040	1507-0105-018	CAP,1UF,35V,20%,TANT
C33041	1507-0105-018	CAP,1UF,35V,20%,TANT
C33042	1501-0103-005	CAP,0.01UF,50V,20%,DISC
C33043	1523-0000-002	CAP,1800pF,50V,X7R,CHIP
C33044	1501-0339-001	CAP,3.3pF,600V,NPO,DISC
C33045	1622-0020-001	CAP,2pF,50V,CHIP
CR33001	4826-0000-002	DIODE,PC0605D ,VARC, 47PF/-4V
CR33002	4826-0000-011	DIODE,MMBV105G,VARC,2.3PF/-3V
CR33003	4814-0000-001	DIODE, 1N823A ,REF,6.2V/7.5MA
CR33004	4828-0000-002	DIODE,PIN,.3 PF,100 NS
CR33005	4828-0000-002	DIODE,PIN,.3 PF,100 NS
CR33006	4828-0000-002	DIODE,PIN,.3 PF,100 NS
FL33001	5801-0000-006	PI FILTER,EMI/RFI 1500pF 8-32*
FL33002	5801-0000-006	PI FILTER,EMI/RFI 1500pF 8-32*
FL33003	5801-0000-006	PI FILTER,EMI/RFI 1500pF 8-32*
FL33004	5801-0000-006	PI FILTER,EMI/RFI 1500pF 8-32*
FL33005	5801-0000-006	PI FILTER,EMI/RFI 1500pF 8-32*
G33001	2850-0000-031	LUG,GND,4
J33001	6042-0016-704	COAX ASSY,086,IF/MARKER OSC BD
J33002	6042-4983-500	COAX ASSY,SR.086,IF MRKER .10L
J33003	2115-9001-008	CONN,RECT.098 RCPT 8-P,SMR08VB
J33004	6042-0016-701	COAX ASSY,086,IF/MARKER OSC BD
J33005	6042-0016-709	COAX ASSY,086,IF/MARKER OSC BD
L33001	1804-0000-010	IND,VAR, .061-.101UH,YEL 618
L33002	1801-0022-001	IND, 22uH 3.3 OHM 1025-52
L33003	1801-0108-001	IND, .10UH,.08OHM,1025-94
L33004	1801-0022-001	IND, 22uH 3.3 OHM 1025-52
L33005	1801-0478-001	IND, .47UH,.35OHM,1025-12
L33006	1801-0478-001	IND, .47UH,.35OHM,1025-12
L33007	1801-0478-001	IND, .47UH,.35OHM,1025-12
L33008	1804-0001-000	IND,VAR, .099-.184UH, BLUE 6.5
L33009	1801-0022-001	IND, 22uH 3.3 OHM 1025-52
L33010	1801-0108-001	IND, .10UH,.08OHM,1025-94
L33011	1801-0108-001	IND, .10UH,.08OHM,1025-94
Q33001	4809-0100-100	TRANS,55100 NPN HF AMP
Q33002	4813-0000-001	TRANS, 3N201 ,N-CH MOSFET
Q33003	4809-0100-100	TRANS,55100 NPN HF AMP
Q33004	4809-0100-100	TRANS,55100 NPN HF AMP
Q33005	4809-0100-100	TRANS,55100 NPN HF AMP
Q33006	4809-0100-200	TRANS,55100-SGS NPN
Q33007	4801-0000-001	TRANSISTOR NPN HS SW
Q33008	4809-0100-100	TRANS,55100 NPN HF AMP
Q33009	4809-0100-100	TRANS,55100 NPN HF AMP
R33001	4702-0223-003	RES,22K,1/4W,5%
R33002	4702-0223-003	RES,22K,1/4W,5%



7010-4931-400

PCB ASSY, IF MKR/OSC (cont)

D1

REFERENCE DESIGNATOR	PART NUMBER	DESCRIPTION
R33003	4702-0223-003	RES,22K,1/4W,5%
R33004	4702-0223-003	RES,22K,1/4W,5%
R33005	4702-0102-003	RES,1.0K,1/4W,5%
R33006	4702-0680-003	RES,68,1/4W,5%
R33007	4702-0101-003	RES,100,1/4W,5%
R33008	4706-3161-001	RES,3.16K,1/4W,1%
R33009	4702-0181-003	RES,180,1/4W,5%
R33010	4702-0471-003	RES,470,1/4W,5%
R33011	4702-0122-003	RES,1.2K,1/4W,5%
R33012	4702-0182-003	RES,1.8K,1/4W,5%
R33013	4702-0121-003	RES,120,1/4W,5%
R33014	4702-0101-003	RES,100,1/4W,5%
R33015	4702-0221-003	RES,220,1/4W,5%
R33016	4702-0101-003	RES,100,1/4W,5%
R33017	4702-0221-003	RES,220,1/4W,5%
R33018	4701-0223-003	RES,22K,1/8W,5%
R33019	4702-0223-003	RES,22K,1/4W,5%
R33020	4702-0102-003	RES,1.0K,1/4W,5%
R33021	4702-0680-003	RES,68,1/4W,5%
R33022	4702-0474-003	RES,470K,1/4W,5%
R33023	4702-0683-003	RES,68K,1/4W,5%
R33024	4752-0103-002	POT 10K OHM
R33025	4702-0103-003	RES,10K,1/4W,5%
R33026	4702-0102-003	RES,1.0K,1/4W,5%
R33027	4702-0331-003	RES,330,1/4W,5%
R33028	4702-0472-003	RES,4.7K,1/4W,5%
R33029	4702-0279-003	RES,2.7,1/4W,5%
R33030	4702-0103-003	RES,10K,1/4W,5%
R33031	4702-0681-003	RES,680,1/4W,5%
R33032	4702-0222-003	RES,2.2K,1/4W,5%
R33033	4702-0473-003	RES,47K,1/4W,5%
R33034	4702-0102-003	RES,1.0K,1/4W,5%
R33035	4702-0222-003	RES,2.2K,1/4W,5%
R33036 SAT	4702-0822-003	RES,8.2K,1/4W,5%
R33037	4702-0683-003	RES,68K,1/4W,5%
R33038	4702-0331-003	RES,330,1/4W,5%
R33039	4702-0221-003	RES,220,1/4W,5%
R33040	4702-0333-003	RES,33K,1/4W,5%
R33041	4702-0561-003	RES,560,1/4W,5%
R33042	4722-6819-001	RES,68.1,1/8W,1%
U33001	3134-0000-011	IC,7908C,1.5A -8V REGULATOR
U33002	3134-0000-004	IC,1658,VC MULTIVIBRATOR



7010-4931-500

PCB ASSY, IF GEN PWR AMP

B

REFERENCE DESIGNATOR	PART NUMBER	DESCRIPTION
1	2506-2515-400	PLATE MOUNTING
2	1400-2516-400	BRACKET MOUNTING
3	2109-0000-007	CLAMP CABLE TYRAP TY34M.8
4	2850-0000-031	LUG,GND,4
5	2801-0125-001	SCREW 2-56 X 1/8 SHSS
6	2803-0250-006	SCREW,4-40 X 1/4 PPHM
7	2803-0313-006	SCREW,4-40 X 5/16 PPHM
9	2114-9001-001	CONTACT PIN26-22GA.SYM001T0.6*
10	1700-2507-000	PC BD, IF GENERATOR PWR
13	5400-0000-002	HEAT SINK,TO-5 TRANS
14	2501-7600-118	SPACER,BR,.312OD,.203ID,.125LG
15	2840-0000-008	WASHER,FLAT,4,AN960-C4
16	6004-6005-400	TY-RAP,4.0 LG
	6008-1000-001	WIRE,UL1213,26GA,7X34,BLK
	6008-1000-003	WIRE,UL1213,26GA,7X34,RED
	6008-1000-005	WIRE,UL1213,26GA,7X34,YEL
	6008-1000-008	WIRE,UL1213,26GA,7X34,VIO
	6008-1000-010	WIRE,UL1213,26GA,7X34,WHT
	6008-1000-018	WIRE,UL1213,26GA,7X34,WHT/VIO
C36001	1501-0331-001	CAP,330pF,1000V,10%,CER,DISC
C36002	1501-0331-001	CAP,330pF,1000V,10%,CER,DISC
C36003	1501-0221-001	CAP,220pF,1000V,10%,DISC
C36004	1501-0103-005	CAP,0.01UF,50V,20%,DISC
C36005	1501-0103-005	CAP,0.01UF,50V,20%,DISC
C36006	1501-0331-001	CAP,330pF,1000V,10%,CER,DISC
C36007	1501-0102-001	CAP,1000pF,500V,CERAMIC,DISC
C36008	1501-0103-005	CAP,0.01UF,50V,20%,DISC
C36009	1501-0103-005	CAP,0.01UF,50V,20%,DISC
C36010	1506-0271-017	CAP,270pF,100V,5%,NPO
C36011	1506-0271-017	CAP,270pF,100V,5%,NPO
C36012	1501-0102-001	CAP,1000pF,500V,CERAMIC,DISC
C36013	1501-0103-005	CAP,0.01UF,50V,20%,DISC
C36014	1501-0103-005	CAP,0.01UF,50V,20%,DISC
C36015	1501-0102-001	CAP,1000pF,500V,CERAMIC,DISC
C36016	1507-0105-018	CAP,1UF,35V,20%,TANT
C36017	1502-0334-012	CAP,0.33UF,50V,5%,MPC
C36018	1501-0680-001	CAP,68pF,1000V,10%,CER,DISC
C36019	1501-0221-001	CAP,220pF,1000V,10%,DISC
C36020	1507-0475-018	CAP,4.7UF,35V,20%,TANT
C36021	1507-0475-018	CAP,4.7UF,35V,20%,TANT
C36022	1507-0475-018	CAP,4.7UF,35V,20%,TANT
C36023	1501-0103-005	CAP,0.01UF,50V,20%,DISC
C36024	1501-0560-001	CAP,56pF,1000V,10%,DISC
CR36001	4828-0000-002	DIODE,PIN,.3 PF,100 NS
CR36002	4828-0000-002	DIODE,PIN,.3 PF,100 NS
CR36003	4828-0000-002	DIODE,PIN,.3 PF,100 NS
CR36004	4828-0000-002	DIODE,PIN,.3 PF,100 NS
CR36005	4828-0000-002	DIODE,PIN,.3 PF,100 NS
CR36006	4815-0000-003	DIODE, 1N4148 ,SIGNAL, 75PRV
CR36007	4816-0000-001	DIODE,5082-2800,S BAR, 70VBR
CR36008	4816-0000-001	DIODE,5082-2800,S BAR, 70VBR



7010-4931-500

PCB ASSY, IF GEN PWR AMP (cont)

B

REFERENCE DESIGNATOR	PART NUMBER	DESCRIPTION
CR36009	4815-0000-003	DIODE, 1N4148 ,SIGNAL, 75PRV
FL36001	5801-0000-006	PI FILTER,EMI/RFI 1500pF 8-32*
FL36002	5801-0000-006	PI FILTER,EMI/RFI 1500pF 8-32*
FL36003	5801-0000-006	PI FILTER,EMI/RFI 1500pF 8-32*
FL36004	5801-0000-006	PI FILTER,EMI/RFI 1500pF 8-32*
FL36005	1526-0000-002	CAP,47pF,500V,FEEDTHRU
J36001	2115-9001-008	CONN,RECT.098 RCPT 8-P,SMR08VB
J36002	6042-0016-706	COAX ASSY,086,IF GEN/AMP BD
J36003	6042-0016-706	COAX ASSY,086,IF GEN/AMP BD
L36001	1801-0689-001	IND, 6.8 UH, 2 OHM,1025-40
L36002	1801-0022-001	IND, 22uH 3.3 OHM 1025-52
L36003	1801-0689-001	IND, 6.8 UH, 2 OHM,1025-40
L36004	1801-0689-001	IND, 6.8 UH, 2 OHM,1025-40
L36005	1801-0338-001	IND, .33UH,.2 OHM,1025-08
L36006	1801-0015-001	IND, 15 UH,2.8OHM,1025-48
L36007	1801-0015-001	IND, 15 UH,2.8OHM,1025-48
L36008	1801-0015-001	IND, 15 UH,2.8OHM,1025-48
L36009	1801-0015-001	IND, 15 UH,2.8OHM,1025-48
Q36001	4809-0001-005	TRANS,66382,NPN,HF AMP
Q36002	4809-0001-005	TRANS,66382,NPN,HF AMP
Q36003	4803-0000-003	TRANS, 2N5109 ,NPN PWR HF AMP
Q36004	4805-0000-001	TRANS,2N2907A,PNP HS SW (3251)
Q36005	4805-0000-001	TRANS,2N2907A,PNP HS SW (3251)
Q36006	4805-0000-001	TRANS,2N2907A,PNP HS SW (3251)
Q36007	4805-0000-003	TRANS, 2N3646 ,NPN HS SW
Q36008	4805-0000-003	TRANS, 2N3646 ,NPN HS SW
Q36009	4805-0000-003	TRANS, 2N3646 ,NPN HS SW
R36001	4702-0101-003	RES,100,1/4W,5%
R36002	4702-0181-003	RES,180,1/4W,5%
R36003	4702-0151-003	RES,150,1/4W,5%
R36004	4702-0331-003	RES,330,1/4W,5%
R36005	4702-0473-003	RES,47K,1/4W,5%
R36006	4702-0101-003	RES,100,1/4W,5%
R36007	4702-0270-003	RES,27,1/4W,5%
R36008	4702-0122-003	RES,1.2K,1/4W,5%
R36009	4702-0681-003	RES,680,1/4W,5%
R36010	4709-0101-003	RES,100,5W,5%,WW
R36011	4702-0681-003	RES,680,1/4W,5%
R36012	4702-0681-003	RES,680,1/4W,5%
R36013	4706-4129-001	RES,41.2,1/4W,1%
R36014	4706-1009-001	RES,10,1/4W,1%
R36015	4706-8259-001	RES,82.5,1/4W,1%
R36016	4706-4129-001	RES,41.2,1/4W,1%
R36017	4706-1009-001	RES,10,1/4W,1%
R36018	4702-0102-003	RES,1.0K,1/4W,5%
R36019	4702-0392-003	RES,3.9K,1/4W,5%
R36020	4702-0222-003	RES,2.2K,1/4W,5%
R36021	4702-0822-003	RES,8.2K,1/4W,5%
R36022	4702-0182-003	RES,1.8K,1/4W,5%
R36023	4753-0202-002	POT, 2K OHM
R36024	4702-0103-003	RES,10K,1/4W,5%



7010-4931-500

PCB ASSY, IF GEN PWR AMP (cont)

B

REFERENCE DESIGNATOR	PART NUMBER	DESCRIPTION
R36025	4702-0472-003	RES,4.7K,1/4W,5%
R36026	4702-0222-003	RES,2.2K,1/4W,5%
R36027	4702-0101-003	RES,100,1/4W,5%
R36028	4702-0272-003	RES,2.7K,1/4W,5%
R36029	4702-0222-003	RES,2.2K,1/4W,5%
R36030	4702-0102-003	RES,1.0K,1/4W,5%
R36031	4702-0221-003	RES,220,1/4W,5%
R36032	4702-0152-003	RES,1.5K,1/4W,5%
R36033	4702-0472-003	RES,4.7K,1/4W,5%
R36034	4701-0103-003	RES,10K,1/8W,5%
R36035	4702-0391-003	RES,390,1/4W,5%
U36001	3133-0000-014	IC,3130,BIMOS OP AMP,METAL CAN
U36002	3133-0000-007	IC,4066B,QUAD BILATERAL SWITCH



7005-9047-100

ASSY, FRONT PANEL

A

REFERENCE DESIGNATOR	PART NUMBER	DESCRIPTION
1	1405-9052-200	FRONT PANEL, RD-301
3	2402-0921-900	KNOB,RND, .438OD,.128ID,.520LG
4	1400-9050-900	BRKT,METER MOUNTING
5	2402-4984-700	KNOB ASSY,INTRL PRF/AM
6	7010-4930-900	PCB ASSY,RANGE DISCRETE
7	7010-4930-800	PCB ASSY, RANGE DIGIT SWITCH
8	2402-0013-300	KNOB
9	2402-4984-800	KNOB ASSY, PULSE WIDTH
10	2800-7600-168	SPACER,AL,.25HEX,4-40ID,.75 LG
11	7010-4931-700	PCB ASSY,MOD MODE SWITCH
12	2401-2501-200	DIAL 2ASY
13	2402-0922-000	KNOB,DUAL,.620OD,.252ID,.460LG
14	7010-4930-700	PCB ASSY,R.F. MODE SWITCH
15	2402-0005-703	KNOB
16	2402-4985-000	KNOB ASSY,10DB STEPPED ATTEN
17	2401-2526-400	DIALASY
18	6009-0000-008	STRIP, CONDUCTOR
19	2403-9050-000	OVERLAY, RD-301A
20	2800-7600-114	SPACER,AL,.500OD,.375ID,.080LG
22	2803-0375-006	SCREW, 4-40 X 3/8 PPHM
23	2803-0500-006	SCREW,4-40 X 1/2 PPHM
24	2804-0250-003	SCREW 6-32X1/4 PFHMS
26	2840-7600-208	WASHER,ALUM,.38OD,.250ID,.020T
27	2840-7600-205	WASHER,ALUM,.50OD,.375ID,.020T
28	2850-0000-081	NUT,TOG SW DRESS.35D,1/4-40ID
29	2803-0125-001	SCREW,4-40 X 1/8 SHS
30	2850-7866-300	STANDOFF,HEX,MALE-FEMALE
31	2840-0000-003	WASHER,LOCK,INT TOOTH,4
32	2840-0000-004	WASHER,LOCK,INT TOOTH,2
33	2850-0000-012	NUT,HEX,SMALL PAT,2-56
34	2850-0000-046	NUT,HEX,EX SM PAT,1/4_32
35	2114-0000-005	CONTACT,M D-SUB 20-24G LOOSE
36	2800-3065-300	SPACER,AL,.37500,.272IO,.062LG
37	2114-0000-006	CONTACT,M D-SUB 24-28G LOOSE
39	2840-0000-016	3/8 INT TOOTH LOCKWASHER
41	6010-0125-100	TUBING,HS, 1/8 ID,CLEAR
42	6011-0027-001	TUBING,TF,22 AWG,NATURAL,TW
43	2114-0000-022	CONTACT,DCANT,CRIMP,22-30,GOLD
45	2127-9900-100	KEY,POLARIZIN,MOLEX 15-04-9209
46	6004-6005-400	TY-RAP,4.0 LG
47	2850-0000-033	NUT,HEX,SMALL PAT,3/8-32
	6008-1000-001	WIRE,UL1213,26GA,7X34,BLK
	6008-1000-002	WIRE,UL1213,26GA,7X34,BRN
	6008-1000-003	WIRE,UL1213,26GA,7X34,RED
	6008-1000-004	WIRE,UL1213,26GA,7X34,ORN
	6008-1000-005	WIRE,UL1213,26GA,7X34,YEL
	6008-1000-006	WIRE,UL1213,26GA,7X34,GRN
	6008-1000-008	WIRE,UL1213,26GA,7X34,VIO
	6008-1000-009	WIRE,UL1213,26GA,7X34,GRY
	6008-1000-010	WIRE,UL1213,26GA,7X34,WHT
	6008-1000-011	WIRE,UL1213,26GA,7X34,WHT/BLK

7005-9047-100

ASSY, FRONT PANEL (cont)

A

REFERENCE DESIGNATOR	PART NUMBER	DESCRIPTION
	6008-1000-012	WIRE,UL1213,26GA,7X34,WHT/BRN
	6008-1000-013	WIRE,UL1213,26GA,7X34,WHT/RED
	6008-1000-014	WIRE,UL1213,26GA,7X34,WHT/ORN
	6008-1000-015	WIRE,UL1213,26GA,7X34,WHT/YEL
	6008-1000-016	WIRE,UL1213,26GA,7X34,WHT/GRN
	6008-1000-017	WIRE,UL1213,26GA,7X34,WHT/BLU
	6008-1000-018	WIRE,UL1213,26GA,7X34,WHT/VIO
	6008-1000-019	WIRE,UL1213,26GA,7X34,WHT/GRY
	6008-3000-001	WIRE,UL1213,22GA,7X30,BLK
	6008-3000-004	WIRE,UL1213,22GA,7X30,ORN
	6008-3000-009	WIRE,UL1213,22GA,7X30,GRY
	6008-3000-010	WIRE,UL1213,22GA,7X30,WHT
AT10001	2901-7633-100	ATTEN,STEP,0- 10DB/ 1DB,1W,SMA
AT10002	2901-7333-000	ATTEN,STEP,0-100DB/100B,3W,SMA
AT10003	2901-7333-100	ATTEN,0-59DB/1DB,3W,SMA
C10001	1507-0336-021	CAP,30UF,20V,20%,TANT
DS10001	4818-0000-020	OPTO LED,HLMP-1301,RED
DS10002	4818-0000-020	OPTO LED,HLMP-1301,RED
DS10003	4818-0000-021	OPTO LED,HLMP-1503,GREEN
DS10004	4818-0000-020	OPTO LED,HLMP-1301,RED
DS10005	4818-0000-020	OPTO LED,HLMP-1301,RED
DS10006	4818-0000-020	OPTO LED,HLMP-1301,RED
DS10007	4818-0000-020	OPTO LED,HLMP-1301,RED
DS10008	4818-0000-020	OPTO LED,HLMP-1301,RED
DS10009	4818-0000-020	OPTO LED,HLMP-1301,RED
DS10010	4818-0000-022	OPTO LED,HCMP-1523 HI PERFGRN*
GL10001	2850-0000-014	LUG,GND,4
J10007	2200-0410-100	CONN,ADAPT,F BNC/F SMASTR BHD*
J10008	2200-0410-100	CONN,ADAPT,F BNC/F SMASTR BHD*
J10009	2200-0410-100	CONN,ADAPT,F BNC/F SMASTR BHD*
J10010	2200-0410-100	CONN,ADAPT,F BNC/F SMASTR BHD*
J10011	2200-0410-100	CONN,ADAPT,F BNC/F SMASTR BHD*
J10012	2113-0000-020	CONN UG1094/U
J10013	2200-0410-100	CONN,ADAPT,F BNC/F SMASTR BHD*
J10014	2200-0410-100	CONN,ADAPT,F BNC/F SMASTR BHD*
J10015	2200-0410-100	CONN,ADAPT,F BNC/F SMASTR BHD*
J10017	2116-0000-008	CONN,D-SUB,M,37-P,CCA(CNI)
J10018	2200-0410-100	CONN,ADAPT,F BNC/F SMASTR BHD*
M10001	2900-0100-804	METER,KW PK/EFF-F MHZ RD301A
P14001	2115-0000-013	CONN,C HSG,.100C,10-P
P27001	2115-0000-013	CONN,C HSG,.100C,10-P
P27002	2115-0000-013	CONN,C HSG,.100C,10-P
P32004	2115-0000-015	CONN,C HSG,.100C,18-P
R10001/S00	4757-0000-001	POT, 10K OHM, MODIFIED
R10002	4702-0391-003	RES,390,1/4W,5%
R10003/R00	4750-7605-901	POT, 10K/100,86A3DG36AA0376R55
R10005	4770-8810-300	POT, 10K OHM,
R10006/S00	4750-7608-300	POT, 5K OHM, 380SW10-5K-S .78
R10007	4702-0391-003	RES,390,1/4W,5%
S10001	5114-0000-008	SWITCH TOG DPDT ON-ON-ON LUG
S10003	5114-0000-001	SWITCH TOG SPDT ON-ON LUG



7005-9047-100

ASSY, FRONT PANEL (cont)

A

REFERENCE DESIGNATOR	PART NUMBER	DESCRIPTION
S10005	5115-0000-001	SWITCH GRAYHILL 30-1
S10006	5114-0000-004	SWITCH TOG DPDT ON-ON LUG
S10008	5115-0000-016	SWITCH, POWER VDE



7010-4931-700

PCB ASSY, MOD MODE SWITCH

A2

REFERENCE DESIGNATOR	PART NUMBER	DESCRIPTION
2	1700-2506-700	BD PC
4	1400-4951-600	BRKT,MODULATION MODE SWITCH
7	2803-0188-006	SCREW,4-40 X 3/16 PPHM
J32001	2115-0000-021	CONN MOLEX 22-05-2181
S32001	5115-0000-011	SWITCH PB1170 CENTRALAB



7010-4930-700

PCB ASSY, RF MODE SWITCH

D1

REFERENCE DESIGNATOR	PART NUMBER	DESCRIPTION
1	1700-4920-700	PC BD,R.F. MODE SWITCH
3	5115-0000-012	SWITCH,PB2112 CENTRALAB
4	1400-4951-500	BRKT,RF MODE SWITCH
5	2803-0188-006	SCREW,4-40 X 3/16 PPHM
J27001	2115-0000-016	WAFER,PCB,.100C,STR,10-P
J27002	2115-0000-016	WAFER,PCB,.100C,STR,10-P
R27001	4702-0821-003	RES,820,1/4W,5%
R27002	4702-0821-003	RES,820,1/4W,5%
R27003	4702-0821-003	RES,820,1/4W,5%
R27004	4702-0821-003	RES,820,1/4W,5%
R27005	4702-0821-003	RES,820,1/4W,5%
R27006	4702-0821-003	RES,820,1/4W,5%



7010-4930-900

PCB ASSY, RANGE DISCRETE

E

REFERENCE DESIGNATOR	PART NUMBER	DESCRIPTION
1	1700-4920-900	PC BD,RANGE DISCRETE
2	2800-3065-300	SPACER,AL,.37500,.272IO,.062LG
CR22001	4818-0000-020	OPTO LED,HLMP-1301,RED
J22001	2129-1001-034	CONN, 34P LO PRF HDR SHORT ST*
R22001	4702-0331-003	RES,330,1/4W,5%
R22002	4750-7615-100	POT, 10K OHM, RV6NAYSD103A .59
R22003	4750-7615-100	POT, 10K OHM, RV6NAYSD103A .59
R22004	4750-7615-100	POT, 10K OHM, RV6NAYSD103A .59
SW22001	5111-5013-000	SWITCH,ROT,PCM,SP,12POS, 30TA
SW22002	5120-0012-000	SWITCH TOG SPDT ON-ON PC
SW22003	5111-5013-000	SWITCH,ROT,PCM,SP,12POS, 30TA
SW22004	5120-0012-000	SWITCH TOG SPDT ON-ON PC
SW22005	5111-5013-000	SWITCH,ROT,PCM,SP,12POS, 30TA
W22001	6003-0001-005	WIRE,HOOK,TFE,30GA,SOLID,GRN



7010-4930-800

PCB ASSY, RANGE DIGIT SWITCH

C2

REFERENCE DESIGNATOR	PART NUMBER	DESCRIPTION
J15001	1700-4920-800	PC BD,RANGE DIGIT SWITCH
S15001	2129-1001-034	CONN, 34P LO PRF HDR SHORT ST*
	7105-5102-009	MECH ASSY,TW SW,RD-301 RANGE



7005-9041-900

ASSY, DISPLAY/COUNTER

A

REFERENCE DESIGNATOR	PART NUMBER	DESCRIPTION
1	1414-9052-500	COVER,DISPLAY
2	2803-0188-006	SCREW,4-40 X 3/16 PPHM
3	1414-9052-700	COVER,SHIELD,DISPLAY PCB
4	1415-9052-400	ENCLOSURE,DISPLAY
A1	7010-9031-900	PCB ASSY,DISPLAY/COUNTER
DS1	4950-1000-100	LED,7SEGRED,10MM,HDSP-F111
DS2	4950-1000-100	LED,7SEGRED,10MM,HDSP-F111
DS3	4950-1000-100	LED,7SEGRED,10MM,HDSP-F111
DS4	4950-1000-100	LED,7SEGRED,10MM,HDSP-F111
DS5	4950-1000-100	LED,7SEGRED,10MM,HDSP-F111
DS6	4950-1000-100	LED,7SEGRED,10MM,HDSP-F111



7010-9031-900

PCB ASSY, DISPLAY/COUNTER

C

REFERENCE DESIGNATOR	PART NUMBER	DESCRIPTION
1	1700-9021-900	PC BD,DISPLAY/COUNTER
2	2506-9052-800	DIVIDER,DISPLAY PCB
3	2508-9052-600	SHIELD,DISPLAY PCB
C1	1620-0390-001T	CAP,39pF,63V
C2	1622-0103-001T	CAP,0.01UF,50V,CHIP,X7R
C3	1622-0102-001T	CAP,1000pF,50V,CHIP,NPO
C4	1622-0102-001T	CAP,1000pF,50V,CHIP,NPO
C5	1620-0390-001T	CAP,39pF,63V
C6	1618-0474-025T	CAP,0.47UF,25V,TANT,SMD
C7	1622-0103-001T	CAP,0.01UF,50V,CHIP,X7R
C8	1622-0103-001T	CAP,0.01UF,50V,CHIP,X7R
C9	1622-0103-001T	CAP,0.01UF,50V,CHIP,X7R
C10	1622-0103-001T	CAP,0.01UF,50V,CHIP,X7R
C11	1622-0104-001T	CAP,0.1UF,50V,CHIP,X7R
C12	1622-0103-001T	CAP,0.01UF,50V,CHIP,X7R
C13	1622-0103-001T	CAP,0.01UF,50V,CHIP,X7R
C14	1622-0103-001T	CAP,0.01UF,50V,CHIP,X7R
C15	1622-0101-001T	CAP,100pF,50V,CHIP
C16	1622-0103-001T	CAP,0.01UF,50V,CHIP,X7R
C17	1622-0103-001T	CAP,0.01UF,50V,CHIP,X7R
C18	1622-0104-001T	CAP,0.1UF,50V,CHIP,X7R
C19	1622-0104-001T	CAP,0.1UF,50V,CHIP,X7R
C20	1622-0104-001T	CAP,0.1UF,50V,CHIP,X7R
C21	1622-0104-001T	CAP,0.1UF,50V,CHIP,X7R
C22	1618-0105-016T	CAP,1UF,16V,TANT,SMD
C23	1622-0104-001T	CAP,0.1UF,50V,CHIP,X7R
CR01	4816-0000-006T	DIODE, HSMS 2802, SOT-23
CR02	4816-0000-006T	DIODE, HSMS 2802, SOT-23
CR03	4815-0000-005T	DIODE, 4148,SIGNAL 75PRV SMD
CR06	4815-0000-005T	DIODE, 4148,SIGNAL 75PRV SMD
J1	2123-0000-135	CONN,SMA,STR,EDGE,BULKHD,JACK
J2	2123-0000-135	CONN,SMA,STR,EDGE,BULKHD,JACK
J4	2123-0000-135	CONN,SMA,STR,EDGE,BULKHD,JACK
J5	2115-0000-120	WAFER,PCB,.100C,R,A,10-P GOLD
L1	2750-0000-029T	BEAD,FERRITE BLM21A601 0805
L2	2750-0000-029T	BEAD,FERRITE BLM21A601 0805
Q1	4809-0000-014T	TRANS,MMBTH10,VHF/UHF NPN
Q2	4809-0000-014T	TRANS,MMBTH10,VHF/UHF NPN
Q3	4801-0000-006T	TRANS,2N2222,NPN HS SW,*SOT*
Q4	4805-0000-004	TRANS,2N2907A,G/P PNP SOT-23
Q5	4805-0000-004T	TRANS,2N2907A,G/P PNP SOT-23
R1	4732-1500-001T	RES,150,1/10W,1%
R2	4732-1500-001T	RES,150,1/10W,1%
R3	4732-3929-001T	RES,39.2,1/10W,1%
R4	4732-5111-001T	RES,5.11K,1/10W,1%
R5	4732-1002-001T	RES,10.0K,1/10W,1%
R6	4732-5111-001T	RES,5.11K,1/10W,1%
R7	4732-1002-001T	RES,10.0K,1/10W,1%
R8	4732-1002-001T	RES,10.0K,1/10W,1%
R9	4732-1002-001T	RES,10.0K,1/10W,1%
R10	4732-1501-001T	RES,1.50K,1/10W,1%,0805



7010-9031-900

PCB ASSY, DISPLAY/COUNTER (cont)

C

REFERENCE DESIGNATOR	PART NUMBER	DESCRIPTION
R11	4732-2740-001T	RES,274,1/10W,1%
R12	4732-6819-001T	RES,68.1,1/10W,1%,0805
R13	4732-3322-001T	RES,33.2K,1/10W,1%
R14	4732-3320-001T	RES,332,1/10W,1%
R15	4732-3320-001T	RES,332,1/10W,1%
R16	4732-3320-001T	RES,332,1/10W,1%
R17	4732-3320-001T	RES,332,1/10W,1%
R18	4732-3320-001T	RES,332,1/10W,1%
R19	4732-3320-001T	RES,332,1/10W,1%
R20	4732-3320-001T	RES,332,1/10W,1%
R21	4732-3320-001T	RES,332,1/10W,1%
R22	4732-3320-001T	RES,332,1/10W,1%
R23	4732-3320-001T	RES,332,1/10W,1%
R24	4732-3320-001T	RES,332,1/10W,1%
R25	4732-3320-001T	RES,332,1/10W,1%
R26	4732-3320-001T	RES,332,1/10W,1%
R27	4732-3320-001T	RES,332,1/10W,1%
R28	4732-3320-001T	RES,332,1/10W,1%
R29	4732-3320-001T	RES,332,1/10W,1%
R30	4732-3320-001T	RES,332,1/10W,1%
R31	4732-3320-001T	RES,332,1/10W,1%
R32	4732-3320-001T	RES,332,1/10W,1%
R33	4732-3320-001T	RES,332,1/10W,1%
R34	4732-3320-001T	RES,332,1/10W,1%
R35	4732-3320-001T	RES,332,1/10W,1%
R36	4732-3320-001T	RES,332,1/10W,1%
R37	4732-3320-001T	RES,332,1/10W,1%
R38	4732-3320-001T	RES,332,1/10W,1%
R39	4732-3320-001T	RES,332,1/10W,1%
R40	4732-3320-001T	RES,332,1/10W,1%
R41	4732-3320-001T	RES,332,1/10W,1%
R42	4732-3320-001T	RES,332,1/10W,1%
R43	4732-3320-001T	RES,332,1/10W,1%
R44	4732-3320-001T	RES,332,1/10W,1%
R45	4732-3320-001T	RES,332,1/10W,1%
R46	4732-3320-001T	RES,332,1/10W,1%
R47	4732-3320-001T	RES,332,1/10W,1%
R48	4732-3320-001T	RES,332,1/10W,1%
R49	4732-3320-001T	RES,332,1/10W,1%
R50	4732-3320-001T	RES,332,1/10W,1%
R51	4732-3320-001T	RES,332,1/10W,1%
R52	4732-3320-001T	RES,332,1/10W,1%
R53	4732-3320-001T	RES,332,1/10W,1%
R54	4732-3320-001T	RES,332,1/10W,1%
R55	4732-3320-001T	RES,332,1/10W,1%
R56	4732-1002-001T	RES,10.0K,1/10W,1%
R57	4732-3320-001T	RES,332,1/10W,1%
R58	4732-3320-001T	RES,332,1/10W,1%
R59	4732-1004-001T	RES,1.0M,1/10W,1%
R60	4732-1002-001T	RES,10.0K,1/10W,1%
R61	4732-1002-001T	RES,10.0K,1/10W,1%



7010-9031-900

PCB ASSY, DISPLAY/COUNTER (cont)

C

REFERENCE DESIGNATOR	PART NUMBER	DESCRIPTION
R62	4732-1002-001T	RES,10.0K,1/10W,1%
R63	4732-1002-001T	RES,10.0K,1/10W,1%
R64	4732-1002-001T	RES,10.0K,1/10W,1%
R65	4732-1002-001T	RES,10.0K,1/10W,1%
R66	4732-1002-001T	RES,10.0K,1/10W,1%
R67	4732-1002-001T	RES,10.0K,1/10W,1%
R68	4732-1002-001T	RES,10.0K,1/10W,1%
R69	4732-3320-001T	RES,332,1/10W,1%
R70	4732-1002-001T	RES,10.0K,1/10W,1%
R71	4732-6819-001T	RES,68.1,1/10W,1%,0805
R72	4732-3322-001T	RES,33.2K,1/10W,1%
R73	4732-3572-001T	RES,35.7K,1/10W,1%
R74	4732-3320-001T	RES,332,1/10W,1%
R75	4732-1001-001T	RES,1.0K,1/10W,1%
R77	4732-1002-001T	RES,10.0K,1/10W,1%
R78	4732-1001-001T	RES,1.0K,1/10W,1%
R79	4732-4750-001T	RES,475,1/10W,1%
R80	4732-1501-001T	RES,1.50K,1/10W,1%,0805
R81	4732-1002-001T	RES,10.0K,1/10W,1%
RA1	4749-0203-005T	POT,SMD 20K OHM
S1	5111-1001-007	SWITCH,16 POS,BINARY CODE,RTRY
S5	5136-0005-000T	SWITCH,HI TEMP,SEALED,5P SMT
U1	3210-3074-000T	IC,DUAL D,FF/SET/RESET INDL
U2	3210-3074-000T	IC,DUAL D,FF/SET/RESET INDL
U3	3210-3004-000T	IC, HEX INVERTER
U4	3213-1033-000T	IC,PRESCLR/4,4GHZ,5V/3V,SO-8
U5	3213-1033-000T	IC,PRESCLR/4,4GHZ,5V/3V,SO-8
U6	3213-1021-000T	IC,TRANSLATOR,PECL-TTL,SO-8
U7	F191-4920-100	PROG SERIAL PROM
U8	3260-0103-200T	IC,EPF8452,CMOS,PLD,PLCC84
W1	4732-0000-001T	RES,0,1/10W,1%
X9	3101-0000-014	SOCKET,DIP,.3CTR,VERT PCB MT
X10	3101-0000-014	SOCKET,DIP,.3CTR,VERT PCB MT
X11	3101-0000-014	SOCKET,DIP,.3CTR,VERT PCB MT
X12	3101-0000-014	SOCKET,DIP,.3CTR,VERT PCB MT
X13	3101-0000-014	SOCKET,DIP,.3CTR,VERT PCB MT
X14	3101-0000-014	SOCKET,DIP,.3CTR,VERT PCB MT
XU7	3101-0600-000	SOCKET,8-PIN DIP



7005-4943-000

ASSY, 475/570-775 MHZ FLTR

E

REFERENCE DESIGNATOR	PART NUMBER	DESCRIPTION
1	2100-4955-000	BLOCK FILTER
2	2803-0188-006	SCREW,4-40 X 3/16 PPHM
3	1414-4955-200	COVER FILTER
4	2400-4955-800	LABEL,FACTORY ALIGNMENT ONLY
C53001	1558-0800-500	CAP VAR,1.0-14pF,250V,5402
C53002	1558-0800-500	CAP VAR,1.0-14pF,250V,5402
C53003	1558-0800-500	CAP VAR,1.0-14pF,250V,5402
C53004	1558-0800-500	CAP VAR,1.0-14pF,250V,5402
C53005	1506-0020-017	CAP,2.2pF,100V,NPO,25
C53006	1506-0010-017	CAP,1pF,100V,MICA,50
C53007	1558-0800-500	CAP VAR,1.0-14pF,250V,5402
C53008	1558-0800-500	CAP VAR,1.0-14pF,250V,5402
C53009	1558-0800-500	CAP VAR,1.0-14pF,250V,5402
C53010	1558-0800-500	CAP VAR,1.0-14pF,250V,5402
C53011	1558-0800-500	CAP VAR,1.0-14pF,250V,5402
C53012	1506-0689-017	CAP,6.8pF,100V,5%,NPO
C53013	1506-0020-017	CAP,2.2pF,100V,NPO,25
C53014	1506-0010-017	CAP,1pF,100V,MICA,50
C53015SAT	1523-0000-006	CAP,0.4pF,50V,HIQ,CHIP
C53015SAT	1523-0000-009	CAP,0.6pF,50V,HIQ,CHIPA
J53001	2123-0000-036	CONN,M SMB,W/TERM,STR BULKHEAD
J53002	2123-0000-036	CONN,M SMB,W/TERM,STR BULKHEAD
J53003	2123-0000-036	CONN,M SMB,W/TERM,STR BULKHEAD
J53004	2123-0000-036	CONN,M SMB,W/TERM,STR BULKHEAD
L53001	1050-0000-073	WIRE,BUS,TINNED COPPER,22GA
L53002	1050-0000-071	WIRE,BUS,TINNED COPPER,18GA
L53003	1050-0000-071	WIRE,BUS,TINNED COPPER,18GA
L53004	1050-0000-071	WIRE,BUS,TINNED COPPER,18GA
L53005	1050-0000-071	WIRE,BUS,TINNED COPPER,18GA
L53006	1801-0337-002	IND, .033UH, .035OHM102604
L53007	1801-0337-002	IND, .033UH, .035OHM102604
L53008	1050-0000-071	WIRE,BUS,TINNED COPPER,18GA
L53009	1050-0000-071	WIRE,BUS,TINNED COPPER,18GA
L53010	1050-0000-071	WIRE,BUS,TINNED COPPER,18GA
L53011	1050-0000-071	WIRE,BUS,TINNED COPPER,18GA
L53012	1050-0000-071	WIRE,BUS,TINNED COPPER,18GA
L53013	1801-0337-002	IND, .033UH, .035OHM102604
L53014	1801-0158-001	IND, .15UH, .1 OHM,1025-00
L53015	1801-0000-007	IND, .068 UH, .060 OHM
L53016	1050-0000-073	WIRE,BUS,TINNED COPPER,22GA

7005-4943-000

ASSY, 475/570-775 MHZ FLTR

F

Contains all parts in Revision E plus the following:

REFERENCE DESIGNATOR	PART NUMBER	DESCRIPTION
C53016SAT	1523-0000-006	CAP,0.4pF,50V,HIQ,CHIP



7005-9041-000

ASSY, DELAY LINE

A

REFERENCE DESIGNATOR	PART NUMBER	DESCRIPTION
1	1414-4952-300	COVER PLATE,DELAY LINE
2	2803-0438-006	SCREW,4-40 X 7/16 PPHM
3	1400-9051-600	BRKT,DELAY LINE MTG
4	6004-6005-400	TY-RAP,4.0 LG
5	6042-0000-007	CABLE,COAX,FLEX,RG-316/U
P50014	2123-0000-037	CONN, F, SMB,RA,PLUG, CR,N,
P50015	2123-0000-037	CONN, F, SMB,RA,PLUG, CR,N,



7005-9041-800

ASSY, CARD FRAME

A

REFERENCE DESIGNATOR	PART NUMBER	DESCRIPTION
1	7010-9031-800	PCB ASSY,RANGE BOARD #2
2	7010-4931-300	PCB ASSY,DISCRIMINATOR #2
4	1402-4954-000	RAIL,CARD FRAME,OUTER
5	1402-4954-100	RAIL,CARD FRAME,INNER
6	1405-4985-100	PANEL,CARD FRAME
7	1400-4953-600	BRACKET,SMB CONN MTG
8	7010-4930-300	PCB ASSY,RANGE BOARD #1
9	7010-4932-800	PC BD ASSY-DISCR BD NO.1
11	6045-4983-700	RBN CA ASSY,DISC #1--DISC #2
12	2803-0250-006	SCREW,4-40 X 1/4 PPHM
13	2803-0438-006	SCREW,4-40 X 7/16 PPHM
TAG #26	6042-4983-900	COAX ASSY,SR.086,DSCM-PRESC.



7010-4930-300

PCB ASSY, RANGE BOARD #1

H

REFERENCE DESIGNATOR	PART NUMBER	DESCRIPTION
1	1700-4920-300	PC BD,RANGE BOARD #1
2	3107-5052-200	INSUL,MYLAR,ADHES,3.8 X 6.88
C19001	1506-0102-017	CAP,1000pF,100V,5%,NPO
C19002	1506-0100-017	CAP,10pF,100V,5%,NPO
C19003	1506-0100-017	CAP,10pF,100V,5%,NPO
C19004	1506-0050-017	CAP,5.6pF,100V,5%,NPO
C19005	1506-0100-017	CAP,10pF,100V,5%,NPO
C19006	1506-0050-017	CAP,5.6pF,100V,5%,NPO
C19007	1501-0103-005	CAP,0.01UF,50V,20%,DISC
C19008	1501-0103-005	CAP,0.01UF,50V,20%,DISC
C19009	1506-0102-017	CAP,1000pF,100V,5%,NPO
C19010	1501-0103-005	CAP,0.01UF,50V,20%,DISC
C19011	1501-0103-005	CAP,0.01UF,50V,20%,DISC
C19012	1506-0102-017	CAP,1000pF,100V,5%,NPO
C19013	1506-0102-017	CAP,1000pF,100V,5%,NPO
C19014	1506-0470-017	CAP,47pF,100V,NPO
C19015SAT	1506-0820-017	CAP,82pF,100V,5%,NPO
C19016	1501-0103-005	CAP,0.01UF,50V,20%,DISC
C19017	1506-0471-017	CAP,470pF,100V,5%,NPO
C19018	1521-0000-008	CAP,0.1UF,50V,DIP,Z5U
C19019	1501-0103-005	CAP,0.01UF,50V,20%,DISC
C19020	1506-0681-017	CAP,680pF,100V,5%,NPO
C19021	1506-0681-017	CAP,680pF,100V,5%,NPO
C19022	1506-0102-017	CAP,1000pF,100V,5%,NPO
C19023	1501-0103-005	CAP,0.01UF,50V,20%,DISC
C19024	1580-4700-045	CAP,47UF,10V,ELE,30
C19025	1580-1000-350	CAP,10UF,35V,ELE
C19026	1506-0220-017	CAP,22PF,100V,5%,NPO
C19027	1506-0100-017	CAP,10pF,100V,5%,NPO
C19028	1521-0000-008	CAP,0.1UF,50V,DIP,Z5U
C19029	1521-0000-008	CAP,0.1UF,50V,DIP,Z5U
C19030	1521-0000-008	CAP,0.1UF,50V,DIP,Z5U
C19031	1521-0000-008	CAP,0.1UF,50V,DIP,Z5U
C19032	1521-0000-008	CAP,0.1UF,50V,DIP,Z5U
C19033	1521-0000-008	CAP,0.1UF,50V,DIP,Z5U
C19034	1521-0000-008	CAP,0.1UF,50V,DIP,Z5U
C19035	1521-0000-008	CAP,0.1UF,50V,DIP,Z5U
C19036	1521-0000-008	CAP,0.1UF,50V,DIP,Z5U
C19037	1521-0000-008	CAP,0.1UF,50V,DIP,Z5U
C19038	1521-0000-008	CAP,0.1UF,50V,DIP,Z5U
C19039	1521-0000-008	CAP,0.1UF,50V,DIP,Z5U
C19040	1521-0000-008	CAP,0.1UF,50V,DIP,Z5U
C19041	1521-0000-008	CAP,0.1UF,50V,DIP,Z5U
C19042	1521-0000-008	CAP,0.1UF,50V,DIP,Z5U
C19043	1521-0000-008	CAP,0.1UF,50V,DIP,Z5U
C19044	1521-0000-008	CAP,0.1UF,50V,DIP,Z5U
C19045	1521-0000-008	CAP,0.1UF,50V,DIP,Z5U
C19046	1521-0000-008	CAP,0.1UF,50V,DIP,Z5U
C19047	1521-0000-008	CAP,0.1UF,50V,DIP,Z5U
C19048	1521-0000-008	CAP,0.1UF,50V,DIP,Z5U
C19049	1521-0000-008	CAP,0.1UF,50V,DIP,Z5U



7010-4930-300

PCB ASSY, RANGE BOARD #1 (cont)

H

REFERENCE DESIGNATOR	PART NUMBER	DESCRIPTION
C19050	1521-0000-008	CAP,0.1UF,50V,DIP,Z5U
C19051	1521-0000-008	CAP,0.1UF,50V,DIP,Z5U
C19052	1521-0000-008	CAP,0.1UF,50V,DIP,Z5U
C19053	1521-0000-008	CAP,0.1UF,50V,DIP,Z5U
C19054	1521-0000-008	CAP,0.1UF,50V,DIP,Z5U
C19055	1521-0000-008	CAP,0.1UF,50V,DIP,Z5U
C19056	1521-0000-008	CAP,0.1UF,50V,DIP,Z5U
CR19001	4815-0000-003	DIODE, 1N4148 ,SIGNAL, 75PRV
CR19002	4815-0000-003	DIODE, 1N4148 ,SIGNAL, 75PRV
CR19003	4815-0000-003	DIODE, 1N4148 ,SIGNAL, 75PRV
CR19004	4815-0000-003	DIODE, 1N4148 ,SIGNAL, 75PRV
CR19005	4816-0000-001	DIODE,5082-2800,S BAR, 70VBR
CR19006	4816-0000-001	DIODE,5082-2800,S BAR, 70VBR
J19002	2129-1001-034	CONN, 34P LO PRF HDR SHORT ST*
L19002	1800-7629-300	XFMR,.1UH,108-177MHZ,BLUE
P30001	6045-4980-200	RBN CA ASSY,RANGE #1- RANGE #2
Q19001	4807-0000-002	TRANS, 2N3905 ,PNP HS SW
Q19002	4809-0000-005	TRANS,66382,NPN HF AMP
Q19003	4809-0000-005	TRANS,66382,NPN HF AMP
Q19004	4809-0000-005	TRANS,66382,NPN HF AMP
Q19005	4807-0000-002	TRANS, 2N3905 ,PNP HS SW
Q19006	4807-0000-002	TRANS, 2N3905 ,PNP HS SW
Q19007	4807-0000-002	TRANS, 2N3905 ,PNP HS SW
Q19008	4807-0000-002	TRANS, 2N3905 ,PNP HS SW
Q19009	4807-0000-002	TRANS, 2N3905 ,PNP HS SW
Q19010	4801-0000-001	TRANSISTOR NPN HS SW
Q19011	4801-0000-001	TRANSISTOR NPN HS SW
R19001	4702-0102-003	RES,1.0K,1/4W,5%
R19002	4702-0272-003	RES,2.7K,1/4W,5%
R19003	4702-0681-003	RES,680,1/4W,5%
R19003SAT	4702-0102-003	RES,1.0K,1/4W,5%
R19003SAT	4702-0471-003	RES,470,1/4W,5%
R19003SAT	4702-0821-003	RES,820,1/4W,5%
R19004	4702-0471-003	RES,470,1/4W,5%
R19005	4702-0682-003	RES,6.8K,1/4W,5%
R19006	4702-0101-003	RES,100,1/4W,5%
R19007	4702-0102-003	RES,1.0K,1/4W,5%
R19008	4702-0473-003	RES,47K,1/4W,5%
R19009	4702-0471-003	RES,470,1/4W,5%
R19010	4702-0101-003	RES,100,1/4W,5%
R19011	4702-0102-003	RES,1.0K,1/4W,5%
R19012	4702-0473-003	RES,47K,1/4W,5%
R19013	4702-0680-003	RES,68,1/4W,5%
R19014	4702-0471-003	RES,470,1/4W,5%
R19015	4702-0471-003	RES,470,1/4W,5%
R19016	4702-0473-003	RES,47K,1/4W,5%
R19017	4702-0471-003	RES,470,1/4W,5%
R19018	4702-0822-003	RES,8.2K,1/4W,5%
R19019	4702-0101-003	RES,100,1/4W,5%
R19020	4702-0102-003	RES,1.0K,1/4W,5%
R19021	4702-0222-003	RES,2.2K,1/4W,5%



7010-4930-300

PCB ASSY, RANGE BOARD #1 (cont)

H

REFERENCE DESIGNATOR	PART NUMBER	DESCRIPTION
R19022	4702-0223-003	RES,22K,1/4W,5%
R19023	4702-0101-003	RES,100,1/4W,5%
R19024	4702-0101-003	RES,100,1/4W,5%
R19026	4702-0471-003	RES,470,1/4W,5%
R19027	4702-0471-003	RES,470,1/4W,5%
R19028	4702-0680-003	RES,68,1/4W,5%
R19029	4702-0101-003	RES,100,1/4W,5%
R19030	4702-0561-003	RES,560,1/4W,5%
R19031	4702-0221-003	RES,220,1/4W,5%
R19032	4702-0182-003	RES,1.8K,1/4W,5%
R19033	4702-0331-003	RES,330,1/4W,5%
R19034	4702-0331-003	RES,330,1/4W,5%
R19035	4702-0331-003	RES,330,1/4W,5%
R19036	4702-0221-003	RES,220,1/4W,5%
R19037	4702-0181-003	RES,180,1/4W,5%
R19038	4702-0471-003	RES,470,1/4W,5%
R19039	4702-0680-003	RES,68,1/4W,5%
R19040	4702-0101-003	RES,100,1/4W,5%
R19041	4702-0561-003	RES,560,1/4W,5%
R19042	4702-0221-003	RES,220,1/4W,5%
R19043	4702-0331-003	RES,330,1/4W,5%
R19044	4702-0331-003	RES,330,1/4W,5%
R19045	4702-0103-003	RES,10K,1/4W,5%
R19046	4702-0121-003	RES,120,1/4W,5%
R19047	4752-0201-002	POT, 200 OHM
R19048	4702-0103-003	RES,10K,1/4W,5%
R19049	4702-0103-003	RES,10K,1/4W,5%
R19050	4702-0332-003	RES,3.3K,1/4W,5%
R19051	4702-0181-003	RES,180,1/4W,5%
R19052	4702-0331-003	RES,330,1/4W,5%
R19053	4702-0681-003	RES,680,1/4W,5%
R19054	4702-0101-003	RES,100,1/4W,5%
TP19001	2114-0000-007	TEST POINT,LOOP PROFILE,WHITE*
U19001	3134-0000-017	IC,12013,D/10/11 PRESCALER
U19002	3211-3390-000	IC,74LS390,DUAL DECADE COUNTER
U19003	3131-0000-028	IC,74LS90,DECADE COUNTER
U19004	3134-0000-008	IC,10116,TRIPLE LINE RECEIVER
U19005	3213-0003-000	IC,10137,UNIV DECADE COUNTER
U19006	3131-0000-029	IC,74LS190,BCD SYN U/D COUNTER
U19007	3131-0000-029	IC,74LS190,BCD SYN U/D COUNTER
U19008	3131-0000-029	IC,74LS190,BCD SYN U/D COUNTER
U19009	3131-0000-029	IC,74LS190,BCD SYN U/D COUNTER
U19010	3131-0000-032	IC,74LS02,QUAD 2-INPUT NOR
U19011	3131-0000-027	IC,74LS30,8-INPUT NAND
U19012	3131-0000-027	IC,74LS30,8-INPUT NAND
U19013	3131-0000-044	IC,74LS00,QUAD 2-INPUT NAND
U19014	3132-0000-002	IC,74S112,DUAL JK FLIP-FLOP
U19015	3131-0000-029	IC,74LS190,BCD SYN U/D COUNTER
U19016	3132-0000-002	IC,74S112,DUAL JK FLIP-FLOP
U19017	3131-0000-044	IC,74LS00,QUAD 2-INPUT NAND
U19018	3131-0000-044	IC,74LS00,QUAD 2-INPUT NAND



7010-4930-300

PCB ASSY, RANGE BOARD #1 (cont)

H

REFERENCE DESIGNATOR	PART NUMBER	DESCRIPTION
U19019	3213-0003-000	IC,10137,UNIV DECADE COUNTER
U19020	3131-0000-029	IC,74LS190,BCD SYN U/D COUNTER
U19021	3131-0000-029	IC,74LS190,BCD SYN U/D COUNTER
U19022	3131-0000-029	IC,74LS190,BCD SYN U/D COUNTER
U19023	3131-0000-029	IC,74LS190,BCD SYN U/D COUNTER
U19024	3131-0000-032	IC,74LS02,QUAD 2-INPUT NOR
U19025	3131-0000-027	IC,74LS30,8-INPUT NAND
U19026	3131-0000-027	IC,74LS30,8-INPUT NAND
U19027	3131-0000-006	IC,74LS76A,DUAL JK FLIP-FLOP
U19028	3132-0000-002	IC,74S112,DUAL JK FLIP-FLOP
U19029	3131-0000-044	IC,74LS00,QUAD 2-INPUT NAND
U19030	3131-0000-029	IC,74LS190,BCD SYN U/D COUNTER
U19031	3132-0000-002	IC,74S112,DUAL JK FLIP-FLOP
U19032	3132-0000-002	IC,74S112,DUAL JK FLIP-FLOP
Y19001	2363-0011-000	XTAL,100.000000MHZ,5 S,HC-18/U
Y19002	2363-0036-000	XTAL,8.091270MHZ,FP,HC-18/U3



7010-9031-800

PCB ASSY, RANGE BOARD #2

B

REFERENCE DESIGNATOR	PART NUMBER	DESCRIPTION
1	1700-9021-800	PC BD,RANGE BOARD #2
C30001	1521-0000-008	CAP,0.1UF,50V,DIP,Z5U
C30002	1506-0680-017	CAP,68pF,100V,5%,NPO
C30003	1506-0102-017	CAP,1000pF,100V,5%,NPO
C30004	1502-0103-010	CAP,0.01UF,50V,2%,PC
C30005	1502-0104-002	CAP,0.1UF,50V,2%,PCARB
C30006	1502-0105-002	CAP,1UF,50V,2%,MPC
C30007	1501-0103-005	CAP,0.01UF,50V,20%,DISC
C30008	1521-0000-008	CAP,0.1UF,50V,DIP,Z5U
C30009	1521-0000-008	CAP,0.1UF,50V,DIP,Z5U
C30010	1506-0680-017	CAP,68pF,100V,5%,NPO
C30011	1506-0102-017	CAP,1000pF,100V,5%,NPO
C30012	1502-0103-010	CAP,0.01UF,50V,2%,PC
C30013	1502-0104-002	CAP,0.1UF,50V,2%,PCARB
C30014	1502-0105-002	CAP,1UF,50V,2%,MPC
C30015	1501-0103-005	CAP,0.01UF,50V,20%,DISC
C30016	1521-0000-008	CAP,0.1UF,50V,DIP,Z5U
C30017	1502-0334-012	CAP,0.33UF,50V,5%,MPC
C30018	1521-0000-008	CAP,0.1UF,50V,DIP,Z5U
C30019	1521-0000-008	CAP,0.1UF,50V,DIP,Z5U
C30020	1580-1000-200	CAP,10UF,25V,ELE,RDL
C30022	1502-0103-010	CAP,0.01UF,50V,2%,PC
C30023	1502-0104-002	CAP,0.1UF,50V,2%,PCARB
C30024	1506-0680-017	CAP,68pF,100V,5%,NPO
C30025	1507-0476-018	CAP,47UF,35V,20%,TANT
C30026	1521-0000-008	CAP,0.1UF,50V,DIP,Z5U
C30027	1521-0000-008	CAP,0.1UF,50V,DIP,Z5U
C30028	1521-0000-008	CAP,0.1UF,50V,DIP,Z5U
C30029	1521-0000-008	CAP,0.1UF,50V,DIP,Z5U
C30030	1580-4700-215	CAP,47UF,25V,ELE,30
C30031	1580-4700-215	CAP,47UF,25V,ELE,30
C30032	1580-4702-105	CAP,47UF,10V,ELE,RDL
C30033	1506-0680-017	CAP,68pF,100V,5%,NPO
C30034	1506-0180-017	CAP,18pF,100V,5%,NPO
C30035	1506-0101-017	CAP,100pF,100V,5%,NPO
C30036	1506-0680-017	CAP,68pF,100V,5%,NPO
C30037	1506-0180-017	CAP,18pF,100V,5%,NPO
C30038	1506-0101-017	CAP,100pF,100V,5%,NPO
C30039	1502-0505-001	CAP,5UF,50V,10%,MPC
CR30001	4815-0000-003	DIODE, 1N4148 ,SIGNAL, 75PRV
CR30002	4815-0000-003	DIODE, 1N4148 ,SIGNAL, 75PRV
CR30003	4815-0000-003	DIODE, 1N4148 ,SIGNAL, 75PRV
CR30004	4815-0000-003	DIODE, 1N4148 ,SIGNAL, 75PRV
CR30005	4815-0000-003	DIODE, 1N4148 ,SIGNAL, 75PRV
CR30006	4815-0000-003	DIODE, 1N4148 ,SIGNAL, 75PRV
CR30007	4818-0000-015	DIODE,LM329C,6.9V ZENER REF
CR30008	4815-0000-003	DIODE, 1N4148 ,SIGNAL, 75PRV
CR30009	4815-0000-003	DIODE, 1N4148 ,SIGNAL, 75PRV
CR30010	4815-0000-003	DIODE, 1N4148 ,SIGNAL, 75PRV
CR30011	4815-0000-003	DIODE, 1N4148 ,SIGNAL, 75PRV
CR30012	4815-0000-003	DIODE, 1N4148 ,SIGNAL, 75PRV



7010-9031-800

PCB ASSY, RANGE BOARD #2 (cont)

B

REFERENCE DESIGNATOR	PART NUMBER	DESCRIPTION
CR30013	4815-0000-003	DIODE, 1N4148 ,SIGNAL, 75PRV
CR30014	4815-0000-003	DIODE, 1N4148 ,SIGNAL, 75PRV
CR30015	4815-0000-003	DIODE, 1N4148 ,SIGNAL, 75PRV
CR30016	4815-0000-003	DIODE, 1N4148 ,SIGNAL, 75PRV
CR30017	4815-0000-003	DIODE, 1N4148 ,SIGNAL, 75PRV
CR30018	4815-0000-003	DIODE, 1N4148 ,SIGNAL, 75PRV
CR30019	4815-0000-003	DIODE, 1N4148 ,SIGNAL, 75PRV
CR30020	4815-0000-003	DIODE, 1N4148 ,SIGNAL, 75PRV
CR30021	4815-0000-003	DIODE, 1N4148 ,SIGNAL, 75PRV
CR30022	4815-0000-003	DIODE, 1N4148 ,SIGNAL, 75PRV
CR30023	4818-0000-015	DIODE,LM329C,6.9V ZENER REF
CR30024	4815-0000-003	DIODE, 1N4148 ,SIGNAL, 75PRV
CR30025	4815-0000-003	DIODE, 1N4148 ,SIGNAL, 75PRV
CR30026	4815-0000-003	DIODE, 1N4148 ,SIGNAL, 75PRV
CR30027	4815-0000-003	DIODE, 1N4148 ,SIGNAL, 75PRV
CR30028	4815-0000-003	DIODE, 1N4148 ,SIGNAL, 75PRV
CR30029	4815-0000-003	DIODE, 1N4148 ,SIGNAL, 75PRV
CR30030	4815-0000-003	DIODE, 1N4148 ,SIGNAL, 75PRV
CR30031	4815-0000-003	DIODE, 1N4148 ,SIGNAL, 75PRV
J30001	2129-1001-026	CONN,ANSLEY 609-2327 26-P M
J30002	2129-1001-034	CONN, 34P LO PRF HDR SHORT ST*
J30003	2115-1002-015	CONN,MOLEX 22-05-2151
J30004	2200-2010-400	CONN,M SMB,PC MTG,STR,.453LG
J30005	2200-2010-400	CONN,M SMB,PC MTG,STR,.453LG
J30006	2115-0000-020	WAFER,PCB,.100C,R.A,10-P
J30007	2200-2010-400	CONN,M SMB,PC MTG,STR,.453LG
J30008	2200-2010-400	CONN,M SMB,PC MTG,STR,.453LG
K30001	4501-0000-002	RELAY,DIP REED,SPST, 12VDC,.5A--
K30002	4501-0000-002	RELAY,DIP REED,SPST, 12VDC,.5A--
K30003	4501-0000-002	RELAY,DIP REED,SPST, 12VDC,.5A--
K30004	4501-0000-002	RELAY,DIP REED,SPST, 12VDC,.5A--
K30005	4501-0000-002	RELAY,DIP REED,SPST, 12VDC,.5A--
K30006	4501-0000-002	RELAY,DIP REED,SPST, 12VDC,.5A--
K30007	4501-0000-002	RELAY,DIP REED,SPST, 12VDC,.5A--
L30001	1801-0688-001	IND, .68UH,.6 OHM,1025-16
Q30001	4807-0000-001	TRANS, 2N3903 ,NPN HS SW
Q30002	4807-0000-002	TRANS, 2N3905 ,PNP HS SW
Q30003	4807-0000-001	TRANS, 2N3903 ,NPN HS SW
Q30004	4807-0000-002	TRANS, 2N3905 ,PNP HS SW
Q30005	4807-0000-001	TRANS, 2N3903 ,NPN HS SW
Q30006	4807-0000-002	TRANS, 2N3905 ,PNP HS SW
Q30007	4807-0000-001	TRANS, 2N3903 ,NPN HS SW
Q30008	4807-0000-001	TRANS, 2N3903 ,NPN HS SW
Q30009	4807-0000-001	TRANS, 2N3903 ,NPN HS SW
Q30010	4807-0000-001	TRANS, 2N3903 ,NPN HS SW
Q30011	4807-0000-002	TRANS, 2N3905 ,PNP HS SW
Q30012	4807-0000-001	TRANS, 2N3903 ,NPN HS SW
Q30013	4807-0000-002	TRANS, 2N3905 ,PNP HS SW
Q30014	4807-0000-001	TRANS, 2N3903 ,NPN HS SW
Q30015	4807-0000-001	TRANS, 2N3903 ,NPN HS SW
Q30016	4807-0000-001	TRANS, 2N3903 ,NPN HS SW



7010-9031-800

PCB ASSY, RANGE BOARD #2 (cont)

B

REFERENCE DESIGNATOR	PART NUMBER	DESCRIPTION
Q30017	4807-0000-001	TRANS, 2N3903 ,NPN HS SW
Q30018	4807-0000-001	TRANS, 2N3903 ,NPN HS SW
Q30019	4807-0000-002	TRANS, 2N3905 ,PNP HS SW
Q30020	4807-0000-001	TRANS, 2N3903 ,NPN HS SW
Q30021	4807-0000-002	TRANS, 2N3905 ,PNP HS SW
Q30022	4807-0000-002	TRANS, 2N3905 ,PNP HS SW
Q30023	4807-0000-002	TRANS, 2N3905 ,PNP HS SW
R30001	4702-0102-003	RES,1.0K,1/4W,5%
R30002	4702-0221-003	RES,220,1/4W,5%
R30003	4702-0153-003	RES,15K,1/4W,5%
R30004	4702-0561-003	RES,560,1/4W,5%
R30005	4702-0221-003	RES,220,1/4W,5%
R30006	4702-0102-003	RES,1.0K,1/4W,5%
R30007	4702-0152-003	RES,1.5K,1/4W,5%
R30008	4702-0331-003	RES,330,1/4W,5%
R30009	4702-0471-003	RES,470,1/4W,5%
R30010	4752-0502-002	POT 5K OHM
R30011	4702-0822-003	RES,8.2K,1/4W,5%
R30012	4702-0103-003	RES,10K,1/4W,5%
R30013	4702-0102-003	RES,1.0K,1/4W,5%
R30014	4702-0331-003	RES,330,1/4W,5%
R30015	4702-0221-003	RES,220,1/4W,5%
R30016	4702-0102-003	RES,1.0K,1/4W,5%
R30017	4702-0152-003	RES,1.5K,1/4W,5%
R30018	4702-0471-003	RES,470,1/4W,5%
R30019	4702-0102-003	RES,1.0K,1/4W,5%
R30020	4702-0121-003	RES,120,1/4W,5%
R30021	4752-0202-002	POT, 2K OHM
R30022	4752-0202-002	POT, 2K OHM
R30023	4702-0682-003	RES,6.8K,1/4W,5%
R30024	4702-0223-003	RES,22K,1/4W,5%
R30025	4702-0102-003	RES,1.0K,1/4W,5%
R30026	4702-0221-003	RES,220,1/4W,5%
R30027	4702-0153-003	RES,15K,1/4W,5%
R30028	4702-0561-003	RES,560,1/4W,5%
R30029	4702-0221-003	RES,220,1/4W,5%
R30030	4702-0471-003	RES,470,1/4W,5%
R30031	4752-0502-002	POT 5K OHM
R30032	4702-0822-003	RES,8.2K,1/4W,5%
R30033	4702-0103-003	RES,10K,1/4W,5%
R30034	4702-0102-003	RES,1.0K,1/4W,5%
R30035	4702-0471-003	RES,470,1/4W,5%
R30036	4702-0331-003	RES,330,1/4W,5%
R30037	4702-0102-003	RES,1.0K,1/4W,5%
R30038	4702-0152-003	RES,1.5K,1/4W,5%
R30039	4702-0221-003	RES,220,1/4W,5%
R30040	4702-0181-003	RES,180,1/4W,5%
R30041	4752-0202-002	POT, 2K OHM
R30042	4752-0202-002	POT, 2K OHM
R30043	4702-0103-003	RES,10K,1/4W,5%
R30044	4702-0223-003	RES,22K,1/4W,5%



7010-9031-800

PCB ASSY, RANGE BOARD #2 (cont)

B

REFERENCE DESIGNATOR	PART NUMBER	DESCRIPTION
R30045	4702-0102-003	RES,1.0K,1/4W,5%
R30046	4702-0101-003	RES,100,1/4W,5%
R30047	4702-0680-003	RES,68,1/4W,5%
R30048	4702-0331-003	RES,330,1/4W,5%
R30049	4702-0331-003	RES,330,1/4W,5%
R30050	4702-0331-003	RES,330,1/4W,5%
R30051	4702-0331-003	RES,330,1/4W,5%
R30052	4702-0561-003	RES,560,1/4W,5%
R30053	4702-0102-003	RES,1.0K,1/4W,5%
R30054	4702-0102-003	RES,1.0K,1/4W,5%
R30055	4702-0332-003	RES,3.3K,1/4W,5%
R30056	4702-0472-003	RES,4.7K,1/4W,5%
R30057	4702-0473-003	RES,47K,1/4W,5%
R30058	4702-0473-003	RES,47K,1/4W,5%
R30059	4702-0222-003	RES,2.2K,1/4W,5%
R30060	4702-0102-003	RES,1.0K,1/4W,5%
R30061	4702-0102-003	RES,1.0K,1/4W,5%
R30062	4752-0104-002	POT 100K OHM
R30063	4706-2152-001	RES,21.5K,1/4W,1%
R30064	4702-0472-003	RES,4.7K,1/4W,5%
R30065	4702-0182-003	RES,1.8K,1/4W,5%
R30066	4752-0102-002	POT 1K OHM
R30067	4702-0560-003	RES,56,1/4W,5%
R30068	4702-0122-003	RES,1.2K,1/4W,5%
R30069	4702-0122-003	RES,1.2K,1/4W,5%
R30070	4702-0221-003	RES,220,1/4W,5%
R30071	4702-0471-003	RES,470,1/4W,5%
R30072	4702-0221-003	RES,220,1/4W,5%
R30073	4702-0471-003	RES,470,1/4W,5%
R30074	4702-0331-003	RES,330,1/4W,5%
R30075	4702-0152-003	RES,1.5K,1/4W,5%
R30076	4702-0102-003	RES,1.0K,1/4W,5%
R30077	4702-0560-003	RES,56,1/4W,5%
R30078	4702-0101-003	RES,100,1/4W,5%
R30079	4702-0560-003	RES,56,1/4W,5%
R30080	4702-0101-003	RES,100,1/4W,5%
R30081	4702-0331-003	RES,330,1/4W,5%
R30082	4702-0332-003	RES,3.3K,1/4W,5%
R30083	4702-0221-003	RES,220,1/4W,5%
R30084	4702-0391-003	RES,390,1/4W,5%
R30085	4702-0479-003	RES,4.7,1/4W,5%
R30086	4702-0560-003	RES,56,1/4W,5%
R30087	4702-0102-003	RES,1.0K,1/4W,5%
R30088	4752-0202-002	POT, 2K OHM
R30089	4701-0223-003	RES,22K,1/8W,5%
U30001	3133-0000-007	IC,4066B,QUAD BILATERAL SWITCH
U30002	3221-0001-000	IC,353,DUAL JFET OP AMP
U30003	3133-0000-007	IC,4066B,QUAD BILATERAL SWITCH
U30004	3221-0001-000	IC,353,DUAL JFET OP AMP
U30005	3131-0000-044	IC,74LS00,QUAD 2-INPUT NAND
U30006	3131-0000-044	IC,74LS00,QUAD 2-INPUT NAND



7010-9031-800

PCB ASSY, RANGE BOARD #2 (cont)

B

REFERENCE DESIGNATOR	PART NUMBER	DESCRIPTION
U30007	3131-0000-037	IC,74LS20,DUAL 4-INPUT NAND
U30008	3133-0000-024	IC,3130,BIMOS OP AMP,PLAST DIP
U30009	3133-0000-006	IC,4049UB,HEX BUFFER/CONVERTER



7010-4931-300

PCB ASSY, DISCRIMINATOR #2

B5

REFERENCE DESIGNATOR	PART NUMBER	DESCRIPTION
	1700-4921-300	PC BOARD,DISCRIMINATOR #2
C35001	1506-0102-017	CAP,1000pF,100V,5%,NPO
C35002	1580-4702-105	CAP,47UF,10V,ELE,RDL
C35003	1506-0103-017	CAP,0.01UF,100V,NPO
C35004	1506-0470-017	CAP,47pF,100V,NPO
C35005	1506-0121-017	CAP,120pF,100V,5%,NPO
C35006	1506-0470-017	CAP,47pF,100V,NPO
C35007	1521-0000-008	CAP,0.1UF,50V,DIP,Z5U
C35008	1506-0332-017	CAP,3000pF,100V,5%,NPO
C35009	1521-0000-008	CAP,0.1UF,50V,DIP,Z5U
C35010	1506-0332-017	CAP,3000pF,100V,5%,NPO
C35011	1506-0332-017	CAP,3000pF,100V,5%,NPO
C35012	1521-0000-008	CAP,0.1UF,50V,DIP,Z5U
C35013	1521-0000-008	CAP,0.1UF,50V,DIP,Z5U
C35014	1521-0000-008	CAP,0.1UF,50V,DIP,Z5U
C35015	1521-0000-008	CAP,0.1UF,50V,DIP,Z5U
C35016	1521-0000-008	CAP,0.1UF,50V,DIP,Z5U
C35017	1521-0000-008	CAP,0.1UF,50V,DIP,Z5U
C35018	1521-0000-008	CAP,0.1UF,50V,DIP,Z5U
C35019	1521-0000-008	CAP,0.1UF,50V,DIP,Z5U
C35020	1521-0000-008	CAP,0.1UF,50V,DIP,Z5U
C35021	1521-0000-008	CAP,0.1UF,50V,DIP,Z5U
J35001	2129-1001-010	CONN,HEADER,10-P STR KEYED
L35001	1801-0128-003	IND, .12UH,.09OHM,1025-96
L35002	1801-0109-001	IND, 1.0 UH, 1 OHM,1025-20
Q35001	4807-0000-002	TRANS, 2N3905 ,PNP HS SW
R35001	4701-0102-003	RES,1.0K,1/8W,5%
R35002	4701-0680-003	RES,68,1/8W,5%
R35003	4701-0332-003	RES,3.3K,1/8W,5%
R35004	4701-0221-003	RES,220,1/8W,5%
R35005	4701-0331-003	RES,330,1/8W,5%
R35006	4701-0331-003	RES,330,1/8W,5%
R35007	4701-0331-003	RES,330,1/8W,5%
U35001	3132-0000-001	IC,74S00,QUAD 2-INPUT NAND
U35002	3132-0000-002	IC,74S112,DUAL JK FLIP-FLOP
U35003	3131-0000-030	IC,74LS191,BIN SYN U/D COUNTER
U35004	3131-0000-033	IC,74LS04,HEX INVERTER
U35005	3131-0000-030	IC,74LS191,BIN SYN U/D COUNTER
U35006	3131-0000-033	IC,74LS04,HEX INVERTER
U35007	3131-0000-030	IC,74LS191,BIN SYN U/D COUNTER
U35008	3132-0000-002	IC,74S112,DUAL JK FLIP-FLOP
U35009	3131-0000-038	IC,74LS74A,DUAL D FLIP-FLOP
U35010	3211-3374-000	IC,74LS374,OCTAL D FLIP-FLOP
U35011	3211-3374-000	IC,74LS374,OCTAL D FLIP-FLOP
U35012	3131-0000-044	IC,74LS00,QUAD 2-INPUT NAND
U35013	3131-0000-042	IC,74LS283,4-BIT BINARY ADDER
U35014	3131-0000-042	IC,74LS283,4-BIT BINARY ADDER
U35015	3131-0000-042	IC,74LS283,4-BIT BINARY ADDER
U35017	3132-0000-001	IC,74S00,QUAD 2-INPUT NAND
U35018	3131-0000-033	IC,74LS04,HEX INVERTER
U35019	3131-0000-044	IC,74LS00,QUAD 2-INPUT NAND

7010-4931-300

PCB ASSY, DISCRIMINATOR #2 (cont)

B5

REFERENCE DESIGNATOR	PART NUMBER	DESCRIPTION
U35020	3132-0000-002	IC,74S112,DUAL JK FLIP-FLOP
U35021	3131-0000-030	IC,74LS191,BIN SYN U/D COUNTER
U35022	3131-0000-030	IC,74LS191,BIN SYN U/D COUNTER
U35023	3131-0000-037	IC,74LS20,DUAL 4-INPUT NAND
U35024	3132-0000-002	IC,74S112,DUAL JK FLIP-FLOP
U35025	3132-0000-001	IC,74S00,QUAD 2-INPUT NAND
U35026	3131-0000-030	IC,74LS191,BIN SYN U/D COUNTER
U35027	3131-0000-030	IC,74LS191,BIN SYN U/D COUNTER
U35028	3131-0000-030	IC,74LS191,BIN SYN U/D COUNTER



7010-4932-800

PCB ASSY, DISCR BD NO.1

K

REFERENCE DESIGNATOR	PART NUMBER	DESCRIPTION
1	1700-4922-800	PC BD,DISCR BD NO.1
2	1415-4952-600	ENCL,DISC,BOTTOM,8.15LG
3	1415-4952-700	ENCL,DISC TOP,8.05 LG
4	1050-0000-075	WIRE,BUS,TINNED COPPER,26GA
7	2803-1000-003	SCREW,4-40 X 1 PFHM
10	2750-0150-500	CORE,BEAD,STACKPOLE 57-0180
11	2803-0250-006	SCREW,4-40 X 1/4 PPHM
12	6000-6990-340	WIRE,MAG,BIFILAR,RED/GRN,34GA
13	6011-0018-001	TUBING,TF,26 AWG,NATURAL,TW
14	6000-6050-260	WIRE,MAG,SINGLE BELDSOL,26 GA
15	6011-0022-001	TUBING,TF,24 AWG,NATURAL,TW
16	1050-0000-074	WIRE,BUS,TINNED COPPER,24GA
C20159SAT	1506-0101-017	CAP,100pF,100V,5%,NPO *
C50001	1517-3295-303	CAP VAR,6-20pF
C50002SAT	1506-0270-017	CAP,27pF,100V,5%,NPO 9 EA PA B317E
C50004	1517-3295-303	CAP VAR,6-20pF
C50005	1506-0182-017	CAP,1800pF,100V,5%,NPO
C50006	1517-3295-303	CAP VAR,6-20pF
C50008	1506-0680-017	CAP,68pF,100V,5%,NPO
C50009	1507-0685-018	CAP,6.8UF,35V,20%,TANT
C50010	1506-0103-016	CAP,0.01UF,50V,5%,NPO
C50011	1521-0000-008	CAP,0.1UF,50V,DIP,Z5U
C50012	1506-0471-017	CAP,470pF,100V,5%,NPO
C50013	1521-0000-008	CAP,0.1UF,50V,DIP,Z5U
C50014	1506-0681-017	CAP,680pF,100V,5%,NPO
C50015	1506-0182-017	CAP,1800pF,100V,5%,NPO
C50016	1506-0680-017	CAP,68pF,100V,5%,NPO
C50017	1507-0685-018	CAP,6.8UF,35V,20%,TANT
C50018	1521-0000-008	CAP,0.1UF,50V,DIP,Z5U
C50019	1506-0471-017	CAP,470pF,100V,5%,NPO
C50020	1507-0566-024	CAP,56UF,6V,20%,TANT
C50021	1521-0000-008	CAP,0.1UF,50V,DIP,Z5U
C50022	1521-0000-008	CAP,0.1UF,50V,DIP,Z5U
C50023	1506-0103-017	CAP,0.01UF,100V,NPO
C50024	1506-0220-017	CAP,22PF,100V,5%,NPO
C50025	1502-0104-002	CAP,0.1UF,50V,2%,PCARB
C50026	1506-0680-017	CAP,68pF,100V,5%,NPO
C50027	1506-0471-017	CAP,470pF,100V,5%,NPO
C50028	1521-0000-008	CAP,0.1UF,50V,DIP,Z5U
C50029	1507-0685-018	CAP,6.8UF,35V,20%,TANT
C50030	1502-0105-007	CAP,1UF,50V,5%,MPC
C50031	1502-0105-007	CAP,1UF,50V,5%,MPC
C50032	1502-0105-007	CAP,1UF,50V,5%,MPC
C50033	1506-0680-017	CAP,68pF,100V,5%,NPO
C50034	1506-0103-016	CAP,0.01UF,50V,5%,NPO
C50035	1521-0000-008	CAP,0.1UF,50V,DIP,Z5U
C50036	1506-0680-017	CAP,68pF,100V,5%,NPO
C50037	1506-0102-017	CAP,1000pF,100V,5%,NPO
C50038	1507-0476-018	CAP,47UF,35V,20%,TANT
C50039	1506-0681-017	CAP,680pF,100V,5%,NPO
C50040	1521-0000-008	CAP,0.1UF,50V,DIP,Z5U

7010-4932-800

PCB ASSY, DISCR BD NO.1 (cont)

K

REFERENCE DESIGNATOR	PART NUMBER	DESCRIPTION
C50041	1506-0103-016	CAP,0.01UF,50V,5%,NPO
C50042	1507-0105-018	CAP,1UF,35V,20%,TANT
C50043	1521-0000-008	CAP,0.1UF,50V,DIP,Z5U
C50044	1508-0157-020	CAP,150UF,15V,TANT,RDL
C50045	1508-0157-020	CAP,150UF,15V,TANT,RDL
C50046	1580-4702-105	CAP,47UF,10V,ELE,RDL
C50047	1523-0000-002	CAP,1800pF,50V,X7R,CHIP
C50048	1506-0020-017	CAP,2.2pF,100V,NPO,25
C50049	1506-0103-017	CAP,0.01UF,100V,NPO
C50050	1506-0101-017	CAP,100pF,100V,5%,NPO
C50051	1620-5090-511	CAP,5pF,50V,CHIP
C50052	1506-0020-017	CAP,2.2pF,100V,NPO,25
C50053	1506-0030-017	CAP,3.3pF,100V,MICA,17
C50054	1521-0000-004	CAP VAR,0.6-4.5pF,500V,7273
C50055	1506-0030-017	CAP,3.3pF,100V,MICA,17
C50056	1506-0050-017	CAP,5.6pF,100V,5%,NPO
C50057	1506-0050-017	CAP,5.6pF,100V,5%,NPO
C50058	1506-0050-017	CAP,5.6pF,100V,5%,NPO
C50059	1620-2210-600	CAP,220pF,100V,CHIP,NPO
C50060	1506-0030-017	CAP,3.3pF,100V,MICA,17
C50061	1506-0020-017	CAP,2.2pF,100V,NPO,25
C50062	1506-0030-017	CAP,3.3pF,100V,MICA,17
C50063	1506-0030-017	CAP,3.3pF,100V,MICA,17
C50064	1506-0101-017	CAP,100pF,100V,5%,NPO
C50065	1506-0270-017	CAP,27pF,100V,5%,NPO
C50066	1506-0050-017	CAP,5.6pF,100V,5%,NPO
C50067	1506-0270-017	CAP,27pF,100V,5%,NPO
C50068	1506-0270-017	CAP,27pF,100V,5%,NPO
C50069	1506-0102-017	CAP,1000pF,100V,5%,NPO
C50070	1506-0101-017	CAP,100pF,100V,5%,NPO
C50071	1523-0000-002	CAP,1800pF,50V,X7R,CHIP
C50072	1506-0101-017	CAP,100pF,100V,5%,NPO
C50074	1506-0103-017	CAP,0.01UF,100V,NPO
C50075	1506-0270-017	CAP,27pF,100V,5%,NPO
C50076	1506-0103-016	CAP,0.01UF,50V,5%,NPO
C50077	1506-0030-017	CAP,3.3pF,100V,MICA,17
C50078	1620-2200-500	CAP,22pF,100V,CHIP,NPO
C50080	1506-0100-017	CAP,10pF,100V,5%,NPO
C50082	1506-0270-017	CAP,27pF,100V,5%,NPO
C50083	1506-0270-017	CAP,27pF,100V,5%,NPO
C50084	1506-0270-017	CAP,27pF,100V,5%,NPO
C50086	1506-0270-017	CAP,27pF,100V,5%,NPO
C50087	1523-0000-002	CAP,1800pF,50V,X7R,CHIP
C50089	1620-2200-500	CAP,22pF,100V,CHIP,NPO
C50090	1506-0220-017	CAP,22PF,100V,5%,NPO
C50092	1521-0000-008	CAP,0.1UF,50V,DIP,Z5U
C50093	1521-0000-008	CAP,0.1UF,50V,DIP,Z5U
C50095	1506-0100-017	CAP,10pF,100V,5%,NPO
C50096	1506-0102-017	CAP,1000pF,100V,5%,NPO
C50097	1506-0102-017	CAP,1000pF,100V,5%,NPO
C50098	1507-0685-018	CAP,6.8UF,35V,20%,TANT



7010-4932-800

PCB ASSY, DISCR BD NO.1 (cont)

K

REFERENCE DESIGNATOR	PART NUMBER	DESCRIPTION
C50099	1507-0685-018	CAP,6.8UF,35V,20%,TANT
C50100	1506-0103-017	CAP,0.01UF,100V,NPO
C50102	1506-0050-017	CAP,5.6pF,100V,5%,NPO
C50103	1506-0102-017	CAP,1000pF,100V,5%,NPO
C50104	1506-0050-017	CAP,5.6pF,100V,5%,NPO
C50105	1506-0102-017	CAP,1000pF,100V,5%,NPO
C50106	1506-0050-017	CAP,5.6pF,100V,5%,NPO
C50107	1506-0050-017	CAP,5.6pF,100V,5%,NPO
C50108	1506-0050-017	CAP,5.6pF,100V,5%,NPO
C50109	1523-0000-002	CAP,1800pF,50V,X7R,CHIP
C50110	1506-0150-017	CAP,15pF,100V,5%,NPO
C50111	1620-5090-511	CAP,5pF,50V,CHIP
C50112	1506-0150-017	CAP,15pF,100V,5%,NPO
C50113	1506-0102-017	CAP,1000pF,100V,5%,NPO
C50114	1506-0150-017	CAP,15pF,100V,5%,NPO
C50115	1506-0102-017	CAP,1000pF,100V,5%,NPO
C50116	1506-0050-017	CAP,5.6pF,100V,5%,NPO
C50117	1620-5090-511	CAP,5pF,50V,CHIP
C50119	1506-0102-017	CAP,1000pF,100V,5%,NPO
C50120	1506-0050-017	CAP,5.6pF,100V,5%,NPO
C50122	1507-0685-018	CAP,6.8UF,35V,20%,TANT
C50123	1506-0030-017	CAP,3.3pF,100V,MICA,17
C50126	1507-0685-018	CAP,6.8UF,35V,20%,TANT
C50127	1506-0050-017	CAP,5.6pF,100V,5%,NPO
C50128	1507-0685-018	CAP,6.8UF,35V,20%,TANT
C50129	1550-0300-500	CAP VAR,2.0-8pF,350V,VPCM
C50130	1506-0102-017	CAP,1000pF,100V,5%,NPO
C50131	1506-0050-017	CAP,5.6pF,100V,5%,NPO
C50132	1521-0000-004	CAP VAR,0.6-4.5pF,500V,7273
C50134	1550-0300-500	CAP VAR,2.0-8pF,350V,VPCM
C50135	1506-0100-017	CAP,10pF,100V,5%,NPO
C50136	1506-0050-017	CAP,5.6pF,100V,5%,NPO
C50137	1506-0102-017	CAP,1000pF,100V,5%,NPO
C50138	1506-0102-017	CAP,1000pF,100V,5%,NPO
C50139	1506-0103-017	CAP,0.01UF,100V,NPO
C50140	1521-0000-008	CAP,0.1UF,50V,DIP,Z5U
C50142	1521-0000-008	CAP,0.1UF,50V,DIP,Z5U
C50143	1521-0000-008	CAP,0.1UF,50V,DIP,Z5U
C50145	1506-0101-017	CAP,100pF,100V,5%,NPO
C50146	1507-0685-018	CAP,6.8UF,35V,20%,TANT
C50147	1521-0000-008	CAP,0.1UF,50V,DIP,Z5U
C50148	1521-0000-008	CAP,0.1UF,50V,DIP,Z5U
C50149	1506-0030-017	CAP,3.3pF,100V,MICA,17
C50150	1523-0000-017	CAP,2pF,100V,CHIP
C50151	1620-1090-511	CAP,1pF,50V,CHIP
C50152	1506-0020-017	CAP,2.2pF,100V,NPO,25
C50153	1620-2200-500	CAP,22pF,100V,CHIP,NPO
C50154	1620-2210-600	CAP,220pF,100V,CHIP,NPO
C50155	1506-0020-017	CAP,2.2pF,100V,NPO,25
C50156	1620-5090-511	CAP,5pF,50V,CHIP
C50157	1523-0000-007	CAP,0.1UF,25V,Z5U,CHIP



7010-4932-800

PCB ASSY, DISCR BD NO.1 (cont)

K

REFERENCE DESIGNATOR	PART NUMBER	DESCRIPTION
C50158	1550-0100-510	CAP VAR,1.0-4.5pF,9410-0
CR50001	4815-0000-003	DIODE, 1N4148 ,SIGNAL, 75PRV
CR50002	4815-0000-003	DIODE, 1N4148 ,SIGNAL, 75PRV
CR50003	4815-0000-003	DIODE, 1N4148 ,SIGNAL, 75PRV
CR50004	4815-0000-003	DIODE, 1N4148 ,SIGNAL, 75PRV
CR50005	4816-0000-003	DIODE,5082-2835,S-BAR 8 VBR
CR50006	4816-0000-003	DIODE,5082-2835,S-BAR 8 VBR
CR50007	4816-0000-003	DIODE,5082-2835,S-BAR 8 VBR
CR50008	4816-0000-003	DIODE,5082-2835,S-BAR 8 VBR
CR50009	4831-0000-001	DIODE,FDH333 ,SIGNAL,HCLL
CR50010	4831-0000-001	DIODE,FDH333 ,SIGNAL,HCLL
CR50011	4831-0000-001	DIODE,FDH333 ,SIGNAL,HCLL
CR50012	4818-0000-015	DIODE,LM329C,6.9V ZENER REF
CR50013	4818-0000-003	DIODE ZENER, 5.1V .5W
CR50014	4815-0000-003	DIODE, 1N4148 ,SIGNAL, 75PRV
CR50015	4815-0000-003	DIODE, 1N4148 ,SIGNAL, 75PRV
CR50016	4818-0000-015	DIODE,LM329C,6.9V ZENER REF
CR50017	4826-0000-013	DIODE,VARAC 30PF/-3V RADIAL
CR50018	4828-0000-002	DIODE,PIN,.3 PF,100 NS
CR50019	4828-0000-002	DIODE,PIN,.3 PF,100 NS
CR50020	4828-0000-002	DIODE,PIN,.3 PF,100 NS
CR50021	4815-0000-003	DIODE, 1N4148 ,SIGNAL, 75PRV
CR50028	4816-0000-001	DIODE,5082-2800,S BAR, 70VBR
CR50029	4815-0000-003	DIODE, 1N4148 ,SIGNAL, 75PRV
CR50030	4818-0000-015	DIODE,LM329C,6.9V ZENER REF
CR50032	4818-0000-015	DIODE,LM329C,6.9V ZENER REF
J50001	2200-2010-400	CONN,M SMB,PC MTG,STR,.453LG
J50002	2115-1002-015	CONN,MOLEX 22-05-2151
J50004	2129-1001-010	CONN,HEADER,10-P STR KEYED
J50005	2200-2010-400	CONN,M SMB,PC MTG,STR,.453LG
J50006	2200-2010-400	CONN,M SMB,PC MTG,STR,.453LG
J50007	2200-2010-400	CONN,M SMB,PC MTG,STR,.453LG
J50008	2200-2010-400	CONN,M SMB,PC MTG,STR,.453LG
J50009	2200-2010-400	CONN,M SMB,PC MTG,STR,.453LG
J50010	2200-2010-400	CONN,M SMB,PC MTG,STR,.453LG
J50011	2200-2010-400	CONN,M SMB,PC MTG,STR,.453LG
J50012	2200-2010-400	CONN,M SMB,PC MTG,STR,.453LG
J50013	2200-2010-400	CONN,M SMB,PC MTG,STR,.453LG
J50014	2200-2010-400	CONN,M SMB,PC MTG,STR,.453LG
J50015	2200-2010-400	CONN,M SMB,PC MTG,STR,.453LG
J50016	2200-2010-400	CONN,M SMB,PC MTG,STR,.453LG
K50001	4501-0000-003	RELAY,DIP REED,SPDT, 12VDC,.2A
K50002	4501-0000-003	RELAY,DIP REED,SPDT, 12VDC,.2A
L50001	1801-0229-001	IND, 2.2 UH,.4 OHM,1025-28
L50002	1801-0109-001	IND, 1.0 UH, 1 OHM,1025-20
L50003	1801-0229-001	IND, 2.2 UH,.4 OHM,1025-28
L50004	1801-0337-002	IND, .033UH,.035OHM102604
L50005	1801-0109-001	IND, 1.0 UH, 1 OHM,1025-20
L50006	1801-0337-002	IND, .033UH,.035OHM102604
L50007	1050-0000-071	WIRE,BUS,TINNED COPPER,18GA
L50008	1801-0337-002	IND, .033UH,.035OHM102604



7010-4932-800

PCB ASSY, DISCR BD NO.1 (cont)

K

REFERENCE DESIGNATOR	PART NUMBER	DESCRIPTION
L50009	1801-0229-001	IND, 2.2 UH,.4 OHM,1025-28
L50010	1801-0337-002	IND, .033UH,.035OHM102604
L50011	1801-0337-002	IND, .033UH,.035OHM102604
L50012	1801-0108-001	IND, .10UH,.08OHM,1025-94
L50013	1801-0229-001	IND, 2.2 UH,.4 OHM,1025-28
L50014	1801-0338-001	IND, .33UH,.2 OHM,1025-08
L50015	1801-0108-001	IND, .10UH,.08OHM,1025-94
L50017	1801-0108-001	IND, .10UH,.08OHM,1025-94
L50018	1801-0478-001	IND, 47UH,.35OHM,1025-12
L50020	1806-0108-002	IND, .1 UH,.13OHM,0819-00
L50022	1806-0108-002	IND, .1 UH,.13OHM,0819-00
L50023	1801-0109-001	IND, 1.0 UH, 1 OHM,1025-20
L50024	1801-0229-001	IND, 2.2 UH,.4 OHM,1025-28
L50025	1801-0478-001	IND, .47UH,.35OHM,1025-12
L50026	1801-0229-001	IND, 2.2 UH,.4 OHM,1025-28
L50027	1801-0109-001	IND, 1.0 UH, 1 OHM,1025-20
L50028	1801-0337-002	IND, .033UH,.035OHM102604
L50029	1801-0109-001	IND, 1.0 UH, 1 OHM,1025-20
L50032	1801-0109-001	IND, 1.0 UH, 1 OHM,1025-20
L50034	1801-0109-001	IND, 1.0 UH, 1 OHM,1025-20
L50035	1801-0109-001	IND, 1.0 UH, 1 OHM,1025-20
L50036	1801-0337-002	IND, .033UH,.035OHM102604
L50038	1801-0109-001	IND, 1.0 UH, 1 OHM,1025-20
L50039	1801-0337-002	IND, .033UH,.035OHM102604
L50040	1801-0109-001	IND, 1.0 UH, 1 OHM,1025-20
L50041	1801-0337-002	IND, .033UH,.035OHM102604
L50042	1801-0000-007	IND, .068 UH, .060 OHM
L50045	1801-0109-001	IND, 1.0 UH, 1 OHM,1025-20
L50049	1806-0108-002	IND, .1 UH,.13OHM,0819-00
L50050	1801-0337-002	IND, .033UH,.035OHM102604
L50052	1801-0109-001	IND, 1.0 UH, 1 OHM,1025-20
L50053	1801-0109-001	IND, 1.0 UH, 1 OHM,1025-20
L50060	6000-6050-260	WIRE,MAG,SINGLE BELDSOL,26 GA
L50062	6000-6050-260	WIRE,MAG,SINGLE BELDSOL,26 GA
L50063	1801-0338-001	IND, .33UH,.2 OHM,1025-08
MXR50001	5250-0804-301	MIXER,700-1500MHz TO-8
MXR50002	5250-0804-301	MIXER,700-1500MHz TO-8
MXR50003	5250-0000-008	PHASE DET.,FLTPK,5-1000MHz
Q50001	4805-0000-003	TRANS, 2N3646 ,NPN HS SW
Q50002	4807-0000-002	TRANS, 2N3905 ,PNP HS SW
Q50003	4807-0000-002	TRANS, 2N3905 ,PNP HS SW
Q50004	4807-0000-001	TRANS, 2N3903 ,NPN HS SW
Q50005	4807-0000-002	TRANS, 2N3905 ,PNP HS SW
Q50006	4807-0000-002	TRANS, 2N3905 ,PNP HS SW
Q50007	4807-0000-001	TRANS, 2N3903 ,NPN HS SW
Q50008	4807-0000-002	TRANS, 2N3905 ,PNP HS SW
Q50009	4807-0000-002	TRANS, 2N3905 ,PNP HS SW
Q50010	4809-0000-005	TRANS,66382
Q50011	4807-0000-002	TRANS, 2N3905 ,PNP HS SW
Q50012	4807-0000-001	TRANS, 2N3903 ,NPN HS SW
Q50013	4807-0000-002	TRANS, 2N3905 ,PNP HS SW



7010-4932-800

PCB ASSY, DISCR BD NO.1 (cont)

K

REFERENCE DESIGNATOR	PART NUMBER	DESCRIPTION
Q50014	4807-0000-001	TRANS, 2N3903 ,NPN HS SW
Q50015	4807-0000-002	TRANS, 2N3905 ,PNP HS SW
Q50016	4801-0000-001	TRANSISTOR NPN HS SW
Q50017	4805-0000-001	TRANS,2N2907A,PNP HS SW (3251)
Q50018	4809-0000-005	TRANS,66382
Q50019	4803-0000-004	TRANS,NPN,LP/VHF AMP
Q50020	5050-2502-005	TRANS, SI NPN,MED PWR L6GHZ
Q50021	5050-2502-005	TRANS, SI NPN,MED PWR L6GHZ
Q50022	4803-0000-004	TRANS,NPN,LP/VHF AMP
Q50026	4807-0000-002	TRANS, 2N3905 ,PNP HS SW
Q50027	4807-0000-001	TRANS, 2N3903 ,NPN HS SW
Q50029	5050-2502-005	TRANS, SI NPN,MED PWR L6GHZ
Q50030	5050-2401-000	TRANS,VN10KM N-CH VMOSFET
Q50031	4807-0000-001	TRANS, 2N3903 ,NPN HS SW
Q50032	5050-2502-005	TRANS, SI NPN,MED PWR L6GHZ
Q50033	5050-2502-005	TRANS, SI NPN,MED PWR L6GHZ
Q50034	4809-0000-005	TRANS,66382
Q50035	4807-0000-002	TRANS, 2N3905 ,PNP HS SW
Q50036	4803-0000-004	TRANS,NPN,LP/VHF AMP
Q50037	5050-2502-005	TRANS, SI NPN,MED PWR L6GHZ
Q50038	4809-0000-005	TRANS,66382
Q50039	4803-0000-004	TRANS,NPN,LP/VHF AMP
Q50040	4807-0000-002	TRANS, 2N3905 ,PNP HS SW
Q50041	4807-0000-001	TRANS, 2N3903 ,NPN HS SW
Q50042	4807-0000-002	TRANS, 2N3905 ,PNP HS SW
Q50043	4807-0000-001	TRANS, 2N3903 ,NPN HS SW
Q50044	5050-2502-005	TRANS, SI NPN,MED PWR L6GHZ
Q50045	4809-0000-005	TRANS,66382
Q50046	4809-0000-005	TRANS,66382
Q50047	4807-0000-002	TRANS, 2N3905 ,PNP HS SW
Q50048	4801-0000-004	TRANS, 2N2905 ,PNP HS SW
R50001	4701-0680-003	RES,68,1/8W,5%
R50002	4701-0101-003	RES,100,1/8W,5%
R50003	4701-0331-003	RES,330,1/8W,5%
R50004	4701-0331-003	RES,330,1/8W,5%
R50005	4701-0122-003	RES,1.2K,1/8W,5%
R50006	4701-0681-003	RES,680,1/8W,5%
R50007	4701-0222-003	RES,2.2K,1/8W,5%
R50008	4701-0101-003	RES,100,1/8W,5%
R50009	4701-0222-003	RES,2.2K,1/8W,5%
R50010	4701-0471-003	RES,470,1/8W,5%
R50011	4701-0222-003	RES,2.2K,1/8W,5%
R50012	4752-0102-002	POT 1K OHM
R50013	4701-0121-003	RES,120,1/8W,5%
R50014	4701-0103-003	RES,10K,1/8W,5%
R50015	4701-0272-003	RES,2.7K,1/8W,5%
R50016	4701-0183-003	RES,18K,1/8W,5%
R50017	4701-0102-003	RES,1.0K,1/8W,5%
R50018	4701-0331-003	RES,330,1/8W,5%
R50019	4701-0330-003	RES,33,1/8W,5%
R50020	4701-0331-003	RES,330,1/8W,5%



7010-4932-800

PCB ASSY, DISCR BD NO.1 (cont)

K

REFERENCE DESIGNATOR	PART NUMBER	DESCRIPTION
R50021	4701-0681-003	RES,680,1/8W,5%
R50022	4701-0102-003	RES,1.0K,1/8W,5%
R50023	4701-0223-003	RES,22K,1/8W,5%
R50024	4701-0331-003	RES,330,1/8W,5%
R50025	4701-0103-003	RES,10K,1/8W,5%
R50026	4706-1002-001	RES,10.0K,1/4W,1%
R50027	4701-0681-003	RES,680,1/8W,5%
R50028	4706-1002-001	RES,10.0K,1/4W,1%
R50029	4701-0181-003	RES,180,1/8W,5%
R50030	4701-0103-003	RES,10K,1/8W,5%
R50031	4701-0103-003	RES,10K,1/8W,5%
R50032	4701-0103-003	RES,10K,1/8W,5%
R50033	4701-0181-003	RES,180,1/8W,5%
R50034	4701-0470-003	RES,47,1/8W,5%
R50035	4701-0271-003	RES,270,1/8W,5%
R50036	4701-0181-003	RES,180,1/8W,5%
R50037	4701-0181-003	RES,180,1/8W,5%
R50038	4701-0103-003	RES,10K,1/8W,5%
R50039	4701-0150-003	RES,15,1/8W,5%
R50039SAT	4701-0123-003	RES,12K,1/8W,5%
R50040	4701-0101-003	RES,100,1/8W,5%
R50041	4701-0472-003	RES,4.7K,1/8W,5%
R50042	4701-0331-003	RES,330,1/8W,5%
R50043	4701-0470-003	RES,47,1/8W,5%
R50044	4701-0472-003	RES,4.7K,1/8W,5%
R50045	4701-0103-003	RES,10K,1/8W,5%
R50046	4701-0330-003	RES,33,1/8W,5%
R50047	4701-0223-003	RES,22K,1/8W,5%
R50047SAT	4701-0183-003	RES,18K,1/8W,5%
R50048	4701-0101-003	RES,100,1/8W,5%
R50049	4701-0122-003	RES,1.2K,1/8W,5%
R50050	4701-0122-003	RES,1.2K,1/8W,5%
R50052	4701-0101-003	RES,100,1/8W,5%
R50053	4701-0222-003	RES,2.2K,1/8W,5%
R50054	4701-0330-003	RES,33,1/8W,5%
R50055	4701-0101-003	RES,100,1/8W,5%
R50056	4701-0473-003	RES,47K,1/8W,5%
R50057	4701-0152-003	RES,1.5K,1/8W,5%
R50058	4701-0473-003	RES,47K,1/8W,5%
R50059	4701-0152-003	RES,1.5K,1/8W,5%
R50060	4752-0503-002	POT 50K OHM
R50061	4701-0103-003	RES,10K,1/8W,5%
R50061SAT	4701-0822-003	RES,8.2K,1/8W,5%
R50062	4701-0102-003	RES,1.0K,1/8W,5%
R50063	4701-0101-003	RES,100,1/8W,5%
R50064	4701-0473-003	RES,47K,1/8W,5%
R50065	4752-0503-002	POT 50K OHM
R50066	4701-0330-003	RES,33,1/8W,5%
R50067	4701-0183-003	RES,18K,1/8W,5%
R50068	4701-0222-003	RES,2.2K,1/8W,5%
R50069	4752-0203-002	POT 20K OHM



7010-4932-800

PCB ASSY, DISCR BD NO.1 (cont)

K

REFERENCE DESIGNATOR	PART NUMBER	DESCRIPTION
R50070	4701-0472-003	RES,4.7K,1/8W,5%
R50071	4701-0823-003	RES,82K,1/8W,5%
R50072	4701-0273-003	RES,27K,1/8W,5%
R50073	4701-0272-003	RES,2.7K,1/8W,5%
R50074	4701-0472-003	RES,4.7K,1/8W,5%
R50075	4701-0563-003	RES,56K,1/8W,5%
R50076	4701-0561-003	RES,560,1/8W,5%
R50077	4752-0103-002	POT 10K OHM
R50078	4701-0103-003	RES,10K,1/8W,5%
R50079	4701-0331-003	RES,330,1/8W,5%
R50080	4701-0104-003	RES,100K,1/8W,5%
R50081	4701-0394-003	RES,390K,1/8W,5%
R50081SAT	4701-0334-003	RES,330K,1/8W,5%
R50082	4701-0223-003	RES,22K,1/8W,5%
R50083	4701-0272-003	RES,2.7K,1/8W,5%
R50084	4701-0221-003	RES,220,1/8W,5%
R50085	4701-0152-003	RES,1.5K,1/8W,5%
R50086	4701-0103-003	RES,10K,1/8W,5%
R50087	4701-0104-003	RES,100K,1/8W,5%
R50088	4701-0471-003	RES,470,1/8W,5%
R50089	4701-0124-003	RES,120K,1/8W,5%
R50090	4752-0104-002	POT 100K OHM
R50091	4701-0104-003	RES,100K,1/8W,5%
R50092	4701-0102-003	RES,1.0K,1/8W,5%
R50093	4701-0223-003	RES,22K,1/8W,5%
R50094	4701-0271-003	RES,270,1/8W,5%
R50095	4701-0823-003	RES,82K,1/8W,5%
R50096	4701-0221-003	RES,220,1/8W,5%
R50097	4701-0221-003	RES,220,1/8W,5%
R50098	4701-0472-003	RES,4.7K,1/8W,5%
R50099	4701-0102-003	RES,1.0K,1/8W,5%
R50100	4701-0123-003	RES,12K,1/8W,5%
R50101	4701-0273-003	RES,27K,1/8W,5%
R50102	4701-0221-003	RES,220,1/8W,5%
R50103	4701-0471-003	RES,470,1/8W,5%
R50104	4701-0680-003	RES,68,1/8W,5%
R50105	4701-0680-003	RES,68,1/8W,5%
R50106	4701-0271-003	RES,270,1/8W,5%
R50107	4701-0471-003	RES,470,1/8W,5%
R50108	4701-0151-003	RES,150,1/8W,5%
R50109	4753-0201-002	POT 200 OHM
R50110	4701-0390-003	RES,39,1/8W,5%
R50111	4701-0151-003	RES,150,1/8W,5%
R50112	4701-0471-003	RES,470,1/8W,5%
R50113	4701-0223-003	RES,22K,1/8W,5%
R50114	4701-0560-003	RES,56,1/8W,5%
R50114SAT	4701-0121-003	RES,120,1/8W,5%
R50114SAT	4701-0151-003	RES,150,1/8W,5%
R50114SAT	4701-0181-003	RES,180,1/8W,5%
R50114SAT	4701-0390-003	RES,39,1/8W,5%
R50114SAT	4701-0820-003	RES,82,1/8W,5%



7010-4932-800

PCB ASSY, DISCR BD NO.1 (cont)

K

REFERENCE DESIGNATOR	PART NUMBER	DESCRIPTION
R50115	4701-0680-003	RES,68,1/8W,5%
R50116	4701-0471-003	RES,470,1/8W,5%
R50117	4701-0181-003	RES,180,1/8W,5%
R50118	4702-0181-003	RES,180,1/4W,5%
R50119	4701-0101-003	RES,100,1/8W,5%
R50120	4701-0181-003	RES,180,1/8W,5%
R50122	4701-0560-003	RES,56,1/8W,5%
R50123	4702-0331-003	RES,330,1/4W,5%
R50124	4701-0273-003	RES,27K,1/8W,5%
R50125	4701-0181-003	RES,180,1/8W,5%
R50126	4702-0181-003	RES,180,1/4W,5%
R50129	4701-0103-003	RES,10K,1/8W,5%
R50131	4702-0151-003	RES,150,1/4W,5%
R50132	4701-0471-003	RES,470,1/8W,5%
R50133	4701-0471-003	RES,470,1/8W,5%
R50134	4701-0221-003	RES,220,1/8W,5%
R50135	4701-0331-003	RES,330,1/8W,5%
R50136	4701-0470-003	RES,47,1/8W,5%
R50138	4701-0392-003	RES,3.9K,1/8W,5%
R50139	4701-0221-003	RES,220,1/8W,5%
R50140	4701-0471-003	RES,470,1/8W,5%
R50141	4701-0151-003	RES,150,1/8W,5%
R50142	4701-0103-003	RES,10K,1/8W,5%
R50146	4701-0470-003	RES,47,1/8W,5%
R50147	4701-0473-003	RES,47K,1/8W,5%
R50148	4701-0680-003	RES,68,1/8W,5%
R50150	4701-0470-003	RES,47,1/8W,5%
R50151	4701-0681-003	RES,680,1/8W,5%
R50152	4701-0471-003	RES,470,1/8W,5%
R50153	4701-0470-003	RES,47,1/8W,5%
R50154	4701-0470-003	RES,47,1/8W,5%
R50155	4701-0222-003	RES,2.2K,1/8W,5%
R50156	4701-0152-003	RES,1.5K,1/8W,5%
R50157	4701-0221-003	RES,220,1/8W,5%
R50158	4752-0503-002	POT 50K OHM
R50159	4701-0473-003	RES,47K,1/8W,5%
R50160	4701-0150-003	RES,15,1/8W,5%
R50161	4701-0681-003	RES,680,1/8W,5%
R50162	4701-0103-003	RES,10K,1/8W,5%
R50163	4701-0681-003	RES,680,1/8W,5%
R50164	4701-0222-003	RES,2.2K,1/8W,5%
R50165	4701-0680-003	RES,68,1/8W,5%
R50166	4701-0101-003	RES,100,1/8W,5%
R50167	4701-0561-003	RES,560,1/8W,5%
R50168	4701-0220-003	RES,22,1/8W,5%
R50169	4701-0101-003	RES,100,1/8W,5%
R50170	4701-0221-003	RES,220,1/8W,5%
R50171	4701-0473-003	RES,47K,1/8W,5%
R50172	4701-0473-003	RES,47K,1/8W,5%
R50173	4701-0150-003	RES,15,1/8W,5%
R50174	4701-0102-003	RES,1.0K,1/8W,5%



7010-4932-800

PCB ASSY, DISCR BD NO.1 (cont)

K

REFERENCE DESIGNATOR	PART NUMBER	DESCRIPTION
R50175	4701-0102-003	RES,1.0K,1/8W,5%
R50176	4701-0681-003	RES,680,1/8W,5%
R50177	4701-0680-003	RES,68,1/8W,5%
R50178	4701-0221-003	RES,220,1/8W,5%
R50179	4701-0471-003	RES,470,1/8W,5%
R50180	4701-0273-003	RES,27K,1/8W,5%
R50181	4701-0102-003	RES,1.0K,1/8W,5%
R50182	4752-0501-002	POT, 500 OHM
R50183	4701-0470-003	RES,47,1/8W,5%
R50184	4701-0101-003	RES,100,1/8W,5%
R50185	4701-0471-003	RES,470,1/8W,5%
R50186	4701-0102-003	RES,1.0K,1/8W,5%
R50187	4701-0102-003	RES,1.0K,1/8W,5%
R50188	4701-0222-003	RES,2.2K,1/8W,5%
R50189	4701-0390-003	RES,39,1/8W,5%
R50190	4701-0102-003	RES,1.0K,1/8W,5%
R50191	4701-0561-003	RES,560,1/8W,5%
R50193	4701-0680-003	RES,68,1/8W,5%
R50194	4701-0471-003	RES,470,1/8W,5%
R50195	4701-0101-003	RES,100,1/8W,5%
R50196	4701-0471-003	RES,470,1/8W,5%
R50197	4701-0104-003	RES,100K,1/8W,5%
R50198	4701-0680-003	RES,68,1/8W,5%
R50199	4701-0152-003	RES,1.5K,1/8W,5%
R50200	4701-0471-003	RES,470,1/8W,5%
R50201	4701-0472-003	RES,4.7K,1/8W,5%
R50203	4701-0470-003	RES,47,1/8W,5%
R50204	4701-0181-003	RES,180,1/8W,5%
R50205	4701-0181-003	RES,180,1/8W,5%
R50206	4701-0221-003	RES,220,1/8W,5%
R50207	4701-0221-003	RES,220,1/8W,5%
R50209	4701-0151-003	RES,150,1/8W,5%
R50210	4701-0222-003	RES,2.2K,1/8W,5%
R50211	4701-0222-003	RES,2.2K,1/8W,5%
R50212	4701-0220-003	RES,22,1/8W,5%
R50213	4701-0220-003	RES,22,1/8W,5%
R50214	4701-0220-003	RES,22,1/8W,5%
R50215	4701-0220-003	RES,22,1/8W,5%
R50216	4701-0151-003	RES,150,1/8W,5%
R50218	4722-1500-001	RES,150,1/8W,1%
R50219	4722-1500-001	RES,150,1/8W,1%
R50220	4701-0390-003	RES,39,1/8W,5%
TB50001	2155-1010-020	TERM STRIP,.100C,STR,20-P
TB50002	2155-1010-020	TERM STRIP,.100C,STR,20-P
TB50003	2155-1010-020	TERM STRIP,.100C,STR,20-P
TP50001	2200-2010-400	CONN,M SMB,PC MTG,STR,.453LG
TP50002	2200-2010-400	CONN,M SMB,PC MTG,STR,.453LG
TP50003	2200-2010-400	CONN,M SMB,PC MTG,STR,.453LG
TP50004	2200-2010-400	CONN,M SMB,PC MTG,STR,.453LG
TP50005	2200-2010-400	CONN,M SMB,PC MTG,STR,.453LG
TP50006	2200-2010-400	CONN,M SMB,PC MTG,STR,.453LG



7010-4932-800

PCB ASSY, DISCR BD NO.1 (cont)

K

REFERENCE DESIGNATOR	PART NUMBER	DESCRIPTION
TP50007	2200-2010-400	CONN,M SMB,PC MTG,STR,.453LG
TP50008	2200-2010-400	CONN,M SMB,PC MTG,STR,.453LG
TP50010	2114-0000-007	TEST POINT,LOOP PROFILE,WHITE*
TP50011	2114-0000-007	TEST POINT,LOOP PROFILE,WHITE*
TP50012	2114-0000-007	TEST POINT,LOOP PROFILE,WHITE*
TP50013	2114-0000-007	TEST POINT,LOOP PROFILE,WHITE*
TP50014	2114-0000-007	TEST POINT,LOOP PROFILE,WHITE*
TP50015	2114-0000-007	TEST POINT,LOOP PROFILE,WHITE*
TP50016	2114-0000-007	TEST POINT,LOOP PROFILE,WHITE*
TP50018	2200-2010-400	CONN,M SMB,PC MTG,STR,.453LG
TP50020	2200-2010-400	CONN,M SMB,PC MTG,STR,.453LG
U50001	3132-0000-004	IC,74S04,HEX INVERTER
U50002	3132-0000-001	IC,74S00,QUAD 2-INPUT NAND
U50003	3131-0000-044	IC,74LS00,QUAD 2-INPUT NAND
U50004	3131-0000-038	IC,74LS74A,DUAL D FLIP-FLOP
U50005	3211-3161-000	IC,74LS161,SYNC 4-BIT BIN CTR
U50007	3221-0001-000	IC,353,DUAL JFET OP AMP
U50008	3214-4098-100	IC,4098B,DUAL MULTIVIBRATOR
U50009	3133-0000-004	IC,4027B,DUAL JK MS FLIP-FLOP
U50010	3133-0000-024	IC,3130,BIMOS OP AMP,PLAST DIP
U50011	3133-0000-001	IC,4001B,QUAD 2-INPUT NOR
U50012	3133-0000-007	IC,4066B,QUAD BILATERAL SWITCH
U50013	3133-0000-024	IC,3130,BIMOS OP AMP,PLAST DIP
U50014	3214-4098-100	IC,4098B,DUAL MULTIVIBRATOR
U50015	3133-0000-007	IC,4066B,QUAD BILATERAL SWITCH
U50016	3133-0000-024	IC,3130,BIMOS OP AMP,PLAST DIP
U50017	3133-0000-024	IC,3130,BIMOS OP AMP,PLAST DIP
U50018	3133-0000-011	IC,4011B,QUAD 2-INPUT NAND
U50019	3133-0000-024	IC,3130,BIMOS OP AMP,PLAST DIP
U50020	5050-2501-100	IC,MSA-0335-22,IC AMP
U50021	5050-2501-100	IC,MSA-0335-22,IC AMP
U50022	5050-2501-100	IC,MSA-0335-22,IC AMP
W50001	6042-4986-500	COAX .086 SR 1.25 LG

7010-4932-800

PCB ASSY, DISCR BD NO.1

L

The following part numbers have been changed:

REFERENCE DESIGNATOR	PART NUMBER	DESCRIPTION
R50039	4701-0123-003	RES,12K,1/8W,5%
R50039SAT	4701-0153-003	RES,15K,1/8W,5%

APPENDIX A - I/O CONNECTORS PIN-OUT TABLES

CONNECTOR	SIGNAL NAME	TYPE	INPUT/OUTPUT	SIGNAL TYPE
J49002	AUX X-BAND	SMA	OUTPUT	RF (X-Band)
J49003	ANLYZER RF X-BAND XMTR	N	OUTPUT	Attenuated Radar UUT Signal
J49004	VCO L-BAND	SMA	OUTPUT	RF (L-Band)
J49005	AM EXT	BNC	INPUT	External AM
J49006	FM EXT	BNC	INPUT	External FM
J49007	50% VIDEO XMTR	BNC	OUTPUT	TTL Video
J49008	AC	ac Male	INPUT	ac Line Power
J49012	IF SCP SWP	BNC	OUTPUT	5 Vp-p 100 Hz
J49016	X-BAND	N	INPUT/OUTPUT	RF (X-Band)
J49020	TEST VIDEO	BNC	INPUT	External Pulse
J49021	TEST RF	BNC	INPUT	RF (L-Band)
J49022	SYNC	BNC	OUTPUT	TTL
J49023	DLYD SYNC	BNC	OUTPUT	TTL
J49024	EXT TRIG	BNC	OUTPUT	2 to 25 Vp Pulse or Sine Wave
J49025	IF	BNC	OUTPUT	IF
J49026	XMTR DET	BNC	OUTPUT	Detected Radar UUT Pulse Signal
J49027	XMTR DSCRM .1V/MHz	BNC	OUTPUT	Reference Pulse (Amplitude Reflects UUT Frequency)
J49028	XMTR HET MON	BNC	OUTPUT	Radar UUT Pulse Modulation



THIS PAGE INTENTIONALLY LEFT BLANK.

APPENDIX B - R1,R2 AUTO THRESHOLD ADJUSTMENT

1. General

When the RANGE SEL Switch is set to R1,R2 AUTO, Range 1 or Range 2 reply is selected according to the width of the UUT transmitter pulse. The R1,R2 AUTO threshold adjustment on the Discriminator #1 PC Board sets the determining width. When the UUT transmitter pulse width is > the determining width, only Range 2 reply is selected. When the UUT transmitter pulse width is < the determining width, only Range 1 reply is selected. The determining width is calibrated to 0.4 μ s. When a different determining width is desired, perform the R1,R2 AUTO Threshold Procedure.

2. R1,R2 AUTO Threshold Procedure

TEST EQUIPMENT: Oscilloscope
Pulse Generator

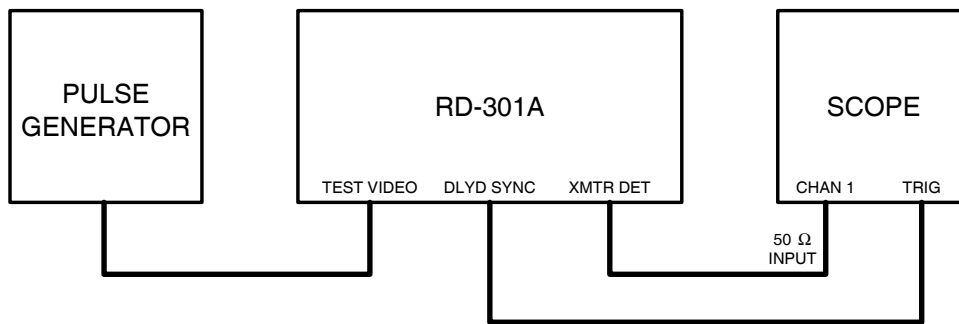

9006010

R1,R2 AUTO Threshold Hookup Diagram
Figure 1

STEP	PROCEDURE
1.	Remove four screws and top cover from RD-301A.
2.	Connect test equipment as shown in Appendix B, Figure 1.
3.	Adjust Pulse Generator for desired determining pulse width (0.2 to 1.0 μ s) at approximately +3 Vp.
4.	Set Oscilloscope to view Range 1 or Range 2 reply delay.

5. Refer to Appendix B, Figure 2 and adjust R50012 fully cw.

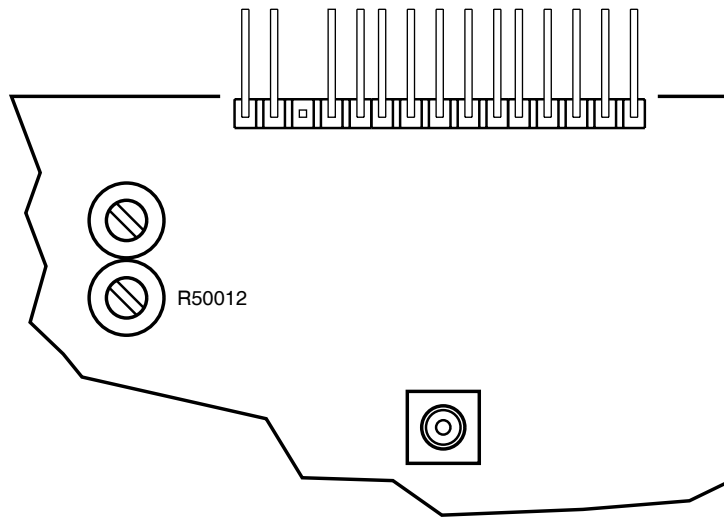

9018001

Discriminator #1 PC Board R1,R2 AUTO Threshold
Figure 2

6. Adjust R50012 ccw until AUTO function changes from Range 1 Reply to Range 2 Reply.
7. Vary Pulse Generator pulse width output and verify AUTO function range reply changes at threshold set in Step 6. Readjust R50012 as necessary.



APPENDIX C - TEST EQUIPMENT REQUIREMENTS

This Appendix contains a list of test equipment suitable for performing all of the maintenance procedures contained in this manual. The equipment listed in this Appendix may exceed the minimum required specifications for some of the procedures contained in this manual.

TYPE	MODEL
3 dB Pad	HP8491A Option 003 or Equivalent
6 dB Pad	HP8491A Option 006 or Equivalent
10:1 Oscilloscope Probe	Included with TEK2465 or Equivalent
20 dB Coupler	NARDA 3004-20 or Equivalent
Bandpass Filter	Generic
Digital Multimeter	FLUKE 8010A or Equivalent
Frequency Counter	HP5361B or Equivalent
Heterodyne Monitor	Aeroflex 7018-0013-600 or Equivalent
L-Band Signal Generator	Aeroflex 2023B w/Option 11 or Equivalent
Modulation Meter	BOONTON 82AD or Equivalent
Oscilloscope	TEK 5032B or Equivalent
Power Meter	Aeroflex 6920 or Equivalent
Power Meter Assembly	N/A
Power Sensor	Aeroflex 6920 or Equivalent
Pulse/Function Generator	HP8116A or Equivalent
Spectrum Analyzer	Aeroflex 2930A or Equivalent
TWT Amplifier	LOGIMETRICS 710X or Equivalent
X-Band Signal Generator	HP8683D or Equivalent
X-Band to L-Band Down Converter	Refer to Appendix D.



THIS PAGE INTENTIONALLY LEFT BLANK.

APPENDIX D - TEST EQUIPMENT CONSTRUCTION

1. Power Meter Assembly

A. General

The Power Meter Assembly measures pulse-modulated X-Band input power to the RD-301A. When used in testing, an X-Band Signal Generator output amplified by a TWT Amplifier provides the pulse-modulated X-Band input signal. The Power Meter Assembly is characterized and measurement readings determine the power level within 1 dB of the output signal to the RD-301A. The Power Meter Assembly verifies the accuracy of the RD-301A measuring radar power levels.

B. Assembly

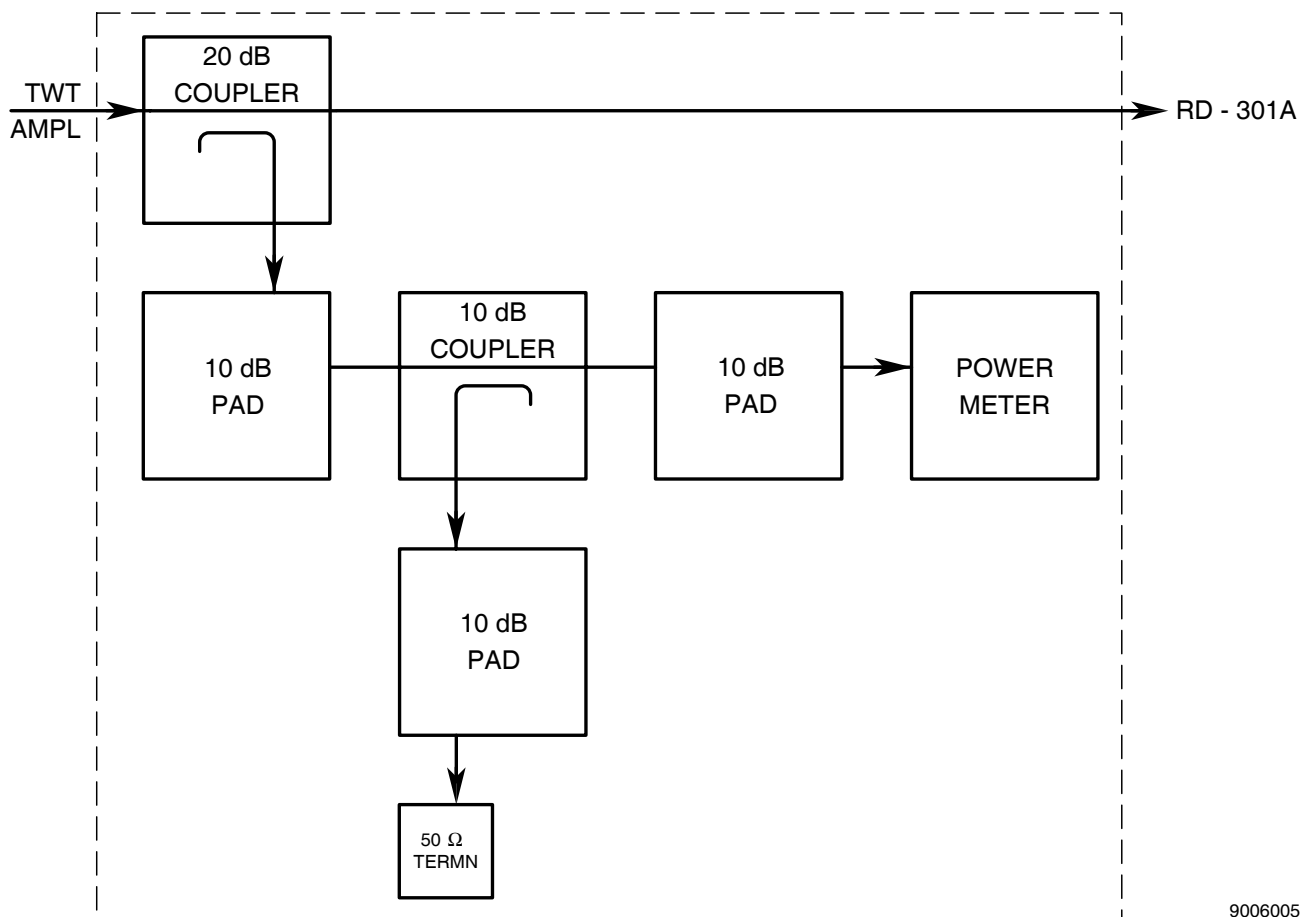

9006005

Power Meter Assembly
Figure 1

STEP

PROCEDURE

1. Refer to Appendix D, Table 1 for list of recommended components or test equipment. Assemble Power Meter Assembly as shown in Appendix D, Figure 1.

EQUIPMENT / COMPONENT	MODEL	QUANTITY
10 dB Coupler	NARDA 4245B40 or Equivalent	1
10 dB Pad	WEINSCHEL 1-10 or Equivalent	3
20 dB Coupler	NARDA 3004 or Equivalent	1
50 Termination	NARDA 378N or Equivalent	1
(Peak Pulse) Power Meter	HP8900D or Equivalent	1

Power Meter Assembly Equipment List
Table 1

2. Characterize Power Meter Assembly from 9295 to 9500 MHz, traceable to the National Institute of Standards and Technology.

NOTE: Once equipment is assembled and characterized, equipment cannot be disassembled without recharacterization.

C. Operation

The characterized Power Meter Assembly provides a referenced readout of the power level (Test RF Level) applied to the Serialized Coaxial Cable. For the Power Meter Verification in para 2-2-2F(5) and Power Meter Calibration in para 2-2-2H(13), the Serialized Coaxial Cable and Waveguide Coupler are both considered. Power levels are adjusted by changing the level of the pulse-modulated output from the X-Band Signal Generator. The power levels are determined from the Power Meter Assembly readout referenced to the Power Meter Assembly characterization/correction chart.

2. X-Band To L-Band Down Converter

A. General

The X-Band to L-Band Down Converter converts the X-band signal, generated by the RD-301A, down to the L-Band signal, compatible with L-Band test equipment. Additionally, the X-Band to L-Band Down Converter allows further conversion to base band by using a Heterodyne Monitor. The base band signal allows Oscilloscope analysis of the X-Band signal.

B. Assembly

Assemble circuits as shown in Appendix D, Figure 2.

- The Low-Pass Filter passes frequencies <1300 MHz.
- The Mixer is a Watkins-Johnson WJM76C or Equivalent.
- The X-Band Conversion Signal Source is a phase-locked Signal Generator or fixed frequency oscillator. The X-Band Conversion Signal Source drives the mixer LO connector at a saturated level (+7 dBm). For RD-301A procedures, the X-Band conversion signal is 8.25 GHz.

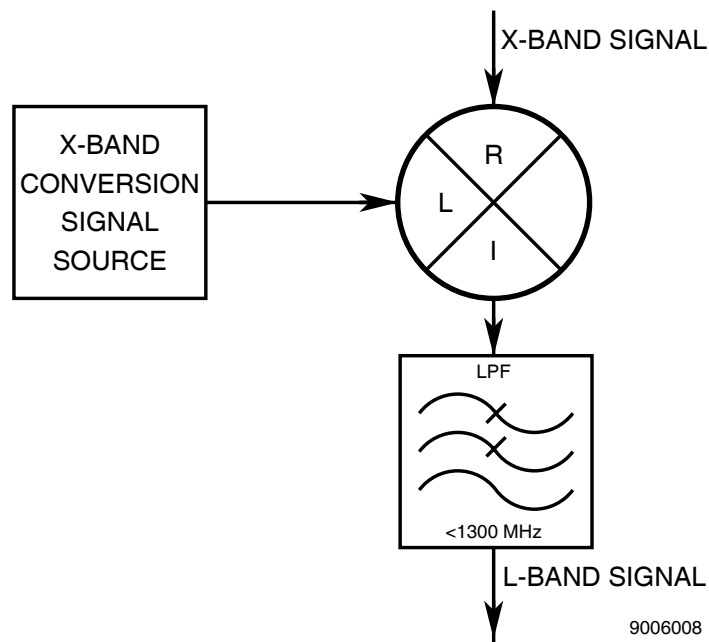

X-Band to L-Band Down Converter
Figure 2



THIS PAGE INTENTIONALLY LEFT BLANK.

APPENDIX E - METRIC/BRITISH IMPERIAL CONVERSION TABLE WITH NAUTICAL DISTANCE CONVERSIONS

TO CONVERT:	INTO:	MULTIPLY BY:	TO CONVERT:	INTO:	MULTIPLY BY:
cm	feet	0.03281	meters	feet	3.281
cm	inches	0.3937	meters	inches	39.37
feet	cm	30.48	m/sec	ft/sec	3.281
feet	meters	0.3048	m/sec	km/hr	3.6
ft/sec	km/hr	1.097	m/sec	miles/hr	2.237
ft/sec	knots	0.5921	miles	feet	5280
ft/sec	miles/hr	0.6818	miles	km	1.609
ft/sec ²	cm/sec ²	30.48	miles	meters	1609
ft/sec ²	m/sec ²	0.3048	miles	nmi	0.8684
grams	ounces	0.03527	miles/hr	ft/sec	1.467
inches	cm	2.54	miles/hr	km/hr	1.609
kg	pounds	2.205	miles/hr	knots	0.8684
kg/cm ²	psi	0.0703	nmi	feet	6080.27
km	feet	3281	nmi	km	1.8532
km	miles	0.6214	nmi	meters	1853.2
km	nmi	0.5396	nmi	miles	1.1516
km/hr	ft/sec	0.9113	ounces	grams	28.34953
km/hr	knots	0.5396	pounds	kg	0.4536
km/hr	miles/hr	0.6214	psi	kg/cm ²	0.0703
knots	ft/sec	1.689	100 ft	km	3.048
knots	km/hr	1.8532	100 ft	miles	1.894
knots	miles/hr	1.1516	100 ft	nmi	1.645



THIS PAGE INTENTIONALLY LEFT BLANK.

APPENDIX F - CONTROLS, CONNECTORS AND INDICATORS

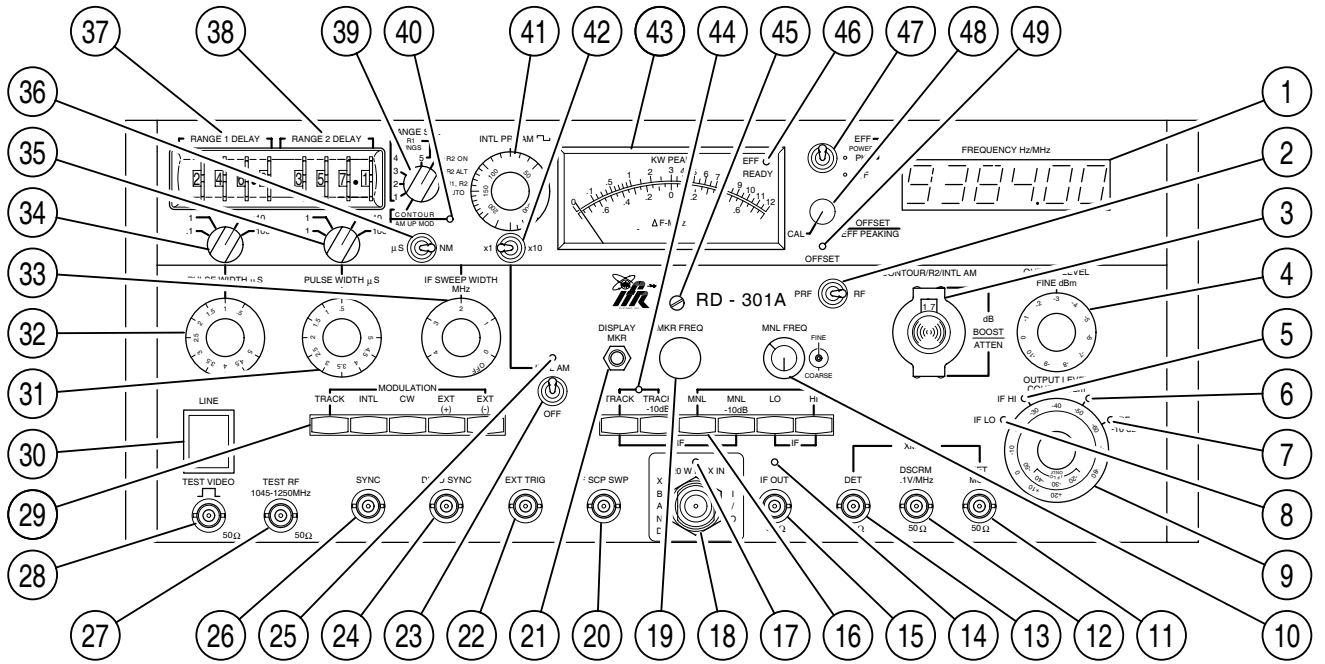

9007001

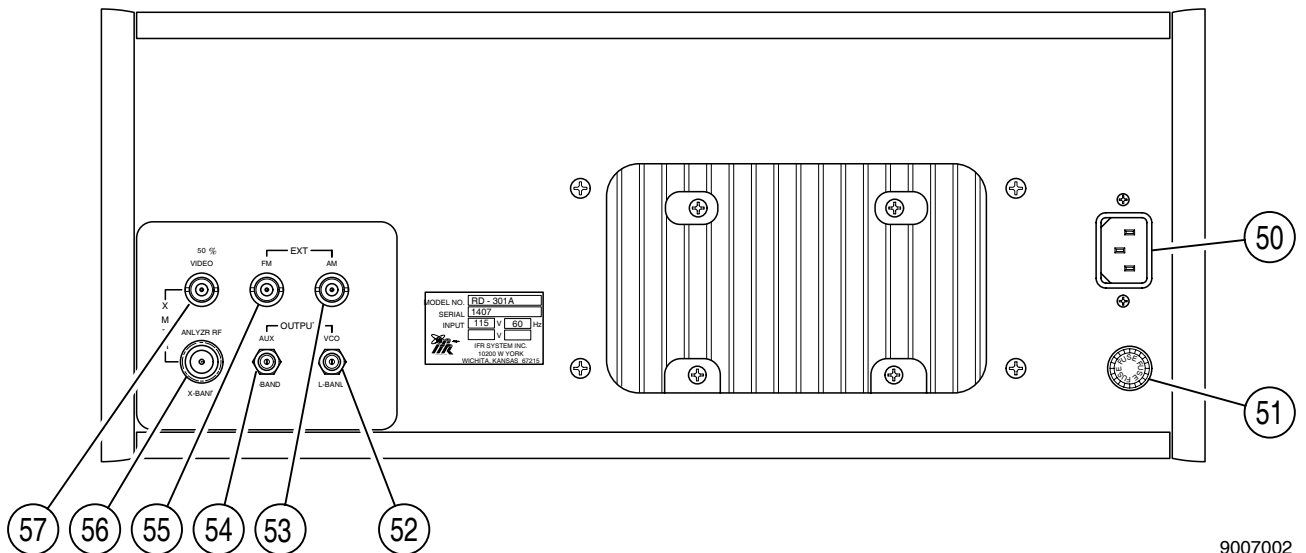

9007002

RD-301A Front and Rear Panels
Figure 1

<ol style="list-style-type: none"> 1. FREQUENCY Hz/MHz Digital Display 2. PRF/RF Switch 3. CONTOUR/R2/INTL AM dB BOOST/ATTEN Control 4. OUTPUT LEVEL FINE dBm Control 5. IF HI Indicator 6. RF Indicator 7. RF -10 dB Indicator 8. IF LO Indicator 9. OUTPUT LEVEL COARSE dBm Control 10. MNL FREQ Controls 11. XMTR HET MON Connector (J49028) 12. XMTR DSCRM .1V/MHz Connector (J49027) 13. XMTR DET Connector (J49026) 14. IF OUT Indicator 15. IF OUT Connector (J49025) 16. RF/IF MODE Pushbutton Switches 17. X-BAND SIGNAL Indicator 18. X-BAND I/O Connector (J49016) 19. MKR FREQ Control 20. IF SCP SWP Connector (J49012) 21. DISPLAY MKR Switch 22. EXT TRIG Connector (J49024) 23. INTL AM Switch 24. DLYD SYNC Connector (J49023) 25. INTL AM Indicator 26. SYNC Connector (J49022) 27. TEST RF 1045-1250 MHz Connector (J49021) 28. TEST VIDEO Connector (J49020) 29. MODULATION MODE Pushbutton Switches 	<ol style="list-style-type: none"> 30. LINE Switch 31. PULSE WIDTH μS Control (RANGE 2) 32. PULSE WIDTH μS Control (RANGE 1) 33. SWEEP WIDTH MHz Control 34. PULSE WIDTH MULTIPLIER Control (RANGE 1) 35. PULSE WIDTH MULTIPLIER Control (RANGE 2) 36. μS/NM Switch 37. RANGE 1 DELAY Thumbwheels 38. RANGE 2 DELAY Thumbwheels 39. RANGE SEL Switch 40. CONTOUR/AM UP MOD Indicator 41. INTL PRF/AM Control 42. X1/X10 INTL PRF/AM Switch 43. PANEL Meter 44. TRACK Indicator 45. PANEL METER ZERO Control 46. EFF READY Indicator 47. METER SELECT Switch 48. ΔF OFFSET/EFF PEAKING Control 49. OFFSET Indicator 50. AC INPUT Connector (49008) 51. FUSE 52. VCO L-BAND OUTPUT Connector (J49004) 53. AM EXT INPUT Connector (J49005) 54. AUX X-BAND OUTPUT Connector (J49002) 55. FM EXT INPUT Connector (J49006) 56. ANALYZER RF X-BAND XMTR Connector (J49003)
---	---

A. RD-301A Front Panel

ITEM	DESCRIPTION
------	-------------

1. FREQUENCY Hz/MHz Digital Display

Displays PRF (Hz), IF (MHz) or RF (MHz) as selected with PRF/RF Switch (2) and RF/IF MODE Pushbutton Switches (16). Marker frequency (MHz) is displayed when DISPLAY MKR Switch (21) is pressed. Refer to Appendix F, Table 1.

FREQUENCY TYPE	MODE	DISPLAY
PRF	RF TRACK/RF TRACK -10 dB	UUT Transmitter PRF
PRF	INTL	RD-301A Internal Oscillator PRF (Internal AM frequency if On)
PRF	EXT (+), EXT (-)	External Trigger Signal PRF
RF	IF LO/IF HI	IF Signal Generator Frequency
RF	IF LO/IF HI DISPLAY MKR Switch (21) pressed	IF Marker Frequency
RF	RF TRACK/RF TRACK -10 dB	RF Signal Generator/UUT Transmitter Frequency
RF	RF MNL/RF MNL -10 dB	RF Signal Generator Frequency

FREQUENCY Hz/MHz Digital Display Control
Table 1

2. PRF/RF Switch

Toggle switch selects type of frequency shown on FREQUENCY Hz/MHz Digital Display (1). Refer to Appendix F, Table 1.

3. CONTOUR/R2/INTL AM dB BOOST/ATTEN Control

Boosts or attenuates output level set with OUTPUT LEVEL COARSE dBm Control (9) and OUTPUT LEVEL FINE dBm Control (4). Inner knob controls level in 1 dB steps (0-9). Outer knob controls level in 10 dB steps (0-50). Selection appears in small viewing window at top center of control.

Boost is activated when RANGE SEL Switch (39) is in CONTOUR/AM MOD UP position and applies to output levels from -127 to -75 dBm. CONTOUR/R2/INTL AM dB BOOST/ATTEN Control boosts contour or internal AM level from 0 to 20 dB above selected output level.

NOTE: Selecting >20 dB boost produces minimal or no additional level increase >20 dB.

Attenuation is activated when RANGE SEL Switch (39) is in any R2 position (R2 ON; R2 ALT or R1,R2 AUTO) or RINGS 1 through 5 with internal AM activated. Range 2 reply or internal AM is attenuated from 0 to -59 dB referenced to Range 1 reply level set with OUTPUT LEVEL COARSE dBm Control (9) and OUTPUT LEVEL FINE dBm Control (4).

ITEM	DESCRIPTION
4. OUTPUT LEVEL FINE dBm Control	Decreases RF or IF output level in 1 dB steps referenced to level set with OUTPUT LEVEL COARSE dBm Control (9). Range is from 0 to -10 dB.
5. IF HI Indicator	Green LED illuminates when IF HI is selected with RF/IF MODE Pushbutton Switches (16). Green indicates color of scale used on OUTPUT LEVEL COARSE dBm Control (9).
6. RF Indicator	Red LED illuminates when RF TRACK or RF MNL is selected with RF/IF MODE Pushbutton Switches (16). Red indicates color of scale used on OUTPUT LEVEL COARSE dBm Control (9).
7. RF -10 dB Indicator	Red LED illuminates when RF TRACK -10 dB or RF MNL -10 dB is selected with RF/IF MODE Pushbutton Switches (16). Red indicates color of scale used on OUTPUT LEVEL COARSE dBm Control (9).
8. IF LO Indicator	Red LED illuminates when IF LO is selected with RF/IF MODE Pushbutton Switches (16). Red indicates color of scale used on OUTPUT LEVEL COARSE dBm Control (9).
9. OUTPUT LEVEL COARSE dBm Control	Varies RF or IF output level in 10 dB increments. Red and green scales on control knob are used according to mode selected with RF/IF MODE Pushbutton Switches (16). Each mode is indicated with an index mark and red or green LED. RF output level is calibrated to -127 dBm using the red scale.
10. MNL FREQ Controls	Sets signal generator frequency for RF MNL, RF MNL -10 dB, IF LO or IF HI mode selected with RF/IF MODE Pushbutton Switches (16). Coarse adjust (outer knob) and fine adjust (inner knob) set frequency shown on FREQUENCY Hz/MHz Digital Display (1).
11. XMTR HET MON Connector (J49028)	Provides output for displaying radar transmitter pulse frequency characteristics on external oscilloscope. BNC connector requires 50 Ω load for operation.
12. XMTR DSCRM .1V/MHz Connector (J49027)	Provides output for displaying radar transmitter frequency versus time characteristics on external oscilloscope. BNC connector requires 50 Ω load for an output calibrated at 0.1 V/MHz. System reference pulse, 5 μ s wide, occurs approximately 15 μ s after transmitter pulse. Reference voltage corresponds to frequency shown on FREQUENCY Hz/MHz Digital Display (1).
13. XMTR DET Connector (J49026)	Provides output for displaying radar transmitter pulse shape characteristics on external oscilloscope. BNC connector requires 50 Ω load to preserve pulse fidelity.

ITEM	DESCRIPTION
14. IF OUT Indicator	Red LED illuminates when IF LO or IF HI is selected with RF/IF MODE Pushbutton Switches (16) and indicates IF output is available at IF OUT Connector (15).
15. IF OUT Connector (J49025)	Provides IF signal generator output. Signal level is set with OUTPUT LEVEL FINE dBm Control (4) and OUTPUT LEVEL COARSE dBm Control (9). BNC connector requires 50 Ω load for operation.
16. RF/IF MODE Pushbutton Switches	Selects one of the following RF or IF operating modes:
	<ul style="list-style-type: none"> ● RF TRACK
	RF signal generator acquires and tracks frequency of UUT transmitter signal received through X-BAND I/O Connector (18). RF Indicator (6) and X-BAND SIGNAL Indicator (17) illuminate when RF TRACK mode is selected.
	<ul style="list-style-type: none"> ● RF TRACK -10 dB
	Used with external 10 dB coaxial attenuator inserted at Waveguide Coupler to provide for UUT transmitters with >12 kW (up to 120 kW) peak power out-put. RF signal generator acquires and tracks frequency of UUT transmitter signal received through X-BAND I/O Connector (18). RF -10 dB Indicator (7) and X-BAND SIGNAL Indicator (17) illuminate when RF TRACK -10 dB mode is selected.
	NOTE: Transmitting replies from the RD-301A while the UUT transmitter is operating during TRACK operations may cause tracking inaccuracies at high generator levels (>-75 dBm). To avoid possible tracking error, the range delay is set greater than the UUT transmitter pulse width.
	<ul style="list-style-type: none"> ● RF MNL
	RF signal generator frequency is set from 9.295 to 9.500 GHz with MNL FREQ Controls (10). Output is calibrated at R/T unit with Serialized Coaxial Cable and Waveguide Coupler. RF Indicator (6) and X-BAND SIGNAL Indicator (17) illuminate when RF MNL mode is selected.
	<ul style="list-style-type: none"> ● RF MNL -10 dB
	Used with external 10 dB Attenuator inserted at Waveguide Coupler to provide for UUT transmitters with >12 kW (up to 120 kW) peak power output. RF signal generator frequency is set from 9.295 to 9.500 GHz with MNL FREQ Controls (10). X-BAND SIGNAL Indicator (17) and RF -10 dB Indicator (7) illuminate when RF MNL -10 dB mode is selected.
	<ul style="list-style-type: none"> ● IF LO
	Activates IF signal generator in low power range from -132 to -20 dBm as selected with OUTPUT LEVEL FINE dBm Control (4) and OUTPUT LEVEL COARSE dBm Control (9). MNL FREQ Controls (10) vary IF frequency from 20 to 70 MHz. IF LO Indicator (8) and IF OUT Indicator (14) illuminate when IF LO mode is selected.

ITEM	DESCRIPTION
● IF HI	<p>Activates IF signal generator in high power range from -92 to +20 dBm as selected with OUTPUT LEVEL FINE dBm Control (4) and OUTPUT LEVEL COARSE dBm Control (9). MNL FREQ Controls (10) vary IF frequency from 20 to 70 MHz. IF HI Indicator (5) and IF OUT Indicator (14) illuminate when IF HI mode is selected.</p>
17. X-BAND SIGNAL Indicator	<p>Red LED illuminates when RF TRACK, RF TRACK -10 dB, RF MNL or RF MNL -10 dB is selected with RF/IF MODE Pushbutton Switches (16) and indicates RF output is available at the X-BAND I/O Connector (18).</p>
18. X-BAND I/O Connector (J49016)	<p>N connector couples RD-301A to UUT through antenna waveguide. Output is calibrated at R/T unit using Serialized Coaxial Cable and Waveguide Coupler furnished with Test Set. Output level is set using the OUTPUT LEVEL COARSE dBm Control (9), OUTPUT LEVEL FINE dBm Control (4) and (if applicable) CONTOUR/R2/INTL AM dB BOOST/ATTEN Control (3).</p> <p>CAUTION: MAXIMUM INPUT LEVEL CANNOT EXCEED 120 W.</p>
19. MKR FREQ Control	<p>Adjusts IF marker frequency when DISPLAY MKR Switch (21) is pressed.</p>
20. IF SCP SWP Connector (J49012)	<p>BNC connector provides an approximate 5 VP-P, 100 Hz ramp output for horizontal drive to external oscilloscope during IF sweep tests.</p>
21. DISPLAY MKR Switch	<p>Momentary contact switch adds marker signal (approximately -20 dBc) to IF output, when pressed. Marker frequency is set with MKR FREQ Control (19) and shown on FREQUENCY Hz/MHz Digital Display (1).</p>
22. EXT TRIG Connector (J49024)	<p>BNC connector used to apply external trigger when EXT (+) or EXT (-) is selected with MODULATION MODE Pushbutton Switches (29). Trigger input requires 2 to 25 V peak pulse or sine wave to initiate range delay.</p>
23. INTL AM Switch	<p>INTL AM (On)/OFF toggle switch adds 50% AM (square wave) to reply pulse output. Frequency is set with INTL PRF/AM Control (41) and X1/X10 INTL PRF/AM Switch (42). Amplitude is set with CONTOUR/R2/INTL AM BOOST/ATTEN Control (3) and is relative to output level set with OUTPUT LEVEL FINE dBm Control (4) and OUTPUT LEVEL COARSE dBm Control (9).</p>
24. DLYD SYNC Connector (J49023)	<p>BNC connector provides delayed synchronous pulse output to external oscilloscope. Leading edge of positive pulse is coincident with leading edge of reply pulse.</p>
25. INTL AM Indicator	<p>Red LED illuminates when internal AM is activated with INTL AM Switch (23).</p>

ITEM	DESCRIPTION
26. SYNC Connector (J49022)	BNC connector provides synchronous pulse output to external oscilloscope. Leading edge of positive pulse is coincident with start of each range delay.
27. TEST RF 1045-1250 MHz Connector (J49021)	BNC connector, providing 50 Ω load, receives L-Band test signals for calibration and verification of tracking circuits.
28. TEST VIDEO Connector (J49020)	BNC connector, providing 50 Ω load, receives external pulse signals and is used with TEST RF 1045-1250 MHz Connector (27) for calibration and verification.
29. MODULATION MODE Pushbutton Switches	Selects range delay trigger source or enables continuous wave output. Selectable modes are as follows:
● TRACK	Starts range delay coincident with leading edge of UUT transmitter pulse at 50% amplitude point.
● INTL	Starts range delay with every leading edge of pulses generated by internal PRF oscillator. Triggering rate is set with INTL PRF/AM Control (41).
● CW	Selects continuous wave RF output at X-BAND I/O Connector (18) or continuous wave IF output at IF OUT Connector (15) according to RF/IF MODE Pushbutton Switches (16).
● EXT (+)	Starts range delay when triggered with rising edge of a 2 to 25 V peak pulse or positive half of sine wave input applied to EXT TRIG Connector (22).
● EXT (-)	Starts range delay when triggered with falling edge of a 2 to 25 V peak pulse or negative half of sine wave input applied to EXT TRIG Connector (22).
30. LINE Switch	Applies power to RD-301A.
31. PULSE WIDTH μ S Control (RANGE 2)	Adjusts Range 2 reply pulse width from 0.05 to 500 μ s, depending on PULSE WIDTH MULTIPLIER Control (RANGE 2) (35) setting. PULSE WIDTH μ S Control (RANGE 2) setting is variable from 0.5 to 5 μ s and is multiplied by the PULSE WIDTH MULTIPLIER Control (RANGE 2) (35) setting to obtain the Range 2 reply pulse width.

ITEM	DESCRIPTION
32. PULSE WIDTH μ S Control (RANGE 1)	Adjusts pulse width from 0.05 μ s to 2.5 ms, depending on PULSE WIDTH MULTIPLIER Control (RANGE 1) (34) setting. PULSE WIDTH μ S Control (RANGE 1) setting is variable from 0.5 to 5 μ s and is multiplied by the PULSE WIDTH MULTIPLIER Control (RANGE 1) (34) setting to obtain the pulse width. Range 1 reply width is set in RF operating modes or IF pulse width is set in IF operating modes according to RF/IF MODE Pushbutton Switches (16).
33. SWEEP WIDTH MHz Control	Sets sweep width (in MHz) of IF signal generator output. Sweep width is set from 0 to 4 MHz. Sweep rate is 100 Hz. Control has detent OFF position.
34. PULSE WIDTH MULTIPLIER Control (RANGE 1)	Selects multiplier (.1, 1, 10, 100 or 500) used with PULSE WIDTH μ S Control (RANGE 1) (32) setting. The PULSE WIDTH MULTIPLIER Control (RANGE 1) setting multiplied by the PULSE WIDTH μ S Control (RANGE 1) (32) setting obtains Range 1 reply or IF pulse width.
35. PULSE WIDTH MULTIPLIER Control (RANGE 2)	Selects multiplier (.1, 1, 10 or 100) used with PULSE WIDTH μ S Control (RANGE 2) (31) setting. The PULSE WIDTH MULTIPLIER Control (RANGE 2) setting multiplied by the PULSE WIDTH μ S Control (RANGE 2) (31) setting obtains Range 2 reply pulse width.
36. μ S /NM Switch	Selects unit of measurement (microseconds [μ S] or nautical miles [NM]) for both Range 1 and Range 2 simulated reply delays.
37. RANGE 1 DELAY Thumbwheels	Sets delay for Range 1 simulated reply. Delay is set from 0.1 to 999.9 in microseconds or nautical miles depending on position of μ S/NM Switch (36). A residual time delay (nominally 0.1 μ s) is added to the delay set by RANGE 1 DELAY Thumbwheels. The source selected by the MODULATION MODE Pushbutton Switches (29) triggers the delay.
38. RANGE 2 DELAY Thumbwheels	Sets delay for Range 2 simulated reply. Delay is set from 0.2 to 999.9 in microseconds or nautical miles depending on position of μ S/NM Switch (36). A residual time delay (nominally 0.4 μ s) is added to the delay set by RANGE 2 DELAY Thumbwheels. The source selected by the MODULATION MODE Pushbutton Switches (29) triggers the delay.

ITEM	DESCRIPTION
39. RANGE SEL Switch	<p data-bbox="381 289 1414 346">Provides simulated reply variations. Nine position rotary switch selects boost, selects number of Range 1 reply rings (1-5) or activates Range 2 reply.</p> <ul style="list-style-type: none"> <li data-bbox="381 367 740 394">● CONTOUR/AM UP MOD <p data-bbox="428 415 1502 579">Provides selectable 0 to 20 dB boost above level set with OUTPUT LEVEL FINE dBm Control (4) and OUTPUT LEVEL COARSE dBm Control (9). Boost is set using CONTOUR/R2/INTL AM dB BOOST/ATTEN Control (3) and only applies when initial output levels are from -75 to -127 dBm. Range 1 reply is boosted when INTL AM Switch (23) is OFF. Internal AM is boosted when INTL AM Switch (23) is set to INTL AM.</p> <li data-bbox="381 600 678 627">● RINGS 1 through 5 <p data-bbox="428 648 1502 762">Selects number of equally spaced simulated Range 1 replies transmitted by the RD-301A. RANGE 1 DELAY Thumbwheels (37) set Ring 1 delay and distance between all succeeding rings (equidistant). Minimum range for Rings 2 through 5 is 0.3 μs or 0.3 nmi.</p> <li data-bbox="381 783 516 810">● R2 ON <p data-bbox="428 831 1502 966">Activates Range 2 reply in addition to Range 1 reply. Range 1 output level is set with OUTPUT LEVEL FINE dBm Control (4) and OUTPUT LEVEL COARSE dBm Control (9). Range 2 output level is attenuated from Range 1 output level with CONTOUR/R2/INTL AM dB BOOST/ATTEN Control (3). Range 2 delay is set with RANGE 2 DELAY Thumbwheels (38).</p> <li data-bbox="381 987 527 1014">● R2 ALT <p data-bbox="428 1035 1502 1148">Activates Range 1 reply with every trigger as selected with MODULATION MODE Pushbutton Switches (29) and Range 2 reply every other trigger. Range 2 output level is attenuated from Range 1 output level with CONTOUR/R2/INTL AM dB BOOST/ATTEN Control (3).</p> <li data-bbox="381 1169 597 1197">● R1/R2 AUTO <p data-bbox="428 1218 1502 1331">Automatically selects Range 1 or Range 2 reply depending on width of UUT transmitter pulse. Only Range 1 reply responds when UUT transmitter pulse width is <0.4 μs. Only Range 2 reply responds when UUT transmitter pulse width is >0.4 μs.</p> <p data-bbox="428 1352 1481 1436">NOTE: If Range 1 delay set by RANGE 1 DELAY Thumbwheels (37) is <0.4 μs, Range 1 reply always responds. If Range 2 delay set by RANGE 2 DELAY Thumbwheels (38) is <0.4 μs, Range 2 reply never responds.</p> <p data-bbox="428 1457 1502 1512">NOTE: The factory calibrated threshold setting is 0.4 μs. The threshold setting is adjustable from 0.2 to 1.0 μs.</p>
40. CONTOUR/AM UP MOD Indicator	<p data-bbox="381 1581 1468 1631">Red LED illuminates when CONTOUR/AM UP position is selected with RANGE SEL Switch (39).</p>

ITEM	DESCRIPTION
41. INTL PRF/AM Control	<p>Used with X1/X10 INTL PRF/AM Switch (42) to regulate the RD-301A internal oscillator frequency (Internal PRF and/or AM frequency). INTL PRF/AM Control sets internal AM frequency when INTL AM Switch (23) is set to INTL AM. INTL PRF/AM Control sets internal PRF when INTL is selected with MODULATION MODE Pushbutton Switches (29). INTL PRF/AM Control sets both internal PRF and AM frequency when INTL AM Switch (23) is set to INTL AM and INTL is selected with MODULATION MODE Pushbutton Switches (29). Frequency is adjustable from 50 to 500 Hz or 500 to 5000 Hz, depending on X1/X10 INTL PRF/AM Switch (42) position.</p>
42. X1/X10 INTL PRF/AM Switch	<p>Selects multiplier (X1 or X10) used with INTL PRF/AM Control (41) setting. The INTL PRF/AM Control (41) setting multiplied by 1 or 10 as selected with the X1/X10 INTL PRF/AM Switch provides the RD-301A internal oscillator frequency.</p>
43. PANEL Meter	<p>Indicates effective peak power of UUT transmitter, peak power of UUT transmitter or frequency offset between UUT transmitter and RD-301A Test Set signal generator. PANEL Meter operates when RF TRACK or RF TRACK -10 dB is selected with RF/IF MODE Pushbutton Switches (16). Function is selected by METER SELECT Switch (47).</p>
	<ul style="list-style-type: none"> <li data-bbox="285 892 545 924">● KW PEAK Scale <p data-bbox="334 942 1390 1108">Indicates effective peak or peak RF power of UUT transmitter at X-BAND I/O Connector (18) using a 0.1 to 12 kW range. KW PEAK Scale is used when METER SELECT Switch (47) is set to EFF POWER or PK POWER positions. For units above 12 kW (up to 120 kW), an external 10 dB Attenuator is connected to the Waveguide Coupler output (UUT power is scale reading multiplied by ten). Power is calibrated and accuracy specified from 1.0 to 12 kW.</p> <p data-bbox="334 1127 1398 1209">NOTE: Correct calibration depends on the use of the Waveguide Coupler and Serialized Coaxial Cable furnished with RD-301A Test Set. If a replacement coupler or cable is used, the Test Set must be recalibrated.</p>
	<ul style="list-style-type: none"> <li data-bbox="285 1228 521 1260">● ΔF-MHz Scale <p data-bbox="334 1278 1398 1394">Displays amount of offset between UUT transmitter frequency and Test Set signal generator frequency. Offset is adjusted with ΔF OFFSET/EFF PEAKING Control (48). The ΔF-MHz Scale is used when METER SELECT Switch (47) is set to ΔF position.</p>
44. TRACK Indicator	<p>Red LED illuminates when Test Set RF signal generator system has acquired and is tracking UUT transmitter frequency.</p>
45. PANEL METER ZERO Control	<p>Inset screw used to align PANEL Meter (43) needle to zero when LINE Switch (30) is OFF.</p>
46. EFF READY Indicator	<p>Green LED illuminates when Test Set is ready to measure UUT effective peak power.</p>

ITEM	DESCRIPTION
47. METER SELECT Switch	<p>Toggle switch selects PANEL Meter (43) operating mode as follows:</p> <ul style="list-style-type: none"> ● EFF (Effective) (Peak) POWER - PANEL Meter (43) displays in kW, the UUT effective peak power resulting from effects of phase distortion and frequency inconsistencies of the UUT transmitter pulse. ● PK (Peak) POWER - PANEL Meter (43) displays UUT peak power in kilowatts. ● ΔF (Frequency Offset) - PANEL Meter (43) displays frequency offset from UUT frequency $\leq \pm 75$ kHz as adjusted by ΔF OFFSET/EFF PEAKING Control (48).
48. ΔF OFFSET/EFF PEAKING Control	<p>Offsets RD-301A internal RF signal generator frequency from UUT transmitter frequency from 0 to ± 0.75 MHz and is used when RF TRACK or RF TRACK -10 dB is selected with RF/IF MODE Pushbutton Switches (16). CAL (detent) position provides zero offset (RF signal generator frequency = UUT transmitter frequency). Offset is displayed using ΔF Scale on PANEL METER (43) when METER SELECT Switch (47) is in ΔF position.</p>
49. OFFSET Indicator	<p>Red LED illuminates when ΔF OFFSET/EFF PEAKING Control (48) is not in CAL (detent) position and RF TRACK or RF TRACK -10 dB is selected with RF/IF MODE Pushbutton Switches (16). LED indicates RD-301A is tracking magnetron frequency with offset determined by ΔF OFFSET/EFF PEAKING Control (48).</p>

B. RD-301A Rear Panel

ITEM	DESCRIPTION
50. AC INPUT Connector (49008)	Provides for 115 to 230 VAC single phase power input to the RD-301A. Power Supply Assembly automatically adjusts according to source voltage available.
51. FUSE	2.0 A, 250 V Fast Blo for 115 VAC operation or 1.0 A, 250 V Fast Blo for 230 VAC operation.
52. VCO L-BAND OUTPUT Connector (J49004)	SMA connector provides VCO sample for testing tracking accuracy at L-Band.
53. AM EXT INPUT Connector (J49005)	BNC connector provides input for external amplitude modulation. Sine, square or triangle wave signal input modulates the RD-301A reply pulse. External modulation source is 0 to 5 Vp-p providing up to 50% AM, depending on source frequency. (3 dB bandwidth at 3 Vp-p and 30% AM is from 30 Hz to 5 kHz.)
54. AUX X-BAND OUTPUT Connector (J49002)	SMA connector provides auxiliary RF output from X-Band front end for signal generator applications and calibrating tracking accuracy of Test Set at X-Band. Output level is set with OUTPUT LEVEL FINE dBm Control (4) and OUTPUT LEVEL COARSE dBm Control (9).
55. FM EXT INPUT Connector (J49006)	BNC connector provides input for external frequency modulation.
56. ANALYZER RF X-BAND XMTR Connector (J49003)	N connector provides radar signal attenuated by 56 to 68 dB for a spectrum analyzer to check X-Band front end.
57. 50% VIDEO XMTR Connector (J49007)	BNC connector provides detected pulses from the radar transmitter at TTL level and sliced at the 50% amplitude points.

APPENDIX G - SPECIFICATIONS

1. RD-301A Radar Test Set Specifications

NOTE: Specifications and features are subject to change without notice.

A. RF Signal Generator:

Frequency: Variable from 9.295 to 9.500 GHz

Tracking:

UUT Frequency: 9.295 to 9.500 GHz

UUT Power: 0.25 to 12 kW

Accuracy:

UUT PULSE WIDTH	ACCURACY
2 to 30 μ s	\pm 25 kHz
0.5 to <2 μ s	\pm 60 kHz
0.1 to <0.5 μ s	\pm 600 kHz
0.05 to <0.1 μ s	\pm 2 MHz

Δ F Offset: \pm MHz from tracking frequency

Accuracy: \pm 20 kHz + 10% of Δ F offset PANEL Meter reading

Output Power: Variable from -127 to -50 dBm (at UUT)

Step: 1 or 10 dB

Accuracy: \pm 2 dB

Contour Boost: Variable from 0 to 20 dB above selected RF Output level between -127 to -75 dBm

Accuracy: \pm 1 dB from 9.310 to 9.410 GHz

Range 2 Attenuation: Variable from 0 to 59 dB below selected RF Output level (Range 1) (\geq -127 dBm)

Step: 1 dB

Accuracy: \pm 1.5 dB

RF Pulse Width: Variable from 0.05 μ s to 2.5 ms

RF ON/OFF Ratio: \geq 70 dB

Source VSWR at Waveguide Coupler: \leq 1.25:1

B. IF Signal Generator

Frequency:	Variable from 20 to 70 MHz
Sweep Width:	Variable from 0 to 4 MHz
Marker Frequency:	Variable from 20 to 70 MHz
Power:	Variable from -130 to +20 dBm
Step:	1 or 10 dB
Accuracy:	$\pm > 2.5$ dB + 1% of selected level
Pulse Width:	Variable from 0.05 μ s to 2.5 ms
ON/OFF Ratio:	≥ 48 dB

C. Modulation

Track:	PRF same as UUT (50 Hz to 20 kHz)
INTL (Internal):	Variable PRF from 50 to 5000 Hz
Internal AM (Square Wave):	
Frequency:	Variable from 50 Hz to 5 kHz
Square Wave Duty Cycle:	50%
Accuracy:	$\pm 2.5\%$
Amplitude:	
Up Modulation:	Variable from 0 to +20 dB
Step:	1 or 10 dB
Accuracy:	± 1 dB for selected RF Output level between -127 to -75 dBm (9.295 to 9.500 GHz)
Down Modulation:	Variable from 0 to -59 dB
Step:	1 or 10 dB
Accuracy:	± 1.5 dB for selected RF Output level above -127 dBm (9.295 to 9.500 GHz)

D. Range

Range 1: 0.1 to 999.9 μ s or nmi (NM) referenced to leading edge of detected UUT pulse at 50% point

Residual Delay: 0 to 0.2 μ s

Range 2: 0.1 to 999.9 μ s or nmi (NM) referenced to leading edge of detected UUT pulse at 50% point

Residual delay: 0.3 to 0.5 μ s

Range Accuracy: Residual delay $\pm 0.01\%$ of selected range delay (Range delay is referenced to 12.3589 μ s/nmi.)

Modes:

CONTOUR: Refer to RF Signal Generator, Contour Boost.

RINGS 1 through 5: Selectable multiples of Range 1

R2 ON: Range 1 and Range 2 active.

R2 ALT: Range 1 active with Range 2 active every other detected Radar transmitter pulse.

R1,R2 AUTO: Range 1 or Range 2 active according to detected radar transmitter pulse width. Range 1 active when Radar transmitter pulse width is $<$ Threshold. Range 2 active when Radar transmitter pulse width is \geq Threshold.

Threshold: Variable from 0.2 to 1.0 μ s (Preset for 0.4 μ s)

E. Frequency Counter

RF:

Resolution: 10 kHz

Accuracy: ± 250 kHz

IF:

Resolution: 1 kHz

Accuracy: $\pm 0.01\%$ of FREQUENCY Hz/MHz Digital Display reading

PRF:

Resolution: 1 Hz

Accuracy: ± 1 Hz + 0.01% of FREQUENCY Hz/MHz Digital Display reading

F. Power Meter

Range:	0.25 kW to 12 kW peak (standard) 1.0 kW to 120 kW peak (option with external 10 dB Attenuator, not calibrated in system)
Accuracy:	±0.6 dB from 1 to 12 kW peak (standard) (at UUT)
Load VSWR:	≤1.25:1

G. Outputs

ANLYZER RF X-BAND XMTR
Connector:

Radar transmitter signal

Level:

56 to 68 dB below radar transmitter level

DLYD SYNC Connector:

Positive pulse coincident with reply pulse
(Range 1 and/or Range 2)

XMTR DET Connector:

Detected Radar transmitter pulse

Level:

0 to +3 Vdc peak Video into 50 Ω

XMTR DSCRM .1V/MHz Connector:

0.1 V/MHz (±10%) into 50 Ω

XMTR HET MON Connector:

Level:

0 to <+0.5 Vdc peak into 50 Ω

SYNC Connector:

Positive pulse

Position:

Dependent on MODULATION MODE Pushbutton
Switches selection:

TRACK	Coincident with Radar transmitter pulse
INTL	Coincident with internal pulse
EXT (+)	Coincident with external trigger
EXT (-)	Coincident with external trigger

H. Inputs

AM EXT INPUT Connector: External AM

Input Impedance: >10 k Ω , ac coupled

Input Voltage: 3 VP-P for 28 to 32% modulation

3 dB Bandwidth at 30% AM: \geq 4970 Hz (30 Hz to 5 kHz)

AM Percent Limit: 0% to 50%

Square Wave Modulation
(typical values):

FREQUENCY	MODULATION	RISE TIME	FALL TIME
500 Hz	50% (10 dB)	28 μ s	60 μ s
500 Hz	30% (6 dB)	24 μ s	40 μ s

EXT TRIG Connector: ac coupled, + or -

Level: 2 to 25 VP

Frequency: 50 Hz to 20 kHz

I. Power

AC INPUT Connector:

Voltage: 103 to 253 VAC

Frequency: 50 to 440 Hz

Power Consumption \leq 150 W



THIS PAGE INTENTIONALLY LEFT BLANK.

APPENDIX H - ABBREVIATIONS

A		F	
AC	Alternating Current	FCC	Federal Communications Commission
ac	Alternating Current	FM	Frequency Modulated
ADF	Automatic Direction Finder	FREQ	Frequency
ADJ	Adjustment	Ft	Feet
AFC	Automatic Frequency Control		
AGC	Automatic Gain Control	G	
AM	Amplitude Modulated	GEN	Generator
AMPL	Amplifier	GHz	Gigahertz (10^9)
ANLYZER	Spectrum Analyzer	GND	Ground
ARINC	Aeronautical Radio, Inc.	H	
ASCII	American Standard Code for Information Interchange	H	Henry
ATE	Automatic Test Equipment	h	Hexadecimal
ATTEN	Attenuation	HET	Heterodyne
AUX	Auxiliary	HI	High
		hr	Hour
B		HZ	Hertz
BCD	Binary-Coded Data	I	
BD	Board	IEEE	Institute of Electrical and Electronic Engineers
BPF	Bandpass Filter	IF	Intermediate Frequency
		INTL	Internal
C		I/O	Input/Output
ccw	Counterclockwise	K	
CHAN	Channel	k Ω	Kilo-ohm (10^3)
cm	Centimeter	kg	Kilograms (10^3)
CMOS	Complementary Metal-Oxide Semiconductor	kHz	Kilohertz (10^3)
CONT	Control	km	Kilometers (10^3)
Cont	Continued	kts	Knots (Velocity)
CW	Continuous Wave	kV	Kilovolts (10^3)
cw	Clockwise	kW	Kilowatts (10^3)
		L	
D		LED	Light Emitting Diode
D/A	Digital to Analog	LO	Local Oscillator
dB	Decibel	LPF	Low-Pass Filter
dBc	Decibels relative to carrier	LRU	Line Repairable Unit
dB _i	Decibels above isotropic		
dB _m	Decibels above one milliwatt		
dc	Direct Current		
DET	Detector		
Div	Division		
DLYD	Delayed		
DMM	Digital Multimeter		
DSCRM	Discriminator		
		E	
EFF	Effective		
EXT	External		
Ext	External		

M		S	
m	Meters	SCOPE	Oscilloscope
Max	Maximum	SCP	Oscilloscope
MDR	Minimum Detectable Range	sec	Seconds
MDS	Minimum Discernible Signal	SEL	Select
mH	Millihenry (10^{-3})	S/N	Serial Number
MHz	Megahertz (10^6)	STC	Sensitivity Time Control
Min	Minimum	SWP	Sweep
MKR	Marker	SYNC	Synchronization
MNL	Manual		
MOD	Modulator	T	
MON	Monitor	TGS	Tangential Sensitivity Signal
ms	Milliseconds (10^{-3})	TRIG	Trigger
mV	Millivolt (10^{-3})	TTL	Transistor-Transistor Logic
		TWT	Traveling Wave Tube
N			
N/A	Not Applicable	U	
NM	Nautical Miles	UUT	Unit Under Test
nmi	Nautical Miles		
ns	Nanoseconds (10^{-9})	V	
		V	Volts
O		VHF	Very High Frequency
OSC	Oscillator	VAC	Volts, Alternating Current
		VCO	Voltage Controlled Oscillator
P		Vdc	Volts, Direct Current
PC	Printed Circuit	VHF	Very High Frequency
pF	Picofarads (10^{-12})	Vp	Volts Peak
PLCS	Places	Vp-p	Volts Peak-to-Peak
PM	Pulse Modulated	VSWR	Voltage Standing Wave Ratio
PPM	Pulse Position Modulated		
ppm	Parts per Million	W	
PRF	Pulse Repetition Frequency	W	Watts
psi	Pounds per Square Inch		
PWM	Pulse Width Modulated	X	
PWR	Power	XCVR	Transceiver
		XMTR	Transmitter
R		XTAL	Crystal
RCT	Rain Echo Attenuation Compensation Technique	ΔF	Delta F (Frequency Change)
RCV	Receive	Ω	Ohms
RCVR	Receiver	μF	Microfarads (10^{-6})
REF	Reference	μs	Microseconds (10^{-6})
RF	Radio Frequency		
RMS	Root Mean Square		
R/T	Receiver/Transmitter		
RTCA	Radio Technical Commission for Aeronautics		

INDEX

8.25 GHz LO Assy	2-2-3, p 50	Floor Assy	2-2-3, p 16
475/570-775 MHz Filter Assy	2-2-3, p 73	Parts List	2-3-1, p 12
Parts List	2-3-1, p 54	Schematic	2-2-3, p 21
Schematic	2-2-3, p 75	Front Panel Assy	2-2-3, p 56
Abbreviations	App H	Parts List	2-3-1, p 43
AGC PCB Assy	2-2-3, p 41	Schematic	2-2-3, p 60
Parts List	2-3-1, p 32	Heterodyne Assy	2-2-3, p 23
Schematic	2-2-3, p 43	Parts List	2-3-1, p 14
Buffer AMP PCB Assy	2-2-3, p 33	Schematic	2-2-3, p 25
Parts List	2-3-1, p 26	Heterodyne PCB Assy	2-2-3, p 24
Schematic	2-2-3, p 35	Parts List	2-3-1, p 15
Calibration Data Sheet	2-2-2, p 80	Schematic	2-2-3, p 25
Calibration Procedures	2-2-2, p 47	IF GEN PWR AMP PCB Assy	2-2-3, p 54
8.25 GHz LO	2-2-2, p 51	Parts List	2-3-1, p 40
100 MHz Clock	2-2-2, p 48	Schematic	2-2-3, p 55
Discriminator	2-2-2, p 77	IF MKR/OSC PCB Assy	2-2-3, p 52
External AM	2-2-2, p 61	Parts List	2-3-1, p 37
IF Generator Power Amplifier	2-2-2, p 59	Schematic	2-2-3, p 53
IF Oscillator	2-2-2, p 56	I/O Connectors Pin-Out Tables	App A
Internal PRF	2-2-2, p 68	Main Diode Switch Assy	2-2-3, p 44
Levelers	2-2-2, p 62	Parts List	2-3-1, p 35
Marker Oscillator	2-2-2, p 54	Schematic	2-2-3, p 46
Power Meter	2-2-2, p 75	Main Diode Switch PCB Assy	2-2-3, p 45
Power Supply	2-2-2, p 47	Parts List	2-3-1, p 36
Pulse Width	2-2-2, p 69	Schematic	2-2-3, p 46
Range Delay	2-2-2, p 73	Metric/British Conversion Table	App E
RF Display Limits	2-2-2, p 53	MOD Mode Switch PCB Assy	2-2-3, p 61
Calibration/Verification	2-2-2, p 1	Parts List	2-3-1, p 46
General	2-2-2, p 1	Schematic	2-2-3, p 62
Precautions	2-2-2, p 1	Power Supply Assy	2-2-3, p 11
Requirements	2-2-2, p 2	Parts List	2-3-1, p 7
Card Frame Assy	2-2-3, p 78	Schematic	2-2-3, p 14
Parts List	2-3-1, p 56	Power Supply PCB Assy	2-2-3, p 12
Coaxial Cable Kit		Parts List	2-3-1, p 8
Parts List	2-3-1, p 5	Schematic	2-2-3, p 14
Composite Assy	2-2-3, p 4	Preventive Maintenance Procedures	2-1-1, p 1
Parts List	2-3-1, p 3	External Cleaning	2-1-1, p 1
Interconnect	2-2-3, p 8	Internal Cleaning	2-1-1, p 1
Controls, Connectors and Indicators		Visual Inspection	2-1-1, p 2
Front Panel	App F, p 3		
Rear Panel	App F, p 12		
Coupler/Splitter Assy	2-2-3, p 27		
Parts List	2-3-1, p 16		
Schematic	2-2-3, p 28		
Delay Line Assy	2-2-3, p 77		
Parts List	2-3-1, p 55		
Discriminator BD #1 PCB Assy	2-2-3, p 90		
Parts List	2-3-1, p 68		
Schematic	2-2-3, p 93		
Discriminator BD #2 PCB Assy	2-2-3, p 87		
Parts List	2-3-1, p 66		
Schematic	2-2-3, p 88		
Display/Counter Assy	2-2-3, p 70		
Parts List	2-3-1, p 50		
Schematic	2-2-3, p 72		
Display/Counter PCB Assy	2-2-3, p 71		
Parts List	2-3-1, p 51		
Schematic	2-2-3, p 72		



Range BD #1 PCB Assy	2-2-3, p 80
Parts List	2-3-1, p 57
Schematic	2-2-3, p 81
Range BD #2 PCB Assy	2-2-3, p 84
Parts List	2-3-1, p 61
Schematic	2-2-3, p 85
Range Digit Switch PCB Assy	2-2-3, p 68
Parts List	2-3-1, p 49
Schematic	2-2-3, p 69
Range Discrete PCB Assy	2-2-3, p 66
Parts List	2-3-1, p 48
Schematic	2-2-3, p 67
Rear Panel Assy	2-2-3, p 9
Parts List	2-3-1, p 6
Schematic	2-2-3, p 10
RF Mode Switch PCB Assy	2-2-3, p 63
Parts List	2-3-1, p 47
Schematic	2-2-3, p 65
Servicing	2-1-1, p 1
Preventive Maintenance Procedures	2-1-1, p 1
External Cleaning	2-1-1, p 1
Internal Cleaning	2-1-1, p 1
Visual Inspection	2-1-1, p 2
Ship Unit	
Parts List	2-3-1, p 2
Specifications	App G
Test Equipment Construction	App D
Test Equipment Requirements	App C
VCO #2 Assy	2-2-3, p 36
Parts List	2-3-1, p 27
Schematic	2-2-3, p 38
Verification Data Sheet	2-2-2, p 37
Verification Procedures	2-2-2, p 5
IF Signal Generator	2-2-2, p 21
Inputs	2-2-2, p 35
INTL Modulation/PRF Counter	2-2-2, p 27
Power Meter	2-2-2, p 31
Range	2-2-2, p 28
RF Signal Generator	2-2-2, p 5
XMTR DSCRM 0.1V MHz	2-2-2, p 33
Video PCB Assy	2-2-3, p 29
Parts List	2-3-1, p 17
Schematic	2-2-3, p 30
X-Band Front End Assy	2-2-3, p 47

As we are always seeking to improve our products, the information in this document gives only a general indication of the product capacity, performance and suitability, none of which shall form part of any contract. We reserve the right to make design changes without notice.

CHINA / Beijing	Tel: [+86] (10) 6539 1166	Fax: [+86] (10) 6539 1778
CHINA / Shanghai	Tel: [+86] (21) 5109 5128	Fax: [+86] (21) 5150 6112
FINLAND	Tel: [+358] (9) 2709 5541	Fax: [+358] (9) 804 2441
FRANCE	Tel: [+33] 1 60 79 96 00	Fax: [+33] 1 60 77 69 22
GERMANY	Tel: [+49] 8131 2926-0	Fax: [+49] 8131 2926-130
HONG KONG	Tel: [+852] 2832 7988	Fax: [+852] 2834 5364
INDIA	Tel: [+91] 80 51150 4501	Fax: [+91] 80 5115 4502
KOREA	Tel: [+82] (2) 3424 2719	Fax: [+82] (2) 3424 8620
SCANDINAVIA	Tel: [+45] 9614 0045	Fax: [+45] 9614 0047
SPAIN	Tel: [+34] (91) 640 11 34	Fax: [+34] (91) 640 06 40
UK / Burnham	Tel: [+44] (0) 1628 604455	Fax: [+44] (0) 1628 662017
UK / Cambridge	Tel: [+44] (0) 1763 262277	Fax: [+44] (0) 1763 285353
UK / Stevenage	Tel: [+44] (0) 1438 742200	Fax: [+44] (0) 1438 727601
	Freephone: 0800 282388	
USA	Tel: [+1] (316) 522 4981	Fax: [+1] (316) 522 1360
	Toll Free: 800 835 2352	

EXPORT CONTROL WARNING: This document contains controlled technology or technical data under the jurisdiction of the Export Administration Regulations (EAR), 15 CFR 730-774. It cannot be transferred to any foreign third party without the specific prior approval of the U.S. Department of Commerce Bureau of Industry and Security (BIS). Violations of these regulations are punishable by fine, imprisonment, or both.

The logo for AEROFLEX, featuring a stylized 'A' with a blue triangle inside, followed by the word 'AEROFLEX' in a bold, sans-serif font. The logo is set against a white background with a blue swoosh underneath.

Our passion for performance is defined by three attributes represented by these three icons: solution-minded, performance-driven, customer-focused.