

2. Calibration/Verification

A. General

(1) Calibration/Verification Schedule

The Calibration/Verification Procedures should be performed as a result of one or more of the following conditions:

- Failure to Meet Specifications

If, during the course of normal operation, the RD-301A or any major function thereof fails to meet the performance specifications according to Appendix G, the Calibration/Verification Procedures should be performed.

If any failure occurs during performance of the Verification Procedures, pertinent Calibration Procedures should be performed according to 2-2-2, Table 1.

- Module/Assembly Replacement

If one or more of the RD-301A assemblies are replaced, the Calibration/Verification Procedures should be performed.

- Annual Calibration/Verification

Aeroflex recommends an annual Calibration/Verification on the RD-301A to maintain proper testing standards.

(2) Controls, Connectors and Indicators

Refer to Appendix F for location of the RD-301A Controls, Connectors and Indicators.

(3) Test Record

Calibration/Verification Data Sheets are provided for recording the results obtained while performing the Calibration/Verification Procedures.

NOTE: It is recommended the technician reproduce copies of the Calibration/Verification Data Sheets, rather than use copies in this manual.

B. Precautions

(1) Safety

Extreme caution should be taken when troubleshooting with live circuits. When performing the Calibration/Verification Procedures, be sure to observe the following precautions:

WARNING: REMOVE ALL JEWELRY OR OTHER COSMETIC APPAREL BEFORE PERFORMING ANY CALIBRATION/VERIFICATION PROCEDURE INVOLVING LIVE CIRCUITS.

WARNING: WHEN WORKING WITH LIVE CIRCUITS OF HIGH POTENTIAL, KEEP ONE HAND IN POCKET OR BEHIND BACK TO AVOID SERIOUS SHOCK HAZARD.

WARNING: USE ONLY INSULATED TROUBLESHOOTING TOOLS WHEN WORKING WITH LIVE CIRCUITS.

WARNING: FOR ADDED INSULATION, PLACE RUBBER BENCH MAT UNDERNEATH ALL POWERED BENCH EQUIPMENT, AS WELL AS A RUBBER MAT UNDERNEATH TECHNICIAN'S CHAIR.

WARNING: HEED ALL WARNINGS AND CAUTIONS CONCERNING MAXIMUM VOLTAGES AND POWER INPUTS.

(2) ESD

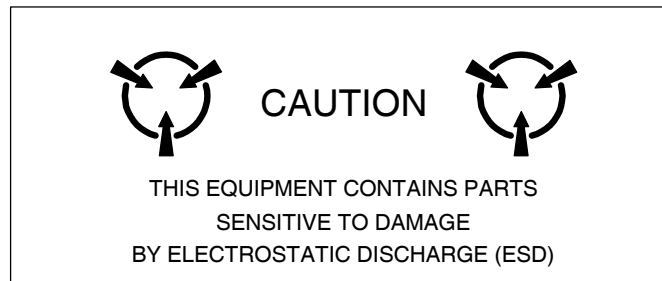

C. Requirements

(1) Performance

It is strongly recommended that personnel thoroughly read and understand all steps of the Calibration/Verification Procedures prior to performing the procedure. Knowledge of power, frequency and waveform to be expected at each test point is recommended. Knowledge of external test equipment connections and operation is also recommended.

● PANEL Meter

Before applying power to RD-301A, verify PANEL Meter (43) indicates zero on power scale. Adjust PANEL METER ZERO Control (45) as needed.

● Serialized Coaxial Cable and Waveguide Coupler

The RD-301A Radar Test Set includes the RD-301A, Serialized Coaxial Cable and Waveguide Coupler. All equipment must be available to verify and calibrate the system.

(2) Test Equipment

Appendix D contains a list of test equipment suitable for performing any procedure contained in this manual. Other equipment meeting specifications listed in Appendix D may be substituted in place of recommended models.

NOTE: For certain procedures in this manual, the equipment listed in Appendix D may exceed minimum required specifications.

NOTE: High quality RG58 BNC coaxial cables should be used to connect test equipment.

(3) Disassembly

No disassembly is required to perform the Verification Procedures. The top cover is removed when performing the Calibration Procedures. Other disassembly procedures are performed only as necessary.

(4) Environment

For best results, environmental conditions should be identical to the conditions at the normal operating location.

IF THIS VERIFICATION PROCEDURE FAILS		THE FOLLOWING CALIBRATION PROCEDURES MUST BE PERFORMED													
		POWER SUPPLY	100 MHz CLOCK	8.25 GHz LO	RF DISPLAY LIMITS	MARKER OSCILLATOR	IF OSCILLATOR	IF GENERATOR POWER AMPLIFIER	EXTERNAL AM	LEVELERS	INTERNAL PRF	PULSE WIDTH	RANGE DELAY	POWER METER	DISCRIMINATOR
RF SIGNAL GENERATOR	FREQUENCY AND RF COUNTER	●	●	●	●										
	TRACKING AND ΔF OFFSET	●	●	●							●			●	
	OUTPUT POWER AND INTERNAL AM AMPLITUDE									●					
	PULSE WIDTH	●	●	●							●				
	RF ON/OFF RATIO									●					
IF SIGNAL GENERATOR	FREQUENCY AND IF COUNTER	●	●	●			●								
	SWEEP WIDTH	●	●	●			●								
	MARKER FREQUENCY	●	●	●		●									
	POWER	●	●	●			●	●							
	PULSE WIDTH	●	●	●							●				
	IF ON/OFF RATIO	●	●	●			●	●		●					
INTL MODULATION/PRF COUNTER		●	●							●	●				
RANGE		●	●	●						●	●	●			
POWER METER													●		
XMTR DSCRM .1V/MHz CONNECTOR		●	●	●							●			●	
INPUTS	AM EXT INPUT CONNECTOR								●						
	EXT TRIG CONNECTOR														

9002002

Verification Failure Calibration Requirements
Table 1

IF THIS ASSEMBLY IS REPAIRED OR REPLACED THE FOLLOWING CALIBRATION PROCEDURES MUST BE PERFORMED	POWER SUPPLY	100 MHz CLOCK	8.25 GHz LO	RF DISPLAY LIMITS	MARKER OSCILLATOR	IF OSCILLATOR	IF GENERATOR POWER AMPLIFIER	EXTERNAL AM	LEVELERS	INTERNAL PRF	PULSE WIDTH	RANGE DELAY	POWER METER	DISCRIMINATOR
8.25 GHz LO	●	●	●											
475/570-775 MHz FILTER ASSEMBLY	●	●	●								●			●
AGC PC BOARD ASSEMBLY	●	●	●	●	●	●	●	●	●					
COUPLER/SPLITTER ASSEMBLY	●	●	●								●			●
DELAY LINE ASSEMBLY	●	●	●								●			●
DISCRIMINATOR #1 PC BOARD ASSEMBLY	●	●	●								●			●
DISCRIMINATOR #2 PC BOARD ASSEMBLY	●	●	●								●			●
DISPLAY COUNTER ASSEMBLY	●	●	●	●		●								
FRONT PANEL ASSEMBLY	●	●	●						●	●	●	●	●	●
HETERODYNE ASSEMBLY														
IF GEN PWR AMPL PC BOARD ASSEMBLY	●	●	●			●	●							
IF MKR/OSC PC BOARD ASSEMBLY	●	●	●		●	●								
MAIN DIODE SWITCH ASSEMBLY	●								●					
POWER SUPPLY ASSEMBLY	●													
PRESCALER PC BOARD ASSEMBLY	●	●	●		●									
RANGE #1 PC BOARD ASSEMBLY	●	●										●		
RANGE #2 PC BOARD ASSEMBLY	●	●	●							●	●			
VCO #2 ASSEMBLY	●	●	●	●					●		●			●
VIDEO PC BOARD ASSEMBLY	●	●	●								●		●	●
X-BAND FRONT END	●	●	●						●		●		●	●

9002001

Assembly Replacement Calibration Requirements
Table 2

D. Verification Procedures

VERIFICATION PROCEDURE	PAGE
RF Signal Generator	5
IF Signal Generator	21
INTL Modulation/PRF Counter	27
Range	28
Power Meter	31
XMTR DSCRM 0.1V/MHz Connector	33
Inputs	35

(1) RF Signal Generator

(a) Frequency and RF Counter

TEST EQUIPMENT: Frequency Counter

STEP	PROCEDURE										
1.	Set RD-301A as follows:										
	<table border="1"> <thead> <tr> <th>CONTROL</th> <th>SETTING</th> </tr> </thead> <tbody> <tr> <td>(2) PRF/RF Switch</td> <td><i>RF</i></td> </tr> <tr> <td>(10) MNL FREQ Controls</td> <td><i>fully ccw</i></td> </tr> <tr> <td>(16) RF/IF MODE Pushbutton Switches</td> <td><i>RF MNL</i></td> </tr> <tr> <td>(29) MODULATION MODE Pushbutton Switches</td> <td><i>INTL</i></td> </tr> </tbody> </table>	CONTROL	SETTING	(2) PRF/RF Switch	<i>RF</i>	(10) MNL FREQ Controls	<i>fully ccw</i>	(16) RF/IF MODE Pushbutton Switches	<i>RF MNL</i>	(29) MODULATION MODE Pushbutton Switches	<i>INTL</i>
CONTROL	SETTING										
(2) PRF/RF Switch	<i>RF</i>										
(10) MNL FREQ Controls	<i>fully ccw</i>										
(16) RF/IF MODE Pushbutton Switches	<i>RF MNL</i>										
(29) MODULATION MODE Pushbutton Switches	<i>INTL</i>										
2.	Apply power to RD-301A and allow for 30 minute stabilization period.										
3.	Connect Frequency Counter high frequency input to X-BAND I/O Connector (18).										
4.	Verify ≤ 9295 MHz on Frequency Counter. Record reading.										
5.	Verify FREQUENCY Hz/MHz Digital Display (1) equals Frequency Counter reading from Step 4 (± 250 kHz).										
6.	Adjust MNL FREQ Controls (10) <i>fully cw</i> .										
7.	Verify ≥ 9500 MHz on Frequency Counter. Record reading.										
8.	Verify FREQUENCY Hz/MHz Digital Display (1) equals Frequency Counter reading from Step 7 (± 250 kHz).										
9.	If RD-301A fails any step, perform Calibration Procedures according to 2-2-2, Table 1.										
10.	Disconnect test equipment.										

(b) Tracking and ΔF Offset

TEST EQUIPMENT: 20 dB Coupler
Frequency Counter
Oscilloscope
Spectrum Analyzer
TWT Amplifier
X-Band Signal Generator

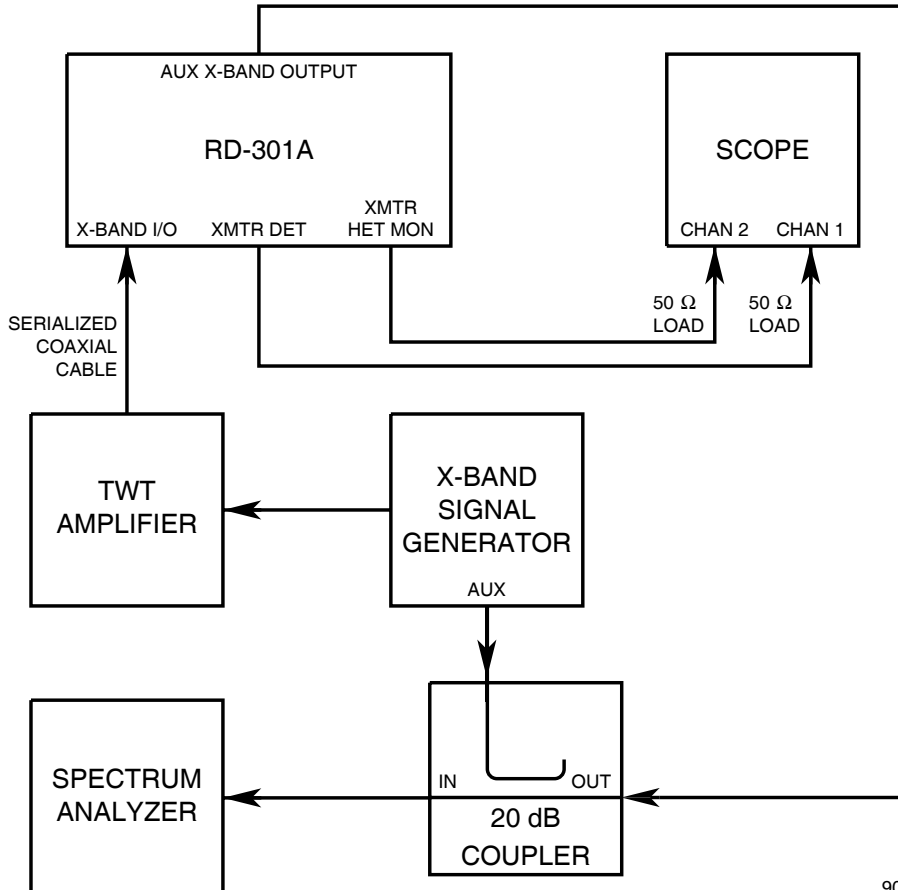

9006007

Tracking Verification Setup
Figure 1

STEP	PROCEDURE												
1.	Set RD-301A as follows:												
	<table border="1"> <thead> <tr> <th>CONTROL</th> <th>SETTING</th> </tr> </thead> <tbody> <tr> <td>(2) PRF/RF Switch</td> <td><i>RF</i></td> </tr> <tr> <td>(4) OUTPUT LEVEL FINE dBm Control</td> <td><i>0</i></td> </tr> <tr> <td>(9) OUTPUT LEVEL COARSE dBm Control</td> <td><i>-50</i></td> </tr> <tr> <td>(16) RF/IF MODE Pushbutton Switches</td> <td><i>RF TRACK</i></td> </tr> <tr> <td>(29) MODULATION MODE Pushbutton Switches</td> <td><i>CW</i></td> </tr> </tbody> </table>	CONTROL	SETTING	(2) PRF/RF Switch	<i>RF</i>	(4) OUTPUT LEVEL FINE dBm Control	<i>0</i>	(9) OUTPUT LEVEL COARSE dBm Control	<i>-50</i>	(16) RF/IF MODE Pushbutton Switches	<i>RF TRACK</i>	(29) MODULATION MODE Pushbutton Switches	<i>CW</i>
CONTROL	SETTING												
(2) PRF/RF Switch	<i>RF</i>												
(4) OUTPUT LEVEL FINE dBm Control	<i>0</i>												
(9) OUTPUT LEVEL COARSE dBm Control	<i>-50</i>												
(16) RF/IF MODE Pushbutton Switches	<i>RF TRACK</i>												
(29) MODULATION MODE Pushbutton Switches	<i>CW</i>												

STEP PROCEDURE

2. Apply power to RD-301A and allow for 30 minute stabilization period.

CAUTION: SOME TWT AMPLIFIERS PRODUCE LARGE OUTPUT POWER SPIKES ON POWER-UP. TEST TWT AMPLIFIER BEFORE CONNECTING TO RD-301A.

3. Connect test equipment as shown in 2-2-2, Figure 1.

NOTE: 20 dB Coupler is used in reverse direction to combine signals and provide greatest isolation.

4. Set TWT Amplifier power On and in Standby mode.

5. Set Oscilloscope with both channels dc coupled as follows:

CONTROL	SETTING
Sweep Speed	5 μ s/Div
Amplitude Scale	50 mV/Div
Trigger	Channel 1

6. Set Spectrum Analyzer as follows:

CONTROL	SETTING
Center Frequency	9295 MHz
Frequency Span	5 kHz/Div
Resolution Bandwidth	3 kHz
Amplitude Scale	10 dB/Div
Reference Level	-40 dBm

7. Set X-Band Signal Generator as follows:

CONTROL	SETTING
Frequency	9295 MHz
Pulse Width	30 μ s
PRF	500 Hz

CAUTION: CONNECTIONS TO TWT AMPLIFIER MUST BE CORRECT BEFORE SWITCHING TO OPERATE MODE.

8. Set TWT Amplifier to Operate mode.

9. Set X-Band Signal Generator output level for PANEL Meter (43) reading of **0.5 kW**.

TRACKING

10. Identify signals on Spectrum Analyzer and adjust attenuation so signals are similar in power level. Refer to 2-2-2, Figure 2.

NOTE: When both signals overlap, RD-301A tracking signal is identified by setting METER SELECT Switch (47) to ΔF and varying ΔF OFFSET/EFF PEAKING Control (48). Another identifying method is narrowing resolution bandwidth of Spectrum Analyzer or changing OUTPUT LEVEL COARSE dBm Control (9) and observing change in signal level.

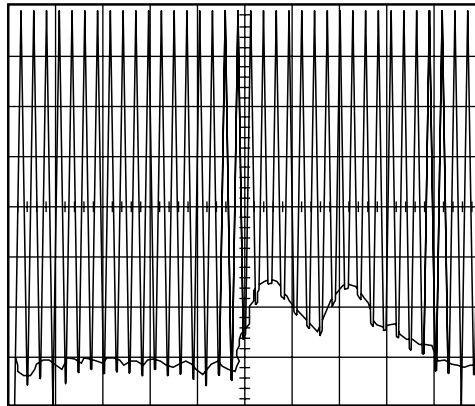

9016008

RD-301A Tracking Spectrum Analyzer Signals
Figure 2

11. Verify frequency difference between signals is ≤ 25 kHz.
12. Adjust Oscilloscope and verify XMTR HET MON Connector (11) output display on Channel 2 shows relatively parallel lines according to 2-2-2, Figure 3.

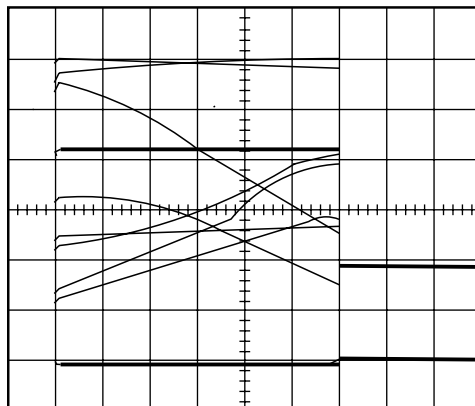

9016009

RD-301A Heterodyne Monitor Tracking Output
Figure 3

13. Set X-Band Signal Generator modulation pulse width to 2 μ s.

STEP	PROCEDURE
------	-----------

14. Verify frequency difference between signals is ≤ 25 kHz.
15. Set Oscilloscope sweep speed to 500 ns/Div and adjust to verify XMTR HET MON Connector (11) output display on Channel 2 shows relatively parallel lines according to 2-2-2, Figure 3.
16. Set Spectrum Analyzer frequency span to 10 kHz/Div.
17. Set X-Band Signal Generator modulation pulse width to 0.5 μ s.
18. Verify frequency difference between signals is ≤ 60 kHz.
19. Set Oscilloscope sweep speed to 100 ns/Div and adjust to verify XMTR HET MON Connector (11) output display on Channel 2 shows relatively parallel lines according to 2-2-2, Figure 3.
20. Set Spectrum Analyzer frequency span to 100 kHz/Div and resolution bandwidth to 1 kHz.
21. Set X-Band Signal Generator modulation pulse width to 0.1 μ s.
22. Verify frequency difference between signals is ≤ 600 kHz.
23. Set Oscilloscope sweep speed to 50 ns/Div and adjust to verify XMTR HET MON Connector (11) output display on Channel 2 shows relatively parallel lines according to 2-2-2, Figure 3.
24. Set Spectrum Analyzer frequency span to 250 kHz/Div.

CAUTION: NARROW WIDTH PULSES MAY INCREASE TWT AMPLIFIER POWER OUTPUT TO HIGH LEVELS THAT MAY DAMAGE EQUIPMENT. WIDEN NARROW PULSE WIDTH AS SOON AS POSSIBLE.

25. Set X-Band Signal Generator modulation pulse width to 0.05 μ s.
26. Verify frequency difference between signals is ≤ 2 MHz.
27. Adjust Oscilloscope and verify XMTR HET MON Connector (11) output display on Channel 2 shows relatively parallel lines according to 2-2-2, Figure 3.
28. Set X-Band Signal Generator modulation pulse width to 30 μ s and frequency to 9400 MHz.
29. Set Spectrum Analyzer as follows:

CONTROL	SETTING
Center Frequency	9400 MHz
Frequency Span	5 kHz/Div
Resolution Bandwidth	3 kHz

30. Set Oscilloscope sweep speed to 5 μ s/Div.
31. Repeat Steps 9 through 27.
32. Set X-Band Signal Generator modulation pulse width to 30 μ s and frequency to 9500 MHz.

 STEP PROCEDURE

33. Set Spectrum Analyzer as follows:

CONTROL	SETTING
Center Frequency	9500 MHz
Frequency Span	5 kHz/Div
Resolution Bandwidth	3 kHz

34. Set Oscilloscope sweep speed to 5 μ s/Div.

35. Repeat Steps 9 through 27.

36. Set X-Band Signal Generator modulation pulse width to 30 μ s and frequency to 9295 MHz.

37. Set Spectrum Analyzer as follows:

CONTROL	SETTING
Center Frequency	9295 MHz
Frequency Span	5 kHz/Div
Resolution Bandwidth	3 kHz
Reference Level	-20 dBm

38. Set Oscilloscope sweep speed to 5 μ s/Div.

39. Set X-Band Signal Generator output level for PANEL Meter (43) reading of **12 kW**.

40. Repeat Steps 10 through 35.

TRACK MODULATION PRF

41. Set X-Band Signal Generator as follows:

CONTROL	SETTING
Frequency	9295 MHz
Pulse Width	5 μ s
PRF	50 Hz

42. Set X-Band Signal Generator output level for PANEL Meter (43) reading of **0.5 kW**.

43. Set Spectrum Analyzer as follows:

CONTROL	SETTING
Center Frequency	9295 MHz
Frequency Span	5 kHz/Div
Resolution Bandwidth	3 kHz

44. Set PRF/RF Switch (2) to **PRF**.

45. Verify FREQUENCY Hz/MHz Digital Display (1) reads **50 Hz** (± 1 Hz).

46. Verify frequency difference between signals is ≤ 25 kHz.

47. Set Oscilloscope sweep speed to 5 μ s/Div and adjust to verify XMTR HET MON Connector (11) output display on Channel 2 shows relatively parallel lines according to 2-2-2, Figure 3.

48. Set X-Band Signal Generator PRF to 2 kHz.

49. Verify FREQUENCY Hz/MHz Digital Display (1) reads **2000 Hz** (± 1 Hz).

 STEP PROCEDURE

50. Verify frequency difference between signals is ≤ 25 kHz.
 51. Adjust Oscilloscope and verify XMTR HET MON Connector (11) output display on Channel 2 shows relatively parallel lines according to 2-2-2, Figure 3.
 52. Set X-Band Signal Generator PRF to 20 kHz.
- NOTE:** Spectrum Analyzer cannot be used effectively at 20 kHz PRF.
53. Verify FREQUENCY Hz/MHz Digital Display (1) reads **20000 Hz** (± 3 Hz).
 54. Adjust Oscilloscope and verify XMTR HET MON Connector (11) output display on Channel 2 shows relatively parallel lines according to 2-2-2, Figure 3.

55. Set X-Band Signal Generator as follows:

CONTROL	SETTING
Frequency	9400 MHz
Pulse Width	5 μ s
PRF	50 Hz

56. Set X-Band Signal Generator output level for PANEL Meter (43) reading of **0.5 kW**.
57. Set Spectrum Analyzer center frequency to 9400 MHz.
58. Repeat Steps 45 through 54.
59. Set X-Band Signal Generator as follows:

CONTROL	SETTING
Frequency	9500 MHz
Pulse Width	5 μ s
PRF	50 Hz

60. Set X-Band Signal Generator output level for PANEL Meter (43) reading of **0.5 kW**.
61. Set Spectrum Analyzer center frequency to 9500 MHz
62. Repeat Steps 45 through 54.

Δ F OFFSET

63. Set X-Band Signal Generator frequency to 9400 MHz.
64. Disconnect 20 dB Coupler from X-Band Signal Generator and AUX X-BAND OUTPUT Connector (54).
65. Connect AUX X-BAND OUTPUT Connector (54) to Frequency Counter.
66. Record Frequency Counter reading.
67. Set METER SELECT Switch (47) to Δ F.
68. Adjust Δ F OFFSET/EFF PEAKING Control (48) until PANEL Meter (43) reads **-0.75 MHz**.
69. Verify Frequency Counter reading equals reading from Step 63 minus 750 kHz (± 95 kHz).

70. Adjust Oscilloscope and verify XMTR HET MON Connector (11) output display on Channel 2 shows cross-hatching according to 2-2-2, Figure 4.

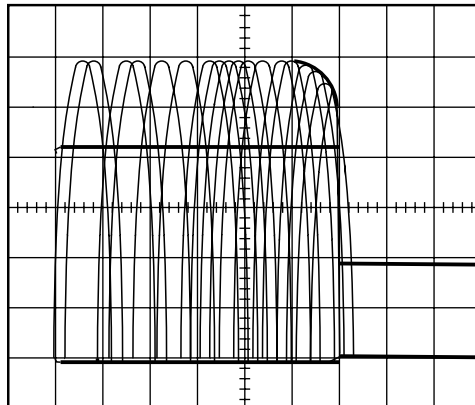

9016013

RD-301A Heterodyne Monitor ΔF Output
Figure 4

71. Adjust ΔF OFFSET/EFF PEAKING Control (48) until PANEL Meter (43) reads **+0.75 MHz**.
72. Verify Frequency Counter reading equals reading from Step 63 plus 750 kHz (± 95 kHz). If not, perform Calibration Procedures according to 2-2-2, Table 1.
73. Adjust Oscilloscope and verify XMTR HET MON Connector (11) output display on Channel 2 shows cross-hatching according to 2-2-2, Figure 4.
74. If RD-301A fails any step, perform Calibration Procedures according to 2-2-2, Table 1.
75. Slowly decrease TWT Amplifier power and set to Standby mode for ≥ 15 minutes.
76. Disconnect test equipment.

(c) Output Power and Internal AM Amplitude

TEST EQUIPMENT: 20 dB Coupler
L-Band Signal Generator
Pulse Generator
Spectrum Analyzer
X-Band Signal Generator

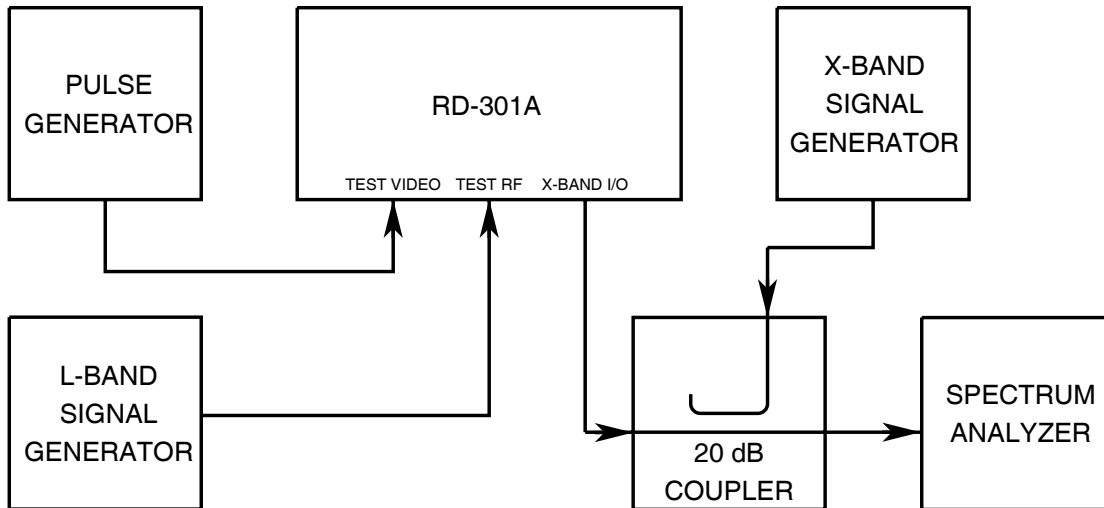

9006009

Output Power Verification Setup
Figure 5

STEP	PROCEDURE																		
1.	Set RD-301A as follows:																		
	<table border="1"> <thead> <tr> <th>CONTROL</th> <th>SETTING</th> </tr> </thead> <tbody> <tr> <td>(2) PRF/RF Switch</td> <td><i>RF</i></td> </tr> <tr> <td>(3) CONTOUR/R2/INTL AM dB BOOST/ATTEN Control</td> <td><i>00</i></td> </tr> <tr> <td>(4) OUTPUT LEVEL FINE dBm Control</td> <td><i>0</i></td> </tr> <tr> <td>(9) OUTPUT LEVEL COARSE dBm Control</td> <td><i>-50</i></td> </tr> <tr> <td>(10) MNL FREQ Controls</td> <td><i>9375 MHZ</i></td> </tr> <tr> <td>(16) RF/IF MODE Pushbutton Switches</td> <td><i>RF MNL</i></td> </tr> <tr> <td>(29) MODULATION MODE Pushbutton Switches</td> <td><i>CW</i></td> </tr> <tr> <td>(39) RANGE SEL Switch</td> <td><i>RINGS 1</i></td> </tr> </tbody> </table>	CONTROL	SETTING	(2) PRF/RF Switch	<i>RF</i>	(3) CONTOUR/R2/INTL AM dB BOOST/ATTEN Control	<i>00</i>	(4) OUTPUT LEVEL FINE dBm Control	<i>0</i>	(9) OUTPUT LEVEL COARSE dBm Control	<i>-50</i>	(10) MNL FREQ Controls	<i>9375 MHZ</i>	(16) RF/IF MODE Pushbutton Switches	<i>RF MNL</i>	(29) MODULATION MODE Pushbutton Switches	<i>CW</i>	(39) RANGE SEL Switch	<i>RINGS 1</i>
CONTROL	SETTING																		
(2) PRF/RF Switch	<i>RF</i>																		
(3) CONTOUR/R2/INTL AM dB BOOST/ATTEN Control	<i>00</i>																		
(4) OUTPUT LEVEL FINE dBm Control	<i>0</i>																		
(9) OUTPUT LEVEL COARSE dBm Control	<i>-50</i>																		
(10) MNL FREQ Controls	<i>9375 MHZ</i>																		
(16) RF/IF MODE Pushbutton Switches	<i>RF MNL</i>																		
(29) MODULATION MODE Pushbutton Switches	<i>CW</i>																		
(39) RANGE SEL Switch	<i>RINGS 1</i>																		
2.	Apply power to RD-301A and allow for 30 minute stabilization period.																		
3.	Connect test equipment as shown in 2-2-2, Figure 5.																		
4.	Set L-Band Signal Generator for 1125 MHz CW signal at +7 dBm.																		
5.	Set Pulse Generator for 5 μ s pulse at TTL level and 1 kHz PRF.																		

STEP PROCEDURE

6. Connect RD-301A X-Band I/O Connector (18) and X-Band Signal Generator to 20 dB Coupler with coupler intentionally reversed for maximum isolation. Set X-Band Signal Generator for 9374.95 MHz CW signal. Adjust X-Band Signal Generator output to same level as RD-301A (\approx -50 dBm).

NOTE: X-Band Signal Generator must have power levels characterized for frequencies used in this procedure. Characterization must be accurate to ± 0.1 dBm.

7. Set Spectrum Analyzer as follows:

CONTROL	SETTING
Center Frequency	9375 MHz
Frequency Span	50 kHz/Div
Resolution Bandwidth	1 kHz
Amplitude Scale	2 dB/Div
Reference Level	-50 dBm
Input Attenuation	0 dB

8. Set OUTPUT LEVEL FINE dBm Control (4) to each position from **-1** to **-10**. Decrease X-Band Signal Generator output level by 1 dB for each setting. Verify difference between RD-301A output level and X-Band Signal Generator output level is ≤ 0.5 dB at each position. Record differences.
9. Set OUTPUT LEVEL FINE dBm Control (4) to **0**.
10. Set OUTPUT LEVEL COARSE dBm Control (9) to each position from **-60** to **-100**. Decrease X-Band Signal Generator output level by 10 dB for each setting. Adjust Spectrum Analyzer reference level and verify difference between RD-301A output level and X-Band Signal Generator output level is ≤ 2 dB at each position. Record differences.
11. Set Spectrum Analyzer resolution bandwidth to 300 Hz and reference level to -105 dBm.
12. Set OUTPUT LEVEL COARSE dBm Control (9) to **-110**. Decrease X-Band Signal Generator output level by 10 dB from last setting in Step 10. Verify difference between RD-301A output level and X-Band Signal Generator output level is ≤ 2 dB. Record difference.
13. Set Spectrum Analyzer for 100 Hz Resolution Bandwidth and reference level to -115 dBm.
14. Set OUTPUT LEVEL COARSE dBm Control (9) to **-120**. Decrease X-Band Signal Generator output level by 10 dB from setting in Step 12. Verify difference between RD-301A output level and X-Band Signal Generator output level is ≤ 2 dB. Record difference.
15. Set OUTPUT LEVEL COARSE dBm Control (9) to **-80**.
16. Set Spectrum Analyzer as follows:

CONTROL	SETTING
Frequency Span	Zero
Resolution Bandwidth	3 MHz
Amplitude Scale	2 dB/Div
Reference Level	-82 dBm

17. Set X-Band Signal Generator output to same level as RD-301A.

CONTOUR BOOST and INTERNAL AM UP MODULATION

NOTE: Because the same level control circuit is used for Contour Boost and Internal AM Up Modulation, levels only need to be verified once.

18. Set RANGE SEL Switch (39) to CONTOUR/AM UP MOD. Verify difference between RD-301A output level and X-Band Signal Generator output level is ≤ 1 dB. Record difference.
19. Set CONTOUR/R2/INTL AM dB BOOST ATTEN Control (3) inner knob to each position from **01** to **09**. Increase X-Band Signal Generator output level by 1 dB for each setting. Verify difference between RD-301A output level and X-Band Signal Generator output level is ≤ 0.5 dB at each position. Record differences.
20. Set CONTOUR/R2/INTL AM dB BOOST ATTEN Control (3) to **10**. Increase X-Band Signal Generator Output Level by 1 dB from last setting in Step 19. Verify difference between RD-301A output level and X-Band Signal Generator output level is ≤ 1 dB. Record difference.
21. Set Spectrum Analyzer reference level to -70 dBm.
22. Set CONTOUR/R2/INTL AM dB BOOST ATTEN Control (3) to **20**. Increase X-Band Signal Generator Output Level by 10 dB. Verify difference between RD-301A output level and X-Band Signal Generator output level is ≤ 1 dB. Record difference.
23. Set CONTOUR/R2/INTL AM dB BOOST ATTEN Control (3) to **00**.

RANGE 2 ATTENUATION and INTERNAL AM DOWN MODULATION

NOTE: Because the same level control circuit is used for Range 2 Attenuation and Internal AM Down Modulation, levels only need to be verified once.

24. Set X-Band Signal Generator output to same level as RD-301A.
25. Set RANGE SEL Switch (39) to **R2 ON**. Verify difference between RD-301A output level and X-Band Signal Generator output level is ≤ 1.5 dB. Record difference.
26. Set CONTOUR/R2/INTL AM dB BOOST ATTEN Control (3) inner knob to each position from **01** to **09**. Decrease X-Band Signal Generator output level by 1 dB for each setting. Verify difference between RD-301A R2 output level and X-Band Signal Generator output level is ≤ 1.5 dB at each position. Record differences.
27. Set CONTOUR/R2/INTL AM dB BOOST ATTEN Control (3) outer knob to each position from **19** to **59**. Decrease X-Band Signal Generator output level by 10 dB for each setting. Verify difference between RD-301A R2 output level and X-Band Signal Generator output level is ≤ 1.5 dB at each position. Record differences.
28. Disconnect test equipment.

(d) Pulse Width

TEST EQUIPMENT: 6 dB Pad
Heterodyne Monitor
L-Band Signal Generator
Oscilloscope
X-Band to L-Band Down Converter

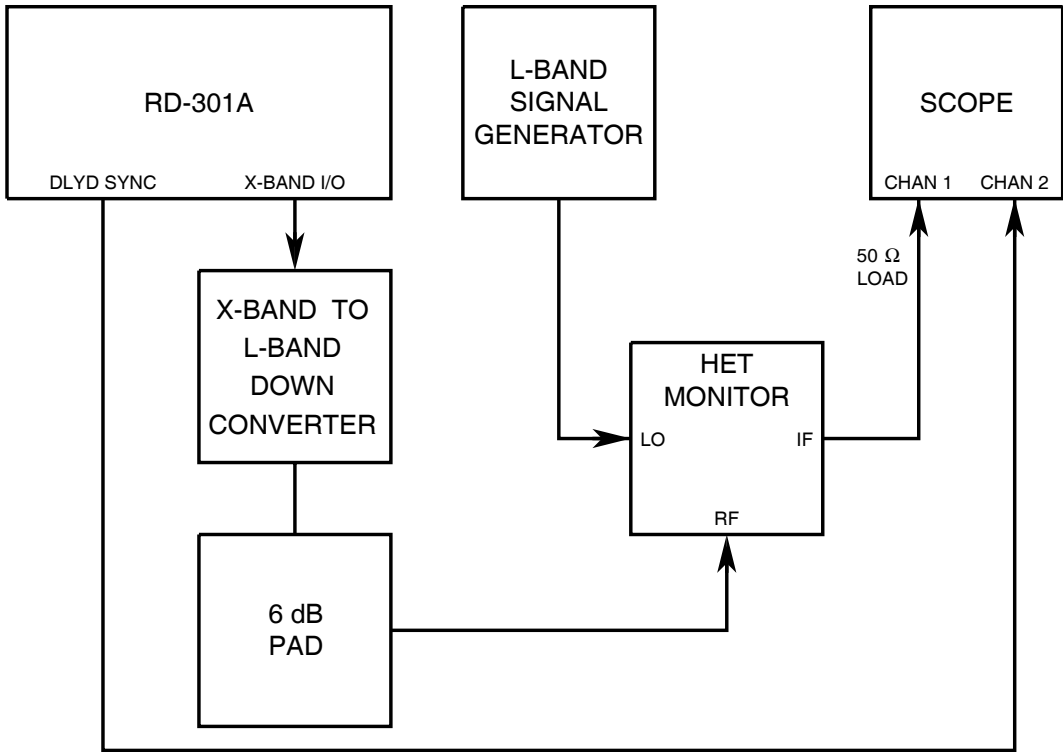

9006006

Pulse Width Verification Setup
Figure 6

STEP

PROCEDURE

1. Set RD-301A as follows:

CONTROL	SETTING
(2) PRF/RF Switch	RF
(4) OUTPUT LEVEL FINE dBm Control	0
(9) OUTPUT LEVEL COARSE dBm Control	-50
(10) MNL FREQ Controls	9375.0 MHz
(16) RF/IF MODE Pushbutton Switches	RF MNL
(29) MODULATION MODE Pushbutton Switches	INTL
(31) PULSE WIDTH μ S Control (RANGE 2)	0.5
(32) PULSE WIDTH μ S Control (RANGE 1)	0.5
(34) PULSE WIDTH MULTIPLIER Control (RANGE 1)	0.1
(35) PULSE WIDTH MULTIPLIER Control (RANGE 2)	0.1
(36) μ S/NM Switch	μS
(37) RANGE 1 DELAY Thumbwheels	000.3
(38) RANGE 2 DELAY Thumbwheels	900.0
(39) RANGE SEL Switch	RINGS 1
(42) X1/X10 INTL PRF/AM Switch	X10

2. Apply power to RD-301A and allow for 30 minute stabilization period.
3. Connect test equipment as shown in 2-2-2, Figure 6.

NOTE: Refer to Appendix D for X-Band to L-Band Down Converter.

4. Set L-Band Signal Generator for 1125 MHz CW signal at +5 dBm.
5. Set PRF/RF Switch (2) to **PRF**.
6. Adjust INTL PRF/AM Control (41) until 1000 Hz is shown on FREQUENCY Hz/MHz Digital Display (1).
7. Set PRF/RF Switch (2) to **RF**.
8. Set Oscilloscope to trigger on Channel 2 and sweep speed to 10 ns/Div.
9. Verify pulse width is 50 ns (± 5 ns). If not, perform Calibration Procedures according to 2-2-2, Table 1.

NOTE: All pulse widths are measured from 50% amplitude on rising edge to 50% amplitude on falling edge. Refer to 2-2-2, Figure 7.

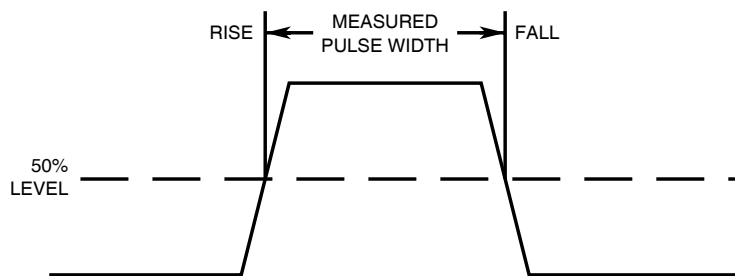

9016002

Pulse Width Measurement Points
Figure 7

10. Set PULSE WIDTH μ S Control (Range 1) (32) to **5**.
11. Set Oscilloscope sweep speed to 100 ns/Div.

STEP	PROCEDURE
12.	Verify pulse width is 500 ns (± 50 ns). If not, perform Calibration Procedures according to 2-2-2, Table 1.
13.	Set PULSE WIDTH MULTIPLIER Control (RANGE 1) (34) to 1 .
14.	Set Oscilloscope sweep speed to 1 μ s/Div.
15.	Verify pulse width is 5 μ s (± 0.5 μ s). If not, perform Calibration Procedures according to 2-2-2, Table 1.
16.	Set PULSE WIDTH MULTIPLIER Control (RANGE 1) (34) to 10 .
17.	Set Oscilloscope sweep speed to 10 μ s/Div.
18.	Verify pulse width is 50 μ s (± 5 μ s). If not, perform Calibration Procedures according to 2-2-2, Table 1.
19.	Set PULSE WIDTH MULTIPLIER Control (RANGE 1) (34) to 100 .
20.	Set PRF/RF Switch (2) to PRF .
21.	Adjust INTL PRF/AM Control (41) until 500 Hz is shown on FREQUENCY Hz/MHz Digital Display (1).
22.	Set PRF/RF Switch (2) to RF .
23.	Set Oscilloscope sweep speed to 100 μ s/Div.
24.	Verify pulse width is 500 μ s (± 50 μ s). If not, perform Calibration Procedures according to 2-2-2, Table 1.
25.	Set PRF/RF Switch (2) to PRF .
26.	Sets PULSE WIDTH μ s Control (RANGE 1) (32) to 0.5 μs .
27.	Set PULSE WIDTH MULTIPLIER Control (RANGE 1) (34) to X500 .
28.	Set X1/X10 INTL PRF Switch (34) to X1 .
29.	Adjust X1/X10 INTL PRF Switch (42) until 125 Hz is shown on FREQUENCY Hz/MHz Digital Display (1).
30.	Verify pulse width is 2.5 ms (2.0 to 3.0 ms).
31.	Set PRF/RF Switch (2) to PRF .
32.	Set RANGE 1 DELAY Thumbwheels (37) to 900.0 .
33.	Set RANGE 2 DELAY Thumbwheels (38) to 000.3 .
34.	Set RANGE SEL Switch (39) R2 ON .
35.	Adjust INTL PRF/AM Control (41) until 1000 kHz is shown on FREQUENCY Hz/MHz Digital Display (1).
36.	Set PRF/RF Switch (2) to RF .
37.	Set Oscilloscope sweep speed to 10 ns/Div.
38.	Verify pulse width is 50 ns (± 5 ns). If not, perform Calibration Procedures according to 2-2-2, Table 1.
39.	Set PULSE WIDTH μ S Control (RANGE 2) (31) to 5 .
40.	Set Oscilloscope sweep speed to 100 ns/Div.
41.	Verify pulse width is 500 ns (± 50 ns). If not, perform Calibration Procedures according to 2-2-2, Table 1.

STEP

PROCEDURE

-
42. Set PULSE WIDTH MULTIPLIER Control (RANGE 2) (35) to **1**.
 43. Set Oscilloscope sweep speed to 1 $\mu\text{s}/\text{Div}$.
 44. Verify pulse width is 5 μs ($\pm 0.5 \mu\text{s}$). If not, perform Calibration Procedures according to 2-2-2, Table 1.
 45. Set PULSE WIDTH MULTIPLIER Control (RANGE 2) (35) to **10**.
 46. Set Oscilloscope sweep speed to 10 $\mu\text{s}/\text{Div}$.
 47. Verify pulse width is 50 μs ($\pm 5 \mu\text{s}$). If not, perform Calibration Procedures according to 2-2-2, Table 1.
 48. Set PULSE WIDTH MULTIPLIER Control (RANGE 2) (35) to **100**.
 49. Set PRF/RF Switch (2) to **PRF**.
 50. Adjust INTL PRF/AM Control (41) until **500 Hz** is shown on FREQUENCY Hz/MHz Digital Display (1).
 51. Set PRF/RF Switch (2) to **RF**.
 52. Set Oscilloscope sweep speed to 100 $\mu\text{s}/\text{Div}$.
 53. Verify pulse width is 500 μs ($\pm 50 \mu\text{s}$). If not, perform Calibration Procedures according to 2-2-2, Table 1.
 54. Disconnect test equipment.

(e) RF ON/OFF Ratio

TEST EQUIPMENT: Spectrum Analyzer

STEP	PROCEDURE
------	-----------

1. Set RD-301A as follows:

CONTROL	SETTING
(2) PRF/RF Switch	RF
(4) OUTPUT LEVEL FINE dBm Control	0
(9) OUTPUT LEVEL COARSE dBm Control	-50
(10) MNL FREQ Controls	9375.00 MHz
(16) RF/IF MODE Pushbutton Switches	RF MNL
(29) MODULATION MODE Pushbutton Switches	CW
(39) RANGE SEL Switch	RINGS 1

2. Apply power to RD-301A and allow for 30 minute stabilization period.
3. Use Serialized Coaxial Cable to connect Spectrum Analyzer to X-BAND I/O Connector (18).
4. Set Spectrum Analyzer as follows:

CONTROL	SETTING
Center Frequency	9375 MHz
Scan Width	5 MHz/Div
Amplitude Scale	10 dB/Div
Reference Level	-40 dBm

5. Center (ON) signal on Spectrum Analyzer display and record level.
6. Set MODULATION MODE Pushbutton Switches (29) to **EXT (+)** without applying external trigger.
7. Verify (OFF) signal level on Spectrum Analyzer is ≥ 70 dB less than level recorded in Step 5. Record level and difference.
8. Disconnect test equipment.

- (2) IF Signal Generator
 - (a) Frequency and IF Counter

TEST EQUIPMENT: Frequency Counter

STEP	PROCEDURE												
1.	Set RD-301A as follows:												
	<table border="1" style="width: 100%; border-collapse: collapse;"> <thead> <tr> <th style="text-align: left;"><u>CONTROL</u></th> <th style="text-align: left;"><u>SETTING</u></th> </tr> </thead> <tbody> <tr> <td>(4) OUTPUT LEVEL FINE dBm Control</td> <td style="text-align: right;"><i>0</i></td> </tr> <tr> <td>(9) OUTPUT LEVEL COARSE dBm Control</td> <td style="text-align: right;"><i>0</i></td> </tr> <tr> <td>(10) MNL FREQ Controls</td> <td style="text-align: right;"><i>fully ccw</i></td> </tr> <tr> <td>(16) RF/IF MODE Pushbutton Switches</td> <td style="text-align: right;"><i>IF HI</i></td> </tr> <tr> <td>(29) MODULATION MODE Pushbutton Switches</td> <td style="text-align: right;"><i>CW</i></td> </tr> </tbody> </table>	<u>CONTROL</u>	<u>SETTING</u>	(4) OUTPUT LEVEL FINE dBm Control	<i>0</i>	(9) OUTPUT LEVEL COARSE dBm Control	<i>0</i>	(10) MNL FREQ Controls	<i>fully ccw</i>	(16) RF/IF MODE Pushbutton Switches	<i>IF HI</i>	(29) MODULATION MODE Pushbutton Switches	<i>CW</i>
<u>CONTROL</u>	<u>SETTING</u>												
(4) OUTPUT LEVEL FINE dBm Control	<i>0</i>												
(9) OUTPUT LEVEL COARSE dBm Control	<i>0</i>												
(10) MNL FREQ Controls	<i>fully ccw</i>												
(16) RF/IF MODE Pushbutton Switches	<i>IF HI</i>												
(29) MODULATION MODE Pushbutton Switches	<i>CW</i>												
2.	Apply power to RD-301A and allow for 30 minute stabilization period.												
3.	Connect Frequency Counter to IF OUT Connector (15).												
4.	Verify ≤ 20 MHz on Frequency Counter. Record reading.												
5.	Verify FREQUENCY Hz/MHz Digital Display (1) equals Frequency Counter reading from Step 4 (± 2 kHz).												
6.	Adjust MNL FREQ Controls (10) <i>fully cw</i> .												
7.	Verify ≥ 70 MHz on Frequency Counter. Record reading.												
8.	Verify FREQUENCY Hz/MHz Digital Display (1) equals Frequency Counter reading from Step 7 (± 7 kHz).												
9.	If RD-301A fails any step, perform Calibration Procedures according to 2-2-2, Table 1.												
10.	Disconnect test equipment.												

(b) Sweep Width

TEST EQUIPMENT: Spectrum Analyzer

STEP	PROCEDURE										
1.	Set RD-301A as follows:										
	<table border="1" style="width: 100%; border-collapse: collapse;"> <thead> <tr> <th style="text-align: left;">CONTROL</th> <th style="text-align: left;">SETTING</th> </tr> </thead> <tbody> <tr> <td>(4) OUTPUT LEVEL FINE dBm Control</td> <td style="text-align: right;"><i>0</i></td> </tr> <tr> <td>(9) OUTPUT LEVEL COARSE dBm Control</td> <td style="text-align: right;"><i>0</i></td> </tr> <tr> <td>(16) RF/IF MODE Pushbutton Switches</td> <td style="text-align: right;"><i>IF HI</i></td> </tr> <tr> <td>(29) MODULATION MODE Pushbutton Switches</td> <td style="text-align: right;"><i>CW</i></td> </tr> </tbody> </table>	CONTROL	SETTING	(4) OUTPUT LEVEL FINE dBm Control	<i>0</i>	(9) OUTPUT LEVEL COARSE dBm Control	<i>0</i>	(16) RF/IF MODE Pushbutton Switches	<i>IF HI</i>	(29) MODULATION MODE Pushbutton Switches	<i>CW</i>
CONTROL	SETTING										
(4) OUTPUT LEVEL FINE dBm Control	<i>0</i>										
(9) OUTPUT LEVEL COARSE dBm Control	<i>0</i>										
(16) RF/IF MODE Pushbutton Switches	<i>IF HI</i>										
(29) MODULATION MODE Pushbutton Switches	<i>CW</i>										
2.	Apply power to RD-301A and allow for 30 minute stabilization period.										
3.	Connect Spectrum Analyzer to IF OUT Connector (15).										
4.	Set Spectrum Analyzer as follows:										
	<table border="1" style="width: 100%; border-collapse: collapse;"> <thead> <tr> <th style="text-align: left;">CONTROL</th> <th style="text-align: left;">SETTING</th> </tr> </thead> <tbody> <tr> <td>Center Frequency</td> <td style="text-align: right;">30 MHz</td> </tr> <tr> <td>Scan Width</td> <td style="text-align: right;">0.5 kHz/Div</td> </tr> <tr> <td>Reference Level</td> <td style="text-align: right;">+20 dBm</td> </tr> <tr> <td>Sweep Speed</td> <td style="text-align: right;">50 ms/Div</td> </tr> </tbody> </table>	CONTROL	SETTING	Center Frequency	30 MHz	Scan Width	0.5 kHz/Div	Reference Level	+20 dBm	Sweep Speed	50 ms/Div
CONTROL	SETTING										
Center Frequency	30 MHz										
Scan Width	0.5 kHz/Div										
Reference Level	+20 dBm										
Sweep Speed	50 ms/Div										
5.	Adjust MNL FREQ Controls (10) for 30 MHz on FREQUENCY Hz/MHz Digital Display (1).										
6.	Adjust SWEEP WIDTH MHz Control (33) cw .										
7.	Verify carrier starts sweeping when SWEEP WIDTH MHz Control (33) passes 0 setting. If not, perform Calibration Procedures according to 2-2-2, Table 1.										
8.	Set SWEEP WIDTH MHz Control (33) to 4 .										
9.	Verify carrier sweep is displayed across 8.0 divisions (4 MHz sweep width) on Spectrum Analyzer. If not, perform Calibration Procedures according to 2-2-2, Table 1.										
10.	Set SWEEP WIDTH MHz Control (33) to OFF .										
11.	Disconnect test equipment.										

(c) Marker Frequency

TEST EQUIPMENT: None

STEP	PROCEDURE														
1.	Set RD-301A as follows:														
	<table border="1" style="width: 100%; border-collapse: collapse;"> <thead> <tr> <th style="text-align: left;">CONTROL</th> <th style="text-align: left;">SETTING</th> </tr> </thead> <tbody> <tr> <td>(2) PRF/RF Switch</td> <td><i>RF</i></td> </tr> <tr> <td>(4) OUTPUT LEVEL FINE dBm Control</td> <td><i>0</i></td> </tr> <tr> <td>(9) OUTPUT LEVEL COARSE dBm Control</td> <td><i>0</i></td> </tr> <tr> <td>(16) RF/IF MODE Pushbutton Switches</td> <td><i>IF HI</i></td> </tr> <tr> <td>(19) MKR FREQ Control</td> <td><i>fully cw</i></td> </tr> <tr> <td>(29) MODULATION MODE Pushbutton Switches</td> <td><i>CW</i></td> </tr> </tbody> </table>	CONTROL	SETTING	(2) PRF/RF Switch	<i>RF</i>	(4) OUTPUT LEVEL FINE dBm Control	<i>0</i>	(9) OUTPUT LEVEL COARSE dBm Control	<i>0</i>	(16) RF/IF MODE Pushbutton Switches	<i>IF HI</i>	(19) MKR FREQ Control	<i>fully cw</i>	(29) MODULATION MODE Pushbutton Switches	<i>CW</i>
CONTROL	SETTING														
(2) PRF/RF Switch	<i>RF</i>														
(4) OUTPUT LEVEL FINE dBm Control	<i>0</i>														
(9) OUTPUT LEVEL COARSE dBm Control	<i>0</i>														
(16) RF/IF MODE Pushbutton Switches	<i>IF HI</i>														
(19) MKR FREQ Control	<i>fully cw</i>														
(29) MODULATION MODE Pushbutton Switches	<i>CW</i>														
2.	Apply power to RD-301A and allow for 30 minute stabilization period.														
3.	Press DISPLAY MKR Switch (21) and verify ≤ 20 MHz on FREQUENCY Hz/MHz Digital Display (1). Record reading.														
4.	Adjust MKR FREQ Control (19) <i>fully cw</i> .														
5.	Press DISPLAY MKR Switch (21) and verify ≥ 70 MHz on FREQUENCY Hz/MHz Digital Display (1). Record reading.														
6.	If RD-301A fails any step, perform Calibration Procedures according to 2-2-2, Table 1.														

(d) Power

TEST EQUIPMENT: Spectrum Analyzer

STEP	PROCEDURE												
1.	Set RD-301A as follows:												
	<table border="1"> <thead> <tr> <th>CONTROL</th> <th>SETTING</th> </tr> </thead> <tbody> <tr> <td>(4) OUTPUT LEVEL FINE dBm Control</td> <td>0</td> </tr> <tr> <td>(9) OUTPUT LEVEL COARSE dBm Control</td> <td>0</td> </tr> <tr> <td>(10) MNL FREQ Controls</td> <td>30 MHz</td> </tr> <tr> <td>(16) RF/IF MODE Pushbutton Switches</td> <td>IF HI</td> </tr> <tr> <td>(29) MODULATION MODE Pushbutton Switches</td> <td>CW</td> </tr> </tbody> </table>	CONTROL	SETTING	(4) OUTPUT LEVEL FINE dBm Control	0	(9) OUTPUT LEVEL COARSE dBm Control	0	(10) MNL FREQ Controls	30 MHz	(16) RF/IF MODE Pushbutton Switches	IF HI	(29) MODULATION MODE Pushbutton Switches	CW
CONTROL	SETTING												
(4) OUTPUT LEVEL FINE dBm Control	0												
(9) OUTPUT LEVEL COARSE dBm Control	0												
(10) MNL FREQ Controls	30 MHz												
(16) RF/IF MODE Pushbutton Switches	IF HI												
(29) MODULATION MODE Pushbutton Switches	CW												
2.	Apply power to RD-301A and allow for 30 minute stabilization period.												
3.	Connect Spectrum Analyzer to IF OUT Connector (15).												
4.	Set Spectrum Analyzer as follows:												
	<table border="1"> <thead> <tr> <th>CONTROL</th> <th>SETTING</th> </tr> </thead> <tbody> <tr> <td>Center Frequency</td> <td>30 MHz</td> </tr> <tr> <td>Scan Width</td> <td>5 MHz/Div</td> </tr> <tr> <td>Amplitude Scale</td> <td>2 dB/Div</td> </tr> <tr> <td>Reference Level</td> <td>-8 dBm</td> </tr> </tbody> </table>	CONTROL	SETTING	Center Frequency	30 MHz	Scan Width	5 MHz/Div	Amplitude Scale	2 dB/Div	Reference Level	-8 dBm		
CONTROL	SETTING												
Center Frequency	30 MHz												
Scan Width	5 MHz/Div												
Amplitude Scale	2 dB/Div												
Reference Level	-8 dBm												
5.	Adjust MNL FREQ Controls (10) for 30 MHz on FREQUENCY Hz/MHz Digital Display (1).												
6.	Verify signal level is 0 dBm (± 2.5 dB). If not, perform Calibration Procedures according to 2-2-2, Table 1.												
7.	Set Spectrum Analyzer reference level to +10 dBm.												
8.	Set OUTPUT LEVEL COARSE dBm Control (9) to +20 .												
9.	Verify signal level is +20 dBm (± 2.7 dB). If not, perform Calibration Procedures according to 2-2-2, Table 1.												
10.	Set RF/IF MODE Pushbutton Switches (16) to IF LO .												
11.	Set OUTPUT LEVEL COARSE dBm Control (9) to -120 .												
12.	Set OUTPUT LEVEL FINE dBm Control (4) to -10 .												
13.	Set Spectrum Analyzer reference level to -134 dBm.												
14.	Verify signal level is -130 dBm (± 3.8 dB). If not, perform Calibration Procedures according to 2-2-2, Table 1.												
15.	Disconnect test equipment.												

(e) Pulse Width

TEST EQUIPMENT: Oscilloscope

STEP	PROCEDURE
------	-----------

1. Set RD-301A as follows:

CONTROL	SETTING
(2) PRF/RF Switch	RF
(4) OUTPUT LEVEL FINE dBm Control	0
(9) OUTPUT LEVEL COARSE dBm Control	0
(10) MNL FREQ Controls	30 MHz
(16) RF/IF MODE Pushbutton Switches	IF HI
(29) MODULATION MODE Pushbutton Switches	INTL
(32) PULSE WIDTH μ S Control (RANGE 1)	0.5
(34) PULSE WIDTH MULTIPLIER Control (RANGE 1)	1
(36) μ S/NM Switch	μS
(39) RANGE SEL Switch	RINGS 1
(42) X1/X10 INTL PRF/AM Switch	X10

2. Apply power to RD-301A and allow for 30 minute stabilization period.
3. Connect Oscilloscope Channel 1 to IF OUT Connector (15) and Oscilloscope Trigger to DLYD SYNC Connector (24).
4. Set PRF/RF Switch (2) to **PRF**.
5. Adjust INTL PRF/AM Control (41) until **1000 Hz** is shown on FREQUENCY Hz/MHz Digital Display (1).
6. Set Oscilloscope sweep speed to 100 ns/Div.
7. Verify pulse width is 500 ns (± 50 ns). If not, perform Calibration Procedures according to 2-2-2, Table 1.

NOTE: All pulse widths are measured from 50% amplitude on rising edge to 50% amplitude on falling edge. Refer to 2-2-2, Figure 7.
8. Set PULSE WIDTH μ S Control (RANGE 1) (32) to **5**.
9. Set PULSE WIDTH MULTIPLIER Control (RANGE 1) (34) to **100**.
10. Adjust INTL PRF/AM Control (41) until **500 Hz** is shown on FREQUENCY Hz/MHz Digital Display (1).
11. Set Oscilloscope sweep speed to 100 μ s/Div.
12. Verify pulse width is 500 μ s (± 50 μ s). If not, perform Calibration Procedures according to 2-2-2, Table 1.
13. Disconnect test equipment.

(f) IF ON/OFF Ratio

TEST EQUIPMENT: Spectrum Analyzer

STEP	PROCEDURE														
1.	Set RD-301A as follows:														
	<table border="1"> <thead> <tr> <th>CONTROL</th> <th>SETTING</th> </tr> </thead> <tbody> <tr> <td>(2) PRF/RF Switch</td> <td>RF</td> </tr> <tr> <td>(4) OUTPUT LEVEL FINE dBm Control</td> <td>0</td> </tr> <tr> <td>(9) OUTPUT LEVEL COARSE dBm Control</td> <td>+20</td> </tr> <tr> <td>(10) MNL FREQ Controls</td> <td>30 MHz</td> </tr> <tr> <td>(16) RF/IF MODE Pushbutton Switches</td> <td>IF HI</td> </tr> <tr> <td>(29) MODULATION MODE Pushbutton Switches</td> <td>CW</td> </tr> </tbody> </table>	CONTROL	SETTING	(2) PRF/RF Switch	RF	(4) OUTPUT LEVEL FINE dBm Control	0	(9) OUTPUT LEVEL COARSE dBm Control	+20	(10) MNL FREQ Controls	30 MHz	(16) RF/IF MODE Pushbutton Switches	IF HI	(29) MODULATION MODE Pushbutton Switches	CW
CONTROL	SETTING														
(2) PRF/RF Switch	RF														
(4) OUTPUT LEVEL FINE dBm Control	0														
(9) OUTPUT LEVEL COARSE dBm Control	+20														
(10) MNL FREQ Controls	30 MHz														
(16) RF/IF MODE Pushbutton Switches	IF HI														
(29) MODULATION MODE Pushbutton Switches	CW														
2.	Apply power to RD-301A and allow for 30 minute stabilization period.														
3.	Connect Spectrum Analyzer to IF OUT Connector (15).														
4.	Set Spectrum Analyzer as follows:														
	<table border="1"> <thead> <tr> <th>CONTROL</th> <th>SETTING</th> </tr> </thead> <tbody> <tr> <td>Center Frequency</td> <td>30 MHz</td> </tr> <tr> <td>Scan Width</td> <td>5 MHz/Div</td> </tr> <tr> <td>Amplitude Scale</td> <td>10 dB/Div</td> </tr> <tr> <td>Reference Level</td> <td>+25 dBm</td> </tr> </tbody> </table>	CONTROL	SETTING	Center Frequency	30 MHz	Scan Width	5 MHz/Div	Amplitude Scale	10 dB/Div	Reference Level	+25 dBm				
CONTROL	SETTING														
Center Frequency	30 MHz														
Scan Width	5 MHz/Div														
Amplitude Scale	10 dB/Div														
Reference Level	+25 dBm														
5.	Center (ON) signal on Spectrum Analyzer display and record level.														
6.	Set MODULATION MODE Pushbutton Switches (29) to EXT (+) without applying external trigger.														
7.	Verify (OFF) signal level on Spectrum Analyzer is ≥ 48 dB less than level recorded in Step 5. Record level and difference.														
8.	Set MODULATION MODE Pushbutton Switches (29) to CW .														
9.	Set MNL FREQ Controls (10) for 60 MHz according to FREQUENCY Hz/MHz Digital Display (1).														
10.	Set Spectrum Analyzer center frequency to 60 MHz .														
11.	Center (ON) signal on Spectrum Analyzer display and record level.														
12.	Set MODULATION MODE Pushbutton Switches (29) to EXT (+) without applying external trigger.														
13.	Verify (OFF) signal level on Spectrum Analyzer is ≥ 48 dB less than level recorded in Step 11. Record level and difference.														
14.	Disconnect test equipment.														

(3) INTL Modulation/PRF Counter

TEST EQUIPMENT: Frequency Counter

STEP	PROCEDURE	SETTING
1.	Set RD-301A as follows:	
	CONTROL	
	(2) PRF/RF Switch	PRF
	(29) MODULATION MODE Pushbutton Switches	INTL
	(42) X1/X10 INTL PRF/AM Switch	X1
2.	Apply power to RD-301A and allow for 30 minute stabilization period.	
3.	Connect Frequency Counter to SYNC Connector (26).	
4.	Adjust INTL PRF/AM Control (41) for 50 Hz sync pulse frequency on Frequency Counter.	
5.	Verify INTL PRF/AM Control (41) setting is within marked area for 50 Hz . If not, perform Calibration Procedures according to 2-2-2, Table 1.	
6.	Verify FREQUENCY Hz/MHz Digital Display (1) reads 50 Hz (± 1 Hz). If not, perform Calibration Procedures according to 2-2-2, Table 1.	
7.	Adjust INTL PRF/AM Control (41) for 500 Hz sync pulse frequency on Frequency Counter.	
8.	Verify INTL PRF/AM Control (41) setting is within marked area for 500 Hz . If not, perform Calibration Procedures according to 2-2-2, Table 1.	
9.	Verify FREQUENCY Hz/MHz Digital Display (1) reads 500 Hz (± 1 Hz). If not, perform Calibration Procedures according to 2-2-2, Table 1.	
10.	Set X1/X10 INTL PRF/AM Switch (42) to X10 .	
11.	Adjust INTL PRF/AM Control (41) for 500 Hz sync pulse frequency on Frequency Counter.	
12.	Verify INTL PRF/AM Control (41) setting is within marked area for 50 Hz . If not, perform Calibration Procedures according to 2-2-2, Table 1.	
13.	Verify FREQUENCY Hz/MHz Digital Display (1) reads 500 Hz (± 1 Hz). If not, perform Calibration Procedures according to 2-2-2, Table 1.	
14.	Verify frequencies in Steps 9 and 10 overlap frequencies in Steps 12 and 13. If not, perform Calibration Procedures according to 2-2-2, Table 1.	
15.	Adjust INTL PRF/AM Control (41) for 5000 Hz sync pulse frequency on Frequency Counter.	
16.	Verify INTL PRF/AM Control (41) setting is within marked area for 500 Hz . If not, perform Calibration Procedures according to 2-2-2, Table 1.	
17.	Verify FREQUENCY Hz/MHz Digital Display (1) reads 5000 Hz (± 2 Hz). If not, perform Calibration Procedures according to 2-2-2, Table 1.	
18.	Disconnect test equipment.	

(4) Range

TEST EQUIPMENT: Pulse Generator
Oscilloscope
X-Band to L-Band Down Converter
L-Band Signal Generator

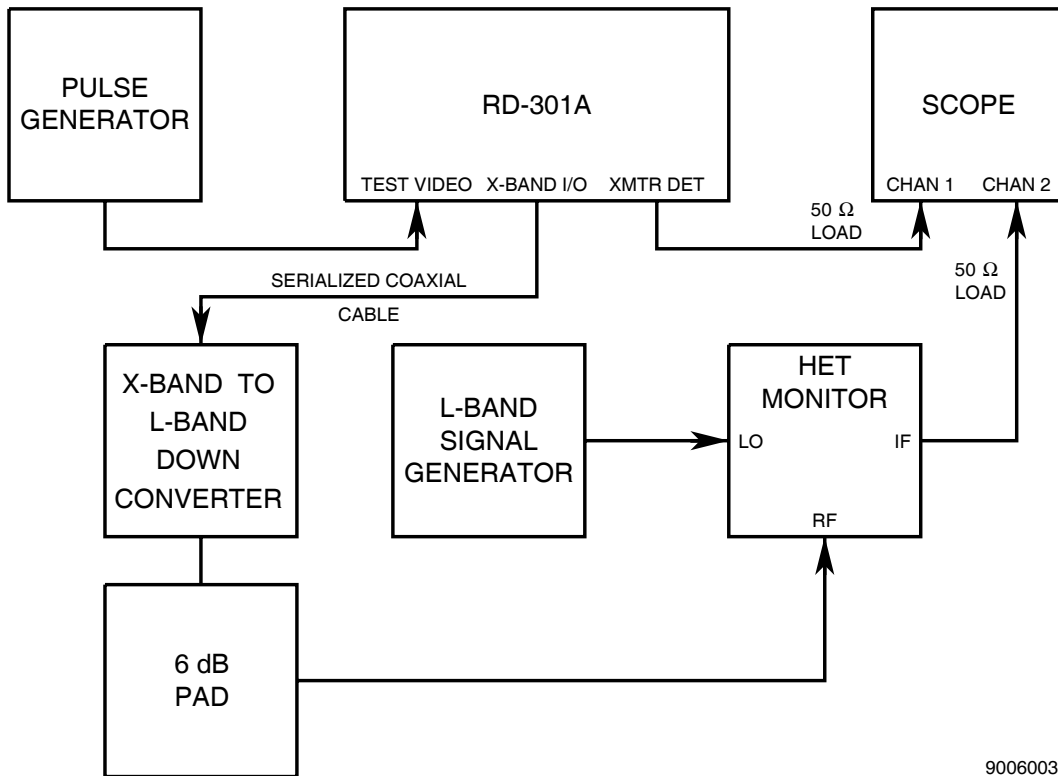

Range Delay Verification Setup
Figure 8

9006003

STEP	PROCEDURE
------	-----------

1. Set RD-301A as follows:

CONTROL	SETTING
(2) PRF/RF Switches	<i>RF</i>
(10) MNL FREQ Controls	<i>9375.0 MHz</i>
(16) RF/IF MODE Pushbutton Switches	<i>RF MNL</i>
(29) MODULATION MODE Pushbutton Switches	<i>TRACK</i>
(31) PULSE WIDTH μ S Control (RANGE 2)	<i>5</i>
(32) PULSE WIDTH μ S Control (RANGE 1)	<i>5</i>
(34) PULSE WIDTH MULTIPLIER Control (RANGE 1)	<i>1</i>
(35) PULSE WIDTH MULTIPLIER Control (RANGE 2)	<i>1</i>
(36) μ S/NM Switch	<i>μS</i>
(37) RANGE 1 DELAY Thumbwheels	<i>000.0</i>
(38) RANGE 2 DELAY Thumbwheels	<i>000.0</i>
(39) RANGE SEL Switch	<i>RINGS 1</i>

2. Apply power to RD-301A and allow for 30 minute stabilization period.
3. Connect test equipment as shown in 2-2-2, Figure 8.

STEP	PROCEDURE
------	-----------

4. Set Pulse Generator for 3 μ s pulse at TTL level and 1 kHz PRF.
5. Set L-Band Signal Generator for 1125 MHz CW signal at +7 dBm.
NOTE: Keep RD-301A and L-Band Signal Generator near same L-Band frequency (zero-beat) for minimum distortion.
6. Set Oscilloscope to display both channels.
NOTE: Insure both Oscilloscope channel delays are calibrated to match.

RANGE 1

7. Verify residual delay is 0.1 μ s (± 0.1 μ s). Record Range 1 residual delay.
NOTE: Measure range and residual delays from leading edge of XMTR DET Connector (13) transmitter pulse to leading edge of X-Band I/O Connector (18) reply pulse at 50% amplitude points.
NOTE: Refer to Appendix D. Subtract fixed delay through X-Band to L-Band Down Converter from RD-301A range delay measurement to obtain actual range delay.
8. Set RANGE 1 DELAY Thumbwheels (37) to **000.1**.
9. Verify range delay is 0.1 μ s + residual delay from Step 7.
10. Set μ S/NM Switch (36) to **NM**.
11. Verify range delay is 1.236 μ s + residual delay from Step 7.
12. Set μ S/NM Switch (36) to **μ S**.
13. Set RANGE 1 DELAY Thumbwheels (37) to **100.0**.
14. Verify range delay is 100 μ s + residual delay from Step 7 (± 10 ns).
15. Set RANGE SEL Switch (39) according to 2-2-2, Table 3 and verify results (leading edge to leading edge at 50% amplitude points).

SETTING	RESULT
RINGS 2	Two reply pulses are present. Ring 2 reply pulse occurs 100 μ s (± 10 ns) after Ring 1 reply pulse.
RINGS 3	Three reply pulses are present. Ring 3 reply pulse occurs 100 μ s (± 10 ns) after Ring 2 reply pulse.
RINGS 4	Four reply pulses are present. Ring 4 reply pulse occurs 100 μ s (± 10 ns) after Ring 3 reply pulse.
RINGS 5	Five reply pulses are present. Ring 5 reply pulse occurs 100 μ s (± 10 ns) after Ring 4 reply pulse.

Range Reply Rings Verification
Table 3

16. Set RANGE SEL Switch (39) to **RINGS 1**.
17. Set RANGE 1 DELAY Thumbwheels (37) to **999.9**.
18. Adjust Oscilloscope and use Δ time to verify range delay is 999.9 μ s + residual delay from Step 7 (± 0.1 μ s).

STEP PROCEDURE

19. Set μ S/NM Switch (36) to **NM**.
20. Verify range delay is 12.358 ms + residual delay from Step 7 ($\pm 1.2 \mu$ s).

RANGE 2

21. Reset RD-301A as follows:

CONTROL

SETTING

(36) μ S/NM Switch	μ S
(37) RANGE 1 DELAY Thumbwheels	100.0
(39) RANGE SEL Control	R2 ON

22. Verify residual delay is 0.4 μ s ($\pm 0.1 \mu$ s). Record Range 2 residual delay. If not, perform calibration procedures according to 2-2-2, Table 1.
23. Set RANGE 2 DELAY Thumbwheels (38) to **000.1**.
24. Verify range delay is 0.1 μ s + residual delay from Step 22. If not, perform calibration procedures according to 2-2-2, Table 1.
25. Set μ S/NM Switch (36) to **NM**.
26. Verify range delay is 1.236 μ s + residual delay from Step 22. If not, perform calibration procedures according to 2-2-2, Table 1.
27. Set μ S/NM Switch (36) to **μ S**.
28. Set RANGE 2 DELAY Thumbwheels (38) to **999.9**.
29. Adjust Oscilloscope and use Δ time to verify range delay to Range 2 reply pulse is 999.9 μ s + residual delay from Step 22 ($\pm 0.1 \mu$ s). If not, perform calibration procedures according to 2-2-2, Table 1.
30. Set μ S/NM Switch (36) to **NM**.
31. Verify range delay to Range 2 reply pulse is 12.358 ms + residual delay from Step 22 ($\pm 1.2 \mu$ s). If not, perform calibration procedures according to 2-2-2, Table 1.
32. Disconnect test equipment.

(5) Power Meter

TEST EQUIPMENT: Bandpass Filter
Power Meter Assembly
TWT Amplifier
X-Band Signal Generator

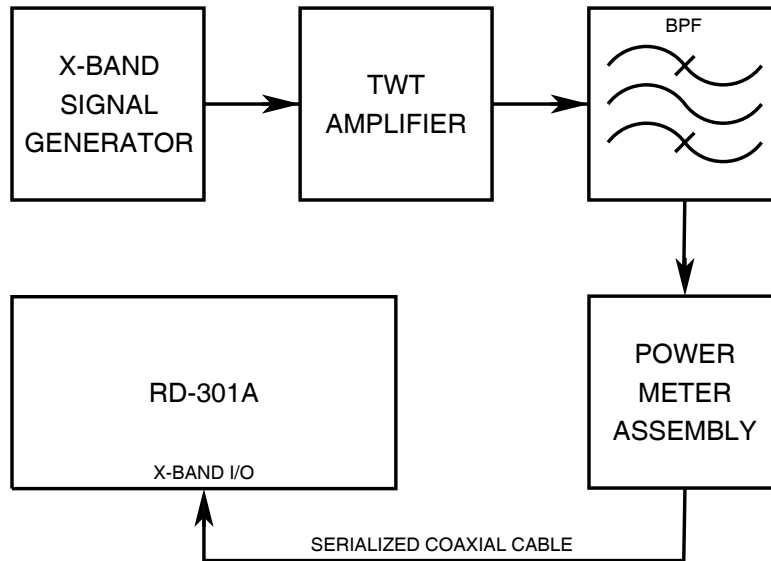

9006004

Power Meter Verification Setup
Figure 9

STEP	PROCEDURE
------	-----------

1. Apply power to RD-301A and allow for 30 minute stabilization period.
2. Set TWT Amplifier power On and in Standby mode.
3. Connect test equipment as shown in 2-2-2, Figure 9.
4. Set X-Band Signal Generator as follows:

CONTROL

SETTING

Frequency	9375 MHz
Pulse Width	3 μ s
PRF	1 kHz

5. Set METER SELECT Switch (47) to **PK POWER**.
6. Record coupling value of Waveguide Coupler used with RD-301A.

NOTE: The coupling value is marked (not tagged value) on Waveguide Coupler.

STEP

PROCEDURE

7. Record 1 kW and 12 kW Test RF Levels from 2-2-2, Table 4 according to Waveguide Coupler Value from Step 6.

WAVEGUIDE COUPLER VALUE	1 kW TEST RF LEVEL	12 kW TEST RF LEVEL
19.0 dB	12.589 W	151.071 W
19.1 dB	12.303 W	147.632 W
19.2 dB	12.023 W	144.272 W
19.3 dB	11.749 W	140.988 W
19.4 dB	11.482 W	137.778 W
19.5 dB	11.220 W	134.642 W
19.6 dB	10.965 W	131.577 W
19.7 dB	10.715 W	128.582 W
19.8 dB	10.471 W	125.655 W
19.9 dB	10.233 W	122.795 W
20.0 dB	10.000 W	120.000 W
20.1 dB	9.772 W	117.268 W
20.2 dB	9.550 W	114.599 W
20.3 dB	9.333 W	111.991 W
20.4 dB	9.120 W	109.441 W
20.5 dB	8.913 W	106.950 W
20.6 dB	8.710 W	104.516 W
20.7 dB	8.511 W	102.137 W
20.8 dB	8.318 W	99.812 W
20.9 dB	8.128 W	97.540 W
21.0 dB	7.943 W	95.319 W

Test RF Levels for Power Meter Verification
Table 4

CAUTION: CONNECTIONS TO TWT AMPLIFIER MUST BE CORRECT BEFORE SWITCHING TO OPERATE MODE.

8. Set TWT Amplifier to Operate mode.
9. Adjust X-Band Signal Generator level until Power Meter Assembly indicates characterized value for 1 kW Test RF Level from Step 7.
10. Verify PANEL Meter (43) indicates **1 kW** (± 148 W). If not, perform Calibration Procedures according to 2-2-2, Table 1.
11. Adjust X-Band Signal Generator level until Power Meter Assembly indicates characterized value for 12 kW Test RF Level from Step 7.
12. Verify PANEL Meter (43) indicates **12 kW** (± 1776 W). If not, perform Calibration Procedures according to 2-2-2, Table 1.
13. Slowly decrease TWT Amplifier power and set to Standby mode for ≥ 15 minutes.
14. Disconnect test equipment.

(6) XMTR DSCRM 0.1V/MHz Connector

TEST EQUIPMENT: Oscilloscope
TWT Amplifier
X-Band Signal Generator

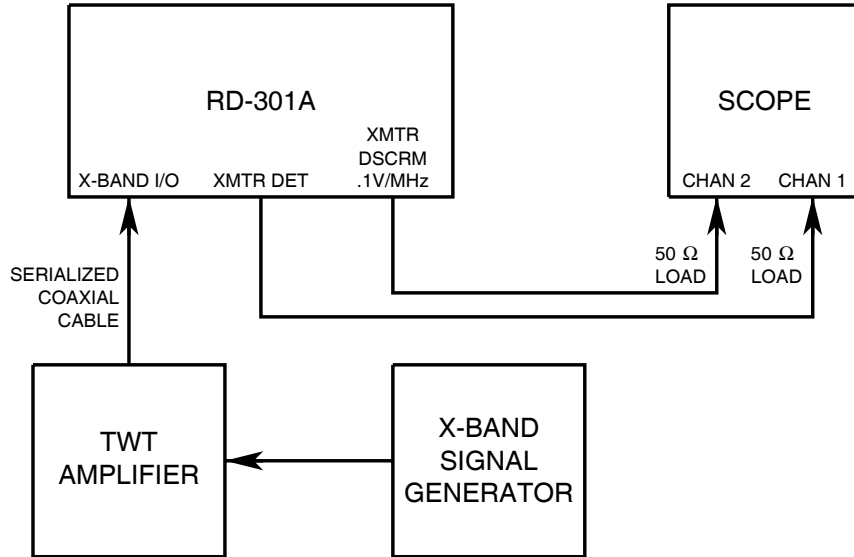

9006017

XMTR DSCRM 0.1V/MHz Connector Verification Setup
Figure 10

STEP	PROCEDURE
------	-----------

1. Set RD-301A as follows:

CONTROL	SETTING
(2) PRF/RF Switch	RF
(4) OUTPUT LEVEL FINE dBm Control	0
(9) OUTPUT LEVEL COARSE dBm Control	-50
(16) RF/IF MODE Pushbutton Switches	RF MNL
(29) MODULATION MODE Pushbutton Switches	TRACK

2. Apply power to RD-301A and allow for 30 minute stabilization period.
3. Connect test equipment as shown in 2-2-2, Figure 10.
4. Set TWT Amplifier power On and in Standby mode.
5. Set Oscilloscope with both channels dc coupled as follows:

CONTROL	SETTING
Sweep Speed	500 ns/Div
Amplitude Scale (Channel 1)	50 mV/Div
Amplitude Scale (Channel 2)	10 mV/Div
Trigger	Channel 1

STEP	PROCEDURE
------	-----------

6. Set X-Band Signal Generator as follows:

CONTROL	SETTING
Frequency	9400 MHz
Pulse Width	5 μ s
PRF	500 Hz

CAUTION: CONNECTIONS TO TWT AMPLIFIER MUST BE CORRECT BEFORE SWITCHING TO OPERATE MODE.

7. Set TWT Amplifier to Operate mode.
8. Set X-Band Signal Generator output level for PANEL Meter (43) reading of **0.5 kW**.
9. Adjust MNL FREQ Controls (10) to align XMTR DSCRM .1V/MHz Connector (12) pulses with XMTR DET Connector (13) pulses.
10. Record FREQUENCY Hz/MHz Digital Display (1) readout as reference.
11. Set Oscilloscope to display only Channel 2 and center pulse level on first horizontal graticule below top of screen.
12. Adjust MNL FREQ Controls (10) for Step 10 reference minus 0.5 MHz as shown on FREQUENCY Hz/MHz Digital Display (1).
13. Verify pulse level on Oscilloscope decreases 50 mV (± 5 mV).
14. Adjust MNL FREQ Controls (10) for Step 10 reference.
15. Set Oscilloscope to center pulse level on second horizontal graticule above bottom of screen.
16. Adjust MNL FREQ Controls (10) for Step 10 reference plus 0.5 MHz as shown on FREQUENCY Hz/MHz Digital Display (1).
17. Verify pulse level on Oscilloscope increases 50 mV (± 5 mV).
18. Slowly decrease TWT Amplifier power and set to Standby mode for ≥ 15 minutes.
19. Disconnect test equipment.

(7) Inputs

(a) AM EXT INPUT Connector

TEST EQUIPMENT: Function Generator
Modulation Meter
X-Band to L-Band Down Converter

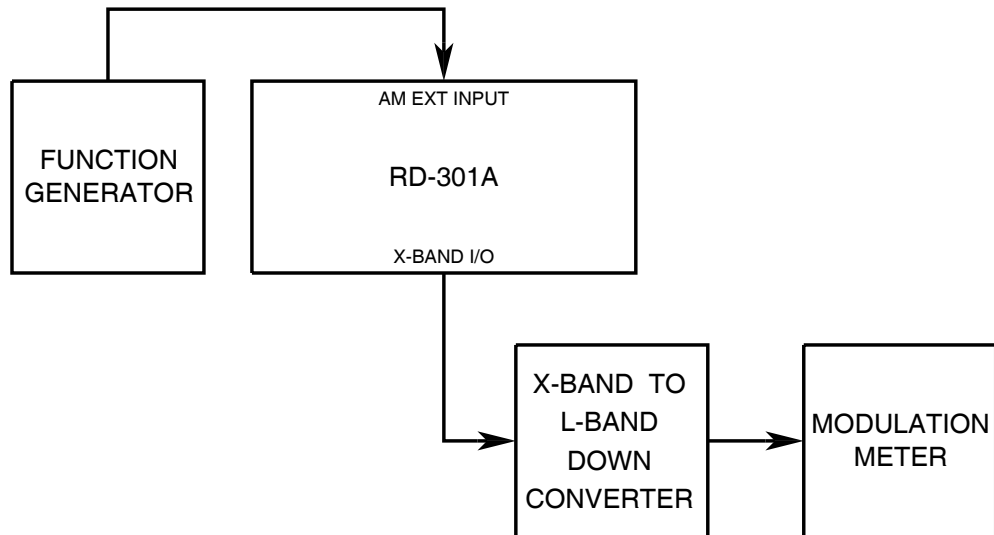

9006016

AM EXT INPUT Connector Verification Setup
Figure 11

STEP	PROCEDURE														
1.	Apply power to RD-301A and allow for 30 minute stabilization period.														
2.	Set RD-301A as follows:														
	<table border="1"> <thead> <tr> <th>CONTROL</th> <th>SETTING</th> </tr> </thead> <tbody> <tr> <td>(2) PRF/RF Switch</td> <td>RF</td> </tr> <tr> <td>(4) OUTPUT LEVEL FINE dBm Control</td> <td>0</td> </tr> <tr> <td>(9) OUTPUT LEVEL COARSE dBm Control</td> <td>-50</td> </tr> <tr> <td>(10) MNL FREQ Controls</td> <td>9375 MHz</td> </tr> <tr> <td>(16) RF/IF MODE Pushbutton Switches</td> <td>RF MNL</td> </tr> <tr> <td>(29) MODULATION MODE Pushbutton Switches</td> <td>CW</td> </tr> </tbody> </table>	CONTROL	SETTING	(2) PRF/RF Switch	RF	(4) OUTPUT LEVEL FINE dBm Control	0	(9) OUTPUT LEVEL COARSE dBm Control	-50	(10) MNL FREQ Controls	9375 MHz	(16) RF/IF MODE Pushbutton Switches	RF MNL	(29) MODULATION MODE Pushbutton Switches	CW
CONTROL	SETTING														
(2) PRF/RF Switch	RF														
(4) OUTPUT LEVEL FINE dBm Control	0														
(9) OUTPUT LEVEL COARSE dBm Control	-50														
(10) MNL FREQ Controls	9375 MHz														
(16) RF/IF MODE Pushbutton Switches	RF MNL														
(29) MODULATION MODE Pushbutton Switches	CW														
3.	Connect test equipment as shown in 2-2-2, Figure 11.														
4.	Set Function Generator for 1 kHz sine wave at 3 Vp-p.														
5.	Verify 30% ($\pm 2\%$) modulation on Modulation Meter. If not, perform Calibration Procedures according to 2-2-2, Table 1.														
6.	Disconnect test equipment.														

(b) EXT TRIG Connector

TEST EQUIPMENT: Oscilloscope
Pulse Generator

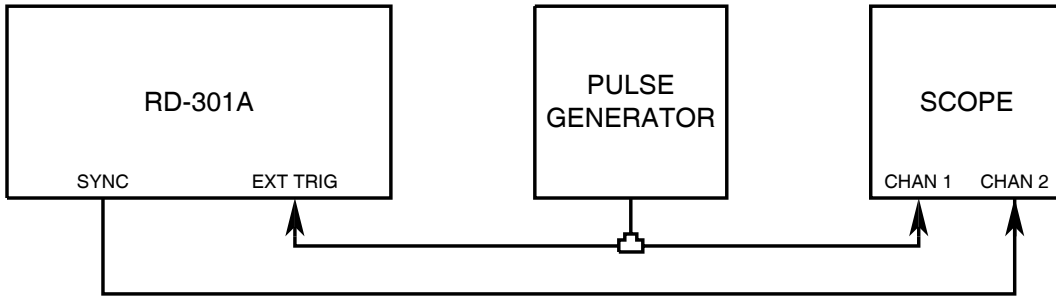

9006015

EXT TRIG Connector Verification Setup
Figure 12

STEP	PROCEDURE
------	-----------

1. Set RD-301A as follows:

CONTROL

SETTING

(2) PRF/RF Switch	PRF
(29) MODULATION MODE Pushbutton Switches	EXT (+)
(36) μ S/NM Switch	μS
(37) RANGE 1 DELAY Thumbwheels	000.3
(39) RANGE SEL Switch	RINGS 1

2. Apply power to RD-301A and allow for 30 minute stabilization period.
3. Connect test equipment as shown in 2-2-2, Figure 12.
4. Set Oscilloscope to trigger on positive edge of Channel 1 input.
5. Set Pulse Generator for 1 μ s wide positive pulse, 2 Vp-p at 1 kHz.
6. Adjust output level of Pulse Generator and verify sync pulse appears.
7. Set MODULATION MODE Pushbutton Switches (29) to **EXT (-)**.
8. Set Pulse Generator for 1 μ s wide negative pulse, 2 Vp-p at 1 kHz.
9. Set Oscilloscope to trigger on negative edge of Channel 1 input.
10. Adjust output level of Pulse Generator and verify sync pulse appears.
11. Disconnect test equipment.



G. Verification Data Sheet

RD-301A S/N: _____ DATE: _____

TECHNICIAN: _____

STEP	DATA	RESULT
(1)	RF Signal Generator	
(a)	Frequency and RF Counter	
	4. Frequency ≤ 9295 MHz	_____
	5. FREQUENCY Hz/MHz Digital Display (1) readout equals Step 4 reading (± 250 kHz)	_____
	7. Frequency ≥ 9500 MHz	_____
	8. FREQUENCY Hz/MHz Digital Display (1) readout equals Step 7 reading (± 250 kHz)	_____
(b)	Tracking and ΔF Offset	
	TRACKING	
	11. Frequency Difference (30 μ s wide pulse)	
	(9295 MHz at 0.5 kW) ≤ 25 kHz	_____
	(9400 MHz at 0.5 kW) ≤ 25 kHz	_____
	(9500 MHz at 0.5 kW) ≤ 25 kHz	_____
	(9295 MHz at 12 kW) ≤ 25 kHz	_____
	(9400 MHz at 12 kW) ≤ 25 kHz	_____
	(9500 MHz at 12 kW) ≤ 25 kHz	_____
	12. XMTR HET MON Connector (11) output	
	(9295 MHz at 0.5 kW)	_____ (✓)
	(9400 MHz at 0.5 kW)	_____ (✓)
	(9500 MHz at 0.5 kW)	_____ (✓)
	(9295 MHz at 12 kW)	_____ (✓)
	(9400 MHz at 12 kW)	_____ (✓)
	(9500 MHz at 12 kW)	_____ (✓)



STEP	DATA	RESULT
14.	Frequency Difference (2 μ s wide pulse)	
	(9295 MHz at 0.5 kW) \leq 25 kHz	-----
	(9400 MHz at 0.5 kW) \leq 25 kHz	-----
	(9500 MHz at 0.5 kW) \leq 25 kHz	-----
	(9295 MHz at 12 kW) \leq 25 kHz	-----
	(9400 MHz at 12 kW) \leq 25 kHz	-----
	(9500 MHz at 12 kW) \leq 25 kHz	-----
15.	XMTR HET MON Connector (11) output	
	(9295 MHz at 0.5 kW)	----- (✓)
	(9400 MHz at 0.5 kW)	----- (✓)
	(9500 MHz at 0.5 kW)	----- (✓)
	(9295 MHz at 12 kW)	----- (✓)
	(9400 MHz at 12 kW)	----- (✓)
	(9500 MHz at 12 kW)	----- (✓)
18.	Frequency Difference (0.5 μ s wide pulse)	
	(9295 MHz at 0.5 kW) \leq 60 kHz	-----
	(9400 MHz at 0.5 kW) \leq 60 kHz	-----
	(9500 MHz at 0.5 kW) \leq 60 kHz	-----
	(9295 MHz at 12 kW) \leq 60 kHz	-----
	(9400 MHz at 12 kW) \leq 60 kHz	-----
	(9500 MHz at 12 kW) \leq 60 kHz	-----
19.	XMTR HET MON Connector (11) output	
	(9295 MHz at 0.5 kW)	----- (✓)
	(9400 MHz at 0.5 kW)	----- (✓)
	(9500 MHz at 0.5 kW)	----- (✓)
	(9295 MHz at 12 kW)	----- (✓)
	(9400 MHz at 12 kW)	----- (✓)
	(9500 MHz at 12 kW)	----- (✓)



STEP	DATA	RESULT
22.	Frequency Difference (0.5 μ s wide pulse)	
	(9295 MHz at 0.5 kW) \leq 600 kHz	-----
	(9400 MHz at 0.5 kW) \leq 600 kHz	-----
	(9500 MHz at 0.5 kW) \leq 600 kHz	-----
	(9295 MHz at 12 kW) \leq 600 kHz	-----
	(9400 MHz at 12 kW) \leq 600 kHz	-----
	(9500 MHz at 12 kW) \leq 600 kHz	-----
23.	XMTR HET MON Connector (11) output	
	(9295 MHz at 0.5 kW)	----- (✓)
	(9400 MHz at 0.5 kW)	----- (✓)
	(9500 MHz at 0.5 kW)	----- (✓)
	(9295 MHz at 12 kW)	----- (✓)
	(9400 MHz at 12 kW)	----- (✓)
	(9500 MHz at 12 kW)	----- (✓)
26.	Frequency Difference (0.05 μ s wide pulse)	
	(9295 MHz at 0.5 kW) \leq 2 MHz	-----
	(9400 MHz at 0.5 kW) \leq 2 MHz	-----
	(9500 MHz at 0.5 kW) \leq 2 MHz	-----
	(9295 MHz at 12 kW) \leq 2 MHz	-----
	(9400 MHz at 12 kW) \leq 2 MHz	-----
	(9500 MHz at 12 kW) \leq 2 MHz	-----
27.	XMTR HET MON Connector (11) output	
	(9295 MHz at 0.5 kW)	----- (✓)
	(9400 MHz at 0.5 kW)	----- (✓)
	(9500 MHz at 0.5 kW)	----- (✓)
	(9295 MHz at 12 kW)	----- (✓)
	(9400 MHz at 12 kW)	----- (✓)
	(9500 MHz at 12 kW)	----- (✓)
TRACK MODULATION PRF		
45.	50 Hz PRF/9295 MHz 49 to 51 Hz	-----
	50 Hz PRF/9400 MHz 49 to 51 Hz	-----
	50 Hz PRF/9500 MHz 49 to 51 Hz	-----



STEP	DATA	RESULT
46.	50 Hz PRF/9295 MHz	
	Frequency difference ≤ 25 kHz	-----
	50 Hz PRF/9400 MHz	
	Frequency difference ≤ 25 kHz	-----
	50 Hz PRF/9500 MHz	
	Frequency difference ≤ 25 kHz	-----
47.	XMTR HET MON Connector (11) output	
	(50 Hz PRF/9500 MHz)	----- (✓)
	(50 Hz PRF/9500 MHz)	----- (✓)
	(50 Hz PRF/9500 MHz)	----- (✓)
49.	2 kHz PRF/9295 MHz 1999 to 2001 Hz	-----
	2 kHz PRF/9400 MHz 1999 to 2001 Hz	-----
	2 kHz PRF/9500 MHz 1999 to 2001 Hz	-----
50.	2 kHz PRF/9295 MHz	
	Frequency difference ≤ 25 kHz	-----
	2 kHz PRF/9400 MHz	
	Frequency difference ≤ 25 kHz	-----
	2 kHz PRF/9500 MHz	
	Frequency difference ≤ 25 kHz	-----
51.	XMTR HET MON Connector (11) output	
	(2 kHz PRF/9500 MHz)	----- (✓)
	(2 kHz PRF/9500 MHz)	----- (✓)
	(2 kHz PRF/9500 MHz)	----- (✓)
53.	20 kHz PRF/9295 MHz	
	Frequency difference ≤ 25 kHz	-----
	20 kHz PRF/9400 MHz	
	Frequency difference ≤ 25 kHz	-----
	20 kHz PRF/9500 MHz	
	Frequency difference ≤ 25 kHz	-----
54.	XMTR HET MON Connector (11) output	
	(20 kHz PRF/9500 MHz)	----- (✓)
	(20 kHz PRF/9500 MHz)	----- (✓)
	(20 kHz PRF/9500 MHz)	----- (✓)



STEP	DATA	RESULT
ΔF OFFSET		
63.	9400 MHz Frequency Counter reading	_____
66.	Offset -0.75 MHz Step 63 - 750 kHz (± 95 kHz)	_____
67.	XMTR HET MON Connector (11) output	_____ (✓)
69.	Offset +0.75 MHz Step 63 + 750 kHz (± 95 kHz)	_____
70.	XMTR HET MON Connector (11) output	_____ (✓)
(c)	Output Power and Internal AM Amplitude	
8.	Level difference between	
	1 dBm position and reference (≤ 0.5 dB)	_____
	2 dBm position and reference (≤ 0.5 dB)	_____
	3 dBm position and reference (≤ 0.5 dB)	_____
	4 dBm position and reference (≤ 0.5 dB)	_____
	5 dBm position and reference (≤ 0.5 dB)	_____
	6 dBm position and reference (≤ 0.5 dB)	_____
	7 dBm position and reference (≤ 0.5 dB)	_____
	8 dBm position and reference (≤ 0.5 dB)	_____
	9 dBm position and reference (≤ 0.5 dB)	_____
	10 dBm position and reference (≤ 0.5 dB)	_____
10.	Level difference between	
	-60 dBm position and reference (≤ 2 dB)	_____
	-70 dBm position and reference (≤ 2 dB)	_____
	-80 dBm position and reference (≤ 2 dB)	_____
	-90 dBm position and reference (≤ 2 dB)	_____
	-100 dBm position and reference (≤ 2 dB)	_____
12.	Level difference between	
	-110 dBm position and reference (≤ 2 dB)	_____
14.	Level difference between	
	-120 dBm position and reference (≤ 2 dB)	_____
CONTOUR BOOST and INTERNAL AM UP MODULATION		
18.	Level difference between	
	-80 dBm position and reference (≤ 1 dB)	_____



STEP	DATA	RESULT
19.	Level difference between	
	01 position and reference (≤ 0.5 dB)	-----
	02 position and reference (≤ 0.5 dB)	-----
	03 position and reference (≤ 0.5 dB)	-----
	04 position and reference (≤ 0.5 dB)	-----
	05 position and reference (≤ 0.5 dB)	-----
	06 position and reference (≤ 0.5 dB)	-----
	07 position and reference (≤ 0.5 dB)	-----
	08 position and reference (≤ 0.5 dB)	-----
	09 position and reference (≤ 0.5 dB)	-----
20.	Level difference between	
	10 position and reference (≤ 1 dB)	-----
22.	Level difference between	
	20 position and reference (≤ 1 dB)	-----
RANGE 2 ATTENUATION and INTERNAL AM DOWN MODULATION		
25.	Level difference between	
	-80 dBm position and reference (≤ 1.5 dB)	-----
26.	Level difference between	
	01 position and reference (≤ 1.5 dB)	-----
	02 position and reference (≤ 1.5 dB)	-----
	03 position and reference (≤ 1.5 dB)	-----
	04 position and reference (≤ 1.5 dB)	-----
	05 position and reference (≤ 1.5 dB)	-----
	06 position and reference (≤ 1.5 dB)	-----
	07 position and reference (≤ 1.5 dB)	-----
	08 position and reference (≤ 1.5 dB)	-----
	09 position and reference (≤ 1.5 dB)	-----
27.	Level difference between	
	19 position and reference (≤ 0.5 dB)	-----
	29 position and reference (≤ 0.5 dB)	-----
	39 position and reference (≤ 0.5 dB)	-----
	49 position and reference (≤ 0.5 dB)	-----
	59 position and reference (≤ 0.5 dB)	-----



STEP	DATA	RESULT
(d)	Pulse Width	
9.	Range 1 pulse 50 ns (45 to 55 ns)	-----
12.	Range 1 pulse 500 ns (450 to 550 ns)	-----
15.	Range 1 pulse 5 μ s (4.5 to 5.5 μ s)	-----
18.	Range 1 pulse 50 μ s (45 to 55 μ s)	-----
24.	Range 1 pulse 500 μ s (450 to 550 μ s)	-----
30.	Range 1 pulse 2.5 ms (2.0 to 3.0 ms)	-----
38.	Range 2 pulse 50 ns (45 to 55 ns)	-----
41.	Range 2 pulse 500 ns (450 to 550 ns)	-----
44.	Range 2 pulse 5 μ s (4.5 to 5.5 μ s)	-----
47.	Range 2 pulse 50 μ s (45 to 55 μ s)	-----
53.	Range 2 pulse 500 μ s (450 to 550 μ s)	-----
(e)	RF ON/OFF Ratio	
5.	ON signal level	-----
7.	OFF signal level	-----
	OFF signal level ≥ 70 dB below ON signal level	-----
(2)	IF Signal Generator	
(a)	Frequency and IF Counter	
4.	Frequency ≤ 20 MHz	-----
5.	FREQUENCY Hz/MHz Digital Display (1) readout equals Step 4 reading (± 2 kHz)	-----
7.	Frequency ≥ 70 MHz	-----
8.	FREQUENCY Hz/MHz Digital Display (1) readout equals Step 7 reading (± 7 kHz)	-----
(b)	Sweep Width	
7.	Carrier starts sweeping past 0 setting	----- (\checkmark)
9.	4 MHz sweep width	----- (\checkmark)
(c)	Marker Frequency	
3.	FREQUENCY Hz/MHz Digital Display (1) readout ≤ 20 MHz	-----
5.	FREQUENCY Hz/MHz Digital Display (1) readout ≥ 70 MHz	-----
(d)	Power	
6.	Signal level 0 dBm (-2.5 to +2.5 dBm)	-----
9.	Signal level +20 dBm (+17.3 to +22.7 dBm)	-----
14.	Signal level -130 dBm (-133.8 to -126.2 dBm)	-----



STEP	DATA	RESULT
(e)	Pulse Width	
	7. 500 ns (450 to 550 ns)	-----
	12. 500 μ s (450 to 550 μ s)	-----
(f)	IF ON/OFF Ratio	
	5. 30 MHz ON signal level	-----
	7. 30 MHz OFF signal level	-----
	OFF signal level \geq 48 dB below ON signal level	-----
	11. 60 MHz ON signal level	-----
	13. 60 MHz OFF signal level	-----
	OFF signal level \geq 48 dB below ON signal level	-----
(3)	INTL Modulation/PRF Counter	
	5. INTL PRF/AM Control (41) is set to 50 Hz	----- (✓)
	6. FREQUENCY Hz/MHz Digital Display (1) readout is 50 Hz (49 to 51 Hz)	-----
	8. INTL PRF/AM Control (41) is set to 500 Hz	----- (✓)
	9. FREQUENCY Hz/MHz Digital Display (1) readout is 500 Hz (499 to 501 Hz)	-----
	12. INTL PRF/AM Control (41) is set to 50 Hz	----- (✓)
	13. FREQUENCY Hz/MHz Digital Display (1) readout is 500 Hz (499 to 501 Hz)	-----
	14. Frequencies in Steps 9 and 10 overlap frequencies in Steps 12 and 13	----- (✓)
	16. INTL PRF/AM Control (41) is set to 500 Hz	----- (✓)
	17. FREQUENCY Hz/MHz Digital Display (1) readout is 5000 Hz (4998 to 5002 Hz)	-----
(4)	Range	
	RANGE 1	
	7. Residual delay 0.1 μ s (0.0 to 0.2 μ s)	-----
	9. Delay 0.1 μ s + Step 7 residual delay	----- (✓)
	11. Delay 1.236 μ s + Step 7 residual delay	----- (✓)
	14. Delay 100 μ s + Step 7 residual delay (\pm 10 ns)	-----
	15. Ring 1 reply pulse to Ring 2 reply pulse is 100 μ s (99.99 to 100.09 μ s)	-----
	Ring 2 reply pulse to Ring 3 reply pulse is 100 μ s (99.99 to 100.09 μ s)	-----
	Ring 3 reply pulse to Ring 4 reply pulse is 100 μ s (99.99 to 100.09 μ s)	-----
	Ring 4 reply pulse to Ring 5 reply pulse is 100 μ s (99.99 to 100.09 μ s)	-----



STEP	DATA	RESULT
18.	Delay 999.9 μ s + Step 7 residual delay ($\pm 0.1 \mu$ s)	-----
20.	Delay 12.358 ms + Step 7 residual delay ($\pm 1.2 \mu$ s)	-----
RANGE 2		
22.	Residual delay 0.4 μ s (0.3 to 0.5 μ s)	-----
24.	Delay 0.1 μ s + Step 22 residual delay	----- (✓)
26.	Delay 1.236 μ s + Step 22 residual delay	----- (✓)
29.	Delay 999.9 μ s + Step 22 residual delay ($\pm 0.1 \mu$ s)	-----
31.	Delay 12.358 ms + Step 22 residual delay ($\pm 1.2 \mu$ s)	-----
(5)	Power Meter	
6.	Waveguide Coupler value	-----
7.	1 kW Test RF Level (2-2-2, Table 4)	-----
	12 kW Test RF Level (2-2-2, Table 4)	-----
10.	PANEL Meter (43) shows 1 kW (852 to 1148 W)	-----
12.	PANEL Meter (43) shows 12 kW (10224 to 13776 W)	-----
(6)	XMTR DSCRM 0.1V/MHz Connector	
10.	FREQUENCY Hz/MHz Digital Display (1) readout	-----
13.	Pulse level decreases 50 mV (45 to 55 mV)	-----
17.	Pulse level increases 50 mV (45 to 55 mV)	-----
(7)	Inputs	
(a)	AM EXT INPUT Connector	
5.	30% Modulation (28% to 32%)	-----
(b)	EXT TRIG Connector	
5.	EXT (+) Sync pulse appears	----- (✓)
9.	EXT (-) Sync pulse appears	----- (✓)



THIS PAGE INTENTIONALLY LEFT BLANK.

H. Calibration Procedures

CALIBRATION PROCEDURE	PAGE
Power Supply	47
100 MHz Clock	48
8.25 GHz LO	51
RF Display Limits.....	53
Marker Oscillator	54
IF Oscillator	56
IF Generator Power Amplifier	59
External AM	61
Levelers	62
Internal PRF.....	68
Pulse Width.....	69
Range Delay.....	73
Power Meter	75
Discriminator	77

(1) Power Supply

- PREREQUISITES:** None
- TEST EQUIPMENT:** Digital Multimeter (DMM)
Oscilloscope
- FIGURE REFERENCE:** 2-2-2, Figure 13

STEP	PROCEDURE
1.	Press LINE Switch (30) to OFF .
2.	Remove four screws from top cover on RD-301A. Slide top cover to rear and remove from RD-301A.
3.	Press LINE Switch (30) to ON .
4.	Use DMM to verify voltages between Test Points listed in 2-2-2, Table 5 and ground at TP49001 Pin 5.

TEST POINT	VOLTAGE LIMITS	RIPPLE VOLTAGE
TB49001 Pin 3 (+5 V)	+4.7 to +5.3 Vdc	≤15 mVp-p
TB49001 Pin 2 (+12 V)	+11.4 to +12.6 Vdc	≤15 mVp-p
TB49001 Pin 4 (-12 V)	-11.4 to -12.6 Vdc	≤15 mVp-p
TB49001 Pin 1 (-24 V)	-22.0 to -25.2 Vdc	≤20 mVp-p

Power Supply Terminal Bus Voltages
Table 5

5. Use Oscilloscope to verify ripple voltages between Test Points listed in 2-2-2, Table 5 and ground at TB49001 Pin 5.
6. Disconnect test equipment and replace top cover on RD-301A.

(2) 100 MHz Clock

PREREQUISITES: Power Supply (para 2-2-2H[1])

TEST EQUIPMENT: Frequency Counter
10:1 Oscilloscope Probe

FIGURE REFERENCE: 2-2-2, Figure 14

STEP	PROCEDURE
1.	Apply power to RD-301A and allow for 30 minute stabilization period.
2.	Refer to para 2-2-2H(1), Step 2 and remove top cover from RD-301A.
3.	Set μ S/NM Switch (36) to μS .
4.	Connect 10:1 Oscilloscope Probe from Frequency Counter to TP19001 on Range #1 PC Board Assembly.
5.	Verify frequency is 100 MHz (± 5 kHz). If not, adjust L19002 on Range #1 PC Board Assembly. Record frequency.
	NOTE: Adjusting L19002 also affects μ s Range Delay and FREQUENCY Hz/MHz Digital Display (1) counter (10 kHz time base).
6.	Set μ S/NM Switch (36) to NM .
7.	Verify frequency at TP19001 is 8.091269 MHz (± 400 Hz). If oscillator is not in tolerance after following proper stabilization procedures and insuring adequate Frequency Counter accuracy, change value of C19015 on Range #1 PC Board Assembly. Refer to Range #1 PC Board Assembly and Circuit Schematic drawings for component location and circuit understanding. Value for C19015 may range from 68 to 100 pF (type NPO). If C19015 is replaced, allow RD-301A to restabilize before retesting. Record frequency.
	NOTE: 100 MHz Clock calibration errors affect the representation of Radar transmitter and RD-301A frequencies shown on the FREQUENCY Hz/MHz Digital Display (1). Frequency Tracking accuracy is not affected by 100 MHz Clock calibration errors.
8.	Disconnect test equipment and replace top cover on RD-301A.

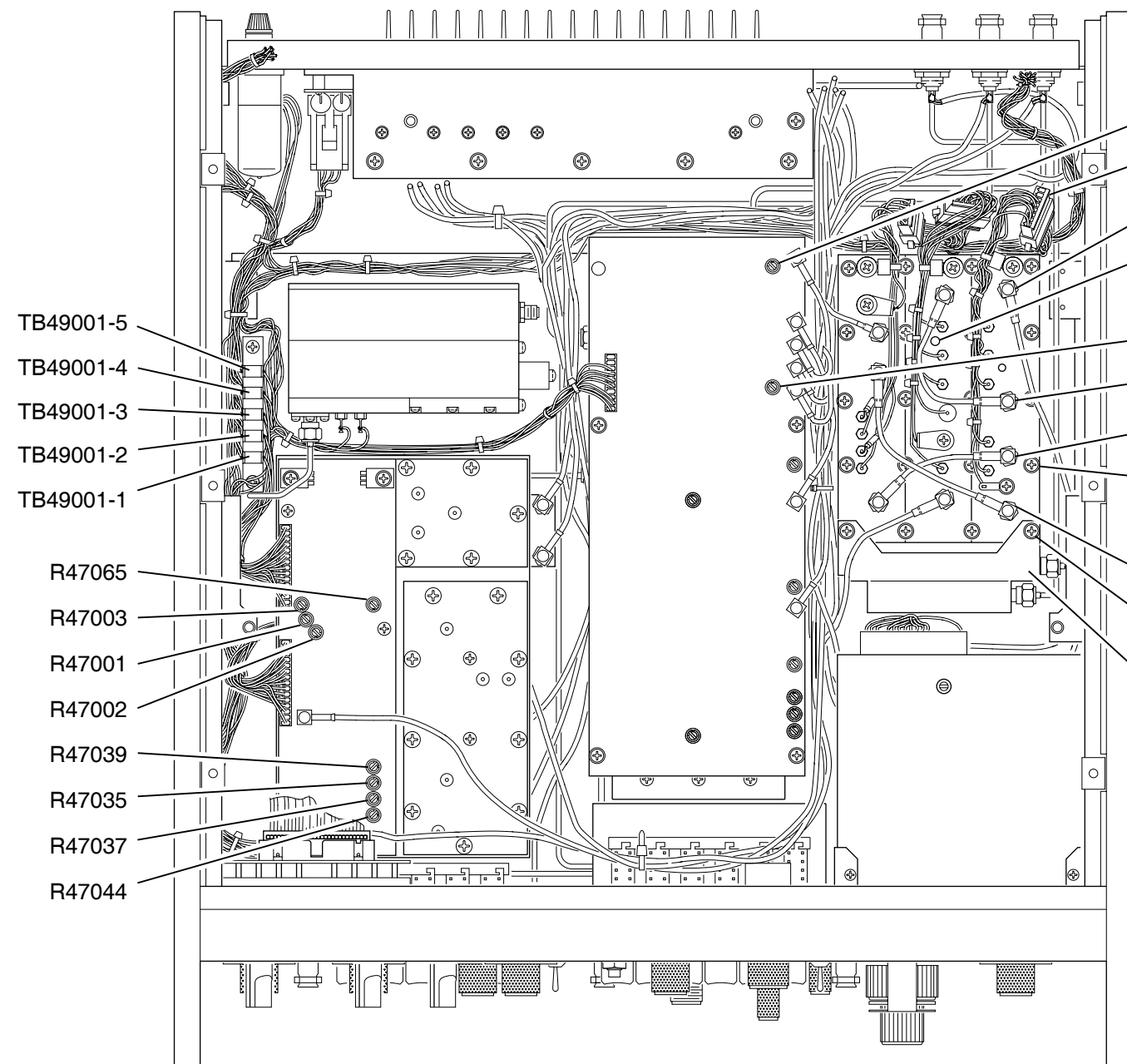

Floor Test Points and Adjustments
Figure 13

- R17128
- P/J33003
- P/J33001
- R36023
- TP19001
- R17143
- P/J33002
- P/J33004
- SCREW (9 PLCS)
- L19002
- P/J33005
- SCREW (2 PLCS)
- BRACKET
- R19047

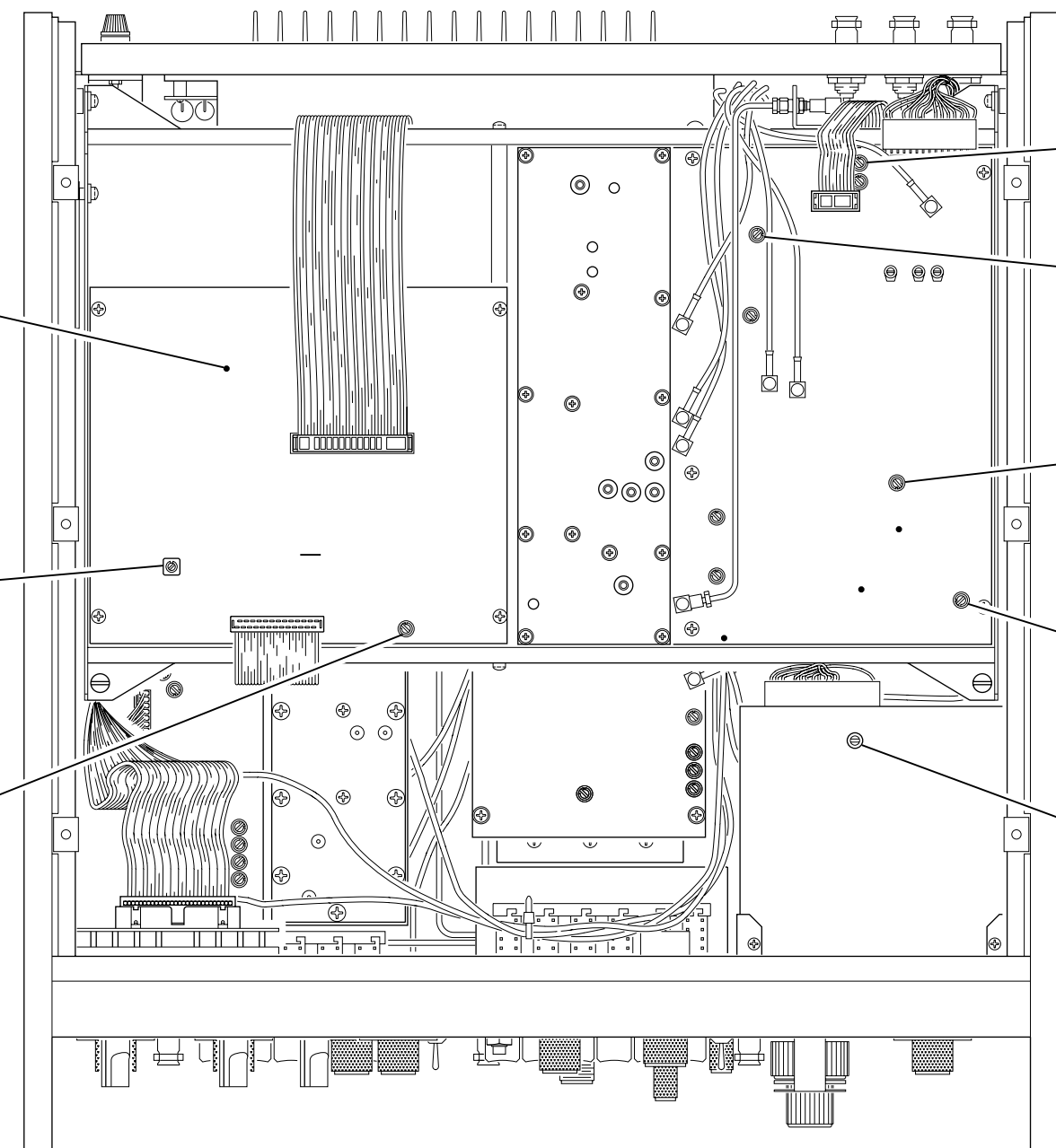

Card Frame (Top) Test Points and Adjustments
Figure 14

9019001

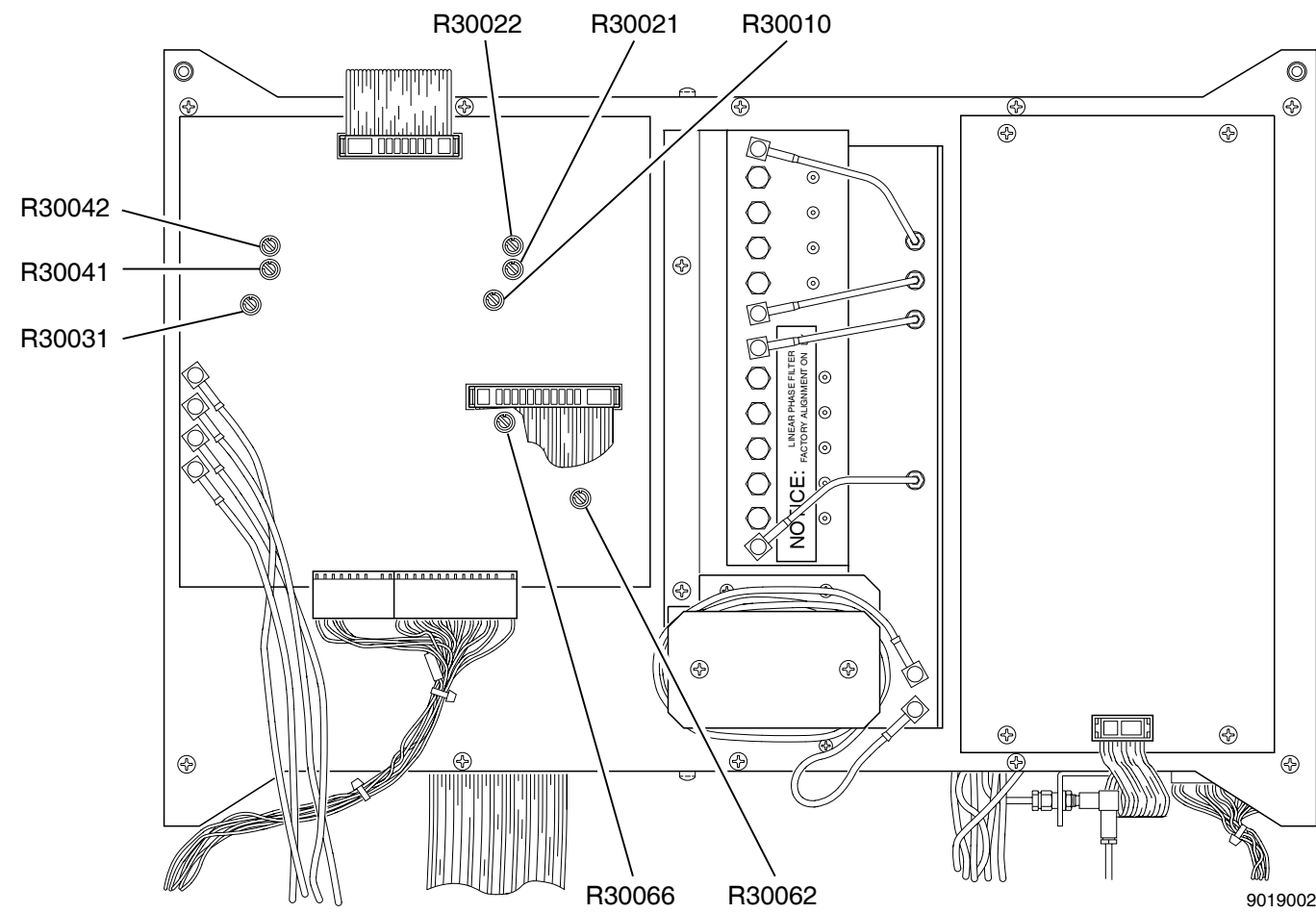

Card Frame (Bottom) Test Points and Adjustments
Figure 15

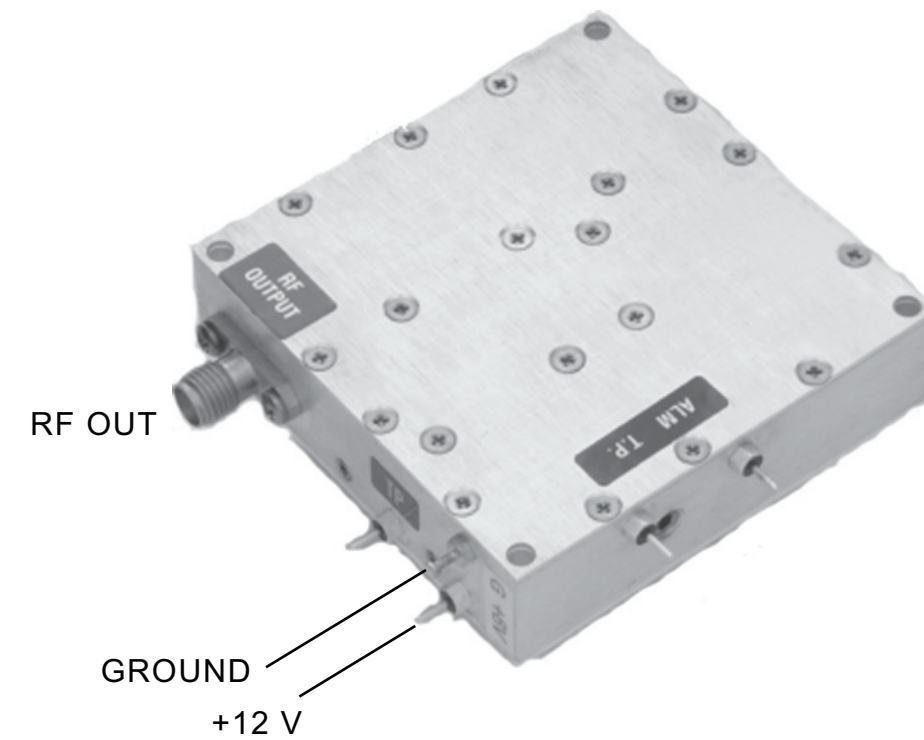

8.25 GHz LO Top Test Points and Adjustments
Figure 16

(3) 8.25 GHz LO

PREREQUISITES: 100 MHz Clock (para 2-2-2H[2])

TEST EQUIPMENT: Digital Multimeter (DMM)
 Frequency Counter

FIGURE REFERENCE: 2-2-2, Figure 16

STEP	PROCEDURE														
1.	Apply power to RD-301A and allow for 30 minute stabilization period.														
2.	Set RD-301A as follows:														
	<table border="1" style="width: 100%;"> <thead> <tr> <th style="text-align: left;">CONTROL</th> <th style="text-align: left;">SETTING</th> </tr> </thead> <tbody> <tr> <td>(2) PRF/RF Switch</td> <td><i>RF</i></td> </tr> <tr> <td>(4) OUTPUT LEVEL FINE dBm Control</td> <td><i>0</i></td> </tr> <tr> <td>(9) OUTPUT LEVEL COARSE dBm Control</td> <td><i>-50</i></td> </tr> <tr> <td>(10) MNL FREQ Controls</td> <td><i>9375 MHz</i></td> </tr> <tr> <td>(16) RF/IF MODE Pushbutton Switches</td> <td><i>MNL</i></td> </tr> <tr> <td>(29) MODULATION MODE Pushbutton Switches</td> <td><i>CW</i></td> </tr> </tbody> </table>	CONTROL	SETTING	(2) PRF/RF Switch	<i>RF</i>	(4) OUTPUT LEVEL FINE dBm Control	<i>0</i>	(9) OUTPUT LEVEL COARSE dBm Control	<i>-50</i>	(10) MNL FREQ Controls	<i>9375 MHz</i>	(16) RF/IF MODE Pushbutton Switches	<i>MNL</i>	(29) MODULATION MODE Pushbutton Switches	<i>CW</i>
CONTROL	SETTING														
(2) PRF/RF Switch	<i>RF</i>														
(4) OUTPUT LEVEL FINE dBm Control	<i>0</i>														
(9) OUTPUT LEVEL COARSE dBm Control	<i>-50</i>														
(10) MNL FREQ Controls	<i>9375 MHz</i>														
(16) RF/IF MODE Pushbutton Switches	<i>MNL</i>														
(29) MODULATION MODE Pushbutton Switches	<i>CW</i>														
3.	Refer to para 2-2-2H(1), Step 2 and remove top cover from RD-301A.														
4.	Examine 8.25 GHz LO for +12 V or -24 V input. Module with +12 V input has red wire at the top of the module labeled +12 V.														
5.	If 8.25 GHz LO is +12 V input, proceed to Step 12. If 8.25 GHz LO is -24 V input proceed to next step.														
6.	Connect Frequency Counter to XTAL MON (Crystal Monitor) Connector on right side of 8.25 GHz LO.														
7.	Place top cover loosely on RD-301A, insuring cable is not damaged.														
8.	Monitor frequency 15 minutes to insure drift is stabilized.														
9.	After stabilization, verify frequency is 103.125 MHz (± 2.1 kHz). Adjust XTAL ADJ (Crystal Adjustment) on 8.25 GHz LO as needed. Allow time for restabilization after adjustment. Record adjusted frequency.														
10.	Use DMM to verify voltage between Φ LCK (Phase Lock) Voltage Terminal on 8.25 GHz LO and ground is -10 Vdc (± 5 Vdc). If voltage is out of tolerance, adjust FREQ ADJ Control for correct voltage.														
11.	Disconnect test equipment and secure top cover to RD-301A.														
12.	Connect Frequency Counter to output side of 8.25 GHz Oscillator pad.														
13.	Verify frequency on Frequency Counter reads 8.25 GHz (± 100 kHz). Record frequency.														
14.	Disconnect test equipment and secure top cover to the RD-301A.														

STEP

PROCEDURE

15. Connect Frequency Counter to X-BAND I/O Connector (18). Verify FREQUENCY Hz/MHz Digital Display (1) matches Frequency Counter reading (± 250 kHz).

NOTE: FREQUENCY Hz/MHz Digital Display (1) accuracy depends on the frequency precision of the 8.25 GHz LO signal and 10 kHz Clock derived from the 100 MHz Oscillator on Range #1 PC Board Assembly. The frequency shown on the FREQUENCY Hz/MHz Digital Display (1) indirectly represents the signal frequency at the X-BAND I/O Connector (18). The FREQUENCY Hz/MHz Digital Display (1) shows the frequency count (10 kHz Clock base) of the prescaled L-Band signal added to a fixed 8250 MHz offset (8.25 GHz LO ideal frequency). The L-Band signal (1045-1250 MHz) generated by the VCO #2 Assembly is converted up by the 8.25 GHz LO signal to provide the X-Band signal at the X-BAND I/O Connector (18).

NOTE: 8.25 GHz LO calibration errors do not affect Frequency Tracking accuracy. The received Radar transmitter signal is converted down by the same 8.25 GHz LO signal the RD-301A L-Band signal is converted up by.

(4) RF Display Limits

PREREQUISITES: 8.25 GHz LO (para 2-2-2H[3])
TEST EQUIPMENT: None
FIGURE REFERENCE: 2-2-2, Figure 13

STEP	PROCEDURE
------	-----------

1. Apply power to RD-301A and allow for 30 minute stabilization period.
2. Set RD-301A as follows:

CONTROL	SETTING
(2) PRF/RF Switch	RF
(4) OUTPUT LEVEL FINE dBm Control	0
(9) OUTPUT LEVEL COARSE dBm Control	-50
(16) RF/IF MODE Pushbutton Switches	MNL
(29) MODULATION MODE Pushbutton Switches	CW

3. Rotate MNL FREQ Controls (10) **fully cw**.
4. Verify 9508 MHz (± 5.0 MHz) on FREQUENCY Hz/MHz Digital Display (1). If not in tolerance, refer to para 2-2-2H(1), Step 2 and remove top cover from RD-301A. Adjust R47035 on AGC PC Board Assembly until **9508 MHz** is shown on FREQUENCY Hz/MHz Digital Display (1).
5. Rotate MNL FREQ Controls (8) **fully ccw**.
6. Verify 9287 MHz (± 5.0 MHz) on FREQUENCY Hz/MHz Digital Display (1). If not in tolerance, refer to para 2-2-2H(1), Step 2 and remove top cover from RD-301A. Adjust R47039 on AGC PC Board Assembly until **9287 MHz** is shown on FREQUENCY Hz/MHz Digital Display (1).
7. Repeat Steps 3 through 6 until no more adjustments are required.
8. If removed, replace top cover on RD-301A and repeat Steps 3 through 6 with top cover on.

(5) Marker Oscillator

PREREQUISITES: 8.25 GHz LO (para 2-2-2H[3])

TEST EQUIPMENT: Frequency Counter

FIGURE REFERENCE: 2-2-2, Figure 13

STEP	PROCEDURE
1.	Refer to para 2-2-2H(1), Step 2 and remove top cover from RD-301A.
2.	Disconnect following coaxial cables and connectors: <ul style="list-style-type: none"> ● P33001 (AGC PC Board Assembly) from J33001 (IF MKR/OSC PC Board Assembly) ● P33002 (IF GEN PWR AMPL PC Board Assembly) from J33002 (IF MKR/OSC PC Board Assembly) ● P33003 (Main Wire Harness Assembly) from J33003 (IF MKR/OSC PC Board Assembly) ● P33004 (Prescaler PC Board Assembly, P/J23003) from J33004 (IF MKR/OSC PC Board Assembly) ● P33005 (Prescaler PC Board Assembly, P/J23004) from J33005 (IF MKR/OSC PC Board Assembly)
3.	Remove two screws and move Bracket away from IF MKR/OSC PC Board Assembly.
4.	Remove nine screws and remove IF MKR/OSC PC Board Assembly from enclosure.
5.	Place IF MKR/OSC PC Board Assembly on insulated medium (thick cardboard recommended), close enough to reconnect coaxial cables and connectors.
6.	Carefully position IF MKR/OSC PC Board Assembly for access to C33034 and L33001. Refer to IF MKR/OSC PC Board Assembly drawing.
7.	Reconnect coaxial cables and connectors disconnected in Step 2 except P/J33005.
8.	Connect Frequency Counter to J33005.
9.	Apply power to RD-301A and allow for 30 minute stabilization period.
10.	Rotate MKR FREQ Control (19) fully ccw .
11.	Press DISPLAY MKR Switch (21).
12.	Verify ≤ 18.0 MHz is shown on Frequency Counter. If not, adjust C33034 on IF MKR/OSC PC Board Assembly.
13.	Rotate MKR FREQ Control (19) fully cw .
14.	Press DISPLAY MKR Switch (21).
15.	Verify Frequency Counter indicates ≥ 74 MHz. <p style="margin-left: 40px;">NOTE: Frequency drifts lower with assembly in enclosure and RD-301A at stabilized temperature.</p>
16.	Replace IF MKR/OSC PC Board Assembly in enclosure. Replace and tighten all screws.
17.	Disconnect Frequency Counter from J33005.

STEP

PROCEDURE

18. Reconnect P33005 to J33005.
19. Replace top cover on RD-301A.
20. Set PRF/RF Switch (2) to **RF** and select **IF HI** on RF/IF MODE Pushbutton Switches (16).
21. Press DISPLAY MKR Switch (21).
22. Verify ≥ 70 MHz is shown on FREQUENCY Hz/MHz Digital Display (1). Record frequency.
23. Rotate MKR FREQ Control (19) **fully ccw**.
24. Press DISPLAY MKR Switch (21).
25. Verify ≤ 20 MHz is shown on FREQUENCY Hz/MHz Digital Display (1). Record frequency.

(6) IF Oscillator

PREREQUISITES: 8.25 GHz LO (para 2-2-2H[3])

TEST EQUIPMENT: Frequency Counter
 Digital Multimeter (DMM)
 Spectrum Analyzer

FIGURE REFERENCE: 2-2-2, Figure 13

STEP	PROCEDURE
1.	Apply power to RD-301A and allow for 30 minute stabilization period.
2.	Refer to para 2-2-2H(1), Step 2 and remove top cover from RD-301A.
3.	Set PRF/RF Switch (2) to RF and select IF HI on RF/IF MODE Pushbutton Switches (16).
4.	Rotate MNL FREQ Controls (10) fully cw .
5.	Verify FREQUENCY Hz/MHz Digital Display (1) indicates 77 MHz. If not, adjust R47037 on AGC PC Board Assembly.
6.	Rotate MNL FREQ Controls (10) fully cw .
7.	Verify FREQUENCY Hz/MHz Digital Display (1) indicates ≤ 18 MHz. If not, adjust R47044 on AGC PC Board Assembly.
8.	Rotate MNL FREQ Controls (10) fully cw .
9.	Verify FREQUENCY Hz/MHz Digital Display (1) indicates ≥ 74 MHz. If not, repeat Steps 5 through 9 until indications are correct. Record correct upper and lower frequency indications and proceed at Step 38. If unable to attain correct indications, proceed at Step 10.
<p>NOTE: Frequency drifts lower with assembly in enclosure and RD-301A at stabilized temperature.</p>	
10.	Press LINE Switch (30) to OFF .
11.	Disconnect following coaxial cables and connectors: <ul style="list-style-type: none"> ● P33001 (AGC PC Board Assembly) from J33001 (IF MKR/OSC PC Board Assembly) ● P33002 (IF GEN PWR AMPL PC Board Assembly) from J33002 (IF MKR/OSC PC Board Assembly) ● P33003 (Main Wire Harness Assembly) from J33003 (IF MKR/OSC PC Board Assembly) ● P33004 (Prescaler PC Board Assembly, P/J23003) from J33004 (IF MKR/OSC PC Board Assembly) ● P33005 (Prescaler PC Board Assembly, P/J23004) from J33005 (IF MKR/OSC PC Board Assembly)
12.	Remove two screws and move Bracket away from IF MKR/OSC PC Board Assembly.
13.	Remove nine screws and remove IF MKR/OSC PC Board Assembly from enclosure.
14.	Place IF MKR/OSC PC Board Assembly on insulated medium (thick cardboard recommended), close enough to reconnect coaxial cables and connectors.

STEP PROCEDURE

15. Carefully position IF MKR/OSC PC Board Assembly for access to C33034 and L33001. Refer to IF MKR/OSC PC Board Assembly drawing.
16. Reconnect coaxial cables and connectors disconnected in Step 11 except P/J33004.
17. Connect Frequency Counter to J33004 with 50 Ω coaxial cable.
18. Connect DMM between ground at TB49001-5 and anode lead of CR47006 on AGC PC Board Assembly. Refer to AGC PC Board Assembly drawing.
19. Press LINE Switch (30) to **ON** and allow for five minute stabilization period.
20. Set R47044 on AGC PC Board Assembly to center position.
21. Adjust R47037 on AGC PC Board Assembly for -18.0 V on DMM.
22. Refer to IF MKR/OSC PC Board Assembly drawing and adjust L47001 on IF MKR/OSC PC Board Assembly for 77.0 MHz on Frequency Counter.
23. Rotate MNL FREQ Controls (10) **fully cw** and adjust R47044 for 17.0 MHz on Frequency Counter.
24. Verify tune line voltage on DMM is \approx -2.0 V.
25. Rotate MNL FREQ Controls (10) **fully cw** and verify 77 MHz on Frequency Counter.
26. Readjust R47037 and R47044 to achieve frequency range from 17.0 to 77.0 MHz.
27. Disconnect Frequency Counter from J33004.
28. Reconnect P33004 to J33004.

MIXER BALANCE ADJUSTMENT

29. Disconnect P33002 from J33002
30. Connect Spectrum Analyzer to J33002.
31. Set Spectrum Analyzer as follows:

CONTROL	SETTING
Center Frequency	50 MHz
Frequency Span	10 MHz/Div
Amplitude Scale	10 dB/Div
Input Attenuation	30 dB

32. Adjust MNL FREQ Controls (10) for **60 MHz** on FREQUENCY Hz/MHz Digital Display (1).
33. Refer to IF MKR/OSC PC Board Assembly drawing and adjust R33024 on IF MKR/OSC PC Board Assembly for maximum 60 MHz signal with minimum spurious signals.
34. Disconnect test equipment.
35. Replace IF MKR/OSC PC Board Assembly in enclosure. Replace and tighten all screws.
36. Reconnect P33002 to J33002.
37. Repeat Steps 3 through 9.

STEP	PROCEDURE
------	-----------

SWEEP WIDTH

38. Connect Spectrum Analyzer to IF OUT Connector (15).
39. Set Spectrum Analyzer as follows:

CONTROL
SETTING

Center Frequency	30 MHz
Frequency Span	500 kHz/Div
Reference Level	+20 dBm
Sweep Speed	50 ms/Div

40. Adjust MNL FREQ Controls (10) for **30 MHz** on FREQUENCY Hz/MHz Digital Display (1).
41. Adjust SWEEP WIDTH MHz Control (33) **cw**.
42. Verify carrier starts sweeping when SWEEP WIDTH MHz Control (33) passes 0 setting. If not, reset SWEEP WIDTH MHz Control (33) as follows:
 - Remove two set screws and dial.
 - Rotate control shaft cw until carrier begins to sweep.
 - Rotate shaft control ccw until sweep stops.
 - Without rotating control, replace dial with index mark set to zero and tighten two set screws.
43. Set SWEEP WIDTH MHz Control (33) to **4**.
44. Verify carrier sweep is displayed across 8.0 divisions (4 MHz sweep width) on Spectrum Analyzer. If not, adjust R31007 on Counter Gating PC Board.
45. Set SWEEP WIDTH MHz Control (33) to **2**.
46. Verify carrier sweep (2 MHz wide) is displayed across 4.0 divisions (± 2 minor divisions) on Spectrum Analyzer. If not, adjust R31007 on Counter Gating PC Board.
47. If needed, adjust R31007 until carrier sweep at 2 and 4 MHz is within 10% of dial setting. Record sweep width at both settings.
48. Set SWEEP WIDTH MHz Control (33) to **OFF**.
49. Disconnect test equipment and replace top cover on RD-301A.

(7) IF Generator Power Amplifier

PREREQUISITES: IF Oscillator (para 2-2-2H[6])

TEST EQUIPMENT: Spectrum Analyzer
Power Meter
L-Band Signal Generator

FIGURE REFERENCE: 2-2-2, Figure 13

STEP	PROCEDURE												
1.	Apply power to RD-301A and allow for 30 minute stabilization period.												
2.	Set RD-301A as follows:												
	<table border="1" style="width: 100%; border-collapse: collapse;"> <thead> <tr> <th style="text-align: left;"><u>CONTROL</u></th> <th style="text-align: left;"><u>SETTING</u></th> </tr> </thead> <tbody> <tr> <td>(2) PRF/RF Switch</td> <td>RF</td> </tr> <tr> <td>(4) OUTPUT LEVEL FINE dBm Control</td> <td>0</td> </tr> <tr> <td>(9) OUTPUT LEVEL COARSE dBm Control</td> <td>-50</td> </tr> <tr> <td>(16) RF/IF MODE Pushbutton Switches</td> <td>IF HI</td> </tr> <tr> <td>(29) MODULATION MODE Pushbutton Switches</td> <td>CW</td> </tr> </tbody> </table>	<u>CONTROL</u>	<u>SETTING</u>	(2) PRF/RF Switch	RF	(4) OUTPUT LEVEL FINE dBm Control	0	(9) OUTPUT LEVEL COARSE dBm Control	-50	(16) RF/IF MODE Pushbutton Switches	IF HI	(29) MODULATION MODE Pushbutton Switches	CW
<u>CONTROL</u>	<u>SETTING</u>												
(2) PRF/RF Switch	RF												
(4) OUTPUT LEVEL FINE dBm Control	0												
(9) OUTPUT LEVEL COARSE dBm Control	-50												
(16) RF/IF MODE Pushbutton Switches	IF HI												
(29) MODULATION MODE Pushbutton Switches	CW												
3.	Refer to para 2-2-2H(1), Step 2 and remove top cover from RD-301A.												
4.	Set Spectrum Analyzer RF for 30 MHz signal at 0 dBm and Amplitude Scale to 2 dB/Div.												
5.	Connect L-Band Signal Generator to Spectrum Analyzer using high quality RG58 BNC coaxial cable.												
6.	Set L-Band Signal Generator for 30 MHz CW signal. Insure all harmonics and spurious signals are ≥ 30 dB below carrier for accurate power measurements.												
7.	Disconnect L-Band Signal Generator from Spectrum Analyzer.												
8.	Connect L-Band Signal Generator to Power Meter using same RG58 BNC coaxial cable.												
9.	Adjust L-Band Signal Generator for 0 dBm on Power Meter.												
10.	Reconnect L-Band Signal Generator to Spectrum Analyzer using same cable. Record reference level of 30 MHz CW signal at 0 dBm on Spectrum Analyzer screen with reference level accurate to ± 0.2 dB.												
11.	Disconnect L-Band Signal Generator from Spectrum Analyzer.												
12.	Connect IF OUT Connector (15) to Spectrum Analyzer using same cable used to set reference level.												
13.	Rotate MNL FREQ Controls (10) to indicate 30 MHz on FREQUENCY Hz/MHz Digital Display (1).												
14.	Adjust R36023 on IF GEN PWR AMPL PC Board Assembly to match signal amplitude on Spectrum Analyzer of 30 MHz reference level recorded in Step 10.												
15.	Disconnect Spectrum Analyzer from IF OUT Connector (15).												
16.	Set Spectrum Analyzer RF for a signal of 60 MHz at 0 dBm.												
17.	Connect L-Band Signal Generator to Spectrum Analyzer using same RG58 BNC coaxial cable.												
18.	Set L-Band Signal Generator for 60 MHz CW signal. Insure all harmonics and spurious signals are ≥ 30 dB below carrier for accurate power measurements.												

STEP

PROCEDURE

19. Disconnect L-Band Signal Generator from Spectrum Analyzer.
20. Connect L-Band Signal Generator to Power Meter using same RG58 BNC coaxial cable.
21. Adjust L-Band Signal Generator for 0 dBm on Power Meter.
22. Reconnect L-Band Signal Generator to Spectrum Analyzer using same cable. Record reference level of 60 MHz CW signal at 0 dBm on Spectrum Analyzer screen with reference level accurate to ± 0.2 dB.
23. Disconnect L-Band Signal Generator from Spectrum Analyzer.
24. Connect IF OUT Connector (15) to Spectrum Analyzer using same cable used to set reference level.
25. Rotate MNL FREQ Controls (10) to indicate **60 MHz** on FREQUENCY Hz/MHz Digital Display (1).
26. Verify Spectrum Analyzer indicates 0 dBm (± 2.5 dB). If not, adjust R36023.
27. If R36023 is adjusted in Step 26, repeat Steps 4 through 26 until 30 MHz and 60 MHz signals both indicate 0 dBm (± 2.5 dB) on Spectrum Analyzer.
28. Disconnect test equipment and replace top cover on RD-301A.

(8) External AM

PREREQUISITES: 100 MHz Clock (para 2-2-2H[2])

TEST EQUIPMENT: Function Generator
Modulation Meter
X-Band to L-Band Down Converter

FIGURE REFERENCE: 2-2-2, Figure 13

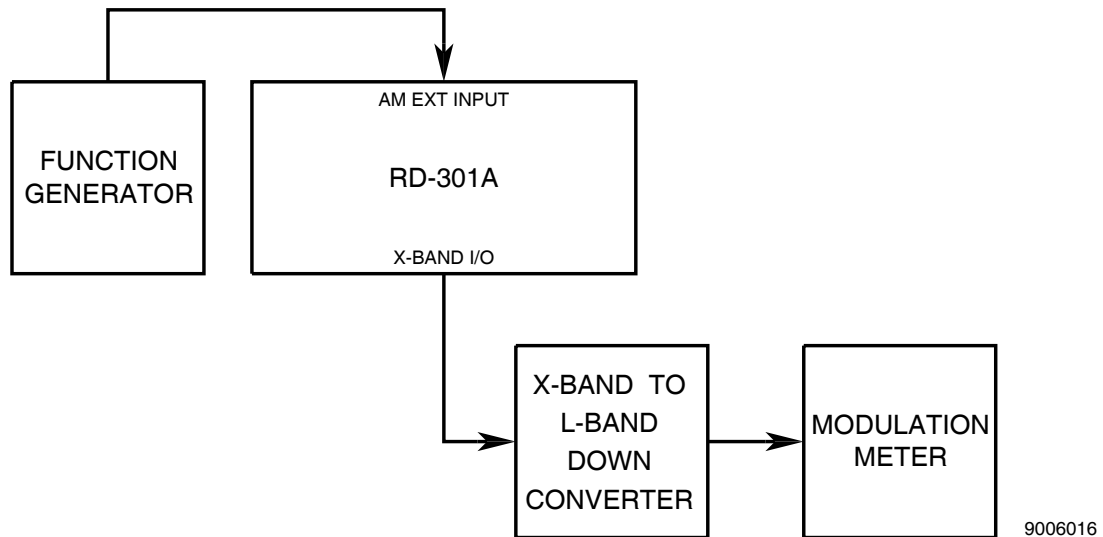

External AM Calibration Setup
Figure 17

STEP	PROCEDURE
------	-----------

1. Apply power to RD-301A and allow for 30 minute stabilization period.
2. Set RD-301A as follows:

CONTROL	SETTING
(2) PRF/RF Switch	RF
(9) OUTPUT LEVEL COARSE dBm Control	-50
(10) MNL FREQ Controls	9375 MHz
(16) RF/IF MODE Pushbutton Switches	RF MNL
(29) MODULATION MODE Pushbutton Switches	CW

3. Refer to para 2-2-2H(1), Step 2 and remove top cover from RD-301A.
4. Connect test equipment as shown in 2-2-2, Figure 17.
5. Set Function Generator for 1 kHz sine wave at 3 Vp-p.
6. Verify 30% ($\pm 2\%$) modulation on Modulation Meter. If not, adjust R47003 on AGC PC Board Assembly.
7. Disconnect test equipment and replace top cover on RD-301A.

(9) Levelers

PREREQUISITES: None

TEST EQUIPMENT: Function Generator
Power Meter
Spectrum Analyzer

FIGURE REFERENCE: 2-2-2, Figure 13

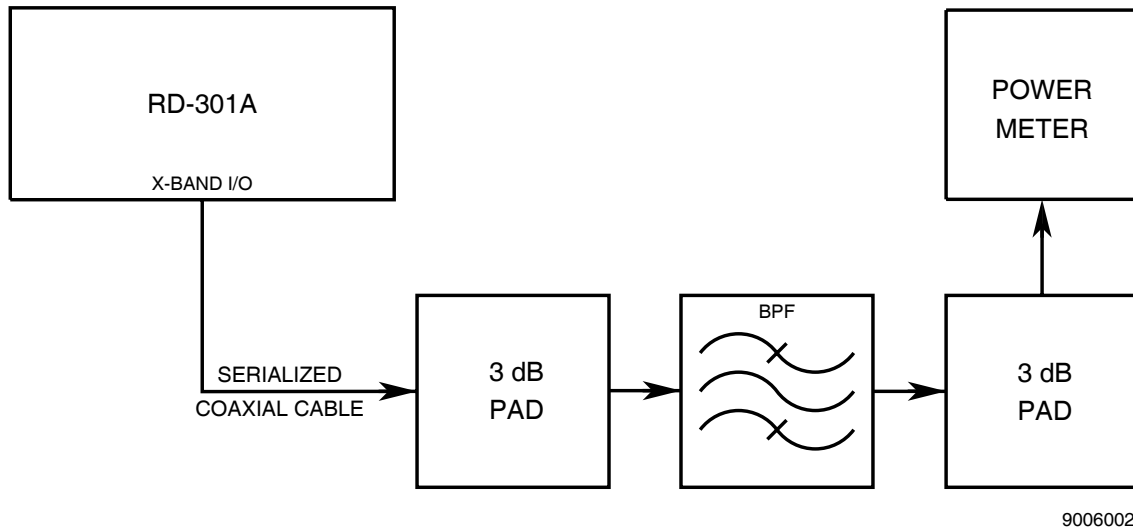

Main Leveler Calibration Setup
Figure 18

STEP	PROCEDURE
------	-----------

1. Apply power to RD-301A and allow for 30 minute stabilization period.
2. Set RD-301A as follows:

CONTROL	SETTING
(2) PRF/RF Switch	RF
(3) CONTOUR/R2/INTL AM dB BOOST/ATTEN Control	00
(4) OUTPUT LEVEL FINE dBm Control	-3
(9) OUTPUT LEVEL COARSE dBm Control	-50
(10) MNL FREQ Controls	9400 MHz
(16) RF/IF MODE Pushbutton Switches	RF MNL
(29) MODULATION MODE Pushbutton Switches	CW
(39) RANGE SEL Switch	RINGS 1

3. Connect test equipment as shown in 2-2-2, Figure 18.

NOTE: Assembled 3 dB Pads and Bandpass Filter require flatness of ± 0.1 dB from 9295 to 9500 MHz. Once loss and flatness of filter-pad assembly have been characterized, assembly should not be disassembled.

4. Move Serialized Coaxial Cable and observe Power Meter display. If display fluctuates more than 0.1 dB, replace Serialized Coaxial Cable.

STEP	PROCEDURE
------	-----------

5. Use Equation 1 to compute X-Band Output Power Level (A). Tolerance is X-Band Output Power Level (A) (± 2 dB).

EQUATION 1: $A = B + C + D$

Where: A = Computed X-Band Output Power Level

B = RD-301A Output Level Settings (OUTPUT LEVEL FINE and COARSE dBm Controls [4] and [9])

C = Waveguide Coupler Value (attenuation) (marked on Waveguide Coupler)

D = Insertion loss of Bandpass Filter and 3 dB Pads

EXAMPLE: RD-301A Output Level Settings (B) = -53.0 dBm

Waveguide Coupler Value (C) = +20.2 dB

Insertion Loss of Bandpass Filter (D) = -7.17 dB

$A = -53.0 \text{ dBm} + +20.2 \text{ dB} + -7.17 \text{ dB}$

$A = -39.97 \text{ dBm}$

6. Compute X-Band Output Power Level upper limit (A + 2 dB).
7. Compute X-Band Output Power Level lower limit (A - 2 dB).
8. Adjust MNL FREQ Controls (10) from **9295 MHz** to **9500 MHz** and verify Power Meter reading stays between upper limit from Step 6 and lower limit from Step 7. If so, proceed at Step 14. If not, proceed at Step 9.
9. Adjust MNL FREQ Controls (10) from **9295 MHz** to **9500 MHz** and record highest and lowest amplitude values. Determine midpoint amplitude value between highest and lowest amplitude values.
10. Refer to para 2-2-2H(1), Step 2 and remove top cover from RD-301A.
11. Adjust MNL FREQ Controls (10) to frequency between **9295 MHz** to **9500 MHz** having power level closest to midpoint amplitude value from Step 9.
12. Adjust R47001 on AGC PC Board Assembly until selected frequency has same power output level as X-Band Output Power Level from Step 5.
13. Adjust MNL FREQ Controls (10) from **9295 MHz** to **9500 MHz** and verify Power Meter reading stays between upper limit from Step 6 and lower limit from Step 7. If so, proceed at Step 14. If not, repeat Steps 9 through 13.
14. Disconnect test equipment.

CONTOUR LEVELER

15. Use Serialized Coaxial Cable to connect Spectrum Analyzer to X-BAND I/O Connector (18).

STEP PROCEDURE

16. Set Spectrum Analyzer as follows:

CONTROL	SETTING
Center Frequency	9360 MHz
Frequency Span	20 MHz/Div
Resolution Bandwidth (uncoupled)	3 MHz
Amplitude Scale	2 dB/Div
Sweep Speed	10 ms/Div
Input Attenuation	10 dB

NOTE: For all leveler procedures, Spectrum Analyzer video filter can be used with caution, when displayed amplitude is not affected.

17. Set OUTPUT LEVEL FINE dBm Control (4) to **-5**.
 18. Set Spectrum Analyzer amplitude scale for 6 division reference level.

NOTE: Steps 19 through 34 use a dual trace, storage Spectrum Analyzer.
 Steps 35 through 40 use a non-storage Spectrum Analyzer.

CONTOUR LEVELER - STORAGE SPECTRUM ANALYZER

19. Set Spectrum Analyzer for Max Hold (Trace B).
 20. Slowly rotate MNL FREQ Controls (10) from 9295 MHz to 9410 MHz.
 21. Store reference trace (Trace B).
 22. Set RANGE SEL Switch (39) to **CONTOUR/AM UP MOD**.
 23. Set Spectrum Analyzer for Max Hold (Trace A).
 24. Slowly rotate MNL FREQ Controls (10) from **9295 MHz** to **9410 MHz**.

NOTE: Using Spectrum Analyzer, Normalizer displays a single trace to represent signal level difference of Trace A with respect to Trace B, referenced to a zero line.

25. Verify Trace A level equals Trace B reference level (± 1 dB) across specified band. If not, adjust R47002 on AGC PC Board Assembly.

NOTE: Difference in level between two signals (Main and Contour) is measured at all frequencies to verify unit meets specifications. Absolute level of two signals, shown by Spectrum Analyzer, is unimportant.

26. Set OUTPUT LEVEL COARSE dBm Control (9) to **-60** and CONTOUR/R2/INTL AM dB BOOST/ATTEN Control (3) to **10**.
 27. Set Spectrum Analyzer for Max Hold (Trace A).
 28. Slowly rotate MNL FREQ Controls (10) from **9295 MHz** to **9410 MHz**.
 29. Verify difference between Trace A level and Trace B reference level is ≤ 1 dB across specified band.
 30. Set OUTPUT LEVEL COARSE dBm Control (9) to **-70** and CONTOUR/R2/INTL AM dB BOOST/ATTEN Control (3) to **20**.
 31. Set Spectrum Analyzer for Max Hold (Trace A).
 32. Slowly rotate MNL FREQ Controls (10) from **9295 MHz** to **9410 MHz**.
 33. Verify difference between Trace A level and Trace B reference level is ≤ 1 dB across specified band.

STEP	PROCEDURE
------	-----------

34. Proceed at Step 41.

CONTOUR LEVELER - NON-STORAGE SPECTRUM ANALYZER

35. Slowly rotate MNL FREQ Controls (10) from **9295 MHz** to **9410 MHz**. While rotating MNL FREQ Controls (10), frequently switch RANGE SEL Switch (39) between **RINGS 1** and **CONTOUR/AM UP MOD**. Verify displayed levels of both modes are equal (± 1 dB). If not, adjust R47002 on AGC PC Board Assembly.
36. Set Spectrum Analyzer amplitude scale to 5 dB/Div.
37. Set OUTPUT LEVEL COARSE dBm Control (9) to **-60** and CONTOUR/R2/INTL AM dB BOOST/ATTEN Control (3) to **10**.
38. Slowly rotate MNL FREQ Controls (10) from **9295 MHz** to **9410 MHz**. While rotating MNL FREQ Controls (10), frequently switch RANGE SEL Switch (39) between **RINGS 1** and **CONTOUR/AM UP MOD**. Verify change from **RINGS 1** to **CONTOUR/AM UP MOD** increases output level by 10 dB (± 1 dB).
39. Set OUTPUT LEVEL COARSE dBm Control (9) to **-70** and CONTOUR/R2/INTL AM dB BOOST/ATTEN Control (3) to **20**.
40. Slowly rotate MNL FREQ Controls (10) from **9295 MHz** to **9410 MHz**. While rotating MNL FREQ Controls (10), frequently switch RANGE SEL Switch (39) between **RINGS 1** and **CONTOUR/AM UP MOD**. Verify change from **RINGS 1** to **CONTOUR/AM UP MOD** increases output level by 20 dB (± 1 dB).

R1/R2 LEVELER

41. Reset RD-301A controls as follows:

CONTROL	SETTING
(2) PRF/RF Switch	PRF
(3) CONTOUR/R2/INTL AM dB BOOST/ATTEN Control	06
(4) OUTPUT LEVEL FINE dBm Control	-5
(9) OUTPUT LEVEL COARSE dBm Control	-50
(29) MODULATION MODE Pushbutton Switches	INTL
(31) PULSE WIDTH μ S Control (RANGE 2)	5
(32) PULSE WIDTH μ S Control (RANGE 1)	5
(34) PULSE WIDTH MULTIPLIER Control (RANGE 1)	100
(36) μ S/NM Switch	μS
(37) RANGE 1 DELAY Thumbwheels	001.0
(38) RANGE 2 DELAY Thumbwheels	700.0
(39) RANGE SEL Switch	R2 ON
(42) X1/X10 INTL PRF/AM Switch	X10

42. Set INTL PRF/AM Control (41) for **700 Hz** on FREQUENCY Hz/MHz Digital Display (1).

43. Set PRF/RF Switch (2) to **RF**.

NOTE: Steps 44 through 52 use a dual trace, storage Spectrum Analyzer. Steps 53 through 55 use a non-storage Spectrum Analyzer.

R1/R2 LEVELER - STORAGE SPECTRUM ANALYZER

44. Set PULSE WIDTH MULTIPLIER Control (RANGE 2) (35) to **0.1**.
45. Set Spectrum Analyzer video filter to .01 and frequency span to 10 MHz/Div.
46. Set Spectrum Analyzer for Max Hold (Trace B).
47. Slowly rotate MNL FREQ Controls (10) from **9295 MHz** to **9410 MHz**.

STEP PROCEDURE

48. Store reference trace (Trace B) (Range 1 Reply Pulse amplitude level).
49. Set PULSE WIDTH MULTIPLIER Control (RANGE 1) (34) to **0.1** and PULSE WIDTH MULTIPLIER Control (RANGE 2) (35) to 100.
50. Set Spectrum Analyzer for Max Hold (Trace A).
51. Slowly rotate MNL FREQ Controls (10) from **9295 MHz** to **9410 MHz**.
52. Verify Trace A level is 6 dB (± 1 dB) below Trace B reference level across specified band. Refer to 2-2-2, Figure 19. If not, adjust R47065 on AGC PC Board Assembly.

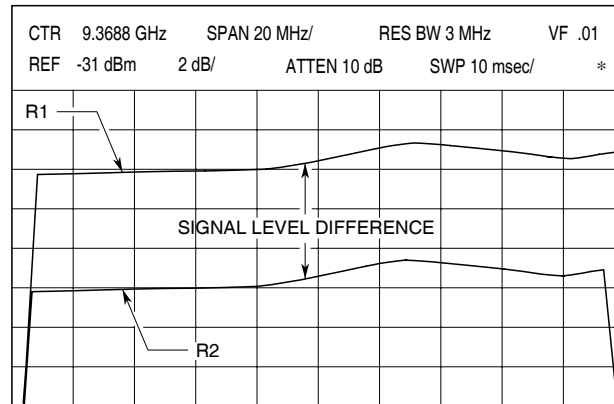

9016011

R1 and R2 Signal Levels as Stored Traces
Figure 19

53. Proceed at Step 57.

R1/R2 LEVELER - NON-STORAGE SPECTRUM ANALYZER

54. Set PULSE WIDTH MULTIPLIER Control (RANGE 2) (35) to **0.1**.
55. Set Spectrum Analyzer frequency span to 1 MHz/Div and sweep speed to 5 ms/Div.

STEP

PROCEDURE

56. Slowly rotate MNL FREQ Controls (10) from **9295 MHz** to **9410 MHz** while tuning Spectrum Analyzer frequency to track pulses. Refer to 2-2-2, Figure 20. Verify difference between R1 and R2 pulse peaks is 6 dB (± 1.5 dB) across specified band. If not, adjust R47065 on AGC PC Board Assembly.

NOTE: Connecting Spectrum Analyzer external trigger input to SYNC Connector (26) may help define pulse peaks.

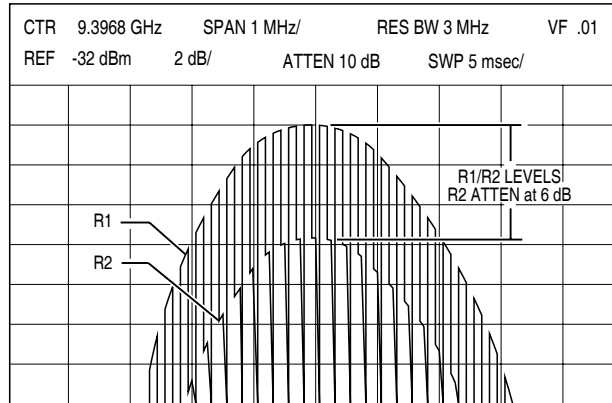

9016012

R1 and R2 Signal Levels
Figure 20

57. Disconnect test equipment and replace top cover on RD-301A.

(10) Internal PRF

PREREQUISITES: 100 MHz Clock (para 2-2-2H[2])

TEST EQUIPMENT: Oscilloscope

FIGURE REFERENCE: 2-2-2, Figure 15

STEP	PROCEDURE								
1.	Apply power to RD-301A and allow for 30 minute stabilization period.								
2.	Set RD-301A as follows:								
	<table border="1" style="width: 100%; border-collapse: collapse;"> <thead> <tr> <th style="text-align: left; border-bottom: 1px solid black;">CONTROL</th> <th style="text-align: left; border-bottom: 1px solid black;">SETTING</th> </tr> </thead> <tbody> <tr> <td>(2) PRF/RF Switch</td> <td>PRF</td> </tr> <tr> <td>(29) MODULATION MODE Pushbutton Switches</td> <td>INTL</td> </tr> <tr> <td>(42) X1/X2 INTL PRF/AM Switch</td> <td>X1</td> </tr> </tbody> </table>	CONTROL	SETTING	(2) PRF/RF Switch	PRF	(29) MODULATION MODE Pushbutton Switches	INTL	(42) X1/X2 INTL PRF/AM Switch	X1
CONTROL	SETTING								
(2) PRF/RF Switch	PRF								
(29) MODULATION MODE Pushbutton Switches	INTL								
(42) X1/X2 INTL PRF/AM Switch	X1								
3.	Connect Oscilloscope to SYNC Connector (26).								
4.	Adjust INTL PRF/AM Control (41) for FREQUENCY Hz/MHz Digital Display (1) reading of 50 Hz .								
5.	Verify INTL PRF/AM Control (41) is within area marked for 50 Hz . If not, reset INTL PRF/AM Control (41) as follows: <ul style="list-style-type: none"> ● Remove two set screws and dial. ● Reset dial onto shaft with INTL PRF/AM Control (41) set to 50. ● Tighten two set screws. 								
6.	Set Oscilloscope with sweep speed at 2 ms/Div to display SYNC Connector (26) output.								
7.	Refer to para 2-2-2H(1), Step 2 and remove top cover from RD-301A.								
8.	Verify sync pulse shown on Oscilloscope has 50% ($\pm 2.5\%$) duty cycle. (Positive excursion is same time as negative excursion $\pm \approx 1$ minor division.) If not, adjust R30062 on Range #2 PC Board Assembly.								
9.	Set INTL PRF/AM Control (41) to initial line marked for 500 Hz .								
10.	Verify FREQUENCY Hz/MHz Digital Display (1) reads 500 Hz (± 1 Hz). If not, adjust R30066 on Range #2 PC Board Assembly.								
11.	Set Oscilloscope sweep speed to 0.2 ms/Div.								
12.	Verify sync pulse shown on Oscilloscope has 50% ($\pm 2.5\%$) duty cycle. (Positive excursion is same time as negative excursion $\pm \approx 1$ minor division.) If not, repeat Steps 4 through 12 until all steps pass.								
13.	Perform INTL Modulation/PRF Counter Verification Procedure (para 2-2-2F[3]).								
14.	Disconnect equipment and replace top cover on RD-301A.								

(11) Pulse Width

- PREREQUISITES:** 8.25 GHz LO (para 2-2-2H[3])
- TEST EQUIPMENT:** 6 dB Pad
Heterodyne Monitor
L-Band Signal Generator
Oscilloscope
X-Band to L-Band Down Converter

FIGURE REFERENCE: 2-2-2, Figure 15

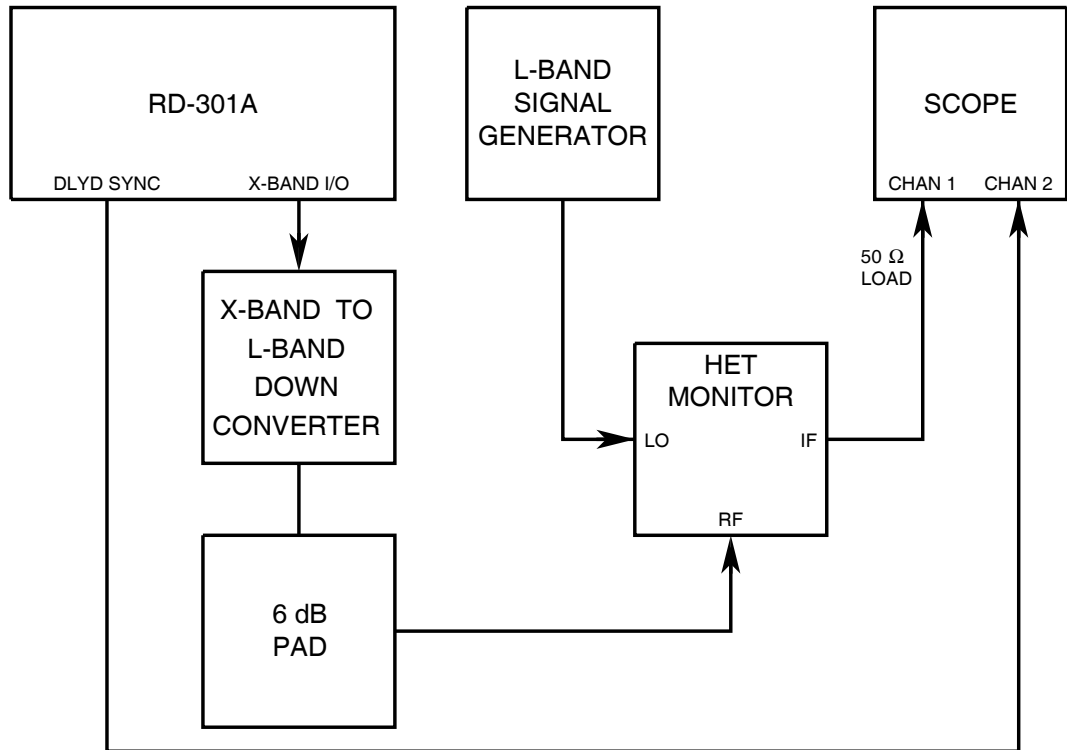

9006006

Pulse Width Calibration Setup
Figure 21

STEP

PROCEDURE

1. Apply power to RD-301A and allow for 30 minute stabilization period.

RANGE #1

2. Set RD-301A as follows:

CONTROL	SETTING
(2) PRF/RF Switch	RF
(4) OUTPUT LEVEL FINE dBm Control	0
(9) OUTPUT LEVEL COARSE dBm Control	-50
(10) MNL FREQ Controls	9375 MHz
(16) RF/IF MODE Pushbutton Switches	RF MNL
(29) MODULATION MODE Pushbutton Switches	INTL
(31) PULSE WIDTH μ S Control (RANGE 2)	0.5
(32) PULSE WIDTH μ S Control (RANGE 1)	0.5
(34) PULSE WIDTH MULTIPLIER Control (RANGE 1)	0.1
(35) PULSE WIDTH MULTIPLIER Control (RANGE 2)	0.1
(36) μ S/NM Switch	μS
(37) RANGE 1 DELAY Thumbwheels	000.3
(38) RANGE 2 DELAY Thumbwheels	900.0
(39) RANGE SEL Switch	RINGS 1
(42) X1/X10 INTL PRF/AM Switch	X10

3. Connect test equipment as shown in 2-2-2, Figure 21.
4. Refer to para 2-2-2H(1), Step 2 and remove top cover from RD-301A.
5. Set L-Band Signal Generator for 1125 MHz CW signal at +5 dBm.
6. Set PRF/RF Switch (2) to **PRF**.
7. Adjust INTL PRF/AM Control (41) until **1000 Hz** is shown on FREQUENCY Hz/MHz Digital Display (1).
8. Set PRF/RF Switch (2) to **RF**.
9. Set Oscilloscope to trigger on Channel 2 and sweep speed to 10 ns/Div.
10. Verify pulse width is 50 ns (± 5 ns). If not, adjust R30022 on RANGE #2 PC Board Assembly.

NOTE: All pulse widths are measured from 50% amplitude on rising edge to 50% amplitude on falling edge. Refer to 2-2-2, Figure 22.

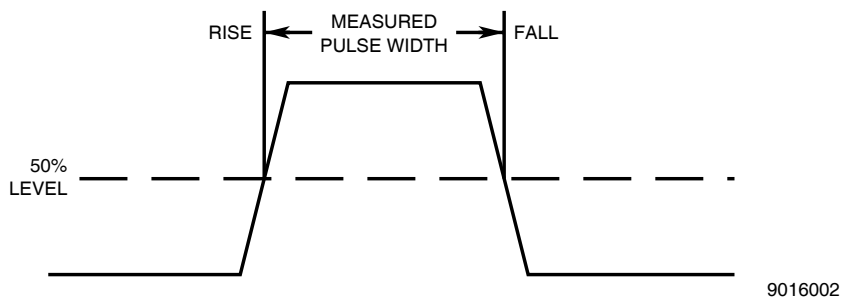

Pulse Width Calibration Measurement Points
Figure 22

11. Set PULSE WIDTH MULTIPLIER Control (RANGE 1) (34) to **1**.

STEP	PROCEDURE
------	-----------

12. Set Oscilloscope sweep speed to 100 ns/Div.
13. Verify pulse width is 500 ns (± 50 ns). If not, adjust R30021 on RANGE #2 PC Board Assembly.
14. Set PULSE WIDTH MULTIPLIER Control (RANGE 1) (34) to **100**.
15. Set PRF/RF Switch (2) to **PRF**.
16. Adjust INTL PRF/AM Control (41) until 500 Hz is shown on FREQUENCY Hz/MHz Digital Display (1).
17. Set PRF/RF Switch (2) to **RF**.
18. Set Oscilloscope sweep speed to 100 μ s/Div.
19. Verify pulse width is 500 μ s (± 50 μ s). If not, adjust R30010 on RANGE #2 PC Board Assembly.
20. Set pulse width to 0.5 μ s.
21. Set PULSE WIDTH MULTIPLIER Control (RANGE 1) (34) to **X500**.
23. Set PRF/RF Switch (2) to **PRF**.
24. Set X1/X10 INTL PRF/AM Switch (42) to **X1**.
25. Adjust X1/X10 INTL PRF/AM Switch (42) until 125 Hz is displayed on FREQUENCY Hz/MHz Digital Display (1).
26. Adjust R30088 on RANGE #2 PC Board Assembly until pulse width is 250.0 μ s.
27. Set Oscilloscope sweep speed to 500 μ s/div. Set pulse width to 5.0 μ s.
28. Verify pulse width is 2.5 ms (2.0 to 3.0 ms).
29. Repeat Steps 1 to 28 until 50 ns, 500 ns, 500 μ s and 2.5 ms pulse width measurements are stable and within specified tolerance ranges.

RANGE #2

30. Set RD-301A as follows:

<u>CONTROL</u>	<u>SETTING</u>
(2) PRF/RF Switch	PRF
(37) RANGE 1 DELAY Thumbwheels	900.0
(38) RANGE 2 DELAY Thumbwheels	000.3
(39) RANGE SEL Switch	R2 ON

31. Adjust INTL PRF/AM Control (41) until 1000 Hz is shown on FREQUENCY Hz/MHz Digital Display (1).
32. Set PRF/RF Switch (2) to **RF**.
33. Set Oscilloscope sweep speed to 10 ns/Div.
34. Verify pulse width is 50 ns (± 5 ns). If not, adjust R30042 on RANGE #2 PC Board Assembly.
35. Set PULSE WIDTH MULTIPLIER Control (RANGE 1) (34) to **1**.
36. Set Oscilloscope sweep speed to 100 ns/Div.
37. Verify pulse width is 500 ns (± 50 ns). If not, adjust R30041 on RANGE #2 PC Board Assembly.
38. Set PULSE WIDTH MULTIPLIER Control (RANGE 2) (35) to **100**.

STEP

PROCEDURE

39. Set PRF/RF Switch (2) to **PRF**.
40. Adjust INTL PRF/AM Control (41) until **500** (500 Hz) is shown on FREQUENCY Hz/MHz Digital Display (1).
41. Set PRF/RF Switch (2) to **RF**.
42. Set Oscilloscope sweep speed to 100 μ s/Div.
43. Verify pulse width is 500 μ s (\pm 50 μ s). If not, adjust R30031 on RANGE #2 PC Board Assembly.
44. Disconnect test equipment and replace top cover on RD-301A.

(12) Range Delay

PREREQUISITES: Pulse Width (para 2-2-2H[11])

TEST EQUIPMENT: Pulse Generator
Oscilloscope
X-Band to L-Band Down Converter
L-Band Signal Generator
L-Band Signal Generator

FIGURE REFERENCE: 2-2-2, Figure 14

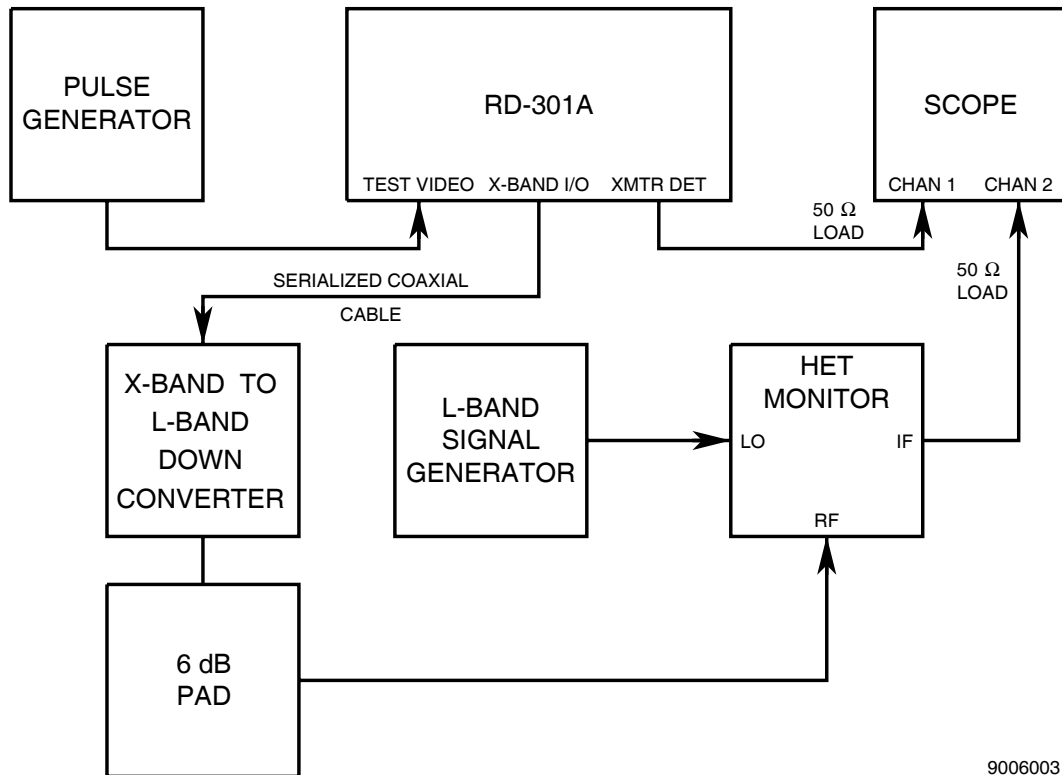

9006003

Range Delay Calibration Setup
Figure 23

STEP

PROCEDURE

1. Apply power to RD-301A and allow for 30 minute stabilization period.
2. Set RD-301A as follows:

CONTROL	SETTING
(2) PRF/RF Switch	RF
(10) MNL FREQ Controls	9375 MHz
(16) RF/IF MODE Pushbutton Switches	RF MNL
(29) MODULATION MODE Pushbutton Switches	TRACK
(31) PULSE WIDTH μ S Control (RANGE 2)	5
(32) PULSE WIDTH μ S Control (RANGE 1)	5
(34) PULSE WIDTH MULTIPLIER Control (RANGE 1)	1
(35) PULSE WIDTH MULTIPLIER Control (RANGE 2)	1
(36) μ S/NM Switch	μS
(37) RANGE 1 DELAY Thumbwheels	100.0
(38) RANGE 2 DELAY Thumbwheels	000.2
(39) RANGE SEL Switch	RINGS 1

3. Refer to para 2-2-2H(1) and remove top cover from RD-301A.
4. Connect test equipment as shown in 2-2-2, Figure 23.
5. Set Pulse Generator for 3 μ s pulse at TTL level and 1 kHz PRF.
6. Set L-Band Signal Generator for 1125 MHz CW signal at +7 dBm.

NOTE: Keep RD-301A and L-Band Signal Generator near same L-Band frequency (zero-beat) for minimum distortion.
7. Set Oscilloscope to display both channels.

NOTE: Insure both Oscilloscope channel delays are calibrated to match.
8. Verify range delay is 0.6 μ s (\pm 0.05 μ s). If not, adjust R19047 on Range #1 PC Board Assembly.

NOTE: Measure range delay from leading edge of transmitter pulse through XMTR DET Connector (13) to leading edge of reply pulse through X-Band I/O Connector (18) at 50% amplitude points.

NOTE: Refer to Appendix D. Subtract fixed delay through X-Band to L-Band Down Converter from RD-301A range delay measurement to obtain actual range delay.
9. Disconnect equipment and replace top cover on RD-301A.

(13) Power Meter

PREREQUISITES: Power Supply (para 2-2-2H[1])

TEST EQUIPMENT: Bandpass Filter
Power Meter Assembly
TWT Amplifier
X-Band Signal Generator

FIGURE REFERENCE: 2-2-2, Figure 13

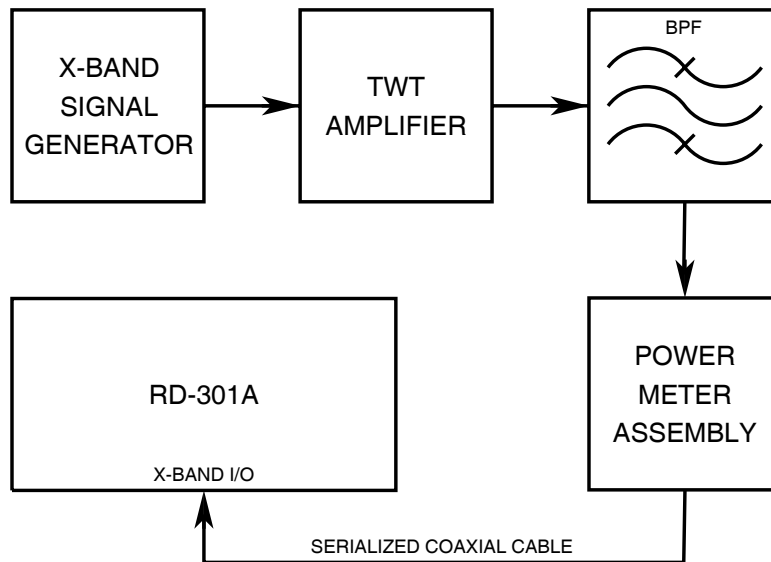

9006004

Power Meter Calibration Setup
Figure 24

STEP	PROCEDURE
------	-----------

1. Apply power to RD-301A and allow for 30 minute stabilization period.
2. Set TWT Amplifier power On and in Standby mode.
3. Connect test equipment as shown in 2-2-2, Figure 24.
4. Set X-Band Signal Generator as follows:

CONTROL	SETTING
Frequency	9375 MHz
Pulse Width	3 μ s
PRF	1 kHz

5. Set METER SELECT Switch (47) to **PK POWER**.

STEP PROCEDURE

6. Record coupling value of Waveguide Coupler used with RD-301A.

NOTE: The coupling value is marked (not tagged value) on Waveguide Coupler.

WAVEGUIDE COUPLER VALUE	2 kW TEST RF LEVEL	10 kW TEST RF LEVEL
19.0 dB	25.179 W	125.893 W
19.1 dB	24.605 W	123.027 W
19.2 dB	24.045 W	120.226 W
19.3 dB	23.498 W	117.490 W
19.4 dB	22.973 W	114.815 W
19.5 dB	22.440 W	112.202 W
19.6 dB	21.930 W	109.648 W
19.7 dB	21.430 W	107.152 W
19.8 dB	20.943 W	104.713 W
19.9 dB	20.466 W	102.329 W
20.0 dB	20.000 W	100.000 W
20.1 dB	19.545 W	97.724 W
20.2 dB	19.100 W	95.499 W
20.3 dB	18.665 W	93.325 W
20.4 dB	18.140 W	91.201 W
20.5 dB	17.825 W	89.125 W
20.6 dB	17.419 W	87.096 W
20.7 dB	17.023 W	85.114 W
20.8 dB	16.635 W	83.176 W
20.9 dB	16.257 W	81.283 W
21.0 dB	15.887 W	79.433 W

Test RF Levels for Power Meter Verification
Table 6

7. Record 2 kW and 10 kW Test RF Levels from 2-2-2, Table 6 according to Waveguide Coupler Value from Step 6.

8. Refer to para 2-2-2H(1), Step 2 and remove top cover from RD-301A.

CAUTION: CONNECTIONS TO TWT AMPLIFIER MUST BE CORRECT BEFORE SWITCHING TO OPERATE MODE.

9. Set TWT Amplifier to Operate mode.

10. Adjust X-Band Signal Generator level until Power Meter Assembly indicates 2 kW Test RF Level from Step 7.

11. Verify PANEL Meter (43) indicates **2 kW** (± 296 W). If not, adjust R17143 on Video PC Board Assembly.

12. Adjust X-Band Signal Generator level until Power Meter Assembly indicates 10 kW Test RF Level from Step 7.

13. Verify PANEL Meter (43) indicates **10 kW** (± 1480 W). If not, adjust R17128 on Video PC Board Assembly.

14. Repeat Steps 10 through 13 until no adjustments are required.

15. Perform Power Meter Verification Procedure (para 2-2-2F[5]).

16. Slowly decrease TWT Amplifier power and set to Standby mode for ≥ 15 minutes.

17. Disconnect test equipment and replace top cover on RD-301A.

(14) Discriminator

PREREQUISITES: Pulse Width (para 2-2-2H[11])

TEST EQUIPMENT: Oscilloscope
TWT Amplifier
X-Band Signal Generator

FIGURE REFERENCE: 2-2-2, Figure 14

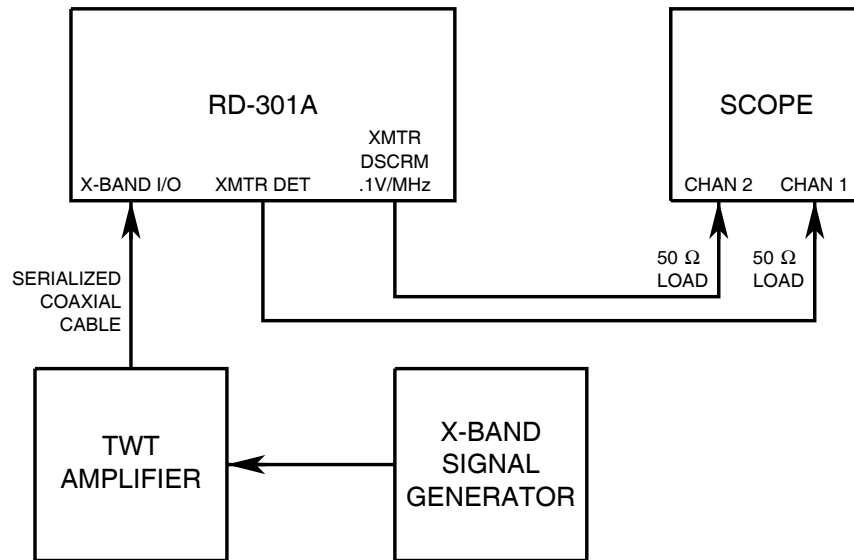

9006017

Discriminator Calibration Setup
Figure 25

STEP	PROCEDURE
------	-----------

1. Apply power to RD-301A and allow for 30 minute stabilization period.
2. Set RD-301A as follows:

CONTROL	SETTING
(2) PRF/RF Switch	RF
(4) OUTPUT LEVEL FINE dBm Control	0
(9) OUTPUT LEVEL COARSE dBm Control	-50
(16) RF/IF MODE Pushbutton Switches	RF MNL
(29) MODULATION MODE Pushbutton Switches	TRACK
(47) METER SELECT Switch	PK POWER
(48) ΔF OFFSET/EFF PEAKING Control	CAL

3. Connect test equipment as shown in 2-2-2, Figure 25.
4. Set TWT Amplifier power On and in Standby mode.
5. Set X-Band Signal Generator for 5 μs wide pulse at 500 Hz PRF.
6. Adjust X-Band Signal Generator frequency for **9350 MHz** as shown on FREQUENCY Hz/MHz Digital Display (1).
7. Set X-Band Signal Generator output level for **0.5 kW** as indicated on PANEL Meter (43).

Subject to Export Control, see Cover Page for details.

STEP

PROCEDURE

8. Refer to para 2-2-2H(1), Step 2 and remove top cover from RD-301A.
CAUTION: CONNECTIONS TO TWT AMPLIFIER MUST BE CORRECT BEFORE SWITCHING TO OPERATE MODE.
9. Set TWT Amplifier to Operate mode.
ΔF OFFSET
10. Set METER SELECT Switch (47) to ΔF.
11. Verify PANEL Meter (43) indicates **0.0 MHz** offset. If not, adjust R50069 on Discriminator #1 PC Board Assembly.
12. Remove ΔF OFFSET/EFF PEAKING Control (48) from CAL position and adjust for **9350 MHz** frequency as shown on FREQUENCY Hz/MHz Digital Display (1).
13. Verify PANEL Meter (43) indicates **0.0 MHz** offset. If not, adjust R50090 on Discriminator #1 PC Board Assembly.
14. If adjustments are made in Step 11 and/or Step 13, repeat Steps 10 through 13 until no adjustments are required.
15. Adjust ΔF OFFSET/EFF PEAKING Control (48) for **+0.5 MHz** on PANEL Meter (43).
16. Verify FREQUENCY Hz/MHz Digital Display (1) indicates **9350.50 MHz**. If not, adjust R50077 on Discriminator #1 PC Board Assembly.
17. If adjustment is made in Step 16, repeat Steps 15 and 16 until all indications are correct without adjustments.
18. Repeat Steps 10 through 14.
19. Adjust ΔF OFFSET/EFF PEAKING Control (48) for **-0.5 MHz** on PANEL Meter (43).
20. Verify FREQUENCY Hz/MHz Digital Display (1) indicates **9349.50 MHz** (± 0.25 MHz).
21. Adjust ΔF OFFSET/EFF PEAKING Control (48) for **0.0 MHz** on PANEL Meter (43).
22. Verify FREQUENCY Hz/MHz Digital Display (1) indicates **9350 MHz** (± 0.25 MHz).
23. Adjust ΔF OFFSET/EFF PEAKING Control (48) for **+0.75 MHz** on PANEL Meter (43).
24. Verify FREQUENCY Hz/MHz Digital Display (1) indicates **9350.75 MHz** (± 0.25 MHz).
25. Adjust ΔF OFFSET/EFF PEAKING Control (48) for **-0.75 MHz** on PANEL Meter (43).
26. Verify FREQUENCY Hz/MHz Digital Display (1) indicates **9349.25 MHz** (± 0.25 MHz).
27. If any step fails, repeat Steps 10 through 26.
28. Set ΔF OFFSET/EFF PEAKING Control (48) to **CAL**.
29. Set METER SELECT Switch (47) to **PK POWER**.

STEP

PROCEDURE

XMTR DSCRM .1V/MHz CONNECTOR

30. Set Oscilloscope with both channels dc coupled as follows:

CONTROL
SETTING

Sweep Speed	5 μ s/Div
Amplitude Scale (Both Channels)	10 mV/Div
Trigger	Channel 1

31. Adjust X-Band Signal Generator frequency for **9400 MHz** as shown on FREQUENCY Hz/MHz Digital Display (1).
32. Set RF/IF MODE Pushbutton Switches (16) to **RF MNL**.
33. Adjust MNL FREQ Controls (10) for **9400 MHz** as shown on FREQUENCY Hz/MHz Digital Display (1). Adjust Oscilloscope and verify XMTR DSCRM .1V/MHz Connector (12) pulse and XMTR DET Connector (13) pulse have same even amplitude.
34. Adjust MNL FREQ Controls (10) for **9400.50 MHz** as shown on FREQUENCY Hz/MHz Digital Display (1).
35. Verify XMTR DSCRM .1V/MHz Connector (12) pulse level increases to 50 mV (± 5 mV) above XMTR DET Connector (13) pulse level. If not, mark current position of R50182 on Discriminator #1 PC Board Assembly and adjust no more than 1/8th turn. Record correct voltage difference.
- NOTE:** If R50182 on Discriminator #1 PC Board Assembly requires more than 1/8th turn of adjustment, Discriminator #1 PC Board Assembly may need module level calibration. Contact Aeroflex Customer Service (800-835-2350) if assistance is needed.
36. Adjust MNL FREQ Controls (10) for **9399.50 MHz** as shown on FREQUENCY Hz/MHz Digital Display (1).
37. Verify XMTR DSCRM .1V/MHz Connector (12) pulse level decreases to 50 mV (± 5 mV) below XMTR DET Connector (13) pulse level. If not, repeat Steps 34 through 37 until all levels are within tolerance. Record correct voltage difference.
38. Slowly decrease TWT Amplifier power and set to Standby mode for ≥ 15 minutes.
39. Disconnect test equipment and replace top cover on RD-301A.



I. Calibration Data Sheet

RD-301A S/N: _____ DATE: _____

TECHNICIAN: _____

STEP	DATA	RESULT
(1) Power Supply		
4.	+5 V (+4.7 to +5.3 Vdc)	-----
	+12 V (+11.4 to +12.6 Vdc)	-----
	-12 V (-11.4 to -12.6 Vdc)	-----
	-24 V (-22.0 to -25.2 Vdc)	-----
5.	+5 V Ripple Voltage ≤ 15 mVp-p	-----
	+12 V Ripple Voltage ≤ 15 mVp-p	-----
	-12 V Ripple Voltage ≤ 15 mVp-p	-----
	-24 V Ripple Voltage ≤ 20 mVp-p	-----
(2) 100 MHz Clock		
5.	100 MHz (99.995 to 100.005 MHz)	-----
7.	8.091269 MHz (8.091243 to 8.09430 MHz)	-----
(3) 8.25 GHz LO		
9.	103.125 MHz (103.1229 to 103.1271 MHz)	-----
10.	-10 Vdc (-5 to -15 Vdc)	-----
12.	Frequency Counter reading 8.25 GHz (± 100 kHz)	-----
15.	FREQUENCY Hz/MHz Digital Display (1) readout ± 250 kHz	-----
(4) RF Display Limits		
4.	9504 MHz (9503 to 9505 MHz)	-----
6.	9291 MHz (9290 to 9292 MHz)	-----
(5) Marker Oscillator		
12.	≤ 18.0 MHz	-----
15.	≥ 74 MHz	-----
22.	FREQUENCY Hz/MHz Digital Display (1) readout ≥ 70 MHz	-----
25.	FREQUENCY Hz/MHz Digital Display (1) readout ≤ 20 MHz	-----



STEP	DATA	RESULT
(6)	IF Oscillator	
	5. FREQUENCY Hz/MHz Digital Display (1) readout 77 MHz	_____ (√)
	7. FREQUENCY Hz/MHz Digital Display (1) readout ≤18 MHz	_____
	9. FREQUENCY Hz/MHz Digital Display (1) readout ≥74 MHz	_____
	21. -18.0 V	_____ (√)
	22. 77.0 MHz	_____ (√)
	23. 17.0 MHz	_____ (√)
	24. ≈-2.0 V	_____ (√)
	25. 77 MHz	_____ (√)
	26. Frequency Range 17.0 to 77.0 MHz	_____ (√)
	MIXER BALANCE ADJUSTMENT	
	33. Maximum 60 MHz signal with minimum spurious signals	_____ (√)
	SWEEP WIDTH	
	42. Carrier starts sweeping past 0 setting.	_____ (√)
	44. 4 MHz sweep width	_____ (√)
	46. 2 MHz sweep width (1.8 to 2.2 MHz)	_____
(7)	IF Generator Power Amplifier	
	6. All harmonics and spurious signals are ≥30 dB below 30 MHz carrier	_____ (√)
	10. 30 MHz reference level 0 dBm (-0.2 to +0.2 dBm)	_____
	14. R36023 adjusted to Step 10 reference level	_____ (√)
	18. All harmonics and spurious signals are ≥30 dB below 60 MHz carrier	_____
	22. 60 MHz reference level 0 dBm (-0.2 to +0.2 dBm)	_____
	26. 0 dBm (-2.5 to +2.5 dBm)	_____
	27. 30 MHz and 60 MHz signal levels 0 dBm (-2.5 to +2.5 dBm)	_____ (√)
(8)	External AM	
	6. 30% modulation (28% to 32%)	_____
(9)	Levelers	
	MAIN LEVELER	
	5. Computed X-Band Output Power Level (A)	
	RD-301A Output Level Settings (B)	_____
	Waveguide Coupler Value (C)	_____
	Insertion Loss of Bandpass Filter and 3 dB Pads	_____
	B + C + D = A	_____
	6. X-Band Output Power Level upper limit (A + 2 dB)	_____



STEP	DATA	RESULT
	7. X-Band Output Power Level lower limit (A - 2 dB)	-----
	8. X-Band Output Power Level from 9295 to 9500 MHz stays between Step 6 and Step 7 limits	----- (√)
	9. Midpoint amplitude value	-----
	12. Midpoint amplitude value = Step 5 X-Band Output Power Level	----- (√)
	13. X-Band Output Power Level from 9295 to 9500 MHz stays between Step 6 and Step 7 limits	----- (√)
	CONTOUR LEVELER - STORAGE SPECTRUM ANALYZER	
	25. -50, 00 settings Trace A level equals Trace B level (± 1 dB)	-----
	29. -60, 10 settings Trace A level equals Trace B level (± 1 dB)	-----
	33. -70, 20 settings Trace A level equals Trace B level (± 1 dB)	-----
	CONTOUR LEVELER - NON-STORAGE SPECTRUM ANALYZER	
	35. RINGS 1 and CONTOUR/AM UP MOD settings have equal levels (± 1 dB)	-----
	38. CONTOUR/AM UP MOD setting level is 10 dB above RINGS 1 setting level (9 to 11 dB)	-----
	40. CONTOUR/AM UP MOD setting level is 20 dB above RINGS 1 setting level (9 to 11 dB)	-----
	R1/R2 LEVELER - STORAGE SPECTRUM ANALYZER	
	52. Trace A level (R2) is 6 dB below Trace B level (R1) (5 to 7 dB)	----- (√)
	R1/R2 LEVELER - NON-STORAGE SPECTRUM ANALYZER	
	56. R2 pulse peaks are 6 dB below R1 pulse peaks (5 to 7 dB)	----- (√)
(10)	Internal PRF	
	5. INTL PRF/AM Control (41) is set to 50 Hz	----- (√)
	8. Sync pulse has 50% (47.5% to 52.5 %) duty cycle	-----
	10. FREQUENCY Hz/MHz Digital Display (1) shows 500 Hz (499 to 501 Hz)	-----
	12. Sync pulse has 50% (47.5% to 52.5 %) duty cycle	-----
	13. RD-301A passes INTL Modification/PRF Counter Verification Procedure (para 2-2-2F[3])	----- (√)
(11)	Pulse Width	
	RANGE 1	
	10. 50 ns (45 to 55 ns)	-----
	13. 500 ns (450 to 550 ns)	-----
	19. 500 μ s (450 to 550 μ s)	-----
	28. 2.5 ms (2.0 to 3.0 ms)	-----
	RANGE 2	
	34. 50 ns (45 to 55 ns)	-----
	37. 500 ns (450 to 550 ns)	-----
	43. 500 μ s (450 to 550 μ s)	-----



STEP	DATA	RESULT
(12)	Range Delay	
	8. 0.6 μ s (0.55 to 0.65 μ s)	-----
(13)	Power Meter	
	6. Waveguide Coupler value	-----
	7. 2 kW Test RF Level (2-2-2, Table 6)	-----
	10 kW Test RF Level (2-2-2, Table 6)	-----
	11. PANEL Meter (43) shows 2 kW (1704 to 2296 W)	-----
	13. PANEL Meter (43) shows 10 kW (8.52 to 11.48 kW)	-----
	15. RD-301A passes Power Meter Verification Procedure (para 2-2-2F[5])	----- (✓)
(14)	Discriminator	
	ΔF OFFSET	
	11. CAL PANEL Meter (43) indicates 0.0 MHz offset	----- (✓)
	13. Out of CAL PANEL Meter (43) indicates 0.0 MHz offset	----- (✓)
	16. Frequency Hz/MHz Digital Display (1) indicates 9350.50 MHz	----- (✓)
	20. Frequency Hz/MHz Digital Display (1) indicates 9349.50 MHz (9349.25 to 9349.75 MHz)	-----
	22. Frequency Hz/MHz Digital Display (1) indicates 9350.00 MHz (9349.75 to 9350.25 MHz)	-----
	24. Frequency Hz/MHz Digital Display (1) indicates 9350.75 MHz (9350.50 to 9351.00 MHz)	-----
	26. Frequency Hz/MHz Digital Display (1) indicates 9349.25 MHz (9349.00 to 9349.50 MHz)	-----
	XMTR DSCRM .1V/MHz CONNECTOR	
	33. XMTR DSCRM .1V/MHz Connector (12) and XMTR DET Connector (13) pulses are same level	----- (✓)
	35. XMTR DSCRM .1V/MHz Connector (12) pulse level is 50 mV above XMTR DET Connector (13) pulse level (45 to 55 mV)	-----
	37. XMTR DSCRM .1V/MHz Connector (12) pulse level is 50 mV below XMTR DET Connector (13) pulse level (45 to 55 mV)	-----