

APPENDIX G - CONTROLS, CONNECTORS AND INDICATORS

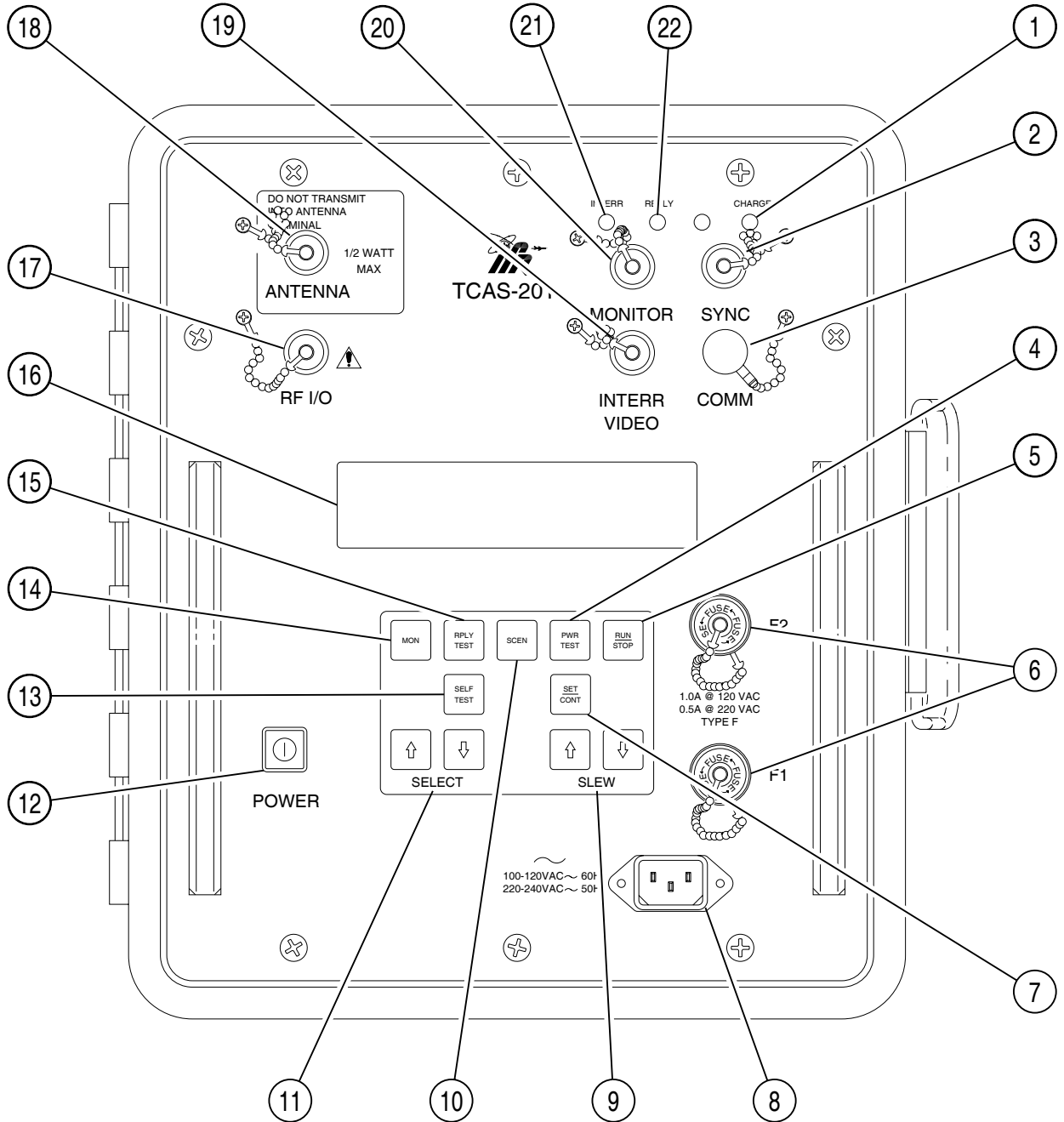

TCAS-201 Front Panel
Figure 1

8507040





CONTROLS, CONNECTORS AND INDICATORS (NUMERIC ORDER)	CONTROLS, CONNECTORS AND INDICATORS (ALPHABETICAL ORDER)																																												
<ol style="list-style-type: none"> 1. CHARGE Indicator 2. SYNC Connector (J10055) 3. COMM Connector (J10053) 4. PWR TEST Key 5. RUN/STOP Key 6. FUSES 7. SET/CONT Key 8. AC PWR Connector (J10050) 9. SLEW Keys 10. SCEN Key 11. SELECT Keys 12. POWER Key 13. SELF TEST Key 14. MON Key 15. RPLY TEST Key 16. DISPLAY 17. RF I/O Connector (J10058) 18. ANTENNA Connector (J10057) 19. INTERR VIDEO Connector (J10054) 20. MONITOR Connector (J10056) 21. INTERR Indicator 22. REPLY Indicator 	<table style="width: 100%; border-collapse: collapse;"> <tr><td>AC PWR Connector (J10050)</td><td style="text-align: right;">8</td></tr> <tr><td>ANTENNA Connector (J10057)</td><td style="text-align: right;">18</td></tr> <tr><td>CHARGE Indicator</td><td style="text-align: right;">1</td></tr> <tr><td>COMM Connector (J10053)</td><td style="text-align: right;">3</td></tr> <tr><td>DISPLAY</td><td style="text-align: right;">16</td></tr> <tr><td>FUSES</td><td style="text-align: right;">6</td></tr> <tr><td>INTERR Indicator</td><td style="text-align: right;">21</td></tr> <tr><td>MONITOR Connector (J10056)</td><td style="text-align: right;">20</td></tr> <tr><td>MON Key</td><td style="text-align: right;">14</td></tr> <tr><td>POWER Key</td><td style="text-align: right;">12</td></tr> <tr><td>PWR TEST Key</td><td style="text-align: right;">4</td></tr> <tr><td>REPLY Indicator</td><td style="text-align: right;">22</td></tr> <tr><td>INTERR VIDEO Connector (J10054)</td><td style="text-align: right;">19</td></tr> <tr><td>RF I/O Connector (J10058)</td><td style="text-align: right;">17</td></tr> <tr><td>RPLY TEST Key</td><td style="text-align: right;">15</td></tr> <tr><td>RUN/STOP Key</td><td style="text-align: right;">5</td></tr> <tr><td>SCEN Key</td><td style="text-align: right;">10</td></tr> <tr><td>SELECT Keys</td><td style="text-align: right;">11</td></tr> <tr><td>SELF TEST Key</td><td style="text-align: right;">13</td></tr> <tr><td>SET/CONT Key</td><td style="text-align: right;">7</td></tr> <tr><td>SLEW Keys</td><td style="text-align: right;">9</td></tr> <tr><td>SYNC Connector (J10055)</td><td style="text-align: right;">2</td></tr> </table>	AC PWR Connector (J10050)	8	ANTENNA Connector (J10057)	18	CHARGE Indicator	1	COMM Connector (J10053)	3	DISPLAY	16	FUSES	6	INTERR Indicator	21	MONITOR Connector (J10056)	20	MON Key	14	POWER Key	12	PWR TEST Key	4	REPLY Indicator	22	INTERR VIDEO Connector (J10054)	19	RF I/O Connector (J10058)	17	RPLY TEST Key	15	RUN/STOP Key	5	SCEN Key	10	SELECT Keys	11	SELF TEST Key	13	SET/CONT Key	7	SLEW Keys	9	SYNC Connector (J10055)	2
AC PWR Connector (J10050)	8																																												
ANTENNA Connector (J10057)	18																																												
CHARGE Indicator	1																																												
COMM Connector (J10053)	3																																												
DISPLAY	16																																												
FUSES	6																																												
INTERR Indicator	21																																												
MONITOR Connector (J10056)	20																																												
MON Key	14																																												
POWER Key	12																																												
PWR TEST Key	4																																												
REPLY Indicator	22																																												
INTERR VIDEO Connector (J10054)	19																																												
RF I/O Connector (J10058)	17																																												
RPLY TEST Key	15																																												
RUN/STOP Key	5																																												
SCEN Key	10																																												
SELECT Keys	11																																												
SELF TEST Key	13																																												
SET/CONT Key	7																																												
SLEW Keys	9																																												
SYNC Connector (J10055)	2																																												

1. Front Panel

Refer to Appendix G, Figure 1.

ITEM	DESCRIPTION
1. CHARGE Indicator	LED indicates the charger is active (ac applied with Test Set Off). Red indicates when battery is charging and green indicates battery is more than 80% charged.
2. SYNC Connector (J10055)	BNC type connector provides Oscilloscope Sync. Long pulse goes from low to high before a reply and from high to low before an interrogation.
3. COMM Connector (J10053)	LEMO type connector not used at this time.
4. PWR TEST Key	Enters Power & Frequency screen onto the DISPLAY.
5. RUN/STOP Key	Initiates or terminates Scenario Test, Reply Test or Monitor actions. The RUN/STOP Key also activates the store or recall operation in the Setup #1 Menu screen.
6. FUSES	Provide safe operation with ac input power applied to the TCAS-201. Refer to Appendix F for correct fuse size and type.
7. SET/CONT Key	Enters Setup Menus onto the DISPLAY. Pressing once from any other screen enters the Setup #1 Menu onto the DISPLAY. Setup #1 Menu allows the user to set initial or default test parameters and control data storage. Pressing once from the Setup #1 Menu enters the Setup #2 Menu onto the DISPLAY. Setup #2 Menu allows the user to set DISPLAY characteristics and Scenario Test Range and Altitude limitations.
8. AC PWR Connector (J10050) 	Provides the input for an external ac power source (100 to 120 VAC at 60 Hz or 220 to 240 VAC at 50 Hz) for recharging the battery or operating the Test Set. The operating voltage range depends on the Line Supply Switch Setting, only serviceable by a qualified technician. Refer to Battery/Voltage Instructions.
9. SLEW Keys	<p>Used to:</p> <ul style="list-style-type: none"> ● Adjust values in Scenario Test, Reply Test and Monitor screens. ● Select Signal Type and adjust Attenuation in Diagnostics screen. ● Set parameters and select memory storage in Setup Menus. <p>Variable slew rates are available, depending on item being edited. Keeping SLEW Key pressed provides greater rate of change, in most instances, than pressing and releasing.</p>
10. SCEN Key	Enters Scenario Test screen (for programming intruder scenarios) onto the DISPLAY.

ITEM	DESCRIPTION
11. SELECT Keys	<p>Used to select:</p> <ul style="list-style-type: none"> ● Items to edit in Setup Menus, Scenario Test screens and Reply Test screens. ● Diagnostics screen from Self Test screen.
12. POWER Key 	<p>Applies power to the Test Set; push On (I) or push Off (O).</p> <p>NOTE: When operating on battery power, an internal automatic time-out removes power from the Test Set following 15 min of no key activity.</p>
13. SELF TEST Key	<p>Enters Self Test screen onto the DISPLAY.</p>
14. MON Key	<p>Enters Monitor screens onto the DISPLAY. When operating in ATCRBS, the TCAS-201 displays the Whisper-Shout Monitor screen. When operating in Mode S, the TCAS-201 displays the Surveillance Monitor screen. Pressing the MON Key from the Surveillance Monitor screen enters the Broadcast Monitor screen onto the DISPLAY.</p>
15. RPLY TEST Key	<p>Enters Reply Test screen onto the DISPLAY. The intruder selected in the Setup #1 Menu determines whether the TCAS-201 displays the ATCRBS or Mode S Reply Test screen.</p>
16. DISPLAY	<p>LCD readout displays various test screens.</p>
17. RF I/O Connector (J10058) 	<p>CAUTION: MAXIMUM INPUT POWER MUST NOT EXCEED +58 dBm (631 W).</p> <p>TNC type connector provides for RF input and output when directly connected with the UUT (Direct Connect).</p>
18. ANTENNA Connector (J10057)	<p>CAUTION: DO NOT TRANSMIT DIRECTLY INTO ANTENNA TERMINAL. MAXIMUM OVER-THE-AIR INPUT POWER MUST NOT EXCEED 1/2 W.</p> <p>BNC type connector is used with the Test Set Antenna (Flat Antenna or Flexible Antenna). Over-the-air testing of the UUT is accomplished through the ANTENNA connector. The connector cover, when attached, provides the 50 Ω load required when connecting the RF I/O Connector to the UUT (Direct Connect) or running the Self Test.</p>
19. INTERR VIDEO Connector (J10054)	<p>BNC type connector provides demodulated (linearly detected) interrogation (only when direct connection with UUT is used) for use with an Oscilloscope.</p>
20. MONITOR Connector (J10056)	<p>BNC type connector provides interrogation and reply pulses clipped at 50% amplitude point to preserve pulse shape.</p>

ITEM	DESCRIPTION
21. INTERR Indicator	Illuminates when the Test Set receives a valid interrogation signal.
22. REPLY Indicator	Illuminates when the Test Set generates a reply signal.

2. Flat Antenna

Refer to Appendix G, Figure 2.

ITEM	DESCRIPTION
23. ANTENNA PUSH BUTTON Switch	Starts or stops testing, same as the RUN/STOP Key.
24. FLAT ANTENNA Connector (J29001)	BNC type connector is used to connect Flat Antenna to TCAS-201 Test Set.

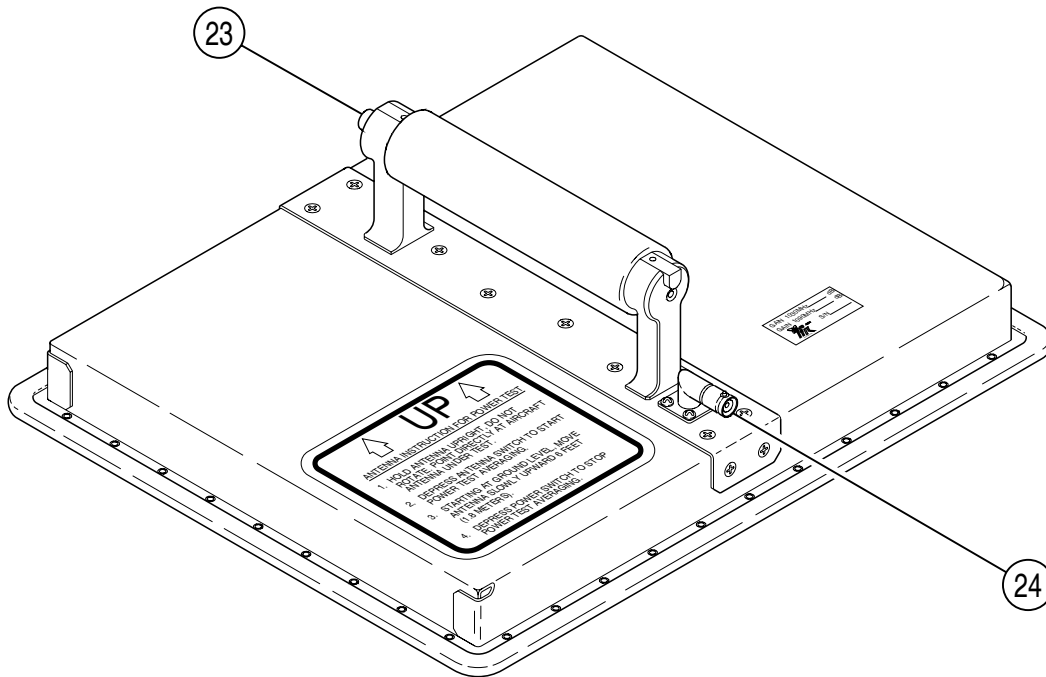

8507007

Flat Antenna
Figure 2