



2. Calibration/Verification

A. General

<u>VERIFICATION PROCEDURE</u>	<u>PAGE</u>
Signal Generator-----	6
Pulse Characteristics-----	8
Parameters-----	11
UUT Measurements-----	17
Self Test-----	23
<u>CALIBRATION PROCEDURE</u>	<u>PAGE</u>
Power Supply-----	31
RF Assy-----	32
LO Source-----	32
Attenuator-----	33
Isolation Null-----	35
Generator Output Power-----	35
Generator Image-----	35
LO Null-----	36
Receive Image-----	36
Receive Power-----	37
Isolation Reset-----	37
Detector Pulse Width-----	38
Direct Connect Set-----	39
RF Bit Detector Set-----	39
Oscillator Compensation-----	40
System-----	42
Self Test-----	42
Receive Power System Recheck-----	42
Isolation System Recheck-----	42
Generator Power System Recheck-----	43
Mixer Nulls-----	43
Threshold Set-----	43

(1) Calibration/Verification Schedule

The Calibration/Verification Procedures should be performed as a result of one or more of the following conditions:

● Failure to Meet Specifications

If, during the course of normal operation, the TCAS-201-2 or any major function thereof fails to meet the performance specifications according to Appendix F, Calibration/Verification Procedures should be performed.

If any failure occurs during performance of Verification Procedures, pertinent Calibration Procedures should be performed according to 2-2-2, Table 15.

● Module/Assembly Replacement

If one or more TCAS-201-2 assemblies are replaced, Calibration Procedures should be performed according to 2-2-2, Table 14.

● Annual Calibration/Verification

Aeroflex recommends an annual Calibration/Verification on the TCAS-201-2 to maintain proper testing standards.

(2) Controls, Connectors and Indicators

Refer to Appendix G for location of external Controls, Connectors and Indicators.

(3) Test Record

Calibration and Verification Data Sheets are provided for recording the results obtained while performing the Calibration or Verification Procedures.

NOTE: It is recommended the technician reproduce copies of the Calibration and Verification Data Sheets, rather than use copies in this manual.

B. Precautions

(1) Safety

WARNING: REMOVE ALL JEWELRY OR OTHER COSMETIC APPAREL BEFORE PERFORMING ANY CALIBRATION/VERIFICATION PROCEDURE INVOLVING LIVE CIRCUITS.

WARNING: WHEN WORKING WITH LIVE CIRCUITS OF HIGH POTENTIAL, KEEP ONE HAND IN POCKET OR BEHIND BACK TO AVOID SERIOUS SHOCK HAZARD.

WARNING: USE ONLY INSULATED TROUBLESHOOTING TOOLS WHEN WORKING WITH LIVE CIRCUITS.

WARNING: FOR ADDED INSULATION, PLACE RUBBER BENCH MAT UNDERNEATH ALL POWERED BENCH EQUIPMENT, AS WELL AS A RUBBER MAT UNDERNEATH TECHNICIAN'S CHAIR.

WARNING: HEED ALL WARNINGS AND CAUTIONS CONCERNING MAXIMUM VOLTAGES AND POWER INPUTS.

(2) ESD



CAUTION: THE POWER SUPPLY ASSY, DIGITAL IF PCB ASSY, FRONT PANEL PULSE PCB ASSY, RF ASSY, AND FRONT PANEL ASSY CONTAIN PARTS SENSITIVE TO DAMAGE BY ELECTROSTATIC DISCHARGE (ESD). ALL PERSONNEL PERFORMING CALIBRATION PROCEDURES SHOULD HAVE KNOWLEDGE OF ACCEPTED ESD PRACTICES AND/OR BE ESD CERTIFIED.

(3) EMC and Safety Compliance

All assemblies, cables, connectors, plastic fasteners, gaskets, fingerstock and miscellaneous hardware within the Test Set are configured to satisfy the safety and EMC compliance standards.

CAUTION: UPON COMPLETION OF ANY MAINTENANCE ACTION; ALL ASSEMBLIES, CABLES, CONNECTORS, PLASTIC FASTENERS, GASKETS, FINGERSTOCK AND MISCELLANEOUS HARDWARE MUST BE CONFIGURED AS INSTALLED AT THE FACTORY.

C. Requirements

(1) Performance

It is strongly recommended that personnel thoroughly read and understand all steps of the procedures to be performed and be familiar with the circuit under test. Knowledge of power, frequency and waveform to be expected at each test point is recommended.

NOTE: When one circuit provides the same pulse characteristic for different pulses, it is necessary to test the specifications for that characteristic only once.

(2) Test Equipment

Appendix B contains a list of test equipment suitable for performing any procedure contained in this manual. Other equipment meeting specifications listed in Appendix B may be substituted in place of recommended models.

NOTE: For certain procedures in this manual, the equipment listed in Appendix B may exceed minimum required specifications.

(3) Disassembly

No disassembly is required to perform Verification Procedures. The Chassis Assy must be removed from Case Assy to perform Calibration Procedures. For better access, the RF Assy is removed from Chassis Assy in Calibration Procedures.

(4) Environment

For best results, environmental conditions should be identical to the conditions at the normal operating location.

If this Assembly is repaired or replaced, the following Calibration Procedures must be performed.		Analog IF Assy	Attenuator PCB Assy	Battery	Decoder Assy	Detector Assy	Digital IF PCB Assy	Driver PCB Assy	Front Panel Pulse PCB Assy	LO Source PCB Assy	Mixer PCB Assy	Power Supply Assy
		Power Supply				●				●		
RF Assy	LO Source							●	●	●		●
	Attenuator		●					●	●			●
	Isolation Null	●	●							●	●	●
	Generator Output Power	●	●							●	●	●
	Generator Image	●	●							●	●	●
	LO Null	●	●							●	●	●
	Receive Image	●	●							●	●	●
	Receive Power	●	●							●	●	●
	Isolation Reset	●	●							●	●	●
	Detector Pulse Width	●				●						●
	Direct Connect Set	●						●				●
	RF Bit Detector Set	●	●					●	●	●	●	●
	Oscillator Compensation	●							●			●
System	Self Test	●	●	●	●	●	●	●	●	●	●	●
	Receive Power System Recheck	●	●				●			●	●	●
	Isolation System Recheck	●	●				●			●	●	●
	Generator Power System Recheck	●	●							●	●	●
	Mixer Nulls	●	●							●	●	●
	Threshold Set	●	●			●				●	●	●

Assembly Replacement Calibration Requirements
Table 14

If this Verification Procedure fails, the following Calibration Procedures must be performed.		Output Frequency	Output Level	Attenuation	Direct Connection	UUT Transmitter Frequency	UUT Transmitter Power
Power Supply							
RF Assy	LO Source	●					
	Attenuator		●	●			●
	Isolation Null		●	●			●
	Generator Output Power		●	●			●
	Generator Image		●	●			●
	LO Null		●	●			●
	Receive Image		●	●			●
	Receive Power		●	●			●
	Isolation Reset						
	Detector Pulse Width						
	Direct Connect Set				●		
	RF Bit Detector Set		●	●			●
	Oscillator Compensation	●				●	
System	Self Test		●	●		●	
	Receive Power System Recheck		●	●		●	●
	Isolation System Recheck		●	●		●	●
	Generator Power System Recheck		●	●		●	●
	Mixer Nulls		●	●		●	●
	Threshold Set		●	●		●	●

Verification Failure Calibration Requirements
Table 15

D. Verification Procedures

NOTE: Pulse spacings are measured from rising edge to rising edge at the 50% amplitude points. Pulse widths are measured from rising edge to falling edge at the 50% amplitude points.

(1) Signal Generator

TEST EQUIPMENT: 3 dB Fixed Attenuator
Universal Timer/Counter
Measuring Receiver
Power Sensor

STEP	PROCEDURE
------	-----------

OUTPUT FREQUENCY

1. Connect Universal Timer/Counter through 3 dB Attenuator to TCAS-201-2 ANTENNA Connector.
2. Set Universal Timer/Counter to measure 1090 MHz with 100 Hz resolution.
3. Press SELF TEST Key and either SELECT Key to enter Diagnostics screen.
4. Set TCAS-201-2 Signal Type to **CW** and Attenuation to **0.0 dB**.
5. Press RUN/STOP Key to initiate test.
6. Verify frequency is 1090 MHz (± 10.0 kHz). If incorrect, perform Calibration Procedures according to 2-2-2, Table 15.
7. Press RUN/STOP Key to terminate test.
8. Disconnect Universal Timer/Counter from 3 dB Attenuator.

OUTPUT LEVEL

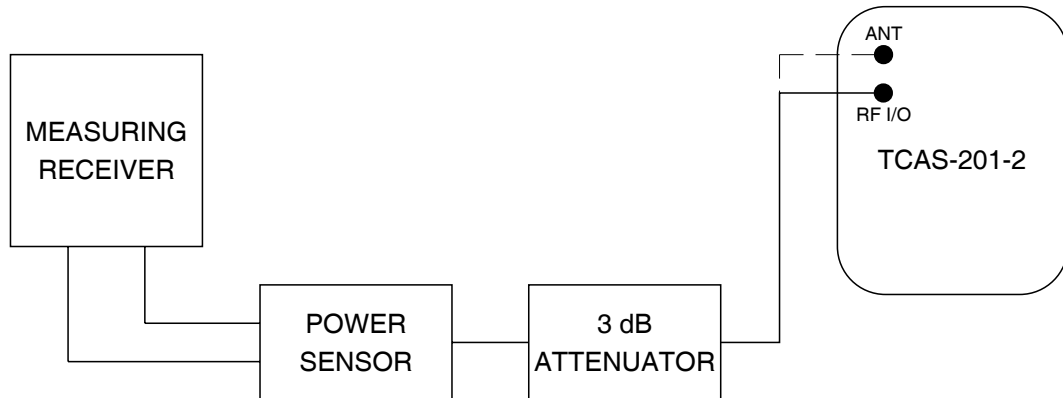

8506004

Level and Attenuation Test Setup Diagram
Figure 19

9. Connect Measuring Receiver through Power Sensor and 3 dB Attenuator to TCAS-201-2 RF I/O Connector (BNC to TNC Adapter is required). Refer to 2-2-2, Figure 19.
10. Set TCAS-201-2 Signal Type to CW and Attenuation to 19.5 dB.

STEP	PROCEDURE
------	-----------

11. Press RUN/STOP Key to initiate test.
12. Verify output is -67.35 dBm (± 2.0 dB), considering 3 dB Attenuator. If incorrect, perform Calibration Procedures according to 2-2-2, Table 15.

ATTENUATION

13. Disconnect 3 dB Attenuator from RF I/O Connector and reconnect to ANTENNA Connector.
14. Set TCAS-201-2 Attenuation to **0.0 dB**.
15. Verify output is 0.4 dBm (± 2.0 dB), considering 3 dB Attenuator. Record as reference.
16. Set TCAS-201-2 Attenuation to **10.0 dB**.
17. Verify output is reference from Step 15 minus 10 dB (± 0.5 dB).
18. Set TCAS-201-2 Attenuation to **20.0 dB**.
19. Verify output is reference from Step 15 minus 20 dB (± 0.5 dB).
20. Set TCAS-201-2 Attenuation to **30.0 dB**.
21. Verify output is reference from Step 15 minus 30 dB (± 0.5 dB).
22. Set TCAS-201-2 Attenuation to **40.0 dB**.
23. Verify output is reference from Step 15 minus 40 dB (± 0.5 dB).
24. Set TCAS-201-2 Attenuation to **50.0 dB**.
25. Verify output is reference from Step 15 minus 50 dB (± 2.0 dB).
26. If output fails any step, perform Calibration Procedures according to 2-2-2, Table 15.
27. Press RUN/STOP Key to terminate test.

DIRECT CONNECTION

28. Disconnect 3 dB Attenuator from ANTENNA Connector and reconnect to RF I/O Connector.
29. Set TCAS-201-2 Attenuation to **0.0 dB**.
30. Press RUN/STOP Key to initiate test.
31. Verify output is reference from Step 15 minus 48.25 dB (± 0.5 dB). If incorrect, perform Calibration Procedures according to 2-2-2, Table 15.
32. Press RUN/STOP Key to terminate test.
33. Disconnect test equipment.

(2) Pulse Characteristics

TEST EQUIPMENT: 3 dB Fixed Attenuator
Heterodyne Monitor
Oscilloscope
RF Signal Generator
Spectrum Analyzer

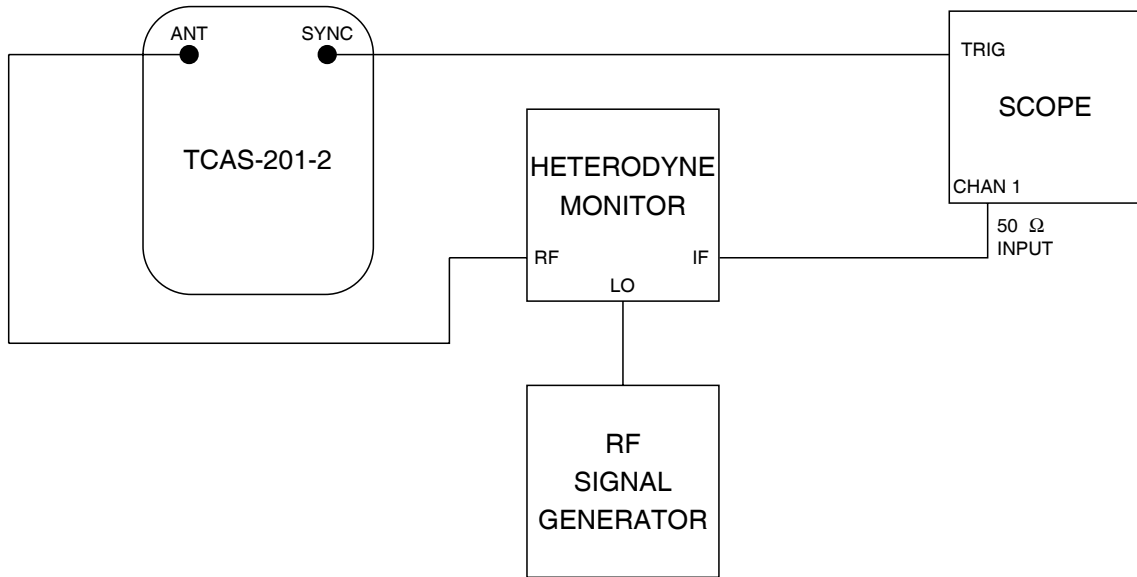

8506002

Pulse Characteristics Test Setup Diagram
Figure 20

STEP	PROCEDURE
------	-----------

1. Connect test equipment according to 2-2-2, Figure 20.
2. Set Oscilloscope to view Channel 1 with a 20 MHz bandwidth limit.
3. Set RF Signal Generator for 1090 MHz at +7 dBm.

SPACING

4. Set TCAS-201-2 as follows:

SCREEN	FIELD	SETTING
Setup Menu #1	INTRUDER TYPE:	ATCRBS
Reply Test	ALTITUDE:	84,100 ft
Diagnostics	SIGNAL TYPE:	MODE C REPLY
	ATTENUATION:	6.0 dB

5. Press RUN/STOP Key to initiate test.
6. Verify F₁ to F₂ pulse spacing is 20.30 μs (±50 ns).
7. Verify F₁ to C₁ pulse spacing is 1.45 μs (±50 ns).
8. Verify F₁ to A₁ pulse spacing is 2.90 μs (±50 ns).

STEP	PROCEDURE
------	-----------

9. Verify F₁ to C₂ pulse spacing is 4.35 μs (±50 ns).
10. Verify F₁ to A₂ pulse spacing is 5.80 μs (±50 ns).
11. Verify F₁ to A₄ pulse spacing is 8.70 μs (±50 ns).
12. Verify F₁ to B₁ pulse spacing is 11.60 μs (±50 ns).
13. Verify F₁ to B₂ pulse spacing is 14.50 μs (±50 ns).
14. Verify F₁ to D₂ pulse spacing is 15.95 μs (±50 ns).
15. Verify F₁ to B₄ pulse spacing is 17.40 μs (±50 ns).
16. Verify F₁ to D₄ pulse spacing is 18.85 μs (±50 ns).
17. Set Reply Test screen Altitude to **83,900 ft**.
18. Verify F₁ to C₄ pulse spacing is 7.25 μs (±50 ns).
19. Press RUN/STOP Key to terminate test.
20. Set TCAS-201-2 Signal Type to **DF16 ACQUISITION**.
21. Press RUN/STOP Key to initiate test.
22. Verify P₁ to P₂ pulse spacing is 1.00 μs (±50 ns).
23. Verify P₁ to P₃ pulse spacing is 3.50 μs (±50 ns).
24. Verify P₁ to P₄ pulse spacing is 4.50 μs (±50 ns).
25. Verify P₁ to D₁ pulse spacing is 8.00 μs (±50 ns).
26. Press RUN/STOP Key to terminate test.

WIDTHS

27. Set TCAS-201-2 Signal Type to **MODE C REPLY**.
28. Press RUN/STOP Key to initiate test.
29. Verify pulse widths are 0.45 μs (±50 ns).
30. Press RUN/STOP Key to terminate test.
31. Set TCAS-201-2 Signal Type to **DF16 ACQUISITION**.
32. Press RUN/STOP Key to initiate test.
33. Verify pulse widths are 0.50 μs (±50 ns).

NOTE: When two adjacent data pulses from D₁ through D₁₂ form a one-zero bit combination, one 1.0 μs wide pulse is transmitted.

RISE AND FALL TIMES

34. Using Δt function, verify P₁ pulse rise time, from 10% amplitude point to 90% amplitude point on rising edge, is 50 to 100 ns.
35. Using Δt function, verify P₁ pulse fall time, from 90% amplitude point to 10% amplitude point on falling edge, is 50 to 200 ns.
36. Press RUN/STOP Key to terminate test.
37. Disconnect test equipment.

AMPLITUDE LEVELS

38. Connect Spectrum Analyzer Input to TCAS-201-2 ANTENNA Connector.

39. Set Spectrum Analyzer as follows:

<u>CONTROL</u>	<u>SETTING</u>
Center Frequency	1090 MHz
Input Attenuation	10 dB

40. Press RUN/STOP Key to initiate test.

41. Record amplitude level of P₁.

42. Verify P₂, P₃, P₄ and D₁ amplitude levels are equal to P₁ level (± 1 dB).

43. Press RUN/STOP Key to terminate test.

44. Set TCAS-201-2 Signal Type to **MODE C REPLY**.

45. Press RUN/STOP Key to initiate test.

46. Record amplitude level of F₁.

47. Verify all pulse amplitude levels are equal to F₁ level (± 1 dB).

48. Press RUN/STOP Key to terminate test.

(3) Parameters

TEST EQUIPMENT: 3 dB Fixed Attenuator
10 dB Coupler
ATC-601-2 Ramp Test Set
Heterodyne Monitor
Oscilloscope
RF Signal Generator
Universal Timer/Counter

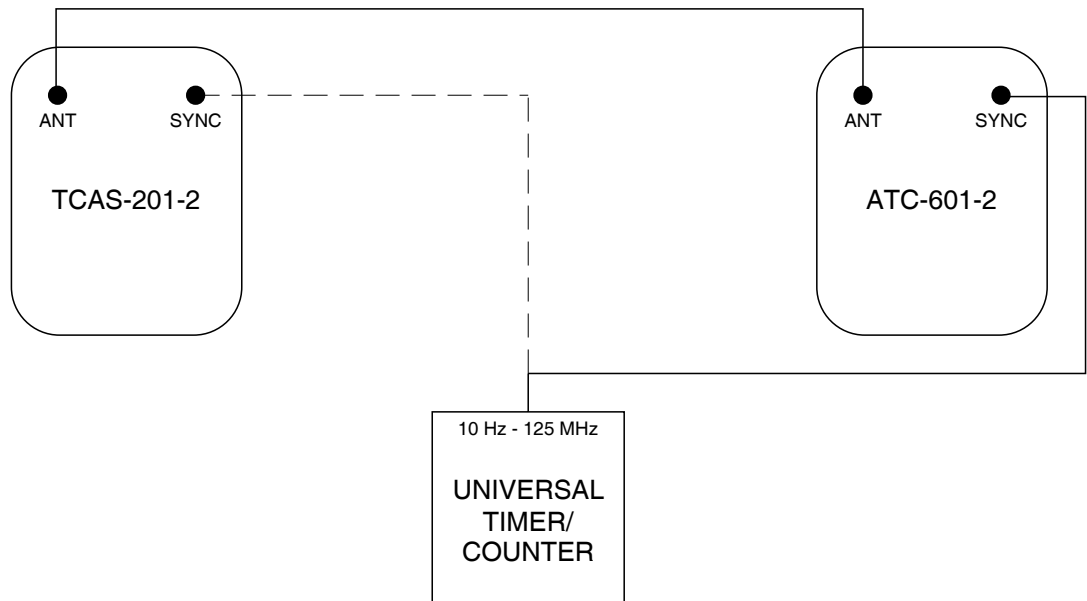

8506011

Percent Reply Test Setup Diagram
Figure 21

STEP	PROCEDURE								
PERCENT REPLY									
1.	Connect test equipment as shown in 2-2-2, Figure 21 with ATC-601-2 SYNC Connector initially connected to Universal Timer/Counter.								
2.	Set Universal Timer/Counter to 0.1 MHz filter and 0.1 Hz resolution.								
3.	Run ATC-601-2 Diagnostics as follows:								
	<table border="1"> <thead> <tr> <th>FIELD</th> <th>SETTING</th> </tr> </thead> <tbody> <tr> <td>SIGNAL TYPE:</td> <td>ITM_ATC_C</td> </tr> <tr> <td>ATTENUATION:</td> <td>00</td> </tr> <tr> <td>PRF:</td> <td>235</td> </tr> </tbody> </table>	FIELD	SETTING	SIGNAL TYPE:	ITM_ATC_C	ATTENUATION:	00	PRF:	235
FIELD	SETTING								
SIGNAL TYPE:	ITM_ATC_C								
ATTENUATION:	00								
PRF:	235								
4.	Record interrogation frequency as measured by Universal Timer/Counter.								
5.	Disconnect ATC-601-2 SYNC Connector from Universal Timer/Counter.								
6.	Connect TCAS-201-2 SYNC Connector to Universal Timer/Counter.								

STEP PROCEDURE

7. Set TCAS-201-2 as follows:

SCREEN	FIELD	SETTING
Setup #1 Menu	INTRUDER TYPE:	ATCRBS
	UUT DIST: HORIZ:	250 ft
	UUT DIST: VERT:	100 ft
ATCRBS Reply Test	RANGE:	0.0 nm
	%REPLY:	100

8. Press RUN/STOP Key from Reply Test screen to initiate test.
9. Record reply frequency as measured by Universal Timer/Counter.
10. Verify Step 9 value/Step 4 value ratio is 100% (-1%).
11. Set TCAS-201-2 %Reply to **10**.
12. Record reply frequency as measured by Universal Timer/Counter.
13. Verify Step 12 value/Step 4 value ratio is 10% ($\pm 1\%$).
14. Set TCAS-201-2 %Reply to **20**.
15. Record reply frequency as measured by Universal Timer/Counter.
16. Verify Step 15 value/Step 4 value ratio is 20% ($\pm 1\%$).
17. Set TCAS-201-2 %Reply to **30**.
18. Record reply frequency as measured by Universal Timer/Counter.
19. Verify Step 18 value/Step 4 value ratio is 30% ($\pm 1\%$).
20. Set TCAS-201-2 %Reply to **40**.
21. Record reply frequency as measured by Universal Timer/Counter.
22. Verify Step 21 value/Step 4 value ratio is 40% ($\pm 1\%$).
23. Set TCAS-201-2 %Reply to **50**.
24. Record reply frequency as measured by Universal Timer/Counter.
25. Verify Step 24 value/Step 4 value ratio is 50% ($\pm 1\%$).
26. Set TCAS-201-2 %Reply to **60**.
27. Record reply frequency as measured by Universal Timer/Counter.
28. Verify Step 27 value/Step 4 value ratio is 60% ($\pm 1\%$).
29. Set TCAS-201-2 %Reply to **70**.
30. Record reply frequency as measured by Universal Timer/Counter.
31. Verify step 30 value/Step 4 value ratio is 70% ($\pm 1\%$).
32. Set TCAS-201-2 %Reply to **80**.
33. Record reply frequency as measured by Universal Timer/Counter.
34. Verify Step 33 value/Step 4 value ratio is 80% ($\pm 1\%$).
35. Set TCAS-201-2 %Reply to **90**.
36. Record reply frequency as measured by Universal Timer/Counter.

STEP

PROCEDURE

37. Verify Step 36 value/Step 4 value ratio is 90% ($\pm 1\%$).
38. Press RUN/STOP Key to terminate test.
39. Disconnect test equipment.

RANGE DELAY

40. Connect test equipment according to 2-2-2, Figure 22 with ATC-601-2 ANTENNA Connector initially connected to Heterodyne Monitor RF input.
41. Set RF Signal Generator for 1030 MHz.

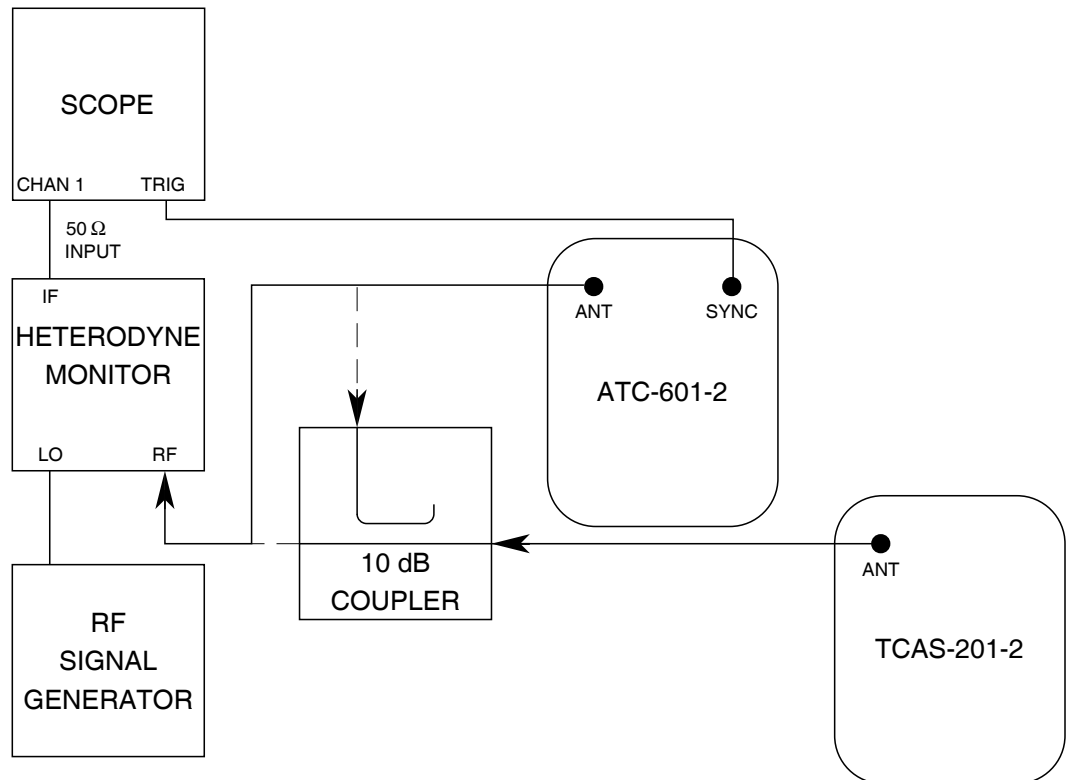

8506009

Range Delay Test Setup Diagram
Figure 22

42. Run ATC-601-2 Diagnostics as follows:

FIELD	SETTING
SIGNAL TYPE:	ITM_ATC_C
ATTENUATION:	00
PRF:	235

43. Position Oscilloscope leading delay cursor on rising edge of P₃ in interrogation.
44. Use delay time and position P₃ rising edge across 0,0 point on Oscilloscope for reference.

STEP	PROCEDURE
------	-----------

45. Disconnect ATC-601-2 ANTENNA Connector from Heterodyne Monitor. Connect ATC-601-2 ANTENNA Connector and Heterodyne Monitor to 10 dB Coupler as shown in 2-2-2, Figure 22.
46. Set RF Signal Generator for 1090 MHz.
47. Set TCAS-201-2 as follows:

SCREEN	FIELD	SETTING
Setup #1Menu	INTRUDER TYPE:	ATCRBS
	UUT DIST: HORIZ:	250 ft
	UUT DIST: VERT:	100 ft
Scenario Test	RANGE:	0.50 nm
	RANGE: RATE:	+0 kt
	ALT: RATE:	+0 fpm

48. Press RUN/STOP Key from Scenario Test screen to initiate test.
49. Use Oscilloscope main time and position trailing delay cursor on rising edge of F₁ in reply.
50. Use delay time and position F₁ rising edge across 0,0 point on Oscilloscope.
51. Verify delay is 9.1795 μ s (\pm 247 ns). Delay = 3.0 μ s reply delay + (12.359 μ s/nmi • 0.5 nmi) range delay.
52. Set TCAS-201-2 Scenario Test screen Range to **30.0 nm**.
53. Using Oscilloscope main time, position trailing delay cursor on rising edge of F₁ in reply.
54. Using delay time, position F₁ rising edge across 0,0 point on Oscilloscope.
55. Verify delay is 373.77 μ s (\pm 247 ns). Delay = 3.0 μ s reply delay + (12.359 μ s/nmi • 30.0 nmi) range delay.
56. Press RUN/STOP Key to terminate ATCRBS range delay test.
57. Disconnect ATC-601-2 ANTENNA Connector and Heterodyne Monitor from 10 dB Coupler. Connect ATC-601-2 ANTENNA Connector directly to Heterodyne Monitor as shown in 2-2-2, Figure 22.
58. Run ATC-601-2 Diagnostics as follows:

FIELD	SETTING
SIGNAL TYPE:	FMT0
PRF:	78
ATTENUATION:	00
ADDRESS:	01FF37

59. Set RF Signal Generator for 1030 MHz.
60. Position Oscilloscope leading delay cursor on SPR in interrogation.
61. Use delay time and position SPR across 0,0 point on Oscilloscope.
62. Disconnect ATC-601-2 ANTENNA Connector from Heterodyne Monitor. Connect ATC-601-2 ANTENNA Connector and Heterodyne Monitor to 10 dB Coupler as shown in 2-2-2, Figure 22.
63. Set RF Signal Generator for 1090 MHz.

STEP	PROCEDURE
------	-----------

64. Set TCAS-201-2 as follows:

SCREEN	FIELD	SETTING
Setup #1 Menu	INTRUDER TYPE:	MODE-S
	UUT DIST: HORIZ:	250 ft
	UUT DIST: VERT:	100 ft
Scenario Test	RANGE:	0.50 nm
	RANGE: RATE:	+0 kt
	ALT: RATE:	+0 fpm
Reply Test	AA:	01FF37

65. Press RUN/STOP Key from Scenario Test screen to initiate test.

66. Use Oscilloscope main time and position trailing delay cursor on rising edge of P₁ in reply.

67. Use delay time and position P₁ rising edge of reply across 0,0 point on Oscilloscope.

68. Verify delay is 134.1795 μ s (\pm 247 ns). Delay = 128.0 μ s reply delay + (12.359 μ s/nmi • 0.5 nmi) range delay.

69. Set TCAS-201-2 Scenario Test screen Range to **30.0 nm**.

70. Use Oscilloscope main time and position trailing delay cursor on rising edge of P₁ in reply.

71. Use delay time and position P₁ rising edge of reply across 0,0 point on Oscilloscope.

72. Verify delay is 498.77 μ s (\pm 247 ns). Delay = 128.0 μ s reply delay + (12.359 μ s/nmi • 30.0 nmi) range delay.

73. Press RUN/STOP to terminate Mode S range delay test.

ALTITUDE

74. Connect test equipment according to 2-2-2, Figure 20.

75. Set RF Signal Generator for 1090 MHz.

76. Set TCAS-201-2 as follows:

SCREEN	FIELD	SETTING
Setup #1 Menu	INTRUDER TYPE:	ATCRBS
	UUT DIST: HORIZ:	250 ft
	UUT DIST: VERT:	100 ft
Reply Test	ALTITUDE:	-1000 ft
Diagnostics	SIGNAL TYPE:	MODE C REPLY

77. Press RUN/STOP Key from Diagnostics Test screen to initiate test.

78. Verify only C₂ pulse is displayed on Oscilloscope between F₁ and F₂ pulses. Verify F₁ to C₂ pulse spacing is 4.35 μ s (\pm 50 ns).

79. Set TCAS-201-2 Reply Test screen Altitude to **126,700 ft**.

80. Verify only C₄ and D₂ pulses are displayed on Oscilloscope between F₁ and F₂ pulses. Verify F₁ to C₄ pulse spacing is 7.25 μ s (\pm 50 ns). Verify F₁ to D₂ pulse spacing is 15.95 μ s (\pm 50 ns).

STEP	PROCEDURE
------	-----------

81. Press RUN/STOP Key to terminate test.

82. Disconnect test equipment.

SQUITTER CONTROL

83. Connect Universal Timer/Counter Input A BNC Connector to TCAS-201-2 SYNC Connector.

84. Set Universal Timer/Counter to measure Single Period.

85. Set TCAS-201-2 Setup #1 Menu screen Intruder Type to **MODE-S** with Squitters **ON**.

86. Press RUN/STOP Key from Scenario Test screen to initiate test.

87. Verify squitter period is 0.8 to 1.2 sec.

88. Press RUN/STOP Key to terminate test.

89. Disconnect test equipment.

(4) UUT Measurements

- TEST EQUIPMENT:**
- 3 dB Fixed Attenuator
 - Heterodyne Monitor
 - Measuring Receiver
 - Mode S Test System (S-1403 Test Auxiliary properly interfaced with ATC-1400A-2 Transponder/DME Test Set)
 - Oscilloscope
 - Power Sensor
 - RF Signal Generator
 - Spectrum Analyzer
 - Universal Timer/Counter

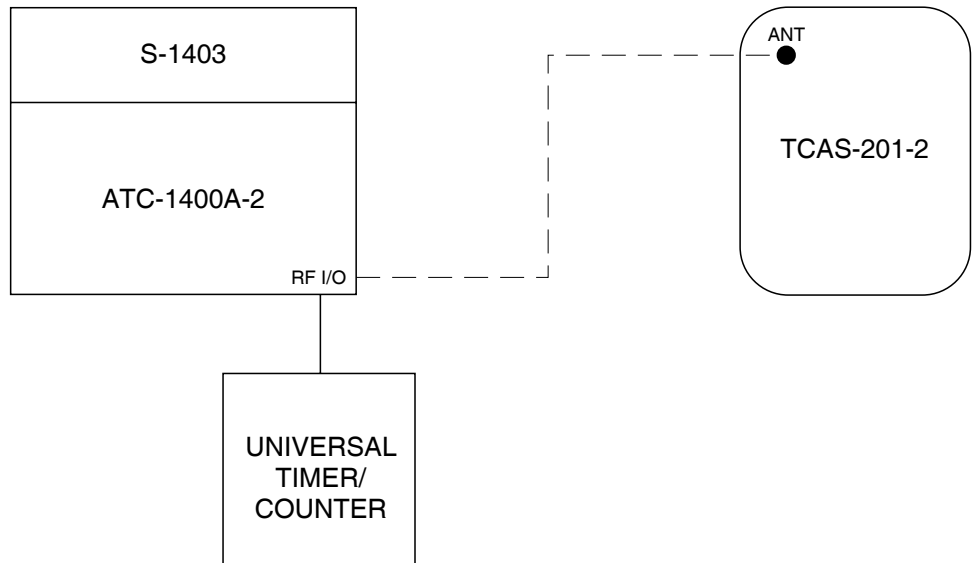

8506010

Frequency Measurement Test Setup Diagram
Figure 23

STEP	PROCEDURE																
	UUT TRANSMITTER FREQUENCY																
1.	Connect test equipment as shown in 2-2-2, Figure 23 with ATC-1400A-2 initially connected to Universal Timer/Counter.																
2.	Set ATC-1400A-2 as follows:																
	<table border="1"> <thead> <tr> <th>CONTROL</th> <th>SETTING</th> </tr> </thead> <tbody> <tr> <td>RF LEVEL Control</td> <td>-10 dBm</td> </tr> <tr> <td>CW/NORM/OFF Switch</td> <td>CW</td> </tr> <tr> <td>PRF/SQTR/ ON/OFF Switch</td> <td>ON</td> </tr> <tr> <td>XPDR MODE Control</td> <td>C</td> </tr> <tr> <td>PRF/SQTR Thumbwheels</td> <td>0010</td> </tr> <tr> <td>FREQ/FUNCTION SELECT Thumbwheels</td> <td>1029 XPDR</td> </tr> <tr> <td>ΔF Thumbwheels</td> <td>0.90 +ΔF</td> </tr> </tbody> </table>	CONTROL	SETTING	RF LEVEL Control	-10 dBm	CW/NORM/OFF Switch	CW	PRF/SQTR/ ON/OFF Switch	ON	XPDR MODE Control	C	PRF/SQTR Thumbwheels	0010	FREQ/FUNCTION SELECT Thumbwheels	1029 XPDR	ΔF Thumbwheels	0.90 + ΔF
CONTROL	SETTING																
RF LEVEL Control	-10 dBm																
CW/NORM/OFF Switch	CW																
PRF/SQTR/ ON/OFF Switch	ON																
XPDR MODE Control	C																
PRF/SQTR Thumbwheels	0010																
FREQ/FUNCTION SELECT Thumbwheels	1029 XPDR																
ΔF Thumbwheels	0.90 + ΔF																

STEP PROCEDURE

3. Verify output frequency is 1029.9 MHz as measured by Universal Timer/Counter. If incorrect, adjust ATC-1400A-2 FREQ/FUNCTION SELECT Thumbwheels and ΔF Thumbwheels as needed.
4. Disconnect ATC-1400A-2 from Universal Timer/Counter and reconnect to TCAS-201-2 as shown in 2-2-2, Figure 23.
5. Set ATC-1400A-2 CW/NORM/OFF Switch to NORM.
6. Set all S-1403 Sequence Menus except one to OFF.
7. Set S-1403 active Sequence Menu for UF00 Mode S output with AQ field set to 1 and octal Address of 00377467. Run S-1403 in Sequence function and set RF vernier level to 0 dB.
8. Set TCAS-201-2 as follows:

SCREEN	FIELD	SETTING
Setup #1 Menu	INTRUDER TYPE:	MODE-S
	SQUITTERS:	OFF
	UUT DIST: HORIZ:	500 ft
	UUT DIST: VERT:	100 ft
	GAIN_1030=	9.3 dB
	LOSS:	1.0 dB
Mode S Reply Test	AA:	01FF37

9. Press RUN/STOP Key from Power & Frequency screen to initiate test.
10. After >30 sec, verify TCAS-201-2 displayed frequency is 1029.9 MHz (±10 kHz).
11. Press RUN/STOP Key to terminate test.
12. Set ATC-1400A-2 CW/NORM/OFF Switch to CW.
13. Disconnect ATC-1400A-2 from TCAS-201-2 and reconnect to Universal Timer/Counter as shown in 2-2-2, Figure 23.
14. Set ATC-1400A-2 FREQ/FUNCTION SELECT Thumbwheels and ΔF Thumbwheels to provide 1030.1 MHz as measured by Universal Timer/Counter.
15. Disconnect ATC-1400A-2 from Universal Timer/Counter and reconnect to TCAS-201-2 as shown in 2-2-2, Figure 23.
16. Set ATC-1400A-2 CW/NORM/OFF Switch to NORM.
17. Press RUN/STOP Key from Power & Frequency screen to initiate test.
18. After >30 sec, verify TCAS-201-2 displayed frequency is 1030.1 MHz (±10 kHz).
19. Press RUN/STOP Key to terminate test.

UUT TRANSMITTER POWER

20. Disconnect ATC-1400A-2 from TCAS-201-2 ANTENNA Connector.
21. Connect Measuring Receiver through Power Sensor to ATC-1400A-2 RF I/O Connector.

STEP	PROCEDURE
------	-----------

22. Set ATC-1400A-2 as follows:

CONTROL	SETTING
CW/NORM/OFF Switch	CW
PRF/SQTR Thumbwheels	0050
FREQ/FUNCTION SELECT Thumbwheels	1030 XPDR
Δ F Thumbwheels	0.00 $+\Delta$ F

23. Set ATC-1400A-2 RF LEVEL Control and S-1403 RfLvl: field for output of -10.05 dBm on Measuring Receiver.
24. Disconnect ATC-1400A-2 from Power Sensor and reconnect to TCAS-201-2 ANTENNA Connector.
25. Set ATC-1400A-2 CW/NORM/OFF Switch to NORM.
26. Press RUN/STOP Key from Power & Frequency screen to initiate test.
27. After >30 sec, verify TCAS-201-2 **ERP AVERAGE**: field is **58.0 dBm** (± 1 dB). ERP is verified with following equations:
- Measured Power = Input Power + RF I/O Connector Attenuation.
 RF I/O Connector Attenuation = 48.25 dB + 19.8 dB = 67.75 dB.
 48.25 dB is verified by para 2-2-2F(1) Steps 28 through 33.
 19.8 dB is programmed default factor for direct connection.
28. Press RUN/STOP Key to terminate test.
29. Disconnect ATC-1400A-2 from TCAS-201-2 ANTENNA Connector.
30. Connect Measuring Receiver through Power Sensor to ATC-1400A-2 RF I/O Connector.
31. Set ATC-1400A-2 CW/NORM/OFF Switch to CW.
32. Set ATC-1400A-2 RF LEVEL Control and S-1403 RfLvl: field for output of -22.05 dBm on Measuring Receiver.
33. Disconnect ATC-1400A-2 from Power Sensor and reconnect to TCAS-201-2 ANTENNA Connector.
34. Set ATC-1400A-2 CW/NORM/OFF Switch to NORM.
35. Press RUN/STOP Key from Power & Frequency screen to initiate test.
36. After >30 sec, verify TCAS-201-2 **ERP AVERAGE**: field is **46.0 dBm** (± 1 dB).
37. Press RUN/STOP Key to terminate test.
38. If any step fails, perform Calibration Procedures according to 2-2-2, Table 15.

PULSE SPACING

39. Connect test equipment as shown in 2-2-2, Figure 24.

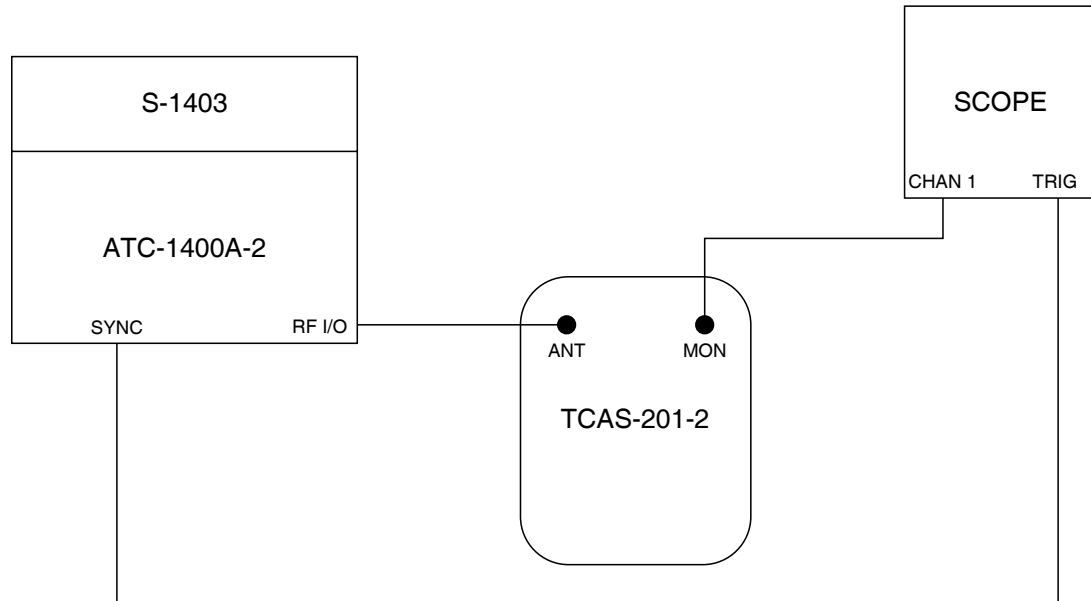

8506012

UUT Pulse Spacing Test Setup Diagram
Figure 24

40. Set ATC-1400A-2 as follows:

CONTROL	SETTING
RF LEVEL Control	-10 dBm
CW/NORM/OFF Switch	NORM
TO/TAC/TD Switch	TO
PRF/SQTR Thumbwheels	0235
DBL INTERR/INTRF PULSE Thumbwheels	002.2 INTERF-

41. Adjust ATC-1400A-2 INTRF PULSE WIDTH Control for approximately 800 ns of pulse width on Oscilloscope.
42. Run S-1403 in ACS function.
43. Press RUN/STOP Key from ATCRBS Monitor screen to initiate test.
44. Verify TCAS-201-2 counts interrogations in **S1**: field (interrogations contain S1 pulse).
45. Set ATC-1400A-2 DBL INTERR/INTRF PULSE Thumbwheels to 001.8 INTERF-.
46. Verify TCAS-201-2 counts interrogations in **S1**: field (interrogations contain S1 pulse).
47. Set ATC-1400A-2 DBL INTERR/INTRF PULSE Thumbwheels to 003.0 INTERF-.

STEP PROCEDURE

48. Verify TCAS-201-2 stops counting interrogations in **S1**: field (interrogations contain no recognizable S₁ pulse).
49. Set ATC-1400A-2 DBL INTERR/INTRF PULSE Thumbwheels to 001.0 INTERF-.
50. Verify TCAS-201-2 stops counting interrogations in **S1**: field (interrogations contain no recognizable S₁ pulse).
51. Set ATC-1400A-2 as follows:

CONTROL	SETTING
XPDR DEV P ₃ /CAL Switch	-Δ
DBL INTERR/INTRF PULSE Thumbwheels	000.0 OFF
XPDR P ₂ /P ₃ DEV Thumbwheels	0.20

52. Verify TCAS-201-2 accepts interrogations.
53. Set ATC-1400A-2 XPDR DEV P₃/CAL Switch to +Δ.
54. Verify TCAS-201-2 accepts interrogations.
55. Set ATC-1400A-2 XPDR P₂/P₃ DEV Thumbwheels to 1.00.
56. Verify TCAS-201-2 rejects interrogations.
57. Set ATC-1400A-2 XPDR DEV P₃/CAL Switch to -Δ.
58. Verify TCAS-201-2 rejects interrogations.
59. Set ATC-1400A-2 XPDR DEV P₃/CAL Switch to CAL.
60. Slew S-1403 P₄:Dv= field to -0.25 μs.
61. Verify TCAS-201-2 accepts interrogations.
62. Slew S-1403 P₄:Dv= field to +0.25 μs.
63. Verify TCAS-201-2 accepts interrogations.
64. Slew S-1403 P₄:Dv= field to -1.00 μs.
65. Verify TCAS-201-2 rejects interrogations.
66. Slew S-1403 P₄:Dv= field to +1.00 μs.
67. Verify TCAS-201-2 rejects interrogations.
68. Press RUN/STOP Key to terminate test.
69. Set ATC-1400A-2 PRF/SQTR Thumbwheels to 0030.
70. Run S-1403 in Sequence function.
71. Press RUN/STOP Key from Mode S Reply Test screen to initiate test.
72. Set ATC-1400A-2 XPDR DEV P₂/CAL Switch to +Δ and XPDR P₂/P₃ DEV Thumbwheels to 0.10.
73. Verify TCAS-201-2 replies to interrogations.
74. Set ATC-1400A-2 XPDR DEV P₂/CAL Switch to -Δ.
75. Verify TCAS-201-2 replies to interrogations.
76. Set ATC-1400A-2 XPDR P₂/P₃ DEV Thumbwheels to 1.00.

STEP	PROCEDURE
------	-----------

77. Verify TCAS-201-2 rejects interrogations.
78. Set ATC-1400A-2 XPDR DEV P₂/CAL Switch to +Δ.
79. Verify TCAS-201-2 rejects interrogations.
80. Set ATC-1400A-2 XPDR DEV P₂/CAL Switch to CAL.
81. Slew S-1403 SPR:Dv= field to -0.10 μs.
82. Verify TCAS-201-2 replies to interrogations.
83. Slew S-1403 SPR:Dv= field to +0.10 μs.
84. Verify TCAS-201-2 replies to interrogations.
85. Slew S-1403 SPR:Dv= field to -1.00 μs.
86. Verify TCAS-201-2 rejects interrogations.
87. Slew S-1403 SPR:Dv= field to +1.00 μs.
88. Verify TCAS-201-2 rejects interrogations.
89. Press RUN/STOP Key to terminate test.

(5) Self Test

STEP	PROCEDURE
------	-----------

1. Disconnect test equipment.
2. Press SELF TEST Key to enter Self Test screen. (The TCAS-201-2 displays results of the last Self Test.)
3. Terminate ANTENNA Connector (J10057) with 50 Ω load connector cover.
4. Press RUN/STOP Key to initiate Self Test. (The top line displays test names while testing and indicates **PASSED** or **FAILURE** at completion. The TCAS-201-2 displays an eight-digit hexadecimal error code with any failure indications. Also, the TCAS-201-2 displays a **PASSED** or **FAILED** indication for each module/assembly.)
5. Verify all modules/assemblies passed test. If Self Test indicates a failure, refer to following table for error code definitions:

TEST	GROUP	VERIFIES	FAILURE CODE (H)	RUNNING ORDER
LO Control	RF	Valid ON/OFF status	00000001	2
LO Detect	RF	LO is locked.	00000002	12
RF Detect	RF	TX level out/attenuation	00000004	13
Battery	Power Supply/ Battery	Voltage is within correct voltage range.	00000010	1
Non-Volatile RAM Battery	Power Supply/ Battery	Battery has sufficient power for RAM to retain memory.	00000020	Only on power-up
DSP Initialization	Digital	Handshake routine	00000040	14
UART	Digital	RS-232 loop back	00400000	8
RAM	Digital	Dual Port RAM (DPR)	01000000	3
		Video RAM	02000000	4
		Non-Volatile RAM	04000000	6
		Display RAM	08000000	5
Attenuator #1	Digital	Level at endline diodes	10000000	9
Attenuator #2	Digital	Level at midline diodes	20000000	9
LO Compensation	Digital	DCXO control voltage	40000000	11
LED	Digital	Interrogation and reply drivers	80000000	7

NOTE: Multiple failures are indicated by the sum of the error codes.

NOTE: If the DPR Test fails, the Self Test does not run the subsequent RAM tests.



E. Verification Data Sheet

TECHNICIAN: _____ DATE: _____

TCAS-201-2 S/N: _____

STEP	DATA	RESULT
(1) Signal Generator		
OUTPUT FREQUENCY		
6.	1090 MHz (± 10.0 kHz)	-----
OUTPUT LEVEL		
12.	-67.35 dBm (± 2.0 dB)	-----
ATTENUATION		
15.	0 dB Attenuation output 0.4 dBm (± 2.0 dB)	-----
17.	10 dB Attenuation output Step 15 minus 10 dB (± 0.5 dB)	-----
19.	20 dB Attenuation output Step 15 minus 20 dB (± 0.5 dB)	-----
21.	30 dB Attenuation output Step 15 minus 30 dB (± 0.5 dB)	-----
23.	40 dB Attenuation output Step 15 minus 40 dB (± 0.5 dB)	-----
25.	50 dB Attenuation output Step 15 minus 50 dB (± 2.0 dB)	-----
DIRECT CONNECTION		
31.	Direct Connection Attenuation Step 15 minus 48.25 dB (± 0.5 dB)	-----
(2) Pulse Characteristics		
SPACING		
6.	ATCRBS F ₁ to F ₂ Pulse Spacing 20.30 μ s (± 50 ns)	-----
7.	ATCRBS F ₁ to C ₁ Pulse Spacing 1.45 μ s (± 50 ns)	-----
8.	ATCRBS F ₁ to A ₁ Pulse Spacing 2.90 μ s (± 50 ns)	-----
9.	ATCRBS F ₁ to C ₂ Pulse Spacing 4.35 μ s (± 50 ns)	-----
10.	ATCRBS F ₁ to A ₂ Pulse Spacing 5.80 μ s (± 50 ns)	-----



STEP	DATA	RESULT
11.	ATCRBS F ₁ to A ₄ Pulse Spacing 8.70 μ s (\pm 50 ns)	-----
12.	ATCRBS F ₁ to B ₁ Pulse Spacing 11.60 μ s (\pm 50 ns)	-----
13.	ATCRBS F ₁ to B ₂ Pulse Spacing 14.50 μ s (\pm 50 ns)	-----
14.	ATCRBS F ₁ to D ₂ Pulse Spacing 15.95 μ s (\pm 50 ns)	-----
15.	ATCRBS F ₁ to B ₄ Pulse Spacing 17.40 μ s (\pm 50 ns)	-----
16.	ATCRBS F ₁ to D ₄ Pulse Spacing 18.85 μ s (\pm 50 ns)	-----
18.	ATCRBS F ₁ to C ₄ Pulse Spacing 7.25 μ s (\pm 50 ns)	-----
22.	Mode S P ₁ to P ₂ Pulse Spacing 1.00 μ s (\pm 50 ns)	-----
23.	Mode S P ₁ to P ₃ Pulse Spacing 3.50 μ s (\pm 50 ns)	-----
24.	Mode S P ₁ to P ₄ Pulse Spacing 4.50 μ s (\pm 50 ns)	-----
25.	Mode S P ₁ to D ₁ Pulse Spacing 8.00 μ s (\pm 50 ns)	-----
WIDTHS		
29.	ATCRBS Pulse Widths 0.45 μ s (\pm 50 ns)	-----
33.	Mode S Pulse Widths 0.50 μ s (\pm 50 ns)	-----
RISE AND FALL TIMES		
34.	Rise Time 50 to 100 ns	-----
35.	Fall Time 50 to 200 ns	-----
AMPLITUDE LEVELS		
41.	Mode S P ₁ Level	-----
42.	Mode S Amplitude equal to P ₁ (\pm 1 dB)	-----(\checkmark)
46.	ATCRBS F ₁ Level	-----
47.	ATCRBS Pulse Amplitude equal to F ₁ (\pm 1 dB)	-----



STEP	DATA	RESULT
(3) Parameters		
PERCENT REPLY		
4.	Interrogation Frequency	-----
9.	100% Reply Frequency	-----
10.	Percent Reply 100% ($\pm 1\%$)	-----
12.	10% Reply Frequency	-----
13.	Percent Reply 10% ($\pm 1\%$)	-----
15.	20% Reply Frequency	-----
16.	Percent Reply 20% ($\pm 1\%$)	-----
18.	30% Reply Frequency	-----
19.	Percent Reply 30% ($\pm 1\%$)	-----
21.	40% Reply Frequency	-----
22.	Percent Reply 40% ($\pm 1\%$)	-----
24.	50% Reply Frequency	-----
25.	Percent Reply 50% ($\pm 1\%$)	-----
27.	60% Reply Frequency	-----
28.	Percent Reply 60% ($\pm 1\%$)	-----
30.	70% Reply Frequency	-----
31.	Percent Reply 70% ($\pm 1\%$)	-----
33.	80% Reply Frequency	-----
34.	Percent Reply 80% ($\pm 1\%$)	-----
36.	90% Reply Frequency	-----
37.	Percent Reply 90% ($\pm 1\%$)	-----
RANGE DELAY		
51.	ATCRBS 0.5 nmi Range Delay 9.1795 μs (± 247 ns)	-----
55.	ATCRBS 30.0 nmi Range Delay 373.77 μs (± 247 ns)	-----
68.	Mode S 0.5 nmi Range Delay 134.1795 μs (± 247 ns)	-----
72.	Mode S 30.0 nmi Range Delay 498.77 μs (± 247 ns)	-----
ALTITUDE		
78.	-1000 ft Altitude Simulation (C2 present)	----- (✓)
80.	126,700 ft Altitude Simulation (C4 and D2 present)	----- (✓)



STEP	DATA	RESULT
SQUITTER CONTROL		
87.	Squitter Period 0.8 to 1.2 sec	-----
(4)	UUT Measurements	
UUT TRANSMITTER FREQUENCY		
10.	1029.9 MHz (± 10 kHz)	-----
18.	1030.1 MHz (± 10 kHz)	-----
UUT TRANSMITTER POWER		
27.	58.0 dBm (± 1 dB)	-----
36.	46.0 dBm (± 1 dB)	-----
PULSE SPACING		
44.	UUT Pulse Spacing ATCRBS TCAS-201-2 accepts 2.2 μ s S ₁ to P ₁	-----(\checkmark)
46.	UUT Pulse Spacing ATCRBS TCAS-201-2 accepts 1.8 μ s S ₁ to P ₁	-----(\checkmark)
48.	UUT Pulse Spacing ATCRBS TCAS-201-2 rejects 3.0 μ s S ₁ to P ₁	-----(\checkmark)
50.	UUT Pulse Spacing ATCRBS TCAS-201-2 rejects 1.0 μ s S ₁ to P ₁	-----(\checkmark)
52.	UUT Pulse Spacing ATCRBS TCAS-201-2 accepts 20.8 μ s P ₁ to P ₃	-----(\checkmark)
54.	UUT Pulse Spacing ATCRBS TCAS-201-2 accepts 21.2 μ s P ₁ to P ₃	-----(\checkmark)
56.	UUT Pulse Spacing ATCRBS TCAS-201-2 rejects 20.0 μ s P ₁ to P ₃	-----(\checkmark)
58.	UUT Pulse Spacing ATCRBS TCAS-201-2 rejects 22.0 μ s P ₁ to P ₃	-----(\checkmark)
61.	UUT Pulse Spacing ATCRBS TCAS-201-2 accepts 22.75 μ s P ₁ to P ₄	-----(\checkmark)
63.	UUT Pulse Spacing ATCRBS TCAS-201-2 accepts 23.25 μ s P ₁ to P ₄	-----(\checkmark)
65.	UUT Pulse Spacing ATCRBS TCAS-201-2 rejects 22.0 μ s P ₁ to P ₄	-----(\checkmark)
67.	UUT Pulse Spacing ATCRBS TCAS-201-2 rejects 24.0 μ s P ₁ to P ₄	-----(\checkmark)
73.	UUT Pulse Spacing Mode S TCAS-201-2 accepts 2.1 μ s P ₁ to P ₂	-----(\checkmark)
75.	UUT Pulse Spacing Mode S TCAS-201-2 accepts 1.9 μ s P ₁ to P ₂	-----(\checkmark)
77.	UUT Pulse Spacing Mode S TCAS-201-2 rejects 1.0 μ s P ₁ to P ₂	-----(\checkmark)



STEP	DATA	RESULT
79.	UUT Pulse Spacing Mode S TCAS-201-2 rejects 3.0 μ s P ₁ to P ₂	_____ (✓)
82.	UUT Pulse Spacing Mode S TCAS-201-2 accepts 4.65 μ s P ₁ to SPR	_____ (✓)
84.	UUT Pulse Spacing Mode S TCAS-201-2 accepts 4.85 μ s P ₁ to SPR	_____ (✓)
86.	UUT Pulse Spacing Mode S TCAS-201-2 rejects 3.75 μ s P ₁ to SPR	_____ (✓)
88.	UUT Pulse Spacing Mode S TCAS-201-2 rejects 5.75 μ s P ₁ to SPR	_____ (✓)
(5) Self Test		
5.	All Modules/Assemblies Pass	_____ (✓)

THIS PAGE INTENTIONALLY LEFT BLANK.

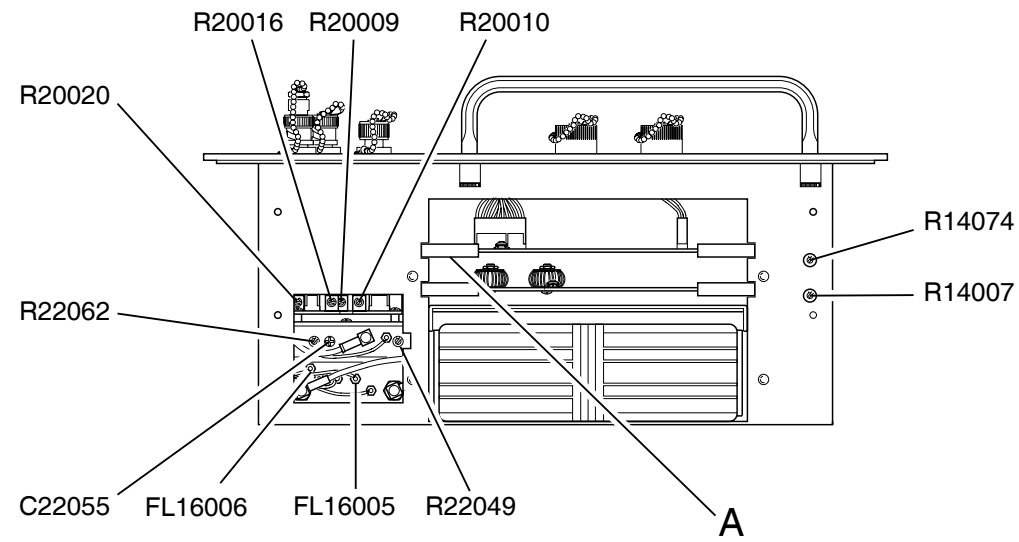

LEFT SIDE VIEW

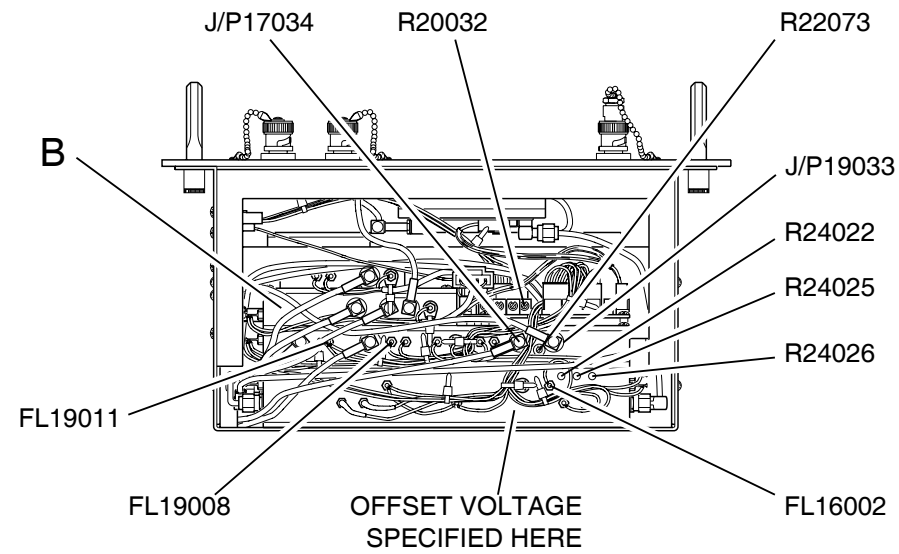

TOP VIEW

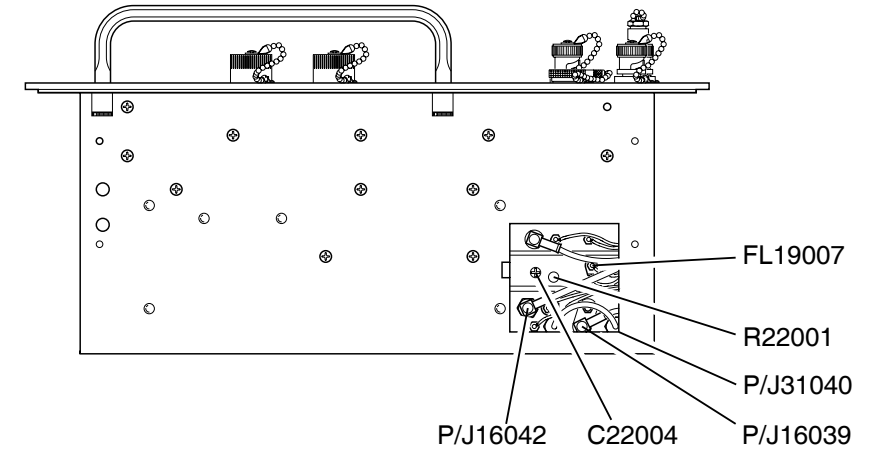

RIGHT SIDE VIEW

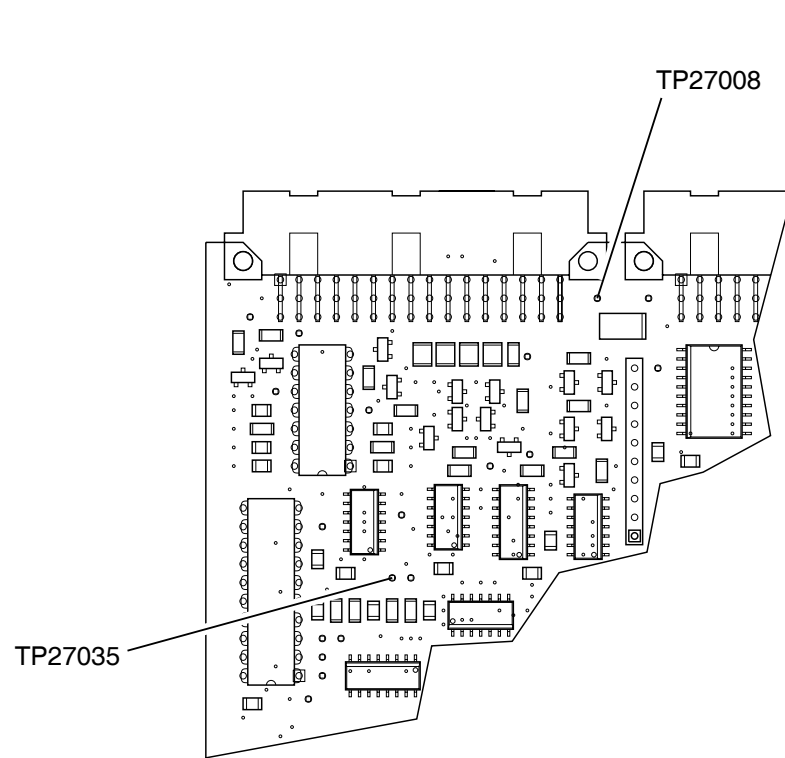

DETAIL A

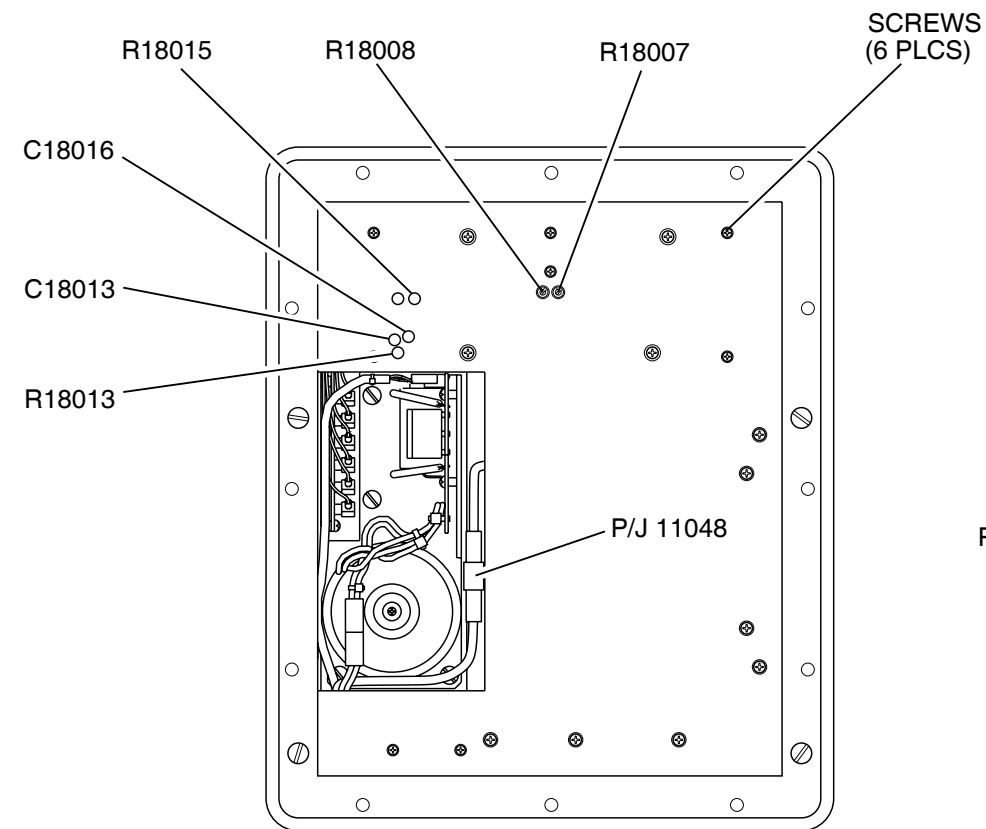

REAR VIEW

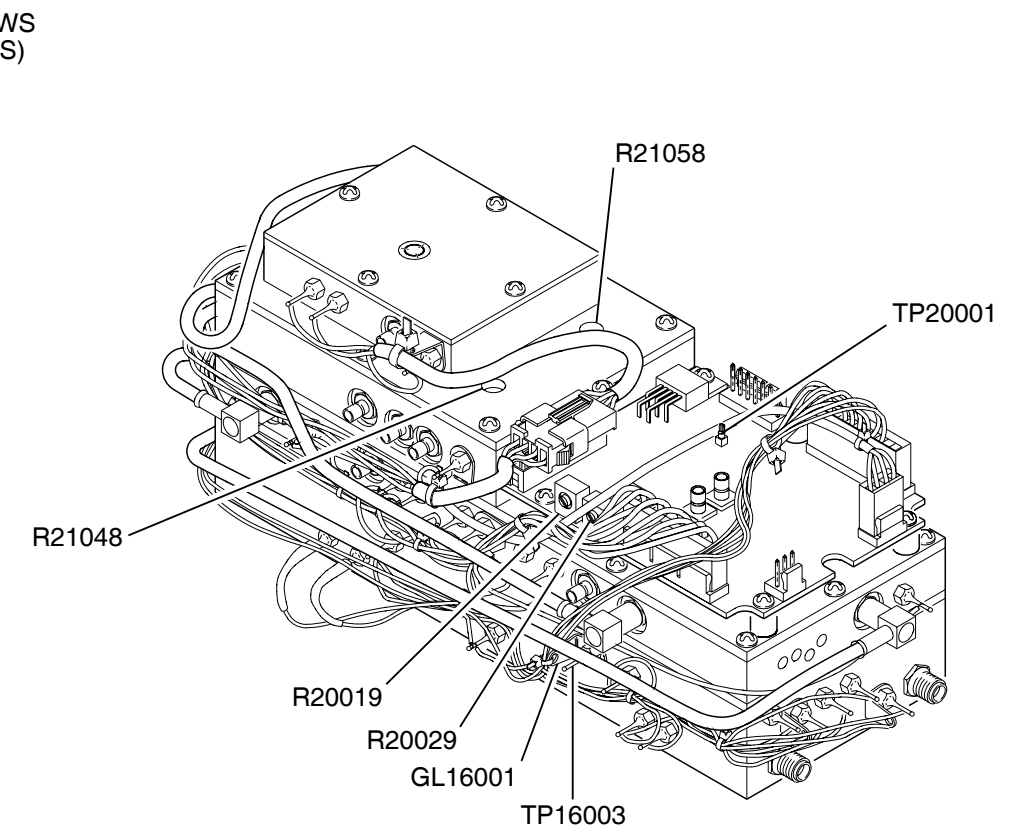

DETAIL B

Test Points and Adjustments
Figure 25

8507026

F. Calibration Procedures

Refer to 2-2-2, Figure 25 for test points and adjustments.

(1) Power Supply

TEST EQUIPMENT: Digital Multimeter

STEP	PROCEDURE
1.	Verify TCAS-201-2 is OFF and not connected to external power source.
2.	Remove 12 screws and lift Chassis Assy from Case Assy.
3.	Connect ac power cable to AC PWR Connector and verify CHARGE Indicator is green.
	NOTE: The CHARGE Indicator illuminates green when battery contains full charge.
4.	Connect Digital Multimeter to P/J11048 and verify 14.2 Vdc (± 0.1 V). Adjust R14007 as needed.
5.	Press POWER Key On.
6.	Use Digital Multimeter to verify +5.1 Vdc (± 0.05 V) between FL19008 and ground (GL16001). Adjust R14074 as needed.
7.	Use Digital Multimeter to verify +12 Vdc (± 0.3 V) between FL19011 and ground (GL16001).
8.	Use Digital Multimeter to verify -12 Vdc (± 0.3 V) between FL16002 and ground (GL16001).
9.	Use Digital Multimeter to verify +11 Vdc (± 0.25 V) between FL16005 and ground (GL16001). If incorrect, remove RF Assy (Steps 20 to 22 of para 2-2-2H[2]). Refer to Driver PCB Assy (2-2-3, Figure 42) and adjust R16054 as needed.

(2) RF Assy

TEST EQUIPMENT: 3 dB Fixed Attenuator
 ATC-1400A-2 Transponder/DME Test Set
 Digital Multimeter
 Universal Timer Counter
 Measuring Receiver
 Oscilloscope
 Power Meter
 Power Sensors (2)
 RF Signal Generator
 Spectrum Analyzer
 Temperature Probe

STEP	PROCEDURE
------	-----------

LO SOURCE

1. Disconnect 10 MHz DCXO output (P16042) from J16042.
2. Short TP16003 to ground.
3. Connect test equipment according to 2-2-2, Figure 26.

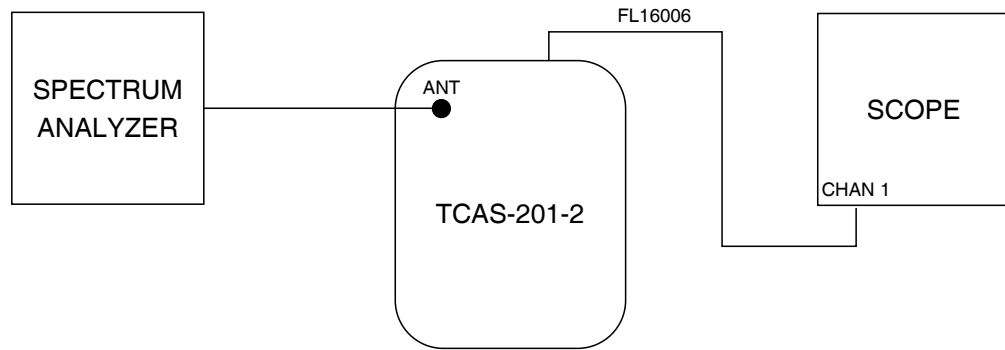

8506007

LO Source Test Setup Diagram
Figure 26

4. Adjust R24022 (OFFSET) for 50% duty cycle trapezoid on Oscilloscope as shown in 2-2-2, Figure 27.

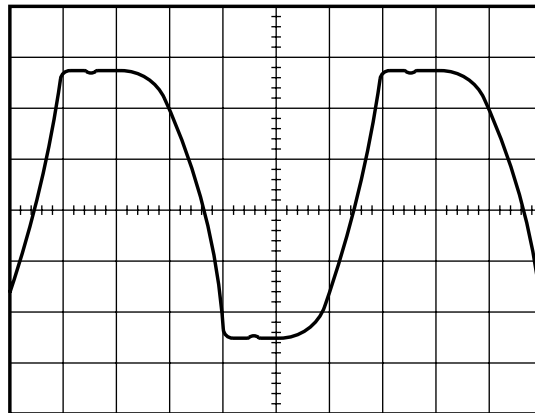

8516001

LO Detect Waveform
Figure 27

STEP	PROCEDURE
------	-----------

5. Set Spectrum Analyzer as follows:

CONTROL	SETTING
Center Frequency	1090 MHz
Frequency Span Mode	1 MHz/Div
Bandwidth	300 kHz
Sweep Time	Slow

6. Press SELF TEST Key and either SELECT Key to enter Diagnostics screen.
7. Set TCAS-201-2 Signal Type to **CW** and Attenuation to **0.0 dB**.
8. Press RUN/STOP Key to initiate test.
9. Verify signal sweep is centered around 1090 MHz.
10. Adjust R24026 (TUNING) and R24025 (DEVIATION) for 1085.5 MHz to 1094.5 MHz sweep width.
11. Disconnect short at TP16003.
12. Reconnect P16042 to J16042.
13. Adjust R24022 (OFFSET) to center signal on 1085.5 MHz.
14. Verify offset voltage at TP16003 is <10 mV different from offset voltage written on RF Assy. Refer to 2-2-2, Figure 25.
15. Adjust R24022 (OFFSET) to center signal on 1094.5 MHz.
16. Verify offset voltage at TP16003 is <10 mV different from offset voltage written on RF Assy.
17. Adjust R24022 (OFFSET) for 1090 MHz on Spectrum Analyzer and TP16003 offset voltage to equal offset voltage written on RF Assy.
18. Press RUN/STOP Key to terminate test.
19. Disconnect test equipment.

ATTENUATOR

20. Press POWER Key. (TCAS-201-2 power is OFF.)
21. Refer to 2-2-2, Figure 25 and remove six screws from Chassis Assy (Rear View).
22. Carefully lift out RF Assy, applying only minimal stress on connecting cables.
23. Press POWER Key.
24. Set TCAS-201-2 Signal Type to **DSP MEASURE =** and Attenuation to **40.0 dB**.
25. Press RUN/STOP Key to initiate test.
26. Adjust R20009 (ZERO VOLT ADJ) for 0 V at TP20001, using Digital Multimeter.
27. Remove P31040 from J31040 and connect test equipment as shown in 2-2-2, Figure 28.
28. Terminate TCAS-201-2 ANTENNA Connector with Connector Cover providing 50 Ω load.
29. Set RF Signal Generator to 1060 MHz at 0 dBm.

STEP

PROCEDURE

30. Set Spectrum Analyzer to 1060 MHz center frequency and 10 MHz/Div scan width.
31. Adjust R20019 (VSWR 50 dB ADJ) for lowest signal level on Spectrum Analyzer.

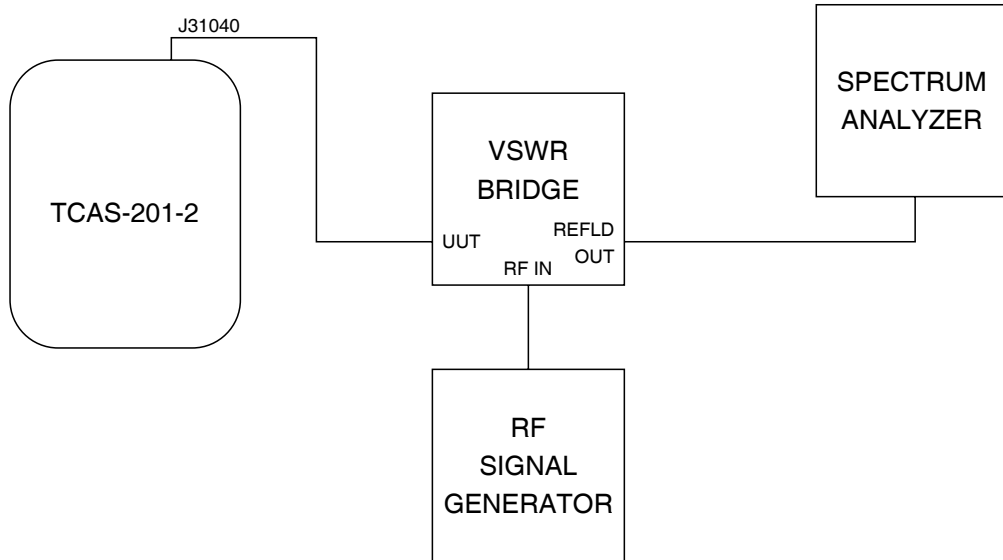

8506014

Attenuator VSWR Test Setup Diagram
Figure 28

32. Disconnect test equipment and reconnect P31040 to J31040.
33. Set TCAS-201-2 Attenuation to **0.0 dB**.
34. Remove P16039 from J16039 and connect test equipment as shown in 2-2-2, Figure 29.

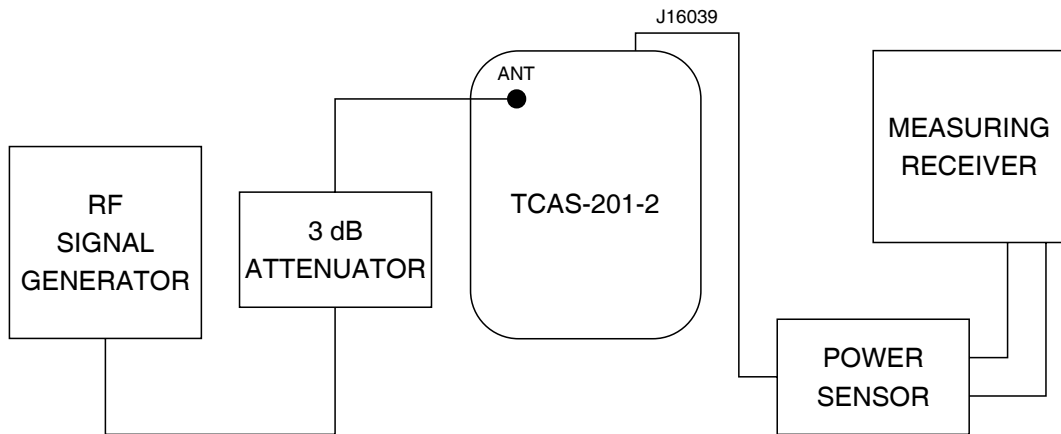

8506005

Attenuator Test Setup Diagram
Figure 29

STEP	PROCEDURE
------	-----------

35. Set RF Signal Generator for TCAS-201-2 input of 1030 MHz at -9.05 dBm, considering 3 dB Attenuator.
36. Set Measuring Receiver to Tuned RF Level Mode and calibrate. Record and set displayed level as zero reference on Measuring Receiver.
37. Set TCAS-201-2 Attenuation to **40.0 dB**.
38. Adjust R20010 (50 dB ADJ OFFSET) for -40 dBm on Measuring Receiver.
39. Set TCAS-201-2 Attenuation to **10.0 dB**.
40. Adjust R20016 (10 dB ADJ SLOPE) for -10 dBm on Measuring Receiver.
41. Set TCAS-201-2 Attenuation to **0.0 dB**.
42. Verify Measuring Receiver is at level recorded in Step 36.
43. Press RUN/STOP Key to terminate test.
44. Disconnect test equipment and reconnect P16039 to J16039.

ISOLATION NULL

45. Disconnect the 30 MHz Receive IF input (P17034) from J17034.
46. Connect 50 Ω termination cover to TCAS-201-2 ANTENNA Connector.
47. Connect Spectrum Analyzer, with center frequency set to 30 MHz, to J17034.
48. Set TCAS-201-2 Signal Type to **CW** and Attenuation to **0.0 dB**.
49. Press RUN/STOP Key to initiate test.
50. Adjust R22062 (ISOLATION) and C22055 for maximum signal nullification at 30 MHz.
51. Adjust R22062 (ISOLATION) for 5 dBm signal level.
52. Press RUN/STOP Key to terminate test.
53. Disconnect Spectrum Analyzer from J17034.
54. Reconnect P17034 to J17034.

GENERATOR OUTPUT POWER

55. Connect Measuring Receiver (set for 1090 MHz) through Power Sensor and 3 dB Attenuator to TCAS-201-2 ANTENNA Connector.
56. Press RUN/STOP Key to initiate test.
57. Adjust R22049 (TX GAIN) for TCAS-201-2 output of +0.4 dBm. Measuring Receiver displays +0.4 less attenuation provided by 3 dB Attenuator.
58. Press RUN/STOP Key to terminate test.

GENERATOR IMAGE

59. Disconnect Power Sensor from 3 dB Attenuator.
60. Connect Spectrum Analyzer through 3 dB Attenuator to TCAS-201-2 ANTENNA Connector.

STEP PROCEDURE

61. Set the Spectrum Analyzer as follows:

CONTROL	SETTING
Center Frequency	1060 MHz
Amp Scale	2 dB/Div
Scan Width	Narrow

62. Press RUN/STOP Key to initiate test.

63. Position peak amplitude point of 1090 MHz at top major graticule.

64. Verify 1030 MHz signal level is >30 dB below 1090 MHz signal level in Step 63. If incorrect, adjust C18013 and C18016 (1030 MHz NULL PHASE ADJ) and either R18013 or R18015 (1030 MHz NULL AMPLITUDE ADJ).

NOTE: One resistor (R18013 or R18015) must remain fully cw for correct TCAS-201-2 operation.

LO NULL

65. Adjust R18007 and R18008 (1060 MHz NULL ADJ) until 1060 MHz signal level is >40 dB below 1090 MHz signal level in Step 63.

66. Press RUN/STOP Key to terminate test.

RECEIVE IMAGE

67. Disconnect 30 MHz (P17034) from J17034 and connect test equipment according to 2-2-2, Figure 30.

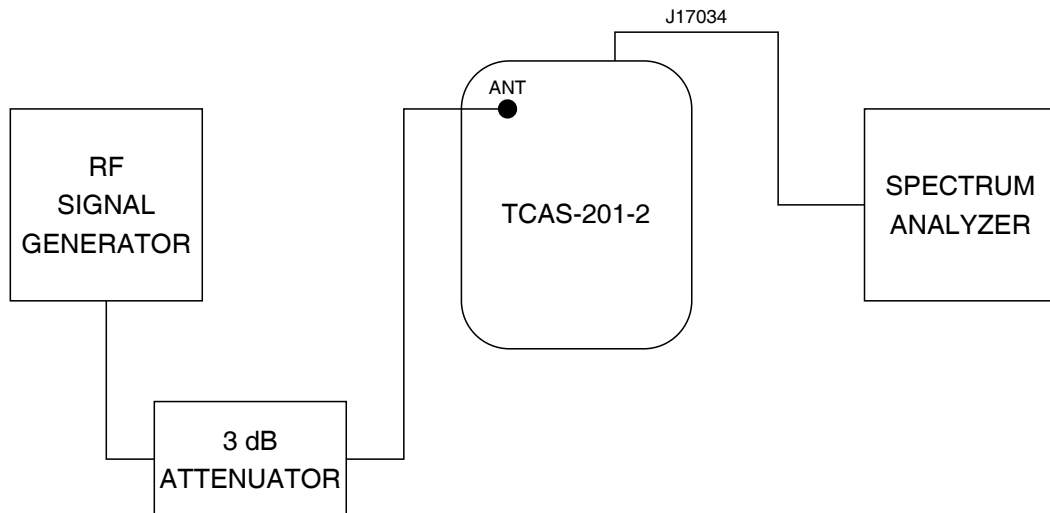

8506003

Receive Image Test Setup Diagram
Figure 30

68. Set TCAS-201-2 Signal Type to **DSP MEASURE=** and Attenuation to **0.0 dB**.

69. Press RUN/STOP Key to initiate test.

STEP	PROCEDURE
------	-----------

70. Set RF Signal Generator for TCAS-201-2 input of 1030 MHz at 0.0 dBm, considering 3 dB Attenuator.
71. Set peak amplitude level of 30 MHz signal as top reference on Spectrum Analyzer.
72. Set RF Signal Generator for a TCAS-201-2 input of 1090 MHz at 0.0 dBm, considering 3 dB Attenuator.
73. Verify 30 MHz signal level on Spectrum Analyzer is >15 dB below reference level in Step 71. If incorrect, return to Step 65 and repeat the LO Null adjustment; otherwise, continue to next step.
74. Press RUN/STOP Key to terminate test.

RECEIVE POWER

75. Set RF Signal Generator for TCAS-201-2 input of 1030.06 MHz at -9.05 dBm, considering 3 dB Attenuator.
76. Press RUN/STOP Key to initiate test.
77. Adjust R22073 (RX GAIN) for 0.0 dBm output at J17034.
78. Press RUN/STOP Key to terminate test.

ISOLATION RESET

79. Disconnect Spectrum Analyzer from J17034.
80. Connect Measuring Receiver through Power Sensor to J17034.
81. Disconnect RF Signal Generator from TCAS-201-2 ANTENNA Connector.
82. Terminate TCAS-201-2 ANTENNA Connector with Connector Cover providing 50 Ω load.
83. Set TCAS-201-2 Signal Type to **CW** and Attenuation to **0.0 dB**.
84. Press RUN/STOP Key to initiate test.
85. Adjust R22062 (ISOLATION) for 5 dBm signal level on Measuring Receiver.
86. Press RUN/STOP Key to terminate test.
87. Disconnect test equipment.

DETECTOR PULSE WIDTH

88. Connect test equipment according to 2-2-2, Figure 31.

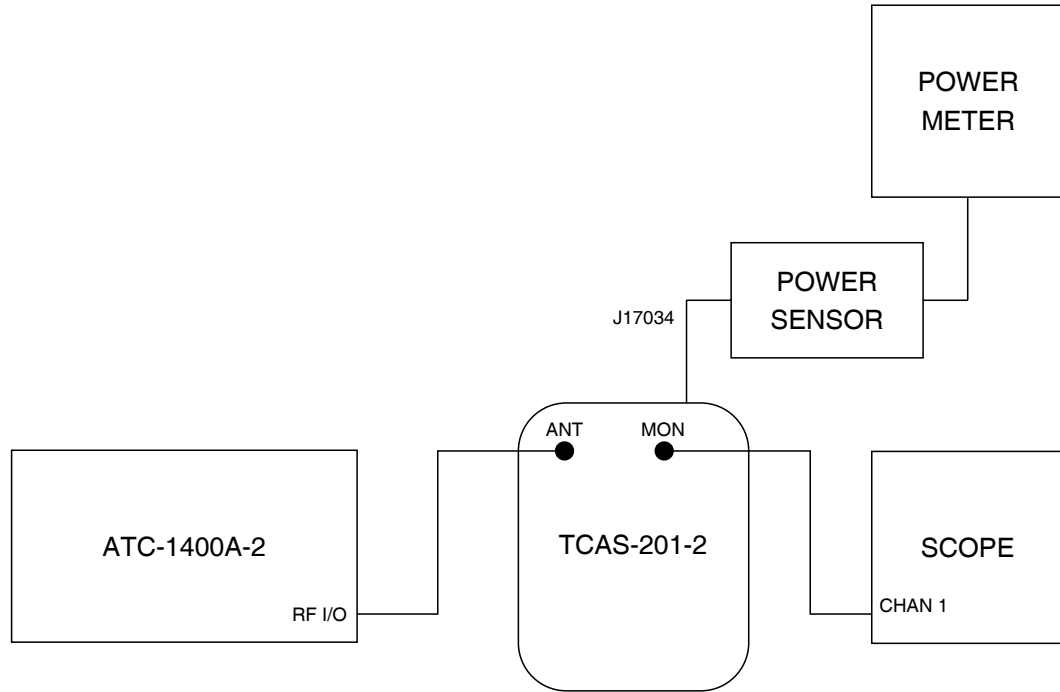

8506008

Detector Pulse Width Test Setup Diagram
Figure 31

89. Set ATC-1400A-2 as follows:

CONTROL	SETTING
CW/NORM/OFF Switch	CW
T _O /TAC/T _D Switch	T _O
PRF/SQTR Thumbwheels	3000
FREQ/FUNCTION SELECT Thumbwheels	1030 MHz XPDR
XPDR PULSE WIDTH Thumbwheels	0.45 μs

90. Set TCAS-201-2 Signal Type to **DSP MEASURE=** and Attenuation to **0.0 dB**.
91. Adjust ATC-1400A-2 RF LEVEL Control to obtain Power Meter levels of +3, -12 and -27 dBm. Record ATC-1400A-2 RF LEVEL -dBm Display reading for each level.
92. Disconnect Power Sensor from J17034.
93. Disconnect P19033 from J19033.
94. Connect P19033 to J17034.
95. Set ATC-1400A-2 RF LEVEL Control to -12 dBm reference established in Step 91 and CW/NORM/OFF Switch to NORM setting.

STEP PROCEDURE

96. Adjust R21058 (PULSE WIDTH) for 0.45 μ s detector pulse width on Oscilloscope.
97. Vary ATC-1400A-2 RF LEVEL Control to +3 and -27 dBm reference levels established in Step 91. Verify pulse width changes <40 ns from 0.45 μ s.
98. Disconnect P19033 from J17034 and reconnect P19033 to J19033.
99. Disconnect test equipment.

DIRECT CONNECT SET

100. Connect test equipment according to 2-2-2, Figure 32 with 3 dB Attenuator initially connected to TCAS-201-2 ANTENNA Connector.

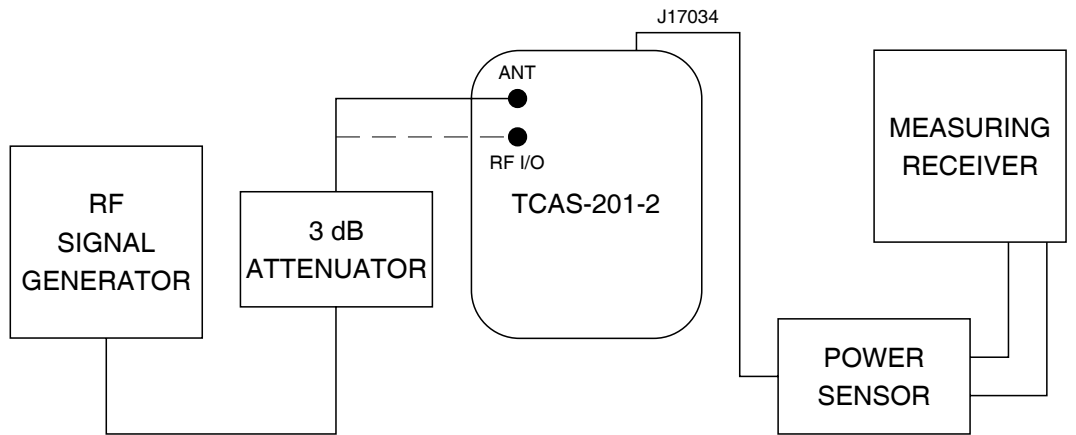

8506006

Direct Connect Set Test Setup Diagram
Figure 32

101. Set TCAS-201-2 Signal Type to **DSP MEASURE=** and Attenuation to **0.0 dB**.
102. Press RUN/STOP Key to initiate test.
103. Set RF Signal Generator for TCAS-201-2 input of 1030.06 MHz at -10 dBm, considering 3 dB Attenuator.
104. Record and set displayed level as zero reference on Measuring Receiver.
105. Disconnect 3 dB Attenuator from TCAS-201-2 ANTENNA Connector and connect 3 dB Attenuator to TCAS-201-2 RF I/O Connector.
106. Terminate TCAS-201-2 ANTENNA Connector with Connector Cover providing 50 Ω load.
107. Adjust R20020 (DIRECT CONNECT POWER ADJ) until Measuring Receiver indicates 48.25 dB below reference level set in Step 104.
108. Press RUN/STOP Key to terminate test.
109. Disconnect test equipment. Reconnect P17034 to J17034.

RF BIT DETECTOR SET

110. Press POWER Key. (TCAS-201-2 power is OFF.)

STEP	PROCEDURE
------	-----------

111. Remove Front Panel Pulse PCB Assy as needed to connect Digital Voltmeter (+) lead to TP27035 and (-) lead to TP27008 (ground).
112. Reinstall Front Panel Pulse PCB Assy.
113. Press POWER Key.
114. Set TCAS-201-2 Signal Type to **CW** and Attenuation to **0.0 dB**.
115. Verify Digital Multimeter reads 10 to 50 mV (45 to 50 mV is nominal) with no RF (no signal activated). Adjust R20029 (ZERO ADJUST) as needed.
116. Press RUN/STOP Key to initiate test.
117. Verify Digital Multimeter indicates 2.80 V. Adjust R20032 (RF DET ADJ) as needed.
118. Repeat Steps 115 through 117 until no adjustment is needed.
119. Press RUN/STOP Key to terminate test.
120. Disconnect Digital Multimeter from test points.

OSCILLATOR COMPENSATION

121. Connect TCAS-201-2 ANTENNA Connector to Universal Timer/Counter.
122. Set Universal Timer/Counter for 10 Hz resolution.
123. Press RUN/STOP Key to initiate test.

CAUTION: DO NOT SHORT TEMPERATURE PROBE TO ASSEMBLY WHILE MAKING CONTACT WITH COMPONENTS OR TRACES ON ANALOG IF PCB ASSY.

124. Insert Temperature Probe (connected to Digital Multimeter) through R22001 adjustment hole and obtain CR22001 temperature reading.
125. Record FL19007 voltage required for temperature obtained in Step 124 as specified in 2-2-2, Table 16.
126. Connect Digital Voltmeter (+) lead to FL19007 and (-) lead to ground.
127. Verify FL19007 voltage equals voltage recorded in Step 125. Adjust R22001 as needed.
128. Verify frequency output is 1090 MHz (± 200 Hz). Adjust C22004 as needed.
129. Press RUN/STOP Key to terminate test.
130. Disconnect test equipment.

CR22001 (°C)	FL19007 (Vdc)	CR22001 (°C)	FL19007 (Vdc)
20	2.93	35	3.08
21	2.94	36	3.09
22	2.95	37	3.10
23	2.96	38	3.11
24	2.97	39	3.12
25	2.98	40	3.13
26	2.99	41	3.14
27	3.00	42	3.15
28	3.01	43	3.16
29	3.02	44	3.17
30	3.03	45	3.18
31	3.04	46	3.19
32	3.05	47	3.20
33	3.06	48	3.21
34	3.07	49	3.22

Oscillator Compensation
Table 16

(3) System

TEST EQUIPMENT: 3 dB Fixed Attenuator
ATC-601-2 Ramp Test Set
Measuring Receiver
Oscilloscope
Power Sensor
RF Signal Generator
Spectrum Analyzer

STEP	PROCEDURE
------	-----------

SELF TEST

1. Perform Self Test (para 2-2-2[D][5]) and verify all modules/assemblies pass.
2. Reinstall RF Assy into Chassis Assy. Refer to 2-2-2, Figure 25 and secure by tightening six screws on Chassis Assy (Rear View).

RECEIVE POWER SYSTEM RECHECK

3. Disconnect P17034 from J17034 and connect test equipment as shown in 2-2-2, Figure 32 with 3 dB Attenuator connected to TCAS-201-2 ANTENNA Connector.
4. Set TCAS-201-2 Signal Type to **DSP MEASURE =** and Attenuation to **0.0 dB**.
5. Set RF Signal Generator for TCAS-201-2 input of 1030.06 MHz at -19.05 dBm, considering 3 dB Attenuator.
6. Press RUN/STOP Key to initiate test.
7. Record and set displayed level as zero reference on Measuring Receiver.
8. Set RF Signal Generator for TCAS-201-2 input of 1030.06 MHz at -9.05 dBm, considering 3 dB Attenuator.
9. Subtract 10 dB from Measuring Receiver reading to obtain compression error.
10. Calculate correct count number using compression error from Step 9 and following equation:

$$\text{Counts} = 128 \cdot 10(\text{compression error}/20)$$

11. Disconnect Power Sensor from J17034.
12. Reconnect P17034 to J17034.
13. Verify TCAS-201-2 **DSP MEASURES =** field displays count number calculated in Step 10. Adjust R22073 (RX GAIN) as needed.
14. Press RUN/STOP Key to terminate test.

ISOLATION SYSTEM RECHECK

15. Adjust RF Signal Generator output level (at 1030 MHz) until TCAS-201-2 **DSP MEASURES =** field displays **64**.
16. Disconnect P17034 from J17034.
17. Connect Oscilloscope Channel 1 to J17034.
18. Adjust Oscilloscope for full screen view of signal. Record signal level as reference.
19. Disconnect RF Signal Generator.

STEP	PROCEDURE
------	-----------

20. Terminate TCAS-201-2 ANTENNA Connector with Connector Cover providing 50 Ω load.
21. Set TCAS-201-2 Signal Type to **CW**.
22. Press RUN/STOP Key to initiate test.
23. Verify signal level equals reference level in Step 18. Adjust R22062 (ISOLATION) as needed.
24. Press RUN/STOP Key to terminate test.
25. Disconnect Oscilloscope from J17034.
26. Reconnect P17034 to J17034.

GENERATOR POWER SYSTEM RECHECK

27. Connect Measuring Receiver through Power Sensor and 3 dB Attenuator to TCAS-201-2 ANTENNA Connector as shown in 2-2-2, Figure 19.
28. Press RUN/STOP Key to initiate test.
29. Verify TCAS-201-2 output is +0.4 dBm, considering 3 dB Attenuator. Adjust R22049 (TX GAIN) as needed.

NOTE: If output is >0.5 dB from +0.4 dBm, resetting RF Bit Detector according to para 2-2-2H(2), Steps 110 to 120, is required.

30. Press RUN/STOP Key to terminate test.

MIXER NULLS

31. Disconnect Measuring Receiver and Power Sensor from the 3 dB Attenuator.
32. Connect Spectrum Analyzer through 3 dB Attenuator to TCAS-201-2 ANTENNA Connector.
33. Press RUN/STOP Key to initiate test.
34. Center 1090 MHz signal on Spectrum Analyzer with peak amplitude referenced at top major graticule.
35. Center 1060 MHz signal on Spectrum Analyzer. Verify 1060 MHz signal amplitude is >40 dB less than 1090 MHz signal level. If incorrect, adjust R18007 and R18008 (1060 MHz NULL ADJ) for lowest amplitude.
36. Press RUN/STOP Key to terminate test.

THRESHOLD SET

37. Connect test equipment as shown in 2-2-2, Figure 33 with Measuring Receiver initially connected through Power Sensor and 3 dB Attenuator to ATC-601-2 ANTENNA Connector.

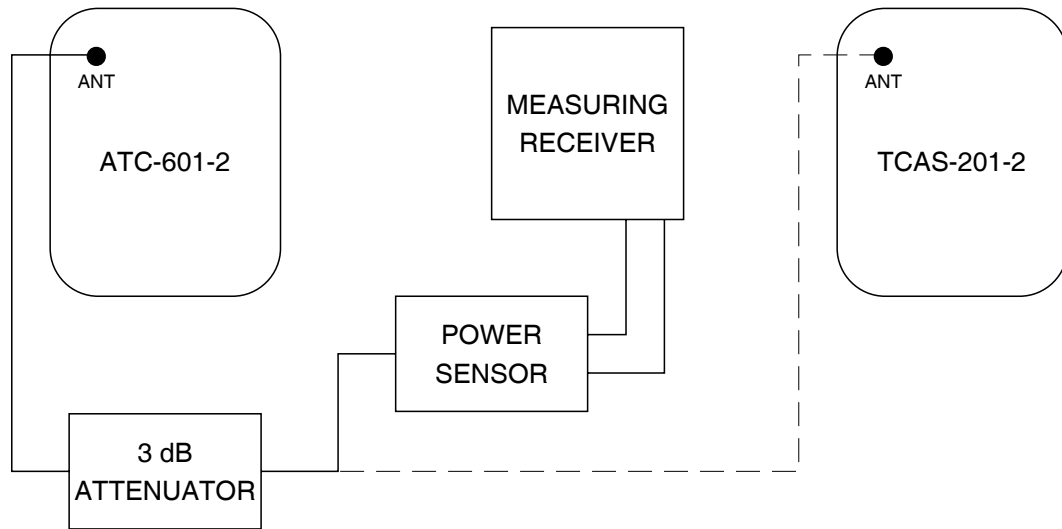

8506013

Threshold Test Setup Diagram
Figure 33

38. Set ATC-601-2 Signal Type to CW_P4 and PRF to 235.
39. Set ATC-601-2 Attenuation for -23.5 dBm on Measuring Receiver. Record Attenuation setting.
40. Disconnect 3 dB Attenuator from Power Sensor and connect to TCAS-201-2 ANTENNA Connector.
41. Set ATC-601-2 Signal Type to ITM_ATC_C at Attenuation referenced in Step 39.
42. Set TCAS-201-2 as follows:

SCREEN	FIELD	SETTING
Setup #1 Menu	INTRUDER TYPE:	ATCRBS
	UUT DIST: HORIZ:	250 ft
	UUT DIST: VERT:	100 ft
	GAIN_1030=	0.0 dB
	LOSS:	1.0 dB
ATCRBS Reply Test	RANGE:	0.0 nm
	%REPLY:	100

43. Press RUN/STOP Key from ATCRBS Reply Test screen to initiate test.
44. Verify $\geq 90\%$ replies ($\leq 10\%$ failures as indicated by count displays in ATC-601-2 Diagnostics Test screen [FAILURE: field/INTERROGATIONS: field ratio]). Adjust R21048 (THRESHOLD) as needed.
45. Increase ATC-601-2 Attenuation 1.0 dB (2 steps from Step 39 reference).
46. Verify TCAS-201-2 shows no replies.
47. Press RUN/STOP Key to terminate test.

STEP

PROCEDURE

48. Disconnect test equipment.
49. Reinstall Chassis Assy into Case Assy and tighten 12 screws with 23 inch•pounds (2.56 newton•meters) of torque.

CAUTION: NYLON WASHERS MUST BE REPLACED PRIOR TO RE-INSTALLATION OF SCREWS TO MAINTAIN WATER RESISTANCE CAPABILITY.



G. Calibration Data Sheet

TECHNICIAN: _____ DATE: _____

TCAS-201-2 S/N: _____

STEP	DATA	RESULT
(1) Power Supply		
4.	14.2 Vdc (± 0.1 V)	_____
6.	+5.1 Vdc (± 0.05 V)	_____
7.	+12 Vdc (± 0.3 V)	_____
8.	-12 Vdc (± 0.3 V)	_____
9.	+11 Vdc (± 0.25 V)	_____
(2) RF Assy		
LO SOURCE		
9.	Signal Sweep Centered on 1090 MHz	_____ (✓)
10.	1085.5 MHz to 1094.5 MHz Minimum Sweep Width	_____ (✓)
14.	Specified Offset Voltage (on RF Assy) Offset Voltage at 1085.5 MHz Specified Offset Voltage ($\pm < 10$ mV)	_____
16.	Offset Voltage at 1094.5 MHz Specified Offset Voltage ($\pm < 10$ mV)	_____
17.	Offset Voltage adjustment	_____ (✓)
ATTENUATOR		
26.	Attenuation Zero Volt adjustment	_____ (✓)
31.	Attenuation VSWR adjustment	_____ (✓)
36.	Receive Level at 0 dB Attenuation	_____
38.	40 dB Attenuation adjustment	_____ (✓)
40.	10 dB Attenuation adjustment	_____ (✓)
42.	Receive Level at 0 dB Attenuation (Step 36 level)	_____
ISOLATION NULL		
50.	30 MHz Signal Nullification	_____ (✓)
51.	30 MHz Signal Level +5 dBm	_____
GENERATOR OUTPUT POWER		
57.	Generator Output Power +0.4 dBm	_____
GENERATOR IMAGE		
64.	1030 MHz Signal Level >30 dB below 1090 MHz Signal Level	_____ (✓)



STEP	DATA	RESULT
LO NULL		
65	1060 MHz Signal Level >40 dB below 1090 MHz Signal Level	_____ (√)
RECEIVE IMAGE		
73.	1090 MHz Receive Signal Level >15 dB below 1030 MHz Signal Level	_____ (√)
RECEIVE POWER		
77.	Receive Power 0.0 dBm	_____
ISOLATION RESET		
85.	30 MHz Signal Level 5 dBm	_____ (√)
DETECTOR PULSE WIDTH		
91.	RF Level Indication +3 dBm -12 dBm -27 dBm	_____ _____ _____
96.	Detector Pulse Width 0.45 μs	_____ (√)
97.	Detector Pulse Width varies <40 ns	_____ (√)
DIRECT CONNECT SET		
104.	RF Level (ANTENNA Connector [18]) -10 dBm	_____
107.	RF Level (RF I/O Connector) Step 104 - 48.25 dB	_____ (√)
RF BIT DETECTOR SET		
115.	Bit Detector Zero Voltage 10 to 50 mV	_____
117.	Bit Detector Active Voltage 2.80 V	_____
OSCILLATOR COMPENSATION		
124.	Oscillator Compensation Diode Temperature	_____
125.	Oscillator Voltage required for Diode Temperature	_____
127.	Oscillator Voltage (Step 125 voltage)	_____
128.	Frequency Output 1090 MHz (±200 Hz)	_____
(3)	System	
SELF TEST		
1.	All Modules/Assemblies Pass	_____ (√)
RECEIVE POWER SYSTEM RECHECK		
7.	RF Signal Level -19.05 dBm	_____
9.	Receive Power Compression Error	_____
10.	Calculated Counts 128 • 10 ^(compression error/20)	_____
13.	Receive Power Counts (Step 10 counts)	_____



STEP	DATA	RESULT
ISOLATION SYSTEM RECHECK		
18.	30 MHz Signal Level (Receive)	_____
23.	30 MHz Signal Level (Transmit) Step 18 Level	_____
GENERATOR SYSTEM RECHECK		
29.	Generator Power +0.4 dBm	_____
MIXER NULLS		
35.	1060 MHz Signal Level >40 dB below 1090 MHz Signal Level	_____ (✓)
THRESHOLD SET		
39.	ATC-601-2 Attenuation for -23.5 dBm (Threshold)	_____
44.	TCAS-201-2 ≥90% Replies	_____ (✓)
46.	TCAS-201-2 No Replies at 1.0 dB below Threshold	_____ (✓)