

SECTION 3 - DISASSEMBLY/REASSEMBLY

1. Disassembly

A. General

Contains instructions necessary to remove and disassemble assemblies within the TCAS-201-2.

PROCEDURE	PAGE
Storage Compartment and Chassis Assy -----	3
Battery -----	6
Line Supply Assy-----	6
Power Supply Assy -----	8
Digital IF PCB Assy-----	10
Front Panel Pulse PCB Assy-----	10
RF Assy-----	12
Front Panel Assy-----	21
Flat Antenna Assy -----	28
Motherboard PCB Assy -----	30

B. Preliminary Considerations

(1) Tools Required

TOOL	SIZE	DESCRIPTION
SCREWDRIVER	#2 #4 #6	PHILLIPS
SCREWDRIVER	#2	SLOTTED
WRENCH (in)	1/4 3/16	SOCKET
WRENCH (in)	3/32 0.05	HEX-HEAD
WRENCH (in)	3/8 1/4 3/16 5/8	OPEN
SOLDERING IRON	N/A	PIN-TYPE

Disassembly Tools
Table 1

(2) Disassembly Precautions

- CAUTION:** TAG EACH WIRE AND CABLE PRIOR TO REMOVAL.
- CAUTION:** AVOID BENDING OR TWISTING SEMI-RIGID COAXIAL CABLES.
- CAUTION:** AVOID PLACING UNDUE STRAIN ON ANY WIRE OR CABLE.
- CAUTION:** AVOID DISCARDING LOOSE ITEMS (NUTS, SCREWS, WASHERS, ETC.).
- CAUTION:** AVOID EXPOSING COMPONENTS TO EXCESSIVE HEAT WHEN REMOVING SOLDER.

(3) ESD

CAUTION: THE POWER SUPPLY PCB ASSY, DIGITAL IF PCB ASSY, FRONT PANEL PULSE PCB ASSY, RF ASSY AND FRONT PANEL ASSY CONTAIN PARTS SENSITIVE TO DAMAGE BY ELECTROSTATIC DISCHARGE (ESD). ALL PERSONNEL PERFORMING DISASSEMBLY SHOULD HAVE KNOWLEDGE OF ACCEPTED ESD PRACTICES AND/OR BE ESD CERTIFIED.



(4) EMC and Safety Compliance

All assemblies, cables, connectors, plastic fasteners, gaskets, fingerstock and miscellaneous hardware within the Test Set are configured to satisfy the safety and EMC compliance standards.

CAUTION: UPON COMPLETION OF ANY MAINTENANCE ACTION; ALL ASSEMBLIES, CABLES, CONNECTORS, PLASTIC FASTENERS, GASKETS, FINGERSTOCK AND MISCELLANEOUS HARDWARE MUST BE CONFIGURED AS INSTALLED AT THE FACTORY.

C. Procedures

(1) Storage Compartment and Chassis Assy

NOTE: Item numbers refer to 2-3-1, Figure 1.

STEP	PROCEDURE
1.	Unlock fasteners (18) securing Storage Compartment (17) to Case Assy (19).
2.	Remove Storage Compartment (17) from Case Assy (19).
3.	Remove 12 screws (1) and nylon washers (2) from Front Panel Assy (3).
4.	Lift Chassis Assy (7) from Case Assy (19).

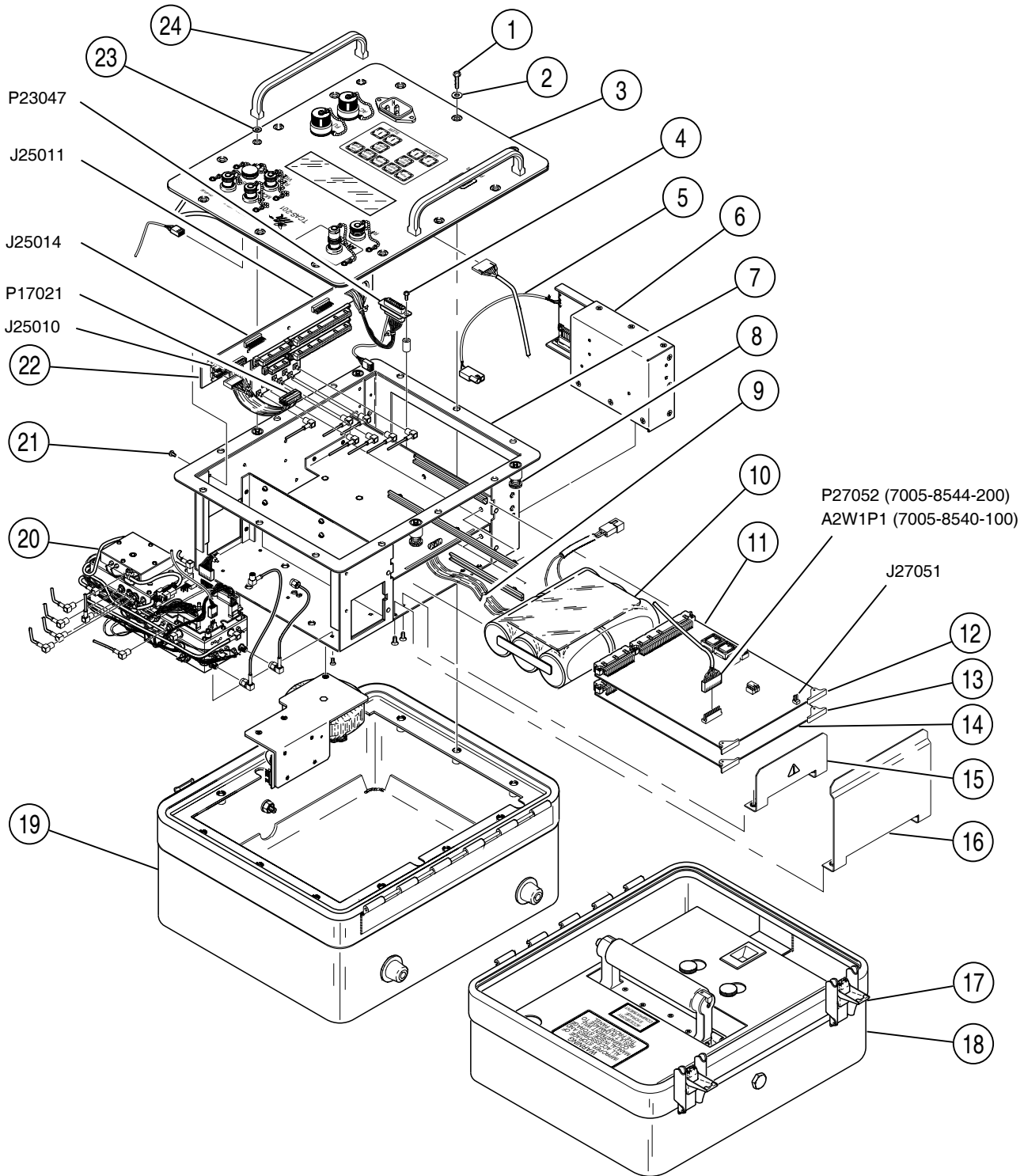

Storage Compartment and Chassis Assy
Figure 1

8507029

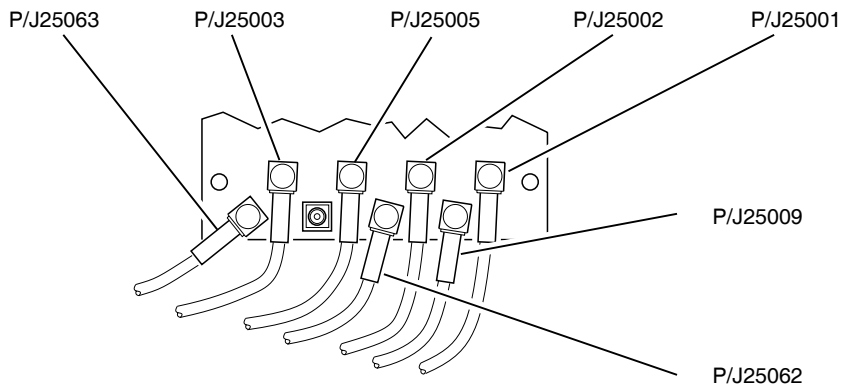
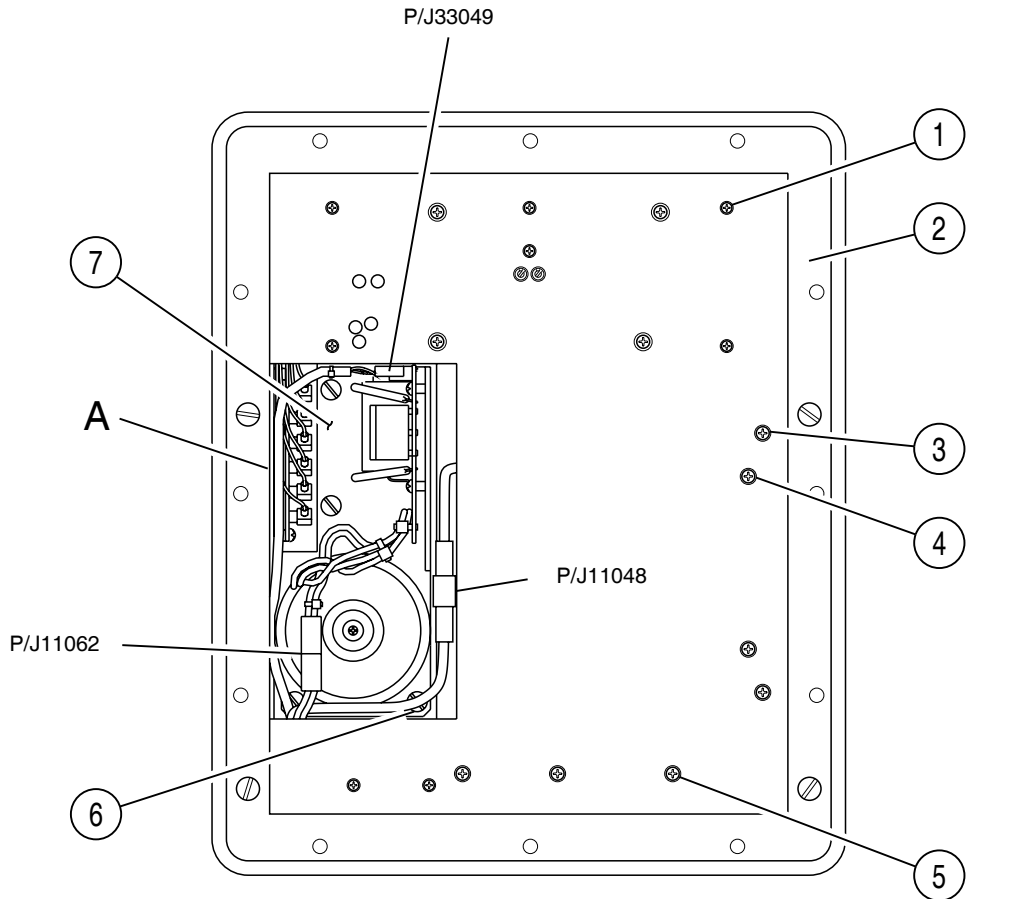

DETAIL A

TCAS-201-2 Rear View
Figure 2

8507028

(2) Battery

NOTE: Item numbers refer to 2-3-1, Figure 2 unless otherwise noted.

STEP	PROCEDURE
1.	Remove Storage Compartment and Chassis Assy (para 2-3-1C[1].
2.	Disconnect battery connector (P/J11048).
3.	Remove two screws (3) from bottom of Chassis Assy (2) and remove PCB retainer (16) (2-3-1, Figure 1).
4.	Remove two screws (4) from bottom of Chassis Assy (2) and remove battery cover (15) (2-3-1, Figure 1).
5.	Refer to 2-3-1, Figure 1 and pull ejector strap (9) to remove battery (10) from Chassis Assy (7).

(3) Line Supply Assy

STEP	PROCEDURE
1.	Remove Storage Compartment and Chassis Assy (para 2-3-1C[1].
	NOTE: For Steps 2 through 4, item numbers refer to 2-3-1, Figure 2.
2.	Disconnect P/J33049.
3.	Disconnect P/J11062.
4.	Loosen three captive screws (6) securing Line Supply Assy (7) to Chassis Assy (2).
5.	Remove Line Supply Assy (7) from Chassis Assy (2).
	LINE SUPPLY PCB ASSY
	NOTE: For Steps 5 through 8, item numbers refer to 2-3-1, Figure 3.
5.	Remove four screws (3) securing Line Supply PCB Assy (2) to bracket (1).
6.	Remove one screw (4) securing bridge rectifier (5) to bracket (1).
7.	Remove one screw (9) securing transformer (6) to bracket (1).
8.	Remove transformer (6), conical washer (8), two insulators (7), bridge rectifier (5) and Line Supply PCB Assy (2) from bracket (1).

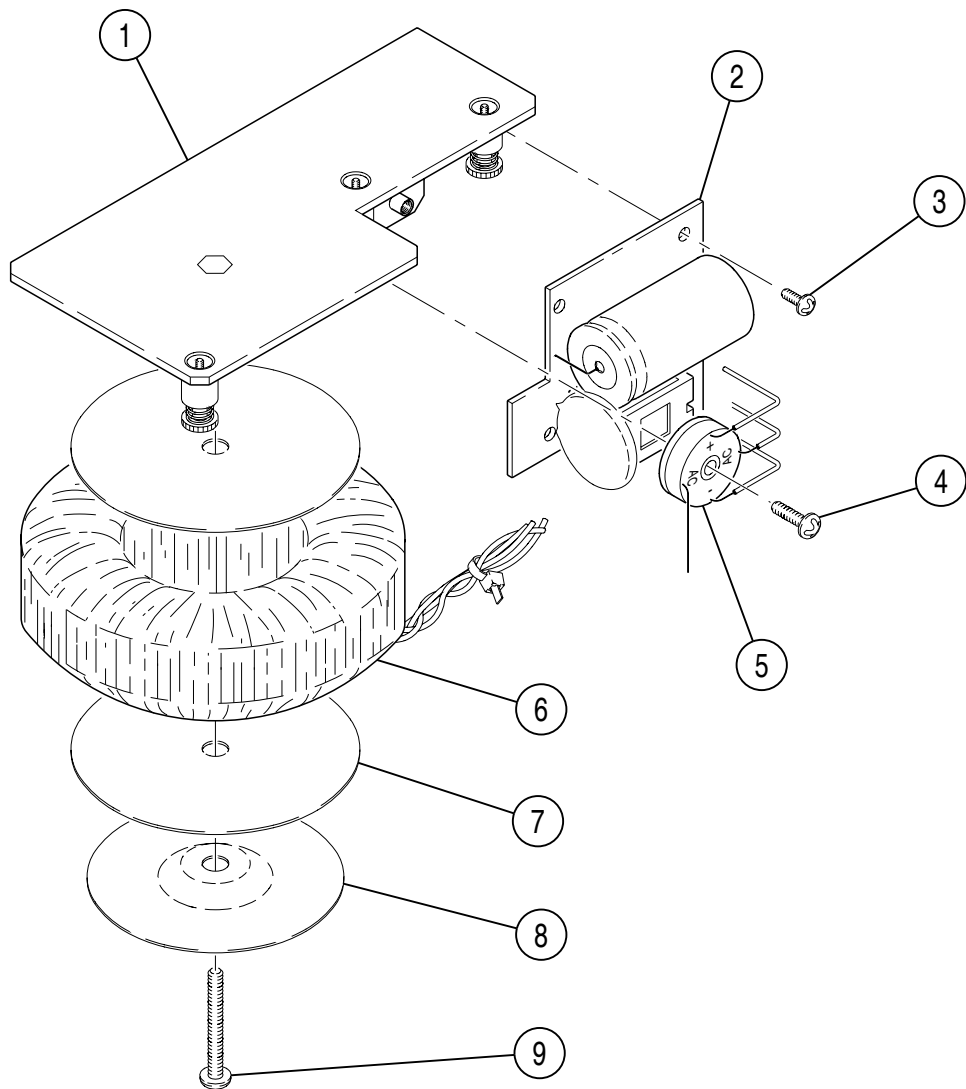

Line Supply Assy
Figure 3

8507027

(4) Power Supply Assy

STEP	PROCEDURE
1.	Remove Storage Compartment and Chassis Assy (para 2-3-1C[1]. NOTE: For Steps 2 and 3, item numbers refer to 2-3-1, Figure 2.
2.	Disconnect battery connector (P/J11048).
3.	Remove three screws (5) securing Power Supply Assy to Chassis Assy. NOTE: For Steps 4 and 5, item numbers refer to 2-3-1, Figure 1.
4.	Lift Power Supply Assy (6) and disconnect J23047 from P23047.
5.	Remove Power Supply Assy (6) from Chassis Assy (7). Carefully guide battery cable (5) out from middle of Chassis Assy cavity and through Power Supply Assy cavity.
POWER SUPPLY PCB ASSY	
NOTE: For Steps 6 through 11, item numbers refer to 2-3-1, Figure 4.	
6.	Remove nine screws (1) from Power Supply Assy.
7.	Remove cover (2) from Power Supply Assy.
8.	Remove four screws (8), four nuts (3), four flat washers (4) and four shoulder washers (5) securing regulators (9), FETs (7) and insulators (6) to enclosure (11).
9.	Remove two hex nut screws (10) securing J23047 to enclosure (11).
10.	Remove nine screws (12) securing Power Supply PCB Assy (13) to enclosure (11).
11.	Remove Power Supply PCB Assy (13) from enclosure (11).

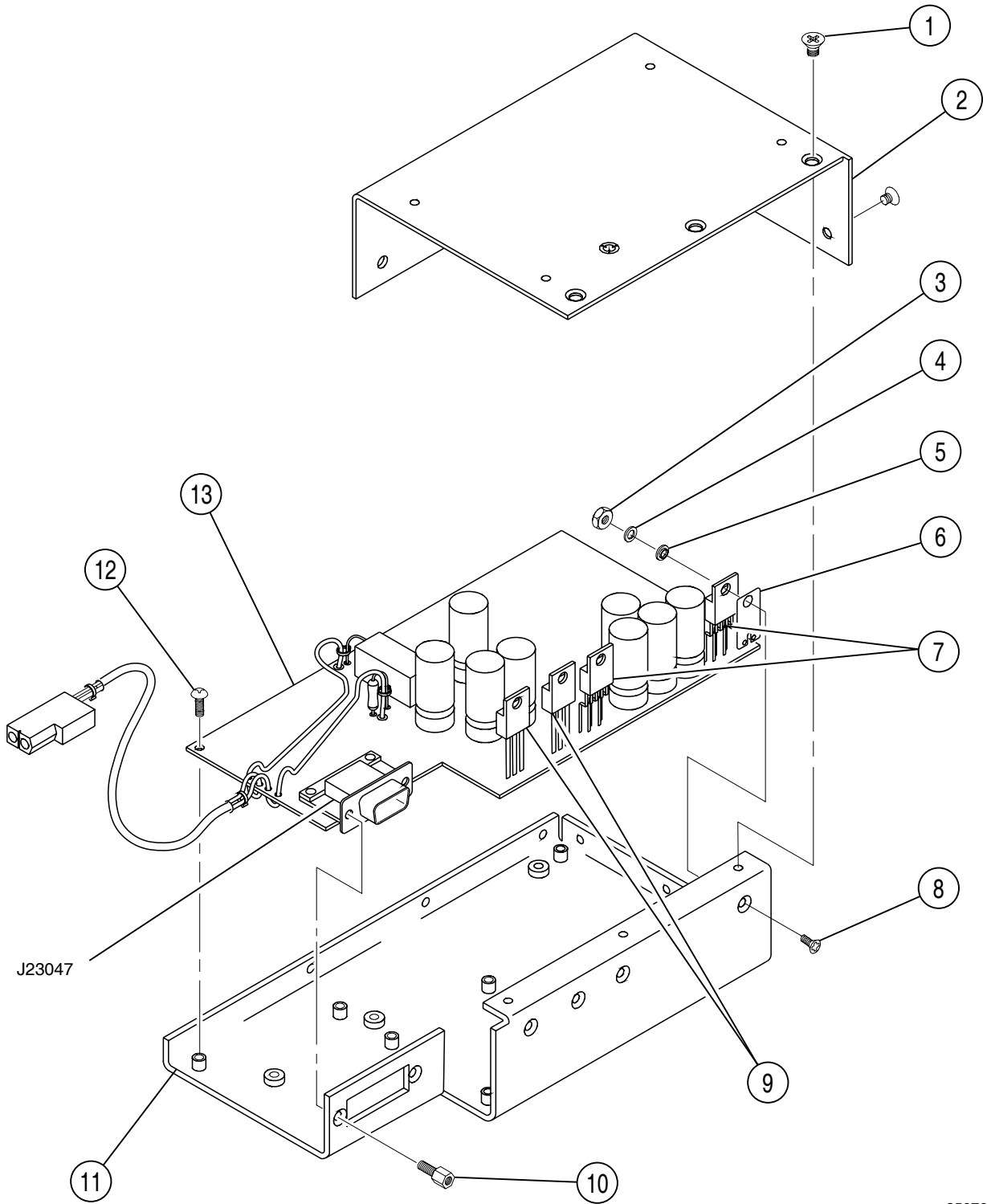

Power Supply Assy
Figure 4

8507031

(5) Digital IF PCB Assy

NOTE: Item numbers refer to 2-3-1, Figure 1 unless otherwise noted.

STEP	PROCEDURE
1.	Remove Storage Compartment and Chassis Assy (para 2-3-1C[1]).
2.	Remove two screws (4) (2-3-1, Figure 2) securing PC board retainer (15) to Chassis Assy (7).
3.	Pull card ejector (13) and remove Digital IF PCB Assy (14) from Chassis Assy (7).

(6) Front Panel Pulse PCB Assy

NOTE: Item numbers refer to 2-3-1, Figure 1 unless otherwise noted.

STEP	PROCEDURE
1.	Remove Storage Compartment and Chassis Assy (para 2-3-1C[1]).
2.	Remove two screws (4) (2-3-1, Figure 2) securing PC board retainer (16) to Chassis Assy (7).
3.	Disconnect P27051 and P27052 from Front Panel Pulse PCB Assy (11).
4.	Pull card ejector (12) and remove Front Panel Pulse PCB Assy (11) from Chassis Assy (7).

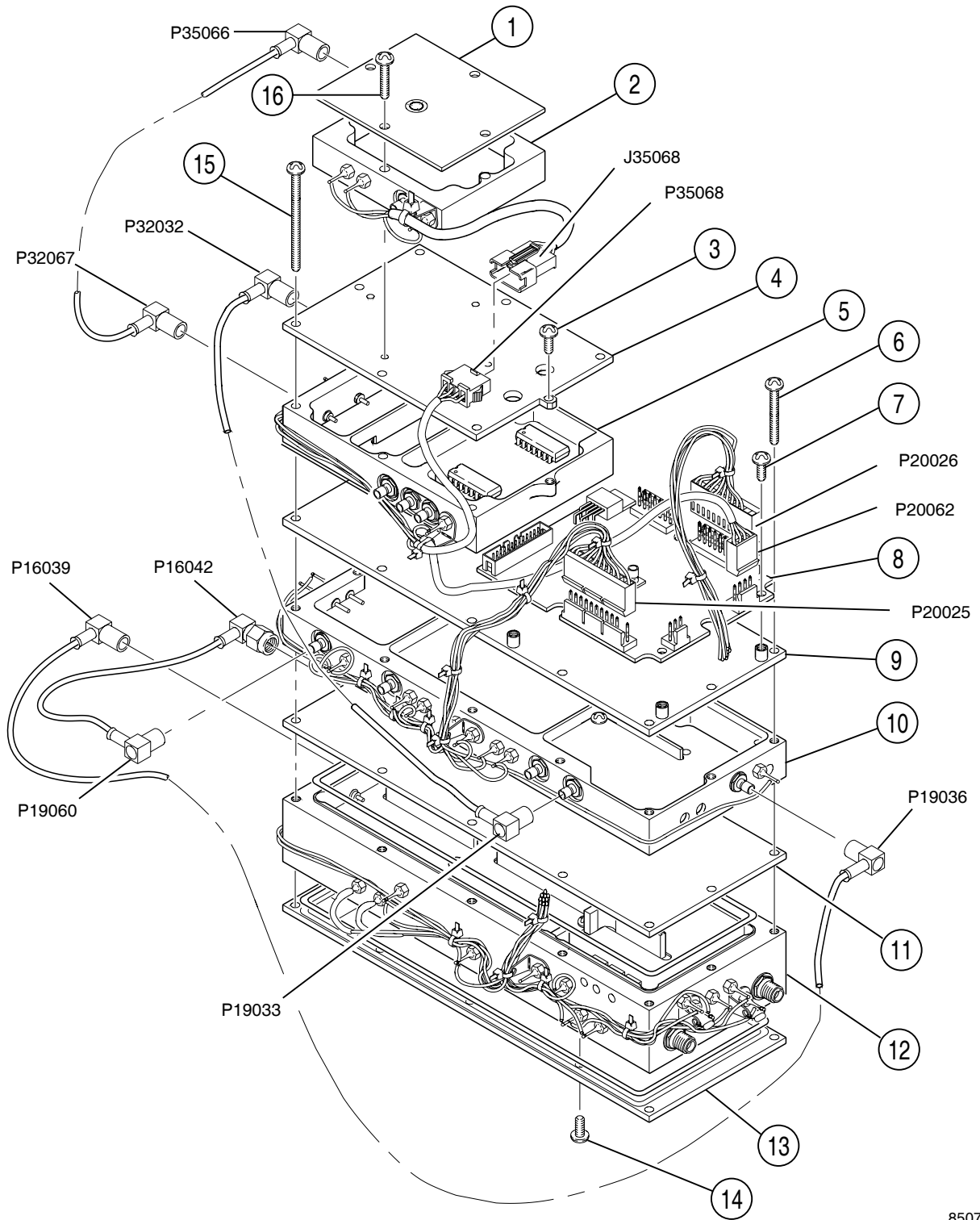

RF Assy
Figure 5

8507015

(7) RF Assy

NOTE: Item numbers refer to 2-3-1, Figure 5 unless otherwise noted.

STEP	PROCEDURE																																				
1.	Remove Storage Compartment and Chassis Assy (para 2-3-1C[1].																																				
2.	Refer to 2-3-1, Figure 2 and remove six screws (1) securing RF Assy to Chassis Assy (2).																																				
3.	Carefully lift RF Assy (20) up and out of Chassis Assy (7), applying minimal stress on connecting cables.																																				
4.	Disconnect cables:																																				
	<table border="0"> <tr> <td>P17037 (Front Panel Assy)</td> <td>FROM</td> <td>J17037 (RF Assy)</td> </tr> <tr> <td>P17038 (Front Panel Assy)</td> <td>FROM</td> <td>J17038 (RF Assy)</td> </tr> <tr> <td>P17027 (Front Panel Assy)</td> <td>FROM</td> <td>J17027 (RF Assy)</td> </tr> <tr> <td>P17022 (Motherboard PCB Assy)</td> <td>FROM</td> <td>J17022 (RF Assy)</td> </tr> <tr> <td>P17024 (Motherboard PCB Assy)</td> <td>FROM</td> <td>J17024 (RF Assy)</td> </tr> <tr> <td>P17021 (Motherboard PCB Assy)</td> <td>FROM</td> <td>J17021 (RF Assy)</td> </tr> <tr> <td>P17034 (Motherboard PCB Assy)</td> <td>FROM</td> <td>J17034 (RF Assy)</td> </tr> <tr> <td>P17064 (Motherboard PCB Assy)</td> <td>FROM</td> <td>J17023 (RF Assy)</td> </tr> <tr> <td>P17030 (Front Panel Assy)</td> <td>FROM</td> <td>J17030 (RF Assy)</td> </tr> <tr> <td>P17031 (Motherboard PCB Assy)</td> <td>FROM</td> <td>J17031 (RF Assy)</td> </tr> <tr> <td>P17065 (Motherboard PCB Assy)</td> <td>FROM</td> <td>J17035 (RF Assy)</td> </tr> <tr> <td>P17035 (Motherboard PCB Assy)</td> <td>FROM</td> <td>J17031 (RF Assy)</td> </tr> </table>	P17037 (Front Panel Assy)	FROM	J17037 (RF Assy)	P17038 (Front Panel Assy)	FROM	J17038 (RF Assy)	P17027 (Front Panel Assy)	FROM	J17027 (RF Assy)	P17022 (Motherboard PCB Assy)	FROM	J17022 (RF Assy)	P17024 (Motherboard PCB Assy)	FROM	J17024 (RF Assy)	P17021 (Motherboard PCB Assy)	FROM	J17021 (RF Assy)	P17034 (Motherboard PCB Assy)	FROM	J17034 (RF Assy)	P17064 (Motherboard PCB Assy)	FROM	J17023 (RF Assy)	P17030 (Front Panel Assy)	FROM	J17030 (RF Assy)	P17031 (Motherboard PCB Assy)	FROM	J17031 (RF Assy)	P17065 (Motherboard PCB Assy)	FROM	J17035 (RF Assy)	P17035 (Motherboard PCB Assy)	FROM	J17031 (RF Assy)
P17037 (Front Panel Assy)	FROM	J17037 (RF Assy)																																			
P17038 (Front Panel Assy)	FROM	J17038 (RF Assy)																																			
P17027 (Front Panel Assy)	FROM	J17027 (RF Assy)																																			
P17022 (Motherboard PCB Assy)	FROM	J17022 (RF Assy)																																			
P17024 (Motherboard PCB Assy)	FROM	J17024 (RF Assy)																																			
P17021 (Motherboard PCB Assy)	FROM	J17021 (RF Assy)																																			
P17034 (Motherboard PCB Assy)	FROM	J17034 (RF Assy)																																			
P17064 (Motherboard PCB Assy)	FROM	J17023 (RF Assy)																																			
P17030 (Front Panel Assy)	FROM	J17030 (RF Assy)																																			
P17031 (Motherboard PCB Assy)	FROM	J17031 (RF Assy)																																			
P17065 (Motherboard PCB Assy)	FROM	J17035 (RF Assy)																																			
P17035 (Motherboard PCB Assy)	FROM	J17031 (RF Assy)																																			

5. Remove RF Assy (20) from Chassis Assy (7).

(a) Driver PCB Assy

NOTE: Item numbers refer to 2-3-1, Figure 5 unless otherwise noted.

STEP	PROCEDURE									
1.	Remove RF Assy (para 2-3-1C[7]).									
2.	Disconnect cables:									
	<table border="0"> <tr> <td>P20062 (Detector Assy)</td> <td>FROM</td> <td>J20062 (Driver PCB Assy)</td> </tr> <tr> <td>P20025 (Analog IF Assy)</td> <td>FROM</td> <td>J20025 (Driver PCB Assy)</td> </tr> <tr> <td>P20026 (SSB Assy)</td> <td>FROM</td> <td>J20026 (Driver PCB Assy)</td> </tr> </table>	P20062 (Detector Assy)	FROM	J20062 (Driver PCB Assy)	P20025 (Analog IF Assy)	FROM	J20025 (Driver PCB Assy)	P20026 (SSB Assy)	FROM	J20026 (Driver PCB Assy)
P20062 (Detector Assy)	FROM	J20062 (Driver PCB Assy)								
P20025 (Analog IF Assy)	FROM	J20025 (Driver PCB Assy)								
P20026 (SSB Assy)	FROM	J20026 (Driver PCB Assy)								
3.	Remove four screws (7) securing Driver PCB Assy (8) to Analog IF cover (9).									
4.	Remove Driver PCB Assy (8) from RF Assy.									

(b) Decoder Assy

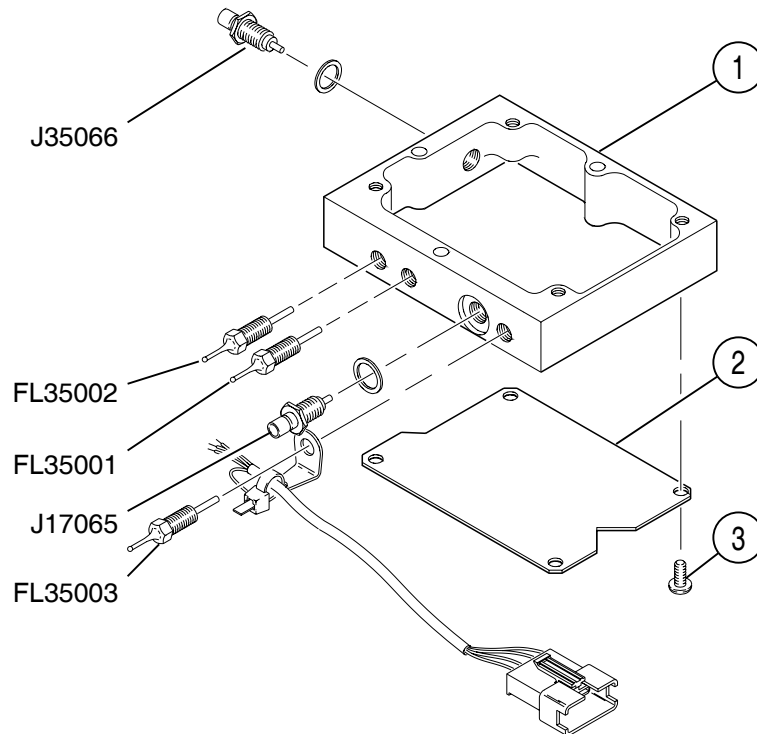

8507016

Decoder Assy
Figure 6

STEP	PROCEDURE
------	-----------

NOTE: For Steps 1 through 4, item numbers refer to 2-3-1, Figure 5.

1. Remove RF Assy (para 2-3-1C[7]).
2. Disconnect cables:

P35068 (Detector Assy)	FROM	J35068 (Decoder Assy)
P35066 (Detector Assy)	FROM	J35066 (Decoder Assy)
3. Remove four screws (16) securing Decoder cover (1) and Decoder Assy (2) to Detector cover (4).
4. Remove Decoder Assy (2) from RF Assy.

DECODER PCB ASSY

NOTE: For Steps 5 through 7, item numbers refer to 2-3-1, Figure 6.

5. Remove solder from Decoder PCB Assy (2) at filter and connector junctions: FL35003, FL35002, J17065, J35066 and FL35001.
6. Remove four screws (3) securing Decoder PCB Assy (2) to Decoder Assy (1).
7. Remove Decoder PCB Assy (2) from Decoder Assy (1).

(c) Detector Assy

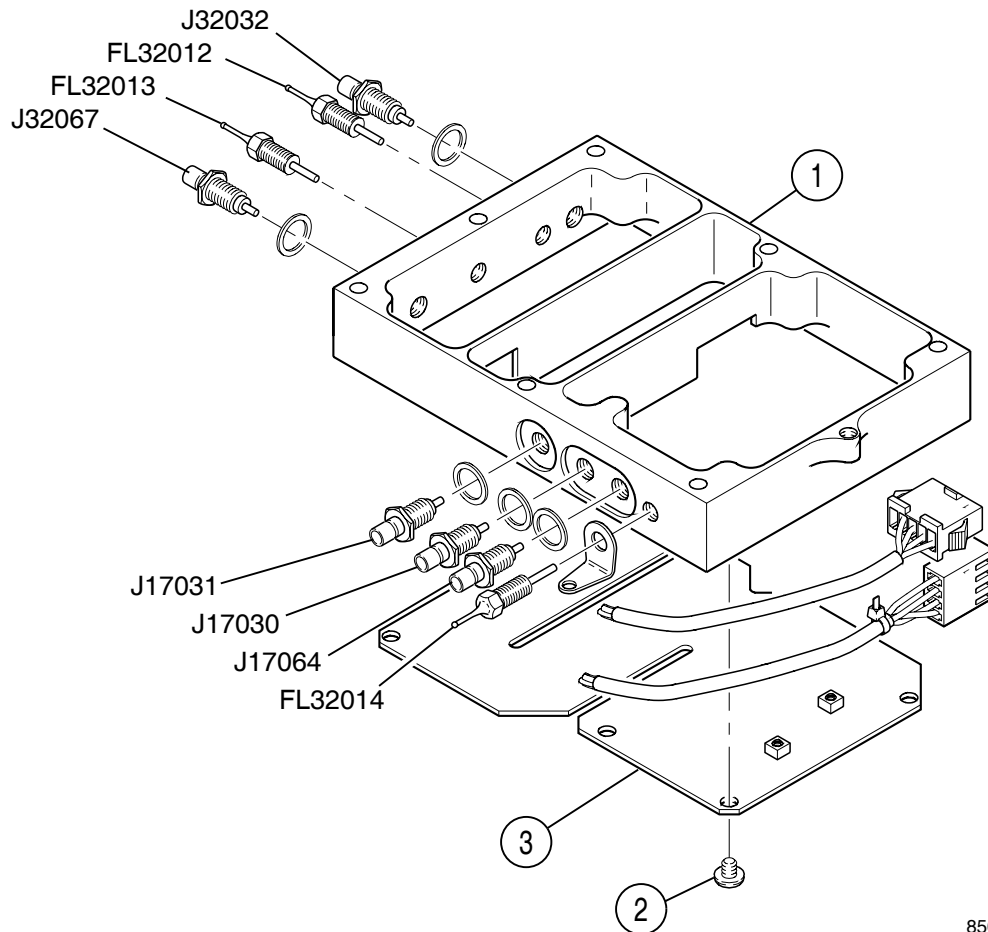

8507017

Detector Assy
Figure 7

STEP	PROCEDURE
------	-----------

NOTE: For Steps 1 through 5, item numbers refer to 2-3-1, Figure 5.

1. Remove Decoder Assy (para 2-3-1C[7][b]).
2. Disconnect cables:

P20062 (Detector Assy)	FROM	J20062 (Driver PCB Assy)
P32032 (Analog IF Assy)	FROM	J32032 (Detector Assy)
P32067 (Decoder Assy)	FROM	J32067 (Detector Assy)
3. Remove seven screws (15) securing Detector Assy (5) to SSB Assy (12).
4. Remove Detector Assy (5) from RF Assy.

STEP

PROCEDURE

DETECTOR PCB ASSY

5. Loosen screw (3) and rotate Detector cover (4).

NOTE: For Steps 6 through 8, item numbers refer to 2-3-1, Figure 7.

6. Remove solder from Detector PCB Assy (3) at filter and connector junctions:

FL32014	J17030	J32067	FL32012
J17064	J17031	FL32013	J32032

7. Remove seven screws (2) securing Detector PCB Assy (3) to Detector Assy (1).
8. Remove Detector PCB Assy (3) from Detector Assy (1).

(d) Analog IF Assy

STEP	PROCEDURE
------	-----------

NOTE: For Steps 1 through 4, item numbers refer to 2-3-1, Figure 5.

1. Remove Detector Assy (para 2-3-1C[7][c]).
2. Disconnect cables:

P19036 (SSB Assy)	FROM	J19036 (Analog IF Assy)
P20025 (Analog IF Assy)	FROM	J20025 (Driver PC Board Assy)
P19033 (Detector Assy)	FROM	J19033 (Analog IF Assy)
P19060 (SSB Assy)	FROM	J19060 (Analog IF Assy)

3. Remove five screws (6) securing Analog IF Assy (10) to SSB Assy (12).
4. Remove Analog IF cover (9) and Analog IF Assy (10) from RF Assy.

ANALOG IF PCB ASSY

NOTE: For Steps 5 through 7, item numbers refer to 2-3-1, Figure 8.

5. Remove solder from Analog IF PCB Assy (1) at filter and connector junctions:

FL19010	FL19006	FL19002	J19060
J19036	FL19005	FL19008	FL19001
J19033	FL19004	J17035	FL19007
J17034	FL19003	FL19011	

6. Remove 14 screws (2) securing Analog IF PCB Assy (1) to Analog IF Assy (3).
7. Remove Analog IF PCB Assy (1) from Analog IF Assy (3).

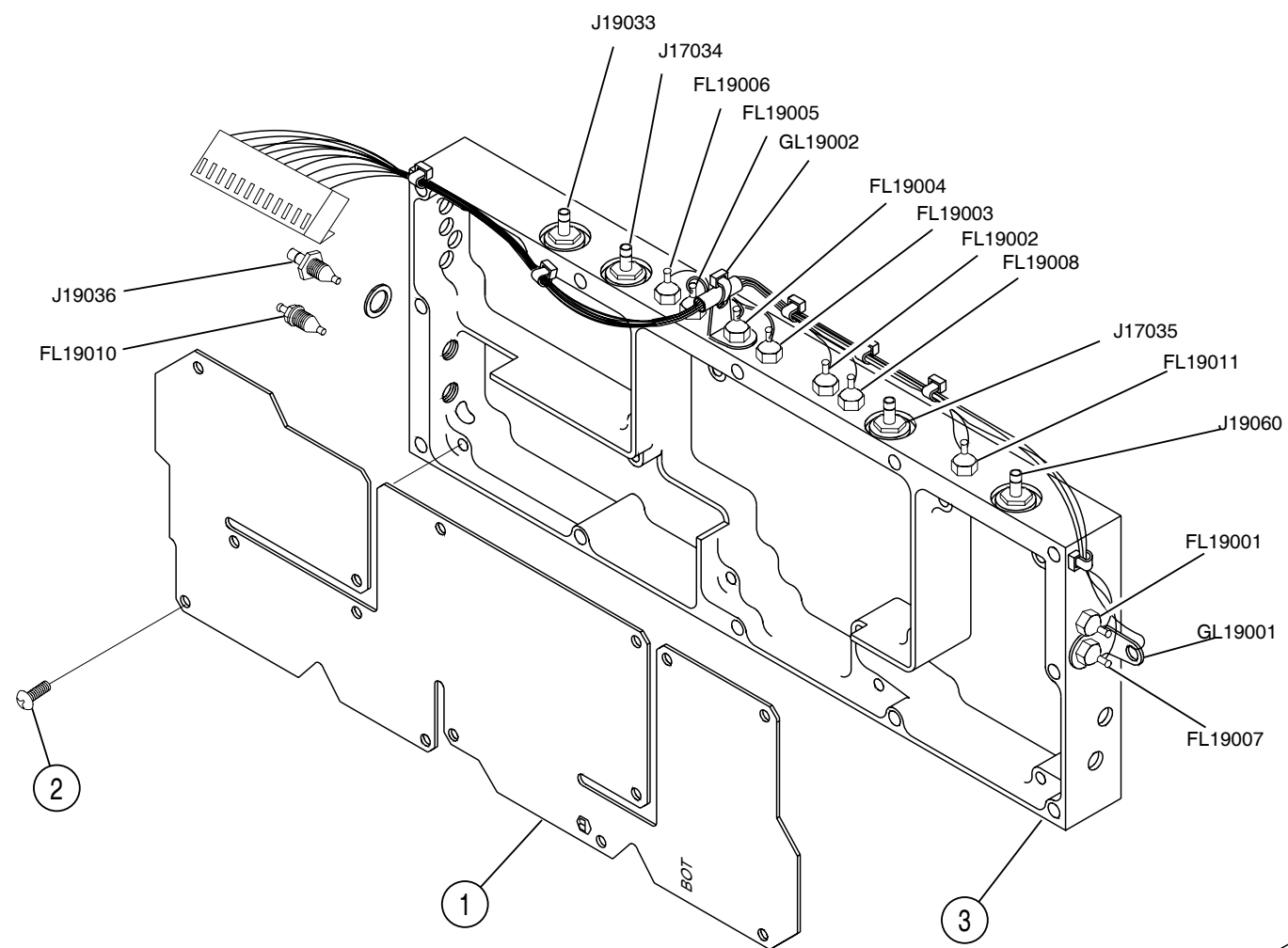

(REV D1)

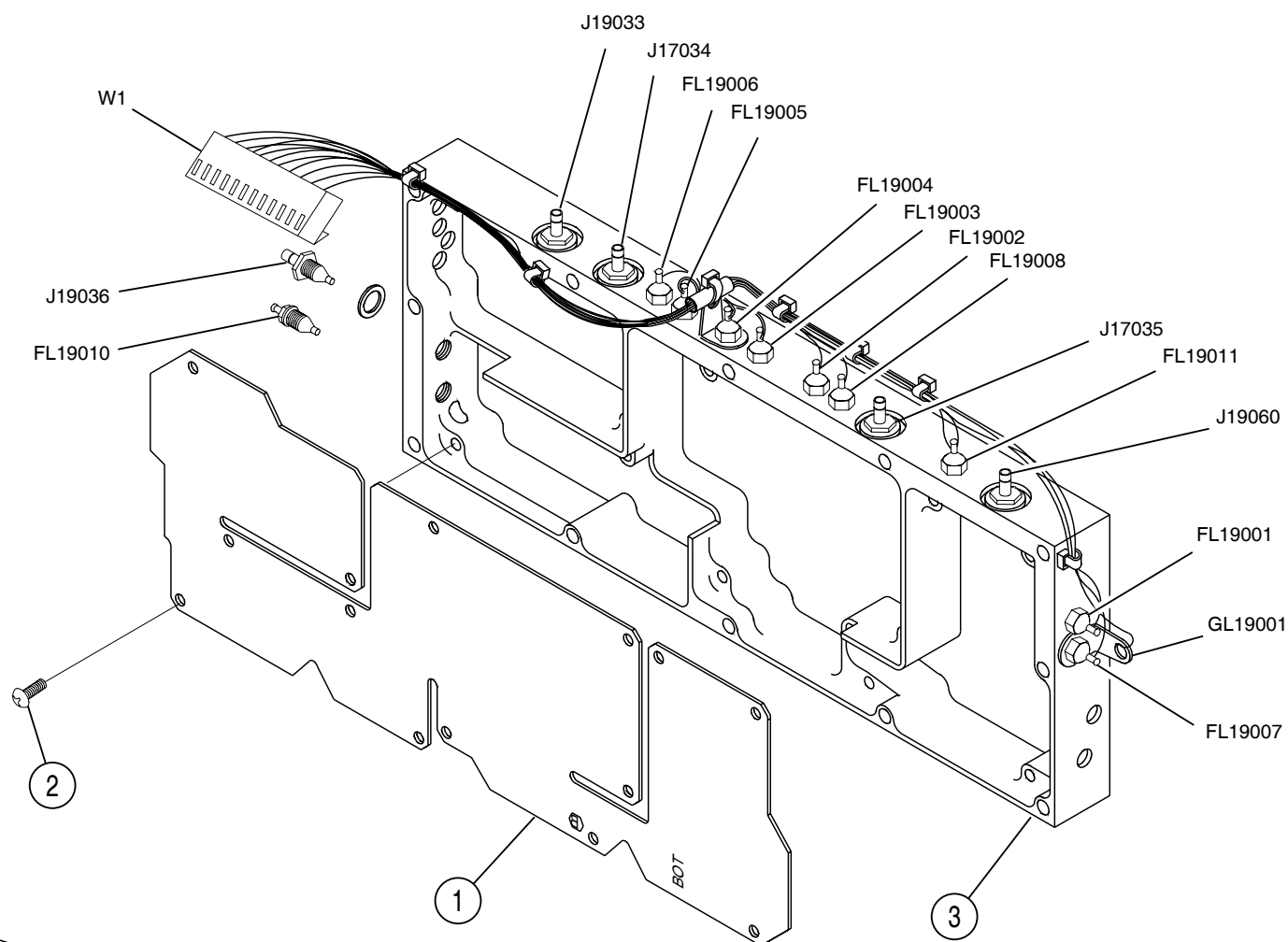

(REV E AND ON)

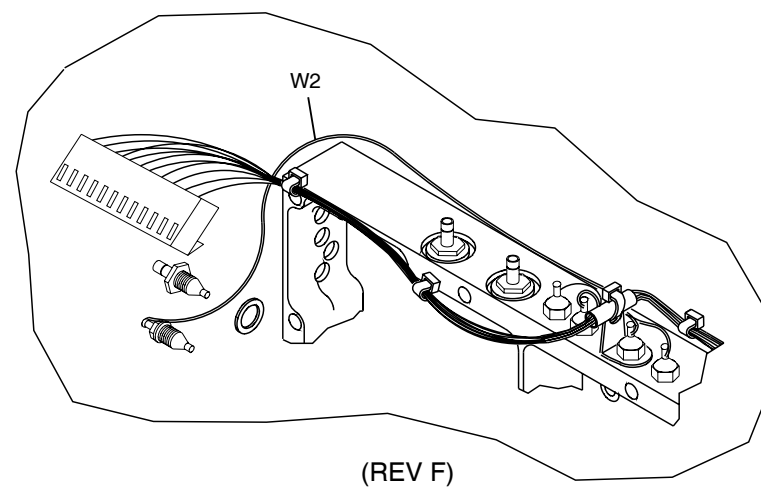

(REV F)

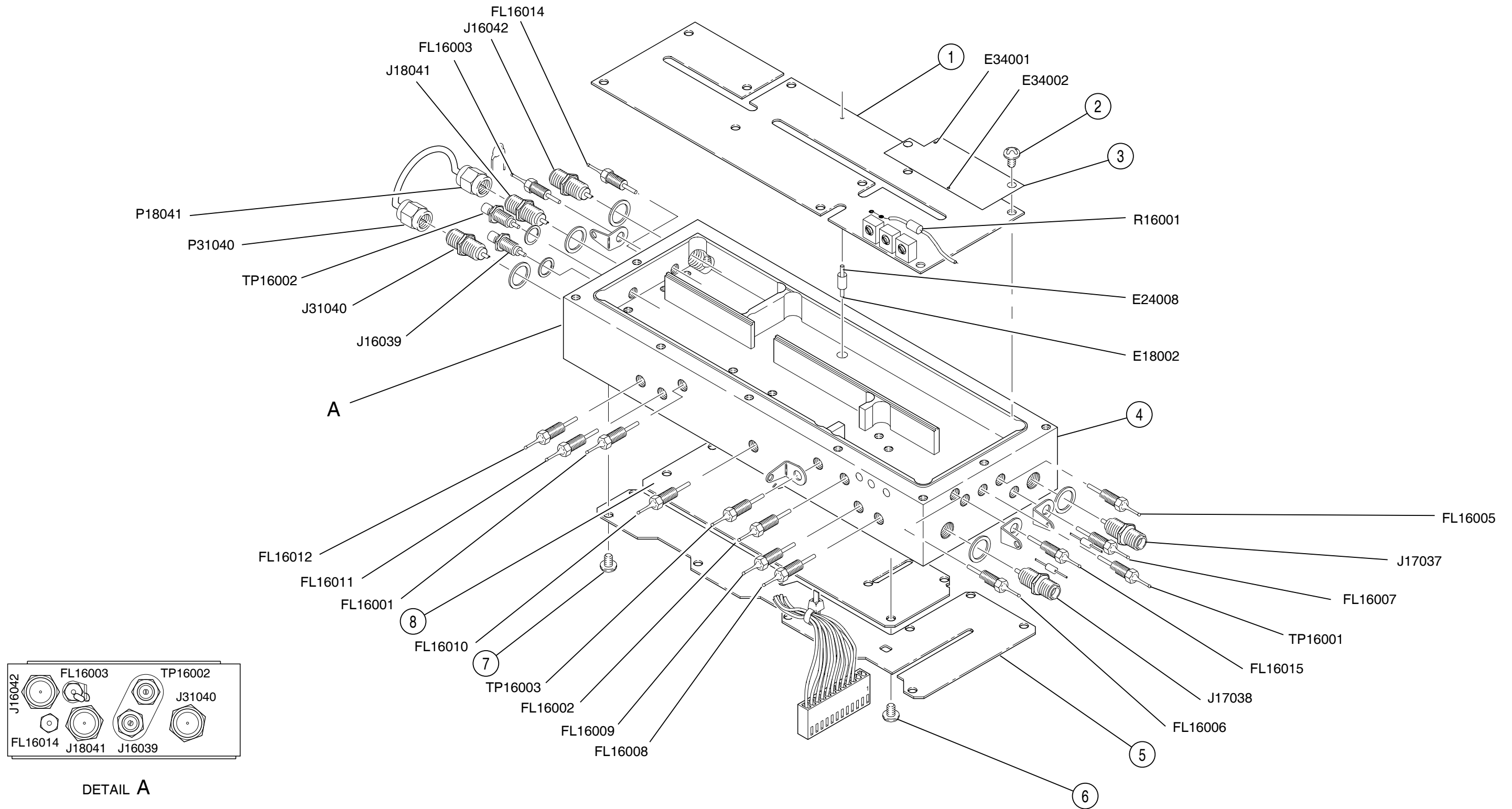

8507032

SSB Assy
Figure 9

(e) SSB Assy

NOTE: Item numbers refer to 2-3-1, Figure 9 unless otherwise noted.

STEP	PROCEDURE												
1.	Remove RF Assy (para 2-3-1C[7]).												
	MIXER PCB ASSY												
2.	Disconnect cables:												
	<table border="0"> <tr> <td>P18041 (Attenuator PCB Assy)</td> <td>FROM</td> <td>J18041 (Mixer PCB Assy)</td> </tr> <tr> <td>P31040 (Attenuator PCB Assy)</td> <td>FROM</td> <td>J31040 (Mixer PCB Assy)</td> </tr> <tr> <td>P16039 (Analog IF Assy)</td> <td>FROM</td> <td>J16039 (SSB Assy) (2-3-1, Figure 5)</td> </tr> </table>	P18041 (Attenuator PCB Assy)	FROM	J18041 (Mixer PCB Assy)	P31040 (Attenuator PCB Assy)	FROM	J31040 (Mixer PCB Assy)	P16039 (Analog IF Assy)	FROM	J16039 (SSB Assy) (2-3-1, Figure 5)			
P18041 (Attenuator PCB Assy)	FROM	J18041 (Mixer PCB Assy)											
P31040 (Attenuator PCB Assy)	FROM	J31040 (Mixer PCB Assy)											
P16039 (Analog IF Assy)	FROM	J16039 (SSB Assy) (2-3-1, Figure 5)											
3.	Refer to 2-3-1, Figure 5 and remove four screws (14) securing Mixer cover (13) to SSB Assy (12).												
4.	Remove solder from Mixer PCB Assy (8) at filter and connector junctions:												
	<table border="0"> <tr> <td>J16039</td> <td>FL16014</td> <td>J18041</td> <td>E18002</td> </tr> </table>	J16039	FL16014	J18041	E18002								
J16039	FL16014	J18041	E18002										
5.	Remove J16039, FL16014 and J18041 from SSB Assy (4).												
6.	Remove five screws (6) securing Mixer PCB Assy (8) to SSB Assy (4).												
7.	Remove Mixer PCB Assy (8) from SSB Assy (4).												
	ATTENUATOR PCB ASSY												
8.	Remove solder from Attenuator PCB Assy (5) at filter and connector junctions:												
	<table border="0"> <tr> <td>J31040</td> <td>FL16010</td> <td>FL16008</td> <td>FL16007</td> </tr> <tr> <td>FL16012</td> <td>FL16009</td> <td>J17038</td> <td>J17037</td> </tr> <tr> <td>FL16011</td> <td></td> <td></td> <td></td> </tr> </table>	J31040	FL16010	FL16008	FL16007	FL16012	FL16009	J17038	J17037	FL16011			
J31040	FL16010	FL16008	FL16007										
FL16012	FL16009	J17038	J17037										
FL16011													
9.	Remove J31040, FL16012, FL16011, FL16010, FL16009, FL16008, J17038, FL16007 and J17037 from SSB Assy (4).												
10.	Remove nine screws (7) securing Attenuator PCB Assy (5) to SSB Assy (4).												
11.	Remove Attenuator PCB Assy (5) from SSB Assy (4).												

LO SOURCE PCB ASSY

12. Remove Analog IF Assy (para 2-3-1C[7][d]).
13. Refer to 2-3-1, Figure 5 and remove LO Source cover (11) from SSB Assy (12).
14. Disconnect cables:

P16042 (Analog IF Assy) **FROM** J16042 (SSB Assy)

15. Remove solder from LO Source PCB Assy (1) and Source Module VCO PCB Assy (3) at filter, test point and connector junctions:

FL16005	FL16006	FL16001	J16042
TP16001	FL16002	TP16001	E24008
FL16015	TP16003	FL16003	

16. Remove FL16005, TP16001, FL16015, FL16006, FL16002, TP16003, FL16001, TP16002, FL16003 and J16042 from SSB Assy (4).
17. Remove 10 screws (2) securing LO Source PCB Assy (1) to SSB Assy (4).
18. Remove LO Source PCB Assy (1) from SSB Assy (4).

SOURCE MODULE VCO PCB ASSY

19. Remove solder and wire from E34001 and E34002.
20. Remove Source Module VCO PCB Assy (3) from LO Source PCB Assy (1).

(8) Front Panel Assy

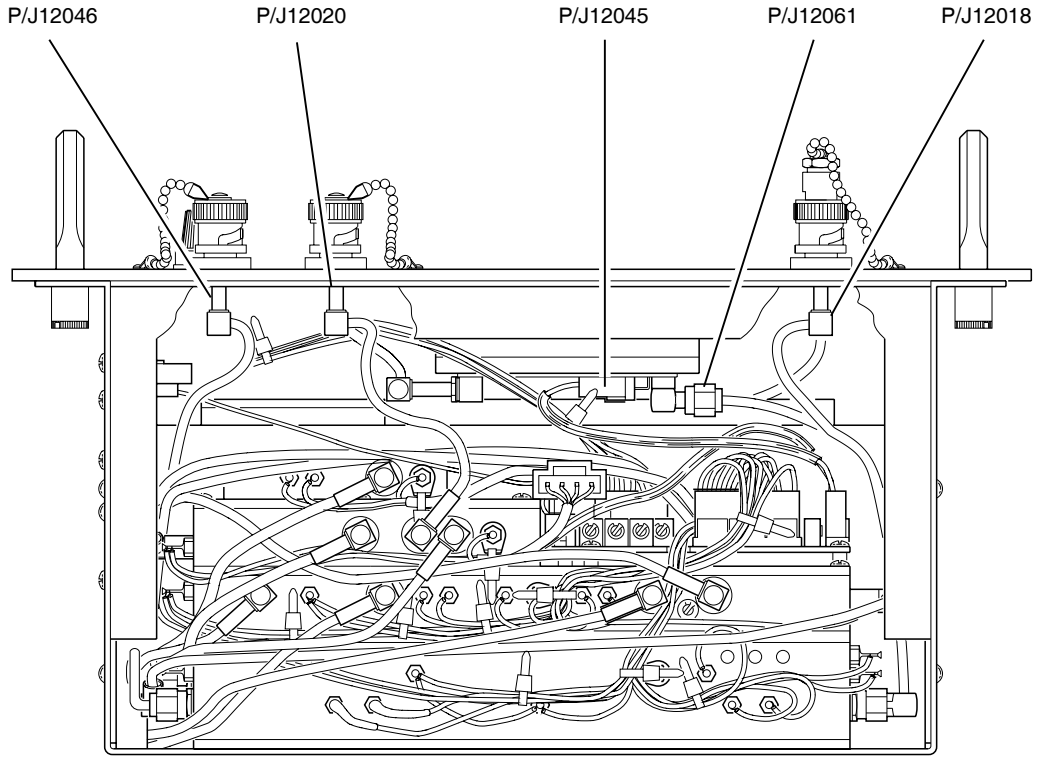

8507020

TCAS-201-2 Top View
Figure 10

STEP	PROCEDURE
------	-----------

1. Remove Storage Compartment and Chassis Assy (para 2-3-1C[1]).
2. Refer to 2-3-1, Figure 2 and disconnect cables:

P30049A (Front Panel Assy)	FROM	J30049A/B (Line Supply Assy)
----------------------------	-------------	------------------------------

3. Refer to 2-3-1, Figure 10 and disconnect cables:

P12018 (RF Assy)	FROM	J12018 (Front Panel Assy)
P12061 (RF Assy)	FROM	J12061 (Front Panel Assy)
P12045 (RF Assy)	FROM	J12045 (Front Panel Assy)
P12020 (RF Assy)	FROM	J12020 (Front Panel Assy)
P12046 (Motherboard PCB Assy)	FROM	J12020 (Front Panel Assy)

STEP

PROCEDURE

NOTE: For Steps 4 through 10, item numbers refer to 2-3-1, Figure 1.

4. Loosen four captive screws (8).
5. Remove two handles (24) and four washers (23) from Front Panel Assy (3).
6. Tilt left side of Front Panel Assy (3) up approximately 30° and disconnect cables:

P27052 (Front Panel Assy)
(7005-8544-200)

FROM J27052 (Front Panel Pulse PCB Assy)

OR

A2W2P1 (Front Panel Assy)
(7005-8540-100)

P27051 (Front Panel Assy)
(7005-8544-200)

FROM J27051 (Front Panel Pulse PCB Assy)

OR

A2W1P1 (Front Panel Assy)
(7005-8540-100)

NOTE: Left side of Chassis Assy (7) has access to PC boards and battery.

7. Set left side of Front Panel Assy (3) on Chassis Assy (7) and tilt right side of Front Panel Assy (3) up approximately 30°.

NOTE: The Keypad ribbon cable is taped to the Front Panel Assy (3) and should be carefully untaped to achieve better access to connecting cables.

8. Disconnect cables:

P25011 (Front Panel Assy)

FROM J25011 (Motherboard PCB Assy)

P25010 (Front Panel Assy)

FROM J25010 (Motherboard PCB Assy)

P25014 (Front Panel Assy)

FROM J25014 (Motherboard PCB Assy)

9. Carefully guide connecting cables and remove Front Panel Assy (3) from Chassis Assy (7).

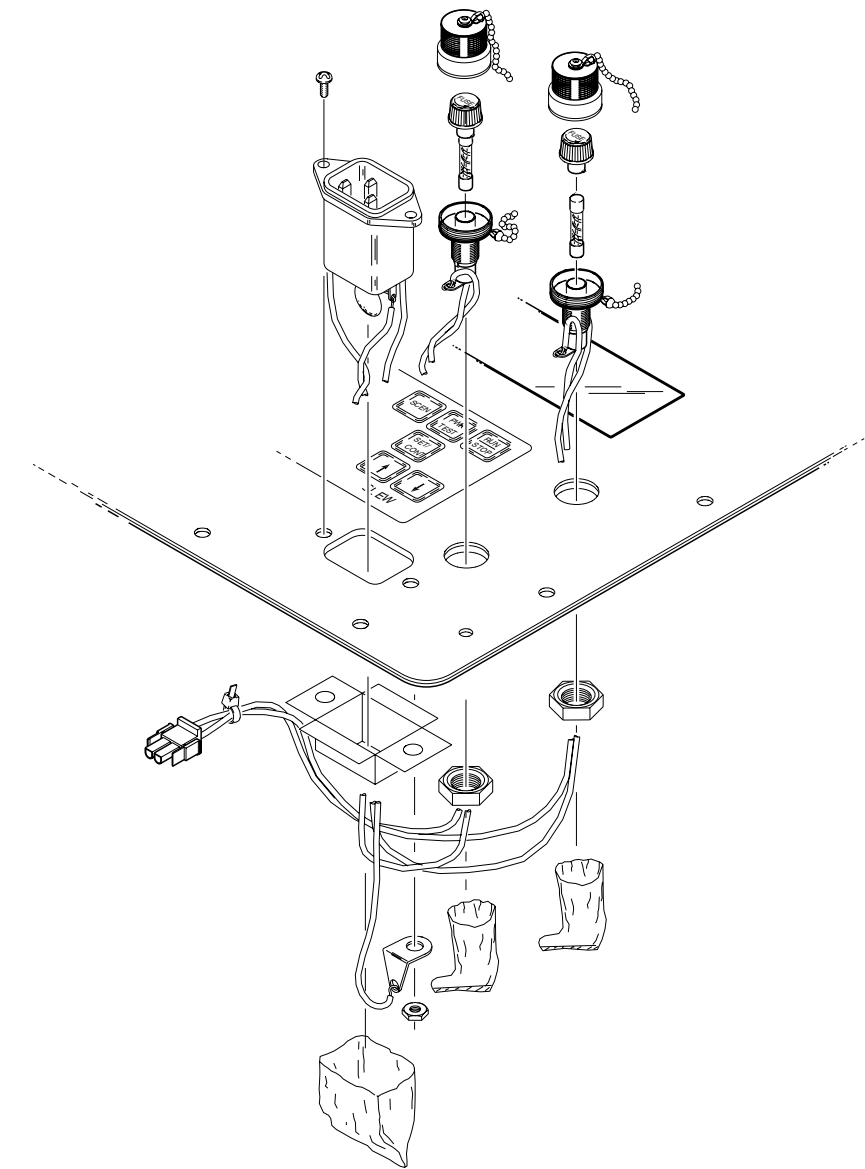
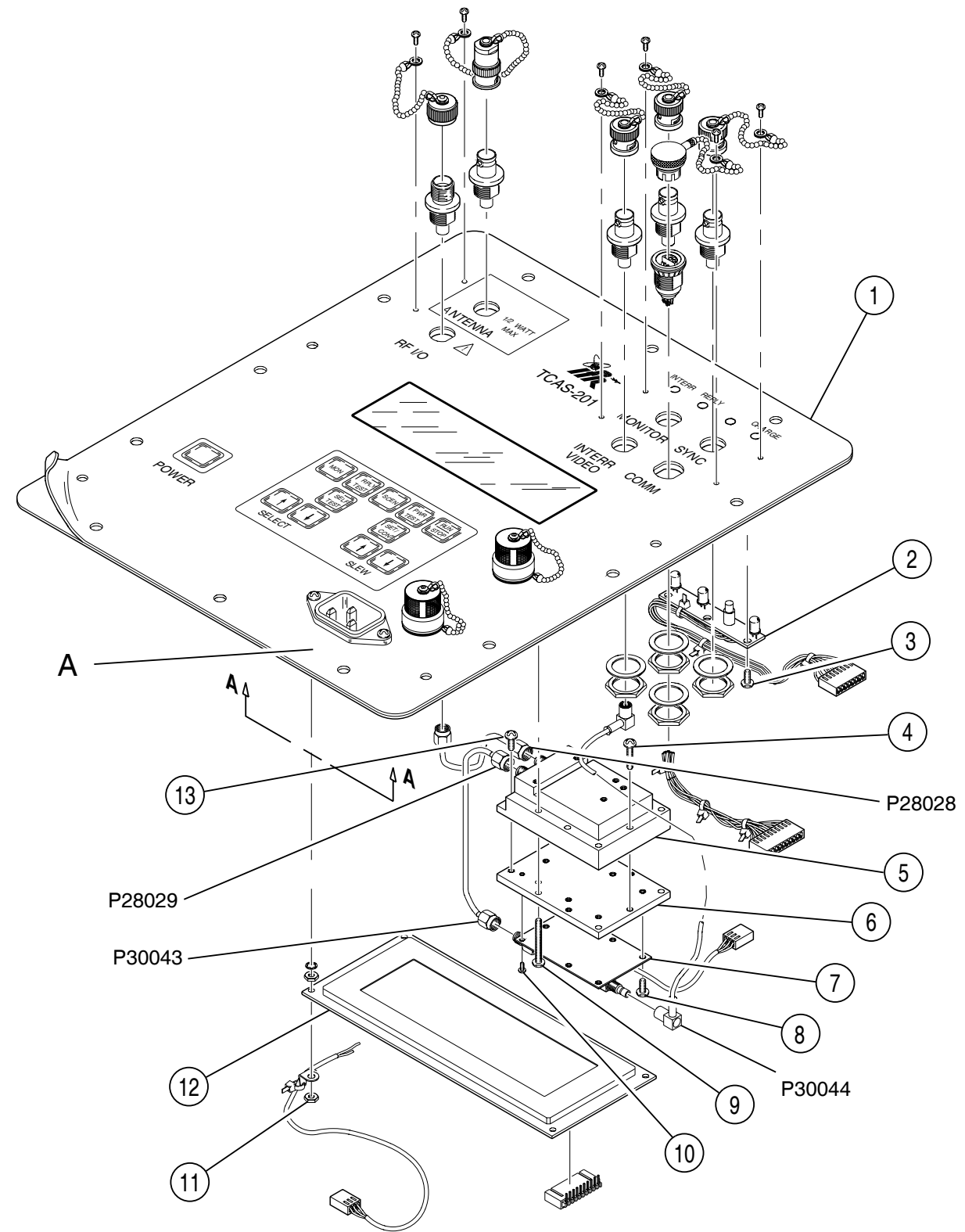

DETAIL A

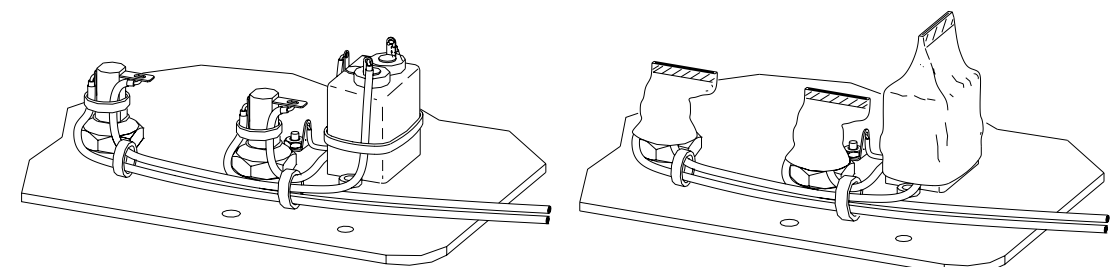

VIEW A - A

8507042

Front Panel Assy (Sheet 1 of 2)
Figure 11

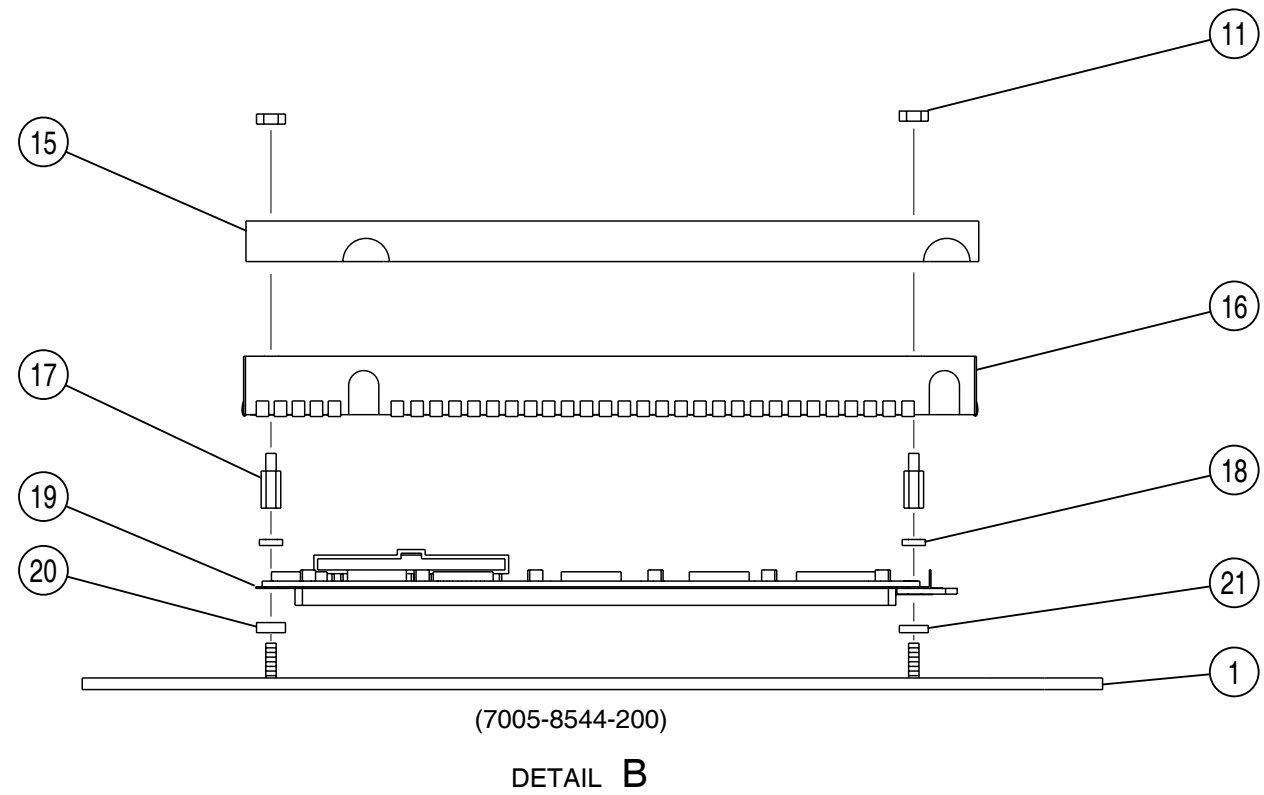
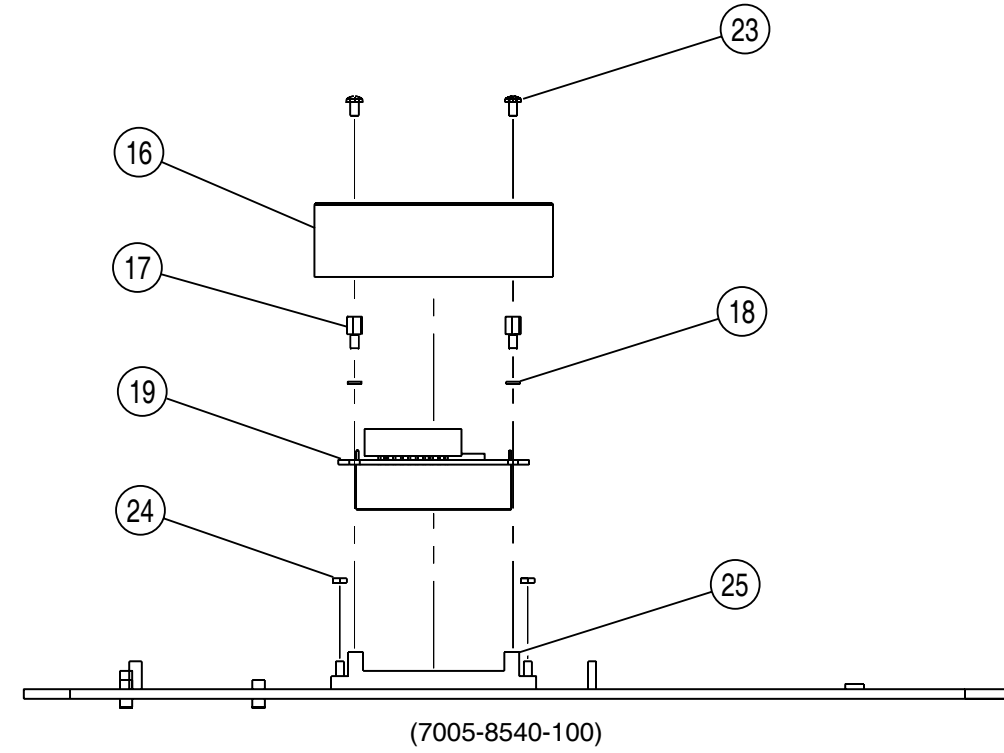
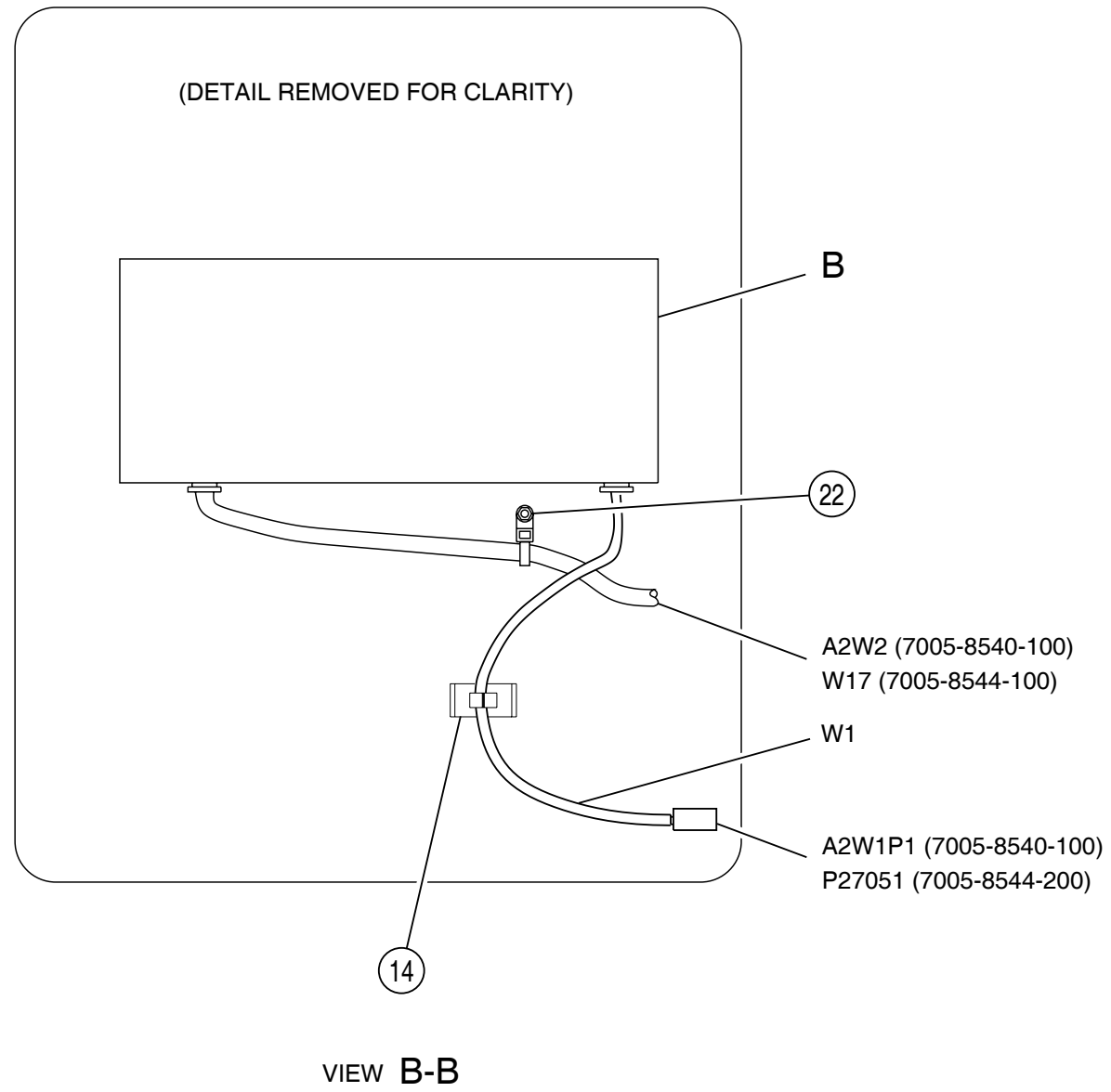

8507034

Front Panel Assy (Sheet 2 of 2)
Figure 11

(a) Video Detector PCB Assy

NOTE: Item numbers refer to 2-3-1, Figure 11 unless otherwise noted.

STEP	PROCEDURE						
1.	Remove Front Panel Assy (para 2-3-1C[7]).						
2.	Disconnect cables:						
	<table border="0"> <tr> <td>P30043 (Power Termination Assy)</td> <td>FROM</td> <td>J30043 (Video Detector PCB Assy)</td> </tr> <tr> <td>P30044 (REPLY VIDEO Connector)</td> <td>FROM</td> <td>J30043 (Video Detector PCB Assy)</td> </tr> </table>	P30043 (Power Termination Assy)	FROM	J30043 (Video Detector PCB Assy)	P30044 (REPLY VIDEO Connector)	FROM	J30043 (Video Detector PCB Assy)
P30043 (Power Termination Assy)	FROM	J30043 (Video Detector PCB Assy)					
P30044 (REPLY VIDEO Connector)	FROM	J30043 (Video Detector PCB Assy)					
3.	Remove seven screws (8) and two screws (10) securing Video Detector PCB Assy (7) to Power Termination cover (6).						
4.	Remove Video Detector PCB Assy (7) from Front Panel Assy (1).						

(b) Power Termination Assy

STEP	PROCEDURE									
1.	Remove Front Panel Assy (para 2-3-1C[7]).									
	NOTE: For Steps 2 through 5, item numbers refer to 2-3-1, Figure 11.									
2.	Disconnect cables:									
	<table border="0"> <tr> <td>P28028 (RF I/O Connector)</td> <td>FROM</td> <td>J28028 (Power Termination Assy)</td> </tr> <tr> <td>P28029 (Video Detector PCB Assy)</td> <td>FROM</td> <td>J28029 (Power Termination Assy)</td> </tr> <tr> <td>P30044 (REPLY VIDEO Connector)</td> <td>FROM</td> <td>J30044 (Video Detector PCB Assy)</td> </tr> </table>	P28028 (RF I/O Connector)	FROM	J28028 (Power Termination Assy)	P28029 (Video Detector PCB Assy)	FROM	J28029 (Power Termination Assy)	P30044 (REPLY VIDEO Connector)	FROM	J30044 (Video Detector PCB Assy)
P28028 (RF I/O Connector)	FROM	J28028 (Power Termination Assy)								
P28029 (Video Detector PCB Assy)	FROM	J28029 (Power Termination Assy)								
P30044 (REPLY VIDEO Connector)	FROM	J30044 (Video Detector PCB Assy)								
3.	Remove four screws (9) securing Power Termination Assy (5) to Front Panel Assy (1).									
4.	Remove three screws (4) and two screws (13) securing Power Termination cover (6).									
5.	Remove Power Termination cover (6) from Power Termination Assy (5).									
	NOTE: For Steps 6 through 13, item numbers refer to 2-3-1, Figure 12.									
	RESISTOR R28002									
6.	Remove two socket head screws (1) securing R28002 (3) to Power Termination Assy (4).									
7.	Remove solder from connection between R28002 (3) and Power Termination PC Board (2).									
8.	Remove R28002 (3) from Power Termination Assy (4).									

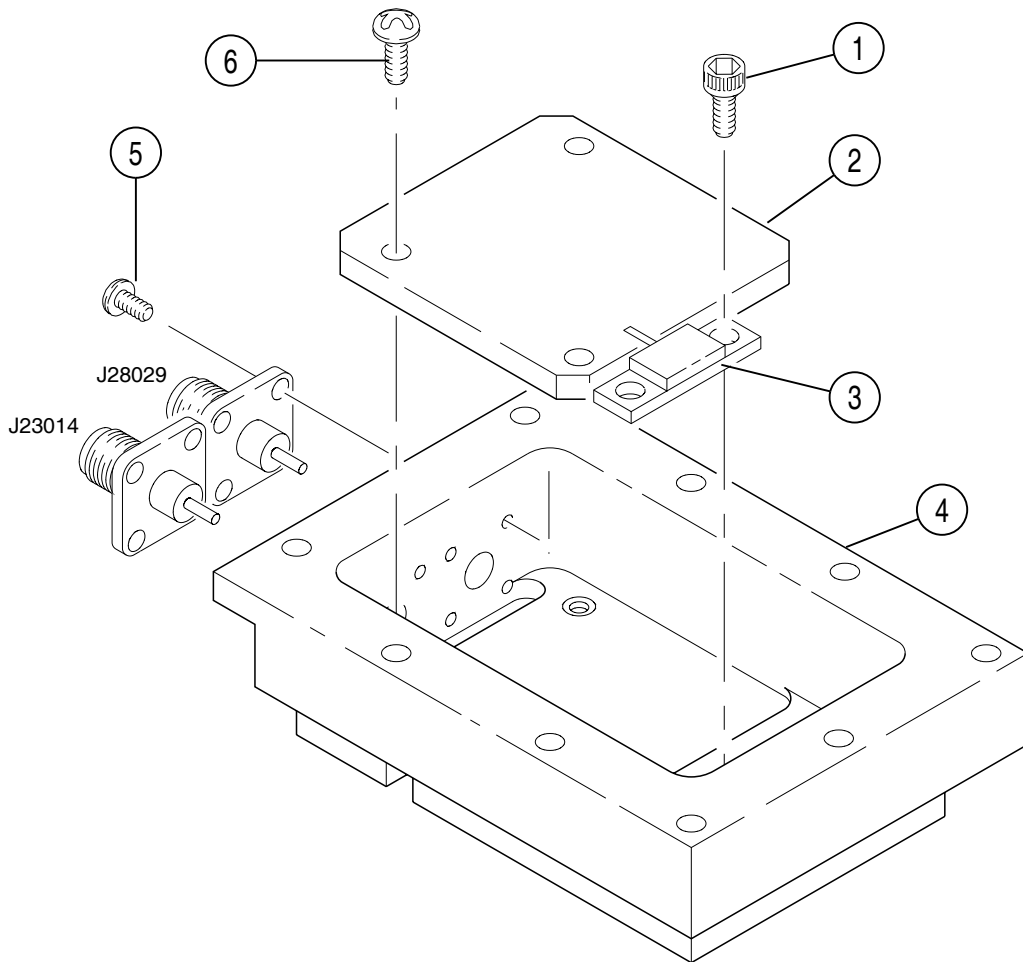

8821011

Power Termination Assy
Figure 12

STEP	PROCEDURE
------	-----------

CONNECTORS J28028 AND J28029

9. Remove four screws (5) securing J28028 or J28029 to Power Termination Assy (4).
10. Remove solder between connector and Power Termination PC Board (2).
11. Remove connector from Power Termination Assy (4).

POWER TERMINATION PC BOARD

12. Remove three screws (6) securing Power Termination PC Board (2) to Power Termination Assy (4).
13. Remove Power Termination PC Board (2) and Power Termination Assy (4).

(c) Front Panel LED PCB Assy

NOTE: Item numbers refer to 2-3-1, Figure 11.

STEP	PROCEDURE
------	-----------

1. Remove Front Panel Assy (para 2-3-1C[7]).
2. Remove three screws (3) securing Front Panel LED PCB Assy (2) to Front Panel Assy (1).
3. Remove Front Panel LED PCB Assy (2) from Front Panel Assy (1).

(d) LCD Display PCB Assy (Modified)

NOTE: Item numbers refer to 2-3-1, Figure 11.

STEP	PROCEDURE
------	-----------

1. Remove Front Panel Assy (para 2-3-1C[7]).
2. ~~(7005-8544-200)~~ Remove four nuts (11) (7005-8544-200) securing LCD (12) to Front Panel Assy (1).
~~(7005-8540-100)~~ Remove four screws (23) (7005-8540-100) securing LCD (12) to Front Panel Assy (1).
3. Remove wire harness restraining nut (22) and remove wire harness (W1) from adhesive clip (14).
4. Remove shield support bracket (15) and slide back grommets from display shield (16). (7005-8544-200 only)
5. Carefully remove display shield (16).
6. Remove four standoffs (17) and four spacers (18).
7. Remove LCD Display PCB Assy (Modified) (19) from Front Panel Assy (1).
8. ~~(7005-8544-200)~~ Note locations of different size washers (20) and (21). Remove four washers (20) and (21).
~~(7005-8540-100)~~ Remove four nuts (24) and display support bracket (25) from Front Panel Assy (1).
9. ~~(7005-8544-200)~~ Disconnect W17P1 from J12059 on LCD Display PCB Assy (Modified) (19).
~~(7005-8540-100)~~ Disconnect A2W2P1 from J27052 on Front Panel Pulse PCB Assy (11) (2-3-1, Figure 1).

(9) Flat Antenna Assy

NOTE: Item numbers refer to 2-3-1, Figure 13 unless otherwise noted.

STEP	PROCEDURE
1.	Remove two screws (13) and cover plate (12) from Flat Antenna Assy (14).
2.	Refer to Detail A in 2-3-1, Figure 13. Remove solder from connections between Antenna PC Board (21) and Splitter PC Board (16).
3.	Refer to Detail A in 2-3-1, Figure 13 and remove two screws (20).
4.	Remove 10 screws (19) securing handle to Flat Antenna Assy (14).
5.	Remove handle from Flat Antenna Assy (14).
FLAT ANTENNA CONNECTOR (J29001)	
6.	Remove six screws (10) securing right plate (11) to left plate (15).
7.	Remove two screws (8) securing J29001 to left plate (15).
8.	Remove two screws (6) and left plate (15) from back plate (18).
9.	Remove solder from connection between J29001 and Splitter PC Board (16).
10.	Remove two screws (8) securing J29001 to right plate (11).
11.	Remove J29001 from back plate (18).
SPLITTER PC BOARD	
12.	Remove two screws (7) and right plate (11) from back plate (18).
13.	Remove solder from switch wire (5) connections on Splitter PC Board (16).
14.	Remove Splitter PC Board (16) from handle.
ANTENNA PUSH BUTTON SWITCH (S29001)	
15.	Remove ring nut (1) from push button switch (4).
16.	Remove two screws (18) securing top handle bracket (3).
17.	Loosen socket head screw (2) in top handle bracket (3).
18.	Remove top handle bracket (3) from handle (9) and back plate (18).
19.	Remove push button switch (4) from top handle bracket (3).

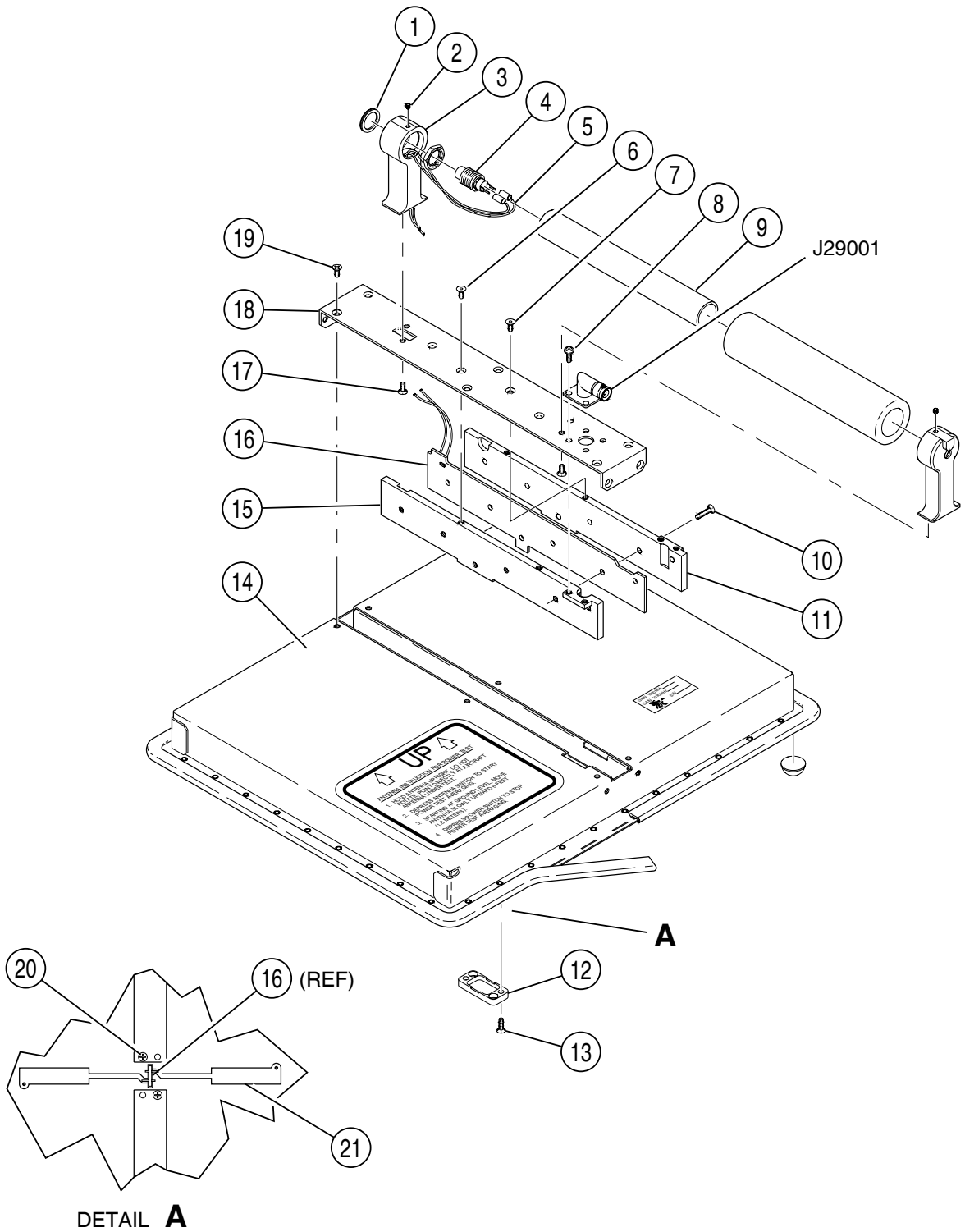

Flat Antenna Assy
Figure 13

8507023

(10) Motherboard PCB Assy

NOTE: Item numbers refer to 2-3-1, Figure 1 unless otherwise noted.

STEP	PROCEDURE	
1.	Remove Power Supply Assy (para 2-3-1C[4]).	
2.	Remove Digital IF PCB Assy (para 2-3-1C[5]).	
3.	Remove Front Panel Pulse PCB Assy (para 2-3-1C[6]).	
3.	Remove Front Panel Assy (para 2-3-1C[8]).	
4.	Remove two screws (4) securing P23047 to the Chassis Assy (7).	
5.	Refer to 2-3-1, Figure 2 and disconnect cables:	
	P33049B (Power Supply Assy)	FROM J33049A/B (Line Supply Assy
	P25001 (RF Assy)	FROM J25001 (Motherboard PCB Assy)
	P25009 (Front Panel Assy)	FROM J25009 (Motherboard PCB Assy)
	P25002 (RF Assy)	FROM J25002 (Motherboard PCB Assy)
	P25062 (RF Assy)	FROM J25062 (Motherboard PCB Assy)
	P25005 (RF Assy)	FROM J25005 (Motherboard PCB Assy)
	P25003 (RF Assy)	FROM J25003 (Motherboard PCB Assy)
	P25065 (RF Assy)	FROM J25065 (Motherboard PCB Assy)
6.	Remove 12 screws (21) securing Motherboard PC Board Assy (22) to Chassis Assy (7).	
7.	Remove Motherboard PCB Assy (22) from Chassis Assy (7).	

2. Reassembly

A. General

Reassembly depends upon extent of disassembly and should be performed with normal repair and/or cleaning. Perform reassembly in reverse sequence of disassembly procedures. Incorporate Special Reassembly Procedures in para 2-3-2C as required.

<u>PROCEDURE</u>	<u>PAGE</u>
Storage Compartment and Chassis Assy -----	3
Battery -----	3
Line Supply Assy-----	3
Power Supply Assy -----	3
Digital IF PCB Assy-----	3
Front Panel Pulse PCB Assy-----	3
RF Assy-----	4
Front Panel Assy-----	5
Flat Antenna Assy -----	5
Motherboard PCB Assy -----	5

B. Preliminary Considerations

(1) Tools Required

Reassembly requires the same tools required for disassembly. Refer to 2-3-1, Table 1.

(2) Reassembly Precautions

- CAUTION:** INSURE ALL COAXIAL CONNECTIONS ARE PROPERLY MATED.
- CAUTION:** AVOID BENDING OR TWISTING SEMI-RIGID COAXIAL CABLES.
- CAUTION:** PLACE ALL RIBBON CABLES TO LAY FLAT AND NEATLY FOLDED.
- CAUTION:** AVOID PLACING UNDUE STRAIN ON ANY WIRE OR CABLE.
- CAUTION:** AVOID OVERTIGHTENING SCREWS AND NUTS INCLUDING COAXIAL CONNECTORS.
- CAUTION:** REPLACE EACH REMOVED PLASTIC FASTENER IN SAME LOCATION AS MARKED AND CONFIGURED AS WAS PRIOR TO REMOVAL.
- CAUTION:** AVOID EXPOSING COMPONENTS TO EXCESSIVE HEAT WHEN SOLDERING.
- CAUTION:** REPLACE WORN SHOULDER WASHERS AND INSULATORS. CAREFULLY REINSTALL SHOULDER WASHERS AND INSULATORS IN CORRECT POSITIONS. FAILURE TO INSTALL SHOULDER WASHERS AND INSULATORS CORRECTLY COULD RESULT IN A SHORT CIRCUIT.

(3) ESD

CAUTION: THE POWER SUPPLY PCB ASSY, DIGITAL IF PCB ASSY, FRONT PANEL PULSE PCB ASSY, RF ASSY AND FRONT PANEL ASSY CONTAIN PARTS SENSITIVE TO DAMAGE BY ELECTROSTATIC DISCHARGE (ESD). ALL PERSONNEL PERFORMING REASSEMBLY SHOULD HAVE KNOWLEDGE OF ACCEPTED ESD PRACTICES AND/OR BE ESD CERTIFIED.

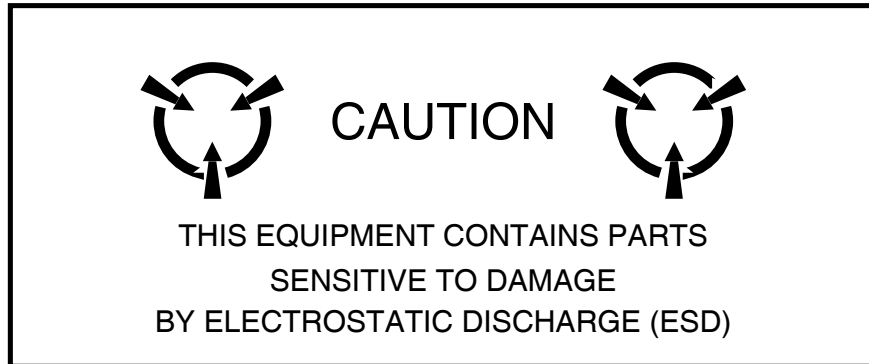

(4) EMC and Safety Compliance

All assemblies, cables, connectors, plastic fasteners, gaskets, fingerstock and miscellaneous hardware within the Test Set are configured to satisfy the safety and EMC compliance standards.

CAUTION: UPON COMPLETION OF ANY MAINTENANCE ACTION; ALL ASSEMBLIES, CABLES, CONNECTORS, PLASTIC FASTENERS, GASKETS, FINGERSTOCK AND MISCELLANEOUS HARDWARE MUST BE CONFIGURED AS INSTALLED AT THE FACTORY.

C. Special Reassembly Procedures

(1) Storage Compartment and Chassis Assy

NOTE: Instrument Case Top (2503-8153-600) and Bottom (1412-8153-500) are a matched set and should not be separated.

- Replace the twelve nylon washers (2840-8110-000) to maintain water resistance capability.
- Tighten twelve screws securing Chassis Assy to Case Assy with 23 inch•pounds (2.56 newton•meters) of torque.

(2) Battery

- Ensure Battery Ejector Strap (1410-7452-300) is installed with doubled-over side facing out.

(3) Line Supply Assy

NOTE: Mounting hardware (one metal washer [on top] and two rubber washers [one washer on bottom, one washer on top] is supplied with transformer, when installed new.

- Hand clean with solvent only. Do not submerge in solvent.
- Apply Loctite 222 (1050-0000-047) to first 1/4 in of threads of screw (2809-1000-006) securing T33001 to Line Supply PCB Assy. Torque screw to 24 inch•pounds (2.71 newton•meters).
- Wires W1 and W2 (E1 through E4) are to be soldered from top side only.

LINE SUPPLY PCB ASSY

- Add S15001 last. Do not submerge switch in solvent, brush clean only.
- Trim leads to 0.070 in maximum.

(4) Power Supply Assy

- Use thermal compound (1050-0000-019) on both sides of mica insulators (4835-0000-103) (four places).

POWER SUPPLY PCB ASSY

- Add T14001 and T14002 last. Do not submerge transformers in solvent, brush clean only.
- Remove thick gold wire with identification labels 5 and 6 from T14001 and T14002 when installed new.

(5) Digital IF PCB Assy

- Apply Loctite 222 (1050-0000-047) to nuts on L26009, L26010 and Q26005.

(6) Front Panel Pulse PCB Assy

NOTE: Metallic top of U27044 is connected to +5 Vdc.

- Add S27001 and U27044 last. Do not submerge switch and IC in solvent.

(7) RF Assy

- No special reassembly procedures required.

(a) Driver PCB Assy

- No special reassembly procedures required.

(b) Decoder Assy

- No special reassembly procedures required.

DECODER PCB ASSY

- No special reassembly procedures required.

(c) Detector Assy

- No special reassembly procedures required.

DETECTOR PCB ASSY

- No special reassembly procedures required.

(d) Analog IF Assy

- No special reassembly procedures required.

ANALOG IF PCB ASSY

- Add Y22001 last. Do not submerge crystal in solvent.
- TAK PAK end of L22027 to PCB Assy.
- Refer to Analog IF PCB Assy Circuit Schematic (2-4-1, Figure 42) for Select At Test (SAT) values for C22080, C22082 and R22065.

(e) SSB Assy

- No special reassembly procedures required.

MIXER PCB ASSY

- Refer to 2-3-2, Figure 14 for special reassembly procedures.

ATTENUATOR PCB ASSY

- No special reassembly procedures required.

LO SOURCE PCB ASSY

- No special reassembly procedures required.

SOURCE MODULE VCO PCB ASSY

- No special reassembly procedures required.

- (8) Front Panel Assy
- Discard nut and washer supplied with XF0001 and XF0002, when installing new.
 - Apply adhesive (1050-0000-288) to threads and seating face of both fuse holders nuts (2850-7894-800). Apply adhesive (1050-0000-289) to fuse holders and nut sealing areas of enclosure. Torque fuse holder nuts (2850-7894-800) to 7 inch•pounds (0.79 newton•meters).
 - Apply adhesive (1050-0000-140) to backside of six screws (2803-0188-006) securing the chains / cables attached to the connector caps to the Front Panel after screws are installed.
 - Before applying Overlay (2403-8553-500) to Front Panel (1405-8158-200), center Lens (3900-8157-100) with conductive side down over opening of Front Panel (1405-8158-200).
 - After installing W1 (Backlight Wire Harness), spot coat E1-1 and E1-2 on top side of the LCD Display PCB Assy (Modified) with conformal coating. Refer to 2-3-2, Figure 15 for location of E1-1 and E1-2.
- (a) Video Detector PCB Assy
- No special reassembly procedures required.
- (b) Power Termination Assy
- Trim R28002 lead to 0.17 in (± 0.01 in) before reinstalling.
 - Position PC Board and R28002 to maintain equal gap at both ends of PC Board (approximately 0.05 in).
 - Spot coat E1 and E2 after reassembly. Avoid over-spray of conformal coating on block flange.
- (c) Front Panel LED PCB Assy
- No special reassembly procedures required.
- (d) LCD Display PCB Assy (Modified)
- No special reassembly procedures required.
- (9) Flat Antenna Assy
- Refer to 2-3-2, Figure 16 for special reassembly procedures.
- (10) Motherboard PCB Assy
- No special reassembly procedures required.

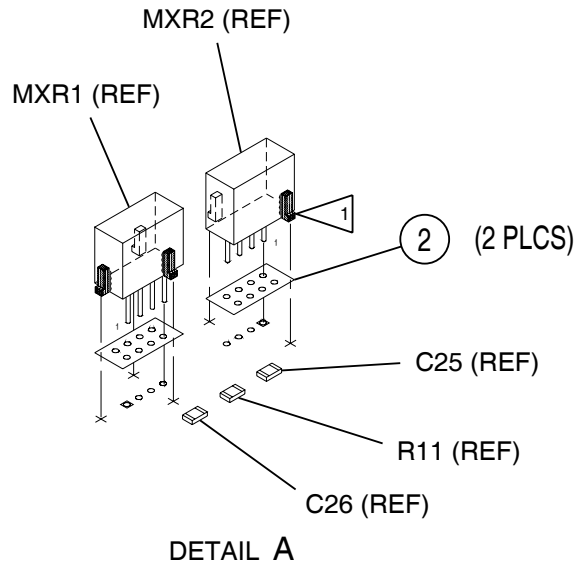
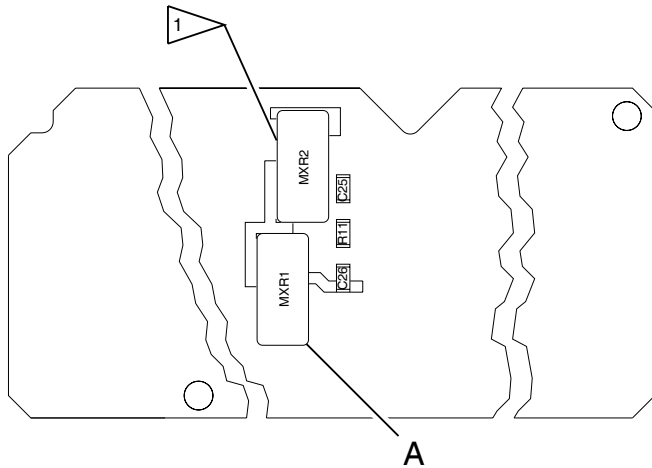

SPECIAL REASSEMBLY PROCEDURES

1 MXR1 & MXR2 MUST BE INSTALLED IN STEPS. WHEN PLACING SOLDER WICK (DPN 1050-0000-207) USE ONLY ESD CERTIFIED, QUICK-RECOVERY SOLDERING STATION WITH 3/32" 30 DEG. CHISEL TIP (TEMPERATURE: $\leq 775^{\circ}\text{F}$ [405°C]).

CAUTION: EXCESSIVE HEAT DESTROYS MIXERS.

STEP 1: SOLDER SOLDER WICK TO SIDES OF MXR1 & MXR2, IN LOCATIONS SHOWN (5 PLCS). SEE DETAIL A.

STEP 2: AFTER SOLDERING SOLDER WICK TO BOTH MIXERS, VERIFY THAT SOLDER HAS NOT BRIDGED TO ANY LEADS.

NO BRIDGING OF SOLDER HERE (3 PLCS)

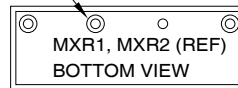

STEP 3: SOLDER MXR1 & MXR2 IN PLACE, THEN TACK SOLDER SOLDER WICK TO GROUND.

CAUTION: DO NOT USE EXCESSIVE HEAT OR SOLDER WHEN SOLDERING TO GROUND.

8530801P

Mixer PCB Assy
Figure 14

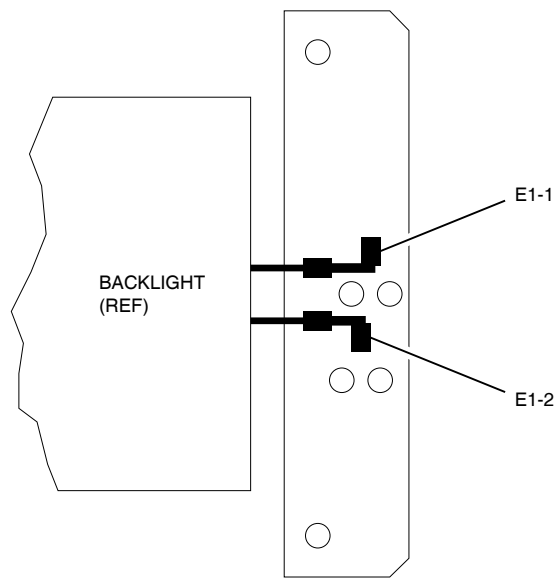

853400P

Solder Points for W1 (Backlight Wire Harness)
Figure 15



THIS PAGE INTENTIONALLY LEFT BLANK.

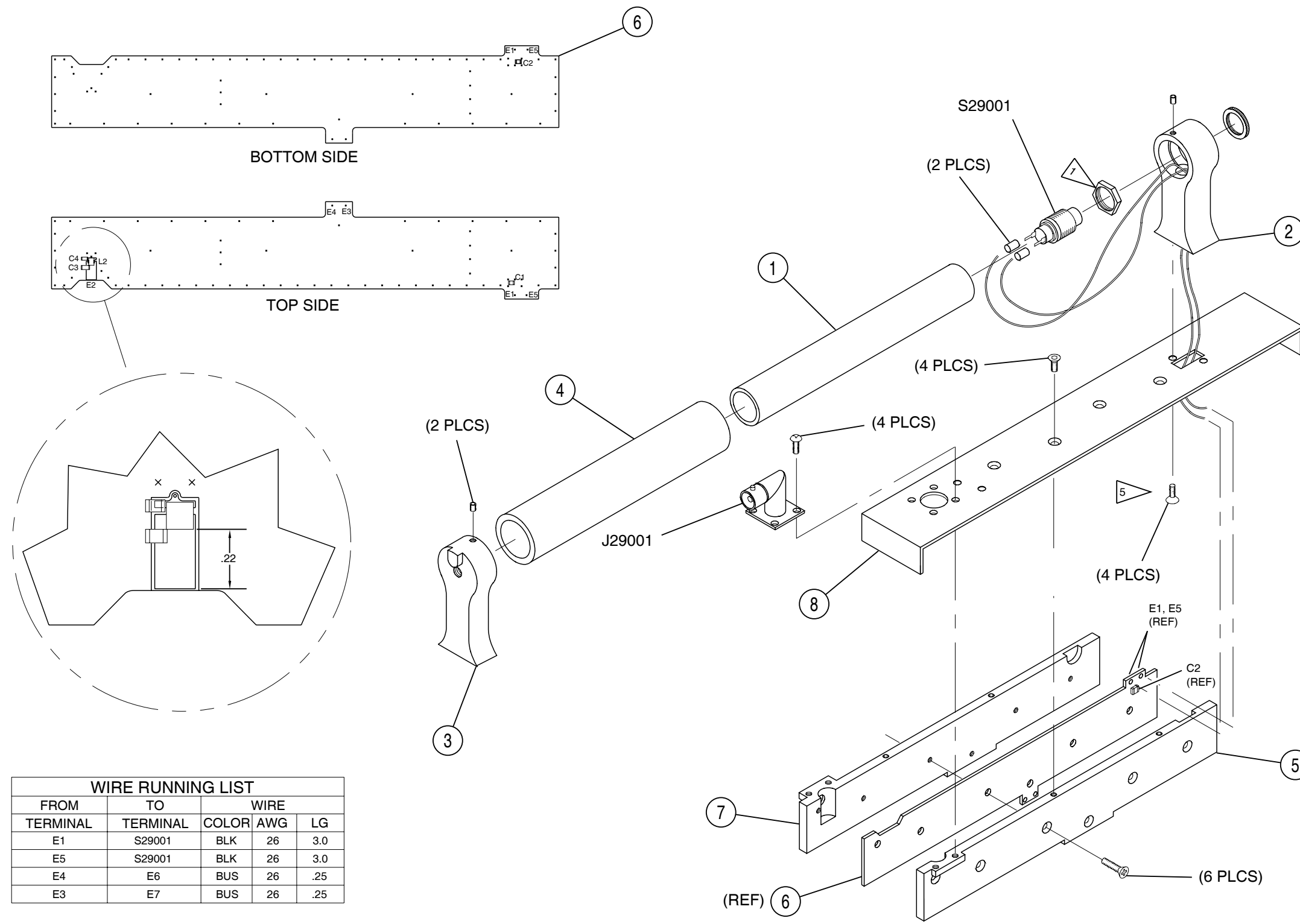

SPECIAL REASSEMBLY PROCEDURES:

1. SCREW NUT ONTO S29001 (FINGER TIGHT).
2. ALL PARTS ON SHEET 1 MUST BE ASSEMBLED IN SEQUENCE:
 - A. MOUNT ITEMS 1, 2, 3 AND 4 PRIOR TO INSTALLING SPLITTER PCB ASSY.
 - B. ASSEMBLE ITEMS 5, 6 AND 7. DO NOT TIGHTEN SCREWS AT THIS TIME.
 - C. SOLDER WIRES TO ITEM 6 AS SHOWN.
 - D. MOUNT ITEMS 5, 6 AND 7 TO ITEM 8. MAKE SURE THAT ITEM 6 IS CENTERED BETWEEN ITEMS 5 AND 7, THEN TIGHTEN ALL SCREWS.
 - E. INSTALL J29001 TIGHT AGAINST ITEM 6. TIGHTEN SCREWS.
3. USE ACCESS HOLE TO SOLDER J29001 TO E2.
4. INSTALL ITEM 9 PRIOR TO INSTALLING ITEMS 10 AND 11.
5. TORQUE SCREWS TO 8 IN/LBS. APPLY LOCTITE 290-21 TO THREADS PRIOR TO ASSEMBLY.

WIRE RUNNING LIST				
FROM	TO	WIRE		
TERMINAL	TERMINAL	COLOR	AWG	LG
E1	S29001	BLK	26	3.0
E5	S29001	BLK	26	3.0
E4	E6	BUS	26	.25
E3	E7	BUS	26	.25

TOLERANCE: ±0.1

8545601M

Flat Antenna Assy (Sheet 1 of 2)
Figure 16

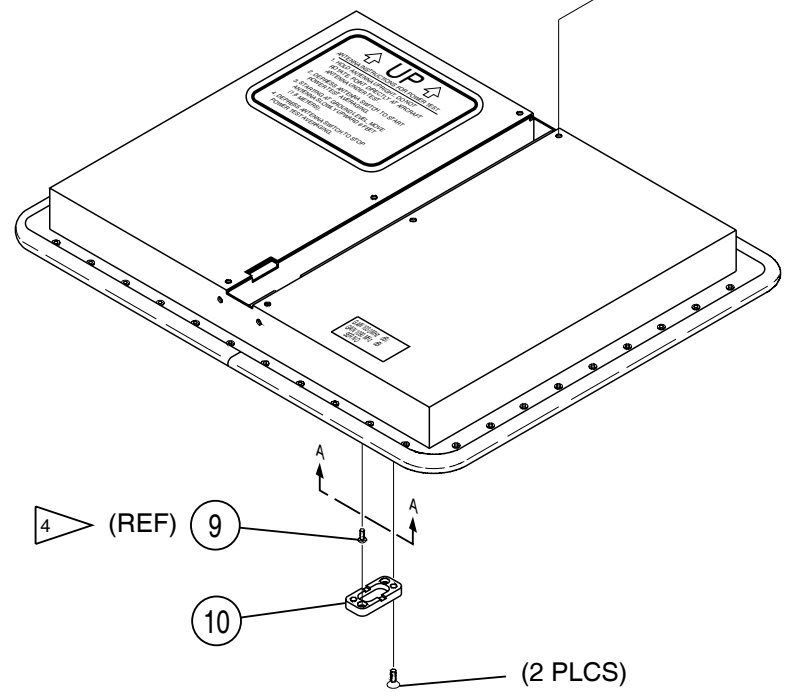
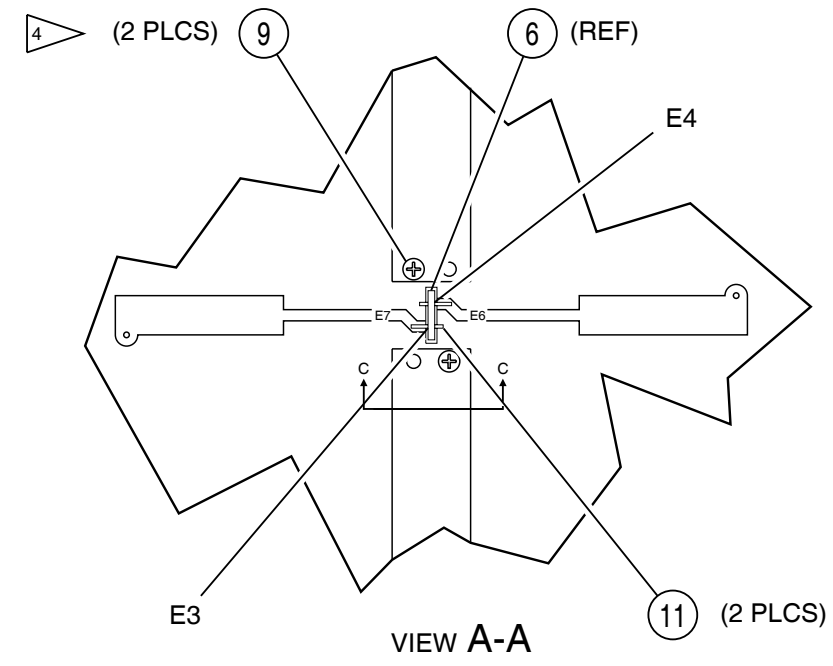
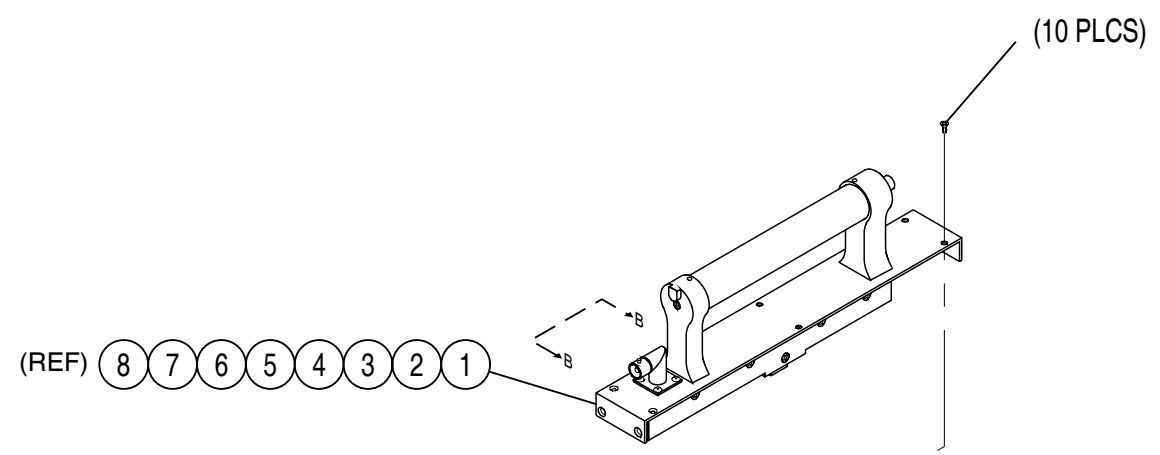
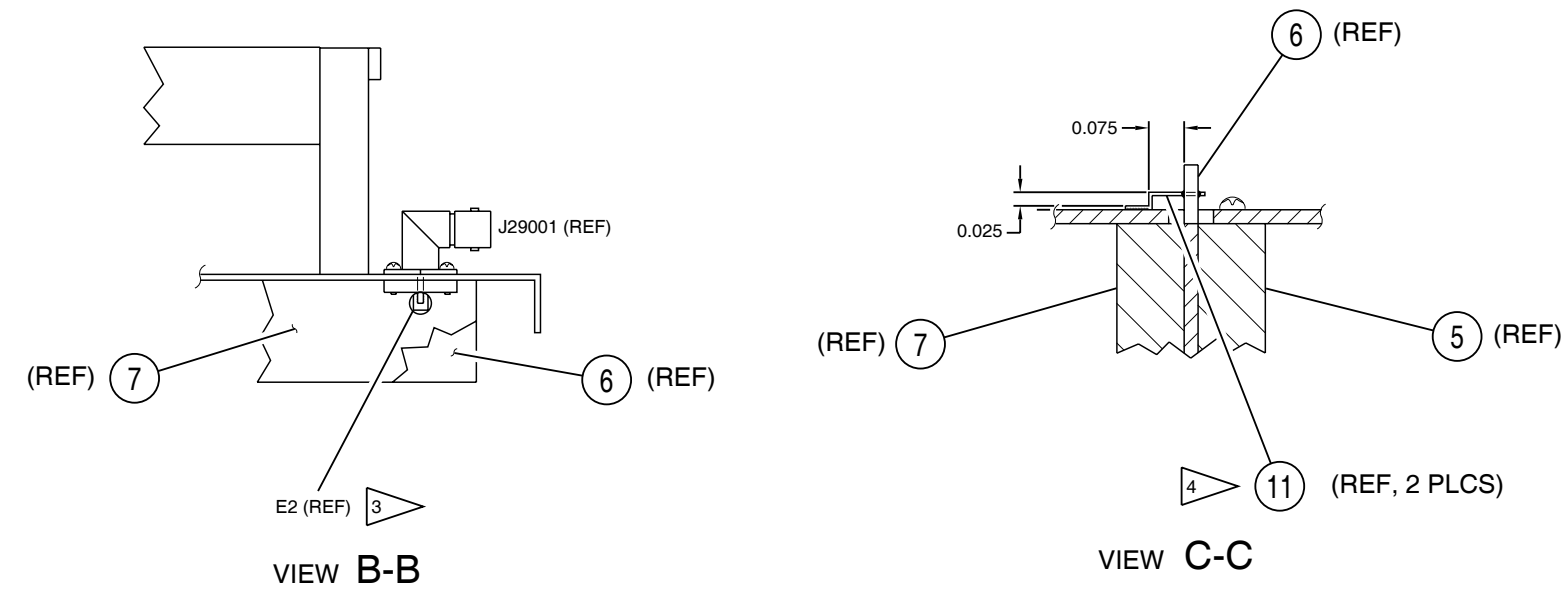

8545602M

Flat Antenna Assy (Sheet 2 of 2)
Figure 16