

LNA - 110 opamps

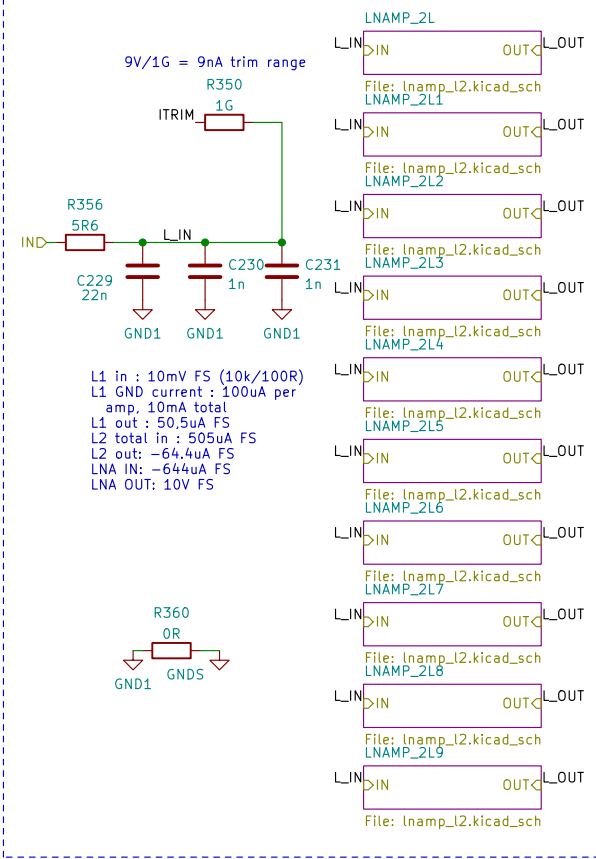

LNA offset & input current compensation DAC + amplifier

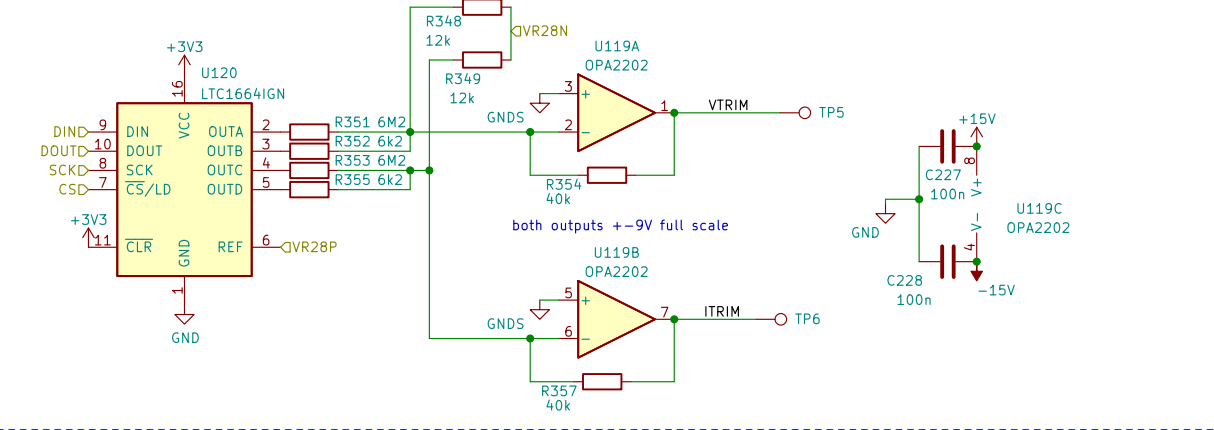

Final LNA summing amp

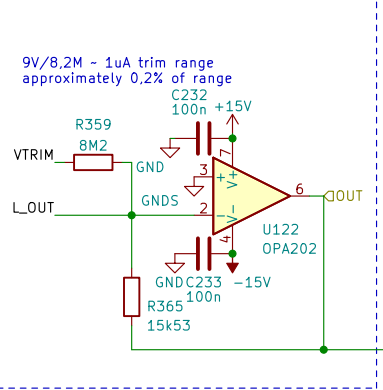

Ground current compensation

