

Sheet: /	
File: rnm_homer.kicad_sch	
Title: Nanovoltmeter – HOMER	
Size: A4	Date: 2022-05-14
KiCad E.D.A. kicad 6.0.5-a6ca702e91-116-ubuntu20.04.1	Rev: 2
	Id: 1/3

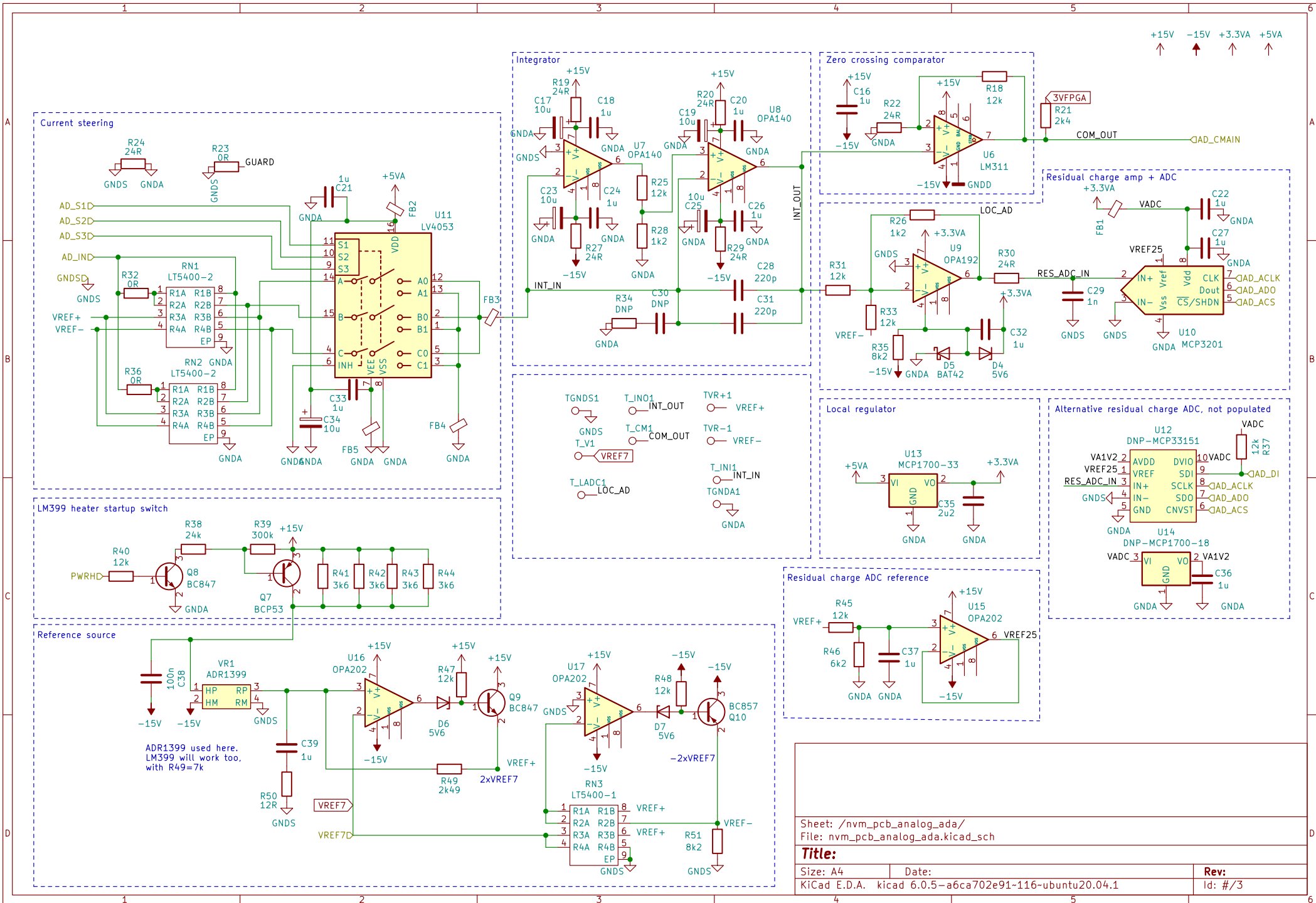

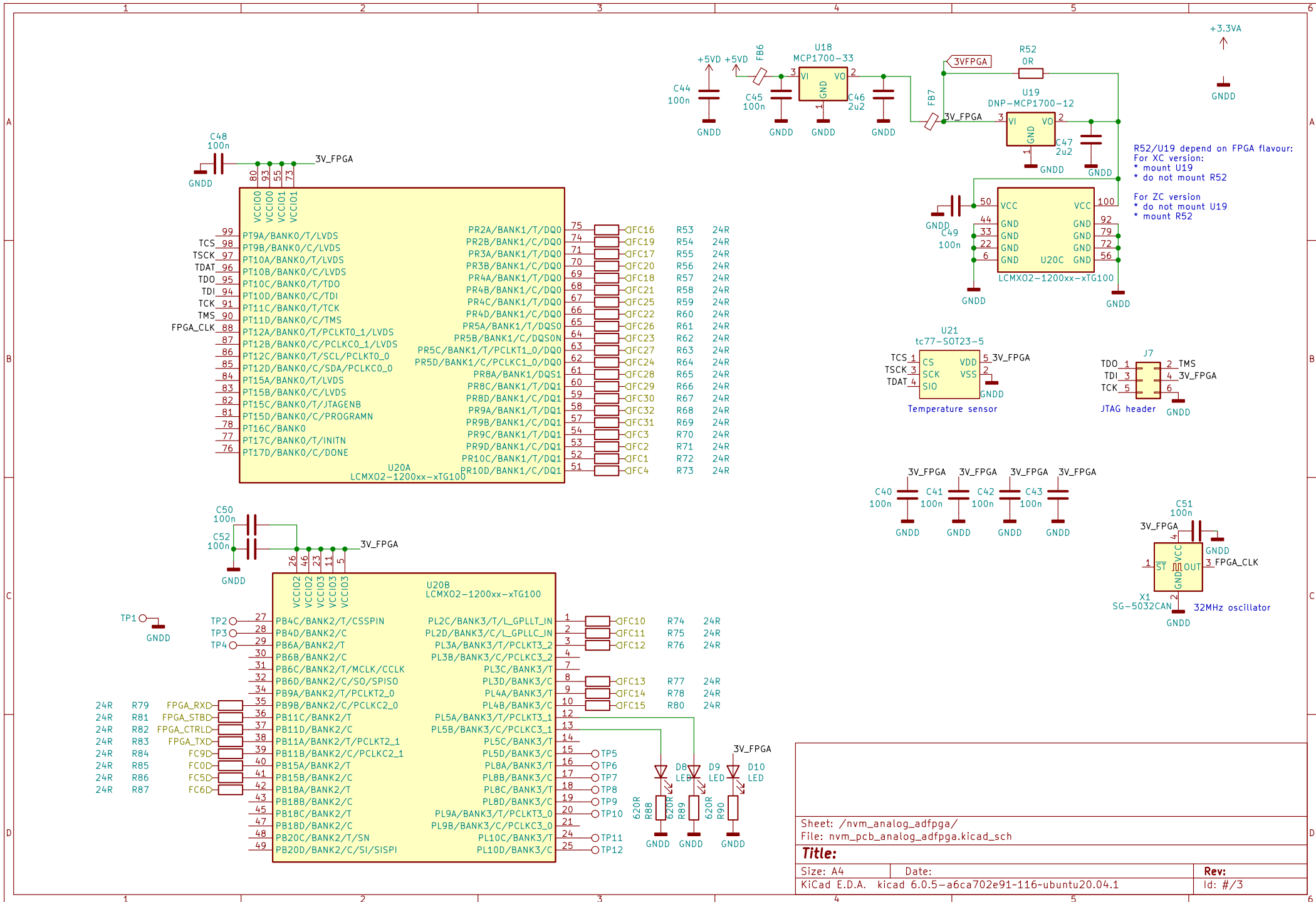

Sheet: /nvm_analog_adfpga/
 File: nvm_pcb_analog_adfpga.kicad_sch

Title:

Size: A4	Date:	Rev:
KiCad E.D.A. kicad 6.0.5-a6ca702e91-116-ubuntu20.04.1		Id: #/3