

KEITHLEY

Model 1801 Nanovolt Preamp

Instruction Manual

A GREATER MEASURE OF CONFIDENCE

WARRANTY

Keithley Instruments, Inc. warrants this product to be free from defects in material and workmanship for a period of 1 year from date of shipment.

Keithley Instruments, Inc. warrants the following items for 90 days from the date of shipment: probes, cables, rechargeable batteries, diskettes, and documentation.

During the warranty period, we will, at our option, either repair or replace any product that proves to be defective.

To exercise this warranty, write or call your local Keithley representative, or contact Keithley headquarters in Cleveland, Ohio. You will be given prompt assistance and return instructions. Send the product, transportation prepaid, to the indicated service facility. Repairs will be made and the product returned, transportation prepaid. Repaired or replaced products are warranted for the balance of the original warranty period, or at least 90 days.

LIMITATION OF WARRANTY

This warranty does not apply to defects resulting from product modification without Keithley's express written consent, or misuse of any product or part. This warranty also does not apply to fuses, software, non-rechargeable batteries, damage from battery leakage, or problems arising from normal wear or failure to follow instructions.

THIS WARRANTY IS IN LIEU OF ALL OTHER WARRANTIES, EXPRESSED OR IMPLIED, INCLUDING ANY IMPLIED WARRANTY OF MERCHANTABILITY OR FITNESS FOR A PARTICULAR USE. THE REMEDIES PROVIDED HEREIN ARE BUYER'S SOLE AND EXCLUSIVE REMEDIES.

NEITHER KEITHLEY INSTRUMENTS, INC. NOR ANY OF ITS EMPLOYEES SHALL BE LIABLE FOR ANY DIRECT, INDIRECT, SPECIAL, INCIDENTAL OR CONSEQUENTIAL DAMAGES ARISING OUT OF THE USE OF ITS INSTRUMENTS AND SOFTWARE EVEN IF KEITHLEY INSTRUMENTS, INC., HAS BEEN ADVISED IN ADVANCE OF THE POSSIBILITY OF SUCH DAMAGES. SUCH EXCLUDED DAMAGES SHALL INCLUDE, BUT ARE NOT LIMITED TO: COSTS OF REMOVAL AND INSTALLATION, LOSSES SUSTAINED AS THE RESULT OF INJURY TO ANY PERSON, OR DAMAGE TO PROPERTY.



Keithley Instruments, Inc. 28775 Aurora Road • Cleveland, Ohio 44139 • 440-248-0400 • Fax: 440-248-6168
1-888-KEITHLEY (534-8453) • www.keithley.com

Sales Offices: BELGIUM: Bergensesteenweg 709 • B-1600 Sint-Pieters-Leeuw • 02-363 00 40 • Fax: 02/363 00 64
CHINA: Yuan Chen Xin Building, Room 705 • 12 Yumin Road, Dewai, Madian • Beijing 100029 • 8610-6202-2886 • Fax: 8610-6202-2892
FINLAND: Tietäjäsentie 2 • 02130 Espoo • Phone: 09-54 75 08 10 • Fax: 09-25 10 51 00
FRANCE: 3, allée des Garays • 91127 Palaiseau Cédex • 01-64 53 20 20 • Fax: 01-60 11 77 26
GERMANY: Landsberger Strasse 65 • 82110 Germering • 089/84 93 07-40 • Fax: 089/84 93 07-34
GREAT BRITAIN: Unit 2 Commerce Park, Brunel Road • Theale • Berkshire RG7 4AB • 0118 929 7500 • Fax: 0118 929 7519
INDIA: Flat 2B, Willocrissa • 14, Rest House Crescent • Bangalore 560 001 • 91-80-509-1320/21 • Fax: 91-80-509-1322
ITALY: Viale San Gimignano, 38 • 20146 Milano • 02-48 39 16 01 • Fax: 02-48 30 22 74
JAPAN: New Pier Takeshiba North Tower 13F • 11-1, Kaigan 1-chome • Minato-ku, Tokyo 105-0022 • 81-3-5733-7555 • Fax: 81-3-5733-7556
KOREA: FL., URI Building • 2-14 Yangjae-Dong • Seocho-Gu, Seoul 137-130 • 82-2-574-7778 • Fax: 82-2-574-7838
NETHERLANDS: Postbus 559 • 4200 AN Gorinchem • 0183-635333 • Fax: 0183-630821
SWEDEN: c/o Regus Business Centre • Frosundaviks Allé 15, 4tr • 169 70 Solna • 08-509 04 679 • Fax: 08-655 26 10
SWITZERLAND: Kriesbachstrasse 4 • 8600 Dübendorf • 01-821 94 44 • Fax: 01-820 30 81
TAIWAN: IFL., 85 Po Ai Street • Hsinchu, Taiwan, R.O.C. • 886-3-572-9077 • Fax: 886-3-572-9031

Model 1801 Nanovolt Preamp Instruction Manual

©1993, Keithley Instruments, Inc.
All rights reserved.
Third Printing April 1999
Cleveland, Ohio, U.S.A.
Document Number: 1801-901-01 Rev. C

Manual Print History

The print history shown below lists the printing dates of all Revisions and Addenda created for this manual. The Revision Level letter increases alphabetically as the manual undergoes subsequent updates. Addenda, which are released between Revisions, contain important change information that the user should incorporate immediately into the manual. Addenda are numbered sequentially. When a new Revision is created, all Addenda associated with the previous Revision of the manual are incorporated into the new Revision of the manual. Each new Revision includes a revised copy of this print history page.

Revision A (Document Number 1801-901-01).....	March 1993
Revision B (Document Number 1801-901-01).....	July 1995
Addendum B (Document Number 1801-901-02).....	October 1995
Revision C (Document Number 1801-901-01)	April 1999

The following safety precautions should be observed before using this product and any associated instrumentation. Although some instruments and accessories would normally be used with non-hazardous voltages, there are situations where hazardous conditions may be present.

This product is intended for use by qualified personnel who recognize shock hazards and are familiar with the safety precautions required to avoid possible injury. Read and follow all installation, operation, and maintenance information carefully before using the product. Refer to the manual for complete product specifications.

If the product is used in a manner not specified, the protection provided by the product may be impaired.

The types of product users are:

Responsible body is the individual or group responsible for the use and maintenance of equipment, for ensuring that the equipment is operated within its specifications and operating limits, and for ensuring that operators are adequately trained.

Operators use the product for its intended function. They must be trained in electrical safety procedures and proper use of the instrument. They must be protected from electric shock and contact with hazardous live circuits.

Maintenance personnel perform routine procedures on the product to keep it operating properly, for example, setting the line voltage or replacing consumable materials. Maintenance procedures are described in the manual. The procedures explicitly state if the operator may perform them. Otherwise, they should be performed only by service personnel.

Service personnel are trained to work on live circuits, and perform safe installations and repairs of products. Only properly trained service personnel may perform installation and service procedures.

Keithley products are designed for use with electrical signals that are rated Installation Category I and Installation Category II, as described in the International Electrotechnical Commission (IEC) Standard IEC 60664. Most measurement, control, and data I/O signals are Installation Category I and must not be directly connected to mains voltage or to voltage sources with high transient over-voltages. Installation Category II connections require protection for high transient over-voltages often associated with local AC mains connections. Assume all measurement, control, and data I/O connections are for connection to Category I sources unless otherwise marked or described in the Manual.

Exercise extreme caution when a shock hazard is present. Lethal voltage may be present on cable connector jacks or test fixtures. The American National Standards Institute (ANSI) states that a shock hazard exists when voltage levels greater than 30V RMS, 42.4V peak, or 60VDC are present. **A good safety practice is to expect that hazardous voltage is present in any unknown circuit before measuring.**

Operators of this product must be protected from electric shock at all times. The responsible body must ensure that operators are prevented access and/or insulated from every connection point. In some cases, connections must be exposed to potential human contact. Product operators in these circumstances must be trained to protect themselves from the risk of electric shock. If the circuit is capable of operating at or above 1000 volts, **no conductive part of the circuit may be exposed.**

Do not connect switching cards directly to unlimited power circuits. They are intended to be used with impedance limited sources. NEVER connect switching cards directly to AC mains. When connecting sources to switching cards, install protective devices to limit fault current and voltage to the card.

Before operating an instrument, make sure the line cord is connected to a properly grounded power receptacle. Inspect the connecting cables, test leads, and jumpers for possible wear, cracks, or breaks before each use.

When installing equipment where access to the main power cord is restricted, such as rack mounting, a separate main input power disconnect device must be provided, in close proximity to the equipment and within easy reach of the operator.

For maximum safety, do not touch the product, test cables, or any other instruments while power is applied to the circuit under test. ALWAYS remove power from the entire test system and discharge any capacitors before: connecting or disconnecting cables or jumpers, installing or removing switching cards, or making internal changes, such as installing or removing jumpers.

Do not touch any object that could provide a current path to the common side of the circuit under test or power line (earth) ground. Always make measurements with dry hands while standing on a dry, insulated surface capable of withstanding the voltage being measured.

The instrument and accessories must be used in accordance with its specifications and operating instructions or the safety of the equipment may be impaired.

Do not exceed the maximum signal levels of the instruments and accessories, as defined in the specifications and operating information, and as shown on the instrument or test fixture panels, or switching card.

When fuses are used in a product, replace with same type and rating for continued protection against fire hazard.

Chassis connections must only be used as shield connections for measuring circuits, NOT as safety earth ground connections.

If you are using a test fixture, keep the lid closed while power is applied to the device under test. Safe operation requires the use of a lid interlock.

If a  screw is present, connect it to safety earth ground using the wire recommended in the user documentation.

The  symbol on an instrument indicates that the user should refer to the operating instructions located in the manual.

The  symbol on an instrument shows that it can source or measure 1000 volts or more, including the combined effect of normal and common mode voltages. Use standard safety precautions to avoid personal contact with these voltages.

The **WARNING** heading in a manual explains dangers that might result in personal injury or death. Always read the associated information very carefully before performing the indicated procedure.

The **CAUTION** heading in a manual explains hazards that could damage the instrument. Such damage may invalidate the warranty.

Instrumentation and accessories shall not be connected to humans.

Before performing any maintenance, disconnect the line cord and all test cables.

To maintain protection from electric shock and fire, replacement components in mains circuits, including the power transformer, test leads, and input jacks, must be purchased from Keithley Instruments. Standard fuses, with applicable national safety approvals, may be used if the rating and type are the same. Other components that are not safety related may be purchased from other suppliers as long as they are equivalent to the original component. (Note that selected parts should be purchased only through Keithley Instruments to maintain accuracy and functionality of the product.) If you are unsure about the applicability of a replacement component, call a Keithley Instruments office for information.

To clean an instrument, use a damp cloth or mild, water based cleaner. Clean the exterior of the instrument only. Do not apply cleaner directly to the instrument or allow liquids to enter or spill on the instrument. Products that consist of a circuit board with no case or chassis (e.g., data acquisition board for installation into a computer) should never require cleaning if handled according to instructions. If the board becomes contaminated and operation is affected, the board should be returned to the factory for proper cleaning/servicing.

Table of Contents

1 General Information

1.1	Introduction	1-1
1.2	Features	1-1
1.3	Warranty information	1-1
1.4	Manual addenda	1-2
1.5	Safety symbols and terms	1-2
1.6	Specifications	1-2
1.7	Unpacking and inspection	1-2
1.7.1	Inspection for damage	1-2
1.7.2	Shipment contents	1-2
1.7.3	Instruction manual	1-2
1.8	Repacking for shipment	1-2
1.9	Model 2001 compatibility	1-3
1.10	Optional accessories	1-3

2 Installation

2.1	Introduction	2-1
2.2	Card configuration	2-2
2.2.1	Preamplifier module	2-2
2.2.2	Power supply card	2-3
2.3	Power supply card preparation	2-4
2.4	Power supply card installation and removal	2-5
2.4.1	Card installation	2-5
2.4.2	Card removal	2-5
2.5	Connections	2-6
2.5.1	Power supply connections	2-6
2.5.2	Output connections to multimeter	2-7
2.5.3	Input signal connections	2-7
2.6	Operating considerations	2-9
2.6.1	Using the thermal isolation container	2-9
2.6.2	Minimum operating distance	2-9

3 Operation

3.1	Introduction	3-1
3.2	Preamplifier operation	3-1
3.2.1	Power-up detection	3-1
3.2.2	Preamplifier configuration menu	3-2
3.2.3	Enabling Model 1801 operation	3-2
3.2.4	Preamp ON/OFF states	3-2
3.2.5	Preamplifier filtering	3-4
3.2.6	Operational differences	3-5
3.2.7	IEEE-488 bus operation	3-7
3.3	Measurements	3-7
3.3.1	DC voltage measurements	3-7
3.3.2	AC voltage measurements	3-9
3.3.3	Four-wire resistance measurements	3-11
3.3.4	Frequency measurements	3-11
3.3.5	Differential thermocouple temperature measurements	3-14
3.4	Measurement considerations	3-18
3.4.1	Thermoelectric potentials	3-18
3.4.2	Source resistance noise	3-20
3.4.3	Magnetic fields	3-21
3.4.4	Electromagnetic interference (EMI)	3-22
3.4.5	Ground loops	3-22
3.4.6	Shielding	3-22

4 Performance Verification

4.1	Introduction	4-1
4.2	Environmental conditions	4-1
4.3	Warm-up period	4-2
4.4	Line power	4-2
4.5	Recommended test equipment	4-2
4.6	Verification limits	4-2
4.7	Restoring default conditions	4-3
4.8	Verification procedures	4-3
4.8.1	DC volts verification	4-3
4.8.2	AC volts verification	4-6
4.8.3	Resistance verification	4-6

5 Service Information

5.1	Introduction	5-1
5.2	Calibration	5-1
5.2.1	Environmental conditions	5-1
5.2.2	Warm-up period	5-1
5.2.3	Line power	5-2
5.2.4	Recommended calibration equipment	5-2
5.2.5	Offset adjustments	5-2
5.2.6	Normal calibration	5-4
5.2.7	Gain constants calibration	5-9

5.3	Principles of operation	5-10
5.3.1	Block diagram	5-10
5.3.2	Preamplifier module	5-10
5.3.3	Power supply cable	5-10
5.3.4	Power supply card	5-10
5.4	Special handling of static-sensitive devices	5-12
5.5	Troubleshooting	5-12
5.5.1	Troubleshooting equipment	5-12
5.5.2	Troubleshooting access	5-12
5.5.3	Troubleshooting procedure	5-12

6 Replaceable Parts

6.1	Introduction	6-1
6.2	Parts lists	6-1
6.3	Ordering information	6-1
6.4	Factory service	6-1
6.5	Component layouts and schematic diagrams	6-1

A Specifications

B Calibration Programs

Introduction	B-1
Program requirements	B-1
General program instructions	B-1

C IEEE-488 Bus Command Summary

List of Illustrations

2 Installation

Figure 2-1	Preamplifier module configuration	2-2
Figure 2-2	Power supply card configuration	2-3
Figure 2-3	Power and output connections	2-4
Figure 2-4	Typical analog output connections	2-5
Figure 2-5	Power supply card installation	2-6
Figure 2-6	Power supply connections	2-7
Figure 2-7	Connections to multimeter input	2-8
Figure 2-8	Input cable connections	2-8
Figure 2-9	Using the thermal isolator container	2-9

3 Operation

Figure 3-1	Filter frequency response curves	3-5
Figure 3-2	Connections for DC voltage measurements	3-8
Figure 3-3	Connections for AC voltage measurements	3-10
Figure 3-4	Connections for 4-wire resistance measurements	3-12
Figure 3-5	Connections for frequency measurements	3-13
Figure 3-6	Connections for differential temperature measurements	3-16
Figure 3-7	Thermal EMF generation	3-19
Figure 3-8	Magnetic field generation	3-21
Figure 3-9	Minimizing interference from magnetic loops	3-21
Figure 3-10	Power line ground loops	3-23
Figure 3-11	Eliminating ground loops	3-24

4 Performance Verification

Figure 4-1	Connections for DC volts verification	4-4
Figure 4-2	Connections for AC volts verification	4-7

5 Service Information

Figure 5-1	Connections for offset voltage adjustment	5-3
Figure 5-2	Connections for offset current adjustment	5-3
Figure 5-3	Calibration connections	5-5
Figure 5-4	Block diagram	5-11

List of Tables

3 Operation

Table 3-1	Power-up error messages	3-2
Table 3-2	CONFIGURE PREAMP menu structure	3-3
Table 3-3	Preamp ON/OFF states	3-3
Table 3-4	Filter response parameters	3-4
Table 3-5	Preamplifier measurement ranges	3-6
Table 3-6	Factory default conditions	3-6
Table 3-7	Preamplifier configuration commands	3-7
Table 3-8	CONFIG TEMPERATURE menu with Model 1801 enabled	3-14
Table 3-9	Differential temperature bus commands	3-18
Table 3-10	Thermoelectric coefficients	3-18

4 Performance Verification

Table 4-1	Recommended test equipment for performance verification	4-2
Table 4-2	Limits for DC volts verification	4-5
Table 4-3	Limits for AC voltage verification	4-6

5 Service Information

Table 5-1	Recommended equipment for calibration	5-2
Table 5-2	Model 1801 IEEE-488 bus calibration commands	5-7
Table 5-3	IEEE-488 bus calibration summary	5-7
Table 5-4	Preamplifier calibration errors	5-9
Table 5-5	Recommended troubleshooting equipment	5-12
Table 5-6	Power supply card troubleshooting procedure	5-13

6 Replaceable Parts

Table 6-1	Electrical, Parts List	6-2
Table 6-2	Mechanical, Parts List	6-3

C IEEE-488 Bus Command Summary

Table C-1	IEEE-488 bus command summary	C-1
-----------	------------------------------------	-----

General Information

1.1 Introduction

This section contains general information about the Model 1801 Nanovolt Preamp option for the Model 2001 Multimeter. The Model 1801 adds 20 μ V, 200 μ V, and 2mV DC volts and 500 μ V RMS AC voltage measurement ranges to the Model 2001 and includes 2m Ω through 200 Ω 4-wire resistance ranges. The Model 1801 can also be used for frequency and differential thermocouple temperature measurements.

Section 1 is arranged in the following manner:

1.2 Features

1.3 Warranty information

1.4 Manual addenda

1.5 Safety symbols and terms

1.6 Specifications

1.7 Unpacking and inspection

1.8 Repacking for shipment

1.9 Model 2001 compatibility

1.10 Optional accessories

1.2 Features

The Model 1801 is designed to be used with the Model 2001 Multimeter. Key features include:

- High sensitivity: The Model 1801 increases the DC voltage measurement sensitivity of the Model 2001 by a factor of 10,000.
- Low noise: Excellent noise rejection ensures minimal noise effects on the measurement.
- Low-thermal input connections: Copper-to-copper input connections are used to minimize offsets caused by thermal EMFs.
- Thermal isolation enclosure: An insulated enclosure is supplied for the preamplifier in order to minimize the effects of temperature variations.
- Integrated operation: Automatic power-up detection of the Model 1801 integrates range and function selection and reading display from the Model 2001 Multimeter front panel. Model 1801 operation can be enabled or disabled with a front panel menu selection.

1.3 Warranty information

Warranty information is located on the inside front cover of this instruction manual. Should your Model 1801 require warranty service, contact the Keithley representative or authorized repair facility in your area for further information. When returning the preamplifier for repair, be sure to fill out and include the service form at the back of this manual in order to provide the repair facility with the necessary information.

1.4 Manual addenda

Any improvements or changes concerning the preamplifier or manual will be explained in an addendum included with unit.

1.5 Safety symbols and terms

The following symbols and terms may be found on an instrument or used in this manual.

The  symbol on an instrument indicates that the user should refer to the operating instructions located in the instruction manual.

The **WARNING** heading used in this manual explains dangers that might result in personal injury or death. Always read the associated information very carefully before performing the indicated procedure.

The **CAUTION** heading used in this manual explains hazards that could damage the preamplifier. Such damage may invalidate the warranty.

1.6 Specifications

Model 1801 specifications are located in Appendix A. These specifications include Model 2001 Multimeter specifications and assume that the Model 2001 is properly calibrated.

1.7 Unpacking and inspection

1.7.1 Inspection for damage

Upon receiving the Model 1801, carefully unpack all items from the shipping carton, and inspect for physical damage. Report any such damage to the shipping agent immediately. Save the packing carton in case the unit must be shipped in the future.

NOTE

Be careful not to throw away the foam thermal isolation enclosure, which is intended for use with the preamplifier module.

1.7.2 Shipment contents

The following items are included with every Model 1801 order:

- Power supply card
- Preamplifier module
- 3-meter power supply connecting cable
- 3-meter low-thermal input cable
- Low-thermal copper shorting strap
- Thermal isolation enclosure
- Model 1801 Instruction Manual
- Additional accessories as ordered

1.7.3 Instruction manual

If an additional Model 1801 Instruction Manual is required, order the manual package, Keithley part number 1801-901-00. The manual package includes an instruction manual and any pertinent addenda.

1.8 Repacking for shipment

Should it become necessary to return the Model 1801 for repair, carefully pack the preamplifier, power supply card, and power cable in the original packing carton or the equivalent, and include the following information:

- Advise as to the warranty status of the unit.
- Write **ATTENTION REPAIR DEPARTMENT** on the shipping label.
- Fill out and include the service form located at the back of this manual.

1.9 Model 2001 compatibility

The Model 1801 can be used only with Model 2001 Multimeters with main microcontroller revision B01 or later firmware. The firmware revision level is displayed during the power-up cycle (the main microcontroller firmware revision level appears on the left). The firmware revision level may also be displayed by using the front panel MENU/GENERAL/SERIAL# selection.

If an earlier version is displayed (Ann), contact your Keithley sales representative regarding an upgrade to your Model 2001 DMM.

1.10 Optional accessories

Model 1483 Low-Thermal Connection Kit

The Model 1483 contains a crimp tool, pure copper lugs, alligator clips, and assorted hardware.

Model 1484 Refill Kit

The Model 1484 includes the following replacement parts for the Model 1483: pure copper lugs, alligator clips, and assorted hardware.

2

Installation

2.1 Introduction

This section includes information on installing the Model 1801 in the Model 2001 Multimeter and making power supply and output connections.

This section is arranged as follows:

- 2.2 **Card configuration:** Discusses the overall configuration of both the preamplifier module and the power supply card.
- 2.3 **Power supply card preparation:** Covers connecting the power supply cable to the card and routing the output leads through the cable clamp.
- 2.4 **Card installation and removal:** Gives the procedure to install the power supply card assembly in the Model 2001 Multimeter and describes how to remove the card.
- 2.5 **Connections:** Covers the basics for connecting the power supply to the preamplifier module, as well as multimeter input connections and analog output connections.
- 2.6 **Operating considerations:** Outlines use of the thermal isolation enclosure and discusses minimum operating distance.

2.2 Card configuration

2.2.1 Preamplifier module

Figure 2-1 shows the configuration of the preamplifier module. Key items include:

❶ INPUT Terminals

The HI and LO INPUT terminals are pure copper studs and nuts intended for connecting input signals to the Model 1801. To minimize thermal EMFs, use only pure copper lugs or wires for connections, and be sure that both the terminals and connecting lugs are clean and free of oxidation. See paragraph 2.4.4 for details on input connections.

CAUTION

The maximum signal between INPUTS HI and LO is 1V @ 100mA peak (inputs over 2mV require one-minute recovery). The maximum volt-

age between LO and chassis ground is 41V peak. Exceeding these limits may result in damage.

❷ Offset Adjustments

V ZERO and I ZERO are externally accessible adjustments for nulling voltage and current offsets respectively. These controls need not be adjusted during normal operation.

NOTE

Improper offset adjustments will degrade performance. The offset adjustments should only be performed using the procedures covered in Section 5.

❸ Power Supply Connector

This connector attaches the preamplifier module to the power supply card using the supplied cable. See paragraph 2.4.1 for details.

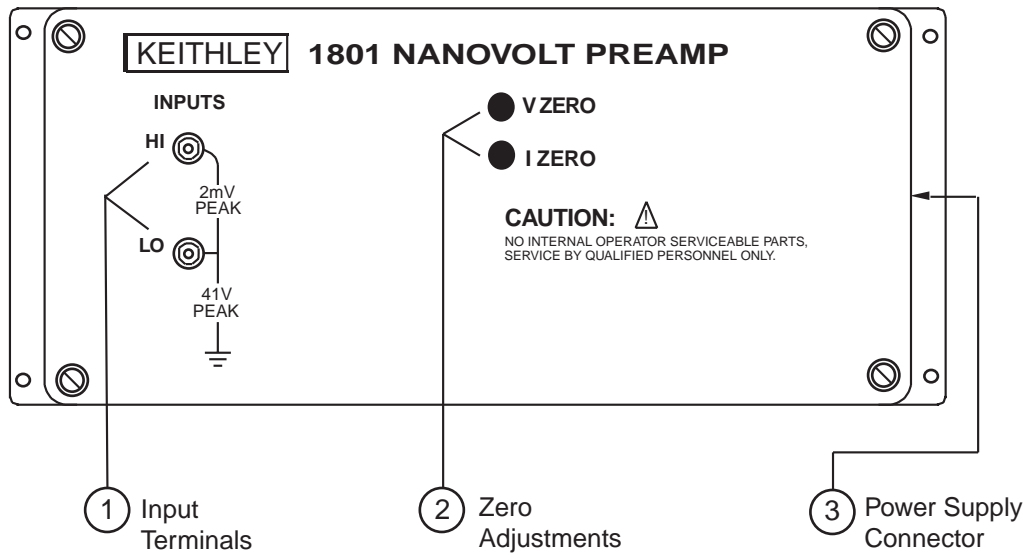

Figure 2-1
Preamplifier module configuration

2.2.2 Power supply card

Figure 2-2 shows the configuration of the power supply card. Components include:

❶ Cover

The plastic cover shields circuit board parts from damage and contamination. In order to open the cover, press in on the cover latch, then swing the cover open on its hinges.

❷ Analog Output

The analog output terminals are intended for connecting the preamplifier output to a monitoring device such as a chart recorder. See paragraph 2.3 for details.

❸ Power Connector

The power connector and connecting cable supply power and control signals to the preamplifier module. They also feed the analog output signal back to the power supply card.

❹ Cable Clamp

The cable clamp provides a strain relief for the output leads and power cable.

❺ Output Leads

The two output leads are terminated with banana plugs intended to connect to the multimeter input jacks. Red is HI, and black is LO. See paragraph 2.5.2 for information on output connections.

❻ Shield Jumper

This jumper allows you to connect the cable shield and preamplifier shell either to earth ground or to input LO. Installing the jumper in the earth ground position allows the unit to meet its stated low common-mode current but will degrade common-mode noise rejection (if an AC signal is floating on input LO). Installing the jumper in the LO position will degrade the common-mode current but will provide the specified common-mode noise rejection.

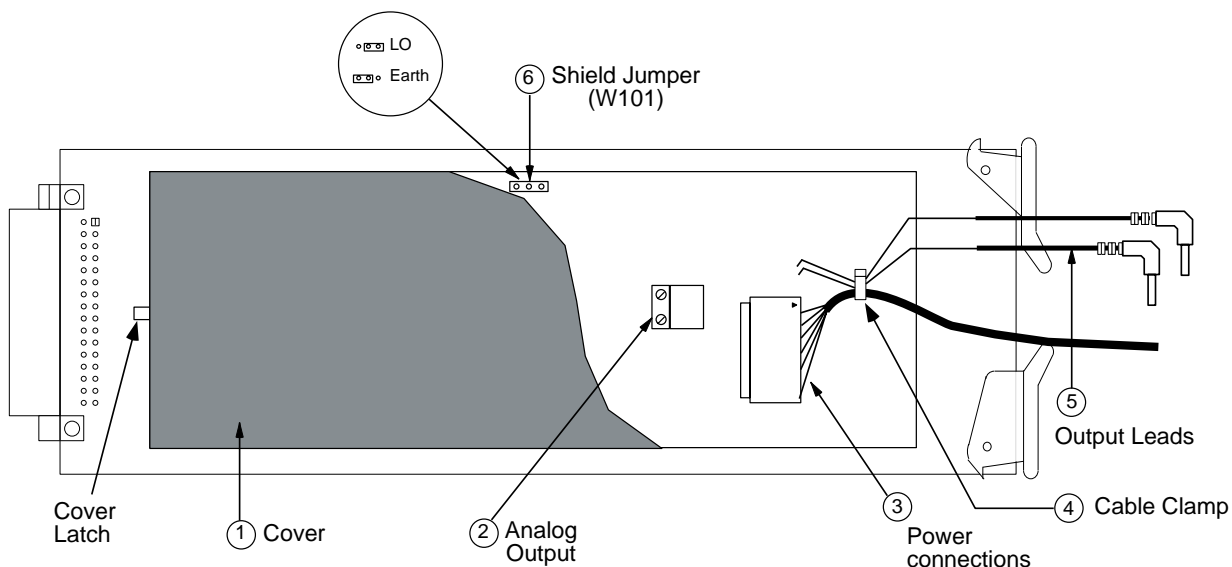

Figure 2-2
Power supply card configuration

2.3 Power supply card preparation

Power and output connections

Before installing the power supply card in the multimeter, make sure the power cable is connected to the power connector (see Figure 2-3).

Shield jumper

The shield jumper connects the cable shield and preamp shell either to earth ground or input LO. This jumper should be installed as follows:

- If low common-mode current is more important than common-mode noise rejection, place the jumper in the earth ground position.
- If common-mode noise rejection is more important than low common-mode current, place the jumper in the LO position.

Analog output connections

The analog output terminals, which are located on the power supply board, provide a 0-2V full scale output for monitoring devices such as chart recorders.

Since the analog output signal is at a relatively high level and has low source impedance, the type of wiring used for connections is not critical. Standard stranded wire of the type used for DMM test leads should be adequate in most cases. Figure 2-4 shows typical analog output connections.

Note that the common-mode current (from LO to earth ground) of any device connected to the analog output terminals will be added to that of the Model 1801/2001. Typical common-mode current levels for a DMM or chart recorder are several micro amps or higher.

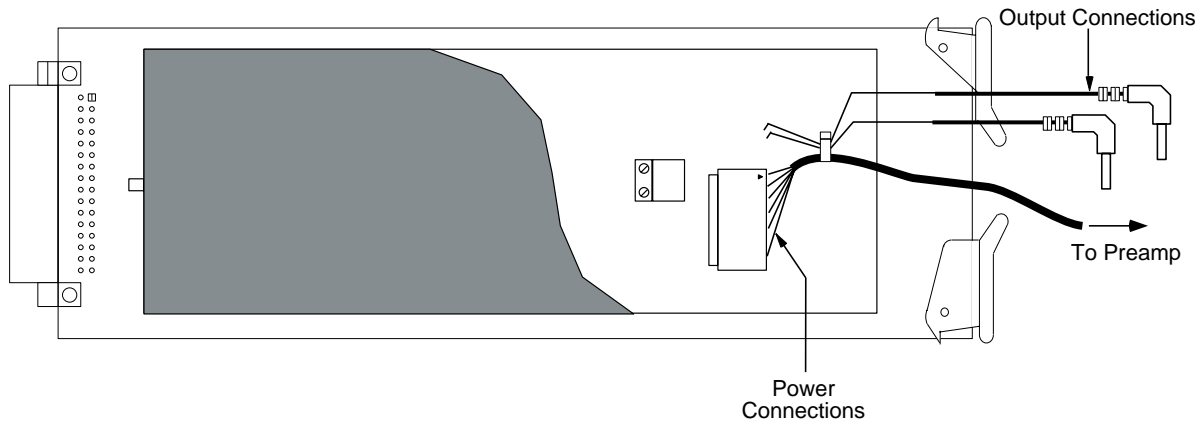

Figure 2-3
Power and output connections

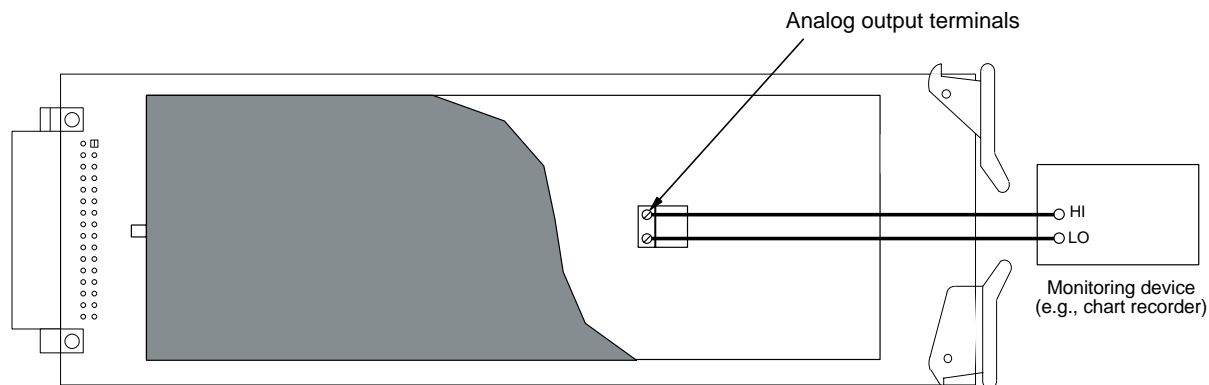

Figure 2-4
Typical analog output connections

2.4 Power supply card installation and removal

This paragraph explains how to install and remove the Model 1801 power supply card assembly in the Model 2001 Multimeter.

2.4.1 Card installation

Perform the following steps, and refer to Figure 2-5 to install the power supply card assembly in the Model 2001 Multimeter:

WARNING

Turn off the Model 2001 Multimeter, and disconnect the line cord before installing or removing the power supply card.

1. Remove the cover plate labeled OPTION SLOT on the rear panel of the Model 2001 Multimeter. To do

so, pry out the two fasteners, then remove the cover plate.

2. Slide the power supply card edges into the guide rails inside the multimeter.
3. With the ejector arms in the unlocked position, carefully push the card all the way forward until the arms engage the ejector cups. Push both arms inward to lock the card into the multimeter.
4. After installation, connect the power cable to the preamp module and the output leads to the multimeter as discussed in paragraph 2.5 below.

2.4.2 Card removal

Follow the steps below to remove the power supply card from the multimeter:

1. Unlock the card by pulling the latches outward.
2. Carefully slide the card out of the multimeter.
3. If the multimeter is to be operated without the power supply card installed, install the OPTION SLOT cover plate.

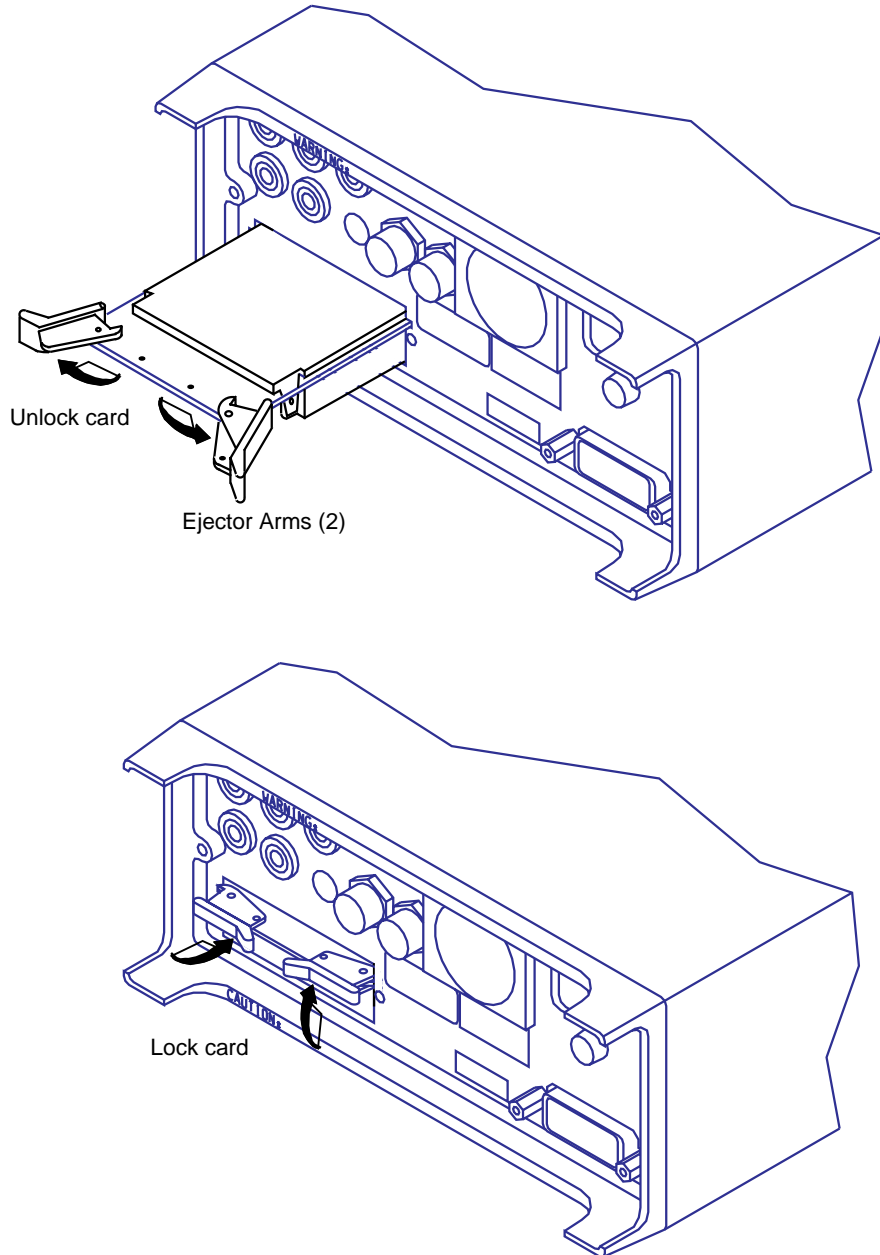

Figure 2-5
Power supply card installation

2.5 Connections

This paragraph provides the information necessary to connect the preamplifier module to the power supply card and multimeter.

2.5.1 Power supply connections

After installing the power supply in the multimeter, connect the preamplifier to the power supply card using the supplied connecting cable, as shown in Figure 2-6.

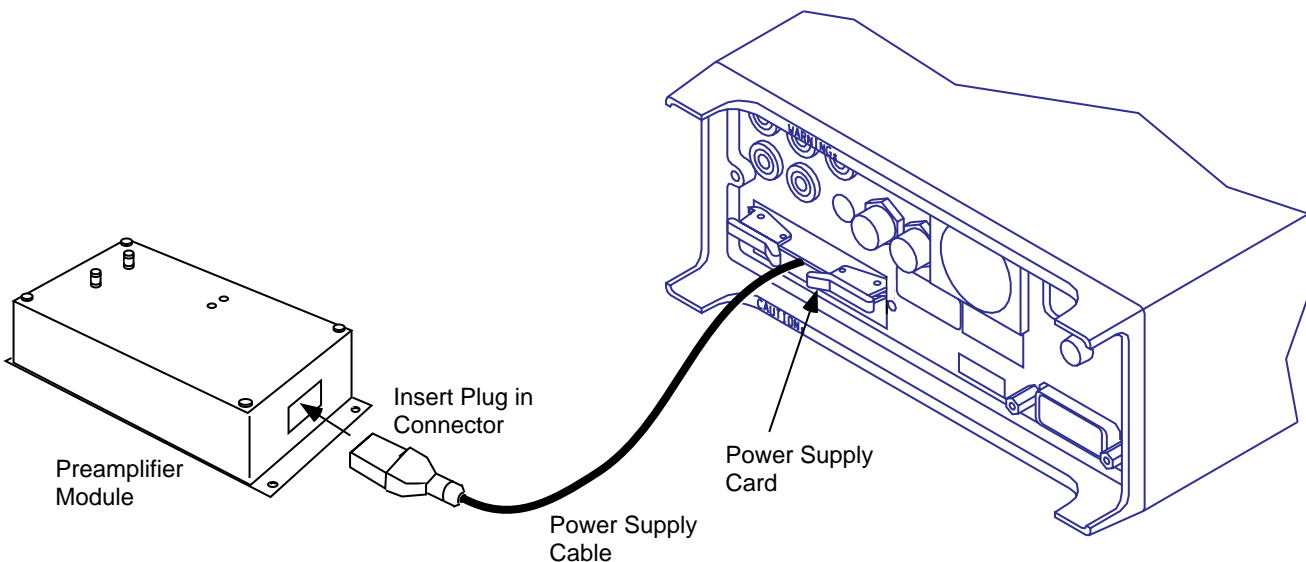

Figure 2-6
Power supply connections

CAUTION

Turn off the Model 2001 Multimeter power before connecting or disconnecting the cable.

2.5.2 Output connections to multimeter

After installation, connect the output leads to the Model 2001 rear panel input jacks, as shown in Figure 2-7. For DCV, ACV, frequency, and temperature measurements, the red lead should be connected to INPUT HI, and the black lead should be connected to INPUT LO.

NOTE

Be sure to select the rear inputs with the front panel INPUTS switch when using the Model 1801. Output connections for 4-wire resistance measurements must be changed, as explained in paragraph 3.3.2 in Section 3.

2.5.3 Input signal connections

Input connections are made directly to the two preamplifier screw terminals, as shown in Figure 2-8. When making input connections, observe the following precautions in order to minimize noise pickup and thermal EMFs:

- Use only shielded low-thermal cables such as the input cable supplied with the Model 1801.
- Use only crimped-on copper lugs and copper wires for all input connections. Crimping results in an airtight connection.
- Copper-to-copper oxide connections result in thermoelectric potentials as high as $1000\mu\text{V}/^\circ\text{C}$ (see paragraph 3.4.1). To avoid these thermals, make sure that all connections are clean and free of oxides. Scotchbrite® copper cleaner can be used to clean connections.
- Do not handle the prepared ends of the input cable. Body oils and salts can result in contamination, affecting connection integrity.

CAUTION

To avoid possible preamplifier damage, keep static electricity discharge away from input terminals.

The supplied input cable can be used for most measurement functions, but some such as thermocouple measurements may require different connecting wires. For input connection information specific to the type of measurement function, refer to paragraph 3.3 in Section 3.

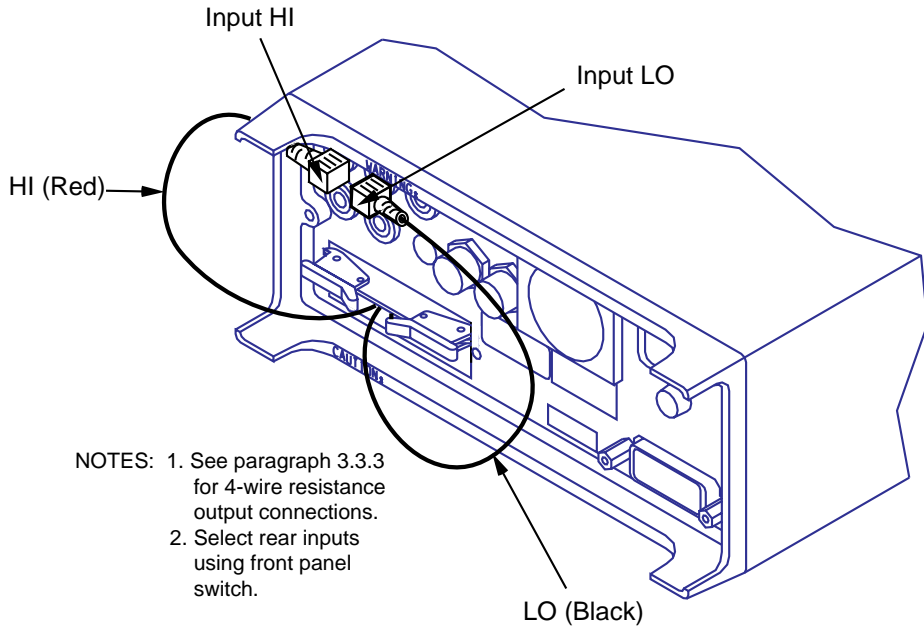
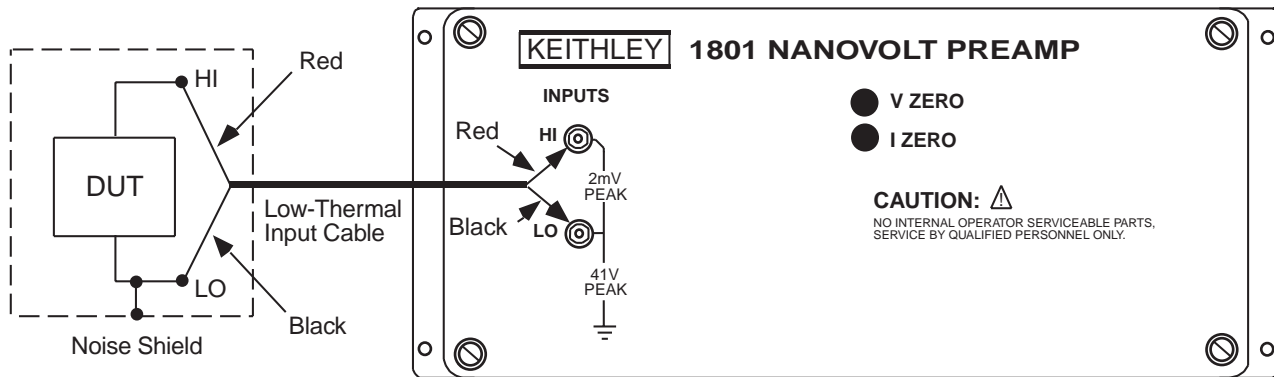

Figure 2-7
Connections to multimeter input



NOTE : 1. Use only clean copper-to-copper connections.
2. See paragraph 3.3 for specific connections each measurement function.

Figure 2-8
Input cable connections

2.6 Operating considerations

2.6.1 Using the thermal isolation container

After making all connections, place the preamplifier module in the thermal isolation container, as shown in Figure 2-9. Route the connecting wires through the slits in each end of the container, then cover the preamplifier with the lid. Allow the preamplifier to thermally stabilize for at least one hour to achieve rated accuracy.

2.6.2 Minimum operating distance

The Model 1801 preamplifier module should be kept a minimum of two feet away from the Model 2001 Multi-meter and other instrumentation to avoid noise pickup due to stray magnetic fields.

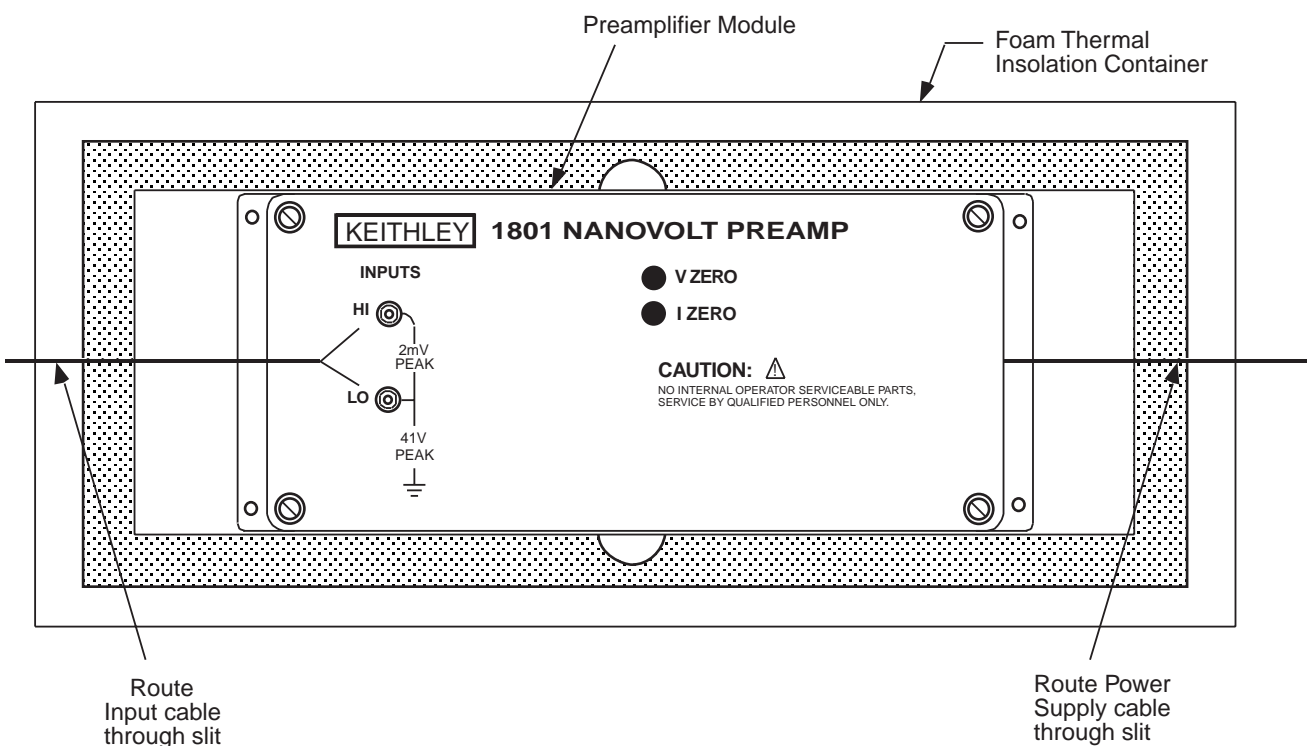

Figure 2-9
Using the thermal isolator container

3

Operation

3.1 Introduction

This section contains basic information on operating the Model 1801 using the host Model 2001 Multimeter. For more detailed information on operating the Model 2001 Multimeter, see the Model 2001 Operator's Manual.

This section is organized as follows:

- 3.2 **Preamplifier operation:** Covers enabling Model 1801 operation, preamplifier filtering, operating restrictions, and summarizes IEEE-488 bus operation.
- 3.3 **Measurements:** Discusses DC and AC voltage measurements, and 4-wire resistance and thermocouple temperature measurements.
- 3.4 **Measurement considerations:** Explains a number of considerations that may apply to Model 1801 measurements.

3.2 Preamplifier operation

3.2.1 Power-up detection

The Model 2001 Multimeter automatically detects the presence of the Model 1801 at power-on. The instrument will indicate the presence of the Model 1801 by displaying the following message if the preamplifier is disabled:

Preamp OFF

If, however, the preamplifier is enabled at power-on, the unit will display the following message:

Preamp ON

Whether the Model 1801 is enabled or disabled at power-on depends on the programmed power-on setup:

- GPIB defaults: Model 1801 always disabled.
- Bench defaults: Model 1801 always enabled.
- User setup: Model 1801 either enabled or disabled depending on the state stored in the recalled setup.

See paragraph 3.2.5 for additional information on saving and recalling setups. Paragraph 3.12.1 of the Model 2001 Operator's Manual explains how to select the instrument setup that goes into effect at power-on.

Note that you can query the instrument over the IEEE-488 bus to determine if the Model 1801 is present by using the *OPT? query. If the preamplifier is present, the instrument will return the following response:

2001-1801

Refer to paragraph 4.9 of the Model 2001 Multimeter Operator's Manual for more details on using the *OPT? query.

Power-up error messages

Table 3-1 summarizes error messages that may occur during power-up when the Model 1801 is installed.

3.2.2 Preamplifier configuration menu

Table 3-2 summarizes the preamplifier configuration menu structure. In order to access this menu, press the front panel CHAN key.

3.2.3 Enabling Model 1801 operation

Follow the procedure below to enable Model 1801 operation:

1. Press the CHAN key. The Model 2001 will display the following:

```
CONFIGURE PREAMP
CONTROL FILTER CALIBRATION
```

2. Select CONTROL, then press ENTER. The unit will display the following:

```
PREAMP CONTROL
ENABLE DISABLE
```

3. Select ENABLE, then press ENTER.
4. Press EXIT to return to normal display. The unit will display the following message to indicate that the preamplifier is enabled:

Preamp ON

5. To disable the preamplifier, repeat steps 1 through 4, but select DISABLE in the PREAMP CONTROL menu. The unit will display the following to indicate that the preamplifier is disabled:

Preamp OFF

NOTE

Once Model 1801 operation is enabled, readings will be scaled accordingly. Disable Model 1801 operation if you intend to make measurements without the Model 1801. Otherwise, incorrect readings will be displayed.

3.2.4 Preamp ON/OFF states

Table 3-3 summarizes operating states the Model 2001 will assume when the preamp is turned on or off.

Table 3-1
Power-up error messages

Error number	Message	Description
-315	“Preamp memory lost”	Cannot recover preamp setup due to corrupt memory.
+516	“Installed option id lost”	Cannot identify Model 1801 as installed option.
+517	“Preamp calibration data lost”	Preamplifier uncalibrated due to lost cal constants.

Table 3-2
CONFIGURE PREAMP menu structure

Menu item	Description
CONTROL ENABLE DISABLE	Enable/disable preamplifier. Enable preamplifier. Disable preamplifier.
FILTER FAST MEDIUM SLOW	Select preamplifier filter. Select fast response filter. Select medium response filter. Select slow response filter.
CALIBRATION CALIBRATION-DATES CALIBRATE ENTER-CAL-CONSTANTS	Calibrate preamplifier. Set calibration dates. Calibrate preamplifier. Input calibration constants.

NOTE: Press CHAN key to access CONFIGURE PREAMP menu. See Section 5 for calibration information.

Table 3-3
Preamp ON/OFF states

Mode	Preamp ON	Preamp OFF
DCV Range DCV Auto-range	2mV OFF	1000V ON
ACV Range ACV Auto-range ACV Type	500 μ V OFF Low-frequency RMS	750V ON Normal RMS
Ω 4W Range Ω 4W Auto-range	200 Ω OFF	200k Ω ON
FREQ Voltage Threshold Range FREQ Voltage Threshold Level	2mV 0	1V 0
TEMP Transducer	Differential thermocouple	4-wire RTD

NOTE: This table lists operating states that change when preamp is enabled or disabled. All other states are unaffected by enabling or disabling preamp.

3.2.5 Preamplifier filtering

The Model 1801 has three analog filters with FAST, MEDIUM, and SLOW responses respectively. These filters are in addition to the Model 2001 filter, which can also be used with the preamplifier. See paragraph 3.9 of the Model 2001 Operator's Manual for details on Model 2001 filtering.

The following paragraphs discuss selecting the filter response and also cover filter frequency response curves. See the specifications in Appendix A for filter settling times.

Selecting filter response

1. Press the CHAN key to bring up the preamplifier configuration menu. The instrument will display the following:

```
CONFIGURE PREAMP
CONTROL FILTER CALIBRATION
```

2. Select FILTER, then press ENTER. The unit will display filter response selections:

```
SELECT PREAMP FILTER
FAST MEDIUM SLOW
```

3. Select the desired filter response, then press ENTER. The FAST response filter provides the least noise reduction and fastest response, while the SLOW response filter gives the most noise reduction and slowest response. Note that only the FAST response filter is available with the ACV and FREQ functions.
4. Press EXIT to return to normal display.

Filter frequency response curves

Each of the preamplifier filters exhibits single-pole, low-pass response. In addition to the filter selection, filter response also depends on the selected range, as summarized in Table 3-4. The table includes the -3dB response point for each set of operating conditions, as well as a filter response number. The filter frequency response number corresponds to the equivalent curve number shown in Figure 3-1. Note that the filter response curves shown are for the preamplifier only and do not include Model 2001 response, which is affected by its own filter parameters as well as the selected integration period.

Table 3-4
Filter response parameters

Function and Range	Filter response					
	FAST		MEDIUM		SLOW	
	-3dB bandwidth	Filter number	-3dB bandwidth	Filter number	-3dB bandwidth	Filter number
DCV: 20μV Ω4W: None	40Hz	3	0.32Hz	6	0.032Hz	7
DCV: 200μV Ω4W: 2mΩ	185Hz	2	3.2Hz	5	0.32Hz	6
DCV: 2mV Ω4W: 20mΩ–200Ω	700Hz	1	32Hz	4	3.2Hz	5

NOTE: Filter numbers correspond to curves shown in Figure 3-1. FAST filter only for ACV and FREQ functions.
 $10\% - 90\% \text{ risetime} = 0.35/\text{Bandwidth (Hz)}$
 $\tau \text{ (s)} = 0.15/\text{Bandwidth (Hz)}$

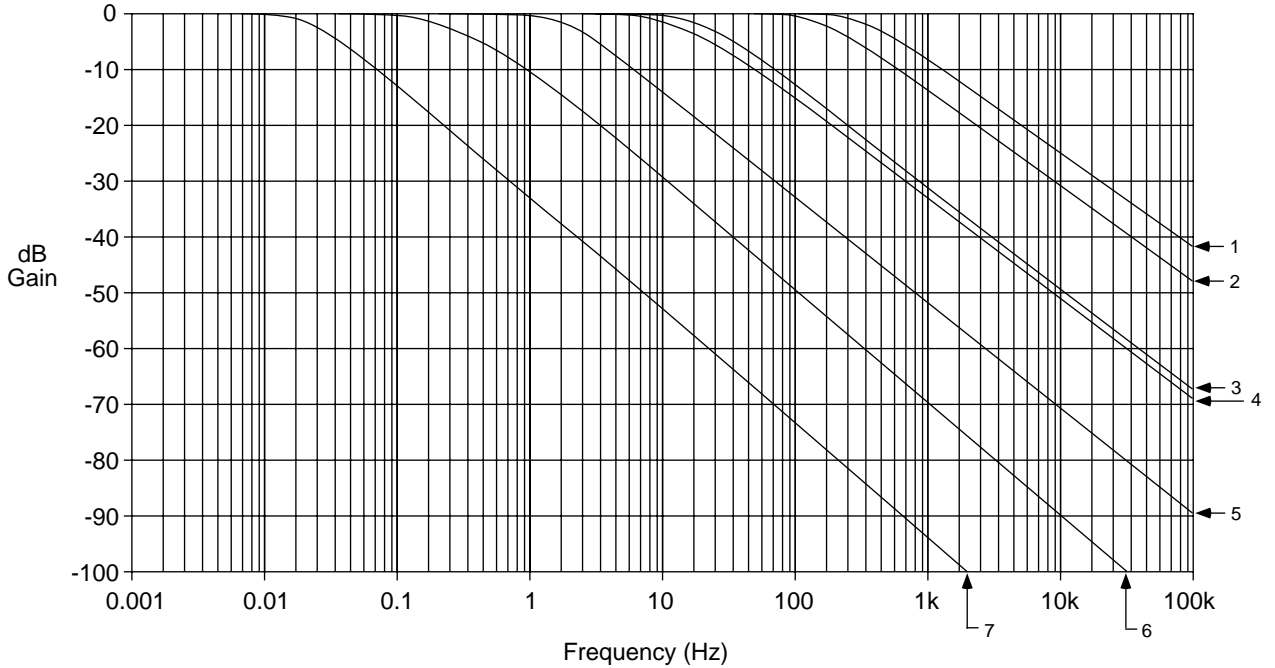

NOTE : Response curves are for preamplifier only.
Number corresponds to conditions listed in Table 3-4.

Figure 3-1
Filter frequency response curves

3.2.6 Operational differences

Functions

The following functions are available when using the Model 1801:

- DC volts
- AC volts (low-frequency RMS only)
- 4-wire ohms
- Frequency (voltage only)
- Thermocouple temperature (differential only)

Note that DC current, AC current, and 2-wire ohms functions are not available when the preamp is turned on. The following message will be displayed if you attempt to

select one of these functions when the Model 1801 is enabled:

Function is not available with Preamp enabled

Ranging

Table 3-5 summarizes the measurement ranges available when using the Model 1801. Note that auto-ranging cannot be used when the preamplifier is enabled. If you attempt to use auto-ranging with the preamp turned on, the instrument will display the following message:

Auto-ranging is not available with Preamp enabled

Table 3-5
Preamplifier measurement ranges

Function	Ranges
DCV	20 μ V, 200 μ V, 2mV
ACV	500 μ V RMS
Ω 4W	2m Ω , 20m Ω , 200m Ω , 2 Ω , 20 Ω , 200 Ω
Frequency*	2mV

* Maximum threshold level range.

Saving setups

Model 1801 setups can be saved by using the SAVESETUP selection in the front panel menu. (See paragraph 3.12.1 of the Model 2001 Operator’s Manual for details.) In order to save a preamplifier setup, select the desired operating conditions, then save your setup as usual. To turn on the Model 1801 when the setup is recalled, first enable the preamplifier before saving the setup. To turn off the preamplifier when the setup is recalled, disable the preamplifier before saving the setup.

Recalling setups

The state of the Model 1801 depends on the type of setup being recalled: GPIB defaults, bench defaults, or user setup.

■ GPIB defaults

When GPIB defaults are recalled, the Model 1801 is always disabled. GPIB defaults are restored with the RESET GPIB selection in the save setup menu, or by sending the *RST command over the bus.

■ Bench defaults

When bench defaults are recalled, any internal conflicts (such as auto-range) with the present operating state are resolved, and the Model 1801 is enabled with the factory default operating conditions summarized in Table 3-6. Bench defaults can be recalled by using the RESET BENCH selection in the save setup menu, or by using the bus :SYSTEM:PRESet command.

Table 3-6
Factory default conditions

Function or operation	Factory default
Function	DCV
DCV Range	2mV
ACV Range	500 μ V
Ohms Range	200 Ω
Ohms Offset Compensation	On
Frequency Threshold Range	2mV
Frequency Threshold Level	0V
Temperature Transducer	Differential Thermocouple
Filter Response	Medium

■ User setups

When a user setup is recalled, the Model 1801 operating state assumes the condition dictated by the recalled setup. If the setup was stored with the Model 1801 disabled, the preamplifier will be disabled when the setup is recalled. If the setup was stored with the Model 1801 enabled, the preamplifier will be enabled when the setup is recalled, and the instrument will assume operating conditions from the recalled setup.

Notes:

1. If a recalled setup requires that the Model 1801 be enabled, and the preamplifier is not installed in the Model 2001, a “Missing hardware” error will be generated. The Model 2001 will then assume its bench default conditions.
2. The preamplifier hardware gain is set to X1,000, and the filter response is set to medium when the Model 1801 is disabled.

Multiple displays

The following multiple displays are not available when using the Model 1801:

- DCV: positive, negative, or positive/negative peak spikes; ACV frequency; simultaneous DCV/ACV.
- ACV: crest factor, frequency.
- FREQ: period

An appropriate error message will be displayed if you select one of the above multiple displays with the preamp enabled. Also note that the **FREQ** bar graph range is limited to 2kHz with the preamp enabled. See paragraph 3.2.2 of the Model 2001 Operator’s Manual for more information on using the multiple displays.

3.2.7 IEEE-488 bus operation

Table 3-7 summarizes additional IEEE-488 bus commands necessary for preamplifier configuration. In general, most of the IEEE-488 bus commands covered in Section 4 of the Model 2001 Operator’s Manual can be used with the Model 1801. However, the same operational restrictions discussed in paragraph 3.2.5 apply to bus programming. If you send an invalid program message, an error will result.

NOTE

Additional commands that control differential thermocouple temperature operation are explained in paragraph 3.3.5.

Table 3-7
Preamplifier configuration commands

Command	Description
:INPut :PREamp :STATe 	Enables (ON or 1) or disables (OFF or 0) preamplifier.
:STATe?	Returns preamp state (1=ON or 0=OFF)
:FILTer <name>	Selects preamp filter response (Name = SLOW MEDium FAST)
:FILTer?	Returns preamplifier state (SLOW, MED, or FAST)

Notes:

1. Angle brackets (<>) are used to indicate parameter type. Do not include brackets in programming message.
2. Upper-case letters indicate command short form.

Example 1: Enable Preamplifier

```
:INP:PRE:STAT ON
```

or,

```
:INPUT:PREAMP:STATE 1
```

Example 2: Select Filter Response

```
:INP:PRE:FILT MED
```

or,

```
:INPUT:PREAMP:FILTER MEDIUM
```

3.3 Measurements

3.3.1 DC voltage measurements

The Model 1801 can detect DC voltages as low as 1pV and measure up to 2mV. Assuming “bench reset” conditions (see paragraph 3.12.1 of the Model 2001 Operator’s Manual), the basic procedure for making DC voltage measurements is as follows:

1. Connect the input cable to the INPUTS terminals on the preamplifier module, and connect the output leads to the Model 2001 rear panel INPUT jacks (see Figure 3-2).
2. Set the INPUTS switch to the REAR position.
3. Press CONFIG DCV, then configure the speed, filter, and resolution as required.
4. Press the DCV key to select the DC volts function.
5. Using the RANGE keys, choose a range consistent with the expected voltage. (Available ranges are: 20µV, 200µV, and 2mV.)
6. Connect the input leads to the voltage source, as shown in Figure 3-2.

CAUTION

Do not exceed 1V peak at 100mA between the INPUTS HI and LO terminals, or the preamplifier may be damaged. (Inputs over 2mV peak will require a one-minute recovery period.)

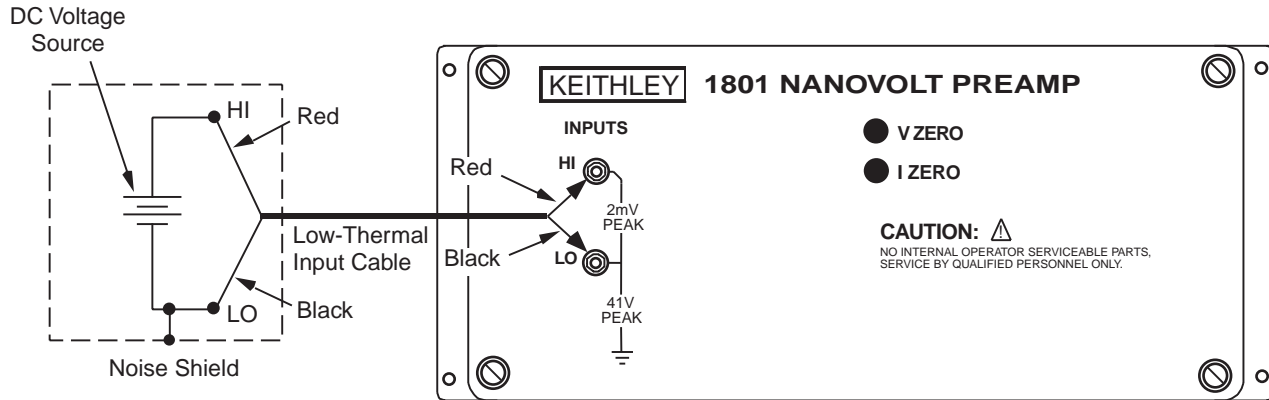

NOTE : Use only clean copper-to-copper connections.

a. Input Connections

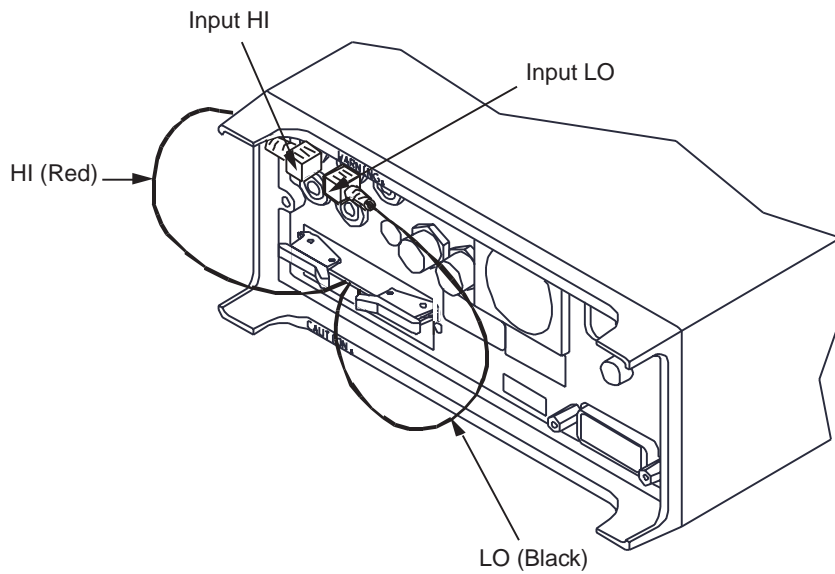

b. Output Connections

Figure 3-2
Connections for DC voltage measurements

7. Observe the display. If the “Overflow” message is displayed, select a higher range. Use the lowest range possible for the best resolution.
8. Take a reading from the display. If the reading is noisy, it may be necessary to change the filter response. (See paragraph 3.2.5 for details on filtering.)

Zeroing

The specification term “when properly zeroed” means that you must establish a baseline for subsequent measurements on that range. All Model 1801 DCV ranges require proper zeroing to achieve rated accuracy. The zeroing procedure described below should be performed at the interval and changes in ambient temperature given in the specifications in Appendix A.

To zero (rel) the Model 1801, follow the steps below:

1. Disable rel if presently enabled by pressing the REL key. The REL annunciator should be off.
2. Select the range to be used for the measurement.
3. Disconnect the input leads from the signal source, then short the ends of the leads together. Allow sufficient time for thermal offsets and noise to stabilize.
4. Press the REL key. The display will read zero.
5. Remove the short, and connect the input leads to the signal to be measured.

3.3.2 AC voltage measurements

The Model 1801 can detect low-frequency RMS AC voltages as low as 100pV and measure a maximum of 500μV RMS. Assuming “bench reset” conditions (see paragraph 3.12.1 of the Model 2001 Operator’s Manual), the basic procedure for making AC voltage measurements is as follows:

1. Connect the input cable to the INPUTS terminals on the preamplifier module, and connect the output leads to the Model 2001 rear panel INPUT jacks (see Figure 3-3).
2. Set the INPUTS switch to the REAR position.
3. Press CONFIG ACV, then select the desired operating conditions.
4. Press the ACV key to select the AC volts function.
5. Connect the input leads to the voltage source, as shown in Figure 3-3.

CAUTION

Do not exceed 1V peak at 100mA between the INPUTS HI and LO terminals, or the preamplifier may be damaged. (Inputs over 2mV peak will require a one-minute recovery period.)

6. Take a reading from the display.

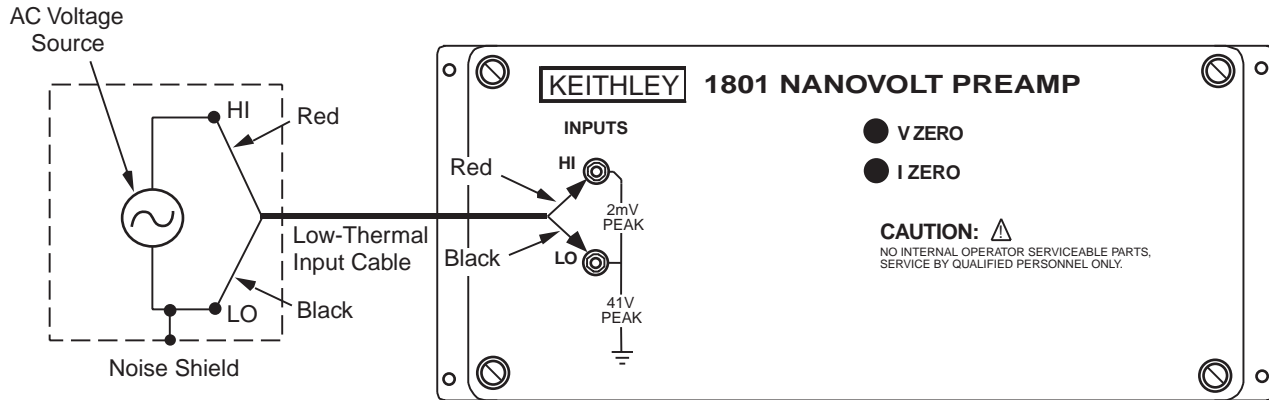

NOTE : Use only clean copper-to-copper connections.

a. Input Connections

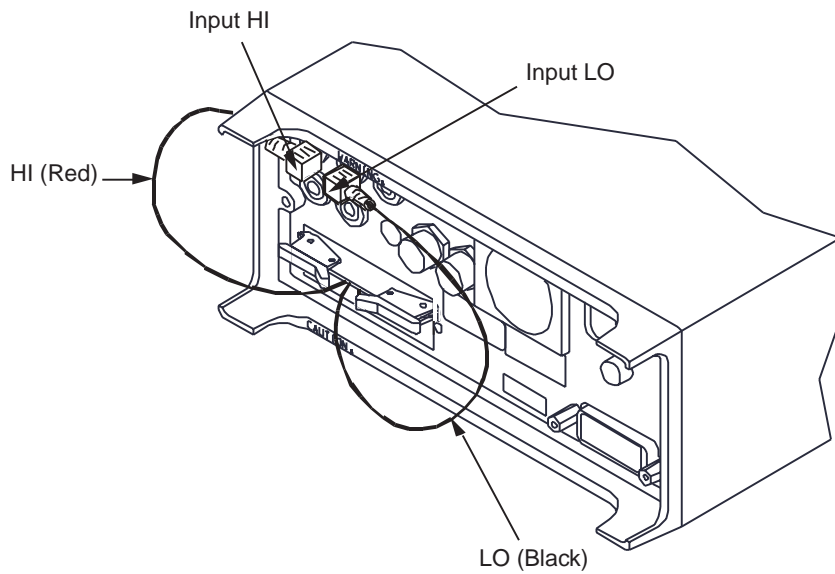

b. Output Connections

Figure 3-3
Connections for AC voltage measurements

3.3.3 Four-wire resistance measurements

The Model 1801 can make 4-wire resistance measurements between 100p Ω and 200 Ω . Assuming “bench reset” conditions (see paragraph 3.12.1 of the Model 2001 Operator’s Manual), the basic procedure for making 4-wire resistance measurements is as follows:

1. Connect the input cable to the INPUTS terminals on the preamplifier module, and connect the output leads to the rear panel SENSE 4 WIRE jacks (see Figure 3-4). Also connect test leads to the rear panel HI and LO INPUT jacks (these leads are necessary to apply the source current to the DUT necessary for 4-wire resistance measurements).
2. Set the INPUTS switch to the REAR position.
3. Press CONFIG Ω 4, then select the desired four-wire resistance operating conditions.
4. Press the Ω 4 key to select the 4-wire ohms function.
5. Using the RANGE keys, choose a range consistent with the expected resistance. (Available ranges are from 2m Ω to 200 Ω in decade steps.)
6. Connect the preamplifier input leads and the DMM HI and LO INPUT leads to the resistance being measured, as shown in Figure 3-4.
7. Observe the display. If the “Overflow” message is displayed, select a higher range. Use the lowest range possible for the best resolution.
8. Take a reading from the display. If the reading is noisy, it may be necessary to change the filter response. (See paragraph 3.2.5 for details on filtering.)

Zeroing

The specification term “when properly zeroed” means that you must establish a baseline for subsequent measurements on that range. All Model 1801 4-wire resistance ranges require proper zeroing to achieve rated accuracy. The zeroing procedure described below should be performed at intervals and changes in ambient temperature given in Appendix A.

To zero (rel) the Model 1801, follow the steps below:

1. Disable rel if presently enabled by pressing the REL key. The REL annunciator should be off.
2. Select the range to be used for the measurement.
3. Disconnect all four leads from the signal source, then short the ends of all four test leads together. Allow

sufficient time for thermal offsets and noise to stabilize.

4. Press the REL key. The display will read zero.
5. Remove the short, and connect all four test leads to the resistance to be measured.

Offset-compensated ohms

Offset-compensated ohms compensates for voltage potentials such as thermal EMFs across the device under test. For maximum accuracy, offset compensation should be used for all Model 1801 resistance measurements.

Offset compensation can be enabled or disabled by pressing CONFIG Ω 4, and then selecting OFFSETCOMP in the CONFIGURE OHMS-4W menu. See paragraph 3.4.3 of the Model 2001 Operator’s Model for additional information.

3.3.4 Frequency measurements

The Model 1801 can make ACV frequency measurements between 1Hz and 1kHz. Assuming “bench reset” conditions (see paragraph 3.12.1 of the Model 2001 Operator’s Manual), the basic procedure for making ACV frequency measurements is as follows:

1. Connect the input cable to the INPUTS terminals on the preamplifier module, and connect the output leads to the rear panel INPUT jacks (see Figure 3-5).
2. Set the INPUTS switch to the REAR position.
3. Press CONFIG FREQ, then choose the desired frequency measurement configuration.
4. Press the FREQ key to select the frequency function.
5. Connect the input leads to the AC voltage source, as shown in Figure 3-5.

CAUTION

Do not exceed 1V peak at 100mA between the INPUTS HI and LO terminals, or the preamplifier may be damaged. (Inputs over 2mV will require a one-minute recovery period.)

6. Take a frequency reading from the display.

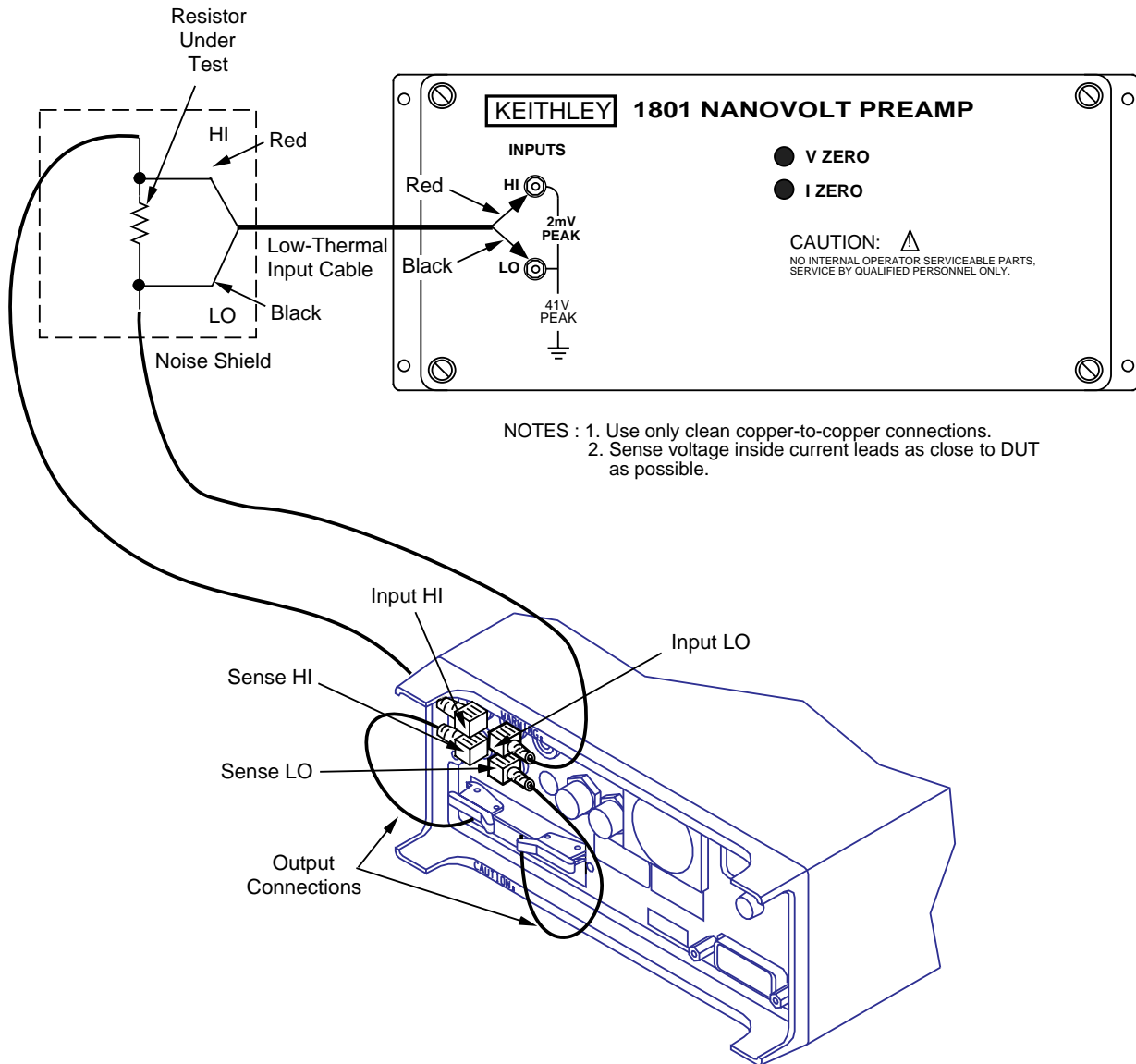
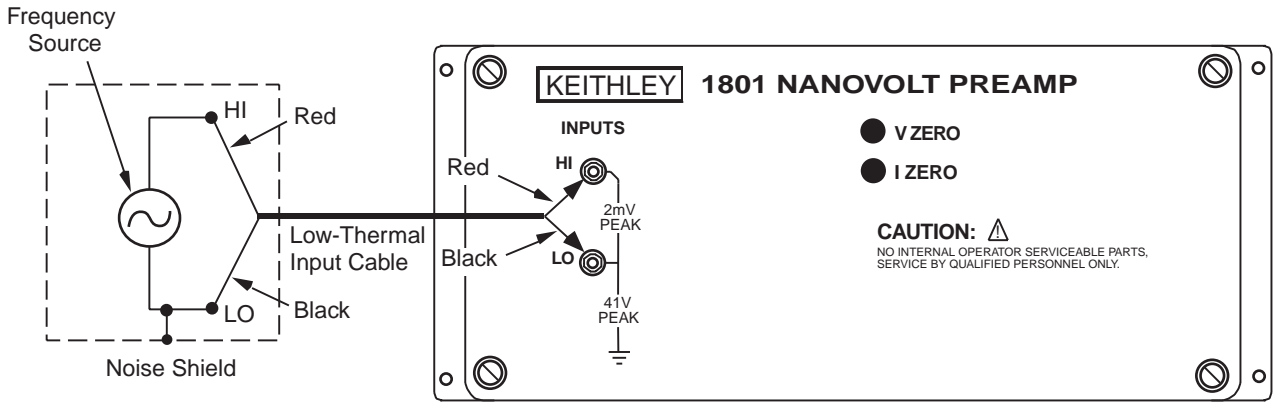
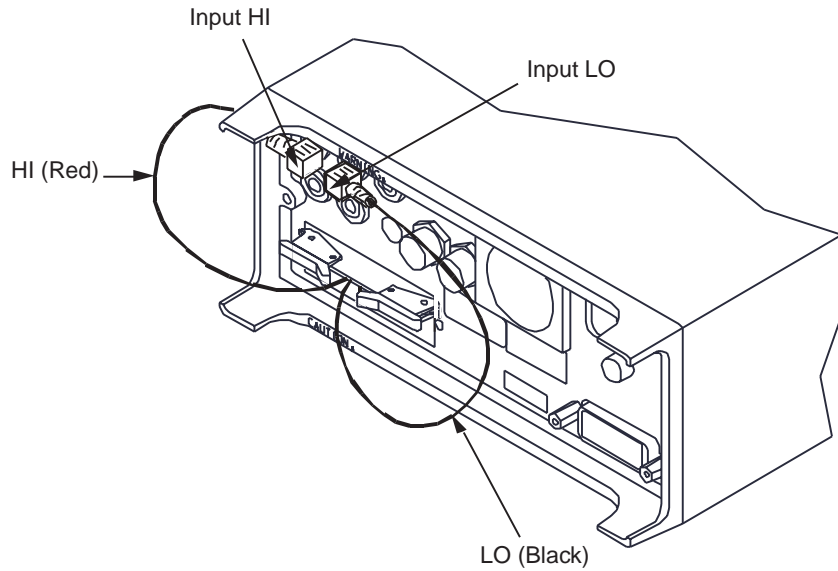

Figure 3-4
Connections for 4-wire resistance measurements



NOTE : Use only clean copper-to-copper connections.

a. Input Connections



b. Output Connections

Figure 3-5
Connections for frequency measurements

3.3.5 Differential thermocouple temperature measurements

The Model 1801 can make differential temperature measurements using two thermocouples connected in a differential configuration. The Model 2001 will then display the difference in temperature between the two thermocouples. The temperature is calculated by using the slope of the thermocouple V-T curve. To keep the change in slope small, the approximate range of measurement is restricted to $\pm 50^{\circ}\text{C}$.

For the seven standard supported thermocouples (J, K, T, E, R, S, B), you must enter the temperature at which the reference thermocouple will be operated during measurement. If an invalid reference temperature is used, the reading will appear as an "Overflow".

To allow for other thermocouple or thermopile types, a USER type thermocouple is included in the selection menu. In order to use this selection, you must enter the thermocouple slope (coefficient) in $\mu\text{V}/^{\circ}\text{C}$. If the USER thermocouple type is selected, it is not necessary to enter

the reference temperature since the thermocouple slope is already known.

Note that differential thermocouples can only be measured with the Model 1801 installed and enabled; otherwise pertinent setup menus will not be available. Also, a differential thermocouple configuration is the only type of temperature sensor allowed when the Model 1801 is enabled.

Note that thermocouples should be connected so that the conductor type with the lower Seebeck coefficient relative to copper is connected to the preamp input terminals. For example, type T is copper-constantan, and the copper leads would be connected to the input terminals.

Differential temperature menu

Table 3-8 summarizes the temperature configuration menu as it appears when the Model 1801 is enabled. Press CONFIG TEMP to access this menu, then make your selections accordingly.

Table 3-8
CONFIG TEMPERATURE menu with Model 1801 enabled

Menu item	Description
SENSOR DIFF-TC SETUP THERMOCOUPLE TYPE J K T E R S B USER-SPECIFIED-SLOPE REF-TEMP REFTEMP = +0000.00 °	Select sensor type. Differential TC setup. Select thermocouple type. Set reference TC temperature
UNITS SPEED FILTER RESLN SET TEMP RESOLUTION AUTO 10m° 1m° 0.1m° 0.01m° 1μ°	Same as normal 2001 operation. Same as normal 2001 operation. Same as normal 2001 operation. Select resolution. Set temperature resolution.

Front panel measurement procedure

The basic procedure for differential thermocouple temperature measurement is as follows:

1. Connect the two thermocouples to the Model 1801 input in a differential configuration, as shown in Figure 3-6.

NOTE

Both thermocouples must be of the same type, or erroneous temperature readings will be displayed.

2. Press CONFIG TEMP. The instrument will display the following:

```
CONFIG TEMPERATURE
SENSOR UNITS SPEED FILTER RESLN
```

3. Select SENSOR, then press ENTER. The Model 2001 will display the following:

```
DIFF-TC SETUP
THERMOCOUPLE-TYPE REF-TEMP
```

4. Select THERMOCOUPLE-TYPE, then press ENTER. The display will appear as follows:

```
DIFFERENTIAL TC TYPE
J K T E R S B ►
◀ USER-DEFINED-SLOPE
```

5. Select either one of the standard thermocouples, or the USER-SPECIFIED-SLOPE, then press ENTER.
6. If you have selected one of the standard thermocouple types, select REF-TEMP, then press ENTER. The Model 2001 will display the reference thermocouple temperature:

```
REFTEMP=+0000.00 °C
```

7. Set the reference thermocouple temperature (T1 or

T2 in Figure 3-6) using the range and cursor keys, then press ENTER, and go on to step 11.

8. If you selected USER-SPECIFIED-SLOPE in step 6, the instrument will prompt you to enter the thermocouple slope in $\mu\text{V}/^\circ\text{C}$ as follows:

```
SLOPE=+00020.0  $\mu\text{V}/^\circ\text{C}$ 
```

9. Use the range and cursor keys to set the slope to the correct value, then press ENTER.
10. Press EXIT. The display will appear as follows:

```
CONFIG TEMPERATURE
SENSOR UNITS SPEED FILTER RESLN
```

11. Select RESLN, then press ENTER. The instrument will display the temperature resolution menu:

```
SET TEMP RESOLUTION
AUTO 10m° 1m° 0.1m° 0.01m° ►
◀ 1 $\mu$ °
```

12. Select the desired temperature display resolution, then press ENTER.
13. Select the remaining temperature operating parameters using the UNITS, SPEED, and FILTER menu selections, as required.
14. Press EXIT to return to normal display.
15. Press TEMP. The instrument will then display the difference in temperature between the reference thermocouple and the measuring thermocouple. The Model 2001 display will indicate the differential temperature and the type of thermocouple as in the following example:

```
+00.00 °C
Diff TC: User Preamp ON
```

Note that the display resolution and units will depend on the corresponding selected menu items, while the displayed thermocouple type will, of course, depend on the type of thermocouple previously selected.

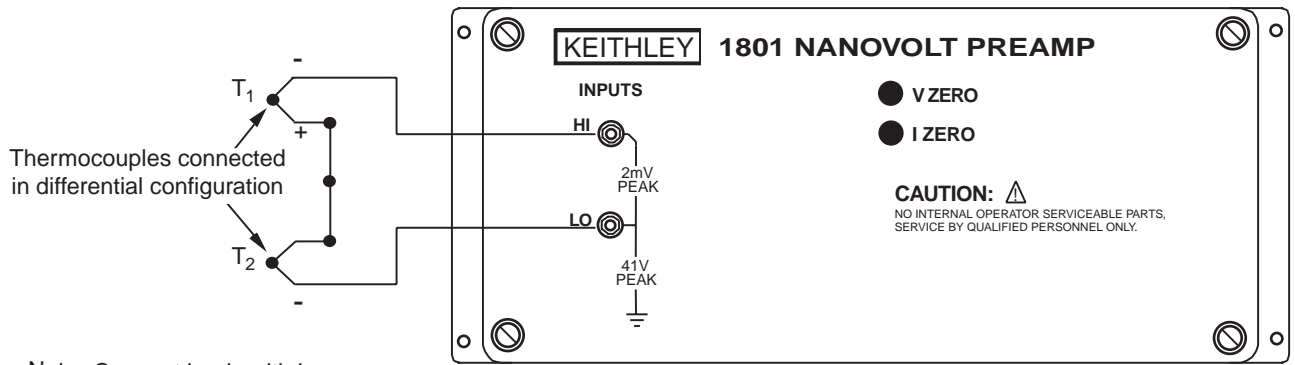

Note: Connect leads with lower Seebeck coefficient relative to copper to preamp.

a. Input Connections

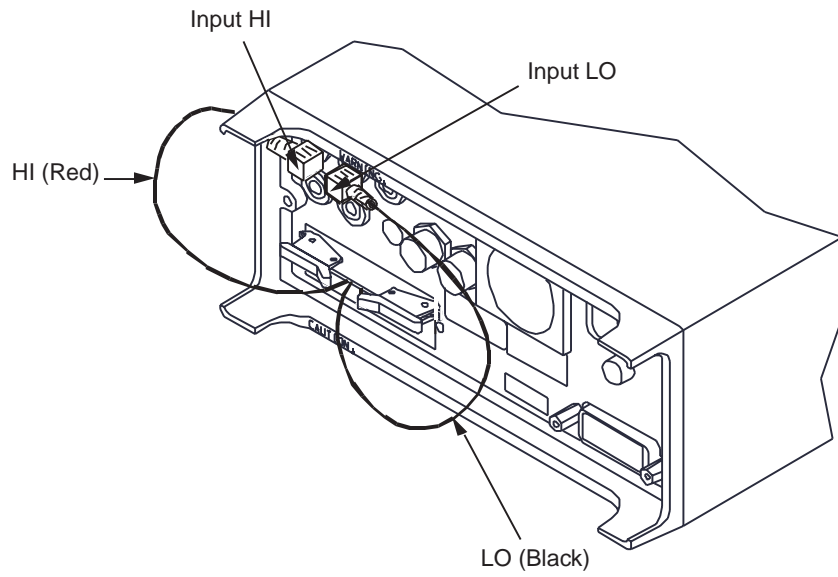

b. Output Connections

Figure 3-6
Connections for differential temperature measurements

Temperature displays

It is important to keep in mind that, with the Model 1801 enabled, the Model 2001 always displays the difference in temperature between the reference thermocouple and the measuring thermocouple in the currently selected temperature units ($^{\circ}\text{C}$, $^{\circ}\text{F}$, or K). This characteristic may result in confusion, particularly when temperature units are changed.

As an example, assume that the reference thermocouple is located in an ice-point reference at 0°C (32°F), and that the measuring thermocouple is at 23°C (73.4°F). With $^{\circ}\text{C}$ units selected, the instrument will, of course, display a differential temperature of 23°C . If the display units are then changed to $^{\circ}\text{F}$, the displayed temperature now becomes 41.4°F ($73.4 - 32 = 41.4$).

Example 1: $^{\circ}\text{C}$ Display

Reference thermocouple temperature: 23°C
 Measuring thermocouple temperature: 45°C
 Displayed temperature: 22°C

Example 2: $^{\circ}\text{F}$ Display

Reference thermocouple temperature: 73.4°F
 Measuring thermocouple temperature: 113°F
 Displayed temperature: 39.6°F

Example 3: K Display

Reference thermocouple temperature: 296K
 Measuring thermocouple temperature: 318K
 Displayed temperature: 22K

Temperature bar graph displays

When the Model 1801 is enabled, the temperature bar graph display limits are reduced to reflect the $\pm 50^{\circ}\text{C}$ temperature range of the Model 1801 regardless of the normal

range of the selected thermocouple type. Otherwise, the temperature bar graphs operate essentially in the same manner as described in paragraph 3.3.2 of the Model 2001 Operator's Manual.

IEEE-488 bus temperature commands

Table 3-9 summarizes additional bus commands associated with the Model 1801 temperature measurement function. The `:DTC:TYPE` command is used to select the type of thermocouple to be used for the differential temperature measurement. If you select one of the standard thermocouple types (J, K, T, E, R, S, or B), you must also program the reference thermocouple temperature using the `:DTC:RTEM` command. If you choose the USER thermocouple type, you must also program the slope (coefficient) of the thermocouple using the `:DTC:USLOPE` command. Note that the slope is programmed in $\text{V}/^{\circ}\text{C}$ over the bus instead of the $\mu\text{V}/^{\circ}\text{C}$ units used from the front panel.

Example 1: Select Thermocouple Type

The following command would be sent to select a J-type thermocouple:

```
:TEMP:DTC:TYPE J
```

Example 2: Program Reference Temperature

The following command would be sent to program a reference temperature of 23° :

```
:TEMP:DTC:RTEM 23
```

Example 3: Program User Thermocouple Slope

The command below will program a thermocouple slope of $10\mu\text{V}/^{\circ}\text{C}$:

```
:TEMP:DTC:USL 10E-6
```

Table 3-9
Differential temperature bus commands

Command	Description
[:SENSe[1]] :TEMPerature :DTCouple :TYPE <type> :TYPE? :USLope <value> :USLope? :RTEMPerature <value> :RTEMPerature? :TRANsducer DTC :TRANsducer?	Sense subsystem. Temperature path. Differential path. Select thermocouple type (type = J K T E R S B USER). Return thermocouple type (J K T R R S B USER). Select thermocouple slope (value = slope in V/°C, 0 is invalid). Return thermocouple slope (V/°C min = -0.099999; max = 0.099999; default = 20E-6). Select reference thermocouple temperature (value = reference temperature in degrees) Return thermocouple reference temperature in degrees; min=-273°C; max=2000°C; default=0°C). Select differential thermocouple transducer. Return transducer type (DTC).

Notes:

1. Angle brackets (<>) are used to indicate parameter type. Do not include brackets in programming message.
2. Upper-case letters indicate command short form.
3. Brackets ([]) indicate command is optional.

3.4 Measurement considerations

Low-level measurements made using the Model 1801 can be adversely affected by various types of noise or other unwanted signals that can make it very difficult to obtain accurate readings. Some of the phenomena that can cause unwanted noise include thermoelectric effects (thermocouple action), source resistance noise, magnetic fields, and radio frequency interference. The following paragraphs discuss the most important of these effects and ways to minimize them.

3.4.1 Thermoelectric potentials

Thermoelectric potentials (thermal EMFs) are small electric potentials generated by differences in temperature at the junction of dissimilar metals. The following paragraphs discuss how such thermals are generated and ways to minimize their effects.

Thermoelectric coefficients

As shown in Table 3-10, the magnitude of thermal EMFs generated depends on the particular materials involved. Best results are obtained with clean copper-to-copper connections as indicated in the table.

Table 3-10
Thermoelectric coefficients

Material	Thermoelectric potential
Copper-Copper	≤0.2μV/°C
Copper-Silver	0.3μV/°C
Copper-Gold	0.3μV/°C
Copper-Lead/tin	1-3μV/°C
Copper-Kovar	40μV/°C
Copper-Silicon	400μV/°C
Copper-Copper Oxide	1000μV/°C

Thermoelectric generation

Figure 3-7 shows a representation of how thermal EMFs are generated. The test leads are made of the A material, while the source under test is the B material. The temperatures between the junctions are T_1 and T_2 . To determine the thermal EMF generated, the following relationship may be used:

$$E_{AB} = Q_{AB}(T_1 - T_2)$$

Where: E_{AB} = Generated thermal EMF

Q_{AB} = Thermoelectric coefficient of material A with respect to material B ($\mu\text{V}/^\circ\text{C}$)

T_1 = Temperature of B to A junction ($^\circ\text{C}$)

T_2 = Temperature of A to B junction ($^\circ\text{C}$)

In the unlikely event that the two junction temperatures are identical, the thermal EMFs will exactly cancel because the generated potentials oppose one another. More often, the two junction temperatures will differ, and considerable thermal EMFs will be generated.

A typical test setup will probably have several copper-to-copper junctions. As pointed out earlier, each junction can have a thermoelectric coefficient as high as $0.2\mu\text{V}/^\circ\text{C}$. Since the two materials will frequently have a several degree temperature differential, it is easy to see how thermal potentials of several microvolts can be generated even if reasonable precautions are taken.

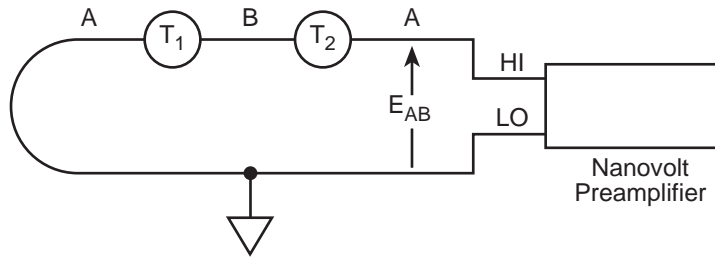

The thermal EMF developed by dissimilar metals A and B in a series circuit is:

$$E_{AB} = Q_{AB} (T_1 - T_2)$$

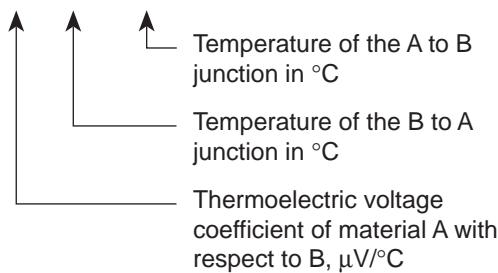

Figure 3-7
Thermal EMF generation

Minimizing thermal EMFs

To minimize thermal EMFs, use only copper wires, lugs, and test leads for the entire test setup. Also, it is imperative that all connecting surfaces are kept clean and free of oxides. As noted in Table 3-2, copper-to-copper oxide junctions can result in thermal EMFs as high as 1mV/°C.

Even when low-thermal cables and connections are used, thermal EMFs can still be a problem in some cases. It is especially important to keep the two materials forming the junction at the same temperature. Keeping the two junctions close together is one way to minimize such thermal problems. Also, keep all junctions away from air currents; in some cases, it may be necessary to thermally insulate sensitive junctions to minimize temperature variations. Always operate the preamplifier module in the thermal isolation enclosure to minimize the effects of air currents.

In some cases, connecting the two thermal junctions together with good thermal contact to a common heat sink may be required. Unfortunately, most good electrical insulators are poor conductors of heat. In cases where such low thermal conductivity may be a problem, special insulators that combine high electrical insulating properties with high thermal conductivity may be used. Some examples of these materials include: hard anodized aluminum, beryllium oxide, specially filled epoxy resin, sapphire, and diamond.

Nulling residual thermal offsets

Even if all reasonable precautions are taken, some residual thermal offsets may still be present. These offsets can be minimized by using the Model 2001 relative feature to null them out. To do so, place the instrument on the range to be used for the measurement, and short the end of the connecting cable nearest the measured source (first disconnect the cable from the source to avoid shorting out the source). After allowing the reading to settle, press the front panel REL button to null the offset, then make your measurement as usual. Note that it may be necessary to re-zero often to counteract preamplifier or thermal drifts, and the rel process should be repeated whenever the range is changed for best accuracy.

3.4.2 Source resistance noise

Noise present in the source resistance can be the limiting factor in the ultimate resolution and accuracy of Model 1801 measurements. The paragraphs below discuss the generation of Johnson noise as well as ways to minimize such noise.

Johnson noise equation

The amount of noise voltage present in a given resistance is defined by the Johnson noise equation as follows:

$$E_{\text{RMS}} = \sqrt{4kTRF}$$

Where: E_{RMS} = RMS value of the noise voltage
 k = Boltzmann's constant ($1.38 \times 10^{-23}\text{J/K}$)
 T = Temperature (K)
 R = Source resistance (ohms)
 F = Noise bandwidth (Hz)

At a room temperature of 293K (20°C), the above equation simplifies to:

$$E_{\text{RMS}} = 1.27 \times 10^{-10} \sqrt{RF}$$

Since the peak to peak noise is five times the RMS value 99% of the time, the peak-to-peak noise can be equated as follows:

$$E_{\text{p-p}} = 6.35 \times 10^{-10} \sqrt{RF}$$

For example, with a source resistance of 10kΩ, the noise over a 0.5Hz bandwidth at room temperature will be:

$$E_{\text{p-p}} = 6.35 \times 10^{-10} \sqrt{(10 \times 10^3)(0.5)}$$

$$E_{\text{p-p}} = 45\text{nV}$$

Minimizing source resistance noise

From the above examples, it is obvious that noise can be reduced in several ways: (1) lower the temperature; (2) reduce the source resistance; and (3) narrow the bandwidth.

Sometimes, cooling the source is the only practical method available to reduce noise. Again, however, the available reduction is not as large as it might seem because the reduction is related to the square root of the change in temperature. For example, to cut the noise in half, the temperature must be decreased from 293K to 73.25K, a four-fold decrease.

The most common method for noise reduction is to reduce bandwidth with filtering. However, there is a tradeoff between noise reduction and response time.

3.4.3 Magnetic fields

When the magnetic flux through a loop changes, a magnetic emf is created. This phenomenon will frequently cause unwanted signals to occur in the test leads of a test system. If the conductor has sufficient length or cross-sectional area, even weak magnetic fields such as those of the earth can create sufficient signals to affect low-level measurements.

As shown in Figure 3-8, generated magnetic fields are determined by the loop area A, the magnetic flux B, as well as the rates of change of these two parameters (dA/dt and dB/dt). Thus, three ways to reduce these effects are: (1) reduce the lengths of the connecting cables, (2) minimize the exposed circuit area, and (3) keep test leads and magnetic field sources stationary. As shown in Figure 3-9a, a large loop area generates a relatively large voltage, while a small loop area shown in Figure 3-9b minimizes the amount of voltage generated.

In extreme cases, magnetic shielding may be required. Special metal with high permeability at low flux densities (such as mu metal) are effective at reducing these effects.

Even when the conductor is stationary, magnetically induced signals may still be a problem. Fields can be produced by various sources such as the AC power line current. Large inductors such as power transformers can

generate substantial magnetic fields, so care must be taken to keep the Model 1801, signal source, and connecting cables a good distance away from these potential noise sources. Using twisted-pair input leads will also help to reduce magnetically induced voltages.

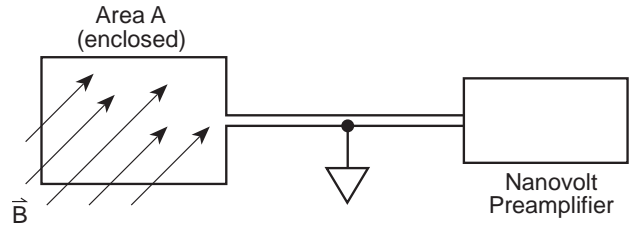

The voltage developed due to a field passing through a circuit enclosing a prescribed area is:

$$V_B = \frac{d\phi}{dt} = \frac{d(\vec{B}A)}{dt} = \vec{B} \frac{dA}{dt} + A \frac{d\vec{B}}{dt}$$

Figure 3-8
Magnetic field generation

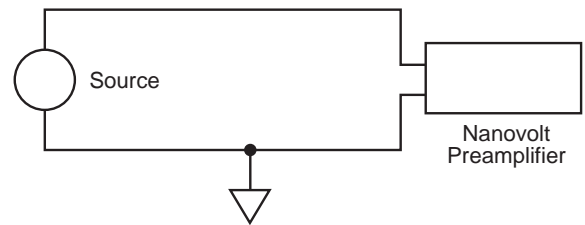

a. Large loop results in larger error voltage

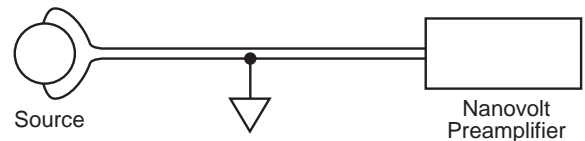

b. Small loop reduces error voltage

Figure 3-9
Minimizing interference from magnetic loops

3.4.4 Electromagnetic interference (EMI)

The electromagnetic interference characteristics of the Model 1801 Nanovolt Preamp comply with the electromagnetic compatibility (EMC) requirements of the European Union (EU) directives as denoted by the CE mark. However, it is still possible for sensitive measurements to be affected by external sources. In these instances, special precautions may be required in the test setup.

Sources of EMI include:

- Radio and TV broadcast transmitters.
- Communications transmitters, including cellular phones and handheld radios.
- Devices incorporating microprocessors and high-speed digital circuits.
- Impulse sources as in the case of arcing in high-voltage environments.

The Model 1801, signal source, and signal leads should be kept as far away as possible from any EMI sources. Additional shielding of the instrument, signal leads, sources, and other measuring instruments will often reduce EMI to an acceptable level. In extreme cases, a specially constructed screen room may be required to sufficiently attenuate the troublesome signal.

The Model 1801 filters may help to reduce EMI effects in some situations. In other cases, additional external filtering may be required. Keep in mind, however, that filtering may have detrimental effects, such as increased settling time, on the measurement.

3.4.5 Ground loops

When two or more instruments are connected together, care must be taken to avoid unwanted signals caused by ground loops. Ground loops usually occur when sensitive instrumentation is connected to other instrumentation

with more than one signal return path such as power line ground. As shown in Figure 3-10, the resulting ground loop causes current to flow through the instrument LO signal leads and then back through power line ground. This circulating current develops a small, but undesirable voltage between the LO terminals of the two instruments. This voltage will be added to the source voltage, affecting the accuracy of the measurement.

Figure 3-11 shows how to connect instruments together to eliminate this type of ground loop problem. Here, the circuit is grounded only at one point in the system. Although some common-mode current still flows through the common-mode impedance Z_{CM} , that current is very small (typically nA or less), and the generated error voltage is insignificant compared to the source voltage.

Ground loops are not normally a problem with instruments like the Model 1801 that have low common-mode current. However, all instruments in the test setup may not be designed in this manner. When in doubt, consult the manual for all instrumentation in the test setup.

3.4.6 Shielding

Proper shielding of all signal paths and sources being measured is important to minimize noise pickup in virtually any low-level measurement situation. Otherwise, interference from such noise sources as line frequency and RF fields can seriously corrupt measurements, compromising the validity of experimental data.

In order to minimize noise, a closed metal shield, completely surrounding the source, is recommended. This shield should be connected to input LO, and LO may also have to be connected to chassis ground. Some experimentation may be required to determine which of the two connecting methods provides the best results.

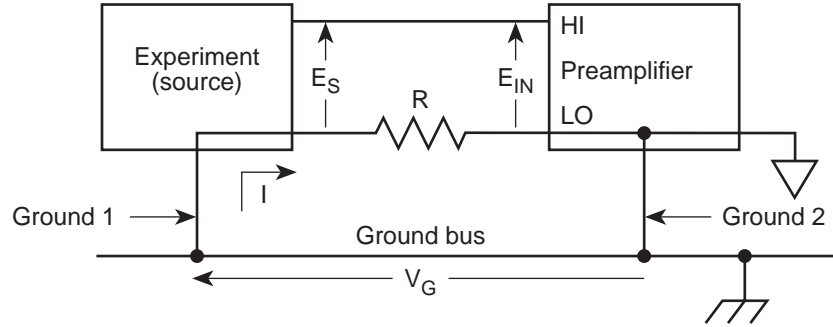

Input voltage to the preamplifier is:

$$E_{IN} = E_S + IR$$

- └ Resistance of input LO connection (typically around 100mΩ)
- └ Current passing through input LO connection due to ground voltages (V_G) in the ground bus (magnitude may be amperes).
- └ Source voltage (desired signal)

IR may exceed E_S by orders of magnitude.

$$E_{IN} \approx IR.$$

Figure 3-10
Power line ground loops

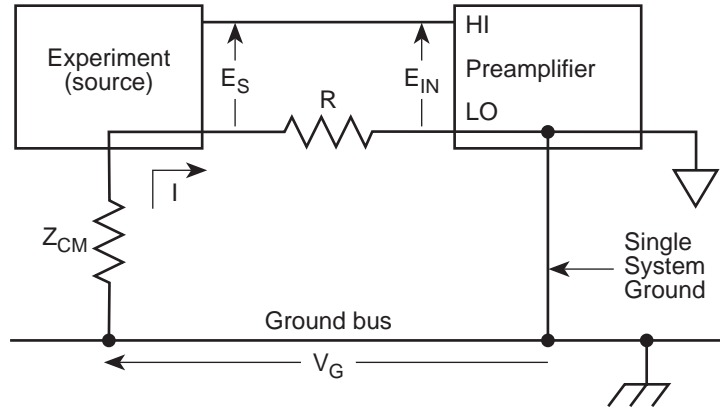

Input voltage to the preamplifier is:

$$E_{IN} = E_S + I R$$

- Resistance of input LO connection (typically around $100\text{m}\Omega$)
- Current passing through Z_{CM} ($\text{M}\Omega$ or $\text{G}\Omega$) due to V_G and currents in the source (magnitude is typically hundreds of nA's).
- Source voltage (desired signal)

$E_{IN} \approx E_S$, since $I R$ is now insignificant compared to E_S .

Figure 3-11
Eliminating ground loops

4

Performance Verification

4.1 Introduction

The procedures in this section are intended to verify that Model 1801 accuracy is within the limits stated in the preamplifier one-year specifications (see Appendix A). These procedures can be performed when the unit is first received to ensure that no damage or misadjustment has occurred during shipment. Verification may also be performed whenever there is a question of preamplifier accuracy, or following calibration, if desired.

WARNING

The procedures in this section are intended only for qualified service personnel. Do not attempt to perform these procedures unless you are qualified to do so.

NOTE

If the preamplifier is still under warranty, and its performance is outside specified limits, contact your Keithley representative or the factory to determine the correct course of action.

This section includes the following:

4.2 Environmental conditions: Covers the temperature and humidity limits for verification.

- 4.3 Warm-up period:** Describes the length of time the Model 1801 should be allowed to warm up before testing.
- 4.4 Line power:** Covers power line voltage ranges during testing.
- 4.5 Recommended equipment:** Summarizes recommended equipment and pertinent specifications.
- 4.6 Verification limits:** Explains how reading limits were calculated.
- 4.7 Restoring factory default conditions:** Gives step-by-step procedures for restoring default conditions before each test procedure.
- 4.8 Verification procedures:** Details procedures to verify measurement accuracy of Model 1801 measurement functions.

4.2 Environmental conditions

DC voltage verification measurements must be made at an ambient temperature of $23 \pm 1^\circ\text{C}$, and at a relative humidity of less than 80%. (Although the Model 1801 could normally be tested at $23 \pm 5^\circ\text{C}$, the low-thermal voltage divider used for DCV verification must be operated at $23 \pm 1^\circ\text{C}$ to meet its stated specifications.) AC voltage verification measurements must be made at an ambient temperature of $23 \pm 5^\circ\text{C}$, and at a relative humidity of less than 80%.

4.3 Warm-up period

The Model 1801 must be allowed to warm up for at least two hours before performing the verification procedures. If the preamplifier has been subjected to temperature extremes (outside the range stated in paragraph 4.2), allow additional time for internal temperatures to stabilize. Typically, it takes one additional hour to stabilize a unit that is 10°C (18°F) outside the specified temperature range.

The test equipment should also be allowed to warm up for the minimum period specified by the manufacturer.

4.4 Line power

The Model 1801 should be tested with the Model 2001 operating from a line voltage in the range of 90-134V or 180-250V at a frequency of 50, 60, or 400Hz.

4.5 Recommended test equipment

Table 4-1 lists all test equipment required for verification. Alternate equipment may be used as long as that equip-

ment has specifications at least as good as those listed in the table.

4.6 Verification limits

The verification limits stated in this section have been calculated using only Model 1801 one year specifications, and they do not include test equipment tolerance. If a particular measurement falls slightly outside the allowed range, recalculate new limits based both on Model 1801 specifications and pertinent calibration equipment specifications. For DC volts verification, additional uncertainty includes both calibrator and low-thermal divider uncertainty.

NOTE

Model 1801 verification procedures assume that the Model 2001 Multimeter is properly calibrated and meets its stated specifications. See the Model 2001 Calibration Manual for performance verification procedures and calibration information.

Table 4-1
Recommended test equipment for performance verification

Manufacturer	Model	Description	Specifications*
Fluke	5700A	Calibrator	DCV: 0.19V, ±11ppm ACV: 450µV, 100Hz:±1.03%
Keithley	262	Low-thermal voltage divider	10 ² to 1 : ±35ppm 10 ³ to 1 : ±35ppm 10 ⁴ to 1 : ±100ppm
Keithley	1507	Low-thermal input cable	

* 90-day calibrator specifications shown include total uncertainty at specified output. Low-thermal divider specifications are for one year.

4.7 Restoring default conditions

Before performing *each* performance verification procedure, restore Model 1801 default conditions as follows:

1. From the normal display mode, press the MENU key. The Model 2001 will display the following:

```
MAIN MENU
SAVESETUP GPIB CALIBRATION ►
```

2. Select SAVESETUP, and press ENTER. The following will be displayed:

```
SETUP MENU
SAVE RESTORE POWERON RESET
```

3. Select RESET, and press ENTER. The display will then appear as follows:

```
RESET ORIGINAL DFLTS
BENCH GPIB
```

4. Select BENCH, then press ENTER. The following will be displayed:

```
RESETTING INSTRUMENT
ENTER to confirm; EXIT to abort
```

5. Press ENTER again to confirm instrument reset. The instrument will return to normal display, and the Model 1801 will be enabled.

4.8 Verification procedures

The following paragraphs contain procedures for verifying preamplifier accuracy specifications for the following measuring functions:

- DC volts
- AC volts

Note that frequency accuracy is a function of the Model 2001 Multimeter and can be verified using the procedure in the Model 2001 Calibration Manual. Temperature accuracy is automatically confirmed by verifying the accuracy of the 2mV DC range, which is used for temperature measurements.

If the Model 1801 is out of specifications and not under warranty, refer to the calibration procedures in Section 5.

WARNING

The maximum common-mode voltage (voltage between INPUT LO and chassis ground) is 41V peak. Exceeding this value may cause a breakdown in insulation, creating a shock hazard.

4.8.1 DC volts verification

DC voltage accuracy is verified by applying accurate DC voltages from a calibrator and low-thermal voltage divider to the Model 2001 input and verifying that the displayed readings fall within specified ranges.

Follow the steps below to verify DCV measurement accuracy.

CAUTION

Do not exceed 1V peak between INPUT HI and INPUT LO, or preamplifier damage may occur. (Inputs over 2mV will require a one-minute recovery period.)

1. Connect the DC calibrator and Model 262 Low-thermal Voltage Divider to the Model 1801 input, as shown in Figure 4-1.

NOTE

Use only shielded, low-thermal cable between the low-thermal divider and the Model 1801 input terminals.

2. Turn on the Model 2001 and the calibrator, and allow a two-hour warm-up period before making measurements.
3. Restore Model 1801 factory default conditions, as explained in paragraph 4.7.
4. Select the Model 1801 20 μ V DC range.

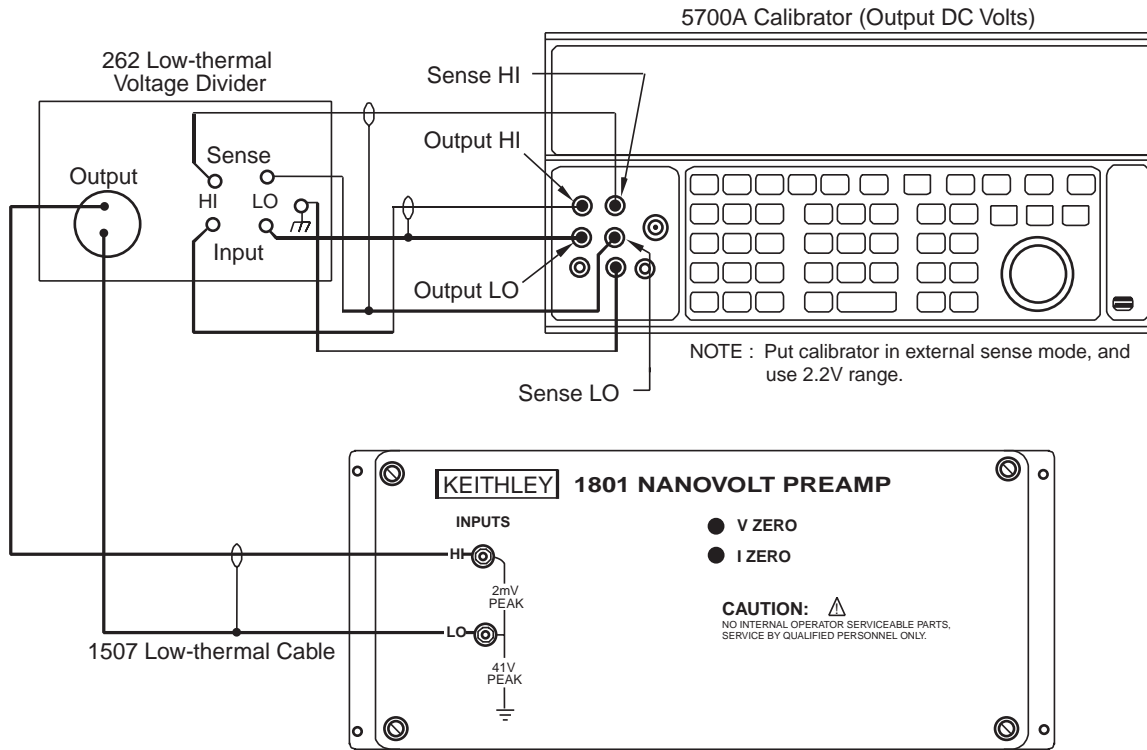

a. Input Connections

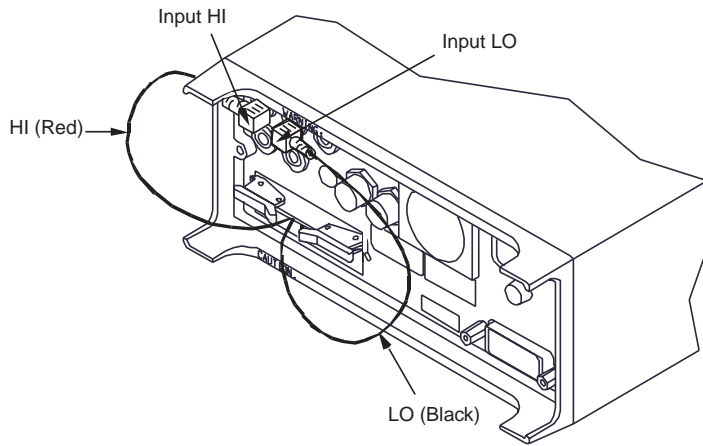

b. Output Connections

Figure 4-1
Connections for DC volts verification

5. Select the SLOW response filter as follows:
 - A. Press the CHAN key. The instrument will display the following:

```
CONFIG PREAMP
CONTROL FILTER CALIBRATION
```
 - B. Select FILTER, then press ENTER. The unit will display filter response selections:

```
SELECT PREAMP FILTER
FAST MEDIUM SLOW
```
 - C. Select the SLOW filter response, then press ENTER.
 - D. Press EXIT to return to normal display.
6. Set the low-thermal divider division ratio to 10^4 , and select the POS+ polarity position.
7. Lock the calibrator on the 2.2V range, and enable external sensing.
8. Set the calibrator output to 0.00000VDC, and allow the reading to settle.
9. Enable the Model 2001 REL mode.
10. Set the calibrator output to +0.190000VDC, and allow the reading to settle.
11. Verify that the Model 2001 reading is within the limits summarized in Table 4-2.
12. Repeat steps 8 through 11 for the remaining ranges, voltages, and divider ratios listed in Table 4-2. Be sure to re-zero each range before making the measurement.
13. Repeat the procedure for each of the ranges with negative Model 1801 input voltages of the same magnitude as those listed in Table 4-2. Set the divider to the NEG- polarity position to reverse polarity.

Table 4-2
Limits for DC volts verification

1801 range	Calibrator voltage	Low-thermal divider ratio	1801 input voltage	Allowable readings (1 year, 23 ±1°C)
20μV	0.190000V	10 ⁴ : 1	19.00000μV	18.99006μV to 19.00994μV
200μV	0.190000V	10 ³ : 1	190.0000μV	189.9466μV to 190.0534μV
2mV	0.190000V	10 ² : 1	1.900000mV	1.899494mV to 1.900506mV

Notes:

1. Repeat procedure for negative voltages.
2. Reading limits do not include calibrator and low-thermal divider uncertainty.

4.8.2 AC volts verification

AC voltage accuracy is checked by applying an accurate AC voltage at 100Hz from an AC calibration source and then verifying that the Model 1801 AC voltage reading falls within the specified range.

CAUTION

Do not exceed 1V peak between INPUT HI and INPUT LO, or preamplifier damage may occur. (Inputs over 2mV peak will require a one-minute recovery period.)

1. Turn on the Model 2001 and calibrator, and allow a two-hour warm-up period before making measurements.
2. Connect the calibrator to the Model 1801 input, as shown in Figure 4-2.
3. Restore Model 1801 factory default conditions, as explained in paragraph 4.7.
4. Select the AC + DC coupling mode as follows:
 - A. Press CONFIG ACV, select COUPLING, then press ENTER.
 - B. Select AC+DC, then press ENTER.
 - C. Press EXIT to return to normal display.
5. Select the ACV function, and make sure that REL is disabled.

NOTE

Do not use REL to null offsets when performing AC volts tests.

6. Set the calibrator output to 450.000 μ V AC RMS at a frequency of 100Hz, and allow the reading to settle.
7. Verify that the Model 2001 reading is within the limits summarized in Table 4-3.

Table 4-3
Limits for AC voltage verification

1801 range	Calibrator voltage	Allowable readings (1 year, 23 \pm 5 $^{\circ}$ C)
500 μ V	450.000 μ V RMS @ 100Hz	422.500 μ V to 477.500 μ V

Note: Limits shown do not include calibrator uncertainty.

4.8.3 Resistance verification

Model 1801 resistance accuracy specifications are derived from Model 2001 current source accuracy as well as Model 1801 DC volts measurement accuracy. As long as the Model 2001 ohms and DC volts functions, and the Model 1801 DC volts function meet their respective accuracy specifications, preamplifier ohms function accuracy is automatically verified, and it is not necessary to separately verify measurement accuracy of the Model 1801 ohms function. See the Model 2001 Calibration Manual for multimeter verification procedures.

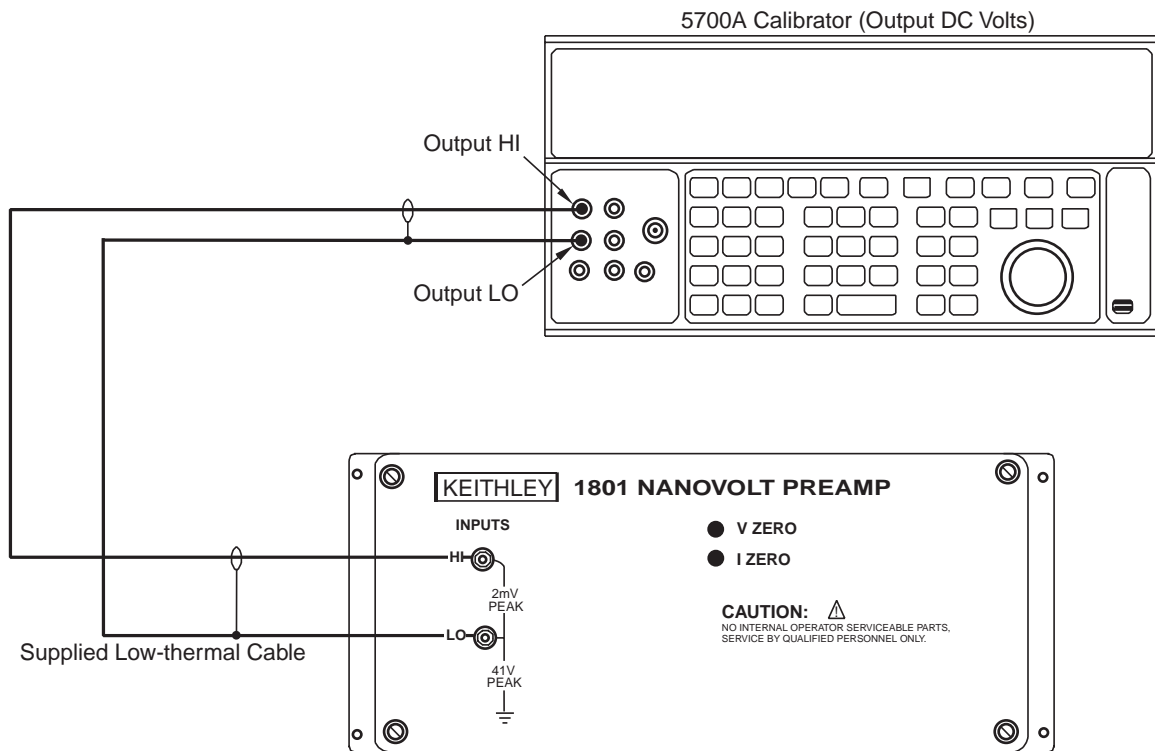

a. Input Connections

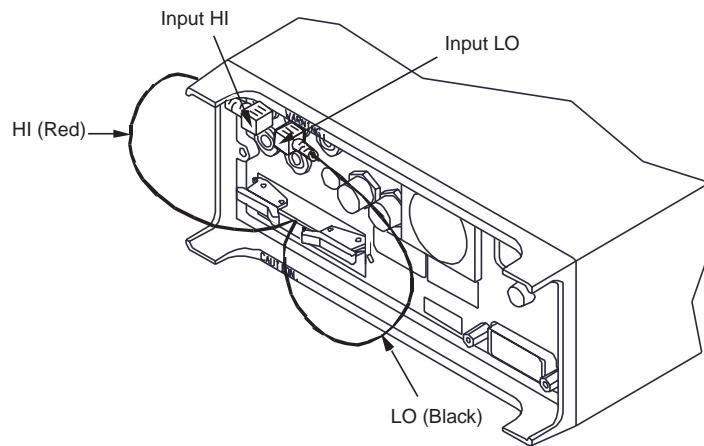

b. Output Connections

Figure 4-2
Connections for AC volts verification

5

Service Information

5.1 Introduction

This section contains information necessary to service the Model 1801 Nanovolt Preamplifier.

WARNING

The information in this section is intended only for qualified service personnel. Do not attempt these procedures unless you are qualified to do so.

Information is arranged as follows:

5.2 Calibration: Covers the equipment and procedures necessary to calibrate the Model 1801.

5.3 Principles of operation: Briefly discusses circuit operation.

5.4 Special handling of static-sensitive devices: Reviews precautions necessary when handling static-sensitive devices.

5.5 Troubleshooting: Presents some troubleshooting tips for the Model 1801.

5.2 Calibration

This section gives detailed procedures for calibrating the Model 1801. Basically, there are two types of calibration procedures:

- Normal calibration, where the Model 1801 preamplifier, power supply card, and Model 2001 are calibrated together as a unit. The normal calibration method should be used in most cases.
- Gain constants calibration, where preamplifier gain constants are manually entered into the Model 2001. This method can be used to transfer gain constants from one power supply card to another when a preamplifier module is to be used with a power supply card other than the one with which it was calibrated.

5.2.1 Environmental conditions

Normal calibration procedures should be performed at an ambient temperature of $23^{\circ} \pm 1^{\circ}\text{C}$, and at a relative humidity of less than 80% unless otherwise noted.

5.2.2 Warm-up period

The Model 1801 must be allowed to warm up for at least two hours before calibration. If the preamplifier has been subjected to temperature extremes (outside the range stated in paragraph 5.2.1), allow additional time for internal temperatures to stabilize. Typically, it takes one additional hour to stabilize a unit that is 10°C (18°F) outside the specified temperature range.

The calibration equipment should also be allowed to warm up for the minimum period specified by the manufacturer.

5.2.3 Line power

The Model 1801 should be calibrated while the Model 2001 is operating from a line voltage in the range of 90-134V or 180-250V at 50, 60, or 400Hz.

5.2.4 Recommended calibration equipment

Table 5-1 lists all test equipment recommended for calibration. Alternate equipment may be used as long as that equipment has specifications at least as good as those listed in the table.

5.2.5 Offset adjustments

The following procedure to null offsets must be performed before performing the normal calibration procedure covered in paragraph 5.2.6. The basic procedure for nulling offsets is as follows:

1. Clean the input terminals, then connect the low-thermal shorting strap to the INPUTS terminals, as

- shown in Figure 5-1. Note that Figure 5-1 also shows the location of the voltage offset control (V ZERO).
2. Make certain the preamplifier module is installed in the thermal isolation enclosure. Remove the lid only while making adjustments.
3. Turn on the Model 2001 power, and make sure the preamplifier is enabled as follows:
 - A. Press the CHAN key.
 - B. Select CONTROL, then press ENTER.
 - C. Select ENABLE, then press ENTER.
4. Select the 20 μ V DC range, and allow a two-hour warm-up period before proceeding with the offset adjustments.
5. Select the slow response filter as follows:
 - A. Press CHAN.
 - B. Select FILTER, then press ENTER.
 - C. Select SLOW, then press ENTER.
 - D. Press EXIT to return to normal display.
6. Adjust the voltage offset control (V ZERO) for a Model 2001 front panel reading of 0 μ V \pm 0.001 μ V.
7. Enable the REL mode to null any remaining offset.
8. Disconnect the low-thermal shorting strap from the INPUTS terminals, and connect the 10k Ω low-thermal resistor to the INPUTS terminals, as shown in Figure 5-2. (For best results, remove the lead plating before use.) Note that the offset current adjustment control (I ZERO) is also shown in Figure 5-2.

Table 5-1
Recommended equipment for calibration

Mfg.	Model	Description	Specifications*
Fluke	5700A	Calibrator	0.2V DC: \pm 11ppm
Keithley	262	Low-thermal Voltage Divider	10 ² : 1, \pm 35ppm 10 ³ : 1, \pm 35ppm 10 ⁴ : 1, \pm 100ppm
Keithley	1507	Low-thermal Cable	
Keithley		Low-thermal Shorting Strap**	
Keithley	Part # R-336-10K	Low-thermal Resistor***	10k Ω , \pm 5%

* 90-day calibrator specifications shown include total uncertainty at specified output. Model 262 specifications are for one year.

** Low-thermal shorting strap is supplied with the Model 1801.

***Remove plating from leads before use.

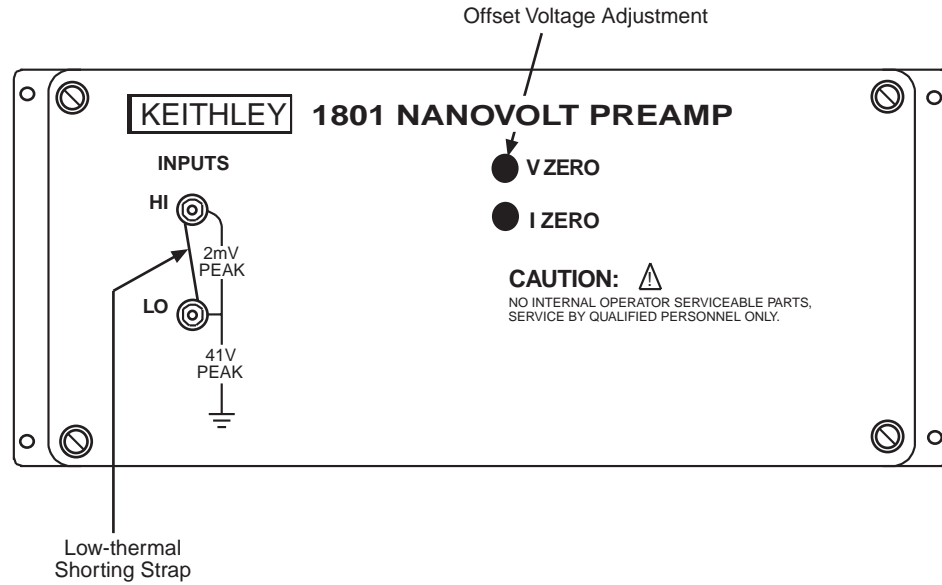

Figure 5-1
Connections for offset voltage adjustment

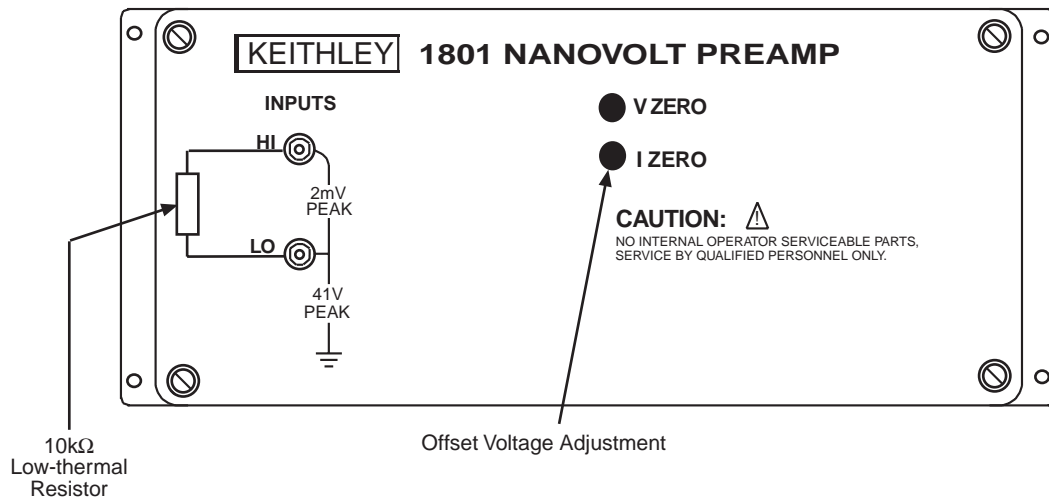

Figure 5-2
Connections for offset current adjustment

9. Make sure that the thermal isolation enclosure lid is in place, and allow two minutes for thermals to settle.
10. Adjust the current offset control (I ZERO) for a Model 2001 front panel reading of $0\mu\text{V} \pm 0.1\mu\text{V}$
11. Disconnect the low-thermal resistor when the offset adjustment is complete.

5.2.6 Normal calibration

The normal calibration procedure calibrates the preamplifier module and its power supply card as a unit. Since the constants derived during the calibration process are stored in NVRAM located on the power supply card, the preamplifier module should normally be used with the power supply card that was used during calibration. (To interchange preamp modules and power supply cards without recalibration, use the gain constants calibration method discussed in paragraph 5.2.7.)

Normal calibration should be performed at least once a year, or every 90 days to ensure the Model 1801 meets the corresponding specifications.

NOTE

Proper calibration of the Model 1801 requires that the Model 2001 Multimeter meets its stated specifications. See the Model 2001 Calibration Manual for information on performance verification and calibration procedures for the Model 2001.

The offset adjustments explained in paragraph 5.2.5 must be performed before calibrating the preamplifier.

Front panel calibration procedure

Follow the steps below to calibrate the Model 1801 from the front panel:

1. Make sure the Model 1801 is properly installed and enabled, as explained in Sections 2 and 3 of this manual.
2. Connect the Model 1801, DC calibrator, and low-thermal voltage divider, as shown in Figure 5-3. Be sure that the preamplifier module is installed in the thermal isolation enclosure, and that the lid is firmly in place.
3. Turn on the Model 2001 and the calibrator, and allow a two-hour warm-up period before continuing with calibration.
4. Set the calibrator to the external sense mode, and lock the unit on the 2.2V range.
5. Set the Model 262 polarity switch to the POS+ position.

6. Press the Model 2001 CHAN key, the instrument will display the following:

```
CONFIGURE PREAMP
CONTROL FILTER CALIBRATION
```

7. Select CALIBRATION, then press ENTER. The Model 2001 will then display the following:

```
PREAMP CAL MENU
CALIBRATION-DATES CALIBRATE ►
```

8. Select CALIBRATE, then press ENTER. The instrument will then prompt you to complete the precal (offset adjustment) procedure before continuing:

PRECAL step must be
done before proceeding.

See paragraph 5.2.5 for details on performing the offset adjustment procedure.

9. Press ENTER, and note that the instrument prompts you to set the calibrator output to 0V:

Set calibrator to 0V

Set the calibrator output to 0.0000V DC, put the unit in operate, then press ENTER on the Model 2001.

10. The Model 2001 will then prompt you to set the divider ratio of the Model 262 to 10^2 as follows:

Set 262 to 10^2

Set the Model 262 divider ratio to 10^2 and the +POS position. Wait two minutes for thermal EMFs to settle, then press ENTER to continue.

11. Next, the instrument will prompt you to set the divider ratio to 10^3 .

Set 262 to 10^3

Set the Model 262 divider ratio to 10^3 , then press ENTER.

12. The unit will then prompt for a 10^4 divider ratio as follows:

Set 262 to 10^4

Set the Model 262 divider ratio to 10^4 , then press ENTER.

13. Next, the Model 2001 will prompt you to set the DC calibrator output voltage to 200mV as follows:

Calibrator to 200 mV

Set the calibrator output to 0.20000V DC.

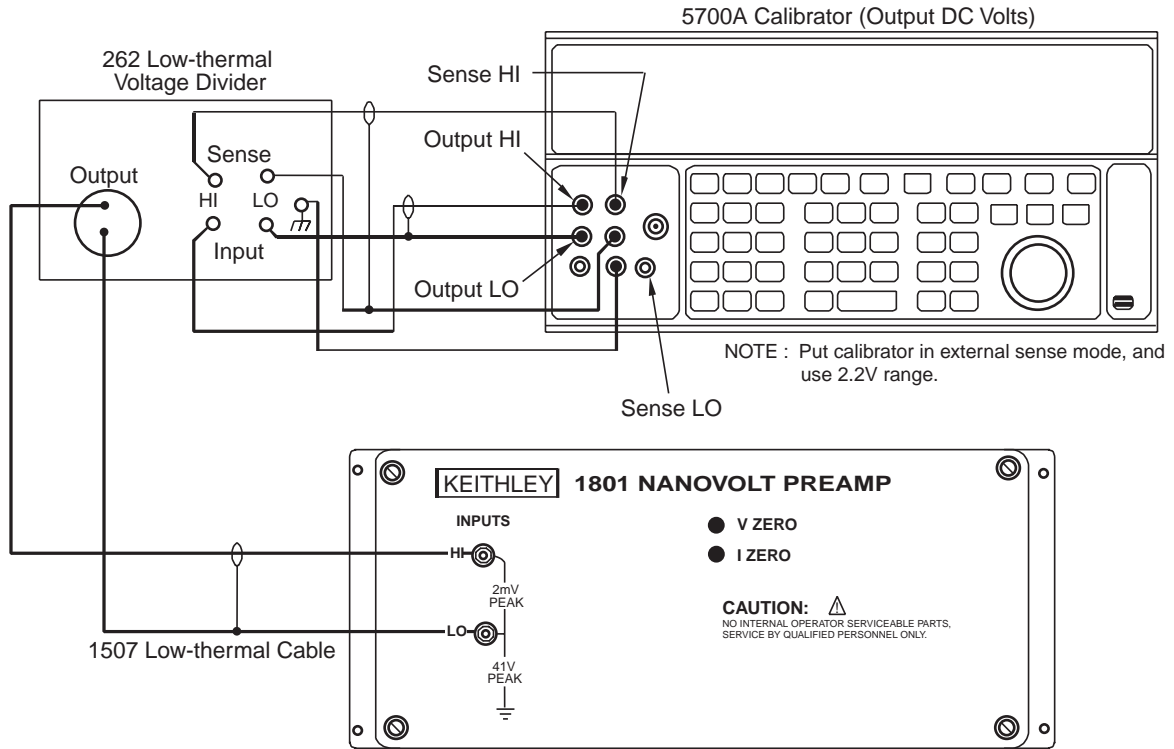

a. Input Connections

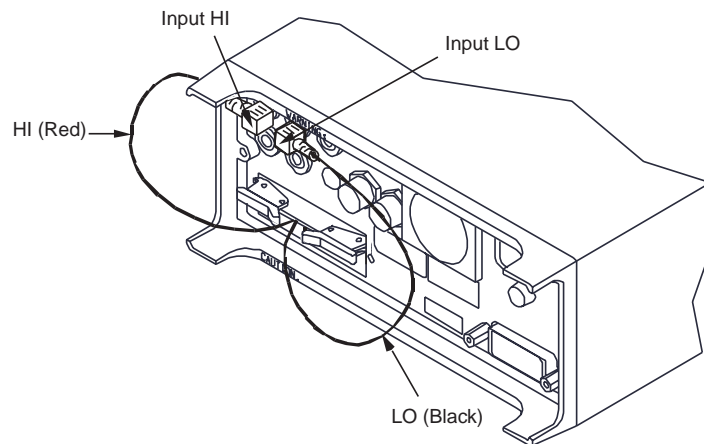

b. Output Connections

Figure 5-3
Calibration connections

14. The Model 2001 will then display the precise calibration voltage:

Cal: 200.00000 mVDC

15. Make sure that the divider ratio is still set to 10^4 . If you are using the recommended 200mV calibration voltage setting, simply press ENTER at this point. Otherwise, set the displayed value to the exact calibration voltage, then press ENTER. (Note: 200mV is recommended for most accurate results.)

16. Next, the unit will prompt you to set the divider ratio to 10^3 as follows:

Set 262 to 10^3

Set the Model 262 divider ratio to 10^3 , then press ENTER.

17. You will then be prompted to set the divider ratio to 10^2 :

Set 262 to 10^2 .

Set the divider ratio to 10^2 , then press ENTER.

18. Next the instrument will prompt you for the calibration date:

CAL DATE: 01/01/93

Change the date as required, then press ENTER.

19. The multimeter will then prompt for the calibration due date:

NEXT CAL: 01/01/94

Change the calibration due date as required, then press ENTER.

20. Finally, the unit will indicate that preamplifier calibration is completed:

PREAMP Cal complete

21. Press ENTER to complete calibration and save new calibration constants. If you wish to abort the process without saving calibration constants, press EXIT instead.

22. Press EXIT to return to normal display.

NOTE

If an error occurs, an appropriate error message will be displayed. See the discussion below on error messages.

IEEE-488 bus calibration procedure

Follow the steps below to calibrate the Model 1801 over the IEEE bus. Table 5-2 lists IEEE-488 bus calibration commands, and Table 5-3 summarizes the bus calibration procedure. (See Appendix B for calibration program listings.) Note that commands must be sent in the order indicated in Table 5-3. To abort the calibration procedure, send :CAL:UNPR:PRE:ABOR.

Procedure

1. Make sure the Model 1801 is properly installed, as explained in Sections 2 and 3 of this manual.

NOTE

The offset adjustments explained in paragraph 5.2.5 must be performed before calibrating the Model 1801.

2. Connect the Model 1801, DC calibrator, and low-thermal voltage divider, as shown in Figure 5-3. Be sure that the preamplifier module is installed in the thermal isolation enclosure, and that the lid is firmly in place.
3. Connect the Model 2001 IEEE-488 bus of the controller you intend to use to send calibration commands to the instrument. Use a shielded IEEE-488 connecting cable to minimize noise.
4. Turn on the Model 2001 and the calibrator, and allow a two-hour warm-up period before continuing with calibration.

Table 5-2
Model 1801 IEEE-488 bus calibration commands

Command	Description
:CALibration :UNPRotected :PREamp :G1K <value> :G1K? :G10K <value> :G10K? :G100K <value> :G100K? :Z1K :Z10K :Z100K :FS1K <value> :FS10K <value> :FS100K <value> :DATE "<string>" :DATE? :NDUE "<string>" :NDUE? :CALCulate :SAVE :ABORT	Calibration root command. Commands not protected by CAL switch. Preamp commands. Directly enter 2mV gain (min = 0.5; max = 1.5; default = 1.0). Request 2mV gain constant. Directly enter 200 μ V gain (min = 0.5; max = 1.5; default = 1.0). Request 200 μ V gain constant. Directly enter 20 μ V gain (min = 0.5; max = 1.5; default = 1.0). Request 20 μ V gain constant. Measure 2mV range zero. Measure 200 μ V range zero. Measure 20 μ V range zero. Measure 2mV range full-scale <value>= 1E-3 to 2E-3. Measure 200 μ V range full- scale. <value> = 100E-6 to 200E-6. Measure 20 μ V range full- scale. <value> = 10E-6 to 20E-6. Send calibration date. Request calibration date. Send calibration due date. Request calibration due date. Calculate calibration constants, test if they are valid (valid range = 0.98 to 1.2). Save calibration constants in NVRAM. Abort calibration procedure.

Notes:

- Upper-case letters indicate command short form. For example, instead of sending ":CALIBRATION:UNPROTECTED:PREAMP:CALCULATE," you can send ":CAL:UNPR:PRE:CALC."
- Angle brackets (<>) indicate command parameters and should not be included in the command.
- Preamplifier calibration constants are stored in NVRAM located on the power supply card.

Table 5-3
IEEE-488 bus calibration summary

Order*	Calibrator voltage	Divider ratio	Calibration command
1	0.0000V	10 ²	:CAL:UNPR:PRE:Z1K
2	0.0000V	10 ³	:CAL:UNPR:PRE:Z10K
3	0.0000V	10 ⁴	:CAL:UNPR:PRE:Z100K
4	0.200000V	10 ⁴	:CAL:UNPR:PRE:FS100K 20E-6
5	0.200000V	10 ³	:CAL:UNPR:PRE:FS10K 200E-6
6	0.200000V	10 ²	:CAL:UNPR:PRE:FS1K 2E-3
7	-	-	:CAL:UNPR:PRE:CALC
	-	-	:CAL:UNPR:PRE:DATE '<cal_date>'
	-	-	:CAL:UNPR:PRE:NDUE '<due_date>'
	-	-	:CAL:UNPR:PRE:SAVE

* Commands must be sent in order shown.

5. Use the GPIB MENU to set the Model 2001 primary address to the value used in the controller program (default = 16).
6. Set the calibrator to the external sense mode, and lock the unit on the 2.2V range.
7. Set the Model 262 polarity switch to the POS+ position, and set the low-thermal divider ratio to 10^2 .
8. Set the calibrator output to 0.0000V DC, put the unit in operate, then wait two minutes for thermal EMFs to settle before continuing.
9. Send the following command strings over the bus:

```
:INP:PRE:STAT ON  
:CAL:UNPR:PRE:Z1K
```

Wait until the instrument completes this step before going on.

10. Set the Model 262 divider ratio to 10^3 .
11. Send the following command string over the bus:

```
:CAL:UNPR:PRE:Z10K
```

Wait until the unit completes this step before continuing.

12. Set the Model 262 divider ratio to 10^4 .
13. Send the following command string over the bus:

```
:CAL:UNPR:PRE:Z100K
```

Wait until the unit finishes this step before proceeding.

14. Set the calibrator output voltage to 0.20000V DC.
15. Make sure that the divider ratio is still set to 10^4 .
16. Send the following command string over the bus:

```
:CAL:UNPR:PRE:FS100K 20E-6
```

Be sure to use the exact calibration value if you are using a voltage other than $20\mu\text{V}$ (input voltage = calibrator voltage/divider ratio). The allowable range is from $10\mu\text{V}$ to $20\mu\text{V}$ ($10\text{E}-6$ to $20\text{E}-6$).

Wait until the unit completes this step before continuing.

17. Set the Model 262 divider ratio to 10^3 , then press ENTER.
18. Send the following command string over the bus:

```
:CAL:UNPR:PRE:FS10K 200E-6
```

Be sure to use the exact calibration value if you are using a voltage other than $200\mu\text{V}$. The allowable range is from $100\mu\text{V}$ to $200\mu\text{V}$ ($100\text{E}-6$ to $200\text{E}-6$). Wait until the unit completes this step before continuing.

19. Set the Model 262 divider ratio to 10^2 .
20. Send the following command string over the bus:

```
:CAL:UNPR:PRE:FS1K 2E-3
```

Be sure to use the exact calibration value if you are using a voltage other than 2mV . The allowable range is from 1mV to 2mV ($1\text{E}-3$ to $2\text{E}-3$). Wait until the unit completes this step before continuing.

21. Send the following command over the bus:

```
:CAL:UNPR:PRE:CALC
```

Wait until the unit completes this step before continuing.

22. Send the following commands to program calibration date and next due date:

```
:CAL:UNPR:PRE:DATE '01/01/93'  
:CAL:UNPR:PRE:NDUE '01/01/94'
```

(Substitute the appropriate dates for those in the above examples.)

23. Send the following command to save calibration constants:

```
:CAL:UNPR:PRE:SAVE
```

NOTE

An error message will be generated if a calibration error occurs. See the discussion below on error messages.

Calibration errors

One of the errors listed in Table 5-4 may occur during the course of calibration. (These errors will appear on the front panel and may be obtained over the bus by using the :SYST:ERR? query.) The most likely causes of these errors are:

- Incorrect connections.
- Wrong calibrator voltage setting.
- Improper low-thermal divider setting.

Table 5-4
Preamplifier calibration errors

Error ID code	Error message
+445	Preamp 1k gain out of spec
+446	Preamp 10k gain out of spec
+447	Preamp 100k gain out of spec

Viewing and changing calibration dates

Preamplifier calibration dates can be viewed or changed by using the CALIBRATION-DATES selection in the PREAMP CAL MENU. To change dates, simply follow the prompts on the display.

5.2.7 Gain constants calibration

The gain constants method of calibration provides a simple method of transferring the calibration constants stored in one power supply card to a different power supply card. This feature is useful in situations where a preamplifier module is to be used with a power supply card other than the one with which it was originally calibrated, and it eliminates having to perform normal calibration whenever a preamplifier module is moved from one power supply card to another.

To use this method, first read the gain constants from the power supply card originally used when calibrating the preamplifier, then store the constants in the new power

supply card. The basic procedures for reading and storing constants are explained in the following paragraphs.

Reading gain constants

There are three gain constants that are derived during normal calibration:

- G1K: $\times 1,000$ gain constant
- G10K: $\times 10,000$ gain constant
- G100K: $\times 100,000$ gain constant

These constants can be read from the front panel or over bus, as outlined below.

■ Reading Constants from the Front Panel

To read gain constants from the front panel, select ENTER-CAL-CONSTANTS in the PREAMP CAL MENU, then press ENTER. Select the desired constant to display, then press ENTER. The unit will then display the present value of the constant. For example, the $\times 1,000$ gain constant may appear as follows:

G1k = 1.0000000

Repeat the process for the other two constants, and record their values for storage in the other power supply card.

■ Reading Constants Over the IEEE-488 Bus

To read constants over the bus, first send the appropriate query:

```
:CAL:UNPR:PRE:G1K?      ( $\times 1,000$  gain constant)
:CAL:UNPR:PRE:G10K?     ( $\times 10,000$  gain constant)
:CAL:UNPR:PRE:G100K?    ( $\times 100,000$  gain constant)
```

After sending the query, address the instrument to talk in the usual manner, then input the constant into a convenient floating-point numeric variable. Constants are returned in standard floating-point format.

Storing constants

Calibration constants can be stored from the front panel or over the bus, as explained below. The nominal (ideal) value for each of these constants is 1.0. The allowable range is from 0.5 to 1.5; if you attempt to enter a value outside this range, a “Parameter data out of range” error will occur.

■ *Storing Constants from the Front Panel*

To enter gain constants from the front panel, select ENTER-CAL-CONSTANTS in the PREAMP CAL MENU, then press ENTER. Select the desired constant to display, then press ENTER. The unit will then display the present value of the constant. Use the range and cursor keys to enter the constant value, then press ENTER to complete the process. Repeat the procedure for the other two constants.

NOTE

Constants entered from the front panel are only temporary and will be lost when power is cycled. In order to save constants permanently, you must use the bus :CAL:UNPR:PRE:SAVE command, as explained below.

■ *Storing Constants Over the IEEE-488 Bus*

To write constants over the bus, send the appropriate command along with the corresponding numeric constant value:

```
:CAL:UNPR:PRE:G1K <value>    (×1,000 gain constant)
:CAL:UNPR:PRE:G10K <value>   (×10,000 gain constant)
:CAL:UNPR:PRE:G100K <value>  (×100,000 gain constant)
```

Here <value> represents the constant value in floating-point numeric format.

To permanently save new gain constants, send the following command after storing new constants:

```
:CAL:UNPR:PRE:SAVE
```

NOTE

Programmed constants are only temporary and will be lost when power is cycled unless the :CAL:UNPR:PRE:SAVE command is sent to permanently save them.

5.3 Principles of operation

The following paragraphs discuss the basic operating principles for the Model 1801, and can be used as an aid in troubleshooting the preamplifier. Refer to drawing number 1801-106, located at the end of Section 6, for a schematic diagram of the power supply card.

5.3.1 Block diagram

Figure 5-4 shows a simplified block diagram of the Model 1801. The unit includes a remote preamplifier, a power supply connecting cable, and a power supply card. Each of these components is briefly discussed below.

5.3.2 Preamplifier module

The remote preamplifier uses a chopper demodulator system. With this topology, the input signal is chopped at a frequency of 288Hz, and it is then magnetically amplified. A narrow-band AC amplifier follows the magnetic components. The signal is then demodulated and amplified, and the resulting DC signal is then fed back to the input to buck the input signal to maintain high input impedance and low input bias current.

5.3.3 Power supply cable

The power supply cable carries the $\pm 9\text{V}$ DC supplies and gain/filter control lines from the power supply card to the preamp module. It also carries the amplified output signal back from the preamp module to the power supply card where it is routed to the Model 2001 Multimeter.

5.3.4 Power supply card

The power supply card is made up of three basic sections: the preamplifier power supply, the common-mode rejection circuit and its power supply, and the control and memory circuits. Each of these sections is briefly discussed below.

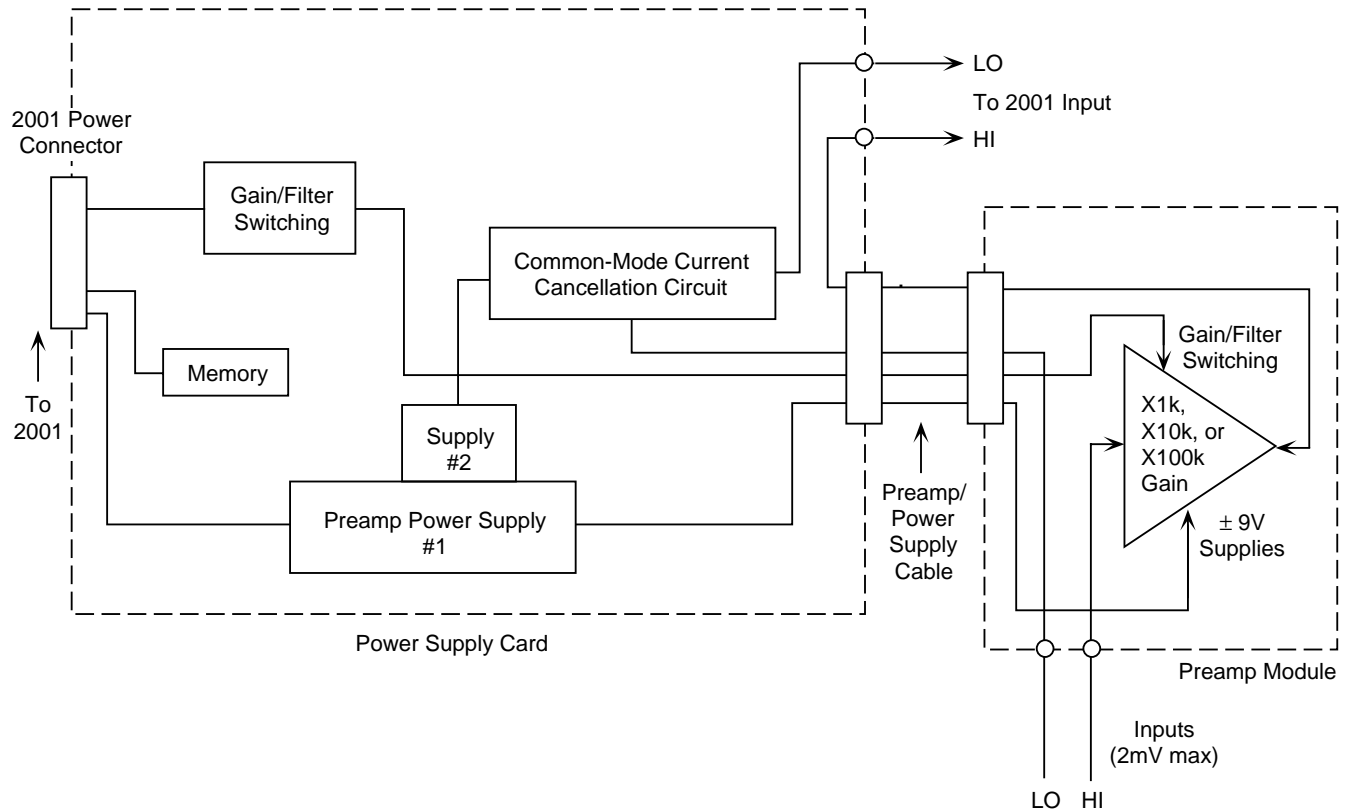

Figure 5-4
Block diagram

Preamplifier power supply

The preamplifier power supply uses a linear, high-frequency, dual-transformer topology operating at a frequency of 4.8kHz. The two-transformer configuration (T101 and T102) reduces the 4.8kHz common-mode current component, which is not fed through the common-mode cancellation circuit (described below). The switching frequency is generated by the 555 timer, U103. The resulting 4.8kHz, 50% duty cycle signal is fed to the switching MOSFETs (Q101 and Q103), which drive the two transformers.

The 4.8kHz signal from the transformers is converted to positive and negative DC voltages by two full-wave rectifiers (CR103). The DC voltages are then filtered by C104 and C105 and then regulated down to their final $\pm 9V$ values by U104 and U105. Additional post-regulation filtering is provided by C102 and C103.

Common-mode rejection circuit

The common-mode rejection circuit is made up of U107, U108, and related components. This circuit senses the common-mode current through R127, and it generates an equal and opposite null current.

The common-mode rejection circuit has its own power supply made up of CR102, U109, U110, and related components. CR102 rectifies the 4.8kHz input signal, while U109 and U110 provide regulation down to the final $\pm 5.2V$ values.

Memory and control circuits

U102, a non-volatile RAM (NVRAM), stores the calibration constants for the preamplifier module. During calibration, constants are stored in U102, and the Model

2001 reads these calibration constants from the device during power-up. Note that data transmission is performed serially.

The gain and filter control circuits include U101, U106, AT101 through AT104, and associated components. Serial control DATA from the Model 2001 is clocked into U101 with the aid of the CLK (clock) signal. Once all control bits are shifted in, the STB (strobe) signal latches the control bits into the U101 outputs, and the control signals are coupled through the four opto-isolators to the preamplifier module. U106 is a power-on hold-off circuit, which inhibits random control information from being sent to the preamplifier module when the instrument is first turned on.

5.4 Special handling of static-sensitive devices

CMOS and other high-impedance devices are subject to possible static discharge damage because of the high-impedance levels involved. When handling such devices, use the precautions listed below.

NOTE

In order to prevent damage, assume that all parts are static-sensitive.

1. Such devices should be transported and handled only in containers specially designed to prevent or dissipate static build-up. Typically, these devices will be received in anti-static containers made of plastic or foam. Keep these parts in their original containers until ready for installation or use.
2. Remove the devices from their protective containers only at a properly grounded workstation. Also, ground yourself with an appropriate wrist strap while working with these devices.
3. Handle the devices only by the body; do not touch the pins or terminals.
4. Any printed circuit board into which the device is to be inserted must first be grounded to the bench or table.
5. Use only anti-static type de-soldering tools and grounded-tip soldering irons.

5.5 Troubleshooting

5.5.1 Troubleshooting equipment

Table 5-5 summarizes recommended equipment for troubleshooting the Model 1801.

Table 5-5
Recommended troubleshooting equipment

Description	Manufacturer and Model	Application
Multimeter Oscilloscope	Keithley 2001 TEK 2243	DCV checks View logic waveforms

5.5.2 Troubleshooting access

In order to gain access to the power supply card circuit board to measure voltages under actual operation conditions, perform the following steps:

1. Turn off the Model 2001 power, and disconnect the line cord and all other equipment.
2. Remove the Model 2001 cover.
3. Install the power supply card in the multimeter.
4. Connect the line cord, and turn on the power to measure voltages (see following paragraph).





5.5.3 Troubleshooting procedure

The preamplifier and power supply cable are not field serviceable and must be returned to the factory or authorized repair facility for service. The power supply card can, however, be serviced in the field, and Table 5-6 summarizes troubleshooting steps. Refer to the schematic diagram and component layout drawing at the end of Section 6 for component locations.

WARNING

Lethal voltages are present within the Model 2001. Some of the procedures may expose you to hazardous voltages. Observe standard safety precautions for dealing with live circuits. Failure to do so could result in personal injury or death.

Table 5-6
Power supply card troubleshooting procedure

Step	Item/component	Required condition	Comments
1	U103, pin 3	4.8kHz, 50% duty cycle square wave	Referenced to digital common (P1034, pin 1).
2	T102, pin 6	0.2V p-p rounded square wave	Referenced to
3	U104, pin 1	-8.5V DC, $\pm 10\%$	Referenced to 
4	U105, pin 2	+8.5V DC, $\pm 10\%$	Referenced to 
5	U108, pin 7	+5V DC, $\pm 10\%$	Referenced to 
6	U108, pin 4	-5V DC, $\pm 10\%$	Referenced to 
7	U107, pins 2, 3, 7	Brief pulse train when range is changed (DATA, CLK, STB pulses)	Referenced 

6

Replaceable Parts

6.1 Introduction

This section contains replacement parts information, schematic diagrams, and component layout drawings for the Model 1801.

6.2 Parts lists

Parts lists for the preamplifier are included in tables integrated with schematic diagrams and component layout drawings for the boards. Parts are listed alphabetically in order of circuit designation.

6.3 Ordering information

To place an order, or to obtain information concerning replacement parts, contact your Keithley representative or the factory (see inside front cover for addresses). When ordering parts, be sure to include the following information:

- Model number (1801)
- Serial number
- Part description
- Circuit description, if applicable
- Keithley part number.

6.4 Factory service

If the preamplifier is to be returned to Keithley Instruments for repair, perform the following:

- Complete the service form at the back of this manual, and include it with the card.
- Carefully pack the preamplifier module and power supply card in the original packing carton.
- Write ATTENTION REPAIR DEPT on the shipping label.

NOTE

It is not necessary to return the Model 2001 Multimeter with the preamplifier. However, be sure that you return both the preamplifier module and the power supply card, as well as the power supply connecting cable.

6.5 Component layouts and schematic diagrams

Component layout drawings and schematic diagrams are included on the following pages integrated with the parts list for the Model 1801.

Table 6-1
Electrical, Parts List

Circuit Designation	Description	Keithley Part Number
AT101-104	IC, PHOTO COUPLER, PS2501A-1	IC-670
C101	CAP, 5600PF, +/-1%, 50VDC, DIPPED MICA	C-362-5600P
C102-105, 109, 119,121	CAP, 10UF, 20%, 20V, TANTALUM	C-179-10
C106, 117	CAP, 1500PF, 10%, 1000V, CERAMIC	C-64-1500P
C108	CAP, .022UF, 5%, 100V, PLASTIC	C-152-.022
C110, 112, 113, 120, 122	CAP, .1UF, 20%, 50V, CERAMIC	C-365-.1
C111	CAP, 100UF, 20%, 25V, ALUM ELEC	C-413-100
C114	CAP, .05UF, 5%, 50V, POLYCARBONATE	C-201-.05
C115	CAP, 1000PF, 10%, 1000V, CERAMIC	C-64-1000P
CR101, 102	DIODE, BRIDGE, VM18	RF-52
J1001	CONN, RT. ANGLE HEADER, 70555	CS-802-1
J1002	CONN, 2 PIN, JOLO BB-125-04	TE-115-2
P1034	CONN, FEMALE, DUAL 16-PIN	CS-455
Q101-103	TRANS, N CHAN MOSPOW FET, 2N7000 (TO-92)	TG-195
R101, 102, 119, 120	RES, 20K, 5%, 1/4W, COMPOSITION OR FILM	R-76-20K
R103-106	RES, 470, 5%, 1/4W, COMPOSITION OR FILM	R-76-470
R107	RES, 4.7K, 5%, 1/4W, COMPOSITION OR FILM	R-76-4.7K
R108	RES, 26.7K, 1%, 1/8W, METAL FILM	R-88-26.7K
R109, 112	RES, 649K, 1%, 1/8W, METAL FILM	R-88-649K
R110, 111	RES, 110K, 1%, 1/8W, METAL FILM	R-88-110K
R113, 121, 125-127	RES, 1K, 5%, 1/4W, COMPOSITION OR FILM	R-76-1K
R115	RES, 330K, 5%, 1/4W, COMPOSITION OR FILM	R-76-330K
R116,117	RES, 22K, 5%, 1/4W, COMPOSITION OR FILM	R-76-22K
R118	RES, 180K, 5%, 1/4W, COMPOSITION OR FILM	R-76-180K
R122	RES, 10K, 5%, 1/4W, COMPOSITION OR FILM	R-76-10K
R123	RES, 100, 5%, 1/4W, COMPOSITION OR FILM	R-76-100
R124	RES, 2.2M, 5%, 1/4W, COMPOSITION OR FILM	R-76-2.2M
R128	RES, 20, 5%, 1/4W, COMPOSITION OR FILM	R-76-20
R129	RES, 33, 5%, 1/4W, COMPOSITION OR FILM	R-76-33
T101	TRANSFORMER	TR-286A
T102	TRANSFORMER	TR-285A
U101	IC, 8-BIT SERIAL-IN LATCH DRIVER, 5841A	IC-536
U102	IC, SERIAL EPROM, 24C01P	IC-737
U103	IC, CMOS TIMER, TLC555CP	IC-521
U104	IC, PROG, VOLT, REG, ICL7663	IC-882
U105	IC, PROG, VOLT, REG, ICL7664	IC-883
U106	IC, SUPPLY VOLTAGE SUPERVISOR, TL7705AC	IC-602
U107	IC, OP-AMP, AD847JN	IC-890
U108	IC, 22V OP-AMP, LT1007ACN8	IC-422
U109	INTEGRATED CIRCUIT	IC-604
U110	IC, +5V REGULATOR, 78L05AC, (T0-92)	IC-603
W101	CONN, 3 PIN	CS-339-3

Table 6-2
Mechanical, Parts List

Description	Keithley Part Number
CABLE ASSEMBLY	1801-304
SHIELDED COVER, BOTTOM	1801-301
CABLE CLAMP	CC-18
SHIELDED COVER, BOTTOM	V-1801-301
STRIP, POLYURETHANE	2001-345-1
SHIELDED COVER, TOP	1801-303
SHIELDED COVER, TOP	V-1801-303
SHIELD, SCANNER BOTTOM	2001-341
INSULATOR, BOTTOM	1801-302
SHIELD, TOP	1801-307
CARD EJECTOR, PLASTIC	FA-237
THERMAL ENCLOSURE W/PACKING MATERIAL	BOX-722

1801-100
ON

LTR.	ECO NO.	REVISION	ENG.	DATE
B	921130	RELEASED	MS	12/1/92
B1	1644B	UPDATED FA-237 PICTORIAL	SZ	8/1/94

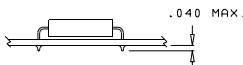
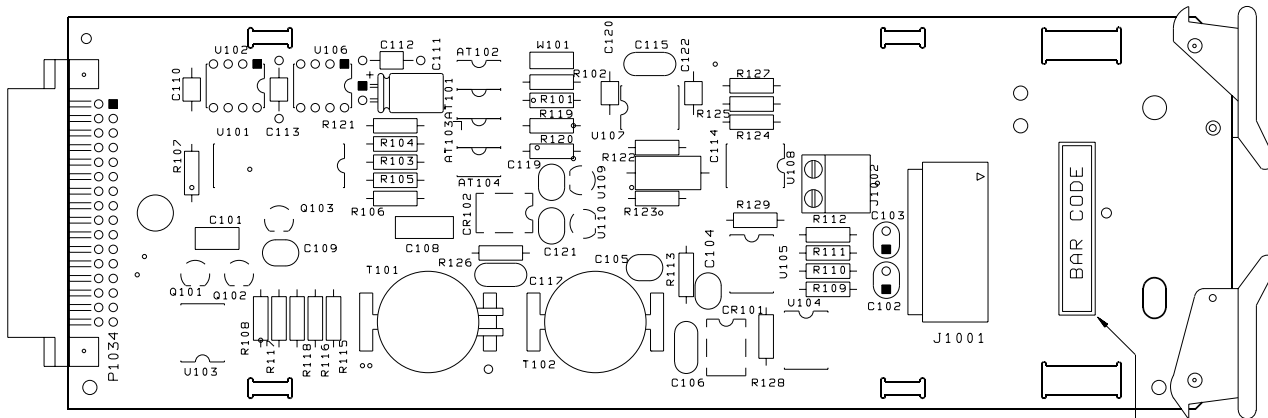

NOTES:

- FOR MORE COMPONENT INFORMATION REFER TO 1801-102 PRODUCT STRUCTURE.
- LEADS MUST NOT EXTEND .040 PAST BOTTOM OF PC BOARD AFTER FLOW SOLDER. (SEE DETAIL)

MODEL	NEXT ASSEMBLY	QTY.	USED ON

DO NOT SCALE THIS DRAWING	DIMENSIONAL TOLERANCES UNLESS OTHERWISE SPECIFIED	DATE 11/16/92	SCALE 2:1	TITLE
				COMPONENT LAYOUT.
				NAND-VOLT RANGE EXTENDER
				NO. 1801-100

KEITHLEY KEITHLEY INSTRUMENTS INC
CLEVELAND, OHIO 44139

XX=±.015 ANG.=±1P DRN. MAH ENG. APPR. KG/MS
XXX=±.005 FRAC.=1/64 MATERIAL SURFACE MAX. 63 FINISH

C

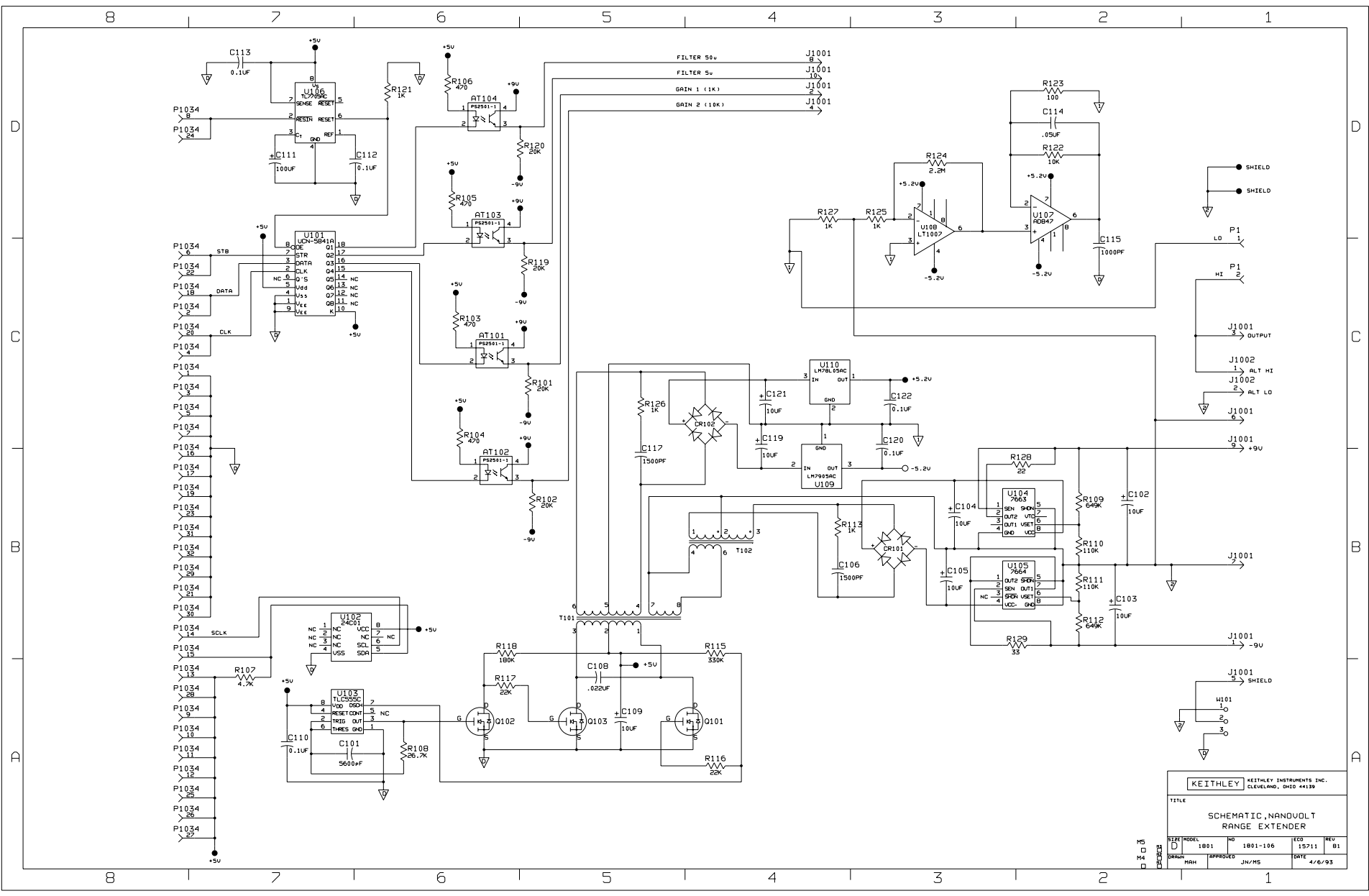

KEITHLEY		KEITHLEY INSTRUMENTS INC.	
		CLEVELAND, OHIO 44139	
TITLE			
SCHEMATIC, NANOVOLT RANGE EXTENDER			
SIZE	MODEL	NO	REV
D	1801	1801-106	15711 01
DATE	APPROVED	JIN/MS	DATE
08/81			4/6/93

MS
M4
D

A

Specifications

MODEL 1801 NANO-VOLT PREAMP

GENERAL NOTES:

- The Model 1801 Nanovolt Preamp consists of a power-supply card that plugs into the Model 2001 scanner slot, the remote nanovolt preamp, and a 3 meter cable to connect the two.
- The Model 1801 Nanovolt Preamp is specified only for use with the Model 2001 Multimeter. Specifications are based on the published Model 2001 performance and are referenced to the 1801 Nanovolt Preamp input. It is assumed the Model 2001 used with the nanovolt preamp is properly calibrated.
- 1801 Nanovolt Preamp specified calibration interval is 1 year.
- The Model 2001 checks for the presence of the nanovolt preamp on power up. If the nanovolt preamp is detected, the front panel menu tree is adjusted accordingly. A subset of the 2001 functions are active with ranges as follows:

FUNCTION

DC Volts
 DC Volts Peak Spikes
 AC Volts Low Frequency rms
 AC Volts Normal rms Average
 Peak, Crest Factor
 DC Current
 DC In-Circuit Current
 AC Current
 2-Wire Ohms
 4-Wire Ohms
 Frequency
 Temperature

RANGES AVAILABLE

20 μ V, 200 μ V, 2mV.
 Not Available.
 500 μ V rms.
 Not Available.
 Not Available.
 Not Available.
 Not Available.
 Not Available.
 Not Available.
 2m Ω , 20m Ω , 200m Ω , 2 Ω , 20 Ω , 200 Ω .
 Available for Limited Frequency Range.
 Only Differential Thermocouple Temperature is Specified. RTD Not Available.

DC VOLTS

DCV ACCURACY¹

RANGE	FULL SCALE	7½ DIGIT RESOLUTION	DEFAULT RESOLUTION	ACCURACY ²				TEMPERATURE COEFFICIENT ±(ppm of reading + ppm of range)/°C Outside Tcal ±5°C
				±(ppm of reading + ppm of range) 24 Hours ³	90 Days ⁴	1 Year ⁴	2 Years ⁴	
20 μ V	±21.000000	1 pV	10 pV	300 + 60	450 + 60	460 + 60	470 + 60	40 + 13
200 μ V	±210.000000	10 pV	100 pV	200 + 20	250 + 20	260 + 20	270 + 20	40 + 2
2 mV	±2.1000000	100 pV	1 nV	200 + 6	250 + 6	260 + 6	270 + 6	40 + 2

DC VOLTAGE UNCERTAINTY = ± ((ppm of reading) × (measured value) + (ppm of range) × (range used)) / 1,000,000.

% ACCURACY = (ppm accuracy) / 10,000.

1PPM OF RANGE = 2 counts at 6½ digits.

INPUT CHARACTERISTICS (HI to LO):

Input Bias Current: Adjustable at preamp to <20pA. Temperature drift less than 25pA/°C.

Zero Drift: Typical variation of zero reading with low thermal short (see Instruction Manual) is less than 10nV, 5nV/°C. (24 hours, TREF: 1°C, 1 PLC, 10-reading digital filter).

DC Input Resistance: >1G Ω .

Transient Input Resistance: >1k Ω 1ms after step input. >10M Ω 4s after step input.

Linearity: <4 ppm of range non-linearity, exclusive of zero offset and noise.

Isolated Polarity Reversal Error: <4 counts at 6½ digits, exclusive of zero offset and noise.

Maximum Input Levels: 1V or 100 mA peak.

Overload Recovery: 1s for <10mV overload, 1 minute for \geq 10mV overload.

COMMON MODE ISOLATION (input LO to 2001 chassis ground):

Isolation Impedance: 1G Ω in parallel with 1nF.

Maximum Common Mode Voltage: 41V peak.

Common Mode Current: <15nA p-p at 50 or 60Hz.

NOISE REJECTION (dB):²

CMRR: ¹ 175dB for DC, 50 or 60 Hz \pm 0.1%, common mode signals up to 5V p-p AC, 41V p-p AC+DC.

NMRR (at 50 or 60 Hz \pm 0.1%, NPLC \geq 1, Line Sync OFF):

FILTER:	SLOW	MEDIUM	FAST
20 uV Range	90 dB	80 dB	60 dB
200 uV Range	90 dB	80 dB	60 dB
2 mV Range	90 dB	60 dB	60 dB

Effective noise is reduced by a factor of 10 for every 20dB of noise rejection (60dB reduces effective noise by 1,000:1).

CMRR is rejection of undesirable AC or DC signal between LO and earth.

With a 1 Ω imbalance in the LO lead.

NMRR is rejection of undesirable AC signal between HI and LO.

PREAMP SETTLING CHARACTERISTICS (nominal, \pm 20%):

FILTER:	10% to 90% Rise Time		
	SLOW	MEDIUM	FAST
20 uV Range	10 s	1 s	10 ms
200 uV Range	1 s	100 ms	2 ms
2 mV Range	100 ms	10 ms	500 μ s

ZERO SUPPRESSION: Adjustable \pm 100 μ V at preamp. 2001 front panel suppression using REL.

INPUT NOISE (with low thermal short): Equivalent noise resistance of 20 Ω . There is no 1/f component, 1PLC integration.⁵

FILTER:	Input Noise		
	SLOW	MEDIUM	FAST
20 uV Range	0.6 nV p-p	2 nV p-p	30 nV p-p
200 uV Range	2 nV p-p	9 nV p-p	40 nV p-p
2 mV Range	6 nV p-p	20 nV p-p	90 nV p-p

MAXIMUM SOURCE RESISTANCE: 10k Ω .

DC VOLTS NOTES:

- Specifications are for 1 PLC, Auto Zero on, 10-reading digital filter, Preamp on SLOW filter.
- When properly zeroed (using zero adjustment initially then REL according to procedure in Instruction Manual) every 20 minutes or whenever the ambient temperature changes by more than 1°C.
- For TCAL ± 1°C, following 15-minute preamp warmup. TCAL is ambient temperature at calibration which is 23°C from factory.
- For TCAL ± 5°C, following 15-minute preamp warmup. Specifications include factory traceability to US NIST.
- For source resistance R_s above 1Ω multiply noise by $\sqrt{\frac{20 + R_s}{20}}$

ANALOG OUTPUT:

Connection: Screw terminals on power supply card.
 Output: ± 2V full scale, maximum 1mA load.
 Gain: 1000 on 2mV range, 10000 on 200μV range, 100000 on 20μV range.
 Noise: Input Noise times gain plus modulation products.
 Modulation Products: Up to 40mV p-p at 288 Hz.
 Accuracy: ± (2% of output + 1mV) when properly zeroed at preamp.

DIFFERENTIAL TEMPERATURE:

Temperature Sensor: Differential thermocouple of type J, K, T, E, R, S, B, or User-entered μV/°C value.
 Measures differential thermocouple voltage using 2mV DC range.
 User enters temperature of the reference thermocouple pair. The °C/μV slope is determined from this value using internal thermocouple tables.
 Differential temperature reading is DCV reading × the °C/μV slope.
 Default resolution (0.1m°C).
 Maximum differential temperature reading 50°C.

Differential Thermocouple Type	Range
J	-200°C to + 760°C
K	-200°C to + 1372°C
T	-200°C to + 400°C
E	-200°C to + 1000°C
R	0°C to + 1768°C
S	0°C to + 1768°C
B	+350°C to + 1820°C

AC VOLTS RMS

AC Magnitude: Low Frequency rms.
 Normal rms, Average, rms, Peak and Crest Factor measurement are not available using the 1801 Nanovolt Preamp.

RMS RANGE	PEAK INPUT	FULL SCALE RMS	7½ DIGIT RESOLUTION	DEFAULT RESOLUTION	ACCURACY ^{1,2}	SIGNAL FREQUENCY	TEMPERATURE COEFFICIENT ³ ±(% of reading + % of range) / °C Outside TCAL ±5°C
500 μV	2 mV	500.000	100 pV	1 nV	6 + 0.1	1 - 100 Hz	1 + 0.03

AC VOLTAGE UNCERTAINTY = ± [(% of reading) × (measured value) + (% of range) × (range used)] / 100.

SETTLING CHARACTERISTICS: <5s to 0.1% of final value.

ACV FREQUENCY

ACV NOTES:

- Specifications apply for a sinewave input, crest factor = 1.4, AC+DC coupling, 1PLC, digital filter off. Accuracy specification applies for 90 days, 1 year or 2 years, TCAL±5°C for 5% to 100% of range. Low frequency rms only, AC+DC coupling. All ACV measurements are made with a preamp gain of 1000 and the fast filter.
- Low frequency mode requires autocal refresh (by changing mode or measurement function, using autocal command, or power up) once every 24 hours.

FREQUENCY RANGE	PERIOD RANGE	DEFAULT RESOLUTION	MINIMUM SIGNAL LEVEL	ACCURACY ±(% of reading)
1Hz-1kHz	1ms - 1s	5 digits	400μV peak	2%

4-WIRE OHMS

RANGE	FULL SCALE	7½ DIGIT RESOLUTION	DEFAULT RESOLUTION	NOMINAL CURRENT SOURCE ¹	OPEN CIRCUIT VOLTAGE	MAXIMUM LEAD RESISTANCE ²	MAXIMUM OFFSET COMPENSATION	MAX DUT POWER DISSIPATION
2 mΩ	± 2.1000000	100 pΩ	1 nΩ	9.2 mA	5V	1.7 Ω	± 20 μV	170 nW
20 mΩ	± 21.0000000	1 nΩ	10 nΩ	9.2 mA	5V	1.7 Ω	± 200 μV	1.7 μW
200 mΩ	± 210.0000000	10 nΩ	100 nΩ	0.98 mA	5V	1.7 Ω	± 200 μV	190 nW
2 Ω	± 2.1000000	100 nΩ	1 μΩ	0.98 mA	5V	1.7 Ω	± 2 mV	1.9 μW
20 Ω	± 21.0000000	1 μΩ	10 μΩ	89 μA	5V	1.7 Ω	± 2 mV	160 nW
200 Ω	± 210.0000000	10 μΩ	100 μΩ	7 μA	5V	1.7 Ω	± 2 mV	10 nW

ACCURACY^{3,4,5}

RANGE	24 Hours ⁶	90 Days ⁷	1 Year ⁷	2 Years ⁷
2 mΩ	350 + 100	550 + 100	560 + 100	570 + 100
20 mΩ	250 + 30	350 + 30	360 + 30	370 + 30
200 mΩ	250 + 30	350 + 30	360 + 30	370 + 30
2 Ω	250 + 10	350 + 10	360 + 10	370 + 10
20 Ω	250 + 10	350 + 10	360 + 10	370 + 10
200 Ω	270 + 10	350 + 10	360 + 10	370 + 10

TEMPERATURE COEFFICIENT ± (ppm of reading + ppm of range) / °C Outside TCAL ±5°C

50 + 3
50 + 3
50 + 3
50 + 3
50 + 3
60 + 3

RESISTANCE VOLTAGE UNCERTAINTY = ± [(ppm of reading) × (measured value) + (ppm of range) × (range used)] / 1,000.00.

% ACCURACY = (ppm accuracy) / 10,000.

1PPM OF RANGE = 2 counts at 6½ digits.

SETTLING CHARACTERISTICS:

FILTER	10% to 90% Rise Time Nominal, $\pm 20\%$			Offset Compensated Ohms Settling Time to Rated Accuracy		
	SLOW	MEDIUM	FAST	SLOW	MEDIUM	FAST
2 m Ω Range	1 s	100 ms	2 ms	5 s	1.5 s	200 ms
20m Ω - 200 Ω Range	100 ms	10 ms	500 μ s	800 ms	150 ms	130 ms

OFFSET COMPENSATION: Internal delay set for settling to rated accuracy.

OHMS VOLTAGE DROP MEASUREMENT: Available as a multiple display.

OHMS NOTES:

- 1 Current source nominal $\pm 9\%$. Calibrated value available as a multiple display.
- 2 Maximum offset compensation plus source current \times measured resistance must be less than source current \times resistance range selected.
- 3 When properly zeroed (using zero adjustment initially then REL according to procedure in Instruction Manual) every 20 minutes or whenever the ambient temperature changes by more than 1°C .
- 4 Ohms specifications are derived from the 1801 DCV specifications and the Model 2001 ohms specifications. Specifications are guaranteed by verifying the 2001 ohms function and the 1801 DCV function separately.
- 5 Offset compensation on, SLOW filter, 10-reading digital filter, High accuracy mode, Auto zero on.
- 6 For TCAL $\pm 1^\circ\text{C}$, following 15-minute preamp warmup. TCAL is ambient temperature at calibration which is 23°C from factory.
- 7 For TCAL $\pm 5^\circ\text{C}$, following 15-minute preamp warmup. Specifications include factory traceability to US NIST.

GENERAL SPECIFICATIONS AND STANDARDS COMPLIANCE

INPUT CONNECTOR: 3mm studs and nuts of pure copper.

POWER: Supplied through scanner slot of the Model 2001.

PREAMP WARMUP: 15-Minutes.

ENVIRONMENT:

Operating Temperature: 0°C to 35°C .

Storage Temperature: -40°C to 70°C .

Humidity: $<80\%$ R.H., 0°C to 35°C .

Magnetic Field Density: <0.1 Tesla.

NORMAL CALIBRATION:

Type: Software. No manual adjustments are required. Adjustments for voltage and current offset are provided for use during measurement setup.

Sources: Model 262 Voltage Divider and a DCV Calibrator with <50 ppm 1 year accuracy specifications.

PHYSICAL:

Remote Preamp Case Dimensions: 35mm high \times 70mm wide \times 140mm long. 1.38in. high \times 2.76in. wide \times 5.5in. long. Add 6mm (0.25in.) to height to include terminals.

Thermal Isolation Enclosure Dimensions: 5 in. wide \times 11 in. \times 4 in. deep.

Remote Preamp Weight: 500g (1.1 lbs.).

Shipping Weight: 2212g (4lbs. 15oz).

ACCESSORIES SUPPLIED: The Model 1801 Nanovolt Preamp consists of a power-supply card that plugs into the Model 2001 scanner slot, the remote nanovolt preamp, and a 3 meter cable to connect the two. In addition, accessories supplied include 3 meters of SC-93 low thermal cable (shielded twisted pair, solid copper wires, unterminated), thermal isolation enclosure, and user's manual.

Specifications subject to change without notice.

B

Calibration Programs

Introduction

This appendix includes programs written in QuickBASIC and Turbo C to aid you in calibrating the Model 1801. See paragraph 5.2 in Section 5 for details on offset adjustments, recommended calibration equipment, test connections, and detailed calibration procedures.

Program requirements

In order to use the calibration programs, you will need the following:

- IBM PC, AT, or compatible computer.
- IOtech Personal488, CEC PC-488, or National Instruments PC-II or IIA IEEE-488 interface for the computer.
- Shielded IEEE-488 cable(s) (Keithley Model 7007).
- MS-DOS or PC-DOS version 3.3 or later.
- Microsoft QuickBASIC version 4.0 or later, or Borland C Turbo C version 2.0 or later.
- IOtech Driver488 IEEE-488 bus driver, Rev. 2.3 or later. (Note: recent versions of Driver488 may not support other manufacturers' interface cards.)

General program instructions

1. With the power off, connect the Model 2001 to the IEEE-488 interface of the computer. If you are using

one of the programs that controls the Fluke 5700A calibrator, connect the calibrator to the IEEE-488 bus as well. Be sure to use shielded IEEE-488 cables for bus connections.

2. Turn on the computer, the Model 2001, and the calibrator. Allow the Model 2001 and 1801 to warm up for at least two hours before performing calibration.
3. Make sure the Model 2001 is set for a primary address of 16. You can check or change the address as follows:
 - A. Press MENU, select GPIB, then press ENTER.
 - B. Select MODE, then press ENTER.
 - C. Select ADDRESSABLE, and press ENTER.
 - D. If the address is set correctly, press EXIT as necessary to return to normal display.
 - E. To change the address, use the cursor keys to set the address to the desired value, then press ENTER. Press EXIT as necessary to return to normal display.
4. If you are using the Fluke 5700A calibrator over the bus (Programs B-3 and B-4), make sure that the calibrator primary address is at its factory default setting of 4.
5. Make sure that the computer bus driver software is properly initialized.
6. Enter the QuickBASIC or Turbo C editor, and type in the desired program. Check thoroughly for errors, then save it using a convenient filename.
7. Compile and run the program, and follow the prompts on the screen to perform calibration.

Program B-1. Calibration Program for Use with Any Suitable Calibrator (QuickBASIC Version)

```
' Model 1801 calibration program for use with any suitable
' DC voltage calibrator.
OPEN "\DEV\IEEEOUT" FOR OUTPUT AS #1          ' Open IEEE-488 output path.
OPEN "\DEV\IEEEIN" FOR INPUT AS #2           ' Open IEEE-488 input path.
IOCTL #1, "BREAK"                            ' Reset interface.
PRINT #1, "RESET"                            ' Warm start interface
PRINT #1, "CLEAR"                            ' Send DCL.
PRINT #1, "REMOTE 16"                        ' Put 2001 in remote.
PRINT #1, "TERM LF EOI"                      ' Set terminator to LF + EOI.
PRINT #1, "OUTPUT 16;:SYST:PRES;*CLS"       ' Initialize 2001.
PRINT #1, "OUTPUT 16;*ESE 1;*SRE 32"       ' Enable OPC and SRQ
C$ = ":CAL:UNPR:PRE:"                        ' 1801 partial command header.
'
GOSUB CheckOpt                               ' Check 1801 installation.
CLS                                           ' Clear CRT.
PRINT "Model 1801 Nanovolt Preamplifier Calibration Program"
PRINT "Calibrator and Model 262 divider ratios must be set manually."
RESTORE CmdList
PRINT
PRINT "Set DC calibrator to external sense, 0V DC output."
PRINT "Place calibrator in operate mode."
PRINT
PRINT "Set 262 polarity to POS+ position."
PRINT "Wait two minutes for thermals to settle."
GOSUB KeyCheck
FOR I = 1 TO 7                               ' Loop for all cal points.
READ Msg$, Cmd$                             ' Read message, cal strings.
PRINT Msg$                                  ' Display prompt message.
IF I = 4 THEN PRINT "Set calibrator output to 200.000mV DC"
IF I < 7 THEN GOSUB KeyCheck                ' Wait for operator input.
IF I < 7 THEN GOSUB Dly                     ' Settling time.
PRINT #1, "OUTPUT 16;"; C$; Cmd$; ";*OPC"   ' Send cal command to 2001.
GOSUB CalEnd                               ' Wait until cal step ends.
NEXT I
GOSUB ErrCheck                              ' Check for errors.
INPUT "Enter calibration date (mm/dd/yy)"; D$
PRINT #1, "OUTPUT 16;:CAL:UNPR:PRE:DATE '"; D$; ""
INPUT "Enter calibration due date (mm/dd/yy)"; D$
PRINT #1, "OUTPUT 16;:CAL:UNPR:PRE:NDUE '"; D$; ""
PRINT #1, "OUTPUT 16;:CAL:UNPR:PRE:SAVE"    ' Save calibration constants.
PRINT "Calibration completed."
END
'
KeyCheck:                                    ' Check for key press routine.
PRINT
PRINT "Press any key to continue (ESC to abort program). "
Wai: I$ = INKEY$: IF I$ = "" THEN GOTO Wai
IF I$ = CHR$(27) THEN                        ' Abort if ESC is pressed.
CLOSE 1: CLOSE 2
PRINT "Program halted."
END
END IF
RETURN
'
```

Program B-1. Calibration Program for Use with Any Suitable Calibrator (QuickBASIC Version) Continued

```

CalEnd:                                     ' Check for cal step completion.
PRINT "Waiting for calibration step"; I; "completion..."
Stat: PRINT #1, "STATUS"                   ' Request bus status.
INPUT #2, ST$                              ' Input status.
IF MID$(ST$, 11, 2) = "S0" THEN GOTO Stat   ' Wait for operation complete.
PRINT #1, "OUTPUT 16;*ESR?"               ' Clear OPC.
PRINT #1, "ENTER 16"
INPUT #2, S
PRINT #1, "SPOLL 16"
INPUT #2, S
RETURN
'

ErrCheck:                                   ' Error check routine.
PRINT #1, "OUTPUT 16::SYST:ERR?"          ' Query error queue.
PRINT #1, "ENTER 16"
INPUT #2, E, Err$
IF E <> 0 THEN
    PRINT                                  ' If error is detected, error
    PRINT Err$                             ' is displayed, and program
    PRINT "Calibration aborted."           ' is halted.
    BEEP
    CLOSE 1: CLOSE 2
    END
END IF
RETURN
'

Dly:                                       ' Delay routine.
T = TIMER
Lp: IF (TIMER - T) < 5 THEN GOTO Lp
RETURN
'

CheckOpt:                                  ' Check for 1801.
PRINT #1, "OUTPUT 16;*OPT?"
PRINT #1, "ENTER 16"
LINE INPUT #2, OPT$
IF INSTR(OPT$, "1801") = 0 THEN
    PRINT "Model 1801 is not installed; program aborted."
    END
END IF
RETURN
'

CmdList:
DATA "Set 262 divider ratio to 10^2.", "Z1K"
DATA "Set 262 divider ratio to 10^3.", "Z10K"
DATA "Set 262 divider ratio to 10^4.", "Z100K"
DATA "Make sure divider is still set to 10^4.", "FS100K 20E-6"
DATA "Set 262 divider ratio to 10^3.", "FS10K 200E-6"
DATA "Set 262 divider ratio to 10^2.", "FS1K 2E-3"
DATA "Calculating constants...", "CALC"

```

Program B-2. Calibration Program for Use with Any Suitable Calibrator (Turbo C Version)

```

/* Model 1801 calibration program for use with any suitable
DC voltage calibrator. */

#include "ieeeeio.h"
#include <stdio.h>
#include <stdlib.h>
#include <conio.h>
#include <string.h>

main()
{
    static char *msg[] = {
        "Set 262 divider ratio to 10^2.",
        "Set 262 divider ratio to 10^3.",
        "Set 262 divider ratio to 10^4.",
        "Make sure divider is still set to 10^4.",
        "Set 262 divider ratio to 10^3.",
        "Set 262 divider ratio to 10^2.",
        "Calculating constants..."
    };
    static char *cmd[] = {
        ":cal:unpr:pre:z1k",":cal:unpr:pre:z10k",
        ":cal:unpr:pre:z100k",":cal:unpr:pre:fs100k 20e-6",
        ":cal:unpr:pre:fs10k 200e-6",
        ":cal:unpr:pre:fs1k 2e-3",
        ":cal:unpr:pre:calc"
    };
    void keypress(),errcheck(),checkopt();
    char date[10];
    int i,calend();
    if (ieeeeinit()==-1){
        printf("Cannot initialize interface.\n");
        exit(1);
    }
    ieeewt("remote 16\n"); /* Put 2001 in remote. */
    ieeewt("clear\n"); /* Send DCL. */
    ieeewt("term lf eoi\n"); /* Set terminator. */
    ieeewt("output 16::syst:pres;*cls\n"); /* Initialize 2001. */
    ieeewt("output 16;*ese 1;*sre 32\n"); /* Enable OPC, SRQ. */
    checkopt(); /* Check for 1801. */
    clrscr(); /* Clear CRT. */
    printf("Model 1801 Calibration Program.\n");
    printf("Calibrator and Model 262 divider ratios"
        " must be set manually.\n");
    printf("Set calibrator to external sense, 0V DC output.\n"
        "Place calibrator in operate mode.\n\n");
    printf("Set 262 to POS+ polarity.\n");
    printf("Wait two minutes for thermals to settle.\n");
    keypress();
    for(i=0;i<=6;i++) { /* Loop for cal points. */
        printf("%s\n",msg[i]);
        if(i==3) printf("Set calibrator output to "
            "200.000mV.\n");
        if (i<6) keypress();
    }
}

```

Program B-2. Calibration Program for Use with Any Suitable Calibrator (Turbo C Version) Continued

```

    if (i<6) delay(5000);
    ieeeptrf("output 16;%s;*opc\n",cmd[i]);
    calend(i);
}
errcheck();
printf("Enter calibration date (mm/dd/yy): ");
scanf("%s",date);
ieeeptrf("output 16::cal:unpr:pre:date '%s'\n",date);
printf("Enter calibration due date (mm/dd/yy): ");
scanf("%s",date);
ieeeptrf("output 16::cal:unpr:pre:ndue '%s'\n",date);
ieeewt("output 16::cal:unpr:pre:save\n");
printf("Calibration completed.\n");
}
void keypress() /* Wait for keypress. */
{
    printf("Press any key to continue.\n");
    while(kbhit()==0);
    getch();
}
int calend(n) /* Check for cal end. */
int n;
{
    char status[40];
    int stat;
    printf("Waiting for cal step %d completion.\n",n+1);
    do {
        ieeewt("status\n");
        ieeerd(status);
    }
    while (status[11]!='0');
    ieeewt("output 16;*esr?\n");
    ieeewt("enter 16\n");
    ieeescnf("%d",&stat);
    ieeewt("spoll 16\n");
    ieeescnf("%d",&stat);
}
void errcheck() /* Check for error. */
{
    char errbuf[100];
    ieeewt("output 16::syst:err?\n");
    ieeewt("enter 16\n");
    ieeerd(errbuf);
    if (atoi(errbuf) !=0){
        printf("%s\n",errbuf);
        printf("Calibration aborted.\n");
        exit(1);
    }
}
void checkopt() /* Check for 1801. */
{
    char buf[40];
    ieeewt("output 16;*opt?\n");
    ieeewt("enter 16\n");

```

Program B-2. Calibration Program for Use with Any Suitable Calibrator (Turbo C Version) Continued

```
ieeed(buf);
if (strstr(buf,"1801") == NULL){
    printf("Model 1801 is not installed;"
        " program aborted.\n");
    exit(1);
}
}
```

Program B-3. Calibration Program for Use with Fluke 5700A Calibrator (QuickBASIC Version)

```

' Model 1801 calibration program for use only with the
' Fluke 5700A calibrator.
OPEN "\DEV\IEEEOUT" FOR OUTPUT AS #1      ' Open IEEE-488 output path.
OPEN "\DEV\IEEEIN" FOR INPUT AS #2       ' Open IEEE-488 input path.
IOCTL #1, "BREAK"                         ' Reset interface.
PRINT #1, "RESET"                         ' Warm start interface
PRINT #1, "CLEAR"                         ' Send DCL.
PRINT #1, "REMOTE 16"                     ' Put 2001 in remote.
PRINT #1, "REMOTE 04"                     ' Put 5700A in remote.
PRINT #1, "TERM LF EOI"                   ' Set terminator to LF + EOI.
PRINT #1, "OUTPUT 16::SYST:PRES;*CLS"     ' Initialize 2001.
PRINT #1, "OUTPUT 16;*ESE 1;*SRE 32"     ' Enable OPC and SRQ.
PRINT #1, "OUTPUT 04;*RST;*CLS"          ' Reset 5700A calibrator.
C$ = ":CAL:UNPR:PRE:"                     ' 1801 partial command header.
'
GOSUB CheckOpt                            ' Check 1801 installation.
CLS                                        ' Clear CRT.
PRINT "Model 1801 Nanovolt Preamplifier Calibration Program"
PRINT "This program controls the Fluke 5700A Calibrator."
PRINT "Model 262 divider ratios must be set manually."
RESTORE CmdList
PRINT #1, "OUTPUT 04;OUT 1V,0HZ"          ' Set 2.2V range.
PRINT #1, "OUTPUT 04;RANGELCK ON"         ' Lock range.
PRINT #1, "OUTPUT 04;OUT 0V,0 HZ"        ' Output 0V.
PRINT #1, "OUTPUT 04;OPER"               ' Put calibrator in operate.
PRINT #1, "OUTPUT 04;EXTSENSE ON"        ' Enable external sense.
PRINT
PRINT "Set 262 polarity to POS+ position."
PRINT "Wait two minutes for thermals to settle."
GOSUB KeyCheck
FOR I = 1 TO 7                            ' Loop for all cal points.
IF I = 4 THEN PRINT #1, "OUTPUT 04;OUT 0.2 V,0 HZ" ' Output 200mV.
READ Msg$, Cmd$                           ' Read message, cal strings.
PRINT Msg$                                 ' Display prompt message.
IF I < 7 THEN GOSUB KeyCheck               ' Wait for operator input.
IF I < 7 THEN GOSUB Dly                    ' Settling time.
PRINT #1, "OUTPUT 16;"; C$; Cmd$; ";*OPC"  ' Send cal command to 2001.
GOSUB CalEnd                              ' Wait until cal step ends.
NEXT I
PRINT #1, "OUTPUT 04;STBY"                 ' Put calibrator in standby.
GOSUB ErrCheck                             ' Check for errors.
INPUT "Enter calibration date (mm/dd/yy)"; D$
PRINT #1, "OUTPUT 16::CAL:UNPR:PRE:DATE '"; D$; ""
INPUT "Enter calibration due date (mm/dd/yy)"; D$
PRINT #1, "OUTPUT 16::CAL:UNPR:PRE:NDUE '"; D$; ""
PRINT #1, "OUTPUT 16::CAL:UNPR:PRE:SAVE"   ' Save calibration constants.
PRINT "Calibration completed."
END
'
KeyCheck:                                 ' Check for key press routine.
PRINT
PRINT "Press any key to continue (ESC to abort program).".
Wai: I$ = INKEY$: IF I$ = "" THEN GOTO Wai
IF I$ = CHR$(27) THEN                      ' Abort if ESC is pressed.
PRINT #1, "OUTPUT 04;STBY"

```

Program B-3. Calibration Program for Use with Fluke 5700A Calibrator (QuickBASIC Version) Continued

```

PRINT #1, "OUTPUT 16;:CAL:UNPR:PRE:ABOR"
CLOSE 1: CLOSE 2
PRINT "Program halted."
END
END IF
RETURN
'
CalEnd:                                ' Check for cal step completion.
PRINT "Waiting for calibration step"; I; "completion..."
Stat: PRINT #1, "STATUS"                ' Request bus status.
INPUT #2, ST$                           ' Input status.
IF MID$(ST$, 11, 2) = "S0" THEN GOTO Stat ' Wait for operation complete.
PRINT #1, "OUTPUT 16;*ESR?"            ' Clear OPC.
PRINT #1, "ENTER 16"
INPUT #2, S
PRINT #1, "SPOLL 16"
INPUT #2, S
RETURN
'
ErrCheck:                                ' Error check routine.
PRINT #1, "OUTPUT 16;:SYST:ERR?"        ' Query error queue.
PRINT #1, "ENTER 16"
INPUT #2, E, Err$
IF E <> 0 THEN
    PRINT                                ' If error is detected, error
    PRINT Err$                            ' is displayed, and program
    PRINT "Calibration aborted."          ' is halted.
    BEEP
    CLOSE 1: CLOSE 2
    END
END IF
RETURN
'
Dly:                                      ' Delay routine.
T = TIMER
Lp: IF (TIMER - T) < 5 THEN GOTO Lp
RETURN
'
CheckOpt:                                ' Check for 1801.
PRINT #1, "OUTPUT 16;*OPT?"
PRINT #1, "ENTER 16"
LINE INPUT #2, OPT$
IF INSTR(OPT$, "1801") = 0 THEN
    PRINT "Model 1801 is not installed; program aborted."
    END
END IF
RETURN
'
CmdList:
DATA "Set 262 divider ratio to 10^2.", "Z1K"
DATA "Set 262 divider ratio to 10^3.", "Z10K"
DATA "Set 262 divider ratio to 10^4.", "Z100K"
DATA "Make sure divider is still set to 10^4.", "FS100K 20E-6"
DATA "Set 262 divider ratio to 10^3.", "FS10K 200E-6"
DATA "Set 262 divider ratio to 10^2.", "FS1K 2E-3"
DATA "Calculating constants...", "CALC"

```

Program B-4. Calibration Program for Use with Fluke 5700A Calibrator (Turbo C Version)

```

/* Model 1801 calibration program for use with the
Fluke 5700A calibrator. */

#include "ieeeeio.h"
#include <stdio.h>
#include <stdlib.h>
#include <conio.h>
#include <string.h>

main()
{
    static char *msg[] = {
        "Set 262 divider ratio to 10^2.",
        "Set 262 divider ratio to 10^3.",
        "Set 262 divider ratio to 10^4.",
        "Make sure divider is still set to 10^4.",
        "Set 262 divider ratio to 10^3.",
        "Set 262 divider ratio to 10^2.",
        "Calculating constants..."
    };
    static char *cmd[] = {
        ":cal:unpr:pre:z1k",":cal:unpr:pre:z10k",
        ":cal:unpr:pre:z100k",":cal:unpr:pre:fs100k 20e-6",
        ":cal:unpr:pre:fs10k 200e-6",
        ":cal:unpr:pre:fs1k 2e-3",
        ":cal:unpr:pre:calc"
    };
    void keypress(),errcheck(),checkopt();
    char date[10];
    int i,calend();
    if (ieeeeinit()==-1){
        printf("Cannot initialize interface.\n");
        exit(1);
    }
    ieeewt("remote 16\n"); /* Put 2001 in remote. */
    ieeewt("remote 04\n"); /* Put 5700A in remote. */
    ieeewt("clear\n"); /* Send DCL. */
    ieeewt("term lf eoi\n"); /* Set terminator. */
    ieeewt("output 16::syst:pres;*cls\n"); /* Initialize 2001. */
    ieeewt("output 16;*ese 1;*sre 32\n"); /* Enable OPC, SRQ. */
    ieeewt("output 04;*rst;*cls\n"); /* Reset 5700A. */
    checkopt(); /* Check for 1801. */
    clrscr(); /* Clear CRT. */
    printf("Model 1801 Calibration Program.\n");
    printf("This program controls the 5700A Calibrator.\n");
    printf("Model 262 divider ratios must be set manually.\n\n");
    ieeewt("output 04;out 1v,0 hz\n"); /* Set 2.2V range. */
    ieeewt("output 04;rangelck on\n"); /* Lock range. */
    ieeewt("output 04;extsense on\n"); /* Enable external sense */
    ieeewt("output 04;out 0 v,0 hz\n"); /* Output 0V. */
    ieeewt("output 04;oper\n"); /* Calibrator in operate. */
    printf("Set 262 to POS+ polarity.\n");
    printf("Wait two minutes for thermals to settle.\n");
    keypress();
    for(i=0;i<=6;i++) { /* Loop for cal points. */

```

Program B-4. Calibration Program for Use with Fluke 5700A Calibrator (Turbo C Version) Continued

```

    if(i==3) ieeewt("output 04;out 0.2 v,0 hz\n");
    printf("%s\n",msg[i]);
    if (i<6) keypress();
    if (i<6) delay(5000);
    ieeeptrf("output 16;%s;*opc\n",cmd[i]);
    calend(i);
}
ieeewt("output 04;stby\n");
errcheck();
printf("Enter calibration date (mm/dd/yy): ");
scanf("%s",date);
ieeeptrf("output 16::cal:unpr:pre:date '%s'\n",date);
printf("Enter calibration due date (mm/dd/yy): ");
scanf("%s",date);
ieeeptrf("output 16::cal:unpr:pre:ndue '%s'\n",date);
ieeewt("output 16::cal:unpr:pre:save\n");
printf("Calibration completed.\n");
}
void keypress() /* Wait for keypress. */
{
    printf("Press any key to continue.\n");
    while(kbhit()==0);
    getch();
}
int calend(n) /* Check for cal end. */
int n;
{
    char status[40];
    int stat;
    printf("Waiting for cal step %d completion.\n",n+1);
    do {
        ieeewt("status\n");
        ieeerd(status);
    }
    while (status[11]!='0');
    ieeewt("output 16;*esr?\n");
    ieeewt("enter 16\n");
    ieeescnf("%d",&stat);
    ieeewt("spoll 16\n");
    ieeescnf("%d",&stat);
}
void errcheck() /* Check for error. */
{
    char errbuf[100];
    ieeewt("output 16::syst:err?\n");
    ieeewt("enter 16\n");
    ieeerd(errbuf);
    if (atoi(errbuf) !=0){
        printf("%s\n",errbuf);
        printf("Calibration aborted.\n");
        exit (1);
    }
}
void checkopt() /* Check for 1801. */
{

```

Program B-4. Calibration Program for Use with Fluke 5700A Calibrator (Turbo C Version) Continued

```
char buf[40];
ieewt("output 16;*opt?\n");
ieewt("enter 16\n");
ieerd(buf);
if (strstr(buf,"1801") == NULL) {
    printf("Model 1801 is not installed;"
        " program aborted.\n");
    exit(1);
}
}
```

C

IEEE-488 Bus Command Summary

Table C-1 summarizes IEEE-488 bus commands associated exclusively with the Model 1801. Refer to the Model 2001 Operator's Manual for additional commands that can be used with the Model 1801.

Table C-1
IEEE-488 bus command summary

Command	Description
:INPut :PREamp :STATe :STATe? :FILTer <name> :FILTer?	Preamp control commands. Enables (ON or 1) or disables (OFF or 0) preamplifier. Returns preamp state (1=ON, 0=OFF). Selects preamp filter response (Name = SLOW MEDium FAST). Returns preamp filter state (SLOW, MED, or FAST).
[:SENSe[1]] :TEMPerature :DTCouple :TYPE <type> :TYPE? :USLope <value> :USLope? :RTEMperature <value> :RTEMperature? :TRANsducer DTC :TRANsducer?	Temperature control commands. Temperature path. Differential path. Select thermocouple type (type = J K T E R S B USER). Return thermocouple type (J K T E R S B USER). Select thermocouple slope (value = slope in V/°C). Return thermocouple slope (V/°C). Select reference thermocouple temperature (value = reference temperature in °C, °F, or K). Return thermocouple reference temperature (°C, °F, or K). Select differential thermocouple transducer. Return transducer type.

Table C-1 (Continued)

IEEE-488 bus command summary

Command	Description
:CALibration :UNPRotected :PREamp :G1K <value> :G1K? :G10K <value> :G10K? :G100K <value> :G100K? :Z1K :Z10K :Z100K :FS1K <value> :FS10K <value> :FS100K <value> :DATE "<string>" :DATE? :NDUE "<string>" :NDUE? :CALCulate :SAVE :ABORt	Calibration commands. Commands not protected by CAL switch. Preamp commands. Directly enter 2mV gain. Request 2mV gain constant. Directly enter 200 μ V gain. Request 200 μ V gain constant. Directly enter 20 μ V gain. Request 20 μ V gain constant. Measure 2mV range zero. Measure 200 μ V range zero. Measure 20 μ V range zero. Measure 2mV range full-scale <value>= 1E-3 to 2E-3 Measure 200 μ V range full- scale. <value> = 100E-6 to 200E-6. Measure 20 μ V range full- scale. <value > = 10E-6 to 20E-6 Send calibration date. Request calibration date. Send calibration due date. Request calibration due date. Calculate calibration constants. Save calibration constants in NVRAM. Abort calibration procedure.

Notes:

1. Angle brackets (<>) are used to indicate parameter type. Do not include brackets in programming message.
2. Upper-case letters indicate command short form.
3. Brackets ([]) indicate command is optional.
4. Commands must be sent in order listed in Table 5-3.

Index

A

AC voltage measurements 3-9
AC volts verification 4-6

B

Block diagram 5-10

C

Calibration 5-1
Calibration programs B-1
Card configuration 2-2
Card installation 2-5
Card removal 2-5
Component layouts and schematic diagrams 6-1
Connections 2-6

D

DC voltage measurements 3-7
DC volts verification 4-3
Differential thermocouple temperature measurements 3-14

E

Electromagnetic interference 3-22
Enabling Model 1801 operation 3-2
Environmental conditions 4-1, 5-1

F

Factory service 6-1
Features 1-1
Four-wire resistance measurements 3-11
Frequency measurements 3-11

G

Gain constants calibration 5-9
General information 1-1
General program instructions B-1
Ground loops 3-22

I

IEEE-488 bus command summary C-1
IEEE-488 bus operation 3-7
Input signal connections 2-7
Inspection for damage 1-2
Installation 2-1
Instruction manual 1-2
Introduction 1-1, 2-1, 3-1, 4-1, 5-1, 6-1, B-1

L

Line power 4-2, 5-2

M

Magnetic fields 3-21
Manual addenda 1-2
Measurement considerations 3-18
Measurements 3-7
Minimum operating distance 2-9
Model 2001 compatibility 1-3

N

Normal calibration 5-4

O

Offset adjustments 5-2
Operating considerations 2-9
Operation 3-1

Operational differences 3-5
Optional accessories 1-3
Ordering information 6-1
Output connections to multimeter 2-7

P

Parts lists 6-1
Performance verification 4-1
Power supply cable 5-10
Power supply card 2-3, 5-10
Power supply card installation and removal 2-5
Power supply card preparation 2-4
Power supply connections 2-6
Power-up detection 3-1
Preamp ON/OFF states 3-2
Preamplifier configuration menu 3-2
Preamplifier filtering 3-4
Preamplifier module 2-2, 5-10
Preamplifier operation 3-1
Principles of operation 5-10
Program requirements B-1

R

Recommended calibration equipment 5-2
Recommended test equipment 4-2
Repacking for shipment 1-2
Replaceable parts 6-1
Resistance verification 4-6
Restoring default conditions 4-3

S

Safety symbols and terms 1-2
Service information 5-1
Shielding 3-22
Shipment contents 1-2
Source resistance noise 3-20
Special handling of static-sensitive devices 5-12
Specifications 1-2, A-1

T

Thermoelectric potentials 3-18
Troubleshooting 5-12
Troubleshooting access 5-12
Troubleshooting equipment 5-12
Troubleshooting procedure 5-12

U

Unpacking and inspection 1-2
Using the thermal isolation container 2-9

V

Verification limits 4-2
Verification procedures 4-3

W

Warm-up period 4-2, 5-1
Warranty information 1-1



Service Form

Model No. _____ Serial No. _____ Date _____

Name and Telephone No. _____

Company _____

List all control settings, describe problem and check boxes that apply to problem. _____

- | | | |
|--|--|--|
| <input type="checkbox"/> Intermittent | <input type="checkbox"/> Analog output follows display | <input type="checkbox"/> Particular range or function bad; specify _____ |
| <input type="checkbox"/> IEEE failure | <input type="checkbox"/> Obvious problem on power-up | <input type="checkbox"/> Batteries and fuses are OK |
| <input type="checkbox"/> Front panel operational | <input type="checkbox"/> All ranges or functions are bad | <input type="checkbox"/> Checked all cables |

Display or output (check one)

- | | |
|-----------------------------------|--|
| <input type="checkbox"/> Drifts | <input type="checkbox"/> Unable to zero |
| <input type="checkbox"/> Unstable | <input type="checkbox"/> Will not read applied input |
| <input type="checkbox"/> Overload | |

- | | |
|---|--|
| <input type="checkbox"/> Calibration only | <input type="checkbox"/> Certificate of calibration required |
| <input type="checkbox"/> Data required | |

(attach any additional sheets as necessary)

Show a block diagram of your measurement system including all instruments connected (whether power is turned on or not). Also, describe signal source.

Where is the measurement being performed? (factory, controlled laboratory, out-of-doors, etc.)

What power line voltage is used? _____ Ambient temperature? _____ °F

Relative humidity? _____ Other? _____

Any additional information. (If special modifications have been made by the user, please describe.)

Be sure to include your name and phone number on this service form.

Specifications are subject to change without notice.

All Keithley trademarks and trade names are the property of Keithley Instruments, Inc. All other trademarks and trade names are the property of their respective companies.

KEITHLEY

Keithley Instruments, Inc.

28775 Aurora Road • Cleveland, Ohio 44139 • 440-248-0400 • Fax: 440-248-6168
1-888-KEITHLEY (534-8453) • www.keithley.com

Sales Offices: BELGIUM:

Bergensesteenweg 709 • B-1600 Sint-Pieters-Leeuw • 02-363 00 40 • Fax: 02/363 00 64

CHINA:

Yuan Chen Xin Building, Room 705 • 12 Yumin Road, Dewai, Madian • Beijing 100029 • 8610-6202-2886 • Fax: 8610-6202-2892

FINLAND:

Tietäjantie 2 • 02130 Espoo • Phone: 09-54 75 08 10 • Fax: 09-25 10 51 00

FRANCE:

3, allée des Garays • 91127 Palaiseau Cédex • 01-64 53 20 20 • Fax: 01-60 11 77 26

GERMANY:

Landsberger Strasse 65 • 82110 Germering • 089/84 93 07-40 • Fax: 089/84 93 07-34

GREAT BRITAIN:

Unit 2 Commerce Park, Brunel Road • Theale • Berkshire RG7 4AB • 0118 929 7500 • Fax: 0118 929 7519

INDIA:

Flat 2B, Willocrissa • 14, Rest House Crescent • Bangalore 560 001 • 91-80-509-1320/21 • Fax: 91-80-509-1322

ITALY:

Viale San Gimignano, 38 • 20146 Milano • 02-48 39 16 01 • Fax: 02-48 30 22 74

JAPAN:

New Pier Takeshiba North Tower 13F • 11-1, Kaigan 1-chome • Minato-ku, Tokyo 105-0022 • 81-3-5733-7555 • Fax: 81-3-5733-7556

KOREA:

FL., URI Building • 2-14 Yangjae-Dong • Seocho-Gu, Seoul 137-130 • 82-2-574-7778 • Fax: 82-2-574-7838

NETHERLANDS:

Postbus 559 • 4200 AN Gorinchem • 0183-635333 • Fax: 0183-630821

SWEDEN:

c/o Regus Business Centre • Frosundaviks Allé 15, 4tr • 169 70 Solna • 08-509 04 679 • Fax: 08-655 26 10

SWITZERLAND:

Kriesbachstrasse 4 • 8600 Dübendorf • 01-821 94 44 • Fax: 01-820 30 81

TAIWAN:

1FL., 85 Po Ai Street • Hsinchu, Taiwan, R.O.C. • 886-3-572-9077 • Fax: 886-3-572-9031