

Technical Summary

**Low Power HCMOS
16-/32-Bit Microprocessor**

3

This document contains both a summary of the MC68HC000 and a detailed set of parametrics. For detailed information on the MC68HC000, refer to the M68000 UM/AD, *M68000 8-/16-/32-Bit Microprocessor User's Manual*.

The primary benefit of the MC68HC000 is reduced power consumption. The device dissipates an order of magnitude less power than the HMOS MC68000.

The MC68HC000 is an implementation of the M68000 16-/32-bit microprocessor architecture. The MC68HC000 has a 16-bit data bus implementation of the M68000 and is upward code compatible with the MC68010 virtual extension and the MC68020 32-bit implementation of the architecture. Any user-mode programs using the MC68HC000 instruction set will run unchanged on the MC68000, MC68008, MC68010, MC68020, MC68030, and MC68040 because the user programming model is identical for all seven processors and the instruction sets are proper subsets of the complete architecture. The following resources are available to the MC68HC000 user:

- 17 32-Bit Data and Address Registers
- 16-Mbyte Direct Addressing Range
- 56 Powerful Instruction Types
- Operations on Five Main Data Types
- Memory-Mapped I/O
- 14 Addressing Modes

This document contains information on a new product. Specifications and information herein are subject to change without notice.

INTRODUCTION

As shown in the user programming model (see Figure 1), the MC68HC000 offers 16 32-bit registers and a 32-bit program counter. The first eight registers (D0–D7) are used as data registers for byte (8-bit), word (16-bit), and long-word (32-bit) operations. The second set of seven registers (A0–A6) and the user stack pointer (USP) can be used as software stack pointers and base address registers. In addition, the registers can be used for word and long-word operations. All 16 registers can be used as index registers.

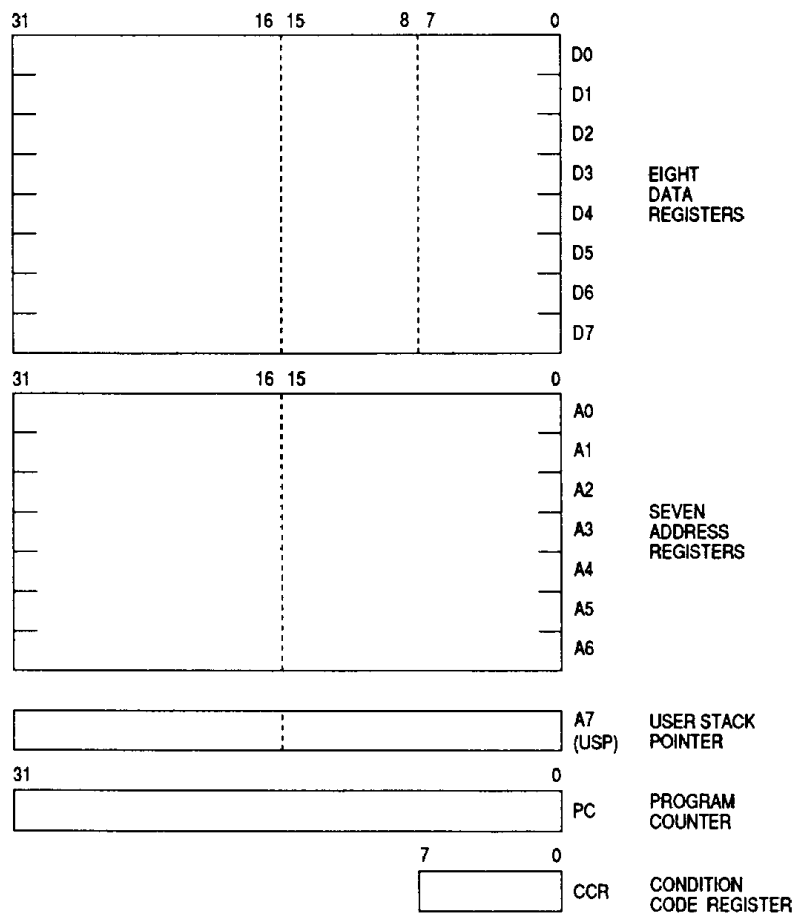

Figure 1. User Programming Model

In supervisor mode (see Figure 2), the upper byte of the status register (SR) and the supervisor stack pointer (SSP) are also available to the programmer.

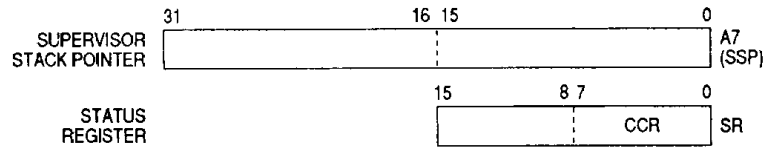

Figure 2. Supervisor Programming Model Supplement

3

The SR (see Figure 3) contains the interrupt mask (eight levels available) as well as the condition codes: extend (X), negative (N), zero (Z), overflow (V), and carry (C). Additional status bits indicate that the processor is in a trace (T) mode and in a supervisor (S) or user state.

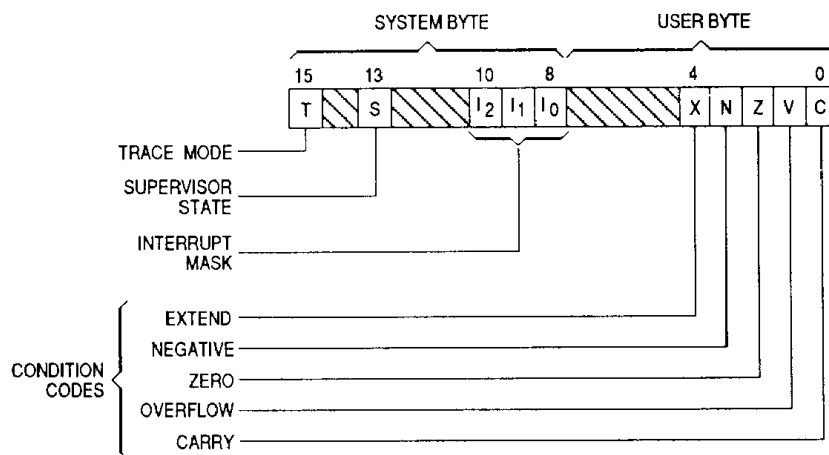

Figure 3. Status Register

DATA TYPES AND ADDRESSING MODES

Five basic data types are supported:

1. Bits
2. BCD Digits (4 Bits)
3. Bytes (8 Bits)
4. Words (16 Bits)
5. Long Words (32 Bits)

In addition, operations on other data types, such as memory addresses, status word data, etc., are provided in the instruction set.

The 14 addressing modes, listed in Table 1, include six basic types:

1. Register Direct
2. Register Indirect
3. Absolute
4. Program Counter Relative
5. Immediate
6. Implied

Included in the register indirect addressing modes is the capability to perform postincrementing, predecrementing, offsetting, and indexing. The program counter relative mode can also be modified via indexing and offsetting.

Table 1. Addressing Modes

Addressing Modes	Syntax
Register Direct Addressing Data Register Direct Address Register Direct	Dn An
Absolute Data Addressing Absolute Short Absolute Long	xxx.W xxx.L
Program Counter Relative Addressing Relative with Offset Relative with Index Offset	d ₁₆ (PC) dg(PC,Xn)
Register Indirect Addressing Register Indirect Postincrement Register Indirect Predecrement Register Indirect Register Indirect with Offset Indexed Register Indirect with Offset	(An) (An) + (An) d ₁₆ (An) dg(An,Xn)
Immediate Data Addressing Immediate Quick Immediate	#xxx #1r#8
Implied Addressing Implied Register	SR USP.SP.PC

NOTES:

- Dn = Data Register
- An = Address Register
- Xn = Address of Data Register Used as Index Register
- SR = Status Register
- PC = Program Counter
- SP = Stack Pointer
- USP = User Stack Pointer
- () = Effective Address
- dg = 8-Bit Offset (Displacement)
- d₁₆ = 16-Bit Offset (Displacement)
- #xxx = Immediate Data

INSTRUCTION SET OVERVIEW

The MC68HC000 instruction set is listed in Table 2. Additional instructions that are variations or subsets of these instructions are listed in Table 3. Special emphasis is given to the instruction set's support of structured high-level languages to facilitate ease of programming. Each instruction, with few exceptions, operates on bytes, words, and long words, and most instructions can use any of the 14 addressing modes. Combining instruction types, data types, and addressing modes, over 1000 useful instructions are provided. These instructions include signed and unsigned, multiply and divide, quick arithmetic operations, BCD arithmetic, and expanded operations (through traps). For detailed information on the MC68HC000 instruction set, refer to M68000 PM/AD, *M68000 Programmer's Reference Manual*.

3

Table 2. Instruction Set Summary

Mnemonic	Description	Mnemonic	Description
ABCD	Add Decimal with Extend	MOVE	Move
ADD	Add	MULS	Signed Multiply
AND	Logical AND	MULU	Unsigned Multiply
ASL	Arithmetic Shift Left	NBCD	Negate Decimal with Extend
ASR	Arithmetic Shift Right	NEG	Negate
Bcc	Branch Conditionally	NOP	No Operation
BCHG	Bit Test and Change	NOT	Ones Complement
BCLR	Bit Test and Clear	OR	Logical OR
BRA	Branch Always	PEA	Push Effective Address
BSET	Bit Test and Set	RESET	Reset External Devices
BSR	Branch to Subroutine	ROL	Rotate Left without Extend
BTST	Bit Test	ROR	Rotate Right without Extend
CHK	Check Register against Bounds	ROXL	Rotate Left with Extend
CLR	Clear Operand	ROXR	Rotate Right with Extend
CMP	Compare	RTE	Return from Exception
DBcc	Test Condition, Decrement and Branch	RTR	Return and Restore
DIVS	Signed Divide	RTS	Return from Subroutine
DIVU	Unsigned Divide	SBCD	Subtract Decimal with Extend
EOR	Exclusive OR	Scc	Set Conditional
EXG	Exchange Registers	STOP	Stop
EXT	Sign Extend	SUB	Subtract
JMP	Jump	SWAP	Swap Data Register Halves
JSR	Jump to Subroutine	TAS	Test and Set Operand
LEA	Load Effective Address	TRAP	Trap
LINK	Link Stack	TRAPV	Trap on Overflow
LSL	Logical Shift Left	TST	Test
LSR	Logical Shift Right	UNLK	Unlink

Table 3. Variations of Instruction Types

Instruction Type	Variation	Description
ADD	ADD ADDA ADDQ ADDI ADDX	Add Add Address Add Quick Add Immediate Add with Extend
AND	AND ANDI ANDI to CCR ANDI to SR	Logical AND And Immediate And Immediate to Condition Codes And Immediate to Status Register
CMP	CMP CMPA CMPM CMPI	Compare Compare Address Compare Memory Compare Immediate
EOR	EOR EORI EORI to CCR EORI to SR	Exclusive OR Exclusive OR Immediate Exclusive OR Immediate to Condition Codes Exclusive OR Immediate to Status Register
MOVE	MOVE MOVEA MOVEM MOVEP MOVEQ MOVE from SR MOVE to SR MOVE to CCR MOVE USP	Move Move Address Move Multiple Registers Move Peripheral Data Move Quick Move from Status Register Move to Status Register Move to Condition Codes Move User Stack Pointer
NEG	NEG NEGX	Negate Negate with Extend
OR	OR ORI ORI or CCR ORI to SR	Logical OR OR Immediate OR Immediate to Condition Codes OR Immediate to Status Register
SUB	SUB SUBA SUBI SUBQ SUBX	Subtract Subtract Address Subtract Immediate Subtract Quick Subtract with Extend

SIGNAL DESCRIPTION

The input and output signals are illustrated functionally in Figure 4 and are described in the following paragraphs.

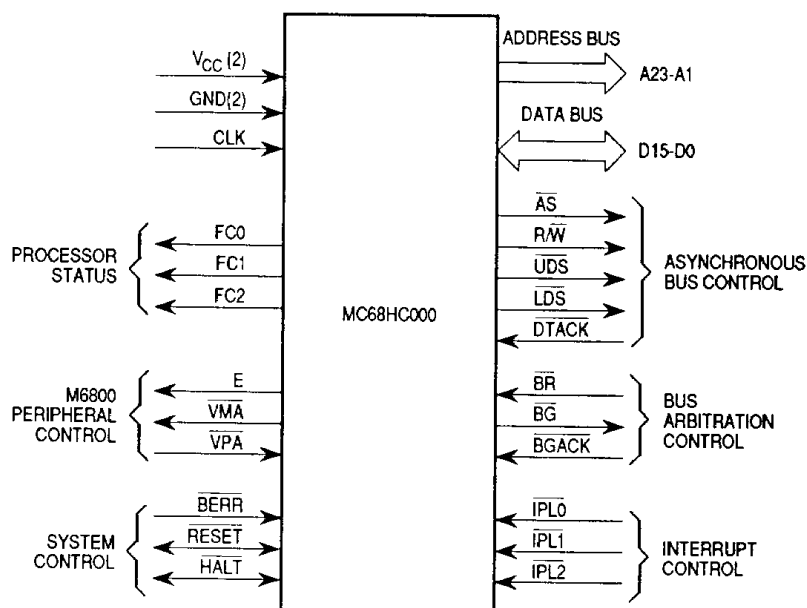

Figure 4. Functional Signal Groups

ADDRESS BUS (A1–A23)

This 24-bit, unidirectional, three-state bus is capable of addressing 16 Mbytes of data. It provides the address for bus operation during all cycles except interrupt cycles. During interrupt cycles, address lines A1, A2, and A3 provide information about what level interrupt is being serviced while address lines A4–A23 are set to a logic high.

DATA BUS (D0–D15)

This 16-bit, bidirectional, three-state bus is the general-purpose data path that can transfer and accept data in either word or byte length. During an interrupt acknowledge cycle, the external device supplies the vector number on data lines D0–D7.

ASYNCHRONOUS BUS CONTROL

Asynchronous data transfers are handled using the following control signals: address strobe, read/write, upper and lower data strobes, and data transfer acknowledge.

Address Strobe (\overline{AS})

This signal indicates a valid address on the address bus.

Read/Write (R/\overline{W})

This signal defines the data bus transfer as a read or write cycle. R/\overline{W} also works in conjunction with the data strobes as explained in the following paragraph.

3

Upper and Lower Data Strobe (\overline{UDS} , \overline{LDS})

These signals control the flow of data on the data bus, as listed in Table 4. When R/\overline{W} is high, the processor will read from the data bus as indicated. When R/\overline{W} is low, the processor will write to the data bus as shown.

Table 4. Data Strobe Control of Data Bus

\overline{UDS}	\overline{LDS}	R/\overline{W}	D8-D15	D0-D7
1	1	—	No Valid Data	No Valid Data
0	0	1	Valid Data Bits 8-15	Valid Data Bits 0-7
1	0	1	No Valid Data	Valid Data Bits 0-7
0	1	1	Valid Data Bits 8-15	No Valid Data
0	0	0	Valid Data Bits 8-15	Valid Data Bits 0-7
1	0	0	Valid Data Bits 0-7*	Valid Data Bits 0-7
0	1	0	Valid Data Bits 8-15	Valid Data Bits 8-15*

*These conditions are a result of current implementation and may not appear on future devices.

Data Transfer Acknowledge ($\overline{\text{DTACK}}$)

This input indicates that the data transfer is complete. When the processor recognizes $\overline{\text{DTACK}}$ during a read cycle, data is latched and the bus cycle is terminated. When $\overline{\text{DTACK}}$ is recognized during a write cycle, the bus cycle is terminated.

BUS ARBITRATION CONTROL

3

Bus request, bus grant, and bus grant acknowledge form a bus arbitration circuit to determine which device will be the bus master.

Bus Request ($\overline{\text{BR}}$)

This input is wire-ORed with all other devices that could be bus masters. This input indicates to the processor that some other device desires to become the bus master.

Bus Grant ($\overline{\text{BG}}$)

This output indicates to all other potential bus master devices that the processor will release bus control at the end of the current bus cycle.

Bus Grant Acknowledge ($\overline{\text{BGACK}}$)

This input indicates that some other device has become the bus master. This signal should not be asserted until the following four conditions are met:

1. A bus grant has been received.
2. Address strobe is inactive, which indicates that the microprocessor is not using the bus.
3. Data transfer acknowledge is inactive, which indicates that neither memory nor peripherals are using the bus.
4. Bus grant acknowledge is inactive, which indicates that no other device is claiming bus mastership.

INTERRUPT CONTROL ($\overline{\text{IPL0}}$, $\overline{\text{IPL1}}$, $\overline{\text{IPL2}}$)

These inputs indicate the encoded priority level of the device requesting an interrupt. Level 7 is the highest priority; whereas, level 0 indicates that no interrupts are requested. Level 7 cannot be masked. The least significant bit is given in $\overline{\text{IPL0}}$, and the most significant bit is contained in $\overline{\text{IPL2}}$. These lines must

remain stable until the processor signals interrupt acknowledge (FC0–FC2 are all high) to ensure that the interrupt is recognized.

SYSTEM CONTROL

The three system control inputs are used to reset or halt the processor and to indicate to the processor that bus errors have occurred.

Bus Error ($\overline{\text{BERR}}$)

This input informs the processor that there is a problem with the cycle currently being executed. Problems may be a result of:

1. Nonresponding devices
2. Interrupt vector number acquisition failure
3. Illegal access request as determined by a memory management unit
4. Other application-dependent errors

The bus error signal interacts with the halt signal to determine if the current bus cycle should be re-executed or if exception processing should be performed.

3

Reset ($\overline{\text{RESET}}$)

This bidirectional signal resets (starts a system initialization sequence) the processor in response to an external reset signal. An internally generated reset (result of a RESET instruction) causes all external devices to be reset, and the internal state of the processor is not affected. A total system reset (processor and external devices) is the result of external $\overline{\text{HALT}}$ and $\overline{\text{RESET}}$ signals applied simultaneously.

Halt ($\overline{\text{HALT}}$)

When this bidirectional signal is driven by an external device, it causes the processor to stop at the completion of the current bus cycle. When the processor is halted using this input, all control signals are inactive and all three-state lines are put in their high-impedance state.

When the processor stops executing instructions, such as in a double bus fault condition, the $\overline{\text{HALT}}$ line is driven by the processor to indicate to external devices that the processor has stopped.

M6800 PERIPHERAL CONTROL

These control signals are used to interface synchronous M6800 peripheral devices with the asynchronous MC68HC000.

Enable (E)

This signal is the standard enable signal common to all M6800-type peripheral devices. The period for this output is 10 MC68HC000 clock periods (six clocks low, four clocks high). Enable is generated by an internal ring counter which may come up in any state (i.e., at power-on, it is impossible to guarantee phase relationship of E to CLK). E is a free-running clock and runs regardless of the state of the bus on the MPU.

3

Valid Peripheral Address ($\overline{\text{VPA}}$)

This input indicates that the device or region addressed is an M6800 Family device and that data transfer should be synchronized with the enable (E) signal. This input also indicates that the processor should use automatic vectoring for an interrupt during an IACK cycle.

Valid Memory Address ($\overline{\text{VMA}}$)

This output is used to indicate to M6800 peripheral devices that a valid address exists on the address bus and that the processor is synchronized to enable. This signal only responds to a valid peripheral address ($\overline{\text{VPA}}$) input, which indicates that the peripheral is an M6800 Family device.

PROCESSOR STATUS (FC0, FC1, FC2)

These function code outputs indicate the state (user or supervisor) and the cycle type currently being executed (see Table 5). The information indicated by the function code outputs is valid whenever address strobe (AS) is active.

Table 5. Function Code Outputs

Function Code Output			Cycle Type
FC2	FC1	FC0	
0	0	0	(Undefined, Reserved)
0	0	1	User Data
0	1	0	User Program
0	1	1	(Undefined, Reserved)
1	0	0	(Undefined, Reserved)
1	0	1	Supervisor Data
1	1	0	Supervisor Program
1	1	1	Interrupt Acknowledge

CLOCK (CLK)

The clock input is a TTL-compatible signal that is internally buffered for development of the internal clocks needed by the processor. The clock input should not be gated off at any time, and the clock signal must conform to minimum and maximum pulse width times. The clock is a constant frequency square wave with no stretching or shaping techniques required.

DATA TRANSFER OPERATIONS

Transfer of data between devices involves the following signals:

1. Address bus A1–A23
2. Data bus D0–D15
3. Control signals

The address and data buses are separate parallel buses used to transfer data using an asynchronous bus structure. In all cycles, the bus master assumes responsibility for deskewing all signals its issues at both the start and end of a cycle. In addition, the bus master is responsible for deskewing the acknowledge and data signals from the slave device.

The following paragraphs explain the read, write, and read-modify-write cycles. The indivisible read-modify-write cycle is the method used by the MC68HC000 for interlocked multiprocessor communications.

READ CYCLE

During a read cycle, the processor receives data from either the memory or a peripheral device. The processor reads bytes of data in all cases. If the instruc-

tion specifies a word (or double word) operation, the processor reads both upper and lower bytes simultaneously by asserting both upper and lower data strobes. When the instruction specifies byte operation, the processor uses an internal A0 bit to determine which byte to read and then issues the data strobe required for that byte. For byte operations, when A0 equals zero, the upper data strobe is issued. When A0 equals one, the lower data strobe is issued. When the data is received, the processor correctly positions it internally.

3

WRITE CYCLE

During a write cycle, the processor sends data to either the memory or a peripheral device. The processor writes bytes of data in all cases. If the instruction specifies a word operation, the processor writes both bytes. When the instruction specifies a byte operation, the processor uses an internal A0 bit to determine which byte to write and then issues the data strobe required for that byte. For byte operations, when A0 equals zero, the upper data strobe is issued. When A0 equals one, the lower data strobe is issued.

READ-MODIFY-WRITE CYCLE

The read-modify-write cycle performs a read, modifies the data in the arithmetic logic unit, and writes the data back to the same address. In the MC68HC000, this cycle is indivisible in that the address strobe is asserted throughout the entire cycle. The test and set (TAS) instruction uses this cycle to provide meaningful communication between processors in a multiple processor environment. TAS is the only instruction that uses the read-modify-write cycles; since TAS only operates on bytes, all read-modify-write cycles are byte operations.

PROCESSING STATES

The MC68HC000 is always in one of three processing states: normal, exception, or halted.

NORMAL PROCESSING

The normal processing state is that associated with instruction execution; the memory references are to fetch instructions and operands and to store results. A special case of normal state is the stopped state which the processor enters when a stop instruction is executed. In this state, no further references are made.

EXCEPTION PROCESSING

The exception processing state is associated with interrupts, trap instructions, tracing, and other exception conditions. The exception may be internally generated by an instruction or by an unusual condition arising during the execution of an instruction. Externally, exception processing can be forced by an interrupt, a bus error, or a reset. Exception processing is designed to provide an efficient context switch so that the processor may handle unusual conditions.

HALTED PROCESSING

The halted processing state is an indication of catastrophic hardware failure. For example, if, during the exception processing of a bus error, another bus error occurs, the processor assumes that the system is unusable and halts. Only an external reset can restart a halted processor. Note that a processor in the stopped state is not in the halted state, nor vice versa.

3

INTERFACE WITH M6800 PERIPHERALS

Motorola's extensive line of M6800 peripherals are directly compatible with the MC68HC000. Some devices that are particularly useful are as follows:

- MC6821 Peripheral Interface Adapter
- MC6840 Programmable Timer Module
- MC6845 CRT Controller
- MC6850 Asynchronous Communications Interface Adapter
- MC6854 Advanced Data Link Controller

To interface the synchronous M6800 peripherals with the asynchronous MC68HC000, the processor modifies its bus cycle to meet the M6800 cycle requirements whenever an M6800 device address is detected. This modification is possible since both processors use memory-mapped I/O.

ELECTRICAL SPECIFICATIONS

MAXIMUM RATINGS

Rating	Symbol	Value	Unit
Supply Voltage	V_{CC}	0.3 to - 6.5	V
Input Voltage	V_{in}	0.3 to - 6.5	V
Operating Temperature Range MC68HC000	T_A	T_L to T_H 0 to 70	C
Storage Temperature	T_{stg}	55 to - 150	C

This device contains circuitry to protect the inputs against damage due to high static voltages or electric fields; however, it is advised that normal precautions be taken to avoid application of any voltage higher than maximum-rated voltages to this high-impedance circuit. Reliability of operation is enhanced if unused inputs are tied to the appropriate logic voltage level (e.g., either GND or V_{CC}).

3

THERMAL CHARACTERISTICS

Characteristic	Symbol	Value	Symbol	Value	Rating
Thermal Resistance (Still Air)	θ_{JA}		θ_{JC}		C W
Ceramic, Type L LC		30		15*	
Ceramic, Type R RC		33		15	
Plastic, Type P		30		15*	
Plastic, Type FN		45*		25*	

*Estimated

CMOS CONSIDERATIONS

The MC68HC000, with its significantly lower power consumption, has other considerations. The CMOS cell is basically composed of two complementary transistors (a P channel and an N channel), and only one transistor is turned on while the cell is in the steady state. The active P-channel transistor sources current when the output is a logic high and presents a high impedance when the output is a logic low. Thus, the overall result is extremely low power consumption because no power is lost through the active P-channel transistor. Also, since only one transistor is turned on during the steady state, power consumption is determined by leakage currents.

Because the basic CMOS cell is composed of two complementary transistors, a virtual semiconductor controlled rectifier (SCR) may be formed when an input exceeds the supply voltage. The SCR that is formed by this high input causes the device to become latched in a mode that may result in excessive current drain and eventual destruction of the device. Although the MC68HC000 is implemented with input protection diodes, care should be exercised to ensure that the maximum input voltage specification is not exceeded. Some systems may require that the CMOS circuitry be isolated from voltage transients; others may require no additional circuitry.

The MC68HC000, implemented in CMOS, is applicable to designs for which the following considerations are relevant:

1. The MC68HC000 completely satisfies the input/output drive requirements of CMOS logic devices.
2. The HCMOS MC68HC000 provides an order of magnitude reduction in power dissipation when compared to the HMOS MC68000. However, the MC68HC000 does not offer a power-down mode. The minimum operating frequency of the MC68HC000 is 4 MHz.

AC ELECTRICAL SPECIFICATIONS DEFINITIONS

The AC specifications presented consist of output delays, input setup and hold times, and signal skew times. All signals are specified relative to an appropriate edge of the clock and possibly to one or more other signals.

The measurement of the AC specifications is defined by the waveforms shown in Figure 5. To test the parameters guaranteed by Motorola, inputs must be driven to the voltage levels specified in that figure. Outputs are specified with minimum and/or maximum limits, as appropriate, and are measured as shown in Figure 5. Inputs are specified with minimum setup and hold times, and are measured as shown. Finally, the measurement for signal-to-signal specifications is also shown.

NOTE

The testing levels used to verify conformance to the AC specifications does not affect the guaranteed DC operation of the device as specified in the DC electrical characteristics.

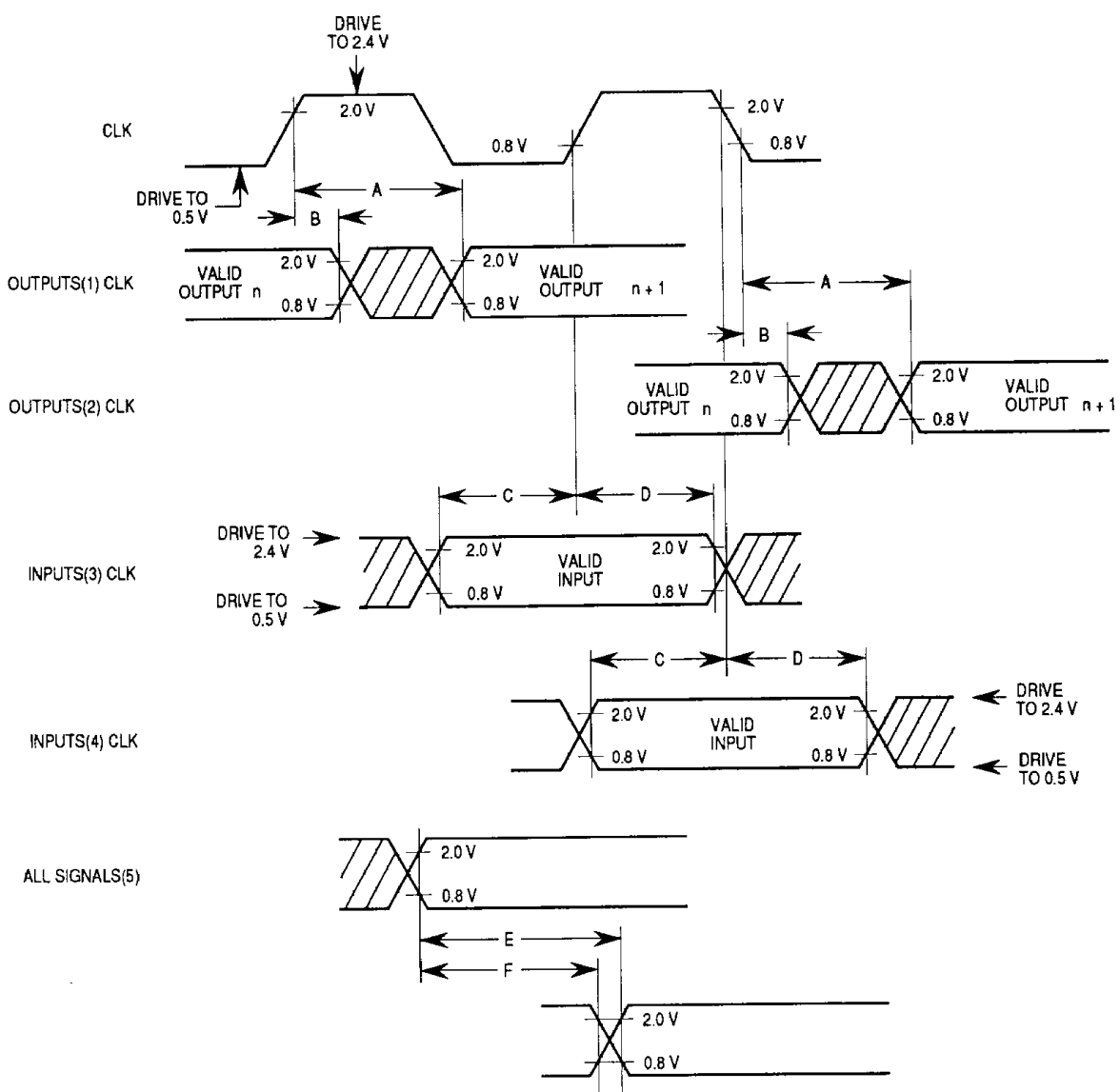

NOTES:

1. This output timing is applicable to all parameters specified relative to the rising edge of the clock.
2. This output timing is applicable to all parameters specified relative to the falling edge of the clock.
3. This input timing is applicable to all parameters specified relative to the rising edge of the clock.
4. This input timing is applicable to all parameters specified relative to the falling edge of the clock.
5. This timing is applicable to all parameters specified relative to the assertion/negation of another signal.

LEGEND:

- A. Maximum output delay specification.
- B. Minimum output hold time.
- C. Minimum input setup time specification.
- D. Minimum input hold time specification.
- E. Signal valid to signal valid specification (maximum or minimum).
- F. Signal valid to signal invalid specification (maximum or minimum).

Figure 5. Drive Levels and Test Points for AC Specifications

AC ELECTRICAL SPECIFICATIONS — CLOCK TIMING (See Figure 6)

Num.	Characteristic	8 MHz*		10 MHz*		12.5 MHz*		16.67 MHz '12F'		16.67 MHz		Unit
		Min	Max	Min	Max	Min	Max	Min	Max	Min	Max	
	Frequency of Operation	4.0	8.0	4.0	10.0	4.0	12.5	8.0	16.7	8.0	16.7	MHz
1	Cycle Time	125	250	100	250	80	250	60	125	60	125	ns
2,3	Clock Pulse Width (Measured from 1.5 V to 1.5 V for 12F)	55	125	45	125	35	125	27	62.5	27	62.5	ns
4,5	Clock Rise and Fall Times	—	10	—	10	—	5	—	5	—	5	ns

*These specifications represent an improvement over previously published specifications for the 8-, 10-, and 12.5-MHz MC68HC000 and are valid only for product bearing date codes of 8827 and later.

3

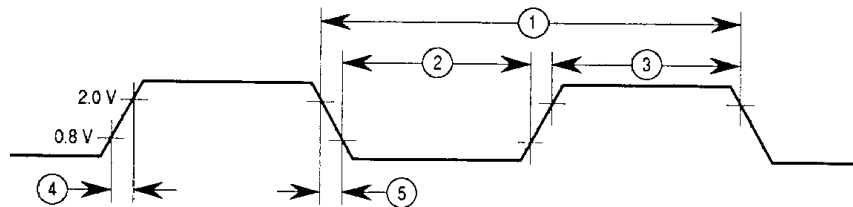

NOTE: Timing measurements are referenced to and from a low voltage of 0.8 V and a high voltage of 2.0 V, unless otherwise noted. The voltage swing through this range should start outside and pass through the range such that the rise or fall will be linear between 0.8 V and 2.0 V.

Figure 6. Clock Input Timing Diagram

DC ELECTRICAL SPECIFICATIONS (V_{CC} = 5.0 Vdc ± 5%; GND = 0 Vdc; T_A = T_L to T_H)

Characteristic	Symbol	Min	Max	Unit
Input High Voltage	V _{IH}	2.0	V _{CC}	V
Input Low Voltage	V _{IL}	GND - 0.3	0.8	V
Input Leakage Current <small>(V_I = 5.25 V)</small>	BERR, BGACK, BR, DTACK, CLK, I _{PL0} -I _{PL2} , VPA HALT, RESET	i _{in}	— 2.5 20	— μA μA
Three-State (Off State) Input Current <small>(V_I = 2.4 V, 0.4 V)</small>	AS, A1-A23, D0-D15, FC0-FC2, LDS, R.W, UDS, VMA	I _{TSI}	— 20	— μA
Output High Voltage <small>(I_{OH} = -400 μA)</small>	E, AS, A1-A23, BG, D0-D15, FC0-FC2, LDS, R.W, UDS, VMA	V _{OH}	V _{CC} - 0.75	— V
Output Low Voltage <small>(I_{OL} = 1.6 mA)</small> <small>(I_{OL} = 3.2 mA)</small> <small>(I_{OL} = 5.0 mA)</small> <small>(I_{OL} = 5.3 mA)</small>	HALT A1-A23, BG, FC0-FC2 RESET E, AS, D0-D15, LDS, R.W, UDS, VMA	V _{OL}	— — — —	0.5 0.5 0.5 0.5 V
Current Dissipation*	f = 8 MHz f = 10 MHz f = 12.5 MHz f = 16.67 MHz	I _D	— — — —	25 30 35 50 mA
Power Dissipation	f = 8 MHz f = 10 MHz f = 12.5 MHz f = 16.67 MHz	P _D	— — — —	0.13 0.16 0.19 0.26 W
Capacitance (V _{in} = 0 V, T _A = 25°C, Frequency = 1 MHz)**		C _{in}	—	20.0 pF
Load Capacitance	HALT All Others	C _L	— —	70 130 pF

*Currents listed are with no loading.

**Capacitance is periodically sampled rather than 100% tested.

3

AC ELECTRICAL SPECIFICATIONS — READ AND WRITE CYCLES

(V_{CC}=5.0 Vdc±5%; GND=0 Vdc; T_A=T_L to T_H; see Figures 7 and 8)

Num.	Characteristic	8 MHz*		10 MHz*		12.5 MHz*		16.67 MHz '12F'		16.67 MHz		Unit
		Min	Max	Min	Max	Min	Max	Min	Max	Min	Max	
6	Clock Low to Address Valid	—	62	—	50	—	50	—	50	—	30	ns
6A	Clock High to FC Valid	—	62	—	50	—	45	—	45	—	30	ns
7	Clock High to Address, Data Bus High Impedance (Maximum)	—	80	—	70	—	60	—	50	—	50	ns
8	Clock High to Address, FC Invalid (Minimum)	0	—	0	—	0	—	0	—	0	—	ns
9 ¹	Clock High to \overline{AS} , \overline{DS} Asserted	3	60	3	50	3	40	3	40	3	30	ns
11 ²	Address Valid to \overline{AS} , \overline{DS} Asserted (Read)/ \overline{AS} Asserted (Write)	30	—	20	—	15	—	15	—	15	—	ns
11A ²	FC Valid to \overline{AS} , \overline{DS} Asserted (Read)/ \overline{AS} Asserted (Write)	90	—	70	—	60	—	30	—	45	—	ns
12 ¹	Clock Low to \overline{AS} , \overline{DS} Negated	—	62	—	50	—	40	—	40	3	30	ns
13 ²	\overline{AS} , \overline{DS} Negated to Address, FC Invalid	40	—	30	—	20	—	10	—	15	—	ns
14 ²	\overline{AS} (and \overline{DS} Read) Width Asserted	270	—	195	—	160	—	120	—	120	—	ns
14A	\overline{DS} Width Asserted (Write)	140	—	95	—	80	—	60	—	60	—	ns
15 ²	\overline{AS} , \overline{DS} Width Negated	150	—	105	—	65	—	60	—	60	—	ns
16	Clock High to Control Bus High Impedance	—	80	—	70	—	60	—	50	—	50	ns
17 ²	\overline{AS} , \overline{DS} Negated to R/ \overline{W} Invalid	40	—	30	—	20	—	10	—	15	—	ns
18 ¹	Clock High to R/ \overline{W} High (Read)	0	55	0	45	0	40	0	40	0	30	ns
20 ¹	Clock High to R/ \overline{W} Low (Write)	0	55	0	45	0	40	0	40	0	30	ns
20A ^{2,6}	\overline{AS} Asserted to R/ \overline{W} Valid (Write)	—	10	—	10	—	10	—	10	—	10	ns
21 ²	Address Valid to R/ \overline{W} Low (Write)	20	—	0	—	0	—	0	—	0	—	ns
21A ²	FC Valid to R/ \overline{W} Low (Write)	60	—	50	—	30	—	20	—	30	—	ns
22 ²	R/ \overline{W} Low to \overline{DS} Asserted (Write)	80	—	50	—	30	—	20	—	30	—	ns
23	Clock Low to Data-Out Valid (Write)	—	62	—	50	—	50	—	50	—	30	ns
25 ²	\overline{AS} , \overline{DS} Negated to Data-Out Invalid (Write)	40	—	30	—	20	—	15	—	15	—	ns
26 ²	Data-Out Valid to \overline{DS} Asserted (Write)	40	—	30	—	20	—	15	—	15	—	ns
27 ⁵	Data-In Valid to Clock Low (Setup Time on Read)	10	—	10	—	10	—	7	—	5	—	ns
28 ²	\overline{AS} , \overline{DS} Negated to \overline{DTACK} Negated (Asynchronous Hold)	0	240	0	190	0	150	0	110	ns	0	110
28A	Clock High to \overline{DTACK} Negated	—	—	—	—	—	—	—	—	0	110	ns
29	\overline{AS} , \overline{DS} Negated to Data-In Invalid (Hold Time on Read)	0	—	0	—	0	—	0	—	0	—	ns
29A	\overline{AS} , \overline{DS} Negated to Data-In High Impedance	—	187	—	150	—	120	—	90	—	90	ns
30	\overline{AS} , \overline{DS} Negated to \overline{BERR} Negated	0	—	0	—	0	—	0	—	0	—	ns
31 ^{2,5}	\overline{DTACK} Asserted to Data-In Valid (Setup Time)	—	90	—	65	—	50	—	40	—	50	ns
32	\overline{HALT} and \overline{RESET} Input Transition Time	0	200	0	200	0	200	0	150	—	150	ns
33	Clock High to \overline{BG} Asserted	—	62	—	50	—	40	—	40	0	30	ns
34	Clock High to \overline{BG} Negated	—	62	—	50	—	40	—	40	0	30	ns
35	\overline{BR} Asserted to \overline{BG} Asserted	1.5	3.5	1.5	3.5	1.5	3.5	1.5	3.5	1.5	3.5	Clks
36 ⁷	\overline{BR} Negated to \overline{BG} Negated	1.5	3.5	1.5	3.5	1.5	3.5	1.5	3.5	1.5	3.5	Clks
37	\overline{BGACK} Asserted to \overline{BG} Negated	1.5	3.5	1.5	3.5	1.5	3.5	1.5	3.5	1.5	3.5	Clks

AC ELECTRICAL SPECIFICATIONS — READ AND WRITE CYCLES (Cont'd)

Num.	Characteristic	8 MHz*		10 MHz*		12.5 MHz*		16.67 MHz '12F'		16.67 MHz		Unit
		Min	Max	Min	Max	Min	Max	Min	Max	Min	Max	
37A ⁸	$\overline{\text{BGACK}}$ Asserted to $\overline{\text{BR}}$ Negated	20	1.5 Clks	20	1.5 Clks	20	1.5 Clks	10	1.5 Clks	10	1.5 Clks	ns
38	$\overline{\text{BG}}$ Asserted to Control, Address, Data Bus High Impedance ($\overline{\text{AS}}$ Negated)	—	80	—	70	—	60	—	50	—	50	ns
39	$\overline{\text{BG}}$ Width Negated	1.5	—	1.5	—	1.5	—	1.5	—	1.5	—	Clks
40	Clock Low to $\overline{\text{VMA}}$ Asserted	—	70	—	70	—	70	—	50	—	50	ns
41	Clock Low to E Transition	—	55	—	45	—	35	—	35	—	35	ns
42	E Output Rise and Fall Time	—	15	—	15	—	15	—	15	—	15	ns
43	$\overline{\text{VMA}}$ Asserted to E High	200	—	150	—	90	—	80	—	80	—	ns
44	$\overline{\text{AS}}$, $\overline{\text{DS}}$ Negated to $\overline{\text{VPA}}$ Negated	0	120	0	90	0	70	0	50	0	50	ns
45	E Low to Control, Address Bus Invalid (Address Hold Time)	30	—	10	—	10	—	10	—	10	—	ns
46	$\overline{\text{BGACK}}$ Width Low	1.5	—	1.5	—	1.5	—	1.5	—	1.5	—	Clks
47 ⁵	Asynchronous Input Setup Time	10	—	10	—	10	—	10	—	5	—	ns
48 ^{2,3}	$\overline{\text{BERR}}$ Asserted to $\overline{\text{DTACK}}$ Asserted	20	—	20	—	20	—	10	—	10	—	ns
49 ⁹	$\overline{\text{AS}}$, $\overline{\text{DS}}$, Negated to E Low	-70	70	-55	55	-45	45	-35	35	-35	35	ns
50	E Width High	450	—	350	—	280	—	220	—	220	—	ns
51	E Width Low	700	—	550	—	440	—	340	—	340	—	ns
52	Data-In Hold from Clock High	—	—	—	—	—	—	—	—	0	—	ns
53	Data-Out Hold from Clock High	0	—	0	—	0	—	0	—	0	—	ns
54	E Low to Data-Out Invalid	30	—	20	—	15	—	10	—	10	—	ns
55	$\overline{\text{R/W}}$ Asserted to Data Bus Impedance Change	30	—	20	—	10	—	0	—	0	—	ns
56 ⁴	$\overline{\text{HALT/RESET}}$ Pulse Width	10	—	10	—	10	—	10	—	10	—	Clks
57	$\overline{\text{BGACK}}$ Negated to $\overline{\text{AS}}$, $\overline{\text{DS}}$, $\overline{\text{R/W}}$ Driven	1.5	—	1.5	—	1.5	—	1.5	—	1.5	—	Clks
57A	$\overline{\text{BGACK}}$ Negated to FC, $\overline{\text{VMA}}$ Driven	1	—	1	—	1	—	1	—	1	—	Clks
58 ⁷	$\overline{\text{BR}}$ Negated to $\overline{\text{AS}}$, $\overline{\text{DS}}$, $\overline{\text{R/W}}$ Driven	1.5	—	1.5	—	1.5	—	1.5	—	1.5	—	Clks
58A ⁷	$\overline{\text{BR}}$ Negated to FC, $\overline{\text{VMA}}$ Driven	1	—	1	—	1	—	1	—	1	—	Clks

*These specifications represent improvement over previously published specifications for the 8-, 10-, and 12.5-MHz MC68HC000 and are valid only for product bearing date codes of 8827 and later.

NOTES:

- For a loading capacitance of less than or equal to 50 pF, subtract 5 ns from the value given in the maximum columns.
- Actual value depends on clock period.
- If #47 is satisfied for both $\overline{\text{DTACK}}$ and $\overline{\text{BERR}}$, #48 may be ignored. In the absence of $\overline{\text{DTACK}}$, $\overline{\text{BERR}}$ is an asynchronous input using the asynchronous input setup time (#47).
- For power-up, the MC68HC000 must be held in the reset state for 100 ms to allow stabilization of on-chip circuitry. After the system is powered up, #56 refers to the minimum pulse width required to reset the processor.
- If the asynchronous input setup time (#47) requirement is satisfied for $\overline{\text{DTACK}}$, the $\overline{\text{DTACK}}$ -asserted to data setup time (#31) requirement can be ignored. The data must only satisfy the data-in to clock low setup time (#27) for the following clock cycle.
- When $\overline{\text{AS}}$ and $\overline{\text{R/W}}$ are equally loaded ($\pm 20\%$), subtract 5 ns from the values given in these columns.
- The processor will negate $\overline{\text{BG}}$ and begin driving the bus again if external arbitration logic negates $\overline{\text{BR}}$ before asserting $\overline{\text{BGACK}}$.
- The minimum value must be met to guarantee proper operation. If the maximum value is exceeded, $\overline{\text{BG}}$ may be re-asserted.
- The falling edge of S6 triggers both the negation of the strobes ($\overline{\text{AS}}$ and $\overline{\text{DS}}$) and the falling edge of E. Either of these events can occur first, depending upon the loading on each signal. Specification #49 indicates the absolute maximum skew that will occur between the rising edge of the strobes and the falling edge of E.

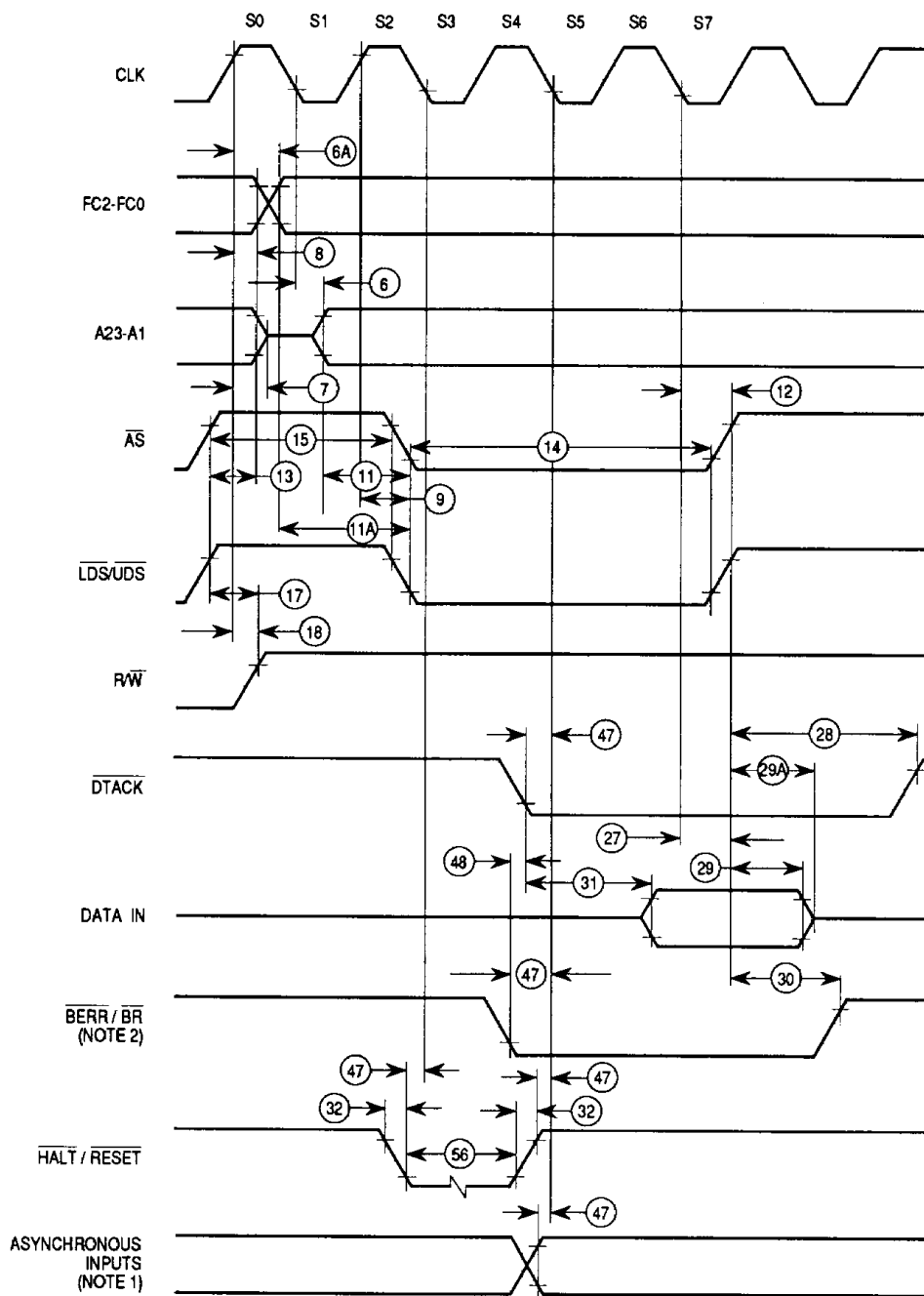

NOTES:

1. Setup time for the asynchronous inputs $\overline{IPL2}$ - $\overline{IPL0}$ and \overline{VPA} (#47) guarantees their recognition at the next falling edge of the clock.
2. \overline{BR} need fall at this time only to ensure being recognized at the end of the bus cycle.
3. Timing measurements are referenced to and from a low voltage of 0.8 V and a high voltage of 2.0 V, unless otherwise noted. The voltage swing through this range should start outside and pass through the range such that the rise or fall is linear between 0.8 V and 2.0 V.

Figure 7. Read Cycle Timing Diagram

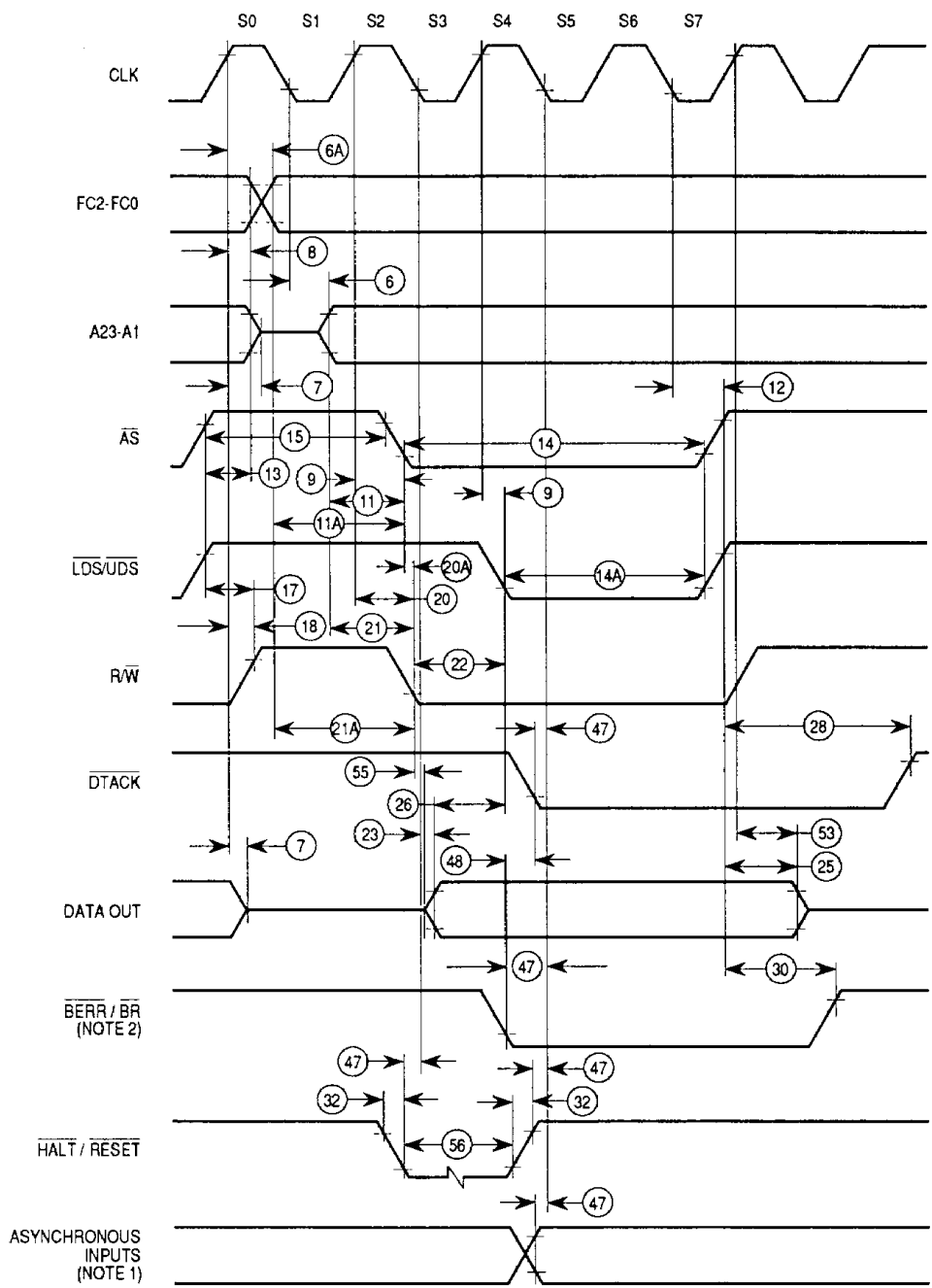

- NOTES:
1. Timing measurements are referenced to and from a low voltage of 0.8 V and a high voltage of 2.0 V, unless otherwise noted. The voltage swing through this range should start outside and pass through the range such that the rise or fall is linear between 0.8 V and 2.0 V.
 2. Because of loading variations, R/\overline{W} may be valid after \overline{AS} even though both are initiated by the rising edge of S2 (specification #20A).

Figure 8. Write Cycle Timing Diagram

AC ELECTRICAL SPECIFICATIONS — PERIPHERAL CYCLES TO M6800

(V_{CC} = 5.0 Vdc ± 5%; GND = 0 Vdc; T_A = T_L to T_H; see Figures 9 and 10)

Num.	Characteristic	8 MHz*		10 MHz*		12.5 MHz*		16.67 MHz '12F'		16.67 MHz		Unit
		Min	Max	Min	Max	Min	Max	Min	Max	Min	Max	
12 ¹	Clock Low to \overline{AS} , \overline{DS} Negated	—	62	—	50	—	40	—	40	3	30	ns
18 ¹	Clock High to R/ \overline{W} High (Read)	0	55	0	45	0	40	0	40	0	30	ns
20 ¹	Clock High to R/ \overline{W} Low (Write)	0	55	0	45	0	40	0	40	0	30	ns
23	Clock Low to Data-Out Valid (Write)	—	62	—	50	—	50	—	50	—	30	ns
27	Data-In Valid to Clock Low (Setup Time of Read)	10	—	10	—	10	—	7	—	5	—	ns
29	\overline{AS} , \overline{DS} Negated to Data-In Invalid (Hold Time on Read)	0	—	0	—	0	—	0	—	0	—	ns
40	Clock Low to \overline{VMA} Asserted	—	70	—	70	—	70	—	50	—	50	ns
41	Clock Low to E Transition	—	55	—	45	—	35	—	35	—	35	ns
42	E Output Rise and Fall Time	—	15	—	15	—	15	—	15	—	15	ns
43	\overline{VMA} Asserted to E High	200	—	150	—	90	—	80	—	80	—	ns
44	\overline{AS} , \overline{DS} Negated to \overline{VPA} Negated	0	120	0	90	0	70	0	50	0	50	ns
45	E Low to Control, Address Bus Invalid (Address Hold Time)	30	—	10	—	10	—	10	—	10	—	ns
47	Asynchronous Input Setup Time	10	—	10	—	10	—	10	—	5	—	ns
49 ²	\overline{AS} , \overline{DS} , Negated to E Low	-70	70	-55	55	-45	45	-35	35	-35	35	ns
50	E Width High	450	—	350	—	280	—	220	—	220	—	ns
51	E Width Low	700	—	550	—	440	—	340	—	340	—	ns
54	E Low to Data-Out Invalid	30	—	20	—	15	—	10	—	10	—	ns

*These specifications represent an improvement over previously published specifications for the 8-, 10-, and 12.5-MHz MC68HC000 and are valid only for product bearing date codes of 8827 and later.

NOTES:

1. For a loading capacitance of less than or equal to 50 pF, subtract 5 ns from the value given in the maximum columns.
2. The falling edge of S6 trigger both the negation of the strobes (\overline{AS} and \overline{DS}) and the falling edge of E. Either of these events can occur first, depending upon the loading on each signal. Specification #49 indicates the absolute maximum skew that will occur between the rising edge of the strobes and the falling edge of E.

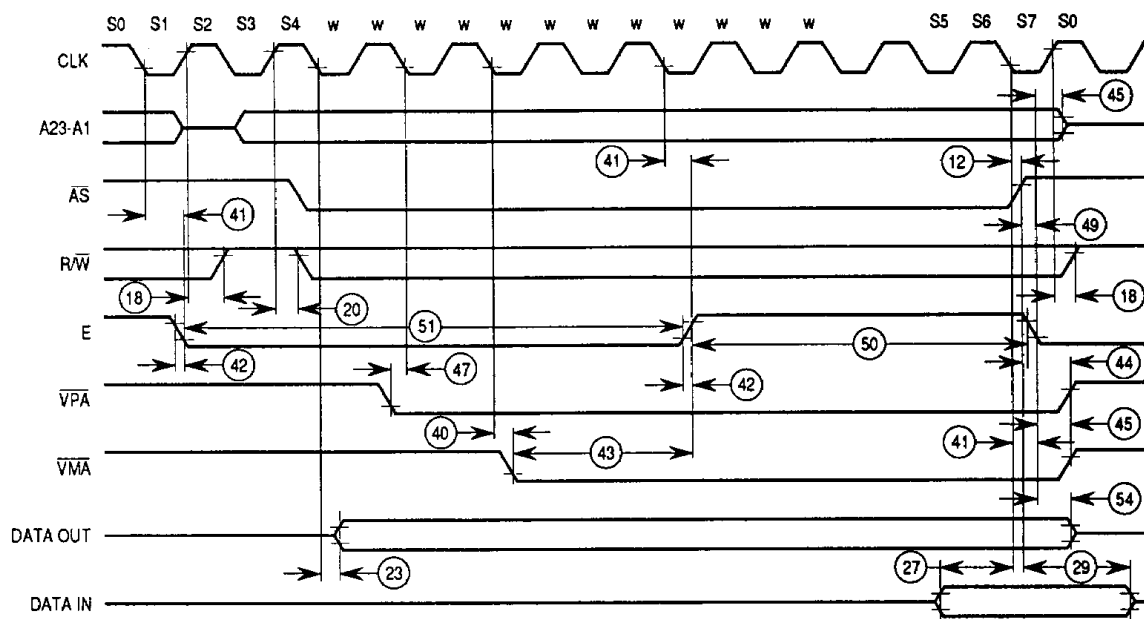

NOTE: This timing diagram is included for those who wish to design their own circuit to generate \overline{VMA} . It shows the best case possibly attainable.

Figure 9. MC68HC000 to M6800 Peripheral Timing Diagram (Best Case)

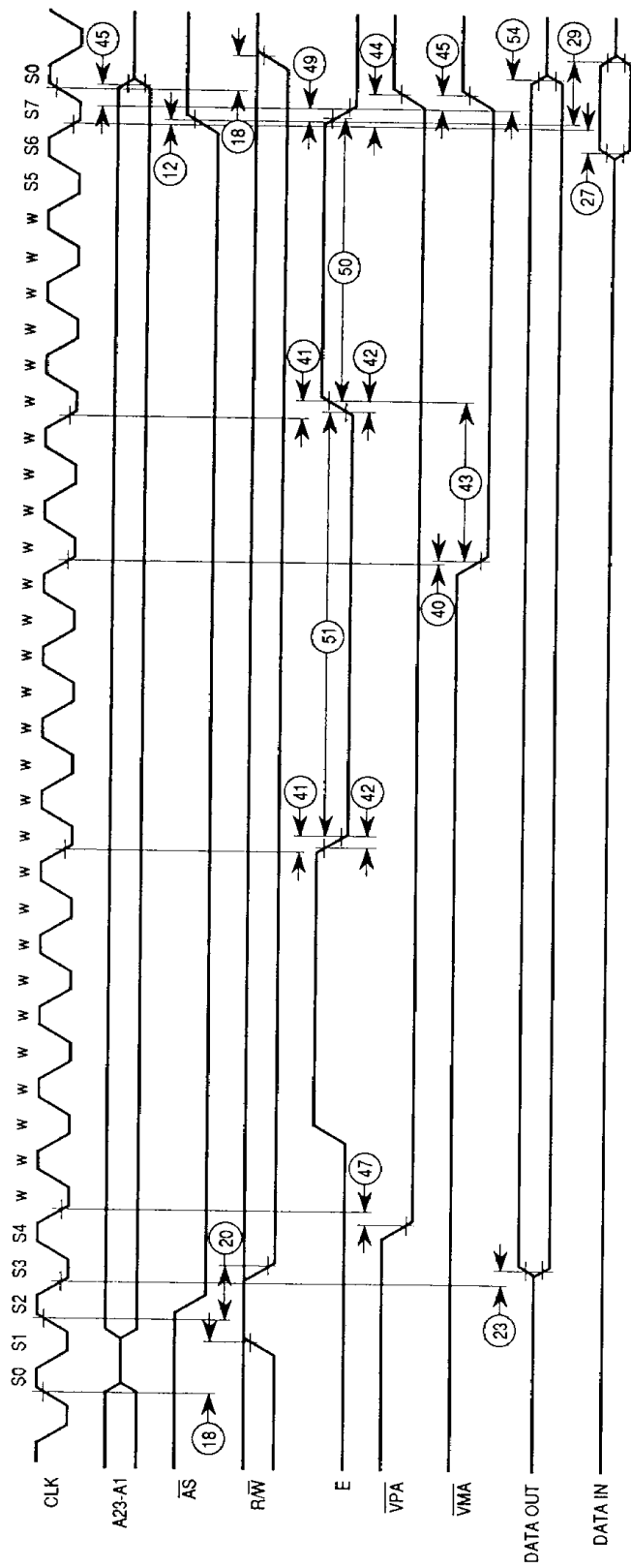

NOTE: This timing diagram is included for those who wish to design their own circuit to generate \overline{VMA} . It shows the worst case possibly attainable.

Figure 10. MC68HC000 to M6800 Peripheral Timing Diagram (Worst Case)

AC ELECTRICAL SPECIFICATIONS — BUS ARBITRATION (V_{CC} = 5.0 Vdc ± 5%; GND = 0 Vdc; T_A = T_L to T_H; see Figures 11-14)

Num.	Characteristic	8 MHz*		10 MHz*		12.5 MHz*		16.67 MHz '12F'		16.67 MHz		Unit
		Min	Max	Min	Max	Min	Max	Min	Max	Min	Max	
7	Clock High to Address, Data Bus High Impedance (Maximum)	—	80	—	70	—	60	—	50	—	50	ns
16	Clock High to Control Bus High Impedance	—	80	—	70	—	60	—	50	—	50	ns
33	Clock High to \overline{BG} Asserted	—	62	—	50	—	40	—	40	0	30	ns
34	Clock High to \overline{BG} Negated	—	62	—	50	—	40	—	40	0	30	ns
35	\overline{BR} Asserted to \overline{BG} Asserted	1.5	3.5	1.5	3.5	1.5	3.5	1.5	3.5	1.5	3.5	Clks
36 ¹	\overline{BR} Negated to \overline{BG} Negated	1.5	3.5	1.5	3.5	1.5	3.5	1.5	3.5	1.5	3.5	Clks
37	\overline{BGACK} Asserted to \overline{BG} Negated	1.5	3.5	1.5	3.5	1.5	3.5	1.5	3.5	1.5	3.5	Clks
37A ²	\overline{BGACK} Asserted to \overline{BR} Negated	20	1.5 Clks	20	1.5 Clks	20	1.5 Clks	10	1.5 Clks	10	1.5 Clks	ns
38	\overline{BG} Asserted to Control, Address, Data Bus High Impedance (\overline{AS} Negated)	—	80	—	70	—	60	—	50	—	50	ns
39	\overline{BG} Width Negated	1.5	—	1.5	—	1.5	—	1.5	—	1.5	—	Clks
46	\overline{BGACK} Width Low	1.5	—	1.5	—	1.5	—	1.5	—	1.5	—	Clks
47	Asynchronous Input Setup Time	10	—	10	—	10	—	10	—	5	—	ns
57	\overline{BGACK} Negated to \overline{AS} , \overline{DS} , R/ \overline{W} Driven	1.5	—	1.5	—	1.5	—	1.5	—	1.5	—	Clks
57A	\overline{BGACK} Negated to FC, \overline{VMA} Driven	1	—	1	—	1	—	1	—	1	—	Clks
58 ¹	\overline{BR} Negated to \overline{AS} , \overline{DS} , R/ \overline{W} Driven	1.5	—	1.5	—	1.5	—	1.5	—	1.5	—	Clks
58A ¹	\overline{BR} Negated to FC, \overline{VMA} Driven	1	—	1	—	1	—	1	—	1	—	Clks

*These specifications represent an improvement over previously published specifications for the 8-, 10-, and 12.5-MHz MC68HC000 and are valid only for product bearing date codes of 8827 and later.

NOTES:

1. The processor will negate \overline{BG} and begin driving the bus again if external arbitration logic negates \overline{BR} before asserting \overline{BGACK} .
2. The minimum value must be met to guarantee proper operation. If the maximum value is exceeded, \overline{BG} may be re-asserted.

3

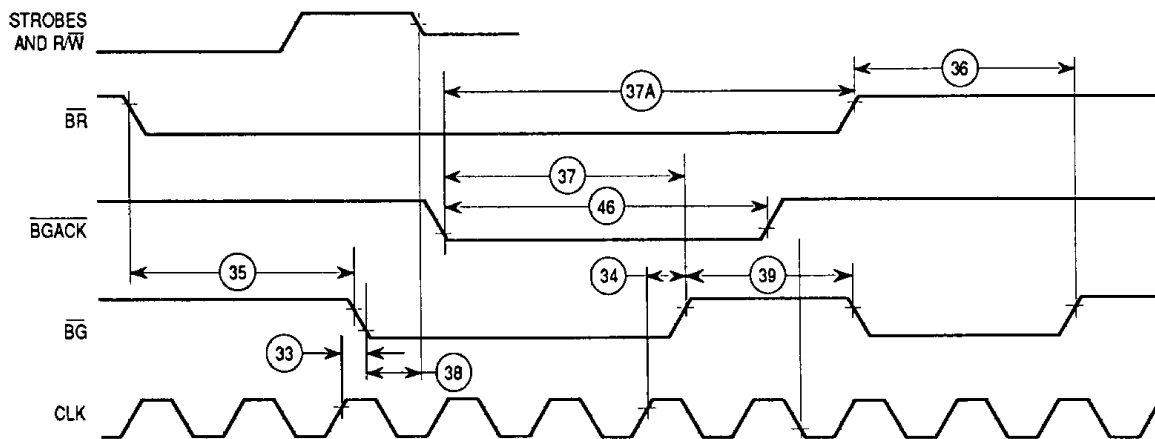

NOTE: Setup time to the clock (#47) for the asynchronous inputs \overline{BERR} , \overline{BGACK} , \overline{BR} , \overline{DTACK} , $\overline{IPL2-IPL0}$, and \overline{VPA} guarantees their recognition at the next falling edge of the clock.

Figure 11. Bus Arbitration Timing Diagram

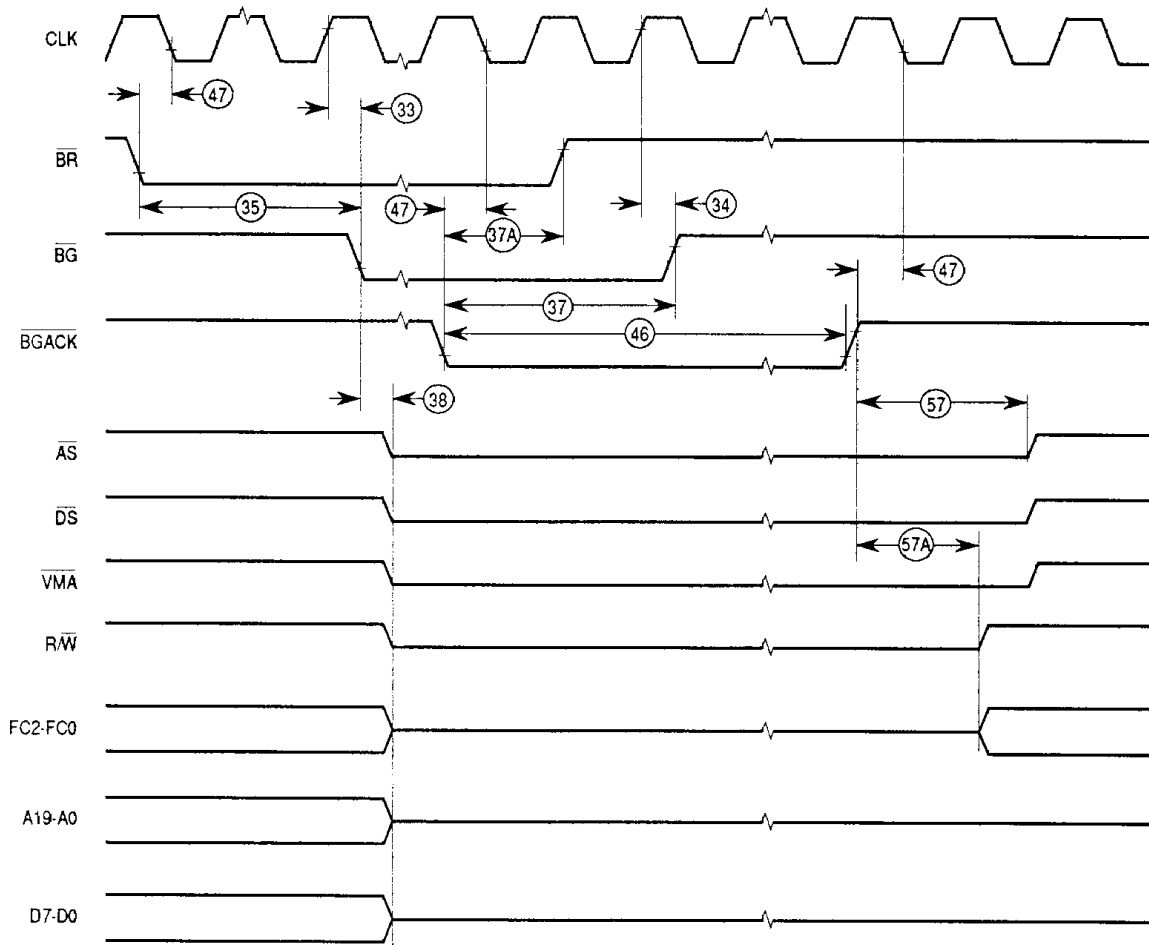

NOTE: Waveform measurements for all inputs and outputs are specified at: logic high 2.0 V, logic low = 0.8 V.

Figure 12. Bus Arbitration Timing — Idle Bus Case

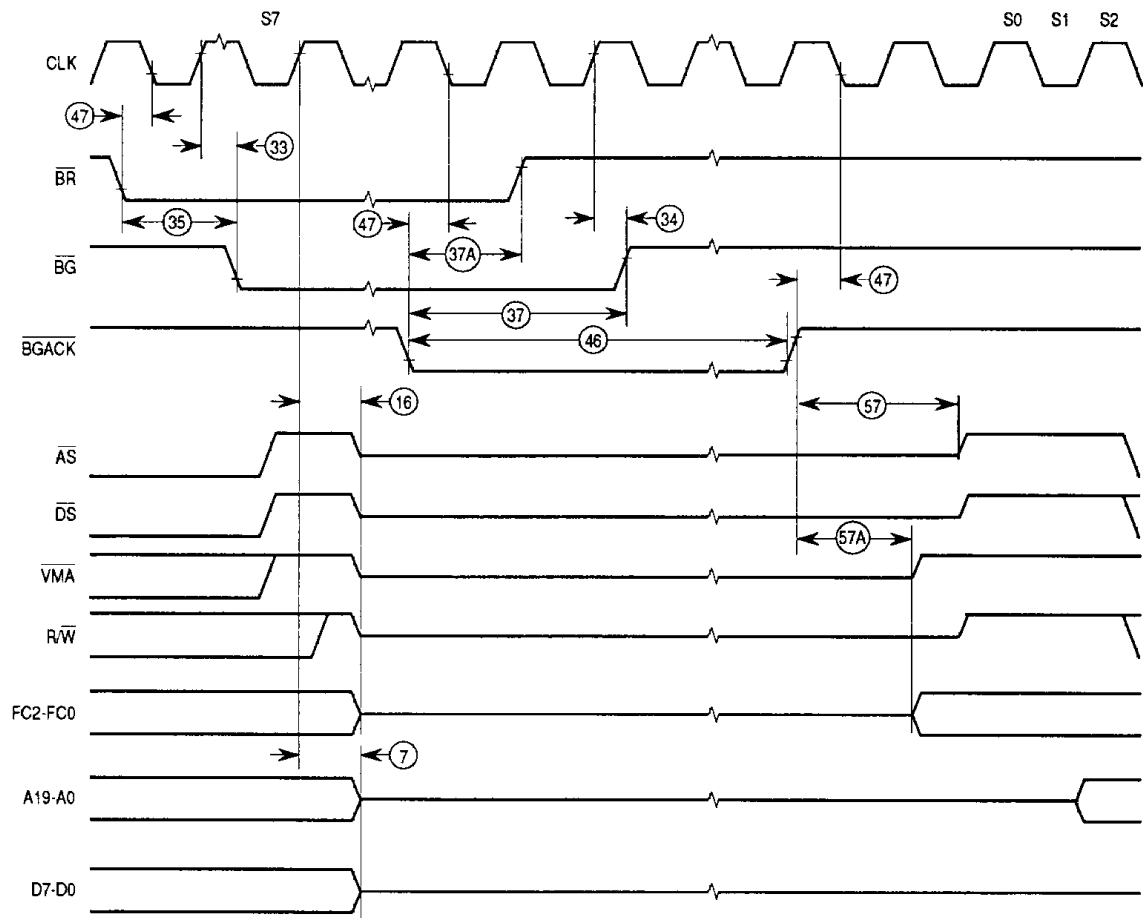

NOTE: Waveform measurements for all inputs and outputs are specified at: logic high 2.0 V, logic low = 0.8 V.

Figure 13. Bus Arbitration Timing — Active Bus Case

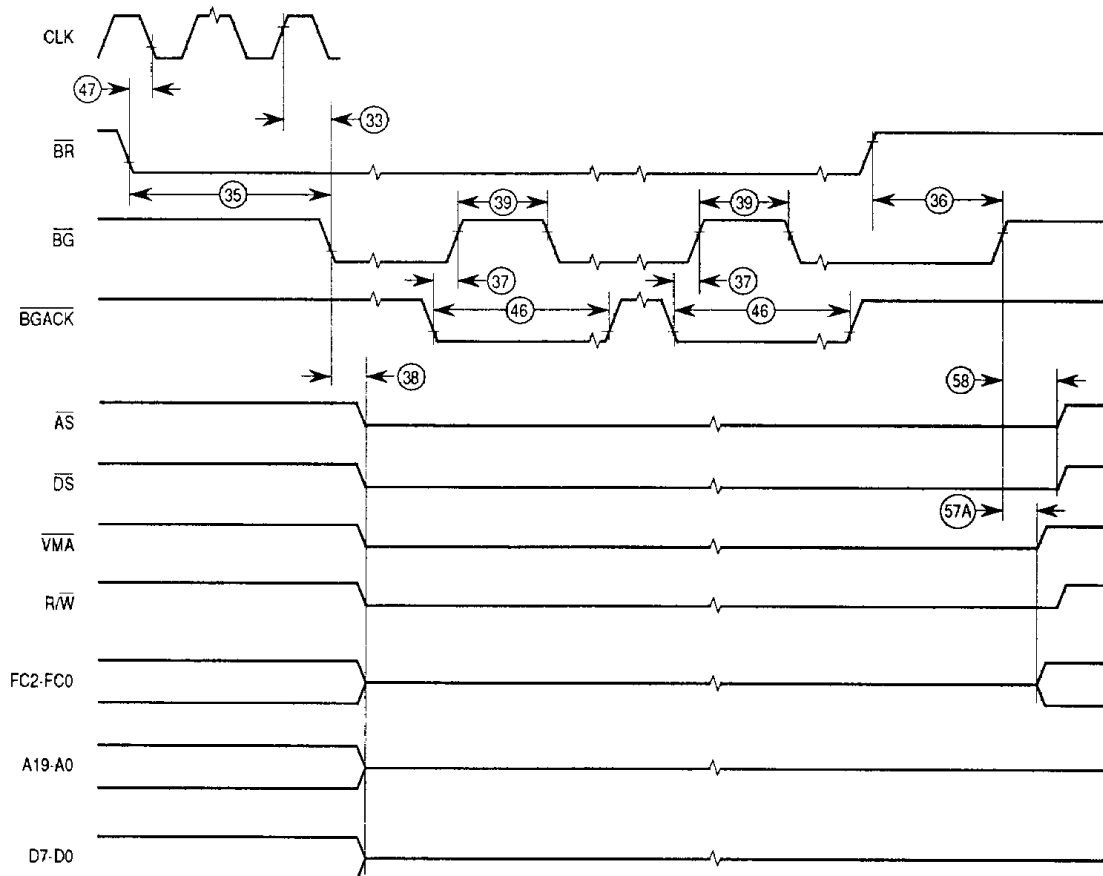

NOTE: Waveform measurements for all inputs and outputs are specified at: logic high 2.0 V, logic low = 0.8 V.

Figure 14. Bus Arbitration Timing — Multiple Bus Request

PIN ASSIGNMENTS

64-LEAD DUAL-IN-LINE PACKAGE

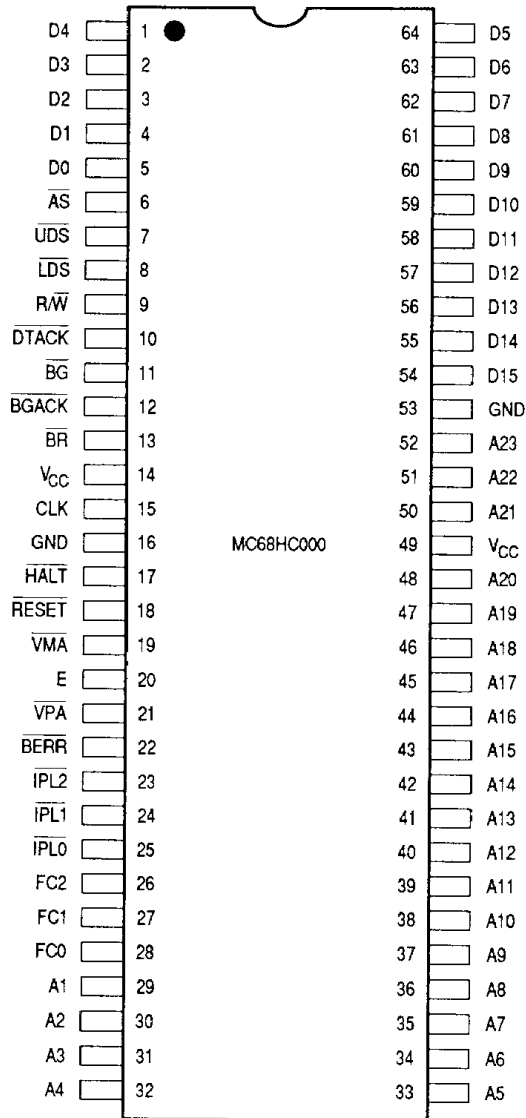

This datasheet has been downloaded from:

www.EEworld.com.cn

Free Download

Daily Updated Database

100% Free Datasheet Search Site

100% Free IC Replacement Search Site

Convenient Electronic Dictionary

Fast Search System

www.EEworld.com.cn