

**Instruction Manual
Model 1923A
IEEE Interface**

**©1982, Keithley Instruments, Inc.
Cleveland, Ohio, U.S.A.
Document Number 32424**

SPECIFICATIONS

I. IEEE-488-1978 BUS IMPLEMENTATION:

Multiline Commands: DCL, SDC, GET, LLO, GTL, UNT, UNL, SPE, SPD.

Uniline Commands: IFC, REN, EOI, SRQ, ATN.

Interface Functions: SH1, AH1, T5, TE0, L4, LE0, SR1, RL1, PP0, DC1, DT1, C0, ET.

Programmable Parameters: Function, Range, Zero, Trigger Modes, Delay, EOI State, SRQ Bus Response, Data Terminators, Data Store to 100 Readings.

Conversion Rate: Nine different conversion rates may be selected: fastest modes for DC volts are:

USEABLE RESOLUTION	INTEGRATION PERIOD	TRIGGER TO FIRST BYTE OUT
4 1/2 digits	4.4ms	27ms
5 1/2 digits	16.67ms*	39ms
*20ms at 50Hz		

Data String: 16 bytes (excluding terminators).

4 1/2-digit Accuracy: $\pm(0.15\% + 1d)$ for 1 year on DCV and Ohms (below 2000k Ω).

Address Modes: TALK ONLY and ADDRESSABLE.

II. STATUS PORT:

Separate port providing function and HI/LO/PASS outputs (open collector, 100mA sink).

IEEE COMMAND GROUPS

HANDSHAKE COMMAND GROUP

DAC = DATA ACCEPTED
RFD = READY FOR DATA
DAV = DATA VALID

UNIVERSAL COMMAND GROUP

ATN = ATTENTION
DCL = DEVICE CLEAR
IFC = INTERFACE CLEAR
LLO = LOCAL LOCK OUT
REN = REMOTE ENABLE
SPD = SERIAL POLL DISABLE
SPE = SERIAL POLL ENABLE

ADDRESS COMMAND GROUP

LISTEN: LAG = LISTEN ADDRESS GROUP
MLA = MY LISTEN ADDRESS
UNL = UNLISTEN
TALK: TAG = TALK ADDRESS GROUP
MTA = MY TALK ADDRESS
UNT = UNTALK
OTA = OTHER TALK ADDRESS

ADDRESSABLE COMMAND GROUP

ACG = ADDRESSED COMMAND GROUP
GET = GROUP EXECUTE TRIGGER
GTL = GO TO LOCAL
SDC = SELECTED DEVICE CLEAR

DEVICE DEPENDENT COMMAND GROUP

FUNCTION: F0 = DCV
F1 = ACV
F2 = k Ω
F3 = AC + DC

RANGE: R0 = AUTO
R1 = 0.2
R2 = 2
R3 = 20
R4 = 200
R5 = 2000
R6 = 20M (Ω only)
Z0 = OFF
Z1 = ON

ZERO:

TRIGGER: T0 = CONT. ON TLK
T1 = ONE SHOT ON TLK
T2 = CONT. ON GET
T3 = ONE SHOT ON GET
T4 = CONT. ON X
T5 = ONE SHOT ON X

RATE: S0 = 4ms INTEGRATION (4 1/2 d)
S1 = LINE CYCLE INTEGRATION (5 1/2 d)
S2 = LINE CYCLE INTEGRATION WITH FILTER 1 (5 1/2 d)
S3 = LINE CYCLE INTEGRATION WITH FILTER 2 (6 1/2 d)
S4 = LINE CYCLE INTEGRATION WITH FILTER 3 (6 1/2 d)
S5 = 100ms INTEGRATION (5 1/2 d)
S6 = 100ms INTEGRATION WITH FILTER 1 (5 1/2 d)
S7 = 100ms INTEGRATION WITH FILTER 2 (6 1/2 d)
S8 = 100ms INTEGRATION WITH FILTER 3 (6 1/2 d)

DELAY: W0 = 0
W1 = 10ms

BUFFER: Q0 = CLEAR
Q1 = STORE 100 READINGS

MODE: M0 = SRQ OFF
M1 = SRQ ON

EOI: K0 = SEND
K1 = DO NOT SEND

TERMINATOR: Y(LF) = CR LF
Y(CR) = LF CR
Y() = ANY ASCII
Y(DEL) = NONE

X = EXECUTE
U = Send status bytes. Sequence is T F R K O S M Y Z W

STATUS COMMAND GROUP

RQS = REQUEST SERVICE
SRQ = SERIAL POLL REQUEST
STB = STATUS BYTE

TABLE OF CONTENTS

Paragraph	Title	Page
SECTION 1—GENERAL INFORMATION		
1.1	Introduction	1-1
1.2	Model 1923A Features	1-1
1.3	Warranty Information	1-1
1.4	Manual Addenda	1-1
1.5	Safety Symbols and Terms	1-1
1.6	Specifications	1-1
1.7	Unpacking and Inspection	1-1
1.8	Preparation for Use	1-1
1.9	Using the Model 1923A Instruction Manual	1-2
SECTION 2—AN OVERVIEW OF THE IEEE-488 BUS		
2.1	Introduction	2-1
2.2	Bus Description	2-1
2.3	IEEE-488 Bus Lines	2-1
2.3.1	Bus Management Lines	2-1
2.3.2	Handshake Lines	2-2
2.3.3	Data Lines	2-3
2.4	Bus Commands	2-3
2.4.1	Uniline Commands	2-3
2.4.2	Universal Commands	2-3
2.4.3	Addressed Commands	2-4
2.4.4	Unaddressed Commands	2-4
2.4.5	Device-Dependent Commands	2-4
2.5	Command Codes	2-4
2.6	Command Sequences	2-4
2.6.1	Addressed Command Sequence	2-6
2.6.2	Universal Command Sequence	2-6
2.6.3	Device-Dependent Command Sequence	2-6
SECTION 3—SYSTEM CONFIGURATION		
3.1	Introduction	3-1
3.2	Hardware Assembly	3-1
3.2.1	Typical Systems	3-1
3.2.2	Bus Connections	3-1
3.2.3	Addressable Mode Selection	3-3
3.2.4	Primary Address Selection	3-3
3.3	Software Assembly	3-4
3.3.1	Controller Interface Routines	3-4
3.3.2	HP-85 Basic Statements	3-4
SECTION 4—OPERATION		
4.1	Introduction	4-1
4.2	General Bus Commands	4-1
4.2.1	REN (Remote Enable)	4-1
4.2.2	IFC (Interface Clear)	4-2
4.2.3	LLO (Local Lockout)	4-2
4.2.4	GTL (Go To Local)	4-2
4.2.5	DCL (Device Clear)	4-3
4.2.6	SDC (Selective Device Clear)	4-3
4.2.7	GET (Group Executive Trigger)	4-3
4.3	Device-Dependent Command Programming	4-4
4.3.1	Execute (X)	4-4
4.3.2	Function (F)	4-5

TABLE OF CONTENTS (CONT.)

Paragraph	Title	Page
4.3.3	Range (R)	4-5
4.3.4	Zero Command (Z)	4-5
4.3.5	Rate (S)	4-6
4.3.6	Rate Command Considerations	4-6
4.3.7	Delay	4-8
4.3.8	Buffer Command	4-9
4.3.9	Buffer Operation	4-9
4.3.10	Programmable Terminator (Y)	4-10
4.3.11	EOI (End or Identify) (K)	4-10
4.3.12	Bus Response Mode (M)	4-10
4.3.13	Status Word (U)	4-10
4.4	Triggering (T)	4-12
4.4.1	Bus Command Triggering	4-12
4.4.2	Front Panel Triggering	4-13
4.4.3	External Triggering	4-13
4.4.4	Bus Times	4-14
4.5	Data Format	4-14
4.6	Service Request	4-16
4.6.1	Serial Polling Sequence	4-16
4.6.2	Status Byte Format	4-16
4.7	Talk Only Operation	4-16
4.8	Status Port	4-17
4.9	Front Panel Error Messages	4-18
4.10	Capability Identification Codes	4-19
4.11	Controller Programs	4-19
4.11.1	PET/CBM 2001	4-19
4.11.2	Apple II	4-20
4.11.3	HP 9825A	4-20
4.11.4	HP 9845B	4-21
4.11.5	TEK 4052	4-21
4.11.6	DEC LSI 11	4-21
4.12	Reading Rates	4-22
4.12.1	Bus Rates	4-22
4.12.2	Bench Rates	4-23
SECTION 5—IEEE COMMAND FLOW CHARTS		
5.1	Introduction	5-1
5.2	DCL—Device Clear	5-1
5.3	IFC—Interface Clear	5-1
5.4	REN—Remote Enable	5-1
5.5	SPE—Serial Poll Enable	5-2
5.6	UNL—Unlisten	5-3
5.7	UNT—Untalk	5-3
5.8	GET—Group Execute Trigger	5-4
5.9	GTL—Go To Local	5-4
5.10	SDC—Selected Device Clear	5-5
5.11	Device-Dependent Commands	5-5
5.12	Wait Commands—W0 or W1	5-6
5.13	Serial Poll	5-7
SECTION 6—THEORY OF OPERATION		
6.1	Introduction	6-1
6.2	Circuit Description	6-1
6.3	Model 1923 and 1923A Differences	6-1

TABLE OF CONTENTS (CONT.)

Paragraph	Title	Page
SECTION 7— MAINTENANCE		
7.1	Introduction	7-1
7.2	Installation	7-1
7.3	Special Handling of Static Sensitive Devices	7-1
7.4	Troubleshooting	7-1
SECTION 8— REPLACEABLE PARTS		
8.1	Introduction	8-1
8.2	Parts List	8-1
8.3	Ordering Information	8-1
8.4	Factory Service	8-1
8.5	Schematic Diagrams and Component Location Drawings	8-1

LIST OF TABLES

Table	Title	Page
2-1	IEEE-488 Bus Command Summary	2-3
2-2	Hexadecimal and Decimal Command Codes	2-4
2-3	Typical Addressed Command Sequence	2-6
2-4	Typical Device-Dependent Command Sequence	2-6
3-1	IEEE Contact Designations	3-3
3-2	Primary Address Switch Positions	3-4
3-3	HP-85 IEEE-488 BASIC Statements	3-5
4-1	General Bus Commands	4-1
4-2	Default Conditions	4-2
4-3	Device-Dependent Command Summary	4-4
4-4	Range Commands	4-5
4-5	Rate Command Parameters	4-6
4-6	Trigger Mode T1 Bus Times (60Hz)	4-14
4-7	Trigger Mode T3 Bus Times (60Hz)	4-14
4-8	Trigger Mode T5 Bus Times (60Hz)	4-14
4-9	Bus Times (50Hz)	4-15
4-10	Error and Data Codes	4-16
4-11	Status Port Pin Assignment	4-17
4-12	Model 192 Capability Identification Codes	4-19
4-13	System Reading Rates	4-22
4-14	Bench Reading Rates	4-23
7-1	Model 1923A Static Sensitive Devices	7-1
7-2	Model 1923/1923A Troubleshooting	7-1
8-1	Replaceable Parts PC-561 and PC-571	8-3

LIST OF FIGURES

Figure	Title	Page
2-1	IEEE Bus Configuration	2-2
2-2	IEEE Handshake Sequence	2-2
2-3	Command Codes	2-5
3-1	System Types	3-1
3-2	IEEE-488 Connector	3-1
3-3	IEEE-488 Connectors	3-2
3-4	Rear Panel of Model 192 Showing Model 1923A Connectors and Switches	3-2
3-5	Contact Assignment	3-3
3-6	Typical IEEE-488 Bus Driver (one of 16)	3-3
3-7	TO/ADDRESSABLE and Primary Address Switches	3-3
4-1	Bus Command Flow	4-1
4-2	Reading Cycle	4-7
4-3	Multiple Sampling Periods	4-7
4-4	Integration Time Periods	4-7
4-5	Filter Response Graph	4-7
4-6	Filter Response to 10 Digit (.0001V) Input Change	4-8
4-7	Filter Response to 3 Digit (.00003V) Input Change	4-8
4-8	W1 Delay Mode (S2 Rate)	4-8
4-9	W0 Delay Mode (S2 Rate)	4-9
4-10	Status Word Format	4-11
4-11	Status Word Example	4-12
4-12	External Trigger Input	4-13
4-13	Trigger Pulse Specifications	4-13
4-14	Data String Format	4-15
4-15	Status Byte Format	4-16
4-16	Enabling Talk Only Mode	4-17
4-17	Status Port Pin Connections	4-17
4-18	Simplified Schematic of Status Output Driver (one of 6)	4-18
4-19	Front Panel Error Messages	4-18
4-20	Continuous Reading Cycle	4-22
4-21	One-Shot Reading Cycle (S0 Mode)	4-23
5-1	DCL Command	5-1
5-2	IFC Command	5-2
5-3	REN Command	5-2
5-4	SPE Command	5-3
5-5	UNL Command	5-3
5-6	UNT Command	5-4
5-7	GET Command	5-4
5-8	GTL Command	5-5
5-9	SDC Command	5-5
5-10	Device-Dependent Command	5-6
5-11	Wait Command	5-6
5-12	Serial Poll	5-7
6-1	Model 192/1923A Block Diagram	6-2
8-1	Model 1923A Hardware	8-1
8-2	Model 1923A Installation	8-2
8-3	Model 1923A-1 PC-571, Component Location Drawing, Dwg. No. 31440	8-5
8-4	Model 1923A-2 PC-561, Component Location Drawing, Dwg. No. 30814	8-7
8-5	Model 1923A-1, Schematic Diagram, Dwg. No. 31441	8-9
8-6	Model 1923A-2, Schematic Diagram, Dwg. No. 30977	8-11

SECTION 1

GENERAL INFORMATION

1.1 INTRODUCTION

The Model 1923A IEEE-488 interface is designed to enhance the capabilities of the Model 192 programmable DMM by allowing the transmission of data and commands over the IEEE bus. The Model 1923A provides all the digital logic necessary to interface the Model 192 to the bus using the standard IEEE-488-1978 protocol. Additionally, the Model 1923A has a status port that may be used with certain front panel programs to control other equipment.

1.2 MODEL 1923A FEATURES

Some of the important Model 1923A features include:

- Easy Installation. If not already factory installed, the interface may be easily installed in the field.
- IEEE-488-1978 Standard. The Model 1923A communicates with other instruments that use the same IEEE-488-1978 standards.
- Standard IEEE-488 Connector. When the interface is installed in the Model 192, the IEEE-488 connector is available on the rear panel of the instrument.
- Simple Primary Address Selection. The primary address of the Model 1923A may easily be set by using the five address switches on the rear panel of the Model 192.
- Talk Only/Addressable Operation. The interface may be set for one of two modes of operation. In the Talk Only mode, the Model 192 outputs data to other devices (for example, a printer). In the Addressable mode, the Model 192 can both receive commands and transmit data over the bus through the interface.
- Status Port. Front panel Program 6 HI/LO/PASS outputs are available through the status port. Also, outputs for DC, AC and Ohms are present on the port.
- External Trigger. An external trigger input is also available on the status port. The trigger input is used to externally trigger the Model 192 to take readings.

1.3 WARRANTY INFORMATION

Warranty information may be found inside the front cover of this manual. Should it become necessary to exercise the warranty, contact your nearest Keithley representative or the factory to determine the proper course of action. Keithley Instruments, Inc. maintains service facilities in the United States, United Kingdom, and throughout Europe. Addresses for these facilities may be found inside the front cover of this manual. Information concerning the application, operation or service of your instrument may be directed to the applications engineer at any of these locations.

1.4 MANUAL ADDENDA

Information concerning improvements or changes to the interface which occur after the printing of this manual may be found on an Addendum sheet attached to the inside back cover of this manual. Be sure to review these changes before attempting to use the interface.

1.5 SAFETY SYMBOLS AND TERMS

The following safety symbols and terms are used in this manual and found on the Model 192:

The symbol  on the instrument indicates that the user should refer to the operating instructions.

The symbol  on the instrument indicates that a potential of 1000V or more may be present on the terminal(s). Standard safety precautions should be observed when such dangerous voltages are encountered.

Information associated with the **WARNING** heading explains dangers that could result in personal injury or death. Information following the **CAUTION** heading explains hazards that could damage the instrument.

1.6 SPECIFICATIONS

Model 1923A specifications may be found immediately preceding this section of the manual.

1.7 UNPACKING AND INSPECTION

The Model 1923A interface was carefully inspected both mechanically and electrically before shipment. Upon receiving the Model 1923A, carefully unpack all items and check for any obvious physical damage that might have occurred during shipment. Report any damage to the shipping agent immediately. Retain the original packing materials in case reshipment is necessary. The following items are shipped with every Model 1923A order:

- Model 1923A IEEE-488 Interface
- Hardware necessary for installation.
- Model 1923A Instruction Manual
- Additional accessories as ordered.

1.8 PREPARATION FOR USE

As shipped, the Model 1923A interface is set to the Addressable mode with the primary address set to 8 at the factory. For information on changing these parameters, refer to Section 3. If the Model 1923A is to be field installed, refer to Section 7 for necessary installation instructions.

1.9 USING THE MODEL 1923A INSTRUCTION MANUAL

This manual includes information necessary for installation, connection, operation, programming, and servicing of the Model 1923A interface option. While user information requirements may differ, the following list of sections will generally be considered the most important:

1. Sections 3 and 4 contain all the information necessary to connect the interface-equipped Model 192 to the bus and program the unit for operation.

2. Section 2 is included to provide a description of IEEE-488 bus operation. Also, Section 5 provides IEEE command flow charts to familiarize the user with the command sequences within the instrument.
3. For the more technically oriented, Sections 6, 7 and 8 contain information on theory of operation, servicing, schematic diagrams, and replaceable parts. Note that installation instructions may be found in Section 7 if the Model 1923A is to be field installed.

The Model 1923 is essentially the same as the Model 1923A as far as programming is concerned. Hardware differences between the two interfaces are covered in Section 6.

SECTION 2

AN OVERVIEW OF THE IEEE-488 BUS

2.1 INTRODUCTION

The IEEE-488 bus is an instrumentation data bus standardized by the Institute of Electronic and Electrical Engineers in 1975. The most recent revision of bus standards was made in 1978; hence the complete description for current bus standards is the IEEE-488-1978 designation.

This section gives a brief description of the general bus structure along with an outline of bus commands. The information presented here is not intended to be an in-depth description of what is truly a very complex set of standards. More complete information on the IEEE-488 bus, which is also frequently referred to as the GPIB (General Purpose Interface Bus), is available from the IEEE and a variety of other sources.

2.2 BUS DESCRIPTION

The IEEE-488 bus was designed as a parallel data transfer medium to optimize data transfer without using an excessive number of bus lines. In keeping with this goal, the bus has only eight data lines that are used for both data and some commands. Five bus management lines and three handshake lines round out the complement of signal lines. Since the bus is of parallel design, all devices connected to the bus have the same information available simultaneously. Exactly what is done with the information by each device depends on many factors, including device capabilities.

A typical bus configuration for controlled operation is shown in Figure 2-1. The typical system will have one controller and one or more instruments to which commands are given and, in most cases, from which data is received. Generally, there are three categories that describe device operation. These designations include: controller; talker; listener.

The controller does what its name implies: it controls other devices on the bus. A talker sends data, while a listener receives data. Depending on the instrument, a particular device may be a talker only, a listener only, or both a talker and a listener. The Model 192, through the 1923A interface, is capable of being both a talker and a listener, but it does not have controller capability.

Any given system can have only one controller (control may be passed to an appropriate device through a special command), but any number of talkers or listeners may be present up to the hardware constraints of the bus. Generally, the bus is limited to 15 devices, but this number may be reduced if higher than normal data transfer rates are required or if longer than normal cables are used.

Several devices may be commanded to listen at once, but only one device may be a talker at any given time. Otherwise, communications would be scrambled much like an individual trying to pick out a single conversation in a large crowd.

Before a device can talk or listen, it must be appropriately addressed. Devices are selected on the basis of their primary address. To avoid confusion, the addressed device is sent a talk or listen command derived from its primary address. Normally, each device on the bus has a unique primary address so that each may be addressed individually. The primary address of the Model 1923A interface is set to 8 at the factory, but it may be changed to any value between 0 and 30 as described in Section 3.

Once the device is addressed to talk or listen, the appropriate bus transactions will take place. For example, if the Model 1923A is properly addressed to talk, it will normally place its data string on the bus one byte at a time. The controller will then read this information, and the appropriate software can then be used to channel the information to the desired location. Other bus functions and instrumentation may be controlled by special bus commands as described in paragraph 2.3.

2.3 IEEE-488 BUS LINES

The signal lines on the IEEE-488 bus are grouped into three general categories. The data lines handle bus information, while the handshake and bus management lines ensure that proper data transfer and bus operation takes place. Each of the bus lines is active low with approximately 0V representing a logic one. The following paragraphs describe the purpose of these lines, which are shown in Figure 2-1.

2.3.1 Bus Management Lines

The bus management group is made up of five signal lines that send certain single-line bus commands and ensure an orderly transfer of data. These lines are used to send the single-line commands described in paragraph 2.4.

1. ATN (Attention)-The attention line is one of the more important management lines. The state of the ATN line determines whether information placed on the data bus by the controller is to be considered data or a command as described in paragraph 2.4.
2. IFC (Interface Clear)-Setting the IFC line true (low) causes the bus to go to a known state by sending the IFC command.
3. REN (Remote Enable)-Setting the REN line low sends the REN command. This sets up instruments on the bus for remote operation.

4. EOI (End Or Identify)-The EOI line is used to terminate a multi-byte transfer sequence.
5. SRQ (Service Request)-The SRQ line is set low by a bus device when it requires service from the controller.

1. DAV (Data Valid)-The source controls the state of the DAV line.
2. NRFD (Not Ready For Data)-The acceptor controls the state of the NRFD line.
3. NDAC (Not Data Accepted)-The acceptor also controls the state of the NDAC line.

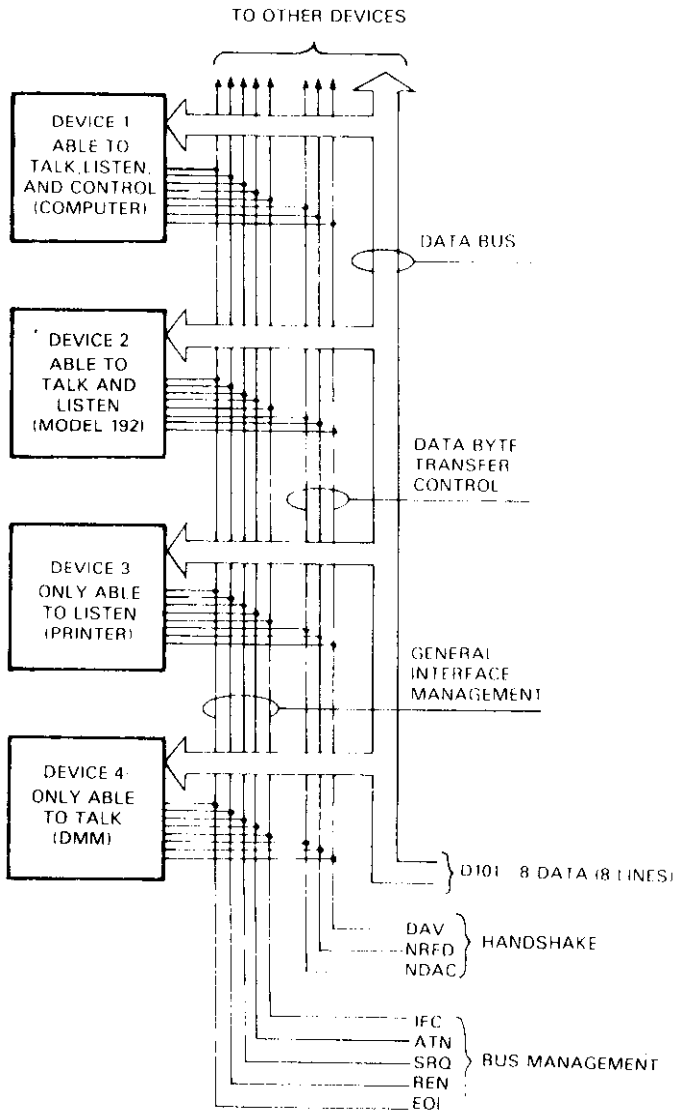

Figure 2-1. IEEE Bus Configuration

2.3.2 Handshake Lines

The bus uses three handshake lines that operate in an interlocked sequence. This method ensures reliable data transfer regardless of the transfer rate. Generally, data transfer will occur at a rate determined by the slowest active device on the bus.

One of the handshake lines is controlled by the data source, while the remaining two lines are controlled by accepting devices. The three bus handshake lines are:

The complete handshake sequence for one data byte is shown in Figure 2-2. Once data is on the bus, the source checks to see that NRFD is high, indicating that all devices on the bus are ready for data. At the same time NDAC should be low from the previous byte transfer. NDAC and NRFD must be stable for about 100ns if the source is a controller. Because of the possibility of a bus hang up, some controllers have time-out routines to display error messages if the handshake sequence stops for any reason.

Once the NRFD and NDAC lines are properly set, the source sets the DAV line low, indicating that data on the bus is now valid. The NRFD line then goes low; the NDAC line then goes high once all devices on the bus have accepted the data. Each device will release the NDAC line at its own rate, but the NDAC line will not go high until the slowest device has accepted the data.

After the NDAC line goes high, the source then sets the DAV line high to indicate that the data on the bus is no longer valid. At this point, the NDAC line returns to its low state. Finally, the NRFD line is released by each of the devices at their own rates, until the NRFD line finally goes high when the slowest device is ready, and the bus is set to repeat the sequence with the next byte of data.

The sequence just described is used to transfer both data and multiline commands. The state of the ATN lines determines whether the data bus contains data or commands as described in paragraph 2.4.

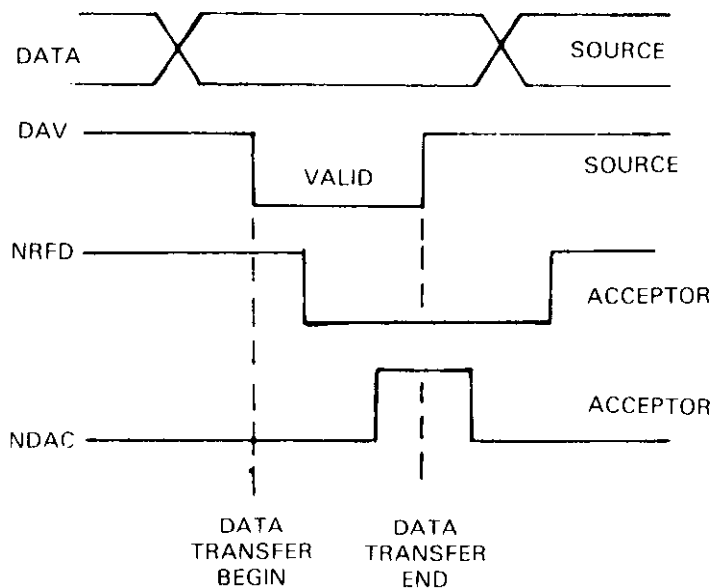

Figure 2-2. IEEE Handshake Sequence

2.3.3 Data Lines

The IEEE-488 bus uses eight data lines that allow data to be transmitted and received in a bit-parallel, byte-serial manner. These eight lines use the convention DIO1 through DIO8 instead of the usual D0 through D7 binary terminology. The data lines are bidirectional and, as with the remaining bus signal lines, low is true.

2.4 BUS COMMANDS

While the hardware aspect of bus is important, the interface would be worthless without appropriate commands to control communications between the various instruments on the bus. This section will briefly describe the purpose of the bus commands which are grouped into the following three general categories:

1. **Uniline commands:** Sent by setting the associated bus line low.
2. **Multiline commands:** General bus commands which are sent with the ATN line low.
3. **Device-Dependent commands:** Special commands that depend on device configurations; sent with ATN high.

These commands are summarized in Table 2-1. Only commands that affect Model 192 operation are covered in this section.

2.4.1 Uniline Commands

Uniline commands are sent by setting the associated bus line low. The ATN, IFC, and REN commands are sent only by the system controller. The SRQ command is asserted by an external device. The EOI command may be sent by either the controller or an external device. The following is a brief description of each command:

1. **REN (Remote Enable)**-When the controller sends the REN command, the instrument will be set up for remote operation. This command should be sent to the instrument before attempting to program over the bus.
2. **EOI**-The EOI command is transmitted by setting the EOI (End Or Identify) line low during the last byte of a multi-byte transfer sequence.
3. **IFC (Interface Clear)**-The IFC command is sent by setting the IFC line low; it sets the bus to a known state.
4. **ATN (Attention)**-The controller sets ATN low when addressing a device or when sending multiline commands. Device-dependent commands are sent with ATN high. The ATN line must remain high while a device transmits its data string.
5. **SRQ (Service Request)**-The SRQ line is set low by an external device when it requires service from the controller. A serial polling sequence, as described in Section 4, must be used to determine which device has requested service.

2.4.2 Universal Commands

Universal commands are multiline commands that require no addressing. All instrumentation equipped to implement the command will do so when the command is transmitted over the bus. As with all multiline commands, the universal commands are sent with ATN low.

1. **LLO (Local Lockout)**-The LLO command may be used to lock out front panel controls.
2. **DCL (Device Clear)**-After a DCL is sent, instrumentation equipped to implement the command will revert to some known state.
3. **SPE (Serial Poll Enable)**-The SPE command is the first step in the serial polling sequence, which is used to determine which instrument has requested service.

Table 2-1. IEEE-488 Bus Command Summary

Command Type	Command	State of ATN Line*	Comments	
Uniline	REN (Remote Enable)	X	Set up for remote operation.	
	EOI	X	Sent by setting EOI low.	
	IFC (Interface Clear)	X	Clears interface	
	ATN (Attention)	Low	Defines data bus contents.	
	SRQ (Service Request)	X	Controlled by external device.	
Multiline	Universal	LLO (Local Lockout)	Low	Locks out front panel controls.
		DCL (Device Clear)	Low	Returns device to default conditions.
		SPE (Serial Poll Enable)	Low	Enables serial polling.
	Addressed	SPD (Serial Poll Disable)	Low	Disables serial polling.
		SDC (Selective Device Clear)	Low	Returns unit to default conditions.
		GTL (Go to Local)	Low	Returns to local control.
	Unaddress	GET (Group Execute Trigger)	Low	Triggers device for reading.
		UNL (Unlisten)	Low	Removes all listeners from bus.
	UNT (Untalk)	Low	Removes all talkers from bus.	
	Device-dependent**		High	Programs Model 192 for various modes.

*X = Don't Care

**See Section 4 for complete description.

4. SPD (Serial Poll Disable)-The SPD command is sent by the controller to remove all instrumentation on the bus from the serial poll mode. The Model 192 will no longer place its status byte on the bus when addressed to talk after the SPD command is sent.

2.4.3 Addressed Commands

Each of these commands must be preceded by a listen command derived from the device's primary address before the instrument will respond. Only the addressed device will respond to each of these commands:

1. SDC (Selective Device Clear)-The SDC command performs essentially the same function as the DCL command except that only the addressed device will respond.
2. GTL (Go To Local)-The GTL command is used to remove instruments from the remote mode of operation. At the same time, local control operation will be restored if the LLO command was previously sent.
3. GET (Group Execute Trigger)-The GET command is used to trigger devices to perform some action that depends on device configuration.

2.4.4 Unaddress Commands

The two unaddress commands are used by the controller to remove all talkers and listeners from the bus simultaneously. No addressing is required to implement these commands.

1. UNL (Unlisten)-All listeners are removed from the bus at once when the UNL command is placed on the bus.
2. UNT (Untalk)-The controller sends the UNT command to clear the bus of any talkers.

2.4.5 Device-Dependent Commands

The meaning of the device-dependent commands is determined by instrument configuration. Generally, these commands are sent as one or more ASCII characters that tell the device to perform a specific function. For complete information on using these commands with the Model 192, refer to Section 4. The IEEE-488 bus treats device-dependent commands as data in that the ATN line is high when the commands are transmitted.

2.5 COMMAND CODES

Each bus command is given a unique code that is transmitted over the bus as 7 bit ASCII data. This section will briefly explain the code groups which are summarized in Figure 2-3. Every command is sent with ATN low.

1. Addressed Command Group (ACG)-Addressed commands are listed in column 0(B) in the table. Column 0(A) lists the corresponding ASCII codes.
2. Universal Command Group (UCG)-Columns 1(A) and 1(B) list the Universal commands and the corresponding ASCII codes.

3. Listen Address Group (LAG)-Columns 2(A) and 3(A) list the ASCII codes corresponding to the primary addresses listed in columns 2(B) and 3(B). The primary address value set by the switches on the rear panel of the Model 192 corresponds to the listed value. For example, if the primary address of the instrument is set to eight, the LAG byte will correspond to the ASCII "(" character.
4. Talk Address Group (TAG)-TAG primary address values and the corresponding ASCII characters are listed in columns 4(A) through 5(B).

The preceding address groups are all grouped together to form the Primary Command Group (PCG). The bus also has another group of commands, called the Secondary Command Group (SCG). These are listed in Figure 2-3 for informational purposes only; the Model 1923A does not respond to these commands, but other devices may have secondary addressing capability.

NOTE

Commands are normally transmitted with the 7 bit code listed in the table. For most devices, the condition of D₇ (DIO8) is unimportant, as shown by the "Don't Care" indication in the table. Some devices, however, may require that D₇ assume a specific logic state before the commands are recognized.

Hexadecimal and decimal values for each of the commands or command groups are listed in Table 2-2. Each value in the table assumes that D₇ is set to 0.

Table 2-2. Hexadecimal and Decimal Command Codes

Command	Hex Value*	Decimal Value
GTL	01	1
SDC	04	4
GET	08	8
LLO	11	17
DCL	14	20
SPE	18	24
SPD	19	25
LAG	20-3F	32-63
TAG	40-5F	64-95
UNL	3F	63
UNT	5F	95

*Values shown with D₇ = 0.

2.6 COMMAND SEQUENCES

The proper command sequence must be sent by the controller before an instrument will respond as intended. The universal commands, such as LLO and DCL require only that ATN be set low before the command is sent. Other commands require that the device be addressed to listen first. This section will briefly describe the bus sequence for several types of commands.

D7 D6 D5 D4				COLUMN- ROW :	X 0 0 0	COMMAND	X 0 0 1	COMMAND	X 0 1 0	PRIMARY ADDRESS	X 0 1 1	PRIMARY ADDRESS	X 1 0 0	PRIMARY ADDRESS	X 1 0 1	PRIMARY ADDRESS	X 1 1 0		X 1 1 1	X
D3	D2	D1	D0		0 (A)	0 (B)	1 (A)	1 (B)	2 (A)	2 (B)	3 (A)	3 (B)	4 (A)	4 (B)	5 (A)	5 (B)	6 (A)	6 (B)	7 (A)	7 (B)
0	0	0	0	0	NUL		DLE	SP	0	0	16	@	0	P	16			p		
0	0	0	1	1	SOH	GTL	DC1	LLO	1	1	17	A	1	Q	17	a		q		
0	0	1	0	2	STX		DC2		2	2	18	B	2	R	18	b		r		
0	0	1	1	3	ETX		DC3	#	3	3	19	C	3	S	19	c		s		
0	1	0	0	4	EOT	SDC	DC4	DCL	4	4	20	D	4	T	20	d		t		
0	1	0	1	5	ENQ		NAK	%	5	5	21	E	5	U	21	e		u		
0	1	1	0	6	ACK		SYN	&	6	6	22	F	6	V	22	f		v		
0	1	1	1	7	BEL		ETB		7	7	23	G	7	W	23	g		w		
1	0	0	0	8	BS	GET	CAN	SPE	8	8	24	H	8	X	24	h		x		
1	0	0	1	9	HT		EM	SPD	9	9	25	I	9	Y	25	i		y		
1	0	1	0	10	LF		SUB		10		26	J	10	Z	26	j		z		
1	0	1	1	11	VT		ESC		11		27	K	11		27	k				
1	1	0	0	12	FF		FS		12		28	L	12		28	l				
1	1	0	1	13	CR		GS		13		29	M	13		29	m				
1	1	1	0	14	SO		RS		14		30	N	14		30	n				
1	1	1	1	15	SI		US		15		UNL	O	15		UNT	o		DEL		

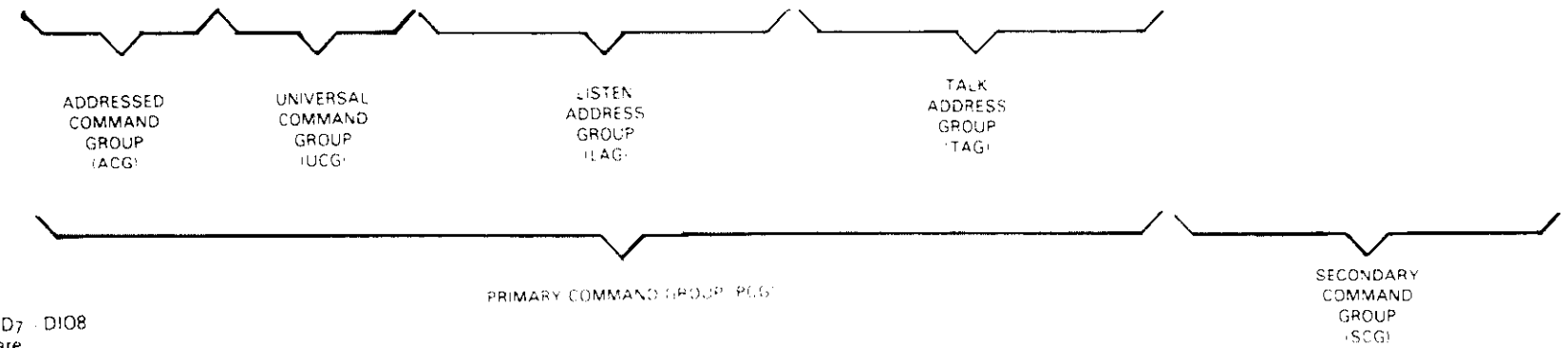

NOTE 1 D0 - DIO1 D7 - DIO8
2 X - Don't Care

Figure 2-3. Command Codes

2.6.1 Addressed Command Sequence

Before a device will respond to one of these commands, it must receive a LAG command derived from its primary address. Table 2-3 shows a typical sequence for the SDC command. The LAG command assumes that the instrument is set at a primary address of eight.

Note that an UNL command is transmitted before the LAG, SDC sequence. This is generally done to remove all other listeners from the bus first so that only the addressed device responds.

2.6.2 Universal Command Sequence

The universal commands are sent by setting ATN low and then placing the command byte on the data bus. For example, the following gives the LLO command:

ATN•LLO

Note that both the ATN and LLO commands are on the bus simultaneously. Also, addressing is not necessary.

2.6.3 Device-Dependent Command Sequence

The device-dependent commands are transmitted with ATN high. However, the device must be addressed to listen first before the commands are transmitted. Table 2-4 shows the command sequence for the following:

FOX

This command, which sets the Model 192 to the DC volts function, is described in detail in Section 4.

Table 2-3. Typical Addressed Command Sequence

Step	Command	ATN State	Data Bus		
			ASCII	Hex	Decimal
1	UNL	Set low	?	3F	63
2	LAG*	Stays low	(28	40
3	SDC	Stays low	EOT	04	4
4		Returns high			

*Assumes primary address = 8.

Table 2-4. Typical Device-Dependent Command Sequence

Step	Command	ATN State	Data Bus		
			ASCII	Hex	Decimal
1	UNL	Set low	?	3F	63
2	LAG*	Stays low	(28	40
3	Data	Set high	F	46	70
4	Data	Stays high	0	30	48
5	Data	Stays high	X	58	88

*Assumes primary address = 8.

SECTION 3 SYSTEM CONFIGURATION

3.1 INTRODUCTION

There are two operating aspects to almost any digital interface. The IEEE-488 standard is no exception to this rule. Not only must the hardware meet certain standards, but all devices, including the controller, must have appropriate software. This section deals with important hardware and software aspects of bus operation.

3.2 HARDWARE ASSEMBLY

Before the Model 192 can be used with the IEEE-488 bus, the instrument must be connected to the bus using a suitable connector. Also, the instrument must be set up for Addressable operation and the primary address must be properly selected as described in this section.

3.2.1 Typical Systems

The IEEE-488 bus is a parallel interface system. As a result, adding more devices is simply a matter of using more cables to make the desired connections. Because of this flexibility, system complexity can range from the very simple to extremely complex.

Figure 3-1 shows some typical system configurations. Figure 3-1(a) shows the simplest possible controlled system. The controller is used to send commands to the instrument, which sends data back to the controller.

The system becomes more complex in Figure 3-1(b), where additional instrumentation is added. Depending on programming, all data may be routed through the controller, or it may be transmitted directly from one instrument to another.

For very complex applications, a much larger computer can be used, as shown in Figure 3-1(c). Tape drives or disks can then be used to store data.

3.2.2 Bus Connections

The Model 192 is connected to the bus through an IEEE-488 connector as shown in Figure 3-2. This connector is designed to be stacked to allow a number of parallel connections on one instrument.

NOTE

To avoid possible mechanical damage, it is recommended that no more than three connectors be stacked on any one instrument. Otherwise the resulting strain, may cause internal damage.

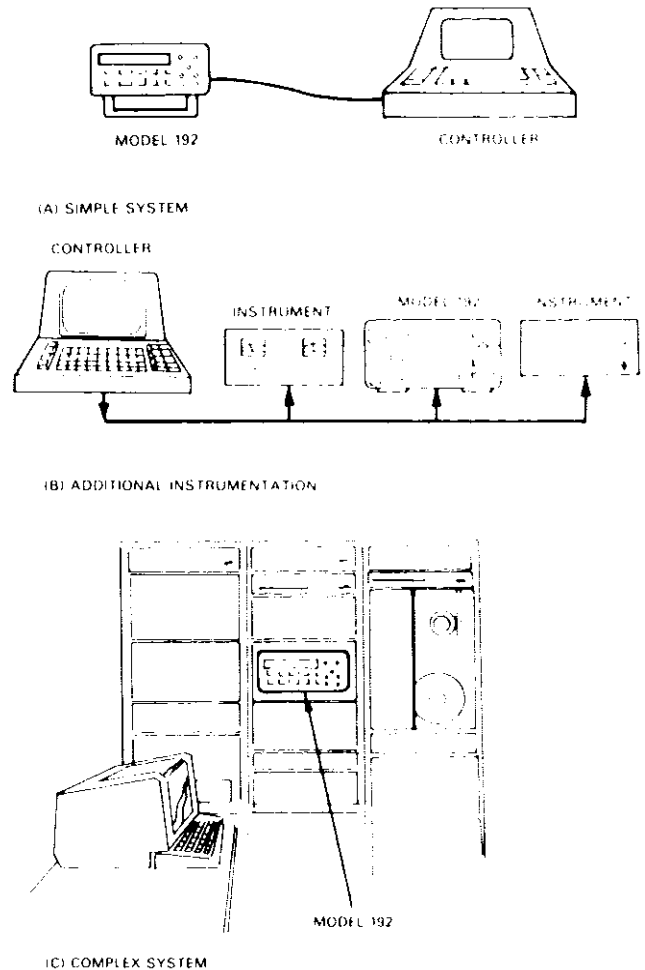

Figure 3-1. System Types

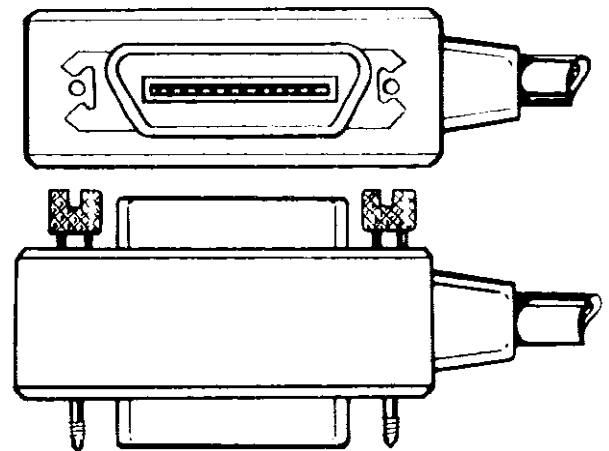

Figure 3-2. IEEE-488 Connector

A typical connecting scheme for the bus is shown in Figure 3-3. Each cable normally has the standard IEEE connector on each end. The Keithley Model 7008 cable, which is six feet in length, is ideal for this purpose. Once the connections are made, the screws should be tightened (securely). For the location of the connector on the rear panel of the Model 192, refer to Figure 3-4.

Custom cables may be constructed using the information in Table 3-1 and Figure 3-5. Table 3-1 lists the contact assignments for the various bus lines, while Figure 3-5 shows contact designations. Contacts 18 through 24 are return lines for the indicated signal lines, while the cable shield is connected to contact 12. Each of these ground lines is connected to digital common in the Model 192 through the Model 1923A interface.

NOTE

The IEEE-488 bus is limited to a maximum of 15 devices, including the controller. Also, the maximum cable length is 20 meters. Failure to observe these limits may result in erratic bus operation.

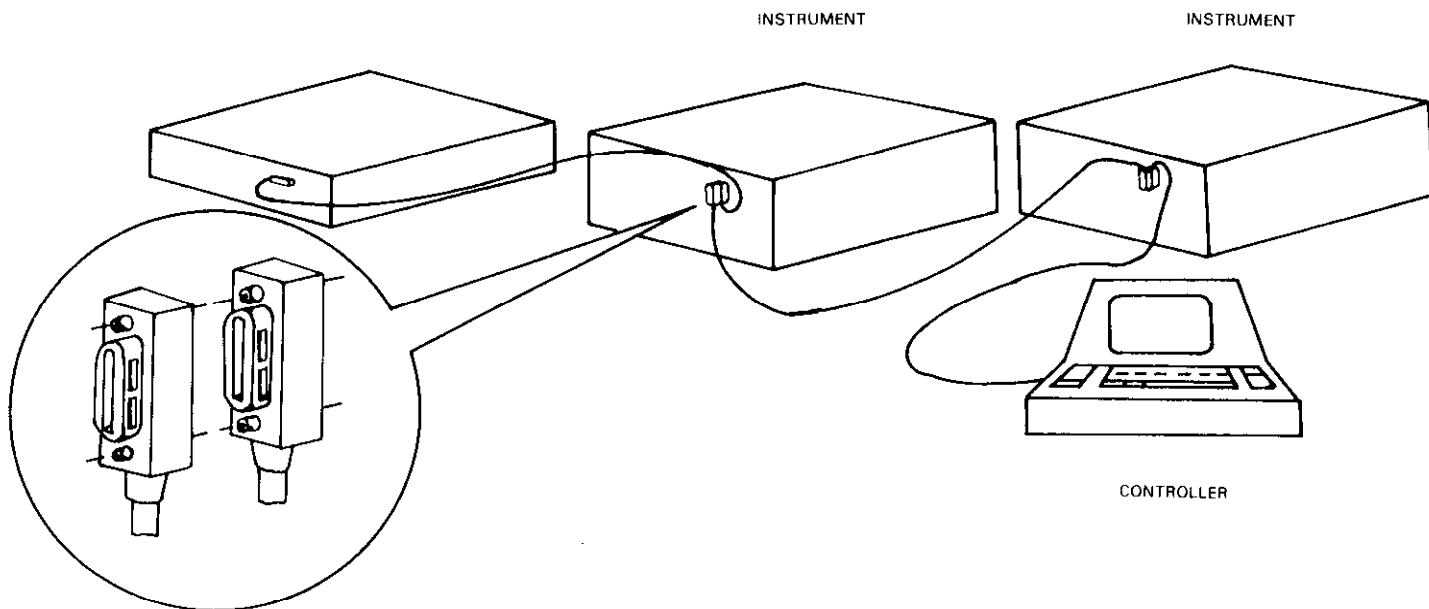

Figure 3-3. IEEE-488 Connections

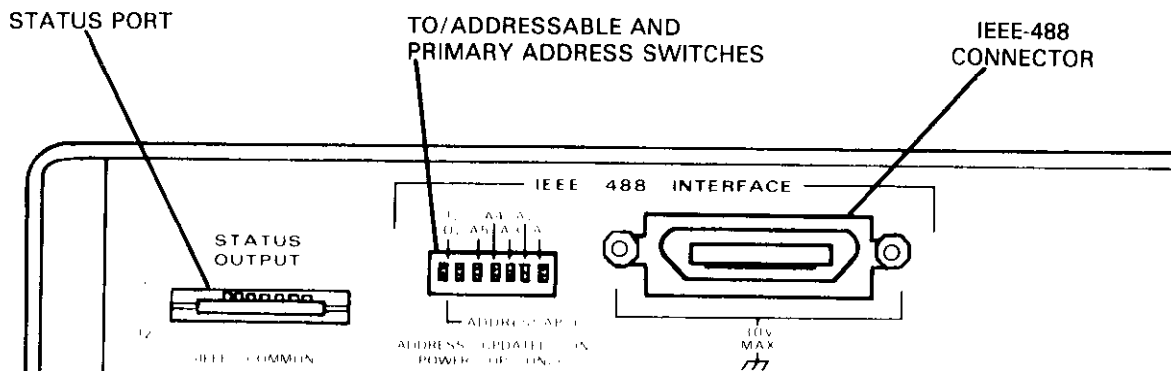

Figure 3-4. Rear Panel of Model 192 Showing Model 1923A Connectors and Switches

Table 3-1. IEEE Contact Designations

Contact Number	IEEE-488 Designation (J1020)	Type
1	DIO1	Data
2	DIO2	Data
3	DIO3	Data
4	DIO4	Data
5	EOI (24)*	Management
6	DAV	Handshake
7	NRFD	Handshake
8	NDAC	Handshake
9	IFC	Management
10	SRQ	Management
11	ATN	Management
12	SHIELD	Ground
13	DIO5	Data
14	DIO6	Data
15	DIO7	Data
16	DIO8	Data
17	REN (24)*	Management
18	Gnd, (6)*	Ground
19	Gnd, (7)*	Ground
20	Gnd, (8)*	Ground
21	Gnd, (9)*	Ground
22	Gnd, (10)*	Ground
23	Gnd, (11)*	Ground
24	Gnd, LOGIC	Ground

*Numbers in parentheses refer to signal ground return of referenced contact number. EOI and REN signal lines return on contact 24.

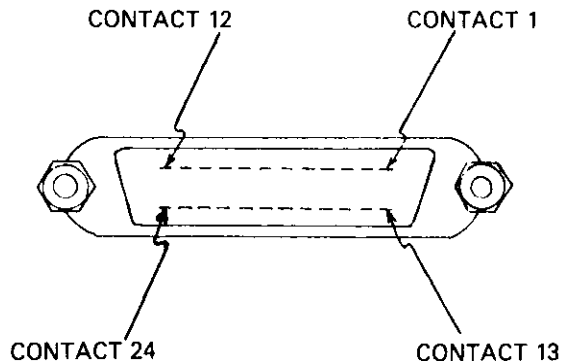

Figure 3-5. Contact Assignments

CAUTION

The digital common within the Model 192 is connected to ground through a 1MΩ resistor. The voltage between IEEE common and power line ground must not exceed 30V or damage to the instrument may occur.

A typical signal line bus driver is shown in Figure 3-6. With the configuration shown, the driver has bidirectional capability. When the I/O control line is high, the line is configured as an output line. When the control line is low, the

driver is set up for input operation. Note that not all signal lines have bidirectional capability. Some lines, such as ATN, will be configured as an output line in the controller and as an input line for all other devices on the bus.

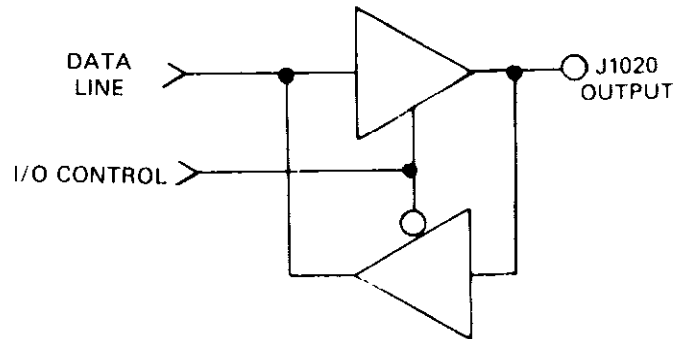

Figure 3-6. Typical IEEE-488 Bus Driver (One of 16)

3.2.3 Addressable Mode Selection

The Model 1923A must be set to the Addressable mode when used with an external controller. Mode selection is done with the TO/ADDRESSABLE mode selection switch located on the rear panel of the Model 192. This switch is grouped with those that set the primary address; these switches are located on the rear panel of the Model 192 as shown in Figure 3-4. Figure 3-7 shows the ADDRESSABLE position for the switch, which may be operated with the point of a pen or pencil.

NOTE

The TO/ADDRESSABLE switch is read only upon power-up. If the mode is changed, the Model 192 must be turned off and then powered-up again before it will recognize the new switch position.

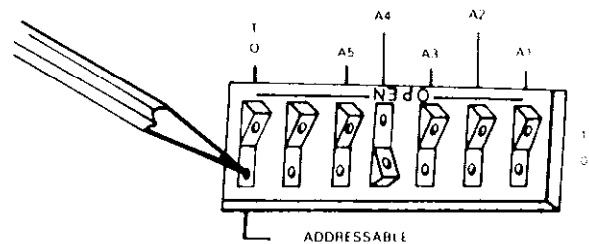

Figure 3-7. TO/ADDRESSABLE and Primary Address Switches (Address Eight Shown)

3.2.4 Primary Address Selection

The Model 192 must receive a listen command before it will respond to the addressed or device-dependent commands sent over the bus. Similarly, a talk command must be sent to the Model 192 before it will transmit its data string, status word, or status byte. Those talk and listen commands are derived from the primary address of the instrument. The primary address of the Model 1923A is set to eight at the factory, but it may be set to any value between 0 and 30 by

placing the primary address switches which are shown in Figure 3-7, in the desired position. The primary address specified in the controller's programming language must agree with the primary address of the Model 1923A.

NOTE

The primary address switch positions are read only upon power-up. If the address is changed, the Model 192 must be turned off and then powered-up again before the new address can be used.

Figure 3-7 shows the correct positions for the factory set value of eight; if a different address is required, the primary address may be changed as outlined in Table 3-2.

Table 3-2. Primary Address Switch Positions

Primary Address	Switch Positions				
	A5	A4	A3	A2	A1
0	0	0	0	0	0
1	0	0	0	0	1
2	0	0	0	1	0
3	0	0	0	1	1
4	0	0	1	0	0
5	0	0	1	0	1
6	0	0	1	1	0
7	0	0	1	1	1
8*	0	1	0	0	0
9	0	1	0	0	1
10	0	1	0	1	0
11	0	1	0	1	1
12	0	1	1	0	0
13	0	1	1	0	1
14	0	1	1	1	0
15	0	1	1	1	1
16	1	0	0	0	0
17	1	0	0	0	1
18	1	0	0	1	0
19	1	0	0	1	1
20	1	0	1	0	0
21	1	0	1	0	1
22	1	0	1	1	0
23	1	0	1	1	1
24	1	1	0	0	0
25	1	1	0	0	1
26	1	1	0	1	0
27	1	1	0	1	1
28	1	1	1	0	0
29	1	1	1	0	1
30	1	1	1	1	0

*Factory Set Value

NOTE: Primary Address 31 (11111 is reserved for UNL and UNT commands and must not be used.

NOTE

If other instrumentation is also connected to the bus, be sure that each device has a different primary address. If this precaution is not observed, erratic bus operation may result.

The primary address switches are binary weighted; A1 is the least significant bit, while A5 the most significant bit. For example, the binary value for the factory set primary address of eight is 01000. Use the tip of a pen or pencil to operate the switches.

NOTE

No instrument on the bus (including the Model 192) should be operated with a primary address of 31, even though it is possible to set the switches to those positions (11111). This address is reserved for the UNL and UNT commands; instruments will respond by removing themselves from the talk or listen modes if primary address 31 is used.

3.3 SOFTWARE ASSEMBLY

The most sophisticated computer in the world would be useless without the necessary software. This basic requirement is also true of the IEEE-488 bus, which requires the use of handler routines as described in this section.

3.3.1 Controller Interface Routines

Before a controller can be used with the IEEE-488 interface, the user must make certain that appropriate handler software is present within the controller. With the HP-85 computer, for example, the HP-IB interface card must be used with an additional I/O ROM, which contains the necessary handler software.

Other small computers that can be used as controllers have limited IEEE command capability. The PET/CBM computers, for example, are incapable of sending the universal and addressed multiline commands from BASIC, although most of these commands may be sent through machine-language routines. The capabilities of other small computers depends on the particular interface being used. Often, little software "tricks" are required to achieve the desired results.

From the preceding discussion, the message is clear: make sure the proper software is being used with the interface. Often, the user may incorrectly suspect that a hardware problem is causing an intermittent fault, when it was the software that was causing the problem all along.

3.3.2 HP-85 BASIC Statements

Many of the programming instructions covered in Section 4 use examples written in Hewlett-Packard Model 85 BASIC. The HP-85 was chosen for these examples because it has a large number of BASIC statements that control IEEE-488 operation. This section covers those HP-85 BASIC statements that are essential to Model 1923A operation.

A complete list of HP-85 IEEE-488 BASIC statements is shown in Table 3-3. All the statements in the table have a one or three digit argument that must be specified. The first digit is the HP-85 interface select code, which is set to 7 at the factory. The last two digits of those statements that require a three digit argument specify the primary address. Generally, only those commands that actually require an address to be sent over the bus need the primary address to be specified.

The statements in the table with the three digit arguments assume that the primary address of the device (in this case the Model 1923A) is set at eight. Other primary addresses require that the last two digits be set to the corresponding value. For example, to send a GTL command to device 21, the following BASIC statement would be used: LOCAL 721.

Some of the statements in the table have two forms; the exact configuration used depends on the desired command. For example, CLEAR 7 will cause a DCL to be sent, while CLEAR 708 causes an SDC to be transmitted to device eight.

The third column of Table 3-3 lists the mnemonics for the command sequences. While most of these have been covered before, a couple of points should be noted. As described earlier, the ATN line is set low by the controller if the data bus contains a multiline command. This is indicated in the table by ANDing the ATN mnemonic with the first command on the bus. For example, ATN•GET means that ATN and GET are sent simultaneously.

Two commands not previously covered are MLA (My Listen Address) and MTA (My Talk Address). These are ordinary PCG (Primary Command Group) addresses sent by the HP-85 to facilitate bus operation in some situations. The Model 1923A will normally ignore these commands, but other devices may require that MLA and MTA be present in the command sequence under certain circumstances.

NOTE

The HP-85 address is set to 21 at the factory. Since each device on the bus must have a unique primary address, do not set the Model 192 to that address to avoid conflicts with the HP-85.

Table 3-3. HP-85 IEEE-488 BASIC Statements

Statement	Action	Bus Command Sequence
ABORTIO 7 CLEAR 7 CLEAR 708 ENTER 708;A\$	Send IFC. Send DCL. Send SDC to device 8. Device 8 addressed to talk. Data placed in A\$.	IFC ATN•DCL ATN•UNL;MTA;LAG;SDC ATN•UNL;MLA;TAG;ATN;data
LOCAL 708 LOCAL LOCKOUT 7 OUTPUT 708;A\$	Send GTL to device 8. Send LLO. Device 8 addressed to listen. Transmit A\$.	ATN•UNL;MTA;LAG;GTL ATN•LLO ATN•MTA;UNL;LAG;ATN;data
REMOTE 7 REMOTE 708	Set REN true. Set REN true. Address device 8 to listen.	REN REN;ATN•UNL;MTA;LAG
RESET 7 SPOLL(708)	Send IFC, cancel REN. Address device 8 to talk. Conduct serial poll.	IFC;REN;REN ATN•UNL;MLA;TAG;SPE;ATN; status byte;ATN•SPD;UNT
TRIGGER 7 TRIGGER 708	Send GET Address device 8 to listen. Send GET.	ATN•GET ATN•UNL;MTA;LAG;GET

SECTION 4 OPERATION

4.1 INTRODUCTION

The Model 1923A is designed to interface the Model 192 programmable DMM to the IEEE-488 bus. Since all operation is done through commands given over the bus, the interface has no operating controls in the usual sense. Instead, all operating functions are controlled by programming.

This section describes important programming functions in detail. Included are: general bus command, device-dependent commands, status word and status byte, and other important operating information.

NOTE

Programming examples in this section assume that the Model 192 primary address is at its factory setting (eight). Those examples with addressed commands will not function unless the instrument's primary address is set to that value. Refer to Section 3 for information on setting the primary address.

4.2 GENERAL BUS COMMANDS

General bus commands are those commands which have the same meaning regardless of instrument configuration. However, not all instruments will respond to every available command, which are grouped into two categories:

1. **Addressed Commands.** These commands require that the primary address of the instrument agrees with the primary address in the controller's programming language.
2. **Unaddressed Commands.** No primary address is required for these commands. All devices equipment to implement these commands will do so simultaneously when the command is sent.

General bus commands are summarized in Table 4-1, which also lists the HP-85 BASIC statement that sends each command. Command flow is further clarified in Figure 4-1. Commands in (a) affect all instruments on the bus simultaneously. Addressed commands in (b) affect only the addressed device.

NOTE

Model 192 IEEE status is normally indicated by the front panel TALK, LISTEN, and REMOTE indicator lights. These indicators are for informational purposes only, and may not show the actual IEEE status of the instrument.

Table 4-1 General Bus Commands

Command	Addressing Required ?	HP-85 BASIC Statement
REN	Yes	REMOTE 708
IFC	No	ABORTIO 7
LLO	No	LOCAL LOCKOUT 7
GTL	Yes	LOCAL 708
DCL	No	CLEAR 7
SDC	Yes	CLEAR 708
GET*	Yes	TRIGGER 708
GET*	No	TRIGGER 7

*GET may be sent with or without addressing.

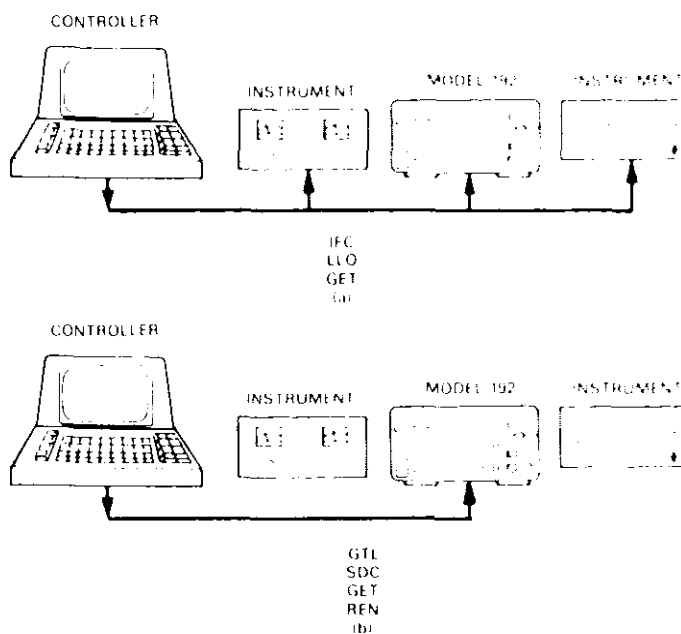

Figure 4-1. Bus Command Flow

4.2.1 REN (Remote Enable)

The remote enable command is sent to the Model 192 by the controller to set it up for remote operation. Generally, this should be done before attempting to program the instrument over the bus. Note that the REN command must be received by the Model 192 before it will respond to many other commands. The instrument will indicate that it is in the remote mode by illuminating its front panel REMOTE indicator.

NOTE

Front panel Programs 3-7 will be cancelled if the Model 192 is placed in the remote mode during their operation. Programs 0 through 8 cannot be entered with the Model 192 in the remote mode. To restore front panel programming operation, the following command sequence must be send over the bus: GTL;DCL.

To place the Model 192 in the remote mode, the controller must perform the following steps:

1. Set the REN line low.
2. Address the Model 192 to listen.

Programming Example: This sequence is automatically sent by the HP-85 when the following is typed into the keyboard:

```
REMOTE 708 (END LINE)
```

After the END LINE key is pressed, the Model 192 REMOTE indicator light should come on. If not, check to see that the instrument is set for the proper primary address. Also, check to see that all bus connections are tight.

To restore front panel programming, type in the following statements into the HP-85 computer:

```
LOCAL 708 (END LINE)  
CLEAR 7 (END LINE)
```

After the END LINE key is pressed the first time, the REMOTE indicator light should go out. After the second statement is entered, front panel programming operation should be restored. The CLEAR 7 statement will also return the instrument to the default conditions listed in Table 4-2.

Table 4-2. Default Conditions

T0	Continuous on Talk
F0	DC Volts
R5	1200 Volts Range
K0	Send EOI with last byte.
Q0	Buffer Disabled
S2	16.667ms Integration Time
M0	Non SRQ Mode
Y	(LF) Terminator is (CR)(LF).
Z0	Zero off
W1	Delay on

4.2.2 IFC (Interface Clear)

The IFC command is sent by the controller to set instruments on the bus to the talk and listen idle states. The Model 192 will respond to the IFC command by cancelling front panel TALK or LISTEN lights if the instrument was previously placed in one of those modes. No other state changes will occur within the instrument.

To send the IFC command, the controller need only set the IFC line true.

Programming Example: Before demonstrating the IFC command, turn on the front panel REMOTE and TALK indicator lights by entering the following statements into the HP-85 computer:

```
REMOTE 708 (END LINE)  
ENTER 708;A$ (END LINE)
```

The front panel REMOTE and TALK indicators should now be on. The IFC command may now be sent by entering the following statement into the HP-85:

```
ABORTIO 7 (END LINE)
```

After the END LINE key is pressed, the TALK light will turn off, indicating the Model 192 is in the talk idle state. Note that the remote mode is not cancelled.

4.2.3 LLO (Local Lockout)

The LLO command is sent by the controller to remove devices from the local operating mode. Once the Model 192 receives the LLO command, all its front panel controls (except POWER) will be inoperative. Note that the instrument must be in the remote mode before it will respond to the LLO command.

To lock out the front panel controls of the Model 192, the controller must perform the following steps:

1. Set ATN low.
2. Send the LLO command to the instrument.

Programming Example: This sequence is automatically performed by the HP-85 when the following statement sequence is typed into the keyboard:

```
REMOTE 708 (END LINE)  
LOCAL LOCKOUT 7 (END LINE)
```

After the END LINE key is pressed the second time, the front panel controls are locked out. Note that no other changes occur within the instrument; all front panel modes remain as previously selected. Local control may be restored by using the GTL command as described in the next paragraph.

4.2.4 GTL (Go To Local)

The GTL command is used to restore operation of the front panel controls. At the same time, the instrument will be taken out of the remote mode.

NOTE

Front panel programming is not restored by the GTL command alone. The following sequence must be sent to the Model 192 to restore front panel programming once it is in the remote mode: GTL;DCL.

To restore local operation of the Model 192, the controller must perform the following bus sequence:

1. Set ATN low.
2. Address the Model 192 to listen.
3. Place the GTL command on the bus.

Programming Example: If the instrument is not on the remote and lockout modes, enter the following statements into the HP-85:

```
REMOTE 708 (END LINE)
LOCAL LOCKOUT 7 (END LINE)
```

Check to see that the front panel controls are locked out.

The GTL sequence is automatically sent by the HP-85 when the following is entered into the keyboard:

```
LOCAL 708 (END LINE)
```

When the END LINE key is pressed, the front panel controls will once again function.

NOTE

The Model 192 will respond in the same way when the REN line is set false. The HP-85 performs this function with the following statement:

```
LOCAL 7
```

4.2.5 DCL (Device Clear)

The DCL command may be used to clear devices on the bus, setting them to a known state. Note that all devices on the bus equipped to implement the DCL command will do so simultaneously. The Model 192 will respond to the DCL command by returning the default conditions listed in Table 4-2.

To send the DCL command, the controller must perform the following steps:

1. Set ATN low.
2. Place the DCL command on the bus.

Programming Example: Place the instrument on the 2k Ω range and enable the zero with the front panel controls. The DCL command sequence may then be sent from the HP-85 by entering the following statement into the HP-85 keyboard:

```
CLEAR 7 (END LINE)
```

After END LINE is pressed, the instrument will return to the default conditions listed in Table 4-2; the 2000 range and DCV indicators will be on, and the ZERO light will go out.

NOTE

Once addressed to listen, the Model 192 must be placed in the talk mode before receiving a DCL or SDC. This may be done with the following HP-85 statement:

```
ENTER 708;A$ (END LINE)
```

4.2.6 SDC (Selective Device Clear)

The SDC command performs the same function as the DCL command except that only the addressed device responds. This command is useful for clearing only selected instru-

ments instead of all instruments simultaneously. The Model 192 will return to the default conditions listed in Table 4-2 after receiving the SDC command.

In order to transmit the SDC command, the controller must perform the following steps:

1. Set ATN low.
2. Address the Model 192 to listen.
3. Place the SDC command on the bus.

Programming Example: Before entering the example statement, place the instrument on the 2k Ω resistance range and enable the zero with the front panel controls. Now enter the following statement:

```
CLEAR 708 (END LINE)
```

After the END LINE key is pressed, the instrument will return to the default conditions listed in the Table 4-2; the 2000 and DCV lights will be on, and the ZERO indicator will go out.

NOTE

Once addressed to listen, the Model 192 must be placed in the talk mode before receiving a DCL or SDC. This may be done with the following HP-85 statement:

```
ENTER 708;A$
```

4.2.7 GET (Group Execute Trigger)

The GET command is sent by the controller to trigger bus devices to perform a certain operation. Using the GET command is only one of several methods that may be used to trigger the Model 192 to take readings. More detailed information on all trigger modes, including GET, may be found in paragraph 4.4.

The Model 192 will respond to the GET command both with and without addressing. To trigger the instrument without addressing, the controller must perform the following steps:

1. Set ATN line low.
2. Place the GET command on the bus.

All devices designed to implement the GET command in this fashion will respond simultaneously.

To use the GET command with addressing, the controller must send the following sequence over the bus:

1. Set ATN low.
2. Address the Model 192 to listen.
3. Place the GET command on the bus.

Programming Example: Place the Model 192 in the one-shot on GET trigger mode with the following statements:

```
REMOTE 708 (END LINE)
OUTPUT 708;"T3X" (END LINE)
```

At this point, the REMOTE and LISTEN indicators will be on. Note that the decimal point on the display has stopped flashing, indicating the instrument is waiting for a trigger.

An unaddressed GET may be sent to the instrument by entering the following into the HP-85 keyboard:

TRIGGER 7 (END LINE)

When the END LINE is pressed, the decimal point on the Model 192 display will flash once, indicating that a reading has been processed. At the same time, the LISTEN light will go out.

An addressed GET may be sent by entering the following statement into the HP-85:

TRIGGER 708 (END LINE)

Once again, the instrument will process one reading as indicated by the single flash of the decimal point.

The Model 192 may be returned to the normal trigger mode by entering the following into the HP-85:

OUTPUT 708; "T0X" (END LINE)

The decimal point will again flash at the conversion rate.

NOTE

Once an addressed GET has been sent to another instrument, the Model 192 will not respond to an unaddressed GET until it receives an addressed GET with its own primary address first.

4.3 DEVICE-DEPENDENT COMMAND PROGRAMMING

The IEEE-488 device-dependent commands are sent to the Model 192 by the controller to control various operating modes such as function, range, conversion rate, display resolution, and filtering. Each command is made up of an ASCII alpha character followed by a number designating a specific parameter. The IEEE bus treats these commands as data in that ATN is false when the commands are transmitted.

HP-85 programming examples will be included throughout this section to clarify programming. Before performing each command example, it is recommended that the Model 192 be returned to its default conditions by turning off the instrument and powering it up again. If the HP-85 should become "hung up" at any point, operation may be restored by holding the SHIFT key down while pressing RESET on the keyboard.

A number of commands may be grouped together in one string. Where command conflicts or illegal commands occur, the instrument will ignore the command string, display the appropriate error messages, and change the value of its status byte. These aspects of Model 192 operation are covered in paragraphs 4.6 and 4.9.

In order to send a device-dependent command, the controller must perform the following bus sequence:

1. Set ATN low.

2. Address the Model 192 to listen.
3. Set ATN high.
4. Send the command string one byte at a time.

Programming Example: The preceding sequence is automatically performed by the HP-85 when the following statement is entered into the computer:

OUTPUT 708; A\$ (END LINE)

A\$ in this case contains the ASCII characters that form the command string.

Commands that affect the Model 192 are summarized in Table 4-3 and are covered in the following paragraphs.

Table 4-3. Device-Dependent Command Summary

FUNCTION:	F0 - DCV	DELAY:	W0 - 0
	F1 - ACV		W1 - 10ms
	F2 - kΩ	BUFFER:	Q0 - CLEAR
	F3 - AC + DC		Q1 - STORE 100 READINGS
RANGE:	R0 - AUTO	MODE:	M0 - SRQ OFF
	R1 - 0.2		M1 - SRQ ON
	R2 - 2	EOI:	K0 - SEND
	R3 - 20		K1 - DO NOT SEND
	R4 - 200	TERMINATOR:	Y(LF) - CR LF
	R5 - 2000		Y(CR) - LF CR
	R6 - 20M (Ω only)		Y() - ANY ASCII
ZERO:	Z0 - OFF		Y(DEL) - NONE
	Z1 - ON		
TRIGGER:	T0 - CONT ON TLK	X - EXECUTE	
	T1 - ONE SHOT ON TLK	U - Send status bytes. Sequence	
	T2 - CONT ON GET		is T F R K Q S M Y Z W.
	T3 - ONE SHOT ON GET		
	T4 - CONT ON X		
	T5 - ONE SHOT ON X		
RATE:	S0 - 4ms INTEGRATION (4 1/2 d)		
	S1 - LINE CYCLE INTEGRATION (5 1/2 d)		
	S2 - LINE CYCLE INTEGRATION WITH FILTER 1 (5 1/2 d)		
	S3 - LINE CYCLE INTEGRATION WITH FILTER 2 (6 1/2 d)		
	S4 - LINE CYCLE INTEGRATION WITH FILTER 3 (6 1/2 d)		
	S5 - 100ms INTEGRATION (5 1/2 d)		
	S6 - 100ms INTEGRATION WITH FILTER 1 (5 1/2 d)		
	S7 - 100ms INTEGRATION WITH FILTER 2 (6 1/2 d)		
	S8 - 100ms INTEGRATION WITH FILTER 3 (6 1/2 d)		

4.3.1 Execute (X)

The execute command is implemented by sending an ASCII "X" over the bus. Its purpose is to tell the Model 192 to execute other device-dependent commands. Generally, the "X" character is the last byte in the command string. The execute character also controls Model 192 operation in the T4 and T5 trigger modes as described in paragraph 4.4.

Programming Example: Enter the following statement sequence into the HP-85 keyboard:

REMOTE 708 (END LINE)
OUTPUT 708; "X" (END LINE)

When the END LINE key is pressed the second time, the front panel LISTEN light will turn on, indicating the Model 192 received the command. No other changes will occur with this example because no other commands were given.

NOTE

Command strings sent without the execute character will not be executed at that time, but will be stored in the command buffer. The next time an execute character is received, the stored commands will be executed, assuming all commands are valid.

4.3.2 Function (F)

The function command places the Model 192 in the DCV, ACV, or ohms mode of operation. The function is changed by sending one of the following sequences over the bus:

- F0 DC Volts
- F1 AC Volts
- F2 k Ω
- F3 AC + DC

Upon power-up, the DC volts function is selected.

NOTE

Sending the F1 or F3 commands with no AC option installed will result in the following front panel conflict error message:

CnFLt

The instrument will assert SRQ if in the appropriate bus response mode; the status byte will also be affected as described in paragraph 4.6.

Programming Example: Place the Model 192 in the DCV mode and enter the following statements into the HP-85 keyboard:

REMOTE 708 (END LINE)
OUTPUT 708; "F2X" (END LINE)

After the END LINE key is pressed the second time, the Model 192 will change to the resistance function, as shown by the k Ω indicator light.

NOTES:

1. When the Model 1910 AC option is installed, the Model 192 will measure AC voltages if the F3 command is sent. Settling time of the Model 1910 option is 1.3 seconds for specified accuracy (0.05% of final reading).
2. Settling time for the 1920 option is 0.5 seconds for rated accuracy (within 0.1%).
3. Settling time for DC voltage measurements is 250ms to within 6 digits at 5 1/2 digit resolution.
4. Settling time for resistance measurements is 250ms to within 6 digits at 5 1/2 digit resolution.

4.3.3 Range (R)

The range command allows the user to control the sensitivity of the instrument through commands given over the bus. Range command parameters are summarized in Table 4-4. Upon power-up, R5 is selected. Note that R6 is an il-

legal range in the DCV and ACV modes. If the R6 command is sent to the Model 192 in those two modes, the instrument will:

1. Display the front panel "CnFLt" message.
2. Set the conflict bit in the status byte.
3. Ignore the entire command string in which the R6 command was given.

Further information on the status byte may be found in paragraph 4.6. Front panel error messages are described in paragraph 4.9.

Programming Example: Place the instrument on the 2000 range with the appropriate front panel button and enter the following statements into the HP-85 keyboard:

REMOTE 708 (END LINE)
OUTPUT 708; "R3X" (END LINE)

After the END LINE key is pressed the second time, the instrument will go to the 20 range as shown by the corresponding range indicator light.

Table 4-4. Range Commands

Command	DCV	ACV	OHMS
R0	Auto	Auto	Auto
R1	.2	.2	.2k
R2	2	2	2k
R3	20	20	20k
R4	200	200	200k
R5	1200	1000	2000k
R6	*	*	20M

*Illegal Ranges

4.3.4 Zero Command (Z)

The zero mode serves as a means for a baseline suppression. When the correct zero command is sent over the bus, the instrument will enter the zero mode, as indicated by the front panel ZERO indicator light. All readings displayed or sent over the bus while zero is enabled are the difference between the stored baseline and the actual voltage level. For example, if a 100mV baseline is stored, 100mV will be subtracted from all subsequent readings as long as the zero mode is enabled. The value of the stored baseline can be a little as a few microvolts or as large as the selected range will permit. The zero mode is controlled by sending one of the following commands over the bus:

- Z0 Zero Disabled
- Z1 Zero Enabled

Upon power-up, Z0 is selected.

Programming Example: With the front panel ZERO button, disable the zero mode and enter the following statements into the HP-85 keyboard:

REMOTE 708 (END LINE)
OUTPUT 708; "Z1X" (END LINE)

After the END LINE key is pressed the second time, the front panel ZERO indicator light will turn on.

NOTES:

1. Setting the range lower than the stored baseline will cause an overflow, as indicated by the front panel "OFLO" message. The overflow condition will also affect the status byte as described in paragraph 4.6.
2. Enabling zero reduces the dynamic range of the measurement. For example, with the instrument on the 2VDC range and a stored baseline of +1.00000 VDC, an input voltage of +2.00000VDC will still overload the A/D converter, even though the display shows only +1.00000VDC.
3. Once zero is enabled, the baseline will be stored when the next A/D conversion is triggered. Zeroed readings will then be displayed with each subsequent triggered conversion. For example, if the Model 192 is placed in one of the one-shot trigger modes, the first trigger following the zero enable command will store the baseline. All remaining triggers received while the zero is enabled will trigger zeroed readings with the previously stored baseline subtracted from the actual signal level.
4. To store a new baseline, the zero must be disabled and then enabled once again. The new baseline will then be stored with the first triggered conversion as previously described.
5. A separate baseline can be stored for each measuring function. For example, 10VDC could be stored for DC voltage measurements, 15VAC for AC voltage measurements, and 50Ω could be stored for resistance measurements.

4.3.5 Rate (S)

The rate command gives the user simultaneous control over several important operating parameters of the Model 192. When the rate command is sent, the following operating parameters are affected:

1. Samples per Reading
2. Integration Period
3. Filter Response
4. Display Resolution

These operating parameters are summarized in Table 4-5, which also shows the appropriate rate command for each combination. The power-up default value for the rate command is S2, corresponding to 6 samples per reading, 16.66ms integration period (at 60Hz), Filter 1 enabled, and 5 ½ digit display resolution.

Programming Example: Enter the following statement sequence into the HP-85 keyboard:

REMOTE 708 (END LINE)
OUTPUT 708; "S0X" (END LINE)

The second time the END LINE key is pressed, the Model 192 display will change to the 4 ½ digit mode. Also, the decimal point will flash at a faster rate because of the shorter 4ms integration period.

4.3.6 Rate Command Considerations

The optimum Model 192 rate mode is determined by a number of factors including noise, desired accuracy, speed requirements, and test set-up architecture. Since there is always a trade-off between required speed and resolution, care must be taken when using the rate commands, which affect samples per reading, integration period, filter response, and display resolution. The following paragraphs detail each of these parameters.

Samples Per Reading: A reading cycle is the period between the time that a reading is triggered and the time resulting data is ready to be displayed or sent over the bus. Figure 4-2 illustrates one reading cycle. At the start of the reading, the instrument is triggered, either internally, or by some outside stimulus. Once the reading is triggered, a specific time interval will pass before data is available. The time period depends on a number of factors, including the rate, mode, function and trigger mode selected. For a more complete description of these time periods, refer to paragraph 4.4.

Table 4-5. Rate Command Parameters

Rate Command	Number of Samples Per Reading	Integration Period	Filter	Display Resolution
S0	1	4.4ms		4 ½
S1	1	16.66ms*		5 ½
S2	6	16.66ms*	Filter 1	5 ½
S3	21	16.66ms*	Filter 2	5 ½
S4	21	16.66ms*	Filter 3	5 ½
S5	1	100ms		6 ½
S6	9	100ms	Filter 1	6 ½
S7	21	100ms	Filter 2	6 ½
S8	21	100ms	Filter 3	6 ½

*At 60Hz. Period is 20ms at 50Hz.

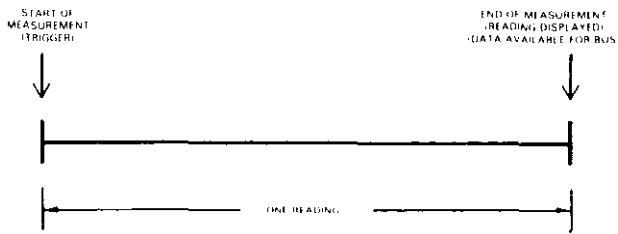

Figure 4-2. Reading Cycle

The input signal applied to the Model 192 input terminals may be a DC voltage, AC voltage, or a resistance to be measured. Depending of the rate command in effect, the signal is sampled one or more times per reading cycle. Figure 4-3 illustrates the number of samples used for the S2 mode of operation. Once the reading is triggered, a total of six sampling periods occur before data is available for display. During each of these sampling periods, the Model 192 performs one A/D (Analog-to-Digital) conversion. While the example in Figure 4-3 shows the number of samples for the S2 mode, other rate modes will change the number of samples per cycle. For example, in the S3, S4, S7, and S8 modes, a total of 21 samples per reading are taken.

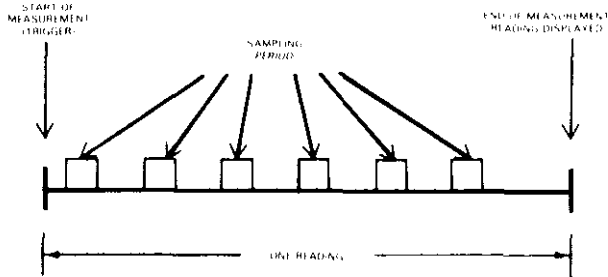

Figure 4-3. Multiple Sampling Periods

Integration Period: The Model 192 performs its A/D conversion through integration. During each sampling period, one complete integration cycle is performed. The length of the integration period, as well as the time interval between integration periods is determined by the selected rate command.

Figure 4-4 shows a representation for integration and interval between integration periods for the S2 mode. The integration period is 16.66ms, while the time interval between integration periods is 35ms.

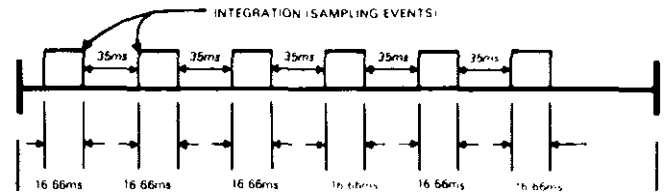

Figure 4-4. Integration Time Periods

Filtering: The Model 192 employs digital filtering techniques to simulate the response of typical 3-pole analog filters. Depending on the rate command selected, one of three filter routines is used by the MPU. For steady-state signals, the selected filter remains enabled. When the input signal changes suddenly, the MPU disables the filter to permit rapid display update.

Figure 4-5 shows the response curves for the three available filters. Note that the point at which the filter is enabled depends on the display resolution mode in use. In the 5 1/2 digit mode, the filter is off until the display is within 6 counts of the final reading. In the 6 1/2 digit mode, the filter is disabled until the reading is within 60 counts of the final value.

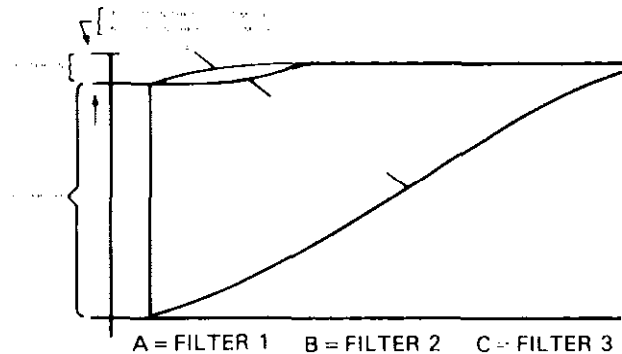

Figure 4-5. Filter Response Graph

Figures 4-6 and 4-7 further demonstrate filter response to input condition changes. These examples assume the Model 192 is being used to measure a nominal 1.5VDC input in the 5 1/2 digit mode on the 2V range. In Figure 4-6(a), a 0.00010V step occurs in the input. Since this change exceeds six counts, the MPU initially switches the filter off. Figure 4-6(b) shows the resulting Model 192 response to this change in input voltage. In Figure 4-7, the step voltage is only 0.00003V, a value that is less than the six digit window. The graph in Figure 4-7(b) shows that the response is much slower because the filter is not disabled. Because of slower response time, a number of reading cycles will be required before the display shows the final value. The number of reading cycles to reach the final value is 15 for filter 1 and 30 for filters 2 and 3.

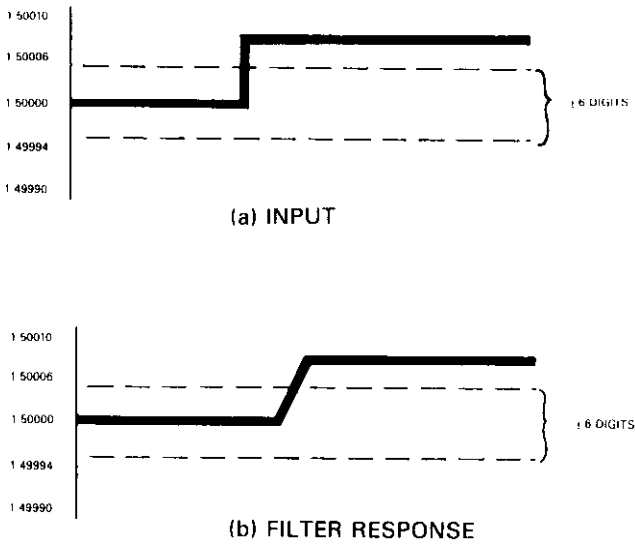
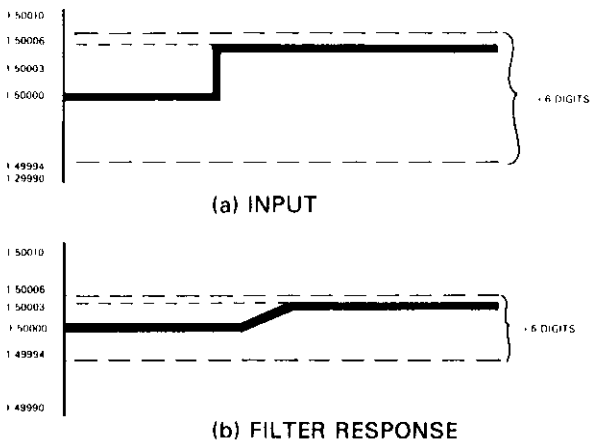

Figure 4-6. Filter Response to 10 Digit (.0001V) Input Change



NOTE: Waveforms are conceptual in nature only, and do not show actual instrument response.

Figure 4-7. Filter Response to 3 Digit (.00003V) Input Change

Display Resolution: The final parameter selected by the rate command is the display resolution of the instrument. Since the S2 mode is selected upon power-up, the instrument will be in the 5½ digit mode when first turned on. Alternately, 4½ or 6½ digit display resolution modes may be selected with the appropriate rate command as outlined in Table 4-5.

NOTE

The rate commands affect only the display resolution; data sent over the IEEE-488 bus always contains 6½ digit information.

4.3.7 Delay (W)

The delay command controls a 10ms delay period that is normally added to the beginning of each integration cycle. The appropriate command may be used to eliminate the 10ms delay in the DC mode only, thus increasing the measuring speed of the instrument. The delay command controls Model 192 operation as follows:

- W0 Eliminate 10ms delay before integration period.
 - W1 Add 10ms delay before integration period.
- Upon power-up, the W1 mode is enabled.

When enabled, the delay is added to each integration period within the reading cycle as shown in Figure 4-8, which demonstrates the use of the W1 delay mode with the S2 rate command. Note that a 14ms delay period occurs between the trigger and the start of the first integration period. Also, there is a 35ms interval between integration periods. In Figure 4-9, the W0 mode is demonstrated. Here, the initial delay period is reduced by 10ms to only 4ms. Also, the time between integration periods is reduced by 10ms to 25ms.

Programming Example: Place the instrument in the DCV mode and enter the following statement sequence into the HP-85 keyboard:

```
REMOTE 708 (END LINE)
OUTPUT 708; "W0X" (END LINE)
```

After the END LINE key is pressed the second time, the 10ms delay will be omitted.

NOTES:

1. The W0 delay mode can be used with any DC voltage range. However, the source resistance must be less than 50kΩ on the 0.2V, 2V, and 20V ranges for specified accuracy.
2. The W0 command has no effect on the AC volts and resistance ranges. The integration delay period is fixed at 14ms when operating in these modes.
3. The W1 delay mode may be used to enable the delay if additional settling time is needed.

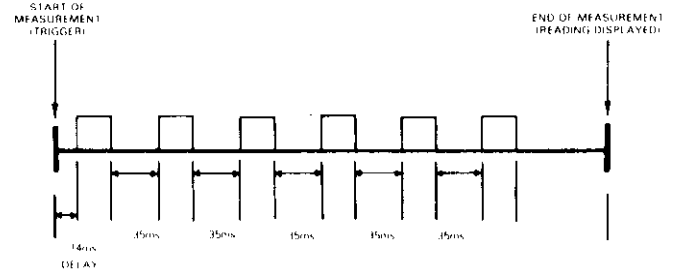

Figure 4-8. W1 Delay Mode (S2 Rate)

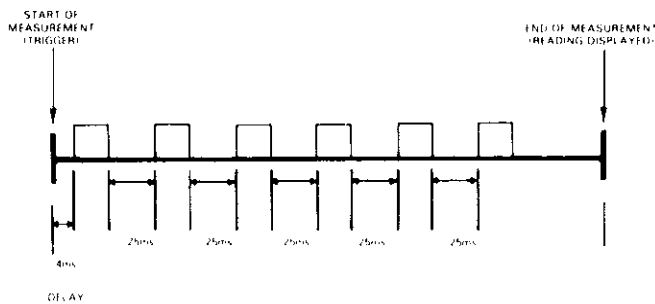

Figure 4-9. W0 Delay Mode (S2 Rate)

4.3.8 Buffer Command (Q)

The Model 192 has an internal buffer that may be used to store up to 100 readings. Operation of the buffer can be controlled by front panel Program 7, as described in the Model 192 Instruction Manual, or through the following commands given over the IEEE bus:

- Q0 Clears buffer and disables storage capability.
 - Q1 Enables buffer data storage.
- Upon power-up, the Q0 mode is enabled.

Programming Example: Enter the following program into the HP-85 computer. Each line of the program is explained by an appropriate comment and must be terminated with the END LINE key.

PROGRAM	COMMENTS
10 REMOTE 708	Set for remote operation.
20 OUTPUT 708; "M1Q1X"	Turn on SRQ and buffer.
30 S = SPOLL(708)	Obtain status byte.
40 IF BITS(S,6) = 0 THEN 30	Is buffer full? (SRQ bit set?)
50 FOR I = 1 TO 100	Loop 100 times.
60 ENTER 708; A\$	Read one buffer location.
70 DISP A\$	Display reading on CRT.
80 NEXT I	Next reading.
90 OUTPUT 708; "Q0X"	Turn off buffer.
100 END	End of program.

When the program is entered into the HP-85, set the Model 192 to default conditions by turning off the power and powering up again. Run the program by pressing the HP-85 RUN key. The Model 192 will immediately begin storing readings. After about 10 seconds, 100 readings similar to the following will be displayed on the CRT of the HP-85:

NDCV-0000.000E+0

The actual values will depend on the selected function and range, and the signal source connected to the instrument.

NOTE

Once the buffer is full, the display will continue to be updated with the most recent data. If the Model 192 is in the M1 bus response mode, an SRQ will be sent by the Model 192 to the controller when the buffer is full.

Data stored by front panel Program 7 may also be recalled over the bus. The basic procedure is demonstrated as follows:

1. Enter front panel Program 7 by pressing the PRGM and 7 buttons in sequence. If the instrument is in remote, programming may be restored by sending a GTL, DCL sequence.
2. Press the ENT button to enter a value of 0 for the r constant.
3. Press ENT again to begin storing readings.
4. After about 11 seconds, the "b FULL" message will be shown on the display.
5. To recall each buffer reading, the following HP-85 statements can be used:

ENTER 708;A\$ (END LINE)
DISP A\$ (END LINE)

6. Further readings may be obtained by repeating step 5.

NOTE

Placing the instrument in the remote mode will cancel Program 7. Also, the front panel buffer reading sequence must not be used while attempting to read the buffer over the bus; doing so will cause the bus to hang-up.

4.3.9 Buffer Operation

One reading is stored in the buffer after each reading conversion. In continuous trigger modes, the buffer will fill at the conversion rate of the instrument. Remember that the rate and delay commands affect the conversion rate. During the one-shot trigger modes, one reading is stored in the buffer each time a trigger is received. Thus, the one-shot modes provide a convenient method of controlling the fill rate of the buffer.

A data input pointer keeps track of the next storage location. If the buffer storage process is interrupted, the data input pointer allows storage to begin at the next memory location. Readings already stored will be retained until a Q0 or Q1 command is received, or until the instrument is turned off.

The data output pointer points to the next storage location to be read. As buffer data is requested, the pointer is incremented. Once all 100 buffer locations have been read, the pointer will cycle around to the beginning and point to the first location. Further readings will read buffer locations again.

The data pointers are reset when Q0 or Q1 command is received by the instrument. The Q0 command clears the buffer and disables buffer operation, thus restoring normal operation. The Q1 command causes the instrument to begin storing another set of readings in the buffer.

Buffer Operating Notes:

1. Once the Q1 command is sent, the instrument will respond to all data requests by sending the contents of one of the buffer locations. To obtain normal data readings, buffer operation must be disabled with the Q0 command.
2. If the M1 bus response mode is programmed, the instrument will send a service request (SRQ) to the controller when the buffer is full. An appropriate bit in the status byte, as described in paragraph 4.6, will be set.

4.3.10 Programmable Terminator (Y)

The Model 192 uses special terminator characters to mark the end of its data string. To allow a wide variety of controllers to be used with the Model 192, the terminator can be programmed by a command given over the bus. The power-up default value is the commonly used carriage return (CR) line feed (LF) sequence. The terminator may be changed by sending the ASCII character Y followed by the desired terminator. Any ASCII character except X and Y command characters may be used.

In addition, special ASCII characters may be sent, resulting in one of the following terminator sequences:

Y(LF) = CR LF (2 Terminators)
Y(CR) = LF CR (2 Terminators)
Y(DEL) = No Terminator

NOTE

Most controllers will wait for a specific terminator (usually a carriage return or line feed) before terminating their input sequence. Programming the Model 192 to send a non-standard terminator may cause the controller to hang-up unless special programming is used.

Programming Example: Enter the following statements into the HP-85 keyboard:

```
REMOTE 708 (END LINE)
OUTPUT 708; "YAX" (END LINE)
ENTER 708; A$ (END LINE)
```

After the second time the END LINE key is pressed, the terminator is changed to the ASCII character A. After the third time the END LINE key is pressed, the HP-85 computer will cease to operate because it is waiting for the standard terminator sequence. The HP-85 may be reset by holding SHIFT down and pressing the RESET key.

4.3.11 EOI (K)

The EOI line on the bus is usually set low by a device during the last byte of its data transfer sequence. In this way, the last byte is properly identified, allowing variable length data words to be transmitted. The Model 192 will normally send EOI during the last byte of its data string or status word. The EOI response of the instrument may be set with one of the

following commands:

K0 Send EOI during last byte.

K1 Send no EOI.

Upon power-up, the K0 mode is enabled.

Programming Example: The EOI response will be suppressed with the following HP-85 statement sequence:

```
REMOTE 708 (END LINE)
OUTPUT 708; "K1X" (END LINE)
```

Note that the HP-85 does not normally rely on EOI to mark the last byte of data transfer. Some controllers, however, may require that EOI be present at the end of transmission.

4.3.12 Bus Response Mode (M)

The bus response mode determines whether or not the Model 192 will request service from the controller through the SRQ line. When the appropriate mode is selected, the instrument will generate an SRQ under certain data or error conditions, as described in paragraph 4.6.

The bus response mode may be programmed as follows:

M0 No SRQ

M1 Send SRQ

Upon power-up, the M0 mode is selected.

Programming Example: The bus response mode may be programmed as follows:

```
REMOTE 708 (END LINE)
OUTPUT 708; "M1X" (END LINE)
```

After the END LINE key is pressed the second time, the Model 192 will be programmed for the M1 bus response mode.

4.3.13 Status Word (U)

The Model 192 has a status word that can be checked by the user to determine the present operating modes of the instrument. Each byte in the status word is a number corresponding to the previously programmed command parameter with the following sequence: T F R K Q S M Y Z W. The status word may be obtained by sending the following command sequence: UX. The instrument will respond by sending its status word instead of the normal data string the next time data is requested. A complete summary of status word parameters is shown in Figure 4-10. Also shown, are the power-on default values the instrument will also revert to the default conditions after receiving a DCL or SDC command over the bus. The EOI and terminator modes remain as programmed by their separate commands.

Programming Example: Set the Model 192 to the default conditions by momentarily powering down the instrument. Enter the following statements into the HP-85 keyboard:

```
REMOTE 708 (END LINE)
OUTPUT 708; "UX" (END LINE)
ENTER 708; A$ (END LINE)
DISP A$ (END LINE)
```

After the END LINE key is pressed the last time, the CRT will show the following default status word: 0050020:01000000.

Figure 4-11 illustrates interpretation of the status word 2130080:01100000.

Note that the returned terminator character is found by ANDing the last character in the terminator with 00001111 and ORing the result with 00110000. For example, the ASCII value for a line feed is 10, which has a binary value of 00001010. ANDing this value with 00001111 yields 00001010. Finally, ORing the result with 00110000 gives 00111010, which is printed out as an ASCII colon.

NOTES:

1. The status word should not be confused with the status byte, which is covered in paragraph 4.6. The status word contains 16 bytes pertaining to selected operating modes of the instrument. The status byte is read with a serial polling sequence and contains information on error and data conditions.
2. The status word can be read only once each time the U command is sent to the instrument. Once the status word is read, the next data transmission will consist of the normal data string.

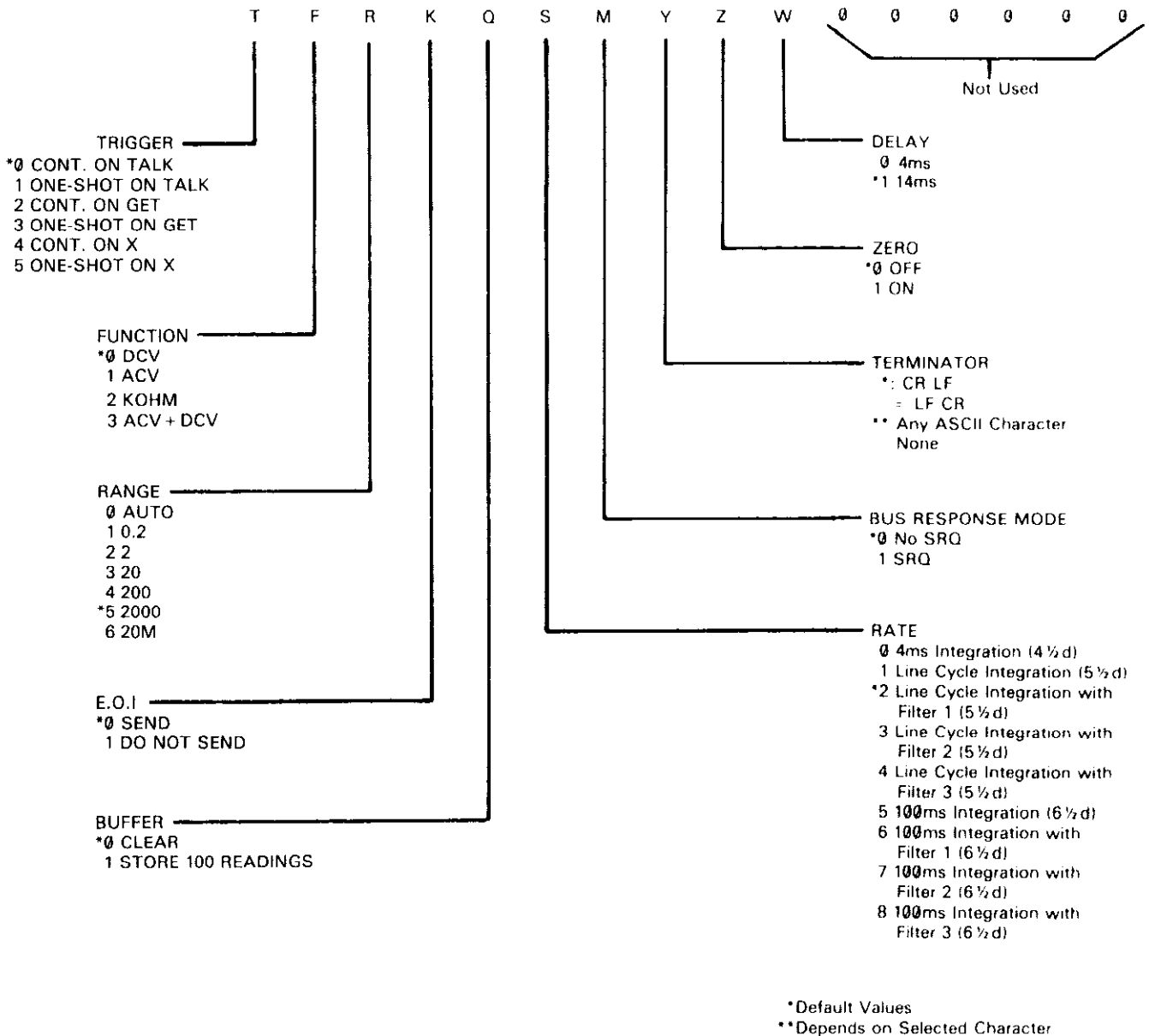
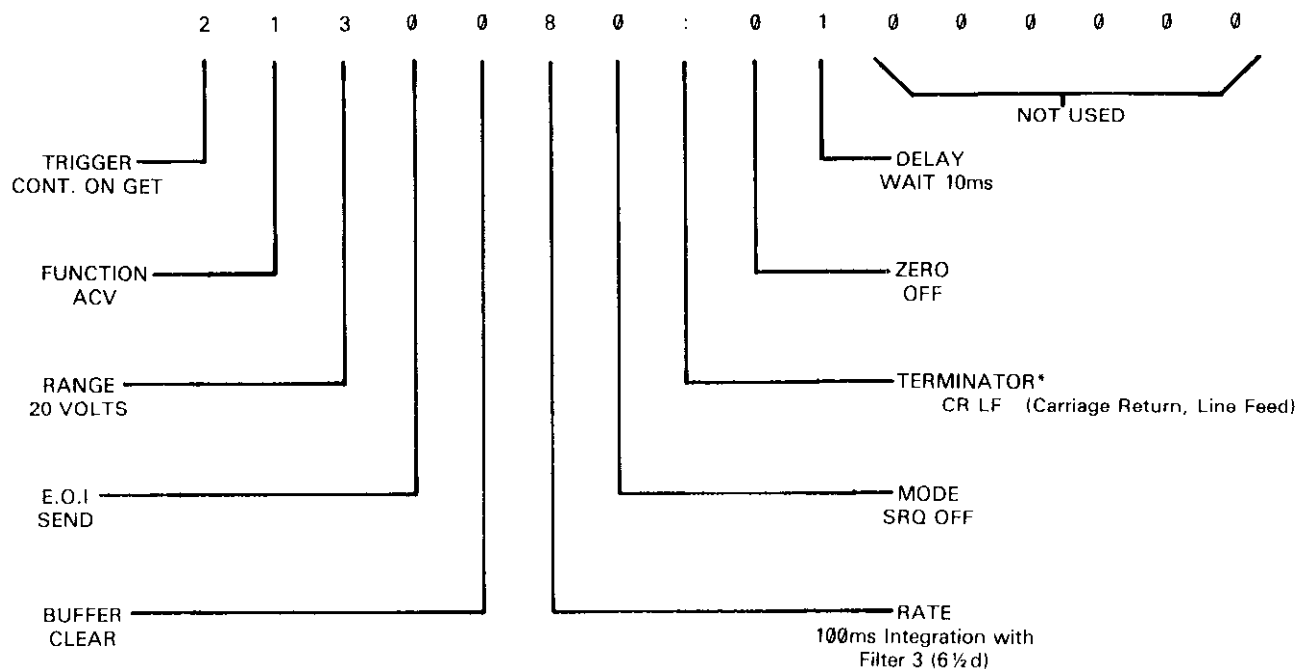

Figure 4-10. Status Word Format



*Formed by using least significant 4 bits of terminator character and "OR ING" it with 30 Hex.

Example: % = 25 Hex will be displayed as 35 Hex = 53 decimal.

Figure 4-11. Status Word Example

4.4 TRIGGERING (T)

Triggering is used to tell the Model 192 to take readings. The trigger stimulus may come from commands sent over the bus, or through the external trigger input or front panel ENT button. Triggering may be done in two basic ways. First, the trigger may be used to start a series of readings with one of the continuous trigger modes. The second method uses a separate trigger for each individual reading using one of the one-shot modes. This section covers each type of triggering detail.

4.4.1 Bus Command Triggering

The Model 192 has six commands that control triggering as follows:

- T0 Continuous On Talk
- T1 One-shot On Talk
- T2 Continuous On GET
- T3 One-shot On Get
- T4 Continuous On X
- T5 One-shot On X

Upon power-up, the T0 mode is enabled.

In the T0 and T1 modes, a talk command is used to trigger the instrument. In the T2 and T3 modes, a GET command performs the trigger function. Finally, the execute (X) character triggers the Model 192 in the T4 and T5 modes.

In the continuous trigger modes, a single command starts an unending series of readings. In one of the one-shot modes, a separate trigger is required for each reading. The continuous modes usually provide the best throughput; however, triggering is usually done in one of the one shot modes because the controller has better control over when a reading is actually taken.

Programming Example: Set the instrument to its default values by momentarily powering the unit down and enter the following statements into the HP-85 keyboard:

```
REMOTE 708 (END LINE)
OUTPUT 708; "T3X" (END LINE)
```

After the END LINE key is pressed the second time, the instrument will be placed in the one-shot on GET trigger mode. The decimal point will stop flashing, indicating the unit is waiting for a trigger.

To trigger the Model 192, enter the following statement into the HP-85:

TRIGGER 708 (END LINE)

When the END LINE is pressed, the decimal point will flash once. This shows that a single reading has been taken. To continue, a separate trigger must be sent for each reading.

The operation of the one-shot on talk and one-shot on X modes is the same, except that the appropriate trigger must be given.

4.4.2 Front Panel Triggering

The Model 192 may be triggered by the front panel ENT button when programmed for an appropriate trigger mode. Generally, a one-shot mode is selected, and the instrument will take one reading each time the ENT button is pressed. If the M1 bus response mode is selected, the instrument will generate an SRQ when the ENT button is operated. This gives the programmer added flexibility, by allowing the instrument to signal the controller when a reading is manually triggered. If the Q1 buffer mode is selected, one reading will be stored in the buffer each time the ENT button is pressed.

Programming Example: Place the instrument in the one-shot on X trigger mode with the following statement sequence:

REMOTE 708 (END LINE)
 OUTPUT 708; "T5X" (END LINE)
 ENTER 708; A\$ (END LINE)

After the END LINE key is pressed the second time, the decimal point will stop flashing, indicating the instrument is waiting for a trigger. At this point, front panel triggering may be implemented by pressing the ENT button once. The decimal point will flash once, showing that a reading has been taken. Each time the ENT button is pressed, one conversion will take place. Note that any of the one-shot modes may be used in this manner, and that the instrument will still respond to the correct trigger command over the bus.

4.4.3 External Triggering

The Model 192 may be externally triggered to take readings by applying a trigger pulse to the external trigger input on the status port. The operation of this trigger mode is similar to that of front panel triggering except for the actual trigger stimulus. If the M1 bus response mode is selected, an SRQ will be generated when an external trigger is received.

NOTE

The external trigger input is available on models with software revision level E-5 or later with one of the following Model 1923 PC boards: PC-561, Rev. D or later; PC-571, Rev. B or later.

Figure 4-12 shows the trigger input pins on the status port. Pin 1 is the trigger input, while pin 7 is common. Figure 4-13 shows the specifications for the trigger input pulse.

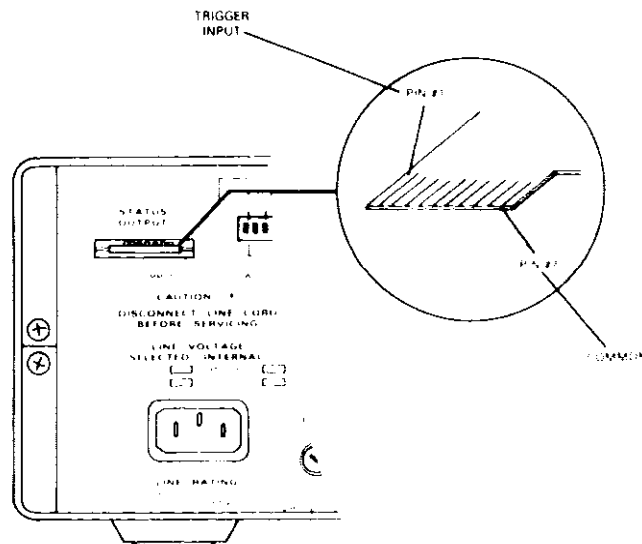

Figure 4-12. External Trigger Input

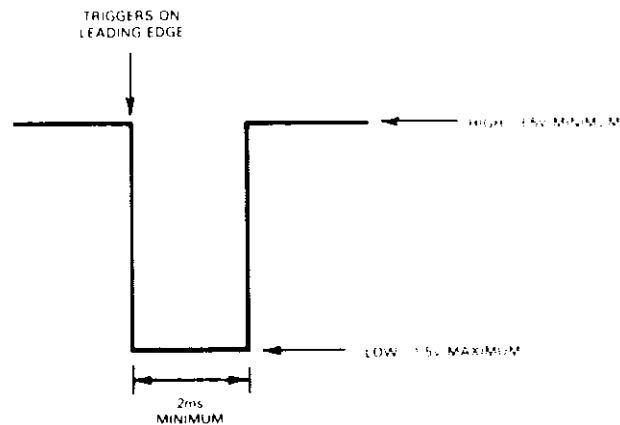

Figure 4-13. Trigger Pulse Specifications

Programming Example: Place the instrument in the one-shot on talk trigger mode by entering the following statements into the HP-85:

REMOTE 708 (END LINE)
 OUTPUT 708; "T1X" (END LINE)

After the END LINE key is pressed the second time, the instrument will go to the one-shot mode and wait for a trigger. To demonstrate external triggering, momentarily connect a jumper between pins 1 and 7 of the status port. Each time the trigger input is pulled low in this manner, the instrument will take one reading, as indicated by the flashing decimal point.

NOTE

The maximum trigger rate in the continuous modes is equal to the reading display rate of the instrument. The maximum trigger rate in the one-shot modes is equal to the trigger to byte-out times listed in Tables 4-6 through 4-9.

Table 4-6. Trigger Mode T1 Bus Times (60Hz)

S-Mode	DCV	ACV	Function	
			kΩ	20MΩ
S0	*37	30	38	102
S1	50	42	48	114
S2	330	270	760	1,480
S3	1,120	920	2,900	5,600
S4	1,120	930	2,900	5,600
S5	134	128	132	1,098
S6	1,240	1,160	4,000	5,000
S7	2,900	2,700	9,700	12,400
S8	2,900	2,700	9,700	12,400

*The W0 mode can be used to decrease trigger to data available time to 27ms.

NOTE: Times in milliseconds.

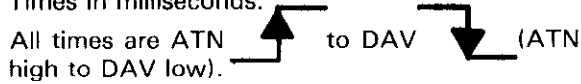
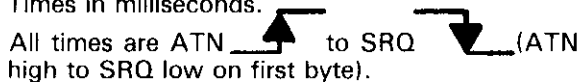

Table 4-7. Trigger Mode T3 Bus Times (60Hz)

S-Mode	DCV	ACV	Function	
			kΩ	20MΩ
S0	*37	28	33	100
S1	50	42	45	114
S2	325	260	740	1,460
S3	1,120	900	2,800	5,500
S4	1,120	900	2,800	5,500
S5	136	126	130	196
S6	1,240	1,120	3,900	12,400
S7	2,900	2,800	9,700	12,400
S8	2,900	2,800	9,700	12,400

*The W0 mode can be used to decrease trigger to data available time to 27ms.

NOTE: Times in milliseconds.



4.4.4 Bus Times

In the one-shot trigger modes, a specific time interval will pass between the time a trigger is received and the time that

data is available for transmission over the bus. The amount of time required depends on the selected trigger mode, the S command mode and the function. Table 4-6 through 4-8 list the bus times for the three one-shot modes with a power line frequency of 60Hz. Times for all Model 192 functions are shown in these tables. Times for the three trigger modes and the DC function at 50Hz are shown in Table 4-9. The following conditions apply to all four tables.

1. All Model 192 conditions are set to their default values except for those modes shown in the table.
2. All times listed are shown in milliseconds.
3. All times shown are typical.

4.5 DATA FORMAT

Model 192 data is transmitted over the bus as a string of 16 to 18 ASCII characters with the format shown in Figure 4-14. The first character indicates the type of reading, while the next three characters indicate the function. The mantissa of the reading is made up of nine characters, including sign and decimal point, while the exponent requires three characters. Depending on terminator programming, 0-2 terminator characters may be used. To obtain the data string from the instrument, the controller must perform the following sequence:

1. Set ATN low.
2. Address the instrument to talk.
3. Set ATN high.
4. Input the data string one byte at a time.

Note that the Model 192 must be in the remote mode before requesting data.

Table 4-8. Trigger Mode T5 Bus Times (60Hz)

S-Mode	DCV	ACV	Function	
			kΩ	20MΩ
S0	*90	79	90	220
S1	138	128	140	270
S2	410	345	840	1,600
S3	1,200	990	2,900	5,600
S4	1,200	1,000	2,900	5,600
S5	470	460	480	600
S6	1,560	1,480	4,200	5,500
S7	3,200	3,000	9,800	12,600
S8	3,200	3,000	9,800	12,600

*The W0 mode can be used to decrease trigger to data available time to 80ms.

NOTE: Times in milliseconds.



Table 4-9. Bus Times (50Hz)

S-Mode	DCV		
	ATN \uparrow DAV \downarrow Trigger Mode T1	ATN \uparrow SRQ \downarrow Trigger Mode T3	ATN \uparrow SRQ \downarrow Trigger Mode T5
S0	*37	*37	87
S1	52	53	152
S2	350	350	450
S3	1,200	1,200	1,300
S4	1,220	1,200	1,300
S5	127	134	480
S6	1,220	1,260	1,580
S7	2,900	3,900	4,250
S8	2,900	3,900	4,250

*The W0 mode can be used to decrease trigger to data available time to 27ms.

NOTE: Times in milliseconds.

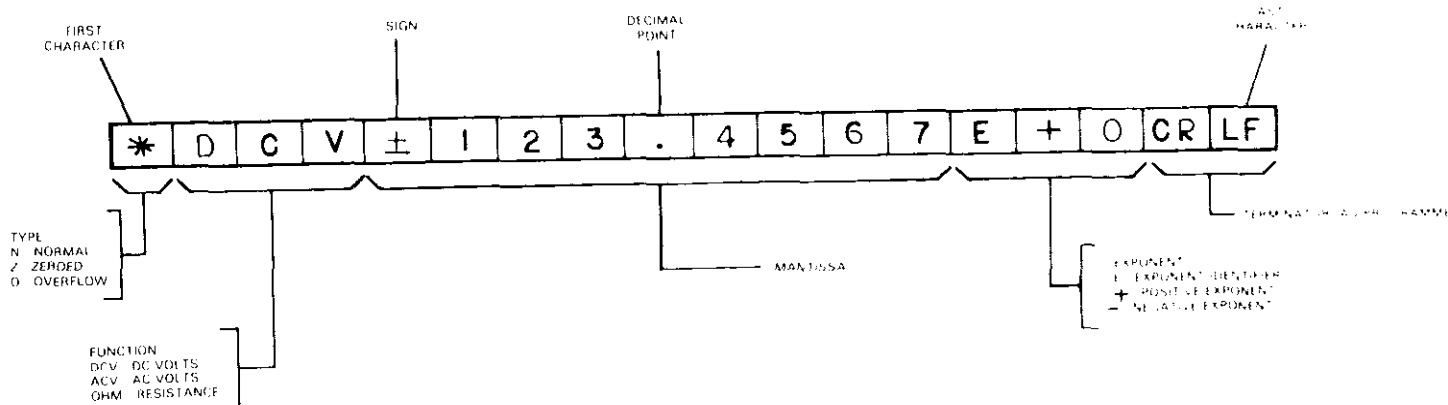

Figure 4-14. Data String Format

Programming Example: The preceding sequence is automatically performed by the HP-85 when the following statement sequence is used:

```
REMOTE 708 (END LINE)
ENTER 708;A$ (END LINE)
DISP A$ (END LINE)
```

After the second statement is executed, the data string will reside inside the computer, where it is stored as A\$. The third statement causes the data string to be displayed on the CRT.

NOTES:

1. Most controllers use one or both of the characters in the default terminator sequence (CR LF) to end their input sequence. Using a non-standard terminator character may cause the controller to hang-up.

2. The bus data always contains 6 ½ digit information regardless of the display resolution mode in use.
3. Terminator characters are not usually printed out.
4. The first digit in the mantissa will be a 4 when the instrument is in overflow. The remaining mantissa digits will show all zeroes when overflow condition occurs.
5. Depending on trigger mode, the instrument may require a trigger first.

Data String Examples:
NDCV + 1.600000E + 0

The instrument is sending a normal reading made in the DCV mode. The reading is +1.6VDC

ZDCV -150.0000E + 0

A zeroed reading of -150VDC is transmitted.

OACV + 40.00000E + 0

An overflow reading on an AC range is sent.

NOHM + 15.00000E + 6

A 15 MΩ resistance reading occurs.

4.6 SERVICE REQUEST

The IEEE-488 bus has a special Service Request line (SRQ) that is set low by instruments when they require service. The Model 192 will assert SRQ if in the M1 bus response mode under one or more of the following conditions:

1. If the instrument has data to send and it is not in talk.
2. If a trigger is received in the one-shot modes.
3. If the instrument receives an illegal device-dependent command or command option.
4. If the instrument receives a conflicting device-dependent command.
5. If the controller attempts to program the instrument when it is not in the remote mode.
6. When the data buffer is full.

Note that conditions 3,4, and 5 will result in front panel error messages as described in paragraph 4.9.

4.6.1 Serial Polling Sequence

Once the controller has received an SRQ, it must determine which instrument on the bus has requested service. To do so, it performs the serial polling sequence as follows:

1. Enables serial polling with the SPE (Serial Poll Enable) command.
2. Addresses the instrument to talk.
3. The instrument then places its status byte on the bus for the controller to read.
4. Disables polling sequence with SPD after all status bytes are collected.

Steps 2 and 3 are repeated for every instrument on the bus with a different talk address for each instrument.

Programming Example: The program below will set the bus response to M1 and display the status byte on the CRT of the HP-85.

PROGRAM	COMMENTS
10 REMOTE 708	Set for remote operation.
20 OUTPUT 708; "M1X"	Set bus response mode for SRQ.
30 S = SPOLL(708)	Conduct serial poll.
40 DISP S	Display status byte.
50 END	End of program.

Table 4-10. Error and Data Codes

Error Flag (Bit 5)	Bit 2	Bit 1	Bit 0	Message
0	0	0	0	Normal
0	0	0	1	Overflow
0	0	1	0	Buffer Full
0	1	0	0	Zeroed Reading
1	0	0	0	Illegal Device-Dependent Command (IDDC)
1	0	0	1	Illegal Device-Dependent Command Option (IDDCO)
1	0	1	0	Conflict Error
1	1	0	0	No Remote

Momentarily power down the instrument and press the HP-85 RUN key twice. After the second time, the CRT will display the number 64, which is the value of the SRQ bit as described in the next paragraph.

NOTE

The HP-85 SPOLL statement reverses the normal SPE and talk command sequence. This may cause a delay in the updating of the Model 192 status byte when conditions change.

4.6.2 Status Byte Format

The Model 192 status byte may be read at any time by the controller whether or not an SRQ was generated by the instrument. The status byte is obtained by using the serial polling sequence as described in the previous paragraph. The format of the status byte is shown in Figure 4-15. Bit 6 is the SRQ flag. If this bit in the Model 192 status byte is set, the SRQ was generated by the instrument. Note that the instrument must be in the M1 bus response mode to set the SRQ flag. Bit 5 is the error flag. It further clarifies the meaning of bits 0 through 2, as summarized in Table 4-10. Note that the values in the table assumes that only one error or data message is present. In some cases, more than one condition bit (B0-B2) may be set, depending on the circumstances. For example, if the zero mode is enabled, and the instrument is in overflow, both B0 and B2 will be set simultaneously.

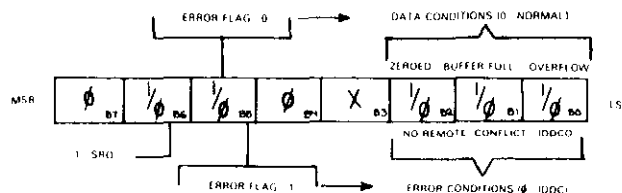

Figure 4-15. Status Byte Format

4.7 TALK ONLY OPERATION

The talk only mode may be used to send data to a listen only device such as a printer. When the Model 192 is in the talk only mode, it will ignore commands given over the bus. The talk only mode is enabled by placing the TO/ADDRESS-ABLE switch in the TO position, as shown in Figure 4-16.

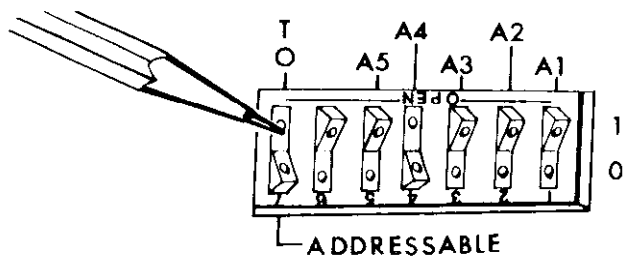

Figure 4-16. Enabling Talk Only Mode
NOTE

The status of the TO/ADDRESSABLE switch is read-only upon power-up. If the switch position is changed, the instrument must be momentarily powered down before it will recognize the new switch condition (the positions of the address switches are not important). Sending commands to the instrument when it is in the talk only mode may cause the controller to hang-up.

When the Model 192 is used in the talk only mode, it may be interfaced with one or more listeners. Each of these devices and associated cabling should conform to IEEE-488-1978 standards.

The Model 192 will transmit its normal data string in bit-parallel byte-serial fashion over the bus as requested by the listeners. The data format is the same one used for Addressable operation and is described in detail in paragraph 4.5.

The talk only mode can be used in conjunction with the front panel programs of the Model 192. Each of the following descriptions assumes that a printer is being used to provide the hard copy of instrument data.

PROGRAM	PRINTOUT
0 Clear	Normal output of measured data.
1 Resolution	
2 Filter	
3 Offset/Scale	Result of $SX + b$
4 Percent Deviation	Result of $[(X-n)/n] \times 100$
5 Min/Max	Normal data output. Minimum and maximum values stored by the instrument.
6 HI/LO/PASS	None
7 Data Logger	Normal data printed at the logging rate selected by constant r.

4.8 STATUS PORT

The status port is an integral part of the Model 1923A interface. Outputs on the port include terminals for front panel Program 6 and terminals to indicate which function is selected. The status port also has an external trigger input that can be used to trigger the Model 192 to take readings as described in paragraph 4.4.

Figure 4-17 shows the terminal configuration for the status port, while Table 4-11 lists the pin assignments. Pins 3, 4, and 5 are High/Low/Pass outputs for front panel Program 6 and are in the high impedance state with respect to IEEE common when disabled. Pins 8, 9, and 10 are DCV, ACV, and Ohms outputs. These pins are operational regardless of the type of front panel or IEEE programming in use.

NOTE

The 5V supply terminal is for reference only and must not be externally loaded.

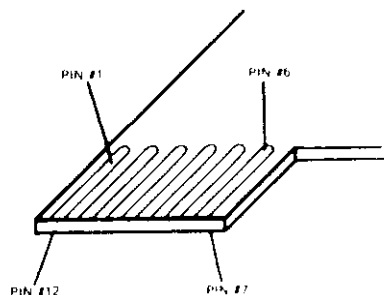

Figure 4-17. Status Port Pin Connections

Table 4-11. Status Port Pin Assignments

Contact	Signal Line
1	External Trigger
2	Not Used
3	HIGH
4	PASS
5	LOW
6	+5V (Not to be externally loaded)
7	Common (IEEE)
8	DCV
9	ACV
10	Ohms
11	Not Used
12	Not Used

Figure 4-18 shows the equivalent circuit of each of the six output drivers. The outputs are open collector and can sink 100mA each. Each output may be pulled up to a maximum of 20V through a suitable resistor or relay coil, which can then be used to control other equipment.

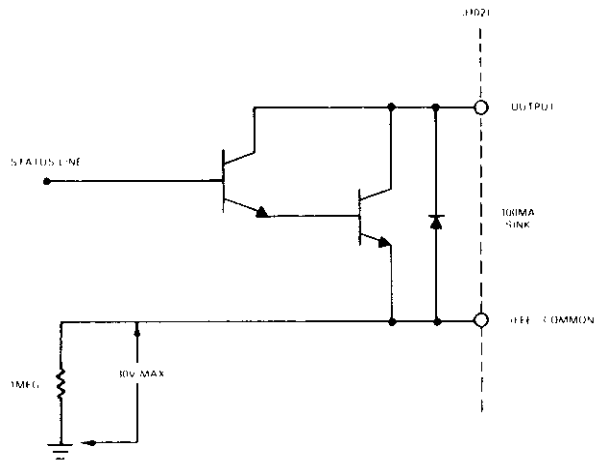

Figure 4-18. Simplified Schematic of Status Output Driver (One of 6)

4.9 FRONT PANEL ERROR MESSAGES

The process of programming the Model 192 involves the proper use of syntax. Syntax is defined as the orderly or systematic arrangement of programming commands or languages. The Model 192 must receive a valid command and proper syntax or it will ignore the command and display front panel error messages.

Device-dependent commands are sent as a string of several characters. Some examples of valid command strings are:

- F1R4T1S1X Multiple command string.
- F2X Single command string.
- F2 X Space is ignored.
- F1.0X Decimal point and any number following is ignored.
- R1234X Only first digit is used; the rest are ignored.

Examples of invalid command strings are:

- H0X Invalid command; H is not a command.
- K5X Invalid command option. 5 is not an option of the K command.

Figure 4-19 shows the front panel error messages used by the Model 192. The message in Figure 4-19 (a) and (b) are messages resulting from improper syntax. The message in Figure 4-19 (c) and (d) results from improper commands.

IDDC Error: An Illegal Device-Dependent Command (IDDC) error will result when the Model 192 is sent an invalid command, such as V1X. This command is invalid because no such command letter exists in the instrument's programming language.

Programming Example: To demonstrate this point, enter the following statements into the HP-85 computer:

```
REMOTE 708 (END LINE)
OUTPUT 708; "V1X" (END LINE)
```

When the END LINE key is pressed the second time, the error message in Figure 4-19 (a) is displayed for about one second.

1ddC

(a) ILLEGAL DEVICE-DEPENDENT COMMAND

1ddC0

(b) ILLEGAL COMMAND OPTION

CnFLt

(c) COMMAND CONFLICT

no rn

(d) NO REMOTE

Figure 4-19. Front Panel Error Messages

IDDCO Error: An Illegal Device-Dependent Command Option (IDDCO) error occurs when the numeric parameter associated with the command is invalid. For example, the command R9X has an invalid option because the instrument has no range associated with that number.

Programming Example: To demonstrate an IDDCO error, enter the following statements into the HP-85 computer:

```
REMOTE 708 (END LINE)
OUTPUT 708; "R9X" (END LINE)
```

After the END LINE key is pressed the second time, the error message in Figure 4-19 (b) is displayed for about one second.

Conflict Error: Some commands or command options may result in conflicts between various operating modes. For example, the command R6X is valid command with the Ohms function, but it is invalid when used with the DCV and ACV functions, since no such range exist for those functions. If a conflicting command is sent, the instrument will display the error message shown in Figure 4-19(c) for one second.

Programming Example: To demonstrate a conflict error, enter the following statements into the HP-85 computer:

```
REMOTE 708 (END LINE)
OUTPUT 708; "R6X" (END LINE)
```

When the end line key is pressed the second time, the instrument displays the message in Figure 4-19(c) for one second.

No Remote Error: The instrument should normally be placed in the remote mode before programming. If programming is attempted without doing so, the error message in Figure 4-19(d) will be displayed.

Programming Example: To demonstrate a No Remote error, enter the following statements into the HP-85 computer:

```
LOCAL 7 (END LINE)
OUTPUT 708; "R1X" (END LINE)
```

When the END LINE key is pressed the second time, the message in Figure 4-19(d) is displayed for one second.

Each of the front panel error messages has a counterpart in the status byte. See paragraph 4.6 for information on which status byte bits are affected by command and syntax errors.

4.10 CAPABILITY IDENTIFICATION CODES

The capability identification codes are part of the IEEE-488-1978 standards. These codes define an instrument's ability to support various interface functions, and should not be confused with programming commands shown elsewhere in this manual.

Table 4-12 lists the capability codes for the Model 192 with the Model 1923A interface installed. The numeric value following each one or two letter code designation defines Model 192 capabilities as follows:

1. SH (Source Handshake Function)-The ability for the Model 192 to initiate the transfer of message/data on the data bus is provided by the SH function.
2. AH (Acceptor Handshake Function)-The ability for the Model 192 to guarantee proper reception of message/data on the data bus is provided by the AH function.
3. T (Talker Function)-The ability for the Model 192 to send device-dependent data over the bus (to other devices) is provided by the T function.
4. L (Listener Function)-The ability for the Model 192 to receive device-dependent data over the bus (from other devices) is provided by the L function. Listener function capabilities of the Model 192 exist only when it (the 192) is addressed to listen.
5. SR (Service Request Function)-The ability for the Model 192 to request service from the controller (in charge of the interface) is provided by the SR function.
6. RL (Remote—Local Function)-The ability for the Model 192 to send information from a programmed or a manual configuration (remote or local configuration) is provided by the RL function.
7. PP (Parallel Poll Function)-The Model 192 does not have parallel polling capabilities.
8. DC (Device Clear Function)-The ability for the Model 192 to be cleared (initialized) is provided by the DC function.
9. DT (Device Trigger Function)-The ability for the Model 192 to have its basic operation started (make a measurement) is provided by the DT function.
10. C (Controller Function)-The Model 192 does not have controller capabilities.

11. TE (Extended Talker Capabilities)-The Model 192 does not have extended talker capabilities.
12. LE (Extended Listener Capabilities)-The Model 192 does not have extended listener capabilities.

Table 4-12. Model 192 Capability Identification Codes

Code	Interface Function
SH1	Source Handshake Capability
AH1	Acceptor Handshake Capability
T5	Talker (Basic Talker, Serial Poll, Talk Only Mode, Unaddressed to Talk if Addressed to Listen)
L4	Listener (Basic Listener, Unaddressed to Listen if Addressed to Talk)
SR1	Complete Service Request Capability
RL1	Complete Remote/Local Capability
PP0	No Parallel Poll Capability
DC1	Complete Device Clear Capability
DT1	Complete Device Trigger Capability
C0	No Controller Capability
E1	Open Collector Bus Drivers
TE0	No Extended Talker Capability
LE0	No Extended Listener Capability

4.11 CONTROLLER PROGRAMS

The Model 192 is easily connected to a wide variety of system controllers through the Model 1923A interface. System instrument designs have been thoroughly checked out with a number of different controllers to ensure complete compatibility.

Most of the programming functions throughout this manual use HP-85 examples. This section gives additional programming information for using the Model 192 with the following controllers: PET/CBM 2001, Apple II, HP 9825A, HP 9845B, TEK 4052, and DEC LSI 11.

Each of the programs in this section is designed to be a simple aid to the user, and is not intended to suit specific needs. More detailed programming information can be found throughout this manual.

These programs display one reading at the controller output, which is usually a CRT display. The data format is an ASCII string with the form:

NDCV + 000.0000E+0 CR LF

A note with each program indicates modifications to change the string into a numeric equivalent of the form:

+000.0000E+00

4.11.1 PET/CBM 2001

The program below obtains one reading from the Model 192 DMM and displays the reading on the PET/CBM 2001 Series CRT screen. Do the following steps:

1. Set switches on Model 192 to addressable mode, primary address 8. (See Section 3.)

2. Connect the Model 192 to PET/CBM 2001 IEEE Interface.
3. Enter the following program using the RETURN key after each line is typed. (Type in line numbers.)
4. Type RUN and depress the RETURN key.
5. The CRT will read "TEST SETUP".
6. To program the Model 192 to the 2V range and take a reading, type in FOR2X and depress the RETURN key.
7. The CRT will read NDCV = 0.000000E 0 for "0" volts in.

PROGRAM	COMMENTS
10 OPEN 6,8	Open file 6, primary address 8.
20 INPUT "TEST SETUP": B\$	Enter programming command. (Example: 2V DC range = FR2X.)
30 PRINT#6,B\$	Output to the IEEE bus.
40 INPUT#6,A\$	Read data from Model 192 via IEEE bus.
50 IF ST = 2 THEN 40	If time out, input again.
60 PRINT A\$	Print data.
70 GO TO 20	Repeat
NOTE: If conversion to numeric variable is desired, omit line 7 and type the following:	
70 A = VAL (MID\$(A\$,5,16))	Convert string to numeric value.
80 PRINT "A = ";A	
90 GO TO 20	Repeat

4.11.2 APPLE II

The following program obtains one reading from the Model 192 and displays the reading on the APPLE II CRT screen, using a California Computer Systems IEEE Interface. Other interfaces may require different programming. Do the following steps:

1. Set switches on Model 192 to the addressable mode, primary address 8. (See Section 3.)
2. Connect the Model 192 to APPLE II and California Computer Systems IEEE Interface.
3. Enter the program below using the RETURN key after each line is typed. (Type in line numbers.)
4. Type in RUN and depress RETURN key.
5. The CRT will read "TEST SETUP".
6. To program the Model 192 to the 2V range and take a reading, type in FOR2X and depress the RETURN key.
7. The CRT will read NDCV + 0.000000E 0 for "0" volts in.

PROGRAM	COMMENTS
10 DIM A\$(20), B\$(20)	To dimension data string.
15 PRINT "TEST SETUP";	
20 INPUT B\$	Enter programming Command. (Example: 2VDC Range = FOR2X.)

30 PR#3	Set to I/O IEEE Interface.
40 PRINT "@(::"	Primary address 8.
50 PRINT """;B\$;" "	Text mode; to output B\$.
60 PRINT "@?:@H:"	Talk
70 PR#0	Set I/O to CRT.
80 INPUT A\$	Input to CRT from IEEE bus.
90 IN#0	Set I/O to keyboard.
100 GO TO 20	Repeat

NOTE: If conversion to numeric variable is desired, add the following:

82 A = VAL(MID\$(A\$,5,15))	Convert string to numeric value.
84 PRINT A	

4.11.3 HP 9825A

The program below obtains one reading from the Model 192 and displays the reading on the HP 9825A using a 98034A HPIB Interface and a 9872A extended I/O ROM. Do the following steps:

1. Set switches on the Model 192 to addressable mode, primary address 8. (See Section 3.)
2. Connect the Model 192 to HP 9825A and 98034A HPIB Interface.
3. Enter the following program, using the STORE key after each line is typed. Line numbers are automatically assigned by the 9825A.
4. Depress the RUN key.
5. The display will read "TEST SETUP".
6. To program the Model 192 to the 2V range and take a reading, type in FOR2X and depress the CONT key. (Note: F=function; 0=DC volts; R=range; 2=2VDC range; F,R,X must be capital letters).
7. Printer will read NDCV + 0.000000E 0 for "0" volts in.

PROGRAM	COMMENTS
0 dim A\$(20), B\$(20)	To dimension data string.
1 dev "192", 708	Define Model 192 DMM.
2 rem "192"	Set to remote.
3 ent "TEST SETUP", A\$	Enter programming command. (Example: 2VDC range = FOR2X.)
4 wrt "192" A\$	Output program command to Model 192 via IEEE bus.
5 red "192" B\$	Read data from Model 192 via IEEE bus.
6 prt B\$	Print data on hard copy printer.
7 gto 3	Repeat

NOTE: If conversion to numeric variable is desired, omit lines 6 and 7 and substitute:

```
6 "e" B$(13,13); flt5          Convert to numeric
                                value.
7 prt val(B$(5))
8 gto 3                          Repeat
```

4.11.4 HP 9845B

The following program obtains one reading from the Model 192 and displays the reading on the HP 9845B CRT screen using a 98034A HPIB Interface and an I/O PROM. Do the following:

1. Set switches on the Model 192 to addressable mode, primary address 8. (See Section 3.)
2. Connect the Model 192 to HP 9845B and 98034A Interface.
3. Enter the following program using the STORE key after each line is typed.
4. Depress the RUN key.
5. The display will read "TEST SETUP" in the lower left corner.
6. To program the Model 192 to the 2V range and take a reading, type in FOR2X and depress the CONT key.
7. Display will read NDCV + 0.000000E 0 for "0" volts in.

PROGRAM	COMMENTS
10 DIM A\$(20), B\$(20)	To dimension data string.
20 E192=708	Define Model 192 DMM.
30 INPUT "TEST SETUP", B\$	Enter programming command (Example: 2VDC range = FOR2X.)
40 OUTPUT E192; B\$	Output program command to Model 192 via IEEE bus.
50 ENTER E192; A\$	Read data from Model 192 via IEEE bus.
60 PRINT A\$	Print data on 9845B CRT.
70 GO TO 30	Repeat

NOTE: If conversion to numeric variable is desired, omit line 60 and substitute:

```
60 PRINT VAL (A$(5;9))          Convert string to
                                numeric value.
70 GO TO 30                      Repeat
```

4.11.5 TEK 4052

The following program obtains one reading from the Model 192 and displays the reading on the TEX 4052 graphics terminal, with an 4051 GPIB Interface. Do the following:

1. Set switch on the Model 192 to the addressable mode, primary switch address 8. (See Section 3.)
2. Connect the Model 192 to TEK 4051 IEEE Interface.
3. Enter the program below using the RETURN key after each line is typed.
4. Type in RUN.
5. The display will read "TEST SETUP".
6. To program the Model 192 to the 2V range and take a reading, type in FOR2X and depress the RETURN key.
7. Display will read NDCV + 0.000000E 0 for "0" volts in.

PROGRAM	COMMENTS
5 PRINT @ 37, 0: 10, 255, 13	
10 PRINT "TEST SETUP"	Prompt for the test setup.
20 INPUT A\$	
30 PRINT @8: A\$	Program the 192 DMM.
40 INPUT % 8: B\$	Get the data from the Model 192 DMM.
50 PRINT B\$	
60 GO TO 10	Repeat

NOTE: If conversion to numeric value is needed, change 40 and 50 to:

```
40 INPUT % 8: A
50 PRINT A
```

4.11.6 DEC LSI 11

The following program obtains one reading from the Model 192 and displays the reading on the DEC LSI 11 micro-computer CRT terminal. The LSI 11 must be hardware configured with 16k words of RAM and an IBV 11 IEEE Interface. The software must be configured with IB software as well as Fortran and the RT 11 operating system. Do the following:

1. Set switches on the Model 192 to addressable mode, primary address 8. (See Section 3.)
2. Connect the Model 192 to the IBV 11 IEEE cable.
3. Enter the program below, using the editor under RT 11 and the name IPHILD.
4. Compile using the fortran compiler as follows:
FORTRAN IPHILD
5. Link with the system and IB Libraries as follows:
LINK IPHILD, IBLIB
6. Type RUN IPHILD and depress the RETURN key.
7. The display will read "TEST SETUP".
8. To program the Model 192 to the 2V range and take a reading, type in FOR2X and depress RETURN key.
9. Display will read NDCV + 0.000000E 0 for "0" volts in.

PROGRAM IPHILD	COMMENTS
INTEGER *2 PRIARDR	
LOGICAL *1 MSG(80), INPUT(80)	
DO 2 I=1,10	
CALL IBSTER (I,0)	!Turn Off IB errors

```

2 CONTINUE
  CALL IBSTER (15,5)
  CALL IBTIMO (120)
  CALL IBTERM ("10)
  CALL IBREN

4 TYPE 5
5 FORMAT (1X,'ENTER ADDRESS',\$)
  ACCEPT 10, PRIADR
10 FORMAT (2I4)
12 TYPE 15
15 FORMAT (1X,'TEST SETUP',\$)
  CALL GESTER (5,MSG,72)
  CALL IBSEOI (MSG,-1, PRIADR)
18 I = IBRECV (INPUT,80,PRIADR)

  INPUT (I + 1) = 0
  CALL PUTSER (7,INPUT,'0')
  CALL IBUNT
  GO TO 12
END

```

!Allow 5 error 15's
!Allow 1 sec. bus timeout.
!Set LF as terminator.
!Turn remote on.

!Input the address 8.

!Prompt for the test setup.
!Get the test setup.
!Program the 192.
!Get the data from the 192.

!Untalk the 192.
!Repeat

4.12 READING RATES

The maximum throughput of the Model 192 depends on the maximum readings rate of each mode of operation as described in the following:

4.12.1 Bus Rates

Continuous Modes: In the continuous modes, each reading is broken up into four phases, N1, N2, N3, and N4. The N1 is the signal integration phase, while N2 through N4 are auto cal phases. Figure 4-20 shows one phase of the reading cycle for 4½, 5½, and 6½ digit modes with W0 enabled. Table 4-13 shows the reading rates for the various S-modes.

Table 4-13. System Reading Rates

S Mode	Display Resolution	Integration Period	Readings Per Second
S0	4½	4.4ms	14
S1	5½	16.66ms*	8*
S2	5½	16.66ms*	8*
S3	5½	16.66ms*	8*
S4	5½	16.66ms*	8*
S5	6½	100ms	2
S6	6½	100ms	2
S7	6½	100ms	2
S8	6½	100ms	2

*At 60Hz line frequency.

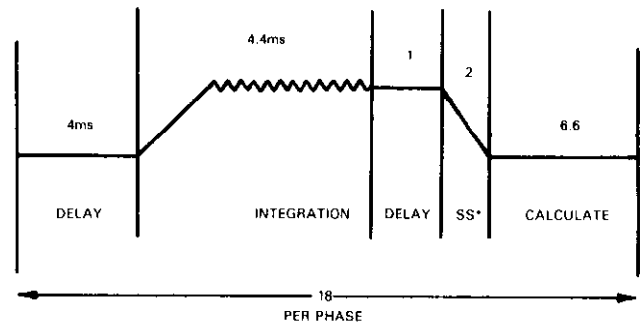

$$\text{READING RATE} = 1 / (4 \times 18) = 14 \text{rdg/sec}$$

(a) 4½ DIGITS AND W0 ENABLED

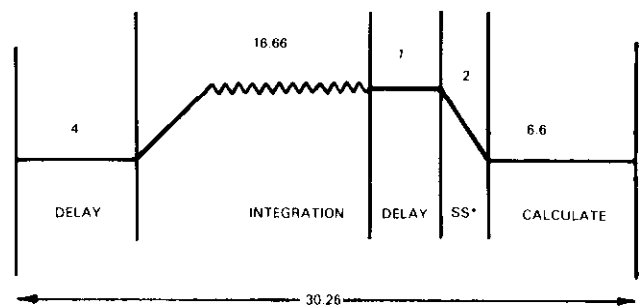

$$\text{READING RATE} = 1 / (4 \times 30.26) = 8 \text{rdg/sec}$$

(b) 5½ DIGITS AND W0 ENABLED

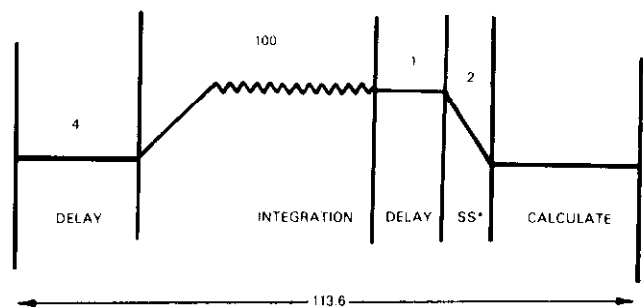

$$\text{READING RATE} = 1 / (4 \times 113.6) = 2 \text{rdg/sec}$$

(c) 6½ DIGITS AND W0 ENABLED

NOTE All times in milliseconds.
*SS Single Slope Portion

Figure 4-20. Continuous Reading Cycles

One-Shot Modes: Figure 4-21 shows one cycle of operation for a one-shot trigger with the S0 rate mode.

Fastest Rate: The fastest rate occurs under the following conditions:

1. Buffer mode set to Q1 (Buffer on)
2. S0 rate mode selected (4½ digits, 4.4ms integration)
3. Continuous trigger modes.

Under these conditions, the buffer will fill at a rate of 33 readings per second.

4.12.2 Bench Rates

Reading rates for the bench mode of operation are shown in Table 4-14. Also shown are the equivalent S-modes that correspond to each rate.

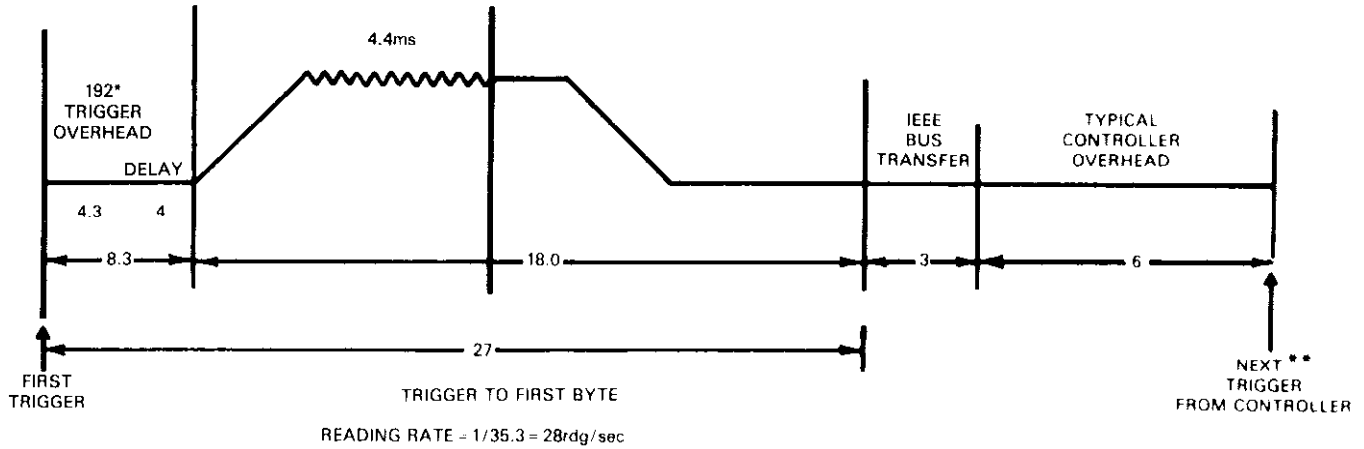

*This time is a distributed time and is shown lumped together for discussion purposes.

**Re-applying trigger will abort cal/zero phases

NOTE: All times shown in milliseconds

Figure 4-21. One-Shot Reading Cycle (S0 Mode)

Table 4-14. Bench Reading Rates

5½ Digit Resolution					6½ Digit Resolution			
Function	Filter	Integration Period (ms)	Readings Per Second	Equivalent S Mode	Filter	Integration Period (ms)	Readings Per Second	Equivalent S Mode
DCV	(F1) Filter off	16.66*	8*	S2	(F2)	100	2	S7
	(F3) Filter on	16.66*	8*	S4	(F3)	100	2	S8
ACV	(F1) Filter off	100	2	S6	(F2)	100	2	S7
	(F3) Filter on	100	2	S8	(F3)	100	2	S8
KΩ	(F1) Filter off	16.66*	8*	S2	(F2)	100	2	S7
	(F3) Filter on	16.66*	8*	S4	(F3)	100	2	S8
20MΩ	(F1) Filter off	16.66*	3	S2	(F2)	100	2	S7
	(F3) Filter on	16.66*	3	S4	(F3)	100	2	S8

*At 60Hz.

SECTION 5 IEEE COMMAND FLOW CHARTS

5.1 INTRODUCTION

This section describes what happens when the Model 192 receives various commands across the IEEE-488 bus (DCL, IFC, REN, etc.). Each command listed is accompanied with a flow chart and a brief description of the command.

Programming the Model 192 across the IEEE bus requires the installation of the IEEE interface option (Model 1923 or 1923A). The interface connects the internal computer of the Model 192 with the IEEE bus.

5.2 DCL-DEVICE CLEAR

Device Clear simultaneously clears all instruments capable of responding to a DCL command by returning the instruments to their initialized states (see Figure 5-1).

The start of the DCL command causes the 68488 GPIA to interrupt the Model 192's microprocessor. Then the programmable parameters are set to the default conditions (refer to Table 4-2). After the parameters are set for default they are then set for the next conversion. If the Model 192 is not in one of the trigger modes (T1, T3 or T5) the sequence transfers to the Auto Cal routine. Otherwise the Model 192 does an A/D conversion and calculates the reading. If the bus requests data, the reading is then transferred to the bus and then to the display. Otherwise, the reading is sent directly to the display. After the reading is displayed the Model 192 does the Auto Cal routine and sets the parameters for the next conversion.

5.3 IFC-INTERFACE CLEAR

Interface Clear simultaneously disables the addressable functions of all instruments capable of responding to an IFC command by placing the Model 192 into a talk/listen idle state (see Figure 5-2).

NOTE

The IFC command only excludes the Model 192 from responding to an addressable command. All other previously programmed functions are unaffected.

At the start of the IFC command the controller places "IFC" on the bus. The talk and listen bits in the GPIA register are cleared and the front panel LEDs for TALK and LISTEN are turned off. The parameters are set for the next conversion and the Model 192 does an A/D conversion and calculates the reading. The reading is transferred to the display and then the Auto Cal routine takes place. After the Auto Cal routine the parameters are once again set for the next conversion.

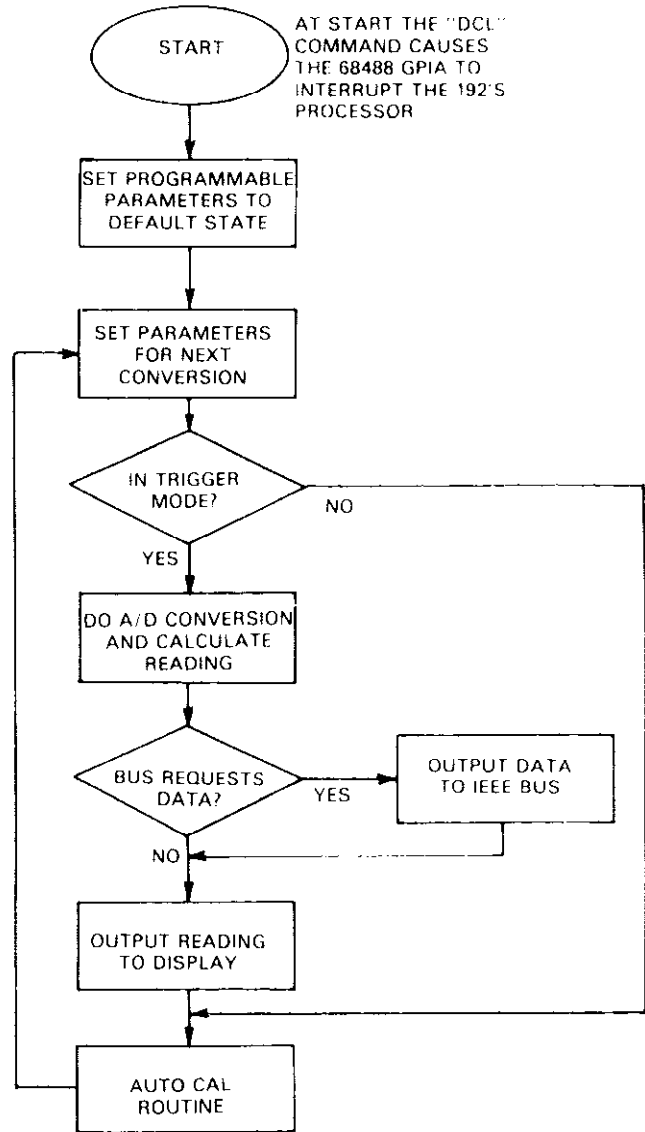

Figure 5-1. DCL Command

5.4 REN-REMOTE ENABLE

Remote Enable simultaneously enables the remote programming function of all instruments capable of responding to a REN command (see Figure 5-3).

NOTE

All other previously programmed functions of the Model 192 are unaffected.

AT THE START THE CONTROLLER PLACES "IFC" ON THE BUS

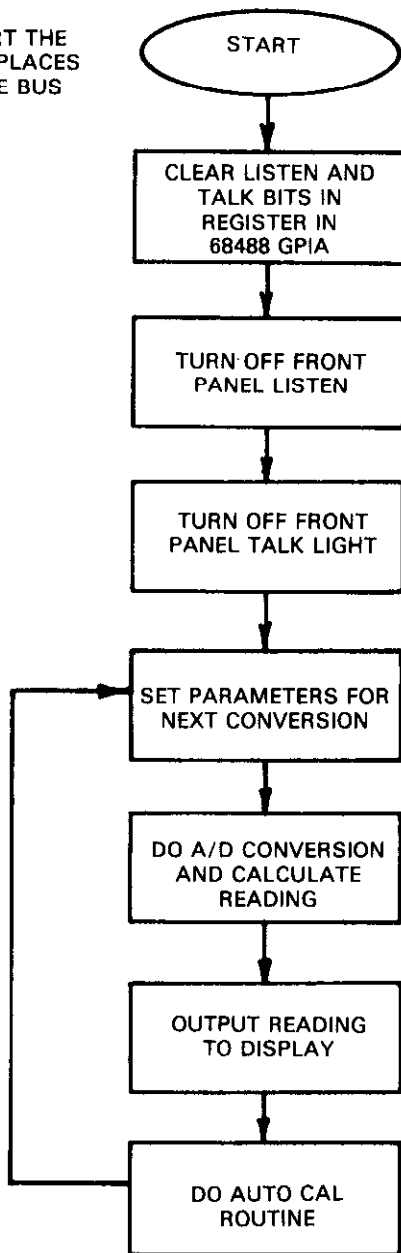

Figure 5-2. IFC Command

At the start of the IFC command the controller places "IFC" on the bus. The remote bits in the GPIA register and the remote flag are set. The REMOTE LED on the front panel is turned on and the parameters are set for the next conversion. The Model 192 does an A/D conversion and calculates the reading. If the bus requests data, then the reading is transferred to the bus and then to the display. Otherwise, the reading is sent directly to the display. After the reading is displayed the Model 192 does the Auto Cal routine and sets the parameters for the next conversion.

AT START THE CONTROLLER PLACES "REN" ON THE BUS

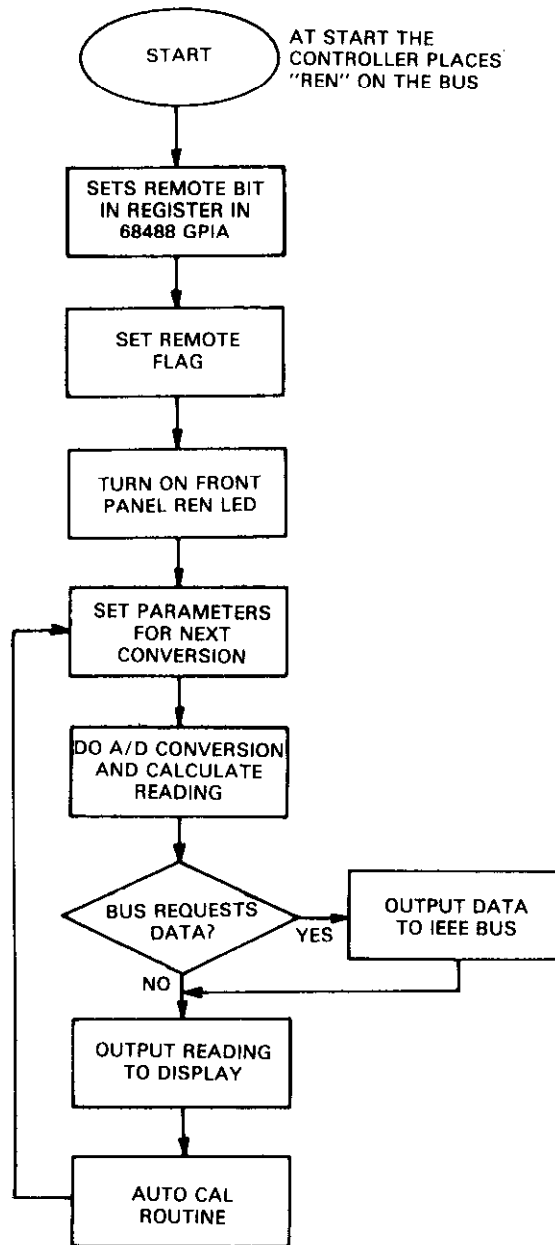

Figure 5-3. REN Command

5.5 SPE-SERIAL POLL ENABLE

Serial Poll Enable simultaneously places all instruments that are capable of serial polling into the serial poll mode (see Figure 5-4). SPE is used to learn the status of all instruments on the bus. Once in the serial poll mode, the controller addresses each instrument. When an instrument receives its Talk address, its status is placed on the bus. The controller continues addressing and collecting status from other instruments on the bus. When status is collected from all the instruments the controller places "SPD" on the bus. SPD (Serial Poll Disable) simultaneously disables the serial poll function from all instruments.

At the start of the SPE command the controller places "SPE" on the bus and addresses the Model 192 to talk. The Model 192 gets a Serial Poll Active State (SPAS) interrupt and places status data onto the bus. The completed handshake clears the SPAS in the Model 192. Then the controller outputs SPD to take the Model 192 out of the serial poll mode and back to previous operation.

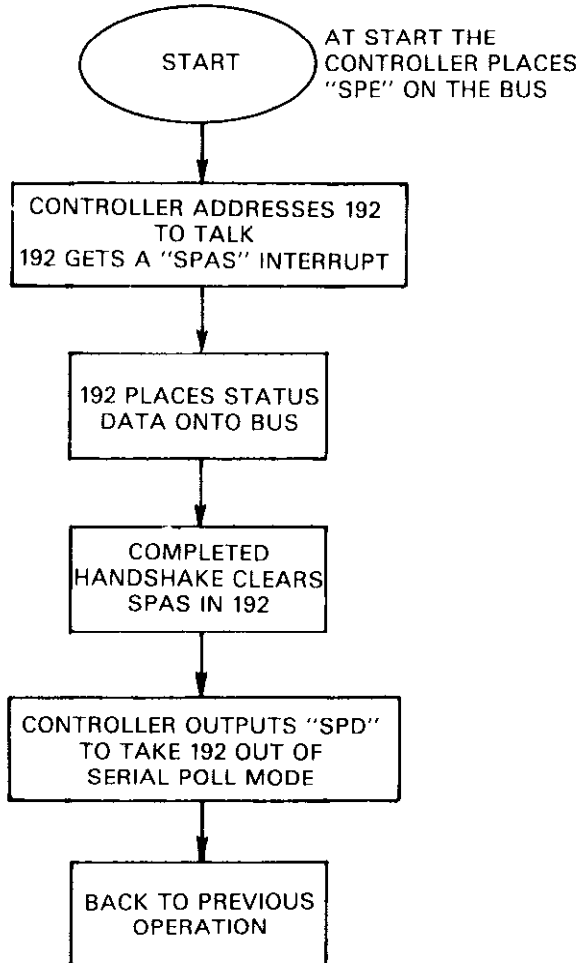

Figure 5-4. SPE Command

5.6 UNL-UNLISTEN

Unlisten removes all addressed listeners from the bus (see Figure 5-5).

NOTE

UNL programs the Model 192 to the listener idle state. All other previously programmed functions are unaffected.

At the start of the UNL command the controller places UNL on the bus. The listen bits of the GPIA register are cleared and the front panel LISTEN LED is turned on. The parameters are set for the next conversion. The Model 192 does

an A/D conversion and calculates the reading. The reading is transferred to the display and then the Auto Cal routine takes place. After the Auto Cal routine, the parameters are once again set for the next conversion.

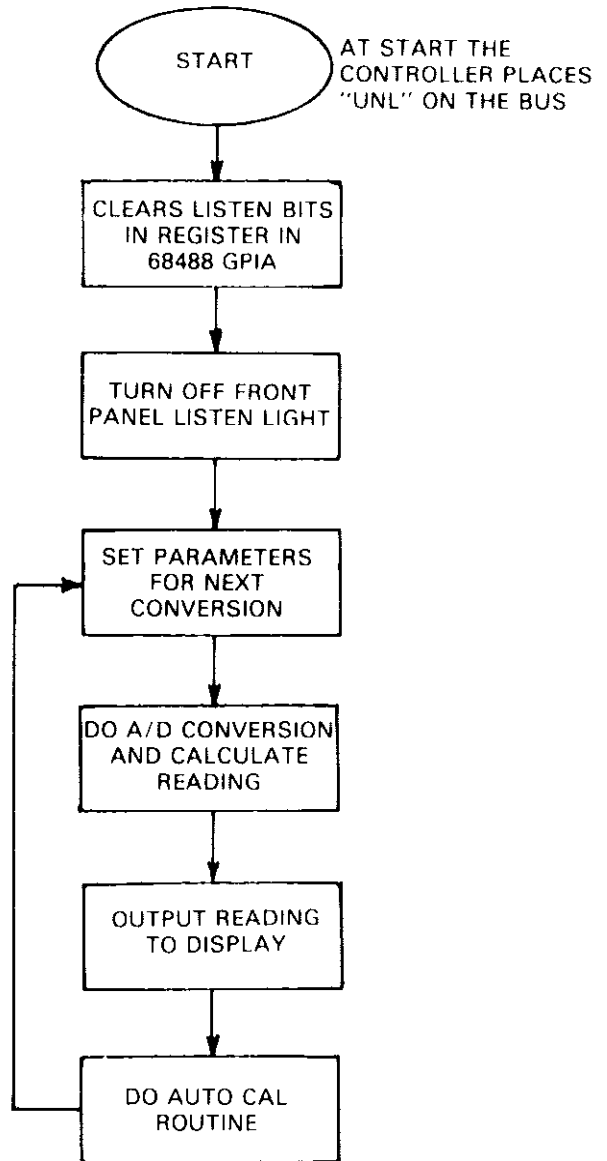

Figure 5-5. UNL Command

5.7 UNT-UNTALK

Untalk removes all addressed "Talkers" from the bus (see Figure 5-6).

NOTE

UNT only excludes the Model 192 from responding to a talk command. All other previously programmed functions are unaffected.

At the start of the UNT command the controller places UNT on the bus. The talk bits of the GPIA register are cleared and the front panel TALK LED is turned on. The parameters are set for the next conversion. The Model 192 does an A/D conversion and calculates the reading. The reading is transferred to the display and then the Auto Cal routine takes place. After the Auto Cal routine the parameters are once again set for the next conversion.

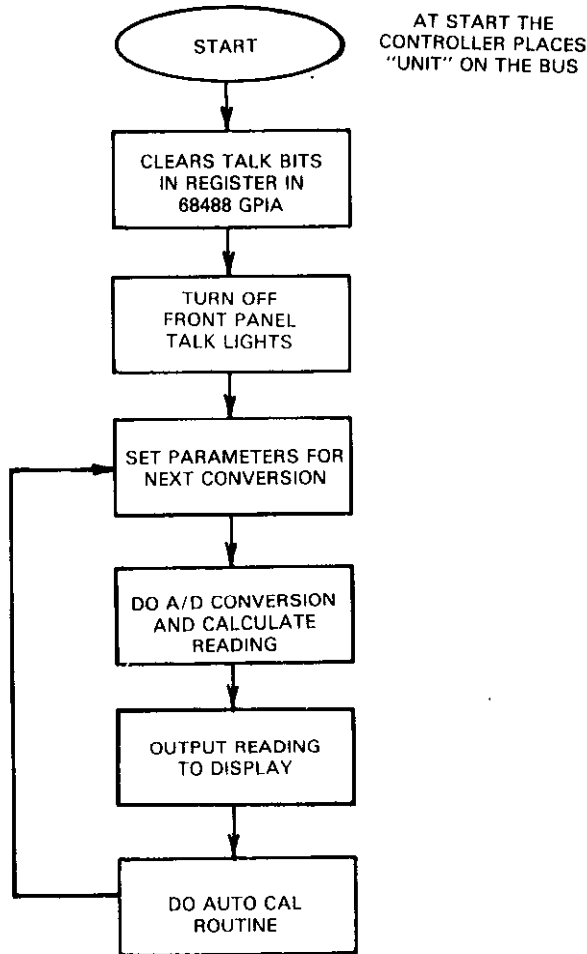

Figure 5-6. UNT Command

5.8 GET-GROUP EXECUTE TRIGGER

Group Execute Trigger triggers one or more devices specified as listeners to function simultaneously (see Figure 5-7).

NOTE

The Model 192 remains in the GET loop until it is reprogrammed.

At the start the GET command causes the GPIA to interrupt the Model 192's microprocessor stopping the present conversion. The parameters are set for the next conversion and Model 192 does an A/D conversion and then calculates the reading. The reading is stored in the buffer and if the bus re-

quests data, the reading is then transferred directly to the bus and then to the display, otherwise, the reading is sent directly to the display. After the reading is displayed the Auto Cal routine takes place and the parameters are set for the next conversion.

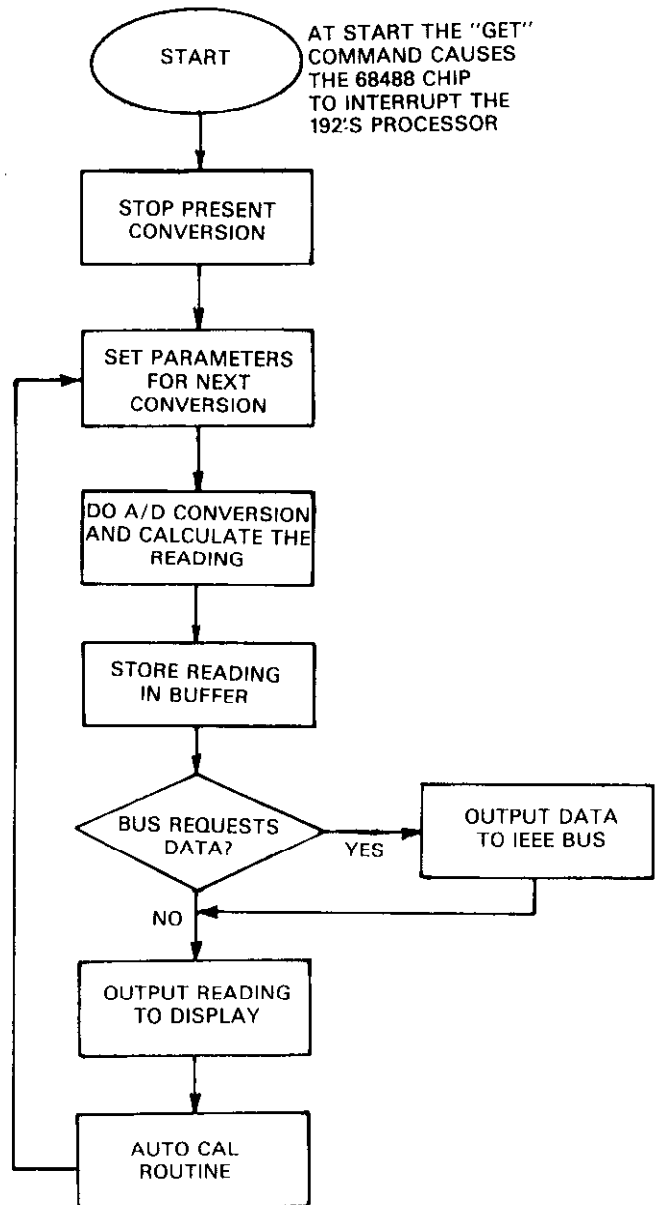

Figure 5-7. GET Command

5.9 GTL-GO TO LOCAL

Go To Local allows the user to return control of an instrument to front panel controls. (see Figure 5-8).

NOTE

GTL only excludes the Model 192 from remote programming. All other previously programmed functions are unaffected.

At the start of the GTL command the controller places GTL on the bus. The remote bits in the GPIA are cleared and so is the remote flag. The front panel controls are returned to local operation and the REMOTE LED is turned off. This ends the GTL command.

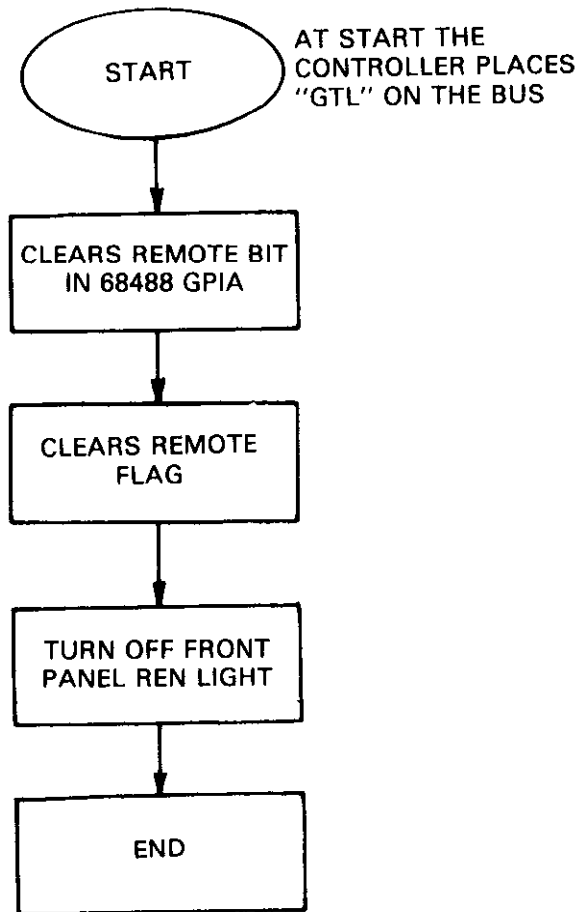

Figure 5-8. GTL Command

5.10 SDC-SELECTIVE DEVICE CLEAR

Selective Device Clear command clears a single addressed instrument. The Model 192 is then returned to the default conditions in Table 4-2. (see Figure 5-9).

At the start, the SDC command causes the GPIA to interrupt the Model 192's microprocessor. Then the programmable parameters are set to the default conditions and then for the next conversion. If there is no trigger command then the sequence is sent directly to the Auto Cal routine. Otherwise, the Model 192 does an A/D conversion and calculates the reading. The reading is stored in the buffer. If the bus requests data, the reading is then transferred to the bus and then to the display. Otherwise, the reading is sent directly to the display. After the reading is displayed the Model 192 does the Auto Cal routine and sets the parameters for the next conversion.

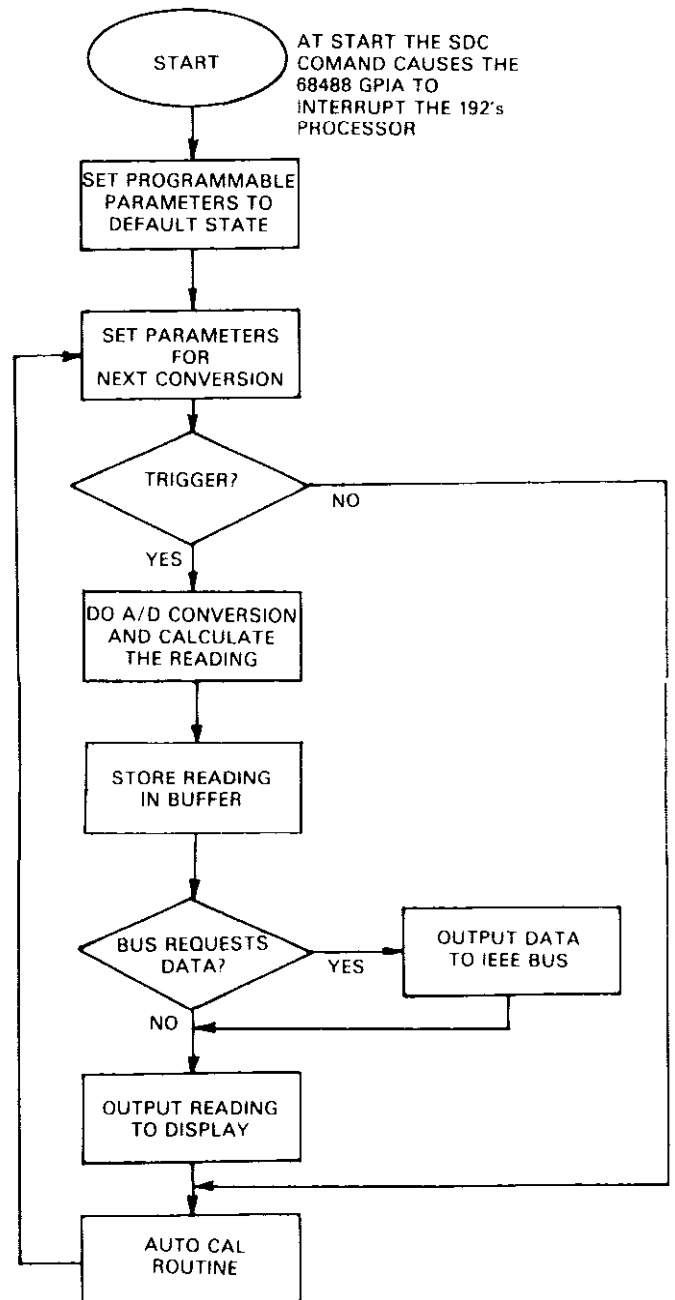

Figure 5-9. SDC Command

5.11 DEVICE-DEPENDENT COMMANDS

Device-dependent command group are instrument programming commands. Commands within this group are specified by the instruments. All device-dependent commands must be followed by a terminator (X) to be executed by the Model 192 (see Figure 5-10).

At the start, the device-dependent command causes the GPIA to interrupt the Model 192 by stopping the present conversion. The temporary register is then updated and if

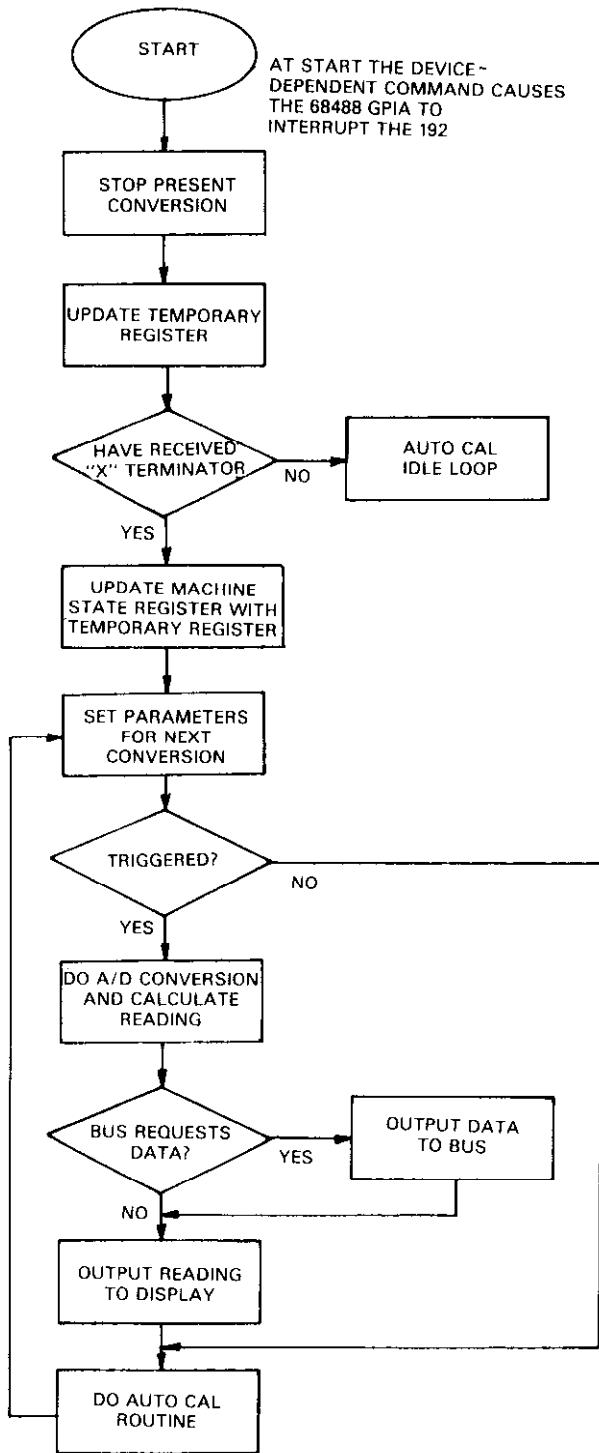

Figure 5-10. Device-Dependent Commands

the X terminator has not been received the sequence is sent to the Auto Cal idle loop. Otherwise, the machine status register is updated along with the temporary register. The parameters are then set for the next conversion and if there is no trigger command the sequence is sent directly to the

Auto Cal routine. Otherwise, the Model 192 does an A/D conversion and calculates the reading. If the bus requests data, the reading then is transferred to the bus and then to the display. Otherwise, the reading is sent directly to the display. After the reading is displayed, the Model 192 does the Auto Cal routine and sets the parameters for the next conversion.

5.12 WAIT COMMANDS-W0 OR W1

The Wait commands program settling time.

W0: Do Not Wait

W1: 10msec.

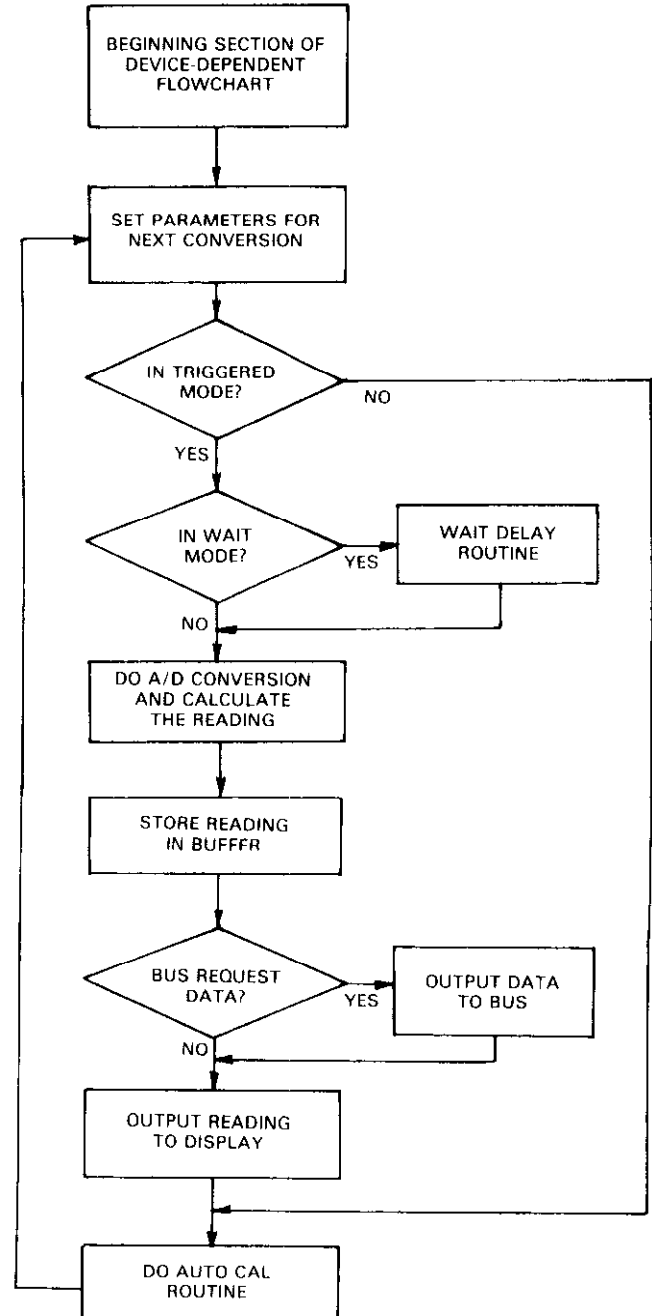

Figure 5-11. Wait Commands

At the start, the wait command causes the GPIA to interrupt the Model 192 by stopping the present conversion. The temporary register is then updated and if the X terminator has not been received, the sequence is sent to the Auto Cal idle loop. Otherwise, the machine status register is updated along with the temporary register. The parameters are then set for the next conversion and if there is no trigger command the sequence is sent directly to the Auto Cal routine. Otherwise, if it is in the wait mode (W1) the sequence is sent to the wait delay routine. With no wait mode (W0) the Model 192 does an A/D conversion and calculates the reading. The reading is stored in the buffer and if the bus requests data, the reading is then transferred to the bus. Otherwise, the reading is sent directly to the display. After the reading is displayed the Model 192 does the Auto Cal routine and sets the parameters for the next conversion.

5.13 SERIAL POLL

The serial poll sequence is shown in Figure 5-12. At the start of the serial poll, the controller has a current status byte. The error flag sends the sequence to one of two branches. The branches sequentially determine if the binary number is 0, 1, 2, or 3, and then takes the appropriate action as shown in Figure 5-12.

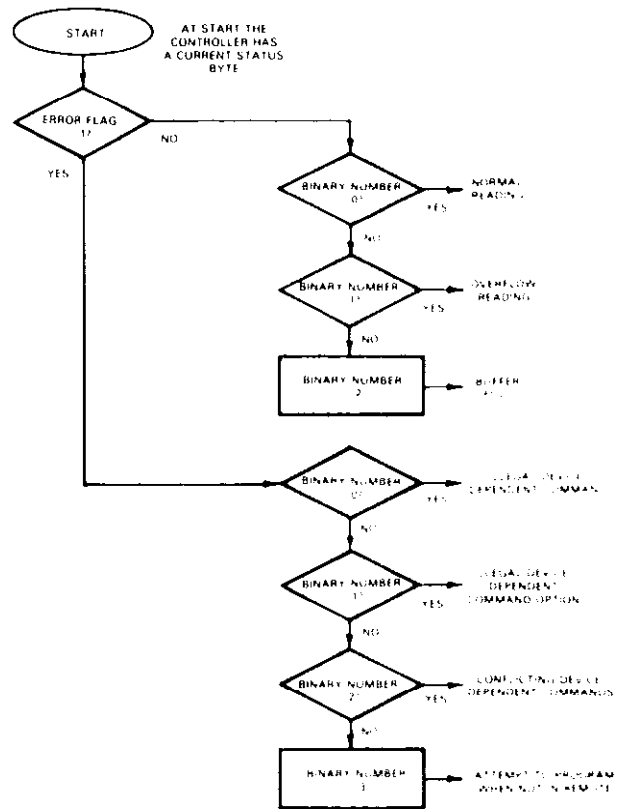

Figure 5-12. Serial Poll

SECTION 6

THEORY OF OPERATION

6.1 INTRODUCTION

This section contains a basic block diagram along with circuit descriptions for the Models 1923 and 1923A. The IEEE-488 interface option enables the Model 192 to be incorporated into a measurement system that utilizes programmed control through the IEEE-488 bus. Explanation of the complicated software is beyond the scope of this section.

6.2 CIRCUIT DESCRIPTION

The entire IEEE-488 interface circuitry is located on a single PCB (PC-561/Schematic 30977D or PC-571/Schematic 31441D). A block diagram of the Models 1923 and 1923A is shown in Figure 6-1. The heart of the IEEE option is the General Purpose Interface Adapter (GPIA) U404. The GPIA is capable of performing all IEEE Talker/Listener protocols. The bidirectional data lines D0 through D7 permit the transfer of data between the microprocessor and the GPIA. The three state IEEE bus buffers U406 and U407 are used to drive the output. Data is buffered by U406 and U407 and is transmitted to the bus via connector J1020.

The primary address switches (S401) select the primary address, and permit selection of 31 primary Talker/Listener address pairs. To address the Model 192 the controller must send the primary address of the Model 192. The factory set primary address of the Model 192 is eight (01000). The microprocessor reads the primary address from S401 and then knows which Talker/Listener address to assign the GPIA (U404) and thus the Model 192.

NOTE

The primary address is updated only upon power-up.

This section is accessed with the address switch enable (ASE) signal. The ASE signal is derived from the GPIA (U404) and enables the three state buffer U405. Enabling U405 places the address on the data bus (D0-D4 and D7).

The status output (Digital Control Output) is available via connector J1021. Peripheral data from the peripheral interface adapter (PIA) U132 via PB0, PB1 and PB2 is inputted serially to U402 via CLK and data lines. When PB1 sends the strobe pulse, U402 shifts the received data into U401 which drives the output lines (1Y-7Y).

6.3 MODEL 1923 AND 1923A DIFFERENCES

Differences between the Models 1923 and 1923A have to do with the external trigger line and EPROM U403. The differences are as follows:

1. The Model 1923A has an external trigger line (pin 4, P1010) running to the Model 192 mother board; whereas, the Model 1923 does not have an external trigger line.
2. The Model 192 mother board (Rev. E and above) has the necessary ROM to accommodate the IEEE option. Therefore, U403 of the IEEE option is not needed on the Model 192 Rev. E and above mother board.

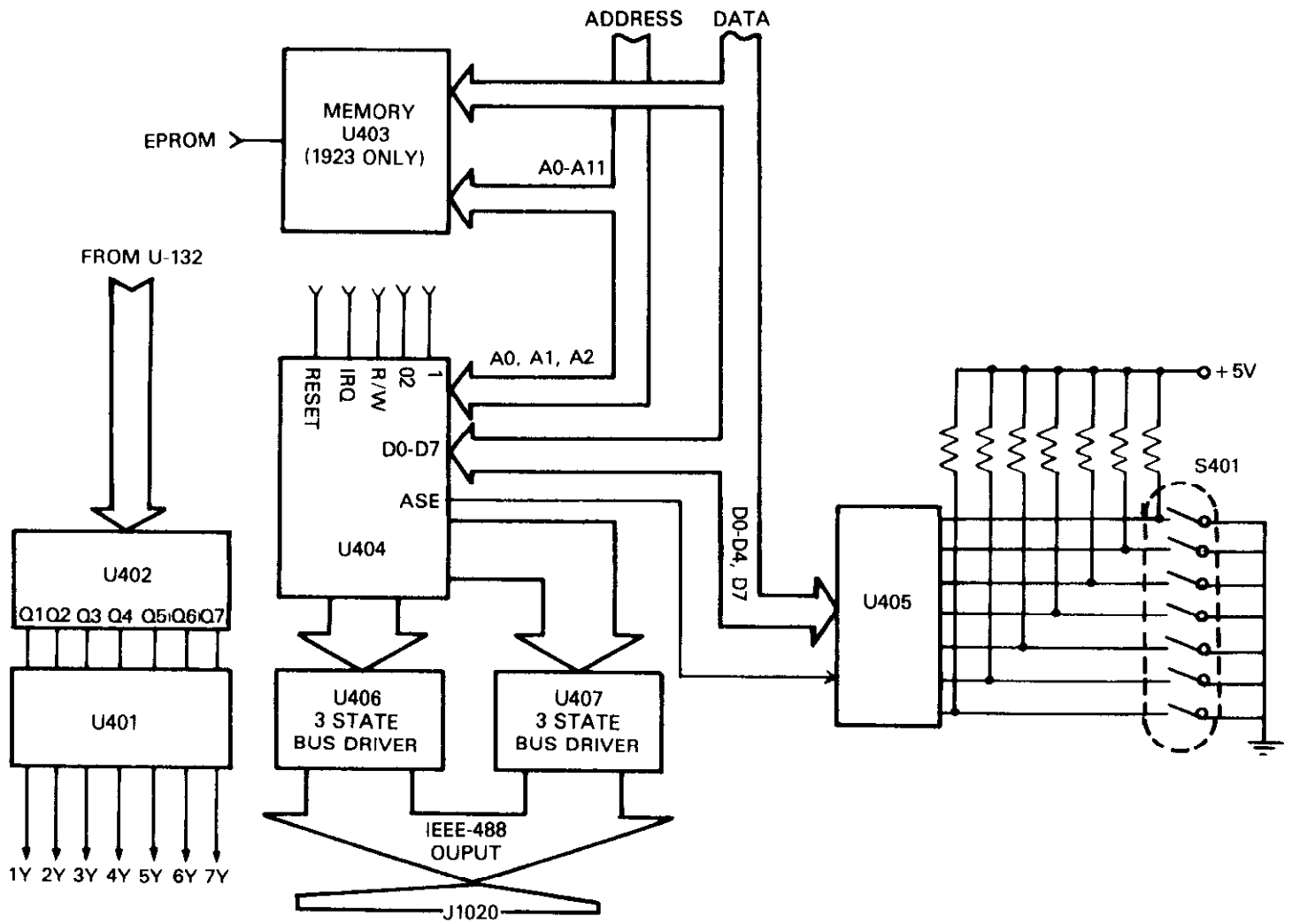

Figure 6-1. Model 1923/1923A Block Diagram

SECTION 7 MAINTENANCE

7.1 INTRODUCTION

This section contains information necessary to maintain the Model 1923A. Installation procedures, troubleshooting information and instructions concerning care in handling static sensitive devices are included.

7.2 INSTALLATION

The Model 1923A is field installable. To install the Model 1923A into a Model 192 use the following procedure:

WARNING

All service information is intended for qualified electronic maintenance personnel only.

1. Remove the top cover.

WARNING

To prevent a shock hazard, remove the line cord and all test leads from the instrument before removing the top cover.

2. Remove the IEEE option cover (30821A).
3. Install the two male/female standoffs (ST-146-2) onto the mother board (PC-559). See Figure 8-1.
4. Plug the cable of the Model 1923A onto the mother board connector (J1010). Align pin 1 of the mother board connector to pin 1 (red wire) of the cable.
5. Place the Model 1923A on the two supporting male/female standoffs while inserting it into the appropriate openings in the rear panel. Make sure the status output connector is not shorted to the rear panel.
6. Install the two phillips head screws through the Model 1923A PC Board and onto the two supporting standoffs (see Figure 8-2).
7. Install the two type 'T' self threading screws onto the IEEE-488 interface connector as shown in Figure 8-2.
8. Reinstall the top cover.

7.3 SPECIAL HANDLING OF STATIC SENSITIVE DEVICES

MOS devices are designed to function at high impedance levels. Normal static charge can destroy these devices. Table 7-1 lists all the static sensitive devices for the Model 1923A. Steps 1 through 7 provide instructions on how to avoid damaging these devices.

Table 7-1. Model 1923 Static Sensitive Devices

Reference Designation	Keithley Part Number
U403	PRO-112-C4
U404	LSI-14

1. Devices should be handled and transported in protective containers, antistatic tubes or conductive foam.
2. Use a properly grounded work bench and a grounding wriststrap.
3. Handle device by the body only.
4. PCBs must be grounded to bench while inserting devices.
5. Use antistatic solder suckers.
6. Use grounded tip soldering irons.
7. After devices are soldered or inserted into sockets they are protected and normal handling can resume.

7.4 TROUBLESHOOTING

Problems related to the Model 1923/1923A may be detected by observing the TALK, LISTEN and REMOTE indicators during operation. If error readings are observed, remove the top cover and unplug the Model 1923/1923A from the mother board. If the error is no longer present then the option is at fault.

Due to the simplicity of the IEEE option direct IC replacement is recommended. If the problem cannot be isolated return the option to the factory. Table 7-2 lists some basic checks to assist in troubleshooting the Model 1923/1923A.

Table 7-2. Model 1923/1923A Troubleshooting

Step	Item/Component	Required Condition	Remarks
1	P1010, pin 1 (+5V) referenced to pin 33 (Com)	+5V \pm 10%	+5V Digital Supply
2	S401 (all)	In the "1" position the switch reads +5V \pm 10%	Primary Address
3	U404 pin 6 (Ø2)	1MHz square wave at 0V to 5V	Clock to U404

SECTION 8 REPLACEABLE PARTS

8.1 INTRODUCTION

This section contains replacement parts information, schematic diagrams and component location drawings for the Model 1923A.

8.2 PARTS LIST

The electrical parts are listed in Table 8-1 in alphabetical order of their circuit designations. U406 and U407 bus transceivers are listed separately for the Model 1923A-1 (PC-571) and the Model 1923A-2 (PC-561). The remaining parts are common to both models and are listed together. Figure 8-1 and 8-2 show the pertinent mechanical parts.

8.3 ORDERING INFORMATION

To place an order, or to obtain information concerning replacement parts, contact your Keithley representative or the factory. See the inside front cover for addresses. When ordering include the following information:

1. Instrument Model Number
2. Instrument Serial Number
3. Part Description
4. Circuit Description (if applicable)
5. Keithley Part Number

8.4 FACTORY SERVICE

If the instrument is to be returned to the factory for service, please complete the service form which follows this section and return it with the instrument.

8.5 SCHEMATIC DIAGRAMS AND COMPONENT LOCATION DRAWINGS

Schematic diagrams and component location drawings follow the replaceable parts list information contained in this section. The drawings are listed as follows:

Figure 8-3—Component location drawing for Model 1923A-1 (PC-571),

Figure 8-4—Component location drawing for Model 1923A-2 (PC-561),

Figure 8-5—Schematic diagram for Model 1923A-1 (PC-571),

Figure 8-6—Schematic diagram for Model 1923A-2 (PC-561),

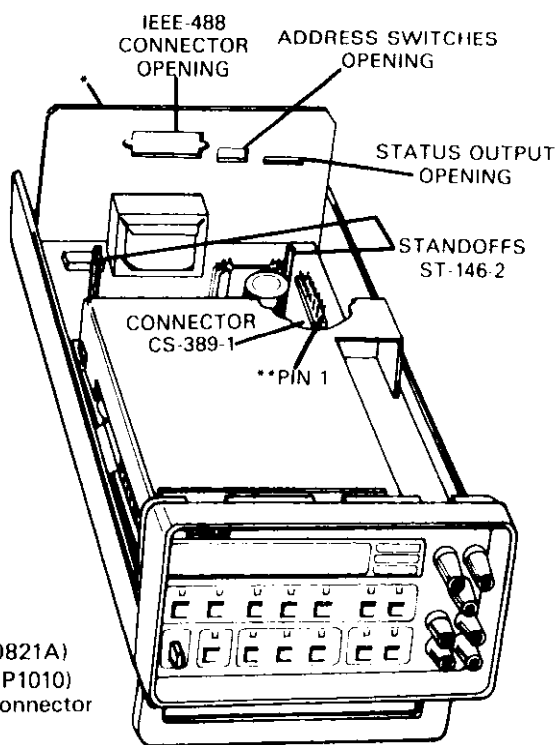

- * Remove IEEE option cover (30821A)
- ** Make sure pin 1 of the cable (P1010) is connected to pin 1 of the connector (J1010).

Figure 8-1. Model 1923A Hardware

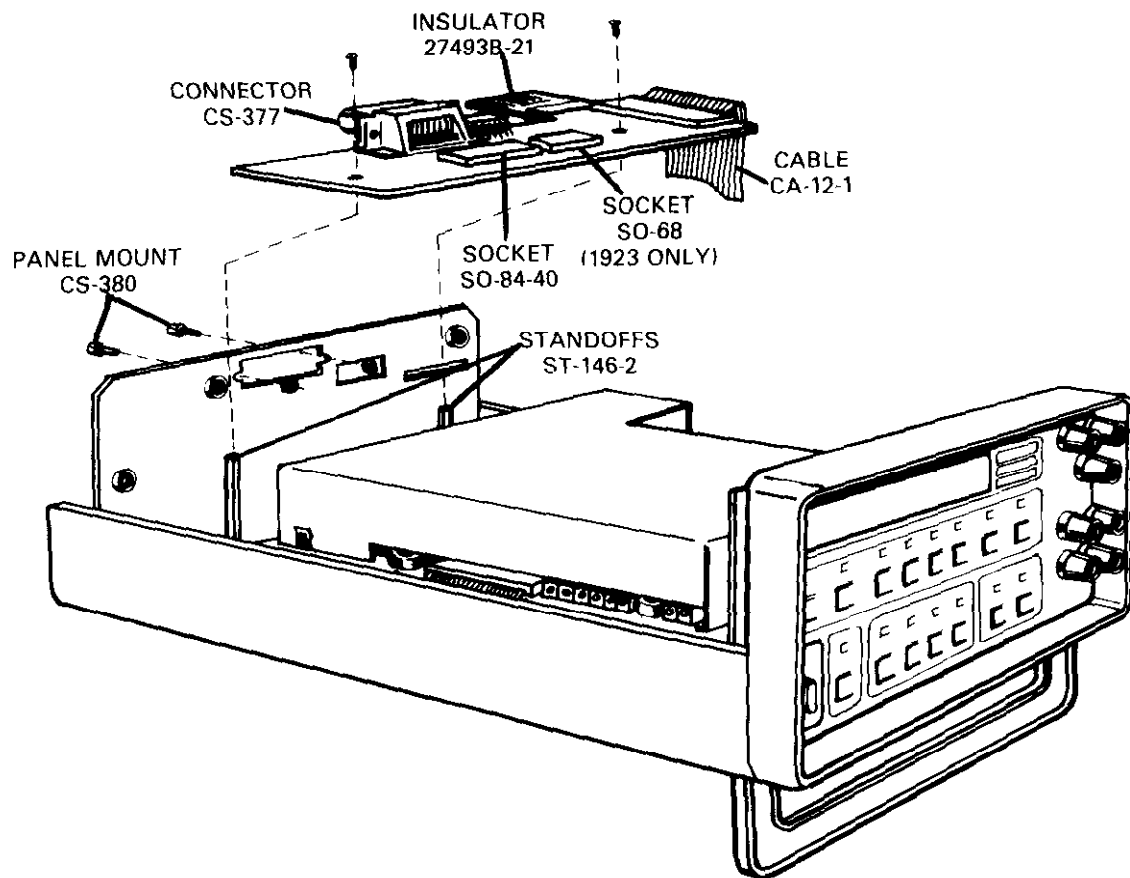
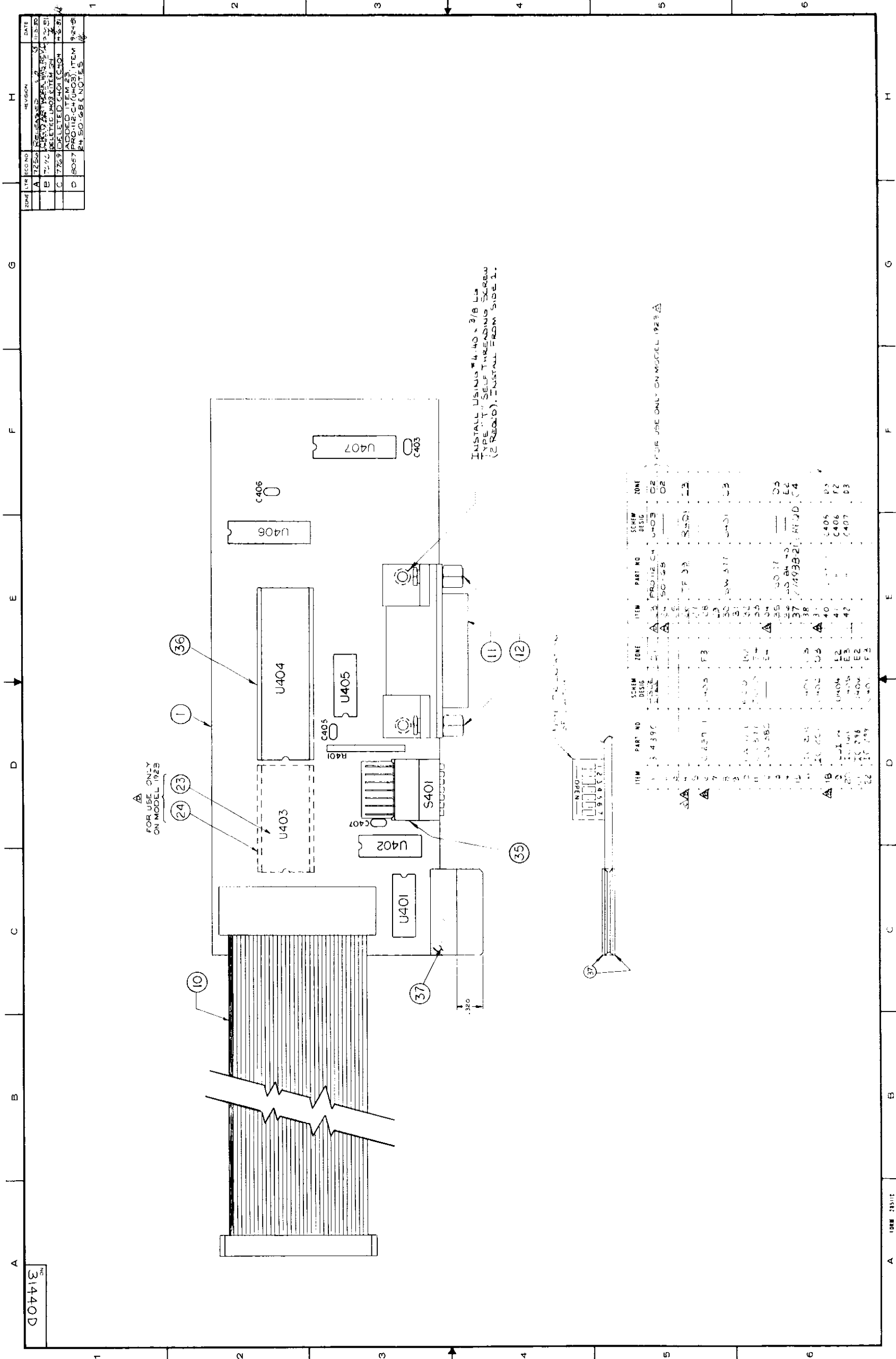

Figure 8-2. Model 1923A Installation

Table 8-1. Replaceable Parts PC-561 and PC-571

Circuit Desig.	Description	Location		Keithley Part No.
		Sch.	Pcb.	
	Keithley Internal P/N 1923-1 PC-571 for use with T.I. IEEE IC's only.			
U406	Bus Transceiver, 75160A	F3	E2	IC-298
U407	Bus Transceiver 75161A	F2	F3	IC-299
	Keithley Internal P/N 1923-2 PC-561 for use with Motorola IEEE IC's only.			
U406	Bus Transceiver, MC3447	F3	E2	IC-229
U407	Bus Transceiver, MC3447	F2	F3	IC-229
	Parts common to both PC-571 or PC-561	Schematic B0977/31441	PC561/ PC571	
C403	.1 μ F, 50V, CerF	F4/F1	F2/F3	C-237-.1
C405	.1 μ F, 50V, CerF	E1/E1	D3/D3	C-237-.1
C406	.1 μ F, 50V, CerF	F1/F4	F2/F2	C-237-.1
C407	.1 μ F, 50V, CerF	A3/A3	D3/D3	C-237-.1
J1020	Connector	G /G	E4/E4	CS-377
P1010	Cable Assembly	1 /1	B2/B2	CA-12-1
R401	Thick Film	SEV/SEV	D3/D3	TF-99
S401	Switch Dip	E5/E5	D3/D3	SW-377
U401	Darlington Array, ULN2003A	B4/B4	C3/C3	IC-206
U402	Hex 3 State Buffer 74LS367	B3/B3	D3/D3	IC-251
U403*	PROM	SEV/SEV	D2/D2	PRO-112-C4
U404	GP1A, 68488	E2/E2	E2/E2	LSI-14
U405	Hex 3 State Buffer 74LS367	D4/D4	E3/E3	IC-161

* Present on Model 1923 only.



REV	BY	DATE	REVISION
A	7/25/52	10/23/52	REVISED TO SHOW WORKS REVISED
B	7/7/52	7/27/52	RELETED ITEM 24
C	7/7/52	7/27/52	DELETED COLLECTION
D	8/27/52	9/24/52	ADDED ITEM 23 PROVIDED C401, C402, C403, C404, C405, C406, C407 AND 50-1081 NOTES

ITEM	PART NO	SCHEM DISC	ZONE	ITEM	PART NO	SCHEM DISC	ZONE
1	3439C	U403	D2	1	3439C	U403	D2
2	3439C	U403	D2	2	3439C	U403	D2
3	3439C	U403	D2	3	3439C	U403	D2
4	3439C	U403	D2	4	3439C	U403	D2
5	3439C	U403	D2	5	3439C	U403	D2
6	3439C	U403	D2	6	3439C	U403	D2
7	3439C	U403	D2	7	3439C	U403	D2
8	3439C	U403	D2	8	3439C	U403	D2
9	3439C	U403	D2	9	3439C	U403	D2
10	3439C	U403	D2	10	3439C	U403	D2
11	3439C	U403	D2	11	3439C	U403	D2
12	3439C	U403	D2	12	3439C	U403	D2
13	3439C	U403	D2	13	3439C	U403	D2
14	3439C	U403	D2	14	3439C	U403	D2
15	3439C	U403	D2	15	3439C	U403	D2
16	3439C	U403	D2	16	3439C	U403	D2
17	3439C	U403	D2	17	3439C	U403	D2
18	3439C	U403	D2	18	3439C	U403	D2
19	3439C	U403	D2	19	3439C	U403	D2
20	3439C	U403	D2	20	3439C	U403	D2
21	3439C	U403	D2	21	3439C	U403	D2
22	3439C	U403	D2	22	3439C	U403	D2
23	3439C	U403	D2	23	3439C	U403	D2
24	3439C	U403	D2	24	3439C	U403	D2
25	3439C	U403	D2	25	3439C	U403	D2
26	3439C	U403	D2	26	3439C	U403	D2
27	3439C	U403	D2	27	3439C	U403	D2
28	3439C	U403	D2	28	3439C	U403	D2
29	3439C	U403	D2	29	3439C	U403	D2
30	3439C	U403	D2	30	3439C	U403	D2
31	3439C	U403	D2	31	3439C	U403	D2
32	3439C	U403	D2	32	3439C	U403	D2
33	3439C	U403	D2	33	3439C	U403	D2
34	3439C	U403	D2	34	3439C	U403	D2
35	3439C	U403	D2	35	3439C	U403	D2
36	3439C	U403	D2	36	3439C	U403	D2
37	3439C	U403	D2	37	3439C	U403	D2
38	3439C	U403	D2	38	3439C	U403	D2
39	3439C	U403	D2	39	3439C	U403	D2
40	3439C	U403	D2	40	3439C	U403	D2
41	3439C	U403	D2	41	3439C	U403	D2
42	3439C	U403	D2	42	3439C	U403	D2
43	3439C	U403	D2	43	3439C	U403	D2
44	3439C	U403	D2	44	3439C	U403	D2
45	3439C	U403	D2	45	3439C	U403	D2
46	3439C	U403	D2	46	3439C	U403	D2
47	3439C	U403	D2	47	3439C	U403	D2
48	3439C	U403	D2	48	3439C	U403	D2
49	3439C	U403	D2	49	3439C	U403	D2
50	3439C	U403	D2	50	3439C	U403	D2

Figure 8-3. Model 1923A-1, PC-571, Component Location Drawing, Dwg. No. 31440

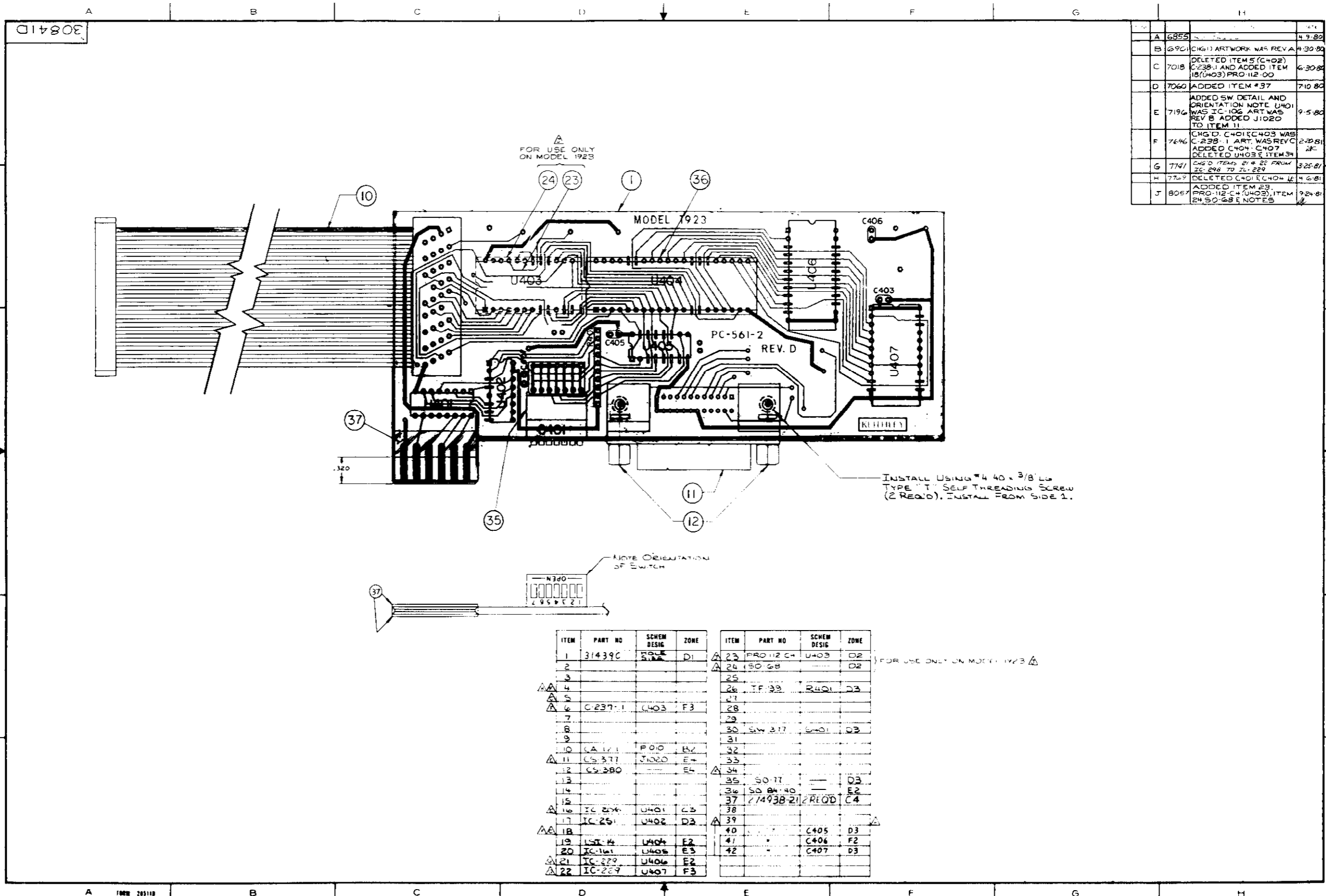

A	6855		4-9-80
B	6901	CHG 11 ARTWORK WAS REV A	4-30-80
C	7018	DELETED ITEM 5 (C402) C238-1 AND ADDED ITEM 18 (U403) PRO-112-00	6-30-80
D	7060	ADDED ITEM #37	7-10-80
E	7196	ADDED SW DETAIL AND ORIENTATION NOTE. U401 WAS IC-106 ART WAS REV B ADDED J1020 TO ITEM 11	9-5-80
F	7446	CHG D. C401 C403 WAS C-238-1 ART. WAS REV C ADDED C404, C407 DELETED U403, ITEM 34	2-22-81
G	7741	CHG D ITEM 21 FROM IC-298 TO IC-229	3-25-81
H	7769	DELETED C401 C404 IC	4-6-81
J	8057	ADDED ITEM 23, PRO-112-C+(U403), ITEM 24, SO-68 & NOTES	9-24-81

ITEM	PART NO	SCHEM DESIG	ZONE	ITEM	PART NO	SCHEM DESIG	ZONE
1	31439C	SOLE SW	D1	23	PRO-112-C+	U403	D2
2				24	SO-68		D2
3				25			
4				26	TF-33	R401	D3
5				27			
6	C-237-1	U403	F3	28			
7				29			
8				30	SW-317	U401	D3
9				31			
10	CA-171	F00	B2	32			
11	CS-377	J1020	E+	33			
12	CS-380		E4	34			
13				35	SO-11		D3
14				36	SO-64-40		E2
15				37	714938-21	2 REOD	C4
16	IC-274	U401	D3	38			
17	IC-251	U402	D3	39			
18				40		C405	D3
19	IC-14	U404	E2	41		C406	F2
20	IC-161	U405	E3	42		C407	D3
21	IC-279	U406	E2				
22	IC-269	U407	F3				

Figure 8-4. Model 1923A-2, PC-561, Component Location Drawing, Dwg. No. 30841

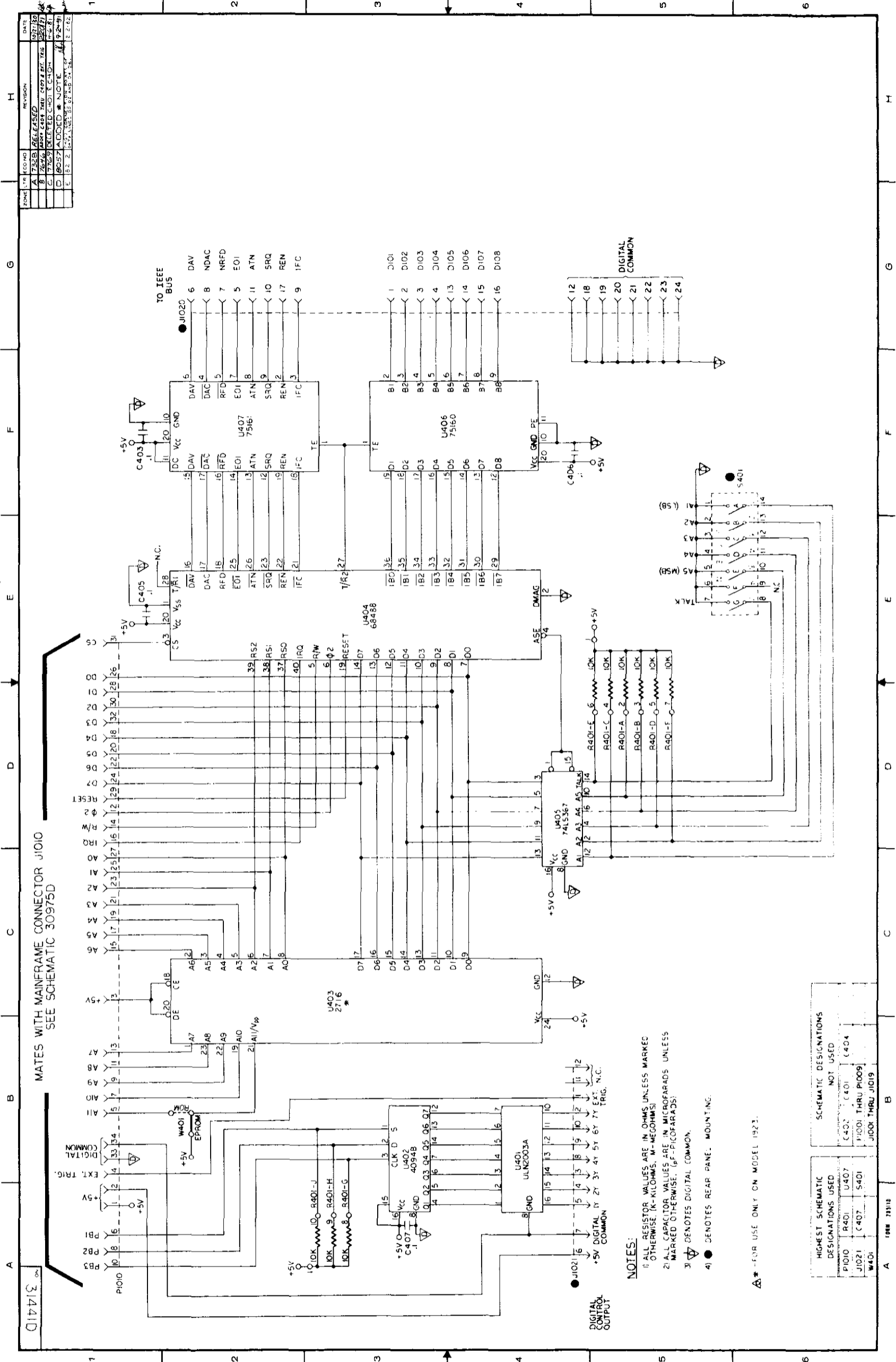

MATES WITH MAINFRAME CONNECTOR J1010
SEE SCHEMATIC 30975D

31441D

- NOTES:
- 1) ALL RESISTOR VALUES ARE IN OHMS UNLESS MARKED OTHERWISE (K-KILOHMS, M-MEGOHMS)
 - 2) ALL CAPACITOR VALUES ARE IN MICROFARADS UNLESS MARKED OTHERWISE (P-PICOFARADS)
 - 3) ⚡ DENOTES DIGITAL COMMON.
 - 4) ● DENOTES REAR PANEL MOUNTING.

▲* - FOR USE ONLY ON MODEL 1923.

HIGHEST SCHEMATIC DESIGNATIONS USED	SCHEMATIC DESIGNATIONS NOT USED
PIC01	C401
R401	C402
U401	C403
U402	J1001 THRU J1009
U403	J1021
U404	W401
U406	

ZONE	TR	ECO-NO	REVISION	DATE
A	732B	RELEASED		10/21/80
B	732B	REVISION	REVISION	10/21/80
C	732B	REVISION	REVISION	10/21/80
D	732B	REVISION	REVISION	10/21/80
E	732B	REVISION	REVISION	10/21/80

Figure 8-5. Model 1923A-1, Schematic Diagram, Dwg. No. 31441

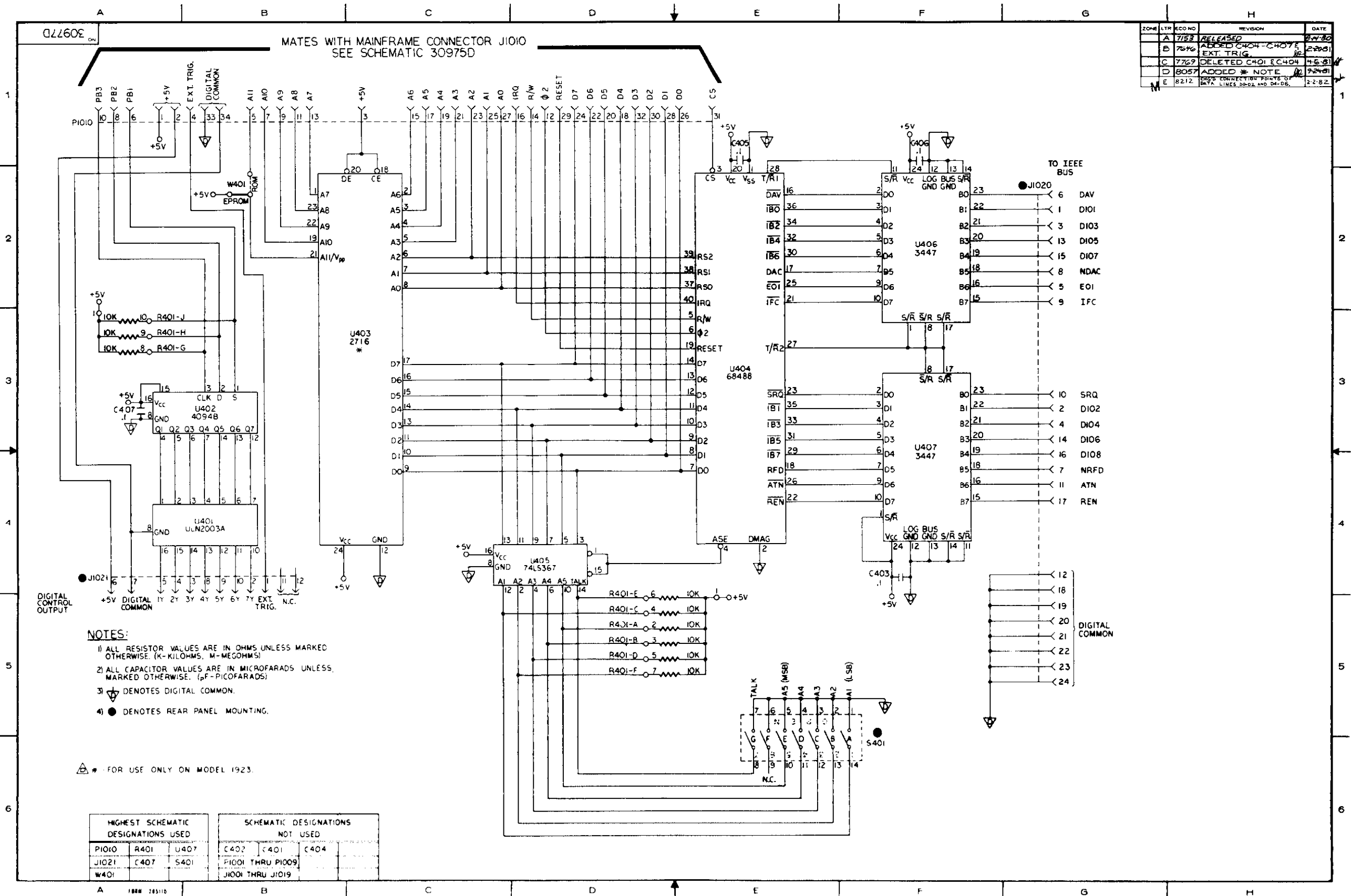
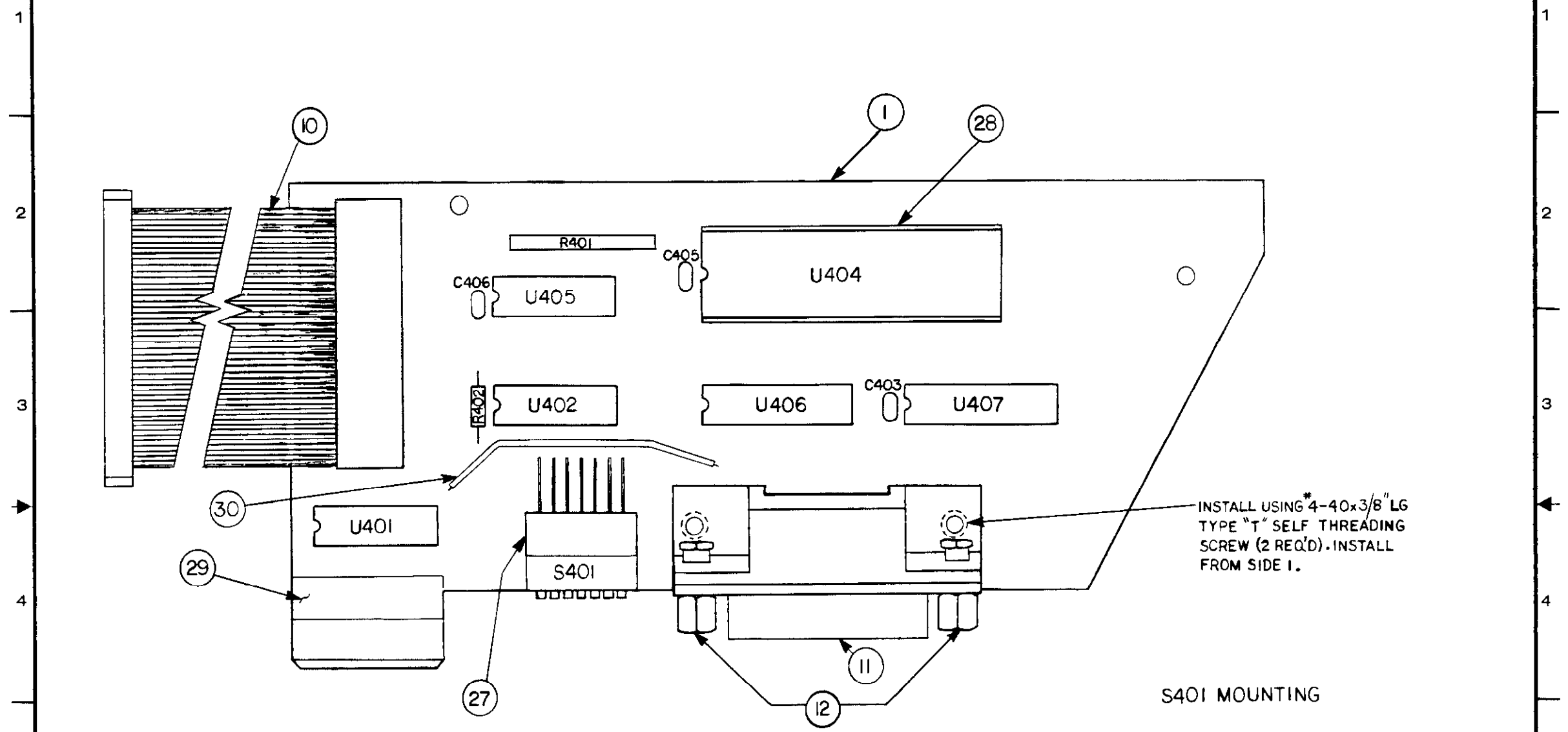

Figure 8-6. Model 1923A-2, Schematic Diagram, Dwg. No. 30977

001-V9261
ON

ZONE	LTR	ECO NO.	REVISION	DATE
A		9008	RELEASED	7/28/83
B		9549	PCARTWORK WAS REV. B	2-2-84



INSTALL USING *4-40x3/8" LG TYPE "T" SELF THREADING SCREW (2 REQ'D). INSTALL FROM SIDE 1.

S401 MOUNTING

ITEM	PART NO.	SCHEM DESIG	ZONE
1	CI923A-102	HOLE SIZE	E1
2			
3			
4			
5	C-237-0.1	C403	E3
6	"	C405	D2
7	"	C406	C2
8			
9			
10	CA-12-1	PI1010	B2
11	CS-377	J1020	D4
12	CS-380		D5
13			
14			
15	IC-206	U401	B4

ITEM	PART NO.	SCHEM DESIG	ZONE
16	IC-251	U402	C3
17	LSI-14	U404	D2
18	IC-250	U405	C2
19	IC-298	U406	D3
20	IC-299	U407	E3
21			
22	TF-99	R401	C2
23	R-76-10K	R402	C3
24			
25	SW-377	S401	C4
26			
27	SC-77		C4
28	SO-84-40		E2
29	27493B-21	2 REQ'D	A4
30	SC-55		C3

DO NOT SCALE THIS DRAWING	DIMENSIONAL TOLERANCES UNLESS OTHERWISE SPECIFIED	DATE 10/13/82	SCALE 2:1	TITLE COMPONENT LAYOUT, IEEE BOARD
KATHLEY Kathley Instruments Inc Cleveland, Ohio 44139	XX = ± 0.15	ANG = ± 1°	DRN CHB	ENG ADP
	XXX = ± 0.06	FRAC = 1/104	MATERIAL	FINISH
SURFACE MAX			NO	NO 1923A-100

MODEL	NEXT ASSEMBLY	QTY
1923A		

901-V23A-106

ZONE	LTR	ECO NO	REVISION	DATE
A		8008	RELEASED	

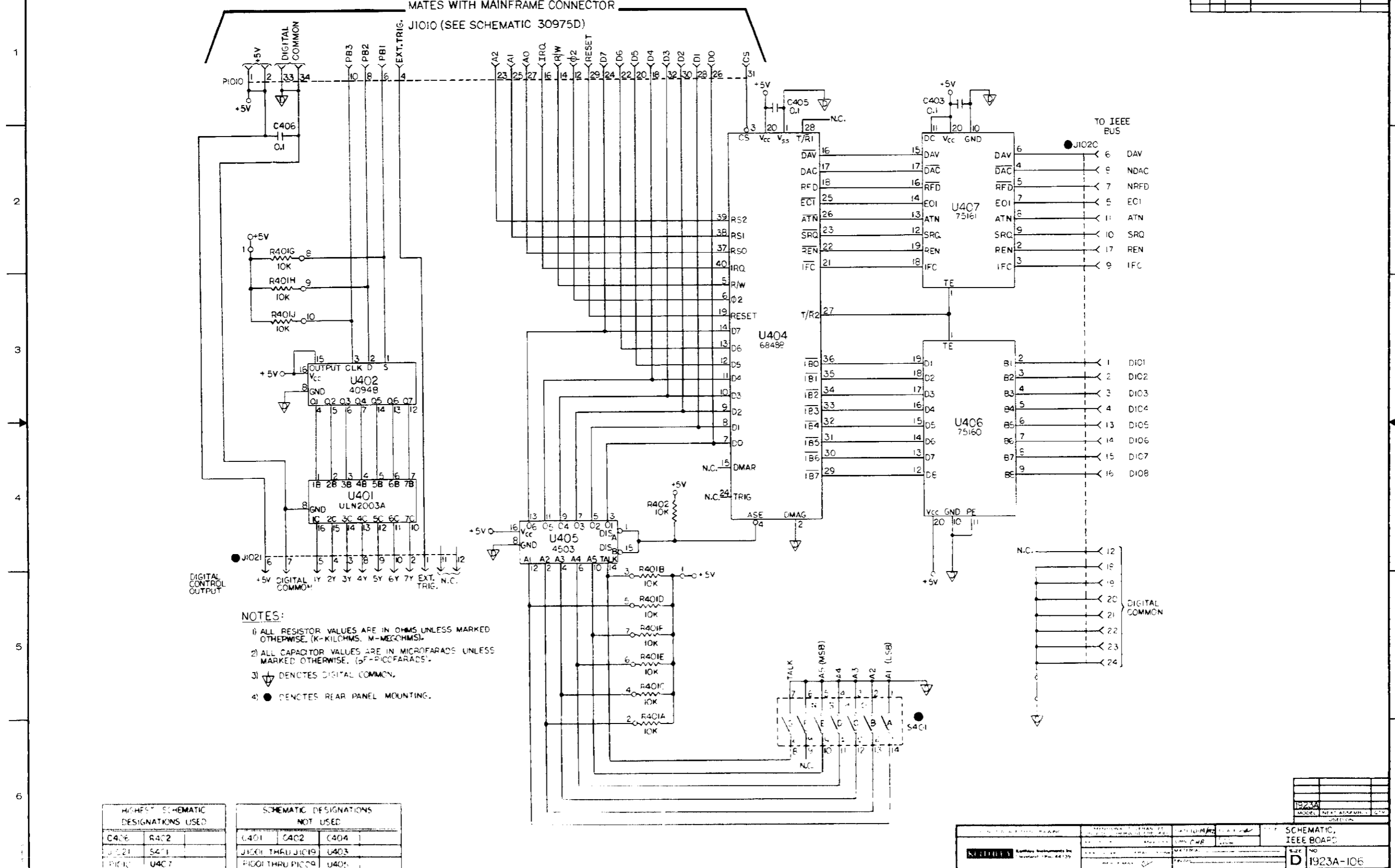

- NOTES:
- 1) ALL RESISTOR VALUES ARE IN OHMS UNLESS MARKED OTHERWISE. (K-KILOHMS, M-MEGOHMS).
 - 2) ALL CAPACITOR VALUES ARE IN MICROFARADS UNLESS MARKED OTHERWISE. (P-PICOFARADS).
 - 3) ▽ DENOTES DIGITAL COMMON.
 - 4) ● DENOTES REAR PANEL MOUNTING.

HIGHEST SCHEMATIC DESIGNATIONS USED		SCHEMATIC DESIGNATIONS NOT USED	
C406	R402	U401	C402
J1021	S401	J1001 THRU J1019	U403
PICK	U407	P1001 THRU P1009	U405

SCHEMATIC, IEEE BOARD		DATE	
NO	D 1923A-106		

**Instruction Manual Addendum
Model 1923A IEEE-488 Interface**

The following change information is supplied as a supplement to the manual in order to provide the user with the latest improvements and corrections in the least possible time. It is recommended that this information be incorporated into the appropriate places in the manual immediately.

Replace the component location drawings (Figures 8-3 and 8-4) and schematic diagrams (Figures 8-5 and 8-6), located at the end of the Model 1923A Instruction Manual, with the following new component layout and schematic diagram:

KEITHLEY

REGISTRATION CARD: Please return. This is the only way we can contact you directly on revisions, upgrades, etc.

MODEL _____ Serial Number _____ Date _____

NAME _____

COMPANY _____ DIV/DEPT _____ BLDG _____ MS _____

STREET ADDRESS _____

CITY _____ STATE/PROVINCE _____ ZIP CODE _____ COUNTRY _____

() _____

Phone _____ (Please Print)

For FREE additional information check below:

Application Notes

Programming Guides

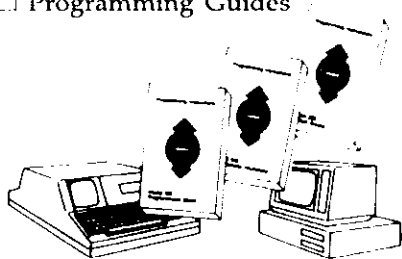
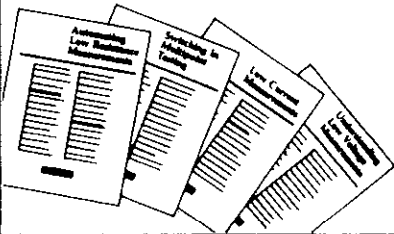

■ TYPE OF FACILITY (42)

Check one.

- F Education/Universities
- G Test/Measurement Equip. Mfg.
- J Semiconductor Mfg. - Commercial
- L Semiconductor Mfg. - Captive
- H Components Mfg. (Resistors, Capacitors, etc.)
- K Aerospace/Defense
- M Utility
- N Computer/Peripheral Mfg.
- P Communications Equip. Mfg.
- B Industrial Controls Mfg.
- Q Chemical/Petroleum Processing
- I Other Processing
- E Research Labs
- R Medical Equip. & Services
- S Automotive/Parts Mfg.
- T Office Equip. Mfg.

■ DEPARTMENT (4)

Check one.

- 2 Research
- 3 Design/Development
- 4 Calibration Lab/Inst. Pool
- 5 Production/Test
- 6 Component Test
- 7 Field Service or Installation
- 8 Quality Assurance/Control
- 0 Purchasing
- 1 Education (Chem., Eng., etc.)
- X Other _____

■ JOB FUNCTION (41)

Check one.

- M Manager
- E Engineer
- S Scientist
- T Technician
- P Professor/Instructor
- V Student
- G Grad Student
- B Purchasing Agent

■ PRODUCT INTEREST(S) (11)

Check one.

- 0 Temperature Instruments
 - 1 Bench DMM
 - 2 System DMM
 - 4 Electrometers/Picoammeters
 - 5 Nanovoltmeters
 - 6 Resistance Instruments
 - 7 Current & Voltage Sources
 - 8 Radiation Instruments
 - 9 IEEE-488/ATE
 - C Counters/Timers
 - D Data Acquisition & Control
 - L Calibration Sources
 - P Parametric Testers
 - V CV Meters
 - S Switching Systems/Scanners (1,2,4-pole and matrix)
- C We are authorized to use the GSA contract



Cleveland, Ohio 44122-9990
P.O. Box 22987
Keithley Instruments, Inc.

POSTAGE WILL BE PAID BY ADDRESSEE

BUSINESS REPLY CARD
FIRST CLASS PERMIT NO. 11759 CLEVELAND, OHIO



NO POSTAGE
NECESSARY
IF MAILED
IN THE
UNITED STATES



3. WHAT EFFECTS, DEVICES OR PHENOMENA DO YOU MEASURE WITH THIS INSTRUMENT?
4. WHAT WAS THE MAIN REASON A KEITHLEY UNIT WAS PURCHASED?
5. DO YOU HAVE ANY DESIGN SUGGESTIONS CONCERNING THIS UNIT?



SERVICE FORM

Model No. _____ Serial No. _____ P.O. No. _____ Date _____

Name _____ Phone _____

Company _____

Address _____

City _____ State _____ Zip _____

List all control settings and describe problem. _____

_____ (Attach additional sheets as necessary.)

Show a block diagram of your measurement system including all instruments connected (whether power is turned on or not). Also describe signal source.

Where is the measurement being performed? (factory, controlled laboratory, out-of-doors, etc.) _____

What power line voltage is used? _____ Variation? _____

Frequency? _____ Ambient Temperature? _____ °F.

Variation? _____ °F. Rel. Humidity? _____ Other? _____

Any additional information. (If special modifications have been made by the user, please describe below.)

*Be sure to include your name and phone number on this service form.