

6

5

4

3

2

1

REVISION RECORD			
LTR	ECO NO:	APPROVED:	DATE:

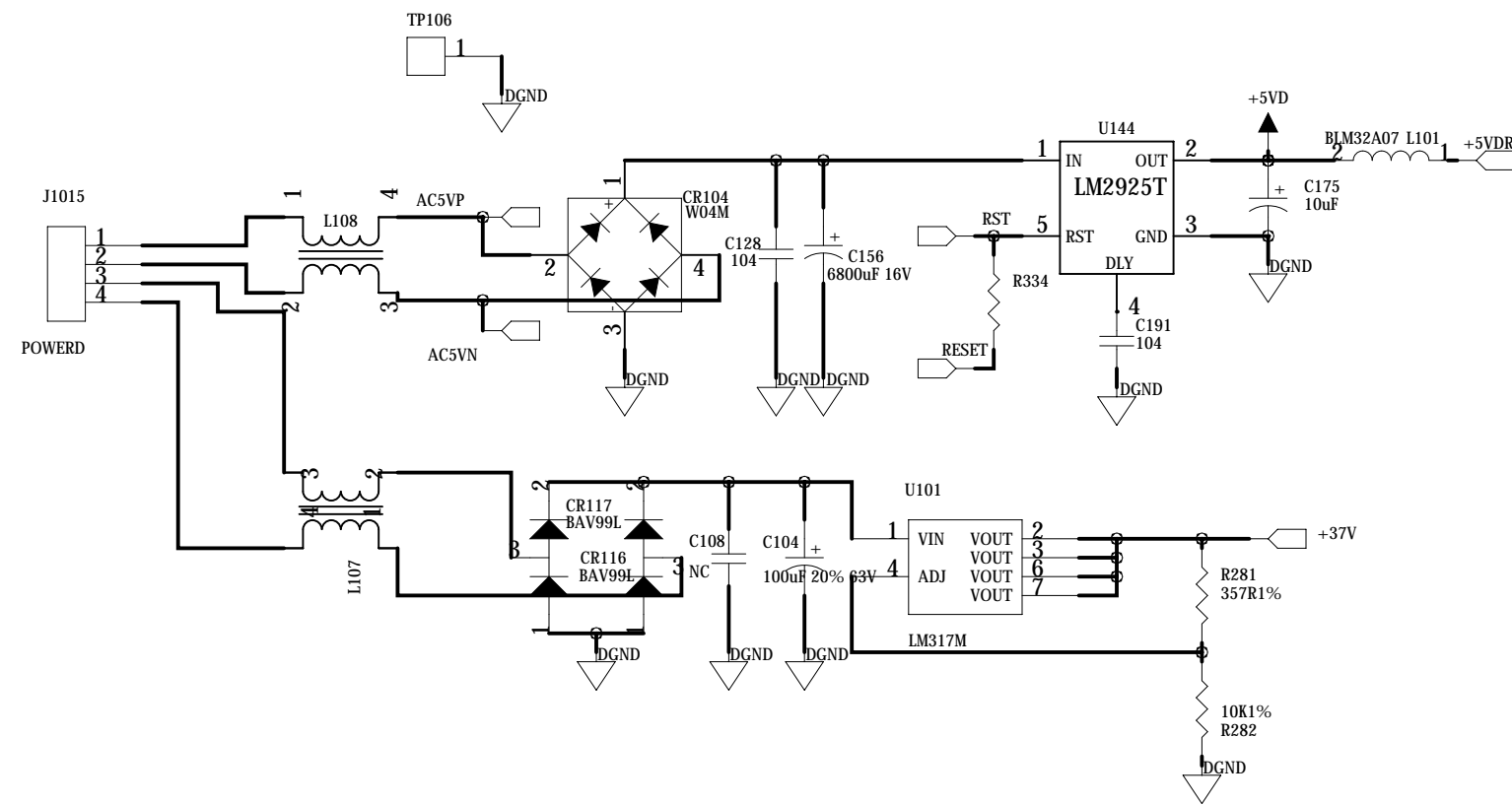
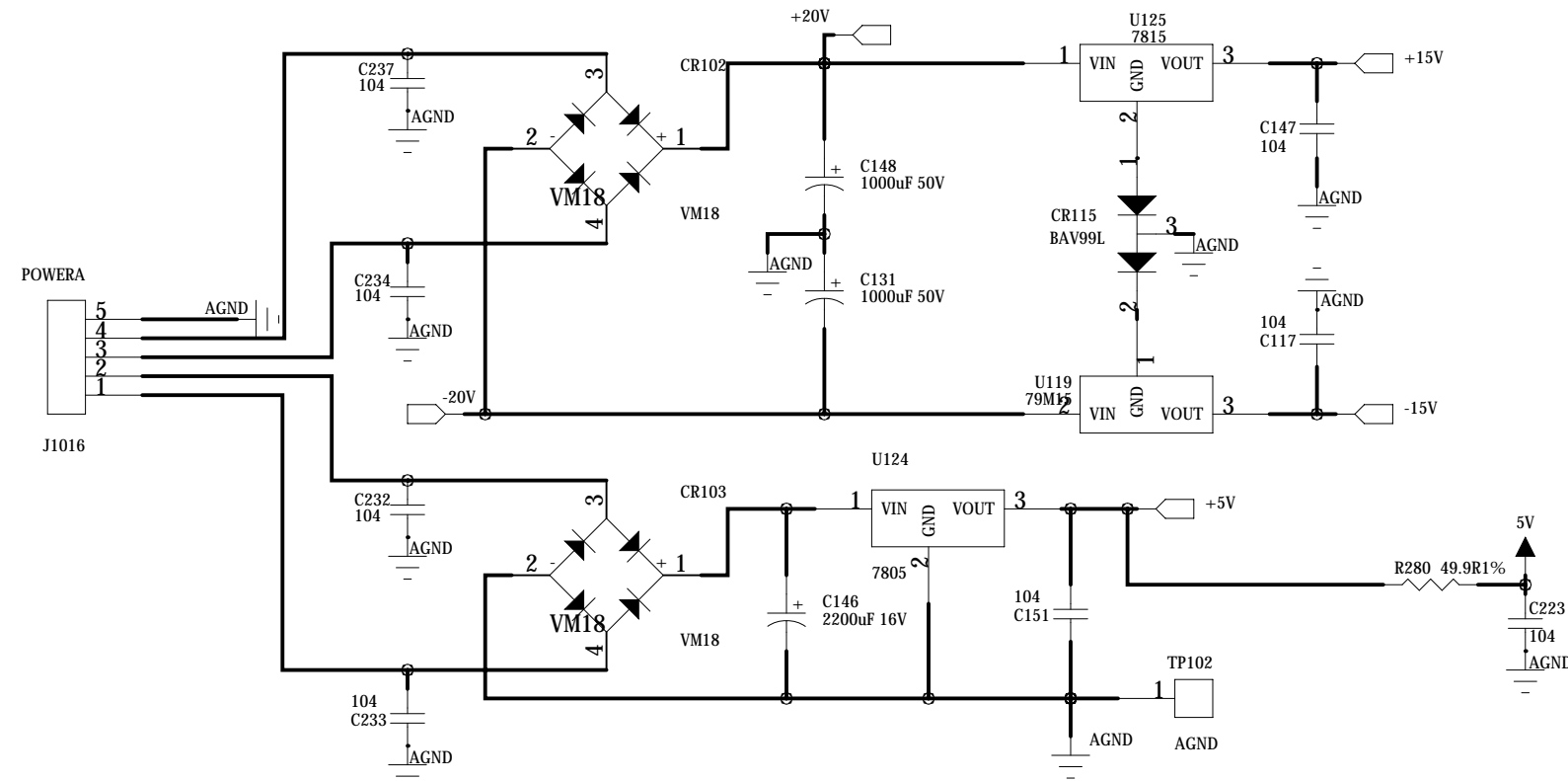

COMPANY: KEITHLEY2000@USER

TITLE: POWER

DRAWN: Randy	DATED: 2013.1.1
CHECKED: <Checked By>	DATED: <Checked Date>
QUALITY CONTROL: <QC By>	DATED: <QC Date>
E-MAIL: jhzyou@126.com	QQ: 249218061

CODE: <Code>	SIZE: C	DRAWING NO: K2000	REV: 1.0
SCALE: <Scale>			SHEET: 9 of 9

6

5

4

3

2

1

REVISION RECORD			
LTR	ECO NO:	APPROVED:	DATE:

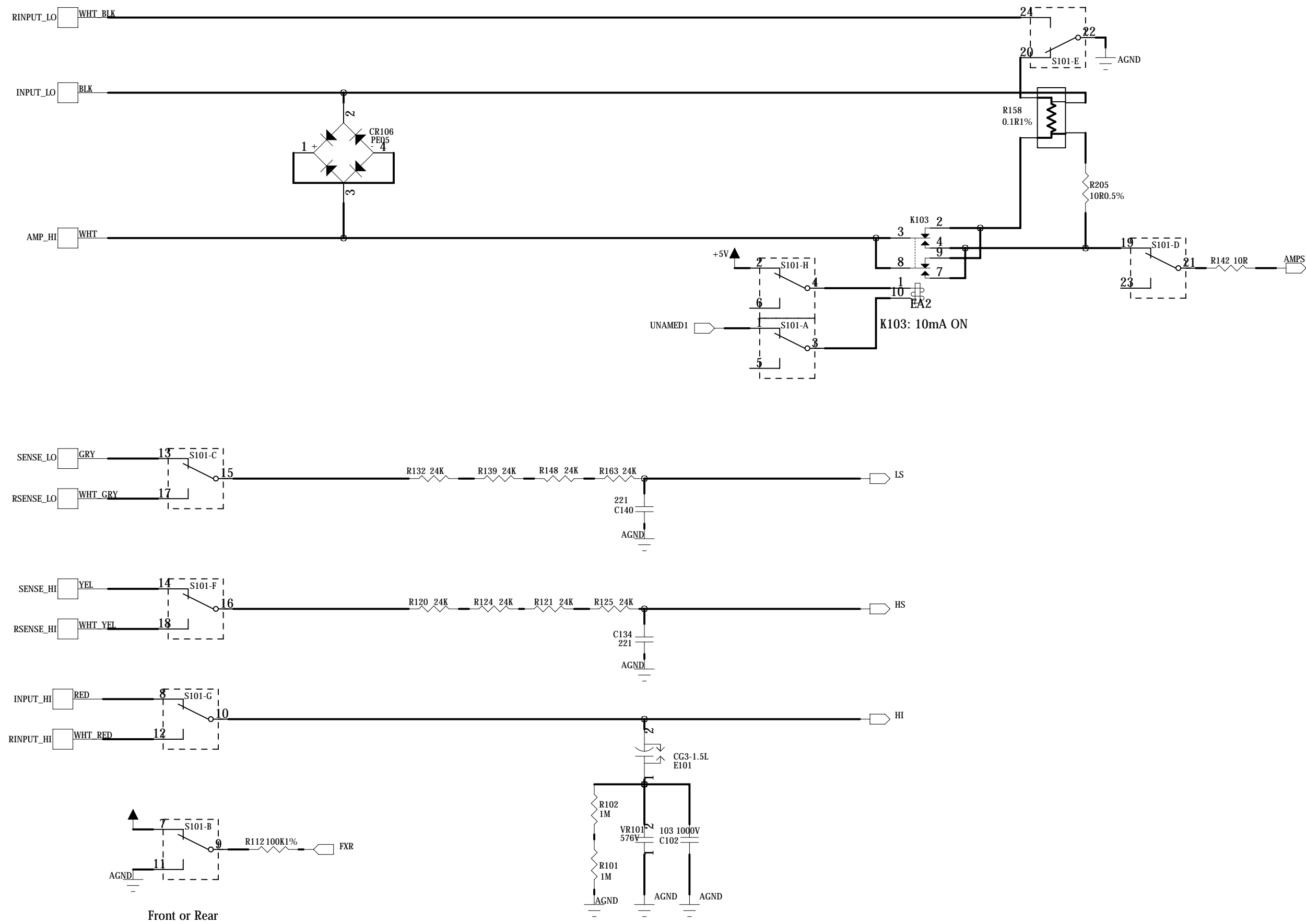

Front or Rear

COMPANY: KEITHLEY2000@USER

TITLE: FRONT/REAR

DRAWN: Randy	DATED: 2013.1.1
CHECKED: <Checked By>	DATED: <Checked Date>
QUALITY CONTROL: <QC By>	DATED: <QC Date>
E-MAIL: jhzyou@126.com	QQ: 249218061

CODE: <Code>	SIZE: C	DRAWING NO: K2000	REV: 1.0
SCALE: <Scale>			SHEET: 2F 9

6

5

4

3

2

1

REVISION RECORD			
LTR	ECO NO:	APPROVED:	DATE:

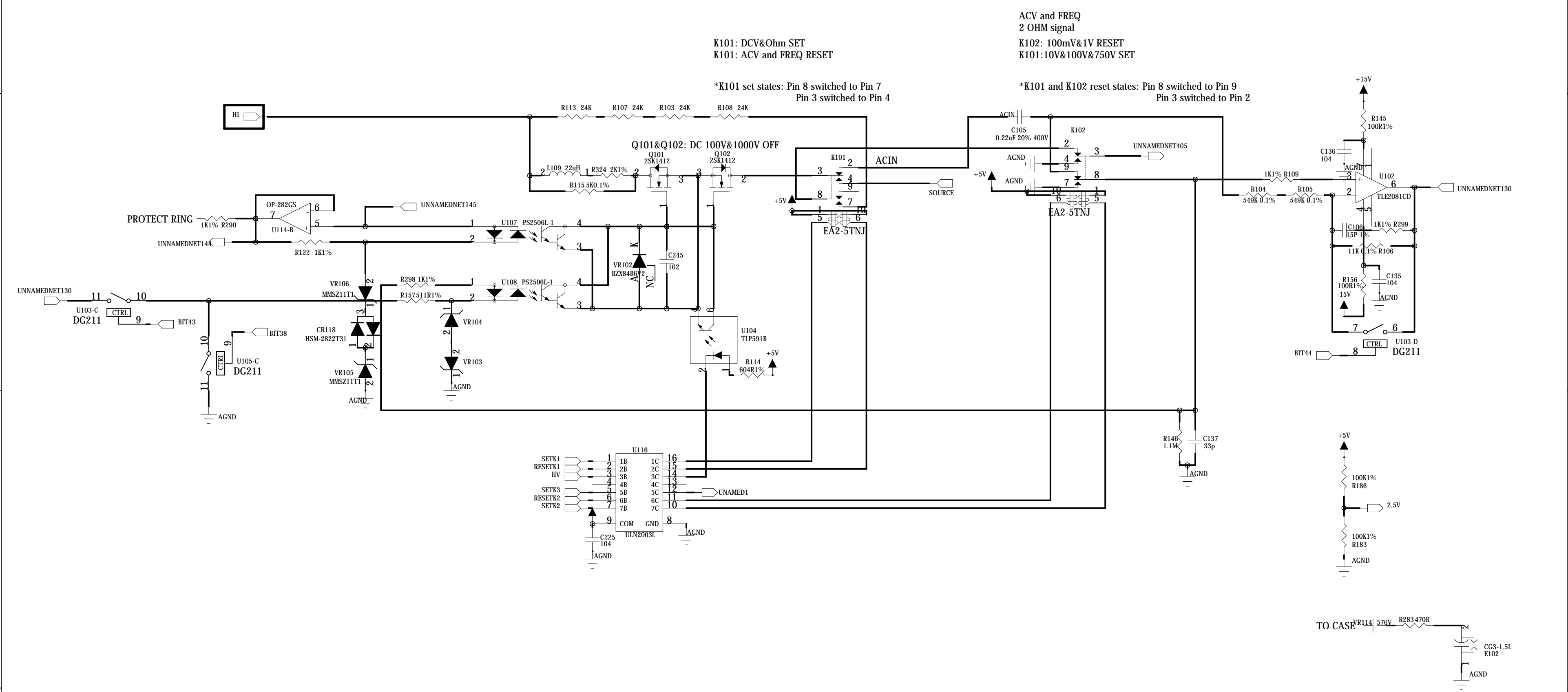

D

D

C

C

B

B

A

A

COMPANY: KEITHLEY2000@USER			
TITLE: SWITCH			
DRAWN: Randy	DATED: 2013.1.1	CODE: <Code>	SIZE: C
CHECKED: <Checked By>	DATED: <Checked Date>	DRAWING NO: K2000	REV: 1.0
QUALITY CONTROL: <QC By>	DATED: <QC Date>	SCALE: <Scale>	SHEET: 3 of 9
E-MAIL: jhzyou@126.com	QQ: 249218061		

Table 2-9
 Ω^2/Ω^4 reference switching

Range	U133 /1.7V	U133 /7V	Q123	Q125	Q124	Q126	Q120
100 Ω	OFF	ON	ON	ON	OFF	OFF	ON
1k Ω	OFF	ON	ON	ON	OFF	OFF	ON
10k Ω	OFF	ON	OFF	OFF	ON	ON	ON
100k Ω	ON	OFF	OFF	OFF	ON	ON	ON
1M Ω	ON	OFF	OFF	OFF	ON	ON	ON
10M Ω	OFF	ON	OFF	OFF	ON	ON	OFF
100M Ω	OFF	ON	OFF	OFF	ON	ON	OFF

REVISION RECORD			
LTR	ECO NO:	APPROVED:	DATE:

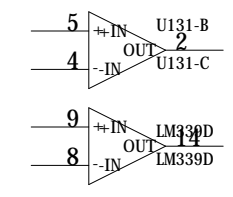
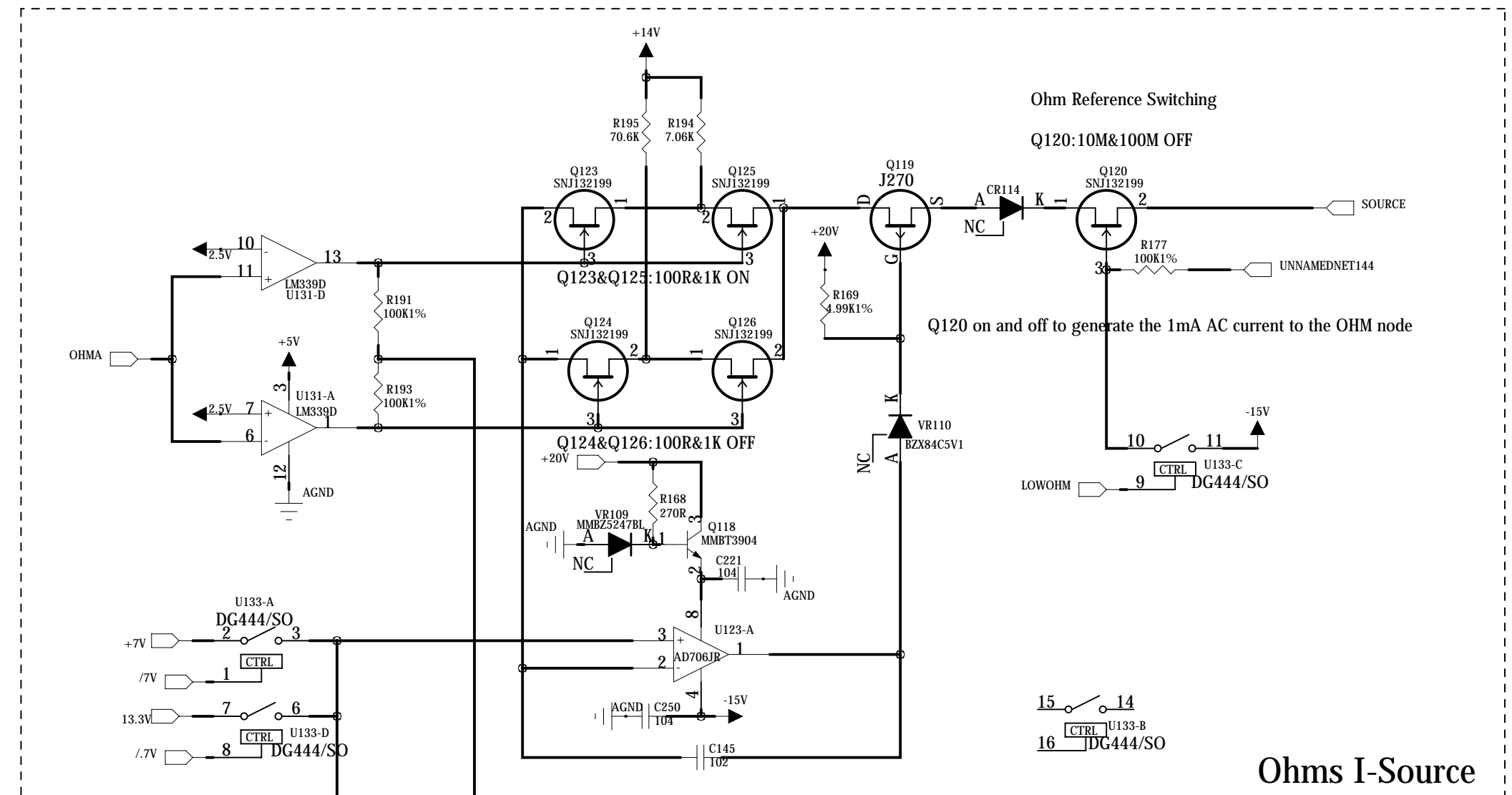

COMPANY: KEITHLEY2000@USER

TITLE: OHMS-SOURCE

DRAWN: Randy	DATED: 2013.1.1
CHECKED: <Checked By>	DATED: <Checked Date>
QUALITY CONTROL: <QC By>	DATED: <QC Date>
E-MAIL: jhzyou@126.com	QQ: 249218061

CODE: <Code>	SIZE: C	DRAWING NO: K2000	REV: 1.0
SCALE: <Scale>			SHEET: 4 of 9

6

5

4

3

2

1

REVISION RECORD			
LTR	ECO NO:	APPROVED:	DATE:

U103 :ACA Pin1 OFF
 U103 :ACV and FREQ Pin8&Pin9 100mV&1V ON
 ACV and FREQ Pin8&Pin9 10V&100V&750V OFF

Table 2-6
 ACV and FREQ signal switching

Range	Q101	Q102	K101*	K102*	U103 pin 8	U103 pin 9	U105 pin 9	U105 pin 8	U103 pin 16	U103 pin 1	U105 pin 1	U111 pin 16
100mV	ON	ON	RESET	RESET	ON	ON	OFF	OFF	OFF	ON	ON	OFF
1V	ON	ON	RESET	RESET	ON	ON	OFF	OFF	OFF	ON	ON	OFF
10V	ON	ON	RESET	SET	OFF	OFF	ON	OFF	OFF	ON	ON	OFF
100V	ON	ON	RESET	SET	OFF	OFF	ON	OFF	OFF	ON	ON	OFF
750V	ON	ON	RESET	SET	OFF	OFF	ON	OFF	OFF	ON	ON	OFF

*K101 and K102 reset states: Pin 8 switched to Pin 9
 Pin 3 switched to Pin 2
 K101 and K102 set states: Pin 8 switched to Pin 7
 Pin 3 switched to Pin 4

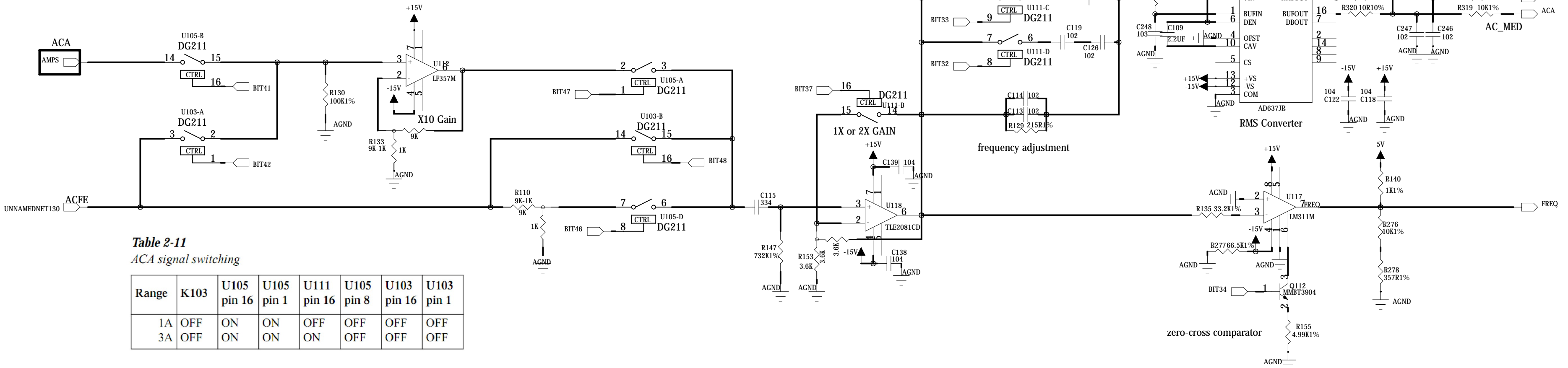

Table 2-11
 ACA signal switching

Range	K103	U105 pin 16	U105 pin 1	U111 pin 16	U105 pin 8	U103 pin 16	U103 pin 1
1A	OFF	ON	ON	OFF	OFF	OFF	OFF
3A	OFF	ON	ON	ON	OFF	OFF	OFF

COMPANY: KEITHLEY2000@USER

TITLE: AC

DRAWN: Randy
 CHECKED: <Checked By>
 QUALITY CONTROL: <QC By>
 E-MAIL: jhzyou@126.com

DATED: 2013.1.1
 DATED: <Checked Date>
 DATED: <QC Date>
 QQ: 249218061

CODE:	SIZE:	DRAWING NO:	REV:
<Code>	C	K2000	1.0

6

5

4

3

2

1

REVISION RECORD			
LTR	ECO NO:	APPROVED:	DATE:

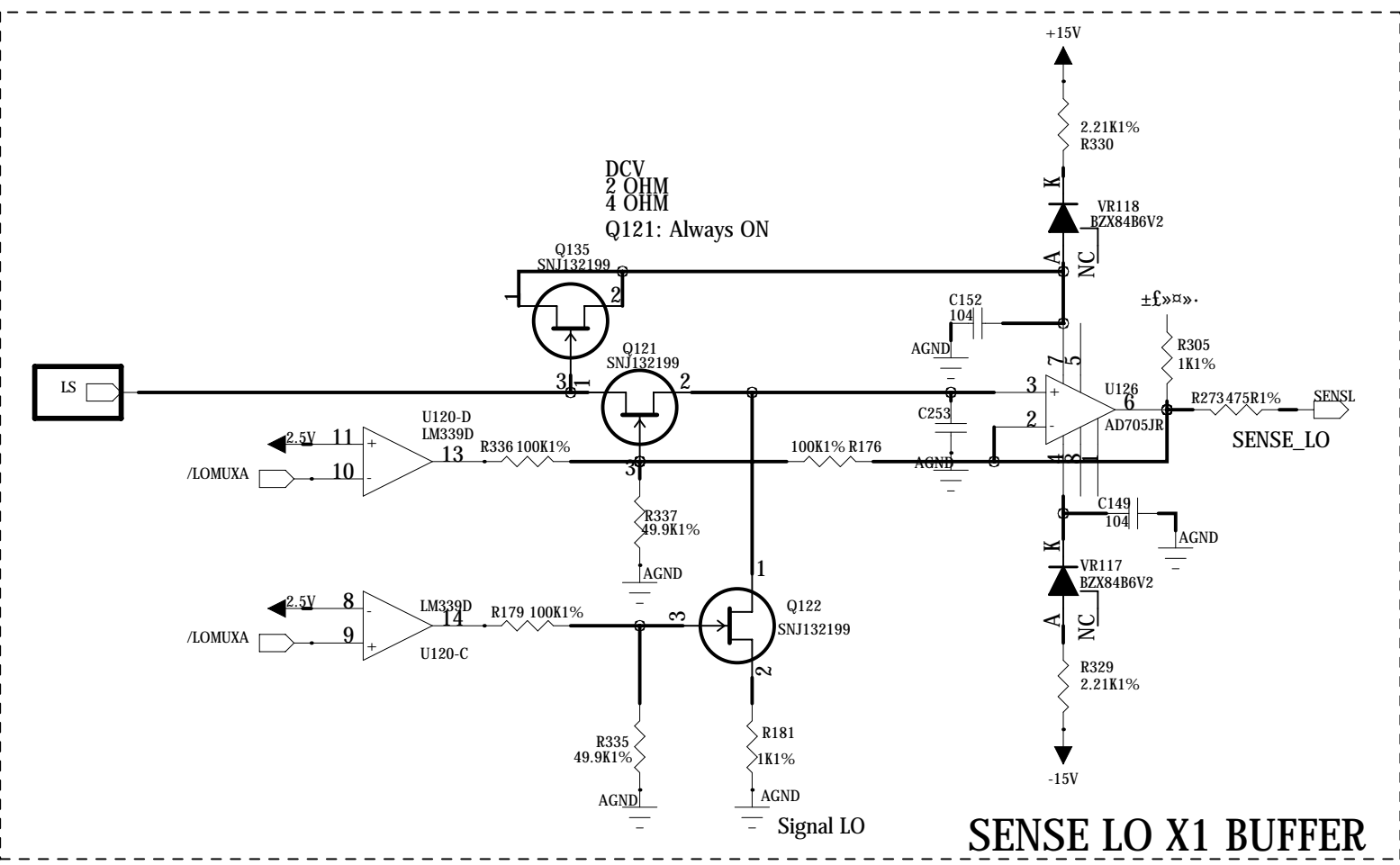
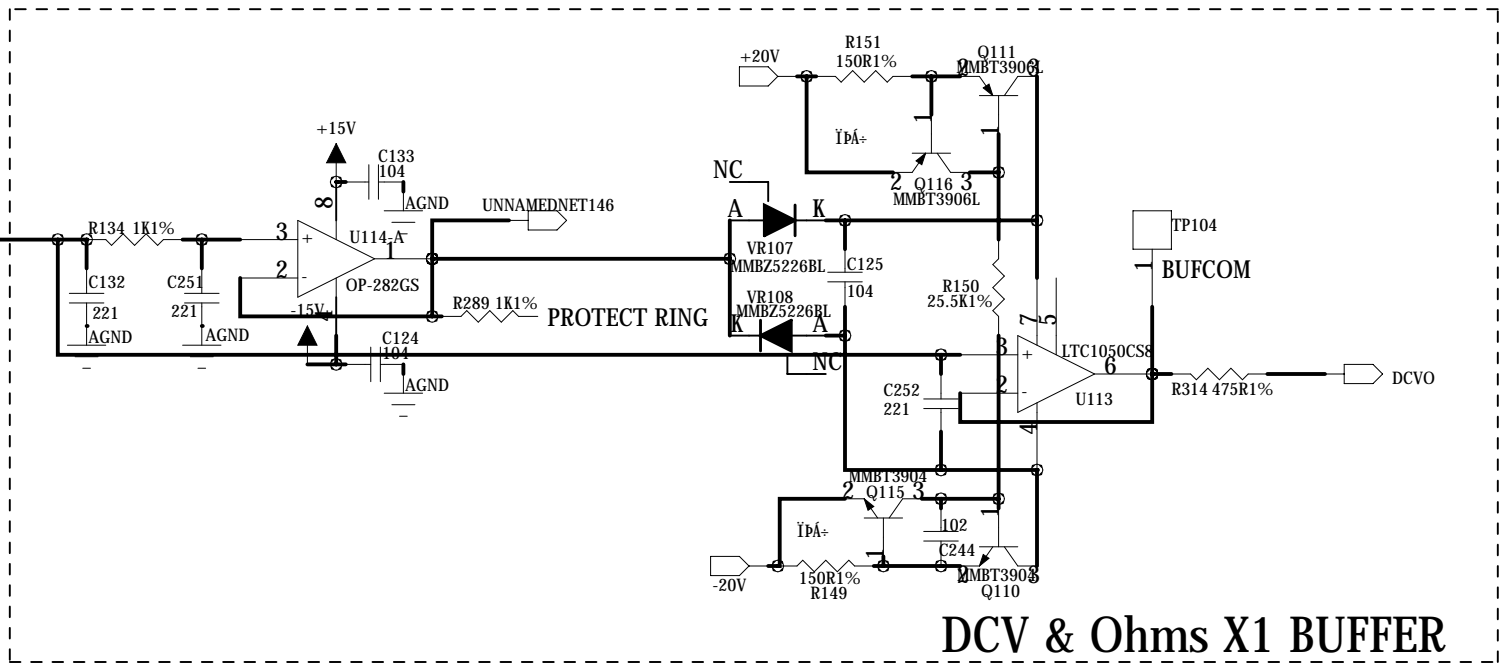
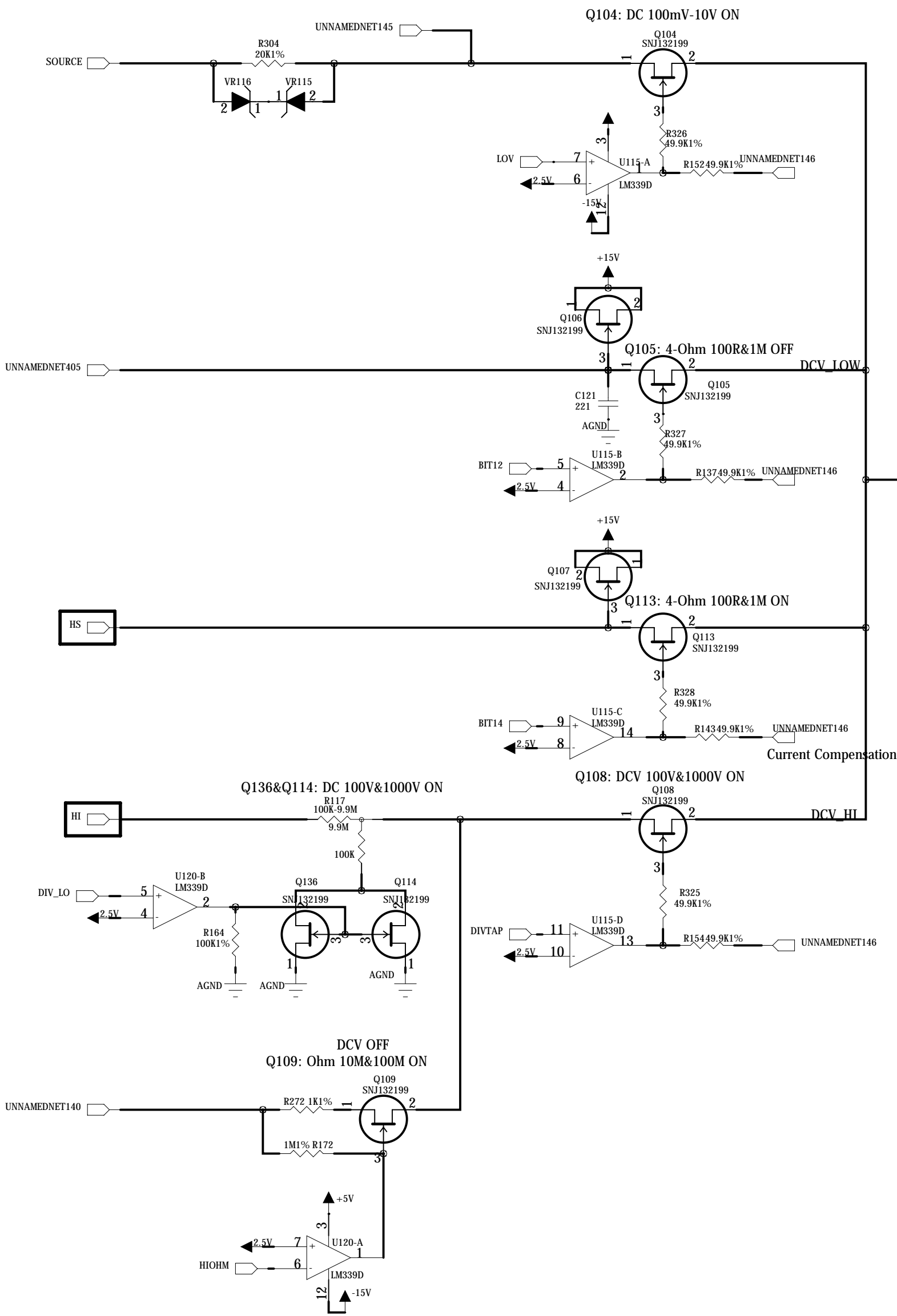

COMPANY: KEITHLEY2000@USER

TITLE: DC

DRAWN: Randy
 CHECKED: <Checked By>
 QUALITY CONTROL: <QC By>
 E-MAIL: jhzyou@126.com

DATED: 2013.1.1
 DATED: <Checked Date>
 DATED: <QC Date>
 QQ: 249218061

CODE: <Code>	SIZE: C	DRAWING NO: K2000	REV: 1.0
SCALE: <Scale>		SHEET: 6 of 9	

6

5

4

3

2

1

REVISION RECORD			
LTR	ECO NO:	APPROVED:	DATE:

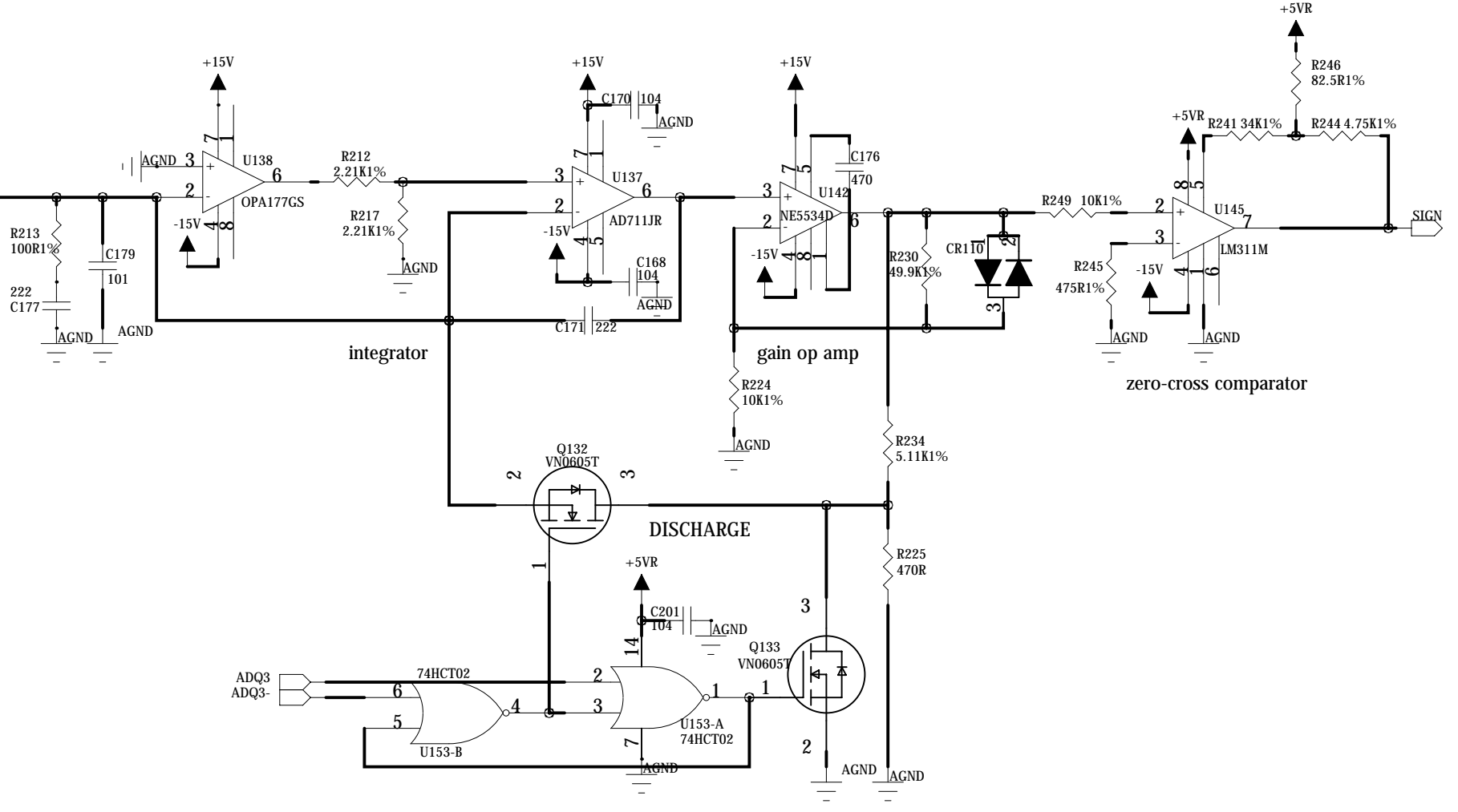
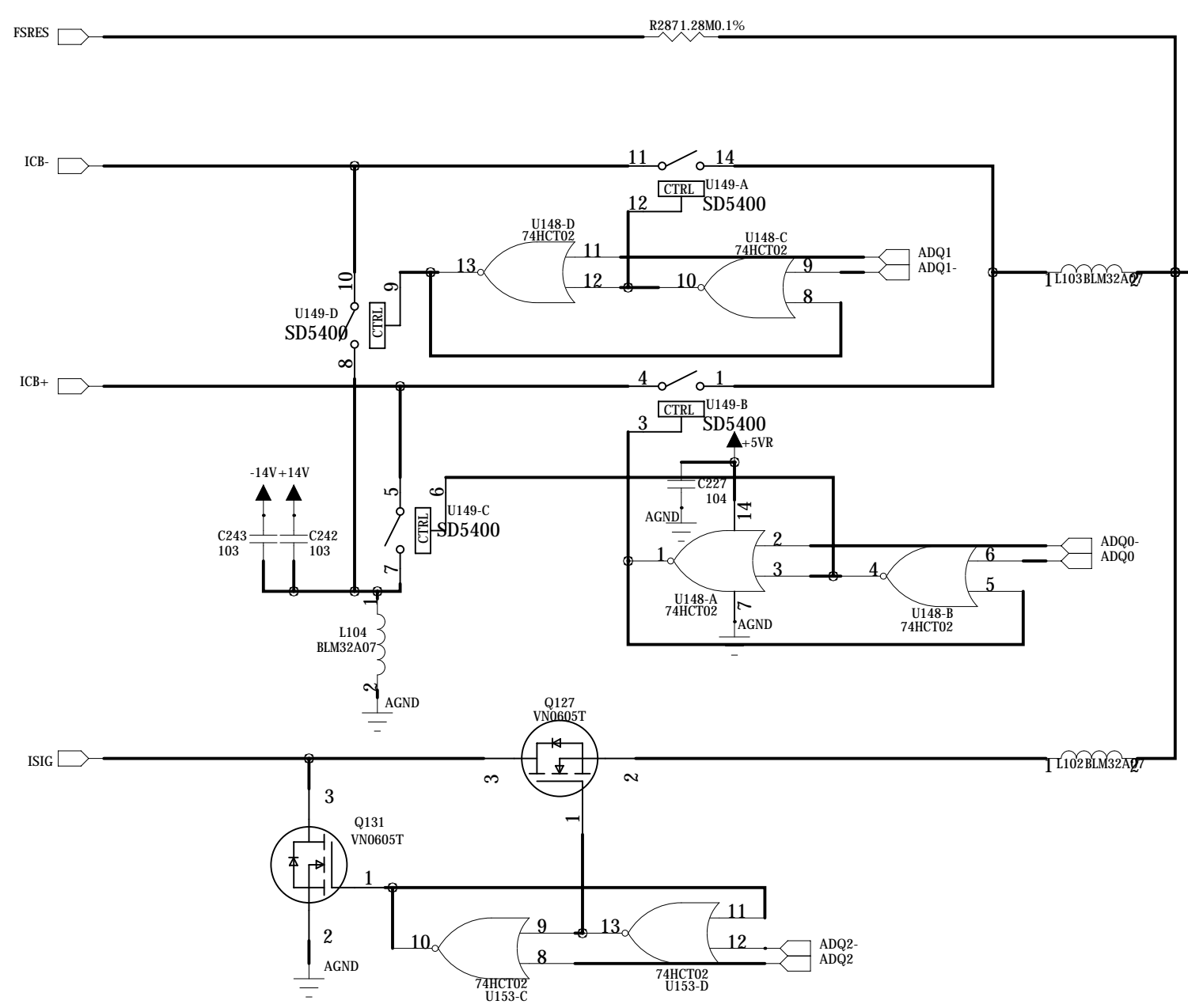
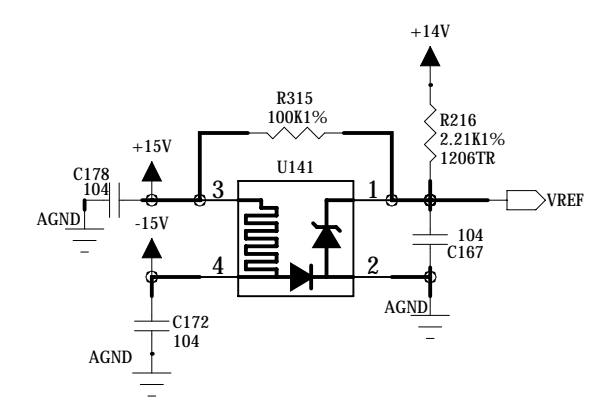
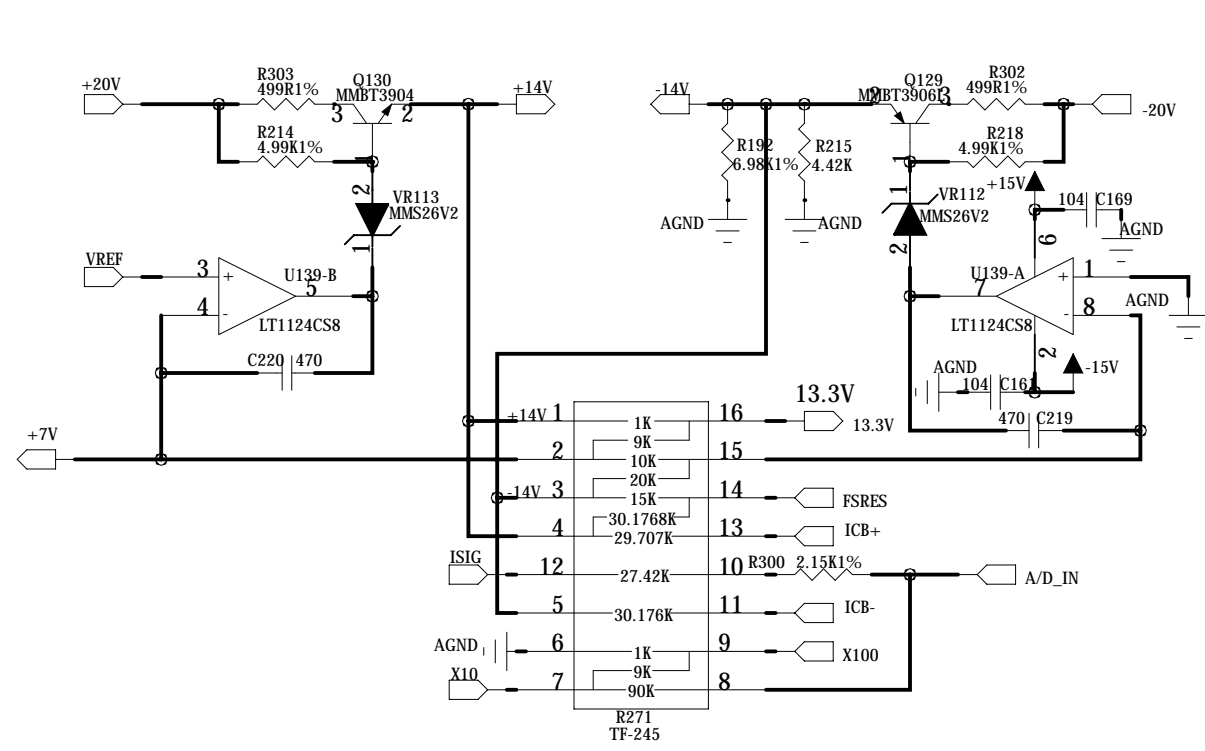

COMPANY: KEITHLEY2000@USER			
TITLE: MULTISLOPE			
DRAWN: Randy	DATED: 2013.1.1	CODE: <Code>	SIZE: C
CHECKED: <Checked By>	DATED: <Checked Date>	DRAWING NO: K2000	REV: 1.0
QUALITY CONTROL: <QC By>	DATED: <QC Date>	SCALE: <Scale>	SHEET: 7F 9
E-MAIL: jhzyou@126.com	QQ: 249218061		

6

5

4

3

2

1

REVISION RECORD			
LTR	ECO NO:	APPROVED:	DATE:

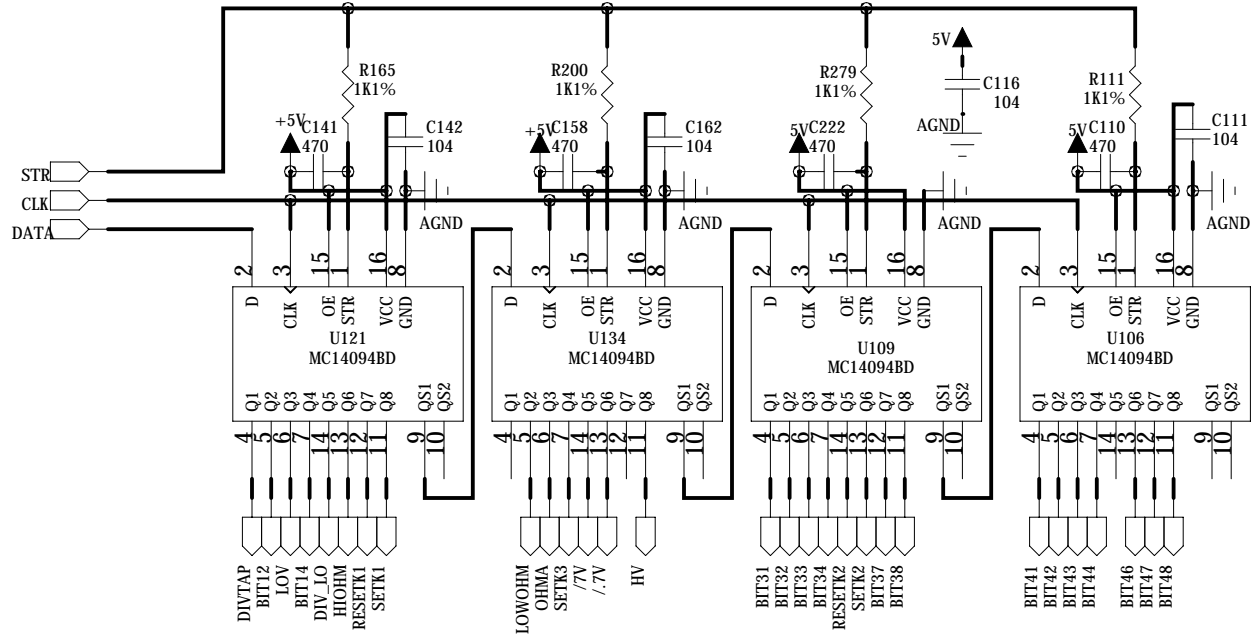
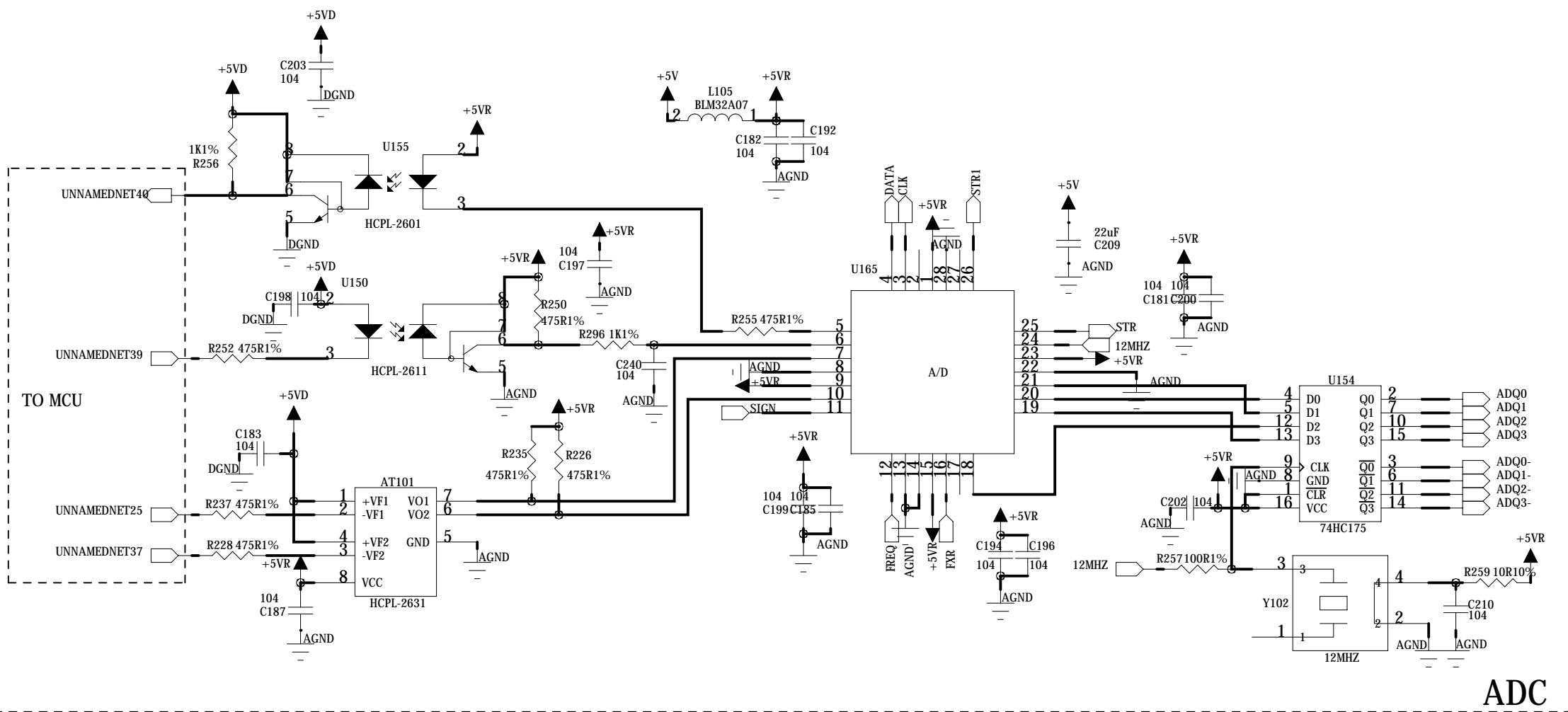

ADC

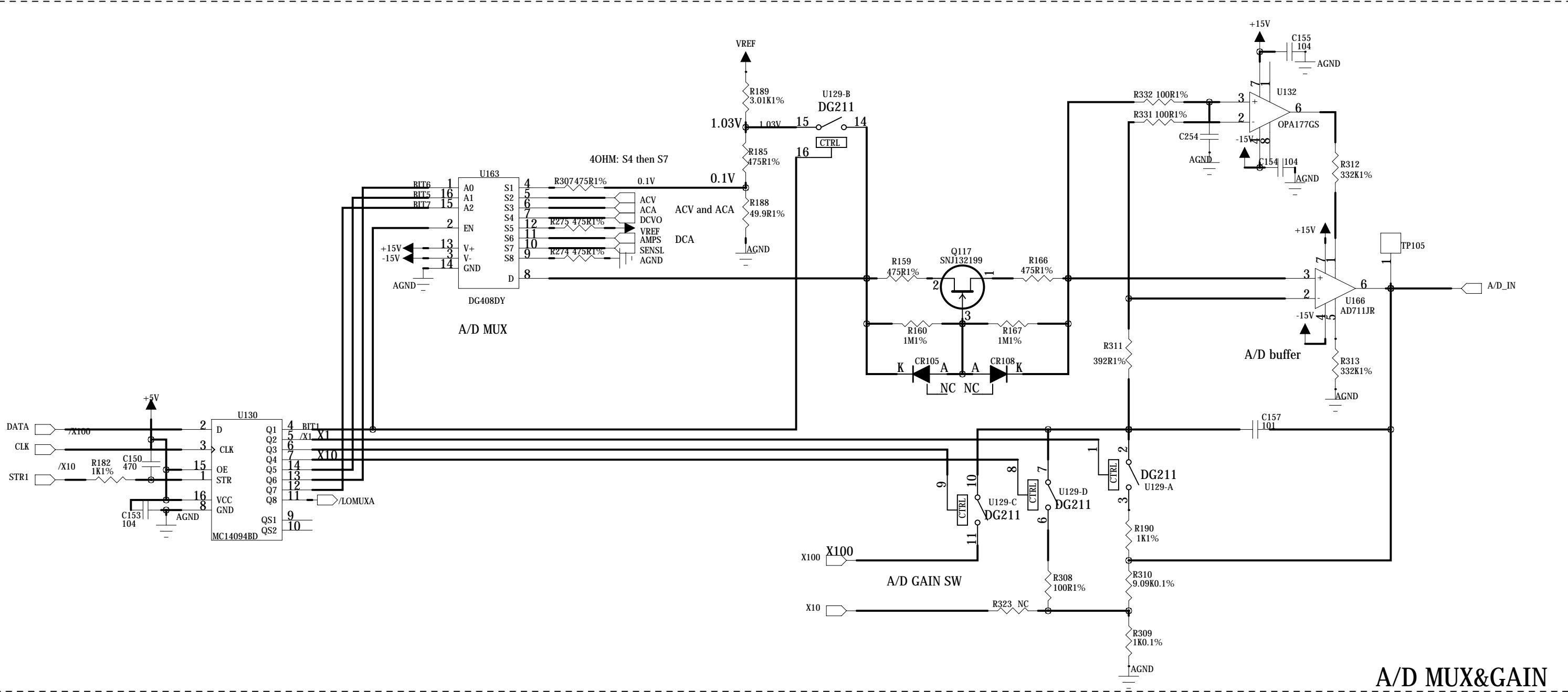

A/D MUX&GAIN

COMPANY: KEITHLEY2000@USER

TITLE: ADMUX_GAIN_AD

DRAWN: Randy
 CHECKED: <Checked By>
 QUALITY CONTROL: <QC By>
 E-MAIL: jhzyou@126.com

DATED: 2013.1.1
 DATED: <Checked Date>
 DATED: <QC Date>
 QO: 249218061

CODE: <Code>	SIZE: C	DRAWING NO: K2000	REV: 1.0
SCALE: <Scale>		SHEET: 8 of 9	

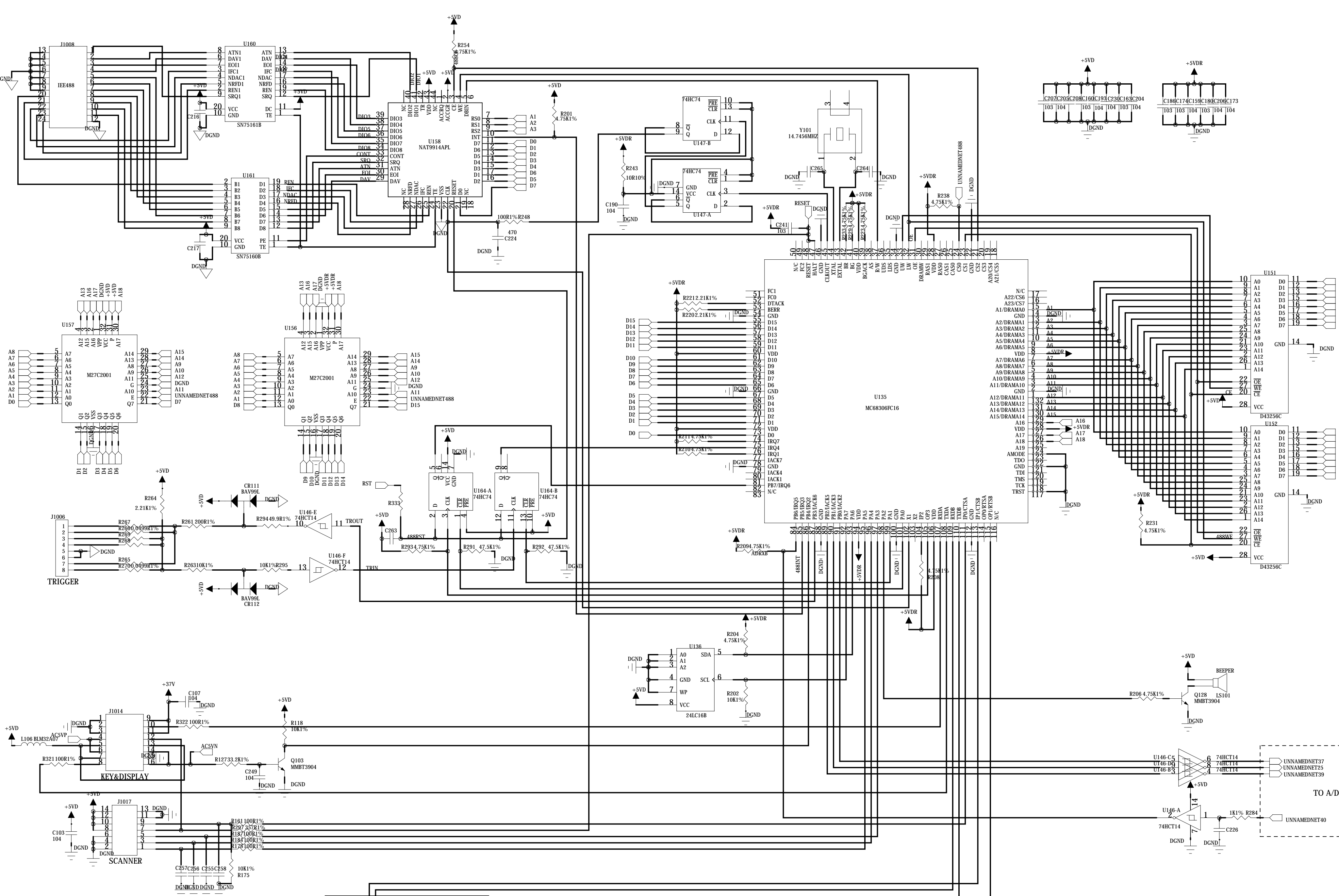

COMPANY:		KEITHLEY2000@USER		
TITLE:		DIGITAL		
CODE:	SIZE:	DRAWING NO.:	REV.:	
<Code>	C	K2000	1.0	
DRAWN:	DATED:	SCALE: <Scale>		
Randy	2013.1.1			
CHECKED:	DATED:			
<Checked By>	<Checked Date>			
QUALITY CONTROL:	DATED:			
<QC By>	<QC Date>			
E-MAIL:	QQ:			
jhzyou@126.com	249218061			
SHEET:		9 of 9		