

# Model 2016 THD Multimeter

Service Manual

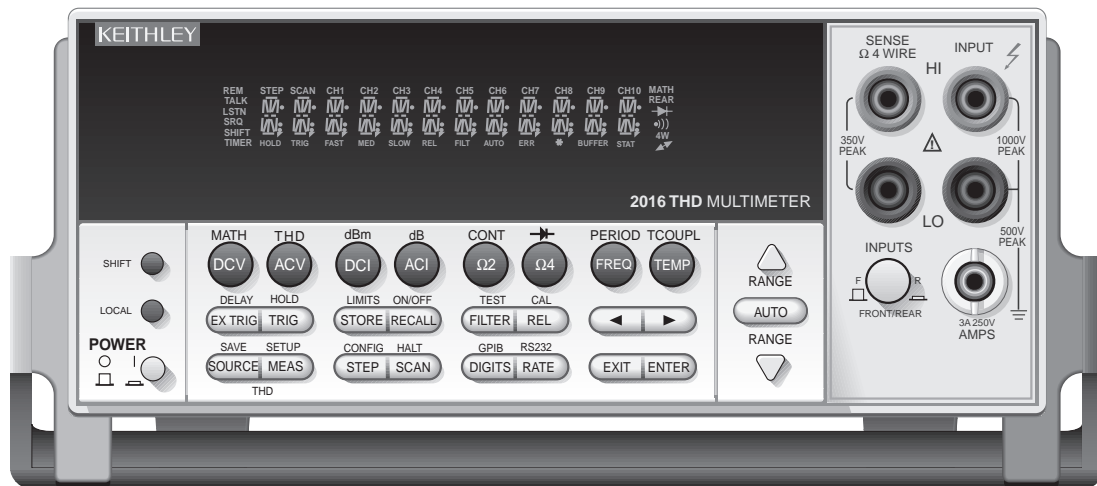

Contains Servicing Information

**KEITHLEY**

---

# WARRANTY

Keithley Instruments, Inc. warrants this product to be free from defects in material and workmanship for a period of 3 years from date of shipment.

Keithley Instruments, Inc. warrants the following items for 90 days from the date of shipment: probes, cables, rechargeable batteries, diskettes, and documentation.

During the warranty period, we will, at our option, either repair or replace any product that proves to be defective.

To exercise this warranty, write or call your local Keithley representative, or contact Keithley headquarters in Cleveland, Ohio. You will be given prompt assistance and return instructions. Send the product, transportation prepaid, to the indicated service facility. Repairs will be made and the product returned, transportation prepaid. Repaired or replaced products are warranted for the balance of the original warranty period, or at least 90 days.

## LIMITATION OF WARRANTY

This warranty does not apply to defects resulting from product modification without Keithley's express written consent, or misuse of any product or part. This warranty also does not apply to fuses, software, non-rechargeable batteries, damage from battery leakage, or problems arising from normal wear or failure to follow instructions.

THIS WARRANTY IS IN LIEU OF ALL OTHER WARRANTIES, EXPRESSED OR IMPLIED, INCLUDING ANY IMPLIED WARRANTY OF MERCHANTABILITY OR FITNESS FOR A PARTICULAR USE. THE REMEDIES PROVIDED HEREIN ARE BUYER'S SOLE AND EXCLUSIVE REMEDIES.

NEITHER KEITHLEY INSTRUMENTS, INC. NOR ANY OF ITS EMPLOYEES SHALL BE LIABLE FOR ANY DIRECT, INDIRECT, SPECIAL, INCIDENTAL OR CONSEQUENTIAL DAMAGES ARISING OUT OF THE USE OF ITS INSTRUMENTS AND SOFTWARE EVEN IF KEITHLEY INSTRUMENTS, INC., HAS BEEN ADVISED IN ADVANCE OF THE POSSIBILITY OF SUCH DAMAGES. SUCH EXCLUDED DAMAGES SHALL INCLUDE, BUT ARE NOT LIMITED TO: COSTS OF REMOVAL AND INSTALLATION, LOSSES SUSTAINED AS THE RESULT OF INJURY TO ANY PERSON, OR DAMAGE TO PROPERTY.

# KEITHLEY

**Keithley Instruments, Inc.** • 28775 Aurora Road • Cleveland, OH 44139 • 440-248-0400 • Fax: 440-248-6168 • <http://www.keithley.com>

**CHINA:**

**Keithley Instruments China** • Yuan Chen Xin Building, Room 705 • 12 Yumin Road, Dewai, Madian • Beijing 100029 • 8610-62022886 • Fax: 8610-62022892

**FRANCE:**

**Keithley Instruments SARL** • BP 60 • 3 Allée des Garays • 91122 Palaiseau Cédex • 33-1-60-11-51-55 • Fax: 33-1-60-11-77-26

**GERMANY:**

**Keithley Instruments GmbH** • Landsberger Strasse 65 • D-82110 Germering, Munich • 49-89-8493070 • Fax: 49-89-84930759

**GREAT BRITAIN:**

**Keithley Instruments, Ltd.** • The Minster • 58 Portman Road • Reading, Berkshire, England RG3 1EA • 44-1189-596469 • Fax: 44-1189-575666

**ITALY:**

**Keithley Instruments SRL** • Viale S. Gimignano 38 • 20146 Milano • 39-2-48303008 • Fax: 39-2-48302274

**NETHERLANDS:**

**Keithley Instruments BV** • Avelingen West 49 • 4202 MS Gorinchem • 31-(0)183-635333 • Fax: 31-(0)183-630821

**SWITZERLAND:**

**Keithley Instruments SA** • Kriesbachstrasse 4 • 8600 Dübendorf • 41-1-8219444 • Fax: 41-1-8203081

**TAIWAN:**

**Keithley Instruments Taiwan** • IFL., 85 Po Ai Street • Hsinchu, Taiwan • 886-3-572-9077 • Fax: 886-3-572-9031

---

# Model 2016 THD Multimeter Service Manual

©1999, Keithley Instruments, Inc.  
All rights reserved.  
Cleveland, Ohio, U.S.A.  
First Printing, May 1999  
Document Number: 2016-902-01 Rev. A

---

## Manual Print History

The print history shown below lists the printing dates of all Revisions and Addenda created for this manual. The Revision Level letter increases alphabetically as the manual undergoes subsequent updates. Addenda, which are released between Revisions, contain important change information that the user should incorporate immediately into the manual. Addenda are numbered sequentially. When a new Revision is created, all Addenda associated with the previous Revision of the manual are incorporated into the new Revision of the manual. Each new Revision includes a revised copy of this print history page.

Revision A (Document Number 2016-902-01) ..... May 1999

---

## Safety Precautions

The following safety precautions should be observed before using this product and any associated instrumentation. Although some instruments and accessories would normally be used with non-hazardous voltages, there are situations where hazardous conditions may be present.

This product is intended for use by qualified personnel who recognize shock hazards and are familiar with the safety precautions required to avoid possible injury. Read the operating information carefully before using the product.

The types of product users are:

**Responsible body** is the individual or group responsible for the use and maintenance of equipment, for ensuring that the equipment is operated within its specifications and operating limits, and for ensuring that operators are adequately trained.

**Operators** use the product for its intended function. They must be trained in electrical safety procedures and proper use of the instrument. They must be protected from electric shock and contact with hazardous live circuits.

**Maintenance personnel** perform routine procedures on the product to keep it operating, for example, setting the line voltage or replacing consumable materials. Maintenance procedures are described in the manual. The procedures explicitly state if the operator may perform them. Otherwise, they should be performed only by service personnel.

**Service personnel** are trained to work on live circuits, and perform safe installations and repairs of products. Only properly trained service personnel may perform installation and service procedures.

Exercise extreme caution when a shock hazard is present. Lethal voltage may be present on cable connector jacks or test fixtures. The American National Standards Institute (ANSI) states that a shock hazard exists when voltage levels greater than 30V RMS, 42.4V peak, or 60VDC are present. **A good safety practice is to expect that hazardous voltage is present in any unknown circuit before measuring.**

Users of this product must be protected from electric shock at all times. The responsible body must ensure that users are prevented access and/or insulated from every connection point. In some cases, connections must be exposed to potential human contact. Product users in these circumstances must be trained to protect themselves from the risk of electric shock. If the circuit is capable of operating at or above 1000 volts, **no conductive part of the circuit may be exposed.**

As described in the International Electrotechnical Commission (IEC) Standard IEC 664, digital multimeter measuring circuits (e.g., Keithley Models 175A, 199, 2000, 2001, 2002, and 2010) are Installation Category II. All other instruments' signal terminals are Installation Category I and must not be connected to mains.

Do not connect switching cards directly to unlimited power circuits. They are intended to be used with impedance limited sources. NEVER connect switching cards directly to AC mains. When connecting sources to switching cards, install protective devices to limit fault current and voltage to the card.

Before operating an instrument, make sure the line cord is connected to a properly grounded power receptacle. Inspect the connecting cables, test leads, and jumpers for possible wear, cracks, or breaks before each use.

For maximum safety, do not touch the product, test cables, or any other instruments while power is applied to the circuit under test. ALWAYS remove power from the entire test system and discharge any capacitors before: connecting or disconnecting cables or jumpers, installing or removing switching cards, or making internal changes, such as installing or removing jumpers.

Do not touch any object that could provide a current path to the common side of the circuit under test or power line (earth) ground. Always make measurements with dry hands while standing on a dry, insulated surface capable of withstanding the voltage being measured.

---

The instrument and accessories must be used in accordance with its specifications and operating instructions or the safety of the equipment may be impaired.

Do not exceed the maximum signal levels of the instruments and accessories, as defined in the specifications and operating information, and as shown on the instrument or test fixture panels, or switching card.

When fuses are used in a product, replace with same type and rating for continued protection against fire hazard.

Chassis connections must only be used as shield connections for measuring circuits, NOT as safety earth ground connections.

If you are using a test fixture, keep the lid closed while power is applied to the device under test. Safe operation requires the use of a lid interlock.

If a  screw is present, connect it to safety earth ground using the wire recommended in the user documentation.

The  symbol on an instrument indicates that the user should refer to the operating instructions located in the manual.

The  symbol on an instrument shows that it can source or measure 1000 volts or more, including the combined effect of normal and common mode voltages. Use standard safety precautions to avoid personal contact with these voltages.

The **WARNING** heading in a manual explains dangers that might result in personal injury or death. Always read the associated information very carefully before performing the indicated procedure.

The **CAUTION** heading in a manual explains hazards that could damage the instrument. Such damage may invalidate the warranty.

Instrumentation and accessories shall not be connected to humans.

Before performing any maintenance, disconnect the line cord and all test cables.

To maintain protection from electric shock and fire, replacement components in mains circuits, including the power transformer, test leads, and input jacks, must be purchased from Keithley Instruments. Standard fuses, with applicable national safety approvals, may be used if the rating and type are the same. Other components that are not safety related may be purchased from other suppliers as long as they are equivalent to the original component. (Note that selected parts should be purchased only through Keithley Instruments to maintain accuracy and functionality of the product.) If you are unsure about the applicability of a replacement component, call a Keithley Instruments office for information.

To clean an instrument, use a damp cloth or mild, water based cleaner. Clean the exterior of the instrument only. Do not apply cleaner directly to the instrument or allow liquids to enter or spill on the instrument. Products that consist of a circuit board with no case or chassis (e.g., data acquisition board for installation into a computer) should never require cleaning if handled according to instructions. If the board becomes contaminated and operation is affected, the board should be returned to the factory for proper cleaning/servicing.

---

# Table of Contents

## 1 Performance Verification

Introduction .....	1-2
Verification test requirements .....	1-3
Environmental conditions .....	1-3
Warm-up period .....	1-3
Line power .....	1-3
Recommended test equipment .....	1-4
Verification limits .....	1-5
Example reading limit calculation .....	1-5
Calculating resistance reading limits .....	1-5
Restoring factory defaults .....	1-6
Performing the verification test procedures .....	1-7
Test summary .....	1-7
Test considerations .....	1-7
Verifying DC voltage .....	1-8
Verifying AC voltage .....	1-10
Verifying DC current .....	1-12
Verifying AC current .....	1-13
Verifying resistance .....	1-14
Verifying temperature .....	1-16
Verifying frequency .....	1-17
Verifying total harmonic distortion .....	1-18
Verifying function generator amplitude .....	1-19

## 2 Calibration

Introduction .....	2-2
Environmental conditions .....	2-3
Warm-up period .....	2-3
Line power .....	2-3
Calibration considerations .....	2-4
Calibration code .....	2-5
Front panel calibration code .....	2-5
Remote calibration code .....	2-5
Comprehensive calibration .....	2-6
Calibration cycle .....	2-6
Recommended equipment .....	2-6
Aborting calibration .....	2-7
Front panel calibration .....	2-7
Preparing the Model 2016 for calibration .....	2-7
Front panel short and open calibration .....	2-8
DC volts calibration .....	2-9

---

Resistance calibration .....	2-11
DC current calibration .....	2-12
AC voltage calibration .....	2-13
AC current calibration .....	2-14
Distortion calibration .....	2-14
Function generator calibration .....	2-15
Setting calibration dates and saving calibration .....	2-16
Remote calibration .....	2-16
Preparing the Model 2016 for calibration .....	2-17
Short and open calibration .....	2-17
DC volts calibration .....	2-18
Resistance calibration .....	2-19
DC current calibration .....	2-20
AC voltage calibration .....	2-21
AC current calibration .....	2-22
Distortion calibration .....	2-22
Function generator calibration .....	2-23
Programming calibration dates .....	2-23
Saving calibration constants .....	2-23
Locking out calibration .....	2-23
Manufacturing calibration .....	2-24
Recommended test equipment .....	2-24
Unlocking manufacturing calibration .....	2-24
Measuring synthesizer signal amplitude .....	2-24
Front panel manufacturing calibration .....	2-25
Remote manufacturing calibration .....	2-26

### 3 Routine Maintenance

Introduction .....	3-2
Setting the line voltage and replacing the line fuse .....	3-2
Replacing the AMPS fuse .....	3-3

### 4 Troubleshooting

Introduction .....	4-2
Repair considerations .....	4-3
Power-on self-test .....	4-4
Front panel tests .....	4-5
KEY test .....	4-5
DISP test .....	4-5
Principles of operation .....	4-6
Power supply .....	4-6
Display board .....	4-8
Digital circuitry .....	4-9



---

Analog circuitry .....	4-11
Distortion digital circuitry .....	4-13
Distortion analog circuitry .....	4-15
Sine generator circuitry .....	4-16
Troubleshooting .....	4-18
Display board checks .....	4-18
Power supply checks .....	4-19
Digital circuitry checks .....	4-20
Analog signal switching states .....	4-21

## 5 Disassembly

Introduction .....	5-2
Handling and cleaning .....	5-3
Handling PC boards .....	5-3
Solder repairs .....	5-3
Static sensitive devices .....	5-4
Assembly drawings .....	5-5
Disassembly procedures .....	5-6
Case cover removal .....	5-6
DMM board removal .....	5-6
DSP board removal .....	5-7
Front panel disassembly .....	5-8
Removing power components .....	5-8
Instrument reassembly .....	5-9
Input terminal wire connections .....	5-9
Power module wire connections .....	5-9
Changing trigger link lines .....	5-10
Main CPU firmware replacement .....	5-11

## 6 Replaceable Parts

Introduction .....	6-2
Parts lists .....	6-2
Ordering information .....	6-2
Factory service .....	6-2
Component layouts .....	6-2

## A Specifications

Accuracy calculations .....	A-9
Calculating DC characteristics accuracy .....	A-9
Calculating AC characteristics accuracy .....	A-9
Calculating dBm characteristics accuracy .....	A-10
Calculating dB characteristics accuracy .....	A-10
Distortion characteristics .....	A-11

---

Calculating generator amplitude accuracy .....	A-12
Additional derating factors .....	A-12
Optimizing measurement accuracy .....	A-13
DC voltage, DC current, and resistance .....	A-13
AC voltage and AC current .....	A-13
Temperature .....	A-13
Optimizing measurement speed .....	A-14
DC voltage, DC current, and resistance .....	A-14
AC voltage and AC current .....	A-14
Temperature .....	A-14

## B Calibration Reference

Introduction .....	B-2
Command summary .....	B-3
Miscellaneous calibration commands .....	B-5
:CODE .....	B-5
:COUNT? .....	B-5
:INIT .....	B-6
:LOCK .....	B-6
:LOCK? .....	B-7
:SAVE .....	B-7
:DATE .....	B-8
:NDUE .....	B-8
DC calibration commands .....	B-9
:STEP1 .....	B-9
:STEP2 .....	B-10
:STEP3 .....	B-10
:STEP4 .....	B-10
:STEP5 .....	B-11
:STEP6 .....	B-11
:STEP7 .....	B-11
:STEP8 .....	B-12
:STEP9 .....	B-12
:STEP10 .....	B-12
:STEP11 .....	B-13
:STEP12 .....	B-13
AC calibration commands .....	B-14
:AC:STEP<n> .....	B-15
Distortion and function generator calibration commands .....	B-16
:DIST:STEP1 .....	B-16
:DIST:STEP2 .....	B-16
:FGEN:STEP1 .....	B-16

---

Manufacturing calibration commands .....	B-17
:AC:STEP<14 15> .....	B-17
:DC:STEP0 .....	B-17
Remote error reporting .....	B-18
Error summary .....	B-18
Error queue .....	B-20
Status byte EAV (Error Available) bit .....	B-20
Generating an SRQ on error .....	B-20
Detecting calibration step completion .....	B-21
Using the *OPC? query .....	B-21
Using the *OPC command .....	B-21
Generating an SRQ on calibration complete .....	B-22

## **C Calibration Program**

Introduction .....	C-2
Computer hardware requirements .....	C-2
Software requirements .....	C-2
Calibration equipment .....	C-2
General program instructions .....	C-3

---

# List of Illustrations

## 1 Performance Verification

Connections for DC volts verification .....	1-8
Connections for AC volts verification .....	1-10
Connections for DC current verification .....	1-12
Connections for AC current verification .....	1-13
Connections for resistance verification (100Ω-10MΩ range) .....	1-14
Connections for resistance verification (100MΩ range) .....	1-15
Connections for frequency verification .....	1-17
Connections for total harmonic distortion verification .....	1-18
Connections for function generator amplitude verification .....	1-19

## 2 Calibration

Low-thermal short connections .....	2-8
Connections for DC volts and ohms calibration .....	2-9
Connections for DC and AC amps calibration .....	2-12
Connections for AC volts calibration .....	2-13
Connections for distortion calibration .....	2-15
Connections for function generator calibration .....	2-15
Synthesizer connections for manufacturing calibration .....	2-25

## 3 Routine Maintenance

Power module .....	3-2
--------------------	-----

## 4 Troubleshooting

Power supply block diagram .....	4-6
Digital circuitry block diagram .....	4-8
Analog circuitry block diagram .....	4-11
Distortion digital circuitry block diagram .....	4-13
Distortion analog circuitry block diagram .....	4-15
Sine generator circuitry block diagram .....	4-16

## 5 Disassembly

Trigger link line connections .....	5-10
-------------------------------------	------

---

# List of Tables

## 1 Performance Verification

Recommended verification equipment .....	1-4
DCV reading limits .....	1-9
ACV reading limits .....	1-11
DCI limits .....	1-12
ACI limits .....	1-13
Limits for resistance verification .....	1-15
Thermocouple temperature verification reading limits .....	1-16

## 2 Calibration

Recommended equipment for comprehensive calibration .....	2-6
Comprehensive calibration procedures .....	2-8
DC volts calibration summary .....	2-10
Ohms calibration summary .....	2-11
DC current calibration summary .....	2-12
AC voltage calibration summary .....	2-13
AC current calibration summary .....	2-14
Distortion and function generator calibration summary .....	2-15
DC voltage calibration programming steps .....	2-18
Resistance calibration programming steps .....	2-19
DC current calibration programming steps .....	2-20
AC voltage calibration programming steps .....	2-21
AC current calibration programming steps .....	2-22
Distortion and function generator calibration steps .....	2-22
Recommended equipment for manufacturing calibration .....	2-24

## 3 Routine Maintenance

Power line fuse .....	3-3
-----------------------	-----

## 4 Troubleshooting

Power supply components .....	4-7
Display board checks .....	4-18
Power supply checks .....	4-19
Digital circuitry checks .....	4-20
DCV signal switching .....	4-21
ACV and FREQ signal switching .....	4-21
$\Omega 2$ signal switching .....	4-22
$\Omega 4$ signal switching .....	4-22
$\Omega 2/\Omega 4$ reference switching .....	4-22
DCA signal switching .....	4-23

---

ACA signal switching .....	4-23
DCV signal multiplexing and gain .....	4-23
ACV and ACA signal multiplexing and gain .....	4-23
DCA signal multiplexing and gain .....	4-24
$\Omega 2$ signal multiplexing and gain .....	4-24
$\Omega 4$ signal multiplexing and gain .....	4-24
Switching device locations .....	4-25

## 5 Disassembly

Input terminal wire colors .....	5-9
Power module wire colors .....	5-9

## 6 Replaceable Parts

DMM (mother) board parts list .....	6-3
Display board parts list .....	6-10
Distortion (DSP) board parts list .....	6-11
Miscellaneous parts list .....	6-15

## B Calibration Reference

Remote calibration command summary .....	B-3
DC calibration commands .....	B-9
AC calibration commands .....	B-14
Distortion and function generator calibration commands .....	B-16
Calibration error summary .....	B-18



# 1 Performance Verification

## Introduction

Use the procedures in this section to verify that Model 2016 THD Multimeter accuracy is within the limits stated in the instrument's one-year accuracy specifications. You can perform these verification procedures:

- When you first receive the instrument to make sure that it was not damaged during shipment, and that the unit meets factory specifications.
- If the instrument's accuracy is questionable.
- Following calibration.

**WARNING** The information in this section is intended only for qualified service personnel. Do not attempt these procedures unless you are qualified to do so.

**NOTE** *If the instrument is still under warranty and its performance is outside specified limits, contact your Keithley representative or the factory to determine the correct course of action. If the unit is not under warranty, and it fails to meet specified limits, refer to the calibration procedures in Section 2.*



## Verification test requirements

Be sure that you perform the verification tests:

- Under the proper environmental conditions.
- After the specified warm-up period.
- Using the correct line voltage.
- Using the proper calibration equipment.
- Using the specified reading limits.

### Environmental conditions

Conduct your performance verification procedures in a test environment that has:

- An ambient temperature of 18° to 28°C (65° to 82°F).
- A relative humidity of less than 80% unless otherwise noted.

### Warm-up period

Allow the Model 2016 THD Multimeter to warm up for at least one hour before conducting the verification procedures.

If the instrument has been subjected to temperature extremes (those outside the ranges stated above), allow additional time for the instrument's internal temperature to stabilize. Typically, allow one extra hour to stabilize a unit that is 10°C (18°F) outside the specified temperature range.

Also, allow the test equipment to warm up for the minimum time specified by the manufacturer.

### Line power

The Model 2016 THD Multimeter requires a line voltage of 100V/120V/220V/240V,  $\pm 10\%$  and a line frequency of 45Hz to 66Hz. Note that the line frequency is automatically sensed at power-up, but the line voltage must be manually set to either 100V/120V or 220V/240V as described in Section 2 of the Model 2016 User's Manual.

## Recommended test equipment

Table 1-1 summarizes recommended verification equipment. You can use alternate equipment as long as that equipment has specifications at least as good as those listed in Table 1-1. Keep in mind, however, that the calibrator will add to the uncertainty of each measurement.

**Table 1-1**  
*Recommended verification equipment*

<i>Fluke 5700A Calibrator:</i>				
<b>DC voltage</b>	<b>AC voltage (1kHz, 50kHz)</b>	<b>DC current</b>	<b>AC current (1kHz)</b>	<b>Resistance</b>
100mV:±14ppm 1.0V:±7ppm 10V:±5ppm 100V:±7ppm 1000V:±9ppm	100mV:±200ppm 1.0V:±82ppm 10V:±82ppm 100V:±90ppm 700V:±85ppm	10mA:±60ppm 100mA:±70ppm 1A:±110ppm 2.2A:±94ppm	1A:±690ppm 2.2A:±682ppm	100Ω:±17ppm 1kΩ:±12ppm 10kΩ:±11ppm 100kΩ:±13ppm 1MΩ:±18ppm 10MΩ:±37ppm 100MΩ:±120ppm
<i>Fluke 5725A Amplifier:</i>				
AC Voltage, 50kHz: 700V, ±375ppm				
<i>Keithley 3930A or 3940 Frequency Synthesizer:</i>				
1V RMS, 1kHz, ±5ppm				
<i>Stanford Research Systems DS-360 Ultra Low Distortion Function Generator:</i>				
1kHz, 0.95V RMS sine wave, -100dB THD				
<i>Miscellaneous Equipment:</i>				
Double banana plug to double banana plug shielded cable BNC to double banana plug shielded cable				

NOTE: The Fluke 5725A amplifier is necessary only if you wish to verify the 750V AC range at 50kHz. Verification at 220V, 50kHz using only the 5700A calibrator is adequate for most applications.

## Verification limits

The verification limits stated in this section have been calculated using only the Model 2016 one-year accuracy specifications, and they do not include test equipment uncertainty. If a particular measurement falls slightly outside the allowable range, recalculate new limits based on both Model 2016 specifications and pertinent calibration equipment specifications.

### Example reading limit calculation

The following is an example of how reading limits have been calculated. Assume you are testing the 10V DC range using a 10V input value. Using the Model 2016 one-year accuracy specification for 10V DC of  $\pm (30\text{ppm of reading} + 5\text{ppm of range})$ , the calculated limits are:

$$\text{Reading limits} = 10\text{V} \pm [(10\text{V} \times 30\text{ppm}) + (10\text{V} \times 5\text{ppm})]$$

$$\text{Reading limits} = 10\text{V} \pm (.0003 + .00005)$$

$$\text{Reading limits} = 10\text{V} \pm .00035\text{V}$$

$$\text{Reading limits} = 9.99965\text{V to } 10.00035\text{V}$$

### Calculating resistance reading limits

Resistance reading limits must be recalculated based on the actual calibration resistance values supplied by the equipment manufacturer. Calculations are performed in the same manner as shown in the preceding example, except, of course, that you should use the actual calibration resistance values instead of the nominal values when performing your calculations.

For example, assume that you are testing the 10k $\Omega$  range using an actual 10.03k $\Omega$  calibration resistance value. Using the Model 2016 one-year 10k $\Omega$  range accuracy of  $\pm (100\text{ppm of reading} + 10\text{ppm of range})$ , the calculated reading limits are:

$$\text{Reading limits} = 10.03\text{k}\Omega \pm [(10.03\text{k}\Omega \times 100\text{ppm}) + (10\text{k}\Omega \times 10\text{ppm})]$$

$$\text{Reading limits} = 10.02890\text{k}\Omega \text{ to } 10.03110\text{k}\Omega.$$

## Restoring factory defaults

Before performing the verification procedures, restore the instrument to its factory defaults as follows:

1. Press **SHIFT** and then **SETUP**. The instrument will display the following prompt:  
RESTORE: FACT.
2. Using either range key, select FACT, then restore the factory default conditions by pressing **ENTER**.
3. Factory defaults will be set as follows:  
Speed: medium  
Filter: 10 readings

# Performing the verification test procedures

## Test summary

Verification test procedures include:

- DC volts
- AC volts
- DC current
- AC current
- Resistance
- Temperature
- Frequency
- Total harmonic distortion
- Function generator amplitude

## Test considerations

When performing the verification procedures:

- Be sure to restore factory defaults as outlined above.
- After restoring factory defaults and selecting the measuring function, select the SLOW integration rate with the RATE key.
- Make sure that the equipment is properly warmed up and connected to the front panel input jacks. Also make sure that the front panel input jacks are selected with the INPUTS switch.
- Do not use autoranging for any verification tests because autorange hysteresis may cause the Model 2016 to be on an incorrect range. For each test signal, you must manually set the correct range for the Model 2016 using the range keys.
- Make sure the calibrator is in operate before you verify each measurement.
- Always let the source signal settle before taking a reading.
- Do not connect test equipment to the Model 2016 through a scanner or other switching equipment.

**WARNING** The maximum common-mode voltage (voltage between INPUT LO and chassis ground) is 500V peak. Exceeding this value may cause a breakdown in insulation, creating a shock hazard. Some of the procedures in this section may expose you to dangerous voltages. Use standard safety precautions when such dangerous voltages are encountered to avoid personal injury caused by electric shock.

## Verifying DC voltage

Check DC voltage accuracy by applying accurate voltages from the DC voltage calibrator to the Model 2016 INPUT jacks and verifying that the displayed readings fall within specified limits.

**CAUTION** Do not exceed 1100V peak between INPUT HI and INPUT LO because instrument damage may occur.

Follow these steps to verify DC voltage accuracy:

1. Connect the Model 2016 HI and LO INPUT jacks to the DC voltage calibrator as shown in Figure 1-1.

**NOTE** Use shielded, low-thermal connections when testing the 100mV and 1V ranges to avoid errors caused by noise or thermal effects. Connect the shield to the calibrator's output LO terminal.

**Figure 1-1**  
Connections for DC volts verification

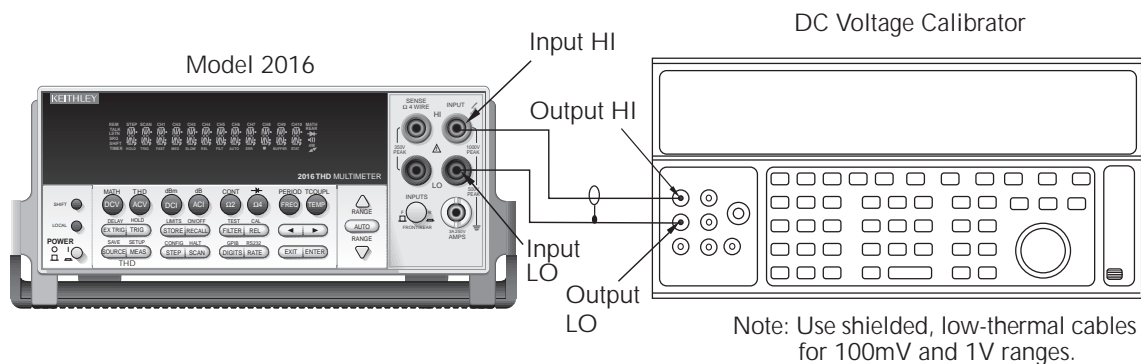

2. Select the DC volts function by pressing the **DCV** key, and set the Model 2016 to the 100mV range. Select the SLOW integration rate with the RATE key.
3. Set the calibrator output to 0.00000mV DC, and allow the reading to settle.
4. Enable the Model 2016 REL mode. Leave REL enabled for the remainder of the DC volts verification tests.
5. Source positive and negative and full-scale voltages for each of the ranges listed in Table 1-2. For each voltage setting, be sure that the reading is within stated limits.

**Table 1-2**  
*DCV reading limits*

<b>Range</b>	<b>Applied DC voltage*</b>	<b>Reading limits (1 year, 18°-28°C)</b>
100mV	100.0000mV	99.9915 to 100.0085mV
1V	1.000000V	0.999963 to 1.000037V
10V	10.00000V	9.99965 to 10.00035V
100V	100.0000V	99.9949 to 100.0051V
1000V	1000.000V	999.949 to 1000.051V

\*Source positive and negative values for each range.

## Verifying AC voltage

Check AC voltage accuracy by applying accurate AC voltages at specific frequencies from the AC voltage calibrator to the Model 2016 inputs and verifying that the displayed readings fall within specified ranges.

**CAUTION** Do not exceed 1100 V peak between INPUT HI and INPUT LO, or  $8 \times 10^7$  V•Hz input, because instrument damage may occur.

Follow these steps to verify AC voltage accuracy:

1. Connect the Model 2016 HI and LO INPUT jacks to the AC voltage calibrator as shown in Figure 1-2.

**Figure 1-2**  
Connections for AC volts verification

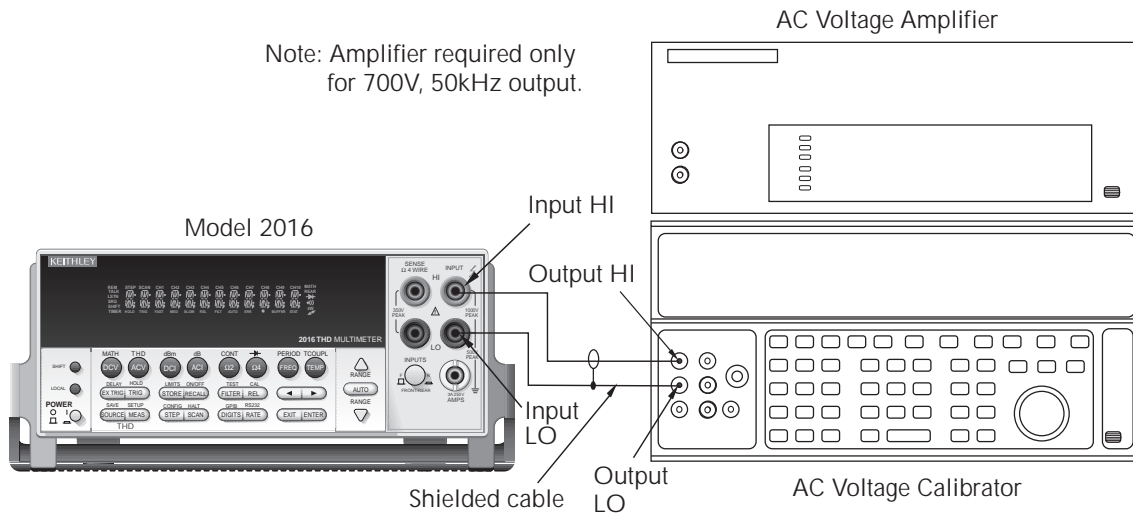



2. Select the AC volts function by pressing the **ACV** key, then choose the SLOW integration rate with the RATE key.
3. Set the Model 2016 for the 100mV range; make sure that REL is disabled.
4. Source 1kHz and 50kHz AC voltages for each of the ranges summarized in Table 1-3, and make sure that the respective Model 2016 readings fall within stated limits.

**Table 1-3**  
*ACV reading limits*

<b>ACV range</b>	<b>Applied AC voltage</b>	<b>1kHz reading limits (1 year, 18°C-28°C)</b>	<b>50kHz reading limits (1 year, 18°C-28°C)</b>
100mV	100.0000mV	99.910 to 100.090mV	99.830 to 100.170mV
1V	1.000000V	0.99910 to 1.00090V	0.99830 to 1.00170V
10V	10.00000V	9.9910 to 10.0090V	9.98300 to 10.0170V
100V	100.0000V	99.910 to 100.090V	99.830 to 100.170V
750V	700.000V*	699.36 to 700.64V	698.79 to 701.21V

\*If the 5725A amplifier is not available, change the 700V @ 50kHz step to 220V @ 50kHz. Reading limits for 220V @ 50kHz = 219.36 to 220.64V.

## Verifying DC current

Check DC current accuracy by applying accurate DC currents from the DC current calibrator to the AMPS input of the Model 2016 and verifying that the displayed readings fall within specified limits.

Follow these steps to verify DC current accuracy:

1. Connect the Model 2016 AMPS and INPUT LO jacks to the calibrator as shown in Figure 1-3.

**Figure 1-3**  
Connections for DC current verification

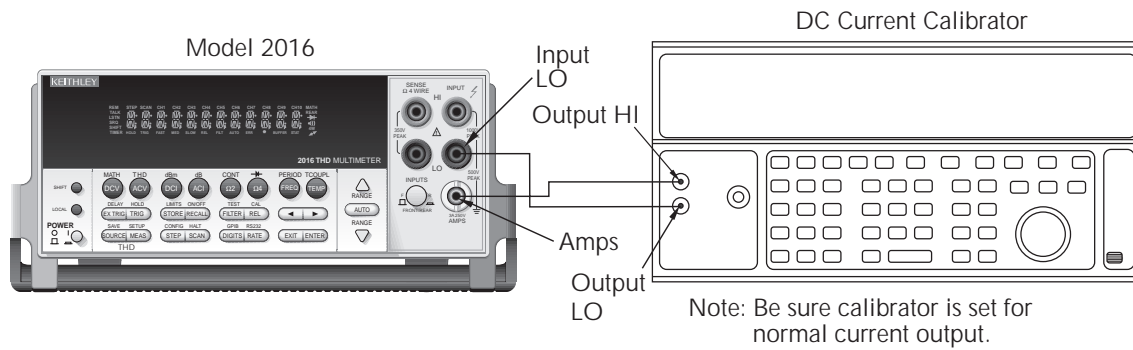

2. Select the DC current measurement function by pressing the **DCI** key, then choose the SLOW integration rate with the RATE key.
3. Set the Model 2016 for the 10mA range.
4. Source positive and negative full-scale currents for each of the ranges listed in Table 1-4, and verify that the readings for each range are within stated limits.

**Table 1-4**  
DCI limits

DCI range	Applied DC current*	Reading limits (1 year, 18°C-28°C)
10mA	10.0000mA	9.99460 to 10.00540mA
100mA	100.0000mA	99.9100 to 100.0900mA
1A	1.00000A	0.999160 to 1.000840A
3A	2.20000A	2.197315 to 2.202685A

\*Source positive and negative currents with values shown.

## Verifying AC current

Check AC current accuracy by applying accurate AC voltage current at specific frequencies from the AC current calibrator to the Model 2016 input and verifying that the displayed readings fall within specified limits. Follow these steps to verify AC current:

1. Connect the Model 2016 AMPS and INPUT LO jacks to the calibrator as shown in Figure 1-4.

**Figure 1-4**  
Connections for AC current verification

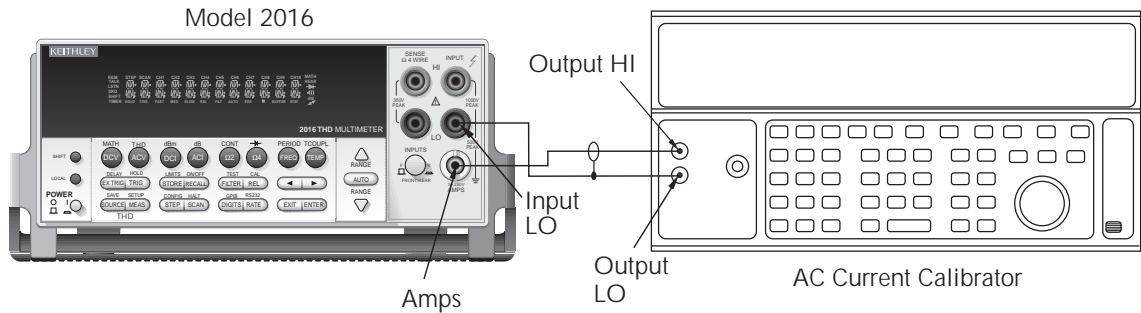

2. Select the AC current function by pressing the **ACI** key, then choose the **SLOW** integration rate with the **RATE** key.
3. Set the Model 2016 for the 1A range.
4. Source 1A and 2.2A, 1kHz full-scale AC currents as summarized in Table 1-5, and verify that the readings are within stated limits.

**Table 1-5**  
ACI limits

ACV range	Applied AC voltage	Reading limits @ 1kHz (1 year, 18°C-28°C)
1A	1.000000A	0.99860 to 1.00140A
3A	2.20000A	2.1949 to 2.2051A

## Verifying resistance

Check resistance by connecting accurate resistance values to the Model 2016 and verifying that its resistance readings are within the specified limits.

**CAUTION** Do not apply more than 1100V peak between INPUT HI and LO or more than 350V peak between SENSE HI and LO, or instrument damage could occur.

Follow these steps to verify resistance accuracy:

1. Using shielded 4-wire connections, connect the Model 2016 INPUT and SENSE jacks to the calibrator as shown in Figure 1-5.

**Figure 1-5**  
Connections for resistance verification (100Ω-10MΩ ranges)

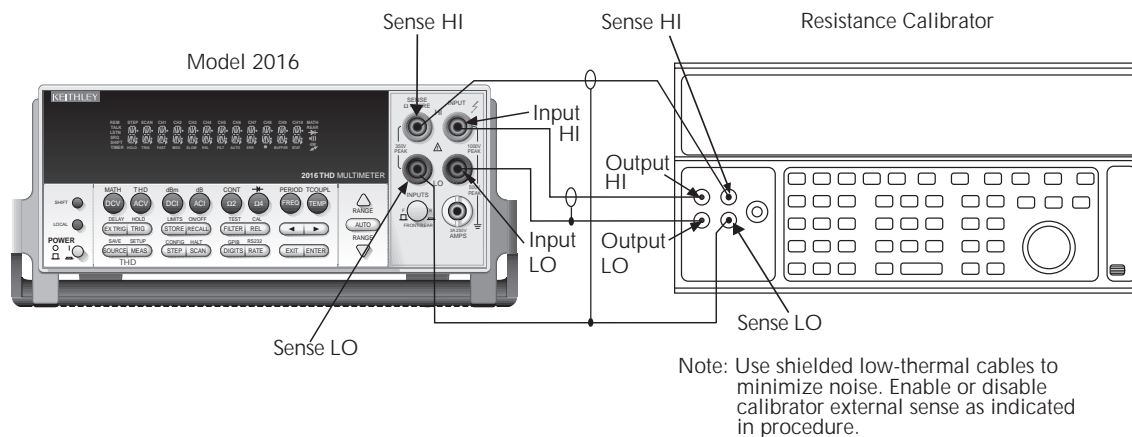

2. Set the calibrator for 4-wire resistance with external sense on.
3. Select the Model 2016 4-wire resistance function by pressing the  $\Omega 4$  key, then choose the SLOW integration rate with the RATE key.
4. Set the Model 2016 for the 100Ω range, and make sure the FILTER is on.
5. Recalculate reading limits based on actual calibrator resistance values.

6. Source the nominal full-scale resistance values for the 100Ω-10MΩ ranges summarized in Table 1-6, and verify that the readings are within calculated limits.
7. Connect the Model 2016 INPUT and SENSE jacks to the calibrator as shown in Figure 1-6.
8. Disable external sense on the calibrator.
9. Set the Model 2016 for the 100MΩ range.
10. Source a nominal 100MΩ resistance value, and verify that the reading is within calculated limits for the 100MΩ range.

**Figure 1-6**  
Connections for resistance verification (100MΩ range)

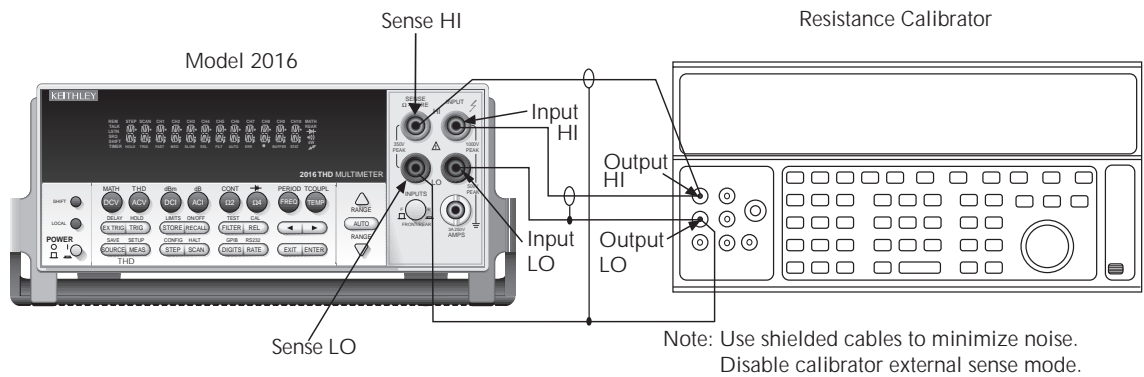

**Table 1-6**  
Limits for resistance verification

Ω Range	Nominal resistance	Nominal reading limits (1 year, 18°C-28°C)	Recalculated limits*
100Ω	100Ω	99.9860 to 100.0140Ω	_____ to _____ Ω
1kΩ	1kΩ	0.999890 to 1.000110kΩ	_____ to _____ kΩ
10kΩ	10kΩ	9.99890 to 10.00110kΩ	_____ to _____ kΩ
100kΩ	100kΩ	99.9890 to 100.0110kΩ	_____ to _____ kΩ
1MΩ	1MΩ	0.999890 to 1.000110MΩ	_____ to _____ MΩ
10MΩ	10MΩ	9.99590 to 10.00410MΩ	_____ to _____ MΩ
100MΩ	100MΩ	99.8470 to 100.1530MΩ	_____ to _____ MΩ

\*Calculate limits based on actual calibration resistance values and Model 2016 one-year resistance accuracy specifications. See 'Verification limits'.

## Verifying temperature

Thermocouple temperature readings are derived from DC volt measurements. For that reason, it is not necessary to independently verify the accuracy of temperature measurements. As long as the DC volts function meets or exceeds its specifications, temperature function accuracy is automatically verified. However, temperature verification procedures are provided below for those who wish to separately verify temperature accuracy.

1. Connect the DC voltage calibrator output terminals to the Model 2016 INPUT jacks using low-thermal shielded connections. (Use 2-wire connections similar to those shown in Figure 1-1.)
2. Configure the Model 2016 for °C units, type J temperature sensor, and 0°C simulated reference junction as follows:
  - a. Press SHIFT, then SENSOR, and note the unit displays the temperature units: UNITS: C. (If necessary, use the cursor and range keys to select °C units.)
  - b. Press ENTER. The unit then displays the thermocouple type: TYPE: J.
  - c. Select a type J temperature sensor, then press ENTER. The unit then displays the reference junction type: JUNC: SIM.
  - d. Make certain that the simulated reference junction type is selected, then press ENTER. The unit then displays the current simulated reference junction temperature: SIM: 023.
  - e. Using the cursor and range keys, set the reference junction temperature to 0°C, then press ENTER to complete the temperature configuration process.
3. Select the temperature function by pressing the TEMP key.
4. Source each of the voltages summarized in Table 1-7, and verify that the temperature readings are within limits. Be sure to select the appropriate thermocouple type for each group of readings. (See step 2 above.)

**Table 1-7**  
*Thermocouple temperature verification reading limits*

Thermocouple type	Applied DC voltage*	Reading limits (1 year, 18°C-28°C)
J	-7.659mV	-190.6 to -189.4°C
	0mV	-0.5 to +0.5°C
	42.280mV	749.5 to 750.5°C
K	-5.730mV	-190.6 to -189.4°C
	0mV	-0.5 to +0.5°C
	54.138mV	1349.2 to 1350.8°C

\*Voltages shown are based on ITS-90 standard using 0°C reference junction temperature. See text for procedure to set reference junction temperature.

## Verifying frequency

Follow the steps below to verify the Model 2016 frequency function:

1. Connect the frequency synthesizer to the Model 2016 INPUT jacks. (See Figure 1-7.)
2. Set the synthesizer to output a 1kHz, 1V RMS sine wave.
3. Select the Model 2016 frequency function by pressing the **FREQ** key.
4. Verify that the Model 2016 frequency reading is between 0.9999kHz and 1.0001kHz.

**Figure 1-7**  
Connections for frequency verification

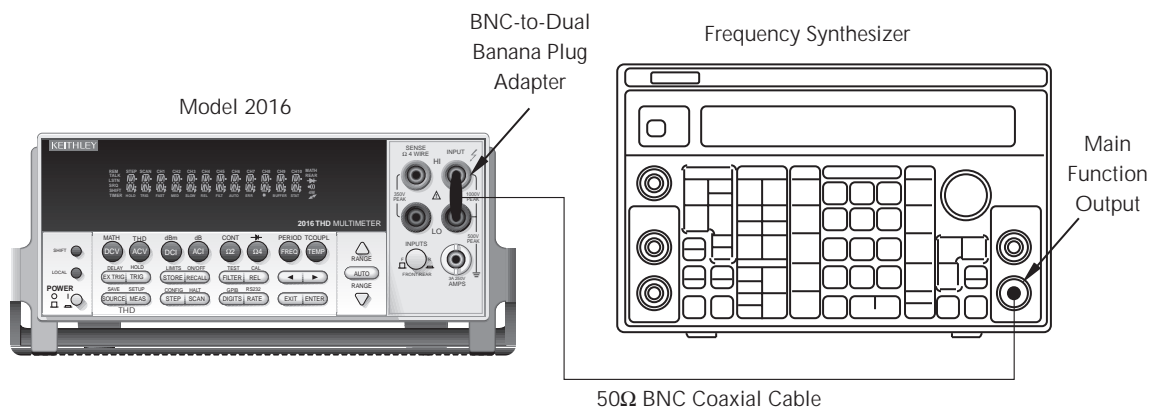

## Verifying total harmonic distortion

Follow the steps below to verify the Model 2016 total harmonic distortion function.

1. Connect the low-distortion function generator to the Model 2016 INPUT jacks. (See Figure 1-8.)

**Figure 1-8**  
Connections for total harmonic distortion verification

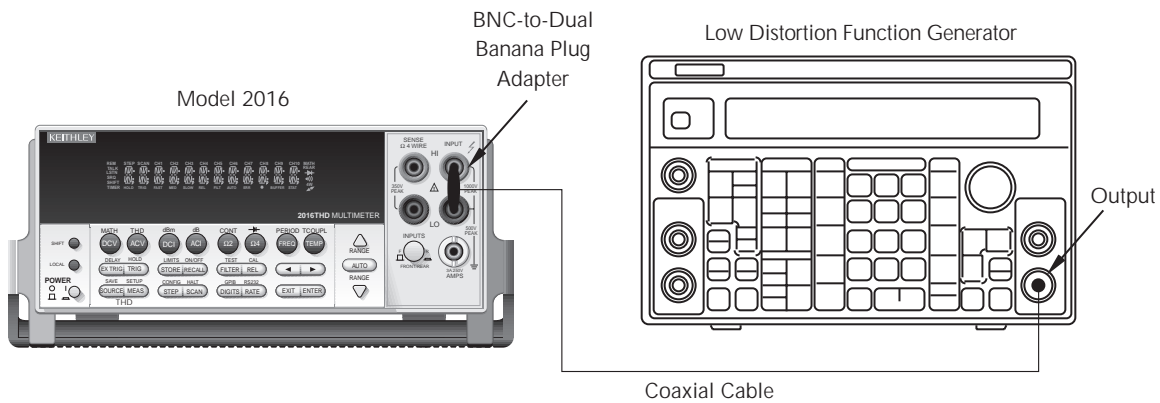

2. Set the function generator to output a 1kHz, 0.95V RMS sine wave with an unbalanced, high-impedance output.
3. Using the MEAS key, set the following operating modes:  
 TYPE: THD  
 FREQ: AUTO  
 UPR HARM: 10  
 UNITS: PERC  
 SFIL: NONE
4. Select the Model 2016 THD function by pressing SHIFT then THD.
5. Use the down RANGE key to select the 1V range.
6. Verify that the Model 2016 THD reading is <math><0.004\%</math>.



## Verifying function generator amplitude

Follow the steps below to verify Model 2016 function generator amplitude:

1. Connect the rear panel SOURCE OUTPUT jack to the front panel INPUT jacks. (See Figure 1-9.)

**Figure 1-9**  
*Connections for function generator amplitude verification*

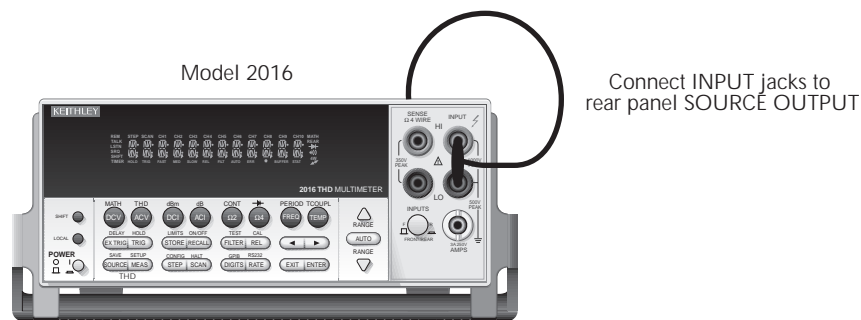

2. Use the SOURCE key to set the function generator operating modes as follows:  
SINE OUT: ON  
FREQ: 1kHz  
IMPEDANCE: HIZ  
AMPL: 9.0000V
3. Press the ACV key to select the AC voltage function, and choose the 10V range.
4. Verify that the AC voltage reading is between 8.968V and 9.032V.

---

# 2 Calibration

## Introduction

Use the procedures in this section to calibrate the Model 2016. Calibration procedures include:

- Comprehensive calibration: Usually the only calibration required in the field.
- Manufacturing calibration: Usually only performed at the factory (unless the unit has been repaired).

**WARNING** The information in this section is intended only for qualified service personnel. Do not attempt these procedures unless you are qualified to do so.

All the procedures require accurate calibration equipment to supply precise DC and AC voltages, DC and AC currents, and resistance values. Comprehensive AC, DC, distortion, or function generator calibration can be performed any time by an operator either from the front panel, or by using the SCPI commands sent either over the IEEE-488 bus or the RS-232 port. DC-only, distortion, and function generator calibration may be performed individually, if desired.

## Environmental conditions

Conduct the calibration procedures in a location that has:

- An ambient temperature of 18° to 28°C (65° to 82°F)
- A relative humidity of less than 80% unless otherwise noted

### Warm-up period

Allow the Model 2016 Multimeter to warm up for at least one hour before performing calibration.

If the instrument has been subjected to temperature extremes (those outside the ranges stated in the above section) allow extra time for the instrument's internal temperature to stabilize. Typically, allow one extra hour to stabilize a unit that is 10°C (18°F) outside the specified temperature range.

Also, allow the test equipment to warm up for the minimum time specified by the manufacturer.

### Line power

The Model 2016 Multimeter requires a line voltage of 100V/120V/220V/240V,  $\pm 10\%$  and a line frequency of 45Hz to 66Hz. Note that the line frequency is automatically sensed at power-up, but the line voltage must be manually set to either 100V/120V or 220V/240V as described in Section 2 of the Model 2016 User's Manual.

## Calibration considerations

When performing the calibration procedures:

- Make sure that the equipment is properly warmed up and connected to the appropriate input jacks. Also make sure that the correct input jacks are selected with the INPUTS switch.
- Make sure the calibrator is in OPERATE before you complete each calibration step.
- Always let the source signal settle before calibrating each point.
- Do not connect test equipment to the Model 2016 through a scanner or other switching equipment.
- If an error occurs during calibration, the Model 2016 will generate an appropriate error message. See *Appendix B* for more information.

**WARNING** The maximum common-mode voltage (voltage between INPUT LO and chassis ground) is 500 V peak. Exceeding this value may cause a breakdown in insulation, creating a shock hazard. Some of the procedures in this section may expose you to dangerous voltages. Use standard safety precautions when such dangerous voltages are encountered to avoid personal injury caused by electric shock.

**CAUTION** Do not exceed 1100V peak between INPUT HI and INPUT LO or 350V peak between SENSE HI and SENSE LO. Exceeding these values may result in instrument damage.

## Calibration code

Before performing comprehensive calibration, you must first unlock calibration by entering the appropriate calibration code.

### Front panel calibration code

For front panel calibration, follow these steps:

1. Access the calibration menu by pressing **SHIFT CAL**, and note that the instrument displays the following:  
CAL: DATES
2. Use the up or down range key to scroll through the available calibration parameters until the unit displays **RUN**, then press **ENTER**.
3. The Model 2016 then prompts you to enter a code:  
CODE? 000000  
(The factory default code is 002016.) Use the left and right arrow keys to move among the digits; use the up range key to increment numbers, and press the down range key to specify alphabetic letters. Confirm the code by pressing **ENTER**.
4. The Model 2016 allows you to define a new calibration code. Use the up and down range keys to toggle between yes and no. Choose **N** if you do not want to change the code. Choose **Y** if you want to change the code. The unit then prompts you to enter a new code. Enter the code, and press **ENTER**.

### Remote calibration code

If you are performing calibration over the IEEE-488 bus or the RS-232 port, send this command to unlock calibration:

```
:CAL:PROT:CODE '<8-character string>'.
```

The default code command is:

```
:CAL:PROT:CODE 'KI002016'.
```

## Comprehensive calibration

The comprehensive calibration procedure calibrates the DCV, DCI, ACV, ACI, ohms, distortion, and generator functions. You can also choose to calibrate only the DCV/DCI and resistance, ACV/ACI, distortion, or generator functions.

These procedures are usually the only calibration required in the field. Manufacturing calibration is normally done only at the factory, but it should also be done in the field if the unit has been repaired. See “Manufacturing calibration” at the end of this section for more information.

### Calibration cycle

Perform comprehensive calibration at least once a year, or every 90 days to ensure the unit meets the corresponding specifications.

### Recommended equipment

Table 2-1 lists the recommended equipment you need for comprehensive, DC only, AC only, distortion, and generator calibration procedures. You can use alternate equipment, such as a DC transfer standard and characterized resistors, as long as that equipment has specifications at least as good as those listed in the table.

**Table 2-1**  
*Recommended equipment for comprehensive calibration*

<i>Fluke 5700A Calibrator:</i>				
<b>DC voltage</b>	<b>AC voltage (1kHz, 50kHz)*</b>	<b>DC current</b>	<b>AC current (1kHz)</b>	<b>Resistance</b>
10V:±5ppm 100V:±ppm	10mV:±710ppm 100mV:±200ppm 1V:±82ppm 10V:±82ppm 100V:±90ppm 700V:±85ppm	10mA:±60ppm 100mA:±70ppm 1A:±110ppm	100mA:±190ppm 1A:±690ppm 2A:±670ppm	1kΩ:±12ppm 10kΩ:±11ppm 100kΩ:±13ppm 1MΩ:±18ppm
<i>Stanford Research Systems DS-360 Ultra Low Distortion Function Generator:</i>				
1V RMS sine wave @ 137Hz, -100dB THD 1V RMS sine wave @ 844Hz, -100dB THD				
<i>Miscellaneous equipment:</i>				
Keithley 8610 low-thermal shorting plug Double banana plug to double banana plug shielded cable BNC to double banana plug shielded cable				

\*1kHz specifications. 10mV and 700V points require 1kHz only.

All calibrator specifications are 90-day, 23°C ±5°C specifications and indicate total absolute uncertainty at specified output.

## Aborting calibration

You can abort the front panel calibration process at any time by pressing EXIT. The instrument will then ask you to confirm your decision to abort with the following message:

ABORT CAL?

Press EXIT to abort calibration at this point, or press any other key to return to the calibration process.

**NOTE** *The Model 2016 will not respond to any remote programming commands while the ABORT CAL? message is displayed.*

## Front panel calibration

Follow the steps in the following paragraphs in the order shown for comprehensive, DC only, AC only, distortion, and function generator calibration procedures.

The procedures for front panel calibration include:

- Preparing the Model 2016 for calibration
- Front panel short and open calibration
- DC voltage calibration
- Resistance calibration
- DC current calibration
- AC voltage calibration
- AC current calibration
- Distortion calibration
- Function generator calibration
- Setting calibration dates

## Preparing the Model 2016 for calibration

1. Turn on the Model 2016, and allow it to warm up for at least one hour before performing calibration procedure.
2. Select the DCV function, and choose SLOW as the RATE (integration time = 10 PLC).
3. Start the calibration process as follows:
  - a. Access the calibration menu by pressing SHIFT then CAL.
  - b. Use the up and down range keys to scroll through the available calibration menu items until the unit displays RUN, then press ENTER.
  - c. At the prompt, enter the calibration code. (The default code is 002016.) Use the left and right arrow keys to move among the digits; use the up range key to increment numbers, and press the down range key to specify alphabetic letters. Confirm the code by pressing ENTER.
  - d. Choose N at the prompt to proceed without changing the code, then press ENTER.



- Choose which of the calibration tests summarized in Table 2-2 you want to run at the CAL: RUN prompt. Use the up and down range keys to scroll through the options; select your choice by pressing ENTER.

**Table 2-2**  
Comprehensive calibration procedures

Procedure	Menu choice	Procedures
Full calibration	ALL	All comprehensive calibration steps. (DC, AC, DIST, FGEN)
DCV, DCI, and ohms	DC	DC voltage, DC current, and resistance calibration.
ACV and ACI	AC	AC voltage and AC current.
Distortion*	DIST	Calibrate distortion.
Function generator*	FGEN	Calibrate function generator.

\*Perform AC calibration first if distortion or function generator calibration is done separately.

## Front panel short and open calibration

At the Model 2016 prompt for a front panel short, do the following:

- Connect the Model 8610 low-thermal short to the instrument front panel INPUT and SENSE terminals as shown in Figure 2-1. Make sure the INPUTS button is not pressed in so that the front inputs are selected. Wait at least three minutes before proceeding to allow for thermal equilibrium.

**Figure 2-1**  
Low-thermal short connections

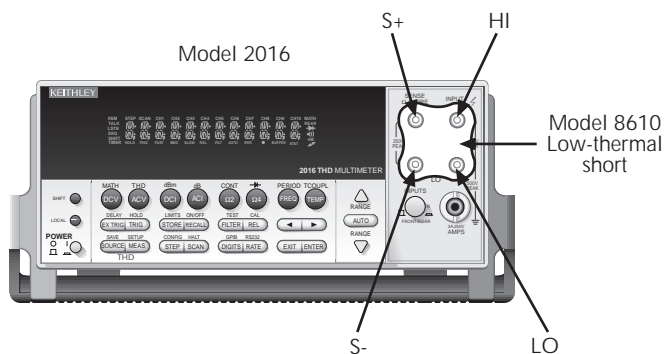

**NOTE** Be sure to connect the low-thermal short properly to the HI, LO, and SENSE terminals. Keep drafts away from low-thermal connections to avoid thermal drift, which could affect calibration accuracy.

2. Press ENTER to start short-circuit calibration. While the unit is calibrating, it will display:  
CALIBRATING
3. When the unit is done calibrating, it will display the following prompt:  
OPEN CIRCUIT
4. Remove the calibration short, and press ENTER. During this phase, the CALIBRATING message will be displayed.

## DC volts calibration

After the front panel short and open procedure, the unit will prompt you for the first DC voltage: +10V. Do the following:

1. Connect the calibrator to the Model 2016 as shown in Figure 2-2. Wait three minutes to allow for thermal equilibrium before proceeding.

**Figure 2-2**  
Connections for DC volts and ohms calibration

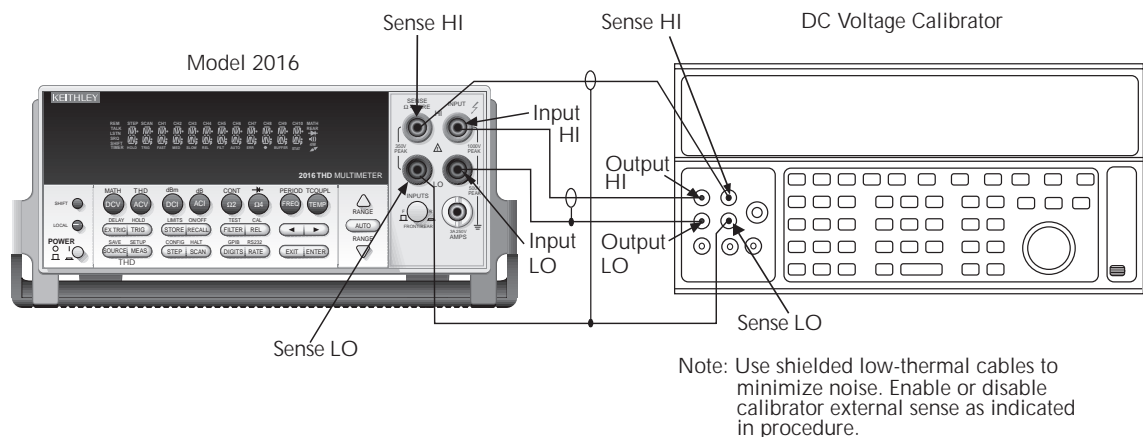

**NOTE** Although 4-wire connections are shown, the sense leads are connected and disconnected at various points in this procedure by turning calibrator external sense on or off as appropriate. If your calibrator does not have provisions for turning external sense on and off, disconnect the sense leads when external sensing is to be turned off, and connect the sense leads when external sensing is to be turned on.

2. Set the calibrator to output DC volts, and turn external sense off.

3. Perform the steps listed in Table 2-3 to complete DC volts calibration. For each calibration step:
  - Set the calibrator to the indicated value, and make sure it is in OPERATE.
  - Press the ENTER key to calibrate that step.
  - Wait until the Model 2016 finishes each step. (The unit will display the CALIBRATING message while calibrating.)

**NOTE** *If your calibrator cannot output the values recommended in Table 2-3, use the left and right arrow keys, and the up and down range keys to set the Model 2016 display value to match the calibrator output voltage.*

**Table 2-3**  
*DC volts calibration summary*

<b>Calibration step</b>	<b>Calibrator voltage</b>	<b>Allowable range</b>
+10V	+10.00000V	+9V to +11V
-10V	-10.00000V	-9V to -11V
100V	+100.0000V	+90V to +110V

## Resistance calibration

Completing the 100V DC calibration step ends the DC voltage calibration procedure. The Model 2016 will then prompt you to connect 1k $\Omega$ . Follow these steps for resistance calibration:

1. Set the calibrator output for resistance, and turn on external sense.

**NOTE** Use external sense (4-wire  $\Omega$ ) when calibrating all resistance ranges. Be sure that the calibrator external sense mode is turned on.

2. Perform the calibration steps summarized in Table 2-4. For each step:
  - Set the calibrator to the indicated value and place the unit in OPERATE. (If the calibrator cannot output the exact resistance value, use the Model 2016 left and right arrow keys and the range keys to adjust the Model 2016 display to agree with the calibrator resistance.)
  - Press the ENTER key to calibrate each point.
  - Wait for the Model 2016 to complete each step before continuing.

**Table 2-4**  
Ohms calibration summary

Calibration step	Calibrator resistance*	Allowable range
1k $\Omega$	1k $\Omega$	0.9k $\Omega$ to 1.1k $\Omega$
10k $\Omega$	10k $\Omega$	9k $\Omega$ to 11k $\Omega$
100k $\Omega$	100k $\Omega$	90k $\Omega$ to 110k $\Omega$
1M $\Omega$	1M $\Omega$	0.9M $\Omega$ to 1.1M $\Omega$

\*Nominal resistance. Adjust Model 2016 calibration parameter to agree with actual value.

## DC current calibration

After the  $1\text{M}\Omega$  resistance point has been calibrated, the unit will prompt you for 10mA. Follow these steps for DC current calibration:

1. Connect the calibrator to the AMPS and INPUT LO terminals of the Model 2016 as shown in Figure 2-3.

**Figure 2-3**  
Connections for DC and AC amps calibration

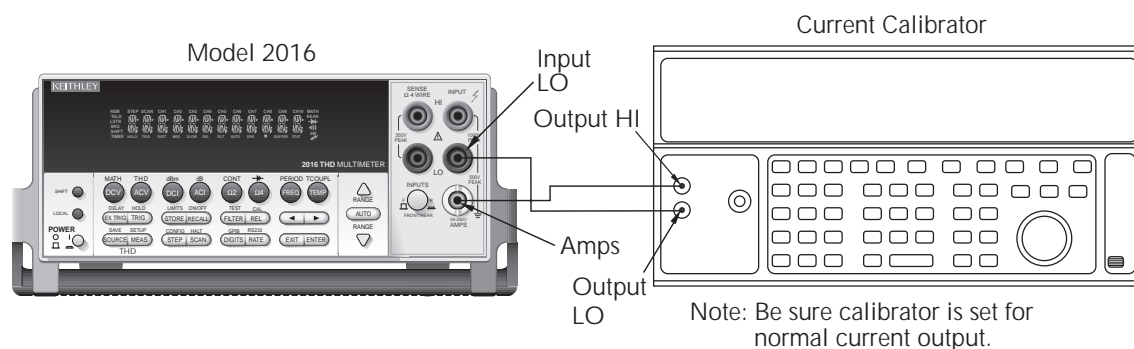

2. Calibrate each current step summarized in Table 2-5. For each step:
  - Set the calibrator to the indicated DC current, and make sure the unit is in OPERATE.
  - Make sure the Model 2016 display indicates the correct calibration current.
  - Press ENTER to complete each step.
  - Allow the Model 2016 to finish each step.

**NOTE** If you are performing DC-only calibration, proceed to “Setting calibration dates.”

**Table 2-5**  
DC current calibration summary

Calibration step	Calibrator current	Allowable range
10mA	10.00000mA	9mA to 11mA
100mA	100.00000mA	90mA to 110mA
1A	1.000000A	0.9A to 1.1A

## AC voltage calibration

Follow these steps for AC voltage calibration:

1. Connect the calibrator to the Model 2016 INPUT HI and LO terminals as shown in Figure 2-4.

**Figure 2-4**  
Connections for AC volts calibration

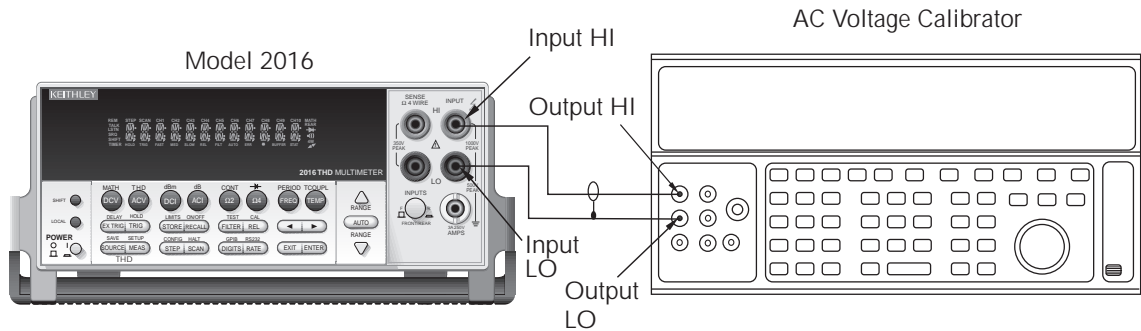

2. Perform the calibration steps summarized in Table 2-6. For each step:
  - Set the calibrator to the indicated value, and make sure the calibrator is in OPERATE.
  - Press ENTER to complete each step.
  - Wait until the Model 2016 completes each step.

**Table 2-6**  
AC voltage calibration summary

Calibration step	Calibrator voltage, frequency
10mV AC at 1kHz	10.00000mV, 1kHz
100mV AC at 1kHz	100.0000mV, 1kHz
100mV AC at 50kHz	100.0000mV, 50kHz
1V AC at 1kHz	1.000000V, 1kHz
1V AC at 50kHz	1.000000V, 50kHz
10V AC at 1kHz	10.00000V, 1kHz
10V AC at 50kHz	10.00000V, 50kHz
100V AC at 1kHz	100.0000V, 1kHz
100V AC at 50kHz	100.0000V, 50kHz
700V AC at 1kHz	700.000V, 1kHz

## AC current calibration

After the 700VAC at 1kHz point has been calibrated, the unit will prompt you for 100mA at 1kHz. Follow these steps for AC current calibration:

1. Connect the calibrator to the AMPS and INPUT LO terminals of the Model 2016 as shown in Figure 2-3.
2. Perform the calibration steps summarized in Table 2-7. For each step:
  - Set the calibrator to the indicated current and frequency and make sure the unit is in OPERATE.
  - Press ENTER to complete each calibration step.
  - Allow the unit to complete each step before continuing.

**Table 2-7**  
*AC current calibration summary*

Calibration step	Calibrator current, frequency
100mA at 1kHz	100.0000mA, 1kHz
1A at 1kHz	1.000000A, 1kHz
2A at 1kHz	2.000000A, 1kHz

## Distortion calibration

1. Following AC current calibration, the Model 2016 will prompt you for the first distortion calibration point (see Table 2-8):  
1V AT 137 HZ
2. Connect the low-distortion function generator to the front panel INPUT jacks (see Figure 2-5).
3. Set the function generator to output a 1V RMS sine wave at a frequency of 137Hz.
4. Press the Model 2016 ENTER key to complete the 137Hz calibration step. The unit will prompt you for the second distortion calibration point:  
1V AT 844 HZ
5. Set the function generator to output a 1V RMS sine wave at a frequency of 844Hz.
6. Press ENTER to complete the 844Hz calibration step.

**Figure 2-5**  
Connections for distortion calibration

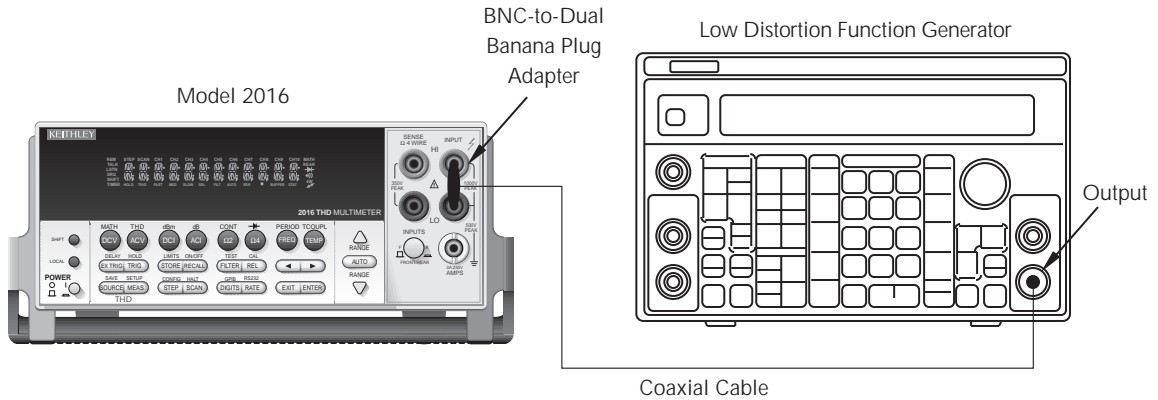

**Table 2-8**  
Distortion and function generator calibration summary

Calibration step	Calibration signal or connections
Distortion, 1V at 137Hz	1V RMS, 137Hz sine wave
Distortion, 1V at 844Hz	1V RMS, 844Hz sine wave
Function generator	SOURCE OUTPUT to INPUT

### Function generator calibration

- Following distortion calibration, the Model 2016 will prompt you to connect the SOURCE OUTPUT jack to the INPUT jacks:  
INPUT FGEN
- Connect the rear panel SOURCE OUTPUT jack to the front panel INPUT jacks. (See Figure 2-6.)
- Press the ENTER key to complete function generator calibration.

**Figure 2-6**  
Connections for function generator calibration





## Setting calibration dates and saving calibration

At the end of the calibration procedure, the instrument will display the CALIBRATION COMPLETE message. Press ENTER to continue, and the Model 2016 will prompt you to enter the calibration date and the calibration due date. Set these dates as follows:

1. At the CAL DATE: prompt, use the left and right arrow keys, and the range keys to set the calibration date, then press ENTER.
2. The unit will then prompt you to enter the next calibration due date with this prompt: CAL NDUE:. Use the left and right arrow keys, and the range keys to set the calibration due date, then press ENTER.
3. The unit will prompt you to save new calibration constants with this message: SAVE CAL? YES. To save the new constants, press ENTER. If you do not want to save the new constants, press the down range key to toggle to NO, then press ENTER.

**NOTE** *Calibration constants calculated during the current calibration procedure will not be saved unless you choose the YES option. Previous calibration constants will be retained if you select NO.*

## Remote calibration

Follow the steps in this section to perform comprehensive procedures via remote. See Appendix B for a detailed list and description of remote calibration commands.

When sending calibration commands, be sure that the Model 2016 completes each step before sending the next command. You can do so either by observing the front panel CALIBRATING message, or by detecting the completion of each step over the bus. (See “Detecting calibration step completion” in Appendix B.)

The procedures for calibrating the Model 2016 via remote include:

- Preparing the Model 2016 for calibration
- Front panel short and open calibration
- DC volts calibration
- Resistance calibration
- DC current calibration
- AC volts calibration
- AC current calibration
- Distortion calibration
- Function generator calibration
- Programming calibration dates
- Saving calibration constants
- Locking out calibration

**NOTE** *As with front panel calibration, you can choose to perform comprehensive, DC-only, AC-only, distortion, or function generator calibration. Be sure to include a space character between each command and parameter.*

## Preparing the Model 2016 for calibration

1. Connect the Model 2016 to the IEEE-488 bus of the computer using a shielded IEEE-488 cable, such as the Keithley Model 7007, or connect the unit to a computer through the RS-232 port using a straight-through 9-pin to 9-pin cable (use a 9-25-pin adapter if necessary).
2. Turn on the Model 2016, and allow it to warm up for at least one hour before performing calibration.
3. Select the DCV function, and choose SLOW as the rate (integration time = 10PLC).
4. Make sure the primary address of the Model 2016 is the same as the address specified in the program that you will be using to send commands. (Use the GPIB key.)
5. Unlock the calibration function by sending this command:  
:CAL:PROT:CODE 'KI002016'  
(The above command shows the default code, KI002016. Substitute the correct code if changed.)
6. Send the following command to initiate calibration:  
:CAL:PROT:INIT

## Short and open calibration

1. Connect the Model 8610 low-thermal short to the instrument INPUT and SENSE terminals as shown in Figure 2-1. Make sure the INPUTS button is not pressed in so that the front inputs are active. Wait at least three minutes before proceeding to allow for thermal equilibrium.

**NOTE** *Be sure to connect the low-thermal short properly to the HI, LO, and SENSE terminals. Keep drafts away from low-thermal connections to avoid thermal drift, which could affect calibration accuracy.*

2. Send the following command:  
:CAL:PROT:DC:STEP1
3. After the Model 2016 completes this step, remove the low-thermal short, and send this command:  
:CAL:PROT:DC:STEP2

## DC volts calibration

After front panel short and open steps, do the following:

1. Connect the calibrator to the Model 2016 as shown in Figure 2-2. Allow three minutes for thermal equilibrium.

**NOTE** Although 4-wire connections are shown, the sense leads are connected and disconnected at various points in this procedure by turning calibrator external sense on or off as appropriate. If your calibrator does not have provisions for turning external sense on and off, disconnect the sense leads when external sensing is to be turned off, and connect the sense leads when external sensing is to be turned on.

2. Perform the calibration steps summarized in Table 2-9. For each step:
  - Set the calibrator to the indicated voltage, and make sure the unit is in operate. (Use the recommended voltage if possible.)
  - Send the indicated programming command. (Change the voltage parameter if you are using a different calibration voltage.)
  - Wait until the Model 2016 completes each step before continuing.

**Table 2-9**  
DC voltage calibration programming steps

Calibration step	Calibrator voltage	Calibration command*	Parameter range
+10V	+10.00000V	:CAL:PROT:DC:STEP3 10	9 to 11
-10V	-10.00000V	:CAL:PROT:DC:STEP4 10	-9 to -11
100V	100.0000V	:CAL:PROT:DC:STEP5 100	90 to 110

\*Use recommended value where possible. Change parameter accordingly if using a different calibrator voltage.

## Resistance calibration

Follow these steps for resistance calibration:

1. Set the calibrator to the resistance mode, and turn on external sensing.

**NOTE** Use external sense (4-wire  $\Omega$ ) when calibrating all resistance ranges. Be sure that the calibrator external sense mode is turned on.

2. Perform the calibration steps summarized in Table 2-10. For each step:
  - Set the calibrator to the indicated resistance, and make sure the unit is in OPERATE. (Use the recommended resistance or the closest available value.)
  - Send the indicated programming command. (Change the command parameter if you are using a different calibration resistance than that shown.)
  - Wait until the Model 2016 completes each step before continuing.

**Table 2-10**  
Resistance calibration programming steps

Calibration step	Calibrator resistance	Calibration command*	Parameter range
1k $\Omega$	1k $\Omega$	:CAL:PROT:DC:STEP6 1E3	900 to 1.1E3
10k $\Omega$	10k $\Omega$	:CAL:PROT:DC:STEP7 10E3	9E3 to 11E3
100k $\Omega$	100k $\Omega$	:CAL:PROT:DC:STEP8 100E3	90E3 to 110E3
1M $\Omega$	1M $\Omega$	:CAL:PROT:DC:STEP9 1E6	900E3 to 1.1E6

\*Use exact calibrator resistance value for parameter.

## DC current calibration

After the 1M $\Omega$  resistance point has been calibrated, follow these steps for DC current calibration:

1. Connect the calibrator to the AMPS and INPUT LO terminals of the Model 2016 as shown in Figure 2-3.
2. Perform the calibration steps listed in Table 2-11. For each step:
  - Set the calibrator to the indicated current, and make sure the unit is in OPERATE. (Use the recommended current if possible.)
  - Send the indicated programming command. (Change the current parameter if you are using a different calibration current.)
  - Wait until the Model 2016 completes each step before continuing.

**NOTE** *If you are performing DC-only calibration, proceed to Programming calibration dates.*

**Table 2-11**  
DC current calibration programming steps

Calibration step	Calibrator current	Calibration command*	Parameter range
10mA	10.00000mA	:CAL:PROT:DC:STEP10 10E-3	9E-3 to 11E-3
100mA	100.00000mA	:CAL:PROT:DC:STEP11 100E-3	90E-3 to 110E-3
1A	1.000000A	:CAL:PROT:DC:STEP12 1	0.9 to 1.1

\*Change parameter if using different current.

## AC voltage calibration

Follow these steps for AC voltage calibration:

1. Connect the calibrator to the Model 2016 INPUT HI and LO terminals as shown in Figure 2-4.
2. Perform the calibration steps summarized in Table 2-12. For each step:
  - Set the calibrator to the indicated voltage and frequency and make sure the unit is in OPERATE. (You must use the stated voltage and frequency.)
  - Send the indicated programming command.
  - Wait until the Model 2016 completes each step before continuing.

**Table 2-12**  
AC voltage calibration programming steps

Calibration step	Calibrator voltage, frequency	Calibration command
10mV AC at 1kHz	10.00000mV, 1kHz	:CAL:PROT:AC:STEP1
100mV AC at 1kHz	100.0000mV, 1kHz	:CAL:PROT:AC:STEP2
100mV AC at 50kHz	100.0000mV, 50kHz	:CAL:PROT:AC:STEP3
1VAC at 1kHz	1.000000V, 1kHz	:CAL:PROT:AC:STEP4
1VAC at 50kHz	1.000000V, 50kHz	:CAL:PROT:AC:STEP5
10VAC at 1kHz	10.00000V, 1kHz	:CAL:PROT:AC:STEP6
10VAC at 50kHz	10.00000V, 50kHz	:CAL:PROT:AC:STEP7
100VAC at 1kHz	100.0000V, 1kHz	:CAL:PROT:AC:STEP8
100VAC at 50kHz	100.0000V, 50kHz	:CAL:PROT:AC:STEP9
700VAC at 1kHz	700.000V, 1kHz	:CAL:PROT:AC:STEP10

## AC current calibration

Follow these steps for AC current calibration:

1. Connect the calibrator to the AMPS and INPUT LO terminals of the Model 2016 as shown in Figure 2-3.
2. Perform the calibration steps summarized in Table 2-13. For each step:
  - Set the calibrator to the indicated current and frequency, and make sure the unit is in OPERATE. (You must use the stated current and frequency.)
  - Send the indicated programming command.
  - Wait until the Model 2016 completes each step before continuing.

**Table 2-13**  
*AC current calibration programming steps*

Calibration step	Calibrator current, frequency	Calibration command
100mA at 1kHz	100.0000mA, 1kHz	:CAL:PROT:AC:STEP11
1A at 1kHz	1.000000A, 1kHz	:CAL:PROT:AC:STEP12
2A at 1kHz	2.000000A, 1kHz	:CAL:PROT:AC:STEP13

## Distortion calibration

1. Connect the low-distortion function generator to the front panel INPUT jacks (see Figure 2-5).
2. Set the function generator to output a 1V RMS sine wave at a frequency of 137Hz.
3. Send the following command to perform the 137Hz calibration step (see Table 2-14):  
:CAL:PROT:DIST:STEP1
4. Set the function generator to output a 1V RMS sine wave at a frequency of 844Hz.
5. Send the following command to perform the 844Hz calibration step:  
:CAL:PROT:DIST:STEP2

**Table 2-14**  
*Distortion and function generator calibration steps*

Calibration step	Calibration signal or connections	Calibration command
Distortion, 1V at 137Hz	1V RMS, 137Hz sine wave	:CAL:PROT:DIST:STEP1
Distortion, 1V at 844Hz	1V RMS, 844Hz sine wave	:CAL:PROT:DIST:STEP2
Function generator	SOURCE OUTPUT to INPUT	:CAL:PROT:FGEN:STEP1

## Function generator calibration

1. Connect the rear panel SOURCE OUTPUT jack to the front panel INPUT jacks (see Figure 2-6.)
2. Send the following command to complete function generator calibration:  
:CAL:PROT:FGEN:STEP1

## Programming calibration dates

Program the present calibration date and calibration due date by sending the following commands:

```
:CAL:PROT:DATE <year>, <month>, <day>  
:CAL:PROT:NDUE <year>, <month>, <day>
```

For example, the following commands assume calibration dates of 5/15/1999 and 5/15/2000 respectively:

```
:CAL:PROT:DATE 1999, 5, 15  
:CAL:PROT:NDUE 2000, 5, 15
```

## Saving calibration constants

After completing the calibration procedure, send the following command to save the new calibration constants:

```
:CAL:PROT:SAVE
```

**NOTE** Calibration constants will not be saved unless the :SAVE command is sent.

## Locking out calibration

After saving calibration, send the following command to lock out calibration:

```
:CAL:PROT:LOCK
```



## Manufacturing calibration

The manufacturing procedure is normally performed only at the factory, but the necessary steps are included here in case the unit is repaired, and the unit requires these calibration procedures.

**NOTE** *If the unit has been repaired, the entire comprehensive calibration procedure should also be performed in addition to the manufacturing calibration procedure.*

### Recommended test equipment

Table 2-15 summarizes the test equipment required for the manufacturing calibration steps. In addition, you will need the calibrator and signal generator (see Table 2-1) to complete the comprehensive calibration steps.

**Table 2-15**  
*Recommended equipment for manufacturing calibration*

<i>Keithley 3930A or 3940 Frequency Synthesizer:</i>  1V RMS, 3Hz, $\pm 5$ ppm 1V RMS, 1kHz, $\pm 5$ ppm
<i>Keithley Model 2001 or 2002 Digital Multimeter:</i>  1V, 3Hz AC, $\pm 0.13\%$
<i>Keithley Model 8610 Low-thermal short</i>

### Unlocking manufacturing calibration

To unlock manufacturing calibration, press and hold in the SOURCE key while turning on the power.

### Measuring synthesizer signal amplitude

The 3Hz synthesizer signal amplitude must be accurately measured using the digital multimeter listed in Table 2-15. Proceed as follows:

1. Connect the synthesizer output to the digital multimeter INPUT jacks. (See Figure 2-7 for typical connections.)
2. Turn on the synthesizer and multimeter and allow a one-hour warm-up period before measuring.
3. Set the synthesizer to output a 1V RMS sine wave at 3Hz; measure and record the signal amplitude.

## Front panel manufacturing calibration

1. Connect the low-thermal short to the rear panel input jacks, and select the rear inputs with the INPUTS switch. Allow three minutes for thermal equilibrium.
2. Press in and hold the SOURCE key while turning on the power.
3. Press SHIFT then CAL, select RUN, then enter the appropriate calibration code (default: 002016).
4. Select ALL at the CAL:RUN prompt.
5. Press ENTER.
6. Perform the entire front panel comprehensive calibration procedure discussed earlier in this section. (See “Comprehensive calibration” earlier in this section.)
7. Connect the synthesizer to the Model 2016 front panel INPUT jacks as shown in Figure 2-7. Select the front input jacks with the INPUTS switch.

**Figure 2-7**  
Synthesizer connections for manufacturing calibration

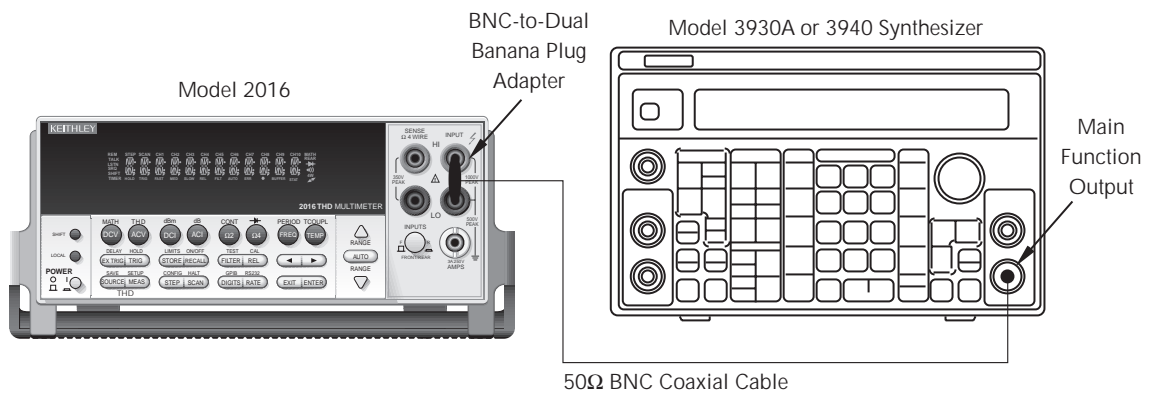

Note: Synthesizer output voltage must be accurately measured. (See text)

8. After the last AC current calibration step, the instrument will prompt you to enter 3Hz at 1V RMS and 1kHz with the following prompts:
  - Low-frequency cal: Set the synthesizer to output a 1V RMS, 3Hz sine wave. Use the left and right arrow keys, and the range keys to adjust the display to agree with the synthesizer amplitude you measured previously, then press ENTER.
  - Frequency cal: Set the synthesizer to output a 1V RMS, 1kHz sine wave. Enter 1.000000kHz at the prompt, then press ENTER.
9. Set the calibration dates, then save calibration to complete the process.

## Remote manufacturing calibration

1. Connect the low-thermal short to the rear panel input jacks, and select the rear inputs with the INPUTS switch. Allow three minutes for thermal equilibrium.
2. Press in and hold the SOURCE key while turning on the power.
3. Enable calibration by sending the :CODE command. For example, the default command is:  
:CAL:PROT:CODE 'KI002016'
4. Initiate calibration by sending the following command:  
:CAL:PROT:INIT
5. Calibrate step 0 with the following command:  
:CAL:PROT:AC:STEP0
6. Perform the entire remote comprehensive calibration procedure discussed earlier in this section. (See “Comprehensive calibration” earlier in this section.)
7. Connect the synthesizer to the Model 2016 INPUT jacks as shown in Figure 2-7. Select the front input jacks with the INPUTS switch.
8. Set the synthesizer to output a 1V RMS, 3Hz sine wave, then send the following command:  
:CAL:PROT:AC:STEP14 <Cal\_voltage>  
Here <Cal\_voltage> is the actual 3Hz synthesizer signal amplitude you measured previously.
9. Set the synthesizer to output a 1V RMS, 1kHz sine wave, then send the following command:  
:CAL:PROT:AC:STEP15 1E3
10. Send the following commands to set calibration dates, save calibration, and lock out calibration:  
:CAL:PROT:DATE <year>, <month>, <day>  
:CAL:PROT:NDUE <year>, <month>, <day>  
:CAL:PROT:SAVE  
:CAL:PROT:LOCK



# 3 Routine Maintenance

## Introduction

The information in this section deals with routine type maintenance that can be performed by the operator and includes procedures for replacing both the line fuse and the amps fuse.

### Setting the line voltage and replacing the line fuse

**WARNING** Disconnect the line cord at the rear panel, and remove all test leads connected to the instrument (front and rear) before replacing the line fuse.

The power line fuse is located in the power module next to the AC power receptacle (see Figure 3-1). If the line voltage must be changed, or if the line fuse requires replacement, perform the following steps:

1. Place the tip of a flat-blade screwdriver into the power module by the fuse holder assembly (see Figure 3-1). Gently push in and to the left. Release pressure on the assembly and its internal spring will push it out of the power module.
2. Remove the fuse, and replace it with the type listed in Table 3-1.

**CAUTION** For continued protection against fire or instrument damage, replace the fuse only with the type and rating listed. If the instrument repeatedly blows fuses, locate and correct the cause of the trouble before replacing the fuse.

3. If configuring the instrument for a different line voltage, remove the line voltage selector from the assembly, and rotate it to the proper position. When the selector is installed into the fuse holder assembly, the correct line voltage appears inverted in the window.
4. Install the fuse holder assembly into the power module by pushing it in until it locks in place.

**Figure 3-1**  
Power module

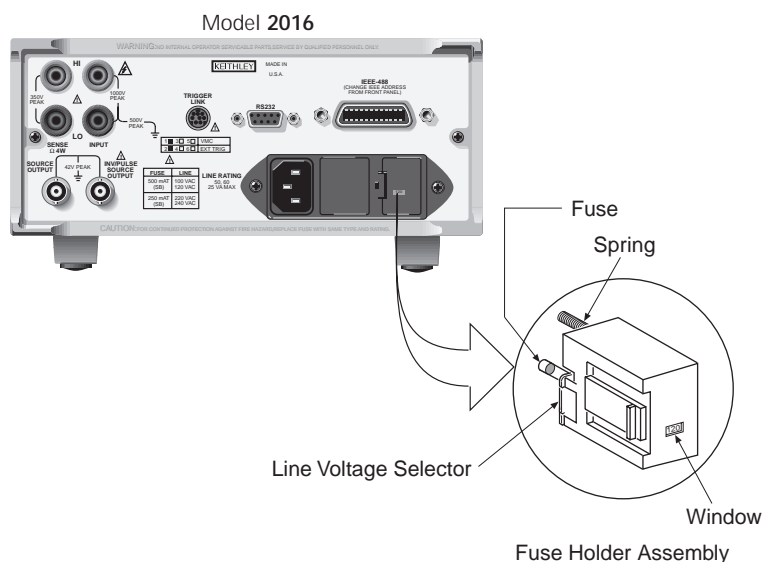

**Table 3-1**  
*Power line fuse*

Line Voltage	Rating	Keithley Part No.
100/120V	1/2A, 250V, 5 × 20 mm, slow-blow	FU-71
200/240V	1/4A, 250V, 5 × 20 mm, slow-blow	FU-96-4

## Replacing the AMPS fuse

The AMPS fuse protects the current input from an over-current condition. Follow the steps below to replace the AMPS fuse.

**WARNING** Make sure the instrument is disconnected from the power line and other equipment before replacing the AMPS fuse.

1. Turn off the power and disconnect the power line and test leads.
2. From the front panel, gently push in the AMPS jack with your thumb, and rotate the fuse carrier one-quarter turn counterclockwise. Release pressure on the jack and its internal spring will push the fuse carrier out of the socket.
3. Remove the fuse and replace it with the same type: 3A, 250V, fast blow, Keithley part number FU-99-1.

**CAUTION** Do not use a fuse with a higher current rating than specified, or instrument damage may occur. If the instrument repeatedly blows fuses, locate and correct the cause of the trouble before replacing the fuse.

4. Install the new fuse by reversing the above procedure.



# Troubleshooting<sup>4</sup>

## Introduction

This section of the manual will assist you in troubleshooting and repairing the Model 2016. Included are self-tests, test procedures, troubleshooting tables, and circuit descriptions. It is left to the discretion of the repair technician to select the appropriate tests and documentation needed to troubleshoot the instrument.

**WARNING** The information in this section is intended only for qualified service personnel. Do not perform these procedures unless you are qualified to do so. Some of these procedures may expose you to hazardous voltages that could cause personal injury or death. Use caution when working with hazardous voltages.



## Repair considerations

Before making any repairs to the Model 2016, be sure to read the following considerations.

**CAUTION**    **The PC-boards are built using surface mount techniques and require specialized equipment and skills for repair. If you are not equipped and/or qualified, it is strongly recommended that you send the unit back to the factory for repairs or limit repairs to the PC-board replacement level. Without proper equipment and training, you could damage a PC-board beyond repair.**

- Repairs will require various degrees of disassembly. However, it is recommended that the Front Panel Tests be performed prior to any disassembly. The disassembly instructions for the Model 2016 are contained in Section 5 of this manual.
- Do not make repairs to surface mount PC-boards unless equipped and qualified to do so (see previous CAUTION).
- When working inside the unit and replacing parts, be sure to adhere to the handling precautions and cleaning procedures explained in Section 5.
- Many CMOS devices are installed in the Model 2016. These static-sensitive devices require special handling as explained in Section 5.
- Whenever a circuit board is removed or a component is replaced, the Model 2016 must be recalibrated. See Section 2 for details on calibrating the unit.

## **Power-on self-test**

During the power-on sequence, the Model 2016 will perform a checksum test on its EPROM (U156 and U157) and test its RAM (U151 and U152). If one of these tests fails, the instrument will lock up.

## Front panel tests

There are two front panel tests: one to test the functionality of the front panel keys and one to test the display. In the event of a test failure, refer to “Display board checks” for details on troubleshooting the display board.

### KEY test

The KEY test allows you to check the functionality of each front panel key. Perform the following steps to run the KEY test:

1. Press SHIFT and then TEST to access the self-test options.
2. Use the up or down RANGE key to display “TEST: KEY”.
3. Press ENTER to start the test. When a key is pressed, the label name for that key is displayed to indicate that it is functioning properly. When the key is released, the message “NO KEY PRESS” is displayed.
4. Pressing EXIT tests the EXIT key. However, the second consecutive press of EXIT aborts the test and returns the instrument to normal operation.

### DISP test

The display test allows you to verify that each segment and annunciator in the vacuum fluorescent display is working properly. Perform the following steps to run the display test:

1. Press SHIFT and then TEST to access the self-test options.
2. Use the up or down RANGE key to display “TEST: DISP”.
3. Press ENTER to start the test. There are four parts to the display test. Each time ENTER is pressed, the next part of the test sequence is selected. The four parts of the test sequence are as follows:
  - a. All annunciators are displayed.
  - b. The segments of each digit are sequentially displayed.
  - c. The 12 digits (and annunciators) are sequentially displayed.
  - d. The annunciators located at either end of the display are sequentially displayed.
4. When finished, abort the display test by pressing EXIT. The instrument returns to normal operation.

## Principles of operation

The following information is provided to support the troubleshooting tests and procedures covered in this section of the manual. Refer to the following block diagrams:

Figure 4-1 — Power supply block diagram

Figure 4-2 — Digital circuitry block diagram

Figure 4-3 — Analog circuitry block diagram

Figure 4-4 — Distortion digital circuitry block diagram

Figure 4-5 — Distortion analog circuitry block diagram

Figure 4-6 — Sine generator circuitry block diagram

### Power supply

The following information provides some basic circuit theory that can be used as an aid to troubleshoot the power supply. A block diagram of the power supply is shown in Figure 4-1.

**Figure 4-1**  
Power supply block diagram

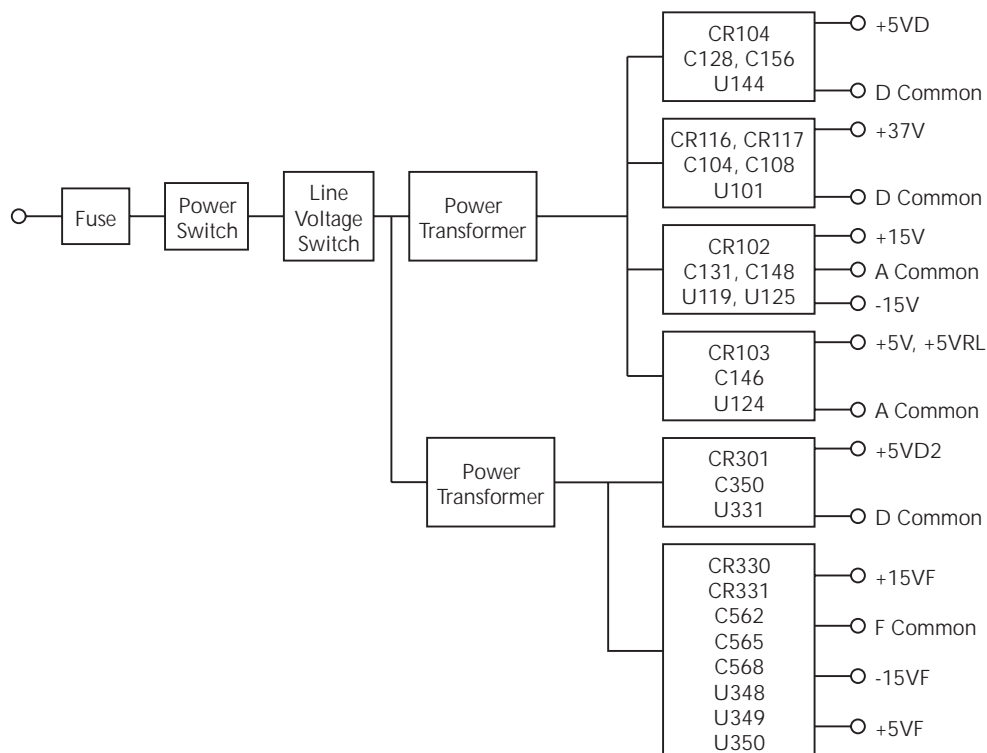

AC power is applied to the AC power module receptacle (J1009). Power is routed through the line fuse and line voltage selection switch of the power module to the power transformer. The power transformer has a total of four secondary windings for the various supplies.

AC voltage for the display filaments is taken from a power transformer secondary at F1 and F2, and then routed to the display board.

Each DC supply uses a rectifier and a capacitive filter, and many supplies use an IC regulator. Table 4-1 summarizes rectifier, filter, and regulator circuits for the various DC supplies.

**Table 4-1**  
*Power supply components*

<b>Supply</b>	<b>Rectifier</b>	<b>Filter</b>	<b>Regulator</b>
+5VD	CR104	C128, C156	U144
+37V	CR116, CR117	C104, C106	U101
+15V	CR102	C148	U125
-15V	CR102	C131	U119
+5V, +5VRL	CR103	C146	U124
+5VD2	CR301	C350	U331
+15VF	CR330	C562	U348
-15VF	CR330	C565	U349
+5VF	CR331	C568	U350

## Display board

Display board components are shown in the digital circuitry block diagram in Figure 4-2.

**Figure 4-2**  
Digital circuitry block diagram

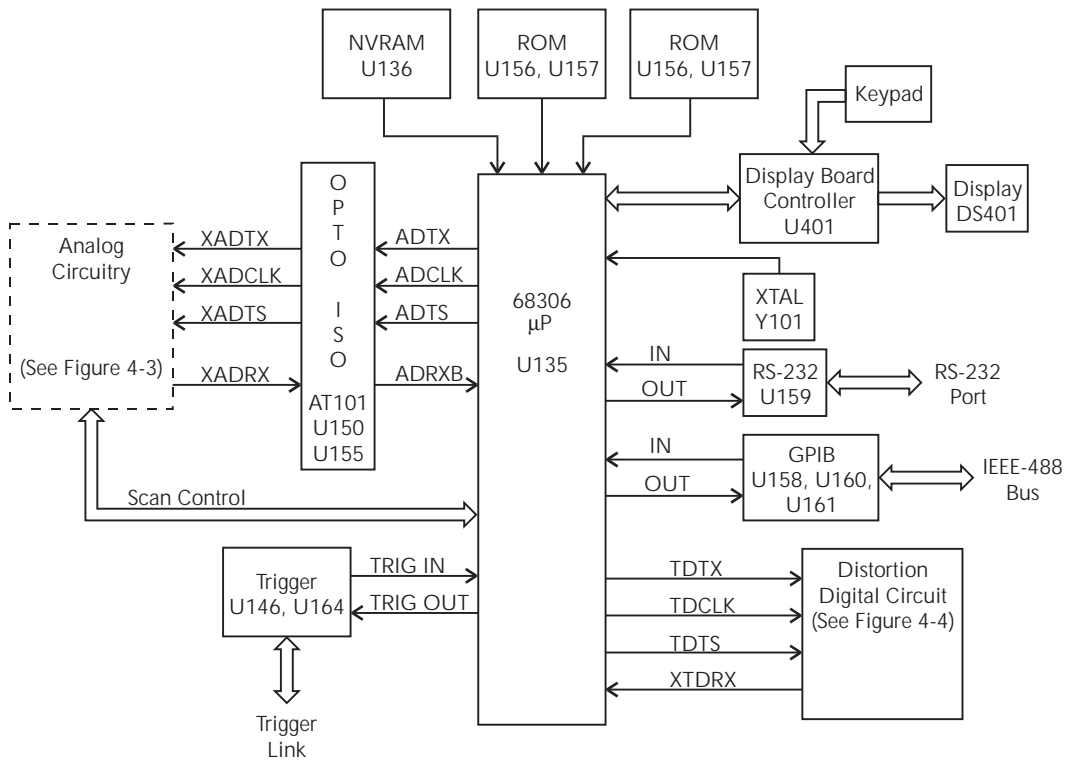

### Microcontroller

U401 is the display board microcontroller that controls the display and interprets key data. The microcontroller uses three internal peripheral I/O ports for the various control and read functions.

Display data is serially transmitted to the microcontroller from the digital section via the TXB line to the microcontroller RDI terminal. In a similar manner, key data is serially sent back to the digital section through the RXB line via TDO. The 4MHz clock for the microcontroller is generated by crystal Y401.

## Display

DS401 is the display module, which can display up to 12 alpha-numeric characters and includes the various annunciators.

The display uses a common multiplexing scheme with each character refreshed in sequence. U402 and U403 are the drivers for the display characters and annunciators. Note that data for the drivers are serially transmitted from the microcontroller (MOSI and PC1).

Filament voltage for the display is derived from the power supply transformer (F1 and F2). The display drivers require +37VDC and +5VDC, which are supplied by U144 (+5VD) and U101 (+37V).

## Key matrix

The front panel keys (S401-S430) are organized into a row-column matrix to minimize the number of microcontroller peripheral lines required to read the keyboard. A key is read by strobing the columns and reading all rows for each strobed column. Key-down data is interpreted by the display microcontroller and sent back to the main microprocessor using proprietary encoding schemes.

## Digital circuitry

Refer to Figure 4-2 for the following discussion on digital circuitry.

### Microprocessor

U135 is a 68306 microprocessor that oversees all operating aspects of the instrument. The MPU has a 16-bit data bus and provides an 18-bit address bus. It also has parallel and serial ports for controlling various circuits. For example, the RXDA, TXDA, RXDB and TXDB lines are used for the RS-232 interface.

The MPU clock frequency of 14.7456MHz is controlled by crystal Y101. MPU RESET is performed momentarily (through C241) on power-up by the +5VD power supply.

### Memory circuits

ROMs U156 and U157 store the firmware code for instrument operation. U157 stores the D0-D7 bits of each data word, and U156 stores the D8-D15 bits.

RAMs U151 and U152 provide temporary operating storage. U152 stores the D0-D7 bits of each data word, and U151 stores the D8-D15 bits.

Semi-permanent storage facilities include NVRAM U136. This IC stores such information as instrument setup and calibration constants. Data transmission from this device is done in a serial fashion.

### **RS-232 interface**

Serial data transmission and reception is performed by the TXDB and RXDB lines of the MPU. U159 provides the necessary voltage level conversion for the RS-232 interface port.

### **IEEE-488 interface**

U158, U160, and U161 make up the IEEE-488 interface. U158, a 9914A GPIA, takes care of routine bus overhead such as handshaking, while U160 and U161 provide the necessary buffering and drive capabilities.

### **Trigger circuits**

Buffering for Trigger Link input and output is performed by U146. Trigger input and output is controlled by the IRQ4 and PB3 lines of the MPU. U164 provides additional logic for the trigger input to minimize MPU control overhead.

At the factory, trigger output is connected to line 1 of the Trigger Link connector (resistor R267 installed). Trigger input is connected to line 2 of the Trigger Link connector (resistor R270 installed).



## Analog circuitry

Refer to Figure 4-3 for the following discussion on analog circuitry.

**Figure 4-3**  
Analog circuitry block diagram

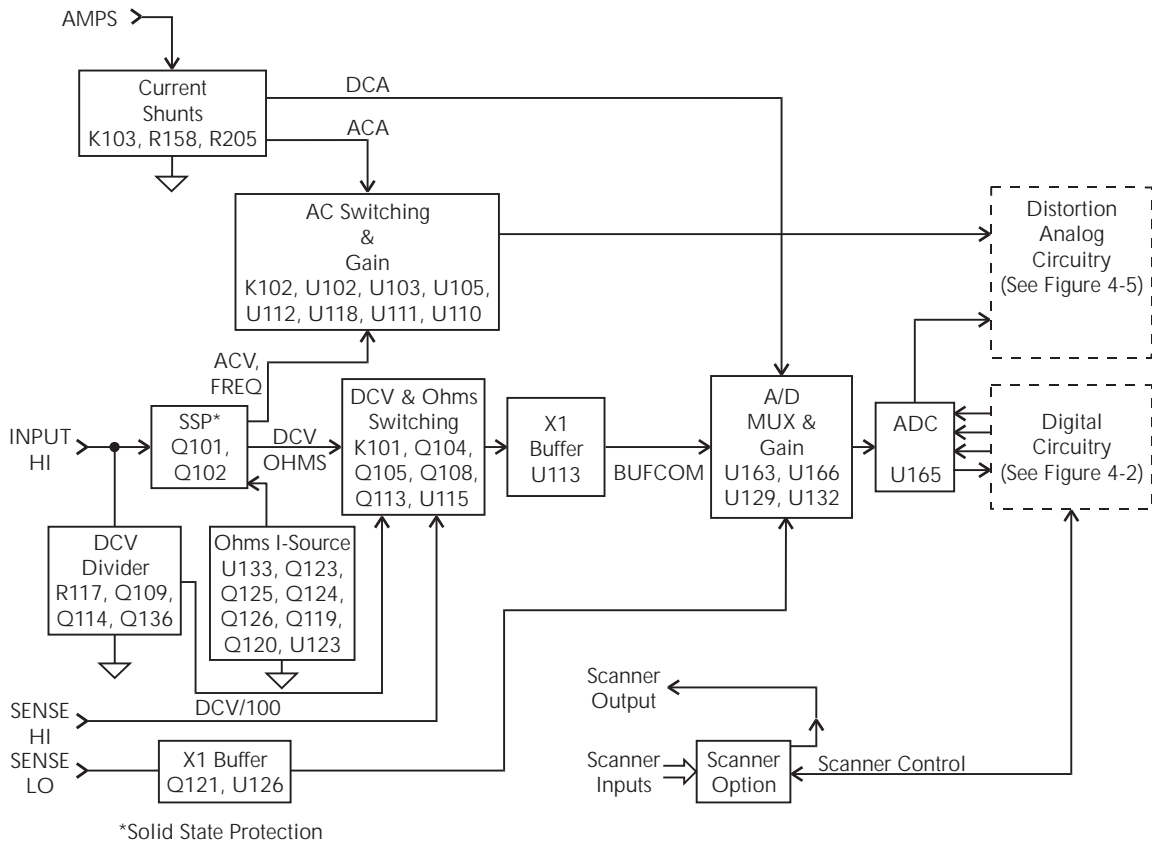

### INPUT HI

INPUT HI protection is provided by the SSP (solid state protection) circuit. The SSP is primarily made up of Q101 and Q102. An overload condition opens Q101 and Q102, which disconnects the analog input signal from the rest of the analog circuit.

Note that for the 100VDC and 1000VDC ranges, Q101 and Q102 of the SSP are open. The DC voltage signal is routed through the DCV Divider (Q114 and Q136 on) to the DCV switching circuit.

## AMPS input

The ACA or DCA input signal is applied to the Current Shunt circuit, which is made up of K103, R158, and R205. For the 10mA DC range,  $10.1\Omega$  (R158 + R205) is shunted across the input. Relay K103 is energized (on) to select the shunts. For all other DCA ranges, and all ACA ranges,  $0.1\Omega$  (R158) is shunted across the input (K103 off).

The ACA signal is then sent to the AC Switching & Gain circuit, while the DCA signal is routed directly to the A/D MUX & Gain circuit.

## Signal switching

Signal switching for DCV and OHMS is done by the DCV & Ohms Switching circuit. FETs Q113, Q105, Q104, and Q108 connect the DCV or ohms signal to the X1 buffer (U113).

Note that the reference current for OHMS is generated by the Ohms I-Source circuit. For 4-wire ohms measurements, SENSE LO is connected to the circuit by turning on Q121.

Signal switching and gain for ACV, FREQ and ACA is done by the AC Switching & Gain circuit, which is primarily made up of K102, U102, U103, U105, U112, U118, U111, and U110. Note that U111 is used for frequency adjustment. The states of these analog switches vary from unit to unit.

## Multiplexer and A/D converter

All input signals, except FREQ, are routed to the A/D MUX & Gain circuit. The multiplexer (U163) switches the various signals for measurement. In addition to the input signal, the multiplexer also switches among reference and zero signals at various phases of the measurement cycle.

When the input signal is selected by the MUX, it is amplified by U132 and U166. Gain is controlled by switches in U129 and associated resistors.

The multiplexed signals of the measurement cycle are routed to the A/D Converter (U165) where it converts the analog signals to digital form. The digital signals are then routed through an opto-isolator to the MPU to calculate a reading.

## Distortion digital circuitry

Refer to Figure 4-4 for the following discussion on the distortion digital circuitry.

**Figure 4-4**  
Distortion digital circuitry block diagram

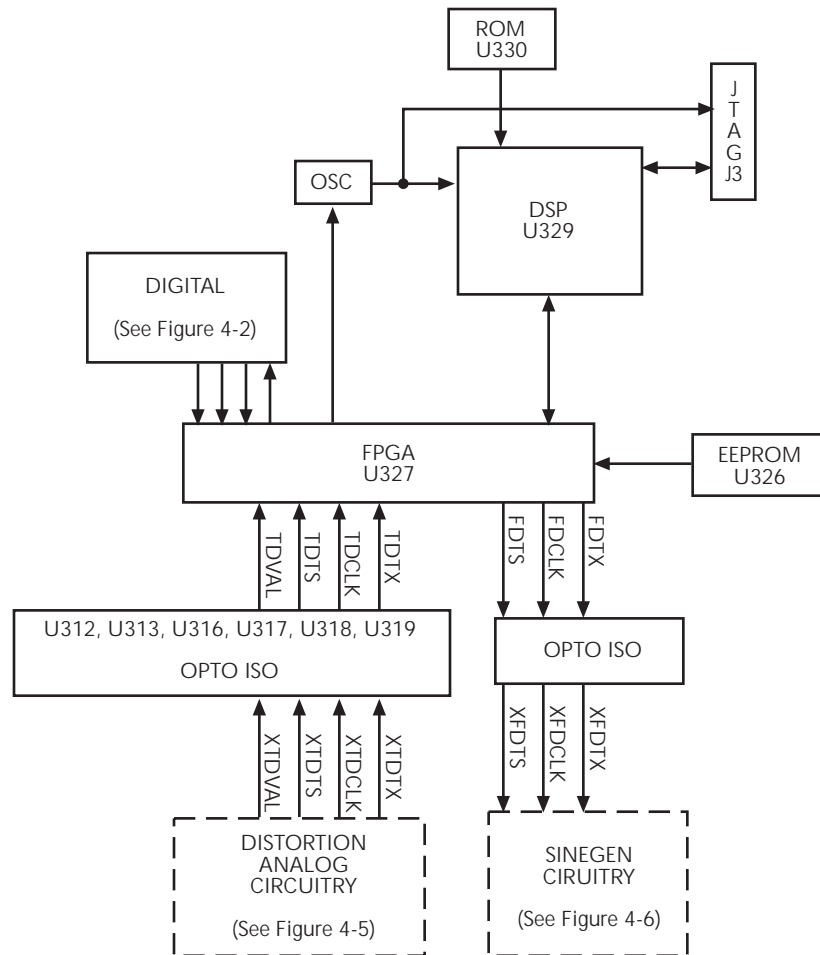

## DSP

U329 is a ADSP21061 digital signal processor that acquires ADC data, performs all distortion and noise calculations, and communicates the results to the microprocessor. The DSP has a 48-bit data bus and provides a 32-bit address bus. It has serial ports for communicating with serial peripherals such as the ADC and DAC converters. The DSP also has 1Mb of internal RAM for temporary data storage.

The DSP clock frequency of 33.0 MHz is controlled by oscillator Y303. DSP reset is performed by U333 through U327 and U326.

ROM U330 stores the firmware code for the DSP.

## JTAG interface

J3 is the JTAG interface, and it is used for monitoring and debugging DSP code.

## FPGA

U327 is an FPGA that provides all interface functions among the DSP, sine generator opto-isolators, distortion analog circuitry, and the microprocessor. Upon power-up, the FPGA is configured by U326, an EEPROM.

## Opto-isolators

U312, U313, U317, and U322 are drivers for the opto-isolators U316, U317, U318, U319, U320, U321, and U304. These isolators eliminate leakage currents and ground currents among the analog, digital, and sine wave generator circuits.

## Distortion analog circuitry

Refer to Figure 4-5 for the following discussion on distortion analog circuitry.

**Figure 4-5**  
Distortion analog circuitry block diagram

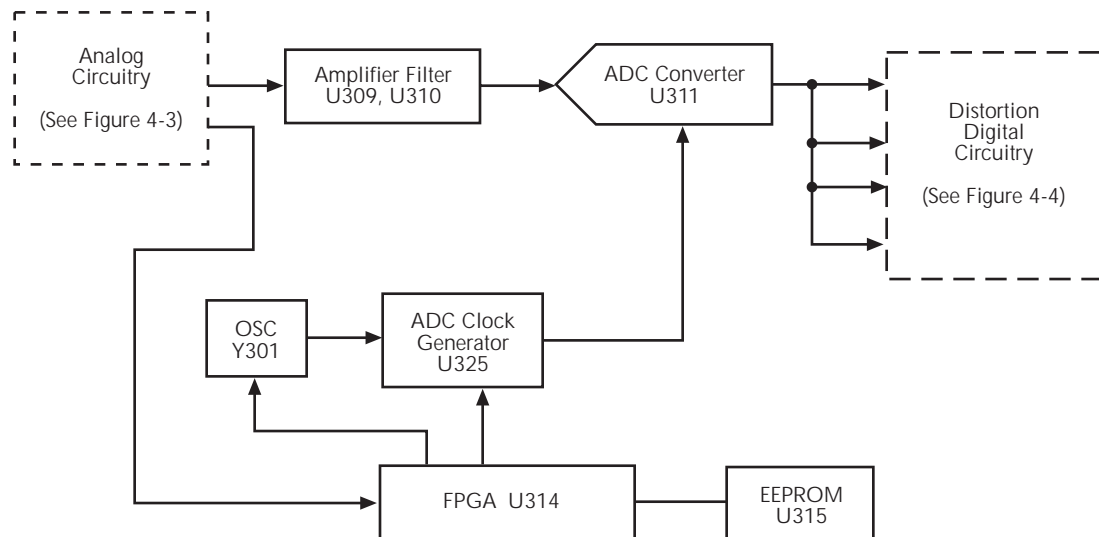

### Amplifier filter

The buffered and scaled AC waveform from the analog circuitry (Figure 4-3) is fed to U309 and U310. U309 and U310 form an amplifier, antialiasing filter, and DC shifting circuit to condition the AC waveform for the distortion measurement ADC converter.

### ADC converter

The distortion measurement circuitry uses a separate ADC converter from the rest of the DMM measurements (see U165 in Figure 4-3). This ADC is a high-speed, high-resolution, low-distortion sigma delta type. The ADC digital output is sent to the DSP through opto-isolators shown in Figure 4-5.

### ADC clock

Y301 is a fixed frequency clock that forms the input to U325, an adjustable frequency clock generator. The output of this generator clocks the ADC setting the acquisition rate. The clock generator frequency is set by the microprocessor and is communicated through U314, the FPGA. The FPGA, U314, is configured by U315, an EEPROM, upon power-up.

## Sine generator circuitry

Refer to Figure 4-6 for the following discussion on the sine generator circuitry.

**Figure 4-6**  
Sine generator circuitry block diagram

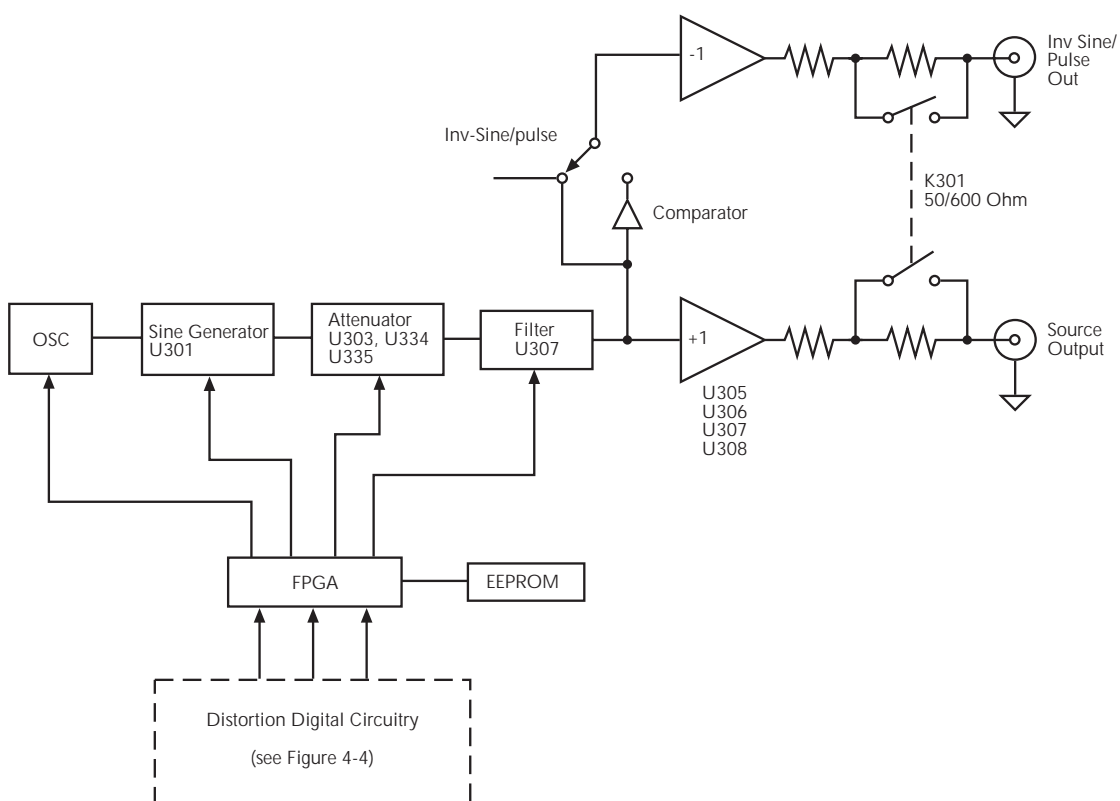

### Sine generator

Y302 is a fixed frequency clock that forms the input to U301, the adjustable frequency sine wave generator. The sine wave generator's frequency is set by the microprocessor through the FPGA, U334, and the opto-isolators U304, U320, and U321.

### Attenuator

U303, U334, U335, and U302 form the adjustable attenuator that adjusts the sine wave output amplitude. The output amplitude is set by the microprocessor through the FPGA, U334, and the opto-isolators U304, U320, and U321.

## Filter

U307, U336, and U337 form a low pass filter with a software-selectable cutoff frequency. This filter is used to reduce spurious noise in the sine wave output. The filter cutoff frequency is set by the microprocessor through the FPGA, U334, and opto-isolators U304, U320, and U321.

## Outputs

The Model 2016 has two outputs. U305, U306, U307, and U308 form the main sine wave output stage.

The secondary output may be either an inverted sine wave of the same magnitude and frequency as the main sine wave output, or a 5V pulse output of the same frequency as the main sine wave. One IC is a comparator that squares up the main sine wave output. Another IC selects whether the sinewave or the comparator is fed to the output.

K301 selects between either 50 $\Omega$  or 600 $\Omega$  output impedance.

## Troubleshooting

Troubleshooting information for the various circuits is summarized below. See Principles of operation for circuit theory.

### Display board checks

If the front panel DISP test indicates that there is a problem on the display board, use Table 4-2.

**Table 4-2**  
*Display board checks*

Step	Item/component	Required condition	Remarks
1	Front panel DISP test.	Verify that all segments operate.	Use front panel display test.
2	P1005, PIN 5	+5V $\pm$ 5%	Digital +5V supply.
3	P1005, PIN 9	+37V $\pm$ 5%	Display +37V supply.
4	U401, PIN 1	Goes low briefly on power up, then goes high.	Microcontroller RESET.
5	U401, PIN43	4MHz square wave.	Controller 4MHz clock.
6	U401, PIN 32	Pulse train every 1msec.	Control from main processor.
7	U401, PIN 33	Brief pulse train when front panel key is pressed.	Key down data sent to main processor.



## Power supply checks

Power supply problems can be checked out using Table 4-3.

**Table 4-3**  
*Power supply checks*

Step	Item/component	Required condition	Remarks
1	Line fuse	Check continuity.	Remove to check.
2	Line voltage	120V/240V as required.	Check power module position.
3	Line power	Plugged into live receptacle, power on.	Check for correct power-up sequence.
4	U144, pin 2	+5V, $\pm 5\%$	+5VD, referenced to Common D.
5	U101, pin 7	+37V, $\pm 5\%$	+37V, referenced to Common D.
6	U125, pin 3	+15V, $\pm 5\%$	+15V, referenced to Common A.
7	U119, pin 3	-15V, $\pm 5\%$	-15V, referenced to Common A.
8	U124, pin 3	+5V, $\pm 5\%$	+5VRL, referenced to Common A.
9	U331, pin 2	+5V, $\pm 3\%$	+5VD2, referenced to Common D.
10	U348, pin 3	+15V, $\pm 5\%$	+15VA, referenced to Common F.
11	U349, pin 3	-15V, $\pm 5\%$	-15VA, referenced to Common F.
12	U350, pin 3	+5V, $\pm 5\%$	+5VA, referenced to Common F.

## Digital circuitry checks

Digital circuit problems can be checked out using Table 4-4.

**Table 4-4**  
*Digital circuitry checks*

Step	Item/component	Required condition	Remarks
1	Power-on test	RAM OK, ROM OK.	Verify that RAM and ROM are functional.
2	U152 pin 14	Digital common.	All signals referenced to digital common.
3	U152 pin 28	+5V	Digital logic supply.
4	U135 pin 48	Low on power-up, then goes high.	MPU RESET line.
5	U135, lines A1-A23	Check for stuck bits.	MPU address bus.
6	U135, lines D1-D15	Check for stuck bits.	MPU data bus.
7	U135 pin 44	14.7456MHz	MPU clock.
8	U159 pin 13	Pulse train during RS-232 I/O.	RS-232 RX line.
9	U159 pin 14	Pulse train during RS-232 I/O.	RS-232 TX line.
10	U158 pins 34-42	Pulse train during IEEE-488 I/O.	IEEE-488 data bus.
11	U158 pins 26-31	Pulses during IEEE-488 I/O.	IEEE-488 command lines.
12	U158 pin 24	Low with remote enabled.	IEEE-488 REN line.
13	U158 pin 25	Low during interface clear.	IEEE-488 IFC line.
14	U135 pin 84	Pulse train.	ADRXB
15	U135 pin 91	Pulse train.	ADTX
16	U135 pin 90	Pulse train.	ADCLK
17	U135 pin 89	Pulse train.	ADTS

## Analog signal switching states

Tables 4-5 through 4-11 provide switching states of the various relays, FETs, and analog switches for the basic measurement functions and ranges. These tables can be used to assist in tracing an analog signal from the input to the A/D multiplexer.

**Table 4-5**  
*DCV signal switching*

Range	Q101	Q102	Q114	Q136	Q109	K101*	Q113	Q105	Q104	Q108	Q121
100mV	ON	ON	OFF	OFF	OFF	SET	OFF	OFF	ON	OFF	ON
1V	ON	ON	OFF	OFF	OFF	SET	OFF	OFF	ON	OFF	ON
10V	ON	ON	OFF	OFF	OFF	SET	OFF	OFF	ON	OFF	ON
100V	OFF	OFF	ON	ON	OFF	SET	OFF	OFF	OFF	ON	ON
1000V	OFF	OFF	ON	ON	OFF	SET	OFF	OFF	OFF	ON	ON

\*K101 set states: Pin 8 switched to Pin 7  
Pin 3 switched to Pin 4

**Table 4-6**  
*ACV and FREQ signal switching*

Range	Q101	Q102	K101*	K102*	U103 pin 8	U103 pin 9	U105 pin 9	U105 pin 8	U103 pin 16	U103 pin 1	U105 pin 1	U111 pin 16
100mV	ON	ON	RESET	RESET	ON	ON	OFF	OFF	OFF	ON	ON	OFF
1V	ON	ON	RESET	RESET	ON	ON	OFF	OFF	ON	OFF	OFF	OFF
10V	ON	ON	RESET	SET	OFF	OFF	ON	OFF	OFF	ON	ON	OFF
100V	ON	ON	RESET	SET	OFF	OFF	ON	OFF	ON	OFF	OFF	OFF
750V	ON	ON	RESET	SET	OFF	OFF	ON	ON	OFF	OFF	OFF	OFF

\*K101 and K102 reset states: Pin 8 switched to Pin 9  
Pin 3 switched to Pin 2  
K101 and K102 set states: Pin 8 switched to Pin 7  
Pin 3 switched to Pin 4

**Table 4-7**  
 $\Omega 2$  signal switching

Range	Q101	Q102	Q114	Q136	Q109	K101*	K102*	Q113	Q105	Q104	Q108	Q121
100 $\Omega$	ON	ON	OFF	OFF	OFF	SET	RESET	OFF	ON	OFF	OFF	ON
1k $\Omega$	ON	ON	OFF	OFF	OFF	SET	RESET	OFF	ON	OFF	OFF	ON
10k $\Omega$	ON	ON	OFF	OFF	OFF	SET	RESET	OFF	ON	OFF	OFF	ON
100k $\Omega$	ON	ON	OFF	OFF	OFF	SET	RESET	OFF	ON	OFF	OFF	ON
1M $\Omega$	ON	ON	OFF	OFF	OFF	SET	RESET	OFF	ON	OFF	OFF	ON
10M $\Omega$	ON	ON	OFF	OFF	ON	SET	RESET	OFF	ON	OFF	OFF	ON
100M $\Omega$	ON	ON	OFF	OFF	ON	SET	RESET	OFF	ON	OFF	OFF	ON

\*K101 set states: Pin 8 switched to Pin 7

Pin 3 switched to Pin 4

K102 reset states:

Pin 8 switched to Pin 9

Pin 3 switched to Pin 2

**Table 4-8**  
 $\Omega 4$  signal switching

Range	Q101	Q102	Q114	Q136	Q109	K101*	Q113	Q105	Q104	Q108	Q121
100 $\Omega$	ON	ON	OFF	OFF	OFF	SET	ON	OFF	OFF	OFF	ON
1k $\Omega$	ON	ON	OFF	OFF	OFF	SET	ON	OFF	OFF	OFF	ON
10k $\Omega$	ON	ON	OFF	OFF	OFF	SET	ON	OFF	OFF	OFF	ON
100k $\Omega$	ON	ON	OFF	OFF	OFF	SET	ON	OFF	OFF	OFF	ON
1M $\Omega$	ON	ON	OFF	OFF	OFF	SET	ON	OFF	OFF	OFF	ON
10M $\Omega$	ON	ON	OFF	OFF	ON	SET	OFF	ON	OFF	OFF	ON
100M $\Omega$	ON	ON	OFF	OFF	ON	SET	OFF	ON	OFF	OFF	ON

\*K101 set states: Pin 8 switched to Pin 7

Pin 3 switched to Pin 4

**Table 4-9**  
 $\Omega 2/\Omega 4$  reference switching

Range	U133/0.7	U133/7V	Q123	Q125	Q124	Q126	Q120
100 $\Omega$	OFF	ON	ON	ON	OFF	OFF	ON
1k $\Omega$	OFF	ON	ON	ON	OFF	OFF	ON
10k $\Omega$	OFF	ON	OFF	OFF	ON	ON	ON
100k $\Omega$	ON	OFF	OFF	OFF	ON	ON	ON
1M $\Omega$	ON	OFF	OFF	OFF	ON	ON	ON
10M $\Omega$	OFF	ON	OFF	OFF	ON	ON	OFF
100M $\Omega$	OFF	ON	OFF	OFF	ON	ON	OFF

**Table 4-10**  
DCA signal switching

Range	K103
10mA	ON
100mA	OFF
1A	OFF
3A	OFF

**Table 4-11**  
ACA signal switching

Range	K103	U105 pin 16	U105 pin 1	U111 pin 16	U105 pin 8	U103 pin 16	U103 pin 1
1A	OFF	ON	ON	OFF	OFF	OFF	OFF
3A	OFF	ON	ON	ON	OFF	OFF	OFF

Tables 4-12 through 4-16 can be used to trace the analog signal through the A/D multiplexer (U163) to the final amplifier stage. These tables show the MUX lines (S3, S4, S6, S7) that are selected for measurement during the SIGNAL phase of the multiplexing cycle. Also included are switching states of analog switches (U129) that set up the gain for the final amplifier stage (U166).

**Table 4-12**  
DCV signal multiplexing and gain

Range	Signal (U163)	U129 pin 1	U129 pin 8	U129 pin 9	Gain (U166)
100mV	S4	OFF	OFF	ON	×100
1V	S4	OFF	ON	OFF	×10
10V	S4	ON	OFF	OFF	×1
100V	S4	OFF	ON	OFF	×10
1000V	S4	ON	OFF	OFF	×1

**Table 4-13**  
ACV and ACA signal multiplexing and gain

Range	Signal (U163)	U129 pin 1	U129 pin 8	U129 pin 9	Gain (U166)
All	S3	ON	OFF	OFF	×1

**Table 4-14***DCA signal multiplexing and gain*

Range	Signal (U163)	U129 pin 1	U129 pin 8	U129 pin 9	Gain (U166)
10mA	S6	OFF	OFF	ON	×100
100mA	S6	OFF	OFF	ON	×100
1A	S6	OFF	OFF	ON	×100
3A	S6	OFF	ON	OFF	×10

**Table 4-15***Ω2 signal multiplexing and gain*

Range	Signal (U163)	U129 pin 1	U129 pin 8	U129 pin 9	Gain (U166)
100Ω	S4	OFF	OFF	ON	×100
1kΩ	S4	OFF	ON	OFF	×10
10kΩ	S4	OFF	ON	OFF	×10
100kΩ	S4	OFF	ON	OFF	×10
1MΩ	S4	ON	OFF	OFF	×1
10MΩ	S4	ON	OFF	OFF	×1
100MΩ	S4	ON	OFF	OFF	×1

**Table 4-16***Ω4 signal multiplexing and gain*

Range	Signal (U163)	U129 pin 1	U129 pin 8	U129 pin 9	Gain (U166)
100Ω	S4 then S7	OFF	OFF	ON	×100
1kΩ	S4 then S7	OFF	ON	OFF	×10
10kΩ	S4 then S7	OFF	ON	OFF	×10
100kΩ	S4 then S7	OFF	ON	OFF	×10
1MΩ	S4 then S7	ON	OFF	OFF	×1
10MΩ	S4 then S7	ON	OFF	OFF	×1
100MΩ	S4 then S7	ON	OFF	OFF	×1

Figure 4-3 provides a block diagram of the analog circuitry. Table 4-17 shows where the various switching devices are located in the block diagram.

**Table 4-17**  
*Switching device locations*

Switching devices	Analog circuit section (see Figure 4-3)
Q101, Q102	SSP (Solid State Protection)
Q114, Q136, Q109	DCV Divider
K101, Q113, Q105, Q104, Q108	DCV and Ohms Switching
Q121	Sense LO
K102, U103, U105, U111	AC switching and Gain
U133, Q120, Q123, Q124, Q125, Q126	Ohms I-Source
K103	Current Shunts
U129, U163	A/D Mux and Gain



# 5 Disassembly



## **Introduction**

This section explains how to handle, clean, and disassemble the Model 2016 THD Multi-meter. Disassembly drawings are located at the end of this section.

## Handling and cleaning

To avoid contaminating PC board traces with body oil or other foreign matter, avoid touching the PC board traces while you are repairing the instrument. Motherboard areas covered by the shield have high-impedance devices or sensitive circuitry where contamination could cause degraded performance.

### Handling PC boards

Observe the following precautions when handling PC boards:

- Wear cotton gloves.
- Only handle PC boards by the edges and shields.
- Do not touch any board traces or components not associated with repair.
- Do not touch areas adjacent to electrical contacts.
- Use dry nitrogen gas to clean dust off PC boards.

### Solder repairs

Observe the following precautions when soldering a circuit board:

- Use an OA-based (organic activated) flux, and take care not to spread the flux to other areas of the circuit board.
- Remove the flux from the work area when you have finished the repair by using pure water with clean, foam-tipped swabs or a clean, soft brush.
- Once you have removed the flux, swab only the repair area with methanol, then blow dry the board with dry nitrogen gas.
- After cleaning, allow the board to dry in a 50°C, low-humidity environment for several hours.

## Static sensitive devices

CMOS devices operate at very high impedance levels. Therefore, any static that builds up on you or your clothing may be sufficient to destroy these devices if they are not handled properly. Use the following precautions to avoid damaging them:

**CAUTION** Many CMOS devices are installed in the Model 2016. Handle all semiconductor devices as being static sensitive.

- Transport and handle ICs only in containers specially designed to prevent static build-up. Typically, you will receive these parts in anti-static containers made of plastic or foam. Keep these devices in their original containers until ready for installation.
- Remove the devices from their protective containers only at a properly grounded work station. Also, ground yourself with a suitable wrist strap.
- Handle the devices only by the body — do not touch the pins.
- Ground any printed circuit board into which a semiconductor device is to be inserted to the bench or table.
- Use only anti-static type desoldering tools.
- Use only grounded-tip solder irons.
- Once the device is installed in the PC board, normally it is adequately protected, and you can handle the boards normally.

## Assembly drawings

Use the following assembly drawings to assist you as you disassemble and reassemble the Model 2016. Also, refer to these drawings for information about the Keithley part numbers of most mechanical parts in the unit. The drawings are located at the end of this section of the manual.

- Front Panel Assembly — 2016-040
- Chassis/Transformer Power Module Assembly — 2016-050
- Front Panel/Chassis Assembly — 2016-051
- Chassis Assembly — 2016-052, 2016-053
- Final Inspection — 2016-080

## Disassembly procedures

### Case cover removal

Follow the steps below to remove the case cover to gain access to internal parts.

**WARNING** Before removing the case cover, disconnect the line cord and any test leads from the instrument.

1. Remove Handle — The handle serves as an adjustable tilt-bail. Adjust its position by gently pulling it away from the sides of the instrument case and swinging it up or down. To remove the handle, swing the handle below the bottom surface of the case and back until the orientation arrows on the handles line up with the orientation arrows on the mounting ears. With the arrows lined up, pull the ends of the handle away from the case.
2. Remove Mounting Ears — Remove the screw that secures each mounting ear. Pull down and out on each mounting ear.

**NOTE** When reinstalling the mounting ears, make sure to mount the right ear to the right side of the chassis, and the left ear to the left side of the chassis. Each ear is marked “RIGHT” or “LEFT” on its inside surface.

3. Remove Rear Bezel — To remove the rear bezel, loosen the two captive screws that secure the rear bezel to the chassis. Pull the bezel away from the case.
4. Removing Grounding Screws — Remove the two grounding screws that secure the case to the chassis. They are located on the bottom of the case at the back.
5. Remove Cover — To remove the case, grasp the front bezel of the instrument, and carefully slide the chassis forward. Slide the chassis out of the metal case.

**NOTE** To gain access to the components under the DMM board shield, remove the shield which is secured to the DMM board by a single screw.

### DMM board removal

Perform the following steps to remove the DMM (106) board. This procedure assumes that the case cover is already removed.

1. Remove the IEEE-488 and RS-232 fasteners.  
The IEEE-488 and the RS-232 connectors each have two nuts that secure the connectors to the rear panel. Remove these nuts.
2. Remove the front/rear switch rod.  
At the switch, place the edge of a flat-blade screwdriver in the notch on the pushrod. Gently twist the screwdriver while pulling the rod from the shaft.

3. Disconnect the front and rear input terminals.

You must disconnect these input terminal connections for both the front and rear inputs:

- INPUT HI and LO
- SENSE HI and LO
- AMPS

Remove all the connections except the front AMPS connection by pulling the wires off the pin connectors. To remove the front panel AMPS input wire (white), first remove the AMPS fuse holder, then use needle-nose pliers to grasp the AMPS wire near fuse housing. Push the wire forward and down to snap the spring out of the fuse housing. Carefully pull the spring and contact tip out of the housing.

4. Unplug cables:

- Unplug the display board ribbon cable from connector J1014.
- Unplug the transformer cables from connectors J1016 and J1015.
- Unplug the OPTION SLOT ribbon cable from connector J1017.

5. Remove the fastening screw that secures the DMM board to the chassis. One of these screws is located along the left side of the unit toward the rear, and it also secures U114. The other screw is located at the right front of the chassis near the front/rear switch, S101.

During reassembly, replace the board, and start the IEEE-488 and RS-232 connector nuts and the mounting screw. Tighten all the fasteners once they are all in place and the board is correctly aligned.

6. Remove the DMM board, which is held in place by edge guides on each side, by sliding it forward until the board edges clear the guides. Carefully pull the DMM board from the chassis.

## DSP board removal

Perform the following steps to remove the DSP (136) board. This procedure assumes that the case cover and the DMM board have been removed.

1. Remove the nuts from the two BNC jacks on the rear panel.

2. Unplug cables:

- Unplug the power entry module cable, J1021.
- Unplug the transformer primary connections, J1018 and J1019.
- Unplug the transformer cable from J1020.
- Unplug the DMM board connectors, J1022, J1024, and J1026.
- Unplug the transformer cable, J1031.

3. Remove all seven screws that secure the DSP board to the chassis.

4. Slide the board toward the front of the chassis until the BNC jacks have cleared the chassis and the board is clear of the guide pins, then remove the board.

During reassembly, replace the board by lining up the guide pins over the slots, then slide the board toward the rear. Loosely install all screws, then install and tighten the BNC jack nuts. Tighten all screws.

## Front panel disassembly

Use the following procedures to remove the display board and/or the pushbutton switch pad.

**NOTE** *You must first remove the case cover, the front/rear input switch, and the front input terminal wires as described earlier in this section.*

1. Unplug the display board ribbon cable from connector J1014.
2. Remove the front panel assembly.  
This assembly has four retaining clips that snap onto the chassis over four pem nut studs. Two retaining clips are located on each side of the front panel. Pull the retaining clips outward and, at the same time, pull the front panel assembly forward until it separates from the chassis.
3. Using a thin-bladed screwdriver, pry the plastic PC board stop (located at the bottom of the display board) until the bar separates from the casing. Pull the display board from the front panel.
4. Remove the switch pad by pulling it from the front panel.

## Removing power components

The following procedures to remove the power transformer and/or power module require that the case cover and motherboard be removed, as previously explained.

### Power transformer removal

Perform the following steps to remove the power transformer:

1. Remove the DMM board.
2. Unplug the transformer wires that attach to the DSP board:
  - For TR-332, unplug J1018 and J1020.
  - For TR-328, unplug J1019 and J1031.
3. Remove the two nuts that secure the transformer to the bottom of the chassis.
4. Pull the black ground wire off the threaded stud, and remove the power transformer from the chassis.

### Power module removal

Perform the following steps to remove the power module:

1. Remove the DMM board.
2. Unplug connector J1021 from the DSP board.
3. Disconnect the power module's ground wire. This green and yellow wire connects to a threaded stud on the chassis with a kep nut.
4. Squeeze the latches on either side of the power module while pushing the module from the access hole.

## Instrument reassembly

Reassemble the instrument by reversing the previous disassembly procedures. Make sure that all parts are properly seated and secured, and that all connections are properly made. To ensure proper operation, replace and securely fasten the shield.

**WARNING** To ensure continued protection against electrical shock, verify that power line ground (green and yellow wire attached to the power module) and the power transformer ground (black wire) are connected to the chassis. When installing the power transformer, be sure to reconnect the black ground wire to the mounting stud on bottom of the chassis. Be sure to install the bottom case screws to assure a good case-to-chassis ground connection.

### Input terminal wire connections

During reassembly, use the information in Table 5-1 to connect input terminal wires.

**Table 5-1**  
*Input terminal wire colors*

Input terminal	Front wire color	Rear wire color
INPUT HI	Red	White/Red
INPUT LO	Black	White/Black
SENSE HI	Yellow	White/Yellow
SENSE LO	Gray	White/Gray
AMPS	White	—

### Power module wire connections

Use the information in Table 5-2 and DETAIL B of drawing 2016-050 to connect power module wires.

**Table 5-2**  
*Power module wire colors*

Location	Wire color
Top wire	Gray
Right top	Violet
Right bottom	White
Left top	Red
Left bottom	Blue



## Changing trigger link lines

The Model 2016 uses two lines of the Trigger Link rear panel connector as External Trigger (EXT TRIG) input and Voltmeter Complete (VMC) output. At the factory, line 1 is configured as VMC and line 2 as EXT TRIG.

**NOTE** Line 1, 3, or 5 of the Trigger Link can be configured as VMC, while line 2, 4, or 6 can be configured as EXT TRIG.

You can change trigger link line configurations by moving the position of resistors inside the unit. Perform the following steps to change trigger link lines:

**WARNING** Make sure the instrument is disconnected from the power line and other equipment before performing the following procedure.

1. Remove the cover from the instrument as explained in “Case cover removal” earlier in this section.
2. The resistors used to select the trigger link lines are located next to the Trigger Link connector as shown in Figure 5-1. The “resistors” are actually solder beads that bridge PC-board pads. If the factory default lines are selected, the solder beads will be located at R270 (line 2, EXT TRIG) and R267 (line 1, VMC).
3. To change a trigger link line:
  - Use a soldering iron and solder sucker to remove the appropriate solder bead.
  - Using a solder with OA-based flux, apply a solder bead to the appropriate resistor location.
  - Replace the cover on the instrument.

**Figure 5-1**  
Trigger link line connections

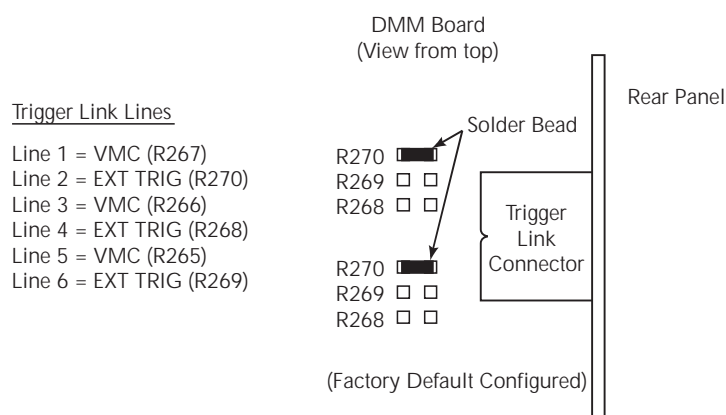

## Main CPU firmware replacement

Changing the firmware may be necessary as upgrades become available. The firmware revision levels for the main and front panel CPUs are displayed during the power-on sequence. (The main firmware revision level is displayed on the left; the front panel firmware revision level is displayed on the right.) For example: REV: A01 A02 indicates a main firmware revision level of A01 and a front panel firmware revision level of A02.

The firmware for the main CPU is located in the EPROMs U156 (EVEN) and U157 (ODD), leadless ICs that reside in chip carriers on the PC board. To replace the CPU firmware, do the following:

**WARNING** **Disconnect the instrument from the power lines and remove the test leads before changing the firmware.**

1. Remove the case cover as described earlier in this section.
2. Locate U156 EVEN and U157 ODD (EPROMs) on the DMM (106) board. They are the only devices installed in chip carriers (sockets).

**CAUTION** **EPROMs U156 and U157 are static-sensitive devices. Be sure to follow the handling precautions explained in Static sensitive devices.**

3. Using an appropriate chip extractor, remove U156 from its chip carrier.
4. Position the new U156 EPROM on the appropriate chip carrier. Make sure the notched corner of the chip is aligned with the notch in the chip carrier.

**NOTE** *Be sure to install the correct EPROMs at the ODD and EVEN locations. The instrument will not function if the EPROMs are installed in the wrong sockets.*

5. With the EPROM properly positioned, push down on the chip until it completely seats into the chip carrier.
6. Repeat steps 3 through 5 for EPROM U157.
7. After installation, make sure the instrument powers up normally before replacing the cover.



# 6 Replaceable Parts

## Introduction

This section contains replacement parts information and component layout drawings for the Model 2016.

## Parts lists

The electrical parts lists for the Model 2016 are shown in Tables 6-1 to 6-3. For part numbers to the various mechanical parts and assemblies, use the miscellaneous parts list in Table 6-4 and the assembly drawings provided at the end of Section 5.

## Ordering information

To place an order, or to obtain information concerning replacement parts, contact your Keithley representative or the factory (see inside front cover for addresses). When ordering parts, be sure to include the following information:

- Instrument model number (Model 2016)
- Instrument serial number
- Part description
- Component designation (if applicable)
- Keithley part number

## Factory service

If the instrument is to be returned to Keithley Instruments for repair, perform the following:

- Call the Repair Department at 1-800-552-1115 for a Return Material Authorization (RMA) number.
- Complete the service form at the back of this manual, and include it with the instrument.
- Carefully pack the instrument in the original packing carton.
- Write ATTENTION REPAIR DEPARTMENT and the RMA number on the shipping label.

## Component layouts

The following component layouts are provided in the following pages:

- Motherboard (DMM board): 2015-100
- Display board: 2010-110
- THD (DSP) board: 2015-130

**Table 6-1**  
DMM (mother) board parts list

Circuit designation	Description	Keithley part no.
AT101	IC, DUAL HIGH CMR/SPEED OPTO, HCPL-2631	IC-588
C102	CAP, .01UF, 10%, 1000V, CERAMIC	C-64-.01
C104	CAP, 100UF, 20%, 63V, ALUM ELEC	C-403-100
C105	CAP, .22UF, 20%, 400V, FILM	C-513-.22
C106	CAP, 15P, 1%, 100V, CERAMIC	C-512-15P
C107	CAP, .1UF, 20%, 50V, CERAMIC	C-418-.1
C108	CAP, .1UF, 20%, 100V, CERAMIC	C-436-.1
C109	CAP, 2.2UF, 20%, 63V, POLYCARB	C-480-2.2
C112,C248	CAP, .01, 5%, 50V, NPO	C-514-.01
C113,C114,C119,C126,C247	CAP, 1000P, 10%, 100V, CERAMIC	C-451-1000P
C115	CAP, .33UF, 20%, 63V, POLYCARBONATE	C-482-.33
C117,C147,C151,C191,C234,C237	CAP, .1UF, 20%, 50V, CERAMIC	C-418-.1
C120	CAP, 270PF, 5%, 100V, CERAMIC	C-465-270P
C121,C132,C134,C140	CAP, 220PF, 10%, 100V, CERAMIC	C-451-220P
C123,C245	CAP, 1000P, 10%, 100V, CERAMIC	C-451-1000P
C131,C148	CAP, 2200UF, 20%, 35V, ALUM ELEC	C-468-2200
C135,C203,C198,C183,C187,C197,C249	CAP, .1UF, 10%, 25V, CERAMIC	C-495-.1
C137	CAP, 33PF, 5%, 100V, CERAMIC	C-465-33P
C145	CAP, 1000pF, 20%, 50V, CERAMIC	C-418-1000P
C146	CAP, 3300UF, 20%, 16V, ALUM ELEC	C-473-3300
C153,111,225,122,118,155,116,202,227,210	CAP, .1UF, 10%, 25V, CERAMIC	C-495-.1
C156	CAP, 6800UF, -20+100%, 16V, ALUMINUM	C-313-6800
C157,C179	CAP, 100PF, 5%, 100V, CERAMIC	C-465-100P
C160,163,174,180,186,207,214-218,208	CAP, .1UF, 10%, 25V, CERAMIC	C-495-.1
C171,C177	CAP, 2200P, 10%, 100V, CERAMIC	C-430-2200P
C175	CAP, 10UF, 20%, 25V, TANTALUM	C-440-10
C178,167,172,169,161,103,128,223,250,149	CAP, .1UF, 10%, 25V, CERAMIC	C-495-.1
C194,182,199,200,136,233,232,193,170,201	CAP, .1UF, 10%, 25V, CERAMIC	C-495-.1
C204-206,190,173,139,138,162,125,152,142	CAP, .1UF, 10%, 25V, CERAMIC	C-495-.1

**Table 6-1**  
DMM (mother) board parts list (continued)

Circuit designation	Description	Keithley part no.
C209	CAP, 22UF, 20%, 25V, TANTALUM	C-440-22
C213,212,133,124,159,154,230,192,196,181	CAP, .1UF, 10%, 25V, CERAMIC	C-495-.1
C221,C168,C185	CAP, .1UF, 10%, 25V, CERAMIC	C-495-.1
C224,141,158,150,176,219,220,110,226,222	CAP, 47P, 5%, 100V, CERAMIC	C-465-47P
C241	CAP, .01UF, 10%, 50V, CERAMIC	C-491-.01
C242,C243	CAP, .01UF, 10%, 50V, CERAMIC	C-491-.01
C244,C240	CAP, 1000pF, 20%, 50V, CERAMIC	C-418-1000P
C251,C253	CAP, 47PF, 10%, 100V, CERAMIC	C-451-47P
C252	CAP, 22PF, 10%, 100V, CERAMIC	C-451-22P
C254,C263	CAP, 47P, 5%, 100V, CERAMIC	C-465-47P
C255,C256,C257,C258	CAP, 270PF, 5%, 100V, CERAMIC	C-465-270P
C264,C265	CAP, 22P, 5%, 100V, CERAMIC	C-465-22P
CR103,CR102	DIODE, BRIDGE, VM18	RF-52
CR104	DIODE, SILICON, W04M	RF-46
CR105,CR108,CR114	DIODE, SWITCHING, MMBD914	RF-83
CR106	DIODE, BRIDGE, PE05	RF-48
CR110,CR118	DIODE, DUAL, HSM-2822T31	RF-95
CR111,CR112,CR115,CR116,CR117	DIODE, DUAL SWITCHING, BAV99L	RF-82
E101,E102	SURGE ARRESTOR, CG3-1.5L	SA-4
J1006	CONN, MICRODIN W/GND FINGERS	CS-792
J1007	CONN, RT ANGLE, MALE, 9 PIN	CS-761-9
J1008	CONN, RIGHT ANGLE, 24 PIN	CS-501
J1014	CONN, HEADER STRAIGHT SOLDER PIN	CS-368-16
J1015	CONNECTOR, HEADER	CS-784-4
J1016	CONN, MALE, 5-PIN (MOLEX 42491) CONNECTOR, HEADER STRAIGHT	CS-784-5
J1017	SOLDER PIN	CS-368-14
J1022	LATCHING HEADER, FRICTON, SGL ROW	CS-724-3
J1024	LATCHING HEADER, 5-PIN	CS-724-5
J1026	CONN, BERG, 4-PIN	CS-724-4
K102,K101	RELAY, MINATURE (DPDT), TQ2E-L2-5V	RL-155
K103	RELAY, MINI SIGNAL REL	RL-163

**Table 6-1**  
DMM (mother) board parts list (continued)

Circuit designation	Description	Keithley part no.
L101,L103,L102,L104	FERRITE CHIP, 600 OHM, BLM32A07	CH-62
L105,L106	FERRITE CHIP, 600 OHM, BLM32A07	CH-62
L107,L108	CHOKE	CH-61
L109	CHOKE	CH-63-22
LS101	BEEPER, 5V, 30MA, BRT1209P-06-C	EM-5
Q101,Q102	TRANS, N-CHAN MOSFET, 2SK1412	TG-276
Q103,Q110,Q112,Q115,Q118,Q128,Q130	TRANS, NPN, MMBT3904	TG-238
Q104-109,113,114,120,123,124,125,126,135	TRANS, N CHANNEL JFET, SNJ132199	TG-294
Q116,Q111,Q129	TRANS, PNP, MMBT3906L	TG-244
Q117,Q121,Q122	N-CHANNEL SILICON JFET	TG-351
Q119	TRANS, P CHANNEL JFET, J270	TG-166
Q127,Q131,Q132,Q133	TRANS, N-MOSFET, VN0605T	TG-243
Q136	TRANS, N CHANNEL JFET, SNJ132199	TG-294
R101,R102	RES, 1M, 5%, 125MW, METAL FILM	R-375-1M
R103,107,108,113,120,121,124,125,132	RES, 24K, 5%, 1W, 200V, THICK FILM	R-437-24K
R104,R105	RES, 549K, .1%, 1/4W, METAL FILM	R-315-549K
R106	RES, 11K, .1%, 1/10W, METAL FILM	R-263-11K
R109	RES, 1K, 1%, 125mW, METAL FILM	R-391-1K
R110,R133	RES NET, 9K-1K, MICRO DIVIDER	TF-246-2
R114	RES, 604, 1%, 100MW, THICK FILM	R-418-604
R115	RES, 5K, .1%, WIREWOUND	R-249-5K
R122,R134,R272,R181	RES, 1K, 1%, 125mW, METAL FILM	R-391-1K
R123	RES, 73.2K, 1%, 100MW, THICK FILM	R-418-73.2K
R127	RES, 33.2K, 1%, 100MW, THICK FILM	R-418-33.2K
R129	RES, 215, 1%, 100MW, THICK FILM	R-418-215
R135	RES, 33.2K, 1%, 100MW, THICK FILM	R-418-33.2K
R139,R148,R163	RES, 24K, 5%, 1W, 200V, THICK FILM	R-437-24K
R140,R256,R299,R334	RES, 1K, 1%, 100MW, THICK FILM	R-418-1K
R142	RES, 10, 5%, 125MW, METAL FILM	R-375-10
R145,R156,R321,R322	RES, 100, 1%, 100MW, THICK FILM	R-418-100
R146	RES, 1.1M, 5%, 125MW, METAL FILM	R-375-1.1M
R147	RES, 732K,1%, 100MW, THICK FILM	R-418-732K

**Table 6-1**  
*DMM (mother) board parts list (continued)*

<b>Circuit designation</b>	<b>Description</b>	<b>Keithley part no.</b>
R149,R151	RES, 150, 1%, 100MW, THICK FILM	R-418-150
R150	RES, 25.5K, 1%, 100MW, THICK FILM	R-418-25.5K
R152,R143,R137	RES, 49.9K, 1%, 125MW, METAL FILM	R-391-49.9K
R153	RES NET, 3.6K MICRO DIVIDER	TF-246-1
R154,R230,R325,R326,R327,R328,R335, R337	RES, 49.9K, 1%, 100MW, THICK FILM	R-418-49.9K
R155	RES, 4.99K, 1%, 100MW, THICK FILM	R-418-4.99K
R157	RES, 511, 1%, 100MW, THICK FILM	R-418-511
R158	RES, .1, 1%, 2W, 4-TERMINAL MOLDED	R-342-.1
R159,R166,R185,R275,R307,R314	RES, 475, 1%, 125mW, METAL FILM	R-391-475
R164,R112	RES, 100K, 1%, 125mW, METAL FILM	R-391-100K
R168	RES, 1K, 5%, 250MW, METAL FILM	R-376-1K
R169,R214,R218	RES, 4.99K, 1%, 100MW, THICK FILM	R-418-4.99K
R172,R167,R160	RES, 1M, 1%, 100MW, THICK FILM	R-418-1M
R176,179,183,186,193,130,177,191,336	RES, 100K, 1%, 100MW, THICK FILM	R-418-100K
R178,184,187,161,213,257,248,308,331, 332	RES, 100, 1%, 100MW, THICK FILM	R-418-100
R188	RES, 49.9, 1%, 125mW, METAL FILM	R-391-49.9
R189	RES, 3.01K, 1%, 125MW, METAL FILM	R-391-3.01K
R192	RES, 6.98K, 1%, 125MW, METAL FILM	R-391-6.98K
R194	RES, 7.06K, 1%, .125W, METAL FILM	R-443-7.06K
R195	RES, 70.6K, 1%, .125W, METAL FILM	R-443-70.6K
R200,190,165,182,111,284,296,298,305, 279	RES, 1K, 1%, 100MW, THICK FILM	R-418-1K
R201,204,223,229,231,233,206,208-211	RES, 4.75K, 1%, 100MW, THICK FILM	R-418-4.75K
R202,R263,R249,R224,R319	RES, 10K, 1%, 100MW, THICK FILM	R-418-10K
R205	RES, 10, .5%, 1/8W, METAL FILM	R-246-10
R215	RES, 4.42K, 1%, 125MW, METAL FILM	R-391-4.42K
R216	RES, 2.21K, 1%, 125mW, METAL FILM	R-391-2.21K
R220,R221,R264,R212,R217,R329,R330	RES, 2.21K, 1%, 100MW, THICK FILM	R-418-2.21K
R225	RES, 470, 5%, 125MW, METAL FILM	R-375-470
R226,R228,R235,R237,R250,R252,R255	RES, 475, 1%, 100MW, THICK FILM	R-418-475
R234	RES, 5.11K, 1%, 100MW, THICK FILM	R-418-5.11K
R238,R244,R254,R293	RES, 4.75K, 1%, 100MW, THICK FILM	R-418-4.75K



**Table 6-1**  
DMM (mother) board parts list (continued)

<b>Circuit designation</b>	<b>Description</b>	<b>Keithley part no.</b>
R241	RES, 34K, 1%, 100MW, THICK FILM	R-418-34K
R243,R259	RES, 10, 10%, 100MW, THICK FILM	R-418-10
R245	RES, 475, 1%, 100MW, THICK FILM	R-418-475
R246	RES, 82.5, 1%, 100MW, THICK FILM	R-418-82.5
R261	RES, 200, 1%, 100MW, THICK FILM	R-418-200
R267,R270	RES, .0499, 1%, 100MW, THICK FILM	R-418-.0499
R271	RES NET	TF-245
R273,R274	RES, 475, 1%, 125mW, METAL FILM	R-391-475
R277	RES, 66.5K, 1%, 100MW, THICK FILM	R-418-66.5K
R280,R294	RES, 49.9, 1%, 100MW, THICK FILM	R-418-49.9
R283	RES, 470, 5%, 125MW, METAL FILM	R-375-470
R287	RES, 1.28M, .1%, 1/8W, METAL FILM	R-176-1.28M
R288,R289,R290,R333	RES, 1K, 1%, 100MW, THICK FILM	R-418-1K
R291,R292	RES, 47.5K, 1%, 100MW, THICK FILM	R-418-47.5K
R295,R118,R175,R276,R282	RES, 10K, 1%, 100MW, THICK FILM	R-418-10K
R297,R278,R281	RES, 357, 1%, 100MW, THICK FILM	R-418-357
R300	RES, 2.15K, 1%, 125MW, THIN FILM	R-423-2.15K
R302,R303	RES, 499, 1%, 100MW, THICK FILM	R-418-499
R304	RES, 20K, 1%, 100MW, THICK FILM	R-418-20K
R309	RES, 1K, .1%, 1/10W, METAL FILM	R-263-1K
R310	RES, 9.09K, .1%, 1/10W, METAL FILM	R-263-9.09K
R311	RES, 392, 1%, 100MW, THICK FILM	R-418-392
R312,R313	RES, 332K, 1%, 100MW, THICK FILM	R-418-332K
R315	RES, 100K, 1%, 100MW, THICK FILM	R-418-100K
R318	RES, 73.2K, 1%, 100MW, THICK FILM	R-418-73.2K
R320	RES, 10, 10%, 100MW, THICK FILM	R-418-10
R324	RES, 2K, 1%, 125mW, METAL FILM	R-391-2K
S101	SWITCH, PUSHBUTTON, 8 POLE	SW-468
TP102,TP103,TP104,TP105,TP106	CONN, TEST POINT	CS-553
U101	IC, VOLTAGE REG, LM317M	IC-846
U102,U118	IC, J-FET, OP-AMP, TLE2081CD	IC-967
U103,U105,U111,U129	IC, CMOS ANALOG SWITCH, DG211DY	IC-768
U104	IC, MOSFET DRIVER, TLP591B	IC-877

**Table 6-1**  
*DMM (mother) board parts list (continued)*

<b>Circuit designation</b>	<b>Description</b>	<b>Keithley part no.</b>
U106,U109,U121,U130,U134	IC, 8 STAGE SHIFT/STORE, MC14094BD	IC-772
U107,U108	IC, PHOTO, DARLINGTON TRANS, PS2506L-1	IC-911
U110	IC, TRMS TO DC CONVERTER, 637JR	IC-796
U112	IC, J-FET OP-AMP, LF357M	IC-966
U114	IC, DUAL J-FET OP-AMP, OP-282GS	IC-968
U116	IC, DARLINGTON ARRAY, ULN2003L	IC-969
U117,U145	IC, VOLT. COMPARATOR, LM311M	IC-776
U119	IC, NEG VOLTAGE REG, -15V, 500MA, 79M15	IC-195
U120,U131,U115	IC, QUAD COMPARATOR, LM339D	IC-774
U123	IC, DUAL PICOAMP OP-AMP, AD706JR	IC-910
U124	IC, +5V REGULATOR, 500MA, 7805	IC-93
U125	IC, POS VOLTAGE REG, +15V, 500MA, 78M15	IC-194
U126,U113	IC, OP-AMP, LTC1050CS8	IC-791
U133	IC, CMOS ANAL SWITCH, DG444DY	IC-866
U135	IC, 16BIT MICROPROCESSOR, MC68306FC16A	LSI-154
U136	IC, SERIAL EPROM, 24LC16B	LSI-153
U137,U166	IC, HI-SPEED BIFET OP-AMP, AD711JR	IC-894
U138,U132	IC, OPA177GS	IC-960
U139	IC, DUAL BIPOLAR OP-AMP, LT1124CS8	IC-955
U141	IC, PRECISION REFERENCE, LM399	196-600A
U142	IC, OP-AMP, NE5534D	IC-802
U144	IC, LOW DROPOUT REGULATOR, LM295T	IC-962
U146	IC, POS NAND GATES/INVERT, 74HCT14	IC-656
U147,U164	IC, DUAL D-TYPE F/F, 74HC74	IC-773
U148,U153	IC, QUAD 2 IN NOR, 74HCT02	IC-809
U149	IC, NCHAN LAT DMOS QUADFET, SD5400CY	IC-893
U150	IC, OPTOCOUPLER, 2611	IC-690
U151,U152	IC, 32KX8 STAT CMOS RAM, D43256C	LSI-93-100

**Table 6-1**  
DMM (mother) board parts list (continued)

Circuit designation	Description	Keithley part no.
U154	IC, QUAD D FLIP FLOP W/CLK, RESET 74HC175	IC-923
U155	IC, OPTOCOUPLER, 2601	IC-239
U156	PROGRAMMED ROM	2016-804*
U157	PROGRAMMED ROM	2016-803*
U158	IC, GPIB ADAPTER, 9914A	LSI-123
U159	IC, +5V RS-232 TRANSCEIVER, MAX202	IC-952
U160	IC, OCTAL INTERFACE BUS, 75160	IC-646
U161	IC, OCTAL INTER BUS TRANS, 75161	IC-647
U163	IC, 8-CHAN ANA MULTIPLEXER, DG408DY	IC-844
U165	PROGRAM	2000-802*
VR101,VR114	VAR, 576V METAL OXIDE	VR-5
VR102,VR117,VR118	DIODE, ZENER, 6.0V, BZX84B6V2	DZ-87
VR103,VR104	DIODE, ZENER, 6.8V, MMSZ5235BT1	DZ-100
VR105,VR106,VR115,VR116	DIODE, ZENER, 11V, MMSZ11T1	DZ-103
VR107,VR108	DIODE, ZENER, 3.3V, MMBZ5226BL	DZ-94
VR109	DIODE, ZENER, 17V, MMBZ5247BL	DZ-104
VR110	DIODE, ZENER, 5.1V, BZX84C5V1	DZ-88
VR112,VR113	DIODE, ZENER, 6.2V, MMSZ6V2	DZ-97
Y101	CRYSTAL	CR-55-1
Y102	OSCILLATOR, HIGH SPEED CMOS, 12MHZ	CR-37

\*Order current firmware revision (for example, B06).

**Table 6-2**  
*Display board parts list*

<b>Circuit designation</b>	<b>Description</b>	<b>Keithley part no.</b>
C401,402,411	CAP, .1UF, 20%, 50V, CERAMIC	C-418-.1
C403,404,405,407,409,410,412	CAP, .1UF, 10%, 25V, CERAMIC	C-495-.1
C406,408	CAP, 33PF, 10%, 100V, CERAMIC	C-451-33P
C413	CAP, 22UF, 20%, 6.3, TANTALUM	C-417-22
CR401,402	DIODE, MBR0520LT1	RF-103
DS401	DISPLAY	DD-52
P1014	CABLE ASSEMBLY	CA-123-16A
R401,402,403,404,406,409,411,414-416	RES, 15k, 1%, 100MW, THICK FILM	R-418-15K
R405,408,410,412	RES, 12.1, 1%, 125MW, METAL FILM	R-391-12.1
R413	RES, 13K, 1%, 100MW, THICK FILM	R-418-13K
R417,418	RES, 15k, 1%, 100MW, THICK FILM	R-418-15K
R419	RES, 10M, 5%, 125MW, METAL FILM	R-375-10M
R420,421	RES, 10K, 1%, 100MW, THICK FILM	R-418-10K
U401	PROGRAMMED ROM	2000-800*
U402,403	IC, LATCHED DRIVERS, UCN-5812EPF-1	IC-732
Y401	CRYSTAL, 4MHZ	CR-36-4M

\* Order current display firmware revision (for example, A02).

**Table 6-3**  
Distortion (DSP) board parts list

Circuit designation	Description	Keithley part no.
C301,352,508,310,532,538,571,505,319,322	CAP, .1UF, 10%, 25V, CERAMIC	C-495-.1
C302,C378-		
C387,C313,C323,C354,C560,C561	CAP, .01UF, 10%, 50V, CERAMIC	C-491-.01
C303,C325,C355,C399,C511,C550,C573,C344	CAP, 10U, 20%, 16V, TANTALUM	C-546-10
C304,C305,C396,C397	CAP, 2200P, 1%, 50V, CERAMIC	C-532-2200P
C308,345,315-318,327,356,306,340-343,349	CAP, .1UF, 10%, 25V, CERAMIC	C-495-.1
C309	CAP, 220PF, 10%, 100V, CERAMIC	C-451-220P
C324,C395	CAP, 7.5P, 10%, 100V, CERAMIC	C-452-7.5P
C326	CAP, 100U, 20%, 16V, ALUM ELEC	C-547-100
C329-338,506,507,509,533-537,570,312,314	CAP, .1UF, 10%, 25V, CERAMIC	C-495-.1
C339,C366	CAP, .1UF, 10%, 25V, CERAMIC	C-495-.1
C346,C347	CAP, 47UF, 20%, 100V, ALUM ELEC	C-521-47
C350	CAP, 4700U, 20%, 16V, ALUM ELEC	C-473-4700
C357,C388,C389,C353	CAP, .01UF, 10%, 50V, CERAMIC	C-491-.01
C358-C365,C307	CAP, 100PF, 5%, 100V, CERAMIC	C-465-100P
C367,C576	CAP, 22UF, 20%, 25V, TANTALUM	C-440-22
C377,C390,C391	CAP, 10U, 20%, 16V, TANTALUM	C-546-10
C392,500,504,510,512,519-522,532,321	CAP, .1UF, 10%, 25V, CERAMIC	C-495-.1
C503	CAP, 33PF, 5%, 100V, CERAMIC	C-465-33P
C513	CAP, .022U, 20%, 100V, FILM	C-576-.022
C514	CAP, 2200P, 1%, 50V, CERAMIC	C-532-2200P
C516	CAP, .1UF, 20%, 63V, POLYCARBONATE	C-482-.1
C518	CAP, .01, 5%, 50V, NPO	C-514-.01
C523,C524	CAP, 22P, 5%, 100V, CERAMIC	C-465-22P
C525	CAP, 1000P, 10%, 100V, CERAMIC	C-451-1000P
C527,C528,C572	CAP, 1000P, 10%, 100V, CERAMIC	C-451-1000P
C551-558,563,564,566,567,569,368-376,320	CAP, .1UF, 10%, 25V, CERAMIC	C-495-.1
C562,C565	CAP, 1000UF, 20%, 50V, ALUM ELEC	C-469-1000
C568	CAP, 2200UF, -20+100%, 25V, ALUM ELEC	C-314-2200
C574,C575	CAP, 10UF, 20%, 25V, TANTALUM	C-440-10
CR301	SCHOTTKY DIODE	RF-121
CR302,CR303	DIODE, SWITCHING, MMBD914	RF-83

**Table 6-3**  
Distortion (DSP) board parts list (continued)

<b>Circuit designation</b>	<b>Description</b>	<b>Keithley part no.</b>
CR306,CR307,CR308,CR309,CR310, CR311,305	DIODE, SWITCHING, MMSD914T19	RF-112
CR312,CR313	SCHOTTKY BARRIER DIODE	RF-108
CR330,CR331	DIODE, SILICON, W04M	RF-46
HS331	HEAT SINK	HS-55
J1018,J1019,J1021	CONNECTOR, HEADER	CS-784-6
J1020	CONN, MALE, 3 PIN	CS-784-3
J1028,J1029	CONN, BNC RIGHT ANGLE PLASTIC	CS-506
J1030	CONN, DUAL, 10-PIN-BERG	CS-389-8
J1031	CONN, MALE, 5-PIN (MOLEX 42491)	CS-784-5
K301	RELAY, MINI SIGNAL REL	RL-163
L301,302,303,305,311-313,315,318,323	FERRITE CHIP, 600 OHM, BLM32A07	CH-62
L306,L307,L308,L309	CHIP INDUCTOR	CH-90-5
L310,L319,L320,L321	FERRITE BEAD	CH-91
L314,L316,L317,L322	CHOKE	CH-61
P1017	CABLE ASSEMBLY	CA-27-19D
Q301	TRANS, N-MOSFET, VN0605T	TG-243
Q302	TRANS, PNP, MMBT3906L	TG-244
R301	RES, 2K, 1%, 100MW, THICK FILM	R-418-2K
R302,R303,R306,R307	RES, 1K, 1%, 100MW, THICK FILM	R-418-1K
R304,R305	RES, 49.9, 1%, 100MW, THICK FILM	R-418-49.9
R308,R310,R316	RES, 10, 10%, 100MW, THICK FILM	R-418-10
R309,R311,R313,R320,R557,R507,R508	RES, 100, 1%, 100MW, THICK FILM	R-418-100
R312	RES, 174, 1%, 100MW, THICK FILM	R-418-174
R322,R500	RES, 49.9, 1%, 100MW, THICK FILM	R-418-49.9
R323	RES, 30.1K, 1%, 100MW, THICK FILM	R-418-30.1K
R326	RES, 2K, .1%, .1W, THIN FILM	R-490-2K
R327	RES, 10K, .1%, .1W, THIN FILM	R-490-10K
R328,R523	RES, 2K, 1%, 100MW, THICK FILM	R-418-2K
R330,R331	RES, 2K, .1%, .1W, THIN FILM	R-490-2K
R338,R520,R530	RES, 10, 10%, 100MW, THICK FILM	R-418-10
R339,R342,R317,R534,R535,R318,R319,R314	RES, 100, 1%, 100MW, THICK FILM	R-418-100
R340,R343,R515,R537,R538,R539,R540	RES, 200, 1%, 100MW, THICK FILM	R-418-200

**Table 6-3**  
Distortion (DSP) board parts list (continued)

Circuit designation	Description	Keithley part no.
R341,R344,R527,R532,R533,R558	RES, 1K, 1%, 100MW, THICK FILM	R-418-1K
R345-R347,R360,R361,R363,550-552	RES, 2.21K, 1%, 100MW, THICK FILM	R-418-2.21K
R348-R351,R321,R357,R559	RES, 475, 1%, 100MW, THICK FILM	R-418-475
R352,R315,R354,R355,R356,R358,R362,353	RES, 475, 1%, 100MW, THICK FILM	R-418-475
R359,R518,R524	RES, 7.5K, 1%, 100MW, THICK FILM	R-418-7.5K
R396,R397,R398,R399	RES, 274, 1%, 100MW, THICK FILM	R-418-274
R501,R329,R332-334,R364-R390,512-514,546	RES, 10K, 1%, 100MW, THICK FILM	R-418-10K
R502	RES, 499K, 1%, 100MW, THICK FILM	R-418-499K
R503,R505	RES, 22.1K, .1%, .1W, THIN FILM	R-490-22.1K
R504,R506	RES, 22.1K, .1%, .1W, THIN FILM	R-490-22.1K
R509,R510,R511	RES, 10K, 1%, 100MW, THICK FILM	R-418-10K
R516	RES, 200, 1%, 100MW, THICK FILM	R-418-200
R517	RES, 20K, 1%, 100MW, THICK FILM	R-418-20K
R519	RES, 121K, 1%, 100MW, THICK FILM	R-418-121K
R525	RES, 15k, 1%, 100MW, THICK FILM	R-418-15K
R526	RES, 45.3K, 1%, 100MW, THICK FILM	R-418-45.3K
R531	RES, 1.37K, 1%, .1W, THICK FILM	R-418-1.37K
R536,R548	RES, 4.02K, 1%, 100MW, THICK FILM	R-418-4.02K
R541	RES, 100K, 1%, 100MW, THICK FILM	R-418-100K
R543	RES, 499K, 1%, 100MW, THICK FILM	R-418-499K
R544	RES, 7.5K, 1%, 100MW, THICK FILM	R-418-7.5K
R545	RES, 3.65K, 1%, 100MW, THICK FILM	R-418-3.65K
R547,553-555,542,R392-394,335,565	RES, 10K, 1%, 100MW, THICK FILM	R-418-10K
R549	RES, 1.74K, 1%, 100MW, THICK FILM	R-418-1.74K
R560,R521,R522	RES, .0499, 1%, 100MW, THICK FILM	R-418-.0499
R561	RES, 26.7K, 1%, 100MW, THICK FILM	R-418-26.7K
R562	RES, 66.5K, 1%, 100MW, THICK FILM	R-418-66.5K
R563	RES, 150K, 1%, 100MW, THICK FILM	R-418-150K
R564	RES, 110K, 1%, 100MW, THICK FILM	R-418-110K
RV301,RV302,RV303,RV304	TRANSIENT VOLTAGE SUPPRESSOR	VR-17
RV305	METAL-OXIDE VARISTOR	VR-18
RV306	METAL-OXIDE VARISTOR	VR-7

**Table 6-3**  
Distortion (DSP) board parts list (continued)

Circuit designation	Description	Keithley part no.
S0330	SOCKET, PLCC-032-T-A	SO-143-32
SO315,SO326,S0346	SOCKET	SO-72
TP301,TP308,TP309,TP304,TP310	CONN, TESTPOINT	CS-985
U301,U325	IC, CMOS, COMPLETE DOS SYNTHESIZER	IC-1141
U302	IC, 12-BIT VOLTAGE OUTPUT DAC	IC-1130
U303	IC, DIFF. AMP, AMP03GP	IC-988
U305,U306,U307,U308,U340,U341,U342, U343	IC, OP-AMP, MC34081BD	IC-1058
U309,U310,U335	IC, DUAL BIPOLAR/JFET OPAMP	IC-1203
U311	IC, 16-BIT CMOS SIGMA-DELTA ADC	LSI-216
U312,U313,U322,U323	IC, HEX SCHMITT INV TRIGG, 74HC14	IC-1103
U314,U327,U344	IC, FPGA, XC5202	LSI-193
U315	PROGRAMMED ROM	2015-806*
U316,U317,U318,U319,U320,U321,U324	IC, OPTOCOUPLER, 2601	IC-239
U326	PROGRAMMED ROM	2015-807*
U329	IC, DSP MICROCOMPUTER	LSI-217
U330	PROGRAMMED ROM	2015-805*
U331	IC, 5A POSITIVE FIXED REGULATOR	IC-1202
U332,U345	IC, SUPPLY VOLT SUPERVISOR, TL7705A	IC-860
U334	IC, 12-BIT SERIAL INPUT MULT DAC	IC-1245
U337,U338	IC, CMOS ANAL SWITCH, DG444DY	IC-866
U339	IC, J-FET, OP-AMP, TLE2081CD	IC-967
U346	PROGRAMMED ROM	2015-808*
U347	IC, VOLT. COMPARATOR, LM311M	IC-776
U348	IC, +15V VOLTAGE REGULATOR	IC-96
U349	IC, -15V VOLTAGE REG, 7915	IC-174
U350	IC, +5V REGULATOR, 500MA, 7805	IC-93
W301,W302,W303,W304	JUMPER	J-24-1
Y301	CRYSTAL, OSCILLATOR, 36MHZ	CR-56-3
Y302	CRYSTAL, OSCILLATOR, 32MHZ	CR-56-2
Y303	CRYSTAL, OSCILLATOR, 33MHZ	CR-56-1

\*Order current firmware revision (for example, A01).



**Table 6-4**  
Miscellaneous parts list

Qty.	Description	Keithley part no.
4	BANANA JACK, PUSH-IN BLACK	BJ-14-0
4	BANANA JACK, PUSH-IN RED	BJ-14-2
1	BEZEL, REAR	428-303D
1	CHASSIS	2015-30F
4	CHOKE	CH-58-1A
1	CONTACT, CURRENT INPUT	2001-313C
1	COVER	2000-307C
1	DISPLAY LENS	2016-311A
2	FOOT	428-319A
2	FOOT, EXTRUDED	FE-22A
2	FOOT, RUBBER	FE-6
1	FRONT PANEL, OVERLAY	2000-303B
1	FRONT PANEL, PRINTED	2015-305A
1	FRONT/REAR SWITCH ROD	2001-322A
1	FUSE HOLDER	FH-35-1
1	FUSE, .5A, 250V	FU-71
1	FUSE, 3A, 250V	FU-99-1
1	HANDLE	428-329F
2	HOLDER, FERRITE	2001-367A
1	JACK, CURRENT INPUT	2001-312D
1	JACK, CURRENT INPUT	V-2001-312D
1	LINE CORD	CO-7
1	MOTHERBOARD SHIELD	2000-306B
1	MOUNTING EAR, LEFT	428-338B
1	MOUNTING EAR, RIGHT	428-328E
1	POWER MODULE	PM-5-1A
1	POWER ROD	2001-320A
1	REAR PANEL	2015-303E
1	RFI CLIP, CHASSIS	2001-366-1A
1	SWITCHPAD	2015-314A
1	TEST LEADS	CA-22
1	TRANSFORMER	TR-328C
1	TRANSFORMER	TR-332A

---

# A Specifications

## DISTORTION CHARACTERISTICS

**VOLTAGE RANGE:** 100mV, 1V, 10V, 100V, 750V (user selectable).

**INPUT IMPEDANCE:** 1M $\Omega$  paralleled by <100pF

**DISPLAY RANGE:** 0–100% or 0–100.00dB.

**RESOLUTION:** 0.0001% or 0.00001dB.

**FUNDAMENTAL FREQUENCY RANGE:** 20Hz–20kHz.

**HARMONIC FREQUENCY RANGE:** 40Hz–50kHz.

**FREQUENCY RESOLUTION:** 0.008Hz.

**FREQUENCY ACCURACY:**  $\pm 0.01\%$  of reading.

**FREQUENCY TEMPERATURE COEFFICIENT:**  $\leq 100$ ppm over operating temperature range.

MEASUREMENT MODE	ACCURACY (1 Year, 23°C $\pm 5^\circ$ C)	RESIDUAL DISTORTION <sup>1</sup>
THD and individual harmonic magnitudes	$\pm 0.8$ dB, 20Hz to 20kHz <sup>2</sup>	0.004% or $-87$ dB 20Hz to 20kHz
THD + n	$\pm 1.5$ dB, 100Hz to 20kHz <sup>2</sup>	0.056% or $-65$ dB 20Hz to 20kHz
SINAD	$\pm 1.5$ dB 100Hz to 20kHz <sup>2</sup>	$+65$ dB 20Hz to 20kHz
AC Level V rms	$\pm(0.13\%$ of reading + 0.009% of range) 20Hz to 20kHz	

### Distortion Measurement Audio Filters

None	C-Message
CCITT Weighting	CCIR/ARM
CCIR	“A” Weighting

**NUMBER OF HARMONICS INCLUDED IN THD CALCULATION:** 2 to 64 (user selectable).

**HI AND LO CUTOFF FILTERS (bus settable):** 20Hz–50kHz. Can be combined to form brickwall bandpass filter.

### Distortion Measurement Reading Rate<sup>3</sup>

FUNDAMENTAL FREQUENCY ACQUISITION MODE	FUNDAMENTAL FREQUENCY RANGE	MINIMUM READINGS PER SECOND
Single acquisition or stored value	20 Hz to 100 Hz	14
	100 Hz to 1 kHz	24
	1 kHz to 20 kHz	28
Automatic	20 Hz to 30 Hz	5.5
	30 Hz to 400 Hz	6
	400 Hz to 20 kHz	6.6

### Frequency Sweep Reading Rate

NUMBER OF FREQUENCIES	TIME (seconds) <sup>4</sup>
5	0.2
30	1.1
100	3.5
200	6.9

## Notes

1. Input signal at full scale.
2.  $V_{IN} \geq 20\%$  of range and harmonics  $> -65\text{dB}$ .
3. Speeds are for default operating conditions (\*RST), and display off, auto range off, binary data transfer, trig delay = 0.
4. Typical times: frequencies in 400–4kHz range, binary data transfer, TRIG DELAY = 0, Display OFF, Auto Range OFF. Data returned is THD measurement plus AC voltage.

---

## GENERATOR CHARACTERISTICS

**FREQUENCY RANGE:** 10–20kHz.

**FREQUENCY RESOLUTION:** 0.007Hz.

**FREQUENCY ACCURACY:**  $\pm(0.015\%$  of reading + 0.007Hz)<sup>1</sup>.

**FREQUENCY TEMPERATURE COEFFICIENT:** <100ppm over operating temperature range.

### SOURCE OUTPUT:

**Waveform:** Sinewave.

**Amplitude Range:** 2V rms (50Ω and 600Ω) or 9.5V rms (HI Z).

**Amplitude Resolution:** 1.25mV rms (50Ω and 600Ω) or 2.5mV rms (HI Z).

**Amplitude Accuracy:**  $\pm(0.3\%$  of setting + 5mV)<sup>1,4</sup>.

**Amplitude Temperature Coefficient:** Typically 0.015%/°C.

**Amplitude Flatness:**  $\pm 0.1\text{dB}^{1,4,5}$ .

**Output Impedance:** 50Ω  $\pm$  1Ω or 600Ω  $\pm$  10Ω, user selectable.

**THD:**  $-64\text{dB}^6$ .

**Noise:** 250μV rms<sup>2</sup>.

**DC Offset Voltage:**  $\pm 3\text{mV}^1$ .

### INV/PULSE OUTPUT (SINEWAVE MODE):

**Frequency:** Same as source output.

**Amplitude Range:** 2V rms (50Ω and 600Ω) or 9.5V rms (HI Z).

**Amplitude Resolution:** 1.25mV (50Ω and 600Ω) or 2.5mV rms (HI Z).

**Amplitude Accuracy:**  $\pm(2.0\%$  of setting + 5mV)<sup>1,4</sup>.

**Amplitude Flatness:**  $\pm 0.1\text{dB}^{1,4,5}$ .

**Output Impedance:** Same as Source Output setting.

**THD:**  $-64\text{dB}^6$ .

**Noise:** 250μV rms<sup>2</sup>.

**DC Offset Voltage:**  $\pm 3\text{mV}$  typ.,  $\pm 13\text{mV}$  max.<sup>1</sup>

### INV/PULSE OUTPUT (PULSE MODE):

**Frequency:** Same as source output.

**Duty Cycle:** 45%  $\pm$  3%.

**Output Impedance:** Same output impedance as the source output.

**Amplitude:** 0.0V  $\pm$  0.07V to 4.9V  $\pm$  0.12V pulse open circuit<sup>1,3</sup>.  
0.0V  $\pm$  0.05V to 3.3V  $\pm$  0.08V pulse 100Ω load<sup>1,3</sup>.

**Overshoot:** 1.0V maximum pulse open circuit<sup>3</sup>.  
0.2V maximum with 100Ω load pulse open circuit<sup>3</sup>.

**Undershoot:** 1.1V maximum pulse open circuit<sup>3</sup>.  
0.45V maximum with 100Ω load pulse open circuit<sup>3</sup>.

**Notes**

1. 1 year, 23°C ±5°C.
2. Measured at  $V_{OUT} = 0V$  with gain 100 amplifier and 2-pole 50kHz low pass filter, Inv/Pulse in sinewave mode, HI Z output impedance, and no load.
3. With HI Z output impedance and 1m 50Ω coaxial cable.
4. HI Z output impedance, no load.
5. 4V output.
6. THD measurement includes harmonics 2 through 5, 1V rms output, HI Z, no load.

**DC CHARACTERISTICS**

CONDITIONS: MED (1 PLC)1 OR SLOW (10 PLC)  
OR MED (1 PLC) WITH FILTER OF 10

ACCURACY: ±(ppm of reading + ppm of range)  
(ppm = parts per million) (e.g., 10ppm = 0.001%)

FUNCTION	RANGE	RESOLUTION	TEST CURRENT OR BURDEN		INPUT RESISTANCE	24 HOUR <sup>14</sup> 23°C ± 1°	90 DAY 23°C ± 5°	1 YEAR 23°C ± 5°	TEMPERATURE COEFFICIENT 0°–18°C & 28°–50°C
			VOLTAGE	VOLTAGE					
VOLTAGE	100.0000 mV	0.1 μV			> 10 GΩ	30 + 30	40 + 35	50 + 35	2 + 6
	1.000000 V	1.0 μV			> 10 GΩ	15 + 6	25 + 7	30 + 7	2 + 1
	10.00000 V	10 μV			> 10 GΩ	15 + 4	20 + 5	30 + 5	2 + 1
	100.0000 V	100 μV			10 MΩ ±1%	15 + 6	30 + 6	45 + 6	5 + 1
	1000.000 V <sup>9</sup>	1 mV			10 MΩ ±1%	20 + 6	35 + 6	45 + 6	5 + 1
RESISTANCE <sup>15</sup>	100.0000 Ω	100 μΩ		1 mA		30 + 30	80 + 40	100 + 40	8 + 6
	1.000000 kΩ	1 mΩ		1 mA		20 + 6	80 + 10	100 + 10	8 + 1
	10.00000 kΩ	10 mΩ		100 μA		20 + 6	80 + 10	100 + 10	8 + 1
	100.0000 kΩ	100 mΩ		10 μA		20 + 6	80 + 10	100 + 10	8 + 1
	1.000000 MΩ	1 Ω		10 μA		20 + 6	80 + 10	100 + 10	8 + 1
	10.00000 MΩ <sup>11</sup>	10 Ω		700 nA // 10MΩ		150 + 6	200 + 10	400 + 10	25 + 1
100.0000 MΩ <sup>11</sup>	100 Ω		700 nA // 10MΩ		800 + 30	1500 + 30	1500 + 30	150 + 1	
CURRENT	10.00000 mA	10 nA		< 0.15 V		60 + 15	300 + 40	500 + 40	50 + 5
	100.0000 mA	100 nA		< 0.03 V		100 + 150	300 + 400	500 + 400	50 + 50
	1.000000 A	1 μA		< 0.3 V		200 + 15	500 + 40	800 + 40	50 + 5
	3.000000 A	10 μA		< 1 V		1000 + 10	1200 + 15	1200 + 15	50 + 5
CONTINUITY 2W	1 kΩ	100 mΩ		1 mA		40 + 100	100 + 100	120 + 100	8 + 1
DIODE TEST	3.00000 V	10 μV		1 mA		20 + 6	30 + 7	40 + 7	8 + 1
	10.00000 V	10 μV		100 μA		20 + 6	30 + 7	40 + 7	8 + 1
	10.00000 V	10 μV		10 μA		20 + 6	30 + 7	40 + 7	8 + 1

**DC OPERATING CHARACTERISTICS<sup>2</sup>**

FUNCTION	DIGITS	READINGS/s	PLCs <sup>8</sup>
DCV (all ranges),	6½ <sup>3,4</sup>	5	10
DCI (all ranges), and	6½ <sup>3,7</sup>	30	1
2W Ohms (<10M range)	6½ <sup>3,5</sup>	50	1
	5½ <sup>3,5</sup>	270	0.1
	5½ <sup>5</sup>	500	0.1
	5½ <sup>5</sup>	1000	0.04
	4½ <sup>5</sup>	2000	0.01

**DC SYSTEM SPEEDS<sup>2,6</sup>**

RANGE CHANGE<sup>3</sup>: 50 / s.

FUNCTION CHANGE<sup>3</sup>: 45 / s.

AUTORANGE TIME<sup>3,10</sup>: <30 ms.

ASCII READINGS TO RS-232 (19.2K BAUD): 55 / s.

MAX. INTERNAL TRIGGER RATE: 2000 / s.

MAX. EXTERNAL TRIGGER RATE: 400 / s.

**DC GENERAL**

LINEARITY OF 10VDC RANGE:  $\pm(2\text{ppm of reading} + 1\text{ppm of range})$ .

DCV,  $\Omega$ , TEMPERATURE, CONTINUITY, DIODE TEST INPUT PROTECTION: 1000V, all ranges.

MAXIMUM 4W $\Omega$  LEAD RESISTANCE: 10% of range per lead for 100 $\Omega$  and 1k $\Omega$  ranges; 1k $\Omega$  per lead for all other ranges.

DC CURRENT INPUT PROTECTION: 3A, 250V fuse.

SHUNT RESISTOR: 0.1 $\Omega$  for 3A, 1A and 100mA ranges. 10 $\Omega$  for 10mA range.

CONTINUITY THRESHOLD: Adjustable 1 $\Omega$  to 1000 $\Omega$ .

AUTOZERO OFF ERROR: Add  $\pm(2\text{ppm of range error} + 5\mu\text{V})$  for <10 minutes and  $\pm 1^\circ\text{C}$  change.

OVERRANGE: 120% of range except on 1000V, 3A and Diode.

**SPEED AND NOISE REJECTION**

RATE	READINGS/S	DIGITS	RMS NOISE 10V RANGE	NMRR <sup>12</sup>	CMRR <sup>13</sup>
10 PLC	5	6½	< 1.5 $\mu\text{V}$	60 dB	140 dB
1 PLC	50	6½	< 4 $\mu\text{V}$	60 dB	140 dB
0.1 PLC	500	5½	< 22 $\mu\text{V}$	—	80 dB
0.01 PLC	2000	4½	< 150 $\mu\text{V}$	—	80 dB

**DC Notes**

- Add the following to ppm of range accuracy specification based on range: 1V and 100V, 2ppm; 100mV, 15ppm; 100 $\Omega$ , 15ppm; <1M $\Omega$ , 2ppm; 10mA and 1A, 2ppm; 100mA, 20ppm.
- Speeds are for 60 Hz operation using factory default operating conditions (\*RST). Autorange off, Display off, Trigger delay = 0.
- Speeds include measurement and binary data transfer out the GPIB.
- Auto zero off.
- Sample count = 1024, auto zero off.
- Auto zero off, NPLC = 0.01.
- Ohms = 24 readings/second.
- 1 PLC = 16.67ms @ 60Hz, 20ms @ 50Hz/400Hz. The frequency is automatically determined at power up.
- For signal levels >500V, add 0.02ppm/V uncertainty for the portion exceeding 500V.
- Add 120ms for ohms.
- Must have 10% matching of lead resistance in Input HI and LO.
- For line frequency  $\pm 0.1\%$ .
- For 1k $\Omega$  unbalance in LO lead.
- Relative to calibration accuracy.
- Specifications are for 4-wire ohms or 2-wire ohms with REL function.

**TRUE RMS AC VOLTAGE AND CURRENT CHARACTERISTICS**ACCURACY <sup>1</sup>:  $\pm$ (% of reading + % of range), 23°C  $\pm$ 5 °C

VOLTAGE RANGE	RESOLUTION	CALIBRATION CYCLE	3 Hz–10 Hz	10 Hz–20 kHz	20 kHz–50 kHz	50 kHz–100 kHz	100 kHz–300 kHz
100.0000 mV	0.1 $\mu$ V						
1.000000 V	1.0 $\mu$ V	90 Days	0.35 + 0.03	0.05 + 0.03	0.11 + 0.05	0.60 + 0.08	4 + 0.5
10.000000 V	10 $\mu$ V						
100.0000 V	100 $\mu$ V	1 Year	0.35 + 0.03	0.06 + 0.03	0.12 + 0.05	0.60 + 0.08	4 + 0.5
750.000 V	1 mV						
TEMPERATURE COEFFICIENT <sup>8</sup>			0.035 + 0.003	0.005 + 0.003	0.006 + 0.005	0.01 + 0.006	0.03 + 0.01

CURRENT RANGE	RESOLUTION	CALIBRATION CYCLE	3 Hz - 10 Hz	10 Hz - 5 kHz
1.000000 A	1 $\mu$ A	90 Day/1 Year	0.30 + 0.04	0.10 + 0.04
3.000000 A	10 $\mu$ A	90 Day/1 Year	0.35 + 0.06	0.15 + 0.06
TEMPERATURE COEFFICIENT <sup>8</sup>			0.035 + 0.006	0.015 + 0.006

**HIGH CREST FACTOR ADDITIONAL ERROR  $\pm$ (% of reading) <sup>7</sup>**

CREST FACTOR:	1–2	2–3	3–4	4–5
ADDITIONAL ERROR:	0.05	0.15	0.30	0.40

**AC OPERATING CHARACTERISTICS <sup>2</sup>**

FUNCTION	DIGITS	READINGS/s	RATE	BANDWIDTH
ACV (all ranges), and	6½ <sup>3</sup>	2s/reading	SLOW	3 Hz–300 kHz
ACI (all ranges)	6½ <sup>3</sup>	1.4	MED	30 Hz–300 kHz
	6½ <sup>4</sup>	4.8	MED	30 Hz–300 kHz
	6½ <sup>3</sup>	2.2	FAST	300 Hz–300 kHz
	6½ <sup>4</sup>	35	FAST	300 Hz–300 kHz

**ADDITIONAL LOW FREQUENCY ERRORS  $\pm$ (% of reading)**

	SLOW	MED	FAST
20Hz – 30Hz	0	0.3	—
30Hz – 50Hz	0	0	—
50Hz – 100Hz	0	0	1.0
100Hz – 200Hz	0	0	0.18
200Hz – 300Hz	0	0	0.10
> 300Hz	0	0	0

**AC SYSTEM SPEEDS <sup>2,5</sup>**FUNCTION/RANGE CHANGE<sup>6</sup>: 4 / s.

AUTORANGE TIME: &lt;3 s.

ASCII READINGS TO RS-232 (19.2K BAUD)<sup>4</sup>: 50 / s.MAX. INTERNAL TRIGGER RATE<sup>4</sup>: 300 / s.MAX. EXTERNAL TRIGGER RATE<sup>4</sup>: 260 / s.

---

## AC GENERAL

**INPUT IMPEDANCE:** 1M $\Omega$   $\pm$ 2% paralleled by <100pF.  
**ACV INPUT PROTECTION:** 1000Vp.  
**MAXIMUM DCV:** 400V on any ACV range.  
**ACI INPUT PROTECTION:** 3A, 250V fuse.  
**BURDEN VOLTAGE:** 1A Range: <0.3V rms. 3A Range: <1V rms.  
**SHUNT RESISTOR:** 0.1 $\Omega$  on all ACI ranges.  
**AC CMRR:** >70dB with 1k $\Omega$  in LO lead.  
**MAXIMUM CREST FACTOR:** 5 at full scale.  
**VOLT HERTZ PRODUCT:**  $\leq 8 \times 10^7$  V·Hz.  
**OVERRANGE:** 120% of range except on 750V and 3A ranges.

## AC Notes

- Specifications are for SLOW rate and sinewave inputs >5% of range.
- Speeds are for 60 Hz operation using factory default operating conditions (\*RST). Auto zero off, Auto range off, Display off, includes measurement and binary data transfer out the GPIB.
- 0.01% of step settling error. Trigger delay = 400ms.
- Trigger delay = 0.
- DETECTOR:BANDwidth 300, NPLC = 0.01.
- Maximum useful limit with trigger delay = 175ms.
- Applies to non-sinewaves >5Hz.
- Applies to 0°–18°C and 28°–50°C.

---

## TRIGGERING AND MEMORY

**READING HOLD SENSITIVITY:** 0.01%, 0.1%, 1%, or 10% of reading.  
**TRIGGER DELAY:** 0 to 99 hrs (1ms step size).  
**EXTERNAL TRIGGER LATENCY:** 200 $\mu$ s + <300 $\mu$ s jitter with autozero off, trigger delay = 0.  
**MEMORY:** 1024 readings.

---

## MATH FUNCTIONS

Rel, Min/Max/Average/StdDev (of stored reading), dB, dBm, Limit Test, %, and mX+b with user defined units displayed.  
**dBm REFERENCE RESISTANCES:** 1 to 9999 $\Omega$  in 1 $\Omega$  increments.

---

## STANDARD PROGRAMMING LANGUAGES

SCPI (Standard Commands for Programmable Instruments)

---

## REMOTE INTERFACE

GPIB (IEEE-488.1, IEEE-488.2) and RS-232C.

---

## FREQUENCY AND PERIOD CHARACTERISTICS<sup>1,2</sup>

ACV RANGE	FREQUENCY RANGE	PERIOD RANGE	GATE TIME	RESOLUTION $\pm$ (ppm of reading)	ACCURACY 90 DAY/1 YEAR $\pm$ (% of reading)
100 mV	3 Hz	333 ms	1 s (SLOW)	0.333	0.01
to	to	to	0.1 s (MED)	3.33	0.01
750 V	500 kHz	2 $\mu$ s	10 ms (FAST)	33.3	0.01



## Frequency Notes

1. Specifications are for squarewave inputs >10% of ACV range, except 100mV range. On 100mV range frequency must be >10Hz if voltage is <20mV.
2. 20% overrange on all ranges except 750V range.

## TEMPERATURE CHARACTERISTICS

THERMOCOUPLE <sup>2,3,4</sup>		90 DAY/1 YEAR (23°C ± 5°C) Relative to Reference Junction		ACCURACY <sup>1</sup>
TYPE	RANGE	RESOLUTION	Reference Junction	
J	-200 to + 760°C	0.001°C	±0.5°C	
K	-200 to + 1372°C	0.001°C	±0.5°C	
T	-200 to + 400°C	0.001°C	±0.5°C	

## Temperature Notes

1. For temperatures <-100°C, add ±0.1°C and >900°C add ±0.3°C.
2. Temperature can be displayed in °C, K or °F.
3. Accuracy based on ITS-90.
4. Exclusive of thermocouple error.

## GENERAL SPECIFICATIONS

**POWER SUPPLY:** 100V / 120V / 220V / 240V ±10%.

**LINE FREQUENCY:** 45Hz to 66Hz, automatically sensed at power-up.

**POWER CONSUMPTION:** 25 VA.

**OPERATING ENVIRONMENT:** Specified for 0°C to 50°C. Specified to 80% R.H. at 35°C.

**STORAGE ENVIRONMENT:** -40°C to 70°C.

**WARRANTY:** 3 years.

**SAFETY:** Conforms with European Union Directive 73/23/EEC, EN 610110-1, UL 3111-1.

**EMC:** Conforms with European Union Directive 89/336/EEC, EN 55011, EN 50082-1, EN 61000-3-2, EN 61000-3-3, FCC part 15 class B.

**WARMUP:** 1 hour to rated accuracy.

**DIMENSIONS: Rack Mounting:** 89mm high × 213mm wide × 370mm deep (3½ in × 8¾ in × 14⅞ in).

**Bench Configuration (with handle and feet):** 104mm high × 238mm wide × 370mm deep (4¼ in × 9¾ in × 14⅞ in).

**NET WEIGHT:** 4.2kg (8.8 lbs).

**SHIPPING WEIGHT:** 5kg (11 lbs).

**VOLT HERTZ PRODUCT:** ≤8 × 10<sup>7</sup>V·Hz.

**ACCESSORIES SUPPLIED:** Model 1751 Safety Test Leads, User Manual, Service Manual.

## Accuracy calculations

The information below discusses how to calculate accuracy for both DC and AC characteristics.

### Calculating DC characteristics accuracy

DC characteristics accuracy is calculated as follows:

$$\text{Accuracy} = \pm(\text{ppm of reading} + \text{ppm of range})$$

(ppm = parts per million, and 10ppm = 0.001%)

As an example of how to calculate the actual reading limits, assume that you are measuring 5V on the 10V range. You can compute the reading limit range from one-year DCV accuracy specifications as follows:

$$\begin{aligned} \text{Accuracy} = & \pm(30\text{ppm of reading} + 5\text{ppm of range}) \\ & \pm[(30\text{ppm} \times 5\text{V}) + (5\text{ppm} \times 10\text{V})] \\ & \pm(150\mu\text{V} + 50\mu\text{V}) \\ & \pm 200\mu\text{V} \end{aligned}$$

Thus, the actual reading range is:  $5\text{V} \pm 200\mu\text{V}$ , or from 4.9998V to 5.0002V.

DC current and resistance calculations are performed in exactly the same manner using the pertinent specifications, ranges, and input signal values.

### Calculating AC characteristics accuracy

AC characteristics accuracy is calculated similarly, except that AC specifications are given as follows:

$$\text{Accuracy} = \pm(\% \text{ of reading} + \% \text{ of range})$$

As an example of how to calculate the actual reading limits, assume that you are measuring 120V, 60Hz on the 750V range. You can compute the reading limit range from ACV one-year accuracy specifications as follows:

$$\begin{aligned} \text{Accuracy} = & \pm(0.06\% \text{ of reading} + 0.03\% \text{ of range}) \\ & \pm[(0.0006 \times 120\text{V}) + (0.0003 \times 750\text{V})] \\ & \pm(0.072\text{V} + 0.225\text{V}) \\ & \pm 0.297\text{V} \end{aligned}$$

In this case, the actual reading range is:  $120\text{V} \pm 0.297\text{V}$ , or from 119.703V to 120.297V.

AC current calculations are performed in exactly the same manner using the pertinent specifications, ranges, and input signal values.

## Calculating dBm characteristics accuracy

As an example of how to calculate the actual reading limits for a 13dBm measurement with a reference impedance of  $50\Omega$ , assume an applied signal 0.998815V. The relationship between voltage and dBm is as follows:

$$dBm = 10 \log \frac{V_{IN}^2 / R_{REF}}{1mW}$$

From the previous example on calculating DC characteristics accuracy, it can be shown that a measurement of 0.998815V on the 1V range has an uncertainty of  $\pm 36.9644mV$ , or 0.998778V to 0.998852V, using one-year specifications.

Expressing 0.998778V as dBm:

$$dBm = 10 \log \frac{(0.998778V)^2 / 50\Omega}{1mW} = 12.99968dBm$$

and expressing 0.998852V as dBm:

$$dBm = \frac{(0.998852V)^2 / 50\Omega}{1mW} = 13.00032dBm$$

Thus, the actual reading range is 13dBm  $\pm 0.00032dBm$ .

dBm and dB for other voltage inputs can be calculated in exactly the same manner using pertinent specifications, ranges, and reference impedances.

## Calculating dB characteristics accuracy

The relationship between voltage and dB is as follows:

$$dB = 20 \log \frac{V_{IN}}{V_{REF}}$$

As an example of how to calculate the actual readings limits for dB, with a user-defined VREF of 10V, you must calculate the voltage accuracy and apply it to above equation.

To calculate a -60dB measurement, assume 10mV RMS for a VREF of 10V. Using the 100mV range, one-year, 10Hz - 20kHz frequency band, and SLOW rate, the voltage limits are as follows:

$$\begin{aligned} \text{Accuracy} = & \pm[(0.06\% \text{ of reading}) + (0.03\% \text{ of range})] \\ & \pm[(0.0006 \times 10mV) + (0.0003 \times 100mV)] \\ & \pm[6\mu V + 30\mu V] \\ & \pm 36\mu V \end{aligned}$$

Thus, the actual reading accuracy is  $10\text{mV} \pm 36\text{mV}$  or  $10.036\text{mV}$  to  $9.964\text{mV}$ . Applying the voltage reading accuracy into the dB equation yields:

$$dBm = 20 \log \frac{10.036\text{mV}}{10\text{V}} = -59.96879\text{dB}$$

$$dBm = 20 \log \frac{9.964\text{mV}}{10\text{V}} = -60.03133\text{dB}$$

Thus, the actual reading accuracy is  $-60\text{dB} + 0.031213\text{dB}$  to  $-60\text{dB} - 0.031326\text{dB}$ .

dBm and dB for other voltage inputs can be calculated in exactly the same manner using pertinent specifications, ranges, and other reference voltages.

## Distortion characteristics

### Distortion figure conversion

Distortion figures can be specified either as a percentage or in dB. You can convert from one form to another as follows:

$$D_{dB} = -20 \log \frac{100}{D_p}$$

Where:  $D_{dB}$  = distortion expressed in dB  
 $D_p$  = distortion as a percentage

For example, the Model 2016 residual distortion specification of 0.004% can be converted to dB as follows:

$$D_{dB} = -20 \log \frac{100}{0.004}$$

$$D_{dB} = -87.96\text{dB}$$

## Calculating generator amplitude accuracy

Function generator amplitude accuracy is rated at  $\pm(0.3\%$  of setting  $+5\text{mV})$ , 9.5V rms HIZ. For example, assuming an amplitude setting of 5V RMS, the actual output may be calculated as follows:

$$\begin{aligned}\text{Amplitude accuracy} &= \pm(0.3\% \text{ of setting} + 5\text{mV}) \\ &= \pm[(0.3\% \times 5) + 5\text{mV}] \\ &= \pm 20\text{mV}\end{aligned}$$

Thus, the actual output amplitude ranges from 4.98V to 5.02V.

## Additional derating factors

In some cases, additional derating factors must be applied to calculate certain accuracy values. For example, an additional derating factor of 0.02ppm/V must be added to DCV specifications for voltages over 500V. Before calculating accuracy, study the associated specifications very carefully to see if any derating factors apply.

## Optimizing measurement accuracy

The configurations listed below assume that the multimeter has had factory setups restored.

### DC voltage, DC current, and resistance:

- Select 6-1/2 digits, 10 PLC, filter ON (up to 100 readings), fixed range.
- Use REL on DC voltage and 2-wire resistance measurements.
- Use 4-wire resistance measurements for best accuracy.

### AC voltage and AC current:

- Select 6-1/2 digits, 10 PLC, filter ON (up to 100 readings), fixed range.

### Temperature:

- Select 6-1/2 digits, 10 PLC, filter ON (up to 100 readings).

## Optimizing measurement speed

The configurations listed below assume that the multimeter has had factory setups restored.

### DC voltage, DC current, and resistance:

- Select 3-1/2 digits, 0.01 PLC, filter OFF, fixed range.

### AC voltage and AC current:

- Select 3-1/2 digits, 0.01 PLC, filter OFF, fixed range.

### Temperature:

- Select 3-1/2 digits, 0.01 PLC, filter OFF.

For all functions, turn off the display and autozero, and set the trigger delay to zero. Use the :SAMPLE:COUNt and READ? bus commands.



# **B** Calibration Reference



## **Introduction**

This appendix contains detailed information about the various Model 2016 remote calibration commands. Section 2 of this manual covers detailed calibration procedures. For information about additional commands to control other instrument functions, refer to the Model 2016 User's Manual.

# Command summary

Table B-1 summarizes Model 2016 calibration commands.

**Table B-1**  
Remote calibration command summary

Command <sup>2</sup>	Description
:CALibration	Calibration root command.
:PROTeCted	All commands in this subsystem are protected by the calibration lock (except queries and :CODE).
:CODE <up to 8 char. string>	Calibration code or password (default: KI002016).
:COUNT?	Request the number of times the unit has been calibrated.
:INITiate	Initiate calibration.
:LOCK	Lock out calibration (opposite of enabling cal with :CODE command).
:LOCK?	Request comprehensive cal lock state. (0 = locked; 1 = unlocked).
:SAVE	Save cal constants to EEROM.
:DATE <year>, <month>, <day>	Send cal date to 2016.
:DATE?	Request cal date from 2016.
:NDUE <year>, <month>, <day>	Send next due cal date to 2016.
:NDUE?	Request next due cal date from 2016.
:DC	DC cal steps.
:STEP0	Rear terminal short step <sup>1</sup> .
:STEP1	Front terminal short circuit.
:STEP2	Open circuit.
:STEP3 <NRf>	10V DC step.
:STEP4 <NRf>	-10V DC step.
:STEP5 <NRf>	100V DC step.
:STEP6 <NRf>	1kΩ 4-wire step.
:STEP7 <NRf>	10kΩ 4-wire step.
:STEP8 <NRf>	100kΩ 4-wire step.
:STEP9 <NRf>	1MΩ 4-wire step.
:STEP10 <NRf>	10mA DC step.
:STEP11 <NRf>	100mA DC step.
:STEP12 <NRf>	1A DC step.

NOTES:

1. DC:STEP0, AC:STEP14, and AC:STEP15 are one-time factory calibration points and are valid only in manufacturing calibration mode.
2. Upper-case letters indicate short form of each command. For example, instead of sending “:CALibration:PROTeCted:INITiate,” you can send “:CAL:PROT:INIT.”

**Table B-1**  
Remote calibration command summary (continued)

Command <sup>2</sup>	Description
:CALibration	Calibration root command.
:PROTected	
:AC	AC cal steps.
:STEP1	10mV AC at 1kHz step.
:STEP2	100mV AC at 1kHz step.
:STEP3	100mV AC at 50kHz step.
:STEP4	1V AC at 1kHz step.
:STEP5	1V AC at 50kHz step.
:STEP6	10V AC at 1kHz step.
:STEP7	10V AC at 50kHz step.
:STEP8	100V AC at 1kHz step.
:STEP9	100V AC at 50kHz step.
:STEP10	700V AC at 1kHz step.
:STEP11	100mA AC at 1kHz step.
:STEP12	1A AC at 1kHz step.
:STEP13	2A AC at 1kHz step <sup>1</sup> .
:STEP14	1V AC at 3Hz step <sup>1</sup> .
:STEP15	1V AC at 1kHz step <sup>1</sup> .
:DIST	Distortion cal steps.
:STEP1	1V RMS at 137Hz step.
:STEP2	1V RMS at 844Hz step.
:FGEN	
:STEP1	Calibrate function generator.

## NOTES:

1. DC:STEP0, AC:STEP14, and AC:STEP15 are one-time factory calibration points and are valid only in manufacturing calibration mode.
2. Upper-case letters indicate short form of each command. For example, instead of sending “:CALibration:PROTected:INITiate,” you can send “:CAL:PROT:INIT.”

## Miscellaneous calibration commands

Miscellaneous commands perform miscellaneous calibration functions such as programming the calibration code and date. These commands are discussed in detail in the following paragraphs.

### :CODE

#### (:CALibration:PROTected:CODE)

<b>Purpose</b>	To program the calibration code or password so that you can perform the calibration procedures.
<b>Format</b>	:cal:prot:code '<char_string>'
<b>Parameter</b>	Up to an 8-character string including letters and numbers.
<b>Description</b>	The :CODE command enables the Model 2016 calibration procedures when performing these procedures over the bus. In general, this command must be sent to the unit before sending any other comprehensive or manufacturing calibration command. The default calibration code is KI002016.

**NOTES** *The :CODE command should be sent only once before performing either the comprehensive or factory calibration. Do not send :CODE before each calibration step. To change the code, first send the present code, then send the new code. The code parameter must be enclosed in single quotes.*

**Example**      :CAL:PROT:CODE 'KI002016'      Send default code of KI002016.

### :COUNT?

#### (:CALibration:PROTected:COUNt?)

<b>Purpose</b>	To determine how many times the Model 2016 has been calibrated.
<b>Format</b>	:cal:prot:coun?
<b>Response</b>	<n> Calibration count.
<b>Description</b>	The :COUNT? command allows you to determine how many times the Model 2016 has been calibrated.

**NOTE** *Use the :COUNT? command to help you monitor for unauthorized calibration procedures.*

**Example**      :CAL:PROT:COUN?      Request calibration count.

## :INIT

### (:CALibration:PROTeCted:INITiate)

<b>Purpose</b>	To initiate comprehensive and factory calibration procedures.
<b>Format</b>	:cal:prot:init
<b>Parameter</b>	None
<b>Description</b>	The :INIT command enables Model 2016 calibration when performing these procedures over the bus. This command must be sent to the unit after sending the :CODE command, but before sending any other calibration command.

**NOTE** *The :INIT command should be sent only once before performing either DC, AC, or factory calibration. Do not send :INIT before each calibration step.*

<b>Example</b>	:CAL:PROT:INIT	Initiate calibration.
----------------	----------------	-----------------------

## :LOCK

### (:CALibration:PROTeCted:LOCK)

<b>Purpose</b>	To lock out comprehensive or manufacturing calibration.
<b>Format</b>	:cal:prot:lock
<b>Parameter</b>	None
<b>Description</b>	The :LOCK command allows you to lock out both comprehensive and manufacturing calibration after completing those procedures. Thus, :LOCK performs the opposite of enabling calibration with the :CODE command.

**NOTE** *To unlock comprehensive calibration, send the :CODE command. To unlock manufacturing calibration, hold in the SOURCE key while turning on the power.*

<b>Example</b>	:CAL:PROT:LOCK	Lock out calibration.
----------------	----------------	-----------------------

**:LOCK?****(:CALibration:PROTeCted:LOCK?)**

<b>Purpose</b>	To read comprehensive calibration lock status.	
<b>Format</b>	:cal:prot:lock?	
<b>Response</b>	0	Comprehensive calibration locked.
	1	Comprehensive calibration unlocked.
<b>Description</b>	The :LOCK? query requests status from the Model 2016 on calibration locked/unlocked state. Calibration must be enabled sending the :CODE command before calibration can be performed.	
<b>Example</b>	:CAL:PROT:LOCK?	Request cal lock state.

**:SAVE****(:CALibration:PROTeCted:SAVE)**

<b>Purpose</b>	To save calibration constants in EEROM after the calibration procedure.	
<b>Format</b>	:cal:prot:save	
<b>Parameter</b>	None	
<b>Description</b>	The :SAVE command stores internally calculated calibration constants derived during both comprehensive and manufacturing calibration in EEROM. (EEROM is non-volatile memory.) Calibration constants will be retained indefinitely once saved. Generally, :SAVE is sent after all other calibration steps (except for :LOCK).	

**NOTE** Calibration will be only temporary unless the :SAVE command is sent to permanently store calibration constants.

<b>Example</b>	:CAL:PROT:SAVE	Save calibration constants.
----------------	----------------	-----------------------------

## :DATE

### (:CALibration:PROTected:DATE)

<b>Purpose</b>	To send the calibration date to the instrument.
<b>Format</b>	:cal:prot:date <year>, <month>, <day>
<b>Parameters</b>	<year> = 1999 to 2098 <month> = 1 to 12 <day> = 1 to 31
<b>Query format</b>	:cal:prot:date?
<b>Response</b>	<year>, <month>, <day>
<b>Description</b>	The :DATE command allows you to store the calibration date in instrument memory for future reference. You can read back the date from the instrument over the bus by using the :DATE? query or the CALIBRATION selection in the front panel CAL menu.

**NOTE** The year, month, and day parameters must be delimited by commas.

<b>Examples</b>	:CAL:PROT:DATE 1999,6,16	Send cal date (6/16/99).
	:CAL:PROT:DATE?	Request cal date.

## :NDUE

### (:CALibration:PROTected:NDUE)

<b>Purpose</b>	To send the next calibration due date to the instrument.
<b>Format</b>	:cal:prot:ndue <year>, <month>, <day>
<b>Parameters</b>	<year> = 1999 to 2098 <month> = 1 to 12 <day> = 1 to 31
<b>Query format</b>	:cal:prot:ndue?
<b>Response</b>	<year>, <month>, <day>
<b>Description</b>	The :NDUE command allows you to store the date when calibration is next due in instrument memory. You can read back the next due date from the instrument over the bus by using the :NDUE? query or the front panel CAL menu.

**NOTE** The next due date parameters must be delimited by commas.

<b>Examples</b>	:CAL:PROT:NDUE 1999,6,16	Send due date (12/16/99).
	:CAL:PROT:NDUE?	Request due date.

## DC calibration commands

The :DC commands perform calibration of the DCV, DCI, and ohms functions. Table B-2 summarizes these calibration commands along with parameter limits.

**Table B-2**  
DC calibration commands

Command	Description	Parameter limits
:CALibration		
:PROTected		
:DC		
:STEP1	Front terminal short circuit.	
:STEP2	Open circuit.	
:STEP3 <NRf>	10V DC calibration step.	9 to 11
:STEP4 <NRf>	-10V DC calibration step.	-9 to -11
:STEP5 <NRf>	100V DC calibration step.	90 to 110
:STEP6 <NRf>	1k $\Omega$ 4-wire calibration step.	900 to 1.1E3
:STEP7 <NRf>	10k $\Omega$ 4-wire calibration step.	9E3 to 11E3
:STEP8 <NRf>	100k $\Omega$ 4-wire calibration step.	90E3 to 110E3
:STEP9 <NRf>	1M $\Omega$ 4-wire calibration step.	900E3 to 1.1E6
:STEP10 <NRf>	10mA DC calibration step.	9E-3 to 11E-3
:STEP11 <NRf>	100mA DC calibration step.	90E-3 to 110E-3
:STEP12 <NRf>	1A DC calibration step.	0.9 to 1.1

### :STEP1

#### (:CALibration:PROTected:DC:STEP1)

<b>Purpose</b>	To perform front terminal short-circuit calibration.	
<b>Format</b>	:cal:prot:dc:step1	
<b>Parameter</b>	None	
<b>Description</b>	:STEP1 performs the short-circuit calibration step in the comprehensive calibration procedure. Connect a low-thermal short (Model 8610) to the front panel input jacks before sending this command.	
<b>Example</b>	:CAL:PROT:DC:STEP1	Perform short-circuit calibration.



**:STEP2****(:CALibration:PROTeCted:DC:STEP2)**

<b>Purpose</b>	To perform front terminal open-circuit calibration.	
<b>Format</b>	:cal:prot:dc:step2	
<b>Parameter</b>	None	
<b>Description</b>	:STEP2 performs the open-circuit calibration step in the comprehensive calibration procedure. Disconnect all cables and accessories from the input jacks before sending this command.	
<b>Example</b>	:CAL:PROT:DC:STEP2	Perform open circuit calibration.

**:STEP3****(:CALibration:PROTeCted:DC:STEP3)**

<b>Purpose</b>	To program the +10V comprehensive calibration step.	
<b>Format</b>	:cal:prot:dc:step3 <Cal_voltage>	
<b>Parameter</b>	<Cal_voltage> = 9 to 11 [V]	
<b>Description</b>	:STEP3 programs the +10V DC comprehensive calibration step. The allowable range of the calibration voltage parameter is from 9 to 11, but 10 is recommended for best results.	
<b>Example</b>	:CAL:PROT:DC:STEP3 10	Program +10V step.

**:STEP4****(:CALibration:PROTeCted:DC:STEP4)**

<b>Purpose</b>	To program the -10V DC comprehensive calibration step.	
<b>Format</b>	:cal:prot:dc:step4 <Cal_voltage>	
<b>Parameter</b>	<Cal_voltage> = -9 to -11 [V]	
<b>Description</b>	:STEP4 programs the -10V DC comprehensive calibration step. The allowable range of the calibration voltage parameter is from -9 to -11, but -10 is recommended for best results.	
<b>Example</b>	:CAL:PROT:DC:STEP4 -10	Program -10V step.

**:STEP5****(:CALibration:PROTeCted:DC:STEP5)**

<b>Purpose</b>	To program the 100V DC comprehensive calibration step.	
<b>Format</b>	:cal:prot:dc:step5 <Cal_voltage>	
<b>Parameter</b>	<Cal_voltage> = 90 to 110 [V]	
<b>Description</b>	:STEP5 programs the 100V DC comprehensive calibration step. The allowable range of the calibration voltage parameter is from 90 to 110, but 100 is recommended for best results.	
<b>Example</b>	:CAL:PROT:DC:STEP5 100	Program 100V step.

**:STEP6****(:CALibration:PROTeCted:DC:STEP6)**

<b>Purpose</b>	To program the 1k $\Omega$ 4-wire comprehensive calibration step.	
<b>Format</b>	:cal:prot:dc:step6 <Cal_resistance>	
<b>Parameter</b>	<Cal_resistance> = 900 to 1.1E3 [ $\Omega$ ]	
<b>Description</b>	:STEP6 programs the 1k $\Omega$ 4-wire resistance comprehensive calibration step. The allowable range of the calibration resistance parameter is from 900 to 1.1E3 but 1E3 is recommended for best results.	
<b>Example</b>	:CAL:PROT:DC:STEP6 1E3	Program 1k $\Omega$ step.

**:STEP7****(:CALibration:PROTeCted:DC:STEP7)**

<b>Purpose</b>	To program the 10k $\Omega$ 4-wire comprehensive calibration step.	
<b>Format</b>	:cal:prot:dc:step7 <Cal_resistance>	
<b>Parameter</b>	<Cal_resistance> = 9E3 to 11E3 [ $\Omega$ ]	
<b>Description</b>	:STEP7 programs the 10k $\Omega$ 4-wire resistance comprehensive calibration step. The allowable range of the calibration resistance parameter is from 9E3 to 11E3, but 10E3 is recommended for best results.	
<b>Example</b>	:CAL:PROT:DC:STEP7 10E3	Program 10k $\Omega$ step.

**:STEP8****(:CALibration:PROTected:DC:STEP8)**

<b>Purpose</b>	To program the 100k $\Omega$ 4-wire comprehensive calibration step.
<b>Format</b>	:cal:prot:dc:step8 <Cal_resistance>
<b>Parameter</b>	<Cal_resistance> = 90E3 to 110E3 [ $\Omega$ ]
<b>Description</b>	:STEP8 programs the 100k $\Omega$ 4-wire resistance comprehensive calibration step. The allowable range of the calibration resistance parameter is from 90E3 to 110E3, but 100E3 is recommended for best results.
<b>Example</b>	:CAL:PROT:DC:STEP8 100E3      Program 100k $\Omega$ step.

**:STEP9****(:CALibration:PROTected:DC:STEP9)**

<b>Purpose</b>	To program the 1M $\Omega$ comprehensive calibration step.
<b>Format</b>	:cal:prot:dc:step9 <Cal_resistance>
<b>Parameter</b>	<Cal_resistance> = 900E3 to 1.1E6 [ $\Omega$ ]
<b>Description</b>	:STEP9 programs the 1M $\Omega$ comprehensive calibration step. The allowable range of the calibration resistance parameter is from 900E3 to 1.1E6. Use the 1E6 value whenever possible, or the closest possible value.
<b>Example</b>	:CAL:PROT:DC:STEP9              Program 1M $\Omega$ calibration step.

**:STEP10****(:CALibration:PROTected:DC:STEP10)**

<b>Purpose</b>	To program the 10mA comprehensive calibration step.
<b>Format</b>	:cal:prot:dc:step10 <Cal_current>
<b>Parameter</b>	<Cal_current> = 9E-3 to 11E-3 [A]
<b>Description</b>	:STEP10 programs the 10mA comprehensive calibration step. The allowable range of the calibration current parameter is from 9E-3 to 11E-3. Use the 10E-3 value whenever possible for best results.
<b>Example</b>	:CAL:PROT:DC:STEP10 10E-3      Program 10mA step.

**:STEP11****(CALibration:PROTected:DC:STEP11)**

<b>Purpose</b>	To program the 100mA comprehensive calibration step.
<b>Format</b>	:cal:prot:dc:step11 <Cal_current>
<b>Parameter</b>	<Cal_current> = 90E-3 to 110E-3 [A]
<b>Description</b>	:STEP11 programs the 100mA comprehensive calibration step. The allowable range of the calibration current parameter is from 90E-3 to 110E-3. Use the 100E-3 value whenever possible for best results.
<b>Example</b>	:CAL:PROT:DC:STEP11 0.1      Program 100mA step.

**:STEP12****(CALibration:PROTected:DC:STEP12)**

<b>Purpose</b>	To program the 1A comprehensive calibration step.
<b>Format</b>	:cal:prot:dc:step12 <Cal_current>
<b>Parameter</b>	<Cal_current> = 0.9 to 1.1 [A]
<b>Description</b>	:STEP12 programs the 1A comprehensive calibration step. The allowable range of the calibration current parameter is from 0.9 to 1.1. Use a value of 1 whenever possible for best results.
<b>Example</b>	:CAL:PROT:DC:STEP12 1      Program 1A step.

## AC calibration commands

The :AC commands perform comprehensive (user) calibration of the ACV and ACI functions. Table B-3 summarizes these calibration commands.

**Table B-3**  
*AC calibration commands*

Command	Description
:CALibration	
:PROTected	
:AC	
:STEP1	10mV AC at 1kHz calibration step.
:STEP2	100mV AC at 1kHz calibration step.
:STEP3	100mV AC at 50kHz calibration step.
:STEP4	1V AC at 1kHz calibration step.
:STEP5	1V AC at 50kHz calibration step.
:STEP6	10V AC at 1kHz calibration step.
:STEP7	10V AC at 50kHz calibration step.
:STEP8	100V AC at 1kHz calibration step.
:STEP9	100V AC at 50kHz calibration step.
:STEP10	700V AC at 1kHz calibration step.
:STEP11	100mA AC at 1kHz calibration step.
:STEP12	1A AC at 1kHz calibration step.
:STEP13	2A AC at 1kHz calibration step.

**:AC:STEP<n>****(CALibration:PROTected:AC:STEP<n>)**

<b>Purpose</b>	To program individual AC calibration steps.	
<b>Format</b>	:cal:prot:ac:step<n>	
<b>Parameters</b>	1	10mV AC at 1kHz calibration step.
	2	100mV AC at 1kHz calibration step.
	3	100mV AC at 50kHz calibration step.
	4	1V AC at 1kHz calibration step.
	5	1V AC at 50kHz calibration step.
	6	10V AC at 1kHz calibration step.
	7	10V AC at 50kHz calibration step.
	8	100V AC at 1kHz calibration step.
	9	100V AC at 50kHz calibration step.
	10	700V AC at 1kHz calibration step.
	11	100mA AC at 1kHz calibration step.
	12	1A AC at 1kHz calibration step.
	13	2A AC at 1kHz calibration step.
<b>Description</b>	The :AC:STEP command programs the 13 individual AC calibration steps; <n> represents the calibration step number. The appropriate signal must be connected to the instrument when programming each step, as summarized in the parameters listed above.	
<b>Example</b>	:CAL:PROT:AC:STEP7	Program 10V, 50kHz step.

## Distortion and function generator calibration commands

Table B-4 summarizes distortion and function generator calibration commands.

**Table B-4**  
Distortion and function generator calibration commands

Command	Description
:CALibration :PROTected :DIST :STEP1 :STEP2 :FGEN :STEP1	Distortion calibration commands. 1V RMS at 137Hz step. 1V RMS at 844Hz step. Function generator calibration command.

### :DIST:STEP1

(:CALibration:PROTected:DIST:STEP1)

### :DIST:STEP2

(:CALibration:PROTected:DIST:STEP2)

<b>Purpose</b>	To perform distortion calibration steps.	
<b>Format</b>	:cal:prot:dist:step1	1V RMS at 137Hz step
	:cal:prot:dist:step2	1V RMS at 844Hz step
<b>Parameters</b>	None	
<b>Description</b>	:DIST:STEP1 and :DIST:STEP2 perform distortion calibration steps. Apply the 1V RMS 137Hz or 844Hz signal before sending these commands.	
<b>Example</b>	:CAL:PROT:DIST:STEP1	Perform 137Hz step.

### :FGEN:STEP1

(:CALibration:PROTected:FGEN:STEP1)

<b>Purpose</b>	To perform function generator calibration.	
<b>Format</b>	:cal:prot:fgen:step1	
<b>Parameter</b>	None	
<b>Description</b>	:FGEN:STEP1 performs function generator calibration. Connect the rear panel SOURCE OUTPUT jack to the front panel INPUT jacks before sending this command.	
<b>Example</b>	:CAL:PROT:FGEN:STEP1	Perform function generator calibration.

## Manufacturing calibration commands

Three calibration steps are only performed at the factory or when the unit has been repaired:

:CALibration:PROTeCted:AC:STEP14	1V AC at 3Hz
:CALibration:PROTeCted:AC:STEP15	1V AC at 1kHz
:CALibration:PROTeCted:DC:STEP0	Rear terminal short circuit

### :AC:STEP<14 | 15>

#### (:CALibration:PROTeCted:AC:STEP<14 | 15>)

<b>Purpose</b>	To program individual AC manufacturing calibration steps.	
<b>Format</b>	:cal:prot:ac:step14 <Cal_voltage> :cal:prot:ac:step15 <Cal_frequency>	
<b>Parameters</b>	<Cal_voltage> = 1 [1V nominal] <Cal_frequency> = 1E3 [1kHz nominal]	
<b>Description</b>	The :AC:STEP14 and :AC:STEP:15 commands program the two manufacturing AC calibration steps. The appropriate signal must be connected to the instrument when programming each step, as summarized by the parameters listed above.	
<b>Examples</b>	:CAL:PROT:AC:STEP14 1	Program AC step 14.
	:CAL:PROT:AC:STEP15 1E3	Program AC step 15.

### :DC:STEP0

#### (:CALibration:PROTeCted:DC:STEP0)

<b>Purpose</b>	To perform rear terminal short-circuit calibration.	
<b>Format</b>	:cal:prot:dc:step0	
<b>Parameter</b>	None	
<b>Description</b>	:STEP0 performs the rear short-circuit calibration step in the manufacturing calibration procedure. Connect a low-thermal short (Model 8610) to the rear panel input jacks, and select the rear inputs before sending this command.	
<b>Example</b>	:CAL:PROT:DC:STEP0	Perform rear short-circuit calibration.



## Remote error reporting

Methods to detect and determine the nature of calibration errors are discussed below.

### Error summary

Table B-5 summarizes Model 2016 calibration errors.

**Table B-5**  
*Calibration error summary*

<b>Error number and description</b>
+400, "10 vdc zero error"
+401, "100 vdc zero error"
+402, "10 vdc full scale error"
+403, "-10 vdc full scale error"
+404, "100 vdc full scale error"
+405, "-100 vdc full scale error"
+406, "1k 2-w zero error"
+407, "10k 2-w zero error"
+408, "100k 2-w zero error"
+409, "10M 2-w zero error "
+410, "10M 2-w full scale error"
+411, "10M 2-w open error"
+412, "1k 4-w zero error"
+413, "10k 4-w zero error"
+414, "100k 4-w zero error"
+415, "10M 4-w sense lo zero error"
+416, "1k 4-w full scale error"
+417, "10k 4-w full scale error"
+418, "100k 4-w full scale error"
+419, "1M 4-w full scale error"
+420, "10M 4-w full scale error"
+421, "10m adc zero error"
+422, "100m adc zero error"
+423, "10m adc full scale error"
+424, "100m adc full scale error"
+425, "1 adc full scale error"
+438, "Date of calibration not set"
+439, "Next date of calibration not set"

**Table B-5**  
*Calibration error summary (continued)*

<b>Error number and description</b>
+450, "100m vac dac error"
+451, "1 vac dac error"
+452, "10 vac dac error"
+453, "100 vac dac error"
+454, "100m vac zero error"
+455, "100m vac full scale error"
+456, "1 vac zero error"
+457, "1 vac full scale error"
+458, "1 vac noise error"
+459, "10 vac zero error"
+460, "10 vac full scale error"
+461, "10 vac noise error"
+462, "100 vac zero error"
+463, "100 vac full scale error"
+464, "750 vac zero error"
+465, "750 vac full scale error"
+466, "750 vac noise error"
+467, "Post filter offset error"
+468, "1 aac zero error"
+469, "1 aac full scale error"
+470, "3 aac zero error"
+471, "3 aac full scale error"
+472, "Input time constant error"
+473, "Frequency gain error"
+480, "Fgen full scale error"
+481, "Fgen DC offset error"
+482, "Fgen frequency gain error"
+485, "1 vac distortion gain error"
+500, "Calibration data invalid"
+513, "AC calibration data lost"
+514, "DC calibration data lost"
+515, "Calibration dates lost"
+516, "Fgen calibration data lost"
+517, "Dist calibration data lost"
+610, "Questionable calibration"

## Error queue

As with other Model 2016 errors, any calibration error will be reported in the bus error queue. You can read this queue by using the `:SYST:ERR?` query. The Model 2016 will respond with the appropriate error message, as summarized in Table B-5.

## Status byte EAV (Error Available) bit

Whenever an error is available in the error queue, the EAV (Error Available) bit (bit 2) of the status byte will be set. Use the `*STB?` query or serial polling to obtain the status byte, then test bit 2 to see if it is set. If the EAV bit is set, an error has occurred, and you can use the `:SYST:ERR?` query to read the error and at the same time clear the EAV bit in the status byte.

## Generating an SRQ on error

To program the instrument to generate an IEEE-488 bus SRQ when an error occurs, send the following command: `*SRE 4`. This command will enable SRQ when the EAV bit is set. You can then read the status byte and error queue as outlined above to check for errors, and to determine the exact nature of the error.

## Detecting calibration step completion

When sending remote calibration commands, you must wait until the instrument completes the current operation before sending a command. You can use either `*OPC?` or `*OPC` to help determine when each calibration step is completed.

### Using the `*OPC?` query

With the `*OPC?` (operation complete) query, the instrument will place an ASCII 1 in the output queue when it has completed each step. To determine when the OPC response is ready, do the following:

1. Repeatedly test the MAV (Message Available) bit (bit 4) in the status byte and wait until it is set. (You can request the status byte by using the `*STB?` query or by serial polling.)
2. When MAV is set, a message is available in the output queue, and you can read the output queue and test for an ASCII 1.
3. After reading the output queue, repeatedly test MAV again until it clears. At this point, the calibration step is completed.

### Using the `*OPC` command

The `*OPC` (operation complete) command can also be used to detect the completion of each calibration step. To use `*OPC` to detect the end of each calibration step, you must do the following:

1. Enable operation complete by sending `*ESE 1`. This command sets the OPC (operation complete bit) in the standard event enable register, allowing operation complete status from the standard event status register to set the ESB (event summary bit) in the status byte when operation complete is detected.
2. Send the `*OPC` command immediately following each calibration command. For example:  
`:CAL:PROT:DC:STEP1;*OPC`  
Note that you must include the semicolon (;) to separate the two commands and that the `*OPC` command must appear on the same line as the calibration command.
3. After sending a calibration command, repeatedly test the ESB (Event Summary) bit (bit 5) in the status byte until it is set. (Use either the `*STB?` query or serial polling to request the status byte.)
4. Once operation complete has been detected, clear OPC status using one of two methods: (1) Use the `*ESR?` query, then read the response to clear the standard event status register, or (2) send the `*CLS` command to clear the status registers. Note that sending `*CLS` will also clear the error queue and operation complete status.

## Generating an SRQ on calibration complete

An IEEE-488 bus SRQ (service request) can be used to detect operation complete instead of repeatedly polling the Model 2016. To use this method, send both \*ESE 1 and \*SRE 32 to the instrument, then include the \*OPC command at the end of each calibration command line, as covered above. Refer to your controller's documentation for information on detecting and servicing SRQs.

---

# C Calibration Program

## Introduction

This appendix includes a calibration program written in BASIC to help you calibrate the Model 2016. Refer to Section 2 for more details on calibration procedures, equipment, and connections.

## Computer hardware requirements

The following computer hardware is required to run the calibration program:

- IBM PC, AT, or compatible computer.
- Keithley KPC-488.2, KPS-488.2, or KPC-488.2AT, or CEC PC-488 IEEE-488 interface for the computer.
- Two shielded IEEE-488 connecting cables (Keithley Model 7007).

## Software requirements

In order to use the calibration program, you will need the following software:

- Microsoft QBasic (supplied with MS-DOS 5.0 or later).
- MS-DOS version 5.0 or later.
- HP-style Universal Language Driver, CECHP.EXE (supplied with Keithley and CEC interface cards listed above).

## Calibration equipment

The following calibration equipment is required:

- Fluke 5700A Calibrator
- Low-distortion function generator
- Keithley Model 8610 Calibration Short
- Double banana plug to BNC cable.

See Section 2 for detailed equipment information.

## General program instructions

1. With the power off, connect the Model 2016 and the calibrator to the IEEE-488 interface of the computer. Be sure to use shielded IEEE-488 cables for bus connections.
2. Turn on the computer, the Model 2016, and the calibrator. Allow the Model 2016 and the calibrator to warm up for at least one hour before performing calibration.
3. Make sure the Model 2016 is set for a primary address of 16. (Use the front panel GPIB key to check or change the address.)
4. Make sure the calibrator primary address is at its factory default setting of 4.
5. Make sure that the computer bus driver software (CECHP.EXE) is properly initialized.
6. Enter the QBasic editor, and type in the program below. Check thoroughly for errors, then save it using a convenient filename.

**NOTE** *The program assumes a default calibration code of KI002016. If the calibration code has been changed, modify the :CAL:PROT:CODE parameter accordingly.*

7. Run the program, and follow the prompts on the screen to perform calibration.

### **Program C-1**

#### *Model 2016 calibration program*

```
' Model 2016 calibration program.
' Rev. 1.0, 4/30/99
OPEN "IEEE" FOR OUTPUT AS #1          ' Open IEEE-488 output path.
OPEN "IEEE" FOR INPUT AS #2          ' Open IEEE-488 input path.
PRINT #1, "INTERM CRLF"              ' Set input terminator.
PRINT #1, "OUTTERM LF"               ' Set output terminator.
PRINT #1, "REMOTE 4 16"              ' Put 2016, 5700A in remote.
PRINT #1, "CLEAR"                    ' Send DCL.
PRINT #1, "OUTPUT 16;:SYST:PRES;*CLS" ' Initialize 2016.
PRINT #1, "OUTPUT 16;*ESE 1;*SRE 32" ' Enable OPC and SRQ
PRINT #1, "OUTPUT 4;*RST;*CLS;STBY"  ' Reset 5700A calibrator.
PRINT #1, "OUTPUT 4;CUR_POST NORMAL" ' Normal current output.
C$ = ":CAL:PROT:"                    ' 2016 partial command header.
'
CLS                                   ' Clear CRT.
PRINT "Model 2016 Multimeter Comprehensive Calibration Program"
PRINT #1, "OUTPUT 16;:CAL:PROT:CODE 'KI002016'" ' Send KI002016 cal code.
PRINT #1, "OUTPUT 16;:CAL:PROT:INIT"    ' Initiate calibration.
GOSUB ErrCheck
RESTORE CmdList
'
FOR I = 1 TO 28                        ' Loop for all cal points.
READ Msg$, Cmd$                       ' Read message, cal strings.
SELECT CASE I                          ' Select cal sequence.
    CASE 1, 2, 26, 27, 28
        PRINT Msg$
        GOSUB KeyCheck
```



```
CASE 3
    PRINT "Connect calibrator to INPUT and SENSE jacks."
    PRINT "Wait 3 minutes."
    GOSUB KeyCheck
    PRINT #1, "OUTPUT 4;EXTSENSE OFF"
    PRINT #1, "OUTPUT 4;"; Msg$
    PRINT #1, "OUTPUT 4;OPER"
CASE 4, 5, 11, 12, 14 TO 22, 24 TO 25
    PRINT #1, "OUTPUT 4;"; Msg$
    PRINT #1, "OUTPUT 4;OPER"
CASE 6 TO 9
    PRINT #1, "OUTPUT 4;"; Msg$
    PRINT #1, "OUTPUT 4;EXTSENSE ON"
    PRINT #1, "OUTPUT 4;OPER"
    PRINT #1, "OUTPUT 4;OUT?"
    PRINT #1, "ENTER 4"
    INPUT #2, R, R$, s
    Cmd$ = Cmd$ + " " + STR$(R)
CASE 10, 13, 23
    J$ = "AMPS"
    IF I = 13 THEN J$ = "INPUT HI"
    PRINT #1, "OUTPUT 4;STBY"
    PRINT "Connect calibrator to "; J$; "and INPUT LO jacks."
    GOSUB KeyCheck
    PRINT #1, "OUTPUT 4;"; Msg$
    PRINT #1, "OUTPUT 4;OPER"
END SELECT
IF I > 2 AND I < 26 THEN GOSUB Settle
PRINT #1, "OUTPUT 16;"; C$; Cmd$; ".*OPC" ' Send cal command to 2016.
GOSUB CalEnd ' Wait until cal step ends.
GOSUB ErrCheck ' Check for cal error.
NEXT I
'
PRINT #1, "OUTPUT 4;STBY"
LINE INPUT "Enter calibration date (yyyy,mm,dd): "; D$
PRINT #1, "OUTPUT 16;:CAL:PROT:DATE "; D$
GOSUB ErrCheck
LINE INPUT "Enter calibration due date (yyyy,mm,dd): "; D$
PRINT #1, "OUTPUT 16;:CAL:PROT:NDUE "; D$
GOSUB ErrCheck
PRINT #1, "OUTPUT 16;:CAL:PROT:SAVE" ' Save calibration constants.
GOSUB ErrCheck
PRINT #1, "OUTPUT 16;:CAL:PROT:LOCK" ' Lock out calibration.
PRINT "Calibration completed."
PRINT #1, "OUTPUT 16;:SYST:PRES"
END
'
```

```

KeyCheck:                                ' Check for key press routine.
WHILE INKEY$ <> "": WEND                  ' Flush keyboard buffer.
PRINT : PRINT "Press any key to continue (ESC to abort program)."
```

---

```

DO: I$ = INKEY$: LOOP WHILE I$ = ""
IF I$ = CHR$(27) THEN GOTO EndProg      ' Abort if ESC is pressed.
RETURN
'
CalEnd:'                                  ' Check for cal step completion.
PRINT "Performing calibration step #"; I
DO: PRINT #1, "SRQ?"                    ' Request SRQ status.
INPUT #2, s                             ' Input SRQ status byte.
LOOP UNTIL s                            ' Wait for operation complete.
PRINT #1, "OUTPUT 16;*ESR?"            ' Clear OPC.
PRINT #1, "ENTER 16"
INPUT #2, s
PRINT #1, "SPOLL 16"                  ' Clear SRQ.
INPUT #2, s
RETURN
'
ErrCheck:                                ' Error check routine.
PRINT #1, "OUTPUT 16;:SYST:ERR?"      ' Query error queue.
PRINT #1, "ENTER 16"
INPUT #2, E, Err$
IF E <> 0 THEN PRINT Err$: GOTO ErrCheck' Display error.
RETURN
'
Settle:                                  ' Calibrator settling routine.
DO: PRINT #1, "OUTPUT 4;ISR?"          ' Query status register.
PRINT #1, "ENTER 4"
INPUT #2, s
LOOP UNTIL (s AND &H1000)              ' Test settle bit.
RETURN
'
EndProg:                                  ' Close files, end program.
BEEP: PRINT "Calibration aborted."
PRINT #1, "OUTPUT 4;STBY"
PRINT #1, "OUTPUT 16;:SYST:PRES"
PRINT #1, "LOCAL 4 16"
CLOSE
END
'
CmdList:
DATA "Connect low-thermal short to inputs, wait 3 minutes.,"DC:STEP1"
DATA "Disconnect low-thermal short from inputs.,"DC:STEP2"
DATA "OUT 10 V,0 HZ","DC:STEP3 10"
DATA "OUT -10 V","DC:STEP4 -10"
DATA "OUT 100 V","DC:STEP5 100"
DATA "OUT 1 KOHM","DC:STEP6"
DATA "OUT 10 KOHM","DC:STEP7"
DATA "OUT 100 KOHM","DC:STEP8"
DATA "OUT 1 MOHM","DC:STEP9"
DATA "OUT 10 MA","DC:STEP10 10E-3"
DATA "OUT 100 MA","DC:STEP11 100E-3"
DATA "OUT 1A","DC:STEP12 1"
DATA "OUT 10 MV,1 KHZ","AC:STEP1"
DATA "OUT 100 MV,1 KHZ","AC:STEP2"

```

```
DATA "OUT 100 MV,50 KHZ","AC:STEP3"  
DATA "OUT 1 V,1 KHZ","AC:STEP4"  
DATA "OUT 1 V,50 KHZ","AC:STEP5"  
DATA "OUT 10 V,1 KHZ","AC:STEP6"  
DATA "OUT 10 V,50 KHZ","AC:STEP7"  
DATA "OUT 100 V,1 KHZ","AC:STEP8"  
DATA "OUT 100 V,50 KHZ","AC:STEP9"  
DATA "OUT 700 V,1 KHZ","AC:STEP10"  
DATA "OUT 100 MA,1 KHZ","AC:STEP11"  
DATA "OUT 1 A,1 KHZ","AC:STEP12"  
DATA "OUT 2 A,1 KHZ","AC:STEP13"  
DATA "Apply 1V RMS @ 137Hz to INPUT jacks","DIST:STEP1"  
DATA "Apply 1V RMS @ 844Hz to INPUT jacks","DIST:STEP2"  
DATA "Connect SOURCE OUTPUT to INPUT jacks","FGEN:STEP1"
```

---

# Index

## A

- Aborting calibration 2-7
- AC calibration commands B-14
- AC current calibration 2-14, 2-22
- AC voltage and AC current A-13, A-14
- AC voltage calibration 2-13, 2-21
- :AC:STEP<14|15> B-17
- :AC:STEP<n> B-15
- Accuracy calculations A-9
- Additional derating factors A-12
- Analog circuitry 4-11
- Analog signal switching states 4-21
- Assembly drawings 5-5

## C

- Calculating AC characteristics accuracy A-9
- Calculating dB characteristics accuracy A-10
- Calculating dBm characteristics accuracy A-10
- Calculating DC characteristics accuracy A-9
- Calculating generator amplitude accuracy A-12
- Calculating resistance reading limits 1-5
- Calibration 2-1
- Calibration code 2-5
- Calibration considerations 2-4
- Calibration cycle 2-6
- Calibration equipment C-2
- Calibration program C-1
- Calibration reference B-1
- Case cover removal 5-6
- Changing trigger link lines 5-10
- :CODE B-5
- Command summary B-3
- Component layouts 6-2
- Comprehensive calibration 2-6
- Computer hardware requirements C-2
- :COUNt? B-5

## D

- :DATE B-8
- DC calibration commands B-9
- DC current calibration 2-12, 2-20
- DC voltage, DC current, and resistance A-13, A-14
- DC volts calibration 2-9, 2-18
- :DC:STEP0 B-17
- Detecting calibration step completion B-21
- Digital circuitry 4-9
- Digital circuitry checks 4-20
- Disassembly 5-1
- Disassembly procedures 5-6

- DISP test 4-5
- Display board 4-8
- Display board checks 4-18
- Distortion analog circuitry 4-15
- Distortion and function generator calibration commands B-16
- Distortion calibration 2-14, 2-22
- Distortion characteristics A-11
- Distortion digital circuitry 4-13
- :DIST:STEP1 B-16
- :DIST:STEP2 B-16
- DMM board removal 5-6
- DSP board removal 5-7

## E

- Environmental conditions 1-3, 2-3
- Error queue B-20
- Error summary B-18
- Example reading limit calculation 1-5

## F

- Factory service 6-2
- :FGEN:STEP1 B-16
- Front panel calibration 2-7
- Front panel calibration code 2-5
- Front panel disassembly 5-8
- Front panel manufacturing calibration 2-25
- Front panel short and open calibration 2-8
- Front panel tests 4-5
- Function generator calibration 2-15, 2-23

## G

- General program instructions C-3
- Generating an SRQ on calibration complete B-22
- Generating an SRQ on error B-20

## H

- Handling and cleaning 5-3
- Handling PC boards 5-3

## I

- :INIT B-6
- Input terminal wire connections 5-9
- Instrument reassembly 5-9
- Introduction 1-2, 2-2, 3-2, 4-2, 5-2, 6-2, B-2, C-2

## K

- KEY test 4-5

---

## L

- Line power 1-3, 2-3
- :LOCK B-6
- :LOCK? B-7
- Locking out calibration 2-23

## M

- Main CPU firmware replacement 5-11
- Manufacturing calibration 2-24
- Manufacturing calibration commands B-17
- Measuring synthesizer signal amplitude 2-24
- Miscellaneous calibration commands B-5

## N

- :NDUE B-8

## O

- Optimizing measurement accuracy A-13
- Optimizing measurement speed A-14
- Ordering information 6-2

## P

- Parts lists 6-2
- Performance verification 1-1
- Performing the verification test procedures 1-7
- Power module wire connections 5-9
- Power supply 4-6
- Power supply checks 4-19
- Power-on self-test 4-4
- Preparing the Model 2016 for calibration 2-7, 2-17
- Principles of operation 4-6
- Programming calibration dates 2-23

## R

- Recommended equipment 2-6
- Recommended test equipment 1-4, 2-24
- Remote calibration 2-16
- Remote calibration code 2-5
- Remote error reporting B-18
- Remote manufacturing calibration 2-26
- Removing power components 5-8
- Repair considerations 4-3
- Replaceable parts 6-1
- Replacing the AMPS fuse 3-3
- Resistance calibration 2-11, 2-19
- Restoring factory defaults 1-6
- Routine maintenance 3-1

## S

- :SAVE B-7
- Saving calibration constants 2-23
- Setting calibration dates and saving calibration 2-16
- Setting the line voltage and replacing the line fuse 3-2
- Short and open calibration 2-17
- Sine generator circuitry 4-16
- Software requirements C-2
- Solder repairs 5-3
- Specifications A-1
- Static sensitive devices 5-4
- Status byte EAV (Error Available) bit B-20
- :STEP1 B-9
- :STEP2 B-10
- :STEP3 B-10
- :STEP4 B-10
- :STEP5 B-11
- :STEP6 B-11
- :STEP7 B-11
- :STEP8 B-12
- :STEP9 B-12
- :STEP10 B-12
- :STEP11 B-13
- :STEP12 B-13

## T

- Temperature A-13, A-14
- Test considerations 1-7
- Test summary 1-7
- Troubleshooting 4-1, 4-18

## U

- Unlocking manufacturing calibration 2-24
- Using the \*OPC command B-21
- Using the \*OPC? query B-21

## V

- Verification limits 1-5
- Verification test requirements 1-3
- Verifying AC current 1-13
- Verifying AC voltage 1-10
- Verifying DC current 1-12
- Verifying DC voltage 1-8
- Verifying frequency 1-17
- Verifying function generator amplitude 1-19
- Verifying resistance 1-14
- Verifying temperature 1-16
- Verifying total harmonic distortion 1-18

## W

- Warm-up period 1-3, 2-3

---

## Service Form

**Model No.** \_\_\_\_\_ **Serial No.** \_\_\_\_\_ **Date** \_\_\_\_\_

**Name and Telephone No.** \_\_\_\_\_

**Company** \_\_\_\_\_

List all control settings, describe problem and check boxes that apply to problem. \_\_\_\_\_

\_\_\_\_\_

Intermittent                       Analog output follows display                       Particular range or function bad; specify \_\_\_\_\_

IEEE failure                       Obvious problem on power-up                       Batteries and fuses are OK

Front panel operational     All ranges or functions are bad                       Checked all cables

Display or output (check one)

Drifts                       Unable to zero                       Unstable

Overload                       Will not read applied input

Calibration only                       Certificate of calibration required                       Data required

(attach any additional sheets as necessary)

Show a block diagram of your measurement including all instruments connected (whether power is turned on or not). Also, describe signal source.

Where is the measurement being performed? (factory, controlled laboratory, out-of-doors, etc.) \_\_\_\_\_

What power line voltage is used? \_\_\_\_\_ Ambient temperature? \_\_\_\_\_ °F

Relative humidity? \_\_\_\_\_ Other? \_\_\_\_\_

Any additional information. (If special modifications have been made by the user, please describe.)

\_\_\_\_\_

Be sure to include your name and phone number on this service form.

**KEITHLEY**

**Keithley Instruments, Inc.**

28775 Aurora Road  
Cleveland, Ohio 44139

Printed in the U.S.A.