

# Model 2231A-30-3 Triple-Channel DC Power Supply Performance Verification

077-1027-00/ July 2014



077-1027-00

A Greater Measure of Confidence



**Model 2231A-30-3**  
**Triple-Channel DC Power Supply**  
**Performance Verification**

© 2014, Keithley Instruments.

Cleveland, Ohio, U.S.A.

All rights reserved.

Any unauthorized reproduction, photocopy, or use of the information herein, in whole or in part, without the prior written approval of Keithley Instruments. is strictly prohibited.

All Keithley Instruments product names are trademarks or registered trademarks of Keithley Instruments. Other brand names are trademarks or registered trademarks of their respective holders.

Document number: 077102700 / July 2014



The following safety precautions should be observed before using this product and any associated instrumentation. Although some instruments and accessories would normally be used with nonhazardous voltages, there are situations where hazardous conditions may be present.

This product is intended for use by qualified personnel who recognize shock hazards and are familiar with the safety precautions required to avoid possible injury. Read and follow all installation, operation, and maintenance information carefully before using the product. Refer to the user documentation for complete product specifications.

If the product is used in a manner not specified, the protection provided by the product warranty may be impaired.

The types of product users are:

**Responsible body** is the individual or group responsible for the use and maintenance of equipment, for ensuring that the equipment is operated within its specifications and operating limits, and for ensuring that operators are adequately trained.

**Operators** use the product for its intended function. They must be trained in electrical safety procedures and proper use of the instrument. They must be protected from electric shock and contact with hazardous live circuits.

**Maintenance personnel** perform routine procedures on the product to keep it operating properly, for example, setting the line voltage or replacing consumable materials. Maintenance procedures are described in the user documentation. The procedures explicitly state if the operator may perform them. Otherwise, they should be performed only by service personnel.

**Service personnel** are trained to work on live circuits, perform safe installations, and repair products. Only properly trained service personnel may perform installation and service procedures.

Keithley Instruments products are designed for use with electrical signals that are measurement, control, and data I/O connections, with low transient overvoltages, and must not be directly connected to mains voltage or to voltage sources with high transient overvoltages. Measurement Category II (as referenced in IEC 60664) connections require protection for high transient overvoltages often associated with local AC mains connections. Certain Keithley measuring instruments may be connected to mains. These instruments will be marked as category II or higher.

Unless explicitly allowed in the specifications, operating manual, and instrument labels, do not connect any instrument to mains.

Exercise extreme caution when a shock hazard is present. Lethal voltage may be present on cable connector jacks or test fixtures. The American National Standards Institute (ANSI) states that a shock hazard exists when voltage levels greater than 30 V RMS, 42.4 V peak, or 60 VDC are present. A good safety practice is to expect that hazardous voltage is present in any unknown circuit before measuring.

Operators of this product must be protected from electric shock at all times. The responsible body must ensure that operators are prevented access and/or insulated from every connection point. In some cases, connections must be exposed to potential human contact. Product operators in these circumstances must be trained to protect themselves from the risk of electric shock. If the circuit is capable of operating at or above 1000 V, no conductive part of the circuit may be exposed.

Do not connect switching cards directly to unlimited power circuits. They are intended to be used with impedance-limited sources. NEVER connect switching cards directly to AC mains. When connecting sources to switching cards, install protective devices to limit fault current and voltage to the card.

Before operating an instrument, ensure that the line cord is connected to a properly-grounded power receptacle. Inspect the connecting cables, test leads, and jumpers for possible wear, cracks, or breaks before each use.

When installing equipment where access to the main power cord is restricted, such as rack mounting, a separate main input power disconnect device must be provided in close proximity to the equipment and within easy reach of the operator.

For maximum safety, do not touch the product, test cables, or any other instruments while power is applied to the circuit under test. ALWAYS remove power from the entire test system and discharge any capacitors before: connecting or disconnecting cables or jumpers, installing or removing switching cards, or making internal changes, such as installing or removing jumpers.

Do not touch any object that could provide a current path to the common side of the circuit under test or power line (earth) ground. Always make measurements with dry hands while standing on a dry, insulated surface capable of withstanding the voltage being measured.

For safety, instruments and accessories must be used in accordance with the operating instructions. If the instruments or accessories are used in a manner not specified in the operating instructions, the protection provided by the equipment may be

impaired.

Do not exceed the maximum signal levels of the instruments and accessories, as defined in the specifications and operating information, and as shown on the instrument or test fixture panels, or switching card.

When fuses are used in a product, replace with the same type and rating for continued protection against fire hazard.

Chassis connections must only be used as shield connections for measuring circuits, NOT as protective earth (safety ground) connections.

If you are using a test fixture, keep the lid closed while power is applied to the device under test. Safe operation requires the use of a lid interlock.

If a  screw is present, connect it to protective earth (safety ground) using the wire recommended in the user documentation.

The  symbol on an instrument means caution, risk of danger. The user must refer to the operating instructions located in the user documentation in all cases where the symbol is marked on the instrument.

The  symbol on an instrument means caution, risk of electric shock. Use standard safety precautions to avoid personal contact with these voltages.

The  symbol on an instrument shows that the surface may be hot. Avoid personal contact to prevent burns.

The  symbol indicates a connection terminal to the equipment frame.

If this  symbol is on a product, it indicates that mercury is present in the display lamp. Please note that the lamp must be properly disposed of according to federal, state, and local laws.

The **WARNING** heading in the user documentation explains dangers that might result in personal injury or death. Always read the associated information very carefully before performing the indicated procedure.

The **CAUTION** heading in the user documentation explains hazards that could damage the instrument. Such damage may invalidate the warranty.

Instrumentation and accessories shall not be connected to humans.

Before performing any maintenance, disconnect the line cord and all test cables.

To maintain protection from electric shock and fire, replacement components in mains circuits — including the power transformer, test leads, and input jacks — must be purchased from Keithley Instruments. Standard fuses with applicable national safety approvals may be used if the rating and type are the same. Other components that are not safety-related may be purchased from other suppliers as long as they are equivalent to the original component (note that selected parts should be purchased only through Keithley Instruments to maintain accuracy and functionality of the product). If you are unsure about the applicability of a replacement component, call a Keithley Instruments office for information.

To clean an instrument, use a damp cloth or mild, water-based cleaner. Clean the exterior of the instrument only. Do not apply cleaner directly to the instrument or allow liquids to enter or spill on the instrument. Products that consist of a circuit board with no case or chassis (e.g., a data acquisition board for installation into a computer) should never require cleaning if handled according to instructions. If the board becomes contaminated and operation is affected, the board should be returned to the factory for proper cleaning/servicing.

Safety precaution revision as of January 2013.

# Table of Contents

---

<b>Introduction .....</b>	<b>1-1</b>
Welcome .....	1-1
Extended warranty .....	1-1
Contact information .....	1-1
<b>Specifications.....</b>	<b>2-1</b>
<b>Performance Verification.....</b>	<b>3-1</b>
Introduction .....	3-1
Test Record.....	3-2
Performance Verification Procedures .....	3-10
Equipment Required .....	3-10
Self Test.....	3-12
Check DC Voltage Setting Accuracy and Voltage Readback Accuracy .....	3-14
Check DC Voltage Line Regulation.....	3-15
Check DC Voltage Load Regulation.....	3-17
Check DC Current and DC Current Readback Accuracy .....	3-18
Check DC Current Line Regulation .....	3-20
Check DC Current Load Regulation.....	3-23
Check Voltage Noise (7 MHz) .....	3-24
Check Voltage Noise (20 MHz).....	3-26
Check Current Noise.....	3-28



---

## Introduction

### In this section:

---

Welcome .....	1-1
Extended warranty.....	1-1
Contact information .....	1-1

## Welcome

Thank you for using a Keithley Instruments product. The Model 2231A-30-3 Triple-Channel Programmable DC Power Supply is a flexible DC source designed to power a wide range of applications. It offers three independent and isolated power channels, allowing you to power circuits with different references or polarities. Each channel can be enabled or disabled as your application requires. Basic current accuracy is 0.2% for all channels and linear regulation delivers low noise – less than 5 mV<sub>pp</sub>. Flexible display modes make it easy to use the two 30 V outputs in combination, and the DB9 interface connector makes it easy to build PC-based systems. This compact power supply covers a wide range of applications without covering a lot of bench space.

## Extended warranty

Additional years of warranty coverage are available on many products. These valuable contracts protect you from unbudgeted service expenses and provide additional years of protection at a fraction of the price of a repair. Extended warranties are available on new and existing products. Contact your local Keithley Instruments office, sales partner, or distributor for details.

## Contact information

If you have any questions after you review the information in this documentation, please contact your local Keithley Instruments office, sales partner, or distributor, or call Keithley Instruments corporate headquarters (toll-free inside the U.S. and Canada only) at 1-888-KEITHLEY (1-888-534-8453), or from outside the U.S. at +1-440-248-0400. For worldwide contact numbers, visit the [Keithley Instruments website](http://www.keithley.com) (<http://www.keithley.com>).





## Specifications

This section contains specifications for the Series 2200 Multichannel Programmable DC Power Supplies. All specifications are guaranteed unless noted as "typical." Typical specifications are provided for your convenience but are not guaranteed. Specifications that are marked with the symbol are checked in Performance Verification.

**Table 1: Model 2231A-30-3 Triple-Channel specifications for channels 1 and 2**

Parameter	Description
Voltage Resolution, nominal	10mV.
√ Voltage Setting Accuracy	± (0.06% of setting + 20mV) at 25 °C ±5 °C.
√ Current Limit, nominal	Defined by constant current setting. Changeover is automatic.
Voltage Temperature Coefficient, typical	± (0.03% of setting) per °C outside of the 25 °C ±5 °C standard range
Constant Current Operation nominal	The unit can be set to be a constant current over a range of voltages.
Current Range	The output current may be adjusted from 0 A to 3A.
Current Resolution, nominal	1 mA.
√ Current Setting Accuracy	± (0.2% + 10mA) at 25 °C ±5 °C.
√ Voltage Limit, nominal	0 to 30 V.
Current Temperature Coefficient	± (0.03% of setting) per °C outside of the 25 °C ±5 °C standard range
Meter, nominal	Internal readback capability. Voltage and current are measured internally.
Current Readback Resolution,	1mA.
√ Current Readback Accuracy	±(0.2% of reading + 10mA) at 25 °C ±5 °C.
Current Readback Temperature	±(0.03% of setting) per °C outside the 25 °C ±5 °C standard range.
Voltage Readback Accuracy	±(0.06% of reading + 20mV) at 25 °C ±5 °C.
Voltage Readback Resolution, Nominal	10mV.
Voltage Readback Temperature Coefficient, typical	±(0.03% of setting) per °C outside the 25 °C ±5 °C standard range.
√ Line Regulation – Voltage	Change over the full rated line voltage range: ±(0.02% + 4mV).
√ Line Regulation – Current	Change over full rated line current range: ±(0.2% + 3mA).
√ Load Regulation – Voltage	Change from 0 to 100% of full scale. Voltage: ±(0.02% + 4mV).
Voltage Range	The output voltage may be adjusted from 0V to 30V.
Channel 1 and 2,nominal	Channels 1 and 2 are symmetrical and isolated. They are primarily targeted at powering analog circuits operating around ground.
Constant Voltage Operation	The instrument may be set to be a constant voltage over a range of currents.
√ Load Regulation – Current	Change from 10 to 90% of full scale. Current: ±(0.2% + 3mA). While not readily testable, similar performance is expected over the 0% to 100% of full scale range of the product.
√ Voltage Ripple, 20 MHz bandwidth	< 6m VRMS and 20mV pkpk.
√ Current Ripple, 20 MHz bandwidth	< 6mA RMS.

**Table 2: Series 2231A Triple-Channel specifications for Channel 3**

Parameter	Description
Current Limit, nominal	Defined by the Constant Current setting. Changeover is automatic.
Voltage Temperature Coefficient, typical	$\pm (0.03\% \text{ of setting})$ per °C outside of the 25 °C $\pm 5$ °C standard range.
Constant Current Operation, nominal	The instrument may be set to be a constant current over a range of voltages.
Current Range	The output voltage may be adjusted from 0 A to 3 A.
Current Resolution, nominal	1mA.
√ Current Setting Accuracy	$\pm (0.2\% + 10\text{mA})$ at 25 °C $\pm 5$ °C.
Voltage Limit, nominal	0 to 5V.
Current Temperature Coefficient, typical	$\pm (0.03\% \text{ of setting})$ per °C outside of the 25 °C $\pm 5$ °C standard range.
Meter, nominal	Internal readback capability. Voltage and current can be measured internally.
Current Readback Resolution, nominal	1mA.
√ Current Readback Accuracy	$\pm(0.2\% \text{ of reading} + 10\text{mA})$ at 25 °C $\pm 5$ °C.
Current Readback Temperature Coefficient, typical	$\pm(0.03\% \text{ of setting})$ per °C outside of the 25 °C $\pm 5$ °C standard range.
√ Voltage Readback Accuracy	$\pm(0.06\% \text{ of reading} + 20\text{mV})$ at 25 °C $\pm 5$ °C.
Voltage Readback Resolution, nominal	10mV.
Voltage Readback Temperature Coefficient, typical	$\pm(0.03\% \text{ of setting})$ per °C outside of the 25 °C $\pm 5$ °C standard range.
√ Line Regulation – Voltage	Change over the full rated line voltage range: $\pm(0.02\% + 4\text{mV})$ .
√ Line Regulation – Current	Change over the full rated line current range: $\pm(0.2\% + 3\text{mA})$ .
√ Load Regulation – Voltage	Change from 0 to 100% of full scale. Voltage: $\pm(0.02\% + 4\text{mV})$ .
√ Load Regulation – Current	Change from 10 to 90% of full scale. Current: $\pm(0.2\% + 3\text{mA})$ .
√ Voltage Ripple, 20 MHz Bandwidth	< 6m VRMS and 20mV p <sub>pk</sub> .

**Table 3: Model 2231A-30-3 combined channel characteristics**

Characteristic	Description
Combined Channel Characteristics, nominal	The instrument can be configured to provide functionality on Channels 1 and 2 together.
Series Combinations, nominal	Delivers up to 60 V when Channel1 and Channel 2 are wired in series. Voltage Readback is the combined voltage. Settings changes are to the combined voltage. Current Readback is for Channel 1 only. If the currents in the two channels are significantly different, there is no indication of CC/CV status for Channel 2.
Available Series Configurations	Channels 1 and 2 are connected in series. Either channel 1 or channel 2 may be the most positive source.
Series Combination Voltage Accuracy, typical	$\pm(0.5\% \text{ of the setting} + 30\text{mV})$ at 25 °C $\pm 5$ °C.
Series Combination Current Accuracy, typical	$\pm(0.2\% + 15\text{mA})$ at 25 °C $\pm 5$ °C for Channel 1 current. The current is only measured for Channel 1. The error is the same as for the Current Measurement Accuracy.
Parallel Combination, nominal	Delivers up to 6A when CH1 and CH2 are wired in parallel. The meter reads back the combined current.
Available Parallel Configurations, nominal	CH1 and CH2 are connected in parallel (+ to + and – to –).
Parallel Combination Voltage Accuracy, typical	$\pm(0.2\% \text{ of setting} + 30\text{mV})$ at 25 °C $\pm 5$ °C
Parallel Combination Current Accuracy, typical	$\pm(0.2\% + 25\text{mA})$ at 25 °C $\pm 5$ °C

**Table 4: Series 2231A Triple-Channel instrument characteristics**

Characteristic	Description
Instrument Characteristics, nominal	Characteristics and specifications of features unique to this product, but unrelated to a particular channel.
Instrument-Specific Mains Requirements	2231A-30-3
	Line Voltage Frequency Fuse Rating Max VA
	Selection Switch
	110V 110-120 50/60Hz 6.3A TH 250V 750
	220V 220-230 50/60Hz 3.15A TH 250V 750

**Table 5: Common characteristics**

Item	Description
Setup Memory, nominal	30 setup memory locations.
Output Timer, nominal	The product includes a timer that can be used to disable the output after predetermined period of time.
Timer Set Time, nominal	The Timer may be set to any value between 1 and 999,999 seconds.
Timer Accuracy	$\pm 100$ ppm.
Software Voltage Limit, nominal	The product offers the opportunity to change the maximum settable voltage on a temporary basis. The MAX VOLT menu entry, when set below hardware maximum limit, disallows adjusting the product to voltages in excess of the MAX VOLT limit.
Cleaning Requirements, nominal	Inspect the power supply as often as operating conditions require. To clean the exterior surface, perform the following steps: 1. Remove loose dust on the outside of the power supply with a lint free cloth. Use care to avoid scratching the display. 2. Use a soft cloth dampened with water to clear the power supply. Use an aqueous solution of 75% isopropyl alcohol for more efficient cleaning. Caution: To avoid damage to the surface of the power supply, do not use any

---

abrasive or chemical cleaning agents.

Caution: Avoid getting moisture inside the instrument during external cleaning.  
Use only enough cleaning solution to dampen the cloth or swab.

---

**Table 6: Common characteristics**

Item	Description
Isolation Voltage, Output to Chassis	Any output can be isolated up to 240 V (DC + peak AC with AC limited to a maximum 3 V pk-pk and a maximum of 60 Hz) relative to the earth ground terminal.
Isolation Voltage, Output to Output	Any output can be isolated up to 240 V (DC + peak AC with AC limited to a maximum of 3 V pk-pk and a maximum of 60 Hz) relative to any other output terminal.

**Table 7: Environment performance**

Parameter	2231A-30-3
Temperature	Operating: +0 °C to +40 °C Nonoperating: -20 °C to 70 °C
Humidity	Operating: 5% to 95% relative humidity at up to 40 °C, noncondensing Nonoperating: 5% to 95% relative humidity at up to +40 °C, 5% to 60% relative humidity above +40 °C up to +70 C, noncondensing
Altitude	Operating: 100% capability up to 2,000 meters above sea level Nonoperating: Up to 4,000 meters

**Table 8: Safety characteristics**

Item	2231A-30-3
Safety Certifications	U.S. Nationally Recognized Testing Laboratory (NRTL) Listing UL61010-1 Safety Requirements for Electrical Equipment for Measurement, Control, and Laboratory Use.
	Canadian Certification CAN/CSA C22.2 No. 61010-1 Safety Requirements for Electrical Equipment for Measurement, Control, and Laboratory Use.
	European Union Compliance Low Voltage Directive 2006/95/EC EN61010-1 Safety Requirements for Electrical Equipment for Measurement, Control, and Laboratory Use.
	Additional Compliance EC61010-1 Safety Requirements for Electrical Equipment for Measurement, Control, and Laboratory Use.
Channel to Channel Isolation Voltage	Any output can be floated up to 240 V (DC + peak AC with AC limited to a maximum 3 Vpk-pk and a maximum of 60 Hz) relative to any other channel terminal. Remote sense terminals should remain within 1 V of their respective outputs to avoid possible damage.
Channel to Ground Isolation Voltage	Any output can be floated up to 240 V (DC + peak AC with AC limited to a maximum 3 Vpk-pk and a maximum of 60 Hz) relative to the earth ground terminal. Remote sense terminals should remain within 1 V of their respective outputs to avoid possible damage.

**Table 9: Electromagnetic Compatibility (EMC) — Measurement, laboratory, and control product family**

Item	2231A-30-3
Regional Certifications, Classifications, and Standards List	EC Council EMC Directive 2004/108/EC Demonstrated using: EN 61326-1:2006 Electrical Equipment for Measurement, Control, and Laboratory 1, 2 Emissions CISPR 11, Class A Immunity IEC 61000-4-2 IEC 61000-4-3 IEC 61000-4-4 IEC 61000-4-5 IEC 61000-4-6 IEC 61000-4-8 IEC 61000-4-11 EN 61000-3-2 EN 61000-3-3 1 1. Emissions that exceed the levels defined by this standard may occur when this equipment is connected to a test object. 2. Use high-quality shielded cables to maintain compliance
Australia	EMC Framework, demonstrated per Emission Standard CISPR11 in accordance with EN61326-1
<b>Immunity</b>	
Immunity, Electrostatic Discharge (ESD), Enclosure Port	IEC 61000-4-2 EN 61326-1, Performance Criterion “B”
Immunity, Conducted Radio Frequency	IEC 61000-4-6 EN 61326-1, Performance Criterion “A”



---

## Performance Verification

### In this section:

---

Introduction .....	3-1
Test Record.....	3-2
Performance Verification Procedures.....	3-10

## Introduction

This section contains performance verification procedures for the  $\checkmark$  specifications symbol. Additional test equipment is required to complete the verification procedures.

Print the test record on the following pages, and use it to record the performance test results for your power supply.

### NOTE

Completion of the performance verification procedure does not update the stored time and date of the latest successful adjustment. The date and time are updated only when the factory adjustment procedures are successfully completed.

The performance verification procedures verify the performance of your instrument. They do not adjust your instrument. If your instrument fails any of the performance verification tests, you should contact Keithley service.

### WARNING

*Observe all safety precautions listed in this manual before using this product and any associated instrumentation. Although some instruments and accessories are used with nonhazardous voltages, there are situations where hazardous conditions may be present. This product is intended for use by qualified personnel who recognize shock hazards and are familiar with the safety precautions required to avoid possible injury. Before using the product, carefully read and follow all installation, operation, and maintenance information. Refer to this manual for complete product specifications. Before performing any maintenance, disconnect the line cord and all test cables. Operators of this instrument must be protected from electric shock at all times. The responsible body must make sure that operators are prevented access and/or insulated from every connection point. In some cases, connections must be exposed to potential human contact. Product operators in these circumstances must be trained to protect themselves from the risk of electric shock. If the circuit can operate at or above 1000 volts, no conductive part of the circuit may be exposed.*



**⚠ CAUTION**

Use properly rated load wires. All load wires must be heavy enough not to overheat when carrying the maximum short-circuit output current of the power supply. If there is more than one load, then any pair of load wires must be capable of safely carrying the full-rated short-circuit output current of the power supply.

**⚠ WARNING**

*Do not loosen any screw on this product. There are no user serviceable components inside.*

## Test Record

Model	Serial number	Procedure performed by	Date
<hr/>			
<b>Test</b>		<b>Passed</b>	<b>Failed</b>
<hr/>			
Self test			
<hr/>			
DC voltage accuracy			
<hr/>			
DC voltage readback accuracy			
<hr/>			
DC voltage line regulation			
<hr/>			
DC voltage load regulation			
<hr/>			
DC current accuracy			
<hr/>			
DC current readback accuracy			
<hr/>			
DC current line regulation			
<hr/>			
DC current load regulation			
<hr/>			
Voltage noise at 7MHz			
<hr/>			
<b>Test</b>		<b>Passed</b>	<b>Failed</b>
<hr/>			
Voltage noise at 20MHz			
<hr/>			
Current noise at 20MHz			
<hr/>			

**Table 10: DC voltage accuracy**

<b>Instrument test voltage</b>	<b>DUT voltage</b>	<b>Test current</b>	<b>Min</b>	<b>Measured</b>	<b>Max</b>
<b>Channel 1</b>					
0%	0.00000V	0.5A	0.00000V	-----	0.02000V
25%	7.50000V	0.5A	7.47550V	-----	7.52450V
50%	15.00000V	0.5A	14.9710V	-----	15.02900V
75%	22.50000V	0.5A	22.47875V	-----	22.52125V
100%	30.00000V	0.5A	29.96650V	-----	30.03350V

<b>Instrument test voltage</b>	<b>DUT voltage</b>	<b>Test current</b>	<b>Min</b>	<b>Measured</b>	<b>Max</b>
<b>Channel 2</b>					
0%	0.00000V	0.5A	0.00000V	-----	0.02000V
25%	7.500000V	0.5A	7.47550V	-----	7.52450V
50%	15.00000V	0.5A	14.9710V	-----	15.02900V
75%	22.50000V	0.5A	22.47875V	-----	22.52125V
100%	30.00000V	0.5A	29.96650V	-----	30.03350V

<b>Instrument test voltage</b>	<b>DUT voltage</b>	<b>Test current</b>	<b>Min</b>	<b>Measured</b>	<b>Max</b>
<b>Channel 3</b>					
0%	0.00000V	2.5A	0.00000V	-----	0.02000V
25%	1.25000V	2.5A	1.22925V	-----	1.27075V
50%	2.50000V	2.5A	2.47850 V	-----	2.52150V
75%	3.75000V	2 .5A	3.72775V	-----	3.77225V

100%            5.00000V            2.5A            4.97700V            -----            5.02300V

**Table 11: DC voltage readback accuracy**

Instrument test voltage	DUT voltage	Test current	Measured voltage	Voltage readout	Absolute difference	Maximum difference
<b>Channel 1</b>						
0%	0.00000V	0.5A	-----	-----	-----	0.02000V
25%	7.50000V	0.5A	-----	-----	-----	0.02450V
50%	15.00000V	0.5A	-----	-----	-----	0.02900V
75%	22.50000V	0.5A	-----	-----	-----	0.03350V
100%	30.00000V	0.5A	-----	-----	-----	0.03800V
Instrument test voltage	DUT voltage	Test current	Measured voltage	Voltage readout	Absolute difference	Maximum difference
<b>Channel 2</b>						
0%	0.00000V	0.5A	-----	-----	-----	0.02000V
25%	7.50000V	0.5A	-----	-----	-----	0.02450V
50%	15.00000V	0.5A	-----	-----	-----	0.02900V
75%	22.50000V	0.5A	-----	-----	-----	0.03350V
100%	30.00000V	0.5A	-----	-----	-----	0.03800V
Instrument test voltage	DUT voltage	Test current	Measured voltage	Voltage readout	Absolute difference	Maximum difference
<b>Channel 3</b>						
0%	0.00000V	2.5A	-----	-----	-----	0.02000V
25%	1.25000V	2.5A	-----	-----	-----	0.02075V
50%	2.50000V	2.5A	-----	-----	-----	0.02150V
75%	3.75000V	2.5A	-----	-----	-----	0.02225V

100%	5.00000V	2.5A	-----	-----	-----	0.02300V
------	----------	------	-------	-------	-------	----------

**Table 12: DC voltage line regulation**

Instrument	Min line	Max line	Nom line	Nom-Min	Max-Nom	Largest	Max value
Channel 1	-----	-----	-----	-----	-----	-----	0.0120000V
Channel 2	-----	-----	-----	-----	-----	-----	0.0120000V
Channel 3	-----	-----	-----	-----	-----	-----	0.0072000V

**Table 13: DC voltage load regulation**

Instrument	Min load	Ref load	Max load	Ref-Min	Max-Ref	(Max-Ref) /0.98	Max value
Channel 1	-----	-----	-----	-----	-----	-----	0.0120000V
Channel 2	-----	-----	-----	-----	-----	-----	0.0120000V
Channel 3	-----	-----	-----	-----	-----	-----	0.0072000V

**Table 14: DC current accuracy**

Instrument test current	Test voltage	DUT current	Min	Measured current	Max
<b>Channel 1</b>					
0%	15 V	0.0000A	0.000000A	-----	0.01000A
25%	15V	0.7500A	0.73850A	-----	0.76150A
50%	15V	1.5000A	1.48700A	-----	1.51300A
75%	15V	2.2500A	2.2355A	-----	2.2645A
100%	15V	3.0000A	2.9840A	-----	3.0160A

Instrument test current	Test voltage	DUT current	Min	Measured current	Max
<b>Channel 2</b>					
0%	15V	0.0000A	0.000000A	-----	0.01000A
25%	15V	0.7500A	0.73850A	-----	0.76150A
50%	15V	1.5000A	1.48700A	-----	1.51300A
75%	15V	2.2500A	2.2355A	-----	2.2645A
100%	15V	3.0000A	2.9840A	-----	3.0160A

Instrument test current	Test voltage	DUT current	Min	Measured current	Max
<b>Channel 3</b>					
0%	3V	0.00000A	0.000000A	-----	0.01000A
25%	3V	0.7500A	0.73850A	-----	0.76150A
50%	3V	1.5000A	1.48700A	-----	1.51300A
75%	3V	2.2500A	2.2355A	-----	2.2645A
100%	3V	3.0000A	2.9840A	-----	3.0160A

**Table 15: DC current readback accuracy**

Instrument test voltage	Test current	Measured current	Current readout	Absolute difference	Maximum difference
<b>Channel 1</b>					
0%	0A	-----	-----	-----	0.0100A
25%	0.75A	-----	-----	-----	0.0115A
50%	1.5A	-----	-----	-----	0.013A

75%	2.25A	-----	-----	-----	0.0145A
100%	3.0A	-----	-----	-----	0.016A

Instrument test voltage	Test current	Measured current	Current readout	Absolute difference	Maximum difference
-------------------------	--------------	------------------	-----------------	---------------------	--------------------

**Channel 2**

0%	0A	-----	-----	-----	0.0100A
25%	0.75A	-----	-----	-----	0.0115A
50%	1.5A	-----	-----	-----	0.013A
75%	2.25A	-----	-----	-----	0.0145A
100%	3.0A	-----	-----	-----	0.016A

Instrument test voltage	Test current	Measured current	current readout	Absolute difference	Maximum difference
-------------------------	--------------	------------------	-----------------	---------------------	--------------------

**Channel 3**

0%	0A	-----	-----	-----	0.0100A
25%	0.75A	-----	-----	-----	0.0115A
50%	1.5A	-----	-----	-----	0.013A
75%	2.25A	-----	-----	-----	0.0145A
100%	3.0A	-----	-----	-----	0.016A

**Table 16: DC current line regulation**

Instrument	Test voltage	Min line	Max line	Nom line	Nom-Min	Max-Nom	Largest	Max value
Channel 1	15V	-----	-----	-----	-----	-----	-----	0.004500A
Channel 2	15V	-----	-----	-----	-----	-----	-----	0.004500A
Channel 3	3V	-----	-----	-----	-----	-----	-----	0.004500A

**Table 17: DC current load regulation**

Instrument	Means @ min volts	Means @ ref volts	Means @ Max volts	Ref-Min	Max-Ref	Largest	Maximum difference
Channel 1	-----	-----	-----	-----	-----	-----	0.003120A
Channel 2	-----	-----	-----	-----	-----	-----	0.003120A
Channel 3	-----	-----	-----	-----	-----	-----	0.003400A

**Table 18: Voltage noise at 7MHz**

Instrument	Voltage test load R1	Measured RMS	Maximum RMS	Measured pk-pk	Maximum pk-pk
Channel 1	40Ω	-----	1mV	-----	5mV
Channel 2	40Ω	-----	1mV	-----	5mV
Channel 3	2.5Ω	-----	1mV	-----	5mV

**Table 19: Voltage noise at 20MHz**

Instrument	Voltage test load R1	Measured RMS	Maximum RMS	Measured pk-pk	Maximum pk-pk
Channel 1	40 Ω	-----	6mV	-----	20mV
Channel 2	40 Ω	-----	6mV	-----	20mV
Channel 3	2.5 Ω	-----	6mV	-----	20mV

**Table 20: Current noise at 20MHz**

<b>Instrument</b>	<b>Current test load R1</b>	<b>Measured RMS</b>	<b>Maximum RMS</b>
Channel 1	1 $\Omega$	-----	6mA
Channel 2	1 $\Omega$	-----	6mA
Channel 3	1 $\Omega$	-----	6mA



## Performance Verification Procedures

The following conditions must be met before performing these procedures:

1. The device under test (DUT) and all test equipment must have been operating continuously for 20 minutes in an environment that meets the operating range specifications for temperature and humidity.

Test setup changes affecting the remote sense require an additional 20-minute warm-up period.

2. The procedures are intended to be used in sequence. If it is necessary to partially test the DUT using an individual test, a 20-minute warm-up period is required for the individual test.
3. You must connect the DUT and the test equipment to the same AC power circuit. Connect the DUT and test instruments into a common power strip if you are unsure of the AC power circuit distribution. Connecting the DUT and test instruments into separate AC power circuits can result in offset voltages between the equipment, which can invalidate this performance verification procedure.
4. The AC power source for the DUT must match the voltage selector switch setting located on the bottom of the DUT.

<b>DUT voltage selector</b>	<b>AC source voltage</b>
110	115V
220	230V

## Equipment Required

These procedures use external equipment to directly check warranted characteristics. The following table lists the required equipment.

**Table 21: Test equipment**

Number	Item	Minimum requirements	Example
1	Connectors	Connectors for hookup wire assemblies and test resistors, item numbers 5, 6, 9, 10, and 11. <ul style="list-style-type: none"> <li>(Qty. 6) #10 fork lugs similar to Tyco part number 52951.</li> <li>(Qty. 14) Stackable, gold-plated banana plugs/jacks similar to Pomona model 4897-0. Used for lower current connections, and connections to the load resistors (items 10 and 11) used for noise testing.</li> <li>(Qty. 4) Sheathed banana jacks similar to Pomona model 4834 to put connectors on the resistors.</li> </ul>	
2	AC power source	Variable AC output from 90 to 265 VAC with at least 750 VA capacity.	Kikusui PCR2000M
3	Electronic load	Variable DC load capable of 6 ADC and 40 VDC	B&K Precision 8510
4	DC voltmeter	Voltage measurement at 12 mV through 40 V to better than 100 ppm accuracy with the ability to multiply the result by a scalar.	Keithley 2000 DMM
5	High-current hookup wire (high-current connections are indicated with bold lines in the setup illustrations)	18 AWG (minimum) hookup wire assemblies. To perform all tests, the following wire assemblies need to be created: <ul style="list-style-type: none"> <li>#10 fork lug to #10 fork lug, Qty. 2.</li> <li>Stackable banana to #10 fork lug, Qty. 2</li> <li>Stackable banana to bare wire, Qty. 2.</li> </ul> Wire lengths are not critical.	
6	Low-current hookup wire (low-current connections are indicated with light lines in the setup illustrations)	22 AWG (minimum) hookup wires. To perform all tests, the following wire assemblies need to be created: <ul style="list-style-type: none"> <li>Banana plug to Banana plug, Qty. 2</li> <li>Bare Wire to stackable Banana, Qty. 2</li> <li>Bare Wire to Banana, Qty. 2</li> </ul> Wire lengths are not critical.	
7	50 mΩ precision shunt resistor	0.050 Ω ±100 ppm at 25 W ±4 ppm/°C temperature coefficient.	Guildline 9230A-50
8	Current sense resistor cabling	Kelvin 4 terminal measuring cables for shunt Resistor to voltmeter.	Guildline 92301 cable set
9	50 mΩ resistor for remote sense testing (2 required) One of these 50 mΩ resistors may be substituted with item 7.	0.050 Ω, 5 W. To perform the tests as illustrated, both leads of each resistor require a Banana Jack connector	OHMITE 15FR050E

Number	Item	Minimum requirements	Example
10	Load resistor for voltage noise testing	Loading resistors for high current in voltage mode and high voltage in current mode. All resistors should be rated for at least 50 W. Ohms tolerance within 5%. Resistor composition is not critical. To perform the tests as illustrated, both leads of the load resistor require a banana plug/jack (or equivalent) to connect to the power supply.	
	CH1	12 $\Omega$ .	Vishay/Dale RH05012R00FE02
	CH2	12 $\Omega$ .	Vishay/Dale RH05012R00FE02
	CH3	2.5 $\Omega$ .	Vishay/Dale RH05012R00FE02
11	Load resistor for current noise testing	1 $\Omega$ , 100 W, 5% To perform the tests as illustrated, both leads of the load resistor require a banana plug/jack (or equivalent) to connect to the power supply.	Vishay/Dale HL10006Z1R000JJ
12	Oscilloscope	20 MHz bandwidth-limited oscilloscope at 1 mV/division.	Tektronix DPO3012
13	Oscilloscope probe	Low capacitance 1 M $\Omega$ /10 M $\Omega$ 1X/10X 6 MHz/200MHz probe.	Tektronix P2220, 1X probe
14	Oscilloscope probe	Low capacitance 10 M $\Omega$ 500 MHz probe	Tektronix P6139A, 10X
15	Coaxial cable	50 $\Omega$ BNC, male-to-male.	Tektronix part number: 012-0482-00
16	BNC adapter	BNC female to banana breakout.	Pomona Electronics 3073

## Self Test

This procedure uses internal routines to verify that the DUT functions and passes its internal self-tests. No test equipment or connections are required.

1. Disconnect all cables from the DUT outputs.
2. Power on the DUT. The front-panel display will light up briefly while the DUT performs its power-on self test. All the display annunciators will light up at once.
3. Review the display with all the annunciators. Visually check if there are any strokes lost on any annunciator.

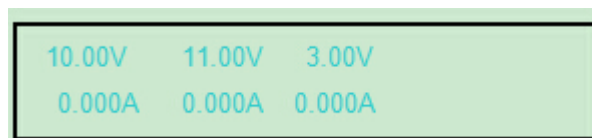

4. If the EEPROM is damaged or the latest operation data in the EEPROM is missing, the display appears as follows:



*ERR EEPROM*

5. If the calibration data in the EEPROM is missing, the display appears as follows:



*ERROR CAL*

6. If the latest operating state of the power supply in the EEPROM is missing, the display appears as follows:



*Error Config Data*

7. If there is no response when you power on the DUT, verify that there is AC power to the power supply, verify the power-line voltage settings, and verify that the correct power-line fuse is installed. If you need more help, contact Keithley.
8. Power off the DUT.

## Check DC Voltage Setting Accuracy and Voltage Readback Accuracy

Equipment required	
AC power source	High current hookup wire (boldline connections)
Electronic load	Low current hookup wire (fine line connections)
DC voltmeter	

For each channel sequentially.

1. Set up the equipment as shown.

**Figure 1: Voltage accuracy, regulation, and protection test setup**

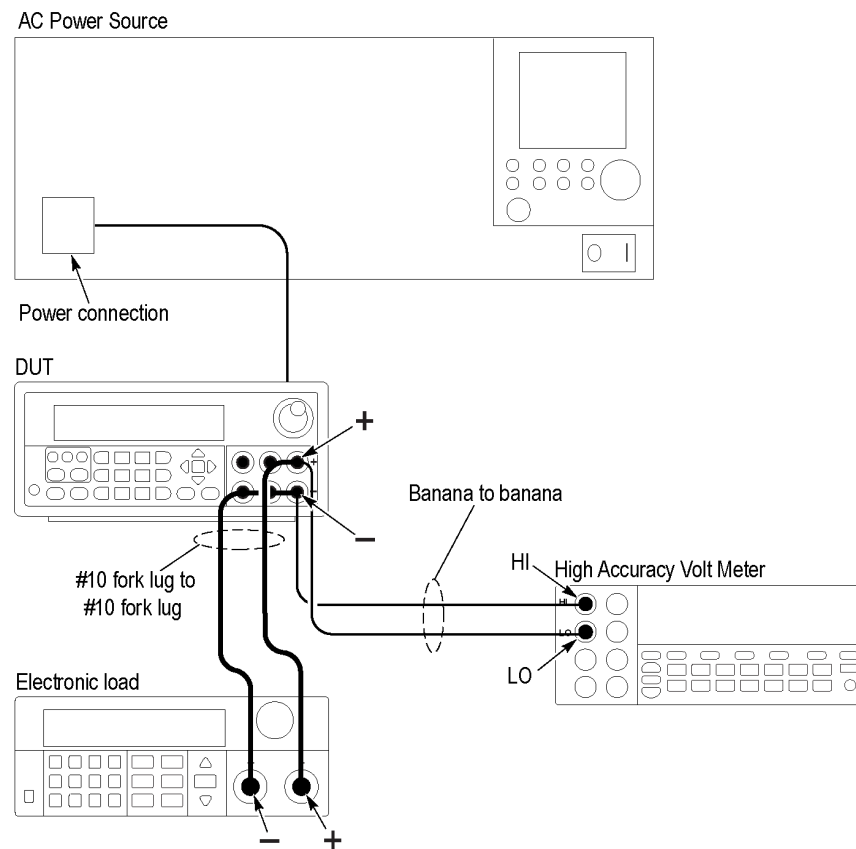

### NOTE

Ensure the warm-up criteria have been met, as described in the Performance Verification Conditions topic.

To assure accurate measurements, the voltmeter must connect as close as possible to the front panel of the DUT. A solution is to use fork lugs between the electronic load and the DUT, and banana plugs between the DUT and voltmeter.

An alternative solution is to use fork lugs for both connections at the DUT.

2. Set the voltmeter as follows:
  - a. Set to measure DC volts.
  - b. Set to auto range.
  - c. Verify that the math mx+b function is disabled (shift+DCV), assuring that volts are being read.
3. Set the electronic load as follows:
  - a. Set to constant current.
  - b. Set to draw a constant current at the test current specified for the channel under test in the table for checking DC Voltage Accuracy without Remote Sense.
4. Set the channel under test to the full scale output current.
5. Set the channel under test to 0% of the full scale output voltage (0 V).
6. Turn the DUT output on.
7. Enter the voltmeter reading into the table for checking DC voltage accuracy without remote sense.
8. Enter the voltmeter reading into the table for checking DC voltage readback accuracy.
9. Enter the channel under test readback voltage into the table for DC voltage readback accuracy.
10. Calculate the difference between the two measurements taken in steps 8 and 9 and enter the absolute value into the difference column of the table.
11. Increase the channel under test output voltage by 25% of the full scale output voltage.
12. Repeat steps 7 through 11 until you complete testing at 100% of full scale.
13. This completes the check for one channel. If needed, return to step 1 to run through the check for the next channel.

## Check DC Voltage Line Regulation

This verification procedure uses the same test setup as the previous procedure. Perform on each channel sequentially.

1. Change the AC power source output to the minimum voltage specified in the following table.

**NOTE**

Ensure the warm-up criteria have been met, as described in the Performance Verification Conditions topic.

DUT voltage selector switch	AC power source voltage
110	99V
110V/220V 	

---

220	198V
110V/220V	
	

---

2. Set the voltmeter as follows:
  - a. Set to measure DC volts.
  - b. Set to auto range.
  - c. Verify that the math mx+b function is disabled (shift+DCV), assuring that volts are being read.
3. Set the electronic load as follows:
  - a. Set to constant current.
  - b. Set to draw the specified test current.



---

Channel	Test current
Channel 1	3A
Channel 2	3A
Channel 3	3A

---

4. Set the channel under test to 100% of the full scale output current.
5. Set the channel under test to 100% of the full scale output voltage.
6. Turn the DUT output on.
7. Enter the voltmeter reading the "min" column of the table for checking DC Voltage Line Regulation for the channel under test.
8. Change the AC power source output to the maximum voltage specified in the following table.

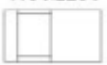
---

DUT voltage selector switch	AC power source voltage
110	132V
110V/220V	
	
220	253V
110V/220V	
	

---

9. Enter the voltmeter reading in the Max column of the table for checking DC Voltage Line Regulation for the channel under test. (See Table 18 )
10. Change the AC power source output to match the voltage selector switch setting of the DUT.

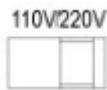
DUT voltage selector switch	AC power source voltage
110 	115V
220 	230V

11. Enter the voltmeter reading the Nom column of the table for checking DC Voltage Line Regulation for the channel under test.
12. Calculate the two values: Nom – Min and Max – Nom. Enter the values into the appropriate columns.
13. Enter the largest of the two values calculated in step 12 into the largest column.
14. This completes the check for one channel. If needed, return to step 1 to run through the verification procedure for the next channel.

### Check DC Voltage Load Regulation

This verification procedure uses the same test setup as the previous procedure. Perform the procedure for each channel sequentially.

#### NOTE

Ensure the warm-up criteria have been met, as described in the Performance Verification Conditions topic.

1. Set the voltmeter as follows:
  - a. Set to measure DC volts.
  - b. Set to auto range.
  - c. Verify that the math mx+b function is disabled (shift+DCV), assuring that volts are being read.
2. Set the electronic load as follows:
  - a. Set to constant current.
  - b. Set to draw 0 A.
3. Set the channel under test to 100% of the full scale output current.
4. Set the channel under test to 100% of the full scale output voltage.
5. Turn the DUT output on.



6. Enter the voltmeter reading in the minimum load column of the table for checking DC Voltage Load Regulation for the channel under test.
7. Increase the electronic load to the reference load test current value.

Channel	Test current
Channel 1	1.5A
Channel 2	1.5A
Channel 3	1.5A

8. Enter the voltmeter reading in the reference load column of the table for checking DC Voltage Load Regulation for the channel under test.
9. Increase the electronic load to the maximum load test current value.

Channel	Maximum load test current
Channel 1	3A
Channel 2	3A
Channel 3	3A

10. Enter the voltmeter reading in the maximum load column of the table for checking DC Voltage Load Regulation for the channel.
  11. Calculate the three values: Ref – Min, Max – Ref, and  $(\text{Max} - \text{Ref})/0.98$ . Enter the values in the appropriate columns.
  12. Enter the largest of the three values calculated in step 11 into the Largest column.
- This completes the verification procedure for one channel. If needed, return to step 1 to run through the procedure for the next channel.

## Check DC Current and DC Current Readback Accuracy

Equipment required	
AC power source	High-current hookup wire (boldline connections)
Electronic load	Low-current hookup wire (fine line connections)
DC voltmeter	

For each channel sequentially.

1. Set up the equipment as shown.

NOTE

Ensure the warm-up criteria have been met, as described in the Performance Verification Conditions topic.

**Figure 2: DC current accuracy and regulation test setup**

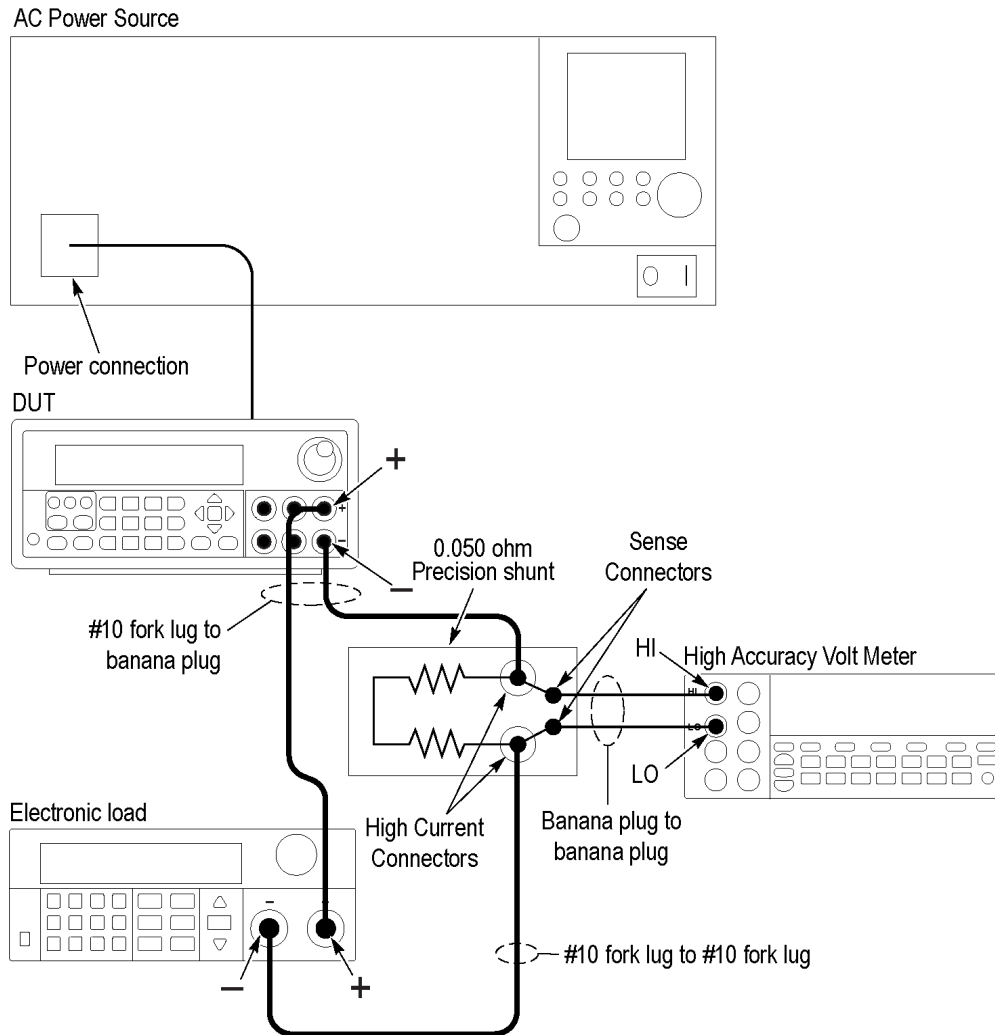



2. Set the voltmeter as follows:
    - a. Set to measure DC volts.
    - b. Set to auto range.
    - c. Set to show amps (instead of volts) by multiplying the voltmeter result by 20.
      - Press Shift +DCV (mX+B).
      - Use the arrow key to move the cursor to the far right until it is positioned on the ^.
      - Press the up range button once so that M=10.00000.
      - Press the arrow key to move the cursor to the first digit and press the up range button once so that M=20.00000.
      - Press the Enter button and check that the display shows B=0.
      - Press the Enter button and check that the display shows UNITS.
      - Use the arrow keys to modify the display to show AMP.
      - Adjust each letter individually.
  3. Set the electronic load as follows:
    - a. Set to Constant Voltage.
    - b. Set to the specified voltage for your channel under test.
  4. Set the channel under test to 0% of the full scale output current.
  5. Set the channel under test to 100% of the full scale output voltage.
  6. Turn the DUT output on.
  7. Enter the voltmeter reading into the table for checking DC current accuracy.
  8. Enter the voltmeter reading into the table for checking DC current readback accuracy.
  9. Enter the channel under test readback current readout in the current readout column of the table for checking current readback accuracy.
  10. Calculate the difference between the two measurements taken in steps 8 and 9. Enter the absolute value of the calculated value into the difference column of the table.
  11. Increase the channel under test output current by 25% of the full scale output current.
  12. Repeat steps 7 through 11 until you complete testing at 100% of the full scale output current.
- This completes the check for one channel. If needed, return to step 1 to run through the procedure for the next channel.

## Check DC Current Line Regulation

This verification procedure uses the same test setup as the previous procedure. For each channel sequentially.

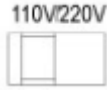

1. Change the AC power source output to the voltage specified in the following table.

DUT voltage selector switch	AC power source voltage
110 	99V
220 	198V

## NOTE

Ensure the warm-up criteria have been met, as described in the Performance Verification Conditions topic.

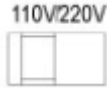
2. Set the voltmeter as follows:
  - a. Set to measure DC volts.
  - b. Set to auto range.
  - c. Set to show amps (instead of volts) by multiplying the voltmeter result by 20.
    - Press Shift+DCV (mX+B).
    - Use the arrow key to move the cursor to the far right until it is positioned on the ^.
    - Press the up range button once so that M=10.00000.
    - Press the arrow key to move the cursor to the first digit and then press the up range button once so that M=20.00000.
    - Press the Enter button and check that the display shows B=0.
    - Press the Enter button and check that the display shows UNITS.
    - Use the arrow keys to modify the display to show AMP.
    - Adjust each letter individually.
3. Set the electronic load as follows:
  - a. Set to constant voltage.
  - b. Set to the specified voltage for your channel under test.
4. Set the channel under test to 100% of the full scale output voltage.
5. Set the channel under test to 100% of the full scale output current.
6. Turn the DUT output on.
7. Enter the voltmeter reading in the Minimum column of the table for DC voltage line regulation for the channel under test.
8. Change the AC power source output to the voltage specified in the following table.

DUT voltage selector switch	AC power source voltage
110 	132V
220 	253V

9. Enter the voltmeter reading in the Max column for the channel under test. (See Table 22.)
10. Change the AC power source output to the voltage specified in the following table.

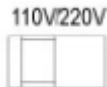
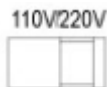
DUT voltage selector switch	AC power source voltage
110 	115V
220 	230 V

11. Enter the voltmeter reading in the Nom column for the channel under test.
12. Calculate the two values: Nom – Min and Max – Nom. Enter the values in the appropriate columns.
13. Select the largest of the two calculations from step 12 and enter the value in the Largest column.
14. Turn the DUT output off.

This completes the verification procedure for one channel. If needed, return to step 1 to run through the procedure for the next channel.

## Check DC Current Load Regulation

This verification procedure uses the same test setup as the previous procedure.

### NOTE

Ensure the warm-up criteria have been met, as described in the Performance Verification Conditions topic.

For each channel sequentially.

1. Set the voltmeter as follows:
  - a. Set to measure DC volts.
  - b. Set to auto range.
  - c. Set to show amps (instead of volts) by multiplying the voltmeter result by 20.
    - Press Shift+DC V (mX+B).
    - Use the arrow key to move the cursor to the far right until it is positioned on the ^.
    - Press the up range button once so that M=10.00000.
    - Press the arrow key to move the cursor to the first digit and then press the up range button once so that M=20.00000.
    - Press the Enter button and check that the display shows B=0.
    - Press the Enter button and check that the display shows UNITS.
    - Use the arrow keys to modify the display to show AMP.
    - Adjust each letter individually.
2. Set the electronic load as follows:
  - a. Set to Constant Voltage.
  - b. Set to output the minimum test voltage level.

Channel	Reference test voltage
Channel 1	3.0V
Channel 2	3.0V
Channel 3	0.5V

3. Set the channel under test to 100% of the full scale output current for your product.
4. Set the channel under test to 100% of the full scale output voltage for your product.
5. Turn the DUT output on.
6. Enter the voltmeter reading in the table for DC current load regulation at the minimum voltage for your product.
7. Increase the electronic load to the reference test voltage level.

Channel	Reference test voltage
Channel 1	15.0V
Channel 2	15.0V
Channel 3	2.5V

8. Enter the voltmeter reading into the table for DC current load regulation at the reference test voltage for the channel under test.
9. Increase the electronic load to the maximum test voltage level.

Channel	Reference test voltage
Channel 1	29.4V
Channel 2	29.4V
Channel 3	4.9V

10. Enter the voltmeter reading into the table for DC current load regulation at the maximum voltage for the channel under test.
11. Calculate the two values: REF – Min and Max – REF. Enter the values into the appropriate columns.
12. Select the larger of the two calculated values from step 11 and enter the value into the Largest column.
13. Power off the DUT and test equipment.

This completes the verification procedure for one channel. If needed, return to step 1 to run through the procedure for the next channel.

## Check Voltage Noise (7 MHz)

Equipment required	
High current hookup wire (bold line connections)	Oscilloscope
Load resistor	Oscilloscope 1X probe

For each channel sequentially.

1. Plug the DUT into your local line power from the mains.
2. Plug the test oscilloscope into the same mains outlet as the DUT.

**NOTE**

Some AC power sources create large amounts of high-frequency noise on the power line that the instrument may not fully reject. Noise directly on the mains is typically better controlled.

Use the same mains outlet for both the DUT and test oscilloscope to avoid ground loops which may cause noise.

3. Power on the DUT and test oscilloscope.

**NOTE**

Ensure the warm-up criteria have been met, as described in the Performance Verification Conditions topic.

4. Set up the equipment as shown. Use the appropriate load resistor depending on the channel being tested.

**Figure 3: 7 MHz test setup**

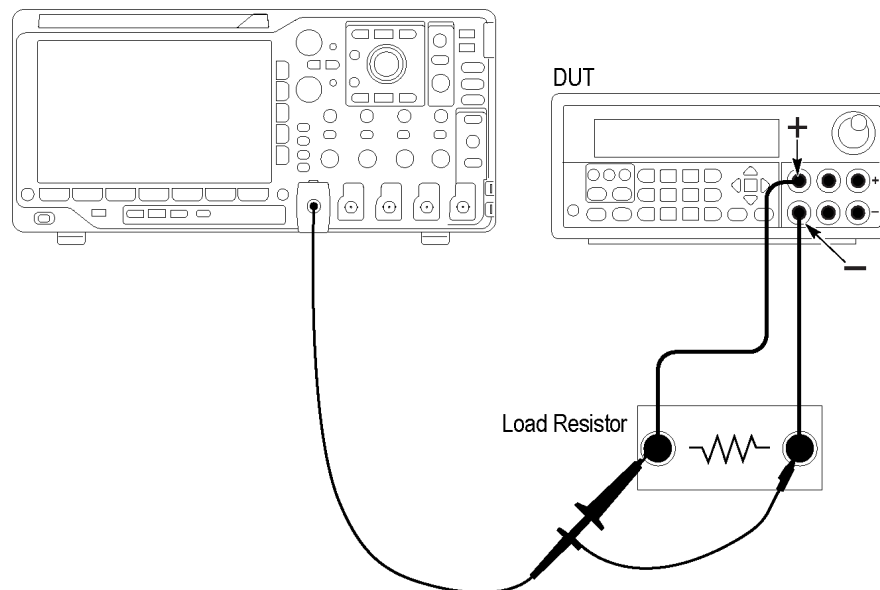



5. Set the oscilloscope as follows:
  - a. 1 mV/division
  - b. 1 M $\Omega$  input resistance
  - c. 20 MHz bandwidth limit
  - d. AC coupled
  - e. Line trigger
  - f. 2 ms/div
  - g. Set to measure V pk-pk and VRMS
6. Set the oscilloscope probe to 1X mode.
7. Set the channel under test to the 100% full scale output voltage.
8. Set the channel under test to the 100% full scale output current.
9. Turn the DUT output on.

### WARNING

*Do not touch the load resistor. The load resistor may become hot enough to cause burns.*

10. Enter the oscilloscope measurements into the table for checking Noise at 7 MHz.  
This completes the verification procedure for one channel. If needed, return to step 1 to run through the procedure for the next channel.

## Check Voltage Noise (20 MHz)

Equipment required	
High-current hookup wire (bold line connections)	Oscilloscope
Load resistor	Coaxial cable (BNC male-male)
BNC female-to-banana	

For each channel sequentially.

1. Plug the DUT into your local line power from the mains.
2. Plug the test oscilloscope into the same mains outlet as the DUT.

## NOTE

Some AC Power Sources create large amounts of high-frequency noise on the power line that the instrument may not fully reject. Noise directly on the mains is typically better controlled.

Use the same mains outlet for both the DUT and test oscilloscope to avoid ground loops which may cause noise.

3. Power on the DUT and test oscilloscope.

## NOTE

Ensure the warm-up criteria have been met, as described in the Performance Verification Conditions topic.

4. Set up the equipment as shown. Use the appropriate load resistor depending on the channel being tested.

**Figure 4: 20 MHz test setup**

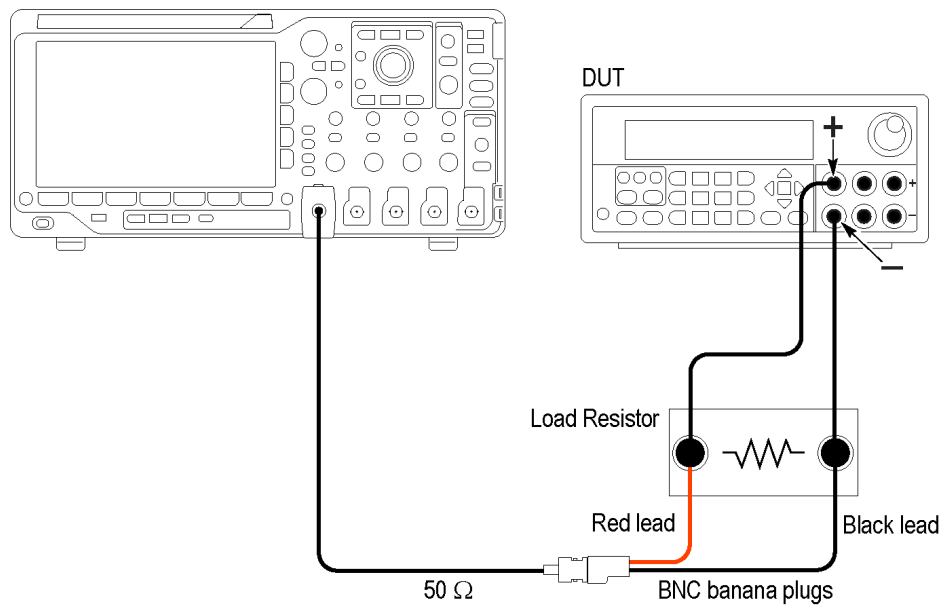

5. Set the oscilloscope as follows:
  - a. 1 mV/division
  - b. 1 M $\Omega$  input resistance
  - c. 20 MHz bandwidth limit
  - d. AC coupled
  - e. Line trigger
  - f. 2 ms/div
  - g. Set to measure V pk-pk and V RMS
6. Set the channel under test to the 100% full scale output voltage.
7. Set the channel under test to the 100% full scale output current.
8. Turn the DUT output on.

### WARNING

*Do not touch the load resistor. The load resistor may become hot enough to cause burns.*

9. Enter the oscilloscope measurements in the table for checking Noise at 20 MHz.  
This completes the verification procedure for one channel. If needed, return to step 1 to run through the procedure for the next channel.

## Check Current Noise

Equipment required	
High-current hookup wire (bold line connections)	Oscilloscope
1 $\Omega$ load resistor	Oscilloscope 10X probe

For each channel sequentially.

1. Plug the DUT into your local line power from the mains.
2. Plug the test oscilloscope into the same mains outlet as the DUT.

### NOTE

Some AC power sources create large amounts of high-frequency noise on the power line that the instrument may not fully reject. Noise directly on the mains is typically better controlled. Use the same mains outlet for both the DUT and test oscilloscope to avoid ground loops which may cause noise.

3. Power on the DUT and test oscilloscope.

## NOTE

Ensure the warm-up criteria have been met, as described in the Performance Verification Conditions topic.

4. Set up the equipment as shown.

**Figure 5: 20 MHz current noise test setup**

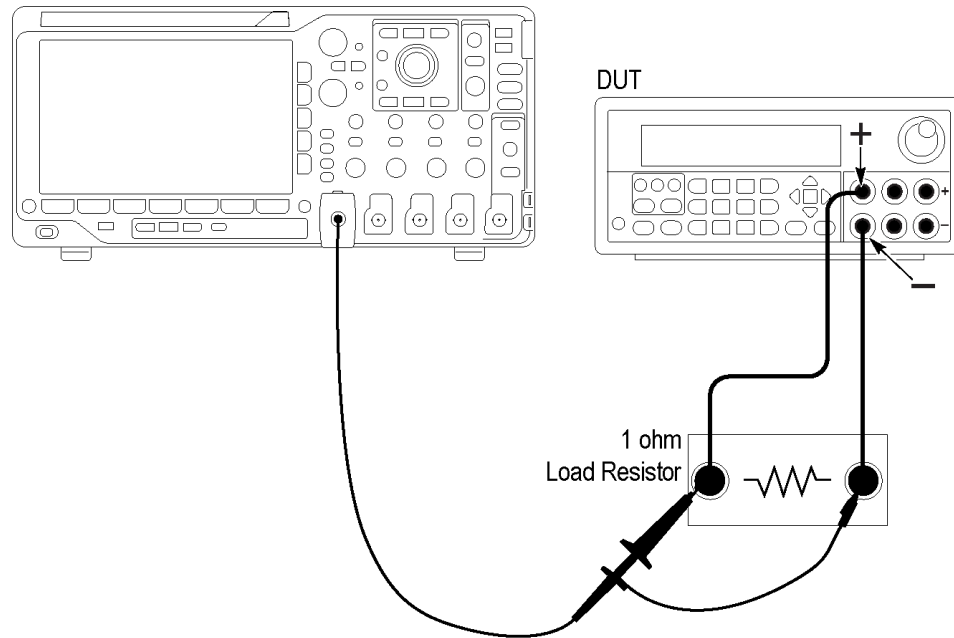

5. Set up the oscilloscope as follows:
  - a. 1 mV/division
  - b. 1 M $\Omega$  input resistance
  - c. 20 MHz bandwidth limit
  - d. AC coupled
  - e. Line trigger
  - f. 2 ms/div
  - g. Set to measure V pk-pk and V RMS
6. Set the channel under test to the 100% full scale output voltage.
7. Set the channel under test to the 100% full scale output current.
8. Turn the DUT output on.

## WARNING

*Do not touch the load resistor. The load resistor may become hot enough to cause burns.*

9. Enter the oscilloscope measurements in the table for Current noise at 20MHz.

10. Power off the DUT and test equipment.

This completes the verification procedure for one channel. If needed, return to step 1 to run through the procedure for the next channel.

Specifications are subject to change without notice.  
All Keithley trademarks and trade names are the property of Keithley Instruments.  
All other trademarks and trade names are the property of their respective companies.

Keithley Instruments  
Corporate Headquarters • 28775 Aurora Road • Cleveland, Ohio 44139 • 440-248-0400 • Fax: 440-248-6168 • 1-888-KEITHLEY • [www.keithley.com](http://www.keithley.com)

---



A Greater Measure of Confidence