

Model 2243 IEEE Interface

Instruction Manual

Contains Operating and Servicing Information

KEITHLEY

WARRANTY

Keithley Instruments, Inc. warrants this product to be free from defects in material and workmanship for a period of 1 year from date of shipment.

Keithley Instruments, Inc. warrants the following items for 90 days from the date of shipment: probes, cables, rechargeable batteries, diskettes, and documentation.

During the warranty period, we will, at our option, either repair or replace any product that proves to be defective.

To exercise this warranty, write or call your local Keithley representative, or contact Keithley headquarters in Cleveland, Ohio. You will be given prompt assistance and return instructions. Send the product, transportation prepaid, to the indicated service facility. Repairs will be made and the product returned, transportation prepaid. Repaired or replaced products are warranted for the balance of the original warranty period, or at least 90 days.

LIMITATION OF WARRANTY

This warranty does not apply to defects resulting from product modification without Keithley's express written consent, or misuse of any product or part. This warranty also does not apply to fuses, software, non-rechargeable batteries, damage from battery leakage, or problems arising from normal wear or failure to follow instructions.

THIS WARRANTY IS IN LIEU OF ALL OTHER WARRANTIES, EXPRESSED OR IMPLIED, INCLUDING ANY IMPLIED WARRANTY OF MERCHANTABILITY OR FITNESS FOR A PARTICULAR USE. THE REMEDIES PROVIDED HEREIN ARE BUYER'S SOLE AND EXCLUSIVE REMEDIES.

NEITHER KEITHLEY INSTRUMENTS, INC. NOR ANY OF ITS EMPLOYEES SHALL BE LIABLE FOR ANY DIRECT, INDIRECT, SPECIAL, INCIDENTAL OR CONSEQUENTIAL DAMAGES ARISING OUT OF THE USE OF ITS INSTRUMENTS AND SOFTWARE EVEN IF KEITHLEY INSTRUMENTS, INC., HAS BEEN ADVISED IN ADVANCE OF THE POSSIBILITY OF SUCH DAMAGES. SUCH EXCLUDED DAMAGES SHALL INCLUDE, BUT ARE NOT LIMITED TO: COSTS OF REMOVAL AND INSTALLATION, LOSSES SUSTAINED AS THE RESULT OF INJURY TO ANY PERSON, OR DAMAGE TO PROPERTY.

KEITHLEY

Keithley Instruments, Inc. • 28775 Aurora Road • Cleveland, OH 44139 • 216-248-0400 • Fax: 216-248-6168 • <http://www.keithley.com>

CHINA:	Keithley Instruments China • Yuan Chen Xin Building, Room 705 • No. 12 Yumin Road, Dewai, Madian • Beijing, China 100029 • 8610-2022886 • Fax: 8610-2022892
FRANCE:	Keithley Instruments SARL • BP 60 • 3 allée des Garays • 91122 Palaiseau Cédex • 31-6-0115155 • Fax: 31-6-0117726
GERMANY:	Keithley Instruments GmbH • Landsberger Straße 65 • 82110 Germering • 49-89-849307-0 • Fax: 49-89-84930759
GREAT BRITAIN:	Keithley Instruments, Ltd. • The Minster • 58 Portman Road • Reading, Berkshire RG30 1EA • 44-01734-575666 • Fax: 44-01734-596469
ITALY:	Keithley Instruments SRL • Viale S. Gimignano 38 • 20146 Milano • 39-2-48303008 • Fax: 39-2-48302274
JAPAN:	Keithley KK • Aibido Bldg. • 7-20-2 Nishishinjuku • Shinjuku-ku, Tokyo 160 • 81-3-5389-1964 • Fax: 81-3-5389-2068
NETHERLANDS:	Keithley Instruments BV • Avelingen West 49 • 4202 MS Gorinchem • 31-(0)183-635333 • Fax: 31-(0)183-630821
SWITZERLAND:	Keithley Instruments SA • Kriesbachstrasse 4 • 8600 Dübendorf • 41-1-8219444 • Fax: 41-1-8203081
TAIWAN:	Keithley Instruments Taiwan • 1, Ming-Yu First Street • Hsinchu, Taiwan, R.O.C. • 886-35-778462 • Fax: 886-35-778455

Model 2243 IEEE Interface Instruction Manual

© 1984, Keithley Instruments, Inc.
Test Instrumentation Group
All rights reserved.
Cleveland, Ohio, U.S.A.
November 1987, Second Printing
Document Number: 2243-901-01 Rev. B

Safety Precautions

The following safety precautions should be observed before using this product and any associated instrumentation. Although some instruments and accessories would normally be used with non-hazardous voltages, there are situations where hazardous conditions may be present.

This product is intended for use by qualified personnel who recognize shock hazards and are familiar with the safety precautions required to avoid possible injury. Read the operating information carefully before using the product.

Exercise extreme caution when a shock hazard is present. Lethal voltage may be present on cable connector jacks or test fixtures. The American National Standards Institute (ANSI) states that a shock hazard exists when voltage levels greater than 30V RMS, 42.4V peak, or 60VDC are present. **A good safety practice is to expect that hazardous voltage is present in any unknown circuit before measuring.**

Before operating an instrument, make sure the line cord is connected to a properly grounded power receptacle. Inspect the connecting cables, test leads, and jumpers for possible wear, cracks, or breaks before each use.

For maximum safety, do not touch the product, test cables, or any other instruments while power is applied to the circuit under test. ALWAYS remove power from the entire test system and discharge any capacitors before: connecting or disconnecting cables or jumpers, installing or removing switching cards, or making internal changes, such as installing or removing jumpers.

Do not touch any object that could provide a current path to the common side of the circuit under test or power line (earth) ground. Always make measurements with dry hands while standing on a dry, insulated surface capable of withstanding the voltage being measured.

Do not exceed the maximum signal levels of the instruments and accessories, as defined in the specifications and operating information, and as shown on the instrument or test fixture rear panel, or switching card.

Do not connect switching cards directly to unlimited power circuits. They are intended to be used with impedance limited sources. NEVER connect switching cards directly to AC main. When connecting sources to switching cards, install protective devices to limit fault current and voltage to the card.

When fuses are used in a product, replace with same type and rating for continued protection against fire hazard.

Chassis connections must only be used as shield connections for measuring circuits, NOT as safety earth ground connections.

If you are using a test fixture, keep the lid closed while power is applied to the device under test. Safe operation requires the use of a lid interlock.

If a  screw is present on the test fixture, connect it to safety earth ground using #18 AWG or larger wire.

The  symbol on an instrument or accessory indicates that 1000V or more may be present on the terminals. Refer to the product manual for detailed operating information.

Instrumentation and accessories should not be connected to humans.

Maintenance should be performed by qualified service personnel. Before performing any maintenance, disconnect the line cord and all test cables.

SPECIFICATIONS

IEEE-488 BUS IMPLEMENTATION

Multiline Commands: DCL, LLO, SDC, GET, GTL, UNT, UNL, SPE, SPD.

Uniline Commands: IFC, REN, EOI, SRQ, ATN.

Interface Functions: SH1, AH1, T6, TE0, L4, LE0, SR1, RL1, PP0, DC1, DT1, C0, E1.

Output Connections: Amphenol or Cinch Series 87 IEEE and printed circuit digital I/O port. All connections on rear panel.

Internal Programmable Parameters: Display Mode, Output, (Prefix Data Format), EOI, SRQ (including mask for over V-limit), Range, Ter-

minator, Character, Inputs (SOURCE, V-LIMIT, DWELL TIME), Output Status.

Digital I/O Port: A separate I/O port consisting of four input and four output lines as well as common (IEEE-488) and +5VDC. Outputs will drive one TTL load. Inputs represent one TTL load. The 224 can be programmed to generate a "SRQ" upon any change in the four bit input data. Mating connector supplied.

2243 PROGRAM CODES

DISPLAY:

- D0 = Source
- D1 = Voltage Limit
- D2 = Dwell Time

FUNCTION:

- F0 = Standby
 - 1. Set output current to zero on 20 μ A range.
 - 2. Reduce voltage limit to less than 32V.
- F1 = Operate
 - Set output to value programmed.

PREFIX (NDCI, V, W):

- G0 = Source, Compliance and Time with prefix is transmitted:
NDCI + n.nnnnE + n, V + n.nn00E + n, W + n.nnnnE + n
- G1 = Source, Compliance and Time.
+ n.nnnnE + n, + n.nn00E + n, + n.nnnnE + n,
NDCI + n.nnnnE + n for current
V + n.nn00E + n for voltage limit
W + n.nnnnE + n for time
"N" is replaced with "O" if an over compliance condition exists.

STATUS WORD:

- G0 status word with model number prefix transmitted:
22400000000:
- G1 status word without model number prefix transmitted:
00000000:

I/O STATUS:

- G0 I/O status with prefix transmitted:
I/Oii,oo
- G1 I/O status without prefix transmitted:
ii,oo
- where i is the input from 0 to 15; where o is the output from 0 to 15.

EOI:

- K0 = EOI transmitted on last byte out.
- K1 = EOI is not transmitted.

SRQ:

- Mnn: nn = 0 to 31 base, 10 or 00000 to 11111 base 2.
 - 0 = bit disabled
 - 1 = bit enabled

Bits: SRQ mask

MSB7: N/A

- 6: N/A
- 5: N/A
- 4: Input Port Change
- 3: End of Dwell Time
- 2: I-Limit Reached
- 1: Over Voltage Limit
- 0: IDDC, IDDCO or -REN (No Remote)

SRQ BYTE:

BITS: DATA

- MSB7 N/A
- 6 SRQ
- 5 Data = 0
- 4 N/A
- 3 Input Port Change
- 2 End of Dwell Time
- 1 I-Limit Reached
- 0 Over Voltage Limit

ERROR

- N/A
- SRQ
- Error = 1
- N/A
- N/A
- REN
- (No Remote)
- IDDCO
- IDDC

RANGES:

- R0 = Auto Range (Force Most Significant Number)
- R5 = Full Scale: 20 μ A 2.0E-5
- R6 = Full Scale: 200 μ A 2.0E-4
- R7 = Full Scale: 2mA 2.0E-3
- R8 = Full Scale: 20mA 2.0E-2
- R9 = Full Scale: 101mA 1.01E-1

IEEE TERMINATOR CHARACTER:

Yc = The (ASCII) byte contains an ASCII character which will be used as the terminator for all data until changed. The power up default is (CR) (LF). [NOTE: ASCII (DEL) indicates no terminator, ASCII (LF) indicates (CR) (LF), and ASCII (CR) indicates (LF) (CR).] Terminators not allowed: All capital letters; all numbers; (blank); + - / , . e

INPUTS:

- I(sign)n.nnnE(sign)nn
- Current Source Output Value
- Limits: 0 to \pm 101.00mA
- V(sign)n.nnnnE(sign)nn
- Voltage Limit
- Limits: 1 to 105V
- W(sign)n.nnnE(sign)nn
- Time
- Limits: 50.00msec to 999.9sec (1msec steps)

I/O PORT:

- On.nnnnEnn
- Set control bits on "X"
- n = 0 to 16 base 10 or 0000 to 1111 base 2
- if 0 then bit low
- if 1 then bit high

OUTPUT STATUS STRING ON TALK:

- U0 = Output status word on next read.
 - Format: 2 2 4 D F G J K R M Y
 - Default: 2 2 4 0 0 0 0 0 0 0 0 :
 - J is cleared to 0 after status word is read.
- U1 = Output I/O status word is read.
 - Read input on X only.
 - I/Oii,oo = I/O

IEEE COMMAND GROUPS

ADDRESS COMMAND GROUP

LISTEN: LAG = LISTEN ADDRESS GROUP
MLA = MY LISTEN ADDRESS
UNL = UNLISTEN
TALK: TAG = TALK ADDRESS GROUP
MTA = MY TALK ADDRESS
UNT = UNTALK
OTA = OTHER TALK ADDRESS

ADDRESSED COMMAND GROUP

ACG = ADDRESSED COMMAND GROUP
GET = GROUP EXECUTE TRIGGER
GTL = GO TO LOCAL
SDC = SELECTIVE DEVICE CLEAR

STATUS COMMAND GROUP

RQS = REQUEST SERVICE
SRQ = SERIAL POLL REQUEST
STB = STATUS BYTE

HANDSHAKE COMMAND GROUP

DAC = DATA ACCEPTED
RFD = READY FOR DATA
DAV = DATA VALID

UNIVERSAL COMMAND GROUP

ATN = ATTENTION
DCL = DEVICE CLEAR
IFC = INTERFACE CLEAR
LLO = LOCAL LOCKOUT
REN = REMOTE ENABLE
SPD = SERIAL POLL DISABLE
SPE = SERIAL POLL ENABLE
EOI = END

TABLE OF CONTENTS

Para.	Title	Page
SECTION 1—GENERAL INFORMATION		
1.1	Introduction	1-1
1.2	Model 2243 Interface Features	1-1
1.3	Warranty Information	1-1
1.4	Manual Addenda	1-1
1.5	Safety Symbols and Terms	1-1
1.6	Using the Model 2243 Programming Manual	1-1
1.7	Specifications	1-1
1.8	Unpacking and Inspection	1-2
SECTION 2—AN OVERVIEW OF THE IEEE-488 BUS		
2.1	Introduction	2-1
2.2	Bus Description	2-1
2.3	IEEE-488 Bus Lines	2-1
2.3.1	Bus Management Lines	2-1
2.3.2	Handshake Lines	2-2
2.3.3	Data Lines	2-2
2.4	Bus Commands	2-2
2.4.1	Uniline Commands	2-3
2.4.2	Universal Commands	2-3
2.4.3	Addressed Commands	2-3
2.4.4	Unaddressed Commands	2-3
2.4.5	Device-Dependent Commands	2-3
2.5	Command Codes	2-4
2.6	Command Sequences	2-5
2.6.1	Addressed Command Sequence	2-5
2.6.2	Universal Command Sequence	2-5
2.6.3	Device-Dependent Command Sequence	2-5
SECTION 3—SYSTEM CONFIGURATION		
3.1	Introduction	3-1
3.2	Hardware Consideration	3-1
3.2.1	Typical Systems	3-1
3.2.2	Bus Connections	3-1
3.2.3	Primary Address Selection	3-3
3.2.4	Digital I/O Port	3-4
3.3	Software Considerations	3-5
3.3.1	Controller Interface Routines	3-5
3.3.2	HP-85 BASIC Statements	3-5
3.3.3	Interface Function Codes	3-6
3.3.4	Model 2243 Interface	3-7
SECTION 4—OPERATION		
4.1	Introduction	4-1
4.2	General Bus Commands	4-1
4.2.1	REN (Remote Enable)	4-1
4.2.2	IFC (Interface Clear)	4-1
4.2.3	LLO (Local Lockout)	4-2
4.2.4	GTL (Go To Local)	4-2
4.2.5	DCL (Device Clear)	4-2
4.2.6	SDC (Selective Device Clear)	4-2
4.2.7	Serial Polling (SPE, SPD)	4-3
4.3	Device-Dependent Command Programming	4-3
4.3.1	Execute (X)	4-5
4.3.2	Display Mode	4-5
4.3.3	Input (I, V, and W)	4-5
4.3.4	I/O Port (O)	4-6

TABLE OF CONTENTS

Para.	Title	Page
4.3.5	Function (F)	4-6
4.3.6	Prefix (G)	4-6
4.3.7	EOI Programming (K)	4-7
4.3.8	SRQ Mode (M) and Status Byte Format	4-7
4.3.9	Range (R)	4-10
4.3.10	Programmable Terminator (Y)	4-10
4.3.11	Status Word (U)	4-11
4.4	Front Panel Error Messages	4-13
4.4.1	IDDC Error	4-13
4.4.2	IDDCO Error	4-13
4.4.3	Remote Error	4-13
SECTION 5—MAINTENANCE		
5.1	Introduction	5-1
5.2	Installation	5-1
5.3	Troubleshooting	5-1
5.3.1	Special Handling of Static Sensitive Devices	5-1
SECTION 6—REPLACEABLE PARTS		
6.1	Introduction	6-1
6.2	Parts List	6-1
6.3	Ordering Information	6-1
6.4	Factory Service	6-1
6.5	Schematic Diagram and Component Location Drawing	6-1

LIST OF ILLUSTRATIONS

Figure	Title	Page
2-1	IEEE Bus Configuration	2-2
2-2	IEEE Handshake Sequence	2-3
2-3	Command Codes	2-6
3-1	System Types	3-1
3-2	IEEE-488 Connector	3-1
3-3	IEEE-488 Connections	3-2
3-4	Rear Panel of Model 224 Showing IEEE Connections and Switches	3-2
3-5	Contact Assignments	3-3
3-6	Typical IEEE-488 Bus Driver (one of 16)	3-3
3-7	Primary Address Switches	3-4
3-8	Digital I/O Port Assignments	3-5
4-1	SRQ Mask Format	4-8
4-2	Status Byte Format	4-9
4-3	Status Word Format	4-12
4-4	I/O Status Format	4-12
4-5	Front Panel Error Messages	4-13
5-1	Model 2243 Installation	5-3
6-1	Model 2243, Component Location Drawing, Dwg. No. 220-130	6-3
6-2	Model 2243, Schematic Diagram, Dwg. No. 220-136	6-5

LIST OF TABLES

Table	Title	Page
2-1	IEEE-488 Bus Command Summary	2-4
2-2	Hexadecimal and Decimal Command Codes	2-4
2-3	Typical Addressed Command Sequence	2-5
2-4	Typical Device-Dependent Command Sequence	2-5
3-1	IEEE Contact Designations	3-3
3-2	Primary Address Switch Positions	3-4
3-3	Digital I/O Port Pin Assignments	3-5
3-4	HP-85 IEEE-488 BASIC Statements	3-6
3-5	Model 2243 Interface Function Codes	3-7
3-6	IEEE Command Groups	3-7
4-1	General Bus Commands	4-1
4-2	Default Values	4-3
4-3	Device-Dependent Command Summary	4-4
4-4	Model 224 Display Mode Commands	4-5
4-5	Input Command Summary	4-6
4-6	I/O Port Command Parameters	4-6
4-7	SRQ Commands and Conditions	4-8
4-8	Status Byte Data and Error Conditions	4-9
4-9	Range Commands	4-10
4-10	I/O Port Status Values	4-12
5-1	Model 2243 Troubleshooting	5-2
5-2	Recommended Test Equipment	5-2
5-3	Model 2243 Static Sensitive Devices	5-2
6-1	Model 2243 Parts List	6-1

SECTION 1 GENERAL INFORMATION

1.1 INTRODUCTION

The Model 2243 is an optional IEEE-488 interface for the Model 224 Programmable Current Source. This interface adds extra versatility to the Model 224 by allowing the transmission of data and commands over the IEEE-488 bus. The interface provides all the logic necessary to interface the Model 224 to the bus using standard IEEE-488-1978 protocol. Additionally, the Model 2243 incorporates a separate digital I/O port that may be used to interface the Model 224 to other digital instrumentation.

1.2 MODEL 2243 INTERFACE FEATURES

Important IEEE-488 interface features include:

1. With the Model 2243 installed, the Model 224 is able to communicate with other instrumentation using the same IEEE-488-1978 standards.
2. Standard IEEE Connector. A standard IEEE-488 connector is available on the rear panel of the instrument for easy connection to the IEEE-488 bus.
3. Simple Primary Address Selection. The primary address of the Model 224 may be easily changed by using the five address switches on the rear panel of the instrument.
4. Digital I/O Port. The interface also includes a digital I/O port which has separate 4 bit input and output connections. Port status may be read and controlled through commands given over the IEEE bus.
5. Programming Versatility. All Model 224 operation is supported by IEEE programming. In addition, numerous other IEEE commands add operating features not available from the front panel.

1.3 WARRANTY INFORMATION

Warranty information may be found inside the front cover of this manual. Should it become necessary to exercise the warranty, contact your Keithley representative or the factory to determine the proper course of action. Keithley Instruments, Inc. maintains service facilities in the United States, United Kingdom, and throughout Europe. Addresses for these facilities may be found inside the front cover of this manual. Information concerning the application, operation, or service of your instrument may be directed to the applications engineer at any of these locations.

1.4 MANUAL ADDENDA

Information concerning improvements or changes to the instrument which occur after the printing of this manual may

be found on an addendum included with this manual. Be sure to review these changes before attempting to program the instrument.

1.5 SAFETY SYMBOLS AND TERMS

The following safety symbols and terms are used in this manual and may be found on the Model 224.

The symbol  on the instrument indicates that the user should refer to the operating instructions.

The symbol  on the instrument indicates that a potential of 1000V or more may be present on the terminal(s). Standard safety precautions should be observed when such dangerous voltages are encountered.

Information associated with the **WARNING** heading explains dangers that could result in personal injury or death.

Information following the **CAUTION** heading explains hazards that could damage the instrument.

1.6 USING THE MODEL 2243 PROGRAMMING MANUAL

This manual contains all the information necessary to connect the Model 2243 to the IEEE-488 bus and program the instrument from a separate bus controller.

This programming manual is divided into the following sections:

1. Section 2 contains a general description of the IEEE-488 bus and its commands.
2. Information necessary to connect the instrument to the bus and set the primary address is contained in Section 3. Also, digital I/O port information can be found in this section.
3. The bulk of the programming information may be found in Section 4. General bus commands as well as commands unique to the Model 2243 are covered in detail.
4. Section 5 contains Maintenance information such as Installation and troubleshooting.
5. Section 6 contains replaceable parts information.

1.7 SPECIFICATIONS

A complete list of IEEE specifications can be found preceding this section.

1.8 UNPACKING AND INSPECTION

The Model 2243 interface was carefully inspected both mechanically and electrically before shipment. Upon receiving the Model 2243, carefully unpack all items and check for any obvious physical damage that may have occurred during shipment. Report any damage to the shipping agent immediately. Retain the original packing material in case reshipment is necessary. The following items are shipped with every Model 2243 order:

- Model 2243 IEEE-488 Interface
- Hardware necessary for installation.
- Model 2243 Instruction Manual
- Additional accessories as ordered.

If an additional instruction manual is required, order the manual package (Keithley Part Number 2243-901-00). The manual package includes an instruction manual and all pertinent addenda.

SECTION 2

AN OVERVIEW OF THE IEEE-488 BUS

2.1 INTRODUCTION

The IEEE-488 bus is an instrumentation data bus adopted by the IEEE (Institute of Electrical and Electronic Engineers) in 1975 and given the IEEE-488 designation. The most recent revision of bus standards was made in 1978; hence the complete description for current bus standards is the IEEE-488-1978 designation.

This section gives a brief description of the general bus structure along with an outline of bus commands. The information presented here is not intended to be an in-depth description of what is truly a very complex set of standards. More complete information on the IEEE-488 bus, which is also frequently referred to as the GPIB (General Purpose Interface Bus), is available from the IEEE and a variety of other sources.

2.2 BUS DESCRIPTION

The IEEE-488 bus was designed as a parallel data transfer medium to optimize data transfer without using an excessive number of bus lines. In keeping with this goal, the bus has only eight data lines that are used for both data and some commands. Five bus management lines and three handshake lines round out the complement of signal lines. Since the bus is of parallel design, all devices connected to the bus have the same information available simultaneously. Exactly what is done with the information by each device depends on many factors, including device capabilities.

A typical bus configuration for controlled operation is shown in Figure 2-1. The typical system will have one controller and one or more instruments to which commands are given and, in most cases, from which data is received. Generally, there are three categories that describe device operation. These designations include: controller; talker; listener.

The controller does what its name implies: it controls other devices on the bus. A talker sends data, while a listener receives data. Depending on the instrument, a particular device may be a talker only, a listener only, or both a talker and a listener.

Any given system can have only one controller (control may be passed to an appropriate device through a special command), but any number of talkers or listeners may be present up to the hardware constraints of the bus. Generally, the bus is limited to 15 devices, but this number may be reduced if higher than normal data transfer rates are required or if longer than normal cables are used.

Several devices may be commanded to listen at once, but only one device may be a talker at any given time. Otherwise,

communications would be scrambled much like an individual's trying to pick out a single conversation out of a large crowd.

Before a device can talk or listen, it must be appropriately addressed. Devices are selected on the basis of their primary address; the addressed device is sent to a talk or listen command derived from its primary address. Normally, each device on the bus has a unique address so that each may be addressed individually.

Once the device is addressed on talk or listen, appropriate bus transactions are set to take place. For example, if an instrument is addressed to talk, it will usually place its data on the bus one byte at a time. The listening device will then read this information, and the appropriate software can then be used to channel the information to the desired location.

2.3 IEEE-488 BUS LINES

The signal lines on the IEEE-488 bus are grouped into three general categories. The data lines handle bus information, while the handshake and bus management lines ensure that proper data transfer and bus operation takes place. Each of the bus lines is active low so that approximately zero volts is a logic one. The following paragraphs describe the purpose of these lines, which are shown in Figure 2-1.

2.3.1 Bus Management Lines

The bus management group is made up of five signal lines that help ensure an orderly transfer of data. These lines are used to send the uniline commands described in paragraph 2.4

1. ATN (Attention)—The ATN line is one of the more important management lines. The state of the ATN line determines whether controller information on the data bus is to be considered data or multiline command as described in paragraph 2.4.
2. IFC (Interface Clear)—Setting the IFC line true (low) causes the bus to go to a known state by sending the IFC command.
3. REN (Remote Enable)—Setting the REN line low sends the REN command. This sets up instruments on the bus for remote operation.
4. EOI (End Or Identify)—The EOI line is used to send the EOI command that usually terminates a multi-byte transfer sequence.
5. SRQ (Service Request)—The SRQ line is set low by a device when it requires service from the controller.

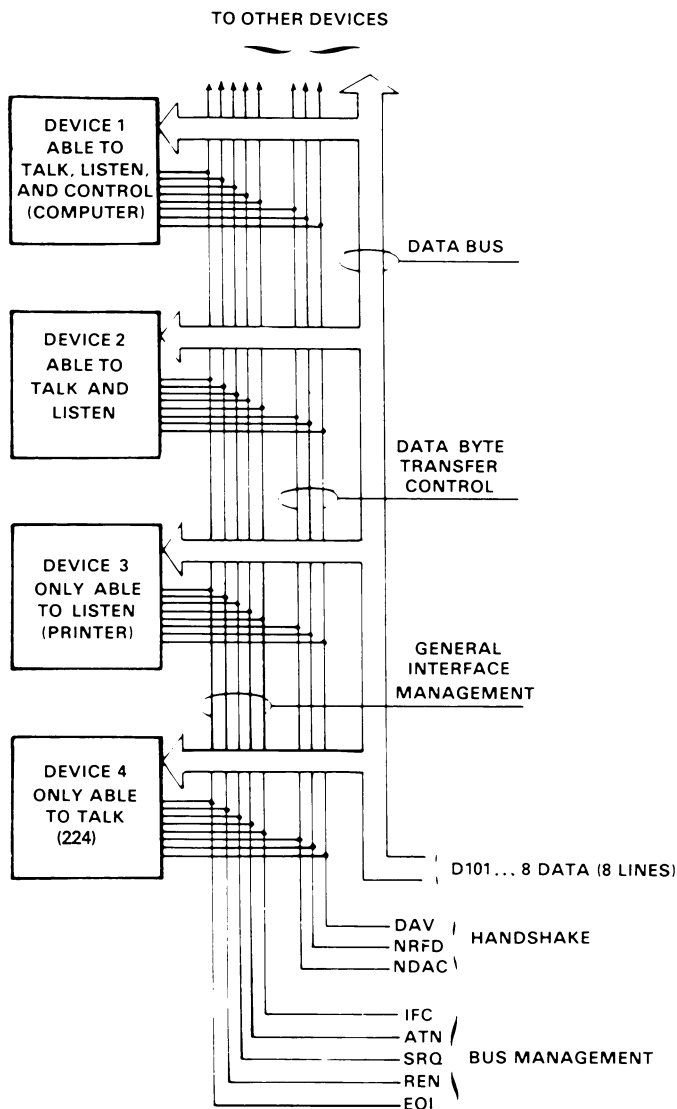

Figure 2-1. IEEE Bus Configuration

2.3.2 Handshake Lines

The bus uses three handshake lines that operate in an interlocked sequence. This method ensures reliable data transfer regardless of the transfer rate. Generally, data transfer will occur at a rate determined by the slowest active device on the bus.

One of the handshake lines is controlled by the data source, while the remaining two lines are controlled by accepting devices. The three bus handshake lines are:

1. DAV (Data Valid)—The source controls the state of the DAV line.
2. NRFD (Not Ready For Data)—The acceptor controls the state of the NRFD line.
3. NDAC (Not Data Accepted)—The acceptor also controls the NDAC line.

The complete handshake sequence for one data byte is shown in Figure 2-2. Once data is on the bus, the source checks to see that NRFD is high, indicating that all devices on the bus are ready for data. At the same time NDAC should be low from the previous byte transfer. If these conditions are not met, the source must then wait until the NRFD and NDAC lines have the correct status. If the source is a controller, NRFD and NDAC must remain stable for at least 100nsec after ATN is set low. Because of the possibility of bus hang up, some controllers have time-out routines to display error messages if the handshake sequence stops for any reason.

Once the NRFD and NDAC lines are properly set, the source sets the DAV line low, indicating that data on the bus is now valid. The NRFD line then goes low; the NDAC line goes high once all devices on the bus have accepted the data. Each device will release the NDAC line at its own rate, but the NDAC line will not go high until the slowest device has accepted the data byte.

After the NDAC line goes high, the source then sets the DAV line high to indicate that the data on the bus is no longer valid. At this point, the NDAC line returns to its low state. Finally, the NRFD line is released by each of the devices at their own rates, until the NRFD line finally goes high when the slowest devices is ready, and the bus is set to repeat the sequence with the next data byte.

The sequence just described is used to transfer both data and multiline commands. The state of the ATN line determines whether the data bus contains data or commands as described in paragraph 2.4.

2.3.3 Data Lines

The IEEE-488 bus uses the eight data lines that allows data to be transmitted and received in a bit-parallel, byte-serial manner. The eight lines use the convention DI01 through DI08 instead of the more common D0 through D7 binary terminology. The data lines are bidirectional and, as with the remaining bus signal lines, low is true.

2.4 BUS COMMANDS

While the hardware aspects of bus is essential, the interface would be essentially worthless without appropriate commands to control communications between the various instruments on the bus. This section briefly describes the purpose of the bus commands, which are grouped into the following three general categories:

1. Uniline commands: Sent by setting the associated bus line low.
2. Multiline commands: General bus commands which are sent over the data lines with the ATN line low.
3. Device-dependent commands: Special commands that depend on device configuration; sent over the data lines with ATN high.

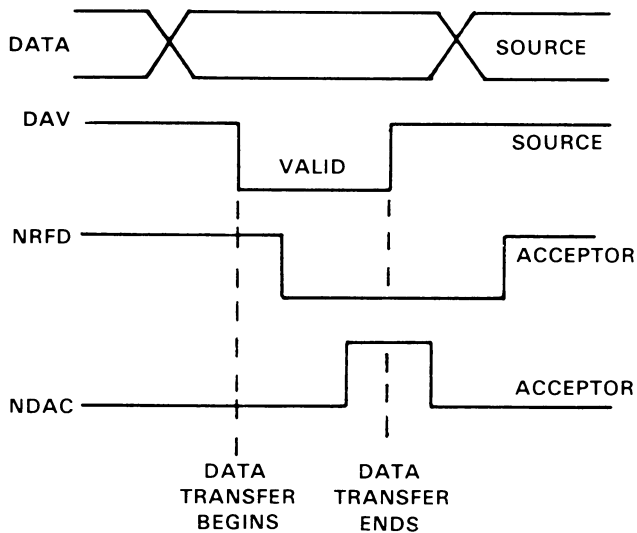

Figure 2-2. IEEE Handshake Sequence

These commands are summarized in Table 2-1.

2.4.1 Uniline Commands

Uniline commands are sent by setting the associated bus line low. The ATN, IFC, and REN commands are asserted only by the system controller. The SRQ command is sent by an external device. The EOI command may be sent by either the controller or an external device depending on the direction of data transfer. The following is a brief description of each command.

1. REN (Remote Enable)—When the controller sends the REN command, the instrument will be set up for remote operation. Generally, the REN command should be sent before attempting to program the instruments over the bus.
2. EOI (End Or Identify)—The EOI command is used to positively identify the last byte in a multi-byte transfer sequence. This allows variable length data words to be transmitted easily.
3. IFC (Interface Clear)—The IFC command is sent to clear the bus and set devices to a known state. Although device configurations differ, the IFC command usually places instruments in the talk and listen idle states.
4. ATN (Attention)—The controller sends ATN while transmitting addresses or multiline commands. Device-dependent commands are sent with the ATN line high (false).
5. SRQ (Service Request)—The SRQ command is asserted by an external device when it requires service from the controller. If more than one device is present, a serial polling sequence, as described in Section 4, must be used to determine which device has requested service.

2.4.2 Universal Commands

Universal commands are multiline commands that require no

addressing. All instrumentation equipped to implement the command will do so simultaneously when the command is transmitted over the bus. As with all multiline commands, the universal commands are sent over the data lines with ATN low.

1. LLO (Local Lockout)—The LLO command is used to lock out front panel controls on devices so equipped.
2. DCL (Device Clear)—After a DCL is sent, instrumentation equipped to implement the command will revert to a known state. Usually, instruments return to their power-up conditions.
3. SPE (Serial Poll Enable)—The SPE command is the first step in the serial polling sequence, which is used to determine which instrument has requested service with the SRQ command.
4. SPD (Serial Poll Disable)—The SPD command is sent by the controller to remove all instrumentation on the bus from the serial poll mode.

2.4.3 Addressed Commands

Addressed commands are multiline commands that must be preceded by a listen command derived from the device's primary address before the instrument will respond. Only the addressed device will respond to each of these commands:

1. SDC (Selective Device Clear)—The SDC command performs essentially the same function as the DCL command except that only the addressed device will respond. Instruments usually return to their default conditions when the SDC command is sent.
2. GTL (Go To Local)—The GTL command is used to remove instruments from the remote mode of operation. Also, front panel control operation will usually be restored if the LLO command was previously sent.
3. GET (Group Execute Trigger)—The GET command is used to trigger devices to perform a specific action that depends on device configuration. Although GET is considered to be an addressed command, many devices respond to GET without being addressed.

2.4.4 Unaddressed Commands

The two unaddressed commands are used by the controller to remove all talkers and listeners from the bus simultaneously. ATN is low when these multiline commands are asserted.

1. UNL (Unlisten)—All listeners are removed from the bus at once when the UNL command is placed on the bus.
2. UNT (Untalk)—The controller sends the UNT command to clear the bus of any talkers.

2.4.5 Device-Dependent Commands

The meaning of the device-dependent commands is determined by instrument configuration. Generally, these commands are sent as one or more ASCII characters that tell the device to perform a specific function. For example, F0 is sent to the Model 2243 to place the instrument in the standby

mode. For complete information on using these commands with the Model 2243, refer to Section 4. The IEEE-488 bus treats device-dependent commands as data in the ATN high (false) when the commands are transmitted.

2.5 COMMAND CODES

Each multiline command is given a unique code that is transmitted over the bus as 7 bit ASCII data. The section briefly explains the code groups which are summarized in Figure 2-3. Every command is sent with ATN low.

1. Addressed Command Group (ACG)—Address commands are listed in column 0(B) in Figure 2-3. Column 0(A) lists the corresponding ASCII codes.
2. Universal Command Group (UCG)—Columns 1(A) and 1(B) list the Universal commands and the corresponding ASCII codes.
3. Listen Address Group (LAG)—Columns 2(A) and 3(A) list the ASCII codes corresponding to the primary addresses listed in columns 2(B) and 3(B). For example, if the primary address of the instrument is set to 12, the LAG byte will correspond to an ASCII comma.
4. Talk Address Group (TAG)—TAG primary address values and the corresponding ASCII characters are listed in columns 4(A) through 5(B).

The preceding address groups are combined together to form the Primary Command Group (PCG). The bus also has another group of commands, called the Secondary Command Group (SCG). These are listed in Figure 2-3 for informational purposes only; the Model 2243 does not respond to these commands, but other devices may have secondary addressing capability.

NOTE

Commands are normally transmitted with the 7 bit code listed in Figure 2-3. For most devices, the condition of D₇ (DI08) is unimportant, as shown by the "Don't Care" indication in the table. Some devices, however, may require that D₇ assume a specific logic state before the commands are recognized.

Hexadecimal and decimal values for each of the commands or command groups are listed in Table 2-2. Each value in the table assumes that D₇ is set to 0.

Table 2-2. Hexadecimal and Decimal Command Codes

Command	Hex Value*	Decimal Value
GTL	01	1
SDC	04	4
GET	08	8
LLO	11	17
DCL	14	20
SPE	18	24
SPD	19	25
LAG	20-3F	32-63
TAG	40-5F	64-95
UNL	3F	63
UNT	5F	95

*Values shown with D₇ = 0.

Table 2-1. IEEE-488 Bus Command Summary

Command Type	Command	State of ATN Line*	Comments	
Uniline	REN (Remote Enable)	X	Set up for remote operation.	
	EOI	X	Sent by setting EOI low.	
	IFC (Interface Clear)	X	Clears Interface	
	ATN (Attention)	Low	Defines data bus contents.	
	SRQ (Service Request)	X	Controlled by external device.	
Multiline	Universal	LLO (Local Lockout)	Low	Locks out front panel controls.
		DCL (Device Clear)	Low	Returns device to default conditions.
		SPE (Serial Poll Enable)	Low	Enables serial polling.
		SPD (Serial Poll Disable)	Low	Disables serial polling.
	Addressed	SDC (Selective Device Clear)	Low	Returns unit to default conditions.
		GTL (Go To Local)	Low	Returns to local control.
	Unaddress	GET (Group Execute Trigger)†	Low	Triggers device.
UNL (Unlisten)		Low	Removes all listeners from bus.	
	UNT (Untalk)	Low	Removes any talkers from bus.	
Device-dependent**		High	Programs Model 224 for various modes.	

†Some devices respond to GET without addressing.

*X = Don't Care

**See Section 4 for complete description.

2.6 COMMAND SEQUENCES

The proper command sequence must be sent by the controller before an instrument will respond as intended. The universal commands, such as LLO and DCL, require only that ATN be set low before the command is sent. Other commands require that the device be addressed to listen first. This section briefly describes the bus sequence for several types of commands.

2.6.1 Addressed Command Sequence

Before a device will respond to one of these commands, it must receive a LAG command derived from its primary address. Table 2-3 shows a typical sequence for the SDC command. The LAG command assumes that the instrument is set at a primary address of 19.

Note that an UNL command is transmitted before the LAG, SDC sequence. This is generally done to remove all other listeners from the bus first so that only the addressed device responds.

2.6.2 Universal Command Sequence

The universal commands are sent by setting ATN low and then placing the command byte on the bus. For example, the following gives the LLO command:

ATN•LLO

Note that both the ATN and LLO commands are on the bus simultaneously. Also, addressing is not necessary.

2.6.3 Device-Dependent Command Sequence

Device-dependent commands are transmitted with ATN high. However, the device must be addressed to listen first

before the commands are transmitted. Table 2-4 shows the sequence for the following command:

FOX

This command, which sets the Model 224/2243 to the stand-by mode, is described in detail in Section 4.

Table 2-3. Typical Addressed Command Sequence

Step	Command	ATN State	Data Bus		
			ASCII	Hex	Decimal
1	UNL	Set low	?	3F	63
2	LAG*	Stays low	3	33	51
3	SDC	Stays low	EOT	04	4
4		Returns high			

*Assumes primary address = 19.

Table 2-4. Typical Device-Dependent Command Sequence

Step	Command	ATN State	Data Bus		
			ASCII	Hex	Decimal
1	UNL	Set low	?	3F	63
2	LAG*	Stays low	3	33	51
3	Data	Set high	F	46	70
4	Data	Stays high	0	30	48
5	Data	Stays high	X	58	88

*Assumes primary address = 19.

D ₇ D ₆ D ₅ D ₄ Bits		D ₃	D ₂	D ₁	D ₀	COLUMN - ROW1	X 0 0 0 COMMAND	X 0 0 1 COMMAND	X 0 1 0 PRIMARY ADDRESS	X 0 1 1 PRIMARY ADDRESS	X 1 0 0 PRIMARY ADDRESS	X 1 0 1 PRIMARY ADDRESS	X 1 1 0 PRIMARY ADDRESS	X 1 1 1 PRIMARY ADDRESS	6 (A)	6 (B)	7 (A)	7 (B)								
0	0	0	0	0	0	0	0 (A)	NUL	0 (B)	1 (A)	1 (B)	1 (A)	2 (B)	2 (A)	0	3 (A)	3 (B)	4 (A)	4 (B)	5 (A)	5 (B)	6 (A)	6 (B)	7 (A)	7 (B)	
0	0	0	0	1	1	1	SOH	GTL	DC1	1	LLO	1	1	1	0	A	17	1	1	0	17	16				
0	0	0	1	0	2	2	STX		DC2	2		2	2	2	B	18	2	2	2	R	18					
0	0	1	1	3	3	3	ETX		DC3	3		3	3	3	C	19	3	3	3	S	19					
0	1	0	0	4	4	4	EOT	SDC	DC4	4	DCL	4	4	4	D	20	4	4	4	T	20					
0	1	0	0	5	5	5	ENO	PPC*	NAK	5	PPU*	5	5	5	E	21	5	5	5	U	21					
0	1	1	0	6	6	6	ACK		SYN	6		6	6	6	F	22	6	6	6	V	22					
0	1	1	1	7	7	7	BEL		ETB	7		7	7	7	G	23	7	7	7	W	23					
1	0	0	0	8	8	8	BS	GET	CAN	8	SPE	8	8	8	H	24	8	8	8	X	24					
1	0	0	1	9	9	9	HT	TCT*	EM	9	SPD	9	9	9	I	25	9	9	9	Y	25					
1	0	1	0	10	10	10	LF		SUB	10		10	10	10	J	26	10	10	10	Z	26					
1	0	1	1	11	11	11	VT		ESC	11		11	11	11	K	27	11	11	11	I	27					
1	1	0	0	12	12	12	FF		FS	12		12	12	12	L	28	12	12	12	\	28					
1	1	0	1	13	13	13	CR		GS	13		13	13	13	M	29	13	13	13	^	29					
1	1	1	0	14	14	14	SO		RS	14		14	14	14	N	30	14	14	14	^	30					
1	1	1	1	15	15	15	SI		US	15		15	15	15	O	UNT	15	15	15	-	UNT					

ADDRESS COMMAND GROUP (ACG)	UNIVERSAL COMMAND GROUP (UCG)	LISTEN ADDRESS GROUP (LAG)	TALK ADDRESS GROUP (TAG)	PRIMARY COMMAND GROUP (PCG)	SECONDARY COMMAND GROUP (SDC)
--------------------------------------	--	-------------------------------------	-----------------------------------	--------------------------------------	--

*PPC (Parallel Poll Configure), PPU (Parallel Poll Unconfigure), and
TCT (Take Control) not implemented by Model 2243
NOTE: D₀ = DIO1...D₇ = DIO8
X = Don't Care

Figure 2-3. Command Codes

SECTION 3 SYSTEM CONFIGURATION

3.1 INTRODUCTION

There are two operating aspects to almost any digital interface. The IEEE-488 standard is no exception to this rule. Not only must the hardware meet certain standards, but all devices, including the controller, must have appropriate software. This section deals with important hardware and software aspects of bus operation. Also included is information pertaining to the Model 2243 digital I/O port.

3.2 HARDWARE CONSIDERATION

Before the Model 2243 can be used with the IEEE-488 bus, the instrument must be connected to the bus with a suitable connector. Also, the primary address must be properly selected as described in this section. But most of all it should be installed in the Model 224. Refer to Section 5.

3.2.1 Typical Systems

The IEEE-488 bus is a parallel interface system. As a result, adding more devices is simply a matter of using more cables to make the desired connections. Because of this flexibility, system complexity can range from the very simple to extremely complex.

Figure 3-1 shows two typical system configurations. Figure 3-1(A) shows the simplest possible controlled system. The controller is used to send commands to the instrument, which sends data back to the controller.

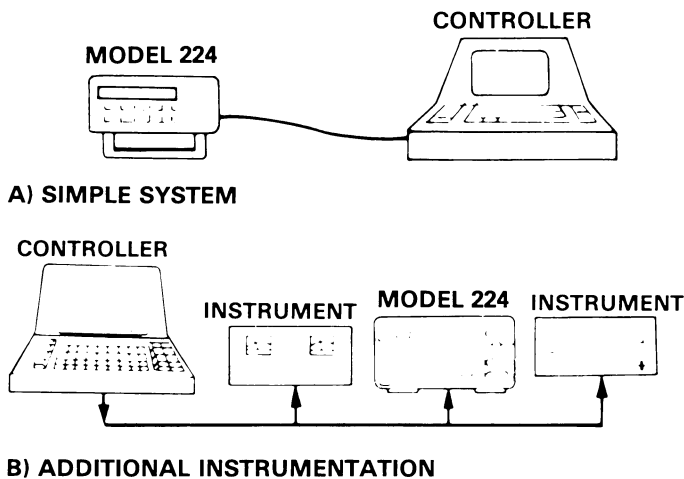

The system becomes more complex in Figure 3-1(B), where additional instrumentation is added. Depending on program-

ming, all data may be routed through the controller, or it may be transmitted directly from one instrument to another.

For very complex applications, a much larger computer can be used. Tape drives or disks can then be used to store data.

3.2.2 Bus Connections

The Model 2243 is connected to the bus through an IEEE-488 connector which is shown in Figure 3-2. This connector is designed to be stacked to allow a number of parallel connections on one instrument.

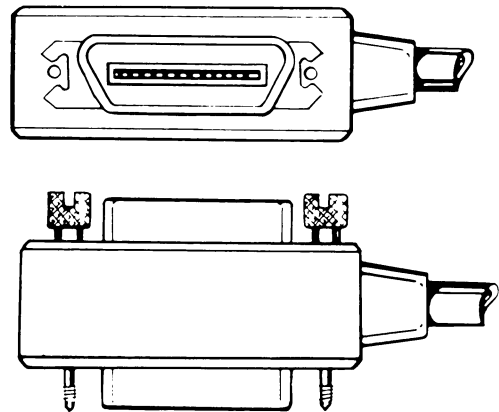

Figure 3-2. IEEE-488 Connector

NOTE

To avoid possible mechanical damage, it is recommended that not more than three connectors be stacked on any one instrument. Otherwise, the resulting strain may cause internal damage.

A typical connecting scheme for the bus is shown in Figure 3-3. Each cable normally has the standard IEEE connector on each end. The Keithley Model 7008-6 cable, which is six feet in length, is ideal for this purpose. Once the connections are made, the screws should be tightened securely. For the location of the connector on the rear panel of the Model 224, refer to Figure 3-4.

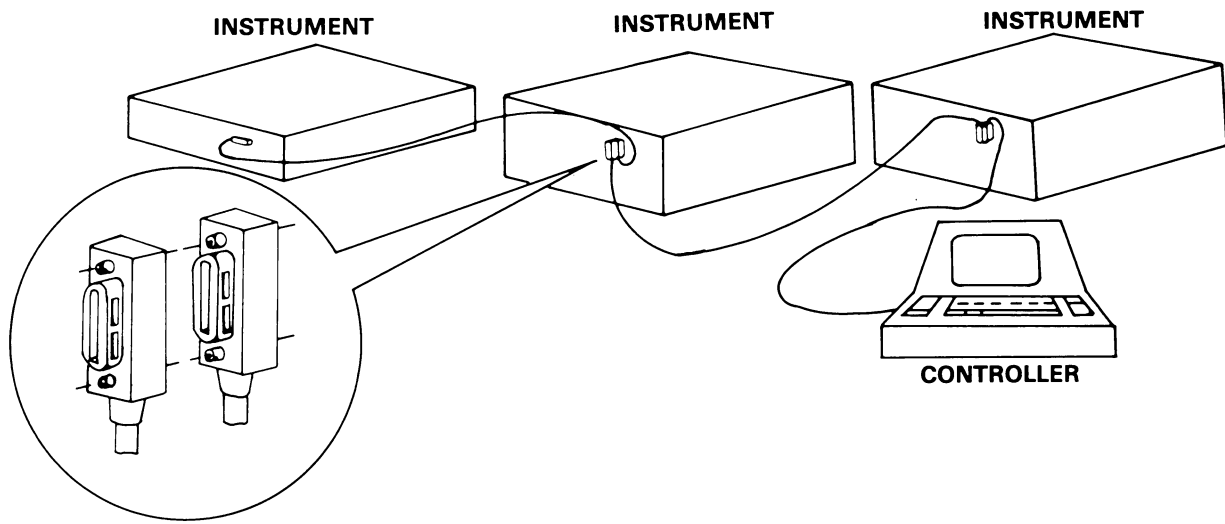

Figure 3-3. IEEE-488 Connections

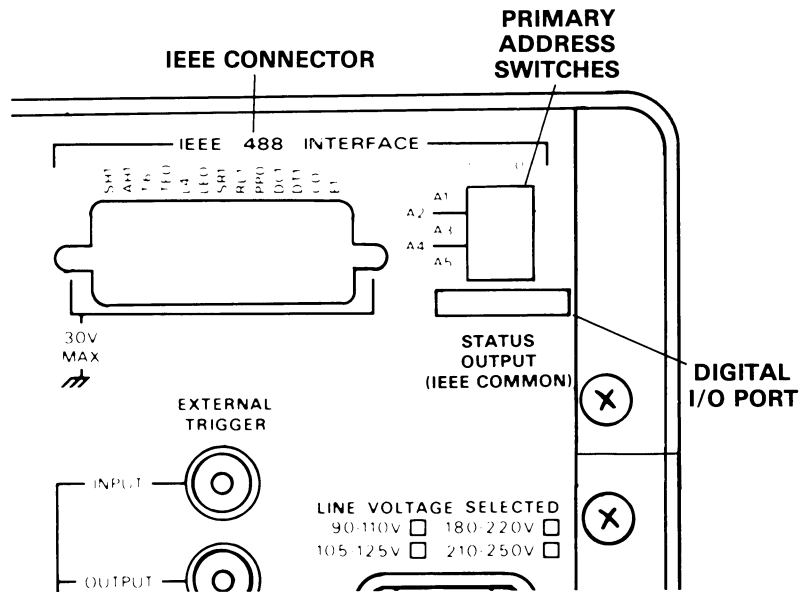

Figure 3-4. Rear Panel of Model 224 Showing IEEE Connections and Switches

NOTE

The IEEE-488 bus is limited to a maximum of 15 devices, including the controller. Also, the maximum cable length is 20 meters. Failure to observe these limits will probably result in erratic bus operation.

Custom cables may be constructed using the information in Table 3-1 and Figure 3-5. Table 3-1 lists the contact assignments for the various bus lines, while Figure 3-5 shows contact designations. Contacts 18 through 24 are return lines for the indicated signal lines, and the cable shield is connected to contact 12. Each ground line is connected to digital common in the Model 2243, but contact 12 within the instrument is left unconnected to avoid ground loops.

NOTE

The connector supplied with the Hewlett-Packard 85 HP-IB interface will require the use of the Keithley Model 7010 IEEE cable adapter. The HP-IB cable connector has an unusually large shoulder that prevents the cable connector from seating properly on the IEEE connector on the rear panel of the Model 224. Connectors on other cables, including those on the Keithley Model 7008, should seat properly without this adapter.

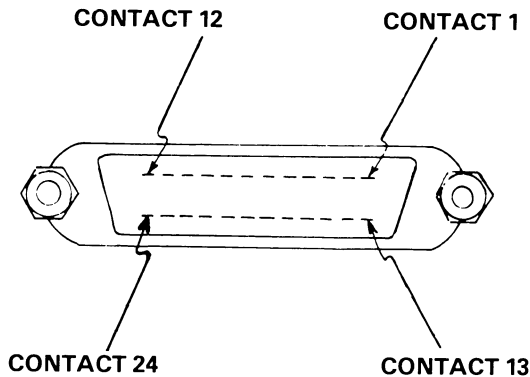

Figure 3-5. Contact Assignments

CAUTION

The voltage between IEEE common and chassis ground must not exceed 30V or damage to the instrument may occur.

A typical signal line bus driver is shown in Figure 3-6. With the configuration shown, the driver has bidirectional capability. When the I/O control line is high, the line is configured as an output line. When the control line is low, the driver is set up for input operation. Note that not all signal lines have bidirectional capability. Some lines, such as ATN, will always be configured as an output line in the controller and as an input line for all other devices on the bus.

Table 3-1. IEEE Contact Designations

Contact Number	IEEE-488 Designation	Type
1	DIO1	Data
2	DIO2	Data
3	DIO3	Data
4	DIO4	Data
5	EOI (24)*	Management
6	DAV	Handshake
7	NRFD	Handshake
8	NDAC	Handshake
9	IFC	Management
10	SRQ	Management
11	ATN	Management
12	SHIELD**	Ground
13	DIO5	Data
14	DIO6	Data
15	DIO7	Data
16	DIO8	Data
17	REN (24)*	Management
18	Gnd, (6)*	Ground
19	Gnd, (7)*	Ground
20	Gnd, (8)*	Ground
21	Gnd, (9)*	Ground
22	Gnd, (10)*	Ground
23	Gnd, (11)*	Ground
24	Gnd, LOGIC	Ground

*Number in parentheses refer to signal ground return of referenced contact number. EOI and REN signal lines return on contact 24.

**The cable shield is normally connected to contact 12. This shield should be connected to ground only at the controller end to avoid ground loop problems.

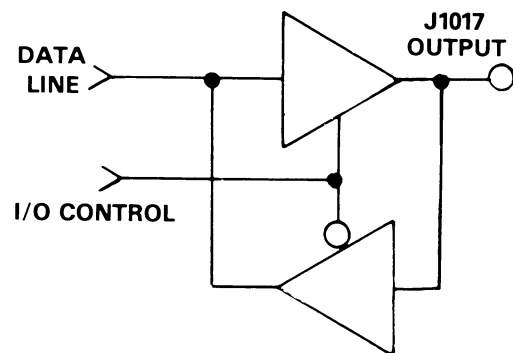

Figure 3-6. Typical IEEE-488 Bus Driver (One of 16)

3.2.3 Primary Address Selection

The Model 2243 must receive a listen command before it will respond to addressed commands. Similarly, the instrument

must receive a talk command before it will transmit its data string, status word, or status byte. These listen and talk commands are derived from the instrument's primary address. The Model 2243 is shipped from the factory with a primary address of 19. The primary address may be set to any value between 0 and 30 as long as address conflicts with other bus instruments are avoided. This may be done by placing the primary address switches, which are shown in Figure 3-7, in the desired positions. Note that the primary address of the instrument must agree with the address specified in the controller's programming language.

NOTE

The primary address switch positions are read only upon power-up. If the address is changed, the Model 224 must be turned off and then powered up again before the new address can be used. The primary address is shown on the display for a short period after power-up as follows: IE nn, where nn represents the primary address value.

Figure 3-7 shows the correct positions for the Model 2243 factory set value of 19; if a different address is required, the primary address may be changed as outlined in Table 3-2.

NOTE

If other instrumentation is also connected to the bus, be sure that each device has a different primary address. If this precaution is not observed, erratic bus operation will probably result.

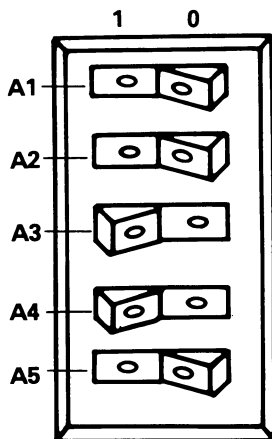

Figure 3-7. Primary Address Switches (Address = 19 Shown)

The primary address switches are binary weighted; A1 is the least significant bit, while A5 the most significant bit. For example, the binary value for the Model 2243 factory set primary address of 19 is 10011. Use the tip of a pen or pencil to operate the switches.

Table 3-2. Primary Address Switch Position

Primary Address (Decimal Value)	Switch Positions				
	A5	A4	A3	A2	A1
0	0	0	0	0	0
1	0	0	0	0	1
2	0	0	0	1	0
3	0	0	0	1	1
4	0	0	1	0	0
5	0	0	1	0	1
6	0	0	1	1	0
7	0	0	1	1	1
8	0	1	0	0	0
9	0	1	0	0	1
10	0	1	0	1	0
11	0	1	0	1	1
12	0	1	1	0	0
13	0	1	1	0	1
14	0	1	1	1	0
15	0	1	1	1	1
16	1	0	0	0	0
17	1	0	0	0	1
18	1	0	0	1	0
19*	1	0	0	1	1
20	1	0	1	0	0
21	1	0	1	0	1
22	1	0	1	1	0
23	1	0	1	1	1
24	1	1	0	0	0
25	1	1	0	0	1
26	1	1	0	1	0
27	1	1	0	1	1
28	1	1	1	0	0
29	1	1	1	0	1
30	1	1	1	1	0

*Model 2243 factory set value.

NOTE: Primary Address 31 (11111) is reserved for UNL and UNT commands and should not be used.

NOTE

Instruments should not be operated with a primary address of 31 even though it is possible to set the Model 2243 address switches to those positions. (11111). This address is reserved for the UNT and UNL commands; erratic operation may result if primary address 31 is used.

3.2.4 Digital I/O Port

The digital I/O port is an integral part of the IEEE interface board. This port is available for convenient connections on the rear panel of the unit, as shown in Figure 3-4. The I/O port has separate 4 bit inputs and outputs as summarized in Table 3-3. Figure 3-8 shows the contact assignments for the port.

The output bit conditions may be controlled with an I/O port command. The status of both input and output lines may be checked with the I/O status command. The instrument can be programmed to generate an SRQ if the status of any input line changes. These aspects of Model 2243 operation are covered in detail in Section 4.

Each output line can drive one TTL load, and each input line represents one TTL load. The signals on these lines must conform to standard TTL logic levels. The input lines are pulled up to +5V through 2.2kΩ resistors.

Table 3-3. Digital I/O Port Pin Assignments

Pin Number	Connection
1	+5V (Use for reference only)
2	+5V (Use for reference only)
3	Input (Bit 3)**
4	Input (Bit 2)
5	Input (Bit 1)
6	Input (Bit 0)*
7	Output (Bit 0)*
8	Output (Bit 1)
9	Output (Bit 2)
10	Output (Bit 3)**
11	IEEE Common †
12	IEEE Common

† Do not exceed 30V between common and chassis ground.

*Bit 0 = Least Significant Bit

**Bit 3 = Most Significant Bit

CAUTION

Pins 11 and 12 of the digital I/O port are connected to IEEE common. The potential between these pins and chassis ground must not exceed 30V or the instrument might be damaged. Pins 1 and 2 of the port are connected to the digital +5V power supply. These connections are for reference only and must not be used to power external components.

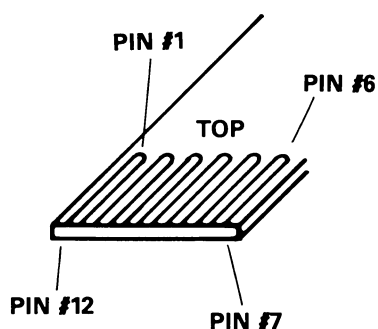

Figure 3-8. Digital I/O Port Assignments

3.3 SOFTWARE CONSIDERATIONS

The most sophisticated computer in the world would be useless without the necessary software. The basic requirement is also true of the IEEE-488 bus, which requires the use of handler routines as described in this section.

3.3.1 Controller Interface Routines

Before a controller can be used with the IEEE-488 interface, the user must make certain that appropriate handler software is present within the controller. With the HP-85 computer, for example, the HP-85 interface card must be used with an additional I/O ROM, which contains the necessary handler software.

Other small computers that can be used as controllers have limited IEEE command capability. The PET/CBM computers, for example, are incapable of sending multiline commands from BASIC, although these commands can be sent through machine-language routines. The capabilities of other small computers depends on the particular interface being used. Often, little software "tricks" are required to achieve the desired results.

From the preceding discussion, the message is clear: make sure the proper software is being used with the interface. Often, the user may incorrectly suspect that a hardware problem is causing fault, when it was the software that was causing the problem all along.

3.3.2 HP-85 BASIC Statements

Many of the programming instructions covered in Section 4 use examples written in Hewlett-Packard Model 85 BASIC. The HP-85 was chosen for these examples because it has a large number of BASIC statements that control IEEE-488 operation. This section covers those HP-85 BASIC statements that are essential to Model 224/2243 operation.

A complete list of HP-85 IEEE-488 BASIC statements is shown in Table 3-4. All the statements in the table have one or three digit arguments that must be specified. The first digit is the HP-85 interface select code, which is set to 7 at the factory. The last two digits of those statements that require a three digit argument specify the primary address. Generally, only those commands that actually require an address to be sent over the bus require that the primary address be specified in the BASIC statement.

Those statements in the table with three digit arguments assume that the primary address of the device is set at 19. Other primary addresses require that the last two digits be set to the corresponding value. For example, to send a GTL command to device 22, the following BASIC statement would be used: LOCAL 722.

Some of the statements in the table have two forms; the exact configuration used depends on the desired command. For

example, CLEAR 7 will cause a DCL to be sent, while CLEAR 719 causes an SDC to be transmitted to device 19.

The third column of Table 3-4 list the mnemonics for the command sequences. While most of these are covered elsewhere, a couple of points should be noted. As described earlier, the ATN line is set low by the controller if the data bus contains a multiline command. This is indicated in the table by ANDing the ATN mnemonic with the first command on the bus. For example, ATN•GET means that ATN and GET are sent simultaneously.

Two commands not previously covered are MLA (My Listen Address) and MTA (My Talk Address). These are ordinary PCG (Primary Command Group) addresses sent by the HP-85 to facilitate bus operation in some situations. The Model 2243 will essentially ignore these commands, but other devices may require that MLA and MTA be present in the command sequence under certain circumstances.

NOTE

The HP-85 address is set to 21 at the factory. Since each device on the bus must have an unique primary address, do not set the Model 2243 to the controller's address to avoid possible conflicts.

3.3.3 Interface Function Codes

The interface function codes are part of the IEEE-488-1978 standards. These codes define an instrument's ability to support various functions and should not be confused with programming commands found elsewhere in this manual.

Table 3-5 lists the codes for the Model 2243. These codes are also listed for convenience on the rear panel of the instrument immediately above the IEEE connector. The numeric value following each one or two letter code defines Model 2243 capabilities as follows:

1. SH (Source Handshake Function)—The ability for the Model 2243 to initiate the transfer of message/data on the data bus is provided by the SH function.
2. AH (Acceptor Handshake Function)—The ability for the Model 2243 to guarantee proper reception of message/data on the data bus is provided by the AH function.
3. T (Talker Function)—The ability for the Model 2243 to send device-dependent data over the bus (to other devices) is provided by the T function. Model 2243 talker capabilities exist after the instrument has been addressed to talk.
4. L (Listener Function)—The ability for the Model 2243 to receive device-dependent data over the bus (from other devices) is provided by the L function. Listener function capabilities of the Model 2243 exist only after it has been addressed to listen.
5. SR (Service Request Function)—The ability for the Model 2243 to request service from the controller is provided by the SR function.
6. RL (Remote-Local Function)—The ability for the Model 2243 to be placed in the remote or local modes is provided by the RL function.
7. PP (Parallel Poll Function)—The Model 2243 does not have parallel polling capabilities.

Table 3-4. HP-85 IEEE-488 BASIC Statements

Statement	Action	Bus Command Sequence
ABORTIO 7 CLEAR 7 CLEAR 719 ENTER 719;A\$	Send IFC. Send DCL. Send SDC to device 19. Device 19 addressed to talk. Data placed in A\$.	IFC ATN•DCL ATN•UNL;MTA;LAG;SDC ATN•UNL;MLA;TAG;ATN;data
LOCAL 7 LOCAL 719 LOCAL LOCKOUT 7 OUTPUT 719;A\$	Set REN False Send GTL to device 19. Send LLO. Device 19 addressed to listen. Transmit A\$.	$\overline{\text{REN}}$ ATN•UNL;MTA;LAG;GTL ATN•LLO ATN•MTA;UNL;LAG; $\overline{\text{ATN}}$;data
REMOTE 7 REMOTE 719	Set REN true. Set REN true. Address device 19 to listen.	REN REN;ATN•UNL;MTA;LAG
RESET 7 SPOLL(719)	Send IFC, cancel REN. Address device 19 to talk. Conduct serial poll.	IFC;REN; $\overline{\text{REN}}$ ATN•UNL;MLA;TAG;SPE; $\overline{\text{ATN}}$; status byte;ATN•SPD;UNT
TRIGGER 7 TRIGGER 719	Send GET without addressing. Address device 19 to listen. Send GET.	ATN•GET ATN•UNL;MTA;LAG;GET

8. DC (Device Clear Function)—The ability for the Model 2243 to be cleared (initialized) is provided by the DC function.
9. DT (Device Trigger Function)—The ability for the Model 2243 to have its basic operation started (begin program operation) is provided by the DT function.
10. C (Controller Function)—The Model 2243 does not have controller capabilities.
11. TE (Extended Talker Capabilities)—The Model 2243 does not have extended talker capabilities.
12. LE (Extended Listener Capabilities)—The Model 2243 does not have extended listener capabilities.

Table 3-5. Model 2243 Interface Function Codes

Code	Interface Function
SH1	Source Handshake Capability
AH1	Acceptor Handshake Capability
T6	Talker (Basic Talker, Serial Poll, Unaddressed To Talk On LAG)
L4	Listener (Basic Listener, Unaddressed To Listen On TAG)
SR1	Service Request Capability
RL1	Remote/Local Capability
PP0	No Parallel Poll Capability
DC1	Device Clear Capability
DT1	Device Trigger Capability
C0	No Controller Capability
E1	Open Collector Bus Drivers
TE0	No Extended Talker Capabilities
LE0	No Extended Listener Capabilities

3.3.4 Model 2243 Interface Commands

Interface commands controlling Model 224/2243 operation are listed in Table 3-6. Not included in the table are device-dependent commands, which are covered in detail in Section 4.

Table 3-6. IEEE Command Groups

HANDSHAKE COMMAND GROUP	
	DAC = DATA ACCEPTED
	RFD = READY FOR DATA
	DAV = DATA VALID
UNIVERSAL COMMAND GROUP	
	ATN = ATTENTION
	DCL = DEVICE CLEAR
	IFC = INTERFACE CLEAR
	LLO = LOCAL LOCKOUT
	REN = REMOTE ENABLE
	SPD = SERIAL POLL DISABLE
	SPE = SERIAL POLL ENABLE
ADDRESS COMMAND GROUP	
LISTEN:	LAG = LISTEN ADDRESS GROUP
	MLA = MY LISTEN ADDRESS
	UNL = UNLISTEN
TALK:	TAG = TALK ADDRESS GROUP
	MTA = MY TALK ADDRESS
	UNT = UNTALK
	OTA = OTHER TALK ADDRESS
ADDRESSED COMMAND GROUP	
	ACG = ADDRESSED COMMAND GROUP
	GET = GROUP EXECUTE TRIGGER
	GTL = GO TO LOCAL
	SDC = SELECTIVE DEVICE CLEAR
STATUS COMMAND GROUP	
	RQS = REQUEST SERVICE
	SRQ = SERIAL POLL REQUEST
	STB = STATUS BYTE
	END = EOI

SECTION 4 OPERATION

4.1 INTRODUCTION

The Model 2243 is an IEEE interface for the Model 224 Programmable Current Source. Since all IEEE operation is done through commands given over the bus, IEEE operation precludes the use of operating controls in the usual sense. Instead, all operating functions are controlled by programming.

This section describes important programming functions in detail. Included are: general bus commands, device-dependent commands, status word and status byte, and other important information. The information presented in this manual assumes that the operator is familiar with all normal aspects of the Model 224/2243 operation, including front panel controls. For information on front panel operation, refer to the Model 224 Instruction Manual.

NOTE

Programming examples in this section assume that the Model 2243 primary address is set to 19. Those examples with addressed commands will not function unless the primary address of the instrument is set to that value. Refer to Section 3 for information on setting the primary address.

4.2 GENERAL BUS COMMANDS

General bus commands are those commands which have the same general meaning regardless of instrument configuration. These commands are grouped into two categories:

1. Addressed Commands. These commands require that the primary address of the instrument agrees with the primary address in the controller's programming language.
2. Unaddressed Commands. No primary address is required for these commands. All devices equipped to implement these commands will do so simultaneously when the command is sent.

General bus commands are summarized in Table 4-1, which also lists the HP-85 BASIC statement that sends each command. Each addressed command statement assumes a primary address of 19.

Table 4-1. General Bus Commands

Command	Addressing Required?	HP-85 BASIC Statement
REN	Yes	REMOTE 719
IFC	No	ABORTIO 7
LLO	No	LOCAL LOCKOUT 7
GTL	Yes	LOCAL 719
DCL	No	CLEAR 7
SDC	Yes	CLEAR 719

4.2.1 REN (Remote Enable)

The remote enable command is sent to the Model 2243 by the controller to set the instrument up for remote operation. Generally, this should be done before attempting to program the instrument over the bus. The Model 224/2243 will indicate that it is in the remote mode by illuminating its front panel REMOTE indicator.

To place the Model 224/2243 in the remote mode, the controller must perform the following steps:

1. Set the REN line true.
2. Address the Model 224/2243 to listen.

NOTE

Setting REN true without addressing will not cause the REMOTE indicator to turn on; however, once REN is true, the REMOTE light will turn on the next time as addressed command is received.

Programming Example—This sequence is automatically sent by the HP-85 when the following is typed into the keyboard.

REMOTE 719 (END LINE)

After the END LINE key is pressed, the Model 224 REMOTE indicator light should come on. If not, check to see that the instrument is set for the proper primary address. Also, check to see that all bus connections are tight.

4.2.2 IFC (Interface Clear)

The IFC command is sent by the controller to set the Model 224/2243 to the talk and listen idle states. The unit will respond to the IFC command by cancelling front panel TALK or LISTEN lights if the instrument was previously placed in one of those modes. No other state changes will occur within the instrument.

To send the IFC command, the controller need only set the IFC line true.

Programming Example—Before demonstrating the IFC command, turn on the front panel REMOTE and TALK indicator lights by entering the following statements into the HP-85 computer:

REMOTE 719 (END LINE)
ENTER 719;A\$ (END LINE)

The front panel REMOTE and TALK indicators should now be on. The IFC command may now be sent by entering the following statement into the HP-85:

ABORTIO 7 (END LINE)

After the END LINE key is pressed, the TALK light will turn off, indicating the Model 224/2243 is in the talk idle state. Note that the remote mode is not cancelled.

4.2.3 LLO (Local Lockout)

The LLO command is sent by the controller to remove the Model 224/2243 from the local operating mode. Once the unit receives the LLO command, all its front panel controls (except POWER) will be inoperative.

NOTE

The REN bus line must be true before the instrument will respond to an LLO command.

To lock out the front panel controls of the Model 224, the controller must perform the following steps:

1. Set ATN true.
2. Send the LLO command to the instrument.

Programming Example—This sequence is automatically performed by the HP-85 when the following statement sequence is typed into the keyboard.

```
REMOTE 719 (END LINE)
LOCAL LOCKOUT 7 (END LINE)
```

After the END LINE key is pressed the second time, the front panel controls are locked out. Note that no other changes occur within the instrument; all front panel modes remain as previously selected. Local control may be restored by setting REN false with the following statement:

```
LOCAL 7 (END LINE)
```

4.2.4 GTL (Go To Local)

The GTL command is used to take the instrument out of the remote mode. To send the GTL command, the controller must perform the following sequence:

1. Set ATN true.
2. Address the Model 224/2243 to listen.
3. Place the GTL command on the bus.

NOTE

The GTL command does not restore operation of locked out Model 224 front panel controls. With some instruments, however, local control operation may be restored by the GTL command. To restore front panel control operation of the Model 224, the controller must set the REN line false.

Programming Example—If the instrument is not in the remote and lockout modes, enter the following statements into the HP-85 computer:

```
REMOTE 719 (END LINE)
LOCAL LOCKOUT 7 (END LINE)
```

Check to see that the REMOTE indicator is on and that the

front panel controls are locked out. The GTL command sequence is automatically sent by the HP-85 with the following statement:

```
LOCAL 719 (END LINE)
```

Note that the REMOTE light on the front panel turns off, but the front panel controls are still locked out.

Front panel control operation can be restored by setting the REN line false with the following HP-85 statement:

```
LOCAL 7 (END LINE)
```

After executing this statement, the front panel controls will again operate.

NOTE

Setting REN false with the LOCAL 7 statement will also take the instrument out of the remote mode.

4.2.5 DCL (Device Clear)

The DCL command may be used to clear the Model 224, setting it to a known state. Note that all devices on the bus equipped to respond to a DCL will do so simultaneously. When the Model 224/2243 receives a DCL command, it will return to the default conditions listed in Table 4-2.

NOTE

Program memory will be cleared of all previously stored data when a DCL or SDC command is received.

To send a DCL command, the controller must perform the following steps:

1. Set ATN true.
2. Place the DCL command on the bus.

Programming Example—Using the front panel controls, enter I-limit, V-limit onto the Model 224. Set the display to V-limit. Turn the output on with the OPERATE button.

```
REMOTE 719 (END LINE)
CLEAR 7 (END LINE)
```

When the END LINE key is pressed the second time, the instrument will return to the default conditions listed in Table 4-2. The SOURCE display LED should be on and the OPERATE light should be off.

4.2.6 SDC (Selective Device Clear)

The SDC command performs the same functions as the DCL command except that only the addressed device responds. This command is useful for clearing only a selected instrument instead of all instruments at once. The Model 224 will return to the default conditions listed in Table 4-2 when responding to an SDC command.

Table 4-2. Default Values (Status on and After SDC or DCL)

Mode	Value	Status
Display	D0	Source
Function	F0	Standby (OPERATE LED is off)
Data Format	G0	Prefix
EOI	K0	Send EOI
SRQ Mode	M0	Disabled
Range	R0	Auto
Terminator	Y(LF)	CR LF
Source	I	Set to 0.000-6A
V-Limit	V1	Set to 3V
I-Limit	I	HI not affected LO not affected
Time	W	50.000E-3
Auto	—	Set to inactive
Trig	—	Set to inactive
Digit	—	Set to inactive
INCR	—	Set to inactive
DECR	—	Set to inactive
Cancel	—	Not performed
Exponent	—	Set to inactive

NOTE

The program memory will be cleared of all previously stored data when a DCL or SDC command is received.

To transmit the SDC command, the controller must perform the following steps:

1. Set ATN true.
2. Address the Model 224/2243 to listen.
3. Place the SDC command on the bus.

Programming Example—Enter V-limit, I-limit and source data into the Model 224. Enter the following statements into the HP-85:

```
REMOTE 719 (END LINE)
CLEAR 706 (END LINE)
```

Note that the instrument did not respond to the SDC because the command was sent with a primary address of six. Now enter the following statement into the HP-85:

```
CLEAR 719 (END LINE)
```

This time, the instrument returns to the default conditions listed in Table 4-2. Note that the program memory is cleared of previously stored data.

4.2.7 Serial Polling (SPE, SPD)

The serial polling sequence is used to obtain the Model 224/2243 status byte. Usually, the serial polling sequence is used to determine which of several devices has requested service over the SRQ line. However, the serial polling sequence may be used at any time to obtain the status byte from the Model 224/2243. For more information on status byte format, refer to paragraph 4.3.8.

The serial polling sequence is conducted as follows:

1. The controller sets the ATN line true.
2. The SPE (Serial Poll Enable) command is placed on the bus by the controller.
3. The Model 224/2243 is addressed to talk.
4. The controller sets ATN false.
5. The instrument then places its status byte on the bus to be read by the controller.
6. The controller then sets the ATN line low and places SPD (Serial Poll Disable) on the bus to end the serial polling sequence.

Steps 3 through 5 may be repeated for other instruments on the bus by using the correct talk address for each instrument. ATN must be true when the talk address is transmitted and false when the status byte is read.

Programming Example—The HP-85 SPOLL statement automatically performs the serial polling sequence. To demonstrate serial polling, momentarily power down the Model 224 and enter the following statement into the HP-85 keyboard:

```
REMOTE 719 (END LINE)
S = SPOLL (719) (END LINE)
DISP S (END LINE)
```

When END LINE is pressed the second time, the computer performs the serial polling sequence. When END LINE is pressed the last time, the status byte value (0) is displayed on the CRT. The status byte has a value of 0 with this example because no bits in the byte are set. Paragraph 4.3.8 covers the status byte format in detail.

4.3 DEVICE-DEPENDENT COMMAND PROGRAMMING

IEEE device-dependent commands are sent to the Model 224/2243 to control various operating modes such as function, display mode, current output, and voltage limit. Each command is made up of an ASCII alpha character followed by one or more numbers designating specific parameters. For example, a voltage value is programmed by sending an ASCII "V" followed by numbers designating the actual voltage value. The IEEE bus treats device-dependent commands as data in that ATN is high when the commands are transmitted.

A number of commands may be grouped together in one-string. A command string is terminated by an ASCII "X" character which tells the instrument to execute the command string. There is no limit as to the number of characters that can be contained in one string as far as the Model 224/2243 is concerned, although string length may be limited by controller capabilities.

If an illegal command or command parameter is present within a command string, the instrument will:

1. Ignore the entire command string.

2. Display appropriate front panel error messages.
3. Set certain bits in its status byte.
4. Generate an SRQ if programmed to do so.

These programming aspects are covered in paragraphs 4.3.8 and 4.4.

HP-85 examples are included throughout this section to clarify programming.

Before using a programming example, it is recommended that the instrument be set to its default values by sending an SDC over the bus. See paragraph 4.2.6 for information on using the SDC command.

NOTE

Program memory will be cleared of previously stored data when an SDC command is sent to the instrument.

If the HP-85 should become "hung up" at any point, operation may be restored by holding the SHIFT key down and then pressing RESET on the keyboard.

In order to send a device-dependent command, the controller must perform the following sequence:

1. Set ATN true.
2. Address the Model 224/2243 to listen.
3. Set ATN false.
4. Send the command string one byte at a time.

Programming Example—Device-dependent commands are sent by the HP-85 using the following statement:

OUTPUT 719; A\$

A\$ in this case contains the ASCII characters that form the command string.

Table 4-3. Device-Dependent Command Summary

Mode	Command	Notes
Display	D0	Source Current
	D1	Voltage Limit
	D2	Dwell Time
Function	F0	Standby 1. Set output current to zero on 20 μ A range. 2. Reduce voltage limit to less than 32V.
	F1	Operate Set to programmed value.
Prefix (Data Format)	G0	Source, Compliance and Time (auto rate) sent with prefix.
	G1	Source, Compliance and Time (auto rate) sent without prefix.
EOI	K0	Send EOI
	K1	Send no EOI
SRQ* (0-31)	M0	Disabled
	M1	IDDC, IDDCO, No Remote
	M2	Over Voltage Limit
	M4	I-Limit reached
	M8	End of Time (auto rate)
	M16	Input Port Change
Range	R0	Auto
	R5	20 μ A (Full scale = 19.995E-6)
	R6	200 μ A (Full scale = 199.95E-6)
	R7	2mA (Full scale = 1.9005E-3)
	R8	20mA (Full scale = 19.995E-3)
	R9	200mA (Full scale = 101.00E-3)
Terminator	Y(ASCII)	Any ASCII except capitals, numbers, + - , . or e
	Y(LF)	CR LF
	Y(CR)	LF CR
	Y(DEL)	None
Inputs	I	Current Source
	V	Voltage Limit (Compliance)
	W	Time (auto rate)
I/O Port	0(0-15)	Set Output Control Bits
Status	U0	Send Status Word
	U1	Send I/O Port Status
Execute	X	Execute other Device-Dependent Commands

*May be programmed to generate SRQ under more than one condition.

NOTE

REN must be true when attempting to program the Model 224/2243. If REN is false, the instrument will respond with a no remote error message as described in paragraph 4.4.

Commands that affect the Model 224 current source are listed in Table 4-3. All the commands listed in Table 4-3 are covered in detail in the following paragraphs.

4.3.1 Execute (X)

The execute command is implemented by sending an ASCII "X" over the bus. Its purpose is to tell the Model 224/2243 to execute the other device-dependent commands. Generally, the "X" character is the last byte in the command string.

NOTE

Command strings sent without an execute character will not be executed at that time. They will be stored in the command buffer. The next time an execute character is received, the stored commands will be executed assuming all commands in the previous string were valid.

Programming Example—Enter the following statements into the HP-85 keyboard:

```
REMOTE 719 (END LINE)
OUTPUT 719; "X" (END LINE)
```

When the END LINE key is pressed the second time, the front panel LISTEN LED turns on, showing that the instrument received the command. No other changes will occur with this example because no other commands were sent.

4.3.2 Display Mode

The display mode commands perform the same operations as the four front panel DISPLAY pushbuttons (except for I-LIMIT) on the instrument. Through the use of these commands, the user can set the display to view the source value V-limit and auto rate time. The display mode commands are summarized in Table 4-4. Upon power up, or after receiving a DCL or SDC command, the instrument will be in the D0 display mode.

Programming Example—Set the instrument to view the V-limit value with the front panel V-LIMIT button. Then enter the following statements into the HP-85 keyboard:

```
REMOTE 719 (END LINE)
OUTPUT 719; "D0X" (END LINE)
```

After this statement sequence is executed, the instrument displays the source value. The V-LIMIT LED will be turned off and the SOURCE LED will be turned on.

Table 4-4. Model 224 Display Mode Commands

Command	Display
D0	Source Current
D1	Voltage Limit
D2	Time (auto rate)

4.3.3 Inputs (I, V and W)

The input commands control the current, V-limit and auto rate time. The input commands that affect the Model 224 operation are:

- I Stores the current source value.
- V Stores the compliance limit value.
- W Stores the time (auto rate).

A complete summary of input commands along with the format of each is shown in Table 4-5. The parameter for each command may be entered in direct or scientific notation as long as the allowable range for each command is not exceeded. Some examples for the various command are as follows:

Desired Result	Command Variations
7.5mA Current Source	I7.5E-3; I.0075; I.75E-2; I.075E-1
25V Compliance Limit	V25, V2.5E+1, V250E-1, V.025E+3
250msec Time	W250E-3; W.25; W25E-2; W2.5E-1

NOTES

1. An IDDCO (Illegal Device-Dependent Command Option) error will occur if the input command parameters is outside of the legal range. A front panel error message will indicate this error; the instrument may also be programmed to generate an SRQ if such an error occurs, as described in paragraph 4.3.8.
2. Time (auto rate) accuracy is guaranteed only if the IEEE bus is idle.

PROGRAM	COMMENTS
10 DIM A\$ [100]	Dimension A\$ for 100 characters.
20 REMOTE 719	Set up instrument for remote operation.
30 CLEAR 719@ OUTPUT 719; "M1X"	Return instrument to default conditions. Enable SRQ on error.
40 CLEAR	Clear CRT.
50 DISP "COMMAND"	Prompt for command input.
60 INPUT A\$	Input command string.
70 OUPUT 719;A\$	Send command string to instrument.
80 S = SPOLL (719)	Conduct Serial Poll; read status byte.

```

90 IF BIT(S,5)=0 THEN    Check for error conditions.
50
100 IF BIT(S,0) THEN    Check for IDDC.
    DISPLAY "ILLEGAL
    COMMAND"
110 IF BIT(S,1) THEN DISP Check for IDDCO.
    "ILLEGAL COMMAND
    OPTION".
120 GO TO 50             Repeat
130 END

```

After the program is entered, depress the HP-85 RUN key. When the computer prompts for a command input, enter the desired command, including the command letter prefix; several commands may be grouped together in one input string. Be sure to terminate each command string with the execute character (X). Programmed data may be observed by using the front panel display.

4.3.4 I/O Port (O)

The I/O port command controls the status of the four output bits on the digital I/O port on the rear panel of the instrument. Information on I/O port pin assignments can be found in Table 3-3. The I/O port command consists of the ASCII "O" character followed by the decimal number that sets the control bits as listed in Table 4-6. Upon power-up, or after a DCL or SDC, the four output lines will be set low.

Programming Example—Enter the following statement sequence into the HP-85 computer:

```

REMOTE 719 (END LINE)
OUTPUT 719; "O15X" (END LINE)

```

When END LINE is pressed the second time, the four output bits go high.

4.3.5 Function (F)

The function commands control the actual output of the Model 224 current source. These commands perform the same operations as the front panel OPERATE button. The output of the Model 224 may be controlled by bus commands as follows:

Table 4-6. I/O Port Command Parameters

Command Parameter*	Output Bit Status			
	Bit 3	Bit 2	Bit 1	Bit 0
0	0	0	0	0
1	0	0	0	1
2	0	0	1	0
3	0	0	1	1
4	0	1	0	0
5	0	1	0	1
6	0	1	1	0
7	0	1	1	1
8	1	0	0	0
9	1	0	0	1
10	1	0	1	0
11	1	0	1	1
12	1	1	0	0
13	1	1	0	1
14	1	1	1	0
15	1	1	1	1

*Parameter must be preceded by ASCII letter "O".

F0 Standby—The source output will be set to zero (0.000-6A). (Model 224 voltage limit < 32V).

F1 Operate—The output will be programmed to the present source value.

Programming Example—Using the front panel OPERATE button, turn the instrument output off and enter the following statements into the HP-85:

```

REMOTE 719 (END LINE)
OUTPUT 719; "F1X" (END LINE)

```

When END LINE is pressed the second time, the front panel OUTPUT indicator comes on.

4.3.6 Prefix (G)

When addressed to talk, the instrument will send a data-string containing information about the programmed current value, compliance voltage limit and time (auto rate). This data string can be sent with or without a prefix. The format of the data string with prefix is as follows:

Table 4-5. Input Command Summary

Command*	Controls	Allowable Range
$I \pm n.nnnnE \pm nn^{**}$	Current Source Value, Amperes	0 to 101mA (5nA steps)
$Vn.nnE \pm nn$	Voltage Limit (compliance)	1 to 105V in 1V Steps
$Wn.nnnE \pm nn$	Time (auto rate)	50msec to 999.9sec in 1msec Steps

NOTES: n = numeric digit

*Commands may be entered in scientific notation or normal notation; scientific notation shown.

**Least digit of mantissa must be 0 or 5.

<u>Current Source</u>	<u>Voltage Compliance Limit</u>	<u>Time (Auto Rate)</u>
$NDCI \pm n.nnnnE \pm n,$	$V \pm n.nn00E \pm n,$	$W \pm n.nnnnE \pm n$

N is replaced by O if an over voltage condition exists.

The format of the data string without a prefix is as follows:

<u>Current Source</u>	<u>Voltage Compliance Limit</u>	<u>Time (Auto Rate)</u>
$\pm n.nnnnE \pm n,$	$\pm n.nn00E \pm n,$	$\pm n.nnnnE \pm n$

Programming Example—A program showing how to send the data string over the IEEE bus follows this paragraph. In order to obtain the data string from the instrument, the controller must perform the following sequence.

1. Set ATN true.
2. Address the Model 224/2243 to talk.
3. Set ATN false.
4. Input the data string one byte at a time.

PROGRAM	COMMENTS
10 DIM A\$ [100]	Dimensions A\$ for 100 characters.
20 REMOTE 719	Set instrument up for remote operation.
30 CLEAR 7	Clear the instrument.
40 OUTPUT 719; "I25E-3V50X"	Programs 25mA source and 50V compliance limit.
50 OUTPUT 719; "G0D0X"	Programs the source display mode and the prefix mode.
60 ENTER 719; A\$	Obtains data string.
70 DISP A\$	Display data string.
80 END	End of program.

Once the program is entered, press the HP-85 RUN key. This runs the program, and the data string will appear on the controller's CRT. The Model 224/2243 is programmed for the source display mode, 25mA source, 50V compliance, prefix mode and the standby mode. If no prefix is desired in the data string, change line 50 in the program to read as follows:

50 OUTPUT 719; "G1D0X"

The G1 command programs the Model 224/2243 to drop the prefix from the data string.

4.3.7 EOI Programming (K)

The EOI (End Or Identify) line is set low by a device during the last byte of its data transfer sequence. In this way, the last byte is positively identified, allowing data words of different lengths to be transmitted. Normally, the Model 224/2243 is programmed to assert EOI during the last byte of its data-

string or status word. Information on instrument data may be found in paragraph 4.3.6, while status word information is contained in paragraph 4.3.8. EOI response of the instrument may be programmed as follows:

K0 Send EOI during last byte.

K1 Send no EOI.

Upon power-up, or after receiving an SDC or DCL, the instrument will be in the K0 mode.

Programming Example—The EOI command will be suppressed with the following statement sequence:

```
REMOTE 719 (END LINE)
OUTPUT 719; "K1X" (END LINE)
```

Note that the HP-85 does not rely on EOI to mark the end of data transmission. Some controllers, however, may require that EOI be present at the end of transmission.

4.3.8 SRQ Mode (M) and Status Byte Format

The SRQ mode command controls which conditions within the instrument will generate an SRQ (Service Request). Once an SRQ has been generated, the status byte can be checked to determine if the SRQ was generated by the Model 224/2243. In addition, other bits in the status are set depending on certain data and error conditions.

The instrument may be programmed to generate an SRQ under one or more of the following conditions:

1. If the instrument receives an Illegal Device Dependent Command (IDDC) or Illegal Device Dependent Command Option (IDDCO), or if the instrument is not in remote when programmed.
2. If the instrument is over voltage limit.
3. If any change occurs on the I/O port input lines.
4. I-LIMIT is reached.
5. End of Time (auto rate)

Upon power-up, or after a DCL or SDC, SRQ is disabled.

SRQ Mask—In order to facilitate SRQ programming, the Model 224/2243 makes use of a mask when generating an SRQ. When the appropriate bit in the mask is set, the instrument will generate an SRQ when those particular conditions exist. Figure 4-1 shows the format of the SRQ mask byte. Bits within the mask can be controlled by sending the ASCII character "M" followed by a decimal number from 0 to 31. Table 4-7 lists the conditions that will cause an SRQ for each command parameter. Note that the instrument can be programmed for one or more conditions simultaneously.

Status Byte Format—The status byte contains information relating to data and error conditions within the instrument. The controller obtains the status byte by using the serial polling sequence described in paragraph 4.2.7. Once the byte resides in the computer, the information in Figure 4-2 can be used when interpreting data and error conditions.

Table 4-7. SRQ Commands and Conditions

SRQ Command	Conditions*				
	I/O Port Change	End Of Time	I-Limit Reached	Over V Limit	IDDC, IDDCO, No Remote
M0**					
M1					X
M2				X	
M3				X	X
M4			X		
M5			X		X
M6			X	X	
M7			X	X	X
M8		X			
M9		X			X
M10		X		X	
M11		X		X	X
M12		X	X		
M13		X	X		X
M14		X	X	X	
M15		X	X	X	X
M16	X				
M17	X				X
M18	X			X	
M19	X			X	X
M20	X		X		
M21	X		X		X
M22	X		X	X	
M23	X		X	X	X
M24	X	X			
M25	X	X			X
M26	X	X		X	
M27	X	X		X	X
M28	X	X	X		
M29	X	X	X		X
M30	X	X	X	X	
M31	X	X	X	X	X

*Indicates those conditions that will generate SRQ.

**M0 disables SRQ.

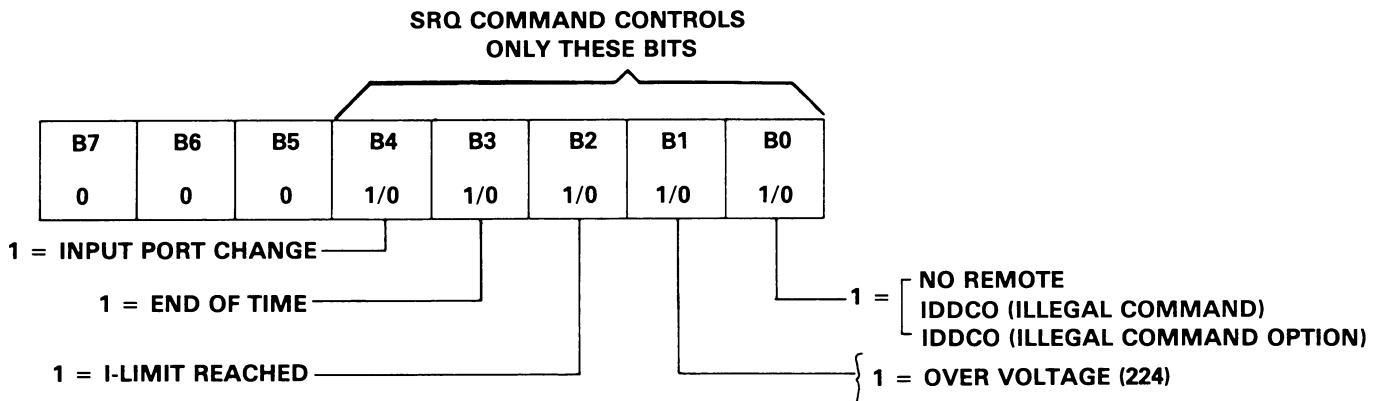

Figure 4-1. SRQ Mask Format

Bit 6 is the SRQ bit. If this bit is set, the service request was made by the Model 224/2243. Bit 5 determines the meaning of bits 0 through 3. If bit 5 is set, the error conditions listed in Table 4-8 apply to bits 0 through 3. If bit 5 is cleared, the data conditions listed in the table apply.

NOTE

Once the Model 224/2243 generates an SRQ, the status byte should be read to clear the SRQ line. Otherwise the instrument will continuously assert SRQ.

Programming Example—Momentarily power down the instrument. Using the front panel controls, program source current and voltage compliance; enter the following program into the HP-85.

PROGRAM	COMMENTS
10 REMOTE 719 @ CLEAR	Set up instrument for remote operation and clear the CRT.
20 BEEP	Beep
30 DISP "B7 B6 B5 B4 B3 B2 B1 B0"	
40 FOR I=7 to 0 STEP-1	Loop eight times.
50 OUTPUT 719; "M1X"	Turn on SRQ.
60 OUPUT 719;"F5X"	Program for F function that does not exist.
70 S=SPOLL(719)	Conduct Serial Poll.
80 DISP BIT(S,I);	Display Status Byte.
90 NEXT I	
100 DISP " ^ ^ ^"	
110 DISP " SRQ ERROR IDDCO"	
120 DISP	
130 END	

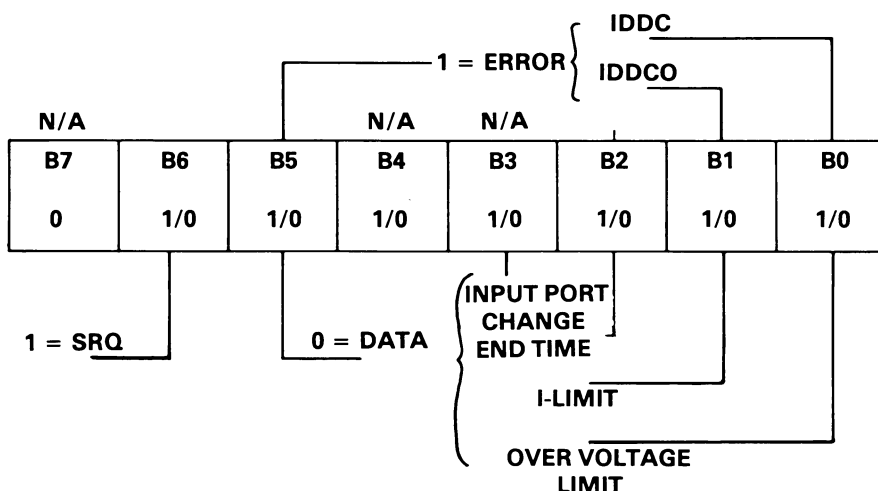

Figure 4-2. Status Byte Format

Table 4-8. Status Byte Data and Error Condition

Bit	Error Conditions (Bit 5 = 1)	Data Conditions (Bit 5 = 0)
0	IDDC (Illegal Command)	Over Voltage (224)
1	IDDCO (Illegal Command Option)	I-Limit Reached
2	No Remote	End of Time
3	None	Input Port Change

NOTE

To align the display properly, type in the program exactly as shown. In line 100 the space between the first quotation marks and the first pointer is four spaces. Then to the next pointer is two spaces, and 11 spaces to the last pointer in the line. In line 110 the space between the first quotation marks and SRQ is two spaces. Then to ERROR is 2 spaces and 7 spaces to IDDCO.

After the program has been entered, press the HP-85 RUN key. Note the CRT, it will be as follows:

```

B7 B6 B5 B4 B3 B2 B1 B0
 0  1  1  0  0  0  1  0
   ^  ^             ^
   SRQ ERROR       IDDCO

```

Bit 6 (B6) is set and that means an SRQ condition exists. Bit 5 (B5) is also set and that means there is an error condition. Bit 1 is set and that means that an Illegal Device-Dependent Command Option (IDDCO) condition exists.

4.3.9 Range (R)

The range commands set the maximum allowable current that may be programmed into the instrument. Table 4-9 shows the range commands. Upon power up, or after a DCL or SDC, the R0 mode (AUTO) is enabled.

NOTES

1. On a given range, the source command parameter can be no larger than that range will allow.
2. If an under range source command is given, a zero source value will be stored.
3. If an over range command is given, the instrument responds with a front panel IDDCO (Illegal Device-Dependent Command Option) error as described in paragraph 4.4.
4. Settling time is less than 3msec to within 0.1% of programmed current value.

Table 4-9. Range Commands

Range Command	Model 224 Current Source		
	Range	Maximum Output	Minimum Step
R0	Auto	± 101mA	5nA
R5	10µA	± 19.995µA	5nA
R6	100µA	± 199.95µA	50nA
R7	1mA	± 1.9995mA	500nA
R8	10mA	± 19.995mA	5µA
R9	100mA	± 101mA	50µA

Programming Example—The following program sets the Model 224 to the 20µA range and then gives a source command of 10µA. The program stops at this point and prompts the user to continue the program. Once the program is running again the controller sends an illegal command option (50mA) to the instrument. Then the program displays an IDDCO on the instrument as well as on the HP-85 CRT.

PROGRAM	COMMENTS
10 REMOTE 719 @ CLEAR	Set up for remote operation and clear the screen.
20 CLEAR 719	Return to default conditions.
30 OUTPUT 719; "R5M1X"	Set instrument to R5 (20µA) range and turn on SRQ.
40 OUTPUT 719; "I10E-6X"	Program 224 for 10µA.
50 DISP "PRESS CONT"	
60 PAUSE	Wait
70 OUTPUT 719; "I50E-3X"	Attempt to program illegal current on this range.
80 S = SPOLL (719)	Conduct serial poll.
90 IF BIT (S,5) AND BIT (S,1) = 1 THEN DISP "ILLEGAL COMMAND OPTION"	Check for IDDCO.
100 OUTPUT 719; "R0X"	Set to auto range.
110 END	End of program.

After entering the program, depress the RUN key. The program sets the Model 224 to the 20µA range; and programs for a current of 10µA. After the computer pauses, use the front panel controls to make sure that the current has entered. Then press the CONT key and observe that the instrument displays IDDCO. The IDDCO is also displayed on the CRT because the status byte was checked by the computer when the error and IDDCO bits were set.

It is important to note that the commands in line 70 would be valid if the instrument were set to proper range. This is taken care of automatically in the R0 mode, since the instrument changes to the appropriate range, depending on the commanded value. To demonstrate this point delete line 30 from the program and run it again. This time the commands in line 70 are accepted by the instrument since it remains in the auto range mode.

4.3.10 Programmable Terminator (Y)

The Model 224/2243 uses special terminator characters to mark the end of its data string or status word. To allow a wide variety of controllers to be used, the terminator can be changed by sending the appropriate command over the bus. The default value is the commonly used carriage return, line feed (CR LF) sequence. The terminator sequence will assume this default value upon power-up or after the instrument receives a DCL or SDC.

The terminator may be programmed by sending the ASCII character "Y" followed by the desired terminator character. Any ASCII character except one of the following may be used:

1. Any capital letter.
2. Any number.
3. Blank
4. + - / , . or e

Special command characters will program the instrument for special terminator sequences as follows:

1. Y(LF) = CR LF (Two terminators)
2. Y(CR) = LF CR (Two terminators)
3. Y(DEL) = No terminator

NOTE

Most controllers use the CR or LF character to terminate their input sequences. Using a nonstandard terminator may cause the controller to hang up unless special programming is used.

Programming Example—The terminator can be eliminated by sending an ASCII DEL with the following HP-85 statements:

```
REMOTE 719 (END LINE)
OUTPUT 719; "Y"; CHR$ (127); "X" (END LINE)
```

When END LINE is pressed the second time, the terminator is suppressed; no terminator will be sent by the instrument when data is requested. The absence of the normal terminator may be verified by entering the following statement into the HP-85 keyboard.

```
ENTER 719; A$ (END LINE)
```

At this point, the HP-85 ceases to operate because it is waiting for the standard CR LF terminator sequence to terminate the ENTER statement. The computer may be reset by holding down the SHIFT key and then pressing RESET on the keyboard. To return the instrument to the normal terminator sequence, enter the following statement into the HP-85:

```
OUTPUT 719; "Y"; CHR$ (10); "X" (END LINE)
```

4.3.11 Status Word (U)

The status word commands allow access to information concerning various operating modes of the instrument, as well as the present status of input and output lines on the digital I/O port. When the correct command is given, the instrument will output the status word or I/O status the next time it is addressed to talk instead of sending its normal data string. The Model 2243 status word commands are:

U0 Send normal status word. The format is the model number (224) followed by bytes representing DFGJKRMY. Information concerning all modes except for SRQ is one byte in length.

U1 Send I/O status: I/O nn,nn, where nn is a number from 0-15.

Figure 4-3 shows the general format of the status word and Figure 4-4 shows the format of I/O information. Both examples show default values; these values will be present upon power-up or after the instrument receives a DCL or SDC. The I/O port values assume that nothing is connected to the I/O port. Table 4-10 shows I/O line conditions for returned I/O status values.

NOTES

1. The status word or I/O status will be sent only once each time the status command is given. Once the status is read, the instrument will send the normal data string the next time it is addressed to talk.
2. SRQ status information contains two bytes. These two bytes will assume the decimal value previously set by the SRQ mode command.
3. The "I/O" prefix on the I/O status will be present only in the G0 mode. The prefix will not be transmitted in the G1 mode.
4. The returned terminator character is derived by ANDing the byte with 00001111 and then ORing the result with the 00110000. For two-byte terminators, this is done with the last byte in the terminator sequence. For example, the last byte in the normal terminator sequence is a LF or ASCII 10 (00001010). Masking with 00001111 yields 00001010. ORing with 00110000 gives 00111010, which is printed out as an ASCII colon (:).
5. To make sure proper status is returned, the status word or I/O status should be read immediately after sending the command. Otherwise, instrument status may change, resulting in erroneous status information.
6. The status word should not be confused with the SRQ status byte. The status word contains a number of bytes pertaining to the various operating modes of the instrument. The status byte is a single byte that is read by using the serial polling sequence and contains information on SRQ status and error or data conditions.
7. The Model number prefix (224) will be present on the status word only in the G0 prefix mode.
8. The J in the status word is set to 1 upon power up. After that it is a zero. The only time a self test is performed is upon power up.
9. Obtaining the status word when the Model 224 is in the I-LIMIT display mode shows that it is in the D0 mode.

Programming Example—To demonstrate the basic method used to obtain the status word and I/O status, enter the following program into the HP-85:

PROGRAM	COMMENTS
10 REMOTE 719	Set up for remote.
20 CLEAR 719	Send SDC.
30 OUTPUT 719; "U0X"	Send status word command.
40 ENTER 719; A\$	Enter status word into computer.
50 CLEAR	Clear CRT
60 DISP "MdIDFGJKRMMY"	
70 DISP A\$	Display status word with model prefix.

```

80 OUTPUT 719; "G1U0X"  Change the G1 prefix
                          mode. Send status word
                          command.
90 ENTER 719; A$         Enter status word into
                          computer.
100 DISP "DFGJKRMMY"    Display status word
110 DISP A$              without model prefix.
120 DISP
130 OUTPUT 719; "G0U1X" Change to G0 mode.
                          Send I/O status com-
                          mand.
140 ENTER 719; A$       Enter I/O status into
                          computer.
150 DISP A$              Display I/O port status
                          with prefix on CRT.
160 OUTPUT 719; "G1U1X" Change to G1 prefix
                          mode. Send I/O status
                          command.
170 ENTER 719; A$       Enter I/O status into com-
                          puter.
180 DISP A$              Display I/O status without
                          prefix on CRT.
190 END

```

Table 4-10. I/O Port Status Values

Returned Value	Input and Output Terminal Conditions*			
	Bit 3	Bit 2	Bit 1	Bit 0
00	L	L	L	L
01	L	L	L	H
02	L	L	H	L
03	L	L	H	H
04	L	H	L	L
05	L	H	L	H
06	L	H	H	L
07	L	H	H	H
08	H	L	L	L
09	H	L	L	H
10	H	L	H	L
11	H	L	H	H
12	H	H	L	L
13	H	H	L	H
14	H	H	H	L
15	H	H	H	H

*H ≅ 5V, L ≅ 0V

After entering the program, depress the HP-85 RUN key. The CRT will then display the status word and the I/O status both with and without prefixes. The status word will show default values because line 20 of the program sends an SDC, which sets the instrument to the default conditions.

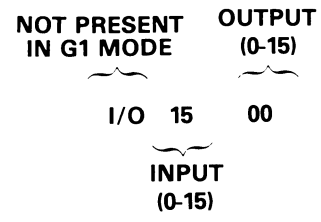

Figure 4-4. I/O Status Format (Default Values Shown)

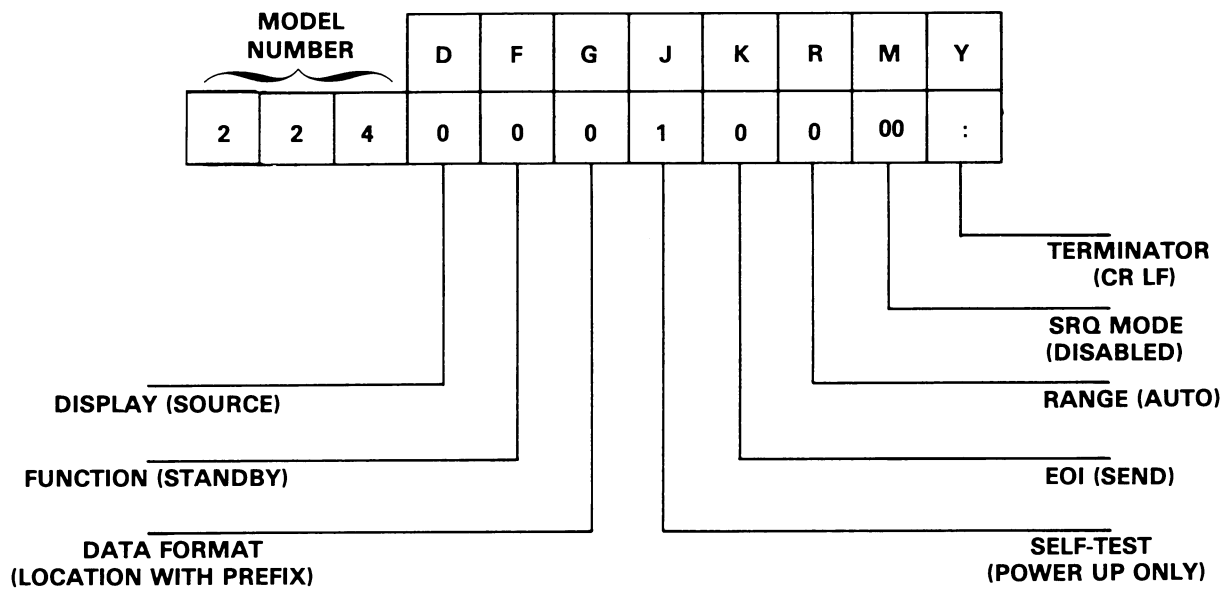

Figure 4-3. Status Word Format (Default Values Shown)

4.4 FRONT PANEL ERROR MESSAGES

The process of programming the Model 224/2243 involves the proper use of syntax. Syntax is defined as the orderly or systematic arrangement of programming commands or languages. The Model 224/2243 must receive valid commands with proper syntax or it will:

1. Ignore the entire command string in which the invalid command appears.
2. Set appropriate bits in the status byte.
3. Generate an SRQ if programmed to do so.
4. Display an appropriate front panel error message.

Device-dependent commands are sent as a string of several ASCII characters. Some examples of valid command strings include:

F0X Single command string.
F0D1WP2X Multiple command string.
W1 X Space is ignored.

Examples of invalid command strings are:

H0X Invalid Command; H is not a command.
F5X Invalid Command Option; 5 is not an option of the F command.

NOTE

If a command is sent without a numeric parameter, a zero is assumed. For example, UX is the same as U0X.

Figure 4-5 shows the front panel error messages employed by the Model 224/2243. The messages in Figure 4-5 results from an Illegal Device-Dependent Commands (IDDC), while the message in Figure 4-5 results from an Illegal Device-Dependent Command Option (IDDCO). The no remote error message in Figure 4-5 (c) results from attempting to program the instrument while it is not in the remote mode.

4.4.1 IDDC Error

An IDDC error results when the Model 224/2243 receives an invalid command such as H1X. This command is invalid because no such letter exists in the instrument's programming language.

Programming Example—To demonstrate an IDDC error, enter the following statements into the HP-85 keyboard:

REMOTE 719 (END LINE)
OUTPUT 719; "H1X" (END LINE)

When END LINE is pressed the second time, the error message in Figure 4-5(a) is displayed for about one second.

4.4.2 IDDCO Error

An IDDCO error occurs when the numeric parameter associated with a legal command letter is invalid. For example, the command D6 has an invalid option because the instrument has no display mode associated with that number.

Programming Example—To demonstrate an IDDCO error, enter the following statements into the HP-85:

REMOTE 719 (END LINE)
OUTPUT 719; "D6X" (END LINE)

When END LINE is pressed the second time, the front panel error message in Figure 4-5(b) is displayed for about one second.

4.4.3 Remote Error

A front panel no remote error message will be displayed if the Model 224/2243 is not in the remote mode when it receives a command over the bus. If an attempt is made to program the instrument when it is not in the remote mode, the no remote message in Figure 4-5(c) will be displayed on the front panel for about one second.

Programming Example—To make sure the instrument is not in the remote mode, enter the following statement into the HP-85:

LOCAL 7 (END LINE)

Now enter the following programming statement into the keyboard:

OUTPUT 719; "G0X" (END LINE)

When this statement is executed, the no remote error message in Figure 4-5(c) is displayed on the front panel of the instrument for about one second.

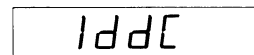
A rectangular box containing the text "IDDC" in a monospaced font.

A) IDDC (ILLEGAL DEVICE-DEPENDENT COMMAND)

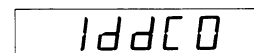
A rectangular box containing the text "IDDCO" in a monospaced font.

B) IDDCO (ILLEGAL DEVICE-DEPENDENT COMMAND OPTION)

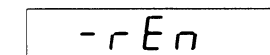
A rectangular box containing the text "-rEn" in a monospaced font.

C) NO REMOTE

Figure 4-5. Front Panel Error Messages

SECTION 5 MAINTENANCE

5.1 INTRODUCTION

This section contains information necessary to maintain the Model 2243 IEEE interface. Two subjects covered in this section are: installation and troubleshooting.

Since there are no calibration points the Model 2243 IEEE interface does not need to be calibrated.

5.2 INSTALLATION

To install the Model 2243 IEEE interface into the Model 224 Programmable Current Source use the following procedure and refer to Figure 5-1.

1. Remove the top cover of the Model 224.

WARNING

Turn the instrument off, remove all test leads from the instrument and disconnect the power cord before removing the top cover.

- A. Remove the two retaining screws located at the rear of the instrument.
 - B. Grasping the top cover at the rear, carefully lift it off the instrument.
 - C. When installing the top cover, make sure that the three tabs located at the front of the cover engage in the front panel assembly.
2. Remove the analog board shield.
 - A. Remove the four slot head screws that secure the shield to the analog board.
 - B. Lift the shield along with the four screws away from the analog board.
 3. Remove the analog board.
 - A. Remove the phillips head screw that is located directly behind the heat sinks of the two power transistors.
 - B. Place the analog board along the side of the Model 224.
 4. Place the standoff (ST-146-2) as shown in Figure 5-1.
 5. Position the Model 2243 into the Model 224 as shown in Figure 5-1.
 6. Secure connector J1017 (CS-443) to the rear panel with the hardware kit (CS-380).
 7. Connect the chassis ground wire as shown in Figure 5-1.
 8. Plug the cable P1004 into J1004 on the mother board. See Figure 5-1. Make absolutely sure that pin 1 of P1004 is connected to pin 1 of J1004.

NOTE

Do not remove the installed ground wire. Use the second nut to install the ground wire of the IEEE interface as shown in Figure 5-1.

9. Reinstall the analog board.
10. Reinstall the analog board shield.
11. Check to see that the input cable is connected securely.
12. Reinstall the top cover.
13. The primary address of the Model 2243 is set at factory to 19 (10011). If a different primary address is required, refer to paragraph 3.2.3.

NOTE

The primary address is updated only upon power up.

5.3 TROUBLESHOOTING

The troubleshooting information in this section is intended for use by qualified personnel who have a basic understanding of the analog and digital circuitry used in an interface such as this. Instructions listed in Table 5-1 have been written to assist in isolating the defective circuit. Isolating the defective component has been left to the troubleshooter.

The first step in troubleshooting the Model 2243 is to verify that the problem is indeed with the Model 2243 and not the Model 224. Check the Model 224's operation, power supplies, digital circuitry and analog circuitry before troubleshooting the Model 2243. These checks can be found in the maintenance section of the Model 224 Instruction Manual.

Once the Model 224 has been verified to be operating properly, proceed with the checks in Table 5-1. The equipment required to troubleshoot the Model 2243 is listed in Table 5-2. Alternate test equipment can be used but the accuracy of the alternate test equipment must at least be equal to the equipment listed in Table 5-2.

5.3.1 Special Handling of Static Sensitive Devices

CMOS devices designed to operate at high impedance levels for low power consumption. As a result, any normal static charge that builds up on your person or clothing may be sufficient to destroy these devices. Table 5-3 lists all the static sensitive devices of the Model 2243. When handling these devices, use the precautions listed below to avoid damaging them.

1. Devices should be handled and transported in protective containers, antistatic tubes or conductive foam.
2. Use a properly grounded workbench and a grounding wristwrap.
3. Handle the devices by the body only.
4. PC boards must be grounded to the bench while inserting the devices.
5. Use antistatic solder removers.
6. Use grounded tip soldering irons
7. After the devices are soldered or inserted into sockets they are protected and normal handling can resume.

Table 5-1. Model 2243 Troubleshooting

Step	Item/Component	Required Condition	Remarks
1	Check the Model 224 for proper operation. Refer to the Model 224 Instruction Manual.		
2	Visual inspection. Verify that all the components are properly seated in the sockets and connectors. Check the chassis ground wire. Check cable J/P1004.		
3	P1004 pins 1,2,3 and 4 referenced to P1004 pins 24, 25 and 26.	+5V \pm 10%	+5V digital supply
4	S401 (A1-A5)	In the "1" position the switch is pulled up to +5V \pm 10%.	Primary address
5	U404 pin 18(Φ E)	1MHz square wave at 0V to +5V	Clock to U404
6	U404 pin 9	+5V signal being pulsed to 0V every 1msec	IRQ line
7	U404 pin 19	+5V (Logic "1")	RESET line
8	Program the Model 224 into remote with a primary address of 19.		(10011)
9	U404 pin 28	Send a device-dependent command over the bus and monitor the ATN line, it should go false (+5V) when the command is sent.	Checking the ATN line.
10*	U404 pins 28 (ATN) 24 (NDAC), 25 (NRFD), 26 (DAV) and the data lines	Refer to Figure 2-2 for required conditions Send data or multiline command over the bus to check these waveforms.	Checking the handshaking sequence.

Note: All the measurements in Table 5-1 are referenced to digital common.

*Step 10 requires a storage type oscilloscope (e.g. Tektronix 7623A).

Table 5-2. Recommended Test Equipment

Item	Description	Specification	Mfg.	Model
A	DMM (Digital Multimeter)	20V range, 4½ digit \pm 0.03% accuracy.	Keithley	175
B	Storage Type Oscilloscope	10MHz Bandwidth	Tektronix	7623A

Table 5-3. Model 2243 Static Sensitive Devices

Reference Designation	Keithley Part No.
U401	IC-251
U402	IC-130
U404	LSI-49

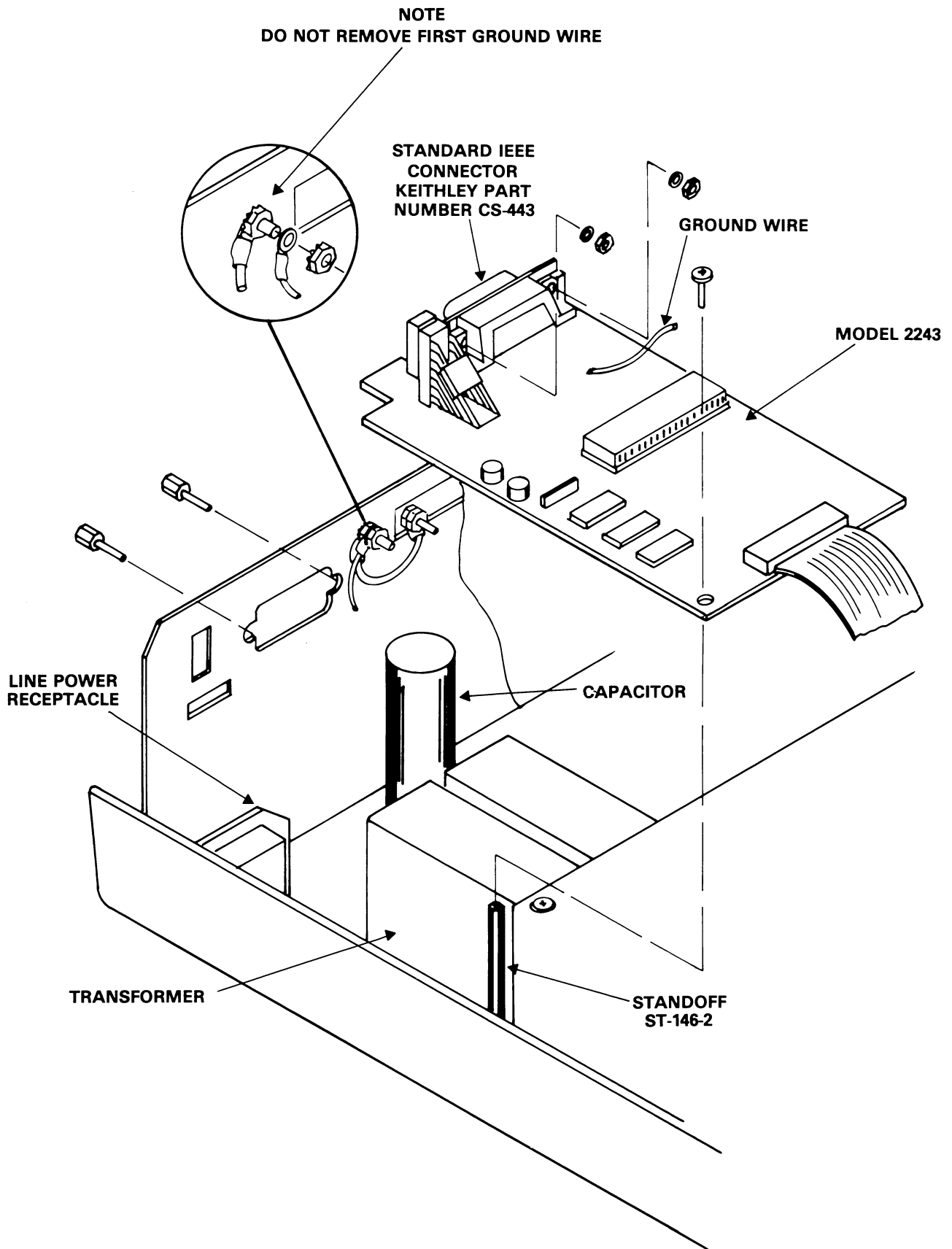

Figure 5-1. Model 2243 Installation

SECTION 6 REPLACEABLE PARTS

6.1 INTRODUCTION

This section contains replaceable parts information, for the Model 2243, a schematic diagram and a component location drawing.

6.2 PARTS LIST

Parts are listed alphabetically in order of their circuit designations. All of the replaceable parts of the Model 2243 are listed in Table 6-1.

6.3 ORDERING INFORMATION

To place an order, or to obtain information concerning replacement parts, contact your Keithley representative or the factory. See the inside front cover of this manual for addresses. When ordering include the following information:

1. Instrument Model Number
2. Instrument Serial Number
3. Part Description

4. Circuit Description (if applicable)

5. Keithley Part Number

If an additional instruction manual is required, order the manual package (Keithley Part Number 2243-901-00). The manual package includes an instruction manual and all pertinent addenda.

6.4 FACTORY SERVICE

If the instrument is to be returned to the factory for service, complete the service form which follows this section and return it with the instrument.

6.5 SCHEMATIC DIAGRAM AND COMPONENT LOCATION DRAWING

The component location drawing of the Model 2243 is shown in Figure 6-1. The schematic diagram of the Model 2243 is shown in Figure 6-2.

Table 6-1. Model 2243 Parts List

Circuit Desig.	Description	Location		Keithley Part No.
		Sch.	Pcb.	
C401	.01 μ F, 500V, Ceramic Disc	H3	E2	C-22-.01
C402	.01 μ F, 500V, Ceramic Disc	F1	C3	C-22-.01
C403	10 μ F, 25V, Aluminum Electrolytic	F1	C3	C-314-10
CR401	Rectifier Bridge (1.5A), W04M	B4	E1	RF-46
CR402	Rectifier Bridge (1.5A), W04M	A4	E1	RF-46
J1017	IEEE Bus Connector	H2	F2	CS-443
P1004	Cable Assembly	C1	C2	CA-10-2
Q401	NPN, Silicon Transistor, 2N3904	C5	C2	TG-47
R401	4.7k, 5%, 1/4W, Composition	D2	C1	R-76-4.7k
R402	4.7k, 5%, 1/4W, Composition	C5	C1	R-76-4.7k
R403	Thick Film Resistor Network	C4	D1	TF-102-2
R404	Thick Film Resistor Network	B4	D1	TF-103-2
R405	100 Ω , 10%, 1/2W, Composition	A5	E1	R-1-100
R406	100 Ω , 10%, 1/2W, Composition	B5	E1	R-1-100
R407	100 Ω , 10%, 1/2W, Composition	A5	E1	R-1-100
R408	100 Ω , 10%, 1/2W, Composition	B5	E1	R-1-100
R409	Thick Film, Resistor Network	F5	E2	TF-100
R410	Thick Film Resistor Network	G2	E2	TF-103-1
R411	33 Ω , 10%, 1W, Composition	G1	E2	R-2-33
S401	Primary Address Switch, Bank of 5 switches	G5	E2	SW-437
U401	8-bit Shift Register, 4094	C2	D2	IC-251
U402	Shift Register, 4021	C3	D2	IC-130
U403	Hex Inverter, 74LS04	SEV	D2	IC-186
U404	GPIB Adapter, 59914	F3	D2	LSI-49
U405	Interface Bus Transceiver, SN75160	G2	E2	IC-298
U406	Decoder/Demultiplexers, 74LS138	E4	D3	IC-182
U407	Hex 3-state Buffer, 74LS367	F4	D3	IC-161
U408	Interface Bus Transceiver, 75161	G3	E3	IC-299
U409	Quad 2 input NAND gate, 74LS00	G3	E3	IC-163

