

Why Power Meters Can't Ensure Wireless Devices Are Working Properly

Introduction

This paper describes the differences between the power measurements made with a power meter and those made with Keithley's Model 2800 RF Power Analyzer. For example, unlike a power meter, which uses a time domain measurement technique, the Model 2800 uses a frequency domain measurement technique. Power meters use a sensor to convert an RF waveform to a low frequency voltage, but the Model 2800 performs a frequency translation of the RF waveform, then determines RF power by digitally processing the individual frequency components of the signal.

A power meter can't measure the center frequency, the power in a specific bandwidth, or the spurious power outside a specific bandwidth. Although a power meter can describe how much power is being generated, the Model 2800 can determine whether the power is being generated at the correct frequency, within the correct bandwidth, and with spurious power within acceptable limits.

For testing mobile phones and RFIC power amplifiers, a power meter can't provide all the information the Model 2800 can. For example, a power meter can't verify a mobile phone or a power amplifier is transmitting at the correct channel and within the channel bandwidth, and that it isn't generating excess spurious power. In production, a power meter can pass a defective phone that's generating the correct power, but in which the power isn't contained within the appropriate channel. As a result, a power meter is inadequate for mobile phone and RFIC power amplifier testing because it can't determine whether the device is transmitting in the correct channel and if the appropriate amount of power is contained within the channel. A Model 2800, or an instrument like it, is the only type of instrument that can test a mobile phone power amplifier and transmitter properly.

Section I describes how a power sensor and power meter work. Section II explains how the Model 2800 operates. Section III compares the two measurement techniques. Each instrument’s ability to test wireless devices is discussed in Section IV. Appendix A explains the power sensor term “video bandwidth.”

I. Power Meters

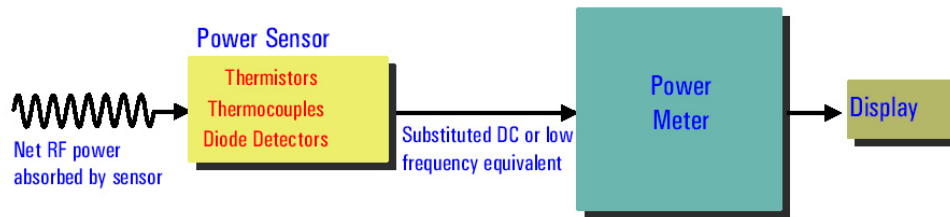

Figure 1. Block diagram of power meter and power sensor

Today’s power sensor/power meter converts RF power to DC or a low frequency equivalent signal, as shown in *Figure 1*. Consequently, both carrier frequency and digitally modulated data are lost. The detected signal represents the envelope of the RF signal. *Figure 2* illustrates one configuration, showing how the power sensor and power meter work together to make wideband power measurements. This configuration uses a RF diode sensor. A typical diode-based RF sensor can detect power over a very wide frequency band, such as 10MHz to 18GHz. Representative signals are shown throughout the schematic.

The sensed DC signal is very low (approximately 160nV for a thermocouple sensor output with 1mW/0dBm applied power or about 50nV for a diode sensor output with 100pW/-70dBm applied power). To avoid transmitting such low level signals, which are susceptible to noise distortion, low level AC amplification circuitry is combined with the power sensor, so high level signals can be transmitted to the meter.

A chopper circuit is employed here to “chop” tiny DC voltages to form a square wave, then amplify them with an AC-coupled system. A 220Hz chopping frequency is typically used. After appropriate amplification (some gain is in the sensor, some gain is in the meter), the higher level AC signal is synchronously detected. The synchronous detection produces an adequate DC level, which can be further processed to provide the measurement result.

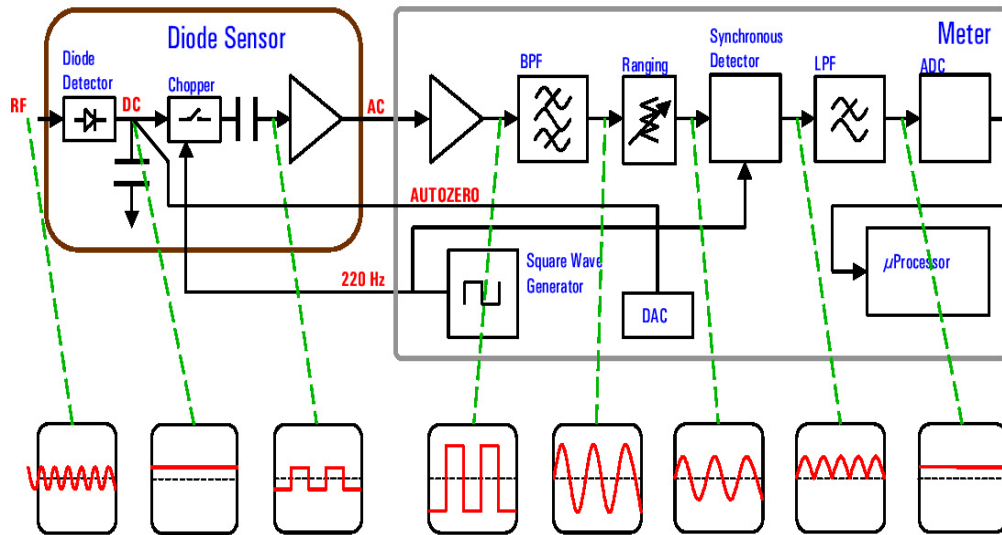

Figure 2. Basic power measurement method of power sensor and power meter

Power detectors can be designed to measure peak power. Appendix A discusses how these sensors are defined using the term “video bandwidth.”

II. Model 2800 RF Power Analyzer

The Model 2800 RF Power Analyzer performs spectrum analysis functions for mobile phone transmitter testing. It operates in frequency bands allocated for mobile phone operation. The analog front end uses a superheterodyne technique to downconvert (or frequency translate) the RF signal to an intermediate frequency (IF), so the signal can be digitally processed. The frequency translation preserves all the information on the frequency components in the RF signal. Multiple digital signal processing techniques allow the Model 2800 to measure channel (in-band) power and adjacent (out-of-band) channel power.

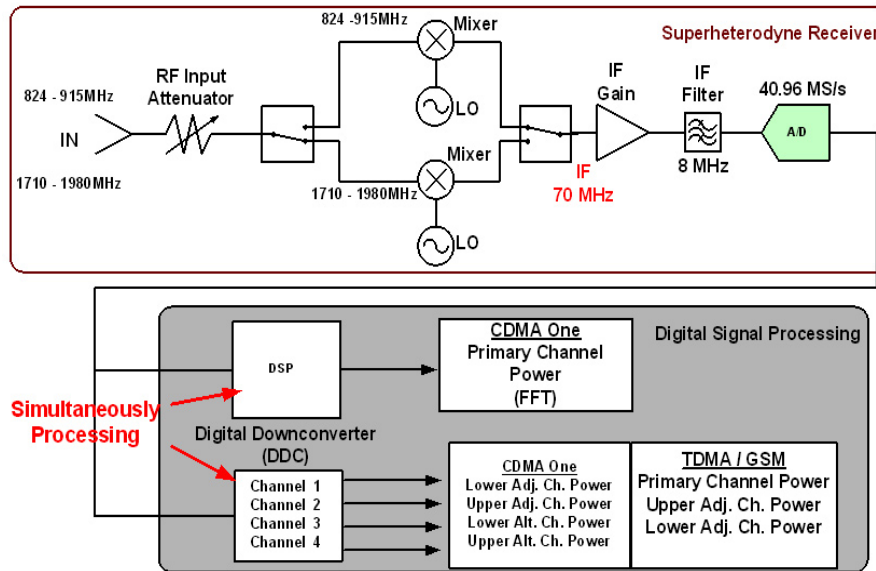

Figure 3. Model 2800 block diagram

The major components in the Model 2800 front end (*Figure 3*) are the RF input attenuator, mixer, local oscillator, IF gain amplifier, bandpass filter and analog-to-digital converter (ADC). A mixer is a three-port device that translates a signal from one frequency to another. In the Model 2800, the attenuated input signal (f_c) feeds into one input of the mixer and the local oscillator signal (f_o) feeds into another. The mixer output consists of the two original input signals, plus the sum ($f_c + f_o$) and difference ($f_c - f_o$) frequencies of the two signals. Of these signals, only the difference frequency ($f_c - f_o$) is of interest in this design. This signal is called the IF (Intermediate Frequency) signal. An IF bandpass filter passes the IF signal and filters out the other signals. The IF filter has an 8MHz bandwidth, which is selected to optimize performance for mobile phone wireless signals. An ADC digitizes the analog signal in order to take advantage of powerful DSP technology. In addition, the RF input attenuator in the Model 2800 is a 0–50dB programmable attenuator, which is used to adjust the incident power into the mixer to prevent mixer gain compression and distortion due to high level signals. Proper adjustment is necessary to ensure the ADC is operating within its full dynamic range.

The Model 2800 uses fast Fourier transform techniques in digital signal processing and multi-channel, narrow-band digital downconversion technology to compute the primary channel (or carrier channel) power and the adjacent (or spurious) channel power. These power measurements are essential to ensure mobile phones transmit power in the intended channel and don't erroneously transmit or leak power into other channels. Mobile

phone communication standards also require that mobile phones not generate spurious power in excess of specified limits. The Model 2800's design has been optimized to make these measurements for production testing. In fact, the Model 2800 can make up to five measurements (primary channel, two adjacent channel power measurements, and two alternate channel power measurements) simultaneously and make them faster than other types of spectrum analysis instruments.

Power meters don't analyze a RF signal in terms of its frequency components, so they can't ensure the power from a mobile phone is being transmitted in the intended channel. Furthermore, power meters can't measure adjacent and alternate channel power to verify a mobile phone isn't generating excessive spurious power.

III. Comparison of the Two Measurement Techniques

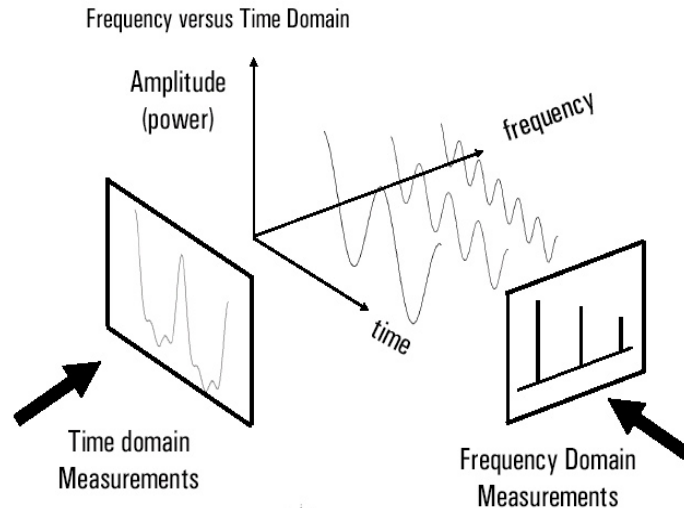

Figure 4. Difference between Model 2800 and power meter measurement technique; frequency domain vs. time domain analysis

Figure 4 illustrates the differences between a power meter and the Model 2800. The power meter analyzes the time domain power signal; the Model 2800 analyzes the signal in terms of its frequency components. The power meter doesn't capture any information on the frequency content of the signal; the Model 2800 can compute the RF power the power meter measures by summing the power of all the frequency components and can compute the power in a narrow portion of the signal's spectrum. The power meter can perform only time domain measurements; the Model 2800 can perform equivalent measurements, as well as

measurements in specific portions of the frequency domain. The Model 2800 is a far more versatile instrument.

The two examples that follow show how a power meter could mistakenly pass a defective phone during production testing because it doesn't measure power using an RF signal's frequency components.

In the first example, two mobile phones are transmitting identical amounts of RF power. *Figure 5* shows the frequency spectra of the transmitted power from each phone. Note that the good phone (the one that's operating properly) has its power properly contained within the transmission channel. On the other hand, the defective phone is generating an equivalent amount of power, but only half the power is in the transmission channel. The other half is outside the transmission channel due to either a defective modulator or power amplifier.

A power meter reads the average power in the time domain signal, so the power meter will read the total average power (P) from the good phone and the defective phone. If the Model 2800's measurement bandwidth is programmed to the bandwidth of the transmission channel, the Model 2800 will read an average power (P) from the good phone. However, the Model 2800 will only read $1/2 * P$ from the defective phone because it has been programmed to read power only in the intended transmission channel. The defective phone is only generating $1/2 * P$ in the transmission channel when it is supposed to be generating P, so the Model 2800 can detect that the defective phone isn't operating properly. The power meter can't distinguish between power in the transmission channel and power outside it, so it would pass the defective phone for shipment to a customer.

In *Figure 6*, a 1.5-meter long RF cable was used to connect the signal generator and the Model 2800; a ~ 0.7 dB cable loss was used as a correction factor. The signal generator was set up to output a 0dBm cdmaOne (IS95) signal. The output frequency was $f_c + \Delta f$, where Δf represents the deviation frequency of the DUT. The DUT channel frequency is represented by f_c , which is 825.06MHz in this measurement.

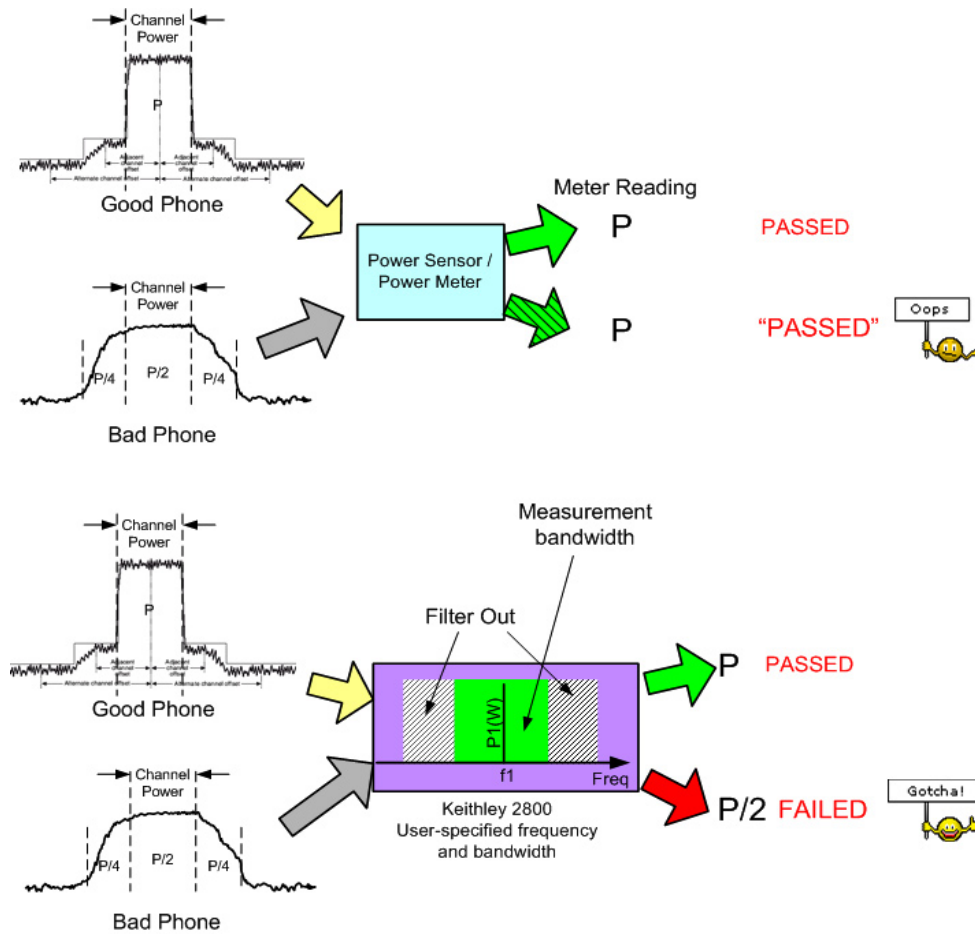

Figure 5. Comparison of measurement results from a power sensor/power meter and a Model 2800 RF power analyzer on two phones with different transmission spectra

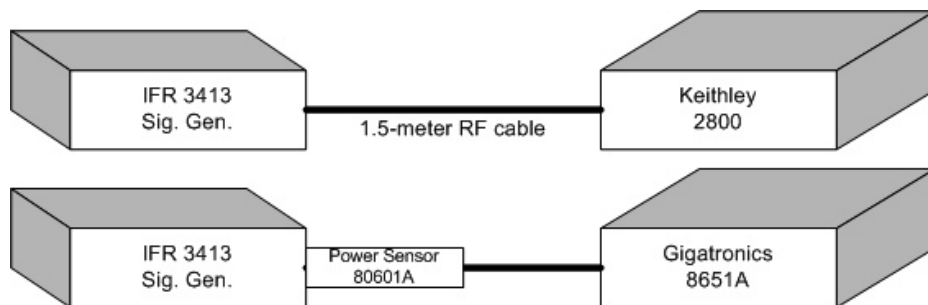

Figure 6. Measurement setups for testing signals that have varying offsets from a center frequency with the Model 2800 and a power meter

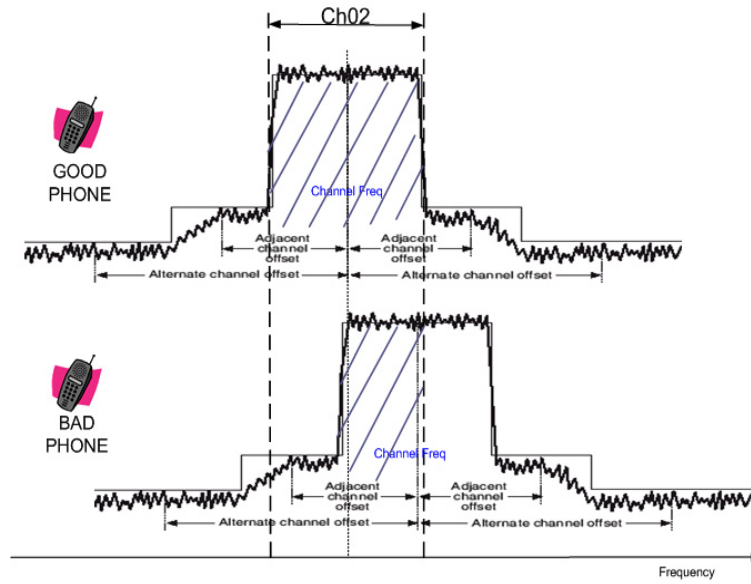

Figure 7. Channel power error caused by DUT channel frequency deviation

Table 1. Model 2800 primary channel measurements vs. power meter power measurements for a signal with increasing offsets from the center frequency

Δf	0 kHz	+100 kHz	+200 kHz	+300 kHz	+400 kHz	+500 kHz
Model 2800	0.06 dBm	-0.25 dBm	-0.60 dBm	-1.04 dBm	-1.56 dBm	-2.03 dBm
Gigatronics 8651A/80601A	0.14 dBm	0.14 dBm	0.14 dBm	0.14 dBm	0.14 dBm	0.14 dBm

The second example (*Figure 7*) shows a situation in which the defective phone is transmitting a signal with the proper power level and frequency spectrum, but at an incorrect frequency. This problem is caused by a defective oscillator circuit. This situation is simulated with a modulated source generating a cdmaOne signal. The source generates a signal at a center frequency, then generates signals at successively larger frequency offsets from the center frequency. Note that, no matter where the RF signal is centered, the power meter reads the same total average power value (see *Table 1*). The Model 2800 is programmed to read the power only in channel 2, the channel in which the mobile device is supposed to be transmitting. As the signal is shifted from the original center frequency, the Model 2800 reads lower and lower power levels as more and more of the signal shifts out of the intended transmission channel.

Again, the power meter can't detect whether the mobile device is transmitting power properly centered in the transmission channel, while the Model 2800 can distinguish between

a transmission at the correct frequency and one at an incorrect frequency. In this situation, the power meter can't distinguish between a good phone and a defective phone; and the power meter would permit the defective phone to be shipped to a customer.

IV. Conclusion

When total RF power transmitted is the key parameter needed to assess a wireless device, a power meter is an excellent solution. Two-way radio systems or antenna systems are two applications where total power is the major parameter that must be measured.

Mobile phone systems involve multiple users operating simultaneously, which requires transmitting devices to operate without interfering with other users. As a result, testing mobile phones requires testing the devices to ensure their RF transmissions are confined to an appropriate channel and that the transmissions don't generate excessive amounts of interfering (spurious) power. A spectrum analysis instrument like the Model 2800 is required to make these frequency domain measurements. A power meter, a time domain measurement device that doesn't acquire the frequency spectrum of the RF signal, can't make the critical tests to qualify a mobile phone properly.

The Model 2800 stands out over other spectrum analysis instruments because it has been specifically designed for production testing of mobile phones. It has a variety of advantages over both power meters and other spectrum analysis devices:

- High speed measurements
 - Channel power measurements as fast as 6ms
 - Up to five simultaneous measurements (channel power, upper and lower adjacent channel power, and upper and lower alternate channel power) in only 26ms
- Pre-configured for measurements of all the major mobile phone standards
- Channel power accuracy better than $\pm 0.5\text{dB}$
- Small size

The Model 2800 allows production test engineers in mobile phone factories to reduce test time and improve production throughput significantly.

Appendix A. Clearing Up the Confusion over a Power Sensor's Video Bandwidth

An RF sensor has a frequency range that represents the frequency bandwidth over which it can detect RF power. A typical frequency range can be as wide as 10MHz to 18GHz. Peak power sensors, which are designed to measure the peak magnitude of an RF transmission, are more complex modules. They have an additional parameter known as the video bandwidth (the other term is modulation bandwidth). This parameter, which can be 300kHz to 5MHz, describes the sensor's ability to capture the power envelope of the modulated signal. Recall that while the RF signal is varying at a carrier frequency (for example, 1950MHz for a WCDMA transmission), the power envelope of the signal is only varying by a frequency of 3.84MHz, the modulation frequency. A sensor with a video bandwidth of 5MHz can capture the time-varying, 3.84MHz-wide envelope of the WCDMA signal and detect the peaks of the signal. A sensor with a lower video bandwidth can't capture the peaks of the WCDMA envelope signal.

The video bandwidth is a measure of how fast the sensor can respond to time-varying voltages. Video bandwidth represents the ability of the power sensor and meter to track the envelope of modulated signals, such as pulsed TDMA signals (PDC, GSM and PHS) and spread spectrum CDMA signals. Inappropriate video bandwidth impacts time-gated average power, peak power and peak-related power measurements. **The video bandwidth doesn't define measurement within a portion of the frequency spectrum.** Power meter sensors respond to time-varying signals and don't provide any frequency spectrum-related information.

The following paragraphs describe how video bandwidth affects peak power measurements of RF signals.

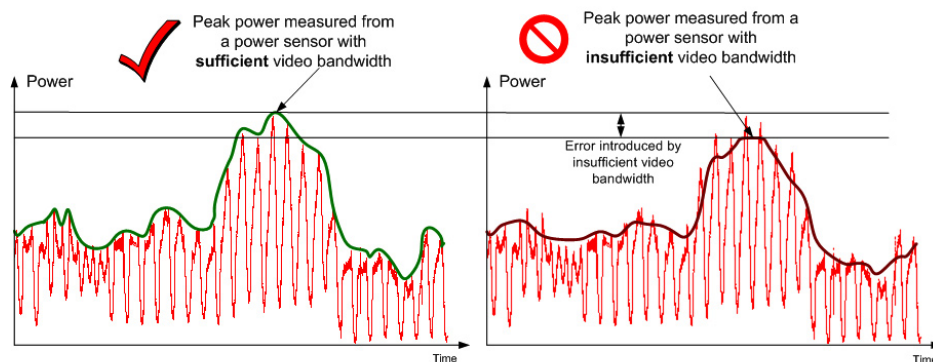

Figure 8. The impact of power sensor's video bandwidth on peak power measurement

In *Figure 8*, the peak power is incorrectly measured by the sensor with insufficient video bandwidth. Video bandwidth is a limitation of how fast a power sensor can track the envelope of a signal.

Table 2. Recommended video bandwidths for peak power measurements of mobile phone signals

Video Bandwidth	Mobile Phone Standards
300 kHz	NADC, GSM, GPRS, EDGE
1.5 MHz	cdmaOne, CDMA2000 1x
5 MHz	W-CDMA, CDMA2000 3x

A wide video bandwidth power sensor isn't always appropriate for low modulation bandwidth RF signals. Trade-offs exist—wider video bandwidth yields less dynamic range, more variation in linearity, and vice versa. For example, a power sensor with 5MHz video bandwidth has a dynamic range from -32dBm to +20dBm, while a sensor with 300kHz video bandwidth provides -42dBm to +20dBm dynamic range.

To maximize dynamic range and minimize peak power measurement error, the video bandwidth should be greater than or equal to the signal's modulation bandwidth.

Table 2 lists recommended power sensor video bandwidths for making peak power measurements on the various types of mobile phones. For example, a cdmaOne signal has a 1.23MHz modulation bandwidth; its recommended video bandwidth is 1.5MHz. For measuring peak power on mobile phones that operate on more than one standard, multiple peak power sensors may be required.

Specifications are subject to change without notice.

All Keithley trademarks and trade names are the property of Keithley Instruments, Inc.

All other trademarks and trade names are the property of their respective companies.

KEITHLEY

Keithley Instruments, Inc.

28775 Aurora Road • Cleveland, Ohio 44139 • 440-248-0400 • Fax: 440-248-6168
1-888-KEITHLEY (534-8453) • www.keithley.com

© Copyright 2004 Keithley Instruments, Inc.
Printed in the U.S.A.

No. 2489
0104

A Greater Measure of Confidence