

**KEITHLEY**

# Model 3322 LCZ Meter

## Operator's Manual

A GREATER MEASURE OF CONFIDENCE

# WARRANTY

Keithley Instruments, Inc. warrants this product to be free from defects in material and workmanship for a period of 1 year from date of shipment.

Keithley Instruments, Inc. warrants the following items for 90 days from the date of shipment: probes, cables, rechargeable batteries, diskettes, and documentation.

During the warranty period, we will, at our option, either repair or replace any product that proves to be defective.

To exercise this warranty, write or call your local Keithley representative, or contact Keithley headquarters in Cleveland, Ohio. You will be given prompt assistance and return instructions. Send the product, transportation prepaid, to the indicated service facility. Repairs will be made and the product returned, transportation prepaid. Repaired or replaced products are warranted for the balance of the original warranty period, or at least 90 days.

## LIMITATION OF WARRANTY

This warranty does not apply to defects resulting from product modification without Keithley's express written consent, or misuse of any product or part. This warranty also does not apply to fuses, software, non-rechargeable batteries, damage from battery leakage, or problems arising from normal wear or failure to follow instructions.

THIS WARRANTY IS IN LIEU OF ALL OTHER WARRANTIES, EXPRESSED OR IMPLIED, INCLUDING ANY IMPLIED WARRANTY OF MERCHANTABILITY OR FITNESS FOR A PARTICULAR USE. THE REMEDIES PROVIDED HEREIN ARE BUYER'S SOLE AND EXCLUSIVE REMEDIES.

NEITHER KEITHLEY INSTRUMENTS, INC. NOR ANY OF ITS EMPLOYEES SHALL BE LIABLE FOR ANY DIRECT, INDIRECT, SPECIAL, INCIDENTAL OR CONSEQUENTIAL DAMAGES ARISING OUT OF THE USE OF ITS INSTRUMENTS AND SOFTWARE EVEN IF KEITHLEY INSTRUMENTS, INC., HAS BEEN ADVISED IN ADVANCE OF THE POSSIBILITY OF SUCH DAMAGES. SUCH EXCLUDED DAMAGES SHALL INCLUDE, BUT ARE NOT LIMITED TO: COSTS OF REMOVAL AND INSTALLATION, LOSSES SUSTAINED AS THE RESULT OF INJURY TO ANY PERSON, OR DAMAGE TO PROPERTY.

**KEITHLEY**

Keithley Instruments, Inc. • 28775 Aurora Road • Cleveland, OH 44139 • 440-248-0400 • Fax: 440-248-6168 • <http://www.keithley.com>

CHINA:	Keithley Instruments China • Yuan Chen Xin Building, Room 705 • 12 Yumin Road, Dewai, Madian • Beijing 100029 • 8610-62022886 • Fax: 8610-62022892
FRANCE:	Keithley Instruments SARL • BP 60 • 3 Allée des Garays • 91122 Palaiseau Cédex • 33-1-60-11-51-55 • Fax: 33-1-60-11-77-26
GERMANY:	Keithley Instruments GmbH • Landsberger Strasse 65 • D-82110 Germering, Munich • 49-89-8493070 • Fax: 49-89-84930759
GREAT BRITAIN:	Keithley Instruments, Ltd. • The Minster • 58 Portman Road • Reading, Berkshire, England RG3 1EA • 44-1189-596469 • Fax: 44-1189-575666
ITALY:	Keithley Instruments SRL • Viale S. Gimignano 38 • 20146 Milano • 39-2-48303008 • Fax: 39-2-48302274
NETHERLANDS:	Keithley Instruments BV • Avelingen West 49 • 4202 MS Gorinchem • 31-(0)183-635333 • Fax: 31-(0)183-630821
SWITZERLAND:	Keithley Instruments SA • Kriesbachstrasse 4 • 8600 Dübendorf • 41-1-8219444 • Fax: 41-1-8203081
TAIWAN:	Keithley Instruments Taiwan • 1FL., 85 Po Ai Street • Hsinchu, Taiwan • 886-3-572-9077 • Fax: 886-3-572-9031

# Model 3322 LCZ Meter

## Operator's Manual

### **Note for Model 3322 LCZ Meters equipped with rev. 2.00 or later firmware.**

Those who have units with earlier firmware can disregard this information. Note that the firmware revision level will be briefly shown on the **A** DISPLAY during the power-up cycle. For example:

-2.00-

### **External Bias Voltage Range**

The external bias voltage range on units with rev. 2.00 and later firmware has been changed from *0 to +35V* to *0 to ±35V*. All references to the external bias voltage range throughout the manual should be modified to reflect this change. Note that the rear panel of newer Model 3322 LCZ Meters with this change will be marked accordingly.

All Keithley product names are trademarks or registered trademarks of Keithley Instruments, Inc.

Other brand and product names are trademarks or registered trademarks of their respective holders.

# Safety Precautions

---

The following safety precautions should be observed before using this product and any associated instrumentation. Although some instruments and accessories would normally be used with non-hazardous voltages, there are situations where hazardous conditions may be present.

This product is intended for use by qualified personnel who recognize shock hazards and are familiar with the safety precautions required to avoid possible injury. Read the operating information carefully before using the product.

The types of product users are:

**Responsible body** is the individual or group responsible for the use and maintenance of equipment, for ensuring that the equipment is operated within its specifications and operating limits, and for ensuring that operators are adequately trained.

**Operators** use the product for its intended function. They must be trained in electrical safety procedures and proper use of the instrument. They must be protected from electric shock and contact with hazardous live circuits.

**Maintenance personnel** perform routine procedures on the product to keep it operating, for example, setting the line voltage or replacing consumable materials. Maintenance procedures are described in the manual. The procedures explicitly state if the operator may perform them. Otherwise, they should be performed only by service personnel.

**Service personnel** are trained to work on live circuits, and perform safe installations and repairs of products. Only properly trained service personnel may perform installation and service procedures.

Exercise extreme caution when a shock hazard is present. Lethal voltage may be present on cable connector jacks or test fixtures. The American National Standards Institute (ANSI) states that a shock hazard exists when voltage levels greater than 30V RMS, 42.4V peak, or 60VDC are present. **A good safety practice is to expect that hazardous voltage is present in any unknown circuit before measuring.**

Users of this product must be protected from electric shock at all times. The responsible body must ensure that users are prevented access and/or insulated from every connection point. In some cases, connections must be exposed to potential human contact. Product users in these circumstances must be trained to protect themselves from the risk of electric shock. If the circuit is capable of operating at or above 1000 volts, **no conductive part of the circuit may be exposed.**

As described in the International Electrotechnical Commission (IEC) Standard IEC 664, digital multimeter measuring circuits (e.g., Keithley Models 175A, 199, 2000, 2001, 2002, and 2010) are Installation Category II. All other instruments' signal terminals are Installation Category I and must not be connected to mains.

Do not connect switching cards directly to unlimited power circuits. They are intended to be used with impedance limited sources. NEVER connect switching cards directly to AC mains. When connecting sources to switching cards, install protective devices to limit fault current and voltage to the card.

Before operating an instrument, make sure the line cord is connected to a properly grounded power receptacle. Inspect the connecting cables, test leads, and jumpers for possible wear, cracks, or breaks before each use.

For maximum safety, do not touch the product, test cables, or any other instruments while power is applied to the circuit under test. ALWAYS remove power from the entire test system and discharge any capacitors before: connecting or disconnecting cables or jumpers, installing or removing switching cards, or making internal changes, such as installing or removing jumpers.

Do not touch any object that could provide a current path to the common side of the circuit under test or power line (earth) ground. Always make measurements with dry hands while standing on a dry, insulated surface capable of withstanding the voltage being measured.

The instrument and accessories must be used in accordance with its specifications and operating instructions or the safety of the equipment may be impaired.

Do not exceed the maximum signal levels of the instruments and accessories, as defined in the specifications and operating information, and as shown on the instrument or test fixture panels, or switching card.

When fuses are used in a product, replace with same type and rating for continued protection against fire hazard.

Chassis connections must only be used as shield connections for measuring circuits, NOT as safety earth ground connections.

If you are using a test fixture, keep the lid closed while power is applied to the device under test. Safe operation requires the use of a lid interlock.

If a  screw is present, connect it to safety earth ground using the wire recommended in the user documentation.

The  symbol on an instrument indicates that the user should refer to the operating instructions located in the manual.

The  symbol on an instrument shows that it can source or measure 1000 volts or more, including the combined effect of normal and common mode voltages. Use standard safety precautions to avoid personal contact with these voltages.

The **WARNING** heading in a manual explains dangers that might result in personal injury or death. Always read the associated information very carefully before performing the indicated procedure.

The **CAUTION** heading in a manual explains hazards that could damage the instrument. Such damage may invalidate the warranty.

Instrumentation and accessories shall not be connected to humans.

Before performing any maintenance, disconnect the line cord and all test cables.

To maintain protection from electric shock and fire, replacement components in mains circuits, including the power transformer, test leads, and input jacks, must be purchased from Keithley Instruments. Standard fuses, with applicable national safety approvals, may be used if the rating and type are the same. Other components that are not safety related may be purchased from other suppliers as long as they are equivalent to the original component. (Note that selected parts should be purchased only through Keithley Instruments to maintain accuracy and functionality of the product.) If you are unsure about the applicability of a replacement component, call a Keithley Instruments office for information.

To clean the instrument, use a damp cloth or mild, water based cleaner. Clean the exterior of the instrument only. Do not apply cleaner directly to the instrument or allow liquids to enter or spill on the instrument.

# Table of Contents

## SECTION 1 — General Information

1.1	INTRODUCTION .....	1-1
1.2	PRODUCT DESCRIPTION .....	1-1
1.2.1	Condensed Specifications .....	1-1
1.2.2	Features .....	1-2
1.3	WARRANTY INFORMATION .....	1-2
1.4	MANUAL ADDENDA .....	1-2
1.5	SAFETY SYMBOLS and TERMS .....	1-2
1.6	INSPECTION .....	1-2
1.7	OPTIONAL ACCESSORIES .....	1-2
1.8	SPECIFICATIONS .....	1-3

## SECTION 2 — Getting Started

2.1	INTRODUCTION .....	2-1
2.2	POWER-UP .....	2-1
2.3	BASIC MEASUREMENTS .....	2-2
2.4	DEVIATION MEASUREMENTS .....	2-4
2.5	COMPARATOR OPERATION .....	2-4

## SECTION 3 — Operation

3.1	INTRODUCTION .....	3-1
3.2	FRONT AND REAR PANEL FAMILIARIZATION .....	3-1
3.2.1	Front Panel .....	3-3
3.2.2	Rear Panel .....	3-8
3.3	POWER-UP PROCEDURE .....	3-9
3.3.1	Line Voltage Setting .....	3-9
3.3.2	Fuse Replacement .....	3-9
3.3.3	Power Cord .....	3-10
3.3.4	Power Up Sequence .....	3-10
3.3.5	Default Conditions .....	3-10
3.4	TEST CONNECTIONS .....	3-10
3.5	BASIC MEASUREMENTS .....	3-12
3.5.1	Measurement Function Selection .....	3-12
3.5.2	Measurement Function Parameter Selection .....	3-12
3.5.3	Equivalent Circuit Selection .....	3-13
3.5.4	Measurement Range Selection .....	3-13
3.6	DEVIATION (▲, %▲) .....	3-16
3.6.1	Setting a Reference Value .....	3-16
3.6.2	Displaying Deviation .....	3-16
3.6.3	Deviation Measurement Range .....	3-16

3.7	COMPARATOR (BIN) .....	3-17
3.7.1	Defining Comparator Limits .....	3-17
3.7.2	Basic Comparator Operation .....	3-18
3.7.3	Comparing Deviation Readings .....	3-18
3.8	SET UP .....	3-19
3.8.1	FREQ (Hz) .....	3-19
3.8.2	DELAY .....	3-20
3.8.3	REF .....	3-20
3.8.4	BIN, LOWER, UPPER .....	3-20
3.8.5	GPIB .....	3-20
3.9	SAVING MEASUREMENT CONFIGURATIONS .....	3-21
3.10	FREQUENCY SELECTION .....	3-21
3.11	SPEED SELECTION .....	3-22
3.12	SIGNAL LEVEL SELECTION .....	3-22
3.13	TRIGGER .....	3-22
3.13.1	Trigger Selection .....	3-22
3.13.2	Trigger Delay .....	3-23
3.14	DC BIAS .....	3-23
3.15	ZERO CORRECTION .....	3-24
3.15.1	Zero Correction Procedures .....	3-24
3.15.2	Equivalent Circuits of Measurement System .....	3-25
3.15.3	Correctable Range .....	3-25
3.16	MEASUREMENT CABLES .....	3-26
3.16.1	Cable Requirements .....	3-26
3.16.2	Additional Error .....	3-27
3.17	ERROR MESSAGES .....	3-27

## SECTION 4 — GPIB Interface

4.1	INTRODUCTION .....	4-1
4.1.1	Major GPIB Specifications .....	4-1
4.1.2	Bus Line Signals and Operations .....	4-2
4.1.3	GPIB Handshaking .....	4-2
4.1.4	Data Transfer Example .....	4-3
4.1.5	Basic Talker Functions .....	4-3
4.1.6	Basic Listener Functions .....	4-3
4.1.7	Major Specifications of Controller Functions .....	4-4
4.1.8	Multi-line Interface Message .....	4-4
4.2	GPIB Programming Example .....	4-6
4.3	GPIB SPECIFICATIONS .....	4-6
4.3.1	Interface Functions .....	4-6
4.3.2	Bus Drivers .....	4-6
4.3.3	Address .....	4-7
4.3.4	Receive and Transmit Codes .....	4-7
4.3.5	Delimiters .....	4-7
4.3.6	Program Codes .....	4-7
4.3.7	Response to Interface Messages .....	4-10
4.3.8	Remote/Local Operation .....	4-11



4.3.9	Service Request (SRQ) .....	4-11
4.3.10	Status Byte .....	4-11
4.3.11	Process Time .....	4-11
4.4	SETTING GPIB ADDRESS AND DELIMITER .....	4-11
4.5	GPIB PROGRAMMING .....	4-13
4.5.1	Setting Messages .....	4-13
4.5.2	Inquiry Messages .....	4-16
4.5.3	Reading Measured Data .....	4-20
4.5.4	Reading Bin Setting .....	4-21
4.6	MEASUREMENTS OVER GPIB .....	4-21
4.6.1	Preparation .....	4-21
4.6.2	Measurement and Reading of Data .....	4-22
4.7	GPIB OPERATING CONSIDERATIONS .....	4-22
4.8	GPIB ERRORS .....	4-23
4.9	EXAMPLE PROGRAMS .....	4-23
4.9.1	GPIB Initialization .....	4-23
4.9.2	Display Setting .....	4-24
4.9.3	Inquiry .....	4-24
4.9.4	SRQ and Serial Poll .....	4-24
4.9.5	Measurements .....	4-25

# List of Illustrations

## SECTION 2 — Getting Started

Figure 2-1	Model 3322 Test Fixture Connection .....	2-3
------------	--	-----

## SECTION 3 — Operation

Figure 3-1	Model 3322 Front Panel .....	3-2
Figure 3-2	Model 3322 Rear Panel .....	3-7
Figure 3-3	Cleaning Air Filter .....	3-8
Figure 3-4	Fuse Replacement .....	3-9
Figure 3-5	Connection to the Device Under Test .....	3-11
Figure 3-6	Equivalent Circuits of Device Under Test .....	3-13
Figure 3-7	OPEN Measurement .....	3-24
Figure 3-8	SHORT Measurement .....	3-25
Figure 3-9	Equivalent Circuits of Measurement System .....	3-25
Figure 3-10	Test Cables .....	3-26

## SECTION 4 — GPIB Interface

Figure 4-1	Interface Connector .....	4-2
Figure 4-2	Handshake Timing Diagram .....	4-3
Figure 4-3	Data Transfer Example .....	4-4
Figure 4-4	Basic Syntax Program Code .....	4-8

# List of Tables

## SECTION 3 — Operation

Table 3-1	Power-up Defaults .....	3-10
Table 3-2	AUTO Function Selections .....	3-12
Table 3-3	AUTO Equivalent Circuit Selections .....	3-13
Table 3-4	Impedance Ranges .....	3-15
Table 3-5	Additional Error of $ Z $ Caused by Test Cables (Reference Data) .....	3-27
Table 3-6	Error Message .....	3-28

## SECTION 4 — GPIB Interface

Table 4-1	Multi-Line Interface Message .....	4-5
Table 4-2	Interface Functions .....	4-6
Table 4-3	Bus Drivers .....	4-6
Table 4-4	List of Program Codes .....	4-9
Table 4-5	Response to Interface Messages .....	4-10
Table 4-6	Status Bytes .....	4-12
Table 4-7	Process Time of Program Codes (Reference Data) .....	4-13
Table 4-8	Setting Messages .....	4-14
Table 4-9	Inquiry Messages .....	4-17
Table 4-10	GPIB Error Messages .....	4-23

# SECTION 1

## General Information

---

---

### 1.1 INTRODUCTION

This section contains general information about the Model 3322.

### 1.2 PRODUCT DESCRIPTION

The Model 3322 LCZ Meter is a high accuracy (0.1% basic accuracy), full function LCZ meter. It includes comparator functions for parts sorting, memory for test configurations, and an IEEE-488 interface to control operation from a computer.

The Model 3322 drives a device under test (DUT) with a known voltage sine wave signal. Impedance is derived by precisely measuring the resultant current that flows through the DUT.

#### 1.2.1 Condensed Specifications

The following condensed specifications help summarize the capabilities of the Model 3322. Complete, detailed instrument specifications are located in Appendix A.

Measurement Functions: L, C, R,  $|Z|$ , Q, D, ESR, G, X,  $\theta$   
These functions can be automatically selected, and deviation (or % deviation) can be displayed.

Basic Accuracy: 0.1% (at 1kHz)

Measurement Ranges (Display):

$|Z|$ : 0.1m $\Omega$  to 19.999M $\Omega$   
C: 0.001pF to 199.99mF  
L: 0.1nH to 19.999kH  
Q, D: 0.0001 to 19999  
 $\theta$ : -180.00° to +179.99°

Measurement Frequency: 100 to 100kHz  
11 frequency selections available; 100, 120, 200, 500, 1k, 2k, 5k, 10k, 20k, 50k or 100kHz

Measurement Signal Level: 1V rms, 50mV rms

Equivalent Circuit: Series, parallel and automatic

DC Bias:

DC Bias: Internal: 2V  
External: 0 to 35V

Zero Correction: Automatic (OPEN, SHORT).

Measuring Time: FAST (64ms), MED (150ms), SLOW (480ms)

Comparator Function: 20 categories

Memory for Test Setups: 10 test configurations can be saved in battery backed-up memory.

## 1.2.2 Features

- High Accuracy — Basic accuracy of 0.1% with display resolution of 0.0001 at 4-1/2 digits.
- Wide Frequency Range — Eleven frequency selections in the range from 100Hz to 100kHz are usable.
- Two Measurement Signal Levels — Selectable sine wave signals of 50mV rms or 1V rms can be applied to the DUT. Also, the signal can be biased by selecting the 2V internal DC bias or by externally applying a DC bias up to 35V.
- Variety of Measurement Functions — In addition to the conventional functions including L, C, R, D and Q, you can also display the equivalent series resistance (ESR), parallel conductance (G), series reactance (X), and polar coordinates expression ( $|Z| - \theta$ ). Further, the deviation from the standard value is also displayed.
- Automatic Function and Range Selection — In addition to the conventional autorange feature, function and the equivalent circuits can also be automatically selected.
- Built-in DC Bias Power Supply — The built-in 2V DC bias power supply is used to measure the capacitance of polarized devices such as electrolytic capacitors and semiconductors.
- Built-in Comparator — Twenty comparator functions facilitate the sorting of parts.
- Battery Backed-up Memory — Up to 10 unique setup configurations can be saved. Battery back-up prevents these setups configurations from being lost after power is turned off.
- IEEE-488 Interface — Allows the instrument to be controlled by a computer.

## 1.3 WARRANTY INFORMATION

Warranty information is located on the inside front cover of this operator's manual. Should your Model 3322 require warranty service, contact the Keithley representative or authorized repair facility in your area for further information. When returning the instrument for repair, be sure to fill out and include the service form at the back of this manual in order to provide the repair facility with the necessary information.

## 1.4 MANUAL ADDENDA

Any improvements or changes concerning the instrument or manual will be explained in an addendum included with the manual. Be sure to note these changes and incorporate them into the manual.

## 1.5 SAFETY SYMBOLS and TERMS

The following symbols and terms may be found on an instrument or used in this manual.

The symbol  on an instrument indicates that the user should refer to the operating instructions located in the instruction manual.

The **WARNING** heading used in this manual explains dangers that might result in personal injury or death. Always read the associated information very carefully before performing the indicated procedure.

The **CAUTION** heading used in this manual explains hazards that could damage the scanner card. Such damage may invalidate the warranty.

## 1.6 INSPECTION

The Model 3322 was carefully inspected, both electrically and mechanically, before shipment. After unpacking all items from the shipping carton, check for any obvious signs of physical damage that may have occurred during transit.

Report any damage to the shipping agent immediately. Save the original packing carton for possible future re-shipment. The following items are included with every Model 3322 order:

- Model 3322 LCZ Meter
- Model 3322 Operator's Manual
- Additional Accessories as ordered.

If an additional operator's manual is required, order the manual package, Keithley part number 3322-900-00. The manual package includes an operator's manual and any pertinent addenda.

## 1.7 OPTIONAL ACCESSORIES

The following accessories are available from Keithley for use with the Model 3322:

1. Model 3323 Direct Test Fixture. Allows leaded parts to be directly inserted into this test fixture. Especially convenient for parts sorting.

2. Model 3324 4-Terminal Alligator Clip Test Lead. Designed for four-terminal components, in which the current-supplying terminals and voltage-measurement terminals are separated.
3. Model 3325 Kelvin Clip Test Lead. Uses two clips for four-terminal connections. Used to measure large or irregularly-shaped components which cannot be inserted into the Model 3323 test fixture.
4. Model 3326 Chip Component Test Leads. This tweezer-type test lead set permits easy connection to surface mounted chip components.

The cables for all the above test leads are shielded to minimize stray capacitance.

## 1.8 SPECIFICATIONS

Model 3322 specifications may be found in Appendix A of this manual.

# SECTION 2

## Getting Started

---

---

### 2.1 INTRODUCTION

This brief section will guide the user through some simple front panel operations. This section is intended to acquaint the user with basic operation. Detailed operation is covered in Section 3.

Abbreviated operations covered in this section include:

1. Basic L, C, R and Z measurements.
2. Deviation measurements.
3. Comparator operation.

#### NOTE

Front and rear panel views of the instrument (which may be helpful in locating controls, annunciators or connectors) are provided by Figures 3-1 and 3-2. These drawings are located in Section 3.

### 2.2 POWER-UP

The instrument is designed to operate from 90-132V or 198-250V line voltage ranges at 48 to 62Hz. Perform the following steps to connect the instrument to line power:

1. Check the rear panel LINE SUPPLY selector switch and make sure the setting agrees with the line volt-

age available in your area. If the switch setting needs to be changed, perform the procedures in paragraph 3.3. Keep in mind that changing the line voltage setting requires a fuse change.

#### CAUTION

To prevent damage to the instrument that may not be covered by the warranty, make sure the rear panel LINE SUPPLY switch is set to the correct line voltage setting.

2. The power cord is supplied with the instrument. Connect the female end of the power cord to AC receptacle on the rear panel, and connect the other end to a grounded AC outlet.

#### WARNING

The instrument is equipped with a 3-wire power cord that contains a separate ground wire and is designed to be used with grounded outlets. When proper connections are made, instrument chassis is connected to the power line ground. If the AC outlet is not grounded, the rear panel safety earth ground terminal must be connected to a known safety earth ground using #18 AWG (or larger) wire.

3. Turn on the instrument by depressing the POWER switch in to the ON position. The instrument will perform its power up sequence (see paragraph 3.3.4). After successfully completing the power up tests, the instrument will assume default conditions that configure the instrument for immediate measurements.

**NOTE**

The instrument is ready for immediate use. However, to achieve rated accuracy, the instrument must be allowed to warm up for at least 1/2 hour.

### 2.3 BASIC MEASUREMENTS

A measurement is performed by applying a known rms signal level at a specific frequency to the DUT and then calculating and displaying the results.

**NOTE**

The following procedure assumes that the instrument is configured to its power-up default conditions. If you are not sure about the setup configuration, simply turn the power off and then on again.

**NOTE**

The following procedure uses the Model 3323 Test Fixture to connect DUT to the instrument (see Figure 2-1). If using test cables, make sure 4-terminal connections are used as explained in paragraph 3.4.

Perform the following steps to make basic L, C, R or Z measurements:

1. Connect the Model 3323 Test fixture to the instrument. This test fixture allows easy DUT connection to the instrument, and provides accurate measurements by eliminating the stray capacitance of test cables.
2. Note that automatic function is selected as denoted by the AUTO annunciator to the left of the **[A]** DISPLAY. In AUTO function, the instrument will auto-

matically select the appropriate function (L, C, R or Z) for the device connected to it.

3. Install the DUT (device under test) into the test fixture. The appropriate function for the DUT will be selected and the measurements will be displayed as follows:

**NOTE**

The exponent symbol annunciators (p, n, u, m, k and M) for the readings are located to the right of each display.

- A. For inductors (L), the **[A]** DISPLAY provides the reading in henries (H), and the **[B]** DISPLAY provides the quality factor (Q).
- B. For capacitors (C), the **[A]** DISPLAY provides the reading in farads (F), and the **[B]** DISPLAY provides the dissipation factor (D).
- C. For resistors (R), the **[A]** DISPLAY provides the reading in ohms ( $\Omega$ ), and the **[B]** DISPLAY provides the quality factor (Q).

The above procedure requires no instrument settings by the operator. The test is completely automated by simply using the power-up default setup configuration to test DUTs. Of course this setup configuration is not desirable for all measurements and thus, requires the operator to modify appropriate operating parameters, such as the test signal level and frequency.

The test signal level and frequency can be modified as follows:

**Signal Level** — On power up, the test signal level is set to 1V rms as denoted by the front panel LEVEL annunciator. To select the alternate signal level (50mV rms), simply press the LEVEL key on the front panel. This key toggles between the two available signal levels.

**Signal Frequency** — On power up, the test frequency is set to 1kHz as denoted by the FREQ annunciator. To select one of the other frequencies (10kHz, 100kHz or 120Hz), press and release the FREQ key until the appropriate annunciator turns on. There are other frequencies that can be selected and is explained in Section 3.



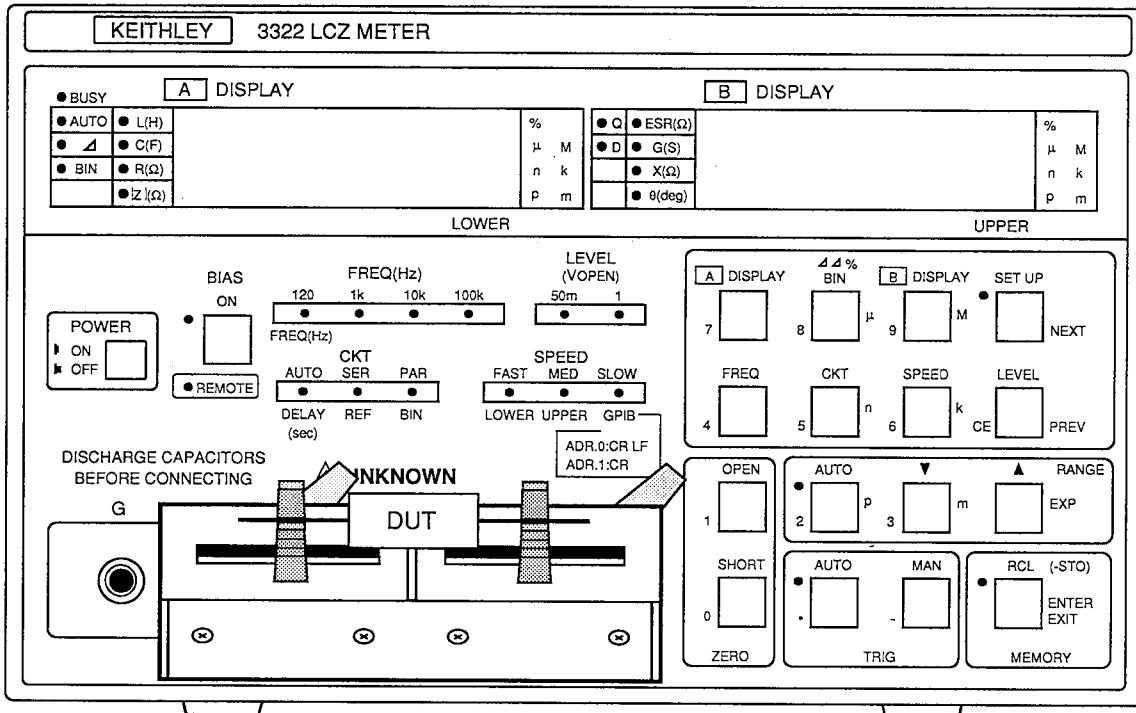

Figure 2-1. Model 3322 Test Fixture Connection

## 2.4 DEVIATION MEASUREMENTS

The instrument can be configured to measure and display the deviation ( $\Delta$  or  $\Delta\%$ ) between a DUT and a defined reference value.

$$\Delta = \text{Measured Value} - \text{Reference Value}$$
$$\Delta\% = (\Delta / \text{Reference Value}) \times 100$$

Perform the following steps to measure the deviation between a resistor that has a nominal rated value of  $1\text{k}\Omega$  and a  $1\text{k}\Omega$  reference value:

1. Configure Instrument for Measurement  
Deviation cannot be measured while the automatic function is enabled (AUTO display annunciator on). To disable AUTO function, press the **[A]** DISPLAY key until only the R function is selected (R annunciator on, AUTO annunciator off).
2. Define Reference Value
  - A. Press and release the SET UP key until the "blue-labeled" REF annunciator blinks on and off. The current reference value will be displayed on the **[B]** DISPLAY.
  - B. Using the data entry keys, enter the reference value of 1k in one of the following two ways:
    - a. Using the "blue-labeled" number keys, press 1, 0, 0, 0 in that order, and press the ENTER key.
    - b. Press the number 1 key, then press the "green-labeled" EXP key. Notice that all the exponent symbols will turn on. To select the  $10^3$  (kilo) exponent, press the "green-labeled" k key. Only the k exponent symbol will remain on. With 1k displayed, press ENTER.
  - C. Exit from the setup mode by pressing the EXIT key.
3. Measure DUT  
Connect the  $1\text{k}\Omega$  resistor to the instrument and note its measured value on the **[A]** DISPLAY.
4. Display Deviation
  - A. To display the deviation ( $\Delta$ ) between the measured value of the  $1\text{k}\Omega$  resistor and  $1\text{k}\Omega$  reference value, use the  $\Delta\Delta\%$ BIN key to select the following combination:  
  
 $\Delta$  display annunciator on  
BIN display annunciator off

% display annunciator off

Note: The % annunciator is located to the right of the display, and above the exponent symbol annunciator.

Example — If the measured reading of the resistor is  $998.1\Omega$ , the deviation ( $\Delta$ ) reading will be  $-.0019\text{k}\Omega$  ( $998.1 - 1000$ ).

- B. To display the percent deviation ( $\Delta\Delta\%$ ) between the measured value and the reference value, use the  $\Delta\Delta\%$ BIN key to select the following combination:

$\Delta$  display annunciator on  
% display annunciator on  
BIN display annunciator off

Example — If the measured reading of the resistor is  $998.1\Omega$ , the deviation reading in percent ( $\Delta\%$ ) will be  $-0.19\%$  ( $[-.0019\text{k} / 1000] \times 100$ ).

When finished measuring deviation, press  $\Delta\Delta\%$ BIN until the  $\Delta$ , % and BIN annunciators are off.

## 2.5 COMPARATOR OPERATION

The Comparator allows DUTs to be compared to defined reading limits and classified into one of up to 20 categories (bins). Upper and lower limits can be set for each of the 20 bins.

Comparator operation is demonstrated by configuring the instrument to accomplish the following task.

### Task:

You have a mixed pile of  $1\text{k}\Omega$ ,  $2\text{k}\Omega$  and  $3\text{k}\Omega$  resistors. A resistor is considered "good" if its measured value is within a tolerance of  $\pm 1\%$ . A resistor is "bad" if it is not within  $\pm 1\%$  tolerance. It is your job to sort the resistors as follows:

1. Place "good"  $1\text{k}\Omega$  resistors in Bin 1.
2. Place "good"  $2\text{k}\Omega$  resistors in Bin 2.
3. Place "good"  $3\text{k}\Omega$  resistors in Bin 3.
4. Place all "bad" resistors in Bin 0.

**Procedure:**

1. Configure Instrument for Measurement  
The Comparator (BIN) cannot be used while the automatic function is enabled (AUTO display annunciator on). To disable AUTO function, press and release the **[A]** DISPLAY key until only the R function is selected (R annunciator on, AUTO annunciator off).
2. Define Comparator Limits
  - A. Press and release the SET UP key until the "blue-labeled" BIN annunciator blinks on and off. A zero (Bin 0) will be displayed on the **[B]** DISPLAY.

**NOTE**

On power up, the upper and lower limits for all bins are set to zero. Upper and lower limits of zero for Bin 0 are satisfactory for this test system. All "bad" resistors will be assigned to this bin. Thus, Bin 0 does not have to be defined.

- B. Select Bin 1 by pressing the 1 key and then the ENTER key.
- C. Press the NEXT key to select LOWER. The "blue-labeled" LOWER annunciator will blink on and off. At this point the current lower limit and upper limit for Bin 1 will be displayed. Verify that both limits are .0000.

**NOTE**

The following steps require data entry. If an incorrect value is keyed in, use the CE key to clear the entry.

- D. Bin 1 is to be used for "good" 1k $\Omega$  resistors, thus the lower limit for this bin is to be 990 (99% of 1000). Using the number keys, key in 9,9,0 in that order, and press the ENTER key. UPPER will be selected as indicated by the blinking UPPER annunciator.
- E. The upper limit for Bin 1 is to be 1010 (101% of 1000). Key in 1, 0, 1, 0 and press ENTER. Note: The instrument will adjust the reading by using the k exponent symbol.

- F. Press the NEXT key. BIN will again be selected and Bin 2 will be displayed.
- G. Press the NEXT key to select LOWER.
- H. Bin 2 is used for "good" 2k $\Omega$  resistors, thus the lower limit for Bin 2 is to be 1980 (99% of 2000). Key in 1, 9, 8, 0 and then press ENTER. UPPER will then be selected.
  - I. The upper limit for Bin 2 is to be 2020 (101% of 2000). Key in 2, 0, 2, 0 and then press ENTER.
  - J. Select Bin 3 by pressing NEXT.
  - K. Press NEXT to select LOWER.
  - L. Bin 3 is used for "good" 3k $\Omega$  resistors, thus the lower limit for Bin 3 is to be 2970 (99% of 3000). Key in 2, 9, 7, 0 and then press ENTER. UPPER will then be selected.
  - M. The upper limit for Bin 3 is to be 3030 (101% of 3000). Key in 3, 0, 3, 0 and then press ENTER.

**NOTE**

For this test system, Bins 4 through 19 are not used. Since the limits for Bin 4 are set to zero, Bins 4 through 19 are considered closed and effectively removed from the test system.

- N. Press EXIT to return the instrument to the normal measurement state.
3. Enable Comparator (BIN)  
To enable the comparator, use the  $\Delta\Delta\%$ BIN key to select the following combination:

BIN display annunciator on  
 $\Delta$  display annunciator off

4. Connect DUT  
When one of the resistors to be tested is connected to the instrument, the **[A]** DISPLAY will provide the bin number that the resistor belongs in. Remember, any resistor that is not within the  $\pm 1\%$  tolerance is assigned to Bin 0.

When finished, press  $\Delta\Delta\%$ BIN until the  $\Delta$ , % and BIN annunciator are off.

**NOTE**

The Comparator can also be used with Deviation to compare deviation readings. See Section 3 for details.

# SECTION 3

## Operation

---

---

### **3.1 INTRODUCTION**

This section covers front panel operation. For operation over the GPIB bus, see Section 4.

### **3.2 FRONT AND REAR PANEL FAMILIARIZATION**

The following information describes the controls, annun-

ciators and connectors on the front and rear panels of the instrument.

The front and rear panels of the instrument are shown in Figure 3-1 and Figure 3-2.



### 3.2.1 Front Panel

**A** DISPLAY/ **B** DISPLAY 4-1/2 Digit Displays — Primarily used to display the measurement for the selected function and function parameter. The selected function and function parameter are indicated by annunciators to the left of the two displays. The annunciators to the right of the displays indicate the magnitude of the reading using exponent symbols (i.e. k, u, M, etc.).

**A** DISPLAY Function Indicators — These annunciators denote the selected function:

AUTO	AUTO function; function, function parameter and equivalent circuits are in the automatic selection mode.
L	Self inductance (H)
C	Electrostatic capacity (F)
R	Resistance ( $\Omega$ )
Z	Impedance ( $\Omega$ )
$\Delta$	Deviation or % deviation; % deviation is denoted by the % annunciator located to the right of the displayed reading.
BIN	Comparator (for parts sorting) enabled.

Note: The values of L, C and R change according to whether the equivalent circuit is in series or parallel mode.

**B** DISPLAY Function Parameter Indicators — These annunciators denote the selected function parameter:

Q	Quality factor
D	Dissipation factor ( $D = 1/Q$ )
ESR	Equivalent series resistance
G	Parallel conductance
X	Series Reactance
$\theta$	Phase angle of impedance

Exponent annunciators (both displays) — The following exponent annunciators are used to denote the magnitude of the reading:

M	= mega = $10^6$
m	= milli = $10^{-3}$
n	= nano = $10^{-9}$
k	= kilo = $10^3$
$\mu$	= micro = $10^{-6}$
p	= pico = $10^{-12}$

Front Panel Indicators:

**BUSY** — This indicator lights when a measurement is being made. This indicator is off while in OPEN or SHORT.

**REMOTE** — This indicator is on when the GPIB interface is in the remote state. While in remote, the front panel controls are disabled.

**FREQ (Hz)** — Denotes the frequency (120Hz, 1kHz, 10kHz or 100kHz) that was selected using the FREQ key. If all these indicators are off, an alternate frequency is selected. To check the frequency selection, press the SETUP key. The frequency will be displayed on the **B** DISPLAY. To return to the normal measurement state, press the EXIT key.

**CKT** — Denotes the equivalent circuit that was selected using the CKT key.

AUTO Automatic selection mode; SER or PAR automatically selected.

SER Series equivalent circuit.

PAR Parallel equivalent circuit.

Note: CKT selections only affect readings on **A** DISPLAY.

**SPEED** — Denotes the measurement speed that was selected by the SPEED key.

FAST High speed (60 to 80ms approx.). This speed lowers basic accuracy.

MED Medium speed (150 to 245ms approx.). Standard speed.

SLOW Slow speed (480 to 600ms approx.). Use when measured values are erratic (noisy).

**LEVEL ( $V_{OPEN}$ )** — Denotes the level of the measurement signal that was selected using the LEVEL key. The frequency of the signal is set by the FREQ key.

50m 50mV rms signal level. Basic accuracy is lowered using this level.

1 Standard 1V rms signal level.

The indicated signal level is the voltage applied to the output while under a "no load" condition. The output impedance of the signal source is approximately 100 $\Omega$ .

When connecting the signal to a device that has an impedance of less than  $1k\Omega$ , loading will cause the signal level to drop below the indicated voltage level.

**Front Panel Controls:**

**POWER ON-OFF** — The “in” position turns power on and the “out” position turns power off. After turning power off, wait at least three seconds before turning it back on.

**BIAS ON** — Pressing this key enables the internal 2V bias power supply. Pressing the key a second time disables the bias supply. With the rear panel BIAS INT/EXT switch set to the EXT position, the BIAS ON key will instead control the externally applied bias supply.

**NOTE**

The bias supply can only be enabled with the C (capacitance) function selected and AUTO function (Display A) disabled.

**[A] DISPLAY** — Use this key to select the desired function (AUTO, L, C, R or Z). The function annunciators located to the left of the [A] DISPLAY denote the selected function. The AUTO function automatically determines the type of device connected to the instrument and selects the appropriate function.

While in AUTO, the following conditions exist:

1. The [B] DISPLAY function parameter is automatically selected. Pressing the [B] DISPLAY key while in AUTO will result in “Err 13”.
2. AUTO CKT is enabled and the appropriate equivalent circuit is selected. Pressing the CKT key will result in “Err 13”.
3.  $\Delta$  (deviation) and BIN cannot be selected. Pressing the  $\Delta\Delta\%$  BIN key will result in “Err 13”. If already in  $\Delta$  or BIN, selecting AUTO will disable  $\Delta$  and BIN.

**[B] DISPLAY** — Use this key to select the desired function parameter (Q, D, ESR, G, X or  $\theta$ ). The annunciators denoting the selected function parameter are located to the left of the [B] DISPLAY. Note that if the AUTO function is selected (AUTO annunciator for [A] DISPLAY

turned on), pressing the [B] DISPLAY will result in “Err 13”.

$\Delta\Delta\%$  BIN — Deviation ( $\Delta$  and  $\Delta\%$ ) and BIN Selection Key. This key is used to enable one or more of these operations. The selected operation(s) is denoted by the [A] DISPLAY annunciator. Operations that can be selected include:

$\Delta\Delta\%$  BIN  $\Delta$ BIN  $\Delta\%$  BIN

Pressing the  $\Delta\Delta\%$  BIN key with  $\Delta\%$  and BIN selected will disable all these functions.

Note: Pressing the  $\Delta\Delta\%$  BIN key while in AUTO function (AUTO annunciator for [A] DISPLAY turned on) will result in “Err 13”.

**CKT** — This key is used to select the equivalent circuit. The selected circuit is denoted by the CKT annunciator. Equivalent circuit selections include:

AUTO SER PAR

In the AUTO mode, SER (series) or PAR (parallel) is automatically selected.

Note: Pressing the CKT key while in AUTO function (AUTO annunciator for [A] DISPLAY turned on) will result in “Err 13”.

**FREQ** — This key is used to select the frequency of the measurement signal. The selected frequency is denoted by the FREQ annunciator. Frequency selections include:

120Hz 1kHz 10kHz 100kHz

To select one of the alternate frequencies, refer to paragraph 3.9.1.

**SPEED** — This key is used to select instrument measurement speed. The selected speed is denoted by the SPEED annunciator. Speed selections include:

FAST MED SLOW

In MED speed, one measurement takes approximately 150ms.

**LEVEL** — This key is used to select the level of the measurement signal. The selected level is denoted by the LEVEL annunciator. Level selections include:

50mV rms    1V rms

**SET UP** — This key is used to enable the auxiliary setup mode. In this mode, parameter values can be checked, or changed to alternate values. While in SET UP, front panel keys correspond to the “blue” and “green” front panel labels, and not the normal “black” labels.

When this key is pressed, SET UP is enabled and the annunciator lamp adjacent to the key turns on. The parameter to be checked or changed is denoted by the blinking annunciator. The current value of the selected parameter is displayed on the **A** DISPLAY or **B** DISPLAY.

The following keys are associated with SET UP operation:

**NEXT** — Each press of this key enables the next SET UP parameter. In general, parameter selections move from left-to-right (as indicated by the blinking indicator) on the front panel for each key press. The seven SET UP parameters that can be selected are as follows:

FREQ DELAY REF BIN LOWER UPPER GPIB

**PREV** — Each press of this key selects the previous parameter. This key operates similarly to the NEXT key, except that, in general, selections move from right-to-left.

**Data Entry Keys** — These keys are used to enter new parameter values while in the SET UP mode. The keys associated with numeric entry include:

0 to 9 — Number keys  
 “.” — Decimal point key  
 “-” — Sign key. Toggles between plus and minus polarity. Plus polarity is implied by the absence of the “-” sign.

If an exponent (see EXP) is not required to input a parameter value, simply input a valid numeric value and press ENTER (see ENTER).

**EXP** — Use this “green” labeled key to enter the exponent part of a parameter value. When this key is first pressed, all the exponent annunciators for the **A** or **B** DISPLAY turn on. To input an exponent, press the desired “green” labeled exponent key ( $\mu$ , M, n, k, p, m). Only the annunciator for the selected exponent will remain lit. The pending parameter value can be entered by pressing ENTER (see ENTER key) or cancel by pressing CE (see CE key).

**CE** — This key is used to cancel a pending parameter value. A blinking least significant digit identifies a pending value. Pressing the CE key will cancel the displayed pending value and default to the previously entered value.

**ENTER/EXIT** — This key is used to enter a pending parameter value, or simply exit SET UP without changing the previous parameter value. If the displayed value is pending (least significant digit blinking), then this key functions as an ENTER key. Otherwise, as an EXIT key, it simply exits the SET UP mode.

Trying to enter an invalid parameter value will result in “Err 12”. Pressing any front panel key will display the previously entered value.

**ZERO** — Performing zero correction measures residual impedance and stray admittance, and then automatically corrects the displayed reading caused by these errors. The following keys are used to perform zero correction:

**OPEN** — Open the input and press OPEN to perform zero correction.

**SHORT** — Short the input and press SHORT to perform zero correction.

**TRIG** — The two following keys are used to control triggering:

**AUTO** — This key toggles between automatic triggering and manual triggering. In AUTO trigger, measurements are made continuously at an interval determined by the selected SPEED. AUTO trigger is denoted by the annunciator adjacent to the key.



**MAN** — In MAN trigger, each press of the MAN key will cause a single measurement to be made. Prior to each actual measurement, the instruments waits for the specified DELAY period.

**RCL (-STO)** — This key is used to store the current instrument setup in memory, or to recall one of ten setups previously stored in memory. To store the current setup in memory, first press the (-STO) key, then press the sign (-) key, then assign a memory location by pressing a number key (0 to 9), then finally press ENTER.

To configure the instrument to a setup previously stored in memory, first press the RCL key, then press a number key (0 to 9) that corresponds to the memory location where the setup is stored, then finally press ENTER.

When the instrument is turned off, the current instrument setup is automatically stored in Memory 0.

**RANGE** — The following keys are used to select the measurement range of the instrument:

**AUTO** — This key toggles between auto ranging and manual ranging. Selecting AUTO range turns on the AUTO annunciator, and automatically selects the most optimum range to make the measurement.

▼ **Down-range** — Each press of this key selects the next lower measurement range.

▲ **Up-range** — Each press of this key selects the next higher measurement range.

Note that manually selecting an invalid range will display an error message. See paragraph 3.5.4 for details.

Notes:

1. It is recommended that manual ranging be used when measuring small change or when comparing parts with essentially the same value.
2. When using AUTO range, the effect of noise could cause the instrument to experience inadvertent range changes. In this situation, use manual ranging.

**Measurement Terminals:**

**UNKNOWN** — The following front panel connectors are used to connect the DUT to the instrument:

- G** — Ground terminal that is connected to the chassis of the instrument. Used for shielding.
- L CUR** — Current detection terminal
- L POT** — Voltage detection terminal (Low)
- H POT** — Voltage detection terminal (High)
- H CUR** — Drive signal output terminal.

The bias voltage and the drive signal can be monitored on these terminals.

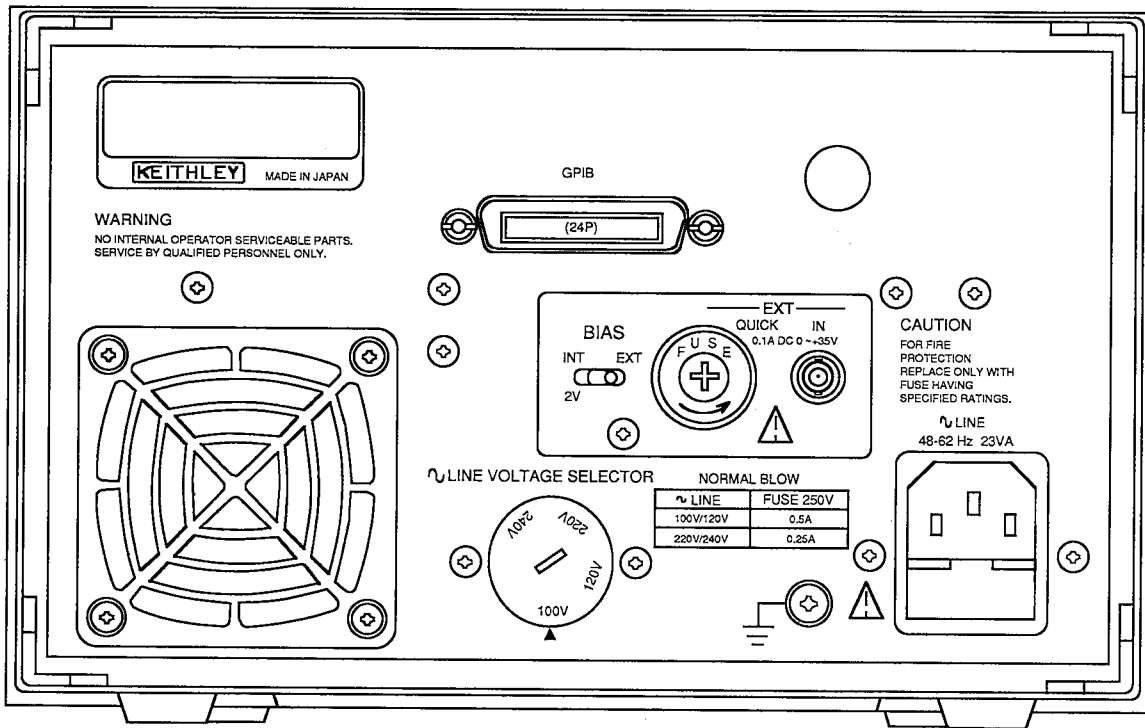

Figure 3-2. Model 3322 Rear Panel

### 3.2.2 Rear Panel

**GPIB** — This connector is used to connect the GPIB interface of the instrument to GPIB interface of a computer. See Section 4 for details.

**BIAS** — The following switch, fuse and input connector pertain to using an external bias supply:

**INT/EXT Switch** — This toggle switch is used to switch between the built-in (INT) bias power supply (2V) and the externally (EXT) applied bias supply (up to 35V).

**Fuse** — Maintenance fuse for the external power supply (0.1A quick acting type)

**IN Connector** — BNC connector used to connect the external bias supply to the instrument power input connector. Use a 0 to +35V supply with low ripple and noise.

#### CAUTION

0 to +35V is the maximum voltage that can be applied to the BIAS IN connector. Voltages outside this range may blow the fuse and cause damage to the instrument.

**Ventilation Fan** — The fan is used to keep the inside of the instrument free from damaging heat build-up. The fan ingests cool air into the instrument and expels warm air out of the vents in the top cover. For proper ventilation:

1. Maintain at least 10cm between the rear panel and a wall.
2. Do not block the air vents in the top cover.
3. Clean the air filter periodically to prevent clogging. Figure 3-3 shows how to remove the filter for cleaning.

#### WARNING

Be sure to turn off the power and remove the power cord before removing or installing the filter.

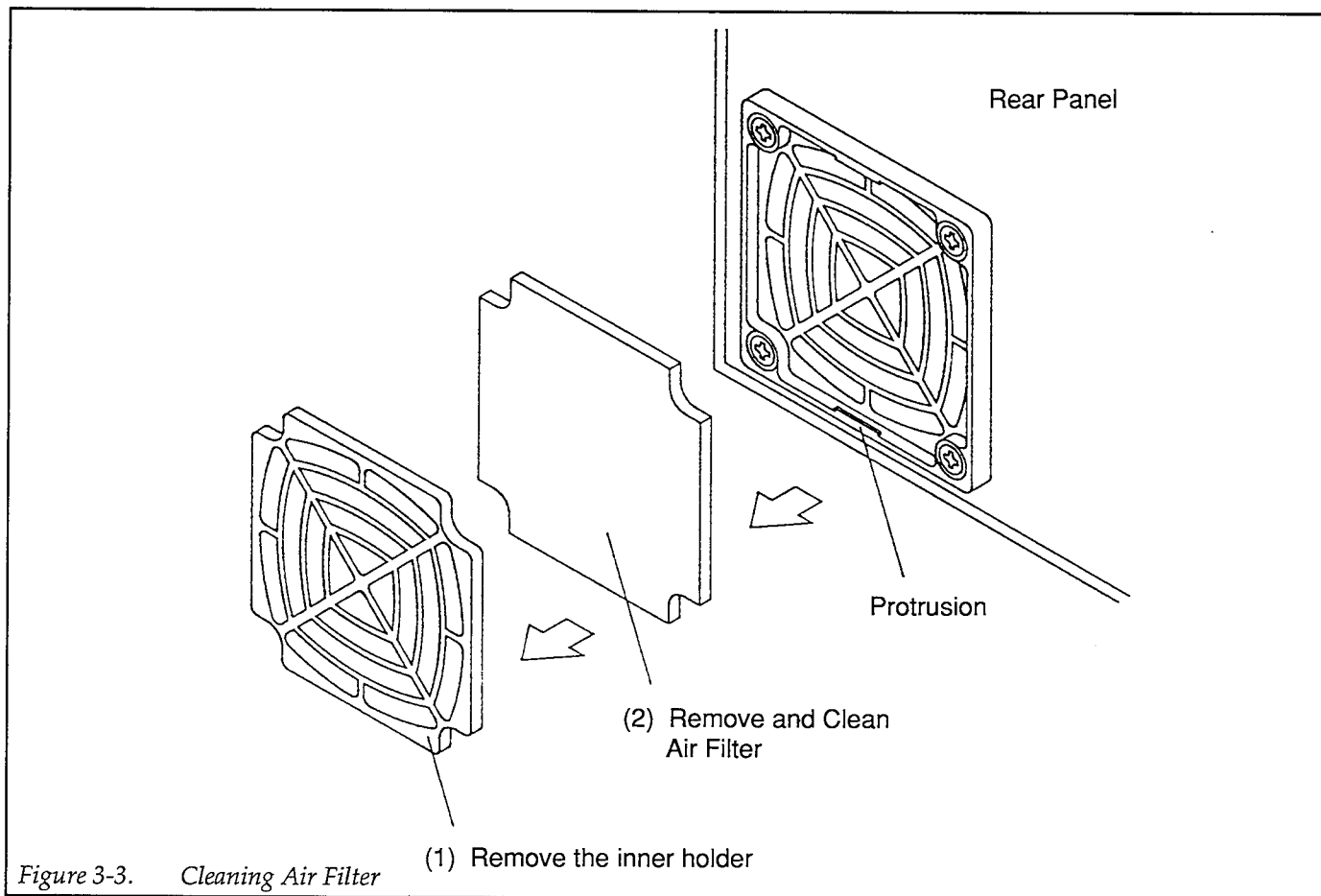

Figure 3-3. Cleaning Air Filter

**LINE SUPPLY**—Set this switch to the available line voltage. Changing the line voltage setting will require a fuse change. See paragraph 3.3.1 for details.

#### CAUTION

To prevent damage to the instrument that may not be covered by the warranty, be sure to turn off power and disconnect the line cord before changing the line voltage setting. Do not use a fuse other than the one specified for the line voltage setting.

**Safety Ground Terminal**—If the instrument is not connected to a safety earth ground through the supplied 3-prong line cord, connect this terminal to a known safety earth ground using #18 AWG (or larger) wire.

**LINE 48-62Hz** — Power Receptacle and Fuse. Use the supplied line cord to connect the instrument to the line power. Fuse replacement is covered in paragraph 3.3.2.

### 3.3 POWER-UP PROCEDURE

#### 3.3.1 Line Voltage Setting

The instrument is designed to operate from 90-132V or 198-250V line voltage ranges at 48 to 62Hz. Perform the following procedure to set the line voltage:

#### WARNING

Make sure the instrument is disconnected from the power line and all other equipment before proceeding.

1. Check the line voltage setting of the LINE SUPPLY switch on the rear panel. To change the setting, use a flat-blade screw driver to set the rotary switch to the setting that best matches the available line power.
2. If the switch setting was changed, install a fuse consistent with the operating voltage as described in the next paragraph.

#### 3.3.2 Fuse Replacement

A rear panel fuse located inside the AC LINE receptacle is used to protect the power line input of the instrument. If the fuse needs to be replaced (line voltage switch setting changed or blown fuse), perform the following steps:

#### WARNING

Make sure the instrument is disconnected from the power line and other equipment before replacing the fuse.

1. Using a flat-blade screw driver, pry open the fuse drawer as shown in Figure 3-4.
2. Remove the fuse from the fuse clip. Notice that there is a spare fuse in front of it.
3. Replace the fuse with the following type:

Line Voltage	Fuse Type
90-132V	0.5A, 250V, 5 × 20mm, Normal Blow
198-250V	0.25A, 250V, 5 × 20mm, Normal Blow

#### CAUTION

Do not use a fuse with a higher current rating than specified, or instrument damage may occur.

4. Push the fuse drawer back into the receptacle.

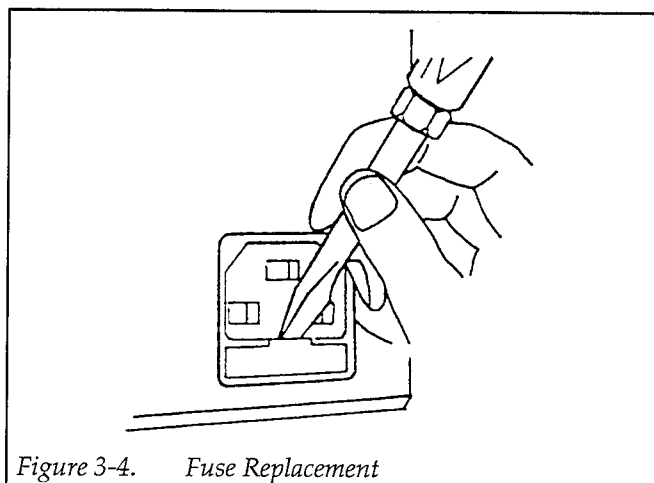

Figure 3-4. Fuse Replacement

### 3.3.3 Power Cord

Connect the female end of the power cord to the AC receptacle on the rear panel of the instrument. Connect the male end of the cord to a grounded AC outlet.

#### WARNING

The instrument is equipped with a 3-wire power cord that contains a separate ground wire and is designed to be used with grounded outlets. When proper connections are made, instrument chassis is connected to the power line ground. If the AC outlet is not grounded, the rear panel safety earth ground terminal must be connected to a known safety earth ground using #18 AWG (or larger) wire.

#### CAUTION

Be sure that the power line voltage agrees with the indicated voltage of the LINE SUPPLY switch. Failure to observe this precaution may result in instrument damage not covered by the warranty.

### 3.3.4 Power Up Sequence

To turn on the instrument, depress the POWER button. During the power up cycle, the unit will perform the following:

1. All annunciators and display segments will turn on for a few seconds. This allows you to check for defective indicators or display digits.
2. The revision level of the firmware is displayed briefly on the **A** DISPLAY. For example:

- 1.10 -

3. The self-check on memory elements and self-calibration of internal circuits are performed. During this period, the "CAL" message will be displayed on the **A** DISPLAY and a countdown from 14 to 0 will take place on the **B** DISPLAY. Any errors that occur are denoted by error messages on the display. Table 3-6 explains the error messages.
4. The unit will begin normal operation in accordance with the power-up configuration discussed in the next paragraph.

### 3.3.5 Default Conditions

Default conditions are the setup conditions that the instrument will return to when the instrument is powered up (or when a DCL or SDC command is sent over the GPIB bus). The default conditions for the instrument are summarized by Table 3-1.

Table 3-1. Power-up Defaults

Parameter	Setting	Remark
<b>A</b> DISPLAY	AUTO	
<b>B</b> DISPLAY	(AUTO)	
$\Delta$ , $\Delta\%$ , BIN	Disabled	
CKT	AUTO	
FREQ	1kHz	
DELAY	Zero	
REF	Zero	
BIN No.	Zero	1, 3
UPPER	Zero at all BINs	
LOWER	Zero at all BINs	
LEVEL	1Vrms	
SPEED	MED	
TRIG	AUTO	
RANGE	AUTO	
Zero correction	No correction	1
BIAS	Off	1
Header output	Inhibit (GPIB "HD 0")	1
SRQ output	Inhibit (GPIB "RQ 0")	1
Address	2	1, 2
Delimiter	<CR> <LF>	1, 2

#### Remarks:

1. The setting for this parameter cannot be saved in one of the ten battery back-up memories. The setting for all other parameters can be returned to the power-down condition by recalling Memory 0.
2. The setting for this parameter is stored in battery backed-up memory and automatically returns to the last programmed value on power-up.
3. Whenever a setup configuration is recalled, the current bin number resets to zero.

### 3.4 TEST CONNECTIONS

In general, 4-wire measurements are made on the device under test using the front panel UNKNOWN BNC type terminals. A test fixture, such as the Model 3323 which connects directly to the front panel, or test cables can be used to make connections to the DUT.

The UNKNOWN terminals are described as follows:

G — Ground terminal for guard that can be used to shield the DUT.

L CUR — Current detection terminal

L POT — Voltage detection terminal (Low)

H POT — Voltage detection terminal (High)

H CUR — Drive signal output terminal. Delivers the DC bias and the sine wave signal.

When using individual cables, refer to Figure 3-5 and use the following rules to connect them:

1. Connect the voltage detection terminals (H POT and L POT) to the inner position on the DUT leads as shown in the illustration.
2. Keep cables as short as possible.
3. If using long cables, twist the two voltage cables together, then twist the two current cables together. Finally, twist the two separate cable pairs together to form one twisted cable assembly.
4. At the DUT, connect the shields of the BNC cables together.

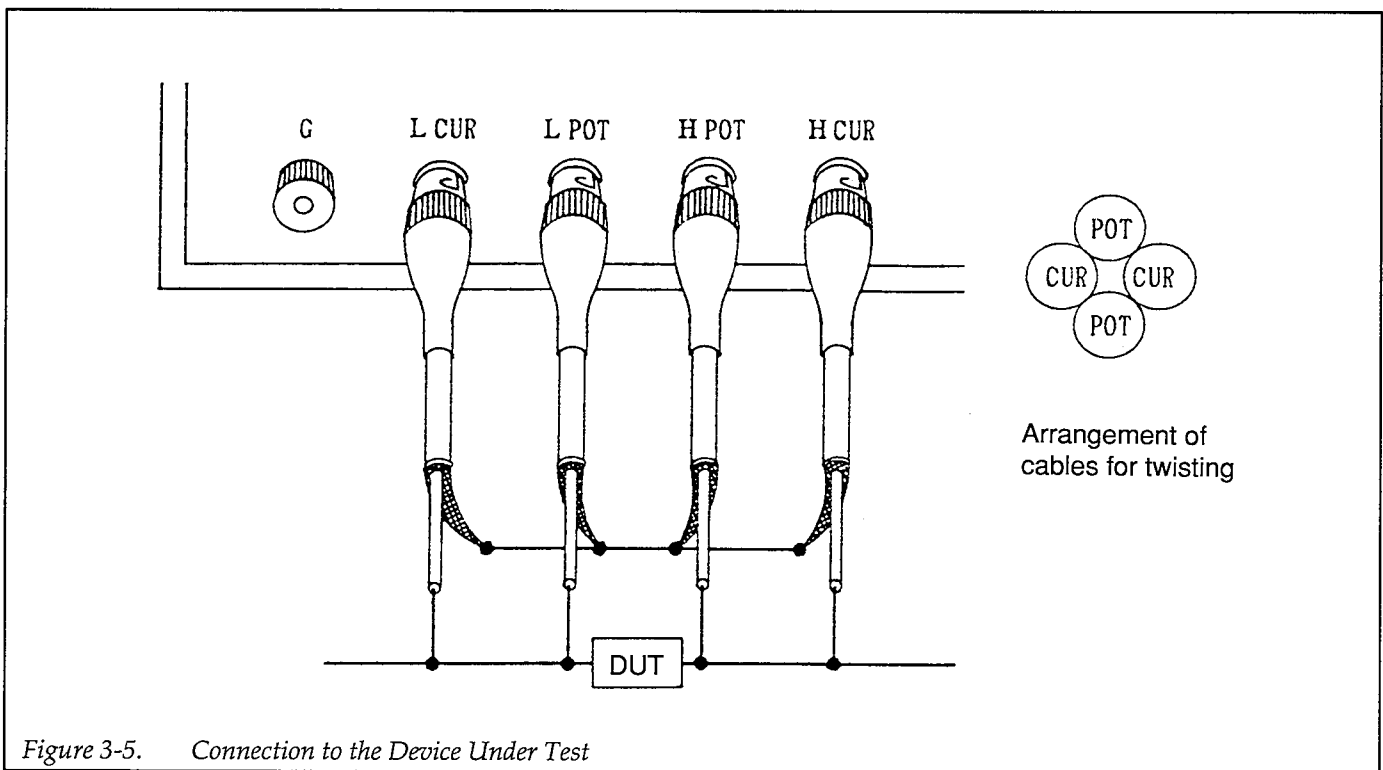

Figure 3-5. Connection to the Device Under Test

### 3.5 BASIC MEASUREMENTS

To achieve rated accuracy, zero correction must first be performed as explained in paragraph 3.15. In general, zero correction is performed by first opening the measurement terminals and pressing the OPEN key. After completion of the OPEN correction, the terminals are then shorted and the SHORT key is pressed.

#### 3.5.1 Measurement Function Selection

The basic measurement functions are selected using the **[A]** DISPLAY key. The selected function is denoted by the annunciators located to the left of the **[A]** DISPLAY. The measurement of the selected function is provided on the **[A]** DISPLAY. The exponent annunciators for the measured reading are located to the right of the **[A]** DISPLAY. Available functions include:

AUTO — Automatic function selection. With AUTO function selected, the instrument will determine the type of device connected to the input and automatically select the appropriate measurement function.

L (H) — Self-inductance (self-induction factor)

C (F) — Electrostatic capacity

R ( $\Omega$ ) — Resistance

|Z| ( $\Omega$ ) — Magnitude of impedance

To select the desired function, simply press and release the **[A]** DISPLAY key until the desired function annunciator is turned on.

Automatic Function Selection — When AUTO is enabled by the **[A]** DISPLAY key, the instrument selects the function, function parameter and equivalent circuit automatically. It does this by measuring the phase angle ( $\theta$ ) of the DUT connected at the input. Table 3-2 defines the selected function and function parameter that is based on the internally (not displayed) measured phase angle ( $\theta$ ):

While in AUTO function:

1. Function parameters are automatically selected. Pressing the **[B]** DISPLAY key will result in "Err 13".
2. The equivalent circuit (CKT) is automatically (AUTO) selected (SER or PAR).

3.  $\Delta$ ,  $\Delta\%$  and BIN are inoperative. Pressing the  $\Delta\Delta\%$  BIN key will result in "Err 13".

Table 3-2. AUTO Function Selections

Internally Measured Phase Angle ( $\theta$ )	Function	Function Parameter
$+90^\circ \pm 30^\circ$	L	Q
$0^\circ \pm 30^\circ$	R	Q
$-90^\circ \pm 30^\circ$	C	D
Other than the above	Z	$\theta$

#### 3.5.2 Measurement Function Parameter Selection

The measurement parameter for the selected function is selected using the **[B]** DISPLAY key. Note however, that if AUTO function is enabled, this key is inoperative (Err 13). In AUTO function, the measurement parameter is automatically selected.

The selected function parameter is denoted by the annunciator located to the left of the **[B]** DISPLAY. The **[B]** DISPLAY provides the reading of the selected parameter, while the exponent part of the reading is located to the right of the display. The available function parameters include:

Q — Quality factor

D — Dissipation factor ( $D = 1/Q$ )

ESR ( $\Omega$ ) — Equivalent series resistance

G (S) — Parallel conductance

X ( $\Omega$ ) — Series reactance

$\theta$  (deg) — Phase angle of impedance

To select the desired function parameter (AUTO off), simply press and release the **[B]** DISPLAY key until the appropriate function parameter annunciator turns on.

When ESR, X or G is selected, the equivalent series resistance, series reactance or parallel conductance is displayed, respectively. The readings for Q, D and  $\theta$  are not related to the equivalent circuit.

### 3.5.3 Equivalent Circuit Selection

The equivalent circuit is selected using the CKT key. Note that if AUTO function is enabled, the CKT key is inoperative (Err 13) and the equivalent circuit is placed in the AUTO mode.

The CKT annunciators on the front panel denote the selected equivalent circuit. The equivalent circuit (series or parallel as shown in Figure 3-6) affects the measured values of L, C and R on the **[A]** DISPLAY. The equivalent circuit selections include:

- AUTO — Automatic equivalent circuit selection
- SER — Series Circuit
- PAR — Parallel Circuit

To select the equivalent circuit (assuming AUTO function is disabled), simply press and release the CKT key until the desired annunciator(s) are turned on.

With AUTO CKT enabled, the instrument selects an equivalent circuit automatically. The selected circuit is determined according to the combination of selected function, function parameter, and phase angle. Table 3-3 summarizes the combinations that determine the equivalent circuit while AUTO CKT is enabled.

### 3.5.4 Measurement Range Selection

Measurement range selection for the selected function can be performed automatically or manually. Reading range for the function parameter (**[B]** DISPLAY) is always selected automatically. The following front panel keys are used for range selection:

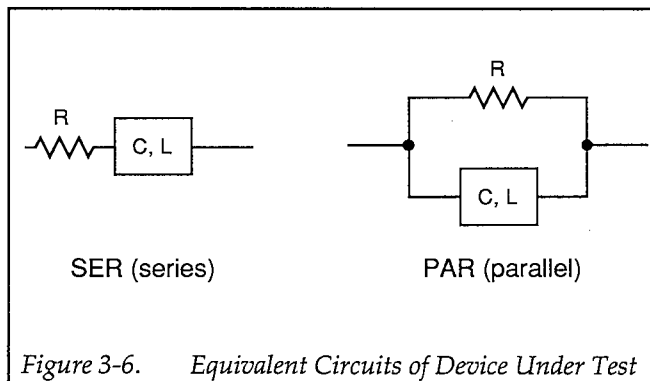

Figure 3-6. Equivalent Circuits of Device Under Test

AUTO — Each press of this key toggles between autorange (AUTO RANGE annunciator on) and manual range.

▼ — Pressing this key disables AUTO range (if enabled) and selects the next lower range.

▲ — Pressing this key disables AUTO range (if enabled) and selects the next higher range.

In AUTO range, the instrument will go to the optimum (most accurate) range to make the measurement. To enable autorange, simply press the AUTO key. The annunciator located adjacent to the AUTO key will turn on. To disable autorange, press AUTO a second time or press one of the manual range keys (▼ or ▲). The ▼ key down ranges while the ▲ key up ranges.

Table 3-4 lists the impedance ranges for the instrument. Notice that the valid measurement range is frequency and level dependent. The reading limits for each range are defined by the Lower Limit Extension and the Upper Limit Extension. The instrument will not display readings that fall outside of these limits. For example, trying to measure 100kΩ on Range 2 will cause the message "OF" to be displayed. The largest allowable reading for Range 2 is 11kΩ. Display messages that result from exceeding range limits include:

Table 3-3. AUTO Equivalent Circuit Selections

Conditions for selection of series mode (SER)		Conditions for selection of parallel mode (PAR)	
Function	Function Parameter	Function	Function Parameter
L, C, R,  Z	ESR, X	L, C, R,  Z	G
L, C, ( Z  ≤ 1kΩ)	Q, D, θ	L, C, ( Z  > 1kΩ)	Q, D, θ
R (θ ≥ 0)	Q, D, θ	R (θ < 0)	Q, D, θ
Z	Q, D, θ		



OF — The measured value is greater than the Upper Limit Extension value.

UF — The measured value is less than the Lower Limit Extension value.

OU — The measured value is out of the operating range of the measurement circuitry.

The optimum measurement is performed on the range that is bounded by the Lower Limit and Upper Limit (see Table 3-4). For example, for a 10kΩ measurement, the most accurate reading will occur on Range 3. In AUTO range, the instrument will automatically measure 10kΩ on Range 3.

When in AUTO range, sufficient noise may prevent the instrument from staying on the optimum range. In this situation, disable AUTO range while on the optimum range. Automatic range changes will not occur when in manual ranging.

Hysteresis — For AUTO ranging, a hysteresis of approximately 10% is used to keep the instrument from changing ranges for a reading that varies along the borderline of two ranges. When a reading is increasing, the instrument will up range immediately after 19,999 counts. For example, on Range 2, assume a reading of 1.9999kΩ. If the reading increases by one count, the instrument up ranges and reads 2.000 kΩ on Range 3. When the reading is decreasing, the instrument will down range after 1800 counts. Continuing with the same example, a decreasing reading will read 1.800 kΩ on Range 3. When the reading decreases one more count, the instrument will down range to Range 2 and read 1.7999 kΩ. Thus, a window of 200 counts is provided for reading variances.

**Measurement Capabilities**

The measurement capability of each function and function parameter is summarized as follows:

**|Z|, R, ESR, X**

Type:	Exponent representation
Resolution:	4 1/2 digits (19999 digits max); Minimum reading = 0.1mΩ
Range:	0.0mΩ, ±(0.1mΩ to 19.999MΩ)

**C**

Type:	Exponent representation
Resolution:	4 1/2 digits (19999 max)
Range:	0.000pF, ±(0.001pF to 199.99mF)
The range of  C  changes according to frequency:	
120Hz	: 0.000nF to 199.99mF
1kHz	: 0.0pF to 19.999mF
10kHz	: 0.00pF to 1.999mF
100kHz	: 0.000pF to 199.99μF

**L**

Type:	Exponent representation
Resolution:	4 1/2 digits (19999 max)
Range:	0.0nH, ±(0.1nH to 19.999kH)
The range of  L  changes according to frequency:	
120Hz	: 0.0μH to 19.999kH
1kHz	: 0.00μH to 1.9999kH
10kHz	: 0.000μH to 199.99H
100kHz	: 0.0nH to 19.999H

**G**

Type:	Floating-point representation
Range:	0.000μS, ±(0.001μS to 199.99S); Equivalent to 1GΩ to 5mΩ
Resolution:	4 1/2 digits (19999 max)

**Q, D**

Type:	Floating-point representation
Resolution:	4 1/2 digits (19999 max)
Range:	.0000, ±(.0001 to 19999)

**θ**

Type:	Fixed-point representation
Resolution:	0.01°
Range:	-180.00° to +179.99°

**Deviation** Range information for deviation is covered in paragraph 3.6.3.

**Calculating Admittance and Susceptance**

$$\theta_y = -\theta$$

$$B = |Y| \cdot \sin \theta_y = -X / (R_s^2 + X^2)$$

Admittance Y (|Y| and  $\theta_y$ ) and susceptance B are not displayed by the instrument, but can be calculated as follows:

$$|Y| = 1 / |Z|$$

where;  $R_s$  is the value of R (=ESR) for the series equivalent circuit (SER).

**Table 3-4. Impedance Ranges**

Level	Frequency	Range	Reference Resistance ( $\Omega$ )	Measurement Range ( $\Omega$ )			
				Lower Limit Extension	Lower Limit **	Upper Limit ***	Upper Limit Extension
1V	100Hz : : 10kHz	*1	100	—	0	5	11
		2	100	0.9	5	2 k	11 k
		3	1 k	980	2 k	20 k	110 k
		4	10 k	9.8 k	20 k	200 k	1.1M
		5	50 k	49 k	200 k	2M	5.5M
		*6	50 k	450 k	2M	20M	$\infty$
	20kHz 50kHz 100kHz	*1	100	—	0	5	11
		2	100	0.9	5	2 k	11 k
		3	1 k	980	2 k	20 k	110 k
		4	10 k	9.8 k	20 k	200 k	1.1M
		*5	10 k	90 k	200 k	2M	$\infty$
		*6	10 k	90 k	200 k	2M	$\infty$
50mV	100Hz : : 10kHz	*1	100	—	0	5	11
		2	100	0.9	5	2 k	11 k
		3	1 k	900	2 k	20 k	110 k
		4	10 k	9 k	20 k	200 k	1.1M
		5	50 k	45 k	200 k	2M	5.5M
		*6	50 k	450 k	2M	20M	$\infty$
	20kHz 50kHz 100kHz	*1	100	—	0	5	11
		2	100	0.9	5	2 k	11 k
		3	1 k	900	2 k	20 k	110 k
		4	10 k	9 k	20 k	200 k	1.1M
		*5	10 k	90 k	200 k	2M	$\infty$
		*6	10 k	90 k	200 k	2M	$\infty$

\*Extension range

\*\*Lower limit values are inclusive.

\*\*\*Upper limit values are not inclusive.

### 3.6 DEVIATION ( $\Delta$ , $\Delta\%$ )

The deviation ( $\Delta$ ) and % deviation ( $\Delta\%$ ) of a function with respect to a reference value can be displayed. Note that deviation of a function parameter cannot be performed.

$$\Delta = \text{Measured value} - \text{Reference value}$$

$$\Delta \% = (\Delta / \text{Reference value}) \times 100$$

Paragraph 3.6.1 explains how to set a reference value, and paragraph 3.6.2 explains how to display deviation.

#### 3.6.1 Setting a Reference Value

SET UP REF is used to set a reference value for deviation measurements.

Reference Range:  $\pm(0.0001\text{p to }19999\text{M})$

Perform the following steps to set a reference value for deviation measurements:

1. Press the SET UP key. The **[A]** DISPLAY will blank and the blue labeled FREQ (Hz) annunciator will blink on and off.
2. Press and release the NEXT key until the REF (blue label) annunciator blinks on and off. The current reference value will be displayed on the **[B]** DISPLAY. If the current reference value is to be retained, exit from this mode by pressing ENTER/EXIT. Otherwise, proceed to the next step.
3. Key in the desired reference value using the numeric entry keys and exponent keys (if necessary). For example, a 1k $\Omega$  reference value can be keyed in by pressing the "1", "0", "0", "0" keys in that order, or by pressing the "1", "EXP", "k" keys in that order.
4. With the desired reference value displayed, press ENTER.

Note: The instrument is still in the REFERENCE SET UP mode. If you entered an incorrect reference value, simply key in the correct value and press ENTER.

5. With the desired reference value displayed, again press ENTER. The instrument will return to the normal measurement state.

#### 3.6.2 Displaying Deviation

With an appropriate reference value established (see previous paragraph), deviation ( $\Delta$  or  $\Delta\%$ ) can be displayed. The procedures in this paragraph assume that the instrument is appropriately configured to measure a DUT.

In general, deviation ( $\Delta$  or  $\Delta\%$ ) is displayed with the use of the  $\Delta\Delta\%$ BIN key. This key simply selects  $\Delta$ ,  $\Delta\%$ , BIN or a deviation/BIN combination ( $\Delta$ BIN or  $\Delta\%$ BIN).

Perform the following steps to display deviation:

1. Deviation cannot be displayed with the instrument in AUTO function. If AUTO function is enabled, use the **[A]** DISPLAY key to disable it and select the appropriate function.
2. Perform one of the following steps (A or B):
  - A.  $\Delta$  Deviation — Press and release the  $\Delta\Delta\%$ BIN key until the  $\Delta$  annunciator turns on, and the % and BIN annunciators turn off. Deviation ( $\Delta$ ) is displayed on the **[A]** DISPLAY.
  - B.  $\Delta\%$  Deviation — Press and release the  $\Delta\Delta\%$ BIN key until the  $\Delta$  and % annunciators turn on, and the BIN annunciator turns off. Deviation ( $\Delta$ ) is displayed on the **[A]** DISPLAY.

Note: Deviation can be used with the Comparator (BIN) and is explained in paragraph 3.7.3.

#### 3.6.3 Deviation Measurement Range

The measurement capabilities for deviation are summarized as follows:

$\Delta$	
Type:	Exponent representation
Display Range:	$\pm 19999$ counts

Notes:

1. When the reference value is zero, the  $\Delta$  value is the same as the measured value.
2. If the displayed measured value is "OF", "UF" or "OU", then the  $\Delta$  reading is also "OF", "UF", or "OU".

$\Delta\%$ 

Type:	Fixed point representation
Display Range:	-199.99% to +199.99%; Resolution: 0.01% (When exceeding this range, "OF" is displayed)

## Notes:

1. When the reference value is zero, the displayed  $\Delta\%$  value is "OF".
2. If the displayed measured value is "OF", "UF" or "OU", then the  $\Delta\%$  reading is also "OF", "UF", or "OU".

### 3.7 COMPARATOR (BIN)

The Comparator allows DUTs to be compared to defined reading limits and classified into one of up to 20 categories (bins). Upper and lower limits can be set for the 20 bins and are designated as Bins 0 through 19.

Bins 1 through 19 are used for comparing and categorizing the readings of measurement functions (L, C, R or Z). For example, if a resistor measures 900 $\Omega$ , it will be assigned to the first bin (starting with bin 1) whose limits will accommodate the value 900. If there are no bins that are defined to accommodate the 900 $\Omega$  reading, the resistor will be assigned to Bin 0.

When enabled with valid limits, Bin 0 becomes a special case bin that first compares the reading of the function parameter (Q, D, ESR, G, X or 0). If the reading of the function parameter is not within the defined limits, it is considered a failed part and is assigned to Bin 0. If however, the reading of the function parameter passes, then the reading of the basic measurement function is compared, and the part is assigned to the appropriate bin as previously explained.

#### 3.7.1 Defining Comparator Limits

The following procedure explains how to define limits for the 20 bins. The values of the limits that you choose will depend on the type of comparison that is to be performed. Basic measurement readings can be compared, or deviation measurement readings can be compared. Details for comparing deviation readings are contained in paragraph 3.7.3.

Perform the following steps to define comparator limits:

1. Select BIN.  
Press and release the SETUP key until the blue-labeled BIN annunciator blinks on and off. The last defined bin will be displayed on the **[B]** DISPLAY. Upon power-up, Bin 0 will be displayed when BIN is selected, and upper and lower limits of all bins will be set to zero.
2. Select Bin 0.  
Press the 0 key ("0" will blink on and off) and press ENTER.
3. Define limits for Bin 0  
If you do not wish to evaluate the function parameter measurement, the lower limit of Bin 0 must be equal to or less than the upper limit (Lower Limit  $\leq$  Upper Limit). For example, to disable evaluation of the function parameter, simply set both upper and lower limits to zero.
  - A. With Bin 0 displayed, press the NEXT key. The LOWER annunciator will blink on and off, and the current lower and upper limits of Bin 0 will be displayed (lower limit on the **[A]** DISPLAY and upper limit on the **[B]** DISPLAY).
  - B. To change the lower limit, perform step a. To retain the displayed lower limit, perform step b.
    - a. Change Limit — Key in the new value using the data entry keys (see paragraph 3.8) and press ENTER. The UPPER annunciator will blink on and off.
    - b. Retain Limit — Press the NEXT key. The UPPER annunciator will blink on and off.
  - C. To change the upper limit, key in the new value and press ENTER.

Note: If there are not going to be any changes to other bins already defined, press EXIT to return to the normal measurement state.
4. Define limits for Bins 1 through 19
  - A. With the limits for Bin 0 still displayed, press NEXT. The BIN annunciator blinks on and off and Bin 1 will be displayed on the **[B]** DISPLAY.
  - B. Press NEXT. The LOWER annunciator will blink on and off and the upper and lower limits of Bin 1 will be displayed.
  - C. To change the lower limit, perform step a. To retain the displayed lower limit, perform step b.
    - a. Change Limit — Key in the new value using the data entry keys (see paragraph 3.8) and press ENTER. The UPPER annunciator will blink on and off.
    - b. Retain Limit — Press the NEXT key. The UPPER annunciator will blink on and off.
  - D. To change the upper limit, key in the new value and press ENTER.

- E. Press NEXT to proceed to the next bin and define the limits as explained in steps B, C and D.
- F. Repeat the basic procedure in steps B through E for as many bins (up to Bin 19) as needed.
- G. After defining the last bin, press EXIT to return to the normal measurement state.

Note: When a bin is closed (Lower Limit  $\geq$  Upper Limit), that bin and all subsequent bins are effectively removed from the test system. For example, for a 5 bin test system, Bins 1 through 5 are defined with valid limits (Lower Limit < Upper Limit). Bin 6 is closed by making the lower limit equal to or greater than the upper limit. For this test system, bins 6 through 19 are not used. All parts will be sorted to bins 0 through 5.

### 5. Check Bin Limits

After defining limits for all the needed bins, it is a good idea to scan through the bins to check for mistakes and make necessary corrections.

To check limits, press and release SETUP until the front panel BIN annunciator blinks on and off. The last defined bin will be displayed. To start at Bin 0, key in 0 and press ENTER. At this point, simply press and release the NEXT key to scroll through the bins. The PREV key can also be used to scroll through the bins. Note that after scrolling past Bin 19 (using NEXT) or past Bin 0 (using PREV), the instrument will automatically return to the normal measurement state. You can return to the normal measurement state at any time by pressing EXIT.

A displayed lower limit can be changed by keying in a new lower limit while the LOWER annunciator is blinking on and off, and pressing ENTER. Conversely, a new upper limit can be entered with the UPPER annunciator blinking.

## 3.7.2 Basic Comparator Operation

- 1. Configure instrument for DUT measurement  
Configure the instrument to measure the device type that you wish to compare and assign to bins. The Compare (BIN) feature cannot be used with AUTO function enabled. If AUTO function is enabled, use the **[A]** DISPLAY key to disable it and manually select the appropriate measurement function.
- 2. Define comparator limits  
Define the limits of the comparator bins as explained in paragraph 3.7.1.

- 3. Select the BIN function  
Press and release the  $\Delta\Delta\%$ BIN key until the BIN display annunciator turns on. Note that this key also controls the deviation selections ( $\Delta$  and  $\Delta\%$ ), so unless you are comparing deviation readings make sure they are not enabled.

If comparing deviation readings, use the  $\Delta\Delta\%$ BIN key to select either  $\Delta$ BIN or  $\Delta\Delta\%$ BIN. See paragraph 3.7.2 for information on comparing deviation readings.

- 4. Test DUT

Connect the DUT to the input of the instrument. Instead of displaying the measured reading of the DUT, the bin number that the device is assigned to is displayed on the **[A]** DISPLAY.

If Bin 0 is open (Lower Limit < Upper Limit), the function parameter (Q, D, ESR, G, X or 0) will first be tested. If the part is not within the defined limits of Bin 0, it will be assigned to Bin 0. If the part is within the limits, then the function measurement (L, C, R or Z) is compared and assigned to the appropriate bin. If there are no bins that will accommodate the measured reading, then the part will be assigned to Bin 0.

When the displayed value for any part is "OF", "UF" or "OU", that part is assigned to Bin 0.

## 3.7.3 Comparing Deviation Readings

The instrument can be configured to use Bins 1 through 19 to compare deviation ( $\Delta$  or  $\Delta\%$ ) readings. In general, deviation readings are the result of subtracting the measured value from a defined reference value. The difference ( $\Delta$ ) or the percentage of the difference ( $\Delta\%$ ) becomes the deviation value. Detailed information on deviation is contained in paragraph 3.6.

When comparing deviation values, make sure the limits for the bins reflect the appropriate deviation readings. For example, assume that you wish to compare devices that have a nominal value of  $1k\Omega$ . For this comparison, a reference value of  $1k\Omega$  would be established. If you wish to assign devices that are within  $\pm 1\%$  ( $\pm 10\Omega$ ) tolerance to Bin 1, you would set the Lower Limit of Bin 1 to  $-1.000$  (for  $\Delta\%$ ) or  $-10.00$  (for  $\Delta$ ), and the Upper Limit to  $1.000$  (for  $\Delta\%$ ) or  $10.00$  (for  $\Delta$ ).

Comparisons begin at the lowest numbered bin. The tested device will be assigned to the first bin whose limits will accommodate the device reading. For this reason, deviation limits must be in an ascending order starting

with the lowest bin. For example, assume that you wish to sort devices into one of the following three categories;  $\pm 1\%$  tolerance,  $\pm 10\%$  tolerance and  $\pm 25\%$  tolerance. The correct way to do this is to define Bin 1 for the 1% limits, Bin 2 for the 10% limits and Bin 3 for the 25% limits. If instead, you defined Bin 1 for the 10% limits and Bin 2 for the 1% limits, devices that have  $\pm 1\%$  tolerance will be assigned to Bin 1 since it is within the defined limits.

After defining comparator limits, and a deviation reference value, deviation comparisons are performed by selecting  $\Delta$ BIN or BIN $\Delta\%$  as explained in step 3 of paragraph 3.7.2.

### 3.8 SET UP

This section explains how to use SET UP to select and set up parameters that are labeled in blue on the front panel. The SET UP parameter selections include:

**FREQ** — Use to select an auxiliary measurement frequency

**DELAY** — Use to get the delay between a manual trigger and the start of the measurement.

**REF** — Use to define a reference value for deviation measurements

**BIN, LOWER, UPPER** — Use to define the upper and lower limits of bins for the comparator.

**GPIB** — Use to set the primary address of the GPIB bus.

To enable SET UP, press the SET UP key. The annunciator next to the key will turn on. The current value of the selected parameter is displayed. Each press of the NEXT key enables the next SETUP parameter and displays its value. In general, selections using the NEXT key move from right-to-left. The PREV key operates in a similar manner except that selections move from left-to-right.

The SETUP mode can be exited by pressing the EXIT key. The instrument will return to the normal measurement state.

#### Data Entry

When using the SET UP mode, numeric values for the selected operation are entered using the data entry keys. The data entry keys include the blue labeled number keys ("0" – "9", ".", "-", and "CE"), and the green labeled exponent keys ("EXP", "u", "M", "n", "k", "p" and "m").

Use the following general rules to enter data for SET UP:

1. Once SET UP is enabled (SET UP annunciator on), the blue labeled data entry keys become functional.
2. Each display has a value range from .0001 to 19999. A value in this range can be keyed in using the number keys (0 – 9), decimal point (.) and polarity sign (-). The - key toggles between minus (-) polarity and plus (+) polarity, which is implied by the absence of the minus sign (-).
3. The exponent part of the value is selected with the EXP key. When the EXP key is pressed, all the exponent annunciators turn on to denote that the green exponent keys (u, M, n, k, p and m) are functional. Exponent is selected simply by pressing the desired exponent key. The annunciator that corresponds to the selected exponent will remain lit. All others will turn off. Exponent symbols are defined as follows:

p = pico =  $10^{-12}$   
 n = nano =  $10^{-9}$   
 u = micro =  $10^{-6}$   
 m = milli =  $10^{-3}$   
 k = kilo =  $10^3$   
 M = Mega =  $10^6$

Note: The instrument will automatically adjust the exponent in order to allow the largest possible mantissa to be displayed. For example, if you enter 0.001M, the instrument will display 1.0000k.

4. Once a number is keyed in, the blinking digit will denote that the displayed value is pending until it is entered. A pending value can be canceled by pressing the CE key. This cancel entry key will cancel the pending value and display the previously defined value.
5. A pending value is entered by pressing the ENTER key.

#### 3.8.1 FREQ (Hz)

The four most used measurement frequencies (120Hz, 1kHz, 10kHz and 100kHz) are usually selected using the FREQ key as explained in paragraph 3.10. FREQ allows any of the additional measurement frequencies to be selected. The 11 frequencies that can be selected include:

100Hz, 120Hz, 200Hz, 500Hz, 1kHz, 2kHz, 10kHz, 20kHz, 50kHz, 100kHz

Perform the following steps to select one of the above frequencies:

1. Use the SET UP key to enable **FREQ** (Hz). The currently selected frequency will be displayed on the **[B]** DISPLAY. To retain this setting, simply press **EXIT** to return to the normal measurement state.
2. To select an alternate frequency, key in the frequency using the data entry keys (see paragraph 3.8 for details) and press **ENTER**.
3. To exit from **SETUP**, press **EXIT**.

Notes:

1. Entering an invalid frequency will result in "Err 12". To clear the error message, press any front panel key.
2. When one of the auxiliary frequencies is selected, all the **FREQ** annunciators will be off when the instrument is in the normal measurement state.

### 3.8.2 DELAY

Trigger delay time is the time delay between a manual trigger and when the measurement starts. Using an appropriate delay period allows the instrument and the device to stabilize before a measurement is taken. A defined delay period is only implemented when in manual trigger (**MAN TRIG**). For continuous trigger (**AUTO TRIG**), the delay is disabled (0 sec).

Range: 0.00 to 199.99[s], Resolution 0.01s

Perform the following steps to set a trigger delay time:

1. Use the SET UP key to enable **DELAY**. The currently selected delay period will be displayed on the **[B]** DISPLAY. To retain this setting, simply press **EXIT** to return to the normal measurement state.
2. To set a different delay period, key in the delay using the data entry keys (see paragraph 3.8 for details) and press **ENTER**.
3. To exit from **SETUP**, press **EXIT**.

Note: The lowest delay period that can be set is 10msec.

### 3.8.3 REF

A reference value from  $\pm(0.0001p$  to  $19999M)$  can be established for deviation measurements. In general, a reference value is established by selecting **REF** with the **SET**

**UP** key, and then entering a valid reference value. Details for establishing a reference value is contained in paragraph 3.6.1.

### 3.8.4 BIN, LOWER, UPPER

**BIN**, **LOWER** and **UPPER** are used to set the upper and lower limits for the bins of the comparator. In general, **BIN** is used to select the bin number, **LOWER** is used to enter the lower limit value, and **UPPER** is used to enter the upper limit value. Complete details on using the comparator are contained in paragraph 3.7.

### 3.8.5 GPIB

**GPIB** is used to set the **GPIB** primary address and the delimiter (terminator). The **GPIB** address can be set from 0 to 30. The delimiter can be set to 0, which is carriage return, line feed (<**CR**> <**LF**>) or to 1, which is carriage return (<**CR**>) only.

The displayed address and delimiter values are separated by a decimal point on the **[B]** DISPLAY. For example, a **GPIB** address of 2 and a <**CR**> <**LF**> delimiter is displayed as follows:

2.0

Perform the following steps to set the **GPIB** address and delimiter:

1. Use the SET UP key to enable **GPIB**. The currently selected **GPIB** address and delimiter value will be displayed on the **[B]** DISPLAY. To retain these settings, simply press **EXIT** to return to the normal measurement state.
2. To set a different address and/or delimiter, key in the valid values using the data entry keys and press **ENTER**. Make sure to separate the two values with a decimal point. If only the **GPIB** address is entered, the delimiter will automatically default to 0 (<**CR**> <**LF**>).
3. To exit from **SETUP**, press **EXIT**.

Note: The **GPIB** address and delimiter are stored in battery backed-up memory and are not lost when power is cycled.

### 3.9 SAVING MEASUREMENT CONFIGURATIONS

Up to 10 measurement configurations can be saved in internal memory. The memory is battery backed-up so that set-up data is not lost after power is cycled.

The 10 memories are designated as Memories 0 through 9. Setup configurations can be saved in and recalled from Memories 1 through 9 at the user's discretion. Memory 0 is a special case where configuration save is not controlled by the user. Upon power-down, the current instrument configuration is stored in Memory 0. When the unit is again turned on, the instrument goes to the power-up default conditions (see Table 3-1). However, the last setup configuration (upon power-down) can be restored by selecting Memory 0. Of course, any other configurations stored in Memories 1 through 9 can instead be restored.

The following operating states are saved in memory:

- A** DISPLAY: Function (L, C, R, Z)
- B** DISPLAY: Function parameter (Q, D, ESR, G, X,  $\theta$ )
- $\Delta\Delta\%$ BIN: Deviation and comparator (BIN) bin as signment
- FREQ: Measurement frequency
- CKT: Equivalent circuit mode
- SPEED: Measurement speed
- LEVEL: Measurement signal level
- RANGE: Range
- TRIG: Trigger mode
- DELAY: Trigger delay time
- REF: Reference value for deviation
- LOWER/UPPER: Lower and upper limits for comparator (BIN)

The GPIB address and delimiter are also backed-up by battery and not lost after power-down. However, these values are not stored in any of the 10 sets of memory. They are controlled by SETUP GPIB (see paragraph 3.8.5).

#### Saving and Recalling a Setup Configuration

Perform the following steps to save the current setup configuration in one of the nine available memories:

1. Press the (-STO) key. The annunciator next to that key will turn on and "0" will be displayed on the **B** DISPLAY.
2. Press the - (sign) key. The "0" will blink on and off.
3. Key in the number (1 through 9) of the memory that you wish to store the configuration, and press Enter.

After pressing enter the setup configuration will be stored in the selected memory designation and the instrument will return to the normal measurement state.

Perform the following steps to recall a setup configuration from one of the 10 available memories:

1. Press the RCL key. The annunciator next to that key will turn on and "0" will be displayed on the **B** DISPLAY.
2. Key in the number (0 through 9) of the memory that contains the setup configuration that you wish to recall and press ENTER.

After pressing ENTER, the instrument will return to the configuration that is defined by the selected memory.

Notes:

1. With a memory designation number displayed, the polarity sign can be changed as needed. If plus (- sign not displayed), the setup will be recalled. Conversely, if minus (-), the setup will be stored.
2. An incorrect value can be cleared with the CE key.
3. If a "0" that is not blinking is entered, the recall operation will not be performed.

### 3.10 FREQUENCY SELECTION

The impedance of a device under test changes with frequency. Therefore, it is advisable to measure the device with its operating frequency.

Use the following guidelines to select a measurement frequency:

- 100Hz and 120Hz: Use to measure large values of C
- 1kHz: Use to measure intermediate values of R, L and C
- 10kHz to 100kHz: Use to measure small values of L and C



To select one of the four measurement frequencies labeled on the front panel (120Hz, 1kHz, 10kHz, 100kHz), press and release the **FREQ** key until the desired frequency is selected. The selected frequency is denoted by the enabled annunciator.

If all the **FREQ** annunciators are off, than an alternate frequency is selected. To check the frequency value or to select one of the alternate frequencies (100Hz, 200Hz, 500Hz, 2kHz, 5kHz, 20kHz, or 50kHz), use **SET UP FREQ** as explained in paragraph 3.8.1.

Using the **FREQ** key to select a frequency will cancel any alternate frequency previously established using **SET UP FREQ**.

### **3.11 SPEED SELECTION**

Measurement speed is the time that it takes the instrument to process a single measurement. There are three measurement speeds that can be selected; **FAST**, **MED**, or **SLOW**.

At a frequency of 1kHz, and assuming range changes do not occur, the following approximate measurement times apply:

**FAST**: 64ms (Note that accuracy is lowered.)

**MED**: 150ms

**SLOW**: 480ms (Use this mode when a measured value is dispersed and it is hard to read.)

At **FAST** speed, accuracy is lowered. Use **SLOW** speed when the measured reading is noisy and hard to read.

The current measurement speed is denoted by the front panel **SPEED** annunciator that is enabled. To select one of the other speeds, press and release the **SPEED** key until the desired speed is selected.

Note: Measurement time changes according to frequency and range. When on an extension measurement range (see paragraph 3.5.4), the measurement time doubles.

### **3.12 SIGNAL LEVEL SELECTION**

The instrument measures devices by applying an rms signal (at the selected frequency) and then measuring the subsequent current. The signal levels that can be selected are 50mV rms and 1V rms.

The 1V signal level can be used for most measurements. For semiconductors that have non-linear characteristics that are affected by signal magnitude, use the 50mV level.

The front panel **LEVEL** annunciator denotes the current signal level. To select the alternate level, simple press the **LEVEL** key once.

The specified signal levels are maintained for devices that have an impedance of 1k $\Omega$  or more. At lower impedances, loading lowers the level of selected signal.

Note: After a signal level is selected, the displays will blank until the next measurement is completed.

### **3.13 TRIGGER**

A trigger is a stimulus that will start a measurement conversion. The instrument can be set for automatic triggering (**AUTO TRIG**) or manual triggering (**MAN TRIG**). Also, a delay time between triggers can be set.

#### **3.13.1 Trigger Selection**

In the automatic (**AUTO**) trigger mode, readings are triggered and measured continuously. The display is constantly refreshed with readings at a rate that is determined by the selected measurement speed (**SPEED**).

In the manual (**MAN**) trigger mode, a trigger will only occur when the front panel **MAN TRIG** key is pressed. Each press of this key will cause one reading to be measured and displayed after the trigger delay period elapses (see paragraph 3.13.2). The advantages of the manual trigger are as follows:

- Retain the measured value on the display
- After connecting a device for sorting (Comparator), you can allow the test system time to stabilize before triggering a reading.

On power-up, AUTO trigger is enabled and is denoted by the annunciator next to the AUTO TRIG key. Note that the BUSY annunciator is also enabled and blinks at the measurement conversion rate. The AUTO TRIG key toggles the instrument between automatic triggering and manual triggering. When AUTO TRIG is disabled, the BUSY annunciator turns off, and the last processed readings are retained on the display.

Automatic triggering can also be disabled by pressing the MAN TRIG key. The first press of this key disables AUTO TRIG and triggers a reading after allowing the trigger delay period to elapse. Each subsequent press of this key will trigger one reading after waiting the trigger delay period.

### 3.13.2 Trigger Delay

In the manual (MAN) trigger mode, a trigger delay period from 0 to 199.9 seconds can be set. When the MAN TRIG key is pressed, the trigger delay period will elapse before the reading occurs. A delay period is useful to allow a device to stabilize before measuring it. It is particularly useful when sorting parts using the comparator. A proper delay period will allow an applied bias voltage to settle before the comparison is performed.

In AUTO TRIG, the trigger delay is disabled (0s).

The delay period is set using SET UP and is explained in detail in paragraph 3.8.2. In general, trigger delay is set by pressing SET UP until DELAY is enabled, the time period is keyed in, and ENTER is pressed.

Note: When a manual trigger occurs, the BUSY annunciator will turn on and remain on until the measurement is completed. When the BUSY annunciator turns off, it indicates to the operator that the test on the device is completed and can be removed.

### 3.14 DC BIAS

When measuring capacitance (C), a DC bias can be applied. This bias allows capacitance changes in semiconductor junctions due to applied voltage to be measured.

The instrument has a built in 2V bias that can be used, or an external bias voltage from 0 to +35V can be applied via

a BNC connector on the rear panel. The bias voltage (and drive signal) can be monitored on the H CUR terminal.

DC bias cannot be used to measure L, R or Z. Pressing the BIAS key while in one of these functions will result in "Err 14".

**Bias Stabilization Time** — When bias is abruptly changed by turning BIAS on to its peak value, some time is required to allow the bias voltage to stabilize before an accurate capacitance measurement can be made. Use the following equation to determine the time required to achieve stability:

$$\text{Stabilization time (in seconds)} = 4 + 0.015C$$

where; C is the capacitance in  $\mu\text{F}$

Perform the following steps use DC bias:

1. If using an external supply, connect it to the BIAS EXT IN BNC connector on the rear panel. Make sure the supply is in standby and is set for 0V.

#### CAUTION

**To prevent damage to the instrument, do not apply voltage that is not within the 0V to +35V range. Also, adhere to the precautions and considerations explained after this procedure.**

2. Set the rear panel BIAS switch. If using the internal supply, set the toggle switch to the INT 2V position. If using an external bias supply, set the toggle switch to the EXT position.
3. Using the **A** DISPLAY key, select the C function. Note that AUTO function must be disabled. DC bias cannot be enabled in AUTO function.
4. Connect the device to be measured.

#### CAUTION

**When checking a polarized device, make sure to observe polarity. Also, make sure to discharge capacitors before connecting them to the input.**

5. Enable DC bias by pressing the BIAS key. When BIAS is enabled, its annunciator will turn on. Note that if a different function is selected, BIAS will disable.

6. If using an external bias source, increase the bias source gradually from zero to the desired level.
7. The capacitance reading using a DC bias will be displayed.
8. If using an external bias source, gradually decrease the level to 0V.
9. Disconnect the device.

#### External Bias Supply Precautions and Considerations:

1. Ripple and Noise — The power supply must have low ripple and noise (<1mV rms). It is recommended that a switching type power supply not be used. If ripple and noise are large, measurement accuracy is lowered.
2. Measuring Large Capacitors with High Voltage — When measuring more than 100μF using a bias of more than 10V, connect the capacitor to the input with the bias supply set to 0V, and then increase the voltage gradually. After completing the measurement, decrease the voltage gradually to 0V and then disconnect the device.
3. Voltage Regulation — For a bias voltage of 10V or more, the voltage level must be changed at a slow rate of speed (<10V/sec). Otherwise, the EXT 0.1A protection fuse (accessed from the rear panel) will blow.

### 3.15 ZERO CORRECTION

Zero correction is performed to cancel the effects of residual impedance and stray admittance caused by test fixtures and test cables.

#### 3.15.1 Zero Correction Procedures

##### OPEN — Stray Admittance Measurement:

Perform the following steps to perform the OPEN correction procedure:

1. Open the measurement terminals as shown in Figure 3-7.
2. Press the OPEN key. The instrument measures the stray admittances for all frequencies, and stores the values in memory. On the **[A]** DISPLAY, the message "OP 23" will be displayed. During the execution of the correction, the display will count down to "OP

0" which signals the end of the correction procedure. The instrument will then return to the normal measurement state using the corrected values to calculate readings. Note that during the execution of the correction procedure, stray capacitance readings will be displayed on the **[B]** DISPLAY.

#### NOTE

For the OPEN correction, make sure L CUR is connected to L POT, and H POT is connected to H CUR as shown in Figure 3-7.

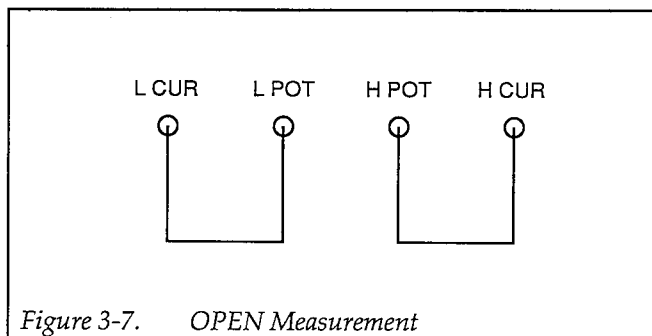

Figure 3-7. OPEN Measurement

##### SHORT — Residual Impedance Measurement:

Perform the following steps to perform the SHORT correction procedure:

1. Short the measurement terminals as shown in Figure 3-8.
2. Press the OPEN key. The instrument measures the stray admittances for all frequencies, and stores the values in memory. On the **[A]** DISPLAY, the message "OP 9" will be displayed. During the execution of the correction, the display will count down to "OP 0", which signals the end of the correction procedure. The instrument will then return to the normal measurement state using the corrected values to calculate readings. Note that during the execution of the correction procedure, stray capacitance readings will be displayed on the **[B]** DISPLAY.

#### NOTE

For the SHORT correction, make sure L CUR, L POT, H POT and H CUR are all connected together as shown in Figure 3-8.

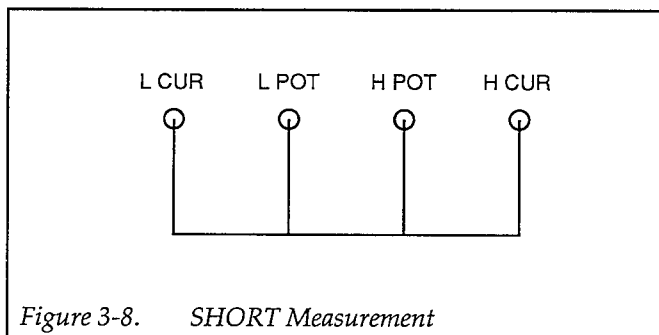

Figure 3-8. SHORT Measurement

### 3.15.2 Equivalent Circuits of Measurement System

If the correction values obtained and stored in memory are represented by measurement circuits shown Figure 3-9 use the following equation to calculate the true impedance:

$$Z_x = 1 / (Y_m - Y_{pp}) - Z_{ss}$$

### 3.15.3 Correctable Range

$|Z_{ss}| < \text{approx. } 3\Omega$  ( $R_{ss} < \text{approx. } 3\Omega$ ,  $L_{ss} < \text{approx. } 5\mu\text{H}$  at 100kHz)

$|Y_{pp}| < \text{approx. } 10\mu\text{s}$  ( $R_{pp} = 1/G_{pp} > \text{approx. } 100\text{k}\Omega$ ,  $C_{pp} < \text{approx. } 16\text{pF}$  at 100kHz)

If a value exceeds the correctable range, an error results, and the correction factor (value of zero) does not change. The instrument measures the overall impedance including residual impedance and stray admittance, and then corrects the residual impedance and the stray admittance by calculation. Therefore, if the magnitude of the residual impedance or stray admittance comes close to the magnitude of the measured impedance, or if the two magnitudes are reversed, the measuring accuracy is lowered. In this case, calibrate the instrument using an external standard.

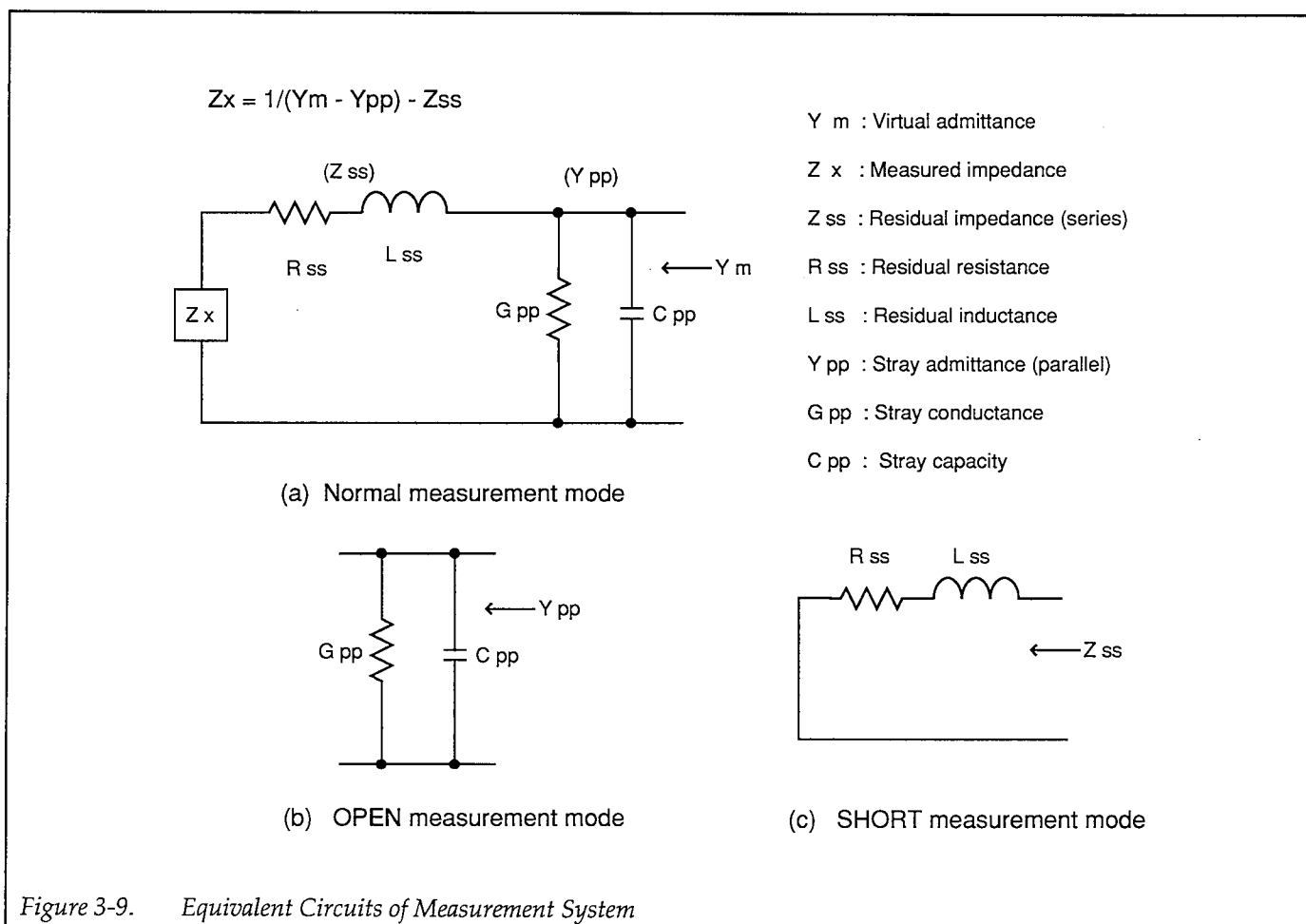

Figure 3-9. Equivalent Circuits of Measurement System

### 3.16 MEASUREMENT CABLES

#### 3.16.1 Cable Requirements

When using the cables, maintain the four-terminal configuration all way to the device under test. Use the coaxial cables, and twist them as illustrated in Figure 3-10(a). Make sure the cables are arranged as shown in the cross-sectional view to minimize errors when performing low impedance measurements. If it is impossible to bundle the four cables, twist the two current cables together, and then twist the two voltage cables separately. The shorter the cables, the less the error.

Perform the OPEN and SHORT zero correction under conditions that are similar to the actual measurement condition. In other words, leave the cables connected to the instrument, and perform the open and short at the DUT end of the cables.

#### Low Impedance Measurements:

Model 3324 4-Terminal Alligator Clip Test Leads — If possible, twist the two current leads and the two voltage leads separately as shown in Figure 3-10(b).

Model 3325 Kelvin Clip Test Leads — If possible twist the two leads together as shown in Figure 3-10(c).

#### High Impedance Measurements:

When measuring high impedances (i.e. low capacitance at high frequency) use cables that are shielded all the way to the test clips. This will minimize stray capacitance between high and low. The Models 3324 and 3325 test leads are properly shielded for this application.

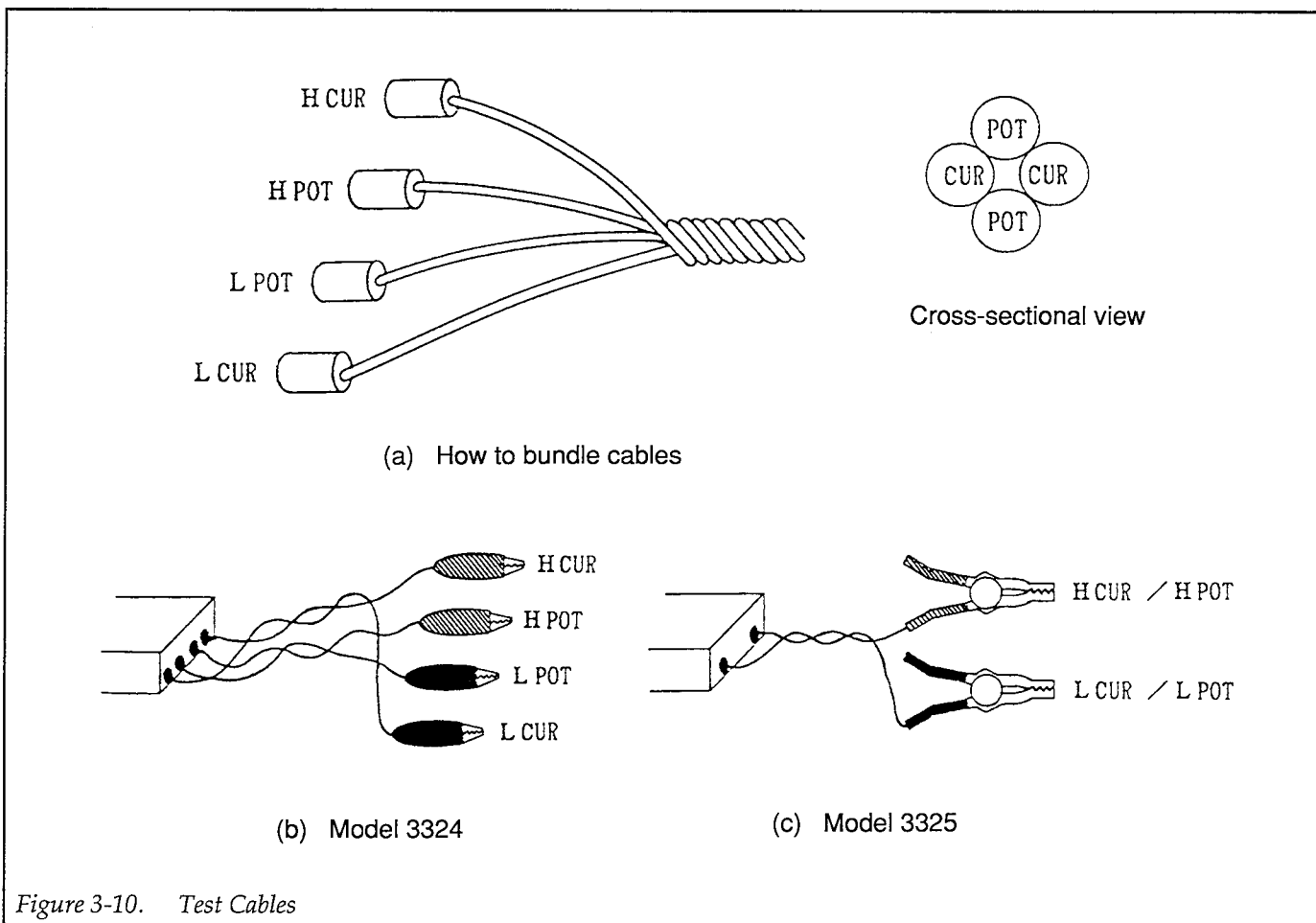

### 3.16.2 Additional Error

The accuracy specifications are based on making measurements at the input connectors of the instrument. When using cables to connect to a the DUT, additional error is introduced due to stray capacitance and voltage drop.

#### Additional Error in High Impedance Region:

The additional error in the high impedance region that is caused by test cables is summarized in Table 3-5.

#### Additional Error in Low Impedance Region:

Test cables add the following error to  $|Z|$  measurements of  $<2\Omega$ :

- 100 to 5kHz: 0.2m [ $\Omega$ ]
- 10kHz: 0.3m
- 20kHz: 0.4m
- 50kHz: 0.7m
- 100kHz: 1.5m

### 3.17 ERROR MESSAGES

Errors may result from the following:

1. Self-check (power-up test or zero measurement during OPEN or SHORT correction).
2. Invalid front panel setting.
3. Programming error over the GPIB bus.

On power-up, the instrument performs self-tests on its memory elements and denotes a failure with one of the following messages that cannot be cleared:

Self-test Failure Messages:

Message	Description
EEEEEE nnnnn	Memory Failure
where: n = 2	Invalid cal constants
n = 4-7	RAM error
n = 9	ROM error

The error messages caused by improper operation that are displayed by the instrument are listed and explained in Table 3-6.

It is possible to get the following messages on the **A** and **B** DISPLAYS if the instrument is exposed to excessive noise fields:

**A** DISPLAY: FFFFFF      **B** DISPLAY: 666666

To clear this error, turn off power and turn power back on after three seconds. If this error occurs frequently, the instrument may be defective. Contact your sales representative or the factory.

Table 3-5. Additional Error of  $|Z|$  Caused by Test Cables (Reference Data)

Reference Resistance ( $\Omega$ )	Frequency				
	5kHz	10kHz	20kHz	50kHz	100kHz
1k $\Omega$	—	—	—	0.05%	0.2%
10k $\Omega$	—	0.02%	0.08%	0.5%	2%
50k $\Omega$	0.05%	0.1%	—	—	—

### Clearing Error Messages

Once an error message is displayed, it will remain displayed until it is cleared by the operator. The instrument is effectively inoperable while the error message is displayed.

Clear from front panel — An error message can be cleared by pressing any front panel key. In this case, the operation inherent to the key does function.

Clear over the GPIB bus – An error can be reset by sending the device clear command (DCL, SDC) over the bus.

Note: If “EEEEEE” or “FFFFFF” is displayed on the **A** DISPLAY section or when an error number exceeds 50, the instrument is not functioning properly. Turn off power, and then turn power on again after three seconds. If the error message does not clear, the instrument is defective. Contact your sales representative or the factory.

Table 3-6. Error Message

Error	Message
Err 12	Entered value exceeds measurement range.
Err 13	Attempted to select a function parameter ( <b>B</b> DISPLAY key), or enable deviation or BIN ΔΔ%BIN key) while AUTO function is enabled.
Err 14	Attempted to enable BIAS, while AUTO, L, R or Z function selected. Bias can only be used for capacitance (C) measurements.
Err 19	Attempted to select a range past the upper or lower limit.
Err 21	(4) Errors that occur during execution of an instrument operation. Occurs during power-up when battery back-up memory fails. GPIB address defaults to 2, and delimiter defaults to <CR> <LF>.
Err 22	Zero correction value exceeds the tolerance.
Err 31	(5) GPIB error caused by programming or inquiry error. Attempted to send a command string that is too long. All commands in string are ignored.
Err 32	Illegal header; received a header that was not defined.
Err 33	Illegal header; inquiry performed when programmed to perform an operation, or operation performed when programmed to perform an inquiry.
Err 34	Illegal parameter; parameter expected but not sent.
Err 35	Illegal parameter; comma (,) which delimits parameters missing.

# SECTION 4

## GPIB Interface

---

---

### 4.1 INTRODUCTION

The GPIB Interface is a general-purpose interface bus system recognized by the IEEE (Institute of Electrical and Electronics Engineers) in 1975 in the U.S and is a method of standardizing the data input/output transfer between measuring instruments and peripherals including remote control functions.

By designing each controller and peripheral device into an interface conforming to this standard, it is possible to establish complete hardware compatibility between each device.

Up to 15 devices may be connected to a single interface bus with data transfer performed by three handshake lines. These handshake lines ensure reliable data transfer between data senders and receivers even though they may have different transfer rates.

Various names have been applied to the GPIB, including IEEE-488 bus. The official name, however, is the "IEEE-

Std 488-1978: IEEE Standard Digital Interface for Programmable Instrumentation."

It has virtually the same specifications as the IEC bus, although the connector differs, making it usable with this bus by means of connector adapters.

#### 4.1.1 Major GPIB Specifications

- Overall cable length: 20m max.
- Cable lengths between device: 4m max.
- Number of devices on bus (including controller): 15 max.
- Transfer method: 3 Handshake Lines
- Transfer rate: 1M bytes/s (max.)
- Data transfer: 8 Bits parallel
- Signal lines:
  - Data bus: 8 Lines
  - Control bus: 8 Lines
  - Handshake lines: DAV, NRFD and NDAC
  - Control lines: ATN, REN, IFC, SRQ and EOI
  - Signal/system grounds: 8 Lines
- Signal logic: Negative
  - True (low-level): 0.8V max.
  - False (high-level): 2.0V min.
- Interface Connector: See Figure 4-1



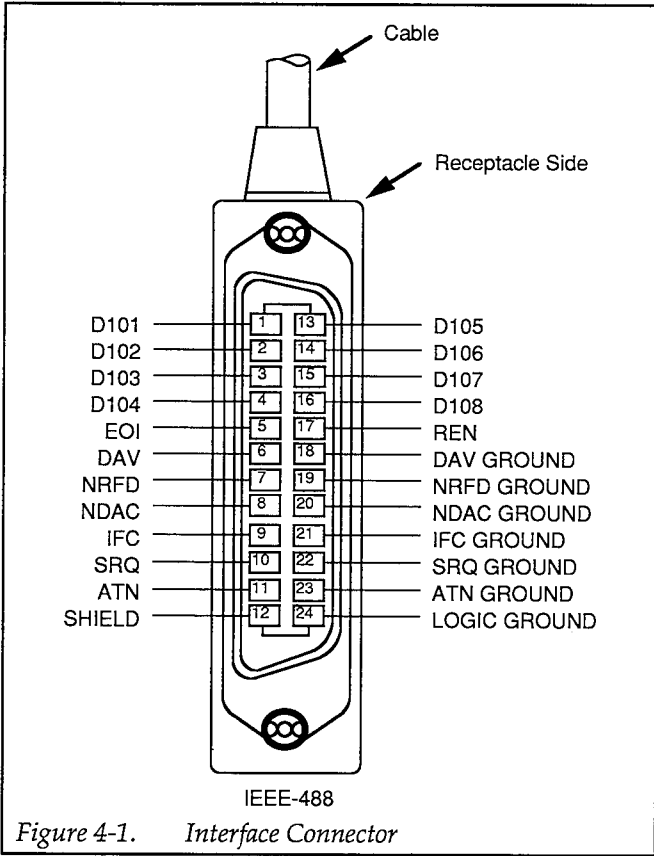

Figure 4-1. Interface Connector

### 4.1.2 Bus Line Signals and Operations

The GPIB bus line consists of 24 lines, including 8 data lines, 8 control lines and 8 signal/system ground lines.

**Data Bus (DIO1 to DIO8)** — These are the data input/output lines which are also used to input and output both address and command information. The type of data present on these lines are identified by means of the ATN line. DIO1 is the least significant bit (LSB).

**Handshake Bus (DAV, NRFD, NDAC)** — These three lines are handshake lines used to ensure reliable data transfer.

- **DAV (DATA Valid)** — This line indicates that the data on the DIO lines sent from a talker or the controller is valid.
- **NRFD (Not Ready For Data)** — This line indicates the condition of readiness of listeners to accept data on the DIO lines.
- **NDAC (Not Data ACcepted)** — This line indicates the condition of acceptance of data by listeners.

**Control Bus (ATN, REN, IFC, SRQ, EOI):**

- **ATN (ATteNtion)** — This line is an output line from the controller which indicates whether the signals on the DIO bus are data signals or commands.
- **REN (Remote ENable)** — This output line from the controller switches devices between remote control and local control.
- **IFC (InterFace Clear)** — The output line from the controller clears the interface of devices.
- **SRQ (Service ReQuest)** — This control line is used to call the controller from a talker or a listener. The controller detects this signal and executes a serial or parallel poll operation.
- **EOI (End Or Identify)** — This is used to indicate the end of a multiple byte transfer sequence or, in conjunction with ATN, to execute a parallel poll.

### 4.1.3 GPIB Handshaking

GPIB handshaking is performed by checking the status of all the listeners and inhibiting the next data transfer until all listeners have received the data. Handshaking allows the slowest device on the bus to perform data transfer reliably. The handshaking operations are executed by the following status signals:

**NRFD = High level.** All listeners are ready for accepting data.

**DAV = Low level.** A talker is outputting valid data to the data bus.

**NDAC = High level.** All listeners have completed data reception.

The handshaking timing diagram is shown in Figure 4-2.

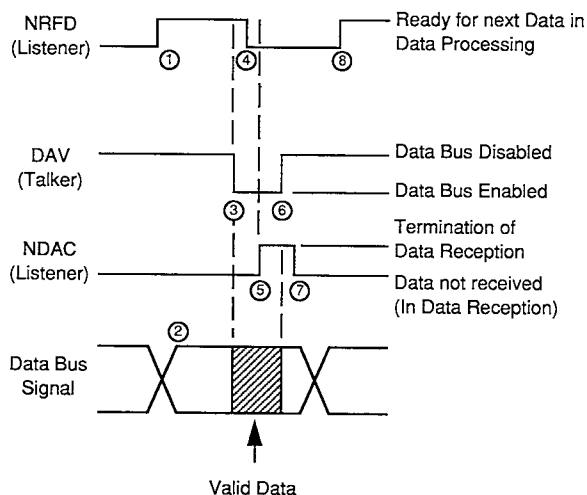

- ① Indicates that all listeners are waiting for data.
- ② The talker outputs data to be sent to the data lines.
- ③ The talker checks NRD and if high, DAV is set low to indicate to the listener that data is valid.
- ④ When the DAV goes low, the listener reads data and NRD is set low, indicating to the talker that data processing is in progress. Each listener sets NDAC high at the completion of data input. The NDAC of the bus is the OR function of the NDACs from each listener.
- ⑤ When all listeners have completed receiving data, NDAC goes high (result of the OR output) indicating to the talker that data reception has been completed.
- ⑥ The talker sets DAV high indicating to the listener that the data on bus is not valid.
- ⑦ The listener checks whether DAV is high and sets NDAC low, completing the handshake.
- ⑧ Indicates that all listeners have completed data processing and is waiting for next data.

Figure 4-2. Handshake Timing Diagram

#### 4.1.4 Data Transfer Example

Figure 4-3 provides a data transfer example using the three-line handshake process. In this example, the data "ABC" is sent, followed by the delimiter "CR/LF".

Whenever the talker address of another device is received.  
 Whenever the device is specified as a listener.  
 Whenever untalk (UNT) is received.  
 Whenever IFC is received.

#### 4.1.5 Basic Talker Functions

- Only one talker may exist on the GPIB at any time.
- When the controller ATN signal is high, data is sent to the listeners.
- Source handshaking is performed automatically.
- A service request (SRQ) is sent to the controller.
- The talker function is enabled for both the local and remote modes.
- The talker function is canceled by any of the following:

#### 4.1.6 Basic Listener Functions

- Two or more listeners may exist on the GPIB at any time.
- When the controller ATN signal is high, data is received from a talker.
- Acceptor handshaking is performed.
- The listener function is canceled by any of the following:
  - Whenever the device is specified as a talker.
  - Whenever unlisten (UNL) is received.
  - Whenever IFC is received.

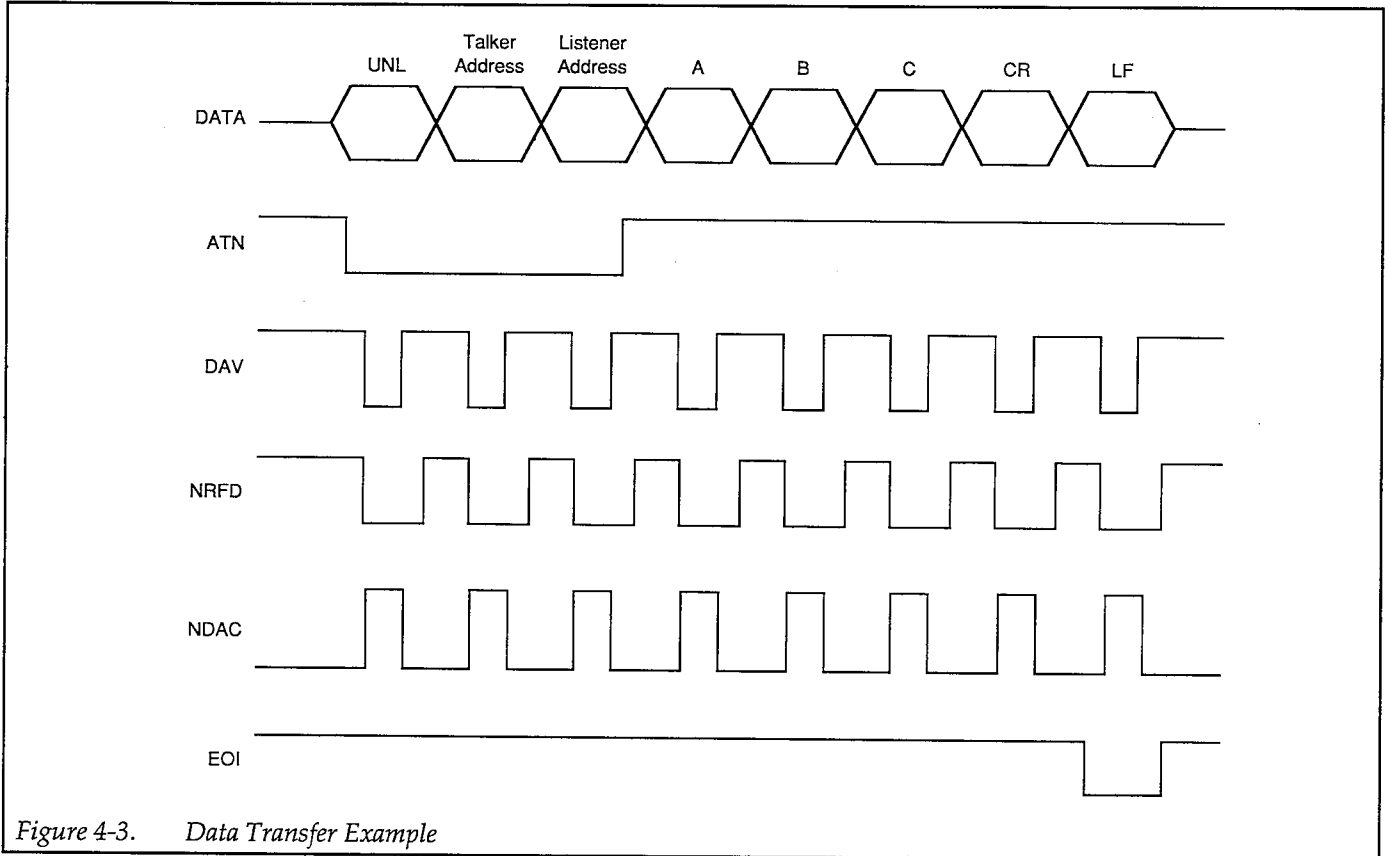

Figure 4-3. Data Transfer Example

### 4.1.7 Major Specifications of Controller Functions

- Only one controller can be active on GPIB.
- Sets the ATN signal low to control the listener and talker, and transmission of commands such as device clear.

- Outputs IFC and REN signals.

### 4.1.8 Multi-line Interface Message

The multi-line interface message is the data output from the controller when the ATN signal is low. This is shown in Table 4-1.



## 4.2 GPIB Programming Example

Most of the functions of the instrument can be controlled by the GPIB, allowing automated test systems to be configured.

When using the GPIB, set the address and delimiters for the GPIB from the panel (see paragraph 3.8.5). Before making any measurements over the GPIB, perform zero correction as explained in paragraph 3.15.

After performing the above operations, the instrument can be programmed to make measurements and read data over the GPIB, as illustrated in the following example program. The following program is written in BASIC 2.0 for the HP 9000 Series 200 computer:

```

100 DIM A$ [64]
110 ABORT 7
120 CLEAR 702
130 OUTPUT 702; "FR 1E3;LV 1;RN 0;SP 1;TR 1;DL
    0;DA 2;DB 1;DE 0;CK 1;TG"
140 ENTER 702;A$
150 PRINT " C(F) D"
160 PRINT A$
170 END
  
```

Sample Data:

```

C (F) D
0.0E-12, 0.0078
  
```

Program Analysis:

```

100      Assign the length of the character string
110 to 120 Initialize the GPIB
130      Set the measurement conditions and the display, and then allow the instrument to start measurements.
FR 1E3:   Frequency = 1kHz
LV1:     Level = 1V
RN0:     Range = AUTO
SP1:     Speed = MED
TR1:     Trigger = Manual
DL0:     Delay = 0s
DA2:     DISP-A = C
DB1:     DISP-B = D
  
```

```

DE0:     Deviation, no bin display
CK1:     Series equivalent circuit
TG:      Apply trigger
140      Reads data.
150      Prints header.
160      Prints data.
  
```

## 4.3 GPIB SPECIFICATIONS

### 4.3.1 Interface Functions

The interface functions of the instrument are listed in Table 4-2.

Table 4-2. Interface Functions

SH1	All functions of transmit handshake
AH1	All functions of receive handshake
T6	Has basic talker function, serial poll, talker canceled by MLA function, no talk only function
L4	Has basic listener function, listener canceled by MTA function, no listen only function
SR1	All functions of service request
RL2	Has remote/local switching function, no lock-out function
PP0	No parallel poll function
DC1	All functions of device clear
DT1	All functions of device trigger
C0	No controller function

### 4.3.2 Bus Drivers

The specifications of the bus drivers of the instrument are listed in Table 4-3.

Table 4-3. Bus Drivers

Data Bus	DIO1 to DIO8	Open Collector
Handshake Bus	NRFD, NDAC DAV	Open collector Tri-state
Control Bus	SRQ EOI	Open collector Tri-state

### 4.3.3 Address

The address of the instrument can be set within the following range:

0 to 30 (Decimal)

### 4.3.4 Receive and Transmit Codes

#### Receive Codes in Listener Mode

ISO 7-bit codes (JIS/ASCII) are used. The MSB (parity bit) of 8-bit data is ignored. Uppercase letters and lowercase letters are treated the same.

<Effective letters>

!"#\$%&'()\*+,-./

0123456789:;<=>?@

ABCDEFGHIJKLMNOPQRSTUVWXYZ

[\*]^\_'

abcdefghijklmnopqrstuvwxyz

{|}~

\* is only for the JIS code. For the ASCII code, a backslash is assigned.

The characters other than the above (control code including space, semicolon, and tab) are ignored and do not enter the receive buffer. <CR> (carriage return) and <LF> (line feed) are effective only for the delimiters indicating the end of the program code.

#### Transmit Codes in Talker Mode

ISO 7-bit codes (JIS/ASCII) are used without parity code (MSB of 8-bit data = 0). Alphabet is transmitted in uppercase letters.

### 4.3.5 Delimiters

#### In Listener Mode (when the instrument receives)

Any <CR>, <LF> or END message (EOI line in data transfer mode = LOW: True), or all of their combinations can be accepted.

#### In Talker Mode (when the instrument transmits)

<CR> or <CR> <LF> — The END message is output with the last letter (of a delimiter) of the transmit data.

### 4.3.6 Program Codes

The instruction used to control the instrument over the GPIB or to read the setting or measured data is called a program code. The program code is classified as follows.

- Setting message: Performs setting or operation command.
- Inquiry message: Reads setting or measured data.

#### Execution

A program code is stored in the receive buffer, interpreted when its delimiter is received, and then executed. When the execution terminates, the receive buffer is cleared and ready for the next receive.

#### Receive Buffer

Capacity of buffer: 256 letters. A space, semicolon, <CR> and <LF> do not enter the receive buffer.

When the instrument receives a long program code in excess of the capacity of receive buffer and the buffer overflow, an error results. In this case, all the codes are ignored, and the receive buffer is cleared.

### Basic Syntax

The basic syntax of the program code is shown Figure 4-4.

Program codes can be sent successively within the capacity of receive buffer. When sending program codes successively, spaces or semicolons can be inserted for easy reading.

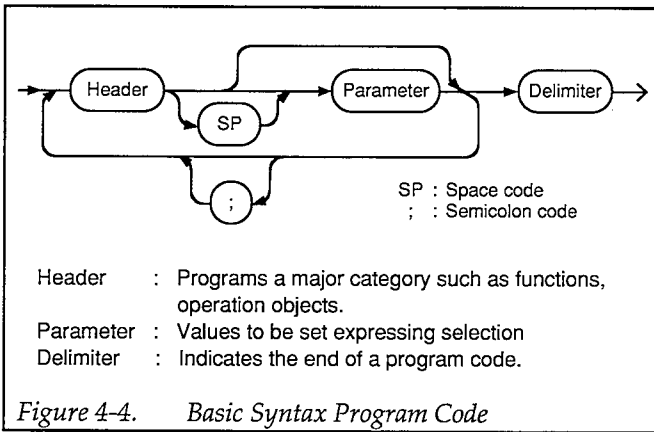

### Parameter

There are three numeric formats for parameters. Any format can be used if the value is within an acceptable range. However, the standard format is determined for each parameter and if a different format is used, it is converted to the standard format. When the number of significant digits is too large, it is rounded to the specified resolution.

<Standard format>

- NR1 (Integer representation format)  
 (Example) 99 056 -1234 +24
- NR2 (Floating-point representation format)  
 (Example) 1.2 .001 -160.5 +003.82
- NR3 (Exponent representation format)  
 (Example) 12E3 9.8E+02 +04.5E-6 -.007E+09

### Program Codes

The program codes for the instrument are provided in Table 4-4.

The standard form is in parenthesis under the header of each setting message. The form for the parameter to be sent is in the parenthesis under the header of output format.

Table 4-4. List of Program Codes

Name or Function of Parameter	Setting Message		Inquiry Message	Output Format	
	Header	Parameter	Header	Header	Parameter
<b>A</b> DISPLAY	DA (NR1)	0 to 4 (to 8) (0 : AUTO)	?DA	DA (NR1)	1 to 8 (5 : AUTO L)
<b>B</b> DISPLAY	DB (NR1)	0 to 5 (0 : Q)	?DB	DB (NR1)	0 to 5 (4 : X)
$\Delta$ /BIN	DE (NR1)	0 to 5 (0 : NORM)	?DE	DE (NR1)	0 to 5
CIRCUIT	CK (NR1)	0 : AUTO, 1 : SER, 2 : PAR	?CK	CK (NR1)	1, 2 (MAN) 3, 4 (AUTO)
REFERENCE	RF (NR3)	0 to +/-19999.E+6	?RF	RF (NR3)	0 to +/-19999.E+6
BIN	BN	m1,m2,m3 (No, Lower, Upper)	?BN	BN	m1,m2,m3 (repeat 20)
MEASURED DATA	—	—	?DT	DT	n1,n2 (DISPLAY-A, B)
FREQUENCY	FR (NR3)	100 to 100E+3 Spot	?FR	FR (NR3)	100 to 100E+3
LEVEL	LV (NR1)	0 : 50mV 1 : 1V	?LV	LV (NR1)	0, 1
RANGE	RN (NR1)	0 to 6 (to 12) 0 : AUTO	?RN	RN (NR1)	1 to 12 (8 : AUTO 2)
SPEED	SP (NR1)	0:FAST, 1:MED 2:SLOW	?SP	SP (NR1)	0 to 2
DELAY	DL (NR2)	0.00 to 199.99	?DL	DL (NR2)	0.00 to 199.99
BIAS ON/OFF	BO (NR1)	0 : OFF, 1 : ON	?BO	BO (NR1)	0 to 1
TRIG MODE	TR (NR1)	0:AUTO, 1:MAN	?TR	TR (NR1)	0 to 1
MAN TRIG	TG	—	—	—	—
ZERO OPEN	OP	—	—	—	—
ZERO SHORT	SH	—	—	—	—
STORE	SR (NR1)	1 to 9	—	—	—



List of Program Codes (Cont.)

Name or Function of Parameter	Setting Message		Inquiry Message	Output Format	
	Header	Parameter	Header	Header	Parameter
RECALL	RC (NR1)	0 to 9	—	—	—
HEADER	HD (NR1)	0 : DISABLE 1 : ENABLE	?HD	HD (NR1)	0 to 1
SERVICE REQUEST	RQ (NR1)	0 : DISABLE 1 : ENABLE	?RQ	RQ (NR1)	0 to 1
STATUS	—	—	?ST	ST (NR1)	0 to 127

Table 4-5. Response to Interface Messages

IFC (Interface Clear)	Initializes the GPIB Interface. (Cancels Listener or Talker)
DCL (Device Clear)  or  SDC (Selective Device Clear)	Resets an error. Clears the transmit and receive buffers of the GPIB.  Holds the issue of SRQ. (Status byte is reset.) Inhibits the issue of SRQ. (Equivalent to "RQ 0") Inhibits the header output. (Equivalent "HD 0") Resets the wait state for end of measurement in manual trigger mode.
GTL (Go To Local)	Establishes the local mode.
GET (Group Execute Trig)	Starts measurement (Same as trigger by program code) Once trigger is applied by the GET command, the next GET command is ignored until the end of measurement.

### 4.3.7 Response to Interface Messages

The response to the interface messages of the instrument are provided by Table 4-5.

Notes:

1. Display parameter and frequency do not change by the IFC command. The IDC command is valid for all the devices connected to the bus.
2. Though the GET command is invalid in the local mode, the DCL and SDC commands are valid in the local mode.
3. The SDC, GTL and GET commands are in the address command group (see Table 4-1). Thus, they are valid only when the instrument is programmed as a listener. On the other hand, the DCL command is in the universal command group, and is always valid for all devices provided with the device clear function.

### 4.3.8 Remote/Local Operation

#### Remote

When the instrument is assigned as a listener when the REN message is true (REN line = Low: 1), the remote mode is established, and the REMOTE light on the front panel turns on. In the remote mode, operation over the GPIB is possible, and the key entry from the front panel (except for error reset) is invalid. Although a measurement is not interrupted when the transition from local to remote is made, the auxiliary setting mode (SET UP) is reset (EXIT).

#### Local

When the REN message becomes false (REN line = High: 0) or when the instrument receives the GTL command, the local mode is established, and the REMOTE light turns off. In the local mode, the settings from the front panel are possible, and the GPIB program codes are ignored. The GET command is also invalid. Measurement cannot be interrupted when the remote mode is changed to the local mode.

### 4.3.9 Service Request (SRQ)

#### Issue SRQ:

When an SRQ is issued, SRQ is sent in the following cases:

- When one measurement is completed in the manual trigger mode
- When the zero correction of OPEN or SHORT is completed

#### Reset SRQ:

- After reading status by performing a serial poll
- After receiving the inquiry message for reading status ("?ST")
- When the device clear command is received. (DCL or SDC command)

### 4.3.10 Status Byte

The status byte sent in response to serial polling and inquiry messages is defined by Table 4-6 as follows.

### 4.3.11 Process Time

The data transfer rate is dependent on the speed of the controller, and the process time of the instrument is slower when making measurements. Table 4-7 provides the process time for standard program codes during non-measurement phases of operation. The process time is slightly different from parameter to parameter.

The process times shown in Table 4-7 includes the following data transfer time:

Receive (to the instrument): approx. 250 $\mu$ s/byte  
Transmit (from the instrument): approx. 120 $\mu$ s/byte

The process time for inquiry messages is the time from the start of program code reception to the completion of response message transmission. When sending a header for an inquiry, add the following value to the process time:

0.5ms approx.

## 4.4 SETTING GPIB ADDRESS AND DELIMITER

The GPIB address and delimiter of the instrument can be set from the front panel using the following format:

aa.d

where; Address aa = 0 to 30

Delimiter d = 0 or 1;

0 = <CR><LF> (carriage return, line feed)

1 = <CR> (carriage return)

Perform the following steps to check of change The GPIB address and delimiter:

1. Press and release the SETUP key until GPIB is selected as denoted by the blinking "blue-labeled" GPIB annunciator. The currently selected address and delimiter will be displayed on the **B** DISPLAY. For example, if the current address is 2 and the delimiter is <CR> <LF>, the following will be displayed:

2.0

To retain the current address and delimiter, press EXIT. Otherwise, proceed to the next step.

Table 4-6. Status Bytes

Bit	Content	Condition to be set (1)	Condition to be reset (1)
7 MSB	Always zero		
6	RQS	When issuing the SRQ command	When receiving the device clear command* After reading the status byte.**
5	ERR	Zero correction error (Correction value is too large.)	When receiving the device clear command After reading the status byte When the zero correction is normally performed.
4	BUSY	Under measurement (Zero correction included)	Under non-measurement
3	Zero	End of zero correction of OPEN or SHORT (Abnormal end included)	When receiving the device clear command After reading the status byte When starting zero correction
2	Always zero		
1	Always zero		
0 LSB	Always zero		

\*Device clear: DCL or SDC command

\*\*Status byte read: Reading of the status byte by the inquiry message "?ST" or serial poll performed when issuing the SRQ command.  
 (Reset is not performed by the serial poll when the SRQ command is not issued.)

Table 4-7. Process Time of Program Codes  
(Reference Data)

Setting Message		Inquiry Message	
Header	Processing Time (Approx.)	Header	Processing Time (Approx.)
DA	6ms	?DA	4ms
DB	5ms	?DB	4ms
DE	5ms	?DE	4ms
CK	5ms	?CK	4ms
RF	7ms	?RF	6ms
BN	14ms	?BN	350ms*
—		?DT	12ms**
FR	7ms	?FR	5ms
LV	5ms	?LV	4ms
RN	5ms	?RN	4ms
SP	4ms	?SP	4ms
DL	7ms	?DL	5ms
BO	5ms	?BO	4ms
TR	4ms	?TR	4ms
TG	3ms	—	
OP	3ms	—	
SH	3ms	—	
SR	5ms	—	
RC	15ms	—	
HD	4ms	?HD	4ms
RQ	4ms	?RQ	4ms
—		?ST	5ms

\*When all data of 20 bins are transmitted

\*\*Approximately 5ms for bin display.

- Using the “blue-labeled” number keys, key in the value of the address and delimiter. Make sure to separate the two values using the decimal point (.) key.
- With the desired address and delimiter values displayed, press the ENTER key.
- Press the EXIT key to return to the normal measurement state.

The entered address and delimiter are retained when power is turned off. However, when they are lost due to a memory error when power is turned on, they become default values (address = 2, delimiter = 0; <CR><LF>).

## 4.5 GPIB PROGRAMMING

Program codes which are used to control the instrument or read the setting or measured data over GPIB are stored in the 256-byte receive buffer, and interpreted and executed when the end of the program code is displayed. The syntax of a program code is as follows.

<Header> <Parameter> <Delimiter>

- Header: Assigns a classification, including functions and operation objectives.
- Parameter: Indicates setting values and selection values. There are three types; NR1 (integer representation), NR2 (floating-point representation) and NR3 (exponent representation)
- Delimiter: <CR>, <LF>, etc. which indicates the end of a program code.

For details on syntax, see paragraph 4.3.6.

When the instrument is placed in the remote mode during measurement, and a setting or inquiry is performed, the measurement is interrupted.

### 4.5.1 Setting Messages

An instruction used to perform an instrument setting or operation is called a setting message. The setting messages for the instrument are provided by Table 4-8.

Examples of setting messages:

“FR 10E3” — Sets frequency to 10kHz.

“DA 0” — **A** DISPLAY, **B** DISPLAY and CKT are placed in the automatic selection mode.

“RC 2” — Setup Memory 2 is recalled.

#### CAUTION

Note that the zero correction operation of OPEN and SHORT and the measurement in the manual trigger mode are held up when the next program code is received during their execution.

Table 4-8. Setting Messages

Parameter Name or Function	Program Code		Operation and Setting Range	Inquiry
	Header	Parameter		
<b>A</b> DISPLAY	DA	NR1 Integer	<Function> Range: 0 = AUTO 1 = L 2 = C 3 = R 4 =  Z  5 to 8 = AUTO	Yes
<b>B</b> DISPLAY	DB	NR1 Integer	<Function Parameter> Range: 0 = Q 1 = D 2 = ESR 3 = G 4 = X 5 = $\theta$	Yes
$\Delta$ /BIN	DE	NR1 Integer	<Deviation and bin display> Range: 0 = Normal 1 = $\Delta$ 2 = $\Delta\%$ 3 = BIN 4 = $\Delta$ BIN 5 = $\Delta\%$ BIN	Yes
CIRCUIT	CK	NR1 Integer	<Equivalent circuit> Range: 0 = AUTO 1 = SER 2 = PAR 3 to 4 = AUTO	Yes
REFERENCE	RF	NR3 Exponent Type	<Reference value of deviation display> Range: 0 and $\pm(0.0001E-12$ to $19999E+6)$ Resoluion: Max. 4-1/2 digits	Yes
BIN	BN	NR1 Integer and NR3 Exponent Type	<Comparator> Format: m1, m2, m3 m1: Bin No. (BIN) m2: Lower Limit (LOWER) m3: Upper Limit (UPPER) Range: m1 = 0 to 19 m2, m3 = 0, and $\pm(0.0001E-12$ to $19999E+6)$	Yes
FREQUENCY	FR	NR3 Exponent Type	<Frequency> Range: 100 to $100E+3$ [Hz] Selections: 100, 120, 200, 500, 1k, 2k, 5k, 10k, 20k, 50k, 100kHz	Yes
LEVEL	LV	NR1 Integer	<Measuring signal level> Range: 0 = 50mVrms 1 = 1Vrms (Open)	Yes

Setting Messages (Cont.)

Parameter Name or Function	Program Code		Operation and Setting Range	Inquiry
	Header	Parameter		
RANGE	RN	NR1 Integer	<Range> Range: 0 = AUTO 1 = MAN Range 1 : : 6 = MAN Range 6 7 to 12 = AUTO	Yes
SPEED	SP	NR1 Integer	<Measuring Speed> Range: 0 = FAST 1 = MED 2 = SLOW	Yes
DELAY	DL	NR2 Floating-point	<Delay Time> Time from the application of trigger to the start of measurement Range: 0.00 to 199.99[s] Resoltuion: 0.01[s]	Yes
BIAS ON/OFF	BO	NR1 Integer	<Bias> Range: 0 = Off 1 = On	Yes
TRIG MODE	TR	NR1 Integer	<Trigger Mode> Range: 0 = AUTO 1 = MAN	Yes
MAN TRIG	TG	—	<Manual Trigger> Establishes manual trigger mode and applies trigger. (Measurement is started.)	No
ZERO OPEN	OP	—	<Stray admittance correction> Starts OPEN correction.	No
ZERO SHORT	SH	—	<Residual impedance correction.> Starts SHORT correction.	No
STORE	SR	NR1 Integer	<Memory Store> Range: 1 to 9	No
RECALL	RC	NR1 Integer	<Memory Recall> Range: 0 to 9	No
HEADER	HD	NR1 Integer	<Header Output> Range: 0 = Inhibit (Not output) 1 = Admit (Output)	Yes
SERVICE REQUEST	RQ	NR1 Integer	<Service Request> Assigns whether or not to output SRQ. Range: 0 = Inhibit (Not output) 1 = Admit (Output)	Yes

## 4.5.2 Inquiry Messages

An instruction to read an instrument setting or the measured data is called an inquiry message. Each message consists of the inquiry header that is preceded with "?". Inquiry messages are listed in Table 4-9. The response to the message is in the format of "header" + "parameter" + "delimiter".

### Headers

The output of a header is optional. The header output is inhibited when power is turned on or when the device clear command is received.

### Parameters

The following formats are available for parameters. The type of output and the number of digits (number of letters) are determined according to the inquiry messages.

- NR1: Integer  
"0", "1", etc.
- NR2: Floating-point representation (no exponent part)  
"12.345", etc. When this format is used, the position of the decimal point may be fixed or variable.
- NR3: Exponent representation (with exponent part)  
"15.75E+03", etc.

When this format is used, the exponent becomes a multiple of 3 in the range of E-12 ( $10^{-12}$ ) to E+06 ( $10^6$ ) which is consistent with the how the front panel display handles exponents.

Generally, a zero in NR3 is expressed by making both the mantissa and exponent zeros ("0.0000E+00"). However, for a measured value, only the mantissa becomes zero.

### Notes:

1. Leading zeros are omitted (except for one zero before a decimal point), and data is right-justified.

2. The plus sign (+) for positive numbers is omitted. However, the plus sign (+) for the exponent is included. The exponent always has two digits.

### Delimiters

The following two delimiters can be selected from the front panel:

- <CR> <LF> (carriage return and line feed)
- <CR> (carriage return only)

The END message is output with the last letter (the last letter after a delimiter) of the response of the instrument to an inquiry (EOI line = Low).

### Notes

1. When the instrument is programmed as a talker without sending an inquiry message, a single blank and a delimiter are output except immediately after a measurement is performed in the manual trigger mode.
2. When more than one inquiry is performed, only the last inquiry is valid. Other inquiries are ignored.
3. The response to an inquiry is canceled when the following operation is performed without receiving the response after sending an inquiry command.

- Program code "TG"
- GET command

Example of response to inquiry:

"?FR" (Frequency) – "1E+03" or "FR 1E+03"  
"?DT" (Measured value) – "123.45E-03, 0.0012" or  
"DT 123.45E-03, 0.0012"

The example responses are shown with and without the header.

Table 4-9. Inquiry Messages

Parameter Name or Function	Inquiry Message Header	Output Format and Content of Inquiry		Setting
		Header	Parameter	
<b>A</b> DISPLAY	?DA	DA	<Function> Type: NR1 (Integer) Range: 1 = L 2 = C 3 = R 4 =  Z  5 = AUTO L 6 = AUTO C 7 = AUTO R 8 = AUTO  Z  No. of letters: 2 (4)	Yes
<b>B</b> DISPLAY	?DB	DB	<Function Parameter> Type: NR1 (Integer) Range: 0 = Q 1 = D 2 = ESR 3 = G 4 = X 5 = $\theta$ No. of letters: 2 (4)	Yes
$\Delta$ /BIN	?DE	DE	<Deviation and bin display> Type: NR1 (Integer) Range: 0 = Normal 1 = $\Delta$ 2 = $\Delta\%$ 3 = BIN 4 = $\Delta$ BIN 5 = $\Delta\%$ BIN No. of letters: 2 (4)	Yes
CIRCUIT	?CK	CK	<Equivalent circuit> Type: NR1 (Integer) Range: 1 = SER 2 = PAR 3 = AUTO SER 4 = AUTO PAR No. of letters: 2 (4)	Yes
REFERENCE	?RF	RF	<Reference value of deviation display> Type: NR3 (Exponent type) Range: 0.0000E+00 and $\pm(0.0001E-12$ to 19999.E+06) Resoluuion: Max. 4-1/2 digits, when not restricted by exponent part. No. of letters: 11 (13)	Yes



Inquiry Messages (Cont.)

Parameter Name or Function	Inquiry Message Header	Output Format and Content of Inquiry		Setting
		Header	Parameter	
BIN	?BN	BN	<Comparator> Format: m1, m2, m3 m1: Bin No. (BIN) m2: Lower Limit (LOWER) m3: Upper Limit (UPPER) Delimited by delimiters for each bin setting in the sequence of BIN 0 to 19 and output in succession from BIN 0 to 19. Type: m1: NR1 (Integer) m2, m3: NR3 (Exponent type) Range: m1 = 0 to 19 m2, m3 = 0.0000E+00 and $\pm(0.0001E-12$ to 19999.E+6) No. of letters: 27 (29) per bin up to 620 with delimiters included.	Yes
MEASURED DATA	?DT	DT	<Measured data> Format: Only bin No. for <b>A</b> DISPLAY and <b>B</b> DISPLAY Type and Range: Different from parameter to parameter No. of letters: 23 (25) max. For details, see paragraph 4.5.3.	No
FREQUENCY	?FR	FR	<Frequency> Type: NR3 (Exponent type) Range: 100E+00 to 100E+03 [Hz] Selections: 100, 120, 200, 500, 1k, 2k, 5k, 10k, 20k, 50k, 100kHz No. of letters: 8 (10)	Yes
LEVEL	?LV	LV	<Measuring signal level> Type: NR1 (Integer) Range: 0 = 50mVrms 1 = 1Vrms No. of letters: 2 (4)	Yes
RANGE	?RN	RN	<Range> Type: NR1 (Integer) Range: 1 = Range 1 :       : 6 = range 6 7 = AUTO range 1 :       : 12 = AUTO range 6 No. of letters: 3 (5)	Yes

## Inquiry Messages (Cont.)

Parameter Name or Function	Inquiry Message Header	Output Format and Content of Inquiry		Setting
		Header	Parameter	
SPEED	?SP	SP	<Measuring speed> Type: NR1 (Integer) Range: 0 = FAST 1 = MED 2 = SLO No. of letters: 2 (4)	Yes
DELAY	?DL	DL	<Delay time> Type: NR2 (Floating-point) Range: 0.00 to 199.99 [s] Resolution: 0.01 [s] Fixed point No. of letters: 7 (9)	Yes
BIAS ON/OFF	?BO	BO	<Bias> Type: NR1 (Integer) Range: 0 = Off 1 = On No. of letters: 2 (4)	Yes
TRIG MODE	?TR	TR	<Trigger mode> Type: NR1 (Integer) Range: 0 = AUTO 1 = MAN No. of letters: 2 (4)	Yes
HEADER	?HD	HD	<Header output> Type: NR1 (Integer) Range: 0 = Inhibit (Not output) 1 = Admit (Output) No. of letters: 2 (4)	Yes
SERVICE REQUEST	?RQ	RQ	<Service request output> Type: NR1 (Integer) Range: 0 = Inhibit (Not output) 1 = Admit (Output) No. of letters: 2 (4)	No
STATUS BYTE	?ST	ST	<Status byte> Type: NR1 (Integer) Range: 0 to 127 Converter to decimal notation and output No. of letters: 4 (6)	No

### 4.5.3 Reading Measured Data

#### Request for Measured Data

Measured data can be read by the following two methods:

- Request data by the inquiry message “?DT”
- Allow the instrument to measure data by the setting message “TG” or the GET command.

1. “?DT”

This command places the last measured reading in the transmit buffer, and is sent when the instrument is programmed to talk. Note that the data output by “?DT” is canceled when an other inquiry message or the setting message “TG” is sent after “?DT”.

2. “TG” or GET Command

When the manual trigger mode (MAN) is established by the “TR1” and trigger is applied by the “TG” or the GET command, the instrument holds the ongoing measurement and starts a new measurement. When the new measurement finishes, the measured data is placed in the transmit buffer. When the instrument is programmed to talk immediately after trigger is applied, the data is sent as soon as that measurement is completed (the listener will wait until the measurement is completed). Note that the data output by “TG” is canceled if another program command is sent after the “TG” command.

If SRQ is enabled, SRQ is output when the measurement is completed. SRQ is sent by applying a trigger from the front panel.

When the next trigger is applied without reading data, the transmit buffer is cleared, but SRQ is not reset.

#### Data Format

Data that correspond to the **A** DISPLAY and the **B** DISPLAY readings are separated (delimited) by a comma (,).

“[HEADER] Data of **A** DISPLAY, Data of **B** DISPLAY Delimiter”

When displaying a bin number (Comparator operation), only the bin number is sent.

“[HEADER] Bin number Delimiter

The header output is enabled and disabled by the setting messages “HD 0” and “HD 1” respectively. A delimiter <CR> <LF> or <CR> is selected from the front panel using SET UP GPIB. The END message (EOI line = Low) is output with the last command of the delimiter.

Each measured value is output in the same format as it is displayed on the front panel, and is summarized as follows:

#### L, C, R, |Z|, ESR, G, X

Type:	NR3 (exponent representation) Exponent part is a multiple of 3.
Resolution:	4-1/2 digits (19999 max. typically 2000 to 19999)
Range:	0.0000E-12, (0.0001E-12 to 19999.E+06) The display range is restricted by the types of parameters, ranges and phase angles. The exponent and a decimal point are output without fail.
“OF”:	“99999.E+06”
“UF”:	“-99999.E+06”
“OU”:	“88888.E+06” (L, C, R,  Z ); 0.0000E+00” )ESR, G, X)
Blank:	“77777.E+06”
No. of letters:	11

#### Q, D

Type:	NR2 (Floating-point representation)
Resolution:	4-1/2 digits (19999 max.)
Range:	0.0000, (0.0001 to 19999.)
“OF”:	“99999.”
“UF”:	“-99999.”
“OU”:	“0.0000”
Blank:	“77777.”
No. of letters:	7

#### θ

Type:	NR2 (Floating-point representation)
Resolution:	0.01
Range:	-180.00 to +179.99
“OU”:	“0.00”
Blank:	“777.77”
No. of letters:	7

?	
Type:	NR3 (Exponent representation) Exponent part is a multiple of 3
Resolution:	4-1/2 digits (19999 max.)
Range:	0.0000E-12, (0.0001E-12 to 19999.E+06)
"OF":	"99999.E+06"
"UF":	"-99999.E+06"
"OU":	"88888.E+06"
Blank:	"77777.E+06"
No. of letters:	11

%	
Type:	NR2 (Fixed point representation)
Resolution:	0.01
Range:	199.99
"OF":	"999.99"
"UF":	"-999.99"
"OU":	"888.88"
Blank:	"777.77"
No. of letters:	7

**BIN**

Type:	NR1 (Integer)
Range:	0 to 19 ("OF", "UF", "OU", blank means 0)
No. of letters:	3

Notes:

1. The plus sign (+) is omitted and is implied by its absence. However, it is included for the exponent.
2. The major differences between the data displayed at the front panel and the GPIB output are as follows:

Front Panel Display	GPIB Output
K,μ, etc. .1234	E+03, E-06, etc. 0.1234
OF, UF, OU	Numbers like "99999.E+06"
Blank; measured value not displayed	Numeric like "77777."

**4.5.4 Reading Bin Setting**

When the bin setting of the comparator is read by the inquiry message "?BN", the setting data of 20 bins are all output in sequence from 0 to 19. The output format of each bin is as follows. The bin number, lower limit and

upper limit are arranged in this order, and delimited by commas (,).

"[Header] Bin No., Lower limit, Upper limit Delimiter"

The header output is enabled and disabled by the optional setting messages "HD 0" and "HD 1", respectively. The delimiter <CR> <LF> or <CR> is selected from the front panel (SET UP GPIB). The END message (EOI line = Low) is output with the last code of the delimiter of bin No. 19. For the other delimiters, the END message is not output.

The format of each parameter is as follows:

**Bin number**

Type:	NR1 (Integer)
Range:	0 to 19
No. of letters:	3

**Lower and Upper Limits**

Type:	NR3 (Exponent representation) Exponent is a multiple of 3
Resolution:	4-1/2 digits
Range:	0.0000E+00, (0.0001E-12 to 19999.E+06)
No. of letters:	11

**4.6 MEASUREMENTS OVER GPIB**

Measurement over the GPIB is basically the same as making measurements from the front panel. Before using the GPIB, make sure front panel operation (Section 3) is understood.

**4.6.1 Preparation**

1. Input/output Connections — Connect a test fixture or test leads to the instrument, and perform zero correction.
2. Initial GPIB Settings:
  - Interface clear (IFC) — Initialize the GPIB system by sending the interface clear command from the controller.
  - Remote enable (REN) — Send the REN message from the controller to enable the instrument to respond to GPIB commands. The REN command must be true (REN line = Low). To control the-

strument over the GPIB, REN must be maintained true unless some front panel operation is needed.

- Device clear (DCL, SDC) — Initialize the GPIB system of the instrument by sending a device clear command from the controller. The transmit and receive buffers will be cleared, and any previous error will reset. SRQ will disable, and the header for an inquiry message will disable.

### 4.6.2 Measurement and Reading of Data

This paragraphs describes how to make a measurement and send the reading (data) over the GPIB bus to the controller.

#### Set Measurement Conditions

Example: "FR 2E3;SP 1;LV 1;RN0"  
 FR 2E3: Frequency = 2kHz  
 SP 1: Measuring speed = MED  
 LV 1: Measuring signal level = 1Vrms (output open)  
 RN 0: Range = Automatic

#### Set Display

Example: "DA 2; DB 1;DE 0;CK 1"  
 DA 2: C is displayed on **A** DISPLAY (electrostatic capacity)  
 DB 1: D is displayed on **B** DISPLAY (Dissipation)  
 DE 0: Deviation and BIN are not displayed (NORMAL)  
 CK1: Equivalent circuit (CKT) is series (SER).

When using the Comparator and Deviation for sorting, additional settings are needed.

Example: "RF 100E-12;DE 5; BN 0,-.0005,.004;BN 1,-2,2;BN 2,-5,5;BN 3,0,0"  
 RF 100E-12: Reference = 100p(F)  
 DE 5: % BIN (sorts the devices by %.)  
 BN 0 ...: BIN 0 = -.0005 to .004; Acceptance range of D  
 BN 1 ... : BIN 1 = -2 to +2 (%)  
 BN 2 ... : BIN 2 = -5 to +5 (%)  
 BN 3,0,0: Closes BINs 3 to 19.

For the above program code, a device in the range of 100pF  $\pm 2\%$ , is assigned to Bin 1, and a device in the range of  $\pm 2\%$  to +5% is assigned to Bin 2.

Devices out of these ranges are assigned to Bin 0.

#### Perform Measurement

Send the following command string to select the manual trigger mode, and make a single measurement:

"TR 1; TG"

TR 1: Selects the manual trigger mode.  
 TG: Applies a trigger and performs one measurement. The GET command can be used instead.

#### Read Data

Once the measurement has been made, the reading (data) is sent to the computer by programming the instrument to talk.

SRQ can be used to ensure that the measurement is completed before sending the reading by programming the instrument to talk. To enable SRQ, send the following command before making the measurement:

"RQ 1"

When an SRQ occurs, serial poll the instrument to confirm that the RQS bit is set, and then program it to talk.

Another way to verify the completion of a measurement is to read the status byte using the "?ST" inquiry message and wait until the BUSY bit (Bit 4) is reset.

### 4.7 GPIB OPERATING CONSIDERATIONS

Before connecting or disconnecting GPIB cables, be sure to turn off the instrument. When other equipment is connected to the bus, turn off that equipment also.

- When using the GPIB, make sure all equipment connected to the bus is turned on.
- Exercise care for delimiters. If the same delimiters are not used, the bus could hang up.
- Up to 15 units (including the controller) can be connected to the GPIB bus at one time.
- Cable length restriction:  
 Total transmission path length =  $2m \times (\text{no. of units})$  or 20m (whichever is shorter). Maximum length of one cable = 4m.
- The GPIB is intended to be used in an environment that is not subjected to excessive electrical noise.

Table 4-10. GPIB Error Messages

Err12	The entered parameter value exceeds the rated range
Err13	Display assignment error While <b>[A]</b> DISPLAY in AUTO, an item of <b>[B]</b> DISPLAY is assigned, CKT is assigned, or deviation display is assigned.
Err14	Illegal request for DC bias While <b>[A]</b> DISPLAY in AUTO, L, R or  Z , you attempted to turn on DC bias.
Err22	Zero correction abnormal Zero correction value exceeds the tolerable range.
Err31	Receive buffer over-flow A program code is too long for the receive buffer. Command string is ignored.
Err32	Illegal header Receives a header that is not assigned.
Err33	Illegal header Though only a setting can be made, an inquiry is made, or though only an inquiry can be made, a setting is made.
Err34	Illegal parameter Required parameter missing.
Err35	Illegal parameter Comma ",", which delimits a parameter, is missing.

## 4.8 GPIB ERRORS

When an error occurs during GPIB bus operation, an error message (see Table 4-10) is displayed and the command string is ignored. After analyzing a displayed GPIB error, it can be cleared by pressing any front panel key or by sending a device clear command over the bus.

## 4.9 EXAMPLE PROGRAMS

This section provides some example programs used to control the instrument over the GPIB. The personal computer used for those examples is listed as follows:

HP 9000 Series 200 Computers

Series 200 computers, HP9816, 9826, 9836, etc.  
BASIC 2.0 software

All the programs assume that the GPIB address of the instrument is set to 2 and the delimiter is set to <CR> <LF>.

### 4.9.1 GPIB Initialization

The following program will initialize the GPIB:

**Sample program to initialize the GPIB:**

```
100 ABORT 7
110 CLEAR 702
```

**Program Analysis:**

Line No.	Operation
100	Send the IFC (Interface Clear) command.
110	Send the SDC (Selective Device Clear) command.

Normally REN is enabled, unless otherwise programmed, and the delimiter is <CR> <LF> unless otherwise programmed by the OUTPUT statement.

**4.9.2 Display Setting**

The following example program will set the display of the instrument. When this program is executed, R and X (series equivalent circuit  $R + jX$ ) will be measured repeatedly at 1kHz. Make sure the GPIB was previously initialized (see paragraph 4.9.1) before using this program.

**Sample program to set the display:**

```
100 OUTPUT 702; "FR 1E3;DA 3;DB 4;DE 0;CK 1;TR 0"
```

**4.9.3 Inquiry**

The following sample program will inquire and display the currently selected frequency and the bin settings for the comparator. Make sure the GPIB was previously initialized (see paragraph 4.9.1) before using this program.

```
100 OUTPUT 702;"HD 0"
200 OUTPUT 702;"?FR"
210 ENTER 702;Fr
220 PRINT "FREQ = ";Fr
230 PRINT
300 OUTPUT 702; "?BN"
310 PRINT "BIN, LOWER, UPPER"
320 DIM A$(64)
330 FOR I=0 TO 19
340 ENTER 702;A$           !ENTER 702;B,L,U
350 PRINT A$              !PRINT B,L,U
360 NEXT I
```

**Program Analysis:**

Line No.	Comment
100	Inhibits a header output.
200 to 220	Inquires and displays the frequency.
300	Inquiry the bin settings (bin No., upper limit and lower limit).
320	Assigns the length of a character-string
330 to 360	Read and print the settings of the 20 bins in sequence.

**4.9.4 SRQ and Serial Poll**

The following sample program will acquire measured data using SRQ. Measurements are performed at a frequency of 1kHz and are displayed on the computer CRT. Make sure the GPIB was previously initialized (see paragraph 4.9.1) before using this program.

**Sample program to SRQ and serial poll:**

```
100 DIM A$(64)
110 OUTPUT 702;"FR 1E3;DA 2;DB 1;DE 0;CK 2;TR 1;SP 1"
120 ON INTR 7 GOSUB 200
130 OUTPUT 702; "RQ 1"
140 OUTPUT 702; "TG"
150 ENABLE INTR 7;2
160 GOTO 160
170 !
180 !
200 S=SPOLL (702)
210 IF BINAND(S,64)=0 THEN 260
220 OUTPUT 702; "?DT"
230 ENTER 702;A$           !ENTER 702;C,D
240 PRINT A$              !PRINT
                          "C=";C;"F,
                          D=";D
250 TRIGGER 702
260 ENABLE INTR 7
270 RETURN
```

**Program Analysis:**

Line No.	Comment
100	Assigns the length of the character string.
110	Sets measurement conditions. Frequency = 1kHz, [A] DISPLAY = C, [B] DISPLAY = D, no deviation and no bin display, parallel equivalent circuit, manual trigger mode, speed = MED.
120	When SRQ is received, branch to the sub-routines starting from line 200.
130	Enable SRQ of the instrument.
140	Applies the remote trigger to make measurement.
150	Admits the SRQ interruption.
200	Performs the serial poll.
210	Confirms that the RQS bit of a status byte is set, waits for the completion of zero correction.
220 to 240	Receives and displays measured values.
250	Applies a trigger by the GET command and allows the instrument to start the next measurement.
260	Admits the next SRQ interruption.

**4.9.5 Measurements**

The following sample program measures an electrolytic capacitor:

**Program Analysis:**

Line No.	Comment
100	Assigns the length of the character string.
110 to 125	Initializes the GPIB.
130	Sets measuring conditions. Measuring signal level = 1V, measurement range = automatic, speed = MED. [A] DISPLAY = C, [B] DISPLAY = ESR, no deviation and no bin display, series equivalent circuit, manual trigger mode, trigger delay time 1s.
140 to 180	Turns on the DC bias and allow capacitor time to charge.
200	Assigns a frequency table.
210	Displays a header.
220 to 340	Read and display the frequency

220, 330	Deletes a frequency from a frequency table.
230	"" is displayed at the end of the table.
240 to 280	Set a frequency and allow to settle.
290	Apply trigger to make a single measurement.
300	Displays a measured frequency.
310 to 320	Read and display the measured value.
350 to 380	Turn off the bias and finish measurement.
400 to 430	Frequency table

**Sample program to measure electrolytic capacitor:**

```

100 DIM A$(64)
110 ABORT 7
120 CLEAR 702
130 OUTPUT 702; "LV 1;RN 0;SP 1;DA 2;DB 2;DE 0;CK
1;TR 1;DL 1"
140 OUTPUT 702;"BO 1"
150 Wtm=15 !wait time (s)
160 T=TIMEDATE+Wtm
170 WHILE TIMEDATE<T
180 END WHILE
200 RESTORE Flist
210 PRINT "FREQ(Hz) C(F) ESR(ohm)"
220 READ F$
230 WHILE F$<>"*"
240 OUTPUT 702;"FR"&F$
250 Wtm=2
260 T=TIMEDATE+Wtm
270 WHILE TIMEDATE<T
280 END WHILE
290 OUTPUT 702;"TG"
300 PRINT " "&F$&" ";
310 ENTER 702;A$
320 PRINT A$
330 READ F$
340 END WHILE
350 OUTPUT 702;"BO 0"
360 PRINT
370 PRINT "End of job"
380 STOP
390 !
400 Flist: !
410 ! Frequency list
420 DATA " 100"," 200"," 500"," 1E3"," 2E3"," 5E3","
10E3"
430 DATA " 20E3"," 50E3","100E3","*"
440 END
  
```



# APPENDIX A

## Model 3322 Specifications

### A.1 MEASUREMENT PARAMETERS

#### Kinds of Parameters

##### • Main Parameters

AUTO: Selects the main parameters, sub-parameters and equivalent circuits automatically.

L: Self-inductance (unit: H, henry)

C: Capacitance (unit: F, farad)

R: Resistance (unit:  $\Omega$ , ohm)

|Z|: Magnitude of impedance (unit:  $\Omega$ )

There are series and parallel measuring modes for each of L, C and R.

##### • Sub-parameters

Q: Quality factor (quality of circuit)

D: Dissipation factor (=  $\tan \delta = 1/Q$ )

ESR: Equivalent series resistance (unit:  $\Omega$ )

G: Parallel conductance (unit: S, siemens;  $1/\Omega$ ; Mho)

X: Series reactance (unit:  $\Omega$ )

$\theta$ : Phase angle of impedance (unit: degree)

##### • Equivalent Circuits

AUTO: Automatic selection

SER: Series

PAR: Parallel

##### • Deviation Measurement

$\Delta$ : Deviation display of main parameters (Display range  $\pm 100\%$  or more)

$\Delta\%$ : % deviation display of main parameters (Display range  $\pm 199.99\%$ )

Note: The deviation of sub-parameters cannot be displayed.

##### • Automatic Parameter Selection

Parameters can be automatically selected by the phase angle of impedance.

$\theta = +90^\circ \pm 30^\circ \rightarrow L - Q$

$\theta = 0^\circ \pm 30^\circ \rightarrow R - Q$

$\theta = -90^\circ \pm 30^\circ \rightarrow C - D$

$\theta = \text{Other than the above} \rightarrow |Z| - \theta$

##### • Automatic Selection of Equivalent Circuits

Equivalent circuits can be automatically selected by the value and phase angle of impedance, and the combination of parameters.

Conditions for Selection of Series Mode	Conditions for Selection of Parallel Mode
L, C, R,  Z  - ESR, X	L, C, R,  Z  - G
L, C ( $ Z  \leq 1k\Omega$ ) - Q, D, $\theta$	L, C ( $ Z  > 1k\Omega$ ) - Q, D, $\theta$
R ( $\theta \geq 0$ ) - Q, D, $\theta$	R ( $\theta < 0$ ) - Q, D, $\theta$
Z  - Q, D, $\theta$	

Specifications subject to change without notice.

#### Displayed Resolution

4-1/2 digits (19999 max)

D and Q Resolution: 0.0001 min

$\theta$  Resolution: 0.01°

#### Measuring (display) Range

R, |Z|, ESR, X: 0.1m $\Omega$  to 19.999M $\Omega$

C: 0.001pF to 199.99mF

L: 0.1nH to 19.999kH

Q, D: 0.0001 to 19999

G: 0.001 $\mu$ S to 199.99S

$\theta$ : -180.00° to +179.99°

These ranges are dependent on the frequency, measuring range, and phase angle of impedance.

#### Accuracy

##### Accuracy Guarantee Conditions

- Warm-up time: 30 minutes.
- Ambient temperature and humidity: 23°  $\pm$  5°C,  $\leq$  90% RH.
- Zero correction: Performed under the above conditions.
- Calibration period: 12 months.

##### Accuracy of |Z| and $\theta$ :

For  $0.2\Omega \leq |Z| \leq 20M\Omega$ , see Table A-1.

For  $|Z| < 0.2\Omega$ , see Table A-2.

For  $|Z| > 20M\Omega$ , see Table A-3.

##### Notes:

1. When a measurement is made at twice line frequency, the measured value may deviate beyond the accuracy range due to interaction with line frequency. In this case, use 100Hz for a 60Hz line and 120Hz for a 50Hz line.
2. When the operating temperature is 5°-40°C, add the value shown in Table A-4 to that in Table A-1. Double the values shown in Table A-2 and A-3.
3. Tables A-1 through A-3 show the worst case value in each impedance range. Obtain the correct accuracy in the following ranges by linear interpolation:

- $|Z| = 1M$  to 20M $\Omega$

In this range, as impedance increases, accuracy decreases.

acc1: Accuracy shown in one range below the range including a Z in Table A-1.

acc2: Accuracy (worst case value) shown in the range including a Z in Table A-1.

- $|Z| = 0.2$  to  $2\Omega$

In this range, as impedance decreases, accuracy decreases.

acc1: Accuracy (worst case value) shown in the range including a Z in Table A-1.

acc2: Accuracy shown in one range above the range including a Z in Table A-1.

$$\text{acc} = [\text{acc1} (Z2 - Z) + \text{acc2} (Z - Z1)] / (Z2 - Z1)$$

Z: Magnitude of measured impedance (measured value)

Z1: Lower limit value of each impedance range in Table A-1.

Z2: Upper limit value of each impedance range in Table A-1.

acc: Measuring accuracy of impedance Z ( $|Z|$  is displayed by %, and  $\theta$  by degree.)

acc1: Measuring accuracy of impedance Z1

acc2: Measuring accuracy of impedance of Z2

When obtaining the accuracy in the ambient temperature ranging from 5°-40°C, add each corresponding value in Table A-4 to acc1 and acc2 in advance.

- Accuracy is not guaranteed in the following ranges.

$$|Z| \geq 20M\Omega$$

$$|Z| \geq 2M\Omega \text{ and frequency } \geq 50kHz$$

$$|Z| < 0.2\Omega$$

#### Accuracy of R, ESR and G

In the case of  $Q < 0.1$  ( $D > 10$ ), use the accuracy of  $|Z|$ :

$$|R| = |Z|$$

$$|ESR| = |Z|$$

$$|G| = 1/|Z|$$

#### Accuracy of L, C and X

In the case of  $Q > 10$  ( $D < 0.1$ ), use the accuracy of  $|Z|$ :

$$L = \frac{|Z|}{2\pi f}$$

$$C = \frac{1}{2\pi f |Z|}$$

$$|X| = |Z|$$

where f is the test frequency in Hz.

Refer to Figure A-1, Conversion from LC to  $|Z|$ .

#### Accuracy of D and Q

In case  $D \ll 1$  ( $Q \gg 1$ ), use the following equations:

$$\text{Accuracy of } D = \pm(0.0175 \times \theta \text{ accuracy (deg)})$$

$$\text{Accuracy of } Q = \pm(0.0175 \times \theta \text{ accuracy (deg)} \times Q^2)$$

In any parameter, add the  $\pm 1/2$  count, i.e., half of the resolution to the displayed value as actual accuracy.

**Table A-1. Accuracy of |Z| and  $\theta$  for  $0.2\Omega \leq |Z| < 20M\Omega$**

Z  ( $\Omega$ )	LEVEL = 1V rms, SPEED = MED or SLOW								LEVEL = 50mVrms, SPEED = MED or SLOW							
	Frequency, (Hz)								Frequency, (Hz)							
	100 120	200 500	1k	2k 5k	10k	20k	50k	100k	100 120	200 500	1k	2k 5k	10k	20k	50k	100k
10M $\leq$  Z <20M	3.0% 1.5°	2.0% 1.0°	1.0% 0.8°	2.0% 1.5°	3.5% 2.0°	4.0% 3.0°	14.0% 8.0°	20.0% 12.0°	7.0% 4.0°	4.5% 2.5°	3.5% 2.0°	6.0% 3.5°	8.5% 5.0°	17.0% 10.0°	–	–
5M $\leq$  Z <10M	1.5% 0.9°	1.0% 0.6°	0.5% 0.4°	1.0% 0.6°	1.8% 1.1°	2.0% 1.3°	7.0% 4.0°	10.0% 6.0°	3.5% 2.0°	2.2% 1.3°	1.7% 1.0°	2.7% 1.6°	3.5% 2.0°	7.0% 4.0°	–	–
2M $\leq$  Z <5M	0.75% 0.45°	0.5% 0.3°	0.3% 0.2°	0.5% 0.3°	0.9% 0.6°	1.0% 0.6°	3.5% 2.0°	5.0% 3.0°	2.0% 1.2°	1.2% 0.8°	0.9% 0.6°	1.2% 0.8°	1.6% 1.0°	3.5% 2.0°	–	–
1M $\leq$  Z <2M	0.36% 0.22°	0.3% 0.15°	0.2% 0.1°	0.3% 0.15°	0.4% 0.2°	0.5% 0.3°	1.6% 1.0°	3.0% 2.0°	1.0% 0.6°	0.6% 0.35°	0.4% 0.25°	0.6% 0.35°	0.8% 0.5°	1.6% 0.9°	12.0% 7.0°	14.0% 8.0°
200k $\leq$  Z <1M	0.25% 0.15°	0.2% 0.12°	0.15% 0.09°	0.2% 0.12°	0.27% 0.16°	0.35% 0.2°	1.0% 0.6°	2.0% 1.2°	0.5% 0.3°	0.4% 0.25°	0.3% 0.18°	0.35% 0.20°	0.4% 0.25°	0.7% 0.4°	6.0% 3.6°	7.0% 4.0°
20k $\leq$  Z <200k	0.15% 0.10°	0.12% 0.06°	0.1% 0.04°	0.18% 0.08°	0.25% 0.15°	0.3% 0.2°	0.6% 0.4°	1.2% 0.8°	0.3% 0.18°	0.2% 0.12°	0.16% 0.08°	0.24% 0.14°	0.32% 0.18°	0.40% 0.23°	1.8% 1.0°	3.0% 1.5°
2k $\leq$  Z <20k	0.14% 0.09°	0.12% 0.05°	0.1% 0.03°	0.12% 0.06°	0.15% 0.08°	0.2% 0.12°	0.4% 0.3°	0.8% 0.6°	0.25% 0.15°	0.18% 0.09°	0.16% 0.06°	0.2% 0.12°	0.24% 0.14°	0.35% 0.20°	1.4% 0.8°	2.0% 1.2°
10 $\leq$  Z <2k	0.13% 0.08°	0.11% 0.05°	0.1% 0.03°	0.11% 0.08°	0.13% 0.1°	0.17% 0.15°	0.4% 0.25°	0.7% 0.5°	0.20% 0.12°	0.18% 0.09°	0.15% 0.06°	0.20% 0.12°	0.23% 0.13°	0.32% 0.18°	1.2% 0.7°	1.6% 1.0°
2 $\leq$  Z <10	0.25% 0.15°	0.2% 0.1°	0.15% 0.07°	0.2% 0.12°	0.32% 0.2°	0.5% 0.3°	0.8% 0.4°	1.5% 0.8°	0.5% 0.3°	0.35% 0.20°	0.25% 0.14°	0.35% 0.20°	0.5% 0.3°	0.7% 0.4°	3.4% 2.0°	4.0% 2.3°
1 $\leq$  Z <2	0.35% 0.22°	0.3% 0.2°	0.2% 0.12°	0.25% 0.15°	0.5% 0.3°	0.7% 0.4°	1.0% 0.6°	2.0% 1.2°	1.0% 0.6°	0.6% 0.4°	0.5% 0.3°	0.6% 0.4°	0.8% 0.5°	1.1% 0.7°	6.0% 3.6°	8.0% 5.0°
0.5 $\leq$  Z <1	0.7% 0.45°	0.6% 0.4°	0.4% 0.25°	0.5% 0.3°	0.8% 0.5°	1.2% 0.7°	1.7% 1.0°	3.3% 2.0°	1.8% 1.1°	1.2% 0.7°	1.0% 0.6°	1.2% 0.7°	1.5% 0.9°	1.8% 1.1°	10.0% 6.0°	14.0% 8.5°
0.2 $\leq$  Z <0.5	1.4% 0.9°	1.1% 0.7°	0.8% 0.5°	1.1% 0.7°	1.25% 0.8°	1.8% 1.1°	2.7% 1.6°	5.5% 3.0°	3.7% 2.2°	2.6% 1.5°	2.0% 1.2°	2.6% 1.5°	2.9% 1.7°	3.4% 2.0°	21.5% 13.0°	28.0% 16.0°

|Z| Accuracy:  $\pm$ % reading shown on upper line.

$\theta$  Accuracy:  $\pm$  degrees shown on lower line.

When SPEED=FAST, accuracy is 2 times amount shown.

**Table A-2. Accuracy of |Z| and  $\theta$  for |Z| < 0.2 $\Omega$**

Z  ( $\Omega$ )	LEVEL = 1V rms, SPEED = MED or SLOW							
	Frequency, (Hz)							
	100 120	200 500	1k	2k 5k	10k	20k	50k	100k
0 $\leq$  Z <0.2	1.7% +0.2m	1.5% +0.2m	1.0% +0.2m	1.3% +0.2m	1.4% +0.3m	2.0% +0.6m	3.0% +1.5m	6.0% +3m

|Z| Accuracy:  $\pm$ (% reading + R) shown.

$\theta$  Accuracy: ( $\theta$  Accuracy for  $0.2 \leq |Z| < 0.5$  in Table A-1)  $\times$  ( $0.2\Omega / |Z|$ )

When SPEED=FAST, accuracy is 2 times amount shown.

**Table A-3. Accuracy of |Z| and  $\theta$  for |Z|  $\geq 20M\Omega$**

Y  (S)	LEVEL = 1V rms, SPEED = MED or SLOW							
	Frequency, (Hz)							
	100 120	200 500	1k	2k 5k	10k	20k	50k	100k
0 $\leq$  Y  $\leq$ 50nS	1.8nS	1.2nS	0.6nS	1.2nS	2.1nS	2.4nS	7.5nS	12nS

|Z| Accuracy: Specified by the  $\pm$  deviation (S) of admittance |Y| shown.

$\theta$  Accuracy: ( $\theta$  Accuracy for  $10M \leq |Z| < 20M$  in Table A-1)  $\times$  ( $|Z| / 20M\Omega$ ).

When SPEED=FAST, accuracy is 2 times amount shown.

Table A-4. Additional Error for 5°-40°C

Z  Ω	LEVEL = 1V <sub>rms</sub>			LEVEL = 50mV <sub>rms</sub>		
	Frequency, (Hz)			Frequency, (Hz)		
	100 to 10k	20k	50k to 100k	100 to 10k	20k	50k to 100k
10M ≤  Z  < 20M	0.2% 0.12°	1.0% 0.6°	2.0% 1.2°	0.3% 0.2°	3.0% 2.0°	— —
5M ≤  Z  < 10M	0.12% 0.07°	0.5% 0.3°	1.0% 0.6°	0.2% 0.12°	1.5% 0.9°	— —
2M ≤  Z  < 5M	0.07% 0.04°	0.25% 0.15°	0.5% 0.3°	0.14% 0.09°	0.75% 0.5°	— —
200k ≤  Z  < 2M	0.04% 0.024°	0.10% 0.06°	0.20% 0.12°	0.1% 0.06°	0.3% 0.2°	0.6% 0.4°
20k ≤  Z  < 200k	0.04% 0.024°	0.10% 0.06°	0.20% 0.12°	0.06% 0.035°	0.15% 0.10°	0.3% 0.2°
2k ≤  Z  < 20k	0.04% 0.024°	0.04% 0.024°	0.08% 0.05°	0.06% 0.035°	0.06% 0.035°	0.15% 0.1°
10 ≤  Z  < 2k	0.04% 0.024°	0.04% 0.024°	0.08% 0.05°	0.06% 0.035°	0.06% 0.035°	0.15% 0.1°
2 ≤  Z  < 10	0.04% 0.024°	0.05% 0.03°	0.10% 0.06°	0.2% 0.12°	0.3% 0.2°	1.0% 0.6°
1 ≤  Z  < 2	0.07% 0.04°	0.08% 0.05°	0.18% 0.1°	0.4% 0.24°	0.6% 0.4°	2.0% 1.2°
0.5 ≤  Z  < 1	0.12% 0.07°	0.13% 0.08°	0.33% 0.2°	0.8% 0.5°	1.2% 0.7°	4.0% 3.5°
0.2 ≤  Z  < 0.5	0.2% 0.12°	0.2% 0.12°	0.6% 0.4°	2.0% 1.2°	3.0% 2.0°	10.0% 6.0°

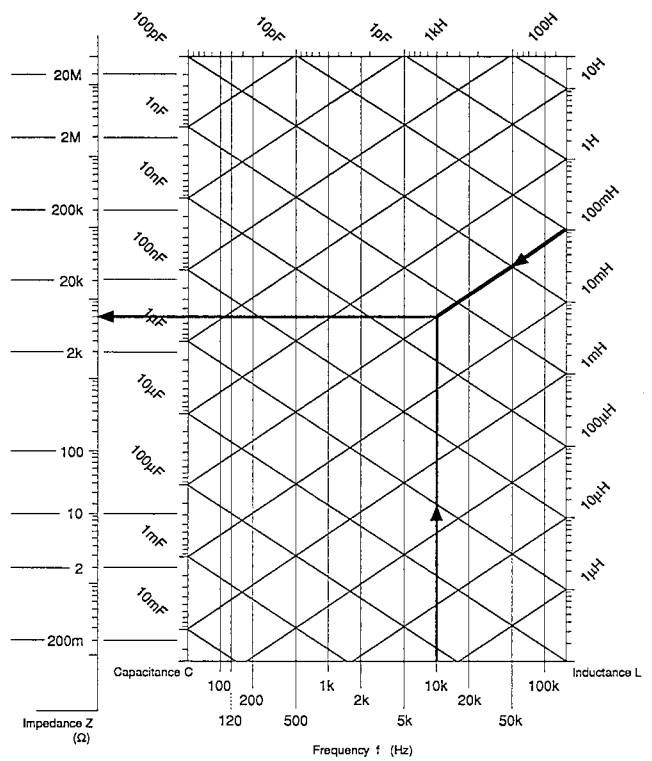
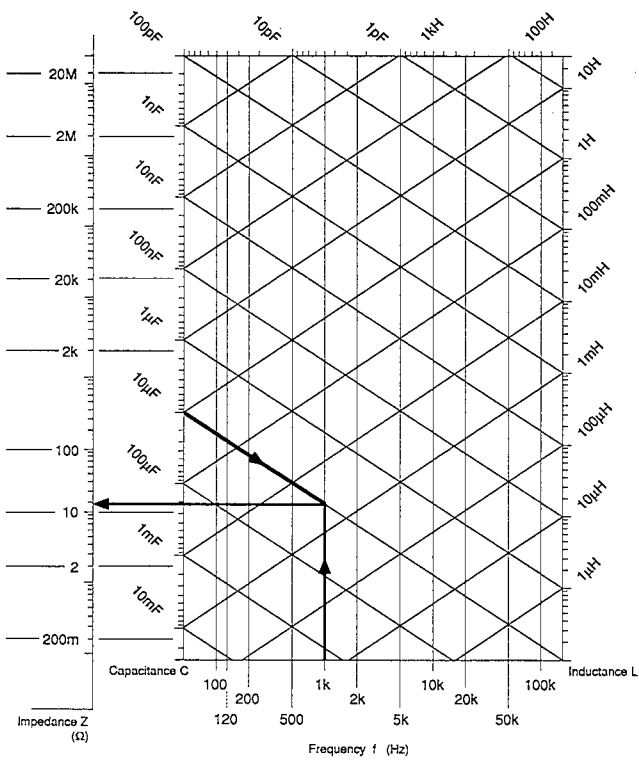
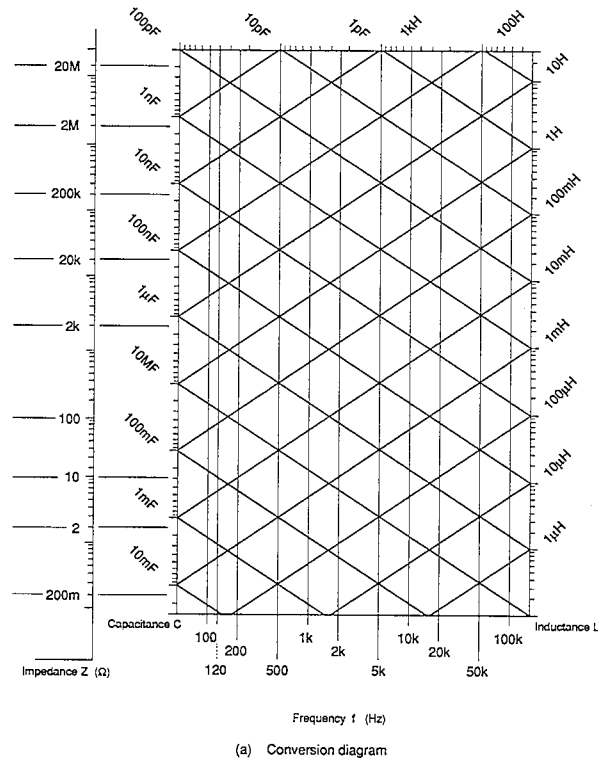

Figure A-1. Conversion Diagram from L or C to  $|Z|$

## Examples of Determining Accuracy

**Ex. 1:** Find the accuracy when  $R=33k\Omega$ ,  $f=10kHz$ ,  $1V$ , while  $Q<0.1$ .

- Find the accuracy from Table A-1, using the following parameters:  $1V$ ,  $10kHz$  and  $20k$  to  $200k\Omega$ .
- When the measuring speed is set to FAST, double the accuracy value.
- When operating within a temperature range from  $5$  to  $40^\circ C$ , add the value in Table A-4.
- When accuracy is needed for  $\geq 1M\Omega$  or  $\leq 2\Omega$ , interpolate the value according to Note 3.
- Add  $\pm 1/2$  count of display value. When the display shows a measured value of  $33.14k\Omega$ , the  $1/2$  count becomes  $0.005k\Omega$ .

**Ex. 2:** Find the accuracy when  $C = 10\mu F$ ,  $f=1kHz$ ,  $50mV$ , while  $D < 0.1$ .

- Find  $|Z|$  from Figure A-1 Conversion Diagram.
  - Find the line descending from  $C = 10\mu F$ . Find the vertical line from frequency =  $1kHz$ . Mark their intersection.
  - Extend a horizontal line from the intersection, to the left side. Read the value of  $|Z|$  ( $\approx 16\Omega$ ). Also, you can calculate the accuracy using the following equation.

$$|Z| = |1/2\pi f C|$$

- Find the accuracy from Table A-1, using the following parameters:  $50mV$ ,  $1kHz$  and  $10$  to  $2k\Omega$ .
- When the measuring speed is set to FAST, double the accuracy value.
- When operating within a temperature range from  $5$  to  $40^\circ C$ , add the value in Table A-4.
- When accuracy is needed for  $\geq 1M\Omega$  or  $\leq 2\Omega$ , interpolate the value according to Note 3.
- Add  $\pm 1/2$  count of display value.

**Ex. 3:** Find the accuracy when  $L = 680\mu H$ ,  $f=100kHz$ , while  $Q > 10$ .

- Find  $|Z|$  from Figure A-1 Conversion Diagram.
  - Draw a straight line from  $L = 680\mu H$ , in parallel with the ascending lines. Find the intersection with the vertical line at frequency =  $100kHz$ .
  - Read  $|Z|$  as shown in Ex. 2. Also, you can calculate the accuracy using the following equation:

$$|Z| = |2\pi f L|$$

- Find the accuracy from Table A-1, using the following parameters:  $f=100kHz$  and  $10$  to  $2k\Omega$ . Repeat procedures 3 to 6 in Ex. 2.

**Ex. 4:** Find the accuracy of  $|Z|$  at any  $\theta$  and for parameters other than  $\theta$ .

- Measure  $|Z|$  and  $\theta$ , or calculate the accuracy, using the other parameters.

$$\begin{aligned} Q &= 1/D & |\theta| &= |\arctan Q| \\ &= 2\pi f L_s / ESR & |z| &= |2\pi f L_s / \sin \theta| \\ &= 1 / (2\pi f C_s ESR) & &= |1 / (2\pi f C_s \sin \theta)| \\ &= 2\pi f C_p / G & &= |1 / (2\pi f C_p \sin \theta)| \\ &= 1 / (2\pi f L_p G) & &= |2\pi f L_p / \sin \theta| \end{aligned}$$

f: Frequency (Hz)

Suffix s: Series equivalent circuit

p: Parallel equivalent circuit

- Find the accuracies of  $|Z|$  and  $\theta$ . Refer to Ex. 1.
- Find the maximums and minimums of  $|Z|$  and  $\theta$  from the measured values and accuracies of  $|Z|$  and  $\theta$ .  
 $Z$  max, min = Measured value  $|Z| \times [1 \pm \text{Accuracy of } |Z| (\%)/100]$   
 $\theta$  max, min = Measured value  $\theta \pm \text{Accuracy } \theta$  (degree)

- Find the maximums and minimums of the parameters for the four sets of combinations of maximums and minimums of  $|Z|$  and  $\theta$ , using the calculating equation of each parameter. B is a susceptance, i.e., an imaginary component of admittance.

$$\begin{aligned} R_s &= |Z| \cos \theta & R_p &= |Z| / \cos \theta \\ ESR &= |Z| \cos \theta & G &= (1/|Z|) \cos \theta \\ X &= |Z| \sin \theta & B &= -(1/|Z|) \sin \theta \\ L_s &= X/2\pi f & L_p &= -1/2\pi f B \\ C_s &= -1/2\pi f X & C_p &= B/2\pi f \\ Q &= |\sin \theta| / \cos \theta & D &= \cos \theta / |\sin \theta| \end{aligned}$$

- The accuracy is the value that the error of  $1/2$  count of display is added to | maximum value - measured value | or | minimum value - measured value |, whichever is greater.

## A.2 MEASURING SIGNAL

### Frequency

Range: 100, 120, 200, 500, 1k, 2k, 5k, 10k, 20k, 50k, 100k (Hz)

Accuracy:  $\pm 0.005\%$  ( $\pm 50$ ppm)

### Signal level (HCUR open voltage with terminal)

1Vrms:  $\pm 3\%$  at 1kHz  
 $\pm 4\%$  at 100Hz to 20kHz  
 $\pm 5\%$  at 50kHz and 100kHz  
 50mVrms:  $\pm 5\%$  at 1kHz  
 $\pm 6\%$  at 100Hz to 20kHz  
 $\pm 7\%$  at 50kHz and 100kHz

### DC bias

Internal: 2V,  $\pm 5\%$   
 External: 0 to 35V

## A.3 MEASURING RANGE

**Number of ranges:** 6 (Reference resistance: 100 $\Omega$ , 1k $\Omega$ , 10k $\Omega$ , 50k $\Omega$ , upper and lower extension ranges 2)

**Selection:** Automatic or manual

## A.4 MEASURING SPEED (reference value)

### Measuring time (fixed range and auto trigger mode)

	Typical at 1kHz, 1k $\Omega$	Maximum on any range, any frequency
FAST:	64ms	80ms
MED:	150ms	245ms
SLOW:	480ms	600ms

### Automatic range switching time (per range)

The automatic range switching time is nearly equal to the measuring time. When the frequency is 500Hz and the impedance is  $\geq 1M\Omega$ , it will take time for the measured value to stabilize. When measuring a device whose impedance changes according to the magnitude of the measuring signal, time will extend until the value of the device becomes stable.

### Level switching stabilization time: 200ms to 4s

The level switching stabilization time will change according to the kinds of devices under test. Time increases when measuring non-linear elements, such as diodes, or when switching from 1V to 50mV. This is the time required for the stabilization of measured values. The time needed to change the device under test is excluded.

### Bias stabilization time: (4 + 0.015C)s

Where C=capacitance of device under test ( $\mu F$ ).

### Frequency switching stabilization time: 150ms to 4s

The frequency switching stabilization time increases when a high frequency is changed to a low frequency (e.g.: 100kHz to 120Hz)

## MEASURING SPEED (reference value) (Cont.)

Also, time changes according to the device under test. This is the time required for the stabilization of the measured value. The time taken to change the device under test is excluded.

### A.5 TRIGGER

**Trigger modes:** Automatic (repeat) and manual

**Trigger delay time:** 0 to 199.99s

### A.6 MEASUREMENT TERMINALS

4 terminals (BNC) + guard terminal

### A.7 COMPARATOR FUNCTIONS

**Number of categories:** 20 max.

**Main parameter judgement:** 1 to 19 sets of upper and lower limits can be set.

**Sub-parameter judgement:** 1 set of upper and lower limits can be judged.

### A.8 SETUP MEMORIES

**Number of Setups:** 10. One of the 10 setups saves the data at power off.

**Memory Content:** All settable data (except bias on-off).

**Battery Life:** 3 years minimum when stored at 40°C max.

### A.9 GPIB

**Interface Functions:** SH1, AH1, T6, L4, SR1, RL2, PP0, DC1, DT1, C0.

**Setting:** Of the items settable via the front panel, all the parameters except address and delimiter of GPIB can be set. Also, trigger, OPEN/SHORT compensation and memory operation can be performed.

**Readout:** All the settable parameters, measurement data and status.

**Standards:** Based on IEEE-488-1978 and IEEE-488A-1980.

**Code:** ISO 7 bit code (ASCII code).

### A.10 GENERAL

**Power requirements:** AC line voltage: selectable to 100V, 120V, 220V, 240V  $\pm 10\%$  (250V max.). 48 to 62Hz, approx. 21VA.

**Operating Environment:** 0° to 40°C, 10 to 90% RH (non-condensing).

**Storage Environment:** -10 to +50°C, 10 to 80% RH (non-condensing).

**Dimensions, Weight:** 216mm wide  $\times$  132.5mm high  $\times$  350mm deep (8-1/2 in.  $\times$  5-1/4 in.  $\times$  13-3/4 in.), excluding protrusions. Net weight 3.6kg (7.9lb.).

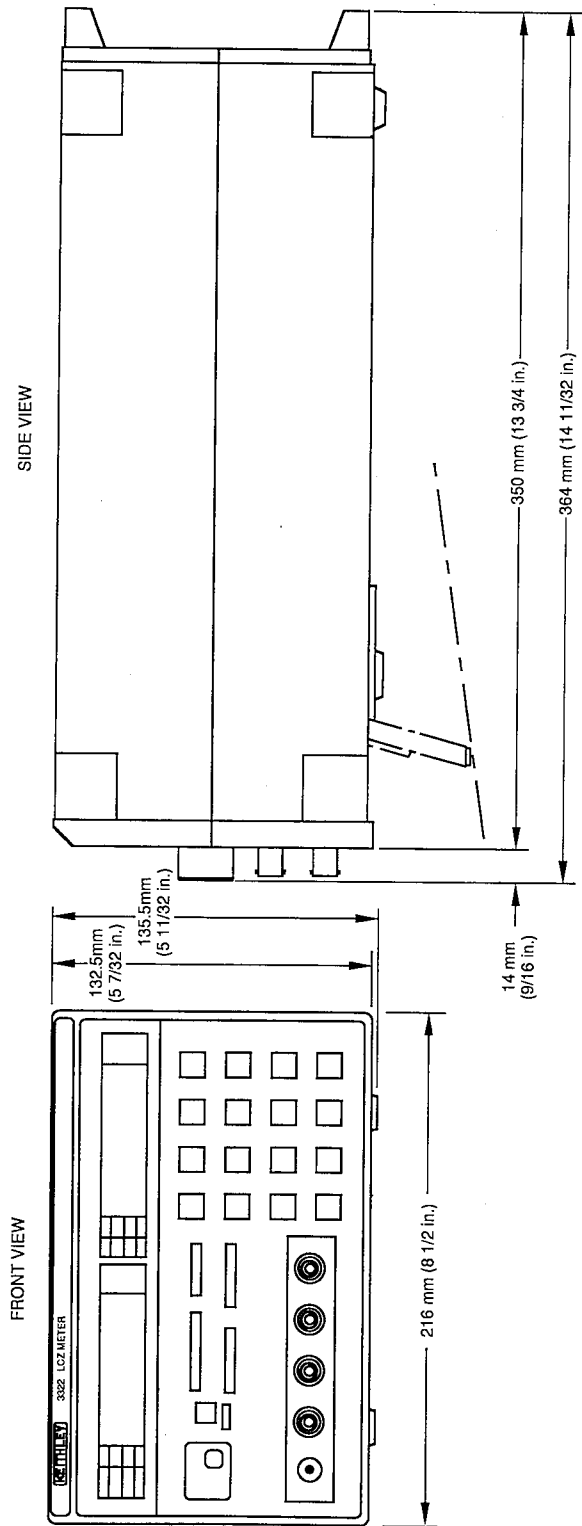

Figure A-2. Dimensions





# Service Form

Model No. \_\_\_\_\_ Serial No. \_\_\_\_\_ Date \_\_\_\_\_

Name and Telephone No. \_\_\_\_\_

Company \_\_\_\_\_

List all control settings, describe problem and check boxes that apply to problem. \_\_\_\_\_

\_\_\_\_\_

- |  |  |  |
|--|--|--|
| <input type="checkbox"/> Intermittent            | <input type="checkbox"/> Analog output follows display   | <input type="checkbox"/> Particular range or function bad; specify _____ |
| <input type="checkbox"/> IEEE failure            | <input type="checkbox"/> Obvious problem on power-up     | <input type="checkbox"/> Batteries and fuses are OK                      |
| <input type="checkbox"/> Front panel operational | <input type="checkbox"/> All ranges or functions are bad | <input type="checkbox"/> Checked all cables                              |

Display or output (check one)

- |                                   |  |
|-----------------------------------|--|
| <input type="checkbox"/> Drifts   | <input type="checkbox"/> Unable to zero              |
| <input type="checkbox"/> Unstable | <input type="checkbox"/> Will not read applied input |
| <input type="checkbox"/> Overload |  |

- |   |  |
|---|--|
| <input type="checkbox"/> Calibration only | <input type="checkbox"/> Certificate of calibration required |
| <input type="checkbox"/> Data required    |  |

(attach any additional sheets as necessary)

Show a block diagram of your measurement system including all instruments connected (whether power is turned on or not). Also, describe signal source.

Where is the measurement being performed? (factory, controlled laboratory, out-of-doors, etc.)

\_\_\_\_\_

What power line voltage is used? \_\_\_\_\_ Ambient temperature? \_\_\_\_\_ °F

Relative humidity? \_\_\_\_\_ Other? \_\_\_\_\_

Any additional information. (If special modifications have been made by the user, please describe.)

\_\_\_\_\_

Be sure to include your name and phone number on this service form.

Specifications are subject to change without notice.

All Keithley trademarks and trade names are the property of Keithley Instruments, Inc. All other trademarks and trade names are the property of their respective companies.



**Keithley Instruments, Inc.**

28775 Aurora Road • Cleveland, Ohio 44139 • 440-248-0400 • Fax: 440-248-6168  
1-888-KEITHLEY (534-8453) • [www.keithley.com](http://www.keithley.com)

**Sales Offices: BELGIUM:**

Bergensesteenweg 709 • B-1600 Sint-Pieters-Leeuw • 02-363 00 40 • Fax: 02/363 00 64

**CHINA:**

Yuan Chen Xin Building, Room 705 • 12 Yumin Road, Dewai, Madian • Beijing 100029 • 8610-6202-2886 • Fax: 8610-6202-2892

**FINLAND:**

Tietäjäsentie 2 • 02130 Espoo • Phone: 09-54 75 08 10 • Fax: 09-25 10 51 00

**FRANCE:**

3, allée des Garays • 91127 Palaiseau Cédex • 01-64 53 20 20 • Fax: 01-60 11 77 26

**GERMANY:**

Landsberger Strasse 65 • 82110 Germering • 089/84 93 07-40 • Fax: 089/84 93 07-34

**GREAT BRITAIN:**

Unit 2 Commerce Park, Brunel Road • Theale • Berkshire RG7 4AB • 0118 929 7500 • Fax: 0118 929 7519

**INDIA:**

Flat 2B, Willocrissa • 14, Rest House Crescent • Bangalore 560 001 • 91-80-509-1320/21 • Fax: 91-80-509-1322

**ITALY:**

Viale San Gimignano, 38 • 20146 Milano • 02-48 39 16 01 • Fax: 02-48 30 22 74

**JAPAN:**

New Pier Takeshiba North Tower 13F • 11-1, Kaigan 1-chome • Minato-ku, Tokyo 105-0022 • 81-3-5733-7555 • Fax: 81-3-5733-7556

**KOREA:**

FL., URI Building • 2-14 Yangjae-Dong • Seocho-Gu, Seoul 137-130 • 82-2-574-7778 • Fax: 82-2-574-7838

**NETHERLANDS:**

Postbus 559 • 4200 AN Gorinchem • 0183-635333 • Fax: 0183-630821

**SWEDEN:**

c/o Regus Business Centre • Frosundaviks Allé 15, 4tr • 169 70 Solna • 08-509 04 679 • Fax: 08-655 26 10

**SWITZERLAND:**

Kriesbachstrasse 4 • 8600 Dübendorf • 01-821 94 44 • Fax: 01-820 30 81

**TAIWAN:**

1FL., 85 Po Ai Street • Hsinchu, Taiwan, R.O.C. • 886-3-572-9077 • Fax: 886-3-572-9031