

AMM1

Analog Measurement Module

The AMM1 Analog Measurement Module combines two important Series 500 functions into a single module: the AMM1 performs analog signal conditioning and switching, and A/D conversion. The analog section of the module provides signal selection and programmable gain for both local and global analog signals connected to the Series 500. After analog conditioning, signals are routed to the A/D converter section of the module for the analog-to-digital conversion process.

The AMM1 has a total of eight local single-ended inputs with unity (x1) local gain. Input signals are applied through on-card screw terminals. Global conditioning consists of a high-speed software-controlled gain amplifier with programmable x1, x2, x5, and x10 gain values. Since all analog inputs connected to the Series 500 pass through the global circuitry, these gain values can be applied to any analog input in the system.

For A/D conversion, the AMM1 utilizes a 12-bit successive approximation converter that provides fast, accurate measurement and conversion. A maximum conversion time of only 25 μ sec and a sample-and-hold acquisition time of 3 μ s allow sampling rates as high as 35.7kHz. To maximize resolution, the AMM1 has five A/D converter ranges (three bipolar, two unipolar) that can be selected by on-card DIP switches.

The AMM1 is designed to be used only in slot 1 of the system baseboard. To install the module, first remove the baseboard top cover and install the module in slot 1 with the component side facing the power supply.

CAUTION: Always turn off the system power before installing or removing modules. To minimize the possibility of EMI radiation, always operate the system with the top cover in place and properly secured.

User-Configured Components

User-configured components for the AMM1 include the input screw terminals and the switches that control A/D converter ranges, as summarized in Table 1. For the locations of these components, refer to Figure 1.

Table 1. AMM1 User-Configured Components

| Description | Designation | Function |
|-----------------|-------------|----------------------------|
| Screw Terminals | | Local inputs, channels 0-7 |
| DIP Switch Set | S101 | A/D Converter range |

All local input signals are applied to screw terminals, which are designed to accept 16-24 gage wire stripped 3/16 of an inch.

Figure 1. AMM1 Module Showing Input Terminals and A/D Converter Range Selection Switches

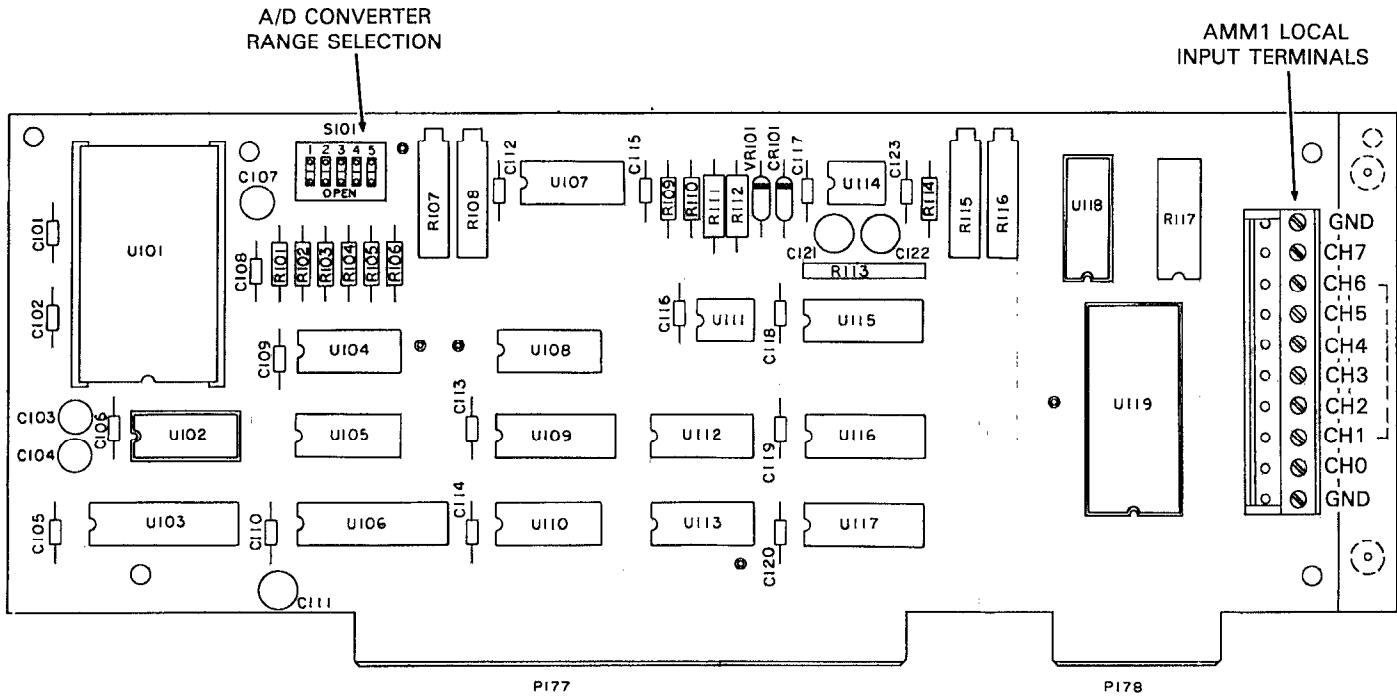

Switch S101 controls the input range of the A/D converter located on the module. Available bipolar ranges include -10 to $+10V$, -5 to $+5V$, and -2.5 to $+2.5V$. The unipolar ranges are 0 to $+10V$ and 0 to $+5V$.

Connection

Local input signals for channels 0 through 7 of the AMM1 are applied to screw terminals located at the back edge of the board. The channel numbers are marked on the board and are shown in Figure 1. Typical connections for channel 0 are shown in Figure 2. Note that the high side of the input signal is applied to the channel 0 terminal, and the low side of the signal is connected to module ground.

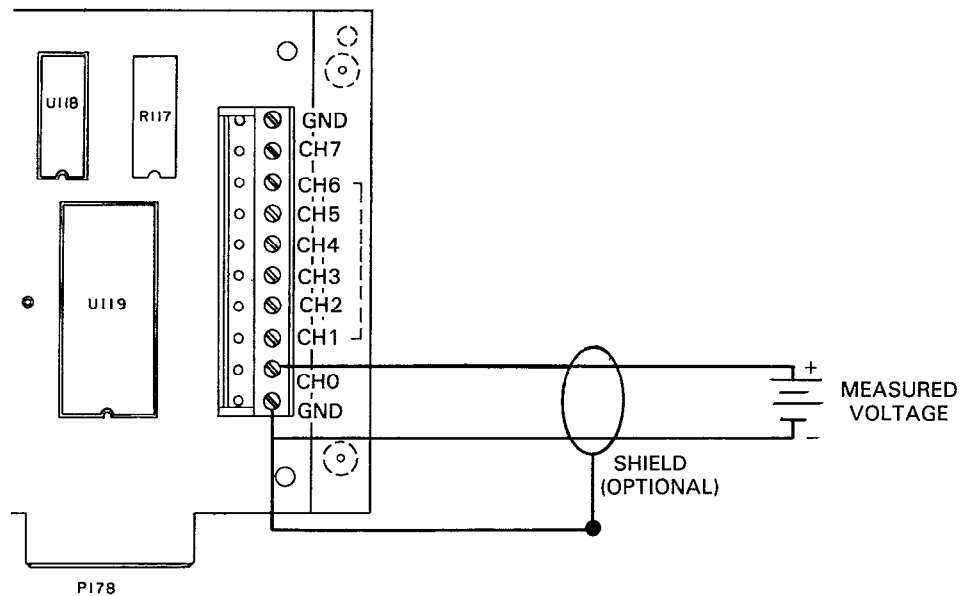

Figure 2. Typical Connection (Channel 0 Shown)

CAUTION: AMM1 inputs are non-isolated, meaning that one side of the input is connected to power line ground. Any signal connected to the AMM1 must also be referenced to power line ground, or module or system damage may occur. Also note the inaccuracies on other channels may result.

In many situations, shielded cable may be required to minimize EMI radiation, or to keep noise to a minimum. If shielded cable is used, connect the shield to ground only, and do not use the shield as a signal carrying lead. Usually, a module ground terminal should be used, but in some cases better results may be obtained by using one of the baseboard ground posts instead. Use the configuration that results in the lowest noise.

For shielding to be effective, the shield must contain both high and low signal wires, and must not carry any other signals. If a number of AMM1 signal input lines are shielded, all shields should be connected to the same ground terminal.

A/D Converter Range Selection

As shipped, the AMM1 is set up for the $\pm 10V$ range, but the module may be reconfigured to one of four other ranges by setting the five DIP switches located on S101 to the correct positions, as summarized in Table 2. To set the A/D converter to a specific range, first turn off system power and then set the switches to the correct positions, either open (off) or closed (on). For example, for the 0 to +5V range, switches 1, 3 and 4 should be closed (on), and switches 2 and 5 should be open (off).

NOTE: The module must be recalibrated if the range is changed. Turn to the Calibration Section of this chapter for AMM1 calibration information.

Table 2. S101 Settings for the A/D Converter Ranges

| Input Range | DIP Switches | | | | |
|---------------|--------------|--------|--------|--------|--------|
| | 1 | 2 | 3 | 4 | 5 |
| -10 to +10V* | Open | Closed | Open | Open | Closed |
| -5 to +5V | Open | Open | Closed | Open | Closed |
| -2.5 to +2.5V | Open | Open | Closed | Closed | Closed |
| 0 to +5V | Closed | Open | Closed | Closed | Open |
| 0 to +10V | Closed | Open | Closed | Open | Open |

*Factory default value

NOTE: A/D converter must be recalibrated if range is changed.

Signal Conditioning

A simplified block diagram of the AMM1 is shown in Figure 3. The module is divided into four general sections: a local multiplexer, a global multiplexer, a programmable gain amplifier (PGA) and a 12-bit A/D converter.

Local input signals from channels 0 to 7 are applied to the local multiplexer for selection. At any given time, only one channel will be selected, as determined by the SELECT CHANNEL command (covered later in this section). The signal from the selected channel is then routed to the global multiplexer for further signal selection and conditioning.

The global multiplexer selects a single signal from among the 10 slots in the signal. In this manner, signals from any of the 10 slots can be selected by software. The global multiplexer is controlled by the SELECT SLOT command, discussed later in this section.

After the signal is selected, the PGA applies software-selectable gains of x1, x2, x5, or x10. When this signal conditioning process is complete, the signal is routed to the 12-bit A/D converter for digitization. After the conversion process, digital data representing the applied signal travels via the baseboard and interface card to the host computer.

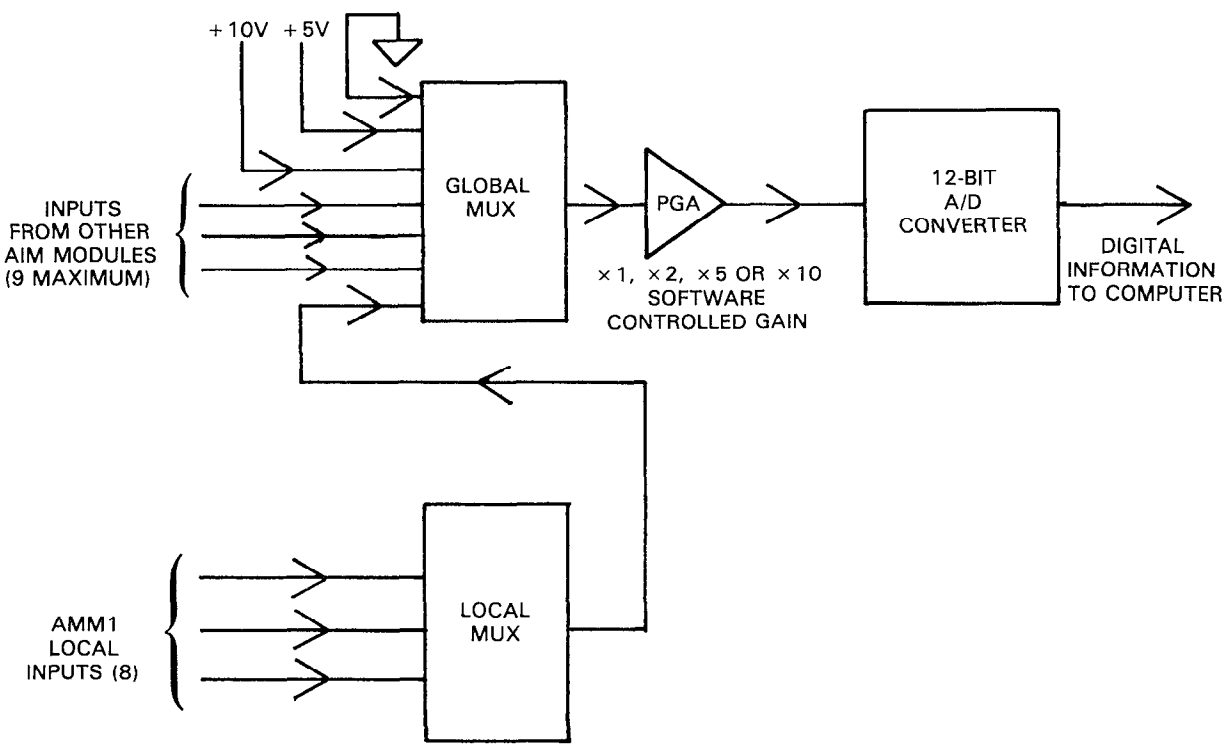

Figure 3. AMM1 Signal Conditioning

Input Filtering

Noise introduced into the input signal can corrupt the accuracy of the measurement. Such noise will usually be seen as an unsteady reading that jumps around, or, in some cases, as a constant offset. In the former case, the presence of noise will usually be quite obvious, but its effects may not be noticeable in the steady-state offset situation. Regardless of the type of noise, however, such unwanted signals can degrade measurement accuracy considerably if enough of the unwanted signal is present.

Frequently, noise is introduced into the signal from 50 or 60Hz power sources. In many cases, such noise can be attenuated by shielding the input signal lines, as discussed earlier. In more difficult situations, however, it may be necessary to filter the input signal to achieve the necessary noise reduction.

When noise is a problem, a single-pole low-pass filter like the one shown in Figure 4 can be connected between the input signal and the corresponding AMM1 channel. Note that the filter is made up of a single capacitor and resistor with the capacitor connected between the AMM1 channel input terminal and the module ground terminal. The resistor is then placed in series with the high input signal lead.

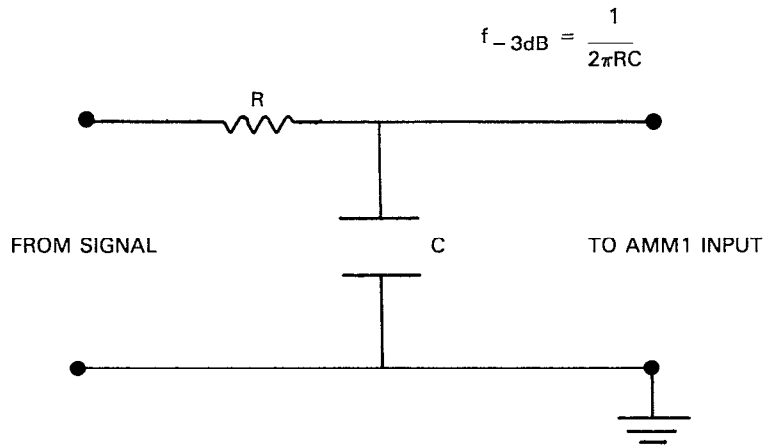

Figure 4. Input Filtering

A common yardstick for a simple filter like the one in Figure 4 is the -3dB or half-power point, which is given as follows:

$$f_{-3dB} = \frac{1}{2\pi RC}$$

where f is in Hz, C is in farads, and R is in ohms. Above this frequency, filter response will roll off (decrease) at a rate of -20dB per decade. Thus, each time the frequency increases by a factor of 10, the filter output voltage decreases by a factor of 10 (-20dB).

Although such filtering can quiet down a noisy signal, there is a trade-off in the form of increased response time. This response time may be important in the case of a rapidly changing input signal. For the filter in Figure 4, the response time to 1% of final value is 4.6RC, while the response time to 0.1% and 0.01% of final value are 6.9RC and 9.2RC, respectively.

As an example, assume that 10 counts of 60Hz noise is present in the input signal. To reduce the noise to one count, an attenuation factor of 10 (-20dB) at 60Hz will be necessary. Thus, the filter should have a -3dB point of 6Hz.

To determine the relative RC values, the above equations can be rearrange to solve for either R or C. If we wish to choose a nominal capacitor value and then solve for the resistance, we have:

$$R = \frac{1}{2\pi C f_{-3dB}}$$

Choosing a nominal value of 2 μ F for C, the necessary resistance is:

$$R = \frac{1}{2\pi(2 \times 10^{-6}) \times 6\text{Hz}}$$

$$R = 13.263\text{k}\Omega$$

The resulting response times with these R and C values would be:

$$\begin{aligned} t(1\%) &= 4.6RC = 122\text{ms} \\ t(0.1\%) &= 6.9RC = 183\text{ms} \\ t(0.01\%) &= 9.2RC = 244\text{ms} \end{aligned}$$

Note that there are a number of RC values that can be used in a given situation. To minimize the effects of the series resistance, however, it is recommended that the value of R be kept under 20k Ω .

Current-to-Voltage Conversion

AMM1 local inputs are designed to accept voltages in the range of $\pm 10\text{V}$. Thus, the AMM1 can be directly connected to many signal sources. Some transducers and instrumentation, however, provide current outputs that must be converted into voltages in order to be measured through an AMM1 input channel.

When connecting current inputs to the AMM1, a resistor should be installed across the input to make the necessary current-to-voltage conversion. One end of the resistor should be connected to the channel input terminals and the other end of the resistor should be connected to module ground.

The value of the resistor can be determined from Ohm's law as follows:

$$R = E/I$$

Where R is the resistance in ohms, E is the maximum desired voltage in volts (usually the upper range limit of the A/D converter), and I is the maximum anticipated current in amps.

As an example, assume the A/D converter range is 0 to +5V and that the expected current lies in the range of 4 to 20mA. The required resistance is:

$$R = 5/0.02$$

$$R = 250\Omega$$

Thus, a 250 Ω resistor should be installed across the input of the channel in question (note that a 250 Ω value is required when using Soft500 engineering units conversion). Since current measurement accuracy is directly related to the accuracy of the resistor, use the smallest tolerance resistor available (typically $\pm 0.1\%$). Suitable 250 Ω precision resistors can be purchased from Dale Resistors, P.N. RN55E2500B.

Analog-to-Digital Converter Timing

When programming high-speed sampling sequences, certain timing constraints concerning the A/D conversion cycle should be kept in mind. When the A/D START command is issued, the converter immediately begins to assess the value of the signal, a process that takes from 20 to 25 μ s to complete. During this period, the sample-and-hold circuitry remains in the hold mode, freezing the signal for the duration of the analog-to-digital conversion process. When the conversion has been completed, the new data is available for reading, and the sample-and-hold circuitry returns automatically to sample mode and begins to track the signal once again.

Because the signal may have changed significantly since the beginning of the last conversion, the sample-and-hold circuitry requires some time to adjust to the new signal voltage level. This time period is known as the "acquisition time" of the sample-and-hold circuitry and is typically 3 μ s for the AMM1 module. Thus, to ensure accuracy, a new conversion should not be triggered for at least 3 μ s following completion of the last conversion, and a total of 28 μ s must be allowed from the start of each conversion to the start of the next one (note that these times are automatically taken into account when using Soft500).

To increase system throughput, data latches have been provided on the AMM1, making data from the previous conversion available while the converter is busy processing another reading. The data is refreshed (updated) as soon as the converter has finished its current assessment (25 μ s after a conversion is triggered).

Using Additional Analog-to-Digital Modules

Some situations may call for the use of an additional A/D converter module in the system to supplement the A/D capabilities of the AMM1. In particular, it may be desirable to increase the resolution of the system by using a 14-bit ADM2 A/D converter in slot 2.

Note that only one AMM1 can be used in a given system since that module must be placed in slot 1.

When using an additional A/D converter module, the analog signal output of the AMM1 will be routed to that module via the daisy chain pathway on the system baseboard. Thus, it would be possible to process certain analog channels through the built-in 12-bit A/D converter of the AMM1, and route other, more critical signals through a separate 14-bit ADM2 module located in slot 2.

Commands

Commands used with the AMM1 are summarized in Table 3. Note that several commands share the CMDA and CMDB locations. The selected command will depend on whether a read or write operation is performed, as indicated in the table.

Table 3. Commands Used with the AMM1

| Command | Address | Signal line |
|------------------|----------------|--------------------|
| SELECT CHANNEL | CFF80 | CMDA (Write) |
| SELECT SLOT | CFF81 | CMDB (Write) |
| GLOBAL GAIN | CFF9A | CMDC |
| A/D LOW DATA | CFF80 | CMDA (Read) |
| A/D HIGH DATA | CFF81 | CMDB (Read) |
| A/D START/STATUS | CFF9B | CMDD |

SELECT CHANNEL

Location: CFF80

The SELECT CHANNEL command is used to control the local signal multiplexer on the AMM1, thus determining which of the local input channels is selected for A/D conversion. This command affects only those signals connected to the AMM1 local inputs, and does not affect input channels connected to modules located in other slots. SELECT CHANNEL must be used in conjunction with the SELECT SLOT command (discussed below) issued with a value of 1 in order to select slot 1.

To select the desired channel, write the appropriate value to the SELECT CHANNEL location, as summarized in Table 4. For example, if channel 7 is to be selected, write that value to the SELECT CHANNEL location, from BASIC, this value can be written with the POKE statement.

Table 4. Values Written to the SELECT CHANNEL Location

| Function | Binary | Hex | Decimal |
|-----------------|---------------|------------|----------------|
| Channel 0 | 00000 | H0 | 0 |
| Channel 1 | 00001 | H1 | 1 |
| Channel 2 | 00010 | H2 | 2 |
| Channel 3 | 00011 | H3 | 3 |
| Channel 4 | 00100 | H4 | 4 |
| Channel 5 | 00101 | H5 | 5 |
| Channel 6 | 00110 | H6 | 6 |
| Channel 7 | 00111 | H7 | 7 |

SELECT SLOT

Location: CFF81

The SELECT SLOT command controls the global multiplexer on the AMM1, selecting the appropriate slot on the Series 500 baseboard from which to read the input channel.

The value to be written to the SELECT SLOT location is always the same as the number of the slot to be selected, as summarized in Table 5. For example, if a signal connected to a channel on the AMM1 in slot 1 is to be selected, a value of 1 would be written to SELECT SLOT (the channel must also be selected with SELECT CHANNEL as discussed previously). Similarly, the values 2-10 would be written for slots 2-10 respectively. The BASIC POKE statement can be used to write the appropriate value to the SELECT SLOT location.

As indicated in Table 5, there are other values besides slot numbers that can be written to this location. These values select ground, +5V, and +10V sources and are intended primarily for diagnostic purposes.

Table 5. Values Written to the SELECT SLOT Location

| Function | Binary | Hex | Decimal |
|--------------------------|--------|-----|---------|
| Ground (0 volts) | 0000 | H0 | 0 |
| Slot 1 | 0001 | H1 | 1 |
| Slot 2 | 0010 | H2 | 2 |
| Slot 3 | 0011 | H3 | 3 |
| Slot 4 | 0100 | H4 | 4 |
| Slot 5 | 0101 | H5 | 5 |
| Slot 6 | 0110 | H6 | 6 |
| Slot 7 | 0111 | H7 | 7 |
| Slot 8 | 1000 | H8 | 8 |
| Slot 9 | 1001 | H9 | 9 |
| Slot 10 | 1010 | HA | 10 |
| +10V Reference | 1101 | HD | 13 |
| Ground (0 volts) | 1110 | HE | 14 |
| +5V Digital Power Supply | 1111 | HF | 15 |

GLOBAL GAIN

Location: CFF9A

The GLOBAL GAIN command controls the PGA (Programmable Gain Amplifier) located on the AMM1 module. Since all analog inputs are processed by the PGA, the GLOBAL GAIN command affects every analog input connected to the Series 500. To avoid random gain factors, this command must be issued at least once after the Series 500 has been powered on. Once the gain value has been selected, it is not necessary to reissue GLOBAL GAIN unless a different PGA gain is desired. The gain factor may, however, be updated before each A/D conversion, as required.

Four programmable gain values, x1, x2, x5, and x10, are available with the PGA. These gains are selected by writing the appropriate number to the GLOBAL GAIN location, as summarized in Table 6. The BASIC POKE statement can be used to write to the desired GLOBAL GAIN location. For example, to select a PGA gain of x5, the value 2 would be written to the GLOBAL GAIN location.

Table 6. Values Written to the GLOBAL GAIN Location

| PGA Gain | Binary | Decimal |
|-----------------|---------------|----------------|
| x1 | 00 | 0 |
| x2 | 01 | 1 |
| x5 | 10 | 2 |
| x10 | 11 | 3 |

A/D LOW DATA

Location: CFF80

The A/D LOW DATA location is used to read the low byte of the results of the A/D conversion process. Since the module incorporates data latches, one conversion may be read while another conversion is in progress. To find out when data from one conversion is available, use the A/D START/STATUS command, discussed below.

A/D LOW DATA shares the CMDA location with the SELECT CHANNEL command. Thus, A/D LOW DATA is a **read-only** command; do not attempt to write to A/D LOW DATA, as this may change the selected channel. To read A/D LOW DATA from BASIC, use the PEEK statement with the appropriate address in the argument.

A/D HIGH DATA

Location: CFF81

The A/D HIGH DATA command performs essentially the same function as the A/D LOW DATA command, except that the high data byte is returned.

A/D HIGH DATA is a **read-only** command that shares the CMDDB location with SELECT SLOT. Any attempt to write to A/D HIGH DATA may alter the selected slot and give erroneous results.

Since the AMM1 has a 12-bit converter, the four most significant bits of the high byte returned by A/D HIGH DATA are not used. These four most significant bits will always be set high and should be masked out when interpreting the reading. From Pascal or BASIC, masking can be done by subtracting 240 from the high byte value (240 is the value of the four most significant bits when all are high). From assembly language, masking the high byte of the returned data can be performed by ANDing with H0F. Doing so will change the four most significant bits from 1s to 0s.

Once both the low and the high data bytes have been obtained, the total number of counts representing A/D converter data can be determined with the following BASIC formula:

$$\mathbf{CO = DL + 256*(DH-240)}$$

CO represents the number of counts, and DL and DH are the low and high bytes respectively. Since the AMM1 uses a 12-bit converter, the number of counts will lie in the range of 0 to 4095.

A/D START/STATUS

Location: CFF9B

The A/D START/STATUS command has two functions: to start the A/D conversion process, and to determine whether or not the A/D converter is busy processing a reading.

Writing to the A/D START/STATUS location will trigger (start) the A/D conversion cycle. Although any value (0-255) can be written to trigger a conversion, a value of 255 should be used to minimize noise.

The A/D conversion cycle takes approximately $25\mu\text{s}$. During this period, the converter should not be re-triggered. Status of the converter can be checked by reading the A/D START/STATUS location. The returned value will depend on whether the converter is ready or busy (see Table 7). To allow sufficient sample-and-hold settling time, a new conversion should be triggered less than $3\mu\text{s}$ after the previous conversion has been completed.

Table 7. Values Read from the A/D START/STATUS Location

| Converter Status | Binary | Hex | Decimal |
|------------------|----------|-----|---------|
| Busy | 11111111 | HFF | 255 |
| Ready | 01111111 | H7F | 127 |

Calibration

This section contains calibration procedures for the AMM1 module. Note that these procedures are intended for use in the field and may not be as accurate as those used at the factory. Calibration accuracy depends both on the accuracy of the equipment used in the procedure as well as the skill of the individual. If you are not familiar with calibration equipment, do not attempt AMM1 calibration.

Environmental Conditions

Calibration should be performed at an ambient temperature of 23°C ($\pm 5^{\circ}$). Turn on the system power and allow it to warm up for at least 10 minutes before beginning the calibration procedure.

Recommended Calibration Equipment

The following equipment is recommended for AMM1 calibration. Other equipment may be used as long as the corresponding specifications are at least as good as those given below.

1. Keithley Model 192 DMM (0.005% basic DC accuracy).
2. EDC Model E100C Millivolt Reference Source (0.005% accuracy).

Calibration Procedures

Use the following procedures to calibrate the PGA, A/D converter, and 10V reference source located on the AMM1 card. Note that the PGA must be properly calibrated before attempting A/D converter calibration. Adjustments, test points, and input connections are shown in Figure 5.

PGA Offset Adjustment

Use the following procedure to null out any offset present in the PGA.

1. Connect a jumper wire between the channel 0 input terminal and a module ground terminal.
2. Connect the DMM high input lead to TP1 (output of the PGA). Connect the DMM low lead to a module ground terminal. Select DCV and autoranging.
3. POKE the SELECT CHANNEL location (CFF80) with a value of 0 in order to select channel 0. POKE the SELECT SLOT location (CFF81) with a value of 1 in order to select slot 1.
4. Select a PGA gain of x10 by POKEing a value of 3 to the GLOBAL GAIN location (CFF9A).
5. Adjust the PGA offset control (R115) for a reading of 0.000V on the DMM.
6. Remove the jumper wire connected between channel 0 and ground.

A/D Converter Calibration

Use Program 1 below as an aid in the following A/D converter calibration procedure. Note that the converter must be recalibrated if the range is changed. Switch positions, and applied signals for the offset and gain calibration points are summarized in Table 8.

1. Select the A/D converter range to be calibrated by setting the switches to the correct positions, as indicated in Table 8.
2. Connect the DC calibrator high signal lead to the channel 0 input terminal. Connect the low calibrator signal lead to module ground. Use shielded cable, but do not use the shield as a signal-carrying lead. Connect the shield to module ground only.
3. Enter and run Program 1 below.
4. Set the calibrator output voltage to the offset calibration voltage for the selected range, as outlined in Table 8. For example, on the 0 to +10V range, apply 0.0024V.
5. Adjust the A/D converter offset control (R107) for a reading of 1 count on the computer CRT.
6. Set the DC calibrator to the gain calibration voltage listed in Table 8 for the selected range. For example, on the 0 to +10V range, the correct value is 9.9951V.
7. Adjust the A/D control (R108) for a reading of 4094 counts on the computer CRT.
8. Repeat steps 4 through 7 until no further change is seen when changing from the offset value to the gain value.

Figure 5. AMM1 Calibration Adjustment and Test Point Locations

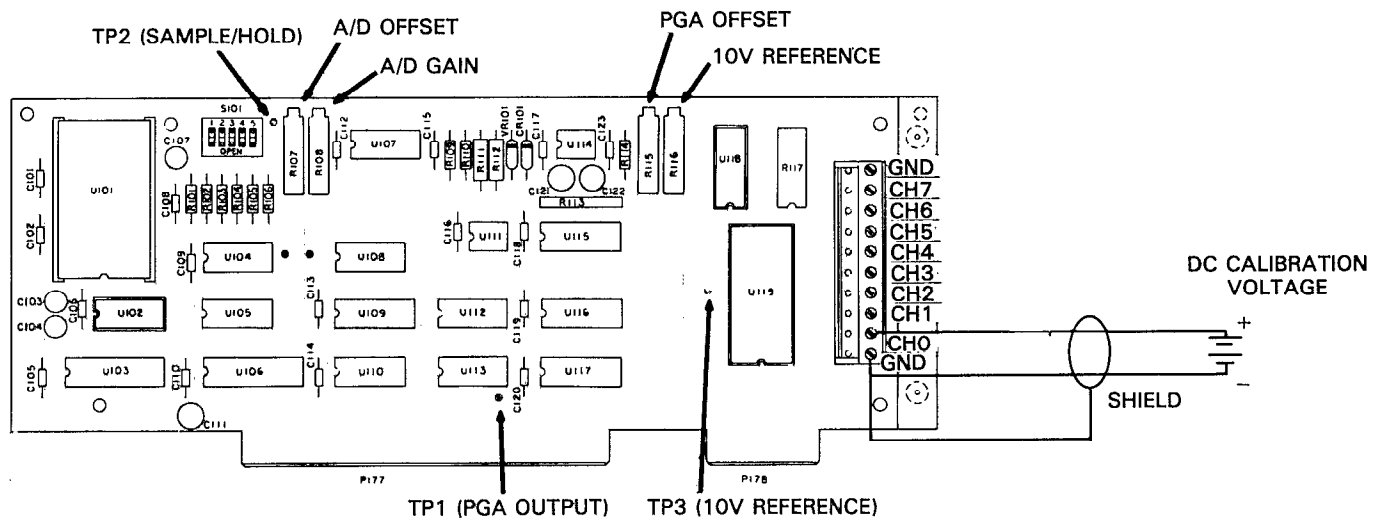

Program 1. AMM1 A/D Converter Calibration

```
10 DEF SEG = &HCFF0:A = &H80:B = &H81:C = &H9A:D = &H9B
20 POKE A,0:POKE B,1:POKE C,0
30 POKE D,255
40 DL = PEEK(A):DH = 256 * (PEEK(B) - 240)
50 R = DL + DH
60 PRINT R
70 GOTO 30
```

Table 8. A/D Converter Ranges and Calibration Values

| Range | DIP Switches* | | | | | Applied Voltage | |
|---------------|---------------|---|---|---|---|---------------------|-----------------------|
| | 1 | 2 | 3 | 4 | 5 | Offset (1 count) | Gain (4094 counts) |
| -10 to +10V | O | C | O | O | C | -9.9951V | +9.9902V |
| -5 to +5V | O | O | C | O | C | -4.9976V | +4.9951V |
| -2.5 to +2.5V | O | O | C | C | C | -2.4988V | +2.4976V |
| 0 to +5V | C | O | C | C | O | +0.0012V | +4.9976V |
| 0 to +10V | C | O | C | O | O | +0.0024V | +9.9951V |

*C = Closed; O = Open

10V Reference Source Calibration

The 10V reference source is used by some other modules in the system as an accurate DC reference. Thus, miscalibration of this source could affect measurement accuracy of those modules. Use the following procedure to adjust the 10V reference.

1. Connect the DMM high lead to TP3 on the module. Connect the DMM low lead to module ground.
2. Select DCV and set the DMM to the 20V or similar range.
3. Adjust the +10V source adjustment (R116) for a reading of exactly 10.000V on the DMM.

Theory of Operation

For the following discussion, please refer to the schematic diagram located on drawing number 500-446.

AMM1 circuitry is divided into four sections: local analog selection circuitry, global selection and conditioning circuitry, analog-to-digital conversion circuitry, and 10V reference.

Local Circuitry

Local selection circuitry is made up of ICs U109 and U118. U118 is an eight channel analog multiplexer IC (6108). Local analog inputs from channels 0-7 are applied to the screw terminals through input protection resistors (R117) to the S1-S8 inputs of U118. The output of the local multiplexer is applied to the global multiplexer discussed below.

The local multiplexer is controlled by U109, a quad transparent latch (74LS75). This latch is controlled by both the CMDA and R/W lines. When both these lines are low (as when the SELECT CHANNEL command is executed), data contained on the D0 through D2 lines is latched into U118, thus selecting the channel determined by the condition of those three data lines.

Global Circuitry

Global circuitry on the AMM1 consists of a 16-channel analog multiplexer and a programmable gain amplifier (PGA). The multiplexer selects among the 10 slots in the system, while the PGA applies selectable x1, x2, x5, or x10 gain values to all analog signals input to the system.

U119, a 16-channel multiplexer (6116), provides the global selection for the Series 500. Ten U119 inputs are from slots 1 to 10, while other inputs allow selection of analog ground, +5V digital, or +10V reference signals. The multiplexer IC is controlled by U117, a quad transparent latch (74LS75). This latch is controlled by the CMDB and R/W lines through U112. When CMDB and R/W are both low (as when the SELECT SLOT command is executed), the data contained on the D0 and D3 data lines will be latched into U117, selecting the appropriate slot or signal via U119.

The output of the global multiplexer is applied to the PGA, U111. The gain of this operational amplifier can be set to one of four values: x1, x2, x5, or x10. The gain of the amplifier is given by:

$$A = 1 + R_f/R_i$$

where R_f and R_i are elements of R113. The exact configuration of these elements is determined by U115. For example, when x5 gain is selected, only S3 in U115 is closed. Thus, R_f has a value of 16k Ω , and R_i has a value of 4k Ω . From the above formula, it can be seen that the correct gain value of x5 will be applied under these conditions.

The gain circuitry is controlled by U116, a quad transparent latch (74LS75). This latch is controlled by the CMDC lines of the baseboard. When the GLOBAL GAIN command is issued, the data contained on D0 and D1 is latched into U115, thereby setting the PGA gain to the programmed value.

A/D Converter

The output of the PGA is applied to the sample-and-hold circuitry (U107). The hold mode of this IC is triggered on receipt of the A/D START/STATUS command. It stays in hold until the status line of the A/D converter goes low, indicating conversion is complete.

From the sample-and-hold circuitry, the signal is routed to S101, which sets the A/D converter range. From S101, the signal travels to the A/D converter input terminals (U101).

The 12-bits of the converter outputs are inverted by elements of U102 and U105 and applied to tri-state latches, U103 and U106 (74LS374). These latches are controlled by the R/W, CMDA, and CMDB lines via elements of U113. When R/W is high, the appropriate latch will be enabled, depending on whether CMDA or CMDB is low. U103 will be enabled when CMDA is low, thus allowing the low data byte to be placed on the data bus. In a similar manner, the high data byte (of which only four bits are used) will be placed on the data bus when U106 is enabled by setting CMDB low.

Calibration potentiometers R107 and R108 provide the offset and gain, respectively, of the A/D converter. The sample-and-hold needs no offset adjustment because the A/D converter offset adjustment has sufficient range to compensate for both offsets.

10V Reference

The 10V source located on the AMM1 is used by other Series 500 modules, such as the AIM3 and AIM7. The reference circuitry consists of U114 and associated components. The output of the 10V reference is applied to the slot connector as well as to the global multiplexer located on the AMM1.

VR101, a zener diode, provides a stable voltage reference for the 10V reference circuitry. U114 acts as a constant current source to keep zener voltage variations to a minimum. Adjustment of the voltage output is performed by R116, which has a limited range of adjustment.

Troubleshooting Information

Use the information contained in Table 9 to troubleshoot the AMM1. To read back digital data from the module, use the program located in the calibration section. The information contained on the component layout drawing (500-440) and schematic diagram (500-446) will also be an essential aid in troubleshooting.

Replacement parts for the AMM1 can be obtained from Keithley Data Acquisition and Control. Part numbers are listed on the component layout drawing.

Table 9. AMM1 Troubleshooting

| Step | Item/Component | Required Condition | Remarks |
|-------------|-----------------------|--|--------------------------------|
| 1 | AMM1 module | Install in slot 1 | Turn power on |
| 2 | Computer | POKE SELECT CHANNEL with 0 | Select channel 0 |
| 3 | Computer | POKE SELECT SLOT with 1 | Select slot 1 |
| 4 | Computer | POKE GLOBAL GAIN with 0 | x1 gain |
| 5 | Channel 0 | Apply +10V input | Reference to ground |
| 6 | TP1 | +10V | Reference to ground |
| 7 | Channel 0 | Apply +5V input | |
| 8 | Computer | POKE GLOBAL GAIN with 1 | x2 gain |
| 9 | TP1 | +10V | |
| 10 | Channel 0 input | Apply +2V | |
| 11 | Computer | POKE GLOBAL GAIN with 2 | x5 gain |
| 12 | TP1 | +10V | |
| 13 | Channel 0 | Apply +1V input | |
| 14 | Computer | POKE GLOBAL GAIN with 3 | x10 gain |
| 15 | TP1 | +10V | |
| 16 | Channel 1-7 inputs | Apply +1V | POKE SELECT CHANNEL |
| 17 | TP1 | +10V | |
| 18 | Channel 0 input | Repeat steps 5-17 with negative voltages | |
| 19 | Computer | POKE GLOBAL GAIN with 0 | x1 gain |
| 20 | Computer | POKE SELECT CHANNEL with 0 | Select channel 0 |
| 21 | Channel 0 | Apply 0 count value | Depends on A/D converter range |
| 22 | Computer | Read back 0 counts | Use Program 1 |
| 23 | Channel 0 value | Apply 4095 count converter range | Depends on A/D range |
| 24 | Computer | Read back 4095 counts | Use Program 1 |

AMM1 Specifications

Input channels

Global: 8 inputs from slots 3-10

Local: 8 single-ended

Global programmable gain amplifier:

Software Programmable gains: x1, x2, x5, x10

Input range:

x1, $\pm 10V$

x2, $\pm 5V$

x5, $\pm 2V$

x10, $\pm 1V$

Accuracy: $\pm(0.01\% + 50\mu V)$

Non-linearity: $\pm 0.005\%$ of full scale

Temperature coefficient: $\pm(0.001\% + 20\mu V/^\circ C)$

Input noise voltage: $30\mu V$ p-p, 0.1Hz to 10kHz

Settling time to 0.01%: $6\mu s$

Small signal bandwidth: 280kHz

Analog-to-Digital converter

Resolution: 12 bits, 1 part in 4096

Input ranges: $\pm 2.5V$, $\pm 5V$, $\pm 10V$, 0 to $+5V$, 0 to $+10V$

Nonlinearity: $\pm 0.025\%$ (± 1 lsb)

Nonlinearity temperature coefficient: $\pm 0.003\%/^\circ C$

Accuracy*: $\pm(0.03\% + 1$ lsb)

Accuracy temperature coefficient: $\pm(0.0035\% \pm 0.11$ lsb) $/^\circ C$

Sample-and-hold acquisition time: $5\mu s$

Conversion time: $25\mu s$ max

Global 10.000V reference

Accuracy: $\pm 0.01\%$

Temperature coefficient: $\pm 0.002\%/^\circ C$

Load current: 10mA max

Noise:

$20\mu V$ p-p, 0.1Hz to 10Hz

$10\mu V$ RMS, 10Hz to 30kHz

NOTE: All amplifier specifications are with respect to input.

*Includes nonlinearity.

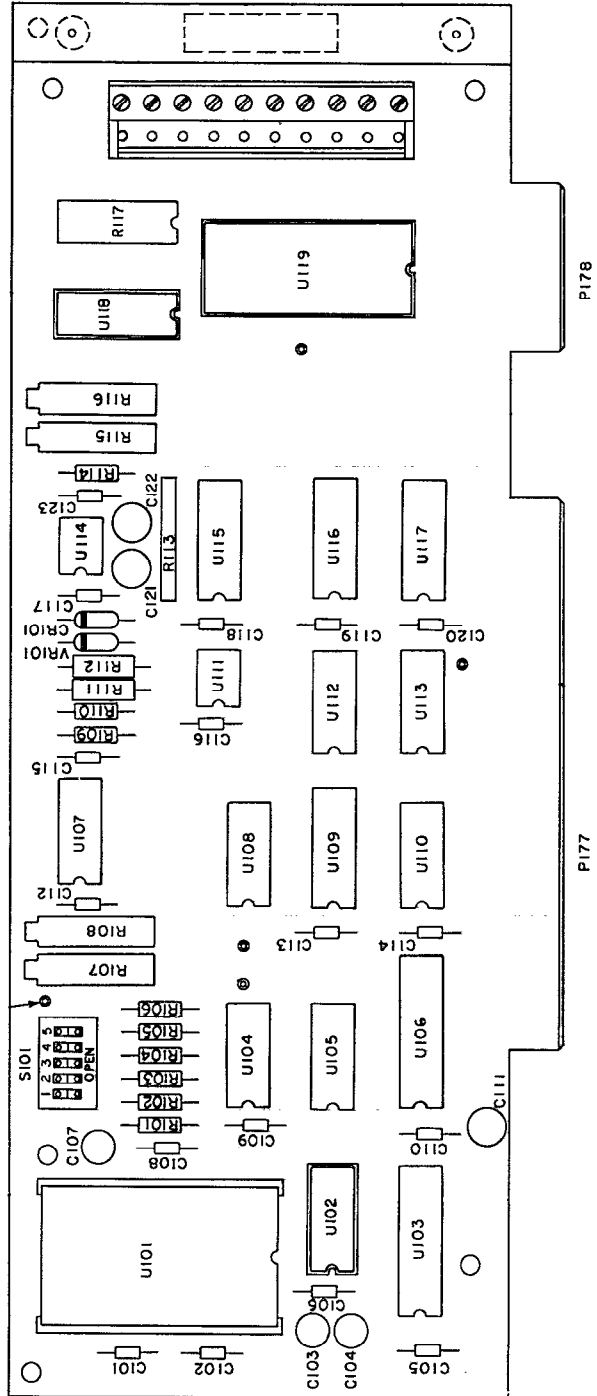

AMM1 COMPONENT LAYOUT

PARTS LIST

| ITEM | PART NO. | SCHEM. DESIG. | ZONE |
|------|-----------|---------------|------|
| 1 | 500-442 | HOLE SIZE | A2 |
| 2 | | | |
| 3 | | | |
| 4 | | | |
| 5 | C-365-0J | C101 | B2 |
| 6 | " | C102 | " |
| 7 | C-314-1.5 | C103 | B3 |
| 8 | " | C104 | " |
| 9 | C-365-0J | C105 | " |
| 10 | " | C106 | " |
| 11 | C-314-L5 | C107 | B2 |
| 12 | C-365-0J | C108 | " |
| 13 | " | C109 | " |
| 14 | " | C110 | B3 |
| 15 | C-314-10 | C111 | " |
| 16 | C-365-0J | C112 | C2 |
| 17 | " | C113 | C3 |
| 18 | " | C114 | " |
| 19 | " | C115 | C2 |
| 20 | " | C116 | D2 |
| 21 | " | C117 | " |
| 22 | " | C118 | " |
| 23 | " | C119 | D3 |
| 24 | " | C120 | " |
| 25 | C-314-10 | C121 | D2 |
| 26 | " | C122 | " |
| 27 | C-365-0J | C123 | " |
| 28 | | | |
| 29 | | | |
| 30 | | | |

| ITEM | PART NO. | SCHEM. DESIG. | ZONE |
|------|--|---------------|------|
| 31 | R-88-110K | R101 | B2 |
| 32 | " | R102 | " |
| 33 | R-88-22JK | R103 | " |
| 34 | R-88-215K | R104 | C2 |
| 35 | " | R105 | " |
| 36 | R-88-6.81K | R106 | " |
| 37 | RP-89-10K | R107 | " |
| 38 | " | R108 | " |
| 39 | R-88-1.82K <small>MAX. OF 100-100</small> | R109 | D2 |
| 40 | R-88-1.82K | R110 | " |
| 41 | R-263-2.78K | R111 | " |
| 42 | R-263-4.59K | R112 | " |
| 43 | TF-174 | R113 | " |
| 44 | R-88-2K | R114 | " |
| 45 | RP-89-10K | R115 | " |
| 46 | RP-89-200 | R116 | E2 |
| 47 | TF-177-1 | R117 | " |
| 48 | | | |
| 49 | | | |
| 50 | | | |
| 51 | RF-28 | CR101 | D2 |
| 52 | | | |
| 53 | | | |
| 54 | | | |
| 55 | RF-28 <small>MAX. OF 100-100</small> | VR101 | D2 |
| 56 | | | |
| 57 | | | |
| 58 | | | |
| 59 | IC-371 | U101 | B2 |
| 60 | IC-186 | U102 | B3 |

| ITEM | PART NO. | SCHEM. DESIG. | ZONE |
|------|----------|---------------|------|
| 61 | IC-242 | U103 | B3 |
| 62 | IC-144 | U104 | C2 |
| 63 | IC-186 | U105 | C3 |
| 64 | IC-242 | U106 | " |
| 65 | IC-430 | U107 | C2 |
| 66 | IC-179 | U108 | " |
| 67 | IC-366 | U109 | C3 |
| 68 | IC-384 | U110 | " |
| 69 | IC-342 | U111 | D2 |
| 70 | IC-179 | U112 | D3 |
| 71 | IC-163 | U113 | " |
| 72 | IC-342 | U114 | D2 |
| 73 | IC-267 | U115 | " |
| 74 | IC-366 | U116 | D3 |
| 75 | " | U117 | " |
| 76 | IC-267 | U118 | E2 |
| 77 | IC-365 | U119 | E3 |
| 78 | | | |
| 79 | | | |
| 80 | | | |
| 81 | SW-450-5 | SI01 | B2 |
| 82 | | | |
| 83 | | | |
| 84 | | | |
| 85 | SO-70 | I REQ'D | A3 |
| 86 | SO-65 | " | E1 |
| 87 | SO-97 | " | B1 |
| 88 | SO-69 | " | F4 |
| 89 | | | |
| 90 | | | |

| ITEM | PART NO. | SCHEM. DESIG. | ZONE |
|------|----------------|---------------|----------|
| 91 | CS-521-2 | J176 | F2 |
| 92 | | | |
| 93 | | | |
| 94 | | | |
| 95 | MC-285 | I REQ'D | F2 |
| 96 | | | |
| 97 | | | |
| 98 | | | |
| 99 | 500-323 | I REQ'D | F3 |
| 100 | 500-322 | " | " |
| 101 | 6-32X 1/16 PPH | 2 REQ'D | " |
| 102 | | | |
| 103 | | | |
| 104 | | | |
| 105 | 24249A | 5 REQ'D | C2,D3,E3 |
| 106 | | | |
| 107 | | | |
| 108 | | | |
| 109 | | | |
| 110 | | | |
| 111 | | | |
| 112 | | | |
| 113 | | | |
| 114 | | | |
| 115 | | | |
| 116 | | | |
| 117 | | | |
| 118 | | | |
| 119 | | | |
| 120 | | | |

* DENOTES SELECTED VALUE.

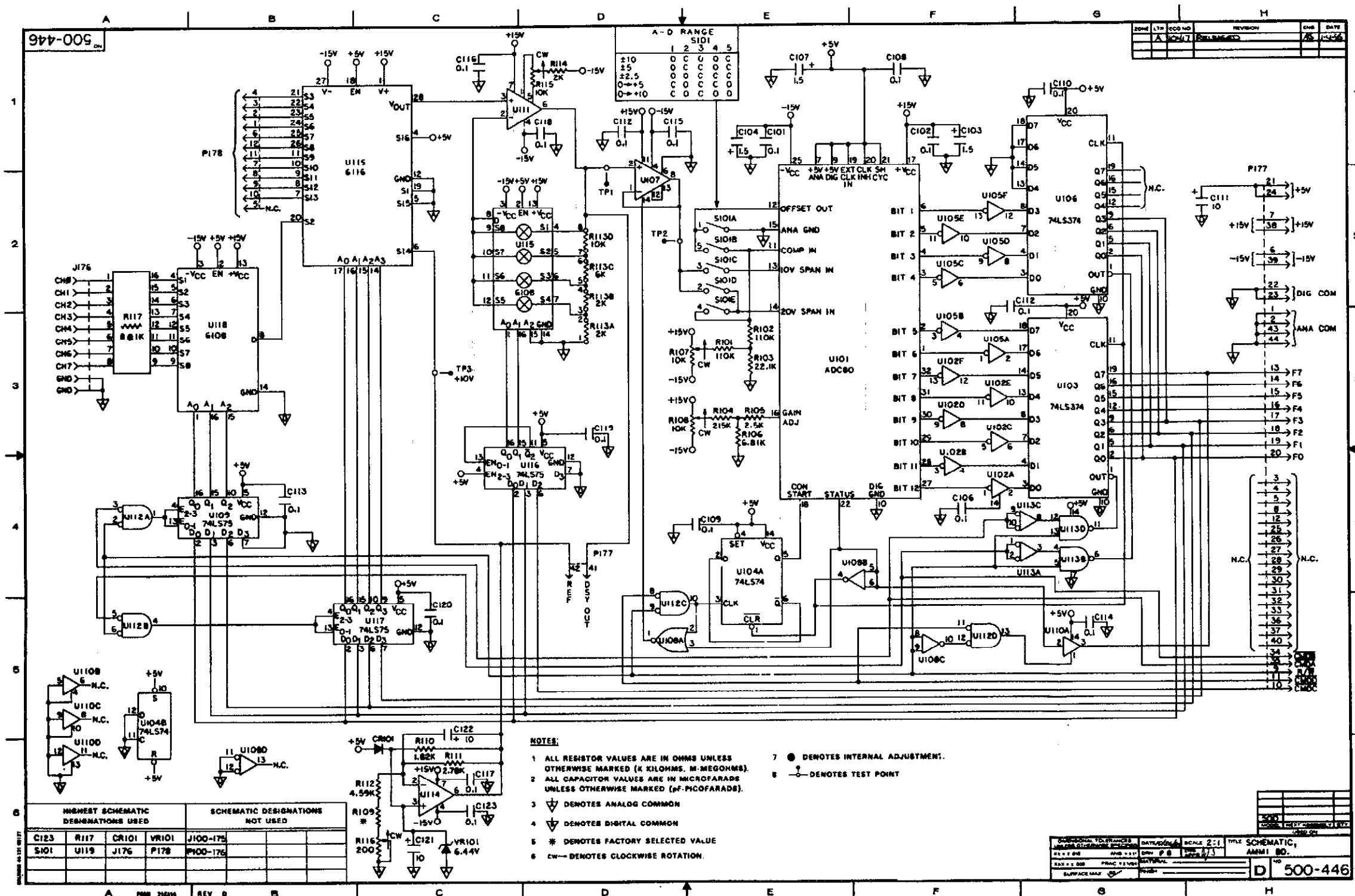

AMM1 SCHEMATIC DIAGRAM