

AIM4

Isolated High-Level Analog Input Module

The AIM4 Isolated High-Level Analog Input Module provides isolation and signal conditioning for four channels of voltage input (from $\pm 50\text{mV}$ to $\pm 5\text{V}$) or current loop input. Because the input channels are completely isolated from other channels and from the system ground, the AIM4 module accepts signals with common mode voltages as high as $\pm 500\text{V}$, and provides protection to $\pm 130\text{V}$ (normal mode). Channel-to-channel isolation is 500V .

The AIM4 module provides switch selected gains of $\times 1$ or $\times 100$. By changing resistor and potentiometer values, individual local gains can be selected for each channel.

The AIM4 module may be placed in slots 3-10 of the baseboard (slots 2-10 if AMM1 is used). To install the module, remove the top cover and insert the module in the desired slot with the component side facing the power supply. Place the AIM4 module as far from the power supply as possible to minimize noise and thermal effects.

CAUTION: Always turn off the power before installing or removing modules. To minimize the possibility of EMI radiation, never operate the system with top cover removed. Connect the + and - inputs of unused channels together.

User-Configured Components

Gain amplification for each channel can be changed by setting switches S101-S104 to the desired positions ($\times 1$ or $\times 100$). As shipped the AIM4 is configured for $\times 1$ gain (see Figure 1).

Installing resistors in the appropriate locations provides current to voltage conversion, allowing connection of current loop inputs.

All inputs are connected to a bank of screw terminals, which provides positive and negative (high and low) terminals for each of the four input channels. See Table 1 for summary of user-configured components.

Table 1. User-Configured Components on the AIM4

Name	Designation	Function
Switches 101-104	S101, S102, S103, S104	Gain setting, channel 0, 1, 2, 3 ($\times 1$ or $\times 100$)
Potentiometer	R101, R105, R109, R113	Trim gain for each channel
Resistors	User Installed	Optional current voltage resistors.
Screw Terminals	162	Input screw terminals, channels 0-3

CAUTION: Maximum input with x1 gain is $\pm 5V$. Maximum input with x100 gain is $\pm 50mV$.

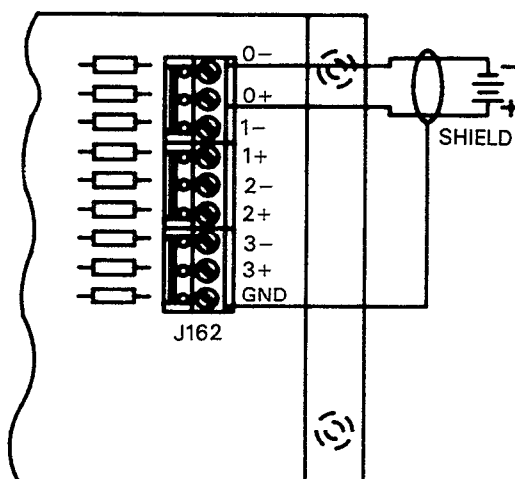

Figure 2. Typical AIM4 Connections

Gain Adjustment

Switches S101-S104 set the gain applied to channels 0-3 to either x1 or x100. To set the gain, place the switch in the desired position. Note that the module is configured for x1 gain as shipped. Remember that the maximum input voltage is $\pm 5V$ (x1 gain) or $\pm 50mV$ (x100 gain). The maximum signal output range of the AIM4 module is $\pm 5V$. Do not apply gains when the resulting voltage will exceed $\pm 5V$ or measurement errors will result.

By changing the values of user-installed resistors, alternate gain factors can be applied to signals connected to the AIM4 module. In this way, the gain for each channel can be determined.

The selection of a resistor should be based on the following formula:

$$G = 1 + 10,000/R$$

Where G is the gain applied to the signal and R is the value in ohms of the installed resistor.

Gain Trimming

Potentiometers R101, R105, R109 and R113 are provided for trimming the gain resistors R102, R106, R110 and R114. If new gain resistors are reinstalled, different potentiometers may be required.

The relationship of the potentiometers and the gain resistor on the total resistance is described by the formula:

$$R_T = \frac{R_R R_P}{R_R + R_P}$$

Where R_T is the total resistance (the value which ultimately affects the gain factor), R_R is the value in ohms of the gain resistor, and R_P is the value in ohms of the potentiometer (trimmed to the desired value).

Current Inputs

With the installation of optional resistors in user-installed locations, the AIM4 module can be configured to accept floating current loop inputs. The resistors are installed between the high and low input terminals converting the current range of the signal to an appropriate voltage range.

The selection of the resistor is based on Ohm's law:

$$E = I \cdot R$$

Voltage (volts) = Current (amps) * Resistance (ohms)

Because the AIM4 module has an input range of $\pm 5V$ (with $\times 1$ gain), these resistors must convert the expected current range into a voltage range within these limits. Therefore, volts should be set to 5, and current set to the upper limit of the expected current range.

With a signal expected to range from 4 to 20mA, for example, Ohm's law yields the following equation:

$$\begin{aligned} 5 \text{ (volts)} &= .02 \text{ (amps)} \cdot R \text{ (resistance)} \\ R &= 250 \end{aligned}$$

As a result, a 250 Ω resistor should be installed for that signal range. The resulting voltage range of 1 to 5V can be further amplified by the PGA (on the AIM1 module) if the input range of the A/D converter is set to $\pm 10V$, or 0-10V.

If there are several loads on the loop (if, for example, an analog chart recorder is being driven at the same time), the compliance voltage at the current loop transmitter may be exceeded. If this is the case, a smaller resistor (possibly 25 Ω) can be installed, and more gain applied to the signal, either globally at the PGA, or locally by changing resistors.

Additional loads in series with the current loop can be connected on either side of the isolated input.

Maintaining Accuracy

Each of the four inputs on the AIM4 module has a separate isolated input stage, each of which feeds a signal to a common output stage. Each input stage has a separate adjustment potentiometer, making it possible to null the input offset. A single adjustment takes care of any output offset. To maintain AIM4 accuracy, the following procedure should be used:

1. Connect a jumper between the + and – inputs of channel 0.
2. Set the gain switch for channel 0 to the x1 position and adjust the output offset control (R119) for a zero reading.
3. Set the gain switch to the x100 position.
4. Adjust the channel 0 input potentiometer (R104) so that a value of 0V is read back from the module.
5. Set the gain switch to the x100 position for each of the other channels.
6. Short the inputs to each of the other three channels and adjust the respective input offset potentiometers for a zero reading. (R10 channel 1, R112 = channel 2, R116 = channel 3).
7. The gain potentiometer for each channel can now be adjusted for x100 gain (50mV input = 5V output).
 - R101 = Channel 0 Gain
 - R105 = Channel 1 Gain
 - R109 = Channel 2 Gain
 - R113 = Channel 3 Gain

Input Attenuation

The AIM4 module may be modified to apply a 100:1 attenuation factor to the input signal, thus allowing the module to measure voltages up to $\pm 100\text{V}$. To modify the AIM4, install a 10Ω resistor in the user installed location for the channel in question. Remove the input inductor for that channel (E102 for channel 0, E104 for channel 1, E106 for channel 2, and E108 for channel 3). In its place, install $990\text{k}\Omega$ resistor. To maintain system accuracy, both resistors should have a maximum tolerance of $\pm 0.1\%$ *

When reading data back from a modified channel, you must correct for the attenuation factor in order to obtain a correct reading. When using commands listed in this manual, simply multiply the voltage reading obtained by a factor of 100. When using the Soft500 system, a similar correction factor must be applied. These correction factors are exclusive of other factors necessary because of certain parameters within the system (such as global gain applied by the AIM1 module).

*May be obtained from Keithley Data Acquisition and Control. Order part number R-263-10k for the 10Ω resistor. Order R-282-90k and R-282-900k and connect in series to make up $990\text{k}\Omega$.

Commands

The AIM4 module commands are summarized in Table 2. The locations of slot-dependent commands are presented in Table 3.

Table 2. Commands used with AIM4

<u>Command</u>	<u>Location</u>
SELECT CHANNEL	CMDA (Slot-dependent)

Table 3. Locations for Slot-dependent CMDA

<u>Slot</u>	<u>Location</u>
Slot 3	CFF84
Slot 4	CFF86
Slot 5	CFF88
Slot 6	CFF8A
Slot 7	CFF8C
Slot 8	CFF8E
Slot 9	CFF90
Slot 10	CFF92

SELECT CHANNEL

Location: Slot-dependent CMDA

The SELECT CHANNEL command location is used by all analog input modules to select individual channels for A/D conversion. When selecting a channel, the number of that channel is written into the CMDA location. On the AIM4 module four channels, numbered 0-3, can be selected with the SELECT CHANNEL command.

SELECT CHANNEL should precede the SELECT SLOT command, which should be issued with the number of the slot in which the AIM4 module is installed. SELECT SLOT affects the global multiplexer on the AIM1 and is described in the reference section for that module.

When measuring the same channel repeatedly, the SELECT CHANNEL command need not be reissued for every measurement. Similarly, when several channels on the same module are read in succession, the SELECT SLOT command need only be issued once at the start of the sequence. Both SELECT SLOT and SELECT CHANNEL must be issued before starting any A/D conversions, or the data will be invalid. See Table 4 for values written to the SELECT CHANNEL location.

Table 4. Values Written to SELECT CHANNEL

<u>Function</u>	<u>Binary</u>	<u>Hex</u>	<u>Decimal</u>
Channel 0	00000	H0	0
Channel 1	00001	H1	1
Channel 2	00010	H2	2
Channel 3	00011	H3	3

AIM4 Module Calibration

Use the procedure below along with the information in Figure 3 to calibrate the AIM4 module. Use shielded cable for calibration connections, connect the shield to module ground only.

1. Place the AIM4 module in slot 4.
2. Connect the DMM high input to the AIM4 analog output (W101). Connect the DMM low level to module ground.
3. Connect jumper wires between the + and – terminals of all channels.
4. POKE the SELECT CHANNEL location (CFF86) with a value of 0 to select channel 0.
5. Place the channel 0 gain switch (S101) to the x1 position and adjust the output offset control (R118) for a reading of 0.000 ± 1 count on the DMM.
6. Place the channel 0 gain switch in the x100 position and adjust the channel 0 input offset control (R104) for a reading of 0.000 ± 1 count on the DMM.
7. Set the gain switches of the other channels to the x100 positions.
8. Adjust the input offset controls for the other three channels in a similar manner. POKE the SELECT CHANNEL location with the values for the desired channel (1 = channel 1, 2 = channel 2, 3 = channel 3). Adjust the input offset control for a reading of 0.000 ± 1 count on the DMM (R108 = channel 1, R112 = channel 2, R116 = channel 3).
9. Remove the shorting jumper from the channel 0 terminals, but leave all gain switches in the x100 positions. Leave all other inputs shorted.
10. Connect the calibrator high terminal to the + input of channel 0. Connect the calibrator low terminal to the – input of channel 0.
11. POKE the SELECT CHANNEL location with a value of 0. Set the calibrator output to a value of 50mV.
12. Adjust the channel 0 gain control for a reading of $5V \pm 1mV$ on the DMM.
13. Repeat steps 10-12 for the three remaining channels. Remove the jumper only from the channel being calibrated. The calibrator must be connected to the channel being calibrated, and the SELECT CHANNEL location must be POKED with the correct value for that channel. Adjust the corresponding channel gain control for a reading of $5V \pm 1mV$ on the DMM with a 50mV input from the calibrator. The inputs for the channels not being calibrated must be kept shorted.

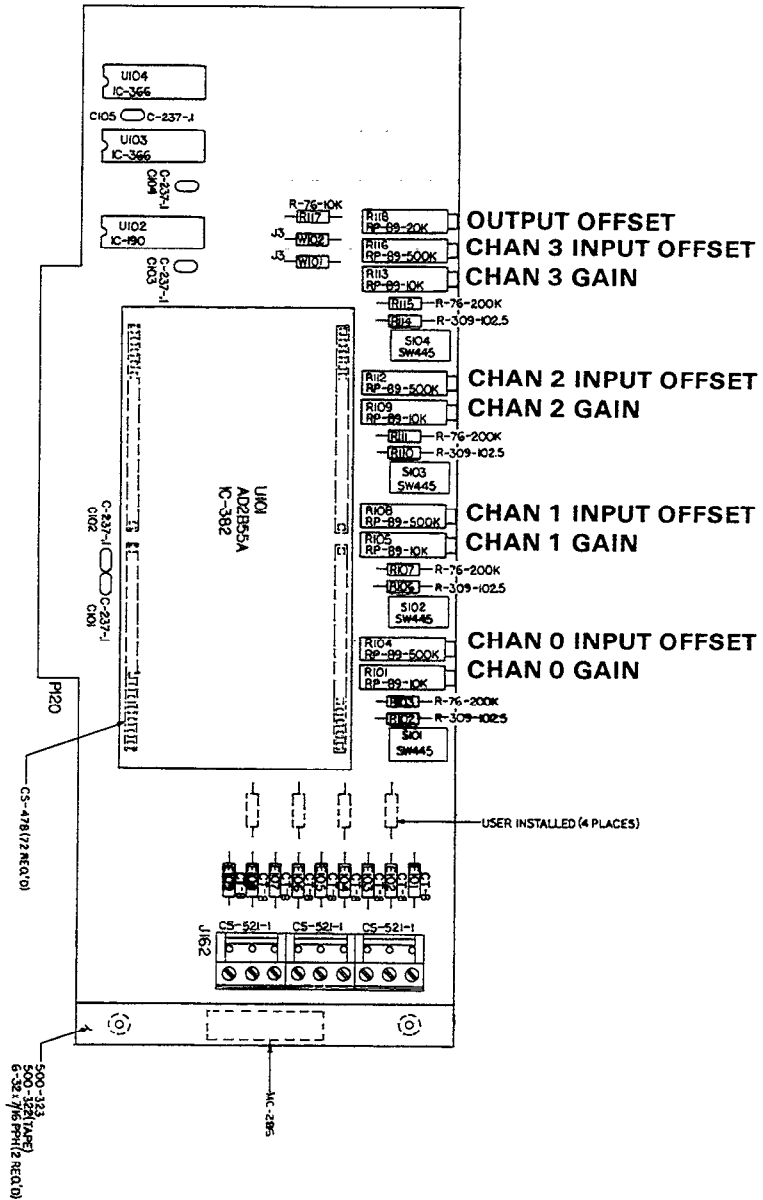

Figure 3. AIM4 Calibration Adjustments

Theory of Operation

Refer to drawing number 500-166 for the following discussion.

The primary component on the AIM4 module is a 4 channel isolated input circuit, U101 (Analog Devices 2B54A). This circuit provides isolated signal conditioning and multiplexing for input signals ranging from $\pm 50\text{mV}$ to $\pm 5\text{V}$. The output of U101 is routed to the AN OUT path on the Series 500 baseboard.

Each of the four input channels is electrically isolated from system ground and from other input channels. Circuits U102 and 103 are responsible for channel selection from among the four channels. U103 stores the value of D0 and D1, as set by the SELECT CHANNEL command (signal line CMDA); U102 decodes the output of U103, producing four outputs, designated Y0-Y3, that drive the channel selection circuitry in U101. U103 is a quad transparent data latch (74LS75), and U102 is a one-of-four binary to decimal decoder (74LS139).

Potentiometers R104, R108, R112, and R116 trim the input offset of Channels 0-3 respectively, and R118 provides an output offset adjustment for U101.

Gain for each channel is set by a switch, a fixed resistor, and a potentiometer. Switches S101-S104 select $\times 1/\times 100$ gain for channels 0-3 respectively, while the parallel combination of the resistor and potentiometer determine the gain of the channel in $\times 100$ mode. R120, R106, R110 and R114 are the gain resistors for channels 0-3 respectively, while potentiometers R101, R105, R109 and R116 are respective trim adjustments for channels 0-3.

AIM4 Specifications

Input channels: 4 isolated from each other and ground

Input characteristics:

Gain: $\times 1$, $\times 100$, switch selectable for each channel. User configurable for other gains with optional resistor.

Input range:

$\times 1$, $\pm 5\text{V}$ max
 $\times 100$, $\pm 50\text{mV}$ max

Accuracy:

Gain:

$\times 1$, $\pm 0.2\%$
 $\times 100$, $\pm 0.2\%$ adjustable to 1 lsb

Gain non-linearity: $\pm 0.02\%$ max

Input offset: $\pm 50\text{mV}$ max, adjustable to zero

Output offset: $\pm 12\text{mV}$ max, adjustable to zero

Temperature coefficient:

$\times 1$, $\pm 0.0025\%/^{\circ}\text{C}$
 $\times 100$, $\pm 0.0050\%/^{\circ}\text{C}$

Input offset: $\pm 5\mu\text{V}/^{\circ}\text{C}$

Output offset: $\pm 50\mu\text{V}/^{\circ}\text{C}$

Input noise voltage: $1\mu\text{V}$ p-p, 0.01Hz to 100Hz, $R_s < 1\text{k}\Omega$

Input bias current: + 8nA max

Input resistance: 100M Ω

Protection: 130V RMS max normal mode, $f \leq 60\text{Hz}$

Isolation: 500V peak, channel to channel or channel to ground

Common mode rejection: 145dB, $\times 100$, $R_i < 100\Omega$, $f \leq 60\text{Hz}$

Normal mode rejection: 55dB, $\times 100$, $f \geq 50\text{Hz}$

Settling time after channel selection: 2.5msec to 0.01%, assuming settled input

