

# PCM1

## AC Power Control Module

---

The PCM1 AC Power Control Module is designed to switch on and off AC line devices - motors, contactors, lamps, and solenoids - without disturbing the operation of the computer or the Series 500.

The PCM1 consists of two elements: the PCM1 card, which plugs into the Series 500 baseboard, and a remote signal connection unit. All AC connection and switching takes place at the remote unit, keeping potentially dangerous and noisy AC voltage outside of the system case. An eight-foot ribbon cable links the remote unit to the plug-in module.

The PCM1 provides four channels of AC switching output, with each channel accepting power signals of 12 to 140V AC, at up to 3A. These channels are switched by solid state relays (with full optical isolation to 1000V AC), and are short-circuit protected by fuses.

The remote unit has screw terminals for signal connection, and LED's to indicate the status of each channel. The PCM1 module may be installed in any available slot.

**WARNING: The remote unit should not be handled unless all AC power has been removed. Mount the remote assembly in an enclosure for maximum safety.**

**CAUTION: Always turn off the power before installing or removing modules. To minimize the possibility of EMI radiation, never operate the system with the main-frame cover removed.**

### User-Configured Components

The PCM1 has two user-configured components: the cable which connects the plug-in PCM1 module to its remote connection unit, and the screw terminals for signal connection (see Table 1).

The linking cable is a 10-contact, flat ribbon cable with connectors at either end. To install the cable, the small arrows on the cable connectors must be matched with similar arrows on the module connector and the remote unit connector. J131 is the jack on the interface board, while P132 is the plug on the remote board. The connectors are keyed so that they can be installed only one way.

The screw terminals located on the remote unit accept 16-24 gauge leads stripped 3/16 of an inch.

**WARNING: Dangerous user-supplied voltages may be present on the remote unit. Use normal safety precautions when using the PCM1 module.**

**Table 1. User-Configured Components on the PCM1 Module**

Name	Designation	Function
Screw Terminals	J135	Screw terminals for signal connection
Cable 1	CB1	Linking cable between plug in module and remote unit
Plug (Remote Board)	P132	Connection for CB1 on remote board
Jack (Interface Board)	J131	Connection for CB1 on interface board

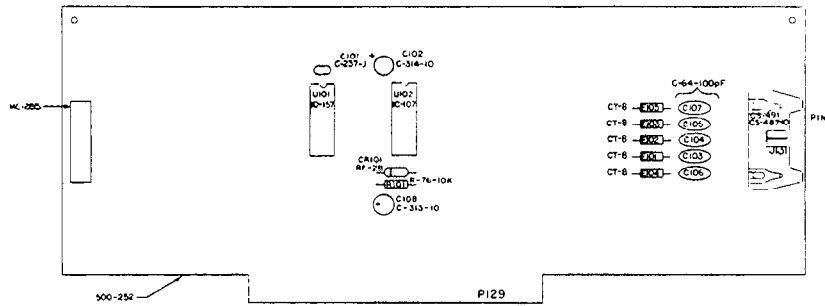

**Figure 1. PCM1 Interface Card**

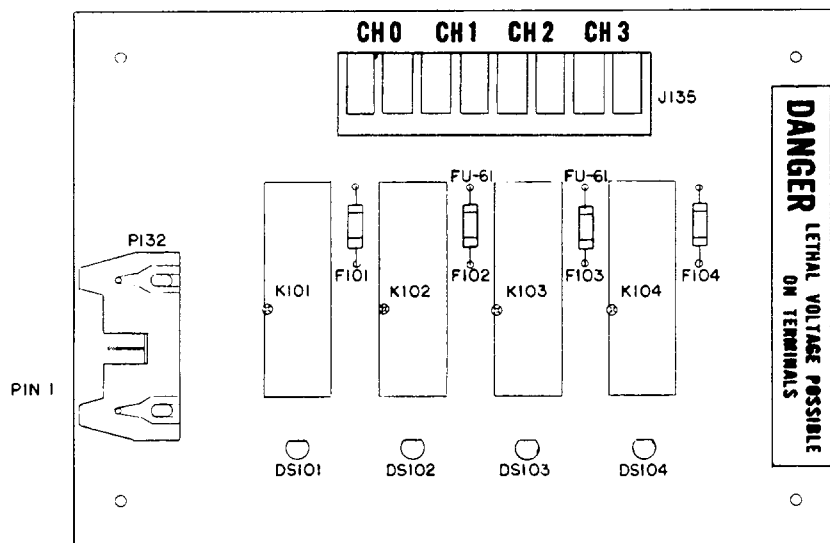

**Figure 2. PCM1 Remote Card**

**Connections**

Terminals for the PCM1 module are marked on the remote unit. When connecting leads, the AC power source should be connected in series with the output load and the connecting screw terminals. A typical connection scheme is illustrated in Figure 3.

**CAUTION:** Each Channel on the PCM1 assembly can control circuits at a maximum of 140V AC, 3A. Exceeding these values may cause damage to the unit.

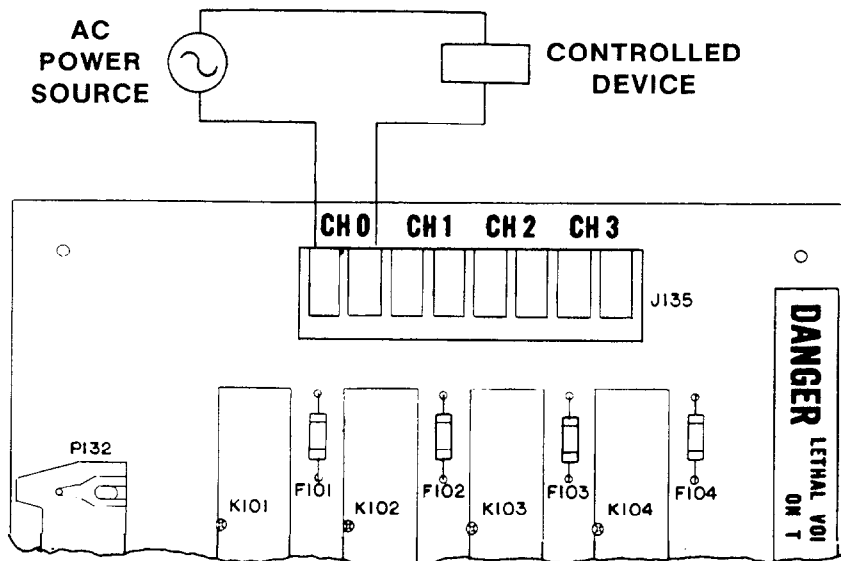

Figure 3. Typical PCM1 Connections (Channel 0 shown)

## Commands

PCM1 module commands are listed in Table 2. Table 3 summarizes the locations for slot-dependent commands.

Table 2. Commands Used with the PCM1 Module

Command	Location
PCM A	Slot-dependent CMDA

Table 3. Locations for Slot-Dependent Commands

Slot	Location
Slot 1	CFF80
Slot 2	CFF82
Slot 3	CFF84
Slot 4	CFF86
Slot 5	CFF88
Slot 6	CFF8A
Slot 7	CFF8C
Slot 8	CFF8E
Slot 9	CFF90
Slot 10	CFF92

## PCM A

Location: Slot-dependent CMDA

The four channels of the PCM1 module are set simultaneously by writing to a single command location: PCM A. The command word written to this location is made up of 8 bits. Each of the lower 4 (least significant) bits sets the status of one channel, and the upper four bits are unused. Therefore, the value written to this location should be a number equivalent to an 8-bit binary value, with the lower 4 bits indicating the status of the four channels (see Table 4).

When switching a single channel on or off, the status of all channels must be known. Each time the status of the channel is changed, the number written to the PCM A location should be retained as a variable in software.

From assembly language, this number can be modified by a logical AND or logical OR statement with a suitable mask for turning a particular channel on or off. An OR statement is used to turn channels on. The mask should contain 1's in the bit positions of the channels to be turned on, and 0's in all other positions. Similarly, an AND statement turns channels off. The AND mask should contain 0's in the bit positions of the channels to be turned on, and 1's in all other positions.

From BASIC, a channel can be turned on or off by adding to, or subtracting from the stored value the decimal value that represents the bit position for that channel. For example, to turn channel 3 on, it would be necessary to add 8 to the stored variable. Note that the PCM A location should always be written to, never read.

**Table 4. Bit Configuration of Values Written to PCM1**

D7	D6	D5	D4	D3	D2	D1	D0
X	X	X	X	Ch3	Ch2	Ch1	Ch0
X	X	X	X	8	4	2	1

X = not used

Ch0-Ch3 = Channels 0 through 3

8, 4, etc. = Decimal bit values

## Theory of Operation

PCM circuitry is located on two cards: an interface card, and a remote card. A diagram for both of these boards is located on schematic drawing number 500-256.

### Interface Card

U101 is a quad bistable data latch (74LS375), which stores information from data lines D0-D3. This latch is refreshed by the negative transition of signal line CMDA, which is buffered and inverted by segments of hex inverter U102C (74LS04).

After being inverted and buffered by other segments of U102, the signal drives the remote solid-state relays (K101-K104) through connector J131.

### **Remote Card**

Signals for channels 0-3 arrive at the remote unit at P132 and are routed to relays K101-K104, respectively (Opto 22 OAC5). Each of these solid-state relays contains an internal light-emitting diode in series with a current limiting resistor, optically driving a phototransistor, a zero voltage circuit, and high-voltage, high-current, switching semiconductors that comprise the AC switching element. After passing through the relay, the signals for channels 0-3 pass through status LEDs, DS101-DS104. When a channel is on, current flows through the relay and status diodes, energizing the relay and turning on the status LED.

The output lines of K101-K104 are protected by 5A, 125V fuses F101-F104, respectively.

## **PCM1 Specifications**

Output Channels: 4

Output characteristics:

Configuration: AC Output

Operating voltage: 24-280V AC

Frequency: 25-65Hz

Current: max 3A at 25°C, derate to 1A at 70°C, min 20mA peak 50A, for 1 cycle surge

Voltage drop: 1.6V max (device on)

Leakage: 5mA max (device off)

Power factor: up to 0.5

Switch form: 1 pole, normally open

Switching technique: optically isolated solid state switch

Switching time: 1/2 cycle max (10ms at 50Hz)

Operating temperature: -30 to +70°C

Isolation:

1000V RMS input to output

350V RMS channel to channel

Status indication: LED for each channel "on"

Connections: screw terminals for 6-24 AWG wire 8' ribbon cable to mainframe card (TTL signals)

Dimensions: 3.5"(89mm)L x 5.0"(127mm)W x 1.8"(46mm)H

Note: Specifications for remote assembly when used with supplied mainframe card.

PCMI COMPONENT LAYOUT

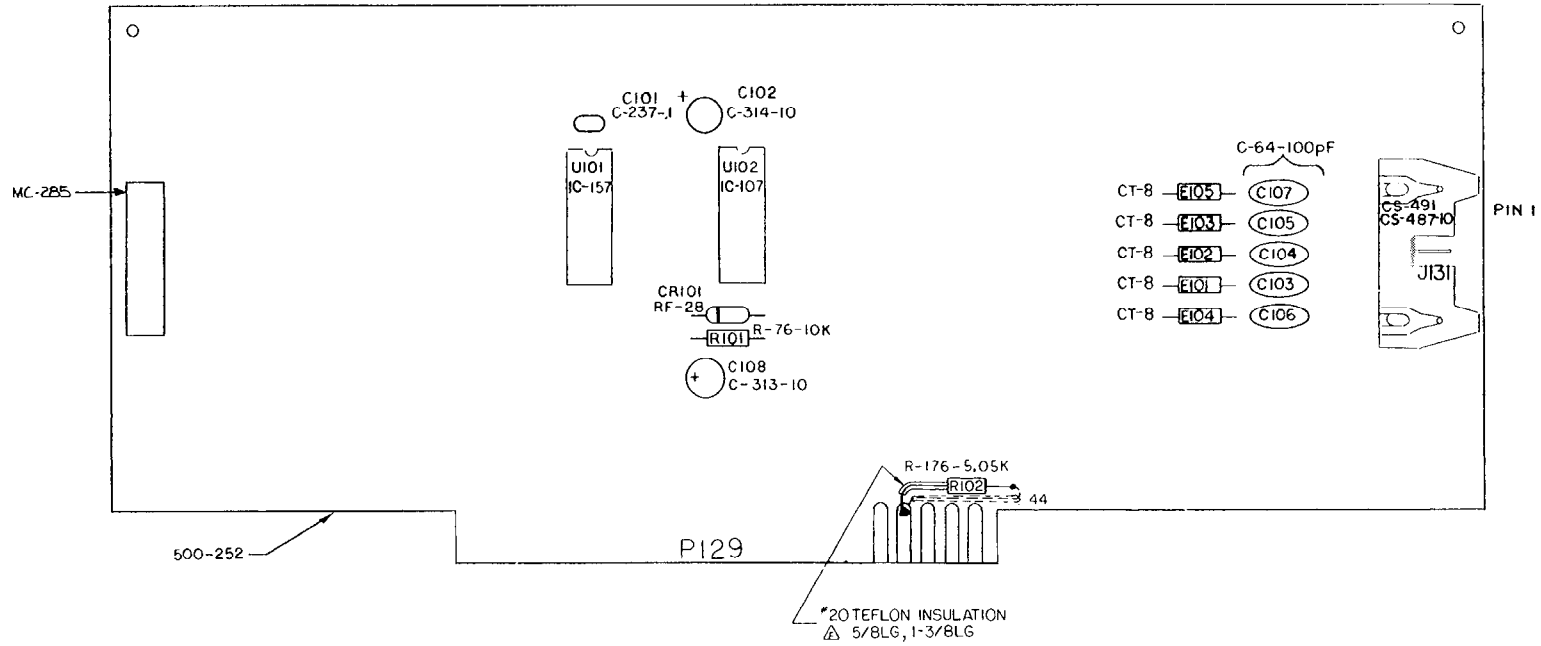





ZONE	LTR	ECO NO	REVISION	ENG	DATE
A		9491	RELEASED	MS	11/18/83
B		10502	UPDATED PER REV D REVISION	MS	2/28/85
C		12704	ADDED R102		3/27/88

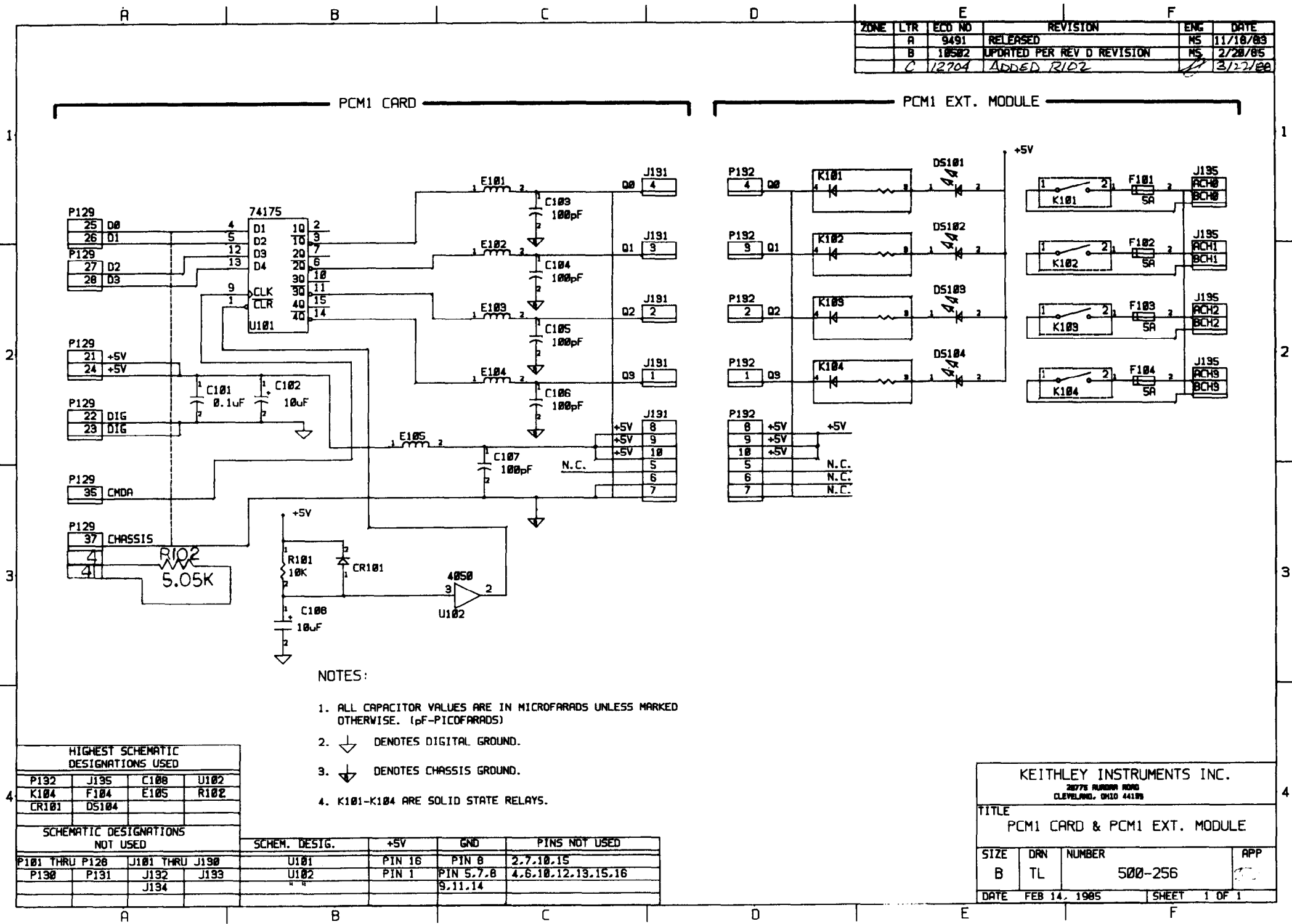

- NOTES:
1. ALL CAPACITOR VALUES ARE IN MICROFARADS UNLESS MARKED OTHERWISE. (pF-PICOFARADS)
  2. ↓ DENOTES DIGITAL GROUND.
  3. ↓ DENOTES CHASSIS GROUND.
  4. K101-K104 ARE SOLID STATE RELAYS.

HIGHEST SCHEMATIC DESIGNATIONS USED			
P132	J195	C108	U102
K104	F104	E105	R102
CR101	DS104		

SCHEMATIC DESIGNATIONS NOT USED			
P101 THRU P128	J101 THRU J190	U101	PIN 16
P130	P131	J192	J193
		J194	

SCHEM. DESIG.	+5V	GND	PINS NOT USED
U101	PIN 16	PIN 8	2,7,10,15
U102	PIN 1	PIN 5,7,8	4,6,10,12,13,15,16
" "		9,11,14	

KEITHLEY INSTRUMENTS INC. 28775 RUMBA ROAD CLEVELAND, OHIO 44139			
TITLE PCM1 CARD & PCM1 EXT. MODULE			
SIZE B	DRN TL	NUMBER 500-256	APP
DATE FEB 14, 1985		SHEET 1 OF 1	

PCM1 SCHEMATIC DIAGRAM