

TABLE OF CONTENTS

| Section | Page | Section | Page |
|---|------|--|-----------|
| 1. GENERAL DESCRIPTION | 1 | 5-4. Troubleshooting | 31 |
| 1-1. General | 1 | 5-5. Procedures to Guide Troubleshooting | 31 |
| 1-2. Features | 1 | | |
| 1-3. Specifications | 2 | 6. CALIBRATION | 35 |
| 1-4. Applications | 3 | 6-1. General | 35 |
| 1-5. Accessories | 4 | 6-2. Calibration Schedule | 35 |
| 1-6. Equipment Shipped | 4 | 6-3. Grid Current Check | 35 |
| 2. OPERATION | 5 | 6-4. DC Amplifier Balance Adjustment | 36 |
| 2-1. Front Panel Controls and Terminals | 5 | 6-5. High-Megohm Resistor Verification | 36 |
| 2-2. Rear Panel Controls and Terminals | 6 | 6-6. Meter Zero Calibration | 36 |
| 2-3. Input Connections | 7 | 6-7. Accuracy Check | 37 |
| 2-4. Preliminary Procedures | 8 | 6-8. Drift Check | 38 |
| 2-5. Voltage Measurements | 9 | 7. ACCESSORIES | 43 |
| 2-6. Off Ground Voltage Measurements | 11 | 7-1. Model 6011 Input Cable | 43 |
| 2-7. Current Measurements | 12 | 7-2. Model 1531 Gripping Probe | 43 |
| 2-8. Resistance Measurements | 14 | 7-3. Model 6301 Guarded Probe | 43 |
| 2-9. Charge Measurements | 17 | 7-4. Model 6012 Triaxial-to- Coaxial Adapter | 43 |
| 2-10. Recorder Outputs | 17 | 7-5. Model 6102A Voltage Divider Probe | 44 |
| 2-11. Unity Gain Output | 18 | 7-6. Model 6103A Voltage Divider Probe | 44 |
| 3. APPLICATIONS | 21 | 7-7. Model 6104 Test Shield | 44 |
| 3-1. General | 21 | 7-8. Model 6105 Resistivity Adapter | 45 |
| 3-2. Current Source | 21 | 7-9. Models 2501 and 2503 Static Detector Probes | 46 |
| 3-3. Static Charge Measurements | 21 | 7-10. Rack Mounting | 46 |
| 3-4. Capacitance Measurements | 21 | 7-11. Model 6013 pH Electrode Adapter | 47 |
| 3-5. Current Integrator | 22 | 7-12. Model 370 Recorder | 48 |
| 3-6. Potentiometric Voltage Measurements | 22 | 8. REPLACEABLE PARTS | 51 |
| 3-7. Measuring Diode Characteristics | 22 | 8-1. Replaceable Parts List | 51 |
| 3-8. Peak-Reading Voltmeter | 23 | 8-2. How to Order Parts | 51 |
| 4. CIRCUIT DESCRIPTION | 25 | Model 601 Replaceable Parts List | 52 |
| 4-1. General | 25 | Schematic Diagram 19428E | 58 |
| 4-2. Voltmeter Operation | 25 | * Change Notice | last page |
| 4-3. Voltmeter Circuit | 26 | * Yellow Change Notice sheet is included only for instrument modifications affecting the instruction manual. | |
| 4-4. Ammeter Operation | 27 | | |
| 4-5. Ohmmeter Operation | 28 | | |
| 4-6. Coulombmeter Operation | 29 | | |
| 5. SERVICING | 31 | | |
| 5-1. General | 31 | | |
| 5-2. Servicing Schedule | 31 | | |
| 5-3. Parts Replacement | 31 | | |



FIGURE 1. Keithley Instruments Model 601 Electrometer.

SECTION 1. GENERAL DESCRIPTION

1-1. GENERAL.

a. The Keithley Model 601 Electrometer is a versatile battery operated instrument which measures wide ranges of dc voltages, currents, resistances and charges. It is a highly refined dc vacuum tube voltmeter that uses an electrometer tube input to provide greater than 10^{14} ohm input resistance. The Model 601 has all the capabilities of conventional VTVMs, but it can also make many more measurements without loading circuits.

b. The Electrometer has nine voltage ranges from 0.001 volt full scale to 10 volts, twenty-eight current ranges from 10^{-14} ampere full scale to 0.3 ampere, twenty-three linear resistance ranges from 100 ohms full scale to 10^{13} ohms, and thirteen charge ranges from 10^{-12} coulomb full scale to 10^{-6} coulomb.

c. The Model 601 offers complete line isolation and excellent off-ground measuring capability. Up to 1500 volts may be applied between the input low terminal and the case, and safe operation is assured with the case grounded. A three-terminal input allows complete guarding of the high terminal.

d. The Model 601 employs matched electrometer input tubes followed by three differential transistor amplifier stages and a transistor output stage. A large amount of negative feedback is used for stability and accuracy.

1-2. FEATURES.

a. Voltmeter accuracy is $\pm 1\%$ of full scale, exclusive of noise and drift.

b. Zero drift of the Model 601 is 200 microvolts per hour maximum averaged over any 24-hour period after warm-up. During the 2-hour warm-up, zero drift is no more than 2 millivolts after the first hour.

c. Two amplifier outputs are available. A switch on the rear panel allows either ± 1 volt or ± 1 milliamperes for full-scale meter deflection. The current output is variable $\pm 5\%$ with 1.4-kilohm recorders. The unity-gain amplifier output is equal to the input voltage within 50 ppm or 100 microvolts, exclusive of zero drift.

d. Current measurements can be made by one of two methods; the normal method in which the current is determined by measuring the voltage drop across a resistor shunting the input, or the fast method in which negative feedback is applied through the shunt resistor. The former method minimizes noise. The latter method reduces the input drop and greatly increases the response speed on the low-current ranges.

e. The 1000-hour life of the batteries enables usage in long-term experiments without interruptions for recharging. Battery life is maintained even when the 1-milliamperes recorder output is used. For further convenience, battery condition is readily checked on the panel meter.

1-3. SPECIFICATIONS.

AS A VOLTMETER:

RANGE: .001 volt full scale to 10 volts in nine 1x and 3x ranges.

ACCURACY: $\pm 1\%$ of full scale on all ranges exclusive of noise and drift.

ZERO DRIFT: After 1-hour warm-up no more than 2 millivolts in the second hour, and in any subsequent 24-hour period, the average drift will not exceed 200 microvolts per hour.

METER NOISE: ± 10 microvolts maximum with input shorted on most sensitive range.

INPUT IMPEDANCE: Greater than 10^{14} ohms shunted by 20 picofarads. Input resistance may also be selected in decade steps from 10 to 10^{11} ohms.

AS AN AMMETER:

RANGE: 10^{-14} ampere full scale to 0.3 ampere in twenty-eight 1x and 3x ranges.

ACCURACY: $\pm 2\%$ of full scale on 0.3 to 10^{-11} ampere ranges using the smallest available Multiplier Switch setting; $\pm 4\%$ of full scale on 3×10^{-12} to 10^{-14} ampere ranges.

METER NOISE: Less than $\pm 3 \times 10^{-15}$ ampere.

GRID CURRENT: Less than 2×10^{-14} ampere.

AS AN OHMMETER:

RANGE: 100 ohms full scale to 10^{13} ohms in twenty-three linear 1x and 3x ranges.

ACCURACY: $\pm 3\%$ of full scale on 100 to 10^8 ohm ranges using the largest available Multiplier Switch setting; $\pm 5\%$ of full scale on 3×10^8 to 10^{13} ohm ranges.

AS A COULOMB METER:

RANGE: 10^{-12} coulomb full scale to 10^{-6} coulomb in thirteen 1x and 3x ranges.

ACCURACY: $\pm 5\%$ of full scale on all ranges. Drift due to grid current does not exceed 2×10^{-14} coulomb per second.

AS AN AMPLIFIER:

INPUT IMPEDANCE: Greater than 10^{14} ohms shunted by 20 picofarads. Input resistance may also be selected in decade steps from 10 to 10^{11} ohms.

OUTPUTS: Unity-gain output and either voltage or current recorder output.

UNITY-GAIN OUTPUT: At dc, output is equal to input within 50 ppm or 100 microvolts, exclusive of zero drift. Up to 0.1 milliampere may be drawn. Output polarity is same as input polarity

VOLTAGE RECORDER OUTPUT: ± 1 volt for full-scale input. Internal resistance is 910 ohms. Output polarity is opposite input polarity.

Gain: 0.1, 0.33, etc. to 1000.

Frequency Response (Within 3 db): dc to 100 cps at a gain of 1000, rising to 50 kc at a gain of 3.3, decreasing to 1 kc at a gain of 0.1.

Noise: Less than 2% rms of full scale at a gain of 1000, decreasing to less than 0.5% at gains below 10.

CURRENT RECORDER OUTPUT: ± 1 milliampere for full-scale input, variable $\pm 5\%$ with 1400-ohm recorders.

GENERAL:

ISOLATION: Input low to case: greater than 10^{10} ohms shunted by 0.0015 microfarad. Input low may be floated up to ± 1500 volts with respect to case.

POLARITY: Meter switch selects left-zero (positive or negative) or center-zero scales. Meter switch does not reverse polarity of outputs.

CONNECTORS: Input: Teflon-insulated triaxial Dage 33050-1. Lo: binding post. Voltage or current output: Amphenol 80-PC2F. Unity gain output, case ground: binding posts.

BATTERY CHECK: Condition of all batteries may be checked with front panel controls.

BATTERIES: Four 2N6 (or 246, VS305 or NEDA 1602); three TR286 (or E286); two RM42R (or E42N or HG42R). 1000 hours battery life.

DIMENSIONS, WEIGHT: 10-1/2 inches high x 6-5/8 inches wide x 10 inches deep; net weight, 14 pounds.

ACCESSORIES SUPPLIED: Model 6011 Input Cable; mating output connector.

1-4. APPLICATIONS.

a. Voltmeter applications include directly measuring potentials across pH electrodes, piezoelectric crystals, capacitors, electro-chemical cells and biological membranes. The Model 601 is also useful as a null detector with potentiometers or bridges in high impedance applications.

b. As a picoammeter the Model 601 can be used with photomultiplier tubes, flame and beta ray ionization detectors, lithium ion drift detectors and gas chromatographs. It is also useful in nuclear studies, plasma physics and vacuum research.

c. As an ohmmeter the Electrometer is ideal for measuring insulation resistance and resistor voltage coefficients. It is useful for measuring "in circuit" resistances, since the Model 601 low terminal can be isolated from case ground. Volume and surface resistivities can be measured with the Model 601 and the Model 6105 Resistivity Adapter.

d. In addition to measuring charge directly other coulombmeter uses are measuring

charge current over a period and obtaining integral curves of time varying currents. The Electrometer can also be used as a charge amplifier to measure piezoelectric crystal outputs.

1-5. ACCESSORIES. (Also see Section 7).

a. Model 6011 Input Cable has 30 inches of low noise triaxial cable with mating triaxial input connector and three alligator clips.

b. Model 6013 pH Electrode Adapter has a 2-foot cable and triaxial connector and accepts Leed & Northrop and Beckman pH electrode connectors. The Adapter allows accurate and convenient pH potential measurements with the Model 601.

c. Model 6301 is a high impedance guarded probe with a 3-foot connecting triaxial cable that allows measurements to be made more conveniently. The Model 6301 has an insulation resistance of over 10^{14} ohms. Using the Probe does not effect any Model 601 specifications.

d. Model 1531 is a gripping probe with a 3-foot connecting triaxial cable. The Model 1531 has an insulation resistance of over 10^{10} ohms.

e. Model 4005 Rack Mounting Kit adapts the Model 601 to rack mounting 10-1/2 inches high x 19 inches wide. The Kit can accommodate two Model 601's side-by-side by using an additional cover.

f. Model 6012 Triaxial-to-Coaxial Adapter permits using the Model 601 with all Keithley electrometer accessories having uhf type coaxial connectors. These include the Models 6102A, 6103A, 6104, 6105, 2501 and 2503. Since circuit low and case ground are connected using the Adapter, the Model 601 should not be floated.

g. Models 6102A and 6103A voltage divider probes, described in Section 7, facilitate measurements and extend the voltage range to 10 kilovolts.

h. Model 6104 Test Shield is suitable for resistance measurements with either 2 or 3-terminal guarded connections, as well as voltage and current tests.

i. Model 6105 Resistivity Adapter is a guarded test fixture for measuring volume and surface resistivities of materials when used with the Model 601 and the Keithley Model 240A High Voltage Supply.

j. Models 2501 and 2503 Static Detector Probes are capacitive voltage dividers with a 10,000:1 ratio, when used with the Probe 3/8 inch from the charged surface.

k. Model 370 Recorder is uniquely compatible with the Model 601 as well as other Keithley microvoltmeters, electrometers and picoammeters. The recorder is a high quality economical instrument that maximizes the performance of the Model 601, and many other Keithley instruments, even in the most critical applications.

1-6. EQUIPMENT SHIPPED. The Model 601 Electrometer is factory calibrated and shipped with all components in place. The shipping carton also contains the Instruction Manual, Model 6011 Input Cable and mating output plug.

cuit high; the inner shield is circuit low (circuit ground); the outer shield is case ground. (See Figure 4.) A shield cap is provided. The LO Terminal, below the Receptacle, is connected to circuit low; it is connected to case ground only if the shorting link on the rear panel is connected.

2-2. REAR PANEL CONTROLS AND TERMINALS (See Figure 3).

a. COARSE ZERO SWITCH. The COARSE ZERO Switch has 11 positions to extend the zeroing capability of the front panel ZERO Controls.

b. OUTPUT Switch. The Switch is a two-position slide switch for the output. In the 1 MA position, the instrument will drive 1-milliampere recorders. In the 1 V position, the output is 1 volt for full-scale meter deflection. Source resistance is approximately 1000 ohms.

c. 1 MA CAL Control. The Control varies the output from 0.95 to 1.05 milliampere for 1400-ohm recorders, so the recorder scale will correspond with the Electrometer meter.

d. OUTPUT Receptacle. A 2-terminal microphone-type receptacle provides 1 volt or 1 milliampere for full-scale meter deflection. Pin No. 2 is at circuit low when the FEEDBACK Switch is at NORMAL. Neither terminal is at ground when the FEEDBACK Switch is at FAST. Both terminals are isolated from case ground.

e. X1 OUTPUT and OHMS GUARD Terminals. The potential between the X1 OUTPUT Terminal and the OHMS GUARD Terminal (circuit low when the FEEDBACK Switch is in NORMAL) is equal to the input voltage with 0.005% linearity or 100 microvolts. When the FEEDBACK Switch is at FAST, the X1 OUTPUT Terminal is at circuit low and the OHMS GUARD Terminal is floating.

f. LO Terminal. A black terminal allows connection to the input low connection. Connecting the LO and CASE GROUND Terminals puts both at case ground.

g. CASE GROUND Terminal. A blue terminal is connected directly to the outside cabinet of the Model 601 and the outside shell of the input connector. It is connected to nothing else within the instrument.

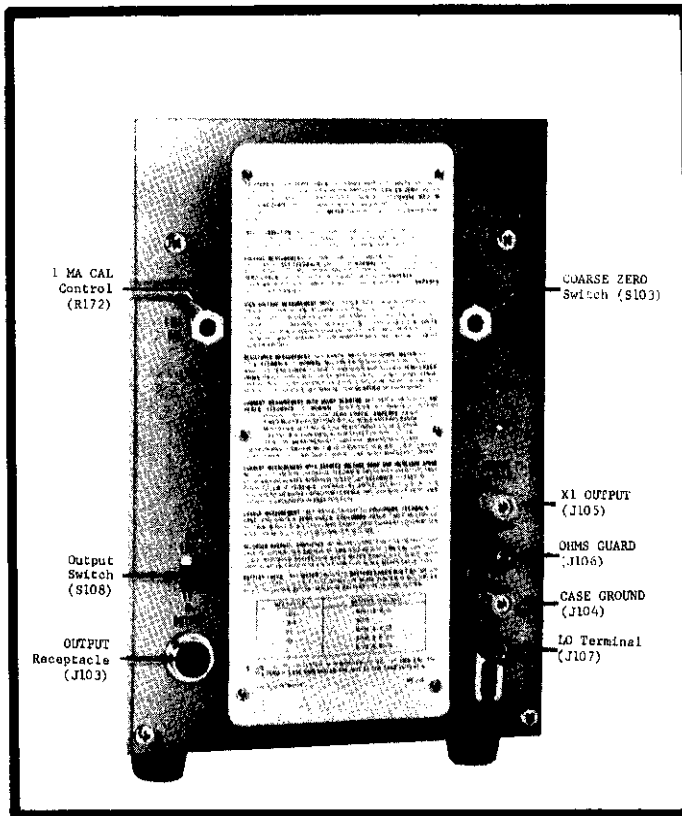

FIGURE 3. Model 601 Rear Panel Controls and Terminals.

NOTE

If the Model 601 will be stored for a long period, remove batteries. Also, make sure the METER Switch is at POWER OFF when the instrument is not being used.

| Lead | Circuit | J101 Terminal |
|---------------------------------|----------------------|---------------|
| heavy wire with red clip cover | Input (circuit) high | Center |
| thin wire with black clip cover | Input (circuit) low | Inner shield |
| thin wire with blue clip cover | Case Ground | Outer shield |

TABLE 1. Color Coding of Alligator Clips for Model 6011 Input Cable.

2-3. INPUT CONNECTIONS.

a. The accessories described in Section 7 are designed to increase the accuracy and convenience of input connections. Use them to gain the maximum capability of the Model 601.

b. The Model 6011 Input Cable, supplied with the instrument, facilitates input connections. Table 1 contains the color coding of the alligator clips. The high terminal is shielded by the inner braid of the triaxial cable up to the miniature alligator clip. If the unshielded clip causes pick up from near-by electric fields, remove it and connect the shielded lead directly to the source.

NOTE

Techniques and applications are thoroughly discussed in the brochure, Electrometer Measurements, by Joseph F. Keithley. It is available from Keithley Instruments, Inc., or its representatives.

c. Carefully shield the input connection and the source being measured, since power line frequencies are well within the pass band of the Electrometer. Unless the shielding is thorough, any alteration in the electrostatic field near the input circuitry will cause definite meter disturbances.

d. Use high resistance, low-loss materials — such as Teflon (recommended), polyethylene or polystyrene — for insulation. The insulation leakage resistance of test fixtures and leads should be several orders magnitude higher than the internal resistance of the source. Excessive leakage reduces the accuracy of readings from high impedance sources. Triaxial or coaxial cables used should be a low-noise type which employ a graphite or other conductive coating between the dielectric and the surrounding shield braid. Amphenol-Borg Electronics Corporation, Microdot, Inc., and Simplex Wire and Cable Company make satisfactory types. Using the supplied Model 6011 Input Cable is a simple way to insure good input connections.

NOTE

Clean, dry connections and cables are very important to maintain the value of all insulation materials. Even the best insulation can be compromised by dust, dirt, solder flux, films of oil or water vapor. A good cleaning agent is methyl alcohol, which dissolves most common dirt without chemically attacking the insulation. Wash salt solutions with distilled water before using the cleaning agent.

e. Any change in the capacitance of the measuring circuit to low will cause extraneous disturbances. Make the measuring setup as rigid as possible, and tie down connecting cables to prevent their movement. A continuous vibration may appear at the output as a sinusoidal signal, and other precautions may be necessary to isolate the instrument and

the connecting cable from the vibration.

f. For low impedance measurements — below 10^8 ohms or above 10^{-8} ampere — unshielded leads may be used. However, keep the leads short.

g. When measuring currents 10^{-14} ampere or less with the FEEDBACK Switch at FAST, some insulators — such as Teflon — may produce random signals which show up as erratic meter deflections. Insulation used in the Model 601 is carefully selected to minimize these signals.

h. It is usually better to connect the Model 601 to the circuit only when a reading is being made. In some cases, the grid current can charge the external test circuitry. One example of this occurs when measuring a capacitor's leakage resistance by observing the decay of the terminal voltage. If the leakage current is less than the grid current, there may be no decay of the terminal voltage when the Electrometer is left connected across the capacitor's terminals.

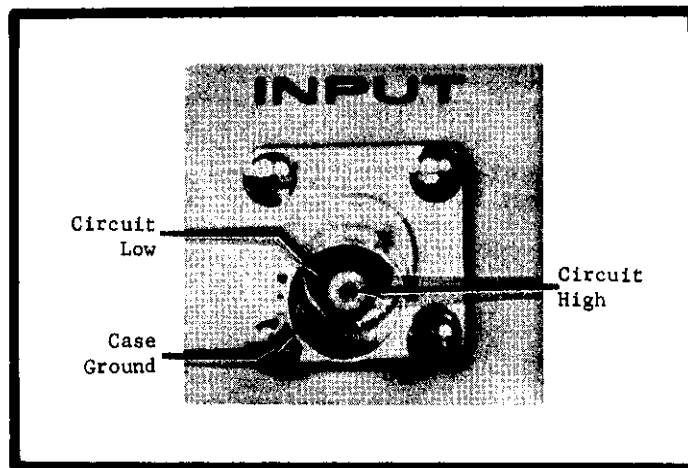

FIGURE 4. Model 601 Triaxial Input Receptacle. The center terminal is circuit or input high; the inner shield is circuit or input low; the outer shield is case ground.

NOTE

Keep the shielded cap on the INPUT Receptacle when the Electrometer is not in a circuit.

i. The Model 6012 Triaxial to Coaxial Adapter enables using coaxial cables and accessories with the Model 601 by adapting the triaxial INPUT connector to the uhf coaxial type.

NOTE

The Adapter connects circuit low to case ground. Do not float the Model 601 when using the Adapter. The instrument chassis will be at the same potential as the input low.

2-4. PRELIMINARY PROCEDURES.

a. Check battery condition by setting the METER Switch to the BATTERY CHECK position. Rotate the Multiplier Switch through the .001 to 0.1 positions, and observe the meter readings. The meter should read one-half of full scale or more for each Multiplier Switch position. Table 2 shows the batteries checked by position. If the reading for any battery is below half scale, replace all batteries. Note new batteries may cause the Model 601 to drift more than normal for at least 72 hours due to change in battery terminal voltage.

| Multiplier position | Battery Checked |
|---------------------|-----------------|
| .001 | B201 & B202 |
| .003 | B203 |
| .01 | B204 & B205 |
| .03 | B206 & B207 |
| 0.1 | B208 & B209 |

TABLE 2. Multiplier Switch Positions for Checking Condition of Batteries

b. Set the controls as follows:

| | |
|-------------------|-----------|
| METER Switch | POWER OFF |
| Range Switch | VOLTS |
| Multiplier Switch | 1 |
| FEEDBACK Switch | NORMAL |
| ZERO CHECK Button | LOCK |

c. Turn the METER Switch to CENTER ZERO. Within ten seconds, the meter needle should come to the center zero position. If not, adjust to meter zero with the MEDIUM and FINE ZERO Controls. Normally, there is no need to use the COARSE ZERO Switch.

d. After a few moments increase the voltage sensitivity by advancing the Multiplier Switch to .3, .1, etc. Continue zeroing with the FINE ZERO Control.

e. After long periods of storage or after an overload, the Model 601 may drift excessively. The electrometer tubes are shock mounted; however, a severe jolt to the Electrometer may cause a zero offset. This is corrected with the Zero Controls. Drifting, though, can occur for several hours.

NOTE

If the Model 601 has been stored for some time, the grid current will exceed the specification when first used, then decrease to below the specified amount after one or two hours of use. This is an inherent characteristic of the electrometer tube; the instrument is not faulty.

f. Although the grid current of the Electrometer is much below that found in conventional voltmeters, it can be observed on the meter. A small voltage results from the grid current charging the input capacitance, and the Electrometer appears to drift when the input is open. Use the ZERO CHECK Button to discharge the build-up.

g. Follow the particular procedures in paragraph 2-5 to 2-9 for measuring voltage, current, resistance and charge. When using Multiplier Switch settings of 10, 3 and 1 in the voltage, current, resistance and charge measuring modes, make sure the Output Switch is set to IV if the output is not connected to a load. Otherwise, the meter shows a loading effect. When the output is connected to a load, this effect is not present.

NOTE

Using the center zero scales decreases accuracy 0.5% because the scale span is shorter.

2-5. VOLTAGE MEASUREMENTS.

a. The Model 601 can be used to measure voltages several ways.

1. In the normal method — FEEDBACK Switch at NORMAL — the unknown voltage is connected to the INPUT Receptacle. Input impedance is 10^{14} ohms, 20 pf.

2. To reduce the slowing effects of input capacity, use the fast method to measure the voltage. A guarded circuit is possible this way.

3. To measure low impedance sources, the Model 601 input resistance can be decreased if desired.

4. Accessory probes extend the Model 601's range to 10 kilovolts.

NOTE

Locking the ZERO CHECK Switch places 10 megohms across input high and low, which may temporarily cause instability in some types of high impedance sources.

b. Normal Method Voltage Measurements.

1. Follow the instructions of paragraph 2-4. Set the controls as follows:

| | |
|-------------------|-------------|
| METER Switch | CENTER ZERO |
| Range Switch | VOLTS |
| Multiplier Switch | 10 |
| FEEDBACK Switch | NORMAL |
| ZERO CHECK Button | LOCK |

2. Connect the unknown voltage to the INPUT Receptacle; unlock the ZERO CHECK Button. Set the METER Switch to + or -, as necessary. Increase sensitivity with the Multiplier Switch. Recheck zero setting after increasing sensitivity.

3. For off-ground measurements, see paragraph 2-6.

c. Fast Method Voltage Measurements. This method reduces the slowing effects of input capacity and allows guarded voltage measurements.

1. Follow the instructions of paragraph 2-4. Set the controls as follows:

| | |
|-------------------|-------------|
| METER Switch | CENTER ZERO |
| Range Switch | VOLTS |
| Multiplier Switch | 10 |
| FEEDBACK Switch | FAST |
| ZERO CHECK | LOCK |

2. Connect CASE GROUND Terminal to OHMS GUARD Terminal, using the shorting link.

3. Connect the unknown voltage to the high (center) terminal of the INPUT Receptacle and to the CASE GROUND Terminal on the rear panel. Use the LO Terminal as a guard between circuit high and low. Unlock the ZERO CHECK Button. Set the METER Switch to + or -, as necessary. Increase sensitivity with the Multiplier Switch. Recheck zero setting after increasing sensitivity.

4. To make off ground voltage measurements, see paragraph 2-6.

d. Low Impedance Measurements. To decrease input resistance, set the Range Switch to one of the AMPERES ranges. The input resistance is now the reciprocal of the current range. For instance, to obtain an input resistance of 10^7 ohms, set the Range Switch to the 10^{-7} AMPERES range. Set the full-scale voltage range with the Multiplier Switch. Operating procedures are the same as subparagraph b. At lower input resistances, the Model 601 will not run off scale as easily in the presence of excessive ac fields. This occurs only when the input is left open.

e. To measure sources more than 10 volts, use one of two divider probes. The Model 6102A 10:1 Divider Probe extends the Model 601's range to 100 volts; overall accuracy is $\pm 3\%$ and input resistance is 10^{10} ohms. The Model 6103A 1000:1 Divider Probe extends the Model 601's range to 10 kilovolts; overall accuracy is $\pm 5\%$ and input resistance is 10^{12} ohms. Follow the same operating procedures with the dividers as in subparagraph b. The Model 6012 Triaxial-to-Coaxial Adapter must be used with the Models 6102A and 6103A Divider Probes. Note, however, using the Adapter connects circuit low to case ground; do not float the Electrometer. The full-scale voltage range is the divider ratio times the Multiplier Switch setting.

NOTE

Operating the Model 601 more than 1500 volts off ground may permanently damage the instrument. Isolation between circuit low and ground may break down somewhere in the circuit, putting the case at an off-ground potential. Since these breakdowns are very difficult to locate, it might not be possible to float the instrument safely again.

2-6. OFF GROUND VOLTAGE MEASUREMENTS.

a. The Model 601 can measure an unknown voltage whose low is up to 1500 volts off ground while its own case is at ground. This allows safe operation of the Electrometer. Its operation is the same as given in paragraph 2-5, except for input connections and some added cautions. These differ, depending upon the FEEDBACK Switch setting.

1. FEEDBACK Switch set to NORMAL. Disconnect the shorting link between the LO and CASE GROUND Terminals on the rear panel. Make sure the Model 601 case is securely connected to an earth ground, and that the low of the unknown voltage is less than 1500 volts off ground. Connect the unknown voltage directly to the INPUT Receptacle. Operate the Model 601 as described for normal method voltage measurements.

2. FEEDBACK Switch set to FAST. Do not use the shorting link. Make sure the Model 601 case is securely connected to an earth ground, and that the low of the unknown voltage is less than 1500 volts off ground. Ground the outer shield of the INPUT Receptacle. Connect the high of the unknown voltage to the center terminal of the INPUT Receptacle. Connect the low to the GUARD Terminal. Use the inner shield of the INPUT Receptacle as a guard. Operate the Model 601 as described for fast method voltage measurements.

NOTE

When the Model 601 is off ground, make sure the shell of a mating plug to the OUTPUT Receptacle is not connected to either pin in the Receptacle.

b. If the Model 6012 Adapter is used, do not float the Model 601. The Adapter connects the input low to the case ground, so that the Model 601 chassis and controls are at the same potential as the low of the unknown source.

NOTE

Use only an insulated blade screwdriver to adjust the COARSE ZERO Switch and 1 MA CAL Control when floating the Model 601. An ordinary screwdriver could short the circuit low to case ground, creating a shock hazard and damaging the external circuitry.

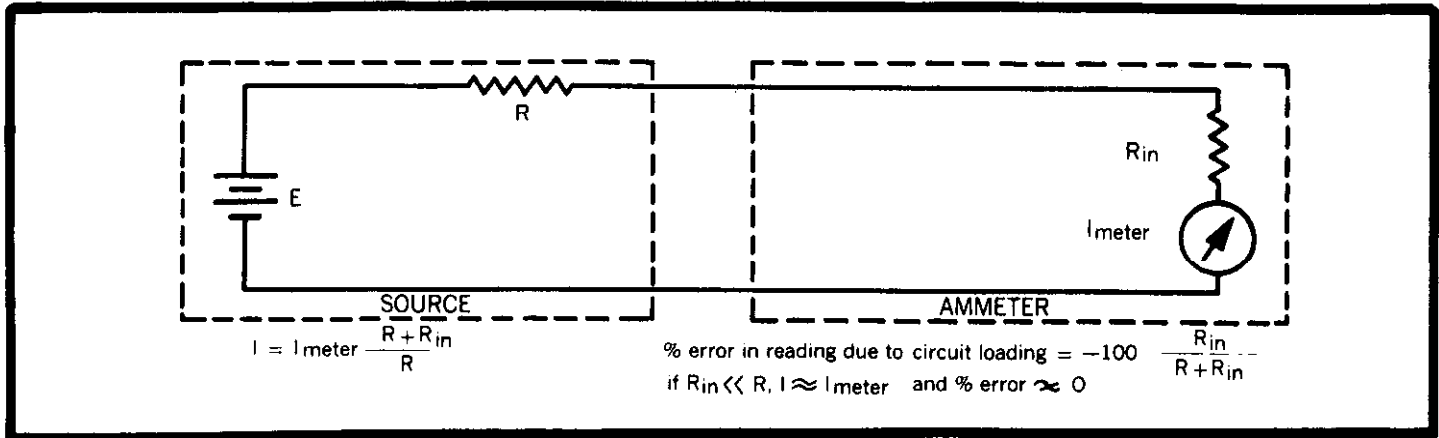

FIGURE 5. Ammeter Circuit Loading. Current sources may be considered a voltage (E) in series with a resistance (R). The current with no ammeter attached is $I=E/R$. When an ammeter is attached to measure the current, the effective input resistance of the ammeter R_{in} is in series with the source resistance (R). The current in the complete circuit is less and $I_{\text{meter}} = E/(R + R_{\text{in}})$. If the effective ammeter input resistance is small compared to R , $I_{\text{meter}} \approx I$ and the error introduced by circuit loading is negligible.

2-7. CURRENT MEASUREMENTS.

a. The Model 601 can measure currents three ways.

1. In the normal method — used on any range — the current is determined by measuring the voltage drop across a resistor shunting the amplifier input. This method is useful when lower noise is more important than faster response speeds or if some damping is needed.

2. In the fast method — for use only below the 10^{-5} ampere range — the shunt resistor is between the amplifier output and input in the feedback loop. This circuit largely neutralizes the effect of input capacity and greatly increases the response speed. Also, the input voltage drop is reduced to a maximum of one millivolt on any range.

3. For galvanometric current measurements, the Model 601 acts as a null indicator between a very accurate current source and the unknown current source. Its off ground operating capability makes it ideal for this application since the reference source and unknown may both have a common grounded terminal.

b. Rise time varies primarily with the current range, the input capacity and the method used. On most ranges, the rise time in the fast mode is less than one second with 50 picofarads across the input. Even with much larger shunt capacities, the negative feedback maintains a short rise time. Given a choice, it is better to place the Electrometer nearer to the current source than to the data reading instrument. Transmitting the input signal through long cables greatly decreases the response speed and increases noise due to the cable capacitance.

c. To measure from a source with both terminals off ground in either method, remove the link between the LO and CASE GROUND Terminals on the rear panel. Connect the unknown current to the INPUT Receptacle. The source must be less than ± 1500 volts off ground (see paragraph 2-6).

d. Normal Method (0.3 to 10^{-14} ampere ranges).

1. Follow the instructions of paragraph 2-4. Set the controls as follows:

| | |
|-------------------|-------------------|
| METER Switch | CENTER ZERO |
| Range Switch | 10^{-1} AMPERES |
| Multiplier Switch | 1 |
| FEEDBACK Switch | NORMAL |
| ZERO CHECK Button | LOCK |

Connect the unknown current to the INPUT Receptacle and unlock the ZERO CHECK Button. Set the METER Switch to + or -, as necessary. Increase the sensitivity with the Range Switch and the Multiplier Switch. Do not set the Multiplier Switch higher than 3 for Range Switch settings 10^{-3} and above. Check zero with the ZERO CHECK Button.

2. Full-scale current range is the settings of the Range Switch times the Multiplier Switch. Use the smallest Multiplier Switch setting possible to minimize input voltage drop and obtain the best accuracy. The input resistor varies with the Range Switch setting, from 10 ohms at 10^{-1} AMPERES to 10^{11} ohms for 10^{-11} AMPERES. Input voltage drop is the percentage of full scale that the meter reads times the Multiplier Switch setting.

NOTE

On the low current ranges, balance out the grid current with the Zero Controls or subtract the value from the reading. To find the amount of grid current, cap the INPUT Receptacle and read the meter.

e. Fast Method (ranges below 10^{-5} ampere).

1. Follow the instructions of paragraph 2-4. Set the controls as follows:

| | |
|-------------------|-------------------|
| METER Switch | CENTER ZERO |
| Range Switch | 10^{-6} AMPERES |
| Multiplier Switch | 1 |
| FEEDBACK Switch | FAST |
| ZERO CHECK Button | LOCK |

Connect the unknown source to the INPUT Receptacle and unlock the ZERO CHECK Button. Set the METER Switch to + or -, as necessary. Increase the sensitivity with the Range Switch and the Multiplier Switch. Do not set the Range Switch to 10^{-5} AMPERES or higher. Check zero with the ZERO CHECK Button.

NOTE

Use only the ZERO CHECK Button to check zero for the fast method. Do not short the input, because this will remove the feedback from the circuit.

2. The full-scale current range is the Range Switch setting times the Multiplier Switch setting. When selecting the Multiplier Switch setting, remember small settings permit lower current source resistance, and larger settings improve instrument zero stability. Check the caution in subparagraph 3a below.

3. With the fast method, the input drop is reduced and the response speed is increased at least 100 times. However, follow these precautions:

a) The internal impedance of the unknown current source should not be less than 0.1 of the value of the feedback resistor being used. Otherwise, adequate feedback voltage cannot be developed at the input, and zero instability results. The feedback resistor value is the reciprocal of the AMPERES range of the Range Switch. Also, the voltage drop across the current source should be at least 100 times the voltage drop across the Model 601.

b) The low side (Pin No. 2) of the OUTPUT Receptacle is no longer connected to the low side of the INPUT Receptacle. Therefore, do not allow the low side of a recorder to be electrically connected, such as through the ground lead of a power cord, to the low side of the current source. Another alternative is using the unity-gain output. (See paragraph 2-11.)

c) Do not use the fast method to measure capacitance unless using a very stable voltage supply. Connecting a capacitor to the input changes the circuit to a differentiator, resulting in extreme sensitivity to very small voltage transients.

f. Galvanometric Method.

1. Operate the Model 601 as a pico-ammeter in the fast method of operation. Use an accurate reference current source to buck out the unknown current source. Connect as shown in Figure 6.

2. Set the METER Switch to CENTER ZERO and use the higher current ranges. Adjust the buckout current to indicate null on the Model 601. Increase the Electrometer's sensitivity as needed. When the Model 601 is as close to null as possible, the known reference current source equals the unknown source \pm the Model 601 current readings.

2-8. RESISTANCE MEASUREMENTS.

a. The Model 601 can measure resistances by three methods.

1. In the normal or two-terminal method (ammeter-voltmeter), the Electrometer measures the voltage drop across the unknown sample as a known, constant current flows through it. The voltage drop is proportional to the resistance of the sample. This method is the simplest for the 100 to 10^{11} ohm ranges.

2. Above 10^{11} ohms or to prevent leakage, the guarded method is better. It results in faster response speeds and also nullifies leakage errors across the Electrometer input, since the potential across the input terminal is small.

3. In the preceding methods, the voltage across the sample cannot be arbitrarily set. In some cases, as in measuring capacitor leakage, these methods involve much more

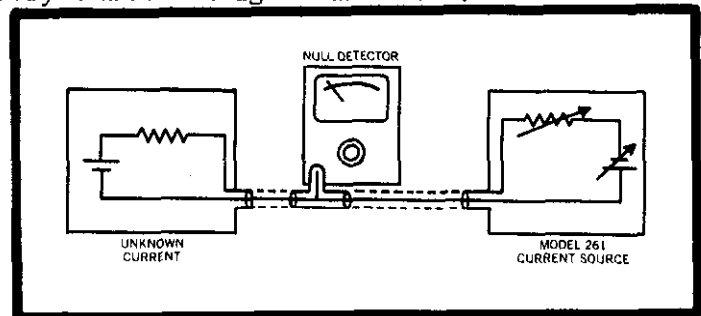

FIGURE 6. Measuring Current by the Galvanometric Method. Use an accurate reference current source to buck out the unknown current source, I_x . The Model 601, on its current ranges, serves as a null detector. Use a uhf-tee fitting and Model 6012 Adapter at the Model 601 input. Connect the Electrometer to the two sources with coaxial cable. Select cable carefully for very low currents (see paragraph 2-3). For off ground measurements, use triaxial cable and connectors, grounding the outer shield.

time than if a larger voltage could be applied. In the external voltage method the Model 601 is used as a fast picoammeter. The unknown resistance sample is connected to an external known voltage source and the current through the sample is measured. Either the normal or fast method may be used. The resistance is calculated from the readings.

NOTE

Discharge any capacitor before removing it from the circuit. Depressing the ZERO CHECK Button shorts the input through a 10-megohm resistor, providing a discharge path.

b. Normal Method (100 to 10^{11} ohm ranges).

1. Follow the instructions of paragraph 2-4. Set the controls as follows:

| | |
|-------------------|-------------|
| METER Switch | + |
| Range Switch | 10^5 OHMS |
| Multiplier Switch | 1 |
| FEEDBACK Switch | NORMAL |
| ZERO CHECK Button | LOCK |

Connect the resistance sample to the INPUT Receptacle. Unlock the ZERO CHECK Button. Check zero with only the ZERO CHECK Button.

NOTE

Do not open circuit the Electrometer on the OHMS ranges; the input will develop up to 10 volts due to its constant current characteristic. Keep the input shorted or the ZERO CHECK Button locked.

2. The full-scale ohms range is the Range Switch setting times the Multiplier Switch setting. Use the largest Multiplier Switch setting possible to obtain the best accuracy.
3. Before making a final reading, manipulate the Multiplier and Range Switches, so the sample is tested at a number of test potentials. The applied test voltage is the percentage of full scale that the meter reads times the Multiplier Switch setting.
4. When the test current is applied, high terminal of the INPUT Receptacle is negative.

NOTE

Shield the input if the resistance sample exceeds 10^8 ohms.

c. Guarded Method (to 10^{14} ohm ranges).

1. Follow the instructions of paragraph 2-4. Set the controls as follows:

| | |
|-------------------|----------------|
| METER Switch | + |
| Range Switch | 10^{11} OHMS |
| Multiplier Switch | 1 |
| FEEDBACK Switch | FAST |
| ZERO CHECK Button | LOCK |

Connect the low impedance side of the resistance sample to the Model 601 GUARD Terminal, and the high impedance side to the center terminal of the INPUT Receptacle. Unlock the ZERO CHECK Button.

2. Read the resistance as outlined for the normal method, subparagraph b.

3. The low terminal of the INPUT Receptacle is now a driven guard. It may be used to minimize the slowing effects of capacity between high and low and errors due to leakage resistance between high and low.

4. The Model 601 Input Cable, supplied with the Model 601, provides a convenient means of making guarded resistance measurements. Connect the shorting link between the CASE GROUND and GUARD Terminals on the rear panel. This allows the CASE GROUND or blue test lead terminal to be connected to the low impedance side of the unknown resistance. The inner shield or the black test clip is the GUARD Terminal.

d. External Voltage Method (to 10^{17} ohms).

1. Turn the ZERO CHECK Switch to LOCK. Connect the sample between the High Terminal of the INPUT Receptacle and the power supply. (See Figure 7.) Put a switch in the high voltage line to ground the low impedance end of the sample when it is disconnected from the potential. Before disconnecting, make sure to lock the ZERO CHECK Button. If the Power Supply must be floating, remove the link between the CASE GROUND and LO Terminals and connect the CASE GROUND Terminal to an earth ground.

2. Set the FEEDBACK Switch to NORMAL. Usually this method is best, since instabilities can arise for resistance samples less than 0.1 the value of the feedback resistor.

3. Apply a potential to the sample before releasing the ZERO CHECK Button. Set the Range Switch to .3 AMPERES and increase sensitivity until a reading is obtained.

4. If the potential applied is at least 100 times the full-scale input drop (Multiplier Switch setting), the resistance is equal to the applied potential divided by the current reading. The high voltage sensitivity of the Model 601, therefore, permits external voltages of 0.1 volt or more to be used.

5. If the potential applied is less than 100 times the input drop, the resistance is equal to the difference between the applied potential and the input drop, all divided by the current reading.

6. If the current is read by the fast method, the input drop is so slight that it need not be included in the calculation. If the capacity shunted across the sample is large, such as encountered in capacitor leakage measurements, the fast method increases response speed and this connection is recommended.

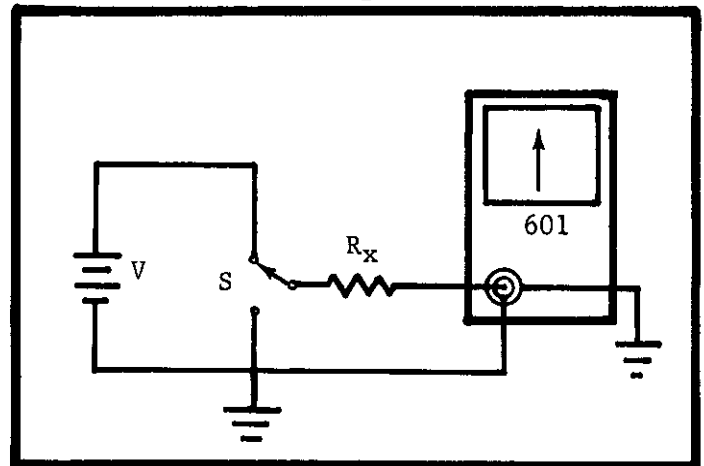

FIGURE 7. Measuring Resistance by the External Voltage Method. A potential from a known source, V , is applied to the unknown resistance sample, R_x . The Model 601 measures the current through R_x , from which the resistance is calculated. Switch S grounds R_x when no potential is applied. Note in above figure the power supply is floating.

2-9. CHARGE MEASUREMENTS.

- a. Follow the instructions of paragraph 2-4. Set the controls as follows:

| | |
|-------------------|--------------------|
| METER Switch | CENTER ZERO |
| Range Switch | 10^{-7} COULOMBS |
| Multiplier Switch | .01 |
| FEEDBACK Switch | FAST |
| ZERO CHECK Button | LOCK |

Unlock the ZERO CHECK Button and then connect the unknown source to the INPUT Receptacle. If the Electrometer reads off scale, increase the Multiplier Switch setting. If the sensitivity is not enough, decrease the Multiplier Switch setting until the reading is on scale. Changing the Multiplier Switch setting does not affect the transfer of charge from the unknown source to the instrument. If increasing sensitivity with the Multiplier Switch does not bring the reading on scale, increase sensitivity with the Range Switch and repeat the above steps.

- b. The full-scale charge range is the Range Switch setting times the Multiplier Switch setting. Grid current contributes 2×10^{-14} coulomb per second maximum.

NOTE

Because of the instrument's RC time constant, wait 20 seconds after discharging internal capacitance on the 10^{-7} coulomb range before making another measurement. On the 10^{-8} coulomb range, wait at least two seconds.

2-10. RECORDER OUTPUTS.

a. For recording with the Model 601, use the Keithley Model 370 Recorder for ease, economy, versatility and performance. The Model 370 is a pen recorder with 10 chart speeds and 1% linearity. It can float up to ± 500 volts off ground. The Model 370's input cable has a connector which mates directly with the OUTPUT Connector on the Model 601; this avoids interface problems often encountered between a measuring instrument and a recorder. The Model 601 OUTPUT, when set to IMA Position, will drive the 370; no preamplifier is needed.

b. Other recorders, oscilloscopes and similar instruments can be used with the Model 601. The Model 601 has two variable outputs, ± 1 volt and ± 1 milliamper, to amplify signals within 1/2% for recorders, oscilloscopes and similar instruments. These can be used on all ranges of the Model 601.

NOTE

The Model 601 may be used with the FEEDBACK Switch in FAST position with other instruments. However, make sure there is no common ground between low terminals of the Electrometer and the other instrument.

c. 1-Volt Output. Connect oscilloscopes and pen recorder amplifiers to the OUTPUT Receptacle. Pin no. 1 is the negative terminal and pin no. 2 is grounded when the FEEDBACK Switch is set to NORMAL. Set the OUTPUT Switch to 1 V. The Model 601 output is now ± 1 volt for full-scale meter deflection on any range. Internal resistance is 910 ohms. The frequency response (± 3 db) is dc to 200 cps at a gain of 1000, rising to 50 kc at a gain of 3.3, and decreasing to 1 kc at a gain of 0.1. Noise is less than 2% rms of full scale at a gain of 1000, decreasing to 0.5% at gains below 10. The METER Switch does not reverse the output polarity.

NOTE

Neither terminal of the OUTPUT Receptacle should be at case ground potential if the instrument is used off ground. Make sure the shell of any mating plug is not connected to either terminal in the Receptacle. The shorting link should not be connected between LO and CASE GROUND. Use a recorder with an input isolated from ground when making off ground measurements.

d. 1-Milliampere Output. Connect 1-milliampere instruments to the OUTPUT Receptacle. Pin no. 1 is the negative terminal. Set the OUTPUT Switch to 1 MA. The output is approximately 1 milliampere for full-scale meter deflection on any range. For exact output, adjust the meter on the .003-volt range with the FINE ZERO Control for full-scale deflection. Then adjust the 1 MA CAL Control until the recorder reads full scale. Check the recorder and meter zero and repeat adjustment if necessary. The METER Switch does not reverse the output polarity. Use only an insulated screwdriver to adjust the COARSE ZERO Switch and the 1 MA CAL Control.

e. For servo rebalance recorders, use a divider across the Model 601 OUTPUT Receptacle. See Figure 8. Set the OUTPUT Switch to 1 MA. Use the 1 MA CAL Control to trim the output for full-scale recorder deflection. Operation is the same as for current outputs.

f. When the FEEDBACK Switch is in the NORMAL position, the negative side of the output terminal is grounded to the LO Terminal. Therefore, no difficulty will be experienced using oscilloscopes and recorders with the Model 601 set for normal operation. In FAST position, however, neither side is grounded. If this is used, make sure there is no common ground between the recorder or oscilloscope and the Model 601 LO Terminal, or use the unity-gain output.

2-11. UNITY GAIN OUTPUT. The unity-gain amplifier can be used as an impedance matching device to minimize circuit loading errors or for convenient connections to a recorder when the FEEDBACK Switch is in FAST position.

a. The unity-gain output is equal to the input within 50 ppm or 100 microvolts when the load resistance is 100 kilohms or better below 10 volts. By placing the Model 601 between a 10^{10} ohm source, for example, and a 0.01% voltmeter with a 1-megohm input resistance, overall accuracy better than 0.025% can be achieved.

1. Connect the voltmeter to the X1 OUTPUT and GUARD Terminals as shown in Figure 6. The GUARD Terminal is connected to LO Terminal with the FEEDBACK Switch in NORMAL. Maximum output amplitude is 10 volts peak-to-peak.

2. Adjust the Model 601 Zero Controls to obtain a zero-voltage reading on the instrument using the unity-gain output. Make sure the latter's sensitivity is high enough

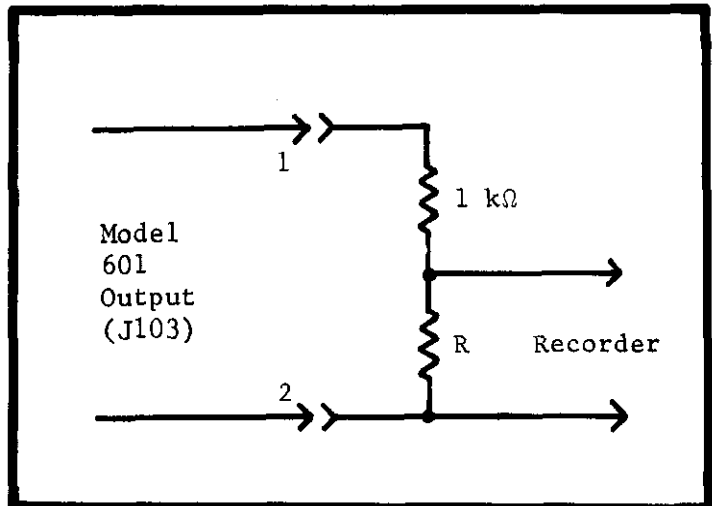

FIGURE 8. Divider Circuits Across Model 601 Output for Driving 50 and 100-Millivolt Recorders. Use 1% resistors in the dividers for 50-millivolt recorders, resistor R is 50Ω ; for 100-millivolt, R is 100Ω .

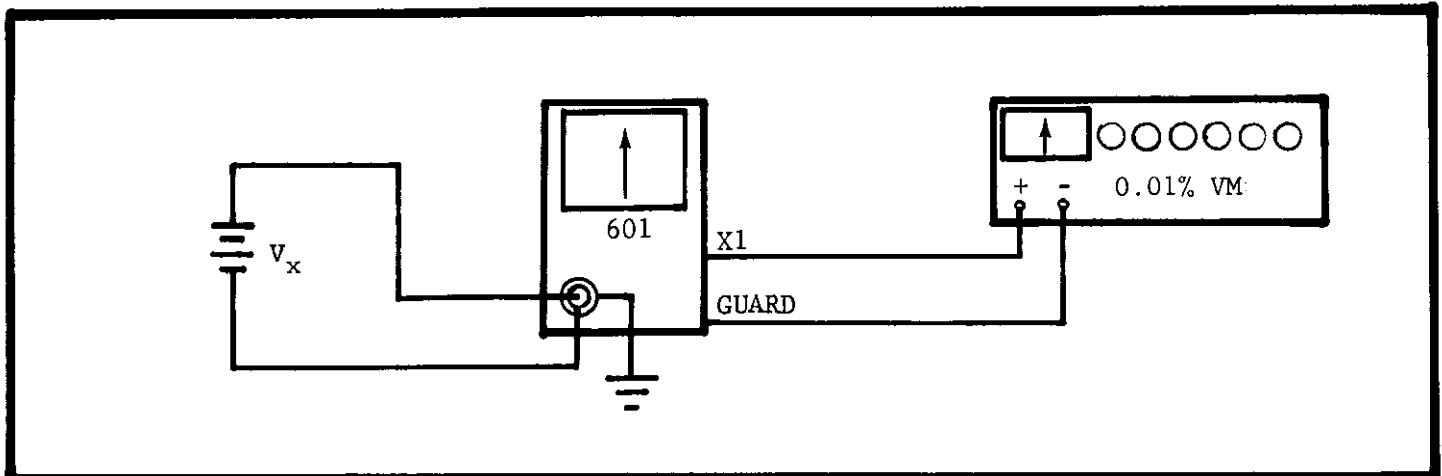

FIGURE 9. Measuring Potential of High Resistance Source with 0.025% Accuracy. The Model 601 is used between a high-resistance source, V_x , and a 0.01% voltmeter to obtain high accuracy without causing circuit loading. The digital voltmeter or, as above, the Keithley Model 662 Differential Voltmeter connects to the Model 601 unity-gain terminals.

for a precise zero adjustment. This adjustment is necessary because a slight zero shift may occur when the Model 601 is changed from the 0.1-volt range or lower to a range above 0.1 volt. The shift, caused by a gain-reducing network switched in by the amplifier on the 1-volt and higher ranges, is too slight to be read on the meter, but it can cause an error in accurate measurements using the unity-gain output.

b. When the FEEDBACK Switch is in FAST position, the unity-gain terminals permit more convenient connections to recorders without special precautions. In this mode, the X1 OUTPUT Terminal is grounded and the GUARD Terminal delivers a full-scale output equal to the Multiplier Switch setting times the input signal.

SECTION 3. APPLICATIONS

3-1. GENERAL. This Section discusses ways of using the Model 601 Electrometer. The versatility of the Model 601 is such that it is almost a complete dc laboratory in itself. Some particular applications are considered. The purpose of these is to suggest uses and techniques to increase the usefulness of the Model 601.

3-2. CURRENT SOURCE. The Model 601 can be used as a $\pm 4\%$ current source on all the current ranges as long as the input voltage drop is less than the Multiplier Switch setting. Follow these procedures:

a. Set the FEEDBACK Switch to NORMAL, the Range Switch to OHMS and the METER Switch to + or -.

b. The current supplied at the INPUT Receptacle is the reciprocal of the OHMS Setting on the Range Switch. (For example, 10^9 OHMS indicates 10^{-9} ampere current at the INPUT Receptacle.)

c. The Multiplier Switch does not affect the current at the INPUT Receptacle. It does affect the maximum input voltage drop, which is equal to the Multiplier Switch setting. For accurate output current, check the meter zero on the .01-volt range.

3-3. STATIC CHARGE MEASUREMENTS. Electrometers are very sensitive to static charges and can readily make qualitative or quantitative measurements.

a. Zero the Model 601; set the FEEDBACK Switch to NORMAL and the Range Switch to VOLTS (10 volts full scale). Bring the charged object near the uncovered, unshielded INPUT Receptacle. Depending upon the distance between the charge and the instrument, a voltage will be induced on the input terminals which can be read on the meter. Check zero frequently, since accumulation of charge due to the electrometer tube grid current will cause a slow drift of the input voltage.

b. Connecting a capacitor across the input reduces the drift due to grid current and also the sensitivity to charge. Therefore, with the FEEDBACK Switch in NORMAL, set the Range Switch to COULOMBS position. The capacitor value connected across the input in farads is equal to the COULOMBS Range.

3-4. CAPACITANCE MEASUREMENTS. The Model 601 can measure capacitance from 500 picofarads to 100 microfarads. The Electrometer charges the capacitor to a known potential and then measures the charge. The resulting capacitance is easily figured.

a. Charge the capacitor as follows:

1. Set the Model 601 front panel controls to:

| | |
|-------------------|------------|
| METER Switch | + |
| Range Switch | VOLTS |
| Multiplier Switch | .001 to 10 |
| FEEDBACK Switch | NORMAL |
| ZERO CHECK Button | LOCK |

2. Connect the unknown capacitor to the INPUT Receptacle. Unlock the ZERO CHECK Button and charge the capacitor to a known voltage by setting the Range Switch to the

OHMS ranges. As the capacitor charges, the meter will advance up scale to show the voltage (percentage of full scale that the meter reads times the Multiplier Switch setting) across the capacitor at any given time.

3. Charge the capacitor to a convenient voltage, such as 0.1, 1, etc. Charge large capacitors to a lower voltage than that used for low-value capacitors. The OHMS ranges control the charging rate: start with the lower ranges and increase the setting as the voltage across the capacitor reaches the desired value.

4. When the capacitor reaches the desired value, quickly set the Range Switch to the VOLTS position. Disconnect the capacitor from the INPUT Receptacle. Or, if more convenient, disconnect the capacitor first and then set the Range Switch to VOLTS.

b. Measure the charge on the capacitor following the instructions in paragraph 2-9.

c. The value of the unknown capacitance is the stored charge divided by the initial voltage:

$$C \text{ (farads)} = \frac{Q \text{ (coulombs)}}{V \text{ (volts)}}$$

3-5. CURRENT INTEGRATOR. The Model 601 works as an integrator for time-varying currents. Figure 10 shows the circuit. Set the Range Switch to COULOMBS. Use the unity-gain output. Output voltage, V_{out} , is

$$V_{out} = \frac{1}{C} \int i \, dt$$

where C is the coulomb range setting in farads.

3-6. POTENTIOMETRIC VOLTAGE MEASUREMENTS. The floating capability, high input impedance, 1-millivolt sensitivity and low zero drift make the Model 601 useful as a null detector in potentiometric voltage measurements. The circuit shown in Figure 11 is useful when no loading of the source voltage, on or off null, can be tolerated. Make the measurements with the center zero scale, following the procedures in paragraph 2-6. When the Model 601 is at null — no meter deflection — the voltage from the known source equals the unknown voltage.

3-7. MEASURING DIODE CHARACTERISTICS. The Model 601 can accurately measure diode characteristics in one simple step without using any other equipment. The circuit is shown in Figure 12. The measurements are made on the OHMS ranges, selecting constant currents down

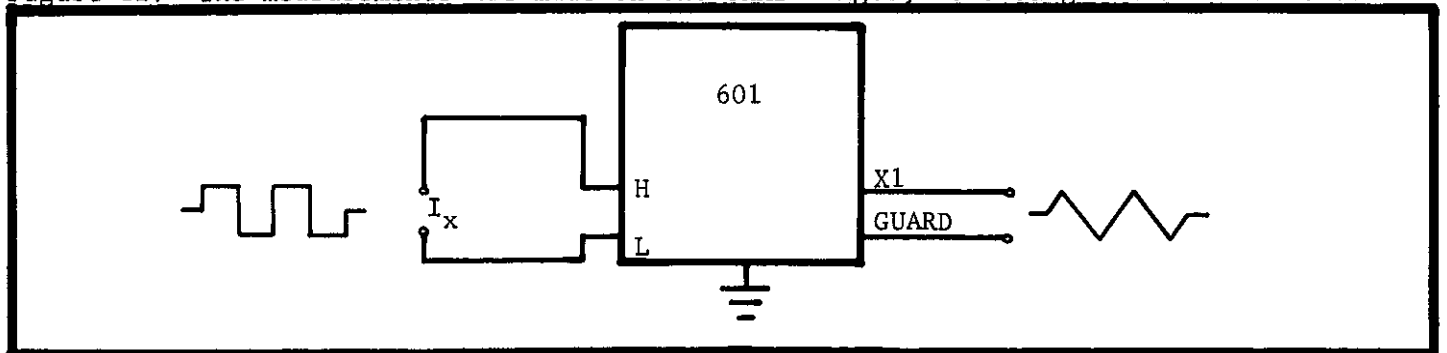

FIGURE 10. Current Integrator. The diagram shows the Model 601 acting as a current integrator. A square wave from a current source, I_x , is applied to the Model 601 input. Using the COULOMBS ranges, the output through the unity-gain terminals is shown.

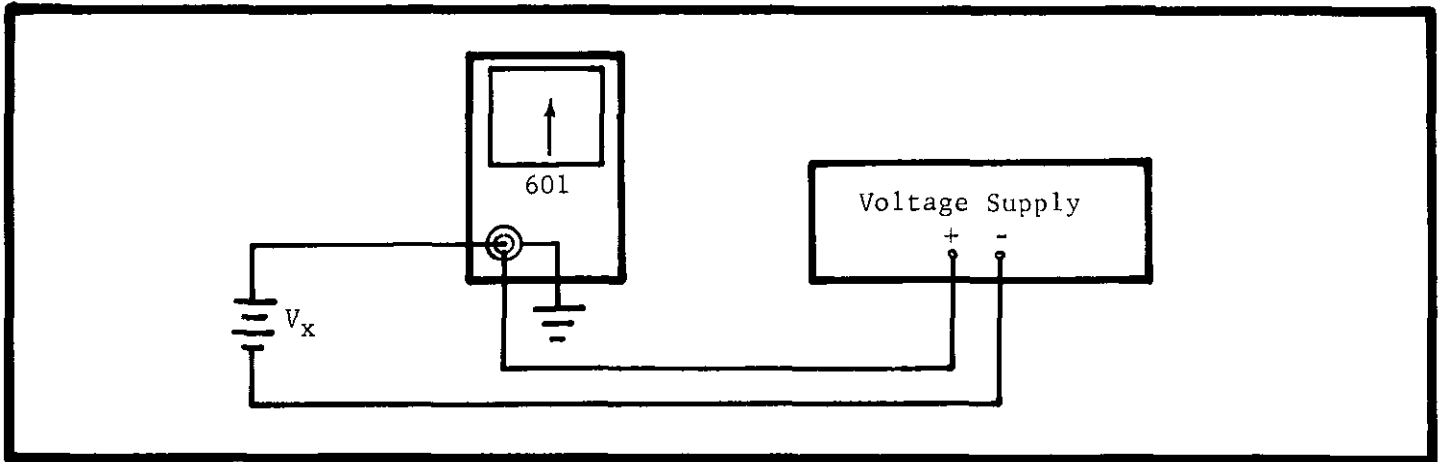

FIGURE 11. Potentiometric Voltage Measurements. An accurate voltage supply is used to buck out the potential from the unknown source, V_x . The Model 601 on the voltage ranges and center-zero scales acts as a null detector.

to 10^{-11} ampere in decade steps and reading the voltage drop across the diode. The characteristic curve can then be plotted in volts and amperes or in volts and ohms. The current polarity is positive out of the center terminal of the INPUT Receptacle. Read the voltage from the positive meter scale.

3-8. PEAK-READING VOLTMETER. The Model 601 easily converts to a peak-reading voltmeter. Set the Range Switch to the COULOMBS ranges and apply the input voltage to the INPUT Receptacle through an external diode. In the circuit shown in Figure 13, if the input resistance (R_i) and diode leakage resistance (R_d) are high and if the time constant of the RC combination is high compared to the period of the signal, the capacitor will charge to the peak value of the applied ac voltage minus the small drop across the diode. The Model 601 input resistance on the VOLTS or COULOMBS ranges is 10^{14} ohms or greater, and may therefore be neglected compared to the leakage resistance of most diodes. The capacitor (C) is selected using the COULOMBS ranges with the FEEDBACK Switch in the NORMAL position. C in farads is equal to the COULOMBS range setting.

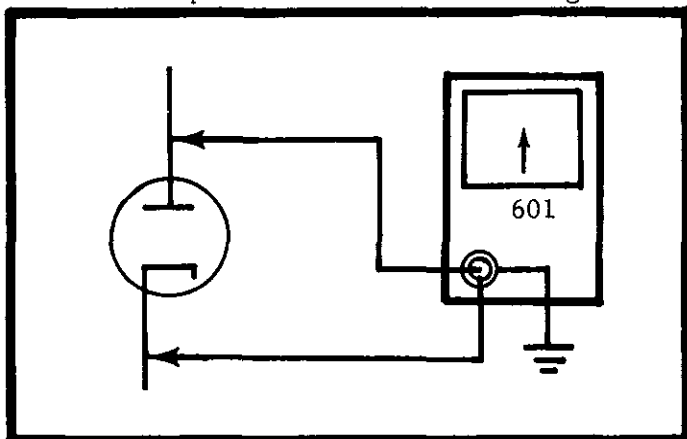

FIGURE 12. Measuring Diode Characteristics with Model 601. Use the OHMS ranges of the Electrometer.

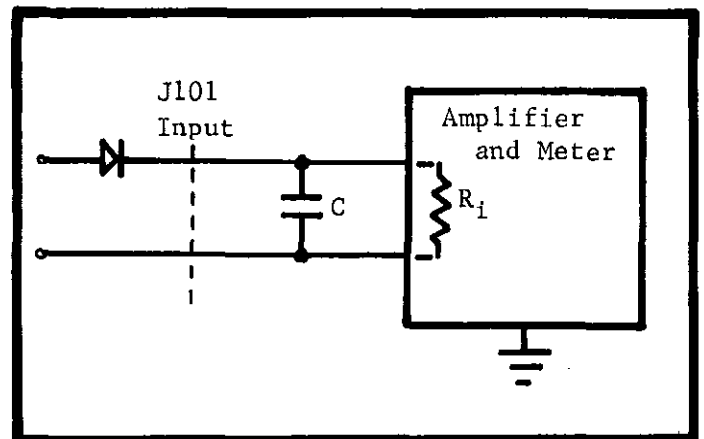

FIGURE 13. Diagram of Model 601 as Peak-Reading Voltmeter. Use the COULOMBS ranges. The diode is external to the voltmeter. C is the capacitor selected with the Range Switch; R_i is the Model 601 input resistance.

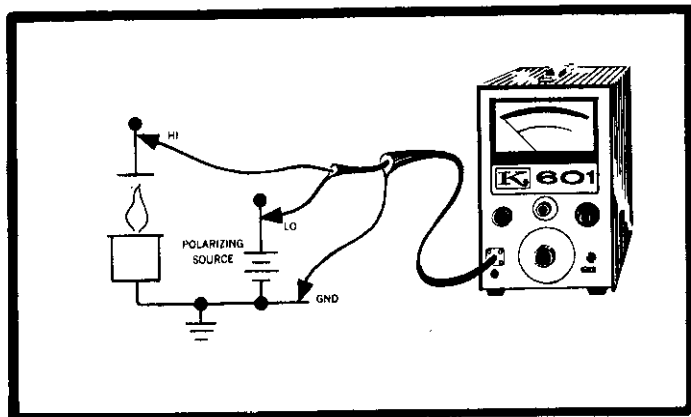

FIGURE 14. Measuring Output of Gas Chromatograph. The Model 601 is useful as a sensitive current detector in a gas chromatograph. Floating the Electrometer permits grounding the polarizing power source and flame column.

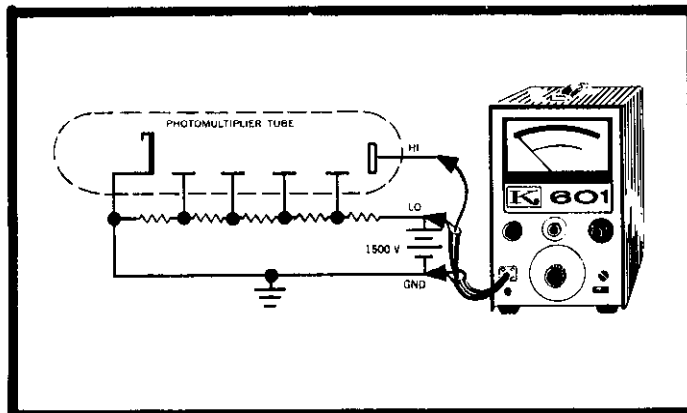

FIGURE 15. Monitoring Anode of Photomultiplier. The Model 601 permits monitoring the anode current of a photomultiplier where both the cathode and power supply must be grounded. With its case grounded, all Model 601 front panel controls are also at ground.

SECTION 4. CIRCUIT DESCRIPTION

4-1. GENERAL. The Keithley Model 601 is basically an extremely stable linear dc voltmeter with a full-scale sensitivity of 1 millivolt and an input impedance of 10^{14} ohms shunted by 20 picofarads. By using the front panel controls, shunt resistors and capacitors are selected to make measurements over a total of 73 voltage, current, resistance and charge ranges. Current and resistance are measured using precision resistance standards, from 10-ohm wirewound resistors to 10^{11} ohm glass-sealed high meoghms resistors. Charge is measured using close tolerance polystyrene film capacitor standards.

4-2. VOLTMETER OPERATION.

a. The voltmeter amplifier has matched electrometer input tubes followed by three differential transistor stages and a transistor output stage. A large amount of negative feedback is used for stability and accuracy. Figure 16 shows the simplified circuit for the voltmeter mode of operation.

b. When there is no input signal and the zero is set, the current (i_a) in the upper loop of Figure 16 equals that in the lower loop (i_b): $i_a = i_b$. With an input signal, the circuit reacts as follows:

1. When a positive voltage, $+e_i$, is applied to the input, the amplifier drives the base of transistor Q202 less negative, and current i_a is decreased causing a voltage drop through the Multiplier Switch resistor, R_m . At equilibrium this drop equals e_i ; therefore, it keeps the voltage drop, e_a , across the amplifier to a fraction of the input voltage.

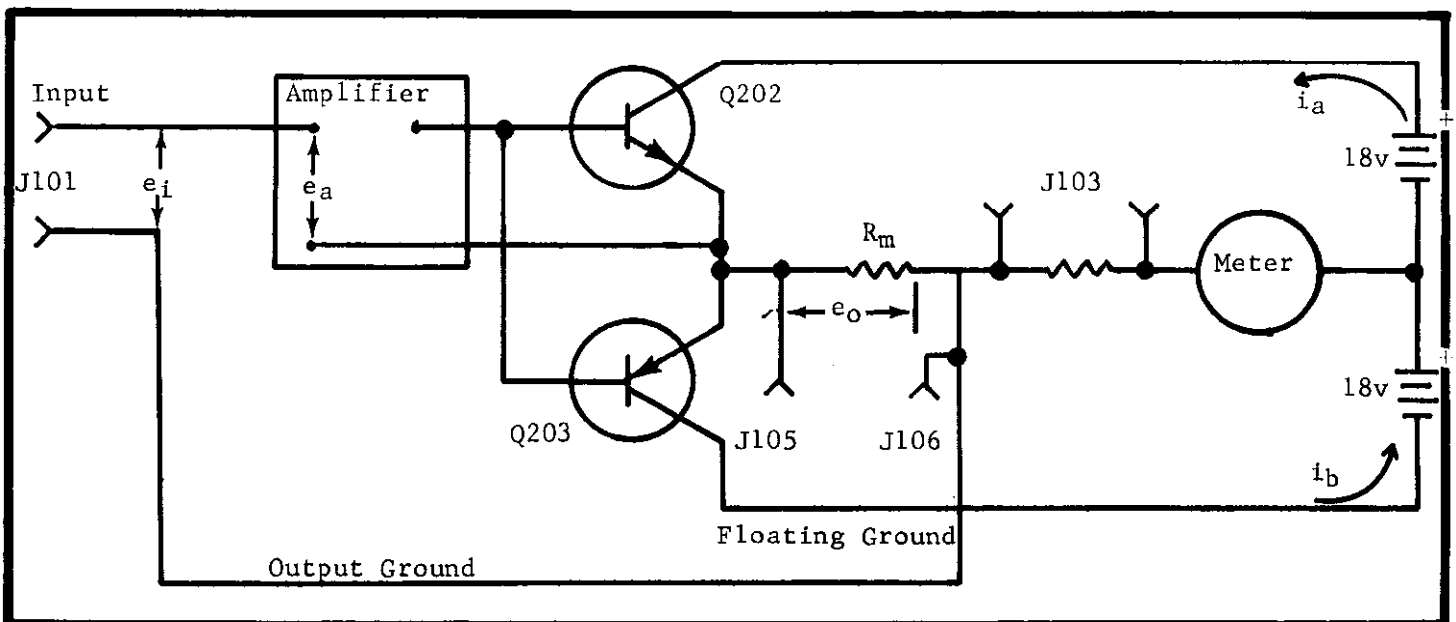

FIGURE 16. Simplified Circuit of Model 601 in Voltmeter Mode. Circuit designations refer to schematic diagram. e_i is the input voltage; e_a is the voltage drop across the amplifier. R_m is the resistor for a given Multiplier Switch setting. e_o is the voltage drop across R_m . J105 is the unity-gain terminal; J106, ohms guard terminal. i_a and i_b are instantaneous currents within the loops. Ground references correspond to schematic diagram.

2. When a negative voltage, $-e_i$, is applied to the input, the amplifier drives the base of transistor Q202 more negative, and i_a is increased. The current in the lower loop, i_b , becomes greater than i_a , producing a voltage drop, e_o , across R_m . The drop is sufficient to null the negative input voltage, e_i , again keeping the voltage drop across the amplifier to a fraction of the input voltage.

3. The voltage drop across the amplifier is $e_a = e_i/(k+1)$; k is the loop gain, approximately 10^5 on the 0.001 to 0.3-volt ranges.

c. The output stage, transistors Q202 and Q203, drives the amplifier common at nearly the same potential as the input signal. Using this circuit, the input can accept voltages up to ± 10 volts without input dividers. This maintains high input impedance and eliminates instabilities which can occur with high resistance dividers.

4-3. VOLTMETER CIRCUIT.

a. Two balanced electrometer tubes are used for the amplifier input. Their filaments are operated in parallel from batteries B201 and B202. Resistors R101 and R114 protect the control grid of V101, the active electrometer tube, from excessive grid current due to overloads. Capacitors C101 and C111 are high-frequency bypasses. The control grid of V102 is returned to amplifier common (floating ground).

NOTE

Refer to Schematic Diagram 19428E for circuit designations.

b. Depressing the ZERO CHECK Button, S102, connects the junction of resistors R101 and R114 to circuit low. This removes all signal from the grid of V101, and the input impedance is reduced to 10 megohms.

c. An emitter follower stage, transistors Q101 and Q102, matches the relatively high output impedance of the electrometer tube to the low input impedance of the differential amplifier stage formed by transistors Q103 and Q104. This latter stage drives a second differential amplifier stage, transistors Q105 and Q106. Transistor Q106 drives the complementary pair output stage, transistors Q202 and Q203.

d. The zero balance controls adjust the dc voltages of the electrometer tube screen grids. The screen grids of V101 and V102 are returned, in effect, to the emitters of transistors Q101 and Q102 through the COARSE and MEDIUM ZERO Switches, S103 and S104. The emitter voltage of Q101 and Q102 can vary, resulting in a negative feedback loop for signals in phase at the electrometer tubes through the Q101 and Q102 emitter circuit back to the V101 and V102 screen grids. This connection stabilizes the electrometer plate potential and tube operating points. Also, for signals arriving at the V101 control grid, the gain of the first stage will be much greater than spurious signals.

e. The voltage drop across the Multiplier Switch resistors, R162 through R170, determines the voltmeter sensitivity. Applying a full-scale signal to the input causes a 1.1 milliamperé current to flow through the meter circuit and the selected Multiplier Switch resistor producing a full-scale meter deflection.

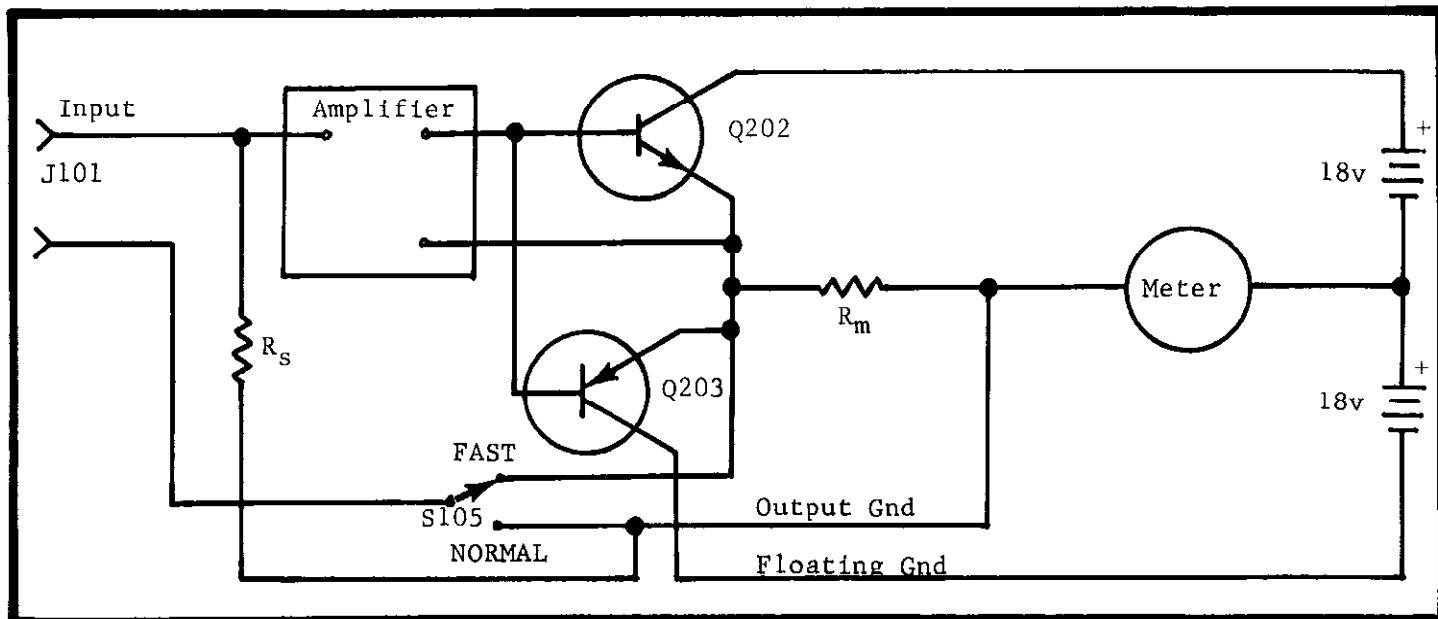

FIGURE 17. Block Diagram of Model 601 as a Picoammeter. Circuit designations refer to schematic diagram. R_m is the resistor for a given Multiplier Switch setting. R_s is the resistor selected by the Range Switch, S101. S105 is the FEEDBACK Switch. Ground references correspond to schematic.

f. The recorder output is derived from the current flow from transistor Q203 through the Multiplier Switch resistor. With the Output Switch, S108, on 1V, ± 1 volt for full-scale deflection is obtained at the output connector, J103, by ± 1.1 milliamperes flowing through resistor R173. With S108 at 1 MA, resistors R171 and R172 are connected across J103, allowing ± 1 milliamperes to pass through an external load. With an external load of 1400 ohms the current may be varied by $\pm 5\%$ by the IMA Cal Control, potentiometer R172.

NOTE

The "normal" and "fast" referred to below are only the positions of the FEEDBACK Switch. "Normal method" is when the Switch is set to NORMAL; "fast method" is when the Switch is set to FAST.

4-4. AMMETER OPERATION.

a. Normal Method. In the normal method of current measurements (FEEDBACK Switch in NORMAL position), one of the Range Switch resistors, R102 through R112, shunts the input. (See Figure 17.) The Model 601 then measures the voltage drop across the resistor. The meter is calibrated to read the current in amperes for the appropriate range.

b. Fast Method. In the fast method of current measurements (FEEDBACK Switch in FAST position), the Model 601 functions as an ammeter with negative feedback. The differential amplifier output is divided by the Multiplier Switch resistors, R162 to R170, and fed back to the amplifier input through a feedback resistor selected with the Range Switch. (See Figure 17.) Amplifier low (floating ground) is connected to the low impedance side of the input, and the output ground is floating. This method increases the response speed by minimizing the effects of input capacity; it also reduces the input drop to less than 1 millivolt.

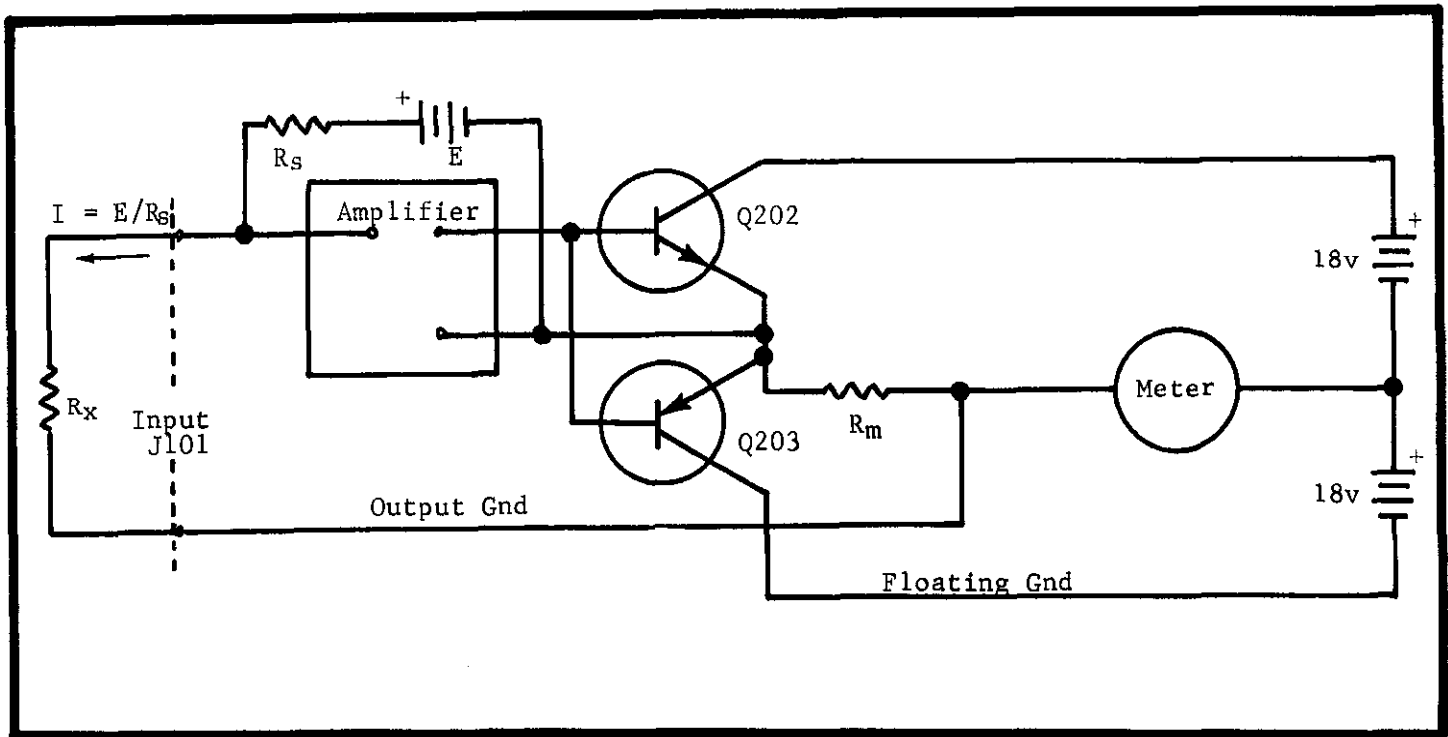

FIGURE 18. Block Diagram of Model 601 for Normal Method of Measuring Resistance. Circuit designations refer to schematic diagram. R_m is the resistor for a given Multiplier Switch setting. R_x is the unknown resistance being measured; E is the voltage source (see paragraph 4-5); R_s is the range resistor selected with the Range Switch. Ground references correspond to the schematic.

4-5. OHMMETER OPERATION.

a. Normal Method. In the normal method of resistance measurements (FEEDBACK Switch in NORMAL position), the Model 601 uses a constant-current, voltage-drop circuit. Refer to Figure 18. R_x is the unknown resistor. A voltage source, E , applies a potential across R_x . The source is obtained from battery B203 through the resistor divider network, R201 through R203. E varies from 0.1 to 8.4 volts, depending upon the OHMS range used. The voltage source is connected between floating ground and the second differential amplifier stage through R_s , the range resistor. R_s is one of the resistors, R102 through R112. Since feedback to the amplifier low (floating ground) keeps the base of transistor Q203 at nearly the same potential as the collector, the current, I , through R_x and R_s is constant. I is equal to E/R_s , regardless of the value of R_x , as long as the voltage drop across R_x does not exceed the Multiplier Switch setting. This circuit provides a true source regardless of the input. The Model 601 can then measure the voltage drop across R_x and indicate the resistance value on its calibrated meter.

b. Guarded Method. In the guarded method of resistance measurements (FEEDBACK Switch in FAST position and the sample resistance connected between the input terminal, J101, and the OHMS GUARD terminal, J106), feedback is applied through the sample. Refer to Figure 19. The circuit is similar to the normal method, except for the feedback. This circuit reduces the slowing effect of the instrument's input capacity. Errors due to leakage are also reduced, since the potential across the input terminal is small. In this mode, amplifier low (floating ground) is connected to the low terminal of the INPUT Receptacle and the output ground is floating. The guard terminal is at output ground potential.

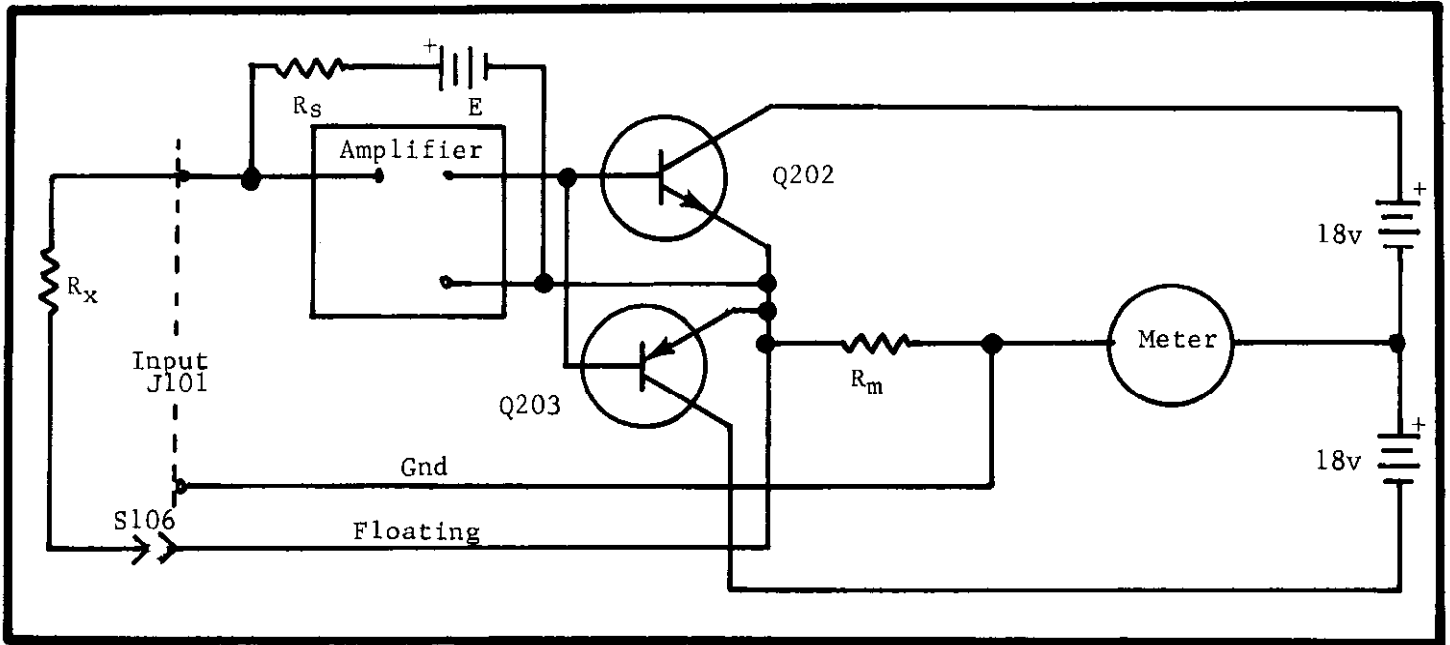

FIGURE 19. Block Diagram of Model 601 for Guarded Method of Measuring Resistance. Circuit designations refer to schematic diagram. R_m is the resistor for a given Multiplier Switch setting. R_x is the unknown resistor being measured; E is the voltage source (see paragraph 4-5); R_s is the range resistor selected with the Range Switch. J106 is the OHMS GUARD terminal. Ground references correspond to the schematic.

4-6. COULOMB METER OPERATION. The Model 601 circuit for measuring charge is similar to that used for an ammeter with the fast method. A negative feedback is applied around a shunt capacitor, C107 to C110, selected with the Range Switch. The shunt capacitor replaces R_s in Figure 17. The stored charge is proportional to the voltage across the capacitor, which is measured by the Model 601 voltmeter circuits. The Model 601 may be used in the Normal or Fast method to measure charge, the same as to measure current.

| Instrument | Use |
|---|---|
| Keithley Instruments Model 153 Microvolt-Ammeter; 10 μ v to 1000v, 200M Ω input resistance, \pm 1% accuracy; float \pm 500v off ground | General circuit checking |
| Keithley Instruments Model 241 Regulated High Voltage Supply; 0 to 1000 v, \pm 0.05% | Source to calibrate 1 to 10-volt ranges |
| Keithley Instruments 260 Nanovolt Source; 10 ⁻³ to 1 v, \pm 0.25% | Source to calibrate 1 mv to 1 v ranges |
| Keithley Instruments Model 6011 Input Cable; supplied with Model 601 | Connecting cable for Models 601 and 260 |
| Keithley Instruments Model 6012 Triaxial to Coaxial UHF Adapter | Adapts the Model 601 for use with instruments and accessories with coaxial connections. |
| Keithley Instruments Model 261 Picoampere Source, 10 ⁻¹⁴ to 10 ⁻⁴ ampere | Source to calibrate current, resistance and charge ranges |
| Keithley Instruments Model 370 Recorder | Monitor drift |
| Keithley Instruments Model 2611 Test Cable; Supplied with Model 261. | Connecting cable for Models 601 and 261 |
| Keithley Instruments Model 515 Megohm Bridge | Verify high-megohm resistors in Range Switch |
| Keithley Instruments Model 662 Guarded Differential Voltmeter; 100 μ v to 500 v, \pm 0.01% | Calibrate Meter zero |

TABLE 3. Equipment Recommended for Model 601 Calibration and Troubleshooting. Use these instruments or their equivalents.

SECTION 5. SERVICING

5-1. GENERAL. Section 5 contains the maintenance and troubleshooting procedures for the Model 601 Electrometer. Follow these procedures as closely as possible to maintain the performance of the instrument.

5-2. SERVICING SCHEDULE. Periodically check the condition of the batteries, using the convenient battery check as described in paragraph 2-4. Except for battery replacement the Model 601 requires no periodic maintenance beyond the normal care required of high-quality electronic equipment. The value of the high-megohm resistors, R110, R111, R112, should be checked approximately every six months for specified accuracy. The dc amplifier balance requires occasional adjustment; see paragraph 6-4.

5-3. PARTS REPLACEMENT.

a. The Replaceable Parts List in Section 8 describes the electrical components of the Electrometer. Replace components only as necessary. Use only reliable replacements which meet the specifications

b. The electrometer tubes, V101 and V102, are specially matched and aged; order only from Keithley Instruments, Inc. In normal use, they should not need replacement before 10,000 hours of operation. They can be checked only by replacement. Standard 5886 tubes could be used in an emergency, but the drift, noise and grid current specifications may not be met.

NOTE

When replacing the electrometer tubes, do not touch the glass base where the leads emerge. Increased leakage will result from any contamination.

c. Transistor pairs Q101, Q102 and Q103, Q104 are matched for dc beta (h_{FE}). Order only from Keithley Instruments, Inc., or its representative; replace only as a pair.

5-4. TROUBLESHOOTING.

a. The procedures which follow give instructions for repairing troubles which might occur in the Model 601. Use the procedures outlined and use only specified replacement parts. Table 3 lists equipment recommended for troubleshooting. If the trouble cannot be readily located or repaired, contact Keithley Instruments, Inc., or its representative.

b. Table 4 contains the more common troubles which might occur. If the repairs indicated in the table do not clear up the trouble, find the difficulty through a circuit-by-circuit check, such as given in paragraph 5-5. Refer to the circuit description in Section 4 to find the more critical components and to determine their function in the circuit. The complete circuit schematic, 19428E, is in Section 8.

5-5. PROCEDURES TO GUIDE TROUBLESHOOTING.

a. If the instrument will not operate, check the condition of the batteries. Then check the OUTPUT Switch. This switch should not be in the IMA Position with no load. If these are found satisfactory, use the following procedures to isolate the trouble.

| Difficulty | Probable Cause | Solution |
|---|--|---|
| Excessive Zero Drift. | Electrometer tubes may be defective | Check V101 and V102; replace if faulty. |
| | DC amplifier not balanced. | Check per paragraph 6-4. |
| | Batteries failing | Replace batteries (paragraph 2-4). |
| Excessive grid current | Excessive humidity or defective electrometer tube. | Check V101 and V102; replace if faulty. |
| | Instrument not used. | Run for seven hours. |
| Excessive microphonics. | Defective electrometer tube | Check V101 and V102; replace if faulty. |
| Cannot meter zero on any range. | See paragraph 5-5. | See paragraph 5-5, d. Step 6. |
| Unable to zero meter on most sensitive range | Incorrect plate voltage on electrometer tube. | Check per paragraph 5-5. |
| Meter will not zero on one Multiplier Switch setting. | Faulty resistor for setting of Multiplier Switch. | Check resistors; replace if faulty. |
| 10 ⁻¹⁰ to 10 ⁻¹⁴ ampere current ranges are out of specifications. | Defective high megohm resistors. | Check per paragraph 6-5. |

TABLE 4. Model 601 Troubleshooting. See paragraph 5-3 for checking V101 and V102.

b. The schematic diagram indicates all tube element voltages and transistor terminal voltages referenced to either floating ground or output ground; a properly operating Electrometer will have these values $\pm 10\%$ if operating from fresh batteries. The control settings for these values are the Range Switch at VOLTS, Multiplier Switch at 1, and the meter zeroed. Measurements are with the Model 153.

c. At times, the meter will not zero on any range with the input shorted. Adjust the COARSE ZERO Switch, S103 (Figure 3), to bring the Model 601 into balance. If this does not work, continue to check the circuits.

1. Check the filaments of the electrometer tubes, V101 and V102, by measuring the voltage drop across the filament dropping resistor, R115 (Figure 23). If both filaments are operating properly, the voltage will read +1.7 volts dc $\pm 10\%$.

2. Inspect the leads from the shock-mounted input printed circuit board, PC-111, to the amplifier printed circuit board, PC-115, for possible breaks.

d. Amplifier.

1. To check the amplifier, disconnect the feedback loop by removing Batteries B206, B207, B208 and B209. This allows each stage of the amplifier to be individually checked. It also eliminates the possibility of applying excessive voltage to the electrometer tube grids, causing serious damage.

2. Connect the Model 153 between the plates of V101 and V102 (Figure 23). Adjust the COARSE and MEDIUM ZERO Controls for null. If a null cannot be reached, check V101, V102, the COARSE and MEDIUM ZERO Control circuits (resistors R129 to R150), and transistors Q101 and Q102. Check the transistors by removing them and adjusting for null again. If null is now reached, replace the transistor pair with a new pair.

3. Check the next stage by connecting the Model 153 across the emitters of Q101 and Q102 (Figure 25) and adjusting the COARSE and MEDIUM ZERO Controls for null. If null is not reached, check this stage and the base circuit of the next stage. Check the base circuit by removing transistors Q103 and Q104 (Figure 25) and again adjusting for null. If null is now reached, replace the transistor pair with a new pair.

4. Check the next stage by connecting the Model 153 across the collectors of Q103 and Q104 (Figure 25), and adjusting the COARSE and MEDIUM ZERO Controls for null. If null is not reached, check this stage and check for shorts in the base circuit of Q105 and Q106 (Figure 25).

5. Connect the Model 153 across the collectors of Q105 and Q106. Adjust the FINE ZERO Control for null. If null is reached, the dc amplifier is operating correctly and the trouble is in the output stage, the feedback stage or in transistor Q201.

6. The feedback loop includes the multiplier resistors, R162 through R170, the recorder output resistors, R173 on 1V position or R171 and R172 on 1 MA position, and the meter. An opening of any of these components prevents zeroing for only that particular multiplier setting.

7. Troubleshoot the output stages, transistors Q202 and Q203, by making voltage measurements with the Model 153 to within $\pm 10\%$ of the specified schematic value.

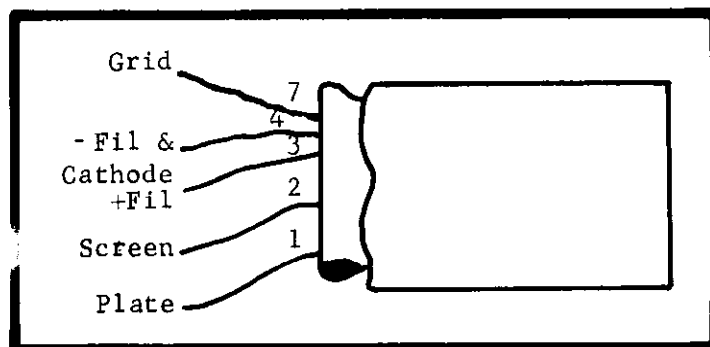

FIGURE 20. Base Connections for Electrometer Tube V101.

SECTION 6. CALIBRATION

6-1. GENERAL.

a. The following procedures are recommended for calibrating and adjusting the Model 601. Use the equipment recommended in Table 3. If proper facilities are not available or if difficulty is encountered, contact Keithley Instruments, Inc., or its representatives to arrange for factory calibration.

b. Procedures are covered for the following: grid current check, dc amplifier balance adjustment, high-megohm resistor verification, calibration of the ohms ranges, meter zero calibration and accuracy check.

6-2. CALIBRATION SCHEDULE.

a. Check grid current (paragraph 6-3) at regular intervals to make sure the electrometer tubes are functioning correctly.

b. The dc amplifier balance adjustment (paragraph 6-4) is necessary about every six months or when amplifier components are replaced.

c. Verify the value of the high-megohm resistors (paragraph 6-5) approximately every six months.

d. Calibrate the meter zero (paragraph 6-6) about once a year or when components are replaced.

e. Check the Model 601 (paragraph 6-7) once a year, after the other adjustments, or if improper operation is suspected.

f. If the Model 601 is not within specifications after the calibrations and adjustments, follow the troubleshooting procedures or contact Keithley Instruments, Inc., or its nearest representative.

6-3. GRID CURRENT CHECK. Check grid current whenever excessive noise or drift is suspected. To read the grid current of the Model 601, set the front panel controls to:

| | |
|-------------------|---------------------------|
| METER Switch | + |
| Multiplier Switch | .01 |
| Range Switch | 10 ⁻¹¹ AMPERES |
| ZERO CHECK Button | Unlocked |
| FEEDBACK Switch | FAST |

| Control | Circuit Designation | Fig. Ref. | Refer to Paragraph |
|-------------------------------|---------------------|-----------|--------------------|
| DC Amplifier Balance | R204 | 23 | 6-4 |
| Meter Center Zero Calibration | R211 | 24 | 6-6 |
| Meter Calibration | R220 | 24 | 6-6 |

TABLE 5. Model 601 Internal Controls. The Table lists all internal controls, the figure picturing the location and the paragraph describing the adjustment.

Cap the INPUT Receptacle. The grid current indicated on the meter should be less than 2×10^{-14} ampere. (This is less than 20% of full scale.) If this is exceeded, check the battery condition and the electrometer tube, V101. If the instrument has not been used for a long time, allow it to run for 7 hours before checking the grid current.

6-4. DC AMPLIFIER BALANCE ADJUSTMENT. Gradual aging of components may require an occasional adjustment of the amplifier balance. Also readjust the DC AMP BAL potentiometer, R204, if amplifier components are replaced.

a. Set the front panel controls to:

| | |
|-------------------|-------------|
| METER Switch | CENTER ZERO |
| Multiplier Switch | 0.1 |
| Range Switch | VOLTS |
| ZERO CHECK Button | LOCK |
| FEEDBACK Switch | NORMAL |

Zero the meter on the 0.1-volt range.

b. Connect the Model 153 across the collectors of transistors Q105 and Q106 (this is across the ends of resistors R152 and R153, Figure 25). Make the connections from the component side of the printed circuit board. Float the Model 153 low terminal.

c. Adjust the DC AMP BAL potentiometer, R204 (Figure 23), until the meter shows a null.

6-5. HIGH-MEGOHM RESISTOR VERIFICATION.

a. About every six months, it is necessary to check the value of the high-megohm resistors, R110 to R112, on the Range Switch. The instrument should be within its rated accuracy for two or three years from the time it leaves the factory. After this, some of the resistors may drift out of tolerance and should be replaced. Faulty high-megohm resistors will affect the accuracies of measurements for the 10^{-9} to 10^{-11} AMPERES and the 10^8 to 10^{12} OHMS settings of the Range Switch.

b. To check these resistors, it is necessary to use a bridge capable of better than 1% accuracy up to 10^{11} ohms. An accurate megohm bridge, such as the Keithley Instruments Model 515 Megohm Bridge which is accurate to 0.25% for these ranges, is therefore necessary. If such equipment is not available, two procedures are recommended to check out the resistors:

1. Return the complete instrument to the factory for resistor calibration.
2. Replace the high-megohm resistors periodically with a certified set from Keithley Instruments to assure absolute calibration accuracy.

6-6. METER ZERO CALIBRATION. Check meter zero whenever components are replaced or other adjustments are made.

a. Turn the METER Switch to METER OFF. Set the mechanical Zero Meter adjustment for zero meter reading (top-scale zero).

b. Turn the Model 601 on. Zero the meter on the .001-volt range. Then switch to the 10-volt range. Set the Multiplier Switch to 10; apply 10 volts $\pm 0.05\%$ to the Model 601 INPUT Receptacle. Adjust the METER CAL potentiometer, R220 (Figure 24), for full scale meter reading.

c. Set the center zero by first zeroing the meter on the .001-volt range. Then switch to the 1-volt range. Set the METER Switch to CENTER ZERO and adjust the CENTER ZERO CAL potentiometer, R211 (Figure 24), for exact center-scale meter zero.

6-7. ACCURACY CHECK.

a. Checking the accuracy is the quickest way to spot faulty Model 601 operation. Perform the check about once a year, if components are replaced, or if other adjustments are made. If accuracy is verified over all ranges, the Model 601 should be able to meet all specifications. If the accuracy must be checked often, check the stability.

b. Voltage. Connect the Model 601 to the Model 241. First, set the Model 601 for the 10-volt range. Increase the input voltage in 1-volt steps from 0 to 10 volts. The Model 601 should indicate the input voltage to $\pm 1\%$ of full scale. Perform the same operation in the 3-volt range. Connect the Model 601 to the Model 260. Check the other voltage ranges for accuracy of $\pm 1\%$ of full scale. Make sure the OUTPUT Switch is in the 1 V position for the 1, 3 and 10 volt ranges (see paragraph 2-4g).

c. Current. Connect the Model 601 to the Model 261 with the Model 2611. Check the full-scale accuracy of all current positions on the Range Switch. For the 10^{-5} to 10^{-11} ampere ranges, set the FEEDBACK Switch to FAST. The Model 601 should indicate the input current to $\pm 2\%$ of full scale from .3 to 10^{-8} ampere ranges, $\pm 4\%$ of full scale from the 10^{-9} to 10^{-11} ampere ranges. For the ranges above 10^{-4} ampere, construct a current source whose output is $\pm 0.25\%$. Set the Model 601 FEEDBACK Switch to NORMAL when calibrating these ranges.

d. Ohms. Check batteries B203, B204 and B205 according to paragraph 2-4. If one or more are low, replace them. A low battery can put all the ohms ranges out of tolerance and not affect the current ranges. Otherwise, all the ohms ranges will be within specifications if the current ranges are within specifications.

e. Coulombs.

1. Calibrate the 10^{-7} through 10^{-10} coulomb ranges using a variable time current source. Set the Model 601 FEEDBACK Switch to NORMAL and the MULTIPLIER Switch to 1. Connect the Model 261 to the Model 601 INPUT Receptacle. Set the Model 261 for 10^{-10} ampere output. Apply the current to the Model 601 for the time noted in Table 6 for each range. This procedure uses the time constant circuit to check the range capacitor accuracy. The Electrometer is being used here as a voltmeter.

2. To check the Model 601 as a charge amplifier, set the FEEDBACK Switch to FAST and the Multiplier Switch to 3. Use Model 261 to provide an input current. With the Range Switch set to the COULOMBS ranges given in Table 7, apply the corresponding input current. Use a stop watch or an oscilloscope to time the rise to full-scale deflection.

| Range Switch Setting | Time Current Applied (seconds) | Meter Reading |
|----------------------|--------------------------------|---------------|
| 10^{-7} COULOMBS | 100 | $93 \pm 5\%$ |
| 10^{-8} COULOMBS | 100 | $63 \pm 5\%$ |
| 10^{-9} COULOMBS | 100 | $63 \pm 5\%$ |
| 10^{-10} COULOMBS | 5 | $100 \pm 5\%$ |

TABLE 6. Data for Calibrating Coulomb Ranges.

| Range Switch Setting | Input Current to Model 601 (ampere) | Minimum Rise Time, Zero to Full Scale (seconds) |
|----------------------|-------------------------------------|---|
| 10^{-7} COULOMBS | 10^{-8} | 30 |
| 10^{-8} COULOMBS | 10^{-9} | 30 |
| 10^{-9} COULOMBS | 10^{-10} | 30 |
| 10^{-10} COULOMBS | 10^{-11} | 30 |

TABLE 7. Coulomb Ranges Accuracy Check. The Table gives the input current needed to check the rise time for each coulomb range.

6-8. DRIFT CHECK. Refer to the accuracy check before performing the drift check.

a. Set the front panel controls to:

| | |
|-------------------|--------|
| METER Switch | + |
| Multiplier Switch | .03 |
| Range Switch | VOLTS |
| ZERO CHECK Button | LOCK |
| FEEDBACK Switch | NORMAL |

Set the Output Switch on the back panel to 1 MA.

b. Connect the Model 601 OUTPUT Receptacle to the Model 370 Recorder. Set the recorder to 1 volt. Make sure the Model 601 chassis cover is attached with at least two screws.

c. Make the drift run for at least 24 hours. The zero drift specification is 200 microvolts per hour maximum averaged over any 24-hour period after warm-up; during two-hour warm-up, no more than 2 millivolts after the first hour (Refer to Figure 21).

d. If the instrument does not meet the zero drift specification, check the batteries. If the batteries are satisfactory and the instrument still does not meet the zero drift specifications, change the electrometer tubes.

NOTE

If new batteries have been installed, the Model 601 drift specification will be exceeded for at least the first 72 hours. It is recommended that new batteries be used for 120 hours before making a drift run.

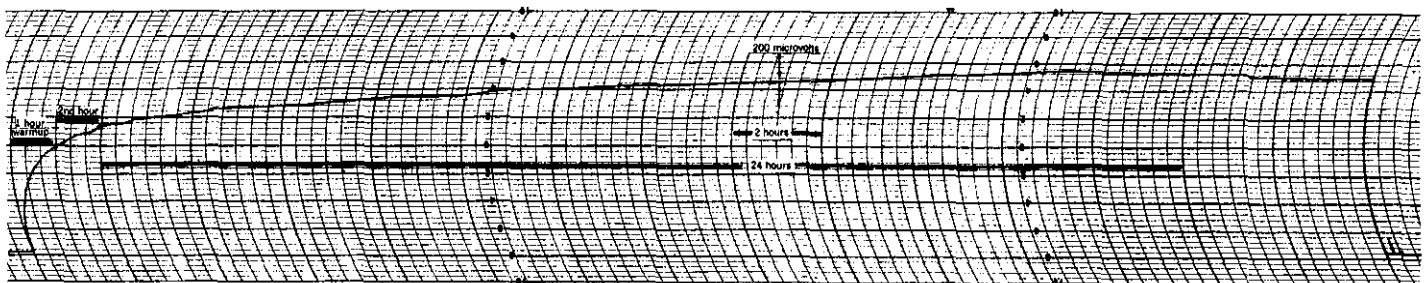

FIGURE 21. Typical Drift Chart for Model 601. The drift run shows the stability of the Electrometer over a 24-hour period. After a 1-hour warm-up, the drift is no more than 2 millivolts in the second hour. In any subsequent 24-hour period, the average drift will not exceed 200 microvolts per hour.

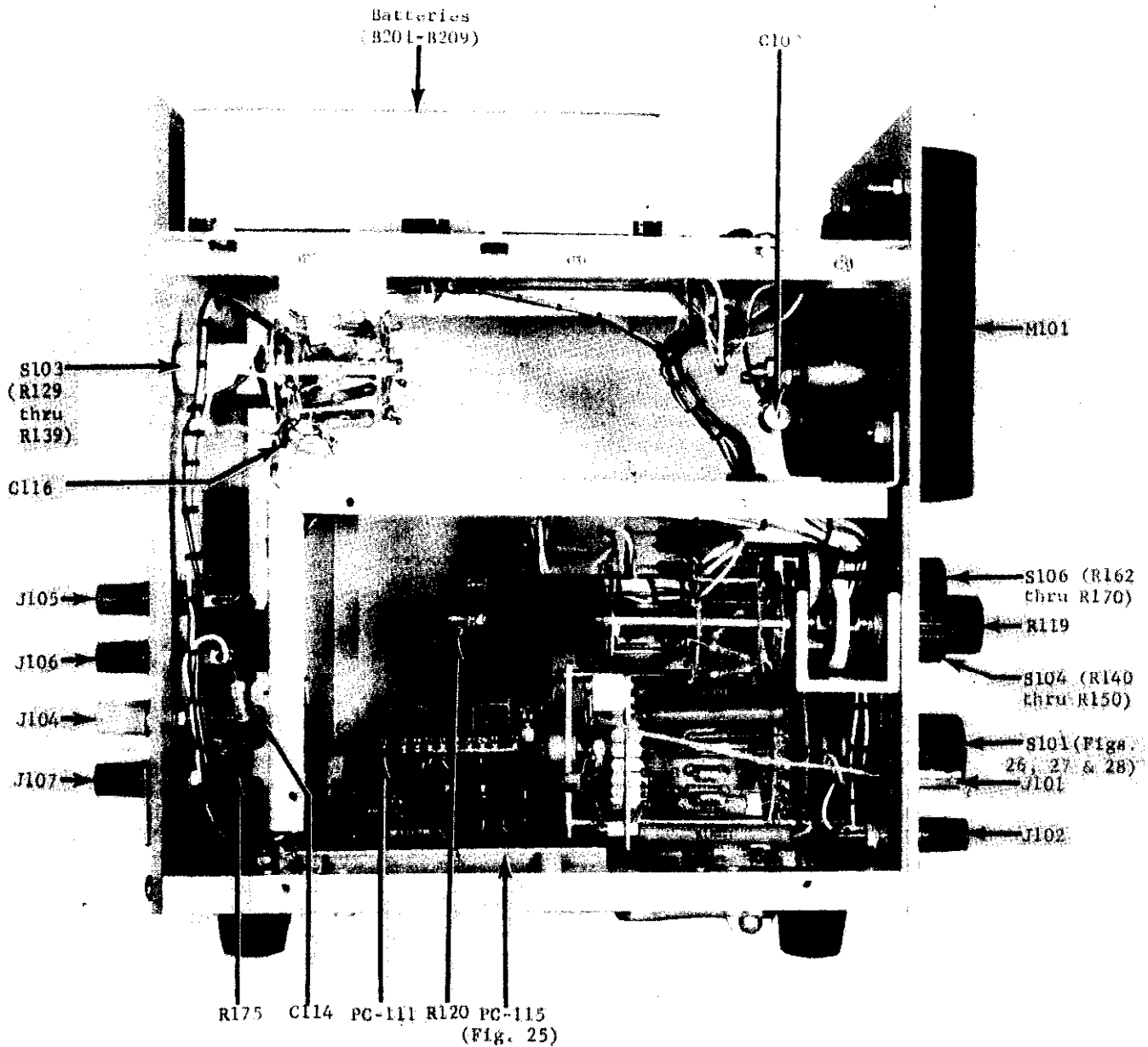

FIGURE 22. Side View of Model 601 Chassis. Front panel faces right. Location of components, printed circuits and switches is shown. Refer to the Parts List for circuit designations. Figure 23 shows the opposite side.

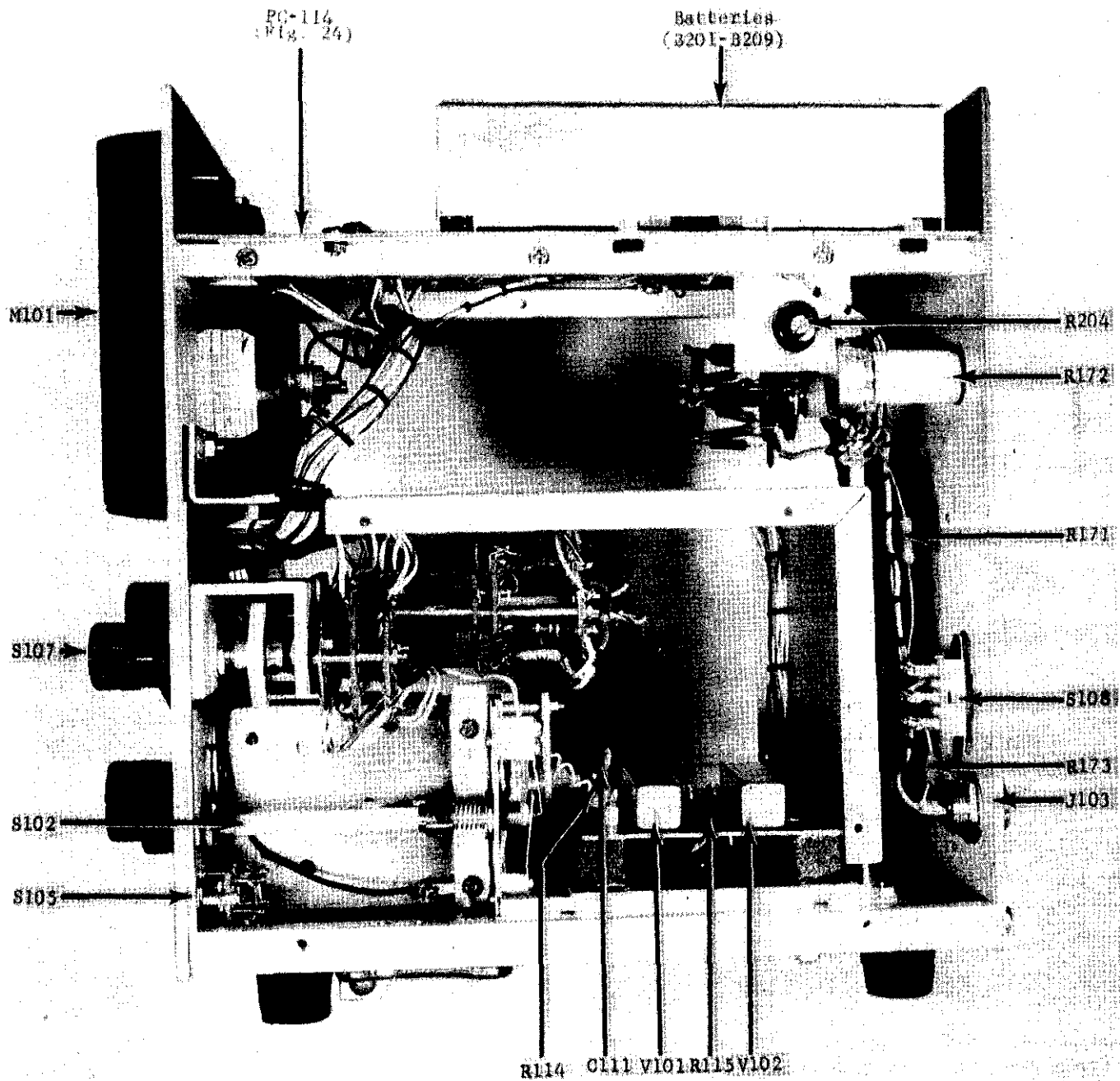

FIGURE 23. Side View of Model 601 Chassis. Front panel faces left. Location of components, printed circuits and switches is shown. Refer to Parts List for circuit designations. Figure 22 shows the opposite side.

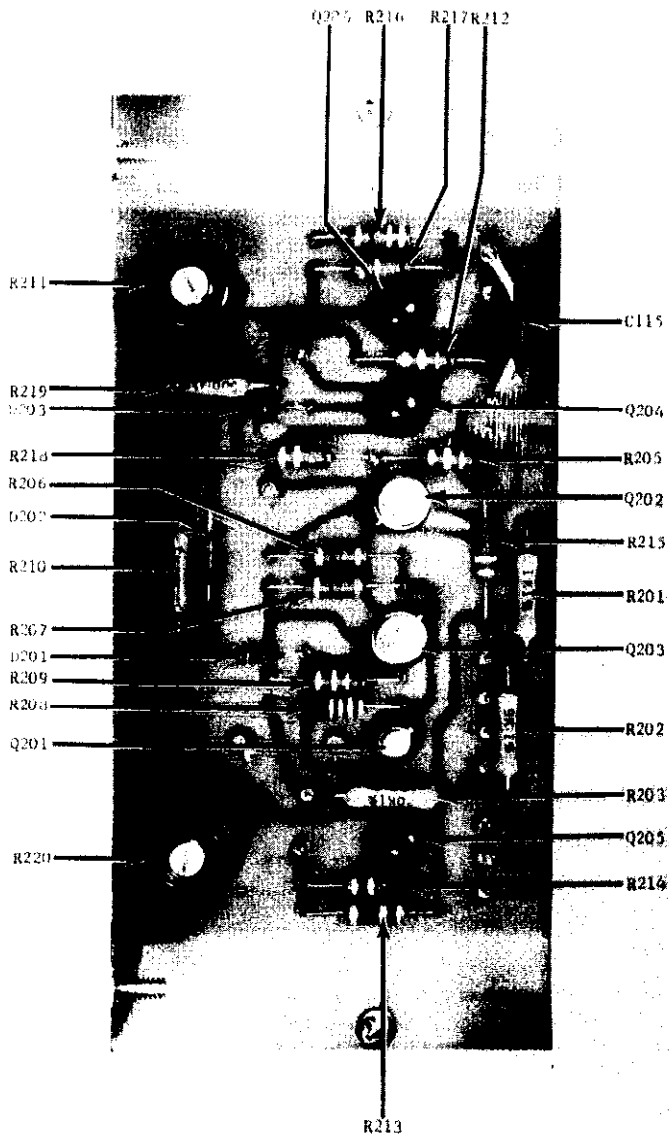

FIGURE 24. Component Locations on Printed Circuit PC-114.

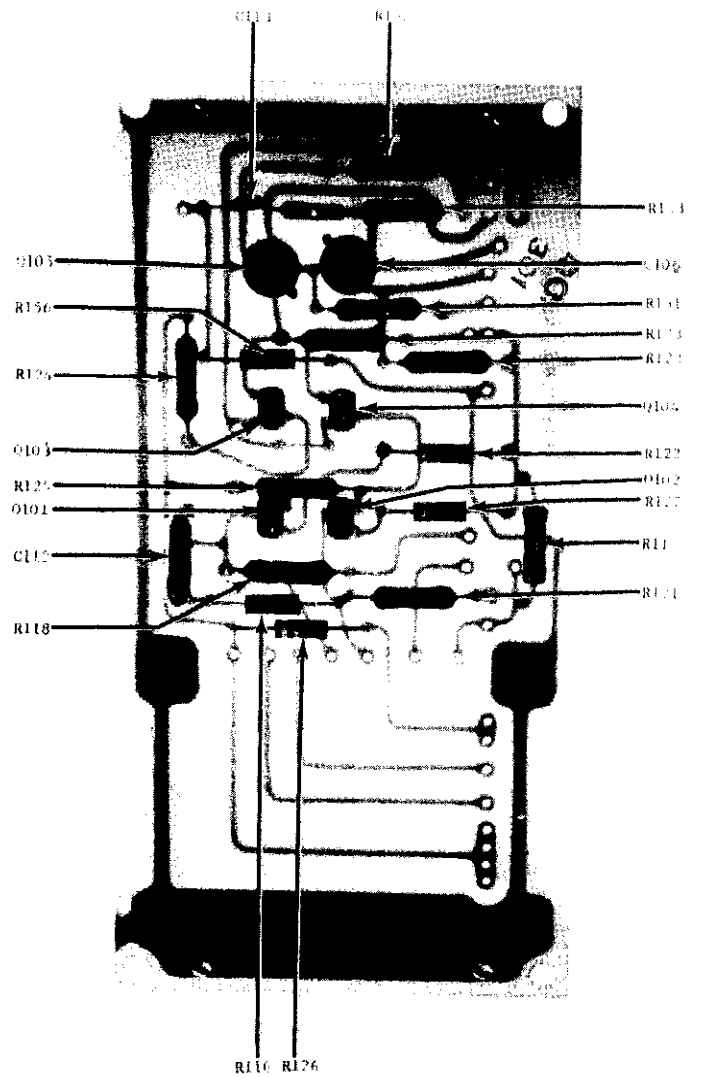

FIGURE 25. Component Locations on Printed Circuit PC-115.

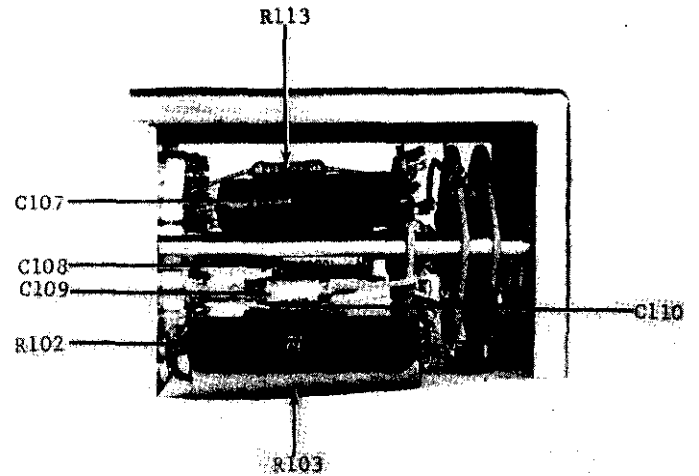
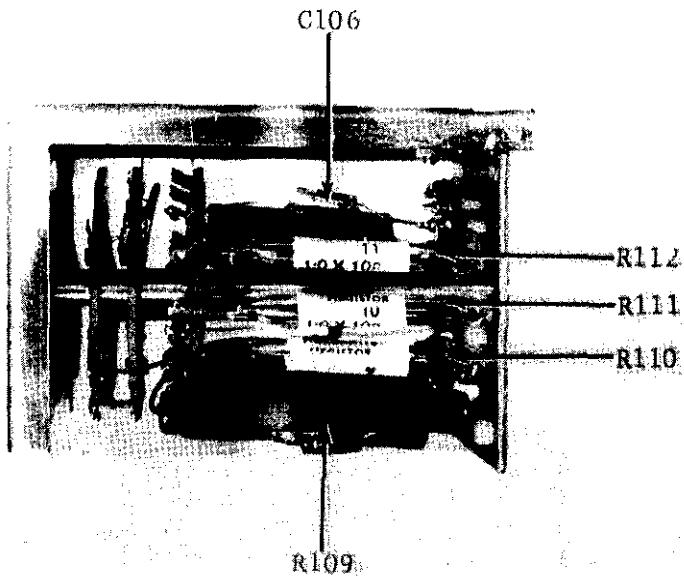

FIGURE 27. Component Locations on Range Switch S101. For other components see Figures 26 and 28.

FIGURE 26. Component Locations on Range Switch S101. For other components see Figures 27 and 28.

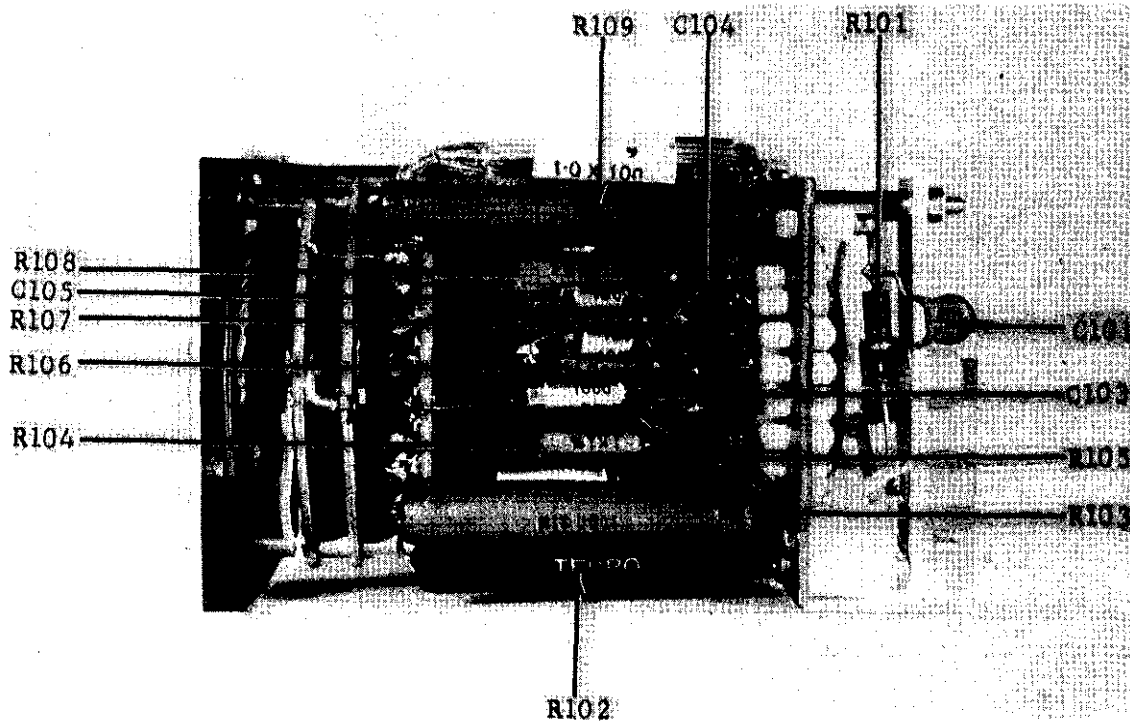

FIGURE 28. Component Locations on Range Switch S101. For other components see Figures 26 and 27.

SECTION 7. ACCESSORIES

7-1. MODEL 6011 INPUT CABLE (Figure 29). The Model 6011 Cable has 30 inches of low-noise triaxial cable with a mating plug (Keithley Part CS-141), which connect directly to the Model 601 INPUT Receptacle. Three alligator clips are on separate leads for three-terminal connections. Refer to Table 1 Page 7 for color coding. One Model 6011 Cable is furnished with each Model 601.

7-2. MODEL 1531 GRIPPING PROBE (Figure 30). The Model 1531 has a gripping probe and 3-foot triaxial cable. Its insulation resistance is 10^{10} ohms. The gripping feature is useful for attaching the probe at a single point for repeated measurements. The cable is terminated by a special triaxial type plug (Keithley Part CS-141). The plug connects directly into the Model 601 INPUT Receptacle. Do not use the Probe for measurements that are more than 500 volts off ground.

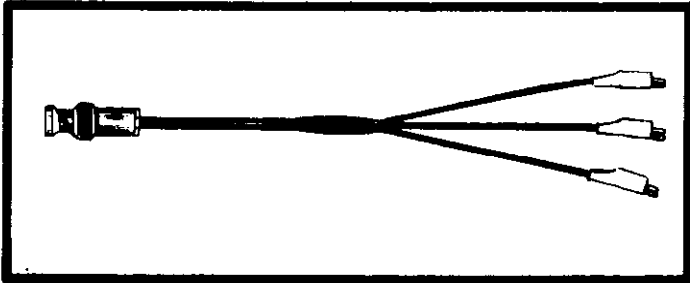

FIGURE 29. Keithley Instruments Model 6011 Input Cable.

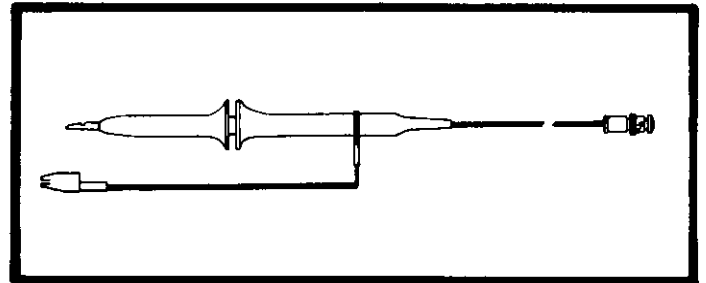

FIGURE 30. Keithley Instruments Model 1531 Gripping Probe.

7-3. MODEL 6301 GUARDED PROBE (Figure 31). The Model 6301 is a guarded probe and shielded lead. Insulation resistance is more than 10^{14} ohms. It consists of a probe and 3 feet of low-noise cable, terminated by a special triaxial type plug (Keithley Part CS-141). The plug connects directly into the Model 601 INPUT Receptacle. Using the Model 6301 allows point-by-point guarded measurements.

7-4. MODEL 6012 TRIAXIAL-TO-COAXIAL ADAPTER (Figure 32). The Model 6012 permits using the Model 601 with all Keithley electrometer accessories having uhf type connectors. Paragraphs 7-5 through 7-9 describe these accessories. One end of the Adapter is equivalent to a Keithley CS-141 plug and the other is a uhf-type connector.

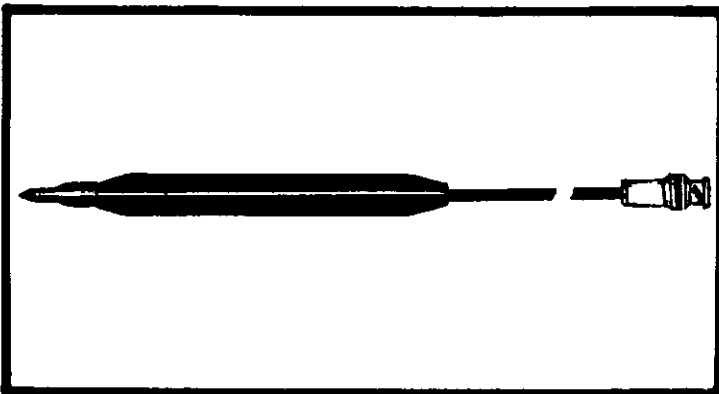

FIGURE 31. Keithley Instruments Model 6301 Guarded Probe.

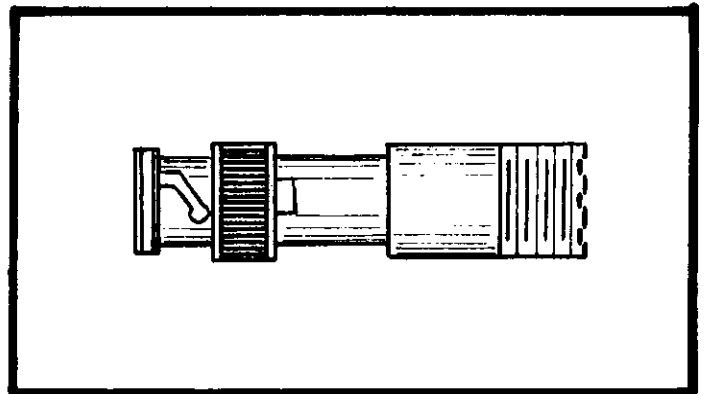

FIGURE 32. Keithley Instruments Model 6012 Triaxial-to-Coaxial Adapter.

NOTE

Do not make off-ground measurements with the Model 601 Electrometer when using the Model 6012 Adapter. The Adapter connects case ground and circuit low, defeating the Model 601 three-terminal input circuit. The chassis would be at the same off-ground potential as the voltage being measured.

7-5. MODEL 6102A VOLTAGE DIVIDER PROBE (Figure 33). The Model 6102A is a 10:1 voltage divider with an input resistance of 10^{10} ohms. It can be used with the Model 601 up to 100 volts with an accuracy of 3%. The Probe is furnished with 30 inches of low-noise coaxial cable, terminated with a uhf plug. Use the Model 6012 Adapter to connect the Probe to the Model 601 INPUT Receptacle. Instructions for using the Probe with the Electrometer are in paragraph 2-5.

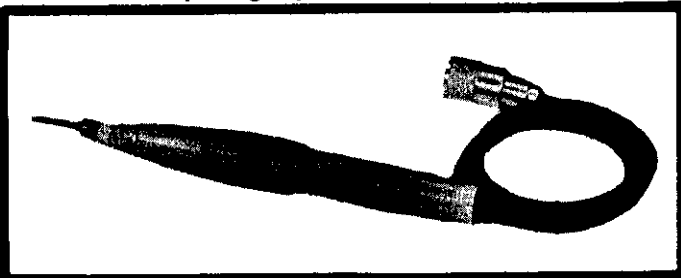

FIGURE 33. Keithley Instruments Model 6102A 10:1 Voltage Divider Probe.

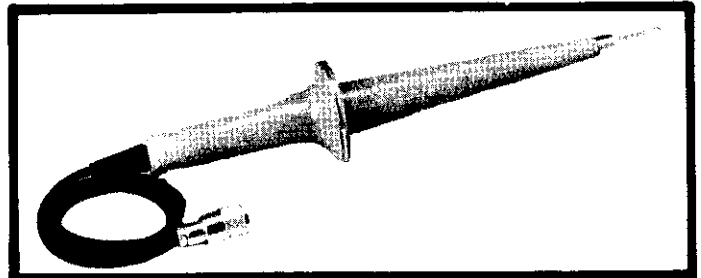

FIGURE 34. Keithley Instruments Model 6103A 1000:1 Voltage Divider Probe.

7-6. MODEL 6103A VOLTAGE DIVIDER PROBE (Figure 34). The Model 6103A is a 1000:1 voltage divider with an input resistance of 10^{12} ohms. It can be used with the Model 601 up to 10 kilovolts with an accuracy of 5%. The Probe is furnished with 30 inches of low-noise coaxial cable, terminated with a uhf plug. Use the Model 6012 Adapter to connect the Probe to the Model 601 INPUT Receptacle. Instructions for using the Probe with the Electrometer are in paragraph 2-5.

7-7. MODEL 6104 TEST SHIELD.

a. The Model 6104 facilitates resistance measurements with either 2-terminal or 3-terminal guarded connections, as well as voltage and current tests.

b. 2-Terminal Operation.

1. Connect the high impedance side of the test sample to the Model 6104 INPUT Terminal. Connect the low impedance side to either black jack marked GROUND, which ever is more convenient.

2. Lock the enclosure and connect the Model 6104 bnc receptacle to the Model 601 INPUT Receptacle, using the Model 6012 Adapter. Use a short coaxial cable. Operate the Model 601 as described in Section 2.

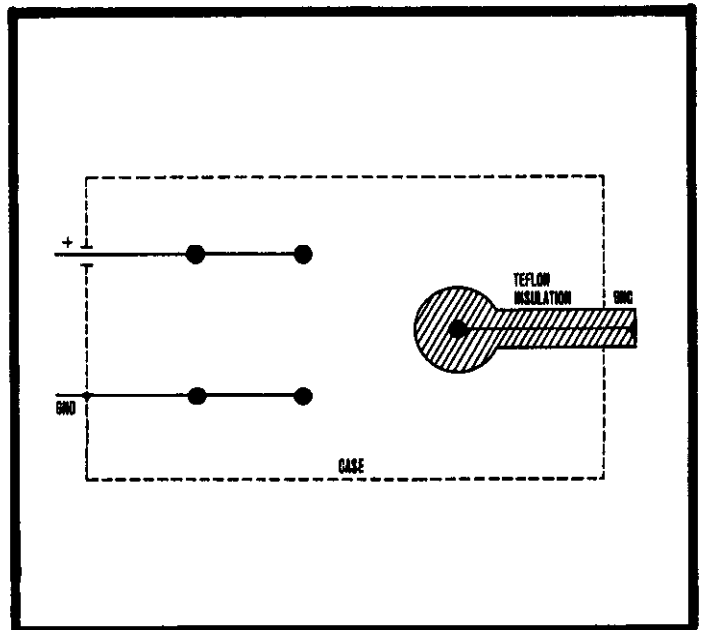

FIGURE 35. Diagram of Model 6104 Circuit.

c. 3-Terminal Operation.

1. For guarded measurements, make the connections as above with some additional steps.
2. Connect the Model 6104 black external plug to the Model 601 OHMS GUARD Terminal.
3. Connect either Terminal marked EXTERNAL SOURCE to the test sample at its high impedance side. Lock the enclosure and connect the Model 6104 to the Electrometer.
4. Connect an external voltage supply to the banana plugs on the side of the Model 6104, positive to red and negative to black. Set the external source (such as the Keithley Model 240A High Voltage Supply) to the desired voltage. Operate the Electrometer as explained in Section 2.

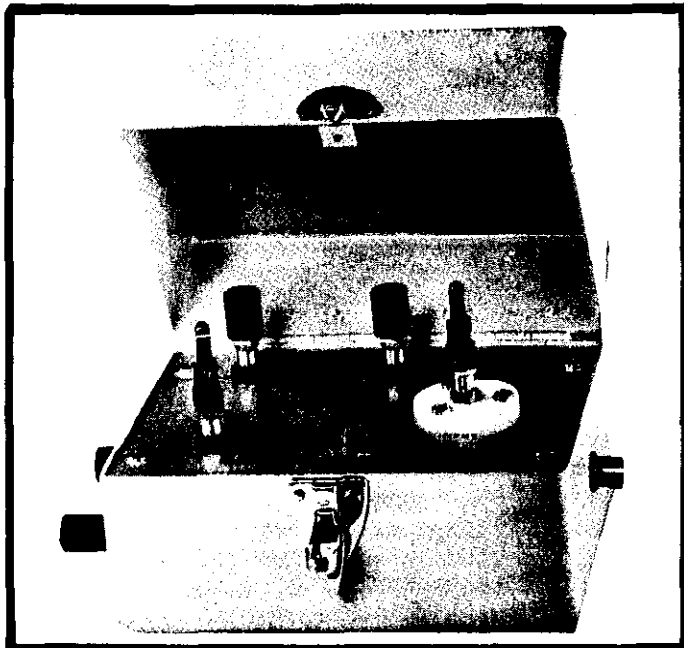

FIGURE 36. Keithley Instruments Model 6104 Test Shield.

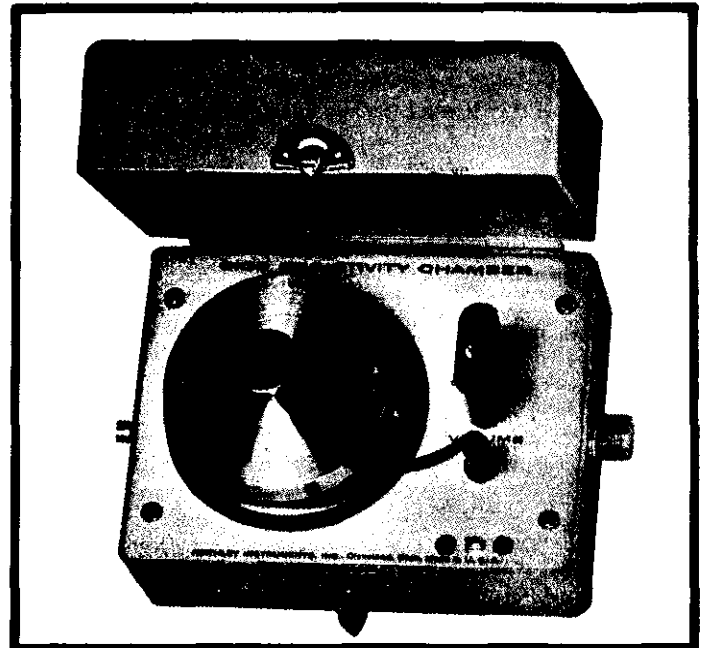

FIGURE 37. Keithley Instruments Model 6105 Resistivity Adapter.

7-8. MODEL 6105 RESISTIVITY ADAPTER.

a. The Model 6105 is a guarded test fixture for measuring resistivities of materials in conjunction with the Model 601 and the Model 240A High Voltage Supply. The complete system directly measures volume resistivities up to 3×10^{19} ohm-cm and surface resistivities up to 10^{18} ohms, in accordance with the procedures of the American Society for Testing and Materials. The shielded Model 6105 is a means for maintaining good sample contact with uniform pressure. The Adapter holds samples up to 4 inches in diameter and .25 inch thick. Maximum excitation voltage is 1000 volts.

b. The Model 6105 Instruction Manual explains the operating procedures for the system, using the Model 240A and an Electrometer.

c. The Model 601 can also be used with the Model 6105 alone. Operate the Model 601 as a constant current source (paragraph 3-2) with the FEEDBACK Switch in FAST position. Connect the OHMS GUARD Terminal on the rear panel to the center terminal of the Model 6105

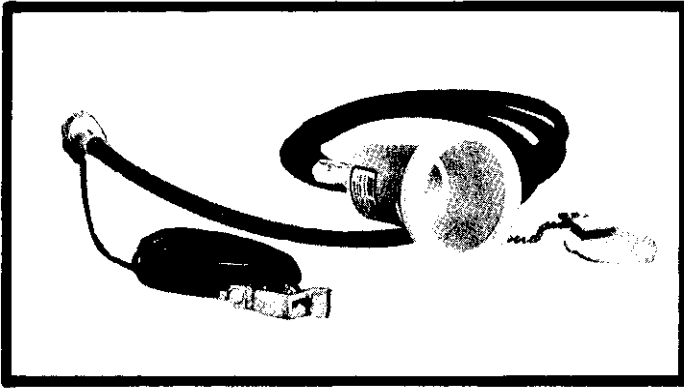

FIGURE 38. Keithley Instruments Model 2501 Static Detector Probe.

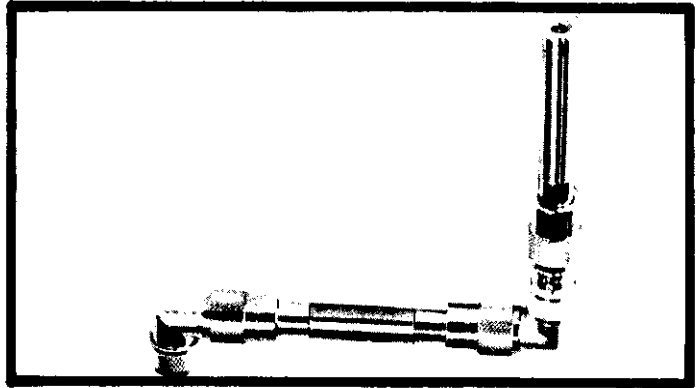

FIGURE 39. Keithley Instruments Model 2503 Static Detector Probe.

Power Receptacle. Other operating procedures are as for the 3-instrument system. The current from the Model 601 is the reciprocal of the OHMS setting of the Range Switch; the voltage is the Multiplier Switch setting times the meter reading.

7-9. MODELS 2501 AND 2503 STATIC DETECTOR PROBES.

a. The Model 2501 is a 10,000:1 capacitive divider when used with the head 3/8 inch from the charged surface. Measurements are accurate within 10%. The Model 2501 consists of a 3-inch diameter head and 10 feet of cable. Connect the Probe to the Model 601 INPUT Receptacle using the Model 6012 Adapter.

b. The Model 2503 is similar to the Model 2501. However, its head is 1/2 inch in diameter and it connects directly into the Electrometer — with the Model 6012 Adapter — without any cable.

7-10. RACK MOUNTING (See Figure 40).

a. The Model 601 is shipped for bench use. The Model 4005 Rack Mounting Kit converts the instrument to rack mounting to the standard EIA 19-inch width.

b. To convert the instrument, remove the two screws at the bottom of each side of the instrument case. Lift off the top cover assembly with the handles; save the four screws. The feet and tilt bail can be removed without removing the bottom cover assembly. Remove the rear feet first. Then, remove the shield in the front of the instrument, remove the front feet and tilt bail and replace the shield.

| Item (See Fig. 40) | Description | Keithley Part No. | Quantity |
|-----------------------|--------------------------|----------------------|----------|
| 1 | Cover Assembly | 20018B | 1 |
| 2 | Mounting Panel | 19396B | 1 |
| 3 | Filler Panel | 19397B | 1 |
| -- | Screw, No. 10 - 3/8, HSS | --- | 12 |
| -- | Kep Nut, No. 10 | --- | 8 |

TABLE 8. Parts List for Keithley Model 4005 Rack Mounting Kit.

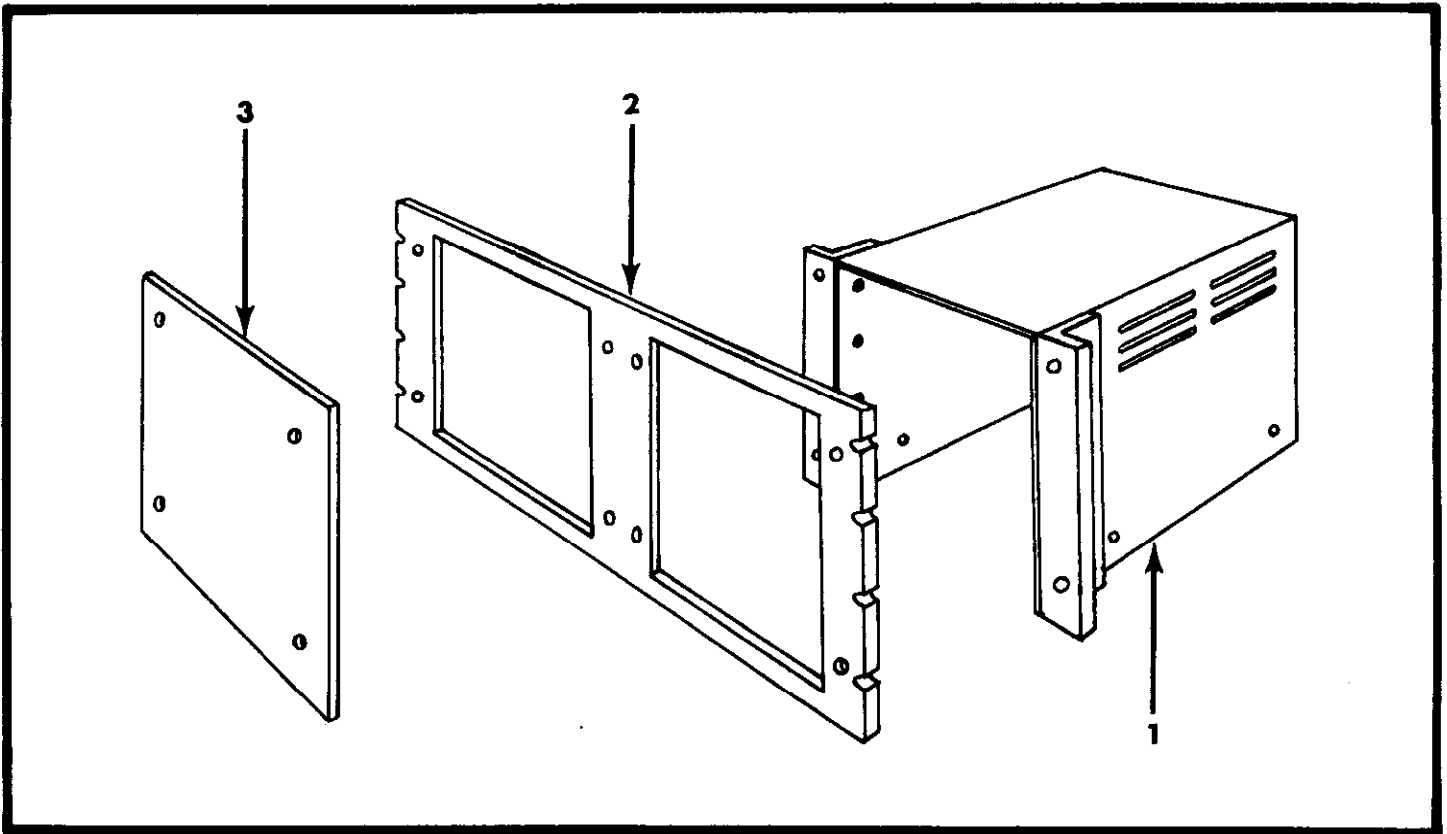

FIGURE 40. Exploded View of Model 4005 Rack Mounting Kit. Refer to Table 7 for parts list.

c. Insert the top cover assembly (1) in place and fasten to the chassis with the four screws previously removed. Attach the mounting panel (2) to the rack with four #10 screws and kep nuts. Fasten the Model 601 to the mounting panel with four #10 screws. Fasten the filler panel (3) to the opening in the mounting panel with four #10 screws and kep nuts.

d. If two Model 601 Electrometers are to be rack mounted side-by-side, another top cover assembly (Keithley Part 19525B) is used instead of item 1 in Figure 40. The filler panel (3) is not used. This Kit will also hold any two Keithley models whose bench dimensions are 10-1/2 inches high x 6-5/8 inches wide x 10 inches deep.

7-11. MODEL 6013 pH ELECTRODE ADAPTER.

a. The Model 6013 is designed to allow accurate and convenient pH potential measurements with the Model 601 Electrometer. It accepts Leeds & Northrop (L&N), Coleman and Beckman (B-C) pH electrode connectors. The Adapter uses Teflon insulation and is fully guarded to insure that the accuracy of the Model 601 is affected in no way.

b. The top of the Model 6013 contains two sets of connectors, one of which accepts an old type L&N electrode, while the other accepts either a new type L&N or the B-C electrode. Connect the electrodes to the proper set. Connect the Adapter cable directly into the Model 601 INPUT Receptacle.

c. Set the Adapter's switch for 601. Set the Model 601 METER Switch to CENTER ZERO. Set the Range Switch to VOLTS. Use the appropriate range for the Multiplier Switch.

NOTE

To check zero on the Electrometer, use only the ZERO CHECK Button on the Model 6013 pH Electrode Adapter. Do not use the ZERO CHECK Button on the Electrometer.

d. For guarded measurements, connect the GUARD Terminal on the Adapter to the Model 601 OHMS GUARD Terminal.

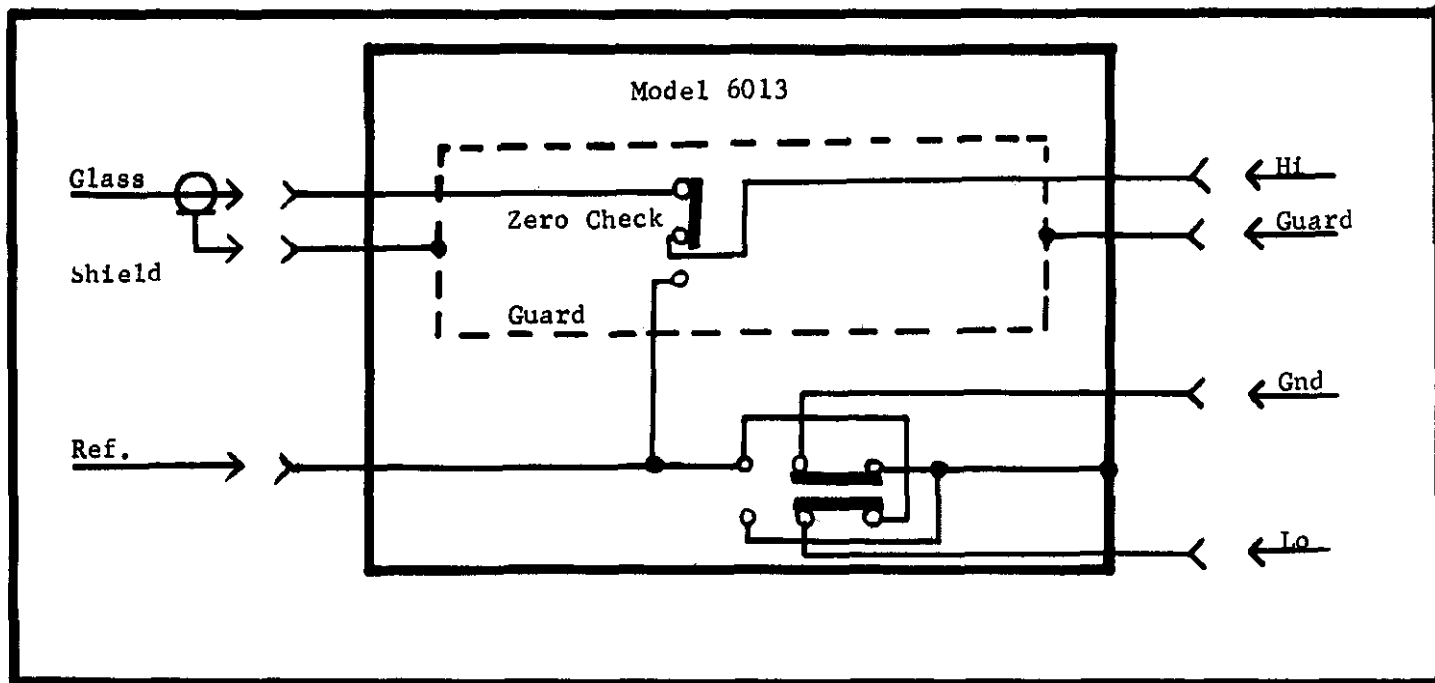

FIGURE 41. Block Diagram of Model 6013 in use with the Model 601.

7-12. MODEL 370 RECORDER.

a. The Model 370 Recorder is uniquely compatible with the Model 601 as well as other Keithley electrometers, microvoltmeters and picoammeters. The Recorder is a high quality economical instrument that maximizes the performance of the Model 601, and many other Keithley instruments, even in the most critical applications. The Model 370 can be used with the Model 601 to record voltage, resistance, currents and charge over the Model 601's entire range.

b. The Model 601 has the output necessary to drive the Recorder directly (1 volt, 1 milliamper), thus eliminating the need for a pre-amplifier. The Model 370 floats ± 500 volts off ground. The Recorder is specially shielded to avoid pickup of extraneous signals. The response time of the Model 370 Recorder is 0.5 second; linearity is $\pm 1\%$ of full scale. Ten chart speeds — from $3/4$ inch per hour to 12 inches per minute — are selectable with front panel controls. The 6-inch chart has a rectilinear presentation. The Model 370 Recorder has a self-priming inking system. Chart paper and ink refills are easy to install.

c. The Model 370 is very easy to use with the Model 601. All that is necessary is connecting the two units, setting the Model 601 Output Switch to LMA and adjusting an easily accessible control for full-scale recorder deflection. The furnished Model 3701 Input Cable mates with the output connector on the Model 601.

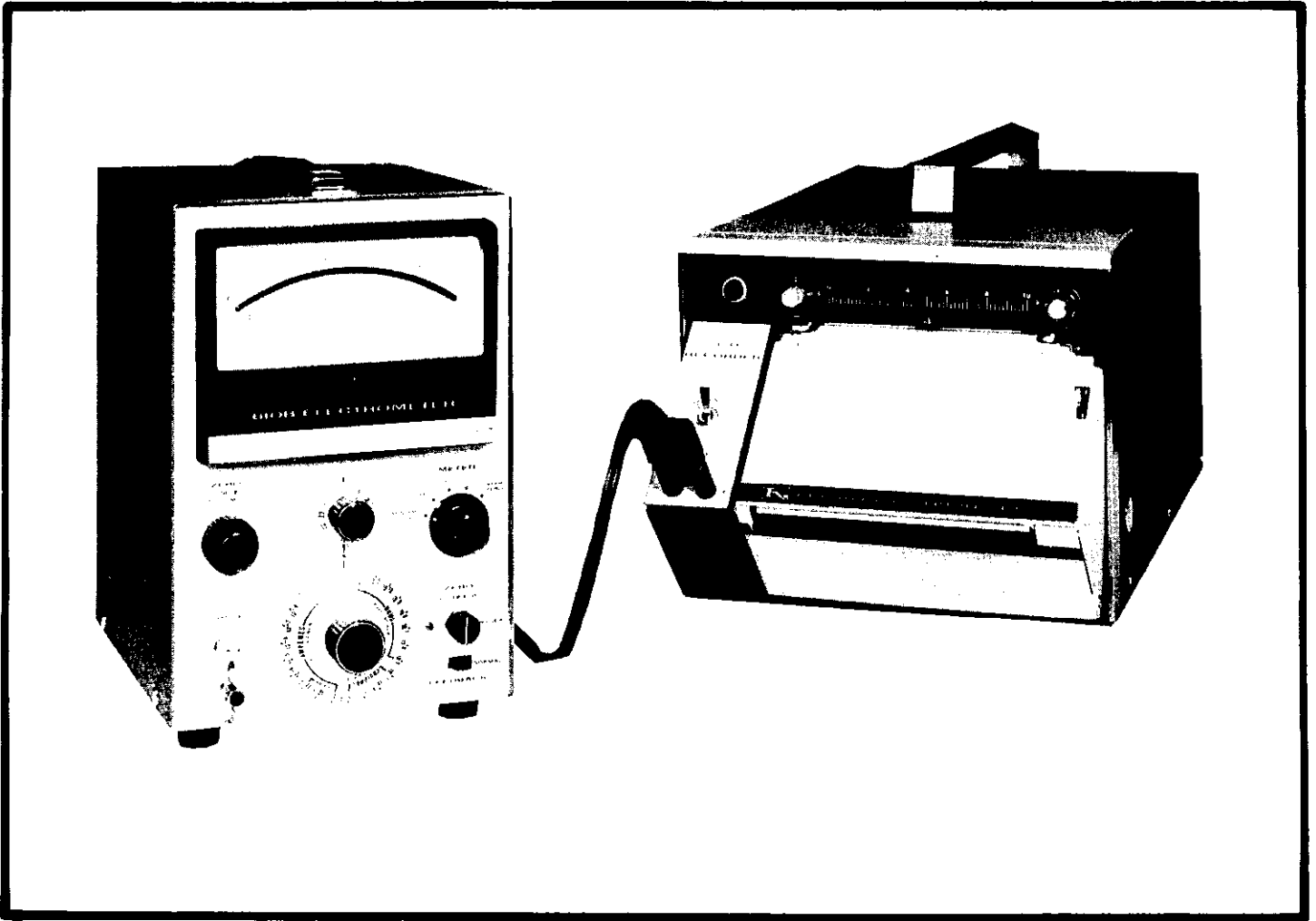

FIGURE 42. Maximum Recording Convenience is Obtained Using the Keithley Model 370, Especially Designed for use with Keithley Electrometers and Other Instruments. The Model 370 can be directly connected to the Model 601 output with the Recorder's accessory cable. Response time, floating capability and other specifications of the Model 370 Recorder are compatible with those of the Model 601 Electrometer.

SECTION 8. REPLACEABLE PARTS

8-1. REPLACEABLE PARTS LIST. The Replaceable Parts List describes the components of the Model 601. The List gives the circuit designation, the part description, a suggested manufacturer, the manufacturer's part number and the Keithley Part Number. The last column indicates the figure picturing the part. The name and address of the manufacturers listed in the "Mfg. Code" column are in Table 10.

8-2. HOW TO ORDER PARTS.

a. For parts orders, include the instrument's model and serial number, the Keithley Part Number, the circuit designation and a description of the part. All structural parts and those parts coded for Keithley manufacture (80164) must be ordered through Keithley Instruments, Inc. or its representatives. In ordering a part not listed in the Replaceable Parts List, completely describe the part, its function and its location.

b. Order parts through your nearest Keithley representative or the Sales Service Department, Keithley Instruments, Inc.

| amp | ampere | No. | Number |
|----------|----------------------------|---------------|------------------------------------|
| CerD | Ceramic, disc | Ω | ohm |
| Comp | Composition | | |
| DCb | Deposited Carbon | p Poly | pico (10^{-12}) Polystyrene |
| ETB | Electrolytic, tubular | Ref. req'd | Reference required |
| f | farad | | |
| Fig. | Figure | μ | micro (10^{-6}) |
| GCb | Glass enclosed carbon | v | volt |
| k | kilo (10^3) | w WW | watt Wirewound |
| M or meg | mega (10^6) or megohms | WWVar. | Wirewound Variable |
| Mfg. | Manufacturer | | |
| MtF | Metal Film | | |
| My | Mylar | | |

TABLE 9. Abbreviations and Symbols.

MODEL 601 REPLACEABLE PARTS LIST

(Refer to Schematic Diagram 19428E for circuit designations.)

BATTERIES

| Circuit Desig. | Description | Mfg. Code | Mfg. Part No. | Keithley Part No. | Fig. Ref. |
|-------------------|----------------|--------------|------------------|----------------------|--------------|
| B201 | 1.35v mercury | 72665 | RM42R | BA-10 | 22, 23 |
| B202 | 1.35v mercury | 72665 | RM42R | BA-10 | 22, 23 |
| B203 | 8.4v mercury | 72665 | TR-286 | BA-18 | 22, 23 |
| B204 | 8.4v mercury | 72665 | TR-286 | BA-18 | 22, 23 |
| B205 | 8.4v mercury | 72665 | TR-286 | BA-18 | 22, 23 |
| B206 | 9v zinc carbon | 09823 | 2N6 | BA-17 | 22, 23 |
| B207 | 9v zinc carbon | 09823 | 2N6 | BA-17 | 22, 23 |
| B208 | 9v zinc carbon | 09823 | 2N6 | BA-17 | 22, 23 |
| B209 | 9v zinc carbon | 09823 | 2N6 | BA-17 | 22, 23 |

CAPACITORS

| Circuit Desig. | Value | Rating | Type | Mfg. Code | Mfg. Part No. | Keithley Part No. | Fig. Ref. |
|-------------------|--------------|--------|------|--------------|------------------|----------------------|--------------|
| C101 | 22 pf | 600 v | CerD | 72982 | ED-22 | C22-22P | 28 |
| C102 | 125 μ f | 15 v | ETB | 73445 | C462 | C3-125M | 22 |
| C103 | .001 μ f | 500 v | Poly | 71590 | CPR-1000J | C138-.001M | 28 |
| C104 | 150 pf | 500 v | Poly | 71590 | CPR-150J | C138-150P | 28 |
| C105 | 150 pf | 500 v | Poly | 71590 | CPR-150J | C138-150P | 28 |
| C106 | 5 pf | 200 v | Poly | 14167 | E1013-1 | C31-5P | 26 |
| C107 | 0.1 μ f | 200 v | Poly | 84171 | 2PJ-104G | C108-.1M | 27 |
| C108 | .01 μ f | 200 v | Poly | 84171 | 2PJ-103G | C108-.01M | 27 |
| C109 | .001 μ f | 200 v | Poly | 84171 | 2PJ-102G | C108-.001M | 27 |
| C110 | 100 pf | 500 v | Poly | 71590 | 2PJ-101G | C108-100P | 27 |
| C111 | 22 pf | 600 v | CerD | 72982 | ED-27 | C22-22P | 23 |
| C112 | 0.1 μ f | 50 v | My | 84411 | 601 PE | C41-.1M | 25 |
| C113 | 680 pf | 600 v | CerD | 72982 | ED-680 | C22-680P | 25 |
| C114 | 0.1 μ f | 50 v | My | 84411 | 601 PE | C41-.1M | 22 |
| C115 | .02 μ f | 600 v | CerD | 72982 | ED-.02 | C22-.02M | 24 |
| C116 | .001 μ f | 600 v | CerD | 72982 | ED-.001 | C22-.001M | 22 |

MISCELLANEOUS PARTS

| Circuit Desig. | Description | Mfg. Code | Keithley Part No. | Fig. Ref. |
|-------------------|-------------------------------|--------------|----------------------|--------------|
| ---- | Battery holder, 2 req'd | 80164 | BH-20 | --- |
| ---- | Battery holder, 3 req'd | 80164 | BH-21 | --- |
| ---- | Battery holder, 4 req'd | 80164 | BH-6 | --- |
| ---- | Battery retain clips, 6 req'd | 80164 | BH-22 | --- |

MISCELLANEOUS PARTS (Con't)

| Circuit Desig. | Description | Mfg. Code | Keithley Part No. | Fig. Ref. |
|-------------------|---|--------------|----------------------|--------------|
| D201 | Silicon diode (Number 1N645) | 01295 | RF-14 | 24 |
| D202 | Silicon diode (Number 1N645) | 01295 | RF-14 | 24 |
| D203 | Silicon diode (Number 1N645) | 01295 | RF-14 | 24 |
| J101 | Receptacle, triaxial, INPUT (Mfg. No. 33050-1) | 95712 | CS-181 | 22, 2 |
| ---- | Plug, triaxial, mate of J101 (Mfg. No. 30197-1) | 95712 | CS-141 | --- |
| J102 | Binding Post, LO (Mfg. No. DF21B) | 58474 | BP11-B | 22, 2 |
| J103 | Receptacle, Microphone, OUTPUT (Mfg. No. 80-PC2F) | 02660 | CS-32 | 23, 3 |
| ---- | (F) Plug, Microphone, mate of J103 (Mfg. No. 80-MC2M) | 02660 | CS-33 | --- |
| J104 | Binding Post, CASE GROUND (Mfg. No. DF21GRN) | 58474 | BP11-GRN | 22, 3 |
| J105 | Binding Post, X1 OUTPUT (Mfg. No. DF21R) | 58474 | BP11-R | 22, 3 |
| J106 | Binding Post, GUARD (Mfg. No. DF21BLU) | 58474 | BP11-BLU | 22, 3 |
| J107 | Binding Post, LO (Mfg. No. DF21B) | 58474 | BP11-B | 22, 3 |
| M101 | Meter | 80164 | ME-53A | 22 |
| S101 | Rotary Switch less components, Range | 80164 | SW-204 | 22, 2 |
| ---- | Rotary Switch with components, Range | 80164 | 19257B | --- |
| ---- | Dial Assembly, Range | 80164 | 17033A | --- |
| S102 | Push Button, ZERO CHECK | 80164 | 14376A | 23, 2 |
| ---- | Knob Assembly, Zero Check | 80164 | 18038A | --- |
| S103 | Rotary Switch less components, COARSE ZERO | 80164 | SW-166 | 22, 3 |
| ---- | Rotary Switch with components, Coarse Zero | 80164 | 19283B | --- |
| S104 | Rotary Switch less components, MEDIUM ZERO | 80164 | SW-209 | 22, 2 |
| ---- | Rotary Switch with components, Medium Zero | 80164 | 19261B | --- |
| S105 | Slide Switch, FEEDBACK | 80164 | 19089A | 23, 2 |
| S106 | Rotary Switch less components, Multiplier | 80164 | SW-205 | 22, 2 |
| ---- | Rotary Switch with components, Multiplier | 80164 | 19263B | --- |
| ---- | Dial Assembly, Multiplier | 80164 | 19223A | --- |
| S107 | Rotary Switch, METER | 80164 | SW-206 | 23, 2 |
| ---- | Knob Assembly, Meter | 80164 | 14825A | --- |
| S108 | Slide Switch, OUTPUT | 80164 | SW-45 | 23, 3 |
| ---- | Knob Assembly, Fine Zero Control | 80164 | 16995A | --- |

(F) Furnished Accessory

RESISTORS

| Circuit Desig. | Value | Rating | Type | Mfg. Code | Mfg. Part No. | Keithley Part No. | Fig. Ref. |
|----------------|---------------------------|--------------|-------|-----------|---------------|----------------------|-----------|
| R101 | 10 M Ω | 10%, 1/2 w | Comp | 01121 | EB | R1-10M | 28 |
| R102 | 10 Ω | 1%, 10 w | WW | 91637 | RS-10 | R34-10 | 27, 28 |
| R103 | 100 Ω | 1%, 10 w | WW | 91637 | RS-10 | R34-100 | 27, 28 |
| R104 | 1 k Ω | 1%, 1/2 w | DCb | 79727 | CFE-15 | R12-1K | 28 |
| R105 | 10 k Ω | 1%, 1/2 w | DCb | 79727 | CFE-15 | R12-10K | 28 |
| R106 | 100 k Ω | 1%, 1/2 w | DCb | 79727 | CFE-15 | R12-100K | 28 |
| R107 | 1 M Ω | 1%, 1/2 w | DCb | 79727 | CFE-15 | R12-1M | 28 |
| R108 | 10 M Ω | 10%, 1 w | DCb | 91637 | DC-1 | R13-10M | 28 |
| R109 | 100 M Ω | 1%, 2 w | DCb | 91637 | D-2 | R14-100M | 26, 28 |
| R110 | 10 ⁹ Ω | +3-0%, 1/R w | GCb | 63060 | RX-1 | R20-10 ⁹ | 26 |
| R111 | 10 ¹⁰ Ω | +3-0%, 1/R w | GCb | 63060 | RX-1 | R20-10 ¹⁰ | 26 |
| R112 | 10 ¹¹ Ω | +3-0%, 1/R w | GCb | 63060 | RX-1 | R20-10 ¹¹ | 26 |
| R113 | 800 k Ω | 1%, 1/2 w | DCb | 79727 | CFE-15 | R12-800K | 27 |
| R114 | 10 M Ω | 10%, 1/2 w | Comp | 01121 | EB | R1-10M | 23 |
| R115 | 10 k Ω | 1%, 1/2 w | DCb | 79727 | CFE-15 | R12-10K | 23 |
| R116 | 2.2 k Ω | 10%, 1/2 w | Comp | 01121 | EB | R1-2.2K | 25 |
| R117 | 150 k Ω | 1%, 1/2 w | DCb | 79727 | CFE-15 | R12-150K | 25 |
| R118 | 150 k Ω | 1%, 1/2 w | MtF | 07716 | CEC | R94-150K | 25 |
| R119 | 10 k Ω | 5%, 2 w | WWVar | 12697 | 62JA | RP42-10K | 22, 2 |
| R120 | 1.2 k Ω | 1%, 1/2 w | DCb | 79727 | CFE-15 | R12-1.2K | 22 |
| R121 | 150 k Ω | 1%, 1/2 w | MtF | 07716 | CEC | R94-150K | 25 |
| R122 | 15 k Ω | 1%, 1/2 w | DCb | 79727 | CFE-15 | R12-15K | 25 |
| R123 | 68 k Ω | 1%, 1/2 w | DCb | 79727 | CFE-15 | R12-68K | 25 |
| R124 | 450 k Ω | 1%, 1/2 w | DCb | 79727 | CFE-15 | R12-450K | 25 |
| R125 | 450 k Ω | 1%, 1/2 w | DCb | 79727 | CFE-15 | R12-450K | 25 |
| R126 | 100 k Ω | 10%, 1/2 w | Comp | 01121 | EB | R1-100K | 25 |
| R127 | 15 k Ω | 1%, 1/2 w | DCb | 79727 | CFE-15 | R12-15K | 25 |
| R128 | 68 k Ω | 1%, 1/2 w | DCb | 79727 | CFE-15 | R12-68K | 25 |
| R129 | 15 k Ω | 1%, 1/2 w | DCb | 79727 | CFE-15 | R12-15K | 22 |
| R130 | 2 k Ω | 1%, 1/2 w | DCb | 79727 | CFE-15 | R12-2K | 22 |
| R131 | 2 k Ω | 1%, 1/2 w | DCb | 79727 | CFE-15 | R12-2K | 22 |
| R132 | 2 k Ω | 1%, 1/2 w | DCb | 79727 | CFE-15 | R12-2K | 22 |
| R133 | 2 k Ω | 1%, 1/2 w | DCb | 79727 | CFE-15 | R12-2K | 22 |
| R134 | 2 k Ω | 1%, 1/2 w | DCb | 79727 | CFE-15 | R12-2K | 22 |
| R135 | 2 k Ω | 1%, 1/2 w | DCb | 79727 | CFE-15 | R12-2K | 22 |
| R136 | 2 k Ω | 1%, k/2 w | DCb | 79727 | CFE-15 | R12-2K | 22 |
| R137 | 2 k Ω | 1%, 1/2 w | DCb | 79727 | CFE-15 | R12-2K | 22 |
| R138 | 2 k Ω | 1%, 1/2 w | DCb | 79727 | CFE-15 | R12-2K | 22 |
| R139 | 2 k Ω | 1%, 1/2 w | DCb | 79727 | CFE-15 | R12-2K | 22 |
| R140 | 402 Ω | 1%, 1/2 w | DCb | 79727 | CFE-15 | R12-402 | 22 |

RESISTORS (Con't)

| Circuit Desig. | Value | Rating | Type | Mfg. Code | Mfg. Part No. | Keithley Part No. | Fig. Ref. |
|----------------|-----------------|-------------|-------|-----------|---------------|-------------------|-----------|
| R141 | 402 Ω | 1%, 1/2 w | DCb | 79727 | CFE-15 | R12-402 | 22 |
| R142 | 402 Ω | 1%, 1/2 w | DCb | 79727 | CFE-15 | R12-402 | 22 |
| R143 | 402 Ω | 1%, 1/2 w | DCb | 79727 | CFE-15 | R12-402 | 22 |
| R144 | 402 Ω | 1%, 1/2 w | DCb | 79727 | CFE-15 | R12-402 | 22 |
| R145 | 402 Ω | 1%, 1/2 w | DCb | 79727 | CFE-15 | R12-402 | 22 |
| R146 | 402 Ω | 1%, 1/2 w | DCb | 79727 | CFE-15 | R12-402 | 22 |
| R147 | 402 Ω | 1%, 1/2 w | DCb | 79727 | CFE-15 | R12-402 | 22 |
| R148 | 402 Ω | 1%, 1/2 w | DCb | 79727 | CFE-15 | R12-402 | 22 |
| R149 | 402 Ω | 1%, 1/2 w | DCb | 79727 | CFE-15 | R12-402 | 22 |
| R150 | 15 k Ω | 1%, 1/2 w | DCb | 79727 | CFE-15 | R12-15K | 22 |
| R151 | 10 k Ω | 10%, 1/2 w | Comp | 01121 | EB | R1-10K | 25 |
| R152 | 80 k Ω | 1%, 1/2 w | DCb | 79727 | CFE-15 | R12-80K | 25 |
| R153 | 80 k Ω | 1%, 1/2 w | DCb | 79727 | CFE-15 | R12-80K | 25 |
| R154 | 1.5 k Ω | 10%, 1/2 w | Comp | 01121 | EB | R1-1.5K | -- |
| R155 | 3.3 k Ω | 10%, 1/2 w | Comp | 01121 | EB | R1-3.3K | -- |
| R156 | 3.3 k Ω | 10%, 1/2 w | Comp | 01121 | EB | R1-3.3K | 25 |
| R157 | 22 k Ω | 1%, 1/2 w | DCb | 79727 | CFE-15 | R12-22K | -- |
| R158 | 22 k Ω | 1%, 1/2 w | DCb | 79727 | CFE-15 | R12-22K | -- |
| R159 | 30 k Ω | 1%, 1/2 w | DCb | 79727 | CFE-15 | R12-30K | -- |
| R160 | 15 k Ω | 1%, 1/2 w | DCb | 79727 | CFE-15 | R12-15K | -- |
| R161 | 2.2 k Ω | 1%, 1/2 w | DCb | 79727 | CFE-15 | R12-2.2K | -- |
| R162 | 9.1 k Ω | 0.5%, 1/2 w | MtF | 07716 | CBC | R61-9.1K | 22 |
| R163 | 2.73 k Ω | 0.5%, 1/2 w | MtF | 07716 | CBC | R61-2.73K | 22 |
| R164 | 910 Ω | 0.5%, 1/2 w | MtF | 07716 | CBC | R61-910 | 22 |
| R165 | 273 Ω | 0.5%, 1/2 w | MtF | 07716 | CBC | R61-273 | 22 |
| R166 | 91 Ω | 0.5%, 1/2 w | MtF | 07716 | CBC | R61-91 | 22 |
| R167 | 27.3 Ω | 0.5%, 1/2 w | MtF | 07716 | CBC | R61-27.3 | 22 |
| R168 | 9.1 Ω | 0.5%, 1/4 w | WW | 01686 | T-2A | R123-9.1 | 22 |
| R169 | 2.73 Ω | 0.5%, 1/4 w | WW | 01686 | T-2A | R123-2.73 | 22 |
| R170 | .91 Ω | 0.5%, 1/4 w | WW | 01686 | T-2A | R123-.91 | 22 |
| R171 | 8.6 k Ω | 1%, 1/2 w | DCb | 79727 | CFE-15 | R12-8.6K | 23 |
| R172 | 20 k Ω | 10%, 5 w | WWVar | 71450 | AW | RP34-20K | 23, 3 |
| R173 | 910 Ω | 0.5%, 1/2 w | MtF | 07716 | CEC | R61-910 | 23 |
| R174 | 10 Ω | 10%, 1/4 w | Comp | 01121 | CB | R76-10 | -- |
| R175 | 470 Ω | 10%, 1/2 w | Comp | 01121 | EB | R1-470 | 22 |
| R176 | 10 Ω | 10%, 1/4 w | Comp | 01121 | CB | R76-10 | -- |
| R201 | 1 k Ω | 1%, 1/2 w | DCb | 79727 | CFE-15 | R12-1K | 24 |
| R202 | 9 k Ω | 1%, 1/2 w | DCb | 79727 | CFE-15 | R12-9K | 24 |
| R203 | 70 k Ω | 1%, 1/2 w | DCb | 79727 | CFE-15 | R12-70K | 24 |
| R204 | 10 k Ω | 10%, 5 w | WWVar | 71450 | AW | RP3-10K | 23 |
| R205 | 180 k Ω | 10%, 1/2 w | Comp | 01121 | EB | R1-180K | 24 |

RESISTORS (Con't)

| Circuit Desig. | Value | Rating | Type | Mfg. Code | Mfg. Part No. | Keithley Part No. | Fig. Ref. |
|-------------------|----------------|------------|-------|--------------|------------------|----------------------|--------------|
| R206 | 820 Ω | 10%, 1/2 w | Comp | 01121 | EB | R1-820 | 24 |
| R207 | 820 Ω | 10%, 1/2 w | Comp | 01121 | EB | R1-820 | 24 |
| R208 | 39 k Ω | 10%, 1/2 w | Comp | 01121 | EB | R1-39K | 24 |
| R209 | 180 k Ω | 10%, 1/2 w | Comp | 01121 | EB | R1-180K | 24 |
| R210 | 1 k Ω | 1%, 1/2 w | DCb | 79727 | CFE-15 | R12-1K | 24 |
| R211 | 1 k Ω | 10%, 5 w | WWVar | 71450 | AW | RP34-1K | 24 |
| R212 | 180 k Ω | 10%, 1/2 w | Comp | 01121 | EB | R1-180K | 24 |
| R213 | 330 Ω | 10%, 1/2 w | Comp | 01121 | EB | R1-330 | 24 |
| R214 | 15 k Ω | 10%, 1/2 w | Comp | 01121 | EB | R1-15K | 24 |
| R215 | 120 k Ω | 10%, 1/2 w | Comp | 01121 | EB | R1-120K | 24 |
| R216 | 330 Ω | 10%, 1/2 w | Comp | 01121 | EB | R1-330 | 24 |
| R217 | 15 k Ω | 10%, 1/2 w | Comp | 01121 | EB | R1-15K | 24 |
| R218 | 120 k Ω | 10%, 1/2 w | Comp | 01121 | EB | R1-120K | 24 |
| R219 | 500 Ω | 1%, 1/2 w | DCb | 79727 | CFE-15 | R12-500 | 24 |
| R220 | 2 k Ω | 10%, 5 w | WWVar | 71450 | AW | RP34-2K | 24 |

TRANSISTORS

| Circuit Desig. | Number | Mfg. Code | Keithley Part No. | Fig. Ref. |
|-------------------|--------|--------------|----------------------|--------------|
| Q101 | A1380 | 80164 | TG-32 | 25 |
| Q102 | A1380 | 80164 | TG-32 | 25 |
| Q103 | A1380 | 80164 | TG-32 | 25 |
| Q104 | A1380 | 80164 | TG-32 | 25 |
| Q105 | S17638 | 07263 | TG-33 | 25 |
| Q106 | S17638 | 07263 | TG-33 | 25 |
| Q201 | A1380 | 73445 | TG-32 | 24 |
| Q202 | 2N1605 | 93332 | TG-22 | 24 |
| Q203 | 2N1381 | 01295 | TG-8 | 24 |
| Q204 | S17638 | 07263 | TG-33 | 24 |
| Q205 | S17638 | 07263 | TG-33 | 24 |
| Q206 | S17638 | 07263 | TG-33 | 24 |

VACUUM TUBES

| Circuit Desig. | Number | Mfg. Code | Keithley Part No. | Fig. Ref. |
|-------------------|--------|--------------|----------------------|--------------|
| V101 | 5886 | 80164 | **EV- 5886-3P | 23 |
| V102 | 5886 | 80164 | **EV- 5886-3P | 23 |

** Replace V101 and V102 as a pair.

| | | | |
|-------|--|-------|---|
| 01121 | Allen-Bradley Corp. Milwaukee, Wis. | 71450 | CTS Corp. Elkhart, Ind. |
| 01295 | Texas Instruments Inc. Semi Conductor-Components Division Dallas, Texas | 71590 | Centralab Division of Globe-Union, Inc. Milwaukee, Wis. |
| 01686 | RCL Electronics, Inc. Riverside, N. J. | 72665 | Mallory Battery Co. Cleveland, Ohio |
| 02660 | Amphenol-Borg Electronics Corp. Broadview, Chicago, Illinois | 72982 | Erie Technological Products, Inc. Erie, Pa. |
| 07263 | Fairchild Camera & Instrument Corp. Semiconductor Division Mountain View, Cal. | 73445 | Amperex Electronic Co. Division of North American Philips Co., Inc. Hicksville, N. Y. |
| 07716 | International Resistance Co. Burlington, Iowa | 79727 | Continental-Wirt Electronics Corp. Philadelphia, Pa. |
| 09823 | Burgess Battery Co. Freeport, Ill. | 80164 | Keithley Instruments, Inc. Cleveland, Ohio |
| 12697 | Clarostat Mfg. Co., Inc. Dover, N. H. | 84171 | Arco Electronics, Inc. Great Neck, N. Y. |
| 14167 | Efcon, Inc. Garden City, Long Island, N. Y. | 84411 | Good-All Electric Mfg. Co. Ogallala, Nebr. |
| 56289 | Sprague Electric Co. North Adams, Mass. | 91637 | Dale Electronics, Inc. Columbus, Nebr. |
| 58474 | Superior Electric Co., The Bristol, Conn. | 93332 | Sylvania Electric Products, Inc. Semiconductor Products Division Woburn, Mass. |
| 63060 | Victoreen Instrument Co. Cleveland, Ohio | 95712 | Dage Electric Co., Inc. Franklin, Ind. |

TABLE 10. Code List of Suggested Manufacturers. (Based on Federal Supply Code for Manufacturers, Cataloging Handbook H4-1.)

CHANGE NOTICE

MODEL 601 ELECTROMETER

January 9, 1967

Page 53. Change to the following:

| Circuit Desig. | Description | Mfg. Code | Keithley Part No. | Fig. Ref. |
|-------------------|-------------|--------------|----------------------|--------------|
| M101 | Meter | 80164 | ME-81 | 22 |

CHANGE NOTICE

August 29, 1967

MODEL 601 ELECTROMETER

Page 3. Change the ISOLATION Specification to the following:

ISOLATION: Circuit ground to chassis ground: greater than 10^9 ohms shunted by 0.0015 microfarad. Circuit ground may be floated up to -1500 volts with respect to chassis ground.

Page 54. Change to the following:

| Circuit Desig. | Value | Rating | Type | Mfg. Code | Mfg. Part No. | Keithley Part No. | Fig. Ref. |
|-------------------|---------------|-----------|------|--------------|------------------|----------------------|--------------|
| R108 | 10 M Ω | 1%, 1/2 w | DCb | 79727 | CFE-15 | R12-10M | 28 |

CHANGE NOTICE

MODEL 6013 pH ELECTRODE ADAPTER

Page 1. The second sentence in the first paragraph should be changed to:

One hole accepts either a Beckman and Coleman (B-C) or a new type Leeds and Northrup connector. The other hole accepts an old type Leeds and Northrup connector.

MODEL 6013
pH ELECTRODE ADAPTER

1. GENERAL.

a. The Keithley Model 6013 pH Electrode Adapter is designed to allow accurate and convenient pH potential measurements with both the Keithley Model 601 Electrometer and the Keithley Model 630 Potentiometric Electrometer. It accepts a Beckman and Coleman (B-C) or a Leeds and Northrup (L&N) connector. The two terminals marked REF accept a banana jack or a phone tip jack.

b. The Adapter uses Teflon insulation on all high impedance connections and is fully guarded to insure that the accuracy of the Model 601 or the Model 630 is affected in no way. The ZERO CHECK Button on the Model 6013 allows checking zero on the Model 601 without shorting the pH electrodes. The Adapter can float off ground with either the Model 601 or the Model 630.

2. USE WITH THE MODEL 601 ELECTROMETER.

a. To use the Model 6013 with the Model 601, set the Transfer Switch on the Model 6013 to the 601 position. Set both the ZERO CHECK Button on the Model 601 and the ZERO CHECK Button on the Model 6013 to the LOCK Position. Place the FEEDBACK Switch on the Model 601 in the FAST Position.

b. Connect the Adapter cable directly into the Model 601 INPUT Receptacle. Connect the TO GUARD Terminal on the Model 6013 to the OHMS GUARD Terminal on the rear panel of the Model 601.

c. Open the ZERO CHECK Button on the Model 601. Insert the pH electrodes into the Model 6013.

d. To obtain a reading, set the Model 601 METER Switch to CENTER ZERO. Set the Range Switch to VOLTS. Use the appropriate range for the Multiplier Switch. Open the ZERO CHECK Button on the Model 6013. Read the voltage off the lower meter scale. To convert the voltage to pH, refer to Figure 2.

NOTE

To check zero on the Model 601, use only the ZERO CHECK Button on the Model 6013. Do not use the ZERO CHECK Button on the Model 601. The Button on the Model 6013 is designed to disconnect the HI electrode before shorting the Model 601 leads. If the Model 601 ZERO CHECK Button is used to check zero, the electrodes will be shorted and may be damaged.

e. The Adapter will float off ground with the Model 601.

3. USE WITH THE MODEL 630 POTENTIOMETRIC ELECTROMETER.

a. To use the Model 6013 with the Model 630, set the Transfer Switch on the Model 6013 to the 630 position.

b. Connect the Adapter cable directly into the Model 630 INPUT Receptacle. Connect the TO GND Terminal on the Model 6013 to the GND Terminal on the front panel of the Model 630.

c. To obtain a reading set the Model 630 NULL Switch to the VTVM Position. Switch the RANGE Switch to the most sensitive range for an on-scale meter deflection. Read the voltage off the meter. To convert the voltage to pH, refer to Figure 2.

NOTE

To check zero on the Model 630 use either the ZERO CHECK Button on the Model 6013 or the DETECTOR INPUT Switch in the ZERO CK Position on the Model 630. Both switches disconnect the source before shorting the leads to the Model 630.

d. For floating measurements open the link between the LO and GND Terminals on the front panel of the Model 630. The Model 6013 will float off ground with the Model 630.

NOTE

If the Adapter becomes contaminated, clean it with distilled water followed by a thorough swabbing with pure methyl alcohol, CH₃OH. This will suffice for most contaminants.

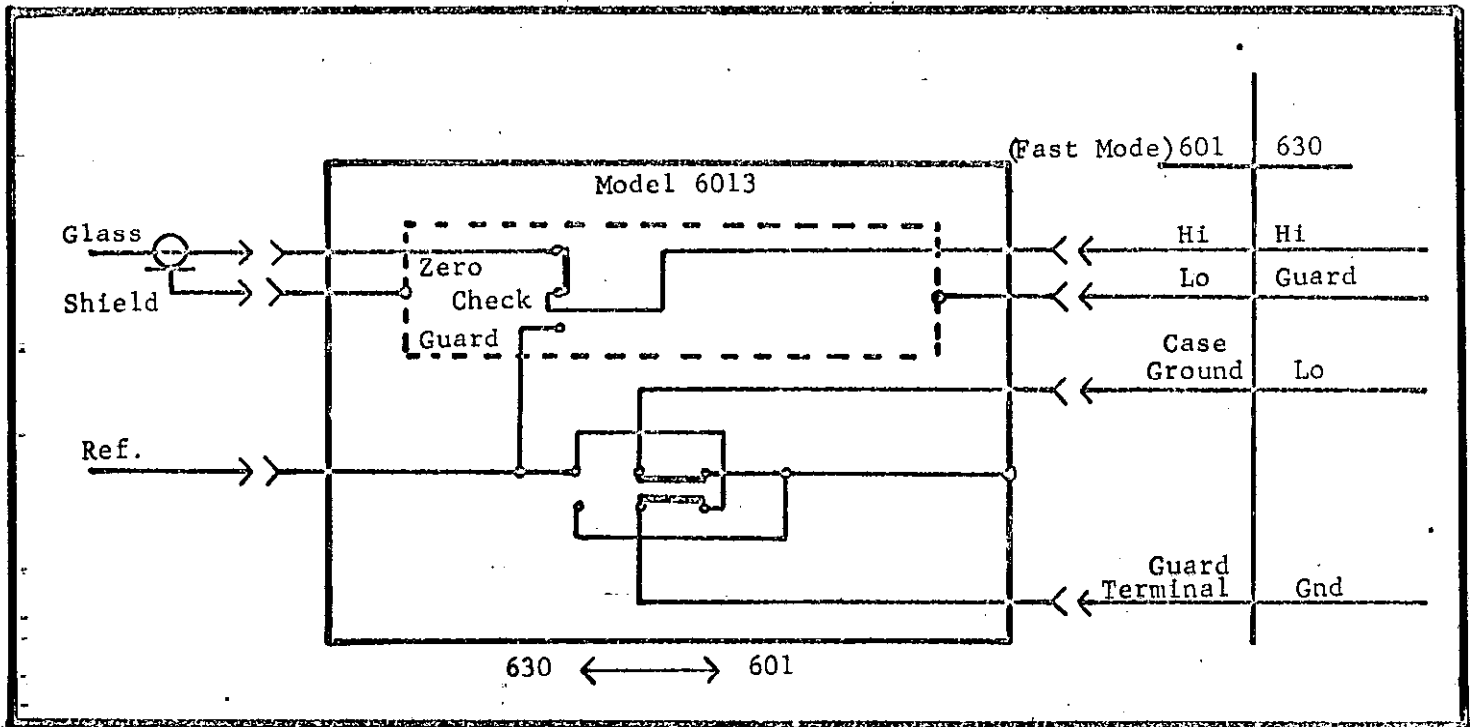

FIGURE 1. Model 6013 pH Electrode Adapter Wiring Diagram.

VOLTAGE TO PH CONVERSION GRAPH

THE GRAPH WAS CONSTRUCTED FROM
CONVERSION TABLES IN THE
BOOK
OF CHEMISTRY AND PHYSICS

THE FORMULA:
$$pH = \frac{E}{0.0591} - \frac{E}{0.4538}$$

WHERE E IS THE POTENTIAL IN VOLTS.
THE TEMPERATURE DEPENDENCE IS
0.77 MV/°C TO BE ADDED ABOVE 25°C
AND SUBTRACTED BELOW 25°C.

DEGREES CENTIGRADE

15
45
65
85
105

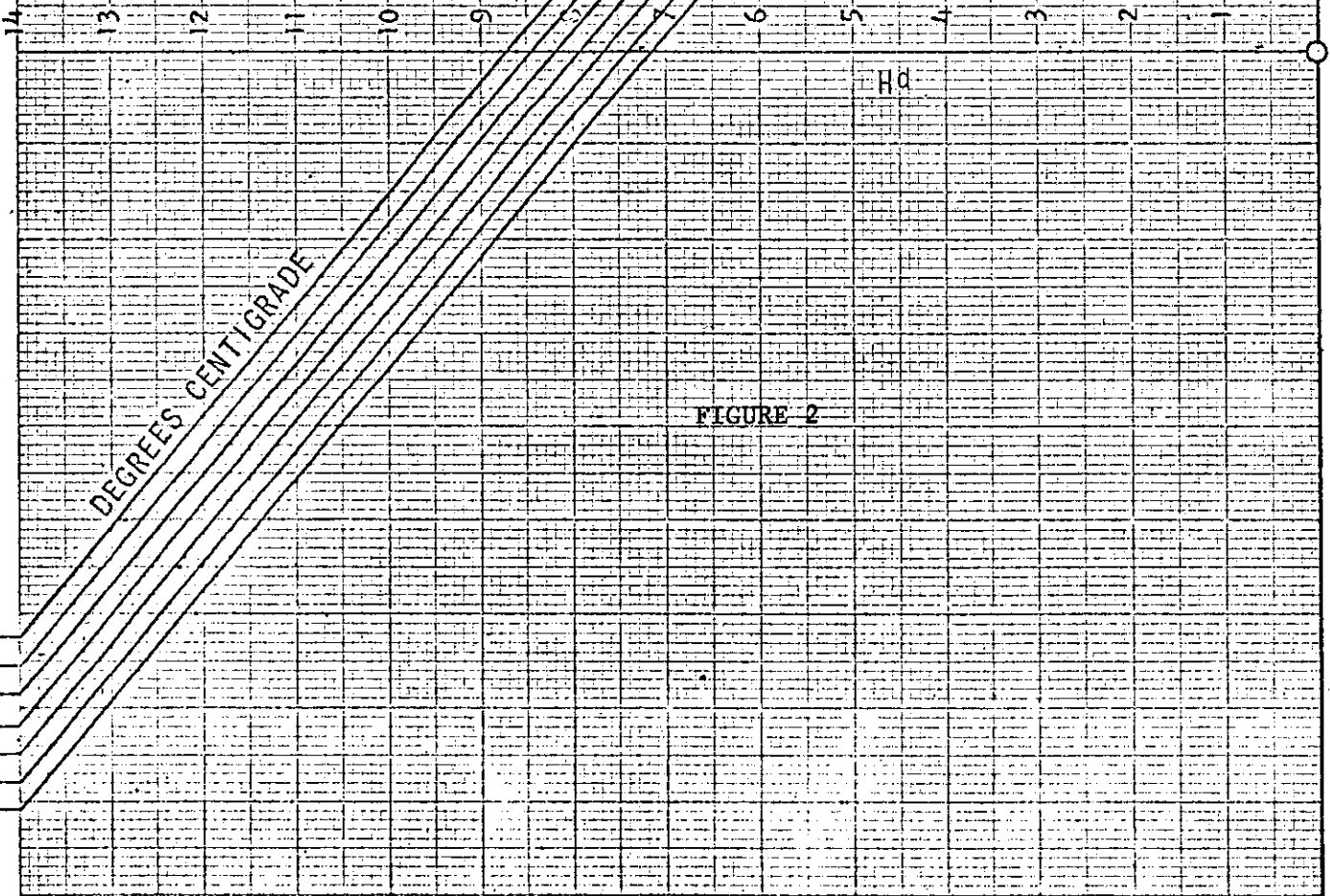
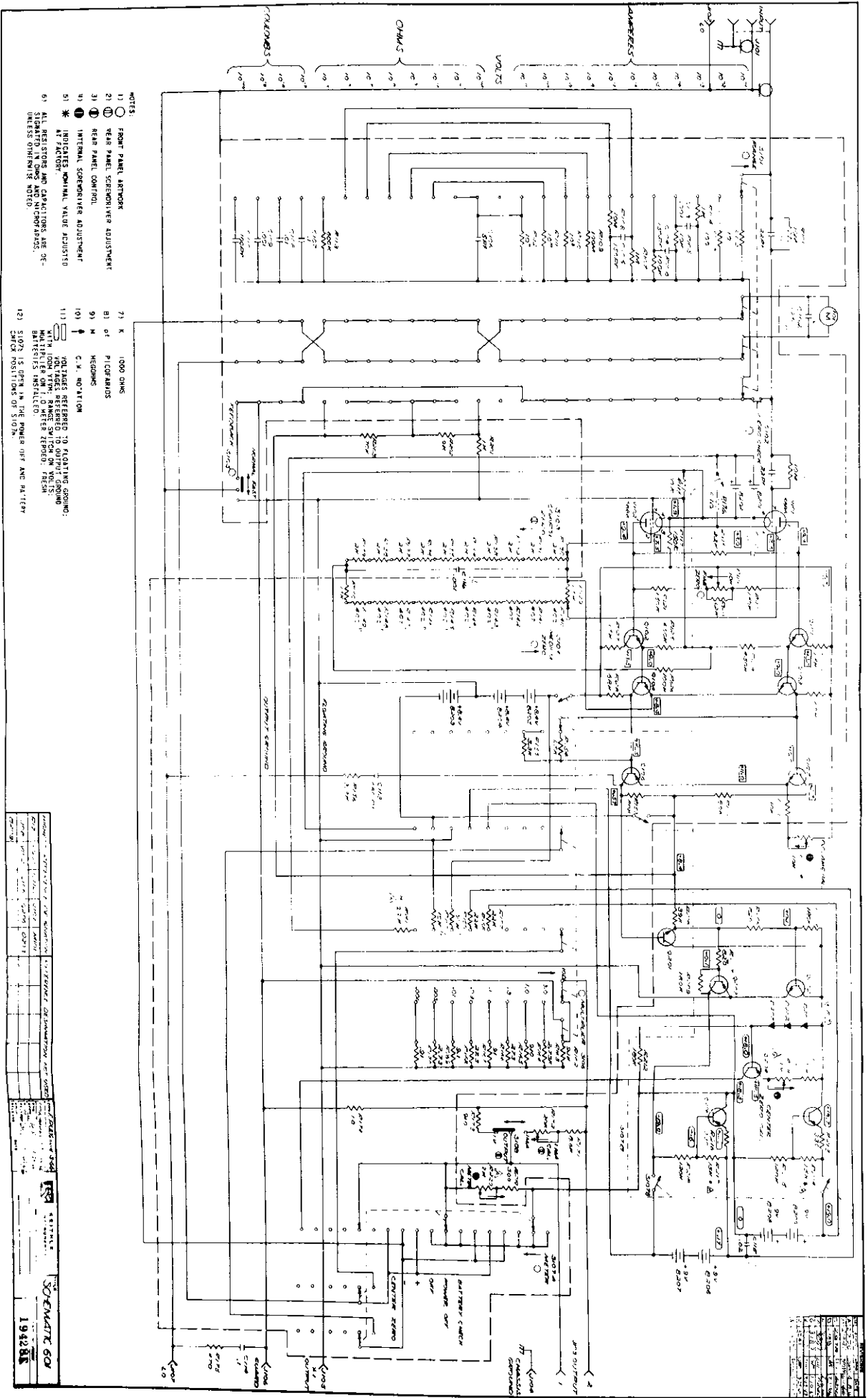

FIGURE 2

MILLIVOLTS
-400 -300 -200 -100 100 200 300 400 500



- NOTES:
- 1) ○ FROM PANEL NETWORK
 - 2) ⊖ REAR PANEL SCREENWIRE ADJUSTMENT
 - 3) ⊕ REAR PANEL CONTROL
 - 4) ⊖ INTERNAL SCREENWIRE ADJUSTMENT
 - 5) * INDICATES NOMINAL VALUE ADJUSTED AT FACTORY.
 - 6) ALL RESISTORS AND CAPACITORS ARE CE-SPECIFIED IN OHMS AND MICROFARADS, UNLESS OTHERWISE NOTED.

- 7) K 1000 OHMS
- 8) P PICOFARADS
- 9) M MEGOHMS
- 10) ↓ C.K. NO ACTION
- 11) ⊖ INDICATES REFERRED TO FLOATING GROUND. ALL VALUES REFERRED TO OUTPUT GROUND WITH 100% VPM. RANGE SWITCH ON 'FEEL' POSITION. BATTERIES INSTALLED.
- 12) SWITCH IS OPEN IN THE POWER OFF AND BATTERY CHECK POSITIONS OF SWITCH.

| REV. | DESCRIPTION | DATE | BY | CHKD. |
|------|----------------|------|----|-------|
| 1 | INITIAL DESIGN | 1942 | | |
| 2 | REVISION | | | |
| 3 | REVISION | | | |
| 4 | REVISION | | | |
| 5 | REVISION | | | |
| 6 | REVISION | | | |
| 7 | REVISION | | | |
| 8 | REVISION | | | |
| 9 | REVISION | | | |
| 10 | REVISION | | | |
| 11 | REVISION | | | |
| 12 | REVISION | | | |
| 13 | REVISION | | | |
| 14 | REVISION | | | |
| 15 | REVISION | | | |
| 16 | REVISION | | | |
| 17 | REVISION | | | |
| 18 | REVISION | | | |
| 19 | REVISION | | | |
| 20 | REVISION | | | |
| 21 | REVISION | | | |
| 22 | REVISION | | | |
| 23 | REVISION | | | |
| 24 | REVISION | | | |
| 25 | REVISION | | | |
| 26 | REVISION | | | |
| 27 | REVISION | | | |
| 28 | REVISION | | | |
| 29 | REVISION | | | |
| 30 | REVISION | | | |
| 31 | REVISION | | | |
| 32 | REVISION | | | |
| 33 | REVISION | | | |
| 34 | REVISION | | | |
| 35 | REVISION | | | |
| 36 | REVISION | | | |
| 37 | REVISION | | | |
| 38 | REVISION | | | |
| 39 | REVISION | | | |
| 40 | REVISION | | | |
| 41 | REVISION | | | |
| 42 | REVISION | | | |
| 43 | REVISION | | | |
| 44 | REVISION | | | |
| 45 | REVISION | | | |
| 46 | REVISION | | | |
| 47 | REVISION | | | |
| 48 | REVISION | | | |
| 49 | REVISION | | | |
| 50 | REVISION | | | |

SCHEMATIC COY
1942

| REV. | DATE | DESCRIPTION |
|------|---------|-------------------------|
| 1 | 12-1-42 | INITIAL DESIGN |
| 2 | 12-1-42 | REVISED TO SHOW CHANGES |
| 3 | 12-1-42 | REVISED TO SHOW CHANGES |
| 4 | 12-1-42 | REVISED TO SHOW CHANGES |
| 5 | 12-1-42 | REVISED TO SHOW CHANGES |
| 6 | 12-1-42 | REVISED TO SHOW CHANGES |
| 7 | 12-1-42 | REVISED TO SHOW CHANGES |
| 8 | 12-1-42 | REVISED TO SHOW CHANGES |
| 9 | 12-1-42 | REVISED TO SHOW CHANGES |
| 10 | 12-1-42 | REVISED TO SHOW CHANGES |
| 11 | 12-1-42 | REVISED TO SHOW CHANGES |
| 12 | 12-1-42 | REVISED TO SHOW CHANGES |

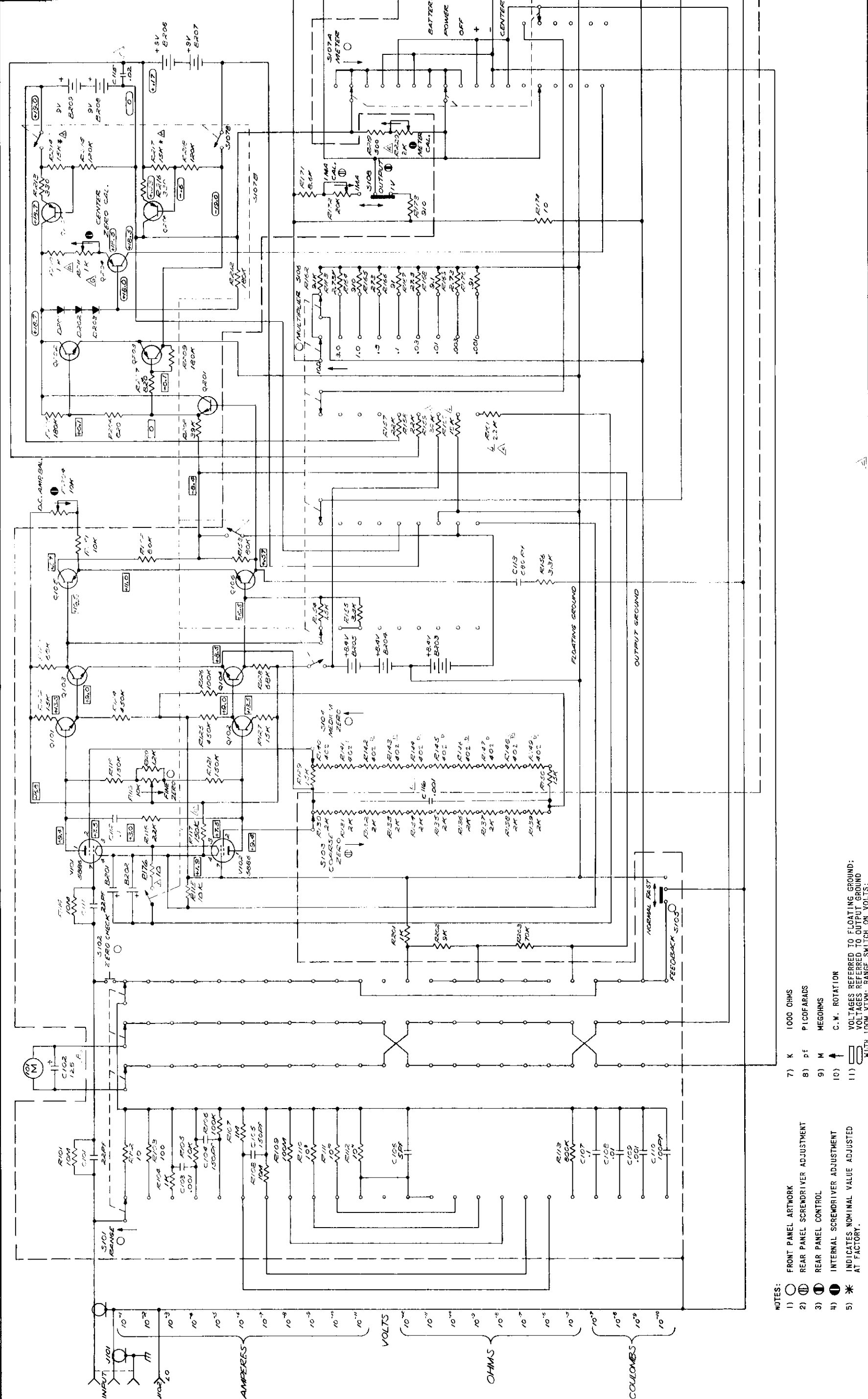

| HIGHEST REFERENCE DESIGNATION | REFERENCE DESIGNATION NOT USED |
|-------------------------------|--------------------------------|
| R171, B206, C116, V107, M101 | |
| S108, V102, Q106, Q208, Q203 | |
| B209 | |

KEITHLEY SCHEMATIC 601
 19428E

NOTES:
 1) FRONT PANEL ARTWORK
 2) REAR PANEL SCREWDRIIVER ADJUSTMENT
 3) REAR PANEL CONTROL
 4) INTERNAL SCREWDRIIVER ADJUSTMENT
 5) INDICATES NOMINAL VALUE ADJUSTED AT FACTORY.
 6) ALL RESISTORS AND CAPACITORS ARE DESIGNATED IN OHMS AND MICROFARADS, UNLESS OTHERWISE NOTED.
 7) K 1000 OHMS
 8) pF PICO FARADS
 9) M MEGOHMS
 10) C.W. ROTATION
 11) VOLTAGES REFERRED TO FLOATING GROUND; VOLTAGES REFERRED TO OUTPUT GROUND WITH 100M V.T.W.; RANGE SWITCH ON VOLTS; MULTIPLIER ON 1.0 METER ZEROED; FRESH BATTERIES INSTALLED.
 12) S107D IS OPEN IN THE POWER OFF AND BATTERY CHECK POSITIONS OF S107A.

| REV. | DATE | BY | CHKD. | DESCRIPTION |
|------|----------|----------|----------|-------------------------|
| 1 | 10-15-50 | W. H. B. | J. H. B. | INITIAL DESIGN |
| 2 | 11-15-50 | W. H. B. | J. H. B. | REVISED FOR MANUFACTURE |
| 3 | 12-15-50 | W. H. B. | J. H. B. | REVISED FOR MANUFACTURE |
| 4 | 1-15-51 | W. H. B. | J. H. B. | REVISED FOR MANUFACTURE |
| 5 | 2-15-51 | W. H. B. | J. H. B. | REVISED FOR MANUFACTURE |
| 6 | 3-15-51 | W. H. B. | J. H. B. | REVISED FOR MANUFACTURE |
| 7 | 4-15-51 | W. H. B. | J. H. B. | REVISED FOR MANUFACTURE |
| 8 | 5-15-51 | W. H. B. | J. H. B. | REVISED FOR MANUFACTURE |
| 9 | 6-15-51 | W. H. B. | J. H. B. | REVISED FOR MANUFACTURE |
| 10 | 7-15-51 | W. H. B. | J. H. B. | REVISED FOR MANUFACTURE |
| 11 | 8-15-51 | W. H. B. | J. H. B. | REVISED FOR MANUFACTURE |
| 12 | 9-15-51 | W. H. B. | J. H. B. | REVISED FOR MANUFACTURE |

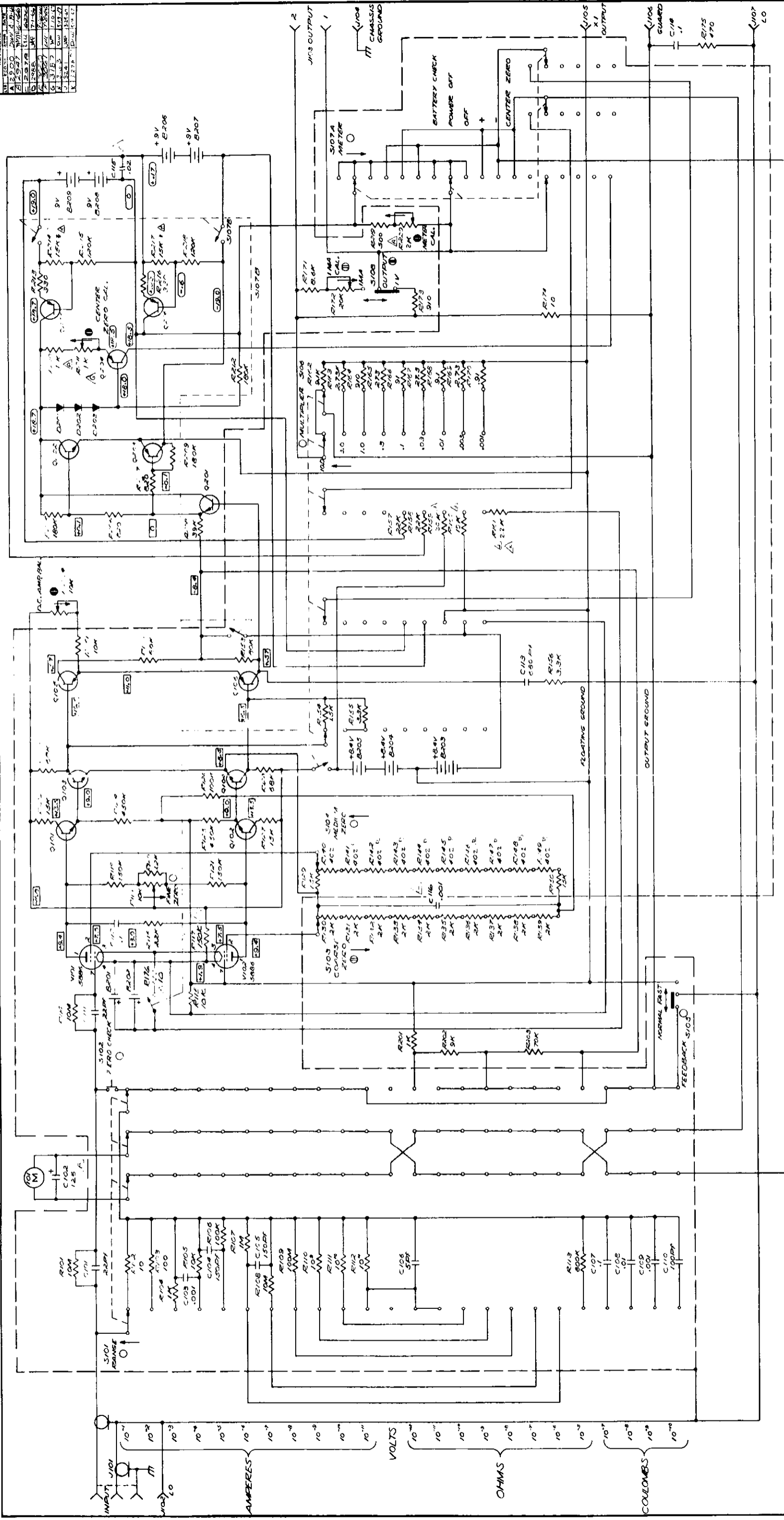

- NOTES:**
- 1) ○ FRONT PANEL ARTWORK
 - 2) ⊕ REAR PANEL SCREWDRIVER ADJUSTMENT
 - 3) ⊖ REAR PANEL CONTROL
 - 4) ⊕ INTERNAL SCREWDRIVER ADJUSTMENT
 - 5) * INDICATES NOMINAL VALUE ADJUSTED AT FACTORY.
 - 6) ALL RESISTORS AND CAPACITORS ARE DESIGNATED IN OHMS AND MICROFARADS, UNLESS OTHERWISE NOTED.
- 7) K 1000 OHMS
 8) pF PICOFARADS
 9) M MEGOHMS
 10) C. W. ROTATION
 11) VOLTAGES REFERRED TO FLOATING GROUND; VOLTAGES REFERRED TO OUTPUT GROUND WITH 100M VTM; RANGE SWITCH ON VOLTS; MULTIPLIER ON 1.0 METER ZEROED; FRESH BATTERIES INSTALLED.
 12) S107a IS OPEN IN THE POWER OFF AND BATTERY CHECK POSITIONS OF S107a.

| REV. | DATE | BY | CHKD. | DESCRIPTION |
|------|----------|----------|----------|-------------------------|
| 1 | 10-15-50 | W. H. B. | J. H. B. | INITIAL DESIGN |
| 2 | 11-15-50 | W. H. B. | J. H. B. | REVISED FOR MANUFACTURE |
| 3 | 12-15-50 | W. H. B. | J. H. B. | REVISED FOR MANUFACTURE |
| 4 | 1-15-51 | W. H. B. | J. H. B. | REVISED FOR MANUFACTURE |
| 5 | 2-15-51 | W. H. B. | J. H. B. | REVISED FOR MANUFACTURE |
| 6 | 3-15-51 | W. H. B. | J. H. B. | REVISED FOR MANUFACTURE |
| 7 | 4-15-51 | W. H. B. | J. H. B. | REVISED FOR MANUFACTURE |
| 8 | 5-15-51 | W. H. B. | J. H. B. | REVISED FOR MANUFACTURE |
| 9 | 6-15-51 | W. H. B. | J. H. B. | REVISED FOR MANUFACTURE |
| 10 | 7-15-51 | W. H. B. | J. H. B. | REVISED FOR MANUFACTURE |
| 11 | 8-15-51 | W. H. B. | J. H. B. | REVISED FOR MANUFACTURE |
| 12 | 9-15-51 | W. H. B. | J. H. B. | REVISED FOR MANUFACTURE |

SCHEMATIC 601
 19428E