Instruction Manual

Models 7012-S and 7012-C
4 × 10 Matrix Cards

Contains Operating and Servicing Information

KEITHLEY

WARRANTY

Keithley Instruments, Inc. warrants this product to be free from defects in material and workmanship for a period of 1 year from date of shipment.

Keithley Instruments, Inc. warrants the following items for 90 days from the date of shipment: probes, cables, rechargeable batteries, diskettes, and documentation.

During the warranty period, we will, at our option, either repair or replace any product that proves to be defective.

To exercise this warranty, write or call your local Keithley representative, or contact Keithley headquarters in Cleveland, Ohio. You will be given prompt assistance and return instructions. Send the product, transportation prepaid, to the indicated service facility. Repairs will be made and the product returned, transportation prepaid. Repaired or replaced products are warranted for the balance of the original warranty period, or at least 90 days.

LIMITATION OF WARRANTY

This warranty does not apply to defects resulting from product modification without Keithley's express written consent, or misuse of any product or part. This warranty also does not apply to fuses, software, non-rechargeable batteries, damage from battery leakage, or problems arising from normal wear or failure to follow instructions.

THIS WARRANTY IS IN LIEU OF ALL OTHER WARRANTIES, EXPRESSED OR IMPLIED, INCLUDING ANY IMPLIED WARRANTY OF MERCHANTABILITY OR FITNESS FOR A PARTICULAR USE. THE REMEDIES PROVIDED HEREIN ARE BUYER'S SOLE AND EXCLUSIVE REMEDIES.

NEITHER KEITHLEY INSTRUMENTS, INC. NOR ANY OF ITS EMPLOYEES SHALL BE LIABLE FOR ANY DIRECT, INDIRECT, SPECIAL, INCIDENTAL OR CONSEQUENTIAL DAMAGES ARISING OUT OF THE USE OF ITS INSTRUMENTS AND SOFTWARE EVEN IF KEITHLEY INSTRUMENTS, INC., HAS BEEN ADVISED IN ADVANCE OF THE POSSIBILITY OF SUCH DAMAGES. SUCH EXCLUDED DAMAGES SHALL INCLUDE, BUT ARE NOT LIMITED TO: COSTS OF REMOVAL AND INSTALLATION, LOSSES SUSTAINED AS THE RESULT OF INJURY TO ANY PERSON, OR DAMAGE TO PROPERTY.



Keithley Instruments, Inc. • 28775 Aurora Road • Cleveland, OH 44139 • 440-248-0400 • Fax: 440-248-6168 • <http://www.keithley.com>

BELGIUM:	Keithley Instruments B.V.	Bergensesteenweg 709 • B-1600 Sint-Pieters-Leeuw • 02/363 00 40 • Fax: 02/363 00 64
CHINA:	Keithley Instruments China	Yuan Chen Xin Building, Room 705 • 12 Yumin Road, Dewai, Madian • Beijing 100029 • 8610-62022886 • Fax: 8610-62022892
FRANCE:	Keithley Instruments Sarl	B.P. 60 • 3, allée des Garays • 91122 Palaiseau Cédex • 01 64 53 20 20 • Fax: 01 60 11 77 26
GERMANY:	Keithley Instruments GmbH	Landsberger Strasse 65 • D-82110 Germering • 089/84 93 07-40 • Fax: 089/84 93 07-34
GREAT BRITAIN:	Keithley Instruments Ltd	The Minster • 58 Portman Road • Reading, Berkshire RG30 1EA • 0118-9 57 56 66 • Fax: 0118-9 59 64 69
INDIA:	Keithley Instruments GmbH	Flat 2B, WILOCRISSA • 14, Rest House Crescent • Bangalore 560 001 • 91-80-509-1320/21 • Fax: 91-80-509-1322
ITALY:	Keithley Instruments s.r.l.	Viale S. Gimignano, 38 • 20146 Milano • 02/48 30 30 08 • Fax: 02/48 30 22 74
NETHERLANDS:	Keithley Instruments B.V.	Postbus 559 • 4200 AN Gorinchem • 0183-635333 • Fax: 0183-630821
SWITZERLAND:	Keithley Instruments SA	Kriesbachstrasse 4 • 8600 Dübendorf • 01-821 94 44 • Fax: 01-820 30 81
TAIWAN:	Keithley Instruments Taiwan	1 Fl. 85 Po Ai Street • Hsinchu, Taiwan, R.O.C. • 886-3572-9077 • Fax: 886-3572-903

Models 7012-S and 7012-C Instruction Manual

New Contact Information

Keithley Instruments, Inc.
28775 Aurora Road
Cleveland, OH 44139

Technical Support: 1-888-KEITHLEY
Monday – Friday 8:00 a.m. to 5:00 p.m (EST)
Fax: (440) 248-6168

Visit our website at <http://www.keithley.com>

Manual Print History

The print history shown below lists the printing dates of all Revisions and Addenda created for this manual. The Revision Level letter increases alphabetically as the manual undergoes subsequent updates. Addenda, which are released between Revisions, contain important change information that the user should incorporate immediately into the manual. Addenda are numbered sequentially. When a new Revision is created, all Addenda associated with the previous Revision of the manual are incorporated into the new Revision of the manual. Each new Revision includes a revised copy of this print history page.

Many product updates and revisions do not require manual changes and, conversely, manual corrections may be done without accompanying product changes. Therefore, it is recommended that you review the Manual Update History.

Revision A (Document Number 7012-901-01)	November 1991
Addendum A (Document Number 7012-901-02)	January 1992
Revision B (Document Number 7012-901-01)	November 1993

Safety Precautions

The following safety precautions should be observed before using this product and any associated instrumentation. Although some instruments and accessories would normally be used with non-hazardous voltages, there are situations where hazardous conditions may be present.

This product is intended for use by qualified personnel who recognize shock hazards and are familiar with the safety precautions required to avoid possible injury. Read the operating information carefully before using the product.

The types of product users are:

Responsible body is the individual or group responsible for the use and maintenance of equipment, for ensuring that the equipment is operated within its specifications and operating limits, and for ensuring that operators are adequately trained.

Operators use the product for its intended function. They must be trained in electrical safety procedures and proper use of the instrument. They must be protected from electric shock and contact with hazardous live circuits.

Maintenance personnel perform routine procedures on the product to keep it operating, for example, setting the line voltage or replacing consumable materials. Maintenance procedures are described in the manual. The procedures explicitly state if the operator may perform them. Otherwise, they should be performed only by service personnel.

Service personnel are trained to work on live circuits, and perform safe installations and repairs of products. Only properly trained service personnel may perform installation and service procedures.

Exercise extreme caution when a shock hazard is present. Lethal voltage may be present on cable connector jacks or test fixtures. The American National Standards Institute (ANSI) states that a shock hazard exists when voltage levels greater than 30V RMS, 42.4V peak, or 60VDC are present. **A good safety practice is to expect that hazardous voltage is present in any unknown circuit before measuring.**

Users of this product must be protected from electric shock at all times. The responsible body must ensure that users are prevented access and/or insulated from every connection point. In some cases, connections must be exposed to potential human contact. Product users in these circumstances must be trained to protect themselves from the risk of electric shock. If the circuit is capable of operating at or above 1000 volts, **no conductive part of the circuit may be exposed.**

As described in the International Electrotechnical Commission (IEC) Standard IEC 664, digital multimeter measuring circuits (e.g., Keithley Models 175A, 199, 2000, 2001, 2002, and 2010) are Installation Category II. All other instruments' signal terminals are Installation Category I and must not be connected to mains.

Do not connect switching cards directly to unlimited power circuits. They are intended to be used with impedance limited sources. NEVER connect switching cards directly to AC mains. When connecting sources to switching cards, install protective devices to limit fault current and voltage to the card.

Before operating an instrument, make sure the line cord is connected to a properly grounded power receptacle. Inspect the connecting cables, test leads, and jumpers for possible wear, cracks, or breaks before each use.

For maximum safety, do not touch the product, test cables, or any other instruments while power is applied to the circuit under test. ALWAYS remove power from the entire test system and discharge any capacitors before: connecting or disconnecting cables or jumpers, installing or removing switching cards, or making internal changes, such as installing or removing jumpers.

Do not touch any object that could provide a current path to the common side of the circuit under test or power line (earth) ground. Always make measurements with dry hands while standing on a dry, insulated surface capable of withstanding the voltage being measured.

The instrument and accessories must be used in accordance with its specifications and operating instructions or the safety of the equipment may be impaired.

Do not exceed the maximum signal levels of the instruments and accessories, as defined in the specifications and operating information, and as shown on the instrument or test fixture panels, or switching card.

When fuses are used in a product, replace with same type and rating for continued protection against fire hazard.

Chassis connections must only be used as shield connections for measuring circuits, NOT as safety earth ground connections.

If you are using a test fixture, keep the lid closed while power is applied to the device under test. Safe operation requires the use of a lid interlock.

If a  screw is present, connect it to safety earth ground using the wire recommended in the user documentation.

The  symbol on an instrument indicates that the user should refer to the operating instructions located in the manual.

The  symbol on an instrument shows that it can source or measure 1000 volts or more, including the combined effect of normal and common mode voltages. Use standard safety precautions to avoid personal contact with these voltages.

The **WARNING** heading in a manual explains dangers that might result in personal injury or death. Always read the associated information very carefully before performing the indicated procedure.

The **CAUTION** heading in a manual explains hazards that could damage the instrument. Such damage may invalidate the warranty.

Instrumentation and accessories shall not be connected to humans.

Before performing any maintenance, disconnect the line cord and all test cables.

To maintain protection from electric shock and fire, replacement components in mains circuits, including the power transformer, test leads, and input jacks, must be purchased from Keithley Instruments. Standard fuses, with applicable national safety approvals, may be used if the rating and type are the same. Other components that are not safety related may be purchased from other suppliers as long as they are equivalent to the original component. (Note that selected parts should be purchased only through Keithley Instruments to maintain accuracy and functionality of the product.) If you are unsure about the applicability of a replacement component, call a Keithley Instruments office for information.

To clean an instrument, use a damp cloth or mild, water based cleaner. Clean the exterior of the instrument only. Do not apply cleaner directly to the instrument or allow liquids to enter or spill on the instrument. Products that consist of a circuit board with no case or chassis (e.g., data acquisition board for installation into a computer) should never require cleaning if handled according to instructions. If the board becomes contaminated and operation is affected, the board should be returned to the factory for proper cleaning/servicing.

7012 SPECIFICATIONS

MODEL 7012-S 4x10 Matrix with Screw Terminals.

MODEL 7012-C 4x10 Matrix with Mass Terminated Connector.

MATRIX CONFIGURATION: 4 rows by 10 columns. Jumpers can be removed to isolate any row from the backplane.

CONTACT CONFIGURATION: 2-pole Form A (Hi, Lo).

CONNECTOR TYPE:

7012-S: Screw terminal, #16AWG maximum wire size, with .092 inch O.D. 28 Conductors maximum. #22AWG typical wire size with .062 inch O.D. 88 Conductor maximum.

7012-C: 96-Pin male Euro card connector. Mates to female twisted wire cable, crimp or solder connector.

MAXIMUM SIGNAL LEVEL:

DC Signals: 110V DC between any two pins, 1A switched. 30VA (resistive load).

AC Signals: 125V RMS or 175V AC peak, between any two pins, 1A switched, 60VA (resistive load).

COMMON MODE VOLTAGE: 175V peak, any pin to chassis.

CONTACT LIFE:

Cold Switching: 10^8 closures.

At Maximum Signal Levels: 10^5 closures.

CHANNEL RESISTANCE (per conductor): $< 1\Omega$.

CONTACT POTENTIAL:

7012-S: < 500 nV per contact pair (Hi, Lo).
 < 1.5 μ V per single contact.

7012-C: < 1 μ V per contact pair (Hi, Lo).
 < 3 μ V per single contact.

OFFSET CURRENT: < 100 pA.

ACTUATION TIME: 3 ms.

ISOLATION:

Path: $>10^9\Omega$, < 50 pF.

Differential: $>10^9\Omega$, < 200 pF.

Common Mode: $>10^9\Omega$, < 400 pF.

CROSS TALK (1MHz, 50 Ω Load): < -40 dB.

INSERTION LOSS (50 Ω Source, 50 Load): < 0.1 dB below 1MHz, < 3 dB below 2MHz.

RELAY DRIVE CURRENT (per relay): 16mA.

ENVIRONMENT:

Operation: 0°C to 50°C , up to 35°C $< 80\%$ RH.

Storage: -25°C to 65°C .

Specifications subject to change without notice.

7012 4x10 Matrix

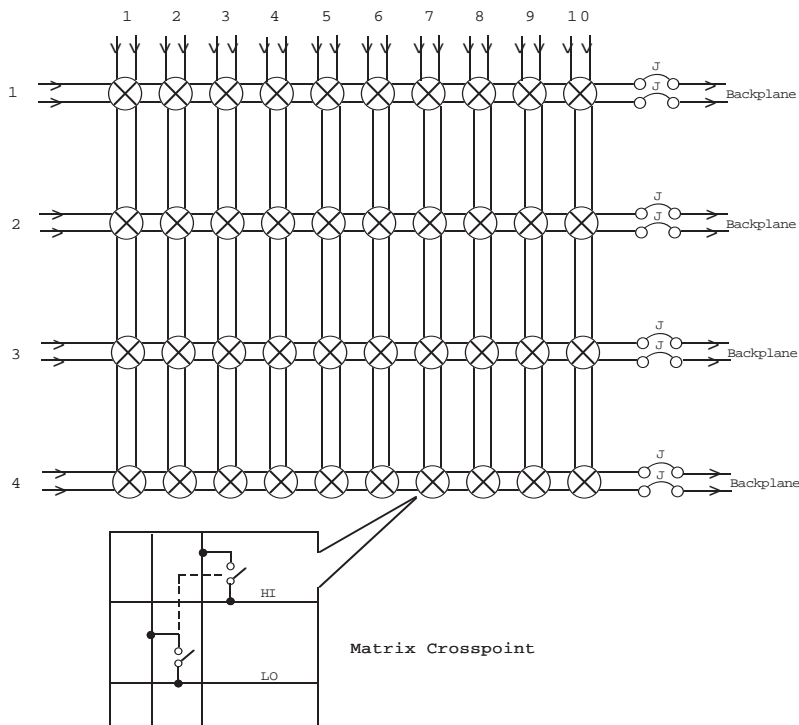

Table of Contents

1.1	Introduction	1-1
1.2	Features.....	1-1
1.3	Warranty information.....	1-2
1.4	Manual addenda	1-2
1.5	Safety symbols and terms	1-2
1.6	Specifications	1-2
1.7	Unpacking and inspection	1-2
1.7.1	Inspection for damage	1-2
1.7.2	Shipping contents.....	1-2
1.7.3	Instruction manual.....	1-3
1.8	Repacking for shipment	1-3
1.9	Optional accessories.....	1-3
2.1	Introduction	2-1
2.2	Basic matrix configuration (4 × 10)	2-1
2.3	Typical matrix switching schemes.....	2-3
2.3.1	Single-ended switching	2-3
2.3.2	Differential switching	2-4
2.3.3	Sensing	2-4
2.3.4	SMU connections.....	2-5
2.4	Matrix expansion.....	2-5
2.4.1	Two-card switching systems	2-5
2.4.2	Mainframe matrix expansion	2-9
3.1	Introduction	3-1
3.2	Handling precautions	3-1
3.3	Connections.....	3-1
3.3.1	Backplane row jumpers.....	3-2
3.3.2	Screw terminal connector card.....	3-2
3.3.3	Multi-pin (mass termination) connector card	3-4
3.4	Typical connection schemes	3-9
3.4.1	Single card system.....	3-9
3.4.2	Two-card system	3-9
3.4.3	Two-mainframe system.....	3-14
3.5	Model 7012 installation and removal	3-14

4.1	Introduction.....	4-1
4.2	Power limits.....	4-1
4.3	Mainframe control of matrix card	4-1
4.3.1	Channel assignments	4-2
4.3.2	Front panel control	4-4
4.3.3	IEEE-488 bus operation.....	4-4
4.4	Matrix switching examples	4-5
4.4.1	Thick film resistor network testing	4-5
4.4.2	Transistor testing	4-10
4.5	Measurement considerations	4-13
4.5.1	Path isolation.....	4-13
4.5.2	Magnetic fields.....	4-14
4.5.3	Radio frequency interference.....	4-14
4.5.4	Ground loops	4-14
4.5.5	Keeping connectors clean.....	4-15
4.5.6	AC frequency response.....	4-15
5.1	Introduction.....	5-1
5.2	Handling and cleaning precautions.....	5-1
5.3	Performance verification	5-2
5.3.1	Environmental conditions.....	5-2
5.3.2	Recommended equipment	5-2
5.3.3	Matrix card connections	5-3
5.3.4	Channel resistance tests.....	5-3
5.3.5	Offset current tests.....	5-4
5.3.6	Contact potential tests.....	5-6
5.3.7	Path isolation tests.....	5-7
5.3.8	Differential and common-mode isolation tests.....	5-9
5.4	Special handling of static-sensitive devices.....	5-11
5.5	Principles of operation.....	5-12
5.5.1	Block diagram	5-12
5.5.2	ID data circuits	5-13
5.5.3	Relay control.....	5-13
5.5.4	Relay power control	5-14
5.5.5	Power-on safeguard	5-14
5.6	Troubleshooting.....	5-15
5.6.1	Troubleshooting equipment.....	5-15
5.6.2	Troubleshooting access.....	5-15
5.6.3	Troubleshooting procedure.....	5-15
6.1	Introduction.....	6-1
6.2	Parts lists	6-1
6.3	Ordering information.....	6-1
6.4	Factory service.....	6-1
6.5	Component layouts and schematic diagrams	6-2

List of Illustrations

Figure 2-1	Model 7012 simplified schematic.....	2-1
Figure 2-2	Model 7001 analog backplane	2-2
Figure 2-4	Single-ended switching example	2-3
Figure 2-3	Matrix row connections to backplane	2-3
Figure 2-5	Differential switching example	2-4
Figure 2-6	Sensing example	2-4
Figure 2-7	SMU connections.....	2-5
Figure 2-8	Two separate 4 × 10 matrices.....	2-6
Figure 2-9	Narrow matrix example (4 × 20)	2-7
Figure 2-10	Wide matrix example (8 × 10).....	2-8
Figure 2-11	Mixed card type example.....	2-9
Figure 2-12	Partial matrix expansion (8 × 20)	2-10
Figure 3-1	Backplane row jumpers.....	3-2
Figure 3-2	Screw terminal connector card.....	3-3
Figure 3-3	Typical terminal block connections	3-3
Figure 3-4	Cable clamp for screw terminal connector card	3-4
Figure 3-5	Multi-pin connector card terminal identification.....	3-5
Figure 3-6	Typical round cable connection techniques	3-7
Figure 3-7	Model 7011-MTR connector pinout.....	3-8
Figure 3-8	Model 7011-KIT-R (with cable) assembly	3-8
Figure 3-9	Single card system example (multi-pin connector card)	3-10
Figure 3-10	Single card system example (screw terminal connector card).....	3-11
Figure 3-11	Two-card system example (multi-pin connector card).....	3-12
Figure 3-12	Two-card system example (screw terminal connector card).....	3-13
Figure 3-13	Two-mainframe system example (multi-pin connector card)	3-15
Figure 3-14	Two-mainframe system example (screw terminal connector card).....	3-16
Figure 3-15	Model 7012-S card installation in Model 7001	3-18
Figure 3-16	Model 7012-C card installation in Model 7001	3-19
Figure 4-1	Channel status display	4-2
Figure 4-2	Display organization for multiplexer channels	4-3
Figure 4-3	Model 7012 programming channel assignments.....	4-3
Figure 4-4	Thick film resistor network testing.....	4-6
Figure 4-5	Four-terminal ohms measurements	4-7
Figure 4-6	Voltage divider checks	4-9
Figure 4-7	Transistor testing.....	4-10
Figure 4-8	DC parameter checks.....	4-12

Figure 4-9 Common-emitter characteristics of an NPN silicon Transistor 4-13

Figure 4-10 Path isolation resistance..... 4-13

Figure 4-11 Voltage attenuation by path isolation resistance 4-13

Figure 4-12 Power line ground loops 4-15

Figure 4-13 Eliminating ground loops 4-15

Figure 5-1 Path resistance testing..... 5-3

Figure 5-2 Common-mode offset current testing..... 5-5

Figure 5-3 Differential offset current testing 5-5

Figure 5-4 Contact potential testing..... 5-6

Figure 5-5 Path isolation testing (guarded) 5-8

Figure 5-6 Differential isolation testing..... 5-10

Figure 5-7 Common-mode isolation testing 5-10

Figure 5-8 Model 7012 block diagram 5-12

Figure 5-9 Start and stop sequences..... 5-13

Figure 5-10 Transmit and acknowledge sequence..... 5-14

List of Tables

Table 3-1	Mass termination accessories	3-4
Table 5-1	Verification equipment.....	5-2
Table 5-2	Path isolation tests.....	5-8
Table 5-3	Differential and common-mode isolation testing.....	5-11
Table 5-4	Recommended Troubleshooting Equipment	5-15
Table 5-5	Troubleshooting procedure	5-16

1

General Information

1.1 Introduction

This section contains general information about the Model 7012 4 × 10 Matrix card.

There are two basic versions of this matrix card; the Model 7012-S and the Model 7012-C. The Model 7012-S assembly consists of a screw terminal connector card and the relay card. External test circuits are wired directly to the screw terminals of the connector card. Also available from Keithley is the Model 7012-ST. This is an extra screw terminal connector card. With an extra connector card, you can wire a second test system without disturbing the wiring configuration of the first test system.

The Model 7012-C assembly consists of a multi-pin (mass termination) connector card and the relay card. External test circuit connections to the matrix are made via the 96-pin male DIN connector on the connector card. Keithley offers a variety of optional accessories that can be used to make connections to the connector card (see paragraph 1.9).

The rest of Section 1 is arranged in the following manner:

1.2 Features

1.3 Warranty information

1.4 Manual addenda

1.5 Safety symbols and terms

1.6 Specifications

1.7 Unpacking and inspection

1.8 Repacking for shipment

1.9 Optional accessories

1.2 Features

The Model 7012 is a two-pole, dual, 4 × 10 (four rows by 10 columns) matrix card. Some of the key features include:

- Low contact potential and offset current for minimal effects on low-level signals.
- The connector board detaches from the relay board allowing easy access to the screw terminals (Model 7012-S) and backplane row jumpers.
- Backplane row jumpers. Cutting jumpers disconnects matrix rows from the Model 7001 analog backplane.

1.3 Warranty information

Warranty information is located on the inside front cover of this instruction manual. Should your Model 7012 require warranty service, contact the Keithley representative or authorized repair facility in your area for further information. When returning the matrix card for repair, be sure to fill out and include the service form at the back of this manual in order to provide the repair facility with the necessary information.

1.4 Manual addenda

Any improvements or changes concerning the matrix card or manual will be explained in an addendum included with the card. Addenda are provided in a page replacement format. Simply replace the obsolete pages with the new pages.

1.5 Safety symbols and terms

The following symbols and terms may be found on an instrument or used in this manual.

The  symbol on an instrument indicates that the user should refer to the operating instructions located in the instruction manual.

The  symbol on an instrument shows that high voltage may be present on the terminal(s). Use standard safety precautions to avoid personal contact with these voltages.

The **WARNING** heading used in this manual explains dangers that might result in personal injury or death. Always read the associated information very carefully before performing the indicated procedure.

The **CAUTION** heading used in this manual explains hazards that could damage the matrix card. Such damage may invalidate the warranty.

1.6 Specifications

Model 7012 specifications are found at the front of this manual. These specifications are exclusive of the matrix mainframe specifications.

1.7 Unpacking and inspection

1.7.1 Inspection for damage

The Model 7012 is packaged in a re-sealable, anti-static bag to protect it from damage due to static discharge and from contamination that could degrade its performance. Before removing the card from the bag, observe the following precautions on handling.

Handling precautions:

1. Always grasp the card by the side edges and shields. Do not touch the board surfaces or components.
2. When not installed in a Model 7001 mainframe, keep the card in the anti-static bag and store it in the original packing carton.

After removing the card from its anti-static bag, inspect it for any obvious signs of physical damage. Report any such damage to the shipping agent immediately.

1.7.2 Shipping contents

The following items are included with every Model 7012 order:

- Model 7012 4 × 10 Matrix Card
- Model 7012 Instruction Manual
- Additional accessories as ordered

1.7.3 Instruction manual

The Model 7012 Instruction Manual is three-hole drilled so that it can be added to the three-ring binder of the Model 7001 Instruction Manual. After removing the plastic wrapping, place the manual in the binder following the mainframe instruction manual. Note that a manual identification tab is included and should precede the matrix card instruction manual.

If an additional instruction manual is required, order the manual package, Keithley part number 7012-901-00. The manual package includes an instruction manual and any pertinent addenda.

1.8 Repacking for shipment

Should it become necessary to return the Model 7012 for repair, carefully pack the unit in its original packing carton or the equivalent, and include the following information:

- Advise as to the warranty status of the matrix card.
- Write ATTENTION REPAIR DEPARTMENT on the shipping label.
- Fill out and include the service form located at the back of this manual.

1.9 Optional accessories

The following accessories are available for use with the Model 7012:

Model 7012-ST — This screw terminal connector card is identical to the one provided with the Model 7012-S assembly. An extra screw terminal connector card allows you to wire a second test system without disturbing the wiring configuration of the first connector card.

Model 7011-KIT-R — This connection kit includes a 96-pin female DIN connector that will mate directly to the connector on the Model 7012-C or to a standard 96-pin male DIN bulkhead connector (see Model 7011-MTR). This connector uses solder cups for connections to external circuitry. It includes an adapter for a round cable and the housing.

Model 7011-MTC-2 — This two-meter round cable assembly is terminated with a 96-pin female DIN connector on each end. It will mate directly to the connector on the Model 7012-C and to a standard 96-pin male DIN bulkhead connector (see Model 7011-MTR).

Model 7011-MTR — This 96-pin male DIN bulkhead connector uses solder cups for connections to external circuitry. It will mate to the Model 7011-KIT-R connector and Model 7011-MTC-2 cable assembly.

2

Matrix Switching Basics

2.1 Introduction

This section covers the basics for matrix switching and is arranged as follows:

- 2.2 **Basic matrix configuration:** Covers the basic 4×10 matrix configuration. The significance of the backplane jumpers is also covered here.
- 2.3 **Typical matrix switching schemes:** Explains some of the basic ways a matrix can be used to source or measure. Covers single-ended switching, differential (floating) switching, and sensing.
- 2.4 **Matrix expansion:** Discusses the various matrix configurations that are possible by using multiple cards.

2.2 Basic matrix configuration (4×10)

A simplified schematic of the Model 7012 matrix card is shown in Figure 2-1. The card is configured as a 4×10 matrix. Each of the 40 crosspoints is made up of a two-pole switch. By closing the appropriate crosspoint switch, any matrix row can be connected to any column in the matrix.

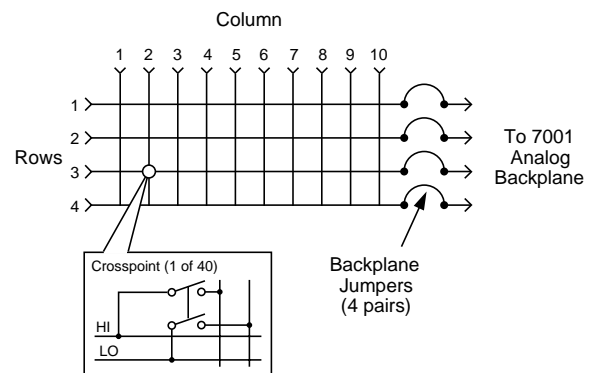

Figure 2-1
Model 7012 simplified schematic

Backplane jumpers

Notice in Figure 2-1 there are four pairs of backplane jumpers located on the relay card. With the jumpers installed, the matrix card is connected to the analog backplane of the Model 7001 allowing matrix expansion with a second 7001 card installed in the mainframe. With the jumpers removed (cut), the matrix card is isolated from another card installed in the mainframe.

The three-pole analog backplane of the mainframe is shown in Figure 2-2. It is through this analog backplane where the rows of a Model 7012 matrix card installed in one slot can be connected to the rows (or banks) of a compatible card installed in the other slot of the mainframe.

Figure 2-3 shows how each row of the Model 7012 is connected to the backplane. Notice that, since the Model 7012 is a two-pole card, there is no connection made to the Guard terminal of the backplane. The Model 7012 is shipped from the factory with the backplane row jumpers installed.

Removing (cutting) the backplane jumpers isolates the card from the backplane, and subsequently, any card installed in the other slot. For information on removing the jumpers, refer to paragraph 3.3.1.

NOTE

The Model 7001 does not provide an analog backplane for the non-701X series cards. As a result, anyone of these cards installed in one slot in the mainframe is electrically isolated from any card installed in the other slot. The only way to connect a Model 7012 to one of these cards is to wire them together.

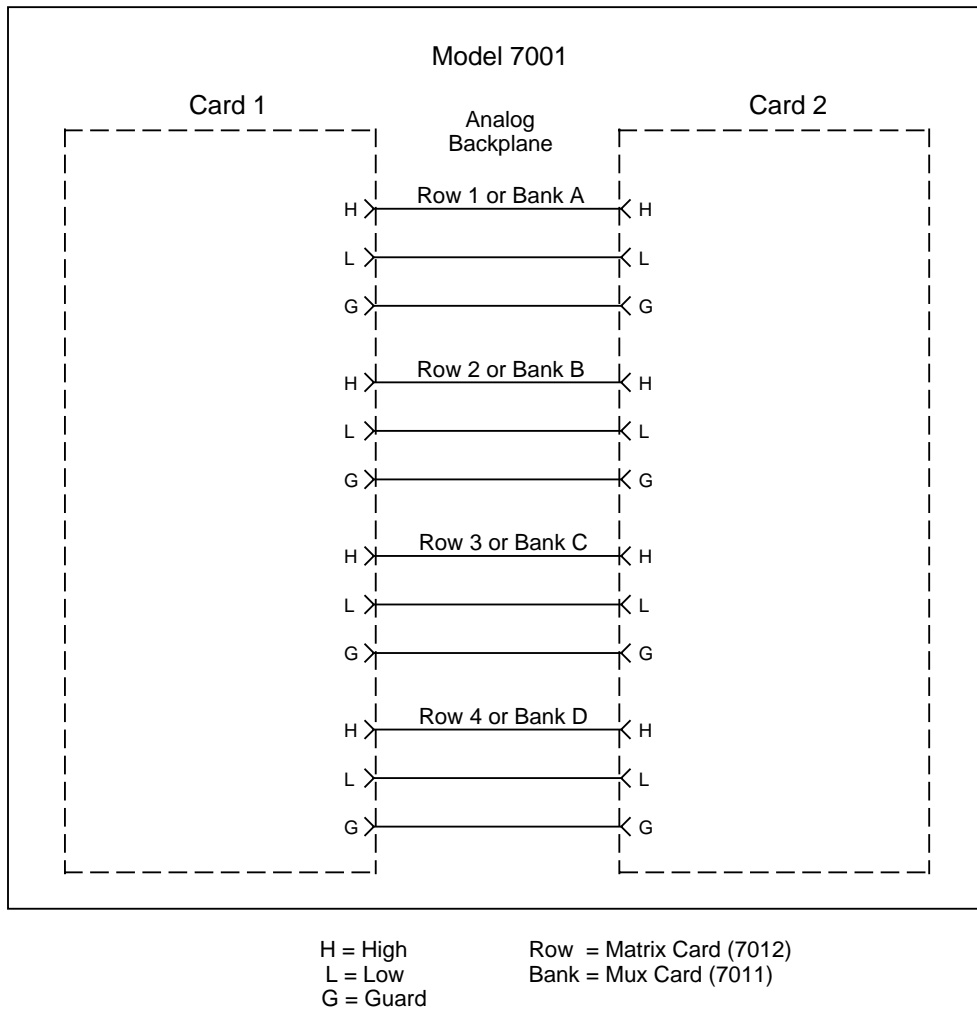

Figure 2-2
Model 7001 analog backplane

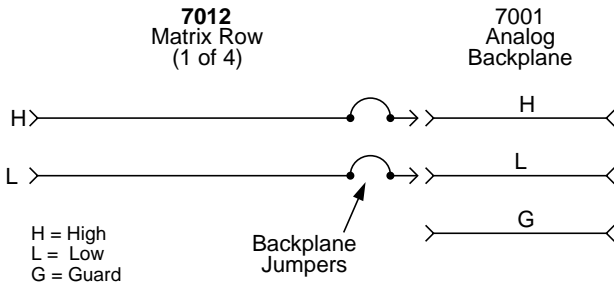

Figure 2-3
Matrix row connections to backplane

2.3 Typical matrix switching schemes

The following paragraphs describe some basic switching schemes that are possible with a two-pole switching matrix. These switching schemes include some various shielding configurations to help minimize noise pick up in sensitive measurement applications. These shields are shown connected to chassis ground. For some test configurations, shielding may prove to be more effective connected to circuit common. Chassis ground is accessible at the rear panel of the Model 7001.

2.3.1 Single-ended switching

In the single-ended switching configuration, the source or measure instrument is connected to the DUT through a single pathway as shown in Figure 2-4.

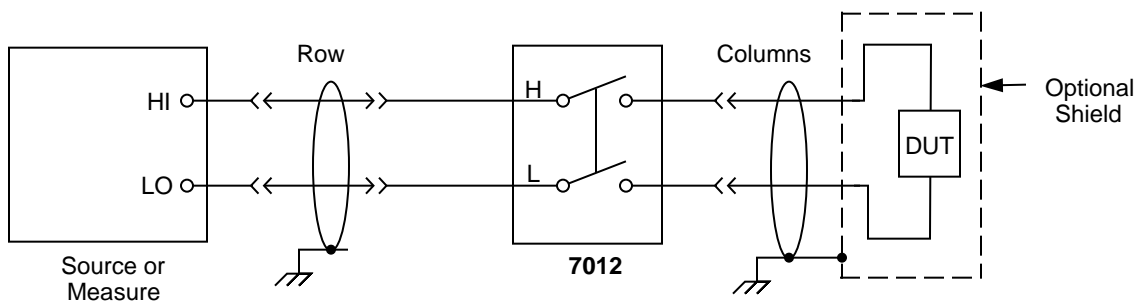

Figure 2-4
Single-ended switching example

2.3.2 Differential switching

The differential or floating switching configuration is shown in Figure 2-5. The advantage of using this configuration is that the terminals of the source or measure instrument are not confined to the same matrix crosspoint. Each terminal of the instrument can be connected to any matrix crosspoint.

2.3.3 Sensing

Figure 2-6 shows how the matrix card can be configured to use instruments that have sensing capability. The main advantage of using sensing is to cancel the effects of matrix card path resistance ($<1\Omega$) and the resistance of external cabling. Whenever path resistance is a consideration, sensing should be used.

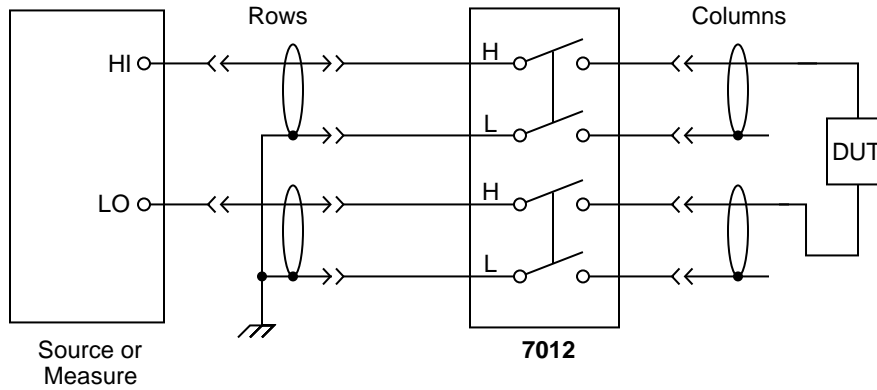

Figure 2-5
Differential switching example

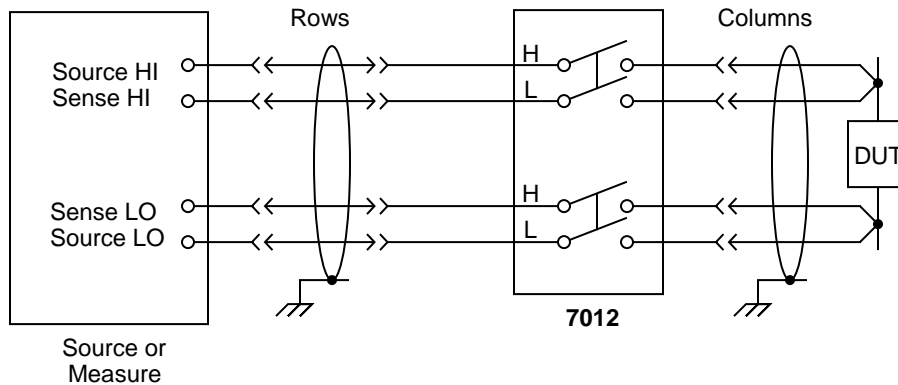

Figure 2-6
Sensing example

2.3.4 SMU connections

Figure 2-7 shows how a Keithley Model 236, 237 or 238 Source Measure Unit could be connected to the matrix card. By using triax cables that are unterminated at one end, the driven guard and chassis ground are physically extended all the way to the card.

2.4 Matrix expansion

With the use of additional matrix cards and mainframes, larger matrices can be configured. Each Model

7001 Switch System mainframe will accommodate up to two cards, and up to six mainframes can be connected together. Thus, a switch system using as many as 12 cards in six mainframes can be configured.

2.4.1 Two-card switching systems

Each Model 7001 Switch System mainframe can accommodate two cards to allow the following switching configurations.

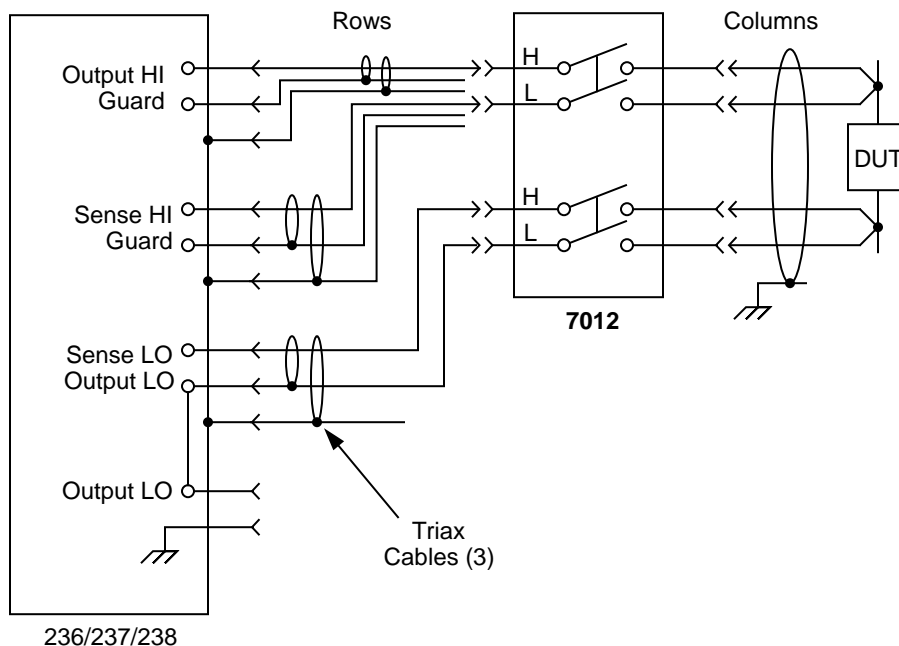

WARNING : Hazardous voltages may be present on GUARD. Make sure all cable shields are properly insulated before applying power.

Figure 2-7
SMU connections

Separate switching systems

Two single-card systems can be configured by removing the backplane jumpers from one of the cards. The two cards will be controlled by the same mainframe, but they will be electrically isolated from each other. Figure 2-8 shows an example using two Model 7012 matrix cards.

Narrow matrix expansion (4×20 matrix)

A narrow 4 row \times 20 column matrix is configured by simply installing two "as shipped" Model 7012s in the Model 7001 mainframe. By leaving the backplane jumpers installed, the rows of the matrix card installed in slot 1 (CARD 1) are automatically connected to the rows of the matrix card installed in slot 2 (CARD 2) through the analog backplane. The 4×20 matrix is shown in Figure 2-9.

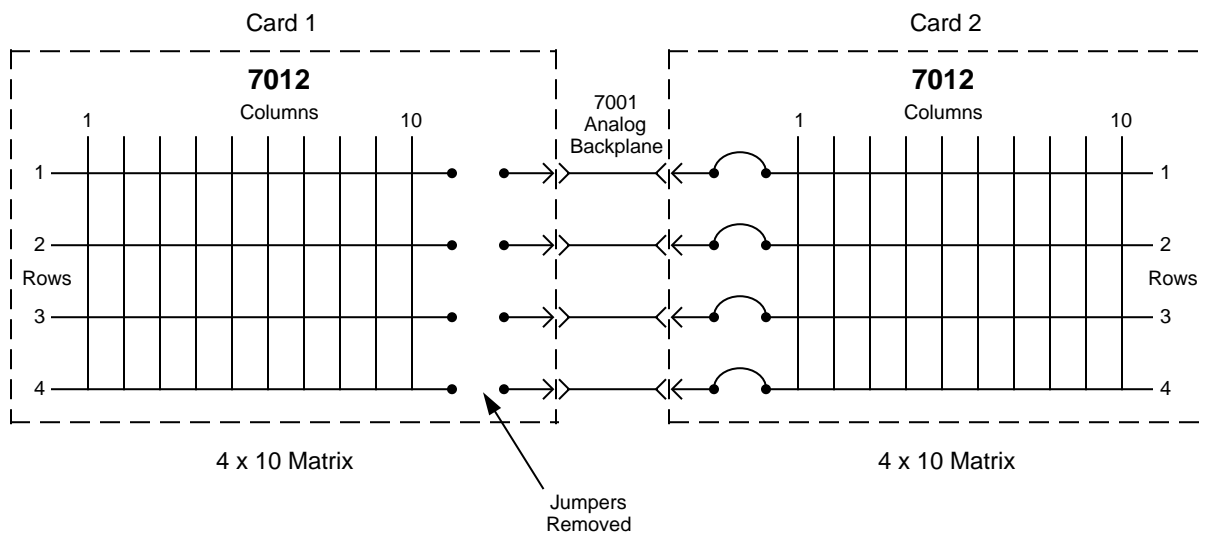

Figure 2-8
Two separate 4×10 matrices

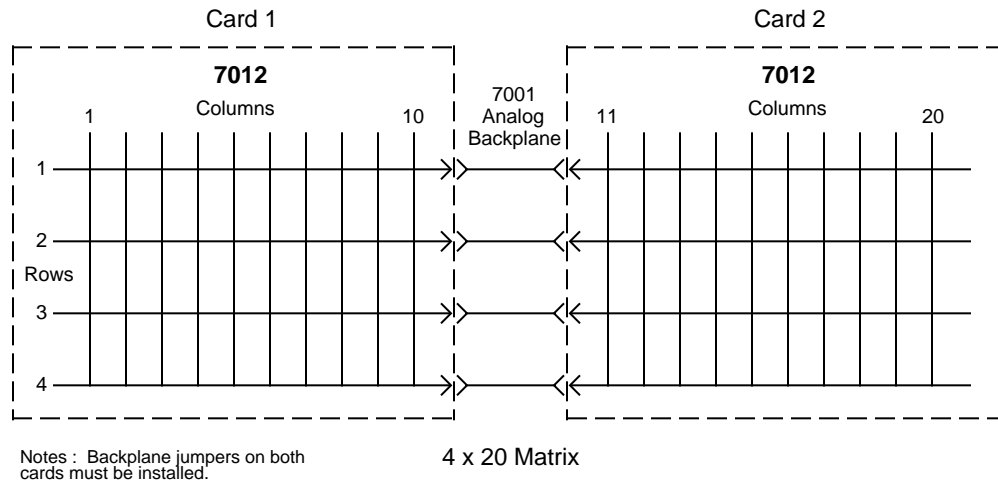

Figure 2-9
Narrow matrix example (4 × 20)

Wide matrix expansion (8 × 10 matrix)

A wide 8 row × 10 column matrix is shown in Figure 2-10. For this configuration, the 10 columns of the two matrix cards must be physically hard-wired together. Also note that the backplane jumpers on one of the cards must be removed in order to isolate the rows of the two cards from each other.

Mixing card types

Different types of cards can be used together to create some unique switching systems. For example, you

could have a Model 7012 matrix card installed in one slot and a Model 7011 multiplexer card installed in the other slot.

Figure 2-11 shows a possible switching system using a matrix card and a multiplexer card. The backplane jumpers for both the matrix and multiplexer cards must be installed. This allows matrix rows to be connected to multiplexer banks. On the multiplexer card, the bank-to-bank jumpers must be removed to maintain isolation between matrix rows. See the instruction manual for the Model 7011 for complete information on the multiplexer card.

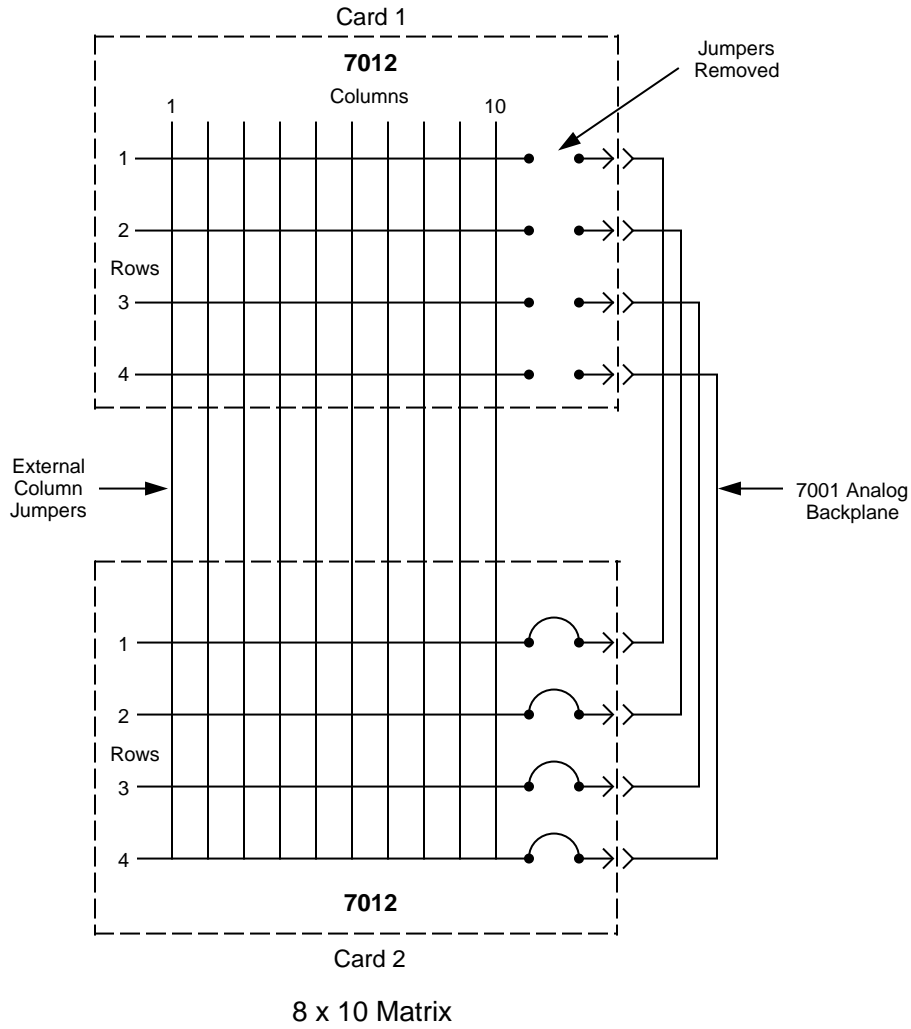
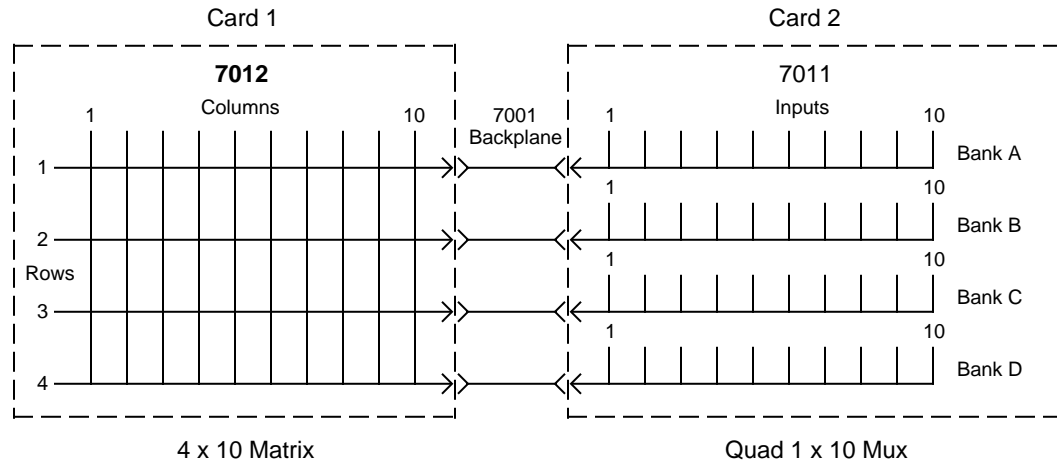

Figure 2-10
Wide matrix example (8 x 10)



Notes : 1. Models 7011 and 7012 backplane jumpers must be installed.
2. Model 7011 bank-to-bank jumpers must be removed.

Figure 2-11
Mixed card type example

2.4.2 Mainframe matrix expansion

Matrices using up to 12 matrix cards are possible by using six Model 7001 mainframes together. Using 12 Model 7012 matrix cards provides 480 cross-points.

In general, connecting the rows of a card in one mainframe to the rows of a card in a second mainframe increases the column numbers of the matrix. For example, if the rows of a 4×20 matrix in one mainframe are connected to the rows of a 4×20 matrix in a second mainframe, the resulting matrix would be 4×40 . Paragraph 3.4.3 explains how to connect a test system using two mainframes.

Partial matrix implementation

A fully implemented matrix provides a relay at each potential crosspoint. For example, a fully implemented 8×20 matrix utilizing four 4×10 matrix cards contains 160 crosspoints. A partially implemented 8×20 matrix would contain fewer crosspoints.

An example of a partially implemented 8×20 matrix is shown in Figure 2-12. The partial matrix is still considered 8×20 , but contains only 120 crosspoints using three Model 7012 matrix cards installed in two Model 7001 mainframes.

Matrix card #1 (7012 #1) installed in one of the slots of the first mainframe (7001 #1) provides a 4×10 matrix. The other slot of the first mainframe should be left empty. If another switching card is left in that slot, make sure it is isolated from the analog backplane (i.e. backplane jumpers removed). The two matrix cards (7012 #2 and #3) installed in the second mainframe (7001 #2) are configured as an 8×10 matrix as explained in paragraph 2.4.2 (Wide Matrix Expansion). Keep in mind that the rows of card #2 must be isolated from the rows of card #3. This is accomplished by removing the jumpers on one of the two cards. Finally, the partially implemented 8×20 matrix is realized by externally hard-wiring the rows of card #1 to the rows of card #2.

An obvious advantage of a partial matrix is that fewer matrix cards are needed. Another reason to use a partial matrix is to keep specific devices from being connected directly to other devices. For example, a source connected to rows 5, 6, 7 or 8 (Figure 2-12) cannot be

connected to a column of Model 7012 #1 with one "accidental" crosspoint closure. Three specific crosspoints must be closed in order to route the source signal to a column of card #1.

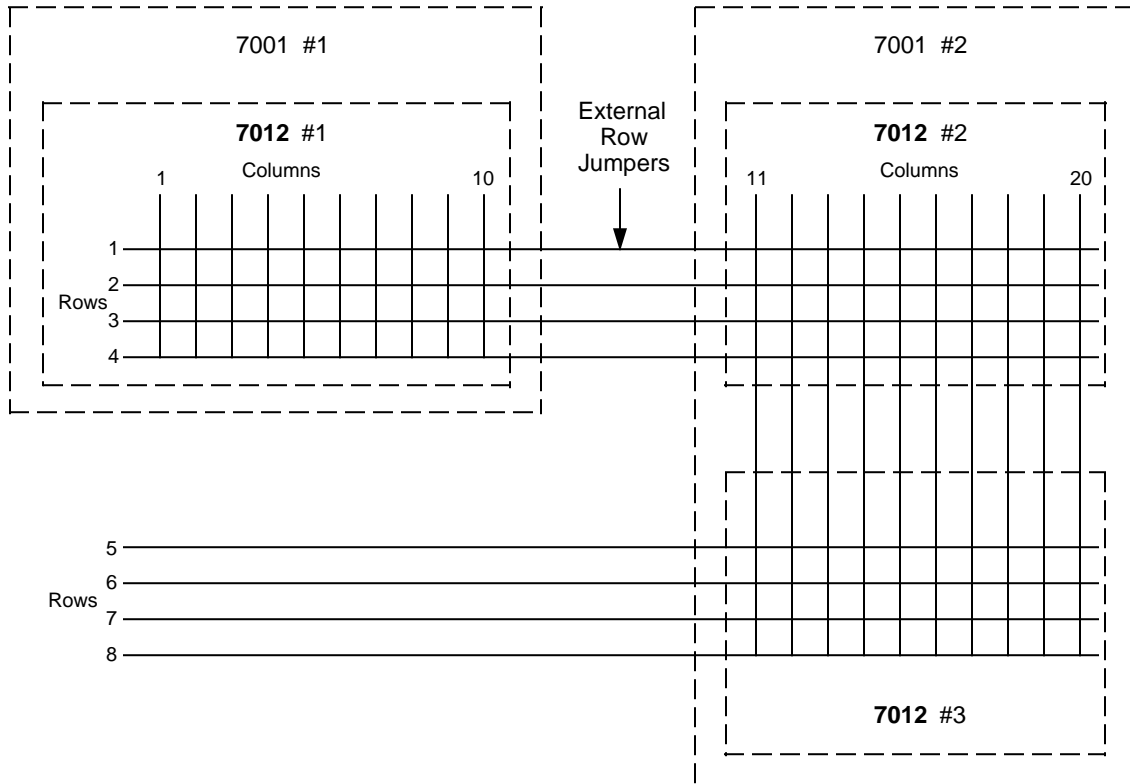

Figure 2-12
Partial matrix expansion (8 × 20)

3

Card Connections & Installation

3.1 Introduction

WARNING

The procedures in this section are intended only for qualified service personnel. Do not perform these procedures unless qualified to do so. Failure to recognize and observe normal safety precautions could result in personal injury or death.

The information in this section is arranged as follows:

- 3.2 **Handling precaution:** Explains precautions that must be followed to prevent contamination to the matrix card assembly. Contamination could degrade the performance of the matrix card.
- 3.3 **Connection:** Covers the basics for connecting external circuitry to the two available connector cards for the matrix; the screw terminal connector card and the multi-pin connector card.
- 3.4 **Typical connection scheme:** Provides some typical connection schemes for single card, two-card and two-mainframe system configurations.
- 3.5 **Model 7012 installation:** Provides a procedure to install the matrix card assembly in the Model 7001 mainframe.

3.2 Handling precautions

To maintain high impedance isolation, care should be taken when handling the relay card to avoid contamination from such foreign materials as body oils. Such contamination can substantially lower leakage resistances, thus degrading performance.

To avoid possible contamination, always grasp the relay and connector cards by the side edges or shields. Do not touch the board surfaces or components. On connectors, do not touch areas adjacent to the electrical contacts. Dirt build-up over a period of time is another possible source of contamination. To avoid this problem, operate the mainframe and matrix card in a clean environment.

If a card becomes contaminated, it should be thoroughly cleaned as explained in paragraph 5.2.

3.3 Connections

This paragraph provides the basic information needed to connect your external test circuitry to the matrix. It includes the removal/installation of the backplane row jumpers on the relay card, and detailed information on the two available connector cards.

WARNING

The following connection information is intended to be used by qualified service personnel. Failure to recognize and observe standard safety precautions could result in personal injury or death.

3.3.1 Backplane row jumpers

The Model 7001 mainframe has an analog backplane that allows the rows of a Model 7012 matrix to be internally connected to a compatible switching card installed in the other slot (see paragraph 2.4.1 for details).

The backplane row jumpers for the matrix card assembly are located on the relay card as shown in Figure 3-1. The card is shipped from the factory with the jumpers installed.

Jumper removal

Perform the following steps to remove backplane row jumpers:

1. If mated together, separate the relay card from the connector card by removing the mounting screw and then pulling the two cards away from each other. Remember to only handle the cards by the edges and shields to avoid contamination.
2. Use Figure 3-1 to locate the jumper(s) that are to be removed.
3. It is not necessary to physically remove the jumpers from the PC board. Using a pair of wire cutters, cut one lead of each jumper.

Jumper installation

Referring to Figure 3-1 for jumper locations, perform the following steps to install backplane row jumpers:

1. If mated together, separate the relay card from the connector card by removing the mounting screw and then pulling the two cards away from each other. Remember to only handle the cards by the edges and shields to avoid contamination.

2. Physically remove a cut jumper by unsoldering it from the PC board.
3. Install a new #22 AWG jumper wire (Keithley P/N J-15) and solder it to the PC board.
4. Remove the solder flux from the PC board. The cleaning procedure is explained in paragraph 5.2.

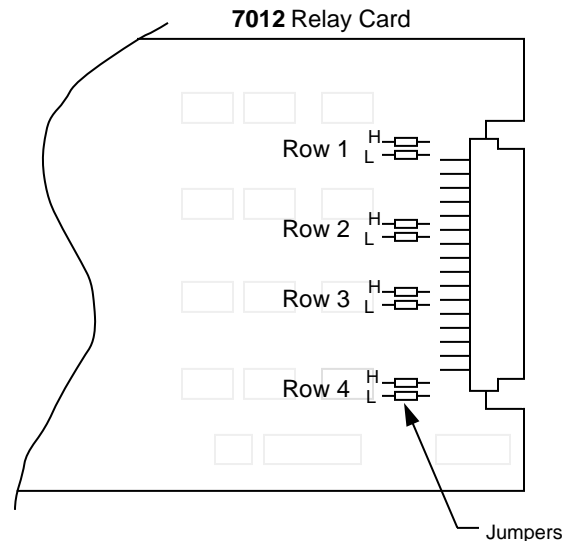

Figure 3-1
Backplane row jumpers

3.3.2 Screw terminal connector card

The screw terminal connector card is shown in Figure 3-2. Connections are made directly to the screw terminals of the four terminal blocks. Each screw terminal will accommodate #16-22 AWG wire.

Wiring procedure

Perform the following procedure to wire circuitry to the screw terminal connector card:

WARNING

Make sure all power is off and any stored energy in external circuitry is discharged.

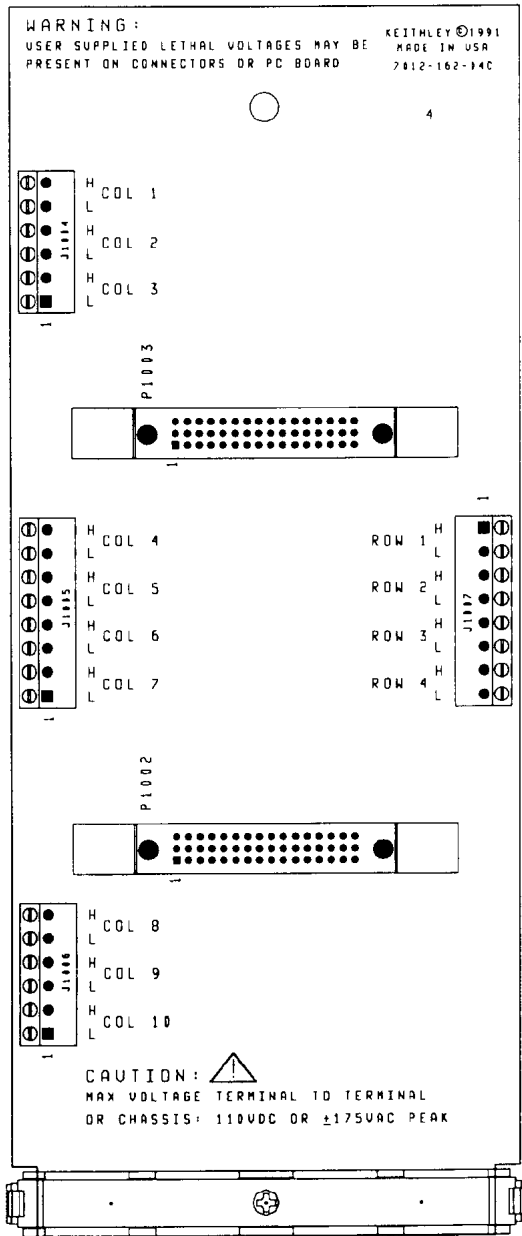

Figure 3-2
Screw terminal connector card

1. If mated together, separate the connector card from the relay card by removing the mounting screw and then pulling the two cards away from each other. Remember to only handle the cards by the edges and shields to avoid contamination.
2. Using an insulated screwdriver, connect the circuitry to the appropriate terminals. Figure 3-3 shows how Column 1 of the matrix would be connected to a DUT.
3. Referring to Figure 3-4, remove the top half of the cable clamp as follows:
 - A. Loosen the cable clamp screw enough to disengage it from the bottom half of the cable clamp.
 - B. Using your thumb and forefinger, press the retaining clips inward and, with your other hand, remove the top half of the clamp.
4. Route wires under wire guide/connector shim.
5. Route the wires through the bottom half of the cable clamp.
6. Replace the top half of the clamp. It simply snaps onto the bottom half of the clamp. Tighten the cable clamp screw. The clamp serves as a strain relief for terminal block wires.
7. Mate the connector card to the relay card. The Model 7012 is now ready to be installed in the Model 7001 mainframe. See paragraph 3.5 for details.

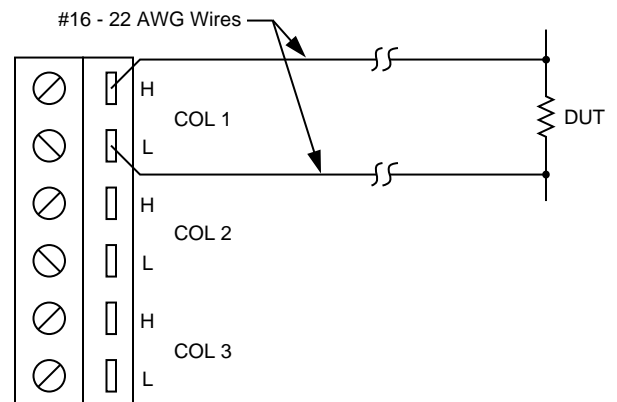

Figure 3-3
Typical terminal block connections

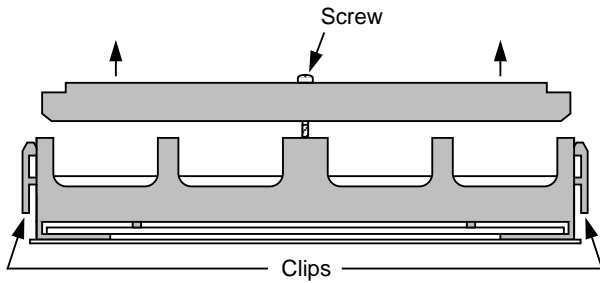

Figure 3-4
Cable clamp for screw terminal connector card

3.3.3 Multi-pin (mass termination) connector card

Since connections to external circuitry are made at the 96-pin male DIN bulkhead connector, there is no need to separate the connector card from the relay card. If the connector card is separated from the relay card, carefully mate them together. Make sure to handle the cards by the edges and shields to avoid contamination.

Terminal identification for the DIN connector of the multi-pin connector card is provided by Figure 3-5. This connector will mate to a 96-pin female DIN connector.

Keithley has a variety of cable and connector accessories available to accommodate connections from the connector card to test instrumentation and DUT (devices under test). In general, these accessories, which are summarized in Table 3-1, utilize a round cable assembly for connections.

Table 3-1
Mass termination accessories

Model	Description
7011-KIT-R	96-pin female DIN connector and housing for round cable.
7011-MTC-2	Two-meter round cable assembly terminated with a 96-pin female DIN connector on each end.
7011-MTR	96-pin male DIN bulkhead connector.

Pins of the Model 7012-C mass termination connector can be identified in one of three ways:

1. Matrix row (1-4) or column (1-10).
2. Connector designation, consisting of rows a-c and columns 1-32.
3. Schematic and component layout designation (1-96).

The following pinout diagrams show the correspondence between these arrangements:

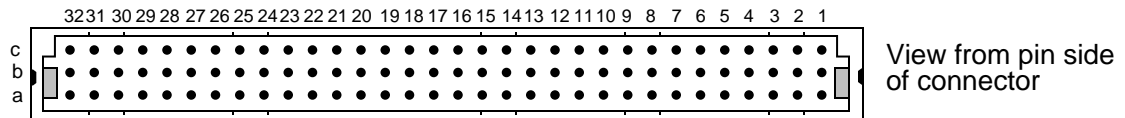

Matrix Terminal		Connector Desig. 1a-32c	Schematic Desig. 1-96	Matrix Terminal		Connector Desig. 1a-32c	Schematic Desig. 1-96
Row 1	HI	8c	72	Col 1	HI	32c	96
	LO	8b	40		LO	32b	64
Row 2	HI	6c	70	Col 2	HI	30c	94
	LO	6b	38		LO	30b	62
Row 3	HI	4c	68	Col 3	HI	28c	92
	LO	4b	36		LO	28b	60
Row 4	HI	2c	66	Col 4	HI	26c	90
	LO	2b	34		LO	26b	58
				Col 5	HI	24c	88
					LO	24b	56
				Col 6	HI	22c	86
					LO	22b	54
				Col 7	HI	20c	84
					LO	20b	52
				Col 8	HI	18c	82
					LO	18b	50
				Col 9	HI	16c	80
					LO	16b	48
				Col 10	HI	14c	78
					LO	14b	46

Notes:

1. Refer to the schematic for shield pins.
2. Short pins 1a to 1b on the mating connector (pins 1 and 33 on schematic) to allow the output relays on the connector card to close.

Figure 3-5
Multi-pin connector card terminal identification

Typical connection techniques

All external circuitry, such as instrumentation and DUTs, that you wish to connect to the matrix card must be terminated with a single 96-pin female DIN connector. The following connection techniques provide some guidelines and suggestions for wiring your circuitry.

WARNING

Before beginning any wiring procedures, make sure all power is off and any stored energy in external circuitry is discharged.

NOTE

It is recommended that external circuitry be connected (plugged in) after the Model 7012 assembly is installed in the Model 7001 mainframe and with the 7001 power off. Installation is covered in paragraph 3.5.

Output relays— The multi-pin connector card uses a relay for each of the four output banks. These output relays are normally open to prevent any hazardous voltages (via the mainframe backplane) from appearing on the pins of the male DIN connector. The output relays will only close when the Model 7011-MTC-2 cable assembly is connected to card. If building your own cable assembly, you must make sure that it shorts pins 1a to 1b of the card connector (Figure 3-8) when it is mated to the card. Shorting pins 1a to 1b allows the output relays to close.

Round cable assemblies — Figure 3-6 shows typical round cable connection techniques using accessories available from Keithley.

In Figure 3-6A, connections are accomplished using a Model 7011-MTC-2 cable and a Model 7011-MTR bulkhead connector. The two-meter round cable is terminated with a 96-pin female DIN connector at each end. This cable mates directly to the multi-pin connector card and to the bulkhead connector. The bulkhead connector has solder cups to allow direct connection to instrumentation and DUT. Figure 3-7 provides pinout for the bulkhead connector. The view shown is from the solder cup end of the connector.

In Figure 3-6B, connections are accomplished using a Model 7011-MTC-2 cable assembly that is cut in half. The 96-pin female DIN connector on one end of the cable mates directly to the multi-pin connector card. The unterminated end of the cable is wired directly to instrumentation and DUT. The other half of the cable assembly could be used for a second switching card.

In Figure 3-6C, connections are accomplished using a custom-built cable assembly that consists of a Model 7011-KIT-R connector and a suitable round cable. Hitachi cable p/n N2807-P/D-50TAB is a 50-conductor round cable. Two of these cables can be used to provide 100 conductors. The connector has solder cups to accommodate the individual wires of the unterminated cable. Figure 3-8 provides an exploded view of the connector assembly and shows how the cable is connected. The connector end of the resultant cable assembly mates directly to the multi-pin connector card. The unterminated end of the cable assembly is wired directly to instrumentation and DUT.

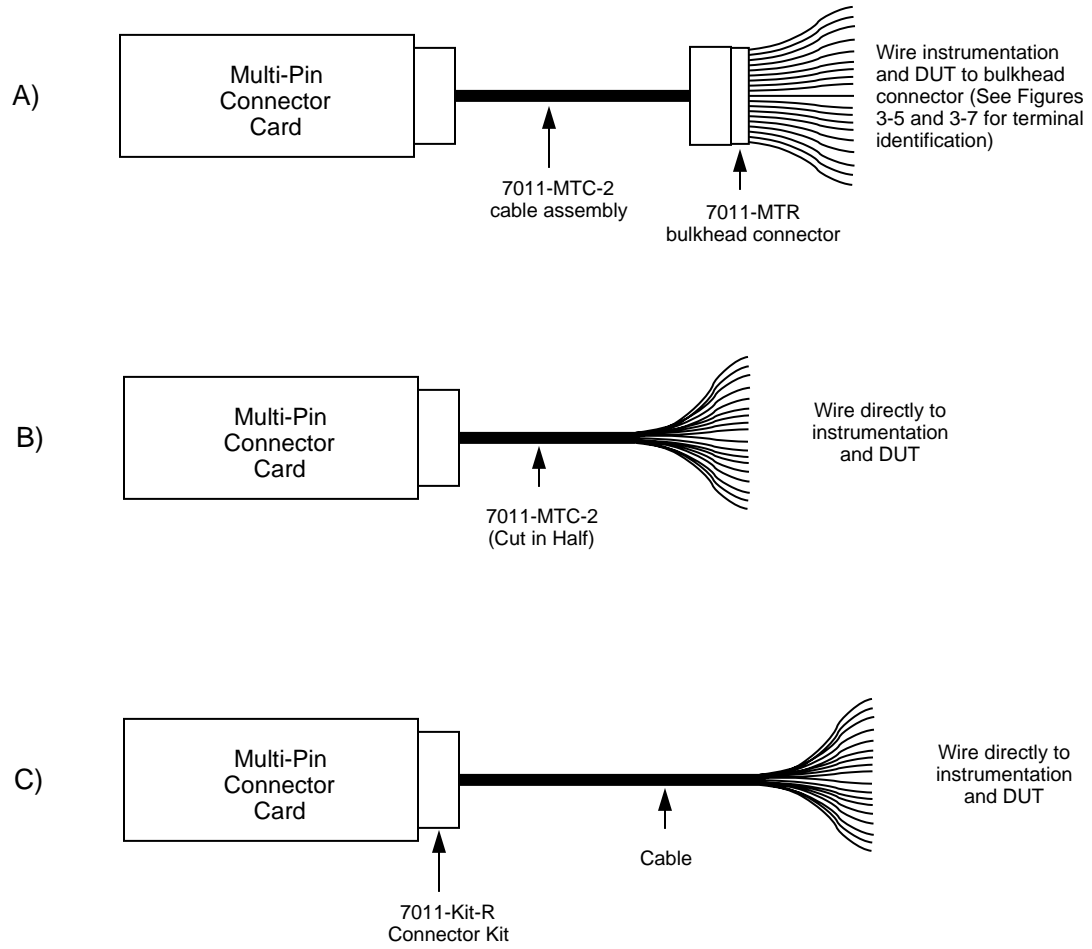

Notes: Figure 3-8 provides an exploded view showing how the connector (with cable) is assembled.

Cable Hitachi p/n N2807-P/D-50TAB is a 50-conductor cable. Two of these cables can be used to supply 100 conductors.

Figure 3-6
Typical round cable connection techniques

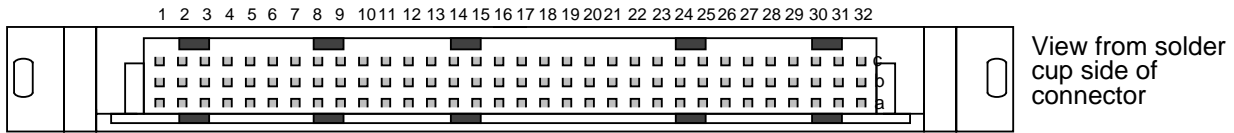

Note : See Figure 3-5 for terminal identification.

Figure 3-7
Model 7011-MTR connector pinout

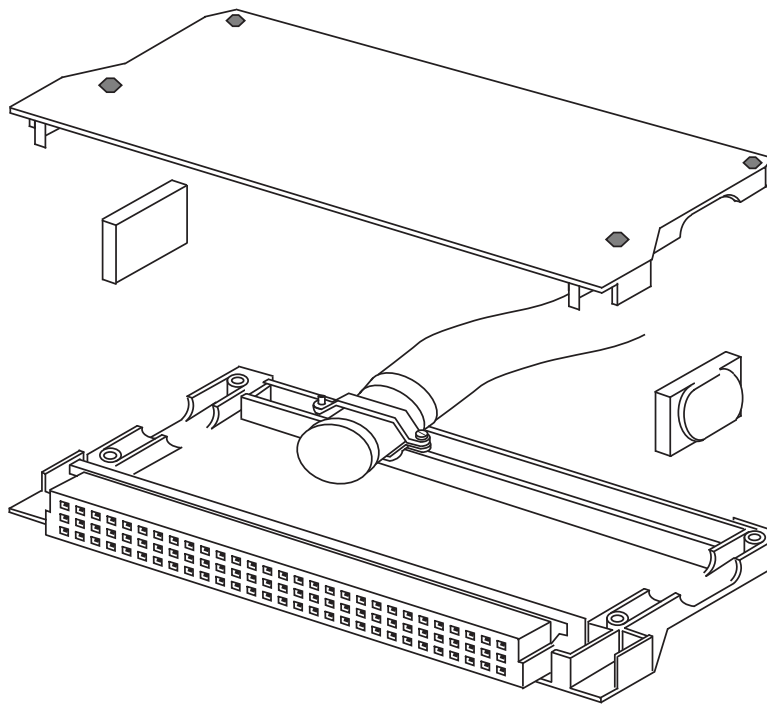

Figure 3-8
Model 7011-KIT-R (with cable) assembly

3.4 Typical connection schemes

The following information provides some typical connection schemes for single card, two-card, and two-mainframe system configurations. Connection schemes for the multi-pin connector card use some of the techniques presented in paragraph 3.3.2. Keep in mind that these are only examples to demonstrate various ways to wire a test system. Connection details for both connector cards (multi-pin and screw terminal connector cards) are provided in paragraph 3.3.

3.4.1 Single card system

Figure 3-9 shows how external connections can be made to a single card system that uses the multi-pin connector card. Instrumentation and DUT are hard-wired to the Model 7011-MTR male bulkhead connector. This connector has solder cups that will accept wire size up to #24 AWG. The test system is connected to the matrix using the Model 7011-MTC-2 round cable assembly. This cable mates directly to both the external bulkhead connector and the Model 7012-C matrix card assembly. Notice that the bulkhead connector is shown mounted to a fixture to help keep the cabling stable during the test.

The single card system in Figure 3-10 is identical to the system in the previous illustration, except for the connection scheme. The system in Figure 3-10 uses the terminal block connector card. With this card, single conductor connections are made directly from the terminal blocks of the connector card to instrumentation and DUT.

When using a single card system, make sure that the card remains electrically isolated from any other

switching cards. There are several ways to ensure isolation for a single card in the Model 7001 mainframe:

1. Vacate the other mainframe slot. If there is a Model 701X card installed in the other slot, remove it.
2. Remove the backplane jumpers on the matrix card. This will disconnect the card from the analog backplane of the mainframe.
3. Remove the backplane jumpers from the switching card installed in the other slot.

3.4.2 Two-card system

Both Figure 3-11 and Figure 3-12 show a system using two matrix cards installed in one Model 7001 mainframe to configure a 4×20 test matrix. In both these connection schemes, row connections of the two matrix cards are accomplished internally through the backplane of the Model 7001 mainframe. To connect rows internally, the backplane row jumpers of both matrix cards must be installed.

Figure 3-11 shows how external connections can be made for the multi-pin connector cards. In this example, a single Model 7011-MTC-2 round cable assembly is cut in half to provide two cables, each of which is unterminated at one end. The unterminated ends of the two cables are hard-wired to instrumentation and DUT as shown in the drawing. The other ends of these cables mate directly to the Model 7012-C matrix card assemblies.

Figure 3-12 shows how external connections can be made for the screw terminal connector card. Single conductor connections are made directly from the screw terminals of the connector card to instrumentation and DUT.

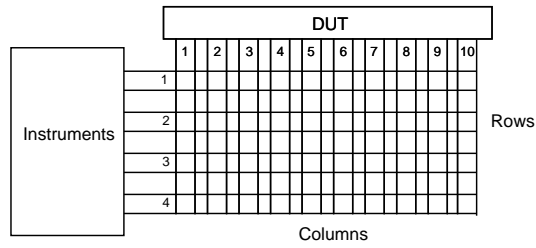
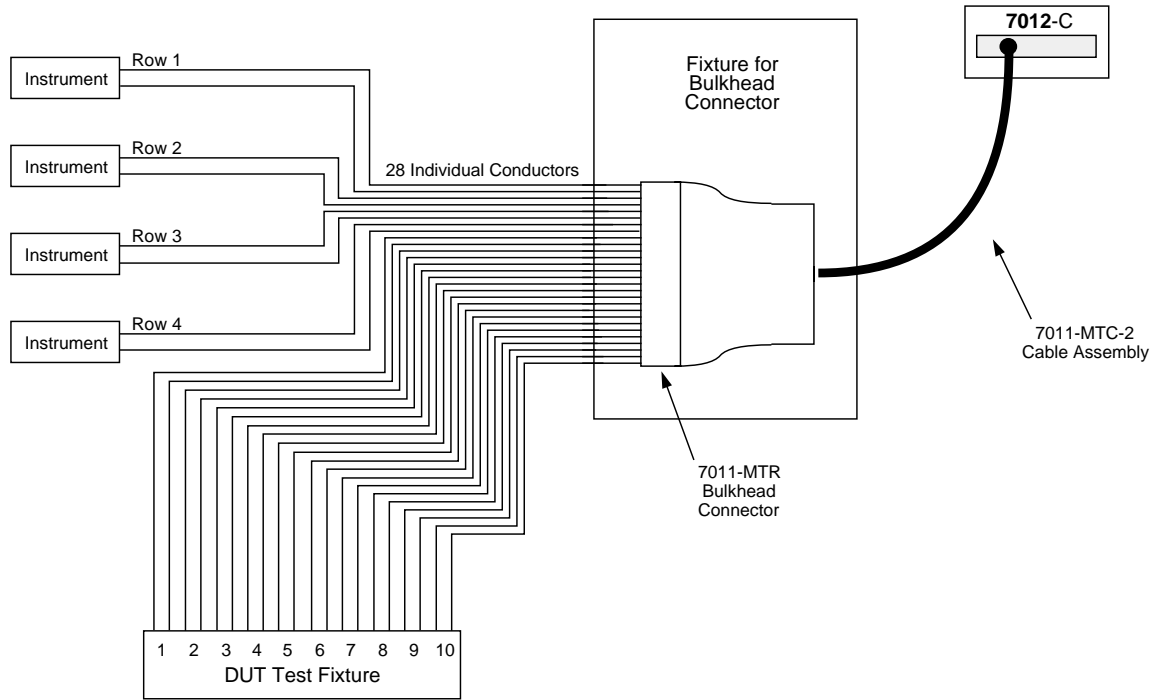

Equivalent Circuit

Figure 3-9
Single card system example (multi-pin connector card)

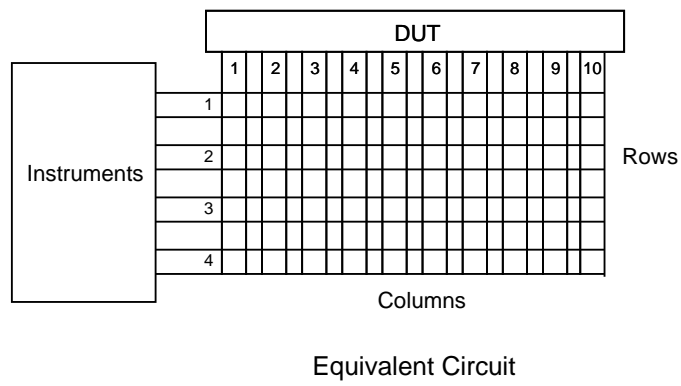
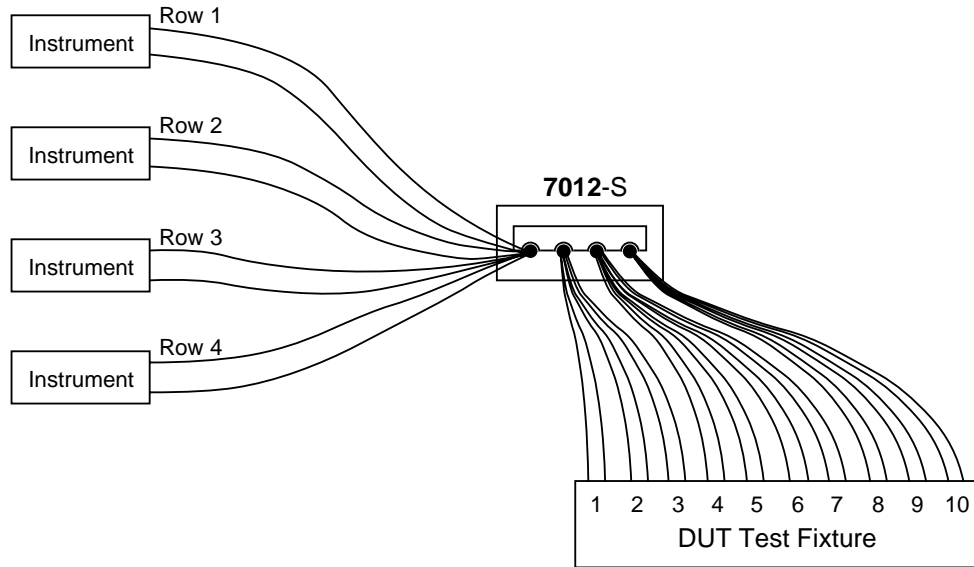

Figure 3-10
Single card system example (screw terminal connector card)

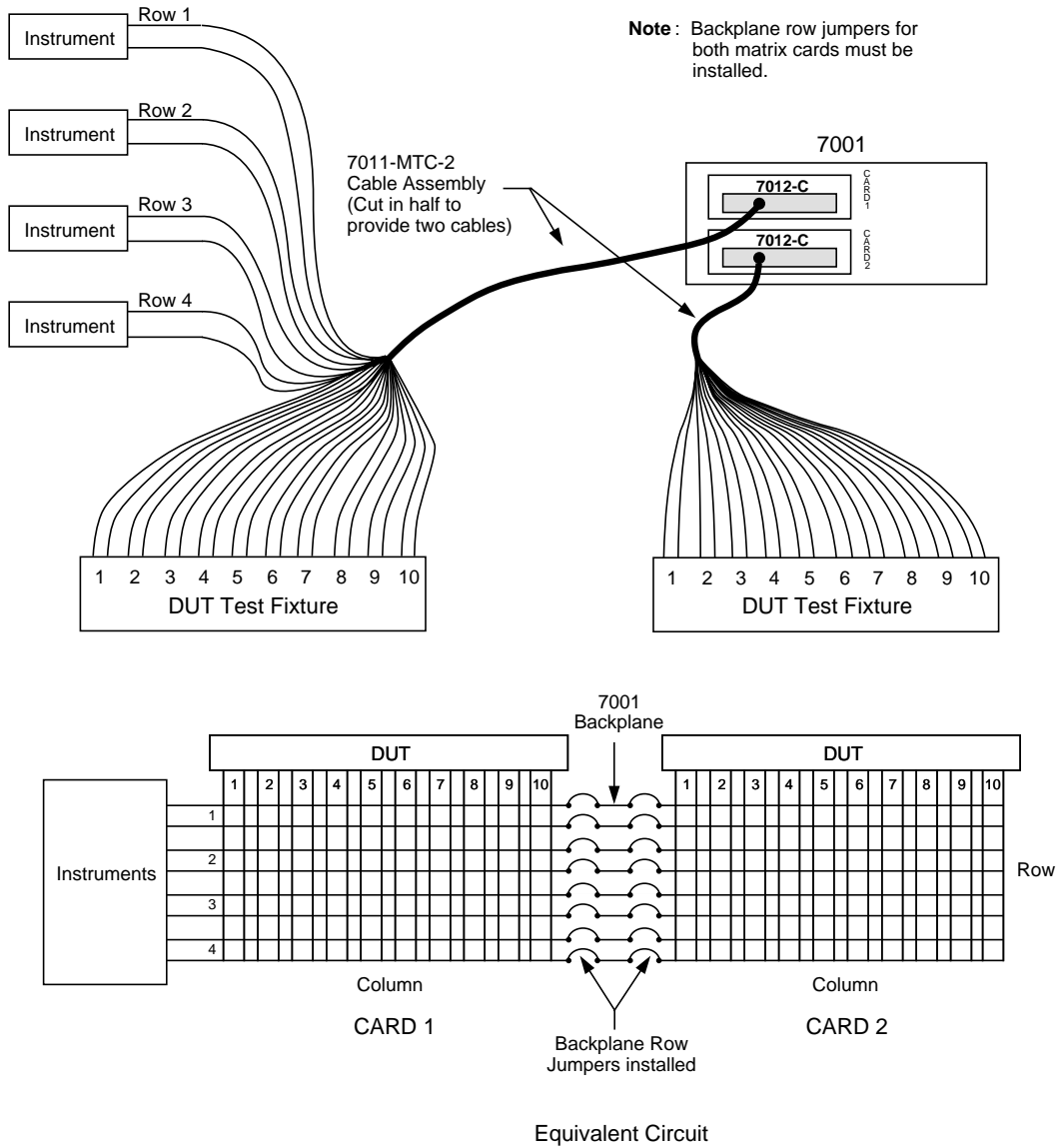

Figure 3-11
Two-card system example (multi-pin connector card)

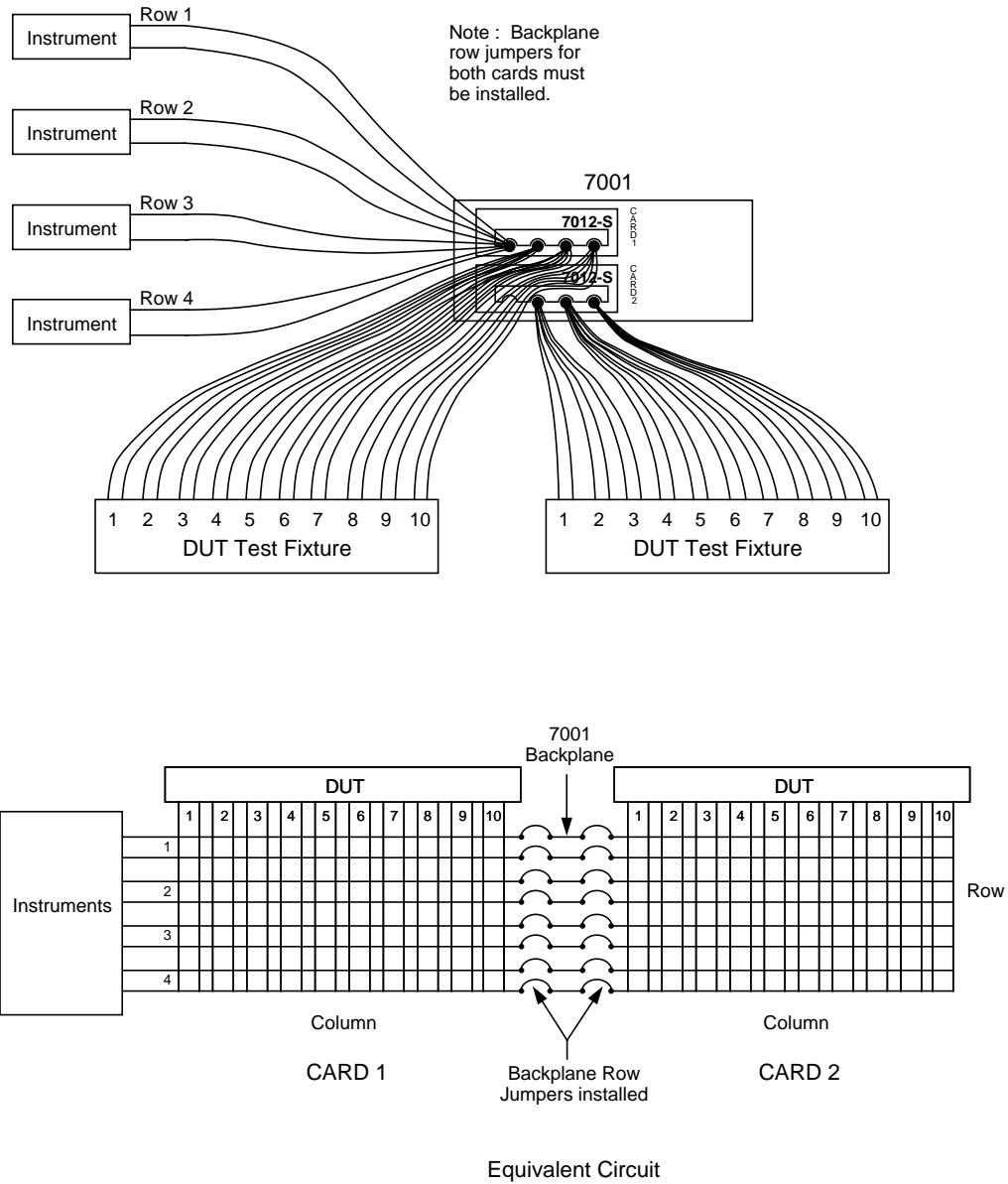

Figure 3-12
Two-card system example (screw terminal connector card)

3.4.3 Two-mainframe system

Figure 3-13 and Figure 3-14 show a system using three matrix cards in two Model 7001 mainframes to configure a 4×30 test matrix. This system is similar to the Two-card System (see previous paragraph), except that a third matrix card (installed in a second mainframe) is added.

Figure 3-13 shows the connection scheme for the multi-pin connector cards. External circuit connections to the Model 7001 #1 mainframe are identical to the ones used for the Two-card System. The third matrix card (installed in Model 7001 #2 mainframe) shows how a custom-built cable can be used to make connections to external circuitry. A suitable round cable can be terminated with a 96-pin female DIN connector (Model 7011-KIT-R) that will mate to the Model 7012-C matrix card assembly. The unterminated end of the cable is connected directly to instrumentation and DUT. Notice that the row connections for the third matrix card are made at the instruments.

Figure 3-14 shows connections for the screw terminal connector card. Single conductor connections are made directly from the screw terminals of the connector card to instrumentation and DUT

3.5 Model 7012 installation and removal

This paragraph explains how to install and remove the Model 7012 matrix card assembly from the Model 7001 mainframe.

WARNING

Installation or removal of the Model 7012 is to be performed by qualified service personnel. Failure to recognize and observe standard safety precautions could result in personal injury or death.

NOTE

If using the screw terminal connector card, make sure your external circuitry is wired to the card (as explained in paragraph 3.3.1) before installing the card assembly in the Model 7001 mainframe.

CAUTION

To prevent contamination to the matrix card that could degrade performance, only handle the card assembly by the edges and shields.

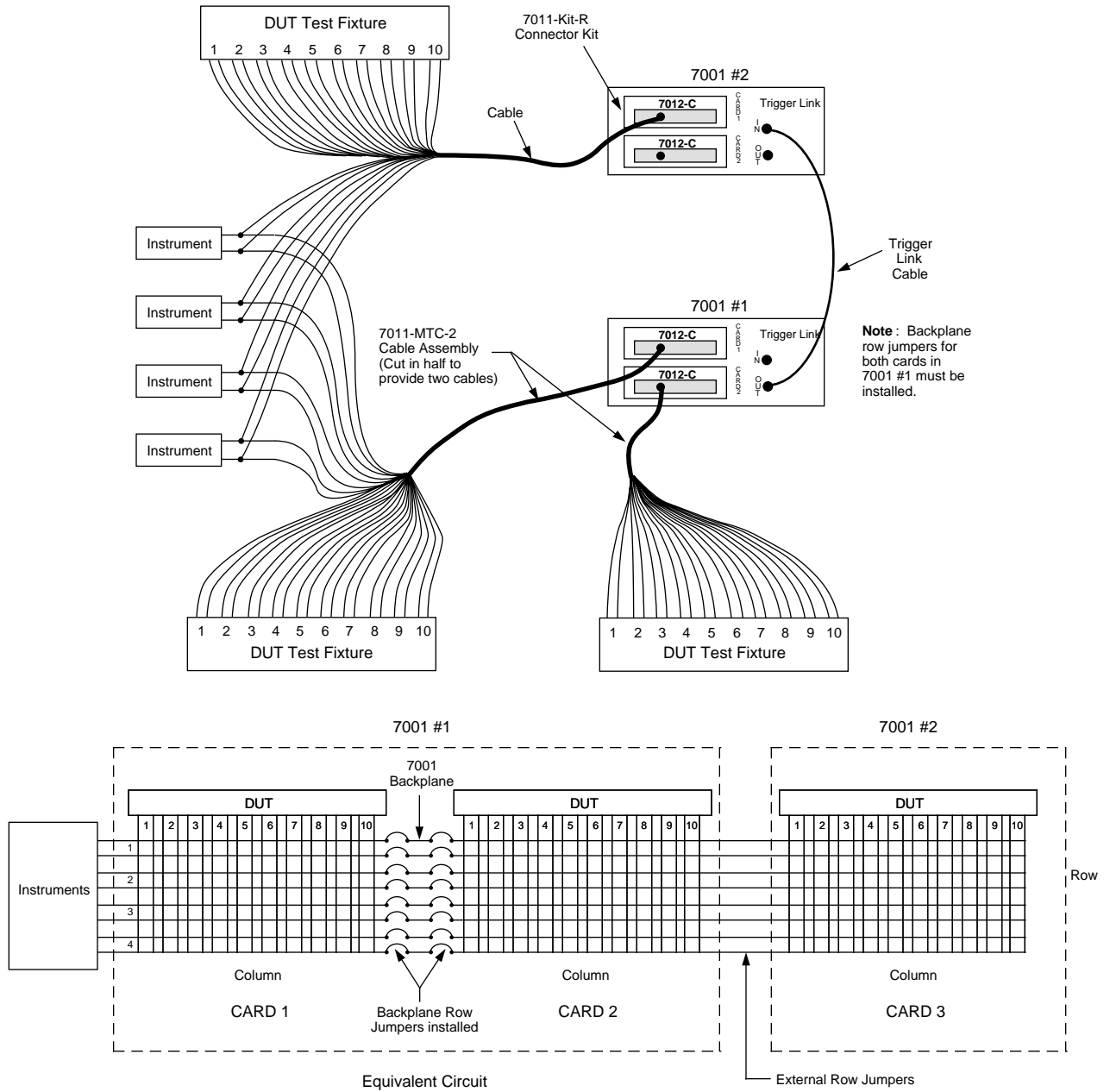

Figure 3-13
Two-mainframe system example (multi-pin connector card)

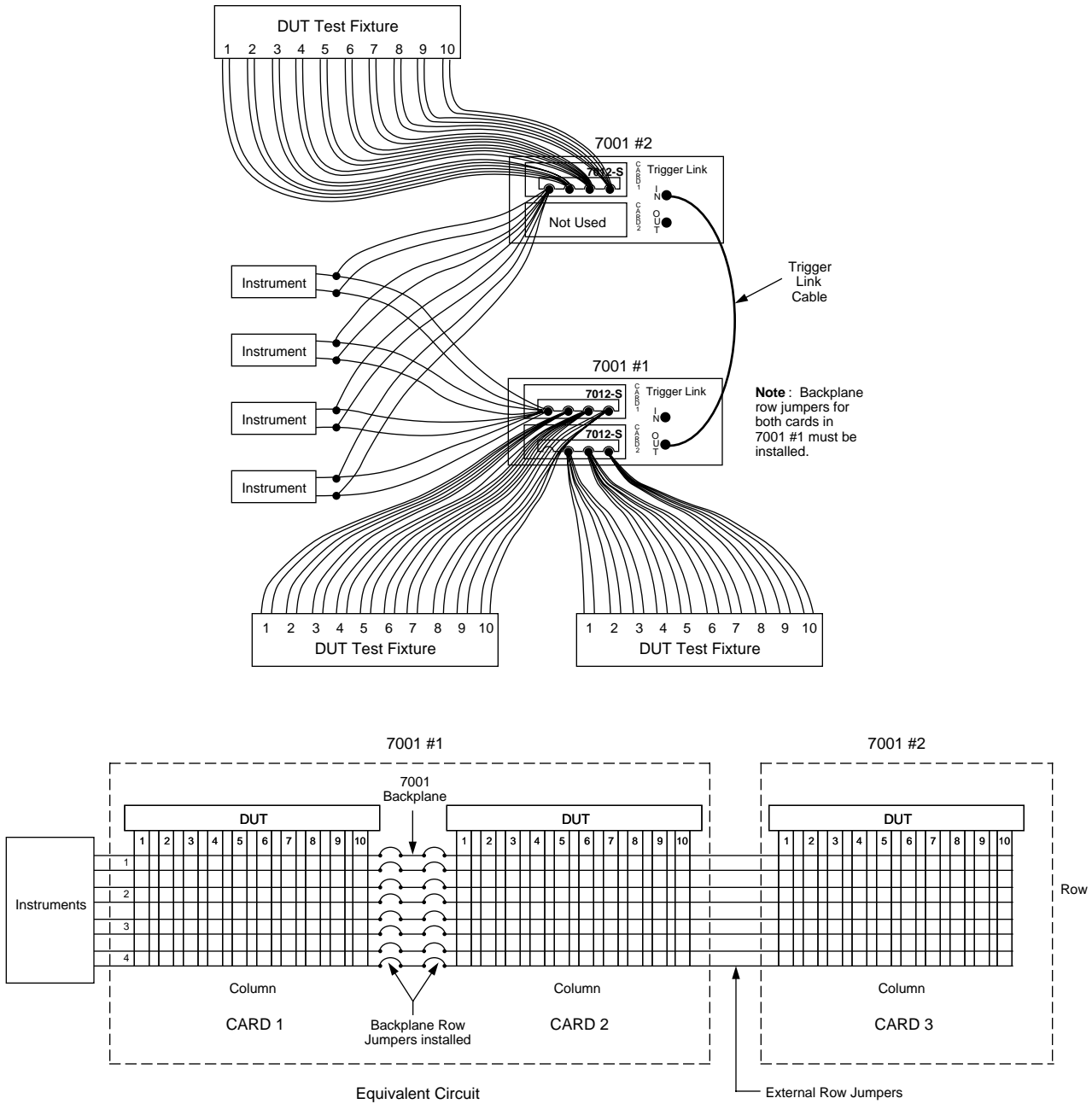

Figure 3-14
Two-mainframe system example (screw terminal connector card)

Matrix card installation

Perform the following steps to install the matrix card assembly in the Model 7001 mainframe:

WARNING

Turn off power from all instrumentation (including the Model 7001 mainframe) and disconnect their line cords. Make sure all power is removed and stored energy in external circuitry is discharged.

1. Mate the connector card to the relay card if they are separated. Install the supplied 4-40 screw at the end of the card to secure the assembly. Make sure to handle the cards by the edges and shields to prevent contamination.
2. Facing the rear panel of the Model 7001, select the slot (CARD 1 or CARD 2) that you wish to install the card in.

3. Referring to Figure 3-15 for Model 7012-S installation, or Figure 3-16 for Model 7012-C installation, feed the matrix card assembly into the desired slot such that the edges of the relay card ride in the rails.
4. With the ejector arms in the unlocked position, push the card assembly all the way into the mainframe until the arms engage into the ejector cups. Then push both arms inward to lock the card into the mainframe.
5. For the 7012-C, also install the screw shown in Figure 3-16.

Matrix card removal

To remove the matrix card assembly, first unlock it by pulling the latches outward, then pull the card assembly out of the mainframe. Remember to handle the card assembly by the edges and shields to avoid contamination that could degrade performance.

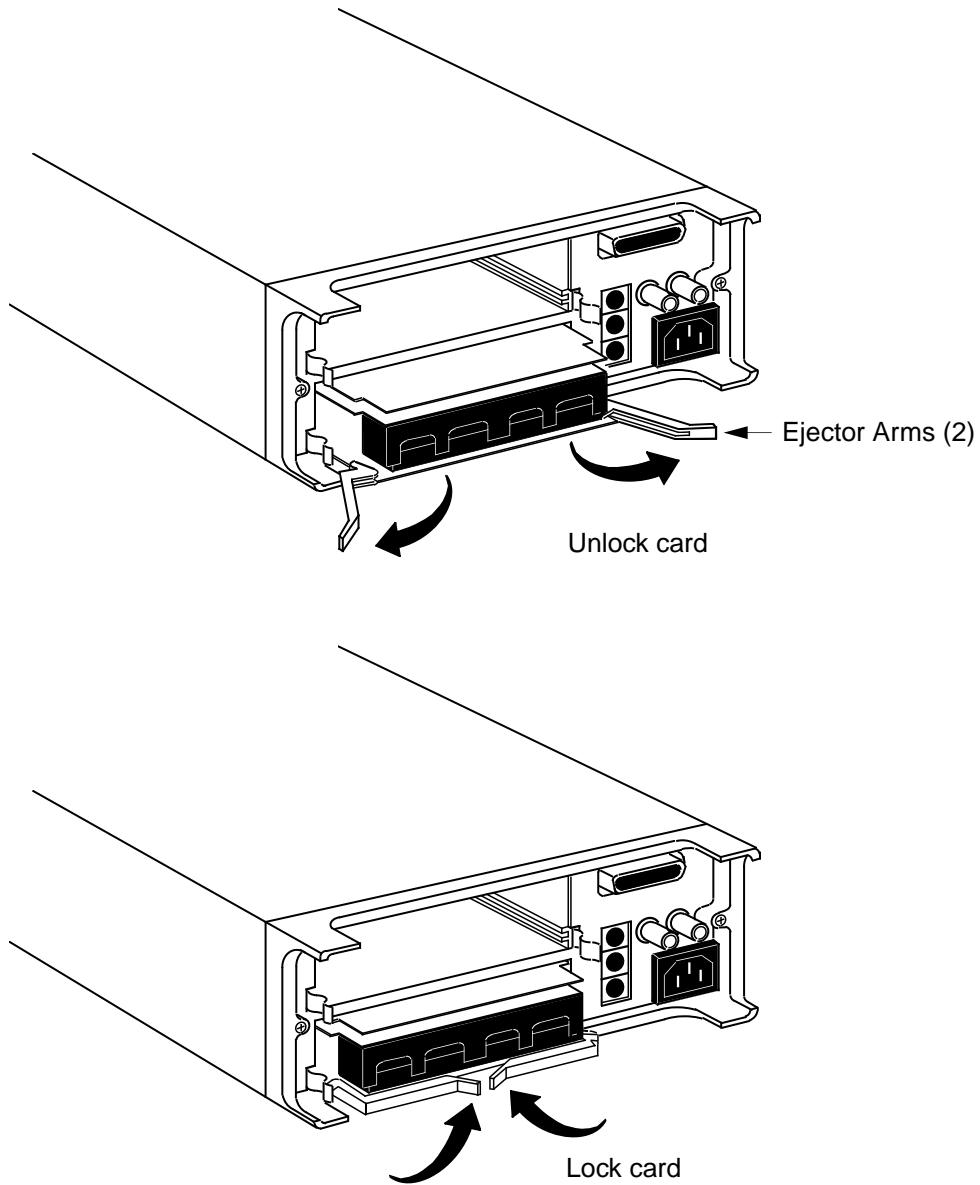

Figure 3-15
Model 7012-S card installation in Model 7001

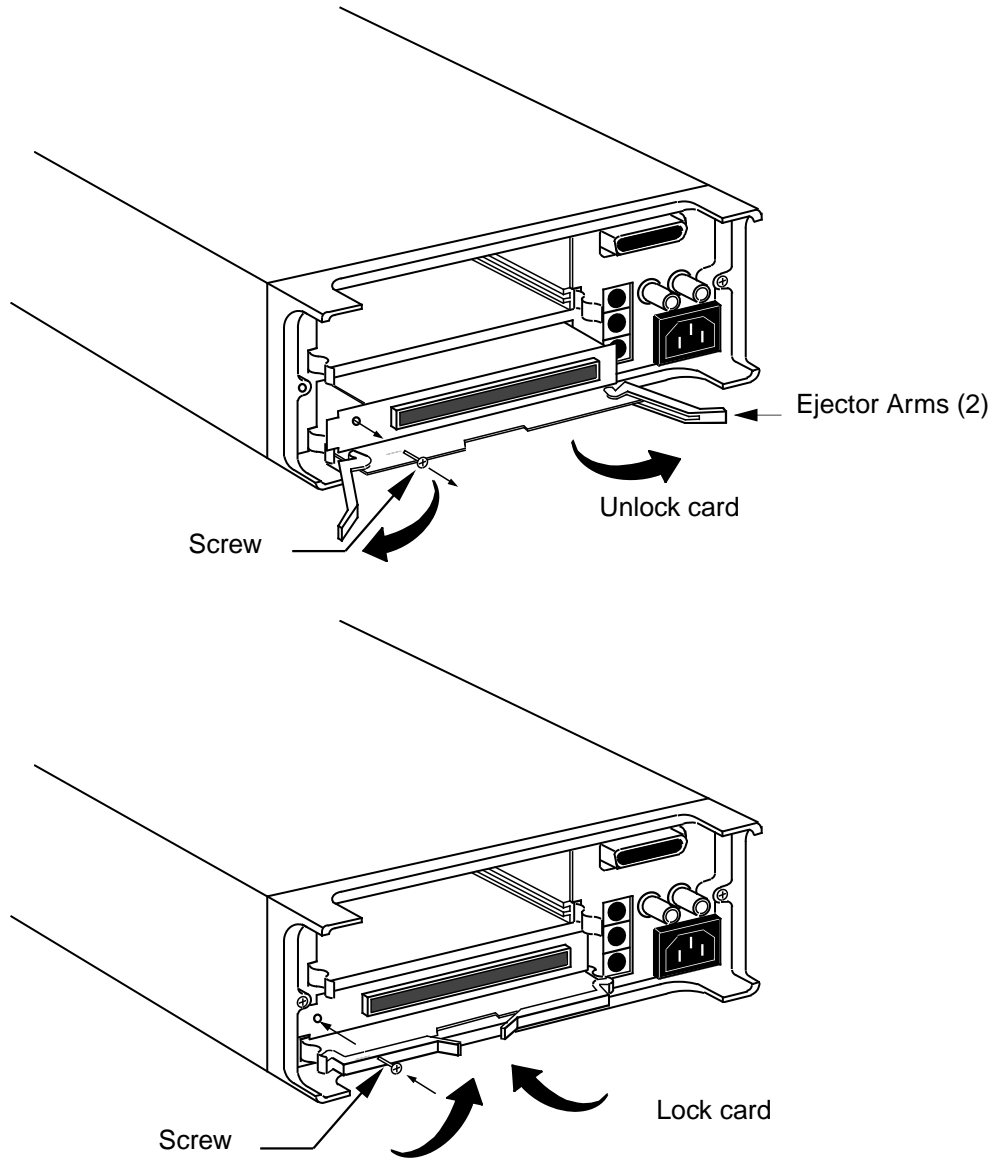

Figure 3-16
Model 7012-C card installation in Model 7001

4

Operation

4.1 Introduction

The information in this section is arranged as follows:

- 4.2 **Power limits:** Summarizes the maximum power limits of the Model 7012 matrix card assembly.
- 4.3 **Mainframe control of matrix card:** Summarizes programming steps to control the matrix card from the Model 7001 Switch System mainframe.
- 4.4 **Multiplexer switching examples:** Provides some typical applications for using the Model 7012.
- 4.5 **Measurement considerations:** Reviews a number of considerations when using the Model 7012 to make measurements.

4.2 Power limits

CAUTION

To prevent damage to the card, do not exceed the maximum signal level specifications of the card.

Maximum signal levels

To prevent overheating or damage to the relays, never exceed the following maximum signal levels:

DC signals: 110V between any two pins (terminals), 1A switched, 30VA (resistive load)

AC signals: 125V rms or 175V AC peak between any two pins (terminals), 1A switched, 60VA (resistive load)

4.3 Mainframe control of matrix card

The following information pertains to the Model 7012 matrix card. It assumes that you are familiar with the operation of the Model 7001 mainframe.

If you are not familiar with the operation of the mainframe, it is recommended that you proceed to Getting Started (Section 3) in the Model 7001 Instruction Manual after reading the following information.

4.3.1 Channel assignments

The Model 7001 has a channel status display (Figure 4-1) that provides the real-time state of each available channel. The left portion of the display is for slot 1 (Card 1), and the right portion is for slot 2 (Card 2).

Notice that the matrix organization of the channel status display corresponds directly to the 4×10 organization of the matrix card. With a matrix card installed, the top row of the display corresponds to Row 1 of the matrix card. The 10 columns of the matrix are labeled 1 through 10 on the display. The next rows down correspond to Rows 2, 3, and 4 respectively.

Matrix organization of the channel status display corresponds to the 4×10 organization of the matrix card

as shown in Figure 4-2. Each channel is designated as a row / column crosspoint.

To control the matrix card from the mainframe, each matrix crosspoint must have a unique CHANNEL assignment. The CHANNEL assignments for the matrix card are provided in Figure 4-3. Each CHANNEL assignment is made up of the slot designator (1 or 2) and the matrix crosspoint. To be consistent with Model 7001 operation, the slot designator, row and column are separated by exclamation points (!). Some examples of CHANNEL assignments:

- CHANNEL 1!1!1 = Slot 1, Row 1, Column 1
- CHANNEL 1!4!10 = Slot 1, Row 4, Column 10
- CHANNEL 2!2!9 = Slot 2, Row 2, Column 9
- CHANNEL 2!3!4 = Slot 2, Row 3, Column 4

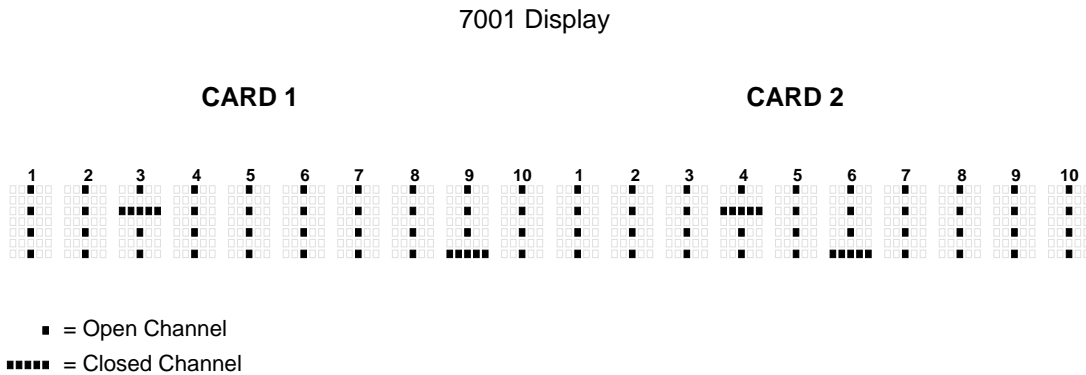

Figure 4-1
Channel status display

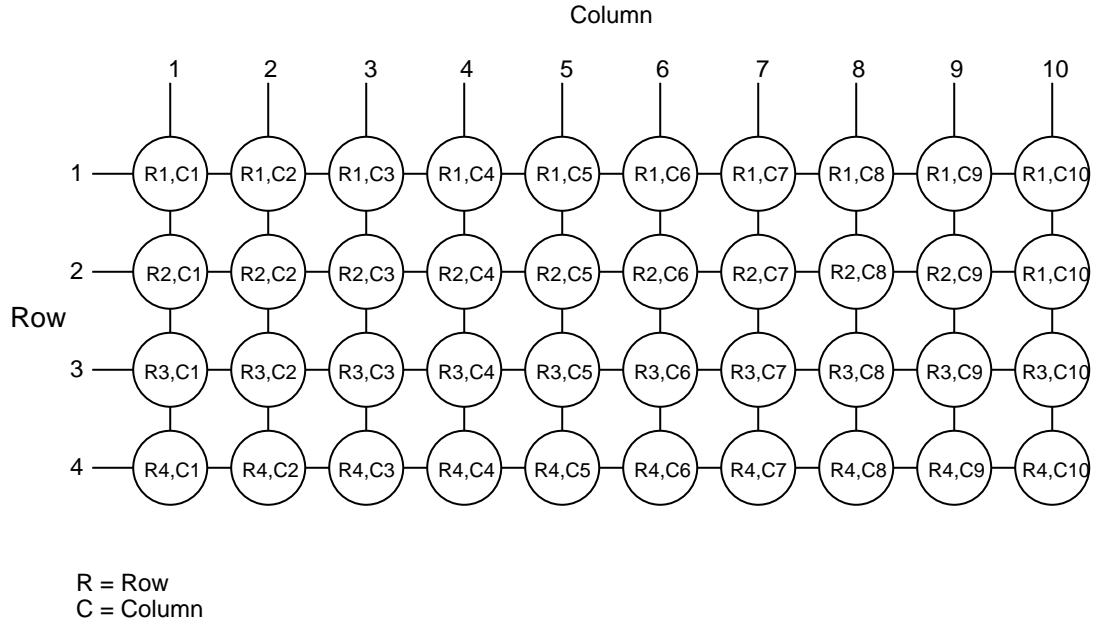
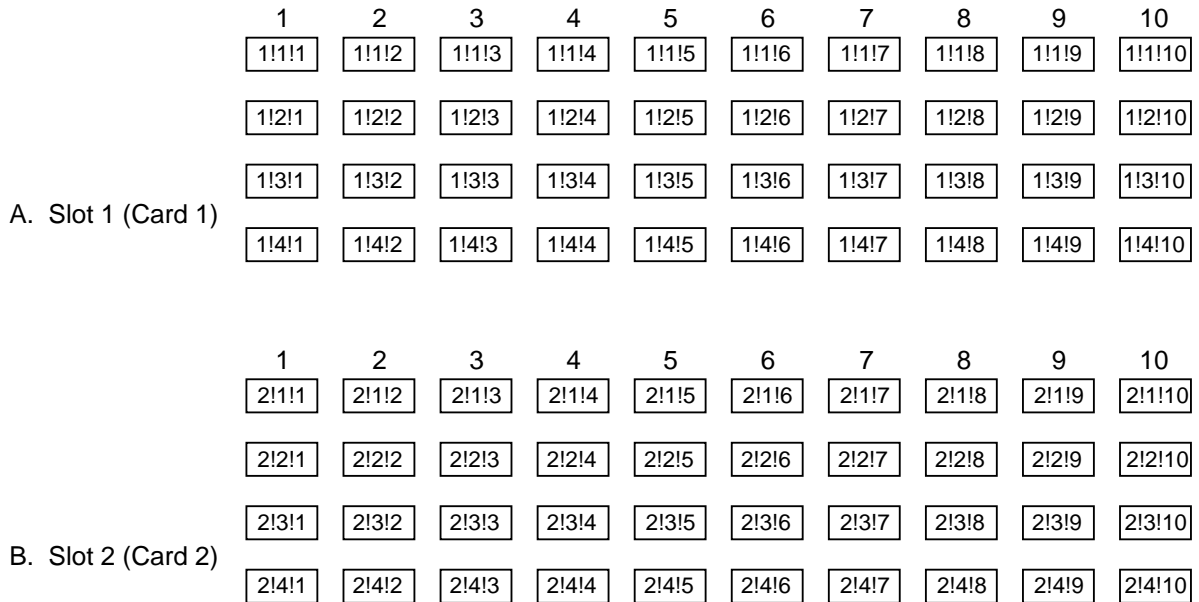

Figure 4-2
Display organization for multiplexer channels



Examples : 1!2!4 = Slot 1, Row 2, Column 4
 2!3!6 = Slot 2, Row 3, Column 6

Figure 4-3
Model 7012 programming channel assignments

4.3.2 Front panel control

Closing and opening channels

A matrix crosspoint is closed from the front panel by simply keying in the channel assignment and pressing CLOSE. For example, to close Row 3, Column 4 crosspoint of a matrix card installed in slot 2, key in the following channel list and press CLOSE:

```
SELECT CHANNELS 2!3!4
```

The above closed channel can be opened by pressing OPEN or OPEN ALL. The OPEN key opens only the channels specified in the channel list, and OPEN ALL opens all channels.

The following display is an example of a channel list that consists of several channels:

```
SELECT CHANNELS 2!1!1, 2!1!3, 2!2!1-2!2!5
```

Notice that channel entries are separated by commas (.). A comma is inserted by pressing ENTER or the right cursor key (▷). The channel range is specified by using the hyphen (-) key to separate the range limits. Pressing CLOSE will close all the channels specified in the channel list. Pressing OPEN (or OPEN ALL) will open the channels.

Scanning channels

Matrix crosspoints are scanned by creating a scan list and configuring the Model 7001 to perform a scan. The scan list is created in the same manner as a channel list (see Closing and Opening Channels). However, the scan list is specified from the "SCAN CHANNEL" display mode. (The SCAN LIST key toggles between the channel list and scan list.) The following shows an example of a scan list:

```
SCAN CHANNELS 2!1!1, 2!1!3, 2!2!1-2!2!5
```

When a scan is performed, the channels specified in the scan list will be scanned in the order that they are presented in the scan list.

A manual scan can be performed by using the RESET default conditions of the Model 7001. RESET is selected from the SAVESETUP menu of the main MENU. When RESET is performed, the mainframe is configured for an infinite number of manual scans. The first press of STEP takes the mainframe out of the idle state. The next press of STEP will close the first channel specified in the scan list. Each subsequent press of STEP will select the next channel in the scan list.

4.3.3 IEEE-488 bus operation

Bus operation is demonstrated using HP BASIC 4.0. The programming statements assume that the primary address of the mainframe is 07.

Closing and opening channels

The following SCPI commands are used to close and open channels:

```
:CLOSe <list>
:OPEN <list>| ALL
```

The following statement closes channels 1!1!1, and 1!1!3 through 1!1!6:

```
OUTPUT 707; ":clos (@ 1!1!1, 1!1!3:1!1!6)"
```

Notice that the colon (:) is used to separate the range limits.

Either of the following statements will open channels 1!1!1, and 1!1!3 through 1!1!6:

```
OUTPUT 707; ":open (@ 1!1!1, 1!1!3:1!1!6)"
OUTPUT 707; ":open all"
```

Scanning channels

There are many commands associated with scanning. However, it is possible to configure a scan using as little as four commands. These commands are listed as follows:

```
*RST
:TRIGger:SEquence:COUNT:AUTO ON"
:SCAN <list>
:INIT
```

The first command resets the mainframe to a default scan configuration. The second command automatically sets the channel count to the number of channels in the scan list, the third command defines the scan list, and the fourth command takes the Model 7001 out of the idle state.

The following program will perform a single scan through all 40 channels of a multiplexer card installed in slot 1:

```
10 OUTPUT 707; "*"RST"
20 OUTPUT 707; ":trig:seq:coun:auto on"
30 OUTPUT 707; ":scan (@ 1!1!1:1!4!10)"
40 OUTPUT 707; ":init"
50 END
```

Line 10 Selects a default configuration for the scan.
 Line 20 Sets channel count to the scan-list-length.
 Line 30 Defines the scan list.
 Line 40 Take the Model 7001 out of the idle state. The scan is configured to start as soon as this command is executed.

When the above program is run, the scan will be completed in approximately 240msec (3msec delay for each relay close and a 3msec delay for each open), which is too fast to view from the front panel. An additional relay delay can be added to the program to slow down the scan for viewing. The program is modified by adding line 25 to slow down the scan. Also, Line 5 is added to the beginning of the program to ensure that all channels are open before the scan is started.

```
5 OUTPUT 707; ":open all"
10 OUTPUT 707; "*"RST"
20 OUTPUT 707; ":trig:seq:coun:auto on"
25 OUTPUT 707; ":trig:del 0.25"
30 OUTPUT 707; ":scan (@ 1!1!1:1!4!10)"
40 OUTPUT 707; ":INIT"
50 END
```

Line 5 Opens all channels.
 Line 25 Sets a 1/4 second delay after each channel closes.

4.4 Matrix switching examples

Some applications to test thick film resistor networks and transistors are provided in the following paragraphs. These applications are intended to demonstrate the versatility of using the matrix card in test systems.

4.4.1 Thick film resistor network testing

A dedicated matrix system for testing thick film resistor networks is shown in Figure 4-4. This particular system provides two different methods to check thick films; four-wire resistance measurements, and voltage measurements using an applied voltage.

The system shown in Figure 4-4 tests two 4-element thick films, but can be expanded to test more by simply using additional Model 7012 matrix cards. The Model 7001 will accommodate two matrix cards. Daisy-chain in six Model 7001s expands the system to 12 matrix cards allowing 24 four-element thick films to be tested.

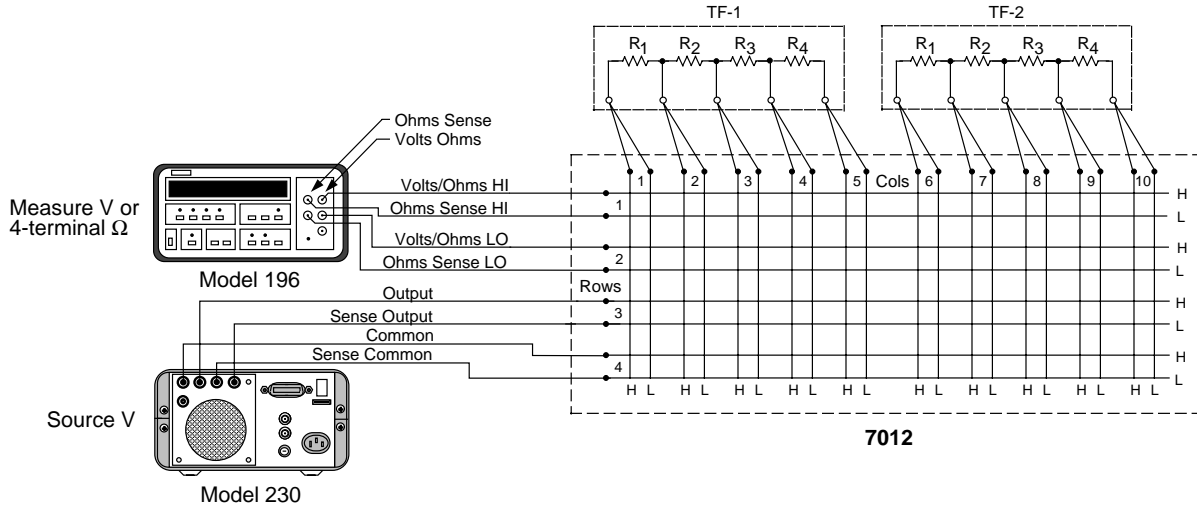

Figure 4-4
Thick film resistor network testing

Four-terminal ohms measurements

For general purpose testing, the Keithley Model 196 can be used to make four-terminal resistance measurements of each thick film. As shown in Figure 4-5, OHMS HI and OHMS SENSE HI are connected to one matrix row, and OHMS LO and OHMS SENSE LO are connected to another matrix row. With this configuration, the resistance of each resistor element and/or combined elements can be measured by closing the appropriate crosspoints. In Figure 4-5, crosspoints 1!1 (Row 1, Column 1) and 2!3 (Row 2, Column 3) are closed to measure the combined resistance of R1 and R2.

The effects of thermal EMFs generated by relay contacts and connections can be cancelled by using the offset compensated ohms feature of the Model 196. (The Model 7012 has been designed to keep relay EMF at a minimal level.) To compensate for thermal EMFs, close two crosspoints (such as 1!1!1 and 1!2!1), this will short the input of the Model 196, enable zero to cancel internal offset, and then enable offset compensated ohms.

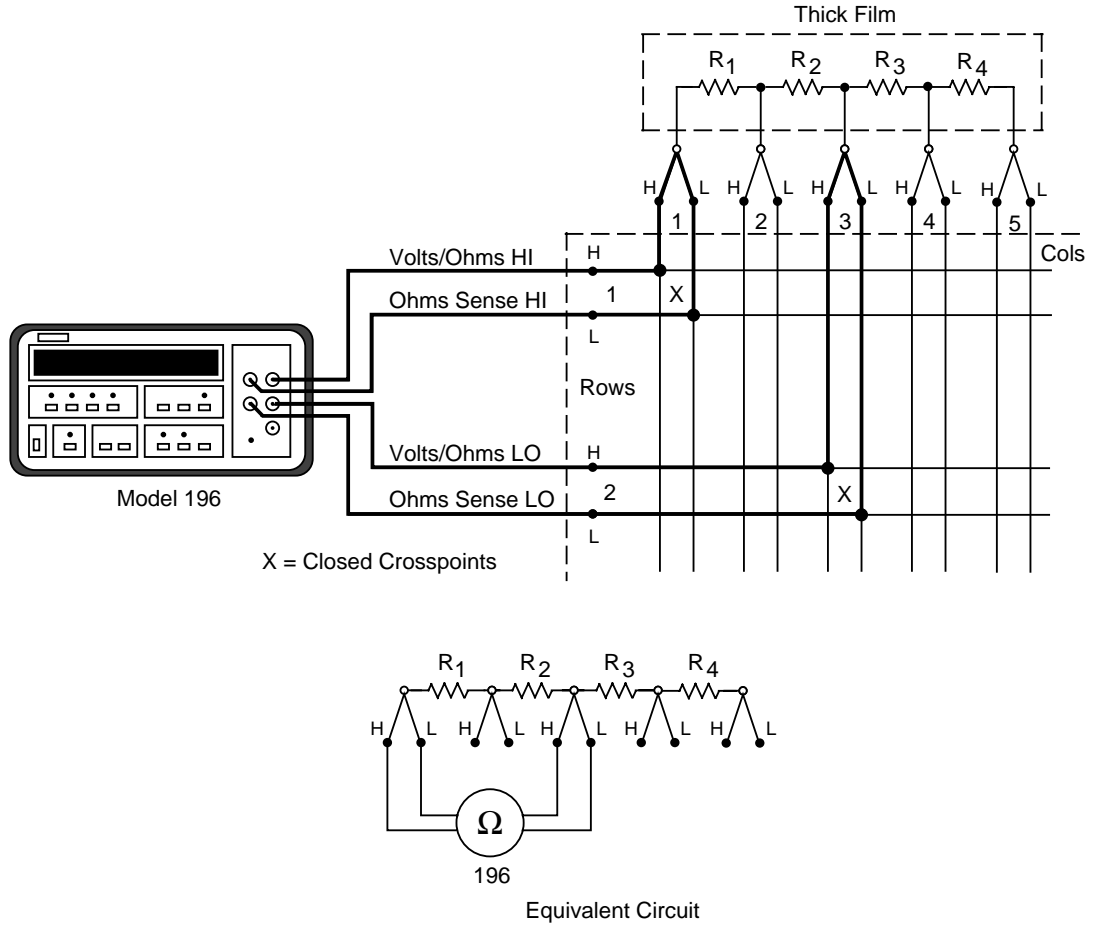

Figure 4-5
Four-terminal ohms measurements

Voltage divider checks

For thick film resistor networks that are to be used as voltage dividers, it may be desirable to test them using voltages that simulate actual operating conditions. This is a particularly useful test for resistor networks that have a voltage coefficient specification. The test system in Figure 4-4 uses a Keithley Model 230 to source voltage and the Model 196 to measure voltage.

A consideration in these checks is the effect of the Model 196 input impedance on voltage measurements. The input impedance is shunted across the resistor being measured. The resultant divider resistance is the parallel combination of the resistor under test and the input impedance. As long as the input impedance is much larger than the resistor being tested, the error introduced into the measurement will be minimal. Minimum input impedance requirements are, of course, determined by the accuracy needed in the measurement. The input impedances of the Model 196 are as follows: 300mV and 3V ranges, 1G Ω ; 30V range, 11M Ω ; 300V range, 10.1M Ω . For better input impedance requirements, the Keithley Model 617 Electrometer can be incorporated into the test system to measure voltage.

Another factor to be considered when checking low voltage dividers is thermal EMFs generated by the matrix card. (The Model 7012 has been designed to keep relay EMF at a minimal level.) A matrix card crosspoint can generate up to 5 μ V of thermal EMF. Thus, when making low voltage measurements be sure to account for this additional error.

Even though four-terminal connections are made at the Model 196 and the resistor networks, the sense leads are internally disconnected from the input of the DMM when the volts function is selected. The simplified test system is shown in Figure 4-6.

The thick film is tested by applying a voltage across the resistor network and measuring the voltage across each resistor element and/or across combined elements. In Figure 4-6, crosspoints 1!3!1 and 1!4!4 are closed to apply voltage across the network, and crosspoints 1!1!3 and 1!2!4 are closed to measure the voltage drop across R3.

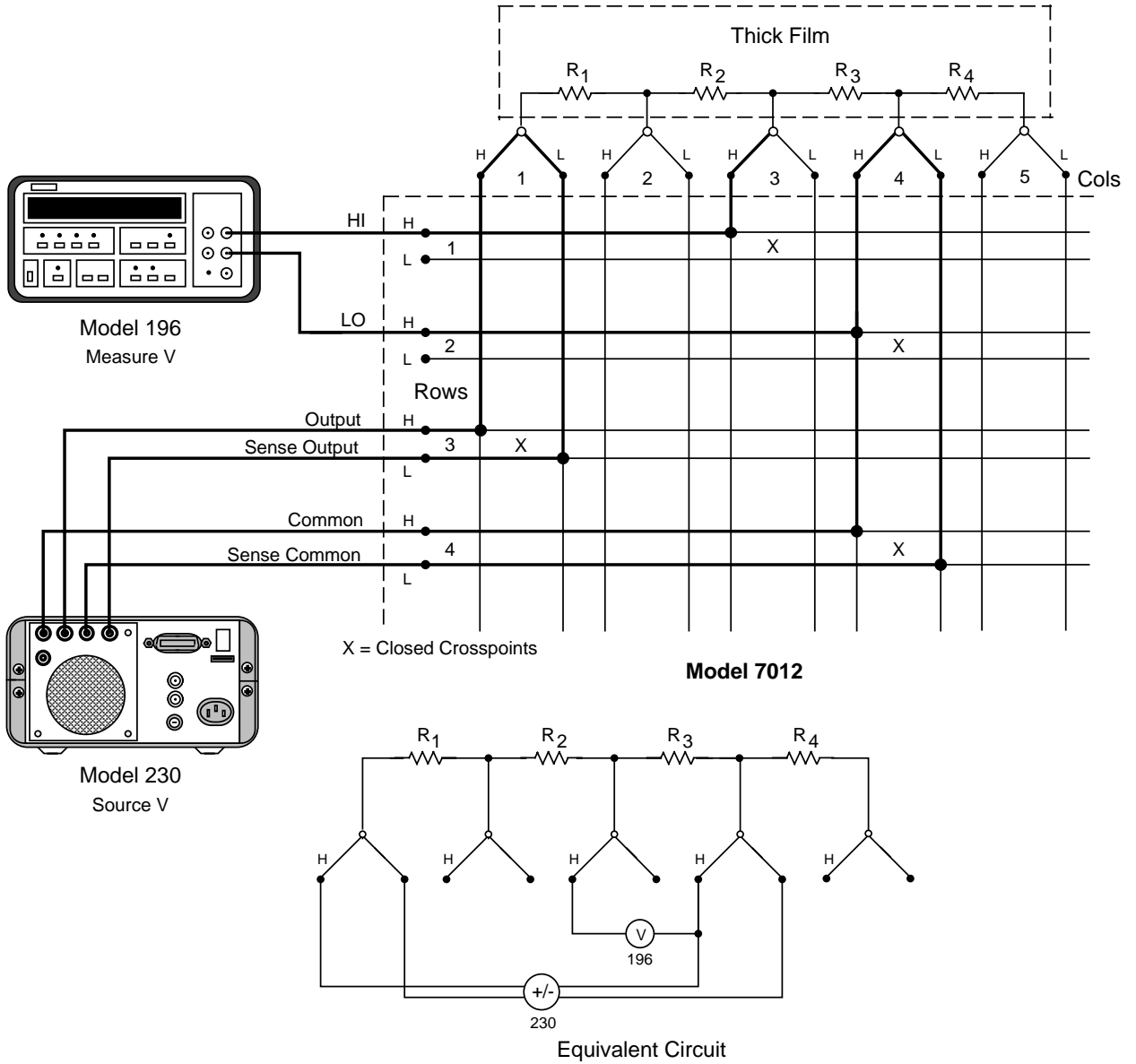

Figure 4-6
Voltage divider checks

4.4.2 Transistor testing

A matrix system for testing DC parameters of transistors is shown in Figure 4-7. This system uses two Source Measure Units (SMU). There are three SMUs available from Keithley; the Model 236 Source Measure Unit, Model 237 High Voltage Source Measure Unit and Model 238 High Current Source Measure Unit. Keep in mind that if using the Models 237 (high voltage capability) or 238 (high current capability), do not exceed the maximum signal levels of the matrix card. Maximum allowable DC signals are 110V and 1A, 30W with resistive load.

This system tests three transistors, but can be expanded to test more by simply using additional Model 7012 matrix cards. The Model 7001 will accommodate two matrix cards. Daisy-chaining six Model 7001s expands the system to 12 matrix cards allowing 36 or more transistors to be tested.

NOTE

The Model 7012 is a general purpose matrix card and cannot be used to check FETs or transistors that have high gain or low power. To test these devices, a matrix card with low offset current and high isolation characteristics must be used.

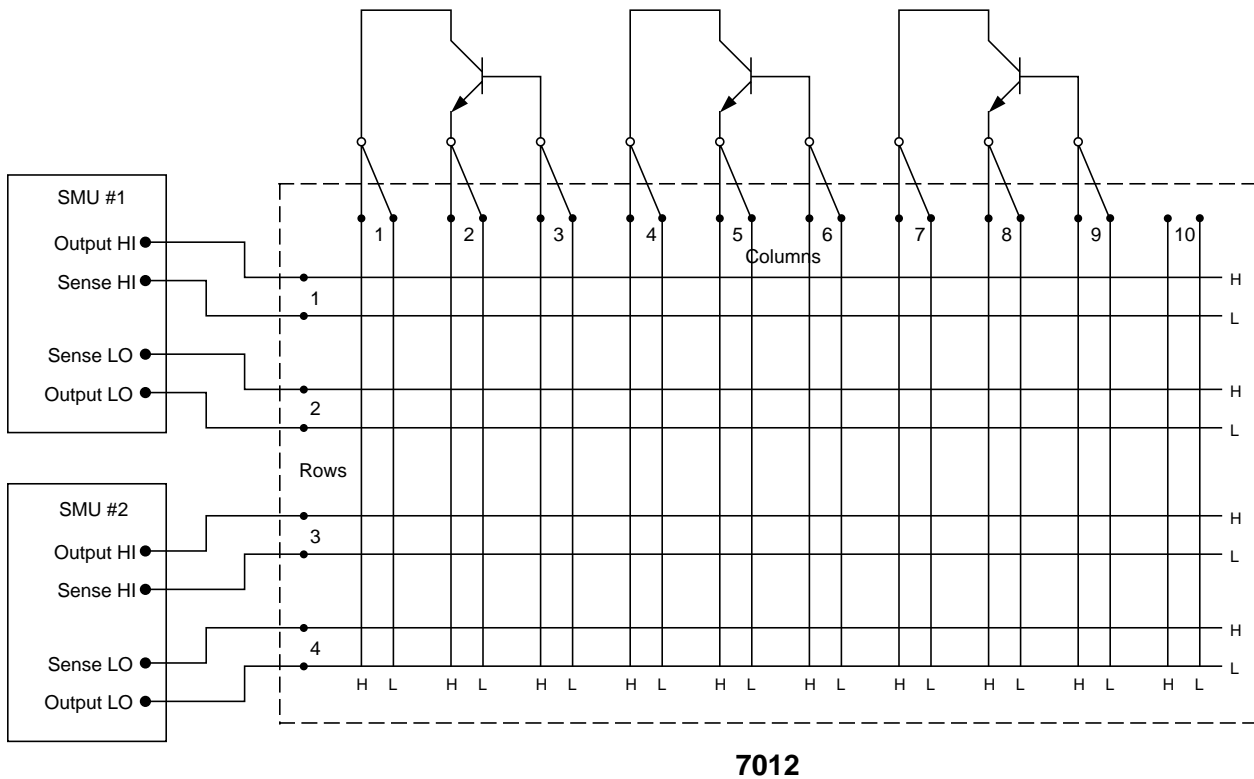

Figure 4-7
Transistor testing

DC parameter checks

With a transistor configured as a common-emitter amplifier, the test system shown in Figure 4-8 can be used to determine the following DC parameters: Collector current (I_C), base current (I_B), current gain, emitter current (I_E) and base-to-emitter voltage (V_{BE}).

Figure 4-8 shows which crosspoints to close to configure the amplifier circuit. SMU #1 is configured to source voltage and measure current. It is used to power the collector circuit (V_{CE}) and measure the collector current (I_C). SMU #2 is configured to source current and measure voltage. It is used to provide the base current (I_B) for the transistor, and will also measure the base-to-emitter voltage (V_{BE}). With collector current (I_C) and base current (I_B) known, the current gain can be calculated as follows:

$$\text{Gain} = \frac{I_C}{I_B}$$

The emitter current (I_E) can be determined by using Kirchoff's Current Law as follows:

$$I_E = I_C + I_B$$

Common-emitter characteristic curves

A profile of the transistor operating characteristics can be obtained by measuring the collector current over a specified voltage range (V_{CE}) for different base bias currents (I_B). For example, Figure 4-9 shows the characteristics of a typical NPN silicon transistor at base bias currents (I_B) of 20 μ A, 40 μ A, 60 μ A, and 80 μ A.

Extensive trigger capabilities facilitate synchronization of the Keithley Source Measure Unit operations. By performing a subordinate sweep, SMU #1 will perform a staircase sweep at every base bias current level set by SMU #2. On every step of each staircase sweep, SMU #1 will source a voltage level (V_{CE}) and measure the subsequent collector current (I_C). For the characteristics shown in Figure 4-9, four staircase sweeps were performed; one staircase sweep at each base bias level.

Refer to a Keithley Source Measure Unit instruction manual for details on performing sweeps.

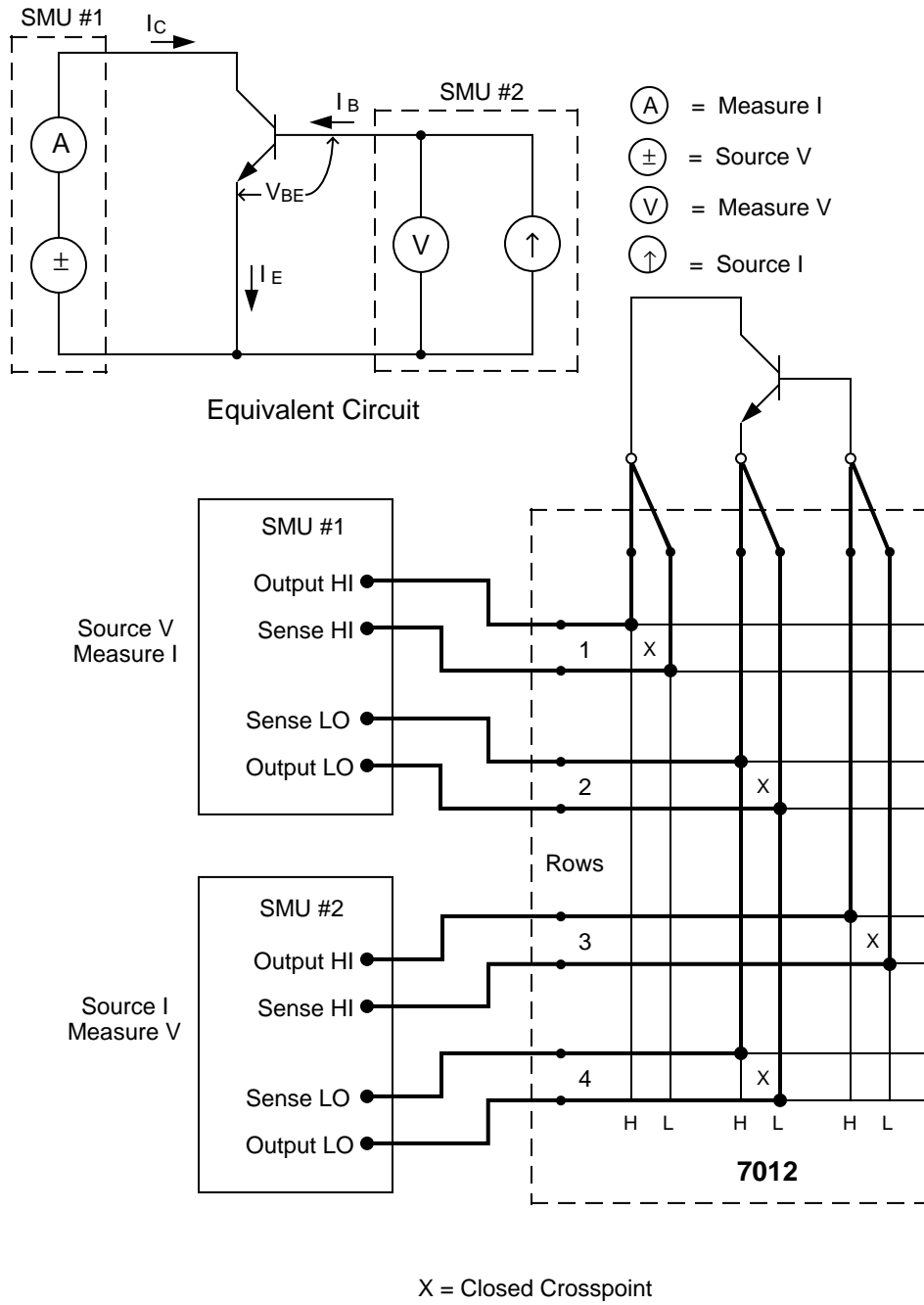

Figure 4-8
DC parameter checks

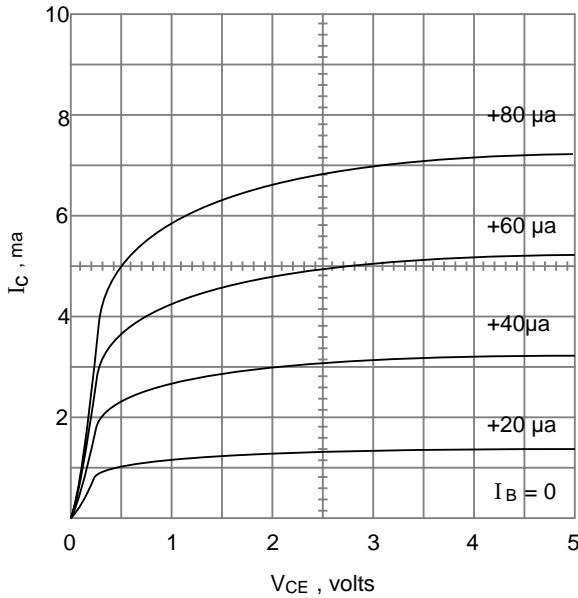

Figure 4-9
Common-emitter characteristics of an NPN silicon Transistor

4.5 Measurement considerations

Many measurements made with the Model 7012 are subject to various effects that can seriously affect low-level measurement accuracy. The following paragraphs discuss these effects and ways to minimize them.

4.5.1 Path isolation

The path isolation is simply the equivalent impedance between any two test paths in a measurement system. Ideally, the path isolation should be infinite, but the actual resistance and distributed capacitance of cables and connectors results in less than infinite path isolation values for these devices.

Path isolation resistance forms a signal path that is in parallel with the equivalent resistance of the DUT, as shown in Figure 4-10. For low-to-medium device resistance values, path isolation resistance is seldom a con-

sideration; however, it can seriously degrade measurement accuracy when testing high-impedance devices. The voltage measured across such a device, for example, can be substantially attenuated by the voltage divider action of the device source resistance and path isolation resistance, as shown in Figure 4-11. Also, leakage currents can be generated through these resistances by voltage sources in the system.

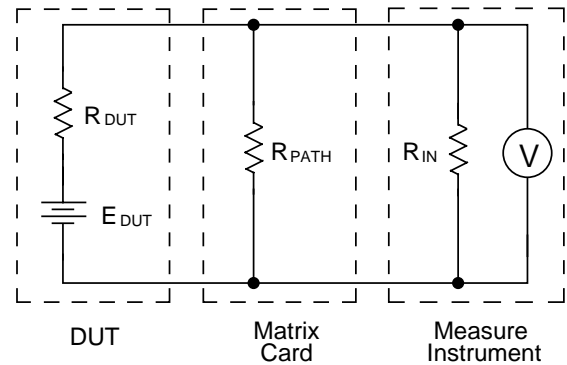

- R_{DUT} = Source Resistance of DUT
- E_{DUT} = Source EMF of DUT
- R_{PATH} = Path Isolation Resistance
- R_{IN} = Input Resistance of Measuring Instrument

Figure 4-10
Path isolation resistance

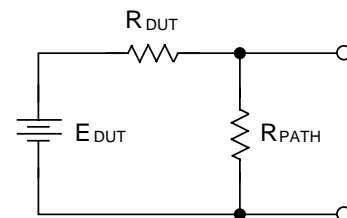

$$E_{OUT} = \frac{E_{DUT} R_{PATH}}{R_{DUT} + R_{PATH}}$$

Figure 4-11
Voltage attenuation by path isolation resistance

Any differential isolation capacitance affects DC measurement settling time as well as AC measurement accuracy. Thus, it is often important that such capacitance be kept as low as possible. Although the distributed capacitance of the matrix card is generally fixed by design, there is one area where you do have control over the capacitance in your system; the connecting cables. To minimize capacitance, keep all cables as short as possible.

4.5.2 Magnetic fields

When a conductor cuts through magnetic lines of force, a very small current is generated. This phenomenon will frequently cause unwanted signals to occur in the test leads of a switching matrix system. If the conductor has sufficient length, even weak magnetic fields like those of the earth can create sufficient signals to affect low-level measurements.

Two ways to reduce these effects are: (1) reduce the lengths of the test leads, and (2) minimize the exposed circuit area. In extreme cases, magnetic shielding may be required. Special metal with high permeability at low flux densities (such as mu metal) is effective at reducing these effects.

Even when the conductor is stationary, magnetically-induced signals may still be a problem. Fields can be produced by various signals such as the AC power line voltage. Large inductors such as power transformers can generate substantial magnetic fields, so care must be taken to keep the switching and measuring circuits a good distance away from these potential noise sources.

At high current levels, even a single conductor can generate significant fields. These effects can be minimized by using twisted pairs, which will cancel out most of the resulting fields.

4.5.3 Radio frequency interference

RFI (Radio Frequency Interference) is a general term used to describe electromagnetic interference over a wide range of frequencies across the spectrum. Such RFI can be particularly troublesome at low signal levels, but it can also affect measurements at high levels if the problem is of sufficient severity.

RFI can be caused by steady-state sources such as radio or TV signals, or some types of electronic equipment (microprocessors, high speed digital circuits, etc.), or it can result from impulse sources, as in the case of arcing in high-voltage environments. In either case, the effect on the measurement can be considerable if enough of the unwanted signal is present.

RFI can be minimized in several ways. The most obvious method is to keep the equipment and signal leads as far away from the RFI source as possible. Shielding the matrix switching card, signal leads, sources, and measuring instruments will often reduce RFI to an acceptable level. In extreme cases, a specially-constructed screen room may be required to sufficiently attenuate the troublesome signal.

Many instruments incorporate internal filtering that may help to reduce RFI effects in some situations. In some cases, additional external filtering may also be required. Keep in mind, however, that filtering may have detrimental effects on the desired signal.

4.5.4 Ground loops

When two or more instruments are connected together, care must be taken to avoid unwanted signals caused by ground loops. Ground loops usually occur when sensitive instrumentation is connected to other instrumentation with more than one signal return path such as power line ground. As shown in Figure 4-12, the resulting ground loop causes current to flow through the instrument LO signal leads and then back through power line ground. This circulating current develops a small but undesirable voltage between the LO terminals of the two instruments. This voltage will be added to the source voltage, affecting the accuracy of the measurement.

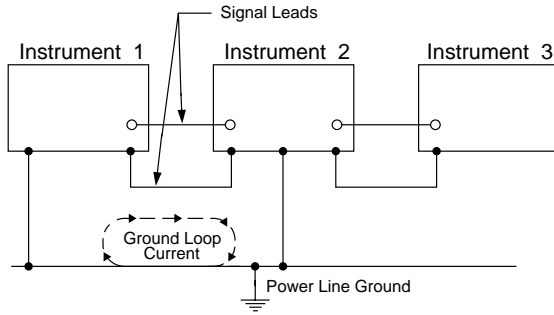

Figure 4-12
Power line ground loops

Figure 4-13 shows how to connect several instruments together to eliminate this type of ground loop problem. Here, only one instrument is connected to power line ground.

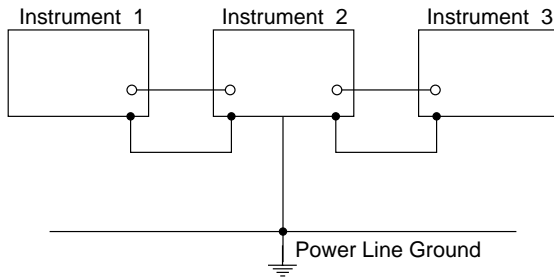

Figure 4-13
Eliminating ground loops

Ground loops are not normally a problem with instruments having isolated LO terminals. However, all instruments in the test setup may not be designed in this

manner. When in doubt, consult the manual for all instrumentation in the test setup.

4.5.5 Keeping connectors clean

As is the case with any high-resistance device, the integrity of connectors can be damaged if they are not handled properly. If connector insulation becomes contaminated, the insulation resistance will be substantially reduced, affecting high-impedance measurement paths.

Oils and salts from the skin can contaminate connector insulators, reducing their resistance. Also, contaminants present in the air can be deposited on the insulator surface. To avoid these problems, never touch the connector insulating material. In addition, the multiplexer card should be used only in clean, dry environments to avoid contamination.

If the connector insulators should become contaminated, either by inadvertent touching, or from air-borne deposits, they can be cleaned with a cotton swab dipped in clean methanol. After thoroughly cleaning, they should be allowed to dry for several hours in a low-humidity environment before use, or they can be dried more quickly using dry nitrogen.

4.5.6 AC frequency response

The AC frequency response of the Model 7012 is important in test systems that switch AC signals. Refer to the specifications at the front of this manual.

5

Service Information

WARNING

The information in this section is intended only for qualified service personnel. Some of the procedures may expose you to hazardous voltages that could result in personal injury or death. Do not attempt to perform these procedures unless you are qualified to do so.

5.1 Introduction

This section contains information necessary to service the Model 7012 matrix card and is arranged as follows:

- 5.2 **Handling and cleaning precautions:** Discusses handling procedures and cleaning methods for the matrix card.
- 5.3 **Performance verification:** Covers the procedures necessary to determine if the card is operating properly.
- 5.4 **Special handling of static-sensitive devices:** Reviews precautions necessary when handling static-sensitive devices.
- 5.5 **Principles of operation:** Briefly discusses circuit operation.
- 5.6 **Troubleshooting:** Presents some troubleshooting tips for the matrix card.

5.2 Handling and cleaning precautions

Because of the high impedance circuits on the Model 7012, care should be taken when handling or servicing the card to prevent possible contamination, which could degrade performance. The following precautions should be taken when handling the matrix card.

Do not store or operate the card in an environment where dust could settle on the circuit board. Use dry nitrogen gas to clean dust off the card if necessary.

Handle the card only by the side edges. Do not touch any board surfaces, components, or connectors. Do not touch areas adjacent to electrical contacts. When servicing the card, wear clean cotton gloves.

If making solder repairs on the circuit board, use an OA-based (organic activated) flux. Remove the flux from these areas when the repair is complete. Use pure water along with plenty of clean cotton swabs to remove the flux. Take care not to spread the flux to other areas of the circuit board. Once the flux has been removed, swab only the repaired area with methanol, then blow dry the board with dry nitrogen gas.

After cleaning, the card should be placed in a 50°C low humidity environment for several hours.

5.3 Performance verification

The following paragraphs discuss performance verification procedures for the Model 7012, including path resistance, offset current, contact potential, and isolation.

With the Model 7012's backplane jumpers installed, the performance verification procedures must be performed with only one matrix card (the one being checked) installed in the Model 7001 mainframe. These conditions do not apply if the backplane jumpers are removed.

CAUTION

Contamination will degrade the performance of the matrix card. To avoid contamination, always grasp the card by the side edges. Do not touch the connectors, and do not touch the board surfaces or components. On plugs and receptacles, do not touch areas adjacent to the electrical contacts.

NOTE

Failure of any performance verification test may indicate that the matrix card is contaminated. See paragraph 5.2 to clean the card.

5.3.1 Environmental conditions

All verification measurements should be made at an ambient temperature between 18° and 28°C, and at a relative humidity of less than 70%.

5.3.2 Recommended equipment

Table 5-1 summarizes the equipment necessary for performance verification, along with an application for each unit.

Table 5-1
Verification equipment

Description	Model or part	Specifications	Applications
DMM	Keithley Model 196	300Ω; 0.01%	Path resistance
Electrometer w/ voltage source	Keithley Model 617	20pA; 1.6% 20nA, 200nA; 0.25% 100V source; 0.2%	Offset current, isolation
Sensitive DVM	Keithley Model 182	3mV; 0.015%	Contact potential
Triax cable (unterminated)	Keithley Model 7025	—	Offset current
Low thermal cable (unterminated)	Keithley Model 1484	—	Contact potential

5.3.3 Matrix card connections

The following information summarizes methods that can be used to connect test instrumentation to the two connector cards. Detailed connection information is provided in Section 3.

Model 7012-S — Instrumentation can simply be hard-wired directly to the screw terminals of the connector card. Jumper wires should be kept as short as possible.

Model 7012-C — One method to make instrument connections to the matrix card is by hard-wiring a 96-pin female DIN connector and then mating it to the connector on the Model 7012-C. Row and column shorting connections can also be done at the connector. The connector in the Model 7011-KIT-R connection kit (see Table 3-1) can be used for this purpose. Pin identification for the multi-pin connector for the matrix card is provided by Figure 3-5.

CAUTION

After making solder connections to a connector, remove solder flux as explained in paragraph 5.2. Failure to clean the solder connections could result in degraded performance preventing the card from passing verification tests.

Before pre-wiring any connectors plugs, study the following test procedures to fully understand the connection requirements.

5.3.4 Channel resistance tests

Referring to Figure 5-1, perform the following steps to verify that each contact of every relay is closing properly and that the resistance is within specification.

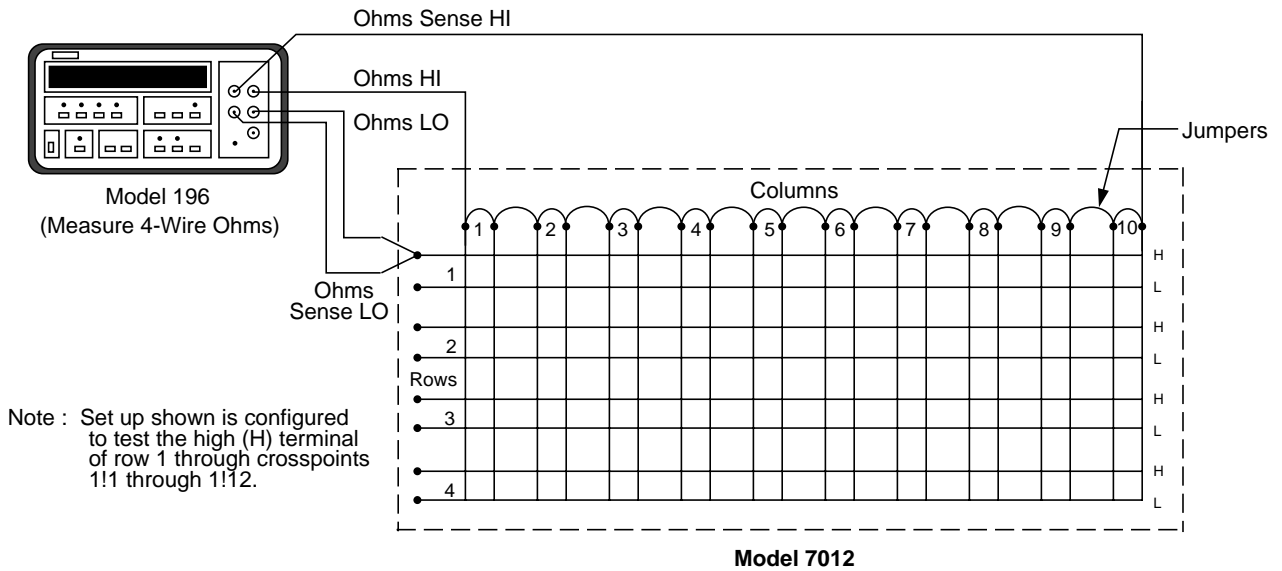

Figure 5-1
Path resistance testing

1. Turn the Model 7001 off if it is on.
2. As shown in Figure 5-1, connect all terminals of matrix columns 1-10 together to form one common terminal.
3. Set the Model 196 to the 300 Ω range and connect four test leads to the OHMS and OHMS SENSE input.
4. Short the four test leads together and zero the Model 196. Leave zero enabled for the entire test.
5. Connect OHMS HI and OHMS SENSE HI of the Model 196 to the common terminal. It is recommended that the physical connections be made at columns 1 and 10 as shown in the illustration.
6. Connect OHMS LO and OHMS SENSE LO to the high (H) terminal of Row 1.
7. Install the Model 7012 in slot 1 (CARD 1) of the Model 7001.
8. Turn on the Model 7001 and program it to close Channel 1!1!1 (Slot 1, Row 1, Column 1). Verify that the resistance of this channel is <1 Ω .
9. Open Channel 1!1!1 and close 1!1!2. Verify that the resistance of this channel is <1 Ω .
10. Open Channel 1!1!2 and close 1!1!3. Verify that the resistance of this channel is <1 Ω .
11. Repeat the basic procedure of opening and closing channels to check the resistance of Row 1 high (H) terminal paths for Columns 4 through 10 (Channels 1!1!4 through 1!1!10).
12. Turn off the Model 7001 and connect the OHMS LO and OHMS SENSE LO test leads of the Model 196 DMM to the low (L) terminal of Row 1.
13. Repeat steps 8 through 11 to check the low (L) channel paths of Row 1.
14. Turn off the Model 7001 and repeat the basic procedure in steps 7 through 13 for Rows 2, 3 and 4.

5.3.5 Offset current tests

These tests check leakage current from high (H) to low (L) (differential), and from high (H) and low (L) to

chassis (common mode) for each pathway. In general, these tests are performed by simply measuring the leakage current with an electrometer. In the following procedure, the Model 617 is used to measure leakage current.

Referring to Figure 5-2, perform the following procedure to check offset current:

1. Turn the Model 7001 off if it is on.
2. Connect the Model 617 electrometer to Row 1 of the matrix card as shown in Figure 5-2. Note that electrometer HI is connected to both high (H) and low (L) of Row 1. Electrometer LO is connected to chassis ground, which is accessible at the rear panel of the mainframe.
3. Install the matrix card in slot 1 (CARD 1) of the Model 7001.
4. On the Model 617, select the 200pA range, and enable zero check and zero correct in that order. Leave zero correct enabled for the entire procedure.
5. Turn on the Model 7001
6. Program the Model 7001 to close Channel 1!1!1.
7. On the Model 617, disable zero check and verify that it is <100pA. This measurement is the leakage current of the pathway.
8. On the Model 617, enable zero check and on the Model 7001, open Channel 1!1!1.
9. Repeat the basic procedure in steps 6 through 8 to check the rest of the pathways (Channels 1!1!2 through 1!1!10) of the row.
10. Turn off the Model 7001 and connect the Model 617 to Row 2. Repeat the basic procedure in steps 6 through 9 to check Channels 1!2!1 through 1!2!10.
11. Repeat the basic procedure in step 10 to check Rows 3 and 4.
12. Turn off the Model 7001.
13. To check differential offset current, connect the Model 617 to Row 1 as shown in Figure 5-3, and repeat steps 4 through 12.

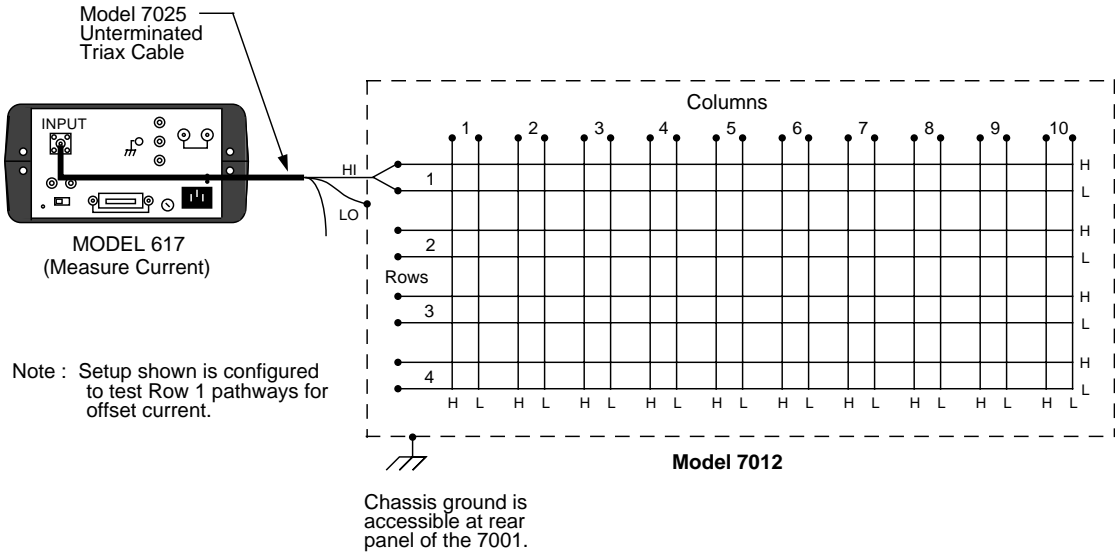

Figure 5-2
Common-mode offset current testing

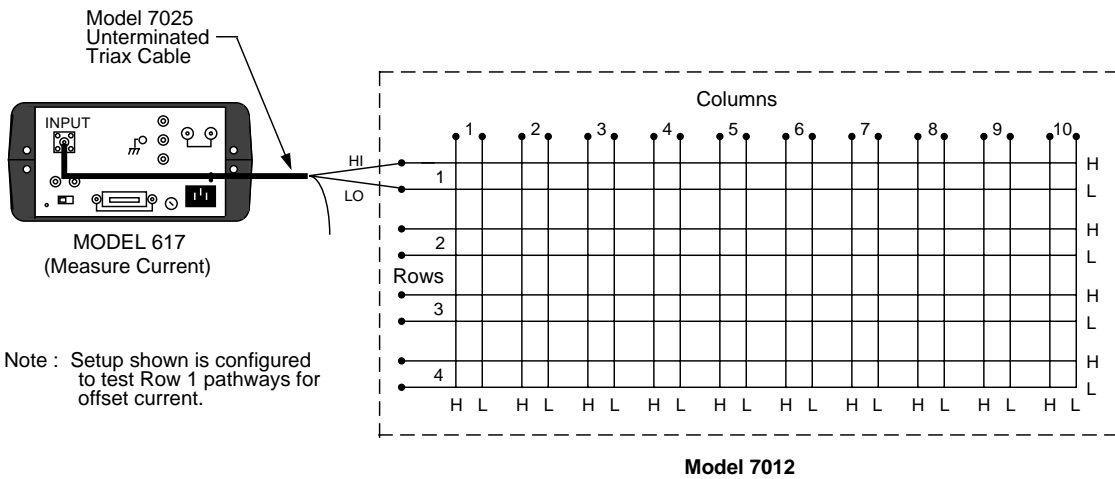

Figure 5-3
Differential offset current testing

5.3.6 Contact potential tests

These tests check the EMF generated by each relay contact pair (H and L) for each pathway. The tests simply consist of using a sensitive digital voltmeter (Model 182) to measure the contact potential.

Perform the following procedure to check contact potential of each path:

1. Turn the Model 7001 off if it is on.
2. Place a short between HI to LO on each input column 1-10.
3. Connect all row HI together on the common bus.
4. Connect all row LO together on the common bus.
5. Place a short between HI to LO on the rows.
6. Connect the Model 182 input leads to HI and LO of the rows.

7. Install the Model 7012 in the Model 7001 slot 1 and turn the Model 7001 on.
8. Allow the Models 7012, 7001, and 182 to warm up for two hours.
9. Select the 3mV range on the Model 182.
10. Press REL READING on the Model 182 to null out internal offsets. Leave REL READING enabled for the entire procedure.
11. Turn the Model 7001 off. Remove the Model 7012 front slot 1. Cut the short from HI to LO on the rows.
12. Install the Model 7012 in the Model 7001 slot 1 and turn power on.
13. Wait 15 minutes.
14. Program the Model 7001 to close Channel 1!1!1.
15. After settling, verify that the reading on the Model 182 is <500mV (7012-S). This measurement represents the contact potential of the pathway.
16. From the Model 7001, open Channel 1!1!1.
17. Repeat steps 14 through 16 for all 40 crosspoints.

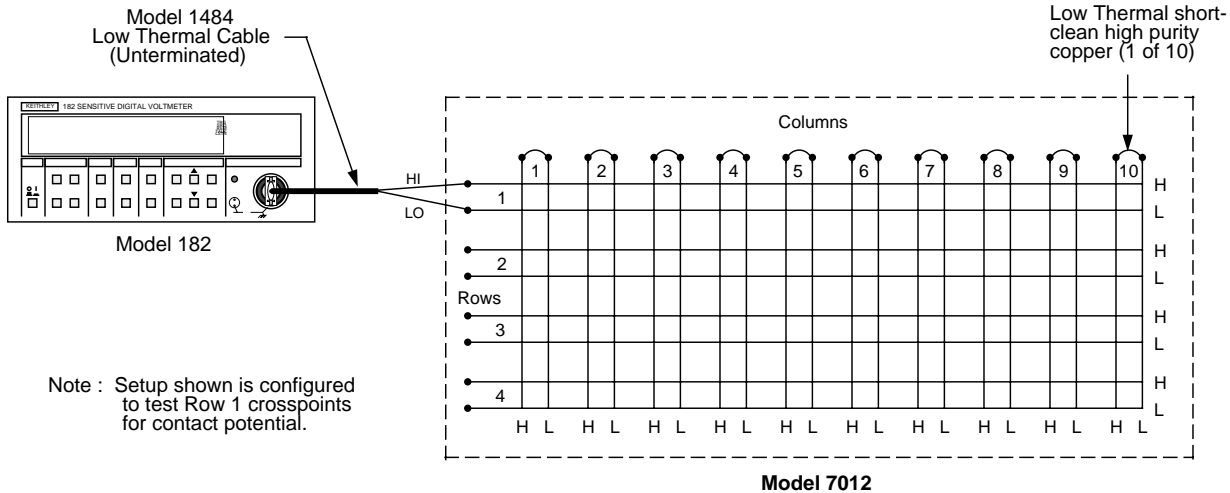

Figure 5-4
Contact potential testing

5.3.7 Path isolation tests

These tests check the leakage resistance (isolation) between adjacent paths. A path is defined as the high (H) and low (L) circuit from a row to a column that results by closing a particular crosspoint. In general, the test is performed by applying a voltage (+100V) across two adjacent paths and then measuring the leakage current across the paths. The isolation resistance is then calculated as $R = V/I$. In the following procedure, the Model 617 functions as both a voltage source and an ammeter. In the V/I function, the Model 617 internally calculates the resistance from the known voltage and current levels, and displays the resistance value.

1. Turn the Model 7001 off if it is on.
2. Jumper the high (H) terminal to the low (L) terminal for each row (see Figure 5-5).
3. Connect the Model 617 to Rows 1 and 2 as shown in Figure 5-5. Make sure the voltage source is in standby. Also, make sure there are no other connections to the card.
4. Install the Model 7012 in slot 1 of the Model 7001.

WARNING

The following steps use high voltage (100V). Be sure to remove power from the circuit before making connection changes.

5. On the Model 617, select the 2pA range, and enable zero check and zero correct in that order. Leave zero correct enabled for the entire procedure.

6. On the Model 617, select the 20pA range and release zero check.
7. On the Model 617, press suppress to cancel offset current and then enable zero check.
8. On the Model 617, set the voltage source for +100V and select the 200nA current range. Make sure the voltage source is in standby.
9. Place the Model 617 in the V/I measurement function by pressing SHIFT OHMS.
10. Turn on the Model 7001 and program it to close Channels 1!1!1 (Row 1, Column 1) and 1!2!2 (Row 2, Column 2).
11. On the Model 617, disable zero check and press OPERATE to source +100V.
12. After allowing the reading on the Model 617 to settle, verify that it is $>1G\Omega$. This measurement is the leakage resistance (isolation) between Row 1, Column 1 and Row 2, Column 2.
13. Place the Model 617 in standby and enable zero check.
14. Turn off the Model 7001.
15. Disconnect the Model 617 from Rows 1 and 2, and in a similar manner, reconnect it to Rows 2 and 3 (picoammeter high to Row 2 and voltage source high to Row 3).
16. Turn on the Model 7001 and program it to close Channels 1!2!2 and 1!3!3.
17. On the Model 617, disable zero check and press OPERATE to source +100V.
18. After allowing the reading on the Model 617 to settle, verify that it is $>1G\Omega$.
19. Using Table 5-2 as a guide, repeat the basic procedure in steps 13 through 18 for the rest of the path pairs (starting with test #3).

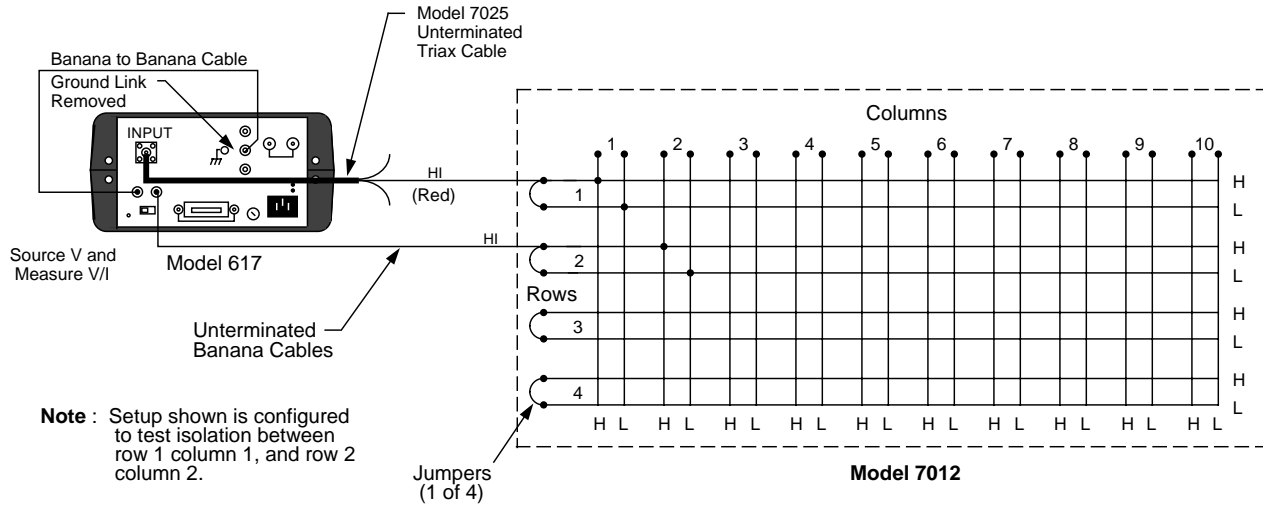

Figure 5-5
Path isolation testing (guarded)

Table 5-2
Path isolation tests

Test no.	Path isolation	Test equipment locations	Channels closed
1	Row 1, Col 1 to Row 2, Col 2	Row 1 and Row 2	1!1!1 and 1!2!2
2	Row 2, Col 2 to Row 3, Col 3	Row 2 and Row 3	1!2!2 and 1!3!3
3	Row 3, Col 3 to Row 4, Col 4	Row 3 and Row 4	1!3!3 and 1!4!4
4	Row 3, Col 4 to Row 4, Col 5	Row 3 and Row 4	1!3!4 and 1!4!5
5	Row 3, Col 5 to Row 4, Col 6	Row 3 and Row 4	1!3!5 and 1!4!6
6	Row 3, Col 6 to Row 4, Col 7	Row 3 and Row 4	1!3!6 and 1!4!7
7	Row 3, Col 7 to Row 4, Col 8	Row 3 and Row 4	1!3!7 and 1!4!8
8	Row 3, Col 8 to Row 4, Col 9	Row 3 and Row 4	1!3!8 and 1!4!9
9	Row 3, Col 9 to Row 4, Col 10	Row 3 and Row 4	1!3!9 and 1!4!10

5.3.8 Differential and common-mode isolation tests

These tests check the leakage resistance (isolation) between high (H) and low (L) (differential), and from high and low to chassis (common-mode) of every row and column. In general, the test is performed by applying a voltage (100V) across the terminals and then measuring the leakage current. The isolation resistance is then calculated as $R = V/I$. In the following procedure, the Model 617 functions as a voltage source and an ammeter. In the V/I function, the Model 617 internally calculates the resistance from the known voltage and current levels, and displays the resistance value.

1. Turn the Model 7001 off if it is on.
2. Connect the Model 617 to Row 1 as shown in Figure 5-6. Make sure the voltage source is in standby. Also, make sure there are no other connections to the card.
3. Install the Model 7012 in slot 1 of the Model 7001.

WARNING

The following steps use high voltage (100V). Be sure to remove power from the circuit before making connection changes.

4. On the Model 617, select the 2pA range, and enable zero check and zero correct in that order. Leave zero correct enabled for the entire procedure.
5. On the Model 617, set the voltage source for +100V, and select the 200nA current range. Make sure the voltage source is still in standby.
6. Place the Model 617 in the V/I measurement function by pressing SHIFT OHMS.
7. Turn on the Model 7001, but do not program any channels to close. All channel crosspoints must be open.
8. On the Model 617, disable zero check and press OPERATE to source 100V.
9. After allowing the reading on the Model 617 to settle, verify that it is $>1G\Omega$. This measurement is the leakage resistance (isolation) of Row 1.
10. Place the Model 617 in standby and enable zero check.
11. Program the Model 7001 to close Channel 1111.
12. On the Model 617, disable zero check and press OPERATE to source +100V.
13. After allowing the reading on the Model 617 to settle, verify that it is also $>1G\Omega$. This measurement checks the isolation of Column 1.
14. Using Table 5-3 as a guide, repeat the basic procedure in steps 10 through 13 for the rest of the columns and rows (test numbers 3 through 14 of the table).
15. Place the Model 617 in standby and turn the Model 7001 off.
16. For each matrix row, jumper the high (H) terminal to the low (L) terminal as shown in Figure 5-7.
17. Connect the Model 617 to Row 1 as shown in Figure 5-7, and repeat steps 7 through 15 to check common-mode isolation.

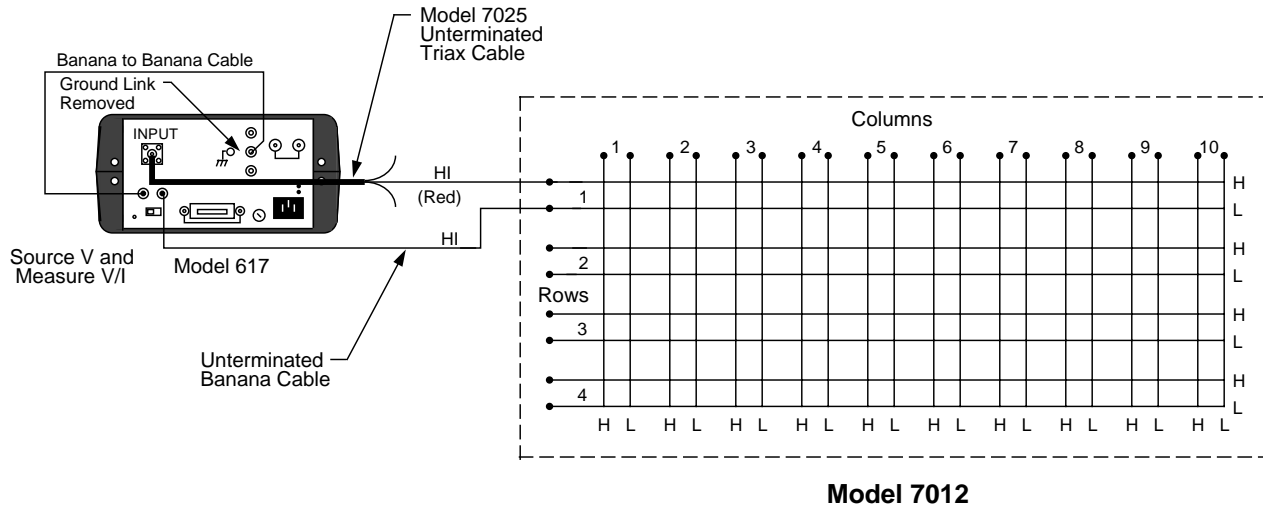

Figure 5-6
Differential isolation testing

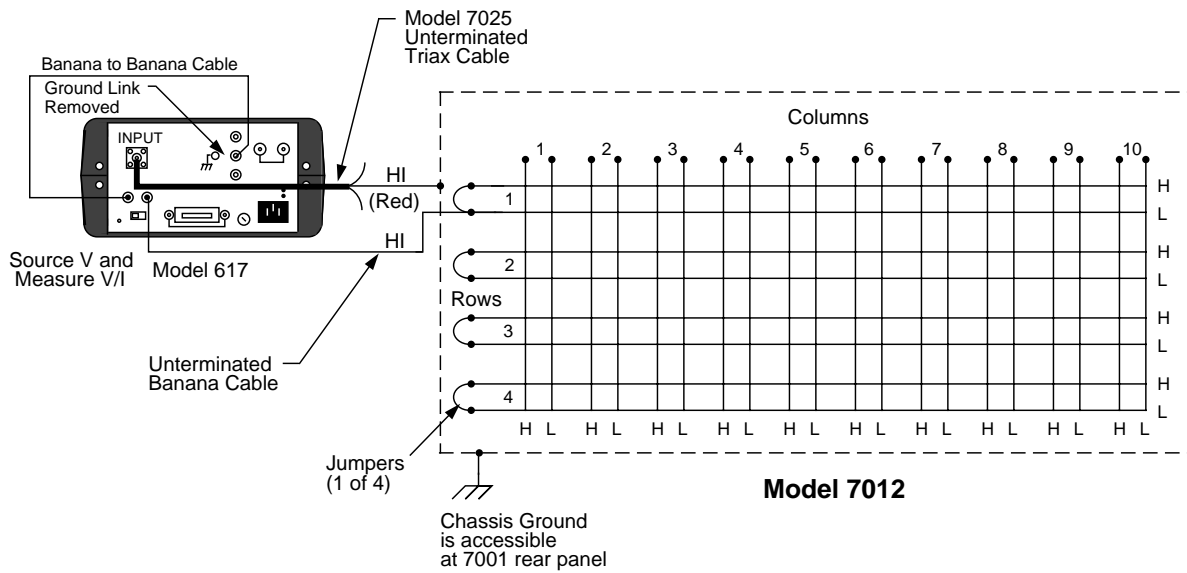

Figure 5-7
Common-mode isolation testing

Table 5-3
Differential and common-mode isolation testing

Test no.	Differential or common-mode test	Channels closed
1	Row 1	None
2	Column 1	1!1!1
3	Column 2	1!1!2
4	Column 3	1!1!3
5	Column 4	1!1!4
6	Column 5	1!1!5
7	Column 6	1!1!6
8	Column 7	1!1!7
9	Column 8	1!1!8
10	Column 9	1!1!9
11	Column 10	1!1!10
12	Row 2	1!1!1 and 1!2!1
13	Row 3	1!1!1 and 1!3!1
14	Row 4	1!1!1 and 1!4!1

5.4 Special handling of static-sensitive devices

CMOS and other high-impedance devices are subject to possible static discharge damage because of the high-impedance levels involved. The following precautions pertain specifically to static-sensitive devices. However, since many devices in the Model 7012 are static-sensitive, it is recommended that they all be treated as static-sensitive.

1. Such devices should be transported and handled only in containers specially designed to prevent or dissipate static build-up. Typically, these devices will be received in anti-static containers made of plastic or foam. Keep these parts in their original containers until ready for installation.
2. Remove the devices from their protective containers only at a properly grounded work station. Also, ground yourself with a suitable wrist strap while working with these devices.
3. Handle the devices only by the body; do not touch the pins.
4. Any printed circuit board into which the device is to be inserted must first be grounded to the bench or table.
5. Use only anti-static type de-soldering tools and grounded-tip soldering irons.

5.5 Principles of operation

The following paragraphs discuss the basic operating principles for the Model 7012, and can be used as an aid in troubleshooting the matrix card. The schematic drawing of the matrix card is shown on drawing number 7012-106, located at the end of Section 6.

5.5.1 Block diagram

Figure 5-8 shows a simplified block diagram of the Model 7012. Key elements include the relay drivers and relays, as well as the ROM, which contains card ID and configuration information. These various elements are discussed in the following paragraphs.

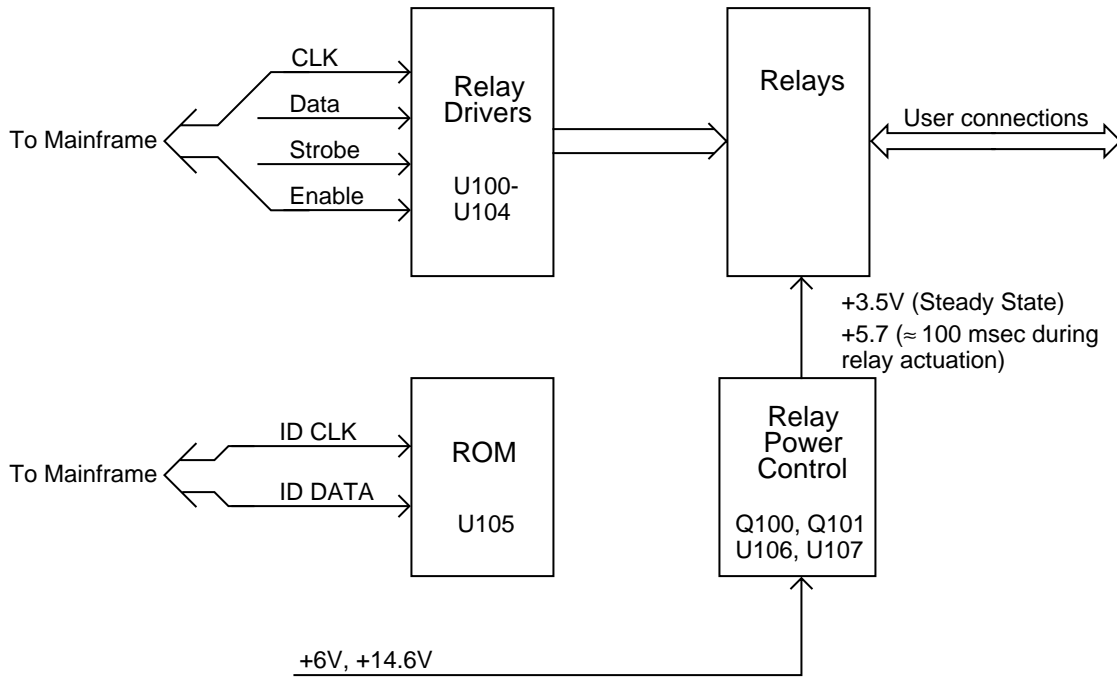

Figure 5-8
Model 7012 block diagram

5.5.2 ID data circuits

Upon power-up, card identification information from each card is read by the mainframe. This ID data includes such information as card ID, hardware settling time, and relay configuration information.

ID data is contained within an on-card EEPROM (U105). In order to read this information, the sequence described below is performed on power-up.

1. The IDDATA line (pin 6 of U105) is set from high to low while the IDCLK line (pin 5 of U105) is held high. This action initiates a start command to the ROM to transmit data serially to the mainframe (Figure 5-9).
2. The mainframe sends the ROM address location to be read over the IDDATA line. The ROM then transmits an acknowledge signal back to the mainframe, and it then transmits data at that location back to the mainframe (Figure 5-10).
3. The mainframe then transmits an acknowledge signal, indicating that it requires more data. The ROM will then sequentially transmit data after each acknowledge signal it receives.

4. Once all data is received, the mainframe sends a stop command, which is a low-to-high transition of the IDDATA line with the IDCLK line held high (see Figure 5-9).

5.5.3 Relay control

Card relays are controlled by serial data transmitted via the relay DATA line. A total of five bytes for each card are shifted in serial fashion into latches located in the card relay driver ICs. The serial data is clocked in by the CLK line. As data overflows one register, it is fed out the Q'S line of the register down the chain.

Once all five bytes have shifted into the card, the STROBE line is set high to latch the relay information into the Q outputs of the relay drivers, and the appropriate relays are energized (assuming the driver outputs are enabled, as discussed below). Note that a relay driver output goes low to energize the corresponding relay.

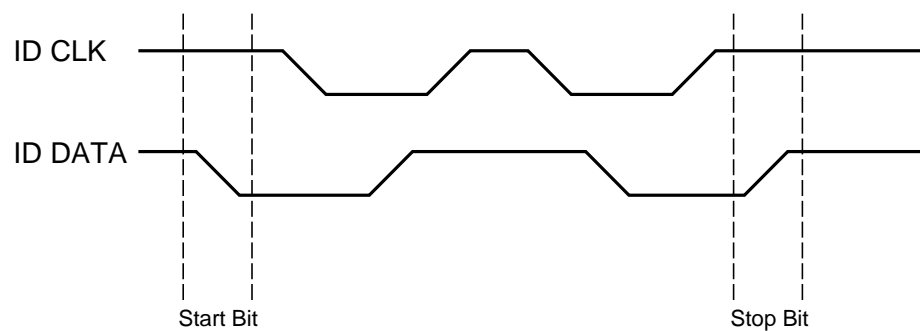

Figure 5-9
Start and stop sequences

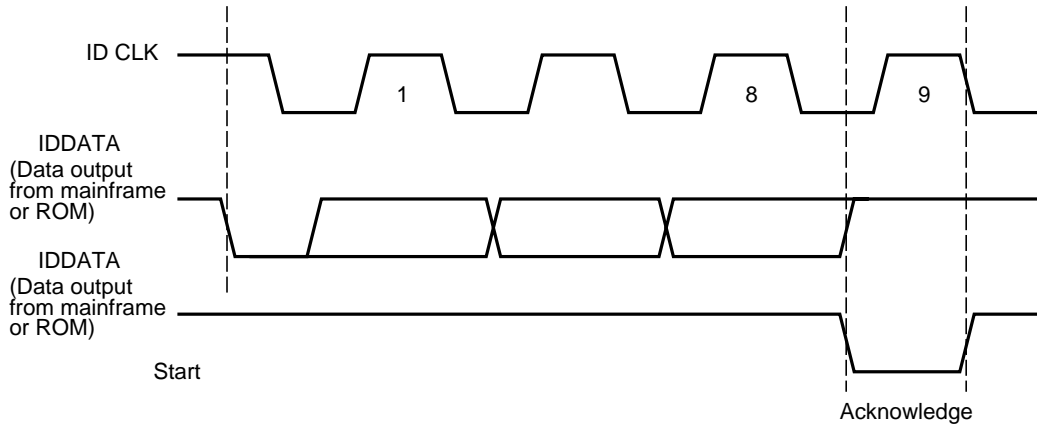

Figure 5-10
Transmit and acknowledge sequence

5.5.4 Relay power control

A relay power control circuit, made up of U106, U107, Q100, Q101, and associated components, keeps power dissipated in relay coils at a minimum, thus reducing possible problems caused by thermal EMFs.

During steady-state operation, the relay supply voltage, +V, is regulated to +3.5V to minimize coil power dissipation. When a relay is first closed, the STROBE pulse applied to U106 changes the parameters of the relay supply voltage regulator, Q100, allowing the relay supply voltage, +V, to rise to +5.7V for about 100msec. This brief voltage rise ensures that relays close as quickly as possible. After the 100msec period has elapsed, the relay supply voltage (+V) drops back down to its nominal steady-state value of +3.5V.

5.5.5 Power-on safeguard

NOTE

The power-on safeguard circuit discussed below is actually located on the digital board in the Model 7001 mainframe.

A power-on safeguard circuit, made up of U114 (a D-type flip-flop) and associated components, ensures that relays do not randomly energize on power-up and power-down. This circuit disables all relays (all relays are open) during power-up and power-down periods.

The PRESET line on the D-type flip-flop is controlled by the 68302 microprocessor, while the CLK line of the D-type flip-flop is controlled by a VIA port line on the 68302 processor. The Q output of the flip-flop drives each switch card relay driver IC enable pin (U100-U104, pin 8).

When the 68302 microprocessor is in the reset mode, the flip-flop PRESET line is held low, and Q out immediately goes high, disabling all relays (relay driver IC enable pins are high, disabling the relays.) After the reset condition elapses ($\approx 200\text{msec}$), PRESET goes high while Q out stays high. When the first valid STROBE pulse occurs, a low logic level is clocked into the D-type flip-flop, setting Q out low and enabling all relay drivers simultaneously. Note that Q out stays low, (enabling relay drivers) until the 68302 processor goes into a reset condition.

5.6 Troubleshooting

5.6.1 Troubleshooting equipment

Table 5-4 summarizes recommended equipment for troubleshooting the Model 7012.

Table 5-4
Recommended Troubleshooting Equipment

Description	Manufacturer and model	Application
Multimeter	Keithley 196	Measure DC voltages
Oscilloscope	TEK 2243	View logic waveforms

5.6.2 Troubleshooting access

In order to gain access to the relay card top surface to measure voltages under actual operation conditions, perform the following steps:

1. Disconnect the connector card from the relay card.
2. Remove the Model 7001 cover.
3. Install the relay card in the CARD 1 slot location.
4. Turn on Model 7001 power to measure voltages (see following paragraph).

5.6.3 Troubleshooting procedure

Table 5-5 summarizes switch card troubleshooting.

WARNING

Lethal voltages are present within the Model 7001 mainframe. Some of the procedures may expose you to hazardous voltages. Observe standard safety precautions for dealing with live circuits. Failure to do so could result in personal injury or death.

CAUTION

Observe the following precautions when troubleshooting or repairing the switch card:

To avoid contamination, which could degrade card performance, always handle the card only by the handle and side edges. Do not touch edge connectors, board surfaces, or components on the card. Also, do not touch areas adjacent to electrical contacts on connectors.

Use care when removing relays from the PC board to avoid pulling traces away from the circuit board. Before attempting to remove a relay, use an appropriate de-soldering tool, such as a solder sucker, to clear each mounting hole completely free of solder. Each relay pin must be free to move in its mounting hole before removal. Also, make certain that no burrs are present on the ends of the relay pins.

Table 5-5
Troubleshooting procedure

Step	Item/Component	Required Condition	Comments
1	GND pad		All voltages referenced to digital ground (GND pad).
2	+6V pad	+6VDC	Relay voltage.
3	+5V pad	+5VDC	Logic voltage.
4	+14.6V pad	+14.6VDC	Relay bias voltage.
5	+V pad	+3.5VDC*	Regulated relay voltage.
6	U105, pin 5	ID CLK pulses	During power-up only.
7	U105, pin 6	ID DATA pulses	During power-up only.
8	U100, pin 7	STROBE pulse	End of relay update sequence.
9	U100, pin 2	CLK pulses	During relay update sequence only.
10	U100, pin 3	DATA pulses	During relay update sequence only.
11	U100-U104, pins 10-18	Low with relay energized; high with relay de-energized.	Relay driver outputs.

*+3.5VDC present at +V pad under steady-state conditions. This voltage rises to +5.7VDC for about 100msec when relay configuration is changed.

6

Replaceable Parts

6.1 Introduction

This section contains replacement parts information, schematic diagrams, and component layout drawings for the Model 7012-S and 7012-C.

6.2 Parts lists

Parts lists for the various circuit boards are included in tables integrated with schematic diagrams and component layout drawings for the boards. Parts are listed alphabetically in order of circuit designation.

6.3 Ordering information

To place an order, or to obtain information concerning replacement parts, contact your Keithley representative or the factory (see inside front cover for addresses).

When ordering parts, be sure to include the following information:

1. Card model number (7012-S or 7012-C)
2. Card serial number
3. Part description
4. Circuit description, if applicable
5. Keithley part number

6.4 Factory service

If the card is to be returned to Keithley Instruments for repair, perform the following:

1. Complete the service form at the back of this manual and include it with the card.
2. Carefully pack the card in the original packing carton.
3. Write ATTENTION REPAIR DEPT on the shipping label.

Note: It is not necessary to return the mainframe with the card.

6.5 Component layouts and schematic diagrams

Component layout drawings and schematic diagrams are included on the following pages integrated with the parts lists:

- Table 1 Parts List, Relay Card for 7012-S and 7012-C.
- 7011-100 Component Layout, Relay Card for 7012-S and 7012-C.
- 7011-106 Schematic, Relay Card for 7012-S and 7012-C.

NOTE

The Model 7011 and 7012 use the same relay card, only the connector cards are different.

- Table 2 Parts List, Screw Terminated Connector Card for 7012-S.

7012-160 Component Layout, Screw Terminated Connector Card for 7012-S.

7012-166 Schematic, Screw Terminated Connector Card for 7012-S.

Table 3 Parts List, Mass Terminated Connector Card for 7012-C.

7012-170 Component Layout, Mass Terminated Connector Card for 7012-C.

7012-176 Schematic, Mass Terminated Connector Card for 7012-C.

Table 1. Relay Board for Model 7012-S and 7012-C, Parts List

Circuit Desig.	Description	Keithley Part No.
	EJECTOR ARM ROLL PIN (FOR EJECTOR ARMS) SHIELD SOCKET (FOR U105) 2-56X1/4 PHILLIPS PAN HD (FOR SCANNER SHIELD) 2-56X3/8 PHILLIPS PAN HEAD (P2001 TO STANDOFF) 4-40X1/4 PHILLIPS PAN HD SEMS SCREW (SCANNER BOARD TO TERMINAL BOARD) 4-40X3/16 PHIL. PAN HD SEMS (FOR Q100)	7011-301 DP-6-1 7011-305 SO-72 2-56X1/4PPH 2-56X3/8PPH 4-40X1/4PPHSEM 4-40X3/16PPHSEM
C100-105,107-109,118,119	CAP,.1UF,20%,50V,CERAMIC	C-365-.1
C106	CAP,.1UF,20%,50V,CERAMIC	C-365-.1
C110,111	CAP,1UF,20%,50V, CERAMIC	C-237-1
C112	CAP, 0.001uF, 20%, 500V, CERAMIC	C-22-.001
C113,114	CAP, 10UF,-20+100%,25V,ALUM ELEC	C-314-10
C115-117	CAP,150PF,10%,1000V,CERAMIC	C-64-150P
J1002,1003	CONNECTOR, MALE	CS-736-2
K100-139	RELAY, ULTRA-SMALL POLARIZED TF2E-5V	RL-149
P2001	CONNECTOR, RIGHT ANGLE MALE	CS-775-1
Q100	TRANS, NPN PWR, TIP31, (TO-220AB)	TG-253
Q101	TRANS,N CHAN MOSPWFET,V11713 (TO-92)	TG-195
R100	RES, 2.49K, 1%, 1/8W, METAL FILM	R-88-2.49K
R101	RES, 1.15K, 1%, 1/8W, METAL FILM	R-88-1.15K
R102,103	RES, 560, 10%, 1/2W, COMPOSITION	R-1-560
R104	RES,1K,1%,1/8W,METAL FILM	R-88-1K
R105	RES,220K,5%,1/4W,COMPOSITION OR FILM	R-76-220K
R106	RES,10K,5%,1/4W,COMPOSITION OR FILM	R-76-10K
U100-104	IC, 8-BIT SERIAL-IN LATCH DRIVER, 5841A	IC-536
U105	EPROM PROGRAM	7012-800-***
U106	IC,RETRIG MONO MULTIVIB,74HC123	IC-492
U107	IC,AJD SHUNT REGULATOR,TL431CLP	IC-677
W100-107	JUMPER	J-15

*** Order current firmware revision level.

001-1102.ON

LTR.	ECO NO.	REVISION	ENG.	DATE
B		PRELIMINARY		
C	910920	RELEASED	MS	9-20-91
D	15129	DELETED 2-56x3/8PPH(2 REQ'D)	SZ	8-5-92
D1	15453	ADDED MC-612, CHART FOR 7014, AND NOTE TO INSTALL W108 TO 7014 ONLY	SZ	9-1-92
D2	15565	RELOCATED MC-285 ON MODEL 7014	AS	11-30-92
E	15452	CHG'D ARTWORK FROM REV D TO E.		5-20-93
E2	25917	CHG'D U08 FROM TC737 TO TC17-100. DELETED R572.	KK	6/18/01

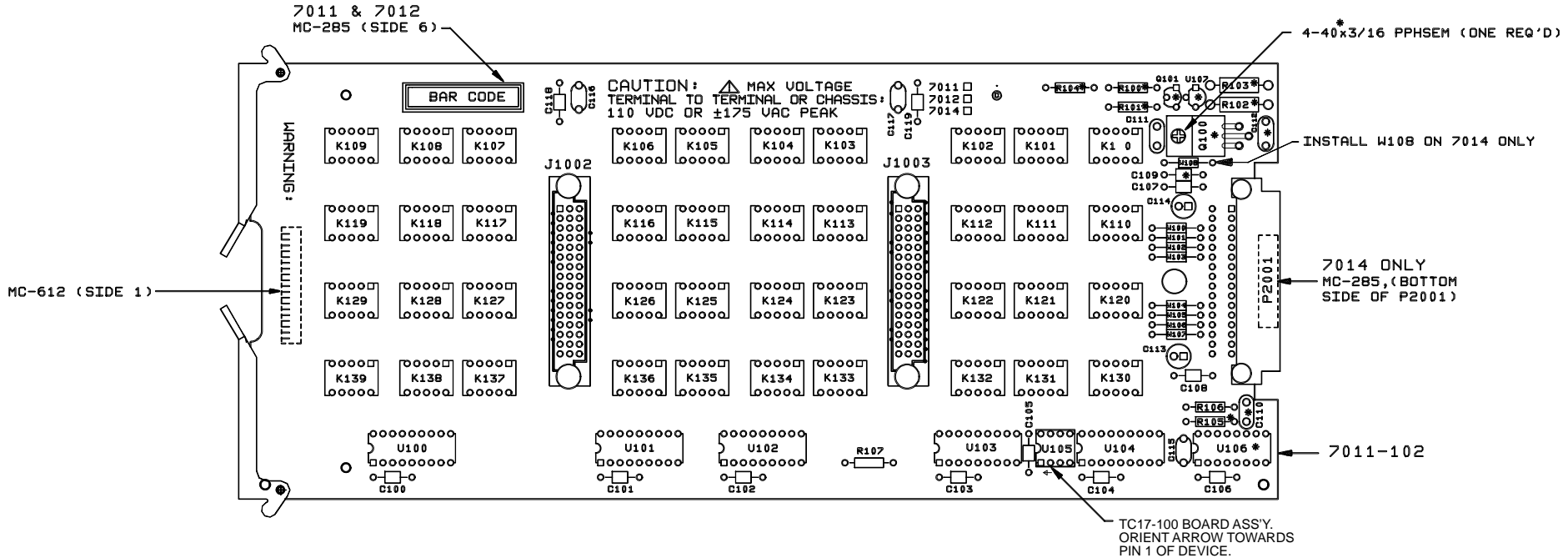

* FOR 7014 BUILD, DO NOT INSTALL THE FOLLOWING PARTS

R100	Q100	U106	C109
R101	Q101	U107	C110
R102			C112
R103			
R104		4-40X3/16PPHSEM	
R105			

NOTE: FOR COMPONENT INFORMATION, REFER TO PRODUCT STRUCTURE FOR 7011, 7012 AND 7014

MODEL	NEXT ASSEMBLY	QTY.
7014	7011-101	1
7012	7011-101	1
7011	7011-101	1

USED ON

DO NOT SCALE THIS DRAWING		DIMENSIONAL TOLERANCES UNLESS OTHERWISE SPECIFIED		DATE 8/12/91	SCALE 5:4	TITLE
KEITHLEY KEITHLEY INSTRUMENTS INC. CLEVELAND, OHIO 44139		XX=±.015	ANG.=±1°	DRN. KEK	ENG. APPR.	COMPONENT LAYOUT SCANNER BOARD
		XXX=±.005	FRAC.=±1/64	MATERIAL		NO. 7011-100
		SURFACE MAX. 3		FINISH		

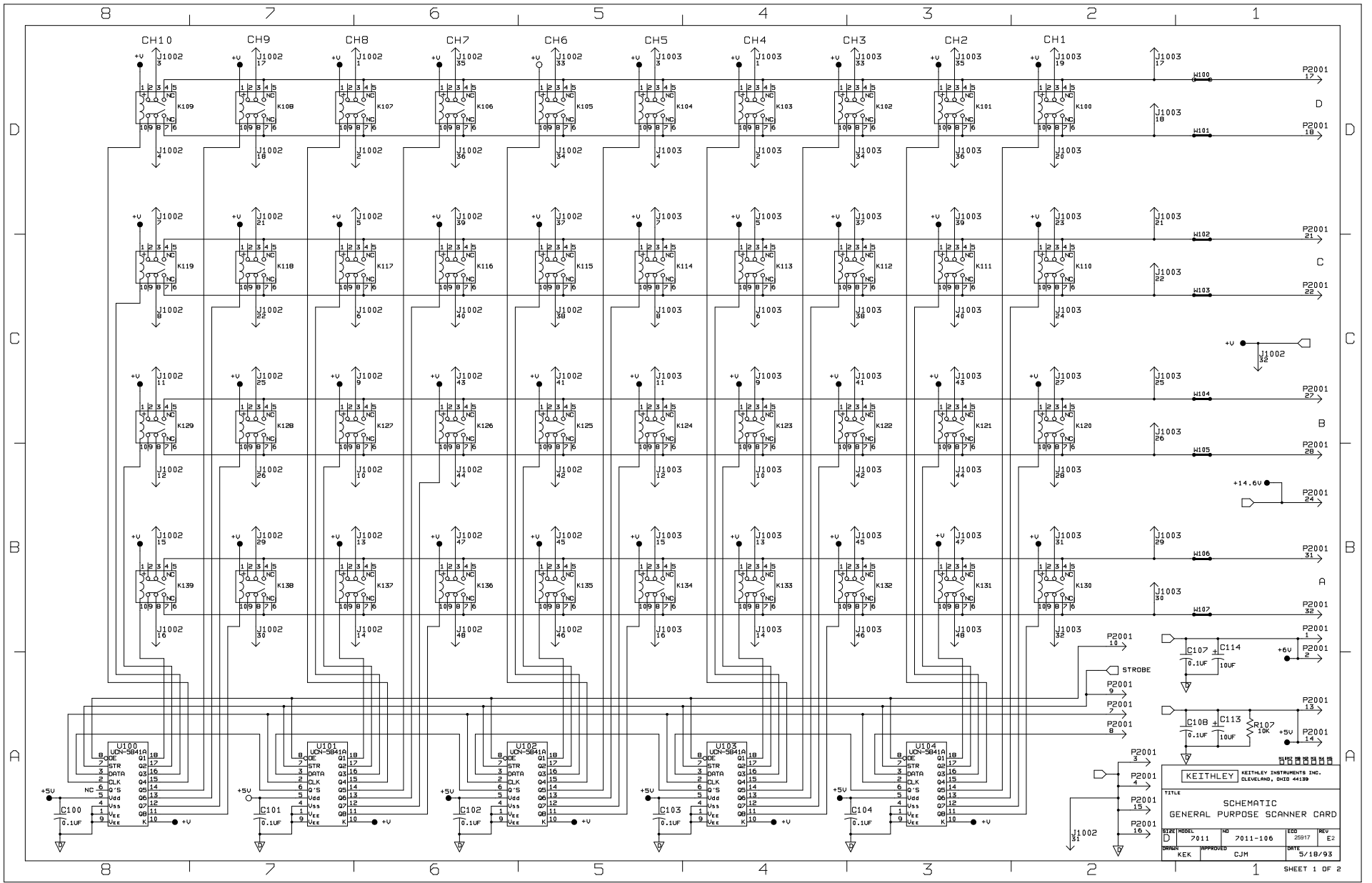

KEITHLEY KEITHLEY INSTRUMENTS INC.
CLEVELAND, OHIO 44139

TITLE
SCHEMATIC
GENERAL PURPOSE SCANNER CARD

SIZE	MODEL	NO	REV
D	7011	7011-106	25917 E2
ORIGIN	APPROVED	DATE	
KEK	CJM	5/18/93	

SHEET 1 OF 2

8 7 6 5 4 3 2 1

D
C
B
A

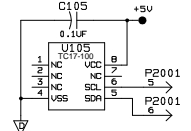
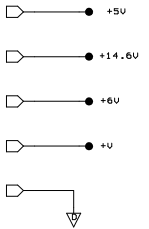

- P2001 NC_11 >
- P2001 NC_12 >
- P2001 NC_19 >
- P2001 NC_20 >
- P2001 NC_23 >
- P2001 NC_25 >
- P2001 NC_26 >
- P2001 NC_29 >
- P2001 NC_31 >

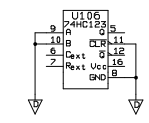
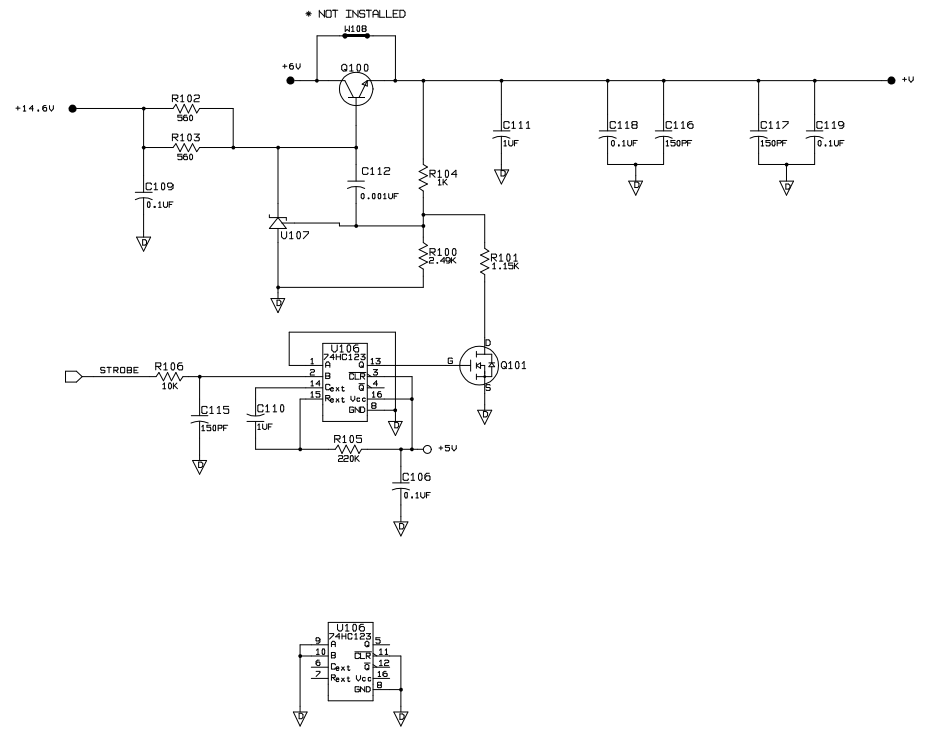

KEITHLEY		KEITHLEY INSTRUMENTS INC.	
		CLEVELAND, OHIO 44139	
TITLE			
SCHEMATIC			
GENERAL PURPOSE SCANNER CARD			
SIZE	MODEL	NO	EDG
D	7011	7011-106	25917
DRGR	APPROVED	DATE	REV
KEK	CJM	5/18/93	E2
			SHEET 2 OF 2

8 7 6 5 4 3 2 1

Table 2. Screw Terminal Board for Model 7012-S, Parts List

Circuit Desig.	Description	Keithley Part No.
J1004,1006 J1005,1007 P1002,1003	CABLE CLAMP CAPTIVE SCREW (FOR TOP CLAMP) CONNECTOR SHIM (FOR P1002, 1003) SHIELD STRIP, POLYURETHANE (FOR BOTTOM CLAMP) TOP CLAMP 2-56X7/16 PHILLIPS PAN HEAD (FOR TERMINAL SHIELD BOARD) CONN, 6 PIN CONN, 8 PIN CONNECTOR, FEMALE	7011-304-2 FA-243-1 7011-309 7011-305 2001-345-1 7011-302 2-56X7/16PPH TE-115-6 TE-115-8 CS-748-3

091-2102.ON

LTR.	ECD NO.	REVISION	ENG.	DATE
B		PRELIMINARY		
C	910920	RELEASED	MS	9-20-91
D	15129	REVISED	S2	8-26-93

- 7011-302 (TOP CLAMP)
- 7011-304-2 (CLAMP SILKSCREEN)
- 2001-345-1 (POLYURETHANE STRIP)
- FA-243-1 (CAPTIVE PANEL SCREW)

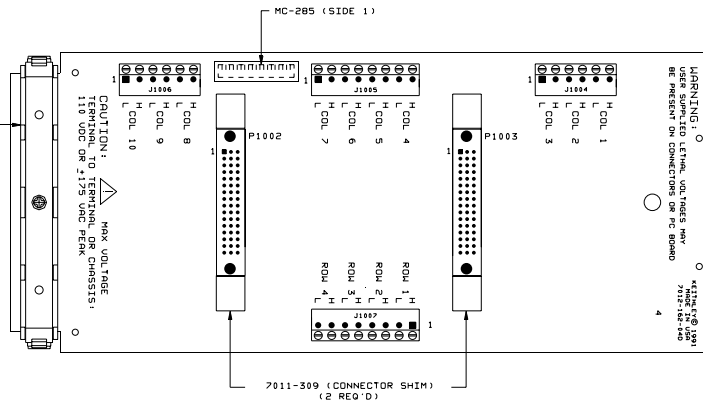

NOTE:
FOR COMPONENT INFORMATION, REFER TO PRODUCT STRUCTURE.

MODEL	NEXT ASSEMBLY	QTY.

DO NOT SCALE THIS DRAWING	DIMENSIONS IN INCHES UNLESS OTHERWISE SPECIFIED	DATE 8/28/91	SCALE 1:1	TITLE COMPONENT LAYOUT
KEITHLEY KEITHLEY INSTRUMENTS INC. CLEVELAND, OHIO 44139	XX=1.015 ANG.=1° DRN. KEK	ENG. JJK/CH	TERMINAL BLOCK BOARD	NO. 7012-160
	XXX=1.005 FRAC.=1/64 MATERIAL	FINISH		
	SURFACE MAX. 63			

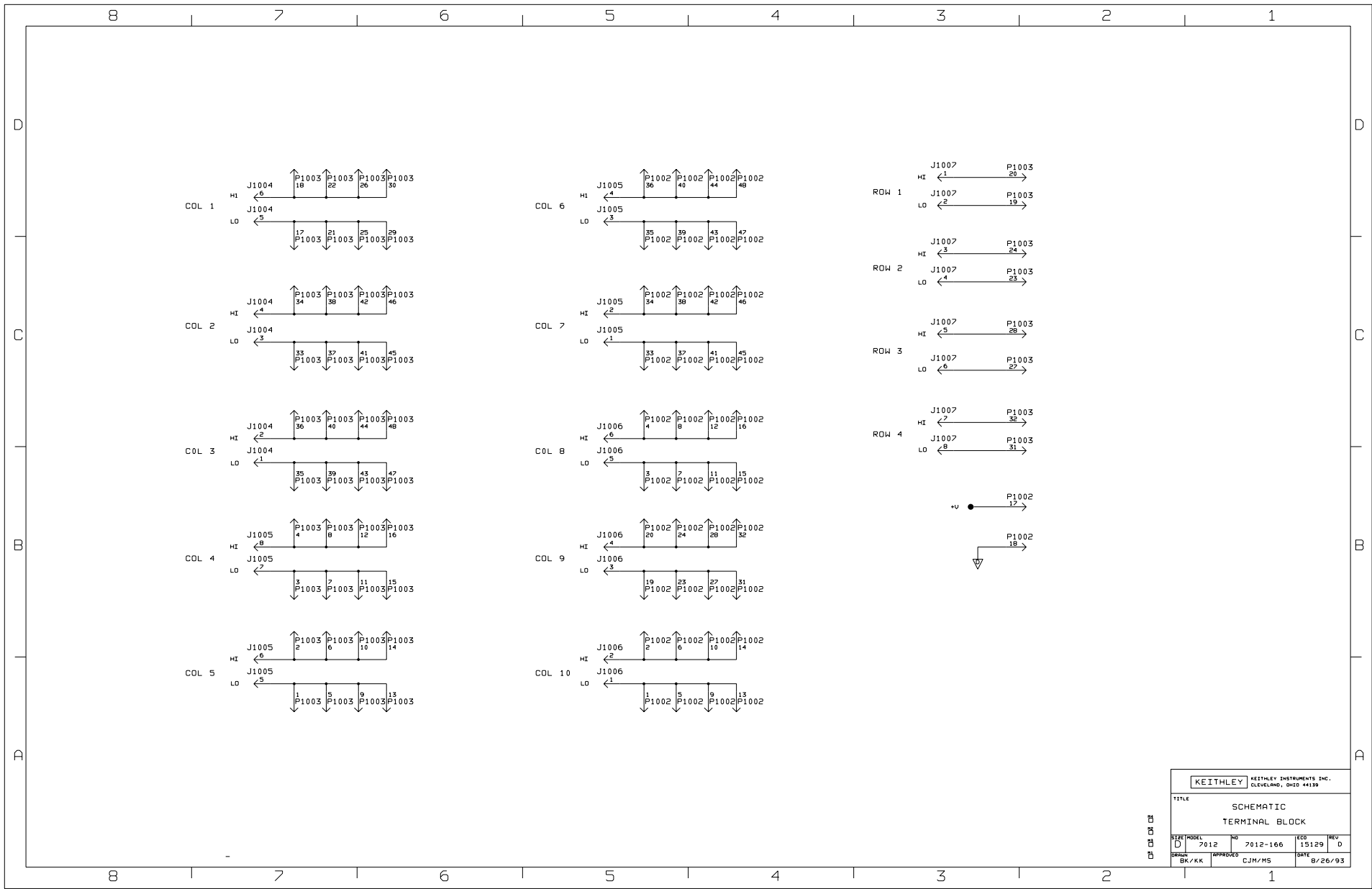

KEITHLEY		KEITHLEY INSTRUMENTS INC.	
		CLEVELAND, OHIO 44139	
TITLE			
SCHEMATIC			
TERMINAL BLOCK			
SIZE	MODEL	NO	ECO
D	7012	7012-166	15129
DESIGN	APPROVED	DATE	REV
BR/KK	CJM/MS	8/26/93	0

Table 3. Mass Terminated Connector Card for 7012-C, Parts List

Circuit Desig.	Description	Keithley Part No.
	BRACKET CONNECTOR SHIM SHIELD STANDOFF	7011-307 7011-309 7011-311 ST-203-1
C101	CAP,.1UF,20%,50V,CERAMIC	C-365-.1
CR101-104	DIODE,SILICON,IN4148 (DO-35)	RF-28
E101,102	BEAD, FERRITE	CT-9
J1004	CONN, 96-PIN, 3 ROWS	CS-514
K101-104	RELAY, ULTRA-SMALL POLARIZED TF2E-4.5V	RL-162
P1002,1003	CONNECTOR, FEMALE	CS-748-3
Q101	TRANS,NPN SILICON,BUK456-1000B	TG-47
R101,102	RES, 220,10%, 1/2W, COMPOSITION	R-1-220
R103	RES,100K,5%,1/4W,COMPOSITION OR FILM	R-76-100K

7012-2102-01

LTR.	ECO NO.	REVISION	ENG.	DATE
B	15005	RELEASED	52	1-2-92

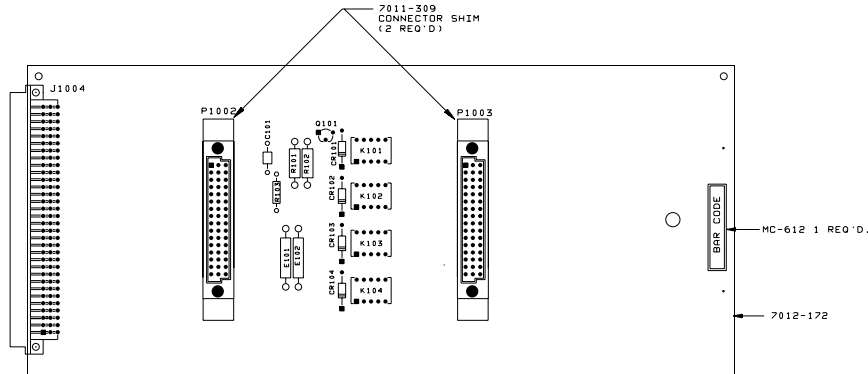

NOTE: FOR COMPONENT INFORMATION
REFER TO PRODUCT STRUCTURE.

7012		
MODEL	NEXT ASSEMBLY	QTY.

DO NOT SCALE THIS DRAWING	DIMENSIONAL TOLERANCES UNLESS OTHERWISE SPECIFIED	DATE 12/18/91	SCALE 1:1	TITLE	COMPONENT LAYOUT, MASS TERM. CARD
KEITHLEY INSTRUMENTS INC. CLEVELAND, OHIO 44139	XX±.015 ANG.±1°	DRN. MAH	ENG. CUN MS APPR. WJK		
	XXX±.005 FRAC.±1/64	MATERIAL			
	SURFACE MAX. 63	FINISH			
				C	NO. 7012-170

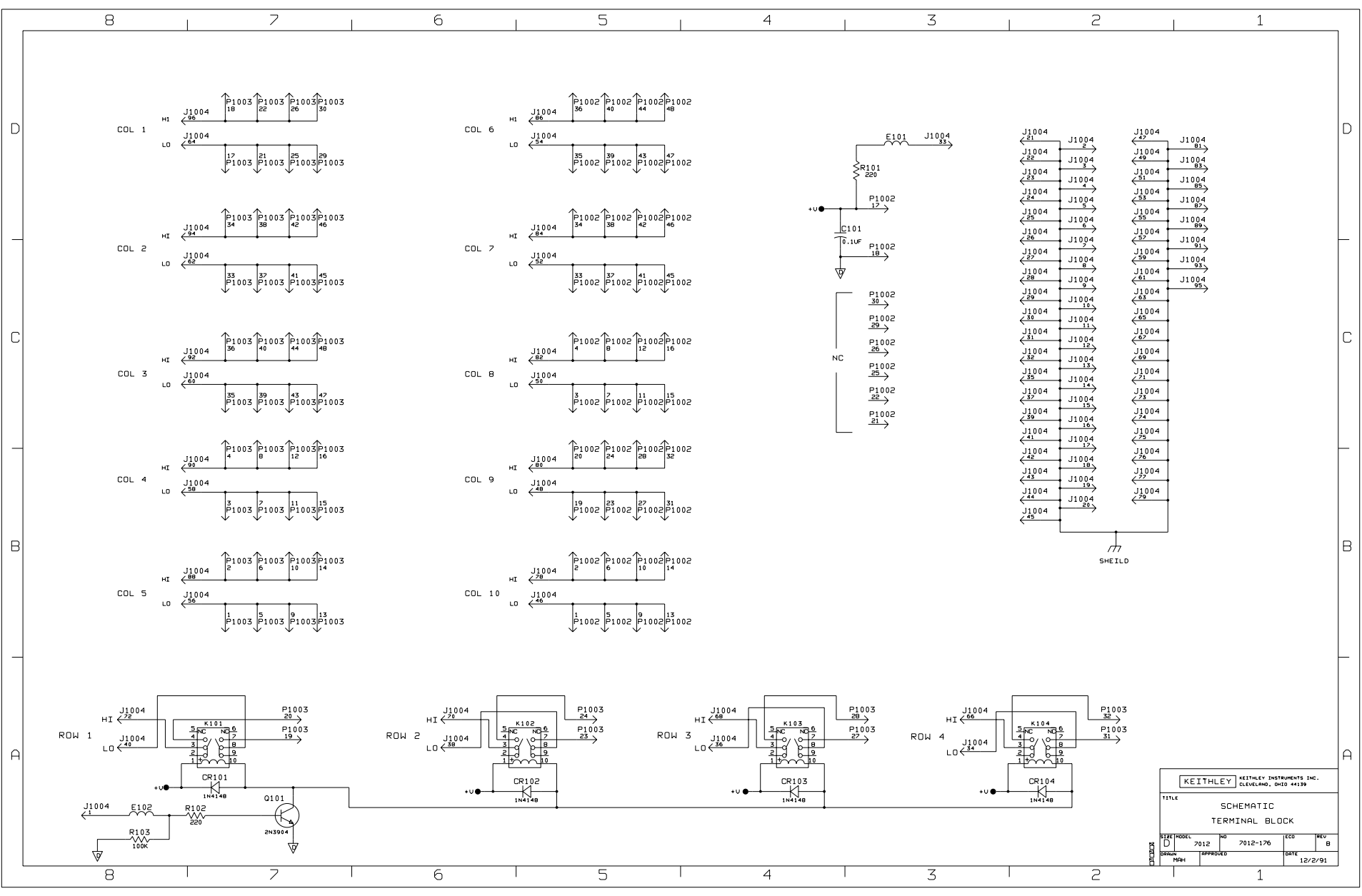

KEITHLEY KEITHLEY INSTRUMENTS INC. CLEVELAND, OHIO 44139			
TITLE SCHEMATIC TERMINAL BLOCK			
SIZE	MODEL	NO	REV
D	7012	7012-176	LED
DATE	APPROVED	DATE	REV
12/2/91			B



Service Form

Model No. _____ Serial No. _____ Date _____

Name and Telephone No. _____

Company _____

List all control settings, describe problem and check boxes that apply to problem. _____

- | | | |
|--|--|--|
| <input type="checkbox"/> Intermittent | <input type="checkbox"/> Analog output follows display | <input type="checkbox"/> Particular range or function bad; specify |
| <input type="checkbox"/> IEEE failure | <input type="checkbox"/> Obvious problem on power-up | <input type="checkbox"/> Batteries and fuses are OK |
| <input type="checkbox"/> Front panel operational | <input type="checkbox"/> All ranges or functions are bad | <input type="checkbox"/> Checked all cables |

Display or output (check one)

- | | |
|-----------------------------------|--|
| <input type="checkbox"/> Drifts | <input type="checkbox"/> Unable to zero |
| <input type="checkbox"/> Unstable | <input type="checkbox"/> Will not read applied input |
| <input type="checkbox"/> Overload | |

- | | |
|---|--|
| <input type="checkbox"/> Calibration only | <input type="checkbox"/> Certificate of calibration required |
| <input type="checkbox"/> Data required | |

(attach any additional sheets as necessary)

Show a block diagram of your measurement system including all instruments connected (whether power is turned on or not). Also, describe signal source.

Where is the measurement being performed? (factory, controlled laboratory, out-of-doors, etc.)

What power line voltage is used? _____ Ambient temperature? _____ °F

Relative humidity? _____ Other? _____

Any additional information. (If special modifications have been made by the user, please describe.)

Be sure to include your name and phone number on this service form.

KEITHLEY

Keithley Instruments, Inc.
28775 Aurora Road
Cleveland, Ohio 44139
Printed in the U.S.A.