

# Model 7065 Hall Effect Card

## Instruction Manual

7065-901-01 Rev. C / July 2009

# WARRANTY

Keithley Instruments, Inc. warrants this product to be free from defects in material and workmanship for a period of one (1) year from date of shipment.

Keithley Instruments, Inc. warrants the following items for 90 days from the date of shipment: probes, cables, software, rechargeable batteries, diskettes, and documentation.

During the warranty period, Keithley Instruments will, at its option, either repair or replace any product that proves to be defective.

To exercise this warranty, write or call your local Keithley Instruments representative, or contact Keithley Instruments headquarters in Cleveland, Ohio. You will be given prompt assistance and return instructions. Send the product, transportation prepaid, to the indicated service facility. Repairs will be made and the product returned, transportation prepaid. Repaired or replaced products are warranted for the balance of the original warranty period, or at least 90 days.

## LIMITATION OF WARRANTY

This warranty does not apply to defects resulting from product modification without Keithley Instruments' express written consent, or misuse of any product or part. This warranty also does not apply to fuses, software, non-rechargeable batteries, damage from battery leakage, or problems arising from normal wear or failure to follow instructions.

THIS WARRANTY IS IN LIEU OF ALL OTHER WARRANTIES, EXPRESSED OR IMPLIED, INCLUDING ANY IMPLIED WARRANTY OF MERCHANTABILITY OR FITNESS FOR A PARTICULAR USE. THE REMEDIES PROVIDED HEREIN ARE BUYER'S SOLE AND EXCLUSIVE REMEDIES.

NEITHER KEITHLEY INSTRUMENTS, INC. NOR ANY OF ITS EMPLOYEES SHALL BE LIABLE FOR ANY DIRECT, INDIRECT, SPECIAL, INCIDENTAL, OR CONSEQUENTIAL DAMAGES ARISING OUT OF THE USE OF ITS INSTRUMENTS AND SOFTWARE, EVEN IF KEITHLEY INSTRUMENTS, INC. HAS BEEN ADVISED IN ADVANCE OF THE POSSIBILITY OF SUCH DAMAGES. SUCH EXCLUDED DAMAGES SHALL INCLUDE, BUT ARE NOT LIMITED TO: COST OF REMOVAL AND INSTALLATION, LOSSES SUSTAINED AS THE RESULT OF INJURY TO ANY PERSON, OR DAMAGE TO PROPERTY.

**KEITHLEY**

A G R E A T E R M E A S U R E O F C O N F I D E N C E

**Keithley Instruments, Inc.**

Corporate Headquarters • 28775 Aurora Road • Cleveland, Ohio 44139  
440-248-0400 • Fax: 440-248-6168 • 1-888-KEITHLEY (1-888-534-8453) • [www.keithley.com](http://www.keithley.com)

# Model 7065 Hall Effect Card Instruction Manual

©1986-2009, Keithley Instruments, Inc.  
All rights reserved.  
Cleveland, Ohio, U.S.A.  
Document number: 7065-901-01 Rev. C / July 2009

The following safety precautions should be observed before using this product and any associated instrumentation. Although some instruments and accessories would normally be used with non-hazardous voltages, there are situations where hazardous conditions may be present.

This product is intended for use by qualified personnel who recognize shock hazards and are familiar with the safety precautions required to avoid possible injury. Read and follow all installation, operation, and maintenance information carefully before using the product. Refer to the user documentation for complete product specifications.

If the product is used in a manner not specified, the protection provided by the product warranty may be impaired.

The types of product users are:

**Responsible body** is the individual or group responsible for the use and maintenance of equipment, for ensuring that the equipment is operated within its specifications and operating limits, and for ensuring that operators are adequately trained.

**Operators** use the product for its intended function. They must be trained in electrical safety procedures and proper use of the instrument. They must be protected from electric shock and contact with hazardous live circuits.

**Maintenance personnel** perform routine procedures on the product to keep it operating properly, for example, setting the line voltage or replacing consumable materials. Maintenance procedures are described in the user documentation. The procedures explicitly state if the operator may perform them. Otherwise, they should be performed only by service personnel.

**Service personnel** are trained to work on live circuits, perform safe installations, and repair products. Only properly trained service personnel may perform installation and service procedures.

Keithley Instruments products are designed for use with electrical signals that are rated Measurement Category I and Measurement Category II, as described in the International Electrotechnical Commission (IEC) Standard IEC 60664. Most measurement, control, and data I/O signals are Measurement Category I and must not be directly connected to mains voltage or to voltage sources with high transient over-voltages. Measurement Category II connections require protection for high transient over-voltages often associated with local AC mains connections. Assume all measurement, control, and data I/O connections are for connection to Category I sources unless otherwise marked or described in the user documentation.

Exercise extreme caution when a shock hazard is present. Lethal voltage may be present on cable connector jacks or test fixtures. The American National Standards Institute (ANSI) states that a shock hazard exists when voltage levels greater than 30V RMS, 42.4V peak, or 60VDC are present. A good safety practice is to expect that hazardous voltage is present in any unknown circuit before measuring.

Operators of this product must be protected from electric shock at all times. The responsible body must ensure that operators are prevented access and/or insulated from every connection point. In some cases, connections must be exposed to potential human contact. Product operators in these circumstances must be trained to protect themselves from the risk of electric shock. If the circuit is capable of operating at or above 1000V, no conductive part of the circuit may be exposed.

Do not connect switching cards directly to unlimited power circuits. They are intended to be used with impedance-limited sources. NEVER connect switching cards directly to AC mains. When connecting sources to switching cards, install protective devices to limit fault current and voltage to the card.

Before operating an instrument, ensure that the line cord is connected to a properly-grounded power receptacle. Inspect the connecting cables, test leads, and jumpers for possible wear, cracks, or breaks before each use.

When installing equipment where access to the main power cord is restricted, such as rack mounting, a separate main input power disconnect device must be provided in close proximity to the equipment and within easy reach of the operator.

For maximum safety, do not touch the product, test cables, or any other instruments while power is applied to the circuit under test. ALWAYS remove power from the entire test system and discharge any capacitors before: connecting or disconnecting cables or jumpers, installing or removing switching cards, or making internal changes, such as installing or removing jumpers.

Do not touch any object that could provide a current path to the common side of the circuit under test or power line (earth) ground. Always make measurements with dry hands while standing on a dry, insulated surface capable of withstanding the voltage being measured.

The instrument and accessories must be used in accordance with its specifications and operating instructions, or the safety of the equipment may be impaired.

Do not exceed the maximum signal levels of the instruments and accessories, as defined in the specifications and operating information, and as shown on the instrument or test fixture panels, or switching card.

When fuses are used in a product, replace with the same type and rating for continued protection against fire hazard.

Chassis connections must only be used as shield connections for measuring circuits, NOT as safety earth ground connections.

If you are using a test fixture, keep the lid closed while power is applied to the device under test. Safe operation requires the use of a lid interlock.

If a  screw is present, connect it to safety earth ground using the wire recommended in the user documentation.

The  symbol on an instrument means caution, risk of danger. The user should refer to the operating instructions located in the user documentation in all cases where the symbol is marked on the instrument.

The  symbol on an instrument means caution, risk of danger. Use standard safety precautions to avoid personal contact with these voltages.

The  symbol on an instrument shows that the surface may be hot. Avoid personal contact to prevent burns.

The  symbol indicates a connection terminal to the equipment frame.

If this  symbol is on a product, it indicates that mercury is present in the display lamp. Please note that the lamp must be properly disposed of according to federal, state, and local laws.

The **WARNING** heading in the user documentation explains dangers that might result in personal injury or death. Always read the associated information very carefully before performing the indicated procedure.

The **CAUTION** heading in the user documentation explains hazards that could damage the instrument. Such damage may invalidate the warranty.

Instrumentation and accessories shall not be connected to humans.

Before performing any maintenance, disconnect the line cord and all test cables.

To maintain protection from electric shock and fire, replacement components in mains circuits - including the power transformer, test leads, and input jacks - must be purchased from Keithley Instruments. Standard fuses with applicable national safety approvals may be used if the rating and type are the same. Other components that are not safety-related may be purchased from other suppliers as long as they are equivalent to the original component (note that selected parts should be purchased only through Keithley Instruments to maintain accuracy and functionality of the product). If you are unsure about the applicability of a replacement component, call a Keithley Instruments office for information.

To clean an instrument, use a damp cloth or mild, water-based cleaner. Clean the exterior of the instrument only. Do not apply cleaner directly to the instrument or allow liquids to enter or spill on the instrument. Products that consist of a circuit board with no case or chassis (e.g., a data acquisition board for installation into a computer) should never require cleaning if handled according to instructions. If the board becomes contaminated and operation is affected, the board should be returned to the factory for proper cleaning/servicing.

# TABLE OF CONTENTS

Instruction Manual Addendum.....0-1

## SECTION 1 — GENERAL INFORMATION

1.1	INTRODUCTION .....	1-1
1.2	FEATURES .....	1-1
1.3	WARRANTY INFORMATION .....	1-1
1.4	MANUAL ADDENDA .....	1-1
1.5	SAFETY SYMBOLS AND TERMS .....	1-1
1.6	SPECIFICATIONS .....	1-2
1.7	UNPACKING AND INSPECTION .....	1-2
1.8	REPACKING FOR SHIPMENT .....	1-2
1.9	RECOMMENDED EQUIPMENT .....	1-2
1.10	SCANNER COMPATIBILITY .....	1-3

## SECTION 2 - OPERATION

2.1	INTRODUCTION .....	2-1
2.2	HANDLING PRECAUTIONS .....	2-1
2.3	MODEL 7065 INSTALLATION .....	2-1
2.3.1	Installation in the Model 705 Scanner .....	2-2
2.3.2	Installation in the Model 706 Scanner .....	2-2
2.4	CONNECTIONS .....	2-4
2.4.1	Card Connectors .....	2-4
2.4.2	Recommended Cables and Wires .....	2-6
2.4.3	Cable and Wire Preparation .....	2-6
2.4.4	Van der Pauw Sample Connections .....	2-8
2.4.5	Bar Type Sample Connections .....	2-11
2.4.6	Bridge and Parallelpiped Type Sample .....	2-16
2.4.7	Shorting the Current Monitor Output .....	2-21
2.4.8	IEEE-488 Bus Connections .....	2-21
2.5	MATRIX AND TEST CONFIGURATIONS .....	2-21
2.5.1	Model 7065 matrix .....	2-21
2.5.2	Test System .....	2-21
2.6	GUARDING METHODS .....	2-24
2.6.1	Principles of Guarding .....	2-24
2.6.2	Current Source Input Guarding .....	2-26
2.6.3	Sample Input Guarding .....	2-28
2.7	RESISTIVITY SELECTION .....	2-33
2.7.1	Selecting the Resistivity Setup .....	2-33
2.7.2	Input Characteristics .....	2-33
2.7.3	Equivalent Input Circuits .....	2-33
2.7.4	Resistivity Setup Criteria .....	2-34
2.8	FRONT PANEL SCANNER PROGRAMMING .....	2-37
2.8.1	Entering the Matrix Mode .....	2-37
2.8.2	Scanner Display Formats .....	2-37
2.8.3	Crosspoint Programming .....	2-38
2.9	IEEE-488 BUS PROGRAMMING .....	2-38
2.9.1	Matrix Bus Commands .....	2-38
2.9.2	Example Programs .....	2-39

2.10	MEASUREMENT CONSIDERATIONS .....	2-39
2.10.1	Input Voltage Levels .....	2-40
2.10.2	Leakage Resistance .....	2-40
2.10.3	Input Loading .....	2-41
2.10.4	Input Capacitance .....	2-41
2.10.5	Electrostatic Interference .....	2-42
2.10.6	RFI .....	2-42
2.10.7	Ground Loops .....	2-43
2.10.8	Offsets .....	2-43

## SECTION 3 — APPLICATIONS

3.1	INTRODUCTION .....	3-1
3.2	RECOMMENDED EQUIPMENT .....	3-1
3.3	HALL EFFECT CONVENTIONS AND PRINCIPLES .....	3-1
3.3.1	Hall Effect Sign Convention .....	3-1
3.3.2	Terminal Conventions .....	3-2
3.3.3	Basic Hall Effect Principles .....	3-2
3.4	VAN DER PAUW RESISTIVITY MEASUREMENTS .....	3-5
3.4.1	Test Configuration .....	3-5
3.4.2	Test Procedure .....	3-5
3.4.3	Resistivity Calculations .....	3-7
3.5	HALL VOLTAGE MEASUREMENTS .....	3-7
3.5.1	Test Configuration .....	3-7
3.5.2	Test Procedure .....	3-8
3.5.3	Hall Coefficient Calculations .....	3-9
3.5.4	Hall Mobility Calculation .....	3-9
3.6	MEASURING BAR TYPE SAMPLES .....	3-9
3.6.1	Test Configurations .....	3-9
3.6.2	Determining Potentiometer Values .....	3-12
3.6.3	Bar Resistivity Measurements .....	3-14
3.6.4	Hall Voltage Measurements .....	3-14
3.6.5	Calculations .....	3-15
3.7	MEASURING BRIDGE AND PARALLELPiped TYPE SPECIMENS .....	3-15
3.7.1	Test Configurations .....	3-15
3.7.2	Resistivity Measurements .....	3-19
3.7.3	Hall Voltage Measurements .....	3-20
3.7.4	Calculations .....	3-20
3.8	SAMPLE RESISTIVITY AND HALL VOLTAGE PROGRAMS .....	3-23
3.8.1	Test Configurations .....	3-23
3.8.2	Instrument Programming .....	3-27
3.8.3	Program Listings .....	3-27

## SECTION 4 — SERVICE INFORMATION

4.1	INTRODUCTION .....	4-1
4.2	HANDLING AND CLEANING PRECAUTIONS .....	4-1
4.3	PERFORMANCE VERIFICATION .....	4-1
4.3.1	Environmental Conditions .....	4-1
4.3.2	Warm Up Period .....	4-1
4.3.3	Recommended Equipment .....	4-1
4.3.4	High-Impedance Considerations .....	4-2
4.3.5	Input Current Verification .....	4-2
4.3.6	Input Resistance Verification .....	4-4
4.3.7	Voltage Offset Verification .....	4-6

4.4	ADJUSTMENTS .....	4-8
4.4.1	Environmental Conditions.....	4-8
4.4.2	Warm Up Period .....	4-8
4.4.3	Recommended Test Equipment .....	4-8
4.4.4	Adjustment Locations.....	4-8
4.4.5	Offset Adjustments .....	4-9
4.4.6	Common-Mode Adjustment .....	4-11
4.5	THEORY OF OPERATION .....	4-12
4.5.1	Relay Switching Circuits .....	4-12
4.5.2	Buffers .....	4-12
4.5.3	Power Supply .....	4-12
4.6	SPECIAL HANDLING OF STATIC-SENSITIVE DEVICES .....	4-14
4.7	TROUBLESHOOTING .....	4-14
4.7.1	Recommended Equipment .....	4-14
4.7.2	Troubleshooting Procedure .....	4-14

## **SECTION 5 — REPLACEABLE PARTS**

5.1	INTRODUCTION .....	5-1
5.2	PARTS LIST .....	5-1
5.3	ORDERING INFORMATION .....	5-1
5.4	FACTORY SERVICE .....	5-1
5.5	COMPONENT LAYOUT AND SCHEMATIC DIAGRAM .....	5-1



# LIST OF TABLES

## SECTION 1 — GENERAL INFORMATION

1-1	Supplied Accessories .....	1-2
1-2	Recommended Hall System Equipment .....	1-3

## SECTION 2 — OPERATION

2-1	Terminal Strip Connections .....	2-4
2-2	Recommended Cables .....	2-6
2-3	Resistivity Select Summary .....	2-33
2-4	Input Characteristic Summary .....	2-33
2-5	Model 705 Unit 1 Column Summary by Card .....	2-37
2-6	Model 705 Column Assignments .....	2-37
2-7	Model 706 Unit 1 Column Summary by Card .....	2-38
2-8	Model 706 Column Assignments .....	2-38
2-9	IEEE-488 Bus Command Summary .....	2-38
2-10	Voltage and Percent Error For Various Time Constants .....	2-42

## SECTION 3 — APPLICATIONS

3-1	Recommended Equipment .....	3-1
3-2	Measurement Units .....	3-1
3-3	Crosspoint Summary for Resistivity Measurements .....	3-5
3-4	Crosspoint Summary for Hall Voltage Measurements .....	3-8
3-5	Minimum and Maximum Potentiometer Values for Hall Bar Measurements .....	3-12
3-6	Crosspoint Configurations for Bar Measurements .....	3-15
3-7	6-Contact Sample Resistivity Measurements .....	3-19
3-8	8-Contact Sample Resistivity Measurements .....	3-19
3-9	6-Contact Sample Hall Voltage Measurements .....	3-20
3-10	8-Contact Sample Hall Voltage Measurements .....	3-20
3-11	HP-85 and HP-9816 Programming Language Differences .....	3-23

## SECTION 4 — SERVICE INFORMATION

4-1	Performance Verification Equipment .....	4-2
4-2	Crosspoint Closed to Measure Sample Input Voltage Offset .....	4-6
4-3	Equipment Needed for Adjustments .....	4-8
4-4	Crosspoints to Close When Adjusting Offsets .....	4-9
4-5	Troubleshooting Equipment .....	4-14
4-6	Troubleshooting Summary .....	4-15

## SECTION 5 — REPLACEABLE PARTS

5-1	Electrical Parts .....	5-2
5-2	Mechanical Parts .....	5-3

# LIST OF ILLUSTRATIONS

## SECTION 2 — OPERATION

2-1	Model 705, Card Installation .....	2-2
2-2	Model 706, Card Installation .....	2-3
2-3	Model 7065 Connectors .....	2-5
2-4	Single Wire Preparation .....	2-6
2-5	Shielded Cable Preparation .....	2-7
2-6	Triaxial Cable .....	2-8
2-7	Connections for Van Der Pauw Samples .....	2-9
2-8	Equivalent Circuit for Van Der Pauw Connections .....	2-10
2-9	Connections for Hall Voltage Measurements of Bar Type Samples .....	2-12
2-10	Equivalent Circuit for Hall Voltage Measurements of Bar Type Samples .....	2-13
2-11	Connections for Resistivity Measurements of Bar Type Samples .....	2-14
2-12	Equivalent Circuit for Resistivity Measurements of Bar Type Samples .....	2-15
2-13	Connections for 6-Contact Samples .....	2-17
2-14	6-Contact Equivalent Circuit (Current 1-2, Voltage 6-4) .....	2-18
2-15	Connections for 8-Contact Samples .....	2-19
2-16	8-Contact Sample Equivalent Circuit (Current 1-2, Voltage 6-4 shown) .....	2-20
2-17	Model 7065 Matrix Configuration .....	2-22
2-18	Basic Hall System Configuration .....	2-23
2-19	Unguarded Circuit .....	2-25
2-20	Guarded Circuit .....	2-26
2-21	Guarding Jumper Configurations .....	2-27
2-22	Shield Removal .....	2-29
2-23	Connections for Unguarded Current Source Input .....	2-30
2-24	Connections for Guarding Using 6167 Adapter .....	2-31
2-25	Equivalent Circuit for Input Guarding .....	2-32
2-26	Low and High Resistivity Equivalent Circuits .....	2-33
2-27	Gain Error, LO vs HI Resistivity Setup .....	2-35
2-28	Noise Performance, LO vs HI Resistivity Setup .....	2-36
2-29	Leakage Resistance Effects .....	2-40
2-30	Input Capacitance Effects .....	2-41
2-31	Exponential Response of Input Voltage .....	2-42
2-32	Multiple Ground Points Create a Ground Loop .....	2-43
2-33	Eliminating Ground Loops .....	2-43
2-34	Offset Cancellation .....	2-44

## SECTION 3 — APPLICATIONS

3-1	Hall-Effect Sign Conventions for n-type Materials .....	3-2
3-2	Hall-Effect Sign Conventions for p-type Materials .....	3-2
3-3	Resistivity Measurement Conventions .....	3-3
3-4	Hall Voltage Measurement Conventions .....	3-4
3-5	Measurement Configuration for Resistivity and Hall Voltage Measurements .....	3-6
3-6	Plot of $f$ vs $Q$ .....	3-7
3-7	Test Configuration for Resistivity Measurements of Bar Sample .....	3-10
3-8	Test Configuration for Hall Voltage Measurement of Bar Sample .....	3-11
3-9	Hall Bar Equivalent Circuit .....	3-13

3-10	Equivalent Potentiometer Circuit, High Resistivity .....	3-14
3-11	Equivalent Potentiometer Circuit, Low Resistivity .....	3-14
3-12	Bar Sample Dimensions .....	3-16
3-13	6-Contact Sample Connections .....	3-17
3-14	8-Contact Sample Connections .....	3-18
3-15	Sample Dimensions Necessary for Calculations .....	3-21
3-16	Test Configuration for Programs 1, 2, 5 and 6 .....	3-24
3-17	Test Configuration for Programs 3 and 7 .....	3-25
3-18	Test Configuration for Programs 4 and 6 .....	3-26

## **SECTION 4 — SERVICE INFORMATION**

4-1	Connections for Input Current Verification .....	4-3
4-2	Connections for Input Resistance Verification .....	4-5
4-3	Connections for Voltage Offset Verification .....	4-7
4-4	Adjustment Locations .....	4-8
4-5	Connections for Voltage Offset Adjustment .....	4-10
4-6	Connections for Common Mode Adjustment .....	4-11
4-7	Common Mode Adjustment Waveform .....	4-11
4-8	Model 7065 Block Diagram .....	4-13

## **SECTION 5 — REPLACEABLE PARTS**

5-1	Model 7065, Component Location Drawing .....	5-4
5-2	Model 7065, Schematic Diagram .....	5-5

**Keithley Instruments, Inc.**  
28775 Aurora Road  
Cleveland, Ohio 44139  
1-888-KEITHLEY  
www.keithley.com

## 1. Introduction

This addendum to the Model 7065 Instruction Manual is being provided in order to supply you with the latest information in the least possible time. Please read over this information before using the Model 7065 Hall Effect Card and associated equipment.

Although this addendum is intended primarily for purchasers of the Model 80A Hall Effect System, those who use the Model 7065 along with their own equipment may also find this information helpful.

## 2. Equipment Changes

References to the Model 705 Scanner throughout the Model 7065 Instruction Manual should be changed to the Model 7001 Switch System.

References to the Model 6167 Guarded Input Adapter throughout the Model 7065 Instruction Manual should be changed to the Model 6172 2-Slot Male to 3-Lug Female Triax Adapter.

References to the Model 7024-10 Triaxial Cable (10 ft) throughout the 7065 Instruction Manual should be changed to Model 7078-TRX-10 3-Slot Triax Cable (10 ft).

The Model 80A Hall Effect System has been discontinued, but drop-in replacements for all of its constituent parts may still be purchased.

The Model 80A consisted of:

- |  |   |
|--|---|
| • Model 7065 Hall Effect Card                        | Still available   |
| • Model 7001 Switch System                           | Still available   |
| • Model 485/4853 picoammeter with IEEE-488 interface | Replace with Model 6485 picoammeter (IEEE-488 interface standard) |
| • Model 220 current source                           | Replace with Model 6220 or 6221 current source                    |
| • Model 196 DMM                                      | Replace with Model 2000 DMM                                       |
| • (3) Model 7008-3 IEEE-488 cables                   | Still available   |

Each of the replacement models features an emulation mode to accept the control commands for the product it replaces, so all of the program code in this manual can be used directly with no modifications.

The main impact of this equipment change is on the example programs listed at the end of paragraph 3.8 in the Model 7065 Instruction Manual. These programs will not work with the Model 7001 Switch System and thus cannot be used with the Model 80A. Modified versions of these programs are included with this addendum.

The various test procedures discussed in Section 3 should also be changed for operation with the new switch system. The Model 7001 need not be placed in the matrix mode, but it must be configured for card type, as discussed in paragraph 5 of this addendum. In addition, you can simultaneously open or close all crosspoints for a given step in a test sequence with the OPEN and CLOSE keys. In order to do so, you must first set up a channel list, as discussed in paragraph 6.

Note that all signal connections covered in the Model 7065 Instruction Manual are still valid and can be used in setting up the Model 80A System.

### 3. Model 7001 Features

Some important Model 7001 features that are applicable to the Model 80A system include:

- Multiple Crosspoint Open/Close: All crosspoints for a given step in the test procedure can be opened or closed with a single keystroke.
- Crosspoint Status Display: The real-time status display monitors the state (closed or open) of all Model 7065 crosspoints.
- Memory: Up to 100 crosspoint patterns (pattern of open and closed crosspoints) can be saved in memory or later recall.
- IEEE-488 Bus: Bus operation conforms to the IEEE-488.2 and SCPI standards.

### 4. Installing the Card in the Model 7001 Switch System

Follow the steps below and refer to Figure 1 to install the Model 7065 Card in the Model 7001 Switch System. Note that some internal connections to the card must be made before installation. See paragraph 2.4 of the Model 7065 Instruction Manual for details on card connections.

---

---

**WARNING** *Internal connections and card installation should be performed only by qualified personnel who recognize potential shock hazards. Turn off the power from all instruments (including the Model 7001 mainframe), and disconnect all line cords before installing or removing the Hall Effect Card.*

---

---

---

---

**CAUTION** *Leave the Model 7065 in its anti-static bag until ready for installation to avoid possible static damage. After removing the card from the mainframe, store it in the anti-static bag.*

---

---

#### Card Installation

Perform the following steps to install the Model 7065 in the Model 7001 mainframe:

1. Make the necessary internal card connections, as discussed in paragraph 2.4 of the instruction manual.
2. Facing the rear panel of the Model 7001, select the slot (CARD 1 or CARD 2) in which you wish to install the Hall Effect Card.

---

**NOTE** The information and programming examples in this addendum assume that the card is installed in the CARD 1 slot. Install the Model 7065 in CARD 1 if you intend to use these examples.

---

3. Referring to Figure 1, slide the card assembly with the component (large shield) side up into the desired slot such that the edges of the card ride in the rails.
4. With the ejector arms in the unlocked position, push the card into the mainframe until the arms engage the ejector cups, then push both arms inward to lock the card into the mainframe.

**Figure 1: Installing the Model 7065 Hall Effect Card in the Model 7001 Switch System**

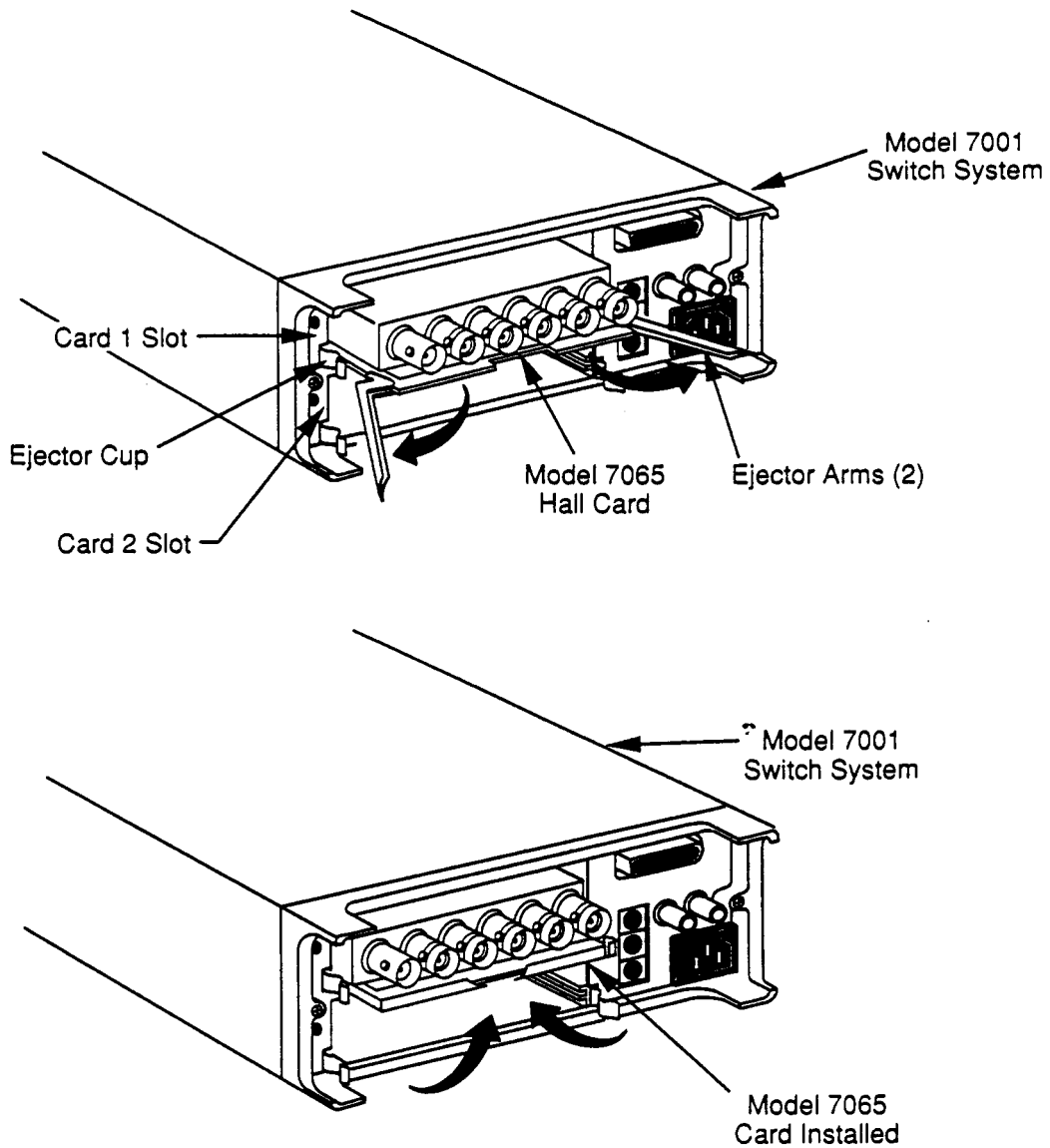

### **Card Removal**

To remove the card, first unlock it by pulling the ejector arms outward, then pull the card out of the mainframe. Store the card in its anti-static bag to avoid possible damage during storage.

### **5. Card Configuration**

The Model 7001 must be properly configured so that it can recognize the Model 7065 card. Follow the steps below to configure the mainframe for use with the Model 7065:

1. From normal display, press the Model 7001 CARD CONFIGURATION key.
2. Select TYPE, then press ENTER.
3. Select SLOT-1 (or SLOT-2 if the card is installed in that slot), then press ENTER.
4. Using the cursor keys, scroll through the card types until the unit displays the Model 7065 card as follows:  
     SLOT-1 CARD: 7065
5. Press ENTER to complete card type configuration.
6. Press EXIT twice to return to normal display.

**NOTE** The #-OF-POLES and CARD-PAIR selections in the card configuration menu do not apply to Model 7065 operation. Although you can set the DELAY parameter, the delay should normally be set to zero when using the Hall Effect Card. Refer to the Model 7001 Instruction Manual for more information on the delay parameter.

## 6. Front Panel Operation

The following paragraphs provide a brief overview on controlling the Model 7065 card from the front panel of the Model 7001 mainframe. For detailed front panel operation, refer to the Model 7001 Instruction Manual.

### Channel Status Display

Figure 2 shows the basic format for Model 7065 channel (crosspoint) display. A three-integer format is used to express channel (crosspoint) assignments. The first (left) integer is the slot number in which the card is installed. Thus, a "1" indicates Slot 1 (CARD 1), and "2" designates Slot 2 (CARD 2). The second (middle) integer designates the row number, 1 through 4. The top row is Row 1, the second from the top is Row 2, the next row is Row 3, and the bottom row is Row 4. The third (right) integer identifies the column. The five matrix columns for each card are shown on the channel status display.

**Examples:** Channel 1!2!3 (Slot 1, Row 2, Column 3)

Channel 2!3!4 (Slot 3, Row 3, Column 4)

**Figure 2: Model 7065/7001 Channel (Crosspoint) Display Assignments**

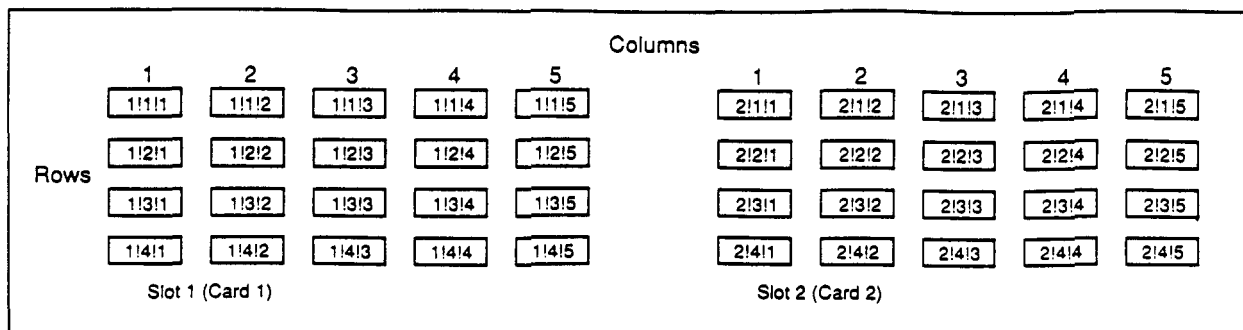

Examples : 1!2!3 (Slot 1, Row 2, Column 3)  
           2!3!4 (Slot 2, Row 3, Column 4)

## Programming a Channel List

One of the key advantages of the Model 7001 over the older Model 705 Scanner is that you can open or close a number of crosspoints simultaneously, instead of having to open or close each crosspoint individually. In order to use this feature, you must first program a channel list, as described below.

1. If necessary, press the SCAN LIST key to display the following:  
SELECT CHANNELS
2. If any channels are presently displayed in the list, press the CLEAR LIST key to clear them.
3. Using the numeric keys, enter the slot, row, and column of the first channel in the list, then press ENTER.
4. Repeat step 3 as necessary for as many channels (crosspoints) as required for the specific test (use the ► key to enter channel separators and terminate the channel list). While entering channels, you can use the DELETE and INSERT keys to erase or add channels in the middle of a list as necessary. You can also use the CLEAR LIST key to erase the entire displayed channel list.

## Closing and Opening Channels

Once a channel list is programmed, simply press the CLOSE key to close all channels (crosspoints) in the list simultaneously. The instrument will indicate the closed channels by turning on the associated channel status indicators.

To open all channels in the list, simply press the OPEN or OPEN ALL key.

## Storing and Recalling Channel Lists in Memory

Since all Hall and resistivity measurements require multiple crosspoint closure sequences, it can still become somewhat tedious to enter a separate channel list for each step in the procedure. A better way is to program channel lists, store them in memory ahead of time, and then recall them one-by-one while progressing through the test procedure (see below for a summary of channel lists for the various tests described in the Model 7065 manual).

Proceed as follows:

1. Program the channel list as described above.
2. Press the CLOSE key to close the channels in the channel list.
3. Press the STORE key.
4. Use the numeric keys to enter the memory location in which you wish to store the current channel list, then press ENTER.
5. Repeat steps 1 through 4 for each channel list required.

Once the channel lists are programmed, you can recall them simply by pressing the RECALL key, entering the memory location with the numeric keys, and then pressing ENTER. Note that all channels (crosspoints) in the list will be closed immediately upon recall. You can also scan through memory locations by setting up a scan list; see the next paragraph for details.

## Scanning Through Channel Lists

The Model 7001 can be programmed to scan through channel lists already stored in memory by setting up a scan list of memory locations. You can then use the STEP key or other appropriate trigger stimulus to cycle through the channel lists instead of having to recall each memory location individually (see the Model 7001 Instruction Manual for more details on triggering).

Set up a scan list as follows:

1. Program your channel lists, and then store them in the desired memory locations, as previously explained.



2. If necessary, press the SCAN LIST key to display the following message:  
SCAN CHANNELS
3. If any channels or memory locations are presently displayed in the list, press the CLEAR LIST key to clear them.
4. Enter each memory location to be included in the scan list by pressing the "M" key, followed by the memory location number; press the ENTER key after each memory location number.
5. To scan through memory locations, simply press the STEP key. As each location is recalled, the channels will be closed immediately.

## 7. Channel List Summary

Tables 1 through 10 provide supplemental Model 7001 channel list information for the various tests described in the Model 7065 Instruction Manual. Each table is cross-referenced to the corresponding table in the manual.

**Table 1: Resistivity Select Summary**

Column 5, Row 4 state*	Resistivity setup
Open	Low resistivity
Closed	High resistivity

\* Model 7001 channel list:      1!4!5 (Slot 1)  
   2!4!5 (Slot 2)

---

*NOTE*    The above table replaces manual Table 2-3 for Model 7001 users.

---

**Table 2: Channel List Summary for Resistivity Measurements**

Voltage designation	Model 7001 channel list	Current applied between	Voltage measured between
V <sub>1</sub>	1!2!1, 1!1!2, 1!3!3, 1!4!4	1-2	3-4
V <sub>2</sub>	1!2!2, 1!1!1, 1!3!3, 1!4!4	2-1	3-4
V <sub>3</sub>	1!2!2, 1!3!1, 1!4!3, 1!1!4	2-3	4-1
V <sub>4</sub>	1!3!2, 1!2!1, 1!4!3, 1!1!4	3-2	4-1
V <sub>5</sub>	1!3!2, 1!4!1, 1!1!3, 1!2!4	3-4	1-2
V <sub>6</sub>	1!4!2, 1!3!1, 1!1!3, 1!2!4	4-3	1-2
V <sub>7</sub>	1!4!2, 1!1!1, 1!2!3, 1!3!4	4-1	2-3
V <sub>8</sub>	1!1!2, 1!4!1, 1!2!3, 1!3!4	1-4	2-3

\* Assumes Model 7065 card is in Slot 1 of Model 7001. For Slot 2, change first digit of each item in every list to 2.

---

**NOTE** The above The above table replaces manual Table 3-3 for Model 7001 users.

---

**Table 3: Channel List Summary for Hall Voltage Measurements**

Voltage designation	Flux	Model 7001 channel list*	Current applied between	Voltage measured between
V <sub>1</sub>	+B	1!1!2, 1!3!1, 1!4!3, 1!2!4	1-3	4-2
V <sub>2</sub>	+B	1!3!2, 1!1!1, 1!4!3, 1!2!4	3-1	4-2
V <sub>3</sub>	+B	1!2!2, 1!4!1, 1!1!3, 1!3!4	2-4	1-3
V <sub>4</sub>	+B	1!4!2, 1!2!1, 1!1!3, 1!3!4	4-2	1-3
V <sub>5</sub>	-B	1!1!2, 1!3!1, 1!4!3, 1!2!4	1-3	4-2
V <sub>6</sub>	-B	1!3!2, 1!1!1, 1!4!3, 1!2!4	3-1	4-2
V <sub>7</sub>	-B	1!2!2, 1!4!1, 1!1!3, 1!3!4	2-4	1-3
V <sub>8</sub>	-B	1!4!2, 1!2!1, 1!1!3, 1!3!4	4-2	1-3

\* Assumes Model 7065 card is in Slot 1 of Model 7001. For Slot 2, change first digit of each item in every list to 2.

---

**NOTE** The above table replaces manual Table 3-4 for Model 7001 users.

---

**Table 4: Channel List Summary for Bar Measurements**

Measurement	Model 7001 channel list*
Resistivity	1!4!2, 1!1!3, 1!2!4
Hall voltage	1!4!2, 1!1!3, 1!2!4, 1!3!5

\* Assumes Model 7065 card is in Slot 1 of Model 7001. For Slot 2, change first digit of each item in every list to 2.

---

**NOTE** The above table replaces manual Table 3-6 for Model 7001 users.

---

**Table 5: Channel List Summary for 6-Contact Sample Resistivity Measurements**

Voltage designation	Model 7001 Channel List*	Current between	Voltage between
V <sub>1</sub>	1!2!3, 1!1!4	1-2	4-6
V <sub>2</sub>	1!3!3, 1!4!4	1-2	3-5
V <sub>3</sub>	1!2!3, 1!1!4	2-1**	4-6
V <sub>4</sub>	1!3!3, 1!4!4	2-1**	3-5

\* Assumes Model 7065 card is in Slot 1 of Model 7001. For Slot 2, change first digit of each item in every list to 2.  
 \*\* Reverse current by programming current source for opposite polarity.

*NOTE* The above table replaces manual Table 3-7 for Model 7001 users.

**Table 6: Channel List Summary for 8-Contact Sample Resistivity Measurements**

Voltage designation	Model 7001 channel list	Current between	Voltage between
V <sub>1</sub>	1!2!3, 1!1!4	1-2	4-6
V <sub>2</sub>	1!3!3, 1!4!4	1-2	5-7
V <sub>3</sub>	1!2!3, 1!1!4	2-1**	4-6
V <sub>4</sub>	1!3!3, 1!4!4	2-1**	5-7

\* Assumes Model 7065 card is in Slot 1 of Model 7001. For Slot 2, change first digit of each item in every list to 2.  
 \*\* Reverse current by programming current source for opposite polarity.

*NOTE* The above table replaces manual Table 3-8 for Model 7001 users.

**Table 7: Channel List Summary for 6-Contact Sample Hall Voltage Measurements**

Voltage designation	Flux polarity	Model 7001 channel list*	Current between**	Voltage between
V <sub>1</sub>	+B	1!1!3, 1!4!4	1-2	6-5
V <sub>2</sub>	+B	1!2!3, 1!3!4	1-2	4-3
V <sub>3</sub>	+B	1!1!3, 1!4!4	2-1	6-5
V <sub>4</sub>	+B	1!2!3, 1!3!4	2-1	4-3
V <sub>5</sub>	-B	1!1!3, 1!4!4	1-2	6-5
V <sub>6</sub>	-B	1!2!3, 1!3!4	1-2	4-3
V <sub>7</sub>	-B	1!1!3, 1!4!4	2-1	6-5
V <sub>8</sub>	-B	1!2!3, 1!3!4	2-1	4-3

\* Assumes Model 7065 card is in Slot 1 of Model 7001. For Slot 2, change first digit of each item in every list to 2.  
 \*\* Reverse current by programming current source for opposite polarity.

---

*NOTE* The above table replaces manual Table 3-9 for Model 7001 users.

---

**Table 8: Channel List Summary for 8-Contact Sample Hall Voltage Measurements**

Voltage designation	Flux polarity	Model 7001 channel list*	Current between**	Voltage between
V <sub>1</sub>	+B	1!1!3, 1!3!4	1-2	6-5
V <sub>2</sub>	+B	1!1!3, 1!3!4	2-1	6-5
V <sub>3</sub>	-B	1!1!3, 1!3!4	1-2	6-5
V <sub>4</sub>	-B	1!1!3, 1!3!4	2-1	6-5

\* Assumes Model 7065 card is in Slot 1 of Model 7001. For Slot 2, change first digit of each item in every list to 2.  
 \*\* Reverse current by programming current source for opposite polarity.

---

*NOTE* The above table replaces manual Table 3-10 for Model 7001 users.

---

**Table 9: Model 7001 Channel List for Measuring Sample Input Offset Voltage**

Sample input #	Model 7001 channel list*
1	1!1!3
2	1!2!3
3	1!3!3
4	1!4!3

\* Assumes Model 7065 card is in Slot 1 of Model 7001. For Slot 2, change first digit of each item in every list to 2.

---

*NOTE* The above table replaces manual Table 4-2 for Model 7001 users.

---

**Table 10: Model 7001 Channel List for Adjusting Offsets**

Sample input #	Model 7001 channel list*
1	1!1!3
2	1!2!3
3	1!3!3
4	1!4!3

\* Assumes Model 7065 card is in slot 1 of Model 7001. For slot 2, change first digit of each item in every list to 2.

---

*NOTE* The above table replaces manual Table 4-2 for Model 7001 users.

---

## 8. IEEE-488 Bus Programming

The Model 7065 can be controlled over the IEEE-488 bus through the host Model 7001 Switch System, as described in the following paragraphs. For more detailed bus information, refer to the Model 7001 Instruction Manual.

### Setting the Model 7001 Primary Address

The factory default primary address of the Model 7001 is set to 7 at the factory. The primary address of the Model 7001 may need to be changed to some other value that does not conflict with other instruments in the system. You can change the primary address of the Model 7001 using the following procedure:

1. From normal display, press the MENU key.
2. Select GPIB, then press ENTER.
3. Select ADDRESS, then press ENTER.
4. Using the numeric keys, enter a primary address value of 8, then press ENTER.
5. Press EXIT as necessary to return to normal display.

### IEEE-488 Bus Commands

Table 11 summarizes the few basic bus commands necessary to perform basic Model operations. Some examples are provided below.

**Table 11: Model 7001 Bus Commands Necessary for Basic Model 7065 Operation**

Command	Description
[:ROUTE]	
:CLOSE <list> :STATe?	Close channels. Request closed channels.
:OPEN <list> ALL	Open selected or all channels.
:CONFigure	Configuration command path.
:SLOT1	Path to Slot 1.
:CTYPe C7065	Configure Slot 1.
:CTYPe?	Request card type.
:SLOT2	Path to Slot 2.
:CTYPe C7065	Configure Slot 2.
:CTYPe?	Request card type.
:MEMory	Path to program memory.
:SAVe M<num>	Saves channel pattern to memory location (1-100).
:RECall M<num>	Recalls channel pattern to memory location (1-100).
Notes: 1. Command short form is indicated by uppercase letters. For example, instead of sending :MEMORY:RECALL M1, you can send :MEM:REC M1. 2. Commands surrounded by brackets [ ] are optional and need not be included in the command string. 3. Sending the OPEN ALL command will put the card in the low-resistivity mode.	

## Command Examples

### Example 1: Configure Card Type

In order to configure the Model 7001 for use with a Model 7065 in Slot 1, send the following command over the bus:

```
:CONF:SLOT1:CTYPE C7065
```

### Example 2: Close Channels

In order to close Row 1, Column 2, and Row 2, Column 3 of a card located in Slot 1, the following command would be sent:

```
:CLOSE (@1!1!2,1!2!3)
```

Note that the channel list must be enclosed in parentheses and preceded by the @ symbol.

### Example 3: Open Channels

Specific channels can be opened by including them in the channel list, as in the following example:

```
:OPEN (@1!1!2,1!2!3)
```

To open all closed channels simultaneously, simply send the following command:

```
:OPEN ALL
```

---

**NOTE** Be careful when using the `OPEN ALL` command. Recall that the card low/high resistivity configuration is determined by the state of Row 4, Column 5. Thus, sending `OPEN ALL` will automatically place the card in the low-resistivity mode.

---

## Example Program

The example program below demonstrates basic programming techniques for controlling the Model 7065 through the Model 7001. The program configures the card type (Model 7065), closes a channel list, and then opens all channels.

The program is written in Hewlett-Packard BASIC. Note that the program assumes that the Model 7065 is installed in Slot 1 of the Model 7001.

**Table 12: Example Program**

Program	Comments
10 REMOTE 708	! Put 7001 in remote.
20 OUTPUT 708; ":CONF:SLOT1:CTYPE C7065"	! Slot 1 = 7065 card.
30 OUTPUT 708; ":CLOS (@1!1!1,1!2!2)"	! Close 1,1 and 2,2.
40 PRINT "PRESS 'CONT' TO OPEN"	
50 PAUSE	
60 OUTPUT 708, ":OPEN ALL"	! Open all channels.

## 9. Example Resistivity and Hall Voltage Programs

Four example programs are included with this addendum. These programs are modified versions of those included in the Model 7065 manual, and they are intended to run only with a Model 80A Hall Effect System. Refer to Section 3 of the Model 7065 Instruction Manual for detailed test descriptions.

---

**NOTE** The Models 2000, 6485, and 622x have emulation modes to accept the command sets used for 196/199, 485, and 220 respectively. If it is desired to use the following programs, see the product manuals for the 2000, 6485, and 622x for instructions on using them in emulation mode.

---

The programs and test configurations include (for Programs 1 and 2, also reference Figure 3 for additional information):

- Program 1, Hall Voltage coefficient
- Program 2, Resistivity of van der Pauw samples
- Program 3, Resistivity of bar samples
- Program 4, Resistivity of 6- and 8-contact samples

**Figure 3: Test Configuration for Programs 1 and 2**

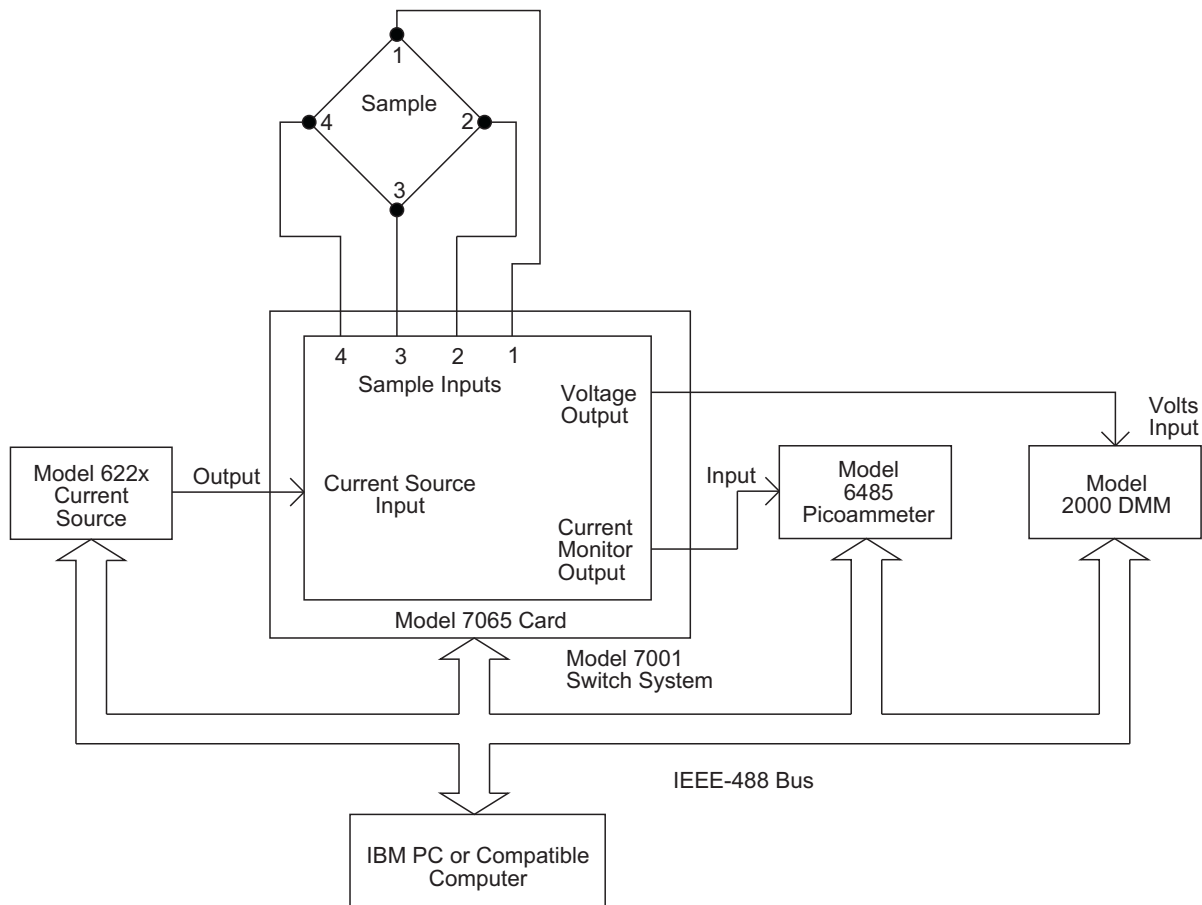

## Program Requirements

The following computer software and hardware is necessary to use these example programs:

- IBM PC, AT, or compatible computer.
- IOtech Personal488, CEC PC-488, or National Instruments PC-II or PC-IIA IEEE-488 interface card for the computer.
- MS-DOS or PC-DOS version 3.3 or later.
- Microsoft QuickBASIC version 4.0 or later.
- IOtech Driver488 bus driver, rev. 2.3 or later (NOTE: Recent versions of Driver488 may not support other manufacturers' interface cards).

## General Program Instructions

1. With all power turned off, connect all instruments to the IEEE-488 bus, and make the necessary signal connections, as covered in the Model 7065 Instruction Manual.
2. Turn on the computer and all instruments, and allow them to warm up for their prescribed warm-up periods for rated accuracy.
3. Make sure the instruments are set for the following primary addresses:

Model 2000: 7 (default is 16)

Model 622x: 12

Model 6485: 22 (default is 14)

Model 7001: 8 (default is 7)

All the above addresses are factory default with the exception of the Model 7001 address, which must be changed to avoid address conflicts (see the instructions in paragraph 8 for details on changing the Model 7001 address).

4. Make sure the IEEE-488 bus driver software is properly initialized.
5. Enter the QuickBASIC editor by typing in the following while in the QuickBASIC directory:

```
QB <Enter>
```

6. Type in the desired program, then check it for errors. Save the program under a convenient filename.
7. Run the program by pressing <Shift> + <F5>. Follow the prompts on the screen to run the test.



## Program 1. Hall Voltage Coefficient

```
'Hall voltage program using Model 7001 Switch System.
OPEN "\DEV\IEEEOUT" FOR OUTPUT AS #1      ' Open IEEE-488 output path.
OPEN "\DEV\IEEEIN" FOR INPUT AS #2       ' Open IEEE-488 input path.
IOCTL #1, "BREAK"                        ' Reset interface.
PRINT #1, "RESET"                        ' Warm start interface
PRINT #1, "CLEAR"                        ' Send device clear.
CLS                                       ' Clear CRT.
DIM V(8)                                 ' Dimension reading array.
PRINT "This program measures Hall voltages and computes the"
PRINT "coefficients. The Hall card must be in the CARD 1 location."
PRINT
PRINT "Press any key to continue..."
DO WHILE INKEY$ = "": LOOP
SelRes:
CLS
PRINT "Select card resistivity setup:"
PRINT
PRINT "(1) Low resistivity"
PRINT "(2) High resistivity"
PRINT : INPUT "Selection"; A
IF A < 1 OR A > 2 THEN GOTO SelRes
Start: PRINT "Initializing instruments."
PRINT #1, "REMOTE 07,08,12,22"           ' Put instruments in remote.
' ***** INITIALIZE THE 7001 *****
PRINT #1, "OUTPUT 08;*RST"               ' Reset 7001.
PRINT #1, "OUTPUT 08;:CONF:SLOT1:CTYPE C7065" ' Slot 1= 7065 card.
PRINT #1, "OUTPUT 08;:CONF:SLOT2:CTYPE NONE" ' No card in slot 2.
PRINT #1, "OUTPUT 08;:OPEN ALL"         ' Open crosspoints.
IF A = 2 THEN PRINT #1, "OUTPUT 08;:CLOSE (@1!4!5)"
' ***** INITIALIZE THE 485 *****
PRINT #1, "OUTPUT 22;R1X"                ' Select 2nA range.
DL = 1: GOSUB Dly                        ' Settling time.
PRINT #1, "OUTPUT 22;C1X"                ' Zero check on.
GOSUB Dly                                ' Settling time.
PRINT #1, "OUTPUT 22;Z1X"                ' REL on.
GOSUB Dly                                ' Settling time.
PRINT #1, "OUTPUT 22;COX"                ' Zero check off.
PRINT #1, "OUTPUT 22;ROG1X"              ' Autorange, no prefix.
' ***** INITIALIZE THE 196 *****
PRINT #1, "OUTPUT 07;ROFOS3G1X"          ' Auto,DCV,rate,no prefix.
' ***** INITIALIZE THE 220 *****
PRINT #1, "OUTPUT 12;V10X"               ' 10V compliance.
InCurr: INPUT "220 current (500fA-2mA)"; I ' Input 220 current.
I = ABS(I)                               ' Positive current only.
IF I < 5E-13 OR I > .002 THEN GOTO InCurr ' Check current limits.
PRINT #1, "OUTPUT 12;I"; I; "X"          ' Program 220 current.
INPUT "Enter sample thickness (cm)"; T   ' Input sample thickness.
T = ABS(T)
INPUT "Enter flux density (gauss)"; B    ' Input flux density.
B = ABS(B)
CLS
PRINT "Apply +B, press any key to continue..."
DO WHILE INKEY$ = "": LOOP
' ***** MAIN MEASUREMENT LOOP *****
RESTORE: DL = 5                          ' Set 5 second delay.
CLS
PRINT "Measuring..."
```

```

PRINT "Measuring..."
FOR J = 1 TO 4
IF J <> 3 THEN GOTO RevCurr
RESTORE
PRINT #1, "OUTPUT 12;I"; I2; "X"
RevCurr: READ C$: C1$ = ":CLOS (@ + C$ + ")"
PRINT #1, "OUTPUT 08;"; C1$
PRINT #1, "OUTPUT 12;FIX"
GOSUB Dly
PRINT #1, "ENTER 07"
INPUT #2, V(J)
IF ABS(V(J)) > 8 THEN GOTO Limit
IF J <> 1 THEN GOTO NoAmp
PRINT #1, "ENTER 22"
INPUT #2, I1
NoAmp: PRINT #1, "OUTPUT 12;FOX"
C1$ = ":OPEN (@ + C$ + ")"
PRINT #1, "OUTPUT 08;"; C1$
NEXT J
BEEP
PRINT #1, "CLEAR"
CLS
PRINT "Measurements complete."
PRINT "Measured current: "; I1
PRINT : PRINT "Measured voltages:"
FOR J = 1 TO 4
PRINT "V"; J; "="; V(J)
NEXT J
PRINT
PA = W * T / (2 * I1 * D1) * (V(1) - V(3))
PB = W * T / (2 * I1 * D2) * (V(2) - V(4))
PRINT "Resistivity calculations:"
PAVG = (PA + PB) / 2
PRINT "PA="; PA
PRINT "PB="; PB
PRINT "PAVG="; PAVG
PRINT
INPUT "Repeat test (Y/N)"; A$
IF LEFT$(A$, 1) = "Y" OR LEFT$(A$, 1) = "y" THEN CLS : GOTO Start
PRINT #1, "OUTPUT 08;:OPEN ALL"
CLOSE 1: CLOSE 2: END '
Limit:
CLS : BEEP
PRINT #1, "CLEAR"
PRINT #1, "OUTPUT 08;:OPEN ALL"
PRINT "Sample voltage is over 8V 7065 limit."
PRINT "Do you wish to:"
PRINT "(1) Restart the measurement"
PRINT "(2) Abort the program"
PRINT
INPUT "Enter choice: "; A
IF A < 1 OR A > 2 THEN GOTO Limit
IF A = 1 THEN CLS : GOTO Start
CLOSE 1: CLOSE 2: END
Dly:
TI = TIMER
Lp: IF (TIMER - TI) < DL THEN GOTO Lp
RETURN
' ***** 7001 CHANNEL LISTS *****
DATA "1:2!3,1!1!4","1:3!3,1!4!4"

```

```

' Reverse current.
' Build command string.
' Close crosspoints.
' Turn on 220 output.
' Wait for reading to settle.
' Address 196 to talk.
' Get 196 reading.
' Check voltage limit.
' Address 485 to talk.
' Input current reading.
' Turn off 220 output.
' Build command string.
' Open crosspoints.
' Loop back for next point.
' Send device clear.
' Display measured voltages.

```

```

' Send device clear.
' Open crosspoints.
' End program.
' Delay subroutine.

```

## Program 2. Resistivity of van der Pauw Samples

```
' Van der Pauw resistivity program using Model 7001 Switch System.
OPEN "\DEV\IEEEOUT" FOR OUTPUT AS #1          ' Open IEEE-488 output path.
OPEN "\DEV\IEEEIN" FOR INPUT AS #2           ' Open IEEE-488 input path.
IOCTL #1, "BREAK"                            ' Reset interface.
PRINT #1, "RESET"                             ' Warm start interface
PRINT #1, "CLEAR"                            ' Send device clear.
CLS                                           ' Clear CRT.
DIM V(8)                                       ' Dimension reading array.
PRINT "This program measures the resistivity of van der Pauw samples."
PRINT "The Hall card must be in the CARD 1 location."
PRINT
PRINT "Press any key to continue..."
DO WHILE INKEY$ = "": LOOP
SelRes:
CLS
PRINT "Select card resistivity setup:"
PRINT
PRINT "(1) Low resistivity"
PRINT "(2) High resistivity"
PRINT : INPUT "Selection"; A
IF A < 1 OR A > 2 THEN GOTO SelRes
Start: PRINT "Initializing instruments."
PRINT #1, "REMOTE 07,08,12,22"                ' Put instruments in remote.
' ***** INITIALIZE THE 7001 *****
PRINT #1, "OUTPUT 08;*RST"                    ' Reset 7001.
PRINT #1, "OUTPUT 08;:CONF:SLOT1:CTYPE C7065" ' Slot 1= 7065 card.
PRINT #1, "OUTPUT 08;:CONF:SLOT2:CTYPE NONE" ' No card in slot 2.
PRINT #1, "OUTPUT 08;:OPEN ALL"              ' Open crosspoints.
IF A = 2 THEN PRINT #1, "OUTPUT 08;:CLOSE (@1!4!5)"
' ***** INITIALIZE THE 485 *****
PRINT #1, "OUTPUT 22;R1X"                     ' Select 2nA range.
DL = 1: GOSUB Dly                             ' Settling time.
PRINT #1, "OUTPUT 22;C1X"                     ' Zero check on.
GOSUB Dly                                     ' Settling time.
PRINT #1, "OUTPUT 22;Z1X"                     ' REL on.
GOSUB Dly                                     ' Settling time.
PRINT #1, "OUTPUT 22;COX"                     ' Zero check off.
PRINT #1, "OUTPUT 22;R0G1X"                   ' Autorange, no prefix.
' ***** INITIALIZE THE 196 *****
PRINT #1, "OUTPUT 07;R0F0S3G1X"               ' Auto,DCV,rate,no prefix.
' ***** INITIALIZE THE 220 *****
PRINT #1, "OUTPUT 12;V10X"                   ' 10V compliance.
InCurr: INPUT "220 current (500fA-2mA)"; I    ' Input 220 current.
I = ABS(I) ' Positive current only.
IF I < 5E-13 OR I > .002 THEN GOTO InCurr     ' Check current limits.
PRINT #1, "OUTPUT 12;I"; I; "X"              ' Program 220 current.
INPUT "Enter sample thickness (cm)"; T       ' Input sample thickness.
T = ABS(T)
CLS
' ***** MAIN MEASUREMENT LOOP *****
RESTORE: DL = 5                               ' Set 5 second delay.
CLS
PRINT "Measuring..."
FOR J = 1 TO 8
READ C$: C1$ = ":CLOS (@" + C$ + ")"         ' Build command string.
PRINT #1, "OUTPUT 08;"; C1$                 ' Close crosspoints.
PRINT #1, "OUTPUT 12;F1X"                   ' Turn on 220 output.
```

```

FOR J = 1 TO 8
IF J <> 5 THEN GOTO RevFlux
RESTORE: PRINT "Reverse field (-B), press any key to continue": BEEP
DO WHILE INKEY$ = "": LOOP
RevFlux: READ C$: C1$ = ":CLOS (@" + C$ + ")"          ' Build command string.
PRINT #1, "OUTPUT 08;"; C1$                          ' Close crosspoints.
PRINT #1, "OUTPUT 12;F1X"                            ' Turn on 220 output.
GOSUB Dly                                             ' Wait for reading to settle.
PRINT #1, "ENTER 07"                                 ' Address 196 to talk.
INPUT #2, V(J)                                       ' Get 196 reading.
IF ABS(V(J)) > 8 THEN GOTO Limit                     ' Check voltage limit.
IF J <> 1 THEN GOTO NoAmp
PRINT #1, "ENTER 22"                                 ' Address 485 to talk.
INPUT #2, I1                                         ' Input current reading.
NoAmp: PRINT #1, "OUTPUT 12;FOX"                    ' Turn off 220 output.
C1$ = ":OPEN (@" + C$ + ")"                          ' Build command string.
PRINT #1, "OUTPUT 08;"; C1$                          ' Open crosspoints.
NEXT J                                               ' Loop back for next point.
BEEP
PRINT #1, "CLEAR"                                    ' Send device clear.
CLS
PRINT "Measurements complete."
PRINT "Measured current: "; I1
PRINT : PRINT "Measured voltages:"
FOR J = 1 TO 8                                       ' Display measured voltages.
PRINT "V"; J; "="; V(J)
NEXT J
PRINT
RHC = 2.5E+07 * T / (B * I1) * (V(2) - V(1) + V(5) - V(6))
RHD = 2.5E+07 * T / (B * I1) * (V(4) - V(3) + V(7) - V(8))
RHAVG = (RHC + RHD) / 2
PRINT "Hall coefficients:"
PRINT "RHC="; RHC
PRINT "RHD="; RHD
PRINT "RHAVG="; RHAVG
PRINT
INPUT "Repeat test (Y/N)"; A$
IF LEFT$(A$, 1) = "Y" OR LEFT$(A$, 1) = "y" THEN CLS : GOTO Start
PRINT #1, "OUTPUT 08;:OPEN ALL"                    ' Open all crosspoints.
CLOSE 1: CLOSE 2: END
Limit:
CLS : BEEP
PRINT #1, "CLEAR"                                    ' Send device clear.
PRINT #1, "OUTPUT 08;:OPEN ALL"                    ' Open crosspoints.
PRINT "Sample voltage is over 8V 7065 limit."
PRINT "Do you wish to:"
PRINT "(1) Restart the measurement"
PRINT "(2) Abort the program"
PRINT
INPUT "Enter choice: "; A
IF A < 1 OR A > 2 THEN GOTO Limit
IF A = 1 THEN CLS : GOTO Start
CLOSE 1: CLOSE 2: END                               ' End program.
Dly:                                                 ' Delay subroutine.
TI = TIMER
Lp: IF (TIMER - TI) < DL THEN GOTO Lp
RETURN
' ***** 7001 CHANNEL LISTS *****
DATA "1!1!2,1!3!1,1!4!3,1!2!4","1!3!2,1!1!1,1!4!3,1!2!4"
DATA "1!2!2,1!4!1,1!1!3,1!3!4","1!4!2,1!2!1,1!1!3,1!3!4"

```

### Program 3. Resistivity of Bar Samples

```

' Bar sample resistivity program using Model 7001 Switch System.
OPEN "\DEV\IEEEEOUT" FOR OUTPUT AS #1      ' Open IEEE-488 output path.
OPEN "\DEV\IEEEEIN" FOR INPUT AS #2       ' Open IEEE-488 input path.
IOCTL #1, "BREAK"                         ' Reset interface.
PRINT #1, "RESET"                          ' Warm start interface
PRINT #1, "CLEAR"                          ' Send device clear.
CLS                                         ' Clear CRT.
PRINT "This program measures the resistivity of bar type samples."
PRINT "The Hall card must be in the CARD 1 location."
PRINT
PRINT "Press any key to continue..."
DO WHILE INKEY$ = "": LOOP
SelRes:
CLS
PRINT "Select card resistivity setup:"
PRINT
PRINT "(1) Low resistivity"
PRINT "(2) High resistivity"
PRINT : INPUT "Selection"; A
IF A < 1 OR A > 2 THEN GOTO SelRes
Start: PRINT "Initializing instruments."
PRINT #1, "REMOTE 07,08,12,22"             ' Put instruments in remote.
' ***** INITIALIZE THE 7001 *****
PRINT #1, "OUTPUT 08;*RST"                 ' Reset 7001.
PRINT #1, "OUTPUT 08;:CONF:SLOT1:CTYPE C7065" ' Slot 1= 7065 card.
PRINT #1, "OUTPUT 08;:CONF:SLOT2:CTYPE NONE" ' No card in slot 2.
PRINT #1, "OUTPUT 08;:OPEN ALL"           ' Open crosspoints.
IF A = 2 THEN PRINT #1, "OUTPUT 08;:CLOSE (@1!4!5)"
' ***** INITIALIZE THE 485 *****
PRINT #1, "OUTPUT 22;R1X"                 ' Select 2nA range.
DL = 1: GOSUB Dly                         ' Settling time.
PRINT #1, "OUTPUT 22;C1X"                 ' Zero check on.
GOSUB Dly                                  ' Settling time.
PRINT #1, "OUTPUT 22;Z1X"                 ' REL on.
GOSUB Dly                                  ' Settling time.
PRINT #1, "OUTPUT 22;COX"                 ' Zero check off.
PRINT #1, "OUTPUT 22;ROG1X"               ' Autorange, no prefix.
' ***** INITIALIZE THE 196 *****
PRINT #1, "OUTPUT 07;ROF0S3G1X"           ' Auto,DCV,rate,no prefix.
' ***** INITIALIZE THE 220 *****
PRINT #1, "OUTPUT 12;V10X"                 ' 10V compliance.
InCurr: INPUT "220 current (500fA-2mA)"; I ' Input 220 current.
I = ABS(I)                                 ' Positive current only.
IF I < 5E-13 OR I > .002 THEN GOTO InCurr ' Check current limits.
PRINT #1, "OUTPUT 12;I"; I; "X"           ' Program 220 current.
INPUT "Enter sample thickness (cm)"; Z    ' Input dimensions.
INPUT "Enter sample X dimension (cm)"; X
INPUT "Enter sample Y dimension (cm)"; Y
Z = ABS(Z): X = ABS(X): Y = ABS(Y)
' ***** MAKE MEASUREMENTS *****
DL = 5                                     ' Set 5 second delay.
CLS
PRINT "Measuring..."
PRINT #1, "OUTPUT 08;:CLOS (@1!4!2,1!1!3,1!2!4)" ' Close channels.
PRINT #1, "OUTPUT 12;F1X"                 ' Turn on 220 output.
GOSUB Dly                                  ' Wait for reading to settle.
PRINT #1, "ENTER 07"                       ' Address 196 to talk.

```

```

GOSUB Dly                                ' Wait for reading to settle.
PRINT #1, "ENTER 07"                      ' Address 196 to talk.
INPUT #2, V(J)                            ' Get 196 reading.
IF ABS(V(J)) > 8 THEN GOTO Limit           ' Check voltage limit.
IF J <> 1 THEN GOTO NoAmp
PRINT #1, "ENTER 22"                      ' Address 485 to talk.
INPUT #2, I1                              ' Input current reading.
NoAmp: PRINT #1, "OUTPUT 12;FOX"          ' Turn off 220 output.
C1$ = ":OPEN (@ + C$ + ")"                ' Build command string.
PRINT #1, "OUTPUT 08;"; C1$              ' Open crosspoints.
NEXT J                                     ' Loop back for next point.
BEEP
PRINT #1, "CLEAR"                          ' Send device clear.
CLS
PRINT "Measurements complete."
PRINT "Measured current: "; I1
PRINT : PRINT "Measured voltages:"
FOR J = 1 TO 8                             ' Display measured voltages.
PRINT "V"; J; "="; V(J)
NEXT J
PRINT
PA = 1.1331 * T / I1 * (V(2) + V(4) - V(1) - V(3))
PB = 1.1331 * T / I1 * (V(6) + V(8) - V(5) - V(7))
PRINT "Resistivity calculations:"
PAVG = (PA + PB) / 2
PRINT "PA="; PA
PRINT "PB="; PB
PRINT "PAVG="; PAVG
PRINT
INPUT "Repeat test (Y/N)"; AS
IF LEFT$(AS, 1) = "Y" OR LEFT$(AS, 1) = "y" THEN CLS : GOTO Start
PRINT #1, "OUTPUT 08;;OPEN ALL"          ' Open all crosspoints.
CLOSE 1: CLOSE 2: END
Limit:
CLS : BEEP
PRINT #1, "CLEAR"                          ' Send device clear.
PRINT #1, "OUTPUT 08;;OPEN ALL"          ' Open crosspoints.
PRINT "Sample voltage is over 8V 7065 limit."
PRINT "Do you wish to:"
PRINT "(1) Restart the measurement"
PRINT "(2) Abort the program"
PRINT
INPUT "Enter choice: "; A
IF A < 1 OR A > 2 THEN GOTO Limit
IF A = 1 THEN CLS : GOTO Start
CLOSE 1: CLOSE 2: END                    ' End program.
Dly:                                       ' Delay subroutine.
TI = TIMER
Lp: IF (TIMER - TI) < DL THEN GOTO Lp
RETURN
' ***** 7001 CHANNEL LISTS *****
DATA "1!2!1,1!1!2,1!3!3,1!4!4","1!2!2,1!1!1,1!3!3,1!4!4"
DATA "1!2!2,1!3!1,1!4!3,1!1!4","1!3!2,1!2!1,1!4!3,1!1!4"
DATA "1!3!2,1!4!1,1!1!3,1!2!4","1!4!2,1!3!1,1!1!3,1!2!4"
DATA "1!4!2,1!1!1,1!2!3,1!3!4","1!1!2,1!4!1,1!2!3,1!3!4"

```

## Program 4. Resistivity of 6- and 8-Contact Samples

```

' 6 and 8-contact sample resistivity program using
' Model 7001 Switch System.
OPEN "\DEV\IEEEOUT" FOR OUTPUT AS #1      ' Open IEEE-488 output path.
OPEN "\DEV\IEEEIN" FOR INPUT AS #2      ' Open IEEE-488 input path.
IOCTL #1, "BREAK"                        ' Reset interface.
PRINT #1, "RESET"                        ' Warm start interface
PRINT #1, "CLEAR"                        ' Send device clear.
CLS                                       ' Clear CRT.
DIM V(4)                                  ' Dimension reading array.
PRINT "This program measures the resistivity 6- and 8-contact samples."
PRINT "The Hall card must be in the CARD 1 location."
PRINT
PRINT "Press any key to continue..."
DO WHILE INKEY$ = "": LOOP
SelRes:
CLS
PRINT "Select card resistivity setup:"
PRINT
PRINT "(1) Low resistivity"
PRINT "(2) High resistivity"
PRINT : INPUT "Selection"; A
IF A < 1 OR A > 2 THEN GOTO SelRes
Start: PRINT "Initializing instruments."
PRINT #1, "REMOTE 07,08,12,22"           ' Put instruments in remote.
' ***** INITIALIZE THE 7001 *****
PRINT #1, "OUTPUT 08;*RST"               ' Reset 7001.
PRINT #1, "OUTPUT 08;:CONF:SLOT1:CTYPE C7065" ' Slot 1= 7065 card.
PRINT #1, "OUTPUT 08;:CONF:SLOT2:CTYPE NONE" ' No card in slot 2.
PRINT #1, "OUTPUT 08;:OPEN ALL"         ' Open crosspoints.
IF A = 2 THEN PRINT #1, "OUTPUT 08;:CLOSE (@1!4!5)"
' ***** INITIALIZE THE 485 *****
PRINT #1, "OUTPUT 22;R1X"               ' Select 2nA range.
DL = 1: GOSUB Dly                       ' Settling time.
PRINT #1, "OUTPUT 22;C1X"               ' Zero check on.
GOSUB Dly                               ' Settling time.
PRINT #1, "OUTPUT 22;Z1X"               ' REL on.
GOSUB Dly                               ' Settling time.
PRINT #1, "OUTPUT 22;COX"               ' Zero check off.
PRINT #1, "OUTPUT 22;ROG1X"             ' Autorange, no prefix.
' ***** INITIALIZE THE 196 *****
PRINT #1, "OUTPUT 07;ROF0S3G1X"         ' Auto,DCV,rate,no prefix.
' ***** INITIALIZE THE 220 *****
PRINT #1, "OUTPUT 12;V10X"              ' 10V compliance.
InCurr: INPUT "220 current (500fA-2mA)"; I ' Input 220 current.
I = ABS(I)                              ' Positive current only.
IF I < 5E-13 OR I > .002 THEN GOTO InCurr ' Check current limits.
I2 = -I
PRINT #1, "OUTPUT 12;I"; I; "X"         ' Program 220 current.
INPUT "Enter sample thickness (cm)"; T  ' Input sample dimensions.
INPUT "Enter sample width (cm)"; W
INPUT "Enter sample D1 dimension (cm)"; D1
INPUT "Enter sample D2 dimension (cm)"; D2
T = ABS(T): W = ABS(W): D1 = ABS(D1): D2 = ABS(D2)
CLS
' ***** MAIN MEASUREMENT LOOP *****
RESTORE: DL = 5                          ' Set 5 second delay.
CLS

```

```

INPUT #2, V                                ' Get 196 reading.
IF ABS(V) > 8 THEN GOTO Limit              ' Check voltage limit.
PRINT #1, "ENTER 22"                       ' Address 485 to talk.
INPUT #2, I1                               ' Input current reading.
PRINT #1, "OUTPUT 12;FOX"                  ' Turn off 220 output.
PRINT #1, "OUTPUT 08;:OPEN (@1!4!2,1!1!3,1!2!4)" ' Open channels.
BEEP
PRINT #1, "CLEAR"                          ' Send device clear.
CLS
PRINT "Measurements complete."
PRINT "Measured current:"; I1
PRINT "Measured voltage:"; V
PRINT
P = V * Y * X / (X * I1)                   ' Calculate resistivity.
PRINT "Resistivity="; P; "ohm-cm"
PRINT
INPUT "Repeat test (Y/N)"; AS
IF LEFT$(AS, 1) = "Y" OR LEFT$(AS, 1) = "y" THEN CLS : GOTO Start
PRINT #1, "OUTPUT 08;:OPEN ALL"            ' Open all crosspoints.
CLOSE 1: CLOSE 2: END
Limit:
CLS : BEEP
PRINT #1, "CLEAR"                          ' Send device clear.
PRINT #1, "OUTPUT 08;:OPEN ALL"            ' Open crosspoints.
PRINT "Sample voltage is over 8V 7065 limit."
PRINT "Do you wish to:"
PRINT "(1) Restart the measurement"
PRINT "(2) Abort the program"
PRINT
INPUT "Enter choice: "; A
IF A < 1 OR A > 2 THEN GOTO Limit
IF A = 1 THEN CLS : GOTO Start
CLOSE 1: CLOSE 2: END                      ' End program.
Dly:                                       ' Delay subroutine.
TI = TIMER
Lp: IF (TIMER - TI) < DL THEN GOTO Lp
RETURN

```



# SECTION 1

## GENERAL INFORMATION

---

### 1.1 INTRODUCTION

This section contains general information about the Model 7065 Hall Card and is arranged as follows:

#### 1.2 Features

#### 1.3 Warranty Information

#### 1.4 Manual Addenda

#### 1.5 Safety Symbols and Terms

#### 1.6 Specifications

#### 1.7 Unpacking and Inspection

#### 1.8 Repacking for Shipment

#### 1.9 Recommended Equipment

#### 1.10 Scanner Compatibility

### 1.2 FEATURES

The Model 7065 Hall Card is designed to assist in making resistivity and Hall voltage measurements on several types of semiconductor specimens. The unit is designed to be used in conjunction with a Keithley Model 705 or 706 Scanner along with a suitable current source and voltmeter. The Model 7065 incorporates the necessary on-card switching and buffering in order to minimize measurement complexity and maximize accuracy.

Key Model 7065 features include:

- Selectable input characteristics for either high- or low-resistivity measurements.
- Solid-state switching is used for measurement paths for higher reliability and lower thermal emfs.
- On-card, low-EMI power supply to maximize isolation and minimize noise effects.
- Provisions for guarded measurements to minimize the effects of leakage resistance and capacitance.
- On-card connection for a picoammeter to verify sample excitation current.

### 1.3 WARRANTY INFORMATION

Warranty information may be found on the inside front cover of this instruction manual. Should your Model 7065 require warranty service, contact the Keithley representative or authorized repair facility in your area for further information. When returning the card for repair, be sure to fill out and include the service form in order to provide the repair facility with the necessary information.

### 1.4 MANUAL ADDENDA

Any improvements or changes concerning the unit or manual will be explained in an addendum included with the unit. Please be sure to note these changes and incorporate them into the manual before operating or servicing the unit.

### 1.5 SAFETY SYMBOLS AND TERMS

The following symbols and terms may be found on the instrument or used in this manual.

The  symbol on the instrument indicates that the user should refer to the operating instructions.

The  symbol on an instrument shows that high voltage may be present on the terminal(s). Use standard safety practices to avoid personal contact with these voltages.

The **WARNING** heading used in this manual explains dangers that might result in personal injury or death. Always read the associated information very carefully before performing the indicated procedure.

The **CAUTION** heading used in this manual explains hazards that could damage the unit. Such damage may void the warranty.

## 1.6 SPECIFICATIONS

For the most recent updates to the Model 7065 specifications, check the Keithley Instruments website at [www.keithley.com](http://www.keithley.com).

## 1.7 UNPACKING AND INSPECTION

Upon receiving the Model 7065, carefully unpack the unit from its shipping carton and inspect the card for any obvious signs of physical damage. Report any such damage to the shipping agent immediately. Save the original packing carton for possible future reshipment.

The following items are included with every Model 7065 order:

- Model 7065 Hall Effect Card.
- Model 7065 Instruction Manual.
- Standard accessories (Table 1-1)
- Additional accessories as ordered.

If an additional instruction manual is required, order the manual package (Keithley Part Number 7065-901-00). The manual package includes an instruction manual and any applicable addenda.

## 1.8 REPACKING FOR SHIPMENT

Should it become necessary to return the Hall Card for repair, carefully pack the unit in the original packing carton or its equivalent. Only the Model 7065 itself need be returned.

Be sure to include the following information:

- Advise as to the warranty status.
- Write ATTENTION REPAIR DEPARTMENT on the shipping label.
- Fill out and include the service form at the back of this manual.

## 1.9 RECOMMENDED EQUIPMENT

Table 1-2 summarizes the instrumentation necessary for a Hall system. This list does not include necessary user-supplied equipment such as a cryostat, electromagnet, magnet power supply, or IEEE-488 controller.

The Keithley equipment summarized in Table 1-2 is briefly described on the next page.

**Table 1-1. Supplied Accessories**

Qty	Keithley Model	Description	Application
1	4801	Low noise coaxial cable	Connects 485 input to 7065 current monitor output
1	4802-10	Low noise coaxial cable (10')	Connects 485 directly to sample for bar, 6 and 8 contact samples
5	7025-10	Triaxial cable (10')	Four to connect sample to 7065 sample inputs, one to connect 220 directly to sample in 6 and 8 contact samples
1	6167	Guarded input adapter	Allows 220 to drive current source input cable at guard potential.
1	7024-3	3' triax cable	Attaches 220/6167 output to 7065 current source input.
1	7024-10	10' triax cable	Same as above
1	4851	BNC short	Shorts 7065 current monitor output.
1	7008-6	6' IEEE cable	Connects bus controller to the above instruments
2	SC-72-0	Black wire (4')	Connect analog ground
1	SC-72-9	White (4')	Connect 220 guard to 7065 GD terminal
2	BG-5	Banana Plug (black)	Terminates black connecting wires.
1	BG-10-1	Banana plug (white)	Terminates white connecting wire.
1	BG-7	Black double banana plug	Used with SC-8 to connect DMM to card.
1	SC-8	2-conductor cable with shield	Used with BG-7 to connect DMM to card.

**Table 1-2. Recommended Hall System Equipment**

Keithley Model Number	Description	Use
196 220 485* 705 or 706	6½ Digit DMM Current Source Picoammeter Scanner	Measure sample voltage Supply sample current Monitor sample current Control Model 7065 Hall Effect Card

\*Not essential but recommended for best accuracy.

NOTE: This listing does not include required user-supplied equipment such as cryostat, electromagnet and power supply, or IEEE-488 bus controller.

**Model 196 DMM:** The Model 196 is recommended for measuring the voltage across the sample under test. Important Model 196 features include:

- 100nV resolution.
- High input resistance (>1G $\Omega$  on 300mV and 3V ranges) for minimum sample loading.
- 6½ digit display resolution.
- Autoranging
- IEEE-488 bus operation.

**Model 220 Current Source:** The Model 220 Current Source is recommended for applying the current to the sample under test. Key Model 220 features include:

- $\pm 0.5\text{pA}$  to  $\pm 101\text{mA}$  DC current output.
- $10^{14}$   $\Omega$  output resistance.
- Programmable voltage compliance limit.
- Complete IEEE-488 bus programmability.

**Model 485 Picoammeter:** The Model 485 Picoammeter can be used to monitor the current being applied to the sample under test. Although not absolutely essential for a measurement system, the use of the Model 485 is recommended to maximize accuracy, especially when testing high-resistivity samples. Important Model 485 features include:

- 0.1pA resolution, 2mA maximum input current.
- 200 $\mu\text{V}$  maximum voltage burden
- Autoranging.

- 4½ digit display resolution.
- IEEE-488 bus operation (with option 4853).

**Models 705 and 706 Scanners:** The Model 7065 Hall Effect Card is designed to plug into the Models 705 or 706 Scanners. The Model 705 can accommodate two cards, while the Model 706 can handle up to 10 scanner cards. Other key features common to both scanner mainframes include:

- Full IEEE-488 bus programmability.
- Daisy chain operation allowing up to four slave mainframes to be controlled with one master.
- Front panel programs for easier system configuration.
- Built-in day/time clock for time stamping of data.

## 1.10 SCANNER COMPATIBILITY

The Model 7065 is designed to be used with the Keithley Models 705 and 706 Scanners. Note, however, that there are certain limitations when using the card in the Model 705.

Limitations for the Model 705 involve the software revision level, which must be B5 or later (the software revision level is displayed as part of the power-up cycle). The reason for this limitation is that Rev. B4 and earlier software does not support the matrix mode, which must be used with the Model 7065. Earlier versions can be upgraded; contact your Keithley representative or the factory for details.



# SECTION 2 OPERATION

---

## 2.1 INTRODUCTION

This section contains information on card installation, connections, test configurations, and scanner programming, and is arranged as follows:

**2.2 Handling Precautions:** Covers precautions that should be observed when handling the Hall effect card.

**2.3 Model 7065 Installation:** Details installation in a Model 705 or 706 scanner mainframe.

**2.4 Connections:** Covers the various connectors on the card and how to connect it to other instruments.

**2.5 Matrix and Test Configurations:** Discusses 7065 matrix and typical system configurations.

**2.6 Guarding Methods:** Describes methods of source input guarding, and discusses sample input guarding as well as guarding principles.

**2.7 Low and High Resistivity Selection:** Covers Model 7065 setup requirements for low and high resistivity samples, and summarizes input characteristics and tradeoffs for each.

**2.8 Front Panel Scanner Programming:** Summarizes programming steps necessary to control the Model 7065 from the front panel of the scanner mainframe.

**2.9 IEEE-488 Bus Scanner Programming:** Reviews method to control the Model 7065 through a scanner mainframe over the IEEE-488 bus.

**2.10 Measurement Considerations:** Covers important factors that must be taken into account when making measurements with the Model 7065.

## 2.2 HANDLING PRECAUTIONS

Because the Model 7065 is designed for very high im-

pe-  
dance measurements, care must be taken when handling the card to avoid contamination from foreign materials such as body oils. Such contamination can drastically lower channel isolation and leakage resistances, degrading performance.

To avoid possible contamination, always grasp the card at the edges. Although the card shields protect most of the circuit board, it is a good idea to avoid touching the exposed board areas. If you remove the shields for any reason, be sure not to touch the exposed board or any components underneath. Particularly sensitive areas include the sample inputs from the sample input jacks to the inputs of the buffer amplifiers.

Dirt build-up over a period of time is another possible contaminating factor. To avoid potential problems, operate the scanner only in a clean environment. If contamination is suspected, the card should be carefully cleaned using the procedure outlined in paragraph 4.2 of this manual.

## 2.3 MODEL 7065 INSTALLATION

The following paragraphs discuss Model 7065 Hall Effect Card installation in both the Models 705 and 706 Scanners. Note that some connections must be made to the Model 7065 before installation, as discussed in paragraph 2.4.

### WARNING

**Turn off the scanner power and disconnect the line cord before installing or removing scanner cards.**

### CAUTION

**Leave the Model 7065 in its anti-static bag until ready for installation to avoid possible static damage.**

### 2.3.1 Installation in the Model 705 Scanner

Refer to Figure 2-1 and install or remove the Model 7065 Hall Card as follows:

1. To install the card, slide it into the desired rear panel slot with the component (large shield) side facing up. Make sure the card edges are properly aligned with the grooves in the receptacle.
2. Once the card is fully seated, lock the card by placing the tabs into the locked position, as shown in Figure 2-1.
3. To remove the card, first unlock the tabs by pulling them outward, then grasp the end of the card at the edges and pull the card free of the scanner.

### 2.3.2 Installation in the Model 706 Scanner

Install the Model 7065 in the Model 706 Scanner using Figure 2-2 as a guide.

1. To install the Hall card, slide it into the desired vertical slot. Looking from the rear, slots are numbered from 1 to 10, left to right. Note that the component (large shield) side of the card should face to the left of the slot. Make certain the card edges are properly aligned with the top and bottom grooves in the slot.
2. Once the card is aligned with the grooves, push the card as far as it will go into the slot until it is properly seated into the slot connector. After the card is properly seated, lock the card with the tabs, as shown in Figure 2-2.
3. To remove the card, unlock the tabs by pulling them outward as shown in Figure 2-2. Grasp the end of the card and pull it free of the mainframe.

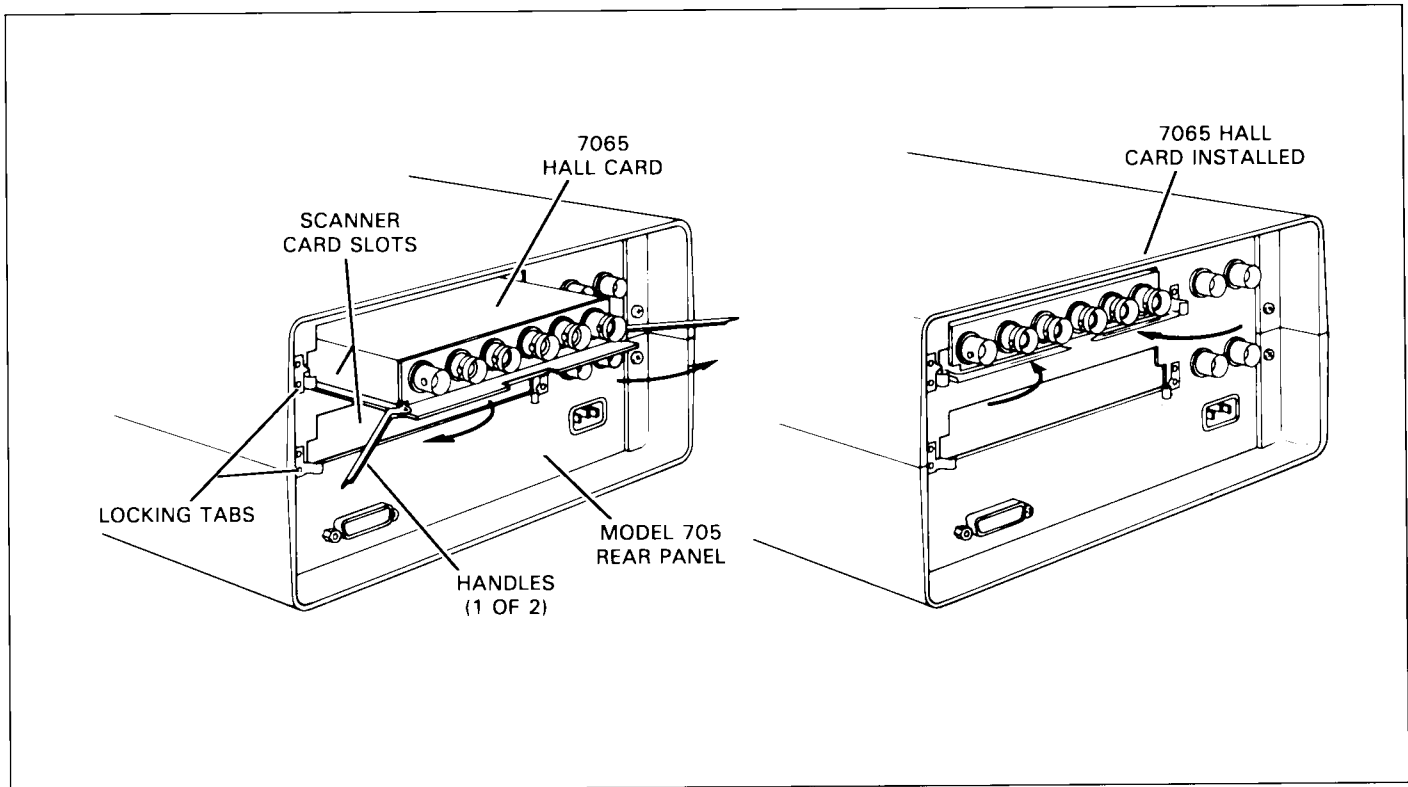

Figure 2-1. Model 705, Card Installation

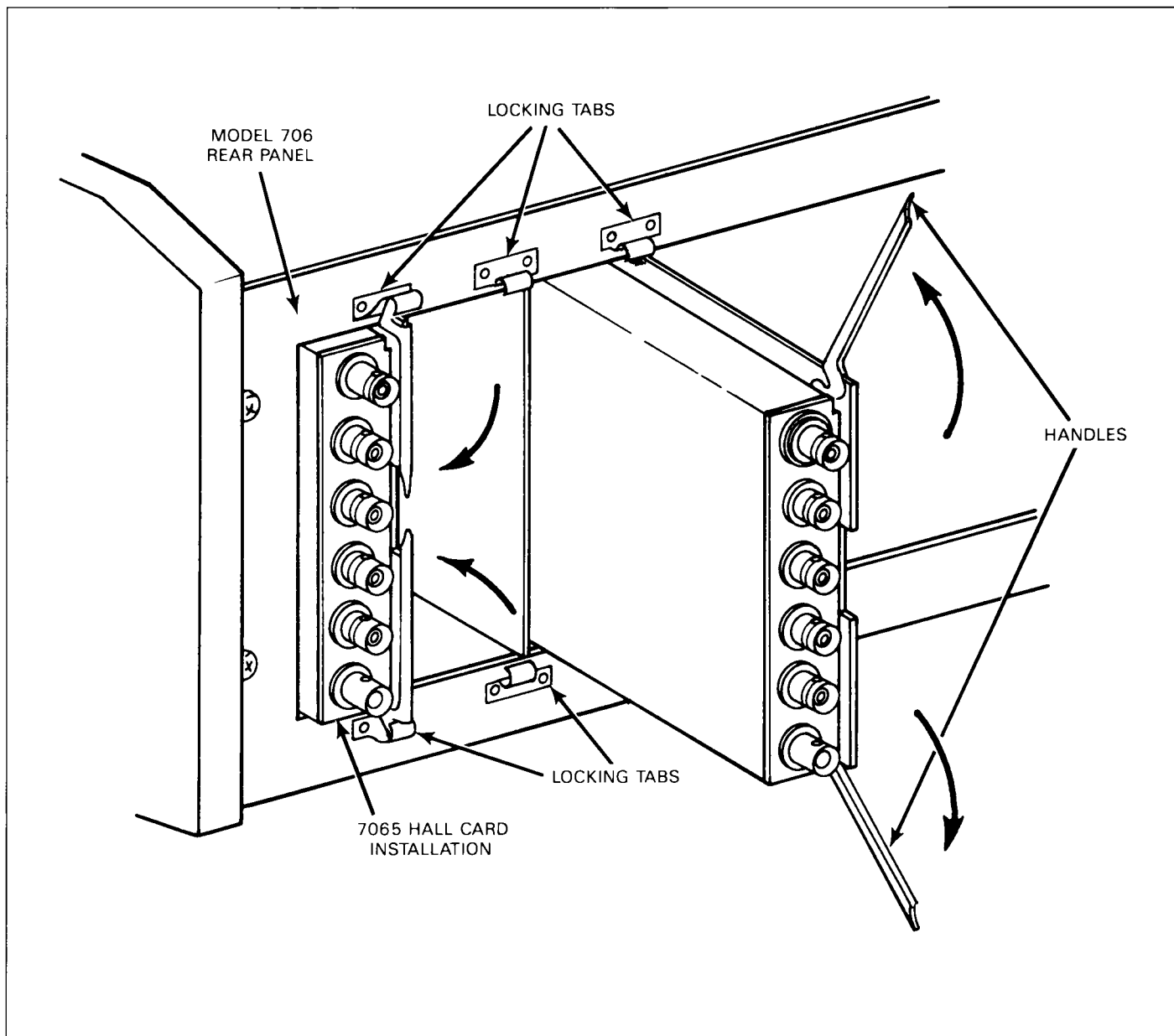

Figure 2-2. Model 706, Card Installation

## 2.4 CONNECTIONS

The following paragraphs discuss the card connector and their purposes and also show typical connecting schemes.

### 2.4.1 Card Connectors

**WARNING**

**Maintain inputs and outputs within 30V of earth ground. Failure to observe this precaution may result in a shock hazard.**

The layout of the Model 7065 is shown in Figure 2-3. Connectors on the card are:

**CURRENT SOURCE INPUT:** A two-lug triaxial connector intended for applying the test current. Note that the inner shield can be connected to source guard using one of the methods described in paragraph 2.6. The Keithley Model 220 is the recommended current source. Maximum allowable input current is 100mA.

**SAMPLE INPUTS (1 through 4):** These are two-lug triaxial connectors, with the inner ring driven at guard potential, while the shell is connected to analog ground. Maximum input overload is 12V.

**CURRENT MONITOR OUTPUT:** An insulated BNC connector recommended for use with a Keithley Model 485

Picoammeter. Maximum input overload is 10mA when using the Model 485.

**CAUTION**

**Be careful not to interchange triax and BNC connectors to avoid damaging them.**

**NOTE**

The caps should be kept in place on the connectors when not in use to prevent possible contamination, which could degrade performance.

**Terminal Block (J2):** These thumb-operated, spring-loaded connectors accept 18-24 gauge wire. Three of the terminals are intended for voltmeter connections, while the remainder allow connection to analog ground or external guard. Terminal assignments are summarized in Table 2-1. Maximum load current is 1mA.

**Table 2-1. Terminal Strip Connections**

Terminal	Description
1	Analog ground
2	Analog ground
3	Hall Bar LO output
4	LO output
5	HI output
6	Guard input



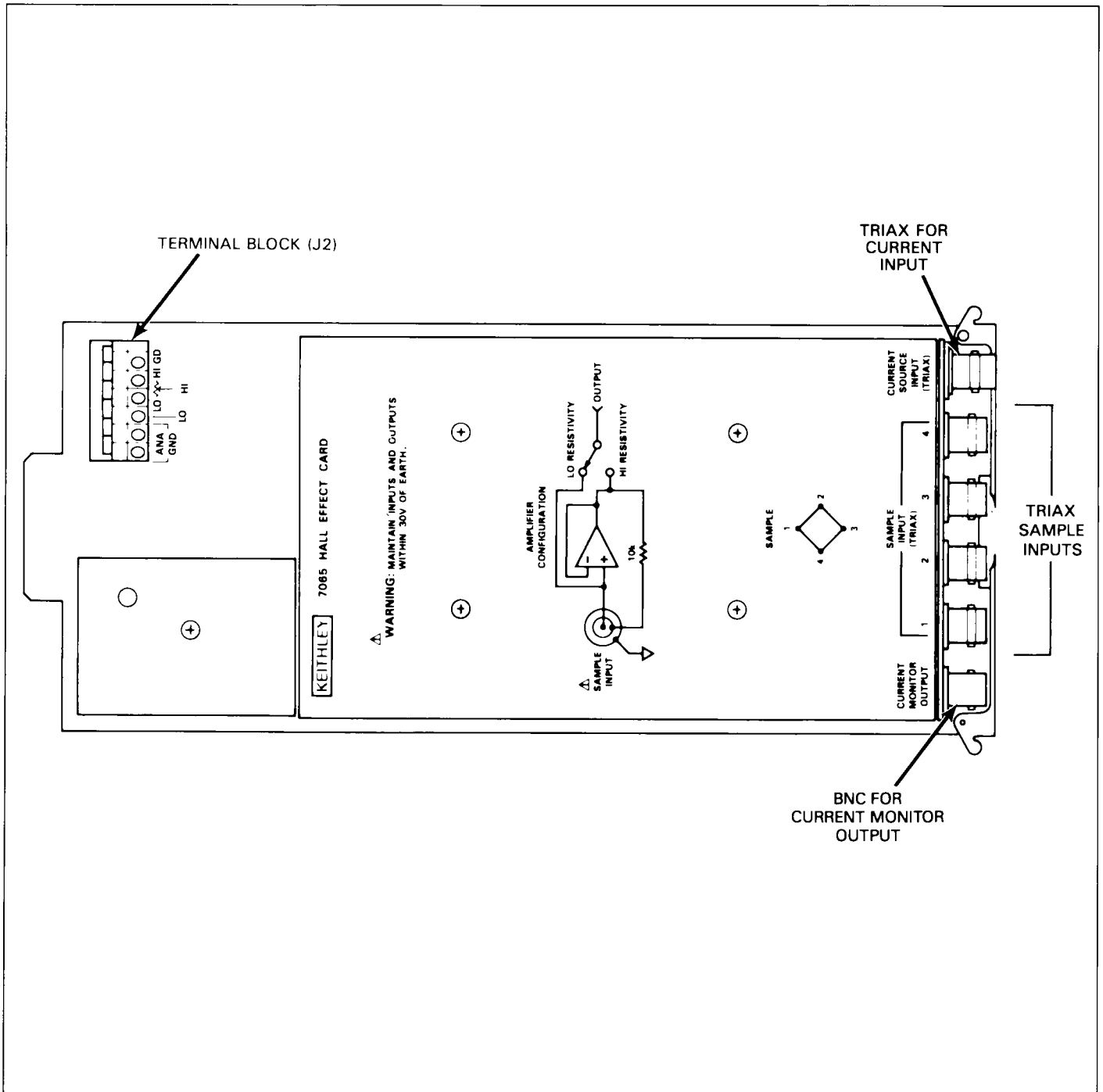

Figure 2-3. Model 7065 Connectors

### 2.4.2 Recommended Cables and Wires

Table 2-2 summarizes cables recommended for test connections. These cables are supplied with the card as standard equipment.

The Model 7024 cables are intended for connecting the Model 220 current source to the Model 7065. The Model 7025 unterminated triaxial cables are intended for sample connections. The coaxial cables are to be used for current monitor output connections. The Model 4801 connects the card to the picoammeter, while the Model 4802 allows the picoammeter to be connected directly to the sample.

Connecting wires between the terminal block and external equipment are supplied. The shielded cable/dual banana plug should be used to connect the DMM to the card, while the white and black wires can be used for guard and analog ground connections, respectively.

**Table 2-2. Recommended Cables**

Cables	Used with
Model 7025-10 triaxial cables (unterminated)	Sample inputs
Model 4801 BNC-to-BNC coaxial cable	Current monitor output
Model 4802-10 BNC Cable (unterminated)	Current monitor output direct to sample.
Model 7024 triaxial cables	Current source input
SC-72 connecting wires with same color single plugs.	
2 - black	Analog ground
1 - white	Guard
SC-8/BG-7	Red to DMM HI (term 5) black/shield to DMM LO (term 4) on J2.

NOTE: These cables are supplied.

### 2.4.3 Cable and Wire Preparation

The necessary cables, wires, and connectors are supplied with the Model 7065; however, these cables and wires must be prepared before use as described below.

#### Single Wire/Banana Plug Preparation

As summarized in Table 2-2, color-coded wires are provided

for making various connections between the Model 7065 and other instruments. A matching color-coded banana plug is included to mate with appropriate jacks on the test instruments.

**NOTE**

A banana plug should always be used to make the connection to a banana jack on an instrument to ensure proper contact.

The supplied SC-72 wires should be prepared and connected to the supplied banana plugs as follows. Refer to Figure 2-4 for the various steps.

1. Strip the end of the wire to be connected to the banana plug approximately 1/2 inch, then twist the strands together.
2. Unscrew the body of the matching color single banana plug and insert the stripped end of the wire through the small hole in the metal part of the plug so the wire comes through the small hole as shown in Figure 2-4.
3. Wrap the wire around the plug base in the same direction as the plastic body screws on, then screw on the plastic body securely.
4. Strip the opposite end of the wire approximately 3/8 inch and twist the strands together. This end is to be connected to the terminal block of the Model 7065.

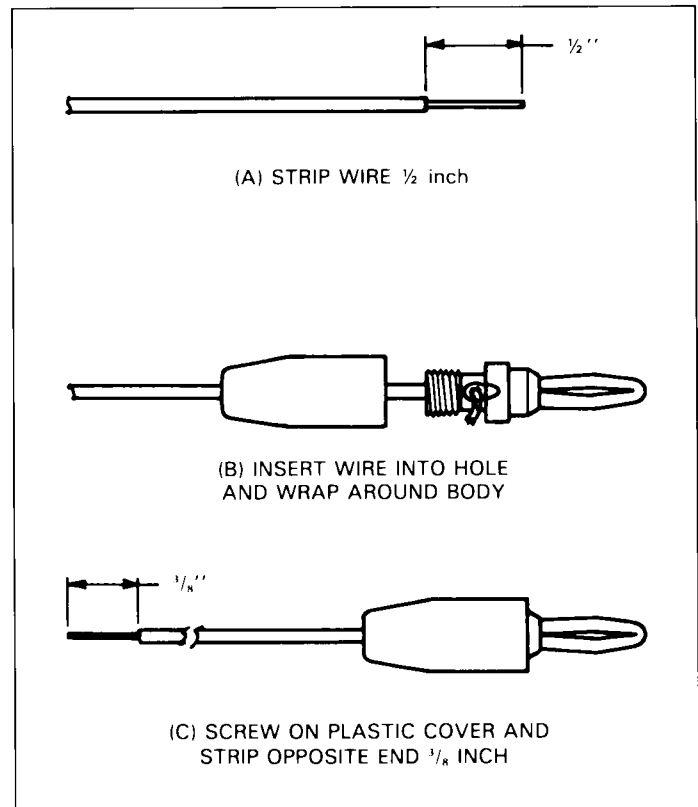

**Figure 2-4. Single Wire Preparation**

### Dual Banana Plug Preparation

A dual banana plug (BG-7) and length of shielded, two-conductor cable (SC-8) is provided with the Hall card. These items are to be used to connect the DMM to the Model 7065.

#### NOTE

To minimize noise, the dual banana plug/shield wire combination should always be used to connect the Model 7065 to the DMM instead of separate wires.

The dual banana plug and 2-conductor shielded cable can be prepared as follows (see Figure 2-5).

1. Strip back about 1¼ inch of outer insulation from the SC-8 shielded 2-conductor wire.
2. Unravel the shield braid and twist the strands together.
3. Strip approximately ¼ inch of insulation from both the red and black wires.
4. Twist the shield braid and black wires together tightly. Also twist the strands on the red wire together.
5. Slip the wire through the back hole in the dual banana plug, then place the red wire end in the hole in the banana plug without the ridge on the body.
6. Slip the black/shield wire end through the hole in the banana plug closest to the body ridge.
7. Secure both red and black wires by tightening the screws for each banana plug (these screws are accessible inside the body directly behind each banana plug). Be careful not to tighten them too tightly.
8. Strip approximately 1 inch of the insulation off the opposite end of the cable, then unravel and shield and twist the strands together.
9. Strip the red and black wire insulation approximately 3/8 inch.
10. Twist the black wire and shield together. Also twist the red wire strands together.
11. The cable is now ready for connection to the terminal block.

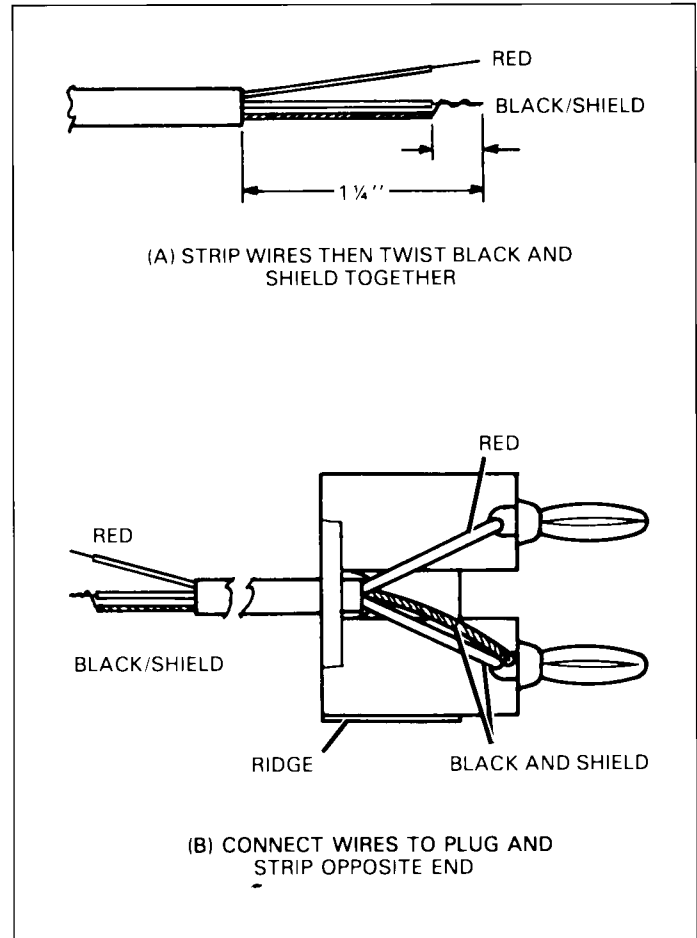

**Figure 2-5. Shielded Cable Preparation**

### Triaxial Cable Preparation

The one end of each Model 7025 triaxial cable must be prepared as follows before it can be connected to the sample under test. Refer to Figure 2-6.

1. Using an X-Acto knife, cut and strip back the outer insulation about 1½ inches.
2. Remove the piece of insulation, then cut away the outer shield back as far as the insulation is stripped.
3. Carefully strip insulation on the inner shield one inch, then cut the shield off.
4. Carefully strip the insulation on the inner conductor to the desired length, then twist the strands together.
5. Repeat steps 1 through 4 for the remaining triaxial cables.

**NOTE**

Make sure the inner and outer shields do not touch one another.

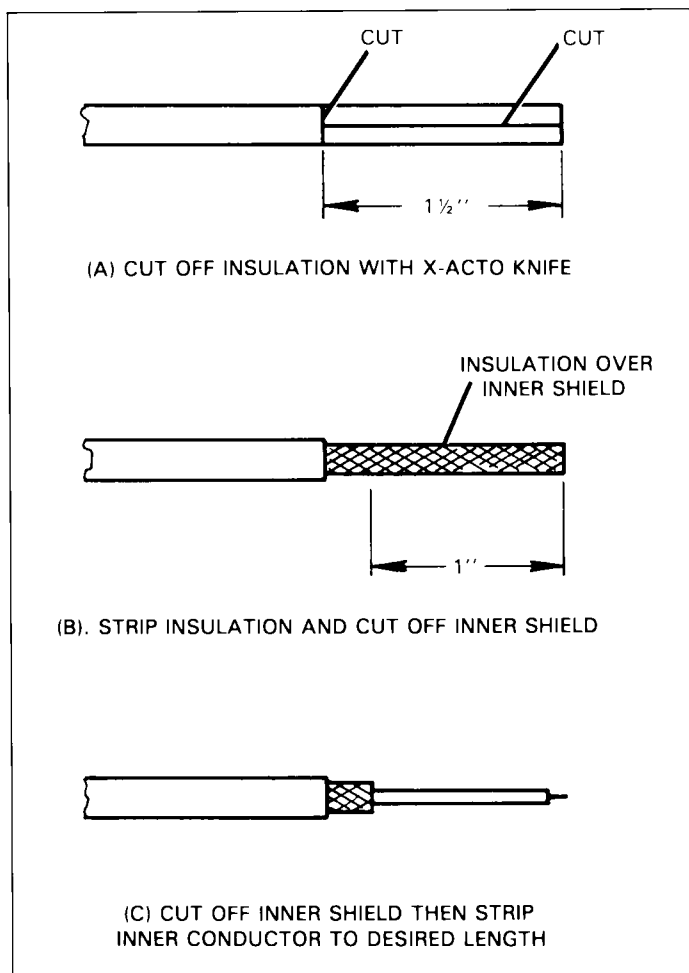

**Figure 2-6. Triaxial Cable**

### Coaxial Cable Preparation

In some instances (bar and bridge samples), the picoammeter must be connected directly to the sample using a Model 4802 coaxial cable. Before use, the coaxial cable should be prepared as follows:

1. Cut back the outer insulation about one inch, then remove it.
2. Remove the exposed shield by cutting it back as far as the insulation.
3. Strip the inner insulation to the desired length, then twist the strands together.

### 2.4.4 Van der Pauw Sample Connections

Figure 2-7 shows typical connections for measurement made using the van der Pauw method, and Figure 2-8 gives an equivalent circuit.

Make connections as follows:

1. Connect the Model 6167 guard adapter to the Model 220 triax output. Connect the Model 6167 guard output to the Model 220 GUARD jack.
2. Connect the Model 6167 Input to the CURRENT SOURCE INPUT jack using a 7024-3 or 7024-10 triaxial cable.

**NOTE**

This setup assumes that the guarded source input configuration is to be used. See paragraph 2.6 for more information on guarding.

3. Connect the four terminals of the sample under test to the SAMPLE INPUTS using supplied triaxial cables. See Figure 2-6 for cable stripping instructions.
4. Connect the Model 485 Picoammeter to the CURRENT MONITOR OUTPUT jack on the Model 7065 using the supplied Model 4801 low-noise cable (use the 4851 shorting plug if no picoammeter is to be used).
5. Connect Model 196 DMM LO to terminal 4 of the Measurement Output terminal strip, and connect DMM HI terminal to terminal 5 of the terminal strip. Use the dual banana plug/cable for DMM connections.



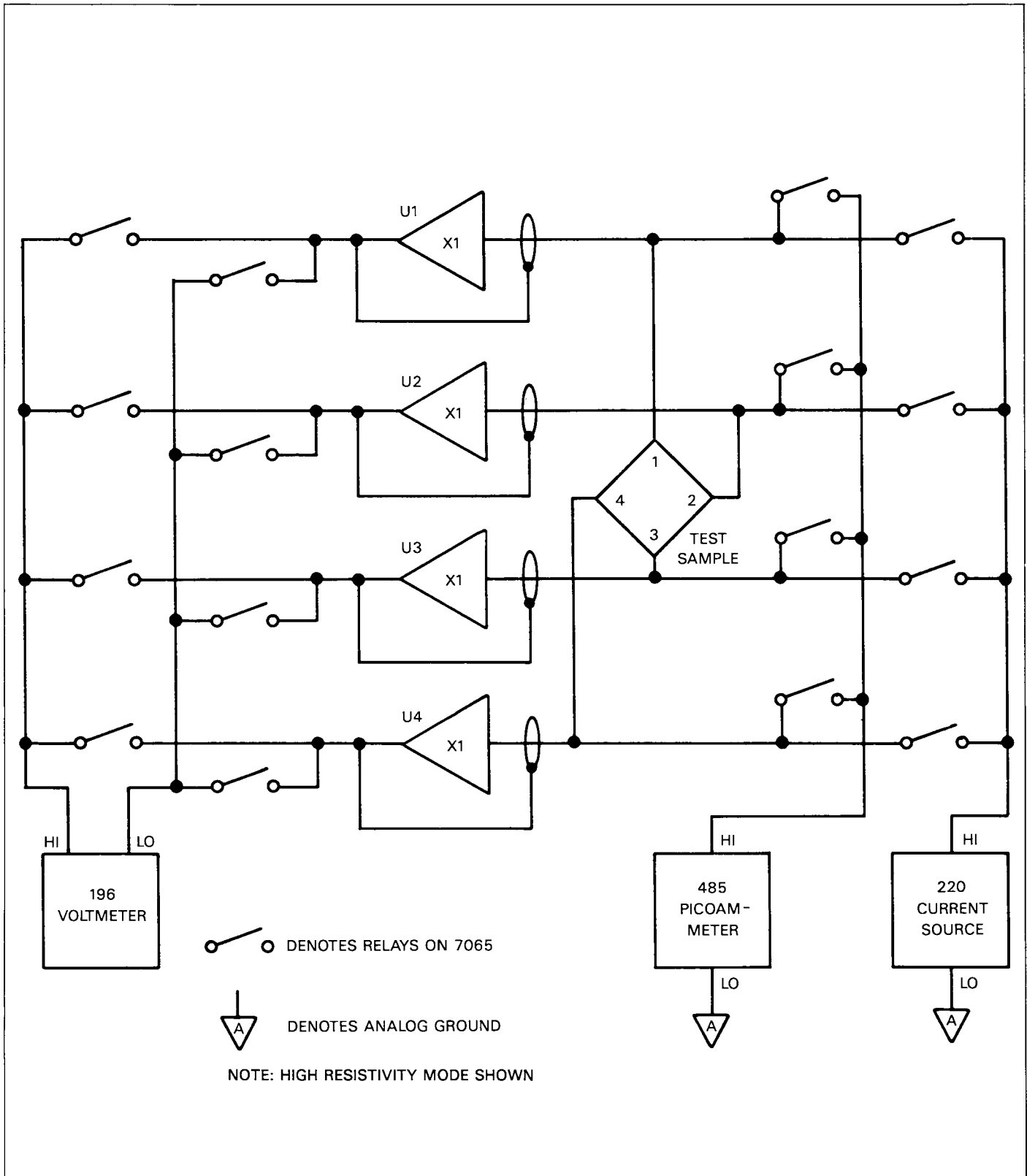

Figure 2-8. Equivalent Circuit for Van der Pauw Connections

---

---

## 2.4.5 Bar Type Sample Connections

### Hall Voltage Measurements

Use the basic scheme shown in Figure 2-9 for Hall voltage measurements on bar type samples. Figure 2-10 shows an equivalent circuit.

Make connections as follows:

1. Connect the sample to the SAMPLE INPUTS, as shown in Figure 2-9. Use the supplied 7025 triaxial cables (see paragraph 2.4.3 for preparation).
2. Mount the Model 6167 guarding adapter on the Model 220 and connect the guard lead to the Model 220 GUARD terminal. Connect a Model 7024 triax cable between the Model 6167 input jack and the Model 7065 Current Source Input.

#### NOTE

This connecting method assumes guarded source input operation. See paragraph 2.6 for more information on guarding.

3. Connect the picoammeter HI input terminal directly to the sample under test through a Model 4802 coaxial cable. Connect a black wire/banana plug between analog ground on the terminal block and Model 485 analog output low.
4. Connect a suitable potentiometer between terminals 4 and 5 of the terminal strip. See paragraph 3.6.2 for details on selecting the correct potentiometer value.
5. Connect VOLTS/OHMS LO to terminal 3 of the strip. Connect DMM HI to the wiper of the potentiometer using the dual banana plug/shield wire.

### Resistivity Connections

Connections for determining the resistivity of bar type samples are essentially the same as for Hall voltage except for the way the DMM is connected. As shown in Figure 2-11, DMM VOLTS/OHMS LO should be connected to terminal 4 of the strip, and DMM HI should be connected to terminal 5. Figure 2-12 shows an equivalent circuit of the test configuration.

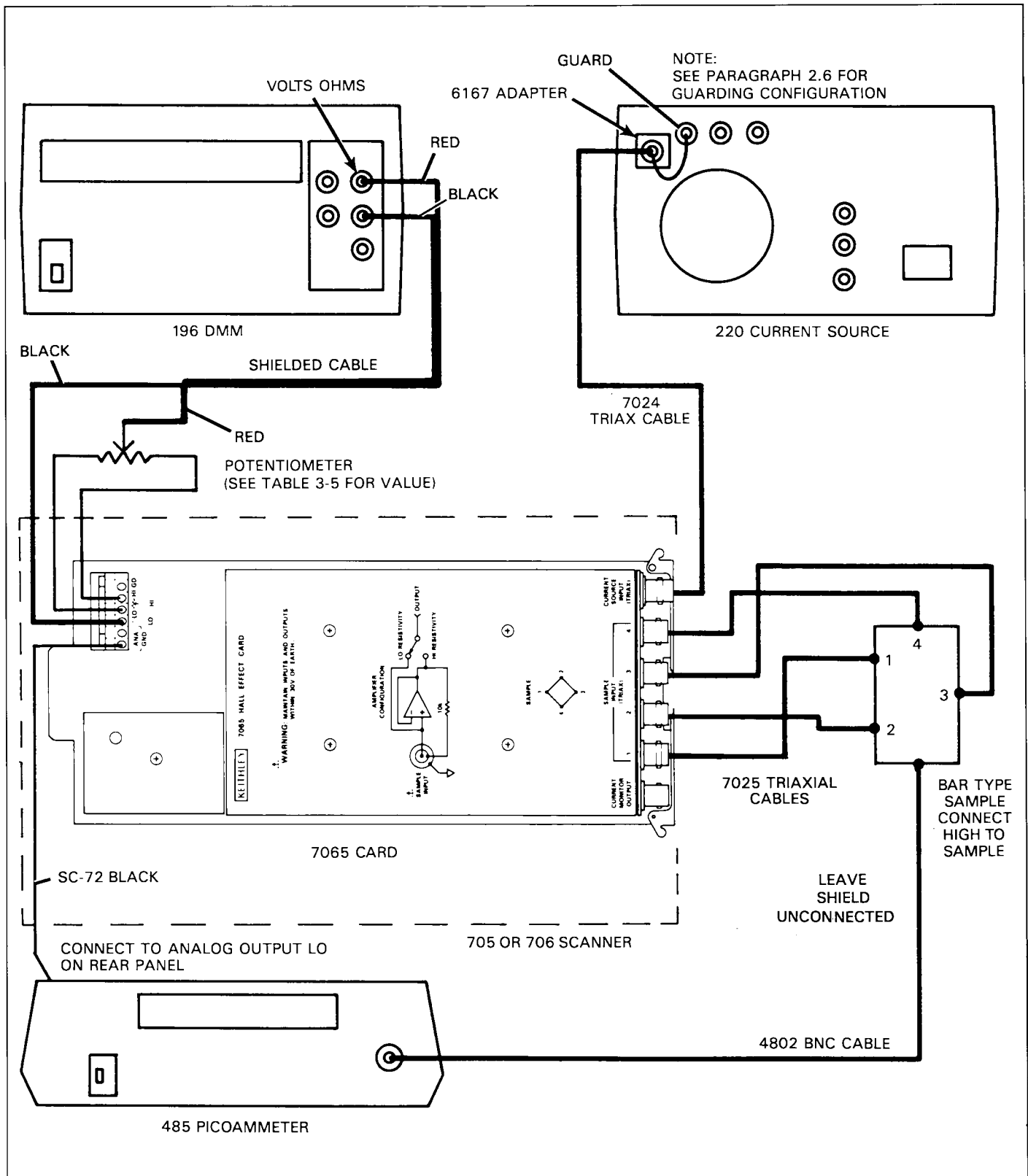

Figure 2-9. Connections for Hall Voltage Measurements of Bar Type Samples



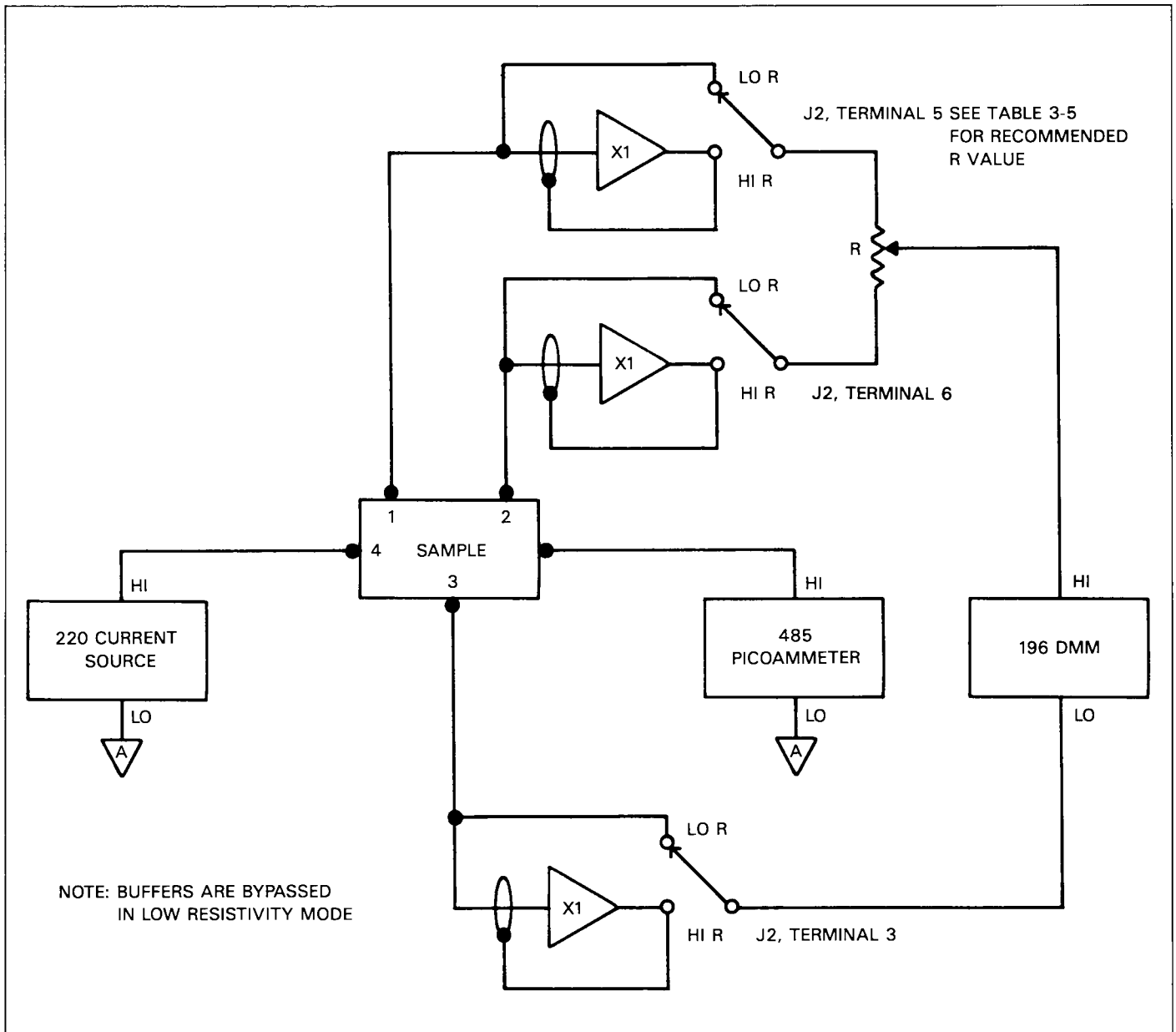

Figure 2-10. Equivalent Circuit for Hall Voltage Measurements of Bar Type Samples

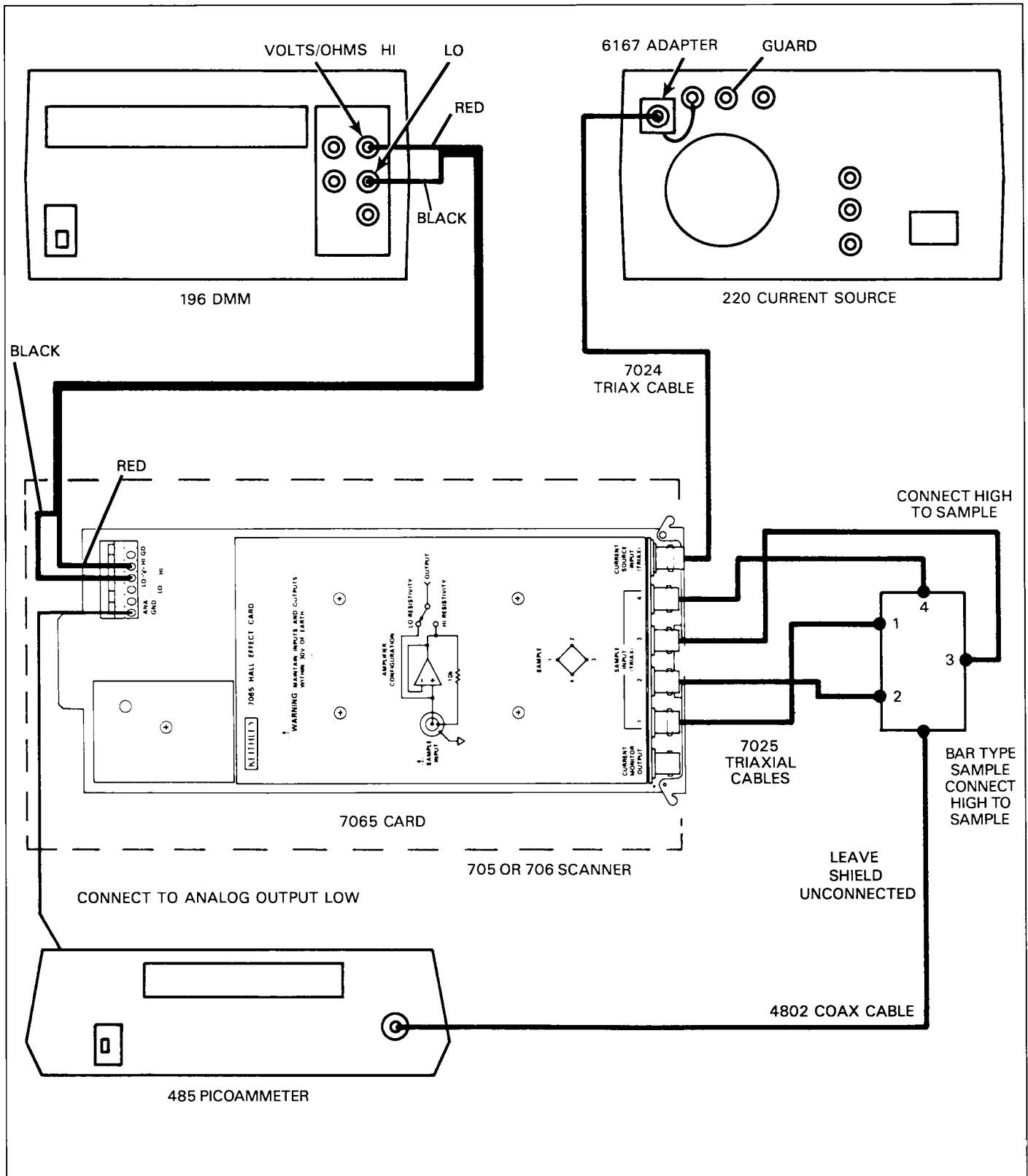

Figure 2-11. Connections for Resistivity Measurements of Bar Type Samples

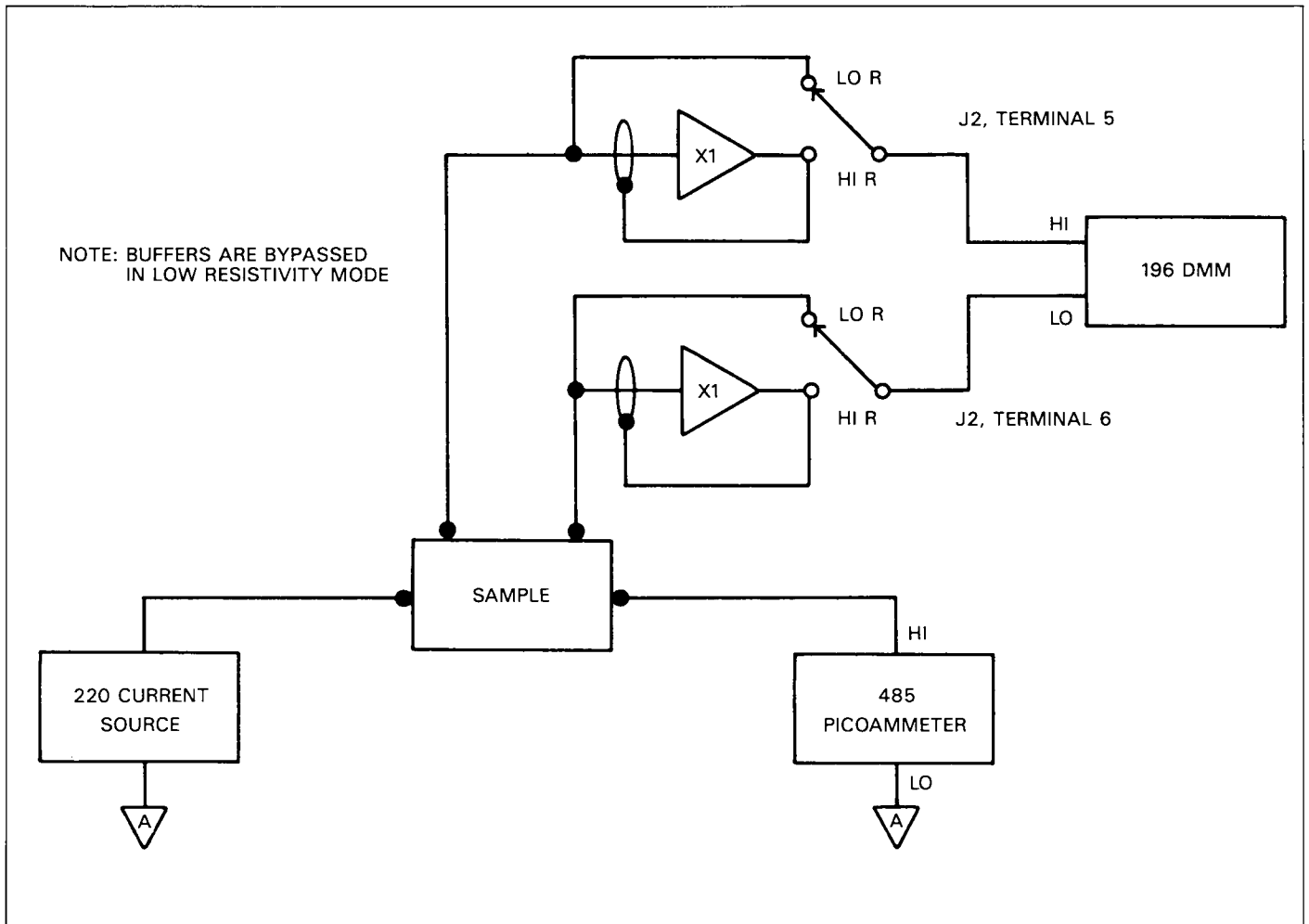

Figure 2-12. Equivalent Circuit for Resistivity Measurements of Bar Type Samples

## 2.4.6 Bridge and Parallelepiped Type Sample Connections

Connections for 6-contact samples are shown in Figure 2-13, while Figure 2-14 gives an equivalent circuit. Figures 2-15 and 2-16 summarize the connections for 8-contact samples.

Make the required connections as follows:

1. Connect the required sample terminals to the four SAMPLE inputs using supplied Model 7025 triaxial cables.
2. Using the supplied 4802 coaxial cable, connect the HI terminal of the picoammeter to the indicated sample terminal.
3. Connect a Model 7025 triaxial cable to the Model 220, as indicated. Connect current source HI (center conductor) to the sample, as shown on the appropriate diagram.
4. Current source low and picoammeter low must be connected together. The method of connection depends on whether or not current input guarding is used, as follows:
  - A. Unguarded: Connect picoammeter analog output LO to the output common terminal of the Model 220 Current Source. The ground link should be removed.
  - B. Guarded: Connect picoammeter analog output LO to the output common terminal of the Model 220 current source. The inner shield should be left floating at the sample end. The Model 6167 must be used to guard the cable, as discussed in paragraph 2.6.
5. Regardless of the current input guarding configuration, Model 220 GUARD must be connected to the GD terminal (6) on the Model 7065 in order to drive the protection circuits on the card.
6. Connect the DMM to the Hall Card as indicated on the appropriate diagram. Use the shielded cable/dual banana plug to make connections.

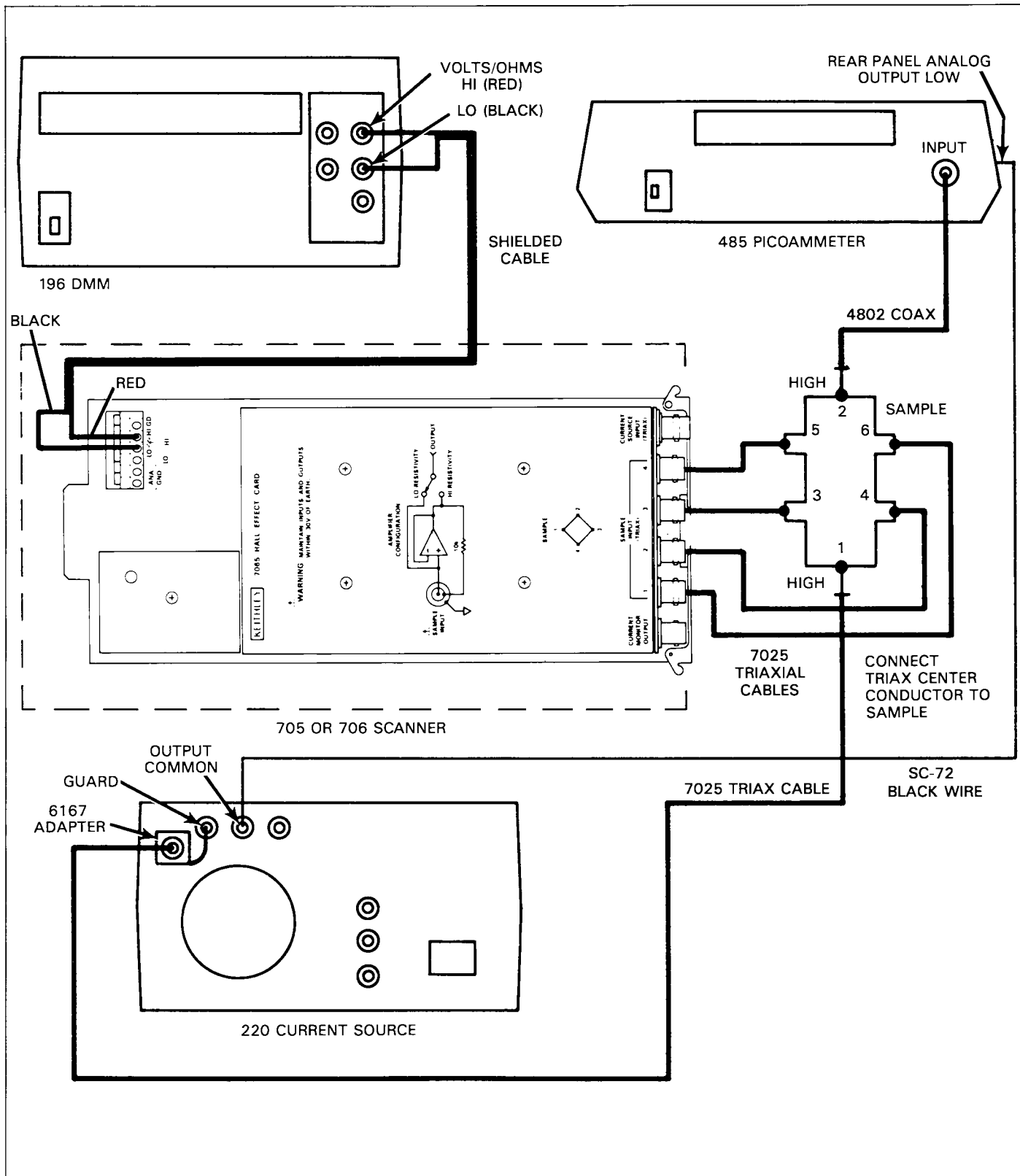

Figure 2-13. Connections for 6-Contact Samples

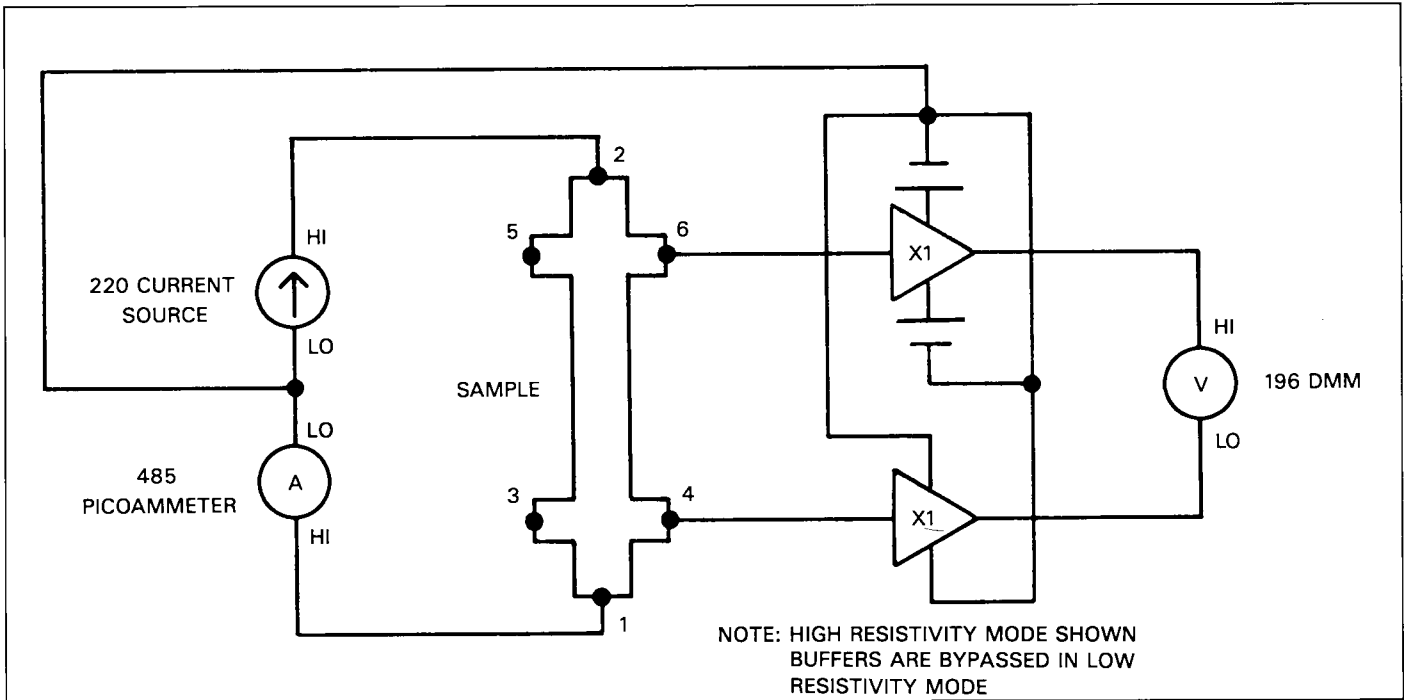

Figure 2-14. 6-Contact Equivalent Circuit (Current 1-2, Voltage 6-4)

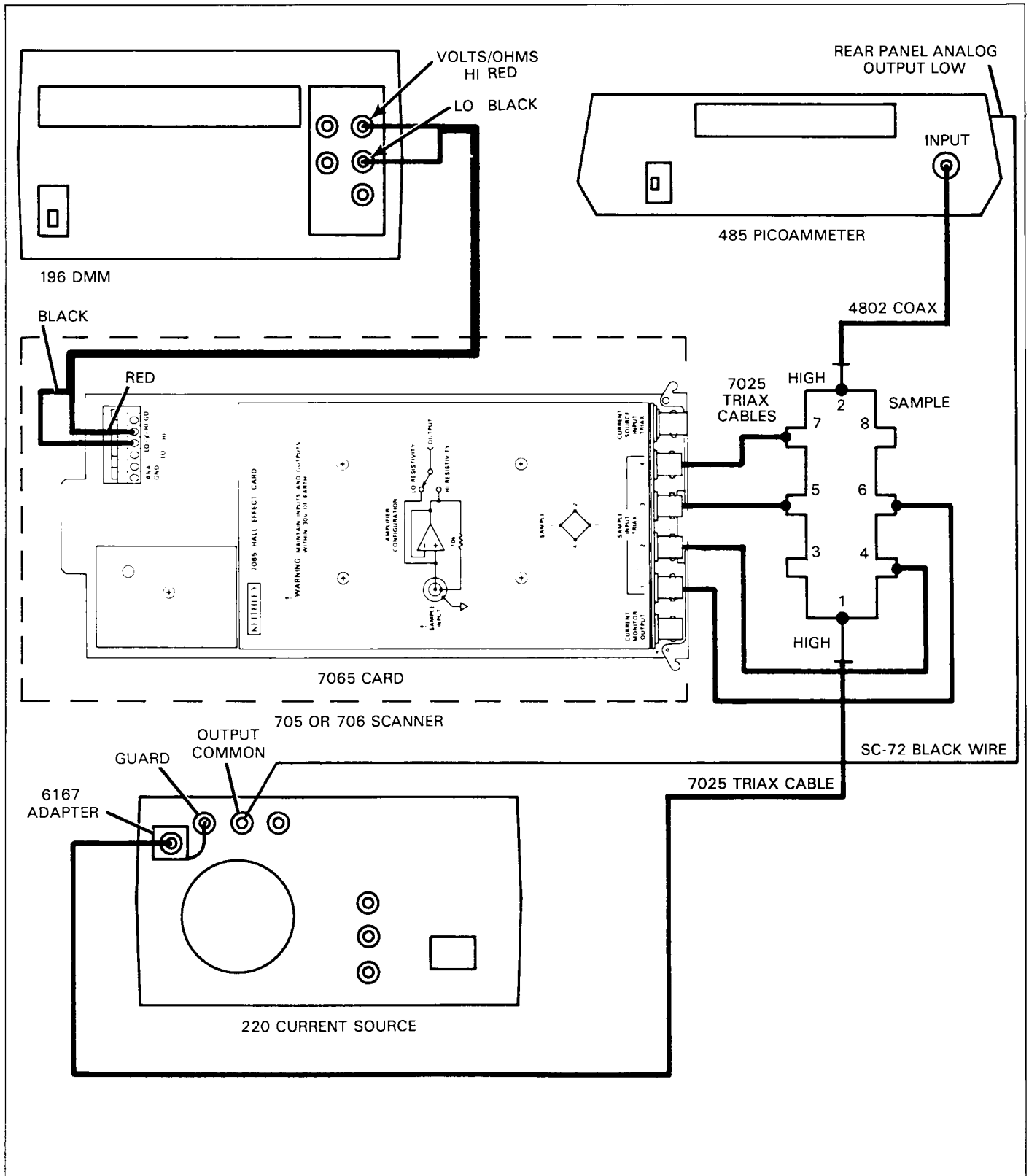

Figure 2-15. Connections for 8-Contact Samples

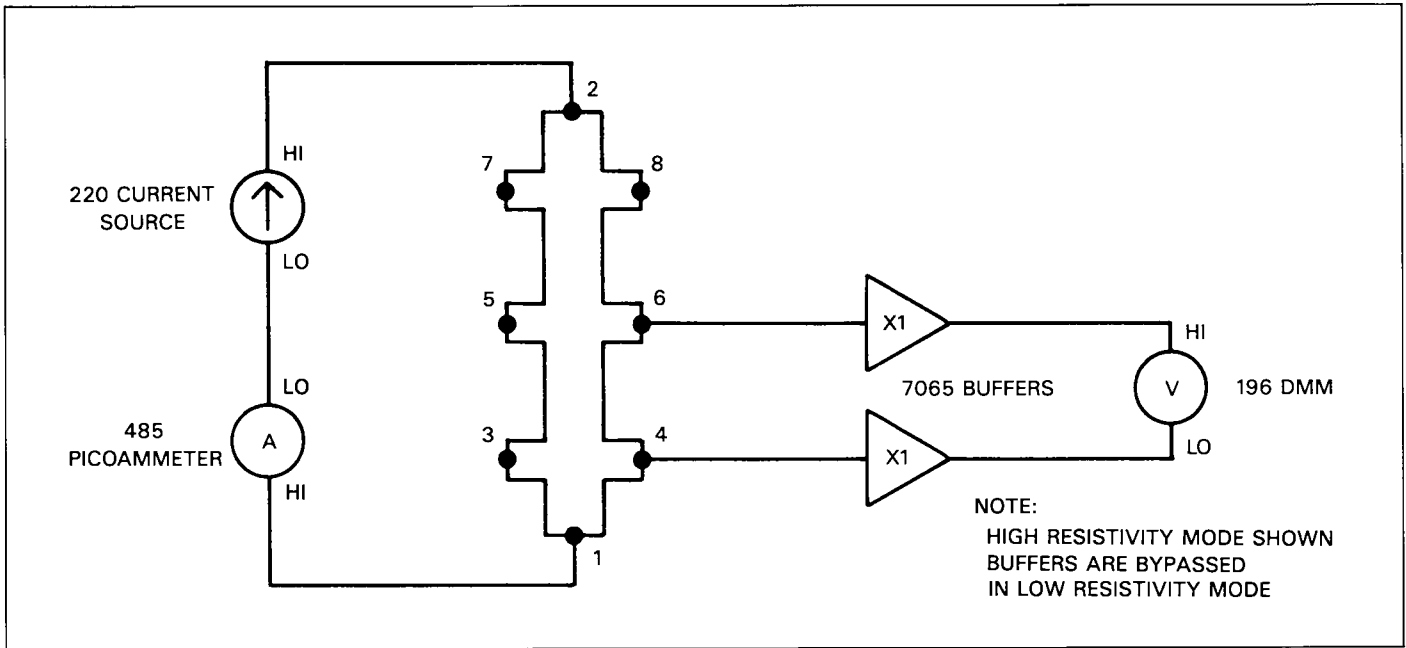

Figure 2-16. 8-Contact Sample Equivalent Circuit (Current 1-2, Voltage 6-4 shown)



### 2.4.7 Shorting the Current Monitor Output

Normally, a system will be setup with a Model 485 or similar picoammeter to accurately measure the sample excitation current. As an alternative, you can configure your system for use without a picoammeter by placing the Model 4851 BNC shorting plug on the CURRENT MONITOR OUTPUT jack in place of the picoammeter connecting cable. This shorting plug is necessary to complete the circuit for the current path. Note that shorting the CURRENT MONITOR OUTPUT is not necessary for bar, 6-contact or 8-contact samples because the picoammeter is connected directly to the sample for those measurements. (In cases where a picoammeter is not used, short out the picoammeter on the wiring diagram).

Another situation requiring use of the shorting plug is when the sample excitation current exceeds the 2mA measurement capability of the Model 485 Picoammeter. In this case, the Model 485 should be disconnected from the Model 7065, and the Model 4851 shorting plug connected in its place.

### 2.4.8 IEEE-488 Bus Connections

Connect each instrument to the IEEE-488 bus using the supplied Model 7008 IEEE-488 cables. Refer to the instrument instruction manuals for pertinent details.

## 2.5 MATRIX AND TEST CONFIGURATIONS

The following paragraphs discuss the matrix configuration of the Model 7065 and detail a basic Hall measurement system.

### 2.5.1 Model 7065 Matrix

The Model 7065 is organized into a 5 X 4 (5 column by 4 row) matrix, as shown in Figure 2-17. Each intersection of a column and row is called a crosspoint and is designated by a small circle on the diagram. By appropriate programming, a particular row can be connected to the desired column by closing the appropriate crosspoint. The conven-

tion used in this manual always designates a crosspoint in column, row format. For example, contact 3,4 refers to column 3, row 4 of the matrix.

Source and measurement devices are connected to the columns, while the samples are connected to the rows. For example, the picoammeter and current source are connected to columns 1 and 2 respectively, while the voltmeter is connected to columns 3 and 4. Column 5 is reserved for Hall bar measurements except for 5,4, which selects low/high resistivity operation.

The four sample inputs are applied to the X1 buffer amplifiers, which have a very high input resistance to minimize loading. In the low-resistivity mode, however, these buffers are effectively bypassed by FET switches. Although not shown on the diagram, the buffers also provide a driven guard for the four sample inputs to minimize the effects of leakage resistance and capacitance.

To demonstrate the versatility of the switching matrix, let us assume that we wish to apply a current through terminals 1 and 2 of the sample and measure the voltage between terminals 4 and 3 of that sample. To apply the current, we would close 2,1 and 1,2, while to measure the voltage, contacts 3,4 and 4,3 would be closed. In this case, current would flow from the source, through 2,1 into terminal 1 of the sample. From there, current would flow out terminal 2, through 1,2, into the picoammeter back to analog ground to complete the path. The act of closing 3,4 and 4,3 would connect the voltmeter to measure the voltage between terminals 4 and 3 through the buffer amplifiers (high resistivity mode).

More information on scanner programming may be found in paragraphs 2.8 and 2.9, while Section 3 covers measurement methods in more detail.

### 2.5.2 Test System

The basic configuration of an IEEE-488 based Hall measurement system is shown in Figure 2-18. A system used solely for resistivity measurements would not require the electromagnet or magnet power supply.

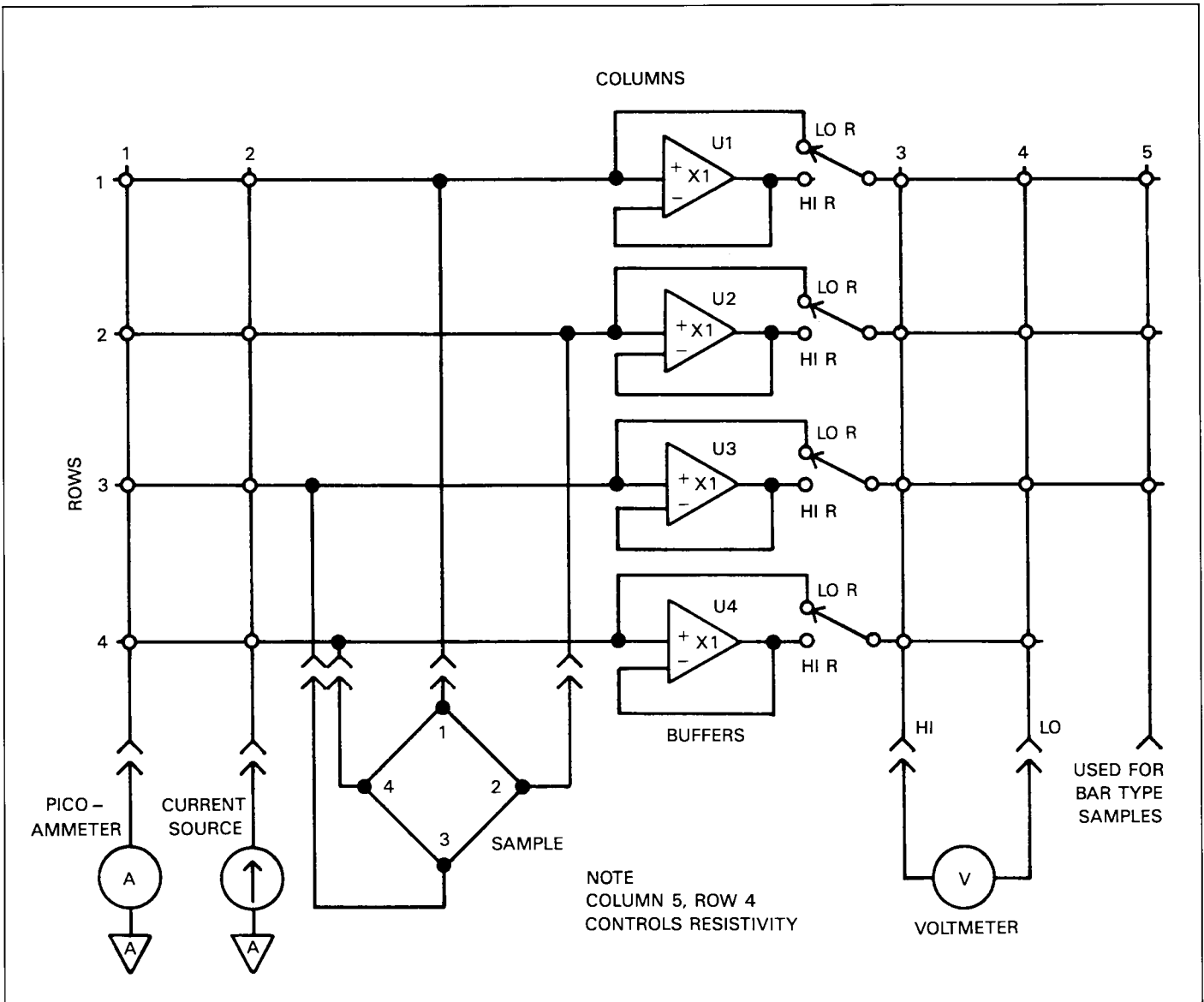

Figure 2-17. Model 7065 Matrix Configuration

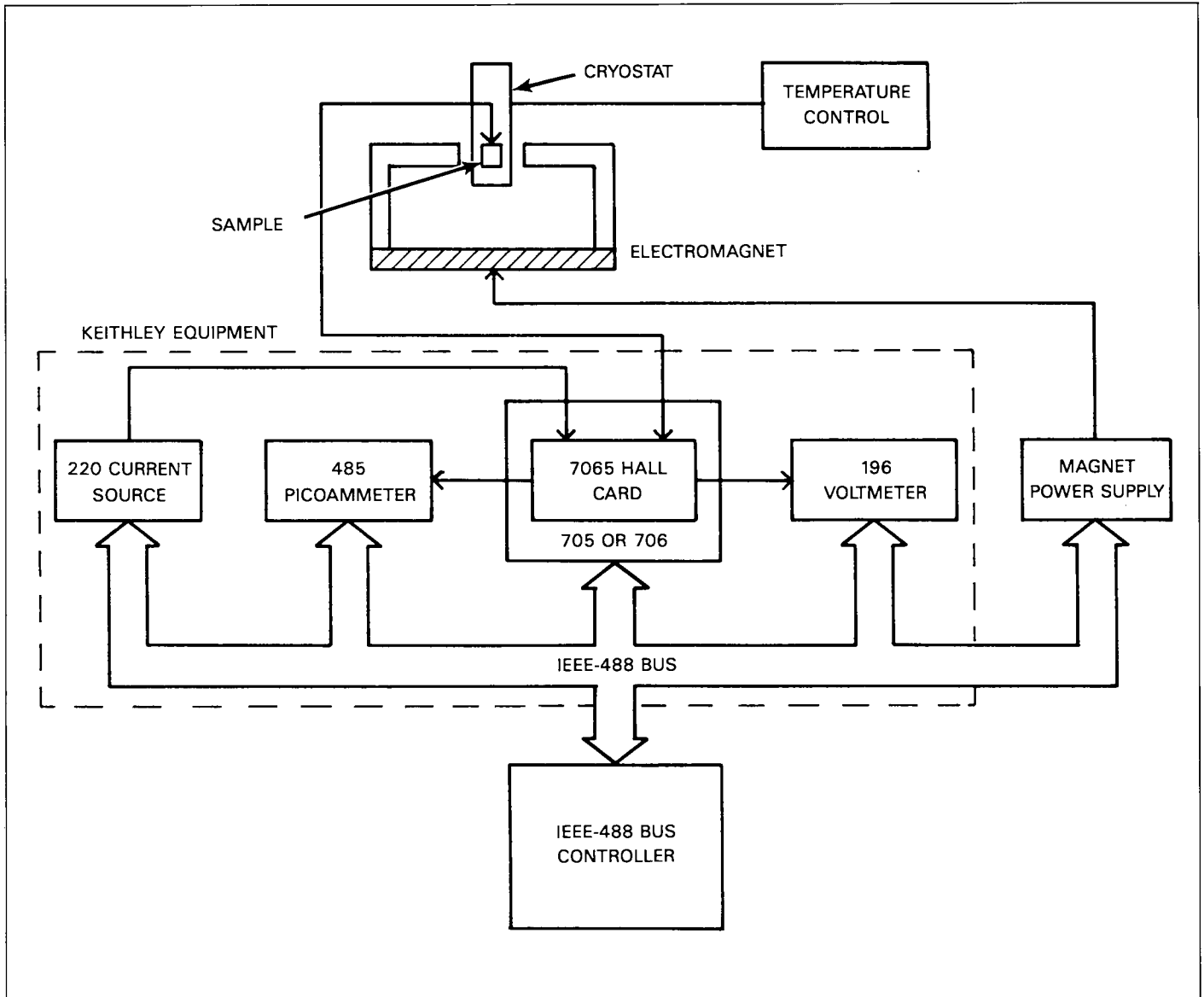

Figure 2-18. Basic Hall System Configuration

Equipment in the system includes:

- 220 Current Source: Applies the current to the sample under test.
- 485 Picoammeter: Measures the current through the sample under test.
- 7065 Hall Card: Switches and buffers applied currents and voltages.
- 705 or 706 Scanner: Controls and supplies power to the 7065 Hall Card.
- 196 Voltmeter: Measures the voltage across the sample under test.
- IEEE-488 Controller: Provides the intelligence to control the instruments in the system.
- Electromagnet: Provides an accurately known magnetic flux for the sample under test (A Hall sensor is sometimes used to measure the magnetic field as well).
- Magnet Power Supply: Supplies the necessary current for the electromagnet.
- Cryostat: Keeps the sample at the desired test temperature.
- Temperature Control: Controls the cryostat to maintain the desired temperature.

## 2.6 GUARDING METHODS

The following paragraphs discuss principles of guarding, methods of guarding on the current source input, and guarding of the sample inputs.

### 2.6.1 Principles of Guarding

Guarding consists of using a conductor driven by a low-impedance source to totally surround the leads carrying a high-impedance signal. If the output voltage of this low-impedance source is kept at the same potential as the signal itself, the result will be reduced leakage effects, decreased response time, and lower noise.

To approach the concept of guarding, let us first consider the unguarded circuit shown in Figure 2-19. Here, the sample voltage is represented by  $E_s$ , while the equivalent resistance is  $R_s$ . The cable leakage impedance is  $Z_L$ , and  $E_M$  represents the actual measured voltage.

The sample resistance and cable impedance form a voltage divider that attenuates the sample voltage as follows:

$$E_M = \frac{Z_L E_s}{Z_L + R_s}$$

Thus, to keep the error caused by leakage resistance under 0.1%, the leakage resistance must be at least 1000 times the sample resistance. For low to medium resistivity samples, the leakage resistance is generally sufficiently high so as to have minimal effects. However, with very high resistivities, the errors due to leakage resistance in unguarded circuits can be intolerably high.

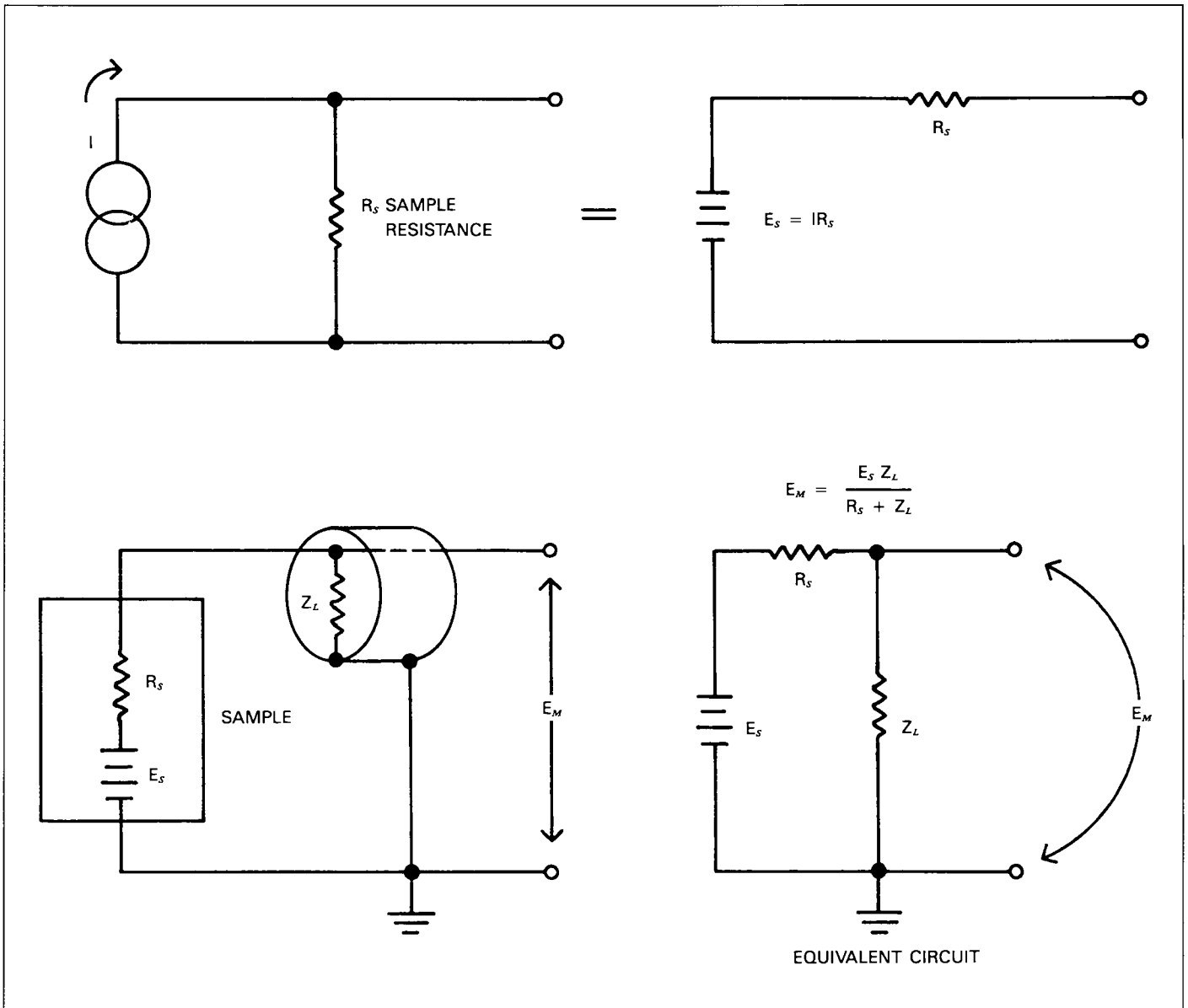
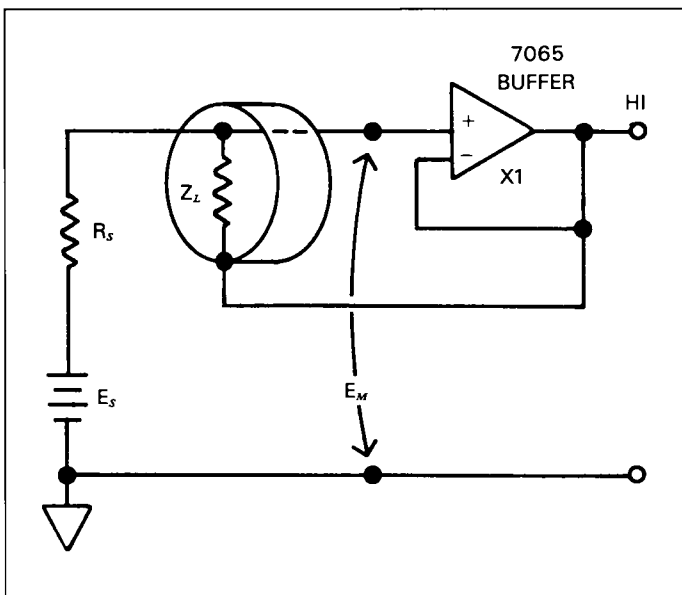

Figure 2-19. Unguarded Circuit

Guarding the circuit minimizes these effects by driving the cable shield at signal potential, as shown in Figure 2-20. Here, the Model 7065 buffer amplifier, which has high input impedance and low output impedance, is used to drive the inner shield. Since the amplifier has unity gain, the potential across the leakage resistance is essentially zero, so that virtually no current flows. Leakage between the inner shield and ground (outer shield) may be considerable, but it is of little consequence since that current is supplied by the buffer amplifier rather than by the sample signal voltage itself.



**Figure 2-20. Guarded Circuit**

In a similar manner, guarding also reduces the effective cable capacitance, resulting in much faster measurements on high-resistivity circuits. Because any distributed capacitance is charged through the relatively low impedance of the buffer amplifier rather than by the source, settling times are shortened considerably by guarding.

As an example, consider the situation where a  $10\text{G}\Omega$  resistance is being measured through a cable that has  $200\text{pF}$  of distributed capacitance. This combination results in an RC time constant of 2sec. Thus, at least 10 seconds must be allowed to allow the circuit to settle to within 1% of final value. In contrast, guarding the circuit could result in a more than hundred-fold reduction in settling time.

## 2.6.2 Current Source Input Guarding

When testing high resistivity samples, the current source input must also be guarded by using the driven guard from the current source itself. The following paragraphs discuss guarded and unguarded operation of the current source input and various connecting methods.

### NOTE

Although you do have the option of selecting guarded or unguarded operation, there is no harm in using the guarded mode for all measurements; it works for all resistivities.

### Guarding Jumpers

As shown in Figure 2-21, two jumpers set up the current source input for either unguarded or guarded operation. The jumper configurations shown at the top of the diagram indicate which of two configurations apply as follows:

1. Unguarded (A): This method can be used only for relatively low resistivity ( $10^5\Omega$  or less resistance) samples (low-resistivity mode).
2. Guarded (B): This configuration is required for use with the high-resistivity mode. Note that the Model 6167 Guarded Adapter must be used in conjunction with the Model 220 in order to drive the inner shield of the triaxial cable at guard potential.

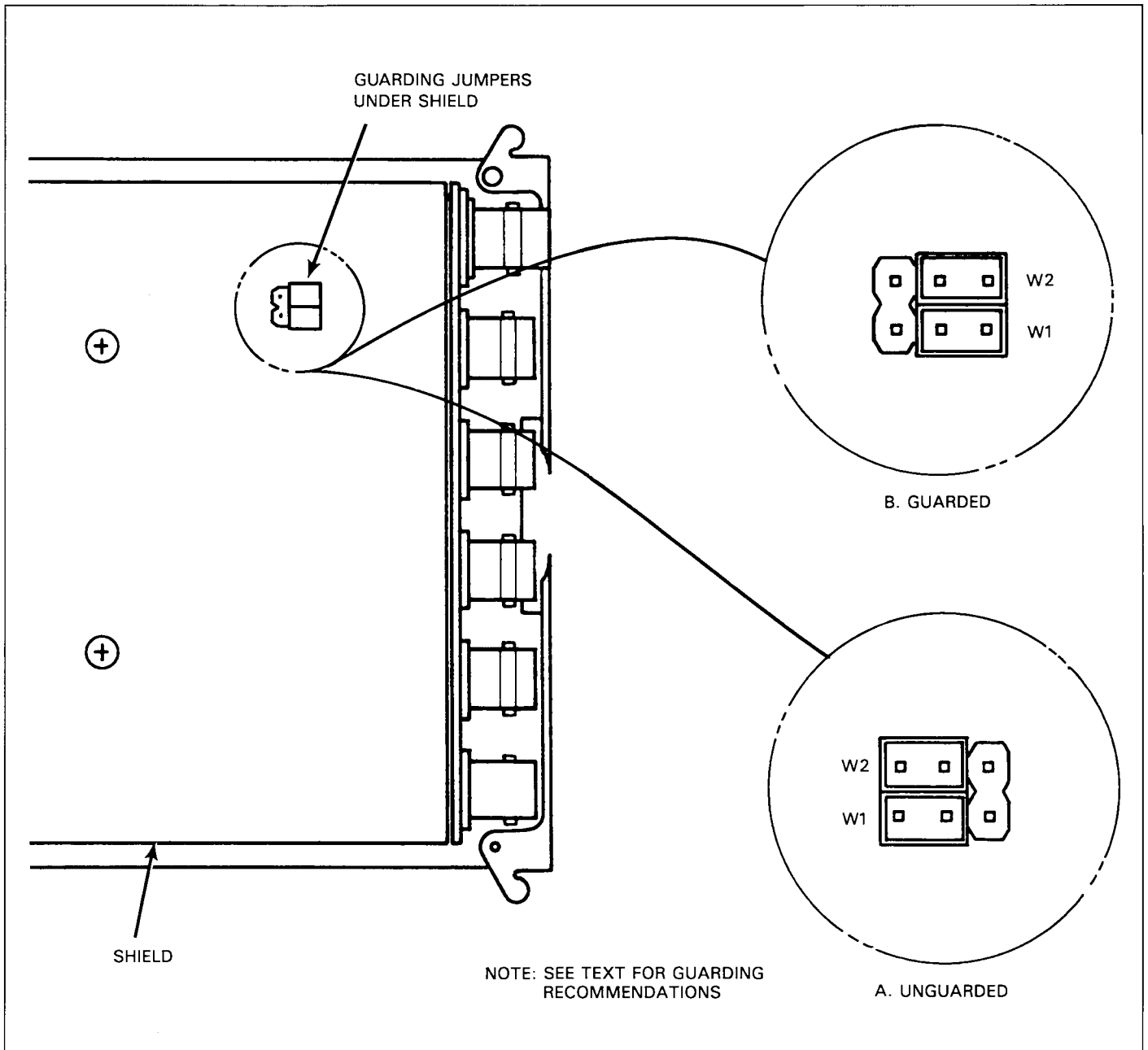

Figure 2-21. Guarding Jumper Configurations

### Changing Jumper Settings

From the factory, the Model 7065 is setup for the guarded configuration. Use the following procedure to change or verify the positions of these jumpers.

1. Turn off the scanner mainframe power and unplug the power line cord. Remove the card from the scanner, if installed.
2. Remove the large analog shield from the Model 7065 card, as shown in Figure 2-22.

#### CAUTION

**Do not touch the board surface or any components on the board as doing so may degrade performance. Handle the board only by the edges.**

3. Place the two jumpers in the desired position(s), as shown in Figure 2-21. Use a pair of needle-nose pliers to avoid touching the PC board.
4. Replace the shield and make additional connections (if necessary) as outlined below before installing the card.

### Unguarded Connections

Use the basic procedure below to connect the Model 220 to the Model 7065 using Figure 2-23 as a guide. Note that this configuration should be used only with the card in the low-resistivity mode, as discussed in paragraph 2.7.

1. Connect the Model 7024 triaxial cable between the Model 220 OUTPUT jack and the Model 7065 CURRENT SOURCE INPUT.
2. Connect a supplied insulated white (with white banana plug) wire between the Model 220 GUARD terminal and terminal 6 (GD) of the terminal block on the Model 7065.

#### CAUTION

**Model 220 GUARD must be connected to Model 7065 guard even though the cable itself is not guarded. The Model 220 guard is used to drive the protection circuits in the Hall card. These circuits protect the source input from damage caused by excessive voltages.**

Figure 2-23 shows an equivalent circuit of these connections. Current source HI is carried through to input HI via the center conductor of the triaxial cable. Source LO is connected to scanner card analog ground through the inner cable shield, and the outer cable shield connects to Model 220 chassis only. Model 220 guard is connected to the guard input on the Model 7065 in order to drive the input protection circuits.

### Guarded Connections

The current source input should be guarded when the card is in the high resistivity mode (paragraph 2.7). Figure 2-24(a) shows the basic connections, which are outlined as follows.

1. Attach the supplied Model 6167 Guard Adapter to the OUTPUT jack of the Model 220.
2. Connect the Model 6167 adapter wire to the Model 220 GUARD jack.
3. Place the adapter switch in the guarded position.
4. Connect the Model 7024 triaxial cable between the triaxial jack on the adapter and the Model 7065 Current Source Input.

An equivalent circuit of this configuration is shown in Figure 2-24(b). Current source output HI is connected to the Hall card input HI through the center cable conductor. Guard connection is made through the Model 6167 to the inner shield of the cable, while output LO now appears on the outer cable shield, and is connected to analog ground in the scanner card.

### 2.6.3 Sample Input Guarding

In order to minimize the effects of leakage resistance and capacitance, the shield of each input cable is guarded by driving the inner shield with the output of the respective buffer amplifier, as shown in Figure 2-25. (Note that the outer shield is at analog ground potential and is not guarded). The same guard potential also surrounds the contacts of the associated relay in order to minimize leakage effects of the switching circuits. Note that guarding is used for both high and low resistivity configurations even though the buffers are effectively switched out of the circuit when the card is configured for low resistivity. Paragraph 2.7 covers resistivity mode selection in detail.



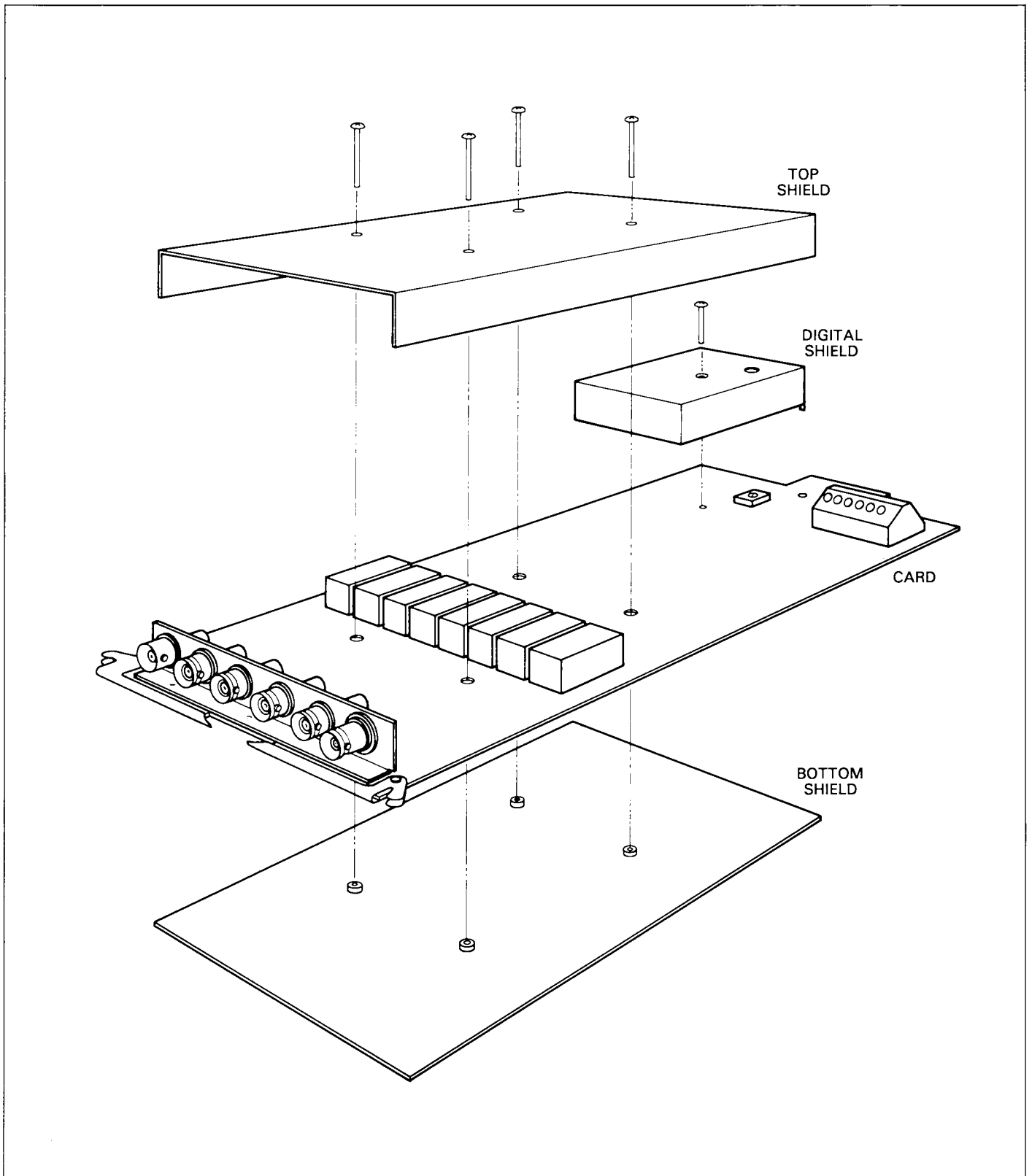

Figure 2-22. Shield Removal

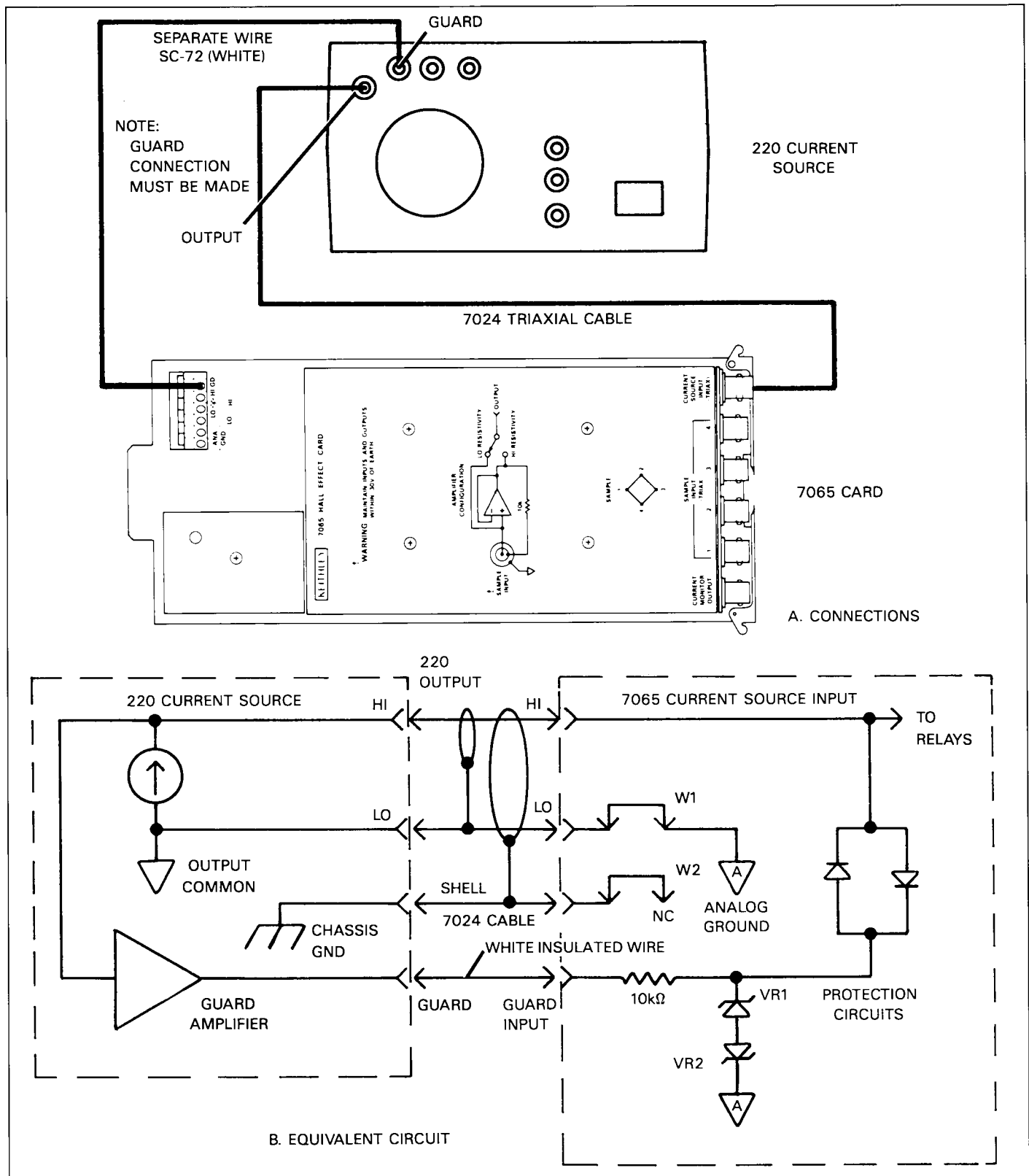

Figure 2-23. Connections for Unguarded Current Source Input

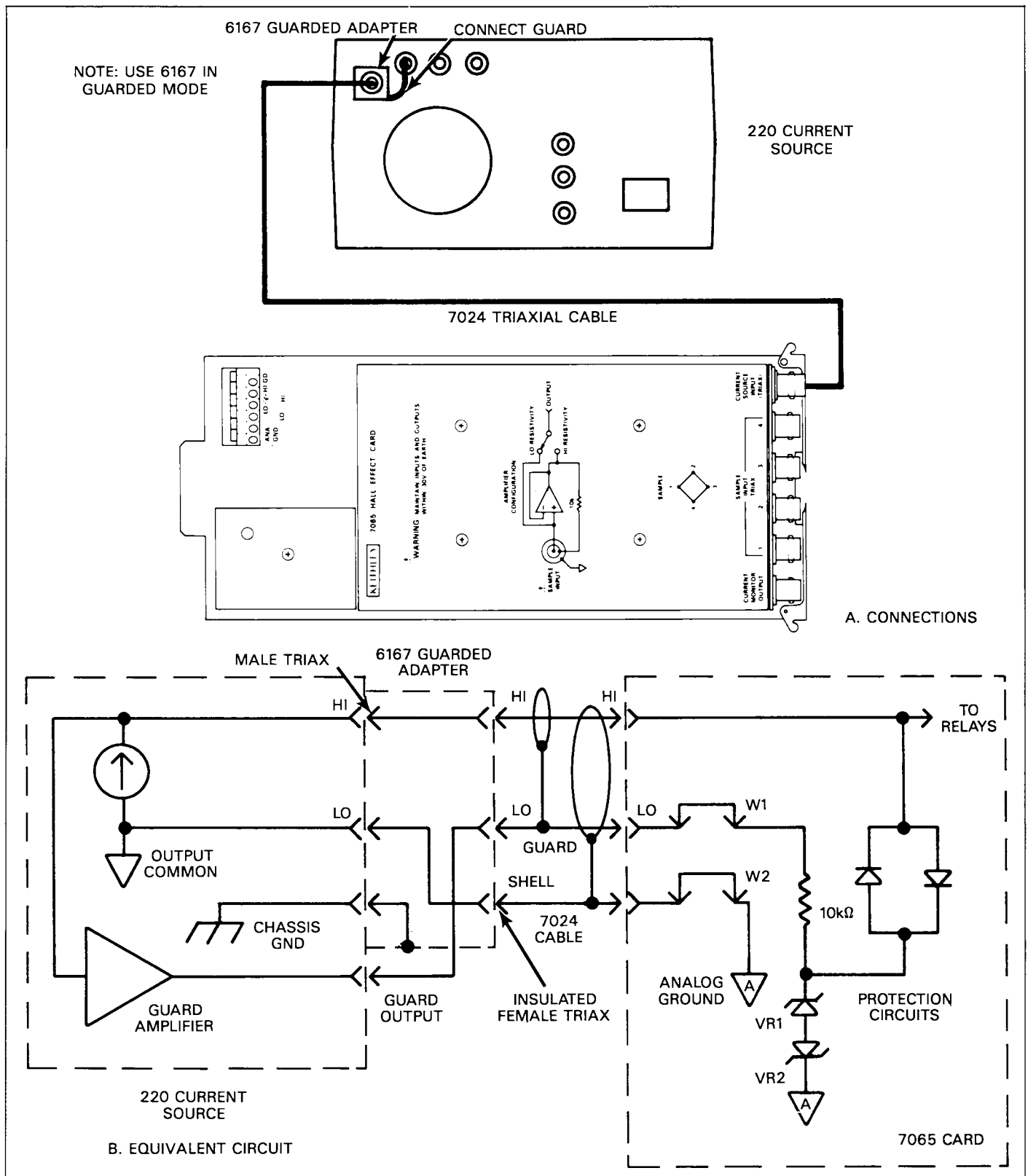

Figure 2-24. Connections for Guarding Using 6167 Adapter

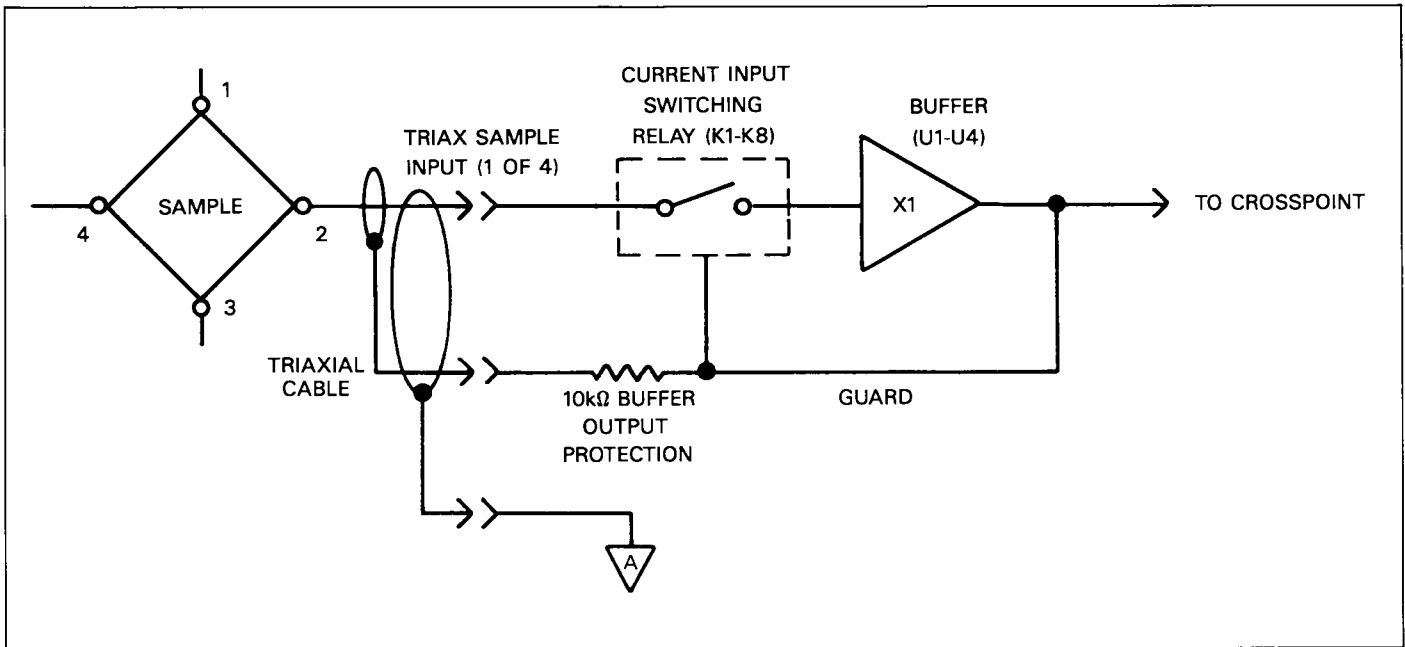

Figure 2-25. Equivalent Circuit for Input Guarding

## 2.7 RESISTIVITY SELECTION

The Model 7065 may be operated in either the low or high resistivity mode, as discussed in the following paragraphs.

### 2.7.1 Selecting the Resistivity Setup

The SAMPLE INPUTS can be programmed for low or high resistivity by controlling the state of crosspoint 5,4 (column 5, row 4). To select high resistivity, close crosspoint 5,4; to select low resistivity, open crosspoint 5,4. Table 2-3 summarizes these programming states. Scanner programming is discussed in paragraphs 2.8 and 2.9.

Note that all four sample inputs are controlled simultaneously by selecting crosspoint 5,4.

**Table 2-3. Resistivity Select Summary**

Column 5, Row 4 State	Resistivity Setup
Open	Low resistivity
Closed	High resistivity

### 2.7.2 Input Characteristics

Table 2-4 summarizes input characteristics for the low and

high resistivity setups. In addition to affecting the resistivity setup, selection also affects input current, noise, and offset voltages. Note that the input characteristics of the low resistivity setup are exclusive of the voltmeter, which can also affect the sample under test.

**Table 2-4. Input Characteristic Summary**

Parameter	Low Resistivity Setup	High Resistivity Setup
Input Impedance	>10GΩ	>100TΩ
Input Bias Current	<0.1nA	<0.15pA
Input Voltage Noise*	<50nV p-p	<10μV p-p

\*0.1Hz to 10Hz bandwidth

### 2.7.3 Equivalent Input Circuits

Figure 2-26 compares the input circuits for the low and high resistivity setups. With the high resistivity setup, the signal is routed through the buffer amplifier, which also provides the guard for the input circuit. In contrast, the signal completely bypasses the buffer amplifier in the low resistivity mode; however, the guard is still driven by the buffer amplifier.

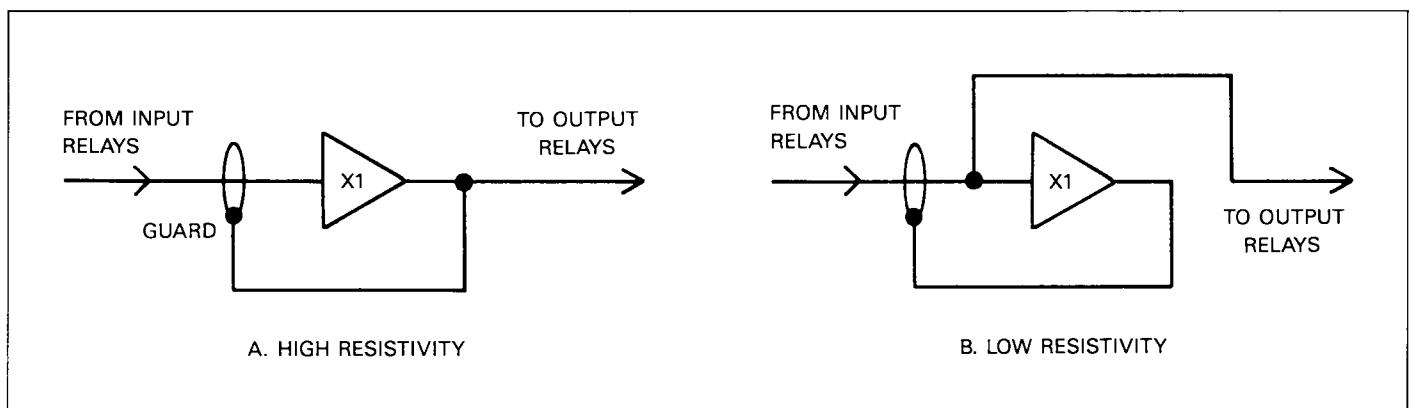

**Figure 2-26. Low and High Resistivity Equivalent Circuits**

---

---

## 2.7.4 Resistivity Setup Criteria

The setup used depends primarily on the resistivity of the sample under test. The following discussion covers general aspects and criteria. Some experimentation may help to obtain the best choice with a particular sample.

For sample resistances above  $1\text{M}\Omega$ , accuracy degradation because of input loading comes into play. Thus, you should always use the high-resistivity setup when measuring samples above  $1\text{M}\Omega$ . For lower sample resistances, however, the best configuration to use is a compromise between noise and gain error performance, as we will now discuss.

Figure 2-27 depicts gain error versus actual sample resistance (calculated from signal voltage and sourced current). The errors shown do not include possible errors caused by current source uncertainty-- only voltage measurement errors are shown.

Total measurement uncertainty is the sum of gain error and noise uncertainty. If we ignore noise uncertainty for the moment, we see from Figure 2-27 that the obvious choice for all samples is the high-resistivity setup. In fact, you may wish to operate the Model 7065 exclusively in the high-resistivity mode if slight errors caused by noise are tolerable (Hall voltages  $>5\text{mV}$  will yield error due to noise uncertainty of  $<0.2\%$ ).

Figure 2-28 illustrates measured noise voltage versus actual sample resistance. The tangential lines are theoretical limits given the thermal (Johnson) noise resistance. Obviously, this limit is improved (for noise due to sample resistivity) if the sample temperature is reduced to liquid nitrogen levels ( $77^\circ\text{K}$  or below). Below sample resistances of  $10\text{k}\Omega$ , however, lowering the temperature will not significantly improve noise performance because instrument noise dominates at room temperature.

In the resistance range of  $10^4 - 10^6\Omega$ , Figure 2-27 shows that, for the low-resistivity setup, best accuracy is achieved if the signal voltage (sourced current,  $I \times R$ ) remains under  $3\text{V}$ . There is another very important reason for doing so: the power dissipated in the sample ( $V^2/R$ ) will then remain under  $1\text{mW}$ , minimizing problems caused by self-heating and temperature coefficients of the sample.

The signal voltage generated during Hall voltage measurements is usually very small-- typically  $20\text{mV}$  or less. If a sample or measurement situation results in very small Hall voltages ( $<5\text{mV}$ ), and the sample resistance is less than  $1\text{M}\Omega$ , it will be advantageous to use the low-resistivity setup. Hall voltages as low as  $2-4\mu\text{V}$  can be measured with less than  $2\%$  uncertainty in this mode by using a Model 181 Nanovoltmeter in place of the Model 196 DMM.

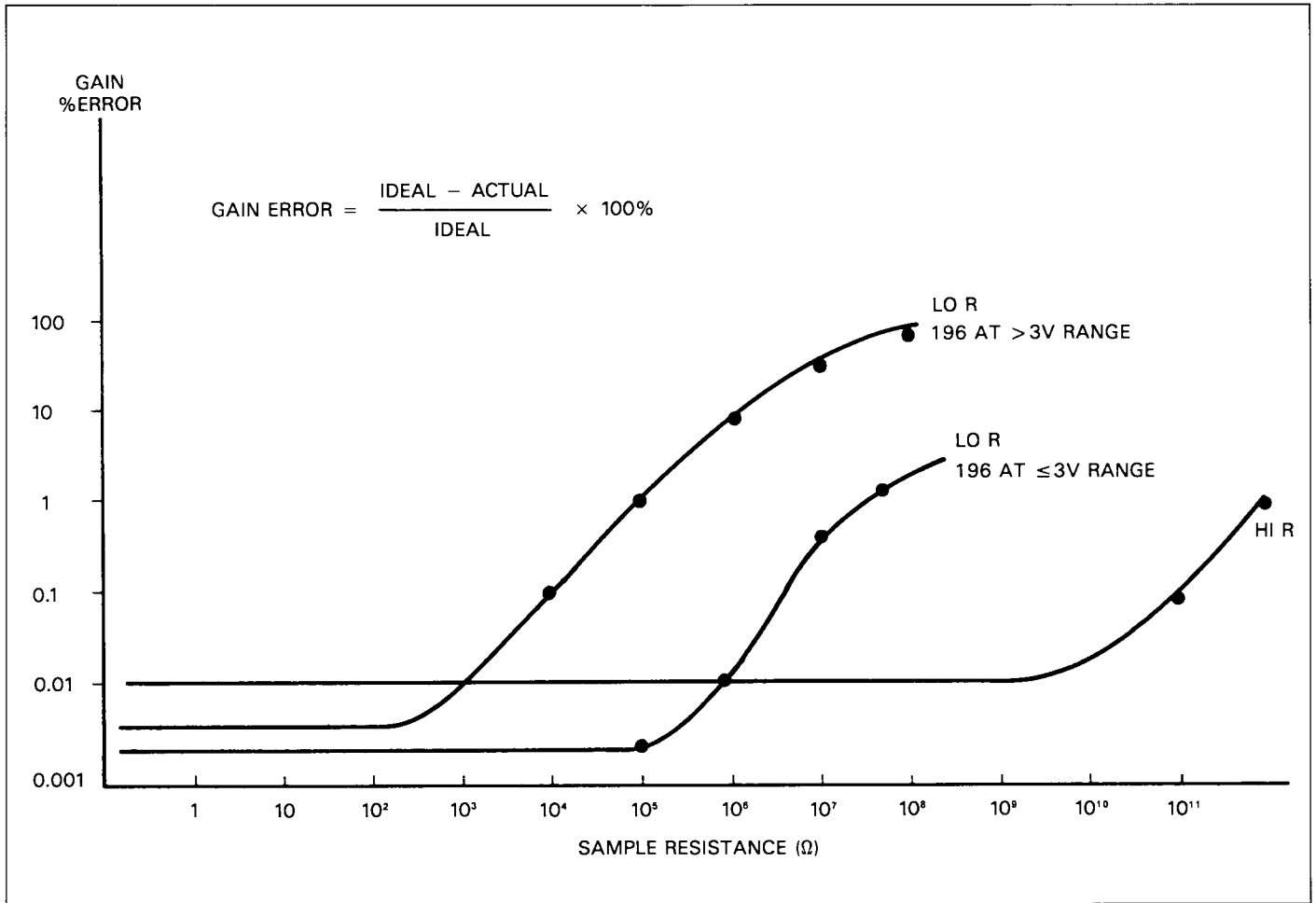

Figure 2-27. Gain Error, LO vs HI Resistivity Setup

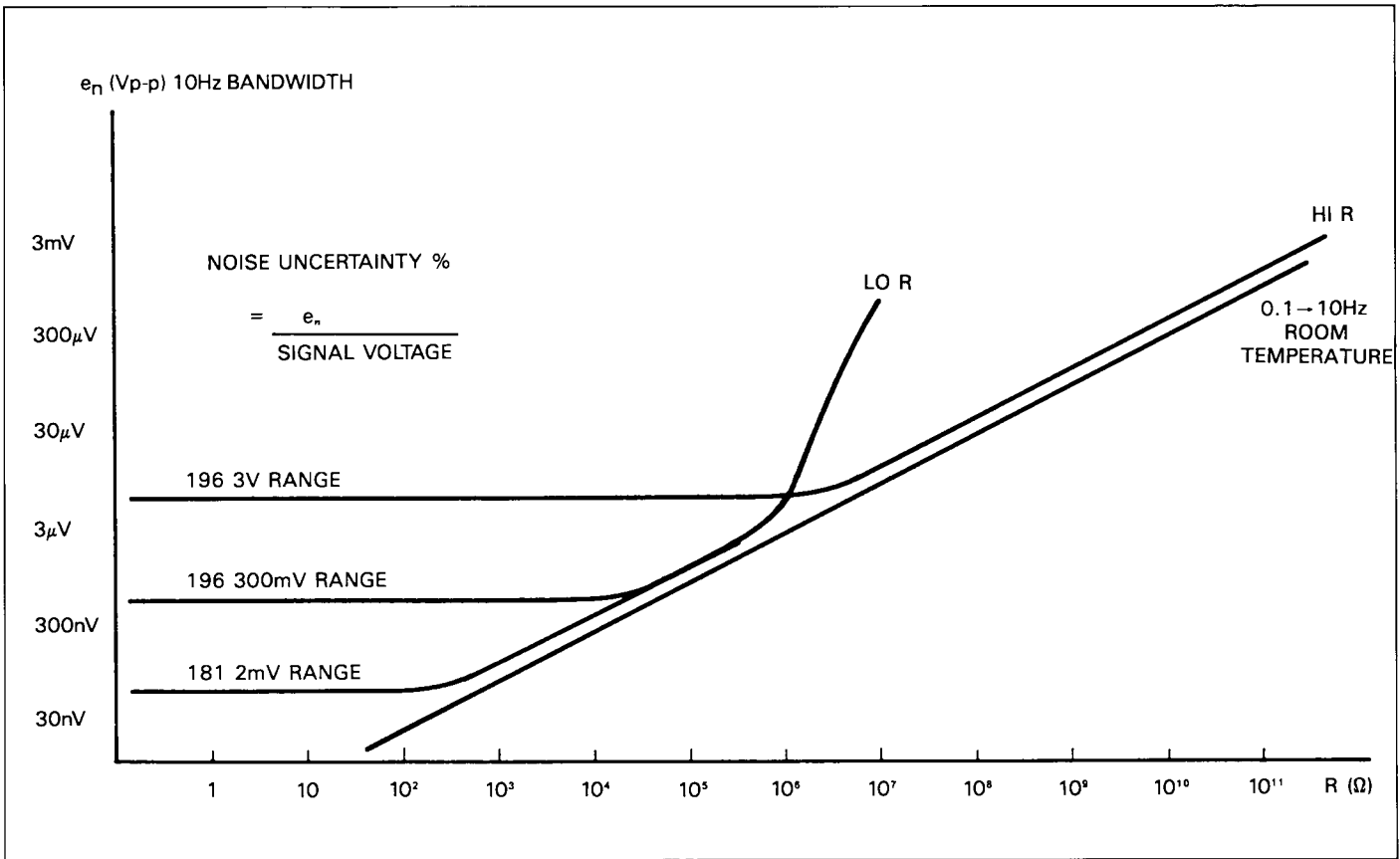

Figure 2-28. Noise Performance, LO vs HI Resistivity Setup



## 2.8 FRONT PANEL SCANNER PROGRAMMING

The following paragraphs discuss front panel operation of the Models 705 and 706 Scanners in general terms. For more complete information, refer to the applicable scanner instruction manual.

### 2.8.1 Entering the Matrix Mode

Since the Model 7065 is organized into a 5 X 4 matrix (see Figure 2-17), the scanner must be setup to operate in the matrix mode as follows:

1. Press PRGM, 6 in sequence to enter the pole selection program. The unit will display the following message:

POLE

2. Press 0, ENTER to select the matrix mode.
3. The unit will then display the status of column 1, row 1. Note that all crosspoints will be open after using Program 6.

### 2.8.2 Scanner Display Formats

#### Model 705 Format

In the matrix mode, the Model 705 display format appears as follows

nn m O or C

Where: nn represents the column number  
 m is the row  
 O and C represent open and closed respectively.

Since the Model 705 can hold two cards, and up to five units can be daisy chained, the total number of possible columns is 50. Table 2-5 summarizes column numbers by card for unit 1, and Table 2-6 lists column numbers by unit. Since column numbers can be confusing, it is recommended that the Model 7065 be used in the card 1 (upper slot), unit 1 location to simplify programming.

**Table 2-5. Model 705 Unit 1 Column Summary by Card**

Card	Model 7065 Column				
	1	2	3	4	5
1 (top slot)	01	02	03	04	05
2 (bottom slot)	06	07	08	09	10

**Table 2-6. Model 705 Column Assignments**

Unit*	Columns	
	Card 1	Card 2
1	1-5	6-10
2	11-15	16-20
3	21-25	26-30
4	31-35	36-40
5	41-45	46-50

\*2 cards per unit

#### Model 706 Format

The Model 706 display format is similar to that of the Model 705 except that an additional digit of column information is displayed:

nnn m o or c

Where: nnn represents the column number  
 m is the row number  
 o or c is the status of the crosspoint (open or closed)

Since each Model 706 has 10 card slots, and up to five units can be daisy chained, the total number of columns is 250. Table 2-7 lists column numbers by card for unit 1, and Table 2-8 summarizes column numbers by unit. Again, the unit should be placed in slot 1, unit 1 where possible to simplify programming.

**Table 2-7. Model 706 Unit 1 Column Summary by Card**

Card	Model 7065 Column				
	1	2	3	4	5
1	001	002	003	003	005
2	006	007	008	009	010
3	011	012	013	014	015
4	016	017	018	019	020
5	021	022	023	024	025
6	026	027	028	029	030
7	031	032	033	034	035
8	036	037	038	039	040
9	041	042	043	044	045
10	046	047	048	049	050

**Table 2-8. Model 706 Column Assignments**

Unit*	Columns
1	1-50
2	51-100
3	101-150
4	151-200
5	201-250

\*10 cards per unit

### 2.8.3 Crosspoint Programming

Use the basic procedure below to display and program crosspoints.

1. Use Program 6 to select the matrix mode (pole 0) as described in paragraph 2.8.1.
2. Display the desired crosspoint either by using the CHANNEL button for sequential access, or by keying in the column and row numbers with the DATA keys. For example, to display column 5, row 2 on the Model 705, press the following: 0, 5, 2.
3. Once the desired crosspoint is displayed, use the OPEN or CLOSE button to update its status, as required.
4. Repeat steps 2 and 3 for all crosspoints to be changed.
5. To open all crosspoints simultaneously, and return the display to column 1, row 1, press the RESET button.

## 2.9 IEEE-488 BUS PROGRAMMING

The Model 7065 may be controlled over the IEEE-488 bus through the host scanner, as described in the following paragraphs. For more detailed bus information, refer to the Model 705 or 706 Instruction Manual.

### 2.9.1 Matrix Bus Commands

Table 2-9 summarizes the commands necessary to put the scanner in the matrix mode, and to close, open, and display crosspoints. The commands are further defined below.

**Table 2-9. IEEE-488 Bus Command Summary**

Command	Description
A0	Select matrix mode
Bnn:m*	Display crosspoint nn,m (705)
Bnnn:m*	Display crosspoint nnn,m (706)
Cnn:m*	Close crosspoint nn,m (705)
Cnnn:m*	Close crosspoint nnn,m (706)
Nnn:m*	Open crosspoint nn,m (705)
Nnnn:m*	Open crosspoint nnn,m (706)
R0	Open all crosspoints, display 1, 1

\*Use of colon is optional.

A0X: Sending this command places the scanner in the matrix mode, opens closed crosspoints, and displays column 1, row 1.

Display (B), close (C), and open (N): These commands perform the indicated operation on the crosspoint specified by the associated parameters. The Model 705 parameter format is:

nn:m

Where: nn specifies the column  
 m specifies the row  
 : delimits the parameters (optional).

Note that the nn and m values are the same as those used when programming the unit from the front panel (see paragraph 2.8). For example, to close column 2, row 1, send the command string C02:1X (or simply C021X without the optional colon delimiter).

The parameter format for the Model 706 is similar and appears as follows:

nnn:m

Where: nnn indicates the column  
 m specifies the row  
 : delimits the column and row parameters (optional).

Again, nnn and m have the same values as when programming the unit over the front panel. For example, to open column 5, row 4, send the command string N005:4X (or simply N0054X without the optional colon delimiter).

R0X: Sending this command opens all crosspoints simultaneously and displays column 1, row 1.

## 2.9.2 Example Programs

The example programs below demonstrate basic programming procedures by setting up the unit for the matrix mode and then closing crosspoints 1,1; 2,2; 3,3; and 4,4. Following operator input, the program then opens all closed crosspoints by sending the R0 command.

The programs are written in Hewlett-Packard Model 85 BASIC. The programming syntax for other similar computers (such as the HP9816) is virtually identical. See the computer programming manual for details.

Note that the programs assume that the Model 7065 is installed in the card 1 slot of unit 1 (daisy chained units).

### Model 705 Program

Program	Comments
10 REMOTE 717	! Put 705 in remote.
20 OUTPUT 717; "A0X"	! Put 705 in matrix mode.
30 OUTPUT 717; "C01:1X"	! Close 1,1.
40 OUTPUT 717; "C02:2X"	! Close 2,2.
50 OUTPUT 717; "C03:3X"	! Close 3,3.
60 OUTPUT 717; "C04:4X"	! Close 4,4.
70 DISP"PRESS 'CONT' TO OPEN CROSSPOINTS"	
80 PAUSE	
90 OUTPUT 717; "R0X"	! Open all crosspoints.
100 END	

### Model 706 Program

Program	Comments
10 REMOTE 718	! Put 706 in remote.
20 OUTPUT 718; "A0X"	! Put 706 in matrix mode.
30 OUTPUT 718; "C001:1X"	! Close 1,1.
40 OUTPUT 718; "C002:2X"	! Close 2,2.
50 OUTPUT 718; "C003:3X"	! Close 3,3.
60 OUTPUT 718; "C004:4X"	! Close 4,4.
70 DISP"PRESS 'CONT' TO OPEN CROSSPOINTS"	
80 PAUSE	
90 OUTPUT 718; "R0X"	! Open all crosspoints.
100 END	

## 2.10 MEASUREMENT CONSIDERATIONS

Many of the measurements made with the Model 7065 are performed on high resistivity devices and at very low current levels. At these levels, a number of factors can affect a measurement. The following paragraphs discuss some considerations when making such measurements.

### 2.10.1 Input Voltage Levels

The input voltage operating range for the SAMPLE INPUTS is limited to  $\pm 8V$  for both high and low resistivity setups. Applying a voltage greater than  $\pm 8V$  but less than  $\pm 12V$  will not damage the card, but accuracy of the measurement will suffer.

**CAUTION**

**The maximum input overload is  $\pm 12V$ ; exceeding this value may cause damage to the Model 7065.**

The voltage developed across the sample will, depend upon both the excitation current and the resistivity of the sample. If the sample resistance is known, you can calculate whether or not a given current will overload the inputs by using Ohm's law:

$$E = IR$$

For example, the voltage developed across a  $100k\Omega$  sample with a  $100\mu A$  current is:

$$E = (100 \times 10^{-6}) (100 \times 10^3)$$

$$E = 10V$$

In this case, the developed voltage is above the  $8V$  input operating range of the Hall card. The solution, of course, is to lower the current so that the voltage is within the required range.

### 2.10.2 Leakage Resistance

At lower resistance levels, the effects of leakage resistance are seldom a consideration because any leakage resistance is generally much higher than the resistance levels in the sample itself. With high-resistivity samples, however, leakage resistance can have a detrimental effect on the measurement. Such leakage resistance can occur in the sample test fixture, the connecting cables, or even at the Model 7065 sample input connectors, especially if these connectors are not kept clean.

To demonstrate how leakage resistance can affect measurement accuracy, let us review the equivalent circuit shown in Figure 2-29. Here  $I_s$  and  $R_s$  represent the source current and sample resistance, while the leakage resistance is  $R_L$ .

$E_s$  is the voltage developed across the sample resistance by the source current,  $I_s$  ( $E_s = I_s \times R_s$ ).  $E_M$  represents the actual input voltage appearing at the device input of the Model 7065.

$R_s$  and  $R_L$  form a voltage divider that attenuates the input signal as follows:

$$E_M = \frac{E_s R_L}{E_s + R_L}$$

Since the Model 7065 has guarded sample inputs, the effects of leakage resistance are minimized. However, in extreme cases where samples with resistance in the  $G\Omega$  or  $T\Omega$  range are being measured, other steps may be necessary to further reduce leakage resistance effects as well. The most obvious remedy is to make sure that the leakage resistance is as high as possible. Use only good quality cables (included), and make these cables as short as possible. Also, it is important that the sample under test, test fixture, and all connectors are kept free of contamination.

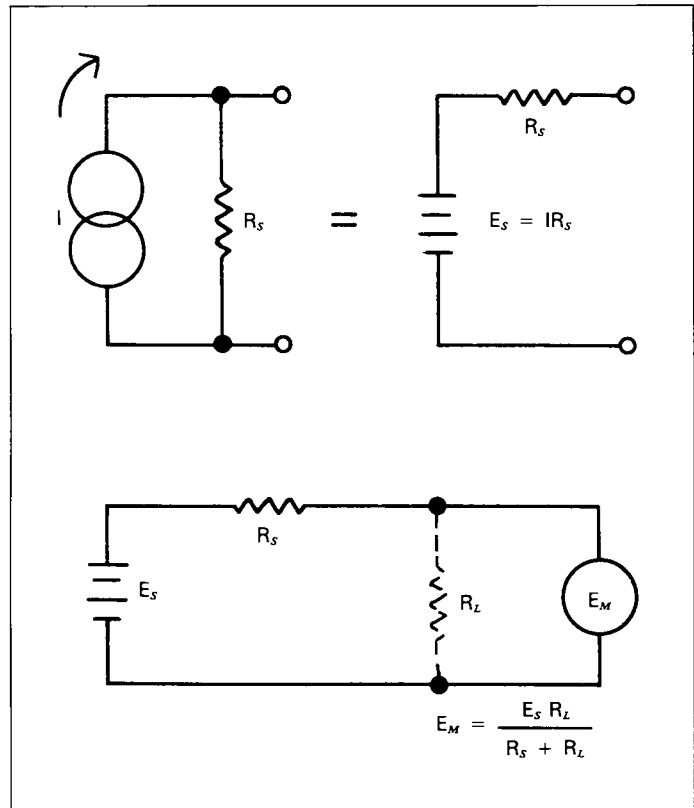

**Figure 2-29. Leakage Resistance Effects**

### 2.10.3 Input Loading

When sample resistance becomes a large percentage of the Hall card input resistance, loading effects can also come into play. The effects are essentially the same as for leakage resistance; in fact, we can use the model in Figure 2-29 with the leakage resistance,  $R_L$ , replaced by the card input resistance,  $R_I$ . We can then determine the percent error for a given sample resistance as follows:

$$\%Error = \frac{R_s}{R_s + R_I} \times 100$$

For example, assume we are measuring a sample with an equivalent resistance of  $100M\Omega$  with the hall card in the low resistivity setup. Under these conditions, the card has a nominal input resistance of  $10G\Omega$  and the Model 196 has a nominal input resistance of  $1G\Omega$  (300mV, 3V ranges), yielding an equivalent resistance of  $909.1M\Omega$ . Thus, the error in this case would be:

$$\%Error = \frac{100M\Omega}{100M\Omega + 909.1M\Omega} \times 100$$

$$\%Error = 9.9\%$$

However, assume we make the same measurement with the Hall card configured for high resistivity, in which case the input resistance increases to  $>100T\Omega$ . The error caused by input loading is now reduced to:

$$\%Error = \frac{100M\Omega}{100M\Omega + 100T\Omega} \times 100$$

$$\%Error = 0.000099\%$$

Here we see the importance of choosing the right resistivity setup for the sample being measured.

### 2.10.4 Input Capacitance

Virtually any circuit has at least some small amount of distributed capacitance that can slow down the response time of high impedance measurements. Even if the test sample itself has minimal capacitance, cable or Model 7065 card input capacitance effects can be noticeable, especially if current input guarding is not used.

To demonstrate input capacitance effects, consider the equivalent circuit shown in Figure 2-30. Here,  $I_s$  and  $R_s$  represent the sourced current and sample resistance, respectively. The voltage developed across the sample resistance as a result of the source current,  $I_s$ , is given as  $E_s$ . The input capacitance is  $C_I$ , and  $E_M$  represents the voltage appearing at the Hall card sample input.

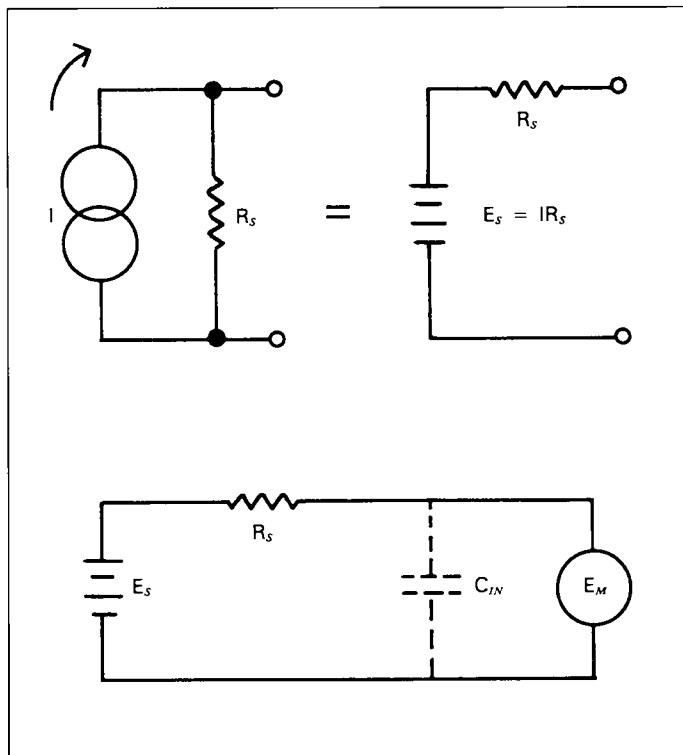

Figure 2-30. Input Capacitance Effects

When the source current,  $I_s$ , is first applied, the voltage,  $E_s$ , across the capacitance (and thus at the sample input) does not instantaneously rise to its final value. Instead,  $C_I$  charges exponentially through  $R_s$  as follows:

$$E_M = E_s (1 - e^{-\frac{t}{RC}})$$

Here, for convenience, we can specify  $R_s$  in megohms,  $C$  in microfarads, and  $t$  in seconds.

Because of  $C_I$  charging, the sample input follows the exponential curve shown in Figure 2-31. At the end of one

time constant ( $R_s C_i$ ), the voltage reaches approximately 63% of final value. At the end of two time constants, the voltage reaches about 86% of final value, and so on. Generally, at least five time constants ( $5R_s C_i$ ) must be allowed for better than 1% accuracy (2-3 time constants per decade of accuracy improvement).

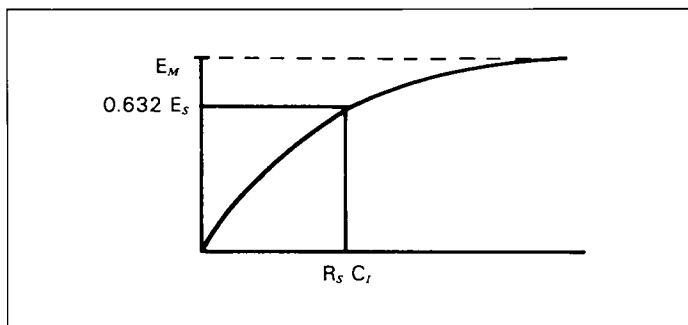

**Figure 2-31. Exponential Response of Input Voltage**

The amount of time that must be allowed will, of course, depend on the relative R and C values. For example, with a sample resistance of  $100G\Omega$  and an input capacitance of  $2pF$  (typically, guarding the input reduces effective capacitance to  $2pF$  or less), a time constant of  $200msec$  results. Thus, at least one second must be allowed to achieve a better than 1% accuracy figure.

We can easily calculate percentage error figures for various RC time constants. Table 2-10 summarizes voltage ratio values and percentage error values for ten different time constants, where  $\tau = R_s C_i$ .

**Table 2-10. Voltage and Percent Error For Various Time Constants**

Time*	$V_M$	%Error
$\tau$	$0.632 E_s$	36 %
$2\tau$	$0.86 E_s$	14 %
$3\tau$	$0.95 E_s$	5 %
$4\tau$	$0.982 E_s$	1.8 %
$5\tau$	$0.993 E_s$	0.647%
$6\tau$	$0.9975 E_s$	0.25 %
$7\tau$	$0.999 E_s$	0.09 %
$8\tau$	$0.99966E_s$	0.033%
$9\tau$	$0.9999 E_s$	0.012%
$10\tau$	$0.99995E_s$	0.005%

\* $\tau = R_s C_{IN}$

## 2.10.5. Electrostatic Interference

Electrostatic interference occurs when an electrically charged object is brought near an uncharged object, thus inducing a charge on the previously uncharged object. At lower impedance levels, the effects of electrostatic action are not noticeable because the low impedance levels allow the induced charge to dissipate quickly. At the high impedance levels of many Model 7065 measurements, however, these charges do not readily dissipate, and erroneous or erratic measurements may result. These unstable readings may be caused in two ways:

1. A DC or slowly-varying electrostatic field.
2. AC electrostatic fields which can cause errors by driving the buffer amplifier into saturation, or through rectification that produces DC errors.

Electrostatic interference is first recognizable when hand or body movements near the sample cause fluctuations in the measurements. Pickup from AC fields can be verified by checking the buffer amplifier outputs with an oscilloscope. The presence of line frequency signals on the outputs are an indication that electrostatic interference is present.

Means of minimizing electrostatic interference include:

1. Shielding. Possibilities include: a shielded room and properly shielding the test fixture.
2. Reduction of electrostatic fields. Moving power lines or other sources away from the test setup reduces the amount of electrostatic interference induced into the experiment.

## 2.10.6 RFI

RFI (Radio Frequency Interference) is a general term frequently used to describe electromagnetic interference over a wide range of frequencies across the spectrum. RFI can be especially troublesome at low signal levels with low-resistivity samples, but it can also affect high level measurements in extreme cases.

RFI can be caused by steady-state sources such as TV or radio broadcast signals, or it can be caused by impulse sources, as in the case of high-voltage arcing. In either case, the effect on the measurement can be considerable if enough unwanted signal is present. The effects of RFI can often be seen as an unusually large offset, or, in the case of impulse source, as sudden, erratic variations in the measurement.

RFI can be minimized by taking one or more of several precautions when making Hall measurements in such electromagnetic environments. The most obvious method is to keep all the instruments and sample as far away as possible from the RFI source. Shielding the experiment, instruments, and test leads will often reduce the interference to an acceptable level. In extreme cases, a specially constructed screen room may be necessary to sufficiently attenuate the troublesome signal.

If all else fails, external filtering of the device input paths may be required. In some cases, a simple one-pole filter may be sufficient; in more difficult cases, multiple-pole notch, or band-stop filters, tuned to the offending frequency range, may be required. Keep in mind, however, that such filtering may have other detrimental effects (such as increased response time) on the measurement.

### 2.10.7 Ground Loops

Ground loops that occur in multiple-instrument test setups can create error signals that cause erratic or erroneous measurements. The configuration shown in Figure 2-32 can introduce errors in two ways. Large ground currents flowing in one of the wires will encounter small resistances, either in the wires, or at the contact points. These small resistances result in voltage drops that can affect the measurement. Even if the ground loop currents are small, magnetic flux cutting across the large loops formed by ground leads can induce sufficient voltages to disturb sensitive measurements.

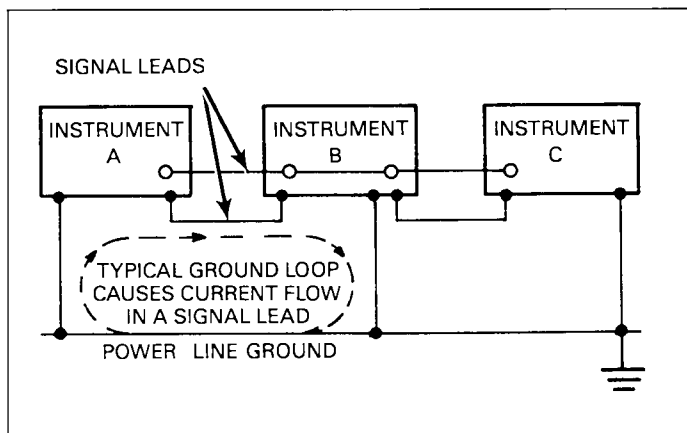

**Figure 2-32. Multiple Ground Points Create a Ground Loop**

To prevent ground loops, instrument signal grounds should be connected to earth ground only at a single point, as shown in Figure 2-33. It is important to assure that no supply or power line currents flow through signal grounds. Sometimes, experimentation can help determine the best arrangement.

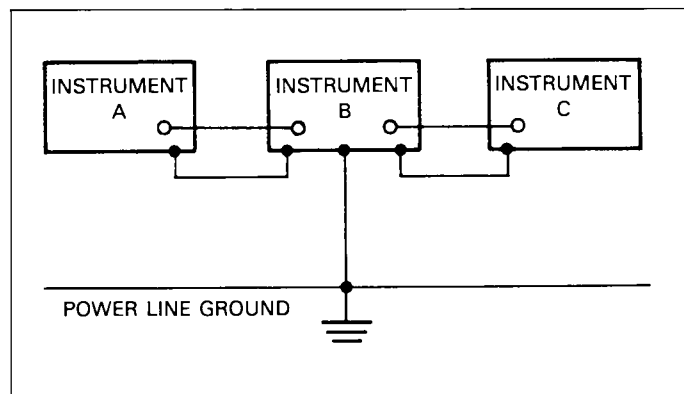

**Figure 2-33. Eliminating Ground Loops**

### 2.10.8 Offsets

Offsets generated by thermals or other factors can degrade measurement accuracy, particularly at low signals levels. Such offsets are normally nulled out as part of the measurement process, but some precautions can be taken to reduce these effects to inconsequential levels.

Offsets can generally be attributed to one or more of three sources:

1. Thermal EMFs generated at relay or connector contacts.
2. Buffer amplifier voltage offsets.
3. Offsets inherent in the measuring instruments (picoammeter or voltmeter).

#### Minimizing Offsets by Measurement Averaging

In most cases, an averaging measurement scheme is used to reduce the effects of such offsets. In the example measurement shown in Figure 2-34, averaging is achieved by taking the measurement twice-- once each with positive and negative current. In (a), the generated voltage  $V_1$  has the same sign as the offset voltage,  $V_{os}$ . However, by reversing the current as in the case of (b), the generated voltage ( $V_2$ ) now has the opposite polarity, although the offset voltage polarity is the same as before.

## OPERATION

Once the voltages are known, the resistance can be calculated as follows:

$$R = \frac{(V_1 + V_{os}) - (-V_2 + V_{os})}{2I}$$

Where:  $R$  = calculated resistance

$V_1$  = measured voltage with positive current

$V_2$  = measured voltage with negative current

$I$  = applied current

$V_{os}$  = combined offset voltage

If we rearrange the above equation and combine terms, we have:

$$R = \frac{V_1 + V_2}{2I}$$

Note that the offset term,  $V_{os}$ , cancels out of the equation, demonstrating the nulling effect of this measurement technique.

### Minimizing Offsets when Averaging is not Used

The measurement scheme is more than adequate for null-

ing offsets in most situations. There are several other precautions that can be taken to minimize offset effects if for some reason the averaging technique is not used.

1. Make sure that the buffer amplifier offsets are properly nulled, as discussed in Section 4. Note that this consideration applies only when using the high resistivity setup because the buffers are not used in the low-resistivity mode.
2. Use the zero or relative features on the measuring instruments to null their offsets. Typically, these functions should be enabled with the sample connected and all necessary crosspoints in the measurement path closed, but with no current applied to the sample.
3. Use the maximum current possible without heating up the sample excessively. For a given sample resistance, the higher the current, the higher the voltage, reducing offset effects. Some compromise between low offsets and minimum sample heating may be necessary when choosing a current value.

### Minimizing Offset Drift

Offset drift, which can be caused by such factors as temperature variation, can also affect measurement accuracy. In order to minimize offset drift, operate the Model 7065 and the measurement instruments in a stable temperature environment. Also, time between measurements should be as short as possible (keeping in mind other constraints such as circuit settling times).

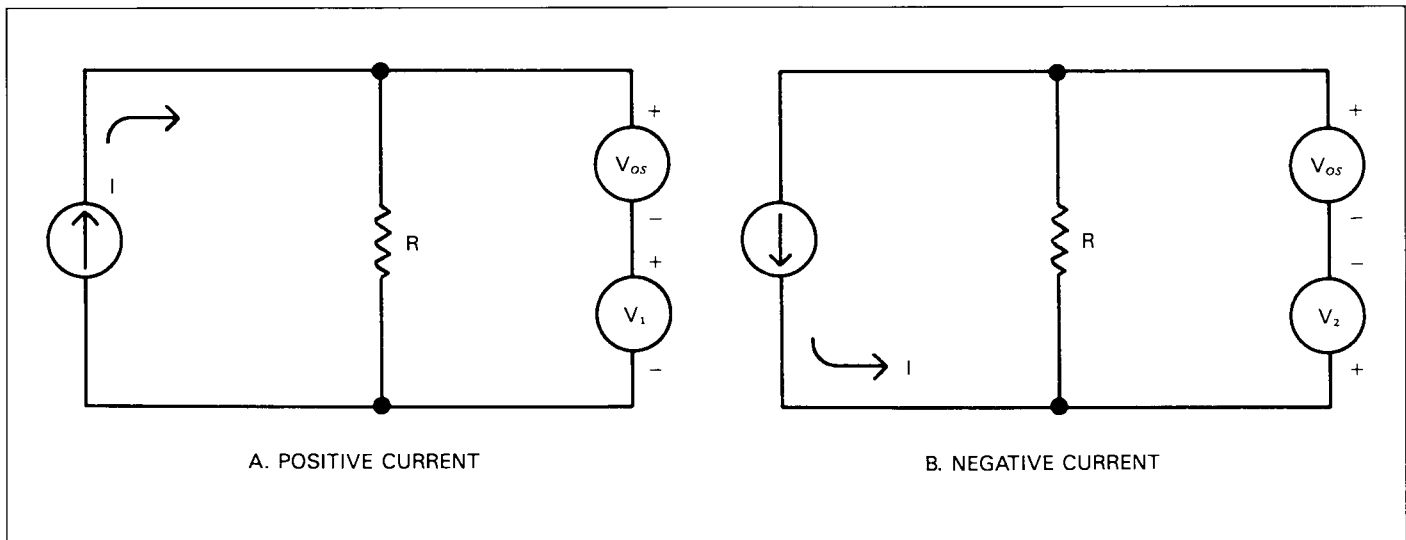

Figure 2-34. Offset Cancellation



# SECTION 3 APPLICATIONS

## 3.1 INTRODUCTION

This section briefly discusses Hall effect, Hall conventions, and gives some typical measurement examples for the Model 7065. This information is intended as an overview on methods for using the Model 7065 and associated instruments for measurements. References are included for more detailed information on making van der Pauw resistivity and Hall effect voltage measurements.

Information in this section includes:

**3.2 Recommended Equipment:** Summarizes the equipment necessary for a complete system.

**3.3 Hall Effect Conventions and Principles:** Covers Hall and terminal conventions used in this manual, and discusses basic Hall effect principles.

**3.4 Van der Pauw Resistivity Measurements:** Covers the basic procedures for determining the resistivity of samples.

**3.5 Hall Voltage Measurements:** Details methods to measure and calculate Hall coefficients and Hall mobility.

**3.6 Measuring Bar Type Samples:** Discusses the procedures necessary for measuring the Hall voltage and resistivity of bar type samples.

**3.7 Measuring Bridge and Parallelepiped Type Specimens:** Outlines basic test procedures for both 6- and 8-contact samples.

**3.8 Sample Resistivity and Hall Voltage Programs:** Lists sample programs that can be used to measure and calculate Hall coefficients and resistivities of typical samples.

## 3.2 RECOMMENDED EQUIPMENT

Table 3-1 summarizes the equipment necessary for a complete Hall measurement system. The Models 196, 220, 485, 705, and 7065 are available from Keithley Instruments, while the remainder of the equipment must be obtained from other sources.

**Table 3-1. Recommended Equipment**

Equipment	Description
Model 196 DMM	Measure sample voltages
Model 220 Current Source	Supply sample current
Model 485 Picoammeter	Measure sample current
Model 705 or 706 Scanner	Control Hall Effect card
Cryostat	Set sample temperature
Magnet	Apply magnetic field
Magnet power supply	Supply magnet power
Gauss meter	Used to measure actual magnetic field strength

## 3.3 HALL EFFECT CONVENTIONS AND PRINCIPLES

The following paragraphs discuss Hall effect sign and sample terminal conventions, as well as basic Hall effect principles.

### 3.3.1 Hall Effect Sign Conventions

Figures 3-1 and 3-2 show the sign conventions for n-type and p-type materials respectively. Table 3-2 summarizes generally accepted units of measure.

**Table 3-2. Measurement Units**

Quantity	Symbol	Units
Sample dimensions	L, t, w, d	cm
Potential difference	V	V
Charge	e, q	C
Carrier concentration	n, p	cm <sup>-3</sup>
Drift mobility	$\mu$	cm <sup>2</sup> /V's
Hall mobility	$\mu_H$	cm <sup>2</sup> /V's
Current density	J	A/cm <sup>2</sup>
Hall coefficient	R <sub>H</sub>	cm <sup>3</sup> /C
Electric field	E	V/cm
Magnetic flux density	B	gauss
Resistivity	$\rho$	$\Omega$ -cm

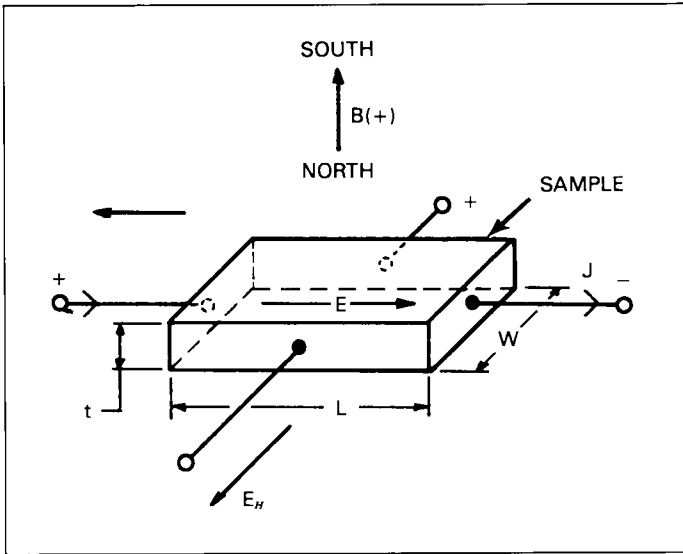

Figure 3-1. Hall-Effect Sign Conventions for n-type Materials

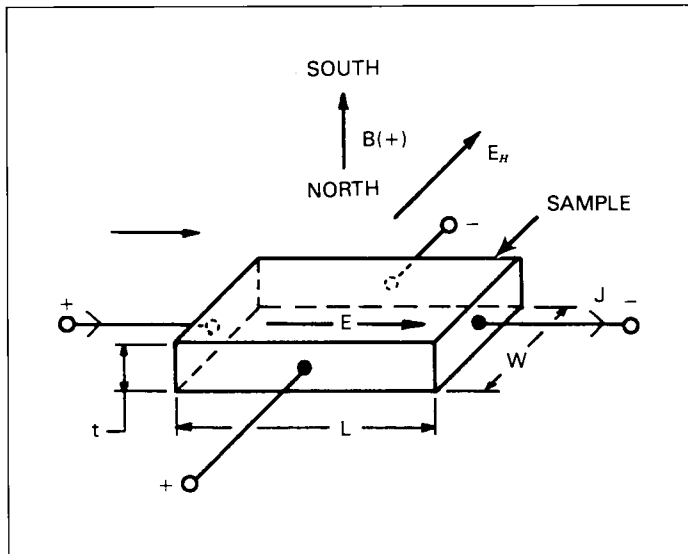

Figure 3-2. Hall-Effect Sign Conventions for p-type Materials

### 3.3.2 Terminal Conventions

Both Hall voltage and resistivity measurements are performed by applying a current to two terminals of a sample, and measuring the resulting voltage at the remaining two terminals.

In the case of van der Pauw resistivity measurements, a current is applied between two terminals, while the voltage is measured between the two opposite terminals, as shown in Figure 3-3. A total of eight such measurements are taken with each possible terminal and current convention. In this manual, these voltages are designated  $V_1$  through  $V_8$ , and are covered in detail in paragraph 3.4.

The connections for Hall voltage measurements are shown in Figure 3-4. Here, current is applied and voltage is measured across the diagonal of the sample. Again eight such measurements are necessary, both with positive and negative current, and positive and negative magnetic flux (often additional measurements are taken with no flux applied). Again, these voltages are designated  $V_1$  through  $V_8$ , as discussed in paragraph 3.5.

Conventions used for bar and bridge specimens are similar, and are covered in paragraphs 3.6 and 3.7 respectively.

### 3.3.3 Basic Hall Effect Principles

For the following discussion, refer to the basic sample configuration shown in Figure 3-1.

If a current,  $I=J/A$ , is applied across the length of the sample, a voltage is developed across that sample. If a magnetic field,  $B$ , is subsequently applied normal (perpendicular) to the current, the carriers are displaced from their normal paths, and a voltage,  $E_H$ , is developed. This voltage is known as the Hall voltage.

Once the Hall voltage is known, the Hall coefficient can be defined as follows:

$$R_H = \frac{E_H}{JB} = \frac{E_H}{qnvB}$$

- Where:  $R_H$  = Hall coefficient
- $E_H$  = Hall voltage
- $J$  = current density
- $B$  = magnetic field
- $n$  = carrier concentration
- $q$  = carrier charge
- $v$  = drift mobility

Once the Hall coefficient is known, carrier concentration and mobility can be calculated when used with the measured resistivity.

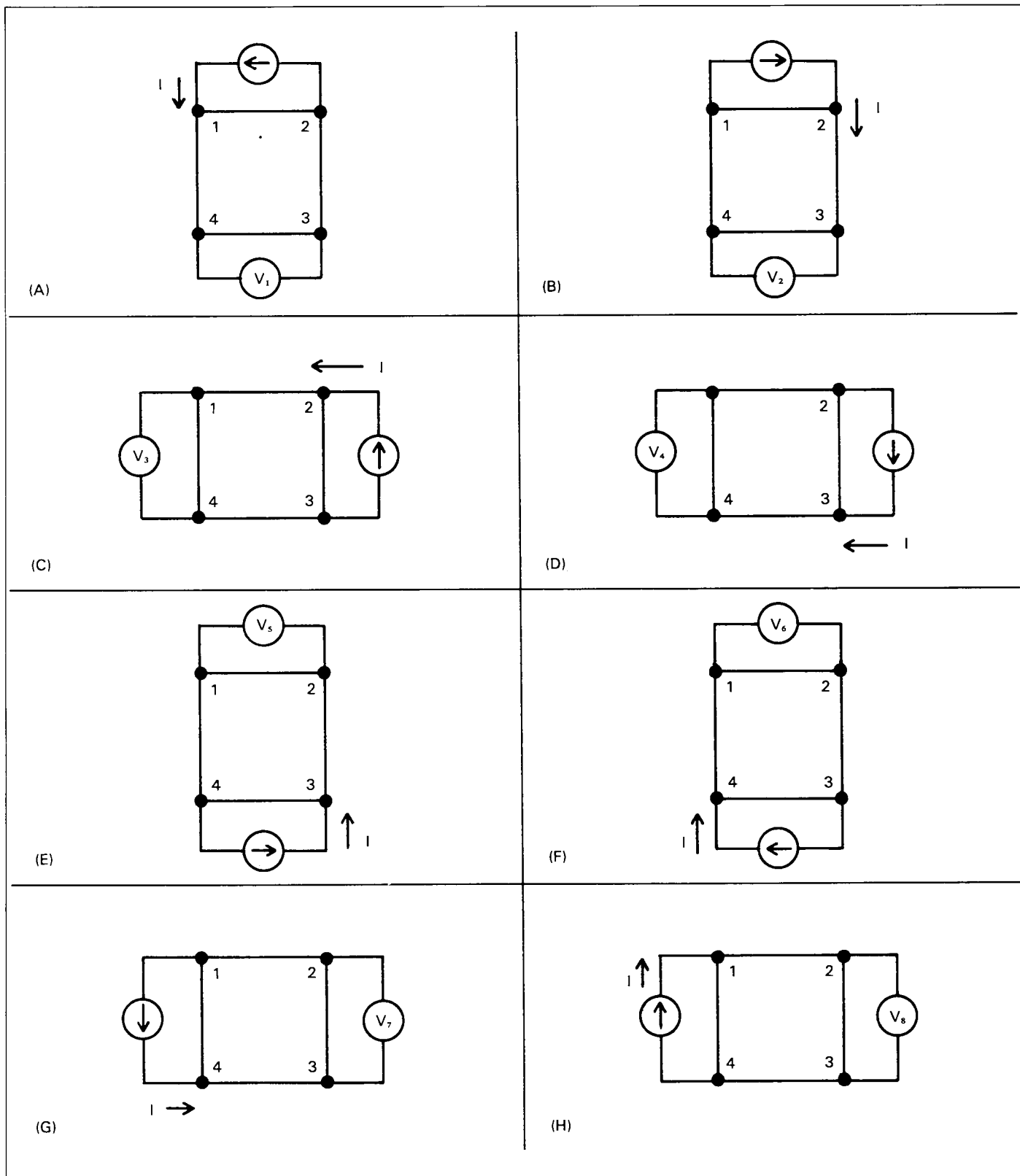

Figure 3-3. Resistivity Measurement Conventions

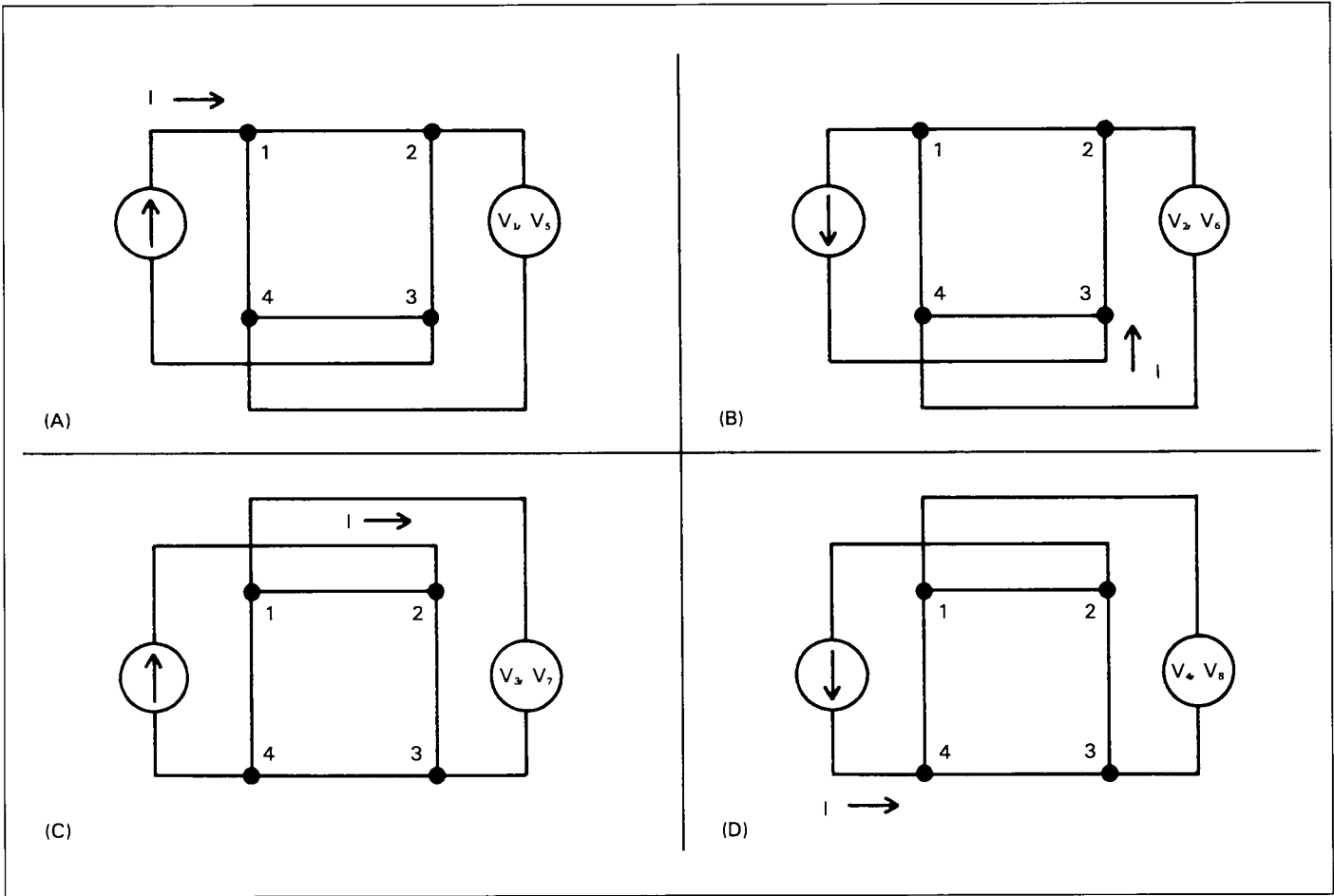

Figure 3-4. Hall Voltage Measurement Conventions

### 3.4 VAN DER PAUW RESISTIVITY MEASUREMENTS

The following paragraphs describe basic test configuration, test procedures, and calculations necessary to make resistivity measurements using the van der Pauw method.

#### 3.4.1 Test Configuration

Figure 3-5 shows the basic test configuration for making resistivity measurements. A detailed connection diagram may be found in Section 2.

#### 3.4.2 Test Procedure

Use the following general procedure to measure parameters necessary to calculate sample resistivity. The procedure assumes that the sample has been stabilized at the desired operating temperature and will remain at that temperature throughout the tests.

1. Turn on all the instruments and allow them to warm up for the prescribed period for rated accuracy.
2. Place the Models 196 and 485 in autoranging. Be sure the Model 196 is in the DCV function.
3. Using front panel Program 6, set the Model 705 Scanner to the matrix mode.

4. Program crosspoint 5,4 to select low or high resistivity. This crosspoint should be open for low resistivity, and it should be closed for high resistivity.
5. Program the Model 220 current to the desired value in the range of 500fA to 100mA. The maximum current that can be used will depend on the resistance of the sample; remember that the maximum Model 7065 input voltage is  $\pm 8V$ . In order to maintain proper sign convention for the measured voltage and to minimize common-mode errors, program only positive currents.
6. Close the crosspoints necessary to measure  $V_1$ , as indicated in Table 3-3. Zero the DMM and enable the REL function on the Model 485.
7. Turn on the 220 output by pressing the OPERATE key.
8. Measure  $V_1$  by noting the reading on the Model 196. Also note the current measured by the Model 485 Picoammeter.
9. Turn off the Model 220 output and open the crosspoints.
10. Re-zero the DMM, enable REL on the Model 485, then turn on the Model 220 output.
11. Measure and record the remaining voltages ( $V_2$  through  $V_8$ ) listed in Table 3-3 by closing the appropriate crosspoints. Be sure to open the crosspoints from the previous measurement before closing crosspoints for the present measurement.

**Table 3-3. Crosspoint Summary for Resistivity Measurements**

Voltage Designation	Crosspoints Closed (Column, Row)*				Current Applied Between	Voltage Measured Between
$V_1$	1,2	2,1	3,3	4,4	1-2	3-4
$V_2$	2,2	1,1	3,3	4,4	2-1	3-4
$V_3$	2,2	1,3	3,4	4,1	2-3	4-1
$V_4$	2,3	1,2	3,4	4,1	3-2	4-1
$V_5$	2,3	1,4	3,1	4,2	3-4	1-2
$V_6$	2,4	1,3	3,1	4,2	4-3	1-2
$V_7$	2,4	1,1	3,2	4,3	4-1	2-3
$V_8$	2,1	1,4	3,2	4,3	1-4	2-3

\*Only those crosspoints shown can be closed for a specific measurement, except 5,4 which controls input configuration for low - or high-resistivity samples.

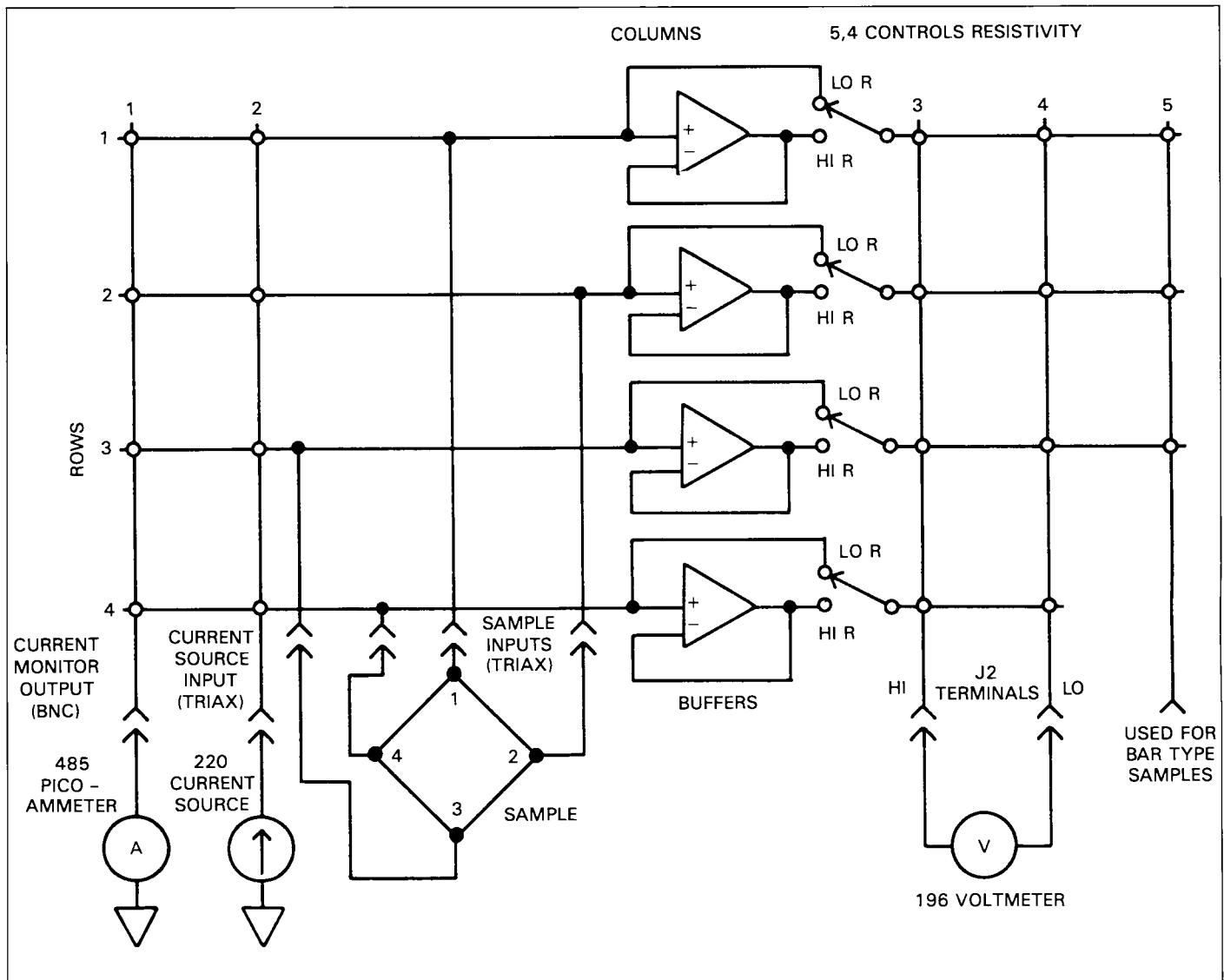

Figure 3-5. Measurement Configuration for Resistivity and Hall Voltage Measurements

### 3.4.3 Resistivity Calculations

Once the voltages and current through the sample have been measured, the resistivity can be calculated as follows. Two values of resistivity,  $p_A$  and  $p_B$ , are computed as follows:

$$p_A = \frac{1.1331 f_A t_s (V_2 + V_4 - V_1 - V_3)}{I}$$

$$p_B = \frac{1.1331 f_B t_s (V_6 + V_8 - V_5 - V_7)}{I}$$

Where:  $p_A$  and  $p_B$  are resistivities in ohm-cm  
 $t_s$  is the sample thickness in cm  
 $V_1$ - $V_8$  represent the voltages measured by the Model 196 (see Table 3-3)  
 $I$  is the current through the sample in amperes, as measured by the Model 485  
 $f_A$  and  $f_B$  are geometrical factors based on sample symmetry, and are related to the two resistance ratios  $Q_A$  and  $Q_B$  as shown below ( $f_A=f_B=1$  for perfect symmetry).

$Q_A$  and  $Q_B$  can be calculated using the measured voltages from Table 3-3 as follows:

$$Q_A = \frac{V_2 - V_1}{V_4 - V_3}$$

$$Q_B = \frac{V_6 - V_5}{V_8 - V_7}$$

$Q$  and  $f$  are related as follows:

$$\frac{Q-1}{Q+1} = \frac{f}{0.693} \operatorname{arc} \cosh \left( \frac{1}{2} e^{\frac{0.693}{f}} \right)$$

A plot of this function is shown in Figure 3-6.

Note that if  $p_A$  and  $p_B$  are not within 10% of one another,

the sample is not sufficiently uniform to determine resistivity.

Once  $p_A$  and  $p_B$  are known, the average resistivity,  $p_{AVG}$  can be determined as follows:

$$p_{AVG} = \frac{p_A + p_B}{2}$$

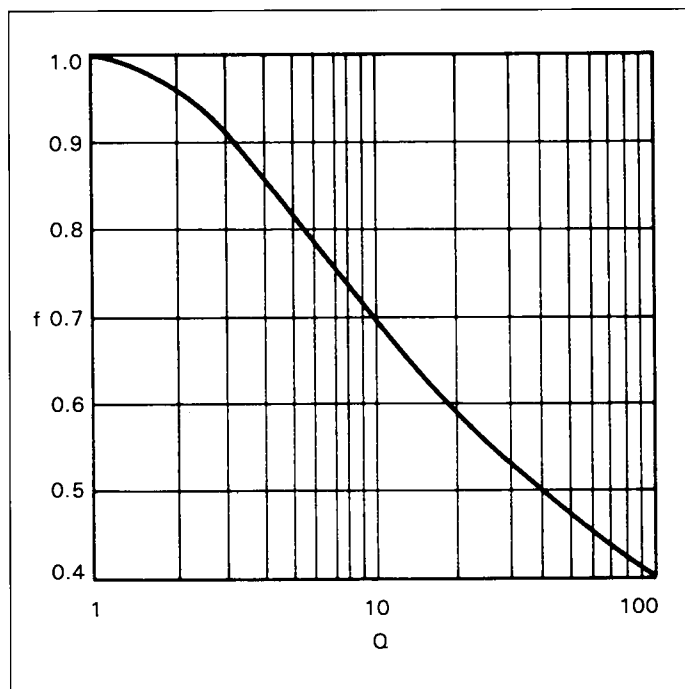

Figure 3-6. Plot of  $f$  vs  $Q$

## 3.5 HALL VOLTAGE MEASUREMENTS

The following paragraphs discuss Hall voltage measurements on van der Pauw type samples.

### 3.5.1 Test Configuration

The sample test configuration shown in Figure 3-5 can be used to measure the parameters necessary to calculate Hall coefficients. Test connection details are located in Section 2. In addition to the equipment shown, a suitable magnet or electromagnet will be necessary to generate the required magnetic field.

### 3.5.2 Test Procedure

Use the procedure below to measure data necessary to calculate Hall coefficients. Note that the sample should be stabilized at the desired temperature before and during the tests. Also, the flux density magnitude must be kept constant during the measurements.

1. Turn on all the instruments and allow them to warm up for the prescribed period for rated accuracy.
2. Place the Models 196 and 485 in autoranging. Be sure the Model 196 is in the DCV function.
3. Using front panel Program 6, set the Model 705 Scanner to the matrix mode.
4. Program crosspoint 5,4 to select low or high resistivity. This crosspoint should be open for low resistivity, and it should be closed for high resistivity.
5. Program the Model 220 current to the desired value in the range of 500fA to 100mA. The maximum current that can be used will depend on the resistance of the sample; remember that the maximum Model 7065 input voltage is  $\pm 8V$ . In order to maintain proper sign convention for the measured voltage, program only positive currents.
6. Close crosspoints 2,1; 1,3; 3,4; and 4,2; then zero the Model 196 and enable the Model 485 relative function.
7. Turn on the Model 220 output by pressing the OPERATE key.
8. Turn on the magnetic field, and set it to the desired positive flux density (+B). Measure and record the value of +B.
9. Measure the voltage  $V_1$  by noting the Model 196 reading.
10. Note and record the current being measured by the Model 485 Picoammeter.
11. Measure and record  $V_2$  through  $V_4$ , as listed in Table 3-4 by closing the appropriate crosspoints. Be sure to open crosspoints from the previous measurement and turn off the Model 220 output. After closing the next crosspoints, re-zero the DMM and enable REL on the Model 485 before turning on the Model 220 output.
12. Reverse the magnetic flux and adjust it to the same magnitude used for positive flux; measure and record the flux value.
13. Measure  $V_5$  through  $V_8$  listed in Table 3-4, now with negative flux (-B).

**Table 3-4. Crosspoint Summary for Hall Voltage Measurements**

Voltage Designation	Flux	Crosspoints Closed (Column, Row)*				Current Applied Between	Voltage Measured Between
$V_1$	+B	2,1	1,3	3,4	4,2	1-3	4-2
$V_2$	+B	2,3	1,1	3,4	4,2	3-1	4-2
$V_3$	+B	2,2	1,4	3,1	4,3	2-4	1-3
$V_4$	+B	2,4	1,2	3,1	4,3	4-2	1-3
$V_5$	-B	2,1	1,3	3,4	4,2	1-3	4-2
$V_6$	-B	2,3	1,1	3,4	4,2	3-1	4-2
$V_7$	-B	2,2	1,4	3,1	4,3	2-4	1-3
$V_8$	-B	2,4	1,2	3,1	4,3	4-2	1-3

\*Only those crosspoints shown can be closed for a specific measurement, except 5,4 which controls card input configuration for low - or high - resistivity samples.



### 3.5.3 Hall Coefficient Calculations

Once the voltages are measured, two Hall coefficients,  $R_{HC}$  and  $R_{HD}$ , can be calculated as follows:

$$R_{HC} = \frac{2.5 \times 10^7 t_s (V_2 - V_1 + V_5 - V_6)}{BI}$$

$$R_{HD} = \frac{2.5 \times 10^7 t_s (V_4 - V_3 + V_7 - V_8)}{BI}$$

Where:  $R_{HC}$  and  $R_{HD}$  are Hall coefficients in  $\text{cm}^3/\text{C}$   
 $t_s$  is the sample thickness in cm  
 $B$  is the magnetic flux in gauss  
 $I$  is the current measured by the Model 485 in amperes  
 $V_1$ - $V_8$  are voltages measured by the Model 196 (see Table 3-4)

Note that  $R_{HC}$  and  $R_{HD}$  should be within 10% of one another, or the sample is not sufficiently uniform.

Once  $R_{HC}$  and  $R_{HD}$  have been calculated, the average Hall Coefficient,  $R_{H_{AVG}}$ , can be determined as follows:

$$R_{H_{AVG}} = \frac{R_{HC} + R_{HD}}{2}$$

### 3.5.4 Hall Mobility Calculation

Once the Hall coefficient and resistivity are known, the Hall

mobility can be calculated as follows:

$$\mu_H = \frac{|R_{H_{AVG}}|}{\rho_{AVG}}$$

Where:  $\mu_H$  = the Hall mobility in  $\text{cm}^2/\text{V-s}$   
 $R_{H_{AVG}}$  = the average Hall coefficient in  $\text{cm}^3/\text{C}$   
 $\rho_{AVG}$  = the average resistivity in  $\text{ohm-cm}$

## 3.6 MEASURING BAR TYPE SAMPLES

The following paragraphs discuss procedures and test configurations for measuring resistivity and Hall voltage measurements on bar samples.

### 3.6.1 Test Configurations

Figures 3-7 and 3-8 show the general test configurations for making resistivity and Hall voltage measurements. The two setups are very similar except for the way the voltmeter is connected. For resistivity measurements (Figure 3-7), the voltmeter is connected between terminal 4 and 5 of the terminal block. For Hall voltage measurements, a suitable potentiometer is to be connected between terminals 4 and 5, while the voltmeter is connected between the wiper of the pot and terminal 3 of the block.

The crosspoints that must be closed depend on whether resistivity or Hall voltage measurements are to be taken. Table 3-6 summarizes which crosspoints to close for each type of measurement.

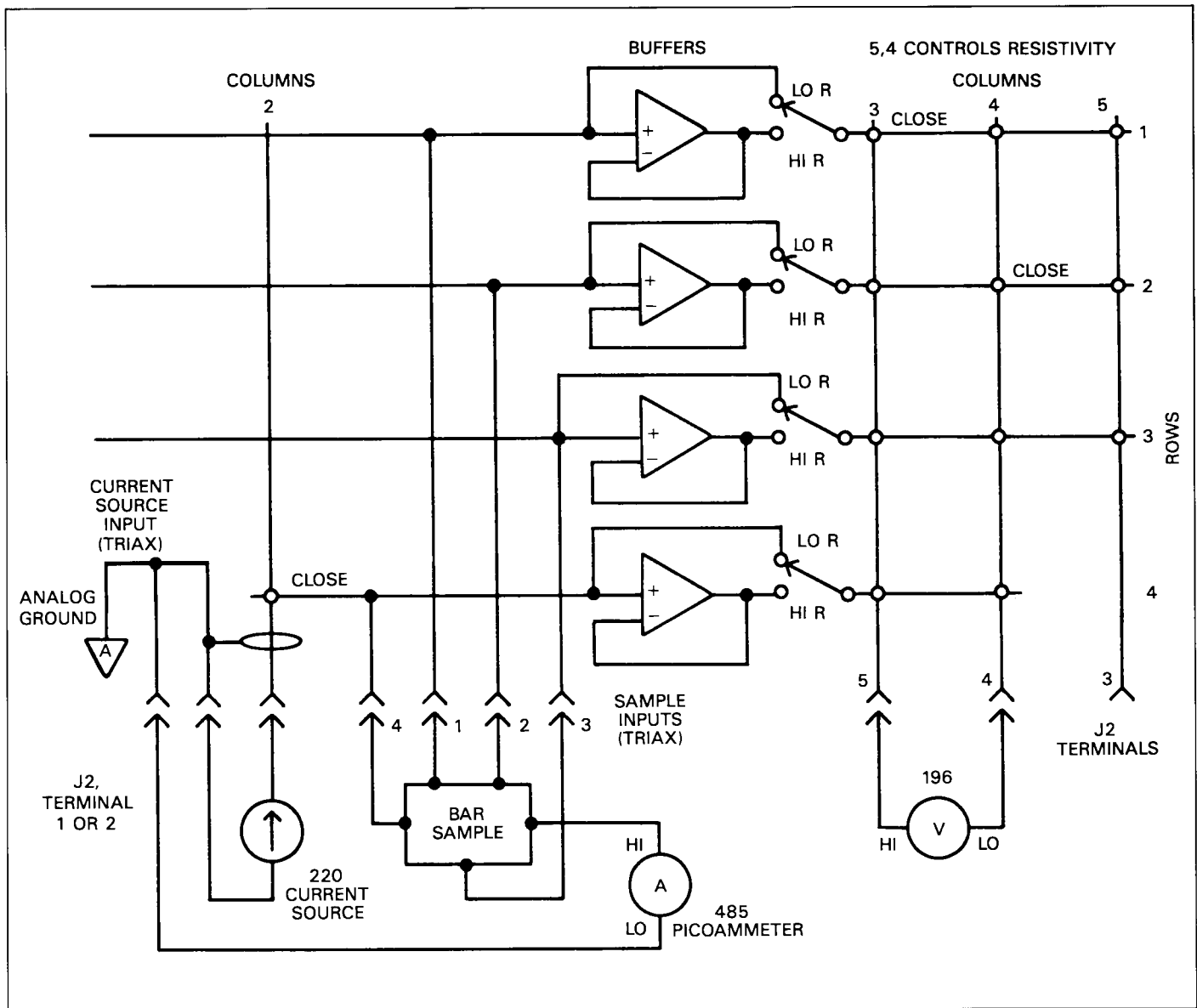

Figure 3-7. Test Configuration for Resistivity Measurements of Bar Samples

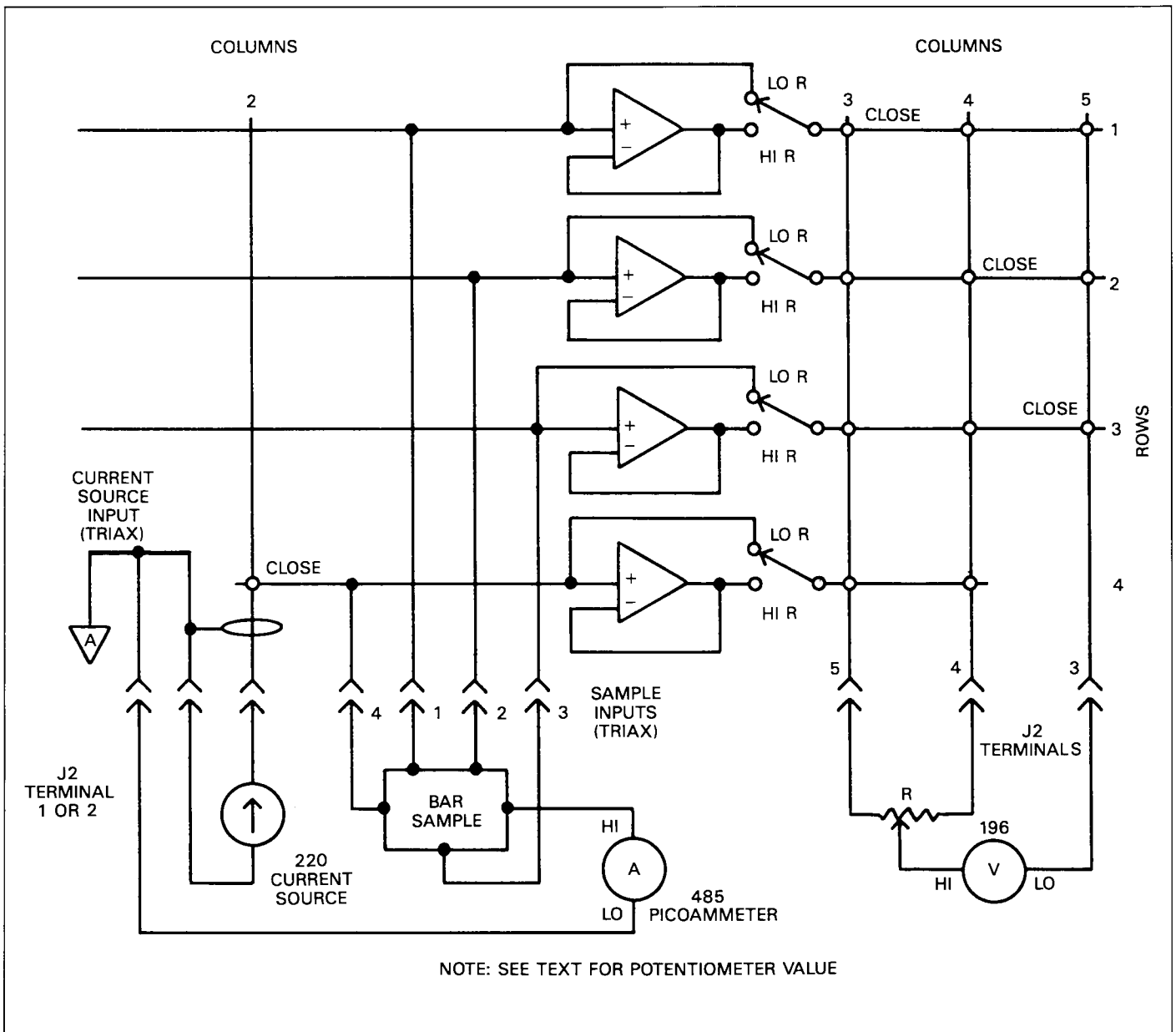

Figure 3-8. Test Configuration for Hall Voltage Measurement of Bar Samples

### 3.6.2 Determining Potentiometer Values

The loading effects of the DMM and potentiometer can affect the accuracy of both low and high resistivity measurements. Table 3-5 summarizes recommended potentiometer values, along with nominal errors. Additional considerations for value selection are discussed below. An equivalent circuit of the card and sample for this discussion is shown in Figure 3-9.

#### High Resistivity

In order to minimize loading errors, the equivalent resistance seen by the buffers must be as high as possible; also, the DMM input resistance must be substantially higher than the equivalent resistance seen at its input. The worst-case condition occurs when the potentiometer wiper is at the center of its adjustment range ( $R = \frac{1}{2}$ ). For example, in the equivalent circuit of Figure 3-10, assume that  $R_p$  has a value of  $200k\Omega$ . In this case,  $R_0 = \frac{1}{2} (\frac{1}{2}) R_p = \frac{1}{4} R_p = 50k\Omega$ .

#### Low Resistivity

For the low-resistivity setup, and for values significantly less than the values listed for  $R_{12}$  in Table 3-5, better accuracy can be obtained by using a different value for  $R_p$  than that shown in the table. Using the equivalent circuit shown in Figure 3-11, the relationship between the error,  $E$ ,  $R_p$ , and  $R_{12}$  is given as follows:

$$E\% \cong \frac{R_p}{4R_{IN}} + \frac{R_{12}}{R_p} \times 100\%$$

Where:  $R_p$  = potentiometer value

$R_{IN}$  = input resistance of the Model 196 ( $R_{IN} = 10M\Omega$  for  $\geq 30V$  range,  $10^6\Omega$  for 300mV, 3V ranges)

Note that this approximation is valid for  $E < 10\%$

**Table 3-5. Minimum and Maximum Potentiometer Values for Hall Bar Measurements**

Resistivity Mode	$R_{12}^*$	196 Range	Recommended $R_p^*$	Additional Error Introduced by $R_p$ (E)
LO	Up to $1k\Omega$	30V, 300V	$200k\Omega$	1%
LO	Up to $10k\Omega$	300mV, 3V	$1M\Omega$	1%
HI	All	All	$50k\Omega$	0.25%

\*See Figure 3-9

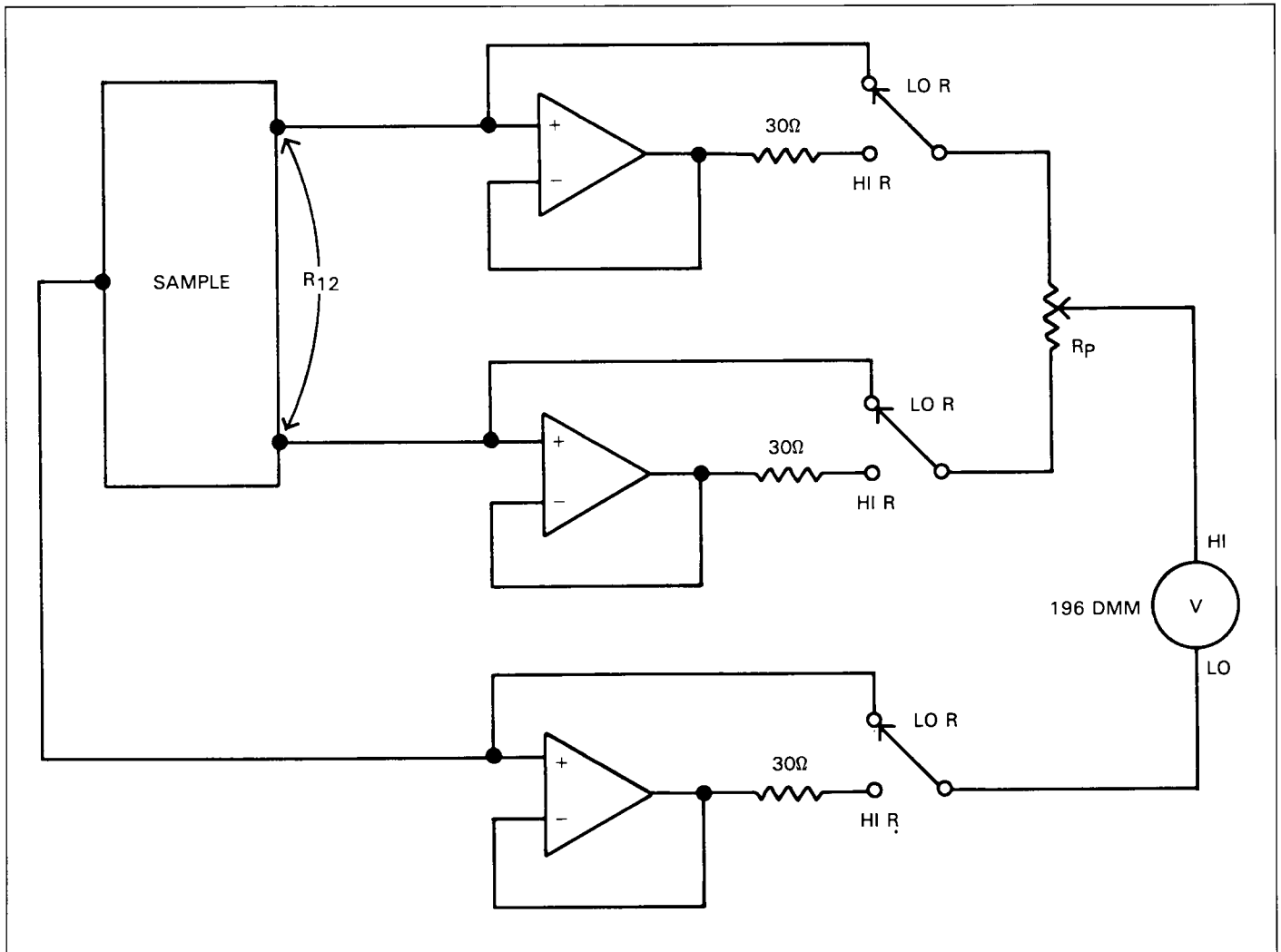
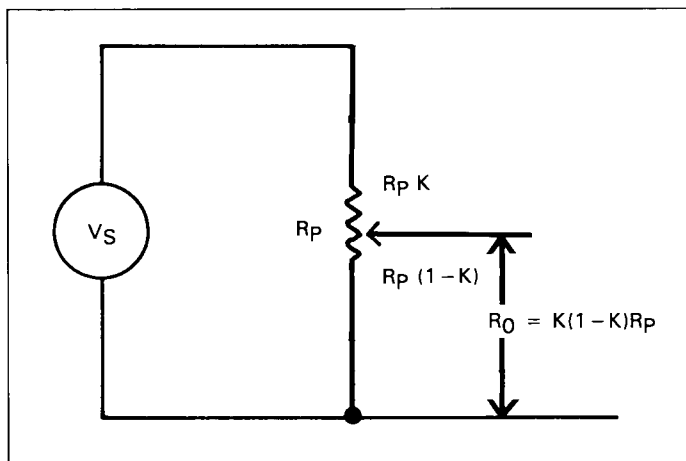
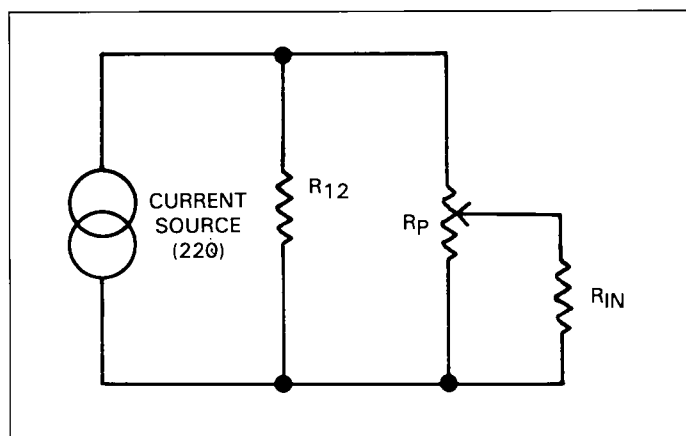

Figure 3-9. Hall Bar Equivalent Circuit



**Figure 3-10. Equivalent Potentiometer Circuit, High Resistivity**



**Figure 3-11. Equivalent Potentiometer Circuit, Low Resistivity**

### 3.6.3 Bar Resistivity Measurements

Use the basic procedure below to make the necessary measurements to determine resistivity of bar type samples. This procedure assumes that the sample temperature is held to the constant desired temperature throughout the test.

1. Turn on all the instruments and allow them to warm up for the prescribed period for rated accuracy.
2. Place the Models 196 and 485 in autoranging. Be sure the Model 196 is in the DCV function.
3. Using front panel Program 6, set the Model 705 Scanner to the matrix mode.
4. Program crosspoint 5,4 to select low or high resistivity.

This crosspoint should be open for low resistivity, and it should be closed for high resistivity.

5. Program the Model 220 current to the desired value in the range of 500fA to 100mA. The maximum current that can be used will depend on the resistance of the sample; remember that the maximum Model 7065 input voltage is  $\pm 8V$ . In order to maintain proper sign convention for the measured voltage, and to minimize common-mode errors, program only positive currents.
6. Close crosspoints 2,4; 3,1; and 4,2 by programming the scanner. Zero the Model 196 and enable the Model 485 relative function.
7. Turn on the Model 220 output by pressing the OPERATE key.
8. Note and record the voltage ( $V_R$ ) and ( $I_R$ ) current readings on the Models 196 and 485.
9. Open all crosspoints by pressing the RESET button on the scanner and turn off the Model 220 output after measurements are complete.

### 3.6.4 Hall Voltage Measurements

The following procedure assumes that the sample is held stable at the desired temperature throughout the tests, and that the applied magnetic flux is also held constant at the desired density.

1. Turn on all instruments and allow them to warm up sufficiently.
2. Select the DCV function on the Model 196, and set both the Model 196 and the Model 485 to autoranging.
3. Using Program 6, set the Model 705 Scanner to the matrix mode.
4. Program crosspoint 5,4 for the desired resistivity setup (open, low resistivity; closed, high resistivity).
5. Program the Model 220 Current Source to the desired (positive) current.
6. Program the scanner to close contacts 2,4; 3,1; 4,2; and 5,3, as summarized in Table 3-6.
7. Enable zero on the Model 196 and the relative function on the Model 485.
8. Turn on the Model 220 output by pressing the OPERATE button.
9. With no magnetic field applied, adjust the potentiometer for a reading of 0V on the Model 196.
10. Turn on the magnetic field and adjust it for the desired intensity.
11. Note and record the Model 196 voltage ( $V_H$ ) as well as the sample current ( $I_H$ ) measured by the Model 485 Picoammeter.
12. Open all crosspoints by pressing RESET on the scanner and turn off the Model 220 output after all measurements are completed.

**Table 3-6. Crosspoint Configurations for Bar Measurements**

Measurement	Closed Crosspoints (Column, Row)			
Resistivity	2,4	3,1	4,2	
Hall Voltage	2,4	3,1	4,2	5,3

$I_H$  = the current in amperes measured by the Model 485

$B$  = the flux density in gauss

$t$  = the sample thickness in cm

$n$  = concentration in electrons/cm<sup>3</sup> (substitute  $p$  for hole conduction in  $p$  type materials).

### 3.6.5 Calculations

#### Resistivity

The resistivity of the sample is related to the measurements as follows:

$$V_R = \rho I_R \frac{x}{yt}$$

Where:  $V_R$  = the voltage measured by the Model 196

$\rho$  = the resistivity in ohm-cm

$I_R$  = the current in amperes measured by the Model 485

$t$  = the sample thickness in cm

$x$  and  $y$  = sample dimensions shown in Figure 3-12 in cm.

#### Hall Voltage

The magnetic field,  $B$ , will generate a Hall voltage,  $V_H$ , as follows:

$$V_H = 6.25 \times 10^{10} \frac{I_H B}{nt}$$

Where:  $V_H$  = the voltage measured by the Model 196 in volts

#### Mobility

Once the resistivity and Hall voltages are known, the mobility,  $\mu$ , can be determined as follows:

$$\mu = 10^8 \frac{xV_H}{yBV_R}$$

Where:  $\mu$  = the mobility in cm<sup>2</sup>/V-s

$V_H$  = the Hall voltage measured by the Model 196

$x, y$  = sample dimensions in cm (Figure 3-12)

$B$  = flux density in gauss

$V_R$  = voltage measured by the Model 196

### 3.7 MEASURING BRIDGE AND PARALLELEPIPED TYPE SPECIMENS

The fundamental procedures for measuring 6- and 8-contact bridge and parallelepiped type specimens are discussed in the following paragraphs.

#### 3.7.1 Test Configurations

Figure 3-13 shows the test setup for 6-contact specimens, and the setup for 8-contact samples is shown in Figure 3-14. In both cases, four sample contacts are connected to the sample inputs on the Model 7065. The current source and picoammeter must be connected directly to the sample itself. Section 2 covers physical connections in more detail.

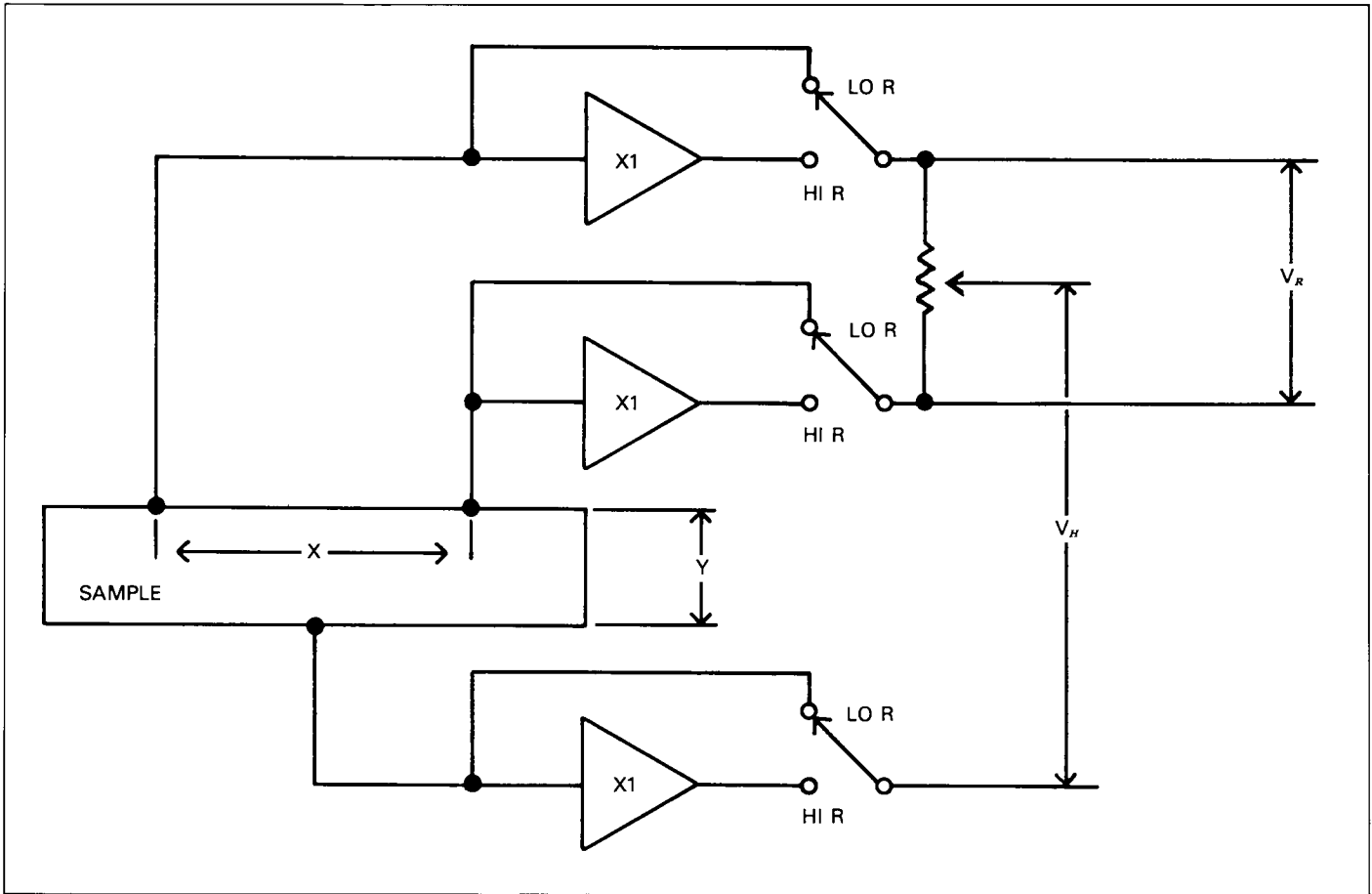

Figure 3-12. Bar Sample Dimensions





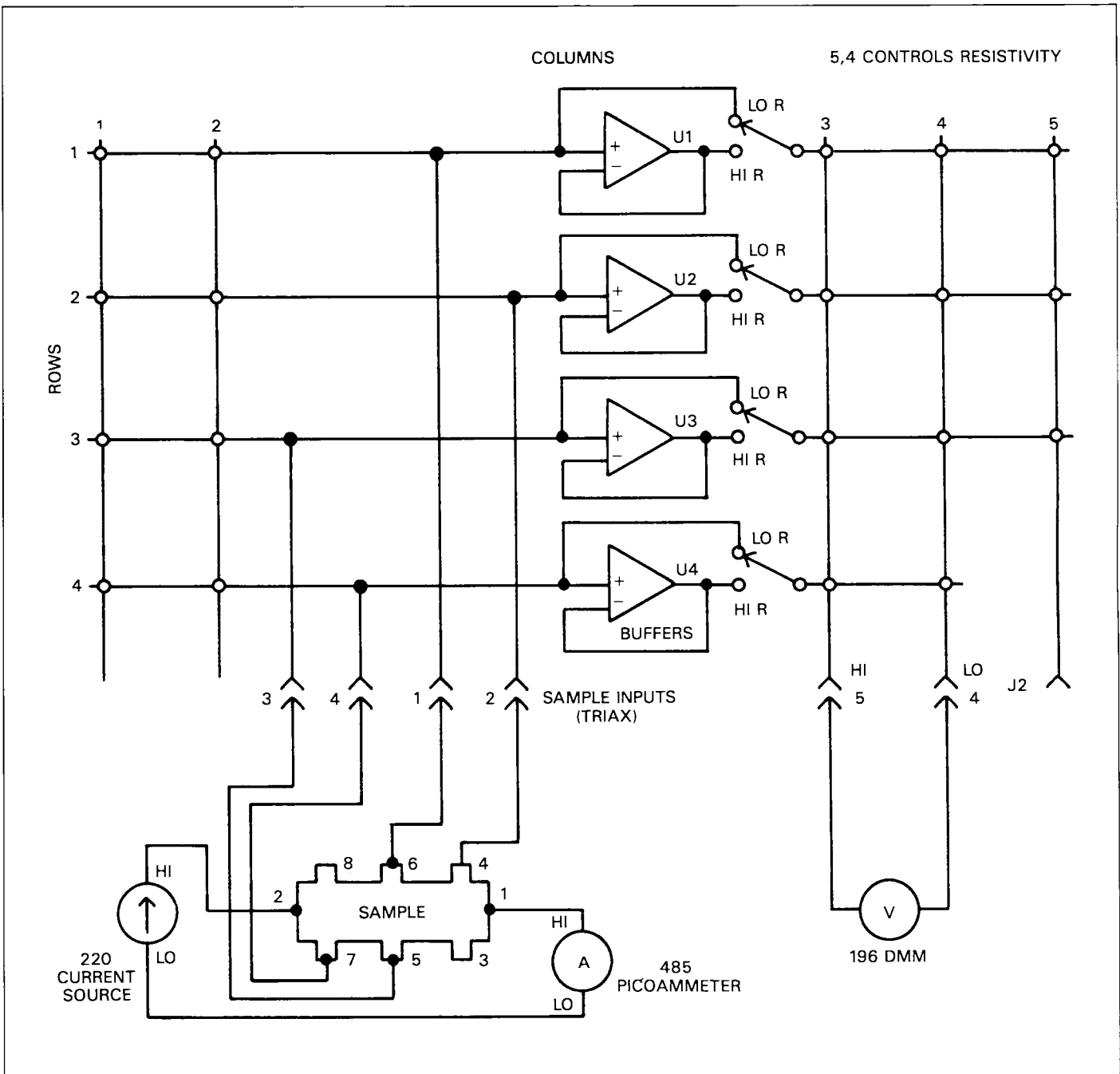

Figure 3-14. 8-Contact Sample Connections

### 3.7.2 Resistivity Measurements

Use the basic procedure below to measure parameters for 6- and 8-contact specimens. As always, the sample should be stabilized at the desired temperature both before and during the tests.

1. Turn on all the instruments and allow them to warm up for the prescribed period for rated accuracy.
2. Place the Models 196 and 485 in autoranging. Be sure the Model 196 is in the DCV function.
3. Using front panel Program 6, set the Model 705 Scanner to the matrix mode.
4. Program crosspoint 5,4 to select low or high resistivity. This crosspoint should be open for low resistivity, and it should be closed for high resistivity.
5. Program the Model 220 current to the desired positive current value in the range of 500fA to 100mA. The maximum current that can be used will depend on the resistance of the sample; remember that the maximum Model 7065 input voltage is  $\pm 8V$ .
6. Close the appropriate crosspoints for the sample by programming the scanner (Table 3-7 or 3-8). Zero the Model 196 and enable the Model 485 relative function.
7. Turn on the Model 220 output by pressing the OPERATE key.
8. Note and record the voltage ( $V_1$ ) and current readings on the Models 196 and 485.
9. Turn off the Model 220 output, open the presently closed crosspoints, and close the second set of crosspoints listed in Table 3-7 or 3-8. Enable REL on the picoammeter then turn the Model 220 output back on. Measure the voltage  $V_2$ .
10. Program the Model 220 for a negative current of the same magnitude as is presently programmed.

11. Note the Model 485 current reading and compare it to the one obtained in step 8. If the current magnitudes are not exactly the same, reprogram the Model 220, as necessary, so that the magnitude of the current is as close as possible to that obtained in step 8.
12. Repeat steps 6 through 11 and measure  $V_3$  and  $V_4$  by closing the crosspoints indicated in the appropriate table (Table 3-7 or 3-8).

**Table 3-7. 6-Contact Sample Resistivity Measurements**

Voltage Designation	Crosspoints Closed (Column, Row)		Current Between	Voltage Between
$V_1$	3,2	4,1	1-2	4-6
$V_2$	3,3	4,4	1-2	3-5
$V_3$	3,2	4,1	2-1*	4-6
$V_4$	3,3	4,4	2-1*	3-5

\*Reverse current by programming source for opposite polarity

**Table 3-8. 8-Contact Sample Resistivity Measurements**

Voltage Designation	Crosspoints Closed (Column, Row)		Current Between	Voltage Between
$V_1$	3,2	4,1	1-2	4-6
$V_2$	3,3	4,4	1-2	5-7
$V_3$	3,2	4,1	2-1*	4-6
$V_4$	3,3	4,4	2-1*	5-7

\*Reverse current by programming source for opposite polarity

### 3.7.3 Hall Voltage Measurements

The following procedure assumes that the sample is held stable at the desired temperature throughout the tests, and that the applied magnetic flux is also held constant at the desired flux density.

1. Turn on all instruments and allow them to warm up sufficiently.
2. Select the DCV function on the Model 196, and set both the Model 196 and the Model 485 to autoranging.
3. Using Program 6, set the Model 705 Scanner to the matrix mode.
4. Program crosspoint 5,4 for the desired resistivity (open, low resistivity; closed, high resistivity).
5. Program the Model 220 Current Source to the desired positive current.
6. Program the scanner to close the first set of contacts listed in Table 3-9 or 3-10.
7. Enable zero on the Model 196 and the relative function on the Model 485.
8. Turn on the Model 220 output by pressing the OPERATE button.

9. Turn on the magnetic flux and adjust it to the desired positive value (+B).
10. Note and record the Model 196 voltage ( $V_1$ ) as well as the sample current measured by the Model 485 Picoammeter.
11. For 6-contact specimens only, measure the voltage  $V_2$ , as indicated in Table 3-9.
12. Reverse the Model 220 current polarity and note the current reading on the Model 485. If necessary, reprogram the current source so that the magnitude of the measured current is as close as possible to that measured in step 10.
13. Measure the remaining voltage(s) as indicated in Table 3-9 or 3-10 using steps 6 through 12 of the above procedure.
14. Reverse the magnetic flux and repeat steps 10 through 13.

### 3.7.4 Calculations

Once the necessary measurements are made, resistivity, Hall voltage, and Hall mobility calculations can be made from the data and certain sample dimensions, which are outlined in Figure 3-15.

**Table 3-9. 6-Contact Sample Hall Voltage Measurements**

Voltage Designation	Flux Polarity	Crosspoints Closed (Column, Row)		Current* Between	Voltage Between
$V_1$	+B	3,1	4,4	1-2	6-5
$V_2$	+B	3,2	4,3	1-2	4-3
$V_3$	+B	3,1	4,4	2-1	6-5
$V_4$	+B	3,2	4,3	2-1	4-3
$V_5$	-B	3,1	4,4	1-2	6-5
$V_6$	-B	3,2	4,3	1-2	4-3
$V_7$	-B	3,1	4,4	2-1	6-5
$V_8$	-B	3,2	4,3	2-1	4-3

\*Reverse current by programming source for opposite polarity

**Table 3-10. 8-Contact Sample Hall Voltage Measurements**

Voltage Designation	Flux Polarity	Crosspoints Closed (Column, Row)		Current* Between	Voltage Between
$V_1$	+B	3,1	4,3	1-2	6-5
$V_2$	+B	3,1	4,3	2-1	6-5
$V_3$	-B	3,1	4,3	1-2	6-5
$V_4$	-B	3,1	4,3	2-1	6-5

\*Reverse current by programming source for opposite polarity

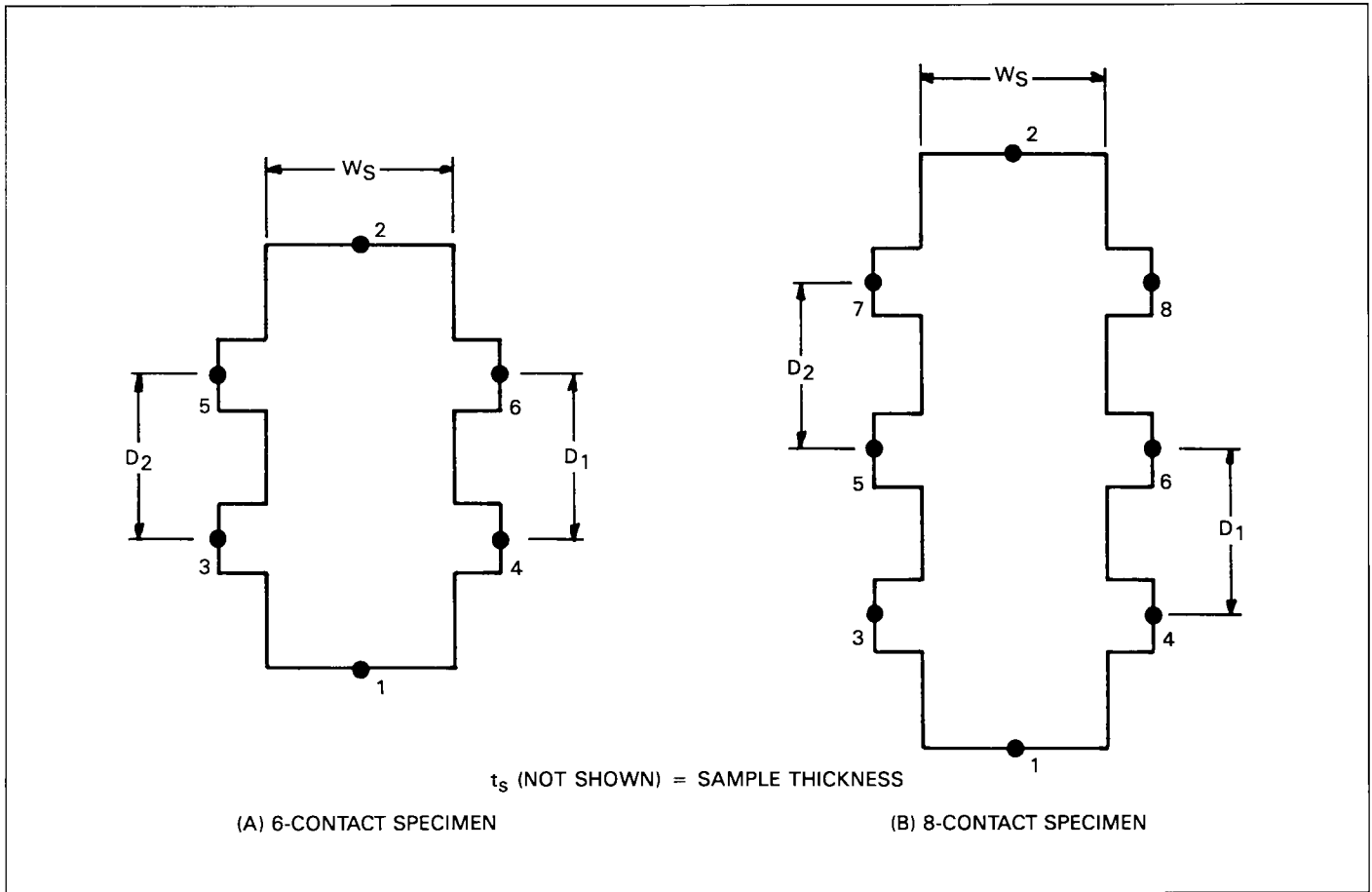

Figure 3-15. Sample Dimensions Necessary for Calculations

**Resistivity Calculations**

Two resistivity values,  $p_A$  and  $p_B$  can be calculated as follows:

$$p_A = \frac{w_s t_s}{2ID_1} (V_1 - V_3)$$

and,

$$p_B = \frac{w_s t_s}{2ID_2} (V_2 - V_4)$$

Where:  $p_A$  and  $p_B$  = resistivity in ohm-cm  
 $w_s$  = sample width in cm  
 $t_s$  = sample thickness in cm  
 $D_1$  and  $D_2$  = sample dimensions (Figure 3-15) in cm  
 $I$  = current measured by the Model 485 in amperes  
 $V_1$ - $V_4$  = voltages measured by the Model 196 (Table 3-7, 6-contact; Table 3-8, 8-contact.)

Once  $p_A$  and  $p_B$  are known, the average resistivity,  $p_{AVG}$ , can be computed as follows:

$$p_{AVG} = \frac{p_A + p_B}{2}$$

Note that  $p_{AVG}$  is also given in ohm-cm

**Hall Voltage Calculations**

For 6-contact samples, two Hall coefficients,  $R_{H1}$  and  $R_{H2}$  can be calculated as follows:

$$R_{H1} = \frac{2.5 \times 10^7 t_s}{BI} (V_1 - V_3 + V_7 - V_5)$$

and,

$$R_{H2} = \frac{2.5 \times 10^7 t_s}{BI} (V_2 - V_4 + V_8 - V_6)$$

Where:  $R_{H1}$  and  $R_{H2}$  = Hall coefficients in  $\text{cm}^3/\text{C}$  (coulomb)  
 $t_s$  = sample thickness in cm  
 $B$  = flux density in gauss  
 $I$  = current in amperes measured by the Model 485  
 $V_1$ - $V_8$  = voltages measured by the Model 196 from Table 3-9

From these two coefficients, the average Hall coefficient,  $R_{H_{AVG}}$ , can be computed in the following manner:

$$R_{H_{AVG}} = \frac{R_{H1} + R_{H2}}{2}$$

Note that  $R_{H_{AVG}}$  is in units of  $\text{cm}^3/\text{C}$

For eight contact samples, only a single coefficient,  $R_H$ , need be derived as follows:

$$R_H = \frac{2.5 \times 10^7 t_s}{BI} (V_1 - V_2 + V_4 - V_3)$$

Where:  $R_H$  = Hall coefficient in  $\text{cm}^3/\text{C}$   
 $t_s$  = sample thickness in cm  
 $B$  = flux density in gauss  
 $I$  = current measured by the Model 485 in amperes  
 $V_1$ - $V_4$  = voltages from Table 3-10 measured by the Model 196.

**Hall Mobility**

The Hall mobility,  $\mu_H$ , can be computed from the Hall coefficient(s) and average resistivity of the specimen as follows:

$$\mu_H = \frac{|R_{H_{AVG}}|}{p_{AVG}}$$

Where:  $\mu_H$  = Hall mobility in  $\text{cm}^2/\text{V-s}$   
 $R_{H_{AVG}}$  = average Hall coefficient in  $\text{cm}^3/\text{C}$   
 $p_{AVG}$  = average resistivity in ohm-cm

For 8-contact samples, substitute  $R_H$  for  $R_{H_{AVG}}$  in the above equation.

### 3.8 SAMPLE RESISTIVITY AND HALL VOLTAGE PROGRAMS

Three programs are included in this section in order to demonstrate fundamental programming techniques. Programs 1 and 5 are intended to determine the Hall coefficients using the van der Pauw method, and Programs 2 and 6 determine the resistivity of van der Pauw samples. Programs 3 and 7 measure bar sample resistivity, and programs 4 and 8 can be used to measure the resistivity of 6- or 8-contact bridge or parallelepiped samples.

Programs 1-4 are written in Hewlett-Packard Model 85 BASIC, but they can be converted to run on other computers with similar programming languages. The programming language for the Hewlett-Packard 9816, for example, is almost identical to that of the Model 85. Table 3-11 summarizes important differences between the two computer programming languages.

Programs 5-8 are written for an IBM PC/XT computer (and some PC compatibles) equipped with a Keithley Model 8573A IEEE-488 interface. Note that the program listings do not include lines 1-6 of the DECL.BAS file which must be added to the front of each program. See the Model 8573A Instruction Manual for details.

**NOTE**

These programs are intended only as examples, and they may not yield optimum accuracy with all measurement conditions.

#### 3.8.1 Test Configurations

Figure 3-16 shows the general test configuration necessary to run Programs 1, 2, 5, and 6. The necessary test fixture, cryostat, magnet, and magnet power supply are not shown on the diagram. Figure 3-17 shows the test configuration for Programs 2 and 7, and Figure 3-18 gives the configuration for Programs 4 and 8.

**Table 3-11. HP-85 and HP-9816 Programming Language Differences**

HP-85 Statement	HP-9816 Equivalent Statement(s)	Comments
CLEAR	C#=CHR\$(255) & CHR\$(75) H#=CHR\$(255) & CHR\$(84) OUTPUT KBD; C#; H#	Clear screen, home cursor
DISP	PRINT	Display variables or literals on CRT.
ENABLE INTR 7; 8 STATUS 7; 1; S	ENABLE INTR 7; 2 STATUS 7; 5; S	Enable SRQ interrupt Clear SRQ interrupt
DISP "MESSAGE" @INPUT A#	INPUT "MESSAGE"; A#	Prompt for and input variable
IF...THEN...ELSE...	IF...THEN... ... ELSE... ...	Conditional branching
ABORT 10 7	END IF ABORT 7	Send IFC

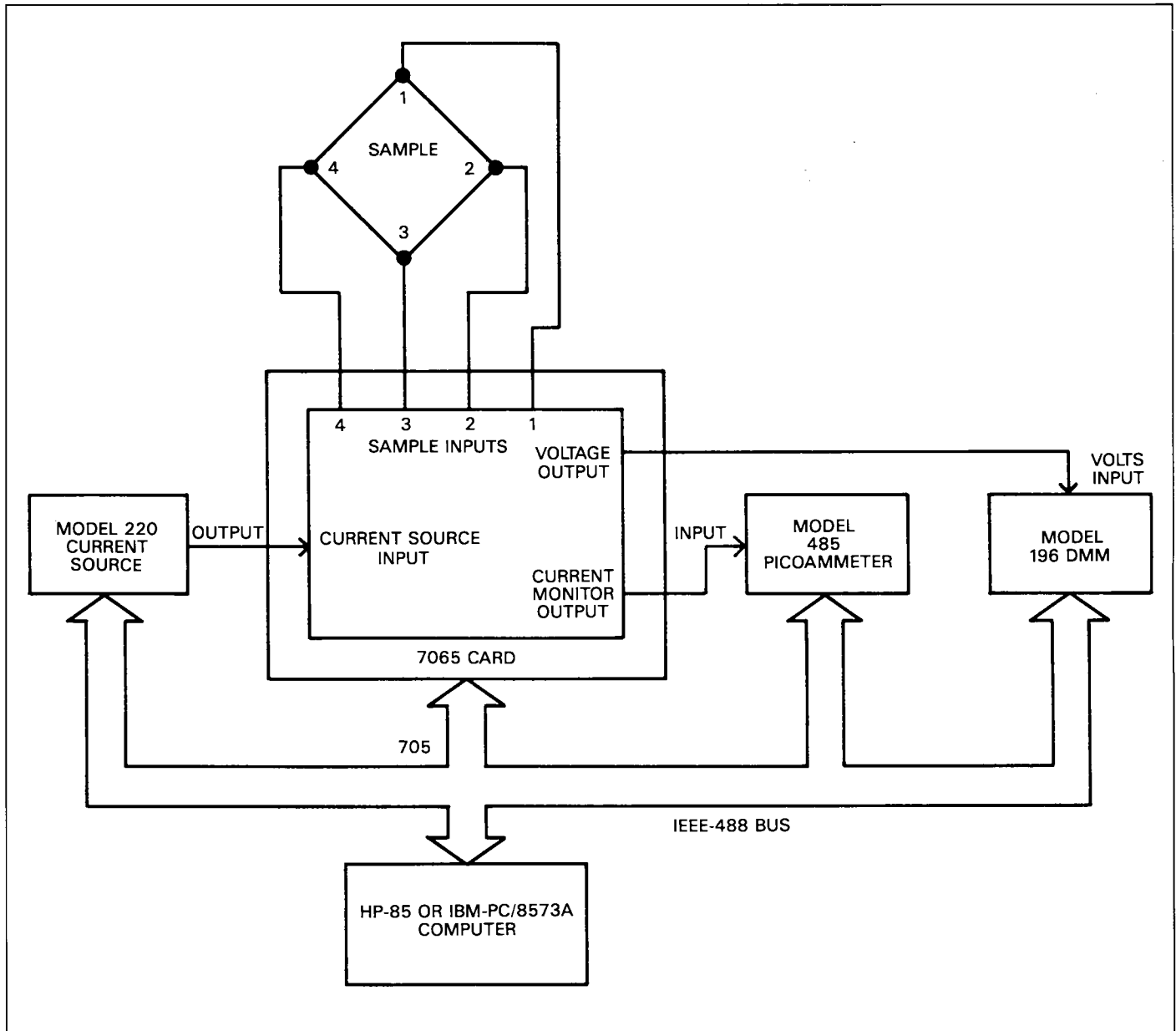

Figure 3-16. Test Configuration for Programs 1, 2, 5, and 6



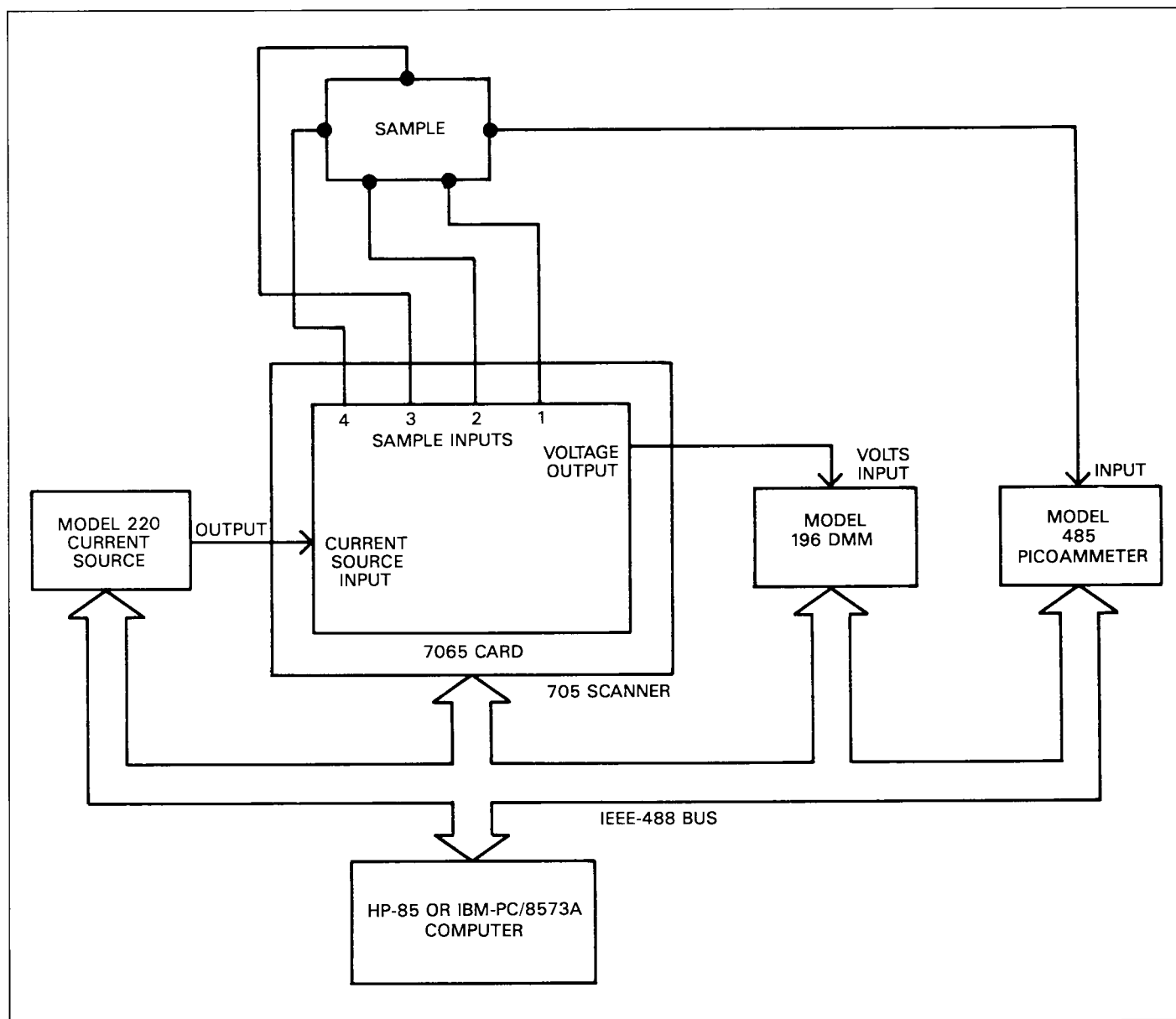

Figure 3-17. Test Configuration for Programs 3 and 7

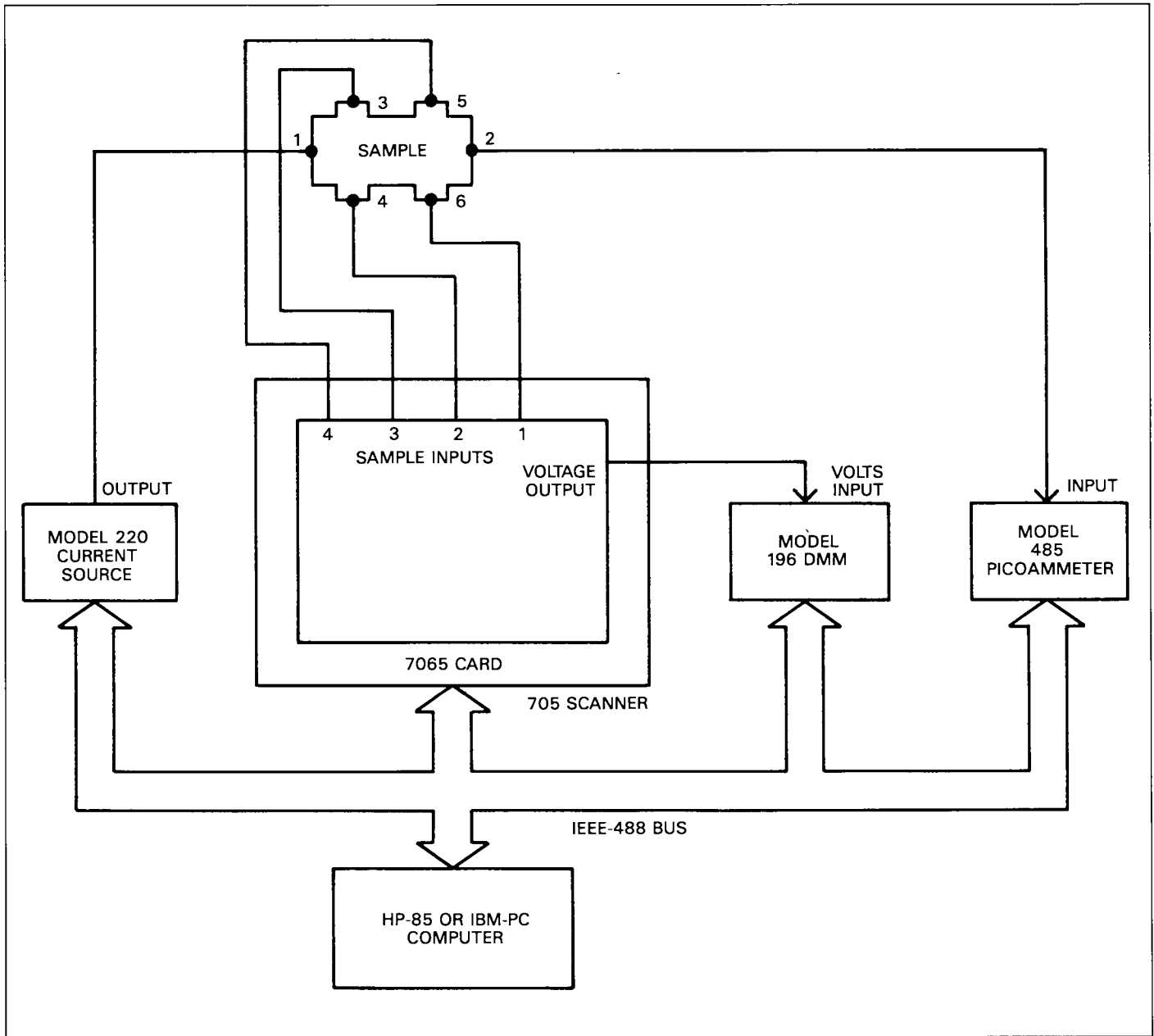

Figure 3-18. Test Configuration for Programs 4 and 8

---

## 3.8.2 Instrument Programming

The instruments in the test setups are programmed as follows:

**Model 196:** The DMM is programmed for autoranging in the DCV function. The instrument is programmed for the continuous trigger mode. Also the data format is configured to eliminate the prefix since only numeric information is required. Finally, the instrument is programmed to operate with 6½ digit, but with no filtering (filtering may be required in some instances, especially with low voltages).

**Model 220:** The current source is programmed for a voltage compliance of 10V. The current value is entered by the user to program the unit during the course of the program. For Programs 4 and 8 only, the current is reversed during the test by programming the Model 220 for a negative current of the same magnitude. Note that no provision is included for verifying that the positive and negative currents have

the same magnitude. Also, averaging is used in all programs except Programs 3 and 7.

**Model 485:** The continuous trigger mode is used and the prefix on the data string is eliminated by appropriate programming. The unit is zero checked at the start of each program for optimum accuracy.

**Model 705:** The scanner is placed in the matrix mode and then crosspoint 5,4 is programmed in accordance with the resistivity configuration desired by the user. Other crosspoints are programmed as required for the various measurements.

## 3.8.3 Program Listings

Programs 1 through 8 listings appear on the following pages.

---

**Program 1**  
**Hall Voltage Measurement (HP-85 Version)**

```
10 CLEAR
20 W=5000 ! FIVE SECOND DELAY
30 DIM A$(25),V(8)
40 P1=712 ! 220 ADDRESS IS 12
50 P2=707 ! 196 ADDRESS IS 7
60 P3=717 ! 705 ADDRESS IS 17
70 P4=722 ! 485 ADDRESS IS 22
80 DISP "THIS PROGRAM MEASURES"
90 DISP "HALL VOLTAGES AND COMPUTES"
100 DISP "THE COEFFICIENTS."
110 DISP "THE 7065 HALL CARD MUST"
120 DISP "BE IN CARD 1 LOCATION."
130 DISP
140 DISP "PRESS 'CONT'"
150 PAUSE
160 CLEAR
170 DISP "SELECT CARD RESISTIVITY SETUP"
180 DISP
190 DISP "<1> LOW RESISTIVITY"
200 DISP "<2> HIGH RESISTIVITY"
210 INPUT A
220 IF A<1 OR A>2 THEN 180
230 IF A=1 THEN Z$="N05:4X" ELSE Z$="C05:4X" ! 705 COMMAND STRING
240 DISP "INITIALIZING INSTRUMENTS"
250 REMOTE P1,P2,P3,P4 ! PUT INSTRUMENTS IN REMOTE
260 CLEAR 7 ! SEND DEVICE CLEAR
270 ! *** INITIALIZE 705 ***
280 OUTPUT P3 ;"A0X" ! MATRIX MODE
290 OUTPUT P3 ;Z$ ! PROGRAM RESISTIVITY
300 ! *** INITIALIZE 485 ***
310 OUTPUT P4 ;"R1X" ! 2NA RANGE
320 WAIT 1000 ! SETTLING TIME
330 OUTPUT P4 ;"C1X" ! ZERO CHECK ON
340 WAIT 1000 ! WAIT FOR READING TO SETTLE
350 OUTPUT P4 ;"Z1X" ! ENABLE REL
360 WAIT 1000 ! WAIT FOR REL TO COMPLETE
370 OUTPUT P4 ;"C0X" ! ZERO CHECK OFF
380 OUTPUT P4 ;"R061X" ! AUTORANGE,NO PREFIX
390 ! *** INITIALIZE 196 ***
400 OUTPUT P2 ;"R0F0S361X" ! AUTO,DCV,RATE,NO PREFIX
410 OUTPUT P1 ;"V10X" ! 220 10V COMPLIANCE.
420 DISP "220 CURRENT (500fA-100MA)"
430 INPUT I ! INPUT 220 CURRENT
440 I=ABS(I) ! POSITIVE CURRENT ONLY
450 IF I<5.E-13 OR I>.1 THEN 420
460 OUTPUT P1 ;"I";I;"X" ! PROGRAM 220 CURRENT
470 DISP "ENTER SAMPLE THICKNESS(CM)"
480 INPUT T ! INPUT SAMPLE THICKNESS
490 T=ABS(T)
500 DISP "ENTER FLUX DENSITY (GAUSS)"
```

---

---

**Program 1**  
**Hall Voltage Measurement (HP-85 Version), Continued**

```
510 INPUT B
520 B=ABS(B)
530 CLEAR
540 DISP "APPLY +B, PRESS 'CONT'"
550 PAUSE
560 ! ***MAIN MEASUREMENT LOOP***
570 RESTORE ! CLEAR DATA POINTER
580 DISP "MEASURING..."
590 FOR J=1 TO 8 ! LOOP FOR ALL 8 VOLTAGES
600 IF J=5 THEN RESTORE @ DISP "REVERSE FIELD (-B), PRESS 'CONT'" @ BEEP @ PAUSE
610 READ A$ ! READ 705 COMMAND STRING
620 OUTPUT P3 ;A$ ! CLOSE CROSSPOINTS
630 OUTPUT P1 ;"FIX" ! TURN ON 220 OUTPUT
640 WAIT W ! WAIT W MSEC FOR READING TO SETTLE
650 ENTER P2 ; V(J) ! GET 196 VOLTAGE READING
660 IF ABS(V(J))>8 THEN GOTO 960 ! CHECK VOLTAGE LIMITS
670 IF J=1 THEN ENTER P4 ; I1 ! GET 485 CURRENT READING
680 OUTPUT P1 ;"FOX" ! TURN OFF 220 OUTPUT
690 READ A$ ! READ 705 COMMAND STRING
700 OUTPUT P3 ;A$ ! OPEN CROSSPOINTS
710 NEXT J ! LOOP BACK FOR NEXT MEASUREMENT
720 BEEP
730 CLEAR
740 CLEAR 7 ! SEND DEVICE CLEAR
750 DISP "MEASUREMENTS COMPLETE"
760 DISP "MEASURED CURRENT";I1
770 FOR J=1 TO 8 ! LOOP AND DISPLAY MEASURED VOLTAGES
780 DISP "V";J;"=";V(J)
790 NEXT J
800 DISP
810 DISP "PRESS 'CONT' TO CALCULATE"
820 DISP "HALL COEFFICIENTS"
830 PAUSE
840 R1=25000000*T/(B*I1)*(V(2)-V(1)+V(5)-V(6))
850 R2=25000000*T/(B*I1)*(V(4)-V(3)+V(7)-V(8))
860 R3=(R1+R2)/2
870 DISP "RHC=";R1
880 DISP "RHD=";R2
890 DISP "RHAV=";R3
900 DISP
910 DISP "REPEAT TEST (Y/N)"
920 INPUT A$
930 IF A$[1,1]="Y" THEN CLEAR @ GOTO 240
940 GOTO 1090
950 ! *** ERROR CHECKING ***
960 CLEAR @ BEEP
970 CLEAR 7 ! SEND DEVICE CLEAR
980 DISP "SAMPLE VOLTAGE IS OVER"
990 DISP "8V 7065 LIMIT"
1000 DISP "DO YOU WISH TO:"
```

**Program 1**  
**Hall Voltage Measurement (HP-85 Version), Continued**

```
1010 DISP "(1) RESTART MEASUREMENT"  
1020 DISP "(2) ABORT THE PROGRAM"  
1030 DISP  
1040 INPUT A  
1050 IF A<1 OR A>2 THEN 1000  
1060 IF A=2 THEN 1090  
1070 CLEAR  
1080 GOTO 240  
1090 END  
1100 ! *** 705 COMMAND STRINGS ***  
1110 DATA "C02:1C01:3C03:4C04:2X"  
1120 DATA "N02:1N01:3N03:4N04:2X"  
1130 DATA "C02:3C01:1C03:4C04:2X"  
1140 DATA "N02:3N01:1N03:4N04:2X"  
1150 DATA "C02:2C01:4C03:1C04:3X"  
1160 DATA "N02:2N01:4N03:1N04:3X"  
1170 DATA "C02:4C01:2C03:1C04:3X"  
1180 DATA "N02:4N01:2N03:1N04:3X"
```

---

**Program 2**  
**Van der Pauw Resistivity (HP-85 Version)**

```
10 CLEAR
20 W=5000 ! FIVE SECOND DELAY
30 DIM A$(25),V(8)
40 P1=712 ! 220 ADDRESS IS 12
50 P2=707 ! 196 ADDRESS IS 7
60 P3=717 ! 705 ADDRESS IS 17
70 P4=722 ! 485 ADDRESS IS 22
80 DISP "THIS PROGRAM MEASURES"
90 DISP "RESISTIVITY OF"
100 DISP "VAN DER PAUW SAMPLES"
110 DISP "THE 7065 HALL CARD MUST"
120 DISP "BE IN CARD 1 LOCATION."
130 DISP
140 DISP "PRESS 'CONT'"
150 PAUSE
160 CLEAR
170 DISP "SELECT CARD RESISTIVITY SETUP"
180 DISP
190 DISP "(1) LOW RESISTIVITY"
200 DISP "(2) HIGH RESISTIVITY"
210 INPUT A
220 IF A<1 OR A>2 THEN 180
230 IF A=1 THEN Z$="N05:4X" ELSE Z$="C05:4X" ! 705 COMMAND STRING
240 DISP "INITIALIZING INSTRUMENTS"
250 REMOTE P1,P2,P3,P4 ! PUT INSTRUMENTS IN REMOTE
260 CLEAR 7 ! SEND DEVICE CLEAR
270 ! *** INITIALIZE 705 ***
280 OUTPUT P3 ;"A0X" ! MATRIX MODE
290 OUTPUT P3 ;Z$ ! PROGRAM RESISTIVITY
300 ! *** INITIALIZE 485 ***
310 OUTPUT P4 ;"R1X" ! 2NA RANGE
320 WAIT 1000 ! SETTLING TIME
330 OUTPUT P4 ;"C1X" ! ZERO CHECK ON
340 WAIT 1000
350 OUTPUT P4 ;"Z1X" ! ENABLE REL
360 WAIT 1000 ! WAIT FOR REL
370 OUTPUT P4 ;"C0X" ! ZERO CHECK OFF
380 OUTPUT P4 ;"R061X" ! AUTORANGE,NO PREFIX
390 ! *** INITIALIZE 196 ***
400 OUTPUT P2 ;"R0F0S361X" ! AUTO,DCV,RATE,NO PREFIX
410 OUTPUT P1 ;"V10X" ! 220 10V COMPLIANCE
420 DISP "220 CURRENT (500fA-100MA)"
430 INPUT I ! INPUT 220 CURRENT
440 I=ABS(I) ! POSITIVE CURRENT ONLY
450 OUTPUT P1 ;"I";I;"X" ! PROGRAM 220 CURRENT
460 DISP "ENTER SAMPLE THICKNESS(CM)"
470 INPUT T ! INPUT SAMPLE THICKNESS
480 T=ABS(T)
490 CLEAR
500 ! ***MAIN MEASUREMENT LOOP***
```

---

**Program 2**  
**Van der Pauw Resistivity (HP-85 Version), Continued**

```
510 RESTORE ! CLEAR DATA POINTER
520 DISP "MEASURING..."
530 FOR J=1 TO 8 ! LOOP FOR ALL 8 VOLTAGES
540 READ A$ ! READ 705 COMMAND STRING
550 OUTPUT P3 ;A$ ! CLOSE CROSSPOINTS
560 OUTPUT P1 ;"F1X" ! TURN ON 220 OUTPUT
570 WAIT W ! WAIT W MSEC FOR READING TO SETTLE
580 ENTER P2 ; V(J) ! GET 196 VOLTAGE READING
590 IF ABS(V(J))>8 THEN GOTO 890 ! CHECK VOLTAGE LIMITS
600 IF J=1 THEN ENTER P4 ; I1 ! GET 485 CURRENT READING
610 OUTPUT P1 ;"F0X" ! TURN OFF 220 OUTPUT
620 READ A$ ! READ 705 COMMAND STRING
630 OUTPUT P3 ;A$ ! OPEN CROSSPOINTS
640 NEXT J ! LOOP BACK FOR NEXT MEASUREMENT
650 BEEP
660 CLEAR
670 CLEAR 7 ! SEND DEVICE CLEAR
680 DISP "MEASUREMENTS COMPLETE"
690 DISP "MEASURED CURRENT";I1
700 FOR J=1 TO 8 ! LOOP AND DISPLAY MEASURED VOLTAGES
710 DISP "V";J;"=";V(J)
720 NEXT J
730 DISP
740 DISP "PRESS 'CONT' TO CALCULATE"
750 DISP "RESISTIVITY"
760 PAUSE
770 R1=1.1331*T/I1*(V(2)+V(4)-V(1)-V(3))
780 R2=1.1331*T/I1*(V(6)+V(8)-V(5)-V(7))
790 R3=(R1+R2)/2
800 DISP "PA=";R1
810 DISP "PB=";R2
820 DISP "PHAV=";R3
830 DISP
840 DISP "REPEAT TEST (Y/N)"
850 INPUT A$
860 IF A$[1,1]="Y" THEN CLEAR @ GOTO 240
870 GOTO 1020
880 ! *** ERROR CHECKING ***
890 CLEAR @ BEEP
900 CLEAR 7 ! SEND DEVICE CLEAR
910 DISP "SAMPLE VOLTAGE IS OVER"
920 DISP "8V 7065 LIMIT"
930 DISP "DO YOU WISH TO:"
940 DISP "(1) RESTART MEASUREMENT"
950 DISP "(2) ABORT THE PROGRAM"
960 DISP
970 INPUT A
980 IF A<1 OR A>2 THEN 930
990 IF A=2 THEN 1020
1000 CLEAR
```



---

**Program 2**  
**Van der Pauw Resistivity (HP-85 Version), Continued**

```
1010 GOTO 240
1020 END
1030 ! *** 705 COMMAND STRINGS ***
1040 DATA "C01:2C02:1C03:3C04:4X"
1050 DATA "N01:2N02:1N03:3N04:4X"
1060 DATA "C02:2C01:1C03:3C04:4X"
1070 DATA "N02:2N01:1N03:3N04:4X"
1080 DATA "C02:2C01:3C03:4C04:1X"
1090 DATA "N02:2N01:3N03:4N04:1X"
1100 DATA "C02:3C01:2C03:4C04:1X"
1110 DATA "N02:3N01:2N03:4N04:1X"
1120 DATA "C02:3C01:4C03:1C04:2X"
1130 DATA "N02:3N01:4N03:1N04:2X"
1140 DATA "C02:4C01:3C03:1C04:2X"
1150 DATA "N02:4N01:3N03:1N04:2X"
1160 DATA "C02:4C01:1C03:2C04:3X"
1170 DATA "N02:4N01:1N03:2N04:3X"
1180 DATA "C02:1C01:4C03:2C04:3X"
1190 DATA "N02:1N01:4N03:2N04:3X"
```

**Program 3**  
**Bar Sample Resistivity (HP-85 Version)**

```

10 CLEAR
20 W=5000 ! FIVE SECOND DELAY
30 P1=712 ! 220 ADDRESS IS 12
40 P2=707 ! 196 ADDRESS IS 7
50 P3=717 ! 705 ADDRESS IS 17
60 P4=722 ! 485 ADDRESS IS 22
70 DISP "THIS PROGRAM MEASURES"
80 DISP "RESISTIVITY OF BAR TYPE SAMPLES"
90 DISP "THE 7065 HALL CARD MUST"
100 DISP "BE IN CARD 1 LOCATION."
110 DISP
120 DISP "PRESS 'CONT'"
130 PAUSE
140 CLEAR
150 DISP "SELECT CARD RESISTIVITY SETUP"
160 DISP
170 DISP "<1> LOW RESISTIVITY"
180 DISP "<2> HIGH RESISTIVITY"
190 DISP
200 INPUT A
210 IF A<1 OR A>2 THEN 150
220 IF A=1 THEN Z$="N05:4X" ELSE Z$="C05:4X" ! 705 COMMAND STRING
230 DISP "INITIALIZING INSTRUMENTS"
240 REMOTE P1,P2,P3,P4 ! PUT INSTRUMENTS IN REMOTE
250 CLEAR 7 ! SEND DEVICE CLEAR
260 ! *** INITIALIZE 705 ***
270 OUTPUT P3 ;"A0X" ! MATRIX MODE
280 OUTPUT P3 ;Z$ ! PROGRAM RESISTIVITY
290 ! *** INITIALIZE 485 ***
300 OUTPUT P4 ;"R1X" ! 2NA RANGE
310 WAIT 1000 ! SETTLING TIME
320 OUTPUT P4 ;"C1X" ! ZERO CHECK ON
330 WAIT 1000
340 OUTPUT P4 ;"Z1X" ! ENABLE REL
350 WAIT 1000
360 OUTPUT P4 ;"C0X" ! ZERO CHECK OFF
370 OUTPUT P4 ;"R061X" ! AUTORANGE,NO PREFIX
380 ! *** INITIALIZE 196 ***
390 OUTPUT P2 ;"R0F0S361X" ! AUTO,DCV,RATE,NO PREFIX
400 OUTPUT P1 ;"V10X" ! 220 10V COMPLIANCE.
410 DISP "220 CURRENT (500fA-100MA)"
420 INPUT I ! INPUT 220 CURRENT
430 I=ABS(I)
440 IF I<5.E-13 OR I>.1 THEN 410
450 OUTPUT P1 ;"I";I;"X" ! PROGRAM 220 CURRENT
460 DISP "ENTER SAMPLE THICKNESS(CM)"
470 INPUT Z
480 Z=ABS(Z)
490 DISP "ENTER SAMPLE X DIMENSION (CM)"
500 INPUT X

```

---

**Program 3**  
**Bar Sample Resistivity (HP-85 Version), Continued**

```
510 X=ABS(X)
520 DISP "ENTER SAMPLE Y DIMENSION (CM)"
530 INPUT Y
540 Y=ABS(Y)
550 CLEAR
560 ! *** MAKE MEASUREMENTS ***
570 OUTPUT P3 ; "C02:4C03:1C04:2X" ! CLOSE CROSSPOINTS
580 OUTPUT P1 ; "F1X" ! TURN ON 220 OUTPUT
590 WAIT W ! WAIT FOR READING TO SETTLE
600 ENTER P2 ; V ! GET VOLTAGE READING FROM 196
610 IF ABS(V)>8 THEN 820 ! CHECK VOLTAGE LIMITS
620 ENTER P4 ; I1 ! GET CURRENT READING FROM 485
630 OUTPUT P1 ; "F0X" ! TURN OFF 220 OUTPUT
640 OUTPUT P3 ; "N02:4N03:1N04:2X" ! OPEN CROSSPOINTS
650 BEEP
660 CLEAR
670 CLEAR 7 ! SEND DEVICE CLEAR
680 DISP "MEASUREMENTS COMPLETE"
690 DISP "MEASURED CURRENT";I1
700 DISP "MEASURED VOLTAGE";V
710 DISP "PRESS 'CONT' TO CALCULATE"
720 DISP "RESISTIVITY"
730 PAUSE
740 P=V*Y*X/(X*I)
750 DISP "RESISTIVITY=";P;"OHM-CM"
760 DISP
770 DISP "REPEAT TEST (Y/N)"
780 INPUT A$
790 IF A$[1,1]="Y" THEN CLEAR @ GOTO 230
800 GOTO 950
810 ! *** ERROR CHECKING ***
820 CLEAR @ BEEP
830 CLEAR 7 ! SEND DEVICE CLEAR
840 DISP "SAMPLE VOLTAGE IS OVER"
850 DISP "8V 7065 LIMIT"
860 DISP "DO YOU WISH TO:"
870 DISP "(1) RESTART MEASUREMENT"
880 DISP "(2) ABORT THE PROGRAM"
890 DISP
900 INPUT A
910 IF A<1 OR A>2 THEN 860
920 IF A=2 THEN 950
930 CLEAR
940 GOTO 230
950 END
```

**Program 4**  
**6- and 8-Contact Sample Resistivity (HP-85 Version)**

```

10 CLEAR
20 W=5000 ! FIVE SECOND DELAY
30 DIM A$(25),V(4)
40 P1=712 ! 220 ADDRESS IS 12
50 P2=707 ! 196 ADDRESS IS 7
60 P3=717 ! 705 ADDRESS IS 17
70 P4=722 ! 485 ADDRESS IS 22
80 DISP "THIS PROGRAM MEASURES"
90 DISP "PARAMETERS TO CALCULATE"
100 DISP "RESISTIVITIES OF 6 OR"
110 DISP "8 CONTACT SAMPLES"
120 DISP "THE 7065 HALL CARD MUST"
130 DISP "BE IN CARD 1 LOCATION."
140 DISP
150 DISP "PRESS 'CONT'"
160 PAUSE
170 CLEAR
180 DISP "SELECT CARD RESISTIVITY SETUP"
190 DISP
200 DISP "(1) LOW RESISTIVITY"
210 DISP "(2) HIGH RESISTIVITY"
220 INPUT A
230 IF A<1 OR A>2 THEN 190
240 IF A=1 THEN Z$="N05:4X" ELSE Z$="C05:4X" ! 705 COMMAND STRING
250 DISP
260 DISP "INITIALIZING INSTRUMENTS"
270 REMOTE P1,P2,P3,P4 ! PUT INSTRUMENTS IN REMOTE
280 CLEAR 7 ! SEND DEVICE CLEAR
290 ! *** INITIALIZE 705 ***
300 OUTPUT P3 ;"A0X" ! MATRIX MODE
310 OUTPUT P3 ;Z$ ! PROGRAM RESISTIVITY
320 ! *** INITIALIZE 485 ***
330 OUTPUT P4 ;"R1X" ! 2NA RANGE
340 WAIT 1000 ! SETTLING TIME
350 OUTPUT P4 ;"C1X" ! ZERO CHECK ON
360 WAIT 1000
370 OUTPUT P4 ;"Z1X" ! ENABLE REL
380 WAIT 1000
390 OUTPUT P4 ;"C0X" ! ZERO CHECK OFF
400 OUTPUT P4 ;"R0G1X" ! AUTORANGE,NO PREFIX
410 ! *** INITIALIZE 196 ***
420 OUTPUT P2 ;"R0F0S3G1X" ! AUTORANGE,DCV,RATE,NO PREFIX
430 OUTPUT P1 ;"V10X" ! 220 10V COMPLIANCE
440 DISP "220 CURRENT (500fA-100MA)"
450 INPUT I ! INPUT 220 CURRENT
460 I=ABS(I)
470 IF I<5.E-13 OR I>.1 THEN 440
480 I2=-I ! DEFINE NEGATIVE CURRENT OF SAME MAGNITUDE
490 OUTPUT P1 ;"I";I;"X" ! PROGRAM 220 CURRENT
500 DISP "ENTER SAMPLE THICKNESS(CM)"

```

---

**Program 4**  
**6- and 8-Contact Sample Resistivity (HP-85 Version), Continued**

```
510 INPUT T
520 T=ABS(T)
530 DISP "ENTER SAMPLE WIDTH (CM)"
540 INPUT W1
550 W1=ABS(W1)
560 DISP "ENTER SAMPLE D1 DIMENSION(CM)"
570 INPUT D1
580 D1=ABS(D1)
590 DISP "ENTER SAMPLE D2 DIMENSION (CM)"
600 INPUT D2
610 D2=ABS(D2)
620 DISP "PRESS 'CONT' TO MEASURE"
630 PAUSE
640 ! ***MAIN MEASUREMENT LOOP***
650 RESTORE ! CLEAR DATA POINTER
660 DISP "MEASURING..."
670 FOR J=1 TO 4 ! LOOP FOR ALL FOUR VOLTAGES
680 IF J=3 THEN RESTORE @ OUTPUT P1 ; "I";I2;"X" ! REVERSE CURRENT
690 READ A$ ! READ 705 COMMAND STRING
700 OUTPUT P3 ;A$ ! CLOSE CROSSPOINTS
710 OUTPUT P1 ;"FIX" ! TURN ON 220 OUTPUT
720 WAIT W ! WAIT FOR READINGS TO SETTLE
730 ENTER P2 ; V(J) ! GET 196 READING
740 IF ABS(V(J))>8 THEN GOTO 1030 ! CHECK READING LIMITS
750 IF J=1 THEN ENTER P4 ; I1 ! INPUT 485 CURRENT READING
760 OUTPUT P1 ;"FOX" ! TURN OFF 220 OUTPUT
770 READ A$ ! READ 705 COMMAND STRING
780 OUTPUT P3 ;A$ ! OPEN CROSSPOINTS
790 NEXT J ! LOOP BACK FOR NEXT MEASUREMENT
800 BEEP
810 CLEAR
820 CLEAR 7 ! SEND DEVICE CLEAR
830 DISP "MEASUREMENTS COMPLETE"
840 DISP "MEASURED CURRENT";I1
850 FOR J=1 TO 4 ! DISPLAY MEASURED VOLTAGES
860 DISP "V";J;"=";V(J)
870 NEXT J
880 DISP
890 DISP "PRESS 'CONT' TO CALCULATE"
900 DISP "RESISTIVITIES"
910 PAUSE
920 P1=W1*T/(2*I1*D1)*(V(1)-V(3))
930 P2=W1*T/(2*I1*D2)*(V(2)-V(4))
940 P3=(P1+P2)/2
950 DISP "pA=";P1
960 DISP "pB=";P2
970 DISP "pAVG=";P3
980 DISP "REPEAT TEST (Y/N)"
990 INPUT A$
1000 IF A$[1,1]="Y" THEN CLEAR @ GOTO 260
```

**Program 4**  
**6- and 8-Contact Sample Resistivity (HP-85 Version), Continued**

```
1010 GOTO 1160
1020 ! *** ERROR CHECKING ***
1030 CLEAR @ BEEP
1040 CLEAR 7 ! SEND DEVICE CLEAR
1050 DISP "SAMPLE VOLTAGE IS OVER"
1060 DISP "8V 7065 LIMIT"
1070 DISP "DO YOU WISH TO:"
1080 DISP "(1) RESTART MEASUREMENT"
1090 DISP "(2) ABORT THE PROGRAM"
1100 DISP
1110 INPUT A
1120 IF A<1 OR A>2 THEN 1070
1130 IF A=2 THEN 1160
1140 CLEAR
1150 GOTO 260
1160 END
1170 ! *** 705 COMMAND STRINGS ***
1180 DATA "C03:2C04:1X"
1190 DATA "N03:2N04:1X"
1200 DATA "C03:3C04:4X"
1210 DATA "N03:3N04:4X"
```

---



---

**Program 5**  
**Hall Voltage Measurement (IBM-PC/8573A Version)**

```

10 CLS
20 DELAY=5000 'FIVE SECOND DELAY
30 DIM V(8)
40 D$= CHR$(20) ' DEFINE DCL COMMAND BYTE
50 P1%=12:P2%=7:P3%=17:P4%=22 'DEFINE INSTRUMENT PRIMARY ADDRESSES
60 NA$="GPIB0":CALL IBFIND(NA$,BRD0%) 'FIND BOARD DESCRIPTOR
70 NA$="DEV1":CALL IBFIND(NA$,M220%) 'FIND 220 DESCRIPTOR
80 NA$="DEV2":CALL IBFIND(NA$,M196%) 'FIND 196 DESCRIPTOR
90 NA$="DEV3":CALL IBFIND(NA$,M705%) 'FIND 705 DESCRIPTOR
100 NA$="DEV4":CALL IBFIND(NA$,M485%) 'FIND 485 DESCRIPTOR
110 CALL IBPAD(M220%,P1%) 'SET 220 PRIMARY ADDRESS
120 CALL IBPAD(M196%,P2%) 'SET 196 PRIMARY ADDRESS
130 CALL IBPAD(M705%,P3%) 'SET 705 PRIMARY ADDRESS
140 CALL IBPAD(M485%,P4%) 'SET 485 PRIMARY ADDRESS
150 PRINT"THIS PROGRAM MEASURES HALL VOLTAGES AND COMPUTES THE"
160 PRINT"COEFFICIENTS. THE HALL CARD MUST BE IN THE CARD 1 LOCATION"
170 PRINT
180 PRINT"PRESS ANY KEY TO CONTINUE"
190 A$=INKEY$:IF A$= "" THEN 190
200 CLS
210 PRINT"SELECT CARD RESISTIVITY SETUP"
220 PRINT
230 PRINT"(1) LOW RESISTIVITY"
240 PRINT"(2) HIGH RESISTIVITY"
250 INPUT A
260 IF A<1 OR A>2 THEN 210
270 IF A=1 THEN Z$="N05:4X" ELSE Z$="C05:4X" '705 COMMAND STRING
280 PRINT"INITIALIZING INSTRUMENTS"
290 V%=1:CALL IBSRE(BRD0%,V%) ' SEND REMOTE ENABLE
300 CALL IBCMD(BRD0%,D$) ' SEND DEVICE CLEAR
310 REM ***** INITIALIZE THE MODEL 705 *****
320 C$="A0X":CALL IBWRT(M705%,C$) ' PUT 705 IN MATRIX MODE
330 CALL IBWRT(M705%,Z$) ' PROGRAM CARD RESISTIVITY SETUP
340 REM ***** INITIALIZE THE 485 *****
350 C$="R1X":CALL IBWRT(M485%,C$) ' SELECT 2NA RANGE
360 FOR I = 1 TO 1000:NEXT I ' SETTLING TIME
370 C$="C1X":CALL IBWRT(M485%,C$) ' ZERO CHECK ON
380 FOR I= 1 TO 1000:NEXT I
390 C$="Z1X":CALL IBWRT(M485%,C$) ' REL ON
400 FOR I = 1 TO 1000:NEXT I
410 C$="C0X":CALL IBWRT(M485%,C$) ' ZERO CHECK OFF
420 C$="R0G1X":CALL IBWRT(M485%,C$) 'AUTORANGE,NO PREFIX
430 REM ***** INITIALIZE THE 196 *****
440 C$="R0F0S3G1X":CALL IBWRT(M196%,C$) 'AUTO,DCV,RATE,NO PREFIX
450 REM **** INITIALIZE THE 220 *****
460 C$="V10X":CALL IBWRT(M220%,C$) ' 220 10V COMPLIANCE
470 INPUT"220 CURRENT (500FA-100MA)";I 'INPUT 220 CURRENT
480 I=ABS(I) 'POSITIVE CURRENT ONLY
490 IF I< 5E-13 OR I>.1 THEN 470
500 C$="I"+STR$(I)+"X":CALL IBWRT(M220%,C$) 'PROGRAM 220 CURRENT

```

---

**Program 5  
Hall Voltage Measurement (IBM-PC/8573A Version), Continued**

```
510 INPUT"ENTER SAMPLE THICKNESS (CM)";T
520 T=ABS(T)
530 INPUT"ENTER FLUX DENSITY (GAUSS)";B
540 B=ABS(B)
550 CLS
560 PRINT"APPLY +B, PRESS ANY KEY TO CONTINUE"
570 A$=INKEY$:IF A$="" THEN 570
580 REM ***** MAIN MEASUREMENT LOOP *****
590 RESTORE
600 CLS
610 PRINT"MEASURING..."
620 FOR J=1 TO 8
630 IF J<>5 THEN 660
640 RESTORE:PRINT"REVERSE FIELD (-B), PRESS ANY KEY TO CONTINUE":BEEP
650 A$=INKEY$:IF A$="" THEN 650
660 READ C$:CALL IBWRT(M705%,C$) 'CLOSE CROSSPOINTS
670 C$="FIX":CALL IBWRT(M220%,C$) 'TURN ON 220 OUTPUT
680 FOR I=1 TO DELAY:NEXT 'WAIT FOR READING TO SETTLE
690 RD$=SPACE$(25):CALL IBRD(M196%,RD$) 'GET 196 READING
700 V(J)=VAL(RD$) 'CONVERT STRING TO NUMERIC, PUT IN ARRAY
710 IF ABS(V(J))>8 THEN 990 'CHECK VOLTAGE LIMITS
720 IF J<>1 THEN 750
730 RD$=SPACE$(25):CALL IBRD(M485%,RD$) 'GET 485 CURRENT READING
740 I1=VAL(RD$) 'CONVERT READING TO NUMERIC
750 C$="F0X":CALL IBWRT(M220%,C$) 'TURN OFF 220 OUTPUT
760 READ C$ 'READ 705 COMMAND STRING
770 CALL IBWRT(M705%,C$) 'OPEN CROSSPOINTS
780 NEXT J 'LOOP BACK FOR NEXT POINT
790 BEEP
800 CALL IBCMD(BRD0%,D$) 'SEND DEVICE CLEAR
810 CLS
820 PRINT"MEASUREMENTS COMPLETE."
830 PRINT"MEASURED CURRENT";I1
840 FOR J=1 TO 8 'LOOP AND DISPLAY MEASURED VOLTAGES
850 PRINT"V";J;"=";V(J)
860 NEXT J
870 PRINT"PRESS ANY KEY TO CALCULATE HALL COEFFICIENTS"
880 A$=INKEY$:IF A$="" THEN 880
890 RHC=2.5E+07*T/(B*I1)*(V(2)-V(1)+V(5)-V(6))
900 RHD=2.5E+07*T/(B*I1)*(V(4)-V(3)+V(7)-V(8))
910 RHAUG=(RHC+RHD)/2
920 PRINT"RHC=";RHC
930 PRINT"RHD=";RHD
940 PRINT"RHAUG=";RHAUG
950 PRINT
960 INPUT"REPEAT TEST (Y/N)";A$
970 IF LEFT$(A$,1)="Y" THEN CLS:GOTO 280
980 GOTO 1100
990 CLS:BEEP
1000 CALL IBCMD(BRD0%,D$) 'SEND DEVICE CLEAR
```



---

---

**Program 5**  
**Hall Voltage Measurement (IBM-PC/8573A Version), Continued**

```
1010 PRINT "SAMPLE VOLTAGE IS OVER 8V 7065 LIMIT"
1020 PRINT "DO YOU WISH TO:"
1030 PRINT "(1) RESTART THE MEASUREMENT"
1040 PRINT "(2) ABORT THE PROGRAM"
1050 PRINT
1060 INPUT A
1070 IF A<1 OR A>2 THEN 1020
1080 IF A=2 THEN 1100
1090 CLS:GOTO 280
1100 END 'END PROGRAM
1110 REM ***** 705 COMMAND STRINGS *****
1120 DATA "C02:1C01:3C03:4C04:2X"
1130 DATA "N02:1N01:3N03:4N04:2X"
1140 DATA "C02:3C01:1C03:4C04:2X"
1150 DATA "N02:3N01:1N03:4N04:2X"
1160 DATA "C02:2C01:4C03:1C04:3X"
1170 DATA "N02:2N01:4N03:1N04:3X"
1180 DATA "C02:4C01:2C03:1C04:3X"
1190 DATA "N02:4N01:2N03:1N04:3X"
```

**Program 6  
Van der Pauw Resistivity (IBM-PC/8573A Version)**

```
10 CLS
20 DELAY=5000 'FIVE SECOND DELAY
30 DIM V(8)
40 D$=CHR$(20) ' DEFINE DCL BYTE
50 P1%=12:P2%=7:P3%=17:P4%=22 'DEFINE INSTRUMENT PRIMARY ADDRESSES
60 NA$="6PIB0":CALL IBFIND(NA$,BRD0%) 'FIND BOARD DESCRIPTOR
70 NA$="DEV1":CALL IBFIND(NA$,M220%) 'FIND 220 DESCRIPTOR
80 NA$="DEV2":CALL IBFIND(NA$,M196%) 'FIND 196 DESCRIPTOR
90 NA$="DEV3":CALL IBFIND(NA$,M705%) 'FIND 705 DESCRIPTOR
100 NA$="DEV4":CALL IBFIND(NA$,M485%) 'FIND 485 DESCRIPTOR
110 CALL IBPAD(M220%,P1%) 'SET 220 PRIMARY ADDRESS
120 CALL IBPAD(M196%,P2%) 'SET 196 PRIMARY ADDRESS
130 CALL IBPAD(M705%,P3%) 'SET 705 PRIMARY ADDRESS
140 CALL IBPAD(M485%,P4%) 'SET 485 PRIMARY ADDRESS
150 PRINT"THIS PROGRAM MEASURES THE RESISTIVITY OF VAN DER PAUW SAMPLES"
160 PRINT"THE HALL CARD MUST BE IN THE CARD 1 LOCATION"
170 PRINT
180 PRINT"PRESS ANY KEY TO CONTINUE"
190 A$=INKEY$:IF A$= "" THEN 190
200 CLS
210 PRINT"SELECT CARD RESISTIVITY SETUP"
220 PRINT
230 PRINT"(1) LOW RESISTIVITY"
240 PRINT"(2) HIGH RESISTIVITY"
250 INPUT A
260 IF A<1 OR A>2 THEN 210
270 IF A=1 THEN Z$="N05:4X" ELSE Z$="C05:4X" '705 COMMAND STRING
280 PRINT"INITIALIZING INSTRUMENTS"
290 V%=1:CALL IBSRE(BRD0%,V%) ' SEND REMOTE ENABLE
300 CALL IBCMD(BRD0%,D$) ' SEND DEVICE CLEAR
310 REM **** INITIALIZE THE MODEL 705 *****
320 C$="A0X":CALL IBWRT(M705%,C$) ' PUT 705 IN MATRIX MODE
330 CALL IBWRT(M705%,Z$) ' PROGRAM CARD RESISTIVITY SETUP
340 REM ***** INITIALIZE THE 485 *****
350 C$="R1X":CALL IBWRT(M485%,C$) ' SELECT 2NA RANGE
360 FOR I = 1 TO 1000:NEXT I ' SETTLING TIME
370 C$="C1X":CALL IBWRT(M485%,C$) ' ZERO CHECK ON
380 FOR I= 1 TO 1000:NEXT I
390 C$="Z1X":CALL IBWRT(M485%,C$) ' REL ON
400 FOR I = 1 TO 1000:NEXT I
410 C$="C0X":CALL IBWRT(M485%,C$) ' ZERO CHECK OFF
420 C$="R0G1X":CALL IBWRT(M485%,C$) 'AUTORANGE,NO PREFIX
430 REM ***** INITIALIZE THE 196 *****
440 C$="R0F0S3G1X":CALL IBWRT(M196%,C$) 'AUTO,DCV,RATE,NO PREFIX
450 REM **** INITIALIZE THE 220 *****
460 C$="V10X":CALL IBWRT(M220%,C$) ' 220 10V COMPLIANCE
470 INPUT"220 CURRENT (500FA-100MA)";I 'INPUT 220 CURRENT
480 I=ABS(I) 'POSITIVE CURRENT ONLY
490 IF I< 5E-13 OR I>.1 THEN 470
500 C$="I"+STR$(I)+"X":CALL IBWRT(M220%,C$) 'PROGRAM 220 CURRENT
```

---

**Program 6**  
**Van der Pauw Resistivity (IBM-PC/8573A Version), Continued**

```
510 INPUT"ENTER SAMPLE THICKNESS (CM)";T
520 T=ABS(T)
530 CLS
540 REM ***** MAIN MEASUREMENT LOOP *****
550 RESTORE
560 CLS
570 PRINT"MEASURING..."
580 FOR J=1 TO 8
590 READ C$:CALL IBWRT(M705%,C$) 'CLOSE CROSSPOINTS
600 C$="F1X":CALL IBWRT(M220%,C$) 'TURN ON 220 OUTPUT
610 FOR I=1 TO DELAY:NEXT 'WAIT FOR READING TO SETTLE
620 RD$=SPACE$(25):CALL IBRD(M196%,RD$) 'GET 196 READING
630 V(J)=VAL(RD$) 'CONVERT STRING TO NUMERIC, PUT IN ARRAY
640 IF ABS(V(J))>8 THEN 920 'CHECK VOLTAGE LIMITS
650 IF J<>1 THEN 680
660 RD$=SPACE$(25):CALL IBRD(M485%,RD$) 'GET 485 CURRENT READING
670 I1=VAL(RD$) 'CONVERT READING TO NUMERIC
680 C$="F0X":CALL IBWRT(M220%,C$) 'TURN OFF 220 OUTPUT
690 READ C$ 'READ 705 COMMAND STRING
700 CALL IBWRT(M705%,C$) 'OPEN CROSSPOINTS
710 NEXT J 'LOOP BACK FOR NEXT POINT
720 BEEP
730 CLS
740 CALL IBCMD(BRD0%,D$) 'SEND DEVICE CLEAR
750 PRINT"MEASUREMENTS COMPLETE."
760 PRINT"MEASURED CURRENT";I1
770 FOR J=1 TO 8 'LOOP AND DISPLAY MEASURED VOLTAGES
780 PRINT"V";J;"=";V(J)
790 NEXT J
800 PRINT"PRESS ANY KEY TO CALCULATE RESISTIVITY OF SAMPLE"
810 A$=INKEY$:IF A$="" THEN 810
820 PA=1.1331*T/I1*(V(2)+V(4)-V(1)-V(3))
830 PB=1.1331*T/I1*(V(6)+V(8)-V(5)-V(7))
840 PAVG=(PA+PB)/2
850 PRINT"PA=";PA
860 PRINT"PB=";PB
870 PRINT"PAVG=";PAVG
880 PRINT
890 INPUT"REPEAT TEST (Y/N)";A$
900 IF LEFT$(A$,1)="Y" THEN CLS:GOTO 280
910 GOTO 1030
920 CLS:BEEP
930 CALL IBCMD(BRD0%,D$) 'SEND DEVICE CLEAR
940 PRINT"SAMPLE VOLTAGE IS OVER 8V 7065 LIMIT"
950 PRINT"DO YOU WISH TO:"
960 PRINT"(1) RESTART THE MEASUREMENT"
970 PRINT"(2) ABORT THE PROGRAM"
980 PRINT
990 INPUT A
1000 IF A<1 OR A>2 THEN 950
```

**Program 6**  
**Van der Pauw Resistivity (IBM-PC/8573A Version), Continued**

```
1010 IF A=2 THEN 1030
1020 CLS:GOTO 280
1030 END 'END PROGRAM
1040 REM ***** 705 COMMAND STRINGS *****
1050 DATA "C01:2C02:1C03:3C04:4X"
1060 DATA "N01:2N02:1N03:3N04:4X"
1070 DATA "C02:2C01:1C03:3C04:4X"
1080 DATA "N02:2N01:1N03:3N04:4X"
1090 DATA "C02:2C01:3C03:4C04:1X"
1100 DATA "N02:2N01:3N03:4N04:1X"
1110 DATA "C02:3C01:2C03:4C04:1X"
1120 DATA "N02:3N01:2N03:4N04:1X"
1130 DATA "C02:3C01:4C03:1C04:2X"
1140 DATA "N02:3N01:4N03:1N04:2X"
1150 DATA "C02:4C01:3C03:1C04:2X"
1160 DATA "N02:4N01:3N03:1N04:2X"
1170 DATA "C02:4C01:1C03:2C04:3X"
1180 DATA "N02:4N01:1N03:2N04:3X"
1190 DATA "C02:1C01:4C03:2C04:3X"
1200 DATA "N02:1N01:4N03:2N04:3X"
```

---

**Program 7**  
**Bar Sample Resistivity (IBM-PC/8573A Version)**

```
10 CLS
20 DELAY=5000 'FIVE SECOND DELAY
30 P1%=12:P2%=7:P3%=17:P4%=22 'DEFINE INSTRUMENT PRIMARY ADDRESSES
40 D$=CHR$(20) ' DEFINE DCL BYTE
50 NA$="GPIB0":CALL IBFIND(NA$,BRD0%) 'FIND BOARD DESCRIPTOR
60 NA$="DEV1":CALL IBFIND(NA$,M220%) 'FIND 220 DESCRIPTOR
70 NA$="DEV2":CALL IBFIND(NA$,M196%) 'FIND 196 DESCRIPTOR
80 NA$="DEV3":CALL IBFIND(NA$,M705%) 'FIND 705 DESCRIPTOR
90 NA$="DEV4":CALL IBFIND(NA$,M485%) 'FIND 485 DESCRIPTOR
100 CALL IBPAD(M220%,P1%) 'SET 220 PRIMARY ADDRESS
110 CALL IBPAD(M196%,P2%) 'SET 196 PRIMARY ADDRESS
120 CALL IBPAD(M705%,P3%) 'SET 705 PRIMARY ADDRESS
130 CALL IBPAD(M485%,P4%) 'SET 485 PRIMARY ADDRESS
140 PRINT"THIS PROGRAM MEASURES THE RESISTIVITY OF BAR TYPE SAMPLES"
150 PRINT"THE HALL CARD MUST BE IN THE CARD 1 LOCATION"
160 PRINT
170 PRINT"PRESS ANY KEY TO CONTINUE"
180 A$=INKEY$:IF A$= "" THEN 180
190 CLS
200 PRINT"SELECT CARD RESISTIVITY SETUP"
210 PRINT
220 PRINT"(1) LOW RESISTIVITY"
230 PRINT"(2) HIGH RESISTIVITY"
240 INPUT A
250 IF A<1 OR A>2 THEN 200
260 IF A=1 THEN Z$="N05:4X" ELSE Z$="C05:4X" '705 COMMAND STRING
270 PRINT"INITIALIZING INSTRUMENTS"
280 V%=1:CALL IBSRE(BRD0%,V%) ' SEND REMOTE ENABLE
290 CALL IBCMD(BRD0%,D$) ' SEND DEVICE CLEAR
300 REM **** INITIALIZE THE MODEL 705 *****
310 C$="A0X":CALL IBWRT(M705%,C$) ' PUT 705 IN MATRIX MODE
320 CALL IBWRT(M705%,Z$) ' PROGRAM CARD RESISTIVITY SETUP
330 REM ***** INITIALIZE THE 485 *****
340 C$="R1X":CALL IBWRT(M485%,C$) ' SELECT 2NA RANGE
350 FOR I = 1 TO 1000:NEXT I ' SETTLING TIME
360 C$="C1X":CALL IBWRT(M485%,C$) ' ZERO CHECK ON
370 FOR I= 1 TO 1000:NEXT I
380 C$="Z1X":CALL IBWRT(M485%,C$) ' REL ON
390 FOR I = 1 TO 1000:NEXT I
400 C$="C0X":CALL IBWRT(M485%,C$) ' ZERO CHECK OFF
410 C$="R0G1X":CALL IBWRT(M485%,C$) 'AUTORANGE,NO PREFIX
420 REM ***** INITIALIZE THE 196 *****
430 C$="R0F0S361X":CALL IBWRT(M196%,C$) 'AUTO,DCV,RATE,NO PREFIX
440 REM **** INITIALIZE THE 220 *****
450 C$="V10X":CALL IBWRT(M220%,C$) ' 220 10V COMPLIANCE
460 INPUT"220 CURRENT (500FA-100MA)";I 'INPUT 220 CURRENT
470 I=ABS(I) 'POSITIVE CURRENT ONLY
480 IF I< 5E-13 OR I>.1 THEN 460
490 C$="I"+STR$(I)+"X":CALL IBWRT(M220%,C$) 'PROGRAM 220 CURRENT
500 INPUT"ENTER SAMPLE THICKNESS (CM)";Z
```

---

**Program 7**  
**Bar Sample Resistivity (IBM-PC/8573A Version), Continued**

```
510 Z=ABS(Z)
520 INPUT"ENTER SAMPLE X DIMENSION (CM)";X
530 X=ABS(X)
540 INPUT"ENTER SAMPLE Y DIMENSION (CM)";Y
550 Y=ABS(Y)
560 REM ***** MAKE MEASUREMENTS *****
570 CLS
580 PRINT"MEASURING..."
590 C$="C02:4C03:1C04:2X":CALL IBWRT(M705%,C$) 'CLOSE CROSSPOINTS
600 C$="FIX":CALL IBWRT(M220%,C$) 'TURN ON 220 OUTPUT
610 FOR I=1 TO DELAY:NEXT 'WAIT FOR READING TO SETTLE
620 RD$=SPACE$(25):CALL IBRD(M196%,RD$) 'GET 196 READING
630 V= VAL(RD$) 'CONVERT STRING TO NUMERIC
640 IF ABS(V)>8 THEN 830 'CHECK VOLTAGE LIMITS
650 RD$=SPACE$(25):CALL IBRD(M485%,RD$) 'GET 485 CURRENT READING
660 I1=VAL(RD$) 'CONVERT READING TO NUMERIC
670 C$="F0X":CALL IBWRT(M220%,C$) 'TURN OFF 220 OUTPUT
680 C$="N02:4N03:1N04:2X":CALL IBWRT(M705%,C$) 'OPEN CROSSPOINTS
690 BEEP
700 CLS
710 CALL IBCMD(BRD0%,D$) 'SEND DEVICE CLEAR
720 PRINT"MEASUREMENTS COMPLETE."
730 PRINT"MEASURED CURRENT";I1
740 PRINT"MEASURED VOLTAGE";V
750 PRINT"PRESS ANY KEY TO CALCULATE RESISTIVITY"
760 A$=INKEY$:IF A$="" THEN 760
770 P=V*Y*X/(X*I1) 'CALCULATE RESISTIVITY
780 PRINT"RESISTIVITY=";P;"OHM-CM"
790 PRINT
800 INPUT"REPEAT TEST (Y/N)";A$
810 IF LEFT$(A$,1)="Y" THEN CLS:GOTO 270
820 GOTO 940
830 CLS:BEEP
840 CALL IBCMD(BRD0%,D$) 'SEND DEVICE CLEAR
850 PRINT"SAMPLE VOLTAGE IS OVER 8V 7065 LIMIT"
860 PRINT"DO YOU WISH TO:"
870 PRINT"(1) RESTART THE MEASUREMENT"
880 PRINT"(2) ABORT THE PROGRAM"
890 PRINT
900 INPUT A
910 IF A<1 OR A>2 THEN 860
920 IF A=2 THEN 940
930 CLS:GOTO 270
940 END 'END PROGRAM
```

---

**Program 8**  
**6- and 8-Contact Sample Resistivity (IBM-PC/8573A Version)**

```
10 CLS
20 DELAY=5000 'FIVE SECOND DELAY
30 DIM V(4)
40 D$=CHR$(20) ' DEFINE DCL COMMAND BYTE
50 P1%=12:P2%=7:P3%=17:P4%=22 'DEFINE INSTRUMENT PRIMARY ADDRESSES
60 NA$="GPIB0":CALL IBFIND(NA$,BRD0%) 'FIND BOARD DESCRIPTOR
70 NA$="DEV1":CALL IBFIND(NA$,M220%) 'FIND 220 DESCRIPTOR
80 NA$="DEV2":CALL IBFIND(NA$,M196%) 'FIND 196 DESCRIPTOR
90 NA$="DEV3":CALL IBFIND(NA$,M705%) 'FIND 705 DESCRIPTOR
100 NA$="DEV4":CALL IBFIND(NA$,M485%) 'FIND 485 DESCRIPTOR
110 CALL IBPAD(M220%,P1%) 'SET 220 PRIMARY ADDRESS
120 CALL IBPAD(M196%,P2%) 'SET 196 PRIMARY ADDRESS
130 CALL IBPAD(M705%,P3%) 'SET 705 PRIMARY ADDRESS
140 CALL IBPAD(M485%,P4%) 'SET 485 PRIMARY ADDRESS
150 PRINT"THIS PROGRAM MEASURES PARAMETERS TO CALCULATE THE RESISTIVITY"
160 PRINT"OF 6- OR 8-CONTACT SAMPLES."
170 PRINT"THE HALL CARD MUST BE IN THE CARD 1 LOCATION"
180 PRINT
190 PRINT"PRESS ANY KEY TO CONTINUE"
200 A$=INKEY$:IF A$= "" THEN 200
210 CLS
220 PRINT"SELECT CARD RESISTIVITY SETUP"
230 PRINT
240 PRINT"(1) LOW RESISTIVITY"
250 PRINT"(2) HIGH RESISTIVITY"
260 INPUT A
270 IF A<1 OR A>2 THEN 220
280 IF A=1 THEN Z$="N05:4X" ELSE Z$="C05:4X" '705 COMMAND STRING
290 PRINT"INITIALIZING INSTRUMENTS"
300 V%=1:CALL IBSRE(BRD0%,V%) ' SEND REMOTE ENABLE
310 CALL IBCMD(BRD0%,D$) ' SEND DEVICE CLEAR
320 REM **** INITIALIZE THE MODEL 705 *****
330 C$="A0X":CALL IBWRT(M705%,C$) ' PUT 705 IN MATRIX MODE
340 CALL IBWRT(M705%,Z$) ' PROGRAM CARD RESISTIVITY SETUP
350 REM ***** INITIALIZE THE 485 *****
360 C$="R1X":CALL IBWRT(M485%,C$) ' SELECT 2NA RANGE
370 FOR I = 1 TO 1000:NEXT I ' SETTLING TIME
380 C$="C1X":CALL IBWRT(M485%,C$) ' ZERO CHECK ON
390 FOR I= 1 TO 1000:NEXT I
400 C$="Z1X":CALL IBWRT(M485%,C$) ' REL ON
410 FOR I = 1 TO 1000:NEXT I
420 C$="C0X":CALL IBWRT(M485%,C$) ' ZERO CHECK OFF
430 C$="R0G1X":CALL IBWRT(M485%,C$) 'AUTORANGE,NO PREFIX
440 REM ***** INITIALIZE THE 196 *****
450 C$="R0F053G1X":CALL IBWRT(M196%,C$) 'AUTO,DCV,RATE,NO PREFIX
460 REM **** INITIALIZE THE 220 *****
470 C$="V10X":CALL IBWRT(M220%,C$) ' 220 10V COMPLIANCE
480 INPUT"220 CURRENT (500FA-100MA)";I 'INPUT 220 CURRENT
490 I=ABS(I)
500 IF I< 5E-13 OR I>.1 THEN 480
```

---

**Program 8**  
**6- and 8-Contact Sample Resistivity (IBM-PC/8573A Version), Continued**

```
510 I2=-I
520 C$="I"+STR$(I)+"X":CALL IBWRT(M220%,C$) 'PROGRAM 220 CURRENT
530 INPUT"ENTER SAMPLE THICKNESS (CM)";T
540 T=ABS(T)
550 INPUT"SAMPLE WIDTH (CM)";W
560 W=ABS(W)
570 INPUT"SAMPLE D1 DIMENSION (CM)";D1
580 INPUT"SAMPLE D2 DIMENSION (CM)";D2
590 D1=ABS(D1):D2=ABS(D2)
600 CLS
610 PRINT"PRESS ANY KEY TO MEASURE"
620 A$=INKEY$:IF A$=" " THEN 620
630 REM ***** MAIN MEASUREMENT LOOP *****
640 RESTORE
650 CLS
660 PRINT"MEASURING..."
670 FOR J=1 TO 4
680 IF J<>3 THEN 710
690 RESTORE 'CLEAR DATA POINTER
700 C$="I"+STR$(I2)+"X":CALL IBWRT(M220%,C$) 'REVERSE CURRENT
710 READ C$:CALL IBWRT(M705%,C$) 'CLOSE CROSSPOINTS
720 C$="F1X":CALL IBWRT(M220%,C$) 'TURN ON 220 OUTPUT
730 FOR I=1 TO DELAY:NEXT 'WAIT FOR READING TO SETTLE
740 RD$=SPACE$(25):CALL IBRD(M196%,RD$) 'GET 196 READING
750 V(J)=VAL(RD$) 'CONVERT STRING TO NUMERIC, PUT IN ARRAY
760 IF ABS(V(J))>8 THEN 1040 'CHECK VOLTAGE LIMITS
770 IF J<>1 THEN 800
780 RD$=SPACE$(25):CALL IBRD(M485%,RD$) 'GET 485 CURRENT READING
790 I1=VAL(RD$) 'CONVERT READING TO NUMERIC
800 C$="F0X":CALL IBWRT(M220%,C$) 'TURN OFF 220 OUTPUT
810 READ C$ 'READ 705 COMMAND STRING
820 CALL IBWRT(M705%,C$) 'OPEN CROSSPOINTS
830 NEXT J 'LOOP BACK FOR NEXT POINT
840 BEEP
850 CLS
860 CALL IBCMD(BRD0%,D$) 'SEND DEVICE CLEAR
870 PRINT"MEASUREMENTS COMPLETE."
880 PRINT"MEASURED CURRENT";I1
890 FOR J=1 TO 4 'LOOP AND DISPLAY MEASURED VOLTAGES
900 PRINT"V";J;"=";V(J)
910 NEXT J
920 PRINT"PRESS ANY KEY TO CALCULATE RESISTIVITIES"
930 A$=INKEY$:IF A$=" " THEN 930
940 PA=W*T/(2*I1*D1)*(V(1)-V(3))
950 PB=W*T/(2*I1*D2)*(V(2)-V(4))
960 PAVG=(PA+PB)/2
970 PRINT"PA=";PA
980 PRINT"PB=";PB
990 PRINT"PAVG=";PAVG
1000 PRINT
```

---



---

**Program 8**  
**6- and 8-Contact Sample Resistivity (IBM-PC/8573A Version), Continued**

```
1010 INPUT"REPEAT TEST (Y/N)";A$
1020 IF LEFT$(A$,1)= "Y" THEN CLS:GOTO 290
1030 GOTO 1150
1040 CLS:BEEP
1050 CALL IBCMD(BRD0%,D$) ' SEND DEVICE CLEAR
1060 PRINT"SAMPLE VOLTAGE IS OVER 8V 7065 LIMIT"
1070 PRINT"DO YOU WISH TO:"
1080 PRINT"(1) RESTART THE MEASUREMENT"
1090 PRINT"(2) ABORT THE PROGRAM"
1100 PRINT
1110 INPUT A
1120 IF A<1 OR A>2 THEN 1070
1130 IF A=2 THEN 1150
1140 CLS:GOTO 290
1150 END 'END PROGRAM
1160 REM ***** 705 COMMAND STRINGS *****
1170 DATA "C03:2C04:1X"
1180 DATA "N03:2N04:1X"
1190 DATA "C03:3C04:4X"
1200 DATA "N03:3N04:4X"
```

## REFERENCES

- ASTM, F76-84. Standard Method for Measuring Hall Mobility and Hall Coefficient in Extrinsic Semiconductor Single Crystals. Annual Bk. ASTM Stds., 1985: 10.05 155.
- Hemenger, P.M. Measurement of High-Resistivity Semiconductors Using the van der Pauw Method. Rev. Sci. Instrum., 1973: 44 698.
- Look, D.C. and Farmer, J.W. Automated, High Resistivity Hall and Photoelectronic Apparatus. J. Phys., E. Sci. Instrumen., 1981: 14 472.
- Van der Pauw, L.J. A Method of Measuring Specific Resistivity and Hall Effects of Discs of Arbitrary Shape. Philips Rec. Repts., 1958: 13 1.
- Wieder, H.H. Laboratory Notes on Electrical and Galvanomagnetic Measurements
- Yeager, J.R., Hall and van der Pauw Measurements of Semiconductors, Keithley Instrum. App. Note, 1984: 510.

# SECTION 4

## SERVICE INFORMATION

---

### 4.1 INTRODUCTION

This section contains the necessary information to service your Model 7065 Hall Effect Card and contains the following information:

**4.2 Handling and Cleaning Precautions:** Discusses handling precautions and cleaning methods for the Model 7065.

**4.3 Performance Verification:** Covers the procedures necessary to determine if the card is operating properly.

**4.4 Adjustments:** Outlines adjustment procedures for the Hall effect card.

**4.5 Theory of Operation:** Briefly discusses circuit operation from a block diagram viewpoint.

**4.6 Special Handling of Static-Sensitive Devices:** Reviews some precautions necessary to avoid damaging static-sensitive devices.

**4.7 Troubleshooting:** Gives some troubleshooting tips for the Model 7065.

### 4.2 HANDLING AND CLEANING PRECAUTIONS

Because of the high impedance of many circuits on the Model 7065, care should be taken during handling or servicing of the card in order to prevent possible performance degradation because of contamination. The following precautions should be taken when handling the scanner card.

1. Handle the card only at the edges of the board whenever possible. Avoid touching any components not associated with the repair.
2. Do not store or operate the card in an environment where dust could settle on the board. Use dry nitrogen gas to clean dust off the card when necessary.

3. If it is necessary to use solder on the circuit board or around the Teflon insulators, remove the flux from these areas when the repair is complete. Use Freon<sup>®</sup> TMS or TE or equivalent to remove the flux. Clean cotton swabs or a clean soft brush can be used to help remove the flux. Once all the flux is removed, swab the area with methanol, then blow dry the board with dry nitrogen gas.

4. After cleaning, the card should be placed in a 50°C low-humidity environment for several hours before resuming normal operation.

### 4.3 PERFORMANCE VERIFICATION

The following paragraphs discuss procedures for verifying offset voltage, input current, and input resistance.

#### 4.3.1 Environmental Conditions

All measurements should be made at an ambient temperature between 18 and 28°C and at a relative humidity less than 70% unless otherwise noted.

#### 4.3.2 Warm Up Period

The Model 7065 should be turned on and allowed to warm up for at least one hour before beginning the verification procedures. Also, the test equipment should be allowed to warm up for the period stated in their respective instruction manuals or specifications.

#### 4.3.3 Recommended Equipment

Table 4-1 summarizes the equipment necessary to perform the verification procedures.

**Table 4-1. Performance Verification Equipment**

Description	Specifications	Manufacturer and Model
Digital Multimeter	100nV DC resolution, ±0.006% accuracy	Keithley 196
Electrometer/Source	1fA sensitivity, ±8V DC output	Keithley 617
Scanner		Keithley 705 or 706
4801 Coax Cable		Supplied
7024 Triax cable		Supplied
7025 Triax Cable		Supplied
4802 cable		Supplied
SC-72 wire		Supplied
SC-81 BG-7 Cable		Supplied

**4.3.4 High-Impedance Considerations**

Because of the high impedances involved with some of the measurements, the cables should be kept as still as possible during the tests.

**4.3.5 Input Current Verification**

**Connections**

Connect the Model 617 Electrometer to the sample input to be verified, as shown in Figure 4-1. Use a Model 7024 triaxial cable to connect the sample input jack to the electrometer. Make sure the ground link is connected between the Model 617 ANALOG OUTPUT COMMON and chassis ground terminals.

**Procedure**

1. Install the Model 7065 in the scanner mainframe and turn on the power. Allow the unit to warm up for one hour.
2. Using Program 6, select the matrix mode (pole 0).
3. Place the electrometer on the 2nA range, enable zero check, and zero correct the electrometer. Make sure the electrometer guard switch is in the off position.
4. Disable zero check and note the reading on the electrometer display. Verify that the reading is less than 100pA exclusive of noise.
5. Enable zero check on the electrometer and place the unit on the 2pA range.
6. Close crosspoint 5, 4 to enable the high resistivity mode.
7. Disable zero check and verify that the current reading is less than 0.15pA exclusive of noise.
8. Enable zero check and open crosspoint 5,4 on the scanner.
9. Repeat steps 3 through 8 for the remaining three sample inputs. The electrometer should be connected to the sample input being tested.

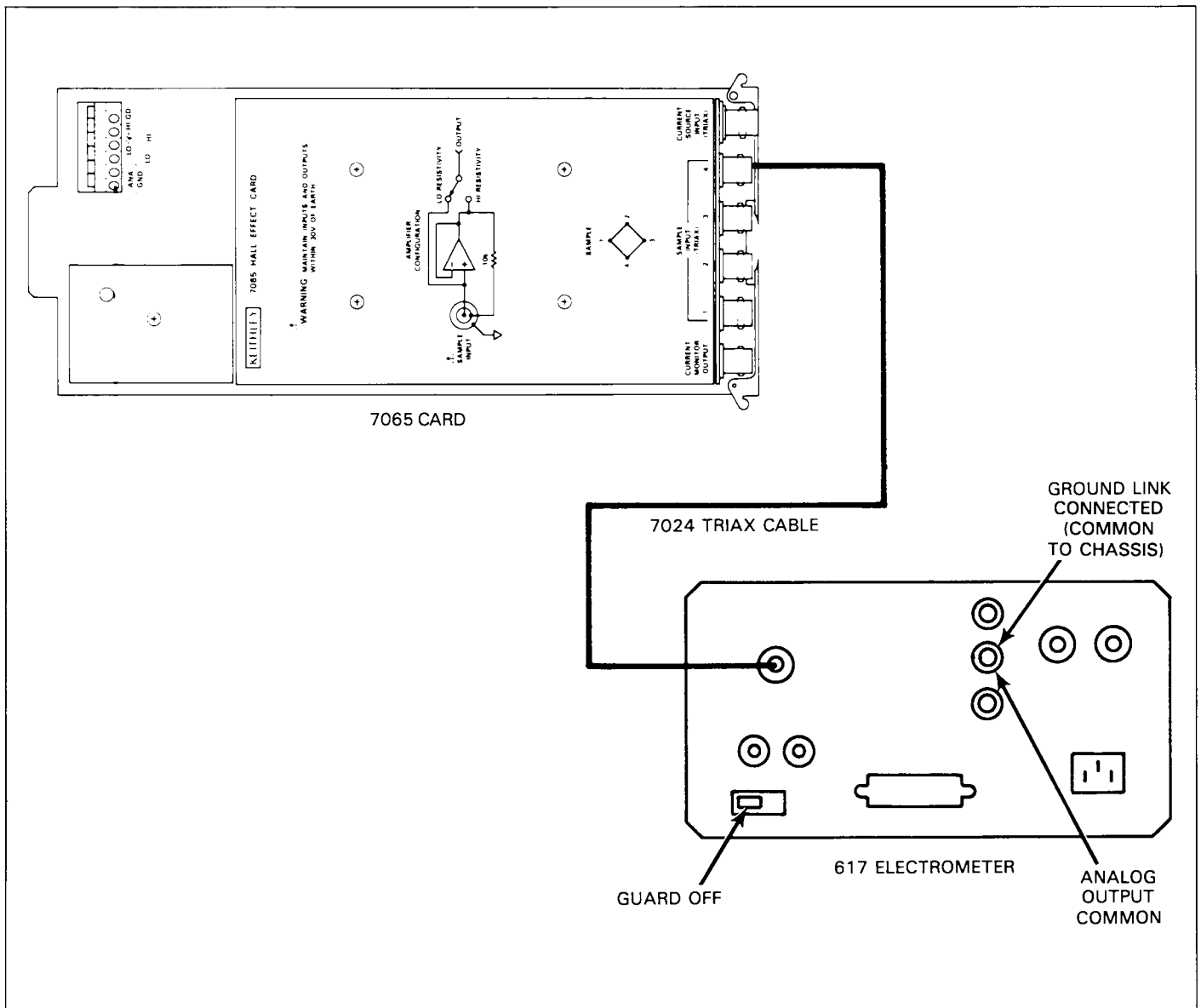

Figure 4-1. Connections for Input Current Verification

### 4.3.6 Input Resistance Verification

#### Connections

Connect the Keithley Model 617 Electrometer to the Hall card, as shown in Figure 4-2. The electrometer should be connected to the sample input jack being tested through a 7024 triaxial cable. Connect the voltage source low terminal to the Model 7065 analog ground using a supplied SC-72 black wire. Connect the second SC-72 black wire between voltage source output high and electrometer analog output common. Make sure the ground link is removed.

#### Procedure

1. Install the Hall card in the mainframe and turn on the power.
2. Using Program 6, select the matrix mode (pole 0). Press ENTER.
3. Select the 20nA range on the electrometer, enable zero check, and then zero correct the instrument. Make sure the low-to-ground link on the electrometer is removed, and that the guard switch is in the off position.
4. Make sure the Model 617 voltage source output is turned off, then disable zero check. Wait for the reading to settle.
5. Enable the suppress feature on the electrometer.
6. Enable zero check and program the Model 617 voltage source for a value of +8V, turn on the output.
7. Release zero check and allow the reading to settle. Note and record the current reading as  $I_1$ .
8. Program the voltage source for an output of -8V.
9. Note the current reading on the electrometer, and record the value as  $I_2$ .
10. Compute the input resistance for the low resistivity setup as follows:
 
$$R = \frac{16}{|I_2 - I_1|}$$
11. Verify that the resistance calculated in step 10 is greater than 10G $\Omega$ . Note typical values may be as high as 10<sup>12</sup> $\Omega$ .
12. Enable zero check, select the 2pA range, and disable suppress. Zero correct the electrometer.
13. Turn off the electrometer voltage source output.
14. Close crosspoint 5, 4 to select high resistivity by programming the scanner.
15. Disable zero check, wait for the reading to settle, and then enable suppress.
16. Turn on the electrometer voltage source output. The voltage source should still be programmed to -8V.
17. Note and record the current reading as  $I_3$ .
18. Program the voltage source to +8V.
19. Note and record the current reading as  $I_4$ .
20. Compute the input resistance for the high resistivity setup as follows:
 
$$R = \frac{16}{|I_3 - I_4|}$$
21. Verify that the resistance calculated in step 20 is greater than 100T $\Omega$ .
22. Turn off the voltage source, enable zero check, and disable suppress.
23. Open crosspoint 5,4 and repeat steps 3 through 22 for the other three sample inputs. The electrometer should be connected to the sample input being tested using the connections shown in Figure 4-2.



### 4.3.7 Voltage Offset Verification

#### Connections

Figure 4-3 shows connection for voltage offset verification. The HI terminal of the DMM is to be connected to terminal 5 of the terminal strip, while the DMM LO terminal and the center contact of the sample input being verified must both be connected to analog ground, as shown on the diagram.

This connection should be made as follows:

1. Prepare the end of a Model 7025 triaxial cable by stripping 1 inch of insulation off the end and cutting off the shields (see Figure 2-6 in Section 2).
2. Twist together the center conductor and one end of an SC-72 wire (black).
3. Place the junction in a small box in between two pieces of foam to prevent air currents from affecting the reading. Also, keep the cable as still as possible.
4. Connect the free end of the black wire to Hall Card analog ground, and connect the triaxial cable to the sample input being tested.

#### Procedure

1. Install the Model 7065 in the scanner mainframe and turn on the power.
2. Using front panel Program 6, select the matrix mode on the scanner (pole 0).
3. Select the DCV function and the 300mV range on the DMM.
4. Temporarily disconnect the DMM and short its input. Zero the DMM, remove the short, and reconnect it to the Hall card.
5. Close the crosspoint for the sample input being tested, as summarized in Table 4-2. For example, for sample input 1, close 3,1.

6. Verify that the DMM reading is  $\leq 10\mu V$  exclusive of noise after settling. If necessary, select suitable DMM filtering to quiet the reading.
7. Close crosspoint 5,4 in order to select the high resistivity mode.
8. Allow sufficient time for the reading to settle, then verify that the DMM reading is less than  $200\mu V$  exclusive of noise. Again, DMM filtering may be required to quiet the reading.

#### NOTE

If the high resistivity offset reading for one of the channels is above specified limits, the offset can be nulled by using the procedure discussed in paragraph 4.4.

**Table 4-2. Crosspoint Closed to Measure Sample Input Voltage Offset**

Sample Input #	Crosspoint Closed (Column, Row)
1	3,1
2	3,2
3	3,3
4	3,4

9. Press the scanner RESET button to open all crosspoints, then re-zero the DMM.
10. Repeat steps 4 through 9 for the remaining three sample inputs. Be sure to connect the 7025 triax cable to the sample input being test.



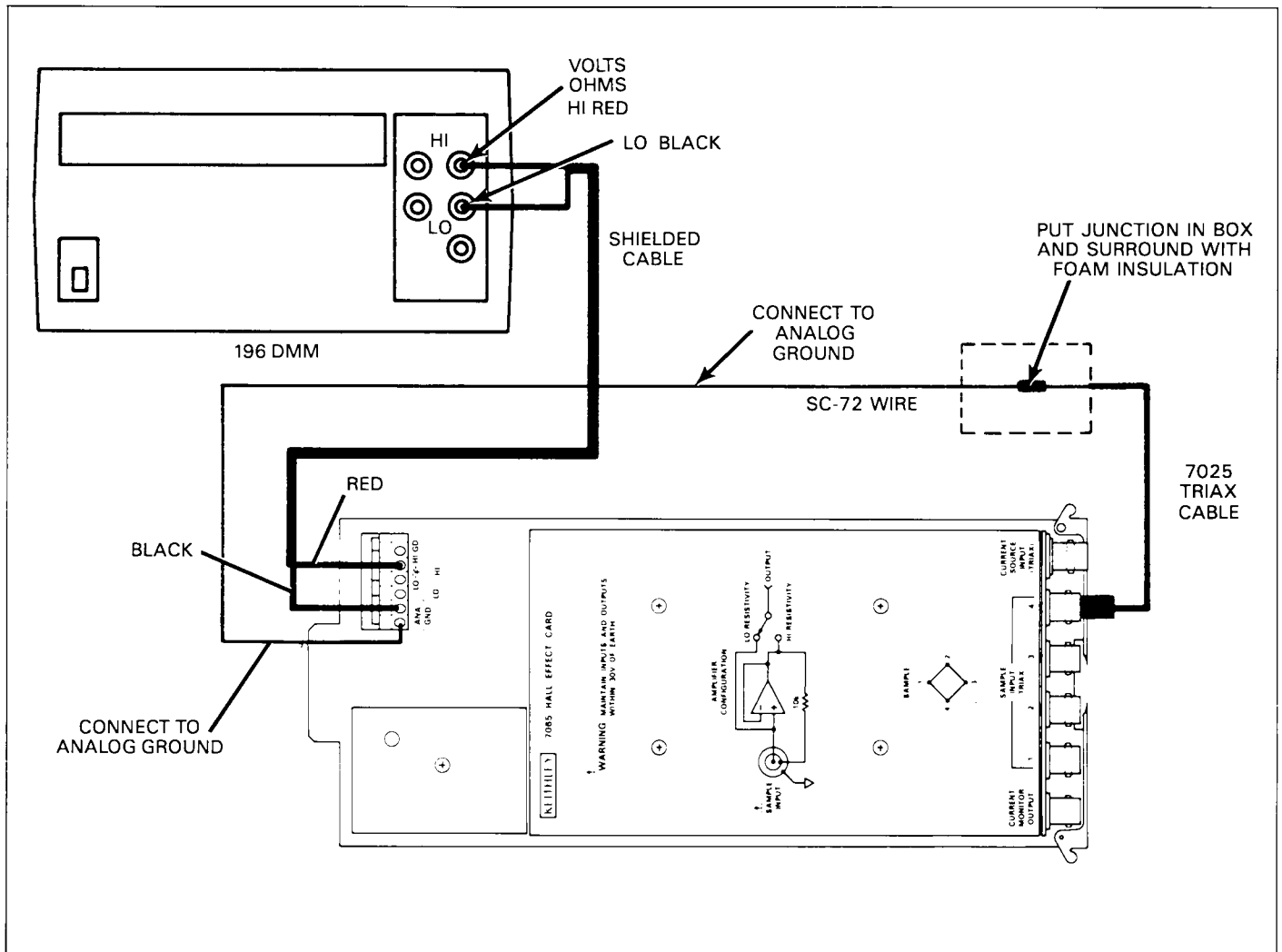

Figure 4-3. Connections for Voltage Offset Verification

## 4.4 ADJUSTMENTS

Offset adjustments for the four sample inputs as well as common mode rejection adjustment are covered in the following paragraphs.

### 4.4.1 Environmental Conditions

All adjustments should be made at an ambient temperature of 18 to 28°C and at a relative humidity of less than 70%.

### 4.4.2 Warm Up Period

The Model 7065 should be allowed to warm up for one hour

before performing the adjustments. Test equipment should also be allowed to warm up for the period stated in the respective instruction manuals.

### 4.4.3 Recommended Test Equipment

Table 4-3 summarizes the equipment necessary to make the adjustments.

### 4.4.4 Adjustment Locations

Figure 4-4 shows the adjustment locations. The four offset adjustments are accessible from the end of the card; each control is adjacent to the associated input connector. The common mode rejection adjustment can be accessed through the hole in the small digital shield.

**Table 4-3. Equipment Needed for Adjustments**

Description	Specifications	Manufacturer and Model
DMM Oscilloscope	100nV sensitivity >10MHz bandwidth 10mV/div sensitivity	Keithley Model 196 TEK 2235
Scanner 10kΩ Resistor Extender Card	¼W, 5%	Keithley Model 705 or 706 Keithley part # R-76-10k  Keithley Model 7061

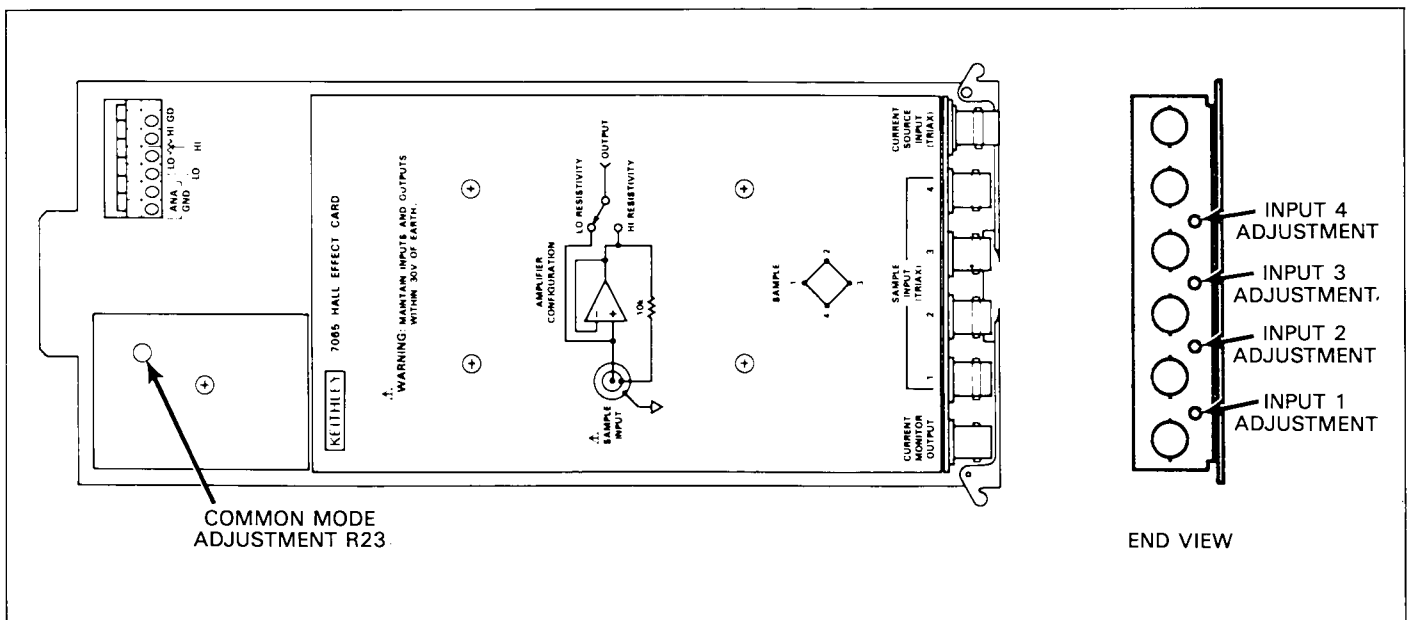

**Figure 4-4. Adjustment Locations**

## 4.4.5 Offset Adjustments

### Connections

Connections for making offset adjustments are shown in Figure 4-5. The HI input lead of the DMM is connected to terminal 5 of the strip, while DMM LO is connected to analog ground. The center connector of the sample input jack being adjusted must also be connected to analog ground on the scanner card. See paragraph 4.3.7 for details on connecting the wire and cables together.

### Procedure

1. With the power off, install the Model 7065 in the scanner mainframe with all shields in place
2. Using Program 6, select the matrix mode (pole 0). Press ENTER.
3. Close crosspoint 5,4 to select the high resistivity mode.
4. Select the 300mV DC range on the DMM. Temporarily disconnect the DMM, short its input, and then enable zero. Remove the short and reconnect the DMM to the Hall card.
5. Close the crosspoint for the sample input you are currently adjusting, as summarized in Table 4-4. For example, to measure sample input #1, close 3,1.
6. Adjust the offset control for the selected sample input for a minimum (null) reading on the DMM (less than 20 $\mu$ V is satisfactory). The controls are accessible through small holes in the bracket at the back of the card (see Figure 4-4). Note that it may be necessary to use DMM filtering to minimize noise.
7. Open the crosspoint now closed.
8. Repeat steps 5 through 7 for the remaining three sample inputs. Be sure to connect the sample input being adjusted to analog common, and also make certain the the appropriate crosspoint is closed for the measurement.

**Table 4-4. Crosspoints to Close When Adjusting Offsets**

Sample Input #	Crosspoint* (Column, Row)
1	3,1
2	3,2
3	3,3
4	3,4

\*Crosspoint 5,4 must also be closed to select high resistivity.

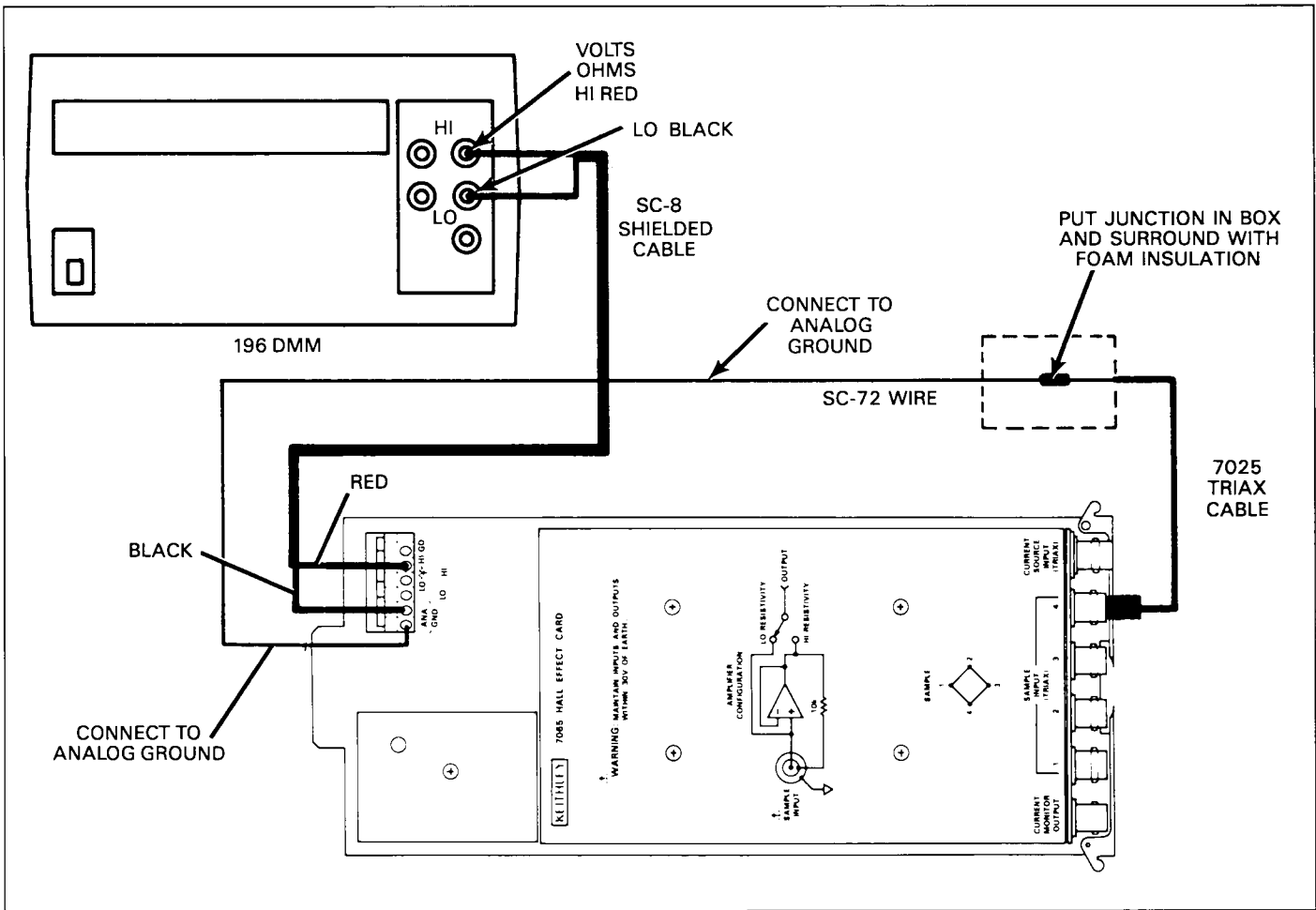

Figure 4-5. Connections for Voltage Offset Adjustment

### 4.4.6 Common-Mode Adjustment

#### Connections

Figure 4-6 shows the necessary connections for this adjustment. The 10kΩ resistor is connected between analog ground on the terminal strip and digital ground, which can be accessed at the screw on the small power supply shield. Connect the oscilloscope high input to analog ground, and connect scope low to digital ground at the shield screw. Use shielded cable between the oscilloscope and the card and resistor (shield, LO center conductor, HI).

#### Procedure

1. Connect the Model 7065 to the scanner through the Model 7061 Universal Adapter Card, used as an extender to allow access to the adjustment. See the Model 7061 Instruction Guide for more information.
2. Make certain that all Model 7065 shields are in place and properly secured.
3. Set the oscilloscope time base and input attenuator to view the waveform shown in Figure 4-7.
4. Adjust the common mode potentiometer (R23) for best symmetry and minimum amplitude of the waveform.
5. Turn off the power and disconnect the resistor and oscilloscope once the adjustment is complete.

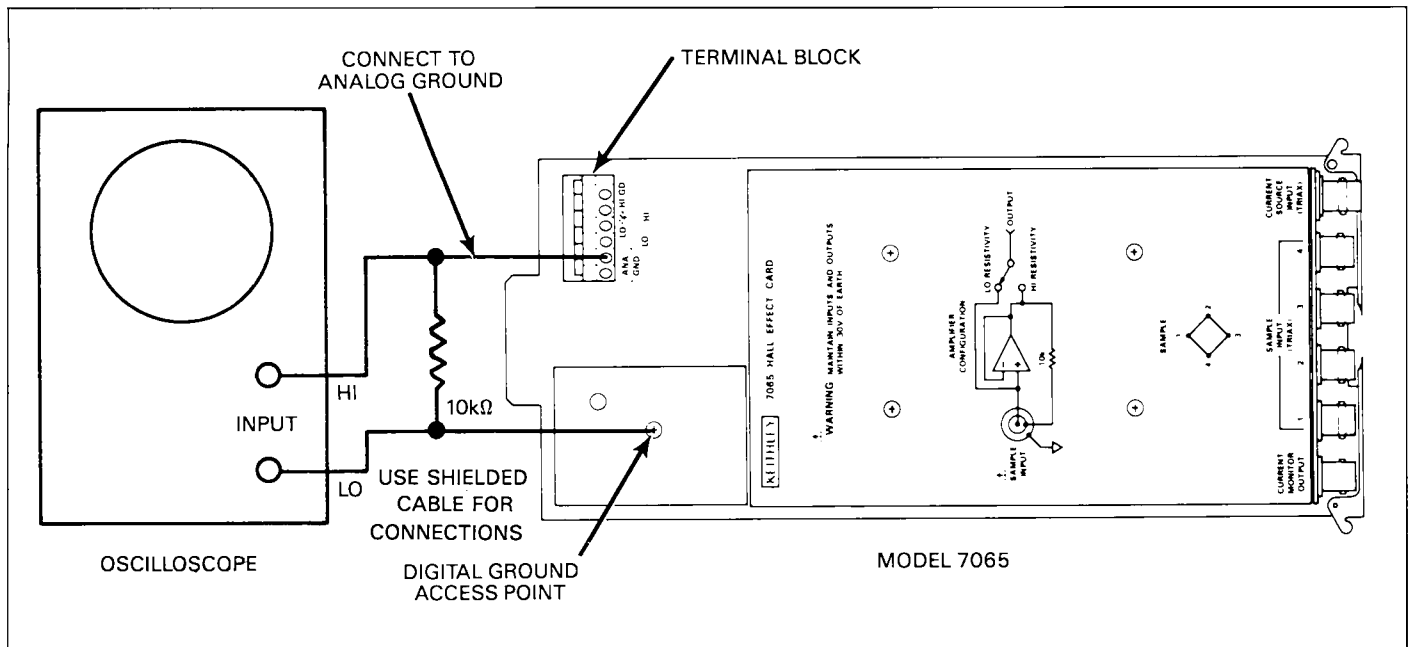

Figure 4-6. Connections for Common Mode Adjustment

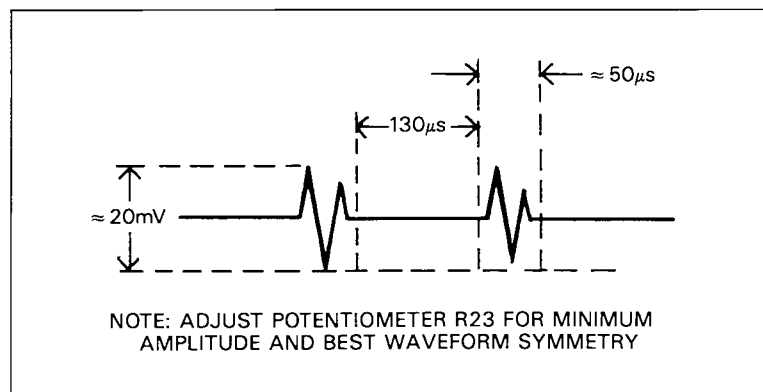

Figure 4-7. Common Mode Adjustment Waveform

---

---

## 4.5 THEORY OF OPERATION

The following paragraphs give a brief description of the major circuits in the Model 7065. Figure 4-8 shows a block diagram of the unit, and the schematic diagram is located on drawing number 7065-106, found at the end of Section 5.

### 4.5.1 Relay Switching Circuits

A large part of Model 7065 operation is concerned with connecting different inputs and outputs together. For that reason, a number of relays and solid-state switching elements are found on the card.

K1 through K8 perform input or current switching for the card. Each of these devices is a special low-current relay with a guard shield to minimize the effects of leakage currents. Note that the current input is protected by Q1, Q2, VR1, and VR2 to limit input compliance voltage to  $\pm 12V$ .

At the output, switching is performed by solid-state elements U11 through U16. Each of these devices is internally controlled by opto-coupling in order to maintain high analog-to-digital isolation.

Some of the switching elements are directly controlled from scanner mainframe signals passed through J1, while others use information derived from the serial control word. For example K3 and K7 are directly controlled, while K4 and K8 are switched by serial control information.

The serial control information is converted to parallel by U5, a shift register, and then buffered by U7 before being applied to the various relays or switching FETs. R2, C1, CR5, and elements of U6 form a power-up/down fail-safe circuit to prevent relays from being inadvertently closed when power is turned on or off.

### 4.5.2 Buffers

An important feature of the Model 7065 is the use of on-card buffers which give the card its very high ( $> 100T\Omega$ )

input impedance, allowing the card to be used to measure high-resistivity samples.

U1 through U4 are special high-quality operational amplifiers configured as non-inverting, unity-gain amplifiers. These components provide both buffering as well as a driven guard for the sample inputs. Voltage offset adjustment for these ICs is performed by R14 through R17 in order to maintain optimum input leakage current and guard performance.

Resistivity setup switching is performed by FETs Q3 through Q11. In low resistivity, the buffers are effectively bypassed by turning on appropriate FETs while turning off others. For example, when low impedance is selected, Q3, Q4, Q9, and Q10 will be on, while Q5 through Q8 are off. Conversely, in high resistivity, Q5 through Q8 are on, while Q3, Q4, Q9, and Q10 are turned off.

### 4.5.3 Power Supply

The power supply section of the Model 7065 has a two-fold purpose: (1) to step up the nominal +6V scanner mainframe supply to  $\pm 12V$ , and (2) to provide a high degree of isolation between the digital circuits of the mainframe and the sensitive analog signal paths on the Model 7065. In order to meet these requirements, a trapezoidal-wave chopper step-up circuit with transformer isolation is used.

The nominal 3.4kHz time base of the chopper is generated by U8, a 555 timer, which has its operating frequency set by C8 and R19. The signal is buffered by Q13 before being applied to the chopper made up of Q12, Q14, and associated components. The nominal 6V peak signal is coupled through a 112:4 step-down transformer, T1, and then is coupled again through a 4:380 step-up transformer, T2. This dual-transformer technique is used to ensure maximum analog-to-digital isolation.

At the secondary of T2, the nominal 17V peak AC signal is rectified by CR6 before being filtered and regulated. C4, C7, and U9 provide filtering and regulation for the +12V supply, and C5, C6, and U10 filter and regulate the -12V supply.

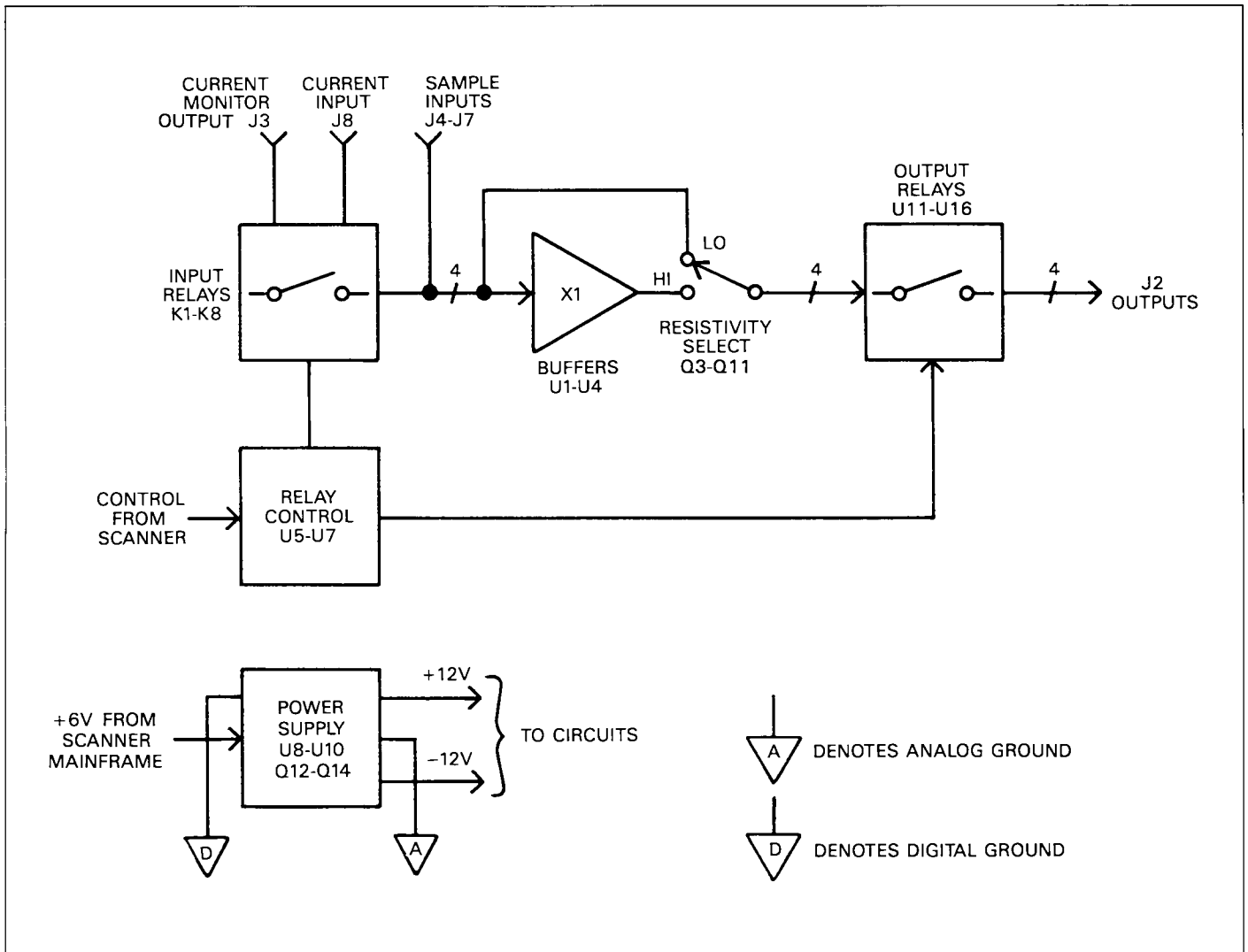

Figure 4-8. Model 7065 Block Diagram

#### 4.6 SPECIAL HANDLING OF STATIC-SENSITIVE DEVICES

CMOS and other high-impedance devices are subject to possible static discharge damage because of the high impedance levels involved. When handling such devices (indicated by \* in the parts list), use the following precautions:

1. Such devices should be transported and handled only in containers specially designed to prevent or dissipate static build-up. Typically, these devices will be received in anti-static containers of plastic or foam. Keep these parts in their original containers until ready for installation.
2. Remove the devices from their protective containers only at a properly-grounded work station. Also, ground yourself with a suitable wrist strap.
3. Handle the devices only by the body; do not touch the pins.
4. Any printed circuit board into which the device is to be inserted must also be grounded to the bench or table.

5. Use only anti-static type de-soldering tools and grounded-tip soldering irons.
6. Once the device is installed in the PC board, it is usually adequately protected, and normal handling can resume.

#### 4.7 TROUBLESHOOTING

##### 4.7.1 Recommended Equipment

Table 4-5 summarizes the equipment necessary for general troubleshooting.

##### 4.7.2 Troubleshooting Procedure

The troubleshooting procedure is summarized in Table 4-6.

**Table 4-5. Troubleshooting Equipment**

Description	Manufacturer and Model	Use
DMM	Keithley 196	Measure DC voltages
Voltage Source	Keithley 230	Apply DC voltages
Oscilloscope	TEK 2235	View waveforms
Extender Card	Keithley 7061	Allow circuit access



Table 4-6. Troubleshooting Summary

Step	Item/Component	Required Condition	Comments
1	U8 pins 4 & 8	+6V DC	Reference to digital ground
2	U8 pin 3	3.4kHz square wave	Chopper time base
3	T1, pins 6-2	≈ 6V peak, 3.4kHz	Chopper signal referred to digital ground.
4	T2, pins 1-3	≈ 17V peak, 3.4kHz	Chopper signal referred to analog ground.
5	U9, pin 3	+16V DC, ±20%	Referenced to analog ground
6	U10, pin 2	-16V DC, ±20%	
7	TP1	+12V DC, ±5%	+12V supply
8	TP2	-12V DC, ±5%	-12V supply
9	U5, pin 1	Pulse train when programming channels	Control strobe
10	U5, pin 2	Pulse train when programming channels	Control data
11	U5, pin 3	Pulse train when programming channels	Control clock
12	Scanner programming	Close crosspoint 5,4	Select high resistivity
13	Current source input (J8)	Connect external +5V source to center conductor	Connect source low to analog ground
14	DMM	Connect DMM between pin 5 of J2, and analog ground	Set DMM to measure DCV.
15	Scanner programming	Close crosspoints 2,1 and 3,1	Select buffer #1
16	DMM	+5V, ±0.1%	Check out sample 1 buffer
17	Voltage source	Set to -5V	Reversed polarity
18	DMM	-5V, ±0.1%	Sample 1 buffer negative input
19	Scanner programming	Open 2,1; 3,1; Close 2,2; 3,2	Select buffer #2
20	DMM	-5V, ±0.1%	Sample 2 buffer, negative input
21	Voltage source	+5V	Reversed polarity
22	DMM	+5V, ±0.1%	Sample 2 buffer positive input
23	Scanner programming	Open 2,2; 3,2; Close 2,3; 3,3	Select buffer #3
24	DMM	+5V, ±0.1%	Sample 3 buffer, positive input
25	Voltage source	-5V	Reversed polarity
26	DMM	-5V, ±0.1%	Sample 3 buffer, negative input
27	Scanner programming	Open 2,3; 3,3 Close 2,4; 3,4	Select buffer #4
28	DMM	-5V, ±0.1%	Sample 4 buffer, negative input
29	Voltage source	-5V	Reversed polarity
30	DMM	+5V, ±0.1%	Sample 4 buffer, positive input
31	Scanner	Press RESET	Open all crosspoints



# SECTION 5

## REPLACEABLE PARTS

---

### 5.1 INTRODUCTION

This section contains a list of replaceable electrical and mechanical parts for the Model 7065. A component layout drawing and schematic diagram are also included.

### 5.2 PARTS LISTS

Electrical parts are listed in order of circuit designation in Table 5-1. Table 5-2 summarizes mechanical parts.

### 5.3 ORDERING INFORMATION

To place a parts order, or to obtain information concerning replacement parts, contact your Keithley representative or the factory (see the inside front cover for addresses). When ordering parts, be sure to include the following information:

1. Hall card model number (7065)
2. Unit serial number
3. Part description
4. Circuit description, if applicable
5. Keithley part number

### 5.4 FACTORY SERVICE

If the Hall card is to be returned to Keithley Instruments for repair or service, perform the following:

1. Complete the service form at the back of this manual and include it with the card.
2. Carefully pack the card in the original packing carton.
3. Write ATTENTION REPAIR DEPARTMENT on the shipping label.

Note that it is not necessary to return the scanner mainframe with the card.

### 5.5 COMPONENT LAYOUT AND SCHEMATIC DIAGRAM

A component layout drawing of the Model 7065 is shown in Figure 5-1. Figure 5-2 shows a schematic diagram of the card.

Table 5-1. Electrical Parts

Circuit Designation	Description	Keithley Part Number
AT1	Analog FET, photon coupled, HHF1	IC-524
C1-C7	Capacitor, 10 $\mu$ F, 25V, Aluminum Electrolytic	C-314-10
C8	Capacitor, 6800pF, 1%, 100V, mica	C-248-6800p
C9	Capacitor, 0.02 $\mu$ F, 20%, 500V, Ceramic Disc	C-22-.02
C10	Capacitor, 3.3pF, 100V, ceramic	C-372-3.3p
C11	Capacitor, 1500pF, 10%, 1000V, ceramic disc	C-64-1500p
CR1-CR4	Diode, rectifier, 1N3595	RF-43
CR5	Diode, silicon, 1N4148	RF-28
CR6	Bridge Rectifier, 1.5A, 400PIV, PF40	RF-46
E1-E17	Terminal, Teflon insulated	TE-105-1
J2	Connector, terminal strip	CS-518-6
J3	Connector, insulated BNC	CS-520
J4-J8	Connector, triax	CS-440
K1-K8	Relay, reed	RL-70
Q1, Q2	Transistor, silicon, NPN, GES5818	TG-138
Q3-Q14*	Transistor, FET, 2N7000	TG-195
R1	Resistor, 10k $\Omega$ , 1/2W, 10%, Composition	R-1-10k
R2-R6	Resistor, 10k $\Omega$ , 1/4W, 5%, Composition	R-76-10k
R7-R9	Resistor, 330k $\Omega$ , 1/4W, 5%, Composition	R-76-330k
R10-R13	Resistor, 1M $\Omega$ , 1/2W, 10%, Composition	R-1-1M
R14-R17	Potentiometer, 100k $\Omega$ , 0.75W	RP-89-100k
R18	Resistor, thick film	TF-177-1
R19	Resistor, 30.1k $\Omega$ , 1/8W, 1%	R-88-30.1k
R20	Resistor, 180k $\Omega$ , 1/4W, 5%, Composition	R-76-180k
R21; R22	Resistor, 22k $\Omega$ , 1/4W, 5%, Composition	R-76-22k
R23	Potentiometer, 10k $\Omega$ , 0.5W	RP-97-10k
R24-R27	Resistor, 22M $\Omega$ , 1/4W, 10%, Composition	R-76-22M
R28	Resistor, 330 $\Omega$ , 1/4W, 5%, Composition	R-76-330
R29-R32	Resistor, 1k $\Omega$ , 1/4W, 5%, Composition	R-76-1k
R33	Resistor, 4.7 $\Omega$ , 1W, 10%, Wirewound, Fusible	R-334-4.7
R34-R42	Resistor, 1M $\Omega$ , 1/4W, 5%, Composition	R-76-1M
U1-U4*	IC, operational amplifier, OPA104	IC-519
U5*	IC, CMOS shift register, 4094	IC-251
U6*	IC, CMOS quad NOR gate, 4011	IC-102
U7*	IC, Bus buffer, 74HC241	IC-520
U8*	IC, CMOS 555 timer	IC-521
U9	IC, +12V regulator, 78L12	IC-522
U10	IC, -12V regulator, 79L12	IC-523
U11-U16	IC, Photovoltaic relay, 3301	IC-525
T1	Transformer	TR-247
T2	Transformer	TR-248
TP1, TP2	Pin, contact	24249
VR1-VR2	Zener diode, 12V, 100mA, 1N5349B	DZ-72-1
W1, W2	Connector, jumper	CS-476

\*These parts are static sensitive. See paragraph 4.6 for handling precautions.

Table 5-2. Mechanical Parts

Quantity	Description	Keithley Part Number
1	Lug for J8	LU-100
2	Washer for J8	WN-13
6	Cap for BNC and triax jacks	CAP-18
1	Bracket, BNC	7065-302
1	Top Analog Shield	7065-304
1	Digital Shield	7065-307
1	Bottom Assembly Shield	7065-121
5	#4-40 × 1 Phillips pan head modified screw for shields	7065-308
3	#4-40 × <sup>3</sup> / <sub>16</sub> Phillips pan head screws for attaching BNC bracket to PC board.	

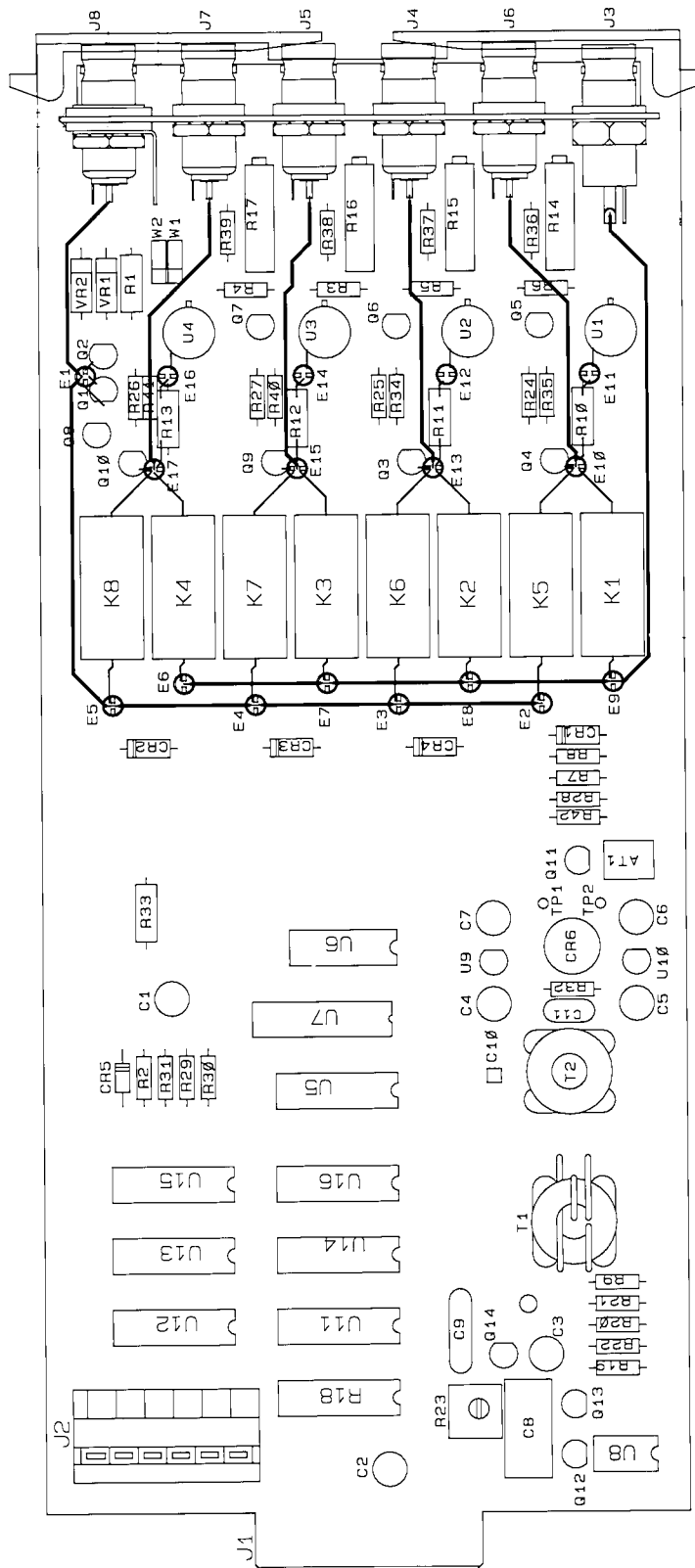
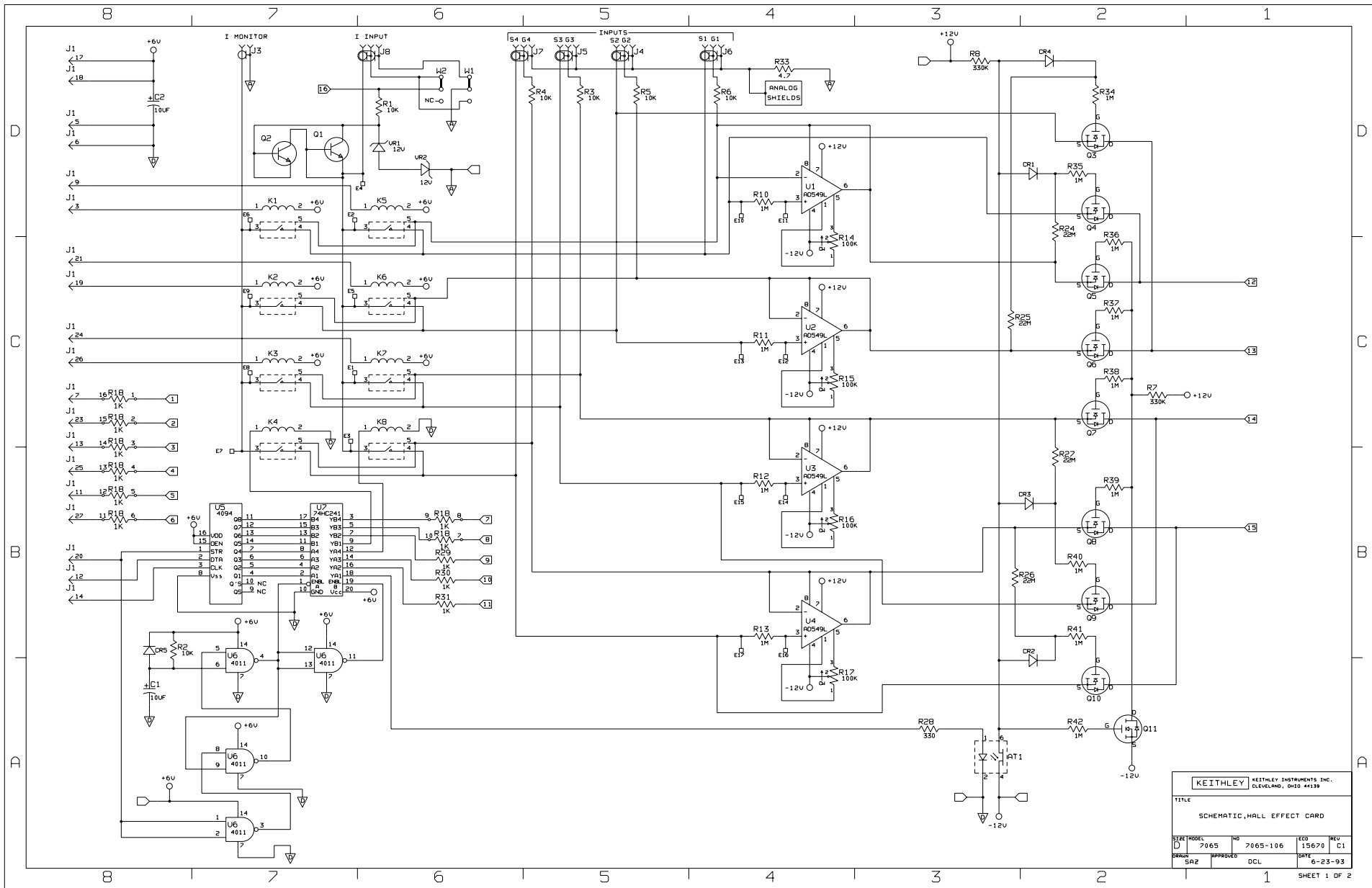
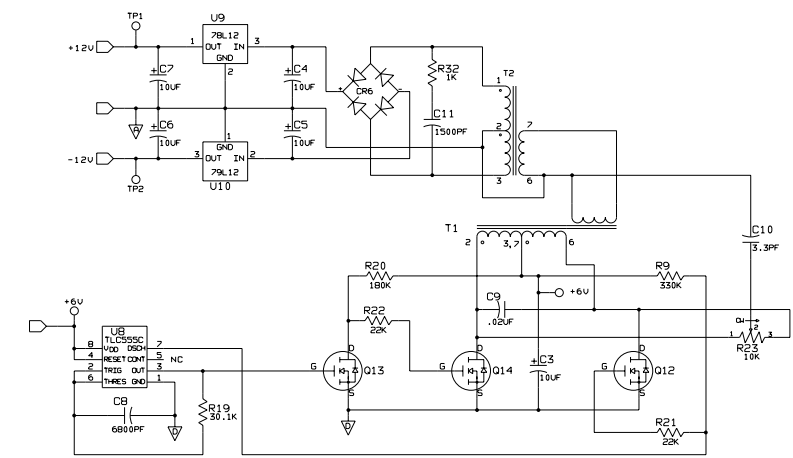
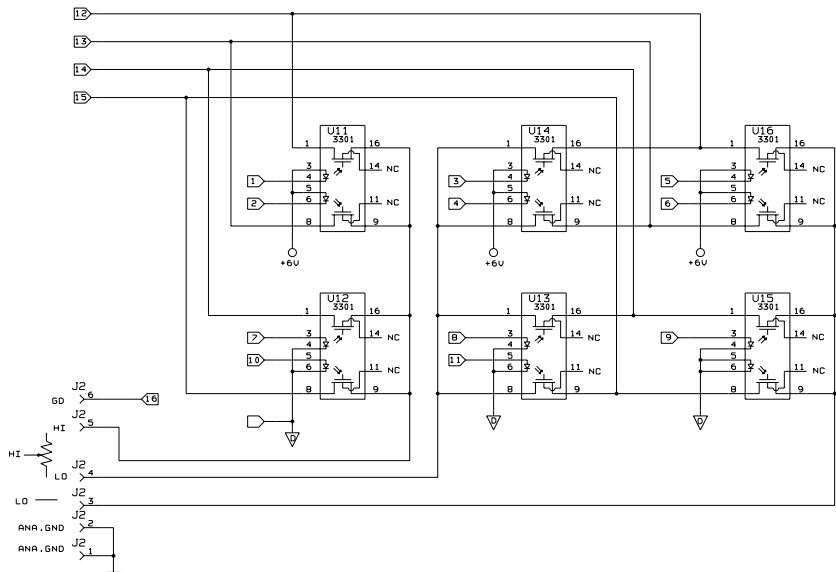

Figure 5-1. Model 7065, Component Location Drawing



KEITHLEY		KEITHLEY INSTRUMENTS INC.	
		CLEVELAND, OHIO 44139	
TITLE			
SCHEMATIC, HALL EFFECT CARD			
DATE	MODEL	NO	REV
D	7065	7065-106	15670 C1
DESIGN	APPROVED	DCL	DATE
SPZ			6-23-93



KEITHLEY		KEITHLEY INSTRUMENTS INC.	
		CLEVELAND, OHIO 44139	
TITLE			
SCHEMATIC, HALL EFFECT CARD			
REV	MODEL	NO	ECO
D	7065	106	15670
DATE	APPROVED	DCL	DATE
8-23			6-23-93
			SHEET 2 OF 2



# INDEX

- Addenda, 1-1
- Adjustments, 4-8
- Bar Sample
  - Connections, 2-11
  - Measurement, 3-9
- Bridge Sample
  - Connections, 2-16
  - Measurements, 3-15
- Cautions, 1-1
- Cleaning, 4-1
- Component Location Drawing, 5-1
- Connections
  - Bar Sample, 2-11
  - Bridge Sample, 2-16
  - Cable and Wire Preparation, 2-6
  - Card Connectors, 2-4
  - IEEE-488 Bus, 2-21
  - Parallelepiped Sample, 2-16
  - Van der Pauw Sample, 2-8
- Contents, Table of, i
- Crosspoint Programming, 2-38
- Current Monitor Output Shorting, 2-21
- Current Source Input Guarding, 2-26
- Electrical Parts, List of, 5-2
- Electrostatic Interference, 2-42
- Equipment, Recommended, 3-1
- Equivalent Input Circuits, 2-33
- Factory Service, 5-1
- Figures, List of, iv
- Ground Loops, 2-43
- Guarding
  - Current Source Input, 2-24
  - Principles, 2-24
  - Sample Input, 2-26
- Hall Effect
  - Principles, 3-2
  - Sign Convention, 3-2
  - Terminal Convention, 3-2
- Hall Voltage Measurements
  - Bar Sample, 3-14
  - Bridge Sample, 3-20
  - Parallelepiped Sample, 3-20
  - Van der Pauw Sample, 3-7
- Hall Mobility Calculations
  - Bar Sample, 3-15
  - Bridge Sample, 3-20
  - Parallelepiped Sample, 3-20
  - Van der Pauw Sample, 3-9
- Handling Precautions, 2-1, 4-1
- High-Impedance Considerations, 4-2
- IEEE-488 Bus
  - Connections, 2-21
  - Programming, 2-38
  - Programs, 2-39, 3-23
- Input
  - Capacitance, 2-41
  - Characteristics, 2-33
  - Loading, 2-41
  - Voltage Levels, 2-40
- Installation
  - Model 705 Scanner, 2-2
  - Model 706 Scanner, 2-2
- Jacks, Input and Output, 2-4
- Leakage Resistance, 2-40
- Matrix Configuration, 2-21
- Measurements
  - Bar Samples, 3-9
  - Bridge Samples, 3-15
  - Parallelepiped Samples, 3-15
  - Van der Pauw Samples, 3-5, 3-7
- Offsets, 2-43
- Operation, General, 2-1
- Parallelepiped Sample
  - Connections, 2-16
  - Measurement, 3-15
- Performance Verification, 4-1
- Programs, Example, 2-39, 3-23
- Replaceable Parts, 5-1
- Resistivity Measurement
  - Bar Sample, 3-14
  - Bridge Sample, 3-19
  - Parallelepiped Sample, 3-19
  - Van der Pauw, 3-5
- Resistivity Selection
  - Equivalent Input Circuit, 2-33
  - Input Characteristics, 2-33
  - Programming, 2-33
  - Setup Criteria, 2-34
- RFI, 2-42
- Safety Precautions
  - Preceding Table of Contents

---

Safety Symbols and Terms, 1-1	Static-Sensitive Devices, 4-14	Verification Procedure
Scanner	Tables, List of, v	Input Current, 4-2
Compatibility, 1-3	Theory of Operation, 4-12	Input Resistance, 4-4
Front Panel Programming, 2-37	Troubleshooting Information, 4-14	Voltage Offset, 4-6
IEEE-488 Bus Programming, 2-38		Warnings, 1-1
Installation of Card In, 2-2		Warranty, 1-1
Schematic Diagram, 5-1	Van der Pauw Sample	
Service Information, 4-1	Connections, 2-8	
Specifications, 1-2	Measurement, 3-5, 3-7	

The number following each entry indicates the page number.

Specifications are subject to change without notice.  
All Keithley trademarks and trade names are the property of Keithley Instruments, Inc.  
All other trademarks and trade names are the property of their respective companies.

---

**KEITHLEY**

A G R E A T E R M E A S U R E O F C O N F I D E N C E

**Keithley Instruments, Inc.**

**Corporate Headquarters** • 28775 Aurora Road • Cleveland, Ohio 44139 • 440-248-0400 • Fax: 440-248-6168 • 1-888-KEITHLEY (534-8453) • [www.keithley.com](http://www.keithley.com)