

Model 7999-3
Multiplexer Card
Instruction Manual

Contains Operating and Servicing Information

KEITHLEY

WARRANTY

Keithley Instruments, Inc. warrants this product to be free from defects in material and workmanship for a period of 1 year from date of shipment.

Keithley Instruments, Inc. warrants the following items for 90 days from the date of shipment: probes, cables, rechargeable batteries, diskettes, and documentation.

During the warranty period, we will, at our option, either repair or replace any product that proves to be defective.

To exercise this warranty, write or call your local Keithley representative, or contact Keithley headquarters in Cleveland, Ohio. You will be given prompt assistance and return instructions. Send the product, transportation pre-paid, to the indicated service facility. Repairs will be made and the product returned, transportation prepaid. Repaired or replaced products are warranted for the balance of the original warranty period, or at least 90 days.

LIMITATION OF WARRANTY

This warranty does not apply to defects resulting from product modification without Keithley's express written consent, or misuse of any product or part. This warranty also does not apply to fuses, software, non-rechargeable batteries, damage from battery leakage, or problems arising from normal wear or failure to follow instructions.

THIS WARRANTY IS IN LIEU OF ALL OTHER WARRANTIES, EXPRESSED OR IMPLIED, INCLUDING ANY IMPLIED WARRANTY OF MERCHANTABILITY OR FITNESS FOR A PARTICULAR USE. THE REMEDIES PROVIDED HEREIN ARE BUYER'S SOLE AND EXCLUSIVE REMEDIES.

NEITHER KEITHLEY INSTRUMENTS, INC. NOR ANY OF ITS EMPLOYEES SHALL BE LIABLE FOR ANY DIRECT, INDIRECT, SPECIAL, INCIDENTAL OR CONSEQUENTIAL DAMAGES ARISING OUT OF THE USE OF ITS INSTRUMENTS AND SOFTWARE EVEN IF KEITHLEY INSTRUMENTS, INC., HAS BEEN ADVISED IN ADVANCE OF THE POSSIBILITY OF SUCH DAMAGES. SUCH EXCLUDED DAMAGES SHALL INCLUDE, BUT ARE NOT LIMITED TO: COSTS OF REMOVAL AND INSTALLATION, LOSSES SUSTAINED AS THE RESULT OF INJURY TO ANY PERSON, OR DAMAGE TO PROPERTY.



Keithley Instruments, Inc. • 28775 Aurora Road • Cleveland, OH 44139 • 440-248-0400 • Fax: 440-248-6168 • <http://www.keithley.com>

CHINA:	Keithley Instruments China • Yuan Chen Xin Building, Room 705 • 12 Yumin Road, Dewai, Madian • Beijing 100029 • 8610-62022886 • Fax: 8610-62022892
FRANCE:	Keithley Instruments SARL • BP 60 • 3 Allée des Garays • 91122 Palaiseau Cédex • 33-1-60-11-51-55 • Fax: 33-1-60-11-77-26
GERMANY:	Keithley Instruments GmbH • Landsberger Strasse 65 • D-82110 Germering, Munich • 49-89-8493070 • Fax: 49-89-84930759
GREAT BRITAIN:	Keithley Instruments, Ltd. • The Minster • 58 Portman Road • Reading, Berkshire RG30 1EA • 44-118-9575666 • Fax: 44-118-9596469
ITALY:	Keithley Instruments SRL • Viale S. Gimignano 38 • 20146 Milano • 39-2-48303008 • Fax: 39-2-48302274
NETHERLANDS:	Keithley Instruments BV • Avelingen West 49 • 4202 MS Gorinchem • 31-(0)183-635333 • Fax: 31-(0)183-630821
SWITZERLAND:	Keithley Instruments SA • Kriesbachstrasse 4 • 8600 Dübendorf • 41-1-8219444 • Fax: 41-1-8203081
TAIWAN:	Keithley Instruments Taiwan • 1FL., 85 Po Ai Street • Hsinchu, Taiwan • 886-3-572-9077 • Fax: 886-3-572-9031

Model 7999-3 Single-Pole Multiplexer Card Instruction Manual

©1999, Keithley Instruments, Inc.
All rights reserved.
Cleveland, Ohio, U.S.A.
First Printing, May 1999
Document Number: 7999-3-901-01 Rev. A

Manual Print History

The print history shown below lists the printing dates of all Revisions and Addenda created for this manual. The Revision Level letter increases alphabetically as the manual undergoes subsequent updates. Addenda, which are released between Revisions, contain important change information that the user should incorporate immediately into the manual. Addenda are numbered sequentially. When a new Revision is created, all Addenda associated with the previous Revision of the manual are incorporated into the new Revision of the manual. Each new Revision includes a revised copy of this print history page.

Revision A (Document Number 7999-3-901-01)..... May 1999

Safety Precautions

The following safety precautions should be observed before using this product and any associated instrumentation. Although some instruments and accessories would normally be used with non-hazardous voltages, there are situations where hazardous conditions may be present.

This product is intended for use by qualified personnel who recognize shock hazards and are familiar with the safety precautions required to avoid possible injury. Read the operating information carefully before using the product.

The types of product users are:

Responsible body is the individual or group responsible for the use and maintenance of equipment, for ensuring that the equipment is operated within its specifications and operating limits, and for ensuring that operators are adequately trained.

Operators use the product for its intended function. They must be trained in electrical safety procedures and proper use of the instrument. They must be protected from electric shock and contact with hazardous live circuits.

Maintenance personnel perform routine procedures on the product to keep it operating, for example, setting the line voltage or replacing consumable materials. Maintenance procedures are described in the manual. The procedures explicitly state if the operator may perform them. Otherwise, they should be performed only by service personnel.

Service personnel are trained to work on live circuits, and perform safe installations and repairs of products. Only properly trained service personnel may perform installation and service procedures.

Exercise extreme caution when a shock hazard is present. Lethal voltage may be present on cable connector jacks or test fixtures. The American National Standards Institute (ANSI) states that a shock hazard exists when voltage levels greater than 30V RMS, 42.4V peak, or 60VDC are present. **A good safety practice is to expect that hazardous voltage is present in any unknown circuit before measuring.**

Users of this product must be protected from electric shock at all times. The responsible body must ensure that users are prevented access and/or insulated from every connection point. In some cases, connections must be exposed to potential human contact. Product users in these circumstances must be trained to protect themselves from the risk of electric shock. If the circuit is capable of operating at or above 1000 volts, **no conductive part of the circuit may be exposed.**

As described in the International Electrotechnical Commission (IEC) Standard IEC 664, digital multimeter measuring circuits (e.g., Keithley Models 175A, 199, 2000, 2001, 2002, and 2010) are Installation Category II. All other instruments' signal terminals are Installation Category I and must not be connected to mains.

Do not connect switching cards directly to unlimited power circuits. They are intended to be used with impedance limited sources. NEVER connect switching cards directly to AC mains. When connecting sources to switching cards, install protective devices to limit fault current and voltage to the card.

Before operating an instrument, make sure the line cord is connected to a properly grounded power receptacle. Inspect the connecting cables, test leads, and jumpers for possible wear, cracks, or breaks before each use.

For maximum safety, do not touch the product, test cables, or any other instruments while power is applied to the circuit under test. ALWAYS remove power from the entire test system and discharge any capacitors before: connecting or disconnecting cables or jumpers, installing or removing switching cards, or making internal changes, such as installing or removing jumpers.

Do not touch any object that could provide a current path to the common side of the circuit under test or power line (earth) ground. Always make measurements with dry hands while standing on a dry, insulated surface capable of withstanding the voltage being measured.

The instrument and accessories must be used in accordance with its specifications and operating instructions or the safety of the equipment may be impaired.

Do not exceed the maximum signal levels of the instruments and accessories, as defined in the specifications and operating information, and as shown on the instrument or test fixture panels, or switching card.

When fuses are used in a product, replace with same type and rating for continued protection against fire hazard.

Chassis connections must only be used as shield connections for measuring circuits, **NOT** as safety earth ground connections.

If you are using a test fixture, keep the lid closed while power is applied to the device under test. Safe operation requires the use of a lid interlock.

If a  screw is present, connect it to safety earth ground using the wire recommended in the user documentation.

The  symbol on an instrument indicates that the user should refer to the operating instructions located in the manual.

The  symbol on an instrument shows that it can source or measure 1000 volts or more, including the combined effect of normal and common mode voltages. Use standard safety precautions to avoid personal contact with these voltages.

The **WARNING** heading in a manual explains dangers that might result in personal injury or death. Always read the associated information very carefully before performing the indicated procedure.

The **CAUTION** heading in a manual explains hazards that could damage the instrument. Such damage may invalidate the warranty.

Instrumentation and accessories shall not be connected to humans.

Before performing any maintenance, disconnect the line cord and all test cables.

To maintain protection from electric shock and fire, replacement components in mains circuits, including the power transformer, test leads, and input jacks, must be purchased from Keithley Instruments. Standard fuses, with applicable national safety approvals, may be used if the rating and type are the same. Other components that are not safety related may be purchased from other suppliers as long as they are equivalent to the original component. (Note that selected parts should be purchased only through Keithley Instruments to maintain accuracy and functionality of the product.) If you are unsure about the applicability of a replacement component, call a Keithley Instruments office for information.

To clean an instrument, use a damp cloth or mild, water based cleaner. Clean the exterior of the instrument only. Do not apply cleaner directly to the instrument or allow liquids to enter or spill on the instrument. Products that consist of a circuit board with no case or chassis (e.g., data acquisition board for installation into a computer) should never require cleaning if handled according to instructions. If the board becomes contaminated and operation is affected, the board should be returned to the factory for proper cleaning/servicing.

7999-3 Single-Pole Multiplexer Card

RELAY SWITCH CONFIGURATION:

- 10 channels of independent 1-pole switching
- 1 channel of 2:1 mux 1-pole switching.
- 2 channels of 4:1 mux 1-pole switching.

CONTACT CONFIGURATION: 1-pole Form A.

CONNECTOR TYPE: 96-pin male DIN card connector.

MAXIMUM SIGNAL: 30V DC, 42V peak between any two inputs or chassis, 1A switched, CAT I.

CONTACT LIFE: **Cold Switching:** 10×10^6 closures.
At Maximum Signal Levels: 2×10^5 closures.

CHANNEL RESISTANCE (per conductor): $<0.5\Omega$.

CONTACT POTENTIAL: $<10\mu\text{V}$ per contact.

ACTUATION TIME: 3ms.

RELAY DRIVE CURRENT (per relay): 8.5mA @ 24V (user supplied).

USER SUPPLIED VOLTAGE: 24V \pm 4V DC, 220mA max.

RELAY CONTROL INPUT: **Relay Closed:** $<2.0\text{V}$.
Relay Open: User supplied voltage.

RELAY DRIVE CONFIGURATION:

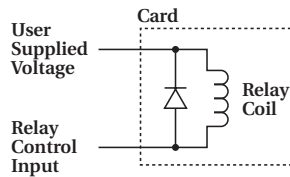

GENERAL

INDICATORS: SMT LED shows status of each relay.

ENVIRONMENT: Operating: 0° to 50°C, up to 35°C <80% RH.

Storage: -25° to 65°C.

EMC: Conforms with European Union Directive 89/336/EEC, EN 55011, EN 50082-1, EN 61000-3-2 and 61000-3-3, FCC part 15 class B.

SAFETY: Conforms with European Union Directive 73/23/EEC, EN 61010-1.

DIMENSIONS: 160mm long \times 108mm wide \times 38mm deep ($6\frac{3}{16}$ " \times $4\frac{1}{4}$ " \times $1\frac{1}{2}$ "). PC board is 152mm long \times 102mm wide (6 " \times 4 ").

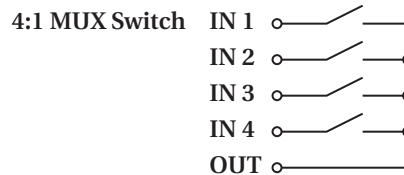
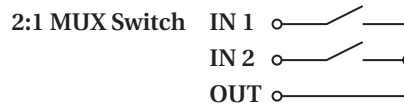

Table of Contents

1	General Information	
	Introduction	1-2
	Feature overview	1-2
	Warranty information	1-2
	Manual addenda	1-2
	Safety symbols and terms	1-3
	Specifications	1-3
	Unpacking and inspection	1-3
	Inspecting for damage	1-3
	Handling precautions	1-3
	Shipment contents	1-4
	Instruction manual	1-4
	Repacking for shipment	1-4
	Recommended connector	1-4
2	Connections	
	Introduction	2-2
	Handling precautions	2-2
	Card configuration	2-2
	Card layout	2-2
	Simplified schematic	2-4
	Card connections	2-7
	Input/output connector	2-7
	Terminal designations	2-7
	Controlling relays	2-8
3	Operating Considerations	
	Introduction	3-2
	Maximum signal considerations	3-2
	Relay power and control	3-2
	Switching considerations	3-2
	Keeping the input/output connector clean	3-2
	RFI/EMI	3-3
	Ground loops	3-3

4 Service Information

Introduction	4-2
Handling and cleaning precautions	4-2
Handling precautions	4-2
Card cleaning	4-2
Performance verification	4-3
Environmental conditions	4-3
Recommended equipment	4-3
Multiplexer card connections	4-3
Channel resistance tests	4-4
Contact potential tests	4-5
Replacing components	4-6
Replacement parts	4-6
Replacement precautions	4-6
Soldering considerations	4-6

5 Replaceable Parts

Introduction	5-2
Parts list	5-2
Ordering information	5-2
Factory service	5-2
Component layout and schematic diagram	5-3

List of Illustrations

2 Connections

Figure 2-1	Card configuration	2-3
Figure 2-2	Simplified schematic	2-5
Figure 2-3	J1 connector terminal designations.....	2-7

3 Operating Considerations

Figure 3-1	Ground loops	3-3
Figure 3-2	Eliminating ground loops	3-4

4 Service Information

Figure 4-1	Channel resistance test connections.....	4-4
Figure 4-2	Contact potential connections.....	4-5

List of Tables

2	Connections	
Table 2-1	Card relay channel summary	2-3
Table 2-2	Signal terminals	2-6
Table 2-3	Control line terminals	2-8
4	Service Information	
Table 4-1	Recommended verification equipment	4-3
5	Replaceable Parts	
Table 5-1	Parts list.....	5-3

1 General Information

Introduction

This section contains general information about the Model 7999-3 Single-Pole Multiplexer Card. This information is organized as follows:

- Feature overview
- Warranty information
- Manual addenda
- Safety symbols and terms
- Specifications
- Unpacking and inspection
- Recommended connector

If you have any questions after reviewing this information, please contact your local Keithley representative or call one of our Applications Engineers at 1-800-348-3735 (U.S. and Canada only). Worldwide phone numbers are listed at the front of this manual.

Feature overview

The Model 7999-3 is a single-pole multiplexer card with the following features:

- 10 channels of independent 1-pole switching
- One channel of 2:1 multiplexer 1-pole switching
- Two channels of 4:1 multiplexer 1-pole switching
- External relay control and +24V DC power connections
- 96-pin male DIN connector for card connections
- LED indicator shows the status of each relay

Warranty information

Warranty information is located at the front of this instruction manual. Should your Model 7999-3 require warranty service, contact the Keithley representative or authorized repair facility in your area for further information. When returning the card for repair, be sure to fill out and include the service form at the back of this manual to provide the repair facility with the necessary information.

Manual addenda

Any improvements or changes concerning the card or manual will be explained in an addendum included with this manual. Be sure to note these changes and incorporate them into the manual.

Safety symbols and terms

The following symbols and terms may be found on the multiplexer card or used in this manual.

The  symbol indicates that the user should refer to the operating instructions located in the manual.

The  symbol shows that high voltage may be present on the terminal(s). Use standard safety precautions to avoid personal contact with these voltages.

The **WARNING** heading used in this manual explains dangers that might result in personal injury or death. Always read the associated information very carefully before performing the indicated procedure.

The **CAUTION** heading used in this manual explains hazards that could damage the multiplexer card. Such damage may invalidate the warranty.

Specifications

Full Model 7999-3 specifications are included at the front of this manual.

Unpacking and inspection

Inspecting for damage

The Model 7999-3 is packaged in a re-sealable, anti-static bag to protect it from damage due to static discharge and from contamination that could degrade its performance. Before removing the card from the bag, observe the precautions on handling discussed below.

Handling precautions

- Always grasp the card by the side edges and covers. Do not touch the connector insulator, board surfaces, or components.
- After removing the card from its anti-static bag, inspect it for any obvious signs of physical damage. Report any such damage to the shipping agent immediately.
- When the card is not installed and connected, keep the card in its anti-static bag, and store it in the original packing carton.

Shipment contents

The following items are included with every Model 7999-3 order:

- Model 7999-3 Single-Pole Multiplexer Card
- Model 7999-3 Instruction Manual
- Additional accessories as ordered

Instruction manual

If an additional Model 7999-3 Instruction Manual is required, order the manual package, Keithley part number 7999-3-901-01. The manual package includes an instruction manual and any pertinent addenda.

Repacking for shipment

Should it become necessary to return the Model 7999-3 for repair, carefully pack the unit in its original packing carton or the equivalent, and include the following information:

- Call the Repair Department at 1-800-552-1115 for a Return Material Authorization (RMA) number.
- Advise as to the warranty status of the card.
- Write ATTENTION REPAIR DEPARTMENT and the RMA number on the shipping label.
- Fill out and include the service form located at the back of this manual.

Recommended connector

The following mating receptacle is recommended for use with the Model 7999-3 96-pin connector:

- AMP 216081-8 series 96 pin DIN receptacle

2 Connections

Introduction

This section contains information about overall card configuration and connections and is organized as follows:

- Handling precautions
- Card configuration
- Connections

WARNING The procedures in this section are intended only for qualified service personnel. Do not perform these procedures unless you are qualified to do so. Failure to recognize and observe normal safety precautions could result in personal injury or death.

Handling precautions

To maintain high-impedance isolation between channels, care should be taken when handling the card to avoid contamination from such foreign materials as body oils and salts. Such contamination can reduce isolation resistance. To avoid possible contamination:

- Always grasp the card by the side edges.
- Do not touch board surfaces, components, or connector insulators.
- Operate the card in a clean environment. If the card becomes contaminated, it should be thoroughly cleaned as explained in Section 4.

Card configuration

Card layout

Figure 2-1 shows the general layout of the Model 7999-3. Items include:

- Input/output connector (J1) — All input/output signal, control, and power connections to the card are made through this connector. See Figure 2-3, Table 2-2, and Table 2-3 for terminal designations.
- Indicator lights — One LED for each relay indicates when that relay is energized.
- Relays (20) — These relays provide card switching for the independent channels, the 2:1 mux, and both 4:1 multiplexers as summarized in Table 2-1.

Table 2-1
Card relay channel summary

Relay	Channel designation	Description
K1 through K6	1 through 6	Independent channels
K7 and K8	7/1 and 7/2	2:1 mux channels
K9 through K12	8/1 through 8/4	4:1 mux #1 channels
K13 through K16	9/1 through 9/4	4:1 mux #2 channels
K17	+12V	+12V channel
K18 through K20		Spare channels

Figure 2-1
Card configuration

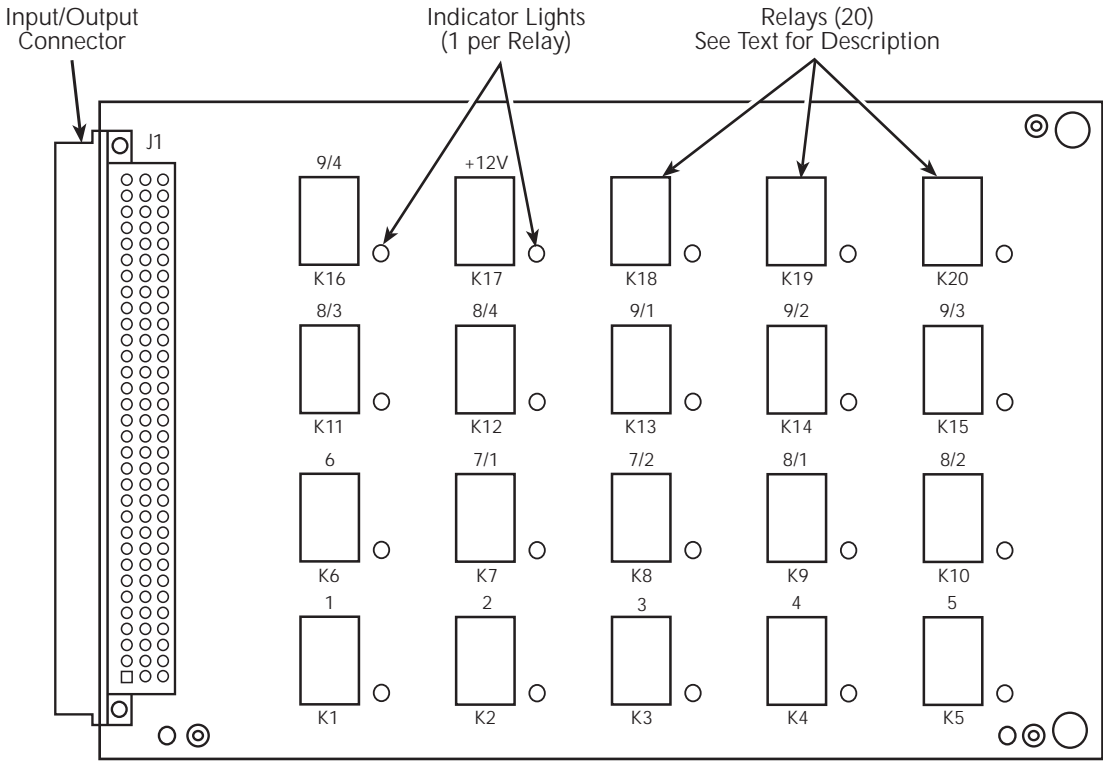

Simplified schematic

Figure 2-2 shows a simplified schematic diagram of the Model 7999-3 showing only signal paths (see Table 2-3 for a summary of control signals). Note that J1 terminal designations are also shown on the diagram. Key sections include:

- Independent channels 1 - 6
- 2:1 multiplexer
- Two 4:1 multiplexers
- +12V channel
- Three spare channels

Figure 2-2
Simplified
schematic

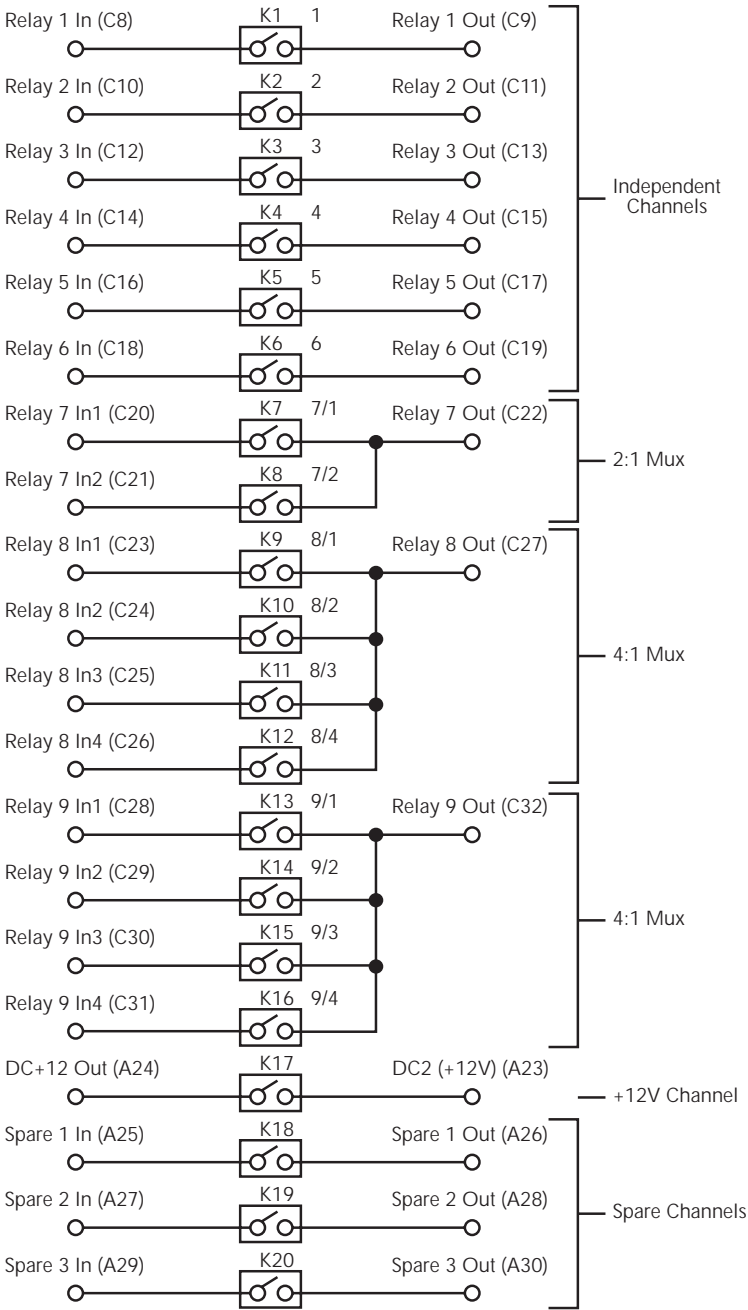

NOTE: J1 terminals in parentheses.

Table 2-2
Signal terminals

Signal	Description	J1 terminal*
RELAY 1 IN	Channel 1 input	C8
RELAY 1 OUT	Channel 1 output	C9
RELAY 2 IN	Channel 2 input	C10
RELAY 2 OUT	Channel 2 output	C11
RELAY 3 IN	Channel 3 input	C12
RELAY 3 OUT	Channel 3 output	C13
RELAY 4 IN	Channel 4 input	C14
RELAY 4 OUT	Channel 4 output	C15
RELAY 5 IN	Channel 5 input	C16
RELAY 5 OUT	Channel 5 output	C17
RELAY 6 IN	Channel 6 input	C18
RELAY 6 OUT	Channel 6 output	C19
RELAY 7 IN1	2:1 mux input #1	C20
RELAY 7 IN2	2:1 mux input #2	C21
RELAY 7 OUT	2:1 mux output	C22
RELAY 8 IN1	4:1 mux #1 input #1	C23
RELAY 8 IN2	4:1 mux #1 input #2	C24
RELAY 8 IN3	4:1 mux #1 input #3	C25
RELAY 8 IN 4	4:1 mux #1 input #4	C26
RELAY 8 OUT	4:1 mux #1 output	C27
RELAY 9 IN1	4:1 mux #2 input #1	C28
RELAY 9 IN2	4:1 mux #2 input #2	C29
RELAY 9 IN3	4:1 mux #2 input #3	C30
RELAY 9 IN4	4:1 mux #2 input #4	C31
RELAY 9 OUT	4:1 mux #1 output	C32
DC(+12V)	External +12V input	A23
DC+12 OUT	+12V output	A24
SPARE 1 IN	Spare #1 input	A25
SPARE 1 OUT	Spare #1 output	A26
SPARE 2 IN	Spare #2 input	A27
SPARE 2 OUT	Spare #2 output	A28
SPARE 3 IN	Spare #3 input	A29
SPARE 3 OUT	Spare #3 output	A30

*See Figure 2-3 for J1 pinouts.

Card connections

Input/output connector

Figure 2-3 shows the terminal configuration for the input/output connector (J1). The connector is organized into three rows, labelled A, B, C, and each row has 32 pins, designated 1 through 32.

Figure 2-3
J1 connector terminal designations

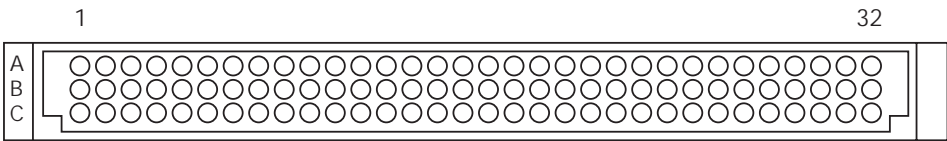

J1 (Terminal Side)

Terminal designations

Signal terminals

Table 2-2 summarizes signal terminal designations. These designations are also shown on the simplified schematic in Figure 2-2.

Control terminals

Table 2-3 lists control terminal designations. A relay is energized by setting the corresponding control line low.

+24V power terminals

To power the relays, +24V DC must be applied to either of the following terminals of J1:

A31 or A32

Table 2-3
Control line terminals

Control or power line*	Relay	Switched signal*	J1 terminal**
CONTROL 1	K1	RELAY 1 (Channel 1)	A1
CONTROL 2	K2	RELAY 2 (Channel 2)	A2
CONTROL 3	K3	RELAY 3 (Channel 3)	A3
CONTROL 4	K4	RELAY 4 (Channel 4)	A4
CONTROL 5	K5	RELAY 5 (Channel 5)	A5
CONTROL 6	K6	RELAY 6 (Channel 6)	A6
CONTROL 7	K7	RELAY 7 IN1 (7/1)	A7
CONTROL 8	K8	RELAY 7 IN2 (7/1)	A8
CONTROL 9	K9	RELAY 8 IN1 (8/1)	A9
CONTROL 10	K10	RELAY 8 IN2 (8/2)	A10
CONTROL 11	K11	RELAY 8 IN3 (8/3)	A11
CONTROL 12	K12	RELAY 8 IN4 (8/4)	A12
CONTROL 13	K13	RELAY 9 IN1 (9/1)	A13
CONTROL 14	K14	RELAY 9 IN2 (9/2)	A14
CONTROL 15	K15	RELAY 9 IN3 (9/3)	A15
CONTROL 16	K16	RELAY 9 IN4 (9/4)	A16
CONTROL 17	K17	DC2 (+12V)	A17
CONTROL 18	K18	SPARE 1	A18
CONTROL 19	K19	SPARE 2	A19
CONTROL 20	K20	SPARE 3	A20

*Set control line low to close channel. See Table 2-2 for a summary of signals and channels.

**See Figure 2-3 for J1 pinouts.

Controlling relays

To control relays, an external +24V DC voltage source must be connected to pin A31 or A32 of J1. A relay is energized by setting the corresponding control signal low (Table 2-3).

3

Operating Considerations

Introduction

This section contains information about operating considerations for the Model 7999-3 Single-Pole Multiplexer Card. The information is organized as follows:

- Maximum signal considerations
- Relay power and control
- Switching considerations

Maximum signal considerations

CAUTION To prevent damage to the Model 7999-3, do not exceed the following maximum signal level specifications of the card:

- **Maximum voltage: 30V DC, 42V Peak**
- **Maximum current: 1A DC, switched**

Relay power and control

To control relays, an external +24V DC voltage source must be connected to either the A31 or A31 terminal of J1. A relay is energized by setting the corresponding control signal low (see Table 2-3).

Switching considerations

Signals that pass through the Model 7999-3 are subject to various effects that can seriously affect their integrity. The following paragraphs discuss these effects and ways to minimize them.

Keeping the input/output connector clean

As is the case with any high-resistance device, the integrity of the 96-pin input/output connector (J1) can be compromised if it is not handled properly. If connector insulation becomes contaminated, the insulation resistance will be substantially reduced, affecting high-impedance measurement paths.

Oils and salts from the skin can contaminate connector insulator, reducing its resistance. Also, contaminants present in the air can be deposited on the insulator surface. To avoid these problems, never touch the connector insulating material. In addition, the multiplexer card should be used only in clean, dry environments to avoid contamination.

If the connector insulator should become contaminated, either by inadvertent touching, or from air-borne deposits, it can be cleaned with a cotton swab dipped in clean methanol. After thorough cleaning, the connector should be allowed to dry for several hours in a low-humidity environment before use, or it can be dried more quickly using dry nitrogen.

RFI/EMI

RFI (Radio Frequency Interference) and EMI (Electromagnetic Interference) are general terms used to describe electromagnetic interference over a wide range of frequencies across the spectrum. Such interference can be particularly troublesome at low signal levels, but it can also affect measurements at high levels if the problem is of sufficient severity.

EMI can be caused by steady-state sources such as radio or TV broadcast signals, or some types of electronic equipment (microprocessors, high speed digital circuits, etc.), or it can result from impulse sources, as in the case of arcing in high-voltage environments. In either case, the effect on the desired signal can be considerable if enough of the unwanted signal is present.

EMI can be minimized in several ways. The most obvious method is to keep the equipment and signal leads as far away from the RFI source as possible. Shielding the multiplexer card, signal leads, sources, and measuring instruments will often reduce RFI to an acceptable level. In extreme cases, a specially-constructed screen room may be required to sufficiently attenuate the troublesome signal.

Ground loops

When two or more devices are connected together, care must be taken to avoid unwanted signals caused by ground loops. Ground loops usually occur when devices are connected with more than one signal return path such as power line ground. As shown in Figure 3-1, the resulting ground loop causes current to flow through LO signal leads and then back through power line ground. This circulating current develops a small but undesirable voltage between the LO terminals of the two devices. This voltage will be induced into the desired signal, affecting its integrity.

Figure 3-1
Ground loops

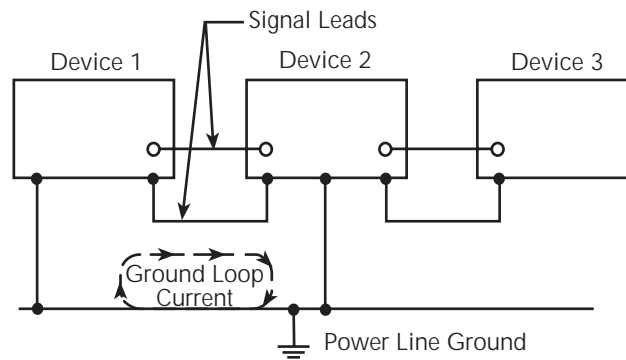
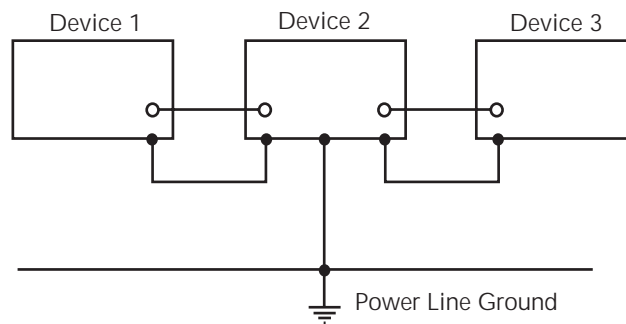

Figure 3-2 shows how to connect several devices together to eliminate this type of ground loop problem. Here, only one device is connected to power line ground.

Ground loops are not normally a problem with isolated LO terminals. However, all devices in the test setup may not be designed in this manner. When in doubt, consult the manual for all instrumentation in the test setup.

Figure 3-2
Eliminating ground loops



4 Service Information

Introduction

This section contains service information for the Model 7999-3. The information is organized as follows:

- Handling and cleaning precautions
- Performance verification
- Component replacement

WARNING The information in this section is intended only for qualified service personnel. Some of the procedures may expose you to hazardous voltages that could result in personal injury or death. Do not perform these procedures unless you are qualified to do so.

Handling and cleaning precautions

Because of the high-impedance areas on the Model 7999-3, care should be taken when handling or servicing the card to prevent possible contamination. The following precautions should be observed when servicing the card.

Handling precautions

Observe the following precautions when handling the multiplexer card:

- Handle the card only by the edges.
- Do not touch connector insulator.
- Do not touch any board surfaces or components not associated with the repair.
- Do not touch areas adjacent to electrical contacts.
- When servicing the card, wear clean cotton gloves.
- Do not store or operate the card in an environment where dust could settle on the circuit board.

Card cleaning

- Use dry nitrogen gas to clean any dust off the circuit board and components.
- Clean the contaminated area with methanol, then blow dry the entire board with dry nitrogen gas.
- After cleaning, allow the card to dry in a 50°C low-humidity environment for several hours before use.

Performance verification

The following paragraphs discuss performance verification procedures for the Model 7999-3, including channel resistance and contact potential.

CAUTION Contamination will degrade the performance of the card. To avoid contamination, always grasp the card by the side edges. Do not touch the input/output connector insulator, and do not touch the board surfaces or components.

NOTE Failure of any performance verification test may indicate that the multiplexer card is contaminated. See "Handling and cleaning precautions" earlier in this section for information on cleaning the card.

Environmental conditions

All verification measurements should be made at an ambient temperature between 18° and 28°C, and at a relative humidity of less than 70%.

Recommended equipment

Table 4-1 summarizes the equipment necessary for performance verification, along with an application for each item.

Table 4-1
Recommended verification equipment

Description	Manufacturer/Model	Specifications	Test
Digital Multimeter	Keithley 2010	10Ω range, 60ppm	Channel resistance
Nanovoltmeter	Keithley 2182	10mV range, 50ppm	Contact potential
Test Lead Sets (2)	Keithley 1681	Banana plug/clips	Channel resistance
Low Thermal Cable	Keithley 2107-4	Low thermal/lugs	Contact potential

Multiplexer card connections

Test equipment connection diagrams in this section are generic in nature and are intended only to show basic connections on how to connect test equipment to the relay under test. See Section 2 for complete details on card connections and terminal designations.

Channel resistance tests

Perform the following steps to verify that each contact of every relay is closing properly and that the channel resistance is within specification.

1. Turn on the Model 2010 DMM, and allow it to warm up for one hour before making measurements.
2. Set the Model 2010 to the 10Ω range, and connect the four test leads to the INPUT and SENSE Ω 4 WIRE jacks.
3. Short the free ends of the four test leads together, and enable REL on the Model 2010 to null out residual resistance. Leave REL enabled for the entire test.
4. Connect the Model 2010 INPUT and SENSE Ω 4 WIRE jacks to the relay to be tested, as shown in Figure 4-1. Note that 4-wire connections to the relay input and output terminals are used.
5. Close the relay being tested.
6. Note the resistance reading on the Model 2010, and verify that it is $<0.5\Omega$.
7. Open the relay being tested
8. Repeat steps 4 through 7 for every relay on the card.

Figure 4-1
Channel resistance test
connections

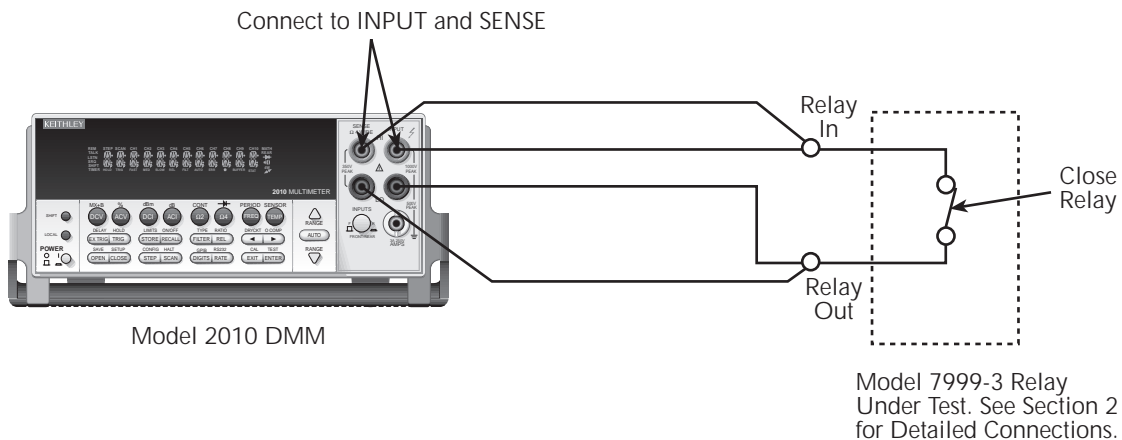

Contact potential tests

Perform the following procedure to check contact potential of each relay:

1. Connect the low-thermal cable to the Model 2182 Nanovoltmeter INPUT jack.
2. Turn on the Model 2182, and allow the unit to warm up for one hour to achieve rated accuracy.
3. Select the Model 2182 10mV range.
4. Temporarily short the Channel 1 HI and LO leads of the low-thermal cable.
5. Enable REL on the Model 2182.
6. Connect the Model 2182 to the relay being tested, as shown in Figure 4-2. Be sure to make connections to the Channel 1 input terminals, and use that channel for measurements.
7. Close the relay being tested.
8. Verify that the Model 2182 reading is $<10\mu\text{V}$.
9. Open the relay being tested.
10. Repeat steps 6 through 9 for all relays on the card.

Figure 4-2
Contact potential
connections

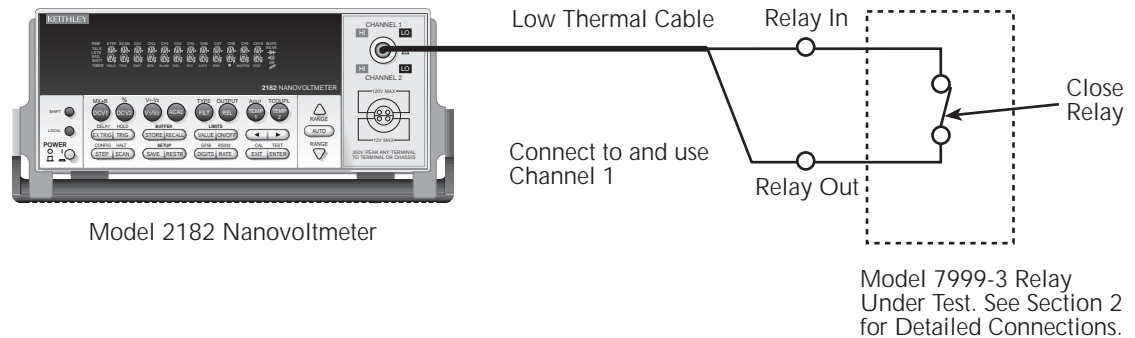

Replacing components

Replacement parts

Replacement parts can be obtained directly from Keithley Instruments, Inc. See the parts list in Section 5 for part numbers.

Replacement precautions

CAUTION Observe the following precautions when replacing components:

- **To avoid contamination, which could degrade card performance, always handle the card only by the handle and side edges. Do not touch the connector, board surfaces, or components on the card.**
- **Use care when removing relays from the PC board to avoid pulling traces away from the circuit board. Before attempting to remove a relay, use an appropriate de-soldering tool, to clear each mounting hole completely free of solder. Each relay pin must be free to move in its mounting hole before removal. Also, make certain that no burrs are present on the ends of the relay pins.**

Soldering considerations

When using solder on the circuit board, observe the following precautions:

- Use an OA-based (organic activated) flux, and take care not to spread the flux to other areas of the circuit board.
- Remove the flux from the work areas when the repair has been completed. Use pure water along with clean cotton swabs or a clean soft brush to remove the flux.
- Once the flux has been removed, swab only the repaired area with methanol, then blow dry the board with dry nitrogen gas.
- After cleaning, allow the card to dry in a 50°C low-humidity environment for several hours before use.

5

Replaceable Parts

Introduction

This section contains replacement parts information and component layout and schematic drawings for the Model 7999-3.

Parts list

The parts list for the Model 7999-3 is shown in Table 5-1.

Ordering information

To place an order, or to obtain information concerning replacement parts, contact your Keithley representative or the factory (see inside front cover for addresses). When ordering parts, be sure to include the following information:

- Card model number (Model 7999-3)
- Card serial number
- Part description
- Component designation (if applicable)
- Keithley part number

Factory service

If the card is to be returned to Keithley Instruments for repair, perform the following:

- Call the Repair Department at 1-800-552-1115 for a Return Material Authorization (RMA) number.
- Complete the service form at the back of this manual, and include it with the card.
- Carefully pack the instrument in the original packing carton.
- Write ATTENTION REPAIR DEPARTMENT and the RMA number on the shipping label.

Component layout and schematic diagram

These component layout and schematic diagram drawings are provided on the following pages:

- Component layout drawing: 7999-3-100
- Schematic diagram: 7999-3-106

Table 5-1

Parts list

Circuit designation	Description	Keithley part no.
CR1 - CR20	Diode, BAV103	RF-89
DS1 - DS20	LED	PL-72-1
J1	Receptacle, 96-pin male	CS-514-1
K1 - K20	Relay, EB2-24NU	RL-233
R1 - R20	Resistor, 150k Ω	R-376-150K

LTR.	ECA NO.	REVISION	ENG.	DATE
A	22904	RELEASED	MAH	4/13/99

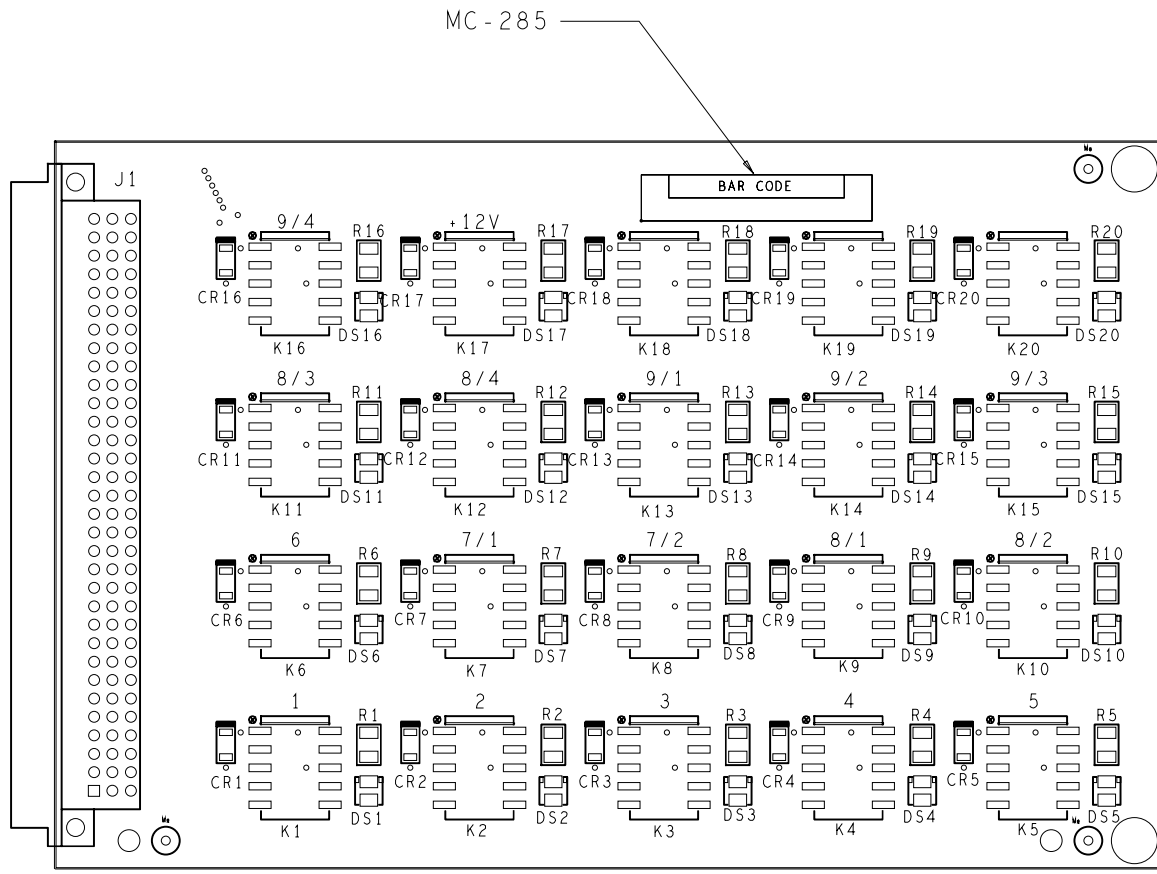

REFER TO THE 7999-3-102 PRODUCT STRUCTURE FOR FURTHER COMPONENT INFORMATION.

MODEL	NEXT ASSEMBLY	QTY.
	USED ON	

KEITHLEY KEITHLEY INSTRUMENTS INC. CLEVELAND, OHIO 44139	DIM ARE IN IN. UNLESS OTHERWISE NOTED	DATE 12/2/98	SCALE 2:1	TITLE
	DIM. TOL. UNLESS OTHERWISE SPECIFIED	DRN MAH	APPR.	COMPONENT LAYOUT
XX+.01 XXX+.005	ANG. .1 FRAC. .1/64	DO NOT SCALE THIS DRAWING	C	NO. 7999-3-100

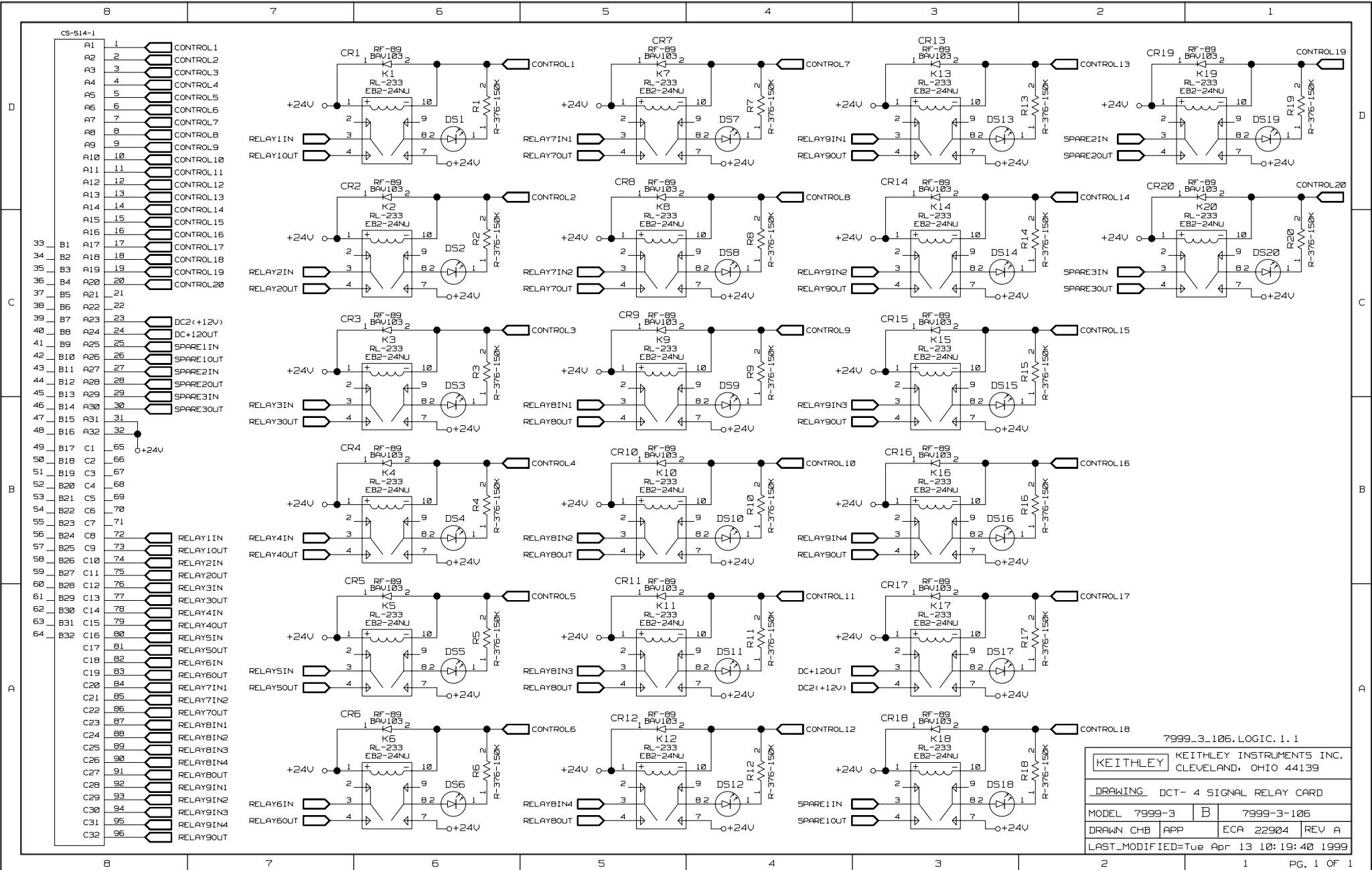

7999_3_106. LOGIC. 1. 1

KEITHLEY		KEITHLEY INSTRUMENTS INC. CLEVELAND, OHIO 44139	
DRAWING DCT- 4 SIGNAL RELAY CARD			
MODEL 7999-3	B	7999-3-106	
DRAWN CHB	APP	ECA 22904	REV A
LAST_MODIFIED=Tue Apr 13 10:19:40 1999			

Index

Symbols

+24V power terminals 2-8

C

Card cleaning 4-2
Card configuration 2-2
Card connections 2-7
Card layout 2-2
Channel resistance tests 4-4
Component layout and schematic diagram 5-3
Connections 2-1
Contact potential tests 4-5
Control terminals 2-7
Controlling relays 2-8

E

Environmental conditions 4-3

F

Factory service 5-2
Feature overview 1-2

G

General Information 1-1
Ground loops 3-3

H

Handling and cleaning precautions 4-2
Handling precautions 1-3, 2-2, 4-2

I

Input/output connector 2-7
Inspecting for damage 1-3
Instruction manual 1-4
Introduction 1-2, 2-2, 3-2, 4-2, 5-2

K

Keeping the input/output connector clean 3-2

M

Manual addenda 1-2
Maximum signal considerations 3-2
Multiplexer card connections 4-3

O

Operating Considerations 3-1
Ordering information 5-2

P

Parts list 5-2
Performance verification 4-3

R

Recommended connector 1-4
Recommended equipment 4-3
Relay power and control 3-2
Repacking for shipment 1-4
Replaceable Parts 5-1
Replacement parts 4-6
Replacement precautions 4-6
Replacing components 4-6
RFI/EMI 3-3

S

Safety symbols and terms 1-3
Service Information 4-1
Shipment contents 1-4
Signal terminals 2-7
Simplified schematic 2-4
Soldering considerations 4-6
Specifications 1-3
Switching considerations 3-2

T

Terminal designations 2-7

U

Unpacking and inspection 1-3

W

Warranty information 1-2

Service Form

Model No. _____ Serial No. _____ Date _____

Name and Telephone No. _____

Company _____

List all control settings, describe problem and check boxes that apply to problem. _____

Intermittent Analog output follows display Particular range or function bad; specify _____

IEEE failure

Obvious problem on power-up

Batteries and fuses are OK

Front panel operational

All ranges or functions are bad

Checked all cables

Display or output (check one)

Drifts

Unable to zero

Unstable

Overload

Will not read applied input

Calibration only

Certificate of calibration required

Data required

(attach any additional sheets as necessary)

Show a block diagram of your measurement including all instruments connected (whether power is turned on or not). Also, describe signal source.

Where is the measurement being performed? (factory, controlled laboratory, out-of-doors, etc.) _____

What power line voltage is used? _____ Ambient temperature? _____ °F

Relative humidity? _____ Other? _____

Any additional information. (If special modifications have been made by the user, please describe.)

Be sure to include your name and phone number on this service form.

KEITHLEY

Keithley Instruments, Inc.

28775 Aurora Road
Cleveland, Ohio 44139

Printed in the U.S.A.