

KEITHLEY

Model 7999-6 GPIB RF Relay Unit

Instruction Manual

A GREATER MEASURE OF CONFIDENCE

WARRANTY

Keithley Instruments, Inc. warrants this product to be free from defects in material and workmanship for a period of 1 year from date of shipment.

Keithley Instruments, Inc. warrants the following items for 90 days from the date of shipment: probes, cables, rechargeable batteries, diskettes, and documentation.

During the warranty period, we will, at our option, either repair or replace any product that proves to be defective.

To exercise this warranty, write or call your local Keithley representative, or contact Keithley headquarters in Cleveland, Ohio. You will be given prompt assistance and return instructions. Send the product, transportation prepaid, to the indicated service facility. Repairs will be made and the product returned, transportation prepaid. Repaired or replaced products are warranted for the balance of the original warranty period, or at least 90 days.

LIMITATION OF WARRANTY

This warranty does not apply to defects resulting from product modification without Keithley's express written consent, or misuse of any product or part. This warranty also does not apply to fuses, software, non-rechargeable batteries, damage from battery leakage, or problems arising from normal wear or failure to follow instructions.

THIS WARRANTY IS IN LIEU OF ALL OTHER WARRANTIES, EXPRESSED OR IMPLIED, INCLUDING ANY IMPLIED WARRANTY OF MERCHANTABILITY OR FITNESS FOR A PARTICULAR USE. THE REMEDIES PROVIDED HEREIN ARE BUYER'S SOLE AND EXCLUSIVE REMEDIES.

NEITHER KEITHLEY INSTRUMENTS, INC. NOR ANY OF ITS EMPLOYEES SHALL BE LIABLE FOR ANY DIRECT, INDIRECT, SPECIAL, INCIDENTAL OR CONSEQUENTIAL DAMAGES ARISING OUT OF THE USE OF ITS INSTRUMENTS AND SOFTWARE EVEN IF KEITHLEY INSTRUMENTS, INC., HAS BEEN ADVISED IN ADVANCE OF THE POSSIBILITY OF SUCH DAMAGES. SUCH EXCLUDED DAMAGES SHALL INCLUDE, BUT ARE NOT LIMITED TO: COSTS OF REMOVAL AND INSTALLATION, LOSSES SUSTAINED AS THE RESULT OF INJURY TO ANY PERSON, OR DAMAGE TO PROPERTY.



Keithley Instruments, Inc. • 28775 Aurora Road • Cleveland, OH 44139 • 440-248-0400 • Fax: 440-248-6168 • <http://www.keithley.com>

BELGIUM:
CHINA:
FRANCE:
GERMANY:
GREAT BRITAIN:
INDIA:
ITALY:
NETHERLANDS:
SWITZERLAND:
TAIWAN:

Keithley Instruments B.V.
Keithley Instruments China
Keithley Instruments Sarl
Keithley Instruments GmbH
Keithley Instruments Ltd
Keithley Instruments GmbH
Keithley Instruments s.r.l.
Keithley Instruments B.V.
Keithley Instruments SA
Keithley Instruments Taiwan

Bergensesteenweg 709 • B-1600 Sint-Pieters-Leeuw • 02/363 00 40 • Fax: 02/363 00 64
Yuan Chen Xin Building, Room 705 • 12 Yumin Road, Dewai, Madian • Beijing 100029 • 8610-62022886 • Fax: 8610-62022892
3, allée des Garays • 91127 Palaiseau Cedex • 01-64 53 20 20 • Fax: 01-60 11 77 26
Landsberger Strasse 65 • 82110 Germering • 089/84 93 07-40 • Fax: 089/84 93 07-34
Unit 2 Commerce Park, Brunel Road • Theale • Reading • Berkshire RG7 4AB • 0118 929 7500 • Fax: 0118 929 7519
Flat 2B, WILOCRISSA • 14, Rest House Crescent • Bangalore 560 001 • 91-80-509-1320/21 • Fax: 91-80-509-1322
Viale S. Gimignano, 38 • 20146 Milano • 02-48 39 16 01 • Fax: 02-48 30 22 74
Postbus 559 • 4200 AN Gorinchem • 0183-635333 • Fax: 0183-630821
Kriesbachstrasse 4 • 8600 Dübendorf • 01-821 94 44 • Fax: 01-820 30 81
1 Fl. 85 Po Ai Street • Hsinchu, Taiwan, R.O.C. • 886-3572-9077 • Fax: 886-3572-903

Model 7999-6 GPIB RF Relay Unit Instruction Manual

©2001, Keithley Instruments, Inc.
All rights reserved.
Cleveland, Ohio, U.S.A.
First Printing, April 2001
Document Number: 7999-6-901-01 Rev. A

Manual Print History

The print history shown below lists the printing dates of all Revisions and Addenda created for this manual. The Revision Level letter increases alphabetically as the manual undergoes subsequent updates. Addenda, which are released between Revisions, contain important change information that the user should incorporate immediately into the manual. Addenda are numbered sequentially. When a new Revision is created, all Addenda associated with the previous Revision of the manual are incorporated into the new Revision of the manual. Each new Revision includes a revised copy of this print history page.

Revision A (Document Number 7999-6-901-01)..... April 2001

Safety Precautions

The following safety precautions should be observed before using this product and any associated instrumentation. Although some instruments and accessories would normally be used with non-hazardous voltages, there are situations where hazardous conditions may be present.

This product is intended for use by qualified personnel who recognize shock hazards and are familiar with the safety precautions required to avoid possible injury. Read the operating information carefully before using the product.

The types of product users are:

Responsible body is the individual or group responsible for the use and maintenance of equipment, for ensuring that the equipment is operated within its specifications and operating limits, and for ensuring that operators are adequately trained.

Operators use the product for its intended function. They must be trained in electrical safety procedures and proper use of the instrument. They must be protected from electric shock and contact with hazardous live circuits.

Maintenance personnel perform routine procedures on the product to keep it operating, for example, setting the line voltage or replacing consumable materials. Maintenance procedures are described in the manual. The procedures explicitly state if the operator may perform them. Otherwise, they should be performed only by service personnel.

Service personnel are trained to work on live circuits, and perform safe installations and repairs of products. Only properly trained service personnel may perform installation and service procedures.

Keithley products are designed for use with electrical signals that are rated Installation Category I and Installation Category II, as described in the International Electrotechnical Commission (IEC) Standard IEC 60664. Most measurement, control, and data I/O signals are Installation Category I and must not be directly connected to mains voltage or to voltage sources with high transient over-voltages. Installation Category II connections require protection for high transient over-voltages often associated with local AC mains connections. The user should assume all measurement, control, and data I/O connections are for connection to Category I sources unless otherwise marked or described in the Manual.

Exercise extreme caution when a shock hazard is present. Lethal voltage may be present on cable connector jacks or test fixtures. The American National Standards Institute (ANSI) states that a shock hazard exists when voltage levels greater than 30V RMS, 42.4V peak, or 60VDC are present. **A good safety practice is to expect that hazardous voltage is present in any unknown circuit before measuring.**

Users of this product must be protected from electric shock at all times. The responsible body must ensure that users are prevented access and/or insulated from every connection point. In some cases, connections must be exposed to potential human contact. Product users in these circumstances must be trained to protect themselves from the risk of electric shock. If the circuit is capable of operating at or above 1000 volts, **no conductive part of the circuit may be exposed.**

Do not connect switching cards directly to unlimited power circuits. They are intended to be used with impedance limited sources. NEVER connect switching cards directly to AC mains. When connecting sources to switching cards, install protective devices to limit fault current and voltage to the card.

Before operating an instrument, make sure the line cord is connected to a properly grounded power receptacle. Inspect the connecting cables, test leads, and jumpers for possible wear, cracks, or breaks before each use.

When installing equipment where access to the main power cord is restricted, such as rack mounting, a separate main input power disconnect device must be provided, in close proximity to the equipment and within easy reach of the operator.

For maximum safety, do not touch the product, test cables, or any other instruments while power is applied to the circuit under test. ALWAYS remove power from the entire test system and discharge any capacitors before: connecting or disconnecting cables or jumpers, installing or removing switching cards, or making internal changes, such as installing or removing jumpers.

Do not touch any object that could provide a current path to the common side of the circuit under test or power line (earth) ground. Always make measurements with dry hands while standing on a dry, insulated surface capable of withstanding the voltage being measured.

The instrument and accessories must be used in accordance with its specifications and operating instructions or the safety of the equipment may be impaired.

Do not exceed the maximum signal levels of the instruments and accessories, as defined in the specifications and operating information, and as shown on the instrument or test fixture panels, or switching card.

When fuses are used in a product, replace with same type and rating for continued protection against fire hazard.

Chassis connections must only be used as shield connections for measuring circuits, NOT as safety earth ground connections.

If you are using a test fixture, keep the lid closed while power is applied to the device under test. Safe operation requires the use of a lid interlock.

If a  screw is present, connect it to safety earth ground using the wire recommended in the user documentation.

The  symbol on an instrument indicates that the user should refer to the operating instructions located in the manual.

The  symbol on an instrument shows that it can source or measure 1000 volts or more, including the combined effect of normal and common mode voltages. Use standard safety precautions to avoid personal contact with these voltages.

The **WARNING** heading in a manual explains dangers that might result in personal injury or death. Always read the associated information very carefully before performing the indicated procedure.

The **CAUTION** heading in a manual explains hazards that could damage the instrument. Such damage may invalidate the warranty.

Instrumentation and accessories shall not be connected to humans.

Before performing any maintenance, disconnect the line cord and all test cables.

To maintain protection from electric shock and fire, replacement components in mains circuits, including the power transformer, test leads, and input jacks, must be purchased from Keithley Instruments. Standard fuses, with applicable national safety approvals, may be used if the rating and type are the same. Other components that are not safety related may be purchased from other suppliers as long as they are equivalent to the original component. (Note that selected parts should be purchased only through Keithley Instruments to maintain accuracy and functionality of the product.) If you are unsure about the applicability of a replacement component, call a Keithley Instruments office for information.

To clean an instrument, use a damp cloth or mild, water based cleaner. Clean the exterior of the instrument only. Do not apply cleaner directly to the instrument or allow liquids to enter or spill on the instrument. Products that consist of a circuit board with no case or chassis (e.g., data acquisition board for installation into a computer) should never require cleaning if handled according to instructions. If the board becomes contaminated and operation is affected, the board should be returned to the factory for proper cleaning/servicing.

7999-6 GPIB RF Relay Unit

Relay Specifications

CONNECTOR TYPE:

Input: Female SMA connector (on relay).
Output: N-type.

CONTACT LIFE: 5×10^6 cycles minimum; 10×10^6 typical.

ACTUATION TIME: 15ms.

FREQUENCY RANGE: DC to 4GHz. Relay paths are 50Ω terminated when open.

INSERTION LOSS: $0.3\text{dB} + 0.115 \times \text{frequency (in GHz)}$.

ISOLATION: 100dB minimum; 130dB typical.

SWR: 1.2 maximum.

GENERAL

INTERFACE: GPIB (IEEE-488.2) and SCPI.

INDICATORS: Power, relay position status and error LED.

CONTACT CLOSURE COUNTERS: One counter per relay path, up to 10 million counts each, maintained in non-volatile memory.

MAXIMUM COMMON MODE: 42V peak, any terminal to earth.

MAXIMUM SWITCHING SIGNAL: 1W CW, CAT I.

POWER: User-supplied 24VDC (22VDC min., 30VDC max.), 1.8A max.

ENVIRONMENT: Operating: 0° to 40°C , up to 35°C <80% RH.

Storage: -25° to 65°C .

EMC: Conforms with European Union Directive 89/336/EEC.

SAFETY: Conforms with European Union Directive 73/23/EEC.

DIMENSIONS: 429mm long \times 133mm wide \times 161mm deep (19.00" \times 5.25" \times 6.34").

ACCESSORIES SUPPLIED: Instruction manual.

Simplified Schematic

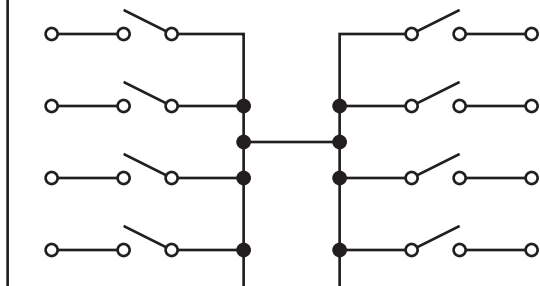

Specifications are subject to change without notice.

Table of Contents

1	General Information	
	Introduction	1-2
	Feature overview	1-2
	Warranty information	1-2
	Manual addenda	1-2
	Safety symbols and terms	1-3
	Specifications	1-3
	Unpacking and inspection	1-3
	Inspection for damage	1-3
	Handling precautions	1-3
	Shipment contents	1-4
	Instruction manual	1-4
	Repacking for shipment	1-4
	Connections	1-4
2	Connections	
	Introduction	2-2
	Handling precautions	2-2
	Configuration	2-2
	Layout	2-2
	Simplified schematic	2-4
	Connections	2-5
	GPIB control connection	2-5
	Power connector	2-8
3	Operation	
	Introduction	3-2
	Maximum signal considerations	3-2
	Bus operation (GPIB)	3-3
	Bus connections	3-3
	Primary address	3-3
	Programming syntax	3-3
	Response messages	3-7
	Status model	3-8
	Event register sets	3-10
	Enable registers	3-11
	Queues	3-11
	Status byte and SRQ	3-13
	Service request enable register	3-14
	Serial polling and SRQ	3-15
	Clearing registers and queues	3-16

Programming enable registers	3-17
Reading registers	3-17
Common commands	3-18
GPIB commands	3-26
ROUTE commands	3-26
:CLOSE.....	3-28
:CONFigure.....	3-29
STATus commands	3-30
:QUEue.....	3-30
SYSTem commands	3-32
Manual operation	3-34
Switching considerations	3-35
Connector integrity	3-35
Voltage Standing Wave Ratio	3-35
Path isolation	3-36
Insertion loss	3-36
RFI/EMI	3-36
Errors	3-37

4 Service Information

Introduction	4-2
Handling and cleaning precautions	4-2
Handling precautions	4-2
Card and connector cleaning	4-2
Performance verification	4-3
Environmental conditions	4-3
Recommended equipment	4-3
Channel resistance tests	4-3
Replacing components	4-4
Replacement parts	4-4
Replacement precautions	4-5
Soldering considerations	4-5
Relay replacement	4-5
Circuit board removal	4-8
GPIB address	4-8

5 Replaceable Parts

Introduction	5-2
Parts list	5-2
Ordering information	5-2
Factory service	5-2
Component layout	5-2

List of Illustrations

2	Connections	
Figure 2-1	General layout (front panel)	2-3
Figure 2-2	General layout (rear panel)	2-4
Figure 2-3	Simplified schematic	2-4
Figure 2-4	GPIB control connector	2-7
Figure 2-5	Power connector	2-8
3	Operation	
Figure 3-1	Command diagram	3-5
Figure 3-2	Controlling relay connections	3-6
Figure 3-3	Status model structure	3-9
Figure 3-4	Standard event status	3-10
Figure 3-5	Status byte and service request (SRQ)	3-13
Figure 3-6	16-bit status register	3-17
Figure 3-7	Standard event enable register	3-20
Figure 3-8	Standard event status register	3-21
Figure 3-9	Service request enable register	3-23
Figure 3-10	Status byte register	3-25
Figure 3-11	Manual operation	3-34
4	Service Information	
Figure 4-1	Channel resistance test connections	4-4
Figure 4-2	Model 7999-6 exploded view	4-6
Figure 4-3	GPIB address switch example	4-9

List of Tables

2	Connections	
Table 2-1	GPIB control connector terminals	2-6
Table 2-2	Power connector pinouts	2-8
3	Operation	
Table 3-1	Parameter types	3-4
Table 3-2	SCPI commands — error queue	3-12
Table 3-3	Common and SCPI commands — reset registers and clear queues	3-16
Table 3-4	IEEE-488.2 common commands and queries	3-18
Table 3-5	:ROUTe subsystem command set	3-27
Table 3-6	:STATus subsystem command set	3-30
Table 3-7	:SYSTem subsystem command set	3-32
Table 3-8	Error and status message	3-37
4	Service Information	
Table 4-1	Recommended verification equipment	4-3
5	Replaceable Parts	
Table 5-1	Parts list—electronic components	5-3
Table 5-2	Parts list—mechanical parts	5-5

1

General Information

Introduction

This section contains general information about the Model 7999-6 GPIB RF Relay. The information is organized as follows:

- Feature overview
- Warranty information
- Manual addenda
- Safety symbols and terms
- Specifications
- Unpacking and inspection
- Connections

If you have any questions after reviewing this information, please contact your local Keithley representative or call one of our Applications Engineers at 1-800-KEITHLEY. Worldwide phone numbers are listed at the front of this manual.

Feature overview

The Model 7999-6 is an IEEE-488 controlled, single or dual, 4 or 6 pole, 19-inch rack mounted relay unit. Additional features of the Model 7999-6 are as follows:

- N-type bulkhead connectors (insulated)
- +24VDC power connections
- LED indicators for error, power, and relay status
- Operating range to 4GHz (relay dependent)
- Can be upgraded from 4-pole to 6-pole relays

Warranty information

Warranty information is located at the front of this instruction manual. Should your Model 7999-6 require warranty service, contact the Keithley representative or authorized repair facility in your area for further information. When returning the Model 7999-6 for repair, be sure to fill out and include the service form at the back of this manual to provide the repair facility with the necessary information.

Manual addenda

Any improvements or changes concerning the Model 7999-6 or manual will be explained in an addendum included with the manual. Be sure to note these changes and incorporate them into the manual.

Safety symbols and terms

The following symbols and terms may be found on the Model 7999-6 or used in this manual.

The  symbol indicates that the user should refer to the operating instructions located in the manual.

The  symbol shows that high voltage may be present on the terminal(s). Use standard safety precautions to avoid personal contact with these voltages.

The **WARNING** heading used in this manual explains dangers that might result in personal injury or death. Always read the associated information very carefully before performing the indicated procedure.

The **CAUTION** heading used in this manual explains hazards that could damage the switch. Such damage may invalidate the warranty.

Specifications

Full Model 7999-6 specifications are included at the front of this manual.

Unpacking and inspection

Inspection for damage

The Model 7999-6 is packaged in a re-sealable, anti-static bag to protect it from damage due to static discharge and from contamination that could degrade its performance. Before removing the Model 7999-6 from the bag, observe the precautions on handling discussed below.

Handling precautions

- Always grasp the Model 7999-6 by the covers. Do not touch board surfaces or components.
- After removing the Model 7999-6 from its anti-static bag, inspect it for any obvious signs of physical damage. Report any such damage to the shipping agent immediately.
- When the Model 7999-6 is not installed and connected, keep the unit in its anti-static bag and store it in the original packing carton.

Shipment contents

The following items are included with every Model 7999-6 order:

- Model 7999-6 GPIB Relay Unit (single or dual 4-pole/6-pole IEEE-488 controlled relay switch)
- Model 7999-6 Instruction Manual (this manual)
- Additional accessories as ordered

Instruction manual

If an additional Model 7999-6 Instruction Manual is required, order the manual package, Keithley part number 7999-6-901-00. The manual package includes an instruction manual and any pertinent addenda.

Repacking for shipment

Should it become necessary to return the Model 7999-6 for repair, carefully pack the unit in its original packing carton or the equivalent, and follow these instructions:

- Call the Repair Department at 1-800-552-1115 for a Return Material Authorization (RMA) number.
- Advise as to the warranty status of the Model 7999-6.
- Write ATTENTION REPAIR DEPARTMENT and the RMA number on the shipping label.
- Fill out and include the Service Form located at the back of this manual.

Connections

The following are available Model 7999-6 connections:

- Power receptacle: 9-pin D-sub connector
- IEEE-488 port (GPIB connector)
- N-type bulkhead connectors

NOTE Refer to Section 2 for detailed connection information.

2

Connections

Introduction

This section contains information about overall switch configuration and connections and is organized as follows:

- Handling precautions
- Configuration
- Connections

WARNING The procedures in this section are intended only for qualified service personnel. Do not perform these procedures unless you are qualified to do so. Failure to recognize and observe normal safety precautions could result in personal injury or death.

Handling precautions

To maintain high-impedance isolation, care should be taken when handling the switch to avoid contamination from foreign materials such as body oils. Such contamination can reduce isolation resistance. To avoid possible contamination:

- Always grasp the switch by the handles or the relay housing.
- Do not touch bulkhead connector insulators.
- Operate the switch in a clean environment. If the switch becomes contaminated, it should be thoroughly cleaned as explained in Section 4.

Configuration

Layout

Figure 2-1 and Figure 2-2 show the general layout of the Model 7999-6 featuring the following:

Connectors:

- Power receptacle (9-pin male D-sub connector)
- GPIB Control: IEEE-488 interface connector
- N-type insulated bulkhead input connectors

Indicators:

- Power LED
- ERR LED (communication error or failed power on self-test)
- Relay state LEDs (one for each relay pole)

Switches:

- Manual toggle switch (one per relay)

Figure 2-1
General layout (front panel)

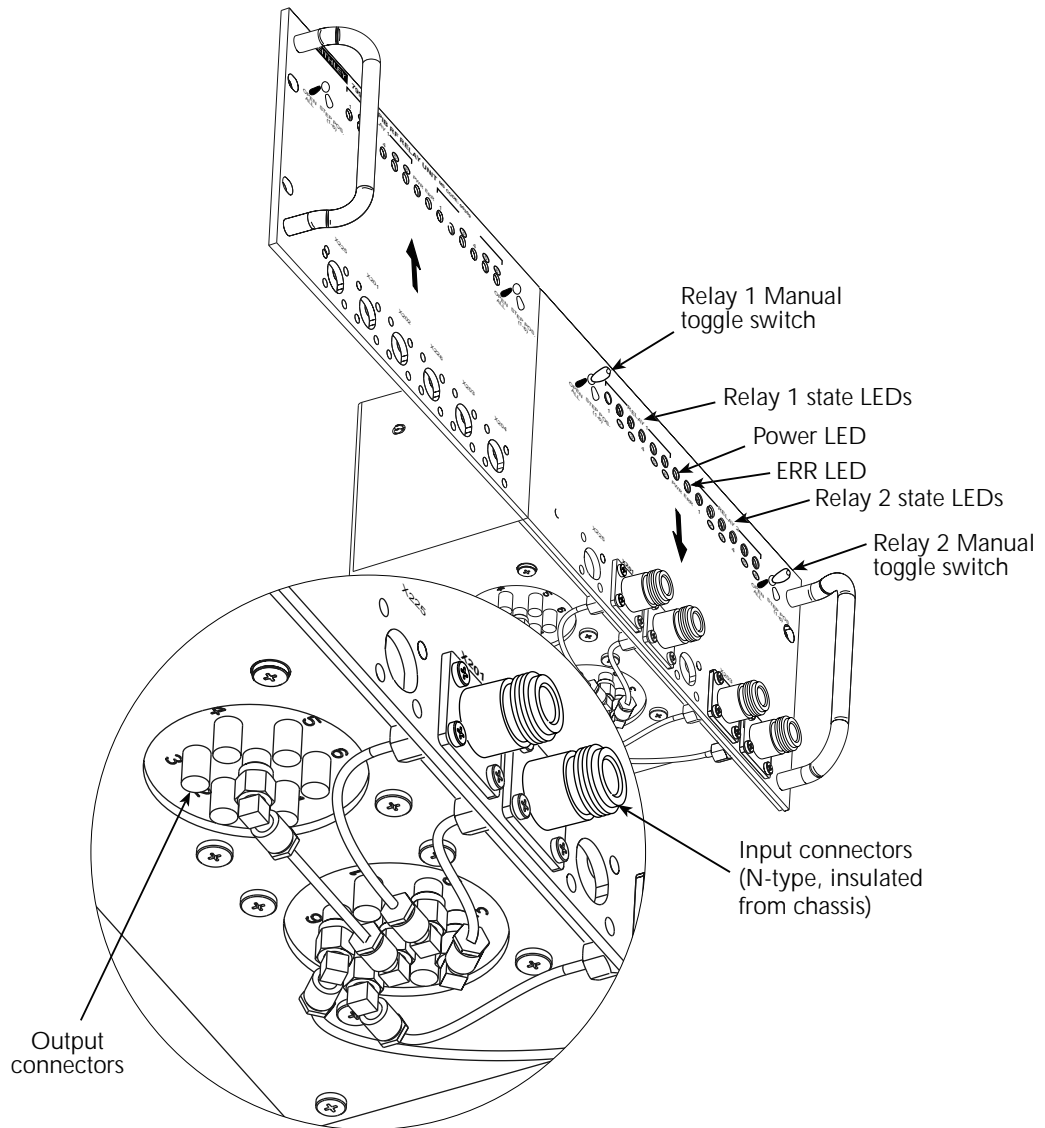
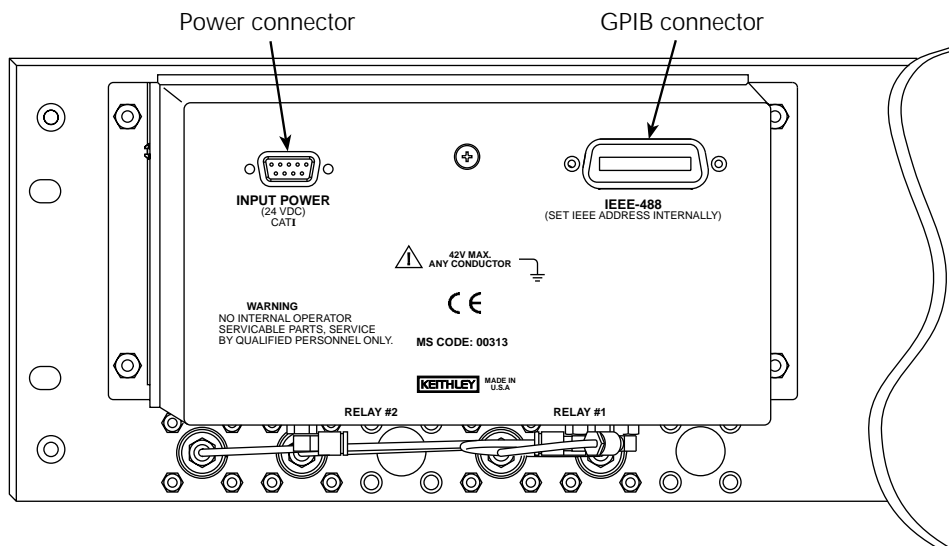

Figure 2-2
General layout (rear panel)



Simplified schematic

Figure 2-3 shows a simplified schematic diagram of the Model 7999-6. The solid lines represent a 4-pole relay; the additional dashed lines represent a 6-pole relay.

Figure 2-3
Simplified schematic

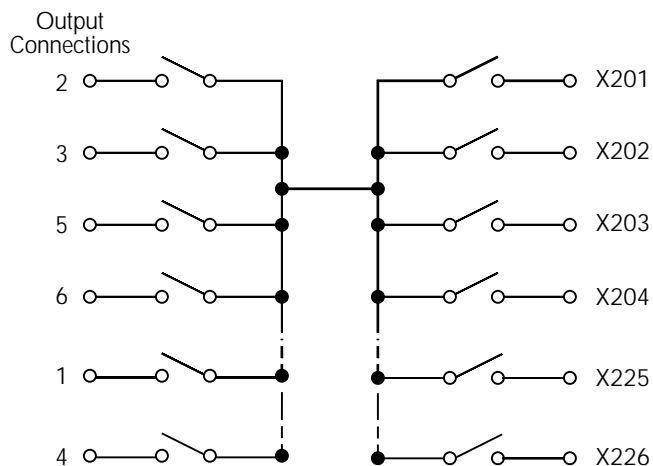

Connections

GPIB control connection

The GPIB control port is connected to the GPIB port of a computer (controller) using a shielded IEEE-488 interface cable with metric mating screws.

Remember the following restrictions when attaching instruments to the GPIB:

- A maximum separation of 4 meters between any two instruments on the bus.
- A maximum total cable length of 20 meters.
- No more than 15 devices on the bus.
- No two instruments having the same address.

If you cannot meet these requirements, the use of bus extenders is recommended.

CAUTION **IEEE-488 common is connected to digital common. Maximum voltage between digital common and earth ground is 0V.**

Connectors may be stacked to allow a number of parallel connections to one instrument. Two screws located on a standard connector maintain secure connections between connectors.

NOTE *To minimize interference caused by electromagnetic radiation, use shielded IEEE-488 cables.*

Connect devices to the GPIB as follows:

1. Line up the cable connector with the connector located on the Model 7999-6. The connector's design allows installation to the port in only one position.
2. Secure connector by tightening screws firmly (do not overtighten).
3. Add any additional connectors to the port as required.
4. Connect the free end of the cable to the controller.
5. Check that the GPIB address and other GPIB protocol information is properly set. (See Section 4 of this manual for GPIB address information.)

Table 2-1
 GPIB control connector terminals

Contact Number	IEEE-488 designation	Type
1	DI01	Data
2	DI02	Data
3	DI03	Data
4	DI04	Data
5	EOI (24)*	Management
6	DAV	Handshake
7	NRFD	Handshake
8	NDAC	Handshake
9	IFC	Management
10	SRQ	Management
11	ATN	Management
12	SHIELD	Ground
13	DI05	Data
14	DI06	Data
15	DI07	Data
16	DI08	Data
17	REN (24)*	Management
18	Gnd (6) *	Ground
19	Gnd (7) *	Ground
20	Gnd (8) *	Ground
21	Gnd (9) *	Ground
22	Gnd (10) *	Ground
23	Gnd (11) *	Ground
24	Gnd, LOGIC	Ground

* Numbers in parentheses refer to signal ground return of referenced contact number. EOI and REN signal lines return on contact 24.

Figure 2-4
GPIB control connector

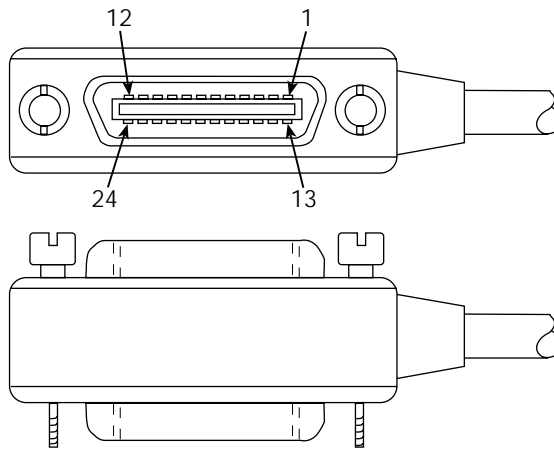

GPIB address

On the main circuit board, there are five GPIB address DIP switches. When shipped from the factory, the GPIB address is set to 3. To change the GPIB address of the relay, refer to Section 4 of this manual.

Power connector

Connect the 24VDC power supply to the power connector. Make sure the power supply is properly wired (UL listed cable with a 9-PIN D-subminiature female connector—the Model 7999-6 power connector's pinouts are shown in Figure 2-5 with the pin descriptions contained in Table 2-2).

WARNING To prevent damage to the Model 7999-6 and to prevent the risk of electric shock, use only a properly rated power supply. The power supply must be double insulated, have the required safety agency approvals for the low voltage directives, EMC directives, and CE certification. It must also provide output current limiting and short-circuit protection.

Table 2-2
Power connector pinouts

Pin Number	Description
1, 2	Positive (+)
3	(Not used)
4, 5	Negative (-)
6, 7, 8, 9	(Not used)

Figure 2-5
Power connector

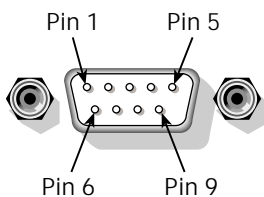

3

Operation

Introduction

This section contains the following operating information for the Model 7999-6:

- “Maximum signal considerations” on page 3-2
- “Bus operation (GPIB)” on page 3-3
- “Status model” on page 3-8
- “Programming enable registers” on page 3-17
- “Common commands” on page 3-18
- “GPIB commands” on page 3-26
- “Manual operation” on page 3-34
- “Switching considerations” on page 3-35
- “Errors” on page 3-37

Maximum signal considerations

WARNING Maximum voltage between any conductor and ground is 42V.

CAUTION To prevent damage to the Model 7999-6, do not exceed the following maximum signal level specifications of the switch:

- Maximum Voltage: 30VDC, 42V peak
- Maximum Switching Signal: 1W CW, CAT I

Bus operation (GPIB)

NOTE *The term GPIB (General Purpose Bus Interface) is used in this manual. GPIB is simply another term for the IEEE-488 bus.*

Bus connections

Before using the switch, you must connect the IEEE-488 connector on the rear panel of the switch to the IEEE-488 connector of the controller. Use a Keithley Model 7077 or similar shielded IEEE-488 cable for this connection. Refer to Section 2 for more information on the IEEE-488 connection.

Primary address

The primary address of the Model 7999-6 must agree with the primary address you intend to specify in the controller's programming language. On the main circuit board, there are five GPIB address DIP switches. When shipped from the factory, the GPIB address is set to 3. To change the GPIB address of the relay, refer to Section 4 of this manual.

Programming syntax

Syntax rules for programming the Model 7999-6 are covered in this paragraph.

Commands and parameters

The general form for SCPI commands is demonstrated in Tables 3-2 through 3-4. They are hierarchical in nature and begin with a root command. For example, to open all channels for relays 1 and 2, send the following command:

```
:OPEN:ALL
```

The root path command for the above example is ROUTe. This is an optional command word (as indicated by the brackets ([]) in the table) and need not be used.

The general form for Common Commands is shown in Table 3-4.

NOTE *Each common command is preceded by a star (*).*

Parameters provide specific types of information. The following list (Table 3-1) contains the definitions of the different parameter types.

Table 3-1
Parameter types

Parameter	Description
<name>	Name parameter: Select a parameter name from a listed group.
<clist>	List of channels. The following examples demonstrate proper format: (@1!1,1!5) Channels 1 and 5 of relay 1
	Boolean: Enable (1 or on) or disable (0 or off) a function.
<NRf>	Numeric representation format: Number can be expressed as an integer, real number or an exponent (e.g. 2.3E6).
<n>	Numeric value: An NRf number or one of the following name parameters: <ul style="list-style-type: none"> -DEFault: Uses the *RST default parameter value -MINimum: Uses the lowest allowable parameter value -MAXimum: Uses the largest allowable parameter value

Short-form commands

Most SCPI command words and name parameters have a short-form version. The short-form versions are identified in the SCPI tables by the upper case characters. Example:

```
:ROUT:CLOS (@1!2,2!4) = :ROUTe:CLOSE (@1!2,2!4)
```

NOTE *Command words and parameter names are not case sensitive.*

Query commands

Query commands request information (queries) and can be identified by the question mark appearing after the command (?). Example:

```
:CLOSE? Queries the channels that are closed.
```

Command messages

Program Message — A program message is made up of one or more command words sent by the computer to the instrument. Some programming operations require several command words.

Single Command Message — This program message uses the command words required to perform a single programming operation. Example:

```
:SYST:ERR? Reads the system error queue.
```

Multiple Command Message — This program message contains two or more command operations. Each command string is separated by a semicolon (;). The following example uses the short-form format to reduce the size of the message:

```
:ROUT:CLOS (@1!2,2!4);:ROUT:CLOS?
```

The above program message closes 1!2 and 2!4, and then queries for closed relays.

Commands that are on the same command level can be executed without having to repeat the entire command path. For example:

```
:ROUT:CONF:CPOL1 4;CPOL2 4
```

Since :CPOL1 and :CPOL2 are on the same command level (see), the :ROUT:CONF command word does not have to be repeated for the second command string. Note also that the leading colon (:) for :CPOL2? is not used. Common commands and SCPI commands can be used in the same program message as long as they are separated by a semicolon (;). Example:

```
*RST;CLOSe (@1!1,1!3)
```

Example command

To connect the N-connector X201 to output 5 of relay 1, send:

```
:ROUT:CLOS (@2!2,1!5);
```

Refer to Figure 3-1 for a diagram of the parts of this command and to Figure 3-2 for an illustration of the physical connections.

Figure 3-1
Command diagram

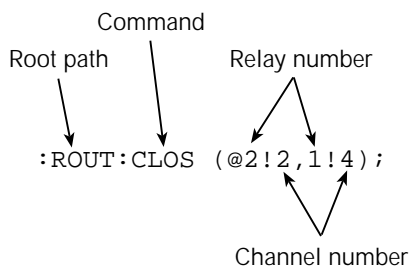
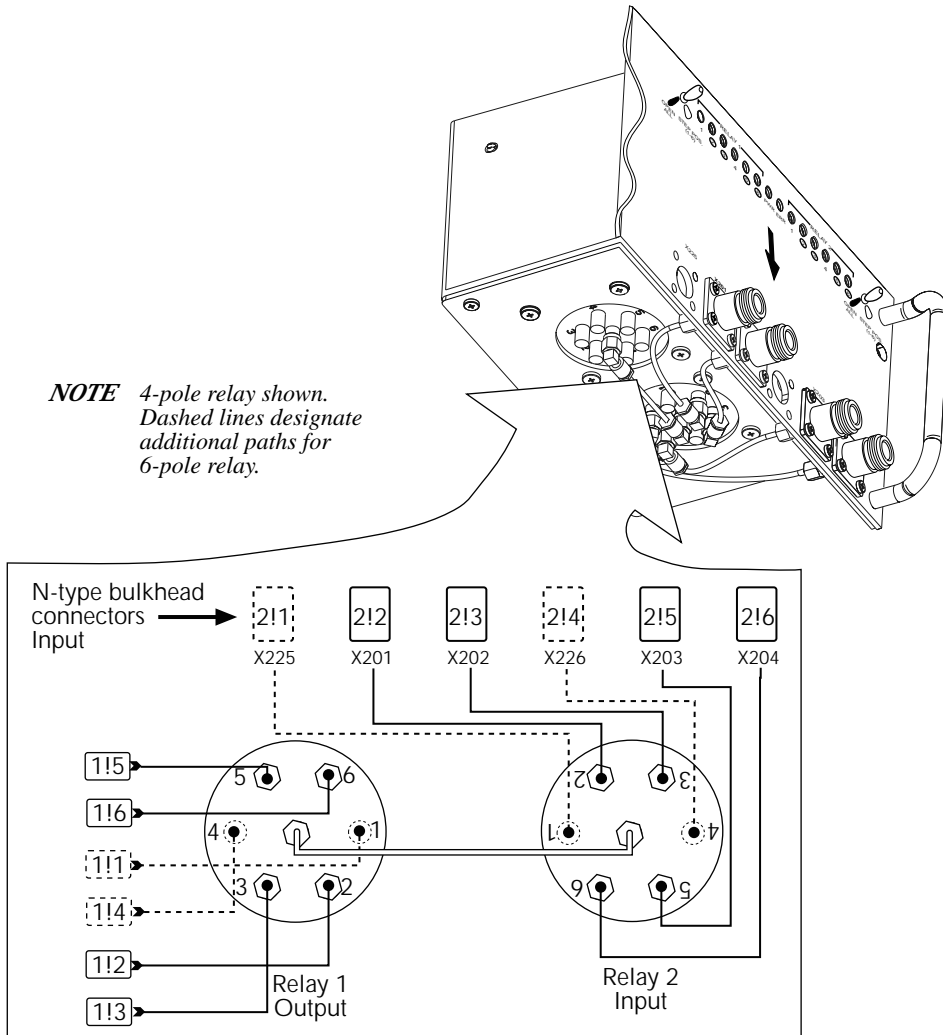

Figure 3-2
Controlling relay connections



The Model 7999-6 contains two relays that are IEEE controlled and connected center-to-center with blocking. The signal is brought in through one of four bulkhead connections and switched to one of four output connections (switching is controlled over the IEEE bus). In our example, relays 2!2 and 1!5 are closed which completes the path from N-type bulkhead connector X201 to relay #1 output connector 5 (see Figure 3-2).

Program message terminator (PMT)

Each program message must be terminated with a LF (line feed), EOI (end or identify), or a LF + EOI. The bus will hang if your computer does not provide this termination. The following example shows how a program message must be terminated:

```
:outp on <PMT>
```

Command execution rules

- Commands execute in the order presented in the program message.
- An invalid command generates an error and is not executed.
- Valid commands preceding an invalid command in a multiple command program message are executed.
- Valid commands following an invalid command in a multiple command program message are ignored.

Response messages

A response message is the message sent by the instrument to the computer in response to a query command program message.

Sending a response message

After sending a query command, the response message is placed in the output queue. When the relay unit is then addressed to talk, the response message is sent from the output queue to the computer.

Multiple response messages

If you send more than one query command in the same program message the multiple response messages for all the queries are sent to the computer when the relay unit is addressed to talk. The responses are sent in the order the query commands were sent and are separated by semicolons (;). Items within the same query are separated by commas (,). The following example shows the response message for a program message that contains four single item query commands:

```
0;1;1;0
```

Response message terminator (RMT)

Each response is terminated with an LF (line feed) and EQI (end or identify). The following example shows how a multiple response message is terminated:

```
0;1;1;0 <RMT>
```

Message exchange protocol

Two rules summarize the message exchange protocol:

Rule 1: You must always tell the relay unit what to send to the computer.

Perform the following two steps to send information from the relay switch to the computer:

1. Send the appropriate query command(s) in a program message.
2. Address the relay switch to talk.

Rule 2: The computer must receive the complete response message before another program message can be sent to the relay unit.

Status model

The relay unit provides status registers and queues allowing the operator to monitor and manipulate the various instrument events. The status structure is shown in Figure 3-3. The heart of the status structure is the status byte register. This register can be read by the user's test program to determine if a service request (SRQ) has occurred, and what event caused it.

Figure 3-3
Status model structure

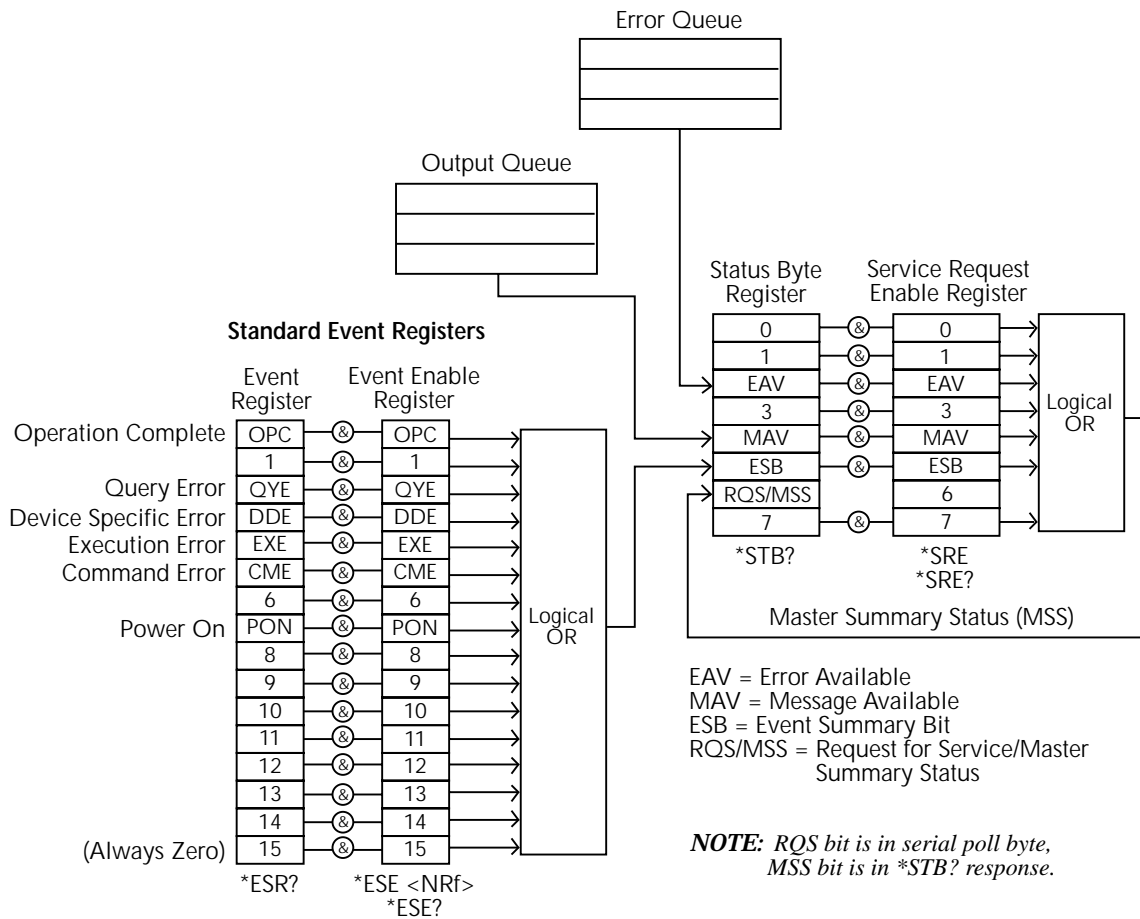

Event register sets

An event register set is made up of an event register and an event enable register. When an event occurs, the appropriate event register bit sets to 1. The bit remains latched (to 1) until the register is reset. When an event register bit is set and its corresponding enable bit is set (as programmed by the user), the output (summary) of the register will set to 1, which in turn sets the summary bit of the status byte register.

Figure 3-4
Standard event status

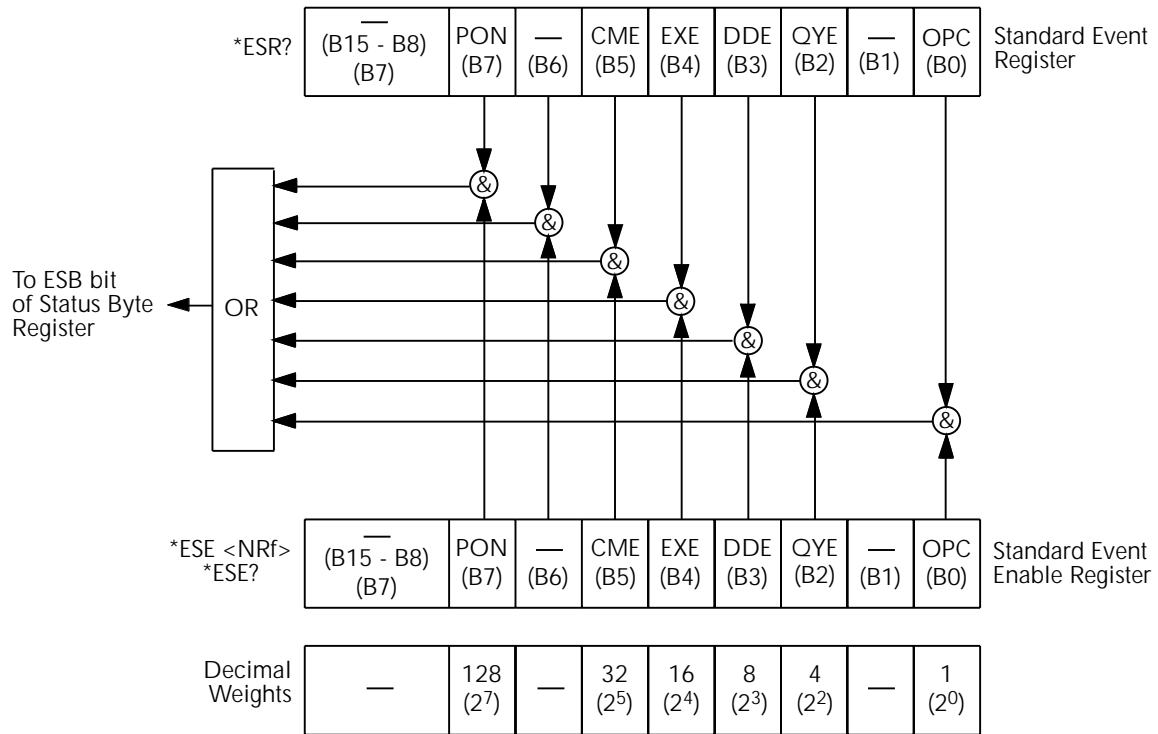

PON = Power On
 CME = Command Error
 EXE = Execution Error
 DDE = Device-Dependent Error
 QYE = Query Error
 OPC = Operation Complete

& = Logical AND
 OR = Logical OR

Enable registers

The enable register is user programmed and serves as a mask for the corresponding event register. An even bit is masked when the corresponding bit in the enable register is cleared (0). When masked, a set bit in an event register cannot set a bit in the status byte register ($1 \text{ AND } 0 = 0$).

To use the status byte register to detect events (i.e., serial poll), unmask the events by setting the appropriate bits of the enable registers.

Use *ESE and *ESE? (common commands) to program and read the standard event register.

Queues

The relay unit uses an output queue and an error queue. The response messages to query commands are placed in the output queue. As various programming errors and status messages occur, they are placed in the error queue (this queue holds up to ten messages). When a queue contains data, it sets the appropriate summary bit of the status byte register.

Output queue

When data is placed in the output queue, the message available bit (MAV) in the status byte register sets. A data message is cleared from the output queue when it is read. The output queue is considered cleared when it is empty. A cleared output queue clears the MAV bit in the status byte register. A message is read from the output queue by addressing the unit to talk after the appropriate query is sent.

The following command sequence enables the MAV bit (B4) of the status byte register set and then causes an SRQ:

*SRE 16	'Enable MAV bit of the status byte to cause an SRQ.
<i>Language specific</i>	'Send a query command to the unit.
<i>Language specific</i>	'Wait for an SRQ indicating ready to read.
<i>Language specific</i>	'Read the query response.

Error queue

When a message is placed in the error queue, the error available bit (EAV) in the status byte register sets. An error/status message is cleared from the error queue when it is read. The error queue is considered cleared when it is empty. A cleared error queue clears the EAV bit in the status byte register.

Read an error message from the error queue by sending either of the following SCPI query commands and then addressing the Model 7999-6 to talk:

```
:SYSTem:ERRor?
:STATus:QUEue?
```

Messages in the error queue are stored in a FIFO (First In-First Out) manner. The commands to read the error queue are listed in Table 3-2. When you read a single message in the error queue, the “oldest” message is read and then removed from the queue. If the queue becomes full, the message “350, ‘queue overflow’” will occupy the last memory location. On power-up, the error queue is empty. When empty, the message “0, No Error” is placed in the queue.

Messages in the error queue are preceded by a code number. Negative (-) numbers are used for SCPI defined messages, and positive (+) numbers are used for Keithley defined messages. The error messages are listed in Table 3-8 on page 3-37.

On power-up, all error messages are enabled and will go into the error queue as they occur. Status messages are not enabled and will not go into the queue. As listed in Table 3-2, there are commands to enable and/or disable messages. For these commands, the <list> parameter is used to specify which messages to enable or disable. The messages are specified by their codes. The following examples show various forms for using the <list> parameter.

```
<list> = (-110)           Single message
        = (-110,-222,-220) Comma separated entries
```

When you enable messages, messages not specified in the list are disabled. When you disable messages, each listed message is removed from the enabled list.

NOTE To prevent all messages from entering the error queue, send the enable command along with the null list parameter as follows: `STATus:QUEue:ENABle ()`.

Table 3-2

SCPI commands — error queue

Command	Description	Default
STATus :QUEue [:NEXT]? :ENABle<list> :ENABle? :DISABle<list> :DISABle? :CLEAr	STATus subsystem: Read error queue: Read and clear oldest error/status message. Specify error and status messages for error queue. Read the enabled messages. Specify messages not to be placed in queue. Read the disabled messages. Clear messages from error queue.	(Note 1) (Note 2) (Note 2)
SYSTem :ERRor? :CLEAr	SYSTem subsystem: Read error queue: Clear messages from error queue.	(Note 1)

Notes:

1. Power-up and *CLS empties the error queue. STATus:PRESet has no effect.
2. Power-up enables error messages and disables status messages. *CLS and STATus:PRESet have no effect.

For more information on these commands, see the specific command listing in the SCPI command section.

Status byte and SRQ

Service request is controlled by two 8-bit registers: the Status Byte Register and the Service Request Enable Registers. Figure 3-5 shows the structure for these registers.

Figure 3-5
Status byte and service request (SRQ)

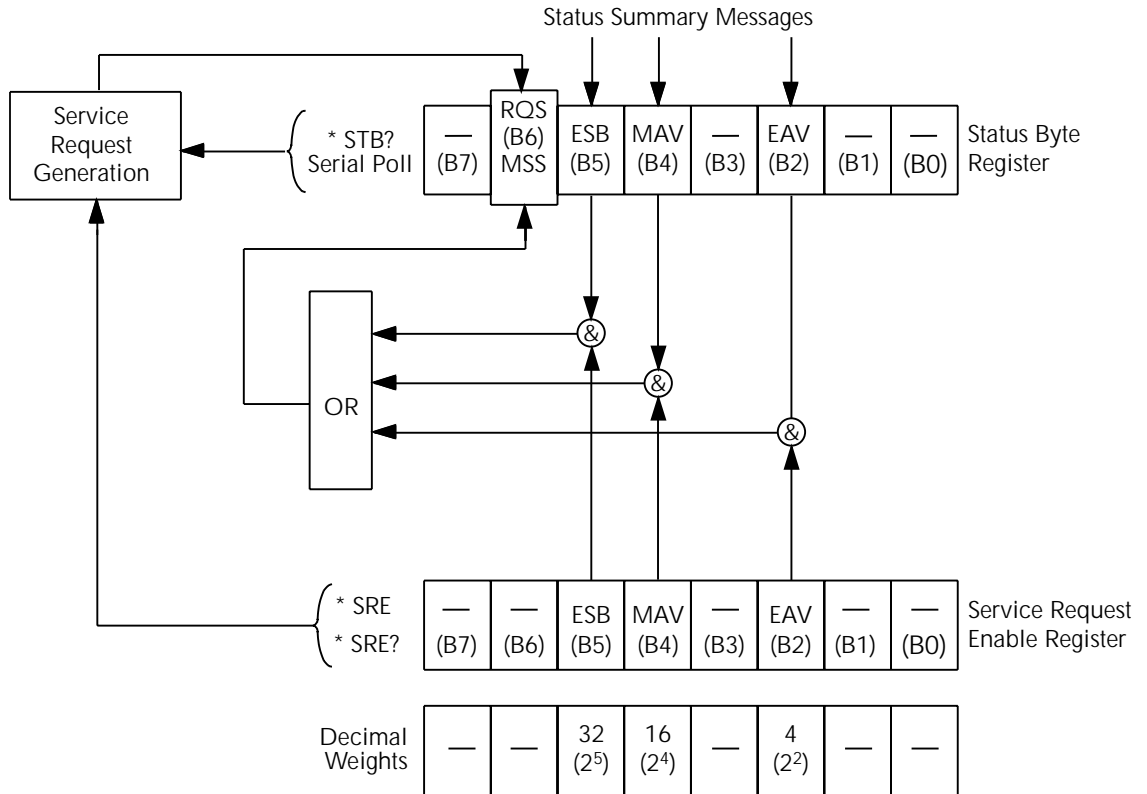

MSS = Master Summary Status & = Logical AND
 RQS = Request for Service OR = Logical OR
 ESB = Event Summary Bit
 MAV = Message Available
 EAV = Error Available

Status byte register

The summary messages from the status registers and queues are used to set or clear the appropriate bits (B2, B4, B5, and B6) of the status byte register. These summary bits do not latch, and their states (0 or 1) are solely dependent on the summary messages (0 or 1). For example, if the standard event register is read, its register will clear. As a result, its summary message will reset to 0, which in turn will reset the ESB bit in the status byte register.

Depending on how it is used, Bit B6 of the status byte register is either the request for service (RQS) bit or the master summary status (MSS) bit:

When using the serial poll sequence of the relay unit to obtain the status byte (a.k.a. serial poll byte), B6 is the RQS bit. See “Serial Polling and SRQ” for details on using the serial poll sequence.

When using the `*STB?` command (see Figure 3-4 on page 3-10) to read the status byte, B6 is the MSS bit.

The status byte register receives the summary bits of the Standard Event Register set and two queues. The register set and queues monitor the various instrument events. When an enabled event occurs, it sets a summary bit in the status byte register. When a summary bit of the status byte is set and its corresponding enable bit is set (as programmed by the user), the RQS/MSS bit will set to indicate that an SRQ has occurred.

Service request enable register

The generation of a service request is controlled by the service request enable register. This register is programmed by the user and is used to enable or disable the setting of bit B6 (RQS/MSS) by the status summary message bits (B2, B4, B5, and B6) of the status byte register. As shown in Figure 3-5, the summary bits are logically ANDed (&) with the corresponding enable bits of the service request enable register. When a set (1) summary bit is ANDed with an enabled (1) bit of the enable register, the logic “1” output is applied to the input of the OR gate and, therefore, sets the MSS/RQS bit in the status byte register.

The individual bits of the service request enable register can be set or cleared by using the `*SRE` common command. To read the service request enable register, use the `*SRE?` query command. The service request enable register clears when power is cycled or a parameter value of 0 is sent with the `*SRE` command (i.e. `*SRE 0`). The commands to program and read the SRQ enable register are listed in Table 3-2.

Serial polling and SRQ

Any enabled event summary bit that goes from 0 to 1 will set bit B6 and generate an SRQ (service request). In your test program, you can periodically read the status byte to check if an SRQ has occurred and what caused it. If an SRQ occurs, the program can, for example, branch to an appropriate subroutine that will service the request.

Typically, SRQs are managed by the serial poll sequence of the relay unit. If an SRQ does not occur, bit B6 (RQS) of the status byte register will remain cleared, and the program will simply proceed normally after the serial poll is performed. If an SRQ does occur, bit B6 of the status byte register will set, and the program can branch to a service subroutine when the SRQ is detected by the serial poll.

The serial poll automatically resets RQS of the status byte register. This allows subsequent serial polls to monitor bit B6 for an SRQ occurrence generated by other event types. After a serial poll, the same event can cause another SRQ, even if the event register that caused the first SRQ has not been cleared.

The serial poll does not clear MSS. The MSS bit stays set until all status byte summary bits are reset.

Clearing registers and queues

When the relay unit is powered up, the bits of all registers in the status structure are clear (set to 0) and the two queues are empty. Commands to reset the event and event enable registers, and the error queue are listed in Table 3-3. In addition to these commands, any enable register can be reset by sending the 0 parameter value with the individual command to program the register.

NOTE *RST has no effect on status structure registers and queues. See “Queues” for details on the error queue.

Table 3-3

Common and SCPI commands — reset registers and clear queues

Commands	Description	Ref
To reset Standard event register: *ESE 0 or *CLS	Reset all bits of the Standard Event Register to 0.	Note 1
To clear error queue: *CLS	Clear all messages from error queue	Note 1
STATus :QUEue { :NEXT } ? :CLEar	STATus subsystem: Error queue: Read and clear the oldest error/status message. Clear all messages from error queue.	Note 2
SYSTEM :ERROR? :CLEar	SYSTEM subsystem: Read and clear the oldest error/status message. Clear all messages from error queue.	Note 2

Notes:

1. The standard event enable register is not reset by STATus:PRESet (see “Status byte and service request commands”).
2. STATus:PRESet has no effect on the error queue.
3. Use either of the two :CLEar commands to clear the error queue.

Programming enable registers

The registers that can be programmed by the user are the enable registers. All other registers in the status structure are read-only registers. The following explains how to ascertain the parameter value for the various commands used to program enable registers. The actual commands are covered later in this section (see Table 3-4).

A command to program an event enable register is sent with a decimal parameter value that determines the desired state (0 or 1) of each bit in the appropriate register. The bit positions of the register (see Table 3-5) indicate the parameter value in binary format. For example, if you wish to set bits B5, B4, and B2 (set the bit's value to 1), the binary value would be 110100 (where B5=1, B4=1, B3=0, B2=1, B1=0, B0=0 and all other bits are 0). The decimal equivalent of binary 110100 is 52. Therefore, the parameter value for the enable command is 52.

Another way to determine the decimal value is to add up the decimal weights for the bits that you wish to set. Note that Figure 3-6 includes the decimal weight for each register bit. To set bits B5, B3, and B2, the parameter value would be the sum of the decimal weights for those bits ($32+16+4 = 52$).

Figure 3-6
16-bit status register

A) Bits 0 through 7

Bit Position	B7	B6	B5	B4	B3	B2	B1	B0
Binary Value	0/1	0/1	0/1	0/1	0/1	0/1	0/1	0/1
Decimal Weights	128 (2^7)	64 (2^6)	32 (2^5)	16 (2^4)	8 (2^3)	4 (2^2)	2 (2^1)	1 (2^0)

B) Bits 8 through 15

Bit Position	B15	B14	B13	B12	B11	B10	B9	B8
Binary Value	0/1	0/1	0/1	0/1	0/1	0/1	0/1	0/1
Decimal Weights	32768 (2^{15})	16384 (2^{14})	8192 (2^{13})	4096 (2^{12})	2048 (2^{11})	1024 (2^{10})	512 (2^9)	256 (2^8)

Reading registers

Any register in the status structure can be read by using the appropriate query (?) command. The specific query commands are covered later in this section (see Table 3-4).

The response message to the query command is a decimal value. To determine which bits in the register are set, convert that decimal value to its binary equivalent. For example, the binary equivalent of decimal 48 is 110000. This binary value indicates that bits B5 and B4 are set.

Common commands

NOTE Each common command is preceded by a star (*).

Common commands are device commands that are common to all devices on the bus. These commands are designated and defined by the IEEE-488.2 standard. Common commands are listed in Table 3-4.

Table 3-4
IEEE-488.2 common commands and queries

Mnemonic	Name	Description
*CLS	Clear status	Clear the standard event register and error queue.
*ESE <NRf>	Event enable command	Program the standard event enable register.
*ESE?	Event enable query	Read the standard event enable register.
*ESR?	Event status register query	Read the standard event enable register and clear it.
*IDN?	Identification query	Returns the manufacturer, model number, serial number, and firmware revision levels of the unit.
*OPC	Operation complete command	Set the operation complete bit in the standard event register after all pending commands have been executed.
*OPC?	Operation complete query	Places an ASCII "1" into the output queue when all pending selected device operations have been completed.
*RST	Reset command	Returns the relay unit to the *RST default condition.
*SRE<NRf>	Service request enable command	Programs the service request enable register.
*SRE?	Service request enable query	Reads the service request enable register.
*STB?	Status byte query	Reads the status byte register.
*TST?	Self-test query	Performs a checksum test on ROM and returns the result.
*WAI	Wait-to-continue command	Wait until all previous commands are executed.

*CLS — Clear status

Clear status registers and error queue

Use the *CLS command to clear (set to 0) the bits of the following registers:

- Standard event register
- Error queue

***ESE <NRf> — Event Enable**

Program the standard event enable register

***ESE? —Event Enable Query**

Read the standard event register

Parameter	<NRf> = 0	Clear register
	1	Set OPC(B0)
	4	Set QYE (B2)
	8	Set DDE(B3)
	16	Set EXE(B4)
	32	Set CME(B5)
	64	Set URQ(B6)
	128	Set PON(B7)
	255	Set all bits

Use the *ESE command to program the Standard Event Enable Register. This command is sent with the decimal equivalent of the binary value that determines the desired state (0 or 1) of the bits in the register. This register is cleared on power-up.

This register is used as a mask for the Standard Event Register. When a standard event is masked, the occurrence of that event will not set the Event Summary Bit (ESB) in the Status Byte Register. Conversely, when a standard event is unmasked (enabled), the occurrence of that event sets the ESB bit. For information on the Standard Event Register and descriptions of the standard event bits, see the *ESR? command.

A cleared bit (0) in the enabled register prevents (masks) the ESB bit in the Status Byte Register from setting when the corresponding standard event occurs. A set bit (1) in the enable register allows (enables) the ESB bit to set when the corresponding standard event occurs.

The Standard Event Enable Register is shown in Figure 3-7 and includes the decimal weight of each bit. The sum of the decimal weights of the bits that you wish to be set is the parameter value that is sent with the *ESE command. For example, to set the CME and QYE bits of the Standard Event Enable Register, send the following command:

```
*ESE 36
```

```
where:  CME (bit B5) = 32
        QYE (bit B2) =  4
        <NRf> = 36
```

If a command error (CME) occurs, bit B5 of the Standard Event Status Register sets. If a query error (QYE) occurs, bit B2 of the Standard Event Status Register sets. Since both of these events are unmasked (enabled) the occurrence of any one of them causes the ESB bit in the Status Byte Register to set. Read the Standard Event Status Register using the *ESE? query command.

Figure 3-7
Standard event enable register

Bit position	(B15 - B8)	B7	B6	B5	B4	B3	B2	B1	B0
Event	—	PON	—	CME	EXE	DDE	QYE	—	OPC
Decimal Weighting	—	128 (2 ⁷)	—	32 (2 ⁵)	16 (2 ⁴)	8 (2 ³)	4 (2 ²)	—	1 (2 ⁰)
Value	—	0/1	—	0/1	0/1	0/1	0/1	—	0/1

Value: 1 = Enable Standard Event
0 = Disable (Mask) Standard Event

Events: PON = Power On
CME = Command Error
EXE = Execution Error
DDE = Device-Dependent Error
QYE = Query Error
OPC = Operation Complete

*ESR? - Event Status Register Query

Reads then clears the standard event status register

Use this command to acquire the value (in decimal) of the Standard Event Register (see Figure 3-8). The binary equivalent of the returned decimal value determines which bits in the register are set. The register is cleared on power-up.

A set bit in this register indicates that a particular event has occurred. For example, for an acquired decimal value of 48, the binary equivalent is 00110000. From this binary value, bits B4 and B5 of the Standard Event Status Register are set. These bits indicate that a device-dependent error and command error have occurred.

The bits of the Standard Event Status Register are described as follows:

- **Bit B0, Operation Complete** — A set bit indicates that all pending selected device operations are completed and the Model 7999-6 is ready to accept new commands. This bit only sets in response to the *OPC command. It is not affected by the *OPC? command.
- **Bit B1** — Not used.
- **Bit B2, Query Error (QYE)** — A set bit indicates that you attempted to read data from an empty Output Queue.
- **Bit B3, Device-Dependent Error (DDE)** — A set bit indicates that an instrument operation did not execute properly due to some internal condition.

- **Bit B4, Execution Error (EXE)** — A set bit indicates that the Model 7999-6 detected an error while trying to execute a command.
- **Bit B5, Command Error (CME)** — A set bit indicates that a command error has occurred. Command errors include:
 - IEEE-488.2 syntax error — Model 7999-6 received a message that does not follow the defined syntax of the IEEE-488.2 standard.
 - Semantic error — Model 7999-6 received a command that was misspelled, or received an optional IEEE-488.2 command that is not implemented.
- **Bit B6** — Not used.
- **Bit B7, Power ON (PON)** — A set bit indicates that the Model 7999-6 has been turned off and turned back on since the last time this register has been read.

Figure 3-8
Standard event status register

Bit position	(B15 - B8)	B7	B6	B5	B4	B3	B2	B1	B0
Event	—	PON	—	CME	EXE	DDE	QYE	—	OPC
Decimal Weighting	—	128 (2 ⁷)	—	32 (2 ⁵)	16 (2 ⁴)	8 (2 ³)	4 (2 ²)	—	1 (2 ⁰)
Value	—	0/1	—	0/1	0/1	0/1	0/1	—	0/1

Value: 1 = Event bit set
2 = Event bit cleared

Events: PON = Power On
CME = Command Error
EXE = Execution Error
DDE = Device-Dependent Error
QYE = Query Error
OPC = Operation Complete

***IDN? — identification query**

Reads identification code

The identification code includes the manufacturer, model number, serial number, and firm-ware revision levels. Identification codes vary with the model number, output formats and out-put types. Power supplies set for the exponential output format and Keithley output types have the following codes:

KEITHLEY INSTRUMENTS INC., MODEL 7999-6, xxxxxxx, yyyy

Where: xxxxxxx is the serial number.
yyyy is the firmware revision level of the digital board ROM.

*OPC — operation complete	Sets OPC bit
*OPC? — operation complete query	Places a “1” in output queue

When *OPC is sent, the OPC bit in the standard event register will set after all pending command operations are complete. When *OPC? is sent, an ASCII “1” is placed in the output queue after all pending command operations are complete.

The following syntax rules explain how to use *OPC and *OPC? with other commands:

NOTE Send *OPC or *OPC?, separated by a semicolon, on the same line as another query. If sent on separate lines, an error occurs. The *OPC? can be sent on the same line with a command that is not a query, or on a separate line as a command (not a query).

*RST — reset	Return relay unit to *RST defaults
---------------------	------------------------------------

When the *RST command is sent, the relay unit performs the following operations:

1. Returns the instrument to the RST default conditions (see “Default” column of SCPI tables) and opens all relay paths.
2. Cancels all pending commands.
3. Cancels response to any previously received *OPC and *OPC? commands.

*SRE <NRf> — Service Request Enable	Program register
*SRE? — Service Request Enable Query	Read register

Parameter	<NRf> = 0	Clears enable register
	4	Set EAV bit (Bit 2)
	16	Set MAV bit (Bit 4)
	32	Set ESB (Bit 5)
	255	Set all bits

Use the *SRE command to program the Service Request Enable Register. Send this command with the decimal equivalent of the binary value that determines the desired state (0 or 1) of each bit in the register. This register is cleared on power-up.

This enable register is used along with the Status Byte Register to generate service requests (SRQ). With a bit in the Service Request Enable Register set, an SRQ occurs when the corresponding bit in the Status Byte Register is set by an appropriate event. For more information on register structure, see the information presented earlier in this section.

The Service Request Enable Register is shown in Figure 3-9. Notice that the decimal weight of each bit is included in the illustration. The sum of the decimal weights of the bits that you wish to set is the value that is sent with the *SRE command. For example, to set the ESB and MAV bits of the Service Request Enable Register, send the following command:

$$\begin{aligned} \text{where: } \quad \text{ESB (bit B5)} &= 32 \\ \quad \quad \quad \text{MAV (bit B4)} &= \underline{16} \\ \quad \quad \quad \langle \text{NRf} \rangle &= 48 \end{aligned}$$

The contents of the Service Request Enable Register can be read using the *SRE? query command.

Figure 3-9
Service request enable register

Bit position	B7	B6	B5	B4	B3	B2	B1	B0
Event	—	—	ESB	MAV	—	EAV	—	—
Decimal Weighting	—	—	32 (2 ⁵)	16 (2 ⁴)	—	4 (2 ²)	—	—
Value	—	—	0/1	0/1	—	0/1	—	—

Event: ESB = Event Summary Bit
 MAV = Message Available Bit
 EAV = Error Available
 MSB = Measurement Summary Bit

Value: 1 = Enable Service Request Event
 0 = Disable (Mask) Service Request Event

*STB? - Status Byte Query

Read Status Byte Register

Use the *STB? query command to acquire the value (in decimal) of the Status Byte Register. The Status Byte Register is shown in Figure 3-10. The binary equivalent of the decimal value determines which bits in the register are set.

All bits, except Bit B6, in this register are set by other event registers and queues. Bit 6 sets when one or more enabled conditions occur.

The *STB? query command does not clear the status byte register. This register can only be cleared by clearing the related registers and queues.

For example, for an acquired decimal value of 48, the binary equivalent is 00110000. This binary value indicates that bits 4 and 5 of the Status Byte Register are set.

The bits of the Status Byte Register are described as follows:

- **Bit 0** — Not used.
- **Bit 1** — Not used.
- **Bit 2, Error Available (EAV)** — A set bit indicates that an error or status message is present in the Error Queue. The message can be read using one of the following SCPI commands:
 - :SYSTem:ERRor?
 - :STATus:QUEue?
- **Bit 3** — Not used.
- **Bit 4, Message Available (MAV)** — A set bit indicates that a message is present in the Output Queue. The message is sent to the computer when the Model 7999-6 is addressed to talk.
- **Bit 5, Event Summary Bit (ESB)** — A set bit indicates that an enabled standard event has occurred. The event can be identified by reading the Standard Event Status Register using the *ESE? query command.
- **Bit 6, Master Summary Status (MSS)/Request Service (RQS)** — A set bit indicates that one or more enabled Status Byte conditions have occurred. Read the MSS bit by using the STB? query command, or perform a serial poll to detect the occurrence of a service request (RQS bit set).
- **Bit 7** — Not used.

Figure 3-10
Status byte register

Bit position	B7	B6	B5	B4	B3	B2	B1	B0
Event	—	MSS RQS	ESB	MAV	—	EAV	—	—
Decimal Weighting	—	64 (2 ⁶)	32 (2 ⁵)	16 (2 ⁴)	—	4 (2 ²)	—	—
Value	—	0/1	0/1	0/1	—	0/1	—	—

Events: MSS = Master Summary Status
RQS = Request Service
ESB = Event Summary Bit
MAV = Message Available
EAV = Error Available
MSB = Measurement Available Bit

Value: 1 = Event bit set
0 = Event bit cleared

*TST? — self-test query

Run relay self test and read result

NOTE This command activates all paths of both relays. Make certain the system is in a state that can permit all paths of both relays to be opened and closed.

Use this query command to perform a self-test for the relay actuation mechanism.

This command initiates the following sequence:

1. All paths of both relays are opened.
2. One path is closed (for both relays) and the indicator is read back. This occurs for each path. This ensures the actuator is energized and that only the single path closed.
3. The command places the coded result (0 or 1) in the output queue.

When the unit is addressed to talk, the coded result is sent from the output queue to the computer.

A returned value of one (1) indicates that the test passed, and a value of zero (0) indicates that the test failed.

WAI — wait-to-continue*Wait until previous commands are completed**

Effectively, the *WAI command is a no-op (no operation) for the relay unit and therefore, does not need to be used.

Two types of device commands exist:

Sequential commands — A command whose operations are allowed to finish before the next command is executed.

Overlapped commands — A command that allows the execution of subsequent commands while device operations of the overlapped command are still in progress.

The *WAI command is used to suspend the execution of subsequent commands until the device operations of all previous overlapped commands are finished. The *WAI command is not needed for sequential commands.

GPIB commands

This section contains Model 7999-6 specific commands for the three different subsystems as follows: “ROUTe commands” on page 3-26, “STATus commands” on page 3-30, and “SYSTEM commands” on page 3-32.

ROUTe commands

A list of the ROUTe commands is contained in Table 3-5. ROUTe commands are used to open and close channels, query closed channels, and to configure the relays (if relay type has been changed). The brackets indicate that [:ROUTe] is optional and need not be included in the command message. Following the table are details defining the use of the specific ROUTe subsystem commands.

Table 3-5
:ROUTE subsystem command set

Commands	Description	Default
[[:ROUTE]	Root path to :ROUTE subsystem commands.	
:CLOSE <clist>	Enter the list of channels to close.	
:CLOSE?	Query which channel(s) are closed. Returns a <clist> of closed channels.	
:COUNT[1]? <clist>	Query the number of times the channel(s) for relay #1 have been closed. Six comma-separated values are returned corresponding to channels 1–6.	
:COUNT2? <clist>	Query the number of times the channel(s) for relay #2 have been closed. Six comma-separated values are returned corresponding to channels 1–6.	
:RCOUNT[1]	Reset closure count for relay #1.	
:RCOUNT[2]	Reset closure count for relay #2.	
:OPEN <clist>	Enter the list of channels to open.	
:ALL	Opens all connections on channels 1 & 2.	
:CONFIGure	Path to configure commands.	
:CPOLe[1] <NRf>	Set the number of poles for channel 1 (4 or 6).	
:CPOLe[1]?	Query the number of poles for channel 1.	
:CPOLe2 <NRf>	Set the number of poles for channel 2 (4 or 6).	
:CPOLe2?	Query the number of poles for channel 2.	

:CLOSE <clist>

Close channel(s)

:CLOSE?

Query closed channel(s)

Parameter

<clist> = (@ chanlist)
where *chanlist* is the list of channels to be closed

Description

Enter the list of channels to close in a <clist>. For example, if you want to close channels 1!2 and 2!5, send ROUT:CLOS (@1!2,2!5).

Query

This query command is used to return a <clist> of presently closed channel(s). For example, if channels 1!2 and 2!5 are closed and ROUT:CLOS? is sent, then the query will return (@1!2,2!5).

:CLOSE**Path to COUNT and RCOunt commands**

This command path is required to access the following COUNT and RCOunt commands. To send any of the following commands, include the command path immediately before the command. For an example, see descriptions.

:COUNT[1]? Count the number of times channel(s) close on relay 1

:COUNT2? Count the number of times channel(s) close on relay 2

Description This command (query only) is used to return six comma-separated values representing closure count (the number of times the channel has been closed). For example, to return the closure count values for relay #1, send `:CLOSE:COUNT1`. The values returned correspond to channels 1–6 of either relay depending on the command issued.

Sending this query to a four-pole relay still returns six values, but, for the four-pole relay, the values for channel 1 and 4 will always return a 0.

To reset this count, see `CLOSE:RCOunt[1]` or `CLOSE:RCOunt2`.

:RCOunt[1] Reset closure count for relay 1

:RCOunt2 Reset closure count for relay 2

Description This command (query only) is used to reset closure count. For example, to return the closure count values for relay #1, send `:CLOSE:RCO1`.

To read instead of resetting closure count, see `CLOSE:COUNT[1]` or `CLOSE:COUNT2`.

Query No query form of this command exists.

:OPEN <clist> Open channel(s)

Parameter `<clist> = (@ chanlist)`
where *chanlist* is the list of channels to be opened.

Description Enter the list of channels to open in a `<clist>`. For example, if you want to open channels 1!2 and 2!5, send `ROUT:OPEN (@1!2,2!5)`.

Query No query form of this command exists.

:OPEN:ALL	Opens all channels on relay 1 and 2
:OPEN(ALL)	Alternative syntax to open all channels on relay 1 and 2

NOTE *Alternative syntax has been included for compatibility reasons. If using this alternative syntax, make sure there is no space between the “N” of OPEN and the first parenthesis “(”.*

Description Use this command to open all connections on relays 1 & 2. For example, to open all channels on both relays (#1 & #2), send:
:OPEN:ALL

Query No query form of this command exists.

:CONFigure Path to CPOLe commands

This command path is required to access the following CPOLe commands. To send any of the following commands, include the command path before the command. For an example, see description.

:CPOLe[1] <NRf>	Sets number of poles for relay 1
:CPOLe[1]?	Query number of poles set on relay 1
:CPOLe2 <NRf>	Sets number of poles for relay 2
:CPOLe2?	Query number of poles set on relay 2

Parameter	<NRf>	= 4	Select 4-pole mode
		= 6	Select 6-pole mode

Description Use this command to set the number of poles for relay 1 and 2, respectively. This is required when changing relay types (e.g., from a four-pole to a six-pole relay). For example, to configure relay #1 as a 6-pole relay, send:

```
CONF:CPOL1 6
```

Query This query command is used to return a response of the presently set mode (either 4 or 6).

STATUS commands

A list of the STATUS commands is contained in . STATUS commands are used to control the status registers of the Model 7999-6. Following the table are details defining the use of the specific STATUS subsystem commands.

The :STATUS command path is required to access all commands contained in the :STATUS subsystem command set. To send any of the commands contained in the :STATUS subsystem command set, include the command path immediately before the command. For an example, see the description of the specific command.

Table 3-6
:STATUS subsystem command set

Commands	Description	Default
:STATUS	Root path to :STATUS subsystem commands.	
:PRESet	Return status registers to default states.	
:QUEue	Path to access error queue.	
[:NEXT]?	Read the most recent error message.	
:ENABle <clist>	Specify error and status messages for queue.	
:ENABle?	Read the enabled messages.	
:DISABle <clist>	Specify messages not to be placed in queue.	
:DISABle?	Read the disabled messages.	
:CLEar	Clear all messages from the error queue.	

:PRESet Reset status registers to default states

Description Use this command to return all status registers to their default states. For example, to reset all status registers to their default states, send:

```
:STAT:PRES
```

Query No query form of this command exists.

:QUEue Path to queue commands

This command path is required to access the following error queue commands. To send any of the following commands, include the command path immediately before the command. For an example, see the descriptions.

[NEXT]?

Read most recent error

NOTE The `:STAT:QUE:NEXT?` is equivalent to the `:SYSTem:ERRor?` command. See the *SYSTem* subsystem for more information.

Description Use this query to read messages placed in the error queue. For example, send:

```
:STAT:QUE:NEXT?
```

After this command is sent and the 7999-6 is addressed to talk, the “oldest” message in the queue is sent to the computer.

The queue holds up to 10 messages. The error queue is a FIFO (first-in, first-out) register. Every time the error queue is queried, the oldest message is read and removed from the queue. If the error queue becomes full, the message “350, ‘Queue overflow’ ” will occupy the last memory location in the register. On power up, the error queue is empty. If empty, the message “0, ‘No Error’ ” is placed in the error queue. The messages in the error queue are preceded by a number. Refer to Table 3-8 on page 3-37 for a listing of error numbers and messages.

:ENABLE <list>

Enable error queue messages

:ENABLE?

Query for enabled error queue messages

Parameter

<list> = (numlist)

where *numlist* is a comma-separated list of messages desired to be enabled for the error queue. See Table 3-8 on page 3-37 for a list of error and status numbers.

Description

Use this command to specify status and error messages enabled for the error queue. On power-up, status messages are *not* enabled and therefore are prevented from going into the queue. All other error messages are enabled and will go into the error queue as they occur. When this command is sent, all messages are first disabled, then the messages specified in the list are enabled. For example, to enable only the -110, -140, and -222 messages, send:

```
:STAT:QUE:ENAB (-110,-140,-222)
```

To disable all messages from entering the error queue, send:

```
:STAT:QUE:ENAB ( )
```

Query

This query command is used to return a list of the presently enabled error messages.

:DISable <list>	Disable error queue messages
:DISable?	Query for disable error queue messages
Parameter	<list> = (numlist) where <i>numlist</i> is a comma-separated list of messages desired to be enabled for the error queue. See Table 3-8 on page 3-37 for a list of error and status numbers.
Description	Use this command to specify status and error messages disabled for the error queue. On power-up, status messages are <i>not</i> enabled and therefore are prevented from going into the queue. All other error messages are enabled and will go into the error queue as they occur unless disabled. For example, to disable the -110, -140, and -222 messages, send: :STAT:QUE:DIS (-110,-140,-222)
Query	This query command is used to return a list of the presently disabled error messages.
:CLEar	Clear all messages from the error queue
Description	Use this command to clear all messages from the error queue. For example, to clear all messages from the error queue, send: :STAT:QUE:CLE
Query	No query form of this command exists.

SYSTEM commands

A list of the SYSTem commands is contained in Table 3-7. The SYSTem command subsystem contains miscellaneous commands.

The :SYSTem command path is required to access all commands contained in the :SYSTem subsystem command set. To send any of the commands contained in the :SYSTem subsystem command set, include the command path before the command. For an example, see the description of the specific command.

Table 3-7
:SYSTem subsystem command set

Commands	Description	Default
:SYSTem	Root path to :SYSTem subsystem commands.	
:ERRor?	Query system error queue	
:VERSion?	Query SCPI version	
:CLEar	Clear messages in error queue	
:SNUMber?	Query the serial number only.	

:ERRor?**Query most recent error**

NOTE The `:SYST:ERR?` is equivalent to the `:STATus:QUEue:NEXT?` command. See the `STATus` subsystem for more information.

Description

Use this query to read messages placed in the error queue. For example, send:

```
:SYST:ERR?
```

After this command is sent and the 7999-6 is addressed to talk, the “oldest” message in the queue is sent to the computer.

The queue holds up to 10 messages. The error queue is a FIFO (first-in, first-out) register. Every time the error queue is queried, the oldest message is read and removed from the queue. If the error queue becomes full, the message “350, ‘Queue overflow’ ” will occupy the last memory location in the register. On power up, the error queue is empty. If empty, the message “0, ‘No Error’ ” is placed in the error queue. The messages in the error queue are preceded by a number. Refer to Table 3-8 on page 3-37 for a listing of error numbers and messages.

:VERsion?**Query SCPI version****Description**

Use this query to read the version of the SCPI standard being used by the Model 7999-6. For example, send:

```
:SYST:VER?
```

:CLEar**Clear all messages from the error queue****Description**

Use this command to clear all messages from the error queue. For example, send:

```
:SYST:CLE
```

Query

No query form of this command exists.

:SNUMber?**Query the serial number****Description**

Use this query to read the Model 7999-6 serial number. For example, send:

```
:SYST:SNUM
```

Manual operation

Toggle switches allow the operator to manually manipulate the relay channels. The switch can OPEN ALL relay channels of the associated relay, or step through the relay closing each channel (see Figure 3-11):

NOTE The manual toggle switches' OPEN ALL position controls the channels on the associated relay. This is different than the :OPEN:ALL command, which opens all of the channels on both relays.

Figure 3-11
Manual operation

NOTE Switches control the state of the associated relay. The switch located to the immediate left of Relay 1 controls the output relay, while the switch to the immediate right of Relay 2 controls the input relay. This figure illustrates the control of relay 1 with a 4-pole relay installed; control of a 6-pole relay or of relay 2 is similar.

Move toggle switch left to "OPEN ALL".

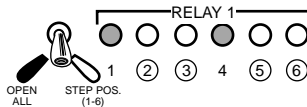

All channels on Relay 1 opened

For each move of the toggle switch right to "STEP POS.", the next relay in sequence closes.

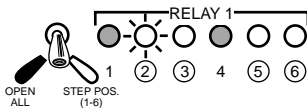

Channel 2 closed

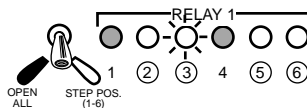

Channel 3 closed

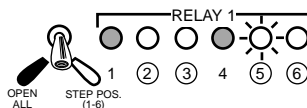

Channel 5 closed

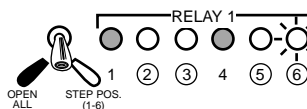

Channel 6 closed

LEGEND	
	LED NOT USED
	LED OFF
	LED ON

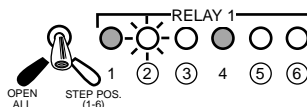

Channel 2 closed

To OPEN ALL channels on the associated relay, push the toggle switch to the left “OPEN ALL” position. All LEDs should extinguish.

To step through the channels closing each one sequentially, push the switch to the right “STEP POS.” position once for each channel. Unused channels (channel 1 and channel 4 if a 4-pole relay is installed) are skipped.

NOTE *The manual toggle switches have no effect on the status model. Also, relay closes initiated by the toggle switches are NOT tallied by the :COUNT[1] and :COUNT2? commands.*

Switching considerations

Signals switched by the Model 7999-6 may be subject to various effects that can seriously affect their integrity. The following paragraphs discuss these effects and ways to minimize them.

Connector integrity

As is the case with any high-resistance device, the integrity of connectors can be damaged if they are not handled properly. If connector insulation becomes contaminated, the insulation resistance will be substantially reduced, affecting high-impedance measurement paths. Refer to Section 4 for cleaning information.

Oils and salts from the skin can contaminate connector insulators, reducing their resistance. Also, contaminants present in the air can be deposited on the insulator surface. To avoid these problems, never touch the connector insulating material. In addition, use the relay only in clean, dry environments to avoid contamination.

Voltage Standing Wave Ratio

The Voltage Standing Wave Ratio (VSWR) is a measurement of mismatch in a cable, waveguide, or antenna system. The measurement is shown as ratio to 1, e.g., a VSWR of 1.2 is actually the ratio of 1.2:1. Refer to the specifications located at the front of this manual for Model 7999-6 VSWR information (specifications are shown with a 50Ω load).

Path isolation

The path isolation is the equivalent impedance between any two test paths in a measurement system. Ideally, the path isolation should be infinite, but the actual resistance and distributed capacitance of cables and connectors results in less than infinite path isolation values for these devices.

Path isolation resistance forms a signal path that is in parallel with the equivalent resistance of the DUT. For low-to-medium device resistance values, path isolation resistance is seldom a consideration; however, it can seriously degrade measurement accuracy when testing high-impedance devices. The voltage measured across such a device, for example, can be substantially attenuated by the voltage divider action of the device source resistance and path isolation resistance. Also, leakage currents can be generated through these resistances by voltage sources in the system. Refer to the specifications located at the front of this manual for Model 7999-6 isolation information.

Insertion loss

Insertion loss indicates signal lost while passing through the switch. This loss occurs in the various signal path components through the switch connectors, PC board traces, and relay. Refer to the specifications located at the front of this manual for Model 7999-6 insertion loss information.

RFI/EMI

RFI (Radio Frequency Interference) and EMI (Electromagnetic Interference) are general terms used to describe electromagnetic interference over a wide range of frequencies across the spectrum. Such interference can be particularly troublesome at low signal levels, but it can also affect measurements at high levels if the problem is of sufficient severity.

EMI can be caused by steady-state sources such as radio or TV broadcast signals, or some types of electronic equipment (microprocessors, high speed digital circuits, etc.), or it can result from impulse sources, as in the case of arcing in high-voltage environments. In either case, the effect on the desired signal can be considerable if enough of the unwanted signal is present.

EMI can be minimized in several ways. The most obvious method is to keep the equipment and signal leads as far away from the RFI source as possible. Shielding the switching switch, signal leads, sources, and measuring instruments will often reduce RFI to an acceptable level. In extreme cases, a specially constructed screen room may be required to sufficiently attenuate the troublesome signal.

Errors

This section contains error and status messages.

Table 3-8
Error and status message

Number	Description	Event
-440	Query UNTERMINATED after indefinite response	EE
-430	Query DEADLOCKED	EE
-420	Query UNTERMINATED	EE
-410	Query INTERRUPTED	EE
-350	Queue overflow	SYS
-330	Self-test failed	EE
-260	Expression error	EE
-241	Hardware missing	EE
-224	Illegal parameter value	EE
-223	Too much data	EE
-222	Data out of range	EE
-221	Settings conflict	EE
-220	Parameter error	EE
-215	Arm deadlock	EE
-214	Trigger deadlock	EE
-213	Initialization ignored	EE
-212	Arm ignored	EE
-211	Trigger ignored	EE
-210	Trigger error	EE
-200	Execution error	EE
-171	Invalid expression	EE
-170	Expression error	EE
-161	Invalid block data	EE
-160	Block data error	EE
-158	String data not allowed	EE
-154	String too long	EE
-151	Invalid string data	EE
-150	String data error	EE
-148	Character data not allowed	EE
-144	Character data too long	EE
-141	Invalid character data	EE
-140	Character data error	EE
-128	Numeric data not allowed	EE
-124	Too many digits	EE
-123	Exponent too large	EE

EE = error event

SE = status event

SYS = system error event

Table 3-8 (Continued)
Error and status message

Number	Description	Event
-121	Invalid character in number	EE
-120	Numeric data error	EE
-113	Undefined header	EE
-112	Program mnemonic too long	EE
-111	Header separator error	EE
-110	Command header error	EE
-110	Command header error	EE
-109	Missing parameter	EE
-108	Parameter not allowed	EE
-105	GET not allowed	EE
-104	Data type error	EE
-103	Invalid separator	EE
-102	Syntax error	EE
-101	Invalid character	EE
-100	Command error	EE
+000	No error	SE
+900	Internal System Error	EE

EE = error event

SE = status event

SYS = system error event

4

Service Information

Introduction

This section contains service information for the Model 7999-6. The information is organized as follows:

- “Handling and cleaning precautions” on page 4-2
- “Performance verification” on page 4-3
- “Replacing components” on page 4-4
- “GPIB address” on page 4-8

WARNING The information in this section is intended only for qualified service personnel. Some of the procedures may expose you to hazardous voltages that could result in personal injury or death. Do not perform these procedures unless you are qualified to do so.

Handling and cleaning precautions

Because of the high-impedance areas on the Model 7999-6, care should be taken when handling or servicing the switch to prevent possible contamination. The following precautions should be observed when servicing the 7999-6.

Handling precautions

Observe the following precautions when handling the switch:

- Handle the Model 7999-6 only by the edges and cover.
- Do not touch connector insulators.
- Do not touch any board surfaces or components not associated with the repair.
- Do not touch areas adjacent to electrical contacts.
- When servicing the 7999-6, wear clean cotton gloves.
- Do not store or operate the 7999-6 in an environment where dust could settle on the circuit board.

Card and connector cleaning

- Use dry nitrogen gas to clean any dust off the circuit board and components.
- Clean the contaminated area with methanol, then blow dry the entire board with dry nitrogen gas.
- If the connector insulators should become contaminated, either by inadvertent touching, or from air-borne deposits, they can be cleaned with a cotton swab dipped in clean methanol.
- Before use, allow items cleaned to dry for several hours in a 50°C low-humidity environment. Use dry nitrogen to decrease drying time.

Performance verification

The following paragraphs discuss performance verification procedures for the Model 7999-6 including a channel resistance verification procedure.

CAUTION Contamination will degrade the performance of the 7999-6. To avoid contamination, always grasp the 7999-6 by the cover; do not touch the connectors.

NOTE Failure of any performance verification test may indicate that the 7999-6 GPIB RF relay unit is contaminated. See “Handling and cleaning precautions” earlier in this section for information on cleaning the 7999-6.

Environmental conditions

All verification measurements should be made at an ambient temperature between 18° and 28°C, and at a relative humidity of less than 70%.

Recommended equipment

Table 4-1 summarizes the equipment necessary for performance verification (channel resistance tests).

Table 4-1
Recommended verification equipment

Manufacturer/Model	Equipment Description	Specifications
Keithley 2010	Digital Multimeter	10Ω range, 60ppm
Keithley 1681	Test Lead Sets (2)	Banana plug/clips

Channel resistance tests

Perform the following steps to verify the relay contact is closing properly, the relay resistance is within specification, and that the relay opens properly.

1. Turn on the Model 2010 DMM, and allow it to warm up for one hour before making measurements.
2. Set the Model 2010 to the 10Ω range, and connect the four test leads to the INPUT and SENSE Ω 4 WIRE jacks.
3. Short the free ends of the four test leads together, and enable REL on the Model 2010 to null out residual resistance. Leave REL enabled for the entire test.

- Connect the Model 2010 INPUT and SENSE Ω 4 WIRE jacks to the NC relay contact and common, as shown in Figure 4-1.

NOTE Use 4-wire connections.

- Close the relay.
- Note the resistance reading on the Model 2010, and verify that it is $<0.1\Omega$.
- Open the relay.
- Note the resistance reading on the Model 2010, and verify that it indicates an open circuit.
- Repeat the measurement for the NO relay (repeat steps 4 through 8 but with the DMM connected to the NO relay contact and common).

Figure 4-1
Channel resistance test connections

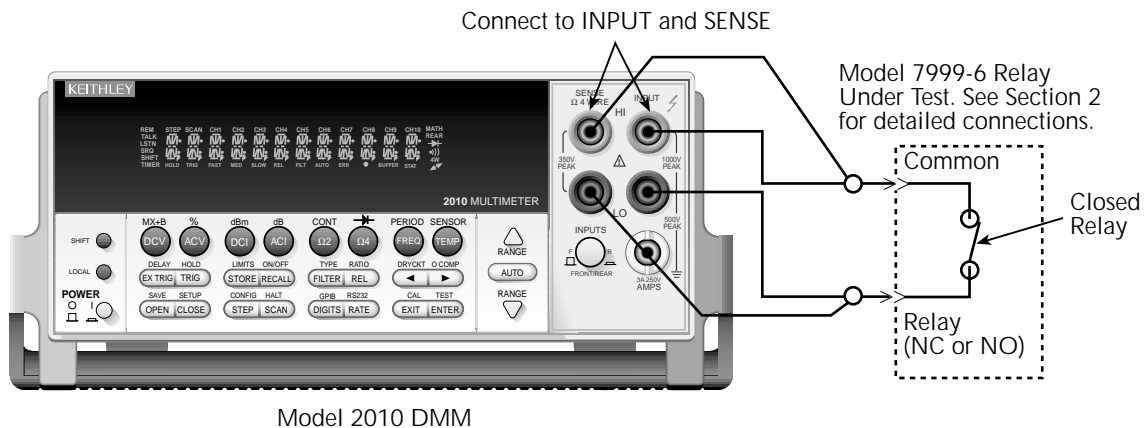

Replacing components

Replacement parts

Replacement parts can be obtained directly from Keithley Instruments, Inc. See the parts list in Section 5 for part numbers.

Replacement precautions

CAUTION Observe the following precautions when replacing components:

- To avoid contamination which could degrade switch performance, always handle the switch only by the covers and side edges. Do not touch the connector, board surfaces, or components on the switch.
- Use care when removing components from the PC board to avoid pulling traces away from the circuit board. Before attempting to remove a relay, use an appropriate de-soldering tool to clear each mounting hole completely free of solder.

Soldering considerations

When using solder on the circuit board, observe the following precautions:

- Use an OA-based (organic activated) flux, and take care not to spread the flux to other areas of the circuit board.
- Remove the flux from the work areas when the repair has been completed. Use pure water along with clean cotton swabs or a clean soft brush to remove the flux.
- Once the flux has been removed, swab only the repaired area with methanol, then blow dry the board with dry nitrogen gas.
- After cleaning, allow the card to dry in a 50°C low-humidity environment for several hours before use.

Relay replacement

Perform the following steps to disassemble the Model 7999-6 to gain access to and replace the relays:

WARNING Before removing the relay enclosure, disconnect all power sources and remove the unit from the instrument rack.

NOTE The 7999-6 supports the standard HP 87104 (SP4T) and the standard HP 87106 (SP6T) relay series of A (4 GHz), B (20 GHz), and C (26.5 GHz). Do not use relays that have the TTL option.

1. Disconnect all power sources and remove the Model 7999-6 from the instrument rack.

NOTE Replacement of the relay does not require removal of the cables from the bulkhead adapters (CS-1092).

2. Noting the position of each cable, remove the cables from the relays (Figure 4-2). This includes the Model 7999-6 cables installed on relay #2 (part number CA-247-3, CA-247-4, and CA-247-5), and also any user installed cables installed on relay #1.
3. Remove the four pan head screws (#6-32 × 5/16) located in the corners of the bottom plate (7999-6-304).

Figure 4-2 (Sheet 1 of 2)
Model 7999-6 exploded view

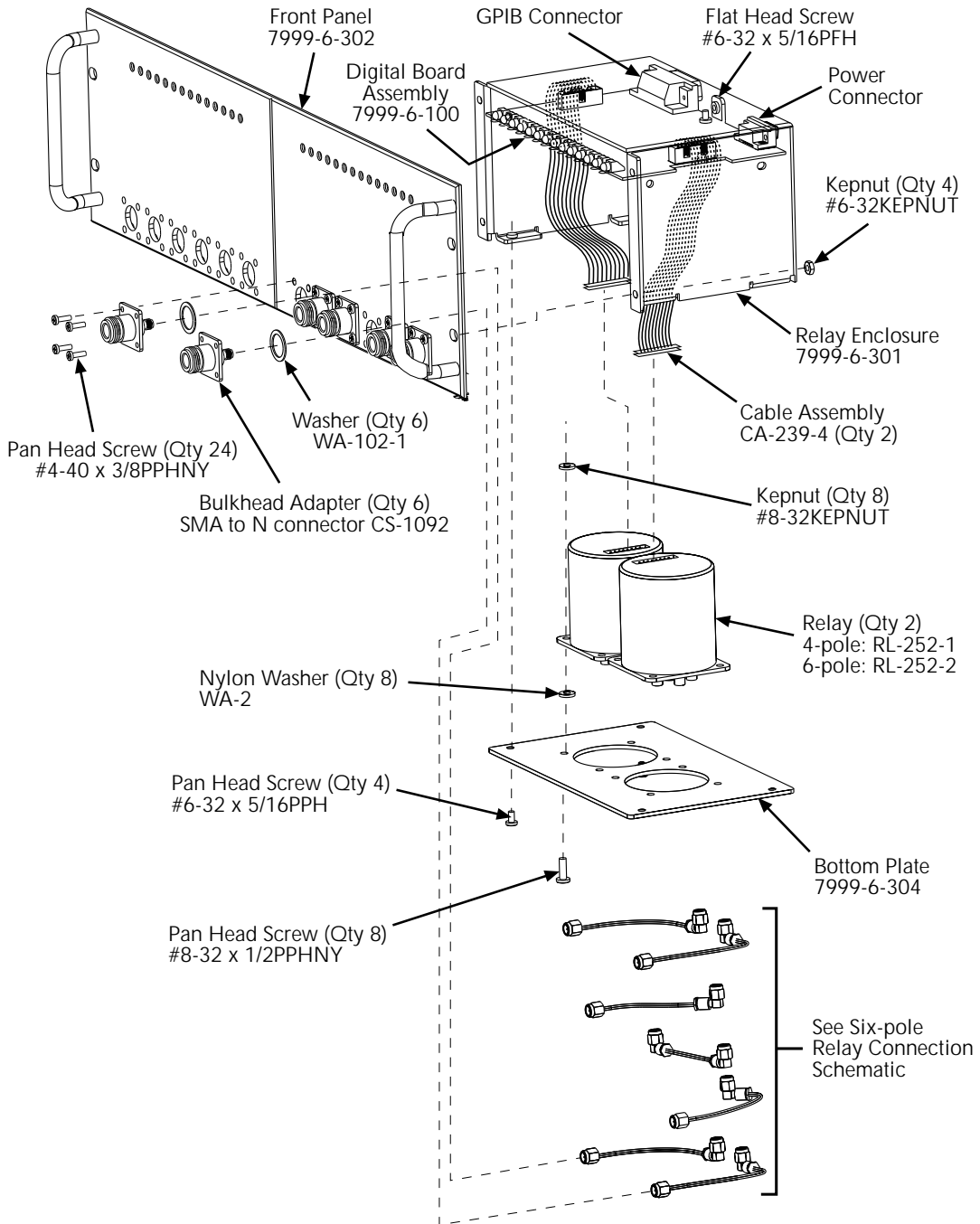
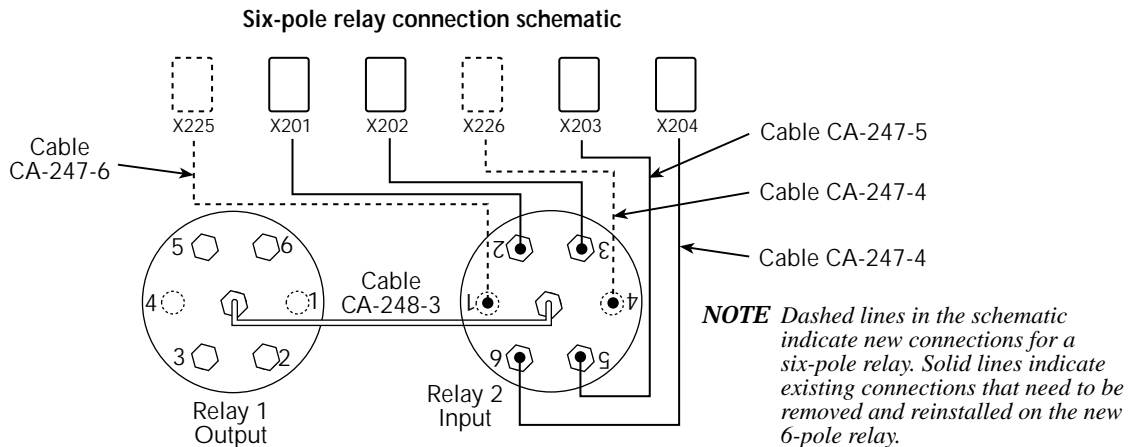

Figure 4-2 (Sheet 2 of 2)
Model 7999-6 exploded view



4. Lower the bottom plate (7999-6-304) away from the relay enclosure (7999-6-301). Two ribbon cable assemblies (CA-239-2) will tether the relays to the digital board assembly (7999-6-100).
5. Disconnect the ribbon cable assemblies (CA-239-2) from the relays (4-pole: RL-252-1 or 6-pole: RL-252-2).
6. Remove the four pan head screws (#8-32 × 1/2), nylon washers (WA-2), and kepnut (#8-32), for each relay.
7. If changing from a 4-pole relay to a 6-pole relay, also complete the following steps. Otherwise continue with Step 8.
 - Install two additional bulkhead adapters (CS-1092). Make sure to place a washer (WA-102-1) between the bulkhead connector and the front panel (7999-6-302).
 - Secure bulkhead adapters (CS-1092) with pan head screws (#4-40 × 3/8PPHNY).
 - Install two cables (CA-247-6 and CA-247-4) onto the bulkhead adapters. (Refer to the dashed lines in the 6-pole relay connection schematic contained in Figure 4-2.) A cable should be attached to each of the six bulkhead adapters.
8. Place the new relay on the bottom plate (7999-6-304) securing with four pan head screws (#8-32 × 1/2), nylon washers (WA-2), and kepnut (#8-32).
9. Attach the free end of the ribbon cable assemblies (CA-239-2) to the relays.
10. Place the bottom plate assembly back into the relay enclosure (7999-6-301) securing with the four pan head screws (#6-32 × 5/16).
11. Install cables (part numbers CA-247-3, CA-247-4, and CA-247-5) between relay #2 and the bulkhead adapters (CS-1092).
12. Connect a cable (CA-248-6) between the center conductor of relay #1 with the center conductor of relay #2.

13. Install user installed cables on relay #1.
14. If changing from a 4-pole relay to a 6-pole relay, make sure to configure the number of poles using the appropriate CONFigure command (see the ROUTe subsystem in Section 3).

Circuit board removal

Perform the following steps to disassemble the Model 7999-6 to gain access to parts on the circuit board:

WARNING Before removing the relay enclosure, disconnect all power sources and remove the unit from the instrument rack.

1. Disconnect all power sources and remove the Model 7999-6 from the instrument rack.
2. Remove the four pan head screws (#6-32 × 5/16) located in the corners of the bottom plate (7999-6-304). (See Figure 4-2.)
3. Lower the bottom plate (7999-6-304) away from the relay enclosure (7999-6-301). Two ribbon cable assemblies (CA-239-2) will tether the relays to the digital board assembly (7999-6-100).
4. Disconnect the ribbon cable assemblies (CA-239-2) from the relays (4-pole: RL-252-1 or 6-pole: RL-252-2).
5. Remove the four kepnuts (#6-32) located in the corners on the back of the front panel (7999-6-302).
6. Separate the relay enclosure (7999-6-301) from the front panel (7999-6-302).
7. Remove the flat head screw (6-32 × 5/16) from the back of the relay enclosure (7999-6-301). This screw secures the digital board assembly (7999-6-100) to the relay enclosure (7999-6-301).
8. Remove the power connector and GPIB connector nuts from the rear panel of the relay enclosure (7999-6-301).
9. Slide the digital board assembly (7999-6-100) out from the relay enclosure (7999-6-301).

To assemble the Model 7999-6, reverse the disassembly instructions. Make sure all parts are properly seated and secured, and that all connections are made properly.

GPIB address

On the main circuit board, there are five GPIB address DIP switches. To change the GPIB address of the relay, use the following procedure:

WARNING Before removing the relay enclosure, disconnect all power sources and remove the unit from the instrument rack.

1. Disconnect all power sources and remove the Model 7999-6 from the instrument rack.

2. Noting the position of each cable, disconnect cables (CA-247-5 and CA-247-6) from bulkhead adapters (CS-1092). (It is not necessary to disconnect the cables from the relays, just from the bulkhead adapters.) Make sure to note the positions to ease re-assembly. (See Figure 4-2.)
3. Remove the four kepnuts (#6-32KEPNUTS) that secure the relay enclosure (7999-6-301) to the front panel (7999-6-302).
4. Separate the relay enclosure (7999-6-301) from the front panel (7999-6-302).
5. Remove the four pan head screws (#6-32 × 5/16) located in the corners of the bottom plate (7999-6-304). (See Figure 4-2.)
6. Lower the bottom plate (7999-6-304) away from the relay enclosure (7999-6-301). Two ribbon cable assemblies (CA-239-2) will tether the relays to the digital board assembly (7999-6-100).
7. Remove the flat head screw (6-32 × 5/16) from the back of the relay enclosure (7999-6-301). This screw secures the digital board assembly (7999-6-100) to the relay enclosure (7999-6-301).
8. Remove the power connector and GPIB connector nuts from the rear panel of the relay enclosure (7999-6-301).
9. Inside the relay enclosure there are five DIP switches. Set the five GPIB address DIP switches to the appropriate position (ON or off) for the desired GPIB address. Each switch has a decimal weight as shown on the board. Add the weight for each switch turned to the ON position for the GPIB address value. For an example of setting the GPIB address to 20, see Figure 4-3.

Figure 4-3
GPIB address switch example

Binary weight	Decimal weight		ON →	Decimal value
00001	1	LSB		0
00010	2			0
00100	4			4
01000	8			0
10000	16	MSB		+ 16
				20
				GPIB address

NOTE There is no GPIB address of 31 (if the switches are set to 31, they will be interpreted as being set to 30).

5

Replaceable Parts

Introduction

This section contains replacement parts information and component layout for the Model 7999-6 (drawing number 7999-6-100).

Parts list

Parts list for the Model 7999-6 are contained in Table 5-1 and Table 5-2.

Ordering information

To place an order, or to obtain information concerning replacement parts, contact your Keithley representative or the factory (see inside front cover for addresses). When ordering parts, be sure to include the following information:

- Switch model number (Model 7999-6)
- Serial number
- Part description
- Component designation (if applicable)
- Keithley part number

Factory service

If the switch is to be returned to Keithley Instruments for repair, perform the following:

- Call the Repair Department at 1-800-552-1115 for a Return Material Authorization (RMA) number.
- Complete the service form at the back of this manual, and include it with the instrument.
- Carefully pack the instrument in the original packing carton.
- Write ATTENTION REPAIR DEPARTMENT and the RMA number on the shipping label.

Component layout

The following component layout drawing is provided on the following page:

- Component layout drawing: 7999-6-100

Table 5-1

Parts list—electronic components

Circuit designation	Description	Keithley part no.
C1	CAP, 10UF, 20%, 25V, TANTALUM	C-440-10
C2, C4, C8, C10, C14, C16, C24, C21	CAP, 0.01UF, 10%, 50V, CERAMIC	C-491-.01
C3, C5-7, C9, C11, C17-C19, C22, C23, C25-C28	CAP, .1UF, 10%, 25V, CERAMIC	C-495-.1
C12, C15	CAP, 15P, 1%, 100V, CERAMIC	C-512-15P
C13	CAP, 47PF, 10%, 100V, CERAMIC	C-451-47P
C20	CAP, 220UF, $\pm 20\%$, 50V ALUM ELEC	C-578-68
C29	CAP, 100UF, 20%, 16V, TANTALUM	C-504-100
C30-36, C39	CAP, .1UF, 10%, 25V, CERAMIC	C-495-.1
C37, C38	CAP, 220UF, $\pm 20\%$, 50V ALUM ELEC	C-507-220
C40, C41	CAP, 47P, 5%, 100V, CERAMIC	C-465-47P
C42	CAP, 100P, 10%, 100V, CERAMIC	C-451-100P
CR1, CR2	DIODE, MBRS140T3 (SMB)	RF-110
DS1	PILOT LIGHT	PL-115-1
DS14	PILOT LIGHT, RED, LED	PL-77
DS2-DS13	PILOT LIGHT, GREEN, LED	PL-78
F1	POLYSWITCH, SMD030-2	FU-103
J2, J4	CONN, HEADER STRAIGHT SOLDER PIN	CS-368-16
J3	CONN, RIGHT ANGLE, 24 PIN	CS-501
J5	CONN, D-SUB MALE, BOARDLOCK TYPE	CS-848-9
L1	FERRITE CHIP 600 OHM	CH-62
L2	CHOKE	CH-87-2
L3	INDUCTOR, .82A	CH-106-1
Q1, Q2, Q3	TRANS, NPN	TG-238
R1, R2, R15, R28, R11	RES ARRAY 4X10K, 5%, .125W	TF-276-10K
R5, R59, R16, R24, R31, R32, R36, R37, R17, R19	RES, 10K, 1%, 100MW, THICK FILM	R-418-10K
R6, R8, R10, R12, R14, R13, R42, R43	RES, 1K, 1%, 100MW, THICK FILM	R-418-1K
R7	RES, 15K, 1%, 100MW, THICK FILM	R-418-15K
R20	RES, 499K, 1%, 100MW, THICK FILM	R-418-499
R21, R22	RES, 2K, 1%, 100MW, THICK FILM	R-418-2K
R23, R25	RES, 4.75K, 1%, 100MW, THICK FILM	R-418-4.75K
R26	RES, 10M, 1%, 125MW, THICK FILM	R-418-10M
R27	RES, 332K, 1%, 100MW, THICK FILM	R-418-332K
R29, R30	RES, 2.21K, 1%, 100MW, THICK FILM	R-418-2.21K
R33, R34, R38, R39	RES, 150K, 1%, 100MW, THICK FILM	R-418-150K
R40, R4, R44, R46-49	RES, 10K, 1%, 100MW, THICK FILM	R-418-10K
R41, R50	RES, 49.9K, 1%, 100MW, THICK FILM	R-418-49.9
RV1	TRANSIENT VOLTAGE SUPPRESSOR	VR-12

Table 5-1 (Continued)

Parts list—electronic components

Circuit designation	Description	Keithley part no.
S1	SWITCH, DIP SPST	SW-509-6A
SO12	SOCKET	SO-143-32
SW101, SW102	SWITCH, TOGGLE	SW-506
TP1-TP5	TEST POINT	CS-1026
U1	MICROCONTROLLER	LSI-161
U2	IC, 2-INPUT OR GATE	IC-1206
U3, U6, U17	IC, HEX SCHMITT INVERT TRIGGER	IC-1397
U4	64K BIT SERIAL FRAM	IC-1381
U5	IC, 5V VOLTAGE REGULATOR	IC-1396
U7, U13	IC, 8 STAGE SHIFT REGISTER	IC-1026
U8	GPIB ADAPTER	LSI-123
U9	IC, OCTAL INTERFACE BUS	IC-646
U10	IC, OCTAL INTER BUS TRANS	IC-647
U11	CMOS Static Ram	LSI-162-70
U12	IC, 512X 8 BIT CMOS (WITH PROGRAM)	7999-6-800-A01
U14-U16, U18	IC, QUAD LOW SIDE DRIVER	IC-1351
Y1	CRYSTAL	CR-41
	Digital Board Assembly	7999-6-100
	RELAY 4GHZ SP4T (4-POLE)	RL-252-1
	RELAY 4GHZ SP6T (6-POLE)	RL-252-2

Table 5-2

Parts list—mechanical parts

Description	Keithley part no.	Comments
Cable Assembly (5" Ribbon)	CA-239-2	Connect relay to PCB
Fastener	FA-148	Rack mount hardware
10-32×3/8 Phillips Pan Head Screw	10-32X3/8PPH	Rack mount screws
Washer	WA-102-1	To mount adapters to front panel
6-32×5/16 Phillips Pan Head Screw	6-32X5/16PPH	To mount bottom plate to enclosure
4-40×3/8 Phillips Pan Head Screw	4-40X3/8PPHNY	To mount bulkhead adapters to front panel
Flange Mount Adapter	CS-1092	SMA jack to N jack
Connector, Hardware Kit	CS-713	To mount CS-501
Screwlock, Female	CS-725	To mount D-sub power
6-32 Kepnut	6-32KEPNUT	To mount enclosure to front panel
6-32×5/16 Phillips Flat Head Screw	6-32X5/16PFH	To mount bracket to enclosure
6-32×1/4 Phillips Pan Head Screw	6-32X1/4PPH	To mount bracket to PCB
Flat Head Screw (8-32)	FA-323-2	To mount HH-30-5 to front panel
Washer, Nylon	WA-2	To mount relays to enclosure
8-32 Kepnut	8-32KEPNUT	To mount relays to enclosure
8-32×1/2 Nylon Phillips Pan Head Screw	8-32X1/2PPHNY	To mount relays to enclosure
Bottom Plate	7999-6-304	
Card Guide	CG-6-1	
Front Panel	7999-6-302	
Grounding Bracket	7999-6-305	
Handle, Round-offset	HH-30-5	
Label	MC-285	
Label	MC-612A	
Relay Enclosure	7999-6-301	
SMA Plug to SMA Right Angle Plug	CA-247-3	
SMA Plug to SMA Right Angle Plug	CA-247-4	
SMA Plug to SMA Right Angle Plug	CA-247-5	
SMA Right Angle Plug to SMA Right Angle Plug	CA-248-3	

LTR.	ECA NO.	REVISION	ENG.	DATE
A		PRELIMINARY	LM/MH	3/15/00
B		PRELIMINARY	LM/MH	5/17/00
C	24726	RELEASED	LM/MH	6/28/00
D	25320	ADDED SW101, SW102 & ASSOC. CIR.	TJA	1/31/01
E	25799	ADDED J6, R51-65	MLH	6/14/01

PRIMARY SIDE COMPONENTS (SIDE-04)

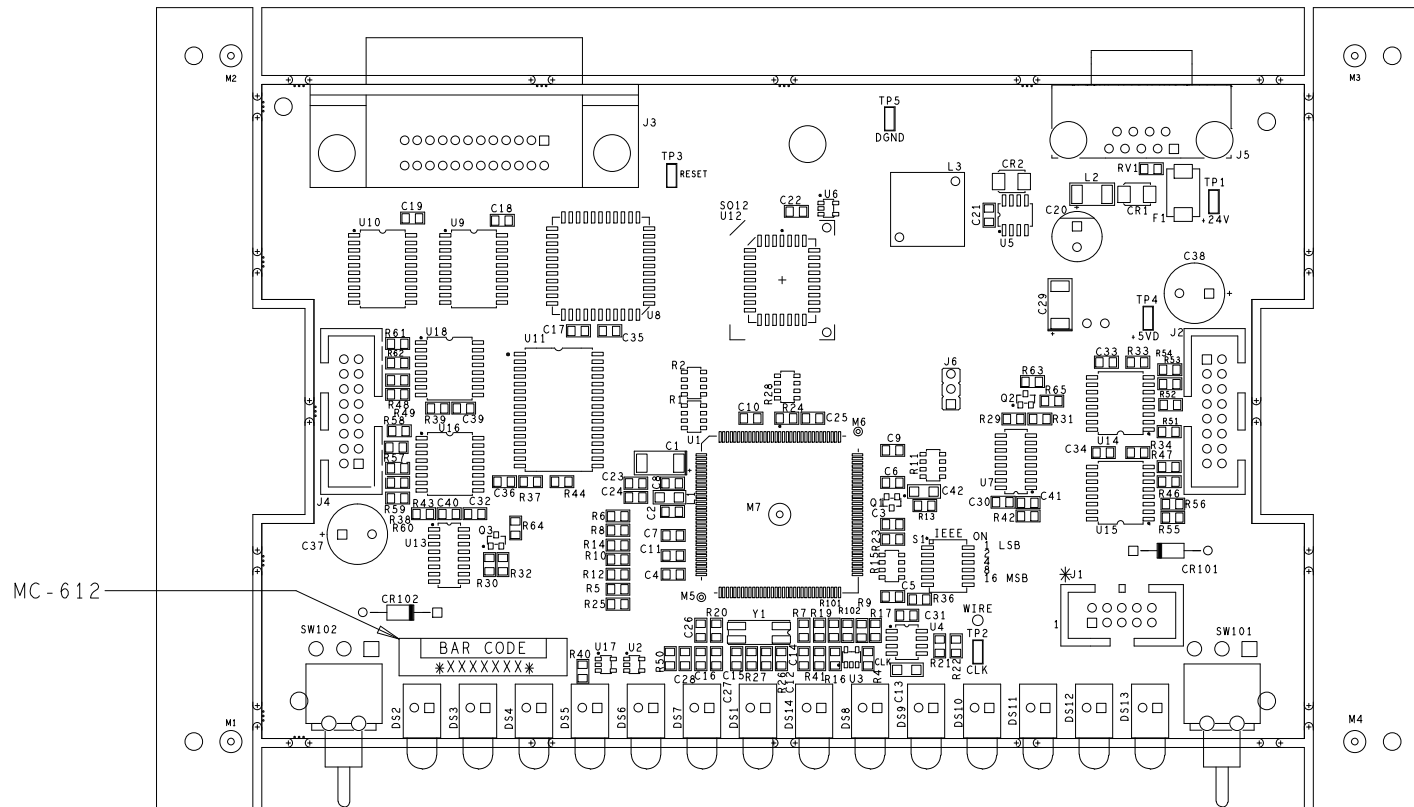

* DO NOT POPULATE *
PTH
J1

NOTE: FOR COMPONENT INFORMATION, REFER TO PRODUCT STRUCTURE.

MODEL	NEXT ASSEMBLY	QTY.
USED ON		

KEITHLEY KEITHLEY INSTRUMENTS INC. CLEVELAND, OHIO 44139	DIM ARE IN IN. UNLESS OTHERWISE NOTED		DATE 3/14/00	SCALE 1:1	TITLE COMPONENT LAYOUT, RF RELAY BOARD
	DIM. TOL. UNLESS OTHERWISE SPECIFIED		DRN MLH	APPR. P.S.	
	XX=+.01 ANG.=+1 XXX=+.005 FRAC.=+1/64		DO NOT SCALE THIS DRAWING		B

Index

:CLear 3-33
:CLOSE 3-27
:CLOSE? 3-27
:CONFigure 3-29
:ERRor? 3-33
:OPEN 3-28
:OPEN:ALL 3-29
:PRESet 3-30
:QUEue 3-30
:SNUMber 3-33
:VERsion? 3-33

Symbols

*CLS 3-18
*ESE 3-19
*ESE? 3-19
*ESR? 3-20
*IDN? 3-21
*OPC 3-22
*OPC? 3-22
*RST 3-22
*SRE 3-22
*SRE? 3-22
*STB? 3-24
*TST? 3-25
*WAI 3-26

Numerics

16-bit status register 3-17

B

Bus connections 3-3

C

Card cleaning 4-2
Channel resistance tests 4-3
Circuit board removal 4-8
Clearing registers and queues 3-16
Command diagram 3-5
Command execution rules 3-7
Command messages 3-4
Commands and parameters 3-3
Common commands 3-18
Component layout 5-2
Configuration 2-2

Connections 1-4
 GPIB 2-5
 introduction 2-2
 SMA 2-8
Connector integrity 3-35
Controlling relay connections 3-6

E

Electronic components 5-3
Enable registers 3-11
Environmental conditions 4-3
Error queue 3-11
Event register sets 3-10
Example command 3-5
Exploded view 4-6, 4-7

F

Factory service 5-2
Flux 4-5

G

General information 1-2
GPIB address 4-8
 switch example 4-9
GPIB control connector terminals 2-6

H

Handling 4-2
Handling precautions 1-3, 2-2, 4-2

I

Insertion loss 3-36
Inspection for damage 1-3
Instruction manual 1-4

L

Layout 2-2

M

Manual addenda 1-2
Manual operation 3-34
Maximum signal considerations 3-2
Mechanical parts 5-5
Message exchange protocol 3-8
Multiple response messages 3-7

O

- Opening or closing the relay 3-26
- Operation
 - GPIB (bus) 3-3
 - Introduction 3-2
- Ordering information 5-2
- Output queue 3-11
- Overview 1-2

P

- Parameter types 3-4
- Parts list 5-2
- Path isolation 3-36
- Performance verification 4-3
- Primary address 3-3
- Program message terminator (PMT) 3-7
- Programming enable registers 3-17
- Programming syntax 3-3

Q

- Query Commands 3-4
- Queues 3-11

R

- Reading registers 3-17
- Recommended verification equipment 4-3
- Relay replacement 4-5
- Repacking 1-4
- Repair department phone number 5-2
- Replacement parts 4-4
- Replacement precautions 4-5

- Replacing components 4-4
- Response message terminator (RMT) 3-7
- Response messages 3-7
- RFI/EMI 3-36

S

- Safety symbols and terms 1-3
- Schematic 2-4
- Sending a response message 3-7
- Serial polling and SRQ 3-15
- Service request enable register 3-14
- Shipment contents 1-4
- Short-form commands 3-4
- Signal considerations 3-2
- Soldering considerations 4-5
- Status byte and SRQ 3-13
- Status Byte Register 3-14
- Status model 3-8
- Switching considerations 3-35
- Symbols and terms 1-3

U

- Unpacking and inspection 1-3

V

- Voltage Standing Wave Ratio 3-35

W

- Warranty 1-2

Service Form

Model No. _____ Serial No. _____ Date _____

Name and Telephone No. _____

Company _____

List all control settings, describe problem and check boxes that apply to problem. _____

Intermittent Analog output follows display Particular range or function bad; specify _____

IEEE failure Obvious problem on power-up Batteries and fuses are OK

Front panel operational All ranges or functions are bad Checked all cables

Display or output (check one)

Drifts Unable to zero Unstable

Overload Will not read applied input

Calibration only Certificate of calibration required Data required

(attach any additional sheets as necessary)

Show a block diagram of your measurement including all instruments connected (whether power is turned on or not). Also, describe signal source.

Where is the measurement being performed? (factory, controlled laboratory, out-of-doors, etc.) _____

What power line voltage is used? _____ Ambient temperature? _____ °F

Relative humidity? _____ Other? _____

Any additional information. (If special modifications have been made by the user, please describe.)

Be sure to include your name and phone number on this service form.

Specifications are subject to change without notice.

All Keithley trademarks and trade names are the property of Keithley Instruments, Inc. All other trademarks and trade names are the property of their respective companies.



Keithley Instruments, Inc.

BELGIUM: Keithley Instruments B.V.
CHINA: Keithley Instruments China
FRANCE: Keithley Instruments Sarl
GERMANY: Keithley Instruments GmbH
GREAT BRITAIN: Keithley Instruments Ltd.
INDIA: Keithley Instruments GmbH
ITALY: Keithley Instruments s.r.l.
KOREA: Keithley Instruments Korea
NETHERLANDS: Keithley Instruments B.V.
SWITZERLAND: Keithley Instruments SA
TAIWAN: Keithley Instruments Taiwan

28775 Aurora Road • Cleveland, Ohio 44139 • 440-248-0400 • Fax: 440-248-6168

1-888-KEITHLEY (534-8453) www.keithley.com

Bergensesteenweg 709 • B-1600 Sint-Pieters-Leeuw • 02/363 00 40 • Fax: 02/363 00 64
Yuan Chen Xin Building, Room 705 • 12 Yumin Road, Dewai, Madian • Beijing 100029 • 8610-6202-2886 • Fax: 8610-6202-2892
3, allée des Garays • 91127 Palaiseau Cédex • 01 64 53 20 20 • Fax: 01 60 11 77 26
Landsberger Strasse 65 • D-82110 Germering • 089/84 93 07-40 • Fax: 089/84 93 07-34
The Minster • 58 Portman Road • Reading, Berkshire RG30 1EA • 0118-9 57 56 66 • Fax: 0118-9 59 64 69
Flat 2B, WILLOCRISSA • 14, Rest House Crescent • Bangalore 560 001 • 91-80-509-1320/21 • Fax: 91-80-509-1322
Viale San Gimignano, 38 • 20146 Milano • 02-48 39 16 01 • Fax: 02-48 30 22 74
2FL., URI Building • 2-14 Yangjae-Dong • Seocho-Gu, Seoul 137-130 • 82-2-574-7778 • Fax: 82-2-574-7838
Postbus 559 • NL-4200 AN Gorinchem • 0183-635333 • Fax: 0183-630821
Kriesbachstrasse 4 • 8600 Dübendorf • 01-821 94 44 • Fax: 01-820 30 81
1FL., 85 Po Ai Street • Hsinchu, Taiwan, R.O.C. • 886-3-572-9077 • Fax: 886-3-572-9031