

Need More Measurement Flexibility? Maybe You Need More Flexible Cabling

Wayne Goeke, Senior Staff Technologist and Lee Stauffer, Senior Staff Technologist Keithley Instruments, Inc.

MANY different types of measurements go into characterizing an electrical device and the processes involved in its manufacture. However, current-voltage (I-V), capacitance-voltage (C-V), and pulse-based measurements are the most commonly made measurement types in these applications. As a result, semiconductor device characterization systems typically include capabilities for making these measurements, with some more successful than others in integrating these measurements in a way that reduces the time and effort required to make them. Perhaps the greatest challenge associated with integrating these measurements is the fundamentally different cabling requirements for each measurement type. Although the cabling from the instrument to the probe station bulkhead and feedthrough is fairly straightforward, many users find the process of connecting the cabling from the bulkhead

to the probe tips to be confusing and difficult. This article explains the different cabling requirements associated with each measurement type (*Table 1*) and describes a new approach to multi-measurement cabling that combines high signal integrity with excellent ease of use.

I-V Measurements' Cabling Requirements

Guarding is crucial to making high integrity low current I-V measurements, so it's

essential to use triaxial cables for these measurements. *Figure 1* illustrates how these measurements can be made using four triaxial cables. The measurement signal is carried on the center conductor, the inner shield is driven as a guard for the signal, and the outer shield is used for safety to shield the user from high voltages that may be applied to the guard and signal conductors. Two cables are necessary in order to achieve a remote sense, or Kelvin, connection on each device terminal. Remote sense cables allow the instrument to sense the voltage at the device accurately. In this figure, the device to be characterized has two terminals.

C-V Measurements' Cabling Requirements

Figure 2 illustrates the cabling for C-V measurements using four coaxial cables. The outer shells are connected together to control the characteristic impedance the signals see. The outer shells of all four cables must be inter-connected near the device under test (DUT).

Pulse Testing Cabling Requirements

Pulsed measurements require the highest bandwidth of the three measurement types, so to prevent reflections off the DUT from reflecting off the source, the cable must have a characteristic impedance that matches the source impedance. Pulsing does not use a remote sense cable. *Figure 3* illustrates a typical connection to a two-terminal DUT. Pulsing is the only one of the three measurement types that connects the DUT to the outer shield of the cable.

Characteristic Impedances

Given the challenges created by these differing cabling requirements for different measurement types, Keithley has developed

Table 1. Cable requirements for I-V, C-V, and Pulsed I-V measurements.

DC I-V Measurements	LCR/C-V Measurements	Pulsed I-V Measurements
<ul style="list-style-type: none"> • Triaxial cables • Kelvin connection • Isolated, driven guards 	<ul style="list-style-type: none"> • Coaxial cables • Kelvin connection • Shields connected at the probe tips 	<ul style="list-style-type: none"> • Coaxial cables • Non-Kelvin connection (single cable) • Shields connected at the probe tips • Shield optionally connected to a probe tip

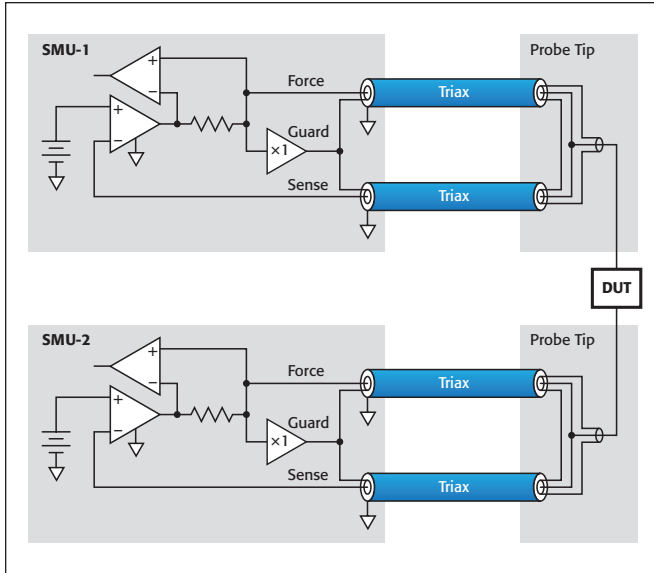

Figure 1: I-V measurement connection scheme for Kelvin connections.

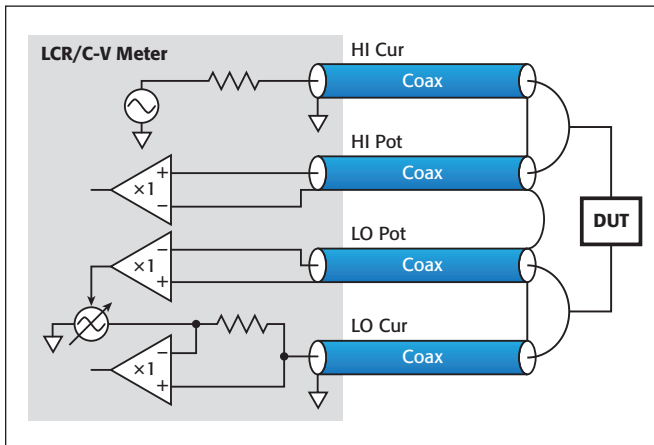

Figure 2: C-V measurement connection scheme for Kelvin connections.

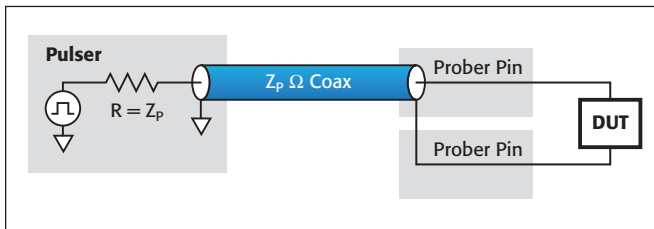

Figure 3: Pulse testing connection scheme for Kelvin connections.

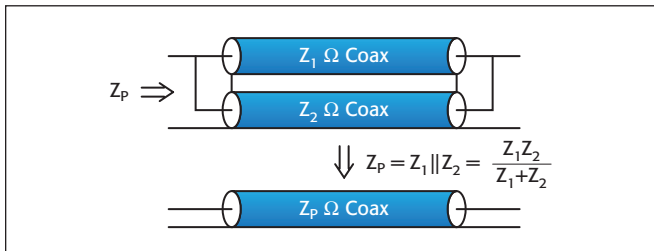

Figure 4: With two parallel transmission lines, the characteristic impedance of the combined transmission line is the parallel combination of each transmission line's characteristic impedances.

a multi-measurement cabling system based on an understanding of two transmission concepts. The first concept is that if there are two parallel transmission lines, the characteristic impedance of the combined transmission line is the parallel combination of each transmission line's characteristic impedances, as shown in *Figure 4*.

The second transmission line concept is that if there are two transmission lines connected in series, as shown in *Figure 5*, the characteristic impedance of the combined transmission line is the sum of the characteristic impedances of the two individual transmission lines.

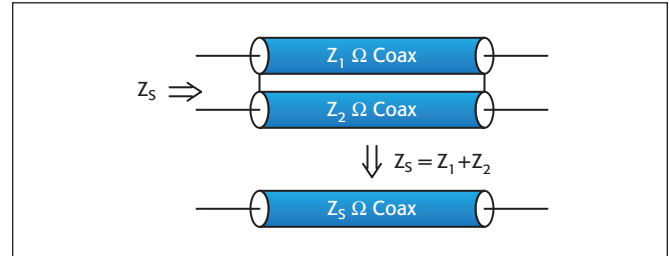

Figure 5: When two transmission lines are connected in series, the characteristic impedance of the combined transmission line is the sum of the two individual transmission lines.

This series arrangement can be observed in a triaxial cable, as shown in *Figure 6*. A triaxial cable is actually two concentrically arranged transmission lines. The inner shield and the center conductor form one transmission line (Z_1) and the inner shield and the outer shield form a second transmission line (Z_2). The center conductor to outer shield interaction has a characteristic impedance (Z_s) equal to the sum of the two transmission lines that share the inner shield.

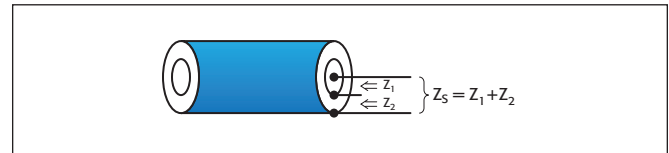

Figure 6: A triaxial cable.

Taking these two transmission line concepts into account, Keithley has developed a cabling kit that supports making I-V, C-V and pulsed I-V measurements with the same set of cables. This reduces the effort required from operators of parameter analyzer systems, who would otherwise be forced to go through the laborious process of re-cabling the connections from the bulkhead/feedthrough to the probe tips each time it was necessary to switch to a new measurement type. Versions of the cable kit are available for use with probers made by Cascade Microtech probers and SUSS MicroTec. Both versions are designed to work with a coaxial Kelvin probe head only.

I-V and C-V Cabling System Overview

Figure 7 illustrates how a DUT can be connected to an LCR/C-V meter. Note that the guard is allowed to float and the outer shields are all interconnected at the prober. (Interconnecting the outer shields does not adversely affect I-V measurements. In some cases, it may even improve I-V measurement performance.) The triaxial cables replace the coaxial cables shown in *Figure 2*. It's possible to switch between I-V and C-V measurements by re-connecting only

the instrument end of the cable. There's also no need to disconnect the wafer from the prober to make the switch, which saves time and ensures consistent probe needle to wafer contact.

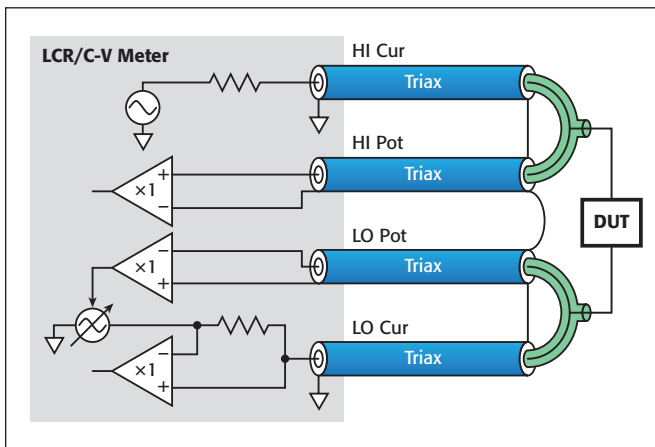

Figure 7: Connections between a DUT and an LCR/C-V meter. Cabling for Pulse Testing

Pulse testing (as well as other test types) requires 50Ω transmission lines to the DUT. If the triaxial cables are designed to have a characteristic impedance of 100Ω from their center connectors to their outer shields and two of these cables are connected in parallel, the combination has a characteristic impedance of 50Ω. In addition, pulsing usually requires one or more DUT pins to be connected to ground. The center connector can be connected to the outer shield by adding a jumper, as shown in Figure 8, to make the ground connection.

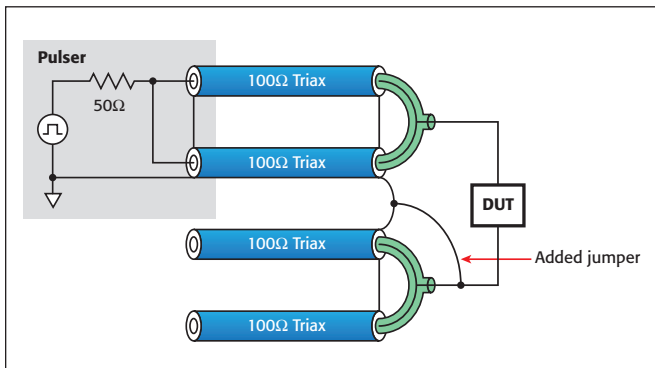

Figure 8: Pulse testing usually requires connecting one or more DUT pins to ground. A jumper can be used to tie the center connector to the outer shield to make this ground connection.

Attaching this jumper at the end of the probe arm would require disconnecting the probe needle from the wafer to protect the wafer; unfortunately, the probe needle area can be difficult to access. Although applying the ground connection at the end of a short cable might seem like a simpler alternative, this would reduce the effective bandwidth of the ground. To obtain a clean 10ns rise time, the ground cable must have an electrical length that is less than 1.5ns (approximately 30cm), which would allow the ground to be applied at the mounting base of the probe manipulator. Adding connectors in the cables near the probe manipulator mounts allows inserting a shorting cap as shown in Figure 9. The shorting cap can be added without

disturbing the probe needle, making it possible to switch from I-V and/or C-V measurements to pulsed measurements without the need to re-probe a wafer site. By allowing an operator to make quick, easy set-up changes while the probe needles are in contact with a wafer, the cap reduces pad damage and maintains the same contact impedance for all three types of measurements.

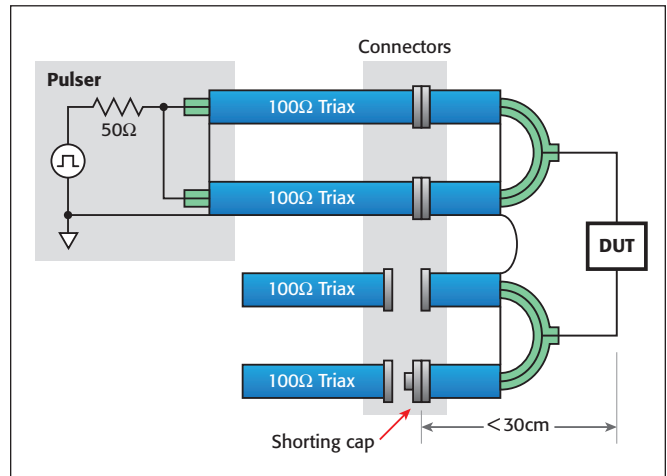

Figure 9: To insert a shorting cap, add connectors in the cables near the probe manipulator mounts.

In order to simplify switching from Kelvin to non-Kelvin measurements, it was necessary to allow the cables to be connected in parallel. This means that cables do not have to be added or removed when changing from one measurement type to another; they can simply be moved from one set of instrument connections to another. Given that most fast pulse instruments require a 50Ω pathway, the parallel combination of cables should yield 50Ω, so each cable must have a characteristic impedance of 100Ω. Most LCR/C-V meters are designed to function with 50Ω cables, but the Keithley Model 4210-CVU instrument for the Model 4200-SCS system is designed for use with 100Ω cables, resulting in slightly improved C-V results.

The main advantage of Keithley's new approach to connecting the instrumentation to the prober is that, no matter which type of measurement is being made, no changes to the probe manipulator cabling are required. This makes it much simpler to switch between I-V measurements, C-V measurements, and pulsed testing, simplifying

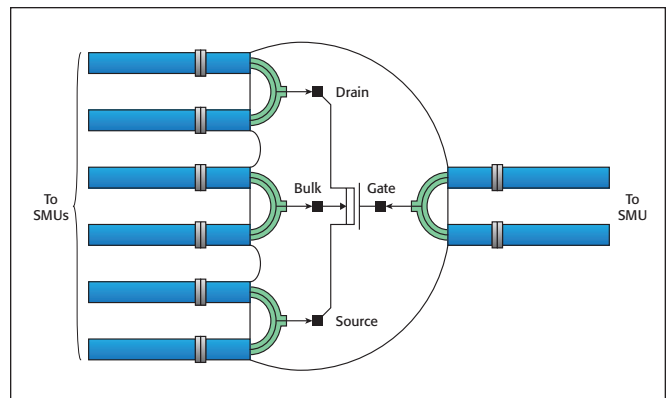

Figure 10: An I-V measurement setup for a four-terminal DUT.

the device characterization process. In addition, the setup changes can be made while the probe needles are in contact with a wafer, reducing pad damage and maintaining the same contact impedance for all three types of measurements.

Many I-V and pulse measurements are made on devices with more than two terminals. The most common device type is a four-terminal MOSFET. **Figure 10** illustrates an I-V measurement setup for a four-terminal DUT.

The connectors can be disconnected and shorting caps inserted into the source and bulk cables to allow making a pulse measurement. **Figure 11** illustrates a pulsed I-V measurement setup.

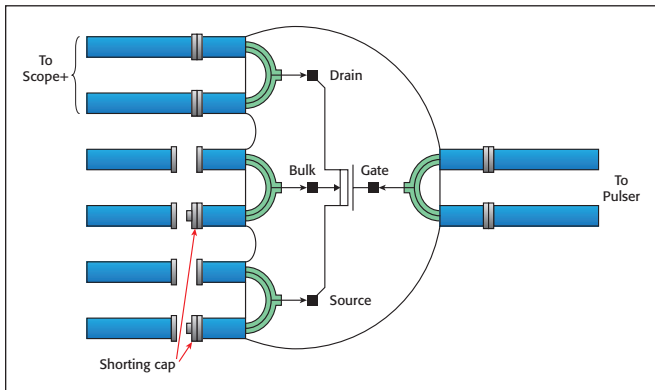

Figure 11: A pulsed I-V measurement setup.

An added benefit of having short cables near the DUT is that it's possible to short together the terminals of a DUT that function at frequencies up to or greater than 1MHz. **Figure 12** shows a four-terminal C-V measurement in which three of the four terminals are connected together to allow making a two-terminal C-V measurement. The frequency at which the C-V measurement can be made can be increased by connecting the three terminals together at the prober rather than at the LCR/C-V meter. **KEITHLEY**

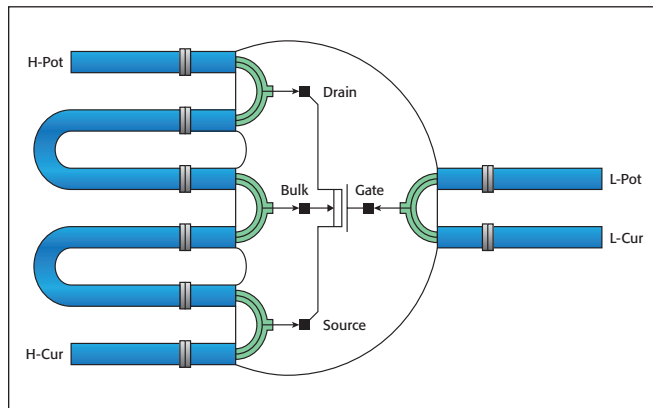

Figure 12: A four-terminal C-V measurement in which three of the four terminals are connected together for a two-terminal C-V measurement.

Specifications are subject to change without notice.
 All Keithley trademarks and trade names are the property of Keithley Instruments, Inc.
 All other trademarks and trade names are the property of their respective companies.



A G R E A T E R M E A S U R E O F C O N F I D E N C E

KEITHLEY INSTRUMENTS, INC. ■ 28775 AURORA ROAD ■ CLEVELAND, OHIO 44139-1891 ■ 440-248-0400 ■ Fax: 440-248-6168 ■ 1-888-KEITHLEY ■ www.keithley.com

BELGIUM
 Sint-Pieters-Leeuw
 Ph: 02-3630040
 Fax: 02-3630064
 info@keithley.nl
 www.keithley.nl

CHINA
 Beijing
 Ph: 8610-82255010
 Fax: 8610-82255018
 china@keithley.com
 www.keithley.com.cn

FRANCE
 Saint-Aubin
 Ph: 01-64532020
 Fax: 01-60117726
 info@keithley.fr
 www.keithley.fr

GERMANY
 Germering
 Ph: 089-84930740
 Fax: 089-84930734
 info@keithley.de
 www.keithley.de

INDIA
 Bangalore
 Ph: 080-26771071, -72, -73
 Fax: 080-26771076
 support_india@keithley.com
 www.keithley.com

ITALY
 Peschiera Borromeo (Mi)
 Ph: 02-5538421
 Fax: 02-55384228
 info@keithley.it
 www.keithley.it

JAPAN
 Tokyo
 Ph: 81-3-5733-7555
 Fax: 81-3-5733-7556
 info.jp@keithley.com
 www.keithley.jp

KOREA
 Seoul
 Ph: 82-2-574-7778
 Fax: 82-2-574-7838
 keithley@keithley.co.kr
 www.keithley.co.kr

MALAYSIA
 Penang
 Ph: 60-4-643-9679
 Fax: 60-4-643-3794
 koh_william@keithley.com
 www.keithley.com

NETHERLANDS
 Gorinchem
 Ph: 0183-635333
 Fax: 0183-630821
 info@keithley.nl
 www.keithley.nl

SINGAPORE
 Singapore
 Ph: 65-6747-9077
 Fax: 65-6747-2991
 koh_william@keithley.com
 www.keithley.com

SWITZERLAND
 Zürich
 Ph: 044-8219444
 Fax: 044-8203081
 info@keithley.ch
 www.keithley.ch

TAIWAN
 Hsinchu
 Ph: 886-3-572-9077
 Fax: 886-3-572-9031
 info_tw@keithley.com
 www.keithley.com.tw

UNITED KINGDOM
 Theale
 Ph: 0118-9297500
 Fax: 0118-9297519
 info@keithley.co.uk
 www.keithley.co.uk