

# The Pluses and Pitfalls of USB DAQ

**Jonathan Tucker, Lead Industry Consultant  
Keithley Instruments, Inc.**

*Using USB-based data acquisition for test and measurement applications has many benefits but also some potential pitfalls.*

## Introduction

The Universal Serial Bus (USB) is gaining favor as an alternative interface for data acquisition and measurement applications. USB is already used in computer peripherals such as printers, mice, and digital cameras as a quick and easy way to connect to a PC. USB connections simplify peripheral installation by eliminating the need to crack open the PC to install a plug-in board.

## What is USB?

Today, virtually all desktop and laptop PCs on the market come equipped with USB ports. These ports have full software support under common operating systems such as Windows 2000 and XP.

Originally created to simplify the connection of external peripherals to personal computers, USB's ease of use has made it

one of the fastest growing buses within the computer and electronics industry today.

## USB Benefits for Test and Measurement

For test and measurement applications, USB data acquisition modules offer a number of significant advantages. USB provides users with a simple means of developing test and measurement applications by offering advantages over PC plug-in boards. These include plug-and-play capability, better noise immunity, cost savings, and portability, among others.

USB DAQ modules offer true plug-and-play capability. Modules connect to a PC USB port using a standard, low-cost cable. When plugged in, the PC automatically identifies the module and installs device driver software, simplifying setup and reducing start up time. This eliminates the need to open a PC to add a board, configure DIP switches and IRQ settings, search for the right device driver, and reboot the system.

USB modules offer good noise immunity, with performance benefits for noise-sensitive measurements. USB cables are typically 1 to 5 meters long, so the I/O circuitry is located further away from the computer's noisy motherboard and power supplies, and closer to the signals they will be measuring.

Most USB modules offer full- and high-speed data transfer rates. Computers configured with USB 1.1 ports can transfer data to and from a USB DAQ module at up to 12 Mbits/second. The full-speed rate is good for data streaming applications and supports data acquisition rates of up to 400kHz. For high-performance applications, USB modules that comply with USB 2.0 and are connected to PCs with a high-speed USB 2.0 port can attain data transfer rates of up to 480 Mbits/second. The increased bandwidth enables multiple I/O operations simultaneously at throughput rates up to 500kHz in each direction, similar to PCI measurement systems.

Easy assembly and portability are also beneficial for most test and measurement applications. Many USB DAQ modules include removable terminal blocks or BNC connectors that conveniently handle all user I/O connections. This design is convenient and cost-effective, eliminating optional screw terminal accessories. Modules are also compact and portable, allowing users to move even the most sophisticated test and measurement applications out of the lab and into the field.

The ready availability of accessories makes USB DAQ modules easily expandable. Using low-cost expansion hubs and USB cables, a single USB port can connect up to 127 data acquisition modules. Most USB modules are also hot-swappable, which means they can be installed or removed while the computer is running, with no need to power down the PC.

Power connections on USB DAQ modules are simple and easy to use, with modules being powered either directly by the bus or through a simple connection to an external power source. Low-powered modules draw less than 100mA at 5V and use the power supplied by the USB port. Self-powered modules draw up to 500mA at 5V.

## Potential Hazards of USB

With all the benefits of USB come a few

hidden hazards, which, if unchecked, can lead to inaccurate measurement results. Being aware of the hazards can help prevent problems.

For starters, unlike PCI boards, which have short substantial ground systems built into the backplane of the PC, USB modules have a long ground connection (up to 5 meters) and active circuitry at both ends. If a USB module is not designed properly, this can cause system lockups, erratic performance, and electromagnetic transients—significant problems for noise-sensitive measurements.

Before choosing a USB data acquisition module, consider the application and the environment. It's also wise to ask a few questions:

1. Will the data acquisition module be susceptible to electrostatic discharge (ESD), lightning, or power surges from motors, switching devices, or other equipment?
2. Are there voltages that have different ground potentials?
3. Will the module be operated in a benign environment?

If the answer is “Yes” to questions 1 or 2, ensure that the system includes proper isolation.

Isolation protects the PC from damage and preserves data integrity by physically separating the electrical connections between circuits, thereby limiting potentially harmful voltage or current from flowing through the system. Isolation can be provided either by adding external signal conditioning accessories to the system, which can be expensive, or by choosing an isolated USB data acquisition module from the start.

A detailed look at different application environments will help explain the role of isolation in each case.

### ESD, Lightning, or Power Surges

Figure 1 shows a typical application scenario in which a sensor is measuring a voltage from a device under test. The sensor is connected to a USB data acquisition module, which in turn is connected to the PC.

A potential danger from some non-isolated modules is system lock-up. The modules can lock up the entire system in response to transient voltages, necessitating a system reboot. In test and measurement applications, this kind of behavior is unacceptable.

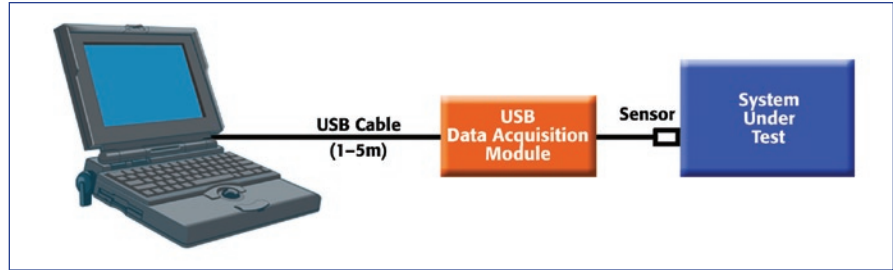

Figure 1. Typical application setup.

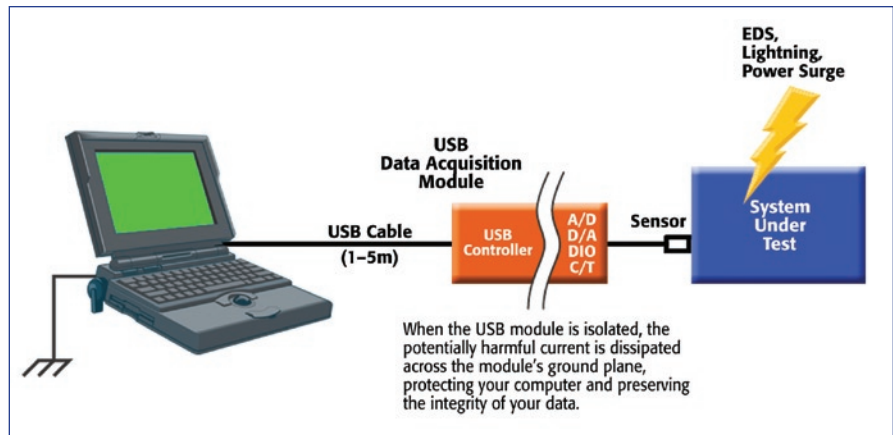

Figure 2. Isolated USB modules protect against surges, ESD, and lightning.

In contrast, isolated modules (shown in Figure 2) dissipate harmful current across the module's ground plane, protecting the entire system.

Even if the transient voltage is small enough not to damage the system, be aware that the data could contain large errors, particularly at high resolutions. For instance, a USB module with 16-bit resolution used to measure a signal in the  $\pm 10V$  range gives an LSB value of 0.31 mV (see Table 1). Therefore, if the module is non-isolated and a transient voltage occurs in the electrical system, the data could be off by hundreds of millivolts. Even in static environments, data could be off by tens of millivolts. This represents a substantial inaccuracy when measuring low-level signals.

Thus, for high-accuracy, low-noise meas-

urements, isolation is critical. A number of electrical components provide isolation. For instance, transformers convert power from fast clock signals with no delay, while optoisolators convert power from slower control signals with a delay in the tens of microseconds. A differential capacitive coupling setup converts power from slow data paths with a delay of 1 microsecond.

### Differing Ground Potentials

Single-ended analog inputs are non-isolated and referenced to earth ground. In non-isolated systems, even digital I/O signals are connected to the same ground. If the system under test shares the same ground as the USB data acquisition module (by virtue of being connected to the building's power system), the difference in ground potential

Table 1. Voltage Ranges at Different Resolutions

Voltage Range	Gain	16-bit resolution LSB Value	12-bit resolution LSB Value
$\pm 10 V$	1	0.31 mV	4.88 mV
$\pm 5 V$	2	0.15 mV	2.44 mV
$\pm 2.5 V$	4	0.08 mV	1.22 mV
$\pm 1.25 V$	8	0.04 mV	0.61 mV

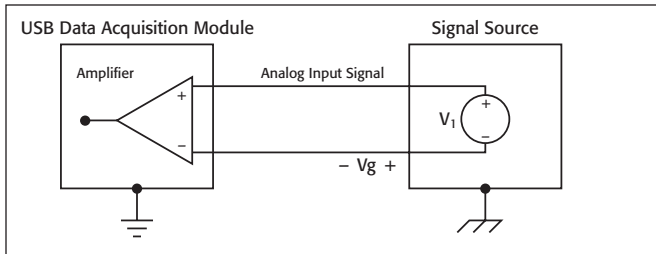

Figure 3. Improperly connected single-ended inputs.

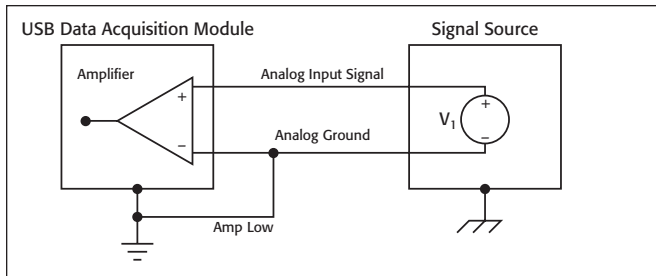

Figure 4. Properly connected single-ended inputs.

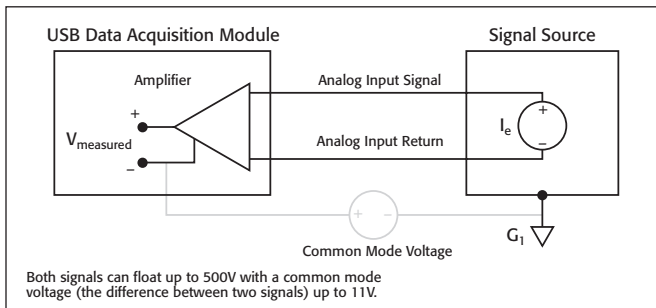

Figure 5. Differential inputs are isolated and eliminate common-mode voltage errors.

between the two devices can be substantial – more than 100mV. Fast switching currents must then travel down the 5-meter USB cable to the PC.

Depending on how single-ended inputs are connected to a module, ground loops errors can be introduced that, when added to the signal and other ground potentials across the USB cable, can not only provide highly inaccurate measurements, but can also damage the system. **Figure 3** shows an example of improperly connecting single-ended inputs.

A better connection scheme for single-ended inputs that reduces ground-loop errors is shown in **Figure 4**.

For the most accurate measurements, use differential inputs (shown in **Figure 5**). Differential inputs are isolated because they are referenced to a ground reference point that is not connected to earth ground. As a result, they eliminate common-mode voltage errors associated with differences in ground potentials.

Therefore, when measuring low-level signals, or signals where noise is a significant part of the measurement, or if there is a common-mode voltage, make sure that the USB data acquisition module provides differential input connections.

## Benign Conditions

In benign environments, where transient electrical spikes and dif-

Keithley's Series KUSB-3100 USB-based data acquisition (DAQ) modules are an alternative to ISA, PCI, and PCMCIA data-acquisition cards. These compact DAQ modules offer true USB 2.0 and 1.1 plug-and-play capability. All Series KUSB-3100 solutions support USB full-speed data rates for data acquisition sampling rates as high as 100 kHz.

Units connect to USB ports on a PC via a standard, low-cost cable. The PC automatically identifies modules and installs the necessary software to operate the unit, greatly reducing start-up time. Modules also install without the need to crack open a PC to add a board, configure DIP switches and IRQ settings, or search for the correct device driver, then reboot the system. A 500V isolation barrier found on all but the base model protects both the computer and the input device from damage caused by voltage spikes, surges, or shorts. This built-in protection also prevents the computer operating system from shutting down, ensuring continuous operation.

The Series KUSB-3100 consists of five different modules to cover a broad range of applications. The modules range from 12-bit to 16-bit resolution with sample rates from 40kS/sec up to 500kS/sec. Connection options include built-in screw terminals, BNC connections, DB-37 connections, or mass termination connections. Built-in connectors eliminate the need for additional accessories, such as cables and screw-terminal panels, which are normally required for ISA and PCI plug-in boards.

All KUSB-3100 Series modules come with a variety of software tools including Quickstart applications, visual programming tools and drivers, and support for LabVIEW™ and TestPoint™. Users can develop applications in Visual Basic and Visual C++ using the supplied ActiveX controls, while Microsoft C developers can use the supplied Software Development Kit (SDK) for writing applications in Windows 2000 or Windows XP.

Series KUSB-3100 modules are suitable for a wide range of measurement applications. Modules can measure voltage, temperature, strain, and vibration and are capable of frequency and event counting and timing for applications in system automation, in-vehicle automotive testing, life science research, and educational teaching labs.



ferent ground potentials do not exist, isolation usually isn't required. In non-isolated systems, the PC is tied directly to the ground system of the sensor, so measurements will be accurate as long as no noise or other errors are added to the voltage source.

While non-isolated solutions may be less expensive to purchase, test and measurement applications rarely are benign. So beware — you may be incurring back-end costs meas-

ured in data accuracies or system failures when you choose a non-isolated solution.

### Conclusion

The benefits of USB for test and measurement applications are many. But, before choosing a USB data acquisition module, consider your application. If transient voltages or differences in ground potentials exist, protect your PC and preserve the integrity

### About the Author

John Tucker is Lead Industry Consultant with Keithley Instruments, Inc. He can be reached at [jtucker@keithley.com](mailto:jtucker@keithley.com), or at 440-498-2718.

of your signal by choosing an isolated USB data acquisition module. 

Specifications are subject to change without notice.

All Keithley trademarks and trade names are the property of Keithley Instruments, Inc.  
All other trademarks and trade names are the property of their respective companies.



**Keithley Instruments, Inc.**

28775 Aurora Road • Cleveland, Ohio 44139 • 440-248-0400 • Fax: 440-248-6168  
**1-888-KEITHLEY (534-8453) • [www.keithley.com](http://www.keithley.com)**

© Copyright 2005 Keithley Instruments, Inc.  
Printed in the U.S.A.

No. 2635  
0605