

KEITHLEY

A Tektronix Company

A GREATER MEASURE OF CONFIDENCE

Your Guide to Creating *High Performance Switching Applications*

INDEX

INTRODUCTION

To design a test system that meets your requirements for accuracy and precision, you need to select appropriate instruments, apply creativity in designing test methods, and pay careful attention to specifications and error terms. Most test system applications are complex enough that it is in the designer's best interest to minimize the number of uncontrolled variables. To accomplish this, the system switch performance should be tightly specified.

Special consideration should be given to tests that approach the specified limits of accuracy, resolution, or sensitivity of the measurement or sourcing instruments. These generally represent the "most critical test requirements," and switching should be selected to support these tests. An application designed to perform against the "most critical test requirements" will usually satisfy other test requirements as well.

The applications outlined in this e-handbook offer a good overview of many of the types of test automation challenges you may face.

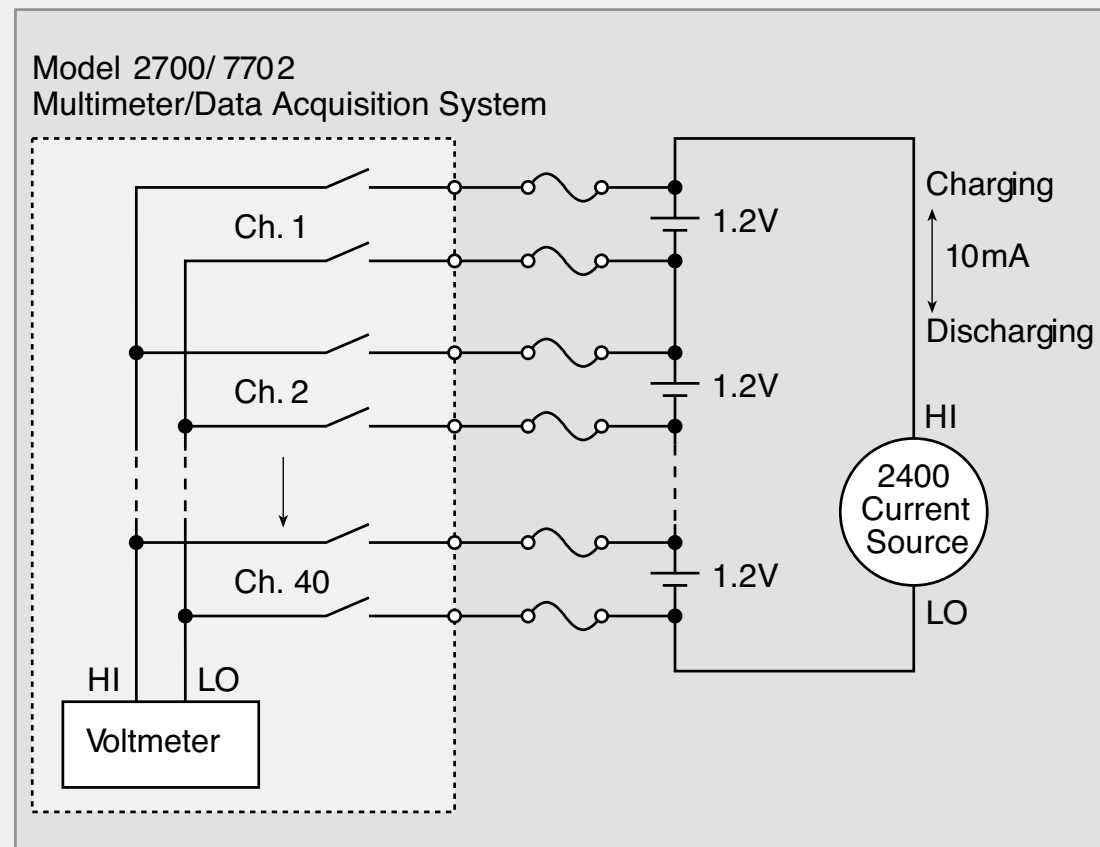

Figure 1. Charging/discharging multiple batteries in series

BATTERY TESTING

Batteries are used in a rapidly expanding variety of consumer and industrial applications. Their testing requirements typically depend on their chemistry, size, specific use, and whether the cells are primary or secondary.

Secondary (rechargeable) batteries are commonly tested using discharge and charge cycling. The discharge characteristics of a secondary battery provide important information about the battery's capacity and life. Charging/discharging a battery often takes several hours, so it is usually desirable to connect several batteries in series in order to charge and discharge them simultaneously. The voltage of each battery can be monitored during charging and discharging using a two-pole scanner.

In some applications, it may be desirable to measure each cell voltage, both with and without a load. Monitoring the voltage decay over time will give an indication of cell quality. While this is particularly true for primary cells, this technique can also be used for secondary cells. Using a scanner makes it possible to monitor the voltage decay of several cells at one time.

The following paragraphs describe the switch configurations for both the charge/discharge cycling test and the voltage monitoring test.

Switching Configurations

Figure 1 illustrates the switch configuration for charging/discharging a string of cells connected in series. In this configuration, a series string of 40 cells is connected to a current source (Model 2400 SourceMeter® Instrument), which charges/discharges the cells. A separate voltage measurement instrument monitors the individual battery voltages through a switch. (Note: In this application, the Model 2400 cannot be used for both current sourcing and voltage measurement, because it is limited to a 5V difference between the input/output HI and sense HI terminals.)

In this particular example, the current source is supplying $\pm 10\text{mA}$ to all 40 cells simultaneously, so all the cells can be either charged or discharged at the same time. The Model 2700 Multimeter/Data Acquisition System, equipped with a Model 7702 40-Channel Differential Multiplexer Module, is used to switch and measure the voltage of each cell. Each cell has a voltage of 1.2V, so the total voltage across the string of cells is 48V. It is important to ensure that the total cell voltage across the string does not exceed the common mode voltage rating and the maximum voltage level of the switch module.

To avoid damage to relays, synchronizing the switch/measure sequence properly is critical. It is particularly important to make certain all other channels are open before closing a particular channel. Inadvertently closing multiple channels will short two or more cells and may damage the relays. Adding a current limiting resistor or fuse in series with each switch will help prevent this type of damage.

To monitor the voltage decay of a series string of cells, load resistors must be switched across individual cells. **Figure 2** illustrates a switching system for testing 80 primary cells. In this example, there are two sets of switches: one set of two-pole switches (two Model 7702 modules) is used to connect the cells to the voltmeter, and one set of isolated switches (two Model 7705 40-Channel Control Modules) is used to connect the load resistors (R_L).

If the load resistor was connected directly across the voltmeter input terminals, the current through the relay contacts would cause a voltage drop and the measured cell voltage would be in error. This error is eliminated if isolated relays are used to switch the load resistors to each cell. The Model 7705 module has 40 isolated relays. In addition, these extra isolated relays will allow the load resistors to be connected or disconnected from each cell at any time during the test cycle.

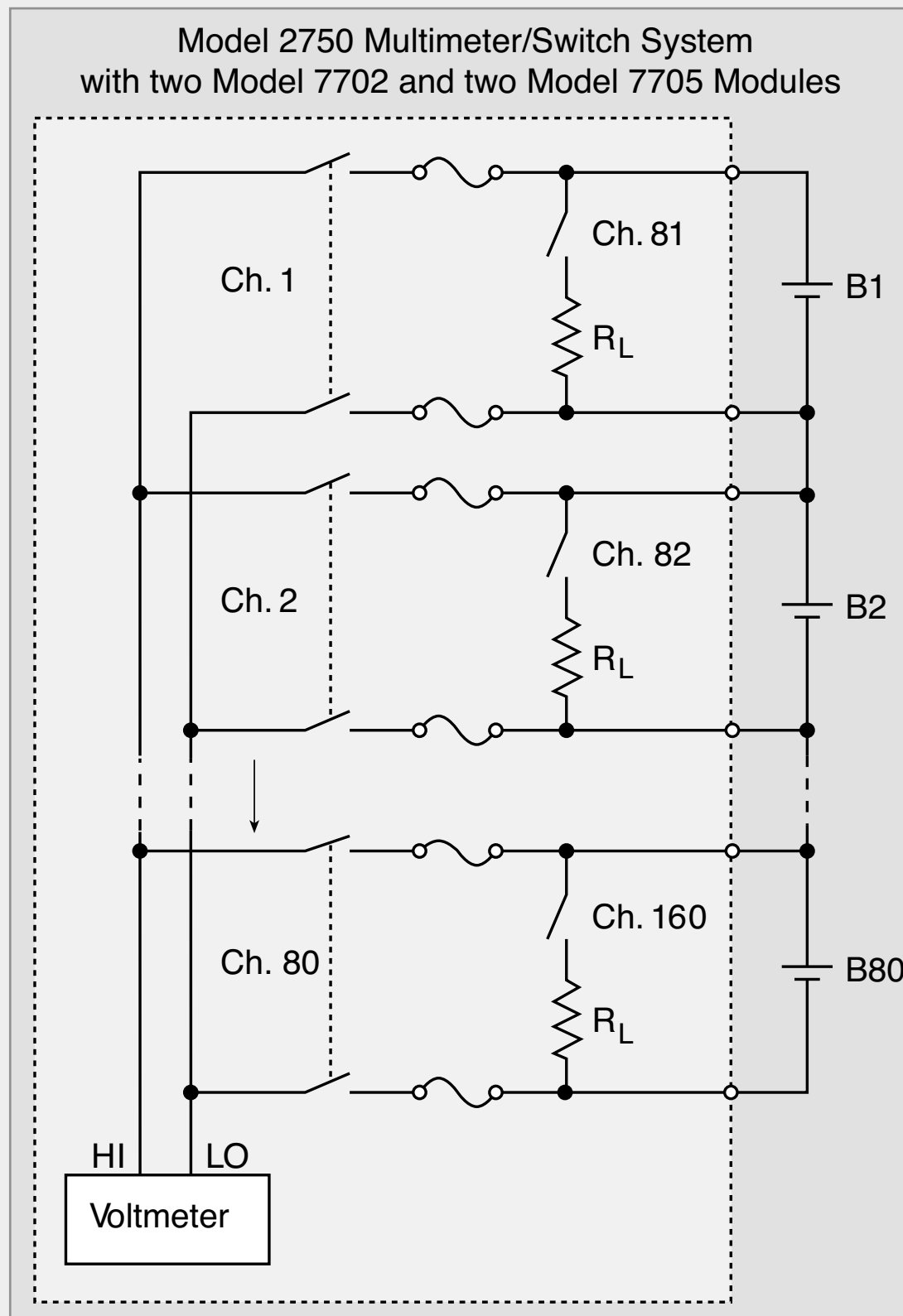
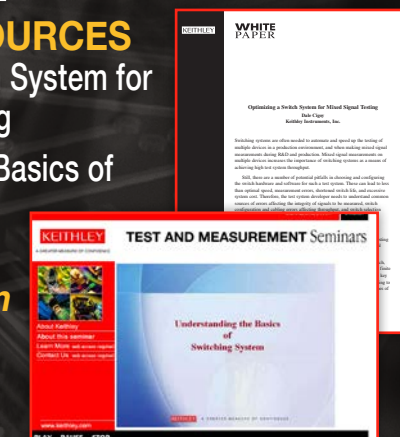

Figure 2. Using isolated relays to switch load resistors to batteries

Want to Explore Further?

FEATURED RESOURCES

- Optimizing a Switch System for Mixed Signal Testing
- Understanding the Basics of Switching Systems
- **Get a Quote or More Information**



ADDITIONAL RESOURCES

- Model 2400 SourceMeter Product Demo
- Model 2700 Multimeter/Data Acquisition System
- Model 7702 40-channel Differential Multiplexer Module
- Model 7705 40-channel, Single-pole Control Module

CAPACITOR LEAKAGE MEASUREMENTS

Capacitors are essential components used in practically every type of electronic equipment. Leakage resistance is one of the many electrical characteristics tested on capacitors. The leakage resistance, often referred to as “IR” (insulation resistance), is expressed in megohm-microfarads. In other cases, the leakage may be expressed as a leakage current at a given voltage, usually the operating voltage.

Capacitor leakage is measured by applying a fixed voltage to the capacitor and measuring the resulting current. The leakage current will decay exponentially over time, so it is necessary to apply the voltage for a known period of time (the soak time) before measuring the current.

For statistical purposes, a quantity of capacitors must be tested to produce useful data. An automated switching system is required to make performing these tests practical.

Switching Configuration

Figure 3 illustrates a capacitor leakage test system that uses the Model 6517B Electrometer/Source, Model 7158 Low Current Scanner Cards, and a Form C Switch Card, such as the Model 7111-S. The cards are installed in a Model 7002 Switch Mainframe.

In this test system, one set of switches (on the Model 7111-S) is used to apply the test voltage to each capacitor. In the normally closed position, one end of the capacitor is connected to circuit LO. When the switch is actuated, the capacitor is connected to the voltage source. Switch actuation is usually staggered (for example, two seconds apart) so that each capacitor may be charged for the same period of time before its leakage is measured. If the maximum test voltage is 110V or less, the Model 7111-S card may be used. If voltages greater than 110V must be applied, use an appropriately rated switch.

A second set of switches (on the Model 7158) connects each capacitor to the picoammeter after a suitable soak period. Note that before the capacitor is switched to the picoammeter, the capacitor is connected to circuit LO. This allows the leakage current to flow continuously while it is being charged up.

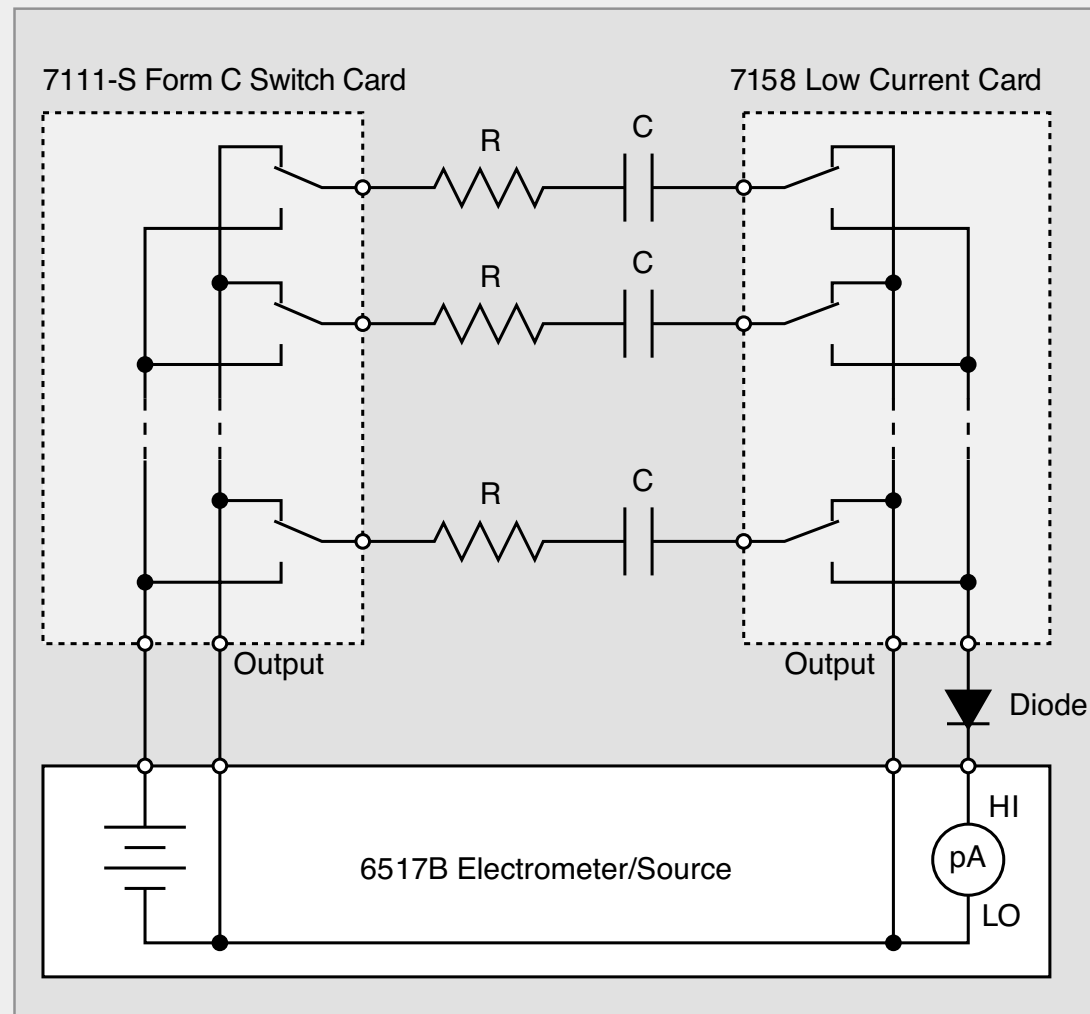

Figure 3. Capacitor leakage test system

For this application, a single instrument provides both the voltage sourcing and the low current measurement functions. The Model 6517B is particularly useful for this application because it can display either resistance or leakage current and will source up to 1000VDC.

After the capacitors have been tested, the voltage source should be set to zero; some time must be allowed for the capacitors to discharge before they are removed from the test fixture. Note that in Figure 3 the capacitors (C) have a discharge path through the normally closed contact of the relays. The test sequence is summarized by:

1. **Quiescent state** - Model 7111-S relays are normally closed and Model 7158 relays are normally closed.
2. **Source voltage (soak time)** - Model 7111-S relays go to normally open and Model 7158 relays remain normally closed.
3. **Measure current** - Model 7111-S relays remain normally open and Model 7158 relays go to normally open.
4. **Discharge capacitors** - Model 7111-S relays go to normally closed and Model 7158 relays go to normally closed.

Since the switches on the Model 7111-S Form C Switch Card remain energized during the measurement of current, any offset current from the card is irrelevant to the measurement.

The resistor (R), which is in series with each capacitor, is an important component in this test system. It limits the charging current of each capacitor and also protects the relays in case a capacitor becomes short-circuited. Also, the resistor limits the AC gain of the feedback ammeter. In general, as the source capacitance increases, the noise gain also increases. The resistor limits this gain to a finite value. A reasonable value is one that results in an RC time constant from 0.5 to two seconds. The forward-biased diode in series with the HI electrometer (μA) terminal also serves to limit the AC gain.

A triax-to-BNC adapter (Model 7078-TRX-BNC) is used to connect the Model 6517B to the Model 7158 card. The capacitors are connected to the Model 7158 cards using low noise coax cables. Insulated wires can be used to connect the Model 7111-S card to the capacitors.

Want to Explore Further?

FEATURED RESOURCES

- Capacitor Leakage Measurements Using a Model 6517A Electrometer
- TestPoint Program to Measure Capacitor Leakage with 6517A/B
- **Get a Quote or More Information**

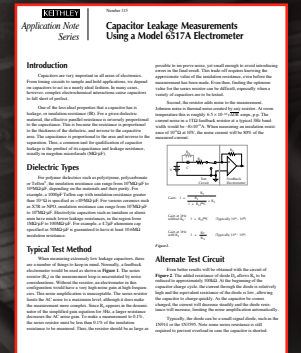

ADDITIONAL RESOURCES

- Model 6517B Electrometer/High Resistance Meter
- Model 7002 400-Channel Switch/Control Mainframe

CONTINUITY TESTING

Continuity checks are typically performed on a variety of devices, including cable assemblies, printed circuit boards, and connectors, to ensure these components have a continuous path where desired. When setting up a continuity test, the engineer must specify the maximum resistance at which the device is considered to be valid. For example, any measured resistance of 1Ω or less would indicate a good device. Continuity checks require measuring low resistance, so a four-wire ohmmeter is normally used to eliminate lead and switch resistance from the measurement.

An isolation resistance or insulation resistance test is often performed in addition to the continuity test. In particular, a multi-conductor cable requires each conductor to provide a continuous path from one end to the other; it also requires each conductor to be isolated from all other conductors.

Given that continuity testing often involves multi-conductor devices, a switch system is useful to connect the ohmmeter to each conductor automatically.

Switching Configuration

Figure 4 illustrates a typical continuity test circuit. Two banks of two-pole switches are used to make four-wire resistance measurements on 20 conductors. To measure the resistance of Conductor 1 using the Model 2700 Multimeter/Data Acquisition System in the four-wire ohms mode, close Ch. 1. In the four-wire ohms mode, this will automatically close Ch. 21 as well. This is repeated for each conductor.

To measure 20 conductors, a Model 2700 with one Model 7702 40-Channel Differential Multiplexer Module is required. Use a Model 2750 Multimeter/Switch System with multiple Model 7702 modules if more than 40 conductors must be tested at one time.

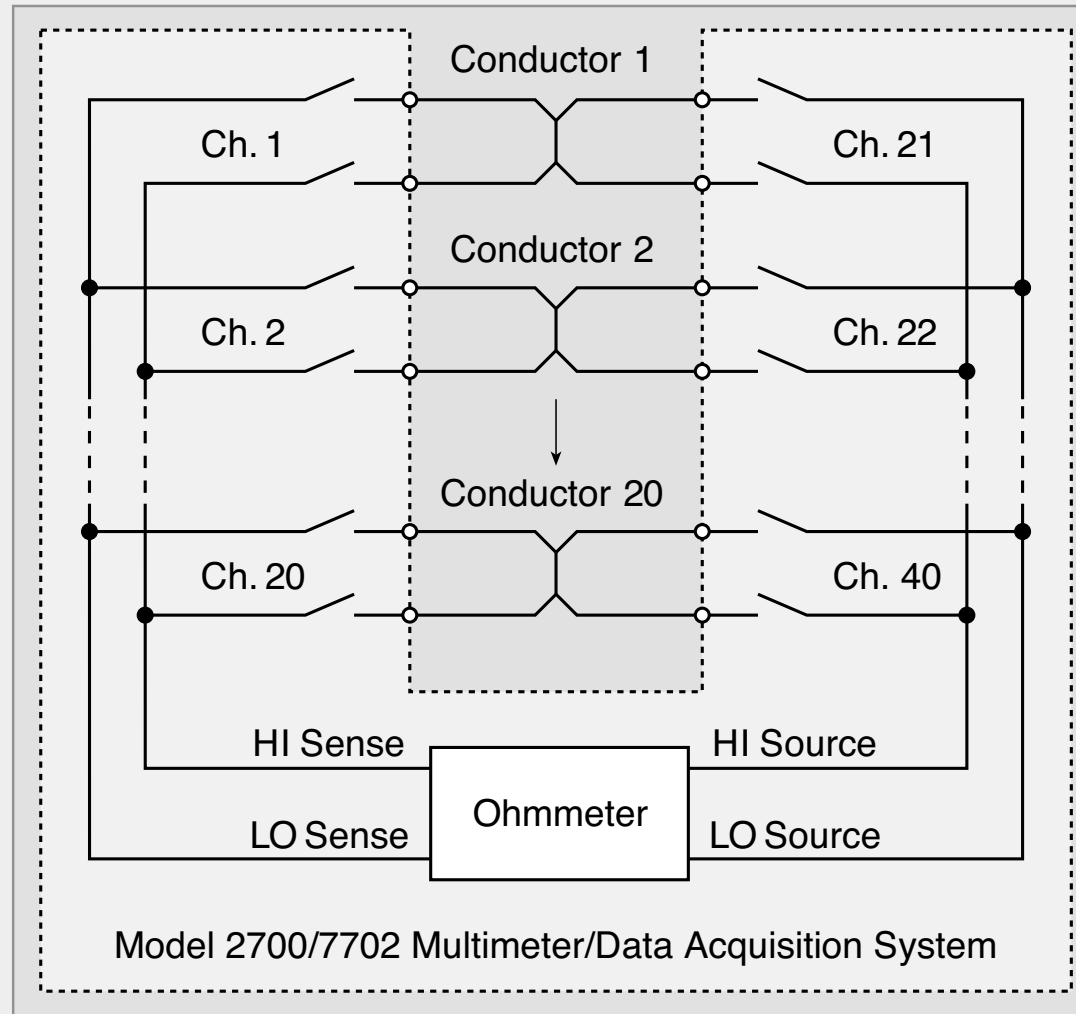

Figure 4. Continuity test system

INSULATION RESISTANCE TESTING

The DC insulation resistance (IR) is the ratio of the DC voltage applied between two conductors separated by an insulator to the total current flowing between the two conductors. The test voltage is applied for a specified period of time before the resulting current is measured. The measured current is usually quite small, so a picoammeter or electrometer is often required to make the measurement.

Sometimes the insulation resistance of a sample is measured only to determine that it is greater than a specified minimum value. For example, any resistance value greater than 10MΩ may be considered acceptable. The accuracy of the measurement is not critical; it is only important that the measured resistance be greater than a specified value. Examples of insulation resistance measurements include measuring the path between traces on a printed circuit board or the resistance between conductors in a multi-conductor cable. IR measurements often involve multiple conductors, so a switching system is often required to switch the picoammeter and the source to all the conductors in the test circuit.

The design and type of switching cards used in an IR test system depend on several factors, including the test voltage, magnitude of resistance, accuracy, common connection, etc. The following section describes two IR test systems.

Switch cards appropriate for high impedance voltage switching include the Models 7158 and 6522. A card with triax connections is necessary if the guard voltage could exceed 30VDC. This precaution is necessary to ensure safety.

Switching Configuration

Figure 5 illustrates a test system for measuring the IR of any one terminal of a multipin connector to all other terminals using the Model 7111-S 40-Channel Form C Switch Card in a Model 7001 Switch Mainframe.

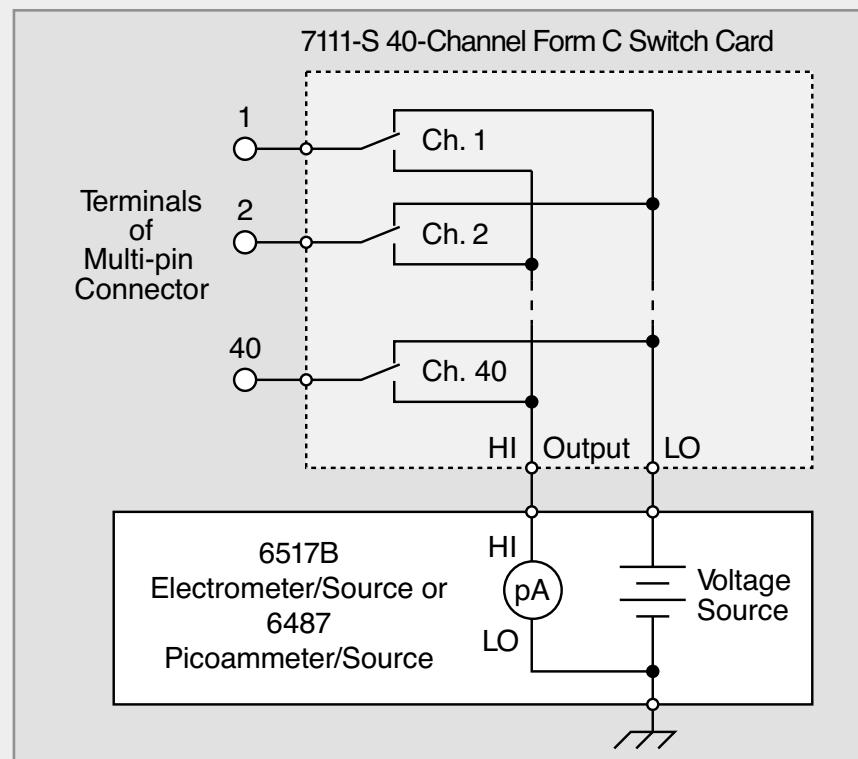

Figure 5. Testing IR from any one terminal of a multipin connector to all others

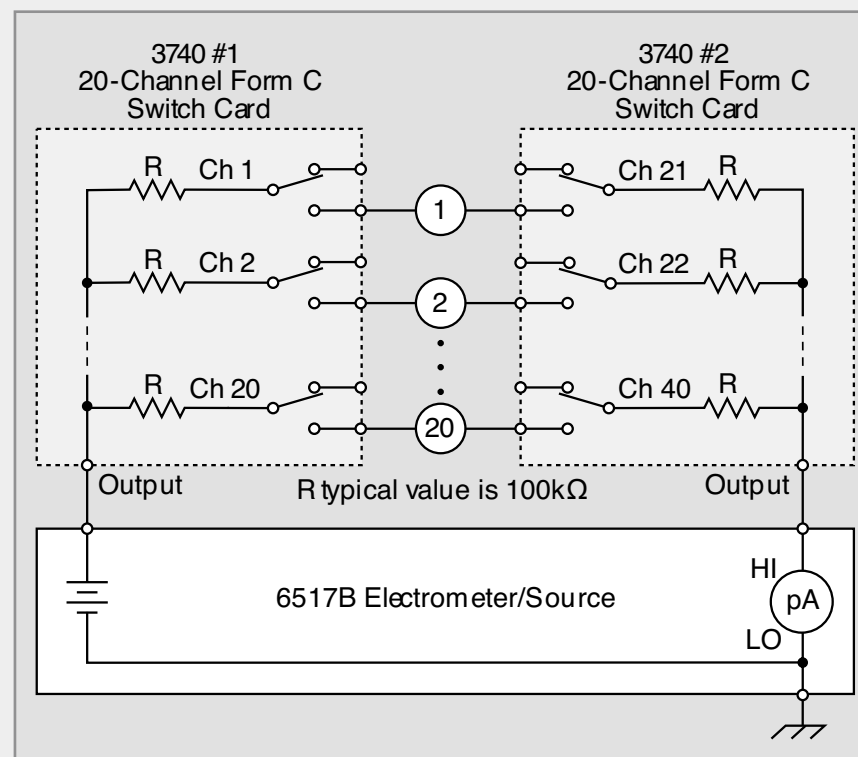

Figure 6. Testing IR between any two terminals

In the de-energized position, the voltage source is connected to all pins under test. When any given channel is selected, the leakage current of that pin to all other pins is measured. The Model 7111-S card has <100pA specified offset current. With a test voltage of 100V, this represents a leakage resistance of 1TΩ. This system in a practical circuit can easily detect leakage resistances of greater than 10GΩ.

Figure 6 shows a system that allows applying the test voltage to one or more terminals while the current is measured from one or more terminals. Note that there are two independent groups of switches connected to each terminal. One group connects the test voltage to the terminals while the other group measures the leakage current. Therefore, the IR can be tested from any terminal to any other or all terminals. Note that all switches will be exposed to the test voltage at some point in the test cycle. Therefore, both groups of switches must be able to withstand the desired test voltage and should have good channel-to-channel isolation to prevent degradation of the measured signal.

In Figure 6, IR can be measured at relatively high voltage (up to 300V) using Model 3740, a 28-channel isolated Form C switch card. The Model 3740 is used in the Model 3706A mainframe. The COM terminal is jumpered on all Form C relays that will be used to change the configuration from switch to multiplex. To measure the insulation resistance between pins 1 and 2, close Channels 1 and 22.

The resistors (R) limit the charging current through the relays. These resistors replace factory installed jumpers on the cards to minimize cable capacitance charge and discharge current. A typical R value is 100kΩ.



INDEX

COMBINING CONTINUITY AND INSULATION RESISTANCE TESTING

Some multiple pin devices require measuring the path resistance or continuity through each conductor (a low resistance) and measuring the insulation resistance between the conductors (a very high resistance). This test system requires switching and measuring both low resistance (<1Ω) and very high resistance (>109Ω).

This test system may be used on a variety of devices, such as connectors, switches, multiple conductor cables, and printed circuit boards.

Switching Configuration

Figure 7 illustrates a combined continuity and IR system for testing multiple conductors using a four-wire DMM or SourceMeter instrument. The resistances R1 through R20 represent the conductor resistances. To measure conductor resistance R1, close Chs. 1 and 21. The resistances Ra and Rb represent leakage resistance between conductors. The leakage resistance can be measured between any two or more conductors. To measure leakage resistance Ra, close Channels 1 and 22. This is essentially the leakage resistance between conductors 1 and 2, given that Ra is much greater than R1.

A single Model 2700 Multimeter/Data Acquisition System with a Model 7702 40-Channel Differential Multiplexer can be used to test up to 20 conductors. A single Model 3706A with a Model 3722 card can be used to test up to 48 conductors. A fully loaded Model 3706A with six Model 3722 cards can test up to 288 channels. When measuring the leakage resistance with a DMM, the maximum applied voltage is usually less than 15V. Also, the maximum measured resistance is usually not greater than 100MΩ. To test the IR at a specified test voltage, use a test configuration such as the Model 2400 SourceMeter instrument with Model 7011 Quad 1x10 Multiplexer Cards in a Model 7001 or 7002 Switch Mainframe.

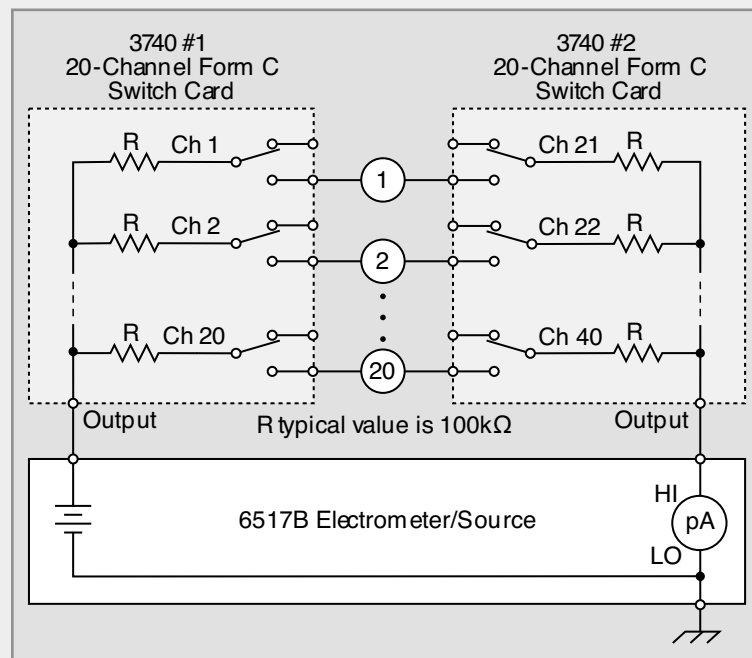

Figure 7. Continuity and IR test system

If a higher test voltage is required or if a higher leakage resistance must be measured, the circuit in Figure 8 may be used. In this diagram, two Model 7154 High Voltage Scanner Cards are used to switch a Model 2410 SourceMeter instrument and Model 2010 Digital Multimeter to eight conductors. This system can measure conductor resistances as low as 0.1mΩ and leakage resistances as high as 300GΩ with a test voltage as high as 1000V. Note that the Model 2410 and Model 2010 are not connected to the card outputs, but are connected to specific channels of the scanner cards. The outputs of the cards are only used to expand the system to measure a larger number of conductors. To measure the resistance of R1, close Chs. 1, 10, 11, and 20. This will connect the Model 2010 across R1. To measure Ra, the leakage resistance between R1 and R2, close Chs. 1, 9, 12, and 19. This will connect the Model 2410 across the leakage resistance (Ra).

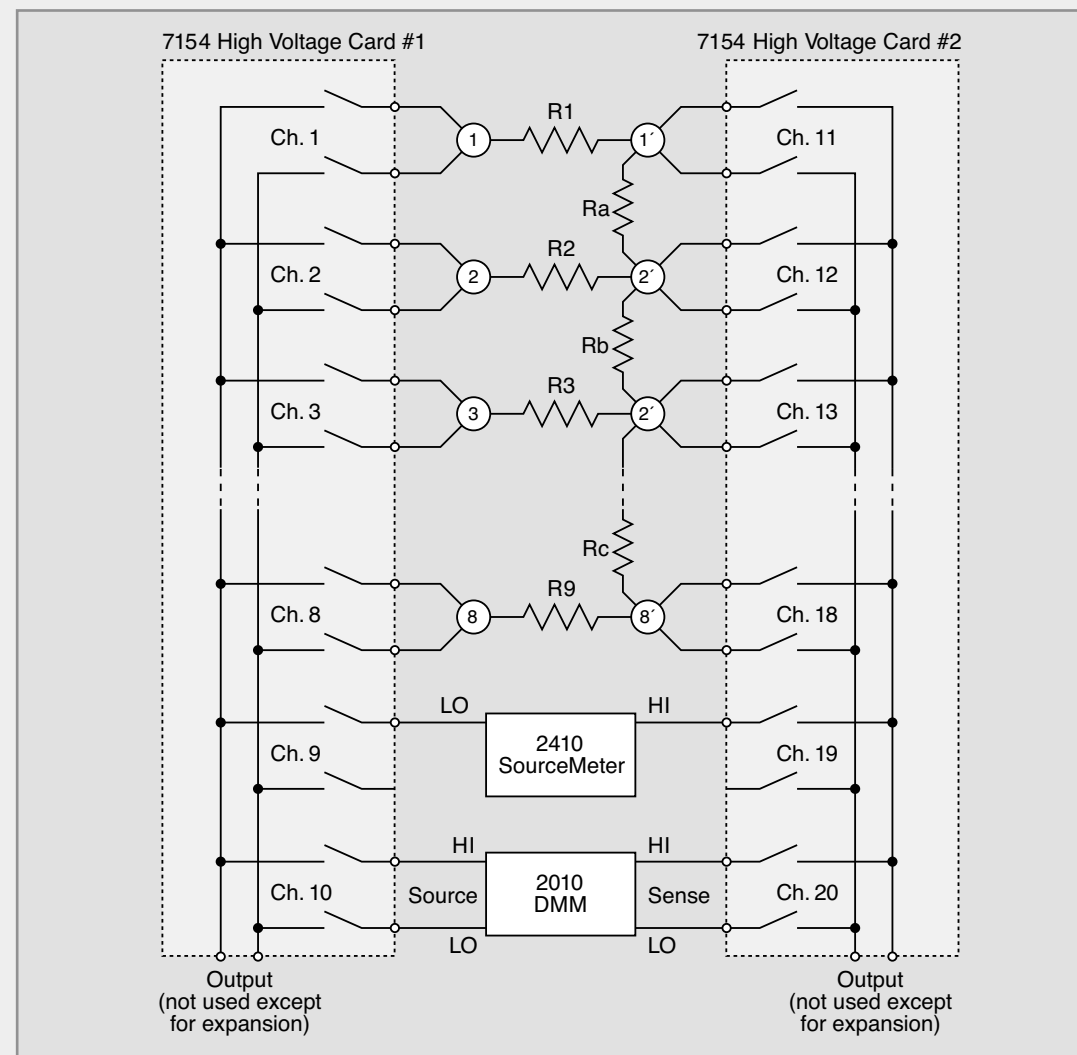

Figure 8. Expanded range continuity/IR system

Want to Explore Further?

FEATURED RESOURCES

- Solutions for Production Testing of Connectors
- Optimizing Switch/Read Rates with Series 2000 DMMs and 7001/7002 Switch Systems
- TestPoint Example to Measure Cable Insulation Resistance with 6517A/B
- [Get a Quote or More Information](#)

ADDITIONAL RESOURCES

- Integra Series Integrated Multimeter/Data Acquisition Systems
- Series 3700A System Switch/Multimeter Quick Start Guide
- Series 3700A System Switch/Multimeter and Plug-In Cards
- Series 2000 High-Performance Digital Multimeters
- Series 2400 SourceMeter Line

INSULATION RESISTANCE TESTING OF PRINTED CIRCUIT BOARDS

Printed circuit boards (PCBs) are used in most electronic products. If a PCB has low insulation resistance (IR), it can degrade the performance of the circuits on the board considerably. Factors that affect the surface resistance of the board include the board material, the presence of coatings such as solder masking or conformal coatings, and board cleanliness. Temperature and relative humidity can also affect the surface resistance.

To test the insulation resistance, special test patterns called coupons are created on printed circuit boards. The resistance typically ranges from $10^7\Omega$ to $10^{16}\Omega$ and is measured with a picoammeter and voltage source. The test coupons usually have several terminals, so test systems include scanners to switch the picoammeter and the voltage source to the terminals.

Switching Configurations

Figure 9 outlines a system to test a single five-terminal (“W”) test pattern. In this circuit, the Model 7011 Quad 1x10 Multiplexer Card is used to connect the voltage source to terminals 1 and 5 together or to terminal 3. The Model 7158 Low Current Switch Card is used to connect the electrometer to terminal 2 or 4.

At the start of the measurement, close Ch. 1. After a specified “soak” time, energize Ch. 41 and measure the current. The ratio of the applied voltage to the measured current is the resistance between terminals 1 and 2. Next, de-energize Ch. 41 and energize Ch. 42 to measure the insulation resistance between terminals 5 and 4. Note that the path from 5 to 4 already has been biased. No additional soak time is needed, so it can be measured immediately. De-energize Ch. 42, then open Ch. 1 and close Ch. 2 to apply the test voltage to terminal 3. The $1M\Omega$ resistor located at Ch. 1 will discharge the voltage at terminals 1 and 5, so it will not interfere with subsequent measurements. After the specified soak time, energize Ch. 41 again to measure the resistance between terminals 3 and 2. De-energize Ch. 41 and energize Ch. 42 to measure the resistance between terminals 3 and 4, which already has been biased.

Note that when none of the channels on the Model 7158 card are energized, terminals 2 and 4 are connected to the LO of the picoammeter (pA), which electrically is the guard terminal. This guard connection will prevent leakage current from de-energized channels from interfering with the measurement.

Five “W” patterns can be tested as described using one Model 7011 card and one Model 7158 card. Model 7111 Form C Switch Cards can be used in place of the Model 7011 card. If this card is used, de-energizing a channel will connect the terminal to circuit LO rather than the voltage source. This will eliminate the need for the $1M\Omega$ resistors. When using either the Model 7011 or 7111 Cards, the test voltage cannot exceed 110V.

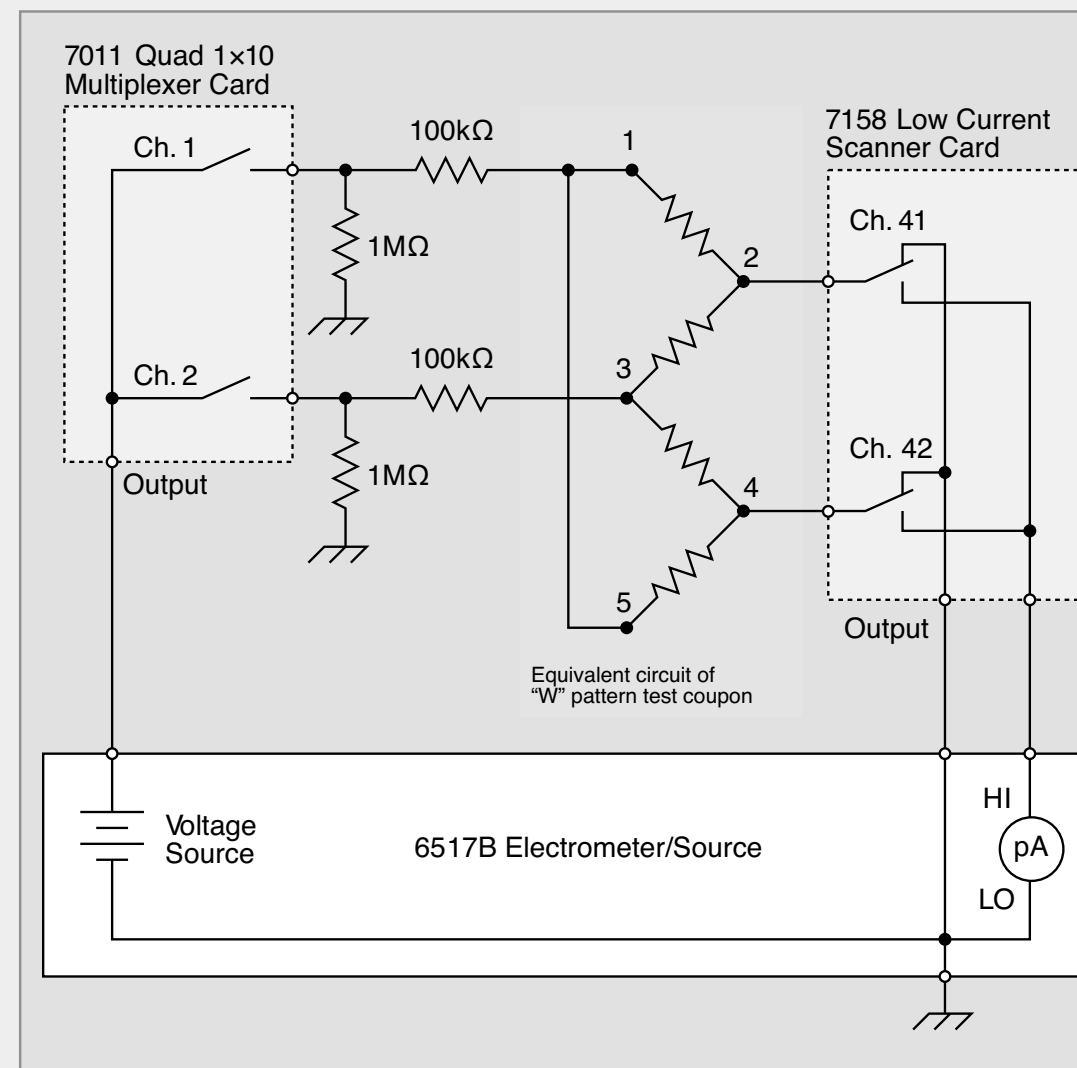

Figure 9. System to test the insulation resistance of one test coupon

The 100kΩ resistors are used to limit the available current in the event of a short-circuited test coupon. Choose current limiting resistors that are no more than 10% of the lowest measured resistance.

Figure 10 shows a circuit to test a coupon with ten two-terminal leakage paths. Each coupon can be thought of as a bank of isolated resistors (R1, R2, R3, R4, etc.). Each resistor requires one voltage channel and one current channel. The Model 7158 card connects the electrometer or picoammeter to one end of each resistor, while the Model 7111-S 40-Channel Form C Switch Card connects the voltage source to the other end of each resistor.

To test resistor R1, first energize Ch. 1 to bias the test coupon. After a specified “soak” period, energize Ch. 21 to measure the resulting current. Continue this process for all of the remaining resistances.

Note that when the channels are de-energized, the corresponding resistor terminals are connected to circuit LO, allowing any charge across the resistances to be dissipated when the resistance is not being measured.

The current limiting resistors (R) protect the scanner cards from damage if the test coupon develops a short circuit.

Low noise coax cables should be used between the test coupons and the Model 7158 cards to avoid noise currents.

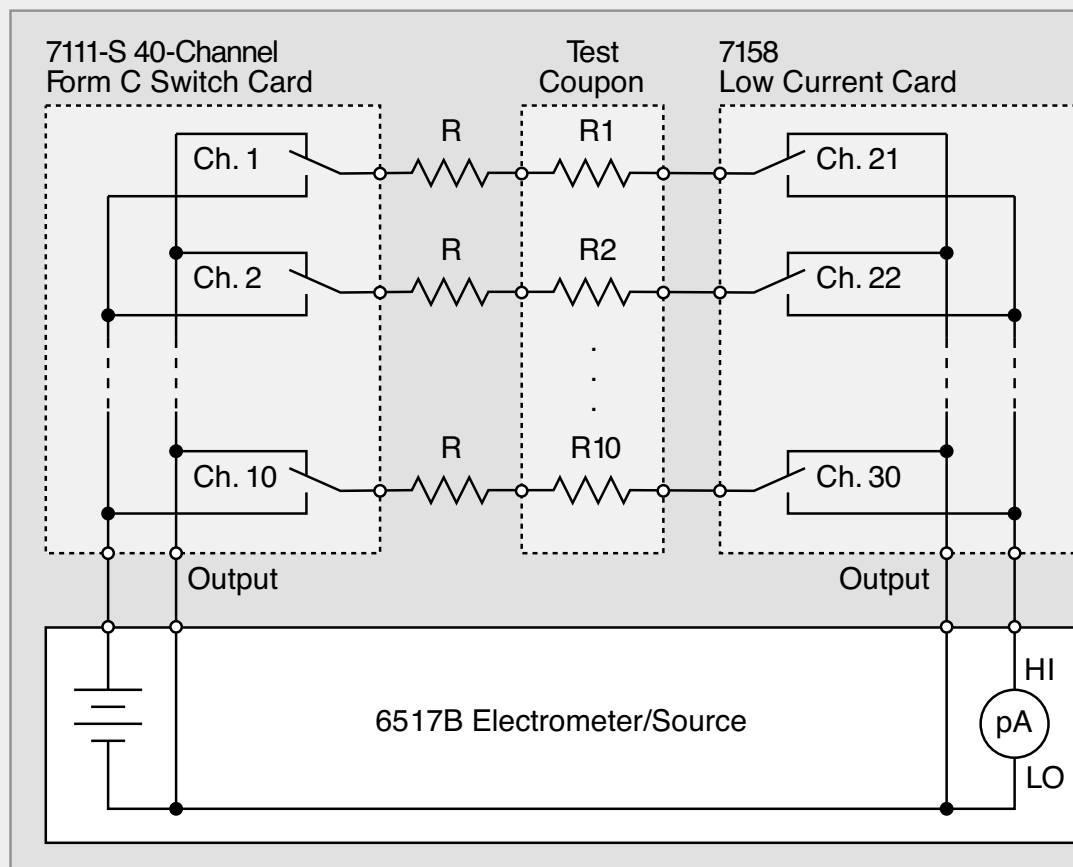
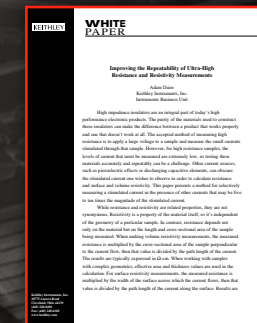

Figure 10. Circuit to test a single ten-resistor coupon

Want to Explore Further?

FEATURED RESOURCES

- Improving the Repeatability of Ultra-High Resistance and Resistivity Measurements
- TestPoint Example to Measure Surface Insulation Resistance with 6517A/B
- **Get a Quote or More Information**



ADDITIONAL RESOURCES

- High Resistance Measurements

CONTACT RESISTANCE

Contact resistance is the resistance to current flow through a closed pair of contacts. These types of measurements are made on components such as connectors, relays, and switches. This resistance is normally very small, ranging from micro-ohms to a few milliohms, so a four-wire measurement method is used. Programmable scanners greatly reduce measurement time by switching one set of test instruments to multiple contacts, such as when testing multi-terminal connectors or when testing many contacts automatically in an environmental chamber.

Switching Configurations

As **Figure 11** shows, all four terminals of the ohmmeter are switched in order to prevent the test lead, path, and switch contact resistances from being added into the measurement. Note the HI and LO Source terminals are connected to one set of two-pole switches, while the HI and LO Sense terminals are connected to another set of two-pole switches. To measure the resistance of Contact 1, close both Chs. 1 and 21, then measure the resistance with the ohmmeter. To measure Contact 2, open Chs. 1 and 21, close Chs. 2 and 22, then measure the resistance again.

A Model 3706A System Switch/Multimeter can be used to measure the contact resistance because it can measure resistances less than 1mΩ and offers offset compensation and dry circuit testing capabilities.

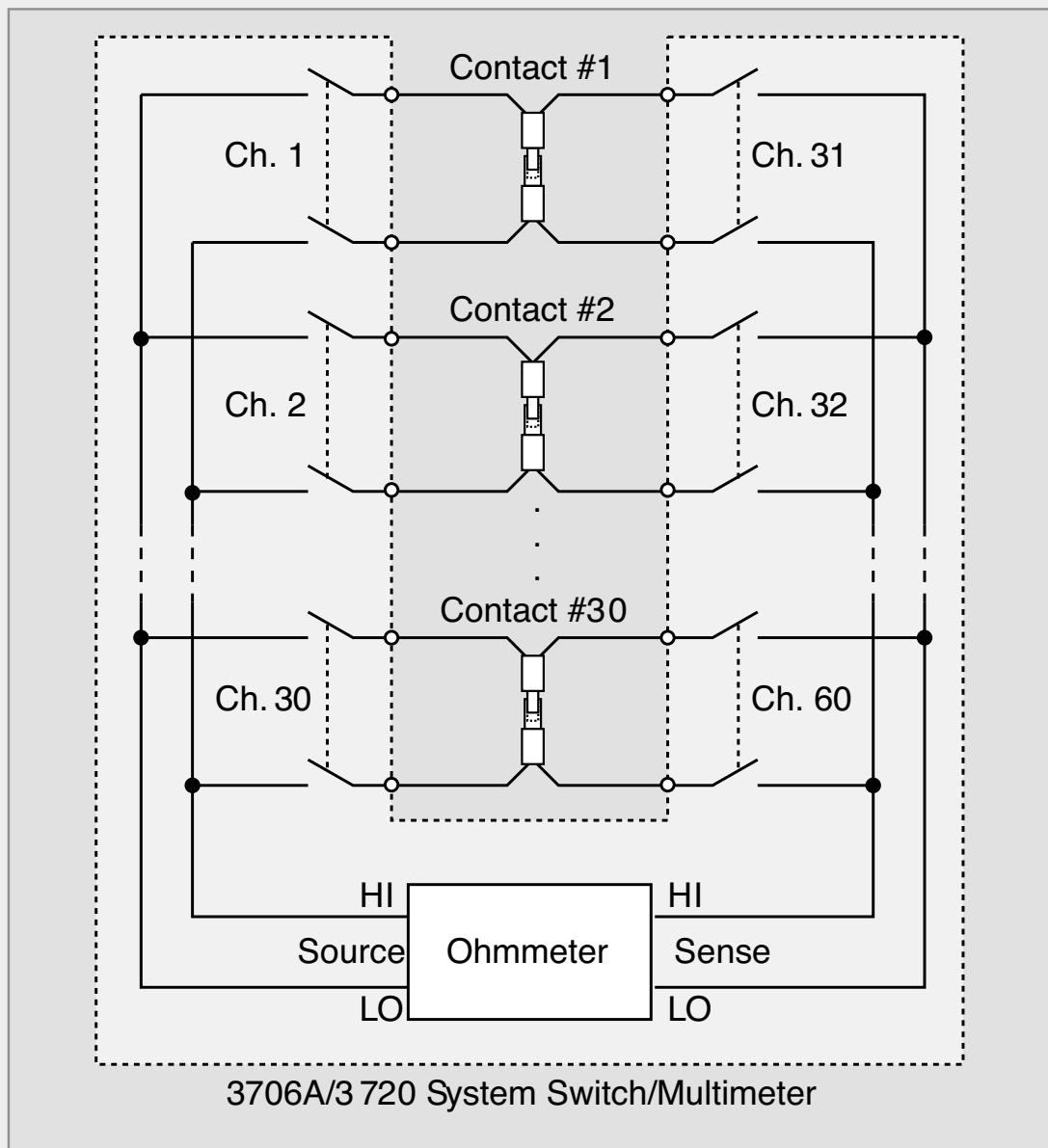

Figure 11. Measuring resistance of 30 contacts

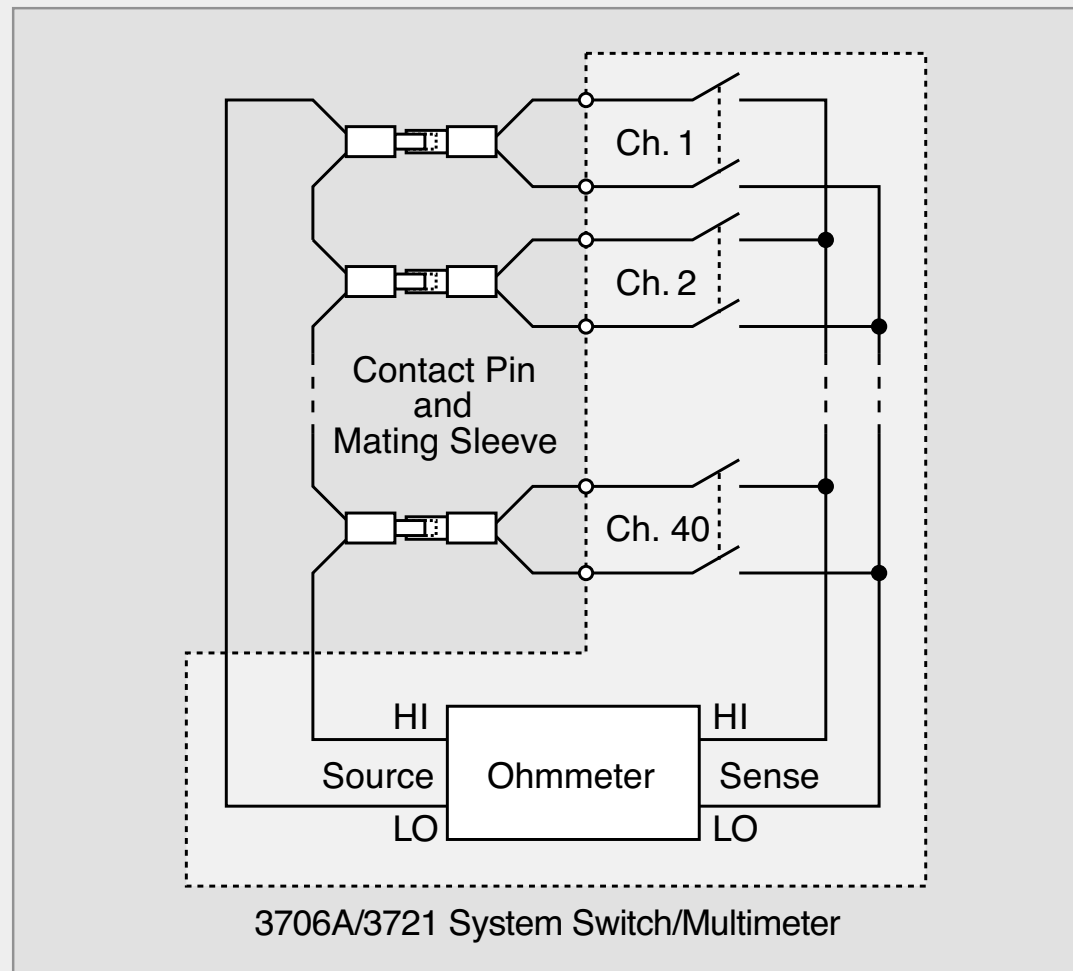

Figure 12. Measuring 96 contacts with a common terminal



INDEX

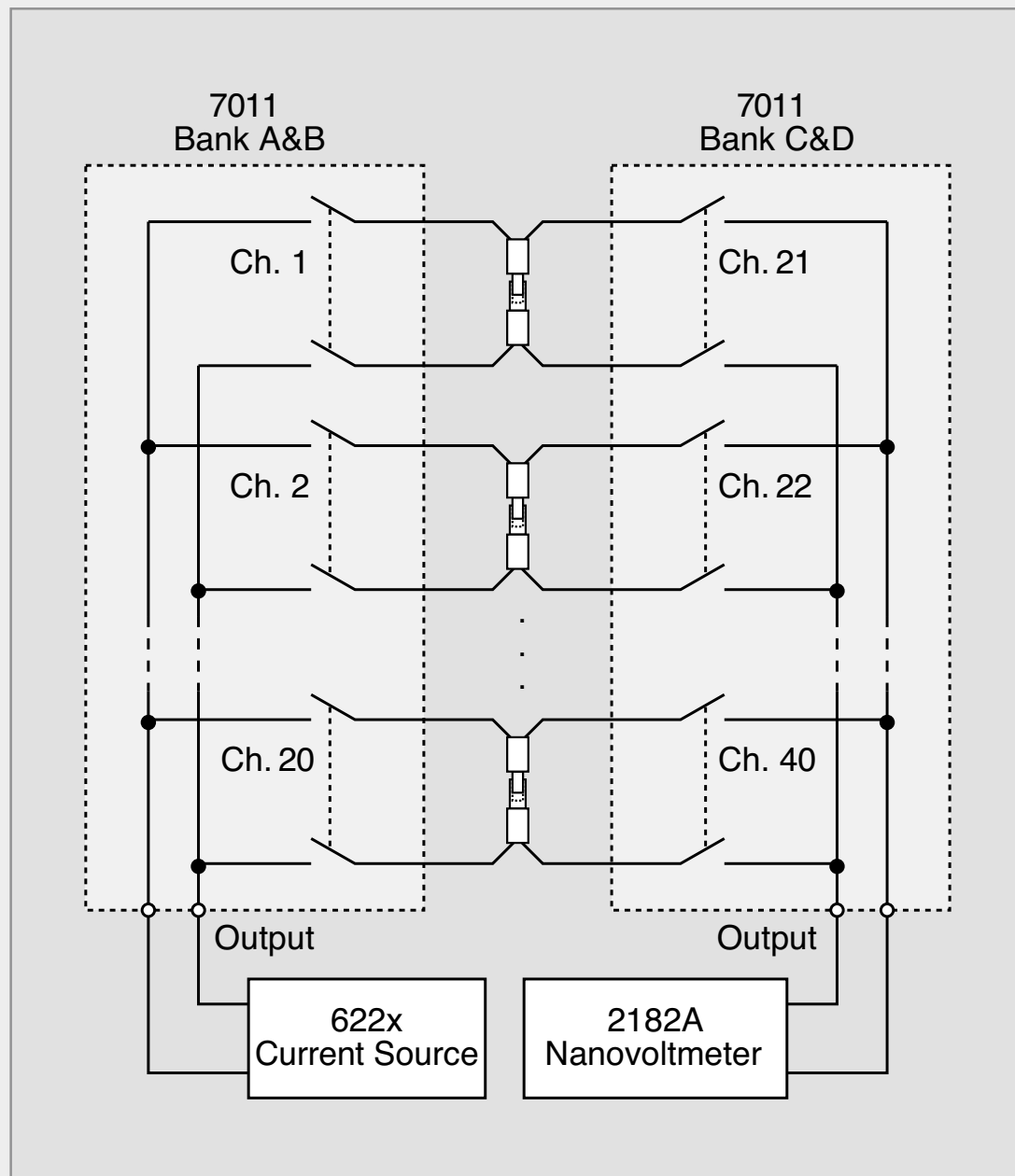

Figure 13. High performance contact resistance system

Contacts used in low level applications are often tested under dry circuit conditions, in which current and voltages are limited to levels that cannot cause changes in the physical and electrical condition of the contact junction. In general, a dry circuit is one in which the open circuit voltage is low, usually 20mV or less, and the short circuit current is limited to 100mA or less.

In some cases, the number of switches required may be reduced by half by connecting the samples in a unique series manner, as shown in **Figure 12**. In this example, all the contact pins are connected in series and each of the mating sleeves is connected to a two-pole switch. In this case, a Model 3706A System Switch/Multimeter is configured with a Model 3721 Dual 1x20 Multiplexer Card and can test up to 40 contacts. Up to 240 contacts can be tested using six Model 3721 modules in one Model 3706A mainframe.

Figure 13 illustrates a high-performance contact resistance system for measuring very low resistances ($\mu\Omega$) at relatively low currents ($<100\mu A$). In this system, a Model 6220 or 6221 Current Source outputs the test current and a Model 2182A Nanovoltmeter measures the voltage drop across each contact. Both the Model 2182A and the Model 622x are switched to each contact using a Model 7011 40-Channel Multiplexer Card. The Model 622x has a programmable voltage compliance limit, so this system can ensure dry circuit testing conditions.

Twenty contacts can be switched using one Model 7011 card and one Model 7001 Switch Mainframe. The Model 7011 card is configured into two 20-channel banks. Two relays can be simultaneously opened or closed automatically by using the mainframe's four-pole switch mode.

Want to Explore Further?

FEATURED RESOURCES

- [Accurate Low-Resistance Measurements Start with Identifying Sources of Error](#)
- [Techniques for Reducing Resistance Measurement Uncertainty: DC Current Reversals vs. Classic Offset Compensation](#)
- [Get a Quote or More Information](#)



ADDITIONAL RESOURCES

- [Model 2182A Nanovoltmeter](#)
- [Model 6220 DC Current Source and Model 6221 AC and DC Current Source](#)



TEMPERATURE SCANNING

Temperature is one of the most commonly measured physical parameters. Temperature is often monitored at several locations, so a scanner is required to switch the measuring instrument to multiple sensors. The type of measuring instrument and scanner card used depends on the type of temperature sensor employed. Three common sensor types are thermocouples, platinum RTDs, and thermistors. When deciding which temperature sensor to use, keep in mind that the thermocouple is the most versatile, the four-wire RTD is the most accurate, and the thermistor is the most sensitive. The use of these sensors is discussed in the following switching configurations.

Switching Configurations

Thermocouples

Thermocouples are the most widely used temperature sensors. They can cover a wide temperature range and provide a robust, reliable sensor. The measured thermocouple voltage is related to the difference between the unknown temperature and a reference temperature. This reference temperature is determined from the cold junction reference (CJR). When thermocouples are to be switched, the reference temperature may be obtained from an internal reference junction located on the switch card, a simulated reference temperature, or an external reference junction. The choice of reference junction is limited by the choice of switch card and by the method of cold junction compensation implemented by the measuring instrument.

Built-In (Internal) Reference Junction. This is the most convenient method to use if the switch card includes the temperature reference. This reference junction is built into the switch module and uses a thermistor, a solid-state sensor, or other type of temperature sensor. Switch modules with built-in CJRs include the Models 7700, 7706, and 7708 modules for the Model 2700/2701/2750 Multimeter/ Data Acquisition/Switch Systems. Switch modules with built-in CJs include Models 3720 and 3721 for the Model 3706A mainframe, with the CJC located on each module's screw terminal accessory (3720-ST and 3721-ST respectively). The Model 2001-TCSCAN 9-Channel Thermocouple Scanner Card for the Models 2000, 2001, 2002, and 2010 DMMs also has a built-in CJR.

Figure 14 shows multiple thermocouples connected to the Model 3706A with a Model 3720 Dual 1x20 Multiplexer Card installed. The Model 3720 has several strategically placed cold junction references to monitor the junction temperatures on the screw terminal card. When the temperature of thermocouple T1 is to be measured, the meter first measures the nearby CJR. When Ch. 1 is closed, the voltage of thermocouple T1 is measured and the temperature reading at the thermocouple is calculated. The Model 2700 with a Model 7700 card can also be used for this application.

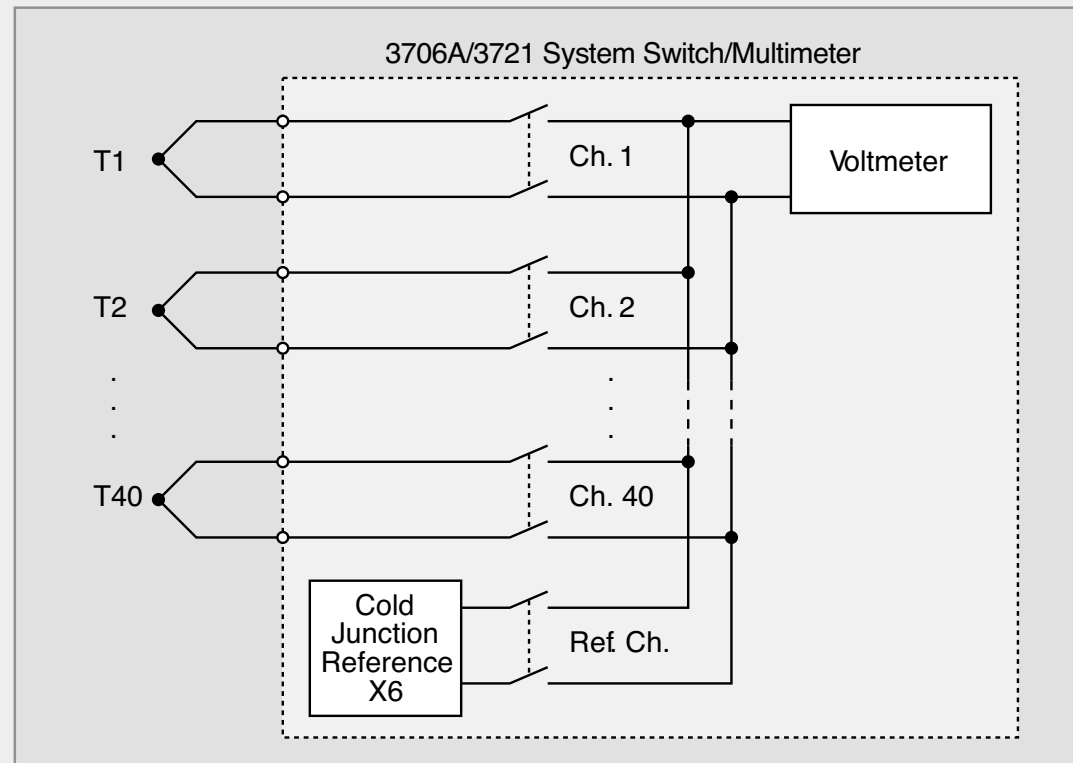

Figure 14. Using the internal reference junction of the Model 3706A/3721

As an alternative to using multiple CJRs, some switch cards employ an on-board isothermal block to keep all the connection terminals at the same temperature. The Model 2001-TCSCAN Thermocouple Scanner Card has isothermal blocks.

Simulated Reference Temperature. In this case, the user inputs a temperature value that approximates the temperature at the input terminals of the DMM. The DMM uses this simulated reference temperature in calculating the temperature at the thermocouple. The simulated reference temperature technique can be used with the Models 2000, 2001, 2002, 2010, 2700, 2701, 2750, and 3706A. The accuracy of the measurements will depend on the accuracy of the simulated temperature. If the ambient temperature changes, then the accuracy of the thermocouple measurements will be degraded.

One method of using a simulated reference temperature is to input the approximate temperature at the location where the thermocouples are connected to the switch card. The reference temperature used should reflect the effects of instrument self-heating, not simply the room's ambient temperature. **Figure 15** illustrates the use of this method. In this case, the temperature reference is at the Model 7702 40-Channel Differential Multiplexer Module's input terminals; therefore, the user must input a best guess of the temperature at these input terminals of the switch module. This is the least accurate way to make temperature measurements, because it requires the user to approximate the reference temperature and does not account for changes

in the ambient temperature or thermal gradients across the card. It is suitable for measurements with relative accuracy but not absolute accuracy. However, this method is the least expensive because a general-purpose switch card or module can be used.

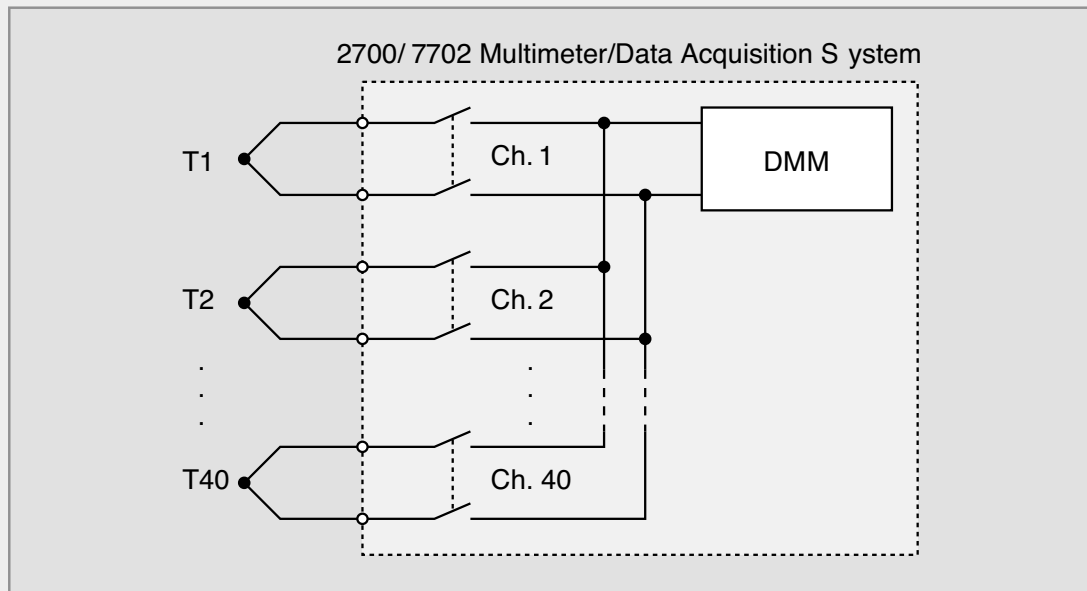

Figure 15. Using simulated reference temperature with the Model 2700/7702

Figure 16 illustrates the use of an ice point as the reference temperature. In this example, a second thermocouple in an ice bath is connected in series back-to-back with each measurement thermocouple. Using this ice point reference is usually the most accurate way to make temperature measurements with thermocouples. To measure the voltage of thermocouple T1, close Ch. 1. The measured voltage is proportional to the temperature T1 with a reference of 0°C. If a meter such as the Model 2700/7702 is being used, simply enter this 0°C reference in the meter as the simulated reference temperature. The Model 2700 will then automatically calculate the temperature T1 based on the measured voltage.

External Reference Junction. For switching modules that do not have built-in reference junctions, a thermistor or four-wire RTD can be used to acquire the reference temperature, such as with the Model 2700, 2701, 2750, or 3706A. In this case, a thermistor is connected to Ch. 1 or a four-wire RTD is connected to Ch. 1 and its paired channel. **Figure 17** shows an example of a thermistor used as the external temperature sensor. To measure the cold junction temperature, close Ch. 1. The Model 2700, 2701, 2750, or 3706A automatically measures the thermistor resistance and calculates the temperature at the sensor. This temperature reading is used by the instrument as the reference temperature for subsequent thermocouple measurements.

The thermistor or RTD should be positioned near the terminals of the channels being used for thermocouple temperature measurements. The leads of

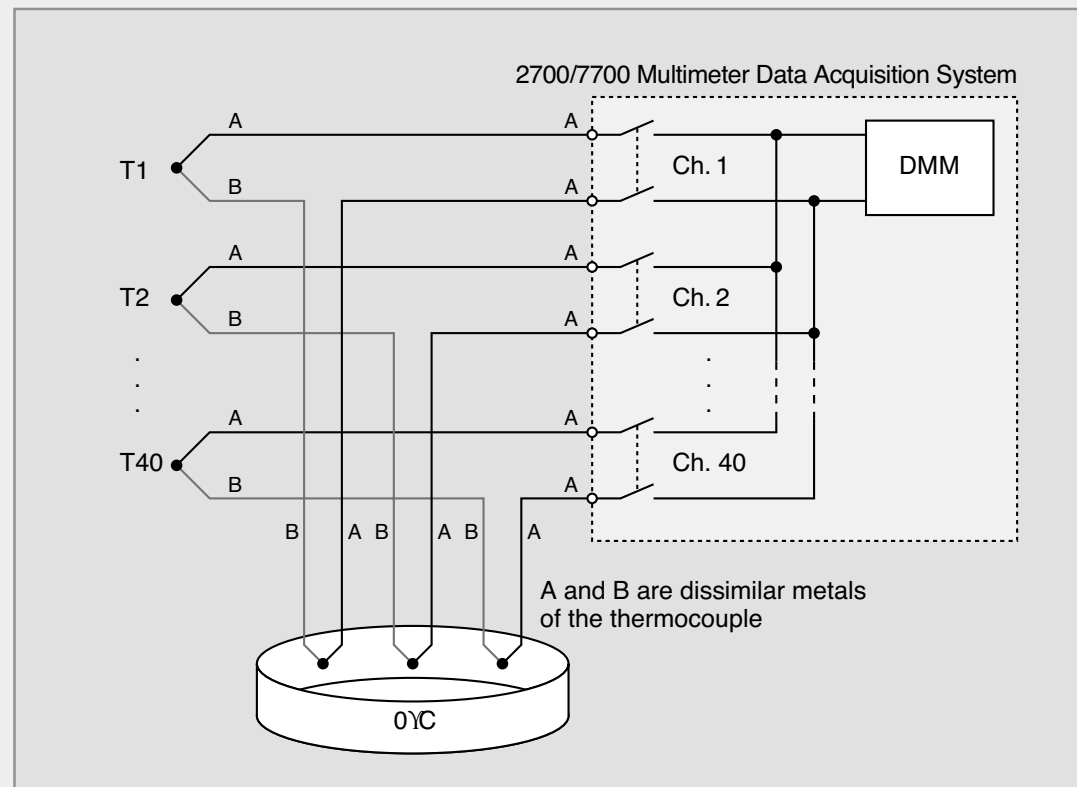

Figure 16. Using “back-to-back” thermocouples and a 0°C reference temperature

this temperature sensor should be insulated to prevent contact with other conductors on the module.

The accuracy of this method depends on how closely coupled the temperature sensor is to the thermocouple terminals.

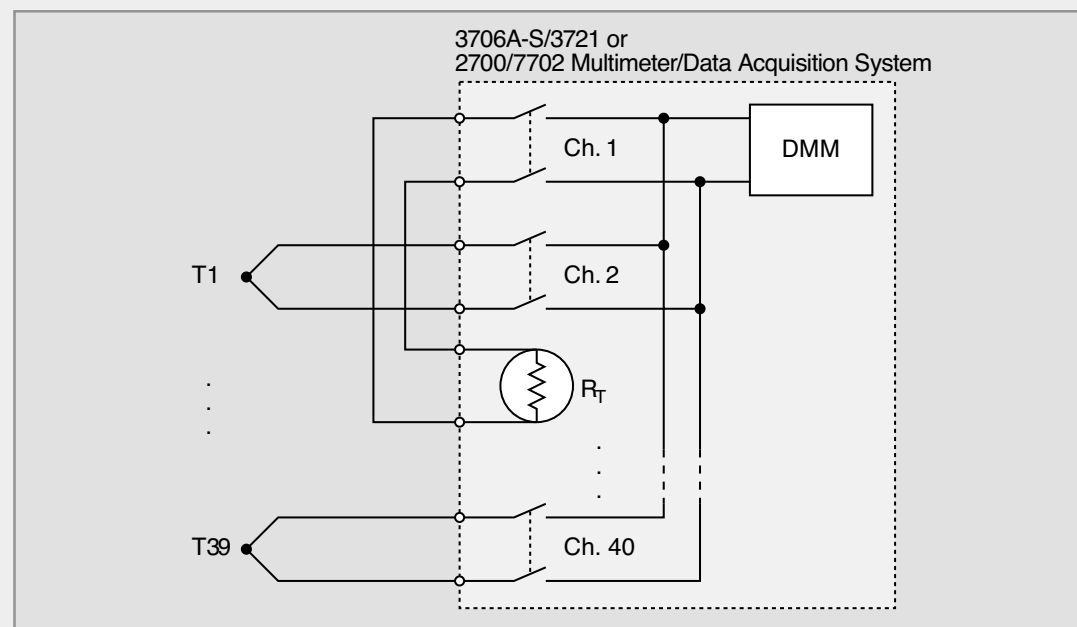

Figure 17. Using a thermistor as an external reference junction

Platinum RTDs

Platinum RTDs may be either wire-wound resistors or thin-film resistors that exhibit a positive temperature coefficient of about 0.4%/°C.

Platinum RTDs offer excellent long-term stability, high accuracy, and good repeatability. Unlike thermocouples, RTDs do not require cold junction compensation. However, RTDs operate over a narrower temperature span, respond more slowly, and are generally more expensive and more fragile than thermocouples.

Figure 18 illustrates a system to measure temperature using RTDs. Twenty RTDs are connected through four-pole switches to a Model 2700 configured as a four-wire ohmmeter. With the Model 2700 and a Model 7702 module, 20 RTDs can be connected and the meter will convert the resistance measurements to temperature automatically. With the Model 3706A and a Model 3721 card, 48 RTDs can be connected and measured.

Thermistors

Thermistors are devices that exhibit a non-linear change in resistance with a change in temperature. Most thermistors have a negative temperature coefficient—in other words, as the temperature increases, the resistance decreases.

Thermistors are the most sensitive of all the temperature sensors and can detect very small changes in temperature quickly. They are a good choice when measuring very small changes in temperature. The downside of this increased sensitivity is a loss of linearity. They are especially non-linear at high temperatures, so it is best to use them for measurements of less than 100°C.

Figure 19 outlines a system for measuring temperature using thermistors. Note that a two-wire resistance measurement is adequate, given that thermistors are usually in the kilo-ohm ranges; therefore, switch and lead resistances have little effect on the overall measurement. To convert the resistance measurement to temperature, it is best to use an instrument that can correct for a thermistor's non-linearity automatically, such as the Model 2700, 2701, 2750, or 3706A. One Model 7702 module installed in a Model 2700 can accommodate up to 40 thermistors. One Model 3722 card installed in a Model 3706A mainframe can accommodate up to 96 thermistors.

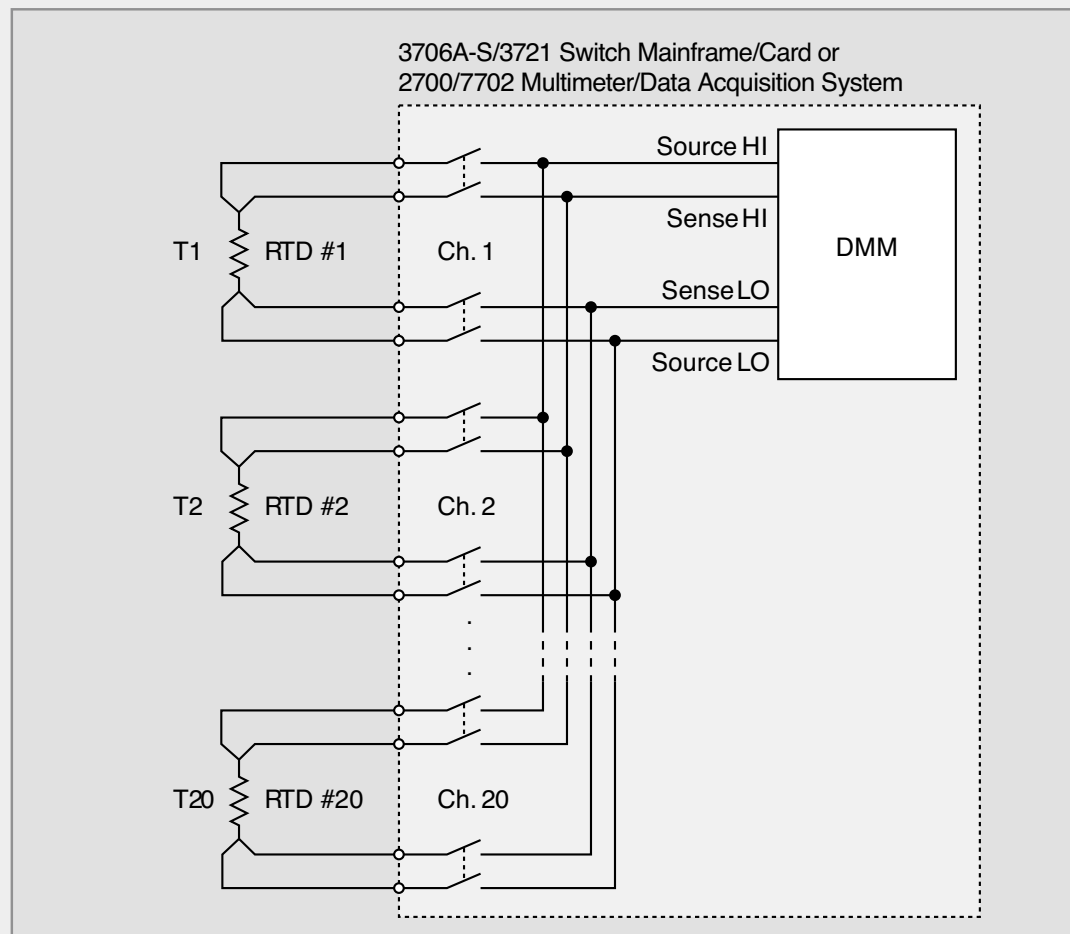

Figure 18. Measuring temperature using RTDs

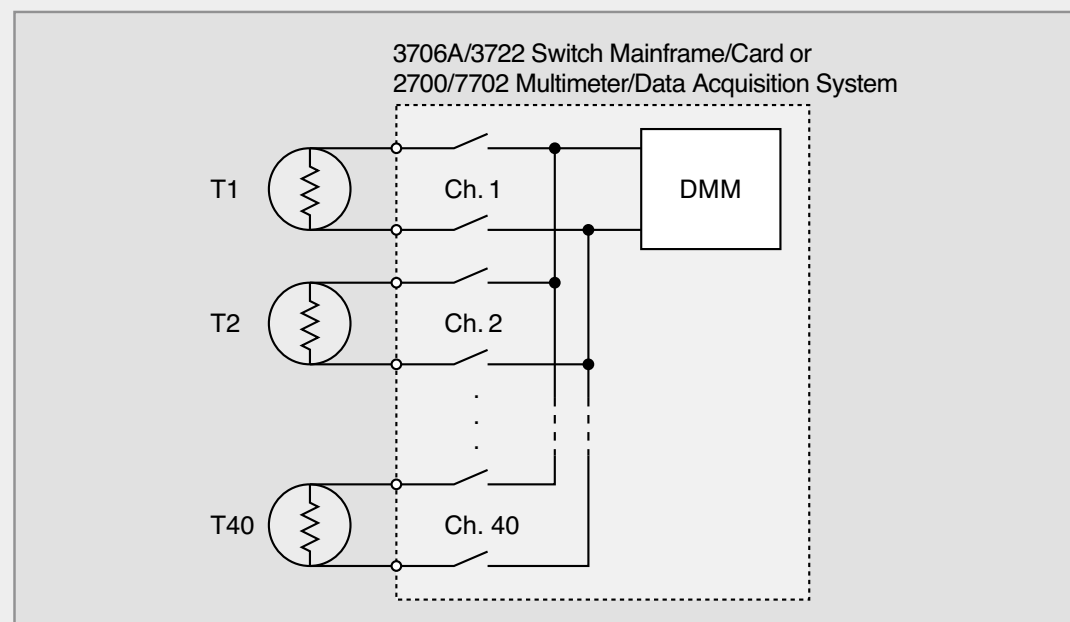
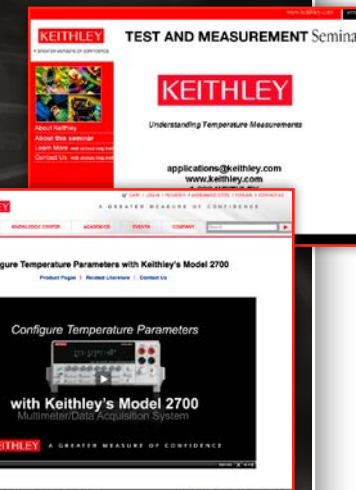

Figure 19. Measuring temperature using thermistors

Want to Explore Further?

FEATURED RESOURCES

- Understanding Temperature Measurements (webinar)
- Configure Temperature Parameters with Keithley's Model 2700
- **Get a Quote or More Information**



ADDITIONAL RESOURCES

- How to Select the Right Temperature Sensor
- Basics of Temperature Measurement: RTDs
- Basics of Temperature Measurement: Thermocouples
- Basics of Temperature Measurement: Thermistors

INDEX

DIODE TESTING

Diodes are widely used non-linear components. When testing diodes, the electrical parameters measured include the forward voltage, the reverse breakdown voltage, and the leakage current. These specific tests can be measured with a single source-measure instrument. When testing multi-diode devices, such as pin grid arrays or DIP packages, switching is required to connect a single source-measure instrument to each individual diode.

Switching Configurations

Figure 20 shows an example of testing multiple diodes in a switching system. This configuration can be used for measuring the forward voltage, the reverse breakdown voltage, and the leakage current. This type of system is often used for production tests in which performing single point pass/fail DC tests on packaged diodes ensures compliance with specifications and sorts out defective parts.

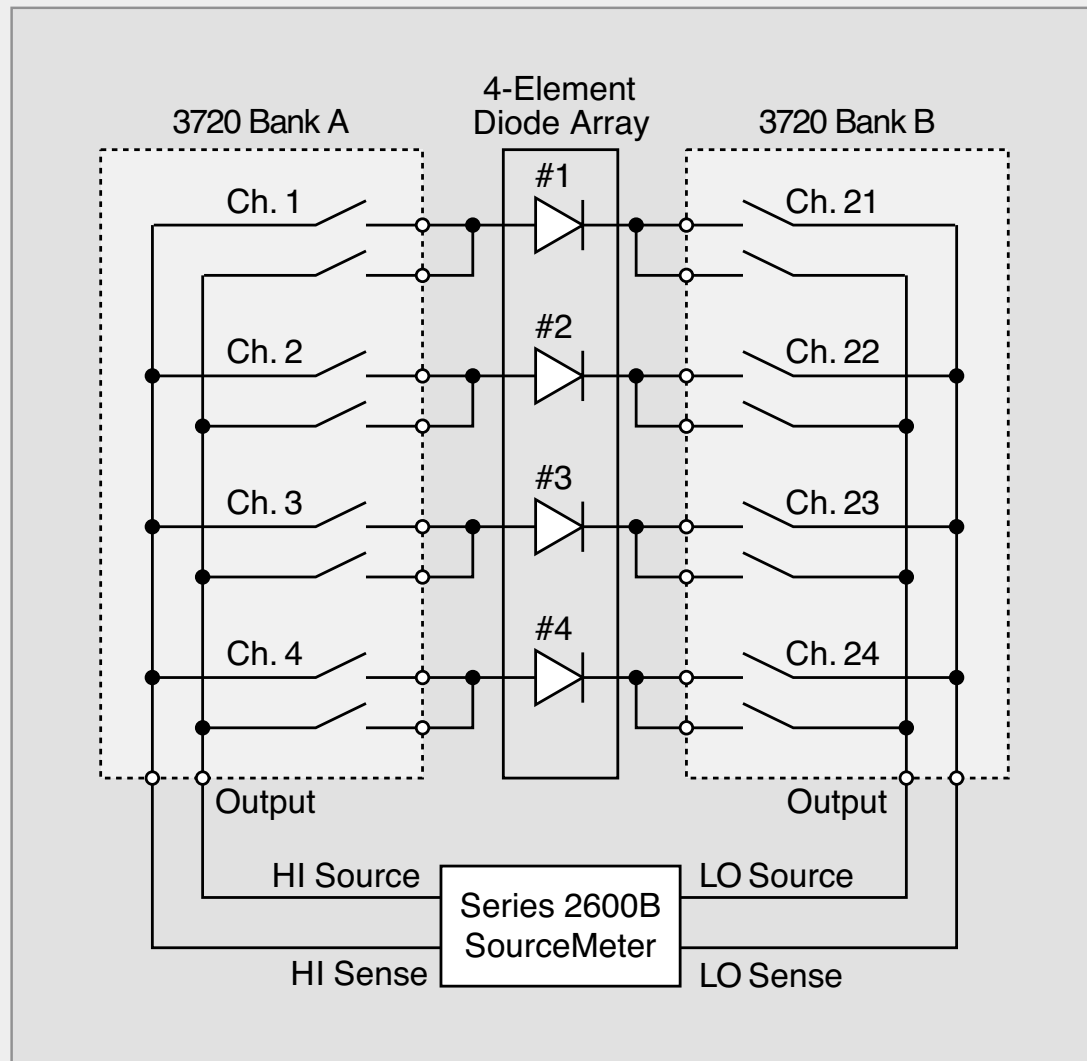

Figure 20. Switching multiple diodes to a Series 2600B System SourceMeter instrument

In this system, each diode is switched to the Series 2600B System SourceMeter instrument through two two-pole switches. The Series 2600B instrument can source and measure both current and voltage.

To connect the System SourceMeter instrument to diode 1, close Chs. 1 and 21. To measure the forward voltage, apply the specified current, then measure the resulting voltage drop. Measure the reverse breakdown voltage by sourcing a specified reverse current bias, then measuring the voltage drop across the diode. To perform the leakage current test, source a specified reverse voltage, then measure the resulting leakage current. Repeat this procedure for all the diodes.

Note that two two-pole relays are used to connect each diode to the Series 2600B. This is done to eliminate error from the voltage drop in the lead resistance. (Offset voltages of the Model 3720 switches can be addressed with the offset-compensated ohms feature of the Series 2600B instrument.) This is particularly important when measuring the forward voltage, because the measured voltages are relatively small (hundreds of millivolts) and the source current may be relatively high (100mA).

For the example in Figure 20, two-pole general-purpose cards, such as the Model 3720 Dual 1x30 Multiplexer Card, can be used. One Model 3720 card will support testing up to 30 diodes.

For measuring smaller leakage currents (<10nA), use the configuration shown in Figure 21. In this example, the Model 7158 Low Current Scanner Card is used to switch ten diodes with a common cathode to the Model 6517B Electrometer/ Source.

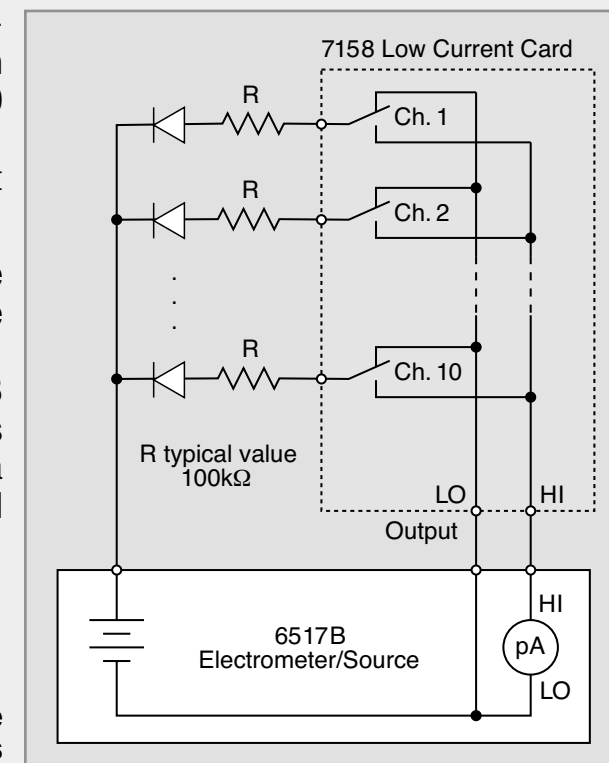

Figure 21. Measuring the leakage current of ten diodes

When measuring the leakage current with this setup, the voltage bias is applied to all the diodes simultaneously through the normally closed contact of each relay. When a particular channel is energized, the leakage current for that diode will be measured. The current limiting resistor (R) is included to prevent test failure in the event a diode is short-circuited.

Figure 22 shows a configuration for testing leakage current of diodes using a Source Measurement Unit (SMU) or a SourceMeter Instrument. In this example, the Output HI terminal of the SMU is connected to the normally open output terminal of the Model 7111-S 40 Channel Form C Switch Card. The Guard terminal of the SMU is connected to the normally closed output terminal of the switch card. The guard voltage is at the same potential as the Output HI terminal, so the test voltage is applied to all diodes at all times through the guard connection. If the SMU is set for a positive output voltage, the diodes will be reverse biased. The Output LO terminal of the SMU is connected to the common anode terminal of the diodes.

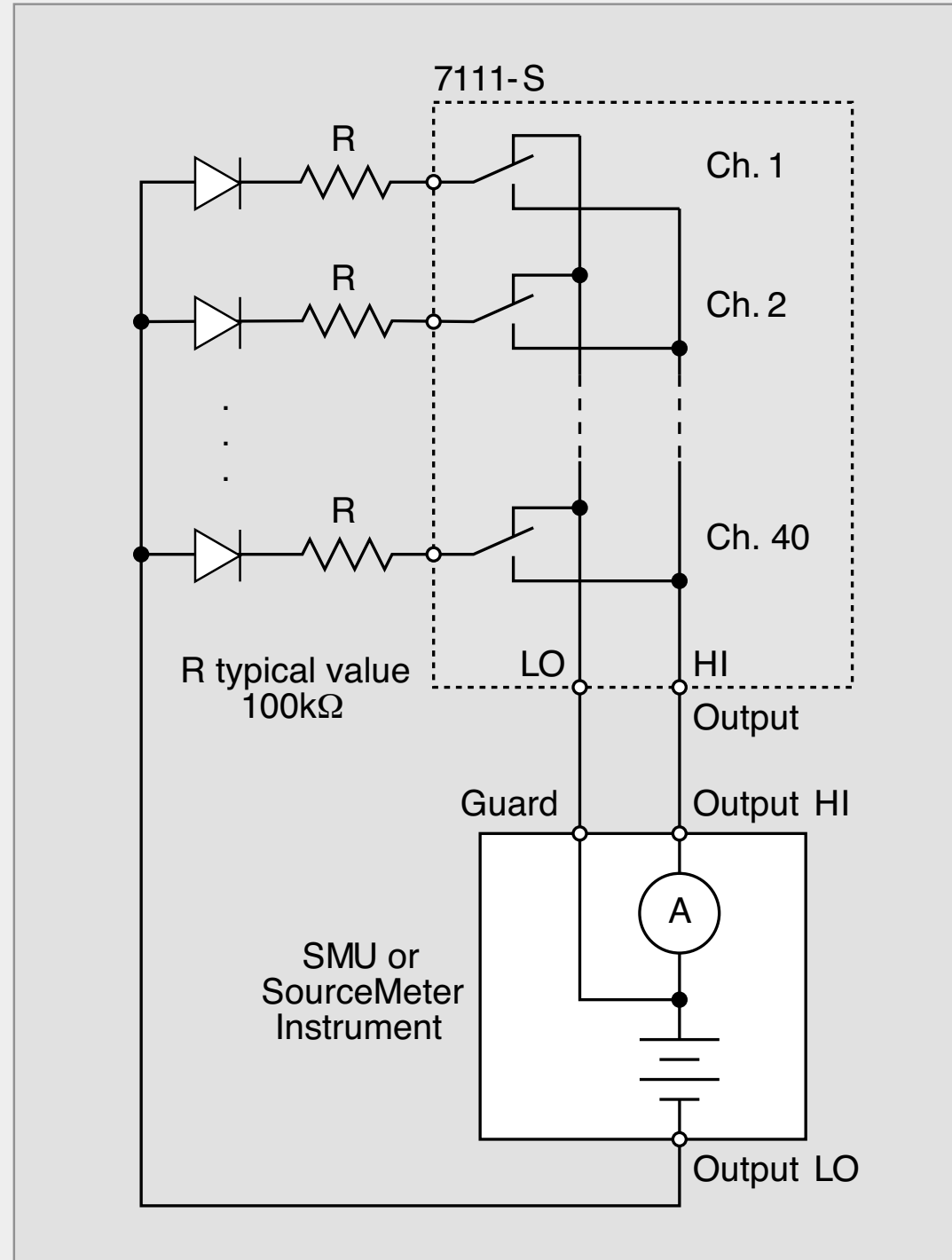

Figure 22. Using an SMU or SourceMeter Instrument to test the leakage current of diodes

Want to Explore Further?

FEATURED RESOURCES

- Diode Production Testing with Series 2600 System SourceMeter® Instruments
- Diode Production Testing with the Series 2400 SourceMeter® Instruments
- [Get a Quote or More Information](#)



ADDITIONAL RESOURCES

- Model 3720 Dual 1x30 Multiplexer
- Model 7154 High-Voltage Scanner Card and Model 7158 Low Current Scanner Card

CAPACITANCE MEASUREMENTS

Capacitance measurements are made to verify that capacitors meet their manufacturer's specifications. For quality control purposes, a group of capacitors may be placed in an environmental chamber and the capacitance of each capacitor tested. Multiple switches connect the capacitors to the capacitance meter.

Test frequency and stray capacitance may impose limitations when switching capacitance. Capacitance measurements are often made at a high frequency (kHz –MHz ranges), so it's important to choose switches carefully to avoid errors due to bandwidth limitations. The capacitance introduced to the system by both the switches and the cable must be corrected for by the LCR meter by using open and short circuit calibration; therefore, it is important to determine if a particular LCR meter is capable of performing the necessary corrections.

Switching Configurations

In **Figure 23**, the Model 7011-S Quad 1x10 Multiplexer Card connects an LCR meter to a number of unknown capacitors (C1 through C8). For any given capacitor measurement, four relays, one in each bank, must be closed. The outputs of the four banks are connected to the LCR meter's four input terminals.

The Model 7011-S card allows making four-wire connections to as many as ten capacitors. However, two sets of channels should be used to perform open and short calibration, so the system can only test up to eight capacitors. When performing the open calibration, the HI CURR and HI POT leads must be connected together using Ch. 9 of each bank; the LO CURR and LO POT leads must also be connected together. When performing the short calibration, all four leads are connected together using Ch. 10 of each bank.

The shields of the four coaxial cables connected to the unknown capacitors are connected to each other. This connection should be made near the capacitor for best accuracy. For simplicity, the shields are not shown in Figure 23. Space limitations on the Model 7011-S card make it necessary to use sub-miniature coax cables. The length of the coaxial cables for all channels should be approximately the same.

With the Model 7011-S card, the test frequency may be as high as 100kHz. The minimum unknown capacitance that can be switched with this card is on the order of 10pF. There is no maximum capacitance other than determined by the card's maximum current rating.

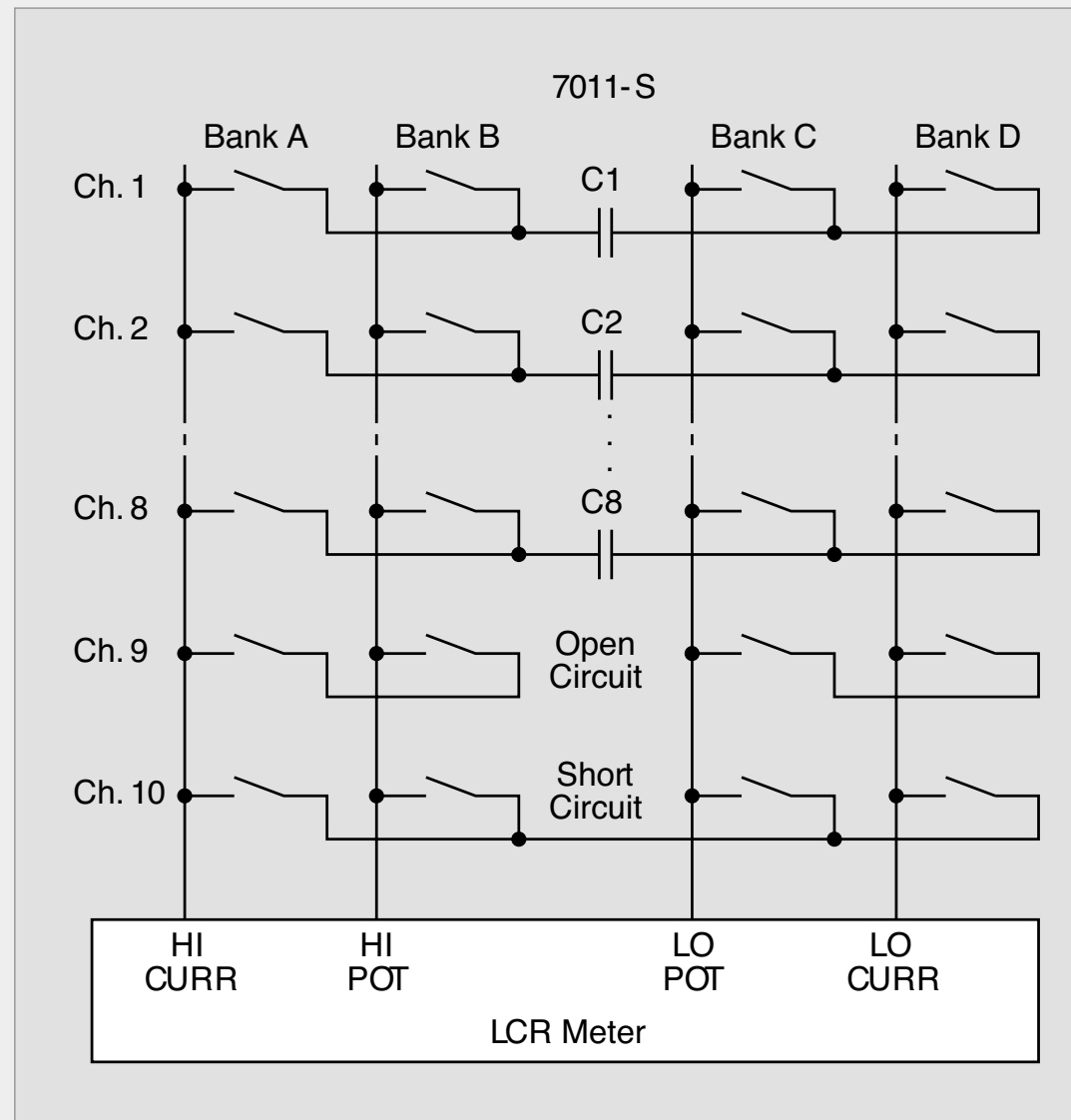

Figure 23. Capacitance measurement using a Model 7011-S card

The system shown can be expanded easily by adding more Model 7011-S cards. The backplane of the scanner mainframe will connect the appropriate banks of each card. Remove any bank-to-bank jumpers from all cards. As more switch cards are added to expand the system, the maximum allowable test frequency may decrease.

The Model 7011-C version is not recommended for this application because the added coupling due to this card's mass-terminated connectors may cause an unacceptable amount of error.

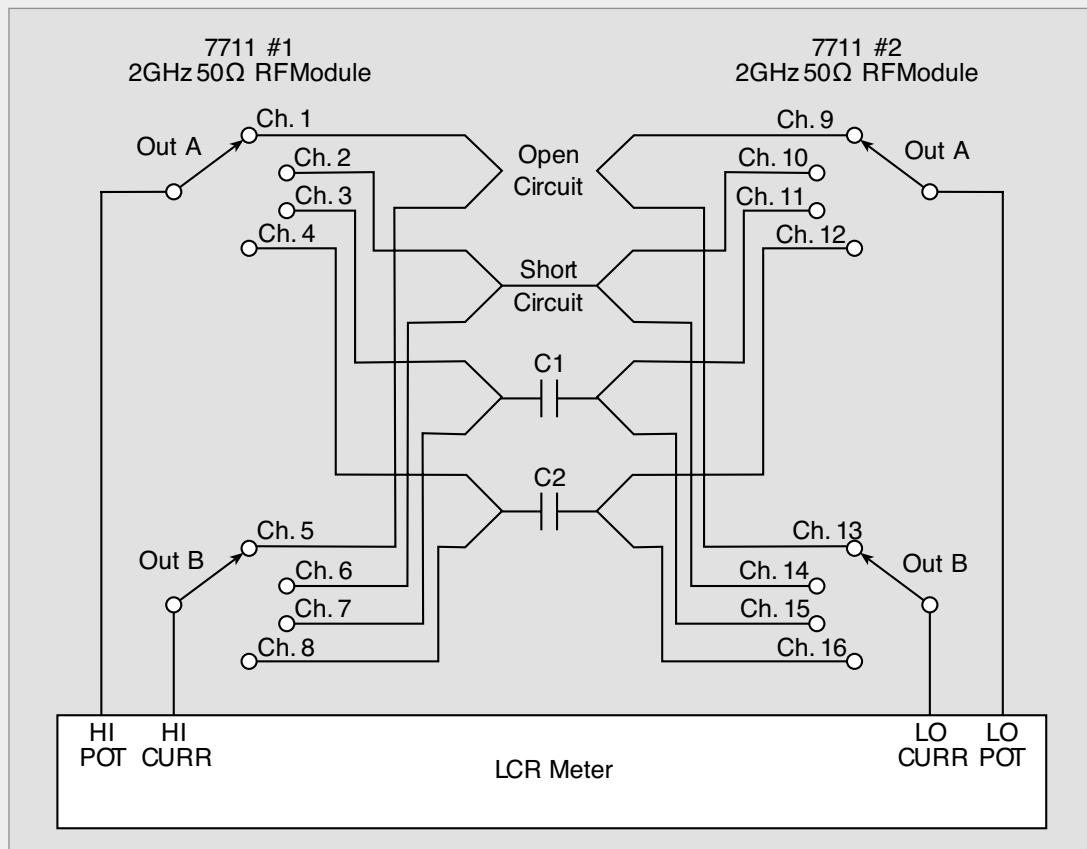

Figure 24. High frequency capacitance measurements with two Model 7711 modules

To measure capacitors at 1MHz or higher, an RF switch card, such as the Model 7711 2GHz 50Ω RF Module, is essential. The Model 7711 consists of two banks of 1x4 multiplexers. As shown in **Figure 24**, two Model 7711 modules provide four-terminal connections from a four-terminal capacitance bridge to test up to two capacitors. One module switches the HI terminals of the bridge, while the second module switches the LO terminals.

The second channel of each bank is connected to a jumper to allow short-circuit calibration. When no channels are selected, the first channel of each bank, which is normally-closed, is connected to an output port. By connecting coax cables to all four output ports as shown, an open-circuit calibration can be performed. Again, note that these cables should be the same length as those for the other channels.

To expand the system and allow testing more capacitors, additional switching modules are needed. With two inputs of one bank connected to the outputs of another module, 1x8 multiplexers are possible instead of 1x4 multiplexers. This system, with a total of six Model 7711 modules, will test up to six capacitors. Similarly, by connecting two modules to yield 1x12 multiplexers, a total of eight modules will test up to ten capacitors.

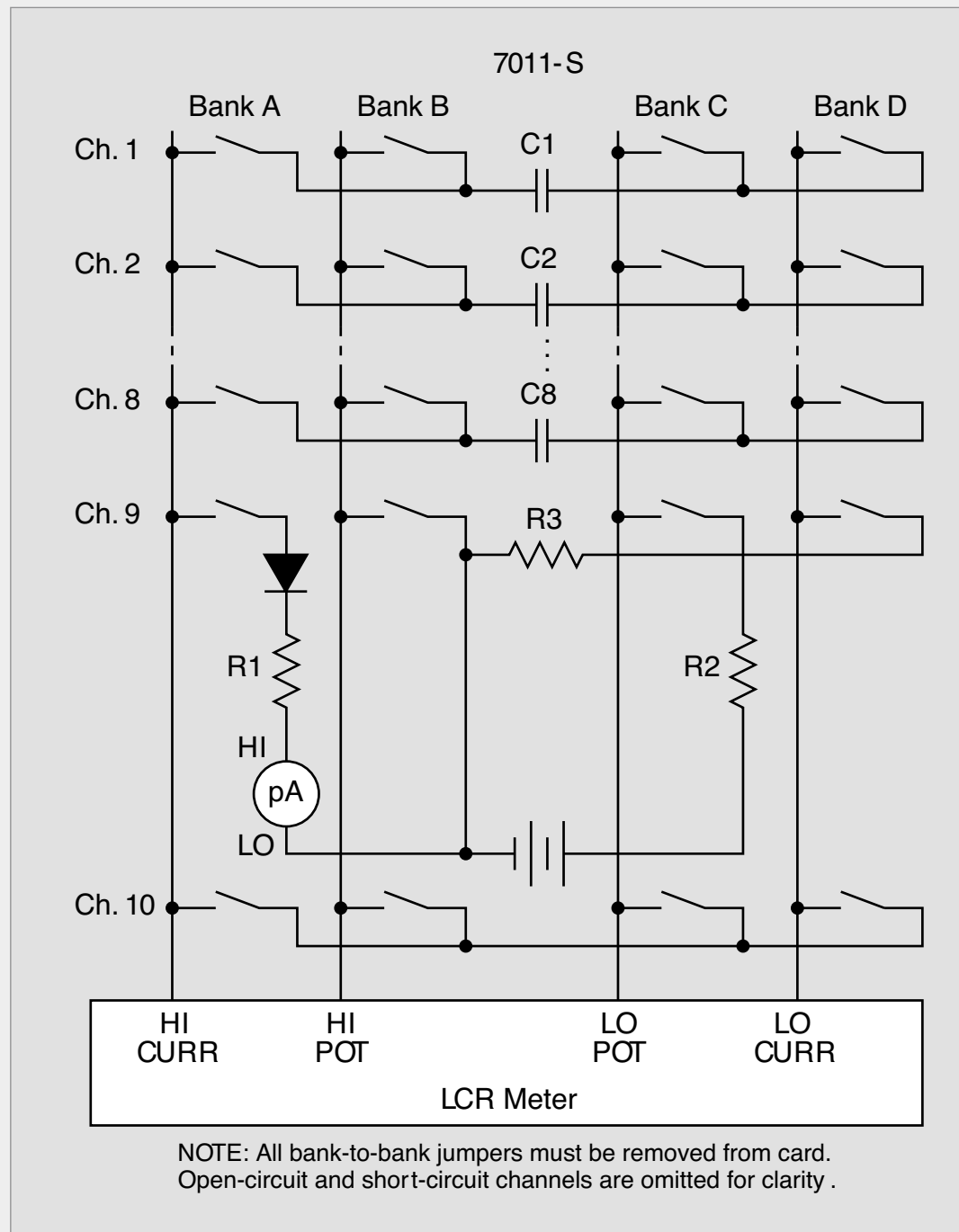

Figure 25. Measuring capacitance and leakage current with a Model 7011-S card



INDEX

Figure 25 illustrates a system that measures both the capacitance and leakage current of capacitors. In this diagram, note the picoammeter (μA) and LCR meter are connected to the capacitors under test via Chs. 9 and 10, respectively. The output ports on the Model 7011-S card have no connections. However, the output ports would be used to increase the total number of capacitors being tested by adding more cards.

To measure the leakage current of C1, the capacitor must first be polarized by closing Chs. 1 and 9 of both Banks B and C. This connects the voltage source across the capacitor through the current limiting resistor, R2. After an appropriate “soak” time, close both Ch. 1/Bank A and Ch. 9/Bank A to connect the picoammeter to the capacitor, then open Ch. 9/Bank B to avoid short-circuiting the picoammeter. Once the leakage has been measured, the capacitor should be discharged by first opening Ch. 9/Bank A and Ch. 9/Bank C. Then close Ch. 9 on Bank B and Bank D, which will place resistor R3 across capacitor C1.

The diode and resistor R1, in series with the picoammeter input, serve two functions. First, the resistor will limit the current in case a capacitor becomes shorted. Second, the diode minimizes the picoammeter noise introduced when measuring capacitors of 1nF or greater. The diode is photosensitive, so it should be enclosed with R1 in a light-tight electrostatic shield.

The capacitance of C1 can now be measured by first opening Ch. 9, Banks B and D, then closing Ch. 10, Banks A through D. This will connect the LCR bridge to capacitor C1. Ensure that all capacitors are discharged before connecting the LCR bridge.

This system is relatively low in cost; however, it has several performance limitations:

- The maximum test voltage is 110VDC. It is capable of measuring a leakage current of 1nA with fair accuracy, so it can verify capacitor leakage resistance of 100V/1nA or 100G Ω .
- The LCR bridge test frequency should be no more than 100kHz.
- The minimum capacitance that can be measured is on the order of 10pF.

Want to Explore Further?

FEATURED RESOURCES

- Model 6485 Picoammeter
- Model 6487 Picoammeter/
Voltage Source
- [Get a Quote or
More Information](#)



ADDITIONAL RESOURCES

- Low Level Measurements Handbook
- Selector Guide and Data Sheet for Cables, Test Leads, and Probes

ACCELERATED LIFETIME TESTING OF CELLULAR PHONE HANDSETS

Lifetime testing is one of the most common types of production tests that cell phone handsets undergo. The handsets are placed in an environmental chamber and are subjected to severe temperature and humidity conditions to test their reliability. Depending on the manufacturer's test specification, the handset may be powered on or powered off during the test. From these tests, the reliability and lifetime of the cell phone can be estimated.

A typical lifetime test system includes a communication analyzer, power supplies, a handset controller, audio test instruments, and a DMM. A switching system makes the necessary connections between the various test instruments and the handsets.

Switching Configurations

Figure 26 is an overview of a cell phone lifetime test system based on Keithley's System 46 Microwave/RF Switch System. Given that this system must be able to switch RF signals, audio signals, and DC signals, a variety of switch cards are required.

In this example, high frequency switches are required to connect the communications analyzer to the handset. Therefore, the RF carrier signal is routed by coaxial relays in the System 46 chassis.

A Model 7011 Quad 1x10 Multiplexer Card routes the 20Hz to 20kHz signals used for the audio testing to and from the handset. For testing the audio quality of the handset, a Model 2015 or 2016 Total Harmonic Distortion (THD) Multimeter allows making quick measurements of a variety of parameters, such as THD, THD plus noise, and signal-to-noise plus distortion (SINAD).

The handset under test is powered by the Model 2306 Battery/Charger Simulator; power is routed to the handsets by the Model 7053 High Current Switch Card. This card, which has 10 channels and can carry up to 5A, can easily handle the high current transients that may flow when the phone is switched from receive mode to transmit mode.

A Model 7020 Digital I/O Interface Card is employed to switch the digital signals used to set the phone to various operating modes during testing. This card provides 40 independent inputs and outputs, so it can be used to control many handsets at once. Isolated relays, such as those used in the Model 7013 Relay Switch Card, can be used to control certain test system requirements, such as the conveyor.

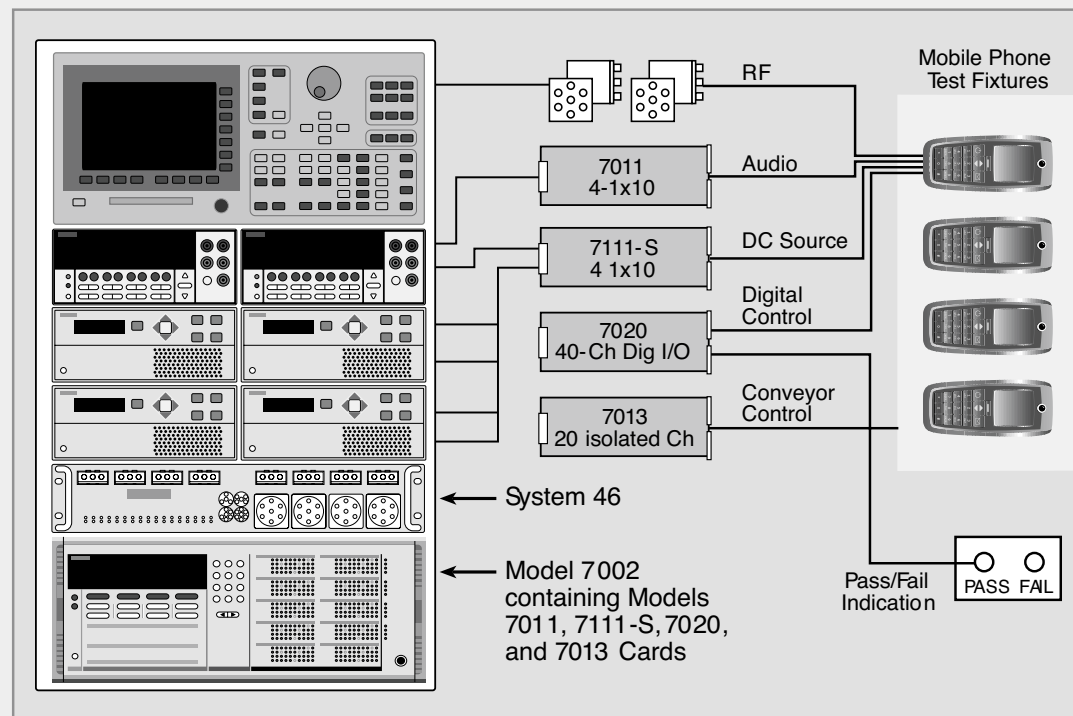

Figure 26. Cell phone test system

Want to Explore Further?

FEATURED RESOURCES

- The Basics of Through-the-Air Audio Quality Test System Characterization
- Maximizing DMM Productivity in Wireless Device Quality Testing
- RF/Microwave Switching Systems Subtleties: Achieving the Performance You Need
- **Get a Quote or More Information**



ADDITIONAL RESOURCES

- Models 2015 and 2015-P 6-1/2 Digit THD Multimeters and Models 2016 and 2016-P 6-1/2 Digit Audio Analyzing Multimeter
- System 46 RF/Microwave Switch System 32 Channel, Unterminated

VCSEL TESTING WITH TRIGGER SYNCHRONIZED SMU INSTRUMENTS

Vertical-cavity surface-emitting lasers (VCSELs) are slowly replacing traditional edge-emitting lasers, most notably in low-bandwidth and short-haul communication systems in which cost is a driving factor. Edge-emitting lasers must be cut from the wafer and edges polished before testing is possible, but VCSEL manufacturers can test their devices at the wafer level.

The light intensity (L) current (I) voltage (V) sweep is a series of measurements performed on VCSELs to determine their operating characteristics. The LIV test involves ramping current through the VCSEL and measuring the resulting light output with a photodetector (PD).

Figure 27 illustrates a simple test system at the wafer level. Two Model 2602B System SourceMeter instruments are used. A wafer probe makes the electrical connection to each device through a probe card. The prober station also positions the optical detector directly over the devices. When the light from the VCSEL shines on the reverse-biased PD, the leakage current increases. The magnitude of the leakage current correlates to the intensity of the light striking the active region.

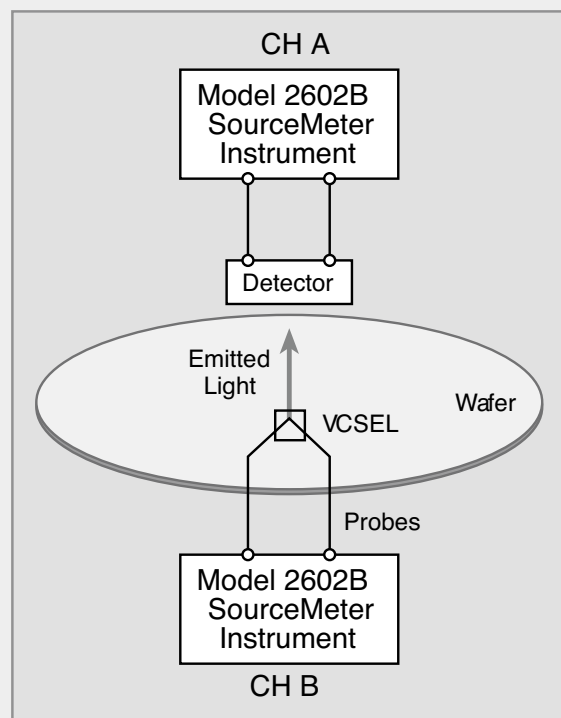

Figure 27. Wafer level testing of VCSELs

Switching Configurations

If the probe card can connect to many devices simultaneously, then a system similar to **Figure 28** can be constructed to test all of the devices each time the probe card makes contact with the wafer.

An individual VCSEL is selected for testing and the corresponding relays are closed for the VCSEL and the PD used to verify the light intensity. The SourceMeter instrument first performs the necessary DC tests, such as forward voltage, reverse breakdown voltage, and leakage current. Then it forces sufficient current to light the VCSEL and channel B of the Model 2602B measures the increased leakage of the PD. Once this testing process is complete, switching channels for the next device are selected.

Measuring the PDs can be done with either a Model 2602B or 2636B, depending on the current sensitivity required by the test specification. The Model 2602B is useful for measuring currents to approximately 100pA, while the Model 2636B reliably measures currents less than 10fA.

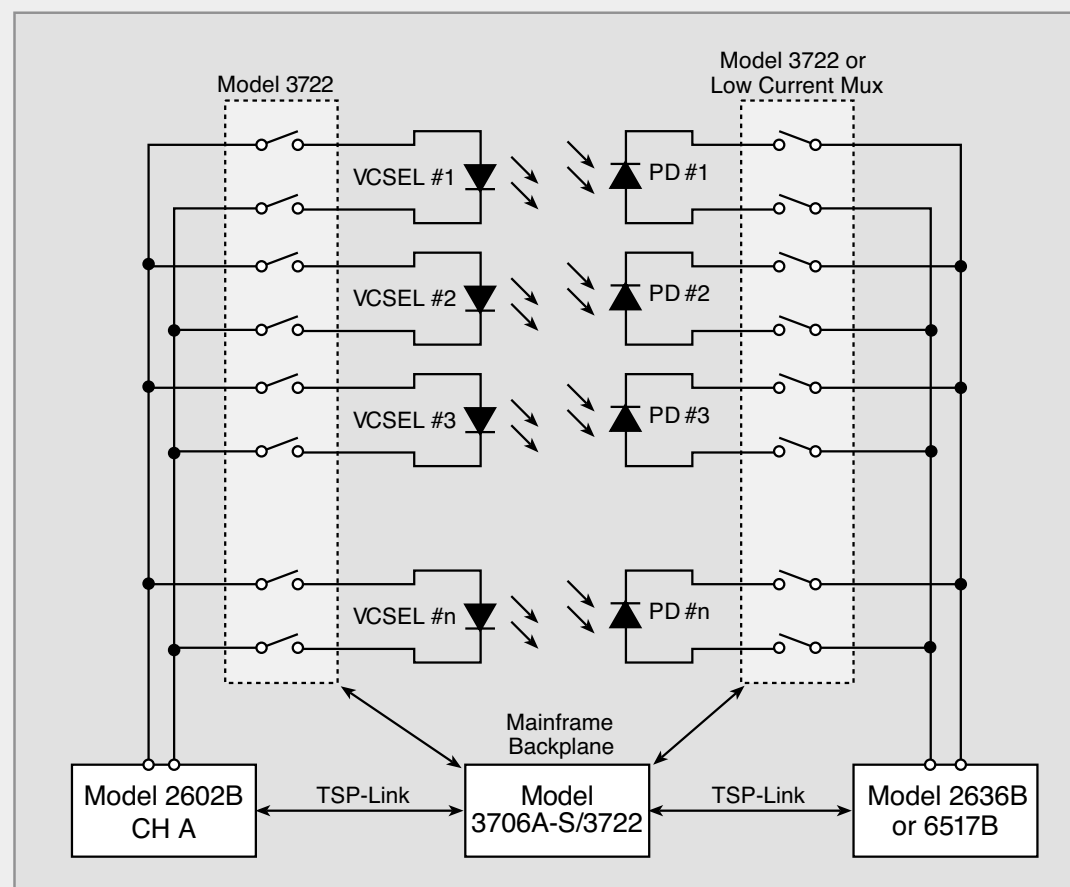

Figure 28. Testing multiple VCSELs

The offset current specification for the Model 3722 Multiplexer Card is <100pA, which may exceed the error budget for the test system. Substituting a Model 7158 Low Current Scanner Card will lower the offset value to <1pA. Note that using a low current card will decrease the number of available channels in the system, since the low current cards only have ten channels for scanning.

Want to Explore Further?

FEATURED RESOURCES

- High Throughput DC Production Testing of Laser Diode Modules and VCSELs with the Model 2602B System SourceMeter Instrument
- VCSEL Testing with the Model 2400 SourceMeter® Instrument
- **Get a Quote or More Information**

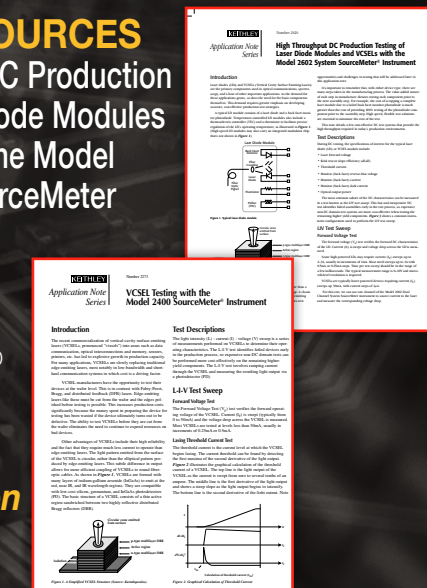

ADDITIONAL RESOURCES

- Instrumenting DWDM Laser Diode Production Tests
- Pulse Testing of Laser Diodes

BURN-IN TESTING FOR SWITCHING POWER SUPPLIES

Switching power supplies are commonly used in telecommunications, desktop computing, and network server hardware; although these supplies are relatively inexpensive, they must be tested rigorously and carefully to maintain a high level of product quality.

Highly accelerated stress screening (HASS) or “burn in” is a common production step for switching power supplies. Extended environmental test is performed to ensure the supplies continue to function properly over the course of their lives. Typically, manufacturers age and monitor thousands of power supplies at once. Perhaps the most significant challenge involved in designing this type of test system is dealing with the high number of channels the system must monitor simultaneously.

Several parameters are typically measured as part of power supply testing, particularly output voltage and temperature. Although the output voltage of a switching power supply may be anywhere from 3V to 48V, the most common output voltages are 5V, 12V, and 15V, and the outputs are usually bipolar. A single switching supply could have as many as six outputs. Obviously, testing multiple switching supplies at once could involve monitoring hundreds of channels. But for purposes of burn-in, only one output is monitored to reduce the huge number of channels.

Temperature measurement during burn-in usually entails monitoring the temperature of the supply, several points in and around the supply, and the general ambient temperature.

The Model 3706A System Switch/Multimeter integrates a 7½-digit multimeter in a single switch matrix enclosure with six rear-panel slots for switching cards, providing an all-in-one switch/read system. This tight integration simplifies switching, measurement, and programming. For burn-in applications, the Model 3706A’s DMM can be used to measure voltage and temperature, while the switch system can be configured with the appropriate switch cards to accommodate up to several hundred channels. The Model 3720 dual 1x30 multiplexer card with automatic CJC for thermocouples is ideal for the voltage and temperature measurements required for power supply burn-in applications.

Figure 29 illustrates a power supply burn-in test system based on the Model 3706A and multiple Model 3720 cards.

This system can assign a measurement function to each channel. As Figure 29 shows, channels 1–60 are all dedicated to thermocouples (TCs), channels 61 through 300 handle DC voltage measurements, and channels 301 to 360, on the last card, are also dedicated to TCs. The Model 3706A, when configured with the Model 3720 switch cards, allows switching and measuring up to 120 channels per second. A system configured with one Model 3706A and six Model 3720s can monitor up to 360 channels every few seconds.

For settings with several test system/stations located throughout the manufacturing area, when two or more systems are used simultaneously, the Model 3706A’s LXI Class B compliance offers a variety of advantages. The operation of each system can be tightly synchronized and the data uploaded to the manufacturing facility’s central computer through the LAN/Ethernet interface for analysis and processing. Features include a 10/100M Base-T Ethernet connection, graphical Web server, LAN-based instrument triggering, and IEEE-1588 precision time protocol (PTP) synchronization. This synchronization technique provides a standard method to synchronize devices on an Ethernet network with microsecond precision for time/event-based programming.

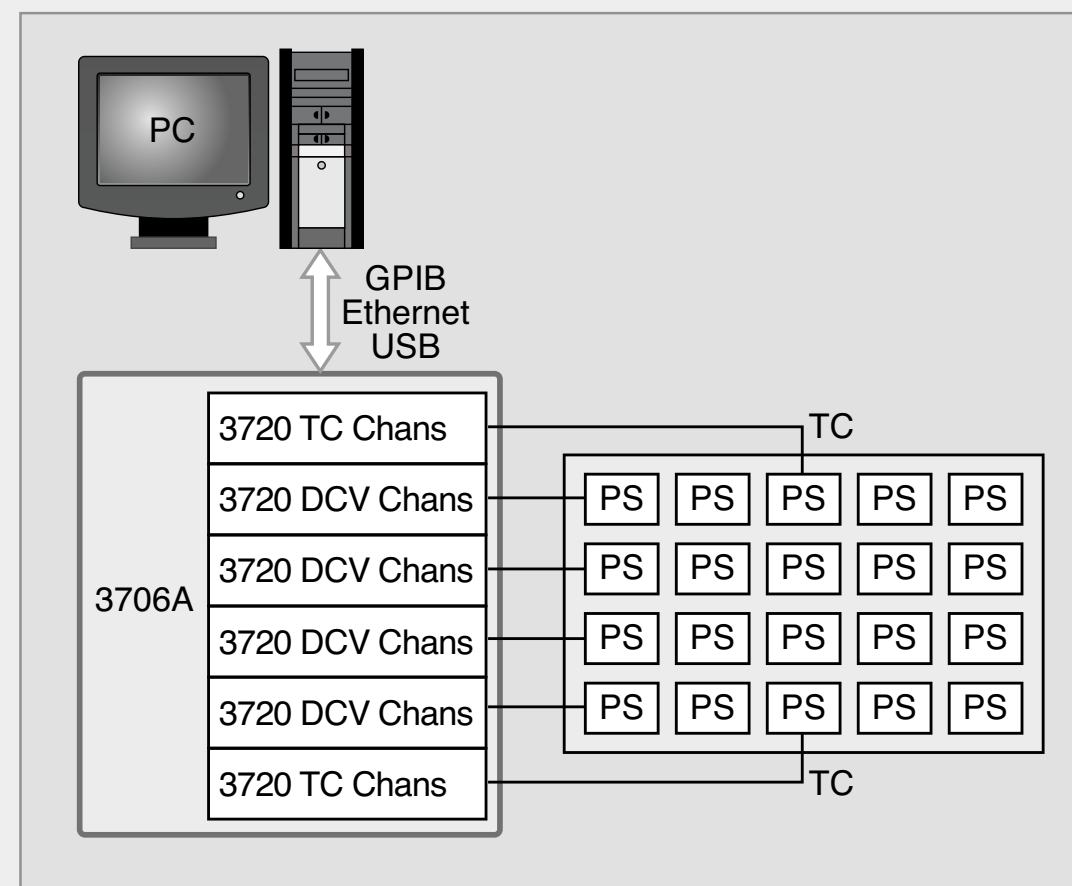
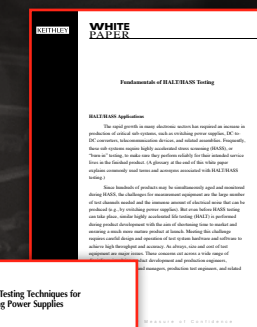

Figure 29. Power supply burn-in system with 3706A System Switch/Multimeter

Want to Explore Further?

FEATURED RESOURCES

- Fundamentals of HALT/HASS Testing
- Burn-in Testing Techniques for Switching Power Supplies
- **Get a Quote or More Information**



ADDITIONAL RESOURCES

- Making AST/Burn-in Testing More Productive with Ethernet-based Instruments
- What IEEE 1588 Means for Your Next T&M System Design

INDEX

SWITCHING GLOSSARY

The following terms are defined to clarify or expand on how they relate specifically to the material in this handbook.

ACTUATION TIME. The time between application of the nominal relay coil voltage and the final closure of the relay contacts after the contact bounce interval.

AUTOMATIC CJC (COLD JUNCTION COMPENSATION). A system for multi-channel thermocouple measurements where the temperature at each thermocouple/switch card junction is sensed and compensated for automatically.

BANDWIDTH. The range of frequencies that can be switched, conducted, or amplified within certain limits. Under given load conditions, bandwidth is defined by the -3dB (half-power) points.

BANK. A group of relays with a common connection for scanning or multiplex applications.

BLOCKING. A multiplexer of matrix arrangement of relays where only one signal path is active at any given time. Common in RF/microwave testing to maintain the characteristic impedance of the test system.

BREAK-BEFORE-MAKE. Disconnecting the present circuit before connecting a new circuit. Also known as Break/Make.

CARRY CURRENT. The maximum continuous current of closed relay contacts. Most relays are rated higher for carry current than switched current. (Heat is generated by I²R losses for carry current and I²R losses plus arcing for switched current.)

CHANNEL. One of several signal paths on a switching card. For scanner (or multiplex) cards, the channel is used as a switched input in measuring circuits or as a switched output in sourcing circuits. For switch cards, each channel's signal paths are independent of other channels.

CHANNEL CROSSTALK. Coupling of a signal from one channel to another or to the output by stray capacitance, inductive coupling, or radiation. Crosstalk is expressed in decibels at a specified load impedance and at a specific frequency.

CHANNEL ISOLATION. On a switching card, the isolation from signal HI and LO of one channel to signal HI and LO of any other channel (or the output on switch or scanner cards). Specified as resistance and capacitance, except for RF cards (decibels and frequency range).

COAXIAL CABLE. A two-conductor cable that has a center conductor surrounded by a shield conductor, the two being coaxial and separated by an insulator.

COIL RESISTANCE. A nominal value of the resistance of the coil winding of a relay.

COLD JUNCTION. The junction in a thermocouple circuit that is at a known temperature. Also known as Reference Junction.

COLD SWITCHING. Closing the relay contacts before applying voltage and current and removing voltage and current before opening the contacts. (Contacts do not make or break current.)

COLUMN. As viewed on the schematic of a matrix card/module, the vertical signal lines that are connected via relays to the horizontal rows.

COMMON MODE. Between two signal lines and a third line (e.g., from signal HI and LO to chassis ground or guard).

COMMON MODE ISOLATION. On a switching card/module, the isolation from signal HI and LO to guard (or shield) for a 3pole circuit, or from signal HI and LO to chassis ground for a two-pole circuit. Specified as resistance and capacitance.

COMMON MODE REJECTION RATIO. The ability of an instrument to reject interference from a common mode voltage at its input terminals with respect to ground. Usually expressed in decibels at a frequency.

COMMON MODE VOLTAGE. A voltage between input low and chassis ground of an instrument.

CONTACT BOUNCE. The intermittent and undesired opening of relay contacts during closure.

CONTACT LIFE. The maximum number of expected closures before failure. Life is dependent on the switched voltage, current, and power. Failure usually occurs when the contact resistance exceeds the end of life value.

CONTACT POTENTIAL. A voltage produced between contact terminals due to the temperature gradient across the relay contacts, and the reed-to-terminal junctions of dissimilar metals. (The temperature gradient is typically caused by the power dissipated by the energized relay coil.)

CONTACT RATING. The voltage, current, and power capacities of relay contacts under specified environmental conditions. See Carry Current and Switched Current.

CONTACT RESISTANCE. For a relay, the resistance in ohms across closed contacts. For a Keithley switching card/module, also includes the tape resistance and connector terminal resistance.

CONTACTS. The surfaces of current carrying elements where electric circuits are opened or closed.

CROSSPOINT. The intersecting point of a column and row in a relay matrix. Specified as (column, row) or (row, column).

CROSSTALK. See *Channel Crosstalk*.

CURRENT SURGE LIMITING. The circuitry necessary to protect relay contacts from excessive transient current.

DIFFERENTIAL INPUT ISOLATION. On a switching card, the isolation from signal HI to LO. Specified as resistance and capacitance.

DIFFERENTIAL MULTIPLEXER. A type of switching card/module where one input is routed to one of several outputs (e.g., sourcing) or one of several inputs is routed to one output (e.g., measuring), and each channel uses a two-pole relay configuration (one pole for signal HI and one pole for signal LO).

DIGITAL I/O. A TTL-level input/output port that is programmable by the mainframe.

DRY CIRCUIT SWITCHING. Switching below specified levels of voltage (e.g., 20mV) and current to minimize any physical and electrical changes in the contact junction.

DRY REED RELAY. A glass-enclosed, hermetically sealed, magnetically actuated contact. No mercury or other wetting material is used.

DUT. An abbreviation for Device Under Test.

ELECTROCHEMICAL EFFECTS. The property that generates current between circuit board conductors due to contamination of the card surface. Minimized with proper handling and cleaning.

ELECTROMECHANICAL RELAY. A relay that uses an electromagnet to move an armature and make or break the relay contacts.

EMI. Abbreviation for Electromagnetic Interference. A term that defines unwanted electromagnetic radiation from a device that could interfere with desired signals in test or communication equipment, for example. RFI (Radio Frequency Interference) and EMI are often used interchangeably.

FLOATING. The condition where a common mode voltage exists between earth ground and the instrument or circuit of interest. (Low of circuit is not at earth potential.) The condition where signal LO in the system is electrically isolated from earth ground.

FORM A. A single-pole, normally open contact configuration. Also called SPST-NO. A two-pole configuration is called 2 Form A.

FORM B. A single-pole, normally closed contact configuration. Also called SPST-NC. A two-pole configuration is called 2 Form B.

FORM C. A single-pole, double-throw contact configuration. Also known as a Transfer Switch. A two-pole configuration is called 2 Form C or DPDT.

GUARDING. A technique that reduces leakage errors and decreases response time. Consists of a guard conductor driven by a low-impedance source surrounding the lead of a high-impedance signal. The guard voltage is kept at or near the potential of the signal.

HOT SWITCHING. Opening and closing relay contacts while voltage and current are applied. (Contacts make or break current.) Degrades contact life. Typically used for digital signal switching to prevent state changes.

IMPEDANCE MATCHING. To optimize power transfer and minimize measurement uncertainty in RF/microwave systems, the ohmic values of source, switch, and measure components are equalized, commonly to 50W. Differences in impedances cause reflection of the signal.

INDEPENDENT SWITCH CARD/MODULE. A type of card where each channel is electrically isolated from all other channels. Also called Isolated Switch Card/Module.

INPUT ISOLATION. On a switching card, the isolation from signal HI to LO (or guard) for a two-pole circuit. Specified as resistance and capacitance.

INSERTION LOSS. The attenuation of signals being routed through a switching card. Specified as a decibel value over a frequency range. Becomes more important with low signal levels or high noise levels.

INSULATION RESISTANCE. The ohmic resistance of insulation. It degrades quickly as humidity increases.

I/O. Abbreviation for input/output, which refers to the transmission of information to an external device (output), and the reception of information from an external device (input).

ISOLATED SWITCH. A type of card where each channel is electrically isolated from all other channels. Also called Independent Switch Card/Module.

ISOLATION. On a switching card/module, the impedance between any stated terminals. Specified as resistance and capacitance. In RF/microwave switching, the ratio of the power level between adjacent channels, which is expressed in decibels over a frequency range. See Input Isolation.

ISOTHERMAL BLOCK. The thermally conductive block that equalizes the temperature of all thermocouple connections.

LATCHING RELAY. A relay that maintains its contacts in the last position assumed without the need to keep the coil energized.

LEAKAGE CURRENT. Error current that flows through insulation resistance when a voltage is applied.

LOW NOISE CABLE. A cable that is coated with a conductive layer between the braid and inner insulator (coax and triax) and under the inner shield (triax). This reduces triboelectric currents caused by friction due to vibration, movement, or temperature fluctuation.

MAINFRAME. A switching instrument that operates according to user commands to connect signals among sourcing and measuring instruments and devices under test. Signal switching is performed on cards that are inserted into the mainframe rack. A mainframe is also referred to as a Scanner, Multiplexer, Matrix, or Programmable Switch.

MAKE-BEFORE-BREAK. Connecting a new circuit before disconnecting the present circuit. Also known as Make/Break.

MATRIX. Connecting multiple inputs to multiple outputs.

MATRIX CARD/MODULE. A type of card with a switching configuration that has columns and rows of relay crosspoints. With a matrix card, since any one point can be connected to any other, you can simultaneously have one input with multiple outputs, multiple inputs with one output, or multiple inputs with multiple outputs.

MERCURY WETTED RELAY. A reed relay in which the contacts are wetted by a film of mercury. Usually has a required position for proper operation; some types are position insensitive.

MODULE. See *Switch Cards/Modules*.

MULTIPLEX. Connecting one instrument to multiple devices under test or multiple instruments to one device under test. Also see Scan.

SWITCHING GLOSSARY

MULTIPLEX CARD. See *Scanner Card*.

NOISE. An undesirable electrical signal from an external source (such as an AC power line, motors, generators, transformers, fluorescent lights, CRT displays, computers, radio transmitters, and others) that is imposed on a desired signal.

NON-BLOCKING. A multiplexer or matrix arrangement of relays where it is possible to switch any signal to any DUT at any time. It has high flexibility and high cost.

NON-LATCHING RELAY. A relay that maintains its closed contact position when the coil is energized and its open contact position when the coil is not energized.

NORMALLY CLOSED CONTACTS. A contact pair that is closed when the relay is not energized.

NORMALLY OPEN CONTACTS. A contact pair that is open when the relay is not energized.

NORMAL MODE. Between two signal lines (e.g., from signal HI to signal LO).

NORMAL MODE REJECTION RATIO. The ability of an instrument to reject an AC interference (usually of line frequency) across its input terminals. Usually expressed in decibels at a frequency.

NORMAL MODE VOLTAGE. A voltage applied between the input high and input low terminals of an instrument.

OFFSET CURRENT. A current that comes from a switching card even though no signals are applied. It comes mostly from the finite coil-to-contact impedance. It is also generated by triboelectric, piezoelectric, and electrochemical effects present on the card.

PATH ISOLATION. On a matrix switching card, the isolation from signal HI and LO of one path to signal HI and LO of any other path. Specified as resistance and capacitance.

PATH RESISTANCE. On a matrix switching card, the resistance per conductor of a closed path, including the contact resistance, wiring resistance, and connector terminal resistance.

PHASE DISTORTION. The shifting of RF/microwave or digital waveforms due to signal paths of different lengths and different propagation delays through test systems. May cause errors in digital testing.

PIEZOELECTRIC CURRENTS. The current caused by mechanical stress to certain insulating materials. To minimize, the stress is removed from the insulators, and materials with low piezoelectric effect are used.

POLE. A set of mating contacts in a relay or switch: normally open, normally closed, or both.

PROPAGATION DELAY. The specified amount of time for a signal to be routed through a previously closed channel of a switching card. The delay must be considered, for example, when the switched signal is used to synchronize other signals.

REED RELAY. A relay using one or more glass-enclosed, hermetically sealed, magnetically actuated contact members. Some types are dry to improve isolation or make them position independent. Some types are mercury wetted to improve switched current rating and make contact resistance more predictable. Also see *Electromechanical Relay* and *Solid State Relay*.

REFERENCE CHANNEL. On a thermocouple scanner card, the channel that measures the temperature of the isothermal block.

REFERENCE OUTPUT. The output signal representing the temperature of the reference channel, usually the isothermal block, on some thermocouple scanner cards/modules.

RELAY. An electrically controlled mechanical device that opens and closes an electrical contact. A relay provides isolation of control signals from switched signals.

RELAY DRIVE. The total current available from the power supply of the mainframe to energize the relay coils on switching cards. This current is derated at elevated temperatures.

RELAY DRIVE CURRENT. The amount of current necessary to energize a relay. Usually specified per channel.

RELAY SETUP. A configuration of open and closed relays.

RELEASE TIME. The time between the removal of the coil voltage and the stabilized opening of the contacts.

RETURN LOSS. A measure of the power reflected back towards the source due to an impedance mismatch among the source, transmission line, and the load. Expressed in dB.

ROW. As viewed on the schematic of a matrix card/module, the horizontal signal lines that are connected via relays to the vertical columns.

SCAN. Sequential connecting (usually break-before-make) of one instrument to multiple devices under test or multiple instruments to one device under test. Also see *Multiplex*.

SCANNER. See *Mainframe*.

SCANNER CARD. A type of switching card where one input is routed to one of several outputs (e.g., sourcing), or one of several inputs is routed to one output (e.g., measuring). The actual switching can be nonsequential (multiplex) or sequential (scan). Also known as a Multiplex Card.

SETTLE TIME. The time required for establishing relay connections and stabilizing user circuits.

SHIELDING. A metal enclosure for the circuit being measured or a metal sleeving surrounding wire conductors (coax or triax cable) to reduce electrostatic interference. The shield is usually connected to the LO terminal of the sensitive instrument.

SINGLE-ENDED MULTIPLEXER. A type of switching card/module where one input is routed to one of several outputs (e.g., sourcing) or one of several inputs is routed to one output (e.g., measuring). Each channel uses a single-pole relay for signal HI and a single common terminal is connected to signal LO for all channels.

SOLID STATE RELAY. A relay that switches electric circuits by use of semiconductor elements without moving parts or conventional contacts.

SMA. A type of miniature coaxial connector used in situations requiring shielded cable for signal connections.

SMB. A type of miniature coaxial connector used in situations requiring shielded cable for signal connections.

SWITCH/MEASURE SYSTEM. An instrument that integrates a switch mainframe and a digital meter into a single chassis. Signal switching is performed on cards/modules that are inserted into the chassis.

SWITCHED CURRENT. The maximum current level that can be reliably handled while opening and closing contacts. Also see *Carry Current*.

SWITCHING CARD/MODULES. The general classification of relay cards. May be subdivided into: independent switch cards (1 input to 1 output), scanner or multiplex cards (1:N, N:1) and matrix cards (M:N).

T/C COLD JUNCTION. See *Cold Junction*.

TEST FIXTURE. An enclosure, sometimes shielded, used for mounting single or multiple devices for testing purposes.

THERMAL OFFSET VOLTAGE. See *Contact Potential*.

TRIAxIAL CABLE. A three-conductor cable that has a center conductor surrounded by an inner shield conductor that is in turn surrounded by an outer shield conductor.

TRIBOELECTRIC CURRENT. The current caused by friction between a conductor and insulator when a cable flexes due to vibrations, movement, or temperature fluctuation. Also see *Low Noise Cable*.

TRIGGER. An external stimulus that initiates one or more instrument functions. Trigger stimuli include: the front panel, an external trigger pulse, and IEEE-488 bus X, Talk, and GET triggers.

TSP. TEST SCRIPT PROCESSOR. An onboard processor, used in a growing number of Keithley instruments and switch mainframes, designed for executing test scripts within the instrument. Using TSP test scripts instead of a PC for instrument control avoids communication delays between the PC controller and instrument, allowing improved test throughput. Test scripts can contain math and decision-making rules that further reduce the interaction between a host PC and the instrument.

TSP-LINK. The TSP-Link master/slave connection offers easy system expansion between Keithley's Series 3700A mainframes. TSP-Link can also be used to connect to other TSP-Link enabled instruments, such as Series 2600B System SourceMeter instruments. All instrumentation connected via TSP-Link can be controlled by the master unit, just as if they were all housed in the same chassis.

VOLTAGE CLAMPING. The circuitry necessary to protect relay contacts from excessive voltage caused by switching current into inductive loads.

VSWR. Abbreviation for Voltage Standing Wave Ratio. A measure of signal reflection along a transmission line. Expressed as a ratio of the highest voltage to the lowest voltage found along the signal path.

For further reading on switching terminology, see the following references:

ANSI/EIA RS-473-1981. *Definitions and Terminology for Relays for Electronic Equipment*. American National Standards Institute, 1981.

ANSI/IEEE Std. 100-1992. *IEEE Standard Dictionary of Electrical and Electronics Terms*. 5th edition. Institute of Electrical and Electronics Engineers, 1992.

***Engineers' Relay Handbook*. 5th edition. Relay and Switch Industry Association (formerly National Association of Relay Manufacturers), 1996.**

SWITCH CARD AND SWITCH MODULE SELECTOR GUIDES

Switching Cards for Series 3700A Mainframes*

*Additional Series 3700A cards are currently in development. For a current list of cards and specifications, visit www.keithley.com.

	3720	3721	3722	3723	3724	3730	3731	3732	3740	3750
No. of Channels	60 (Dual 1×30)	40 (dual 1×20)	96 (dual 1×48)	60 (dual 1×30) or 120 single pole (dual 1×60)	60 (dual 1×30)	6×16	6×16	448 crosspoints (Quad 4×28)	32	40 digital I/O, 4 counter/totalizers, and 2 isolated analog outputs
Card Config.	Multiplexer	Multiplexer	Multiplexer	Multiplexer	Multiplexer	Matrix	Matrix	Matrix	Independent	Independent
Type of Relay	Latching electromechanical	Latching electromechanical	Latching electromechanical	Dry reed	FET solid-state	Latching electromechanical	Dry reed	Dry reed	Latching electromechanical	N/A
Contact Configuration	2 Form A	2 Form A	2 Form A	1 Form A	2 Form A	2 Form A	2 Form A	1 Form A	28 Form C, 4 Form A	N/A
Max. Voltage	300 V	300 V (ch 1–40), 60 V (ch 41–42)	300 V	200 V	200 V	300 V	200 V	200 V	300 VDC/250 VAC (Form A)	N/A
Max. Current Switched	1 A	2 A (ch 1–40), 3 A (ch 41–42)	1 A	1 A	0.1 A	1 A	1 A	0.75 A	2 A (Form C), 7 A (Form A)	N/A
Comments	2 independent 1×30 multiplexers. Automatic temperature reference when used with screw terminal accessory (Model 3720-ST)	2 independent 1×20 multiplexers. Automatic temperature reference when used with screw terminal accessory (Model 3721-ST)	2 independent 1×48 multiplexers	2 independent 1×30 multiplexers	2 independent 1×30 multiplexers. Automatic temperature reference when used with screw terminal accessory (Model 3724-ST)	Columns can be expanded through the backplane or isolated by relays	Relay actuation time of 0.5ms. Columns can be expanded through the backplane or isolated by relays	Banks can be connected together via bank configuration relays to create a single 4×112 or dual 4×56 matrix. Analog backplane relays also included for card to card expansion. Row expansion with 3732-ST-R accessory to create a dual 8×28 or single 16×28 matrix.	32 general purpose independent channels.	All-in-one card design. 40 bidirectional I/O. Four 32-bit counter/totalizers. 2 programmable analog (V or I) outputs.

Plug-in Card Accessories

	3720	3721	3722	3723	3724	3730	3731	3732	3740	3750
Cables	3720-MTC-1.5, 3720-MTC-3	3721-MTC-1.5, 3721-MTC-3	3722-MTC-1.5, 3722-MTC-3, 3722-MTC-3/MM	3723-MTC-1.5, 3723-MTC-3	3724-MTC-1.5, 3724-MTC-3	3721-MTC-1.5, 3721-MTC-3	3721-MTC-1.5, 3721-MTC-3	3720-MTC-1.5, 3720-MTC-3	3721-MTC-1.5, 3721-MTC-3	3721-MTC-1.5, 3721-MTC-3
Screw Terminal Block	3720-ST	3721-ST		3723-ST, 3723-ST-1	3724-ST	3730-ST	3731-ST	3732-ST-C, 3732-ST-R	3740-ST	3750-ST
Connector Kits	3791-KIT78-R	3790-KIT50-R	3792-KIT104-R, 3792-KIT104-R/F	3791-KIT78-R	3791-KIT78-R	3790-KIT50-R	3790-KIT50-R	3791-KIT78-R	3790-KIT50-R	3790-KIT50-R
Tools	3791-CIT		3791-CIT	3791-CIT	3791-CIT			3791-CIT		

Let us offer advice on your application

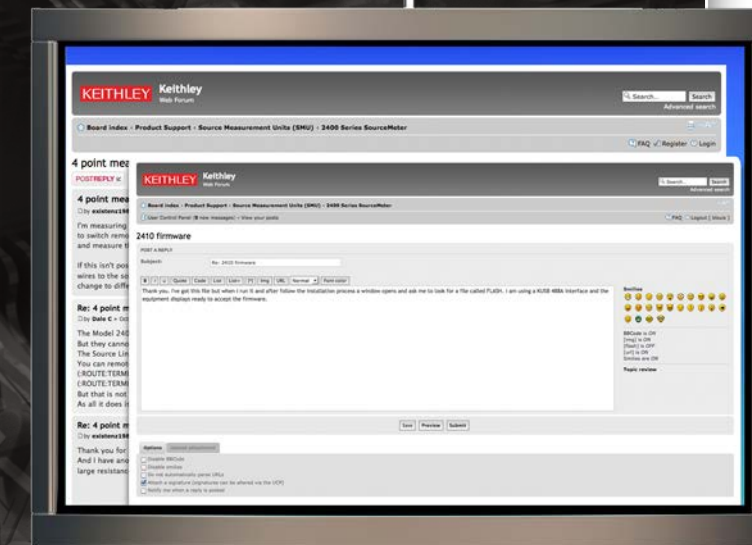

JOIN THE DISCUSSION ON OUR APPLICATION FORUM

INDEX

SWITCH CARD AND SWITCH MODULE SELECTOR GUIDES

Switching Cards for 7001 and 7002 Mainframes

Card	No. of Channels	Card Config.	Contact Config.	Max. Voltage	Max. Current	Max. Power	Contact Potential	Offset Current	Max. Recomm. Frequency	Connection Type	CE	Comments
HIGH DENSITY							HIGH DENSITY					
7011-C	40	Multiplexer	2 form A	110 V	1 A	60 VA	<1 μ V	<100 pA	2 MHz	Connector	Yes	Four independent 1x10 multiplexers, connection to backplane
7011-S	40	Multiplexer	2 form A	110 V	1 A	60 VA	<500 nV	<100 pA	2 MHz	Screw term.	Yes	Four independent 1x10 multiplexers, connection to backplane
7012-C	4x10	Matrix	2 form A	110 V	1 A	60 VA	<1 μ V	<100 pA	2 MHz	Connector	Yes	Rows connect to analog backplane
7012-S	4x10	Matrix	2 form A	110 V	1 A	60 VA	<500 nV	<100 pA	2 MHz	Screw term.	Yes	Rows connect to analog backplane
7013-C	20	Isolated Switch	2 form A	110 V	1 A	60 VA	<1 μ V	<100 pA	10 MHz	Connector	Yes	
7013-S	20	Isolated Switch	2 form A	110 V	1 A	60 VA	<500 nV	<100 pA	10 MHz	Screw term.	Yes	
7015-C	40	Multiplexer	2 form A	175 V	34 mA	0.3 VA	<5 μ V	<1nA	500 kHz	Connector	Yes	Solid state switch for high reliability
7015-S	40	Multiplexer	2 form A	175 V	34 mA	0.3 VA	<5 μ V	<1nA	500 kHz	Screw term.	Yes	Solid state switch for high reliability
7018-C	28	Multiplexer	3 form A	110 V	1 A	60 VA	<5 μ V	<100 pA	2 MHz	Connector	Yes	3 pole switching
7018-S	28	Multiplexer	3 form A	110 V	1 A	60 VA	<5 μ V	<100 pA	2 MHz	Screw term.	Yes	3 pole switching
7035	36	Multiplexer	2 form A	60 V	1 A	30 VA	<1 μ V	<100 pA	10 MHz	Connector	Yes	9 independent 1x4 multiplexers
7036	40	Isolated Switch	1 form A	60 V	1 A	30 VA	<4 μ V	<100 pA	10 MHz	Connector	Yes	40 independent channels of one-pole switching
7111-S	40	Multiplexer	1 form C	110 V	1 A	60 VA	<500 nV	<100 pA	2 MHz	Screw term.	Yes	Four independent 1x10 multiplexers, connection to backplane
LOW VOLTAGE							LOW VOLTAGE					
7168	8	Multiplexer	2 form A	10 V	50mA		<30 nV		1 kHz	Screw term.	Yes	
HIGH VOLTAGE							HIGH VOLTAGE					
7154	10	Multiplexer	2 form A	1100 V	500mA	10 VA	<35 μ V		1 MHz	Screw term.	Yes	
CONTROL							CONTROL					
7020 7020-D*	80	Digital I/O								Connector	Yes	40 inputs/40 outputs
7021	30/20	Multiplexer/ Digital I/O	2 form A	110 V	1 A	30 VA	<3 μ V	<100 pA	10 MHz	Connector	Yes	Dual multiplexers. Up to 30 channels, 10 digital inputs, 10 digital outputs.
7037-D*	30/20	Isolated/ Digital I/O	1 form A	110 V	1 A	30 VA	<4 μ V	<100 pA	10 MHz	Connector	Yes	30 independent channels of one-pole switching, 10 digital inputs, 10 digital outputs
7065												Hall Effect measurement buffer card

Let us offer advice on your application

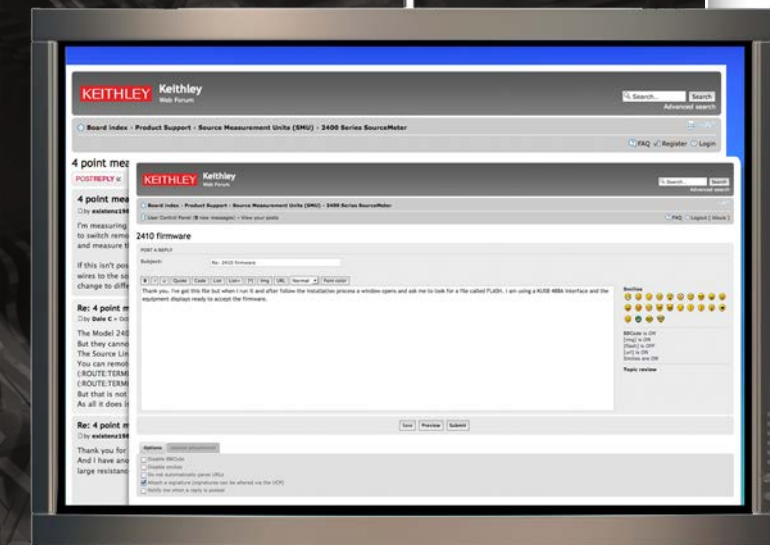

JOIN THE DISCUSSION ON OUR APPLICATION FORUM

INDEX

SWITCH CARD AND SWITCH MODULE SELECTOR GUIDES

Switching Cards for 7001 and 7002 Mainframes (cont.)

Card	No. of Channels	Card Config.	Contact Config.	Max. Voltage	Max. Current	Max. Power	Contact Potential	Offset Current	Max. Recomm. Frequency	Connection Type	CE	Comments
LOW CURRENT							LOW CURRENT					
7152	4x5	Matrix	2 form A	200 V	500 mA	10 VA	<20 μ V	<1 pA	60 MHz	Connector	Yes	
7153	4x5	Matrix	2 form A	1300 V	500 mA	10 VA	<50 μ V	<1 pA	60 MHz	Connector	Yes	
7158	10	Multiplexer	1 form C	30 V	100 mA		<200 μ V	<1 pA	1 MHz	BNC	Yes	
HIGH CURRENT							HIGH CURRENT					
7053	10	Multiplexer	2 form C	300 V	5 A	100 VA	<1 mV		1 MHz	Screw term.		
RF							RF					
7016A	double 1x4	2 isolated switches	1 pole, 4 throw	30 V	500 mA	10 VA	<6 μ V		2 GHz	SMA	Yes	Optional 50 Ω termination

* Cards with a -D suffix feature D-sub connectors.

Switching Cards for 707B, 707A, 708B and 708A Mainframes

Card	No. of Channels	Card Config.	Contact Config.	Max. Voltage	Max. Current	Max. Power	Contact Potential	Offset Current	Max. Recomm. Frequency	Connection Type	CE	Comments
LOW CURRENT							LOW CURRENT					
7072	8x12	Matrix	2 form A	200 V	1 A	10 VA	<20 μ V	<1 pA	15 MHz	3-lug triax	Yes	Optimized for semiconductor applications.
7072-HV	8x12	Matrix	2 form A	1300 V	1 A	10 VA	<20 μ V	<1 pA	4 MHz	3-lug triax		
7174A	8x12	Matrix	2 form A	200 V	2 A			<100 fA	30 MHz	3-lug triax	Yes	
HIGH FREQUENCY							HIGH FREQUENCY					
7073	8x12	Matrix	1 form A	200 V	1 A	30 VA	<2 μ V	<200 pA	30 MHz	BNC	YES	
7173-50	4x12	Matrix	2 form C	30 V	0.5 A	10 VA	<15 μ V	<200 pA	200 MHz	BNC	Yes	

Let us offer advice on your application

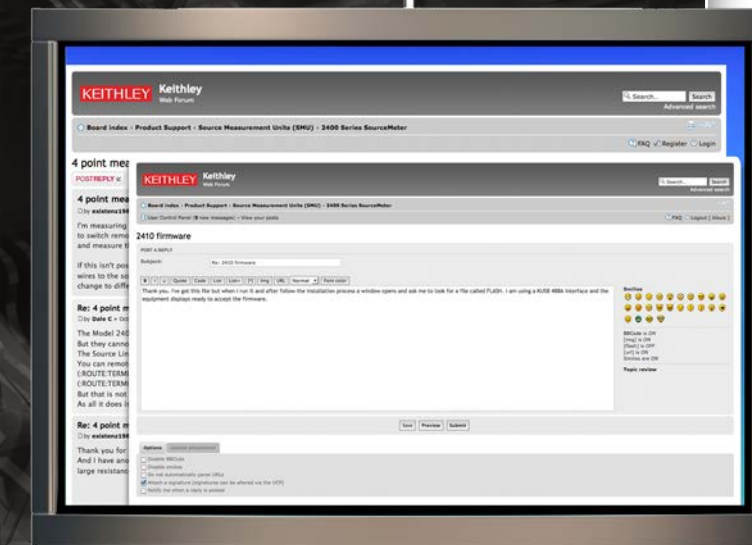

JOIN THE DISCUSSION ON OUR APPLICATION FORUM

INDEX

SWITCH CARD AND SWITCH MODULE SELECTOR GUIDES

Switching Cards for 2000, 2001, 2002, and 2010 Multimeters

	No. of Channels	Card Config.	Contact Config.	Max. Voltage	Max. Current	Max. Power	Contact Potential	Connection Type	CE	Comments
GENERAL PURPOSE							GENERAL PURPOSE			
2000-SCAN	10	Multiplexer	2 form A	110 V	1 A	30 VA	<1 μ V	Screw terminal	Yes	Configurable to four-pole
2001-SCAN	10	Multiplexer	2 form A	110V	1 A	30 VA	<1 μ V	Screw terminal	Yes	2001, 2002 only; configurable to four-pole; two high-speed channels
THERMOCOUPLE										
2001-TCSCAN	9	Multiplexer	2 form A	110 V	1 A	30 VA	<1 μ V	Screw terminal	Yes	Built-in cold junction reference

Switch/Control Modules for 2700, 2701 and 2750 Multimeter/Data Acquisition/Switch Systems

Module	# Analog Inputs	Configuration	Differential*	Four-Pole	Type of Connector	Max. Voltage	Max. Switched Current	Current Measurement Channels	Digital I/O	Switch Speed	Other
7700	20	Multiplexer w/ CJC	1x20 or two 1x10	1x10	Screw terminals	300 V	1 A	2 channels @ 3 A	N/A	3 ms	Maximum power = 125 VA.
7701	32	Multiplexer	1x32 or two 1x16	1x16	D-sub	150 V	1 A	N/A	N/A	3 ms	Maximum power = 125 VA.
7702	40	Multiplexer	1x40 or two 1x20	1x20	Screw terminals	300 V	1 A	2 channels @ 3 A	N/A	3 ms	Maximum power = 125 VA.
7703	32	Multiplexer	1x32 or two 1x16	1x16	D-sub	300 V	500 mA	N/A	N/A	1 ms	Reed relays.
7705	40	Independent SPST	N/A	N/A	D-sub	300 V	2 A	N/A	N/A	3 ms	Maximum power = 125 VA.
7706	20	Multiplexer w/ CJC	1x20 or two 1x10	1x10	Screw terminals	300 V	1 A	N/A	16 Digital Out Only	3 ms	(2) \pm 12 V analog output channels & 100 kHz event counter/totalizer. Maximum power = 125 VA.
7707	10	Multiplexer/ Digital I/O	1x10 or two 1x5	1x5	D-sub	300 V	1 A	N/A	32 Digital I/O	3 ms	Maximum power = 125 VA. (4) eight-bit word I/O.
7708	40	Multiplexer w/ CJC	1x40 or two 1x20	1x20	Screw terminals	300 V	1 A	N/A	N/A	3 ms	Maximum power = 125 VA.
7709	48	6x8 Matrix	Yes	Yes	D-sub	300 V	1 A	N/A	N/A	3 ms	Connects to internal DMM. Daisy chain multiple cards for up to a 6x40 matrix. Maximum power = 125 VA.
7710	20	Multiplexer w/ CJC	1x20 or two 1x10	1x10	Screw terminals	60 V	100 mA	N/A	N/A	0.5 ms	Maximum power = 4.2 VA
7711	8	Multiplexer	two 1x4	No	SMA	30 Vrms, 60 VDC	0.5 A	N/A	N/A	10 ms	2 GHz, maximum power = 20 W per module
7712	8	Multiplexer	two 1x4	No	SMA	30 Vrms, 42 VDC	0.5 A	N/A	N/A	10 ms	3.5 GHz, maximum power = 20 W per module

* Can be disconnected from internal DMM for routing external signals.

Let us offer advice on your application



JOIN THE DISCUSSION ON OUR APPLICATION FORUM

INDEX





SWITCH CARD AND SWITCH MODULE SELECTOR GUIDES



Source/Switch Modules for 2790 SourceMeter®

Airbag Test System

Module	# Analog Inputs	Card Configuration	Current Source	Voltage Source	I/V Converter	Current Measure	Contact Potential	Type of Connector	Switch Speed
7751	12	Four 1 form A, plus four four-pole or eight two-pole	0–50 mA	50–500 V	Yes	0–50 µA	<3 µV	Screw terminals	3 ms
7752	12	Four 1 form A, plus four four-pole or eight two-pole	0–50 mA		No		<3 µV	Screw terminals	3 ms
7753	12	Four 1 form A, plus four four-pole or eight two-pole	0–50 mA	50–500 V	Yes	0–500 µA	<3 µV	Screw terminals	3 ms

SWITCH SYSTEM MAINFRAMES

Product Family	Switch/Measure Systems		ATE Switch/Control System	
	MODEL 3706A, 3706A-NFP	MODEL 2700, 2701, 2750	MODEL 7001	MODEL 7002
				
	System Switch with optional High Performance Multimeter and Plug-In Cards	Integrated Switching/ Measurement/ Datalogging Systems	80 Ch - 2 Slot Half Rack Switch Mainframe	400 Ch - 10 Slot Full Rack Switch Mainframe
Max. Channels or Crosspoints per Chassis	Up to 576 ch or 2688 crosspoints per mainframe	Up to 80 per mainframe (2700, 2701), up to 200 per mainframe (2750)	Up to 80 per mainframe	Up to 400 per mainframe
Card Slots	6	2 (2700, 2701), 5 (2750)	2	10
Automatic CJC	Yes (optional)	Yes (optional)	—	—

Product Family	Semiconductor System Switch		
	MODEL 707B	MODEL 708B	SYSTEM 46, 46T
			
	6-Slot, Semiconductor Switching Matrix - New Features and Improved Performance	Single-Slot, Semiconductor Switching Matrix - New Features and Improved Performance	RF/Microwave Switch System, 32 Channel Unterminated & Terminated
Max. Channels or Crosspoints per Chassis	Up to 576 per mainframe	Up to 96 per mainframe	Up to 32 RF/microwave ch
Card Slots	6	1	0
Automatic CJC	—	—	—

Let us offer advice on your application

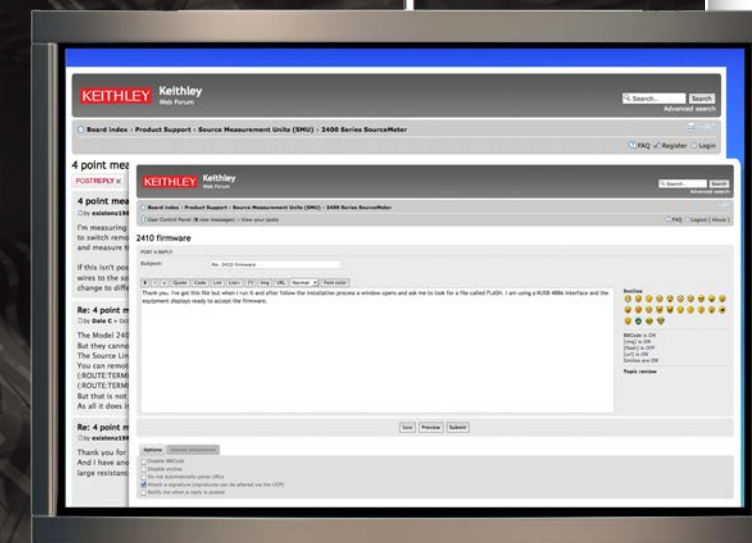

JOIN THE DISCUSSION ON OUR APPLICATION FORUM

INDEX

WANT TO LEARN MORE?



Keithley Instruments hosts an online applications forum to encourage idea exchange, discussions among users. **Join the discussion today.**

To learn more about how Keithley can enhance the productivity of your test and measurement applications, contact your local Keithley representative or ask us a question online.

CONTACT US BY PHONE, FAX, MAIL, OR EMAIL:

KEITHLEY CORPORATE HEADQUARTERS

Keithley Instruments, Inc
28775 Aurora Road
Cleveland, Ohio 44139

Phone: 440-248-0400
Toll-free: 800-552-1115
Fax: 440-248-6168
info@keithley.com

Consult with a Keithley applications engineer and learn how to get the most from your Keithley products

WORLDWIDE HEADQUARTERS

Within the USA: 1-888-534-8453
Outside the USA: + 1-440-248-0400
Email: applications@keithley.com
Additional information at www.keithley.com

EUROPE

Germany: (+49) 89-84-93-07-40

ASIA

China: (+86) 10 8447 5556
Japan: (+81) 120-441-046
Korea: (+82) 2 6917-5000
Taiwan: (+886) 3 572 9077



Specifications are subject to change without notice. All Keithley trademarks and trade names are the property of Keithley Instruments, Inc. All other trademarks and trade names are the property of their respective companies.

A Greater Measure of Confidence

KEITHLEY
A Tektronix Company

KEITHLEY INSTRUMENTS, INC. ■ 28775 AURORA RD. ■ CLEVELAND, OH 44139-1891 ■ 440-248-0400 ■ Fax: 440-248-6168 ■ 1-888-KEITHLEY ■ www.keithley.com

BRAZIL
55-11-4058-0229
www.keithley.net.br

CHINA
86-10-8447-5556
www.keithley.com.cn

FRANCE
01-69868360
www.keithley.fr

GERMANY
49-89-84930740
www.keithley.de

INDIA
080-30792600
www.keithley.in

ITALY
02-5538421
www.keithley.it

JAPAN
Tokyo: 81-3-6714-30
Osaka: 81-06-6396-1630
www.keithley.jp

KOREA
82-2-6917-5000
www.keithley.co.kr

MALAYSIA
60-4-643-9679
www.keithley.com

MEXICO
52-55-5424-7905
www.keithley.com

SINGAPORE
01-800-8255-2835
www.keithley.com.sg

SWITZERLAND
41-56-460-78-90
www.keithley.ch

TAIWAN
886-3-572-9077
www.keithley.com.tw

UNITED KINGDOM
044-1344-392450
www.keithley.co.uk

For further information on how to purchase or to locate a sales partner please visit www.keithley.com/buy