

Test & Measurement product catalog

14



A Greater Measure of Confidence

KEITHLEY
A Tektronix Company

Contents

Source Measure Unit (SMU) Instruments	1
Semiconductor Test.	57
Parametric Test Systems	76
Low Level Measurements and Sourcing	121
Switching and Control.	171
Digital Multimeters and Systems	241
DC Power Supplies	307
Accessories.	367
Customer Service	409
How to Purchase	410
Equipment Services	411
Safety Considerations.	412
Replacement Products.	414

Index

Products and General

Accessories	367–414	Integrating Sphere	102–104, 112–114	Selector Guide—Integra Systems	280
Adapter, Cable, and Stabilizer Kits	398–399	Laser Diode LIV Test System	105–107	Selector Guide—Low Current/High Resistance Measurement Products	141–142
Adapters	386–396	Laser Diode Mounts	119	Selector Guide—Low Voltage/Low Resistance Measurement Products	126
Airbag Test System	300–304	Low Current/High Resistance Measurement Products	139–167	Selector Guide—Optoelectronics Test Solutions	96
Audio Analyzing Multimeters	267–274	Low Voltage/Low Resistance Measurement Products	121–138	Selector Guide—Plug-In Cards for Series 3700A	185–186
Battery/Charger Simulator	337–357	LXI Products	166–169, 174–183, 226–231	Selector Guide—Rack Mount Kits	402
Battery Simulator	337–357	Multimeter/Data Acquisition/Switch Systems	276–284	Selector Guide—Switch Card Accessories for 7001, 7002	215
Bench Kits	402	Multimeters	241–301	Selector Guide—Switch Cards and Accessories for 707B, 708B, 707A, and 708A	231
Cables	372–383	Nanovoltmeter	127–132	Selector Guide—Switch Cards for 7001, 7002	214–215
Calibration Services	411	Ordering Information	410–411	Selector Guide—Test Leads and Probes	368
Charger Simulator	337–357	Parametric Test Systems	76–87	Semiconductor Characterization Systems	58–71
Connectors	386–396	Photodiode Meter	111, 153–155	Semiconductor Parametric Test and Device Characterization	57–85
Current Sources	115–121, 133–137	Picoammeters	146–155	Software	298–299
Customer Support	409–414	Probes	368–371	Source Measure Unit (SMU) Instruments	2–56, 115–120, 300–305
DC Power Supplies	307–366	Pulsed Laser Diode Test System	97–101	SourceMeter® SMU Instruments	300–305
Digital Multimeters	241–301	Rack Mount Kits	402–404	Switching and Control	171–255
Electrometers	156–164	Remote PreAmp Mounting Accessories	406	TEC SourceMeter® SMU Instruments	115–121
Ethernet Multimeter/Data Acquisition/Switch Systems	276–284	Repair Services	411	Test Fixtures	399, 400
ExcelINX-1A Excel Add-In	298, 299	Replacement Products	414	Test Leads and Probes	368–371
Fiber Alignment Photodiode Meter	153–155	Safety Considerations	412	THD Multimeters	267–274
GPIB Communications	407–408	Screw Terminals	390–391	Trigger Accessories	401–402
Hall Effect Solutions	165, 223	Selector Guide—Cables	372–373	Voltage Sources	1–366, 115–121, 149–152
High Voltage DC Power Supplies	330–335, 362–366	Selector Guide—Connectors, Adapters, and Tools	386–387		
High Voltage Protection Modules	366, 390, 406	Selector Guide—Digital Multimeters	244–245		
IEEE-488 Communications	407–408	Selector Guide—IEEE-488 Interface Boards	407		
Integra Systems Multimeter/Data Acquisition/Switch Systems	276–284	Selector Guide—Integra System Plug-In Modules	284–285		
Integra Systems Plug-In Modules and Accessories	285–297				

Index

Model Numbers

25	Laser Diode Test System Kit	105	2220G-30-1	Programmable Dual Channel DC Power Supply with GPIB Interface	330
46	RF/Microwave Switch System	236	2220GJ-30-1	Programmable Dual Channel DC Power Supply with GPIB Interface for Japan	330
46T	RF/Microwave Switch System	239	2220J-30-1	Programmable Dual Channel DC Power Supply for Japan	330
213-CON	Analog Output Connector	387	2230-30-1	Programmable Triple Channel DC Power Supply	330
236-ILC-3	Safety Interlock Cable	374	2230G-30-1-JUMPER	Shorting Jumper	388
237-ALG-2	Low Noise Triax Cable	374	2230G-30-1	Programmable Triple Channel DC Power Supply with GPIB Interface	330
237-BAN-3A	Triax to Banana Plug	387	2230GJ-30-1-JUMPER	Shorting Jumper	388
237-BNC-TRX	Male BNC to 3-lug Female Triax Adapter	387	2230GJ-30-1	Programmable Triple Channel DC Power Supply with GPIB Interface for Japan	330
237-TRX-BAR	3-lug Triax Barrel	387	2230J-30-1	Programmable Triple Channel DC Power Supply for Japan	330
237-TRX-NG	3-slot Triax to 3-lug Female Triax Adapter	387	2231A-30-3	195W Triple Channel DC Power Supply	334
237-TRX-T	3-slot Male to Dual 3-lug Female Triax Tee Adapter	387	2260-005	Cable, 0.5m (1.6 ft.)	375
237-TRX-TBC	3-lug Female Triax Bulkhead Connector	388	2260-006	Cable, 0.5m (1.6 ft.)	375
386-7598-xx	RMU2U Rack Mount Cosmetic Filler Panel	402	2260-007	Cable, 0.5m (1.6 ft.)	375
707B	Six-slot Semiconductor Switch Mainframe	226	2260-008	Test Lead Set	369
708B	Single-slot Semiconductor Switch Mainframe	226	2260B-30-36	Programmable DC 360W Power Supply, 30V, 36A	320
1600A	High Voltage Probe	368	2260B-30-72	Programmable DC 720W Power Supply, 30V, 72A	320
1651	50 Ampere Shunt	368	2260B-80-13	Programmable DC 360W Power Supply, 80V, 13.5A	320
1681	Clip-on Test Lead Set	368	2260B-80-27	Programmable DC 720W Power Supply, 80V, 27A	320
1751	Safety Test Leads	368	2260B-EXTERM	Extended Terminal Test Leads	369
1752	Premium Safety Test Lead Kit	368	2260B-RMK-EIA	Rack Mount Kit (EIA racks)	402
1754	Universal Test Lead Kit	369	2260B-RMK-JIS	Rack Mount Kit (JIS racks)	402
2000	6½-Digit Multimeter	254	2280S-32-6	Precision Measurement DC Power Supply, 32V, 6A	324
2000/2000-SCAN	6½-Digit DMM/Scanner Combination	254	2280S-60-3	Precision Measurement DC Power Supply, 60V, 3.2A	324
2000-Benchkit	Benchtop Restore Kit	402	2290-5	5kV Power Supply, 120VAC Nominal Input Voltage	362
2000-MTC-2	Cable Assembly	374	2290-5-MHV	RG-8A/U Coaxial Cable, 3m (10 ft)	375
2000-MTCD-2	Cable Assembly	375	2290-5-RMK-1	Single Fixed Rack Mount Kit for 5kV Power Supply	402
2000-SCAN	10-channel, General-Purpose Scanner Card	254, 260	2290-5-RMK-2	Dual Fixed Rack Mount Kit for 5kV Power Supply	403
2001	7½-Digit High Performance Multimeter	259	2290-5-SHVBH	Panel Mount Connector	389
2001/MEM1	High Performance 7½-Digit DMM with 32K Memory	260	2290-5-SHV	RG-8A/U Coaxial Cable, 3m (10 ft)	375
2001/MEM2	High Performance 7½-Digit DMM with 128K Memory	260	2290-10	10kV Power Supply	362
2001-SCAN	10-channel Scanner Card with two high-speed channels	254, 260	2290-10-RMK-1	Single Fixed Rack Mount Kit for 5kV Power Supply	403
2001-TCSCAN	9-channel, Thermocouple Scanner Card with built-in cold junction	254, 265	2290-10-RMK-2	Dual Fixed Rack Mount Kit for 5kV Power Supply	403
2002	8½-Digit High Performance Multimeter	259	2290-10-SHVBH	10kV SHV Female Bulkhead Connector	389
2002/MEM1	High Performance 8½-Digit DMM with 32K Memory	260	2290-10-SHV	RG-213/U Coaxial Cable, 3m (10 ft)	375
2002/MEM2	High Performance 8½-Digit DMM with 128K Memory	260	2290-10-SHVUC	RG-213/U Coaxial Cable, 3m (10 ft)	375
2010	Low Noise 7½-Digit Autoranging Multimeter	265	2290E-5	5kV Power Supply, 240VAC Nominal Input Voltage	362
2015	6½-Digit THD Multimeter	267	2290-INT-CABLE	Safety interlock cable, 3.05m (10 ft)	376
2015-P	6½-Digit Audio Analyzing DMM	267	2290J-5	5kV Power Supply, 100VAC Nominal Input Voltage	362
2016	6½-Digit Audio Analyzing Multimeter w/9V Source Output	267	2290-PM-200	10kV Protection Module	366, 406
2016-P	Audio Analyzing DMM w/9V Source Output	267	2302	Battery Simulator	344
2100	6½-Digit USB Digital Multimeter	250	2303	High Speed Precision Readback Power Supply (45W)	358
2107.*	Low-Thermal Input Cables with Spade Lugs	375	2303-PJ	High Speed Precision Readback Power Supply (45W, 500mA range replaces 5mA range)	358
2110	5½-Digit Dual-Display Digital Multimeter	246	2304A	High Speed Precision Readback Power Supply (100W)	358
2182-325A	Silver Solder	388	2306	Battery/Charger Simulator	344
2182A	Nanovoltmeter	127	2306-PJ	Battery/Charger Simulator with 500mA Range	344
2182-KIT	Low-Thermal Connector with Strain Relief	388	2306-VS	Dual-Channel Battery/Charger Simulator with External Triggering	350
2187-4	Test Lead Kit	369			
2188	Low-Thermal Calibration Shorting Plug	388			
2220-30-1	Programmable Dual Channel DC Power Supply	330			

Model numbers

INDEX

1.888.KEITHLEY (U.S. only)

www.keithley.com

KEITHLEY

A Tektronix Company

A Greater Measure of Confidence

2308	Portable Device Battery/Charger Simulator	337	2790	SourceMeter Airbag Test System	300
2400	200V, 1A, 20W SourceMeter® SMU Instrument	43	3390	50MHz Arbitrary Waveform/Function Generator	166
2450-Benchkit	Benchtop Restore Kit for Models 2450-RACK and 2450-NFP-RACK	403	3700A	System Switch/Multimeter and Plug-In Cards	138, 174, 275
2450	SourceMeter SMU Instrument	36	3706A-NFP	Six-slot System Switch with High Performance DMM, without front panel display and keypad	174
2450-TLINK	Trigger Link Adapter Cable for Model 2450	401	3706A	Six-slot System Switch with High Performance DMM	174
2450-TRX-BAN	Triax to Banana Jack Adapter Cables for Model 2450	376	3706A-SNFP	Six-slot System Switch, without front panel display and keypad	174
2499-DIGIO	Digital I/O Expansion Module	389	3706A-S	Six-slot System Switch	174
2500INT-2-Ge	Integrating Sphere with Germanium Detector	112	3706-BAN	Banana Test Leads/Adapter Cable, 1.4m (4.6 ft)	369
2500INT-2-IGAC	Integrating Sphere with Cooled Indium Gallium Arsenide Detector	112	3706-BKPL	Analog Backplane Extender Board	390
2500INT-2-Si	Integrating Sphere with Silicon Detector	112	3706-TLK	Test Lead Kit	369
2500INT-FC/APC	FC/APC Connector for 2500-INT Integrating Sphere	389	3720	Dual 1×30 Multiplexer Card	186
2500INT-FC/PC	FC/PC Connector for 2500-INT Integrating Sphere	389	3720-MTC-1.5	78-pin D-sub Female to 78-pin D-sub Male Cable, 1.5m (5 ft)	376
2500INT-SMA	SMA Connector for 2500-INT Integrating Sphere	389	3720-MTC-3	78-pin D-sub Female to 78-pin D-sub Male Cable, 3m (10 ft)	376
2502	Dual-Channel Picoammeter	111, 153	3720-MTC-*	78-pin D-sub Female to 78-pin D-sub Male Cable	376
2510-AT	Autotuning TEC SourceMeter SMU Instrument	115	3720-ST	Screw Terminal Block	390
2510	TEC SourceMeter SMU Instrument	115	3721	Dual 1×20 Multiplexer Card	188
2520INT	Integrating Sphere for Pulsed Measurements	102	3721-MTC-1.5	50-pin D-sub Female to 50-pin D-sub Male Cable, 1.5m (5 ft)	376
2520/KIT1	Pulsed Laser Diode Measurement Kit	98, 103	3721-MTC-3	50-pin D-sub Female to 50-pin D-sub Male Cable, 3m (10 ft)	376
2520	Pulsed Laser Diode Test System	97	3721-ST	Screw Terminal Block	390
2600-ALG-2	2m (6.6 ft.) Cable	376	3722	Dual 1×48, High Density, Multiplexer Card	190
2600-BAN	Banana Test Leads/Adapter Cable	369	3722-MTC-1.5	104-pin D-sub Male to 104-pin D-sub Female Cable, 1.5m (5 ft)	376
2600-KIT	Screw Terminal Connector	389	3722-MTC-1.5/MM	104-pin D-sub Male to 104-pin D-sub Male Cable, 1.5m (5 ft)	376
2600-PCT-xB	Parametric Curve Tracer Configurations	90	3722-MTC-3	104-pin D-sub Male to 104-pin D-sub Female Cable, 3m (10 ft)	376
2600-PCT-x	Parametric Curve Tracer Configurations	57, 72, 90	3722-MTC-3/MM	104-pin D-sub Male to 104-pin D-sub Male Cable, 3m (10 ft)	376
2600-TLINK	25-pin Digital I/O Port to Trigger Link Adapter	401	3723	Dual 1×30, High Speed, Reed Relay, Multiplexer Card	192
2600-TRIAx	Triax Adapter	389	3723-ST-1	Screw Terminal Block	390
2601B	Single-channel System SourceMeter SMU Instrument (3A DC, 10A Pulse)	10	3723-ST	Screw Terminal Block	390
2602B	Dual-channel System SourceMeter SMU Instrument (3A DC, 10A Pulse)	10	3724	Dual 1×30 FET Multiplexer Card	194
2604B	Dual-channel System SourceMeter SMU Instrument (3A DC, 10A Pulse, Benchtop Version)	10	3724-ST	Screw Terminal Block	390
2611B	Single-channel System SourceMeter SMU Instrument (200V, 10A Pulse)	10	3730	6×16, High Density, Matrix Card	197
2612B	Dual-channel System SourceMeter SMU Instrument (200V, 10A Pulse)	10	3730-ST	Screw Terminal Block	390
2614B	Dual-channel System SourceMeter SMU Instrument (200V, 10A Pulse, Benchtop Version)	10	3731	6×16 High Speed Reed, Reed Relay, Matrix Card	199
2634B	Dual-channel System SourceMeter SMU Instrument (1fA, 10A Pulse, Benchtop Version)	10	3731-ST	Screw Terminal Block	390
2635B	Single-channel System SourceMeter SMU Instrument (0.1fA, 10A Pulse)	10	3732	Quad 4×28, Ultra-High Density, Reed Relay Matrix Card	201
2636B	Dual-channel System SourceMeter SMU Instrument (0.1fA, 10A Pulse)	10	3732-ST-C	Screw Terminal Block	391
2651A	50A, High Power System SourceMeter SMU Instrument	25	3732-ST-R	Screw Terminal Block	391
2651A-KIT	High Current, Low Impedance, Coaxial Cable Assembly	376	3740	General Purpose Card with 32 Independent Channels	205
2657A	High Power System SourceMeter SMU Instrument	32	3740-ST	Screw Terminal Block	391
2657A-LIM-3	Low Interconnect Module	389	3750	Multifunction Control Card	207
2657A-PM-200	200V Protection Module	390	3750-ST	Screw Terminal Block	391
2700	DMM, Data Acquisition, Datalogging System w/2 Slots	276	3790-KIT50-R	50-pin Female D-sub Connector Kit	391
2701	DMM, Data Acquisition, Datalogging System w/2 Slots and Ethernet Support	276	3791-CIT	Contact Insertion and Extraction Tool	391
2750	DMM, Data Acquisition, Switching, Datalogging System w/5 Slots	276	3791-KIT78-R	78-pin Female D-sub Connector Kit	391
			3792-KIT104-R	104-pin Male D-sub Connector Kit	391

Index

Model Numbers

3792-KIT104-R/F	Female D-sub Connector Kit	391	6171	3-slot Male to 2-lug Female Triax Adapter	392
4200-BTI-1A	Ultra-Fast NBTI/PBTI Package for the Model 4200-SCS	65	6172	2-slot Male to 3-lug Female Triax Adapter	392
4200-CASE	Transport Case for 4200-SCS	406	6220/2182A	Complete Delta Mode System, w/DC Current Source, Nanovoltmeter, and all necessary cables	133
4200-CVU-PROBER-KIT	Accessory Kit	398	6220/6514/2000/7001	High Impedance Semiconductor Resistivity and Hall Effect Test System	165
4200-CVU-PWR	Adapter Kit	398	6220	DC Precision Current Source	133
4200-KEY-RM	Rack Mount Kit	403	6221/2182A	Complete Delta Mode System, w/AC and DC Current Source, Nanovoltmeter, and all necessary cables	133
4200-MAG-BASE	Magnetic Base	406	6221	AC and DC Current Source	133
4200-MTRX*	Ultra Low Noise SMU Triax Cable	377	6430	Sub-femtoamp Remote SourceMeter Instrument	51
4200-PA	Remote PreAmp Option for 4200-SMU and 4210-SMU	59	6482	Dual-Channel Picoammeter/Voltage Source	143
4200-PCT-x	Parametric Curve Tracer Configurations	57, 72, 90	6485	Picoammeter	146
4200-PRB-C	SMA to SSMC Y Adapter Cable	377	6487	Picoammeter/Voltage Source	149
4200-RM	Fixed Rack Mount Kit	403	6514	Programmable Electrometer	156
4200-RPC*	Remote PreAmp Cable	377	6517B	Electrometer/High Resistance Meter	161
4200-SCS	Parameter Analyzer	55, 58	6517B-ILC-3	Interlock Cable	378
4200-TMB	Triax Mounting Bracket	406	6517-ILC-3	Interlock Cable	378
4200-TRX*	Ultra Low Noise PreAmp Triax Cable	377	6517-RH	Humidity Probe	370
4200-VAC-BASE	Vacuum Base	406	6517-TP	Thermocouple Bead Probe	371
4210-CVU	Integrated C-V Instrument	60	6521	Low Current, 10-channel Scanner Card (for Model 6517B)	164
4210-MMPC-C	Multi-measurement Cable Set	62, 398	6522	Low Current, High Impedance Voltage, High Resistance, 10-channel Scanner Card (for Model 6517B)	164
4210-MMPC-S	Multi-measurement Cable Set	62, 398	7001	80-channel Switch/Control Mainframe	210
4210-SMU	High Power Source-Measure Unit	59	7001-PNL	Blank Panel for Model 7001	392
4220-PGU	High Voltage Pulse Generator	59	7002	400-channel Switch/Control Mainframe	212
4225-PMU	Ultra-Fast I-V Module	61	7002-RMK-1	Fixed Rack Mount Kit	405
4225-RPM	Remote Amplifier/Switch	59	7002-RMK-2	Slide Rack Mount Kit	405
4288-1	Fixed Rack Mount Kit	403	7006*	Single-Shielded GPIB Cable	408
4288-2	Fixed Rack Mount Kit	403	7007*	Double-Shielded Premium GPIB Cable	408
4288-4	Fixed Rack Mount Kit	403	7009-5	Shielded RS-232 Cable	378
4288-5	Fixed Rack Mount Kit	403	7010	Shielded IEEE-to-IEEE Adapter	408
4288-7	Rear Support Mount Kit	404	7011-C	Quad 1x10 Multiplexer with 96-pin Mass Terminated Connector Board	216
4288-9	Fixed Rack Mount Kit	404	7011-KIT-R	96-pin Female DIN Connector	392
4288-10	Rear Support Mount Kit	404	7011-MTC-1	1m (3.3 ft) Mass Terminated Cable Assembly	378
4299-1	Heavy Duty, Single Rack Mount Kit	404	7011-S	Quad 1x10 Multiplexer with Screw Terminal Connector Board	216
4299-2	Heavy Duty, Dual Rack Mount Kit	404	7011-ST	Extra Quick Disconnect Screw Terminal Board	392
4299-3	Universal Single Unit Rack Mount Kit	404, 405	7012-C	4x10, 2-Pole Matrix with 96-pin Mass Terminated Connector Board	217
4299-4	Universal Dual Unit Rack Mount Kit	404	7012-S	4x10, 2-Pole Matrix with Screw Terminal Connector Board	217
4299-5	1U Vent Panel	405	7012-ST	Extra Quick Disconnect Screw Terminal Board	392
4299-7	Universal Fixed Rack Mount Kit	405	7013-C	20-channel, 2-pole Independent Switch with 96-pin Mass Terminated Connector Board	218
4299-8	Single Fixed Rack-Mount Kit	405	7013-S	20-channel, 2-pole Independent Switch with Screw Terminal Connector Board	218
4299-9	Dual Fixed Rack-Mount Kit	405	7013-ST	Extra Quick Disconnect Screw Terminal Board	392
4299-10	Dual Fixed Rack-Mount Kit	405	7015-C	40-channel, 2-pole Independent Switch with 96-pin Mass Terminated Connector Board	218
4299-11	Dual Fixed Rack-Mount Kit	405	7015-S	40-channel, 2-pole Independent Switch with Screw Terminal Connector Board	218
4801	Low Noise Coax Cable	377	7015-ST	Extra Quick Disconnect Screw Terminal Board	392
4802-10	Low Noise Coax Cable	377	7018-C	Quad 1x10 Multiplexer with 96-pin Mass Terminated Connector Board	219
4803	Low Noise Coax Cable Kit	377			
4851	BNC Shorting Plug	392			
5804	Test Lead Set	369			
5805	Kelvin Probes	370			
5806	Kelvin Clip Lead Set	370			
5807-7	Helical Spring Point Test Leads	370			
5808	Low Cost, Single Pin, Kelvin Probes	370			
5809	Low Cost, Kelvin Clip Lead Set	370			
6011	2-slot Triax Cable	378			

1.888.KEITHLEY (U.S. only)

www.keithley.com

KEITHLEY

A Greater Measure of Confidence

A Tektronix Company

7018-S	Dual 1×14 Multiplexer with Screw Terminal Connector Board	219	7701	32-channel, Differential Multiplexer Module	287
7018-ST	Extra Quick Disconnect Screw Terminal Board	393	7702	40-channel Differential Multiplexer Module with Screw Terminals	288
7019C-MTCL-2	6-wire Kelvin Extender and Instrument Cable	378	7703	32-channel, High Speed, Differential Multiplexer Module	289
7020-D	Digital I/O Card with D-sub Connectors	220	7703-306A	DB50 Male Connector Kit (solder cup) with Shell	394
7020	Digital I/O Card with 96-pin Mass Terminated Connector Board	220	7705	40-channel, Single-pole Control Module	290
7020-MTC-2	2m (6.6 ft) Mass Terminated Cable Assembly	378	7705-MTC-2	2m (6.6 ft) 50-conductor Male to Female D-sub Cable Assembly	381
7024-*	2-slot Triax Cable	379	7706	All-in-One I/O Module	291
7025-10	2-slot Triax Cable	379	7707	32-channel Digital I/O Module with 10-channel Differential Multiplexer	292
7035	9 Bank 1×4 Multiplexer Switching Card	219	7707-MTC-2	2m (6.6 ft) 25-conductor Male to Female D-sub Cable Assembly	381
7035-MTC-2	2m (6.6 ft) Mass Terminated Cable Assembly	379	7708	40-channel Differential Multiplexer Module with Automatic CJC and Screw Terminals	293
7036-MTC-2	2m (6.6 ft) Mass Terminated Cable Assembly	379	7709	6×8 Matrix Module	294
7036	Single-Pole Relay Card	221	7709-308A	DB25 Male Connector Kit (solder cup) with Shell	394
7037-D	Single-Pole Relay Digital I/O Card with D-Sub Connectors	221	7710	20-channel Solid-state Differential Multiplexer Module	295
7051-*	General Purpose BNC to BNC Cable	379	7711	2GHz 50Ω RF Module	296
7053	10-channel High Current Scanner with Screw Terminal Connections	222	7711-BNC-SMA	Male SMA to Female BNC Cables	381
7065	Hall Effect Card	223	7712	3.5GHz 50Ω RF Module	297
7072	8×12 Semiconductor Matrix Card	232	7712-SMA-1	SMA Cable, Male to Male, 1m (3.3 ft)	381
7072-HV	8×12 High Voltage Semiconductor Matrix Card	233	7712-SMA-N	Female SMA to Male N-Type Adapter	394
7072-TRT	Triax Removal Tool	393	7751	High Voltage Source/Switch Module	305
7074-CIT	Contact Extraction Tool	393	7752	Low Voltage, Current-Source-Only Source/Switch Module	305
7078-CIT	Contact Insertion and Extraction Tool	393	7753	1MΩ High Voltage Source/Switch Module	305
7078-DIN	1.8m (6 ft) Cable	379	7754-3	BNC to Alligator Cable: 0.9m (3 ft)	381
7078-HCT	Contact Crimping Pliers	393	7755	50Ω Feed-Through Terminator	394
7078-KIT	38-pin Plug Assembly	393	7788	50-pin D Subminiature Connector Kit	395
7078-MTC-5	1.5m (5 ft) Mass Terminated Cable Assembly	380	7789	50-pin/25-pin (both male) D-Shell Kit	395
7078-MTR	38-pin Bulkhead Mount Receptacle	393	7790	50-pin Male, 50-pin Female, 25-pin Male IDC D-Shell Connector Kit	395
7078-TRX-*	3-slot Triax Cable	380	8007-GND-3	Safety Ground Wire	381
7078-TRX-6IN	3-slot Triax Cable	380	8009	Resistivity Chamber	399
7078-TRX-BNC	3-slot Male Triax to BNC Adapter	393	8010-CTB	Customizable Test Board	406
7078-TRX-GND	3-slot Male Triax to BNC Adapter	393	8010-DTB-220	Device Test Board with TO-220 Socket (1.5kV)	406
7078-TRX-TBC	3-lug Female Triax Bulkhead Connector	394	8010-DTB	Device Test Board for TO-247 Devices (3kV, 100A)	406
7079	Slide Rack Mount Kit	405	8011	Test Socket Kit	400
7111-S	Quad 1×10 Form C Multiplexer with Screw Terminal Connector Board	216	8020	High Power Interface Panel	92
7152	4×5 Low Current Matrix Card	222	8101-4TRX	4-pin Transistor Fixture	400
7152-HCT	Contact Crimping Pliers	394	8101-PIV	DC and Pulse I-V Demo Fixture	400
7152-KIT	6-pin Plug Assembly with Strain Relief and Contacts	394	8501-*	Trigger Link Cable	401
7152-MTC-*	Five Low Noise Triax Cables	380	8503	DIN-to-BNC Trigger Cable	401
7152-MTR	6-pin Bulkhead Mount Receptacle	394	8505	Male to 2 Female Y-DIN Cable	401
7152-TRX-10	Five 3m (10 ft) Low Noise Triax Cables	380	8530	Centronics Adapter	408
7153	4×5 High Voltage Low Current Matrix Card	224	8542-301	1.8m (6 ft) LIV Test System Cable	381
7153-TRX	2m (6.6 ft) Low Noise Cable Assembly	380	8544	Butterfly Telecom Laser Diode Mount Bundle with 8542-301 and CA-321-1 cables	119
7154	High Voltage Scanner Card	224	8544-TEC	Butterfly Telecom Laser Diode Mount Bundle with TEC, thermistor, and AD592CN temperature sensor, with 8542-301 and CA-322-1 cables	119
7158	Low Current Scanner Card	225	8605	High Performance Modular Test Leads	371
7168	8-channel Nanovolt Scanner Card	225	8606	High Performance Modular Probe Kit	371
7173-50	4×12, High Frequency Two-pole Matrix Card	234	8607	1kV Source Banana Cable Set	382
7173-50-CSEP	Cable Set	381	8608	High Performance Clip Lead Set	371
7174A	8×12 High Speed, Low Current Matrix	235			
7401	Type K Thermocouple Wire	371			
7700	20-channel, Differential Multiplexer Module w/Automatic CJC and Screw Terminals	286			

Index

Model Numbers

8608	High Performance Clip Lead Set.....	371
8610	Low Thermal Shorting Plug.....	395
8620	Four-Wire DMM Shorting Plug.....	395
8680	RTD Probe Adapter.....	395
8681	Low Cost RTD.....	371
A		
ACS-2600-RTM	Wafer Level Reliability option to ACS.....	89
ACS Basic Edition		
	Semiconductor Parametric Test Software for Component and Discrete Devices.....	87
B		
BG-18	Dual Banana to BNC Coaxial Adapter.....	395
C		
CA-18-1	1.2m (4 ft) Shielded Cable, Dual Banana Plug.....	382
CA-19-2	RG58 Cable, 1.5m (5 ft).....	382
CA-109A	Test Lead Set.....	371
CA-126-1	Digital I/O Cable, 1.5m (5 ft).....	382
CA-180-3A	CAT5 Crossover Cable.....	382
CA-321-1	Temperature Control Cable.....	382
CA-322-1	Dual Temperature Control Cable.....	382
CA-404B	RG188 Coax Cable, 2m (6.5 ft).....	382
CA-405B	RG188 Coax Cable, 15cm (6 in).....	382
CA-406B	RG188 Coax Cable, 33cm (13 in).....	382
CA-446A	Coax Cable, 3m (9.8 ft).....	383
CA-447A	Coax Cable, 1.5m (4.9 ft).....	383
CA-451A	RG188 Coax Cable, 10.8cm (4.25 in).....	383
CA-452A	RG188 Coax Cable, 20.4cm (8 in).....	383
CA-557-*	8-pin Male to 8-pin Male Cable Assembly.....	383
CA-558-2	25-pin DSUB Interlock Cable.....	383
CA-559-0A	Banana to Banana Jumper (102mm).....	383
CA-559-2A	Banana to Banana Jumper (102mm).....	383
CA-561-0A	Banana to Banana Jumper (305mm).....	383
CA-561-2A	Banana to Banana Jumper (305mm).....	383
CA-563C	BNC to Banana Jumper (240mm).....	384
CA-568-xA	Protective Earth Safety Ground Cable with Eye Lugs.....	384
CAP-18	Protective Shield/Cap for BNC Connectors.....	395
CAP-31	Protective Shield/Cap for 3-lug Triax Connectors.....	395
CS-400	DB25 Male Solder Cup.....	395
CS-458	Interlock Connector Kit.....	396
CS-565	BNC Barrel.....	396
CS-630	3-lug Female Triax Bulkhead Connector.....	396
CS-631	3-slot Male Triax Cable Mount Connector.....	396
CS-701	BNC Tee Adapter.....	396
CS-719	3-lug Triax Jack Receptacle.....	396
CS-846	Eight Position Connector with Screw Terminals.....	396
CS-1247	SMA Female to BNC Male Adapter.....	396
CS-1249	SMA Female to SMB Plug Adapter.....	396
CS-1251	BNC Female to SMB Plug Adapter.....	396
CS-1252	SMA Male to BNC Female Adapter.....	396
CS-1281	SMA Female to SMA Female Adapter.....	396
CS-1305	Interlock Connector.....	397
CS-1390	Male LEMO Triax to Female SMA Adapter.....	397

CS-1391	SMA Tee Adapter.....	397
CS-1423-3	Miniature Mating Connector.....	397
CS-1479	SMA Male to BNC Male Adapter.....	397
CS-1592-2	2-pin Male Screw Terminal Connector Plug.....	397
CS-1626-2	2-pin Female Screw Terminal Connector Block.....	397
CS-1629-8	8-pin Female Cable Termination Block.....	397
CS-1638-12	12-pin Rear Panel Output Connector.....	397
CS-1655-15	15-pin Rear Panel Output Connector.....	397
E		
EM-50A	Modified Power Splitter.....	406
ExcelINX-1A	Excel Add-In.....	299
H		
HV-CA-554-x	High Voltage Triax to Triax Cable (3kV rated).....	384
HV-CA-571-3	High Voltage Triax to Unterminated Cable.....	384
HV-CS-1613	High Voltage Triax Feed Through Connector/Barrel (female to female) (3kV rated).....	397
K		
KPCI-488LPA	IEEE-488.2 Interface Board for the PCI Bus.....	407
KUSB-488B	IEEE-488.2 USB-to-GPIB Interface Adapter for USB Port... ..	407
L		
LR8028	Component Test Fixture.....	400
R		
RMU 2U	Basic Power Supply Rack Kit.....	405
S		
S46-SMA-0.5	SMA Cable, Male to Male, 0.15m (0.5 ft).....	384
S46-SMA-1	SMA Cable, Male to Male, 0.3m (1 ft).....	384
S500	Integrated Test System.....	82
S530	Parametric Test Systems.....	76
SC-9	Low Noise Coax Cable.....	384
SC-22	Low Noise Triax Cable.....	384
SC-93	Low Thermal, 2-Conductor Shielded Cable.....	385
SC-182	Low Inductance Coaxial Cable.....	385
SC-200	Shielded Twisted Pair Cable.....	385
Series 2200	Programmable DC Power Supplies.....	315
Series 2260B	360W and 720W Programmable DC Power Supplies.....	319
Series 2280S	Precision Measurement, Low Noise, Programmable DC Power Supplies.....	323
Series 2290	High Voltage Power Supplies.....	362
Series 2400	SourceMeter Line.....	43, 108
Series 2600B	System SourceMeter® SMU (Source-Measure Unit) Instruments.....	10
Series 3700A	System Switch/Multimeter and Plug-In Cards.....	174
SHV-CA-553-x	High Voltage Triax to SHV Cable.....	384
System 25	Laser Diode Test System Kit.....	105
System 46	RF/Microwave Switch System, 32 Channels, Unterminated .	236
System 46T	RF/Microwave Switch System, 32 Channels, Terminated . . .	239
T		
TL-24	SMA Torque Wrench.....	397
U		
USB-B-1	USB Cable, 1m (3.3 ft).....	385

1.888.KEITHLEY (U.S. only)

www.keithley.com

KEITHLEY

A Greater Measure of Confidence

A Tektronix Company

Technical Support Web Forums

24/7 online assistance for your product support and applications questions

- **Application Forum** – Submit questions to experienced Keithley applications engineers at any time.
- **Discussions** – Join ongoing discussions and add your suggestions, comments, and stories.
- **Archive** – Search previous questions similar to yours and read how they were answered.
- **How-to Videos** – View step-by-step videos on demand and as often as you need at www.youtube.com/KeithleyInst

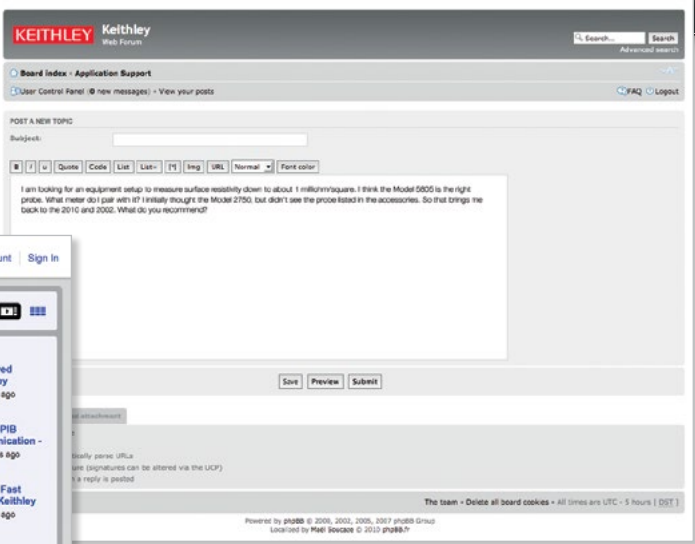
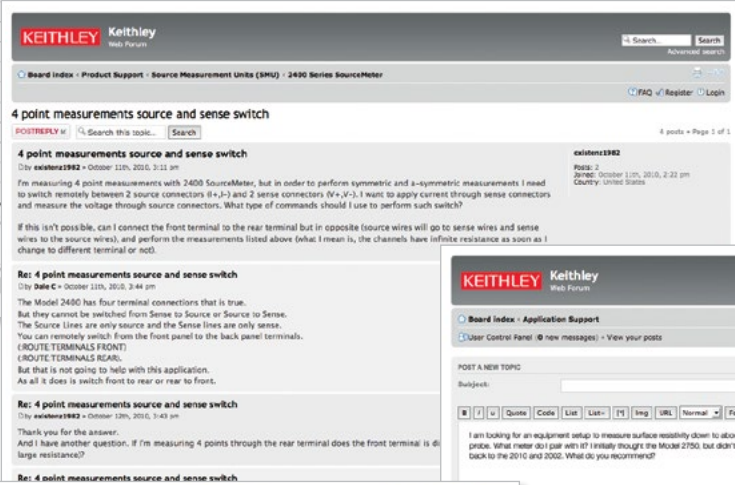
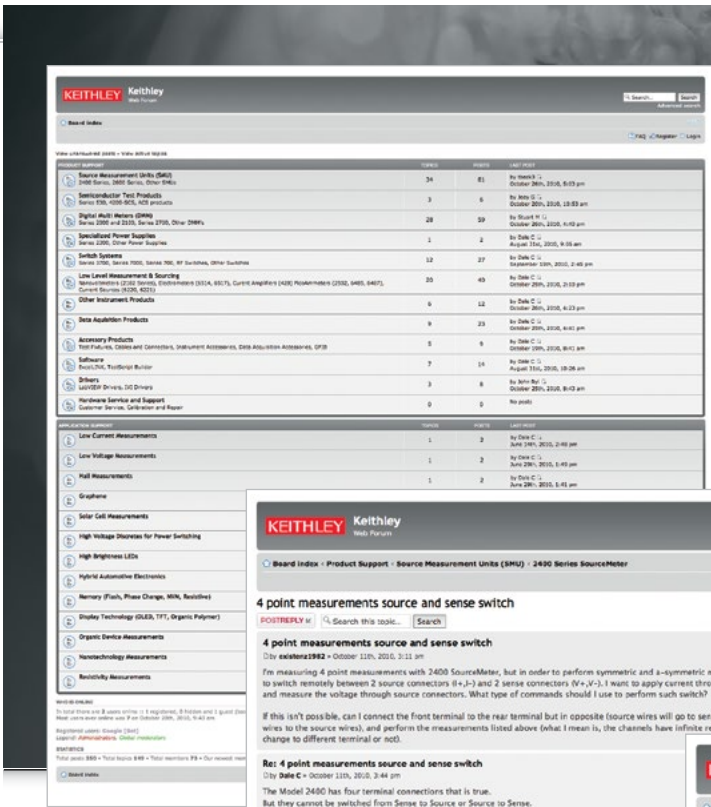

Other information resources

Access a 24/7 online library of web based seminars and literature, including applications notes, articles, handbooks, white papers, and more.

1.888.KEITHLEY (U.S. only)

www.keithley.com



A Greater Measure of Confidence

A Tektronix Company

SourceMeter® SMU Instruments

Selector Guide

Series 2600B

2601B

2602B

2604B

2611B

2612B

2614B

2634B

2635B

2636B

2651A

2657A

2450

Series 2400

2400

2401

2410

2420

2425

2430

2440

6430

4200-SCS

Technical Information	2
Source Measure Unit (SMU) Instruments	8
System SourceMeter Multi-Channel I-V Test Solutions	10
Single-Channel System SourceMeter SMU Instrument (3A DC, 10A Pulse)	
Dual-Channel System SourceMeter SMU Instrument (3A DC, 10A Pulse)	
Dual-Channel System SourceMeter SMU Instrument (3A DC, 10A Pulse, Benchtop Version)	
Single-Channel System SourceMeter SMU Instrument (200V, 10A Pulse)	
Dual-Channel System SourceMeter SMU Instrument (200V, 10A Pulse)	
Dual-Channel System SourceMeter SMU Instrument (200V, 10A Pulse, Benchtop Version)	
Dual-Channel System SourceMeter SMU Instrument (1fA, 10A Pulse, Benchtop Version)	
Single-Channel System SourceMeter SMU Instrument (0.1fA, 10A Pulse)	
Dual-Channel System SourceMeter SMU Instrument (0.1fA, 10A Pulse)	
High Power System SourceMeter SMU Instrument	25
High Power System SourceMeter SMU Instrument	32
SourceMeter SMU Instrument	36
SourceMeter SMU Instruments	43
General-Purpose SourceMeter SMU Instrument	
21V SourceMeter SMU Instrument	
High Voltage SourceMeter SMU Instrument	
High Current SourceMeter SMU Instrument	
100W SourceMeter SMU Instrument	
1kW Pulse Mode SourceMeter SMU Instrument	
5A SourceMeter SMU Instrument	
Sub-Femtoamp Remote SourceMeter SMU Instrument	51
Parameter Analyzer	55

Technical Information

All of Keithley's source measure unit (SMU) instruments can source voltage while measuring current and source current while measuring voltage. Some also measure resistance. All are fully programmable instruments that can stand alone as complete source, measurement, and automation solutions. They are also easy to integrate into larger systems.

Keithley's SMU instruments are faster, easier to use, and more economical than using individual power supplies and measurement instruments that are harnessed together. Additionally, they provide more accurate and repeatable results. Keithley's SMU instruments are ideal for production and automation, yet precise and sensitive enough for laboratory applications.

Keithley's SMU instruments include our Series 2400 SourceMeter[®] SMU instruments, Series 2600B System SourceMeter SMU instruments, and Model 4200-SCS Semiconductor Characterization System.

How does an SMU instrument work?

SMU instruments can be used as stand-alone constant voltage or constant current sources and as stand-alone voltmeters or ammeters. However, their real strength is their ability to simultaneously source and measure—applying voltage to a device under test (load) and measuring the current flowing through it, or supplying current to a load and measuring the voltage drop across it.

The SMU instrument topology (Figure 1) protects the device under test (DUT) from damage due to accidental overloads, thermal runaway, and other problems. Both the current and voltage source are programmable with readback to maximize device measurement integrity. If the readback reaches a programmed compliance limit, then the source is clamped at the limit, providing fault protection.

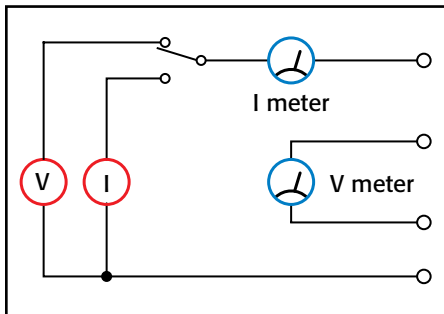

Figure 1. Basic SMU instrument topology

SourceMeter[®] SMU Instruments

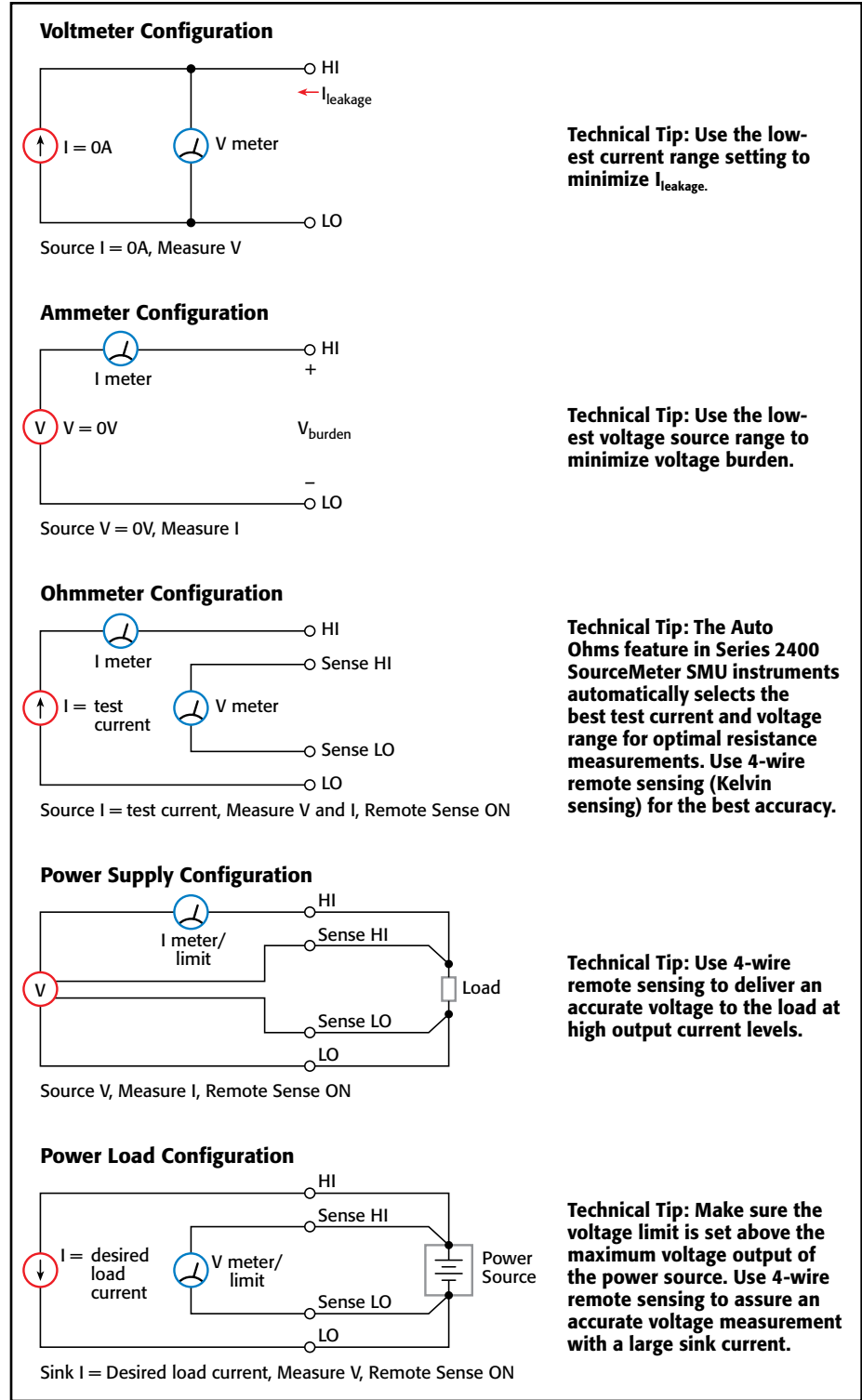

Figure 2. SMU instrument configurations

1.888.KEITHLEY (U.S. only)

www.keithley.com

KEITHLEY
 A Tektronix Company

A Greater Measure of Confidence

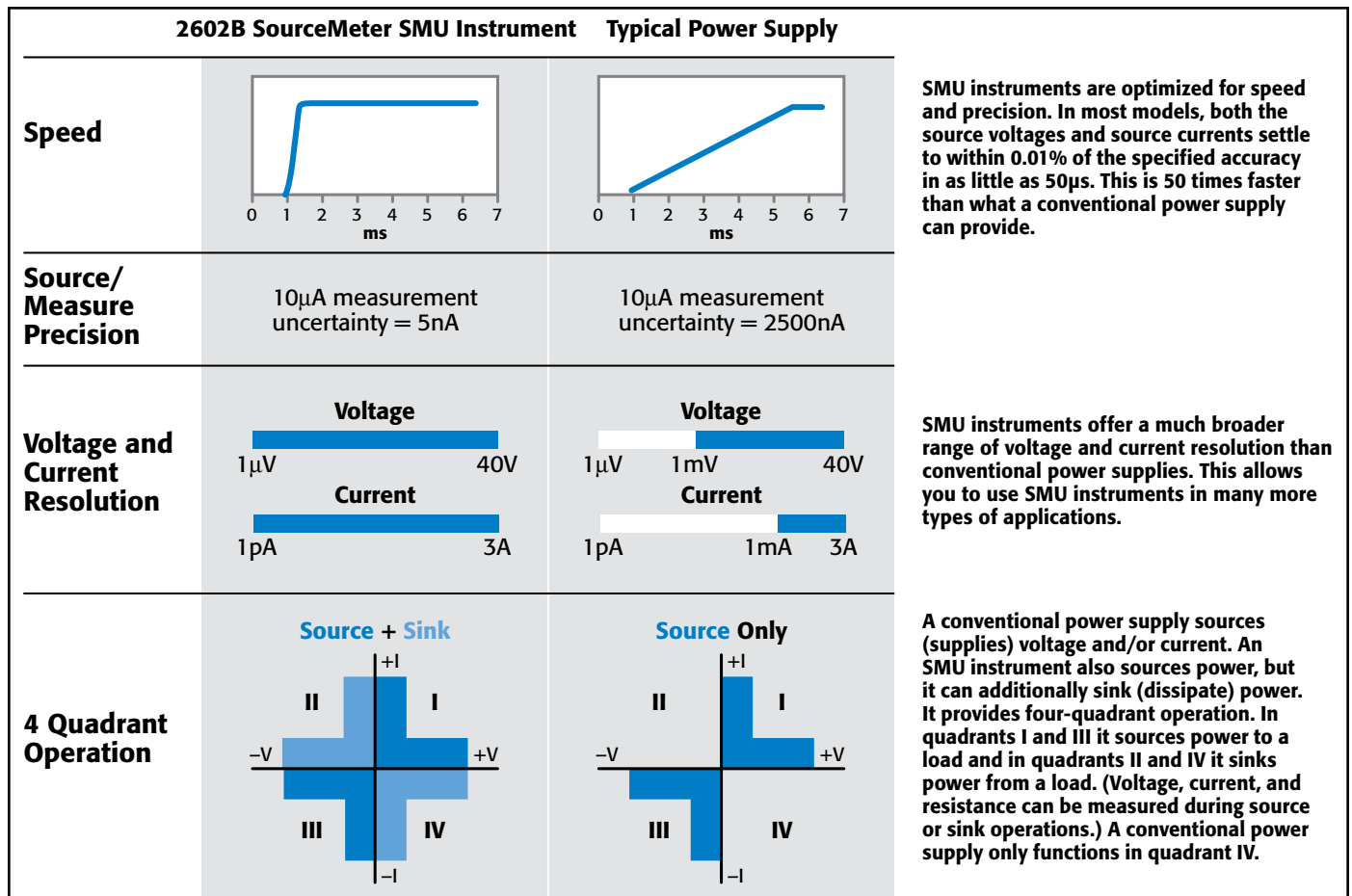

SMU instruments are optimized for speed and precision. In most models, both the source voltages and source currents settle to within 0.01% of the specified accuracy in as little as 50 μ s. This is 50 times faster than what a conventional power supply can provide.

SMU instruments offer a much broader range of voltage and current resolution than conventional power supplies. This allows you to use SMU instruments in many more types of applications.

A conventional power supply sources (supplies) voltage and/or current. An SMU instrument also sources power, but it can additionally sink (dissipate) power. It provides four-quadrant operation. In quadrants I and III it sources power to a load and in quadrants II and IV it sinks power from a load. (Voltage, current, and resistance can be measured during source or sink operations.) A conventional power supply only functions in quadrant IV.

Figure 3. Precision power supplies vs. SMU instruments

Advantages

Many advantages are achieved by combining source and measurement circuitry into a single unit:

- Supports faster test times with improved accuracy and repeatability
- Allows you to source voltage or current while making time-stamped voltage, current, and resistance measurements without changing connections
- Eliminates many of the complex synchronization, connection, and programming issues associated with using multiple instruments
- Minimizes the time required for test station development, setup, and maintenance
- Lowers the overall cost of system ownership

What are the most popular SMU instrument configurations?

The fully isolated, floating configuration of Keithley's SMU instruments provide maximum flexibility in configuring test setups. SMU instruments can be configured as many different instruments (Figure 2). This makes them invaluable tools in flexible product test racks and in R&D test bench tools.

How does an SMU instrument compare to a precision power supply?

The power supply capabilities of Keithley's SMU instruments surpass those provided by conventional power supplies. This is illustrated in Figure 3. In addition to the highly stable DC power source, low noise, and readback, Keithley's SMU instruments include other features not usually available on conventional power supplies. For example, most SMU instru-

ments offer a Pulse mode, include programmable delays, and provide a test sequencer that allows you to set up and execute tests without PC intervention. Figure 4 illustrates a typical precision power supply test that uses an SMU instrument.

I-V characterization

Keithley's SMU instruments are core instruments for I-V characterization tests. Their ability to source voltage while simultaneously measuring current or source current while simultaneously measuring voltage can be combined with both DC and sweep operations to perform measurements such as forward voltage (V_F), reverse leakage, and reverse breakdown voltage (V_B) without changing a single connection to the device under test (Figure 5).

Built-in features allow multiple SMU instruments to be synchronized for parametric measure-

1.888.KEITHLEY (U.S. only)

www.keithley.com

Technical Information

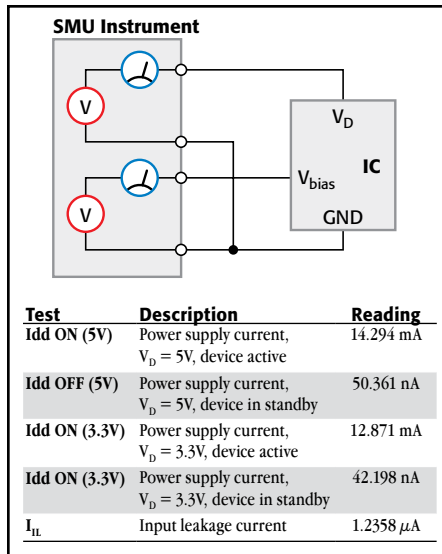

Figure 4. Typical precision power supply tests

ments like threshold voltage, beta, and transconductance. Output interlocks provide controlled access to a test fixture, which is particularly important for the extended voltage range of the Model 2657A (up to 3000V). Guarded 4-wire connections provide high quality measurements over a wide range (0.1fA to 10A).

A family of semiconductor curves can be obtained with just two SMU instruments (Figure 6). At each step of base current from SMU1, SMU2 sweeps V_{CE} and measures I_C . An SMU instrument can store data from a sweep in its buffer, thus reducing data transfer time to a computer. A family of curves could also be produced using pulse-sweeps to reduce power dissipation within a device.

Built-In Sweeps

Keithley's SMU instruments simplify capturing the data needed to characterize a wide range of devices with the SMU instruments' built-in pulsed and DC sweeps, including linear staircase, logarithmic staircase, and custom sweeps (Figure 7). Sweeps coupled with other throughput enhancements like built-in limit inspection, digital I/O, and a component handling interface are ideal for high speed, nonstop production environments. All sweep configurations can be programmed for single-event or continuous operation.

SourceMeter® SMU Instruments

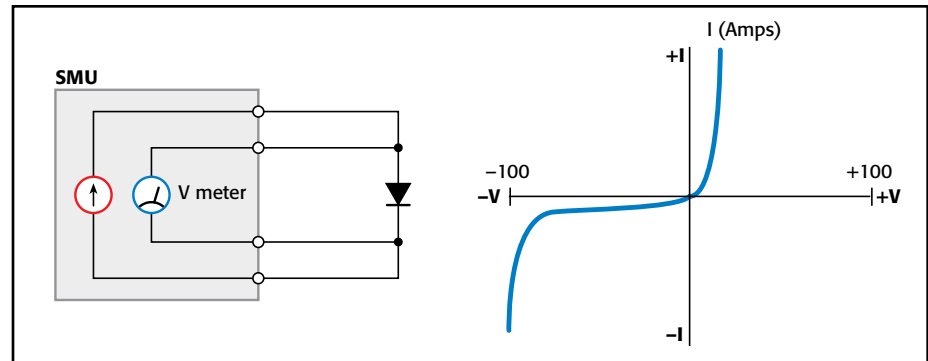

Figure 5. Typical diode characterization

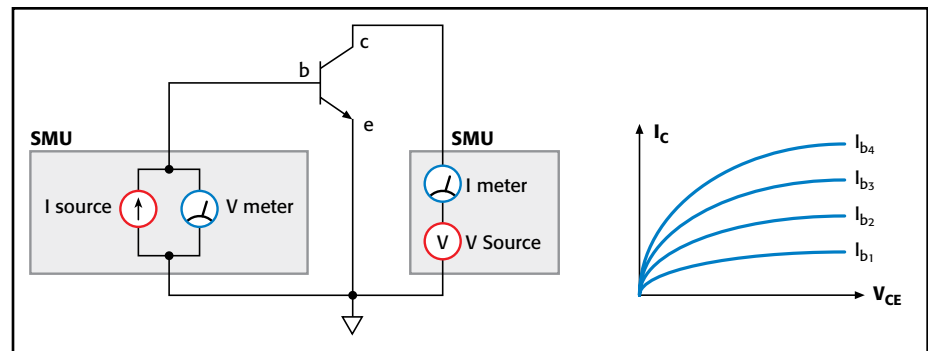

Figure 6. Typical family of curves for transistors

Instrumentation and software solutions for I-V characterization

Figure 8 illustrates various hardware and software solutions for I-V characterization. In the first example, Series 2400 SourceMeter SMU instruments are connected to a PC.

In the second example, selected Series 2600B SourceMeter SMU instruments are connected with TSP-Link Technology technology. TSP-Link Technology seamlessly integrates multiple Series 2600B SMU instruments into a single system that can be programmed and controlled as a single instrument through the master 2600B SMU instrument or the PC.

The third example is the Model 4200-SCS Parameter Analyzer. This system includes an embedded PC, Windows® operating system, and mass storage. It is a complete DC characterization solution for semiconductor devices and test structures. It supports up to nine SMU modules and provides an array of Windows based software that is so intuitive that even a novice can use the system with ease. This point-and-click software supplies a full range of functionality,

including: managing tests, generating reports, automating test sequencing, and creating user libraries. The Model 4200-SCS is a complete one box solution that combines sub-femtoamp resolution with real-time plotting and analysis. Key capabilities include instrument and prober drivers, interfaces to popular modeling/circuit simulation software, and WLR test capabilities.

High-Speed I-V Functional Testing

Keithley's SMU instruments are designed for maximum throughput on the production floor. Each SMU instrument provides high-speed measurements, an internal pass/fail comparator, programmable test sequencing, and digital I/O to control material handlers (Figure 9). Single- or multi-point pass/fail testing can be performed on a wide range of components, such as: network devices, circuit protection devices, active discrete devices, and sensors. The onboard pass/fail comparator simplifies high-speed pass/fail tests by avoiding the delay caused by computer and GPIB bus interaction. The buffer memory stores results, again avoiding the computer/GPIB bus interaction delay.

1.888.KEITHLEY (U.S. only)

www.keithley.com

KEITHLEY
A Tektronix Company

A Greater Measure of Confidence

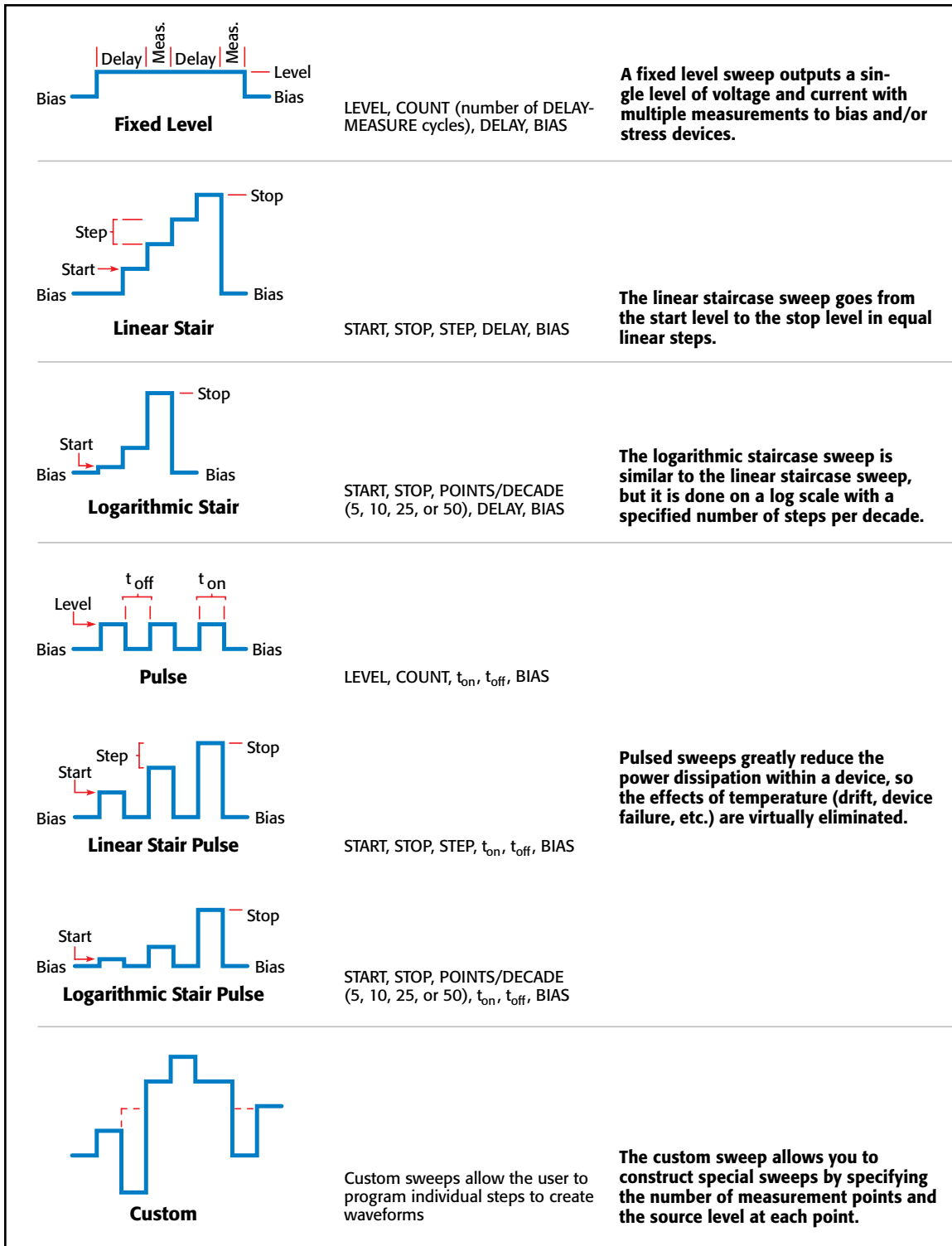

Figure 7. Various sweeps supported by SMU instruments.

1.888.KEITHLEY (U.S. only)

www.keithley.com

A Greater Measure of Confidence

KEITHLEY
A Tektronix Company

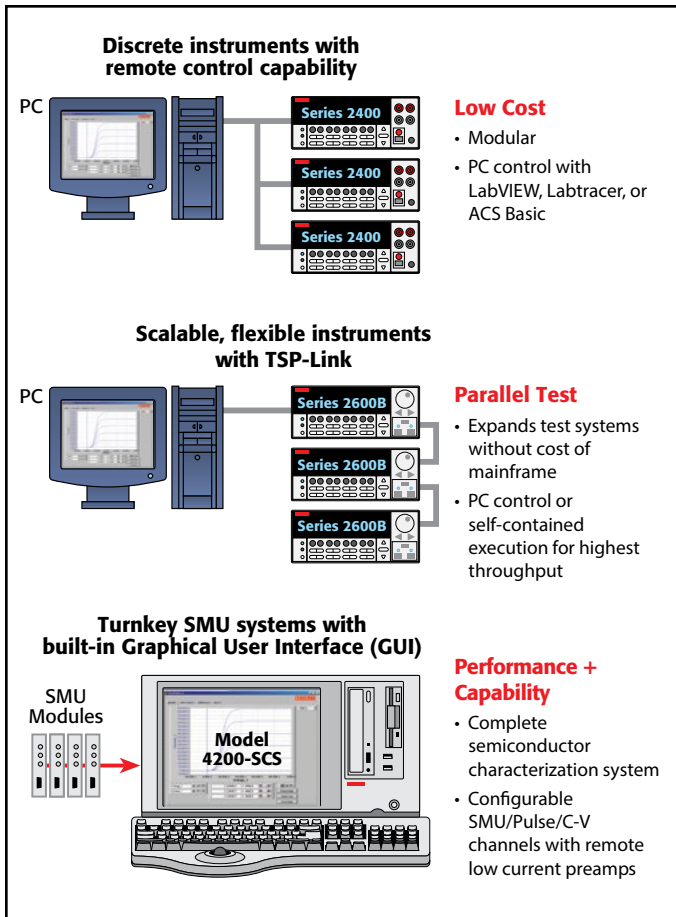

Figure 8. Examples of I-V characterization solutions

Need more test pins?

Keithley's new TSP-Link Technology is a high speed interface for system expansion. It allows you to connect a virtually unlimited number of Series 2600B SourceMeter SMU instruments in a master/slave configuration (Figure 10). All connected Series 2600B SMU instruments can be programmed and operated under the control of the master instrument. TSP-Link Technology provides an easy way to scale your system's channel count up or down to match changing application needs. There is no chassis involved.

In Series 2400 SourceMeter SMU instruments, Trigger Link can be used to coordinate multiple instruments with hardware triggers.

Parallel test capability

Series 2600B SMU instruments support true parallel testing. Each 2600B in a system can run its own test sequences, so the number of devices that can be tested in parallel is equivalent to the number of 2600B SMU instruments in the system. Parallel testing coupled with the 20,000 rdgs/s of each 2600B creates a system that offers extremely high throughput.

Advanced automation for system throughput

Series 2600B TSP® Technology

Any Series 2600B SMU instrument or 2600B-based system can run high speed, embedded test scripts with Test Script Processor (TSP) technology. TSP technology eliminates more than 90% of GPIB/LAN traffic and performs advanced tests without PC intervention (Figure 11). TSP test scripts allow throughput gains of up to 10× over equivalent PC-based programs controlling the same instruments via GPIB. TSP test scripts can be loaded and run from the front panel or over the system's GPIB interface. A single TSP test script, running on the master 2600B unit, can control all Series 2600B channels and acquire data from any Series 2600B SMU instrument connected to the system with TSP-Link Technology.

A Series 2600B-based system can stand alone as a complete measurement and automation solution for semiconductor device or component testing with the master 2600B unit controlling sourcing, measurements, pass/fail decisions, test sequence flow control, binning, the component handler, prober, and much more.

Source-Memory List

The Source-Memory List in Series 2400 SourceMeter SMU instruments, now available in emulation mode on Series 2600B SourceMeter SMU instruments, is a key feature for production testing. This programmable sequencer lets you set up a complete sequence of up to 100 tests. Each test can contain totally different test conditions, measurements, math, pass/fail, and binning criteria. The tests are executed sequentially without additional external commands. Conditional branching leads to different points on the test list, depending on the results.

The Source-Memory Sweep feature allows you to store up to 100 unique source and measure configurations in nonvolatile memory. This feature makes it possible to sweep through a group of source memory locations and execute a complete test sequence all at one time.

Digital I/O

Digital communication is one of the most common requirements of a production test system because of the need to communicate with handlers, binning equipment, and user controls. The SMU instruments' digital I/O can also be used to interact with racks of instruments to trigger events, start readings, and collect results. Digital triggering and response enable fast and reliable results that are not dependent on the communication bus in use. (Digital I/O is not available on the Model 2401, 2604B, 2614B, and 2634B.)

Contact check

The optional Contact Check function eliminates measurement errors and false product failures by verifying good connections to the DUT quickly and easily before testing begins. In just 350µs (Series 2400) or 1ms (Series 2600B), this function's verification and notification routine ensures that you have good contact to a device before sending energy through it and spending time testing it (Figure 12). (The Contact Check function is not available on Models 2401, 2604B, 2614B, and 2634B.)

Some of the problems this function can detect while verifying connector, fixture, and test harness integrity are contact fatigue, breakage, contamination, corrosion, loose or broken connections, and relay failures. If a bad contact is detected, it can abort the measurement, protecting the DUT. Three methods of fault notification are provided.

1.888.KEITHLEY (U.S. only)

www.keithley.com

KEITHLEY
A Tektronix Company

A Greater Measure of Confidence

Technical Information

SourceMeter® SMU Instruments

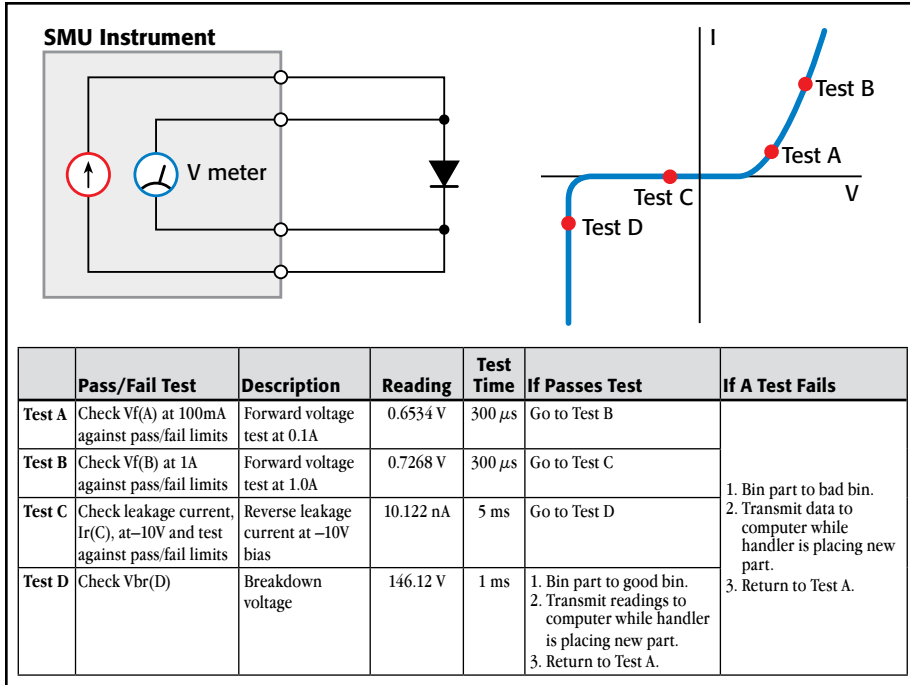

Figure 9. Typical high speed I-V functional test

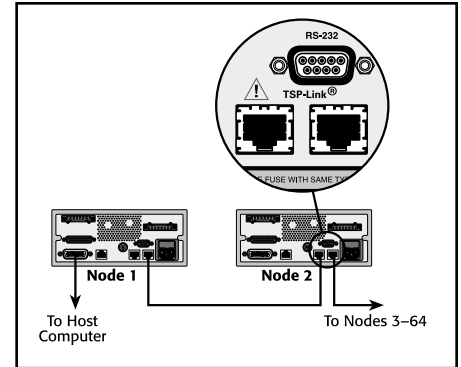

Figure 10. Series 2600B back panel

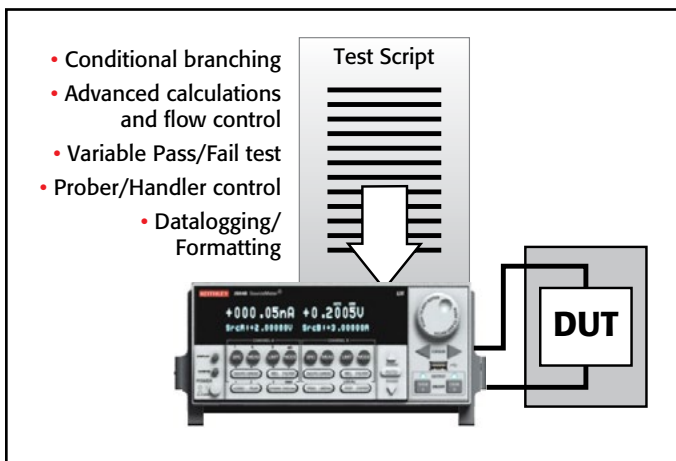

Figure 11. Series 2600B test script

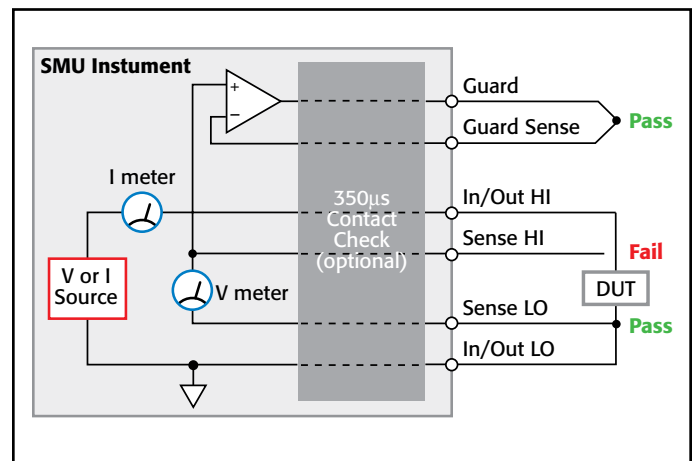

Figure 12. Series 2400 contact check

The Contact Check function was designed for high throughput 4-wire and 6-wire test applications. In Series 2400 SourceMeter SMU instruments, three reference value choices (2 Ω , 15 Ω , and 50 Ω) are supplied. If the resistance of good connections normally exceeds 50 Ω , then the built-in

contact check function is not suitable for that application and alternative approaches should be considered. Series 2600B SMU instruments provide more flexibility with programmable values.

1.888.KEITHLEY (U.S. only)

www.keithley.com

A Greater Measure of Confidence

KEITHLEY
A Tektronix Company

Selector Guide

SourceMeter® SMU Instruments

20–100W BENCH SMU INSTRUMENTS

MODEL	2400, 2401 2400-C 2400-LV	2410 2410-C	2420 2420-C	2425 2425-C	2440 2440-C	2450
Page	43	43	43	43	43	36
POWER OUTPUT	22 W	22 W	66 W	110W	55 W	20 W
CURRENT CAPABILITY						
Min.	±1 pA	±1 pA	±10 pA	±10 pA	±10 pA	±10 fA
Max.	±1.05 A	±1.05 A	±3.15 A	±3.15 A	±5.25 A	±1.05 A
VOLTAGE CAPABILITY						
Min.	±100 nV	±100 nV	±100 nV	±100 nV	±100 nV	±10 nV
Max.	±21/±210 V ²	±1100 V	±63 V	±105 V	±42 V	±210 V
OHMS RANGE³	<0.2 Ω to >200 MΩ	<0.2 Ω to >200 MΩ	<0.2 Ω to >200 MΩ	<0.2 Ω to >200 MΩ	<2.0 Ω to >200 MΩ	<2.0 Ω to >200 MΩ
BASIC ACCURACY						
I	0.035%	0.035%	0.035%	0.035%	0.035%	0.020%
V	0.015%	0.015%	0.015%	0.015%	0.015%	0.012%
Ω	0.06 %	0.07 %	0.06 %	0.06 %	0.06 %	0.043%
READING SPEED	2,081 rdgs/s	2,081 rdgs/s	2,081 rdgs/s	2,081 rdgs/s	2,081 rdgs/s	3,130 rdgs/s
FEATURE SUMMARY						
Pulse Mode	No	No	No	No	No	No
Embedded Scripting/ Execution	Source-Memory List	Source-Memory List	Source-Memory List	Source-Memory List	Source-Memory List	Source-Memory List, Config List, Test Script Processor (TSP®) Technology
Contact Check	-C version	-C version	-C version	-C version	-C version	No
Selectable Front/Rear Inputs	Yes	Yes	Yes	Yes	Yes	Yes
Test Leads/Cables	Banana	Banana	Banana	Banana	Banana	Front: Banana Rear: Triax
Computer Interface	IEEE-488, RS-232	IEEE-488, RS-232	IEEE-488, RS-232	IEEE-488, RS-232	IEEE-488, RS-232	USB 2.0, LAN/LXI 1.4 Core, IEEE-488
Digital I/O	1 In/4 Out with built-in component handler interfaces (except Model 2401).	1 In/4 Out with built-in component handler interfaces.	1 In/4 Out with built-in component handler interfaces.	1 In/4 Out with built-in component handler interfaces.	1 In/4 Out with built-in component handler interfaces.	6 digital I/O-trigger lines
Other	6½-digit resolution. 6 wire ohms mode. LabView drivers.	6½-digit resolution. 6 wire ohms mode. LabView drivers.	6½-digit resolution. 6 wire ohms mode. LabView drivers.	6½-digit resolution. 6 wire ohms mode. LabView drivers.	6½-digit resolution. 6 wire ohms mode. LabView drivers.	5 inch capacitive touchscreen. 6½-digit resolution. Built-in “Quickset” configuration modes. Context-sensitive help. Scalable to 32 channels with TSP-Link Technology. KickStart out-of-the box software. LabView drivers. IVI drivers.
Compliance	CE, UL	CE	CE	CE	CE	CE, NRTL listed

1. In pulse mode.
2. Models 2401 and 2400-LV 21V max.
3. Ohms measurements on Series 2600 instruments are user-calculated.

1.888.KEITHLEY (U.S. only)

www.keithley.com

KEITHLEY

A Tektronix Company

A Greater Measure of Confidence

Selector Guide

SourceMeter® SMU Instruments

20-100W SYSTEM SMU INSTRUMENTS		100-200W POWER SMU INSTRUMENTS			LOW CURRENT SMU INSTRUMENTS	
2601B 2602B 2604B	2611B 2612B 2614B	2430 2430-C	2651A	2657A	2634B 2635B 2636B	6430
10	10	43	25	32	10	51
40 W/channel	30 W/channel	1100 W ¹	2,000W pulsed/200W DC	180 W	30 W/channel	2 W
±100 fA	±100 fA	±10 pA	±100 fA	±1 fA	±0.1 fA (2635B, 2636B) ±1 fA (2634B)	±0.01 fA
±3 A DC/10 A pulsed per channel	±1.5 A DC/10 A pulsed per channel	±10.5 A ¹	±50A (±100 A when two units are connected in parallel)	±120 mA	±1.5 A DC/10 A pulsed per channel	±105 mA
±100 nV	±100 nV	±100 nV	±100 nV	±100 nV	±100 nV	±1 μV
±40 V	±200 V	±105 V	±40 V	±3000 V	±200 V	±210 V
0.5 μΩ to 40 TΩ	0.5 μΩ to 100 TΩ	<0.2 Ω to >200 MΩ	<0.1 μΩ to 20 TΩ	<0.4 Ω to 100 PΩ	0.5 μΩ to 10 PΩ	<2.0 Ω to >20 TΩ
0.02 %	0.02 %	0.035%	0.02 %	0.02 %	0.02 %	0.035%
0.015%	0.015%	0.015%	0.015%	0.015%	0.015%	0.012%
Based on V and I range	Based on V and I range	0.06 %	Based on V and I range	Based on V and I range	Based on V and I range	0.063%
20,000 rdgs/s	20,000 rdgs/s	2,081 rdgs/s	38,500 rdgs/s and 1μs per pt digitizer	38,500 rdgs/s and 1μs per pt digitizer	20,000 rdgs/s	256 rdgs/s
Yes	Yes	Yes	Yes	Yes	Yes	No
Test Script Processor (TSP®) Technology	Test Script Processor (TSP®)	Source-Memory List	Test Script Processor (TSP®)	Test Script Processor (TSP®)	Test Script Processor (TSP®)	Source-Memory List
Yes (not available for 2604B)	Yes (not available for 2614B)	-C version	Yes	Yes	Yes (not available for 2634B)	No
Rear only	Rear only	Yes	Rear only	Rear Only	Rear only	Rear and Preamp
Screw terminal; adapters available for banana or triax	Screw terminal; adapters available for banana or triax	Banana	Screw terminal; adapters available for banana or triax	HV triax	Triax	Triax
USB 2.0, LAN/LXI-C, IEEE-488, RS-232	USB 2.0, LAN/LXI-C, IEEE-488, RS-232	IEEE-488, RS-232	LAN/LXI, IEEE-488, RS-232	LAN/LXI-C, IEEE-488, RS-232	USB 2.0, LAN/LXI, IEEE-488, RS-232	IEEE-488, RS-232
14 digital I/O-trigger lines (no digital I/O available for 2604B)	14 digital I/O-trigger lines (no digital I/O available for 2614B)	1 In/4 Out with built-in component handler interfaces (except Model 2401).	14 digital I/O trigger lines	14 digital I/O trigger lines	14 digital I/O-trigger lines (no digital I/O available for 2634B)	1 In/4 Out with built-in component handler interfaces
6½-digit resolution. Scalable to 64 channels with TSP-Link Technology (not available for 2604B). Built-in Web-based characterization software. LabView driver.	6½-digit resolution. Scalable to 64 channels with TSP-Link Technology (not available for 2614B.) Built-in Web-based characterization software. LabView driver.	6½-digit resolution. 6 wire ohms mode. LabView drivers.	6½-digit resolution. Scalable to 32 channels with TSP-Link Technology. 6 wire ohms mode. Built-in Web-based characterization software. LabView drivers.	6½-digit resolution. Scalable to 32 channels with TSP-Link Technology. 6 wire ohms mode. Built-in Web-based characterization software. LabView drivers.	6½-digit measurement resolution. Scalable to 64+ channels with TSP-Link Technology (not available for 2634B.) Built-in Web-based characterization software. LabView driver.	6½-digit resolution. 6 wire ohms mode. LabView drivers.
CE, UL	CE, UL	CE	CE, UL	CE, ETL	CE, UL	CE

Selector guide: Source Measure Unit (SMU) Instruments

SMU INSTRUMENTS

1.888.KEITHLEY (U.S. only)

www.keithley.com

KEITHLEY

A Greater Measure of Confidence

A Tektronix Company

Series 2600B

- Tightly integrated, 4-quadrant voltage/current source and measure instruments offer best in class performance with 6½-digit resolution
- Family of models offer industry's widest dynamic range: 10A pulse to 0.1fA and 200V to 100nV
- Built-in web browser based software enables remote control through any browser, on any computer, from anywhere in the world
- Compatibility with the Keithley IVy mobile app enables true plug & play I/V characterization and test through any Android device
- TSP (Test Script Processing) technology embeds complete test programs inside the instrument for best-in-class system-level throughput
- TSP-Link expansion technology for multi-channel parallel test without a mainframe
- Software emulation for Keithley's Model 2400 SourceMeter SMU Instrument
- USB 2.0, LXI-C, GPIB, RS-232, and digital I/O interfaces
- Free software drivers and development/debug tools
- Optional ACS-Basic semiconductor component characterization software

System SourceMeter® SMU Instruments



The Series 2600B System SourceMeter SMU Instruments are the industry's leading current/voltage source and measure solutions, and are built from Keithley's third generation SMU technology. The Series 2600B offers single- and dual-channel models that combine the capabilities of a precision power supply, true current source, 6½-digit DMM, arbitrary waveform generator, pulse generator, and electronic load – all into one tightly integrated instrument. The result is a powerful solution that significantly boosts productivity in applications ranging from bench-top I-V characterization through highly automated production test. Built-in web browser based software enables I-V testing through any computer from anywhere in the world. Or, use your Android smart device to perform plug & play I-V testing with fingertip control with the Keithley IVy application. For automated system applications, the Series 2600B's Test Script Processor (TSP®) runs complete test programs from inside the instrument for industry-best throughput. In larger, multi-channel applications, Keithley's TSP-Link® Technology works together with TSP Technology to enable high-speed, SMU-per-pin parallel testing. Because Series 2600B SourceMeter SMU Instruments have fully isolated channels that do not require a mainframe, they can be easily reconfigured and re-deployed as your test applications evolve.

Perform Quick I-V characterization with Android™ Devices

The Series 2600B is compatible with the Keithley IVy application that is the fastest and easiest way to perform current-voltage (I-V) characterization, troubleshoot your device under test (DUT), and share the measurement results with others. It allows you to visualize, interact with, and share measurement results without programming, while gaining a deeper understanding of your DUT. These unique capabilities boost productivity across a wide range of applications in R&D, education, QA/EA, and more.



Perform quick I-V characterization with fingertip control to gain insight into your DUT.

Series 2600B

System SourceMeter® SMU Instruments

Ordering Information

- 2601B** Single-channel System SourceMeter SMU Instrument (3A DC, 10A Pulse)
- 2602B** Dual-channel System SourceMeter SMU Instrument (3A DC, 10A Pulse)
- 2604B** Dual-channel System SourceMeter SMU Instrument (3A DC, 10A Pulse, Benchtop Version)
- 2611B** Single-channel System SourceMeter SMU Instrument (200V, 10A Pulse)
- 2612B** Dual-channel System SourceMeter SMU Instrument (200V, 10A Pulse)
- 2614B** Dual-channel System SourceMeter SMU Instrument (200V, 10A Pulse, Benchtop Version)
- 2634B** Dual-channel System SourceMeter SMU Instrument (1fA, 10A Pulse, Benchtop Version)
- 2635B** Single-channel System SourceMeter SMU Instrument (0.1fA, 10A Pulse)
- 2636B** Dual-channel System SourceMeter SMU Instrument (0.1fA, 10A Pulse)

Accessories Supplied

Operators and Programming Manuals

2600-ALG-2: Low Noise Triax Cable with Alligator Clips, 2m (6.6 ft.) (two supplied with 2634B and 2636B, one with 2635B)

2600-Kit: Screw Terminal Connector Kit (2601B/2602B/2604B/2611B/2612B/2614B)

2600B-800A: Series 2400 Emulation Script for Series 2600B (supplied on USB memory stick)

7709-308A: Digital I/O Connector

CA-180-3A: TSP-Link/Ethernet Cable (two per unit)

TSP Express Software Tool (embedded)

Test Script Builder Software (supplied on CD)

LabVIEW Driver (supplied on CD)

ACS Basic Edition Software (optional)

Unmatched Throughput for Automated Test with TSP Technology

For test applications that demand the highest levels of automation and throughput, the Model 2600B's TSP technology delivers industry-best performance. TSP technology goes far beyond traditional test command sequencers... it fully embeds then executes complete test programs from within the SMU instrument itself. This virtually eliminates all the time-consuming bus communications to and from the PC controller, and thus dramatically improves overall test times.

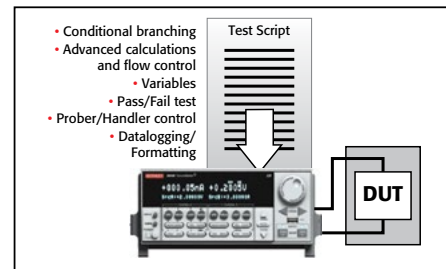

TSP technology executes complete test programs from the 2600B's non-volatile memory.

SMU-Per-Pin Parallel Testing with TSP-Link Technology

TSP-Link is a channel expansion bus that enables multiple Series 2600B's to be inter-connected and function as a single, tightly-synchronized, multi-channel system. The 2600B's TSP-Link Technology works together with its TSP technology to enable high-speed, SMU-per-pin parallel testing. Unlike other high-speed solutions such as large ATE systems, the 2600B achieves parallel test performance without the cost or burden of a mainframe. The TSP-Link based system also enables superior flexibility, allowing for quick and easy system re-configuration as test requirements change.

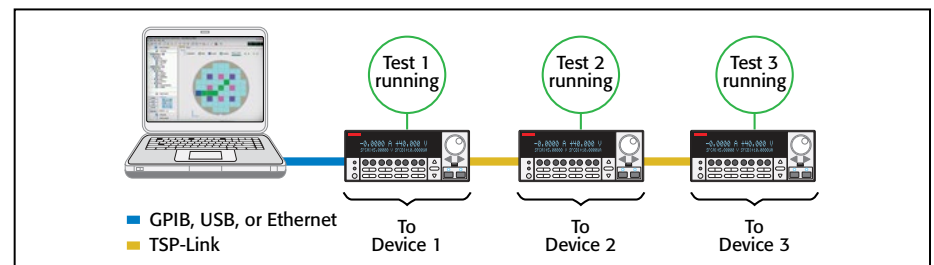

SMU-Per-Pin Parallel Testing using TSP and TSP-Link improves test throughput and lowers the cost of test.

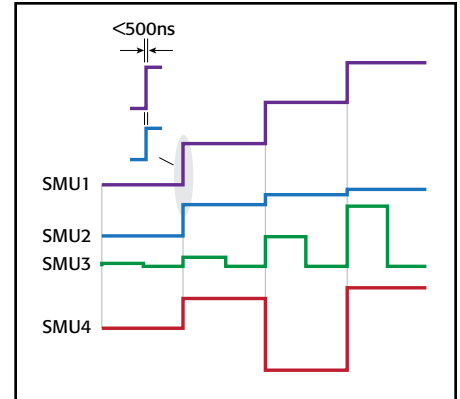

All channels in the TSP-Link system are synchronized to under 500ns.

Model 2400 Software Emulation

The Series 2600B is compatible with test code developed for Keithley's Model 2400 SourceMeter SMU instrument. This enables an easier upgrade from Model 2400-based test systems to Series 2600B, and can improve test speeds by as much as 80%. In addition, it provides a migration path from SCPI programming to Keithley's TSP technology, which when implemented can improve test times even more. For complete support of legacy test systems, the Model 2400's Source-Memory-List test sequencer is also fully supported in this mode.

Third-generation SMU Instrument Design Ensures Faster Test Times

Based on the proven architecture of earlier Series 2600 instruments, the Series 2600B's SMU instrument design enhances test speed in several ways. For example, while earlier designs used a parallel current ranging topology, the Series 2600B uses a patented series ranging topology, which provides faster and smoother range changes and outputs that settle more quickly.

1.888.KEITHLEY (U.S. only)

www.keithley.com

A Greater Measure of Confidence

KEITHLEY

A Tektronix Company

Scalable, integrated source and measure solutions

SMU INSTRUMENTS

Series 2600B

System SourceMeter® SMU Instruments

Scalable, integrated source and measure solutions

The Series 2600B SMU instrument design supports two modes of operation for use with a variety of loads. In normal mode, the SMU instrument provides high bandwidth performance for maximum throughput. In high capacitance (high-C) mode, the SMU instrument uses a slower bandwidth to provide robust performance with higher capacitive loads.

Simplify Semiconductor Component Test, Verification, and Analysis

The optional ACS Basic Edition software maximizes the productivity of customers who perform packaged part characterization during development, quality verification, or failure analysis. Key features include:

- Rich set of easy-to-access test libraries
- Script editor for fast customization of existing tests
- Data tool for comparing results quickly
- Formulator tool that analyzes captured curves and provides a wide range of math functions

For more information about the ACS Basic Edition software, please refer to the ACS Basic Edition data sheet.

Powerful Software Tools

In addition to compatibility with the Keithley IVy smart device app, embedded web browser based software, and optional ACS Basic Edition software, the free Test Script Builder software tool is provided to help users create, modify, debug, and store TSP test scripts. Table 1 describes key features of Series 2600B software tools.

Three New Dual-Channel Bench-Top Models of Series 2600B Offer Industry-Best Value and Performance

For applications that do not require leading-edge system-level automation capabilities, Keithley has expanded the Series 2600B to include 3 new value-priced “bench-top” models – the 2604B, 2614B, and 2634B. These models offer similar performance to Models 2602B, 2612B, and 2636B, respectively, however do not include TSP-Link, Contact Check, and Digital I/O capabilities.

Complete Automated System Solutions

Keithley’s S500 Integrated Test Systems are highly configurable, instrument-based systems for semiconductor characterization at the device, wafer, or cassette level. Built on our proven Series 2600B System SourceMeter SMU instruments, our S500 Integrated Test Systems

Table 1. Series 2600B software tools

Feature/Functionality	Keithley IVy Mobile App	Built-in Web Browser Based App	Test Script Builder (TSB)	ACS Basic Edition
Description	Quick I-V characterization tool for bench and lab users to visualize, interact and share measurement data via Android devices.	Built-in web browser based software for I-V characterization	Custom script writing tool for TSP instruments	Semiconductor characterization software for component test, verification, and analysis
Capability	Basic	General	Advanced	High Performance
Supported Hardware	Series 2600B	Series 2600B	Series 2600B, Series 3700	Series 2400, Series 2600B, 4200-SCS
Supported Buses	Not Applicable	LAN/LXI	GPIO, RS-232, LAN/LXI, USB	GPIO, LAN/LXI
Functionality	Visualize data in time mode, two terminal I-V mode and family of curves mode. Analyze collected data interactively with smart device’s built-in capabilities. Share data instantly via mobile networks/Wi-Fi	Linear/Log Sweeps, Pulsing, Custom sweeps, Single point source-measures. Note: Uses new 2600B’s new API’s for precision timing and channel synchronization	Custom scripts with total flexibility, full featured debugger	Intuitive, wizard-based GUI, Rich set of test libraries, curve trace capability
Data Management	.csv and graphic data export	.csv export	User defined	Formulator tool with wide range of math functions
Installation	Free download from app stores	Not necessary. Embedded in the instrument.	Free Download or CD Install on PC.	Optional purchase

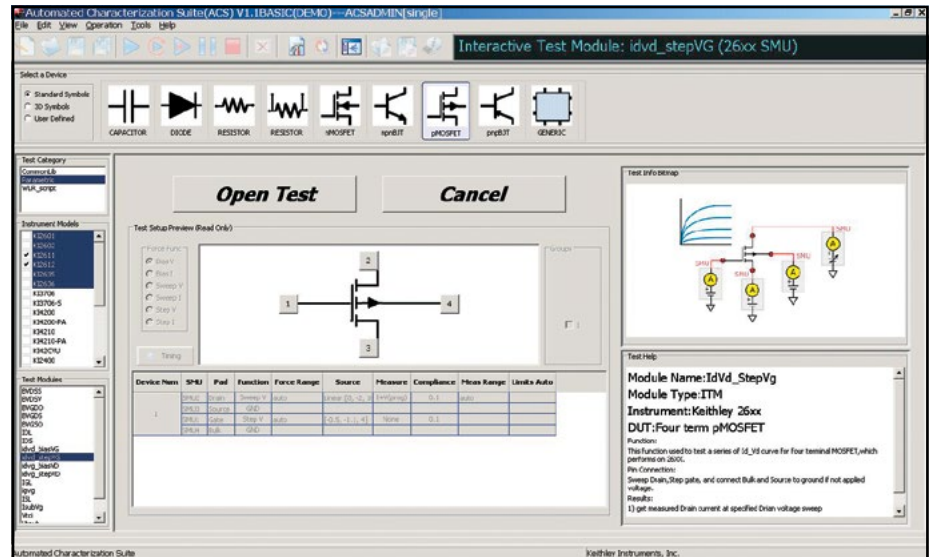

When you need to acquire data on a packaged part quickly, the wizard-based user interface of ACS Basic Edition makes it easy to find and run the test you want, like this common FET curve trace test.

provide innovative measurement features and system flexibility, scalable to your needs. The unique measurement capability, combined with the powerful and flexible Automated Characterization Suite (ACS) software, provides a comprehensive range of applications and features not offered on other comparable systems on the market.



The flexible software architecture of ACS Basic Edition allows configuring systems with a wide range of controllers and test fixtures, as well as the exact number of SourceMeter SMU instruments the application requires.

1.888.KEITHLEY (U.S. only)

www.keithley.com

KEITHLEY

A Greater Measure of Confidence

A Tektronix Company

Series 2600B

System SourceMeter® SMU Instruments

TYPICAL APPLICATIONS

I-V functional test and characterization of a wide range of devices, including:

- Discrete and passive components
 - Two-leaded – Sensors, disk drive heads, metal oxide varistors (MOVs), diodes, zener diodes, sensors, capacitors, thermistors
 - Three-leaded – Small signal bipolar junction transistors (BJTs), field-effect transistors (FETs), and more
- Simple ICs – Optos, drivers, switches, sensors, converters, regulators
- Integrated devices – small scale integrated (SSI) and large scale integrated (LSI)
 - Analog ICs
 - Radio frequency integrated circuits (RFICs)
 - Application specific integrated circuits (ASICs)
 - System on a chip (SOC) devices
- Optoelectronic devices such as light-emitting diodes (LEDs), laser diodes, high brightness LEDs (HBLEDs), vertical cavity surface-emitting lasers (VCSELs), displays
- Wafer level reliability
 - NBTI, TDDDB, HCI, electromigration
- Solar Cells
- Batteries
- And more...

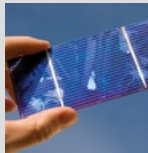
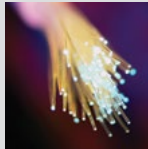
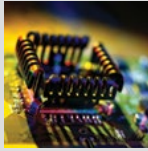

In the first and third quadrants, Series 2600B SMU instruments operate as a source, delivering power to a load. In the second and fourth quadrants, they operate as a sink, dissipating power internally.

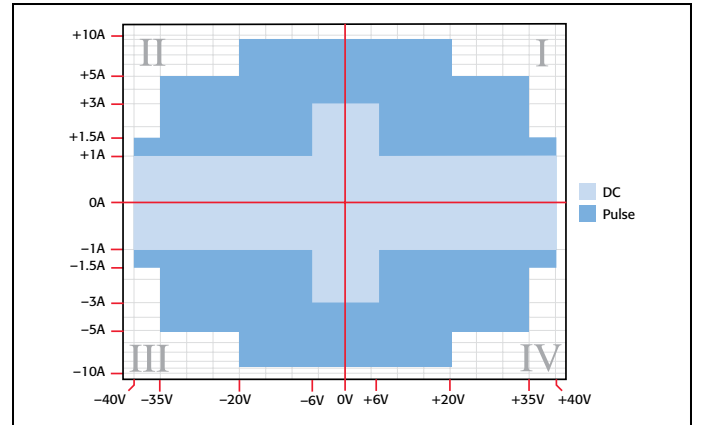

Models 2601B, 2602B, and 2604B I-V capability

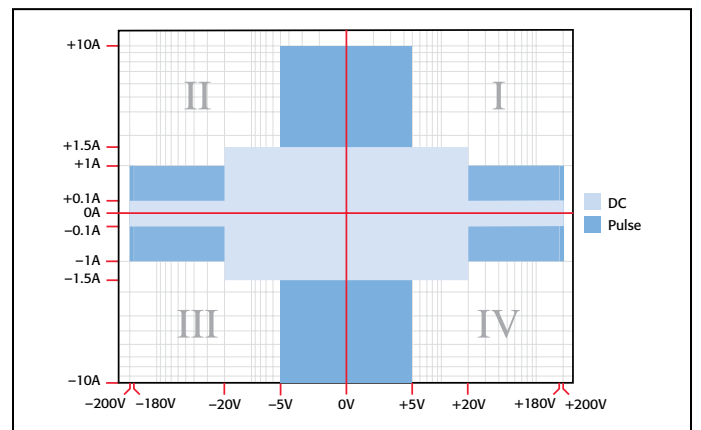

Models 2611B, 2612B, and 2614B I-V capability

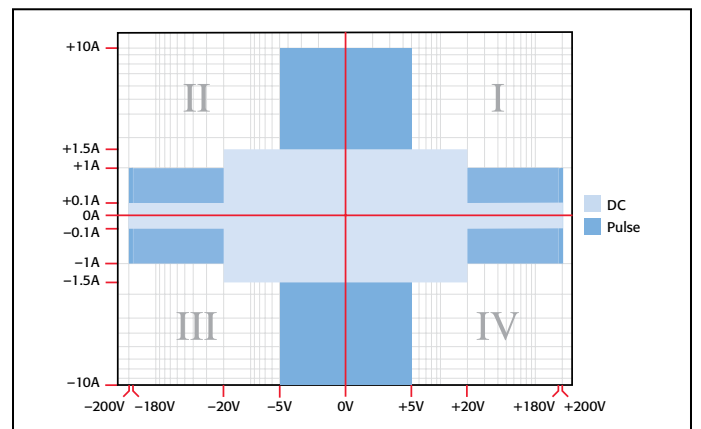

Models 2634B, 2635B, and 2636B I-V capability



Model 2604B/2614B rear panel
(Single channels 2601B, 2611B, 2635B not shown)



Model 2636B rear panel

1.888.KEITHLEY (U.S. only)

www.keithley.com

A Greater Measure of Confidence

KEITHLEY
A Tektronix Company

Scalable, integrated source and measure solutions

SMU INSTRUMENTS

SPECIFICATION CONDITIONS

This document contains specifications and supplemental information for the Models 2601B, 2602B, and 2604B System SourceMeter® SMU instruments. Specifications are the standards against which the Models 2601B, 2602B, and 2604B are tested. Upon leaving the factory, the 2601B, 2602B, and 2604B meet these specifications. Supplemental and typical values are non-warranted, apply at 23°C, and are provided solely as useful information.

Accuracy specifications are applicable for both normal and high capacitance modes.

The source and measurement accuracies are specified at the SourceMeter CHANNEL A (2601B, 2602B, and 2604B) or SourceMeter CHANNEL B (2602B and 2604B) terminals under the following conditions:

1. 23°C ± 5°C, <70% relative humidity
2. After 2 hour warm-up
3. Speed normal (1 NPLC)
4. A/D auto-zero enabled
5. Remote sense operation or properly zeroed local operation
6. Calibration period = 1 year

SOURCE SPECIFICATIONS

VOLTAGE SOURCE SPECIFICATIONS

VOLTAGE PROGRAMMING ACCURACY¹

Range	Programming Resolution	Accuracy (1 Year) 23°C ± 5°C ±(% rdg. + volts)	Typical Noise (peak-peak) 0.1Hz–10Hz
100 mV	5 μV	0.02% + 250 μV	20 μV
1 V	50 μV	0.02% + 400 μV	50 μV
6 V	50 μV	0.02% + 1.8 mV	100 μV
40 V	500 μV	0.02% + 12 mV	500 μV

TEMPERATURE COEFFICIENT (0°–18°C and 28°–50°C)²: ±(0.15 × accuracy specification)/°C. Applicable for normal mode only. Not applicable for high capacitance mode.

MAXIMUM OUTPUT POWER AND SOURCE/SINK LIMITS³: 40.4W per channel maximum. ±40.4V @ ±1.0A, ±6.06V @ ±3.0A, four quadrant source or sink operation.

VOLTAGE REGULATION: Line: 0.01% of range. **Load:** ±(0.01% of range + 100μV).

NOISE 10Hz–20MHz: <20mV peak-peak (typical), <5mV RMS (typical), 6V range.

CURRENT LIMIT/COMPLIANCE⁴: Bipolar current limit (compliance) set with single value. Minimum value is 10nA. Accuracy same as current source.

OVERSHOOT: <±(0.1% + 10mV) typical. Step size = 10% to 90% of range, resistive load, maximum current limit/compliance.

GUARD OFFSET VOLTAGE: <4mV typical. Current <10mA.

CURRENT SOURCE SPECIFICATIONS

CURRENT PROGRAMMING ACCURACY

Range	Programming Resolution	Accuracy (1 Year) 23°C ± 5°C ±(% rdg. + amps)	Typical Noise (peak-peak) 0.1Hz–10Hz
100 nA	2 pA	0.06% + 100 pA	5 pA
1 μA	20 pA	0.03% + 800 pA	25 pA
10 μA	200 pA	0.03% + 5 nA	60 pA
100 μA	2 nA	0.03% + 60 nA	3 nA
1 mA	20 nA	0.03% + 300 nA	6 nA
10 mA	200 nA	0.03% + 6 μA	200 nA
100 mA	2 μA	0.03% + 30 μA	600 nA
1 A ⁵	20 μA	0.05% + 1.8 mA	70 μA
3 A ⁵	20 μA	0.06% + 4 mA	150 μA
10 A ^{5,6}	200 μA	0.5% + 40 mA (typical)	

TEMPERATURE COEFFICIENT (0°–18°C and 28°–50°C)⁷: ±(0.15 × accuracy specification)/°C.

MAXIMUM OUTPUT POWER AND SOURCE/SINK LIMITS⁸: 40.4W per channel maximum. ±1.01A @ ±40.0V, ±3.03A @ ±6.0V, four quadrant source or sink operation.

CURRENT REGULATION: Line: 0.01% of range. **Load:** ±(0.01% of range + 100pA).

VOLTAGE LIMIT/COMPLIANCE⁹: Bipolar voltage limit (compliance) set with a single value. Minimum value is 10mV. Accuracy is the same as voltage source.

OVERSHOOT: <±0.1% typical (step size = 10% to 90% of range, resistive load; see Current Source Output Settling Time for additional test conditions).

ADDITIONAL SOURCE SPECIFICATIONS

TRANSIENT RESPONSE TIME: <70μs for the output to recover to within 0.1% for a 10% to 90% step change in load.

VOLTAGE SOURCE OUTPUT SETTLING TIME: Time required to reach within 0.1% of final value after source level command is processed on a fixed range.

100mV, 1V Ranges: <50μs typical.

6V Range: <100μs typical.

40V Range¹⁰: <150μs typical.

CURRENT SOURCE OUTPUT SETTLING TIME: Time required to reach within 0.1% of final value after source level command is processed on a fixed range. Values below for $I_{out} \times R_{load} = 1V$ unless noted.

3A Range: <80μs typical (current less than 2.5A, $R_{load} > 2\Omega$).

1A–10mA Ranges: <80μs typical ($R_{load} > 6\Omega$).

1mA Range: <100μs typical.

100μA Range: <150μs typical.

10μA Range: <500μs typical.

1μA Range: <2.5ms typical.

100nA Range: <25ms typical.

DC FLOATING VOLTAGE: Output can be floated up to ±250VDC from chassis ground.

REMOTE SENSE OPERATING RANGE¹¹:

Maximum voltage between HI and SENSE HI = 3V.

Maximum voltage between LO and SENSE LO = 3V.

VOLTAGE OUTPUT HEADROOM:

40V Range: Max. output voltage = 42V – total voltage drop across source leads (maximum 1Ω per source lead).

6V Range: Max. output voltage = 8V – total voltage drop across source leads (maximum 1Ω per source lead).

OVER TEMPERATURE PROTECTION: Internally sensed temperature overload puts unit in standby mode.

VOLTAGE SOURCE RANGE CHANGE OVERSHOOT: <300mV + 0.1% of larger range (typical). Overshoot into a 100kΩ load, 20MHz BW.

CURRENT SOURCE RANGE CHANGE OVERSHOOT: <5% of larger range + 300mV/ R_{load} (typical with source settling set to SETTLE_SMOOTH_100NA). See Current Source Output Settling Time for additional test conditions.

NOTES

1. Add 50μV to source accuracy specifications per volt of HI lead drop.
2. High Capacitance Mode accuracy is applicable at 23°C ± 5°C only.
3. Full power source operation regardless of load to 30°C ambient. Above 30°C and/or power sink operation, refer to "Operating Boundaries" in the Series 2600B Reference Manual for additional power derating information.
4. For sink mode operation (quadrants II and IV), add 0.06% of limit range to the corresponding current limit accuracy specifications. Specifications apply with sink mode operation enabled.
5. Full power source operation regardless of load to 30°C ambient. Above 30°C and/or power sink operation, refer to "Operating Boundaries" in the Series 2600B Reference Manual for additional power derating information.
6. 10A range accessible only in pulse mode.
7. High Capacitance Mode accuracy is applicable at 23°C ± 5°C only.
8. Full power source operation regardless of load to 30°C ambient. Above 30°C and/or power sink operation, refer to "Operating Boundaries" in the Series 2600B Reference Manual for additional power derating information.
9. For sink mode operation (quadrants II and IV), add 10% of compliance range and ±0.02% of limit setting to corresponding voltage source specification. For 100mV range add an additional 60mV of uncertainty.
10. Add 150μs when measuring on the 1A range.
11. Add 50μV to source accuracy specifications per volt of HI lead drop.

1.888.KEITHLEY (U.S. only)

www.keithley.com

KEITHLEY
A Tektronix Company

A Greater Measure of Confidence

2601B, 2602B, 2604B

System SourceMeter® SMU Instruments

SOURCE SPECIFICATIONS (continued)

PULSE SPECIFICATIONS

Region	Maximum Current Limit	Maximum Pulse Width ¹²	Maximum Duty Cycle ¹³
1	1 A @ 40 V	DC, no limit	100%
1	3 A @ 6 V	DC, no limit	100%
2	1.5 A @ 40 V	100 ms	25%
3	5 A @ 35 V	4 ms	4%
4	10 A @ 20 V	1.8 ms	1%

MINIMUM PROGRAMMABLE PULSE WIDTH^{14, 15}: 100 μ s. NOTE: Minimum pulse width for settled source at a given I/V output and load can be longer than 100 μ s.

PULSE WIDTH PROGRAMMING RESOLUTION: 1 μ s.

PULSE WIDTH PROGRAMMING ACCURACY¹⁵: $\pm 5\mu$ s.

PULSE WIDTH JITTER: 2 μ s (typical).

QUADRANT DIAGRAM:

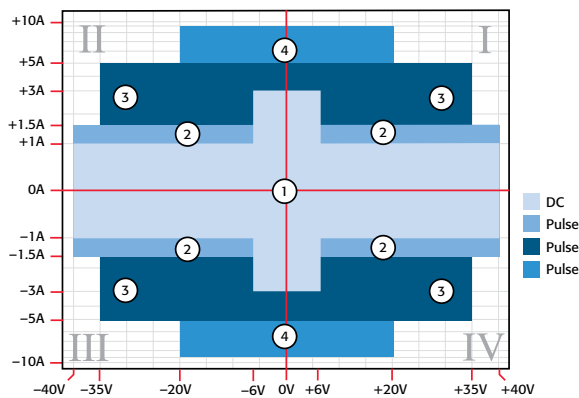

NOTES

12. Times measured from the start of pulse to the start off-time; see figure below.

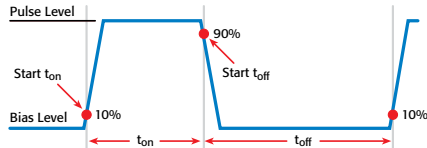

13. Thermally limited in sink mode (quadrants II and IV) and ambient temperatures above 30°C. See power equations in the reference manual for more information.

14. Typical performance for minimum settled pulse widths:

Source Value	Load	Source Settling (% of range)	Min. Pulse Width
6 V	2 Ω	0.2%	150 μ s
20 V	2 Ω	1%	200 μ s
35 V	7 Ω	0.5%	500 μ s
40 V	27 Ω	0.1%	400 μ s
1.5 A	27 Ω	0.1%	1.5 ms
3 A	2 Ω	0.2%	150 μ s
5 A	7 Ω	0.5%	500 μ s
10 A	2 Ω	0.5%	200 μ s

Typical tests were performed using remote operation, 4W sense, and best, fixed measurement range. For more information on pulse scripts, see the Series 2600B Reference Manual.

15. Times measured from the start of pulse to the start off-time; see figure below.

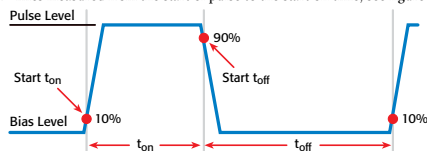

METER SPECIFICATIONS

VOLTAGE MEASUREMENT ACCURACY^{16, 17}

Range	Default Display Resolution ¹⁸	Input Resistance	Accuracy (1 Year) 23°C \pm 5°C \pm (% rdg. + volts)
100 mV	100 nV	>10 G Ω	0.015% + 150 μ V
1 V	1 μ V	>10 G Ω	0.015% + 200 μ V
6 V	10 μ V	>10 G Ω	0.015% + 1 mV
40 V	10 μ V	>10 G Ω	0.015% + 8 mV

TEMPERATURE COEFFICIENT (0°–18°C and 28°–50°C)¹⁹: $\pm(0.15 \times \text{accuracy specification})/^\circ\text{C}$. Applicable for normal mode only. Not applicable for high capacitance mode.

CURRENT MEASUREMENT ACCURACY¹⁷

Range	Default Display Resolution ²⁰	Voltage Burden ²¹	Accuracy (1 Year) 23°C \pm 5°C \pm (% rdg. + amps)
100 nA	100 fA	<1 mV	0.05% + 100 pA
1 μ A	1 pA	<1 mV	0.025% + 500 pA
10 μ A	10 pA	<1 mV	0.025% + 1.5 nA
100 μ A	100 pA	<1 mV	0.02% + 25 nA
1 mA	1 nA	<1 mV	0.02% + 200 nA
10 mA	10 nA	<1 mV	0.02% + 2.5 μ A
100 mA	100 nA	<1 mV	0.02% + 20 μ A
1 A	1 μ A	<1 mV	0.03% + 1.5 mA
3 A	1 μ A	<1 mV	0.05% + 3.5 mA
10 A ²²	10 μ A	<1 mV	0.4% + 25 mA (typical)

CURRENT MEASURE SETTTLING TIME (Time for measurement to settle after a V_{step})²³: Time required to reach within 0.1% of final value after source level command is processed on a fixed range. Values for $V_{\text{out}} = 1\text{V}$ unless noted. Current Range: 1mA. Settling Time: <100 μ s (typical).

TEMPERATURE COEFFICIENT (0°–18°C and 28°–50°C)²⁴: $\pm(0.15 \times \text{accuracy specification})/^\circ\text{C}$. Applicable for normal mode only. Not applicable for high capacitance mode.

CONTACT CHECK²⁵ (not available on Model 2604B)

Speed	Maximum Measurement Time To Memory For 60Hz (50Hz)	Accuracy (1 Year) 23°C \pm 5°C \pm (%rdg. + ohms)
FAST	1 (1.2) ms	5% + 10 Ω
MEDIUM	4 (5) ms	5% + 1 Ω
SLOW	36 (42) ms	5% + 0.3 Ω

ADDITIONAL METER SPECIFICATIONS

MAXIMUM LOAD IMPEDANCE:

Normal Mode: 10nF (typical). High Capacitance Mode: 50 μ F (typical).

COMMON MODE VOLTAGE: 250VDC.

COMMON MODE ISOLATION: >1G Ω , <4500pF.

OVERRRANGE: 101% of source range, 102% of measure range.

MAXIMUM SENSE LEAD RESISTANCE: 1k Ω for rated accuracy.

SENSE INPUT IMPEDANCE: >10G Ω .

NOTES

16. Add 50 μ V to source accuracy specifications per volt of HI lead drop.

17. De-rate accuracy specifications for NPLC setting < 1 by increasing error term.

Add appropriate % of range term using table below.

NPLC Setting	100mV Range	1V–40V Ranges	100nA Range	1 μ A–100mA Ranges	1A–3A Ranges
0.1	0.01%	0.01%	0.01%	0.01%	0.01%
0.01	0.08%	0.07%	0.1%	0.05%	0.05%
0.001	0.8 %	0.6 %	1%	0.5 %	1.1 %

18. Applies when in single channel display mode.

19. High Capacitance Mode accuracy is applicable for 23°C \pm 5°C only.

20. Applies when in single channel display mode.

21. Four-wire remote sense only with current meter mode selected. Voltage measure set to 100mV or 1V range only.

22. 10A range accessible only in pulse mode.

23. Compliance equal to 100mA.

24. High Capacitance Mode accuracy is applicable for 23°C \pm 5°C only.

25. Includes measurement of SENSE HI to HI and SENSE LO to LO contact resistances.

1.888.KEITHLEY (U.S. only)

www.keithley.com

A Greater Measure of Confidence

KEITHLEY
A Tektronix Company

Series 2600B specifications

SMU INSTRUMENTS

2601B, 2602B, 2604B

System SourceMeter[®] SMU Instruments

HIGH CAPACITANCE MODE^{26, 27, 28}

VOLTAGE SOURCE OUTPUT SETTLING TIME: Time required to reach 0.1% of final value after source level command is processed on a fixed range. Current limit = 1A.

Voltage Source Range	Settling Time with $C_{load} = 4.7\mu\text{F}$
100 mV	200 μs (typical)
1 V	200 μs (typical)
6 V	200 μs (typical)
40 V	7 ms (typical)

CURRENT MEASURE SETTLING TIME: Time required to reach 0.1% of final value after voltage source is stabilized on a fixed range. Values below for $V_{out} = 1\text{V}$ unless noted.

Current Measure Range	Settling Time
3 A – 1 A	<120 μs (typical) ($R_{load} > 2\Omega$)
100 mA – 10 mA	<100 μs (typical)
1 mA	< 3 ms (typical)
100 μA	< 3 ms (typical)
10 μA	< 230 ms (typical)
1 μA	< 230 ms (typical)

CAPACITOR LEAKAGE PERFORMANCE USING HIGH-C SCRIPTS²⁹: Load = $5\mu\text{F} || 10\text{M}\Omega$. Test: 5V step and measure. 200ms (typical) @ 50nA.

MODE CHANGE DELAY:

100 μA Current Range and Above:
 Delay into High Capacitance Mode: 10ms.
 Delay out of High Capacitance Mode: 10ms.
1 μA and 10 μA Current Ranges:
 Delay into High Capacitance Mode: 230ms.
 Delay out of High Capacitance Mode: 10ms.

VOLTMETER INPUT IMPEDANCE: 10G Ω in parallel with 3300pF.

NOISE, 10Hz–20MHz (6V Range): <30mV peak-peak (typical).

VOLTAGE SOURCE RANGE CHANGE OVERSHOOT: <400mV + 0.1% of larger range (typical). Overshoot into a 100k Ω load, 20MHz BW.

NOTES

26. High Capacitance Mode specifications are for DC measurements only.
27. 100nA range is not available in High Capacitance Mode.
28. High Capacitance Mode utilizes locked ranges. Auto Range is disabled.
29. Part of KI Factory scripts. See reference manual for details.

GENERAL

IEEE-488: IEEE-488.1 compliant. Supports IEEE-488.2 common commands and status model topology.

USB CONTROL (REAR): USB 2.0 device, TMC488 protocol.

RS-232: Baud rates from 300bps to 115200bps.

ETHERNET: RJ-45 connector, LXI Class C, 10/100BT, no auto MDIX.

EXPANSION INTERFACE: The TSP-Link expansion interface allows TSP enabled instruments to trigger and communicate with each other. (Not available on Model 2604B).

Cable Type: Category 5e or higher LAN crossover cable.

Length: 3 meters maximum between each TSP enabled instrument.

LXI COMPLIANCE: LXI Class C 1.4.

LXI TIMING: Total Output Trigger Response Time: 245 μs min., 280 μs typ., (not specified) max. Receive LAN[0-7] Event Delay: Unknown. Generate LAN[0-7] Event Delay: Unknown.

DIGITAL I/O INTERFACE: (Not available on Model 2604B)

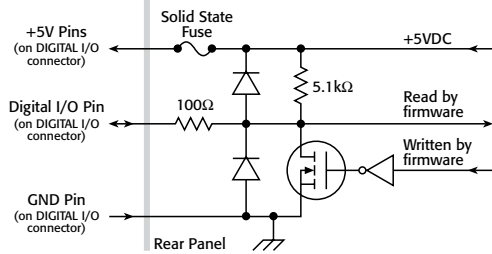

Connector: 25-pin female D.

Input/Output Pins: 14 open drain I/O bits.

Absolute Maximum Input Voltage: 5.25V.

Absolute Minimum Input Voltage: -0.25V.

Maximum Logic Low Input Voltage: 0.7V, +850 μA max.

Minimum Logic High Input Voltage: 2.1V, +570 μA .

Maximum Source Current (flowing out of Digital I/O bit): +960 μA .

Maximum Sink Current @ Maximum Logic Low Voltage (0.7V): -5.0mA.

Absolute Maximum Sink Current (flowing into Digital I/O pin): -11mA (not including Model 2604B).

5V Power Supply Pins: Limited to 250mA total for all three pins, solid state fuse protected.

Output Enable: Active high input pulled down internally to ground with a 10k Ω resistor; when the output enable input function has been activated, each SourceMeter channel will not turn on unless the output enable pin is driven to >2.1V (nominal current = 2.1V/10k Ω = 210 μA).

USB FILE SYSTEM (FRONT): USB 2.0 Host: Mass storage class device.

POWER SUPPLY: 100V to 250VAC, 50–60Hz (auto sensing), 240VA max.

COOLING: Forced air. Side intake and rear exhaust. One side must be unobstructed when rack mounted.

EMC: Conforms to European Union Directive 2004/108/EEC, EN 61326-1.

SAFETY: Conforms to European Union Directive 73/23/EEC, EN 61010-1, and UL 61010-1.

DIMENSIONS: 89mm high \times 213mm wide \times 460mm deep (3½ in \times 8½ in \times 17½ in). Bench Configuration (with handle and feet): 104mm high \times 238mm wide \times 460mm deep (4¼ in \times 9½ in \times 17½ in).

WEIGHT: 2601B: 4.75kg (10.4 lbs). 2602B, 2604B: 5.50kg (12.0 lbs).

ENVIRONMENT: For indoor use only.

Altitude: Maximum 2000 meters above sea level.

Operating: 0°–50°C, 70% R.H. up to 35°C. Derate 3% R.H./°C, 35°–50°C.

Storage: -25°C to 65°C.

SEE PAGES 23 AND 24 FOR MEASUREMENT SPEEDS AND OTHER SPECIFICATIONS.

1.888.KEITHLEY (U.S. only)

www.keithley.com

KEITHLEY

A Tektronix Company

A Greater Measure of Confidence

2611B, 2612B, 2614B

System SourceMeter® SMU Instruments

SPECIFICATION CONDITIONS

This document contains specifications and supplemental information for the Models 2611B, 2612B, and 2614B System SourceMeter® SMU instruments. Specifications are the standards against which the Models 2611B, 2612B, and 2614B are tested. Upon leaving the factory the 2611B, 2612B, and 2614B meet these specifications. Supplemental and typical values are non-warranted, apply at 23°C, and are provided solely as useful information.

Accuracy specifications are applicable for both normal and high capacitance modes.

The source and measurement accuracies are specified at the SourceMeter CHANNEL A (2611B, 2612B, and 2614B) or SourceMeter CHANNEL B (2612B, 2614B) terminals under the following conditions:

1. 23°C ± 5°C, <70% relative humidity.
2. After 2 hour warm-up.
3. Speed normal (1 NPLC).
4. A/D auto-zero enabled.
5. Remote sense operation or properly zeroed local sense operation.
6. Calibration period = 1 year.

SOURCE SPECIFICATIONS

VOLTAGE SOURCE SPECIFICATIONS

VOLTAGE PROGRAMMING ACCURACY¹

Range	Programming Resolution	Accuracy (1 Year) 23°C ±5°C ±(% rdg. + volts)	Typical Noise (Peak-Peak) 0.1Hz–10Hz
200 mV	5 μ V	0.02% + 375 μ V	20 μ V
2 V	50 μ V	0.02% + 600 μ V	50 μ V
20 V	500 μ V	0.02% + 5 mV	300 μ V
200 V	5 mV	0.02% + 50 mV	2 mV

TEMPERATURE COEFFICIENT (0°–18°C and 28°–50°C)²: ±(0.15 × accuracy specification)/°C. Applicable for normal mode only. Not applicable for high capacitance mode.

MAXIMUM OUTPUT POWER AND SOURCE/SINK LIMITS³: 30.3W per channel maximum. ±20.2V @ ±1.5A, ±202V @ ±100mA, four quadrant source or sink operation.

VOLTAGE REGULATION: Line: 0.01% of range. Load: ±(0.01% of range + 100 μ V).

NOISE 10Hz–20MHz: <20mV peak-peak (typical), <3mV RMS (typical), 20V range.

CURRENT LIMIT/COMPLIANCE⁴: Bipolar current limit (compliance) set with single value. Minimum value is 10nA. Accuracy is the same as current source.

OVERSHOOT: <±(0.1% + 10mV) (typical). Step size = 10% to 90% of range, resistive load, maximum current limit/compliance.

GUARD OFFSET VOLTAGE: <4mV (current <10mA).

CURRENT SOURCE SPECIFICATIONS

CURRENT PROGRAMMING ACCURACY⁵

Range	Programming Resolution	Accuracy (1 Year) 23°C ±5°C ±(% rdg. + amps)	Typical Noise (Peak-Peak) 0.1Hz–10Hz
100 nA	2 pA	0.06% + 100 pA	5 pA
1 μ A	20 pA	0.03% + 800 pA	25 pA
10 μ A	200 pA	0.03% + 5 nA	60 pA
100 μ A	2 nA	0.03% + 60 nA	3 nA
1 mA	20 nA	0.03% + 300 nA	6 nA
10 mA	200 nA	0.03% + 6 μ A	200 nA
100 mA	2 μ A	0.03% + 30 μ A	600 nA
1 A ⁶	20 μ A	0.05% + 1.8 mA	70 μ A
1.5 A ⁶	50 μ A	0.06% + 4 mA	150 μ A
10 A ^{6,7}	200 μ A	0.5% + 40 mA (typical)	

TEMPERATURE COEFFICIENT (0°–18°C and 28°–50°C)⁸: ±(0.15 × accuracy specification)/°C. Applicable for normal mode only. Not applicable for high capacitance mode.

MAXIMUM OUTPUT POWER AND SOURCE/SINK LIMITS⁹: 30.3W per channel maximum. ±1.515A @ ±20V, ±101mA @ ±200V, four quadrant source or sink operation.

CURRENT REGULATION: Line: 0.01% of range. Load: ±(0.01% of range + 100pA).

VOLTAGE LIMIT/COMPLIANCE¹⁰: Bipolar voltage limit (compliance) set with a single value. Minimum value is 20mV. Accuracy is the same as voltage source.

OVERSHOOT: <±0.1% (typical). Step size = 10% to 90% of range, resistive load; see Current Source Output Settling Time for additional test conditions.

ADDITIONAL SOURCE SPECIFICATIONS

TRANSIENT RESPONSE TIME: <70 μ s for the output to recover to within 0.1% for a 10% to 90% step change in load.

VOLTAGE SOURCE OUTPUT SETTLING TIME: Time required to within reach 0.1% of final value after source level command is processed on a fixed range.

Range	Settling Time
200 mV	<50 μ s (typical)
2 V	<50 μ s (typical)
20 V	<110 μ s (typical)
200 V	<700 μ s (typical)

CURRENT SOURCE OUTPUT SETTLING TIME: Time required to reach within 0.1% of final value after source level command is processed on a fixed range. Values below for $I_{out} \cdot R_{load} = 2V$ unless noted.

Current Range	Settling Time
1.5 A – 1 A	<120 μ s (typical) ($R_{load} > 6\Omega$)
100 mA – 10 mA	<80 μ s (typical)
1 mA	<100 μ s (typical)
100 μ A	<150 μ s (typical)
10 μ A	<500 μ s (typical)
1 μ A	<2 ms (typical)
100 nA	<20 ms (typical)

DC FLOATING VOLTAGE: Output can be floated up to ±250VDC from chassis ground.

REMOTE SENSE OPERATING RANGE¹¹: Maximum voltage between HI and SENSE HI = 3V. Maximum voltage between LO and SENSE LO = 3V.

VOLTAGE OUTPUT HEADROOM:

200V Range: Max. output voltage = 202.3V – total voltage drop across source leads (maximum 1 Ω per source lead).

20V Range: Max. output voltage = 23.3V – total voltage drop across source leads (maximum 1 Ω per source lead).

OVER TEMPERATURE PROTECTION: Internally sensed temperature overload puts unit in standby mode.

VOLTAGE SOURCE RANGE CHANGE OVERSHOOT: <300mV + 0.1% of larger range (typical). Overshoot into a 200k Ω load, 20MHz BW.

CURRENT SOURCE RANGE CHANGE OVERSHOOT: <5% of larger range + 300mV/ R_{load} (typical – With source settling set to SETTLE_SMOOTH_100NA). See Current Source Output Settling Time for additional test conditions.

NOTES

1. Add 50 μ V to source accuracy specifications per volt of HI lead drop.
2. High Capacitance Mode accuracy is applicable at 23°C ±5°C only.
3. Full power source operation regardless of load to 30°C ambient. Above 30°C and/or power sink operation, refer to "Operating Boundaries" in the Series 2600B Reference Manual for additional power derating information.
4. For sink mode operation (quadrants II and IV), add 0.06% of limit range to the corresponding current limit accuracy specifications. Specifications apply with sink mode operation enabled.
5. Accuracy specifications do not include connector leakage. Derate accuracy by $V_{out}/2E11$ per °C when operating between 18°–28°C. Derate accuracy by $V_{out}/2E11 + (0.15 \cdot V_{out}/2E11)$ per °C when operating <18°C and >28°C.
6. Full power source operation regardless of load to 30°C ambient. Above 30°C and/or power sink operation, refer to "Operating Boundaries" in the Series 2600B Reference Manual for additional power derating information.
7. 10A range accessible only in pulse mode.
8. High Capacitance Mode accuracy is applicable at 23°C ±5°C only.
9. Full power source operation regardless of load to 30°C ambient. Above 30°C and/or power sink operation, refer to "Operating Boundaries" in the Series 2600B Reference Manual for additional power derating information.
10. For sink mode operation (quadrants II and IV), add 10% of compliance range and ±0.02% of limit setting to corresponding voltage source specification. For 200mV range add an additional 120mV of uncertainty.
11. Add 50 μ V to source accuracy specifications per volt of HI lead drop.

PULSE SPECIFICATIONS

Region	Maximum Current Limit	Maximum Pulse Width ¹²	Maximum Duty Cycle ¹³
1	100 mA @ 200 V	DC, no limit	100%
1	1.5 A @ 20 V	DC, no limit	100%
2	1 A @ 180 V	8.5 ms	1%
3 ¹⁴	1 A @ 200 V	2.2 ms	1%
4	10 A @ 5 V	1 ms	2.2%

MINIMUM PROGRAMMABLE PULSE WIDTH¹⁵: 100 μ s. NOTE: Minimum pulse width for settled source at a given I/V output and load can be longer than 100 μ s.

PULSE WIDTH PROGRAMMING RESOLUTION: 1 μ s.

PULSE WIDTH PROGRAMMING ACCURACY¹⁶: ±5 μ s.

PULSE WIDTH JITTER: 2 μ s (typical).

1.888.KEITHLEY (U.S. only)

www.keithley.com

A Greater Measure of Confidence

KEITHLEY
A Tektronix Company

2611B, 2612B, 2614B

System SourceMeter® SMU Instruments

SOURCE SPECIFICATIONS (continued)

PULSE SPECIFICATIONS (continued)

QUADRANT DIAGRAM:

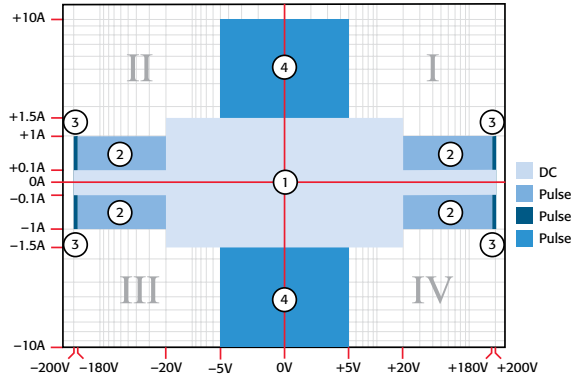

NOTES

12. Times measured from the start of pulse to the start off-time; see figure below.

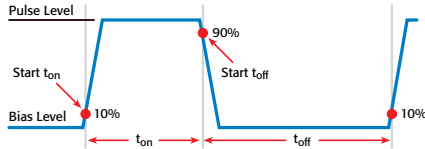

13. Thermally limited in sink mode (quadrants II and IV) and ambient temperatures above 30°C. See power equations in the reference manual for more information.

14. Voltage source operation with 1.5 A current limit.

15. Typical performance for minimum settled pulse widths:

Source Value	Load	Source Settling (% of range)	Min. Pulse Width
5 V	0.5 Ω	1%	300 μs
20 V	200 Ω	0.2%	200 μs
180 V	180 Ω	0.2%	5 ms
200 V (1.5 A Limit)	200 Ω	0.2%	1.5 ms
100 mA	200 Ω	1%	200 μs
1 A	200 Ω	1%	500 μs
1 A	180 Ω	0.2%	5 ms
10 A	0.5 Ω	0.5%	300 μs

Typical tests were performed using remote operation, 4W sense, and best, fixed measurement range. For more information on pulse scripts, see the Series 2600B Reference Manual.

16. Times measured from the start of pulse to the start off-time; see figure below.

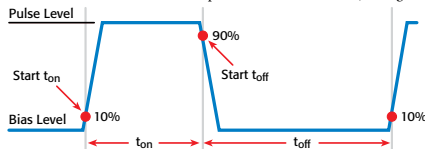

METER SPECIFICATIONS

VOLTAGE MEASUREMENT ACCURACY^{17, 18}

Range	Default Display Resolution ¹⁹	Input Resistance	Accuracy (1 Year) 23°C ±5°C ±(% rdg. + volts)
200 mV	100 nV	>10 GΩ	0.015% + 225 μV
2 V	1 μV	>10 GΩ	0.02% + 350 μV
20 V	10 μV	>10 GΩ	0.015% + 5 mV
200 V	100 μV	>10 GΩ	0.015% + 50 mV

TEMPERATURE COEFFICIENT (0°–18°C and 28°–50°C)²⁰: ±(0.15 × accuracy specification)/°C. Applicable for normal mode only. Not applicable for high capacitance mode.

CURRENT MEASUREMENT ACCURACY^{18, 21}

Range	Default Display Resolution ²²	Voltage Burden ²³	Accuracy (1 Year) 23°C ±5°C ±(% rdg. + amps)
100 nA	100 fA	<1 mV	0.06% + 100 pA
1 μA	1 pA	<1 mV	0.025% + 500 pA
10 μA	10 pA	<1 mV	0.025% + 1.5 nA
100 μA	100 pA	<1 mV	0.02% + 25 nA
1 mA	1 nA	<1 mV	0.02% + 200 nA
10 mA	10 nA	<1 mV	0.02% + 2.5 μA
100 mA	100 nA	<1 mV	0.02% + 20 μA
1 A	1 μA	<1 mV	0.03% + 1.5 mA
1.5 A	1 μA	<1 mV	0.05% + 3.5 mA
10 A ²⁴	10 μA	<1 mV	0.4% + 25 mA (typical)

CURRENT MEASURE SETTling TIME (Time for measurement to settle after a Vstep)²⁵: Time required to reach 0.1% of final value after source level command is processed on a fixed range. Values for V_{out} = 2V unless noted. Current Range: 1mA. Settling Time: <100μs (typical).

TEMPERATURE COEFFICIENT (0°–18°C and 28°–50°C)²⁶: ±(0.15 × accuracy specification)/°C. Applicable for normal mode only. Not applicable for high capacitance mode.

CONTACT CHECK²⁷ (not available on Model 2614B)

Speed	Maximum Measurement Time to Memory For 60Hz (50Hz)	Accuracy (1 Year) 23°C ±5°C ±(%rdg. + ohms)
FAST	1 (1.2) ms	5% + 10 Ω
MEDIUM	4 (5) ms	5% + 1 Ω
SLOW	36 (42) ms	5% + 0.3 Ω

ADDITIONAL METER SPECIFICATIONS

MAXIMUM LOAD IMPEDANCE:

Normal Mode: 10nF (typical). High Capacitance Mode: 50μF (typical).

COMMON MODE VOLTAGE: 250VDC.

COMMON MODE ISOLATION: >1GΩ, <4500pF.

OVERRANGE: 101% of source range, 102% of measure range.

MAXIMUM SENSE LEAD RESISTANCE: 1kΩ for rated accuracy.

SENSE INPUT IMPEDANCE: >10GΩ.

1.888.KEITHLEY (U.S. only)

www.keithley.com

KEITHLEY

A Tektronix Company

2611B, 2612B, 2614B

System SourceMeter® SMU Instruments

METER SPECIFICATIONS (continued)

NOTES

17. Add 50 μ V to source accuracy specifications per volt of HI lead drop.
 18. De-rate accuracy specifications for NPLC setting <1 by increasing error term. Add appropriate % of range term using table below.
- | NPLC Setting | 200mV Range | 2V–200V Ranges | 100nA Range | 1 μ A–100mA Ranges | 1A–1.5A Ranges |
|--------------|-------------|----------------|-------------|------------------------|----------------|
| 0.1 | 0.01% | 0.01% | 0.01% | 0.01% | 0.01% |
| 0.01 | 0.08% | 0.07% | 0.1% | 0.05% | 0.05% |
| 0.001 | 0.8% | 0.6% | 1% | 0.5% | 1.1% |
19. Applies when in single channel display mode.
 20. High Capacitance Mode accuracy is applicable at 23°C \pm 5°C only.
 21. Accuracy specifications do not include connector leakage. De-rate accuracy by $V_{out}/2E11$ per °C when operating between 18°–28°C. De-rate accuracy by $V_{out}/2E11 + (0.15 * V_{out}/2E11)$ per °C when operating <18° and >28°C.
 22. Applies when in single channel display mode.
 23. Four-wire remote sense only and with current meter mode selected. Voltage measure set to 200mV or 2V range only.
 24. 10A range accessible only in pulse mode.
 25. Compliance equal to 100mA.
 26. High Capacitance Mode accuracy is applicable at 23°C \pm 5°C only.
 27. Includes measurement of SENSE HI to HI and SENSE LO to LO contact resistances.

HIGH CAPACITANCE MODE 28, 29, 30

VOLTAGE SOURCE OUTPUT SETTLING TIME: Time required to reach within 0.1% of final value after source level command is processed on a fixed range. Current limit = 1A.

Voltage Source Range	Settling Time with $C_{load} = 4.7\mu$ F
200 mV	600 μ s (typical)
2 V	600 μ s (typical)
20 V	1.5 ms (typical)
200 V	20 ms (typical)

CURRENT MEASURE SETTLING TIME: Time required to reach within 0.1% of final value after voltage source is stabilized on a fixed range. Values below for $V_{out} = 2V$ unless noted.

Current Measure Range	Settling Time
1.5 A – 1 A	<120 μ s (typical) ($R_{load} > 6\Omega$)
100 mA – 10 mA	<100 μ s (typical)
1 mA	< 3 ms (typical)
100 μ A	< 3 ms (typical)
10 μ A	< 230 ms (typical)
1 μ A	< 230 ms (typical)

CAPACITOR LEAKAGE PERFORMANCE USING HIGH-C SCRIPTS³¹: Load = 5 μ F || 10M Ω .

Test: 5V step and measure. 200ms (typical) @ 50nA.

MODE CHANGE DELAY:

100 μ A Current Range and Above:

- Delay into High Capacitance Mode: 10ms.
- Delay out of High Capacitance Mode: 10ms.

1 μ A and 10 μ A Current Ranges:

- Delay into High Capacitance Mode: 230ms.
- Delay out of High Capacitance Mode: 10ms.

VOLTMETER INPUT IMPEDANCE: 30G Ω in parallel with 330pF.

NOISE, 10Hz–20MHz (20V Range): <30mV peak-peak (typical).

VOLTAGE SOURCE RANGE CHANGE OVERTHOOT (for 20V range and below): <400mV + 0.1% of larger range (typical). Overshoot into a 200k Ω load, 20MHz BW.

NOTES

28. High Capacitance Mode specifications are for DC measurements only.
29. 100nA range is not available in High Capacitance Mode.
30. High Capacitance Mode utilizes locked ranges. Auto Range is disabled.
31. Part of KI Factory scripts, See reference manual for details.

SEE PAGES 23 AND 24 FOR MEASUREMENT SPEEDS AND OTHER SPECIFICATIONS.

GENERAL

IEEE-488: IEEE-488.1 compliant. Supports IEEE-488.2 common commands and status model topology.

USB CONTROL (REAR): USB 2.0 device, TMC488 protocol.

RS-232: Baud rates from 300bps to 115200bps.

ETHERNET: RJ-45 connector, LXI Class C, 10/100BT, no auto MDIX.

EXPANSION INTERFACE: The TSP-Link expansion interface allows TSP enabled instruments to trigger and communicate with each other. (Not available on Model 2614B.)

Cable Type: Category 5e or higher LAN crossover cable.

Length: 3 meters maximum between each TSP enabled instrument.

LXI COMPLIANCE: LXI Class C 1.4.

LXI TIMING: Total Output Trigger Response Time: 245 μ s min., 280 μ s typ., (not specified) max. **Receive LAN[0-7] Event Delay:** Unknown. **Generate LAN[0-7] Event Delay:** Unknown.

DIGITAL I/O INTERFACE: (Not available on Model 2614B)

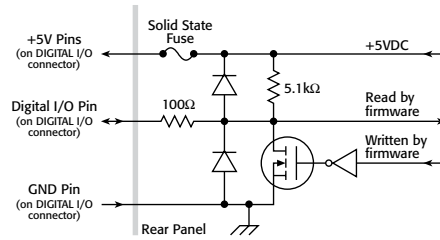

Connector: 25-pin female D.

Input/Output Pins: 14 open drain I/O bits.

Absolute Maximum Input Voltage: 5.25V.

Absolute Minimum Input Voltage: –0.25V.

Maximum Logic Low Input Voltage: 0.7V, +850 μ A max.

Minimum Logic High Input Voltage: 2.1V, +570 μ A.

Maximum Source Current (flowing out of Digital I/O bit): +960 μ A.

Maximum Sink Current @ Maximum Logic Low Voltage (0.7V): –5.0mA.

Absolute Maximum Sink Current (flowing into Digital I/O pin): –11mA.

5V Power Supply Pins: Limited to 250mA total for all three pins, solid state fuse protected.

Safety Interlock Pin: Active high input. >3.4V @ 24mA (absolute maximum of 6V) must be externally applied to this pin to ensure 200V operation. This signal is pulled down to chassis ground with a 10k Ω resistor. 200V operation will be blocked when the INTERLOCK signal is <0.4V (absolute minimum –0.4V). See figure below:

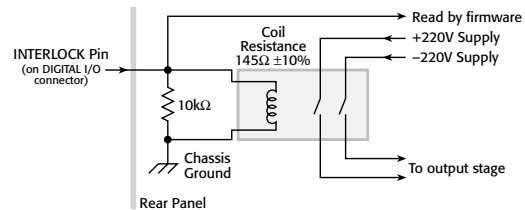

USB FILE SYSTEM (FRONT): USB 2.0 Host: Mass storage class device.

POWER SUPPLY: 100V to 250VAC, 50–60Hz (auto sensing), 240VA max.

COOLING: Forced air. Side intake and rear exhaust. One side must be unobstructed when rack mounted.

EMC: Conforms to European Union Directive 2004/108/EEC, EN 61326-1.

SAFETY: Conforms to European Union Directive 73/23/EEC, EN 61010-1, and UL 61010-1.

DIMENSIONS: 89mm high \times 213mm wide \times 460mm deep (3 $\frac{1}{2}$ in \times 8 $\frac{3}{8}$ in \times 17 $\frac{1}{2}$ in). Bench Configuration (with handle and feet): 104mm high \times 238mm wide \times 460mm deep (4 $\frac{1}{8}$ in \times 9 $\frac{3}{8}$ in \times 17 $\frac{1}{2}$ in).

WEIGHT: 2611B: 4.75kg (10.4 lbs). 2612B, 2614B: 5.50kg (12.0 lbs).

ENVIRONMENT: For indoor use only. **Altitude:** Maximum 2000 meters above sea level.

Operating: 0°–50°C, 70% R.H. up to 35°C. Derate 3% R.H./°C, 35°–50°C.

Storage: –25°C to 65°C.

1.888.KEITHLEY (U.S. only)

www.keithley.com

KEITHLEY

A Greater Measure of Confidence

A Tektronix Company

2634B, 2635B, 2636B

System SourceMeter® SMU Instruments

SPECIFICATION CONDITIONS

This document contains specifications and supplemental information for the Models 2634B, 2635B, and 2636B System SourceMeter® SMU instruments. Specifications are the standards against which the Models 2634B, 2635B, and 2636B are tested. Upon leaving the factory the 2634B, 2635B, and 2636B meet these specifications. Supplemental and typical values are non-warranted, apply at 23°C, and are provided solely as useful information.

Accuracy specifications are applicable for both normal and high capacitance modes.

The source and measurement accuracies are specified at the SourceMeter CHANNEL A (2634B, 2635B, and 2636B) or SourceMeter CHANNEL B (2634B, 2636B) terminals under the following conditions:

- 23°C ± 5°C, <70% relative humidity.
- After 2 hour warm-up
- Speed normal (1 NPLC)
- A/D auto-zero enabled
- Remote sense operation or properly zeroed local sense operation
- Calibration period = 1 year

SOURCE SPECIFICATIONS

VOLTAGE SOURCE SPECIFICATIONS

VOLTAGE PROGRAMMING ACCURACY¹

Range	Programming Resolution	Accuracy (1 Year) 23°C ± 5°C ±(% rdg. + volts)	Typical Noise (peak-peak) 0.1Hz–10Hz
200 mV	5 μV	0.02% + 375 μV	20 μV
2 V	50 μV	0.02% + 600 μV	50 μV
20 V	500 μV	0.02% + 5 mV	300 μV
200 V	5 mV	0.02% + 50 mV	2 mV

TEMPERATURE COEFFICIENT (0°–18°C and 28°–50°C)²: ±(0.15 × accuracy specification)/°C. Applicable for normal mode only. Not applicable for high capacitance mode.

MAXIMUM OUTPUT POWER AND SOURCE/SINK LIMITS³: 30.3W per channel maximum. ±20.2V @ ±1.5A, ±202V @ ±100mA, four quadrant source or sink operation.

VOLTAGE REGULATION: Line: 0.01% of range. Load: ±(0.01% of range + 100μV).

NOISE 10Hz–20MHz: <20mV pk-pk (typical), <3mV rms (typical), 20V range.

CURRENT LIMIT/COMPLIANCE⁴: Bipolar current limit (compliance) set with single value. Minimum value is 100pA. Accuracy is the same as current source.

OVERSHOOT: <±(0.1% + 10mV) typical (step size = 10% to 90% of range, resistive load, maximum current limit/compliance).

GUARD OFFSET VOLTAGE: <4mV (current <10mA).

CURRENT SOURCE SPECIFICATIONS

CURRENT PROGRAMMING ACCURACY

Range	Programming Resolution	Accuracy (1 Year) 23°C ± 5°C ±(% rdg. + amps)	Typical Noise (peak-peak) 0.1Hz–10Hz
1 nA	20 fA	0.15% + 2 pA	800 fA
10 nA	200 fA	0.15% + 5 pA	2 pA
100 nA	2 pA	0.06% + 50 pA	5 pA
1 μA	20 pA	0.03% + 700 pA	25 pA
10 μA	200 pA	0.03% + 5 nA	60 pA
100 μA	2 nA	0.03% + 60 nA	3 nA
1 mA	20 nA	0.03% + 300 nA	6 nA
10 mA	200 nA	0.03% + 6 μA	200 nA
100 mA	2 μA	0.03% + 30 μA	600 nA
1 A ⁵	20 μA	0.05% + 1.8 mA	70 μA
1.5 A ⁵	50 μA	0.06% + 4 mA	150 μA
10 A ^{5,6}	200 μA	0.5% + 40 mA (typical)	

TEMPERATURE COEFFICIENT (0°–18°C and 28°–50°C)⁷: ±(0.15 × accuracy specification)/°C. Applicable for normal mode only. Not applicable for high capacitance mode.

MAXIMUM OUTPUT POWER AND SOURCE/SINK LIMITS⁸: 30.3W per channel maximum. ±1.515A @ ±20V, ±101mA @ ±200V, four quadrant source or sink operation.

CURRENT REGULATION: Line: 0.01% of range. Load: ±(0.01% of range + 100pA).

VOLTAGE LIMIT/COMPLIANCE⁹: Bipolar voltage limit (compliance) set with a single value. Minimum value is 20mV. Accuracy is the same as voltage source.

OVERSHOOT: <±0.1% typical (step size = 10% to 90% of range, resistive load, maximum current limit/compliance; see Current Source Output Settling Time for additional test conditions).

ADDITIONAL SOURCE SPECIFICATIONS

TRANSIENT RESPONSE TIME: <70μs for the output to recover to within 0.1% for a 10% to 90% step change in load.

VOLTAGE SOURCE OUTPUT SETTLING TIME: Time required to reach within 0.1% of final value after source level command is processed on a fixed range.

Range	Settling Time
200 mV	<50 μs (typical)
2 V	<50 μs (typical)
20 V	<110 μs (typical)
200 V	<700 μs (typical)

CURRENT SOURCE OUTPUT SETTLING TIME: Time required to reach within 0.1% of final value after source level command is processed on a fixed range. Values below for I_{out} · R_{load} = 2V unless noted.

Current Range	Settling Time
1.5 A – 1 A	<120 μs (typical) (R _{load} > 6Ω)
100 mA – 10 mA	<80 μs (typical)
1 mA	<100 μs (typical)
100 μA	<150 μs (typical)
10 μA	<500 μs (typical)
1 μA	<2 ms (typical)
100 nA	<20 ms (typical)
10 nA	<40 ms (typical)
1 nA	<150 ms (typical)

DC FLOATING VOLTAGE: Output can be floated up to ±250VDC.

REMOTE SENSE OPERATING RANGE¹⁰: Maximum voltage between HI and SENSE HI = 3V. Maximum voltage between LO and SENSE LO = 3V.

VOLTAGE OUTPUT HEADROOM:

200V Range: Max. output voltage = 202.3V – total voltage drop across source leads (maximum 1Ω per source lead).

20V Range: Max. output voltage = 23.3V – total voltage drop across source leads (maximum 1Ω per source lead).

OVER TEMPERATURE PROTECTION: Internally sensed temperature overload puts unit in standby mode.

VOLTAGE SOURCE RANGE CHANGE OVERSHOOT: <300mV + 0.1% of larger range (typical). Overshoot into a 200kΩ load, 20MHz BW.

CURRENT SOURCE RANGE CHANGE OVERSHOOT: <5% of larger range + 300mV/R_{load} (typical – With source settling set to SETTLE_SMOOTH_100NA). See Current Source Output Settling Time for additional test conditions.

PULSE SPECIFICATIONS

Region	Maximum Current Limit	Maximum Pulse Width ¹¹	Maximum Duty Cycle ¹²
1	100 mA @ 200 V	DC, no limit	100%
1	1.5 A @ 20 V	DC, no limit	100%
2	1 A @ 180 V	8.5 ms	1%
3 ¹³	1 A @ 200 V	2.2 ms	1%
4	10 A @ 5 V	1 ms	2.2%

MINIMUM PROGRAMMABLE PULSE WIDTH^{14, 15}: 100μs. NOTE: Minimum pulse width for settled source at a given I/V output and load can be longer than 100μs.

PULSE WIDTH PROGRAMMING RESOLUTION: 1μs.

PULSE WIDTH PROGRAMMING ACCURACY¹⁵: ±5μs.

PULSE WIDTH JITTER: 50μs (typical).

QUADRANT DIAGRAM:

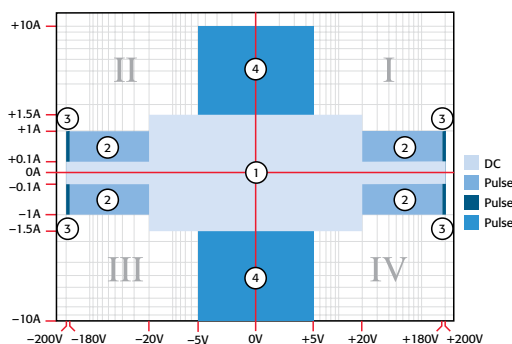

1.888.KEITHLEY (U.S. only)

www.keithley.com

KEITHLEY

A Tektronix Company

A Greater Measure of Confidence

2634B, 2635B, 2636B

System SourceMeter® SMU Instruments

SOURCE SPECIFICATIONS (continued)

NOTES

1. Add 50 μ V to source accuracy specifications per volt of HI lead drop.
2. High Capacitance Mode accuracy is applicable at 23°C \pm 5°C only.
3. Full power source operation regardless of load to 30°C ambient. Above 30°C and/or power sink operation, refer to "Operating Boundaries" in the Series 2600B Reference Manual for additional power derating information.
4. For sink mode operation (quadrants II and IV), add 0.06% of limit range to the corresponding current limit accuracy specifications. Specifications apply with sink mode operation enabled.
5. Full power source operation regardless of load to 30°C ambient. Above 30°C and/or power sink operation, refer to "Operating Boundaries" in the Series 2600B Reference Manual for additional power derating information.
6. 10A range accessible only in pulse mode.
7. High Capacitance Mode accuracy is applicable at 23°C \pm 5°C only.
8. Full power source operation regardless of load to 30°C ambient. Above 30°C and/or power sink operation, refer to "Operating Boundaries" in the Series 2600B Reference Manual for additional power derating information.
9. For sink mode operation (quadrants II and IV), add 10% of compliance range and \pm 0.02% of limit setting to corresponding voltage source specification. For 200mV range add an additional 120mV of uncertainty.
10. Add 50 μ V to source accuracy specifications per volt of HI lead drop.
11. Times measured from the start of pulse to the start off-time; see figure below.

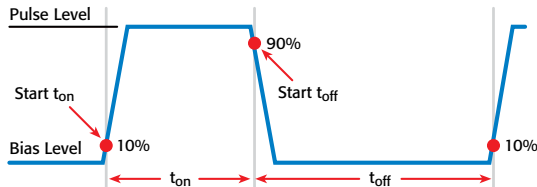

12. Thermally limited in sink mode (quadrants II and IV) and ambient temperatures above 30°C. See power equations in the Reference Manual for more information.
13. Voltage source operation with 1.5 A current limit.
14. Typical performance for minimum settled pulse widths:

Source Value	Load	Source Settling (% of range)	Min. Pulse Width
5 V	0.5 Ω	1%	300 μ s
20 V	200 Ω	0.2%	200 μ s
180 V	180 Ω	0.2%	5 ms
200 V (1.5 A Limit)	200 Ω	0.2%	1.5 ms
100 mA	200 Ω	1%	200 μ s
1 A	200 Ω	1%	500 μ s
1 A	180 Ω	0.2%	5 ms
10 A	0.5 Ω	0.5%	300 μ s

Typical tests were performed using remote operation, 4W sense, and best, fixed measurement range. For more information on pulse scripts, see the Series 2600B Reference Manual.

15. Times measured from the start of pulse to the start off-time; see figure below.

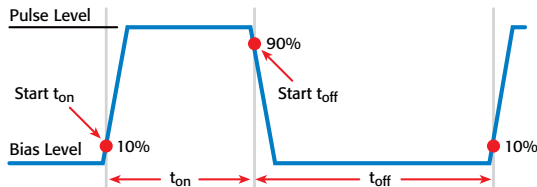

METER SPECIFICATIONS

VOLTAGE MEASUREMENT ACCURACY^{16, 17}

Range	Default Display Resolution ¹⁸	Input Resistance	Accuracy (1 Year) 23°C \pm 5°C \pm (% rdg. + volts)
200 mV	100 nV	>10 ¹⁴ Ω	0.015% + 225 μ V
2 V	1 μ V	>10 ¹⁴ Ω	0.02% + 350 μ V
20 V	10 μ V	>10 ¹⁴ Ω	0.015% + 5 mV
200 V	100 μ V	>10 ¹⁴ Ω	0.015% + 50 mV

TEMPERATURE COEFFICIENT (0°–18°C and 28°–50°C)¹⁹: \pm (0.15 \times accuracy specification)/°C. Applicable for normal mode only. Not applicable for high capacitance mode.

CURRENT MEASUREMENT ACCURACY¹⁷

Range	Default Display Resolution ²⁰	Voltage Burden ²¹	Accuracy (1 Year) 23°C \pm 5°C \pm (% rdg. + amps)
*100 pA ^{22, 23}	0.1 fA	<1 mV	0.15% + 120 fA
1 nA ^{22, 24}	1 fA	<1 mV	0.15% + 240 fA
10 nA	10 fA	<1 mV	0.15% + 3 pA
100 nA	100 fA	<1 mV	0.06% + 40 pA
1 μ A	1 pA	<1 mV	0.025% + 400 pA
10 μ A	10 pA	<1 mV	0.025% + 1.5 nA
100 μ A	100 pA	<1 mV	0.02% + 25 nA
1 mA	1 nA	<1 mV	0.02% + 200 nA
10 mA	10 nA	<1 mV	0.02% + 2.5 μ A
100 mA	100 nA	<1 mV	0.02% + 20 μ A
1 A	1 μ A	<1 mV	0.03% + 1.5 mA
1.5 A	1 μ A	<1 mV	0.05% + 3.5 mA
10 A ²⁵	10 μ A	<1 mV	0.4% + 25 mA

* 100 pA range not available on Model 2634B.

CURRENT MEASURE SETTLING TIME (Time for measurement to settle after a Vstep)²⁶: Time required to reach within 0.1% of final value after source level command is processed on a fixed range. Values for V_{out} = 2V unless noted. Current Range: 1mA. Settling Time: <100 μ s (typical).

TEMPERATURE COEFFICIENT (0°–18°C and 28°–50°C)²⁷: \pm (0.15 \times accuracy specification)/°C. Applicable for normal mode only. Not applicable for high capacitance mode.

CONTACT CHECK²⁸ (Not available on Model 2634B)

Speed	Maximum Measurement Time to Memory For 60Hz (50Hz)	Accuracy (1 Year) 23°C \pm 5°C \pm (%rdg. + ohms)
FAST	1 (1.2) ms	5% + 10 Ω
MEDIUM	4 (5) ms	5% + 1 Ω
SLOW	36 (42) ms	5% + 0.3 Ω

ADDITIONAL METER SPECIFICATIONS

MAXIMUM LOAD IMPEDANCE:

Normal Mode: 10nF (typical). High Capacitance Mode: 50 μ F (typical).

COMMON MODE VOLTAGE: 250VDC.

COMMON MODE ISOLATION: >1G Ω , <4500pF.

OVERRANGE: 101% of source range, 102% of measure range.

MAXIMUM SENSE LEAD RESISTANCE: 1k Ω for rated accuracy.

SENSE INPUT IMPEDANCE: >10¹⁴ Ω .

1.888.KEITHLEY (U.S. only)

www.keithley.com

A Greater Measure of Confidence

KEITHLEY

A Tektronix Company

Series 2600B specifications

SMU INSTRUMENTS

2634B, 2635B, 2636B

System SourceMeter[®] SMU Instruments

METER SPECIFICATIONS (continued)

NOTES

16. Add 50µV to source accuracy specifications per volt of HI lead drop.
17. De-rate accuracy specifications for NPLC setting <1 by increasing error term. Add appropriate % of range term using table below.

NPLC Setting	200mV Range	2V–200V Ranges	100nA Range	1µA–100mA Ranges	1A–1.5A Ranges
0.1	0.01%	0.01%	0.01%	0.01%	0.01%
0.01	0.08%	0.07%	0.1%	0.05%	0.05%
0.001	0.8 %	0.6 %	1%	0.5 %	1.1 %

18. Applies when in single channel display mode.
19. High Capacitance Mode accuracy is applicable at 23°C ±5°C only.
20. Applies when in single channel display mode.
21. Four-wire remote sense only and with current meter mode selected. Voltage measure set to 200mV or 2V range only.
22. 10-NPLC, 11-Point Median Filter, <200V range, measurements made within 1 hour after zeroing. 23°C ± 1°C
23. Under default specification conditions: ±(0.15% + 750fA).
24. Under default specification conditions: ±(0.15% + 1pA).
25. 10A range accessible only in pulse mode.
26. Delay factor set to 1. Compliance equal to 100mA.
27. High Capacitance Mode accuracy is applicable at 23°C ±5°C only.
28. Includes measurement of SENSE HI to HI and SENSE LO to LO contact resistances.

HIGH CAPACITANCE MODE 29, 30, 31

VOLTAGE SOURCE OUTPUT SETTLING TIME: Time required to reach within 0.1% of final value after source level command is processed on a fixed range. Current limit = 1A.

Voltage Source Range	Settling Time with $C_{load} = 4.7\mu F$
200 mV	600 µs (typical)
2 V	600 µs (typical)
20 V	1.5 ms (typical)
200 V	20 ms (typical)

CURRENT MEASURE SETTLING TIME: Time required to reach within 0.1% of final value after voltage source is stabilized on a fixed range. Values below for $V_{out} = 2V$ unless noted.

Current Measure Range	Settling Time
1.5 A – 1 A	<120 µs (typical) ($R_{load} > 6\Omega$)
100 mA – 10 mA	<100 µs (typical)
1 mA	< 3 ms (typical)
100 µA	< 3 ms (typical)
10 µA	< 230 ms (typical)
1 µA	< 230 ms (typical)

CAPACITOR LEAKAGE PERFORMANCE USING HIGH-C SCRIPTS³²: Load = 5µF || 10MΩ.
Test: 5V step and measure. 200ms (typical) @ 50nA.

MODE CHANGE DELAY:

100µA Current Range and Above:
Delay into High Capacitance Mode: 10ms.
Delay out of High Capacitance Mode: 10ms.

1µA and 10µA Current Ranges:
Delay into High Capacitance Mode: 230ms.
Delay out of High Capacitance Mode: 10ms.

VOLTMETER INPUT IMPEDANCE: 30GΩ in parallel with 3300pF.

NOISE, 10Hz–20MHz (20V Range): <30mV peak-peak (typical).

VOLTAGE SOURCE RANGE CHANGE OVERTHOOT (for 20V range and below): <400mV + 0.1% of larger range (typical). Overshoot into a 200kΩ load, 20MHz BW.

NOTES

29. High Capacitance Mode specifications are for DC measurements only.
30. 100nA range and below are not available in high capacitance mode.
31. High Capacitance Mode utilizes locked ranges. Auto Range is disabled.
32. Part of KI Factory scripts. See reference manual for details.

SEE PAGES 23 AND 24 FOR MEASUREMENT SPEEDS AND OTHER SPECIFICATIONS.

GENERAL

IEEE-488: IEEE-488.1 compliant. Supports IEEE-488.2 common commands and status model topology.

USB CONTROL (REAR): USB 2.0 device, TMC488 protocol.

RS-232: Baud rates from 300bps to 115200bps. Programmable number of data bits, parity type, and flow control (RTS/CTS hardware or none).

ETHERNET: RJ-45 connector, LXI Class C, 10/100BT, no auto MDIX.

EXPANSION INTERFACE: The TSP-Link expansion interface allows TSP enabled instruments to trigger and communicate with each other. (Not available on Model 2614B.)

Cable Type: Category 5e or higher LAN crossover cable.

Length: 3 meters maximum between each TSP enabled instrument.

LXI COMPLIANCE: LXI Class C 1.4.

LXI TIMING: Total Output Trigger Response Time: 245µs min., 280µs typ., (not specified) max. **Receive LAN[0-7] Event Delay:** Unknown. **Generate LAN[0-7] Event Delay:** Unknown.

DIGITAL I/O INTERFACE: (Not available on Model 2614B)

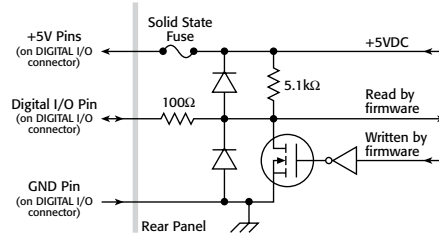

Connector: 25-pin female D.

Input/Output Pins: 14 open drain I/O bits.

Absolute Maximum Input Voltage: 5.25V.

Absolute Minimum Input Voltage: -0.25V.

Maximum Logic Low Input Voltage: 0.7V, +850µA max.

Minimum Logic High Input Voltage: 2.1V, +570µA.

Maximum Source Current (flowing out of Digital I/O bit): +960µA.

Maximum Sink Current @ Maximum Logic Low Voltage (0.7V): -5.0mA.

Absolute Maximum Sink Current (flowing into Digital I/O pin): -11mA.

5V Power Supply Pins: Limited to 250mA total for all three pins, solid state fuse protected.

Safety Interlock Pin: Active high input. >3.4V @ 24mA (absolute maximum of 6V) must be externally applied to this pin to ensure 200V operation. This signal is pulled down to chassis ground with a 10kΩ resistor. 200V operation will be blocked when the INTERLOCK signal is <0.4V (absolute minimum -0.4V). See figure below:

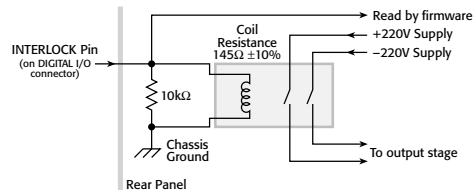

USB FILE SYSTEM (FRONT): USB 2.0 Host: Mass storage class device.

POWER SUPPLY: 100V to 250VAC, 50–60Hz (auto sensing), 240VA max.

COOLING: Forced air. Side intake and rear exhaust. One side must be unobstructed when rack mounted.

EMC: Conforms to European Union Directive 2004/108/EEC, EN 61326-1.

SAFETY: Conforms to European Union Directive 73/23/EEC, EN 61010-1, and UL 61010-1.

DIMENSIONS: 89mm high × 213mm wide × 460mm deep (3½ in × 8¾ in × 17½ in). Bench Configuration (with handle and feet): 104mm high × 238mm wide × 460mm deep (4¼ in × 9¾ in × 17½ in).

WEIGHT: 2635B: 4.75kg (10.4 lbs). 2634B, 2636B: 5.50kg (12.0 lbs).

ENVIRONMENT: For indoor use only. **Altitude:** Maximum 2000 meters above sea level.

Operating: 0°–50°C, 70% R.H. up to 35°C. Derate 3% R.H./°C, 35°–50°C.

Storage: -25°C to 65°C.

1.888.KEITHLEY (U.S. only)

www.keithley.com

KEITHLEY

A Greater Measure of Confidence

A Tektronix Company

Applicable to Models 2601B, 2602B, 2604B, 2611B, 2612B, 2614B, 2634B, 2635B, and 2636B.

MEASUREMENT SPEED SPECIFICATIONS ^{1, 2, 3}

MAXIMUM SWEEP OPERATION RATES (operations per second) FOR 60Hz (50Hz):

A/D Converter Speed	Trigger Origin	Measure To Memory Using User Scripts	Measure To GPIB Using User Scripts	Source Measure To Memory Using User Scripts	Source Measure To GPIB Using User Scripts	Source Measure To Memory Using Sweep API	Source Measure To GPIB Using Sweep API
0.001 NPLC	Internal	20000 (20000)	10500 (10500)	7000 (7000)	6200 (6200)	12000 (12000)	5900 (5900)
0.001 NPLC	Digital I/O	8100 (8100)	7100 (7100)	5500 (5500)	5100 (5100)	11200 (11200)	5700 (5700)
0.01 NPLC	Internal	5000 (4000)	4000 (3500)	3400 (3000)	3200 (2900)	4200 (3700)	3100 (2800)
0.01 NPLC	Digital I/O	3650 (3200)	3400 (3000)	3000 (2700)	2900 (2600)	4150 (3650)	3050 (2775)
0.1 NPLC	Internal	580 (490)	560 (475)	550 (465)	550 (460)	575 (480)	545 (460)
0.1 NPLC	Digital I/O	560 (470)	450 (460)	545 (460)	540 (450)	570 (480)	545 (460)
1.0 NPLC	Internal	59 (49)	59 (49)	59 (49)	59 (49)	59 (49)	59 (49)
1.0 NPLC	Digital I/O	58 (48)	58 (49)	59 (49)	59 (49)	59 (49)	59 (49)

MAXIMUM SINGLE MEASUREMENT RATES (operations per second) FOR 60Hz (50Hz):

A/D Converter Speed	Trigger Origin	Measure To GPIB	Source Measure To GPIB	Source Measure Pass/Fail To GPIB
0.001 NPLC	Internal	1900 (1800)	1400 (1400)	1400 (1400)
0.01 NPLC	Internal	1450 (1400)	1200 (1100)	1100 (1100)
0.1 NPLC	Internal	450 (390)	425 (370)	425 (375)
1.0 NPLC	Internal	58 (48)	57 (48)	57 (48)

MAXIMUM MEASUREMENT RANGE CHANGE RATE: <150 μ s for ranges >10 μ A, typical. When changing to or from a range \geq 1A, maximum rate is <450 μ s, typical.

MAXIMUM SOURCE RANGE CHANGE RATE: <2.5ms for ranges >10 μ A, typical. When changing to or from a range \geq 1A, maximum rate is <5.2ms, typical.

MAXIMUM SOURCE FUNCTION CHANGE RATE: <1ms, typical.

COMMAND PROCESSING TIME: Maximum time required for the output to begin to change following the receipt of the smux.source.level or smux.source.level command. <1ms typical.

NOTES

1. Tests performed with a 2602B, 2612B, or 2636B on Channel A using the following equipment: PC Hardware (Pentium[®] 4 2.4GHz, 512MB RAM, National Instruments PCI-GPIB). Driver (NI-486.2 Version 2.2 PCI-GPIB). Software (Microsoft[®] Windows[®] 2000, Microsoft Visual Studio 2005, VISA version 4.1).
2. Exclude current measurement ranges less than 1mA.
3. 2635B/2636B with default measurement delays and filters disabled.

TRIGGERING AND SYNCHRONIZATION SPECIFICATIONS ¹

TRIGGERING:

- Trigger in to trigger out: 0.5 μ s, typical.
- Trigger in to source change:² 10 μ s, typical.
- Trigger Timer accuracy: \pm 2 μ s, typical.
- Source change² after LXI Trigger: 280 μ s, typical.

SYNCHRONIZATION:

- Single-node synchronized source change:⁴ <0.5 μ s, typical.
- Multi-node synchronized source change:⁴ <0.5 μ s, typical.

NOTES

1. TSP-Link not available on Models 2604B, 2614B, and 2634B.
2. Fixed source range, with no polarity change.

Applicable to Models 2601B, 2602B, 2604B, 2611B, 2612B, 2614B, 2634B, 2635B, and 2636B.

SUPPLEMENTAL INFORMATION

FRONT PANEL INTERFACE: Two-line vacuum fluorescent display (VFD) with keypad and rotary knob.

Display:

- Show error messages and user defined messages
- Display source and limit settings
- Show current and voltage measurements
- View measurements stored in dedicated reading buffers

Keypad Operations:

- Change host interface settings
- Save and restore instrument setups
- Load and run factory and user defined test scripts (i.e. sequences) that prompt for input and send results to the display
- Store measurements into dedicated reading buffers

PROGRAMMING: Embedded Test Script Processor (TSP) accessible from any host interface. Responds to individual instrument control commands. Responds to high speed test scripts comprised of instrument control commands and Test Script Language (TSL) statements (e.g. branching, looping, math, etc.). Able to execute high speed test scripts stored in memory without host intervention.

Minimum Memory Available: 16MB (approximately 250,000 lines of TSL code).

Test Script Builder: Integrated development environment for building, running, and managing TSP scripts. Includes an instrument console for communicating with any TSP enabled instrument in an interactive manner. Requires:

- VISA (NI-VISA included on CD) Pentium III 800MHz or faster personal computer
- Microsoft .NET Framework (included on CD) Microsoft Windows 98, NT, 2000, or XP
- Keithley I/O Layer (included on CD)

Software Interface: TSP Express (embedded), Direct GPIB/VISA, READ/WRITE for VB, VC/C++, LabVIEW, LabWindows/CVI, etc.

READING BUFFERS: Dedicated storage area(s) reserved for measurement data. Reading buffers are arrays of measurement elements. Each element can hold the following items:

- Measurement Source setting (at the time the measurement was taken)
- Measurement status Range information
- Timestamp

Two reading buffers are reserved for each SourceMeter channel. Reading buffers can be filled using the front panel STORE key and retrieved using the RECALL key or host interface.

Buffer Size, with timestamp and source setting: >60,000 samples.

Buffer Size, without timestamp and source setting: >140,000 samples.

Accuracy: ±100ppm.

SYSTEM EXPANSION: The TSP-Link expansion interface allows TSP enabled instruments to trigger and communicate with each other. Not applicable for Models 2604B, 2614B, and 2634B. See figure below:

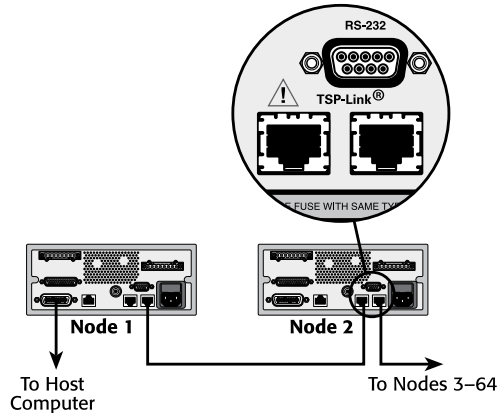

Each SourceMeter SMU instrument has two TSP-Link connectors to facilitate chaining instruments together.

Once SourceMeter SMU instruments are interconnected via TSP-Link, a computer can access all of the resources of each SourceMeter SMU instrument via the host interface of any SourceMeter SMU instrument.

A maximum of 32 TSP-Link nodes can be interconnected. Each SourceMeter SMU instrument consumes one TSP-Link node.

TIMER: Free running 47-bit counter with 1MHz clock input. Reset each time instrument powers up. Rolls over every 4 years.

Timestamp: TIMER value automatically saved when each measurement is triggered.

Resolution: 1µs.

ACCESSORIES AVAILABLE

SOFTWARE

ACS-BASIC Component Characterization Software

RACK MOUNT KITS

- 4299-1 Single Rack Mount Kit with front and rear support
- 4299-2 Dual Rack Mount Kit with front and rear support
- 4299-5 1U Vent Panel

CABLES AND CONNECTORS

- 2600-BAN Banana Test Leads/Adapter Cable. For a single 2601B/2602B/2604B/2611B/2612B/2614B SMU instrument channel
- 2600-KIT Extra screw terminal connector, strain relief, and cover for a single SourceMeter channel (one supplied with 2601B/2611B, two with 2602B/2604B/2612B/2614B)
- 2600-FIX-TRIAx Phoenix-to-Triax Adapter for 2 wire sensing
- 2600-TRIAx Phoenix-to-Triax Adapter for 4 wire sensing
- 7078-TRX* 3-Slot, Low Noise Triax Cable, 0.3m–6.1m. For use with 2600-TRIAx Adapter
- 7078-TRX-GND 3-Slot male triax to BNC adapter (guard removed)
- 7709-308A Digital I/O Connector (model specific)
- 8606 High Performance Modular Probe Kit. For use with 2600B-BAN

GPIB INTERFACES AND CABLES

- 7007-1 Double Shielded GPIB Cable, 1m (3.3 ft.)
- 7007-2 Double Shielded GPIB Cable, 2m (6.6 ft.)
- KPCI-488LPA IEEE-488 Interface/Controller for the PCI Bus

DIGITAL I/O, TRIGGER LINK, AND TSP-LINK

- 2600-TLINK Digital I/O to TLINK Adapter Cable, 1m
- CA-126-1A Digital I/O and Trigger Cable, 1.5m
- CA-180-3A CAT5 Crossover Cable for TSP-Link and direct Ethernet connection (two supplied)

TEST FIXTURES

- 8101-PIV DC, Pulse I-V and C-V Component Test Fixture
- 8101-4TRX 4 Pin Transistor Fixture
- LR8028 Component Test Fixture – Optimized for device testing at up to 200V/1A

SWITCHING

- Series 3700A DMM/Switch Systems
- 707B Semiconductor Switching Matrix Mainframe

CALIBRATION AND VERIFICATION

- 2600-STD-RES Calibration Standard 1GΩ Resistor for Models 2634B, 2635B, and 2636B

SERVICES AVAILABLE FOR ALL SERIES 2600B MODELS

EXTENDED WARRANTIES

- 26xxB-EW 1 Year Factory Warranty extended to 2 years
- 26xxB-3Y-EW 1 Year Factory Warranty extended to 3 years
- 26xxB-5Y-EW 1 Year Factory Warranty extended to 5 years

CALIBRATION CONTRACTS

- C/26xxB-3Y-STD 3 Calibrations within 3 years
- C/26xxB-5Y-STD 5 Calibrations within 5 years
- C/26xxB-3Y-DATA 3 Calibrations within 3 years and includes calibration data before and after adjustment
- C/26xxB-5Y-DATA 5 Calibrations within 5 years and includes calibration data before and after adjustment
- C/26xxB-3Y-17025 3 ISO-17025 accredited calibrations within 3 years
- C/26xxB-5Y-17025 5 ISO-17025 accredited calibrations within 5 years

1.888.KEITHLEY (U.S. only)

www.keithley.com

KEITHLEY

A Tektronix Company

A Greater Measure of Confidence

2651A

- **Source or sink:**
 - 2,000W of pulsed power ($\pm 40V$, $\pm 50A$)
 - 200W of DC power ($\pm 10V$ @ $\pm 20A$, $\pm 20V$ @ $\pm 10A$, $\pm 40V$ @ $\pm 5A$)
- Easily connect two units (in series or parallel) to create solutions up to $\pm 100A$ or $\pm 80V$
- 1pA resolution enables precise measurement of very low leakage currents
- 1 μs per point (1MHz), 18-bit sampling, accurately characterizes transient behavior
- 1% to 100% pulse duty cycle for pulse width modulated (PWM) drive schemes and device-specific drive stimulus
- Combines a precision power supply, current source, DMM, arbitrary waveform generator, V or I pulse generator with measurement, electronic load, and trigger controller—all in one instrument
- Includes TSP[®] Express I-V characterization software, LabVIEW[®] driver, and Keithley's Test Script Builder software development environment

APPLICATIONS

- Power semiconductor, HBLED, and optical device characterization and testing
- Solar cell characterization and testing
- Characterization of GaN, SiC, and other compound materials and devices
- Semiconductor junction temperature characterization
- High speed, high precision digitization
- Electromigration studies
- High current, high power device testing

50A, High Power System SourceMeter[®] SMU Instrument



The high power Model 2651A SourceMeter SMU Instrument is specifically designed to characterize and test high power electronics. This SMU instrument can help you improve productivity in applications across the R&D, reliability, and production spectrums, including high brightness LEDs, power semiconductors, DC-DC converters, batteries, solar cells, and other high power materials, components, modules, and subassemblies.

The Model 2651A offers a highly flexible, four-quadrant voltage and current source/load coupled with precision voltage and current meters. It can be used as a:

- Semiconductor characterization instrument
- V or I waveform generator
- V or I pulse generator
- Precision power supply
- True current source
- Digital multimeter (DCV, DCI, ohms, and power with 6½-digit resolution)
- Precision electronic load

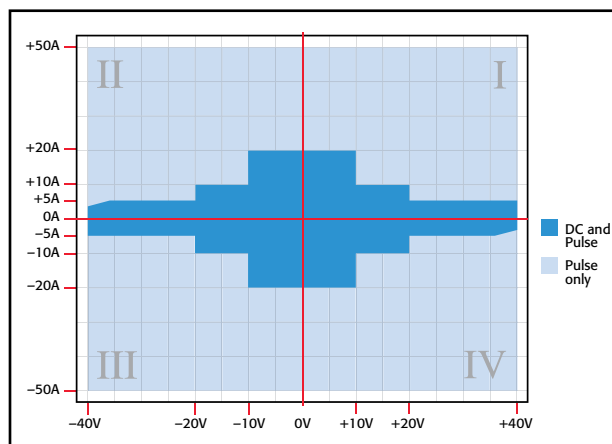

The Model 2651A can source or sink up to $\pm 40V$ and $\pm 50A$.

Two Measurement Modes: Digitizing or Integrating

Precisely characterize transient and steady-state behavior, including rapidly changing thermal effects, with the two measurement modes in the Model 2651A. Each mode is defined by its independent analog-to-digital (A/D) converters.

The Digitizing Measurement mode enables 1 μs per point measurements. Its 18-bit A/D converters allow you to precisely measure transient characteristics. For more accurate measurements, use its Integrating Measurement mode, which is based on 22-bit A/D converters.

1.888.KEITHLEY (U.S. only)

www.keithley.com

A Greater Measure of Confidence

KEITHLEY
A Tektronix Company

2651A

Ordering Information

2651A High Power System SourceMeter® SMU Instrument

Accessories Supplied

2651A-KIT-1A: Low Impedance Cable Assembly (1m)

CS-1592-2: High Current Phoenix Connector (male)

CS-1626-2: High Current Phoenix Connector (female)

CA-557-1: Sense Line Cable Assembly (1m)

7709-308A: Digital I/O Connector

CA-180-3A: TSP-Link/Ethernet Cable

Documentation CD

Software Tools and Drivers CD

ACCESSORIES AVAILABLE

2600-KIT	Screw Terminal Connector Kit
ACS-BASIC	Component Characterization Software
4299-6	Rack Mount Kit
8011	Test Socket Kit

Two A/D converters are used with each measurement mode (one for current and the other for voltage), which run simultaneously for accurate source readback that does not sacrifice test throughput.

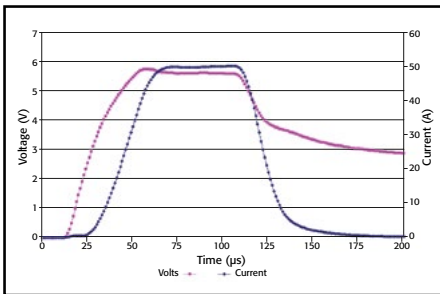

The dual digitizing A/D converters sample at up to 1µs/point, enabling full simultaneous characterization of both current and voltage waveforms.

High Speed Pulsing

The Model 2651A minimizes the unwanted effects of self heating during tests by accurately sourcing and measuring pulses as short as 100µs. Additional control flexibility enables you to program the pulse width from 100µs to DC and the duty cycle from 1% to 100%. A single

1.888.KEITHLEY (U.S. only)

www.keithley.com

50A, High Power System SourceMeter® SMU Instrument

unit can pulse up to 50A; combine two units to pulse up to 100A.

Expansion Capabilities

Through TSP-Link Technology technology, multiple Model 2651As and selected Series 2600B SMU instruments can be combined to form a larger integrated system with up to 64 channels. Precision timing and tight channel synchronization are guaranteed with built-in 500ns trigger controllers. True SMU instrument-per-pin testing is assured with the fully isolated, independent channels of the SourceMeter SMU instruments.

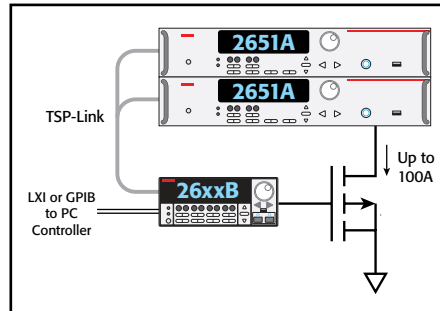

Keithley's TSP and TSP-Link Technologies enable true SMU-per-pin testing without the power and/or channel limitations of a mainframe-based system.

Also, when two Model 2651As are connected in parallel with TSP-Link Technology, the current range is expanded from 50A to 100A. When two units are connected in series, the voltage range is expanded from 40V to 80V. Built-in intelligence simplifies testing by enabling the units to be addressed as a single instrument, thus creating an industry-best dynamic range (100A to 1pA). This capability enables you to test a much wider range of power semiconductors and other devices.

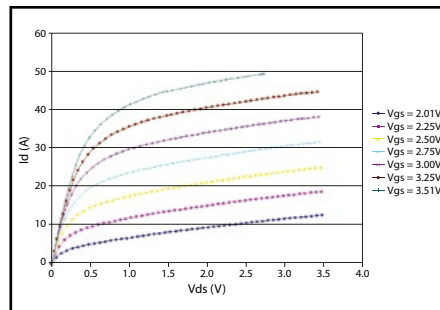

Precision measurements to 50A (100A with two units) enable a more complete and accurate characterization.

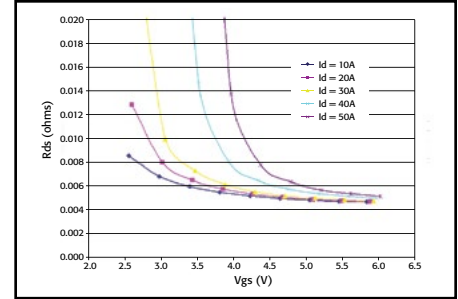

1µV measurement resolution and current sourcing up to 50A (100A with two units) enable low-level Rds measurements to support next-generation devices.

Standard Capabilities of Series 2600B SMU Instruments

Each Model 2651A includes all the features and capabilities provided in most Series 2600B SMU instruments, such as:

- Ability to be used as either a bench-top I-V characterization tool or as a building block component of multiple-channel I-V test systems
- TSP Express software to quickly and easily perform common I-V tests without programming or installing software
- ACS Basic Edition software for semiconductor component characterization (optional). ACS Basic now features a Trace mode for generating a suite of characteristic curves.
- Keithley's Test Script Processor (TSP®) Technology, which enables creation of custom user test scripts to further automate testing, and also supports the creation of programming sequences that allow the instrument to operate asynchronously without direct PC control.
- Parallel test execution and precision timing when multiple SMU instruments are connected together in a system
- LXI compliance
- 14 digital I/O lines for direct interaction with probe stations, component handlers, or other automation tools
- USB port for extra data and test program storage via USB memory device

2651A

50A, High Power System SourceMeter® SMU Instrument

Specification Conditions

This document contains specifications and supplemental information for the Model 2651A High Power System SourceMeter SMU instrument. Specifications are the standards against which the Model 2651A is tested. Upon leaving the factory, the Model 2651A meets these specifications. Supplemental and typical values are non-warranted, apply at 23°C, and are provided solely as useful information.

Accuracy specifications are applicable for both normal and high-capacitance modes.

Source and measurement accuracies are specified at the Model 2651A terminals under these conditions:

- 23° ±5°C, <70 percent relative humidity
- After two-hour warm-up
- Speed normal (1 NPLC)
- A/D autozero enabled
- Remote sense operation or properly zeroed local operation
- Calibration period: One year

VOLTAGE ACCURACY SPECIFICATIONS 1, 2

Range	SOURCE			MEASURE		
	Programming Resolution	Accuracy ±(% reading + volts)	Noise (Vpp) (typical) 0.1 Hz to 10 Hz	Default Display Resolution	Integrating ADC Accuracy ³ ±(% reading + volts)	High-Speed ADC Accuracy ⁴ ±(% reading + volts)
100.000 mV	5 μV	0.02% + 500 μV	100 μV	1 μV	0.02% + 300 μV	0.05% + 600 μV
1.00000 V	50 μV	0.02% + 500 μV	500 μV	10 μV	0.02% + 300 μV	0.05% + 600 μV
10.0000 V	500 μV	0.02% + 5 mV	1 mV	100 μV	0.02% + 3 mV	0.05% + 8 mV
20.0000 V	500 μV	0.02% + 5 mV	1 mV	100 μV	0.02% + 5 mV	0.05% + 8 mV
40.0000 V	500 μV	0.02% + 12 mV	2 mV	100 μV	0.02% + 12 mV	0.05% + 15 mV

CURRENT ACCURACY SPECIFICATIONS 5

Range	SOURCE			MEASURE		
	Programming Resolution	Accuracy ±(% reading + amps)	Noise (Ipp) (typical) 0.1Hz to 10Hz	Default Display Resolution	Integrating ADC Accuracy ³ ±(% reading + amps)	High-Speed ADC Accuracy ⁴ ±(% reading + amps)
100.000 nA	2 pA	0.1 % + 500 pA	50 pA	1 pA	0.08% + 500 pA	0.08% + 800 pA
1.00000 μA	20 pA	0.1 % + 2 nA	250 pA	10 pA	0.08% + 2 nA	0.08% + 4 nA
10.0000 μA	200 pA	0.1 % + 10 nA	500 pA	100 pA	0.08% + 8 nA	0.08% + 10 nA
100.000 μA	2 nA	0.03% + 60 nA	5 nA	1 nA	0.02% + 25 nA	0.05% + 60 nA
1.00000 mA	20 nA	0.03% + 300 nA	10 nA	10 nA	0.02% + 200 nA	0.05% + 500 nA
10.0000 mA	200 nA	0.03% + 8 μA	500 nA	100 nA	0.02% + 2.5 μA	0.05% + 10 μA
100.000 mA	2 μA	0.03% + 30 μA	1 μA	1 μA	0.02% + 20 μA	0.05% + 50 μA
1.00000 A	200 μA	0.08% + 3.5 mA	300 μA	10 μA	0.05% + 3 mA	0.05% + 5 mA
5.00000 A	200 μA	0.08% + 3.5 mA	300 μA	10 μA	0.05% + 3 mA	0.05% + 5 mA
10.0000 A	500 μA	0.15% + 6 mA	500 μA	100 μA	0.12% + 6 mA	0.12% + 12 mA
20.0000 A	500 μA	0.15% + 8 mA	500 μA	100 μA	0.08% + 8 mA	0.08% + 15 mA
50.0000 A ⁶	2 mA	0.15% + 80 mA	N/A	100 μA	0.05% + 50 mA ⁷	0.05% + 90 mA ⁸

NOTES

1. Add 50μV to source accuracy specifications per volt of HI lead drop.
2. For temperatures 0° to 18°C and 28° to 50°C, accuracy is degraded by ±(0.15 × accuracy specification)/°C. High-capacitance mode accuracy is applicable at 23° ±5°C only.
3. Derate accuracy specification for NPLC setting <1 by increasing error term. Add appropriate typical percent of range term for resistive loads using the table below.

NPLC Setting	100mV Range	1V to 40V Ranges	100nA Range	1μA to 100mA Ranges	1A to 20A Ranges
0.1	0.01%	0.01%	0.01%	0.01%	0.01%
0.01	0.08%	0.07%	0.1 %	0.05%	0.1 %
0.001	0.8 %	0.6 %	1 %	0.5 %	1.8 %

4. 18-bit ADC. Average of 1000 samples taken at 1μs intervals.
5. At temperatures 0° to 18°C and 28° to 50°C, 100nA to 10μA accuracy is degraded by ±(0.35 × accuracy specification)/°C. 100μA to 50A accuracy is degraded by ±(0.15 × accuracy specification)/°C. High-capacitance mode accuracy is applicable at 23° ±5°C only.
6. 50A range accessible only in pulse mode.
7. 50A range accuracy measurements are taken at 0.008 NPLC.
8. Average of 100 samples taken at 1μs intervals.

1.888.KEITHLEY (U.S. only)

www.keithley.com

A Greater Measure of Confidence

KEITHLEY

A Tektronix Company

2651A

50A, High Power System SourceMeter® SMU Instrument

DC POWER SPECIFICATIONS

MAXIMUM OUTPUT POWER: 202W maximum.

SOURCE/SINK LIMITS ¹:

Voltage: $\pm 10.1\text{V}$ at $\pm 20.0\text{A}$, $\pm 20.2\text{V}$ at $\pm 10.0\text{A}$, $\pm 40.4\text{V}$ at $\pm 5.0\text{A}$ ².
Four-quadrant source or sink operation.

Current: $\pm 5.05\text{A}$ at $\pm 40\text{V}$ ², $\pm 10.1\text{A}$ at $\pm 20\text{V}$, $\pm 20.2\text{A}$ at $\pm 10\text{V}$.
Four-quadrant source or sink operation.

CAUTION: Carefully consider and configure the appropriate output-off state and source and compliance levels before connecting the Model 2651A to a device that can deliver energy. Failure to consider the output-off state and source and compliance levels may result in damage to the instrument or to the device under test.

PULSE SPECIFICATIONS

MINIMUM PROGRAMMABLE PULSE WIDTH ³: $100\mu\text{s}$. Note: Minimum pulse width for settled source at a given I/V output and load can be longer than $100\mu\text{s}$.

PULSE WIDTH PROGRAMMING RESOLUTION: $1\mu\text{s}$.

PULSE WIDTH PROGRAMMING ACCURACY ³: $\pm 5\mu\text{s}$.

PULSE WIDTH JITTER: $2\mu\text{s}$ (typical).

PULSE RISE TIME (TYPICAL):

Current Range	R_{load}	Rise Time (typical)
50 A	$0.05\ \Omega$	$26\ \mu\text{s}$
50 A	$0.2\ \Omega$	$57\ \mu\text{s}$
50 A	$0.4\ \Omega$	$85\ \mu\text{s}$
20 A	$0.5\ \Omega$	$95\ \mu\text{s}$
50 A	$0.8\ \Omega$	$130\ \mu\text{s}$
20 A	$1\ \Omega$	$180\ \mu\text{s}$
10 A	$2\ \Omega$	$330\ \mu\text{s}$
5 A	$8.2\ \Omega$	$400\ \mu\text{s}$

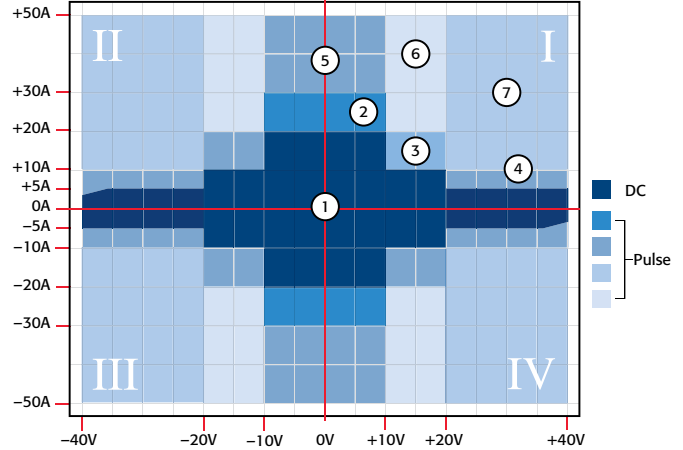

Region	Region Maximums	Maximum Pulse Width ³	Maximum Duty Cycle ⁴
1	5 A at 40 V	DC, no limit	100%
1	10 A at 20 V	DC, no limit	100%
1	20 A at 10 V	DC, no limit	100%
2	30 A at 10 V	1 ms	50%
3	20 A at 20 V	1.5 ms	40%
4	10 A at 40 V	1.5 ms	40%
5	50 A at 10 V	1 ms	35%
6	50 A at 20 V	$330\ \mu\text{s}$	10%
7	50 A at 40 V	$300\ \mu\text{s}$	1%

NOTES

- Full power source operation regardless of load to 30°C ambient. Above 30°C or power sink operation, refer to "Operating Boundaries" in the Model 2651A Reference manual for additional power derating information.
- Quadrants 2 and 4 power envelope is trimmed at 36V and 4.5A.
- Times measured from the start of pulse to the start of off-time; see figure below.

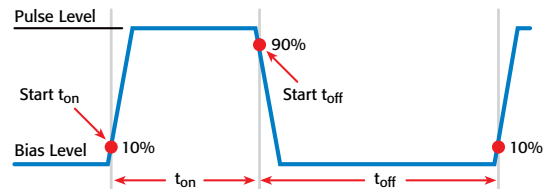

- Thermally limited in sink mode (quadrants 2 and 4) and ambient temperatures above 30°C . See power equations in the Model 2651A Reference Manual for more information.



The Model 2651A supports GPIB, LXI, Digital I/O, and Keithley's TSP-Link Technology for multi-channel synchronization.

1.888.KEITHLEY (U.S. only)

www.keithley.com

KEITHLEY
A Tektronix Company

A Greater Measure of Confidence

ADDITIONAL SOURCE SPECIFICATIONS

NOISE (10Hz to 20MHz): <100mV peak-peak (typical), <30mV RMS (typical), 10V range with a 20A limit.

OVERSHOOT:

Voltage: <±(0.1% + 10mV) (typical). Step size = 10% to 90% of range, resistive load, maximum current limit/compliance.

Current: <±(0.1% + 10mV) (typical). Step Size = 10% to 90% of range, resistive load. See Current Source Output Settling Time specifications for additional test conditions.

RANGE CHANGE OVERTHOOT:

Voltage: <300mV + 0.1% of larger range (for <20V ranges) (typical).

<400mV + 0.1% of larger range (for ≥20V ranges) (typical).
Overshoot into a 100kΩ load, 20MHz bandwidth.

Current: <5% of larger range + 360mV/R_{load} (for >10μA ranges) (typical). I_{out} × R_{load} = 1V.

VOLTAGE SOURCE OUTPUT SETTLING TIME: Time required to reach within 0.1% of final value after source level command is processed on a fixed range.¹

Range	Settling Time (typical)
1 V	< 70 μs
10 V	<160 μs
20 V	<190 μs
40 V	<175 μs

CURRENT SOURCE OUTPUT SETTLING TIME: Time required to reach within 0.1% of final value after source level command is processed on a fixed range. Values below for I_{out} × R_{load}.

Current Range	R _{load}	Settling time (typical)
20 A	0.5 Ω	<195 μs
10 A	1.5 Ω	<540 μs
5 A	5 Ω	<560 μs
1 A	1 Ω	< 80 μs
100 mA	10 Ω	< 80 μs
10 mA	100 Ω	<210 μs
1 mA	1 kΩ	<300 μs
100 μA	10 kΩ	<500 μs
10 μA	100 kΩ	< 15 ms
1 μA	1 MΩ	< 35 ms
100 nA	10 MΩ	<110 ms

TRANSIENT RESPONSE TIME:

10V and 20V Ranges: <70μs for the output to recover to within 0.1% for a 10% to 90% step change in load.

40V Range: <110μs for the output to recover to within 0.1% for a 10% to 90% step change in load.

GUARD OFFSET VOLTAGE: <4mV, current <10mA.

REMOTE SENSE OPERATING RANGE²:

Maximum Voltage between HI and SENSE HI: 3V.

Maximum Voltage between LO and SENSE LO: 3V.

MAXIMUM IMPEDANCE PER SOURCE LEAD:

Maximum impedance limited by 3V drop by remote sense operating range.

Maximum resistance = 3V/source current value (amperes) (maximum of 1Ω per source lead).

3V = I di/dt.

VOLTAGE OUTPUT HEADROOM:

5A Range: Maximum output voltage = 48.5V – (Total voltage drop across source leads).

10A Range: Maximum output voltage = 24.5V – (Total voltage drop across source leads).

20A Range: Maximum output voltage = 15.9V – (Total voltage drop across source leads).

OVERTEMPERATURE PROTECTION: Internally sensed temperature overload puts unit in stand-by mode.

LIMIT/COMPLIANCE: Bipolar limit (compliance) set with single value.

Voltage³: Minimum value is 10mV; accuracy is the same as voltage source.

Current⁴: Minimum value is 10nA; accuracy is the same as current source.

NOTES

1. With measure and compliance set to the maximum current for the specified voltage range.
2. Add 50μV to source accuracy specifications per volt of HI lead drop.
3. For sink mode operation (quadrants II and IV), add 0.6% of limit range to the corresponding voltage source accuracy specifications. For 100mV range add an additional 60mV of uncertainty. Specifications apply with sink mode enabled.
4. For sink mode operation (quadrants II and IV), add 0.6% of limit range to the corresponding current limit accuracy specifications. Specifications apply with sink mode enabled.

ADDITIONAL MEASUREMENT SPECIFICATIONS**CONTACT CHECK¹**

Speed	Maximum Measurement Time to Memory for 60Hz (50Hz)	Accuracy (1 Year) 23° ± 5°C ±(% reading + ohms)
Fast	1.1 ms (1.2 ms)	5% + 15 Ω
Medium	4.1 ms (5 ms)	5% + 5 Ω
Slow	36 ms (42 ms)	5% + 3 Ω

NOTES

1. Includes measurement of SENSE HI to HI and SENSE LO to LO contact resistances.

ADDITIONAL METER SPECIFICATIONS**MAXIMUM LOAD IMPEDANCE:**

Normal Mode: 10nF (typical), 3μH (typical).

High-Capacitance Mode: 50μF (typical), 3μH (typical).

COMMON MODE VOLTAGE: 250V DC.

COMMON MODE ISOLATION: >1GΩ, <4500pF.

MEASURE INPUT IMPEDANCE: >10GΩ.

SENSE HIGH INPUT IMPEDANCE: >10GΩ.

MAXIMUM SENSE LEAD RESISTANCE: 1kΩ for rated accuracy.

OVERRANGE: 101% of source range, 102% of measure range.

HIGH-CAPACITANCE MODE^{1,2}

ACCURACY SPECIFICATIONS³: Accuracy specifications are applicable in both normal and high-capacitance modes.

VOLTAGE SOURCE OUTPUT SETTLING TIME: Time required to reach within 0.1 % of final value after source level command is processed on a fixed range.⁴

Voltage Source Range	Settling Time with C _{load} = 4.7μF (typical)
1 V	75 μs
10 V	170 μs
20 V	200 μs
40 V	180 μs

MODE CHANGE DELAY:

100μA Current Range and Above:

Delay into High-Capacitance Mode: 11ms.

Delay out of High-Capacitance Mode: 11ms.

1μA and 10μA Current Ranges:

Delay into High-Capacitance Mode: 250ms.

Delay out of High-Capacitance Mode: 11ms.

MEASURE INPUT IMPEDANCE: >10GΩ in parallel with 25nF.

VOLTAGE SOURCE RANGE CHANGE OVERTHOOT: <400mV + 0.1% of larger range (typical).
Overshoot into a 100kΩ load, 20MHz bandwidth.

NOTES

1. High-capacitance mode specifications are for DC measurements only and use locked ranges. Autorange is disabled.
2. 100nA range is not available in high-capacitance mode.
3. Add an additional 2nA to the source current accuracy and measure current accuracy offset for the 1μA range.
4. With measure and compliance set to the maximum current for the specified voltage range.

MEASUREMENT SPEED SPECIFICATIONS ^{1, 2}

MAXIMUM SWEEP OPERATION RATES (operations per second) FOR 60Hz (50Hz):

A/D Converter Speed	Trigger Origin	Measure To Memory Using User Scripts	Measure To GPIB Using User Scripts	Source Measure To Memory Using User Scripts	Source Measure To GPIB Using User Scripts	Source Measure To Memory Using Sweep API	Source Measure To GPIB Using Sweep API
0.001 NPLC	Internal	20000 (20000)	9800 (9800)	7000 (7000)	6200 (6200)	12000 (12000)	5900 (5900)
0.001 NPLC	Digital I/O	8100 (8100)	7100 (7100)	5500 (5500)	5100 (5100)	11200 (11200)	5700 (5700)
0.01 NPLC	Internal	4900 (4000)	3900 (3400)	3400 (3000)	3200 (2900)	4200 (3700)	4000 (3500)
0.01 NPLC	Digital I/O	3500 (3100)	3400 (3000)	3000 (2700)	2900 (2600)	4150 (3650)	3800 (3400)
0.1 NPLC	Internal	580 (480)	560 (470)	550 (465)	550 (460)	560 (470)	545 (460)
0.1 NPLC	Digital I/O	550 (460)	550 (460)	540 (450)	540 (450)	560 (470)	545 (460)
1.0 NPLC	Internal	59 (49)	59 (49)	59 (49)	59 (49)	59 (49)	59 (49)
1.0 NPLC	Digital I/O	58 (48)	58 (49)	59 (49)	59 (49)	59 (49)	59 (49)
HS ADC	Internal	38500 (38500)	18000 (18000)	10000 (10000)	9500 (9500)	14300 (14300)	6300 (6300)
HS ADC	Digital I/O	12500 (12500)	11500 (11500)	7500 (7500)	7000 (7000)	13200 (13200)	6000 (6000)

HIGH SPEED ADC BURST MEASUREMENT RATES ³

Burst Length (readings)	Readings per Second	Bursts per Second
100	1,000,000	400
500	1,000,000	80
1000	1,000,000	40
2500	1,000,000	16
5000	1,000,000	8

MAXIMUM SINGLE MEASUREMENT RATES (operations per second) FOR 60Hz (50Hz)

A/D Converter Speed	Trigger Origin	Measure To GPIB	Source Measure To GPIB	Source Measure Pass/Fail To GPIB
0.001 NPLC	Internal	1900 (1800)	1400 (1400)	1400 (1400)
0.01 NPLC	Internal	1450 (1400)	1200 (1100)	1100 (1100)
0.1 NPLC	Internal	450 (390)	425 (370)	425 (375)
1.0 NPLC	Internal	58 (48)	57 (48)	57 (48)

MAXIMUM MEASUREMENT RANGE CHANGE RATE: >4000 per second for >10 μ A (typical).

MAXIMUM SOURCE RANGE CHANGE RATE: >325 per second for >10 μ A, typical. When changing to or from a range \geq 1A, maximum rate is >250 per second, typical.

COMMAND PROCESSING TIME: Maximum time required for the output to begin to change following the receipt of the smua.source.levelv or smua.source.leveli command. <1ms typical.

NOTES

1. Tests performed with a Model 2651A on channel A using the following equipment: Computer hardware (Intel® Pentium® 4 2.4GHz, 2GB RAM, National Instruments™ PCI-GPIB). Driver (NI-488.2 Version 2.2 PCI-GPIB). Software (Microsoft® Windows® XP, Microsoft Visual Studio® 2010, VISA™ version 4.1).
2. Exclude current measurement ranges less than 1mA.
3. smua.measure.adc has to be enabled and the smua.measure.count set to the burst length.

TRIGGERING AND SYNCHRONIZATION SPECIFICATIONS

TRIGGERING:

- Trigger In to Trigger Out: 0.5 μ s (typical).
- Trigger In to Source Change ¹: 10 μ s (typical).
- Trigger Timer Accuracy: \pm 2 μ s (typical).
- Source Change ¹ After LXI Trigger: 280 μ s (typical).

SYNCHRONIZATION:

- Single-Node Synchronized Source Change ¹: <0.5 μ s (typical).
- Multi-Node Synchronized Source Change ¹: <0.5 μ s (typical).

NOTES

1. Fixed source range with no polarity change.

1.888.KEITHLEY (U.S. only)

www.keithley.com

KEITHLEY

A Tektronix Company

A Greater Measure of Confidence

2651A

50A, High Power System SourceMeter[®] SMU Instrument

SUPPLEMENTAL INFORMATION

FRONT PANEL INTERFACE: Two-line vacuum fluorescent display (VFD) with keypad and navigation wheel.

DISPLAY:

Show error messages and user defined messages. Display source and limit settings.
 Show current and voltage measurements View measurements stored in dedicated (6½-digit to 4½-digit) reading buffers.

KEYPAD OPERATIONS:

Change host interface settings.
 Save and restore instrument setups.
 Load and run factory and user defined test scripts that prompt for input and send results to the display.
 Store measurements into dedicated reading buffers.

PROGRAMMING: Embedded Test Script Processor (TSP[®]) scripting engine is accessible from any host interface.

Responds to individual instrument control commands.
 Responds to high speed test scripts comprised of instrument control commands and Test Script Language (TSL) statements (for example, branching, looping, and math).
 Able to execute high speed test scripts stored in memory without host intervention.

MINIMUM USER MEMORY AVAILABLE: 16MB (approximately 250,000 lines of TSP code).

TEST SCRIPT BUILDER: Integrated development environment for building, running, and managing TSP scripts. Includes an instrument console for communicating with any TSP enabled instrument in an interactive manner. Requires:

- VISA (NI-VISA included on CD),
- Microsoft[®] .NET Framework (included on CD),
- Keithley I/O Layer (included on CD),
- Intel[®] Pentium III 800MHz or faster personal computer,
- Microsoft Windows[®] 2000, XP, Vista[®], or 7.

TSP EXPRESS (embedded): Tool that allows users to quickly and easily perform common I-V tests without programming or installing software. To run TSP Express, you need:

- Java[™] Platform, Standard Edition 6,
- Microsoft Internet Explorer[®], Mozilla[®] Firefox[®], or another Java-compatible web browser.

SOFTWARE INTERFACE: TSP Express (embedded), direct GPIB/VISA, read/write with Microsoft Visual Basic[®], Visual C/C++[®], Visual C#[®], LabVIEW[™], CEC TestPoint[™] Data Acquisition Software Package, NI LabWindows[™]/CVI, etc.

READING BUFFERS: Nonvolatile memory uses dedicated storage areas reserved for measurement data. Reading buffers are arrays of measurement elements. Each element can hold the following items:

Measurement	Source setting (at the time the measurement was taken)
Measurement status	Range information
Timestamp	

Two reading buffers are reserved for each Model 2651A channel. Reading buffers can be filled using the front panel STORE key and retrieved using the RECALL key or host interface.

Buffer Size, with timestamp and source setting: >60,000 samples.

Buffer Size, without timestamp and source setting: >140,000 samples.

SYSTEM EXPANSION: The TSP-Link expansion interface allows TSP-enabled instruments to trigger and communicate with each other. See figure below.

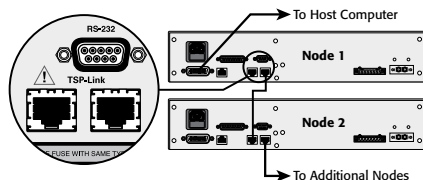

Each Model 2651A has two TSP-Link connectors to make it easier to connect instruments together in sequence.

Once source-measure instruments are interconnected through the TSP-Link expansion interface, a computer can access all the resources of each source-measure instrument through the host interface of any Model 2651A.

A maximum of 32 TSP-Link nodes can be interconnected. Each source-measure instrument consumes one TSP-Link node.

TIMER: Free-running 47-bit counter with 1MHz clock input. Resets each time instrument power is turned on. If the instrument is not turned off, the timer is reset to zero every 4 years.

Timestamp: TIMER value is automatically saved when each measurement is triggered.

Resolution: 1µs.

Timestamp Accuracy: ±100ppm.

GENERAL

DIGITAL I/O INTERFACE:

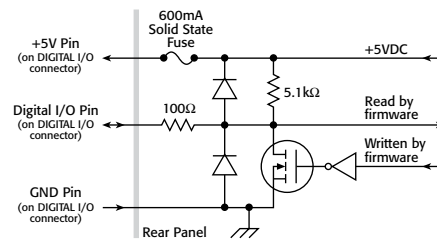

Connector: 25-pin female D.

Input/Output Pins: 14 open drain I/O bits.

Absolute Maximum Input Voltage: 5.25V.

Absolute Minimum Input Voltage: -0.25V.

Maximum Logic Low Input Voltage: 0.7V, +850µA max.

Minimum Logic High Input Voltage: 2.1V, +570µA.

Maximum Source Current (flowing out of digital I/O bit): +960µA.

Maximum Sink Current At Maximum Logic Low Voltage (0.7): -5.0mA.

Absolute Maximum Sink Current (flowing into digital I/O pin): -11mA.

5V Power Supply Pin: Limited to 250mA, solid-state fuse protected.

Output Enable Pin: Active high input pulled down internally to ground with a 10kΩ resistor; when the output enable input function has been activated, the Model 2651A channel will not turn on unless the output enable pin is driven to >2.1V (nominal current = 2.1V/10kΩ = 210µA).

IEEE-488: IEEE-488.1 compliant. Supports IEEE-488.2 common commands and status model topology.

RS-232: Baud rates from 300bps to 115200bps. Programmable number of data bits, parity type, and flow control (RTS/CTS hardware or none). When not programmed as the active host interface, the Model 2651A can use the RS-232 interface to control other instrumentation.

ETHERNET: RJ-45 connector, LXI, 10/100BT, Auto MDIX.

LXI COMPLIANCE: LXI Class C 1.2.

Total Output Trigger Response Time: 245µs minimum, 280µs (typical), (not specified) maximum.

Receive Lan[0-7] Event Delay: Unknown.

Generate Lan[0-7] Event Delay: Unknown.

EXPANSION INTERFACE: The TSP-Link Technology expansion interface allows TSP-enabled instruments to trigger and communicate with each other.

Cable Type: Category 5e or higher LAN crossover cable. 3 meters maximum between each TSP-enabled instrument.

USB: USB 2.0 host controller.

POWER SUPPLY: 100V to 250V AC, 50Hz to 60Hz (autosensing), 550VA maximum.

COOLING: Forced air; side and top intake and rear exhaust.

WARRANTY: 1 year.

EMC: Conforms to European Union EMC Directive.

SAFETY: UL listed to UL61010-1:2004. Conforms to European Union Low Voltage Directive.

DIMENSIONS: 89mm high × 435mm wide × 549mm deep (3.5 in. × 17.1 in. × 21.6 in.).

BENCH CONFIGURATION (with handle and feet): 104mm high × 483mm wide × 620mm deep (4.1 in. × 19 in. × 24.4 in.).

WEIGHT: 9.98kg (22 lbs).

ENVIRONMENT: For indoor use only.

ALTITUDE: Maximum 2000 meters above sea level.

OPERATING: 0° to 50°C, 70% relative humidity up to 35°C. Derate 3% relative humidity/°C, 35° to 50°C.

STORAGE: -25° to 65°C.

1.888.KEITHLEY (U.S. only)

www.keithley.com

A Greater Measure of Confidence

KEITHLEY
A Tektronix Company

Model 2651A specifications

SMU INSTRUMENTS

2657A

High Power System SourceMeter[®] SMU Instrument



High power SourceMeter SMU instrument

- Source or sink up to 180W of DC or pulsed power ($\pm 3000V @ 20mA$, $\pm 1500V @ 120mA$)
- 1fA low current resolution
- Dual 22-bit precision ADCs and dual 18-bit 1 μs per point digitizers for high accuracy and high speed transient capture
- Fully TSP[®] compliant for easy system integration with Series 2600B System SourceMeter models
- Combines a precision power supply, current source, DMM, arbitrary waveform generator, V or I pulse generator, electronic 18-bit load, and trigger controller – all in one instrument
- Includes TSP[®] Express characterization software, LabVIEW[®] driver, and Keithley's Test Script Builder software development environment

TYPICAL APPLICATIONS

- Power semiconductor device characterization and testing
- Characterization of GaN, SiC, and other compound materials and devices
- Breakdown and leakage testing to 3kV
- Characterization of sub-millisecond transients

The Model 2657A is a high voltage, high power, low current source measure unit (SMU) instrument that delivers unprecedented power, precision, speed, flexibility, and ease of use to improve productivity in R&D, production test, and reliability environments. The Model 2657A is designed specifically for characterizing and testing high voltage electronics and power semiconductors, such as diodes, FETs, and IGBTs, as well as other components and materials in which high voltage, fast response, and precise measurements of voltage and current are required. The Model 2657A offers the highest power and best low current performance in the industry. It is supported by the industry's most powerful parametric characterization software platforms to grow with you as your applications evolve.

The Model 2657A offers highly flexible, four-quadrant voltage and current source/load coupled with precision voltage and current meters. It can be used as a:

- Semiconductor characterization instrument
- V or I waveform generator
- V or I pulse generator
- Precision power supply with V and I readback
- True current source
- Digital multimeter (DCV, DCI, ohms, and power with 6½-digit resolution)
- Precision electronic load

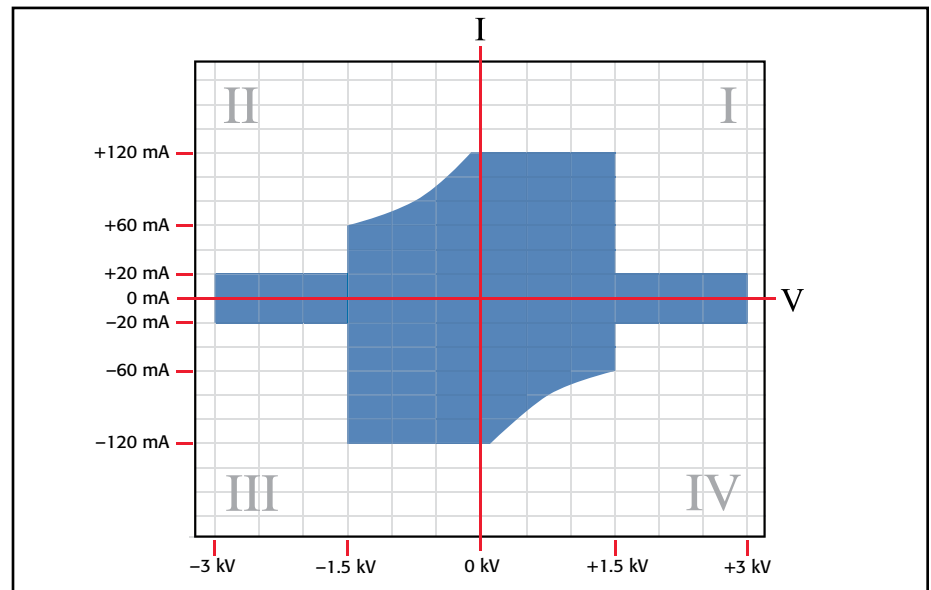

The Model 2657A can source or sink up to 3000V @ 20mA or 1500V @ 120mA.

1.888.KEITHLEY (U.S. only)

www.keithley.com

A Greater Measure of Confidence

KEITHLEY
A Tektronix Company

2657A

High Power System SourceMeter SMU Instrument

Ordering Information

2657A High Power System SourceMeter SMU Instrument

Cables must be purchased separately. Please contact your local sales office for configuration assistance.

8010 High Power Device Test Fixture

Accessories Supplied

7709-308A Digital I/O and Interlock Connector

CA-180-3A TSP-Link/Ethernet Cable Documentation CD

Software tools and drivers CD

ACCESSORIES AVAILABLE

2657A-LIM-3	Low Interconnect Module
2657A-PM-200	200V Protection Module
4299-6	Fixed Rack Mount Kit
SHV-CA-553-x	High Voltage Triax to SHV Cable (1, 2, 3m)
HV-CA-554-x	High Voltage Triax to Triax Cable (0.5, 1, 2, 3m)
HV-CA-571-3	High Voltage Triax to Unterminated Cable
HV-CS-1613	High Voltage Triax Feedthrough Connector

ACCESSORIES SUPPLIED WITH THE 8010

CA-558-2	25-pin D-sub Interlock Cable for 26xxA
CA-560-x	4mm Black and Red Banana Cables, 8 in.
CA-562-x	6mm Black and Red Banana Cables, 10 in.
CA-563	BNC to Banana Cable, 9.5 in.
CA-568-120	Safety Earth Ground Cable
8010-DTB	Device Test Board with TO-247 Socket

ACCESSORIES AVAILABLE FOR THE 8010

8010-CTB	Customizable Test Board
8010-DTB-220	Device Test Board with TO-220 Socket (1.5kV)

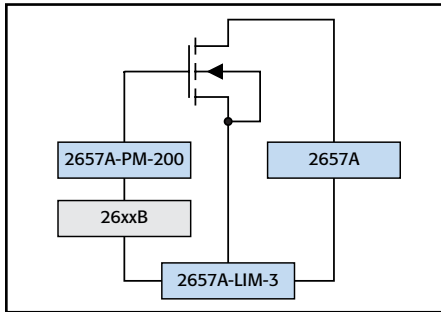

The Model 2657A can be combined with Series 2600B and Model 4200-SCS SMU instruments to support multi-terminal test capability. The Models 2657A-PM-200 Protection Module and 2657A-LIM-3 Low Interconnect Module make it easier to connect multiple instruments to a probe station safely (not required for connecting to the Model 8010 High Power Device Test Fixture).

Two Measurement Modes: Digitizing or Integrating

Precisely characterize transient and steady-state behavior, including rapidly changing thermal effects, with the two measurement modes in the Model 2657A. Each mode is defined by its independent analog-to-digital (A/D) converters.

The digitizing measurement mode provides speeds up to 1 μ s per sample. The dual 18-bit digitizers allow you to capture voltage and current transients simultaneously. In the integrating measurement mode, the dual 22-bit integrating analog to digital converters allow more precise measurement of voltage and current. Two A/D converters are used with each measurement mode, one for current and the other for voltage, that run simultaneously for accurate source readback that does not sacrifice test throughput.

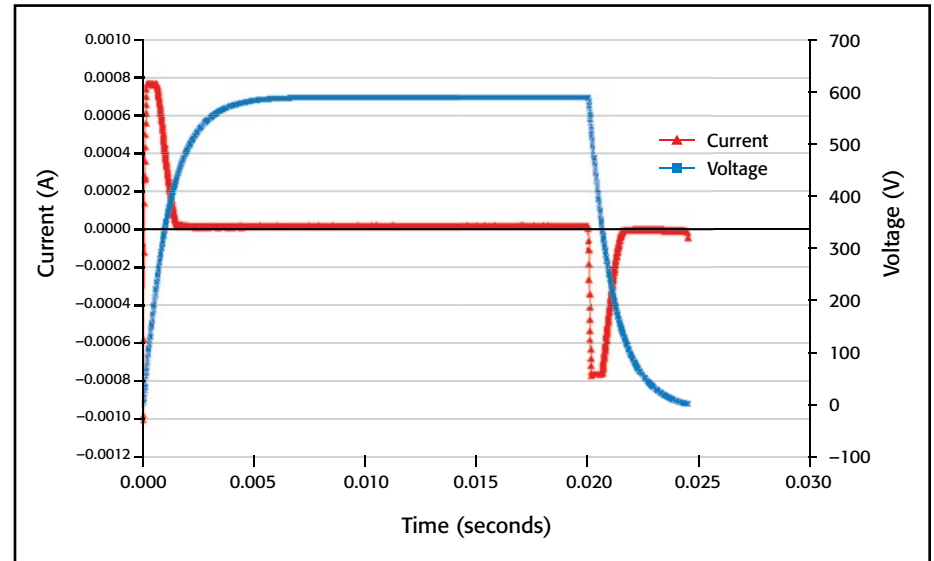

The dual high speed A/D converters sample as fast as 1 μ s per point, enabling full simultaneous characterization of both voltage and current.

Expansion Capabilities

Through TSP-Link Technology technology, the Model 2657A can be linked with Series 2600B SMU instruments to form a larger integrated system with up to 32 nodes. Precision timing and tight channel synchronization are guaranteed with built-in 500ns trigger controllers. The fully isolated, independent channels of the SourceMeter SMU instruments make true SMU-per-pin testing possible.

High Power Device Test Fixture

The Model 8010 High Power Device Test Fixture provides safe and easy connections for testing packaged high power devices at up to 3000V or 100A. The Model 8010 provides connections for a high voltage SourceMeter SMU instrument (Model 2657A), one or two high current SourceMeter SMU instruments (Model 2651A), and three low power SourceMeter SMU instruments (Series 2600B or Model 4200-SCS SMU instruments). This allows devices with two terminals (diodes) or three terminals (transistors) or even four or five terminals to be characterized safely and accurately. The Model 8010 has full interlock capability for up to six SourceMeter SMU instruments. The Model 8010 has integrated protection circuits that protect the low voltage SourceMeter SMU instruments from high voltages the Model 2657A can output should a device fault occur. The Model 8010 includes both a high current (100A) and a high voltage (3000V) test socket. Various replacement test socket modules are available, including TO-247, TO-220, axial lead, and a blank socket module that allows building a custom socket. In addition to standard banana jumpers, the Model 8010 has rear-panel scope and thermal probe ports to simplify system integration.

1.888.KEITHLEY (U.S. only)

www.keithley.com

A Greater Measure of Confidence

KEITHLEY

A Tektronix Company

High power SourceMeter SMU instrument

SMU INSTRUMENTS

2657A

High Power System SourceMeter SMU Instrument

Standard Capabilities of Series 2600B SMU Instruments

Each Model 2657A includes all the features and capabilities provided in Series 2600B SourceMeter SMU instruments:

- Flexibility for use as either a bench-top I-V characterization tool or as a building block component of multiple channel I-V test systems.
- TSP Express software to perform common I-V tests quickly and easily without programming or installing software.
- ACS Basic Edition software for semiconductor component characterization (optional). ACS Basic Edition now features a "Trace" mode for generating a suite of characteristic curves.
- Keithley's Test Script Processor (TSP) technology supports creating and running custom user test scripts for high speed test automation, as well as creating programming sequences that allow the instrument to operate asynchronously without direct PC control.
- Parallel test execution and precision timing when multiple Series 2600B SMU instruments are connected together in a system.
- LXI Class C compliance.
- 14 digital I/O lines for direct connection to a probe station, component handler, or other automation tools.
- USB port for extra data and test program storage via USB memory device.

Model 2657A Condensed Specifications

VOLTAGE ACCURACY SPECIFICATIONS ¹

Range	SOURCE		MEASURE		
	Programming Resolution	Accuracy ±(% rdg + volts)	Display Resolution	Integrating ADC Accuracy ² ±(% rdg + volts)	High Speed ADC Accuracy ³ ±(% rdg + volts)
200 V	5 mV	0.03% + 50 mV	100 μV	0.025% + 50 mV	0.05% + 100 mV
500 V	10 mV	0.03% + 125 mV	100 μV	0.025% + 100 mV	0.05% + 200 mV
1500 V	40 mV	0.03% + 375 mV	1 mV	0.025% + 300 mV	0.05% + 600 mV
3000 V	80 mV	0.03% + 750 mV	1 mV	0.025% + 600 mV	0.05% + 1.2 V

CURRENT ACCURACY SPECIFICATIONS ⁴

Range	SOURCE		MEASURE		
	Programming Resolution	Accuracy ±(% rdg + amps)	Display Resolution	Integrating ADC Accuracy ² ±(% rdg + amps)	High Speed ADC Accuracy ³ ±(% rdg + amps)
1 nA	30 fA	0.1% + 2E ⁻¹² + VoE ⁻¹⁵	1 fA	0.1% + 6E ⁻¹³ + VoE ⁻¹⁵	0.2% + 6E ⁻¹³ + VoE ⁻¹⁵
10 nA	300 fA	0.1% + 5E ⁻¹² + VoE ⁻¹⁵	10 fA	0.1% + 5E ⁻¹² + VoE ⁻¹⁵	0.2% + 5E ⁻¹² + VoE ⁻¹⁵
100 nA	3 pA	0.1% + 6E ⁻¹¹ + VoE ⁻¹³	100 fA	0.1% + 6E ⁻¹¹ + VoE ⁻¹³	0.2% + 6E ⁻¹¹ + VoE ⁻¹³
1 μA	30 pA	0.03% + 700 pA	1 pA	0.025% + 400 pA	0.08% + 800 nA
10 μA	300 pA	0.03% + 5 nA	10 pA	0.025% + 1.5 nA	0.08% + 3 nA
100 μA	3 nA	0.03% + 60 nA	100 pA	0.02% + 25 nA	0.05% + 50 nA
1 mA	30 nA	0.03% + 300 nA	1 nA	0.02% + 200 nA	0.05% + 400 nA
2 mA	60 nA	0.03% + 1.2 μA	1 nA	0.02% + 500 nA	0.05% + 1 μA
20 mA	600 nA	0.03% + 12 μA	10 nA	0.02% + 5 μA	0.05% + 10 μA
120 mA	3 μA	0.03% + 36 μA	100 nA	0.02% + 24 μA	0.05% + 50 μA

1. For temperatures 0° to 18°C and 28° to 50°C, accuracy is degraded by ±(0.15 × accuracy specification)^{°C}.

2. Derate accuracy specification for NPLC setting <1 by increasing error term. Add appropriate typical percent of range term for resistive loads using the table below.

NPLC Setting	200 V and 500 V Ranges	1500 V and 3000 V Ranges	100 nA Range	1 μA to 120 mA Ranges
0.1	0.01%	0.01%	0.01%	0.01%
0.01	0.08%	0.07%	0.1%	0.05%
0.001	0.8%	0.6%	1%	0.5%

3. 18-bit ADC. Average of 1000 samples taken at 1μs intervals.

4. For temperatures 0° to 18°C and 28° to 50°C, accuracy is degraded by ±(0.35 × accuracy specification)^{°C}.

SUPPLEMENTAL CHARACTERISTICS

TYPICAL VOLTAGE SOURCE NOISE: 0.005% of range.

TYPICAL CURRENT SOURCE NOISE: 0.08% of range.

TYPICAL VOLTAGE SOURCE SETTLING: <1ms to 200V, <7ms to 3000V.

TYPICAL CURRENT SOURCE SETTLING: <5ms to 120mA, <200ms to 1μA.

Specifications are subject to change without notice.



Model 8010 High Power Device Test Fixture

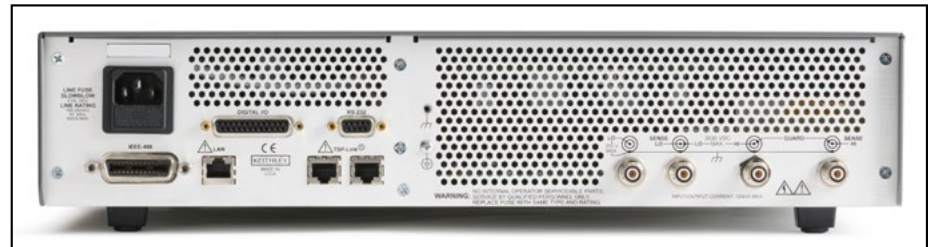

Model 2657A rear panel

1.888.KEITHLEY (U.S. only)

www.keithley.com

KEITHLEY

A Tektronix Company

A Greater Measure of Confidence

2657A

High Power System SourceMeter SMU Instrument

TRIGGERING AND SYNCHRONIZATION SPECIFICATIONS

TRIGGERING: Trigger In to Trigger Out: 0.5 μ s, typical.

SYNCHRONIZATION: Single- or multi-node synchronized source change: <0.5 μ s, typical.

PROGRAMMING

TEST SCRIPT BUILDER: Integrated development environment for building, running, and managing TSP scripts.

TSP EXPRESS (Embedded): Tool that allows users to perform common I-V tests quickly and easily without programming or installing software.

SOFTWARE INTERFACE: TSP Express (Embedded), Direct GPIB/VISA, Read/Write with VB, VC/C++, VC#, LabVIEW™, TestPoint™, LabWindows™/CVI, etc.

SYSTEM EXPANSION

The TSP-Link expansion interface allows TSP-enabled instruments to trigger and communicate with each other. See figure below:

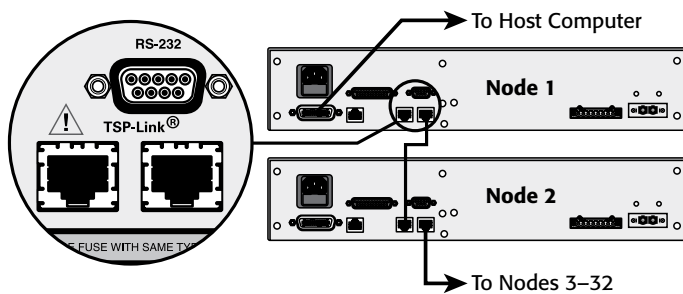

GENERAL

USB: USB 2.1 Host Controller, supports external data storage.

CONTACT CHECK: $\pm 50\Omega$.

PC INTERFACE: IEEE-488.1 and .2; LXI Ethernet; RS-232.

DIGITAL I/O INTERFACE: Input/Output Pins: 14 open drain I/O bits. 5.25V max.

POWER SUPPLY: 100V to 250VAC, 50Hz–60Hz (auto sensing), 550VA max.

COOLING: Forced air. Side and top intake and rear exhaust.

EMC: Conforms to European Union EMC Directive.

SAFETY: ETL listed (PENDING). Conforms to European Union Low Voltage Directive.

WARRANTY: 1 year.

DIMENSIONS: 89mm high \times 435mm wide \times 549mm deep (3.5 in \times 17.1 in \times 21.6 in). Bench Configuration (with handle and feet): 104mm high \times 483mm wide \times 620mm deep (4.1 in \times 19 in \times 24.4 in).

WEIGHT: 9.98kg (22 lbs).

ENVIRONMENT: For indoor use only.

CALIBRATION PERIOD: One year.

2450

SourceMeter® SMU Instrument



The Model 2450 is Keithley's next-generation SourceMeter source measure unit (SMU) instrument that truly brings Ohm's law (current, voltage, and resistance) testing right to your fingertips. Its innovative graphical user interface (GUI) and advanced, capacitive touchscreen technology allow intuitive usage and minimize the learning curve to enable engineers and scientists to learn faster, work smarter, and invent easier. The Model 2450 is the SMU for everyone: a versatile instrument, particularly well-suited for characterizing modern scaled semiconductors, nano-scale devices and materials, organic semiconductors, printed electronics, and other small-geometry and low-power devices. All this combined with Keithley SMU precision and accuracy allows users to Touch, Test, Invent® with the new favorite go-to instrument in the lab for years to come.

Learn Faster, Work Smarter, and Invent Easier

Unlike conventional instruments with dedicated pushbutton technology and small, obscure, limited-character displays, the Model 2450 features a five-inch, full-color, high-resolution touchscreen that facilitates ease of use, learning, and optimizes overall speed and productivity. A simple icon-based menu structure reduces configuration steps by as much as 50 percent and eliminates the cumbersome multi-layer menu structures typically used on soft-key instruments. Built-in, context-sensitive help enables intuitive operation and minimizes the need to review a separate manual. These capabilities combined with its application versatility make the Model 2450 the SMU instrument inherently easy to use for basic and advanced measurement applications, regardless of your experience level with SMU instruments.



Model 2450 main home screen.



Model 2450 icon-based menu.

Fourth-Generation, All-in-One SMU Instrument

The Model 2450 is the fourth-generation member of Keithley's award-winning SourceMeter family of SMU instruments and leverages the proven capabilities of the Model 2400 SourceMeter SMU Instrument. It offers a highly flexible, four-quadrant voltage and current source/load coupled with precision voltage and current meters. This all-in-one instrument can be used as a:

- Precision power supply with V and I readback
- True current source
- Digital multimeter (DCV, DCI, ohms, and power with 6½-digit resolution)
- Precision electronic load
- Trigger controller

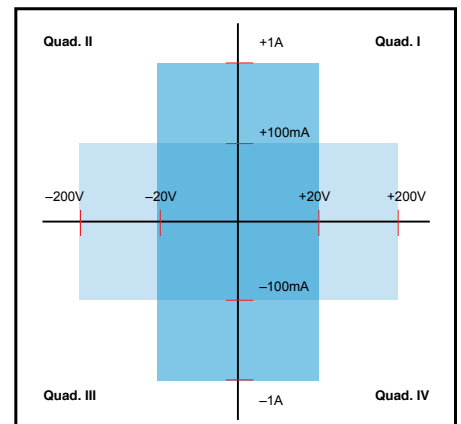

Model 2450 power envelope.

- Capabilities of analyzers, curve tracers, and I-V systems at a fraction of their cost
- Five-inch, high resolution capacitive touchscreen GUI
- 0.012% basic measure accuracy with 6½-digit resolution
- Enhanced sensitivity with new 20mV and 10nA source/measure ranges
- Source and sink (four-quadrant) operation
- Four "Quickset" modes for fast setup and measurements
- Built-in, context-sensitive front panel help
- Front panel input banana jacks; rear panel input triaxial connections
- 2450 SCPI and TSP® scripting programming modes
- Model 2400 SCPI-compatible programming mode
- Front panel USB memory port for data/programming/configuration I/O

1.888.KEITHLEY (U.S. only)

www.keithley.com

2450

SourceMeter® SMU Instrument

Ordering Information

- 2450** 200V, 1A, 20W SourceMeter Instrument
- 2450-NFP** 200V, 1A, 20W SourceMeter Instrument, with No Front Panel
- 2450-RACK** 200V, 1A, 20W SourceMeter Instrument, without Handle
- 2450-NFP-RACK** 200V, 1A, 20W SourceMeter Instrument, with No Front Panel and No Handle

Accessories Supplied

- 8608** High Performance Test Leads
- USB-B-1** USB Cable, Type A to Type B, 1m (3.3 ft)
- CS-1616-3** Safety Interlock Mating Connector
- CA-180-3A** TSP-Link/Ethernet Cable
- Documentation CD
- 2450 QuickStart Guide
- Test Script Builder Software (supplied on CD)
- KickStart Startup Software (supplied on CD)
- LabVIEW and IVI Drivers available at www.keithley.com

Model 2400	Model 2450
V-Ranges: 200mV – 200V	V-Ranges: 20mV – 200V
I-Ranges: 1 μ A – 1A	I-Ranges: 10nA – 1A
0.012% Basic Accuracy	0.012% Basic Accuracy
Wideband Noise: 4mV _{rms} Typ.	Wideband Noise: 2mV _{rms} Typ.
Sweep Types: Linear, Log, Custom, Source-Memory	Sweep Types: Linear, Log, Dual Linear, Dual Log, Custom, Source-Memory (SCPI 2400 Mode)
5000 Point Reading Buffer >2000 Readings/Sec.	>250,000 Point Reading Buffer >3000 Readings/Sec.
SCPI Programming GPIB	SCPI (2400 + 2450) + TSP Programming GPIB, USB, Ethernet (LXI)
Front/Rear Banana Jacks	Front: Banana Jacks, Rear: Triax

Comparison of Model 2400 vs Model 2450.

Ease of Use Beyond the Touchscreen

In addition to its five-inch, color touchscreen, the Model 2450 front panel has many features that supplement its speed, user-friendliness, and learnability, including a USB 2.0 memory I/O port, a HELP key, a rotary navigation/control knob, a front/rear input selector button, and banana jacks for basic bench applications. The USB 2.0 memory port supports easy data storing, saving instrument configurations, loading test scripts, and system upgrades. Plus, all front panel buttons are backlit to enhance visibility in low-light environments.



Model 2450 front panel with high-resolution, capacitive touchscreen.

Four “Quickset” modes simplify user setup. With one touch, the instrument can be quickly configured for various operating modes without the need to configure the instrument indirectly for this operation.

Comprehensive Built-in Connectivity

Rear panel access to rear-input triax connectors, remote control interfaces (GPIB, USB 2.0, and LXI/Ethernet), D-sub 9-pin digital I/O port (for internal/external trigger signals and handler control), instrument interlock control, and TSP-Link® jacks enables easy configuration of multiple instrument test solutions and eliminates the need to invest in additional adapter accessories.

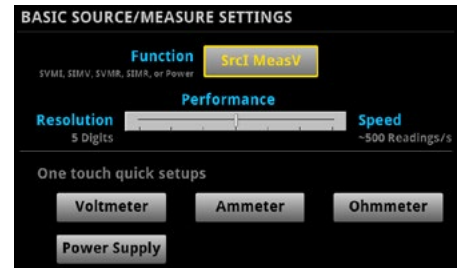

Quickset modes enable fast setup and time to measurements.

1.888.KEITHLEY (U.S. only)

www.keithley.com

A Greater Measure of Confidence

KEITHLEY
A Tektronix Company

Model 2450 SourceMeter® SMU Instrument

SMU INSTRUMENTS

2450

SourceMeter® SMU Instrument

Model 2450 SourceMeter® SMU Instrument

SMU INSTRUMENTS

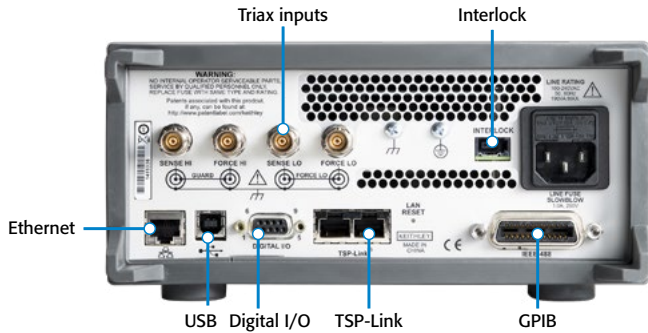

Rear panel connections are optimized for signal integrity.

Convert Raw Data to Information

The Model 2450 provides a full plotting and sheet view to display sweeps, measurement data, and charting right on the screen. It also supports exporting to a spreadsheet for further analysis, dramatically improving productivity for research, bench-top testing, device qualification, and debugging.

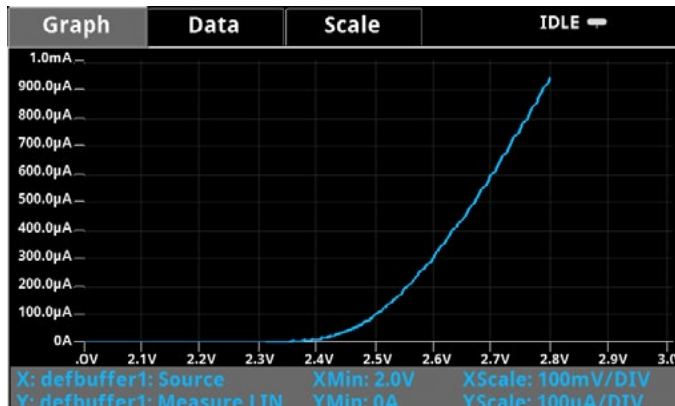

DATA SHEET

Buffer: defbuffer1 [Up Arrow] [Down Arrow] Jump Refresh

	Time	Source	Measure
1	05/08 09:50	0	-2.51326e-07
2	09:50:03.6	0.1	6.38803e-05
3	09:50:05.3	0.2	0.000127991
4	09:50:05.8	0.3	0.00019225
5	09:50:06.4	0.4	0.000256259
6	09:50:06.9	0.5	0.000320488
7	09:50:07.5	0.6	0.000384533
8	09:50:08.0	0.7	0.000448547
9	09:50:08.6	0.8	0.000512793
10	09:50:09.1	0.9	0.000576823
11	09:50:09.7	1	0.000641066

Full data display, charting, and export to a spreadsheet lets you convert raw data to useful information.

1.888.KEITHLEY (U.S. only)

www.keithley.com

TYPICAL APPLICATIONS

Ideal for current/voltage characterization and functional test of a wide range of today's modern electronics and devices, including:

- **Nanomaterials and Devices**
 - Graphene
 - Carbon nanotubes
 - Nanowires
 - Low power nanostructures
- **Semiconductor Structures**
 - Wafers
 - Thin films
- **Organic Materials and Devices**
 - E-inks
 - Printable electronics
- **Energy Efficiency and Lighting**
 - LEDs/AMOLEDs
 - Photovoltaics/Solar cells
 - Batteries
- **Discrete and Passive Components**
 - Two-leaded: Resistors, diodes, zener diodes, LEDs, disk drive heads, sensors
 - Three-leaded: Small signal bipolar junction transistors (BJTs), field effect transistors (FETs), and more
- **Material Characterization**
 - Resistivity
 - Hall Effect

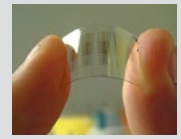
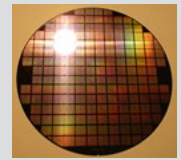
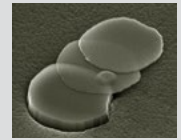
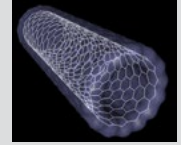

TriggerFlow™ Building Blocks for Instrument Control and Execution

The Model 2450 incorporates Keithley's new TriggerFlow triggering system that allows user control of instrument execution. Similar to developing a flow chart, TriggerFlow diagrams are created using four fundamental building blocks:

- **Wait** – Waits for an event to occur before the flow continues
- **Branch** – Branches when a condition has been satisfied
- **Action** – Initiates an action in the instrument, for example, measure, source, delay, set digital I/O, etc.
- **Notify** – Notifies other equipment that an event has occurred

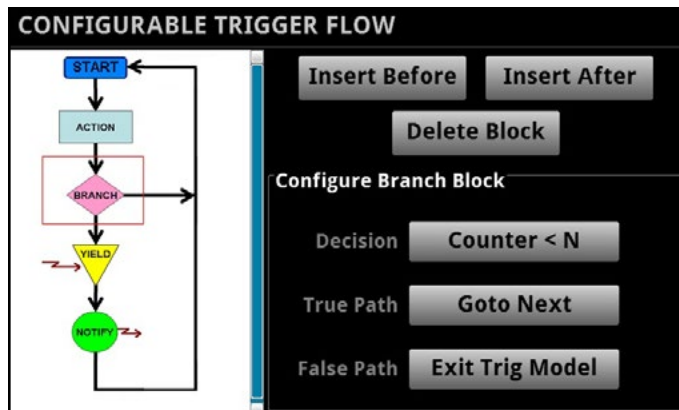

TriggerFlow building blocks let users create very simple to very complex triggering models.

A TriggerFlow model using a combination of these building blocks can be created from the front panel or by sending remote commands. With the TriggerFlow system, users can build triggering models from very simple to complex with up to 255 block levels. The Model 2450 also includes basic triggering functions, including immediate, timer, and manual triggering.

Unmatched System Integration and Programming Flexibility

When the 2450 is integrated as part of a multi-channel I-V test system, the Test Script Processor (TSP®) embedded scripting capability allows test scripts to be run by the instrument, enabling the user to create powerful measurement applications with significantly reduced development times. TSP technology also offers channel expansion without a mainframe. Keithley's TSP-Link® channel expansion bus, which uses a 100 Base T Ethernet cable, connects multiple 2450 instruments and other TSP instruments such as Keithley's Series 2600B SourceMeter SMU instruments and Series 3700A Switch/Multimeter systems in a master-slave configuration that behaves as one integrated system. The TSP-Link expansion bus supports up to 32 units per GPIB or IP address, making it easy to scale a system to fit an application's particular requirements.

The 2450 also includes a SCPI programming mode that optimizes the instrument's new features, as well as a SCPI 2400 mode that provides backwards compatibility with the existing Model 2400 SourceMeter instrument. Not only does this preserve your 2400 investment but it also eliminates re-work normally associated with upgrading to a new instrument with new capabilities.

Parallel Test Capability

With the TSP technology in the 2450, multiple devices can be tested in parallel to meet the needs of device research, advanced semiconductor lab applications, and even high throughput production test. This parallel testing capability enables each instrument in the system to run its own complete test sequence, creating a fully multi-threaded test environment. The number of tests that can be run in parallel on a 2450 can be as high as the number of instruments in the system.

Free Instrument Control Start-up Software and Web Interface

KickStart, Keithley's new instrument control non-programming start-up software, lets users start taking measurements in minutes. In most cases, users merely need to make quick measurements, graph the data, and store the data to disk to perform analysis in software environments such as Excel.

KickStart offers the following functionality:

- Instrument configuration control to perform I-V characterization
- Native X-Y graphing, panning, and zooming
- Spreadsheet/tabular viewing of data
- Saving and exporting data for further analysis
- Saving of test setups
- Screenshot capturing of graph
- Annotation of tests
- Command line dialog for sending and receiving data
- HTML help
- GPIB, USB 2.0, Ethernet compliant

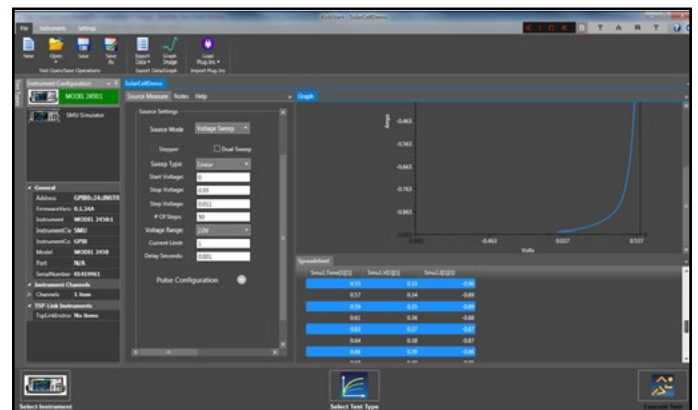

With KickStart start-up software, users are ready to take measurements in minutes.

Simplified Programming with Ready-to-Use Instrument Drivers

For users who want to create their own customized application software, native National Instruments LabVIEW® drivers, IVI-C, and IVI-COM drivers are available at www.keithley.com.

1.888.KEITHLEY (U.S. only)

www.keithley.com

KEITHLEY

A Greater Measure of Confidence

A Tektronix Company

ACCESSORIES AVAILABLE

TEST LEADS AND PROBES

1754	2-wire Universal 10-Piece Test Lead Kit
5804	Kelvin (4-Wire) Universal 10-Piece Test Lead Kit
5805	Kelvin (4-Wire) Spring-Loaded Probes
5806	Kelvin Clip Lead Set
5808	Low Cost Single-pin Kelvin Probe Set
5809	Low Cost Kelvin Clip Lead Set
8605	High Performance Modular Test Leads
8606	High Performance Modular Probe Kit
8608	High Performance Clip Lead Set

CABLES, CONNECTORS, ADAPTERS

237-ALG-2	3-slot Male Triax Connector to 3 Alligator Clips
237-BAN-3A	Triax to Banana Plug
2450-TRX-BAN	Triax to Banana Adapter. Converts the 4 Triax adapters on the rear panel to 5 banana jacks
7078-TRX*	3-slot, Low Noise Triax Cable
7078-TRX-GND	3-slot Male Triax To BNC Adapter (guard removed)
8607	2-wire, 1000V Banana Cables, 1m (3.3 ft)
CA-18-1	Shielded Dual Banana Cable, 1.2m (4 ft)
CAP-31	Protective Shield/Cap for 3-lug Triax Connectors
CS-1546	Triax 3-lug Special Shorting Plug. Shorts center pin to outer shield
CS-1616-3	Safety Interlock Mating Connector

COMMUNICATION INTERFACES & CABLES

KPCI-488LPA	IEEE-488 Interface for PCI Bus
KUSB-488B	IEEE-488 USB-to-GPIB Interface Adapter
7007-1	Shielded GPIB Cable, 1m (3.3 ft)
7007-2	Shielded GPIB Cable, 1m (6.6 ft)
CA-180-3A	CAT5 Crossover Cable for TSP-Link/Ethernet
USB-B-1	USB Cable, Type A to Type B, 1m (3.3 ft)

TRIGGERING AND CONTROL

2450-TLINK	DB-9 to Trigger Link Connector Adapter.
8501-1	Trigger Link Cable, DIN-to-DIN, 1m (3.3 ft)
8501-2	Trigger Link Cable, DIN-to-DIN, 2m (6.6 ft)

RACK MOUNT KITS

4299-8	Single Fixed Rack Mount Kit
4299-9	Dual Fixed Rack Mount Kit
4299-10	Dual Fixed Rack Mount Kit. Mount one 2450 and one Series 26xxB
4299-11	Dual Fixed Rack Mount Kit. Mount one 2450 and one Series 2400, Series 2000, etc.
2450-BenchKit	Ears and Handle for 2450-NFP-RACK and 2450-RACK models

TEST FIXTURES

8101-PIV	DC Test Fixture
----------	-----------------

SERVICES AVAILABLE

2450-3Y-EW	1 Year Factory Warranty extended to 3 years from date of shipment
2450-5Y-EW	1 Year Factory Warranty extended to 5 years from date of shipment
C/2450-3Y-17025	KeithleyCare® 3 Year ISO 17025 Calibration Plan
C/2450-3Y-DATA	KeithleyCare 3 Year Calibration w/Data Plan
C/2450-3Y-STD	KeithleyCare 3 Year Std. Calibration Plan
C/2450-5Y-17025	KeithleyCare 5 Year ISO 17025 Calibration Plan
C/2450-5Y-DATA	KeithleyCare 5 Year Calibration w/Data Plan
C/2450-5Y-STD	KeithleyCare 5 Year Std. Calibration Plan

Voltage Specifications^{1,2}

Source				Measure ³		
Range	Resolution	Accuracy (23° ± 5°C) 1 Year ±(% setting + volts)	Noise (RMS) (<10Hz)	Resolution	Input Resistance	Accuracy (23° ± 5°C) 1 Year ±(% rdg. + volts)
20.00000 mV	500 nV	0.100% + 200 μ V	1 μ V	10 nV	>10 G Ω	0.100% + 150 μ V
200.0000 mV	5 μ V	0.015% + 200 μ V	1 μ V	100 nV	>10 G Ω	0.012% + 200 μ V
2.000000 V	50 μ V	0.020% + 300 μ V	10 μ V	1 μ V	>10 G Ω	0.012% + 300 μ V
20.00000 V	500 μ V	0.015% + 2.4 mV	100 μ V	10 μ V	>10 G Ω	0.015% + 1 mV
200.0000 V	5 mV	0.015% + 24 mV	1 mV	100 μ V	>10 G Ω	0.015% + 10 mV

Current Specifications^{1,2}

Source				Measure ³		
Range	Resolution	Accuracy (23° ± 5°C) ⁴ 1 Year ±(% setting + amps)	Noise (RMS) (<10Hz)	Resolution	Voltage Burden	Accuracy (23° ± 5°C) 1 Year ±(% rdg. + amps)
10.00000 nA ⁵	500 fA	0.100% + 100 pA	500 fA	10 fA	<100 μ V	0.100% + 50 pA
100.0000 nA ⁵	5 pA	0.060% + 150 pA	500 fA	100 fA	<100 μ V	0.060% + 100 pA
1.000000 μ A	50 pA	0.025% + 400 pA	5 pA	1 pA	<100 μ V	0.025% + 300 pA
10.00000 μ A	500 pA	0.025% + 1.5 nA	40 pA	10 pA	<100 μ V	0.025% + 700 pA
100.0000 μ A	5 nA	0.020% + 15 nA	400 pA	100 pA	<100 μ V	0.020% + 6 nA
1.000000 mA	50 nA	0.020% + 150 nA	5 nA	1 nA	<100 μ V	0.020% + 60 nA
10.00000 mA	500 nA	0.020% + 1.5 μ A	40 nA	10 nA	<100 μ V	0.020% + 600 nA
100.0000 mA	5 μ A	0.025% + 15 μ A	100 nA	100 nA	<100 μ V	0.025% + 6 μ A
1.000000 A	50 μ A	0.067% + 900 μ A	3 μ A	1 μ A	<100 μ V	0.030% + 500 μ A

TEMPERATURE COEFFICIENT (0°–18°C and 28°–50°C): $\pm(0.15 \times \text{accuracy specification})/^\circ\text{C}$.

- Speed = 1 PLC.
- All specifications are guaranteed with output ON.
- Accuracies apply to 2- and 4-wire mode when properly zeroed.
- For sink mode, 1 μ A to 100mA range accuracy is $\pm(0.15\% + \text{offset} \times 4)$. For 1A range, accuracy is $\pm(1.5\% + \text{offset} \times 8)$.
- Rear panel triax connections only.

Resistance Measurement Accuracy (Local or Remote Sense)^{2,3}

Range	Default Resolution ⁶	Default Test Current	Normal Accuracy (23°C ± 5°C)	Enhanced Accuracy ⁷ (23°C ± 5°C)
			1 Year, $\pm(\% \text{ rdg.} + \text{ohms})$	1 Year, $\pm(\% \text{ rdg.} + \text{ohms})$
<2.000000 Ω^8	1 $\mu\Omega$	User defined	Source I_{ACC} + Meas. V_{ACC}	Meas. I_{ACC} + Meas. V_{ACC}
20.00000 Ω	10 $\mu\Omega$	100 mA	0.098% + 0.003 Ω	0.073% + 0.001 Ω
200.0000 Ω	100 $\mu\Omega$	10 mA	0.077% + 0.03 Ω	0.053% + 0.01 Ω
2.000000 k Ω	1 m Ω	1 mA	0.066% + 0.3 Ω	0.045% + 0.1 Ω
20.00000 k Ω	10 m Ω	100 μ A	0.063% + 3 Ω	0.043% + 1 Ω
200.0000 k Ω	100 m Ω	10 μ A	0.065% + 30 Ω	0.046% + 10 Ω
2.000000 M Ω	1 Ω	1 μ A	0.110% + 300 Ω	0.049% + 100 Ω
20.00000 M Ω	10 Ω	1 μ A	0.110% + 1 k Ω	0.052% + 500 Ω
200.0000 M Ω	100 Ω	100 nA	0.655% + 10 k Ω	0.349% + 5k Ω
>200.0000 M Ω^8	—	User defined	Source I_{ACC} + Meas. V_{ACC}	Meas. I_{ACC} + Meas. V_{ACC}

TEMPERATURE COEFFICIENT (0°–18°C and 28°–50°C): $\pm(0.15 \times \text{accuracy specification})/^\circ\text{C}$.

SOURCE CURRENT, MEASURE RESISTANCE MODE:

Total uncertainty = I_{source} accuracy + V_{measure} accuracy (4-wire remote sense).

SOURCE VOLTAGE, MEASURE RESISTANCE MODE:

Total uncertainty = V_{source} accuracy + I_{measure} accuracy (4-wire remote sense).

GUARD OUTPUT IMPEDANCE: 0.5 Ω (DC) in ohms mode.

- 6.5 digit measure resolution
- Source readback enabled. Offset compensation ON.
- Source Current, Measure Resistance or Source Voltage, Measure Resistance only.

1.888.KEITHLEY (U.S. only)

www.keithley.com

KEITHLEY

A Tektronix Company

A Greater Measure of Confidence

OPERATING CHARACTERISTICS

MAX. OUTPUT POWER:	20W, four-quadrant source or sink operation.												
SOURCE LIMITS:	V_{source}: ±21V (≤ 1A range), ±210V (≤ 100mA range) I_{source}: ±1.05A (≤ 20V range), ±105mA (≤ 200V range)												
OVERRRANGE:	105% of range, source and measure.												
REGULATION:	Voltage: Line: 0.01% of range. Load: 0.01% of range + 100μV. Current: Line: 0.01% of range. Load: 0.01% of range + 100pA.												
SOURCE LIMITS:	Voltage Source Current Limit: Bipolar current limit set with single value. Min. 10% of range. Current Source Voltage Limit: Bipolar voltage limit set with single value. Min. 10% of range.												
V-LIMIT / I-LIMIT ACCURACY:	Add 0.3% of setting and ±0.02% of reading to base specification.												
OVERSHOOT:	Voltage Source: <0.1% typical (full scale step, resistive load, 20V range, 10mA I-Limit). Current Source: <0.1% typical (1mA step, R _{load} = 10kΩ, 20V range)												
RANGE CHANGE OVERSHOOT:	Overshoot into a fully resistive 100kΩ load, 10Hz to 20MHz BW, adjacent ranges: 250mV typical												
OUTPUT SETTling TIME:	Time required to reach 0.1% of final value, 20V range, 100mA I-Limit: <200μs typical.												
MAXIMUM SLEW RATE:	0.2V/μs, 200V range, 100mA limit into a 2kΩ load (typical)												
OVER VOLTAGE PROTECTION:	User selectable values, 5% tolerance. Factory default = none.												
VOLTAGE SOURCE NOISE:	10Hz–1MHz (RMS): 2mV typical into a resistive load.												
COMMON MODE VOLTAGE:	250V DC.												
COMMON MODE ISOLATION:	>1GΩ, <1000pF.												
NOISE REJECTION (TYPICAL):	<table border="1"> <thead> <tr> <th>NPLC</th> <th>NMRR</th> <th>CMRR</th> </tr> </thead> <tbody> <tr> <td>0.01</td> <td>—</td> <td>60 dB</td> </tr> <tr> <td>0.1</td> <td>—</td> <td>60 dB</td> </tr> <tr> <td>1</td> <td>60 dB</td> <td>100 dB*</td> </tr> </tbody> </table> <p>* Except lowest two current ranges ~90dB.</p>	NPLC	NMRR	CMRR	0.01	—	60 dB	0.1	—	60 dB	1	60 dB	100 dB*
NPLC	NMRR	CMRR											
0.01	—	60 dB											
0.1	—	60 dB											
1	60 dB	100 dB*											
LOAD IMPEDANCE:	20nF typical (standard). Stable into 50μF typical (High-C mode). High-C mode valid for ≥100μA ranges, ≥200mV ranges.												
MAX. VOLTAGE DROP BETWEEN FORCE and SENSE TERMINALS:	5V.												
MAX. SENSE LEAD RESISTANCE:	1MΩ for rated accuracy.												
SENSE INPUT IMPEDANCE:	>10GΩ.												
GUARD OFFSET VOLTAGE:	<300μV, typical												

System Measurement Speeds ⁹

READING RATES (READINGS/SECOND) TYPICAL FOR 60Hz (50Hz):

SCRIPT (TSP) Programmed

NPLC/Trigger Origin	Measure				Source-Measure Sweep			
	To Mem.	To GPIB	To USB	To LAN	To Mem.	To GPIB	To USB	To LAN
0.01 / Internal	3130 (2800)	2830 (2570)	2825 (2600)	2790 (2530)	1710 (1620)	1620 (1540)	1630 (1540)	1620 (1540)
0.01 / External	2170 (2050)	2150 (2030)	2170 (2040)	2160 (1990)	1670 (1590)	1580 (1500)	1590 (1510)	1580 (1510)
0.1 / Internal	540 (460)	530 (450)	530 (450)	530 (450)	470 (410)	460 (400)	470 (400)	470 (400)
0.1 / External	500 (430)	490 (420)	500 (430)	500 (420)	470 (400)	460 (390)	460 (400)	460 (400)
1.00 / Internal	59 (49)	58 (49)	59 (49)	59 (49)	58 (48)	58 (48)	58 (48)	58 (48)
1.00 / External	58 (48)	57 (48)	58 (48)	58 (48)	57 (48)	57 (47)	57 (48)	57 (48)

SCPI Programmed ¹⁰

NPLC/Trigger Origin	Measure				Source-Measure Sweep			
	To Mem.	To GPIB	To USB	To LAN	To Mem.	To GPIB	To USB	To LAN
0.01 / Internal	3130 (2800)	3060 (2760)	3000 (2790)	3010 (2710)	1710 (1630)	1610 (1600)	1440 (1380)	1690 (1590)
0.01 / External	2350 (2200)	2320 (2170)	2340 (2190)	2320 (2130)	1680 (1590)	1560 (1570)	1410 (1360)	1660 (1560)
0.1 / Internal	540 (460)	540 (450)	540 (460)	540 (450)	470 (410)	470 (410)	450 (390)	470 (410)
0.1 / External	510 (440)	510 (430)	510 (440)	510 (430)	470 (400)	470 (400)	450 (390)	470 (400)
1.00 / Internal	59 (49)	59 (49)	59 (49)	59 (49)	58 (48)	58 (48)	57 (48)	58 (48)
1.00 / External	58 (49)	58 (49)	58 (49)	58 (49)	58 (48)	58 (48)	57 (47)	58 (48)

⁹ Reading rates applicable for voltage or current measurements, autozero off, autorange off, filter off, binary reading format, and source readback off.

¹⁰ SCPI programming mode. Speeds do not apply to SCPI 2400 mode.

GENERAL CHARACTERISTICS (default mode unless specified)

FACTORY DEFAULT STANDARD POWER-UP: SCPI MODE.

SOURCE OUTPUT MODES: Fixed DC Level, Memory/Configuration List (mixed function), Stair (linear and log).

SOURCE MEMORY LIST: 100 points max. (SCPI 2400 Mode only).

MEMORY BUFFER: >250,000 readings. Includes selected measured value(s) and time stamp.

REAL-TIME CLOCK: Lithium battery backup (3 yr. + battery life).

REMOTE INTERFACES:

GPIO: IEEE-488.1 compliant. Supports IEEE-488.2 common commands and status model topology.

USB Device (rear panel, type B): 2.0 Full Speed USBTMC.

USB Host (front panel, type A): USB 2.0, support for flash drives, FAT32.

Ethernet: RJ-45 (10/100BT)

DIGITAL I/O INTERFACE:

Lines: 6 Input/Output user defined for digital I/O or triggering

Connector: 9-pin female D

Input Signal Levels: 0.7V (maximum logic low), 3.7V (minimum logic high)

Input Voltage Limits: -0.25V (Abs. minimum), +5.25V (Abs. maximum)

Maximum Source Current: +2.0mA @ >2.7V (per pin)

Maximum Sink Current: -50mA @ 0.7V (per pin, solid-state fuse protected)

5V Power Supply Pin: Limited to 500mA @ >4V (solid-state fuse protected)

Handler: User definable Start of Test, End of Test, 4 category bits

PROGRAMMABILITY: SCPI or TSP command sets.

TSP MODE: Embedded Test Script Processor (TSP) accessible from any host interface.

IP CONFIGURATION: Static or DHCP

EXPANSION INTERFACE: The TSP-Link expansion interface allows TSP enabled instruments to trigger and communicate with each other.

LXI COMPLIANCE: 1.4 LXI Core 2011.

DISPLAY: 5 inch capacitive touch, color TFT WVGA (800×480) with LED backlight.

INPUT SIGNAL CONNECTIONS: **Front:** Banana. **Rear:** Triaxial (3-lug)

INTERLOCK: Active High Input

COOLING: Forced air, variable speed.

OVER TEMPERATURE PROTECTION: Internally sensed temperature overload puts unit in standby mode.

POWER SUPPLY: 100V to 240V RMS, 50–60Hz (automatically detected at power up).

VA RATING: 190 volt-amps max.

ALTITUDE: Maximum 2000 meters above sea level.

EMC: Conforms to European Union EMC Directive.

SAFETY: NRTL listed to UL61010-1 and UL61010-2-30. Conforms with European Union Low Voltage Directive.

VIBRATION: MIL-PRF-28800F Class 3 Random.

WARM-UP: 1 hour to rated accuracies.

DIMENSIONS: (With handle and bumpers): 106mm high × 255mm wide × 425mm deep (4.18 in × 10.05 in × 16.75 in). (Without handle and bumpers): 88mm high × 213mm wide × 403mm deep (3.46 in × 8.39 in × 15.87 in.)

WEIGHT: With bumpers and handle: 4.04 kg (8.9 lbs.).

Without bumpers and handle: 3.58 kg (7.9 lbs.).

ENVIRONMENT: Operating: 0°–50°C, 70% R.H. up to 35°C. Derate 3% R.H./°C, 35°–50°C.

Storage: -25°C to 65°C.

ACCESSORIES SUPPLIED: Test Leads, USB Cable, Ethernet/TSP Cable, Interlock Adapter, Power Cord, Quick Start Guide, CD User's Manual.

1.888.KEITHLEY (U.S. only)

www.keithley.com

Series 2400

SourceMeter® SMU Instruments



- Five instruments in one (IV Source, IVR Measure)
- Seven models: 20–100W DC, 1000W pulsed, 1100V to 1µV, 10A to 10pA
- Source and sink (4-quadrant) operation
- 0.012% basic measure accuracy with 6½-digit resolution
- 2-, 4-, and 6-wire remote V-source and measure sensing
- 1700 readings/second at 4½ digits via GPIB
- Pass/Fail comparator for fast sorting/binning
- Available high speed sense lead contact check function
- Programmable DIO port for automation/handler/prober control (except Model 2401)
- Standard SCPI GPIB, RS-232 and Keithley Trigger Link interfaces
- Keithley LabTracer 2.0 I-V curve tracing application software (download)

Keithley's Series 2400 Source Measure Unit (SMU) Instruments are designed specifically for test applications that demand tightly coupled sourcing and measurement. All SourceMeter models provide precision voltage and current sourcing as well as measurement capabilities. Each SourceMeter SMU instrument is both a highly stable DC power source and a true instrument-grade 6½-digit multimeter. The power source characteristics include low noise, precision, and readback. The multimeter capabilities include high repeatability and low noise. The result is a compact, single-channel, DC parametric tester. In operation, these instruments can act as a voltage source, a current source, a voltage meter, a current meter, and an ohmmeter. Manufacturers of components and modules for the communications, semiconductor, computer, automotive, and medical industries will find the SourceMeter SMU instruments invaluable for a wide range of characterization and production test applications.

Advantages of a Tightly Integrated Instrument

By linking source and measurement circuitry in a single unit, these instruments offer a variety of advantages over systems configured with separate source and measurement instruments. For example, they minimize the time required for test station development, setup, and maintenance, while lowering the overall cost of system ownership. They simplify the test process itself

by eliminating many of the complex synchronization and connection issues associated with using multiple instruments. And, their compact half-rack size conserves precious "real estate" in the test rack or bench.

Power of Five Instruments in One (IV Source, IVR Measure)

The tightly coupled nature of a SourceMeter SMU instrument provides many advantages over solutions configured from separate instruments, such as a precision power supply and a digital multimeter. For example, it provides faster test times by reducing GPIB traffic and simplifies the remote programming interface. It also protects the device under test from damage due to accidental overloads, thermal runaway, etc. Both the current and voltage source are programmable with readback to help maximize device measurement integrity. If the readback reaches a programmed compliance limit, then the source is clamped at the limit, providing fault protection.

ACCESSORIES AVAILABLE

TEST LEADS AND PROBES

1754	2-Wire Universal 10-Piece Test Lead Kit
5804	Kelvin (4-Wire) Universal 10-Piece Test Lead Kit
5805	Kelvin (4-Wire) Spring-Loaded Probes
5808	Low Cost Single-pin Kelvin Probe Set
5809	Low Cost Kelvin Clip Lead Set
8607	2-Wire, 1000V Banana Cables, 1m (3.3 ft)
CA-18-1	Shielded Dual Banana Cable, 1.2m (4 ft)

SWITCHING HARDWARE

7001	Two-Slot Switch System
7002	Ten-Slot Switch System
7019-C	6-Wire Ohms Switch Card
7053	High-Current Switch Card

CABLES/ADAPTERS

7007-1	Shielded GPIB Cable, 1m (3.3 ft)
7007-2	Shielded GPIB Cable, 2m (6.6 ft)
7009-5	RS-232 Cable
8620	Shorting Plug

COMMUNICATION INTERFACE

KPCI-488LPA	IEEE-488 Interface/Controller for the PCI Bus
KUSB-488B	IEEE-488 USB-to-GPIB Interface Adapter

TRIGGERING AND CONTROL

2499-DIGIO	Digital I/O Expander Assembly (not for Model 2401)
8501-1	Trigger Link Cable, DIN-to-DIN, 1m (3.3 ft)
8501-2	Trigger Link Cable, DIN-to-DIN, 2m (6.6 ft)
8502	Trigger Link to BNC Breakout Box
8503	Trigger Link Cable, DIN-to-Dual BNC, 1m (3.3 ft)
8505	Male to 2-Female Y-DIN Cable for Trigger Link

RACK MOUNT KITS

4288-1	Single Fixed Rack Mount Kit
4288-2	Dual Fixed Rack Mount Kit
4288-4	Dual Fixed Rack Mount Kit
4288-5	Shelf Type Side by Side Rack Mounting Kit
4288-9	Dual Fixed Rack Mounting Kit

SOFTWARE

LabTracer 2.0	Curve Tracing Software (downloadable)
---------------	---------------------------------------

1.888.KEITHLEY (U.S. only)

www.keithley.com

KEITHLEY

A Greater Measure of Confidence

A Tektronix Company

Tightly coupled precision sourcing and measurement

SMU INSTRUMENTS

Series 2400

Ordering Information

- 2400** 200V, 1A, 20W SourceMeter SMU Instrument
- 2400-C** 200V, 1A, 20W SourceMeter SMU Instrument with Contact Check
- 2401** 20V, 1A, 20W SourceMeter SMU Instrument
- 2410** 1100V, 1A, 20W SourceMeter SMU Instrument
- 2410-C** 1100V, 1A, 20W SourceMeter SMU Instrument with Contact Check
- 2420** 60V, 3A, 60W SourceMeter SMU Instrument
- 2420-C** 60V, 3A, 60W SourceMeter SMU Instrument with Contact Check
- 2425** 100V, 3A, 100W SourceMeter SMU Instrument
- 2425-C** 100V, 3A, 100W SourceMeter SMU Instrument with Contact Check
- 2430** 100V, 10A, 1000W Pulse Mode SourceMeter SMU Instrument
- 2430-C** 100V, 10A, 1000W Pulse Mode SourceMeter SMU Instrument with Contact Check
- 2440** 40V, 5A, 50W SourceMeter SMU Instrument
- 2440-C** 40V, 5A, 50W SourceMeter SMU Instrument with Contact Check

Accessories Supplied

- Model 8605 Test Leads
- LabVIEW Software Driver (downloadable)
- LabTracer Software (downloadable)

SourceMeter® SMU Instruments

I-V Characteristics

All SourceMeter SMU instruments provide four-quadrant operation. In the first and third quadrants they operate as a source, delivering power to a load. In the second and fourth quadrants they operate as a sink, dissipating power internally. Voltage, current, and resistance can be measured during source or sink operation.

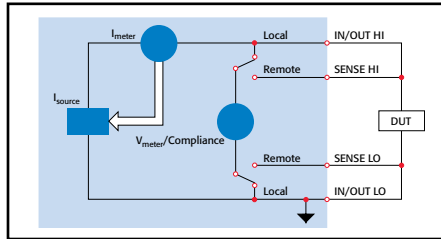

Source I-Measure V, I, or Ω configuration

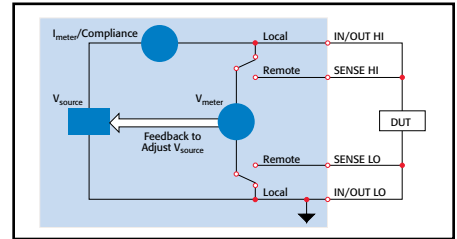

Source V-Measure I, V, or Ω configuration

Series 2400 SourceMeter SMU Instruments

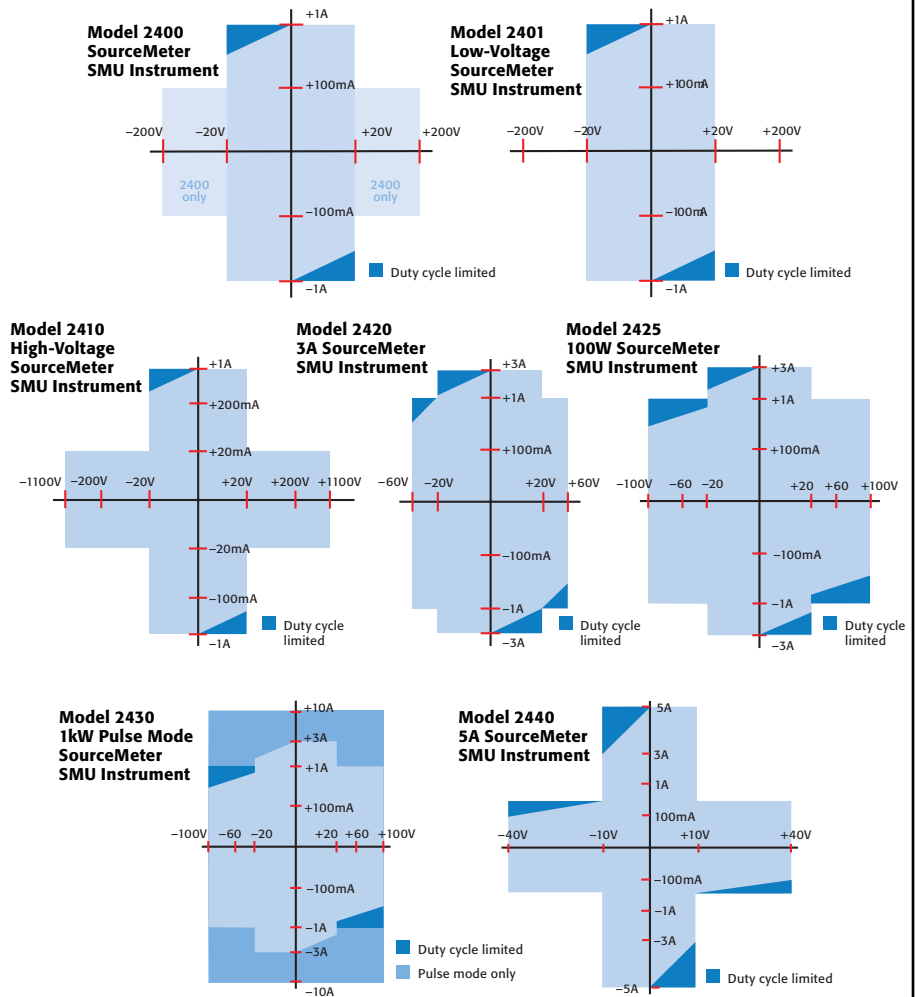

Automation for Speed

A SourceMeter SMU instrument streamlines production testing. It sources voltage or current while making measurements without needing to change connections. It is designed for reliable operation in non-stop production environments. To provide the throughput demanded by production applications, the SourceMeter SMU instrument offers many built-in features that allow it to run complex test sequences without computer control or GPIB communications slowing things down.

Standard and Custom Sweeps

Sweep solutions greatly accelerate testing with automation hooks. Three basic sweep waveforms are provided that can be programmed for single-event or continuous operation. They are ideal for I/V, I/R, V/I, and V/R characterization.

- **Linear Staircase Sweep:** Moves from the start level to the stop level in equal linear steps
- **Logarithmic Staircase Sweep:** Done on a log scale with a specified number of steps per decade
- **Custom Sweep:** Allows construction of special sweeps by specifying the number of measurement points and the source level at each point
- Up to 1700 readings/second at 4½ digits to the GPIB bus
- 5000 readings can be stored in the non-volatile buffer memory

Built-In Test Sequencer (Source Memory List)

The Source Memory list provides faster and easier testing by allowing you to setup and execute up to 100 different tests that run without PC intervention.

- Stores up to 100 instrument configurations, each containing source settings, measurement settings, pass/fail criteria, etc.
- Pass/fail limit test as fast as 500µs per point
- Onboard comparator eliminates the delay caused when sending data to the computer for analysis
- Built-in, user definable math functions to calculate derived parameters

Example Test Sequence

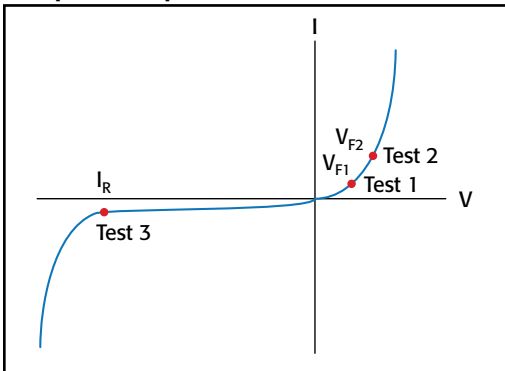

Test	Pass/Fail Test	If Passes Test	If Fails Test
Test 1	Check V_{F1} at 100mA against pass/fail limits	Go to Test 2	
Test 2	Check V_{F2} at 1A against pass/fail limits	Go to Test 3	1. Bin part to bad bin 2. Transmit data to computer while handler is placing new part
Test 3	Check leakage current at -500V and test against pass/fail limits	1. Bin part to good bin 2. Transmit readings to computer while handler is placing new part 3. Return to Test 1	3. Return to Test 1

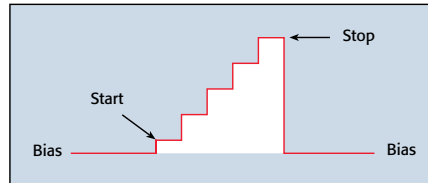

Linear staircase sweep

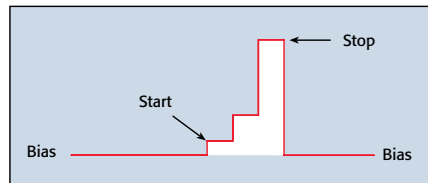

Logarithmic staircase sweep

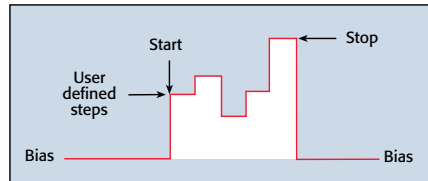

Custom sweep

TYPICAL APPLICATIONS

Devices:

- Discrete semiconductor devices
- Passive devices
- Transient suppression devices
- ICs, RFICs, MMICs
- Laser diodes, laser diode modules, LEDs, photodetectors
- Circuit protection devices: TVS, MOV, Fuses, etc.
- Airbags
- Connectors, switches, relays
- High brightness LEDs (DC and pulse)

Tests:

- Leakage
- Low voltage/resistances
- LIV
- IDDQ
- I-V characterization
- Isolation and trace resistance
- Temperature coefficient
- Forward voltage, reverse breakdown, leakage current
- DC parametric test
- DC power source
- HIPOT
- Photovoltaic cell efficiency (source and sink)
- Dielectric withstanding

Series 2400

SourceMeter® SMU Instruments

Digital I/O Interface

The digital I/O interface can link a SourceMeter SMU instrument to many popular component handlers, including Aetrium, Aeco, and Robotronics. Other capabilities of the interface include:

- Tight systems integration for applications such as binning and sorting
- Built-in component handler interface
- Start of test and end of test signals
- 5V, 300mA power supply
- Optional expander accessory (Model 2499-DIGIO) adds 16 digital I/O lines

The digital I/O interface is available on all Series 2400 SourceMeter instruments except the Model 2401.

Trigger Link Interface

All SourceMeter SMU instruments include Keithley's unique Trigger Link interface which provides high-speed, seamless communications with many of Keithley's other instruments. For example, use the Trigger Link interface to connect a SourceMeter SMU instrument with a Series 7000 Switching System for a complete multi-point test solution. With Trigger Link, the Series 7000 Switching Systems can be controlled by a SourceMeter SMU instrument during a high-speed test sequence independent of a computer and GPIB.

Optional Contact Check Function

The Contact Check function makes it simple to verify good connections quickly and easily before an automated test sequence begins. This eliminates measurement errors and false product failures associated with contact fatigue, breakage, contamination, loose or broken connection, relay failures, etc. Some capabilities of this function are:

- 350 μ s verification and notification process time
- The output of the SourceMeter SMU instrument is automatically shut off after a fault and is not re-activated until good contact is verified, protecting the device under test from damage and the operator from potential safety hazards.
- 3 pass/fail threshold values: 2 Ω , 15 Ω , and 50 Ω
- No energy passes through the device under test during the operation.
- Enabled either from the front panel or remotely over the GPIB
- 3 fault notification methods

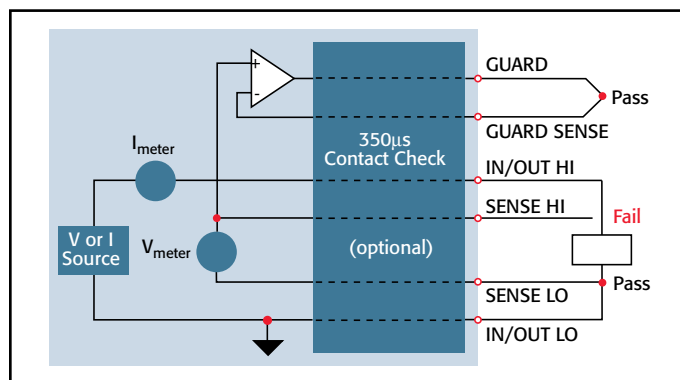

Contact check option for 4-wire or 6-wire applications

Unique 6-Wire Ohms Technique

SourceMeter SMU instruments can make standard 4-wire, split Kelvin, and 6-wire, guarded ohms measurements and can be configured for either the constant current or constant voltage method. The 6-wire ohms technique:

- Uses guard and guard sense leads in addition to the 4-wire sense and source leads.
- Locks out parallel current paths when measuring resistor networks or hybrid circuits to isolate the component under test.
- Allows users to configure and plot data easily from Series 2400 SourceMeter SMU instruments, making characterization of two, three, and four terminal devices a snap.

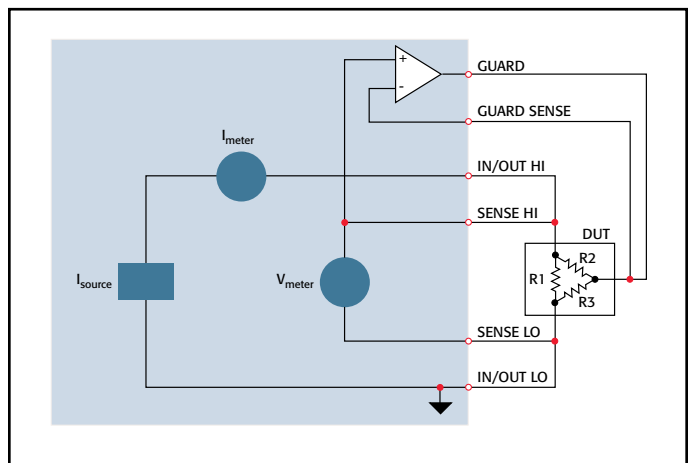

6-Wire Ohms Circuit. All test current flows through R1 because the high current guard drives the voltage across R2 to 0V.

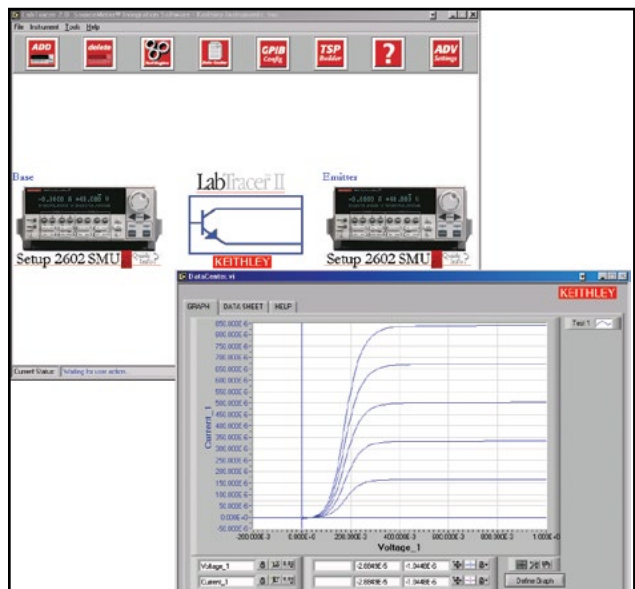

Free LabTracer 2.0 device characterization software (downloadable)

1.888.KEITHLEY (U.S. only)

www.keithley.com

KEITHLEY

A Greater Measure of Confidence

A Tektronix Company

Voltage Accuracy (Local or Remote Sense)

Model	Range	Programming Resolution	Source ¹ Accuracy (1 Year) 23°C ±5°C ±(% rdg. + volts)	Default Measurement Resolution	Measurement ^{2,3,4} Accuracy (1 Year) 23°C ±5°C ±(% rdg. + volts)	Output Slew Rate (±30%)	Source/Sink Limit
2400, 2400-C, 2401	200.000 mV	5 μV	0.02% + 600 μV	1 μV	0.012% + 300 μV		
	2.00000 V	50 μV	0.02% + 600 μV	10 μV	0.012% + 300 μV		±21 V @ ±1.05 A
	20.0000 V	500 μV	0.02% + 2.4 mV	100 μV	0.015% + 1.5 mV	0.08 V/μs	±210 V @ ±105 mA*
	200.000 V*	5 mV	0.02% + 24 mV	1 mV	0.015% + 10 mV	0.5 V/μs	
2410, 2410-C	200.000 mV	5 μV	0.02% + 600 μV	1 μV	0.012% + 300 μV		
	2.00000 V	50 μV	0.02% + 600 μV	10 μV	0.012% + 300 μV		±21 V @ ±1.05 A
	20.0000 V	500 μV	0.02% + 2.4 mV	100 μV	0.015% + 1 mV	0.15 V/μs	±1100 V @ ±21 mA
	1000.00 V	50 mV	0.02% + 100 mV	10 mV	0.015% + 50 mV	0.5 V/μs	
2420, 2420-C	200.000 mV	5 μV	0.02% + 600 μV	1 μV	0.012% + 300 μV		
	2.00000 V	50 μV	0.02% + 600 μV	10 μV	0.012% + 300 μV		±21 V @ ±3.15 A
	20.0000 V	500 μV	0.02% + 2.4 mV	100 μV	0.015% + 1 mV	0.08 V/μs	±63 V @ ±1.05 A
	60.0000 V	1.5 mV	0.02% + 7.2 mV	1 mV	0.015% + 3 mV	0.14 V/μs	
2425, 2425-C	200.000 mV	5 μV	0.02% + 600 μV	1 μV	0.012% + 300 μV		
	2.00000 V	50 μV	0.02% + 600 μV	10 μV	0.012% + 300 μV		±21 V @ ±3.15 A
	20.0000 V	500 μV	0.02% + 2.4 mV	100 μV	0.015% + 1 mV	0.08 V/μs	±105 V @ ±1.05 A
	100.0000 V	2.5 mV	0.02% + 12 mV	1 mV	0.015% + 5 mV	0.25 V/μs	
2430, 2430-C	200.000 mV	5 μV	0.02% + 600 μV	1 μV	0.012% + 300 μV		±105 V @ ±1.05 A
	2.00000 V	50 μV	0.02% + 600 μV	10 μV	0.012% + 300 μV		±105 V @ ±10.5 A
	20.0000 V	500 μV	0.02% + 2.4 mV	100 μV	0.015% + 1 mV	0.08 V/μs	(pulse mode only)
	100.0000 V	2.5 mV	0.02% + 12 mV	1 mV	0.015% + 5 mV	0.25 V/μs	
2440, 2440-C	200.000 mV	5 μV	0.02% + 600 μV	1 μV	0.012% + 300 μV		
	2.00000 V	50 μV	0.02% + 600 μV	10 μV	0.012% + 300 μV		±10.5 V @ ±5.25 A
	10.0000 V	500 μV	0.02% + 1.2 mV	100 μV	0.015% + 750 μV	0.08 V/μs	±42 V @ ±1.05 A
	40.0000 V	5 mV	0.02% + 4.8 mV	1 mV	0.015% + 3 mV	0.25 V/μs	

*Not available on Model 2401.

TEMPERATURE COEFFICIENT (0°–18°C and 28°–50°C): ±(0.15 × accuracy specification)/°C.

VOLTAGE REGULATION: Line: 0.01% of range. Load: 0.01% of range + 100μV.

OVER VOLTAGE PROTECTION: User selectable values, 5% tolerance. Factory default = none.

CURRENT LIMIT: Bipolar current limit (compliance) set with single value. Min. 0.1% of range.

OVERSHOOT: <0.1% typical (full scale step, resistive load, 10mA range).

ADDITIONAL SOURCE SPECIFICATIONS (All Models)

TRANSIENT RESPONSE TIME: 30μs minimum for the output to recover to its spec. following a step change in load.

COMMAND PROCESSING TIME: Maximum time required for the output to begin to change following the receipt of .SOURce:VOLTage|CURRent <nrf> command. **Autorange On:** 10ms. **Autorange Off:** 7ms.

OUTPUT SETTLING TIME: Time required to reach 0.1% of final value after command is processed. 100μs typical. Resistive load. 10μA to 100mA range.

DC FLOATING VOLTAGE: Output can be floated up to ±250VDC (Model 2440 ±40VDC) from chassis ground.

REMOTE SENSE: Up to 1V drop per load lead.

COMPLIANCE ACCURACY: Add 0.3% of range and ±0.02% of reading to base specification.

OVER TEMPERATURE PROTECTION: Internally sensed temperature overload puts unit in stand-by mode.

RANGE CHANGE OVERSHOOT: Overshoot into a fully resistive 100kΩ load, 10Hz to 1MHz BW, adjacent ranges: 100mV typical, except 20V/200V (20V/60V on Model 2420), 20V/100V on Model 2425 and 2430, range boundary, and Model 2440.

MINIMUM COMPLIANCE VALUE: 0.1% of range.

ADDITIONAL PULSE MODE SOURCE SPECIFICATIONS (2430 and 2430-C only)

MAXIMUM DUTY CYCLE: 8%, hardware limited, 10A range only. All other ranges 100%.

MAXIMUM PULSE WIDTH: 5ms from 90% rising to 90% falling edge, 2.5ms 10A range.

MINIMUM PULSE WIDTH: 150μs.

MINIMUM PULSE RESOLUTION: 50μs typical, 70μs max., limited by system jitter.

SOURCE ACCURACY: Determined by settling time and source range specifications.

OUTPUT SETTLING TIME 0.1%:

800μs typ., source I = 10A into 10Ω, limited by voltage slew rate.

500μs typ., source I = 10A into 1Ω, limited by voltage slew rate.

OUTPUT SLEW RATE:

Voltage (10Ω load): 0.25V/μs ±30% on 100V range. 0.08V/μs ±30% on 20V range, 10A range.

Current (0Ω load): 0.25A/μs ±30% on 100V range. 0.08A/μs ±30% on 20V range, 10A range.

NOTES

- 2400, 2401, 2410 Only: Specifications valid for continuous output currents below 105mA. For operation above 105mA continuous for >1 minute, derate accuracy 10%/35mA above 105mA.
- Speed = Normal (1 PLC). For 0.1 PLC, add 0.005% of range to offset specifications, except 200mV, 1A, 10A ranges, add 0.05%. For 0.01 PLC, add 0.05% of range to offset specifications, except 200mV, 1A, 10A ranges, add 0.5%.
- Accuracies apply to 2- or 4-wire mode when properly zeroed.
- In pulse mode, limited to 0.1 PLC measurement.

1.888.KEITHLEY (U.S. only)

www.keithley.com

A Greater Measure of Confidence

KEITHLEY

A Tektronix Company

Current Accuracy (Local or Remote Sense)

Model	Range	Programming Resolution	Source ^{1,3} Accuracy (1 Year) 23°C ±5°C ±(% rdg. + amps)	Default Measurement Resolution	Measurement ^{5,6,7} Accuracy (1 Year) 23°C ±5°C ±(% rdg. + amps)	Source/Sink Limit
2400, 2400-C, 2401	1.00000 µA	50 pA	0.035% + 600 pA	10 pA	0.029% + 300 pA	±1.05A @ ±21 V ±105 mA @ ±210 V ⁸
	10.0000 µA	500 pA	0.033% + 2 nA	100 pA	0.027% + 700 pA	
	100.000 µA	5 nA	0.031% + 20 nA	1 nA	0.025% + 6 nA	
	1.00000 mA	50 nA	0.034% + 200 nA	10 nA	0.027% + 60 nA	
	10.0000 mA	500 nA	0.045% + 2 µA	100 nA	0.035% + 600 nA	
	100.000 mA	5 µA	0.066% + 20 µA	1 µA	0.055% + 6 µA	
	1.00000 A ²	50 µA	0.27 % + 900 µA	10 µA	0.22 % + 570 µA	
2410, 2410-C	1.00000 µA	50 pA	0.035% + 600 pA	10 pA	0.029% + 300 pA	±1.05A @ ±21 V ±21 mA @ ±1100 V
	10.0000 µA	500 pA	0.033% + 2 nA	100 pA	0.027% + 700 pA	
	100.000 µA	5 nA	0.031% + 20 nA	1 nA	0.025% + 6 nA	
	1.00000 mA	50 nA	0.034% + 200 nA	10 nA	0.027% + 60 nA	
	10.0000 mA	500 nA	0.045% + 4 µA	100 nA	0.035% + 1.2 µA	
	100.000 mA	5 µA	0.066% + 20 µA	1 µA	0.055% + 6 µA	
	1.00000 A ²	50 µA	0.27 % + 900 µA	10 µA	0.22 % + 570 µA	
2420, 2420-C	10.0000 µA	500 pA	0.033% + 2 nA	100 pA	0.027% + 700 pA	±3.15A @ ±21 V ±1.05 A @ ±63 V
	100.000 µA	5 nA	0.031% + 20 nA	1 nA	0.025% + 6 nA	
	1.00000 mA	50 nA	0.034% + 200 nA	10 nA	0.027% + 60 nA	
	10.0000 mA	500 nA	0.045% + 2 µA	100 nA	0.035% + 600 nA	
	100.000 mA	5 µA	0.066% + 20 µA	1 µA	0.055% + 6 µA	
	1.00000 A ²	50 µA	0.067% + 900 µA	10 µA	0.066% + 570 µA	
	3.00000 A ²	50 µA	0.059% + 2.7 mA	10 µA	0.052% + 1.71 mA	
2425, 2425-C	10.0000 µA	500 pA	0.033% + 2 nA	100 pA	0.027% + 700 pA	±3.15A @ ±21 V ±1.05 A @ ±105 V
	100.000 µA	5 nA	0.031% + 20 nA	1 nA	0.025% + 6 nA	
	1.00000 mA	50 nA	0.034% + 200 nA	10 nA	0.027% + 60 nA	
	10.0000 mA	500 nA	0.045% + 2 µA	100 nA	0.035% + 600 nA	
	100.000 mA	5 µA	0.066% + 20 µA	1 µA	0.055% + 6 µA	
	1.00000 A ²	50 µA	0.067% + 900 µA	10 µA	0.060% + 570 µA	
	3.00000 A ²	50 µA	0.059% + 2.8 mA	10 µA	0.052% + 1.71 mA	
2430, 2430-C	10.0000 µA	500 pA	0.033% + 2 nA	100 pA	0.027% + 700 pA	±1.05A @ ±105 V ±10.5 A @ ±105 V (pulse mode only)
	100.000 µA	5 nA	0.031% + 20 nA	1 nA	0.025% + 6 nA	
	1.00000 mA	50 nA	0.034% + 200 nA	10 nA	0.027% + 60 nA	
	10.0000 mA	500 nA	0.045% + 2 µA	100 nA	0.035% + 600 nA	
	100.000 mA	5 µA	0.066% + 20 µA	1 µA	0.055% + 6 µA	
	1.00000 A	50 µA	0.067% + 900 µA	10 µA	0.060% + 570 µA	
	3.00000 A ²	50 µA	0.059% + 2.8 mA	10 µA	0.052% + 1.71 mA	
	10.00000 A ⁴	500 µA	0.089% + 5.9 mA	10 µA	0.082% + 1.71 mA	
2440, 2440-C	10.0000 µA	500 pA	0.033% + 2 nA	100 pA	0.027% + 700 pA	±5.25A @ ±10.5 V ±1.05 A @ ±42 V
	100.000 µA	5 nA	0.031% + 20 nA	1 nA	0.025% + 6 nA	
	1.00000 mA	50 nA	0.034% + 200 nA	10 nA	0.027% + 60 nA	
	10.0000 mA	500 nA	0.045% + 2 µA	100 nA	0.035% + 600 nA	
	100.000 mA	5 µA	0.066% + 20 µA	1 µA	0.055% + 6 µA	
	1.00000 A	50 µA	0.067% + 900 µA	10 µA	0.060% + 570 µA	
	5.00000 A	50 µA	0.10 % + 5.4 mA	10 µA	0.10 % + 3.42 mA	

TEMPERATURE COEFFICIENT (0°–18°C and 28°–50°C): ±(0.15 × accuracy specification)/°C.

CURRENT REGULATION: Line: 0.01% of range. Load: 0.01% of range (except Model 2440 5A range 0.05%) + 100pA.

VOLTAGE LIMIT: Bipolar voltage limit (compliance) set with single value. Min. 0.1% of range.

OVERSHOOT: <0.1% typical (1mA step, RL = 10kΩ, 20V range for Model 2400, 2401, 2410, 2420, 2425, 2430), (10V range for Model 2440).

CONTACT CHECK SPECIFICATIONS (requires -C version)

(Not available for Model 2401)

SPEED: 350µs for verification and notification.

CONTACT CHECK:	2 Ω	15 Ω	50 Ω
No contact check failure	<1.00 Ω	<13.5 Ω	<47.5 Ω
Always contact check failure	>3.00 Ω	>16.5 Ω	>52.5 Ω

NOTES

- 2400, 2401, 2410 Only: Specifications valid for continuous output currents below 105mA. For operation above 105mA continuous for >1 minute, derate accuracy 10%/35mA above 105mA.
- Full operation (1A) regardless of load to 30°C (50°C for Model 2420 and 2440). Above 30°C (50°C for Model 2420 and 2440) ambient, derate 35mA/°C and prorata 35mA/Ω load. 4-wire mode. For current sink operation on 1A, 3A, or 5A ranges, maximum continuous power is limited to approximately 1/2 rated power or less, depending on current, up to 30°C ambient. See power equations in the User's Manual to calculate allowable duty cycle for specific conditions.
- For sink mode, 1µA to 100mA range, accuracy is:
Model 2400, 2401: ±(0.15% + offset*4). Models 2410, 2420, 2425, 2430, 2440: ±(0.5% + offset*3).
For 1A range, accuracy is:
Model 2400, 2401: ±(1.5% + offset*8). Models 2410, 2420, 2425, 2430, 2440: ±(1.5% + offset*3).
- 10A range only in pulse mode. Limited to 2.5ms pulse width maximum. 10% duty cycle maximum.
- Speed = Normal (1 PLC). For 0.1 PLC, add 0.005% of range to offset specifications, except 200mV, 1A, 10A ranges, add 0.05%. For 0.01 PLC, add 0.05% of range to offset specifications, except 200mV, 1A, 10A ranges, add 0.5%.
- Accuracies apply to 2- or 4-wire mode when properly zeroed.
- In pulse mode, limited to 0.1 PLC measurement.
- Model 2400 and 2400-C only.

1.888.KEITHLEY (U.S. only)

www.keithley.com

KEITHLEY

A Tektronix Company

A Greater Measure of Confidence

Resistance Measurement Accuracy (Local or Remote Sense)^{1, 2, 5}

Range	Default Resolution	Default Test Current 2400, 2401, 2410	Default Test Current 2420, 2425, 2430, 2440	Normal Accuracy (23°C ±5°C) 1 Year, ±(% rdg. + ohms)			Enhanced Accuracy (23°C ±5°C) ⁴ 1 Year, ±(% rdg. + ohms)
				2400, 2401	2410	2420, 2425, 2430, 2440	2400, 2401
<0.20000 Ω ³	–	–	–	Source I _{ACC} + Meas. V _{ACC}	Source I _{ACC} + Meas. V _{ACC}	Source I _{ACC} + Meas. V _{ACC}	Source I _{ACC} + Meas. V _{ACC}
2.00000 Ω ³	10 μΩ	–	1 A	Source I _{ACC} + Meas. V _{ACC}	Source I _{ACC} + Meas. V _{ACC}	0.17% + 0.0003Ω	Source I _{ACC} + Meas. V _{ACC}
20.0000 Ω	100 μΩ	100 mA	100 mA	0.10% + 0.003 Ω	0.11% + 0.006 Ω	0.10% + 0.003 Ω	0.07% + 0.001 Ω
200.0000 Ω	1 mΩ	10 mA	10 mA	0.08% + 0.03 Ω	0.09% + 0.1 Ω	0.08% + 0.03 Ω	0.05% + 0.01 Ω
2.00000 kΩ	10 mΩ	1 mA	1 mA	0.07% + 0.3 Ω	0.08% + 0.6 Ω	0.07% + 0.3 Ω	0.05% + 0.1 Ω
20.0000 kΩ	100 mΩ	100 μA	100 μA	0.06% + 3 Ω	0.07% + 6 Ω	0.06% + 3 Ω	0.04% + 1 Ω
200.000 kΩ	1 Ω	10 μA	10 μA	0.07% + 30 Ω	0.07% + 60 Ω	0.07% + 30 Ω	0.05% + 10 Ω
2.00000 MΩ ⁶	10 Ω	1 μA	1 μA	0.11% + 300 Ω	0.12% + 600 Ω	0.11% + 300 Ω	0.05% + 100 Ω
20.0000 MΩ ⁷	100 Ω	1 μA	1 μA	0.11% + 1 kΩ	0.12% + 2.4 kΩ	0.11% + 1 kΩ	0.05% + 500 Ω
200.000 MΩ ³	1 kΩ	100 nA	–	0.66% + 10 kΩ	0.66% + 24 kΩ	Source I _{ACC} + Meas. V _{ACC}	0.35% + 5 kΩ
>200.000 MΩ ³	–	–	–	Source I _{ACC} + Meas. V _{ACC}	Source I _{ACC} + Meas. V _{ACC}	Source I _{ACC} + Meas. V _{ACC}	Source I _{ACC} + Meas. V _{ACC}

TEMPERATURE COEFFICIENT (0°–18°C and 28°–50°C): ±(0.15 × accuracy specification)/°C.

SOURCE I MODE, MANUAL OHMS: Total uncertainty = I source accuracy + V measure accuracy (4-wire remote sense).

SOURCE V MODE, MANUAL OHMS: Total uncertainty = V source accuracy + I measure accuracy (4-wire remote sense).

6-WIRE OHMS MODE: Available using active ohms guard and guard sense. Max. Guard Output Current: 50mA (except 1A range). Accuracy is load dependent. Refer to White Paper no. 2033 for calculation formula.

GUARD OUTPUT IMPEDANCE: <0.1Ω in ohms mode.

NOTES

- Speed = Normal (1 PLC). For 0.1 PLC, add 0.005% of range to offset specifications, except 200mV, 1A, 10A ranges, add 0.05%. For 0.01 PLC, add 0.05% of range to offset specifications, except 200mV, 1A, 10A ranges, add 0.5%.
- Accuracies apply to 2- or 4-wire mode when properly zeroed.
- Manual ohms only – except 2420, 2425, 2430, 2440 for 2Ω range and 2400, 2401, or 2410 for 200MΩ range.
- Source readback enabled, offset compensation ON. Also available on 2410, 2420, 2425, 2430, and 2440 with similar accuracy enhancement.
- In pulse mode, limited to 0.1 PLC measurement.
- Except 2440; default test current is 5μA.
- Except 2440; default test current is 0.5μA.

SERVICES AVAILABLE

2400-3Y-EW	1-year factory warranty extended to 3 years from date of shipment
2400-C-3Y-EW	1-year factory warranty extended to 3 years from date of shipment
2401-3Y-EW	1-year factory warranty extended to 3 years from date of shipment
2410-3Y-EW	1-year factory warranty extended to 3 years from date of shipment
2410-C-3Y-EW	1-year factory warranty extended to 3 years from date of shipment
2420-3Y-EW	1-year factory warranty extended to 3 years from date of shipment
2420-C-3Y-EW	1-year factory warranty extended to 3 years from date of shipment
2425-3Y-EW	1-year factory warranty extended to 3 years from date of shipment
2425-C-3Y-EW	1-year factory warranty extended to 3 years from date of shipment
2430-3Y-EW	1-year factory warranty extended to 3 years from date of shipment
2430-C-3Y-EW	1-year factory warranty extended to 3 years from date of shipment
2440-3Y-EW	1-year factory warranty extended to 3 years from date of shipment
2440-C-3Y-EW	1-year factory warranty extended to 3 years from date of shipment
C/2400-3Y-ISO	3 (ISO-17025 accredited) calibrations within 3 years of purchase for Models 2400, 2400-C, 2400-IV*
C/2401-3Y-ISO	3 (ISO-17025 accredited) calibrations within 3 years of purchase for Model 2401*
C/2410-3Y-ISO	3 (ISO-17025 accredited) calibrations within 3 years of purchase for Models 2410, 2410-C*
C/2420-3Y-ISO	3 (ISO-17025 accredited) calibrations within 3 years of purchase for Models 2420, 2420-C*
C/2425-3Y-ISO	3 (ISO-17025 accredited) calibrations within 3 years of purchase for Models 2425, 2425-C*
C/2430-3Y-ISO	3 (ISO-17025 accredited) calibrations within 3 years of purchase for Models 2430, 2430-C*
C/2440-3Y-ISO	3 (ISO-17025 accredited) calibrations within 3 years of purchase for Models 2440, 2440-C*
TRN-2400-1-C	Course: Unleashing the Power of Your SourceMeter SMU Instrument

*Not available in all countries

1.888.KEITHLEY (U.S. only)

www.keithley.com

A Greater Measure of Confidence

KEITHLEY

A Tektronix Company

System Speeds

MEASUREMENT¹

MAXIMUM RANGE CHANGE RATE: 75/second.

MAXIMUM MEASURE AUTORANGE TIME: 40ms (fixed source).²

Sweep Operation³ Reading Rates (rdg./second) for 60Hz (50Hz):

Speed	NPLC/Trigger Origin	Measure		Source-Measure		Source-Measure ⁵ Pass/Fail Test ^{4, 5}		Source-Memory ⁴	
		To Mem.	To GPIB	To Mem.	To GPIB	To Mem.	To GPIB	To Mem.	To GPIB
Fast	0.01 / internal	2081 (2030)	1754	1551 (1515)	1369	902 (900)	981	165 (162)	165
IEEE-488.1 Mode	0.01 / external	1239 (1200)	1254	1018 (990)	1035	830 (830)	886	163 (160)	163
Fast	0.01 / internal	2081 (2030)	1198 (1210)	1551 (1515)	1000 (900)	902 (900)	809 (840)	165 (162)	164 (162)
IEEE-488.2 Mode	0.01 / external	1239 (1200)	1079 (1050)	1018 (990)	916 (835)	830 (830)	756 (780)	163 (160)	162 (160)
Medium	0.10 / internal	510 (433)	509 (433)	470 (405)	470 (410)	389 (343)	388 (343)	133 (126)	132 (126)
IEEE-488.2 Mode	0.10 / external	438 (380)	438 (380)	409 (360)	409 (365)	374 (333)	374 (333)	131 (125)	131 (125)
Normal	1.00 / internal	59 (49)	59 (49)	58 (48)	58 (48)	56 (47)	56 (47)	44 (38)	44 (38)
IEEE-488.2 Mode	1.00 / external	57 (48)	57 (48)	57 (48)	57 (47)	56 (47)	56 (47)	44 (38)	44 (38)

Single Reading Operation Reading Rates (rdg./second) for 60Hz (50Hz):

Speed	NPLC/Trigger Origin	Measure To GPIB	Source-Measure ⁵ To GPIB	Source-Measure Pass/Fail Test ^{5, 7} To GPIB
Fast (488.1)	0.01 / internal	537	140	135
Fast (488.2)	0.01 / internal	256 (256)	79 (83)	79 (83)
Medium (488.2)	0.10 / internal	167 (166)	72 (70)	69 (70)
Normal (488.2)	1.00 / internal	49 (42)	34 (31)	35 (30)

Component for 60Hz (50Hz):^{4, 6}

Speed	NPLC/Trigger Origin	Measure To GPIB	Source Pass/Fail Test	Source-Measure Pass/Fail Test ^{5, 7} To GPIB
Fast	0.01 / external	1.04 ms (1.08 ms)	0.5 ms (0.5 ms)	4.82 ms (5.3 ms)
Medium	0.10 / external	2.55 ms (2.9 ms)	0.5 ms (0.5 ms)	6.27 ms (7.1 ms)
Normal	1.00 / external	17.53 ms (20.9 ms)	0.5 ms (0.5 ms)	21.31 ms (25.0 ms)

NOTES

¹ Reading rates applicable for voltage or current measurements. Auto zero off, autorange off, filter off, display off, trigger delay = 0, and binary reading format.

² Purely resistive load. 1µA and 10µA ranges <65ms.

³ 1000 point sweep was characterized with the source on a fixed range.

⁴ Pass/Fail test performed using one high limit and one low math limit.

⁵ Includes time to re-program source to a new level before making measurement.

⁶ Time from falling edge of START OF TEST signal to falling edge of END OF TEST signal.

⁷ Command processing time of :SOURce:VOLTage|CURRent:TRIGgered <nrf> command not included.

GENERAL

Noise Rejection:

	NPLC	NMRR	CMRR
Fast	0.01	—	80 dB
Medium	0.1	—	80 dB
Slow	1	60 dB	100 dB ¹

¹ Except lowest 2 current ranges = 90dB.

LOAD IMPEDANCE: Stable into 20,000pF typical.

COMMON MODE VOLTAGE: 250V DC (40V DC for Model 2440).

COMMON MODE ISOLATION: >10⁹Ω, <1000pF.

OVERRANGE: 105% of range, source and measure.

MAX. VOLTAGE DROP BETWEEN INPUT/OUTPUT AND SENSE TERMINALS: 5V.

MAX. SENSE LEAD RESISTANCE: 1MΩ for rated accuracy.

SENSE INPUT IMPEDANCE: >10¹⁰Ω.

GUARD OFFSET VOLTAGE: <150µV, typical (300µV for Models 2430, 2440).

SOURCE OUTPUT MODES:

- Pulse (Model 2430 only)
- Fixed DC level
- Memory List (mixed function)
- Stair (linear and log)

MEMORY BUFFER: 5,000 readings @ 5 digits (two 2,500 point buffers). Includes selected measured value(s) and time stamp. Lithium battery backup (3 yr+ battery life).

SOURCE MEMORY LIST: 100 points max.

PROGRAMMABILITY: IEEE-488 (SCPI-1995.0), RS-232, 5 user-definable power-up states plus factory default and *RST.

DIGITAL INTERFACE:

Interlock: Active low input.

Handler Interface: Start of test, end of test, 3 category bits. +5V@ 300mA supply. Not available on Model 2401.

Digital I/O: 1 trigger input, 4 TTL/Relay Drive outputs (33V @ 500mA, diode clamped). Not available on Model 2401.

POWER SUPPLY: 100V to 240V rms, 50–60Hz (automatically detected at power up). **Model 2400, 2401:** 190VA. **Model 2410:** 210VA. **Model 2420:** 220VA. **Model 2425, 2430:** 250VA. **Model 2440:** 240VA.

COOLING: **Model 2401:** Convection. **Model 2410, 2420, 2425, 2430, 2440:** Forced air, variable speed.

EMC: Conforms to European Union Directive 89/336/EEC, EN 61326-1.

SAFETY: UL listed to UL 61010B-1:2003; Conforms to European Union Low Voltage Directive.

VIBRATION: MIL-PRF-28800F Class 3 Random.

WARM-UP: 1 hour to rated accuracies.

DIMENSIONS: 89mm high × 213mm wide × 370mm deep (3½ in × 8½ in × 14½ in). **Bench Configuration (with handle and feet):** 104mm high × 238mm wide × 370mm deep (4½ in × 9½ in × 14½ in).

WEIGHT: 3.21kg (7.08 lbs) (Model 2425, 2430, 2440: 4.1kg, 9.0 lbs).

ENVIRONMENT: **Operating:** 0°–50°C, 70% R.H. up to 35°C. Derate 3% R.H./°C, 35°–50°C. **Storage:** –25°C to 65°C.

1.888.KEITHLEY (U.S. only)

www.keithley.com

KEITHLEY

A Greater Measure of Confidence

A Tektronix Company

6430

Sub-femtoamp Remote SourceMeter[®] SMU Instrument



- **0.4fA p-p (4E-16A) noise (typical)**
- **Remote PreAmp can be located at the signal source to minimize cable noise**
- **>10¹⁶Ω input resistance on voltage measurements**
- **High speed – up to 2000 readings/second**
- **Up to 6½-digit resolution**
- **Fast characterization of components with programmable digital I/O and interfaces**

measure readings per second into internal memory. Currents can be measured in as little as 5ms on the 100nA range, decreasing to just a few hundred microseconds on the higher ranges.

The Model 6430's distinguishing features include its excellent low current sensitivity and the Remote PreAmp, which makes this sensitivity useful by eliminating long input cables. The Remote PreAmp is an integral part of the Model 6430's feedback measuring system that cannot be operated independently from the measurement mainframe, although it can be separated from the mainframe by up to two meters of connection cable carrying high level signals.

Applications

The Model 6430's capabilities make it equally useful for research work and for evaluating sophisticated components in test labs for low-current, high-resistance, or sensitive semiconductor measurements. The low noise and drift performance of the Model 6430 also makes it well suited for research studies in single electron devices, highly resistive nanowires and nanotubes, polymers, highly resistive nanomaterials, and electrochemical amperometry applications.

High Speed Data Handling

The Model 6430 can read more than 2000 readings per second into its internal memory buffer. The IEEE-488 bus output can transmit up to 75 source/measure readings per second to an external computer controller, including pass/fail indication.

The Model 6430 Sub-Femtoamp Remote SourceMeter SMU Instrument combines the voltage and current sourcing and measurement functions of Keithley's popular SourceMeter SMU instruments with sensitivity, noise, and input resistance specifications superior to electrometers. This unique combination of broad functionality and exceptional measurement integrity is made possible by the Model 6430's Remote PreAmp, which offers a very sensitive bi-directional amplifier with sensitive feedback elements for measuring or sourcing currents at the device being tested. The high level signals output by the Remote PreAmp are sent to the controlling mainframe via a two-meter cable. This allows the user to make a direct or very short connection to the signal, minimizing the effects of cable noise.

The Model 6430 makes voltage, current, and resistance measurements at speeds no electrometer can match. It can read up to 2000 source/

measure readings per second into internal memory. Currents can be measured in as little as 5ms on the 100nA range, decreasing to just a few hundred microseconds on the higher ranges.

The Model 6430's distinguishing features include its excellent low current sensitivity and the Remote PreAmp, which makes this sensitivity useful by eliminating long input cables. The Remote PreAmp is an integral part of the Model 6430's feedback measuring system that cannot be operated independently from the measurement mainframe, although it can be separated from the mainframe by up to two meters of connection cable carrying high level signals.

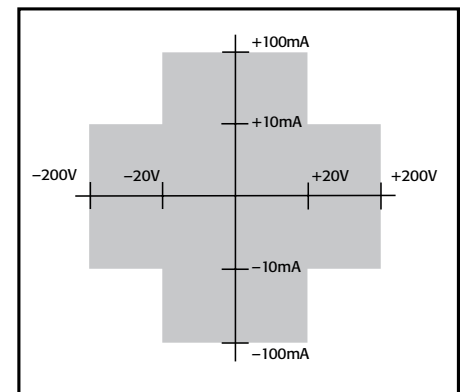

The Model 6430 provides four-quadrant sourcing of up to 2.2W, as well as measurement sensitivity down to sub-femtoamp and microvolt levels. It can measure currents from the 1pA range (with just 0.4fA p-p noise typical) up to the 100mA range at up to 20V. Voltage ranges from 200mV to 200V are available. Current and voltage range settings define the maximum source or sink voltage or current.

1.888.KEITHLEY (U.S. only)

www.keithley.com

A Greater Measure of Confidence

KEITHLEY

A Tektronix Company

Combines broad functionality with exceptional measurement integrity

SMU INSTRUMENTS

6430

Ordering Information

6430 Sub-femtoamp Remote SourceMeter SMU Instrument

Accessories Supplied

- 6430-322-1B** Low Noise Triax Cable, 3-slot triax to alligator clips, 20cm (8 in)
- 8607** Safety High Voltage Dual Test Leads
- CA-186-1B** Banana Lead to Screw Terminal Adapter
- CAP-31** 3-lug Protective Cap (2)
- Instruction Manual**

ACCESSORIES AVAILABLE

7007-1	Shielded GPIB Cable, 1m (3.3 ft)
7007-2	Shielded GPIB Cable, 2m (6.6 ft)
7007-4	Shielded GPIB Cable, 4m (13.1 ft)
7007-05	Shielded GPIB Cable, 0.5m (1.6 ft)
7078-TRX-6IN	3-slot, Low Noise, 0.15m (0.5 ft) Guarded Triax Cable
8501-1	Trigger Link Cable, 1m (3.3 ft)
8501-2	Trigger Link Cable, 2m (6.6 ft)
8502	Trigger Link Adapter Box
8503	Trigger Link DIN-to-BNC Trigger Cable
KPCI-488LPA	IEEE-488 Interface/Controller for the PCI Bus
KUSB-488B	IEEE-488 USB-to-GPIB Interface Adapter

SERVICES AVAILABLE

TRN-2400-1-C	Course: Unleashing the Power of Your SourceMeter SMU Instrument
6430-3Y-EW	1-year factory warranty extended to 3 years from date of shipment
C/6430-3Y-ISO	3 (ISO-17025 accredited) calibrations within 3 years of purchase*

*Not available in all countries

Sub-Femtoamp Remote SourceMeter® SMU Instrument

Typical applications:

Semiconductor measurements

Gate leakage or channel leakage in FET-based components can generate errors in MOSFETs, JFETs, analog switches, and many other circuits. By allowing researchers to measure extremely low-level currents and voltages, the Model 6430 can help them understand the design limitations of these components and investigate alternative device structures or materials.

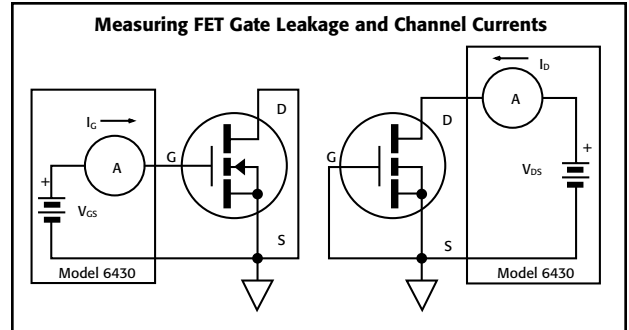

SET research

The Model 6430's superior low current measurement ability (0.4fA p-p noise typical) makes it extremely useful for single electron transistor (SET) and quantum-dot research. Using a technique similar to a lock-in, the 6430 can measure currents with 1aA sensitivity ($10^{-18}A = 6$ electrons/second).

The Measurement Industry's Lowest Noise and Drift

This data illustrates the Model 6430's impressive stability over a five-hour period, as well as its low short-term noise performance. This signal trace was acquired using the instrument's AUTOFILTER with a 5-second rise time on the 1pA range. The inset close-up is a snapshot of the filtered signal, showing the Model 6430's low noise during the first 100-second period. The data was taken in a laboratory environment where temperature varied about 1°C, with the instrument's IN/OUT HI and SENSE leads capped.

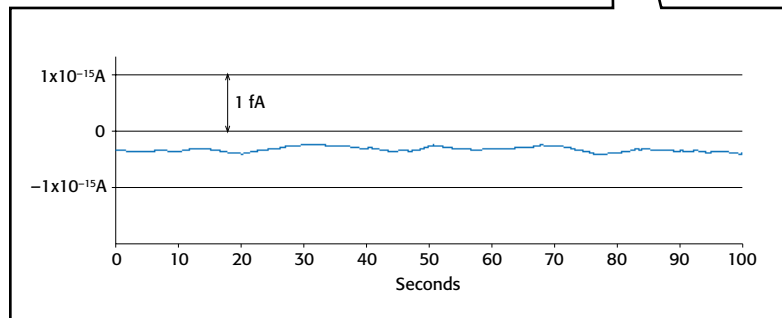
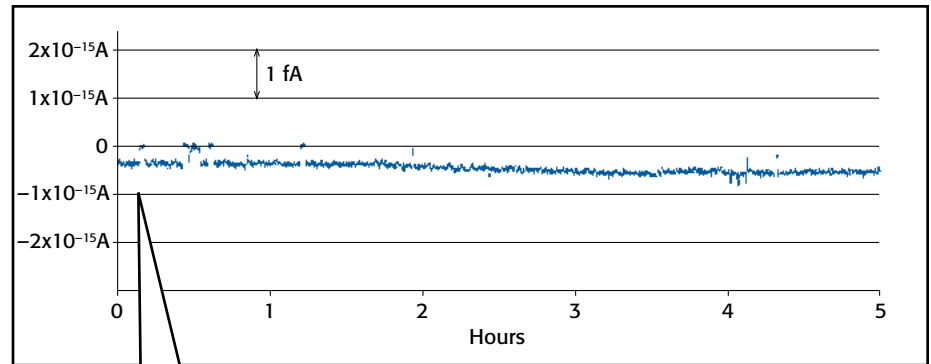

1.888.KEITHLEY (U.S. only)

www.keithley.com

KEITHLEY
A Tektronix Company

A Greater Measure of Confidence

CONDENSED MEASURE SPECIFICATIONS ¹

VOLTAGE MEASUREMENT ACCURACY (4-WIRE SENSE)³

Range	Max. Resolution	Input ² Resistance	Accuracy (23°C ± 5°C) 1 Year, ±(%rdg + volts)
200.000 mV	1 μV	>10 ¹⁶ Ω	0.012% + 350 μV
2.00000 V	10 μV	>10 ¹⁶ Ω	0.012% + 350 μV
20.0000 V	100 μV	>10 ¹⁶ Ω	0.015% + 1.5 mV
200.000 V	1 mV	>10 ¹⁶ Ω	0.015% + 10 mV

TEMPERATURE COEFFICIENT (0°–18°C and 28°–40°C): ±(0.15 × accuracy specification)/°C.

ADDITIONAL MEASURE SPECIFICATIONS

OUTPUT SETTLING TIME (typical to 10% of final value): <2s, 1pA and 10pA ranges; <50ms, 100pA through 10nA ranges; <5ms, 100nA through 100mA ranges.

CURRENT NOISE: When observed over 1 minute intervals, peak to peak noise will be within 400nA (typical) during 90% of the intervals using Autofilter (5s 10% to 90% rise time), with triax connectors capped, Autozero OFF, Source Delay = 0, on the 1pA range for at least 3 minutes.

CURRENT MEASUREMENT ACCURACY (2- OR 4-WIRE SENSE)⁴

Range	Max. Resolution	Voltage Burden ⁵	Accuracy (23°C ± 5°C) 1 Year ±(%rdg + amps)
1.00000 pA	10 aA	< 1mV	1.0 % + 7 fA
10.0000 pA	100 aA	< 1mV	0.50 % + 7 fA
100.000 pA	1 fA	< 1mV	0.15 % + 30 fA
1.00000 nA	10 fA	< 1mV	0.050 % + 200 fA
10.0000 nA	100 fA	< 1mV	0.050 % + 2 pA
100.000 nA	1 pA	< 1mV	0.050 % + 20 pA
1.00000 μA	10 pA	< 1mV	0.050 % + 300 pA
10.0000 μA	100 pA	< 1mV	0.050 % + 2 nA
100.000 μA	1 nA	< 1mV	0.025 % + 6 nA
1.00000 mA	10 nA	< 1mV	0.027 % + 60 nA
10.0000 mA	100 nA	< 1mV	0.035 % + 600 nA
100.000 mA	1 μA	< 1mV	0.055 % + 6 μA

TEMPERATURE COEFFICIENT (0°–18°C and 28°–40°C): ±[(0.15 × accuracy specification) + 1fA]/°C.

INPUT CURRENT: <3fA at 23°C, <40% RH; typically ±0.5fA/°C around 23°C, <40% RH.

RESISTANCE MEASUREMENT ACCURACY (4-WIRE SENSE WITH REMOTE PREAMP)

Source I Mode, Auto Ohms

Range	Max. Resolution	Default Test Current	Normal Accuracy (23°C ± 5°C) 1 Year, ±(%rdg + ohms)	Enhanced Accuracy (23°C ± 5°C) ⁷ 1 Year, ±(%rdg + ohms)
<2.00000 Ω ⁶	1 μΩ	—	Source I _{ACC} + Measure V _{ACC}	Measure I _{ACC} + Measure V _{ACC}
20.0000 Ω	100 μΩ	100 mA	0.098% + 0.003 Ω	0.068% + 0.001 Ω
200.000 Ω	1 mΩ	10 mA	0.077% + 0.03 Ω	0.048% + 0.01 Ω
2.00000 kΩ	10 mΩ	1 mA	0.066% + 0.3 Ω	0.040% + 0.1 Ω
20.0000 kΩ	100 mΩ	100 μA	0.063% + 3 Ω	0.038% + 1 Ω
200.000 kΩ	1 Ω	10 μA	0.082% + 30 Ω	0.064% + 10 Ω
2.00000 MΩ	10 Ω	1 μA	0.082% + 300 Ω	0.064% + 100 Ω
20.0000 MΩ	100 Ω	1 μA	0.085% + 1 kΩ	0.067% + 500 Ω
200.000 MΩ	1 kΩ	100 nA	0.085% + 10 kΩ	0.068% + 5 kΩ
2.00000 GΩ	10 kΩ	10 nA	0.085% + 100 kΩ	0.070% + 50 kΩ
20.0000 GΩ	100 kΩ	1 nA	0.085% + 1 MΩ	0.070% + 500 kΩ
200.000 GΩ	1 MΩ	100 pA	0.205% + 10 MΩ	0.185% + 5 MΩ
2.00000 TΩ	10 MΩ	10 pA	0.822% + 100 MΩ	0.619% + 50 MΩ
20.0000 TΩ	100 MΩ	1 pA	2.06% + 1 GΩ	1.54% + 500 MΩ
>20.0000 TΩ ⁶	—	—	Source I _{ACC} + Measure V _{ACC}	Measure I _{ACC} + Measure V _{ACC}

TEMPERATURE COEFFICIENT (0°–18°C and 28°–40°C): ±(0.15 × accuracy specification)/°C.

SOURCE I MODE, MANUAL OHMS: Total uncertainty = I source accuracy + V measure accuracy (4-wire sense).

SOURCE V MODE: Total uncertainty = V source accuracy + I measure accuracy (4-wire sense).

6-WIRE OHMS MODE: Available using active ohms guard and guard sense (mainframe rear panel ONLY). **Max. Guard Output Current:** 50 mA. Accuracy is load dependent. Refer to manual for calculation formula.

MAINFRAME GUARD OUTPUT RESISTANCE: 0.1Ω in ohms mode.

NOTES

- Speed = 10 PLC, Autofilter ON, properly zeroed and settled.
- Source I mode, I = 0.
- Voltage measurement accuracy is not affected by the remote preamp.
- Current measurement accuracy is not affected by the remote preamp; however, the 1pA through 100nA ranges are available only when using a preamp.
- 4-wire mode.
- Manual ohms mode only.
- Source readback enabled, offset compensation ON. Source delay must be programmed such that the source is fully settled for each reading.

CONDENSED SYSTEM SPEEDS

MEASUREMENT¹

MAXIMUM RANGE CHANGE RATE: 75/second.

SINGLE READING OPERATION READING RATES (rdg/second) FOR 60Hz (50Hz):

Speed	NPLC/ Trigger Origin	Measure To GPIB	Source- Measure ³ To GPIB	Source-Measure Pass/Fail Test ^{2,3} To GPIB
Fast	0.01 / internal	256 (256)	83 (83)	83 (83)
Medium	0.10 / internal	181 (166)	73 (70)	73 (70)
Normal	1.00 / internal	49 (42)	35 (31)	34 (30)

CONDENSED SOURCE SPECIFICATIONS⁴VOLTAGE PROGRAMMING ACCURACY (4-WIRE SENSE)⁵

Range	Programming Resolution	Accuracy (1 Year) 23°C ±5°C ±(% rdg. + volts)	Noise (peak-peak) 0.1Hz – 10Hz
200.000 mV	5 μV	0.02% + 600 μV	5 μV
2.00000 V	50 μV	0.02% + 600 μV	50 μV
20.0000 V	500 μV	0.02% + 2.4 mV	500 μV
200.000 V	5 mV	0.02% + 24 mV	5 mV

TEMPERATURE COEFFICIENT (0°–18°C and 28°–40°C): ±(0.15 × accuracy specification)/°C.

MAX. OUTPUT POWER: 2.2W (four quadrant source or sink operation).

SOURCE/SINK LIMITS: ±21V @ ±105mA, ±210V @ ±10.5mA.

VOLTAGE REGULATION: Line: 0.01% of range. Load: 0.01% of range + 100μV.

NOISE 10Hz–1MHz (p-p): 10mV.

OVER VOLTAGE PROTECTION: User selectable values, 5% tolerance. Factory default = None.

CURRENT LIMIT: Bipolar current limit (compliance) set with single value. Min. 0.1% of range.

CURRENT PROGRAMMING ACCURACY (WITH REMOTE PREAMP)

Range	Programming Resolution	Accuracy (1 Year) ⁴ 23°C ±5°C ±(% rdg. + amps)	Noise (peak-peak) 0.1Hz – 10Hz
1.00000 pA	50 aA	1.0 % + 10 fA	5 fA
10.0000 pA	500 aA	0.50 % + 30 fA	10 fA
100.000 pA	5 fA	0.15 % + 40 fA	20 fA
1.00000 nA	50 fA	0.050 % + 200 fA	50 fA
10.0000 nA	500 fA	0.050 % + 2 pA	500 fA
100.000 nA	5 pA	0.050 % + 20 pA	3 pA
1.00000 μA	50 pA	0.050 % + 300 pA	20 pA
10.0000 μA	500 pA	0.050 % + 2 nA	200 pA
100.000 μA	5 nA	0.031 % + 20 nA	500 pA
1.00000 mA	50 nA	0.034 % + 200 nA	5 nA
10.0000 mA	500 nA	0.045 % + 2 μA	50 nA
100.000 mA	5 μA	0.066 % + 20 μA	500 nA

TEMPERATURE COEFFICIENT (0°–18°C and 28°–40°C): ±(0.15 × accuracy specification)/°C.

MAX. OUTPUT POWER: 2.2W (four quadrant source or sink operation).

SOURCE/SINK LIMITS: ±10.5mA @ ±210V, ±105mA @ ±21V.

CURRENT REGULATION: Line: 0.01% of range. Load: 0.01% of range + 1fA.

VOLTAGE LIMIT: Bipolar voltage limit (compliance) set with single value. Min. 0.1% of range.

NOTES

1. Reading rates applicable for voltage or current measurements. Auto zero off, autorange off, filter off, display off, trigger delay = 0, source auto clear off, and binary reading format.
2. Pass/Fail test performed using one high limit and one low math limit.
3. Includes time to re-program source to a new level before making measurement.
4. For sink mode, 1pA to 100mA range, accuracy is ±(0.15% + offset⁶).
5. Voltage source accuracies are not affected by the remote preamp.

GENERAL

Noise Rejection:	NPLC	NMRR	CMRR
Fast	0.01	—	80 dB
Medium	0.1	—	80 dB
Normal	1	60 dB	90 dB

LOAD IMPEDANCE: Stable into 20,000pF on the 100mA through 100μA ranges, 470pF on the 10μA and 1μA ranges, and 100pF on the nA and pA ranges. Refer to the User's Manual for details on measuring large capacitive loads.

COMMON MODE VOLTAGE: ±42VDC maximum.

COMMON MODE ISOLATION: >10°Ω, <1000pF.

OVERRANGE: 105% of range, source and measure.

MAX. VOLTAGE DROP BETWEEN INPUT/OUTPUT AND SENSE TERMINALS: 5V. (To meet specified accuracy with 4-wire sense, refer to the User's Manual.)

MAX. SENSE LEAD RESISTANCE: 10Ω for rated accuracy.

SENSE INPUT RESISTANCE: 1MΩ.

MAINFRAME GUARD OFFSET VOLTAGE: 300μV, typical.

PREAMP GUARD OFFSET VOLTAGE: 1mV, typical.

PREAMP GUARD OUTPUT RESISTANCE: 110kΩ.

SOURCE OUTPUT MODES: Fixed DC level, Memory List (mixed function), Stair (linear and log).

SOURCE MEMORY LIST: 100 points max.

MEMORY BUFFER: 5,000 readings @ ½ digits (two 2,500 point buffers). Includes selected measured value(s) and time stamp. Lithium battery backup (3 yr+ battery life).

DIGITAL INTERFACE:

Safety Interlock: Active low input.

Handler Interface: Start of test, end of test, 3 category bits. +5V @ 300mA supply.

Digital I/O: 1 trigger input, 4 TTL/Relay Drive outputs (33V @ 500mA sink, diode clamped).

PROGRAMMABILITY: IEEE-488 (SCPI-1995.0), RS-232, 5 user-definable power-up states plus factory default and *RST.

POWER SUPPLY: 100V–240V rms, 50–60Hz (automatically detected at power up), 100VA max.

EMC: Conforms with European Union Directive 89/336/EEC EN 55011, EN 50082-1, EN 61000-3-2 and 61000-3-3, FCC part 15 class B.

SAFETY: Conforms with European Union Directive 73/23/EEC EN 61010-1.

VIBRATION: MIL-PRF-28800F, Class 3.

WARM-UP: 1 hour to rated accuracies.

DIMENSIONS: 89mm high × 213mm wide × 370mm deep (3½ in × 8¾ in × 14½ in). Bench Configuration (with handle and feet): 104mm high × 238mm wide × 370mm deep (4¼ in × 9½ in × 14½ in).

Amplifier: 20mm high × 57mm wide × 97mm deep (0.783 in × 2.225 in × 3.75 in).

WEIGHT: 5.9kg (13 lbs).

ENVIRONMENT: Operating: 0°–40°C, 60% R.H. (non-condensing) up to 35°C. Derate 5% R.H./°C, 35°–40°C. Storage: –25°C to 65°C. Non-condensing humidity.

1.888.KEITHLEY (U.S. only)

www.keithley.com

KEITHLEY

A Tektronix Company

A Greater Measure of Confidence

4200-SCS

Parameter Analyzer

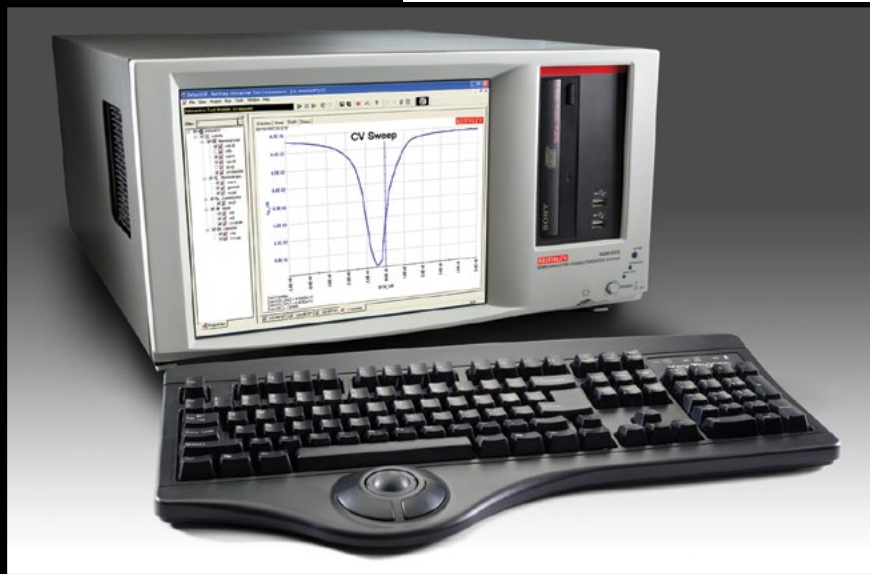

- Characterize devices with up to 9 source measure unit (SMU) instruments
- Sub-femtoamp resolution measurements with optional preamps
- Ultra-fast I-V module for pulse and pulse I-V capabilities
- C-V instrument makes C-V measurements as easy as DC I-V
- Ultra low frequency C-V measurement capability
- Familiar, point-and-click Windows® environment and intuitive GUI
- Easy to use for both interactive and automated tests
- Real-time plotting and analysis allow users to view results before a test has completed and to take preemptive action as needed
- Embedded PC provides the additional benefits of a networked instrument including mapping network drives and making test results available to the corporate network
- Simultaneously acquires data, analyzes plots, and prints reports
- Ideal for device characterization, device modeling, reliability testing, and failure analysis
- Includes instrument and prober drivers as well as interfaces to popular modeling and circuit simulation software

APPLICATIONS:

Semiconductor Devices

- On-wafer parametric test
- Wafer level reliability
- Packaged device characterization
- High κ gate charge trapping
- Isothermal testing of devices and materials subject to self-heating effects
- Charge pumping to characterize interface state densities in MOSFET devices
- Resistive or capacitive MEMS drive characterization

Optoelectronic Devices

- Semiconductor laser diode DC/CW characterization
- DC/CW characterization of transceiver modules
- PIN and APD characterization

Technology Development

- Carbon nanotube characterization
- Materials research
- Electrochemistry

The easy-to-use Model 4200-SCS performs laboratory grade DC I-V, C-V, and pulse device characterization, real-time plotting, and analysis with high precision and sub-femtoamp resolution. It is the best tool available for interactive parametric analysis and device characterization. It offers the most advanced capabilities available in a fully integrated characterization system, including a complete, embedded PC with Windows operating system and mass storage. Its self-documenting, point-and-click interface speeds and simplifies the process of taking data, so users can begin analyzing their results sooner.

Its Keithley Interactive Test Environment (KITE) is so intuitive that even a novice can use the system with ease. This point-and-click software offers a full range of functionality, from managing tests, organizing results, and generating reports to creating user libraries. Sophisticated and simple test sequencing and external instrument drivers make it simple to perform automated testing with combined DC I-V, pulse, and C-V measurements.

The modular design of the Model 4200-SCS provides you with tremendous flexibility. It supports up to nine internal source measure unit (SMU) instruments and optional Remote PreAmps that extend the resolution of any SMU from 100fA to 0.1fA. Its hardware options also include four switch matrix configurations, meters, pulse generators, and more.

Optional instruments can be integrated into the Model 4200-SCS, such as dual-channel pulse generators, a dual-channel digital oscilloscope, and a C-V instrument, which is a capacitance-voltage instrument that performs capacitance measurements from femtofarads to nanofarads at frequencies from 1kHz to 10MHz.

The C-V option includes the new C-V Power package, which supports high power C-V measurements up to 400V and 300mA, up to 60V of differential DC bias, and quasistatic C-V measurements.

The exceptional low current performance of the Model 4200-SCS makes it the perfect solution for research studies of single electron transistors (SETs), molecular electronic devices, and other nanoelectronic devices that require I-V characterization. The 4200-SCS can also be used to make four-probe van der Pauw resistivity and Hall voltage measurements.

For more information on the Model 4200-SCS, see page 58.

1.888.KEITHLEY (U.S. only)

www.keithley.com

1.888.KEITHLEY (U.S. only)

www.keithley.com

A Greater Measure of Confidence

KEITHLEY
A Tektronix Company

Semiconductor Test

4200-SCS
4200-BTI-A
2600-PCT-x
4200-PCT-x
Series S530
S500
ACS
ACS Basic Edition
ACS-2600-RTM
2600-PCT-xB

2520
2520INT
System 25
Series 2400
2502
2500INT
2510
2510-AT
8544,
8544-TEC

Parameter Analyzer	58
Ultra-Fast NBTI/PBTI Package for the Model 4200-SCS	65
Parametric Curve Tracer Configurations	72
Parametric Test Systems	76
Integrated Test Systems	82
Automated Characterization Suite Software	84
Semiconductor Parametric Test Software for Component and Discrete Devices	87
Wafer Level Reliability Option for ACS	89
Parametric Curve Tracer Configurations	90

Related Products

Series 2600B System SourceMeter® Multi-Channel I-V Test Solutions	10
Series 2400 SourceMeter Line	43
Semiconductor Switch Matrix Mainframes	226

Optoelectronics Test

Technical Information	94
Selector Guide	96
Pulsed Laser Diode Test System	97
Integrating Sphere for Pulsed Measurements	102
Laser Diode LIV Test System	105
SourceMeter® SMU Instruments	108
Dual-Channel Picoammeter for Photodiode Measurements	111
Integrating Sphere	112
TEC SourceMeter SMU Instrument	115
Autotuning TEC SourceMeter SMU Instrument	115
Laser Diode Mounts for LIV Test Systems	119

4200-SCS

Parameter Analyzer

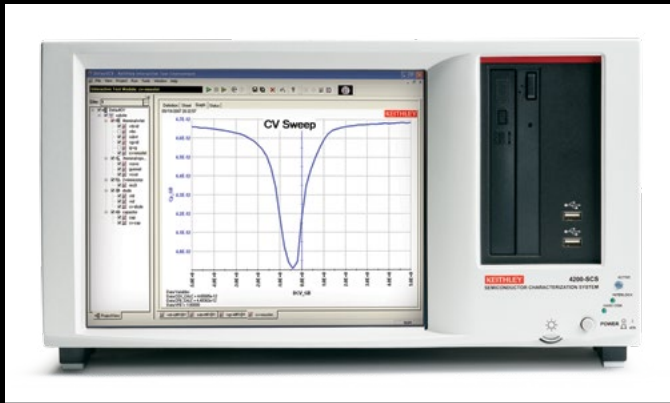

- Over 450 application tests and data supplied for quick startup
- Performs DC I-V, C-V, and Pulsed I-V measurements
- Ultra-fast I-V modules synchronized for transient, waveform capture and pulsed I-V capabilities
- High speed, simultaneous data acquisition of I and V at 200MS/s
- Intuitive GUI for fast test setup, data analysis, graphing, and printing of test results
- Test sequencing and looping control without programming
- JEDEC-compliant reliability sample tests for stress/measure, looping, and data analysis
- Easily integrate switching matrixes or other external equipment
- Analytical prober and cryogenic temperature controller drivers included

A Total Parametric Analysis System

The 4200-SCS with KITE software is a modular, fully integrated parameter analyzer that performs electrical characterization of materials, semiconductor devices, and processes. From basic I-V and C-V measurement sweeps to advanced ultra-fast pulsed I-V, waveform capture, and transient I-V measurements, the 4200-SCS provides the researcher or engineer with critical parameters needed for design, development, production, or reliability testing.

With a Microsoft® Windows® operating system, the 4200-SCS with KITE software provides sophisticated test capabilities with the ease of a graphical user interface, powerful graphing, and parameter extraction, enabling you to get to your results faster with minimal training.

Modular Design Accommodates Changing Test Requirements and Protects Your Investment

With nine measurement slots and a wide variety of instrument modules, you can configure the Model 4200-SCS precisely to your test requirements.

- **Precision DC I-V** measurements are the cornerstone of device and material testing. Up to nine medium or high power DC Source Measurement Units (SMUs) can source and measure voltage or current from 100fA to 1A and from 1 μ V to 210V. The current measurement resolution can be extended to 100nA with the addition of a Model 4200-PA pre-amplifier.
- **AC impedance** testing is easy with the most comprehensive C-V solutions in the market. The 4200-SCS can be configured to support multi-frequency, quasistatic, and very low frequency (VLF) C-V. The Model 4210-CVU Multi-Frequency C-V Module offers test frequencies from 1kHz to 10MHz and measures capacitance from attofarads to microfarads. The VLF C-V technique operates from 10mHz–10Hz.
- **Pulse and transient** measurements add a time domain dimension and allow for dynamic characteristics to be explored. The Model 4225-PMU Ultra-Fast I-V module has two independent voltage sources that can slew the voltage at IV/ns while simultaneously measuring both the voltage and the current. When multiple modules are installed, they are internally synchronized to less than 3ns.

Model	4200-SCS-PK1	4200-SCS-PK2	4200-SCS-PK3	4200-SCS
Description	2-channel, high resolution I-V	2-channel, high resolution I-V and C-V	4-channel, high resolution, high power I-V and C-V	Configured by user
Total # of SMUs	2 medium power	2 medium power	2 medium power, 2 high power	Up to 9 high or medium power
Total No. of PAs	1	1	2	Optional
Current Range and Resolution	100 mA / 0.1 fA	100 mA / 0.1 fA	1 A / 0.1 fA	1 A / 0.1 fA
Voltage Range and Resolution	± 210 V / 1 μ V	± 210 V / 1 μ V	± 210 V / 1 μ V	± 210 V / 1 μ V
Capacitance-Voltage Module	No	Yes	Yes	Optional
Pulse	No	No	No	Optional
Test Fixture	Yes 8101-PIV	Yes 8101-PIV	Yes 8101-PIV	Optional

1.888.KEITHLEY (U.S. only)

www.keithley.com

KEITHLEY

A Tektronix Company

A Greater Measure of Confidence

4200-SCS

Ordering Information

4200-SCS Customize to your test needs, or select from popular configured solutions tailored to your application.

Instrument Modules

- 4200-SMU** Medium Power Source-Measure Unit
- 4210-SMU** High Power Source-Measure Unit
- 4200-PA** Remote PreAmp Option for 4200-SMU and 4210-SMU
- 4210-CVU** Integrated C-V Instrument
- 4225-PMU** Ultra-Fast I-V Module
- 4225-RPM** Remote Amplifier/Switch
- 4220-PGU** High Voltage Pulse Generator

Probe Station Cable Kits Multi-measurement Performance Cables

- 4210-MMPC-C**
for Cascade Microtech
- 4210-MMPC-L**
for Lucas Signatone
- 4210-MMPC-S**
for Suss MicroTec
- 4210-MMPC-W**
for Wentworth

Parameter Analyzer

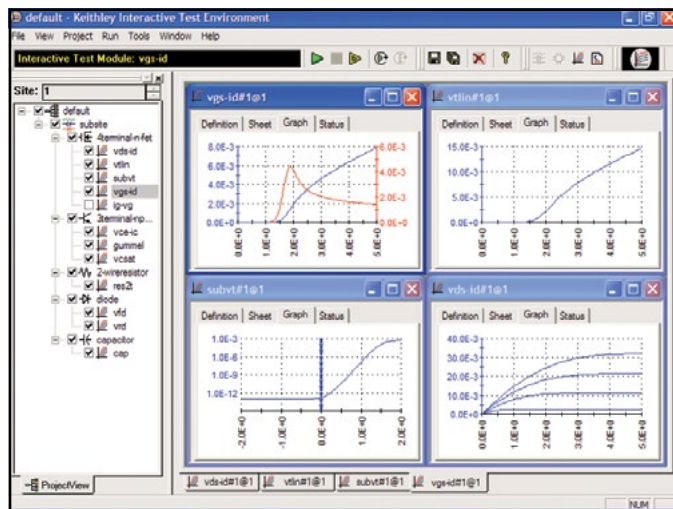

The Keithley Interactive Test Environment (KITE) is designed to let users understand device behavior quickly. When running a test sequence, users can view results and plots for completed tests while the sequence is still running.

KITE Simplifies Complex Testing

The Keithley Interactive Test Environment (KITE) provides a unified parameter measurement interface that allows characterization tests to be performed without complex programming. With the largest library of user-modifiable application tests on the market, more than 450 and growing, KITE makes it easy to begin making complex measurements immediately. Conveniently organized, libraries let you easily create a single test or a sequence of tests for:

- MOSFETs
- BJT transistors
- Diodes
- Resistors
- Capacitors
- Solar cells
- Carbon nanotubes
- Non-volatile memory (NVM)
- Nanoscale devices
- Reliability
- Failure analysis
- LED and OLED
- MEMS
- Biological devices
- Electrochemistry
- Modeling

Because you want test results quickly, real-time results are available numerically or graphically on the front panel display or can be saved to any drive connected to the 4200-SCS. Additionally, you can export data to a network drive and view the results at your convenience. During the research phase, KITE's built-in parameter extraction tools enable calculated parameters and test data to be graphed in KITE's sophisticated, report-ready graphing tool.

Effortless Test Sequencing

KITE provides "point and click" test sequencing on a device, a group of devices, or a number of probe sites on a wafer. One sequence can include DC I-V, C-V, and pulse tests.

Probe Station Control

Keithley provides integrated prober control for popular semiautomatic wafer probe stations. A "manual" prober mode prompts the operator to perform prober operations during a test sequence.

Providing Unparalleled Flexibility

In addition to KITE, three other software tools enable you to configure and operate the 4200-SCS:

- Keithley Configuration Utility (KCON) – Allows test engineers to define the configuration of GPIB instruments, switch matrices, and analytical probes connected to the 4200-SCS. It also provides diagnostic functions.
- Keithley User Library Tool (KULT) – Assists test engineers to create custom test routines as well as use existing Keithley and third-party C-language subroutine libraries. Users can edit and compile

1.888.KEITHLEY (U.S. only)

www.keithley.com

A Greater Measure of Confidence

KEITHLEY
A Tektronix Company

4200-SCS

Parameter Analyzer

subroutines, then integrate libraries of subroutines with KITE, allowing the 4200-SCS to control an entire test rack from a single user interface. (Note: Requires optional Model 4200-Compiler.)

- Keithley External Control Interface (KXCI) – Controls the 4200-SCS from an external computer via GPIB bus.

Model 4200-SMU Medium Power and 4210-SMU High Power SMU instruments

Precision DC I-V measurements are the cornerstone of device and materials electrical characterization. The SMU instruments in the 4200-SCS can source either voltage or current, and can simultaneously measure both the voltage and current. Typically, the DC I-V measurements performed by these SMU instruments are used for very precise (0.01%) or very sensitive (1fA, 1 μ V) measurements in the timeframe of milliseconds to seconds. The SMU instruments can also provide continuous power output, allowing tests to run for hours, or even weeks, without interruption.

The SMU instruments in the 4200-SCS are fully integrated in the 4200-SCS chassis and incorporate the latest measurement technologies including:

- 24-bit A/D converters on every SMU
- Full remote sense (Kelvin) capability
- Broadest dynamic range of current, from <1fA to 1A

- Broadest dynamic range of voltage from <1 μ V to 200V
- Up to nine medium or high power SMU instruments can source/measure simultaneously

The 4200-SCS has been used by thousands of engineers and researchers around the world to electrically characterize their devices and materials. This has resulted in the largest library of standard tests available. More than 400 different libraries are supplied, demonstrating precision DC I-V tests on:

- CMOS MOSFETS and devices
- Bipolar devices
- Diodes and pn junctions
- Solar cells
- Nanotech devices
- And nearly every other material and device imaginable

Additional capabilities include:

- Data for most types of tests can be acquired and plotted in real time with a resolution of milliseconds to seconds
- Wide variety of standard sweep types are available, including linear and log sweeps, voltage and current sweeps, and even arbitrary custom sweeps
- Up to nine SMU instruments can be installed in a single chassis, and all nine can be used simultaneously or independently.

Model 4210-CVU C-V Instrument

C-V measurements are as easy to perform as I-V measurements with the integrated C-V instrument. This optional capacitance-voltage instrument performs capacitance measurements from femtoFarads (fF) to microFarads (μ F) at frequencies from 1kHz to 10MHz. Also available is the 4200-CVU-PWR option that supports:

- High power C-V measurements up to 400V (200V per device terminal)—for testing high power devices, such as MEMs, LDMOS devices, displays, etc.
- DC currents up to 300mA—for measuring capacitance when a transistor is on.

The innovative design of the 4210-CVU has eight patents pending and is complemented by the broadest C-V test and analysis library available in any commercial C-V measurement solution. It also supplies diagnostic tools that ensure the validity of your C-V test results.

With this system, you can configure linear or custom C-V and C-f sweeps with up to 4096 data points. In addition, through the open environment of the 4200-SCS, you can modify any of the included tests, such as:

- C-V, C-t, and C-f measurements and analysis of:
 - Complete solar cell libraries, including DLCP
 - High and low κ structures
 - MOSFETs
 - BJTs
 - Diodes
 - III-V compound devices
 - Carbon nanotube (CNT) devices
- Doping profiles, T_{OX} , and carrier lifetime tests
- Junction, pin-to-pin, and interconnect capacitance measurements

The C-V instrument integrates directly into the Model 4200-SCS chassis. It can be purchased as an upgrade to existing systems or as an option for new systems.

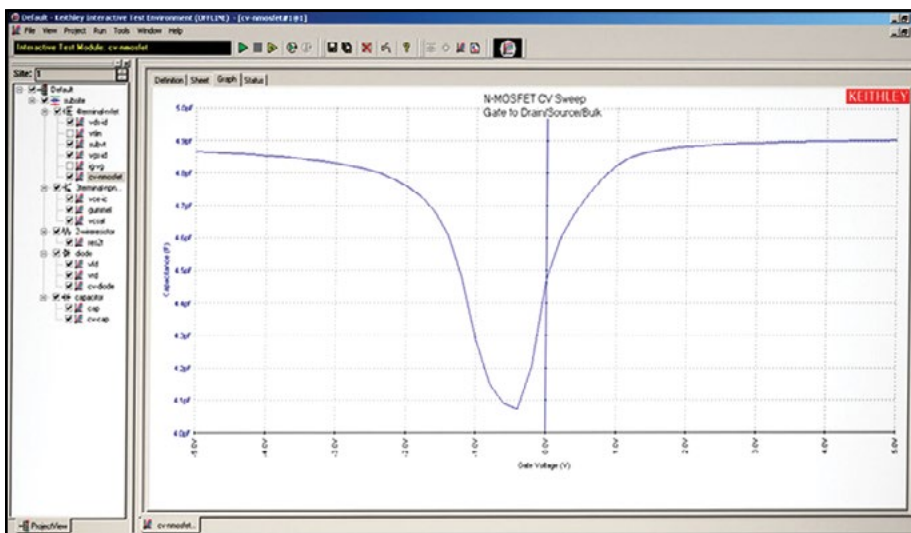

C-V curve from a MOSFET transistor measured with the 4210-CVU

1.888.KEITHLEY (U.S. only)

www.keithley.com

Model 4225-PMU Ultra-Fast I-V Module

The Model 4225-PMU Ultra Fast I-V Module is the latest addition to the growing range of instrumentation options for the Model 4200-SCS Parameter Analyzer. It integrates ultra-fast voltage waveform generation and signal observation capabilities into the Model 4200-SCS's already powerful test environment to deliver unprecedented I-V testing performance, expanding the system's materials, device, and process characterization potential dramatically. Just as important, it makes ultra-fast I-V sourcing and measurement as easy as making DC measurements with a traditional high-resolution source measure unit (SMU).

Three types of measurements are necessary to characterize a device, material, or process thoroughly. The first two are precision DC I-V measurements (usually made with the Model 4200-SCS's SMU instruments) and AC impedance measurements (which can be made with the Model 4210-CVU C-V Instrument). The Model 4225-PMU represents the last segment of this characterization triangle—ultra-fast I-V or transient I-V measurements.

Some of the functionality provided by the Model 4225-PMU includes:

- Voltage outputs with programmable timing from 60ns to DC in 10ns steps
- Measuring I and V simultaneously, at acquisition rates of up to 200 megasamples/second (MS/s)
- Choosing from two voltage source ranges ($\pm 10V$ or $\pm 40V$) and four current measurement ranges (800mA, 200mA, 10mA, 100 μA)
- Also, each module provides two channels of integrated simultaneous I-V sourcing and measurement; plug in up to six modules in a single chassis for twelve synchronized channels.

Two optional instruments offer additional functionality:

- The optional Model 4220-PGU Pulse Generator Unit offers a voltage-sourcing-only alternative to the 4225-PMU.
- The optional Model 4225-RPM Remote Amplifier/Switch expands current ranges (10mA, 1mA, 100 μA , 10 μA , 1 μA , 100nA), switches sourcing/measurement between the Model 4225-PMU, Model 4210-CVU, Model 4200-SMU, and 4210-SMU.

Each plug-in 4225-PMU module provides two channels of integrated sourcing and measurement but occupies only a single slot in the Model 4200-SCS's nine-slot chassis. Unlike competitive solutions, each channel of the 4225-PMU combines high speed voltage outputs (with pulse widths ranging from 60 nanoseconds to DC) with simultaneous current and voltage.

Model 4225-PMU Applications

- Ultra-fast general-purpose I-V measurements
- Pulsed I-V and transient I-V measurements
- Flash, PCRAM, and other non-volatile memory tests
- Isothermal testing of medium-sized power devices
- Materials testing for scaled CMOS, such as high- κ dielectrics
- NBTI/PBTI reliability tests



Each Model 4200-SCS chassis can accommodate up to six Model 4225-PMU modules to provide up to twelve ultra-fast source and measure channels.



Cascade probe station with a Model 4225-RPM Remote Amplifier/Switch

1.888.KEITHLEY (U.S. only)

www.keithley.com

A Greater Measure of Confidence

KEITHLEY

A Tektronix Company

Multi-Measurement Cables

Keithley offers the only probe cable kits that support I-V, C-V, and Ultra-Fast I-V signals. These high performance cable kits simplify switching between DC I-V, C-V, and Ultra-Fast I-V testing configurations by eliminating the need for re-cabling when you change from one type of measurement to another. Their patent-pending design also eliminates the need to lift the probe needles for each cable change. The cable kits:

- Save time by avoiding the laborious process of re-cabling the connections from the test instruments to the probe every time a new measurement type is required.
- Prevent the cabling errors that often occur during difficult cable changes, which in turn prevents the measurement errors produced from faulty cabling.
- Reduce wafer pad damage by making setup changes while the probe needles remain in contact with the wafer. This also allows you to maintain the same contact impedance for each type of measurement.

The following cable kits are available:

- Model 4210-MMPC-C for Cascade Microtech probes
- Model 4210-MMPC-L for Lucas Signatone probes
- Model 4210-MMPC-S for SUSS MicroTec probes
- Model 4210-MMPC-W for Wentworth probes

Contact the factory for other supported probes.

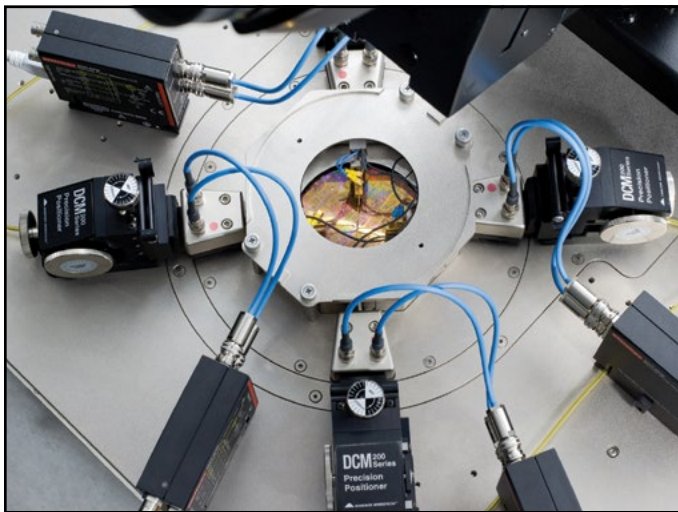

The 4210-MMPC cable kits include a provision for connecting the shields/grounds of all the probes together near the probe tips, providing the best high frequency performance.

How to Use

When changing between I-V and C-V measurements:

- DO NOT lift the probe needles
- DO NOT replace any cables

Simply reposition the cable at the bulkhead to access the appropriate instrument.

When performing Ultra-Fast I-V tests, one or more of the probes may need to be attached to the shield/ground of the pulse source. The cables facilitate this easily with supplied shorting caps.

Occasionally, two or more probes need to be connected in parallel. The patented design of the 4210-MMPC cable sets support this functionality.

For Even More Simplicity

You can eliminate the need to reposition cables at the bulkhead when switching between I-V, C-V and Ultra-Fast I-V measurements with Keithley's Model 4225-RPM Remote Amplifier/Switch. All instrument connections at the bulkhead are fed into the switch, which automatically connects the desired instrument to the positioner.

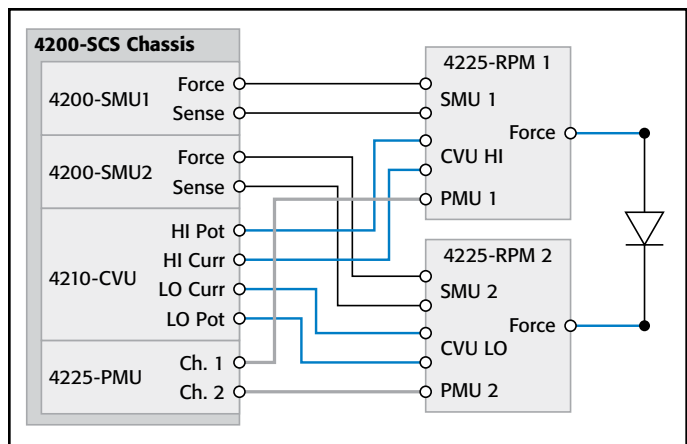

This closeup of two Model 4225-RPMs highlights the DC SMU, C-V, and ultra-fast I-V cable connections.

4200-SCS Condensed Specifications (Note: See the 4200 Technical Data Sheet for complete specifications.)

4200-SCS CHASSIS CORE CAPABILITIES

Integrate Intel Core2Duo processor, 2Gb Ram, 500Gb HDD, 1024X768 LCD, 9 slots, USB, Ethernet, GPIB, external monitor, over 200W of measurement power.

4200-SMU MEDIUM POWER SOURCE-MEASURE UNIT (2.1 watts max.)

MAXIMUM NUMBER OF UNITS PER CHASSIS: 9.
VOLTAGE RANGE: ±200V, 4 ranges from 200mV to 200V full scale.
BASIC VOLTAGE ACCURACY: 0.01% measure, 0.02% source.
VOLTAGE RESOLUTION: 0.1µV to 100µV.
CURRENT RANGE: ±100mA, 7 ranges from 100nA to 100mA full scale.
BASIC CURRENT ACCURACY: 0.03% measure, 0.04% source.
CURRENT RESOLUTION: 0.1pA to 100pA.
WITH OPTIONAL 4200-PA: Adds 5 low current ranges with resolution down to 0.1fA.

4210-SMU HIGH POWER SOURCE-MEASURE UNIT (21 watts max.)

MAXIMUM NUMBER OF UNITS PER CHASSIS: 9.
VOLTAGE RANGE: ±200V, 4 ranges from 200mV to 200V full scale.
BASIC VOLTAGE ACCURACY: 0.01% measure, 0.02% source.
VOLTAGE RESOLUTION: 0.1µV to 100µV.
CURRENT RANGE: ±1A, 8 ranges from 100nA to 1A full scale.
BASIC CURRENT ACCURACY: 0.03% measure, 0.04% source.
CURRENT RESOLUTION: 0.1pA to 100pA.
WITH OPTIONAL 4200-PA: adds 5 low current ranges with resolution down to 0.1fA.

4210-CVU MULTI-FREQUENCY CAPACITANCE-VOLTAGE UNIT

MAXIMUM NUMBER OF UNITS PER CHASSIS: 1 (consult factory for more).
MEASUREMENT PARAMETERS: Cp, Cs, G, R, D, Z, theta.
FREQUENCY RANGE: 1kHz to 10MHz variable.
MEASUREMENT RANGES: 100fF to 100µF typical full scale.
TYPICAL RESOLUTION: 1aF, 1nanoSiemens, 0.001 degree.
AC SIGNAL: 10mV to 100mV programmable.
DC BIAS: ±30V on either High or Low outputs (±60V differential), 10mA max current.
OPTIONAL 4200-CVU-PWR-PKG: Utilizes SMU instruments for ±200V (400V differential) up to 300mA.

RAMP RATE QUASISTATIC C-V

MAXIMUM NUMBER OF UNITS PER CHASSIS: Requires two SMU instruments per channel.
MEASUREMENT PARAMETERS: Cp, DCV, timestamp.
RANGING: 1pF to 1nF.
RAMP RATES: 0.1V/s to 1V/s.
DCV: ±200V.
TYPICAL ACCURACY: 5% at 1V/s ramp rate.

VERY LOW FREQUENCY C-V (VLF-CV)

MAXIMUM UNITS PER CHASSIS: Requires two SMU instruments (either Model 4200-SMU or 4210-SMU) and two Model 4200-PA Remote Preamplifiers. Any two SMU instruments/PAs can be used for a VLF C-V measurement.
MEASUREMENT PARAMETERS: CP-GP, Cp-D, Cs-Rs, Cs-D, R-jX, Z-Theta, DCV, Timestamp.
FREQUENCY RANGE: 10mHz to 10Hz.
MEASUREMENT RANGE: 1pF to 10nF.
TYPICAL RESOLUTION: 3.5 digits, minimum typical 10ff.
AC SIGNAL: 10mV to 3V rms.
DC BIAS: ±20V on the High terminal, 1µA maximum.

4225-PMU ULTRA-FAST I-V UNIT

MAXIMUM NUMBER OF UNITS PER CHASSIS: 6.
CHANNELS PER UNIT: 2 independent or synchronized.
VOLTAGE RANGE: ±40V, 2 ranges of 10V and 40V.
BASIC VOLTAGE ACCURACY: 0.25%.
VOLTAGE RESOLUTION: 250µV, 750µV.
CURRENT RANGE: ±800mA, 4 ranges from 100µA to 800mA.
BASIC CURRENT ACCURACY: 0.25%.
CURRENT RESOLUTION: 14 bits, 10nA to 10mA.
WITH OPTIONAL 4225-RPM REMOTE AMPLIFIER/SWITCH: Adds 3 low current ranges 100nA, 1µA, 10µA.
CORE A/D CONVERTER: Two per channel, 4 per unit, 5ns, 200MHz, 14 bits, 1GB memory.
CORE VOLTAGE SLEW RATE: 1V/ns.
BEST VOLTAGE PULSE WIDTH: 20ns to 10V.
TYPICAL CURRENT MEASURE PULSE WIDTH: 60ns.

EXTENDED WARRANTIES AND CALIBRATION SERVICES

EXTENDED WARRANTIES		CALIBRATION SERVICES	
The 1 year factory warranty is extended 3 or 5 years from date of shipment. Includes calibration and return shipping.		The calibration service provides 3 or 5 calibrations per year with before and after, ANSI/NCSL Z540-1 compliant data reports.	
4200-3Y-EW or 4200-5Y-EW	Includes 4200-SCS mainframe including all SMUs and preamplifiers.	4200-3Y-CAL or 4200-5Y-CAL	Includes the 4200-SCS mainframe, all SMUs and preamplifiers.
4210-3Y-EW or 4210-5Y-EW	Includes 4210-CVU module. Requires purchase of 4200-3Y or 4200-5Y extended warranty.	4200-CVU-3Y-CAL or 4200-CVU-5Y-CAL	Includes 4210-CVU module. Requires purchase of 4200-3Y-CAL or 4200-5Y-CAL.
4225-3Y-EW or 4225-5Y-EW	Includes 4225-PMU module. Requires purchase of 4200-3Y or 4200-5Y extended warranty.	4200-PMU-3Y-CAL or 4200-PMU-5Y-CAL	Includes 4225-PMU module. Requires purchase of 4200-3Y-CAL or 4200-5Y-CAL.
4225-RPM-3Y-EW or 4225-RPM-5Y-EW	Includes 4225-RPM module. Requires purchase of 4200-3Y or 4200-5Y extended warranty.	4200-RPM-3Y-CAL or 4200-RPM-5Y-CAL	Includes 4225-RPM module. Requires purchase of 4200-3Y-CAL or 4200-5Y-CAL.

1.888.KEITHLEY (U.S. only)

www.keithley.com

A Greater Measure of Confidence

KEITHLEY

A Tektronix Company

Instrument Modules

Instrument Modules	Description	Supplied Accessories
4200-SMU	Medium Power Source-Measure Unit for 4200-SCS, 100mA to 100fA, 200V to 1 μ V, 2 Watts	<i>If configured with a preamp:</i> (4) 4200-TRX-2 Ultra Low Noise Triax Cables, 2m (6.6 ft) (1) 236-ILC-3 Interlock Cable, 3m (10 ft) <i>If configured without a preamp:</i> (2) 4200-TRX-2 Ultra Low Noise Triax Cables, 2m (6.6 ft) (2) 4200-MTRX-2 Mini Ultra Low Noise Triax Cables, 2m (6.6 ft) (1) 236-ILC-3 Interlock Cable, 3m (10 ft)
4210-SMU	High Power Source-Measure Unit for 4200-SCS, 1A to 100fA, 200V to 1 μ V, 20 Watts	<i>If configured with a preamp:</i> (4) 4200-TRX-2 Ultra Low Noise Triax Cables, 2m (6.6 ft) (1) 236-ILC-3 Interlock Cable, 3m (10 ft) <i>If configured without a preamp:</i> (2) 4200-TRX-2 Ultra Low Noise Triax Cables, 2m (6.6 ft) (2) 4200-MTRX-2 Mini Ultra Low Noise Triax Cables, 2m (6.6 ft) (1) 236-ILC-3 Interlock Cable, 3m (10 ft)
4200-PA	Remote PreAmp Option for 4200-SMU and 4210-SMU, extends SMU to 0.1fA resolution	(1) 4200-RPC remote preamp cable, 2m (6.6 ft)
4210-CVU	Capacitance-Voltage (C-V) Module	(4) CA-447A SMA Cables, male to male, 100 Ω , 1.5m (5 ft) • (4) CS-1247 Female SMA to Male BNC Adapters (2) CS-701 BNC Tee Adapters • (1) TL-24 SMA Torque Wrench
4225-PMU	Ultra-Fast I-V Module	(4) SMA-to-SMA 50 Ω cables, 2m (6.6 ft) (2) SMA-to-SSMC Y-Cable Assembly, 6 in.
4225-RPM	Remote Amplifier/Switch	(1) SMA-to-SMA 50 Ω Cable, 20cm (7.9 in), (1) Triax-to-BNC Adapter, (1) BNC-to-SMA Adapter, (1) RPM Cable, 2.1m (6.9 ft)
4220-PGU	High Voltage Pulse Generator	(4) SMA-to-SMA 50 Ω cables, 2m (6.6 ft), (2) SMA-to-SSMC Y-Cable Assembly, 6 in.

Switching Systems and Cards

	Description	Supplied Accessories
707B	6-slot Switching Matrix Mainframe	CA-180-4A CAT 5 Ethernet Crossover Cable, 1m (3.3 ft) • CA-179-2A CAT 5 Ethernet Cable 3m (10 ft) CO-7 Line Cord • Rear Fixed Rack Mount Hardware
708B	Single-slot Switching Matrix Mainframe	CA-180-4A CAT 5 Ethernet Crossover Cable, 1m (3.3 ft) • CA-179-2A CAT 5 Ethernet Cable 3m (10 ft) • CO-7 Line Cord
7072	8 \times 12, Semiconductor Matrix Card	
7072-HV	8 \times 12, High Voltage, Semiconductor Matrix Card	
7173-50	4 \times 12, Two-Pole, High Frequency, Matrix Card	
7174A	8 \times 12, High Speed, Low Leakage Current, Matrix Card	

OPTIONAL ACCESSORIES

CONNECTORS AND ADAPTERS

CS-565	Female BNC to Female BNC Adapter
CS-701	BNC Tee Adapter (female, male, female)
CS-719	3-lug Triax Jack Receptacle
CS-1247	SMA Female to BNC Male Adapter
CS-1249	SMA Female to SMB Plug Adapter
CS-1251	BNC Female to SMB Plug Adapter
CS-1252	SMA Male to BNC Female Adapter
CS-1281	SMA Female to SMA Female Adapter
CS-1382	Female MMBX Jack to Male SMA Plug Adapter
CS-1390	Male LEMO Triax to Female SMA Adapter
CS-1391	SMA Tee Adapter (female, male, female)
CS-1479	SMA Male to BNC Male Adapter
237-BAN-3A	Triax Cable Center Conductor terminated in a safety banana plug
237-BNC-TRX	Male BNC to 3-lug Female Triax Adapter
237-TRX-BAR	3-lug Triax Barrel Adapter (female to female)
237-TRX-T	3-slot Male to Dual 3-lug Female Triax Tee Adapter
7078-TRX-BNC	3-Slot Male Triax to BNC Adapter
7078-TRX-GND	3-Slot Male Triax to Female BNC Connector (guards removed)

TEST FIXTURES

8101-4TRX	4-pin Transistor Fixture
8101-PIV	Pulse LV Demo Fixture
LR8028	Component Test Fixture

CABINET MOUNTING ACCESSORIES

4200-RM	Fixed Cabinet Mount Kit
---------	-------------------------

CABLES AND CABLE SETS

NOTE: All 4200-SCS systems and instrument options are supplied with required cables, 2m (6.5 ft.) length.

CA-19-2	BNC to BNC Cable, 1.5m
CA-404B	SMA to SMA Coaxial Cable, 2m
CA-405B	SMA to SMA Coaxial Cable, 15cm
CA-406B	SMA to SMA Coaxial Cable, 33cm
CA-446A	SMA to SMA Coaxial Cable, 3m
CA-447A	SMA to SMA Coaxial Cable, 1.5m
CA-451A	SMA to SMA Coaxial Cable, 10.8cm
CA-452A	SMA to SMA Coaxial Cable, 20.4cm
236-ILC-3	Safety Interlock Cable, 3m
237-ALG-2	Low Noise Triax Input Cable terminated with 3 alligator clips, 2m
4210-MMPC-C	Multi-Measurement (I-V, C-V, Pulse) Prober Cable Kit for Cascade Microtech I2000 prober series
4210-MMPC-S	Multi-Measurement (I-V, C-V, Pulse) Prober Cable Kit for SUSS MicroTec PA200/300 prober series
4200-MTRX-*	Ultra Low Noise SMU Triax Cable: 1m, 2m, and 3m options
4200-PRB-C	SMA to SSMC Y Cable with local ground
4200-RPC-*	Remote PreAmp Cable: 0.3m, 2m, 3m, 6m options
4200-TRX-*	Ultra Low Noise PreAmp Triax Cable: 0.3m, 2m, 3m options
7007-1	Double-Shielded Premium GPIB Cable, 1m
7007-2	Double-Shielded Premium GPIB Cable, 2m

ADAPTER, CABLE, AND STABILIZER KITS

4200-CVU-PWR	CVU Power Package for \pm 200V C-V
4200-CVU-PROBER-KIT	Accessory Kit for connection to popular analytical probers
4200-PMU-PROBER-KIT	General Purpose Cable/Connector Kit. For connecting the 4225-PMU to most triax and coax probe stations. One kit required per 4225-PMU module.
4200-Q-STBL-KIT	Addresses oscillation when performing pulse I-V tests on RF transistors

REMOTE PREAMP MOUNTING ACCESSORIES

4200-MAG-BASE	Magnetic Base for mounting 4200-PA on a prober platen
4200-TMB	Triaxial Mounting Bracket for mounting 4200-PA on a triaxial mounting panel
4200-VAC-BASE	Vacuum Base for mounting 4200-PA on a prober platen

SOFTWARE

ACS-BASIC	Component Characterization Software
-----------	-------------------------------------

DRIVERS

4200ICCAP-6.0	IC-CAP Driver and Source Code for 4200-SCS: UNIX/Windows (shareware only)
---------------	---

OTHER ACCESSORIES

EM-50A	Modified Power Splitter
TL-24	SMA Torque Wrench
4200-CART	Roll-Around Cart for 4200-SCS
4200-CASE	Transport Case for 4200-SCS
4200-MAN	Printed Manual Set

1.888.KEITHLEY (U.S. only)

www.keithley.com

KEITHLEY

A Tektronix Company

A Greater Measure of Confidence

4200-BTI-A

- **Best-in-class test speed allows faster, more complete device characterization**
 - Begin measuring BTI degradation as soon as 30ns after stress is removed
 - Measure transistor V_T in less than 1 μ s using I_D - V_G sweep method
- **Model 4225-RPM Remote Amplifier/Switch**
 - Switches automatically between low-level precision DC I-V (via standard SMUs) and ultra-fast I-V measurements with no need for re-cabling
 - Improves single-pulse source and measurement performance by minimizing cable parasitic effects and increasing low current sensitivity
- **Best high-speed, low-current measurement sensitivity available in a single-box integrated solution**
 - Supports sub-microsecond pulse characterization of drain current at reduced drain voltage, minimizing drain-to-source fields that could otherwise skew test results
 - Ensures the source/measure instrumentation won't be the limiting factor when making low-level measurements
 - Detects degradation trends sooner during the test, reduces the time needed to perform process reliability monitoring
- **Simple, predictable interconnect scheme prevents measurement problems due to incorrect DUT connections**

Ultra-Fast NBTI/PBTI Package for the Model 4200-SCS



The Model 4200-BTI-A Ultra-Fast BTI Package combines Keithley's advanced DC I-V and ultra-fast I-V measurement capabilities with automatic test executive software to provide the most advanced NBTI/PBTI test platform available in the semiconductor test industry. The 4200-BTI-A package, which builds on the Model 4200-SCS semiconductor parameter analyzer's powerful test environment, includes all the instruments, interconnects, and software needed to make the most sophisticated NBTI and PBTI measurements on leading-edge silicon CMOS technology:

- One Model 4225-PMU Ultra-Fast I-V Module
- Two Model 4225-RPM Remote Amplifier/Switches
- Automated Characterization Suite (ACS) Software
- Ultra-Fast BTI Test Project Module
- Cabling

APPLICATIONS

- **Single-Pulse Charge Trapping/ high- κ dielectric characterization**
- **Silicon-On-Insulator testing**
- **LDMOS/GaAs isothermal characterization**
- **Flash RTS ID**
- **Phase-change random access memory (PCRAM) testing**
- **Ultra-fast NBTI characterization**
- **Charge pumping measurements**
- **Thermal impedance characterization**
- **MEMs capacitor testing**
- **Random telegraph signal (RTS) CMOS**
- **Charge-based capacitance measurement (CBCM) Materials testing for scaled CMOS, such as high- κ dielectrics**
- **NBTI/PBTI reliability tests**

1.888.KEITHLEY (U.S. only)

www.keithley.com

A Greater Measure of Confidence

KEITHLEY
A Tektronix Company

4200-BTI-A

- **Optional Multi-Measurement Performance Cables (MMPC) optimize measurement performance of configurations that combine DC I-V, C-V, and ultra-fast I-V capabilities**
- **ACS software supports building complex test sequences including up to 20 measurement sequences and full prober integration**
 - DC I-V and ultra-fast I-V measurements can be easily integrated into a stress-measure sequence
 - Degradation and recovery behaviors can be characterized using either AC or DC stress
 - Combine spot measurements with precision SMU sweeps in pretesting and posttesting
 - Incorporate single pulse charge trapping (SPCT) measurements into longer stress-measure sequences
- **Support for handling large data sets required in device reliability modeling and process monitoring applications**
- **Support for hot chucks and fully and semi automatic probers, including wafer maps, wafer- and cassette-level sample plans**

Ultra-Fast NBTI/PBTI Package for the Model 4200-SCS

Model 4225-PMU Ultra-Fast I-V Module

This module is the hardware core of the ultra-fast I-V measurement capability essential for characterizing NBTI and PBTI degradation in microseconds, allowing for more accurate lifetime measurements for Designed-In Reliability (DIR) that support modeling for device and circuit design. It integrates a sophisticated two-channel waveform generator with high-speed voltage and current measurement capabilities, a deep measurement buffer, and a real-time test execution engine.

Unlike traditional pulse generation solutions, the Model 4225-PMU can be programmed to output the complex waveforms required in ultra-fast BTI testing. And, unlike traditional Arbitrary Waveform Generators (AWGs), the waveforms' duration and complexity aren't limited by bitmap or memory depth. Instead, the 4225-PMU employs a high-level waveform description language that uses the concept of segments, segment libraries, and looping. In addition, the waveform description specifies exactly when measurements must be made during the waveform and the type of measurement to be made.

Spot, step sweep, smooth sweep, and sample measurement types are supported and multiple measurement types can be linked to form a test sequence. The programmable sample period can be set as fast as 5ns, so most measurements will include multiple samples. The system's real-time test execution engine automatically calculates the mathematical mean of the samples, which reduces the volume of data that must be transferred and parsed during the course of the test. The resulting measurements are streamed back to the high-level test module for near-real-time analysis and test termination.

For additional information on this module's capabilities and specifications, consult the Model 4225-PMU data sheet.

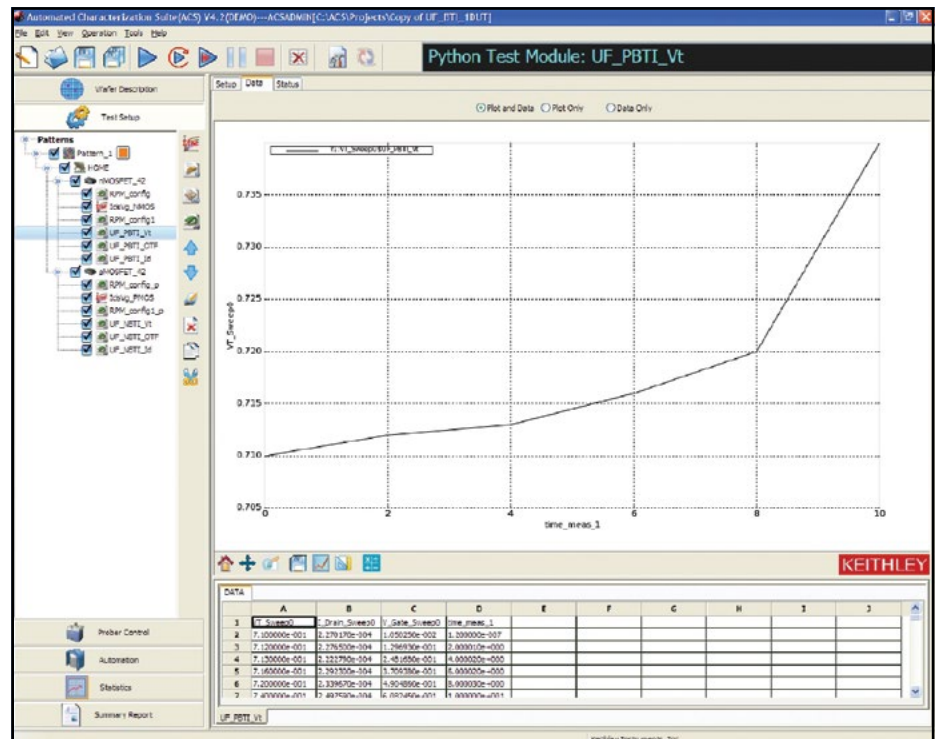

The Model 4225-PMU/4225-RPM's combination of superior speed and sensitivity allow characterizing voltage threshold (V_T) directly with high-speed I_D - V_G sweeps. Measuring V_T directly makes it unnecessary to correlate the single-point I_D measurement to actual V_T levels.

1.888.KEITHLEY (U.S. only)

www.keithley.com

KEITHLEY

A Tektronix Company

A Greater Measure of Confidence

4200-BTI-A

Ordering Information

4200-BTI-A

Ultra-Fast BTI Package for the Model 4200-SCS (includes one Model 4225-PMU Ultra-Fast I-V Module, two Model 4225-RPM Remote Amplifier/Switches, Ultra-Fast BTI Test Project Module, and one copy of the Automated Characterization Suite (ACS) software

Accessories Supplied

For the 4225-PMU:

SMA to SMA 50Ω cables, 2m (4 ea.)

SMA to SSMC Y-Cable Assembly, 6 in (2 ea.)

ACCESSORIES AVAILABLE

- 4210-MMPC-C Multi Measurement Performance Cables for Cascade probe stations using SSMC probe pin connections. One kit required per manipulator.
- 4210-MMPC-L Multi Measurement Performance Cables for Lucas Signatone probe stations using SSMC probe pin connections. One kit required per manipulator.
- 4210-MMPC-S Multi Measurement Performance Cables for Suss probe stations using SSMC probe pin connections. One kit required per manipulator.
- 4210-MMPC-W Multi Measurement Performance Cables for Wentworth probe stations using SSMC probe pin connections. One kit required per manipulator.
- 4225-PMU Extra Ultra-Fast I-V Module
- 4225-RPM Extra Remote Amplifier/Switch. Up to two of these units can be used with a single 4225-PMU module.
- 4200-PMU-PROBER-KIT General Purpose Cable/Connector Kit. For connecting the 4225-PMU to most triax and coax probe stations. One kit required per 4225-PMU module.

Ultra-Fast NBTI/PBTI Package for the Model 4200-SCS

Model 4225-RPM Remote Amplifier/Switch

This module is designed to maximize the Model 4225-PMU's current measurement sensitivity. The 4225-RPM's independent force and sense connections to the DUT maximize its pulse, DC, and C-V performance. Its built-in switching capabilities allow the Model 4200-SCS to switch automatically between making ultra-fast I-V measurements with the 4225-PMU and DC I-V measurements with the system's 4200-SMU and 4210 source-measure units (SMU instruments).

Model 4225-RPM modules are required for ultra-fast BTI testing; if the 4225-PMU module is used without them, it employs a recursive technique to compensate for cable influences such as load line effects and is typically used for isothermal I-V testing. This recursive technique is inappropriate for use in BTI reliability applications in which measurements must be both as short as possible and highly temporally deterministic in order to minimize the relaxation effects.

By making it possible to locate the pulse source close to the device under test (DUT), the 4225-RPM helps minimize the cable length and corresponding cable parasitic effects. The shorter cables result in reduced cable capacitance, reduced load-line effects, and reduced source overshoot. Placing the pulse source and high speed measurement circuits near the DUT allows the cable length to be reduced so that the round-trip propagation delay is shorter than the rise or fall time of the desired pulse.

For additional details and specifications on the Model 4225-RPM, consult the Model 4225-PMU data sheet.

Speed and Sensitivity

Bias temperature instability is a highly dynamic phenomenon that requires sensitive, high-speed measurements for accurate characterization. Assuming all other factors are constant, measurement physics largely defines the relationship between measurement speed and sensitivity. When making sub-millisecond measurements, all sources of noise must be taken into account; for sub-microsecond applications, quantum effects can't be ignored. The 4200-BTI-A package provides the optimal combination of measurement speed and sensitivity for ultra-fast BTI testing because it's engineered to approach the limits of measurement physics while ensuring high ease of use. The package is optimized to provide accurate ultra-fast results without the use of RF structures and interconnects.

Reduce Unwanted Source-Drain Fields

To eliminate hot carrier injection effects or unwanted charge displacement during BTI testing, minimizing drain-to-source fields is critical. All BTI characterization techniques involve measuring drain current with a voltage applied to the drain. Given that the drain current is proportional to the

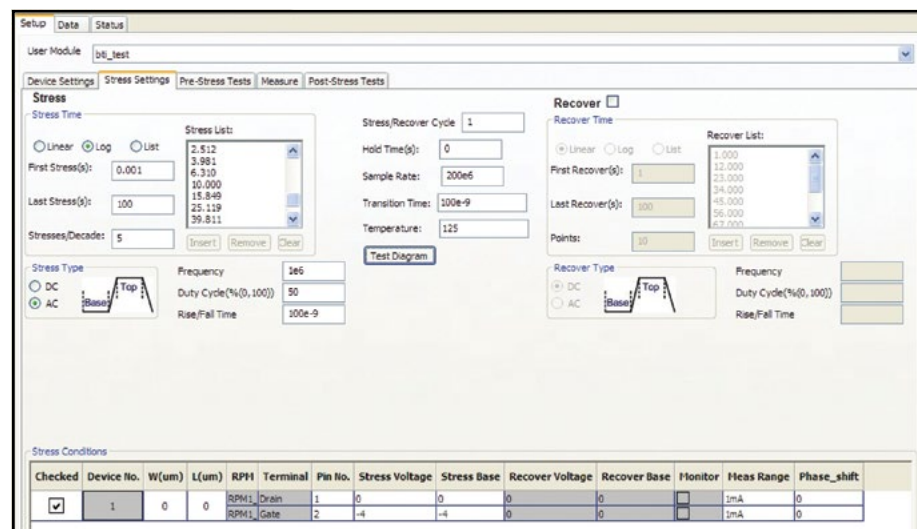

Define stress timing and stress conditions easily using familiar parameters like timing – log, linear, custom list; measurements per decade; AC or DC stress; optional recovery test sequence; and test sample rate (speed).

1.888.KEITHLEY (U.S. only)

www.keithley.com

KEITHLEY

A Greater Measure of Confidence

A Tektronix Company

4200-BTI-A

Ultra-Fast NBTI/PBTI Package for the Model 4200-SCS

Disadvantages of BTI systems developed in house

Until now, some researchers have been forced to configure their own ultra-fast BTI test systems. These in-house-developed systems typically combine a pulse generator or arbitrary waveform generator with an oscilloscope equipped with current probes or some type of transimpedance amplifier to help measure low current. Although it is possible to build a BTI system that is suitable for a very specific set of electrical conditions if the instruments and interconnect are carefully selected, several major technical challenges remain:

- **Waveform generation.** Standard pulse generators and arbitrary waveform generators are designed to generate a waveform on a fixed recurring interval, rather than the Log(time) scale required for most reliability tests, including NBTI and PBTI testing.
- **Measurement timing and data storage.** Although oscilloscopes can be configured to trigger based on a waveform feature (such as a falling edge, for example), they are not designed to store samples selectively for specific portions of the waveform. This makes it necessary to store very large data sets for postprocessing. Only the most expensive oscilloscopes or those with costly memory expansion options can store enough data to compensate for these shortcomings.
- **Precision, accuracy, and sensitivity.** Oscilloscopes, current probes, and transimpedance amplifiers all have independently defined performance specifications and they are not necessarily optimized to work together. It is often very difficult to combine these components in a way that provides optimal performance across a wide dynamic range in order to achieve precise and accurate current measurements at high speeds.
- **Interconnect.** Systems built in house typically use splitters and bias tees, which limit the performance of the test setup. For example, a bias tee might limit bandwidth from 100ns to 10 μ s. Although this is suitable for high speed measurements, it prevents making any meaningful prestress and poststress DC measurements as part of the stress–measure sequence. It also prevents making measurements in the intermediate range of 10 μ s to DC.
- **Test control and data management.** Traditional oscilloscopes don't support data streaming, so results transfer must wait until the test ends. Once the test is complete, massive amounts of data must be transferred to the control computer for postprocessing, which requires parsing complex waveforms into individual test results, followed by further reduction of the data into actual measurements.
- **Test termination.** Given that the test results can't be analyzed until the data is transferred from the oscilloscope, the test duration must be determined prior to test initiation. This makes it impossible to terminate the test based in parametric shifts or to detect catastrophic failures in real time.
- **Automation.** Wafer- or cassette-level automation requires control of both the test instruments and the wafer probe station, which systems built in house typically wouldn't provide. Also, incorporating sophisticated features like conditional test termination would add considerable complexity to the custom software necessary to run a system of this type.
- **Higher channel count.** Even for an in-house-built system that works well, pressures to increase the channel or test system count may arise. Typical test system maintenance issues such as calibration, operation, and correlation related to these custom setups can easily consume a disproportionate amount of the available resources.

drain-to-source field, the more sensitive the drain current measurement is, the lower the required drain voltage must be. The 4200-BTI-A package's superior low current measurement capability allows the use of lower drain voltages to produce more accurate results.

Reduced Relaxation Time

The 4225-BTI-A package's superior speed and sensitivity allow making degradation measurements faster than any other commercial test system available. Single-point ID spot measurements can be completed in less than 1 μ s and ten-point ID-VG step sweeps can be made in less than 10 μ s. A sub-microsecond smooth sweep can be performed in less than 1 μ s.

Software

The Ultra-Fast BTI test software module brings together the measurement capabilities of the Model 4225-PMU and 4225-RPM through an intuitive interface that doesn't compromise test flexibility. It makes it easy to define stress timing, stress conditions, and a wide range measurement sequences from spot I_D , On-The-Fly (OTF), or I_D - V_G sweeps. The test module allows measuring recovery effects as well as degradation. It also offers prestress and poststress measurement options that incorporate the Model 4200-SCS's DC SMU instruments for high-precision low-level measurements.

Stress Settings

The Ultra-Fast BTI Test Module employs familiar parameter setting for building stress–measure timing sequences. The stress set-up screen makes defining log or linear timing or building a custom list of time intervals to trigger intra-stress measurements both easy and quick.

Intuitive Test Sequence Development

The Ultra-Fast BTI Test Module makes creating a powerful test sequence as uncomplicated as selecting one or more measurement types, then entering the appropriate values for voltage levels and measurement parameters in the intuitive interface. No coding or script writing is required. Select from four measurement types and chain up to 20 measurements together to form a ready-to-run measurement sequence:

- **Spot.** The spot measurement is a single measurement made while the gate and drain are pulsed. The measurement result is the mean value of the samples taken after the drain settles and before the pulse ends.
- **Step Sweep.** The step sweep is very similar to a conventional DC SMU sweep, in which

1.888.KEITHLEY (U.S. only)

www.keithley.com

KEITHLEY

A Tektronix Company

A Greater Measure of Confidence

4200-BTI-A

Ultra-Fast NBTI/PBTI Package for the Model 4200-SCS

each step in the sweep includes a settling period and an integration (or averaging) period.

- **Smooth Sweep.** The smooth sweep does not include settling times, and the signal is sampled continuously throughout the sweep.
- **Sample.** A sample measurement is much like the smooth sweep measurement, except that it is performed at a constant set of voltage conditions on the gate and drain.

Test Automation Speeds Data Sample Acquisition

The ability to acquire large, statistically significant samples of data quickly is key to reliability modeling. Advances in ultra thin film transistors have further increased the required sample size due to the increasingly random nature of the defects in these devices. As a result, it's critical to use a test environment that supports wafer- and cassette-level automation. This environment must also be capable of handling the extremely large data sets associated with reliability testing. The test environment provided with the Automated Characterization Suite software supports full automation capabilities compatible with both semi and fully automatic probe stations.

Interconnect

The 4200-BTI-A package provides all the cabling and connectors required to connect to standard coaxial probe manipulators. For enhanced measurement accuracy, many users add an optional multi-measurement performance cable kit that connects the Model 4200-SCS to a probe manipulator, simplifying switching between DC I-V, C-V, and ultra-fast I-V testing configurations. This kit eliminates the need for re-cabling, as well as maximizing signal fidelity by eliminating the measurement errors that often result from cabling errors. Versions engineered for Cascade Microtech and SUSS MicroTec probers are available. There's also a general-purpose kit for connecting the 4225-PMU to other triaxial and coaxial probe stations.

Additional Applications

The Model 4225-PMU's ultra-fast I-V capabilities are not limited to low-voltage pMOS and nMOS reliability testing. It can drive up to 800mA or 40V with pulse widths from 30ns to several seconds in length. This remarkable dynamic range is suitable for a wide variety of other applications.

Keithley's Model 4200-SCS replaces a variety of electrical test tools with a single, tightly integrated characterization solution that's ideal for a wide variety of applications. To assure customers of the ongoing viability of their systems, Keithley has continually enhanced the system's hardware and software. This ongoing commitment ensures a cost-effective system upgrade path to address new testing needs as they arise. That means Model 4200-SCS users will never have to buy a new Parameter Analyzer because the old one is obsolete. The Model 4200-SCS is engineered to adapt readily to the industry's changing test needs—making our customers' capital investments stretch further and improving ROI.

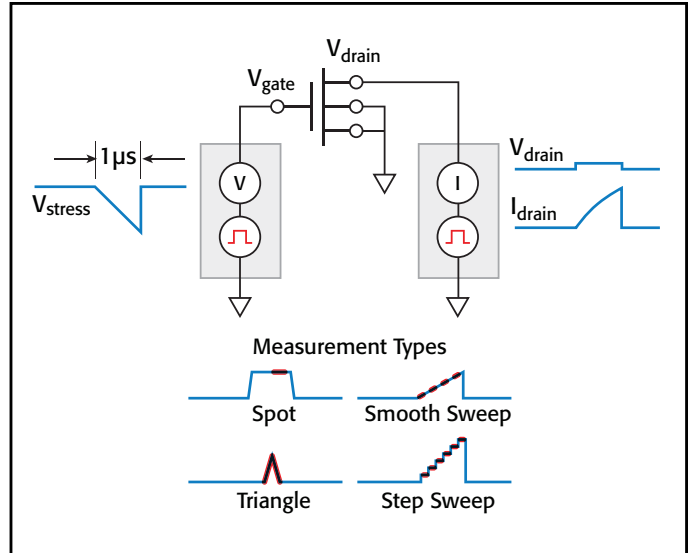

The Ultra-Fast BTI test software module supports spot, step sweep, smooth sweep, and sample measurement types. Each type's timing is defined by the test sample rate and the individual measurement settings. The software module also provides control over the voltage conditions between each element in the test sequence, for maximum flexibility and ease of use, even when defining complex test sequences.

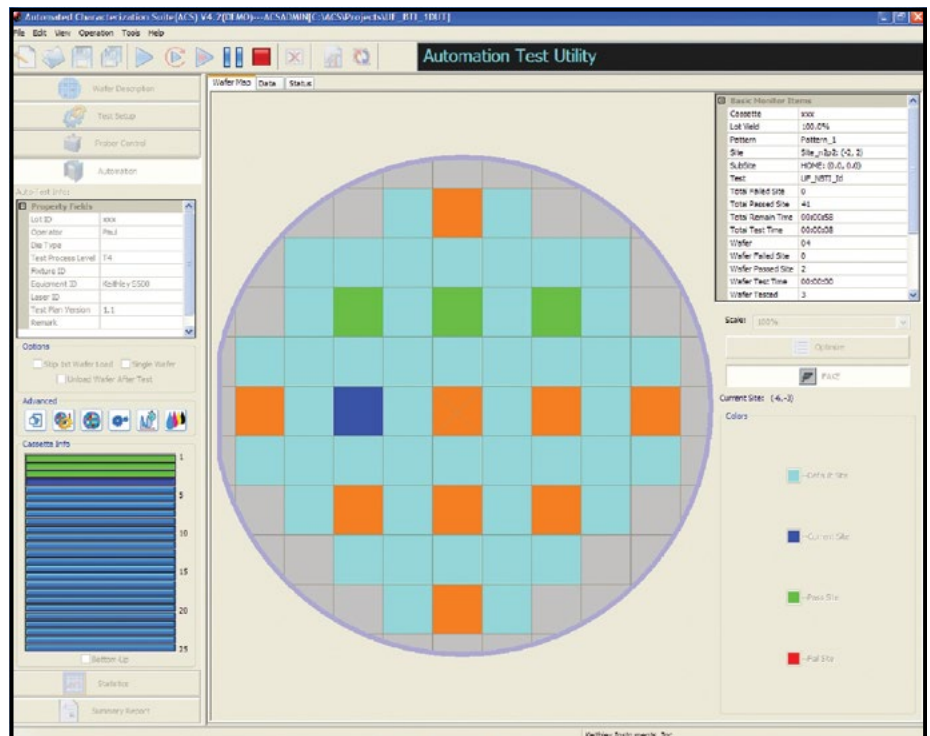

ACS software provides wafer- and cassette-level automation capabilities compatible with semi and fully automatic probe stations.

1.888.KEITHLEY (U.S. only)

www.keithley.com

A Greater Measure of Confidence

KEITHLEY

A Tektronix Company

4200-BTI-A

Ultra-Fast NBTI/PBTI Package for the Model 4200-SCS

Specifications

4225-RPM REMOTE AMPLIFIER/SWITCH Optional Accessory for the 4225-PMU

The 4225-RPM provides lower current measurement ranges to the 4225-PMU.

Low current measure ranges supports wide range of measurements, from nanotechnology to BTI (Bias Temperature Instability) on leading-edge CMOS devices

This is a single-channel accessory; order two Model 4225-RPMs to support the two channels of the Model 4225-PMU.

Supports switching to the Model 4200-SCS's SMU instruments or 4210-CVU, allowing for a wide range of tests without re-cabling.

Built-in bypass mode allows access to the Model 4225-PMU's higher current measurement ranges.

PULSE/LEVEL¹

	4225-PMU with 4225-RPM
V _{OUT}	-10 V to +10 V
Accuracy ² into open load	±(0.5% ±10 mV)
Resolution	< 0.5 mV
Output Connectors	Triaxes, source and sense
Baseline Noise	±(0.39% + 1 mV) RMS typical
Overshoot/Pre-shoot/Ringing ³	±2% of amplitude ±20 mV

4225-RPM REMOTE AMPLIFIER/SWITCH (must be used in conjunction with 4225-PMU)

TYPICAL MINIMUM TIMING PARAMETER FOR CURRENT MEASUREMENT

Range	100 nA	1 µA	10 µA	100 µA	1 mA	10 mA
Recommended Minimum Pulse Width ^{4,5}	134 µs	20.4 µs	8.36 µs	1.04 µs	370 ns	160 ns
Recommended Minimum Measure Window ⁵	10 µs	1.64 µs	1 µs	130 ns	40 ns	20 ns
Accuracy (DC)	±(0.5% + 1nA)	±(0.5% + 1nA)	±(0.5% + 30nA)	±(0.5% + 100nA)	±(0.5% + 1µA)	±(0.5% + 10µA)
Recommended Minimum Transition Time ^{5,6}	1 µs	360 ns	360 ns	40 ns	30 ns	20 ns
Noise ^{5,7}	200 pA	2 nA	5 nA	50 nA	300 nA	1.5 µA
Settling Time ^{5,8}	100 µs	15 µs	6 µs	750 ns	250 ns	100 ns

VOLTAGE MEASURE

±10V

RECOMMENDED MINIMUM PULSE WIDTH^{4,5}: 160ns.

RECOMMENDED MINIMUM MEASURE WINDOW⁵: 20ns.

ACCURACY (DC): 0.25% + 10mV.

RECOMMENDED MINIMUM TRANSITION TIME^{5,6}: 20ns.

NOISE^{5,7}: 1mV.

SETTLING TIME^{5,8}: 100ns.

NOTES

- Performance at the triax output connectors of the 4225-RPM when using a 2m RPM interconnect cable between the 4225-PMU and 4225-RPM Remote Pulse Measure unit.
- 100mV to 10V.
- Typical, with transition time of 100ns (0-100%).
- Recommended minimum pulse width = (Setting Time)/0.75
- Typical values, into an open.
- Recommended rise/fall time to minimize overshoot.
- RMS noise measured over the Recommended Minimum Measure Window for the given voltage or current range, typical.
- Time necessary for the signal to settle to the DC accuracy level. (Example: the 10mA measurement range's settling time refers to the period required for the signal to settle to within 0.35% of the final value. Calculated as Accuracy = 0.25% + 10µA = 0.25% + (10µA/10mA) = 0.25% + 0.1% = 0.35%.)

All specifications apply at 23° ±5°C, within one year of calibration, RH between 5% and 60%, after 30 minutes of warmup.

1.888.KEITHLEY (U.S. only)

www.keithley.com

KEITHLEY

A Tektronix Company

A Greater Measure of Confidence

4200-BTI-A

Ultra-Fast NBTI/PBTI Package for the Model 4200-SCS

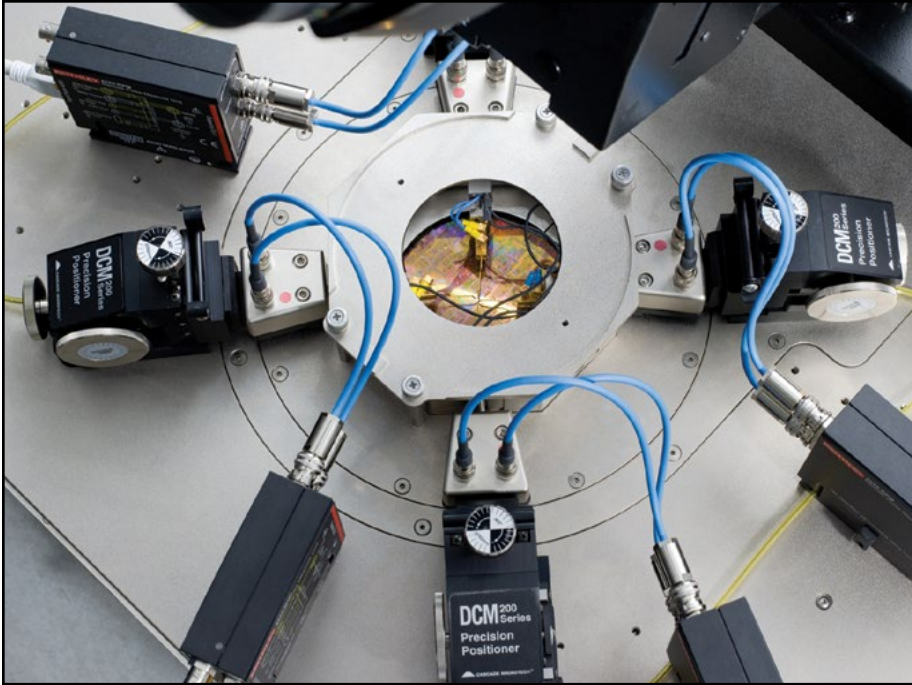

This top-down view of a Cascade Microtech analytical probe station illustrates best practices for interconnecting the Model 4225-RPM Remote Amplifier/Switch to the prober using the blue Multi-Measurement Performance cables.

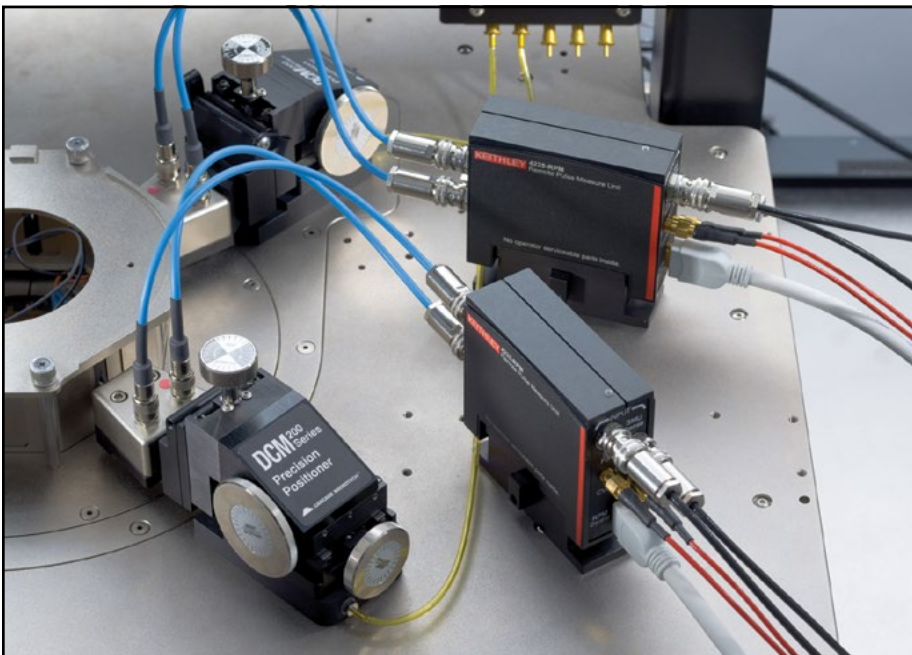

This closeup of two Model 4225-RPMs highlights the DC SMU, C-V, and ultra-fast I-V cable connections.

1.888.KEITHLEY (U.S. only)

www.keithley.com

A Greater Measure of Confidence

KEITHLEY
A Tektronix Company

2600-PCT-x 4200-PCT-x



Model 4200-PCT-4 on K420 Cart



Model 2600-PCT-4

High Power Device Characterization

Characterizing and testing today's high power semiconductor devices and components is placing a high demand on test equipment. Device design engineers need equipment that can support them throughout the complete lifecycle of a power device. Today, high power characterization systems are available in two main forms — complete turnkey systems and building blocks that must be configured by the user

and completed with good software. Turnkey systems can be set up and running quickly, but they can be quite expensive and limited in the breadth of testing that can be performed.

Keithley's Parametric Curve Tracer configurations are complete solutions configured with a variety of high quality instruments, cables, test fixturing, and software. This building block approach offers the advantages of easy upgrading or modification to meet changing test needs. For example, a low cost 200V/10A system can be purchased initially, and 50A or 100A capability can be easily added later. Additionally, these instruments and accessories can be used across different test system platforms, such as for reliability or device qualification testing.

Keithley's Parametric Curve Trace configurations include everything necessary for the characterization engineer to develop a complete test system quickly. ACS Basic Edition software provides complete device characterization, including both real-time trace mode for quickly checking fundamental device parameters like breakdown voltage and full parametric mode for extracting precise device parameters. ACS Basic Edition goes beyond traditional curve tracer interfaces by offering a broad array of sample device libraries. More important, users have complete control of all test resources, allowing them to create more advanced tests than previously possible on a curve tracer.

- **Configurable power levels**
 - From 200V to 3kV
 - From 1A to 100A
- **Wide dynamic range**
 - From μ V to 3kV
 - From fA to 100A
- **Capacitance-voltage methods**
 - \pm 400V multi-frequency C-V
 - 200V ramp rate C-V
 - 20V very low frequency (VLF) C-V
- **DC or pulsed I-V to 50 μ s**
- **High voltage and high current channels have both 24-bit precision A/D converters and 18-bit high speed (1 μ s) digitizers**
- **Test management software includes both trace mode for real-time control and Parametric mode for parameter extraction**

APPLICATIONS

- **Power semiconductor device characterization and testing**
- **Characterization of GaN and SiC, LDMOS, and other devices**
- **Reliability studies on power devices**
- **Incoming inspection and device qualification**

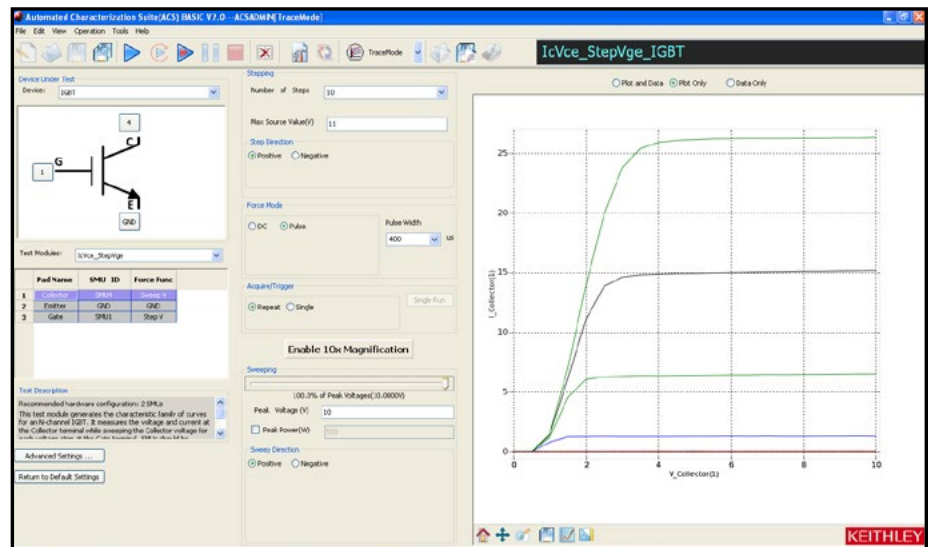

ACS Basic Edition Software quickly captures output characteristics of an IGBT device.

2600-PCT-x 4200-PCT-x

Ordering Information

- 2600-PCT-1** Low Power
- 2600-PCT-2** High Current
- 2600-PCT-3** High Voltage
- 2600-PCT-4** High Voltage and Current
- 4200-PCT-2** High Current + C-V
- 4200-PCT-3** High Voltage + C-V
- 4200-PCT-4** High Voltage and Current + C-V

Accessories Supplied

ACS-BASIC Component Test Software

8010 High Power Device Test Fixture (includes 8010-CTB, 8010-DTB, and 8010-DTB-220)

KUSB-488B USB to GPIB Adapter (Series 2600B configurations only)

All cables and adapters

Sample parts

4200-CVU-PWR (4200-SCS configurations only)

Note: Computer and monitor not included with 2600-PCT-x configurations

ACCESSORIES AVAILABLE

2651A	High Power System SourceMeter (adds 50A to any system, max 100A)
2657A	High Power System SourceMeter (adds 3kV to any system, max of one unit per system)
8010-CTB	Customizable Test Board
8010-DTB	Device Test Board with TO-247 socket
8010-DTB-220	Device Test Board with TO-220 socket
70161-MSA	Keyboard/Monitor Arm for K420 and K475 Carts
HV-CA-554-1	HV Triax Cables (three required for 2657A)
K475 Workstation Tower	Mobile cart for all PCT configurations
K420 Workbench Cart	Mobile cart for smaller PCT configurations

Parametric Curve Tracer Configurations

The Keithley Parametric Curve Trace configurations are complete characterization tools that include all of the key elements necessary for power device characterization.

The measurement channels consist of high quality Keithley SourceMeter (trademark) and/or Semiconductor Characterization instruments. The dynamic range and accuracy of these instruments is orders of magnitude beyond what a traditional curve tracer could offer.

To achieve this performance, Keithley has developed a set of precision cables to connect the instruments to the test fixture. For the high voltage channel, custom triax cables provide a guarded pathway that enables fast settling and very low currents, even at the full 3kV. For the high current channel, special low inductance cables provide fast rise time pulses to minimize device self heating effects.

Equally critical is a safe, efficient test fixture. The 8010 provides an interlocked, shielded environment that allows for both low current, high voltage testing and high current, low voltage testing. Included with the test fixture are the same high performance connectors that mate with the precision cables. Also included are protection circuits to prevent the high voltage channel from destroying the base/gate channel in the event of a device fault.

Configuration Selector Guide

Model ¹		Collector/ Drain Supply ²		Step Generator Base/Gate Supply	Auxiliary Supply
		High Voltage Mode	High Current Mode		
Low Power	2600-PCT-1	200 V/10 A	200 V/10 A	200 V/10 A	N/A
	2600-PCT-2	200 V/10 A	40 V/50 A	200 V/10 A	200 V/10 A
High Current	4200-PCT-2 plus C-V	200 V/1 A	40 V/50 A	200 V/1 A	200 V/1 A
	2600-PCT-3	3 kV/120 mA	200 V/10 A	200 V/10 A	200 V/10 A
High Voltage	4200-PCT-3 plus C-V	3 kV/120 mA	200 V/1 A	200 V/1 A	200 V/1 A
	2600-PCT-4	3 kV/120 mA	40 V/50 A	200 V/10 A	200 V/10 A
High Current and High Voltage	4200-PCT-4 plus C-V	3 kV/120 mA	40 V/50 A	200 V/1 A	200 V/1 A

1. Contact your Keithley field applications engineer for custom configurations
2. Add a Model 2651A to increase High Current Mode to either 50A or 100A.



Model 2600-PCT-4



Model 4200-SCS

1.888.KEITHLEY (U.S. only)

www.keithley.com

A Greater Measure of Confidence

KEITHLEY
A Tektronix Company

2600-PCT-x 4200-PCT-x

Parametric Curve Tracer Configurations

Typical Power Transistor Parameters

Parameter	Symbol	Test Method ¹	Maximum Range	Typical Best Resolution	Typical Accuracy
Breakdown Voltage	Bvds, Bvceo	Id-Vd or Id (pulse)	±3000 V ²	100 μV, 10 fA	0.05% rdg + 0.05% rng
On-State Current (DC)	Vdson, Vcesat, Vf	Id-Vd	±20 A ⁴ , Optional: ±40 A ⁴	100 nA, 1 μV	0.05% rdg + 0.05% rng
On-State Current (Pulse)	Vdson, Vcesat, Vf	Id-Vd	±50 A ⁴ , Optional: ±100 A ⁴	100 μA, 1 μV	0.05% rdg + 0.05% rng
Drain/Collector Leakage Current	Idss, Ir/Icbo, Iceo	Id-Vd	±20 mA @ 3000 ^{2,5}	10 fA, 1 μV	0.2% rdg + 1% rng
Gate/Base Leakage Current	Igss, Ib	Ig-Vg	±1 A or, ±10 A Pulsed ³	10 fA, 1 μV	0.2% rdg + 1% rng
On-State Threshold Voltage or Cutoff Voltage	Vth, Vf, Vbeon, Vcesat	Id-Vg	±200 V ³	10 fA, 1 μV	0.2% rdg + 0.5% rng
Forward Transfer Admittance or Forward Transconductance	yfs Gfs, Hfe, gain	Vd-Id @ Vds	1 ms ~ 1000 s ⁶	1 pA, 1 μV	1%
On-State Resistance	RDS(on), Vcesat	Vd-Vg @ Id	<100 μΩ ⁷	10 μΩ, 1 μV	1%
Input Capacitance	Ciss	C-V 100 kHz	10 nF ⁸ ±200 V	10 fF, 10 μV	Better than 1% at C<10 nF
Output Capacitance	Coss	C-V 100 kHz	10 nF ⁸ ±200 V	10 fF, 10 μV	Better than 1% at C<10 nF
Reverse Transfer Capacitance	Crss	C-V 100 kHz	10 nF ⁸ ±200 V	10 fF, 10 μV	Better than 1% at C<10 nF

1. Test method used for extracting the parameter. Only typical MOSFET listed, but similar method for other devices.
2. Model 2657A High Power System SourceMeter® SMU Instrument.
3. Model 2636A SourceMeter SMU Instrument or Model 4210-SMU.
4. Model 2651A High Power System SourceMeter SMU Instrument or optional dual Model 2651A High Power System SourceMeter SMU Instruments.
5. Maximum 20mA at 3000V, 120mA at 1500V.
6. Typical extracted capability (Example: 1mA/1V ~ 1A/1mV).
7. Typical extracted capability (Example: 1mV/10A).
8. Max. ±200VDC (±400VDC differential) bias with 4210-CVU and 4200-CVU-PWR.

Flexible, safe test fixture for 3kV and 100A



8010 Test Fixture



High current, low inductance cables



High voltage, low noise triaxial cables

1.888.KEITHLEY (U.S. only)

www.keithley.com

A Greater Measure of Confidence

KEITHLEY
A Tektronix Company

2600-PCT-x 4200-PCT-x

Parametric Curve Tracer Configurations

Semiconductor Parametric Test Software for Component and Discrete Devices

ACS Basic Edition software is specifically tuned to take advantage of the high performance capabilities of the Keithley instrumentation and includes several sample libraries for performing common high power device tests. Unlike other systems, the software allows the user almost unlimited flexibility in configuring all of the measurement channels to create tests far beyond what a traditional curve tracer could achieve.

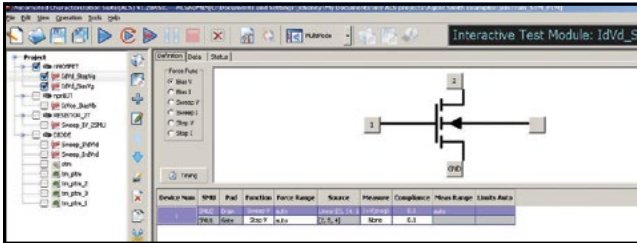

Multi test mode allows multiple tests to be performed on a device.

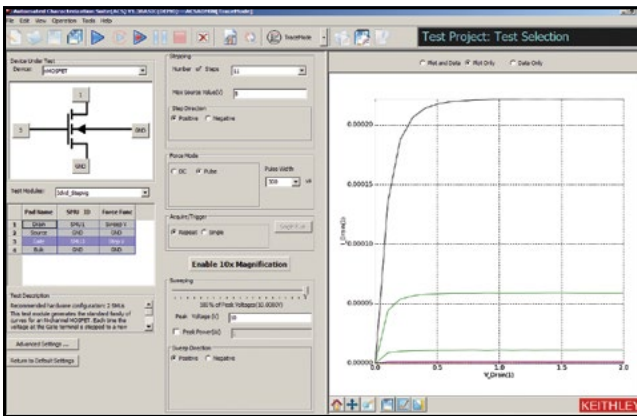

Trace mode supports interactive testing of a device.

SUMMARY OF TYPICAL TESTS

Device	Leakage	Breakdown	Gain	On-State
Bipolar Junction Transistor	IEBO, IECO, IEVEB, ICVCB	BVCBO, BVCEI, BVCEO, BVCEV, BVEBO, BVECO	HFE	IBCO, IBEO, IBICVBE, IBVBE, ICBO, ICEV, ICVCE_BiasIB, ICVCE_BiasVB, ICVCE_StepIB, ICVCE_StepVB, VBCO, VCE
MOSFET	IDL, IDS_ISD, IGL, ISL	BVDSS, BVDSV, BVGDO, BVGDS, BVGSO	GM	IDVD_BiasVG, IDVD_StepVG, IDVG_BiasVD, IDVG_StepVD, IDVG_StepVSub, IGVG, VTCI, VTEXT, VTEXT_IISQ
Diode	IRDVRD	VBRIRD	NA	DYNAMICZ, IFDVF, VFDIFD, VRDIRD
Resistor	NA	NA	NA	IV
Capacitor	IV		NA	

FORMULATOR FUNCTION SUMMARY

Type	Functions
Math	ABS, AVG, DELTA, DIFF, EXP, LN, LOG, LOG10, SQRT
Parametric Extractions	GMMAX, RES, RES_4WIRE, RES_AVG, SS, SSVTCI, TTF_DID_LGT, TTF_LGDID_T, TTF_DID_T, TTF_LGIDID_LGT, VTCI, VTILINGM, VTSATGM
Fitting	EXPFIT, EXPFITA, EXPFITB, LINFIT, LINFITSLP, LINFITXINT, LINFITYINT, REGFIT, REGFITSLP, REGFITXINT, REGFITXINT, REGFIT_LGX_LGY, REGFIT_LGX_X, REGFIT_X_LGY, TANFIT, TANFITSLP, TANFITXINT, TANFITYINT
Manipulation	AT, FINDD, FINDLIN, FINDU, FIRSTPOS, JOIN, LASTPOS, MAX, MAXPOS, MIN, MINPOS, POW, SMOOTH

Parametric curve tracer configurations

SEMICONDUCTOR

1.888.KEITHLEY (U.S. only)

www.keithley.com

KEITHLEY

A Tektronix Company

A Greater Measure of Confidence

S530

- Semiconductor industry's most cost-effective fully automatic parametric testers
- Optimized for use in environments with a broad mix of products, where high flexibility and system speed are critical
- Choice of low current or high voltage system configurations
 - Low current configuration supports measurement of low current characteristics such as sub-threshold leakage, gate leakage, etc.
 - High voltage configuration is optimized for monitoring processes used for GaN, SiC, and Si LDMOS power devices
- Compatible with popular fully automatic probe stations
- Instrument options for sourcing pulses, frequency measurements, and low voltage measurements
- Cabled-out tester configuration maximizes prober interface flexibility and expands voltage range
 - Compatible with Keithley's Model 9139A Probe Card Adapter
 - Supports reuse of existing five-inch probe card libraries
- Proven instrumentation technology ensures high measurement accuracy and repeatability in both the lab and the fab

Parametric Test Systems



Keithley's S530 Parametric Test Systems can address all the DC and C-V measurements required in process control monitoring, process reliability monitoring, and device characterization because they are built on proven sourcing and measurement technology.

Optimized for High-Mix Test Environments

S530 Parametric Test Systems are designed for production and lab environments that must handle a broad range of devices and technologies, offering industry-leading test plan flexibility, automation, probe station integration, and test data management capabilities. Keithley has brought more than 30 years of expertise in delivering a wide range of standard and custom parametric testers to customers around the world to the design of these test solutions.

Simple Software Migration and High Hardware Reuse

S530 systems are designed with capabilities that speed and simplify system startups and maximize reuse of your existing test resources. For example, the software that controls these systems is compatible with many new and legacy automatic probe stations, so you may be able to eliminate the cost of a new one. In addition, the S530's cabled-out configuration typically allows continued use of your existing probe card library. Several optional applications services can help you keep getting the full value of your existing prober and probe card investments. Keithley can also provide assistance to speed the development, conversion, or repurposing of your existing test recipes for use with S530 systems.

Semiconductor Industry's Most Powerful Standard Parametric Test System

Two different system configurations are available to address different parametric test application environments. The S530 Low Current System, which is configurable from two to eight source measure unit (SMU) channels, provides sub-picoamp measurement resolution and low current guarding

1.888.KEITHLEY (U.S. only)

www.keithley.com

Table 1. S530 System Selector Guide

System Capabilities		Key Range and Offset Performance
S530 Low Current System <ul style="list-style-type: none"> • Source up to 200V or 1A • Measure current with femto-amp resolution and sub pico-amp offset • 2 to 8 SMU channels¹ • Options for C-V, pulse sourcing, frequency measurements, and low-voltage measurements • Up to 60 pins full Kelvin plus connection for chuck 		
S530 High Voltage System <ul style="list-style-type: none"> • Source up to 1000V or 1A • Use 200V SMU to measure current with femto-amp resolution and pico-amp offset • Use 1000V SMU to measure current with ten pico-amp resolution and nano-amp offset • 3 to 7 SMU channels¹ • Options for C-V, pulse sourcing, frequency measurements, and low-voltage measurements • Up to 24 pins full Kelvin plus connection for chuck 		

1. Depending on instrument options within the system.

all the way to the probe card, which makes it ideal for characterizing sub-micron silicon MOS technologies. The S530 High Voltage System, configurable from three to seven SMU channels, can source up to 1000V for use in the difficult breakdown and leakage tests that automotive electronics and power management devices demand.

All Series S530 systems are equipped with Keithley’s proven high power SMU instruments, which provide up to 20W source or sink capability on both the 200V and 20V ranges. This level of power is essential for complete characterization of the high power devices and circuits prevalent in today’s mobile devices. Whether the application is testing LDMOS Si or GaN BJTs, this higher power capability provides greater visibility into device performance. That means S530 systems can handle high power device testing without compromising the low current sub-picoamp sensitivity needed to monitor mainstream device processes. In contrast, competitive parametric test systems are limited to medium power 2W SMU instruments, so they cannot match the S530 systems’ range of applications.

Full Kelvin Standard Configurations

All too often, currents higher than a few milliamps lead to measurement errors as a result of voltage drops across the interface cables and pathways. To prevent this drop in measurement integrity, both the low current and high voltage S530 systems provide full Kelvin measurements (also known as remote voltage sense) at the probe card. Full Kelvin measurements are particularly critical to ensuring measurement accuracy given the 20W capability of the high power SMU instruments used in S530 systems.

Industry’s Most Powerful High Voltage Parametric Test System

The S530 High Voltage Semiconductor Parametric Test System is the only parametric tester available that’s capable of full Kelvin high voltage performance on up to 24 pins, a capability that’s invaluable for characterizing today’s higher power devices. The system incorporates a high voltage SMU that sources up to 1000V at 20mA (20W max.). Two high voltage pathways allow making either direct high-side current measurements (in which a single SMU is used to both source and measure the high side of the DUT) or higher sensitivity low-side low current measurements (in which one SMU is used to source high voltage to the high side of the DUT and a different SMU is used to force 0V and measure the current of the low side).

System Architecture

Each S530 system configuration is made up of five layers:

- Instruments layer – In addition to SMU instruments, the S530 offers options for sourcing pulses or making C-V, frequency, or low voltage measurements.
- Pathways layer – S530 systems provide high fidelity signal pathways that can be dynamically reconfigured to allow any instrument to be connected to any pin or set of pins during test.
- Cable interface layer – All system interconnects are constructed of fully shielded and guarded triaxial low leakage, high voltage cables to ensure higher measurement integrity.
- Probe card adapter (PCA) layer – This layer extends the shield and guard to the probe card to ensure measurement integrity. Also, the PCA provides auxiliary inputs for instruments that require direct access to the probe card and must bypass the signal path switch matrix.
- Probe card layer – This layer includes the custom cards supplied by your probe card vendors.

Signal Pathways

The core of each S530 test system is a set of high fidelity signal pathways through the system switch that direct signals between instruments and test pins. The S530 has eight high fidelity pathways that can be used to route instruments to pins dynamically. For example, up to eight SMU instruments can be routed to any pin (or number of pins) at one time. The S530 Low Current System uses switch matrices that deliver uniform performance across all eight pathways. The S530 High Voltage System uses switch matrices with specific pathways for high voltage/low leakage measurements and also for C-V. Refer to models 7174A and 7072-HV data sheets for more details.

Table 2. S530 Pathway Performance

Pathway Type	Key Characteristics	Maximum Voltage	Maximum Current	Comments
Low Current I-V ¹	Ultra low leakage	200V	1A	Limited to 200V max. Provides best low-level signal performance and excellent C-V performance.
High Voltage I-V ²	1300V	1300V	1A	Supports low-level measurements but not quite as low as the Low Current pathway.
General-Purpose I-V ²		200V	1A	Suitable for the majority of parametric tests, except for very low current and/or high voltage tests.
C-V ²		200V	1A	Excellent C-V performance but not suitable for DC I-V measurements.

1. Available only on low current system.
2. Available only on high voltage system.

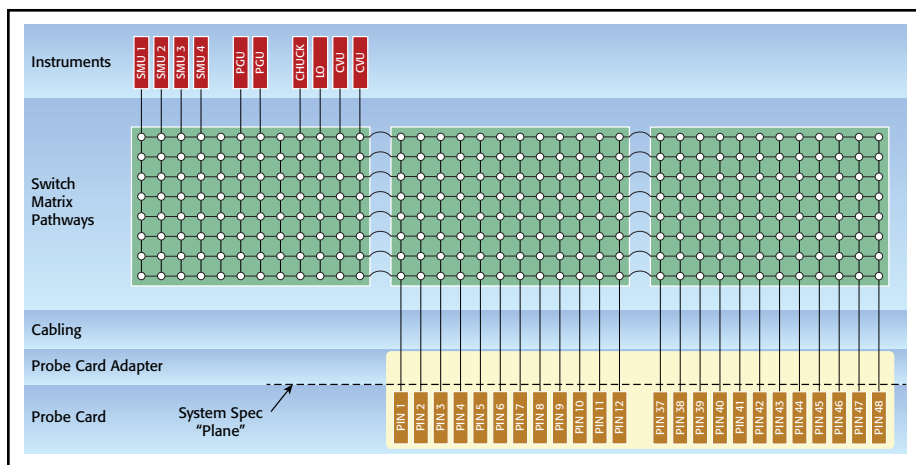

Every S530 system is made up of five layers: instruments, switch pathways, cable interface, probe card adapter, and probe card.

Proven SMU Technology

All source measurement units (SMU instruments) built into S530 Parametric Test Systems are based on Keithley's production-qualified instrument technology to ensure high measurement accuracy and repeatability and extended hardware life. The SMU instruments are four-quadrant sources, so they can source or sink current or voltage. In addition to precision sourcing circuits, they include programmable limits (compliance) across all ranges, which helps protect both devices and probe tips from damage due to device breakdown. Each SMU also measures both voltage and current while sourcing, which ensures that parameter calculations reflect actual conditions rather than simply the programmed conditions.

System Measurement Options

For a wider range of test structures and measurements, the S530 can be equipped with several measurement options:

- Capacitance-Voltage (C-V) Unit – Capable of measuring a 10pF capacitor at 1MHz with a typical accuracy of 1%.
- Pulse Generator Unit – The optional pulse generator unit supports open load pulse amplitudes from $\pm 100\text{mV}$ to $\pm 40\text{V}$, with pulse widths from 100ns to 1s and pulse transitions from 50ns to 200ms. Up to six pulse channels can be added (in increments of two channels). Add one to three dual-channel units for applications such as flash memory testing.
- Frequency measurements – For measuring test structures such as ring oscillators, a frequency measurement option is available for the S530. This option uses one port on the switch matrix and is intended to allow the user to measure ring oscillator structures. The option has a frequency range of 10kHz to 20MHz and can measure signals from 10mV rms to 1V rms.
- Low-voltage measurements – An optional 7½-digit digital multimeter (DMM) augments the voltage measurement capabilities to allow both differential and non-differential voltage measurements from sub-500 μV to 400V (up to 1000V in S530 High Voltage system) for measuring structures including van der Pauw, contact chains, metal resistors and other devices where small voltages must be measured accurately.

Ground Unit (GNDU)

All SMU instruments are referenced to the ground unit or GNDU. During a test, the GNDU provides both a common reference and a return path for current sourced by the SMU instruments. The GNDU signal is formed by combining all the Source LO and Sense LO signals and referencing them to system ground. The system can easily be configured for a range of ground system configurations to accommodate various probe station ground schemas.

Standard 9139A Probe Card Adapter

The standard probe card adapter (PCA) for the S530 parametric test systems is the proven Model 9139A. Several key features and performance advantages have made it the industry's leading choice of PCA for more than 20 years:

- Low offset currents that maximize low current performance.
- Low noise performance that helps ensure the integrity of low-level voltage measurements.
- Minimally invasive, low profile design that allows easy camera integration.
- 64 inputs – Configurable to support both standard cable connections from the tester and auxiliary inputs for instruments that bypass the pathway matrix.
- 500V pin-to-pin isolation (1000V when connecting only to every other pin).

High flexibility cabled-out configuration

S530 systems are “cabled-out” configurations to provide the broad interconnect flexibility that high-mix fab and lab environments demand. These systems can be interfaced to a variety of probing solutions, including high performance circular probe cards, cost-effective rectangular edge-connector probe cards, and even special high performance cards for applications that involve extreme temperatures or demand high durability.

Table 4. S530 System Cabling Options

Cabling Options	Probe Card Type	Features	Benefits
Standard Keithley 9139A PCA (S400-type)	Circular ceramic	Extends driven guard to probe pin	Superior low current measurements. Supports up to 64 pins; easily configured for auxiliary inputs for additional instrument options
Custom Cabled to Existing PCA Type	Typically for five-inch rectangular probe cards using edge card connectors	Compatible with existing probe card library	Reduces migration cost by reusing existing probe cards
Unterminated Cables	Cables connected to pathway output with unterminated cable ends	Ready to cable to existing interface or fixture	Provides recommended cable to optimize system performance
No Cables	Custom probe card	No need to purchase a cable solution	Use cable system provided by custom probe card vendor

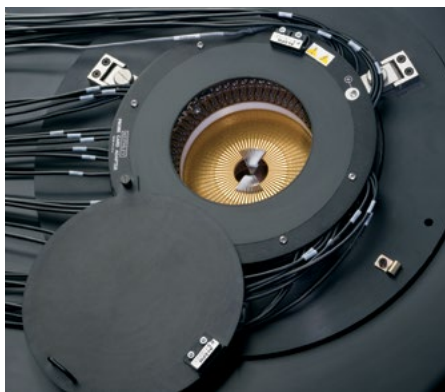

The Model 9139A Probe Card Adapter has been trusted by the industry for more than 10 years. Its combination of low current performance and high voltage capability makes it the ideal companion to the S530 Parametric Test Systems.

Alternative Probe Card Adapters (PCAs)

Optional probe card adapters are available for all S530 configurations. In the simplest form, the edge connector used to interface to a rectangular probe card (typically referred to as five-inch probe cards) is a PCA. This type of PCA provides the most cost-effective solution for applications involving mid-range signal levels. If desired, the Model 9139A PCA can be configured into any S530 system as an option. This PCA is designed for interfacing the system to circular probe cards (from Keithley-approved vendors) via pogo pin connections. Probe-station-specific adapter plates can be specified during ordering to ensure the Model 9139A's compatibility with a variety of popular probe stations.

Probe Cards

Unlike testhead-based systems, S530 systems are easily adaptable for use with a wide range of probe card types, so you likely won't need to

replace your existing (and expensive) probe card library. Although Keithley recommends the use of the Model 9139A PCA and approved probe card vendors, we recognize you have made a major investment in your current cards. If probe card reuse is critical to your capital equipment strategy, consult an applications team member to learn about connection options that can protect your probe card investment.

System Software

Keithley's S530 system relies on the Keithley Test Environment (KTE) software for test development and execution. Hosted a standard industrial PC with a Linux OS, KTE incorporates decades of Keithley parametric test experience into its latest generation test system. Measurement routines and test plans can be easily written, converted, or re-used, helping you get up and running faster. That simplifies using your S530 system effectively in conjunction with existing test systems. S530 software includes all the key system software operations:

- Wafer description
- Test macro development
- Test plan development
- Limits setting
- Wafer or cassette level testing with automatic prober control
- Test data management

User Access Points (UAPs) for Added Flexibility

User Access Points or UAPs can be used to modify the operational flow of the test sequence at key events like “load wafer,” “start test,” “end cassette,” etc. They are useful for adding system capabilities like reading wafer cassette RFID tags or reading wafer IDs using an OCR system. During test operation, an enabled UAP triggers the execution of one or more custom operations defined in a script or executable program.

System Diagnostics and Reliability Tools

Diagnostics can be performed routinely to ensure the system is performing as expected and won't generate false failures or false passes. The S530 systems' diagnostics capability verifies system functionality quickly and easily. Key steps in the diagnostics process include configuration verification, communications pathway tests, signal pathway testing, and SMU source-measure tests. Even the cable interface

1.888.KEITHLEY (U.S. only)

www.keithley.com

A Greater Measure of Confidence

KEITHLEY

A Tektronix Company

and PCA are included in the diagnostics process to ensure complete system functionality. This diagnostics process is designed to detect and localize a wide range of system problems, speed troubleshooting, and maximize uptime.

High Voltage Instrument Protection Modules

The S530 High Voltage System contains a 1kV SMU that might be used on one terminal of a DUT while applying a 200V SMU or the CVU to another terminal. If a test sequence or a failed DUT presents too much voltage to one of these lower voltage instruments, serious instrument damage is possible. To minimize the potential for these problems, Keithley engineers have developed protection modules that prevent damaging voltages from harming the 200V SMU instruments and CVU without compromising their low-level measurement capabilities.

Industrial PC with RAID Mirror Drive

Even the highest quality disk drives are subject to routine failures, so regular system backups are critical. S530 systems incorporate a high

reliability industrial controller including the RAID (Redundant Array of Independent Disks) option, designed to maintain a mirror of the master drive at all times. In the event of a drive failure, the mirror drive becomes the master and the user is notified that a drive replacement should be scheduled immediately. With a RAID mirror drive, a failed drive represents a scheduled repair rather than a downed system.

Support Services and Contracts

Keithley's worldwide network of service and applications professionals provides expert support services ranging from initial installation and calibration to repairs and test plan migration services. These services maximize system utilization and uptime while reducing your overall cost of ownership.

- **Installation and Probe Station Integration Services** – Includes the setup and verification of the system, as well as probe station integration. This includes setting up probe station communications and installing the probe card adapter.

- **Calibration Services** – All S530 Parametric Test Systems are calibrated onsite by a certified Keithley field service engineer.¹ Keithley provides a range of internationally recognized accredited calibration services, including A2LA (American Association for Laboratory Accreditation) accredited calibration.²
- **Repair Services** – Repair services ranging from on-site service contracts to self-service module-swaps are available.
- **Test Plan Migration Services** – Keithley's experienced applications engineers are skilled at converting your existing test plans to the S530 system software environment. This includes conversion of data objects like user test libraries, wafer description files, cassette plans, etc.
- **Correlation Studies** – Keithley applications engineers can perform correlation studies, comparing your existing parametric test system's capability to the S530's and analyzing the underlying performance differences.

1. While most components of the system are calibrated on site, certain components are calibrated at one of Keithley's worldwide network of service facilities.
2. A2LA accredited calibration services are available in the United States and Germany.

Specification Conditions

23°C ±5°C, 1 year.

RH between 5% and 60% after 1 hour warm-up.

System-level specifications are to the end of the Keithley PCA.

All specs are based on 1 year calibration cycle for individual instruments.

Measurement Specifications @ 1 PLC (Power Line Cycle) unless otherwise noted.

Capacitance Specifications are typical @ quiet mode.

General I/V Source Specifications

MAXIMUM OUTPUT POWER PER SMU: 20W (four quadrant source or sink operation).

COMPLIANCE: Compliance resolution and accuracy are determined by the corresponding range used.

Condensed Specifications

Low Current System

Current Range	Max. Voltage	MEASURE		SOURCE	
		Resolution	Accuracy	Resolution	Accuracy
1 A	200 V	10 µA	0.03% + 1.5 mA + 1.3 pA/V	20 µA	0.05% + 1.8 mA + 1.3 pA/V
100 mA	200 V	1 µA	0.02% + 20.0 µA + 1.3 pA/V	2 µA	0.03% + 30.0 µA + 1.3 pA/V
10 mA	200 V	100 µA	0.02% + 2.5 µA + 1.3 pA/V	200 nA	0.03% + 6.0 µA + 1.3 pA/V
1 mA	200 V	10 nA	0.02% + 200.0 nA + 1.3 pA/V	20 nA	0.03% + 300.0 nA + 1.3 pA/V
100 µA	200 V	1 nA	0.02% + 25.0 nA + 1.3 pA/V	2 nA	0.03% + 60.0 nA + 1.3 pA/V
10 µA	200 V	100 nA	0.03% + 1.5 nA + 1.3 pA/V	200 pA	0.03% + 5.0 nA + 1.3 pA/V
1 µA	200 V	10 pA	0.03% + 500.6 pA + 1.3 pA/V	20 pA	0.03% + 800.6 pA + 1.3 pA/V
100 nA	200 V	1 pA	0.06% + 100.6 pA + 1.3 pA/V	2 pA	0.06% + 100.6 pA + 1.3 pA/V
10 nA	200 V	100 fA	0.15% + 3.6 pA + 1.3 pA/V	200 fA	0.15% + 5.6 pA + 1.3 pA/V
1 nA	200 V	10 fA	0.15% + 880.0 fA + 1.3 pA/V	20 fA	0.15% + 2.6 pA + 1.3 pA/V
100 pA	200 V	1 fA	0.15% + 760.0 fA + 1.3 pA/V		

Voltage Range	Max. Current	MEASURE		SOURCE	
		Resolution	Accuracy	Resolution	Accuracy
200 V	100 mA	1 mV	0.02% + 50 mV	5 mV	0.02% + 50 mV
20 V	1 A	100 µV	0.02% + 5 mV	500 µV	0.02% + 5 mV
2 V	1 A	10 µV	0.02% + 480 µV	50 µV	0.02% + 730 µV
200 mV	1 A	1 µV	0.02% + 355 µV	5 µV	0.02% + 505 µV

Capacitance	10kHz	100kHz	1MHz
10 pF	0.50%	0.50%	1.00%
100 pF	0.50%	0.50%	1.00%
1 nF	0.50%	0.50%	4.00%
10 nF	0.50%	0.50%	5.00%
100 nF	1.00%	1.00%	5.00%

MAXIMUM SIGNAL LEVEL: 100mV.

DC VOLTAGE RANGE: ±30V.

1.888.KEITHLEY (U.S. only)

www.keithley.com

KEITHLEY

A Tektronix Company

A Greater Measure of Confidence

High Voltage System ¹

Current Range	Max. Voltage	MEASURE		SOURCE	
		Resolution	Accuracy	Resolution	Accuracy
1 A	200 V	10 μ A	0.03% + 1.5 mA + 0.94 pA/V	20 μ A	0.05% + 1.8 mA + 0.94 pA/V
100 mA	200 V	1 μ A	0.02% + 20.0 μ A + 0.94 pA/V	2 μ A	0.03% + 30.0 μ A + 0.94 pA/V
20 mA	1100 V	100 μ A	0.04% + 1.2 μ A + 0.94 pA/V	500 nA	0.05% + 4.0 μ A + 0.94 pA/V
10 mA	200 V	100 μ A	0.02% + 2.5 μ A + 0.94 pA/V	200 nA	0.03% + 6.0 μ A + 0.94 pA/V
1 mA	1100 V	10 nA	0.03% + 200.0 nA + 0.94 pA/V	50 nA	0.03% + 300.0 nA + 0.94 pA/V
100 μ A	1100 V	1 nA	0.03% + 25.0 nA + 0.94 pA/V	5 nA	0.03% + 60.0 nA + 0.94 pA/V
10 μ A	1100 V	100 nA	0.03% + 1.5 nA + 0.94 pA/V	500 pA	0.03% + 5.0 nA + 0.94 pA/V
1 μ A	1100 V	10 pA	0.03% + 504.1 pA + 0.94 pA/V	50 pA	0.04% + 804.1 nA + 0.94 pA/V
100 nA	200 V	1 pA	0.06% + 104.1 pA + 0.94 pA/V	2 pA	0.06% + 104.1 pA + 0.94 pA/V
10 nA	200 V	100 fA	0.15% + 7.1 pA + 0.94 pA/V	200 fA	0.15% + 9.1 pA + 0.94 pA/V
1 nA	200 V	10 fA	0.15% + 4.4 pA + 0.94 pA/V	20 fA	0.15% + 6.1 pA + 0.94 pA/V
100 pA	200 V	1 fA	0.15% + 4.3 pA + 0.94 pA/V		

¹ Specifications using high performance pathways. When the general purpose pathways are used:

- Maximum voltage is limited to 200V.
- Leakage increases by 3.6pA/V.
- Less accuracy in lower ranges (100pA through 1 μ A).

Voltage Range	Max. Current	MEASURE		SOURCE	
		Resolution	Accuracy	Resolution	Accuracy
1000 V	20 mA	10 mV	0.015% + 50.2 mV	50 mV	0.02% + 100.2 mV
200 V	1 A	1 mV	0.015% + 50.0 mV	5 mV	0.02% + 50.1 mV
20 V	1 A	100 μ V	0.015% + 5.0 mV	500 μ V	0.02% + 5.1 mV
2 V	1 A	10 μ V	0.02% + 374.0 μ V	50 μ V	0.02% + 680.0 mV
200 mV	1 A	1 μ V	0.015% + 324.0 μ V	5 μ V	0.02% + 680.0 mV

Capacitance	10 kHz	100 kHz	1 MHz
10 pF	0.50%	0.50%	3.00%
100 pF	0.50%	0.50%	2.00%
1 nF	0.50%	0.50%	7.00%
10 nF	0.50%	0.50%	5.00%
100 nF	1.00%	1.00%	5.00%

Using dedicated C-V paths.

MAXIMUM SIGNAL LEVEL: 100mV

DC VOLTAGE RANGE: \pm 30V

PULSE GENERATOR UNIT OPTION

NUMBER OF CHANNELS PER PGU: 2.

MAXIMUM VOLTAGE: \pm 40V.

TYPICAL PULSE WIDTH RANGE: 100ns to 1s.

TYPICAL PULSE TRANSITIONS: 50ns to 200ms.

FREQUENCY ANALYSIS OPTION

TYPICAL FREQUENCY MEASUREMENT RANGE:

10kHz to 20MHz.

TYPICAL AMPLITUDE MEASUREMENT RANGE:

10mV_{RMS} to 1V_{RMS}.

LOW-VOLTAGE DMM OPTION

7.5 digit resolution.

LOWEST RANGES: 100mV with 10nV resolution. 1V with 100nV resolution.

GENERAL

SYSTEM CABINET SIZE: 60.0cm wide \times 91.5cm deep \times 190.5cm high (23.7 in. \times 36.0 in. \times 75.0 in.).

NOMINAL LINE POWER: 100V, 115V, 220V, 240V (50Hz, 60Hz).

POWER CONSUMPTION: Rated at 2.4kVA for the 2kW power distribution unit.

RECOMMENDED OPERATING CONDITIONS:

Temperature: 23° \pm 5°C (73.4°F \pm 9°F).

Humidity: 30% to 60% relative humidity, non-condensing, after a two hour warm up time.

Refer to S530 Administrative Guide for more system and facilities details.

S500

- Highly configurable, instrument-based system
- Ideal for SMU-per-pin Wafer Level Reliability (WLR) testing, high speed parallel test, die sorting and binning, NBTI, Process Control Monitoring (PCM)
- Intuitive test setup, data gathering and analysis with ACS software
- Keithley's TSP-Link Technology backplane provides high speed measurement throughput
- Flexible solution to meet emerging and mature testing needs
- Full control of automated and semi-automated probers
- Develop and execute tests at the device, site, wafer, and cassette level

Integrated Test System

Versatile Systems with the Instrument Advantage

S500 Integrated Test Systems are highly configurable, instrument-based systems for semiconductor characterization at the device, wafer, or cassette level. Built on our proven instrumentation, S500 Integrated Test Systems provide innovative measurement features and system flexibility, scalable to your needs. The unique measurement capability, combined with the powerful and flexible Automated Characterization Suite (ACS) software, provides a comprehensive range of applications and features not offered on other comparable systems on the market. Specific capabilities and system configurations include:

- Full-range source measure unit (SMU) instrument specifications, including sub-femtoamp measurement, ensure a wide range of measurements on almost any device.
- Pulse generation and ultra-fast I-V for memory characterization, charge pumping, single-pulse PIV (charge trap analysis), and PIV sweeps (self-heating avoidance).
- Low or high channel-count systems, including parallel test, with Keithley's system-enabling and scalable SMU instruments.
- High voltage, current, and power source-measure instrumentation for testing devices such as power MOSFETs and display drivers.
- Switching, probe cards, and cabling take the system all the way to your DUT.

Flexibility Combined with Applications Experience

S500 Integrated Test Systems are designed around three standard Keithley principles: configuration, integration, and customization. What this means to you is that you will receive a comprehensive test system for semiconductor characterization with both industry-leading Keithley hardware and highly configurable ACS software applications that include device characterization, reliability/WLR, parametric, and component functional test. With Keithley's proven instrumentation and user-friendly ACS software, the S500 is configured, integrated, and customized with the applications experience that only Keithley can provide.

Value-Focused Systems and Service

- Assessment of individual application needs for customization
- Proposal of integrated system configuration
- Installation and system user support
- Management of system-out cabling and probe card adaptation
- Implement training, test code development, and applications services
- Assurance of turnkey solutions for future applications



1.888.KEITHLEY (U.S. only)

www.keithley.com

Key System Components

- **4200-SCS lab-grade parameter analyzer characterizes devices using unique instrumentation modules such as sub-femtoamp SMU instruments, capacitance-voltage units, pulse generators, and ultra-fast I-V units**
- **Series 2600B family of System SourceMeter SMU Instruments offering a wide dynamic range of 1fA to 10A and 1 μ V to 200V, combines into a high channel-count system via the Keithley TSP-Link interface**
- **Model 707B high speed switch matrix integrates seamlessly with Series 2600B System SourceMeter SMU Instruments via the Keithley TSP-Link interface for a complete multipoint test solution**
- **Model 2410 High Voltage 20W SourceMeter Unit sources up to 1100V, 1A**
- **Model 2651A High Power System SourceMeter SMU Instrument offers 2000W pulsed power, 200W DC power, and up to 50A @ 40V with pA and μ V resolution**
- **ACS software provides intuitive test setup, data gathering and analysis for parametric characterization from single die to full cassette**
- **Full control of automated and semi-automated probers, as well as other test instruments, further simplifies device test and characterization**

Flexible and User-Friendly Software Environment

Each comprehensive S500 test system includes advanced components and productivity features to make workflow smooth and easy. The ACS application software is designed to perform complex functions, such as:

- Wafer description
- Test setup
- Prober control
- Test execution
- Real-time and post-test analysis

The integrated test plan and wafer description function allows the user to set up single or multiple test plans on one wafer and selectively execute them later, either manually or automatically. Additionally, the user has maximum flexibility for performing applications—easily switching between lab use (manual) and production (fully automated) using the same test plan.

High Throughput WLR

SMU-per-pin configuration is especially beneficial in scaled CMOS reliability testing.

- Ideal for DC “on-the-fly” NBTI testing
- High speed measurements produce lifetime predictions from two to five times faster than conventional WLR solutions
- Embedded Test Script Processor (TSP[®]) technology and deep measurement buffers ensure deterministic timing on all pins
- Up to 200V stress and picoamp measurements provide a wide range of capabilities and technologies
- Real-time plotting provides visibility into tests as they occur

Automated Device Characterization

Exceptional balance of high precision testing and automated data gathering.

- Flexible configurations to meet current and emerging test needs
- Powerful analysis, presentation, and reporting tools
- Control full and semi-automatic probers with intuitive setup and operation



Parametric Die Sort

Uniquely suited for multi-site parallel testing for die sort and other high throughput applications.

- Multi-group testing allows groups of SMU instruments to execute in parallel on different devices, structures, or dies
- True parallel test is enabled through distributed processing with embedded Test Script Processor (TSP[®]) technology in each SMU.
- High voltage and high current capabilities provide capabilities across a wide range of technologies
- Large library of ready-to-use tests and parameter extractions



ACS

- Supports a wide array of instruments and probers
- Intuitive GUI simplifies I-V tests, analysis, and results from bench-top to fully automated parametric testers
- Develop and execute tests at the device, site, wafer, and cassette level
- Intuitive GUI for test plan development and interactive operation
- Interactive and real-time data plotting
- Highly portable test projects with minimal or no modifications
- Supports multiple SMUs for parallel testing
- Flexible, modular software accommodates evolving and mature test requirements

APPLICATIONS

Compatible with emerging and mature testing needs for:

- Component characterization
- Device characterization
- Parametric test
- Reliability test
- Die sort

Ordering Information

ACS Automated Characterization Suite Software

Automated Characterization Suite Software

One Powerful Software Solution—A Wide Range of Hardware Configurations

Keithley's Automated Characterization Suite (ACS) is a flexible, interactive software test environment designed for device characterization, parametric test, reliability test, and even simple functional tests. ACS supports a wide array of Keithley instrumentation and systems, hardware configurations, and test settings, from a few bench-top instruments for use in a QA lab to fully integrated and automated rack-based parametric testers.

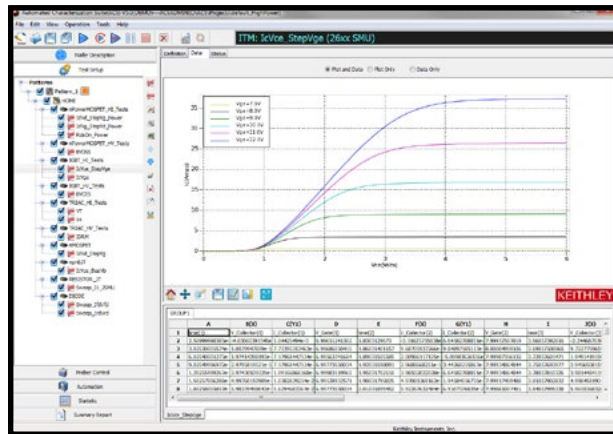

ACS offers exceptional testing and analysis flexibility, plus its intuitive GUI helps novice users be productive almost immediately, regardless of their level of programming experience. The GUI simplifies configuring test instrumentation, making I-V measurements, getting results, and analyzing them quickly because no coding is required. Even if you're an infrequent user, you can go from creating a new test setup to characterizing new devices in a fraction of the time required by older test development approaches. Just as important, ACS provides all the tools you need to set up tests, analyze data, and export your results—without ever leaving the ACS environment.

ACS – From Lab to Fab

The diagram illustrates the ACS software ecosystem. It shows a progression from a desktop computer with ACS software to a rack-mounted mainframe (Model 707B), then to a parameter analyzer (4200-SCS), an integrated test system (S500), and finally a semi-parametric test system (S530) located inside a large industrial machine. The software interface is shown running on each of these devices.

**Series 2600 SourceMeter®
SMU Instruments***

**4200-SCS
Parameter
Analyzer**

**S500
Integrated
Test System**

**S530 Semi
Parametric
Test System**

707B Switch Mainframe

* Excludes Models 2604B, 2614B, and 2634B.

Choose ACS for What It Gives You that Others Don't

There are many alternatives on the market for creating characterization applications, but ACS offers major advantages that competitive solutions can't match, such as a choice of three powerful project development options. With ACS, you can create the tests you need in the way that best suits your application's requirements and your own programming preferences.

- You say you're a researcher and you just need to make a quick test of common parameters and properties on a single device? We've packaged the same tests that our semiconductor customers use to verify their products into **easy-to-use applications libraries**. These libraries help

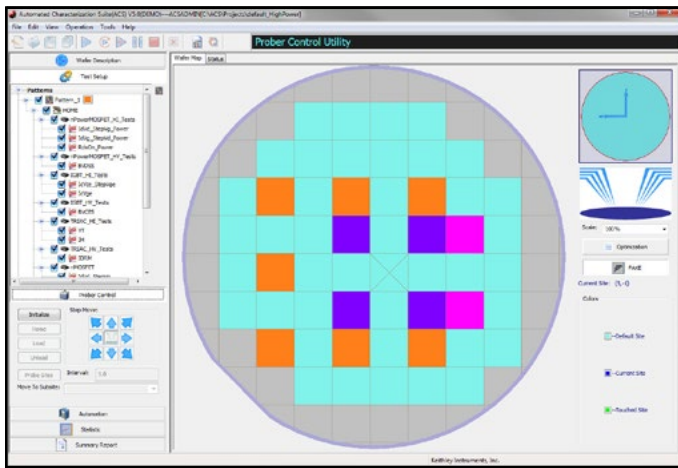

Interactive probe station control speeds and simplifies test development and debugging by combining interactive testing with manual probe station control.

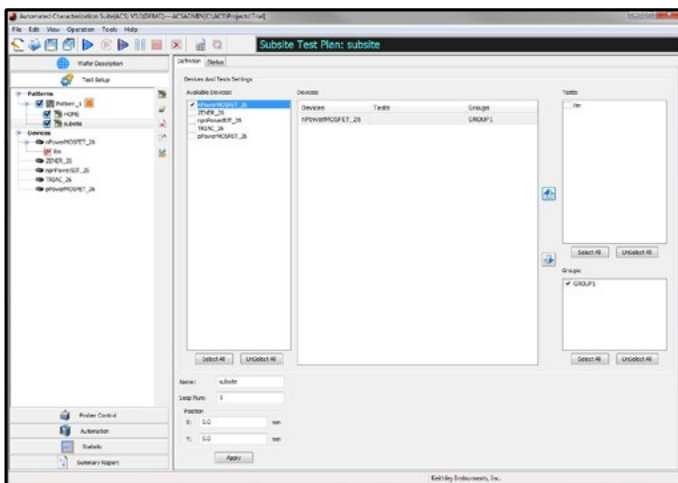

ACS lets you map devices and tests to sites and subsites, eliminating the need to duplicate each test for each subsite and reducing your test development time significantly.

you get the data you need to validate your work quickly so you can get back to your research sooner.

- Need more test development flexibility? Our **interactive test development GUI** lets you select bias and sweep conditions, acquire raw data, then use the built-in formulator tool to extract meaningful results—all without writing code.
- For the ultimate test development flexibility, modify one of the existing test scripts in our applications libraries using the **embedded script editing and debugging tools**.

Automate Your Data Gathering Processes

Need the throughput advantages of a semi-automatic or fully automatic wafer probe station to get a lot of data fast? The wafer prober automation option for ACS makes it easy to interface a variety of popular probe stations into your test setup. This option includes a wafer description utility (for creating a virtual wafer to use in creating wafer-level sampling plans), real-time wafer maps with binning capabilities (for designating a device's disposition before it's packaged, in die sorting, etc.), a cassette sample plan utility (for designating which wafers are to be tested), and a post-test cassette and wafer review utility (for exploring and comparing test results from multiple wafers interactively).

Many of the tools and capabilities built into ACS enhance automated device characterization:

- Wafer- and cassette-level automation
- Limits file generation tool
- Test results binning, including interactive binning plot
- Test map—map device and tests to sites and subsites
- Interactive probe station control mode
- Real-time plotting
- Single or per-wafer Keithley data file
- SQLite™ database and binning file output options
- Lot summary report generator
- Integrated support for Keithley Series 2600¹ and Series 2650A High Power System SourceMeter® SMU instruments
- Integrated scripting editor and GUI builder
- Integrated support for C (with Model 4200-SCS Parameter Analyzer only), Python, and Lua (for Series 2600¹) programming languages

Share Test Projects and Results

ACS offers a common set of key elements that work across a wide range of hardware configurations, which saves time and increases productivity. Systems perform consistently from one hardware implementation to another, so, for example, it's easy to transfer your knowledge of an ACS-based system used in single-device component characterization to another designed for wafer level testing.

Similarly, test projects and sequences you create for one Keithley ACS hardware configuration will run on compatible setups in other test settings with little or no modification. This portability across a range of configu-

1.888.KEITHLEY (U.S. only)

www.keithley.com

A Greater Measure of Confidence

KEITHLEY

A Tektronix Company

rations reduces the effort involved in transferring a new device from one lab or department to another and simplifies comparing results obtained in various test settings. This is possible because ACS employs common open-standard file interfaces for projects, wafer maps, output files, etc. as well as common test libraries and instrument drivers, which also means you can be confident of high results correlation whether your tests are run on a system with a single Series 2600¹ SMU instrument or a fully automated custom die sort tool with dozens of these instruments.

Maximize the Productivity of Your Keithley Hardware

The tools in ACS simplify test development and maximize the speed of each Keithley instrument linked into the system. For example, ACS builds on the throughput advantages inherent in Keithley's newest family of high performance source measurement units, the Series 2600B System SourceMeter[®] SMU instruments. These advantages include:

- The on-board Test Script Processor (TSP[®]) technology in each instrument that allows each 2600¹ to operate independently of the ACS system's controller
- The TSP-Link[®] Technology high speed communications bus used to network multiple Series 2600¹ SMU instruments together
- True parallel test execution
- Precision timing

Together, ACS and Keithley TSP-based hardware offer the highest throughput in the industry to lower the cost of test without requiring you to spend time learning new programming concepts or languages before getting the data needed to accomplish your goals.

¹ Excludes Models 2604B, 2614B, and 2634B.

Add More Hardware to Adapt to Changing Needs

High scalability and a flexible architecture simplify configuring an ACS system to match your specific testing requirements or to upgrade an existing system to handle new test needs as they evolve. Our wide range of source-measure and switching capabilities provides a solid foundation for configuring customized applications because ACS software can control virtually any instrument or peripheral with a standard hardware interface. For example, third-party LCR meters can be easily integrated into any ACS system and drivers are available for popular instruments. Also, ACS's integrated scripting environment can control any GPIB instrument the application may require, such as a hot chuck controller.

Many ACS systems are configured using one or more of Keithley's innovative Series 2600¹ System SourceMeter SMU instruments, which are optimized for precision sourcing and measurement synchronization to capture high speed events. These systems offer unmatched testing speed and accuracy because they provide an SMU-per-pin architecture. ACS system configurations can support any number from two to more than 40 SMU instruments in a single rack for true parallel characterization applications.

ACS also makes it easy to integrate other types of Keithley hardware into your system to meet specialized test requirements, such as:

- High channel count switching—Model 707B Six-slot Switch Mainframe
- Combination of switching and measurement—Series 3700A Switch/Multimeters
- Higher resolution, lower current, or other capabilities such as C-V or pulse testing—Model 4200-SCS Parameter Analyzer
- 40V/50A range (80V/100A when connecting two units) of Model 2651A or 3kV/120mA range of Model 2657A High Power System SourceMeter SMU instruments

Broad Range of Applications

ACS-based Integrated Test Systems are complete solutions for applications such as parametric die sort, high power semiconductor component characterization, and wafer level reliability testing. When paired with appropriate semi-automatic and fully-automatic probe stations, their hardware configurations and test project development can be easily optimized for specific tasks. ACS leverages the on-board test script processors in Series 2600¹ System SourceMeter SMU instruments into a multi-processor environment that's ideal for true parallel test in both single- and multi-site configurations. This multi-processor environment provides high parallel throughput while speeding and simplifying test project development. Multi-site testing capabilities are embedded throughout ACS from the wafer description utility to the test results output file or binning file, for example:

- Multi-site parallel testing brings the highest possible throughput for both parametric die sort and WLR applications
- Configurable for special applications like MEMS testing
- Easily customize test flows with user access points (UAPs) that execute scripts or call custom utilities

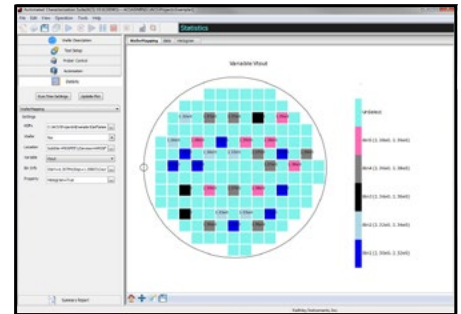

Wafer and binning map tools allow you to browse through the test results on either a wafer-by-wafer or site-by-site basis. You can also overlay traces from multiple sites to make quick comparisons.

1.888.KEITHLEY (U.S. only)

www.keithley.com

KEITHLEY

A Tektronix Company

A Greater Measure of Confidence

ACS Basic Edition

Semiconductor Parametric Test Software for Component and Discrete Devices



- **Designed for packaged devices (MOSFETs, BJTs, IGBTs, diodes, resistors, etc.)**
- **Rich set of test libraries for fast and easy test setup and execution without programming**
- **Built-in data analysis tools for quick analysis of parametric data**
- **Supports Keithley's Series 2600B, Series 2400, and Model 2651A and Model 2657A System SourceMeter SMU instruments**
- **FREE optional off-line version for developing test setups on a different PC**
- **Windows® 7 and XP compatible**

Ordering Information

ACS-BASIC Component Characterization Software

ACS-BASIC-UPGRADE (available for existing ACS Basic customers)

Optimized for parametric testing of component and discrete (packaged) semiconductor devices, ACS Basic Edition maximizes the productivity of technicians and engineers in research and development. The versatile architecture of this software allows it to meet the wide ranging and ever changing requirements of semiconductor device testing. It supports all of Keithley's source and measure instrument products, including Series 2600B, Series 2400, and Model 2651A and Model 2657A SourceMeter® SMU instruments.

This powerful, yet cost effective solution includes Keithley's rich set of proven parametric libraries. Simply choose the desired test and begin running it to immediately start gathering data and analyzing it. Users also have the option of customizing any test with the embedded script editor.

The built-in data analysis tools allow users to quickly analyze the parametric data. For example, place device curves developed from newly collected data over "golden" curves for fast comparisons. To perform specialized calculations on raw data, use the mathematical formulator tool to create customized parameter calculations. Data can be easily saved in graphical and/or tabular formats.

ACS Basic offers three modes of operation:

- **Single Test Mode**—for single device, single test operations
- **Multi Test Mode**—for multiple test operations on a single device
- **Trace Mode**—for mapping out the operating range and characteristics of a semiconductor device while minimizing the risk of damage to it. This mode offers an interactive method of controlling the voltage level of a sweep with a slide bar or the arrow keys on the PC keyboard.

Related Products

For applications requiring wafer level testing, use ACS Integrated Test Systems or ACS Wafer Level Reliability Systems. These systems supply a wafer map, prober automation capabilities, and analysis options for yield monitoring as well as related statistical calculations for maximizing productivity in wafer level test environments.

ACCESSORIES AVAILABLE

2600-FIX-TRX	Grounded Phoenix-to-Triax Cable Adapter
8101-4TRX	Leaded Component Test Fixture
ACS-COMP	PC for Installed and Bench-top ACS Systems
KUSB-488A	IEEE-488.2 USB-to-GPIB Interface Adapter for USB Port
LR-8028	DIP Component Test Fixture

KEY APPLICATIONS

- **Materials and device development**
- **Quality assurance**
- **Device inspection**

1.888.KEITHLEY (U.S. only)

www.keithley.com

A Greater Measure of Confidence

KEITHLEY
A Tektronix Company

ACS systems optimized for component characterization applications

SEMICONDUCTOR

ACS Basic Edition

Semiconductor Parametric Test Software for Component and Discrete Devices

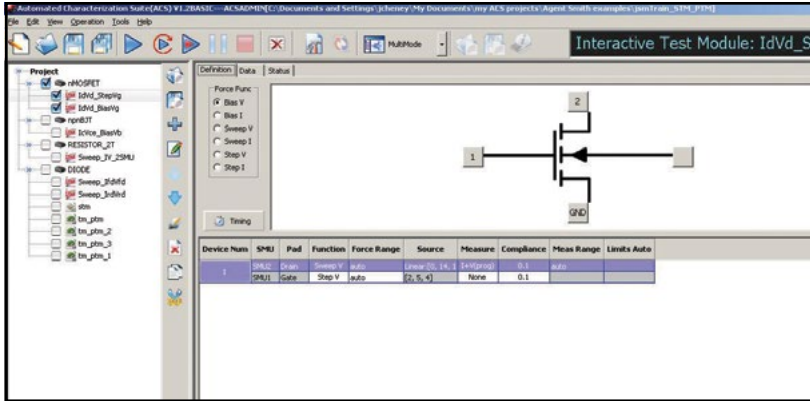

Multi Test Mode allows multiple tests to be performed on a device.

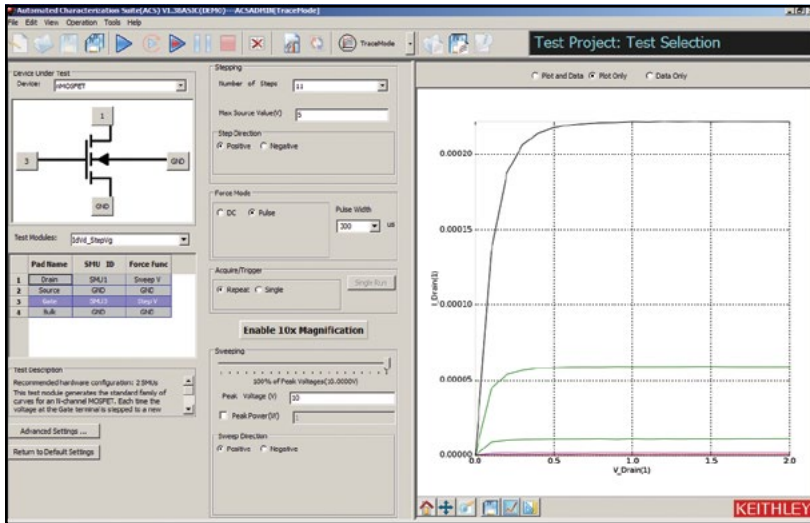

Trace Mode supports interactive testing of a device.

SUMMARY OF TYPICAL TESTS

Device	Leakage	Breakdown	Gain	On-State
Bipolar Junction Transistor	IEBO, IECO, IEVEB, ICVCB	BVCBO, BVCEI, BVCEO, BVCEV, BVEBO, BVECO	HFE	IBCO, IBEO, IBICVBE, IBVBE, ICBO, ICEV, ICVCE_BiasIB, ICVCE_BiasVB, ICVCE_StepIB, ICVCE_StepVB, VBCO, VCE
MOSFET	IDL, IDS_ISD, IGL, ISL	BVDSS, BVDSV, BVGDO, BVGDS, BVGSO	GM	IDVD_BiasVG, IDVD_StepVG, IDVG_BiasVD, IDVG_StepVD, IDVG_StepVSUB, IGVG, VTCl, VTEXT, VTEXT_IISQ
Diode	IRDVRD	VBRIRD	NA	DYNAMICZ, IFDVFED, VFDIFD, VRDIRD
Resistor	NA	NA	NA	IV
Capacitor	IV	NA	NA	

FORMULATOR FUNCTION SUMMARY

Type	Functions
Math	ABS, AVG, DELTA, DIFF, EXP, LN, LOG, LOG10, SQRT
Parametric Extractions	GMMAX, RES, RES_4WIRE, RES_AVG, SS, SSVTCI, TTF_DID_LGT, TTF_LGDID_T, TTF_DID_T, TTF_LGDID_LGT, VTCl, VTILINGM, VTSATGM
Fitting	EXPFIT, EXPFITA, EXPFITB, LINFIT, LINFITSPL, LINFITXINT, LINFITYINT, REGFIT, REGFITSPL, REGFITXINT, REGFITYINT, REGFIT_LGX_LGY, REGFIT_LGX_Y, REGFIT_X_LGY, TANFIT, TANFITSPL, TANFITXINT, TANFITYINT
Manipulation	AT, FINDD, FINDLIN, FINDU, FIRSTPOS, JOIN, LASTPOS, MAX, MAXPOS, MIN, MINPOX, POW, SMOOTH

ACS-2600-RTM

- Leverages unique strengths of Keithley Series 2600 System SourceMeter® SMU instruments – including system scalability and measurement speed
- System configurations from 2 to 44 channels
- Comprehensive JEDEC-compliant test suite
- Optimized for both emerging and mature technologies
- Supports both sequential and parallel testing
- Fully automatic single-site and multi-site capability
- Compatible with all popular wafer probe stations
- Real-time plotting and wafer mapping

APPLICATIONS

- Device reliability
 - HCI, NBTI, PBTI
- Gate oxide integrity
 - TDDB, V_{RAMP} , J_{RAMP}
- Metal interconnect
 - Isothermal electromigration
 - Poly heater
 - Constant current
 - ILD TDDB

Ordering Information

ACS-2600-RTM
Wafer Level Reliability
Option to ACS

Wafer Level Reliability Option to ACS



Keithley has taken the power of its Automated Characterization Suite (ACS) software and focused it on wafer level reliability (WLR) testing. ACS-2600-RTM is an option to ACS that leverages the measurement speed and system integration capabilities of Keithley's Series 2600 System SourceMeter® SMU instruments. The result—you can produce lifetime predictions from two to five times faster than you can with conventional WLR test solutions, allowing you to accelerate your technology development, process integration, and process monitoring for faster time to market.

With the ACS-2600-RTM option, ACS offers comprehensive single- and parallel-device WLR testing capability. Integrated with our innovative Series 2600 SourceMeter SMU instruments, your WLR system will provide unmatched testing speed and accuracy via an SMU-per-pin architecture. A single 2600 dual-channel source measure unit (SMU) is suitable for single-device reliability testing. Or take advantage of the TSP-Link® Technology bus on the Series 2600 SMU instruments for systems with as many as 44 SMU channels (2 for each 2600) for testing large numbers of devices in parallel and increasing overall system productivity. In

addition to precise low-level measurements, the Series 2600 SMU instruments can supply high voltage (200V) and high current (1.5A) sourcing and measurement to every test structure pad. This maximizes system flexibility, so you don't need one solution for gate oxide integrity and a different system for metal interconnect reliability. Looking for a complete system solution? Keithley offers ACS with its highly configurable S500 Integrated Test Systems and application development services.

Extensive Software Capabilities

No coding is required to take full advantage of the source-measure capability of the Series 2600s or the tools included in the ACS software environment. The ACS-2600-RTM option provides a powerful stress/measure sequencing tool with an interactive interface for testing device reliability, gate oxide integrity, and metal interconnects (EM). Its flexible test sequencing capabilities support pre- and post-testing, as well as intra-stress testing and stress monitoring. During testing, you can log raw reliability data into the database and/or plot it in real time. This real-time plotting provides a “sneak peek” at a test's outcome to let you know whether time-consuming tests are on track to deliver meaningful results. After testing, use the easy point-and-click analysis offered by the integrated Formulator, which is populated with standard parametric extraction calculations. In addition, a variety of modeling, line fitting, and standard math functions allow custom data manipulation without programming.

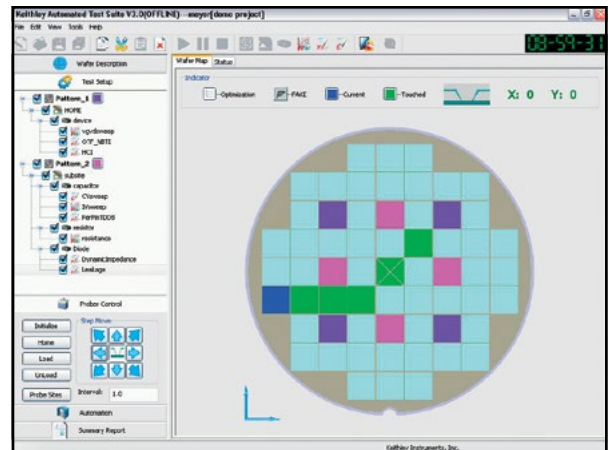

1.888.KEITHLEY (U.S. only)

www.keithley.com

A Greater Measure of Confidence

KEITHLEY
A Tektronix Company

Wafer level reliability option to ACS

SEMICONDUCTOR

2600-PCT-xB

Parametric Curve Tracer Configurations



High Power Device Characterization

Developing and using MOSFETS, IGBTs, diodes and other high power devices requires comprehensive device-level characterization such as breakdown voltage, on-state current and capacitance measurements. Keithley's line of high power Parametric Curve Trace configurations supports the full spectrum of device types and test parameters. Keithley's Parametric Curve Trace configurations include everything necessary for the characterization engineer to develop a complete test system quickly. ACS Basic Edition software provides complete device characterization, including both real-time trace mode for quickly checking fundamental device parameters like breakdown voltage and full parametric mode for extracting precise device parameters. ACS Basic Edition goes beyond traditional curve tracer interfaces by offering a broad array of sample libraries. More important, users have complete control of all test resources, allowing the creation of more advanced tests than previously possible on a curve tracer.

- Complete solutions engineered for optimum price and performance
- Field upgradable and reconfigurable – convert your PCT to a reliability or wafer sort tester
- Configurable power levels:
 - From 200V to 3kV
 - From 1A to 100A
- Wide dynamic range:
 - From μ V to kV
 - From fA to 100A
- Full range of capacitance-voltage (C-V) capability :
 - From fF to μ F
 - Supports 2, 3, and 4 terminal devices
 - Up to 3kV DC bias
- High performance test fixture supports a range of package types
- Probe station interface supports most probe types including HV triax, SHV coax, standard triax, and others

Electrical characterization of a variety of power device types, including:

MOSFET	BJT
IGBT	Diode
Triac	Capacitor
Resistor	And many more...

Measurements of key parameters, such as:

Breakdown Voltage (Bvdss, Bvceo)	On-State Current (Vdson, Vcesat, Vf)
Drain/Collector Leakage (Idss, Ir/Icbo, Iceo)	Gate/Base Leakage (Igss, Ib)
Threshold or Cutoff voltage (Vth, Vf, Vbeon)	Forward Transfer (yfs, Gfs, Hfe, gain)
Capacitance (Ciss, Coss, Crss)	And many more...

APPLICATIONS

- Power semiconductor device characterization and testing
- Characterization of GaN and SiC, LDMOS and other devices
- Reliability studies on power devices
- Incoming inspection and device qualification

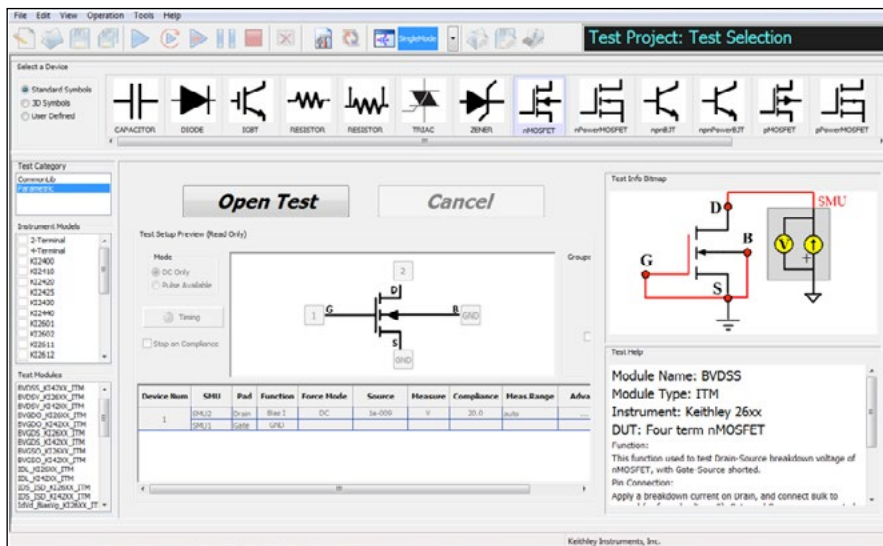

1.888.KEITHLEY (U.S. only)

www.keithley.com

KEITHLEY
A Tektronix Company

A Greater Measure of Confidence

A Tektronix Company

2600-PCT-xB

Ordering Information

- 2600-PCT-1B** Low Power
- 2600-PCT-2B** High Current
- 2600-PCT-3B** High Voltage
- 2600-PCT-4B** High Voltage and High Current

Accessories Supplied

ACS Basic Component Test Software

KUSB-488B USB to GPIB Adapter

All cables and adapters for connecting to the 8010 Test Fixture or 8020 High Power Interface Panel

Note: PC and monitor not included; user must supply a Windows XP/7 PC with a USB port.

ACCESSORIES AVAILABLE

2651A	High Power System SourceMeter (adds 50A to any system, max 100A)
2657A	High Power System SourceMeter (adds 3kV to any system, max of one unit per system)
K420	Workbench Cart Mobile cart for smaller PCT configurations
K475	Workstation Tower Mobile cart for all PCT configurations
PCT-CVU	Multi-frequency Capacitance-voltage (C-V) Meter
70161-MSA	Keyboard/Monitor Arm for K420 and K475 Carts
8020	High Power Interface Panel: Ideal for connecting to probe stations
8010	High Power Device Test Fixture

8010 OPTIONS

CVU-3K-KIT	Bias Tee kit for up to 3kV C-V
CVU-200-KIT	Bias Tee kit for up to 400V C-V
8010-CTB	Customizable Test Board
8010-DTB	Device Test Board with TO-247 socket
8010-DTB-220	Device Test Board with TO-220 socket
8010-DTB-CT	Device Test Board compatible with Tek curve tracer sockets

Parametric Curve Tracer Configurations

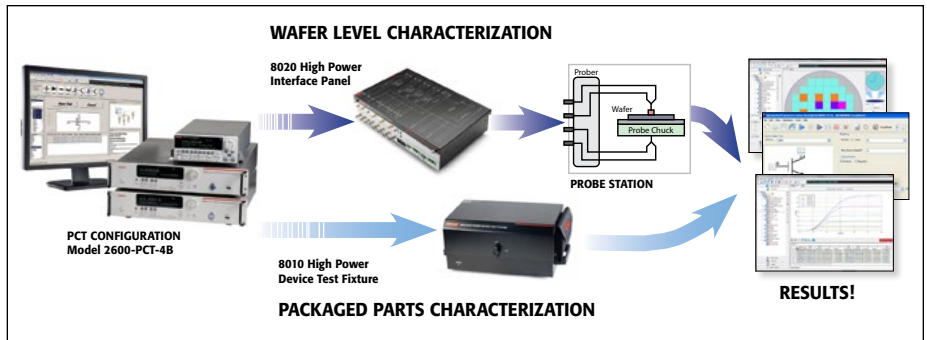

Keithley's Parametric Curve Trace configurations support both package part and wafer level testing.

Keithley's Parametric Curve Trace configurations are complete characterization tools that include the key elements necessary for power device characterization. The measurement channels consist of Keithley SourceMeter® Source Measure Unit (SMU) Instruments and an optional Multi-frequency capacitance-voltage (C-V) meter. The dynamic range and accuracy of these instruments is orders of magnitude beyond what a traditional curve tracer could offer.

Complete System Accessories

To achieve this performance, Keithley has developed a complete set of precision cables to connect the instrumentation to either Keithley's Model 8010 High Power Device Test Fixture for package part testing, or the Model 8020 High Power Interface Panel for wafer level testing. For the high voltage channel, custom triax cables provide a guarded pathway that enables fast settling and very low currents, even at the full 3kV. For the high current channel, special low inductance cables provide fast rise time pulses to minimize self heating effects.

High Voltage Capacitance-Voltage (C-V)

Testing device capacitance versus DC voltage is becoming more and more important. Keithley offers the Model PCT-CVU Multi-frequency capacitance-voltage meter. When combined with the optional 200V or 3kV bias tees, capacitance vs. voltage can be measured on two, three or four terminal devices. Capacitances from pF to 100nF can be measured, with test frequencies from 10kHz to 2MHz. ACS Basic Edition software provides over 60 canned tests for C-V including MOSFET Ciss, Coss, Crss, Cgd, Cgs, Cds, and a full suite of other devices such as BJTs and diodes. As always, users have complete control to develop their own test algorithms in ACS Basic Edition.

Configuration Selector Guide

Model ¹	Collector/ Drain Supply ²		Step Generator Base/Gate Supply	Auxiliary Supply
	High Voltage Mode	High Current Mode		
Low Power 2600-PCT-1B	200 V/10 A	200 V/10 A	200 V/10 A	N/A
High Current 2600-PCT-2B	200 V/10 A	40 V/50 A	200 V/10 A	200 V/10 A
High Voltage 2600-PCT-3B	3 kV/120 mA	200 V/10 A	200 V/10 A	200 V/10 A
High Current and High Voltage 2600-PCT-4B	3 kV/120 mA	40 V/50 A	200 V/10 A	200 V/10 A

- Contact your Keithley field applications engineer for custom configurations.
- Add a Model 2651A to increase high current mode to 50A or 100A.
- PCT-CVU Multi-Frequency capacitance meter can be added to any configuration.

1.888.KEITHLEY (U.S. only)

www.keithley.com

A Greater Measure of Confidence

KEITHLEY
A Tektronix Company

Typical Power Transistor Parameters

Parameter	Symbol	Test Method ¹	Maximum Range	Typical Best Resolution	Typical Accuracy
Breakdown Voltage	Bvdss, Bvceo	Id-Vd or Id (pulse)	±3000 V ²	100 μV, 10 fA	0.05% rdg + 0.05% rng
On-State Current (DC)	Vdson, Vcesat, Vf	Id-Vd	±20 A ⁴ , Optional: ±40 A ⁴	100 nA, 1 μV	0.05% rdg + 0.05% rng
On-State Current (Pulse)	Vdson, Vcesat, Vf	Id-Vd	±50 A ⁴ , Optional: ±100 A ⁴	100 μA, 1 μV	0.05% rdg + 0.05% rng
Drain/Collector Leakage Current	Idss, Ir/Icbo, Icco	Id-Vd	±20 mA @ 3000 ^{2,5}	10 fA, 1 μV	0.2% rdg + 1% rng
Gate/Base Leakage Current	Igss, Ib	Ig-Vg	±1 A or, ±10 A Pulsed ³	10 fA, 1 μV	0.2% rdg + 1% rng
On-State Threshold Voltage or Cutoff Voltage	Vth, Vf, Vbeon, Vcesat	Id-Vg	±200 V ³	10 fA, 1 μV	0.2% rdg + 0.5% rng
Forward Transfer Admittance or Forward Transconductance	yfs Gfs, Hfe, gain	Vd-Id @ Vds	1 ms ~ 1000 s ⁶	1 pA, 1 μV	1%
On-State Resistance	RDS(on), Vcesat	Vd-Vg @ Id	<100 μΩ ⁷	10 μΩ, 1 μV	1%
Input Capacitance	Ciss	C-V 100 kHz	100 nF ⁸ ±3 kV	10 fF, 100 μV	Typical 5%+2pF
Output Capacitance	Coss	C-V 100 kHz	100 nF ⁸ ±3 kV	10 fF, 100 μV	Typical 5%+2pF
Reverse Transfer Capacitance	Crss	C-V 100 kHz	100 nF ⁸ ±3 kV	10 fF, 100 μV	Typical 5%+2pF

1. Test method used for extracting the parameter. Only typical MOSFET listed, but similar method for other devices.
2. Model 2657A High Power System SourceMeter[®] SMU Instrument.
3. Model 2636B SourceMeter SMU Instrument.
4. Model 2651A High Power System SourceMeter SMU Instrument or optional dual Model 2651A High Power System SourceMeter SMU Instruments.
5. Maximum 20mA at 3000V, 120mA at 1500V.
6. Typical extracted capability (Example: 1mA/1V ~ 1A/1mV).
7. Typical extracted capability (Example: 1mV/10A).
8. Max. ±200VDC (or ±3kV) bias with PCT-CVU and CVU-3K-KIT.



8010 High Power Device Test Fixture



8020 High Power Interface Panel



High current, low inductance cables



High voltage, low noise triaxial cables



Model 2600-PCT-4B with Model 8010 Test Fixture

1.888.KEITHLEY (U.S. only)

www.keithley.com

KEITHLEY

A Tektronix Company

A Greater Measure of Confidence

Semiconductor Parametric Test Software for Component and Discrete Devices

ACS Basic Edition software is specifically tuned to take advantage of the high performance capabilities of the Keithley instrumentation and includes several sample libraries for performing common high power device tests. Unlike other systems, the software allows the user almost unlimited flexibility in configuring all of the measurement channels to create tests far beyond what a traditional curve tracer could achieve.

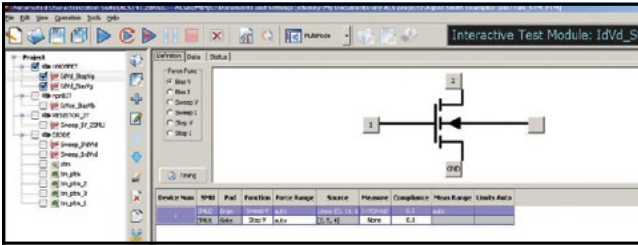

Multi test mode allows multiple tests to be performed on a device.

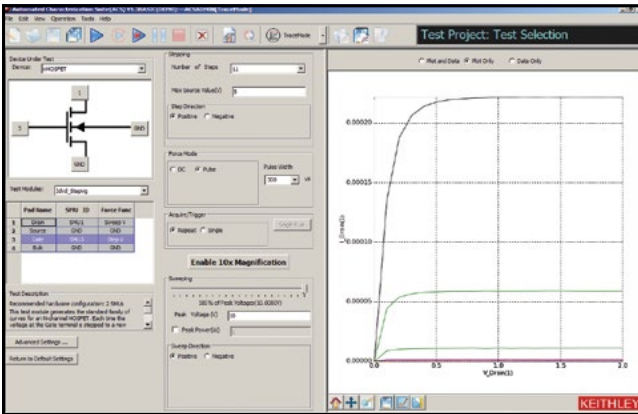

Trace mode supports interactive testing of a device.

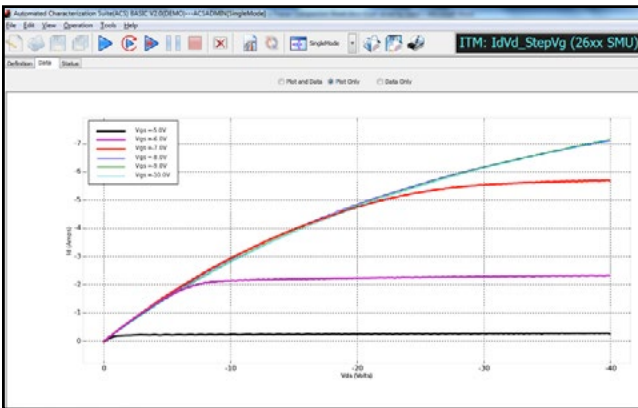

Compared to a traditional curve tracer, PCT graphics offer high resolution, on-screen data analysis, complete graph customization, and easy export to any word processor or reporting software.

SUMMARY OF TYPICAL TESTS

Device	Leakage	Breakdown	Gain	On-State
Bipolar Junction Transistor	IEBO, IEEO, IEVEB, ICVCB	BVCBO, BVCEI, BVCEO, BVCEV, BVEBO, BVECO	HFE	IBCO, IBEO, IBICVBE, IBVBE, ICBO, ICEV, ICVCE_BiasIB, ICVCE_BiasVB, ICVCE_StepIB, ICVCE_StepVB, VBCO, VCE
MOSFET	IDL, IDS_ISD, IGL, ISL	BVDSS, BVDSV, BVGDO, BVGDS, BVGSO	GM	IDVD_BiasVG, IDVD_StepVG, IDVG_BiasVD, IDVG_StepVD, IDVG_StepVSub, IGVG, VTCl, VTEXT, VTEXT_IISQ
Diode	IRDVRD	VBRIRD	NA	DYNAMICZ, IFDVF, VFDIFD, VRDIRD
Resistor	NA	NA	NA	IV
Capacitor	IV	Ciss, Coss, Crss, Cgd, Cds, Cgs	NA	Independent bias on up to 4 terminals.

FORMULATOR FUNCTION SUMMARY

Type	Math
Math	ABS, AVG, DELTA, DIFF, EXP, LN, LOG, LOG10, SQRT
Parametric Extractions	GMMAX, RES, RES_4WIRE, RES_AVG, SS, SSVTCI, TTF_DID_LGT, TTF_LGDID_T, TTF_DID_T, TTF_LGDDID_LGT, VTCl, VTILINGM, VTSATGM
Fitting	EXPFIT, EXPFITA, EXPFITB, LINFIT, LINFITSLP, LINFITXINT, LINFITYINT, REGFIT, REGFITSLP, REGFITXINT, REGFITXINT, REGFIT_LGX_LGY, REGFIT_LGX_Y, REGFIT_X_LGY, TANFIT, TANFITSLP, TANFITXINT, TANFITXINT
Manipulation	AT, FINDD, FINDLN, FINDU, FIRSTPOS, JOIN, LASTPOS, MAX, MAXPOS, MIN, MINPOX, POW, SMOOTH

Parametric curve tracer configurations

SEMICONDUCTOR

1.888.KEITHLEY (U.S. only)

www.keithley.com



A Tektronix Company

A Greater Measure of Confidence

Technical Information

Active optoelectronic device characterization requires more than a current source

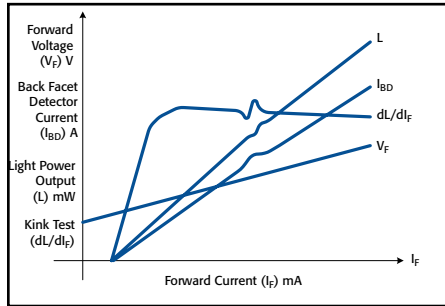

Figure 1. Classic LIV curves associated with semiconductor laser diodes.

Active optoelectronic devices are basic semiconductor junctions. To be fully tested, they require not only forward I-V characterization, but also reverse I-V characterization. While conventional laser diode drivers are valuable for providing drive current in the optics lab, these current sources aren't suitable for developing a complete understanding of a semiconductor device. The SourceMeter® line provides a full range of source and measure capability optimized for semiconductor characterization.

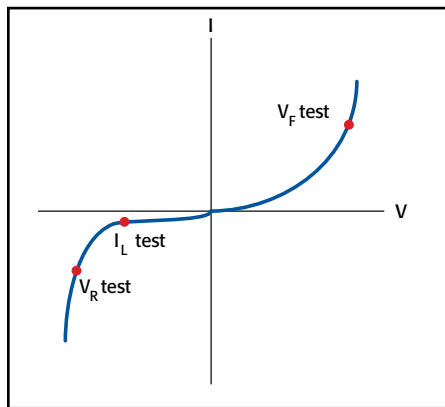

Figure 2. Characterization of semiconductor junctions requires measuring reverse breakdown (V_R), leakage current (I_L), and forward voltage (V_F).

A complete characterization of an active optoelectronic device requires forcing both forward and reverse currents and voltages. For instance, the reverse breakdown test requires sourcing

Optoelectronics Test

a very small, precise reverse current (10nA) while measuring the voltage. The limited current prevents permanent damage to the device, while allowing a precise breakdown voltage to be measured. Given the breakdown voltage, it's now possible to force a reverse bias that won't harm the device while leakage is measured. This leakage current value is often used to qualify the device for further testing.

Four-quadrant source capabilities

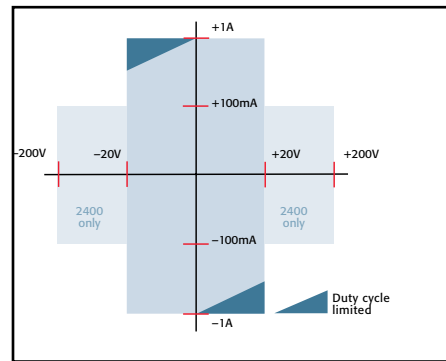

Figure 3. The Model 2400 can source or sink either current or voltage. Other SourceMeter SMU instruments offer different ranges, providing a very wide dynamic range from as low as a 1 μ A range or 200mV to 5A or 1000V.

The SourceMeter product line combines a full four-quadrant precision source (see Figure 3) with measurement capability. Source and measure ranges provide a very wide dynamic range from as low as a 1 μ A range or 200mV to 5A or 1000V. These very wide dynamic ranges allow testing diverse devices from delicate AlGaAs laser diodes to silicon avalanche photodiodes.

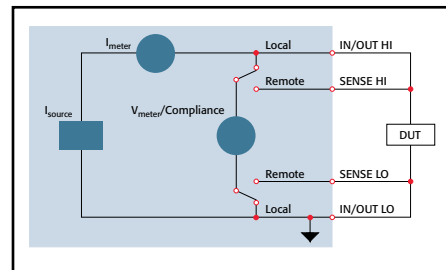

Figure 4. In current source mode, a SourceMeter SMU instrument can force current while measuring voltage. The remote voltage sense ensures the programmable voltage compliance isn't exceeded.

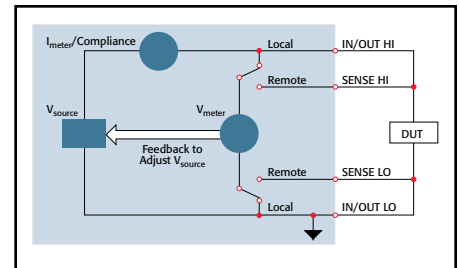

Figure 5. In voltage source mode, a SourceMeter SMU instrument forces a voltage and measures current. Remote sense of the voltage ensures the desired voltage at the DUT.

Verifying device connections

Series 2400 SourceMeter SMU instruments all offer the Contact Check option, which automatically verifies all test leads are connected to the DUT prior to energizing the test leads or executing a test sequence. Figure 6 shows Contact Check identifying a disconnected remote sense test lead. Without the sense test lead connected, the voltage compliance couldn't be controlled during test execution.

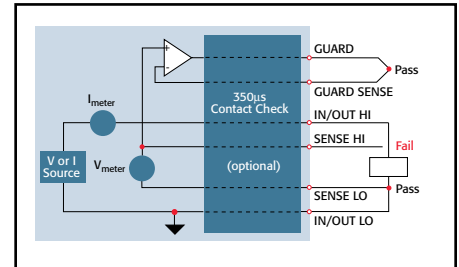

Figure 6. The contact check option verifies the force, sense, and guard test leads are properly connected to the DUT before testing begins.

Remote voltage measurement

SourceMeter SMU instruments offer two- or four-wire measurement configurations. Two-wire voltage measurement shares test leads with the source as shown in Figure 7a. When sourcing high currents, the voltage drop across the test lead becomes significant with respect to the forward voltage across the DUT.

1.888.KEITHLEY (U.S. only)

www.keithley.com

KEITHLEY
A Tektronix Company

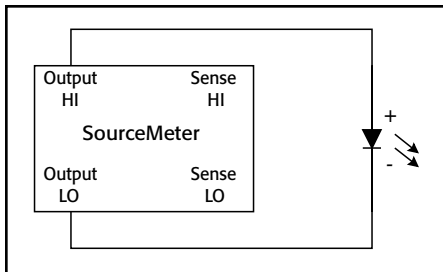

Figure 7a. Two-wire measurement

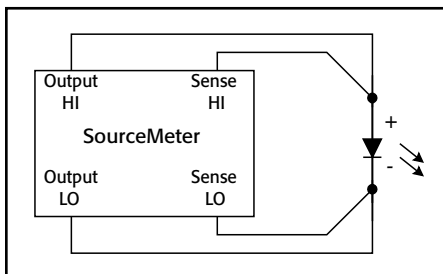

Figure 7b. Four-wire or Kelvin measurement

Four-wire voltage measurement uses dedicated test leads for measuring the voltage drop across the DUT. Since the voltage measurement circuit has very high impedance inputs, the current through the measuring test leads is low. The IR drop across the measurement test leads is an extremely small fraction of the voltage dropped across the DUT.

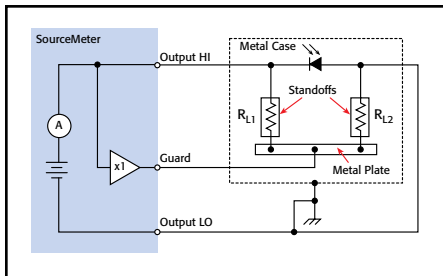

Figure 8. The cable guard circuit drives the guard conductor at the same potential as the output HI conductor.

Low level current measurements require a driven guard

Unique to precision measurement equipment, the driven guard minimizes the electrical potential difference between the conductors that surround the source test lead and the test lead (see Figure 8). When the electrical potential between the source test lead and guard test lead is low,

the potential leakage paths are neutralized. This technique requires an additional instrumentation amplifier that senses the output of the programmed source and drives the guard circuit with the same potential with enough current to overcome any leakage between the guard components and ground.

Deterministic trigger I/O

Conventional instruments typically support a simple trigger in/trigger out convention. The challenge to the engineer is controlling the trigger interaction between instruments. It is often that case that simple trigger I/O doesn't allow for differences in instrument behaviors or synchronization of multiple instruments. Figure 9 shows the trigger scheme available on most optoelectronic instrumentation.

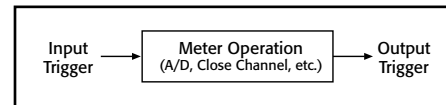

Figure 9. Typical trigger input/output scheme

A Series 2400 instrument breaks the measurement cycle into three parts, as shown in Figure 10. The three components are the source phase, delay phase, and measurement phase (also known as the SDM cycle.) The Series 2400 trigger model allows each phase in the SDM cycle to be programmed so that it can be gated by an input trigger and also to be programmed so that completion of each phase generates an output trigger.

While many instruments are limited to a single trigger in and single trigger out, Series 2400 instruments use a Trigger Link.

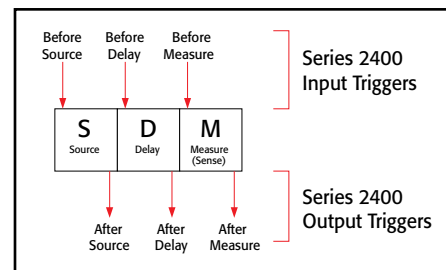

Figure 10. Series 2400 instrument's trigger input/output scheme

Precision characterization of active optoelectronic components often requires multiple instruments working together. For instance, two Series 2400 instruments can be used together: one SourceMeter SMU instrument to drive the device

and another SourceMeter SMU instrument connected to a photodiode to record the optical output of the active device. Figure 11 shows two Series 2400 instruments working synchronously together to characterize an LED.

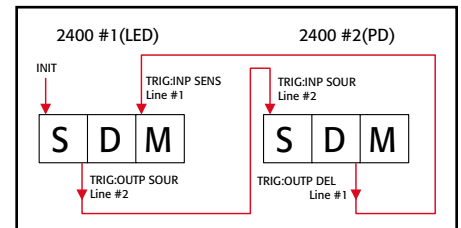

Figure 11. SDM triggers to synchronize two Series 2400 instruments.

Notice how trigger in and trigger out are tied to different parts of the SDM cycle to ensure that measurements on the LED and the PD are made at the same time. This same technique can be applied to ensure that the source current is stable prior to making an optical spectrum measurement with an additional instrument.

Complete DUT protection

DUT protection is a major concern for optoelectronic devices. SourceMeter SMU instruments are ideal for providing a safe electrical environment for delicate active optoelectronic devices.

- Normal output off mode drives the output terminals toward 0V. This action de-energizes the device and more importantly the inductive test leads. The rate of discharge can be controlled with the source range settings. This provides a better environment than shorting relays in conventional laser diode drivers.
- SourceMeter SMU instruments provide programmable compliance, range compliance, and voltage protection settings to ensure that the DUT isn't subjected to excess voltages or currents.
- Contact check ensures all test leads are in contact with the DUT prior to energizing the device.

In addition, the SourceMeter family is built on a heritage of precision semiconductor test and characterization of much more sensitive devices than active optoelectronic components.

LIV Test Systems

	2602B	2612B	System 25	2520
Page	10	10	105	97
Max. Drive Current	3 A DC / 10 A pulsed per channel	1.5 A DC / 10 A pulsed per channel	5 A	5 A
Source Mode	DC (Continuous Wave)	Pulse / DC (Continuous Wave)	DC (Continuous Wave)	Pulse / DC (Continuous Wave)
Number of Channels	1 Laser Drive, 1 Photodiode	1 Laser Drive, 1 Photodiode	1 Laser Drive, 2 Photodiode	1 Laser Drive, 2 Photodiode

Optical Power Measurement

	2502	6487	6485	Photodiode Measurement 2635B/2636B
Page	111	149	65	10

CURRENT MEASURE

	2502	6487	6485	2635B/2636B
From	15 fA	20 fA	20 fA	120 fA
To	20 mA	20 mA	20 mA	10 A

PHOTODIODE VOLTAGE BIAS

	2502	6487	6485	2635B/2636B
	100V (each channel)	500 V	none	200 V

FEATURES

	2502	6487	6485	2635B/2636B
Optical Measurement Head	2500INT Series (Si & Ge) (190nm – 1800nm)	2500INT Series (Si & Ge) (190nm – 1800nm)	2500INT Series (Si & Ge) (190nm – 1800nm)	
Number of Channels	2	1	1	1/2
Instrument Connection	3-slot Triax	3-slot Triax	BNC	3-slot Triax
Communication	GPIB, RS-232	GPIB, RS-232	GPIB, RS-232	GPIB, RS-232, Ethernet (LXI)

Laser Diode and LED Current Drivers

	2601B	2611B	2401	2420	2440	2520	6220 6221
Page	10	10	108, 43	108 43	108 43	97	97

CURRENT SOURCE

	2601B	2611B	2401	2420	2440	2520	6220 6221
From	5 pA	5 pA	±10 pA	±500 pA	±500 pA	70 µA	80 fA
To	3 A DC / 10 A pulsed per channel	1.5 A DC / 10 A pulsed per channel	±1.05 A	±3 A	±5A	+ 5A	±100 mA
Type	DC/Pulse	DC/Pulse	DC	DC	DC	DC/Pulse	DC/Pulse

VOLTAGE MEASURE

	2601B	2611B	2401	2420	2440	2520	6220 6221
From	1 µV	1 µV	1 µV	10 µV	10 µV	60 µV	10 nV (w/2182A)
To	40 V	200 V	21 V	60 V	40 V	10 V	100 V (w/2182A)

FEATURES

	2601B	2611B	2401	2420	2440	2520	6220 6221
Instrument Connection	Screw Terminal	Screw Terminal	Banana	Banana	Banana	10Ω BNC	3-slot Triax
Communication	GPIB/RS-232, TSP, Ethernet (LXI)	GPIB/RS-232, TSP, Ethernet (LXI)	GPIB/RS-232	GPIB/RS-232	GPIB/RS-232	GPIB/RS-232	GPIB/RS-232, Ethernet (6221 only)

1.888.KEITHLEY (U.S. only)

www.keithley.com

A Greater Measure of Confidence

KEITHLEY
A Tektronix Company

2520

Pulsed Laser Diode Test System



- Simplifies laser diode LIV testing prior to packaging or active temperature control
- Integrated solution for in-process LIV production testing of laser diodes at the chip or bar level
- Sweep can be programmed to stop on optical power limit
- Combines high accuracy source and measure capabilities for pulsed and DC testing
- Synchronized DSP based measurement channels ensure highly accurate light intensity and voltage measurements
- Programmable pulse on time from 500ns to 5ms up to 4% duty cycle
- Pulse capability up to 5A, DC capability up to 1A
- 14-bit measurement accuracy on three measurement channels (V_{fr} front photodiode, back photodiode)
- Measurement algorithm increases the pulse measurement's signal-to-noise ratio
- Up to 1000-point sweep stored in buffer memory eliminates GPIB traffic during test, increasing throughput
- Digital I/O binning and handling operations
- IEEE-488 and RS-232 interfaces



Remote Electrical Test Head included

recently, these producers were forced to use relatively slow and cumbersome test stands for testing laser diodes at the chip and bar level, which often led to production bottlenecks.

Higher Resolution for Higher Yields

To achieve the required signal-to-noise ratio, traditional chip- and bar-level LIV testing solutions have required the use of boxcar averagers or test system control software modifications to allow averaging several pulsed measurements. The resolution of these measurements is critical for the "kink" test and threshold current calculations. With earlier test system designs, particularly when performing the kink test, low resolution and poor linearity of the analog digitizer made it extremely difficult to discriminate between noise in the measurement and an actual device kink. The Model 2520's unique DSP-based measurement approach automatically

The Model 2520 Pulsed Laser Diode Test System is an integrated, synchronized system for testing laser diodes early in the manufacturing process, when proper temperature control cannot be easily achieved. The Model 2520 provides all sourcing and measurement capabilities needed for pulsed and continuous LIV (light-current-voltage) testing of laser diodes in one compact, half-rack instrument. The tight synchronization of source and measure capabilities ensures high measurement accuracy, even when testing with pulse widths as short as 500ns.

LIV Test Capability

The Model 2520 can perform pulsed LIV testing up to 5A and continuous LIV testing up to 1A. Its pulsed testing capability makes it suitable for testing a broad range of laser diodes, including the pump laser designs for Raman amplifiers. The instrument's ability to perform both DC and pulsed LIV sweeps on the same device simplifies analyzing the impact of thermal transients on the LIV characteristics of the laser diode.

Maximize Throughput and Eliminate Production Bottlenecks

By working in cooperation with leading laser diode manufacturers, Keithley designed the Model 2520 specifically to enhance chip- and bar-level test stand yield and throughput. Its integrated design, ease of use, high speed, and high accuracy provides a complete solution to help laser diode manufacturers meet their production schedules. Producers of laser diodes face constant pressure to increase test throughput and optimize return on investment for their capital equipment used in production testing. Until

APPLICATIONS

Production testing of:

- Telecommunication laser diodes
- Optical storage read/write head laser diodes
- Vertical Cavity Surface-Emitting Lasers (VCSELs)
- Thermal impedance
- Junction temperature response

1.888.KEITHLEY (U.S. only)

www.keithley.com

A Greater Measure of Confidence

KEITHLEY

A Tektronix Company

Multi-channel pulsed test of laser diodes

SEMICONDUCTOR

2520**Ordering Information****2520 Pulsed Laser Diode Test System with Remote Test Head****2520/KIT1****Pulsed Laser Diode Measurement Kit (includes 2520, 2520INT, and 3 ft. triax cable)****Accessories Supplied****User's Manual, Quick Reference Guide, Triax Cables (2), BNC 10 Ω Coaxial Cables (4)****ACCESSORIES AVAILABLE**

2520INT-1-GE	Integrating Sphere (1 inch) with Germanium Detector
7007-1	Double Shielded GPIB Cable, 1m (3.3 ft.)
7007-2	Double Shielded GPIB Cable, 2m (6.6 ft.)
KPCI-488LPA	IEEE-488 Interface/Controller for the PCI Bus
KUSB-488B	IEEE-488 USB-to-GPIB Adapter for USB Port

SERVICES AVAILABLE

2520-3Y-EW	1-year factory warranty extended to 3 years from date of shipment
C/2520-3Y-DATA 3 (Z540-1 compliant)	calibrations within 3 years of purchase*

*Not available in all countries

Pulsed Laser Diode Test System

identifies the settled region of the pulsed waveforms measured. This means the Model 2520 stores only that portion of the pulse that is "flat" and contains meaningful data. All measurements made in the flat portion of the pulse are averaged to improve the Signal-to-Noise ratio still further. If greater resolution is required, the Model 2520 can be programmed to perform several pulse and measure cycles at the same pulse amplitude. By making it possible to conduct more thorough testing at the bar or chip level, the Model 2520 also eliminates the wasted time and costs associated with assembling then scrapping modules with non-compliant diodes.

Simple, One-Box Test Solution

The Model 2520 offers three channels of source and measurement circuitry. All three channels are controlled by a single digital signal processor (DSP), which ensures tight synchronization of the sourcing and measuring functions. The laser diode drive channel provides a current source coupled with voltage measurement capability. Each of the two photodetector channels supplies an adjustable voltage bias and voltage compliance, in addition to current measurement capability. These three channels provide all the source and measure capabilities needed for full LIV characterization of laser diodes prior to integration into temperature controlled modules. By eliminating the need for GPIB commands to perform test sweeps with multiple separate instruments, the Model 2520's integrated sourcing and measurement allows a significant improvement in throughput.

Remote Test Head Maximizes Signal-to-Noise Ratio

The mainframe and remote test head architecture of the Model 2520 is designed to enhance pulsed measurement accuracy, even at the sub-microsecond level. The remote test head ensures the measurement circuitry is located near the DUT, mounted on the fixture, minimizing cable effects. As the schematic in **Figure 1** shows, traditional semi-custom systems typically employed in the past require significant integration. The architecture of the Model 2520 (**Figure 2**) offers a far more compact and ready-to-use solution.

High Speed Pulse and Measure to Minimize Thermal Effects

The Model 2520 can accurately source and measure pulses as short as 500 nanoseconds to minimize unwanted thermal effects during LIV testing. Users can program the pulse width from 500ns to 5ms and pulse off time from 20 μ s to 500ms. There is a software duty cycle limit of 4% for currents higher than 1A. To ensure greater accuracy, the instrument provides pulse width programming resolution levels of 10 μ s (off time) and 100ns (on time).

Prior to the introduction of the Model 2520, test instrument limitations often placed barriers on test performance. However, with the Model 2520, the limiting factor is not the test instrument, but the

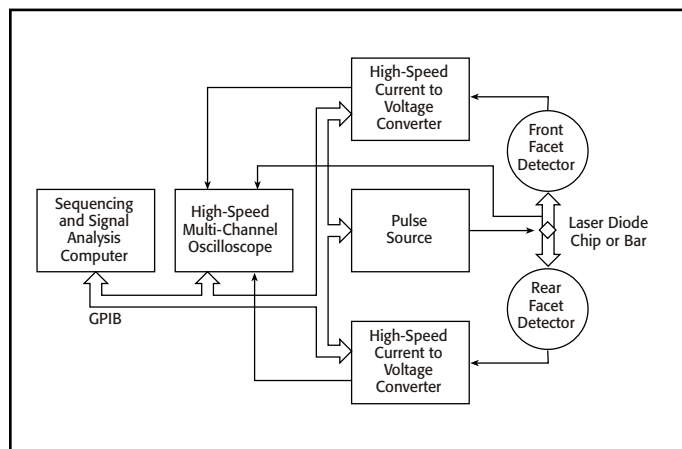

Figure 1. This schematic reflects the current testing practices of major laser diode manufacturers. Note that the use of discrete test components increases the integration and programming effort, while severely limiting the flexibility of the test system.

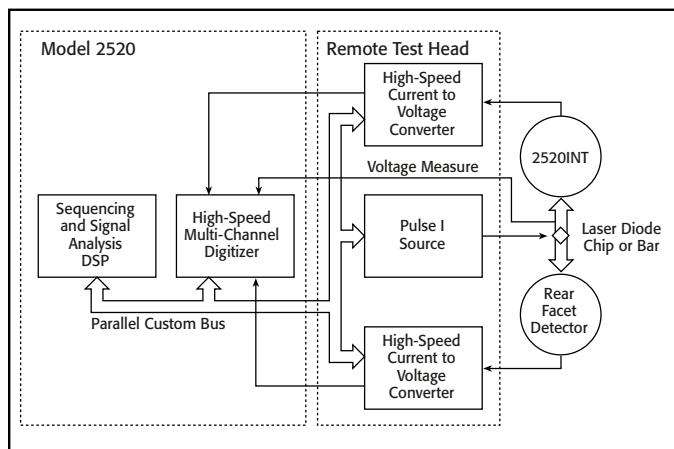

Figure 2. The Model 2520 integrates synchronization, source, and measure capabilities in a single half-rack instrument (with remote test head) to provide maximum flexibility and test throughput.

1.888.KEITHLEY (U.S. only)

www.keithley.com**KEITHLEY**

A Tektronix Company

A Greater Measure of Confidence

physics of the connections to the device. Keithley's optoelectronics applications engineers have addressed these issues by studying and documenting the optimum cable configuration to enhance measurement accuracy with extremely fast pulses. **Figure 3** illustrates the results of a typical pulse LIV sweep test with the Model 2520. In this test, a 100-point pulsed LIV sweep using a $1\mu\text{s}$ pulse width, at 1% duty cycle, was completed in just 110ms (including data transfer time), several orders of magnitude faster than existing, semi-custom test systems.

ESD Protection

A laser diode's material make-up, design, and small size make it extremely sensitive to temperature increases and electrostatic discharges (ESDs). To prevent damage, prior to the start of the test and after test completion, the Model 2520 shorts the DUT to prevent transients from destroying the device. The instrument's 500 nanosecond pulse and measure test cycle minimizes device heating during test, especially when a short duty cycle is used.

Test Sequencing and Optimization

Up to five user-definable test setups can be stored in the Model 2520 for easy recall. The Model 2520's built-in Buffer Memory and Trigger Link interface can reduce or even eliminate time-consuming GPIB traffic during a test sequence. The Buffer Memory can store up to 1000 points of measurement data during the test sweep. The Trigger Link combines six independent software selectable trigger lines on a single connector for simple, direct control over all instruments in a system. This interface allows the Model 2520 to operate autonomously following an input trigger. The Model 2520 can be programmed to output a trigger to a compatible OSA or wavelength meter several nanoseconds prior to outputting a programmed drive current value to initiate spectral measurements.

Accessories and Options

The Model 2520 comes with all the interconnecting cables required for the main instrument and the remote test head. Production test practices vary widely (automated vs. semi-automated vs. manual), so the cable assemblies from the remote test head to the DUT can vary significantly. To accommodate these differing requirements, Keithley has developed the Model 2520 RTH to DUT Cable Configuration Guide to help customers determine the proper cable assemblies to use to connect the remote test head (RTH) to the DUT.

Interface Options

The Model 2520 provides standard IEEE-488 and RS-232 interfaces to speed and simplify system integration and control. A built-in digital I/O interface can be used to simplify external handler control and binning operations.

Additional LIV Test Solutions

For production testing laser diodes after they have been packaged in temperature controlled modules, Keithley offers the Laser Diode LIV Test System with increased 28-bit core measurement resolution, allowing for more detailed characterization. This flexible system combines all the DC measurement capabilities required to test these modules with tight temperature control over the DUT in a modular instrument package. Configured from proven Keithley instrumentation, the basic configuration can be easily modified to add new measurement functions as new testing needs evolve.

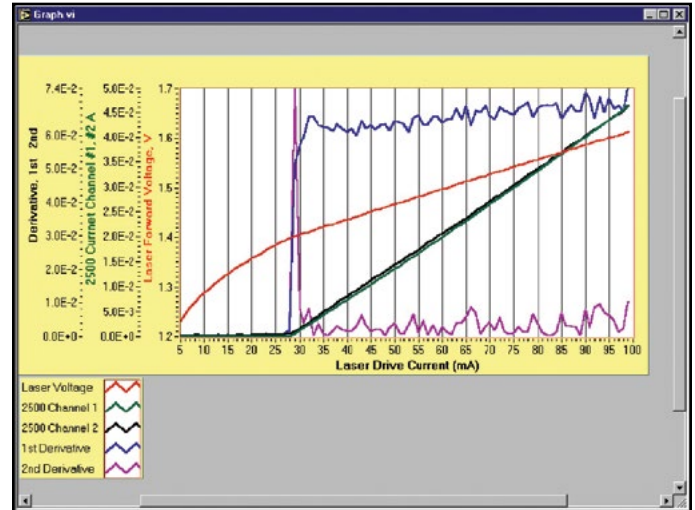

Figure 3. This plot illustrates the Model 2520's pulsed LIV sweep capability. The sweep was programmed from 0 to 100mA in 1mA steps. Pulse width was programmed at $1\mu\text{s}$ at 1% duty cycle, providing for a complete sweep in just 10ms (excluding data transfer time).



Figure 4. Model 2520 Remote Test Head

LASER DIODE PULSE OR DC CURRENT SOURCE SPECIFICATIONS

DRIVE CURRENT					OFF CURRENT ⁴			
Source Range	Programming Resolution	Approx. Electrical Resolution	Accuracy ^{1, 6} ±(%rdg. + mA) ^{2, 3}	RMS Noise (typical) (1kHz–20MHz)	Range	Programming Resolution	Approx. Electrical Resolution	Accuracy ¹ ±(%rdg. + mA)
0–500 mA	10 μA	8 μA	0.2 + 0.45	70 μA	0–15 mA	1 μA	7 nA typ.	0.2 + 0.45
0–1.0 A DC 0–5.0 A Pulse	100 μA	80 μA	0.2 + 4.5	800 μA	0–150 mA	10 μA	70 nA typ.	0.2 + 4.5

TEMPERATURE COEFFICIENT (0°–18°C & 28°–50°C): ±(0.15 × accuracy specification)/°C.

PULSE ON TIME¹⁹: 500ns to 5ms, 100ns programming resolution.

PULSE OFF TIME¹⁹: 20μs to 500ms, 10μs programming resolution.

PULSE DUTY CYCLE^{19, 20, 21}: 0 to 99.6% for ≤1.0A; 0 to 4% for >1.0A.

VOLTAGE COMPLIANCE: 3V to 10V, 10mV programming resolution⁵.

POLARITY: 1 quadrant source, polarity reversal available through internal relay inversion.

OUTPUT OFF: <200mΩ short across laser diode; measured at Remote Test Head connector.

LASER DIODE VOLTAGE MEASURE SPECIFICATIONS

Range	Minimum Resolution	Accuracy ±(%rdg. + volts) ^{1, 12}	RMS Noise (typical) ¹³
5.00 V	0.33 mV	0.3% + 6.5 mV	60 μV
10.00 V	0.66 mV	0.3% + 8 mV	120 μV

TEMPERATURE COEFFICIENT (0°–18°C & 28°–50°C): ±(0.15 × accuracy specification)/°C.

MAX. LEAD RESOLUTION: 100Ω for rated accuracy.

INPUT IMPEDANCE: 2MΩ differential, 1MΩ from each input to common.

Input bias current ±7.5μA max.

PHOTODIODE VOLTAGE BIAS SOURCE SPECIFICATIONS (each channel)

RANGE: 0 to ±20VDC.

PROGRAMMING RESOLUTION: 10mV.

ACCURACY: ±(1% + 50mV).

CURRENT: 160mA max. with V-Bias shorted to I-Measure.

RMS NOISE (1kHz to 5MHz): 1mV typical.

PHOTODIODE CURRENT MEASURE SPECIFICATIONS (each channel)

Range	Minimum Resolution ⁴	DC Input Impedance	Accuracy ±(%rdg. + current) ^{1, 2}	RMS Noise (typical) ³
10.00 mA	0.7 μA	< 10 Ω	0.3% + 20 μA	90 nA
20.00 mA	1.4 μA	< 6 Ω	0.3% + 65 μA	180 nA
50.00 mA	3.4 μA	< 3 Ω	0.3% + 90 μA	420 nA
100.00 mA	6.8 μA	<2.5 Ω	0.3% + 175 μA	840 nA

TEMPERATURE COEFFICIENT (0°–18°C & 28°–50°C): ±(0.15 × accuracy specification)/°C.

INPUT PROTECTION: The input is protected against shorting to the associated channel's internal bias supply. The input is protected for shorts to external supplies up to 20V for up to 1 second with no damage, although calibration may be affected.

SYSTEM SPEEDS

READING RATES (ms)^{15, 16}

Number of Source Points ¹⁷	To Memory	To GPIB
1	5.3	6.8
10 ¹⁸	9.5	18
100 ¹⁸	48	120
1000 ¹⁸	431	1170

Setting and Range	Load ⁷	Pulse Mode	Pulse Overshoot Max. ^{6, 8, 9}	Rise/Fall Time ^{6, 8, 9, 10}	
				Typical	Max.
500 mA	10 Ω ¼ Watt	Fast	1.0%	55 ns	80 ns
500 mA	10 Ω ¼ Watt	Slow	0.1%	1 μs	1.3 μs
5.00 A	1.5 Ω 1 Watt	Fast	1.0%	100 ns	130 ns
5.00 A	1.5 Ω 1 Watt	Slow	0.1%	1 μs	1.3 μs

GENERAL

DC FLOATING VOLTAGE: User may float common ground up to ±10VDC from chassis ground.

COMMON MODE ISOLATION: >10⁹Ω.

OVERRANGE: 105% of range on all measurements and voltage compliance.

SOURCE OUTPUT MODES:

- Fixed DC Level
- Fixed Pulse Level
- DC Sweep (linear, log, and list)
- Pulse Sweep (linear, log, and list)
- Continuous Pulse (continuous – low jitter)

PROGRAMMABILITY: IEEE-488 (SCPI-1995.0), RS-232, 5 user-definable power-up states plus factory default and *RST.

DIGITAL INTERFACE:

Safety Interlock: External mechanical contact connector and removable key switch.

Aux. Supply: +5V @ 300mA supply.

Digital I/O: 2 trigger input, 4 TTL/Relay Drive outputs (33V @ 500mA max., diode clamped).

Trigger Link: 6 programmable trigger input/outputs.

Pulse Trigger Out BNC: +5V, 50Ω output impedance, output trigger corresponding to current source pulse; pulse to trigger delay <100ns. See Figure 3.

MAINS INPUT: 100V to 240V rms, 50–60Hz, 140VA.

EMC: Conforms to European Union Directive 89/336/EEC (EN61326-1).

SAFETY: Conforms to European Union Directive 73/23/EEC (EN61010-1) CAT 1.

VIBRATION: MIL-PRF-28800F Class 3, Random.

WARM-UP: 1 hour to rated accuracy.

DIMENSIONS, WEIGHT:

Main Chassis, bench configuration (with handle & feet): 105mm high × 238mm wide × 416mm deep (4¼ in. × 9¼ in. × 16¼ in.). 2.67kg (5.90 lbs).

Remote Test Head: 95mm high × 178mm deep (with interlock key installed) × 216mm wide (3½ in. × 7 in. × 8½ in.). 1.23kg (2.70 lbs).

ENVIRONMENT:

Operating: 0°–50°C, 70% R.H. up to 35°C. Derate 3% R.H./°C, 35°–50°C.

Storage: –25° to 65°C.

1.888.KEITHLEY (U.S. only)

www.keithley.com

KEITHLEY

A Tektronix Company

A Greater Measure of Confidence

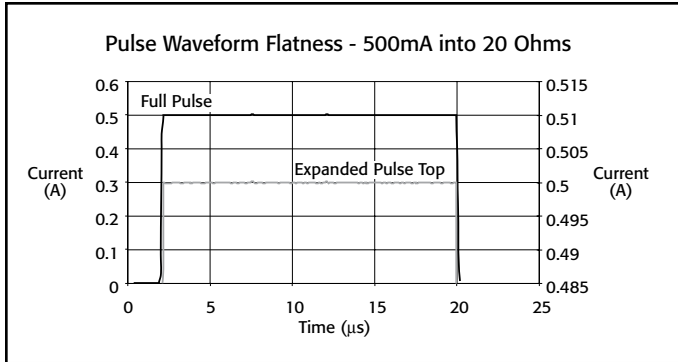

Figure 1

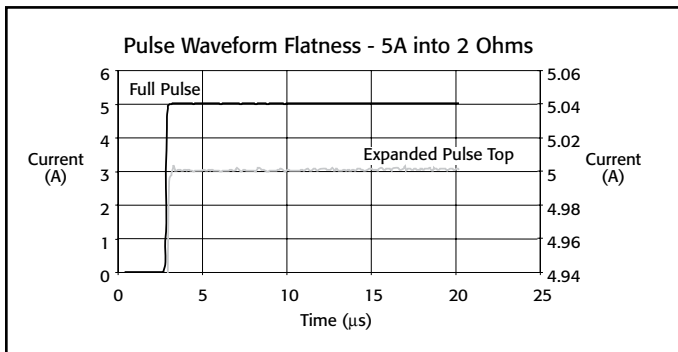

Figure 2

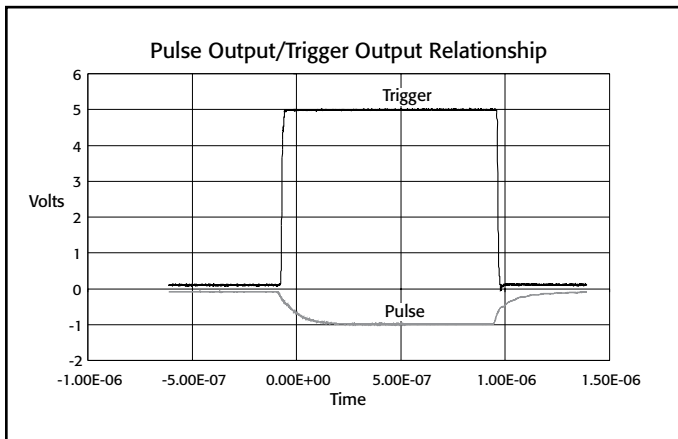

Figure 3

NOTES

1. 1 year, 23°C ±5°C.
2. If $\sqrt{\text{Duty Cycle}} \cdot I$ exceeds 0.2, accuracy specifications must be derated with an additional error term as follows:
 500mA Range: $\pm 0.1\% \text{ rdg.} \cdot \sqrt{D} \cdot I$
 5A Range: $\pm 0.3\% \text{ rdg.} \cdot \sqrt{D} \cdot I$
 where: I = current setting
 D = duty cycle
 This derating must also be applied for a period equal to the time that $\sqrt{D} \cdot I$ was ≥ 0.2 .
3. Not including overshoot and setting time.
4. Pulse mode only.
5. Output: 500mA DC on 500mA range and 1A DC on 5A range.
6. Refer to Model 2520 Service Manual for test setup of current accuracy.
7. Figures 1 and 2 are typical pulse outputs into resistive loads.
8. Typical.
9. Per ANSI/IEEE Std 181-1977.
10. Per ANSI/IEEE Std 181-1977 10% to 90%.
11. DC accuracy $\pm 700\text{mV}$ @ output terminal. 0.2Ω typical output impedance.
12. At DC, 10µs measurement pulse width, filter off.
13. Standard deviation of 10,000 readings with 10µs pulse width, filter off, with I source set to 0A DC.
14. The A/D converter has 14 bit resolution. The useful resolution is improved by reading averaging. The useful resolution is:

$$\text{Useful Resolution} = \frac{\text{Range}}{2^{14}} \cdot \frac{1}{\sqrt{\frac{\text{Pulse Width (ns)} - 400\text{ns}}{100\text{ns}} \cdot \text{Averaging Filter Setting}}}$$
15. Excluding total programmed (Pulse ON time + Pulse OFF time).
16. Front panel off, calc off, filter off, duty cycle <10%, binary communications.
17. Returning 1 voltage and 2 current measurements for each source point.
18. Sweep mode.
19. Valid for both continuous pulse and sweep modes.
20. Shown is the Power Distribution % based on current settings.
21. Timing Cycle ($P\%/(pw + pd)$): 4% max.

2520INT

Integrating Sphere for Pulsed Measurements



- **Optimized for laser diode pulse testing**
- **Suitable for production and laboratory environments**
- **Built-in germanium detector**
- **Works seamlessly with the Model 2520 Pulsed Laser Diode Test System**

interior is highly reflective Spectralon, which scatters, reflects, and diffuses the source beam the DUT produces. This spreads the light from the DUT uniformly over the sphere's interior surface with minimal absorption loss. The detector, which reads the amount of optical power produced by the DUT, is mounted on the interior surface. Due to the multiple diffuse reflections within the sphere, the amount of optical radiation that strikes the detector is the same as that which falls on any other point on the sphere's interior. To convert the attenuated signal measured by the detector into an accurate optical power measurement, the sphere and detector are calibrated as a unit.

Simplifies Beam Alignment

In a typical laser diode manufacturing line, the laser diode is not coupled to an optical fiber until the final stages of the packaging process. Therefore, any pulse testing performed on a laser diode at the bar- or chip-level would require a difficult and time-consuming beam alignment process in order to focus all of the diode's output on the optical detector.

To ensure acceptance of the complete beam with maximum divergence angles, the sphere can be located up to 3 millimeters from the DUT, positioned so the diode's light output enters the ¼-inch port on the sphere's side. Any light that enters the sphere is captured in the measurement taken by the Model 2520.

The Model 2520INT Integrating Sphere is designed to optimize the Model 2520 Pulsed Laser Diode Test System's optical power measurement capabilities. It allows the testing of devices with pulse widths as short as 500ns. The short pulses of the Model 2520 combined with the speed of the Model 2520INT make them ideal for measuring the optical power of laser diodes at the bar or chip level, before these devices are integrated into temperature-controlled modules. When connected to the Model 2520 via a low noise triax cable, the Model 2520INT allows the Model 2520 to make direct, high accuracy measurements of a laser diode's optical power. The results are expressed in milliwatts.

Designed Specifically for Pulsed Laser Diode Testing

Keithley developed the Model 2520INT to address the challenges specific to pulse testing laser diodes, which include short pulse periods and fast rise times. For example, when testing laser diodes in pulse mode, the optical head used must provide a response that's fast enough to measure light pulses as short as 500ns. Many optical power detectors are hampered by long rise times, so they can only measure a portion of the laser diode's light output. Even when using a "fast" detector, many detectors are not good for analog signal measurement. By linking the Model 2520 with the optimum combination of sphere and detector characteristics, Keithley provides the low-level sensitivity needed to ensure accurate pulse measurements.

Easier Laser Diode Power Measurements

An integrating sphere is inherently insensitive to variations in the beam profile produced by a device under test (DUT). The Model 2520INT's interior is highly reflective Spectralon, which scatters, reflects, and diffuses the source beam the DUT produces. This spreads the light from the DUT uniformly over the sphere's interior surface with minimal absorption loss. The detector, which reads the amount of optical power produced by the DUT, is mounted on the interior surface. Due to the multiple diffuse reflections within the sphere, the amount of optical radiation that strikes the detector is the same as that which falls on any other point on the sphere's interior. To convert the attenuated signal measured by the detector into an accurate optical power measurement, the sphere and detector are calibrated as a unit.

APPLICATIONS

Bar- or chip-level LIV production testing of:

- **980 or 1480 EDFA pump lasers**
- **Raman amplifiers**
- **Telecommunication laser diodes**
- **High power telecommunication VCSELS**

ACCESSORIES REQUIRED

2520	Pulsed Laser Diode Test System
7078-TRX	Low Noise Triax Cable

1.888.KEITHLEY (U.S. only)

www.keithley.com

KEITHLEY
A Tektronix Company

A Greater Measure of Confidence

2520INT

Ordering Information

2520INT-1-Ge
1 inch Integrating
Sphere with
Germanium Detector

2520/KIT1
Pulsed Laser Diode
Measurement
Package (Includes
2520, 2520INT, and
3-foot triax cable)

Accessories Supplied

Quick Start Guide, calibration data (supplied as a printed chart and in CSV format on a floppy diskette), base and 1/4–20 post for mounting

Integrating Sphere for Pulsed Measurements

Attenuation of Laser Diode Output

Detectors usually have a maximum power limit of a few milliwatts before the detector is over-saturated. The Model 2520INT Integrating Sphere's highly reflective Spectralon interior surface eliminates the problem of detector saturation. This coating reflects and diffuses the light output from the DUT uniformly over the interior surface of the sphere, which inherently attenuates the level of power read by the built-in detector. The power level at any point on the sphere's interior surface is far less than the power level of a beam that falls directly on the detector. This allows testing much higher power devices without risking detector damage. The Model 2520INT's design attenuates the power output of a laser diode by approximately 100:1.

Optimized for Telecommunications Wavelengths

The Model 2520INT's germanium detector is capable of detecting wavelengths from 800–1700nm. The detector and the sphere are calibrated as a unit in 10nm increments at wavelengths that are of particular interest for laser diode testing (950–1010nm and 1280–1620nm). Calibration constants are provided in printed form as well as in CSV format on a floppy diskette to simplify programming them into a test system. When combined with the Model 2520INT, the Model 2520 Pulsed Laser Diode Test system is capable of measuring power ranging from 14.5mW to 7W, depending on the wavelength (see the specifications for power ranges by wavelengths of interest).

Fiber Tap for Additional Measurements

The Model 2520INT offers production test engineers the flexibility to decrease overall testing time by supporting multiple optical measurements simultaneously. An additional port on the sphere is compatible with an SMA connector; together, the port and fiber tap can be used to output a fraction of the measured light to an external instrument (such as a spectrometer) via a multimode fiber for additional optical measurements.

Eliminates Back Reflections

During testing, the stability of a laser diode can be significantly affected by back reflections from objects in the optical path. The geometry of the Model 2520INT and the diffusing properties of its reflective interior help prevent back reflection and ensure greater device stability during testing.

Production or Laboratory Environments

A slight curvature on the face of the sphere makes Model 2520INT easier to integrate into an automated test system. This curvature allows additional room to connect the sphere to the DUT electrically and simplifies integration with other system components.

The Model 2520INT is designed with four strategically located mounting holes for flexible mounting on laboratory tables or in automated test fixtures. Two of the holes are sized to accommodate metric fixtures, while the other two are designed for use with English fixtures. The Model 2520INT comes with a 1/4–20 base and post.

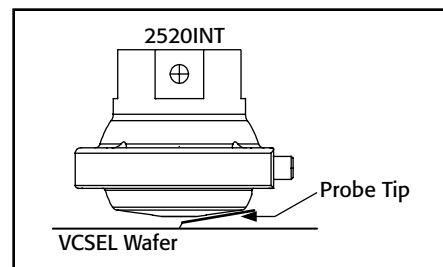

A slight curvature on the face of the sphere allows additional room to connect the DUT electrically in close quarters, such as in wafer probing.

1.888.KEITHLEY (U.S. only)

www.keithley.com

A Greater Measure of Confidence

KEITHLEY
A Tektronix Company

Simplifies pulsed measurements of optical power

SEMICONDUCTOR

2520INT

Integrating Sphere for Pulsed Measurements

Specifications

FULL ACCEPTANCE ANGLE¹: 90° vertical, 50° horizontal (max.).

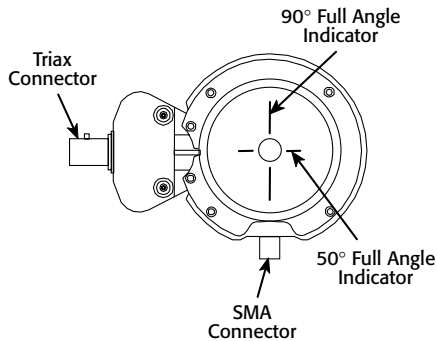

Frontal View of Integrating Sphere Showing Full Acceptance Angle Indicators

OPERATING WAVELENGTH RANGE: 800–1700nm.

CONTINUOUS WAVE (CW) CALIBRATION WAVELENGTH RANGE²: 950–1010nm and 1280–1620nm.

Wavelength (nm)	Measurable Optical Power Range ³	Typical Responsivity ⁴ (mA/W)	Resolution ⁵ (mW)
980	29mW–7W	3.5	0.2
1310	17mW–4W	6.0	0.1
1480	14.5mW–3.5W	7.0	0.1
1550	13.5mW–3W	7.5	0.1

MAXIMUM REVERSE BIAS: 5V (recommended).

DARK CURRENT AT MAX REVERSE BIAS: 4μA (typ.); 10μA (max.).

PHOTODIODE ELECTRICAL CONNECTIONS ON 3 LUG TRIAX⁶:

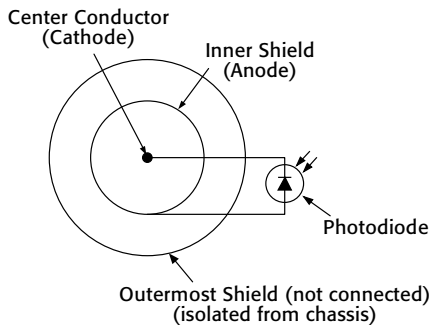

PULSED OPERATION: The 2520INT supports the pulse capabilities of the 2520 Pulsed Laser Diode Test System.

FIBER TAP PORT: Connector Type: SMA. Numerical Aperature (NA): 0.22 (typ.).

Multi-Mode Patch Cord Core Diameter (μm)	Typical Attenuation (dB)
400	39.5
100	53
62.5	58.2
50	63

GENERAL

INPUT PORT DIAMETER: 0.25 in (6.35mm).

RECOMMENDED CALIBRATION CYCLE: 1 year.

OPERATING TEMPERATURE: 0°–50°C.

STORAGE TEMPERATURE: –25°C–65°C.

DIMENSIONS⁸: 60.0mm long × 86.4mm high × 45.7mm deep (2.36 in × 3.40 in × 1.80 in).

WEIGHT⁸: 0.15kg (0.33 lbs).

NOTES

- Maximum distance from input port to accept at full maximum acceptance angle: 3.1mm (0.12 in).
- Calibration performed at 10nm wavelength intervals.
- Based on detector being linear to up to 25mA photocurrent and on a signal to noise ratio (SNR) ≥ 100:1.
- Calibration of the 2520INT is performed with an open fiber tap port. The power measurement will increase by approximately 1% with an SMA patch cord attached to the port.
- Based on resolution of Model 2520 at 10mA (lowest) current measurement range.
- This configuration MUST have a NEGATIVE (reverse) bias voltage applied. If a positive (forward) bias is applied, the detector (photodiode) will become damaged.
- Use of single mode fiber is not recommended.
- Only for integrating head, does not include post and base.

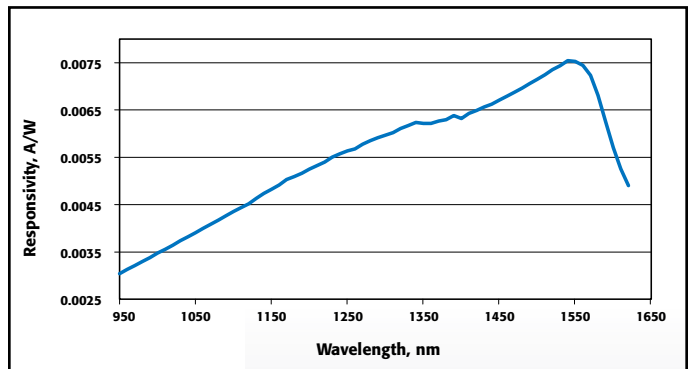

Typical responsivity of the Model 2520INT

System 25

Laser Diode Test System Kit



Shown: S25-22224 fully assembled and installed in optional 8000-10 equipment rack (laser diode module not included)

- Programmable LIV test system for laser diode modules
- Sweep and measure 400 points in <8s
- Very low noise current source (50 μ A) for laser diode drive
- Up to 5A laser diode drive current
- Measures optical power directly
- 1fA resolution for dark current measurements
- Fully digital P-I-D loop for temperature control
- $\pm 0.005^\circ\text{C}$ temperature stability, $\pm 0.001^\circ\text{C}$ setpoint resolution
- Trigger Link, source memory, and buffer memory support automatic test sequencing, which greatly reduces GPIB bus traffic to improve test throughput
- Expandable and flexible for future requirements

Complete DC Test System with Temperature Control

Keithley's LIV (light-current-voltage) Test System Kit is designed to help manufacturers of laser diode modules (LDMs) keep pace with production demands by allowing them to boost yield and throughput. The LIV test system combines all the DC measurement capabilities required to test these modules with optical power measurement and tight temperature control over the device under test in an integrated instrument package. The LIV test system is configured from proven Keithley instrumentation; the basic configuration can be easily modified to add new measurement functions or to allow for new connections.

Tight Integration Ensures Higher Test Speeds

The LIV test system allows for fast, easy integration and high test speeds because all the building blocks come from the same supplier. All

newer Keithley instruments include the Trigger Link feature and digital I/O lines, as well as standard IEEE-488 (GPIB) and RS-232 interfaces, to speed and simplify system integration and control. The Trigger Link feature combines independent software selectable trigger lines on a single connector for simple, direct control over all instruments in a system without the need for constant traffic over the GPIB. This feature is particularly useful for reducing total test time if the test involves a sweep. The digital I/O lines simplify external handler control and binning operations.

Source memory and buffer memory, provided by Models 2400-LV, 2420, 2440, and 2502, enable elimination of GPIB traffic during sweep testing. Source memory is a built-in "programmable test sequencer" for configuring up to 100 different tests. The buffer memory stores data that can be downloaded to the PC via the GPIB after an LIV test sweep is complete. Source memory, buffer memory, and Trigger Link work in concert to form an autonomous test system—all it takes to begin the test sequence is a "start of test" command from the PC. Benchmark testing has demonstrated that these features allow the system to complete a 400-point LIV test sweep with data transfer to the PC in less than eight seconds.

Easy to Program, Easy to Use

Each kit comes complete with the necessary cables and hardware to use the system. Having all the instrumentation supplied by the same vendor simplifies system programming and improves ease of use. All instruments in the standard system respond to the same SCPI command structure. LabVIEW[®] and Visual Instrument drivers and demonstration software are also available to simplify application development.

Flexible System Configuration Options

In addition to the standard system configurations, LIV test systems can be customized to accommodate virtually any test sequence or setup requirement. Adding new capabilities or expanding existing ones is as simple as adding a new Keithley instrument or switch system. For example, to add isolation resistance measurements, just include any of Keithley's Series 2000 Digital Multimeters in the configuration.

To accommodate multiple pin-out schemes, choose a Series 7000 Switch Mainframe and plug in one or more switch cards, such as the Model 7012 4 \times 10 Matrix Card or the Model 7053 High Current Scanner Card for switching up to 5A. Automated switching makes it simple to accommodate future pin-out configuration changes.

1.888.KEITHLEY (U.S. only)

www.keithley.com

KEITHLEY

A Tektronix Company

A Greater Measure of Confidence

Complete test solutions for individual application needs

SEMICONDUCTOR

System 25

Laser Diode LIV Test System Kit

A custom configuration and ordering guide is available to simplify selecting all the critical items needed to complete a system.

Single Vendor Solution

In addition to the assurance of hardware and software compatibility, systems integrators can be confident they'll get all the technical support they need to complete and maintain their systems from a single source. Keithley's applications engineers can help systems integrators optimize the performance of each instrument in the system to ensure high speed and accuracy from the system as a whole.

High Accuracy Building Blocks

The standard LIV test system provides a fast, flexible solution for testing LDMs by combining the functions of several high speed, high accuracy Keithley instruments:

- **Model 2400-LV, 2401, 2420, or 2440 SourceMeter® SMU instrument.** During LIV testing, the SourceMeter SMU instrument provides a current sweep to drive the laser diode. It also synchronizes the measurements made by other instruments in the system. The Models 2400-LV, 2420, and 2440 SourceMeter SMU instruments are part of Keithley's SourceMeter family and were developed specifically for test applications that demand tightly coupled precision voltage and current sourcing and measurement. Selecting the instrument's high current range eliminates the potential for range change glitches if currents higher than 1A are needed during the LIV sweep. The Model 2420 offers drive current of up to 3A. The Model 2440 offers up to 5A of drive current for demanding pump laser control.
- **Model 2502 Dual Photodiode Meter.** The Model 2502 measures the current flow in the back facet photo detector and combines with the Model 2500INT Integrating Sphere to directly measure optical power. Both optical power measurement channels are fully independent. The measurement timing circuitry is shared between both channels to provide simultaneous measurements to optimize LIV performance. Each channel has eight measurement ranges and provides a resolution high enough to measure dark currents of the photodiode. The isolated bias sources provide up to 100V of bias. The Model 2502 has a high speed analog output that allows the LIV system to be combined with a fiber alignment system.
- **Model 2510-AT TEC SourceMeter SMU instrument.** The Model 2510-AT is a 50W bipolar instrument that controls the operation of an LDM's Thermo-Electric Cooler or TEC (sometimes called a "Peltier device") during LIV testing. During testing, the Model 2510-AT measures the internal temperature of the LDM from any of a variety of temperature sensors, then drives power through the TEC in order to maintain the LDM's temperature at the desired setpoint.

The Model 2510-AT's software-based, fully digital P-I-D (proportional-integral-differential) control provides excellent temperature stability. This high stability allows for very fine control over the output wavelength and over the optical power of the LDM during testing. Another Model 2510-AT can be added to include ambient fixture control, if the test will be done under a variety of ambient conditions. The instrument includes a low-level TEC resistance measurement function to check TECs for mechanical damage during module assembly.

The Model 2510-AT offers autotuning capability. P, I, and D (proportional, integral, and derivative) values for closed loop temperature control are determined by the instrument using a modified Zeigler-Nichols algorithm. This eliminates the need for users to experiment by inputting various P, I, and D coefficients repeatedly in order to determine the optimal values.

- **Model 2500INT Integrating Sphere.** This accessory for the Model 2502 accepts direct optical input and provides for accurate L measurement without being sensitive to polarization mode or beam profile at the end of the fiber. The integrating sphere is available with a silicon, germanium, or cooled indium gallium arsenide detector to ensure accurate optical power measurements at any wavelength.
- **Model 854x.** The 854x Laser Diode Mount Series makes it easier than ever to configure a complete laser diode LIV test system for continuous wave test applications. These fixtures provide highly stable temperature control for all telecommunications laser diodes. They offer an easy-to-use platform for testing laser diodes used in telecommunications. They are designed to speed and simplify setting up test systems for all laser diode/photodiode/thermoelectric cooler/thermistor configurations.

For additional information on any of the building blocks of the LIV test system, refer to the data sheet for that instrument.

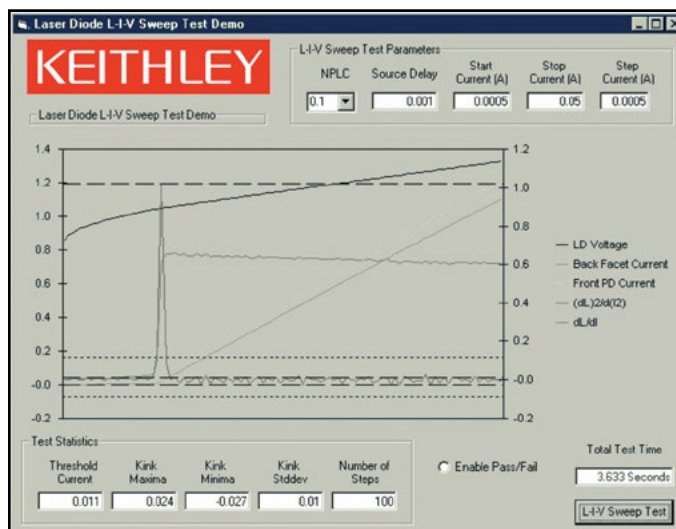

A demonstration software package, written in Visual Basic, is available with the LIV test system to give programmers a head start on creating their own applications. Using the demonstration package, users can set a variety of test parameters, including NPLC (integration time), Source Delay (settling time before measurement), Start Current, Stop Current, and Step Current. These parameters allow users to define the current sweep range and make speed and accuracy trade-offs by adjusting Source Delay and NPLC. The resulting data can be analyzed to determine threshold current and kink statistics. The total test time includes the instrument setup, LIV sweep, and data transfer times (but not the computation times).

1.888.KEITHLEY (U.S. only)

www.keithley.com

KEITHLEY

A Tektronix Company

A Greater Measure of Confidence

System 25

Laser Diode LIV Test System Kit

Ordering Information

S25-

Source/Measure

- 0 2400-LV or 2401/2502 General Purpose
- 2 2420/2502 Transmitter/Pump
- 4 2440/2502 Pump Laser

Temperature Control

- 0 None
- 1 2510-AT Single Temp. Control
- 2 2510-AT/2510-AT Dual Temp. Control

Integrating Spheres

- 00 None
- 21 2500INT-2-SI 2" Sphere, Silicon
- 22 2500INT-2-GE 2" Sphere, Germanium
- 23 2500INT-2-IGAC 2" Sphere, Cooled InGaAs

Laser Diode Mounts

- 0 None
- 4 8544 14-Pin Butterfly Mount
- 4t 8544-TEC 14-Pin Butterfly w/TEC Control

Select the instrument and accessory for your application. Review the detailed specifications of each instrument in individual catalog sections.

ACCESSORIES INCLUDED IN EACH OPTION

SOURCE/MEASURE

- Includes: 2400-LV, 2401, 2420, or 2440 SourceMeter SMU Instrument
- 2502 Photodiode Meter
- (2) GPIB Interface Cables
- Trigger Link Cable
- Integrating Sphere Cable and adapter (Triax, 6172 adapter)
- DUT Cables (terminated in Alligator clips)
- Rackmount Conversion Kit

TEMPERATURE CONTROL

- Includes: 2510-AT SourceMeter SMU Instrument(s)
- GPIB Interface Cable(s)
- DUT Cables
- Rackmount Conversion Kit

INTEGRATING SPHERE

- Includes: 2500INT Integrating Sphere
- ½" open input port
- Post Stand

LASER DIODE MOUNT

- Includes: 854x Laser Diode Mount
- Easy Connect Multi Terminated Laser Diode Cables
- Easy Connect Multi Terminated Temperature Cables

CUSTOM SYSTEMS

Custom systems are available. Contact your local Keithley sales person.

ASSEMBLY SERVICES

The S25 Systems are not assembled. If you would like assembly service, contact your local Keithley salesperson.

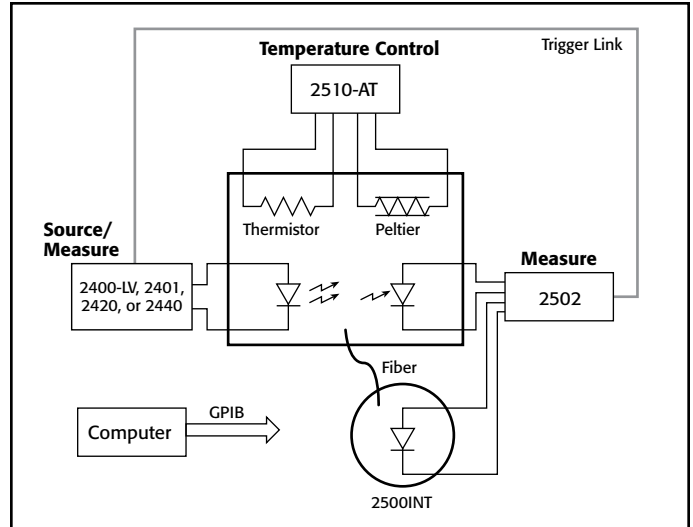

Figure 1. The standard LIV test system is designed for applications that require the highest measurement accuracy. The Model 2420 SourceMeter SMU instrument drives the laser diode, sweeping the drive current from 0A up to 3A in programmable steps. At each step in the sweep, the Model 2420 records the current and voltage measurements, while the Model 2502 measures and records the current flow in the photodiodes. When the sweep is complete, the raw measurement data from the Model 2420 and the Model 2502 is uploaded to the PC for analysis. The LIV Demo Software can calculate first and second derivatives of the back facet monitor diode or the external photo detector.

ACCESSORIES AVAILABLE

CABLES

- 7007-1 Double Shielded GPIB Cable, 1m (3.3 ft.)
- 7007-2 Double Shielded GPIB Cable, 2m (6.6 ft.)

CABINETS

(System kit is supplied with all necessary rack mount hardware. Purchase appropriate cabinet and assembly services separately.)

- 8000-10 Equipment Cabinet 10" high (holds 4 instruments)
- 8000-14A Equipment Cabinet 14" high
- 8000-17A Equipment Cabinet 17.5" high

GPIB CARDS

(GPIB communication required for complete LIV capabilities.)

- KPCI-488LPA IEEE-488 Interface/Controller for the PCI Bus
- KUSB-488B IEEE-488 USB-to-GPIB Adapter for USB Port

1.888.KEITHLEY (U.S. only)

www.keithley.com

A Greater Measure of Confidence

KEITHLEY
A Tektronix Company

**2400-LV, 2400-C,
2401, 2420, 2420-C,
2440, 2440-C**

SourceMeter® SMU Instruments for Optoelectronic I-V Testing



- **Designed for production testing of VCSELs, transmitter, high power pump lasers, and other high current electronic components**
- **Key building block for programmable LIV test system for laser diode modules**
- **Very low noise current source (50 μ A) for laser diode drive**
- **Up to 5A laser diode drive current**
- **Trigger Link, Source Memory, and buffer memory support automatic test sequencing**
- **Reduced GPIB bus traffic improves test throughput**
- **Expandable and flexible for future requirements**
- **Built-in comparator for fast pass/fail testing**
- **Digital I/O handler interface**
- **1000 readings/second at 4 $\frac{1}{2}$ digits**
- **Optional contact check function**

The SourceMeter family was developed specifically for test applications that demand tightly coupled precision voltage and current sourcing and concurrent measurement, including source read back. This family of instruments can be easily programmed to drive laser diodes throughout the characterization process. Any of them can also be programmed to act as a synchronization controller to ensure simultaneous measurements during the test sequence. Selecting a fixed current range eliminates the potential for range offsets that appear as kinks during the LIV sweep testing. The Models 2400-LV and 2401 offer a drive current of up to 1A, ideal for testing VCSEL devices.

The Model 2420 offers a tighter accuracy specification that allows for precise control of transmitter laser devices. In addition to higher accuracy, the Model 2420 offers a drive current of up to 3A for devices that need drive currents greater than 1A, such as pump lasers used in EDFA amplifiers.

The Model 2440 5A SourceMeter SMU Instrument further broadens the capabilities offered by the popular SourceMeter line. The dynamic range and functionality of the Model 2440 makes it ideal for applications such as testing high power pump lasers for use in optical amplifiers, laser bar tests, and testing other higher power components. Manufacturers of Raman pump laser modules and optical amplifiers will find it invaluable for a wide range of design and production test applications.

A Keithley SourceMeter SMU instrument provides a complete, economical, high throughput solution for component production testing, all in one compact, half-rack box. It combines source, measure, and control capabilities in a form factor that's unique to the industry. The SourceMeter is also suitable for making a wide range of low power DC measurements, including resistance at a specified current or voltage, breakdown voltage, leakage current, and insulation resistance.

Single Box Solution

By linking source and measurement circuitry in a single unit, a SourceMeter SMU instrument offers a variety of advantages over systems configured with separate source and measurement instruments. For example, it minimizes the time required for test station development, setup, and maintenance, while lowering the overall cost of system ownership. It simplifies the test process itself by eliminating many of the complex synchronization and connection issues associated with using multiple instruments. Its compact, half-rack size conserves "real estate" in the test rack or bench.

ACCESSORIES AVAILABLE

LASER DIODE MOUNTS

8542	Dual In-Line Telecom Laser Diode Mount Bundle
8544	Butterfly Telecom Laser Diode Mount Bundle
8544-TEC	Butterfly Telecom Laser Diode Mount Bundle with TEC, thermistor, and AD592CN temperature sensor

COMMUNICATION INTERFACE

KPCI-488LPA	IEEE-488 Interface/Controller for the PCI Bus
KUSB-488B	IEEE-488 USB-to-GPIB Adapter for USB Port

SWITCHING HARDWARE

7001	Two-Slot Switch System
7002	Ten-Slot Switch System
7053	High-Current Switch Card

TEST LEADS AND PROBES

5806	Kelvin Clip Lead Set
------	----------------------

CABLES/ADAPTERS

2499-DIGIO	Digital I/O Expansion Assembly
7007-1	Shielded GPIB Cable, 1m (3.3 ft)
7007-2	Shielded GPIB Cable, 2m (6.6 ft)
7009-5	RS-232 Cable
8501-1	Trigger Link Cable, 1m (3.3 ft)
8501-2	Trigger Link Cable, 2m (6.6 ft)
8502	Trigger Link Adapter Box

RACK MOUNT KITS

4288-1	Single Fixed Rack Mount Kit
4288-2	Dual Fixed Rack Mount Kit

1.888.KEITHLEY (U.S. only)

www.keithley.com

KEITHLEY

A Tektronix Company

A Greater Measure of Confidence

2400-LV, 2400-C, 2401, 2420, 2420-C, 2440, 2440-C

Ordering Information

2400-LV Low Voltage SourceMeter

Measurements up to 20V and 1A, 20W Power Output

2400-C General-Purpose SourceMeter

Contact Check, Measurements up to 200V and 1A, 20W Power Output

2401 Low Voltage SourceMeter

Measurements up to 20V and 1A, 20W Power Output

2420 High-Current SourceMeter

Measurements up to 60V and 3A, 60W Power Output

2420-C High-Current SourceMeter

Contact Check, Measurements up to 60V and 3A, 60W Power Output

2440 5A SourceMeter

Measurements up to 40V and 5A, 50W Power Output

2440-C 5A SourceMeter

Contact Check, Measurements up to 40V and 5A, 50W Power Output

Accessories Supplied

Test Leads, User's Manual, Service Manual, and LabVIEW® Drivers

SourceMeter® SMU Instruments for Optoelectronic I-V Testing

High Throughput to Meet Demanding Production Test Schedules

A SourceMeter SMU instrument's highly integrated architecture offers significant throughput advantages. Many features of this family enable them to "take control" of the test process, eliminating additional system bus traffic and maximizing total throughput. Built-in features that make this possible include:

- Source Memory List test sequencer with conditional branching
- Handler/prober interface
- Trigger Link compatibility with switching hardware and other instruments from Keithley
- High speed comparator, pass/fail limits, mathematical scaling
- Deep memory buffer

The SourceMeter SMU instruments also offer standard RS-232 and GPIB interfaces for integration with a PC. Adding one of Keithley's versatile switch systems enables fast, synchronized multi-point testing.

Testing Optoelectronic Components

Use a SourceMeter SMU instrument to measure a component's electrical performance characteristics and to drive laser diodes and other components.

Types of Optoelectronic Components

- Laser diodes
- Laser diode modules
- Photodetectors
- Light-emitting diodes (LEDs)
- Photovoltaic cells

Typical Tests

- LIV test (laser diodes and LEDs)
- Kink test (laser diode)
- I-V characterization

Model	2400-LV/2400-C/2401	2420/2420-C	2440/2440-C
Description	General Purpose	3 A	5 A
Power Output	20 W	60 W	50 W
Voltage Range	$\pm 1 \mu\text{V}$ to $\pm 20 \text{ V}$	$\pm 1 \mu\text{V}$ to $\pm 63 \text{ V}$	$\pm 1 \mu\text{V}$ to $\pm 42 \text{ V}$
Current Range	$\pm 50 \text{ pA}$ to $\pm 1.05 \text{ A}$	$\pm 500 \text{ pA}$ to $\pm 3.15 \text{ A}$	$\pm 500 \text{ pA}$ to $\pm 5.25 \text{ A}$
Ohms Range	$<0.2 \Omega$ to $>200 \Omega$	$<0.2 \Omega$ to $>200 \text{ M}\Omega$	$<2.0 \Omega$ to $>200 \text{ M}\Omega$
Applications	Optoelectronic components. VCSELs.	Transmitter modules. EDFA pumps.	5A pump laser diodes. Raman amplifiers.

Models 2400-LV/2401 SourceMeter Instruments

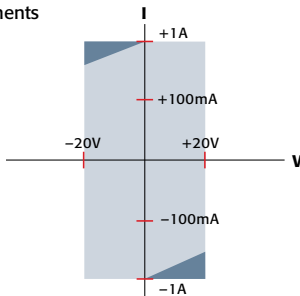

The Models 2400-LV and 2401 are ideal for testing a wide variety of devices, including diodes, resistors, resistor networks, active circuit protection devices, and portable battery-powered devices and components.

Model 2420 3A SourceMeter Instrument

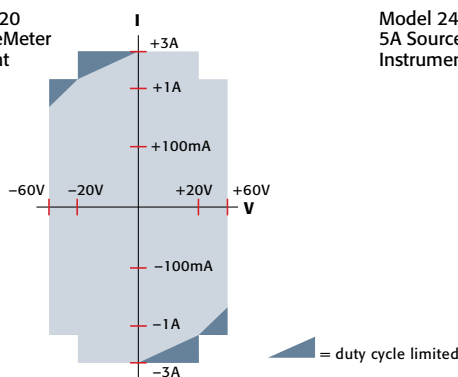

Choose the Model 2420 for testing higher power resistors, thermistors, I_{DDQ} , solar cells, batteries, and high-current or medium power diodes, including switching and Schottky diodes.

Model 2440 5A SourceMeter Instrument

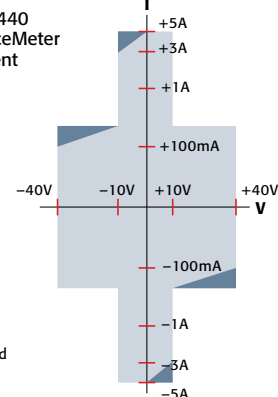

The Model 2440's wide dynamic range is well-suited for applications such as testing high-power pump lasers for use in optical amplifiers and laser bar tests, as well as testing other higher power components.

1.888.KEITHLEY (U.S. only)

www.keithley.com

A Greater Measure of Confidence

KEITHLEY

A Tektronix Company

Tightly coupled source and measure for active component testing

SEMICONDUCTOR

2400-LV, 2400-C, 2401, 2420, 2420-C, 2440, 2440-C

SourceMeter® SMU Instruments for Optoelectronic I-V Testing

Faster, Easier, and More Efficient Testing and Automation

Coupled Source and Measure Capabilities

The tightly coupled nature of a SourceMeter SMU instrument provides many advantages over separate instruments. The ability to fit a source and a meter in a single half-rack enclosure saves valuable rack space and simplifies the remote programming interface. Also, the tight control and a single GPIB address inherent in a single instrument result in faster test times for ATE applications due to reduced GPIB traffic.

Standard and Custom Sweeps

SourceMeter SMU instruments provide sweep solutions that greatly accelerate testing with automation hooks for additional throughput improvement.

Optional Contact Check

The Contact Check option available on all Series 2400 SourceMeter SMU instruments allows quick verification of a good connection to the DUT before functional testing proceeds. This feature helps prevent the loss of precious test time due to damaged, corroded, or otherwise faulty contacts in a test fixture. The innovative contact check design completes the verification and notification process in less than 350 μ s; comparable capabilities in other test equipment can require up to 5ms to perform the same function. Contact check failure is indicated on the instrument's front panel and over the GPIB bus. The digital I/O interface can also be used to communicate contact failure to the component handler in automated applications.

SOURCEMETER SMU INSTRUMENT SPECIFICATIONS

The following tables summarize the capabilities of the Models 2400-LV, 2420, and 2440.

2400-LV SOURCEMETER (I-V MEASUREMENTS)

Current Programming Accuracy

Range	Programming Resolution	Accuracy (1 Year) 23°C ± 5°C ± (% rdg. + amps)
1.00000 μ A	50 pA	0.035% + 600 pA
10.0000 μ A	500 pA	0.033% + 2 nA
100.000 μ A	5 nA	0.031% + 20 nA
1.00000 mA	50 nA	0.034% + 200 nA
10.0000 mA	500 nA	0.045% + 2 μ A
100.000 mA	5 μ A	0.066% + 20 μ A
1.00000 A	50 μ A	0.27 % + 900 μ A

Voltage Measurement Accuracy

Range	Default Resolution	Input Resistance	Accuracy (1 Year) 23°C ± 5°C ± (% rdg. + volts)
200.000 mV	1 μ V	> 10 G Ω	0.01 % + 300 μ V
2.00000 V	10 μ V	> 10 G Ω	0.012% + 300 μ V
20.0000 V	100 μ V	> 10 G Ω	0.015% + 1.5 mV

2420 SOURCEMETER (I-V MEASUREMENTS)

Current Programming Accuracy

Range	Programming Resolution	Accuracy (1 Year) 23°C ± 5°C ± (% rdg. + amps)
10.0000 μ A	500 pA	0.033% + 2 nA
100.000 μ A	5 nA	0.031% + 20 nA
1.00000 mA	50 nA	0.034% + 200 nA
10.0000 mA	500 nA	0.045% + 2 μ A
100.000 mA	5 μ A	0.066% + 20 μ A
1.00000 A	50 μ A	0.067% + 900 μ A
3.00000 A	50 μ A	0.059% + 2.7 mA

Voltage Measurement Accuracy

Range	Default Resolution	Input Resistance	Accuracy (1 Year) 23°C ± 5°C ± (% rdg. + volts)
200.000 mV	1 μ V	> 10 G Ω	0.012% + 300 μ V
2.00000 V	10 μ V	> 10 G Ω	0.012% + 300 μ V
20.0000 V	100 μ V	> 10 G Ω	0.015% + 1 mV
60.0000 V	1 mV	> 10 G Ω	0.015% + 3 mV

2440 SOURCEMETER (I-V MEASUREMENTS)

Current Programming Accuracy

Range	Programming Resolution	Accuracy (1 Year) ³ 23°C ± 5°C ± (% rdg. + amps)
10.0000 μ A	500 pA	0.033% + 2 nA
100.000 μ A	5 nA	0.031% + 20 nA
1.00000 mA	50 nA	0.034% + 200 nA
10.0000 mA	500 nA	0.045% + 2 μ A
100.000 mA	5 μ A	0.066% + 20 μ A
1.00000 A	50 μ A	0.067% + 900 μ A
5.00000 A	50 μ A	0.10 % + 5.4 mA

Voltage Measurement Accuracy

Range	Default Resolution	Input Resistance	Accuracy (1 Year) 23°C ± 5°C ± (% rdg. + volts)
200.000 mV	1 μ V	> 10 G Ω	0.012% + 300 μ V
2.00000 V	10 μ V	> 10 G Ω	0.012% + 300 μ V
10.0000 V	100 μ V	> 10 G Ω	0.015% + 750 μ V
40.0000 V	1 mV	> 10 G Ω	0.015% + 3 mV

1.888.KEITHLEY (U.S. only)

www.keithley.com

KEITHLEY

A Tektronix Company

A Greater Measure of Confidence

2502

Dual-Channel Picoammeter for Photodiode Measurements



- Dual-channel instrument for low current measurements
- $\pm 100V$ bias source
- Measure current from 1fA to 20mA
- 1fA current measurement resolution
- 0–10V analog output for high resolution optical power feedback
- 3000-point buffer memory on each channel allows data transfer after test completion
- Digital I/O and Trigger Link for binning and sweep test operations
- IEEE-488 and RS-232 interfaces

Ordering Information

2502 Dual-Channel Picoammeter

Accessories Supplied
User's Manual

SERVICES AVAILABLE

2502-3Y-EW	1-year factory warranty extended to 3 years from date of shipment
C/2502-3Y-DATA	3 (Z540-1 compliant) calibrations within 3 years of purchase*

*Not available in all countries

High Accuracy Dark Current Measurements

The Model 2502's 2nA current measurement range is ideal for measuring dark currents with 1fA resolution. Once the level of dark current has been determined, the instrument's REL function automatically subtracts the dark current as an offset so the measured values are more accurate for optical power measurements.

Voltage Bias Capability

The Model 2502 provides a choice of voltage bias ranges: $\pm 10V$ or $\pm 100V$. This choice gives the system integrator the ability to match the bias range more closely to the type of photodetector being tested, typically $\pm 10V$ for large area photodetectors and $\pm 100V$ for avalanche-type photodetectors. This ability to match the bias to the photodetector ensures improved measurement linearity and accuracy.

Ratio and Delta Measurements

The Model 2502 can provide ratio or delta measurements between the two completely isolated channels, such as the ratio of the back facet monitor detector to the fiber-coupled photodetector at varying levels of input current. These functions can be accessed via the front panel or the GPIB interface. For test setups with multiple detectors, this capability allows for targeted control capabilities for the laser diode module.

Interface Options

To speed and simplify system integration and control, the Model 2502 includes the Trigger Link feature and digital I/O lines, as well as standard IEEE-488 and RS-232 interfaces. The Trigger Link feature combines six independent software selectable trigger lines on a single connector for simple, direct control over all instruments in a system. This feature is especially useful for reducing total test time if the test involves a sweep. The Model 2502 can sweep through a series of measurements based on triggers received from the SourceMeter® SMU Instrument. The digital I/O lines simplify external handler control and binning operations.

For additional information and detailed specifications, see page 153.

The Model 2502 combines Keithley's expertise in low-level current measurements with high speed current measurement capabilities. Each channel of this instrument consists of a voltage source paired with a high speed picoammeter. Each of the two channels has an independent picoammeter and voltage source with measurements made simultaneously across both channels.

Wide Dynamic Measurement Range

The Model 2502 offers current measurement ranges from 2nA to 20mA in decade steps. This provides for all photodetector current measurement ranges for testing laser diodes and LEDs in applications such as LIV testing, LED total radiance measurements, measurements of cross-talk and insertion loss on optical switches, and many others. The Model 2502 meets industry testing requirements for the transmitter as well as pump laser modules.



Model 2502 rear panel

1.888.KEITHLEY (U.S. only)

www.keithley.com

A Greater Measure of Confidence

KEITHLEY
A Tektronix Company

Dual-channel optical power measurement

SEMICONDUCTOR

2500INT

Integrating Sphere

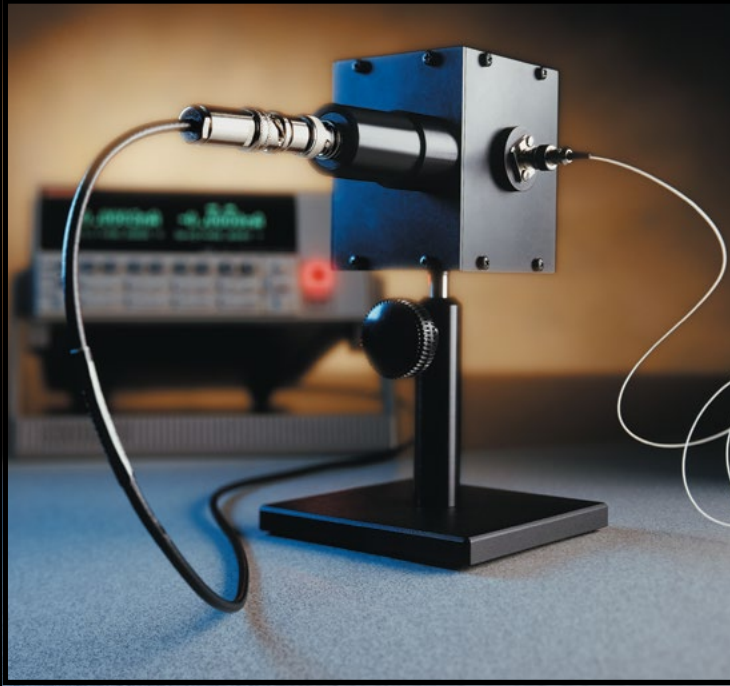

- Choose from silicon, germanium, or cooled indium gallium arsenide detectors
- Spectralon® sphere interior ensures high reflectivity
- Part of Keithley's high throughput system for production testing of laser diodes and LEDs

Ordering Information

2500INT-2-Si

Integrating Sphere
with Silicon Detector

2500INT-2-Ge

Integrating Sphere with
Germanium Detector

2500INT-2-IGAC

Integrating Sphere with
Cooled Indium Gallium
Arsenide Detector

Accessories Supplied

Quick Start Guide, Calibration
Chart for each sphere,
TEC Controller (included with
2500INT-2-IGAC)

The Model 2500INT Integrating Sphere is the latest addition to Keithley's growing line of solutions for LIV (light-current-voltage) testing. When connected via a low noise triax cable to the Model 2502 Dual Photodiode Meter included in Keithley's LIV Test System, the integrating sphere allows the system to make direct measurements of optical power, with results expressed in watts. The integrating sphere simplifies production testing of laser diodes (LDs), light emitting diodes (LEDs), and other optical components by eliminating common optical power measurement problems related to detector alignment, beam profile, polarization, and back reflection.

Choice of Three Detector Types

The Model 2500INT is available with a silicon (2500INT-2-Si), germanium (2500INT-2-Ge), or cooled indium gallium arsenide (InGaAs) detector (2500INT-2-IGAC), each calibrated with the sphere. Spheres equipped with cooled indium gallium arsenide detectors include a controller to regulate the detector's temperature.

Unaffected by DUT Beam Profile

Laser diodes can produce non-gaussian beam profiles, which can lead to inaccurate optical power measurements due to underfill or overfill of the detector. While a number of methods are available to correct for underfill and overfill, these methods can add to the overall inaccuracy of the measurement.

In contrast, an integrating sphere is inherently insensitive to beam profiles. The interior of the Model 2500INT integrating sphere has a highly reflective Spectralon surface, which scatters, reflects, and diffuses the source beam produced by the device under test (DUT). This spreads the light from the DUT uniformly over the interior surface of the sphere with minimal absorption loss. A detector can be placed on the interior surface of the sphere, then the sphere/detector combination can be calibrated. The amount of optical radiation striking the detector is the same as any other point on the sphere interior due to the multiple diffuse reflections within the sphere. Therefore, the calibration and resulting measurement accuracy are independent of beam profile.

The Model 2500INT's Spectralon surface offers a variety of other advantages. It is a nearly perfect diffuse reflector, exhibiting Lambertian reflectance properties, so it reflects equally in all directions, regardless of viewing angle. This eliminates the inaccuracies associated with less diffuse materials by distributing the optical radiation more evenly over the interior of the sphere. In addition, a Spectralon surface offers high reflectance for wavelengths from 250–2500nm, which makes it ideal for laser diode measurement applications. It is also chemically inert, which helps ensure stable measurements in harsh environments.

Eases Beam Alignment

If an integrating sphere is not used in laser diode testing, the entire beam from the laser must shine directly onto the detector in order to measure optical power accurately. However, it is difficult to align a laser and detector with the high degree of precision required, particularly when the laser is operating outside of the visible spectrum. With the use of an integrating sphere, beam alignment is trivial because any light that enters the sphere will be spread evenly across its interior surface. Simply stated, it is easier to direct a laser into a 1/2-inch port than it is to direct a laser onto a 5mm detector. The sphere

APPLICATIONS

Production testing of:

- Laser diode modules
- Chip on submount laser diodes
- Laser diode bars
- LEDs
- Passive optical components

1.888.KEITHLEY (U.S. only)

www.keithley.com

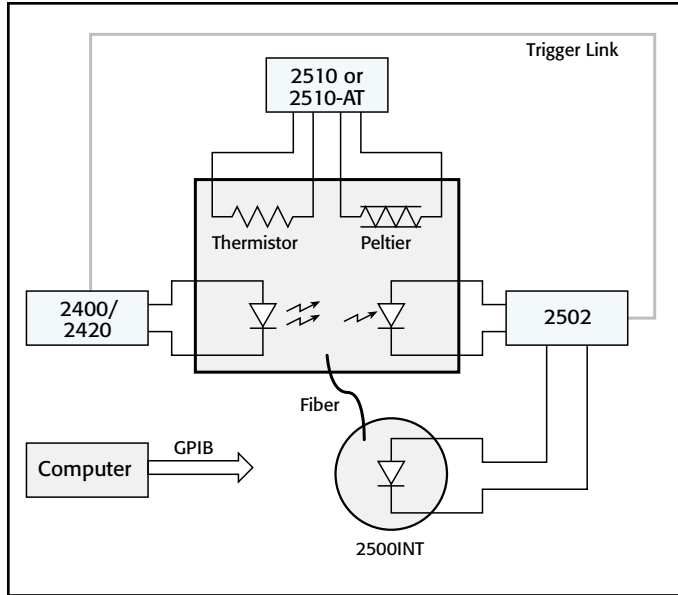

The Model 2500INT allows the LIV Test System to measure optical inputs directly and to display power measurements in watts. Other instruments in the LIV Test System include the Model 2502 Dual Photodiode Meter, the Model 2510 TEC SourceMeter[®] SMU Instrument, and either the Model 2400 or Model 2420 SourceMeter SMU Instrument. Each integrating sphere is characterized at the factory and provided with a calibration constant for every 25 nanometers in the detector's range. Prior to testing, the user simply enters the constant in the Model 2502 Dual Photodiode Meter to ensure accurate measurements of optical power for that wavelength.

is insensitive to input beam alignment up to 40° off normal or divergences up to 40° half-angle.

Minimizes Polarization Concerns

The randomizing effects of multiple reflections within Keithley's integrating sphere minimize beam polarization problems that can affect optical measurement accuracy when measuring polarized sources. Beam polarization is of particular concern for manufacturers of distributed feedback lasers (DFBs) and Vertical Cavity Surface Emitting Lasers (VCSELs).

Eliminates Back Reflection

The stability of a laser diode is significantly affected by back reflections from objects in the optical path. The geometric nature of the integrating sphere and the diffusing properties of the sphere's reflective material help prevent back reflection and ensure greater device stability during testing.

Attenuates High Power Laser Diode Outputs

Detectors have specified maximum power capability, which is typically just a few milliwatts. By spreading the output power evenly over its interior surface, an integrating sphere automatically attenuates the power from the source; therefore, the power level at any point on the sphere surface is far less than that of a beam that falls directly on the detector. The Model 2500INT sphere is particularly useful for testing high-power laser diodes because it provides calibrated attenuation of the laser diode output, which prevents damage to the detector due to the high density of the output or other problems associated with saturation of the detector.

Designed Specifically for Laser Diode Testing

The design of the Model 2500INT Integrating Sphere is optimized for measuring the optical power of laser diodes. Each sphere is two inches in diameter with a 1/2-inch input port suitable for fiber or direct light (as in chip on submount applications). The port and detector are positioned so there is no need to use a baffle to prevent the input from shining directly onto the detector.

	Silicon Detector	Germanium Detector	Cooled InGaAs Detector
Wavelength Range	190–1100 nm	800–1800 nm	900–1670 nm
Peak Wavelength (λ_p)	960 nm	1550 nm	1550 nm
Sensitivity at Peak Wavelength	Excellent at 960 nm	Good at 1550 nm	Excellent at 1550 nm
Sensitivity at Certain Wavelengths			
Visible	***	N/A	N/A
980 nm	***	**	**
1310 nm	N/A	**	***
1550 nm	N/A	**	***
>1550 nm	N/A	**	***
Speed	***	*	**
Calibration Accuracy/Stability	Spectral response changes rapidly with temperature at wavelengths >1000nm.	Spectral response changes rapidly with temperature and λ above λ_p .	Extremely stable (Spectral response is stable because λ calibration is fixed at constant operating temperatures, i.e., -10°C.)
Cost	\$	\$\$	\$\$\$

* = Good ** = Better *** = Best N/A = not applicable

Detector Selection Criteria

When choosing the most appropriate detector for a specific application, consider the following selection criteria:

- Wavelengths of maximum interest
- Sensitivity at wavelength of interest
- Speed
- Cost
- Calibration accuracy/stability

SPECIFICATIONS

TYPICAL REFLECTANCE DATA FOR SPECTRALON MATERIAL

Wavelength (nm)	Spectralon
500	0.991
600	0.992
700	0.992
800	0.991
900	0.992
1000	0.993
1100	0.992
1200	0.992
1300	0.992
1400	0.991
1500	0.990
1600	0.989
1700	0.986
1800	0.987

PHYSICAL, THERMO-OPTICAL, AND ELECTRONIC PROPERTIES OF SPECTRALON MATERIAL

Property	ASTM Test	Value
Density	N/A	1.25–1.5g/cm ³
Water Permeability	D-570	<0.001% (hydrophobic)
Hardness	D-785	20–30 Shore D
Thermal Stability	N/A	Decomposes at >400°C
Coefficient of Linear Expansion	D-696	5.5–6.5 × 10 ⁻⁵ in/in -°F; 10 ⁻⁴ °C ⁻¹
Vacuum Stability	N/A	No outgassing except for entrained air
Flammability	N/A	Non-flammable (UL rating V-O) Incompatible with non-polar solvents and greases
Yield Stress	D-638	208psi
Ultimate Stress	D-638	891psi
Young's Modulus	N/A	35774psi
Elongation in 2 in.	D-638	42.8%
Elongation at Failure	E-132	91.3%
Poisson's Ratio	D-621	0.296
Deformation under Load	D-621	13.3% @ 250 lbs. 22.6% @ 500 lbs.
Absorbance (ax)	N/A	0.07
Emittance (e)	N/A	0.88
Volume Resistivity	N/A	>10 ¹⁸ Ω/cm
Dielectric Strength	D-149	18V/μm
Refractive Index	D-542	1.35
Flammability Rating	UL-94	V-O

PHOTODIODE SPECIFICATIONS

	Silicon	Germanium	Cooled Indium Gallium Arsenide
Wavelength Range	190–1100nm	800–1800nm	900–1670nm
Peak Sensitivity Wavelength	960nm	1550nm	1550nm
Operating Temperature	-20° to +60°C	-55° to +60°C	-40° to +70°C
Storage Temperature	-55° to +80°C	-55° to +80°C	-55° to +85°C
Active Area	2.4mm × 2.4mm	5.0mm (diameter)	3.0mm (diameter)
Measurement Temperature	—	—	-10°C
Thermistor Allowable Dissipation	—	—	0.2mW
Peltier Element	—	—	1.5A
Allowable Current	—	—	1.0A

ACCESSORIES AVAILABLE

(Appropriate cables and connectors are required to operate the Model 2500INT Integrating Sphere and must be ordered separately. They are not included with the instrument.)

7078-TRX-1	Low-Noise Triax Cable, 0.3m (1 ft)
7078-TRX-3	Low-Noise Triax Cable, 0.9m (3 ft)
7078-TRX-5	Low-Noise Triax Cable, 1.5m (5 ft)
7078-TRX-10	Low-Noise Triax Cable, 3.0m (10 ft)
7078-TRX-12	Low-Noise Triax Cable, 3.5m (12 ft)
7078-TRX-20	Low-Noise Triax Cable, 6.0m (20 ft)
2500INT-FC/APC	FC/APC Connector for 2500INT
2500INT-FC/PC	FC/PC Connector for 2500INT
2500INT-SMA	SMA Connector for 2500INT
6172	2-Slot Male to 3-Lug Female Triax Adapter

1.888.KEITHLEY (U.S. only)

www.keithley.com

2510 2510-AT

TEC SourceMeter® SMU Instrument Autotuning TEC SourceMeter SMU Instrument



The Models 2510 and 2510-AT TEC SourceMeter SMU instruments enhance Keithley's CW (Continuous Wave) test solution for high speed LIV (light-current-voltage) testing of laser diode modules. These 50W bipolar instruments were developed in close cooperation with leading manufacturers of laser diode modules for fiber-optic telecommunications networks. Designed to ensure tight temperature control for the device under test, the Model 2510 was the first in a line of highly specialized instruments created for telecommunications laser diode testing. It brings together Keithley's expertise in high speed DC sourcing and measurement with the ability to control the operation of a laser diode module's Thermo-Electric Cooler or TEC (sometimes called a Peltier device) accurately.

The Model 2510-AT expands the capability of the Model 2510 by offering autotuning capability. P,

I, and D (proportional, integral, and derivative) values for closed loop temperature control are determined by the instrument using a modified Zeigler-Nichols algorithm. This eliminates the need for users to determine the optimal values for these coefficients experimentally. In all other respects, the Model 2510 and Model 2510-AT provide exactly the same set of features and capabilities.

The SourceMeter Concept

The Model 2510 and Model 2510-AT draw upon Keithley's unique SourceMeter concept, which combines precision voltage/current sourcing and measurement functions into a single instrument. SourceMeter SMU instruments provide numerous advantages over the use of separate instruments, including lower acquisition and maintenance costs, the need for less rack space, easier system integration and programming, and a broad dynamic range.

Part of a Comprehensive LIV Test System

In a laser diode CW test stand, the Model 2510 or Model 2510-AT can control the temperature of actively cooled optical components and assemblies (such as laser diode modules) to within $\pm 0.005^\circ\text{C}$ of the user-defined setpoint. During testing, the instrument measures the internal temperature of the laser diode module from any of a variety of temperature sensors, then drives power through the TEC within the laser diode module in order to maintain its temperature at the desired setpoint.

Figure 1. The capabilities of the Models 2510 and 2510-AT are intended to complement those of other Keithley instruments often used in laser diode module LIV testing, including the Model 2400 and 2420 SourceMeter SMU instruments, the Model 2502 Dual Photodiode Meter, and the Model 2500INT Integrating Sphere.

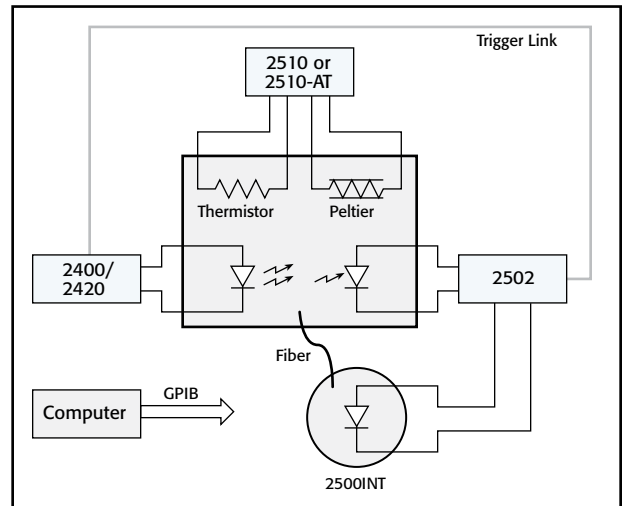

Ordering Information

2510	TEC SourceMeter
2510-AT	Autotuning TEC SourceMeter SMU Instrument

Accessories Supplied

User's Manual, Input/Output Connector

ACCESSORIES AVAILABLE

2510-RH	Resistive Heater Adapter for Model 2510
2510-CAB	4-Wire Unshielded Cable, Phoenix Connector to Unterminated End
7007-1	Shielded IEEE-488 Cable, 1m (3.3 ft)
7007-2	Shielded IEEE-488 Cable, 2m (6.6 ft)
KPCI-488LPA	IEEE-488 Interface/Controller for the PCI Bus
KUSB-488B	IEEE-488 USB-to-GPIB Adapter for USB Port

SERVICES AVAILABLE

2510-3Y-EW	1-year factory warranty extended to 3 years from date of shipment
2510-AT-3Y-EW	1-year factory warranty extended to 3 years from date of shipment
C/2510-3Y-DATA	3 (Z540-1 compliant) calibrations within 3 years of purchase for Models 2510, 2510-AT*

*Not available in all countries

1.888.KEITHLEY (U.S. only)

www.keithley.com

A Greater Measure of Confidence

KEITHLEY
A Tektronix Company

Precision temperature control for TECs with autotuning PID for optimal performance

SEMICONDUCTOR

2510 2510-AT

- 50W TEC Controller combined with DC measurement functions
- Fully digital P-I-D control
- Autotuning capability for the thermal control loop (2510-AT)
- Designed to control temperature during laser diode module testing
- Wide temperature setpoint range (-50°C to $+225^{\circ}\text{C}$) and high setpoint resolution ($\pm 0.001^{\circ}\text{C}$) and stability ($\pm 0.005^{\circ}\text{C}$)
- Compatible with a variety of temperature sensor inputs—thermistors, RTDs, and IC sensors
- Maintains constant temperature, current, voltage, and sensor resistance
- AC Ohms measurement function verifies integrity of TEC
- Measures and displays TEC parameters during the control cycle
- 4-wire open/short lead detection for thermal feedback element
- IEEE-488 and RS-232 interfaces
- Compact, half-rack design

APPLICATIONS

Control and production testing of thermoelectric coolers (Peltier devices) in:

- Laser diode modules
- IR charge-coupled device (CCD) arrays and charge-injection devices (CID)
- Cooled photodetectors
- Thermal-optic switches
- Temperature controlled fixtures

1.888.KEITHLEY (U.S. only)

www.keithley.com

TEC SourceMeter[®] SMU Instrument Autotuning TEC SourceMeter SMU Instrument

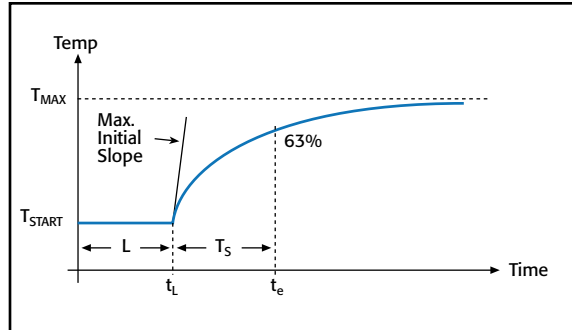

Figure 2.

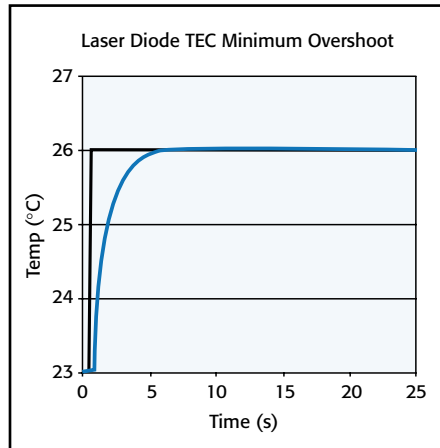

Figure 3.

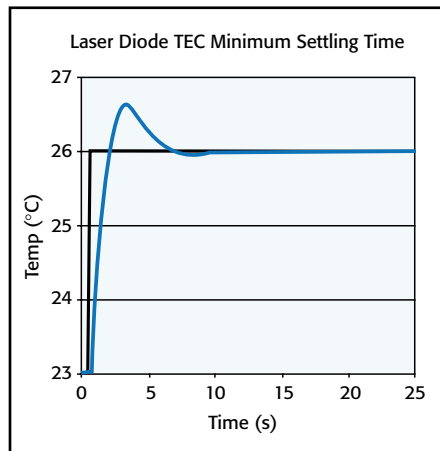

Figure 4.

Active temperature control is very important due to the sensitivity of laser diodes to temperature changes. If the temperature varies, the laser diode's dominant output wavelength may change, leading to signal overlap and crosstalk problems.

Autotuning Function

The Model 2510-AT Autotuning TEC SourceMeter SMU instrument offers manufacturers the ability to automatically tune the

temperature control loop required for CW testing of optoelectronic components such as laser diode modules and thermo-optic switches. This capability eliminates the need for time-consuming experimentation to determine the optimal P-I-D coefficient values.

The Model 2510-AT's P-I-D Auto-Tune software employs a modified Ziegler-Nichols algorithm to determine the coefficients used to control the P-I-D loop. This algorithm ensures that the final settling perturbations are damped by 25% each cycle of the oscillation. The autotuning process begins with applying a voltage step input to the system being tuned (in open loop mode) and measuring several parameters of the system's response to this voltage step function. The system's response to the step function is illustrated in Figure 2. The lag time of the system response, the maximum initial slope, and the TAU [63% (1/e)] response time are measured, then used to generate the Kp (proportional gain constant), Ki (integral gain constant), and Kd (derivative gain constant) coefficients.

The autotuning function offers users a choice of a minimum settling time mode or a minimum overshoot mode, which provides the Model 2510-AT with the flexibility to be used with a variety of load types and devices. For example, when controlling a large area TEC in a test fixture optimized for P, I, and D values, minimum overshoot protects the devices in the fixture from damage (Figure 3). For temperature setpoints that do not approach the maximum specified temperature for the device under test, the minimum settling time mode can be used to speed up the autotuning function (Figure 4).

50W Output

As the complexity of today's laser diode modules increases, higher power levels are needed in temperature controllers to address the module's cooling needs during production test. The 50W

2510 2510-AT

TEC SourceMeter® SMU Instrument Autotuning TEC SourceMeter SMU Instrument

(5A @ 10V) output allows for higher testing speeds and a wider temperature setpoint range than other, lower-power solutions.

High Stability P-I-D Control

When compared with other TEC controllers, which use less sophisticated P-I (proportional-integral) loops and hardware control mechanisms, this instrument's software-based, fully digital P-I-D control provides greater temperature stability and can be easily upgraded with a simple firmware change. The resulting temperature stability ($\pm 0.005^\circ\text{C}$ short term, $\pm 0.01^\circ\text{C}$ long term) allows for very fine control over the output wavelength and optical power of the laser diode module during production testing of DC characteristics. This improved stability gives users higher confidence in measured values, especially for components or sub-assemblies in wavelength multiplexed networks. The derivative component of the instrument's P-I-D control also reduces the required waiting time between making measurements at various temperature setpoints. The temperature setpoint range of -50°C to $+225^\circ\text{C}$ covers most of the test requirements for production testing of cooled optical components and sub-assemblies, with a resolution of $\pm 0.001^\circ\text{C}$.

Before the introduction of the Model 2510-AT, configuring test systems for new module designs and fixtures required the user to determine the best combination of P, I, and D coefficients through trial-and-error experimentation. The Model 2510-AT's autotuning function uses the modified Zeigler-Nichols algorithm to determine the optimal P, I, and D values automatically.

Adaptable to Evolving DUT Requirements

The Model 2510 and Model 2510-AT are well suited for testing a wide range of laser diode modules because they are compatible with the types of temperature sensors most commonly used in these modules. In addition to 100Ω , $1\text{k}\Omega$, $10\text{k}\Omega$, and $100\text{k}\Omega$ thermistors, they can handle inputs from 100Ω or $1\text{k}\Omega$ RTDs, and a variety of solid-state temperature sensors. This input flexibility ensures their adaptability as the modules being tested evolve over time.

Programmable Setpoints and Limits

Users can assign temperature, current, voltage, and thermistor resistance setpoints. The thermistor resistance setpoint feature allows higher correlation of test results with actual performance in the field for laser diode modules because reference resistors are used to control the temperature of the module. Programmable power, current, and temperature limits offer maximum protection against damage to the device under test.

Accurate Real-Time Measurements

Both models can perform real-time measurements on the TEC, including TEC current, voltage drop, power dissipation, and resistance, providing valuable information on the operation of the thermal control system.

Peltier (TEC) Ohms Measurement

TEC devices are easily affected by mechanical damage, such as sheer stress during assembly. The most effective method to test a device for damage after it has been incorporated into a laser diode module is to perform a low-level AC (or reversing DC) ohms measurement. If there is a change in the TEC's resistance value when compared with the manufacturer's specification, mechanical damage is indicated. Unlike a standard DC resistance measurement, where the current passing through the device can produce device heating and affect the measured resistance, the reversing DC ohms method does not and allows more accurate measurements.

Open/Short Lead Detection

Both models of the instrument use a four-wire measurement method to detect open/short leads on the temperature sensor before testing. Four-wire measurements eliminate lead resistance errors on the measured value, reducing the possibility of false failures or device damage.

Interface Options

Like all newer Keithley instruments, both models of the instrument include standard IEEE-488 and RS-232 interfaces to speed and simplify system integration and control.

Optional Resistive Heater Adapter

The Model 2510-RH Resistive Heater Adapter enables either model of the instrument to provide closed loop temperature control for resistive heater elements, rather than for TECs. When the adapter is installed at the instrument's output terminal, current flows through the resistive heater when the P-I-D loop indicates heating. However, no current will flow to the resistive heater when the temperature loop calls for cooling. The resistive element is cooled through radiation, conduction, or convection.

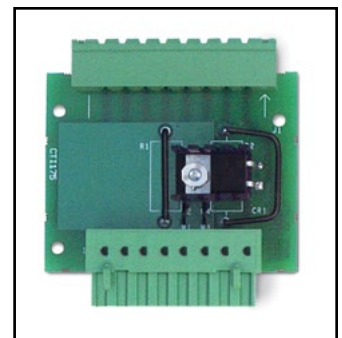

Figure 6. Optional heater adapter

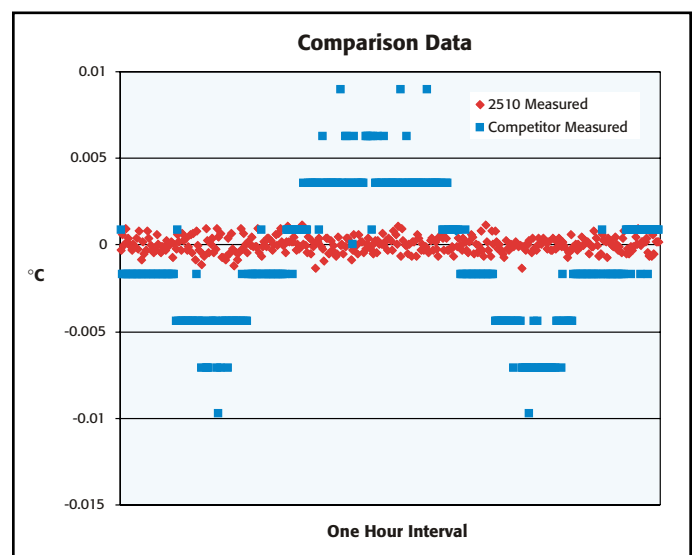

Figure 5. This graph compares the Model 2510/2510-AT's A/D converter resolution and temperature stability with that of a leading competitive instrument. While the competitive instrument uses an analog proportional-integral (P-I) control loop, it displays information in digital format through a low-resolution analog-to-digital converter. In contrast, the Model 2510/2510-AT uses a high-precision digital P-I-D control loop, which provides greater temperature stability, both over the short term ($\pm 0.005^\circ\text{C}$) and the long term ($\pm 0.01^\circ\text{C}$).

1.888.KEITHLEY (U.S. only)

www.keithley.com

KEITHLEY

A Tektronix Company

A Greater Measure of Confidence

Precision temperature control for TECs with autotuning PID for optimal performance

SEMICONDUCTOR

2510 2510-AT

TEC SourceMeter® SMU Instrument Autotuning TEC SourceMeter SMU Instrument

SPECIFICATIONS

The Models 2510 and 2510-AT TEC SourceMeter SMU instruments are designed to:
Control the power to the TEC to maintain a constant temperature, current, voltage, or thermistor resistance.
Measure the resistance of the TEC.
Provide greater control and flexibility through a software P-I-D loop.

CONTROL SYSTEM SPECIFICATIONS

SET: Constant Peltier Temperature, Constant Peltier Voltage, Constant Peltier Current. Constant Thermistor Resistance.
CONTROL METHOD: Programmable software PID loop. Proportional, Integral, and Derivative gains independently programmable.
SETPOINT SHORT TERM STABILITY: $\pm 0.005^\circ\text{C rms}^{1,6,7}$.
SETPOINT LONG TERM STABILITY: $\pm 0.01^\circ\text{C}^{1,6,8}$.
SETPOINT RANGE: -50°C to 225°C .
UPPER TEMPERATURE LIMIT: 250°C max .
LOWER TEMPERATURE LIMIT: -50°C max .
SETPOINT RESOLUTION: $\pm 0.001^\circ\text{C}$, $< \pm 400\mu\text{V}$, $< \pm 200\mu\text{A}$ 0.01% of nominal (25°C) thermistor resistance.
HARDWARE CURRENT LIMIT: 1.0A to 5.25A $\pm 5\%$.
SOFTWARE VOLTAGE LIMIT: ± 0.5 to 10.5V $\pm 5\%$.

THERMAL FEEDBACK ELEMENT SPECIFICATIONS³

Sensor Type	RTD		Thermistor				Solid State	
	100 Ω	1 k Ω	100 Ω	1 k Ω	10 k Ω	100 k Ω	Current Output (I_{ss})	Voltage Output (V_{ss})
Excitation ¹³	2.5 mA 4 V max	833 μA	2.5 mA 8 V max	833 μA 8 V max	100 μA 8 V max	33 μA 6.6 V max	+13.5 V 833 μA	2.5 mA 15.75V max
Nominal Resistance Range	0–250 Ω	0–2.50 k Ω	0–1 k Ω	0–10 k Ω	0–80 k Ω	0–200 k Ω		
Excitation Accuracy ^{1,3}	$\pm 1.5\%$	$\pm 2.9\%$	$\pm 2.9\%$	$\pm 2.9\%$	$\pm 2.9\%$	$\pm 2.9\%$	$\pm 12\%$	$\pm 2.9\%$
Nominal Sensor Temperature Range	-50° to $+250^\circ\text{C}$	-50° to $+250^\circ\text{C}$	-50° to $+250^\circ\text{C}$	-50° to $+250^\circ\text{C}$	-50° to $+250^\circ\text{C}$	-50° to $+250^\circ\text{C}$	-40° to $+100^\circ\text{C}$	-40° to $+100^\circ\text{C}$
Calibration	α , β , δ settable	α , β , δ settable	A, B, C settable	A, B, C settable	A, B, C settable	A, B, C settable	Slope & offset	Slope & offset
Measurement Accuracy ^{1,3} \pm (% rdg + offset)	$0.04 + 0.07 \Omega^2$	$0.04 + 0.04 \Omega^2$	$0.04 + 0.07 \Omega^2$	$0.04 + 0.4 \Omega^2$	$0.02 + 3 \Omega$	$0.04 + 21 \Omega$	$0.03 + 100 \text{ nA}$	$0.03 + 500 \mu\text{V}$

THERMISTOR MEASUREMENT ACCURACY¹⁹

Nominal Thermistor Resistance	Accuracy vs. Temperature			
	0 $^\circ\text{C}$	25 $^\circ\text{C}$	50 $^\circ\text{C}$	100 $^\circ\text{C}$
100 Ω	0.021 $^\circ\text{C}$	0.035 $^\circ\text{C}$	0.070 $^\circ\text{C}$	0.27 $^\circ\text{C}$
1 k Ω	0.015 $^\circ\text{C}$	0.023 $^\circ\text{C}$	0.045 $^\circ\text{C}$	0.18 $^\circ\text{C}$
10 k Ω	0.006 $^\circ\text{C}$	0.012 $^\circ\text{C}$	0.026 $^\circ\text{C}$	0.15 $^\circ\text{C}$
100 k Ω	0.009 $^\circ\text{C}$	0.014 $^\circ\text{C}$	0.026 $^\circ\text{C}$	0.13 $^\circ\text{C}$

OPEN/SHORTED ELEMENT DETECTION SOFTWARE LINEARIZATION FOR THERMISTOR AND RTD

Common Mode Voltage: 30VDC.
Common Mode Isolation: $>10^9\Omega$, $<1000\text{pF}$.
Max. Voltage Drop Between Input/Output Sense Terminals: 1V.
Max. Sense Lead Resistance: 100 Ω for rated accuracy.
Sense Input Impedance: $>10^8\Omega$.

TEC OUTPUT SPECIFICATIONS

OUTPUT RANGE: $\pm 10\text{VDC}$ at up to $\pm 5\text{ADC}$.¹⁵
OUTPUT RIPPLE: $<5\text{mV rms}^9$.
AC RESISTANCE EXCITATION: $\pm(9.6\text{mA} \pm 90\mu\text{A})$.¹⁴

TEC MEASUREMENT SPECIFICATIONS³

Function	1 Year, 23 $^\circ\text{C} \pm 5^\circ\text{C}$
Operating Resistance ^{2, 10, 11, 12}	$\pm(2.0\%$ of rdg + 0.1Ω)
Operating Voltage ^{2,10}	$\pm(0.1\%$ of rdg + 4mV)
Operating Current ¹⁰	$\pm(0.4\%$ of rdg + 8mA)
AC Resistance ^{2, 18}	$\pm(0.10\%$ of rdg + 0.02Ω)

OPEN SHORTED THERMOELECTRIC DETECTION

LOAD IMPEDANCE: Stable into 1 μF typical.
COMMON MODE VOLTAGE: 30VDC maximum.
COMMON MODE ISOLATION: $>10^9\Omega$, $<1500\text{pF}$.
MAX. VOLTAGE DROP BETWEEN INPUT/OUTPUT SENSE TERMINALS: 1V.
MAX. SENSE LEAD RESISTANCE: 1 Ω for rated accuracy.
MAX. FORCE LEAD RESISTANCE: 0.1 Ω .
SENSE INPUT IMPEDANCE: $>400\text{k}\Omega$.

GENERAL

NOISE REJECTION:

SPEED	NPLC	NMRR ¹⁶	CMRR ¹⁷
Normal	1.00	60 dB	120 dB ¹

SOURCE OUTPUT MODES: Fixed DC level.
PROGRAMMABILITY: IEEE-488 (SCPI-1995.0), RS-232, 3 user-definable power-up states plus factory default and *RST.
POWER SUPPLY: 90V to 260V rms, 50–60Hz, 75W.
EMC: Complies with European Union Directive 98/336/EEC (CE marking requirements), FCC part 15 class B, CTSPR 11, IEC 801-2, IEC 801-3, IEC 801-4.
VIBRATION: MIL-PRF-28800F Class 3 Random Vibration.
WARM-UP: 1 hour to rated accuracies.
DIMENSIONS, WEIGHT: 89mm high \times 213 mm high \times 370mm deep (3½ in \times 8½ in \times 14⅞ in). Bench configuration (with handle and feet): 104mm high \times 238mm wide \times 370mm deep (4⅞ in \times 9½ in \times 14⅞ in). Net Weight: 3.21kg (7.08 lbs).
ENVIRONMENT: Operating: 0 $^\circ$ –50 $^\circ\text{C}$, 70% R.H. up to 35 $^\circ\text{C}$. Derate 3% R.H./ $^\circ\text{C}$, 35 $^\circ$ –50 $^\circ\text{C}$. **Storage:** -25° to 65 $^\circ\text{C}$.

NOTES

- Model 2510 and device under test in a regulated ambient temperature of 25 $^\circ\text{C}$.
- With remote voltage sense.
- 1 year, 23 $^\circ\text{C} \pm 5^\circ\text{C}$.
- With $I_{load} = 5\text{A}$ and $V_{load} = 0\text{V}$.
- With $I_{load} = 5\text{A}$ and $V_{load} = 10\text{V}$.
- With 10k Ω thermistor as sensor.
- Short term stability is defined as 24 hours with Peltier and Model 2510 at 25 $^\circ\text{C} \pm 0.5^\circ\text{C}$.
- Long term stability is defined as 30 days with Peltier and Model 2510 at 25 $^\circ\text{C} \pm 0.5^\circ\text{C}$.
- 10Hz to 10MHz measured at 5A output into a 2 Ω load.
- Common mode voltage = 0V (meter connect enabled, connects Peltier low output to thermistor measure circuit ground). $\pm(0.1\%$ of rdg. + 0.1 Ω) with meter connect disabled.
- Resistance range 0 Ω to 20 Ω for rated accuracy.
- Current through Peltier $> 0.2\text{A}$.
- Default values shown, selectable values of 3 μA , 10 μA , 33 μA , 100 μA , 833 μA , 2.5mA. Note that temperature control performance will degrade at lower currents.
- AC ohms is a dual pulsed measurement using current reversals available over bus only.
- Settable to $<400\mu\text{V}$ and $<200\mu\text{A}$ in constant V and constant I mode respectively.
- For line frequency $\pm 0.1\%$.
- For 1k Ω unbalance in LO lead.
- Resistance range 0 Ω to 100 Ω for rated accuracy.
- Accuracy figures represent the uncertainty that the Model 2510 may add to the temperature measurement, not including thermistor uncertainty. These accuracy figures are for thermistors with typical A,B,C constants.

1.888.KEITHLEY (U.S. only)

www.keithley.com

KEITHLEY
A Tektronix Company

A Greater Measure of Confidence

8544, 8544-TEC

- Compatible with Keithley laser diode LIV test solutions
- Simplifies configuration of LIV test systems
- Choice of three fixture designs, all with necessary cables
- Cables also available separately
- Ambient temperature control on TEC version

Ordering Information

- 8544** Butterfly Telecom Laser Diode Mount Bundle with 8542-301 and CA-321-1 cables
- 8544-TEC** Butterfly Telecom Laser Diode Mount Bundle with TEC, thermistor, and AD592CN temperature sensor, with 8542-301 and CA-322-1 cables

Accessories Supplied

- 8542-301** LIV Cable to connect Model 2500 and 24XX to the fixture, 1.8m (6 ft.) (supplied with 8544 and 8544-TEC)
- CA-321-1** Temp Control Cable to connect Model 2510 to fixture, 1.8m (6 ft.) (supplied with 8544)
- CA-322-1** Dual Temp Control Cable to connect (2) Model 2510 to fixture, 1.8m (6 ft.) (supplied with 8544-TEC)

Laser Diode Mounts for LIV Test Systems

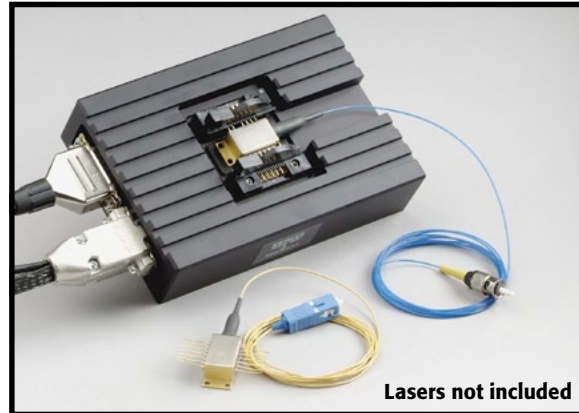

The 8544 Laser Diode Mount Series makes it easier than ever to configure a complete laser diode LIV test system for continuous wave test applications. These fixtures provide highly stable temperature control for all telecommunications laser diodes. They offer an easy-to-use platform for testing laser diodes used in telecommunications. They are designed to speed and simplify setting up test systems for all laser diode/photodiode/thermoelectric cooler/thermistor configurations.

Three different fixture bundle designs are available, all of which are compatible with Keithley's popular laser diode LIV test systems. Each bundle includes all cabling required to connect the test instrumentation to the test fixture. Cables are also available separately.

All 14 pin DIL and butterfly laser packages can be mounted on the 8544 Series. For higher power butterfly packages without integral thermoelectric coolers (TECs), the Model 8544-TEC offers a TEC and both thermistor and AD592CN sensors.

APPLICATIONS

- Continuous wave laser diode LIV characterization

SPECIFICATIONS

This series covers the offering of Laser Diode Mounts (LDM) for use with Continuous LIV Test Solutions. The following products: 2400-LV/2420/2440, 2500/2502, and 2510/2510AT are recommended for use with these products.

LASER TEMPERATURE CONTROL

TEMPERATURE RANGE: 0° to +80°C.

SENSOR TYPE 2 (Model 8544-TEC Only): 10kΩ thermistor, AD592CN.

REFERENCED MOUNT SPECIFICATIONS

LASER DIODE PACKAGE

Model	8544	8544-TEC
Socket	Butterfly 14 pin	Butterfly 14 pin
Base Plate	0.1" centers	0.1" centers

ACCESSORIES AVAILABLE

2400-LV/2420/2440	SourceMeter® SMU Instruments ¹
2502	Dual Photodiode Meter
2510/2510AT	TEC Control Meters (AT: Auto Tune feature)

GENERAL

RECOMMENDED MAXIMUM RATINGS⁵:

Drive Current (Amps): 2.

Measured Voltage (Volts): 3.

WEIGHT⁶: 1.0 lbs (0.45kg).

DIMENSIONS⁶: 32mm high × 95mm wide × 140mm deep (1.2in × 3.75 in × 5.5 in).

NOTES

1. The other SourceMeter offerings from Keithley, Models 2400, 2410, 2425, and 2430, are not recommended for use with the 8542-301 and Laser Diode Mounts unless proper interlock and safety precautions are observed (especially voltage protection).
2. The 8544-TEC unit is shipped with the 10kΩ thermistor wired. This is the more commonly requested configuration. The AD592CN sensor wires are available but not connected.
3. The triax inner shield is available on pin 2 of the 8542-301A. This will allow flexibility for the customer to exchange the wire in the LDM from pin 6 to pin 2.
4. To use the second 2510 (DB-15 pins 9–15), the customer must internally wire the 8544-TEC Mount to the DUT thermocouple. See the Quick Start Guide for wiring configuration.
5. Ratings are based on use of mount with provided cables and average majority of laser diode characteristics.
6. The weight and dimension is the mounting unit without the cables.

1.888.KEITHLEY (U.S. only)

www.keithley.com

A Greater Measure of Confidence

KEITHLEY
A Tektronix Company

1.888.KEITHLEY (U.S. only)

www.keithley.com

A Greater Measure of Confidence

KEITHLEY
A Tektronix Company

Low Level Measurements and Sourcing

	Low Voltage/Low Resistance Measurements
	Technical Information 122
	Selector Guide 126
2182A	Nanovoltmeter 127
6220	DC Current Source 133
6221	AC and DC Current Source 133
Series 3700A	System Switch/Multimeter and Plug-In Cards . . . 138
	Low Current/High Resistance Measurements
	Technical Information 139
	Selector Guide 141
6482	Dual-Channel Picoammeter/Voltage Source 143
6485	Picoammeter 146
6487	Picoammeter/Voltage Source 149
2502	Dual-Channel Picoammeter 111
6514	Programmable Electrometer 156
6517B	Electrometer/High Resistance Meter 160
6521	Low Current, 10-channel Scanner Card (for Model 6517x Electrometer) 164
6522	Low Current, High Impedance Voltage, High Resistance, 10-channel Scanner Card (for Model 6517x Electrometer) 164
6220/6514/2000/7001	High Impedance Semiconductor Resistivity and Hall Effect Test Configurations 165
	Arbitrary Waveform/Function Generator
3390	50MHz Arbitrary Waveform/Function Generator . . 166

Technical Information

How to Select a Voltmeter

Many kinds of instruments can measure voltage, including digital multimeters (DMMs), electrometers, and nanovoltmeters. Making voltage measurements successfully requires a voltmeter with significantly higher input impedance than the internal impedance (source impedance) of the device under test (DUT). Without it, the voltmeter will measure less potential difference than existed before the voltmeter was connected. Electrometers have very high input impedance (typically in the order of $100T\Omega$ [$10^{14}\Omega$]), so they're the instrument of choice for high impedance voltage measurements. DMMs and nanovoltmeters can typically be used for measuring voltages from $10M\Omega$ sources or lower. Nanovoltmeters are appropriate for measuring low voltages (microvolts or less) from low impedance sources.

Low Voltage Measurements

Significant errors may be introduced into low voltage measurements by offset voltage and noise sources that can normally be ignored when measuring higher signal levels. Steady offsets can generally be nulled out by shorting the ends of the test leads together, then enabling the instrument's zero (relative) feature. The following paragraphs discuss non-steady types of error sources that can affect low voltage measurement accuracy and how to minimize their impact on the measurements.

Thermoelectric EMFs

The most common sources of error in low voltage measurements are thermoelectric voltages (thermoelectric EMFs) generated by temperature differences between junctions of conductors (Figure 1).

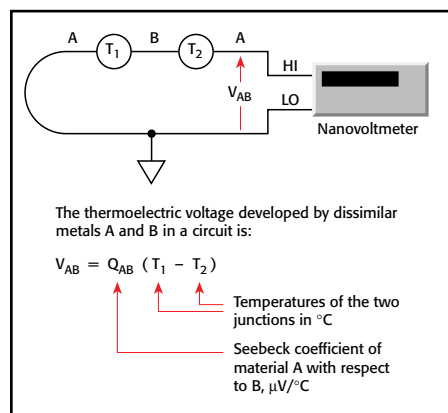

Figure 1. Thermoelectric EMFs

Constructing circuits using the same material for all conductors minimizes thermoelectric EMF generation. For example, connections made by crimping copper sleeves or lugs on copper wires results in cold-welded copper-to-copper junctions,

Low Voltage/Low Resistance Measurements

which generate minimal thermoelectric EMFs. Also, connections must be kept clean and free of oxides.

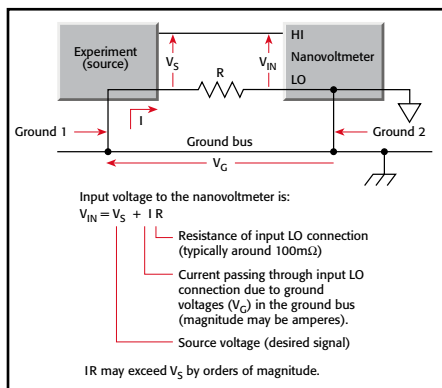

Figure 2a. Multiple grounds (ground loops)

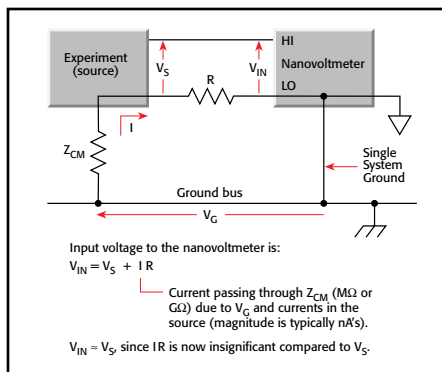

Figure 2b. Single system ground

Minimizing temperature gradients within the circuit also reduces thermoelectric EMFs. A way to minimize such gradients is to place all junctions in close proximity and provide good thermal coupling to a common, massive heat sink. If this is impractical, thermally couple each pair of corresponding junctions of dissimilar materials to minimize their temperature differentials which will also help minimize the thermoelectric EMFs.

Johnson Noise

The ultimate limit to how well the voltmeter can resolve a voltage is defined by Johnson (thermal) noise. This noise is the voltage associated with the motion of electrons due to their thermal energy. All sources of voltage will have internal resistance and thus produce Johnson noise. The noise voltage developed by any resistance can be calculated from the following equation:

$$V = \sqrt{4kTBR}$$

k = Boltzmann's constant (1.38×10^{-23} J/K)

T = absolute temperature of the source in Kelvin

B = noise bandwidth in Hz

R = resistance of the source in ohms

From this equation, it can be observed that Johnson noise may be reduced by lowering the temperature and by decreasing the bandwidth of the measurement. Decreasing the bandwidth of the measurement is equivalent to increasing the response time of the instrument; thus, in addition to increasing filtering, the bandwidth can be reduced by increasing instrument integration (typically in multiples of power line cycles).

Ground Loops

When both the signal source and the measurement instrument are connected to a common ground bus, a ground loop is created (Figure 2a). This is the case when, for instance, a number of instruments are plugged into power strips on different instrument racks. Frequently, there is a difference in potential between the ground points. This potential difference—even though it may be small—can cause large currents to circulate and create unexpected voltage drops. The cure for ground loops is to ground the entire measurement circuit at only one point. The easiest way to accomplish this is to isolate the DUT (source) and find a single, good earth-ground point for the measuring system, as shown in Figure 2b. Avoid grounding sensitive measurement circuits to the same ground system used by other instruments, machinery, or other high power equipment.

Magnetic Fields

Magnetic fields generate spurious voltages in two circumstances: 1) if the field is changing with time, and 2) if there is relative motion between the circuit and the field (Figure 3a). Changing magnetic fields can be generated from the motion of a conductor in a magnetic field, from local AC currents caused by components in the test system, or from the deliberate ramping of the magnetic field, such as for magnetoresistance measurements.

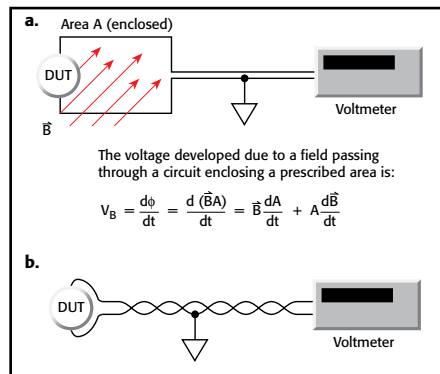

Figure 3. Minimizing interference from magnetic fields with twisted leads

To minimize induced magnetic voltages, leads must be run close together and should be tied down to

1.888.KEITHLEY (U.S. only)

www.keithley.com

KEITHLEY

A Tektronix Company

Technical Information

minimize movement. Twisted pair cabling reduces the effects of magnetic fields in two ways: first, it reduces the loop area through which the magnetic field is interfering; second, a magnetic field will create voltages of opposite polarities for neighboring loops of the twisted pair that will cancel each other. (Figure 3b)

Low Resistance Measurements

Low resistances ($<10\Omega$) are typically best measured by sourcing current and measuring voltage. For very low resistances (micro-ohms or less) or where there are power limitations involved, this method will require measuring very low voltages, often using a nanovoltmeter. Therefore, all the low voltage techniques and error sources described previously also apply here. Low resistance measurements are subject to additional error sources. The next sections describe methods to minimize some of these.

Lead Resistance and Four-Wire Method

Resistance measurements in the normal range ($>10\Omega$) are generally made using the two-wire method shown in Figure 4a. The main problem with the two-wire method for low resistance measurements ($<10\Omega$) is the error caused by lead resistance. The voltage measured by the meter will be the sum of the voltage directly across the test resistance

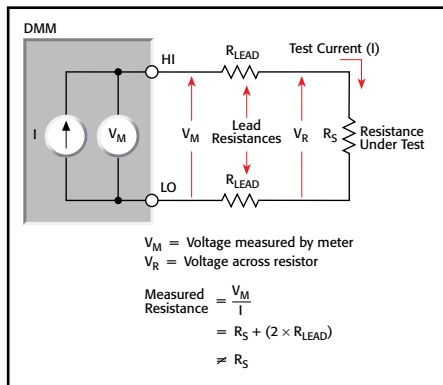

Figure 4a. Two-wire resistance measurement: Lead resistance error

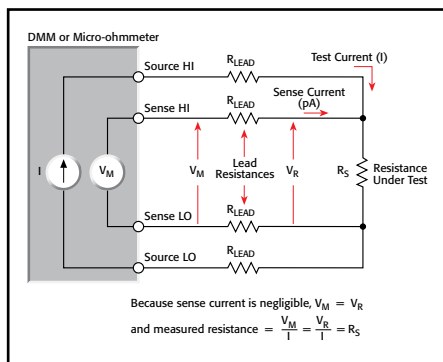

Figure 4b. Four-wire resistance measurement

Low Voltage/Low Resistance Measurements

and the voltage drop across the leads. Typical lead resistances lie in the range of $1\text{m}\Omega$ to $100\text{m}\Omega$. Therefore, the four-wire (Kelvin) connection method shown in Figure 4b is preferred for low resistance measurements. In this configuration, the test current is forced through the DUT through one set of test leads while the voltage is measured using a second set of leads called the sense leads. There is very little current running through the sense leads, so the sense lead resistance has effectively been eliminated.

Thermoelectric EMFs

Thermoelectric voltages can seriously affect low resistance measurement accuracy. Given that resistance measurements involve controlling the current through the DUT, there are ways to overcome these unwanted offsets in addition to those mentioned in the low voltage measurement section, namely, the offset-compensated ohms method and the current-reversal method.

- Offset Compensation Technique (Figure 5a)** applies a source current to the resistance being measured only for part of the measurement cycle. When the source current is on, the total voltage measured by the instrument is the sum of the voltage due to the test current and any thermoelectric EMFs present in the circuit. During the second half of the measurement cycle, the source current is turned off and the only voltage measured is that due to the thermoelectric EMF. This unwanted offset voltage can now be subtracted from the voltage measurement made during the first half of the delta mode cycle.
- With the Offset Compensation technique, the source current is decided by the instrument. To characterize at a specific current or a variety of currents, the Current Reversal technique/Two-step Delta technique (described below) will provide more flexibility.
- Current Reversal Technique/Two-Step Delta Technique (Figure 5b)**
- Thermoelectric EMFs can also be cancelled by taking two voltages with test currents of opposite polarity. The voltage due to the test current can now be calculated using the formula shown in Figure 5b. This method provides 2x better signal-to-noise ratio and, therefore, better accuracy than the offset compensation technique. (This is the method employed by the Model 2182A Nanovoltmeter/Model 622x Current Source combination.)

For these methods to be effective, the consecutive measurements need to be made rapidly when compared with the thermal time constant of the circuit under test. If the instruments' response speed is too low, changes in the circuit temperature during the measurement cycle will cause changes in the thermoelectric EMFs, with the result that the thermoelectric EMFs are no longer fully cancelled.

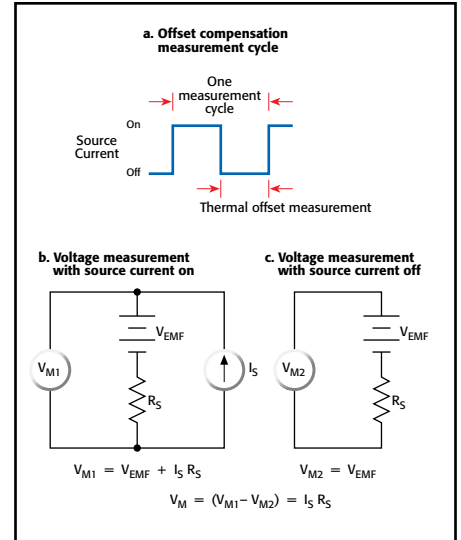

Figure 5a. Subtracting thermoelectric EMFs with Offset Compensation

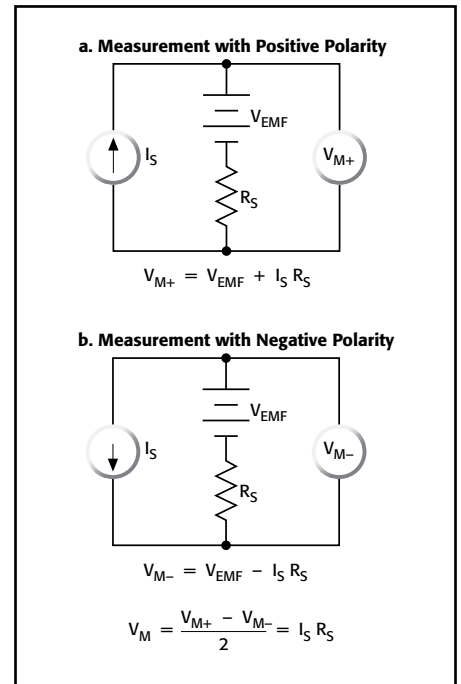

Figure 5b. Canceling thermoelectric EMFs with Current Reversal

1.888.KEITHLEY (U.S. only)

www.keithley.com

A Greater Measure of Confidence

KEITHLEY
A Tektronix Company

Technical Information

Resistance Measurements on the Nanoscale

Three-Step Delta Technique

The three-step delta technique eliminates errors due to changing thermoelectric voltages (offsets and drifts) and significantly reduces white noise. This results in more accurate low resistance measurements (or more accurate resistance measurements of any type when it is necessary to apply very low power to DUTs that have limited power handling capability). This technique offers three advantages over the two-step delta technique.

A delta reading is a pair of voltage measurements made at a positive test current and a negative test current. Both the two-step and three-step delta techniques can cancel *constant* thermoelectric voltage by alternating the test current. The three-step technique can also cancel *changing* thermoelectric voltages by alternating the current source three times to make two delta measurements: one at a negative-going step and one at a positive going step. This eliminates errors caused by changing thermoelectric EMFs 10× better than the two-step technique (Figure 6).

The three-step technique provides accurate voltage readings of the intended signal unimpeded by thermoelectric offsets and drifts only if the current source alternates quickly and the voltmeter makes accurate voltage measurements within a short time interval. The Model 622x Current Source paired with the Model 2182A Nanovoltmeter is optimized for this application. These products implement the three-step tech-

nique in a way that offers better white noise immunity than the two-step technique by spending over 90% of its time performing measurements. In addition, the three-step technique is faster, providing 47 readings/second to support a wider variety of applications. Interestingly, the formula used for the three-step technique is identical to that used for differential conductance (Figure 10).

Pulsed, Low Voltage Measurements

Short test pulses are becoming increasingly important as modern electronics continue to shrink in size. Short pulses mean less power put into the DUT. In very small devices, sometimes even a small amount of power is enough to destroy them. In other devices, a small amount of power could raise the temperature significantly, causing the measurements to be invalid.

With superconducting devices, a small amount of heat introduced while making measurements can raise the device temperature and alter the results. When sourcing current and measuring voltage, the sourced current dissipates heat (I^2R) into the device and leads. With the lowest resistance devices ($<10\mu\Omega$), the power dissipated during the measurement may be primarily at contact points, etc., rather than in the device itself. It is important to complete the measurement before this heat can be conducted to the device itself, so fast pulsed measurements are critical even at these lowest resistances.

With higher resistance devices, significant power is dissipated within the device. Therefore, with these devices, it is even more important to reduce the measurement power by reducing the source current or the source pulse width. Many tests measure device properties across a range of currents, so reducing the current is not usually an option. Shorter pulses are the only solution.

The Model 6221 Current Source was designed with microsecond rise times on all ranges to enable short pulses. The Model 2182A Nanovoltmeter offers a low latency trigger, so that a measurement can begin as little as $10\mu s$ after the Model 6221 pulse has been applied. The entire pulse, including a complete nanovolt measurement, can be as short as $50\mu s$. In addition, all pulsed measurements of the 6221/2182A are line synchronized. This line synchronization, combined with the three-step delta technique, causes all 50/60Hz noise to be rejected (Figure 7).

Dry Circuit Testing

Applications that involve measuring contact resistance may require that existing oxide layers remain unbroken during the measurement. This can be done by limiting the test current to less than 100mA and the voltage drop across the sample to no more than 20mV. Most low resistance meters have this “dry circuit” measurement technique built in.

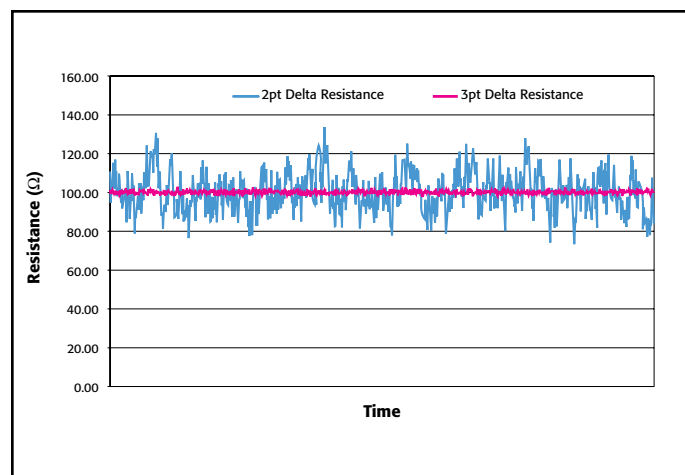

Figure 6. 1000 delta resistance readings using 100Ω resistor and 10nA source current.

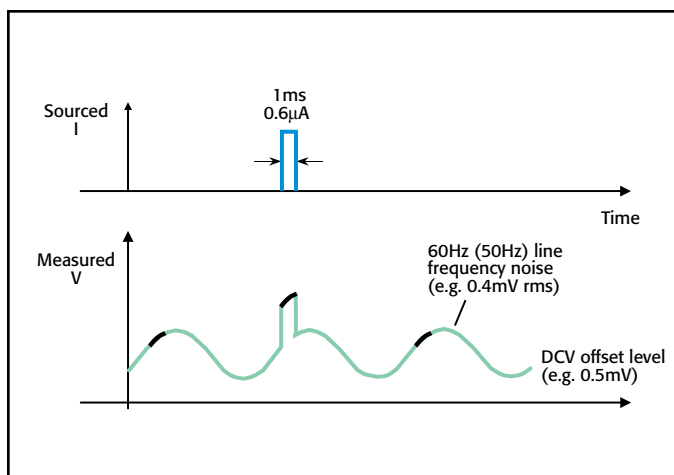

Figure 7. Operating at low voltage levels, measurements are susceptible to line frequency interference. Using line synchronization eliminates line frequency noise.

1.888.KEITHLEY (U.S. only)

www.keithley.com

KEITHLEY
A Tektronix Company

A Greater Measure of Confidence

Technical Information

Resistance Measurements on the Nanoscale

Nanovolt Level Resistance Measurements

In the macroscopic world, conductors may have obeyed Ohm's Law (Figure 8a), but in the nanoscale, Ohm's definition of resistance is no longer relevant (Figure 8b). Because the slope of the I-V curve is no longer a fundamental constant of the material, a detailed measurement of the slope of that I-V curve at every point is needed to study nanodevices. This plot of differential conductance ($dG = dI/dV$) is the most important measurement made on small scale devices, but presents a unique set of challenges.

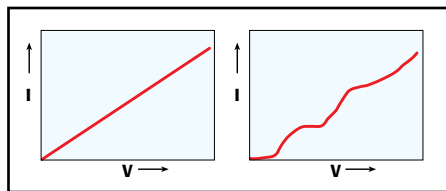

Figure 8a. Macroscopic scale (Classical)

Figure 8b. Nanoscale (Quantum)

Differential conductance measurements are performed in many areas of research, though sometimes under different names, such as: electron energy spectroscopy, tunneling spectroscopy, and density of states. The fundamental reason that differential conductance is interesting is that the conductance reaches a maximum at voltages (or more precisely, at electron energies in eV) at which the electrons are most active. This explains why dI/dV is directly proportional to the density of states and is the most direct way to measure it.

Existing Methods of Performing Differential Conductance

The I-V Technique:

The I-V technique performs a current-voltage sweep (I-V curve) and takes the mathematical derivative. This technique is simple, but noisy. It only requires one source and one measurement instrument, which makes it relatively easy to coordinate and control. The fundamental problem is that even a small amount of noise becomes a large noise when the measurements are differentiated (Figure 9). To reduce this noise, the I-V curve and its derivative must be measured repeatedly. Noise will be reduced by \sqrt{N} , where N is the number of times the curve is measured.

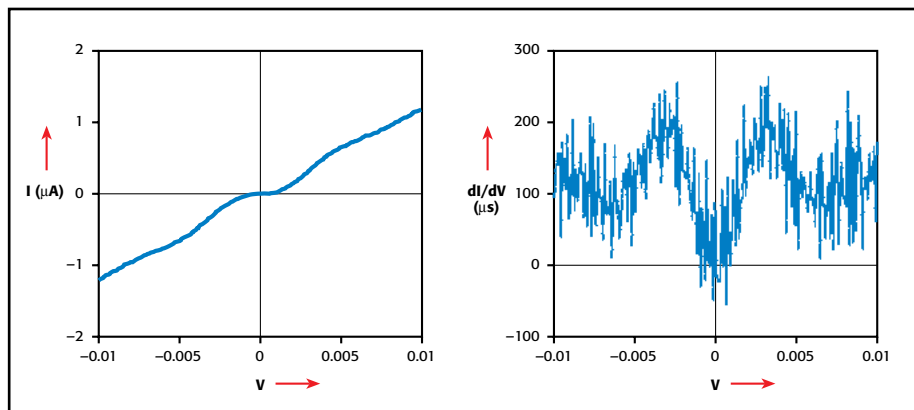

Figure 9a. I-V curve

Figure 9b. Differentiated I-V curve. True dI/dV curve obscured by noise.

The AC Technique:

The AC technique superimposes a low amplitude AC sine wave on a stepped DC bias to the sample. It then uses lock-in amplifiers to obtain the AC voltage across and AC current through the DUT. The problem with this method is that while it provides a small improvement in noise over the I-V curve technique, it imposes a large penalty in system complexity, which includes precise coordination and computer control of six to eight instruments. Other reasons for the complexity of the system include the challenges of mixing the AC signal and DC bias, of ground loops, and of common mode current noise.

Keithley has developed a new technique that is both simple and low noise: the four-wire, Source Current–Measure Voltage technique.

Four-Wire, Source Current – Measure Voltage Technique

Now there is another approach to differential conductance. This technique is performed by adding an alternating current to a linear staircase sweep. The amplitude of the alternating portion of the current is the differential current, dI (Figure 10). The differential current is constant throughout the test. After the voltage is measured at each current step, the delta voltage between consecutive steps is calculated. Each delta voltage is averaged with the previous delta voltage to calculate the differential voltage, dV . The differential conductance, dG , can now be derived using dI/dV . This technique requires only one measurement sweep when using the Model 2182A Nanovoltmeter and a Model 622x Current Source, so it is faster, quieter, and simpler than any previous method.

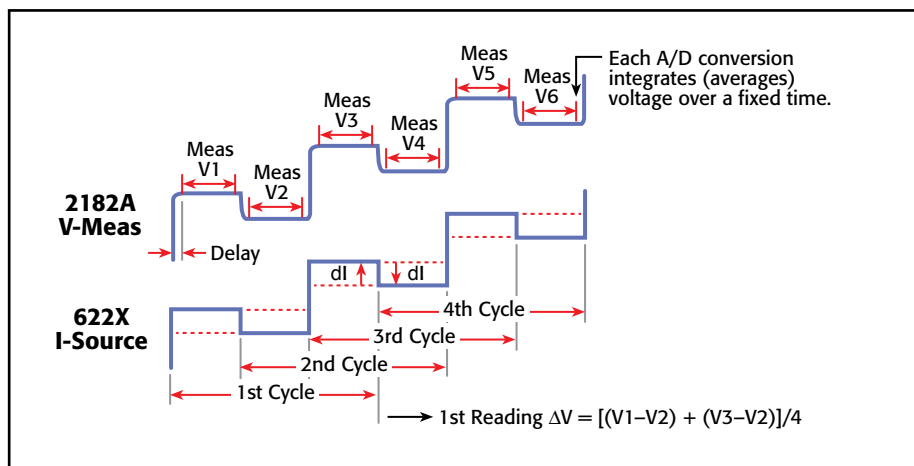

Figure 10. Detail of applied current and measured device voltage

1.888.KEITHLEY (U.S. only)

www.keithley.com

A Greater Measure of Confidence

KEITHLEY
A Tektronix Company

Technical information: Low resistance measurements on the nanoscale

LOW LEVEL MEASURE & SOURCE

Selector Guide

Low Voltage/Low Resistance Meters

Model	2182A	6220/6221	3706A	2750	2010	2002
Page	127	133	138	276	265	259
VOLTAGE RANGE (Full Scale)						
From	10 mV	N/A	100 mV	100 mV	100 mV	200 mV
To	100 V	N/A	300 V	1000 V	1000 V	1000 V
Input Voltage Noise	1.2 nV rms	N/A	100 nV rms	<1.5 μ V rms	100 nV rms	150 nV rms
CURRENT RANGE						
From	N/A	100 fA DC (also 2 pA peak AC, 6221 only)	N/A	N/A	N/A	N/A
To	N/A	\pm 105 mA DC (also 100 mA peak AC, 6221 only)	N/A	N/A	N/A	N/A
RESISTANCE RANGE						
From ¹	10 n Ω ³	10 n Ω (when used with 2182A)	0.9 m Ω	0.4 m Ω	0.9 m Ω	1.2 m Ω
To ²	100 M Ω ³	100 M Ω (when used with 2182A)	100 M Ω	100 M Ω	100 M Ω	1 G Ω
THERMOCOUPLE TEMPERATURE						
From	-200°C	N/A	-150°C	-200°C	-200°C	-200°C
To	1820°C	N/A	1820°C	1820°C	1372°C	1820°C
FEATURES						
IEEE-488	•	•	•	•	•	•
RS-232	•	•	•	•	•	•
CE	•	•	•	•	•	•
Input Connection	Special low thermoelectric w/copper pins. Optional 2187-4 Modular Probe Kit adds banana plugs, spring clips, needle probes, and alligator clips.	Trigger Link, Digital I/O, Ethernet	Rear panel 15 pin D-SUB. Optional accessories: 3706-BAN, 3706-BKPL, 3706-TLK	Banana jacks (4)	Banana jacks (4)	Banana jacks (4)
Special Features	Delta mode and differential conductance with Model 6220 or 6221. Pulsed I-V with Model 6221. Analog output. IEEE-488. RS-232.	Controls Model 2182A for low-power resistance and I-V measurements.	Dry circuit. Offset compensation. Plug-in switch/relay modules. USB. LXI Class B/Ethernet with IEEE-1588 protocol. Digital I/O.	Dry circuit. Offset compensation. DMM. IEEE-488. RS-232. Digital I/O. Plug-in modules.	Dry circuit. Offset compensation. DMM. IEEE-488. RS-232. Plug-in scanner cards.	8½ digits. DMM. Plug-in scanner cards.

NOTES

1. Lowest resistance measurable with better than 10% accuracy.
2. Highest resistance measurable with better than 1% accuracy.
3. Delta mode, offset voltage compensation with external current source. 10n Ω if used with 5A test current with Model 2440.

1.888.KEITHLEY (U.S. only)

www.keithley.com

KEITHLEY
A Tektronix Company

A Greater Measure of Confidence

2182A

Nanovoltmeter



- Make low noise measurements at high speeds, typically just 15nV p-p noise at 1s response time, 40–50nV p-p noise at 60ms
- Delta mode coordinates measurements with a reversing current source at up to 24Hz with 30nV p-p noise (typical) for one reading. Averages multiple readings for greater noise reduction
- Synchronization to line provides 110dB NMRR and minimizes the effect of AC common-mode currents
- Dual channels support measuring voltage, temperature, or the ratio of an unknown resistance to a reference resistor
- Built-in thermocouple linearization and cold junction compensation

Flexible, Effective Speed/Noise Trade-offs

The Model 2182A makes it easy to choose the best speed/filter combination for a particular application's response time and noise level requirements. The ability to select from a wide range of response times allows optimizing speed/noise trade-offs. Low noise levels are assured over a wide range of useful response times, e.g., 15nV p-p noise at 1s and 40-50nV p-p noise at 60ms are typical. **Figure 1** illustrates the Model 2182A's noise performance.

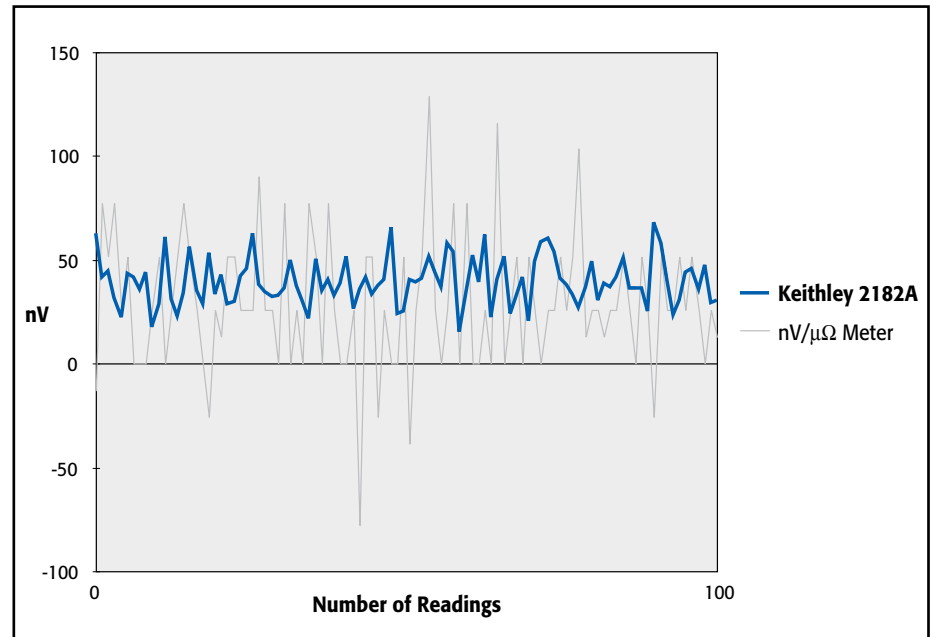

Figure 1. Compare the Model 2182A's DC noise performance with a nanovolt/micro-ohm-meter's. All the data shown was taken at 10 readings per second with a low thermal short applied to the input.

1.888.KEITHLEY (U.S. only)

www.keithley.com

A Greater Measure of Confidence

KEITHLEY
A Tektronix Company

Low noise measurements for research, metrology, and other low voltage testing applications

LOW LEVEL MEASURE & SOURCE

2182A

Ordering Information

2182A Nanovoltmeter

Accessories Supplied

2107-4 Low Thermal Input Cable with spade lugs, 1.2m (4 ft).

User manual, service manual, contact cleaner, line cord, alligator clips.

ACCESSORIES AVAILABLE

2107-30	Low Thermal Input Cable with spade lugs, 9.1m (30 ft)
2182-KIT	Low Thermal Connector with strain relief
2187-4	Low Thermal Test Lead Kit
2188	Low Thermal Calibration Shorting Plug
4288-1	Single Fixed Rack Mount Kit
4288-2	Dual Fixed Rack Mount Kit
7007-1	Shielded GPIB Cable, 1m (3.2 ft)
7007-2	Shielded GPIB Cable, 2m (6.5 ft)
7009-5	Shielded RS-232 Cable, 1.5m (5 ft)
8501-1	Trigger Link Cable, 1m (3.2 ft)
8501-2	Trigger Link Cable, 2m (6.5 ft)
8503	Trigger Link Cable to 2 male BNC connectors
KPCI-488LPA	IEEE-488 Interface/Controller for the PCI Bus
KUSB-488B	IEEE-488 USB-to-GPIB Interface Adapter

SERVICES AVAILABLE

2182A-3Y-EW	1-year factory warranty extended to 3 years from date of shipment
C/2182A-3Y-ISO	3 (ISO-17025 accredited) calibrations within 3 years of purchase*

* Not available in all countries

APPLICATIONS

Research

- Determining the transition temperature of superconductive materials
- I-V characterization of a material at a specific temperature
- Calorimetry
- Differential thermometry
- Superconductivity
- Nanomaterials

Metrology

- Intercomparisons of standard cells
- Null meter for resistance bridge measurements

Nanovoltmeter

Reliable Results

Power line noise can compromise measurement accuracy significantly at the nanovolt level. The Model 2182A reduces this interference by synchronizing its measurement cycle to line, which minimizes variations due to readings that begin at different phases of the line cycle. The result is exceptionally high immunity to line interference with little or no shielding and filtering required.

Optimized for Use with Model 6220/6221 Current Sources

Device test and characterization for today's very small and power-efficient electronics requires sourcing low current levels, which demands the use of a precision, low current source. Lower stimulus currents produce lower—and harder to measure—voltages across the devices. Linking the Model 2182A Nanovoltmeter with a Model 6220 or 6221 Current Source makes it possible to address both of these challenges in one easy-to-use configuration.

When connected, the Model 2182A and Model 6220 or 6221 can be operated like a single instrument. Their simple connections eliminate the isolation and noise current problems that plague other solutions. The Model 2182A/622X combination allows making delta mode and differential conductance measurements faster and with less noise than the original Model 2182 design allowed. The Model 2182A will also work together with the Model 6221 to make pulse-mode measurements.

The 2182A/622X combination is ideal for a variety of applications, including resistance measurements, pulsed I-V measurements, and differential conductance measurements, providing significant advantages over earlier solutions like lock-in amplifiers or AC resistance bridges. The 2182A/622X combination is also well suited for many nanotechnology applications because it can measure resistance without dissipating much power into the device under test (DUT), which would otherwise invalidate results or even destroy the DUT.

An Easy-to-Use Delta Mode

Keithley originally created the delta mode method for measuring voltage and resistance for the Model 2182 and a triggerable external current source, such as the Model 2400 SourceMeter® SMU instrument. Basically, the delta mode automatically triggers the current source to alternate the signal polarity, and then triggers a nanovoltmeter reading at each polarity. This current reversal technique

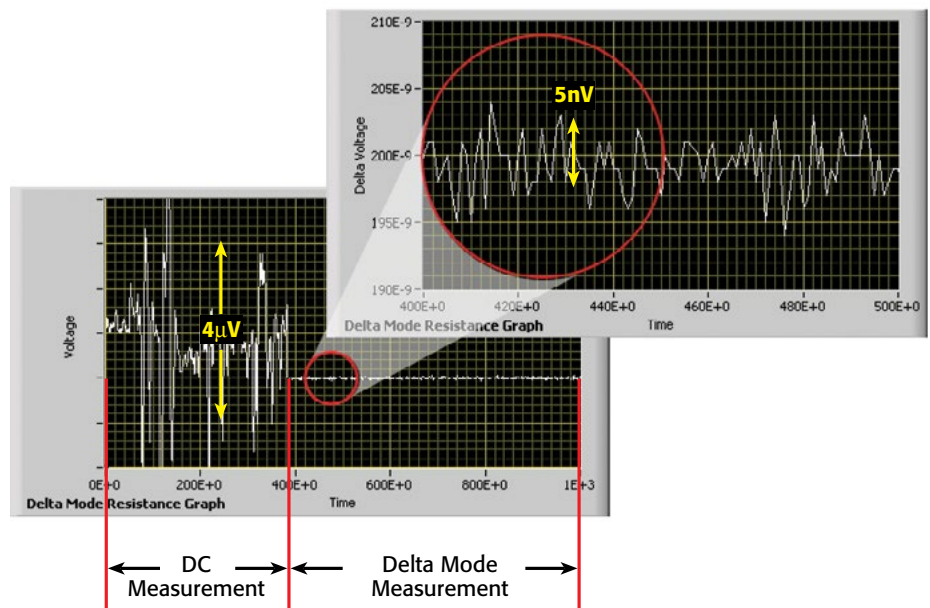

Figure 2. Results from a Model 2182A/6220 using the delta mode to measure a 10mΩ resistor with a 20µA test current. The free Model 6220/6221 instrument control example start-up software used here can be downloaded from www.keithley.com.

1.888.KEITHLEY (U.S. only)

www.keithley.com

KEITHLEY
A Tektronix Company

A Greater Measure of Confidence

2182A

Nanovoltmeter

cancels out any constant thermoelectric offsets, so the results reflect the true value of the voltage being measured. The improved delta mode for the Model 2182A and the Model 622X current sources uses the same basic technique, but the way in which it's implemented has been simplified dramatically. The new technique can cancel thermoelectric offsets that drift over time (not just static offsets), produces results in half the time of the original technique, and allows the current source to control and configure the Model 2182A. Two key presses are all that's required to set up the measurement. The improved cancellation and higher reading rates reduce measurement noise to as little as 1nV.

Differential Conductance Measurements

Characterizing non-linear tunneling devices and low temperature devices often requires measuring differential conductance (the derivative of a device's I-V curve). When used with a Model 622X current source, the Model 2182A is the industry's fastest, most complete solution for differential conductance measurements, providing 10X the speed and significantly lower noise than other instrumentation options. There's no need to average the results of multiple sweeps, because data can be obtained in a single measurement pass, reducing test time and minimizing the potential for measurement error.

Pulsed Testing with the Model 6221

When measuring small devices, introducing even tiny amounts of heat to the DUT can raise its temperature, skewing test results or even destroying the device. When used with the Model 2182A, the Model 6221's pulse capability minimizes the amount of power dissipated into a DUT. The Model 2182A/6221 combination synchronizes the pulse and measurement. A measurement can begin as soon as 16 μ s after the Model 6221 applies the pulse. The entire pulse, including a complete nanovolt measurement, can be as short as 50 μ s.

In the delta, differential conductance, and pulse modes, The Model 2182A produces virtually no transient currents, so it's ideal for characterizing devices that can be easily disrupted by current spikes (see Figure 4).

Metrology Applications

The Model 2182A combines the accuracy of a digital multimeter with low noise at high speeds for high-precision metrology applications. Its low noise, high signal observation time, fast measurement rates, and 2ppm accuracy provide the most cost-effective meter available today for applications such as intercomparison of voltage standards and direct measurements of resistance standards.

Nanotechnology Applications

The Model 2182A combined with the Model 622X current source or Series 2400 SourceMeter[®] SMU instrument is a highly accurate and repeatable solution for measuring resistances on carbon nanotube based materials and silicon nanowires.

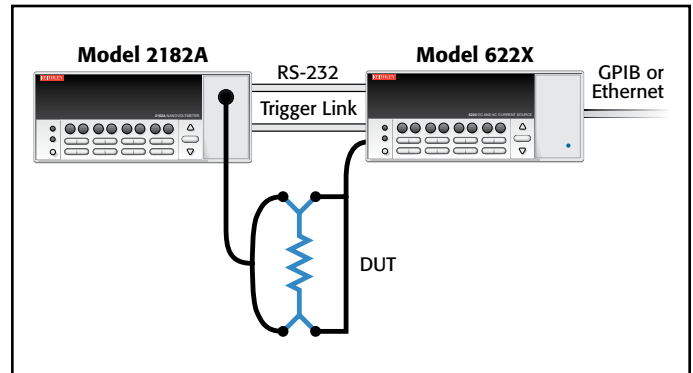

Figure 3. It's simple to connect the Model 2182A to the Model 6220 or 6221 to make a variety of measurements. The instrument control example start-up software available for the Model 622X current sources includes a step-by-step guide to setting up the instrumentation and making proper connections.

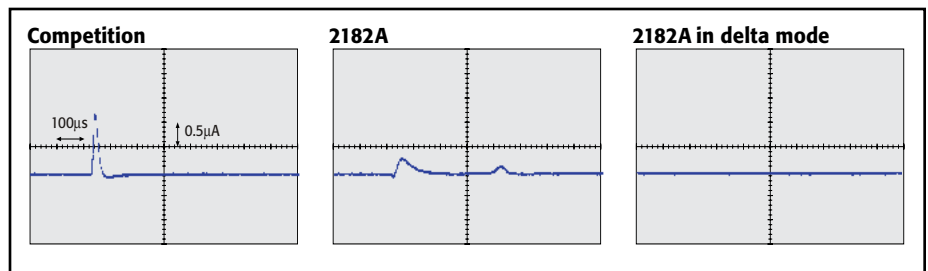

Figure 4. The Model 2182A produces the lowest transient currents of any nanovoltmeter available.

Research Applications

The Model 2182A's 1nV sensitivity, thermoelectric EMF cancellation, direct display of "true" voltage, ability to perform calculations, and high measurement speed makes it ideal for determining the characteristics of materials such as metals, low resistance filled plastics, and high and low temperature superconductors.

1.888.KEITHLEY (U.S. only)

www.keithley.com

A Greater Measure of Confidence

KEITHLEY
A Tektronix Company

Low noise measurements for research, metrology, and other low voltage testing applications

LOW LEVEL MEASURE & SOURCE

2182A

Nanovoltmeter

Three Ways to Measure Nanovolts

DC nanovoltmeters. DC nanovoltmeters and sensitive DMMs both provide low noise DC voltage measurements by using long integration times and highly filtered readings to minimize the bandwidth near DC. Unfortunately, this approach has limitations, particularly the fact that thermal voltages develop in the sample and connections vary, so long integration times don't improve measurement precision. With a noise specification of just 6nV p-p, the Model 2182A is the lowest noise digital nanovoltmeter available.

AC technique. The limitations of the long integration and filtered readings technique have led many people to use an AC technique for measuring low resistances and voltages. In this method, an AC excitation is applied to the sample and the voltage is detected synchronously at the same frequency and an optimum phase. While this technique removes the varying DC component, in many experiments at high frequencies, users can experience problems related to phase shifts caused by spurious capacitance or the L/R time constant. At low frequencies, as the AC frequency is reduced to minimize phase shifts, amplifier noise increases.

The current reversal method. The Model 2182A is optimized for the current reversal method, which combines the advantages of both earlier approaches. In this technique, the DC test current is reversed, then the difference in voltage due to the difference in current is determined. Typically, this measurement is performed at a few hertz (a frequency just high enough for the current to be reversed before the thermal voltages can change). The Model 2182A's low noise performance at measurement times of a few hundred milliseconds to a few seconds means that the reversal period can be set quite small in comparison with the thermal time constant of the sample and the connections, effectively reducing the impact of thermal voltages.

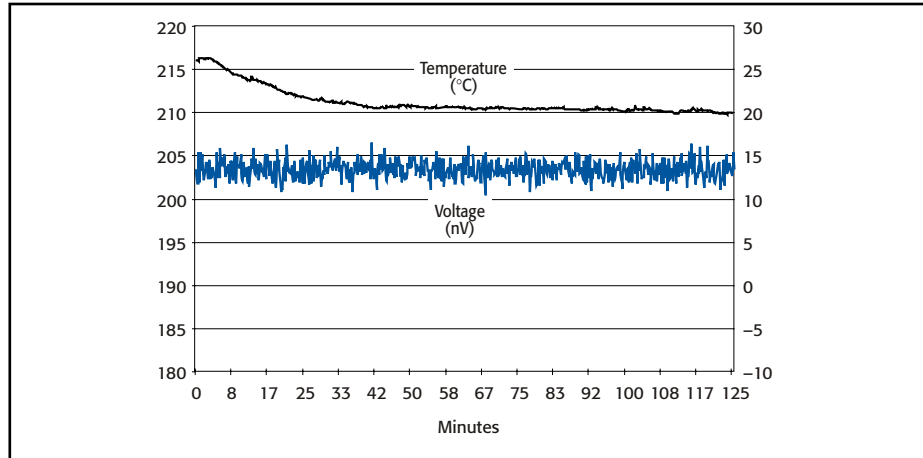

Figure 5. The Model 2182A's delta mode provides extremely stable results, even in the presence of large ambient temperature changes. In this challenging example, the 200nV signal results from a 20 μ A current sourced by a Model 6221 through a 10m Ω test resistor.

Optional Accessory: Model 2187-4 Low Thermal Test Lead Kit

The standard cabling provided with the Model 2182A Nanovoltmeter and Model 622X Current Sources provides everything normally needed to connect the instruments to each other and to the DUT. The Model 2187-4 Low Thermal Test Lead Kit is required when the cabling provided may not be sufficient for specific applications, such as when the DUT has special connection requirements. The kit includes an input cable with banana terminations, banana extensions, sprung-hook clips, alligator clips, needle probes, and spade lugs to accommodate virtually any DUT. The Model 2187-4 is also helpful when the DUT has roughly 1G Ω impedance or higher. In this case, measuring with the Model 2182A directly across the DUT will lead to loading errors. The Model 2187-4 Low Thermal Test Lead Kit provides a banana cable and banana jack extender to allow the Model 2182A to connect easily to the Model 622X's low impedance guard output, so the Model 2182A can measure the DUT voltage indirectly. This same configuration also removes the Model 2182A's input capacitance from the DUT, so it improves device response time, which may be critical for pulsed measurements.



Figure 6. Model 2187-4 Test Lead Kit



Figure 7. Model 2182A rear panel

1.888.KEITHLEY (U.S. only)

www.keithley.com

Volts Specifications (20% over range)

CONDITIONS: 1PLC with 10 reading digital filter or 5PLC with 2 reading digital filter.

Channel 1 Range	Resolution	Input Resistance	Accuracy: ±(ppm of reading + ppm of range) (ppm = parts per million) (e.g., 10ppm = 0.001%)				Temperature Coefficient 0°–18°C & 28°–50°C
			24 Hour ¹ T _{CAL} ±1°C	90 Day T _{CAL} ±5°C	1 Year T _{CAL} ±5°C	2 Year T _{CAL} ±5°C	
10.000000 mV ^{2,3,4}	1 nV	>10 GΩ	20 + 4	40 + 4	50 + 4	60 + 4	(1 + 0.5)/°C
100.000000 mV	10 nV	>10 GΩ	10 + 3	25 + 3	30 + 4	40 + 5	(1 + 0.2)/°C
1.00000000 V	100 nV	>10 GΩ	7 + 2	18 + 2	25 + 2	32 + 3	(1 + 0.1)/°C
10.0000000 V	1 μV	>10 GΩ	2 + 1 ⁵	18 + 2	25 + 2	32 + 3	(1 + 0.1)/°C
100.000000 V ⁴	10 μV	10 MΩ ±1%	10 + 3	25 + 3	35 + 4	52 + 5	(1 + 0.5)/°C
Channel 2^{6,10}							
100.000000 mV	10 nV	>10 GΩ	10 + 6	25 + 6	30 + 7	40 + 7	(1 + 1)/°C
1.00000000 V	100 nV	>10 GΩ	7 + 2	18 + 2	25 + 2	32 + 3	(1 + 0.5)/°C
10.0000000 V	1 μV	>10 GΩ	2 + 1 ⁵	18 + 2	25 + 2	32 + 3	(1 + 0.5)/°C

CHANNEL 1/CHANNEL 2 RATIO: For input signals ≥1% of the range, Ratio Accuracy = $\frac{\text{Channel 1 Reading} + \text{Channel 1 Accuracy}}{\text{Channel 2 Reading} - \text{Channel 2 Accuracy}} - \frac{\text{Channel 1 Reading}}{\text{Channel 2 Reading}}$

DELTA (hardware-triggered coordination with Series 24XX, Series 26XXA, or Series 622X current sources for low noise R measurement):

Accuracy = accuracy of selected Channel 1 range plus accuracy of I source range.

DELTA MEASUREMENT NOISE WITH 6220 or 6221: Typical 3nVrms/√Hz (10mV range)²¹. 1Hz achieved with 1PLC, delay = 1ms, RPT filter = 23 (20 if 50Hz).

PULSE-MODE (WITH 6221): Line synchronized voltage measurements within current pulses from 50μs to 12ms, pulse repetition rate up to 12Hz.

PULSE MEASUREMENT NOISE: Typical rms noise, R_{DUT}<10Ω: * $V_{RMS} + \frac{C}{\text{meas_time} * \sqrt{\text{pulse_avg_count}}}$

where meas_time (seconds) = pulse width – pulse_meas_delay in 33μs increments.

The constant C varies by range as follows: **10mV Range:** 0.16nV*s. **100mV Range:** 0.60nV*s. **1V Range:** 2.2nV*s. **10V Range:** 18nV*s.

* meas_time(sec) = pulsewidth – source_delay in 33μs increments.

DC Noise Performance⁷ (DC noise expressed in volts peak-to-peak)

Response time = time required for reading to be settled within noise levels from a stepped input, 60Hz operation.

Channel 1

Response Time	NPLC, Filter	10 mV	100 mV	Range 1 V	10 V	100 V	NMRR ⁸	CMRR ⁹
25.0 s	5, 75	6 nV	20 nV	75 nV	750 nV	75 μV	110 dB	140 dB
4.0 s	5, 10	15 nV	50 nV	150 nV	1.5 μV	75 μV	100 dB	140 dB
1.0 s	1, 18	25 nV	175 nV	600 nV	2.5 μV	100 μV	95 dB	140 dB
667 ms	1, 10 or 5, 2	35 nV	250 nV	650 nV	3.3 μV	150 μV	90 dB	140 dB
60 ms	1, Off	70 nV	300 nV	700 nV	6.6 μV	300 μV	60 dB	140 dB

Channel 2^{6,10}

25.0 s	5, 75	—	150 nV	200 nV	750 nV	—	110 dB	140 dB
4.0 s	5, 10	—	150 nV	200 nV	1.5 μV	—	100 dB	140 dB
1.0 s	1, 10 or 5, 2	—	175 nV	400 nV	2.5 μV	—	90 dB	140 dB
85 ms	1, Off	—	425 nV	1 μV	9.5 μV	—	60 dB	140 dB

VOLTAGE NOISE VS. SOURCE RESISTANCE¹¹

(DC noise expressed in volts peak-to-peak)

Source Resistance	Noise	Analog Filter	Digital Filter
0 Ω	6 nV	Off	100
100 Ω	8 nV	Off	100
1 kΩ	15 nV	Off	100
10 kΩ	35 nV	Off	100
100 kΩ	100 nV	On	100
1 MΩ	350 nV	On	100

TEMPERATURE (Thermocouples)¹²

(Displayed in °C, °F, or K. Accuracy based on ITS-90, exclusive of thermocouple errors.)

TYPE	RANGE	RESOLUTION	ACCURACY 90 Day/1 Year 23° ±5°C Relative to Simulated Reference Junction
J	–200 to +760°C	0.001 °C	±0.2 °C
K	–200 to +1372°C	0.001 °C	±0.2 °C
N	–200 to +1300°C	0.001 °C	±0.2 °C
T	–200 to +400°C	0.001 °C	±0.2 °C
E	–200 to +1000°C	0.001 °C	±0.2 °C
R	0 to +1768°C	0.1 °C	±0.2 °C
S	0 to +1768°C	0.1 °C	±0.2 °C
B	+350 to +1820°C	0.1 °C	±0.2 °C

1.888.KEITHLEY (U.S. only)

www.keithley.com

A Greater Measure of Confidence

KEITHLEY
A Tektronix Company

Operating Characteristics ^{13, 14} 60Hz (50Hz) Operation

Function	Digits	Readings/s	PLCs
DCV Channel 1,	7.5	3 (2)	5
Channel 2,	7.5 ^{17, 19}	6 (4)	5
Thermocouple	6.5 ^{18, 19}	18 (15)	1
	6.5 ^{18, 19, 20}	45 (36)	1
	5.5 ^{17, 19}	80 (72)	0.1
	4.5 ^{16, 17, 19}	115 (105)	0.01
Channel 1/Channel 2 (Ratio),	7.5	1.5 (1.3)	5
Delta with 24XX, Scan	7.5 ^{17, 19}	2.3 (2.1)	5
	6.5 ¹⁸	8.5 (7.5)	1
	6.5 ^{18, 20}	20 (16)	1
	5.5 ¹⁷	30 (29)	0.1
	4.5 ¹⁷	41 (40)	0.01
Delta with 622X	6.5	47 (40.0) ²²	1

System Speeds ^{13, 15}

RANGE CHANGE TIME: ¹⁴	<40 ms (<50 ms).
FUNCTION CHANGE TIME: ¹⁴	<45 ms (<55 ms).
AUTORANGE TIME: ¹⁴	<60 ms (<70 ms).
ASCII READING TO RS-232 (19.2K Baud):	40/s (40/s).
MAX. INTERNAL TRIGGER RATE: ¹⁶	120/s (120/s).
MAX. EXTERNAL TRIGGER RATE: ¹⁶	120/s (120/s).

Measurement Characteristics

A/D LINEARITY: $\pm(0.8\text{ppm of reading} + 0.5\text{ppm of range})$.

FRONT AUTOZERO OFF ERROR

10mV–10V: Add $\pm(8\text{ppm of range} + 500\mu\text{V})$ for <10 minutes and $\pm 1^\circ\text{C}$.

NOTE: Offset voltage error does not apply for Delta Mode.

AUTOZERO OFF ERROR

10mV: Add $\pm(8\text{ppm of range} + 100\text{nV})$ for <10 minutes and $\pm 1^\circ\text{C}$.

100mV–100V: Add $\pm(8\text{ppm of range} + 10\mu\text{V})$ for <10 minutes and $\pm 1^\circ\text{C}$.

NOTE: Offset voltage error does not apply for Delta Mode.

INPUT IMPEDANCE

10mV–10V: $>10\text{G}\Omega$, in parallel with $<1.5\text{nF}$ (Front Filter ON).

10mV–10V: $>10\text{G}\Omega$, in parallel with $<0.5\text{nF}$ (Front Filter OFF).

100V: $10\text{M}\Omega \pm 1\%$.

DC INPUT BIAS CURRENT: $<60\text{pA DC}$ at 23°C , -10V to 5V . $<120\text{pA}$ @ 23°C , 5V to 10V .

COMMON MODE CURRENT: $<50\text{nA p-p}$ at 50Hz or 60Hz .

INPUT PROTECTION: 150V peak to any terminal. 70V peak Channel 1 LO to Channel 2 LO.

CHANNEL ISOLATION: $>10\text{G}\Omega$.

EARTH ISOLATION: 350V peak , $>10\text{G}\Omega$ and $<150\text{pF}$ any terminal to earth. Add 35pF/ft with Model 2107 Low Thermal Input Cable.

Analog Output

MAXIMUM OUTPUT: $\pm 1.2\text{V}$.

ACCURACY: $\pm(0.1\% \text{ of output} + 1\text{mV})$.

OUTPUT RESISTANCE: $1\text{k}\Omega \pm 5\%$.

GAIN: Adjustable from 10^{-9} to 10^6 . With gain set to 1, a full range input will produce a 1V output.

OUTPUT REL: Selects the value of input that represents 0V at output. The reference value can be either programmed value or the value of the previous input.

Triggering and Memory

WINDOW FILTER SENSITIVITY: 0.01%, 0.1%, 1%, 10%, or full scale of range (none).

READING HOLD SENSITIVITY: 0.01%, 0.1%, 1%, or 10% of reading.

TRIGGER DELAY: 0 to 99 hours (1ms step size).

EXTERNAL TRIGGER DELAY: 2ms + $<1\text{ms jitter}$ with auto zero off, trigger delay = 0.

MEMORY SIZE: 1024 readings.

Math Functions

Rel, Min/Max/Average/Std Dev/Peak-to-Peak (of stored reading), Limit Test, %, and $mX+b$ with user-defined units displayed.

Remote Interface

Keithley 182 emulation.

GPIB (IEEE-488.2) and RS-232C.

SCPI (Standard Commands for Programmable Instruments).

GENERAL

POWER SUPPLY: 100V/120V/220V/240V.

LINE FREQUENCY: 50Hz, 60Hz, and 400Hz, automatically sensed at power-up.

POWER CONSUMPTION: 22VA.

MAGNETIC FIELD DENSITY: 10mV range 4.0s response noise tested to 500 gauss.

OPERATING ENVIRONMENT: Specified for 0° to 50°C . Specified to 80% RH at 35°C .

STORAGE ENVIRONMENT: -40° to 70°C .

EMC: Complies with European Union Directive 89/336/EEC (CE marking requirement), FCC part 15 class B, CISPR 11, IEC 801-2, IEC-801-3, IEC 801-4.

SAFETY: Complies with European Union Directive 73/23/EEC (low voltage directive); meets EN61010-1 safety standard. Installation category I.

VIBRATION: MIL-T-28800E Type III, Class 5.

WARM-UP: 2.5 hours to rated accuracy.

DIMENSIONS: **Rack Mounting:** 89mm high \times 213mm wide \times 370mm deep (3.5 in \times 8.375 in \times 14.563 in). **Bench Configuration (with handles and feet):** 104mm high \times 238mm wide \times 370mm deep (4.125 in \times 9.375 in \times 14.563 in).

SHIPPING WEIGHT: 5kg (11 lbs).

NOTES

- Relative to calibration accuracy.
- With Analog Filter on, add 20ppm of reading to listed specification.
- When properly zeroed using REL function. If REL is not used, add 100nV to the range accuracy.
- Specifications include the use of ACAL function. If ACAL is not used, add 9ppm of reading/ $^\circ\text{C}$ from T_{CAL} to the listed specification. T_{CAL} is the internal temperature stored during ACAL.
- For 5PLC with 2-reading Digital Filter. Use $\pm(4\text{ppm of reading} + 2\text{ppm of range})$ for 1PLC with 10-reading Digital Filter.
- Channel 2 must be referenced to Channel 1. Channel 2 HI must not exceed 125% (referenced to Channel 1 LO) of Channel 2 range selected.
- Noise behavior using 2188 Low Thermal Short after 2.5 hour warm-up. $\pm 1^\circ\text{C}$. Analog Filter off. Observation time = $10\times$ response time or 2 minutes, whichever is less.
- For L_{SYNC} On, line frequency $\pm 0.1\%$. If L_{SYNC} Off, use 60dB.
- For $1\text{k}\Omega$ unbalance in LO lead. AC CMRR is 70dB.
- For Low Q mode On, add the following to DC noise and range accuracy at stated response time: 200nV p-p @ 25s, 500nV p-p @ 4.0s, $1.2\mu\text{V p-p}$ @ 1s, and $5\mu\text{V p-p}$ @ 85ms.
- After 2.5 hour warm-up, $\pm 1^\circ\text{C}$, 5PLC, 2 minute observation time, Channel 1 10mV range only.
- For Channel 1 or Channel 2, add 0.3°C for external reference junction. Add 2°C for internal reference junction.
- Speeds are for 60Hz (50Hz) operation using factory defaults operating conditions (*RST). Autorange Off, Display Off, Trigger Delay = 0, Analog Output off.
- Speeds include measurements and binary data transfer out the GPIB. Analog Filter On, 4 readings/s max.
- Auto Zero Off, NPLC = 0.01.
- 10mV range, 80 readings/s max.
- Sample count = 1024, Auto Zero Off.
- For L_{SYNC} On, reduce reading rate by 15%.
- For Channel 2 Low Q mode Off, reduce reading rate by 30%.
- Front Auto Zero off, Auto Zero off.
- Applies to measurements of room temperature resistances $<10\Omega$, Isource range $\leq 20\mu\text{A}$.
- Display off, delay 1ms.

1.888.KEITHLEY (U.S. only)

www.keithley.com

KEITHLEY

A Tektronix Company

A Greater Measure of Confidence

6220 6221

6220 and 6221

- Source and sink (programmable load) 100fA to 100mA
- $10^{14}\Omega$ output impedance ensures stable current sourcing into variable loads
- 65000-point source memory allows executing comprehensive test current sweeps directly from the current source
- Built-in RS-232, GPIB, Trigger Link, and digital I/O interfaces
- Reconfigurable triax output simplifies matching the application's guarding requirements
- Model 220 emulation mode eliminates need to reprogram existing applications

6221 Only

- Source AC currents from 4pA to 210mA peak to peak for AC characterization of components and materials. The 6221's 10MHz output update rate generates smooth sine waves up to 100kHz
- Built-in standard and arbitrary waveform generators with 1mHz to 100kHz frequency range. Applications include use as a complex programmable load or sensor signal and for noise emulation
- Programmable pulse widths as short as 5 μ s, limiting power dissipation in delicate components. Supports pulsed I-V measurements down to 50 μ s when used with Model 2182A Nanovoltmeter
- Built-in Ethernet interface for easy remote control without a GPIB controller card

DC Current Source AC and DC Current Source



The Model 6220 DC Current Source and Model 6221 AC and DC Current Source combine ease of use with exceptionally low current noise. Low current sourcing is critical to applications in test environments ranging from R&D to production, especially in the semiconductor, nanotechnology, and superconductor industries. High sourcing accuracy and built-in control functions make the Models 6220 and 6221 ideal for applications like Hall measurements, resistance measurements using delta mode, pulsed measurements, and differential conductance measurements.

The need for precision, low current sourcing. Device testing and characterization for today's very small and power-efficient electronics requires sourcing low current levels, which demands the use of a precision, low current source. Lower stimulus currents produce lower—and harder to measure—voltages across the device. Combining the Model 6220 or 6221 with a Model 2182A Nanovoltmeter makes it possible to address both of these challenges.

AC current source and current source waveform generator. The Model 6221 is the only low current AC source on the market. Before its introduction, researchers and engineers were forced to build their own AC current sources. This cost-effective source provides better accuracy, consistency, reliability, and robustness than “home-made” solutions. The Model 6221 is also the only commercially available current source waveform generator, which greatly simplifies creating and outputting complex waveforms.

Simple programming. Both current sources are fully programmable via the front panel controls or from an external controller via RS-232 or GPIB interfaces; the Model 6221 also features an Ethernet interface for remote control from anywhere there's an Ethernet connection. Both instruments can source DC currents from 100fA to 105mA; the Model 6221 can also source AC currents from 4pA to 210mA peak to peak. The output voltage compliance of either source can be set from 0.1V to 105V in 10mV steps. Voltage compliance (which limits the amount of voltage applied when sourcing a current) is critical for applications in which overvoltages could damage the device under test (DUT).

Drop-in replacement for the Model 220 current source. These instruments build upon Keithley's popular Model 220 Programmable Current Source; a Model 220 emulation mode makes it easy to replace a Model 220 with a Model 6220/6221 in an existing application without rewriting the control code.

Define and execute current ramps easily. Both the Models 6220 and 6221 offer tools for defining current ramps and stepping through predefined sequences of up to 65,536 output values using a trigger or a timer. Both sources support linear, logarithmic, and custom sweeps.

APPLICATIONS

- Nanotechnology
 - Differential conductance
 - Pulsed sourcing and resistance
- Optoelectronics
 - Pulsed I-V
- Replacement for AC resistance bridges (when used with Model 2182A)
 - Measuring resistance with low power
- Replacement for lock-in amplifiers (when used with Model 2182A)
 - Measuring resistance with low noise

1.888.KEITHLEY (U.S. only)

www.keithley.com

A Greater Measure of Confidence

KEITHLEY
A Tektronix Company

Precision low current sourcing

LOW LEVEL MEASURE & SOURCE

6220 6221

Ordering Information

6220 DC Precision Current Source

6221 AC and DC Current Source

6220/2182A

Complete Delta Mode System, w/DC Current Source, Nanovoltmeter, and all necessary cables (GPIB cables not included)

6221/2182A

Complete Delta Mode System, w/AC and DC Current Source, Nanovoltmeter, and all necessary cables (GPIB cables not included)

Accessories Supplied

237-ALG-2 6.6 ft (2m), Low Noise, Input Cable with Triax-to-Alligator Clips

8501-2 6.6 ft (2m) Trigger Link Cable to connect 622x to 2182A

CA-180-3A Ethernet Crossover Cable (6221 only)

CA-351 Communication Cable between 2182A and 622x

CS-1195-2 Safety Interlock Connector

**Instruction manual on CD
Getting Started manual (hardcopy)
Software (downloadable)**

ACCESSORIES AVAILABLE

7006.*	GPIB Cable with Straight-On Connector
7007-1	Shielded IEEE-488 Cable, 1m (3.3 ft)
7007-2	Shielded IEEE-488 Cable, 2m (6.6 ft)
7078-TRX-5	5 ft (1.5m), Low Noise, Triax-to-Triax Cable (Male on Both Ends)
KPCI-488LPA	IEEE-488 Interface/Controller for the PCI Bus
KUSB-488B	IEEE-488 USB-to-GPIB Interface Adapter

SERVICES AVAILABLE

6220-3Y-EW	1-year factory warranty extended to 3 years from date of shipment
6221-3Y-EW	1-year factory warranty extended to 3 years from date of shipment
C/6220-3Y-ISO	3 (ISO-17025 accredited) calibrations within 3 years of purchase*
C/6221-3Y-ISO	3 (ISO-17025 accredited) calibrations within 3 years of purchase*

*Not available in all countries

1.888.KEITHLEY (U.S. only)

www.keithley.com

DC Current Source AC and DC Current Source

The Model 6221's combination of high source resolution and megahertz update rates makes it capable of emulating high fidelity current signals that are indistinguishable from analog current ramps.

Free Instrument Control Example Start-up Software

The instrument control example software available for the sources simplifies both performing basic sourcing tasks and coordinating complex measurement functions with the Keithley Model 2182A. The software, developed in the LabVIEW® programming environment, includes a step-by-step measurement guide that helps users set up their instruments and make proper connections, as well as program basic sourcing functions. The advanced tools in the package support delta mode, differential conductance, and pulse mode measurements. From this package, users can print out the instrument commands for any of the pre-programmed functions, which provides a starting point for incorporating these functions into customized applications.

Differential Conductance

Differential conductance measurements are among the most important and critical measurements made on non-linear tunneling devices and on low temperature devices. Mathematically, differential conductance is the derivative of a device's I-V curve. The Model 6220 or 6221, combined with the Model 2182A Nanovoltmeter, is the industry's most complete solution for differential conductance measurements. Together, these instruments are also the fastest solution available, providing 10× the speed and significantly lower noise than other options. Data can be obtained in a single measurement pass, rather than by averaging the result of multiple sweeps, which is both time-consuming and prone to error. The Model 622X and Model 2182A are also easy to use because the combination can be treated as a single instrument. Their simple connections eliminate the isolation and noise current problems that plague other solutions.

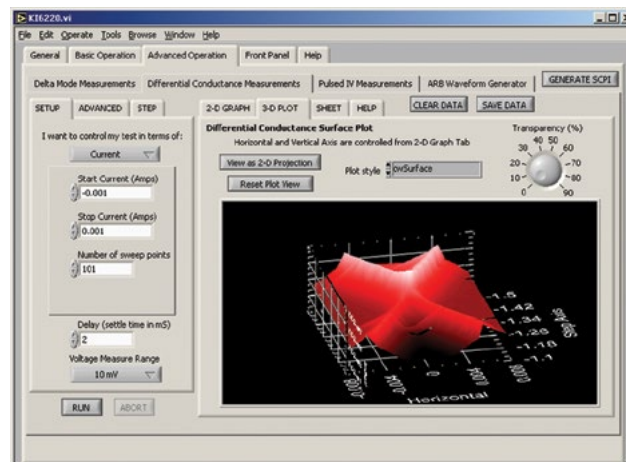

Figure 1. Perform, analyze, and display differential conductance measurements.

Delta Mode

Keithley originally developed the delta mode method for making low noise measurements of voltages and resistances for use with the Model 2182 Nanovoltmeter and a triggerable external current source. Essentially, the delta mode automatically triggers the current source to alternate the signal polarity, then triggers a nanovoltmeter reading at each polarity. This current reversal technique cancels out any constant thermoelectric offsets, ensuring the results reflect the true value of the voltage.

This same basic technique has been incorporated into the Model 622X and Model 2182A delta mode, but its implementation has been dramatically enhanced and simplified. The technique can now cancel thermoelectric offsets that drift over time, produce results in half the time of the previous technique, and allow the source to control and configure the nanovoltmeter, so setting up the measurement takes just two key presses. The improved cancellation and higher reading rate reduces measurement noise to as little as 1nV.

6220 6221

DC Current Source AC and DC Current Source

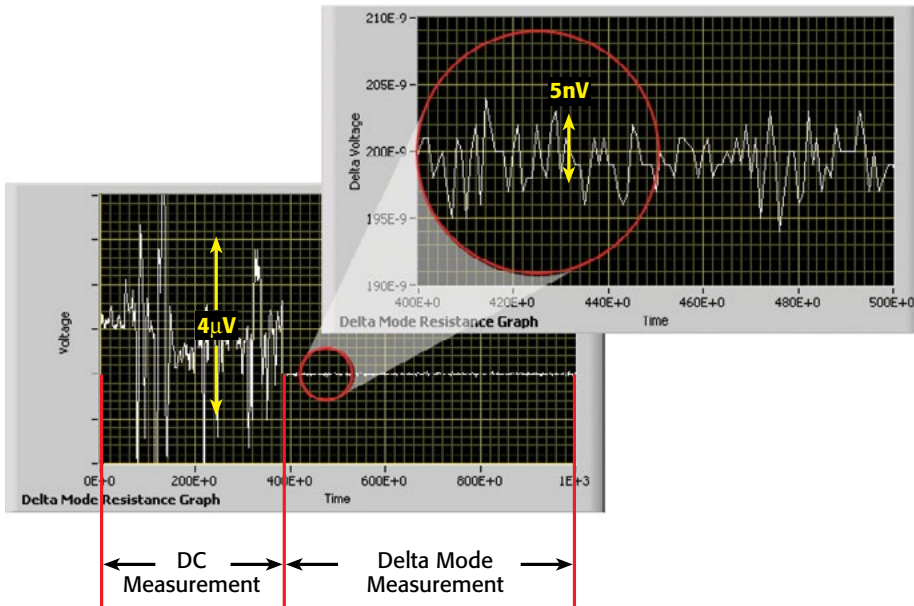

Figure 2. Delta mode offers 1000-to-1 noise reduction.

The delta mode enables measuring low voltages and resistances accurately. Once the Model 622X and the Model 2182A are connected properly, the user simply presses the current source's Delta button, followed by the Trigger button, which starts the test. The Model 622X and the Model 2182A work together seamlessly and can be controlled via the GPIB interface (GPIB or Ethernet with the Model 6221). The free example control software available for the Model 622X includes a tutorial that "walks" users through the delta mode setup process.

Pulsed Tests

Even small amounts of heat introduced by the measurement process itself can raise the DUT's temperature, skewing test results or even destroying the device. The Model 6221's pulse measurement capability minimizes the amount of power dissipated into a DUT by offering maximum flexibility when making pulsed measurements, allowing users to program the optimal pulse current amplitude, pulse interval, pulse width, and other pulse parameters.

The Model 6221 makes short pulses (and reductions in heat dissipation) possible with microsecond rise times on all ranges. The Model 6221/2182A combination synchronizes the pulse and measurement—a measurement can begin as soon as $16\mu\text{s}$ after the Model 6221 applies the pulse. The entire pulse, including a complete nanovolt measurement, can be as short as $50\mu\text{s}$. Line synchronization between the Model 6221 and Model 2182A eliminates power line related noise.

Standard and Arbitrary Waveform Generator

The Model 6221 is the only low current AC source on the market. It can be programmed to generate both basic waveforms (sine, square, triangle, and ramp) and customizable waveforms with an arbitrary waveform generator (ARB) that supports defining waveforms point by point. It can generate waveforms at frequencies ranging from 1mHz to 100kHz at an output update rate of 10 megasamples/second.

Performance Superior to AC Resistance Bridges and Lock-In Amplifiers

The Model 622X/2182A combination provides many advantages over AC resistance bridges and lock-in amplifiers, including lower noise, lower current sourcing, lower voltage measurements, less power dissipation into DUTs, and lower cost. It also eliminates the need for a current pre-amplifier.

Models 6220 and 6221 vs. Homemade Current Sources

Many researchers and engineers who need a current source attempt to get by with a voltage source and series resistor instead. This is often the case when an AC current is needed. This is because, until the introduction of the Model 6220/6221, no AC current sources were available on the market. However, homemade current sources have several disadvantages vs. true current sources:

- **Homemade Current Sources Don't Have Voltage Compliance.** You may want to be sure the voltage at the terminals of your homemade "current source" never exceeds a certain limit (for example, 1–2V in the case of many optoelectronic devices). The most straightforward way to accomplish this is to reduce the voltage source to that level. This requires the series resistor to be reduced to attain the desired current. If you want to program a different current, you must change the resistor while the voltage is held constant! Another possibility is to place a protection circuit in parallel with the DUT. These do not have precise voltage control and always act as a parallel device, stealing some of the programmed current intended for the DUT.
- **Homemade Current Sources Can't Have Predictable Output.** With a homemade "current source" made of a voltage source and series resistor, the impedance of the DUT forms a voltage divider. If the DUT resistance is entirely predictable, the current can be known, but if the DUT resistance is unknown or changes, as most devices do, then the current isn't a simple function of the voltage applied. The best way to make the source predictable is to use a very high value series resistor (and accordingly high voltage source), which is in direct contradiction with the need for compliance.
- While it's possible to know (if not control) the actual current coming from such an unpredictable source, this also comes at a cost. This can be done with a supplemental measurement of the current, such as using a voltmeter to measure the voltage drop across the series resistor. This measurement can be used as feedback to alter the voltage source or simply recorded. Either way, it requires additional equipment, which adds complexity or error. To make matters worse, if the homemade current source is made to be moderately predictable by using a large series resistor, this readback would require using an electrometer to ensure accuracy.

1.888.KEITHLEY (U.S. only)

www.keithley.com

A Greater Measure of Confidence

KEITHLEY

A Tektronix Company

6220 6221

DC Current Source AC and DC Current Source

The Model 6221 can also expand the capabilities of lock-in amplifiers in applications that already employ them. For example, its clean signals and its output synchronization signal make it an ideal output source for lock-in applications such as measuring second and third harmonic device response.

Model 2182A Nanovoltmeter

The Model 2182A expands upon the capabilities of Keithley's original Model 2182 Nanovoltmeter. Although the Model 6220 and 6221 are compatible with the Model 2182, delta mode and differential conductance measurements require approximately twice as long to complete with the Model 2182 as with the Model 2182A. Unlike the Model 2182A, the Model 2182 does not support pulse mode measurements.

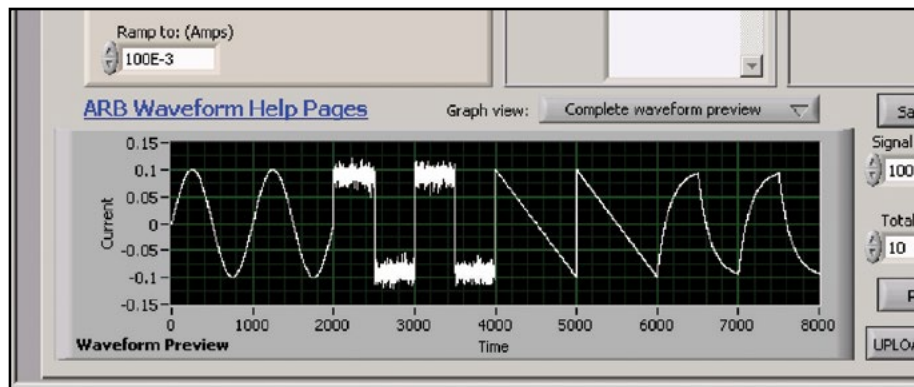

Figure 4. The Model 6221 and the free example start-up control software make it easy to create complex waveforms by adding, multiplying, stringing together, or applying filters to standard wave shapes.

APPLICATIONS OF 622X/2182A COMBINATION:

- Easy instrument coordination and intuitive example software simplifies setup and operation in many applications.
- Measure resistances from 10nΩ to 100MΩ. One measurement system for wide ranging devices.
- Low noise alternative to AC resistance bridges and lock-in amplifiers for measuring resistances.
- Coordinates pulsing and measurement with pulse widths as short as 50μs (6221 only).
- Measures differential conductance up to 10× faster and with lower noise than earlier solutions allow. Differential conductance is an important parameter in semiconductor research for describing density of states in bulk material.
- Delta mode reduces noise in low resistance measurements by a factor of 1000.
- For low impedance Hall measurements, the delta mode operation of the Model 622X/2182A combination provides industry-leading noise performance and rejection of contact potentials. For higher impedance Hall measurements (greater than 100MΩ), the Model 4200-SCS can replace the current source, switching, and multiple high impedance voltage measurement channels. This provides a complete solution with pre-programmed test projects.

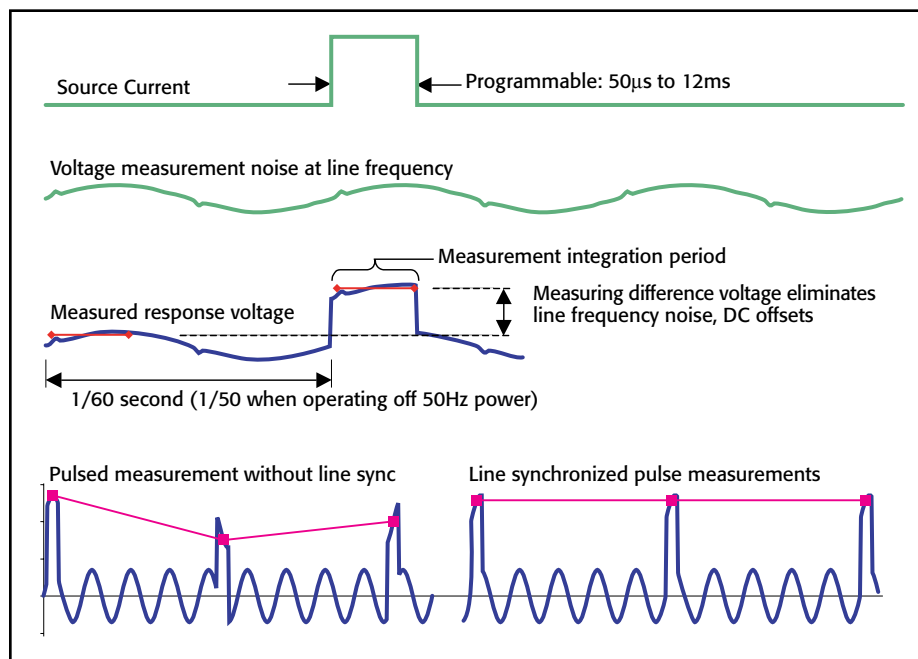

Figure 3. Measurements are line synchronized to minimize 50/60Hz interference.

6220 6221

DC Current Source AC and DC Current Source

Source Specifications

Range (+5% over range)	Accuracy (1 Year) 23°C ±5°C ±(% rdg. + amps)	Programming Resolution	Temperature Coefficient/°C 0°–18°C & 28°–50°C	Typical Noise (peak-peak)/RMS ³ 0.1Hz–10Hz	Typical Noise (peak-peak)/RMS ³ 10Hz–(Bw)	Settling Time ^{1,2} (1% of Final Value)		
						6221 Only	6220, 6221 with Output Response Slow (Max.)	
2 nA	0.4 % + 2 pA	100 fA	0.02 % + 200 fA	400 / 80 fA	250 / 50 pA	10kHz	90 μs	100 μs
20 nA	0.3 % + 10 pA	1 pA	0.02 % + 200 fA	4 / 0.8 pA	250 / 50 pA	10kHz	90 μs	100 μs
200 nA	0.3 % + 100 pA	10 pA	0.02 % + 2 pA	20 / 4 pA	2.5 / 0.5 nA	100kHz	30 μs	100 μs
2 μA	0.1 % + 1 nA	100 pA	0.01 % + 20 pA	200 / 40 pA	25 / 5.0 nA	1MHz	4 μs	100 μs
20 μA	0.05% + 10 nA	1 nA	0.005% + 200 pA	2 / 0.4 nA	500/100 nA	1MHz	2 μs	100 μs
200 μA	0.05% + 100 nA	10 nA	0.005% + 2 nA	20 / 4 nA	1.0 / 0.2 μA	1MHz	2 μs	100 μs
2 mA	0.05% + 1 μA	100 nA	0.005% + 20 nA	200 / 40 nA	5.0 / 1 μA	1MHz	2 μs	100 μs
20 mA	0.05% + 10 μA	1 μA	0.005% + 200 nA	2 / 0.4 μA	20 / 4.0 μA	1MHz	2 μs	100 μs
100 mA	0.1 % + 50 μA	10 μA	0.01 % + 2 μA	10 / 2 μA	100 / 20 μA	1MHz	3 μs	100 μs

ADDITIONAL SOURCE SPECIFICATIONS

OUTPUT RESISTANCE: >10¹¹Ω (2nA/20nA range).
OUTPUT CAPACITANCE: <10pF, <100pF Filter ON (2nA/20nA range).
LOAD IMPEDANCE: Stable into 10μH typical, 100μH for 6220, or for 6221 with Output Response SLOW.
VOLTAGE LIMIT (Compliance): Bipolar voltage limit set with single value. 0.1V to 105V in 0.01V programmable steps.
MAX. OUTPUT POWER: 11W, four quadrant source or sink operation.
GUARD OUTPUT ACCURACY: ±1mV for output currents <2mA (excluding output lead voltage drop).
PROGRAM MEMORY: Number of Locations: 64K. Offers point-by-point control and triggering, e.g. sweeps.
MAX. TRIGGER RATE: 1000/s.
RMS NOISE 10Hz–20MHz (2nA–20mA Range): Less than 1mVrms, 5mVp-p (into 50Ω load).

SOURCE NOTES

- Settling times are specified into a resistive load, with a maximum resistance equal to 2V/1_{full scale} of range. See manual for other load conditions.
- Settling times to 0.1% of final value are typically <2× of 1% settling times.
- Typical values are non warranted, apply at 23°C, represent the 50th percentile, and are provided solely as useful information.

2182A MEASUREMENT FUNCTIONS

DUT RESISTANCE: Up to 1GΩ (1ns) (100MΩ limit for pulse mode).
DELTA MODE RESISTANCE MEASUREMENTS AND DIFFERENTIAL CONDUCTANCE: Controls Keithley Model 2182A Nanovoltmeter at up to 24Hz reversal rate (2182 at up to 12Hz).
PULSE MEASUREMENTS (6221 ONLY):
Pulse Widths: 50μs to 12ms, 1pA to 100mA.
Repetition Interval: 83.3ms to 5s.

ARBITRARY FUNCTION GENERATOR (6221 only)

WAVEFORMS: Sine, Square, Ramp, and 4 user defined arbitrary waveforms.
FREQUENCY RANGE: 1mHz to 100kHz.⁵
FREQUENCY ACCURACY: ±100ppm (1 year).
SAMPLE RATE: 10 MSPS.
AMPLITUDE: 4pA to 210mA peak-peak into loads up to 10¹²Ω.
AMPLITUDE RESOLUTION: 16 bits (including sign).
AMPLITUDE ACCURACY (<10kHz):⁵
Magnitude: ±(1% rdg + 0.2% range).
Offset: ±(0.2% rdg + 0.2% range).
SINE WAVE CHARACTERISTICS:
Amplitude Flatness: Less than 1dB up to 100kHz.⁶
SQUARE WAVE CHARACTERISTICS:
Overshoot: 2.5% max.⁶
Variable Duty Cycle:⁴ Settable to 1μs min. pulse duration, 0.01% programming resolution.
Jitter (RMS): 100ns + 0.1% of period.⁶
RAMP WAVE CHARACTERISTICS:
Linearity: <0.1% of peak output up to 10kHz.⁶
ARBITRARY WAVE CHARACTERISTICS:
Waveform Length: 2 to 64K points.
Jitter (RMS): 100ns + 0.1% of period.⁶

WAVEFORM NOTES

- Minimum realizable duty cycle is limited by current range response and load impedance.
- Amplitude accuracy is applicable into a maximum resistive load of 2V/1_{full scale} of range. Amplitude attenuation will occur at higher frequencies dependent upon current range and load impedance.
- These specifications are only valid for the 20mA range and a 50Ω load.

GENERAL

COMMON MODE VOLTAGE: 250V rms, DC to 60Hz.
COMMON MODE ISOLATION: >10¹⁰Ω, <2nF.
SOURCE OUTPUT MODES: Fixed DC level, Memory List.
REMOTE INTERFACE:
 IEEE-488 and RS-232C.
 SCPI (Standard Commands for Programmable Instruments).
 DDC (command language compatible with Keithley Model 220).
PASSWORD PROTECTION: 11 characters.
DIGITAL INTERFACE:
Handler Interface: Start of test, end of test, 3 category bits, +5V@300mA supply.
Digital I/O: 1 trigger input, 4 TTL/Relay Drive outputs (33V@500mA, diode clamped).
OUTPUT CONNECTIONS:
 Teflon insulated 3-lug triax connector for output.
 Banana safety jack for GUARD, OUTPUT I.O.
 Screw terminal for CHASSIS.
 DB-9 connector for EXTERNAL TRIGGER INPUT, OUTPUT, and DIGITAL I/O.
 Two position screw terminal for INTERLOCK.
INTERLOCK: Maximum 10Ω external circuit impedance.
POWER SUPPLY: 100V to 240V rms, 50–60Hz.
POWER CONSUMPTION: 120VA.
ENVIRONMENT:
For Indoor Use Only: Maximum 2000m above sea level.
Operating: 0°–50°C, 70%R.H. up to 35°C. Derate 3% R.H./°C, 35°–50°C.
Storage: –25°C to 65°C, guaranteed by design.
EMC: Conforms to European Union Directive 89/336/EEC, EN 61326-1.
SAFETY: Conforms to European Union Directive 73/23/EEC, EN61010-1.
VIBRATION: MIL-PRF-28800F Class 3, Random.
WARMUP: 1 hour to rated accuracies.
Passive Cooling: No fan.
DIMENSIONS:
Rack Mounting: 89mm high × 213mm wide × 370mm deep (3.5 in. × 8.375 in. × 14.563 in.).
Bench Configuration (with handle and feet): 104mm high × 238mm wide × 370mm deep (4.125 in. × 9.375 in. × 14.563 in.).

1.888.KEITHLEY (U.S. only)

www.keithley.com

KEITHLEY

A Greater Measure of Confidence

A Tektronix Company

Series 3700A

System Switch/Multimeter and Plug-In Cards



- Combines the functions of a system switch and a high performance multimeter
- LXI Class B compliance with IEEE 1588 time synchronization
- 3½- to 7½-digit measurement resolution
- Embedded Test Script Processor (TSP®) offers unparalleled system automation, throughput, and flexibility
- Extended low ohms (1Ω) range with 100nΩ resolution
- Extended low current (10μA) range with 1pA resolution
- >14,000 readings/second
- Low noise, <0.1ppm rms noise on 10VDC range
- Expanded dry circuit range (2kΩ)
- Four-wire open lead detection (source and sense lines)

For more information about Series 3700A systems, see page 174.

1.888.KEITHLEY (U.S. only)

www.keithley.com

A Series 3700A system combines the functionality of an instrument grade relay switching system with a high performance multimeter. Integrating the multimeter within the mainframe ensures you of a high quality signal path from each channel to the multimeter. This tightly integrated switch and measurement system can meet the demanding application requirements of a functional test system or provide the flexibility needed in stand-alone data acquisition and measurement applications. It is ideal for multiple pin count applications where relay switching can be used to connect multiple devices to source and measurement instruments.

The high performance multimeter in the Series 3700A offers low noise, high stability 3½- to 7½-digit readings for leading-edge measurement performance. This flexible resolution supplies a DC reading rate from >14,000 readings/second at 3½ digits to 60 readings/second at 7½ digits, offering customers maximum reading throughput and accuracy. The multimeter also provides an expanded low ohms (1Ω) range, low current (10μA) range, and dry circuit (1Ω to 1kΩ) range, extending utility beyond typical DMM applications.

The multimeter supports 13 built-in measurement functions, including: DCV, ACV, DCI, ACI, frequency, period, two-wire ohms, four-wire ohms, three-wire RTD temperature, four-wire RTD temperature, thermocouple temperature, thermistor temperature, and continuity. In-rack calibration is supported, which reduces both maintenance and calibration time. Onboard memory can store up to 650,000 readings, and the USB device port provides easy transfer of data to memory sticks.

Single-Channel Reading Rates

Resolution	DCV/	
	2-Wire Ohms	4-Wire Ohms
7½ Digits (1 NPLC)	60	29
6½ Digits (0.2 NPLC)	295	120
5½ Digits (0.06 NPLC)	935	285
4½ Digits (0.006 NPLC)	6,200	580
3½ Digits (0.0005 NPLC)	14,000	650

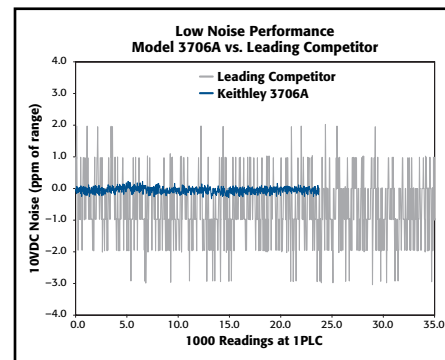

Compare the Model 3706A's 10V DC noise and speed performance with that of the leading competitor. All the data was taken at 1PLC with a low thermal short applied to the input, which resulted in 10× lower noise and 7× faster measurements for the Model 3706A.

APPLICATIONS

- System- and rack-level signal referencing
- Power supply burn-in testing (PC, network, telecom)
- Low ohms testing (contacts, connectors, relays)
- Temperature profiling
- Plant/environment monitoring and control
- Automotive and aerospace systems
- Consumer product certification/testing laboratories

Technical Information

An ammeter is an instrument for measuring electric current flow, calibrated in amperes. There are two main types of ammeter architectures: shunt ammeters and feedback ammeters.

Shunt vs. Feedback Ammeters

Shunt ammeters are the most common type and work in many applications; feedback ammeters are more appropriate when measuring small currents; their use is growing because the typical magnitude of the test currents used today is decreasing. However, choosing the proper ammeter depends not only on the magnitude of the current, but also on characteristics (most typically, the impedance) of the device under test (DUT).

Shunt Ammeters: DMMs

Shunt ammeters are the most common ammeter type and are found in almost all digital multimeters (DMMs). These meters measure current by developing a voltage at the input terminal that is proportional to the current being measured (Figure 1).

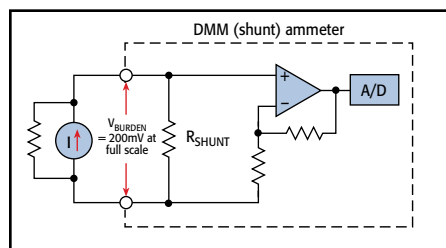

Figure 1

The main drawback associated with shunt ammeters is their fundamentally high input impedance design. This drawback becomes more significant with decreasing current, because a larger shunt resistor must be used in order to develop a measurable voltage. However, as long as the shunt resistor is significantly smaller than the resistance of the DUT and the currents to be measured are not very small (not much lower than microamp level [$10^{-6}A$]), shunt ammeters work fine.

Voltage Burden

The terminal voltage of an ammeter is called the voltage burden. This voltage burden developed across the meter could result in significantly lower current through the load than before the meter was inserted, therefore, the ammeter can't read the current it was intended to measure.

An ideal ammeter would not alter the current flowing in the circuit path, so it would have zero resistance and zero voltage burden. A real ammeter will always introduce a non-zero voltage burden. In general, the error term caused by an ammeter is stated as the ammeter's voltage burden divided by the resistance

Low Current/High Resistance Measurements

of the DUT. A shunt ammeter's voltage burden is typically on the order of hundreds of millivolts.

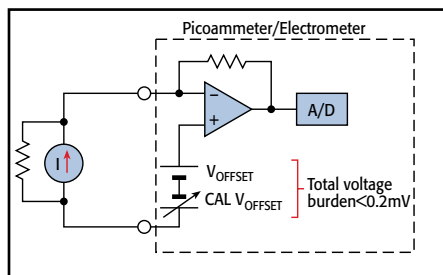

Figure 2

Feedback Ammeter

Feedback ammeters are closer to "ideal" than shunt ammeters, and should be used for current measurements of microamps or less ($10^{-6}A$) or where it is especially critical to have an ammeter with low input impedance. Instead of developing a voltage across the terminals of the ammeter, a feedback ammeter develops a voltage across the feedback path of a high gain operational amplifier (Figure 2). This voltage is also proportional to the current to be measured; however, it is no longer observed at the input of the instrument, but only through the output voltage of the op-amp. The input voltage is equal to the output voltage divided by the op-amp gain (typically 100,000), so the voltage burden has now typically been reduced to microvolts. The feedback ammeter architecture results in low voltage burden, so it produces less error when measuring small currents and when measuring currents generated by low impedance devices. Keithley electrometers and picoammeters employ feedback ammeter technology.

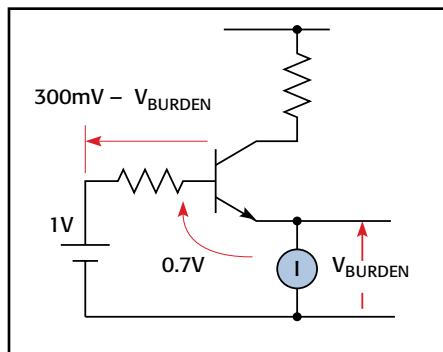

Figure 3

Figure 3 illustrates the problems caused by high voltage burden when measuring the emitter current of a transistor. Even though the basic current measurement could be well within the measuring capability of the DMM, the DMM's voltage burden significantly reduces the voltage applied to the DUT, resulting in

lower measured emitter current than intended. If a picoammeter or electrometer were used instead, the voltage burden would cause a negligible change in emitter current.

Sources of Generated Current Error

Low current measurements are subject to a number of error sources that can have a serious impact on measurement accuracy. All ammeters will generate some small current that flows even when the input is open. These offset currents can be partially nulled by enabling the instrument current suppress. External leakage currents are additional sources of error; therefore, making properly guarded and/or shielded connections is important. The source impedance of the DUT will also affect the noise performance of the ammeter. In addition, there are other extraneous generated currents in the test system that could add to the desired current, causing errors. The following paragraphs discuss various types of generated currents and how to minimize their impact on the measurements.

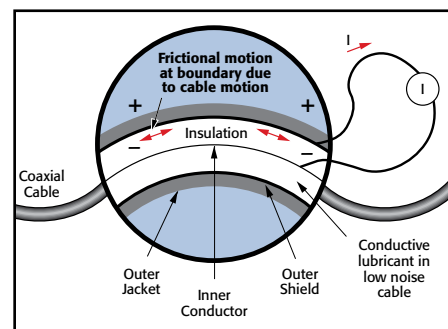

Figure 4

Triboelectric effects are created by charge imbalance due to frictional effects between a conductor and an insulator, as shown in Figure 4. Keithley's low noise cables greatly reduce this effect by introducing an inner insulator of polyethylene coated with graphite underneath the outer shield. The graphite provides lubrication and a conducting equipotential cylinder to equalize charges and minimize the charge generated.

Piezoelectric currents are generated when mechanical stress is applied to certain crystalline materials when used for insulated terminals and interconnecting hardware. In some plastics, pockets of stored charge cause the material to behave in a manner similar to piezoelectric materials. An example of a terminal with a piezoelectric insulator is shown in Figure 5. To minimize the current due to this effect, remove mechanical stresses from the insulator and use insulating materials with minimal piezoelectric and stored charge effects.

1.888.KEITHLEY (U.S. only)

www.keithley.com

A Greater Measure of Confidence

KEITHLEY
A Tektronix Company

Technical information: Low current/high resistance measurements

LOW LEVEL MEASURE & SOURCE

Technical Information

Low Current/High Resistance Measurements

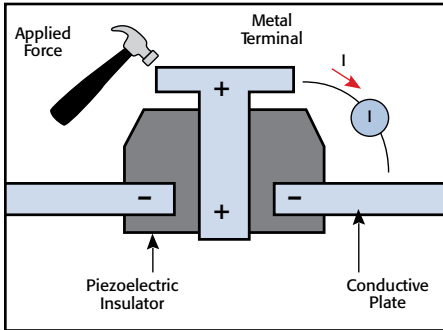

Figure 5

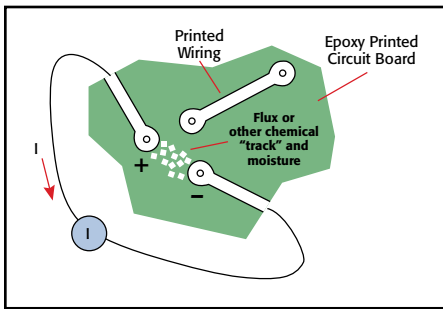

Figure 6

Contamination and humidity can produce error currents, which arise from electrochemical effects that occur when contaminants (in the form of ionic chemicals) create weak “batteries” between two conductors on a circuit board. For example, commonly used epoxy printed circuit boards, if not thoroughly cleaned of etching solution, flux, oils, salts (e.g., fingerprints) or other contaminants, can generate currents of a few nanoamps between conductors (see Figure 6). To avoid the effects of contamination and humidity, select insulators that resist water absorp-

tion and keep humidity to moderate levels. Also, keep all insulators clean and free of contamination.

Figure 7 summarizes approximate magnitudes of the various currents.

High Resistance Measurements

For high resistance measurements (>1GΩ), a constant voltage is most often applied across the unknown resistance. The resulting current is measured from an ammeter placed in series, and the resistance can be found using Ohm’s law ($R=V/I$). This method of applying a voltage and measuring the current (as opposed to applying a current and measuring the voltage), is preferred for high resistance measurements, because high resistances often change as a function of applied voltage. Therefore, it’s important to measure the resistance at a relevant and controllable voltage. This method most often requires measuring low currents using an electrometer or picoammeter. All the low current techniques and error sources described in previous paragraphs also apply here.

Leakage currents are typical sources of error in high resistance measurements. They are generated by unwanted high resistance paths (leakage resistance) between the measurement circuit and nearby voltage sources; they can be reduced by employing proper guarding techniques, using clean, quality insulators, and minimizing humidity.

Typical resistance values of various insulating materials are shown in Figure 8. Absorbed moisture may also change the resistance of certain insulators

by orders of magnitude. Table 1 shows a qualitative description of water absorption and other effects.

Alternating Polarity Method

When measuring materials with very high resistivity, background currents may cause significant measurement errors. They may be due to charge stored in the material (dielectric absorption), static or triboelectric charge, or piezoelectric effects.

The Alternating Polarity Method can virtually eliminate the effects of background currents in the sample. In this method, a bias voltage of positive polarity is applied, then the current is measured after a predetermined delay. Next, the polarity is reversed and the current is measured again, using the same delay. The polarity reversal process can be repeated any number of times. The resistance is calculated based on a weighted average of the most recent current measurements.

Volume Resistivity (Ohm-cm)	Material	PROPERTY		
		Resistance to Water Absorption	Minimal Piezoelectric Effects	Minimal Triboelectric Effects
$10^{16} - 10^{18}\Omega$	Sapphire	+	+	0
$10^{17} - 10^{18}\Omega$	Teflon®	+	-	-
$10^{14} - 10^{18}\Omega$	Polyethylene	0	+	0
$10^{12} - 10^{18}\Omega$	Polystyrene	0	0	-
$10^{17} - 10^{18}\Omega$	Kel-F®	+	0	-
$10^{12} - 10^{14}\Omega$	Ceramic	-	0	+
$10^{12} - 10^{14}\Omega$	Nylon	-	0	-
$10^{10} - 10^{17}\Omega$	Glass Epoxy	-	0	0
$10^{10} - 10^{15}\Omega$	PVC	+	0	-
$10^5 - 10^{12}\Omega$	Phenolic	-	+	+

KEY: + Material very good in regard to the property.
 0 Material moderately good in regard to the property.
 - Material weak in regard to the property.

Table 1

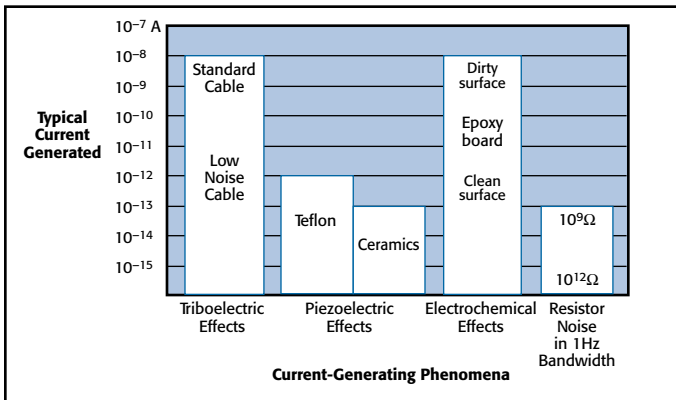

Figure 7

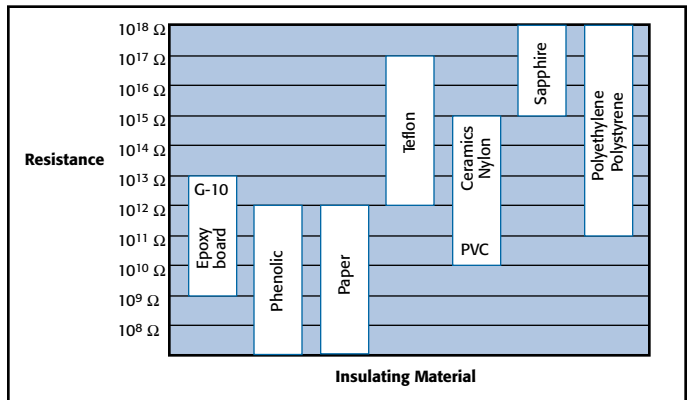

Figure 8

1.888.KEITHLEY (U.S. only)

www.keithley.com

KEITHLEY

A Tektronix Company

Selector Guide

Low Current/High Resistance Measurements

Selector Guide: Picoammeters, Electrometers, Source Measure Unit (SMU) Instruments (Measurement)

	Picoammeters				Electrometers		Source Measure Unit (SMU) Instruments
MODEL	6482	6485	6487	2502	6514	6517B	6430
Page	143	146	149	111	156	160	51
CURRENT MEASURE							
From ¹	20 fA	20 fA	20 fA	15 fA	<1 fA	<1 fA	400 nA
To	20 mA	20 mA	20 mA	20 mA	20 mA	20 mA	100 mA
VOLTAGE MEASURE							
From ²					10 μ V	10 μ V	10 μ V
To					200 V	200 V	200 V
RESISTANCE MEASURE⁴							
From ⁵			10 Ω		10 Ω	100 Ω	100 $\mu\Omega$
To ⁶			1 P Ω		200 G Ω	10 P Ω ³	10 P Ω ³
CHARGE MEASURE							
From ²					10 fC	10 fC	
To					20 μ C	2 μ C	
FEATURES							
Input Connection	3 Slot Triax	BNC	3 Slot Triax	3 Slot Triax	3 Slot Triax	3 Slot Triax	3 Slot Triax
IEEE-488	•	•	•	•	•	•	•
RS-232	•	•	•	•	•	•	•
Guard					•	•	•
CE	•	•	•	•	•	•	•
Other	6½ digits. Dual \pm 30V bias sources.	5½ digits. Autoranging. 1000 rdg/s.	5½ digits. Built-in 500V source. Alternating voltage method for HI-R sweeps.	5½ digits. Dual channel. Built-in 100V source per channel.	5½ digits. Replaces Models 6512, 617-HIQ.	5½ digits. Built-in \pm 1kV source. Temperature, RH measurements. Alternating polarity method for HI-R. Plug-in switch cards available. Replaces 6517A.	SourceMeter with Remote PreAmp to minimize cable noise.

NOTES

- Includes noise.
- Digital resolution limit. Noise may have to be added.
- P Ω (Petaohms) = $10^{15}\Omega$.
- Resistance is measured with the Model 237 using Source V/Measure I or Source I/Measure V, but not directly displayed.
- Lowest resistance measurable with better than 1% accuracy.
- Highest resistance measurable with better than 10% accuracy.

1.888.KEITHLEY (U.S. only)

www.keithley.com

A Greater Measure of Confidence

KEITHLEY
A Tektronix Company

Selector Guide

Low Current/High Resistance Measurements

Selector Guide: Sources and Source Measure Unit (SMU) Instruments (*Sourcing*)

MODEL	Current Sources		Source Measure Unit (SMU) Instruments	
	6220	6221	2657A	6430
Page	133	133	32	51
Current Source	•	•	120 mA	•
Voltage Source			3000 V	•
Sink	•	•	180 W	•
CURRENT OUTPUT				
Accuracy ¹	2 pA	2 pA DC 4 pA AC	0.03%	10 fA
Resolution ²	100 fA	100 fA (DC & AC)	1 fA	50 aA
Maximum	±105 mA	±105 mA	±120 mA	±105 mA
VOLTAGE OUTPUT				
From			±100 μ V	±5 μ V
To			±3000 V	±210 V
POWER OUTPUT	11 W	11 W	180 W	2.2 W
CURRENT LIMIT			120 mA	1 fA to 105 mA
VOLTAGE LIMIT	105 V	105 V	3000 V	0.2 mV to 210 V
ACCURACY (\pmSetting)				
I	0.05%	0.05%	0.03%	0.03%
V			0.03%	0.02%
FEATURES				
Output Connector	3 Slot Triax	3 Slot Triax	HV Triax	3 Slot Triax
Ethernet		•	LXI compliant	
RS-232	•	•		•
IEEE-488	•	•	•	•
Memory	65,000 pt.	65,000 pt.	250K readings	2500 pt.
Remote Sense			•	•
Current Source Guard	•	•	•	•
CE	•	•	•	•
Other	Controls 2182A for low-power resistance and I-V measurements.	AC and DC current source. ARB waveforms up to 100kHz. Controls 2182A like 6220, adds pulsed I-V	Source/measure capability. Pulse mode. USB port.	

1. Best absolute accuracy of source.

2. Resolution for lowest range, smallest change in current that source can provide.

1.888.KEITHLEY (U.S. only)

www.keithley.com

KEITHLEY
A Tektronix Company

A Greater Measure of Confidence

6482

Dual-Channel Picoammeter/ Voltage Source

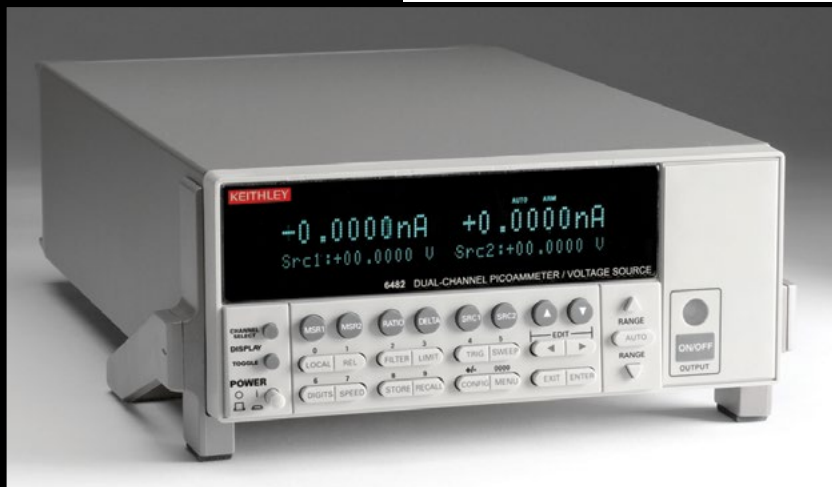

- **Dual-channel, 6½-digit measurement capability**
- **Dual ±30V bias sources**
- **Measure currents up to 20mA**
- **Measure currents with 1fA resolution**
- **0–10V analog output for high resolution measurement feedback**
- **Supports assembly process, final testing, parts binning, and specification**
- **3000-point buffer memory on each channel allows data transfer after test completion**
- **Trigger Link for binning and sweep test operations**
- **IEEE-488 and RS-232 interfaces**

APPLICATIONS

- **Manufacturing component test**
- **Dual diode testing**
- **Semiconductor component testing**
- **Multi-pin component testing**
- **Ion beam monitoring**
- **Electron microscopy**

The Model 6482 Dual-Channel Picoammeter/Voltage Source provides two independent picoammeter/voltage source channels for a wide range of low-level measurement applications that require dual-channel measurements. Building off of the proven measurement capabilities of Keithley's Model 6485 5½-digit Picoammeter, the Model 6482 adds higher measurement resolution, a second measurement channel, and dual, independent 30V voltage bias sources.

With its dual channel measurement capabilities, the Model 6482 is a great measurement tool for analyzing multi-channel devices, monitoring currents in multiple locations on materials, and recording data from multiple sensors at once. The dual channels facilitate easier control and data aggregation. The greater channel density increases the number of instruments (and channels) that can fit in confined spaces.

Programmable Limits and Filters

As with most Keithley instruments, the Model 6482's current and voltage limits can be programmed to ensure device protection during critical points, such as start of test. These instruments also provide average and median filters, which can be applied to the data stored in the buffer memory.

Ratio and Delta Measurements

The Model 6482 can provide ratio or delta measurements between the two completely isolated channels. These functions can be accessed via either the front panel or the GPIB interface. For test setups with multiple detectors, this capability enables targeted control capabilities.

Features that Expand Test and Measurement Flexibility

- **Scaled voltage analog output.** The Model 6482 can transmit measurement results to devices such as DMMs, data acquisition boards, oscilloscopes, or strip chart recorders.
- **220V overload protection.** With this high overload protection and a robust design, the Model 6482 can withstand abusive overflows.
- **One-touch front panel design.** Functions can be configured easily with the push of a button - without complicated function menus.
- **Built-in Trigger Link interface.** The Trigger Link interface simplifies synchronizing the Model 6482 with other instruments and voltage sources and combines six independent selectable trigger lines on a single connector for simple, direct control over all instruments in a system.
- **RS-232 and IEEE-488 interfaces.** These interfaces make it easy to integrate the Model 6482 into automated test and measurement systems.
- **Display on/off switch.** For research on light-sensitive components, such as measuring the dark currents of photodiodes, the front panel display can be switched off to avoid introducing light that could significantly reduce the accuracy of the results.
- **REL and LOG functions.** The Model 6482 can make relative readings with respect to a baseline value or display the logarithm of the absolute value of the measured current.
- **Rear panel triax inputs.** Triax inputs ensure premium noise protection. Triax-to-BNC adapters, which are included, allow inexpensive, easy-to-use BNC cables to be employed in situations where noise is less of a concern.

1.888.KEITHLEY (U.S. only)

www.keithley.com

A Greater Measure of Confidence

KEITHLEY

A Tektronix Company

6482

Dual-Channel Picoammeter/ Voltage Source

Ordering Information

- 6482** **Dual Channel Picoammeter/Voltage Source (120V line power voltage)**
- 6482/E** **Dual Channel Picoammeter/Voltage Source (220-240V line power voltage)**
- 6482/J** **Dual Channel Picoammeter/Voltage Source (100V line power voltage)**

Accessories Supplied

- 7078-TRX-BNC**
Triax-to-BNC Connector (2x)

ACCESSORIES AVAILABLE

CABLES

- 237-ALG-* Low Noise Triax Cable with Alligator Clips
- 4802-10 Low Noise BNC Input Cable, 3m (10 ft)
- 4803 Low Noise Cable Kit
- 7007-1 Shielded IEEE-488 Cable, 1m (3.3 ft)
- 7007-2 Shielded IEEE-488 Cable, 2m (6.6 ft)
- 7007-4 Shielded IEEE-488 Cable, 4m (13.1 ft)
- 7078-TRX-* 3-Slot Triax Cable
- 7009-5 RS-232 Cable
- 7754-3 BNC to Alligator Cable, 0.9m (3 ft)
- 8607 Banana Cable set for Analog Output
- 8501-1 Trigger Link Cable with Male Micro-DIN Connectors at each End, 1m (3.3 ft)
- 8501-2 Trigger Link Cable with Male Micro-DIN Connectors at each End, 2m (6.6 ft)
- 8503 DIN-to-BNC Trigger Cable

ADAPTERS

- 237-TRX-BAR 3-lug Triax Barrel
- 7078-TRX-BNC Female BNC to 3-Slot Male Triax for connecting BNC cable into triax fixture
- CS-565 BNC Barrel

RACK MOUNT KITS

- 4288-1 Single Fixed Rack Mounting Kit
- 4288-2 Dual Fixed Rack Mounting Kit

GPIB INTERFACES

- KPCI-488LPA IEEE-488 Interface/Controller for the PCI Bus
- KUSB-488B IEEE-488 USB-to-GPIB Interface Adapter

SERVICES AVAILABLE

- 6482-3Y-EW 1 Year Factory Warranty extended to 3 years from date of shipment
- 6482-5Y-EW 1 Year Factory Warranty extended to 3 years from date of shipment
- C/6482-3Y-DATA 3 (Z-540-1 compliant) calibrations within 3 years of purchase for Model 6482
- C/6482-5Y-DATA 5 (Z-540-1 compliant) calibrations within 5 years of purchase for Model 6482
- C/6482-3Y-ISO 3 (ISO-17025 accredited) calibrations within 3 years of purchase for Model 6482
- C/6482-5Y-ISO 5 (ISO-17025 accredited) calibrations within 5 years of purchase for Model 6482

Dual-channel picoammeter/voltage source

LOW LEVEL MEASURE & SOURCE

1.888.KEITHLEY (U.S. only)

www.keithley.com

A Greater Measure of Confidence



SPECIFICATION CONDITIONS

This document contains specifications and supplemental information for the Model 6482 Dual-Channel Picoammeter/Voltage Source instrument. Specifications are the standards against which the Model 6482 is tested. Upon leaving the factory, the Model 6482 meets these specifications. Supplemental and typical values are nonwarranted, apply at 23°C, and are provided solely as useful information. The Model 6482 provides two independent picoammeter/voltage source channels for a wide range of measurement applications. The Model 6482 includes an analog output jack on the rear panel for each channel.

Source and measurement accuracies are specified at the Model 6482 terminals under these conditions:

1. 23° ± 5°C, <70 percent relative humidity.
2. After a one-hour warm-up period.
3. Speed normal (1 NPLC).
4. A/D autozero enabled.
5. Properly zeroed operation.
6. Calibration period: One year.

MEASUREMENT SPECIFICATIONS¹

Range	Maximum Resolution	Accuracy ^{1,2} 23° ± 5°C ±(% rdg + offset)	Temperature Coefficient 0°–18°C & 28°–50°C ±(%rdg + offset)/°C	DC Input Impedance ³ (maximum)
2.000000 nA	1 fA	1.00% + 2 pA	0.01 + 200 fA	20 kΩ
20.00000 nA	10 fA	0.40% + 2 pA	0.01 + 200 fA	20 kΩ
200.0000 nA	100 fA	0.30% + 200 pA	0.02 + 20 pA	200 Ω
2.000000 μA	1 pA	0.20% + 200 pA	0.02 + 20 pA	200 Ω
20.00000 μA	10 pA	0.10% + 20 nA	0.01 + 2 nA	2.0 Ω
200.0000 μA	100 pA	0.10% + 20 nA	0.01 + 2 nA	2.0 Ω
2.000000 mA	1 nA	0.10% + 2 μA	0.02 + 200 nA	0.2 Ω
20.00000 mA	10 nA	0.10% + 2 μA	0.02 + 200 nA	0.2 Ω

VOLTAGE BIAS SPECIFICATIONS

Range	Resolution	Accuracy 23°C ± 5°C	Maximum Current	Load Regulation ⁴	Temperature Coefficient
±10 V	<400 μV	±(0.15% of setting + 5 mV)	20 mA	< 0.30%, 0 to 20 mA	150 ppm/°C
±30 V	<4 mV	±(0.3% of setting + 50 mV)	20 mA	< 0.30%, 0 to 20 mA	300 ppm/°C

ANALOG OUTPUT SPECIFICATIONS

OUTPUT VOLTAGE RANGE (output is inverting)²: –10V out for positive full scale input, +10V out for negative full scale input.

OUTPUT IMPEDANCE: 1kΩ typical.

Range	Accuracy 23°C ± 5°C ±(% rdg. + offset)	Temperature Coefficient 0°–18°C & 28°–50°C ±(%rdg. + offset)/°C	Typical Rise Time (10% to 90%)
2.000000 nA	6.0% + 90 mV	0.30% + 7 mV	6.1 ms
20.00000 nA	3.0% + 9 mV	0.11% + 700 μV	6.1 ms
200.0000 nA	6.0% + 90 mV	0.30% + 4 mV	395 μs
2.000000 μA	3.0% + 9 mV	0.11% + 400 μV	395 μs
20.00000 μA	6.0% + 90 mV	0.30% + 4 mV	135 μs
200.0000 μA	2.5% + 9 mV	0.11% + 400 μV	135 μs
2.000000 mA	6.0% + 90 mV	0.30% + 4 mV	21 μs
20.00000 mA	2.5% + 9 mV	0.11% + 400 μV	21 μs

TYPICAL NOISE FLOOR MEASUREMENT SPECIFICATIONS

Range	Typical Noise Floor RMS (1 STDEV), 100 Samples			
	0.01 NPLC	0.1 NPLC	1.0 NPLC	10 NPLC
2.000000 nA	2.5 pA	1.5 pA	45 fA	15 fA
20.00000 nA	2.5 pA	1.5 pA	45 fA	15 fA
200.0000 nA	200 pA	120 pA	2 pA	500 fA
2.000000 μA	200 pA	120 pA	2 pA	500 fA
20.00000 μA	20 nA	12 nA	200 pA	50 pA
200.0000 μA	20 nA	12 nA	200 pA	50 pA
2.000000 mA	2 μA	1.5 μA	25 nA	5 nA
20.00000 mA	2 μA	1.5 μA	25 nA	5 nA

TYPICAL SPEED AND NOISE REJECTION

Digits	Readings per Second			NMRR
	GPIB (SCPI)	GPIB (488.1)	NPLC	
4½	700	900	0.01	—
5½	60	475	0.1	—
6½	58	58	1	60 dB

GENERAL

SOURCE CAPACITANCE: Stable to 10.0nF (typical).

INPUT BIAS CURRENT⁵: 50fA max. @ 23°C.

INPUT VOLTAGE BURDEN⁶: 4.0mV maximum.

VOLTAGE SOURCE SLEW RATE: 3.0ms/V (typical).

COMMON MODE VOLTAGE: 200VDC.

COMMON MODE ISOLATION: Typically 10⁹Ω in parallel with 150nF.

OVERRRANGE: 105% of measurement range.

MEMORY BUFFER: 6000 readings (two 3000 point buffers). Includes selected measured value(s) and time stamp.

PROGRAMMABILITY: IEEE-488.2, RS-232, five user-definable power-up states plus factory default and *RST.

OUTPUT ENABLE CONNECTOR:

Output Enable: Active low input.

Input line: SOT (start of test) trigger input.

POWER SUPPLY: 100V, 120V, 220V, 240V (±10%), 50Hz or 60Hz, 50VA maximum.

WARRANTY: 1 year.

EMC: Conforms to European Union EMC Directive.

VIBRATION: MIL-T-28800F random class 3.

SAFETY: Conforms to European Union Low Voltage Directive.

WARM-UP: 1 hour to rated accuracy.

DIMENSIONS:

Rack Mount: 89mm high × 213mm wide × 370mm deep (3.5 in. × 8.4 in. × 14.6 in.).

Bench Configuration (with handle and feet): 104mm high × 238mm wide × 370mm deep (4.1 in. × 9.4 in. × 14.6 in.).

WEIGHT: 23.1kg (10.5 lb.).

ENVIRONMENT: For indoor use only.

Altitude: Maximum 2000m (6562 ft.) above sea level.

Operating: 0° to 50°C, 70 % relative humidity up to 35°C. Derate 3% relative humidity/°C, 35° to 50°C.

Storage: –25° to 65°C.

NOTES

1. Speed = Normal (1.0 NPLC), filter on.
2. One year.
3. Measured as DVin/Alin at full scale (and zero) input currents.
4. Measured as DVin/Alin at full scale (20mA) and zero load currents.
5. Specification by design.
6. Measured (at input triaxial connector) as DWin at full scale (20mA) versus zero input currents.

1.888.KEITHLEY (U.S. only)

www.keithley.com

KEITHLEY

A Tektronix Company

A Greater Measure of Confidence

6485

Picoammeter



- Cost-effective low current measurement solution
- 10fA resolution
- 5½-digit resolution
- <200µV burden voltage
- Up to 1000 readings/second
- Built-in Model 485 emulation mode
- IEEE-488 and RS-232 interfaces
- Analog output

ammeters, or user-designed solutions. With a price that's comparable to a general purpose DMM, the Model 6485 makes picoamp-level measurements affordable for virtually any laboratory or production floor.

Low Voltage Burden and Higher Accuracy

While DMMs typically employ shunt ammeter circuitry to measure current, the Model 6485 is a feedback picoammeter. This design reduces voltage burden by several orders of magnitude, resulting in a voltage burden of less than 200µV on the lower measurement ranges. The low voltage burden makes the Model 6485 function much more like an ideal ammeter than a DMM, so it can make current measurements with high accuracy, even in circuits with very low source voltages.

Successor to the Model 485

The Model 6485 builds on the strengths of one of Keithley's most popular picoammeters, the Model 485, offering an additional 20mA measurement range, as well as much higher measurement speeds. With a top speed of up to 1000 readings per second, the Model 6485 is the fastest picoammeter Keithley has ever made. It offers ten times greater resolution than the Model 485 on every range. A time-stamped 2500-reading data buffer provides minimum, maximum, and standard deviation statistics. A built-in emulation mode simplifies upgrading existing applications originally configured with a Model 485. This emulation mode makes it possible to control the Model 6485 with any custom code written to control the Model 485. Refer to the comparison table for additional information.

	Model 485	Model 6485
Current Ranges	2nA–2mA	2nA–20mA
Voltage Burden	200µV	200µV (1mV on 20mA range)
Reading Rate	3/s	1000/s
Digits	4½	5½
Analog Output	Yes	Yes
Battery Option	Yes	No
Storage Buffer	100 points	2500 points

When do you need a picoammeter?

Measuring low DC currents often demands a lot more than a digital multimeter (DMM) can deliver. Generally, DMMs lack the sensitivity required to measure currents less than 100nA. Even at higher currents, a DMM's input voltage drop (voltage burden) of hundreds of millivolts can make accurate current measurements impossible. Electrometers can measure low currents very accurately, but the circuitry needed to measure extremely low currents, combined with functions like voltage, resistance, and charge measurement, can increase an electrometer's cost significantly. The Model 6485 Picoammeter combines the economy and ease of use of a DMM with low current sensitivity near that of an electrometer.

1.888.KEITHLEY (U.S. only)

www.keithley.com
KEITHLEY

A Tektronix Company

A Greater Measure of Confidence

6485

Picoammeter

Ordering Information

6485 Picoammeter

Accessories Supplied

CAP-18	Protective Shield/ Cap (2-lug)
4801	Low Noise BNC Input Cable, 1.2m (4 ft)

APPLICATIONS

- **Beam monitoring and radiation monitoring**
- **Leakage current testing in insulators, switches, relays, and other components**
- **SEM beam current measurements**
- **Galvanic coupling measurements**
- **Optoelectronic device testing and characterization**
- **Optical fiber alignment**
- **Circuit test and analysis in DCLF circuits**
- **Sensor characterization**
- **I-V measurements of semiconductors and other devices**
- **Nanoelectronic device characterization**
- **Capacitor leakage**
- **Teaching labs**

Features that Expand Test and Measurement Flexibility

- **Scaled voltage analog output.** This output allows the Model 6485 to transmit measurement results to devices like DMMs, data acquisition boards, oscilloscopes, or strip chart recorders.
- **220V overload protection.** This high overload protection and a robust design let the Model 6485 withstand abusive overflows.
- **One-touch front panel design.** Functions can be configured easily with the push of a button, without complicated function menus.
- **Built-in Trigger Link interface.** The Trigger Link interface simplifies synchronizing the Model 6485 with other instruments and voltage sources. This interface combines six independent selectable trigger lines on a single connector for simple, direct control over all instruments in a system.
- **RS-232 and IEEE-488 interfaces.** These interfaces make it easy to integrate the Model 6485 into automated test and measurement systems.
- **Display on/off switch.** For research on light-sensitive components, such as measuring the dark currents of photodiodes, the front panel display can be switched off to avoid introducing light that could significantly reduce the accuracy of the results.
- **REL and LOG functions.** The Model 6485 can make relative readings with respect to a baseline value or display the logarithm of the absolute value of the measured current.
- **Resistance calculations.** The Model 6485 can calculate resistance by dividing an externally sourced voltage value by the measured current.
- **Rear panel BNC inputs.** Inexpensive, easy-to-use BNC cables can be employed, rather than more expensive triax cables.

ACCESSORIES AVAILABLE

CABLES

4802-10	Low Noise BNC Input Cable, 3m (10 ft)
4803	Low Noise Cable Kit
7007-1	Shielded IEEE-488 Cable, 1m (3.3 ft)
7007-2	Shielded IEEE-488 Cable, 2m (6.6 ft)
7007-4	Shielded IEEE-488 Cable, 4m (13.1 ft)
7009-5	RS-232 Cable
7754-3	BNC to Alligator Cable, 0.9m (3 ft)
8607	Banana Cable set for Analog Output
8501-1	Trigger Link Cable with Male Micro-DIN Connectors at each End, 1m (3.3 ft)
8501-2	Trigger Link Cable with Male Micro-DIN Connectors at each End, 2m (6.6 ft)
8503	DIN-to-BNC Trigger Cable

ADAPTERS

CS-565	BNC Barrel
7078-TRX-BNC	Female BNC to 3-Slot Male Triax for connecting BNC cable into triax fixture

RACK MOUNT KITS

4288-1	Single Fixed Rack Mounting Kit
4288-2	Dual Fixed Rack Mounting Kit

GPIB INTERFACES

KPCI-488LPA	IEEE-488 Interface/Controller for the PCI Bus
KUSB-488B	IEEE-488 USB-to-GPIB Interface Adapter

SERVICES AVAILABLE

6485-3Y-EW	1-year factory warranty extended to 3 years from date of shipment
C/6485-3Y-ISO	3 (ISO-17025 accredited) calibrations within 3 years of purchase*

*Not available in all countries

1.888.KEITHLEY (U.S. only)

www.keithley.com

A Greater Measure of Confidence

KEITHLEY
A Tektronix Company

Measures low currents quickly, accurately, and economically

LOW LEVEL MEASURE & SOURCE

Range	5½ Digit Default Resolution	Accuracy (1 Year) ¹ ±(% rdg. + offset) 18°–28°C, 0–70% RH	Typical RMS Noise ²	Analog Rise Time ³ (10% to 90%)
2 nA	10 fA	0.4 % + 400 fA	20 fA	8 ms
20 nA	100 fA	0.4 % + 1 pA	100 fA	8 ms
200 nA	1 pA	0.2 % + 10 pA	1 pA	500 μs
2 μA	10 pA	0.15% + 100 pA	10 pA	500 μs
20 μA	100 pA	0.1 % + 1 nA	100 pA	500 μs
200 μA	1 nA	0.1 % + 10 nA	1 nA	500 μs
2 mA	10 nA	0.1 % + 100 nA	10 nA	500 μs
20 mA	100 nA	0.1 % + 1 μA	100 nA	500 μs

TEMPERATURE COEFFICIENT: 0°–18°C & 28°–50°C. For each °C, add 0.1 × (% rdg + offset) to accuracy spec.

INPUT VOLTAGE BURDEN: <200μV on all ranges except <1mV on 20mA range.

MAXIMUM INPUT CAPACITANCE: Stable to 10nF on all nA ranges and 2μA range; 1μF on 20μA and 200μA ranges, and on mA ranges.

MAXIMUM COMMON MODE VOLTAGE: 42V.

MAXIMUM CONTINUOUS INPUT VOLTAGE: 220 VDC.

ISOLATION (Meter COMMON to chassis): Typically >5×10¹¹Ω in parallel with <1nF.

NMRR¹ (50 or 60Hz): 60dB.

ANALOG OUTPUT: Scaled voltage output (inverting 2V full scale on all ranges) 3% ±2mV, 1kΩ impedance.

NOTES

- At 1 PLC – limited to 60 rdgs/second under this condition.
- At 6 PLC, 1 standard deviation, 100 readings, filter off, capped input – limited to 10 rdgs/sec under this condition.
- Measured at analog output with resistive load >100kΩ.

IEEE-488 BUS IMPLEMENTATION

MULTILINE COMMANDS: DCL, LLO, SDC, GET, GTL, UNT, UNL, SPE, SPD.

IMPLEMENTATION: SCPI (IEEE-488.2, SCPI-1996.0); DDC (IEEE-488.1).

UNILINE COMMANDS: IFC, REN, EOI, SRQ, ATN.

INTERFACE FUNCTIONS: SH1, AH1, T5, TE0, L4, LE0, SR1, RL1, PP0, DC1, DT1, C0, E1.

PROGRAMMABLE PARAMETERS: Range, Zero Check, Zero Correct, EOI (DDC mode only), Trigger, Terminator (DDC mode only), Calibration (SCPI mode only), Display Format, SRQ, REL, Output Format, V-offset Cal.

ADDRESS MODES: TALK ONLY and ADDRESSABLE.

LANGUAGE EMULATION: Keithley Model 485 emulation via DDC mode.

RS-232 IMPLEMENTATION:

Supports: SCPI 1996.0.

Baud Rates: 300, 600, 1200, 2400, 4800, 9600, 19.2k, 38.4k, 57.6k.

Protocols: Xon/Xoff, 7 or 8 bit ASCII, parity-odd/even/none.

Connector: DB-9 TXD/RXD/GND.

GENERAL

INPUT CONNECTOR: BNC on rear panel.

DISPLAY: 12 character vacuum fluorescent.

RANGING: Automatic or manual.

OVERRANGE INDICATION: Display reads “OVRFLOW.”

CONVERSION TIME: Selectable 0.01 PLC to 60 PLC (50 PLC under 50Hz operation). (Adjustable from 200μs to 1s)

READING RATE:

- To internal buffer: 1000 readings/second¹
- To IEEE-488 bus: 900 readings/second^{1, 2}

Notes:

- 0.01 PLC, digital filters off, front panel off, auto zero off.
- Binary transfer mode. IEEE-488.1.

BUFFER: Stores up to 2500 readings.

PROGRAMS: Provide front panel access to IEEE address, choice of engineering units or scientific notation, and digital calibration.

EMC: Conforms with European Union Directive 89/336/EEC, EN61326-1.

SAFETY: Conforms with European Union Directive 73/23/EEC, EN61010-1.

TRIGGER LINE: Available, see manual for usage.

DIGITAL FILTER: Median and averaging (selectable from 2 to 100 readings).

ENVIRONMENT:

Operating: 0°–50°C; relative humidity 70% non-condensing, up to 35°C. Above 35°C, derate humidity by 3% for each °C.

Storage: –25° to +65°C.

WARM-UP: 1 hour to rated accuracy (see manual for recommended procedure).

POWER: 100–120V or 220–240V, 50–60Hz, 30VA.

PHYSICAL:

Case Dimensions: 90mm high × 214mm wide × 369mm deep (3½ in. × 8½ in. × 14½ in.).

Working Dimensions: From front of case to rear including power cord and IEEE-488 connector: 394mm (15.5 in.).

Net Weight: <2.8 kg (<6.1 lbs).

Shipping Weight: <5 kg (<11 lbs).

1.888.KEITHLEY (U.S. only)

www.keithley.com

KEITHLEY

A Tektronix Company

A Greater Measure of Confidence

6487

Picoammeter/Voltage Source



- 10fA resolution
- 5½-digit resolution
- <200µV burden voltage
- Alternating Voltage method ohms measurements
- Automated voltage sweeps for I-V characterization
- Floating measurements up to 500V
- Up to 1000 readings/second
- Built-in Model 486 and 487 emulation mode
- IEEE-488 and RS-232 interfaces
- Analog output
- Digital I/O

a price that's comparable to a high-end DMM, the Model 6487 makes picoamp-level measurements affordable for virtually any laboratory or production floor.

Low Voltage Burden and Higher Accuracy

While DMMs typically employ shunt ammeter circuitry to measure current, the Model 6487 is a feedback picoammeter. This design reduces voltage burden by several orders of magnitude, resulting in a voltage burden of less than 200µV on the lower measurement ranges. The low voltage burden makes the Model 6487 function much more like an ideal ammeter than a DMM, so it can make current measurements with high accuracy, even in circuits with very low source voltages.

Successor to the Model 487

The Model 6487 builds on the strengths of one of Keithley's most popular picoammeters, the Model 487, offering an additional 20mA measurement range, as well as much higher measurement speeds, up to 1000 readings per second. It simplifies device characterization with built-in voltage sweeping capability and the Alternating Voltage method for high resistances. A time-stamped 3000-reading data buffer provides minimum, maximum, and standard deviation statistics. A built-in emulation mode makes it possible to control the Model 6487 with any custom code written to control the Model 487.

Features that Expand Test and Measurement Flexibility

- **Direct resistance measurements.** Optimized for resistances from 50Ω to 5×10¹⁴Ω using the Source Voltage/Measure Current method.
- **Alternating Voltage method resistance measurements.** This method improves resistance measurements on devices with high background current or high noise. It extends the measurable resistance range up to 10¹⁶Ω.
- **500V overload protection.** This high overload protection and a robust design let the Model 6487 tolerate abusive overflows, including accidentally shorting the voltage source directly into the ammeter.

The 5½-digit Model 6487 Picoammeter/Voltage Source improves on the measurement capability of the award-winning Model 6485, and adds a high resolution 500V source. It provides higher accuracy and faster rise times than the 6485, as well as a damping function for use with capacitive devices. With eight current measurement ranges and high speed autoranging, this cost-effective instrument can measure currents from 20fA to 20mA, take measurements at speeds up to 1000 readings per second, and source voltage from 200µV to 505V.

The Model 6487's 10fA resolution, superior sensitivity, voltage sweeping, and Alternating Voltage resistance measurements make it well suited for characterizing low current devices. Using the latest current measurement technology, it is significantly less expensive than other instruments that perform similar functions, such as optical power meters, tera-ohmmeters, competitive picoammeters, or user-designed solutions. With

	Model 487	Model 6487
Current Ranges	2 nA–2 mA	2 nA–20 mA
Voltage Burden	200 µV	200 µV (1 mV on 20 mA range)
Reading Rate	Up to 180/s	Up to 1000/s
Voltage Sweeps	No	Yes
Alternating Voltage Ohms	No	Yes
Analog Output	Yes (non-inverting)	Yes (inverting)
Storage Buffer	512 points	3000 points
Best V Source Resolution	1 mV	0.2 mV

1.888.KEITHLEY (U.S. only)

www.keithley.com

A Greater Measure of Confidence

KEITHLEY

A Tektronix Company

Measures low currents and high resistances quickly, accurately, and economically

LOW LEVEL MEASURE & SOURCE

6487**Ordering Information****6487 Picoammeter/
Voltage Source****Accessories Supplied****CA-186-1B****Ground Connection
Cable, Banana
to Screw-Lug****CAP-31****Protective Shield/
Cap (3-lug)****CS-459****Safety Interlock Plug****7078-TRX-3****Low Noise Triax Input
Cable, 1m (3 ft)****8607****High Voltage Banana
Cable Set for Voltage
Source Output**

Picoammeter/Voltage Source

- **Rear panel triax input.** This allows the picoammeter to be used in floating operation, up to 500V. When not floating, the addition of a triax to BNC adapter allows inexpensive, easy-to-use BNC cables to be employed, rather than more expensive triaxial cables.
- **RS-232 and IEEE-488 interfaces.** These interfaces make it easy to integrate the Model 6487 into automated test and measurement systems.
- **Scaled voltage analog output.** This output allows the Model 6487 to transmit measurement results to devices like DMMs, data acquisition cards, oscilloscopes, or strip chart recorders.
- **Built-in Trigger Link interface.** The Trigger Link interface simplifies synchronizing the Model 6487 with other instruments and voltage sources. This interface combines six independent selectable trigger lines on a single connector for simple, direct control over all instruments in a system.
- **Display on/off switch.** For research on light-sensitive components, such as measuring the dark currents of photodiodes or I-V measurements on unpackaged semiconductors, the front panel display can be switched off to avoid introducing light that could significantly reduce the accuracy of the results.
- **One-touch front panel design.** Functions can be configured easily with the push of a button, without complicated function menus.

A Broad Range of Low Current Applications

Wafer-Level Photodiode Testing

The Model 6487 Picoammeter/Voltage Source can be paired with a calibrated light source and a probing fixture to create a cost-effective photodiode test system. Multiple Model 6487s can be connected to the DUT's probe pads to provide photocurrent readings or, with the addition of a switch matrix, one picoammeter can take current measurements from multiple pads. In the first step of the measurement process, performed in total darkness, the Model 6487 produces a voltage sweep and then measures the resulting dark current. In the second step, a voltage bias is applied and the resulting photocurrent is measured while the light level is increased in calibrated steps. The same basic test configuration can be used for testing positive intrinsic negative (PIN) and avalanche photodiodes (APDs). The 6487's high resolution on the 10V source range provides superior sweeping and biasing when small biases are required. The 500V source capability is necessary to bias APDs.

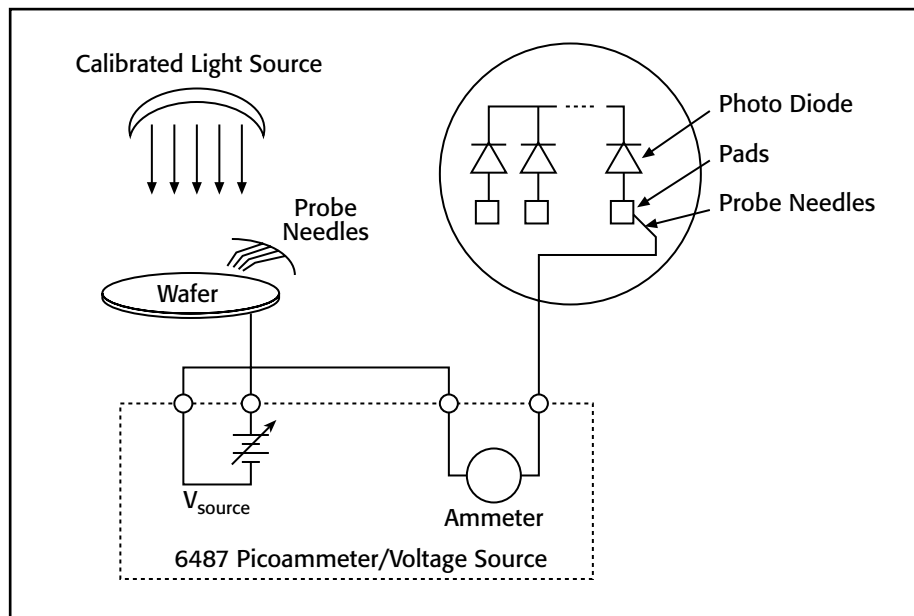
**APPLICATIONS**

- **Resistance/resistivity measurements**
- **Beam monitoring and radiation monitoring**
- **Leakage current testing in insulators, switches, relays, and other components**
- **Galvanic coupling measurements**
- **I-V characterization on semiconductor and optoelectronic devices**
- **Fiber alignment**
- **Circuit test and analysis in DCLF circuits**
- **Sensor characterization**
- **Capacitor leakage**

1.888.KEITHLEY (U.S. only)

www.keithley.com**KEITHLEY**
A Tektronix Company

A Greater Measure of Confidence

Monitoring and Control of Focused Ion Beam Currents

In semiconductor fabrication, focused ion beam systems are often used for nanometer-scale imaging, micromachining, and mapping. Careful monitoring of the magnitude of the beam current with an ion detector is critical. The ion detector generates a secondary current that's proportional to the current of the primary ion beam. When this secondary current is measured, it can be used to control the intensity of the primary beam. However, this secondary current is very low, often just a few picoamps, so the instrumentation measuring it must provide high measurement accuracy and repeatability, as well as sub-picoamp resolution. The Model 6487's wide measurement range and 5½-digit resolution make it ideal for this application. Signal connections to the Model 6487 are made through the instrument's triax connector. Often, a detector may require high voltage to attract ions, making the 6487's 500V source a necessity.

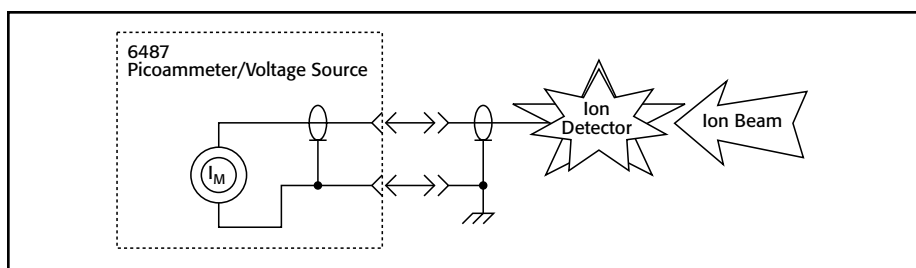

High Resistance Measurements

The Model 6487 Picoammeter can be used to measure high resistances ($>1G\Omega$) in applications such as insulation resistance testing. A constant voltage is placed in series with the unknown resistance and the picoammeter. The voltage drop across the picoammeter is negligible, so all the voltage appears across the unknown resistance. The resulting current is measured by the picoammeter and the resistance is calculated using Ohm's Law ($R = V/I$). To prevent generated current due to electrostatic interference, the unknown resistance is housed in a shielded test fixture. A small series resistor may be added to reduce noise if the unknown resistor has high stray capacitance across it.

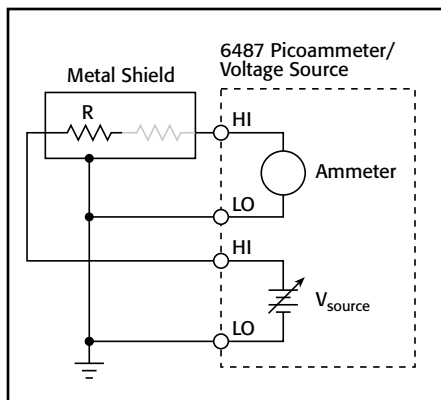

When do you need a picoammeter?

Measuring low DC currents often demands a lot more than a digital multimeter can deliver. Generally, DMMs lack the sensitivity required to measure currents less than 100nA. Even at higher currents, a DMM's input voltage drop (voltage burden) of hundreds of millivolts can make accurate current measurements impossible. Electrometers can measure low currents very accurately, but the circuitry needed to measure extremely low currents, combined with functions like voltage, resistance, and charge measurement, can increase an electrometer's cost significantly. The Model 6487 Picoammeter/Voltage Source combines the economy and ease of use of a DMM with low current sensitivity near that of an electrometer.

ACCESSORIES AVAILABLE

CABLES

6517-ILC-3	Interlock Cable for 8009 Resistivity Test Fixture
7007-1	Shielded IEEE-488 Cable, 1m (3.3 ft)
7007-2	Shielded IEEE-488 Cable, 2m (6.6 ft)
7007-4	Shielded IEEE-488 Cable, 4m (13.1 ft)
7078-TRX-10	Low Noise Triax Cable, 3.0m (10 ft)
7078-TRX-20	Low Noise Triax Cable, 6.0m (20 ft)
8501-*	Trigger Link Cable with male Micro-DIN connectors at each end, 1m or 2m (3.3 ft or 6.6 ft)

ADAPTERS

237-TRX-BAR	Triax Barrel
7078-TRX-BNC	Triax-to-BNC Adapter

TEST FIXTURES

8009	Resistivity Test Fixture
------	--------------------------

RACK MOUNT KITS

4288-*	Single or Dual Fixed Rack Mounting Kit
--------	--

GPIB INTERFACES

KPCI-488LPA	IEEE-488 Interface/Controller for the PCI Bus
KUSB-488B	IEEE-488 USB-to-GPIB Interface Adapter

SERVICES AVAILABLE

6487-3Y-EW	1-year factory warranty extended to 3 years from date of shipment
C/6487-3Y-ISO	3 (ISO-17025 accredited) calibrations within 3 years of purchase*

*Not available in all countries

1.888.KEITHLEY (U.S. only)

www.keithley.com

A Greater Measure of Confidence

KEITHLEY

A Tektronix Company

Measures low currents and high resistances quickly, accurately, and economically

LOW LEVEL MEASURE & SOURCE

Range	5½ Digit Default Resolution	Accuracy (1 Year) ¹ ±(% rdg. + offset) 18°–28°C, 0–70% RH	Typical RMS Noise ²	Typical Analog Rise Time (10% to 90%) ³ Damping ⁴	
				Off	On
2 nA	10 fA	0.3 % + 400 fA	20 fA	4 ms	80 ms
20 nA	100 fA	0.2 % + 1 pA	20 fA	4 ms	80 ms
200 nA	1 pA	0.15% + 10 pA	1 pA	300 μs	1 ms
2 μA	10 pA	0.15% + 100 pA	1 pA	300 μs	1 ms
20 μA	100 pA	0.1 % + 1 nA	100 pA	110 μs	110 μs
200 μA	1 nA	0.1 % + 10 nA	100 pA	110 μs	110 μs
2 mA	10 nA	0.1 % + 100 nA	10 nA	110 μs	110 μs
20 mA	100 nA	0.1 % + 1 μA	10 nA	110 μs	110 μs

TEMPERATURE COEFFICIENT: 0°–18°C & 28°–50°C. For each °C, add $0.1 \times (\% \text{ rdg} + \text{offset})$ to accuracy spec.

INPUT VOLTAGE BURDEN: <200μV on all ranges except <1mV on 20mA range.

MAXIMUM INPUT CAPACITANCE: Stable to 10nF on all nA ranges and 2μA range; 1μF on 20μA and 200μA ranges, and on mA ranges.

MAXIMUM CONTINUOUS INPUT VOLTAGE: 505 VDC.

NMRR⁵: (50 or 60Hz): 60dB.

ISOLATION (Ammeter Common or Voltage Source to chassis): Typically $>1 \times 10^{11} \Omega$ in parallel with <1nF.

MAXIMUM COMMON MODE VOLTAGE (between chassis and voltage source or ammeter): 505 VDC.

ANALOG OUTPUT: Scaled voltage output (inverting 2V full scale on all ranges): 2.5% ±2mV.

ANALOG OUTPUT IMPEDANCE³: <100Ω, DC–2kHz.

VOLTAGE SOURCE:

Range (Max.)	Step Size (typical)	Accuracy ⁵ ±(% prog. + offset) 18°–28°C, 0–70% R.H.	Noise (p-p) 0.1–10 Hz	Temperature Coefficient	Typical Rise Time ^{6,8} (10%–90%)	Typical Fall Time ^{7,8} (90%–10%)
±10.100	200 μV	0.1 % + 1 mV	<50 μV	(0.005% + 20 μV)/°C	250 μs	150 μs
±50.500	1 mV	0.1 % + 4 mV	<150 μV	(0.005% + 200 μV)/°C	250 μs	300 μs
±505.00	10 mV	0.15% + 40 mV	<1.5 mV	(0.008% + 2 mV)/°C	4.5 ms	1 ms

SELECTABLE CURRENT LIMIT: 2.5mA, 250μA, 25μA for 50V and 500V ranges, 25mA additional limit for 10V range. All current limits are –20%/+35% of nominal.

WIDEBAND NOISE⁹: <30mVp-p 0.1Hz–20MHz.

TYPICAL TIME STABILITY: ±(0.003% + 1mV) over 24 hours at constant temperature (within 1°C, between 18°–28°C, after 5 minute settling).

OUTPUT RESISTANCE: <2.5Ω.

VOLTAGE SWEEPS: Supports linear voltage sweeps on fixed source range, one current or resistance measurement per step.

Maximum sweep rate: 200 steps per second. Maximum step count 3000. Optional delay between step and measure.

RESISTANCE MEASUREMENT (V/I): Used with voltage source; resistance calculated from voltage setting and measured current.

Accuracy is based on voltage source accuracy plus ammeter accuracy. Typical accuracy better than 0.6% for readings between 1kΩ and 1TΩ.

ALTERNATING VOLTAGE RESISTANCE MEASUREMENT: Offers alternating voltage resistance measurements for resistances from 10³Ω to 10¹³Ω. Alternates between 0V and user-selectable voltage up to ±505V.

NOTES

- At 1 PLC – limited to 60 rdgs/s under this condition.
- At 6 PLC, 1 standard deviation, 100 readings, filter off, capped input – limited to 10 rdgs/sec under this condition.
- Measured at analog output with resistive load >2kΩ.
- Maximum rise time can be up to 25% greater.
- Accuracy does not include output resistance/load regulation.
- Rise Time is from 0V to ± full-scale voltage (increasing magnitude).
- Fall Time is from ± full-scale voltage to 0V (decreasing magnitude).
- For capacitive loads, add CAV/Limit to rise time, and CΔV/1mA to fall time.
- Measured with LO connected to chassis ground.

REMOTE OPERATION

IEEE-488 BUS IMPLEMENTATION: SCPI (IEEE-488.2, SCPI-1996.0); DDC (IEEE-488.1).

LANGUAGE EMULATION: Keithley Model 486/487 emulation via DDC mode.

RS-232 IMPLEMENTATION:

Supports: SCPI 1996.0.

Baud Rates: 300, 600, 1200, 2400, 4800, 9600, 19.2k, 38.4k, 57.6k.

Protocols: Xon/Xoff, 7 or 8 bit ASCII, parity-odd/even/none.

Connector: DB-9 TXD/RXD/GND.

GENERAL

AMMETER INPUT CONNECTOR: Three lug triaxial on rear panel.

ANALOG OUTPUT CONNECTOR: Two banana jacks on rear panel.

VOLTAGE SOURCE OUTPUT CONNECTOR: Two banana jacks on rear panel.

INTERLOCK CONNECTOR: 4 pin DIN.

TRIGGER LINE: Available, see manual for usage.

DISPLAY: 12 character vacuum fluorescent.

DIGITAL FILTER: Median and averaging (selectable from 2 to 100 readings).

RANGING: Automatic or manual.

AUTORANGING TIME³: <250ms (analog filter off, 1PLC).

OVERRANGE INDICATION: Display reads "OVRFLOW."

CONVERSION TIME: Selectable 0.01PLC to 60PLC (50PLC under 50Hz operation). (Adjustable from 200μs to 1s)

READING RATE:

To internal buffer 1000 readings/second¹

To IEEE-488 bus 900 readings/second^{1,2}

BUFFER: Stores up to 3000 readings.

PROGRAMS: Provide front panel access to IEEE address, choice of engineering units or scientific notation, and digital calibration.

EMC: Conforms with European Union Directive 89/336/EEC, EN61326-1.

SAFETY: Conforms with European Union Directive 73/23/EEC, EN61010-1, CAT I.

ENVIRONMENT:

Operating: 0°–50°C; relative humidity 70% non-condensing, up to 35°C. Above 35°C, derate humidity by 3% for each °C.

Storage: –10°C to +65°C.

WARM-UP: 1 hour to rated accuracy (see manual for recommended procedure).

POWER: 100–120V or 220–240V, 50–60Hz, (50VA).

PHYSICAL:

Case Dimensions: 90mm high × 214mm wide × 369mm deep (3½ in. × 8½ in. × 14½ in.).

Working Dimensions: From front of case to rear including power cord and IEEE-488 connector: 394mm (15.5 inches).

NET WEIGHT: <4.7 kg (<10.3 lbs).

NOTES

- 0.01PLC, digital filters off, front panel off, auto zero off.
- Binary transfer mode. IEEE-488.1.
- Measured from trigger in to meter complete.

1.888.KEITHLEY (U.S. only)

www.keithley.com

KEITHLEY

A Tektronix Company

A Greater Measure of Confidence

2502

Dual-Channel Picoammeter



- Dual-channel instrument for optical power measurements, beam measurements, and nanoscale materials and device research
- $\pm 100V$ source for bias requirements
- Measure photodetector current from 1fA to 20mA
- 1fA current measurement resolution
- Measure optical power directly when used with Model 2500INT Integrating Sphere
- 0–10V analog output for high resolution optical power feedback
- Provides a high accuracy, high speed fiber alignment solution
- Supports assembly process, final testing, parts binning, and specification
- Allows faster alignment of the fiber with the laser diode's optimum light emitting region
- Combines fiber alignment and device characterization processes
- User-programmable photodetector calibration coefficients
- 3000-point buffer memory on each channel allows data transfer after test completion
- Digital I/O and Trigger Link for binning and sweep test operations
- IEEE-488 and RS-232 interfaces

a Trigger Link interface that's unique to Keithley instruments, the Model 2502 can offer the fastest throughput available today for LIV testing of laser diode modules. These instruments are ruggedly engineered to meet the reliability and repeatability demands of continuous operation in round-the-clock production environments.

Low-Level, High Speed Measurements

The Model 2502 combines Keithley's expertise in low-level current measurements with high speed current measurement capabilities. Each channel of this instrument consists of a voltage source paired with a high speed picoammeter. Each of the two channels has an independent picoammeter and voltage source with measurements made simultaneously across both channels.

Part of a High Speed LIV Test System

In a laser diode module DC/CW test stand, the Model 2502 provides the voltage bias to both the back facet monitor diode and a Model 2500INT Integrating Sphere or to a fiber-coupled photodetector. At the same time it applies the voltage biases, it measures the current outputs of the two photodetectors and converts these outputs to measurements of optical power. The conversion is performed with the user-programmed calibration coefficient for the wavelength of the laser diode module. Fast, accurate measurements of optical power are critical for analyzing the coupling efficiency and optical power characteristics of the laser diode being tested. When testing modules with multiple detectors, the Model 2502 packs more testing capabilities into less test rack space.

Fiber Alignment

The Model 2502's built-in high speed analog output makes it suitable for precision fiber alignment tasks. This instrument combines the ability to align the optical fiber quickly and accurately with a laser diode's optimum light emitting region and the capability to make precision LIV measurements, all in the same test fixture. The Model 2502's wide dynamic range allows early beam skirt detection, reducing the time required for fiber alignment. An LIV sweep can be performed during the alignment process to optimize fiber location for an entire operating range. High speed feedback minimizes delays in the alignment process, so it's unnecessary to sacrifice alignment speed to ensure accurate device characterization.

Wide Dynamic Measurement Range

The Model 2502 offers low current measurement ranges from 2nA to 20mA in decade steps. This provides for all photodetector current measurement ranges for testing laser diodes and LEDs in applications such as LIV testing, LED total radiance measurements, measurements of cross-talk and insertion loss on optical switches,

The Model 2502 Dual-Channel Picoammeter provides two independent picoammeter-voltage source channels for a wide range of low level measurement applications including laser diode testing. The Model 2502 is also designed to increase the throughput of Keithley's LIV (light-current-voltage) test system for production testing of laser diode modules (LDMs). Developed in close cooperation with leading manufacturers of LDMs for fiberoptic telecommunication networks, this dual-channel instrument has features that make it easy to synchronize with other system elements for tight control over optical power measurements. The Model 2502 features a high speed analog output that allows using the LIV test system at the fiber alignment stage of the LDM manufacturing process. Through the use of buffer memory and



Model 2502 rear panel

1.888.KEITHLEY (U.S. only)

www.keithley.com

KEITHLEY

A Tektronix Company

A Greater Measure of Confidence

Measures low currents and high resistances quickly, accurately, and economically

LOW LEVEL MEASURE & SOURCE

2502

Ordering Information

2502 Dual-Channel Picoammeter

Accessories Supplied
User's Manual

ACCESSORIES AVAILABLE

7007-1	Shielded IEEE-488 Cable, 1m (3.3 ft)
7007-2	Shielded IEEE-488 Cable, 2m (6.6 ft)
7009-5	Shielded RS-232 Cable
7078-TRX-3	Low Noise Triax Cable, 0.9m (3 ft)
8501-1	Trigger Link Cable, 1m (3.3 ft)
KPCI-488LPA	IEEE-488 Interface/Controller for the PCI Bus
KUSB-488B	IEEE-488 USB-to-GPIB Interface Adapter

SERVICES AVAILABLE

2502-3Y-EW	1-year factory warranty extended to 3 years from date of shipment
C/2502-3Y-DATA	3 (Z540-1 compliant) calibrations within 3 years of purchase*

*Not available in all countries

Dual-Channel Picoammeter

and many others. The Model 2502 meets industry testing requirements for the transmitter as well as pump laser modules. The extensive current measurement range provides excellent sensitivity and resolution for beam current and radiation monitoring measurements.

High Accuracy Dark Current Measurements

The Model 2502's 2nA current measurement range is ideal for measuring dark currents and other low currents with 1fA resolution. Once the level of dark current has been determined, the instrument's REL function automatically subtracts the dark current as an offset so the measured values are more accurate for optical power measurements.

Voltage Bias Capability

The Model 2502 provides a choice of voltage bias ranges: $\pm 10V$ or $\pm 100V$. This choice gives the system integrator the ability to match the bias range more closely to the type of photodetector being tested, typically $\pm 10V$ for large area photodetectors and $\pm 100V$ for avalanche-type photodetectors. This ability to match the bias to the photodetector ensures improved measurement linearity and accuracy. Also, the 100V range provides a source voltage for an SEM target bias supply.

High Testing Throughput

The Model 2502 is capable of taking 900 readings/second per channel at $4\frac{1}{2}$ -digit resolution. This speed is comparable with the measurement speed of the Model 2400 SourceMeter SMU instrument, which is often used in conjunction with the Model 2502 to perform optoelectronic device test and characterization. Both instruments support Trigger Link (a proprietary "hardware handshaking" triggering system that's unique to Keithley products) and buffer memory. When programmed to execute a sweep, Trigger Link ensures measurement integrity by keeping the source and measurement functions working in lock step while the buffer memories record the measurements. Together, source memory, buffer memory, and Trigger Link eliminate GPIB traffic during a test sweep, improving test throughput dramatically.

APPLICATIONS

- Scanning electron microscope (SEM) beam measurements
- Production testing of:
 - Laser diode modules
 - Chip on submount laser diodes
 - LEDs
- Passive optical components
- Laser diode bars
- Fiber alignment

Ratio and Delta Measurements

The Model 2502 can provide ratio or delta measurements between the two completely isolated channels, such as the ratio of the back facet monitor detector to the fiber-coupled photodetector at varying levels of input current. These functions can be accessed via the front panel or the GPIB interface. For test setups with multiple detectors, this capability allows for targeted control capabilities for the laser diode module.

Programmable Limits and Filters

As with most Keithley instruments, the Model 2502's current and voltage limits can be programmed to ensure device protection during critical points such as start of test, etc. These instruments also provide Average and Median filters, which can be applied to the data stored in the buffer memory.

Adaptable to Evolving DUT Requirements

Unlike optical power meters with integrated detectors, the Model 2502 allows the user to choose from a wide range of measurement capabilities simply by selecting an appropriate photodetector and programming the calibration coefficient of this detector at the wavelength of choice.

Interface Options

To speed and simplify system integration and control, the Model 2502 includes the Trigger Link feature and digital I/O lines, as well as standard IEEE-488 and RS-232 interfaces. The Trigger Link feature combines six

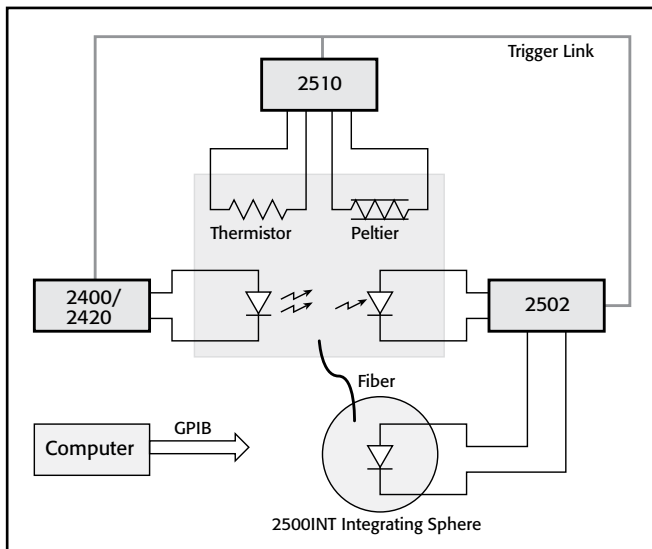

The Model 2502 is designed for tight integration with other Keithley instruments that are often used in LIV test systems for laser diode modules. These other instruments include the Model 2400 SourceMeter® and Model 2510 TEC SourceMeter SMU instruments.

1.888.KEITHLEY (U.S. only)

www.keithley.com



A Tektronix Company

A Greater Measure of Confidence

independent software selectable trigger lines on a single connector for simple, direct control over all instruments in a system. This feature is especially useful for reducing total test time if the test involves a sweep. The Model 2502 can sweep through a series of measurements based on triggers received from other instruments. The digital I/O lines simplify external handler control and binning operations.

The Model 2502 Dual-Channel Picoammeter can measure and display either photodiode current or optical power for two photodiodes with appropriate user-supplied optical power gain/wavelength calibration factors.

The Model 2502 includes an analog output jack on the rear panel for each channel.

Measurement Specifications

Range	Maximum Resolution	Accuracy ^{1,2} 23°C ±5°C ±(% rdg. + offset)	Temperature Coefficient 0°-18°C & 28°-50°C ±(%rdg. + offset)/°C	Dc Input Impedance ³ (Maximum)
2.000000 nA	1 fA	1.00% + 2 pA	0.01 + 200 fA	20 kΩ
20.00000 nA	10 fA	0.40% + 2 pA	0.01 + 200 fA	20 kΩ
200.0000 nA	100 fA	0.30% + 200 pA	0.02 + 20 pA	200 Ω
2.000000 μA	1 pA	0.20% + 200 pA	0.02 + 20 pA	200 Ω
20.00000 μA	10 pA	0.10% + 20 nA	0.01 + 2 nA	2.0 Ω
200.0000 μA	100 pA	0.10% + 20 nA	0.01 + 2 nA	2.0 Ω
2.000000 mA	1 nA	0.10% + 2 μA	0.02 + 200 nA	0.2 Ω
20.00000 mA	10 nA	0.10% + 2 μA	0.02 + 200 nA	0.2 Ω

MAXIMUM INPUT: ±20.0mA.

TYPICAL SPEED AND NOISE REJECTION⁴

Digits	Readings/s		NPLC	NMRR
	GPIB (SCPI)	GPIB (488.1)		
4½	700	900	0.01	—
5½	460	475	0.1	—
6½	58	58	1	60 dB

PHOTODIODE VOLTAGE BIAS SPECIFICATIONS²

Range	Resolution	Accuracy 23°C ±5°C	Maximum Current	Load Regulation ⁵	Temperature Coefficient
0 to ±10 V	<400 μV	±(0.15% of setting + 5 mV)	20 mA	< 0.30%, 0 to 20 mA	150 ppm/°C
0 to ±100 V	<4 mV	±(0.3% of setting + 50 mV)	20 mA	< 0.30%, 0 to 20 mA	300 ppm/°C

ANALOG OUTPUT SPECIFICATIONS

OUTPUT VOLTAGE RANGE⁹: Output is inverting: -10V out for positive full scale input.
+10V out for negative full scale input.

OUTPUT IMPEDANCE: 1kΩ typical.

Range	Accuracy 23°C ±5°C ±(%output + offset)	Temperature Coefficient 0°-18°C & 28°-50°C ±(%output + offset)/°C	Rise Time Typical (10% to 90%)
2.000000 nA	6.0% + 90 mV	0.30% + 7 mV	6.1 ms
20.00000 nA	3.0% + 9 mV	0.11% + 700 μV	6.1 ms
200.0000 nA	6.0% + 90 mV	0.30% + 4 mV	395 μs
2.000000 μA	3.0% + 9 mV	0.11% + 400 μV	395 μs
20.00000 μA	6.0% + 90 mV	0.30% + 4 mV	135 μs
200.0000 μA	2.5% + 9 mV	0.11% + 400 μV	135 μs
2.000000 mA	6.0% + 90 mV	0.30% + 4 mV	21 μs
20.00000 mA	2.5% + 9 mV	0.11% + 400 μV	21 μs

GENERAL

Typical Noise Floor Measurement Specification⁶

Range	Typical Noise Floor RMS (1 STDEV), 100 Samples			
	0.01 NPLC	0.1 NPLC	1.0 NPLC	10 NPLC
2.000000 nA	2 pA	1 pA	40 fA	15 fA
20.00000 nA	2 pA	1 pA	40 fA	15 fA
200.0000 nA	200 pA	100 pA	2 pA	500 fA
2.000000 μA	200 pA	100 pA	2 pA	500 fA
20.00000 μA	20 nA	10 nA	200 pA	50 pA
200.0000 μA	20 nA	10 nA	200 pA	50 pA
2.000000 mA	2 μA	1 μA	25 nA	5 nA
20.00000 mA	2 μA	1 μA	25 nA	5 nA

SOURCE CAPACITANCE: Stable to 10.0nF typical.

INPUT BIAS CURRENT⁷: 50fA max. @ 23°C.

INPUT VOLTAGE BURDEN⁸: 4.0mV max.

VOLTAGE SOURCE SLEW RATE: 3.0ms/V typical.

COMMON MODE VOLTAGE: 200VDC.

COMMON MODE ISOLATION: Typically 10⁹Ω in parallel with 150nF.

OVERRANGE: 105% of measurement range.

MEMORY BUFFER: 6000 readings (two 3000 point buffers). Includes selected measured value(s) and time stamp.

PROGRAMMABILITY: IEEE-488 (SCPI-1995.0), RS-232, five user-definable power-up states plus factory default and *RST.

DIGITAL INTERFACE:

Enable: Active low input.

Handler Interface: Start of test, end of test, 3 category bits. +5V @ 300mA supply.

Digital I/O: 1 trigger input, 4 TTL/Relay Drive outputs (33V @ 500mA, diode clamped).

POWER SUPPLY: 100V/120V/220V/240V ±10%.

LINE FREQUENCY: 50, 60Hz.

POWER DISSIPATION: 60VA.

EMC: Complies with European Union Directive 89/336/EEC.

VIBRATION: MIL-T-28800F Random Class 3.

SAFETY: Complies with European Directive 73/23/EEC.

WARM-UP: 1 hour to rated accuracy.

DIMENSIONS: 89mm high × 213mm wide × 370mm deep (3½ in × 8½ in × 14½ in). Bench configuration (with handle and feet): 104mm high × 238mm wide × 370mm deep (4½ in × 9½ in × 14½ in).

WEIGHT: 23.1kg (10.5 lbs).

ENVIRONMENT:

Operating: 0°-50°C, 70% R.H. up to 35°C non-condensing. Derate 3% R.H./°C, 35°-50°C.

Storage: -25° to 65°C, non-condensing.

NOTES

- Speed = Normal (1.0 NPLC), Filter On.
- 1 year.
- Measured as ΔVin/ΔIin at full scale (and zero) input currents.
- Dual channel, internal trigger, measure only, display off, Autorange off, Auto Zero off, source delay = 0, filters off, limits off, CALC5 and CALC6 off, 60Hz.
- Measured as ΔVin/ΔIin at full scale (20mA) and zero load currents.
- Noise floor measured as rms (1 standard deviation), 100 samples, Filter off, open (capped) input.
- Specification by design.
- Measured (at input triax) as ΔVin at full scale (20mA) vs. zero input currents.
- The analog output voltage for each channel is referenced to that channel's floating ground.

1.888.KEITHLEY (U.S. only)

www.keithley.com

KEITHLEY

A Greater Measure of Confidence

A Tektronix Company

6514

Programmable Electrometer



The Model 6514 Electrometer combines flexible interfacing capabilities with current sensitivity, charge measurement capabilities, resolution, and speed that are equal or superior to our earlier electrometers. The Model 6514's built-in IEEE-488, RS-232, and digital I/O interfaces make it simple to configure fully automated, high speed systems for low-level testing.

The 5½-digit Model 6514 is designed for applications that demand fast, yet precise measurements of low currents, voltages from high resistance sources, charges, or high resistances.

The Model 6514's exceptional measurement performance comes at an affordable price. While its cost is comparable with that of many high end DMMs, the Model 6514 offers far greater current sensitivity and significantly lower voltage burden (as low as 20μV) than other instruments can provide.

- <1fA noise
- >200TΩ input impedance on voltage measurements
- Charge measurements from 10fC to 20μC
- High speed—up to 1200 readings/second
- Interfaces readily with switches, computers, and component handlers
- Cancels voltage and current offsets easily

Ordering Information

6514 Programmable Electrometer

Accessories Supplied
237-ALG-2 Low Noise Triax Cable, 3-Slot Triax to Alligator Clips, 2m (6.6 ft)

SERVICES AVAILABLE

6514-3Y-EW	1-year factory warranty extended to 3 years from date of shipment
C/6514-3Y-ISO	3 (ISO-17025 accredited) calibrations within 3 years of purchase*
TRN-LLM-1-C	Course: Making Accurate Low-Level Measurements

*Not available in all countries

1.888.KEITHLEY (U.S. only)

www.keithley.com

R&D on a Budget

The Model 6514 offers the flexibility and sensitivity needed for a wide array of experiments, providing better data far faster than older electrometer designs. Applications include measuring currents from light detectors and other sensors, beam experiments, and measuring resistances using a current source. In addition to use by researchers in areas such as physics, optics, and materials science, the Model 6514's affordable price makes it an attractive alternative to high end DMMs for low current measurement applications, such as testing resistance and leakage current in switches, relays, and other components. For more information on how the Model 6514 does this, refer to the section titled "Low Voltage Burden."

The Model 6514 builds on the features and capabilities of the Keithley electrometers that preceded it. For example, like those instruments, a built-in constant current source simplifies measuring resistance.

Two analog outputs—a 2V output and a preamp output—are available for recording data with strip-chart recorders.

ACCESSORIES AVAILABLE

CABLES

237-ALG-2	Low Noise Triax Cable, 3-Slot Triax to Alligator Clips
7007-1	Shielded IEEE-488 Cable, 1m (3.3 ft)
7007-2	Shielded IEEE-488 Cable, 2m (6.6 ft)
7009-5	RS-232 Cable
7078-TRX-3	Low Noise Triax Cable, 3-Slot Triax Connectors, 0.9m (3 ft)
7078-TRX-10	Low Noise Triax Cable, 3-Slot Triax Connectors, 3m (10 ft)
7078-TRX-20	Low Noise Triax Cable, 3-Slot Triax Connectors, 6m (20 ft)
8501-1	Trigger-Link Cable, 1m (3.3 ft)
8501-2	Trigger-Link Cable, 2m (6.6 ft)

RACK MOUNT KITS

4288-1	Single Fixed Rack Mounting Kit
4288-2	Dual Fixed Rack Mounting Kit

ADAPTERS

7078-TRX-BNC	3-Lug Triax to BNC Adapter
237-TRX-NG	Triax Male-Female Adapter with Guard Disconnected
237-TRX-T	3-Slot Male Triax to Dual 3-Lug Female Triax Tee Adapter
237-TRX-TBC	3-Lug Female Triax Bulkhead Connector (1.1kV rated)
7078-TRX-TBC	3-Lug Female Triax Bulkhead Connector with Cap

GPIB INTERFACES

KPCI-488LPA	IEEE-488 Interface/Controller for the PCI Bus
KUSB-488B	IEEE-488 USB-to-GPIB Interface Adapter

Economical Component Testing

Once, electrometers were simply considered too slow to keep up with the high throughput that production test applications demand. The Model 6514 is designed for fast, sensitive measurements, providing speeds up to 1200 readings per second with fast integration or 17 measurements per second with 60Hz line-cycle integration. It offers 10fA resolution on 2nA signals, settling to within 10% of the final value in just 15ms. A normal-mode rejection ratio (NMRR) of 60dB allows making accurate low current measurements, even in the presence of line frequency induced currents, which is a common concern in production floor environments. The instrument's sensitivity makes it easy to determine the leakage resistance on capacitances up to 10nF or even on higher capacitances when a series resistor is used.

While the Model 6514 can be easily operated manually using the front panel controls, it can also be externally controlled for automated test applications. Built-in IEEE-488 and RS-232 interfaces make it possible

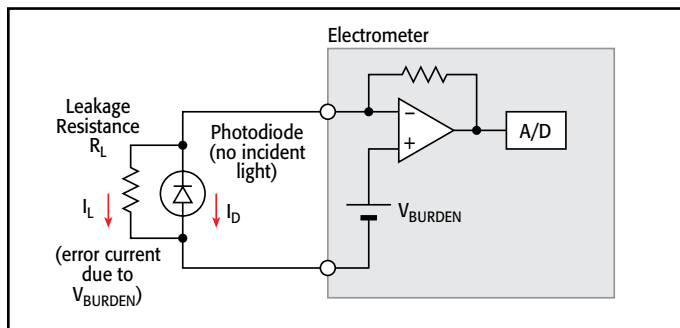

Figure 1. Dark Current Measurement with Burden Voltage Uncorrected

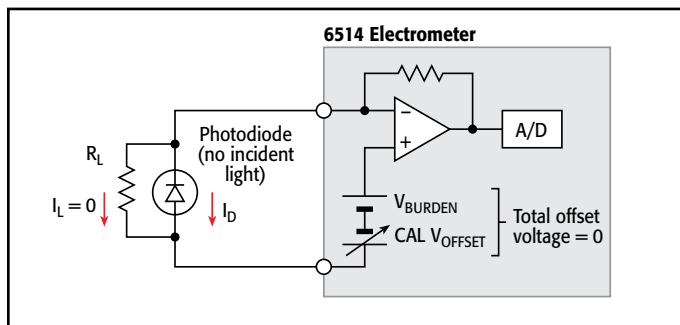

Figure 2. Dark Current Measurement with Burden Voltage Corrected

to program all instrument functions over the bus through a computer controller. The instrument's interfaces also simplify integrating external hardware, such as sources, switching systems, or other instruments, into the test system. A digital I/O interface can be used to link the Model 6514 to many popular component handlers for tight systems integration in binning, sorting, and similar applications.

These features make the Model 6514 a powerful, low cost tool for systems designed to test optical devices and leakage resistance on low-value capacitors, switches, and other devices, particularly when the test system already includes a voltage source or when the source current/measurement voltage technique is used to determine resistance.

Low Voltage Burden

The Model 6514's feedback ammeter design minimizes voltage offsets in the input circuitry, which can affect current measurement accuracy. The instrument also allows active cancellation of its input voltage and current offsets, either manually via the front panel controls or over the bus with IEEE-488 commands.

Dark Current Measurements

When measuring dark currents (Figure 1) from a device such as a photodiode, the ammeter reads the sum of two different currents. The first current is the dark current (I_D) generated by the detector with no light falling upon the device (in other words, the signal of interest); the second one is the leakage current (I_L) generated by the voltage burden (V_{BURDEN}) appearing at the terminals of the ammeter. In a feedback ammeter, the primary "voltage burden" is the amplifier offset voltage. This leakage current represents an error current. Without the use of cancellation techniques, $I_L = V_{BURDEN}/R_L$. Figure 2 illustrates how the Model 6514's CAL V_{OFFSET} is adjusted to cancel V_{BURDEN} to within the voltage noise level of a few microvolts, so the measured current is only the true dark current (I_D) of the photodiode. In a similar manner, offset currents can also be cancelled. Earlier electrometers used an internal numerical correction technique in which the voltage burden was still present, so the measured dark current included the error term $I_L = V_{BURDEN}/R_L$.

Voltage Burden and Measurement Error

Electrometers provide current measurement with lower terminal voltage than is possible when making DMM measurements. As shown in Figure 3, DMMs measure current using a shunt resistance that develops a voltage (typically 200mV full-range) in the input circuit. This creates a terminal voltage (V_{BURDEN}) of about 200mV, thereby lowering the measured current. Electrometers reduce this terminal voltage by using the feedback ammeter configuration illustrated in Figure 1. The Model 6514 lowers this terminal voltage still further—to the level of the voltage noise—by canceling out the small offset voltage that remains, as shown in Figure 2. Any error signals that remain are negligible in comparison to those that can occur when measuring current with a DMM.

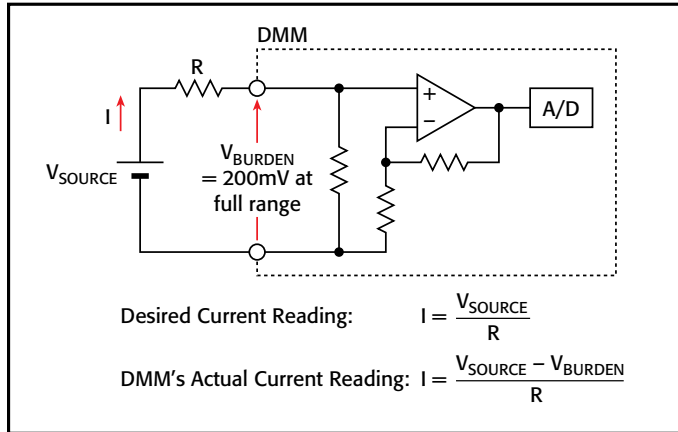

Figure 3. Errors Due to Burden Voltage when Measuring with a DMM

The example below compares a DMM's voltage burden errors with the 6514's.

If: $V_{SOURCE} = 1V$, $R = 50k\Omega$

The desired current reading is: $I = \frac{1V}{50k\Omega} = 20\mu A$

Actual Reading (20 μA range on DMM): $V_{BURDEN} = 200mV$

$$I = \frac{1V - 200mV}{50k\Omega} = \frac{800mV}{50k\Omega} = 16\mu A = 20\% \text{ Burden error with a DMM}$$

Refer to Figure 3.

6514 Actual Reading: $V_{BURDEN} = 10\mu V$

Refer to Figure 2. $I = \frac{0.999990V}{50k\Omega} = 19.9998\mu A = 0.001\% \text{ Burden error with the 6514}$

DMM Offset Currents

Typically, offset currents in DMMs are tens or hundreds of picoamps, which severely limits their low current measuring capabilities compared to the Model 6514 with 3fA input bias current.

APPLICATIONS

- High resistivity measurements
- Leakage currents
- Ion selective electrode measurements
- pH measurements
- Conductivity cells
- Potentiometry

VOLTS

Range	5½-Digit Resolution	Accuracy (1 Year) ¹ 18°–28°C ±(%rdg+counts)	Temperature Coefficient 0°–18°C & 28°–50°C ±(%rdg+counts)/°C
2 V	10 μV	0.025 + 4	0.003 + 2
20 V	100 μV	0.025 + 3	0.002 + 1
200 V	1 mV	0.06 + 3	0.002 + 1

NOTES

1. When properly zeroed, 5½-digit. Rate: Slow (100ms integration time).

NMR: 60dB on 2V, 20V, >55dB on 200V, at 50Hz or 60Hz $\pm 0.1\%$.

CMRR: >120dB at DC, 50Hz or 60Hz.

INPUT IMPEDANCE: >200T Ω in parallel with 20pF, <2pF guarded (10M Ω with zero check on).

SMALL SIGNAL BANDWIDTH AT PREAMP OUTPUT: Typically 100kHz (–3dB).

AMPS

Range	5½-Digit Resolution	Accuracy (1 Year) ¹ 18°–28°C ±(%rdg+counts)	Temperature Coefficient 0°–18°C & 28°–50°C ±(%rdg+counts)/°C
20 pA	100 aA ²	1 + 30	0.1 + 5
200 pA	1 fA ²	1 + 5	0.1 + 1
2 nA	10 fA	0.2 + 30	0.1 + 2
20 nA	100 fA	0.2 + 5	0.03 + 1
200 nA	1 pA	0.2 + 5	0.03 + 1
2 μA	10 pA	0.1 + 10	0.005 + 2
20 μA	100 pA	0.1 + 5	0.005 + 1
200 μA	1 nA	0.1 + 5	0.005 + 1
2 mA	10 nA	0.1 + 10	0.008 + 2
20 mA	100 nA	0.1 + 5	0.008 + 1

NOTES

1. When properly zeroed, 5½-digit. Rate: Slow (100ms integration time).

2. aA = $10^{-18}A$, fA = $10^{-15}A$.

INPUT BIAS CURRENT: <3fA at T_{CAL} (user adjustable). Temperature coefficient = 0.5fA/°C.

INPUT BIAS CURRENT NOISE: <750aA p-p (capped input), 0.1Hz to 10Hz bandwidth, damping on. Digital filter = 40 readings.

INPUT VOLTAGE BURDEN at $T_{CAL} \pm 1^\circ C$ (user adjustable):

<20 μV on 20pA, 2nA, 20nA, 2 μA , 20 μA ranges.

<100 μV on 200pA, 200nA, 200 μA ranges.

<2mV on 2mA range.

<4mV on 20mA range.

TEMPERATURE COEFFICIENT OF INPUT VOLTAGE BURDEN: <10 $\mu V/^\circ C$ on pA, nA, μA ranges.

PREAMP SETTling TIME (to 10% of final value): 2.5s typical on pA ranges, damping off, 3s typical on nA ranges, 15ms on nA ranges, 5ms on μA and mA ranges.

NMR: >95dB on pA, 60dB on nA, μA , and mA ranges at 50Hz or 60Hz $\pm 0.1\%$. Digital Filter = 40.

OHMS

Range	5½-Digit Resolution	Accuracy (1 Year) ¹ 18°–28°C ±(% rdg+counts)	Temperature Coefficient 0°–18°C & 28°–50°C ±(% rdg+counts)/°C	Test Current (nominal)
2 k Ω	10 m Ω	0.20 + 10	0.01 + 2	0.9 mA
20 k Ω	100 m Ω	0.15 + 3	0.01 + 1	0.9 mA
200 k Ω	1 Ω	0.25 + 3	0.01 + 1	0.9 mA
2 M Ω	10 Ω	0.25 + 4	0.02 + 2	0.9 μA
20 M Ω	100 Ω	0.25 + 3	0.02 + 1	0.9 μA
200 M Ω	1 k Ω	0.30 + 3	0.02 + 1	0.9 μA
2 G Ω	10 k Ω	1.5 + 4	0.04 + 2	0.9 nA
20 G Ω	100 k Ω	1.5 + 3	0.04 + 1	0.9 nA
200 G Ω	1 M Ω	1.5 + 3	0.04 + 1	0.9 nA

NOTES

1. When properly zeroed, 5½-digit. Rate: Slow (100ms integration time).

MAXIMUM OPEN CIRCUIT VOLTAGE: 250V DC.

PREAMP SETTling TIME (To 10% of final reading with <100pF input capacitance): 2k Ω through 200k Ω : 2ms; 20M Ω through 200M Ω : 90ms. 2G Ω through 200G Ω : 1s.

1.888.KEITHLEY (U.S. only)

www.keithley.com

KEITHLEY

A Greater Measure of Confidence

A Tektronix Company

COULOMBS		Accuracy (1 Year) ^{1,2} 18°–28°C	Temperature Coefficient 0°–18°C & 28°–50°C
Range	6½-Digit Resolution	±(%rdg+counts)	±(%rdg+counts)/°C
20 nC	10 fC	0.4 + 50	0.04 + 10
200 nC	100 fC	0.4 + 50	0.04 + 10
2 µC	1 pC	1 + 50	0.05 + 10
20 µC	10 pC	1 + 50	0.05 + 10

Notes:

- Charge acquisition time must be <1000s, derate 2% for each additional 10,000s.
- When properly zeroed, 6½-digit. Rate: Slow (100ms integration time).

INPUT BIAS CURRENT: <4fA at T_{CAL}. Temperature coefficient = 0.5fA/°C.

IEEE-488 BUS IMPLEMENTATION

MULTILINE COMMANDS: DCL, LLO, SDC, GET, GTL, UNT, UNL, SPE, SDP.
IMPLEMENTATION: SCPI (IEEE-488.2, SCPI-1996.0); DDC (IEEE-488.1).
UNILINE COMMANDS: IFC, REN, EOI, SRQ, ATN.
INTERFACE FUNCTIONS: SH1, AH1, T5, TE0, L4, LE0, SR1, RL1, PP0, DC1, DT1, C0, E1.
PROGRAMMABLE PARAMETERS: Function, Range, Zero Check, Zero Correct, EOI (DDC mode only), Trigger, Terminator (DDC mode only), Data Storage 2500 Storage, Calibration (SCPI mode only), Display Format, SRQ, REL, Output Format, Guard, V-offset Cal, I-offset Cal.
ADDRESS MODES: TALK ONLY and ADDRESSABLE.
LANGUAGE EMULATION: 6512, 617, 617-HIQ emulation via DDC mode.
TRIGGER TO READING DONE: 150ms typical, with external trigger.
RS-232 IMPLEMENTATION:
Supports: SCPI 1996.0.
Baud Rates: 300, 600, 1200, 2400, 4800, 9600, 19.2k, 38.4k, 57.6k.
Protocols: Xon/Xoff, 7 or 8 bit ASCII, parity-odd/even/none.
Connector: DB-9 TXD/RXD/GND.

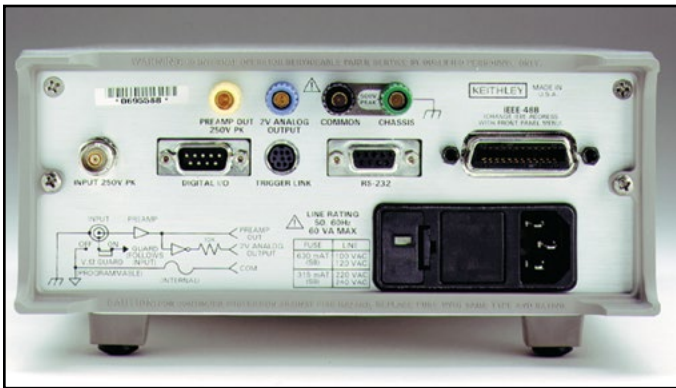

Model 6514 rear panel

GENERAL

OVERRANGE INDICATION: Display reads "OVRFLOW."
RANGING: Automatic or manual.
CONVERSION TIME: Selectable 0.01PLC to 10PLC.
PROGRAMS: Provide front panel access to IEEE address, choice of engineering units or scientific notation, and digital calibration.
MAXIMUM INPUT: 250V peak, DC to 60Hz sine wave; 10s per minute maximum on mA ranges.
MAXIMUM COMMON MODE VOLTAGE (DC to 60Hz sine wave): Electrometer, 500V peak.
ISOLATION (Meter COMMON to chassis): Typically 10¹⁰Ω in parallel with 500pF.
INPUT CONNECTOR: Three lug triaxial on rear panel.
2V ANALOG OUTPUT: 2V for full range input. Inverting in Amps and Coulombs mode. Output impedance 10kΩ.
PREAMP OUTPUT: Provides a guard output for Volts measurements. Can be used as an inverting output or with external feedback in Amps and Coulombs modes.
DIGITAL INTERFACE:
Handler Interface: Start of test, end of test, 3 category bits.
Digital I/O: 1 Trigger input, 4 outputs with 500mA sink capability.
Connector: 9 pin D subminiature, male pins.
EMC: Conforms with European Union Directive 89/336/EEC EN55011, EN50082-1, EN61000-3-2, EN61000-3-3, FCC part 15 class B.
SAFETY: Conforms with European Union Directive 73/23/EEC EN61010-1.
GUARD: Switchable voltage and ohm guard available.
TRIGGER LINE: Available, see manual for usage.
READING STORAGE: 2500 readings.
READING RATE:
 To internal buffer 1200 readings/second¹
 To IEEE-488 bus 500 readings/second^{1,3}
 To front panel 17 readings/second at 60Hz;²
 15 readings/second at 50Hz.²

Notes:

- 0.01PLC, digital filters off, front panel off, auto zero off.
- 1.00PLC, digital filters off.
- Binary transfer mode.

DIGITAL FILTER: Median and averaging (selectable from 2 to 100 readings).
DAMPING: User selectable on Amps function.
ENVIRONMENT:
Operating: 0°–50°C; relative humidity 70% non-condensing, up to 35°C.
Storage: –25° to +65°C.
WARM-UP: 1 hour to rated accuracy (see manual for recommended procedure).
POWER: 90–125V or 210–250V, 50–60Hz, 60VA.
PHYSICAL:
Case Dimensions: 90mm high × 214mm wide × 369mm deep (3½ in. × 8⅝ in. × 14⅞ in.).
Working Dimensions: From front of case to rear including power cord and IEEE-488 connector: 15.5 inches.
Net Weight: <4.6kg (<10.1 lbs).
Shipping Weight: <9.5kg (<21 lbs).

1.888.KEITHLEY (U.S. only)

www.keithley.com



A Greater Measure of Confidence

A Tektronix Company

6517B

Electrometer/High Resistance Meter



- Measures resistances up to $10^{16}\Omega$
- 1fA–20mA current measurement range
- $<20\mu\text{V}$ burden voltage on lowest current ranges
- $200\text{T}\Omega$ input impedance
- $<3\text{fA}$ bias current
- Up to 425 rdgs/s
- 0.75fA p-p noise
- Built-in $\pm 1\text{kV}$ voltage source
- Unique voltage reversal method for high resistance measurements
- Optional plug-in scanner cards

near-ideal circuit loading. These specifications ensure the accuracy and sensitivity needed for accurate low current and high impedance voltage, resistance, and charge measurements in areas of research such as physics, optics, nanotechnology, and materials science. A built-in $\pm 1\text{kV}$ voltage source with sweep capability simplifies performing leakage, breakdown, and resistance testing, as well as volume ($\Omega\text{-cm}$) and surface resistivity (Ω/square) measurements on insulating materials.

Wide Measurement Ranges

The Model 6517B offers full autoranging over the full span of ranges on current, resistance, voltage, and charge measurements:

- Current measurements from 1fA to 20mA
- Voltage measurements from $10\mu\text{V}$ to 200V
- Resistance measurements from 50Ω to $10^{16}\Omega$
- Charge measurements from 10fC to $2\mu\text{C}$

Improved High Resistivity Measurements

Many test applications require measuring high levels of resistivity (surface or volume) of materials. The conventional method of making these measurements is to apply a sufficiently large voltage to a sample, measure the current that flows through the sample, then calculate the resistance using Ohm's Law ($R=V/I$). While high resistance materials and devices produce very small currents that are difficult to measure accurately, Keithley's electrometers and picoammeters are used successfully for such measurements.

Even with high quality instrumentation, inherent background currents in the material can make these measurements difficult to perform accurately. Insulating materials, polymers, and plastics typically exhibit background currents due to piezoelectric effects, capacitive elements charged by static electricity, and polarization effects. These background currents are often equal to or greater than the current stimulated by the applied voltage. In these cases, the result is often unstable, providing inaccurate resistance or resistivity readings or even erroneous negative values. Keithley's Model 6517B is designed to solve these problems and provides consistent, repeatable, and accurate measurements for a wide variety of materials and components, especially when used in combination with the Model 8009 Resistivity Test Fixture.

Alternating Polarity Method

The Model 6517B uses the Alternating Polarity method, which virtually eliminates the effect of any background currents in the sample. First and second order drifts of the background currents are also canceled out. The Alternating Polarity method applies a voltage of positive polarity, then the current is measured after a specified delay (Measure Time). Next, the polarity is reversed and the current measured again, using the same delay. This process is repeated continuously, and the resistance is calculated based on a weighted average of the four most recent current measurements. This method typically



1.888.KEITHLEY (U.S. only)

www.keithley.com
KEITHLEY
 A Tektronix Company

A Greater Measure of Confidence

6517B

Ordering Information

6517B Electrometer/High Resistance Meter

Accessories Supplied

237-ALG-2 Low Noise Triax Cable, 3-slot Triax to Alligator Clips, 2m (6.6 ft)

8607 Safety High Voltage Dual Test Leads

6517-TP Thermocouple Bead Probe

CS-1305 Interlock Connector

ACCESSORIES AVAILABLE

CABLES

6517B-ILC-3	Interlock Cable
7007-1	Shielded IEEE-488 Cable, 1m (3.2 ft)
7007-2	Shielded IEEE-488 Cable, 2m (6.5 ft)
7009-5	RS-232 Cable
7078-TRX-3	Low Noise Triax Cable, 3-Slot Triax Connectors, 0.9m (3 ft)
7078-TRX-10	Low Noise Triax Cable, 3-Slot Triax Connectors, 3m (10 ft)
7078-TRX-20	Low Noise Triax Cable, 3-Slot Triax Connectors, 6m (20 ft)
8501-1	Trigger Link Cable, 1m (3.3 ft)
8501-2	Trigger Link Cable, 2m (6.6 ft)
8503	Trigger Link Cable to 2 male BNCs, 1m (3.3 ft)
8607	1kV Source Banana Cables

PROBES

6517-RH	Humidity Probe with Extension Cable
6517-TP	Temperature Bead Probe (included with 6517B)

TEST FIXTURE

8009	Resistivity Test Fixture
------	--------------------------

OTHER

CS-1305	Interlock Connector
---------	---------------------

ADAPTERS

237-BNC-TRX	Male BNC to 3-Lug Female Triax Adapter
237-TRX-NG	Triax Male-Female Adapter with Guard Disconnected
237-TRX-T	3-Slot Male Triax to Dual 3-Lug Female Triax Tee Adapter
237-TRX-TBC	3-Lug Female Triax Bulkhead Connector (1.1kV rated)
7078-TRX-BNC	3-Slot Male Triax to BNC Adapter
7078-TRX-GND	3-Slot Male Triax to BNC Adapter with guard removed
7078-TRX-TBC	3-Lug Female Triax Bulkhead Connector with Cap

RACK MOUNT KITS

4288-1	Single Fixed Rack Mounting Kit
4288-2	Dual Fixed Rack Mounting Kit

SCANNER CARDS

6521	Low Current Scanner Card
6522	Voltage/Low Current Scanner Card

GPIB INTERFACES

KPCI-488LPA	IEEE-488 Interface/Controller for the PCI Bus
KUSB-488B	IEEE-488 USB-to-GPIB Interface Adapter

Electrometer/High Resistance Meter

produces a highly repeatable, accurate measurement of resistance (or resistivity) by the seventh reversal on most materials (i.e., by discarding the first three readings). For example, a 1mm-thick sample of $10^{14}\Omega\text{-cm}$ material can be measured with 0.3% repeatability in the Model 8009 test fixture, provided the background current changes less than 200fA over a 15-second period.

Simple DMM-like Operation

The Model 6517B is designed for easy, DMM-like operation via the front panel, with single-button control of important functions such as resistance measurement. It can also be controlled via a built-in IEEE-488 interface, which makes it possible to program all functions over the bus through a computer controller.

High Accuracy High Resistance Measurements

The Model 6517B offers a number of features and capabilities that help ensure the accuracy of high resistance measurement applications. For example, the built-in voltage source simplifies determining the relationship between an insulator's resistivity and the level of source voltage used. It is well suited for capacitor leakage and insulation resistance measurements, tests of the surface insulation resistance of printed circuit boards, voltage coefficient testing of resistors, and diode leakage characterization.

Temperature and Humidity Stamping

Humidity and temperature can influence the resistivity values of materials significantly. To help you make accurate comparisons of readings acquired under varying conditions, the Model 6517B offers a built-in type K thermocouple and an optional Model 6517-RH Relative Humidity Probe. A built-in data storage buffer allows recording and recalling readings stamped with the time, temperature, and relative humidity at which they were acquired.

Accessories Extend Measurement Capabilities

A variety of optional accessories can be used to extend the Model 6517B's applications and enhance its performance.

Scanner Cards. Two scanner cards are available to simplify scanning multiple signals. Either card can be easily inserted in the option slot of the instrument's back panel. The Model 6521 Scanner Card offers ten channels of low-level current scanning. The Model 6522 Scanner Card

provides ten channels of high impedance voltage switching or low current switching.

Test Fixture. The Model 8009 Resistivity Chamber is a guarded test fixture for measuring volume and surface resistivities of sample materials. It has stainless-steel electrodes built to ASTM standards. The fixture's electrode dimensions are pre-programmed into the Model 6517B, so there's no need to calculate those values then enter them manually. This accessory is designed to protect you from contact with potentially hazardous voltages—opening the lid of the chamber automatically turns off the Model 6517B's voltage source.

Applications

The Model 6517B is well suited for low current and high impedance voltage, resistance, and charge measurements in areas of research such as physics, optics, and materials science. Its extremely low voltage burden makes it particularly appropriate for use in solar cell applications, and its built-in voltage source and low current sensitivity make it an excellent solution for high resistance measurements of nanomaterials such as polymer based nanowires. Its high speed and ease of use also make it an excellent choice for quality control, product engineering, and production test applications involving leakage, breakdown, and resistance testing. Volume and surface resistivity measurements on non-conductive materials are particularly enhanced by the Model 6517B's voltage reversal method. The Model 6517B is also well suited for electrochemistry applications such as ion selective electrode and pH measurements, conductivity cells, and potentiometry.

Model 6517B Enhancements

The Model 6517B is an updated version, replacing the earlier Model 6517A, which was introduced in 1996. Software applications created for the Model 6517A using SCPI commands can run without modifications on the Model 6517B. However, the Model 6517B does offer some useful enhancements to the earlier design. Its internal battery-backed memory buffer can now store up to 50,000 readings, allowing users to log test results for longer periods and to store more data associated with those readings. The new model also provides faster reading rates to the internal buffer (up to 425 readings/second) and to external memory via the IEEE bus (up to 400 readings/second). Several connector modifications have been incorporated to address modern connectivity and safety requirements.

1.888.KEITHLEY (U.S. only)

www.keithley.com

A Greater Measure of Confidence

KEITHLEY
A Tektronix Company

Simplifies measuring high resistances and the resistivity of insulating materials

LOW LEVEL MEASURE & SOURCE

VOLTS		ACCURACY (1 Year) ¹ 18°–28°C	TEMPERATURE COEFFICIENT 0°–18°C & 28°–50°C
5½-DIGIT RANGE	RESOLUTION	±(%rdg+counts)	±(%rdg+counts)/°C
2 V	10 μV	0.025 + 4	0.003 + 2
20 V	100 μV	0.025 + 3	0.002 + 1
200 V	1 mV	0.06 + 3	0.002 + 1

NMRR: 2V and 20V ranges >60dB, 200V range >55dB. 50Hz or 60Hz².

CMRR: >120dB at DC, 50Hz or 60Hz.

INPUT IMPEDANCE: >200TΩ in parallel with 20pF, <2pF guarded (1MΩ with zero check on).

SMALL SIGNAL BANDWIDTH AT PREAMP OUTPUT: Typically 100kHz (–3dB).

NOTES

- When properly zeroed, 5½-digit, 1 PLC (power line cycle), median filter on, digital filter = 10 readings.
- Line sync on.

AMPS		ACCURACY (1 Year) ¹ 18°–28°C	TEMPERATURE COEFFICIENT 0°–18°C & 28°–50°C
5½-DIGIT RANGE	RESOLUTION	±(%rdg+counts)	±(%rdg+counts)/°C
20 pA	100 aA ²	1 + 30	0.1 + 5
200 pA	1 fA ²	1 + 5	0.1 + 1
2 nA	10 fA	0.2 + 30	0.1 + 2
20 nA	100 fA	0.2 + 5	0.03 + 1
200 nA	1 pA	0.2 + 5	0.03 + 1
2 μA	10 pA	0.1 + 10	0.005 + 2
20 μA	100 pA	0.1 + 5	0.005 + 1
200 μA	1 nA	0.1 + 5	0.005 + 1
2 mA	10 nA	0.1 + 10	0.008 + 2
20 mA	100 nA	0.1 + 5	0.008 + 1

INPUT BIAS CURRENT: <3fA at T_{CAL}. Temperature coefficient = 0.5fA/°C, 20pA range.

INPUT BIAS CURRENT NOISE: <750aA p-p (capped input), 0.1Hz to 10Hz bandwidth, damping on. Digital filter = 40 readings, 20pA range.

INPUT VOLTAGE BURDEN at T_{CAL} ±1°C:
 <20μV on 20pA, 2nA, 20nA, 2μA, and 20μA ranges.
 <100μV on 200pA, 200nA, and 200μA ranges.
 <2mV on 2mA range. <5mV on 20mA range.

TEMPERATURE COEFFICIENT OF INPUT VOLTAGE BURDEN: <10μV/°C on pA, nA, and μA ranges.

PREAMP SETTling TIME (to 10% of final value) Typical: 0.5sec (damping off) 2.0 sec (damping on) on pA ranges. 15msec on nA ranges damping off, 1msec on μA ranges damping off. 500μsec on mA ranges damping off.

NMRR: >60dB on all ranges at 50Hz or 60Hz².

NOTES

- When properly zeroed, 5½-digit, 1PLC (power line cycle), median filter on, digital filter = 10 readings.
- aA = 10⁻¹⁸A, fA = 10⁻¹⁵A.
- Line sync on.

OHMS (Normal Method)

RANGE	5½-DIGIT RESOLUTION	ACCURACY ¹ (10–100% Range) 18°–28°C (1 Year)	TEMPERATURE COEFFICIENT (10–100% Range) 0°–18°C & 28°–50°C	AUTO V SOURCE	AMPS RANGE
		±(% rdg+counts)	±(% rdg+counts)		
2 MΩ	10 Ω	0.125 + 1	0.01 + 1	40 V	200 μA
20 MΩ	100 Ω	0.125 + 1	0.01 + 1	40 V	20 μA
200 MΩ	1 kΩ	0.15 + 1	0.015 + 1	40 V	2 μA
2 GΩ	10 kΩ	0.225 + 1	0.035 + 1	40 V	200 nA
20 GΩ	100 kΩ	0.225 + 1	0.035 + 1	40 V	20 nA
200 GΩ	1 MΩ	0.35 + 1	0.110 + 1	40 V	2 nA
2 TΩ	10 MΩ	0.35 + 1	0.110 + 1	400 V	2 nA
20 TΩ	100 MΩ	1.025 + 1	0.105 + 1	400 V	200 pA
200 TΩ	1 GΩ	1.15 + 1	0.125 + 1	400 V	20 pA

NOTES

- Specifications are for auto V-source ohms, when properly zeroed, 5½-digit, 1PLC, median filter on, digital filter = 10 readings. If user selectable voltage is required, use manual mode. Manual mode displays resistance (up to 10¹⁸Ω) calculated from measured current. Accuracy is equal to accuracy of V-source plus accuracy of selected Amps range.

PREAMP SETTling TIME: Add voltage source settling time to preamp settling time in Amps specification. Ranges over 20GΩ require additional settling based on the characteristics of the load.

OHMS (ALTERNATING POLARITY METHOD)

The alternating polarity sequence compensates for the background (offset) currents of the material or device under test. Maximum tolerable offset up to full scale of the current range used.

Using Keithley 8009 fixture

REPEATABILITY: $\Delta I_{BG} \times R/V_{ALT} + 0.1\%$ (1σ) (instrument temperature constant ±1°C).

ACCURACY: $(V_{SRC,Err} + I_{MEAS,Err} \times R)/V_{ALT}$

where: ΔI_{BG} is a measured, typical background current noise from the sample and fixture.

V_{ALT} is the alternating polarity voltage used.

$V_{SRC,Err}$ is the accuracy (in volts) of the voltage source using V_{ALT} as the setting.

$I_{MEAS,Err}$ is the accuracy (in amps) of the ammeter using V_{ALT}/R as the reading.

VOLTAGE SOURCE

RANGE	5½-DIGIT RESOLUTION	ACCURACY (1 Year) 18°–28°C	TEMPERATURE COEFFICIENT 0°–18°C & 28°–50°C
		±(% setting + offset)	±(% setting+offset)/°C
100 V	5 mV	0.15 + 10 mV	0.005 + 1 mV
1000 V	50 mV	0.15 + 100 mV	0.005 + 10 mV

MAXIMUM OUTPUT CURRENT:

100V Range: ±10mA, hardware short circuit protection at <14mA.

1000V Range: ±1mA, hardware short circuit protection at <1.4mA.

SETTLING TIME:

100V Range: <8ms to rated accuracy.

1000V Range: <50ms to rated accuracy.

NOISE (typical):

100V Range: <2.6mV rms.

1000V Range: <2.9mV rms.

1.888.KEITHLEY (U.S. only)

www.keithley.com

KEITHLEY

A Tektronix Company

A Greater Measure of Confidence

COULOMBS

RANGE	5½-DIGIT RESOLUTION	ACCURACY (1 Year) ^{1,2} 18°-28°C ±(%rdg+counts)	TEMPERATURE COEFFICIENT 0°-18°C & 28°-50°C ±(%rdg+counts)/°C
2 nC	10 fC	0.4 + 5	0.04 + 3
20 nC	100 fC	0.4 + 5	0.04 + 1
200 nC	1 pC	0.4 + 5	0.04 + 1
2 μC	10 pC	0.4 + 5	0.04 + 1

NOTES

- Specifications apply immediately after charge acquisition. Add

$$(4fA + \frac{|Q_{AV}|}{RC}) T_x$$

where T_x = period of time in seconds between the coulombs zero and measurement and Q_{AV} = average charge measured over T_x , and $RC = 300,000$ typical.

- When properly zeroed, 5½-digit, 1PLC (power line cycle), median filter on, digital filter = 10 readings.

INPUT BIAS CURRENT: <4fA at T_{CAL} . Temperature coefficient = 0.5fA/°C, 2nC range.

TEMPERATURE (Thermocouple)

THERMOCOUPLE TYPE	RANGE	ACCURACY (1 Year) ¹ 18°-28°C ±(% rdg + °C)
K	-25°C to 150°C	±(0.3% + 1.5°C)

NOTES

- Excluding probe errors, $T_{cal} \pm 5^\circ\text{C}$, 1 PLC integration time.

HUMIDITY

RANGE	ACCURACY (1 Year) ¹ 18°-28°C, ±(% rdg + % RH)
0-100%	±(0.3% + 0.5)

NOTES

- Humidity probe accuracy must be added. This is ±3% RH for Model 6517-RH, up to 65°C probe environment, not to exceed 85°C.

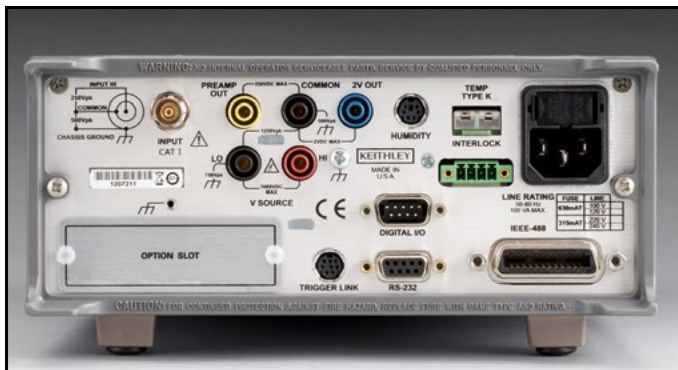

Model 6517B rear panel

IEEE-488 BUS IMPLEMENTATION

IMPLEMENTATION: SCPI (IEEE-488.2, SCPI-1999.0).

TRIGGER TO READING DONE: 150ms typical, with external trigger.

RS-232 IMPLEMENTATION: Supports: SCPI 1991.0. Baud Rates: 300, 600, 1200, 2400, 4800, 9600, 19.2k, 38.4k, 57.6k, and 115.2k.

FLOW CONTROL: None, Xon/Xoff.

CONNECTOR: DB-9 TXD/RXD/GND.

GENERAL

OVERRANGE INDICATION: Display reads "OVERFLOW" for readings >105% of range. The display reads "OUT OF LIMIT" for excessive overrange conditions.

RANGING: Automatic or manual.

CONVERSION TIME: Selectable 0.01PLC to 10PLC.

MAXIMUM INPUT: 250V peak, DC to 60Hz sine wave; 10sec per minute maximum on mA ranges.

MAXIMUM COMMON MODE VOLTAGE (DC to 60Hz sine wave): Electrometer, 500V peak; V Source, 750V peak.

ISOLATION (Meter COMMON to chassis): >10¹⁰Ω, <500pF.

INPUT CONNECTOR: Three lug triaxial on rear panel.

2V ANALOG OUTPUT: 2V for full range input. Non-inverting in Volts mode, inverting when measuring Amps, Ohms, or Coulombs. Output impedance 10kΩ.

PREAMP OUTPUT: Provides a guard output for Volts measurements. Can be used as an inverting output or with external feedback in Amps and Coulombs modes.

EXTERNAL TRIGGER: TTL compatible External Trigger and Electrometer Complete.

GUARD: Switchable voltage guard available.

DIGITAL I/O AND TRIGGER LINE: Available, see manual for usage.

EMC: Conforms to European Union Directive 89/336/EEC, EN 61326-1.

SAFETY: Conforms to European Union Directive 73/23/EEC, EN 61010-1.

READING STORAGE: 50,000.

READING RATES:

To Internal Buffer: 425 readings/second¹.

To IEEE-488 Bus: 400 readings/second^{1,2}.

Bus Transfer: 3300 readings/second².

- 0.01PLC, digital filters off, front panel off, temperature + RH off, Line Sync off.
- Binary transfer mode.

DIGITAL FILTER: Median and averaging.

ENVIRONMENT: Operating: 0°-50°C; relative humidity 70% non-condensing, up to 35°C. Storage: -25° to +65°C.

ALTITUDE: Maximum 2000 meters above sea level per EN 61010-1.

WARM-UP: 1 hour to rated accuracy (see manual for recommended procedure).

POWER: User selectable 100, 120, 220, 240VAC ±10%; 50/60Hz, 100VA max.

PHYSICAL: Case Dimensions: 90mm high × 214mm wide × 369mm deep (3½ in. × 8½ in. × 14½ in.).

Working Dimensions: From front of case to rear including power cord and IEEE-488 connector: 15.5 inches.

Net Weight: 5.4kg (11.8 lbs.).

Shipping Weight: 6.9kg (15.11 lbs.).

SERVICES AVAILABLE

6517B-3Y-EW 1-year factory warranty extended to 3 years from date of shipment

C/6517B-3Y-ISO 3 (ISO-17025 accredited) calibrations within 3 years of purchase*

*Not available in all countries

1.888.KEITHLEY (U.S. only)

www.keithley.com

A Greater Measure of Confidence

KEITHLEY
A Tektronix Company

6521 6522

- 10 channels of multiplex switching
- Install directly in 6517B's option slot
- Choose from low current scanning or high impedance voltage switching with low current switching
- <200 μ V contact potential
- <1pA offset current
- Compatible with Keithley's Model 6517 and 6517A Electrometers

Ordering Information

- 6521 Low Current, 10-channel Scanner Card**
- 6522 Low Current, High Impedance Voltage, 10-channel Scanner Card**

SERVICES AVAILABLE

6521-3Y-EW	1-year factory warranty extended to 3 years from date of shipment
6522-3Y-EW	1-year factory warranty extended to 3 years from date of shipment

Low Current, 10-channel Scanner Cards for 6517B



Two optional 10-channel plug-in scanner cards are available to extend the measurement performance of the Model 6517B Electrometer/High Resistance Meter. The cards install directly into the option slot in the back panel of the Model 6517B. The cards are also compatible with the Models 6517A and 6517.

The Model 6521 Low Current Scanner Card is a 10-channel multiplexer, designed for switching low currents in multipoint testing applications or when the test configuration must be changed. Offset current on each channel is <1pA and high isolation is maintained between each channel (>10¹⁵ Ω). The Model 6521 maintains the current path even when the channel is deselected, making it a true current switch. BNC input connectors help provide shielding for sensitive measurements and make the card compatible with low noise coaxial cables. The Model 6521 is well suited for automating reverse leakage tests on semiconductor junctions or gate leakage tests on FETs.

The Model 6522 Voltage/Low Current Scanner Card can provide up to ten channels of low-level current, high impedance voltage, high resistance, or charge switching. Although it is similar to the Model 6521 in many ways, the Model 6522's input connectors are 3-lug triax. The card can be software configured for high impedance voltage switching of up to 200V. Triaxial connectors make it possible to float the card 500V above ground and drive guard to 200V.

MODEL 6521 SPECIFICATIONS

CHANNELS PER CARD: 10.
FUNCTIONS: Amps.
CONTACT CONFIGURATION: Single pole, "break-before-make" for signal HI input. Signal LO is common for all 10 channels and output. When a channel is off, signal HI is connected to signal LO.
CONNECTOR TYPE: Inputs BNC, Outputs Triaxial.
SIGNAL LEVEL: 30V, 500mA, 10VA (resistive load).
CONTACT LIFE: >10⁶ closures at maximum signal level; >10⁷ closures at low signal levels.
CONTACT RESISTANCE: <1 Ω .
CONTACT POTENTIAL: <200 μ V.
OFFSET CURRENT: <1pA (<30fA typical at 23°C, <60% RH).
ACTUATION TIME: 2ms.
COMMON MODE VOLTAGE: <30V peak.
ENVIRONMENT: Operating: 0° to 50°C up to 35°C at 70% R.H. **Storage:** -25° to 65°C.

MODEL 6522 SPECIFICATIONS

CHANNELS PER CARD: 10.
FUNCTIONS: Volts, Amps.
CONTACT CONFIGURATION: Single pole, "break-before-make" for signal HI input. Signal LO is common for all 10 channels and output. When a channel is off, signal HI is connected to signal LO. 6517B can also configure channels as voltage switches.
CONNECTOR TYPE: Inputs: Triaxial. Outputs: Triaxial.
SIGNAL LEVEL: 200V, 500mA, 10VA (resistive load).
CONTACT LIFE: >10⁶ closures at maximum signal level; >10⁷ closures at low signal levels.
CONTACT RESISTANCE: <1 Ω .
CONTACT POTENTIAL: <200 μ V.
OFFSET CURRENT: <1pA (<30fA typical at 23°C, <60% RH).
CHANNEL ISOLATION: >10¹³ Ω , <0.3pF.
INPUT ISOLATION: >10¹⁰ Ω , <125pF (Input HI to Input LO).
ACTUATION TIME: 2ms.
COMMON MODE VOLTAGE: <300V peak.
ENVIRONMENT: Operating: 0° to 50°C up to 35°C at 70% R.H. **Storage:** -25° to 65°C.

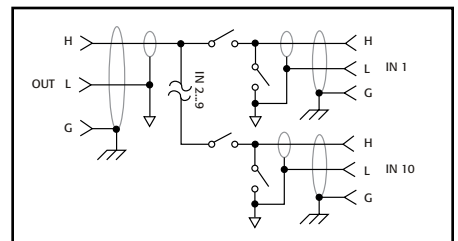
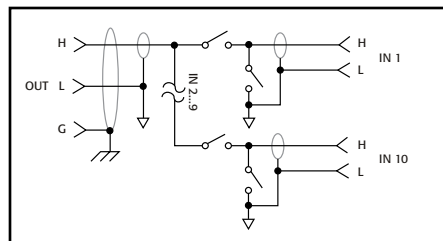

6220/6514/ 2000/7001



The Model 6220 Current Source offers material researchers $\pm 0.1\text{pA/step}$ to $\pm 105\text{mA}$ DC output, combined with $10^{14}\Omega$ output resistance.



The Model 6514 Electrometer provides $>200\text{T}\Omega$ input impedance and $<3\text{fA}$ input bias current.



The Model 2000 6 1/2-Digit Multimeter provides $0.1\mu\text{V}$ of sensitivity.



The Model 7001 Switch/Control Mainframe controls the 7152 4x5 Low Current Matrix Card, which provides contacts with $<1\text{pA}$ offset current.

Ordering Information

6220	DC Current Source
6514	Programmable Electrometer
2000	Digital Multimeter

Options

7001	Switch System
7152	4x5 Low Current Matrix Card

High Impedance Semiconductor Resistivity and Hall Effect Test Configurations

Alternative Economical Approaches to Hall Coefficient and Resistivity Measurements

Occasionally, when working with samples with very high resistivity, semi-insulating GaAs, and similar materials with resistivities above $10^8\Omega$, alternative system configurations may be able to produce more reliable data than standard, pre-configured Hall Effect systems. Such systems demand careful shielding and guarding, and typically include a current source, two electrometer buffers, and an isolated voltmeter. The schematics show two suggested configurations for these high resistivity applications: one that requires manual switching and one with automated switching.

The range of the systems shown here is very wide. The high resistance end is limited by the minimum output of the current source. A current of 100pA can be supplied with an accuracy of about 2%. If the resistance of each leg of the sample is no more than $1\text{T}\Omega$, the maximum voltage developed will be 100V , within the range of the Model 6220 current source and the Model 6514 electrometer. This system will provide good results with samples as low as 1Ω per leg, if a test current level of 100mA is acceptable. Even at $100\text{m}\Omega$ per leg, accuracy is approximately 2%.

Leakage currents are the most important sources of error, especially at very high resistances. One important advantage of this circuit is that a guard voltage is available for three of the sample terminals, which virtually eliminates both leakage currents and line capacitance. The fourth terminal is at circuit LO or ground potential and does not need guarding.

Call Keithley for additional guidance in selecting equipment for specific high resistivity applications.

ACCESSORIES AVAILABLE

7007-1	Shielded IEEE-488 Cable, 1m (3.3 ft)
7007-2	Shielded IEEE-488 Cable, 2m (6.6 ft)
7078-TRX-10	Triax Cable, 3m (10 ft)
KPCI-488LPA	IEEE-488 Interface/Controller for the PCI Bus
KUSB-488B	IEEE-488 USB-to-GPIB Interface Adapter

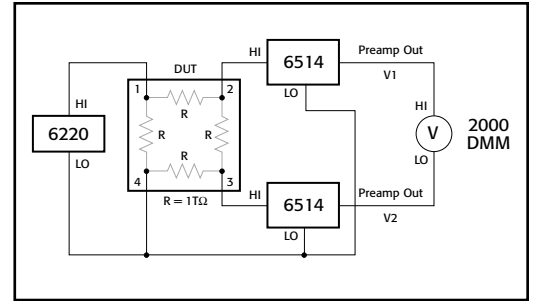

The equipment configuration with manual switching (above) was developed for very high resistance van der Pauw or Hall Effect measurements. This measurement system includes a Model 6220 current source, two Model 6514 electrometers (used as unity-gain buffers), and a Model 2000 digital multimeter (DMM). The current source has a built-in guard, which minimizes the time constant of the current source and cable. The insulation resistance of the leads and supporting fixtures for the sample should be at least 100 times the DUT resistance (R). The entire sample holder must be shielded to avoid electrostatic pickup. If the sample is in a dewar, this should be part of the shield.

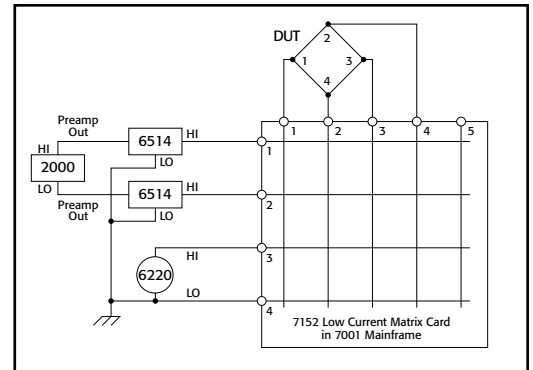

One Model 7152 Matrix Card, housed in a Model 7001 mainframe, is used to connect the electrometers and the current source to the sample. Two Model 6514 electrometers are used as unity gain buffers, and their output difference is measured with a Model 2000 DMM. To ensure faster measurement time, guarded measurements are made by turning the Guard switch ON for both of the Model 6514s, and by guarding the Model 6220 output. Call Keithley's Applications Department for cabling information.

1.888.KEITHLEY (U.S. only)

www.keithley.com

A Greater Measure of Confidence

KEITHLEY
A Tektronix Company

Hall Effect systems for high resistivity applications

LOW LEVEL MEASURE & SOURCE

3390

50MHz Arbitrary Waveform/ Function Generator



- **BEST IN CLASS PERFORMANCE**
- **50MHz sine wave frequency**
- **25MHz square wave frequency**
- **Arbitrary waveform generator with 256k-point, 14-bit resolution**
- **Built-in function generator capability includes: sine, square, triangle, noise, DC, etc.**
- **Precision pulses and square waves with fast (5ns) rise/fall times**
- **Built-in 10MHz external time base for multiple unit synchronization**
- **Built-in AM, FM, PM, FSK, PWM modulation**
- **Frequency sweep and burst capability**
- **Waveform creation software, KiWAVE, included**
- **LXI Class C compliance**

synthesis (DDS) techniques to achieve this level of performance and functionality.

The exceptional signal quality of the Model 3390 is a result of its high resolution, fast rise and fall times, and deep memory. This combined with its low price makes it the ideal solution for applications that use the 50MHz bandwidth and below. Lower speed instruments cannot provide the signal accuracy of the Model 3390, even at bandwidths they were specifically designed for.

Arbitrary Waveform Generation (ARB)

With the Model 3390, you can precisely replicate real world signals. This 14-bit ARB provides the ability to define waveforms with up to 256,000 data points and generate them at a sampling rate of 125MSamples/second. For ease of use, up to four user-defined waveforms can be stored in the onboard non-volatile memory.

Function Generation

Standard output waveforms can be created by pressing one button on the front panel. Ten standard waveforms are provided, including the basic sine, square, ramp, and triangle shapes. The Model 3390 offers the highest repetition rates of any instrument in its class, allowing you to better emulate the signals you need to test.

Pulse Generation

Pulse capabilities have become critically important as devices being tested have become smaller, more sensitive, and more complex. To accurately duplicate the signals these tiny devices receive, very clean pulses with crisp edges are mandatory, which is why the Model 3390 offers the fastest rise time (5ns) and cleanest pulse shapes for this class of instrument.

Modulating Waveforms

The ability of the Model 3390 to modulate at high internal frequencies allows you to accurately simulate real-world conditions. Modulate any of your signals with the built-in AM, FM, PM, PWM, or FSK source, or use your own external modulation source.

Noise Generation

Inject noise into your device under test with the press of a button. The adjustable amplitude and offset parameters control how much or how little noise is produced. The fast rise times and high speed capability provides the precise noise simulation your applications require.

Keithley has paired the best-in-class performance of the Model 3390 Arbitrary Waveform/Function Generator with the best price in the industry to provide your applications with superior waveform generation functionality and flexibility at an unparalleled price.

From its fully featured Arbitrary Waveform Generator (ARB) to its high speed and ease-of-use, the Model 3390 is a complete signal generation solution for all your waveform application needs up to 50MHz.

Versatile Waveform Creation Capabilities

The Model 3390 generates highly stable and accurate waveforms that allow you to create almost any desired shape. It uses direct digital

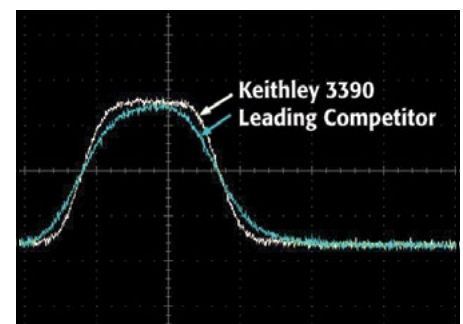

The faster rise time results in cleaner pulses.

1.888.KEITHLEY (U.S. only)

www.keithley.com

3390

Ordering Information

3390 50MHz Arbitrary Waveform/Function Generator

Accessories Supplied

Arbitrary Waveform Generator with power cord

One universal serial bus (USB) cable (USB-B-1)

One pattern generator cable (005-003-00003)

One Ethernet crossover cable (CA-180-3A)

CD-ROM containing user's manual

ACCESSORIES AVAILABLE

4299-3	Single Rack Mount Kit
4299-4	Dual Rack Mount Kit
7755	50Ω Feed Through Terminator
7051-2	General Purpose BNC to BNC Cable (2ft)
7007-1	Shielded GPIB Cable, 1m
USB-B-3	USB cable, Type A to Type B, 3m (10ft)
KPCI-488LPA	IEEE-488 Interface/Controller for the PCI bus
KUSB-488B	IEEE-488 USB-to-GPIB Interface Adapter

SERVICES AVAILABLE

3390-3Y-EW	1-year factory warranty extended to 3 years from date of shipment
C/3390-3Y-DATA	3 (Z540-1 compliant) calibrations within 3 years of purchase*

*Not available in all countries

50MHz Arbitrary Waveform/Function Generator

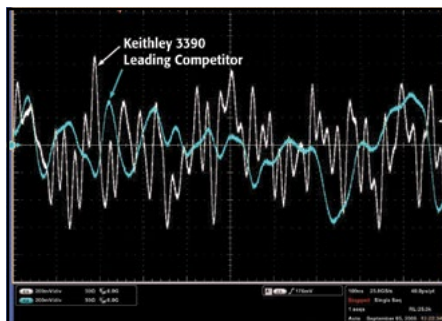

The 20MHz noise bandwidth of the Model 3390 is 2x better than the competition's.

Pattern Generation

The Model 3390 is the only instrument in its class with a Digital Pattern mode. It provides the ability to transmit arbitrary 16-bit patterns via a multi-pin connector located on the rear panel of the instrument. This feature can be used for applications such as testing clock and data signals directly, sending simple protocols to devices under test, and simulating simple control functions. With Keithley's KiWAVE software package, you can easily create complex and long patterns, which the Model 3390 can generate at varying speeds and amplitudes.

10MHz External Reference Expands Flexibility

The built-in 10MHz external time base is included at no extra cost. This external time base makes it simple to control multiple instruments from the same source, connect multiple Model

3390s together, and synchronize multiple signals of any shape.

Ease of Use

This instrument is easy to use. In most cases, pressing one button on the front panel or performing one or two mouse clicks on your PC is all that is necessary to generate or modify a waveform. The KiWAVE software package helps you define and manage waveforms, apply filters to waveforms, and display waveforms on a PC. In addition, the GPIB, USB, LAN, and LXI interfaces can connect the Model 3390 to most devices under test, instruments, and test fixtures.

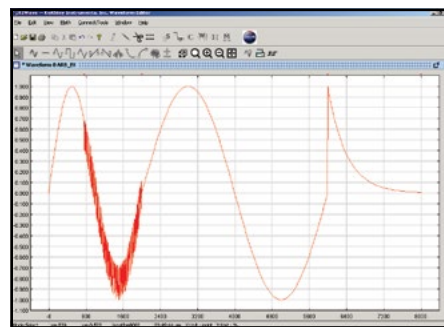

KiWAVE Waveform Editing Utility

LXI Class C Compliance

The Model 3390 supports the physical, programmable, LAN, and Web portions of the emerging LAN eXtensions for Instrumentation (LXI) standard. The instrument can be monitored and controlled from any location on the LAN network via its LXI Web page.



Model 3390 rear panel

1.888.KEITHLEY (U.S. only)

www.keithley.com

KEITHLEY

A Greater Measure of Confidence

A Tektronix Company

50MHz arbitrary waveform/function generator

LOW LEVEL MEASURE & SOURCE

Specifications

DISPLAY: Graph mode for visual verification of signal settings.

CAPABILITY:

Standard Waveforms: Sine, Square, Ramp, Triangle, Pulse, Noise, DC.

Built-in Arbitrary Waveforms: Exponential Rise and Fall, Negative ramp, Sin(x)/x, Cardiac.

Waveform Characteristics

SINE

FREQUENCY: 1 μ Hz to 50MHz.

AMPLITUDE FLATNESS^{1,2} 0.1dB (<100kHz)
(Relative to 1kHz): 0.15dB (<5MHz)
0.3dB (<20MHz)
0.5dB (<50MHz).

HARMONIC DISTORTION^{2,3} (Unit: dBc):

DC to 20kHz: -65(<1Vpp) -65(\geq 1Vpp)
20kHz to 100kHz: -65(<1Vpp) -60(\geq 1Vpp)
100kHz to 1MHz: -50(<1Vpp) -45(\geq 1Vpp)
1MHz to 20MHz: -40(<1Vpp) -35(\geq 1Vpp)
20MHz to 50MHz: -30(<1Vpp) -30(\geq 1Vpp).

TOTAL HARMONIC DISTORTION^{2,3}:

DC to 20kHz, V \geq 0.5Vpp THD \leq 0.06% (typical).

SPURIOUS^{2,4} (non-harmonic): DC to 1MHz: -70dBc.

1MHz to 50MHz: -70dBc + 6dB/octave.

PHASE NOISE (10K Offset): -115 dBc/Hz, typical when f \geq 1MHz, V \geq 0.1Vpp.

SQUARE

FREQUENCY: 1 μ Hz to 25MHz.

RISE/FALL TIME: <10ns.

OVERSHOOT: <2%.

VARIABLE DUTY CYCLE: 20% to 80% (to 10MHz), 40% to 60% (to 25MHz).

ASYMMETRY: 1% of period + 5ns (@ 50% duty).

JITTER (RMS): 1ns + 100ppm of period.

RAMP, TRIANGLE

FREQUENCY: 1 μ Hz to 200kHz.

LINEARITY: <0.1% of peak output.

SYMMETRY: 0.0% ~ 100.0%.

PULSE

FREQUENCY: 500 μ Hz to 10MHz.

PULSE WIDTH: 20ns minimum, 10ns res. (period \leq 10s).

VARIABLE EDGE TIME: <10ns to 100ns.

OVERSHOOT: <2%.

JITTER (RMS): 300ps + 0.1ppm of period.

NOISE

BANDWIDTH: 20MHz typical.

ARBITRARY

FREQUENCY: 1 μ Hz to 10MHz.

LENGTH: 2 to 256K.

RESOLUTION: 14 bits (including sign).

SAMPLE RATE: 125Msamples/s.

MIN RISE/FALL TIME: 30ns typical.

LINEARITY: <0.1% of peak output.

SETTLING TIME: <250ns to 0.5% of final value.

JITTER(RMS): 6ns + 30ppm.

NON-VOLATILE MEMORY: 4 waveforms * 256K points.

COMMON CHARACTERISTIC

FREQUENCY RESOLUTION: 1 μ Hz.

AMPLITUDE RANGE: 10mVpp to 10Vpp in 50 Ω
20mVpp to 20Vpp in Hi-Z.

AMPLITUDE ACCURACY^{1,2} (at 1kHz): \pm 1% of setting \pm 1mVpp.

AMPLITUDE UNITS: Vpp, Vrms, dBm.

AMPLITUDE RESOLUTION: 4 digits.

DC OFFSET RANGE (Peak AC + DC):

\pm 5V in 50 Ω , \pm 10V in Hi-Z.

DC OFFSET ACCURACY^{1,2}

\pm 2% of offset setting, \pm 0.5% of amplitude setting.

DC OFFSET RESOLUTION: 4 digits.

MAIN OUTPUT IMPEDANCE: 50 Ω typical.

MAIN OUTPUT ISOLATION: 42Vpk maximum to earth.

MAIN OUTPUT PROTECTION: Short-circuit protected; overload automatically disables main output.

INTERNAL FREQUENCY REFERENCE ACCURACY⁵:

\pm 10ppm in 90 days, \pm 20ppm in 1 year.

EXTERNAL FREQUENCY REFERENCE STANDARD/OPTION: Standard.

EXTERNAL FREQUENCY INPUT:

Lock Range: 10MHz \pm 500Hz.

Level: 100mVpp ~ 5Vpp.

Impedance: 1k Ω typical, AC coupled.

Lock Time: <2 seconds.

EXTERNAL LOCK RANGE: 10MHz.

FREQUENCY OUTPUT:

Level: 632mVpp (0dBm), typical.

Impedance: 50 Ω typical, AC coupled.

PHASE OFFSET:

Range: -360° to +360°.

Resolution: 0.001°.

Accuracy: 8ns.

MODULATION

MODULATION TYPE: AM, FM, PM, FSK, PWM, Sweep, and Burst.

AM

CARRIER: Sine, Square, Ramp, ARB.

SOURCE: Internal/External.

INTERNAL MODULATION: Sine, Square, Ramp, Triangle, Noise, ARB.

FREQUENCY (Internal): 2mHz to 20kHz.

DEPTH: 0.0% ~ 120.0%.

FM

CARRIER: Sine, Square, Ramp, ARB.

SOURCE: Internal/External.

INTERNAL MODULATION: Sine, Square, Ramp, Triangle, Noise, ARB.

FREQUENCY (Internal): 2mHz to 20kHz.

DEVIATION: DC ~ 25MHz.

PM

CARRIER: Sine, Square, Ramp, ARB.

SOURCE: Internal/External.

INTERNAL MODULATION: Sine, Square, Ramp, Triangle, Noise, ARB.

FREQUENCY (INTERNAL): 2mHz to 20kHz.

DEVIATION: 0.0° to 360°.

PWM

CARRIER: Pulse.

SOURCE: Internal/External.

INTERNAL MODULATION: Sine, Square, Ramp, Triangle, Noise, ARB.

FREQUENCY (INTERNAL): 2mHz to 20kHz.

DEVIATION: 0% ~ 100% of pulse width.

FSK

CARRIER: Sine, Square, Ramp, ARB.

SOURCE: Internal/External.

INTERNAL MODULATION: 50% duty cycle Square.

FREQUENCY (INTERNAL): 2mHz to 100kHz.

EXTERNAL MODULATION INPUT⁶

VOLTAGE RANGE: \pm 5V full scale.

INPUT RESISTANCE: 8.7k Ω typical.

BANDWIDTH: DC to 20kHz.

SWEEP

WAVEFORMS: Sine, Square, Ramp, ARB.

TYPE: Linear or logarithmic.

DIRECTION: Up or down.

SWEEP TIME: 1ms ~ 500s.

TRIGGER: Internal, External, or Manual.

MARKER: Falling edge of sync signal (programmable frequency).

1.888.KEITHLEY (U.S. only)

www.keithley.com

KEITHLEY

A Tektronix Company

3390

50MHz Arbitrary Waveform/ Function Generator

BURST⁷

WAVEFORMS: Sine, Square, Ramp, Triangle, Noise, ARB.

TYPE: Internal/External.

START/STOP PHASE: -360° to $+360^\circ$.

INTERNAL PERIOD: $1\mu\text{s}$ ~ 500s.

GATED SOURCE: External trigger.

TRIGGER SOURCE: Internal, External, or Manual.

TRIGGER INPUT

LEVEL: TTL compatible.

SLOPE: Rising or falling (selectable).

PULSE WIDTH: $>100\text{ns}$.

IMPEDANCE: $>10\text{k}\Omega$, DC coupled.

LATENCY: $<500\text{ns}$.

TRIGGER OUTPUT

LEVEL: TTL compatible into $\geq 1\text{k}\Omega$.

PULSE WIDTH: $>400\text{ns}$.

OUTPUT IMPEDANCE: 50Ω typical.

MAXIMUM RATE: 1MHz.

FAN-OUT: ≤ 4 Keithley 3390s.

PATTERN MODE

CLOCK MAXIMUM RATE: 50MHz.

OUTPUT: Level: TTL compatible into $\geq 2\text{k}\Omega$.

Output Impedance: 110Ω typical.

PATTERN LENGTH: 2 to 256K.

GENERAL

POWER SUPPLY: CAT II 110–240VAC $\pm 10\%$.

POWER CORD FREQUENCY: 50Hz to 60Hz.

POWER CONSUMPTION: 50VA max.

OPERATING ENVIRONMENT: 0° to 50°C .

STORAGE TEMPERATURE: -30° to 70°C .

INTERFACE: USB, LAN, LXI-C, GPIB.

LANGUAGE: SCPI-1993, IEEE-488.2.

DIMENSIONS: 107mm high \times 224mm wide \times 380mm deep (4.2 in. \times 8.8 in. \times 15 in.).

WEIGHT: 4.08kg.

SAFETY: Conforms with European Union Directive 73/23/EEC, EN 61010-1.

EMC: Conforms with European Union Directive 89/336/EEC, EN 61326-1.

WARM-UP: 1 hour.

NOTES

1. Add $10\%^\circ\text{C}$ of spec for offset and amplitude for operation outside the range of 18° to 28°C .
2. Autorange enabled.
3. DC offset set to 0V.
4. Spurious output at low amplitude is -75dBm typical.
5. Add $1\text{ppm}^\circ\text{C}$ average for operation outside the range of 18° to 28°C .
6. FSK uses trigger input (1MHz maximum).
7. Sine and square waveforms above 10MHz are allowed only with an "infinite" burst count.

1.888.KEITHLEY (U.S. only)

www.keithley.com

A Greater Measure of Confidence

KEITHLEY

A Tektronix Company

Model 3390 specifications

LOW LEVEL MEASURE & SOURCE



LOW LEVEL MEASURE & SOURCE

1.888.KEITHLEY (U.S. only)

www.keithley.com

A Greater Measure of Confidence



Switching and Control

Series 3700A Selector Guide

7001

7002

Selector Guide

Selector Guide

707B

708B

Selector Guide

System 46

System 46T

Technical Information	172
System Switch/Multimeter and Plug-In Cards.	174
Plug-In Cards and Accessories for Series 3700A.	184
Plug-In Cards for Series 3700A.	186–207
80-channel Switch/Control Mainframe	210
400-channel Switch/Control Mainframe	212
Switch Cards for 7001, 7002	214–215
Switch Card Accessories for 7001, 7002	215
Switch Cards for 7001, 7002	216–225
Six-slot Semiconductor Switching Matrix Mainframe	226
Single-slot Semiconductor Switching Matrix Mainframe	226
Switch Cards and Accessories for 707B, 708B	231
Switch Cards for 707B, 708B	231–235
32-channel, Unterminated, RF/Microwave Switch System	236
32-channel, Terminated, RF/Microwave Switch System	239

Technical Information

Achieving required system accuracies and precision requires selection of appropriate instruments, creativity in designing test methods, and careful attention to specifications and error terms. Most test system designs are complex enough that it is in the designer's best interest to minimize the number of uncontrolled variables. To accomplish this, the system switch performance should be tightly specified.

Special consideration should be given to tests that approach the specified limits of accuracy, resolution, or sensitivity of the measurement or sourcing instruments. These generally represent the "most critical test requirements," and switching should be selected to support these tests. A system designed to perform against the "most critical test requirements" will usually satisfy other test requirements as well.

How Do I Specify a Switch System for My Application?

Whether you are designing your own switching system or preparing to contact Keithley's applications department for assistance, you need to define certain parameters for your test system and understand how you want everything interconnected.

First, define your parameters. This includes:

- Measurements—List all the required measurement types and accuracies.
- Sources—List all the sources required.
- Quantity—List the number of terminals on the DUT and how many devices are involved.
- Signal characteristics—List signal types, levels and frequency, and impedance requirements.
- Speed—What are the speed requirements?

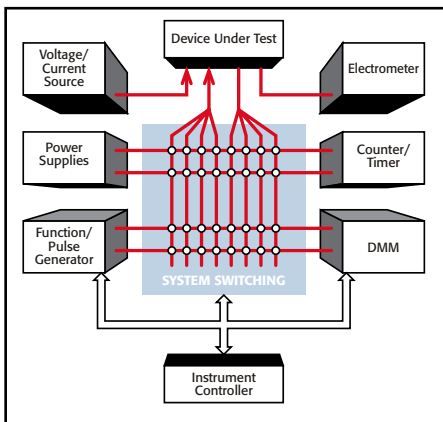

Figure 1. General Purpose Test System

- Environment—Temperature, humidity, etc.
- Communication interface—GPIB, RS-232, Ethernet, USB

Next, sketch the system. Given the number of terminals on the device and the number of instruments (source and measure), develop a picture of what type of switch and configuration will be needed. This is likely to be an iterative process as you identify what types of switching equipment are actually available.

Once you have done the groundwork, you are ready to configure the switching for your test system:

- Determine the appropriate switch and switch card configurations
- Select the appropriate switch system
- Select source and measure equipment
- Select cables and/or other accessories
- Identify need for fuses, limit resistors, diodes, etc.
- Determine the uncertainties and compare them with the required accuracies

Switching Configurations

The variety and size of switching configurations available determine the efficiency of the final switching design, including the amount and complexity of cabling and interconnect at the time of system integration. These are the basic building blocks of any switching system.

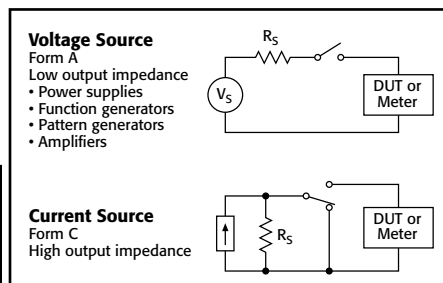

Figure 2. Example Switching Configurations

A switching configuration can be described by the electrical property being switched, its mechanical construction, or its function in the test system (Figure 2). These descriptions of the signal paths or electrical interconnects are necessary for laying out and wiring the test system.

A matrix switch (Figure 3) is the most versatile type of system switching. But first, a word on terminology here — Do not confuse a switch matrix

1.888.KEITHLEY (U.S. only)
www.keithley.com

A Greater Measure of Confidence

KEITHLEY
A Tektronix Company

Switching and Control

(often called a switching mainframe) with a matrix switch. With a matrix switch, any input can be connected to any output, singly or in combination. This helps minimize the need for complex wiring and interconnect systems and can simplify the DUT interface. Although a matrix switch will work in virtually any switching application, it should not necessarily be your first choice of switch configuration.

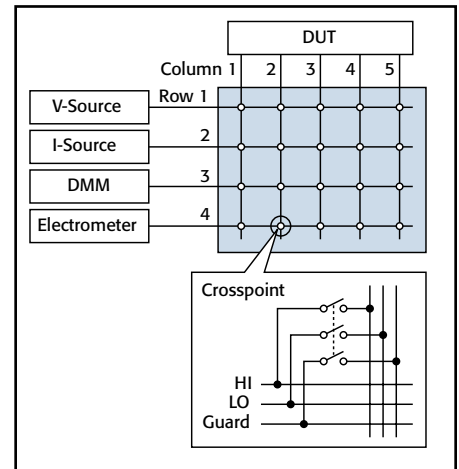

Figure 3. Matrix Switch

Consider an example where you need to connect four different instruments to ten different test points on a device-under-test. If you need to be able to connect any combination of instruments to any combination of test points at any time, then you do need a matrix switch. But, if you only need to connect one instrument to one test point at any time, then you can combine a four-to-one multiplexer with a one-to-ten multiplexer to make your connections. The multiplexer approach only uses 14 relays, while the full matrix uses 40. If you simply choose a matrix switch for the second example, you will end up paying for 26 relay channels you don't need. Careful planning can result in a more compact and economical switch system.

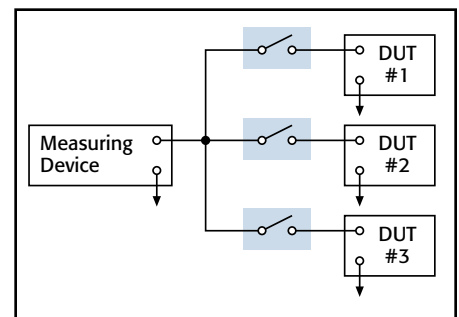

Figure 4. Multiplex Switch

Technical Information

Switching and Control

A multiplex switch (Figure 4) connects one instrument to multiple devices under test or multiple instruments to one device under test. The multiplex switch is useful in combination with matrix or other configurations to expand switching capacity by sharing electrical paths, to provide additional isolation and reduce crosstalk between channels, or to build special configurations.

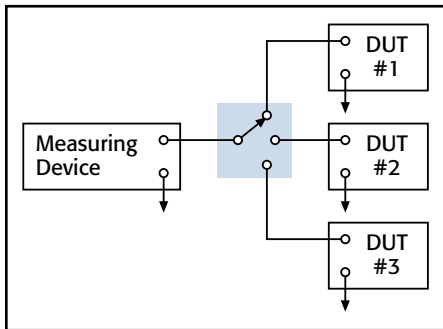

Figure 5. Scanner Switch

A scanner (Figure 5) is a special case of multiplex switching in which switch closures are sequential or serial, sometimes with the capability to skip channels.

The isolated switch configuration consists of individual uncommitted relays, often with multiple poles. Isolated switches are not connected to any other circuit, and are therefore free for building very flexible and unique combinations of input/output configurations with the addition of some external wiring. This type of switch can be useful for creating additional isolation between circuits, providing safety interlock, actuating other relays or circuits, or building special topologies such as binary ladders and tree structures.

Electrical Specifications

Electrical specifications of the switching cards contribute significantly to the overall performance and signal integrity in the test system. When trying to achieve high accuracy, resolution, and sensitivity or to route high frequency signals, high currents, and high voltages with minimum degradation in the test signal, the electrical performance of the switch card must be known. Match the system's critical test requirements against the specified performance of the switch. If the requirement is to measure a one-volt reference to one microvolt, be certain that the contact potential of the switch is not hundreds of microvolts. If switching of power supply voltage is required, be certain that the switch has sufficient current carrying capacity. When measuring resistances of less than one k Ω , be certain the switch will support four-wire measurements.

CHARACTERISTICS	NECESSARY FOR:
Contact potential (limits low voltage signal switching)	Precision measurement of voltage signals of less than 1V, as in reference testing, drift testing, and temperature coefficient testing.
Current offset (limits low current signal switching)	Measurement of signals of less than 1mA, as in semiconductor characterization and insulation resistance tests.
Characteristic impedance	Signal integrity in RF switching.
Thermocouple cold junction reference	Accurate measurements of thermocouple sensor devices.
Four-wire (automatic pairing of channels to facilitate switching of source and sense leads)	Precision measurement of resistance less than 1k Ω and switching of remote sensing voltage supplies.
Maximum current	Switching of power supplies and high power circuits.
Maximum voltage	Isolation and safety in high voltage systems.
Maximum power	Determining maximum current and/or maximum voltage that a relay can switch to prevent damaging the printed circuit board and relays.
Switch life	Determining maximum switch activations that can be expected under hot or cold switching.

Figure 6. Switching Performance Characteristics

The switching card specifications represent the performance of a single card. If additional cards are connected together, actual performance parameters such as offset current and insertion loss will be a function of the entire system, not just a single card. Each extra card and connecting cable adds some degradation. It may be necessary to characterize the entire system (including switching) in some applications.

Figure 6 describes a few performance characteristics and where they apply to improve system performance. There are many other characteristics to consider, depending on the type and level of signal being switched and the expected performance from the test system. The switching selector guides group switching cards according to key performance features. Many switches actually fit into multiple categories and you should look carefully at all of the switch card specifications before making a final selection. Refer to Keithley's Switching Handbook for a more in-depth discussion of switching specifications and their effect on measurement performance.

Mainframe Capabilities

A switching mainframe provides a convenient mechanical and programming environment for Keithley switching cards and can be selected to suit the size of the system. The Model 3706A offers six slots in a full rack 2U high enclosure and is compatible with a growing family of high density and high speed switching cards. For more diverse signal ranges the Models 7001 (two-slot) and 7002 (ten-slot) switch systems are compatible with the full range of more than 30 cards.

For low level semiconductor applications, the Model 707B (six slots) and 708B (one slot) main-

frames are compatible with six specialized high density configurations including high speed, low leakage matrix configurations.

Switching Density

The high channel capacity Keithley mainframes provide reduces the complexity of a switch application by minimizing the number of mainframes and cards required. The Model 3706A is our highest density switching mainframe offering up to 576 two-wire multiplexer channels in a single 2U high, full rack mainframe. The half-rack 7001 has a capacity of up to 80 two-pole channels, and the ten-slot 7002 can accommodate 400 two-pole channels. The 707B can handle up to 576 channels or matrix crosspoints, while the 708B can accommodate up to 96 channels or crosspoints. The high density cards for each of these mainframes are designed for easy interconnect and wiring.

Channel Status

The Series 3700A with its LXI class B compliance offers an elaborate embedded web browser interface for intuitive point and click control and monitoring of all switch positions. The Series 7000 and 700 switch mainframes provide a visual display of each switch position on the front panel.

Expansion

The mainframe Models 3706A, 7001, 7002, and 707B each provide an analog backplane that can be used to make connections between cards when building large matrix or multiplexer configurations that require several cards. The backplane eliminates intercard wiring and increases configuration flexibility.

1.888.KEITHLEY (U.S. only)

www.keithley.com

A Greater Measure of Confidence

KEITHLEY
A Tektronix Company

Series 3700A

System Switch/Multimeter and Plug-In Cards



- Six-slot system switch mainframe with optional high performance multimeter
- Multi-processor architecture optimized for high throughput scanning and pattern switching applications
- Remote PC control via Ethernet, USB, and GPIB interfaces
- Up to 576 two-wire or 720 one-wire multiplexer channels in one mainframe
- Up to 2,688 one-pole matrix crosspoints in one mainframe
- Embedded Test Script Processor (TSP®) offering unparalleled system automation, throughput, and flexibility
- TSP-Link Technology master/slave connection provides easy system expansion and seamless connection to Series 2600 and 2600B SourceMeter® SMU instruments
- Capable of over 14,000 readings per second to memory with optional high performance multimeter
- LXI interface with embedded Web browser interface for test setup, maintenance, and basic application control

The Series 3700A offers scalable, instrument grade switching and multi-channel measurement solutions that are optimized for automated testing of electronic products and components. The Series 3700A includes four versions of the Model 3706A system switch mainframe along with a growing family of plug-in switch and control cards. When the Model 3706A mainframe is ordered with the high performance multimeter, you receive a tightly integrated switch and measurement system that can meet the demanding application requirements in a functional test system or provide the flexibility needed in stand-alone data acquisition and measurement applications.

Maximizes System Control and Flexibility

To provide users with greater versatility when designing test systems, the Series 3700A mainframes are equipped with many standard features. For example, easy connectivity is supported with three remote interfaces: LXI/Ethernet, General Purpose Interface Bus (GPIB), and Universal Serial Bus (USB). Fourteen digital I/O lines are also included, which are programmable

and can be used to control external devices such as component handlers or other instruments. Additionally, system control can be greatly enhanced by using our Test Script Processor (TSP) technology. This technology provides “smart” instruments with the ability to perform distributed processing and control at the instrument level versus a central PC.

High Quality Switching at a Value Price

The Series 3700A builds upon Keithley's tradition of producing innovative, high quality, precise signal switching. This series offers a growing family of high density and general purpose plug-in cards that accommodates a broad range of signals at very competitive pricing. The Series 3700A supports applications as diverse as design validation, accelerated stress testing, data acquisition, and functional testing.

Model 3706A Mainframe

The Series 3700A includes the base Model 3706A system switch/multimeter mainframe with three options for added flexibility. This mainframe contains six slots for plug-in cards in a compact 2U high (3.5 inches/89mm) enclosure that easily accommodates the needs of medium to high channel count applications. When fully loaded, a mainframe can support up to 576 two-wire multiplexer channels or 2,688 one-pole matrix crosspoints for unrivaled density and economical per channel costs.

High Performance, 7½-digit Multimeter (DMM)

The high performance multimeter option provides up to 7½-digit measurements, offering 26-bit resolution to support your ever-increasing test accuracy requirements. This flexible resolution supplies a DC reading rate from >14,000 readings/second at 3½ digits to 60 readings/second at 7½ digits to accommodate a greater span of applications.

The multimeter does not use a card slot, so you maintain all six slots in your mainframe. In addition, the multimeter is wired to the mainframe's analog backplane, ensuring a high quality signal path from each card channel to the multimeter.

The multimeter supports 13 built-in measurement functions, including: DCV, ACV, DCI, ACI, frequency, period, two-wire ohms, four-wire ohms, three-wire RTD temperature, four-wire RTD temperature, thermocouple temperature, thermistor temperature, and continuity. In addition, the multimeter offers extended low ohms (1Ω) and low current ($10\mu A$) ranges. In-rack calibration is supported, which reduces both maintenance and calibration time.

Single Channel Reading Rates

NPLC	DCV/ 2 Wire Ohms		4 Wire Ohms
	4 Wire Ohms		
1.0	60		29
0.2	295		120
0.06	935		285
0.006	6,200		580
0.0005	14,100		650

1.888.KEITHLEY (U.S. only)

www.keithley.com

KEITHLEY

A Tektronix Company

A Greater Measure of Confidence

Series 3700A

System Switch/Multimeter and Plug-In Cards

Ordering Information

Mainframes

3706A Six-slot system switch with high performance DMM

3706A-NFP

Six-slot system switch with high performance DMM, without front panel display and keypad

3706A-S Six-slot system switch

3706A-SNFP

Six-slot system switch, without front panel display and keypad

Plug-in Cards

3720 Dual 1×30 multiplexer card (auto CJC when used with 3720-ST)

3721 Dual 1×20 multiplexer card (auto CJC when used with 3721-ST)

3722 Dual 1×48, high density, multiplexer card

3723 Dual 1×30, high speed, reed relay multiplexer card

3724 Dual 1×30 FET multiplexer card

3730 6×16, high density, matrix card

3731 6×16 high speed, reed relay matrix card

3732 Quad 4×28, ultra-high density, reed relay matrix card

3740 32 channel isolated switch card

3750 Multifunction control card

Accessories Supplied

Test Script Builder Software Suite CD

Ethernet Crossover Cable (CA-180-3A)

Series 3700A Product CD (includes LabVIEW®, IVI C, and IVI.COM drivers)

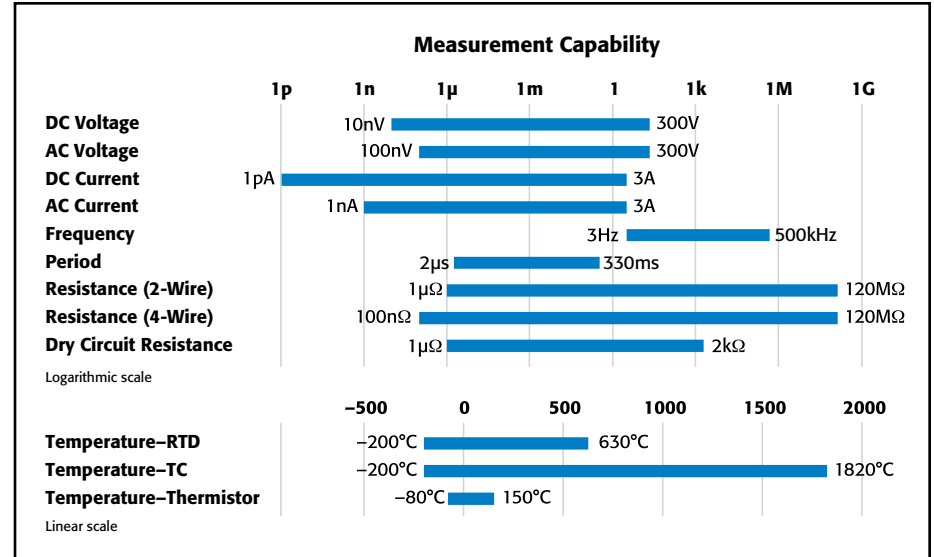

Measurement capabilities of the high performance multimeter

ACCESSORIES AVAILABLE

GPIB INTERFACES AND CABLES

7007-1	Shielded GPIB Cable, 1m (3.5ft)
7007-2	Shielded GPIB Cable, 2m (6.6ft)
KPCI-488LPA	IEEE-488 Interface/Controller for the PCI Bus
KUSB-488B	IEEE-488 USB-to-GPIB Interface Adapter

DIGITAL I/O, TRIGGER LINK, AND TSP-LINK

2600-TLINK	Trigger I/O to Trigger Link Interface Cable, 1m (3.3 ft)
CA-126-1	Digital I/O and Trigger Cable, 1.5m (4.9 ft)
CA-180-3A	CAT5 Crossover Cable for TSP-Link

MULTIMETER CONNECTORS

3706-BAN	DMM Adapter Cable, 15-pin D-sub to banana jacks, 1.4m (4.6 ft)
3706-BKPL	Analog Backplane Extender Board, 15-pin D-sub to terminal block
3706-TLK	Test Lead Kit, includes 3706-BAN and plug-in test lead accessories
8620	Shorting Plug

RACK MOUNT KIT

4288-10	Fixed Rear Rack Mount Kit
---------	---------------------------

SERVICES AVAILABLE

Mainframe Models 3706A and 3706A-NFP

3706A-3Y-EW	1 Year Factory Warranty Extended to 3 Years
3706A-5Y-EW	1 Year Factory Warranty Extended to 5 Years
C/3706A-3Y-STD	Calibration Contract, 3 Years, Standard Calibration*
C/3706A-3Y-DATA	Calibration Contract, 3 Years, Z540 Compliant Calibration with Data*
C/3706A-3Y-ISO	Calibration Contract, 3 Years, ISO 17025 Accredited Calibration*
C/3706A-5Y-STD	Calibration Contract, 5 Years, Standard Calibration*
C/3706A-5Y-DATA	Calibration Contract, 5 Years, Z540 Compliant Calibration with Data*
C/3706A-5Y-ISO	Calibration Contract, 5 Years, ISO 17025 Accredited Calibration*

Mainframe Models 3706A-S and 3706A-SNFP

3706A-S-3Y-EW	1 Year Factory Warranty Extended to 3 Years
3706A-S-5Y-EW	1 Year Factory Warranty Extended to 5 Years

SOFTWARE SERVICES

SYSTEM DEVELOPMENT OR IMPLEMENTATION

Other service contracts are available; please contact us for details.

*Not available in all countries.

1.888.KEITHLEY (U.S. only)

www.keithley.com

KEITHLEY

A Tektronix Company

A Greater Measure of Confidence

System switch with high performance multimeter

SWITCHING AND CONTROL

Series 3700A

System Switch/Multimeter and Plug-In Cards

TSP Distributed Control Increases Test Speed and Lowers Test Cost

TSP technology enhances instrument control by allowing users the choice of using standard PC control or of creating embedded test scripts that are executed on microprocessors within the instrument. By using TSP test scripts instead of a PC for instrument control, you avoid communication delays between the PC controller and instrument, which results in improved test throughput. Test scripts can contain math and decision-making rules that further reduce the interaction between a host PC and the instrument.

This form of distributed control supports the autonomous operation of individual instruments or groups of instruments and can possibly remove the need for a high level PC controller, which lowers test and ownership costs. This is the same proven TSP technology found in our innovative Series 2600B System SourceMeter® SMU instruments.

TSP-Link Technology for Easy and Seamless System Coordination and Expansion

If your channel density requirements grow or if you need to process more signal types, use TSP-Link Technology to expand your system. The TSP-Link master/slave connection offers easy system expansion between Series 3700A mainframes. You can also use TSP-Link Technology to connect to other TSP-Link enabled instruments such as Series 2600B SourceMeter SMU instruments. Everything connected with TSP-Link can be controlled by the master unit, just as if they were all housed in the same chassis.

This high speed system expansion interface lets users avoid the complex and time consuming task of expanding their remote interfaces to another mainframe. There is no need to add external triggers and remote communication cables to individual instruments, since all TSP-Link connected devices can be controlled from a single master unit.

Test Script Builder Software Suite

Test Script Builder is a software tool that is provided with all Series 3700A instruments to help users easily create, modify, debug, and store TSP test scripts. It supplies a project/file manager window to store and organize test scripts, a text-sensitive program editor to create and modify test TSP code, and an immediate instrument control window to send Ethernet, GPIB, and USB commands and to receive data from the instrument. The immediate window also allows users to see the output of a given test script and simplifies debugging.

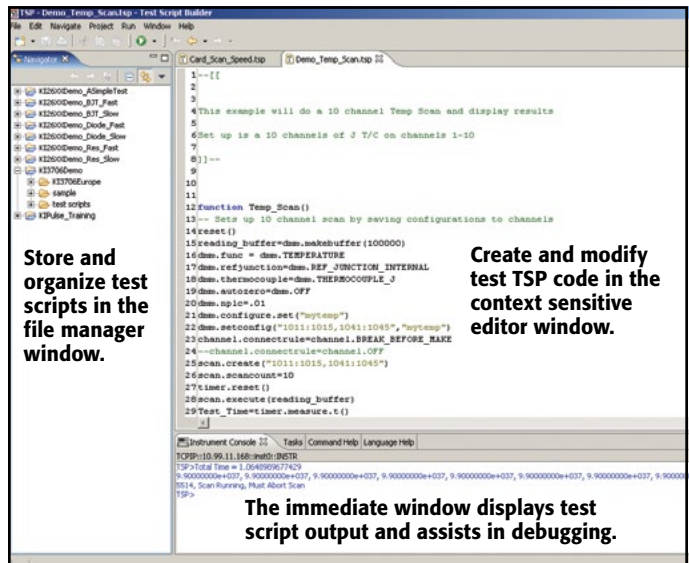

Test Script Builder Software Suite

LXI Version 1.4

LXI Core 2011 with LXI Clock Synchronization, LXI Timestamped Data, LXI Event Messaging, LXI Event Log.

Transportable Memory, USB 2.0 Device Port

All Model 3706A mainframes contain a USB device port for easy transfer of readings, configurations, and test scripts to memory sticks. This port, which is located on the front panel, provides you with easy access to and portability of measurement results. Simply plug in a memory stick and, with a few simple keystrokes, gain access to virtually unlimited memory storage. Additional capabilities include: saving and recalling system configurations and storage for TSP scripts.

Series 3700A

System Switch/Multimeter and Plug-In Cards

Embedded Web Server

The built-in Web interface offers a quick and easy method to control and analyze measurement results. Interactive schematics of each card in the mainframe support point-and-click control for opening and closing switches. A scan list builder is provided to guide users through the requirements of a scan list (such as trigger and looping definitions) for more advanced applications. When the mainframe is ordered with the multimeter, additional Web pages are included for measurement configuration and viewing, including a graphing toolkit.

Built-in Web Server Interface

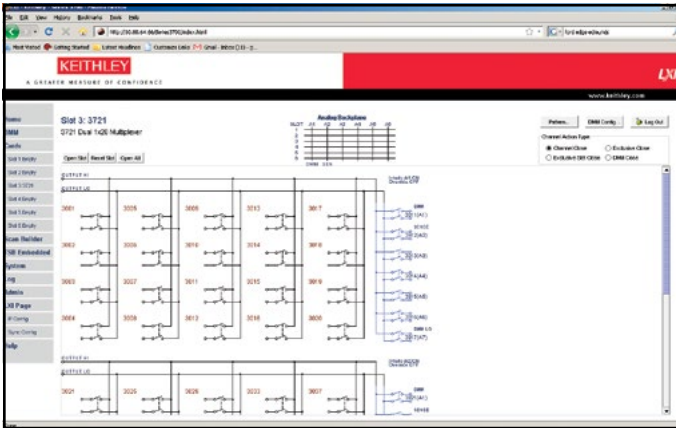

1. Configure your switch channels and measurement functions.

Configure the DMM to make your measurements at the desired speed, resolution, etc. and assign them to the desired channels.



2. Build and run your automated scan list. The toolkit makes it easy to build and execute an automated sequence of channel-open and channel-close commands and triggered multimeter measurements.



3. Analyze your data. View your results in real-time or historical mode with point-and-click simplicity. Data can be exported directly to your PC in either numerical or graphical formats for presentation or other applications.



Model 3706A front panel



Model 3706A-S front panel



Model 3706A-NFP and Model 3706A-SNFP front panel



Model 3706A rear panel

1.888.KEITHLEY (U.S. only)

www.keithley.com

A Greater Measure of Confidence

KEITHLEY
A Tektronix Company

System switch with high performance multimeter

SWITCHING AND CONTROL

Series 3700A

System Switch/Multimeter and Plug-In Cards

High Performance Multimeter Specifications (Rev. A)

DC Specifications

CONDITIONS: 1 PLC or 5 PLC.

For <1PLC, add appropriate "ppm of range" adder from "RMS Noise" table.

Includes rear panel Analog Backplane connector and transducer conversion. Refer to DC Notes for additional card uncertainties.

Function	Range ¹	Resolution	Test Current or Burden Voltage	Input Resistance or Open Circuit Voltage ²	Accuracy: ±(ppm of reading + ppm of range) (ppm = parts per million) (e.g., 10ppm = 0.001%)			Temperature Coefficient 0°–18°C and 28°–50°C
					24 Hour ³ 23°C ± 1°C	90 Day 23°C ± 5°C	1 Year 23°C ± 5°C	
Voltage ⁴	100.00000 mV ¹⁹	0.01 μV		>10 GΩ or 10 MΩ ±1%	10 + 9	25 + 9	30 + 9	(1 + 5)°C
	1.0000000 V ¹⁹	0.1 μV		>10 GΩ or 10 MΩ ±1%	7 + 2	25 + 2	30 + 2	(1 + 1)°C
	10.000000 V	1 μV		>10 GΩ or 10 MΩ ±1%	7 + 2	20 + 2	25 + 2	(1 + 1)°C
	100.00000 V	10 μV		10 MΩ ±1%	15 + 6	35 + 6	40 + 6	(5 + 1)°C
	300.00000 V	100 μV		10 MΩ ±1%	20 + 6	35 + 6	40 + 6	(5 + 1)°C
Resistance ^{4, 5, 6, 7}	1.0000000 Ω	0.1 μΩ	10 mA	8.2 V	15 + 80	40 + 80	60 + 80	(8 + 1)°C
	10.000000 Ω	1 μΩ	10 mA	8.2 V	15 + 9	40 + 9	60 + 9	(8 + 1)°C
	100.00000 Ω	10 μΩ	1 mA	13.9 V	15 + 9	45 + 9	65 + 9	(8 + 1)°C
	1.0000000 kΩ	100 μΩ	1 mA	13.9 V	20 + 4	45 + 4	65 + 4	(8 + 1)°C
	10.000000 kΩ	1 mΩ	100 μA	9.1 V	15 + 4	40 + 4	60 + 4	(8 + 1)°C
	100.00000 kΩ	10 mΩ	10 μA	14.7 V	20 + 4	45 + 5	65 + 5	(8 + 1)°C
	1.0000000 MΩ	100 mΩ	10 μA	14.7 V	25 + 4	50 + 5	70 + 5	(8 + 1)°C
	10.000000 MΩ	1 Ω	0.64 μA/10 MΩ	6.4 V	150 + 6	200 + 10	400 + 10	(70 + 1)°C
	100.00000 MΩ	10 Ω	0.64 μA/10 MΩ	6.4 V	800 + 30	2000 + 30	2000 + 30	(385 + 1)°C
	Dry Circuit Resistance ^{6, 8}	1.0000000 Ω	1 μΩ	10 mA	27 mV	25 + 80	50 + 80	70 + 80
10.000000 Ω		10 μΩ	1 mA	20 mV	25 + 80	50 + 80	70 + 80	(8 + 1)°C
100.00000 Ω		100 μΩ	100 μA	20 mV	25 + 80	90 + 80	140 + 80	(8 + 1)°C
1.0000000 kΩ		1 mΩ	10 μA	20 mV	25 + 80	180 + 80	400 + 80	(8 + 1)°C
2.0000000 kΩ		10 mΩ	5 μA	20 mV	25 + 80	320 + 80	800 + 80	(8 + 1)°C
Continuity (2W)	1.000 kΩ	100 mΩ	1 mA	13.9 V	40 + 100	100 + 100	100 + 100	(8 + 1)°C
Current ⁹	10.000000 μA	1 pA	<61 mV		40 + 50	300 + 50	500 + 50	(35 + 9)°C
	100.00000 μA	10 pA	<105 mV		50 + 9	300 + 30	500 + 30	(50 + 5)°C
	1.0000000 mA	100 pA	<130 mV		50 + 9	300 + 30	500 + 30	(50 + 5)°C
	10.000000 mA	1 nA	<150 mV		50 + 9	300 + 30	500 + 30	(50 + 5)°C
	100.00000 mA	10 nA	<0.4 V		50 + 9	300 + 30	500 + 30	(50 + 5)°C
	1.0000000 A	100 nA	<0.6 V		200 + 60	500 + 60	800 + 60	(50 + 10)°C
	3.0000000 A	1 μA	<1.8 V		1000 + 75	1200 + 75	1200 + 75	(50 + 10)°C

TEMPERATURE

(Displayed in °C, °F, or K. Exclusive of probes errors.)

THERMOCOUPLES (Accuracy based on ITS-90):

Type	Range	Resolution	90 Day/1 Year, 23°C ± 5°C Simulated reference junction	90 Day/1 Year, 23°C ± 5°C Using 3720, 3721, or 3724 Cards	Range	90 Day/1 Year, 23°C ± 5°C Using 3720, 3721, or 3724 Cards	Temperature Coefficient 0°–18°C and 28°–50°C
J	–150 to + 760°C	0.001°C	0.2°C	1.0°C	–200 to –150°C	1.5°C	0.03°C/°C
K	–150 to +1372°C	0.001°C	0.2°C	1.0°C	–200 to –150°C	1.5°C	0.03°C/°C
N	–100 to +1300°C	0.001°C	0.2°C	1.0°C	–200 to –100°C	1.5°C	0.03°C/°C
T	–100 to +400°C	0.001°C	0.2°C	1.0°C	–200 to –100°C	1.5°C	0.03°C/°C
E	–150 to +1000°C	0.001°C	0.2°C	1.0°C	–200 to –150°C	1.5°C	0.03°C/°C
R	+400 to +1768°C	0.1°C	0.6°C	1.8°C	0 to +400°C	2.3°C	0.03°C/°C
S	+400 to +1768°C	0.1°C	0.6°C	1.8°C	0 to +400°C	2.3°C	0.03°C/°C
B	+1100 to +1820°C	0.1°C	0.6°C	1.8°C	+350 to +1100°C	2.8°C	0.03°C/°C

4-WIRE RTD OR 3-WIRE RTD (100Ω platinum [PT100], D100, F100, PT385, PT3916, or user 0Ω to 10kΩ) (Selectable Offset compensation On or Off):

For 3-wire RTD, dmm.connect=dmm.CONNECT_FOUR_WIRE, ≤0.1Ω lead resistance mismatching in Input HI and LO. Add 0.25°C/0.1Ω of lead resistance mismatch.

4-Wire RTD	–200 to +630°C	0.01°C	0.06°C	0.003°C/°C
3-Wire RTD	–200 to +630°C	0.01°C	0.75°C	0.003°C/°C

THERMISTOR: 2.2kΩ, 5kΩ, and 10kΩ. Not recommended with Model 3724 card. See Model 3724 manual for "Measurement Considerations."

	–80 to +150°C	0.01°C	0.08°C	0.002°C/°C
--	---------------	--------	--------	------------

1.888.KEITHLEY (U.S. only)

www.keithley.com

KEITHLEY

A Tektronix Company

A Greater Measure of Confidence

Series 3700A

System Switch/Multimeter and Plug-In Cards

DC SPEEDS vs. RMS NOISE

Single Channel, 60Hz (50Hz) Operation.
1PLC and 5PLC RMS noise are included in DC Specifications.

RMS Noise¹⁶, PPM of Range
RMS Noise Calculator:
Add 2.5 × “RMS Noise” to “ppm of range”
(e.g., 10V @ 0.006 PLC)
“ppm of range” = 2.5 × 7.0 ppm + 2 ppm

Measurements into Buffer (rdg/s)¹³

Measurement to PC (ms/rdg) Azero Off¹³

Function	NPLC	Aperture (ms)	Digits	100mV	1V	10V	100V	300V	Azero On	Azero Off	Ethernet	GPIB	USB
DCV	5 ¹⁴	83.3 (100)	7½	1.0	0.07	0.05	0.7	0.2	9.5 (8)	12 (10)	86.3 (104)	86.1 (102.8)	86.3 (103.1)
	1 ¹⁴	16.7 (20)	7½	0.9	0.12	0.1	0.8	0.35	42 (33)	59.8 (49.5)	19.4 (22.7)	19.5 (22.8)	19.9 (23.2)
	0.2 ^{12,14}	3.33 (4.0)	6½	2.5	0.32	0.3	2.5	1.0	50 (40)	60 (50)	19.4 (22.7)	19.5 (22.8)	19.9 (23.2)
	0.2 ¹⁴	3.33 (4.0)	6½	3.5	1.7	0.7	3.5	1.5	120 (100)	295 (235)	7.6 (8.3)	6.2 (6.8)	6.4 (7.0)
	0.06 ¹⁵	1.0 (1.2)	5½	12	3.0	1.5	8.0	3.5	205 (165)	935 (750)	1.40 (1.80)	1.50 (1.80)	1.60 (2.30)
	0.006 ¹⁵	0.100 (0.120)	4½	55	15	7.0	70	35	218 (215)	6,200 (5,500)	0.55 (0.57)	0.65 (0.67)	0.75 (0.77)
	0.0005 ¹⁵	0.0083 (0.001)	3½	325	95	95	900	410	270 (270)	14,600 (14,250)	0.50 (0.5)	0.60 (0.60)	0.70 (0.70)
2WΩ (≤10kΩ)				10-100Ω	1kΩ	10kΩ							
	5 ¹⁴	83.3 (100)	7½	2.0	0.5	0.4	—	—	9.5 (8)	12 (10)	87.0 (105)	86.1 (103)	86.5 (104)
	1 ¹⁴	16.7 (20)	7½	3.5	0.8	0.6	—	—	42 (33)	59.8 (49.5)	21.0 (24.3)	19.5 (22.8)	19.9 (23.2)
	0.2 ^{12,14}	3.33 (4.0)	6½	6.5	1.7	1.5	—	—	50 (40)	60 (50)	21.0 (24.3)	19.5 (22.8)	19.9 (23.2)
	0.2 ¹⁴	3.33 (4.0)	6½	8.0	4.5	5.5	—	—	120 (100)	295 (235)	7.6 (8.3)	6.2 (6.8)	6.4 (7.0)
	0.06 ¹⁵	1.0 (1.2)	5½	15	6	6.5	—	—	205 (165)	935 (750)	1.40 (1.80)	1.50 (1.80)	1.60 (2.30)
	0.006 ¹⁵	0.100 (0.120)	4½	60	15	15	—	—	218 (215)	6,200 (5,500)	0.55 (0.57)	0.65 (0.67)	0.75 (0.77)
0.0005 ¹⁵	0.0083 (0.001)	3½	190	190	190	—	—	270 (270)	14,100 (13,700)	0.50 (0.5)	0.60 (0.60)	0.70 (0.70)	
DCI				10µA	100µA	1mA-10mA	1A	3A					
	5 ¹⁴	83.3 (100)	7½	3.5	1.6	1.6	2.9	2.0	9.5 (8)	12 (10)	88 (103)	86.1 (102.8)	86.3 (103.1)
	1 ¹⁴	16.7 (20)	6½	3.5	1.1	1.1	2.2	1.8	42 (33)	59.8 (49.5)	21.0 (22.7)	19.5 (22.8)	19.8 (23.1)
	0.2 ^{12,14}	3.33 (4.0)	5½	50	5.0	3.0	4.0	8.0	50 (40)	60 (50)	19.4 (22.7)	19.5 (22.8)	19.8 (23.1)
	0.2 ¹⁴	3.33 (4.0)	4½	100	35	12	4.0	8.0	120 (100)	295 (235)	7.6 (8.3)	6.2 (6.8)	6.4 (7.0)
	0.06 ¹⁵	1.0 (1.2)	4½	350	35	20	8.0	20	205 (165)	935 (750)	1.40 (1.80)	1.50 (1.80)	1.60 (2.30)
	0.006 ¹⁵	0.100 (0.120)	4½	400	200	40	50	100	218 (215)	6,200 (5,500)	0.55 (0.57)	0.65 (0.67)	0.75 (0.77)
0.0005 ¹⁵	0.0083 (0.001)	3½	2500	450	250	325	750	270 (270)	14,100 (13,700)	0.50 (0.5)	0.60 (0.60)	0.70 (0.70)	
4WΩ				1Ω	10-100Ω	1kΩ	10kΩ						
	5 ¹⁴	83.3 (100)	7½	5.5	0.8	0.5	0.5	—	5 (4)	5.9 (4.7)	173 (206)	173 (206)	173 (206)
	1 ¹⁴	16.7 (20)	7½	15	1.4	0.5	0.7	—	23.5 (18.5)	29 (23)	39 (46)	39 (46)	39 (46)
	0.2 ^{12,14}	3.33 (4.0)	5½	100	30	10	50	—	26.5 (21)	30 (24)	39 (46)	39 (46)	39 (46)
	0.2 ¹⁴	3.33 (4.0)	5½	300	50	10	63	—	80 (60)	120 (95)	12.3 (14.5)	11.3 (13.3)	11.7 (13.7)
	0.06 ¹⁵	1.0 (1.2)	4½	500	50	15	70	—	140 (110)	285 (225)	6.2 (7.2)	6.3 (7.3)	6.5 (7.6)
	0.006 ¹⁵	0.100 (0.120)	4½	750	75	30	100	—	200 (195)	580 (565)	4.2 (4.4)	4.3 (4.5)	4.6 (4.8)
0.0005 ¹⁵	0.0083 (0.001)	3½	3500	450	250	250	—	210 (205)	650 (645)	4.2 (4.4)	4.3 (4.5)	4.6 (4.8)	
4WΩ OCOMP				1Ω	10-100Ω	1kΩ	10kΩ						
	5 ¹⁴	83.3 (100)	7½	5.5	0.8	0.5	0.5	—	2.5 (2.0)	2.9 (2.3)	343 (427)	341 (425)	342 (426)
	1 ¹⁴	16.7 (20)	7½	16	1.5	0.7	1.5	—	12.7 (10)	14 (11.2)	77 (95)	74 (92)	75 (93)
	0.2 ^{12,14}	3.33 (4.0)	6½	45	4.5	2.1	3.5	—	14 (11.2)	15 (12)	70 (86.5)	70 (86.5)	70 (86.5)
	0.2 ¹⁴	3.33 (4.0)	5½	500	50	13	30	—	46.5 (37)	56 (44)	22.7 (25)	20.5 (23)	21.1 (24)
0.0005 ¹⁵	0.0083 (0.001)	3½	4500	650	400	400	—	129 (125)	215 (210)	6.7 (6.7)	6.8 (6.8)	7 (7)	
Dry-CktΩ OCOMP				1-10Ω	100Ω	1kΩ	2kΩ						
	5 ¹⁴	83.3 (100)	6½	8.0	10	10	8.0	—	2.5 (2.0)	2.9 (2.3)	347 (430)	345 (428)	346 (429)
	1 ¹⁴	16.7 (20)	5½	17	22	25	28	—	12 (9.5)	13 (10)	80 (99)	77 (95)	78 (97)
	0.2 ^{12,14}	3.33 (4.0)	4½	50	50	50	50	—	14 (11.2)	15 (12)	70 (86.5)	70 (86.5)	70 (86.5)
	0.2 ¹⁴	3.33 (4.0)	3½	500	1000	1000	1500	—	35 (30)	45 (36)	27 (33)	25 (31)	26 (32)
0.0005 ¹⁵	0.0083 (0.001)	2½	8500	8500	8500	8500	—	84 (84)	115 (110)	10.7 (10.7)	10.7 (10.7)	11 (11)	

RTD SPEEDS vs. NOISE

1 PLC and 5 PLC Noise are included in RTD Specifications.

Single Channel, 60Hz (50Hz) Operation				Add °C to Reading ¹⁶		Measurements into Buffer ¹³ (rdg/s)		Measurement to PC ¹³ (ms/rdg) Azero Off		
Function	NPLC	Aperture (ms)	Digits	4-Wire	3-Wire	Azero On	Azero Off	Ethernet	GPIB	USB
OCOMP OFF	5 ¹⁴	83.3 (100)	7½	0	0	5 (4)	5.9 (4.7)	173 (206)	173 (206)	173 (206)
	1 ¹⁴	16.7 (20)	7½	0	0	23.5 (18.5)	29 (23)	39 (46)	39 (46)	39 (46)
	0.2 ^{12,14}	3.33 (4.0)	5½	0.01	0.01	26.5 (21)	30 (24)	39 (46)	39 (46)	39 (46)
	0.2 ¹⁴	3.33 (4.0)	5½	0.18	0.18	80 (60)	120 (95)	12.3 (14.5)	11.3 (13.3)	11.7 (13.7)
	0.06 ¹⁵	1.0 (1.2)	4½	0.24	0.24	140 (110)	285 (225)	6.2 (7.2)	6.3 (7.3)	6.5 (7.6)
	0.006 ¹⁵	0.100 (0.120)	4½	0.37	0.37	200 (195)	580 (565)	4.2 (4.4)	4.3 (4.5)	4.6 (4.8)
	0.0005 ¹⁵	0.0083 (0.001)	3½	3.10	3.10	209 (205)	650 (645)	4.2 (4.4)	4.3 (4.5)	4.6 (4.8)
OCOMP ON	5 ¹⁴	83.3 (100)	7½	0	0	2.5 (2.0)	2.9 (2.3)	343 (427)	341 (425)	342 (426)
	1 ¹⁴	16.7 (20)	7½	0	0	12.7 (10)	14 (11.2)	77 (95)	74 (92)	75 (93)
	0.2 ^{12,14}	3.33 (4.0)	6½	0.02	0.02	14 (11.2)	15 (12)	70 (86.5)	70 (86.5)	70 (86.5)
	0.2 ¹⁴	3.33 (4.0)	5½	0.38	0.38	46.0 (37)	56 (44)	22.7 (25)	20.5 (23)	21.1 (24)
	0.0005 ¹⁵	0.0083 (0.001)	3½	4.67	4.67	128 (125)	215 (210)	6.7 (6.7)	6.8 (6.8)	7 (7)

1.888.KEITHLEY (U.S. only)

www.keithley.com

KEITHLEY

A Greater Measure of Confidence

A Tektronix Company

Series 3700A

System Switch/Multimeter and Plug-In Cards

SYSTEM PERFORMANCE ^{13, 14}

$\frac{3}{2}$ -Digit Mode, Azero off, nPLC = 0.0005. Time includes function change from either DCV or 2W Ω to listed function.

Function	Function Change (ms)	Range Change (ms)	Auto-range (ms)
DCV or 2W Ω (<10k Ω)	10	10	10
4W Ω (<10k Ω)	20	20	20
DCI	10	10	10
Frequency or Period ¹⁷	110	10	—
ACV or ACI ¹⁷	20	85	300

Buffer Transfer Speed	Ethernet	GPIB	USB
Average for 1000 readings	2450/s	2000/s	1800/s
Average for 1000 readings with timestamp	2300/s	1800/s	1600/s

Card	Command	Single Command Execution Time (ms)		
		Ethernet	GPIB	USB
3720, 3721, 3722, 3730	channel.close (ch_list) or channel.open (ch_list)	5.7	5.8	6.1
3723, 3724, 3731, 3732 ¹⁸	channel.close (ch_list) or channel.open (ch_list)	2.3	2.4	2.7
3740	channel.close (ch_list 1-28) or channel.open (ch_list 1-28)	10.7	10.8	11.1
	channel.close (ch_list 29-32) or channel.open (ch_list 29-32)	22.7	22.8	23.1

DC MEASUREMENT CHARACTERISTICS

DC VOLTS

A-D LINEARITY: 1.0ppm of reading + 2.0 ppm of range.

INPUT IMPEDANCE: 100mV–10V Ranges: Selectable >10G Ω // <400pF or 10M Ω \pm 1%.
100V–300V Ranges: 10M Ω \pm 1%.

INPUT BIAS CURRENT: <50pA at 23°C with dmm.autozero=dmm.OFF or dmm.inputdivider=dmm.ON.

COMMON MODE CURRENT: <500nA p-p for \leq 1MHz.

AUTOZERO OFF ERROR: For DCV \pm 1°C and \leq 10 minutes, add \pm (8ppm of reading + 5 μ V).

INPUT PROTECTION: 300V all ranges.

COMMON MODE VOLTAGE: 300V DC or 300Vrms (425V peak for AC waveforms) between any terminal and chassis.

RESISTANCE

MAX. 4W Ω LEAD RESISTANCE: 5 Ω per lead for 1 Ω range; 10% of range per lead for 10 Ω –1k Ω ranges; 1k Ω per lead for all other ranges.

MAX. 4W Ω LEAD RESISTANCE (DRY CKT): 0.5 Ω per lead for 1 Ω range; 10% of range per lead for 10 Ω –100 Ω ranges; 50 Ω per lead for 1k Ω –2k Ω ranges.

INPUT IMPEDANCE: 1 Ω –10 Ω Ranges: 99k Ω \pm 1% // <1 μ F.
100 Ω –2k Ω Ranges: 10M Ω \pm 1% // <0.015 μ F.

OFFSET COMPENSATION: Selectable on 4W Ω 1 Ω –10k Ω ranges.

OPEN LEAD DETECTOR: Selectable per channel. 1.5 μ A, \pm 20% sink current per DMM SHI and SLO lead. Default on.

CONTINUITY THRESHOLD: Adjustable 1 to 1000 Ω .

AUTOZERO OFF ERROR: For 2W Ω \pm 1°C and \leq 10 minutes, add \pm (8ppm of reading + 0.5m Ω) for 10 Ω and 5m Ω for all other ranges.

INPUT PROTECTION: 300V all ranges.

DC MEASUREMENT CHARACTERISTICS (continued)

DC CURRENT

AUTOZERO OFF ERROR: For \pm 1°C and \leq 10 minutes, add \pm (8ppm of reading + range error). Refer to table below.

Range	3 A	1 A	100 mA	10 mA	1 mA	100 μ A	10 μ A
Shunt Resistance guaranteed by design	0.05 Ω	0.05 Ω	1 Ω	10 Ω	100 Ω	1 k Ω	6 k Ω
Burden Voltage	<1.75 V	<0.55 V	<0.4 V	<150 mV	<130 mV	<105 mV	<61 mV
Burden Voltage with 3721 card	<2.35 V	<1.15 V	<0.4 V	<150 mV	<130 mV	<105 mV	<61 mV
Autozero OFF "of range" Error	100 μ A	100 μ A	5 μ A	0.5 μ A	50 nA	5 nA	0.85 nA
For each additional amp after \pm 1.5A input, add the following to ppm of range:							
	—	120	60	60	60	60	95

INPUT PROTECTION: 3A, 250V fuse.

THERMOCOUPLES

CONVERSION: ITS-90.

REFERENCE JUNCTION: Internal, External, or Simulated (Fixed).

OPEN LEAD DETECTOR: Selectable per channel. Open >1.15k Ω \pm 50 Ω . Default on.

COMMON MODE ISOLATION: 300V DC or 300Vrms (425V peak for AC waveforms), >10G Ω and <350pF any terminal to chassis.

DC NOTES

- 20% overrange on DC functions except 1% on 300V range and 3.33% on 3A range.
- \pm 5% (measured with 10M Ω input resistance DMM, >10G Ω DMM on 10M Ω and 100M Ω ranges). Refer to table for other 2W/4W configurations. For Dry Circuit, +20%, <1mV with dmm.offsetcompensation=ON for 100 Ω –2k Ω ranges.

Range	2W	4W	4W–Kelvin	Ocomp 4W	Ocomp 4W–Kelvin
1, 10 Ω	8.2 V	8.2 V	8.2 V	12.1 V	12.1 V
100, 1k Ω	13.9 V	14.1 V	13.9 V	15.0 V	12.7 V
10k Ω	9.1 V	9.1 V	9.1 V	0.0 V	0.0 V
100k, 1M Ω	12.7 V	14.7 V	12.7 V	—	—
10M, 100M Ω	6.4 V	6.4 V	6.4 V	—	—

- Relative to calibration accuracy.
- Add the following additional uncertainty with -ST accessory:

Card	\pm (ppm of range)			\pm (ppm of reading + ppm of range)			
	100 mV	1 V	10 V	100k Ω	1M Ω	10M Ω	100M Ω
3720, 3721, 3722, and 3730	45	4.5	—	8 + 5	8 + 0.5	—	—
3723	60	6.0	—	8 + 6	8 + 0.5	—	—
3724	45	4.5	—	8 + 5	80 + 0.5	250 + 1	5000 + 1
3731	800	80	8	8 + 80	40 + 8	0 + 25	0 + 15
3732 (Quad 4x28)	200	20	2	8 + 20	40 + 2	0 + 7	0 + 4

- Specifications are for 4-wire Ω , 1 Ω –1k Ω with offset compensation on. For Series 3700A plug-in cards, L_{sync} and offset compensation on. 1 Ω range is 4-wire only. Model 3724 card: 1k Ω –100M Ω ranges only. Model 3731 card: 100 Ω –100M Ω ranges only.

For 2-wire Ω specifications, add the following to "ppm of range" uncertainty:

DMM Connect Relays	Rel Enable	Near Panel Connector			
		or 3700 Card	3724 Card	3731 Card	
CONNECT_ALL	ON	100 m Ω	500 m Ω	900 m Ω	
CONNECT_ALL	OFF	1.5 Ω	64 Ω	2.3 Ω	
CONNECT_TWO_WIRE	ON	700 m Ω	1.2 Ω	1.5 Ω	
CONNECT_TWO_WIRE	OFF	1.5 Ω	64 Ω	2.3 Ω	

- Test current with dmm.offsetcompensation=OFF, \pm 5%.

- Add the following to "ppm of reading" uncertainty when using Series 3700A Plug-in Cards in Operating Environment \geq 50%RH.

Card	10k Ω	100k Ω	1M Ω	10M Ω	100M Ω
3720, 3721, 3724, 3730, 3731, 3732 (Quad 4x28) with MTC D-Shell connector	1 ppm	10 ppm	0.01%	0.1%	1%
3720, 3721, 3724, 3730, 3731, 3732 (Quad 4x28) with -ST screw terminal module	10 ppm	100 ppm	0.1%	1%	10%
3722 and 3723	10 ppm	100 ppm	0.1%	1%	10%

Series 3700A Plug-in Cards Operating Environment: Specified for 0° to 50°C, \leq 70%RH at 35°C.

- Dry-Ckt Ω is 4-wire only. Specifications with offset compensation and L_{sync} on.

Card	Ranges
3720, 3721, and 3730	1 Ω – 2 k Ω
3722, 3723, and 3732	10 Ω – 2 k Ω
3724	1 k Ω – 2 k Ω
3731	100 Ω – 2 k Ω

1.888.KEITHLEY (U.S. only)

www.keithley.com

KEITHLEY

A Tektronix Company

A Greater Measure of Confidence

Series 3700A

System Switch/Multimeter and Plug-In Cards

DC NOTES (continued)

9. Includes Analog Backplane 15-pin rear panel connector. For 3721, refer to DC Current table for additional uncertainties.

10. For I_{SYNC} On, line frequency $\pm 0.1\%$.

	nPLC	5	1	<0.2	<0.01
I_{SYNC} On	NMRR	110 dB	90 dB	45 dB	—
I_{SYNC} Off	NMRR	60 dB, ± 2 dB	60 dB, ± 2 dB	—	—

11. For 1k Ω unbalance in LO lead. AC CMRR is 70dB.

	nPLC	5	1	0.2 ¹²	≤ 0.2
CMRR		140 dB	140 dB	120 dB	80 dB

12. For I_{SYNC} On.

13. Reading rates are for 60Hz (50Hz) operation using factory defaults operating conditions dmm.reset("all"). Autorange off. dmm.autodelay=dmm.OFF, dmm.opendetector=dmm.OFF, format.data=format.SREAL. Ranges as follows: DCV = 10V, 2W Ω /4W Ω = 1k Ω , DCI = 1mA, Dry-Ckt Ω = 10 Ω , ACI = 1mA, and ACV = 1V. For

Dry-Ckt Ω with Offset Comp OFF 2k Ω , 60 rdg/s max. Dry-Ckt Ω with Offset Comp ON 2k Ω , 29.5 rdg/s max. For temperature reading rates use DCV for T/C and 2W Ω for Thermistor. Speeds are typical and include measurements and data transfer out the Ethernet, GPIB, or USB.

14. DMM configured for single reading. dmm.measurecount=1, and print(dmm.measure()). May require additional settling delays for full accuracy, depending on measurement configuration.

15. DMM configured for multisample readings and single buffer transfer. dmm.measurecount=1000, buf=dmm.makebuffer(1000), dmm.measure(buf), and printbuffer(1,1000,buf).

16. dmm.autozero=dmm.ON. RMS noise using low thermal short for DCV, 2W Ω , 4W Ω , and Dry-Ckt Ω . For DCI, dmm.connect=dmm.CONNECT_NONE or 0. For RTD, noise using low thermal 190 Ω precision resistor. Includes Model 3721 card accuracies. RMS noise values are typical.

17. For DCV or 2W Ω to Frequency or Period, dmm.nplc=0.2 and dmm.aperture=0.01 sec. For ACI or ACV, dmm.detectorbandwidth=300. For ACI or ACV with dmm.autodelay=dmm.ON, best speed is 65ms.

18. Speeds are within same multiplexer bank. Add an additional 8ms when changing banks or slots.

19. When properly zeroed using REL function.

AC Specifications

			Accuracy: $\pm(\%$ of reading + $\%$ of range) 23°C \pm 5°C								
Function	Range ¹	Resolution	Calibration Cycle	3 Hz–5 Hz	5 Hz–10 Hz	10 Hz –20 kHz	20 kHz–50 kHz	50 kHz–100 kHz	100 kHz–300 kHz		
Voltage ²	100.0000 mV	0.1 μ V	90 Day (100mV–100V)	1.0 + 0.03	0.30 + 0.03	0.05 + 0.03	0.11 + 0.05	0.6 + 0.08	4.0 + 0.5		
	1.000000 V	1 μ V		1.0 + 0.03	0.30 + 0.03	0.06 + 0.03	0.12 + 0.05	0.6 + 0.08	4.0 + 0.5		
	10.00000 V	10 μ V	1 Year (100mV–100V)	1.0 + 0.03	0.30 + 0.03	0.06 + 0.03	0.12 + 0.05	0.6 + 0.08	4.0 + 0.5		
	100.0000 V	100 μ V		1.0 + 0.05	0.30 + 0.05	0.05 + 0.05	0.11 + 0.08	0.6 + 0.11	4.0 + 0.8		
	300.0000 V	1 mV	90 Day	1.0 + 0.05	0.30 + 0.05	0.05 + 0.05	0.11 + 0.08	0.6 + 0.11	4.0 + 0.8		
	300.0000 V	1 mV		1 Year	1.0 + 0.05	0.30 + 0.05	0.06 + 0.05	0.12 + 0.08	0.6 + 0.11	4.0 + 0.8	
Temp. Coeff. /°C ³ (all ranges)				0.010 + 0.003	0.030 + 0.003	0.005 + 0.003	0.006 + 0.005	0.01 + 0.006	0.03 + 0.01		
			Accuracy: $\pm(\text{ppm of reading} + \text{offset ppm})$								
Current ²	1.000000 mA ⁷	1 nA	90 Day/1 Year	1.0 + 0.04	0.30 + 0.04	0.08 + 0.03	0.09 + 0.03	0.09 + 0.03			
	10.00000 mA	10 nA		1.0 + 0.04	0.30 + 0.04	0.08 + 0.03	0.09 + 0.03	0.09 + 0.03			
	100.0000 mA	100 nA	90 Day/1 Year	1.0 + 0.04	0.30 + 0.04	0.08 + 0.03	0.09 + 0.03	0.09 + 0.03			
	1.000000 A	1 μ A		1.0 + 0.04	0.30 + 0.04	0.20 + 0.04	0.88 + 0.04	2.0 + 0.04			
	3.000000 A	10 μ A	90 Day/1 Year	1.0 + 0.05	0.30 + 0.05	0.20 + 0.05	0.88 + 0.05	2.0 + 0.05			
	Temp. Coeff. /°C ³ (all ranges)				0.10 + 0.004	0.030 + 0.004	0.005 + 0.003	0.006 + 0.005	0.006 + 0.005		
			Accuracy: $\pm(\text{ppm of reading} + \text{offset ppm})$								
Frequency ⁴ and Period			3 Hz–500 kHz			3 Hz–500 kHz			333 ms–2 μ s		
	100.0000 mV	0.333 ppm	90 Day/1 Year (all ranges)	80 + 0.333	80 + 0.333	(0.25 s gate)					
	to	3.33 ppm		80 + 3.33	80 + 3.33	(100 ms gate)					
300.0000 V	33.3 ppm	80 + 33.3		80 + 33.3	(10 ms gate)						

ADDITIONAL UNCERTAINTY $\pm(\%$ of reading)

Low Frequency Uncertainty	Detector Bandwidth			Additional Uncertainty $\pm(\%$ of reading)	Detector Bandwidth	Crest Factor ⁵ Maximum Crest Factor: 5 at full-scale			
	3 (3 Hz–300 kHz)	30 (30 Hz–300 kHz)	300 (300 Hz–300 kHz)			1–2	2–3	3–4	4–5
20 Hz–30 Hz	0	0.3	—	5 Hz–10 Hz	3	0.50	1.20	1.30	1.40
30 Hz–50 Hz	0	0	—	10 Hz–30 Hz	3	0.20	0.30	0.60	0.90
50 Hz–100 Hz	0	0	4.0	30 Hz–100 Hz	3 or 30	0.20	0.30	0.60	0.90
100 Hz–200 Hz	0	0	0.72	>100 Hz	3 or 30	0.05	0.15	0.30	0.40
200 Hz–300 Hz	0	0	0.18	300 Hz–500 Hz	300 only	0.50	1.20	1.30	1.40
300 Hz–500 Hz	0	0	0.07	≥ 500 Hz	300 only	0.05	0.15	0.30	0.40
>500 Hz	0	0	0						

1.888.KEITHLEY (U.S. only)

www.keithley.com

A Greater Measure of Confidence

KEITHLEY

A Tektronix Company

Series 3700A

System Switch/Multimeter and Plug-In Cards

AC SPEEDS Single Channel, 60Hz (50Hz) Operation

Function	Detector Bandwidth	NPLC	Aperture (ms)	Measurements into Buffer ^a (rdg/s)			Measurement to PC ^a (ms/rdg)		
				Digits	Azero On	Azero Off	Ethernet	GPIB	USB
ACI / ACV	3	N/A	N/A	6½	0.45 (0.45)	N/A	2150 (2150)	2150 (2150)	2150 (2150)
	30	N/A	N/A	6½	2.5 (2.5)	N/A	400 (400)	400 (400)	400 (400)
	300	1.0 ¹⁰	16.67 (20)	6½	42 (33)	59.5 (50)	19.4 (22.7)	19.5 (22.8)	19.8 (23.1)
	300	0.2 ¹⁰	3.33 (4.0)	6½	120 (100)	295 (235)	7.6 (8.3)	6.2 (6.8)	6.4 (7.0)
	300	0.06 ¹¹	1.0 (1.2)	5½	170 (165)	935 (750)	1.40 (1.80)	1.50 (1.80)	1.60 (2.30)
	300	0.006 ¹¹	0.100 (0.120)	4½	218 (215)	6,200 (5,500)	0.55 (0.57)	0.65 (0.67)	0.75 (0.77)
300	0.0005 ¹¹	0.0083 (0.001)	3½	218 (215)	14,600 (14,250)	0.50 (0.5)	0.60 (0.60)	0.70 (0.70)	
Frequency/Period	N/A	N/A	10–273	N/A	2× input period + gate time	N/A	2× input period + gate time + 2.7ms	2× input period + gate time + 2.8ms	2× input period + gate time + 3.1ms

AC MEASUREMENT CHARACTERISTICS

AC VOLTS

MEASUREMENT METHOD: AC-coupled, True RMS.

INPUT IMPEDANCE: 1MΩ ±2% // by <150pF.

INPUT PROTECTION: 300VDC or 300Vrms rear inputs or 37xx cards.

AC CURRENT

MEASUREMENT METHOD: AC-coupled, True RMS.

Range	3 A	1 A	100 mA	10 mA	1 mA
Shunt Resistance guaranteed by design	0.05 Ω	0.05 Ω	1.0 Ω	10 Ω	100 Ω
Burden Voltage Rear Panel	<1.75 V rms	<0.55 V rms	<0.4 V rms	<150 mV rms	<125 mV rms
Burden Voltage 3721 Card	<2.4 V rms	<1.0 V rms	<0.6 V rms	<200 mV rms	<130 mV rms

INPUT PROTECTION: 3A, 250V fuse.

FREQUENCY AND PERIOD

MEASUREMENT METHOD: Reciprocal Counting technique.

GATE TIME: dmm.aperture=0.273→0.01. Default 0.01s.

AC GENERAL

AC CMRR⁶: 70dB.

VOLT-HERTZ PRODUCT: ≤8×10⁷ Volt-Hz (guaranteed by design), ≤2.1×10⁷ Volt-Hz verified. Input frequency verified for ≤3×10⁵ Hz.

AC NOTES

- 20% overrange on AC functions except 1% on 300V and 3.33% on 3A. Default resolution is 5½ digits, maximum useable resolution is 6½ with 7½ digits programmable.
- Specification are for Detector Bandwidth 3 and sinewave inputs >5% of range. Detector Bandwidth 3 and 30 are multi-sample A/D conversions. Detector bandwidth 300 is a single A/D conversion, programmable from 0.0005PLC to 15PLC. Default condition set to 1PLC.
- Applies to 0°–18°C and 28°–50°C.
- Specified for square wave inputs. Input signal must be >10% of ACV range. If input is <20mV on the 100mV range then the frequency must be >10Hz. For sinewave inputs, frequency must be >100Hz.
- Applies to non-sinewave inputs 5Hz→10kHz, and DC content ≤3% of range.
- For 1kΩ unbalance in LO lead.
- For Model 3721, 1mA ACI, add 0.05% to “of reading” uncertainty from 250Hz → 10kHz.
- Shunt resistance guaranteed by design.
- Reading rates are for 60Hz (50Hz) operation using factory defaults operating conditions dmm.reset(“all”), Autorange off, dmm.autodelay=dmm.OFF, dmm.opendetector=dmm.OFF, format.data=format.SREAL. Ranges as follows: DCV = 10V, 2WΩ/4WΩ = 1kΩ, DCI = 1mA, Dry-Ckt Ω = 10Ω, ACI = 1mA, and ACV = 1V. For Dry-Ckt Ω with Offset Comp OFF 2kΩ, 60 rdg/s max. Dry-Ckt Ω with Offset Comp ON 2kΩ, 29.5 rdg/s max. For temperature reading rates use DCV for T/C and 2WΩ for Thermistor. Speeds are typical and include measurements and data transfer out the Ethernet, GPIB, or USB.
- DMM configured for single reading, dmm.measurecount=1, and print(dmm.measure()). May require additional settling delays for full accuracy, depending on measurement configuration.
- DMM configured for multisample readings and single buffer transfer, dmm.measurecount=1000, buf=dmm.makebuffer(1000), dmm.measure(buf), and printbuffer(1,1000,buf).

1.888.KEITHLEY (U.S. only)

www.keithley.com

KEITHLEY

A Tektronix Company

A Greater Measure of Confidence

Series 3700A

System Switch/Multimeter and Plug-In Cards

GENERAL

EXPANSION SLOTS: 6.

POWER LINE: Universal, 100V to 240V.

LINE FREQUENCY: 50Hz and 60Hz, automatically sensed at power-up.

POWER CONSUMPTION: 28VA with DMM and display, up to 140VA with six 37xx cards.

REAL TIME CLOCK: Battery backed, 10 years typical life.

EMC: Conforms to European Union EMC Directive.

SAFETY: Conforms to European Union Low Voltage Directive.

VIBRATION: MIL-PRF-28800F Class 3, Random.

WARM-UP: 2 hours to rated accuracy.

DIGITAL I/O: 25-pin female D-shell.

	I/O 1-9	I/O 10-14	Vext
$I_{\text{SINK, max}}$	5 mA	250 mA	—
$I_{\text{SOURCE, max}}$	960 μA	980 μA	—
Absolute V_{IN}	5.25 V to -0.25 V	5.25 V to -0.25 V	5 V to 33 V
$V_{\text{IH, min}}$	2.2 V	2.2 V	—
$V_{\text{IL, max}}$	0.7 V	0.7 V	—
$V_{\text{OL, max}}$ at 5mA I_{sink}	0.7 V	0.7 V	—
$V_{\text{OL, max}}$ at $I_{\text{sink, max}}$	—	2.3 V	—
$V_{\text{OH, min}}$, 0.4mA source	2.7 V	2.4 V	—
Min V_{IN} pulse	2 μs	10 μs	—
Min V_{O} pulse	1 μs	50 μs	—

I/O 1-9

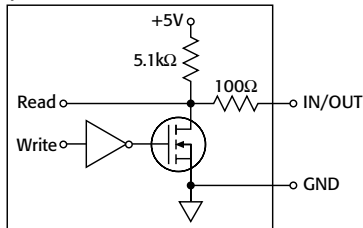

I/O 10-14

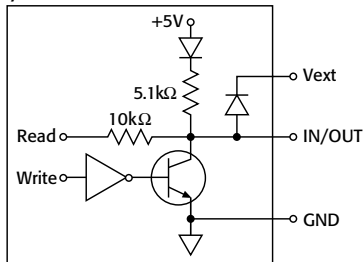

TRIGGERING AND MEMORY:

Window Filter Sensitivity: 0.01%, 0.1%, 1%, 10%, or full-scale of range (none).

Trigger Delay: 0 to 99 hrs. (10 μs step size).

External Trigger Delay: <10 μs .

Memory: Up to 650,000 time-stamped readings with Web page disabled. Additional memory available with external "thumb drive."

Non-volatile Memory: Single user save setup, with up to 75 DMM configurations and ≥ 600 channel patterns (dependent on name length, DMM function and configuration, and pattern image size). Additional memory available with external "thumb drive."

MATH FUNCTIONS: Rel, dB, Limit Test, %, 1/x, and mX+b with user defined displayed.

REMOTE INTERFACE:

Ethernet: RJ-45 connector, LXI Class B Version 2, 10/100BT, no auto MDIX.

GPIO: IEEE-488.1 compliant. Supports IEEE-488.2 common commands and status model topology.

USB Device (rear panel, type B): Full speed, USBTMC compliant.

USB Host (front panel, type A): USB 2.0, support for thumb drives.

LXI COMPLIANCE: LXI Class B Version 2 with IEEE 1588 precision time protocol.

LXI TIMING (applies to scanning) and SPECIFICATION:

Receive LAN[0-7] Event Delay: n/s (not specified) min., 800 μs typ., n/s max.

Alarm to Trigger Delay: 25 μs min., 50 μs typ., n/s max.

Generate LAN[0-7] Event: n/s min., 800 μs typ., n/s max. (minimums are probabilistic and represent a 95% confidence factor).

Clock Accuracy: 25ppm.

Synchronization Accuracy: <150ns (probabilistic and represents a 95% confidence factor).

Timestamp Accuracy: 100 μs .

Timestamp Resolution: 20ns.

LANGUAGE: Embedded Test Script Processor (TSP) accessible from any host interface.

Responds to individual Instrument Control Library (ICL) commands. Responds to high-speed test scripts comprised of ICL commands and Test Script Language (TSL) statements (e.g., branching, looping, math, etc.). Able to execute high-speed test scripts stored in memory without host intervention.

IP CONFIGURATION: Static or DHCP.

PASSWORD PROTECTION: 11 characters

MINIMUM PC HARDWARE: Intel Pentium 3, 800MHz, 512Mbyte RAM, 210Mbyte disk space or better.

OPERATING SYSTEMS/SOFTWARE: Windows® 2000 and XP compatible, supports Web browsers with Java plug-in (requires Java plug-in 1.6 or higher). Web pages served by 3706A.

OPERATING ENVIRONMENT: Specified for 0° to 50°C, $\leq 80\%$ RH at 35°C, altitude up to 2000 meters.

STORAGE ENVIRONMENT: -40° to 70°C.

DIMENSIONS:

Rack Mounted: 89mm high \times 483mm wide \times 457mm deep (3.5 in. \times 19 in. \times 18 in.).

Bench Configuration (includes handle and feet): 104mm high \times 483mm wide \times 457mm deep (4.125 in. \times 19 in. \times 18 in.)

SHIPPING WEIGHT: 13kg (28 lbs).

1.888.KEITHLEY (U.S. only)

www.keithley.com

KEITHLEY

A Greater Measure of Confidence

A Tektronix Company

Series 3700A

- Multiplexer, matrix, and I/O cards
- Relay closures automatically counted and stored in each card's onboard memory
- Unlimited contact life with solid-state relay (Model 3724)
- Automatic CJC for temperature measurements when used with screw terminal accessory (Models 3720, 3721, 3724)

Ordering Information

3720	Dual 1×30 Multiplexer Card	186
3721	Dual 1×20 Multiplexer Card	188
3722	Dual 1×48, High Density, Multiplexer Card	190
3723	Dual 1×30, High Speed, Reed Relay, Multiplexer Card	192
3724	Dual 1×30 FET Multiplexer Card	194
3730	6×16, High Density, Matrix Card	197
3731	6×16, High Speed, Reed Relay, Matrix Card	199
3732	Quad 4×28, Ultra-High Density, Reed Relay, Matrix Card	201
3740	General Purpose Card with 32 Independent Channels	205
3750	Multifunction Control Card	207

Plug-in Cards for Series 3700A Mainframes

Specifications for Plug-In Cards

Additional Series 3700A cards are currently in development. For a current list of cards and specifications, visit www.keithley.com.

	3720	3721	3722
Page	186	188	190
No. of Channels	60 (Dual 1×30)	40 (dual 1×20)	96 (dual 1×48)
Card Config.	Multiplexer	Multiplexer	Multiplexer
Type of Relay	Latching electromechanical	Latching electromechanical	Latching electromechanical
Contact Configuration	2 Form A	2 Form A	2 Form A
Max. Voltage	300 V	300 V (ch 1–40), 60 V (ch 41–42)	300 V
Max. Current Switched	1 A	2 A (ch 1–40), 3 A (ch 41–42)	1 A
Comments	2 independent 1×30 multiplexers. Automatic temperature reference when used with screw terminal accessory (Model 3720-ST)	2 independent 1×20 multiplexers. Automatic temperature reference when used with screw terminal accessory (Model 3721-ST)	2 independent 1×48 multiplexers

Plug-in Card Accessories

	3720	3721	3722
Cables	3720-MTC-1.5, 3720-MTC-3	3721-MTC-1.5, 3721-MTC-3	3722-MTC-1.5, 3722-MTC-1.5/MM, 3722-MTC-3, 3722-MTC-3/MM
Screw Terminal Block	3720-ST	3721-ST	
Connector Kits	3791-KIT78-R	3790-KIT50-R	3792-KIT104-R, 3792-KIT104-R/F
Tools	3791-CIT		3791-CIT

1.888.KEITHLEY (U.S. only)

www.keithley.com

KEITHLEY
A Tektronix Company

A Greater Measure of Confidence

Series 3700A

Plug-in Cards for Series 3700A Mainframes

3723	3724	3730	3731	3732	3740	3750
192	194	197	199	201	205	207
60 (dual 1×30) or 120 single pole (dual 1×60)	60 (dual 1×30)	6×16	6×16	448 crosspoints (Quad 4×28)	32	40 digital I/O, 4 counter/totalizers, and 2 isolated analog outputs
Multiplexer	Multiplexer	Matrix	Matrix	Matrix	Independent	Independent
Dry reed	FET solid-state	Latching electromechanical	Dry reed	Dry reed	Latching electromechanical	N/A
1 Form A	2 Form A	2 Form A	2 Form A	1 Form A	28 Form C, 4 Form A	N/A
200 V	200 V	300 V	200 V	200 V	300 VDC/250 VAC (Form A)	N/A
1 A	0.1 A	1 A	1 A	0.75 A	2 A (Form C), 7 A (Form A)	N/A
2 independent 1×30 multiplexers	2 independent 1×30 multiplexers. Automatic temperature reference when used with screw terminal accessory (Model 3724-ST)	Columns can be expanded through the backplane or isolated by relays	Relay actuation time of 0.5ms. Columns can be expanded through the backplane or isolated by relays	Banks can be connected together via bank configuration relays to create a single 4×112 or dual 4×56 matrix. Analog backplane relays also included for card to card expansion. Row expansion with 3732-ST-R accessory to create a dual 8×28 or single 16×28 matrix.	32 general purpose independent channels.	All-in-one card design. 40 bidirectional I/O. Four 32-bit counter/totalizers. 2 programmable analog (V or I) outputs.

3723	3724	3730	3731	3732	3740	3750
3720-MTC-1.5, 3720-MTC-3	3720-MTC-1.5, 3720-MTC-3	3721-MTC-1.5, 3721-MTC-3	3721-MTC-1.5, 3721-MTC-3	3732-MTC-1.5, 3732-MTC-3	3721-MTC-1.5, 3721-MTC-3	3721-MTC-1.5, 3721-MTC-3
3723-ST, 3723-ST-1	3724-ST	3730-ST	3731-ST	3732-ST-C, 3732-ST-R	3740-ST	3750-ST
3791-KIT78-R	3791-KIT78-R	3790-KIT50-R	3790-KIT50-R	3791-KIT78-R	3790-KIT50-R	3790-KIT50-R
3791-CIT	3791-CIT			3791-CIT		

1.888.KEITHLEY (U.S. only)

www.keithley.com

A Greater Measure of Confidence

KEITHLEY
A Tektronix Company

Plug-in cards for Series 3700A mainframes

SWITCHING AND CONTROL

3720

Dual 1×30 Multiplexer Card

60 differential channels, automatic CJC w/3720-ST accessory

- 60 two-pole channels or 30 four-pole channels for general purpose switching
- Automatic CJC for temperature measurements when used with 3720-ST accessory
- Analog backplane connection relays provide easy bank and card interconnections
- 300V, 1A switched or 2A carry signal capacity; 60W, 125VA
- Screw terminal connections provided with removable 3720-ST accessory
- Relay closures stored in onboard memory
- Latching electromechanical relays

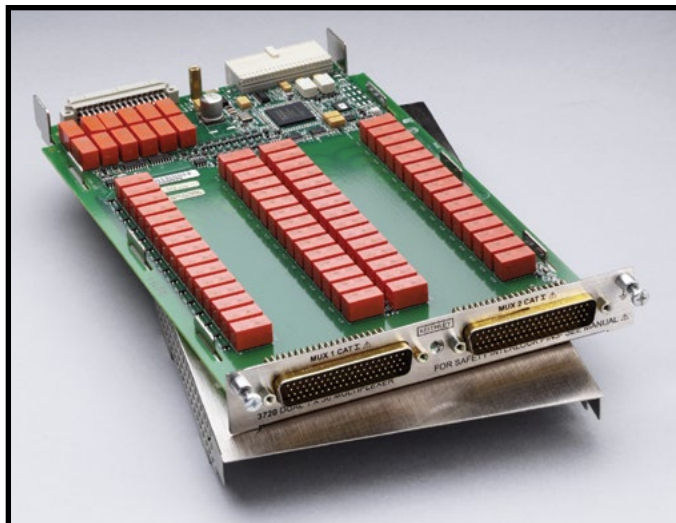

The Model 3720 offers two independent banks of 1×30 two-pole multiplexers. It is ideal for general purpose switching, including temperature measurements. The two banks can automatically be connected to the Series 3700A mainframe backplane and optional DMM through the analog backplane connection relays. This connection allows the mainframe to reconfigure the card to a single 1×60 two-pole multiplexer or to enable card-to-card expansion for even larger configurations.

Other features of the Model 3720 include its ability to be reconfigured to coordinated four-pole operation for additional measurement flexibility. Furthermore, the Model 3720 supports thermocouple-type temperature measurements when used with the Model 3720-ST (screw terminal) accessory providing automatic cold junction compensation (CJC).

The Model 3720 uses two 78-pin male D-sub connectors for signal connections. For screw terminal or automatic CJC, use the detachable Model 3720-ST accessory.

Ordering Information

3720 **Dual 1×30**
Multiplexer Card

ACCESSORIES AVAILABLE

3720-MTC-1.5	78 Pin D-sub Female to Male Cable, 1.5m (5 ft.)
3720-MTC-3	78 Pin D-sub Female to Male Cable, 3m (10 ft.)
3720-ST	Screw Terminal Block (required for auto CJC thermocouple measurements)
3791-CIT	Contact Insertion and Extraction Tool
3791-KIT78-R	78 Pin Female D-sub Connector Kit (contains 2 female D-sub connectors and 156 solder-cup contacts)
7401	Type K Thermocouple Wire (100 ft.)

SERVICES AVAILABLE

3720-3Y-EW-STD	1-year factory warranty extended to 3 years from date of shipment
3720-5Y-EW-STD	1-year factory warranty extended to 5 years from date of shipment
C/3720-3Y-STD	3 (Z540-1 compliant) calibrations within 3 years of purchase*

*Not available in all countries

1.888.KEITHLEY (U.S. only)

www.keithley.com

Dual 1×30 Multiplexer Card

60 differential channels, automatic CJC w/3720-ST accessory

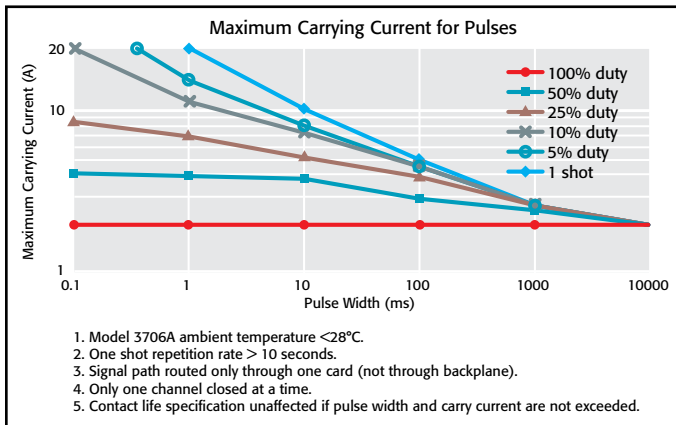
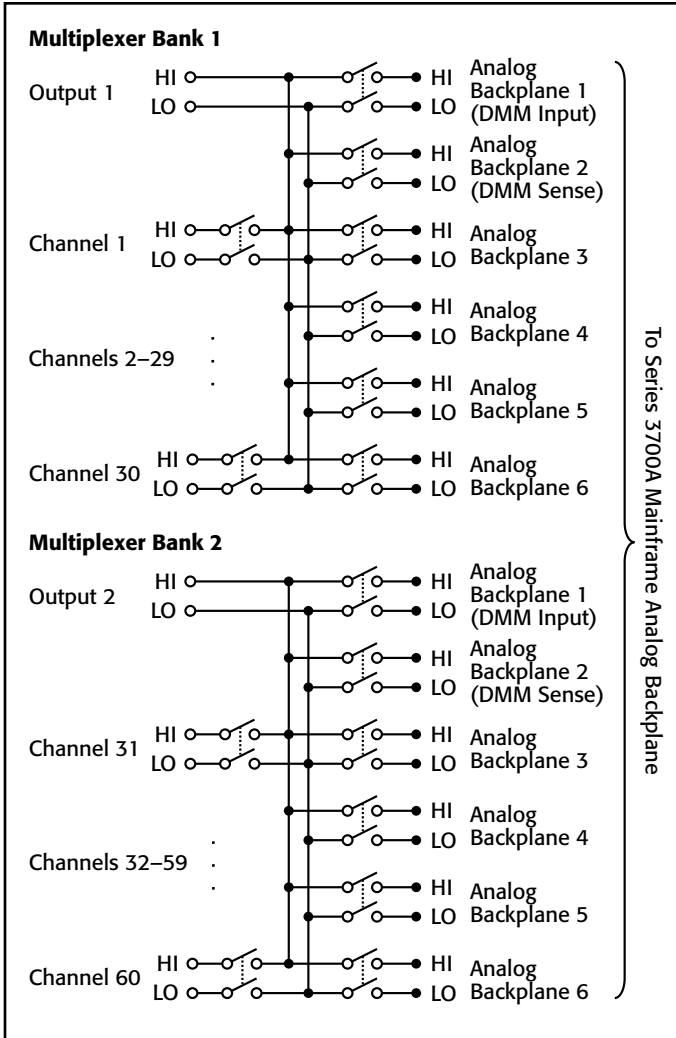

MULTIPLEXER CONFIGURATION: Two independent 1×30 2-pole multiplexers. Banks can be isolated from the backplane by relays. Card can be configured for 2 and 4 wire.

CONTACT CONFIGURATION: 2 pole form A.

CONNECTOR TYPE: Two 78 pin male D-shells.

MODEL 3720-ST SCREW TERMINAL OPTION: #22 AWG typical wire size with 0.062 inch O.D. 124 conductors maximum. #16 AWG maximum wire size with 0.092 inch O.D. 36 conductors per card maximum.

MAXIMUM SIGNAL LEVEL: Channels 1–60: 300V DC or RMS, 1A switched (2A carry), 60W, 125VA.

COMMON MODE VOLTAGE: 300V DC or RMS between any terminal and chassis.

VOLT-HERTZ LIMIT: 8×10⁷.

CONTACT LIFE: >10⁵ operations at maximum signal level. >10⁸ operations no load.¹

	Dual 1×30 ³	Single 1×60 ^{2,3}
Channel Resistance (end of contact life)	<1.0 Ω	<1.5 Ω
Contact Potential (differential)	<±1 μV	<±3 μV
Offset Current	<±250 pA	<±250 pA
Isolation		
Differential	10 ⁹ Ω, 250 pF	10 ⁹ Ω, 450 pF
Bank-Bank	10 ¹⁰ Ω, 75 pF	—
Channel-channel	10 ⁹ Ω, 75 pF	10 ⁹ Ω, 75 pF
Common Mode	10 ⁹ Ω, 200 pF	10 ⁹ Ω, 400 pF
Crosstalk Channel-channel		
300kHz	<-60 dB	<-55 dB
1MHz	<-50 dB	<-50 dB
20MHz:	<-25 dB	<-20 dB
Bandwidth	30 MHz	10 MHz

TYPICAL SCANNING SPEEDS:

- Switch Only⁴: Sequential scanning, single channel, immediate trigger advance: >120 ch/s.
- With Measurements Into Memory⁵:
 - DCV (10V range) or 2W Ohms (1kΩ range): >110 ch/s.
 - Thermocouple: >110 ch/s.
 - 3- or 4-Wire RTD: >100 ch/s.
 - 4-Wire Ohms (1kΩ range): >100 ch/s.
 - ACV (10V range): >110 ch/s.

GENERAL

- ACTUATION TIME:** 4ms.
- TEMPERATURE ACCURACY using Automatic CJC with 3720-ST accessory:** 1°C for J, K, T and E types (see mainframe specification for details).
- RELAY TYPE:** Latching electromechanical.
- RELAY DRIVE SCHEME:** Matrix.
- INTERLOCK:** Backplane relays disabled when interlock connection is removed.
- OPERATING ENVIRONMENT:** Specified for 0° to 50°C. Specified to 70% R.H. at 35°C.
- STORAGE ENVIRONMENT:** -25° to 65°C.
- WEIGHT:** 2.5 lbs.
- SAFETY:** Conforms to European Union Directive 73/23/EEC, EN61010-1.
- EMC:** Conforms to European Union Directive 2004/108/EC, EN61326-1.

NOTES

- Open detector enabled during thermocouple measurements. Minimum signal level 10mV, 10μA.
- 3706A mainframe with all DMM backplane relays disconnected. Maximum two card backplane relays closed.
- Connections made using 3720-ST accessory.
- Scanning script local to 3706A mainframe, within same bank, and break before make switching.
- 3706A mainframe with autorange off, limits off, dmm.autozero=0, dmm.autodelay=0, 4½ digits (NPLC=0.006), for ACV dmm.detectorbandwidth=300, for OHMS dmm.offsetcompensation=off, dmm.opendetector=off. Scanning script local to mainframe, sequential scan within same bank (2 pole) or card (4 pole), and break before make switching.

1.888.KEITHLEY (U.S. only)

www.keithley.com



A Tektronix Company

A Greater Measure of Confidence

3721

Dual 1×20 Multiplexer Card

40 differential channels, automatic CJC w/3721-ST accessory

- 40 two-pole or 20 four-pole channels for general purpose switching
- 2 dedicated channels for current measurements, 3A capacity
- Automatic CJC for temperature measurements when used with 3721-ST accessory
- 4-wire common side ohms input supports 40 channels of 4-wire ohms measurements
- Analog backplane connection relays provide easy bank and card interconnections
- 300V, 2A switched or 3A carry signal capacity; 60W, 125VA
- Latching electromechanical relays

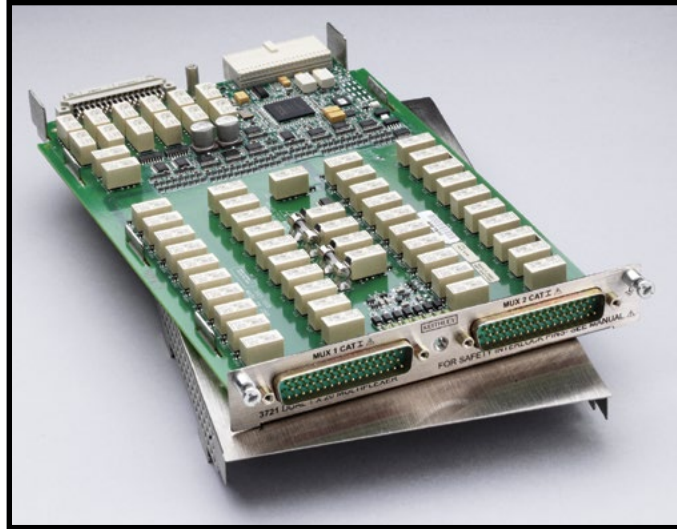

The Model 3721 offers two independent banks of 1×20 two-pole multiplexers that are ideal for general purpose switching, including temperature measurements. The two banks can automatically be connected to the Series 3700A mainframe backplane and optional DMM through the analog backplane connection relays. This connection allows the mainframe to reconfigure the Model 3721 as a single 1×40 two-pole multiplexer or to enable card-to-card expansion for even larger configurations.

The Model 3721 provides a number of other features. In addition to the 40 channels, two fused channels are supplied for current measurements. Also, the Model 3721 includes dedicated inputs that enable 40 channels of four-wire common side ohms measurements. For thermocouple type measurements, automatic cold junction compensation (CJC) is supported when used with the Model 3721-ST (screw terminal) accessory.

The Model 3721 uses two 50-pin male D-sub connectors for signal connections. For screw terminal or automatic CJC, use the detachable Model 3721-ST accessory.

Ordering Information

3721 Dual 1×20 Multiplexer Card

ACCESSORIES AVAILABLE

3721-MTC-1.5	50 Pin D-sub Female to Male Cable, 1.5m (5 ft.)
3721-MTC-3	50 Pin D-sub Female to Male Cable, 3m (10 ft.)
3721-ST	Screw Terminal Block (required for auto CJC thermocouple measurements)
3790-KIT50-R	50 Pin Female D-sub Connector Kit (contains 2 female D-sub connectors and 100 solder-cup contacts)
7401	Type K Thermocouple Wire (100 ft.)

SERVICES AVAILABLE

3721-3Y-EW-STD	1-year factory warranty extended to 3 years from date of shipment
3721-5Y-EW-STD	1-year factory warranty extended to 5 years from date of shipment
C/3721-3Y-STD	3 (Z540-1 compliant) calibrations within 3 years of purchase*

*Not available in all countries

1.888.KEITHLEY (U.S. only)

www.keithley.com

A Greater Measure of Confidence

KEITHLEY
A Tektronix Company

Dual 1×20 Multiplexer Card

40 differential channels, automatic CJC w/3721-ST accessory

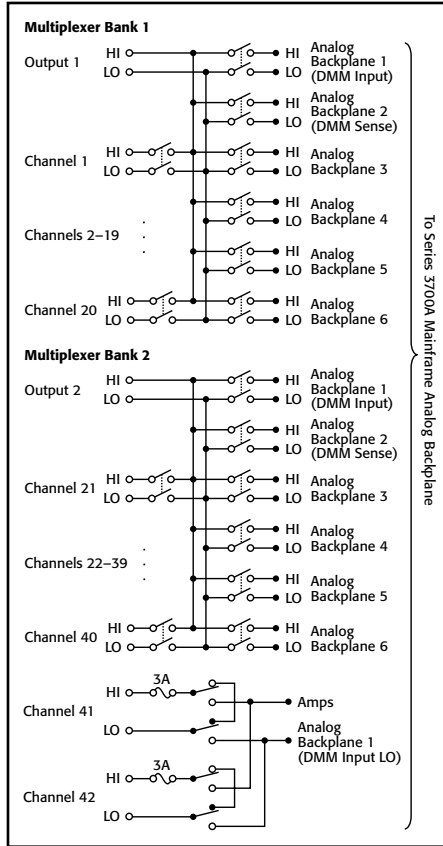

Two pole mode

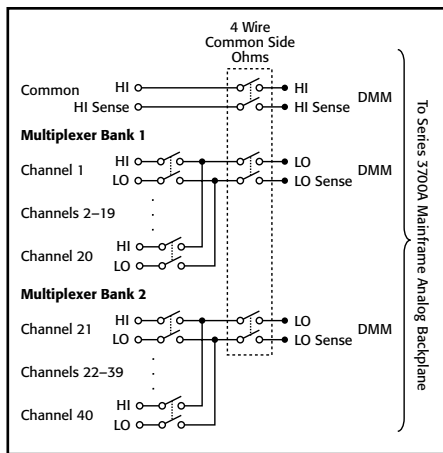

Four-wire common side ohm mode

MULTIPLEXER CONFIGURATION: Two independent 1×20 2-pole multiplexers. Banks can be connected together via relay creating a single 1×40 multiplexer. Banks can be isolated from the backplane by relays. Card can be configured for common side Ohms measurement via backplane relays. **Channel 41–42:** Multiplex one of two 2-pole current signals into DMM.

CONTACT CONFIGURATION: 2 pole form A.

CONNECTOR TYPE: Two 50 pin male D-shells. Removable screw terminal option.

MAXIMUM SIGNAL LEVEL: **Channels 1–40:** 300V DC or RMS, 2A switched (3A carry), 60W, 125VA maximum. **Channels 41–42:** 60V DC or 30V RMS, 3A switched, 60W, 125VA maximum. Fused 3A, 250V RMS.

COMMON MODE VOLTAGE: **Channels 1–40:** 300V DC or RMS between any terminal and chassis.

VOLT-HERTZ LIMIT: 8×10⁷.

CONTACT LIFE: >10⁸ operations at maximum signal level. >10⁹ operations no load.¹

TYPICAL SCANNING SPEEDS:

Switch Only*: Sequential scanning, single channel, immediate trigger advance: >120 ch/s.

With Measurements Into Memory⁵:

DCV (10V range) or 2W Ohms (1kΩ range): >110 ch/s

Thermocouple: >110 ch/s.

3- or 4-Wire RTD: >100 ch/s.

4-Wire Ohms (1kΩ range): >100 ch/s.

ACV (10V, 400Hz range) or ACI (1A, 400Hz range): >110 ch/s.

NOTES

- Open detector enabled during thermocouple measurements. Minimum signal level 10mV, 10μA.
- 3706A mainframe with all DMM backplane relays disconnected. Maximum two card backplane relays closed.
- Connections made using 3721-ST accessory.
- Scanning script local to 3706A mainframe, within same bank, and break before make switching.
- 3706A mainframe with autorange off, limits off, dmm.autozero=0, dmm.autodelay=0, 4½ digits (NPLC=0.006), for ACV dmm.detectorbandwidth=300, for OHMS dmm.offsetcompensation=off, dmm.opendetector=off. Scanning script local to mainframe, sequential scan within same bank (2 pole) or card (4 pole), and break before make switching.

	Dual 1×20 ³	Single 1×40 ^{2,3}
Channel Resistance (end of contact life)	<1.0 Ω	<1.5 Ω
Contact Potential (differential)	<±1 μV	<±3 μV
Offset Current	<±250 pA	<±250 pA
Isolation		
Differential	10 ⁹ Ω, 280 pF	10 ⁹ Ω, 530 pF
Bank-Bank	10 ¹¹ Ω, 60 pF	—
Channel-channel	10 ⁹ Ω, 50 pF	10 ⁹ Ω, 50 pF
Common Mode	10 ⁹ Ω, 180 pF	10 ⁹ Ω, 480 pF
Crosstalk Channel-channel		
300kHz	<-60 dB	<-60 dB
1MHz	<-50 dB	<-50 dB
20MHz:	<-25 dB	<-15 dB
Bandwidth	28 MHz	9 MHz

GENERAL

ACTUATION TIME: 4ms.

TEMPERATURE ACCURACY using Automatic CJC with 3721-ST accessory: 1°C for J, K, T, and E types (see mainframe specification for details).

RELAY TYPE: Latching electromechanical.

RELAY DRIVE SCHEME: Direct.

INTERLOCK: Backplane relays disabled when interlock connection is removed.

OPERATING ENVIRONMENT: Specified for 0° to 50°C. Specified to 70% R.H. at 35°C.

STORAGE ENVIRONMENT: -25° to 65°C.

WEIGHT: 2.25 lbs.

SAFETY: Conforms to European Union Directive 73/23/EEC, EN61010-1.

EMC: Conforms to European Union Directive 2004/108/EC, EN61326-1.

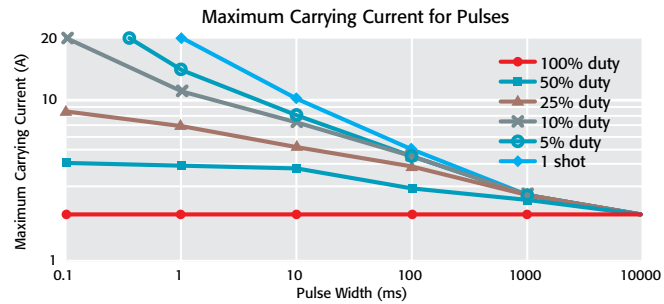

- Model 3706A ambient temperature <28°C.
- One shot repetition rate > 10 seconds.
- Signal path routed only through one card (not through backplane).
- Only one channel closed at a time.
- Contact life specification unaffected if pulse width and carry current are not exceeded.

3722

Dual 1×48, High Density, Multiplexer Card 96 differential channels, 300 Volts/1 Amp

- 96 two-pole or 48 four-pole channels for general purpose measurements
- Analog backplane connection relays provide easy bank and card interconnections
- 300V, 1A switched or 2A carry signal capacity; 60W, 125VA
- 1μV and 100pA offsets
- 25MHz bandwidth
- Relay closures stored in onboard memory
- Latching electromechanical relays
- Scan and measure over 110 channels/second

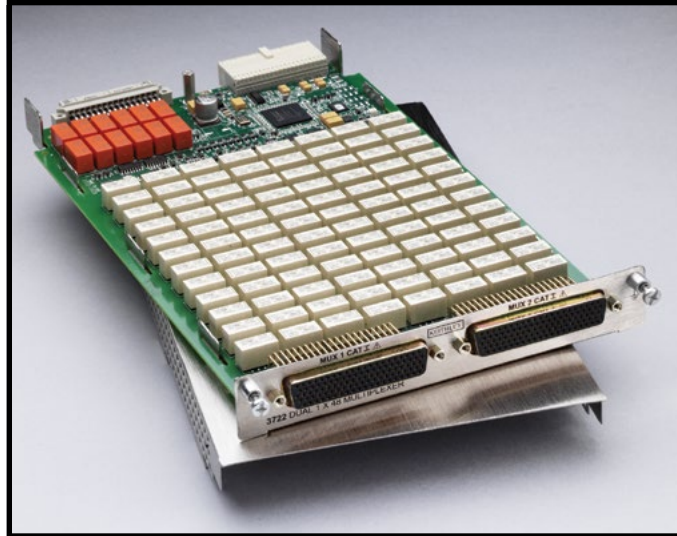

The Model 3722 offers two independent banks of 1×48 two-pole multiplexers, which is ideal for applications that require a high channel count. The two banks can automatically be connected to the Series 3700A mainframe backplane and optional DMM through the analog backplane connection relays. This connection allows the mainframe to reconfigure the card as a single 1×96 two-pole multiplexer or to enable card-to-card expansion for even larger configurations. Another feature of this card is the latching electromechanical relays. They can accommodate 300V, 1A switched signal levels.

The Model 3722 uses two 104-pin D-sub connectors for signal connections. A solder style connector kit (Model 3792-KIT104-R) and pre-assembled cables (Model 3722-MTC-1.5 and 3722-MTC-3) are available for card connections.

Ordering Information

3722 **Dual 1×48, High Density, Multiplexer Card**

ACCESSORIES AVAILABLE

3722-MTC-1.5	104-pin D-sub Male to Female Cable, 1.5m (5 ft.)
3722-MTC-1.5/MM	104-pin D-sub Male to Male Cable, 1.5m (5 ft.)
3722-MTC-3	104-pin D-sub Male to Female Cable, 3m (10 ft.)
3722-MTC-3/MM	104-pin D-sub Male to Male Cable, 3m (10 ft.)
3791-CIT	Contact Insertion and Extraction Tool
3792-KIT104-R	104-pin Male D-sub Connector kit (contains 2 male D-sub connectors with housings and 208 solder-cup contacts)
3792-KIT104-R/F	104-pin Female D-sub Connector kit (contains 2 female D-sub connectors with housings and 208 solder-cup contacts)

SERVICES AVAILABLE

3722-3Y-EW-STD	1-year factory warranty extended to 3 years from date of shipment
3722-5Y-EW-STD	1-year factory warranty extended to 5 years from date of shipment
C/3722-3Y-STD	3 (Z540-1 compliant) calibrations within 3 years of purchase*

*Not available in all countries

1.888.KEITHLEY (U.S. only)

www.keithley.com

Dual 1×48, High Density, Multiplexer Card

96 differential channels, 300 Volts/1 Amp

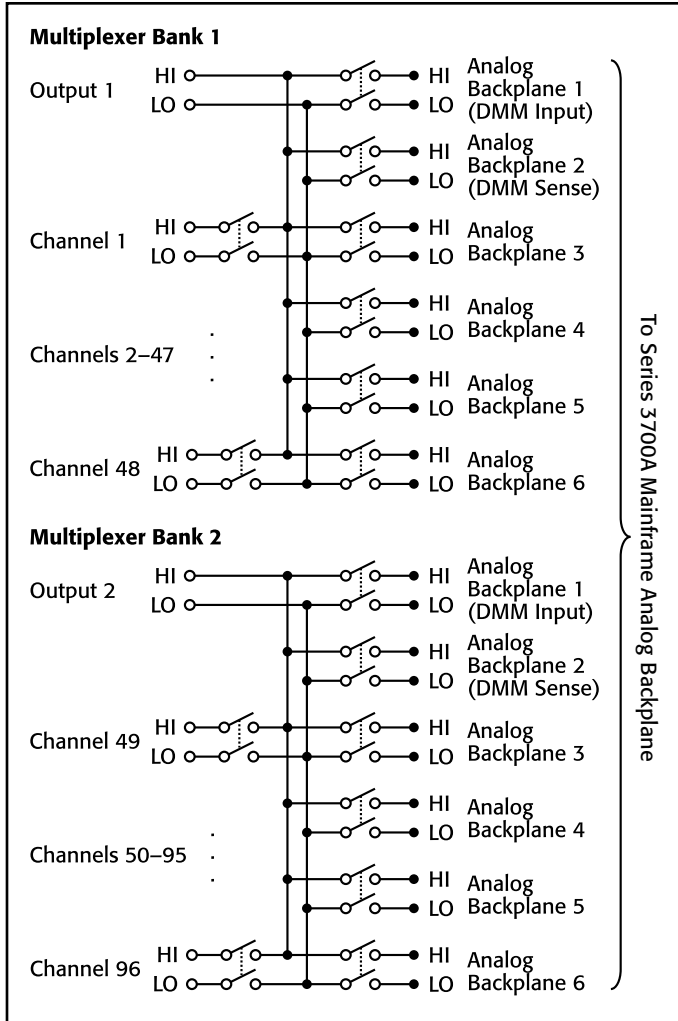

MULTIPLEXER CONFIGURATION: Two independent 1×48 2-pole multiplexers. Banks can be connected together via relays creating a single 1×96 multiplexer. Banks can be isolated from the backplane by relays. Card can be configured for 2- and 4-wire mode.

CONTACT CONFIGURATION: 2 pole form A.

CONNECTOR TYPE: Two 104 pin female D-shells.

MAXIMUM SIGNAL LEVEL: 300V DC or RMS, 1A switched (2A carry), 60W, 125VA.

COMMON MODE VOLTAGE: 300V DC or RMS between any terminal and chassis.

VOLT-HERTZ LIMIT: 8×10⁷.

CONTACT LIFE: >10⁵ operations at maximum signal level. >10⁸ operations no load.¹

	Dual 1×48 ²	Single 1×96
Channel Resistance (end of contact life)	<1.5 Ω	<2.5 Ω
Contact Potential (differential)	<±1 μV	<±2 μV
Offset Current	<100 pA	<100 pA
Isolation		
Differential	5×10 ⁹ Ω, 200 pF	5×10 ⁹ Ω, 400 pF
Bank-Bank	10 ⁹ Ω, 50 pF	—
Channel-channel	10 ⁹ Ω, 50 pF	10 ⁹ Ω, 50 pF
Common Mode	10 ¹⁰ Ω, 200 pF	10 ¹⁰ Ω, 400 pF
Crosstalk Channel-channel		
300kHz	<-65 dB	<-65 dB
1MHz	<-55 dB	<-55 dB
20MHz	<-30 dB	<-30 dB
Bandwidth	25 MHz	15 MHz

TYPICAL SCANNING SPEEDS:

Switch Only³: Sequential scanning, single channel, immediate trigger advance: >120 ch/s.

With Measurements Into Memory⁴:

DCV (10V range) or 2W Ohms (1kΩ range): >110 ch/s.

3- or 4-Wire RTD: >100 ch/s.

4-Wire Ohms (1kΩ range): >100 ch/s.

ACV (10V, 400Hz range): >110 ch/s.

GENERAL

ACTUATION TIME: 4ms.

RELAY TYPE: Latching electromechanical.

RELAY DRIVE SCHEME: Matrix.

OPERATING ENVIRONMENT: Specified for 0° to 50°C. Specified to 70% R.H. at 35°C.

STORAGE ENVIRONMENT: -25° to 65°C.

WEIGHT: 2.5 lbs.

SAFETY: Conforms to European Union Directive 73/23/EEC, EN61010-1.

EMC: Conforms to European Union Directive 2004/108/EC, EN61326-1.

NOTES

- Minimum signal level 10mV, 10μA.
- 3706A mainframe with all DMM backplane relays disconnected. Maximum two card backplane relays closed.
- Scanning script local to 3706A mainframe, within same bank, and break before make switching.
- 3706A mainframe with autorange off, limits off, dmm.autozero=0, dmm.autodelay=0, 4½ digits (NPLC=.006), for ACV dmm.detectorbandwidth=300, for OHMS dmm.offsetcompensation=off. Scanning script local to mainframe, sequential scan within same bank (2 pole) or card (4 pole), and break before make switching.

3723

Dual 1×30, High Speed, Multiplexer Card

60 differential channels, long life reed relays

- 60 two-pole or 30 four-pole channels for high speed scanning
- 120 channel single-pole mode for one-wire (common side) measurements
- Analog backplane connection relays provide easy bank and card interconnections
- 200V, 1A switched or 1.25A carry signal capacity; 15W
- Relay actuation time <0.5ms
- 20MHz bandwidth
- Ideal for multi-channel I-V testing with Series 2600B SourceMeter® SMU instruments
- Long life dry reed relays (>10⁹ operations)

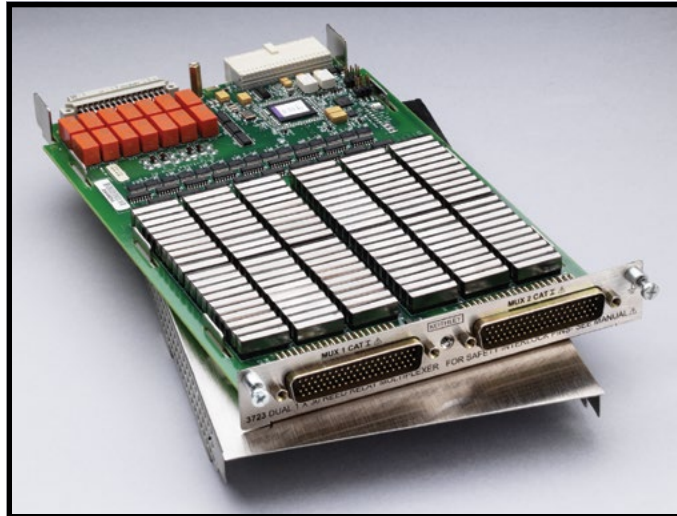

The Model 3723 offers two independent banks of high speed 1×30 two-pole multiplexers that are ideal for high speed scanning applications. The two banks can automatically be connected to the Series 3700A mainframe backplane and optional DMM through the analog backplane connection relays. This connection allows the mainframe to reconfigure the Model 3723 as a single 1×60 two-pole multiplexer or as a single 1×120 single-pole multiplexer. It also enables card-to-card expansion for even larger configurations.

By using high speed reed relays with actuation times of less than 0.5ms, this card can meet demanding throughput applications. Another feature of the Model 3723 is its single-ended, one-pole mode, which supports up to 120 channels of single-wire measurements.

The Model 3723 uses two 78-pin D-sub connectors for signal connections. For screw terminal connections, use the Model 3723-ST for two- and four-pole configurations or the Model 3723-ST-1 for single-wire applications.

ACCESSORIES AVAILABLE

3720-MTC-1.5	78 Pin D-sub Female to Male Cable, 1.5m (5 ft.)
3720-MTC-3	78 Pin D-sub Female to Male Cable, 3m (10 ft.)
3723-ST	Screw Terminal Block
3723-ST-1	Screw Terminal Block for single-pole applications
3791-CIT	Contact Insertion and Extraction Tool
3791-KIT78-R	78 Pin Female D-sub Connector Kit (contains 2 female D-sub connectors and 156 solder-cup contacts)

SERVICES AVAILABLE

3723-3Y-EW-STD	1-year factory warranty extended to 3 years from date of shipment
3723-5Y-EW-STD	1-year factory warranty extended to 5 years from date of shipment
C/3723-3Y-STD	3 (Z540-1 compliant) calibrations within 3 years of purchase*

*Not available in all countries

Ordering Information

3723 Dual 1×30, High Speed, Reed Relay, Multiplexer Card

1.888.KEITHLEY (U.S. only)

www.keithley.com

Dual 1×30, High Speed, Multiplexer Card

60 differential channels, long life reed relays

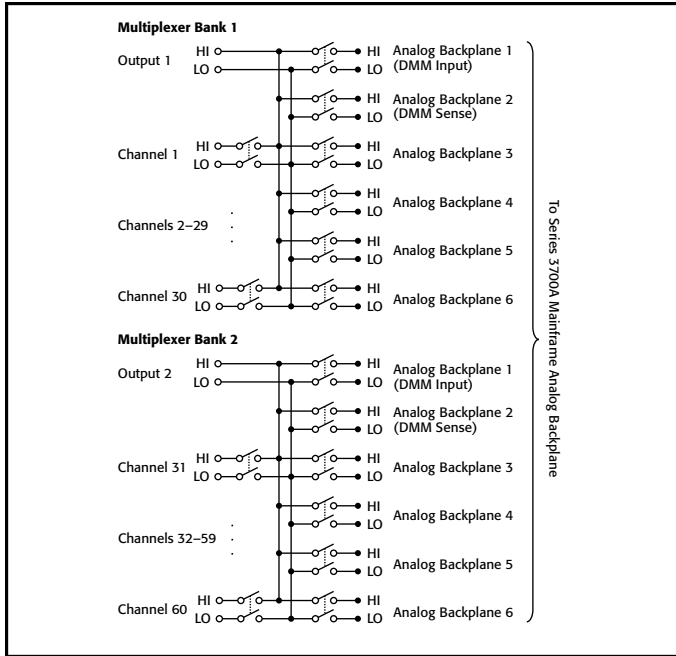

Two-pole mode

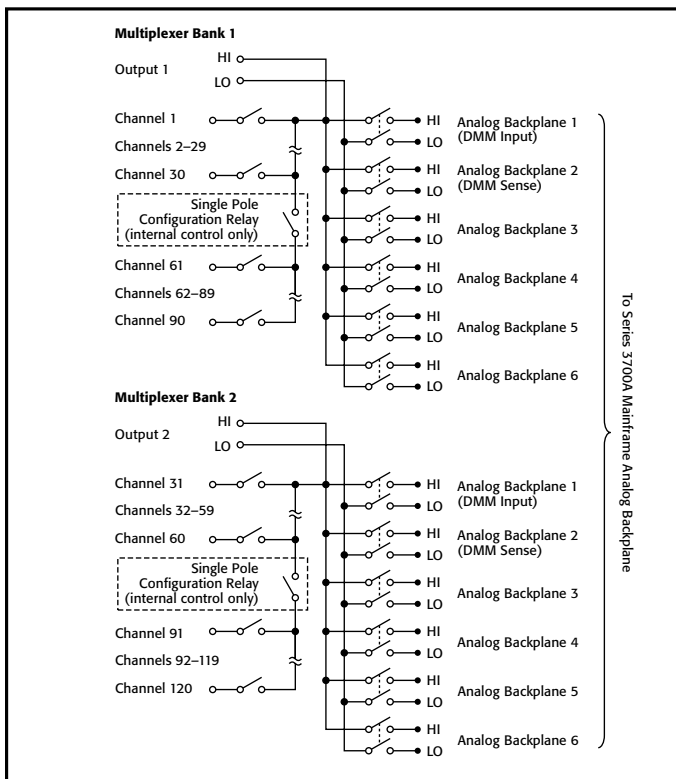

Single-pole mode

MULTIPLEXER CONFIGURATION: Two independent 1×30 2-pole multiplexers. Banks can be connected together via relay creating a single 1×60 multiplexer. Banks can be isolated from the backplane by relays. Card can be configured for 1-, 2-, and 4-wire.

CONTACT CONFIGURATION: 2 pole form A.

CONNECTOR TYPE: Two 78-pin male D-shells.

MODEL 3723-ST SCREW TERMINAL OPTION: #22 AWG typical wire size with 0.062 inch O.D. 124 conductors maximum. #16 AWG maximum wire size with 0.092 inch O.D. 36 conductor per card maximum.

MAXIMUM SIGNAL LEVEL: 200V DC or RMS, 1A switched (1.25A carry), 15W.

COMMON MODE VOLTAGE: 300V DC or RMS between any terminal and chassis.

VOLT-HERTZ LIMIT: 8×10⁷.

CONTACT LIFE: Reed: >10⁹ operations, no load. 10⁷ operations @ 100V, 10mA.

EMR: >10⁸ operations @ 5V, 10mA. 10⁵ operations @ maximum signal level.

	Dual 1×30 ¹	Single 1×60 ^{1,2}
Channel Resistance (end of contact life)	<1.5 Ω	<2.0 Ω
Contact Potential: Differential	<±6 μV	<±6 μV
Single-Ended	<±12 μV	<±12 μV
Offset Current	<250 pA	<250 pA
Isolation		
Differential	10 ¹⁰ Ω, 260 pF	10 ¹⁰ Ω, 500 pF
Bank-Bank	10 ¹⁰ Ω, 75 pF	—
Channel-channel	10 ¹⁰ Ω, 75 pF	10 ¹⁰ Ω, 75 pF
Common Mode	10 ¹⁰ Ω, 280 pF	10 ⁹ Ω, 625 pF
Crosstalk Channel-channel		
300kHz	<-55 dB	<-55 dB
1MHz	<-50 dB	<-45 dB
20MHz	<-20 dB	<-20 dB
Bandwidth	20 MHz	10 MHz

TYPICAL SCANNING SPEEDS:

Switch Only³: Sequential scanning, single channel, immediate trigger advance: >1000 ch/s.

With Measurements Into Memory⁴:

DCV (10V range) or 2W Ohms (1kΩ range): >800 ch/s.

3- or 4-Wire RTD: >450 ch/s.

4-Wire Ohms (1kΩ range): >450 ch/s.

ACV (10V, 400Hz range): >800 ch/s.

GENERAL

ACTUATION TIME: <0.5ms.

RELAY TYPE: Dry reed.

RELAY DRIVE SCHEME: Direct.

RELAY DRIVE CURRENT: 10mA.

INTERLOCK: Backplane relays disabled when interlock connection is removed.

OPERATING ENVIRONMENT: Specified for 0° to 50°C. Specified to 70% R.H. at 35°C.

STORAGE ENVIRONMENT: -25° to 65°C.

WEIGHT: 3.0 lbs.

SAFETY: Conforms to European Union Directive 73/23/EEC, EN61010-1.

EMC: Conforms to European Union Directive 2004/108/EC, EN61326-1.

NOTES

- Connections made using 3723-ST accessory.
- 3706A mainframe with all DMM backplane relays disconnected. Maximum two card backplane relays closed.
- Scanning script local to 3706A mainframe, within same bank, and break before make switching.
- 3706A mainframe with autorange off, limits off, dmm.autozero=0, dmm.autodelay=0, 4½ digits (NPLC=0.006), for ACV dmm.detectorbandwidth=300, for OHMS dmm.offsetcompensation=off. Scanning script local to mainframe, sequential scan within same bank (2 pole) or card (4 pole), and break before make switching.

1.888.KEITHLEY (U.S. only)

www.keithley.com

KEITHLEY

A Greater Measure of Confidence

A Tektronix Company

3724

Dual 1×30 FET Multiplexer Card

60 differential channels, automatic CJC with 3724-ST accessory

Dual 1×30 FET multiplexer card

- 60 two-pole or 30 four-pole solid-state channels
- Scanning speeds greater than 1250 channels/second (switch only)
- Optically isolated, solid-state FET relays provide unlimited contact life
- 200V, 0.1A switch/carry signal capacity; 800mW
- Automatic CJC for temperature measurements when used with 3724-ST accessory
- Analog backplane connection relays provide easy bank and card interconnections
- Screw terminal connections provided with removable 3724-ST accessory
- Ideal for maintenance-free, long-life thermocouple temperature measurements

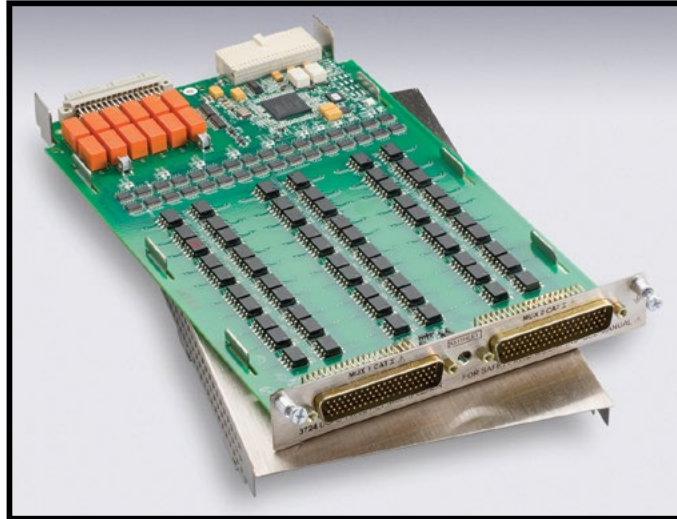

The Model 3724 provides two independent banks of solid-state relays arranged as 1×30 two-pole multiplexers that are ideal for high reliability, high speed multipoint measurement applications including temperature. The two banks can automatically be connected to the Series 3700A mainframe backplane and optional DMM through the analog backplane connection relays. This connection allows the mainframe to reconfigure the card to a single 1×60 two-pole multiplexer or to enable card-to-card expansion for even larger configurations.

The solid-state FET relay technology supports fast switching times with scanning rates of greater than 1250 channels/second and provides unlimited contact life. In addition, the Model 3724 supports thermocouple temperature measurements when used with the Model 3724-ST (screw terminal) accessory providing automatic cold junction compensation (CJC).

The Model 3724 uses two 78-pin male D-sub connectors for signal connections. For screw terminal or automatic CJC, use the detachable Model 3724-ST accessory.

ACCESSORIES AVAILABLE

3720-MTC-1.5	78-pin female-to-male D-sub Cable Assembly, 1.5m (4.9 ft)
3720-MTC-3	78-pin female-to-male D-sub Cable Assembly, 3m (9.8 ft)
3724-ST	Screw Terminal Block (required for auto CJC thermocouple measurements)
3791-CIT	Contact Insertion and Extraction Tool
3791-KIT78-R	78-pin female D-sub Connector Kit (contains 2 female D-sub connectors and 156 solder-cup contacts)

SERVICES AVAILABLE

3724-3Y-EW-STD	1-year factory warranty extended to 3 years from date of shipment
3724-5Y-EW-STD	1-year factory warranty extended to 5 years from date of shipment
C/3724-3Y-DATA	3 (Z540-1 compliant) calibrations within 3 years of purchase*

*Not available in all countries

Ordering Information

3724 **Dual 1×30 FET Multiplexer Card**

SWITCHING AND CONTROL

1.888.KEITHLEY (U.S. only)

www.keithley.com

A Greater Measure of Confidence

KEITHLEY
A Tektronix Company

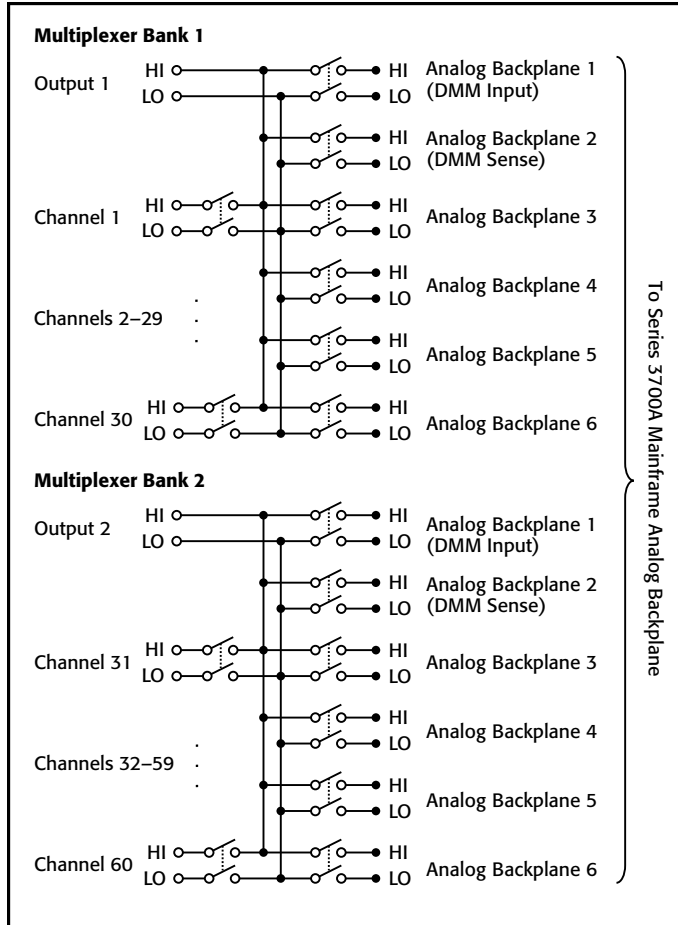

Model 3724 Specifications

MULTIPLEXER CONFIGURATION: Two independent 1×30, 2-pole multiplexers. Banks can be connected together via relay creating a single 1×60 multiplexer. Banks can be isolated from the backplane by relays. Card can be configured for 2- and 4-wire.

CONTACT CONFIGURATION: 2-pole form A.

CONNECTOR TYPE: Two 78-pin male D-shells.

MODEL 3724-ST SCREW TERMINAL OPTION: #22AWG typical wire size with 0.062 inch O.D. 124 conductors maximum. 16 AWG maximum wire size with 0.092 inch O.D. 36 conductor per card maximum.

MAXIMUM SIGNAL LEVEL: 200V DC or 141V RMS between any terminal, 0.1A switched (0.1A carry), 800mW.

COMMON MODE VOLTAGE: 300V DC or RMS between any terminal and chassis.

VOLT-HERTZ LIMIT: 10⁷.

CONTACT LIFE:

Solid State: > unlimited.

EMR (Backplane): >1×10⁸ operations @ 5V, 10mA.

1×10⁵ operations @ max. signal level.

	Dual 1×30 ¹	Single 1×60 ^{1,2}
Channel Resistance	<62Ω (54Ω @ 23°C)	<64Ω (58Ω @ 23°C)
Contact Potential (differential)	<±2 μV	<±2.5 μV
Offset Current	<10 nA (<±100 pA @ 23°C/60% R.H.)	<10 nA (<±100 pA @ 23°C/60% R.H.)
Isolation		
Differential	10 ⁹ Ω, 500 pF	10 ⁹ Ω, 1100 pF
Bank-Bank	10 ⁹ Ω, 100 pF	—
CH-CH	10 ⁹ Ω, 125 pF	10 ⁹ Ω, 125 pF
Common Mode	10 ⁹ Ω, 150 pF	10 ⁹ Ω, 700 pF
Crosstalk CH-CH		
300 kHz	-40 dB	-40 dB
1 MHz	-30 dB	-30 dB
Bandwidth	2 MHz	1 MHz

NOTES

1. Connections made using 3724-ST.

2. 3706A mainframe with all DMM backplane relays disconnected. Maximum two card backplane relays closed.

3724

Dual 1×30 FET Multiplexer Card

60 differential channels, automatic CJC with 3724-ST accessory

3724 Card/3706A Multimeter Condensed Specifications

TEMPERATURE

Displayed in °C, °F, or K. Exclusive of probe errors.

Displayed in °C, °F, or K. Exclusive of probe errors.

THERMOCOUPLES (accuracy based on ITS-90)

Type	Range	Resolution	90 Day/1 Year 23°C ± 5°
J	-150 to +760°C	0.001°C	1.0°C
K	-150 to +1372°C	0.001°C	1.0°C
N	-100 to +1300°C	0.001°C	1.0°C
T	-100 to +400°C	0.001°C	1.0°C
E	-150 to +1000°C	0.001°C	1.0°C
R	+400 to +1768°C	0.1°C	1.8°C
S	+400 to +1768°C	0.1°C	1.8°C
B	+1100 to +1820°C	0.1°C	1.8°C

DC SPECIFICATIONS

3724 CARD/3706A MULTIMETER UNCERTAINTY SPECIFICATIONS:

Function	Range	Notes
Voltage	All	Add 4.5 μV to PPM "of range"
Resistance	100 kΩ	Add 8 PPM to "of reading"
Resistance	1 MΩ	Add 80 PPM to "of reading"
Resistance	10 MΩ	Add 250 PPM to "of reading"
Resistance	100 MΩ	Add 5000 PPM to "of reading"
Resistance 2-wire	1 kΩ through 100 MΩ	Add 1.2 Ω (with REL) to PPM "of range" Add 64Ω (without REL) to PPM "of range"
Resistance 4-wire and Dry Circuit	1 Ω, 10 Ω, and 100 Ω	Ranges Not Available (maximum lead resistance exceeded, see manual for measurement considerations)

CONDITIONS: 1 PLC or 5 PLC.

ACCURACY: ±(ppm of reading + ppm of range) (ppm = parts per million; e.g., 10ppm = 0.001%).

GENERAL

ACTUATION TIME: <0.2ms.

TEMPERATURE ACCURACY USING AUTOMATIC CJC WITH 3724-ST ACCESSORY: 1°C for J, K, T, and E type (see mainframe specification for details).

RELAY TYPE: Optically isolated FET.

RELAY DRIVE SCHEME: Direct.

INTERLOCK: Backplane relays disabled when interlock connection removed.

RELAY DRIVE CURRENT: 4mA.

OPERATING ENVIRONMENT: Specified for 0°C to 50°C. Specified to 70% R.H. at 35°C.

STORAGE ENVIRONMENT: -25°C to 65°C.

WEIGHT: 1.13 kg (2.5 lbs.).

SAFETY: Conforms to European Union Directive 73/23/EEC, EN61010-1.

EMC: Conforms to European Union Directive 2004/108/EC, EN61326-1.

TYPICAL SCANNING SPEEDS, SWITCH ONLY¹:

Sequential scanning, single channel, immediate trigger advance: >1250 ch/s.

TYPICAL SCANNING SPEEDS, WITH MEASUREMENTS INTO MEMORY²:

DCV (10V range) or 2WΩ (1kΩ range): >1000 ch/s.

Thermocouple: >1000 ch/s.

3- or 4-Wire RTD: >450 ch/s.

4-Wire Ω (1kΩ range): >450 ch/s.

ACV (10V, 400Hz range): >1000 ch/s.

POWER BUDGET INFORMATION:

Quiescent Power (mW): 1150.

Channel Relay Power (mW) Each: 20.

Backplane Relay Power Consumption (mW) Each: 100.

See Chapter 8 of the Series 3700A user's manual for more detailed information.

NOTES

- Scanning script local to mainframe, within same bank, break before make.
- 3706A mainframe with autorange off, limits off, dmm.autodelay=0, dmm.autozero=0, 4½ digits (NPLC=.006), for ACV dmm.detectorbandwidth=300, for OHMS dmm.offsetcompensation=off, dmm.opendetector=off. Scanning script local to mainframe, sequential scan within same bank (2 pole) or card (4 pole), and break before make switching.

1.888.KEITHLEY (U.S. only)

www.keithley.com

KEITHLEY

A Tektronix Company

A Greater Measure of Confidence

3730

6×16, High Density, Matrix Card

96 two-pole crosspoints with column expansion relays

- 6 row by 16 column matrix (2-pole)
- Analog backplane connection relays provide easy column expansion
- 300V, 1A switched or 2A carry signal capacity; 60W, 125VA
- Screw terminal connections provided on removable 3730-ST accessory
- 2μV and 100pA offsets
- Relay closures stored in onboard memory
- Latching electromechanical relays

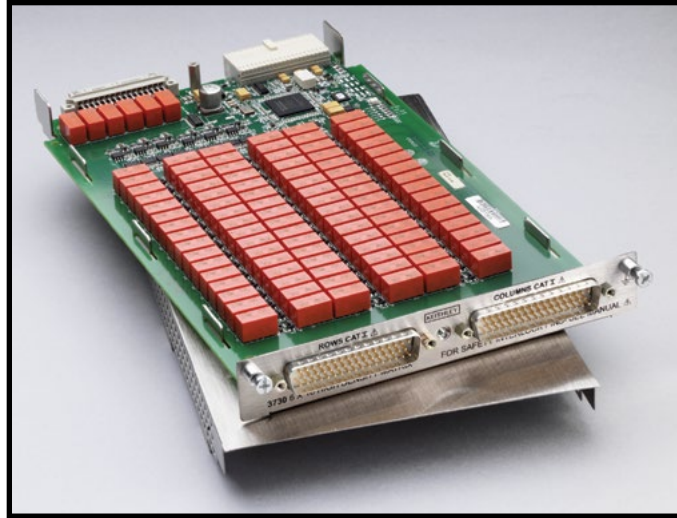

The Model 3730 is a two-pole, 6 row by 16 column matrix card. It can connect up to six differential instrument channels to any combination of 16 DUTs (devices under test). Any row can be connected to the Series 3700A mainframe backplane by using the analog backplane connection relays. This allows for easy matrix column expansion. A matrix of up to 6 rows by 96 columns can be supported within a single Model 3706A mainframe (with six Model 3730 cards).

The Model 3730 uses two 50-pin male D-sub connectors for signal connections. For screw terminal connections, use the detachable Model 3730-ST accessory.

ACCESSORIES AVAILABLE

3721-MTC-1.5	50 Pin D-sub Female to Male Cable, 1.5m (5 ft.)
3721-MTC-3	50 Pin D-sub Female to Male Cable, 3m (10 ft.)
3730-ST	Screw Terminal Block
3790-KIT50-R	50 Pin Female D-sub Connector Kit (contains 2 female D-sub connectors and 100 solder-cup contacts)

SERVICES AVAILABLE

3730-3Y-EW-STD	1-year factory warranty extended to 3 years from date of shipment
3730-5Y-EW-STD	1-year factory warranty extended to 5 years from date of shipment
C/3730-3Y-STD	3 (Z540-1 compliant) calibrations within 3 years of purchase*

*Not available in all countries

Ordering Information

3730 **6×16, High Density,
Matrix Card**

1.888.KEITHLEY (U.S. only)

www.keithley.com

A Greater Measure of Confidence

KEITHLEY
A Tektronix Company

High density 6×16 matrix card

SWITCHING AND CONTROL

3730

6×16, High Density, Matrix Card

96 two-pole crosspoints with column expansion relays

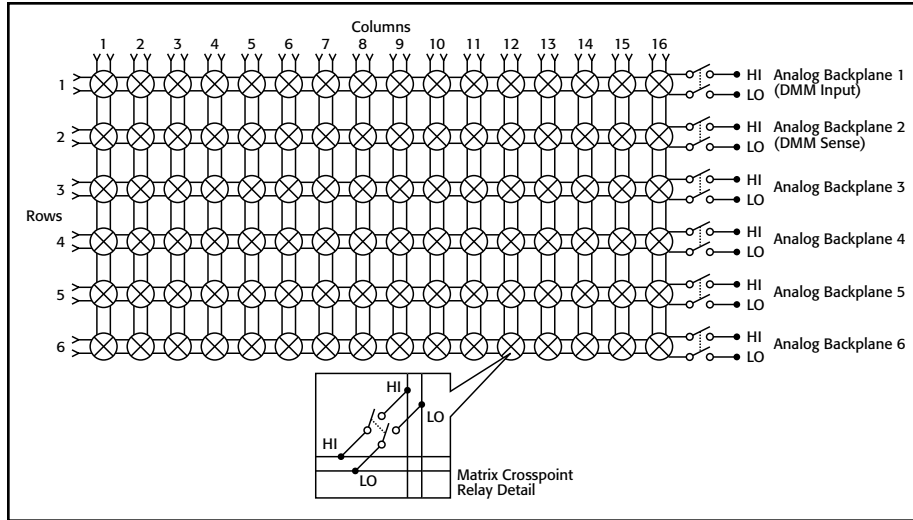

MATRIX CONFIGURATION: 6 row by 16 column matrix. Columns can be expanded using the backplane or isolated by relays.

CONTACT CONFIGURATION: 2 pole form A.
CONNECTOR TYPE: Two 50 pin male D-shells.

MODEL 3730-ST SCREW TERMINAL OPTION: #22 AWG typical wire size with 0.062 inch O.D. 88 conductors maximum. #16 AWG maximum wire size with 0.092 inch O.D. 44 conductor per card maximum.

MAXIMUM SIGNAL LEVEL: 300V DC or RMS, 1A switched (2A carry), 60W, 125VA.

COMMON MODE VOLTAGE: 300V DC or RMS between any terminal and chassis.

VOLT-HERTZ LIMIT: 8×10^7 .

CONTACT LIFE: $>10^5$ operations @ maximum signal level. $>10^8$ operations no load.¹

	$6 \times 16^{2,3}$
Channel Resistance (end of contact life)	$<1.0 \Omega$
Contact Potential (differential)	$<\pm 2 \mu V$
Offset Current	$<\pm 100 \text{ pA}$
Isolation	
Differential	$10^{10} \Omega, 250 \text{ pF}$
Channel-channel	$10^{10} \Omega, 75 \text{ pF}$
Common Mode	$10^{10} \Omega, 150 \text{ pF}$
Crosstalk Channel-channel	
300kHz	$<-65 \text{ dB}$
1MHz	$<-55 \text{ dB}$
20MHz	$<-30 \text{ dB}$
Bandwidth	27 MHz

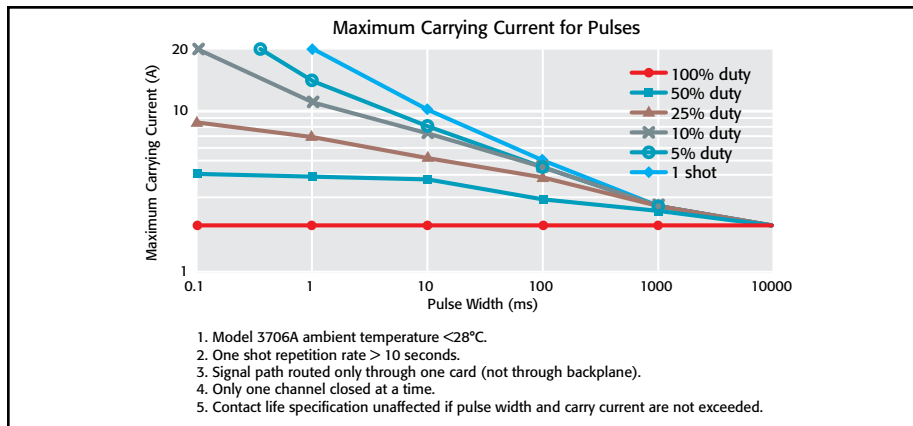

GENERAL	
ACTUATION TIME:	4ms.
RELAY TYPE:	Latching electromechanical.
RELAY DRIVE SCHEME:	Hybrid Matrix.
INTERLOCK:	Backplane relays disabled when terminal assembly is removed.
OPERATING ENVIRONMENT:	Specified for 0° to 50°C . Specified to 70% R.H. at 35°C .
STORAGE ENVIRONMENT:	-25° to 65°C .
WEIGHT:	2.5 lbs.
SAFETY:	Conforms to European Union Directive 73/23/EEC, EN61010-1.
EMC:	Conforms to European Union Directive 2004/108/EC, EN61326-1.

NOTES

- Minimum signal level 10mV, 10 μA .
- Connections made using 3730-ST accessory.
- 3706A mainframe with all DMM backplane relays disconnected.

1.888.KEITHLEY (U.S. only)

www.keithley.com

KEITHLEY

A Tektronix Company

A Greater Measure of Confidence

3731

- 6 row by 16 column matrix (2-pole) using high speed, long life reed relays
- Analog backplane connection relays provide easy column expansion
- 200V, 1A switched or 2A carry signal capacity; 10W, 10VA
- Screw terminal connections provided on removable 3731-ST accessory
- Relay actuation time of 0.5ms
- Ideal for multi-channel I-V testing with Series 2600B Systems
- Long life dry reed relays (>10⁹ operations)

Ordering Information

3731 **6×16 High Speed, Reed Relay, Matrix Card**

6×16 High Speed, Reed Relay, Matrix Card

96 two-pole crosspoints with column expansion relays

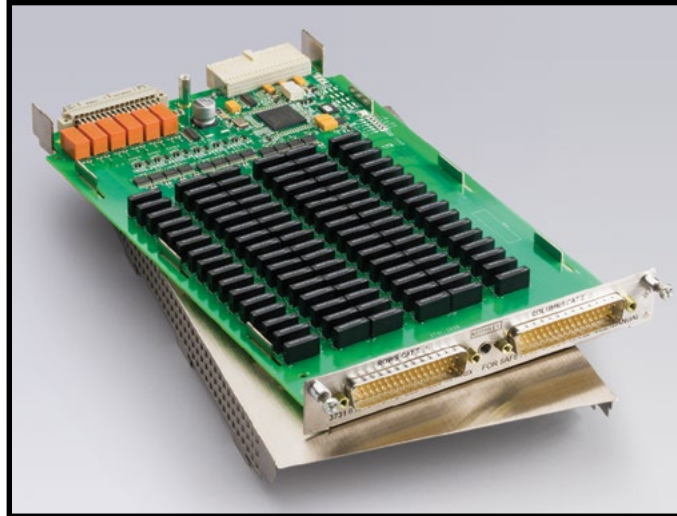

The Model 3731 is a two-pole, 6 row by 16 column reed relay matrix card. By using high speed reed relays with actuation times of 0.5ms, this card meets the requirements of demanding throughput applications while offering users the additional benefit of long life, exceeding one billion operations. The card can connect up to six differential instrument channels to any combination of 16 DUTs (devices under test). Any row can be connected to the Series 3700A mainframe backplane by using the analog backplane connection relays. This allows for easy matrix column expansion. A matrix of up to 6 rows by 96 columns can be supported within a single 3706A mainframe (with six Model 3731 cards).

The Model 3731 uses two 50-pin male D-sub connectors for signal connections. For screw terminal connections, use the detachable Model 3731-ST accessory.

ACCESSORIES AVAILABLE

3721-MTC-1.5	50-pin D-sub Female to Male Cable, 1.5m (5 ft.)
3721-MTC-3	50-pin D-sub Female to Male Cable, 3m (10 ft.)
3731-ST	Screw Terminal Block
3790-KIT50-R	50-pin Female D-sub Connector Kit (contains 2 female D-sub connectors and 100 solder-cup contacts)

SERVICES AVAILABLE

3731-3Y-EW-STD	1-year factory warranty extended to 3 years from date of shipment
3731-5Y-EW-STD	1-year factory warranty extended to 5 years from date of shipment
C/3731-3Y-STD	3 (Z540-1 compliant) calibrations within 3 years of purchase*

*Not available in all countries

1.888.KEITHLEY (U.S. only)

www.keithley.com

A Greater Measure of Confidence

KEITHLEY
A Tektronix Company

High speed 6x16 reed matrix card

SWITCHING AND CONTROL

3731

6×16 High Speed, Reed Relay, Matrix Card 96 two-pole crosspoints with column expansion relays

Model 3731 specifications

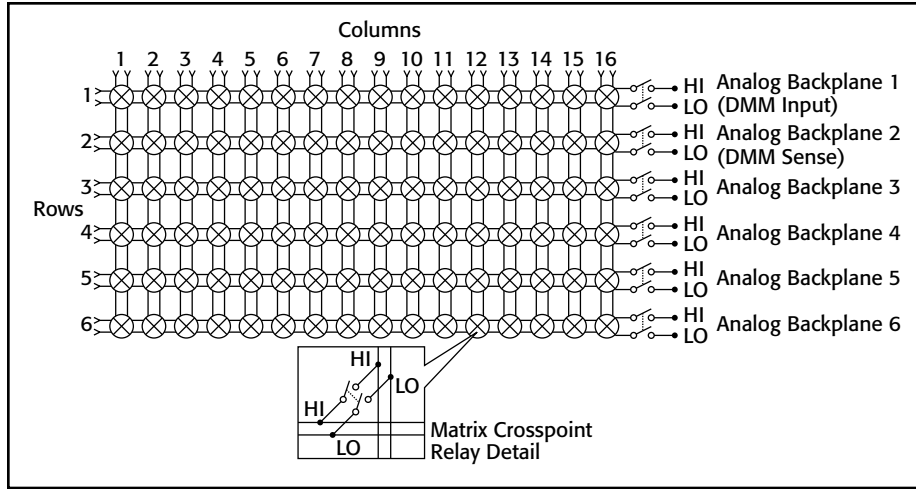

96 Two-Pole Crosspoints with Column Expansion Relays

MATRIX CONFIGURATION: 6 row by 16 column matrix. Columns can be expanded using the backplane or isolated by relays.

CONTACT CONFIGURATION: 2-pole form A.

CONNECTOR TYPE: Two 50-pin male D-shells.

MODEL 3731-ST SCREW TERMINAL OPTION:

Typical wire size: #22 AWG with .062 inch O.D.;

88 conductors maximum

Maximum wire size: #16 AWG with .092 inch O.D.;

44 conductors per card maximum.

MAXIMUM SIGNAL LEVEL: 200V DC or peak AC, 1A switched (2A carry), 10W, 10VA.

COMMON MODE VOLTAGE: 200V DC or peak AC between any signal path to a signal path or ground.

VOLT-HERTZ LIMIT: 8×10⁷.

CONTACT LIFE:

Reed: >10⁹ operations no load. >8×10⁶ operations @ 100V, 10mA.

EMR (Backplane): >10⁸ operations @ 5V, 10mA and 10⁵ operations @ maximum signal level.

6×16^{1,2}

Channel Resistance (end of contact life)	<1.5 Ω
Contact Potential (differential)	<±80 μV
Offset Current	<±500 pA
Isolation	
Differential	3×10 ⁹ Ω, 300 pF
Channel-channel	3×10 ⁹ Ω, 100 pF
Common Mode	3×10 ⁹ Ω, 150 pF
Crosstalk Channel-channel	
300kHz	<-60 dB
1MHz	<-50 dB
15MHz	<-20 dB
Bandwidth	19 MHz

GENERAL

ACTUATION TIME: 0.5ms.

RELAY TYPE: Reed.

RELAY DRIVE SCHEME: Direct drive.

INTERLOCK: Backplane relays disabled when terminal assembly is removed.

OPERATING ENVIRONMENT: Specified for 0° to 50°C. Specified to 70% R.H. at 35°C.

STORAGE ENVIRONMENT: -25° to 65°C.

WEIGHT: 2.2 lbs.

SAFETY: Compliant with European Union Low Voltage Directive

EMC: Compliant with European Union EMC Directive 2004/108/EC, EN61326-1.

NOTES

1. Connections made using 3731-ST.

2. 3706A mainframe with all DMM backplane relays disconnected.

SWITCHING AND CONTROL

1.888.KEITHLEY (U.S. only)

www.keithley.com

A Greater Measure of Confidence

KEITHLEY
A Tektronix Company

3732

Quad 4×28, Ultra-High Density, Reed Relay Matrix Card

448 one-pole crosspoints with bank configuration and backplane connection relays

- Four independent banks of 4×28 single pole matrices
- 200V, 1.2A carry or 0.75A switched signal capacity; 15W, 15VA
- Bank configuration relays enable alternative matrix sizes, including:
 - Dual 4×56 (1 wire)
 - Single 4×112 (1 wire)
 - Single 4×56 (2 wire)
- Optional accessory, Model 3732-ST-R, enables screw terminal access and additional matrix sizes including:
 - Dual 8×28 (1 wire)
 - Single 16×28 (1 wire)
 - Single 8×28 (2 wire)
- Analog backplane connection relays provide easy card-to-card column expansion
- Long life dry reed relays (>10⁹ operations)
- Ideal for high channel count I-V testing with Series 2600B Systems

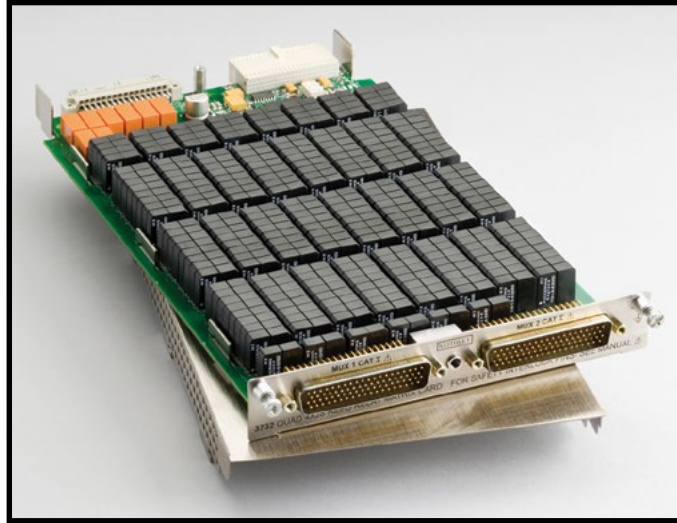

The ultra-high density Model 3732 matrix card is comprised of four banks, each with 4 rows by 28 columns of reed relays. This provides 448 single-pole crosspoints for maximum connection versatility in high channel count applications. For even greater flexibility, bank configuration relays are mounted on the card. They offer an automated method of connecting banks to enable two additional matrix configurations: single 4×112 and dual 4×56. This feature allows the matrix size to be easily adapted to existing or future applications. For differential (2-wire) measurements, a two-pole mode can be selected that enables automatic pairing of crosspoints to create a dual 4×28 or single 4×56 configuration. For larger matrix sizes, analog backplane relays are provided that enable rows to connect to the Series 3700A mainframe backplane. This allows, for example, a matrix of up to 4 rows by 672 columns within a single 3706A mainframe using six Model 3732 cards.

The card uses optimized reed relays that offer both low contact potential and low current offset to minimize the switching errors that often accompany this relay technology. Additionally, these relays provide greater signal voltage (200V) and current (1.2A carry) dynamic range while supporting the long life and fast actuation times necessary in many automated test applications.

The Model 3732 uses two 78-pin male D-sub connectors for signal and configuration connections. For screw terminal connections, two accessories are offered. Use the 3732-ST-R for the 16×28 or dual 8×28 matrix configurations. Use the 3732-ST-C for the 4×112, dual 4×56, or base quad 4×28 matrix configurations.

ACCESSORIES AVAILABLE

3732-ST-C	Screw Terminal Block for matrix configurations: Quad 4×28 (1 wire) Dual 4×28 (2 wire) Single 4×56 (2 wire) Dual 4×56 (1 wire) Single 4×112 (1 wire)
3732-ST-R	Screw Terminal Block for matrix configurations: Dual 8×28 (1 wire) Single 8×28 (2 wire) Single 16×28 (1 wire)
3732-MTC-1.5	78-pin, D-sub Female-to-Male Cable, 1.5m (5 ft.)
3732-MTC-3	78-pin, D-sub Female-to-Male Cable, 3m (10 ft.)
3791-CIT	Contact Insertion and Extraction Tool
3791-KIT78-R	78-pin, Female D-sub Connector Kit (contains 2 female D-sub connectors and 156 solder-cup contacts)

SERVICES AVAILABLE

3732-3Y-EW-STD	1-year factory warranty extended to 3 years from date of shipment
3732-5Y-EW-STD	1-year factory warranty extended to 5 years from date of shipment
C/3732-3Y-STD	3 (Z540-1 compliant) calibrations within 3 years of purchase*
*Not available in all countries	

Ordering Information

3732 Quad 4×28, Ultra-High Density, Reed Relay Matrix Card

1.888.KEITHLEY (U.S. only)

www.keithley.com

A Greater Measure of Confidence

KEITHLEY
A Tektronix Company

Quad 4×28, ultra-high density, reed relay matrix card

SWITCHING AND CONTROL

Quad 4x28, Ultra-High Density, Reed Relay Matrix Card

448 one-pole crosspoints with bank configuration and backplane connection relays

Quad 4x28 (1-wire) or Dual 4x28 (2-wire) Matrix Configuration

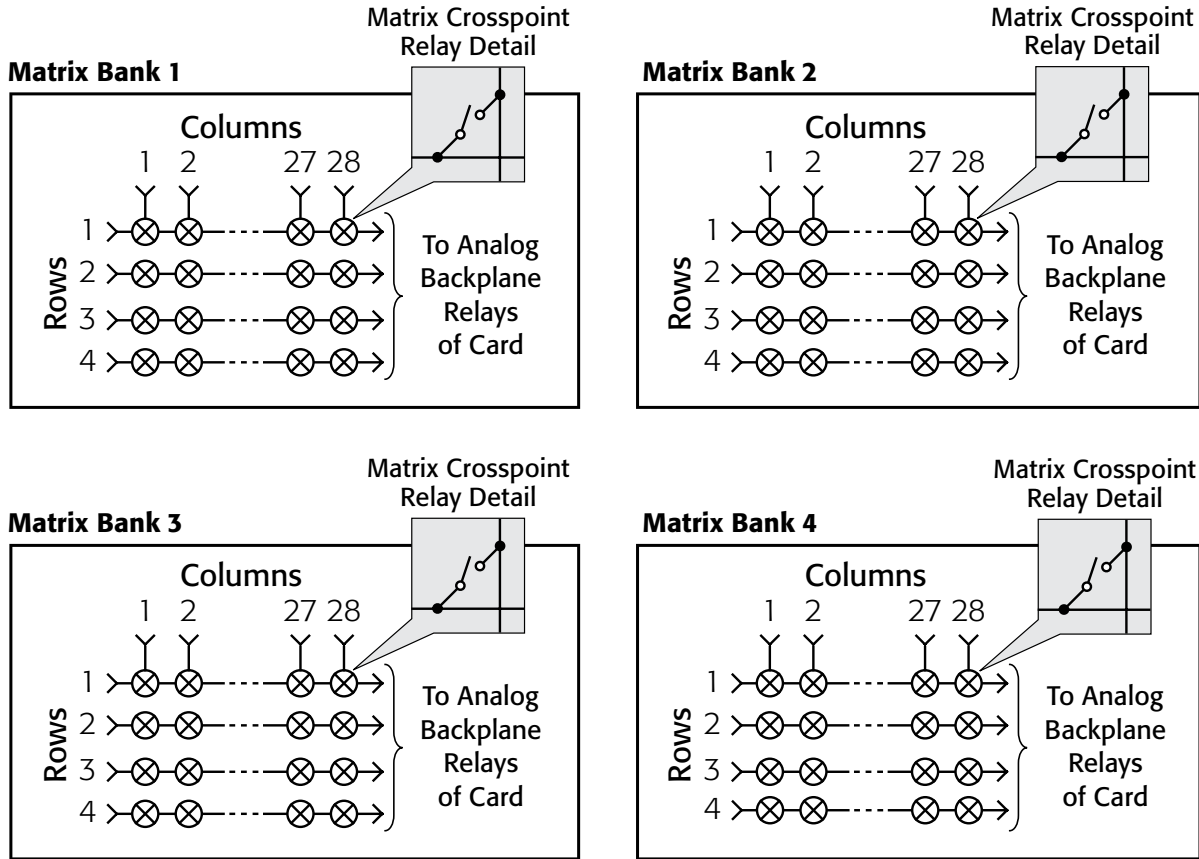

Analog Backplane Connection Relays

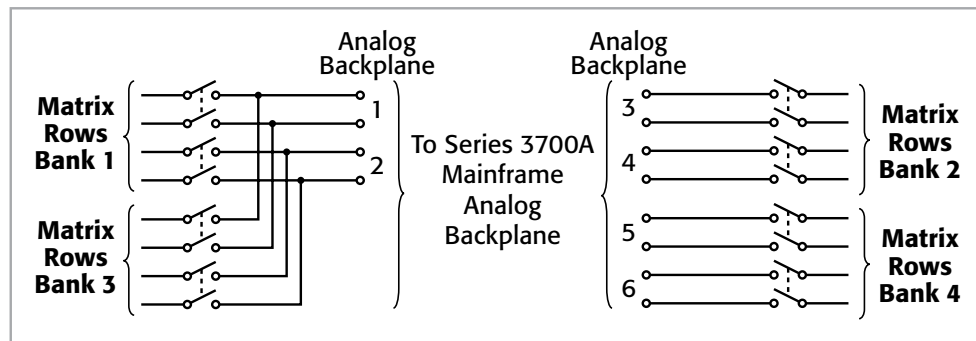

3732

Quad 4×28, Ultra-High Density, Reed Relay Matrix Card

448 one-pole crosspoints with bank configuration and backplane connection relays

Additional Matrix Configurations Using Bank Configuration Relays

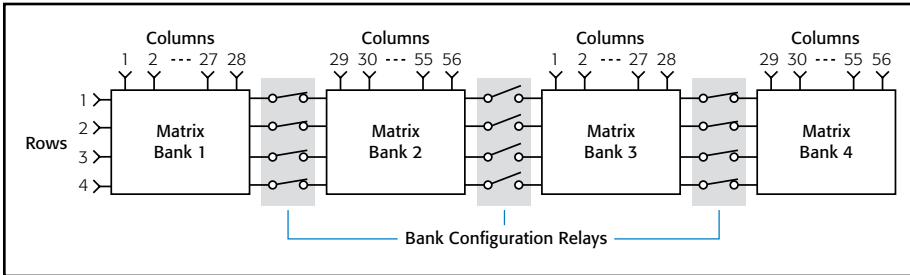

Dual 4×56 (1-wire) or single 4×56 (2-wire) matrix configuration using bank configuration relays

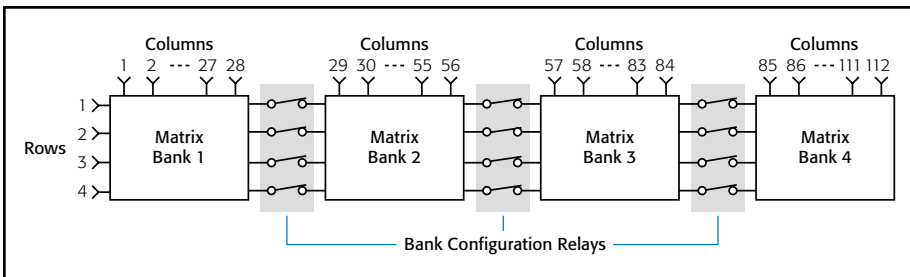

Single 4×112 (1-wire) matrix configuration using bank configuration relays

Additional Matrix Configurations Using the Model 3732-ST-R Screw Terminal Block

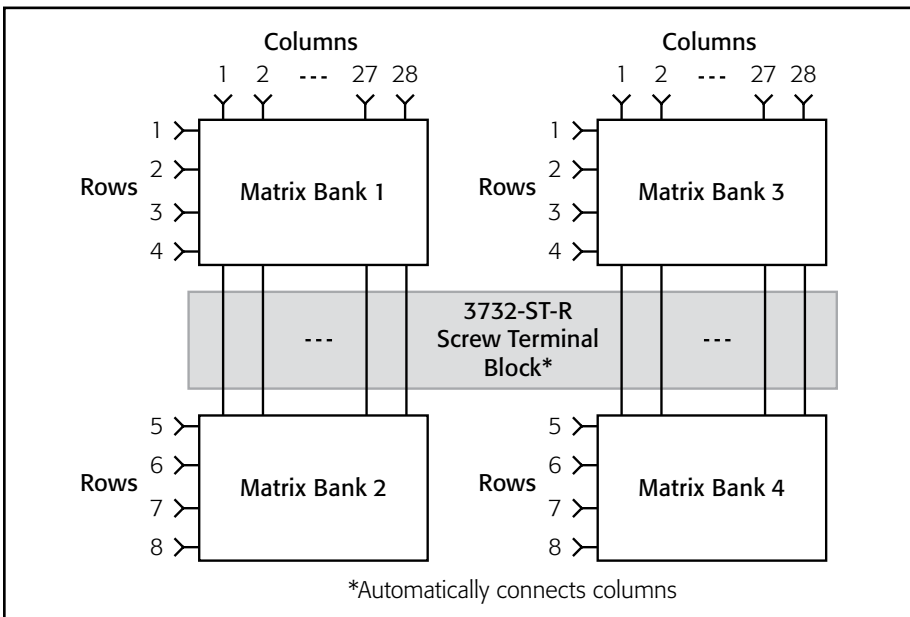

Dual 8×28 (1-wire) or single 8×28 (2-wire) matrix configuration using one Model 3732-ST-R screw terminal block

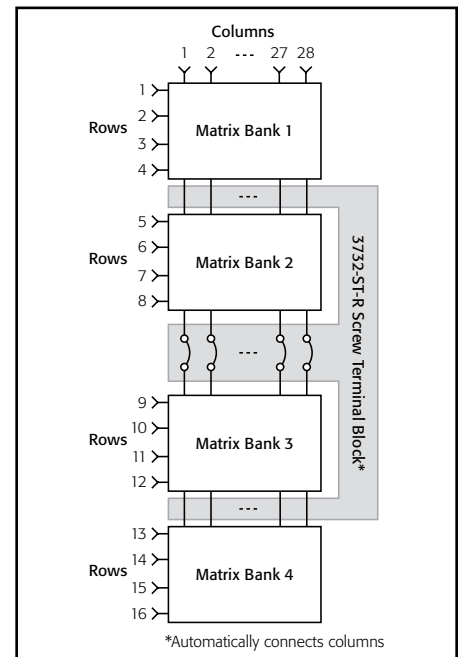

Single 16×28 (1-wire) matrix configuration using one Model 3732-ST-R screw terminal block

1.888.KEITHLEY (U.S. only)

www.keithley.com

A Greater Measure of Confidence

KEITHLEY
A Tektronix Company

Model 3732 specifications

SWITCHING AND CONTROL

3732

Quad 4×28, Ultra-High Density, Reed Relay Matrix Card

448 one-pole crosspoints with bank configuration and backplane connection relays

MATRIX CONFIGURATION: Four banks, each with 4 rows by 28 columns of reed relays. Bank configuration and analog backplane relays are included for additional matrix configurations. Banks can be connected together via relays creating dual 4×56 matrices or a single 4×112 matrix. Row expansion is available using optional screw terminal accessories.

CONTACT CONFIGURATION: Single-pole form A.

CONNECTOR TYPE: Two 78-pin male D-shells.

MODEL 3732-ST-R SCREW TERMINAL OPTION: Provides terminal block access and column jumper blocks for extended row configurations including Dual 8×28 (1W), Single 8×28 (2W), and Single 16×28 (1W).

Typical Wire Size: #22 AWG with 0.062 inch O.D.; 88 conductors per card maximum.

Maximum Wire Size: #16 AWG with 0.092 inch O.D.; 44 conductors per card maximum.

MODEL 3732-ST-C SCREW TERMINAL OPTION: Provides terminal block access for Quad 4×28 (1W), Dual 4×28 (2W), Dual 4×56 (1W), Single 4×56 (2W), and Single 4×112 (1W) matrix configurations.

Typical Wire Size: #22 AWG with 0.062 inch O.D.; 88 conductors per card maximum.

Maximum Wire Size: #16 AWG with 0.092 inch O.D.; 44 conductors per card maximum.

MAXIMUM SIGNAL LEVEL: 200VDC or peak AC, 0.75A switched (1.2A carry), 15W/15VA max. switch power.

COMMON MODE VOLTAGE: 200VDC or peak AC between any signal path to a signal path or ground.

VOLT-HERTZ LIMIT: 8×10⁷.

CONTACT LIFE: Reed: >10⁹ operations no load, >8×10⁶ operations @ 100V, 10mA.

EMR (Backplane): >10⁸ operations @ 5V, 10mA and 10⁵ operations at maximum signal level.

MODEL 3732 PARAMETERS

Parameter	Quad 4×28 ^{1,2}	Dual 4×56 ^{1,2}	Single 4×112 ^{1,2}	Dual 8×28 ^{2,3}	Single 16×28 ^{2,3}
Channel Resistance (end of life)	<1.5 Ω	<2.0 Ω	<2.5 Ω	<1.6 Ω	<2.0 Ω
Contact Potential (differential)	<±10 μV	<±20 μV	N/A	<±15 μV	N/A
Contact Potential (single ended)	<±20 μV	<±40 μV	<±65 μV	<± 20 μV	<±20 μV
Offset Current	<±0.5 nA	<±1.0 nA	<±2.0 nA	<±1.0 nA	<±2.0 nA
Isolation					
CH-CH	3×10 ⁹ Ω/150 pF	1.5×10 ⁹ Ω/300 pF	7.5×10 ⁸ Ω/600 pF	2×10 ⁹ Ω/200 pF	1.5×10 ⁹ Ω/300 pF
Common mode	1.5×10 ⁹ Ω/300 pF	1.5×10 ⁹ Ω/300 pF	7.5×10 ⁸ Ω/600 pF	2×10 ⁹ Ω/200 pF	1.5×10 ⁹ Ω/300 pF
Crosstalk Ch-Ch					
300 kHz	<-37 dB	<-37 dB	<-37 dB	<-37 dB	<-37 dB
1 MHz	<-26 dB	<-26 dB	<-26 dB	<-26 dB	<-26 dB
15 MHz	<-7 dB	<-7 dB	<-7 dB	<-7 dB	<-7 dB
Bandwidth	15 MHz	15 MHz	10 MHz	15 MHz	15 MHz

1. Connections made using Model 3732-ST-C.
2. Model 3706A mainframe with all DMM backplane relays disconnected.
3. Connections made using Model 3732-ST-R.

GENERAL

POWER BUDGET INFORMATION:

Quiescent Power Usage:

Mode	Quiescent Power
Quad 4×28	780 mW
Dual 4×56	916 mW
Single 4×112	984 mW
Dual 8×28	780 mW
Single 16×28	780 mW

Channel Relay Power Consumption (each): 17mW.

Backplane Relay Power Consumption (each): 100mW.

For additional power-budgeting information, refer to the Series 3700A Module Schematics and Connections section in the Series 3700A User's Manual (part no. 3700S-900-01).

ACTUATION TIME: 0.6ms.

RELAY TYPE: Reed (signal relays); EMR (backplane relays)

RELAY DRIVE SCHEME: Direct drive.

RELAY DRIVE CURRENT: 3.2mA.

INTERLOCK: Backplane relays disabled when terminal assembly interlock signal removed. When asserted allows system to read and save ID configuration bits.

EMC: Compliant with European Union EMC Directive.

SAFETY: Compliant with European Union Low Voltage Directive.

OPERATING ENVIRONMENT: Specified for 0° to 50°C. Specified to 70% relative humidity at 35°C.

STORAGE ENVIRONMENT: -25° to 65°C.

WEIGHT: 3.40 lbs (1.54kg).

1.888.KEITHLEY (U.S. only)

www.keithley.com

KEITHLEY

A Tektronix Company

A Greater Measure of Confidence

3740

32-channel Isolated Switch Card

28 Form C relays and 4 high power Form A relays

- 28 general purpose Form C relays rated for 300V, 2A switched or 3A carry signal capacity; 60W, 125VA
- 4 high current Form A relays rated for 250VAC, 7A or 30VDC, 7A switched capacity; 210W
- Analog backplane connection relays provided for user interconnections
- Screw terminal connections provided on removable 3740-ST accessory
- Relay closures stored in onboard memory
- Latching electromechanical relays

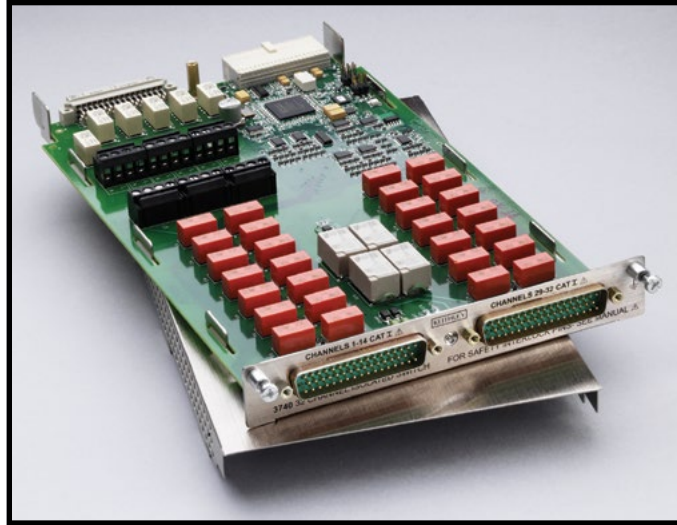

The Model 3740 offers 28 general-purpose form C channels that are ideal for routing power or other control devices. For higher power applications of up to 7A, four additional high current form A channels are provided.

If any general purpose signal requires routing to the Series 3700A mainframe backplane, terminal blocks are located on the card, which are enabled with jumpers. Custom configurations can be created with the user accessible terminal blocks. For additional protection, an onboard temperature sensor will notify the mainframe when the card's operating temperature exceeds 70°C, compromising system specifications.

The Model 3740 uses two 50-pin male D-sub connectors for signal connections. For screw terminal connections, use the detachable Model 3740-ST accessory.

Ordering Information

3740 General Purpose Card with 32 Independent Channels

ACCESSORIES AVAILABLE

3721-MTC-1.5	50-pin D-sub Female to Male Cable, 1.5m (5 ft.)
3721-MTC-3	50-pin D-sub Female to Male Cable, 3m (10 ft.)
3740-ST	Screw Terminal Block
3790-KIT50-R	50-pin Female D-sub Connector Kit (contains 2 female D-sub connectors and 100 solder cup contacts)

SERVICES AVAILABLE

3740-3Y-EW-STD	1-year factory warranty extended to 3 years from date of shipment
3740-5Y-EW-STD	1-year factory warranty extended to 5 years from date of shipment
C/3740-3Y-STD	3 (Z540-1 compliant) calibrations within 3 years of purchase*

*Not available in all countries

1.888.KEITHLEY (U.S. only)

www.keithley.com

A Greater Measure of Confidence

KEITHLEY
A Tektronix Company

32-channel Isolated Switch Card

28 Form C relays and 4 high power Form A relays

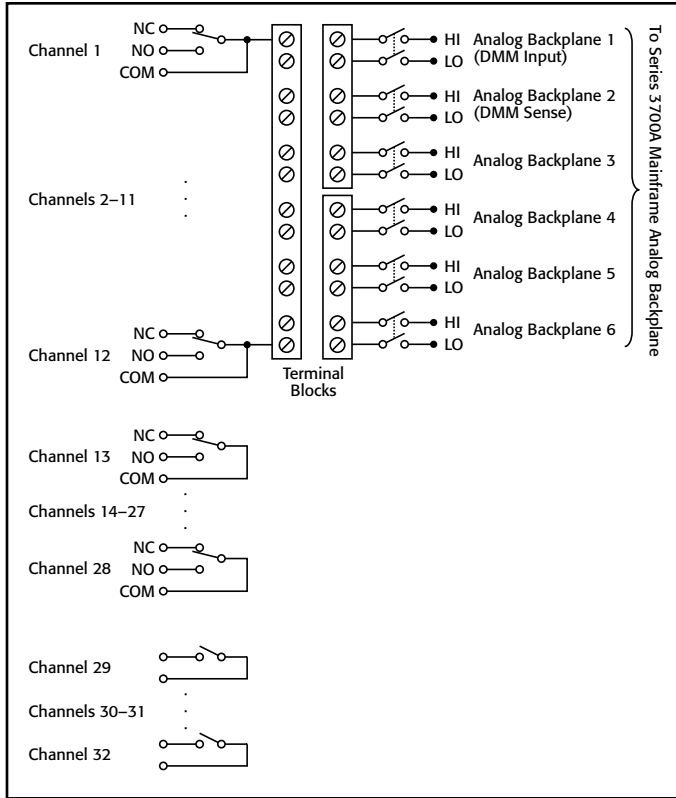

RELAY SWITCH CONFIGURATION: 32 general purpose independent channels. 28 channels of Form C switching at 2A and 4 channels of Form A switching at 7A. Relays can be connected to each other and backplane via removable terminal blocks.

CONTACT CONFIGURATION: **General Purpose:** 1 pole Form C. **High Current:** 1 pole Form A. **CONNECTOR TYPE:** Two 50 pin male D-shells.

MODEL 3740-ST SCREW TERMINAL OPTION: #22 AWG typical wire size with 0.062 inch O.D. 84 conductors maximum. #16 AWG maximum wire size with 0.092 inch O.D. 44 conductors per card maximum.

MAXIMUM SIGNAL LEVEL: **Form C:** 300V DC or RMS, 2A switched (3A carry), 60W, 125VA. **Form A:** 250VAC 7A, 30VDC 7A, 210W.

COMMON MODE VOLTAGE: 300V DC or RMS between any terminal and chassis.

VOLT-HERTZ LIMIT: 8×10^7 .

CONTACT LIFE: **Form C:** $>10^5$ operations at maximum signal level, $>10^8$ operations no load.¹ **Form A:** $>10^5$ operations at maximum signal level, $>5 \times 10^7$ operations no load.¹

CHANNEL RESISTANCE (end of contact life): $<0.5\Omega$.

CONTACT POTENTIAL: $<\pm 3\mu V$ typical per contact.

ISOLATION: **Channel-channel:** $10^9\Omega$, $<200pF$. **Common Mode:** $>10^{10}\Omega$, $<150pF$.

Crosstalk (Channel-channel, 50 Ω load-50 Ω source): **100kHz:** $<-50dB$. **1MHz:** $<-35dB$. **10MHz:** $<-15dB$.

BANDWIDTH: 30MHz.

GENERAL

OVER-TEMPERATURE: Temperature sensor indicates over temperature.

ACTUATION TIME: **Form C:** 4ms. **Form A:** 10ms.

RELAY TYPE: **Form C:** Latching electromechanical. **Form A:** Nonlatching electromechanical.

RELAY DRIVE SCHEME: Direct.

INTERLOCK: Backplane relays disabled when interlock connection is removed.

OPERATING ENVIRONMENT: Specified for 0° to 50°C. Specified to 70% R.H. at 35°C.

STORAGE ENVIRONMENT: -25° to 65°C.

WEIGHT: 2.5 lbs.

SAFETY: Conforms to European Union Directive 73/23/EEC, EN61010-1.

EMC: Conforms to European Union Directive 2004/108/EC, EN61326-1.

NOTES

1. Minimum signal level 10mV, 10 μA .

1.888.KEITHLEY (U.S. only)

www.keithley.com

KEITHLEY

A Tektronix Company

A Greater Measure of Confidence

3750

- 40 bidirectional digital input/output bits
- High current driver outputs for sinking (300mA)
- Internal 5V, 50mA logic supply for powering external logic circuits
- 2 isolated analog output channels, programmable to $\pm 12V$, 0–20mA, or 4–20mA
- 4 gated 32-bit counters with 1MHz input rate
- Screw terminal connections provided with removable 3750-ST accessory
- External supply voltage supported on digital I/O

Ordering Information

3750 **Multifunction
Control Card**

ACCESSORIES AVAILABLE

3721-MTC-1.5	50-pin female-to-male D-sub Cable Assembly, 1.5m (4.9 ft)
3721-MTC-3	50-pin female-to-male D-sub Cable Assembly, 3m (9.8 ft)
3750-ST	Screw Terminal Block
3790-KIT50-R	50-pin female D-sub Connector Kit (contains 2 D-sub connectors and 100 solder cup contacts)

SERVICES AVAILABLE

3750-3Y-EW-STD	1-year factory warranty extended to 3 years from date of shipment
3750-5Y-EW-STD	1-year factory warranty extended to 5 years from date of shipment
C/3750-3Y-DATA	3 (Z540-1 compliant) calibrations within 3 years of purchase*

*Not available in all countries

1.888.KEITHLEY (U.S. only)

www.keithley.com

Multifunction Control Card

40 digital I/O bits, 2 analog output channels, and 4 counters



Use the Model 3750 to monitor and control your automated test system. The flexibility and speed provided by the 40 digital I/O bits, four counters, and two analog outputs make it well-suited for a wide variety of system control applications.

Digital I/O

The Model 3750 offers 40 digital I/O bits arranged in five banks. Each bank is comprised of eight bits each, and each bank can be programmed as either input or output. Digital I/O is often used to control processes and monitor the status of switches, contacts, and other control points. Additional features include scanning capabilities, such as writing a unique output pattern or reading banks of inputs at rates up to 1000 rdgs/second. Also, pattern matching is available, making it ideal for complex event algorithms.

Further versatility is provided by supporting external voltage levels of up to 30V and output current sink levels of 300mA for control of external devices like RF/microwave relays.

Analog Outputs

The two analog outputs of the Model 3750 are designed for general purpose applications such as setpoint control or as bias supplies to your device under test. For maximum utility, these outputs are programmable as voltage ($\pm 12V$) or current (0–20mA or 4–20mA). A number of protection features are provided, including monitoring for current and/or voltage compliance and the ability to disconnect automatically during fault conditions. Output relays are supplied for each channel, ensuring mechanical isolation between your control device and the analog output.

Counters

Four 32-bit counters are provided with a maximum input rate of 1MHz. Each counter has a gate input that offers precise control of event counting and totalizing for a broad range of system components, such as: fixtures, limit switches, pass/fail indicators, revolutions, or time-related quantities. The counters, like the digital I/O, can be used in scanning operations and pattern matching as well as supporting reading rates of up to 1000 rdgs/second.

Self-calibration

When your Model 3706A mainframe is equipped with the high performance multimeter option, hardware and software is provided for self-calibration of analog outputs (voltage and current) and counter thresholds.

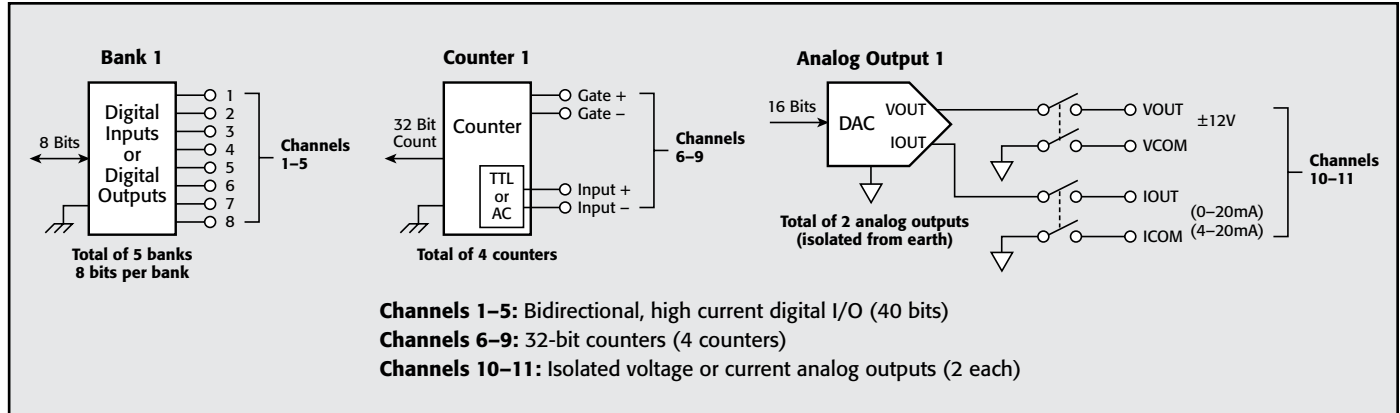

Figure 1. Block diagram

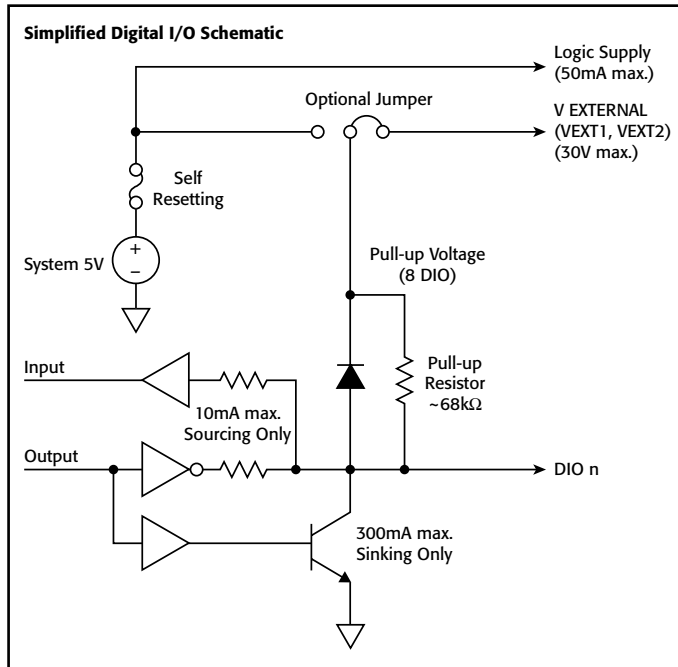

Figure 2. Simplified I/O schematic

Specifications

DIGITAL I/O¹

CONFIGURATION: 40 bidirectional digital I/O bits arranged in 5 banks of 8 bits each.

Each bank can be configured for either input or output capability. 1 bank of I/O is equivalent to 1 system channel.

DIGITAL INPUT SPECIFICATIONS

An internal weak pull-up resistor of approximately 68kΩ is provided on the card for each I/O. This pull-up resistor can be removed via onboard jumper on a channel (8 bit) basis. The pull-up voltage can either connect to the internally supplied 5V or an externally supplied voltage of up to 30V via onboard jumper. An internal 5V supply connection is separately available to run external logic circuits.

DIGITAL INPUT LOGIC LOW VOLTAGE: 0.8V max.

DIGITAL INPUT LOGIC HIGH VOLTAGE: 2V min.

DIGITAL INPUT LOGIC LOW CURRENT: -600μA max @ 0V.

DIGITAL INPUT LOGIC HIGH CURRENT: 50μA max @ 5V.

LOGIC: Positive true.

SYSTEM INPUT MINIMUM READ SPEED²: 1000 readings/second.

MAXIMUM EXTERNALLY SUPPLIED PULL-UP VOLTAGE: 30V.

MAXIMUM EXTERNALLY SUPPLIED VOLTAGE TO ANY DIGITAL I/O LINE: Pull-up voltage (5V internal or up to 30V external).

DIGITAL OUTPUT SPECIFICATIONS

Each output has an internal fly-back diode for driving inductive loads. Each output is protected against continuous short circuits and over temperature. An internal 5V supply connection is separately available to run external logic circuits.

DIGITAL OUTPUT LOGIC HIGH VOLTAGE: 2.4V minimum @ I_{out} = 10mA, sourcing only.

DIGITAL OUTPUT LOGIC LOW VOLTAGE: 0.5V maximum @ I_{out} = -300mA, sinking only.

MAXIMUM OUTPUT SINK CURRENT: 300mA per output, 3.0A total per card.

LOGIC: Positive true.

SYSTEM OUTPUT MINIMUM WRITE SPEED³: 1000 readings/second.

MAXIMUM EXTERNALLY SUPPLIED VOLTAGE TO ANY DIGITAL I/O LINE: Pull-up voltage (5V internal or up to 30V external).

ALARM: Trigger generation is supported for a maskable pattern match or state change on any of channels 1 through 5.

PROTECTION: Optional disconnect (set to inputs) during output fault conditions.

INTERNAL 5V LOGIC SUPPLY: The internal logic supply is designed for powering external logic circuits of up to 50mA maximum. The logic supply is internally protected with a self-resetting fuse. Fuse reset time < 1 hour.

NOTES

- All channels power up configured as inputs.
- All channels configured as inputs.
- All channels configured as outputs.

COUNTER/TOTALIZER INPUT

MAXIMUM COUNT: $2^{32} - 1$.
MAXIMUM INPUT RATE: 1MHz, rising or falling edge, programmable.
MINIMUM INPUT PULSE WIDTH: 500ns.
INPUT SIGNAL LEVEL: 200mV p-p (minimum), 42V peak (maximum).
THRESHOLD: AC (0V) or TTL logic level.
GATE INPUT: TTL-HI (Gate+), TTL-LO (Gate-) or NONE.
MINIMUM GATE INPUT SETUP TIME: 1 μ s.
COUNT RESET: Manual or Read + Reset.
SYSTEM INPUT MINIMUM READ SPEED: 1000 readings/second.
ALARM: Trigger generation is supported for a count match or counter overflow on any of channels 6 through 9.

ANALOG VOLTAGE OUTPUT

The isolated analog voltage output is designed for general purpose, low power applications.
OUTPUT AMPLITUDE: $\pm 12V$ up to 10mA.
OVERLOAD CURRENT: 21mA minimum.
RESOLUTION: 1mV.
FULL SCALE SETTling TIME: 1ms to 0.1% of output.
DC ACCURACY: $\pm(\%$ of output + mV):
 1 Year 23° $\pm 5^{\circ}C$: 0.15% + 16mV.
 90 Day 23° $\pm 5^{\circ}C$: 0.1% + 16mV.
 24 Hour 23° $\pm 5^{\circ}C$: 0.04% + 16mV.
TEMPERATURE COEFFICIENT: $\pm(0.02\% + 1.2mV)^{\circ}C$.
10mV MAXIMUM UPDATE RATE: 350 μ s to 1% accuracy. System limited.
OUTPUT FAULT DETECTION: System fault detection is available for short circuit output/current compliance.
ISOLATION: 300V peak channel to channel or channel to chassis.
PROTECTION: Optional disconnect during output fault conditions.
MINIMUM GUARANTEED STABLE CAPACITIVE LOAD: 10nF.

NOTES

- Programming up to 1% over full scale range is supported.
- Measured with standard load shown in Figure 3.
- Measured with >10M Ω input DMM (DCV, filter, 1 PLC rate). Warm-up time is 1 hour @ 10mA load with 3750-ST.

ANALOG CURRENT OUTPUT

The isolated analog current output is designed for 0–20mA or 4–20mA unipolar modes of operation.
OUTPUT AMPLITUDE: 0 to 20mA or 4 to 20mA.
COMPLIANCE VOLTAGE: 11V minimum.
MAXIMUM OPEN CIRCUIT VOLTAGE: 16V.
RESOLUTION: 1 μ A.
FULL SCALE SETTling TIME: 1ms to 0.1% of output.
DC ACCURACY: $\pm(\%$ of output + μ A):
 1 Year 23° $\pm 5^{\circ}C$: 0.15% + 18 μ A.
 90 Day 23° $\pm 5^{\circ}C$: 0.1% + 18 μ A.
 24 Hour 23° $\pm 5^{\circ}C$: 0.04% + 18 μ A.
TEMPERATURE COEFFICIENT: $\pm(0.02\% + 1.6\mu A)^{\circ}C$.
OUTPUT FAULT DETECTION: System fault detection is available for open circuit output/voltage compliance.
ISOLATION: 300V peak channel to channel or channel to chassis.
PROTECTION: Optional disconnect during output fault conditions.

NOTES

- Measured with standard load shown in Figure 3.
- Measured with <2 Ω shunt DMM (DCI, filter, 1 PLC rate). Warm-up time is 1 hour with 3750-ST.

GENERAL

CONNECTOR TYPE: Two 50-pin male D-shells.
OPERATING ENVIRONMENT: Specified for 0°C to 50°C. Specified to 70% R.H. at 35°C.
STORAGE ENVIRONMENT: –25°C to 65°C.
WEIGHT: 1.27kg (2.80 lbs.).
SAFETY: Conforms to European Union Directive 73/23/EEC, EN61010-1.
EMC: Conforms to European Union Directive 2004/108/EC, EN61326-1.
POWER BUDGET INFORMATION:
Quiescent Power: 3300mW.
Digital Outputs Each Channel (1 through 5): 325mW.
Analog Channel Each (10 and 11): 820mW.
Totalizer Channel All (6 through 9): 730mW.
 Analog channels and counter channels may optionally be turned off to conserve system power.
 See Chapter 8 of the Series 3700A user's manual for more detailed information.

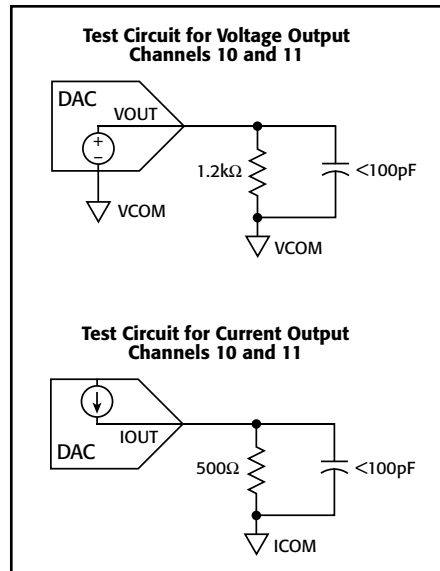

Figure 3. Standard load test circuits

7001

Switch/Control Mainframe
80-channel

- Supports industry's broadest range of signals
- Integrates easily with DMM and SourceMeter® SMU instruments
- Full channel status display
- 2 card slots
- Supports 17 switch/control cards

Ordering Information

7001 80-channel Switch/
Control Mainframe

required, reducing the amount of switching hardware needed. Higher density also provides extra capacity and flexibility.

Analog backplane. The 7001's analog backplane is used by the high density switch cards. The backplane eliminates intercard wiring and increases configuration flexibility. Two cards can be connected through the backplane to create a 1×80 multiplexer, a 4×20 matrix, or a multiplexer/matrix combination that provides matrix row expansion.

Channel status display. See the status of every channel simultaneously. The vacuum fluorescent display of the 7001 shows the open/close status of each channel in the mainframe simultaneously. The graphical display pattern makes it much easier to configure a test system, make modifications, or debug an existing program. The status of the cards in both slots is displayed side by side on the same screen.

Easy to set up and use. The 7001 has a number of built-in features that make it easy to set up, run, change, or modify. It conforms to IEEE-488.2 and SCPI (Standard Commands for Programmable Instruments). All aspects of the instrument can be programmed from the front panel and over the IEEE bus.

Trigger Link. Trigger Link is a high speed trigger bus that provides simple trigger coordination between the Model 7001 and other instruments. This bus eliminates GPIB communication delays during scanning to increase overall system throughput dramatically.

17 switch/control cards available. The 7001 switch cards accommodate a broad range of signals, maintain very high accuracy, and will not degrade signal quality. By minimizing signal errors, these cards will prevent degradation due to offset voltage, isolation resistance, and leakage current.

With its broad range of available cards, the 7001 provides multi-pole switching. Cards such as the 7011 can be used in either 2- or 4-pole configuration. If a card does not have the pole capacity required, the 7001 can still accommodate the application—just select the CARD PAIR function. It allows the channel closures in both slots to be synchronized for up to 8-pole switching.

Matrix cards are displayed in row-column format. Only the available rows and columns of the card are displayed. Rows are horizontal and columns are vertical.

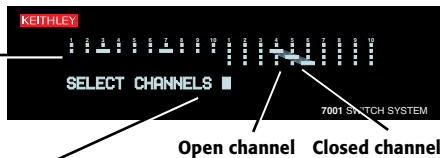

Matrix crosspoints are entered in row-column format. The first number selects the card, the second is the row, and the third number is the column.



Multiplexer card display. The first row across represents channels 1 to 10. The second row is channels 11 to 20. Only the available channels are displayed.

Scan in any order. A scan does not have to be a contiguous set of channels. Scan forward, backward, or skip channels.

Display indicates scanning. As a scan sequence is executed, the display updates to show the scanning action.

ACCESSORIES AVAILABLE

COMMUNICATION INTERFACES
AND CABLES

7007-1	Double Shielded, Premium GPIB Cable, 1m
7007-2	Double Shielded, Premium GPIB Cable, 2m
KPCI-488LPA	IEEE-488 Interface/Controller for the PCI Bus
KUSB-488B	IEEE-488 USB-to-GPIB Interface Adapter

RACK MOUNT KITS

4288-1	Single Fixed Rack Mount Kit
4288-2	Dual Fixed Rack Mount Kit

TRIGGERING

8501-1	Trigger Link Cable, DIN-to-DIN, 1m
8501-2	Trigger Link Cable, DIN-to-DIN, 2m
8503	Trigger Link Cable, DIN-to-dual BNC, 1m
8505	Male to 2-Female Y-DIN Cable for Trigger Link

SERVICES AVAILABLE

7001-3Y-EW	1-year factory warranty extended to 3 years from date of shipment
------------	---

1.888.KEITHLEY (U.S. only)

www.keithley.com

KEITHLEY
A Tektronix Company

A Greater Measure of Confidence

7001

Switch/Control Mainframe

80-channel

System

CAPACITY: 2 plug-in cards per mainframe.

MEMORY: Battery backed-up storage for 100 switch patterns.

SWITCH SETTling TIME: Automatically selected by the mainframe for each card. Additional time from 0 to 99999.999 seconds can be added in 1ms increments.

TRIGGER SOURCES:

- External Trigger (TTL-compatible, programmable edge, 600ns minimum pulse, rear panel BNC).
- IEEE-488 bus (GET, *TRG)
- Trigger Link
- Manual (front panel)
- Internal Timer, programmable from 1ms to 99999.999 seconds in 1ms increments.

STATUS OUTPUT: Channel Ready (TTL-compatible signal, rear panel BNC). Low going pulse (10 μ s typical) issued after relay settling time. For two different switch cards, 7001 will be set to the slowest relay settling time.

SWITCHING SEQUENCE: Automatic break-before-make.

MAINFRAME DIGITAL I/O: 4 open-collector outputs (30V maximum pull-up voltage, 100mA maximum sink current, 10 Ω output impedance), 1 TTL compatible input, 1 common.

RELAY DRIVE: 700mA maximum for both card slots.

CARD SIZE: 32mm high \times 114mm wide \times 272mm long (1 $\frac{1}{4}$ in \times 4 $\frac{1}{2}$ in \times 10 $\frac{3}{4}$ in).

CARD COMPATIBILITY: Fully compatible with all 7XXX cards.

Throughput

EXECUTION SPEED OF SCAN LIST¹:

	7011 Card	7015 Card
Individual Channels:	130/second	500/second
Memory Setups:	125/second	450/second

TRIGGER EXECUTION TIME (maximum time from activation of Trigger Source to start of switch open or close²):

Source	Latency	Jitter
GET ³	200 μ s	<50 μ s
*TRG ³	5.0 ms	
Trigger Link	200 μ s	<13 μ s
External	200 μ s	<13 μ s

NOTES

- Rates include switch settling time of cards: 3ms for 7011 and 500 μ s for 7015 cards.
- Excluding switch settling time.
- Assuming no IEEE-488 commands are pending execution.

IEEE-488 Command Execution Time

Command	Execution Time ¹	
	Display Off	Display On
OPEN (@!1)	7.5 ms	8.5 ms
CLOS (@!1)	7.5 ms	8.5 ms
MEM:REC M1	5.0 ms	6.0 ms

NOTES

- Measured from the time at which the command terminator is taken from the bus to the time at which the relay begins to open or close.

Analog Backplane

SIGNALS: Four 3-pole rows (Hi, Lo, Guard). These signals provide matrix and multiplexer expansion between cards within one mainframe.

MAXIMUM VOLTAGE: 250V DC, 250V rms, 350V AC peak, signal path to signal path or signal path to chassis.

MAXIMUM CURRENT: 1A peak.

PATH ISOLATION:

- >10¹⁰ Ω , <50pF path to path (any Hi, Lo, Guard to another Hi, Lo, Guard).
- >10¹⁰ Ω , <50pF differential (Hi to Lo or Hi, Lo to Guard).
- >10⁹ Ω , <75pF path to chassis.

CHANNEL CROSSTALK: <-65dB @ 1MHz (50 Ω load).

BANDWIDTH: <3dB loss at 100MHz (50 Ω load).

IEEE-488 BUS IMPLEMENTATION

STANDARDS CONFORMANCE: Conforms to SCPI-1990, IEEE-488.2, and IEEE-488.1.

MULTILINE COMMANDS: DCL, LLO, SDC, GET, GTL, UNT, UNL, SPE, SPD.

UNLINE COMMANDS: IFC, REN, EOJ, SRQ, ATN.

INTERFACE FUNCTIONS: SH1, AH1,T5, TE0, L4, LE0, SRI, RLI, PPO, DC1, DT1, CO, EI.

GENERAL

DISPLAY: Dual-line vacuum fluorescent.

- 1st line:20-character alphanumeric.
- 2nd line:32-character alphanumeric.

REAR PANEL CONNECTORS:

- IEEE-488
- 8-pin micro-DIN connector for digital I/O
- 8-pin micro-DIN for Trigger Link
- 8-pin micro-DIN for Trigger Link expansion
- BNC for External Trigger
- BNC for Channel Ready

POWER: 100V to 240Vrms, 50/60Hz, 50VA maximum.

EMC: Conforms to European Union Directive 89/336/EEC, EN61326-1.

SAFETY: Conforms to European Union Directive 73/23/EEC, EN61010-1.

EMI/RFI: Meets VDE 0871B and FCC Class B.

ENVIRONMENT:

- Operating: 0°–50°C, <80% relative humidity (0°–35°C).
- Storage: -25° to +65°C.

DIMENSIONS, WEIGHT: 89mm high \times 216mm wide \times 375mm deep (3 $\frac{1}{2}$ in \times 8 $\frac{1}{2}$ in \times 14 $\frac{3}{4}$ in). Net weight 3.4kg (7 $\frac{1}{2}$ lbs).

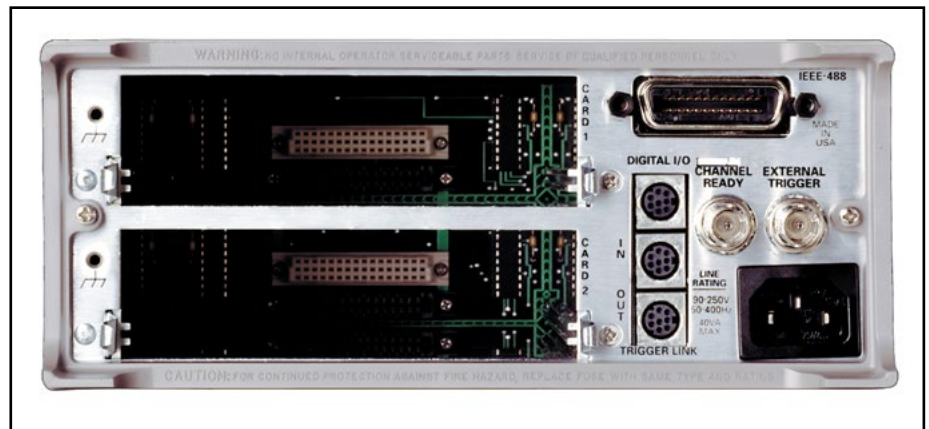

Model 7001 rear panel

1.888.KEITHLEY (U.S. only)

www.keithley.com

A Greater Measure of Confidence

KEITHLEY
A Tektronix Company

7002

Switch/Control Mainframe

400-channel



- Interactive channel status display
- Optional light pen for front panel programming
- Integrates easily with DMM and SourceMeter® SMU instruments
- Full channel status display
- 10 card slots
- Supports 17 switch/control cards

Ordering Information

**7002 400-channel Switch/
Control Mainframe**

The Model 7002 Switch System is a 10-slot mainframe that supports up to 400 2-pole multiplexer channels or 400 matrix crosspoints. The front panel includes a unique interactive display of channel status for quick programming. Scanning speeds of up to 300 channels per second are possible with the high density switch cards. The wide selection of more than 30 different switch cards makes the 7002 one of the most flexible switching mainframes available.

Reduce the Size and Cost of Your Switching Application.

Up to 400 channels of 2-pole switching. A single Model 7002 mainframe can accommodate up to ten 40-channel cards. That's 400 channels in a single full-rack package that is only 178mm high (7 in). This level of density provides some important advantages. First, it reduces the amount of switching hardware required for a given application. Second, it provides high flexibility. The high density cards can be used with the special signal cards to cover all your signal needs for a large application with one mainframe.

Switch a wide range of signals. The 7002 is fully compatible with all 7001 switch cards. From this broad selection of 17 cards, you can assemble a switch configuration that will ensure signal integrity and minimize errors. These cards allow the 7002 to switch DC signals from femtoamps to amps, nanovolts to kilovolts, as well as RF and optical signals.

Switch a wide range of signals. The 7002 is fully compatible with all 7001 switch cards. From this broad selection of 17 cards, you can assemble a switch configuration that will ensure signal integrity and minimize errors. These cards allow the 7002 to switch DC signals from femtoamps to amps, nanovolts to kilovolts, as well as RF and optical signals.

Analog backplane. The analog backplane used by the high density cards adds configuration flexibility and eliminates intercard wiring. For example, the outputs of a multiplexer card can be connected to the row inputs of a matrix card. Or, the outputs of ten multiplexer cards can be connected to form one large 1×400 multiplexer. Intercard wiring is eliminated by using the analog backplane to form these configurations.

Faster Test Development

Unique channel status display. The interactive front panel display helps shorten the time required to configure the 7002 and develop test software. The display indicates the open/close status of each channel in the mainframe. This information is very useful when programming the 7002 and developing application software. Knowing the channel status also helps to verify proper operation during the debug phase.

Light pen programming. An optional light pen provides point and click programming from the front panel. By selecting the desired channels or range of channels, the scan list can be built, matrix patterns created, channels opened or closed, and patterns stored in memory. The 7002's non-volatile memory stores up to 500 complete switch patterns.

Automatic card configuration. When the high density cards are installed, the 7002 automatically configures each slot independently for the proper card. The channel status display on the front panel adjusts to show each card's capacity and configuration.

Front panel Info key. At the touch of a button, the operator receives context-sensitive, on-line information to help configure the system. This information is displayed on a 52-character alphanumeric display for clear and readable messages. There is no need to refer constantly to the operator's manual. All information messages, operating instructions, and prompts are available in English, German, and French. Just select the desired language in the configuration menu.

Programmable channel closure restrictions. The 7002 allows specific channels to be locked out from closure. This restriction can be conditional based on the open/close state of other channels or crosspoints. This capability is useful to prevent certain signals from being accidentally connected to high power circuits, for example.

ACCESSORIES AVAILABLE

COMMUNICATION INTERFACES AND CABLES

7007-1	Double Shielded, Premium GPIB Cable, 1m
7007-2	Double Shielded, Premium GPIB Cable, 2m
7078-PEN	Programming Light Pen (includes holder)
KPCI-488LPA	IEEE-488 Interface/Controller for the PCI Bus
KUSB-488B	IEEE-488 USB-to-GPIB Interface Adapter

RACK MOUNT KITS

7002-RMK-1	Fixed Rack Mount Kit
7002-RMK-2	Slide Rack Mount Kit

TRIGGERING

8501-1	Trigger Link Cable, DIN-to-DIN, 1m
8501-2	Trigger Link Cable, DIN-to-DIN, 2m
8503	Trigger Link Cable, DIN-to-dual BNC, 1m
8505	Male to 2 Female Y-DIN Cable for Trigger Link

SERVICES AVAILABLE

7002-3Y-EW	1-year factory warranty extended to 3 years from date of shipment
------------	---

1.888.KEITHLEY (U.S. only)

www.keithley.com

A Greater Measure of Confidence

KEITHLEY
A Tektronix Company

7002

Switch/Control Mainframe

400-channel

System Throughput

300 channel per second scanning. The 7002 can scan through up to 300 channels per second. This scan process can be controlled by the internal time base of the 7002 or through external triggers. The scan sequence is controlled by what appears in the scan list. The scan list can include channels, ranges of channels, and memory locations. This approach gives maximum flexibility while obtaining maximum throughput.

Built-in Scan Control and Trigger Link. The built-in scan control eliminates the need for the computer to control every step of the test procedure. Simply program the 7002 to control the channel spacing, scan spacing, and number of scans. Trigger Link gives you access to six independent hardware trigger lines on a single cable.

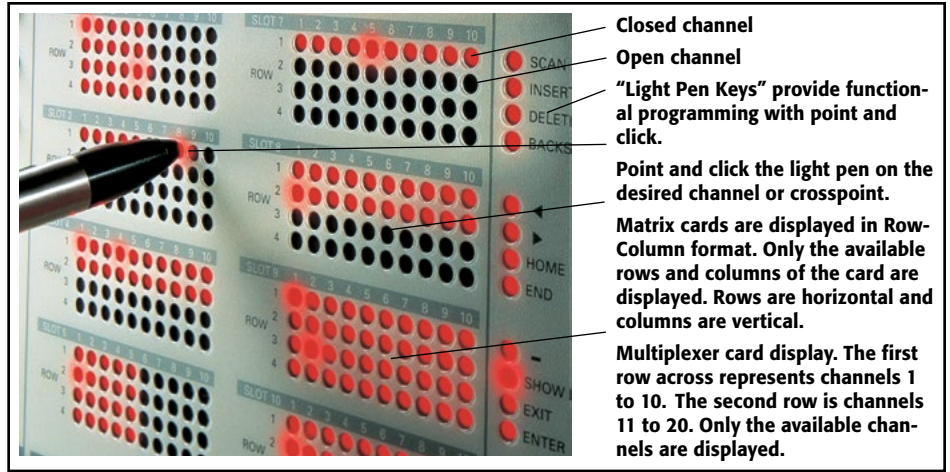

SYSTEM

CAPACITY: 10 plug-in cards per mainframe.

MEMORY: Battery backed-up storage for 500 switch patterns.

SWITCH SETTling TIME: Automatically selected by the mainframe. For different switchcards, 7002 will be set to the slowest relay settling time. Additional time from 0 to 99999.999 seconds can be added in 1ms increments.

TRIGGER SOURCES:

External Trigger (TTL-compatible, programmable edge, 600ns minimum pulse, rear panel BNC).

IEEE-488 bus (GET, *TRG)

Trigger Link

Manual (front panel)

Internal Timer, programmable from 1.0ms to 99999.999 seconds in 1.0ms increments.

STATUS OUTPUT: Channel Ready (TTL-compatible signal, rear panel BNC). Low going pulse (10μs typical) issued after relay settling time.

SWITCHING SEQUENCE: Break-before-make (programmable).

MAINFRAME DIGITAL I/O: Four open collector outputs (30V maximum, 100mA maximum sink current, 10Ω output impedance), one TTL compatible input, one common, one +5V.

RELAY DRIVE: 3.5A maximum for all 10 card slots.

CARD SIZE: 32mm high × 114mm wide × 272mm long (1¼ in × 4½ in × 10¾ in).

CARD COMPATIBILITY: Fully compatible with all 7001 cards.

ANALOG BACKPLANE

SIGNALS: Four 3-pole rows (Hi, Lo, Guard). These signals provide matrix and multiplexer expansion between cards within one mainframe.

MAXIMUM VOLTAGE: 250V DC, 250V rms, 350V AC peak, signal path to signal path or signal path to chassis.

MAXIMUM CURRENT: 1A peak.

PATH ISOLATION:

>10¹⁰Ω, <50pF path to path (any Hi, Lo, Guard to another Hi, Lo, Guard)

>10¹⁰Ω, <50pF differential (Hi to Lo or Hi, Lo to Guard).

>10¹⁰Ω, <75pF path to chassis.

CHANNEL CROSSTALK: <-65dB @ 1MHz (50Ω load).

BANDWIDTH: <3dB loss at 100MHz (50Ω load).

THROUGHPUT

EXECUTION SPEED OF SCAN LIST (channels or memory locations per second):

	Channels	Memories
Break-Before-Make	OFF 300	243
	ON 270	189

TRIGGER EXECUTION TIME (maximum time from activation of Trigger Source to start of switch open or close²):

Source	Latency	Jitter
GET1	200 μs	<15 μs
*TRG2, 3	3.0 ms	
Trigger Link	200 μs	<10 μs
External	200 μs	<10 μs
Timer		<25 μs

NOTES

1. Excluding switch settling time.
2. Assuming no IEEE-488 commands are pending execution.
3. Display off.

IEEE-488 COMMAND EXECUTION TIME

Command	Execution Time ¹
CLOS (@!1)	<8 ms + Relay Settle Time
OPEN (@!1)	<8 ms + Relay Settle Time
MEM:REC M1	<9 ms + 2× Relay Settle Time (BBM ON)
	<9 ms + Relay Settle Time (BBM OFF)

NOTES

1. Measured from the time at which the command terminator is taken from the bus to relay energize. With display OFF.

IEEE-488 BUS IMPLEMENTATION

STANDARDS CONFORMANCE: Conforms to SCPI-1990, IEEE-488.2, and IEEE-488.1.

MULTILINE COMMANDS: DCL, LLO, SDC, GET, GTL, UNT, UNL, SPE, SPD.

UNILINE COMMANDS: IFC, REN, EOI, SRQ, ATN.

INTERFACE FUNCTIONS: SH1, AH1, T5, TE0, L4, LE0, SRI, RLI, PPO, DCL1, DT1, C0, E1.

All aspects of 7002 operation are available from the front panel or over the IEEE-bus interface. The 7002 conforms to IEEE-488.2 and the SCPI (Standard Commands for Programmable Instruments) command language protocol.

- Scan List
- Scan Spacing
- Channel Spacing
- Number of Scans
- Number of Channels
- Trigger Source
- Single Channel Mode
- Channel Restrictions
- Save Mainframe Configuration Setups
- Digital I/O
- Card Pair
- Channel Delay
- Number of Poles
- Channel Pattern Memory

GENERAL

DISPLAY: Dual-line vacuum fluorescent. 1st line: 20-character alphanumeric. 2nd line: 32-character alphanumeric. Channel status LED grid.

LIGHT PEN OPTION: Provides interactive programming of channels, cross points, scan lists, and memory.

REAR PANEL CONNECTORS: IEEE-488; 9-pin DB9 Female; 8-pin micro DIN for Trigger Link; 8-pin micro DIN for Trigger Link expansion; BNC for External Trigger; BNC for Channel Ready

POWER: 100V to 240Vrms, 50/60Hz, 110VA maximum.

EMC: Complies with European Union Directive 89/336/EEC, EN61326-1.

SAFETY: Conforms to European Union Directive 73/23/EEC, EN61010-1).

EMI/RFI: Meets VDE 0871B and FCC Class B.

ENVIRONMENT: Operating: 0°C to 50°C, <80% RH (0°C to 35°C). **Storage:** -25°C to +65°C.

DIMENSIONS, WEIGHT: 178mm high × 438mm wide × 448mm deep (7 in × 17¼ in × 17½ in). Net weight 9.1kg (20 lb).

1.888.KEITHLEY (U.S. only)

www.keithley.com

A Greater Measure of Confidence

KEITHLEY
A Tektronix Company

Selector Guide

Switch Cards for 7001, 7002

No. of Channels	Card Config.	Contact Config.	Max. Voltage	Max. Current	Max. Power	Contact Potential	Max. Offset Current	Recomm. Frequency	Connection Type	CE	Comments	
HIGH DENSITY												
7011-C	40	Multiplexer	2 form A	110V	1A	60VA	<1 μ V	<100pA	2MHz	Connector	Yes	Four independent 1 \times 10 multiplexers, connection to backplane
7011-S	40	Multiplexer	2 form A	110V	1A	60VA	<500nV	<100pA	2MHz	Screw term.	Yes	Four independent 1 \times 10 multiplexers, connection to backplane
7012-C	4 \times 10	Matrix	2 form A	110V	1A	60VA	<1 μ V	<100pA	2MHz	Connector	Yes	Rows connect to analog backplane
7012-S	4 \times 10	Matrix	2 form A	110V	1A	60VA	<500nV	<100pA	2MHz	Screw term.	Yes	Rows connect to analog backplane
7013-C	20	Isolated Switch	2 form A	110V	1A	60VA	<1 μ V	<100pA	10MHz	Connector	Yes	
7013-S	20	Isolated Switch	2 form A	110V	1A	60VA	<500nV	<100pA	10MHz	Screw term.	Yes	
7015-C	40	Multiplexer	2 form A	175V	34mA	0.3VA	<5 μ V	<1nA	500kHz	Connector	Yes	Solid state switch for high reliability
7015-S	40	Multiplexer	2 form A	175V	34mA	0.3VA	<5 μ V	<1nA	500kHz	Screw term.	Yes	Solid state switch for high reliability
7018-C	28	Multiplexer	3 form A	110V	1A	60VA	<5 μ V	<100pA	2MHz	Connector	Yes	3 pole switching
7018-S	28	Multiplexer	3 form A	110V	1A	60VA	<5 μ V	<100pA	2MHz	Screw term.	Yes	3 pole switching
7035	36	Multiplexer	2 form A	60V	1A	30VA	<1 μ V	<100pA	10MHz	Connector	Yes	9 independent 1 \times 4 multiplexers
7036	40	Isolated Switch	1 form A	60V	1A	30VA	<4 μ V	<100pA	10MHz	Connector	Yes	40 independent channels of 1-pole switching
7111-S	40	Multiplexer	1 form C	110V	1A	60VA	<500nV	<100pA	2MHz	Screw term.	Yes	Four independent 1 \times 10 multiplexers, connection to backplane
Control												
7020	80	Digital I/O								Connector	Yes	40 inputs/40 outputs
7020-D*												
7037-D*	30/20	Isolated/ Digital I/O	1 form A	110V	1A	30VA	<4 μ V	<100pA	10MHz	Connector	Yes	30 independent channels of 1-pole switching, 10 digital inputs, 10 digital outputs
7065												Hall Effect measurement buffer card
See page 223 for details.												
HIGH CURRENT												
7053	10	Multiplexer	2 form A	300V	5A	100VA	<1mV		1MHz	Screw term.		
HIGH VOLTAGE												
7154	10	Multiplexer	2 form A	1100V	500mA	10VA	<35 μ V		1MHz	Screw term.	Yes	
LOW CURRENT												
7152	4 \times 5	Matrix	2 form A	200V	500mA	10VA	<20 μ V	<1pA	60MHz	Connector	Yes	
7153	4 \times 5	Matrix	2 form A	1300V	500mA	10VA	<50 μ V	<1pA	60MHz	Connector	Yes	
7158	10	Multiplexer	1 form C	30V	100mA		<200 μ V	<1pA	1MHz	BNC	Yes	
LOW VOLTAGE												
7168	8	Multiplexer	2 form A	10V	50mA		<30nV		1kHz	Screw term.	Yes	

1.888.KEITHLEY (U.S. only)

www.keithley.com

KEITHLEY
A Tektronix Company

A Greater Measure of Confidence

Selector Guide Switch Card Accessories

7001, 7002, 705, 706 Switch Card Accessories

	Cables			Connectors	Adapters	Tools	
7011-C	7011-MTC-1	7011-MTC-2		7011-KIT-R			
7011-S				7011-ST			
7111-S							
7012-C	7011-MTC-1	7011-MTC-2		7011-KIT-R			
7012-S				7012-ST			
7013-C	7011-MTC-1	7011-MTC-2		7011-KIT-R			
7013-S				7013-ST			
7015-C	7011-MTC-1	7011-MTC-2		7011-KIT-R			
7015-S				7015-ST			
7018-C	7011-MTC-1	7011-MTC-2		7011-KIT-R			
7018-S				7018-ST			
7020	7020-MTC-2			7011-KIT-R (incl.)			
7020-D				7020-DT			
7035	7035-MTC-2			7011-KIT-R (incl.)			
7036	7036-MTC-2			7011-KIT-R (incl.)			
7037-D				7037-DT			
7152	7152-MTC-2, -10	7152-TRX-10		7152-KIT 7152-MTR		7152-HCT 7074-HCT	7074-CIT
7153	7153-TRX						
7158	4801	4802-10	4803		4804		

Selector guide: Switch cards for 7001, 7002

1.888.KEITHLEY (U.S. only)

www.keithley.com

A Greater Measure of Confidence

KEITHLEY
A Tektronix Company

SWITCHING AND CONTROL

7011-C, 7011-S, 7111-S

40-channel Multiplexer Cards Quad 1×10 Multiplexer Configuration

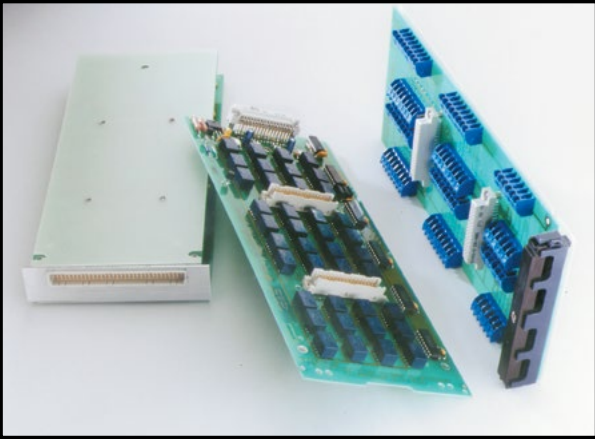

- Quad 1×10 multiplexer for 2-, 4-, or 8-pole operation
- Connects to 7001/7002 backplane for easy expandability
- 500nV, 100pA offsets

Ordering Information

7011-C	Quad 1×10 Multiplexer with 96-pin Mass Terminated Connector Board
7011-S	Quad 1×10 Multiplexer with Screw Terminal Connector Board
7111-S	Quad 1×10 Form C Multiplexer with Screw Terminal Connector Board

ACCESSORIES AVAILABLE

FOR 7011-C:

7011-KIT-R	96-pin Female Connector Kit
7011-MTC-1	96-pin Mass Terminated Cable, Female to Female, 1m
7011-MTC-2	96-pin Mass Terminated Cable, Female to Female, 2m

FOR 7011-S AND 7111-S:

7011-ST	Extra Screw Terminal Connection Board
---------	---------------------------------------

SERVICES AVAILABLE

7011-C-3Y-EW	1-year factory warranty extended to 3 years from date of shipment
7011-S-3Y-EW	1-year factory warranty extended to 3 years from date of shipment
7111-S-3Y-EW	1-year factory warranty extended to 3 years from date of shipment

The Model 7011 40-channel multiplexer has four independent banks of 1×10 switching. Each channel is 2-pole. These four banks can be combined for a wide variety of switching configurations—for example, dual 1×20, or 1×10 and 1×30, or one large 1×40. The 7001 mainframe can automatically configure the 7011 to switch 4-pole signals by combining channel pairs. This gives you a dual 1×10 4-pole multiplexer or a single 1×20 4-pole multiplexer.

Each of the four multiplexer outputs on this card connects to the 7001/7002 analog backplane through removable jumpers for even greater flexibility. Two 7011 cards can be used to make a single 1×80 multiplexer with all intercard connections through the backplane. The 7011 multiplexer outputs can also be connected to the rows of the 7012 via the backplane for row expansion.

The Model 7111-S is a form C version of the 7011-S. The 7111-S is a low-voltage, quad 1×10, single-pole form C multiplexer card. The 7111-S assembly consists of a screw terminal connector card and a relay card. External test circuits are wired directly to the screw terminals of the connector card.

These cards automatically configure the 7001 or 7002 mainframe. Two connection options are available, screw terminal for maximum flexibility or a single 96-pin quick disconnect connector.

MULTIPLEX CONFIGURATION: Four independent 1×10 2-pole multiplex banks or two independent 1×10 4-pole multiplex banks. Adjacent banks can be connected together. Jumpers can be removed to isolate any bank from the backplane.

CONTACT CONFIGURATION: 2-pole Form A (Hi, Lo) (1-pole form C for 7111-S).

CONNECTOR TYPE:

7011-C: 96-pin male DIN connector.

7011-S and 7111-S: Screw terminal, #16AWG maximum wire size, with 0.092 inch O.D. 28 conductors per card maximum. #22AWG typical wire size with 0.062 inch O.D. 88 conductors per card maximum.

MAXIMUM SIGNAL LEVEL:

DC Signals: 110V DC between any two pins, 1A switched, 30VA (resistive load).

AC Signals: 125V rms and 175V AC peak, between any two pins, 1A switched, 60VA (resistive load).

COMMON MODE VOLTAGE: 175V peak, any pin to chassis.

CONTACT LIFE: Cold Switching: 10⁸ closures. **At Maximum Signal Levels:** 10⁵ closures.

CHANNEL RESISTANCE (per conductor): <1Ω.

CONTACT POTENTIAL: 7011-C: <1μV per channel contact pair <3μV typical per single contact. 7011-S, 7111-S: <2μV per contact pair <5μV typical per single contact.

OFFSET CURRENT: <100pA.

ACTUATION TIME: 3ms.

ISOLATION:

Bank: >10°Ω, <25pF.

Channel to Channel: >10°Ω, <50pF.

Differential: Configured as 1×10:

>10°Ω, <100pF. Configured as 1×40:
>10°Ω, <200pF.

Common Mode: Configured as 1×10:

>10°Ω, <200pF. Configured as 1×40:
>10°Ω, <600pF.

CROSSTALK (1MHz, 50Ω Load): Bank: <-40dB. Channel: <-40dB.

INSERTION LOSS (50Ω Source, 50Ω Load): <0.1dB below 1MHz, <3dB below 2MHz.

RELAY DRIVE CURRENT (per relay):

7011-C, -S: 16mA

7111-S: 28mA

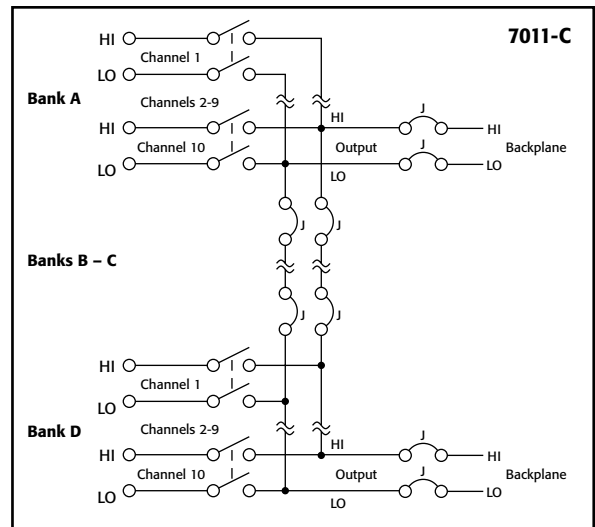

1.888.KEITHLEY (U.S. only)

www.keithley.com

KEITHLEY

A Tektronix Company

A Greater Measure of Confidence

7012-C 7012-S

4x10 Matrix Cards



- 4x10 2-pole matrix
- Available with screw terminal or mass terminated connections
- Rows connect to 7001/7002 backplane for easy matrix expandability
- 500nV, 100pA offsets

Ordering Information

7012-C 4x10, 2-Pole Matrix with 96-pin Mass Terminated Connector Board

7012-S 4x10, 2-Pole Matrix with Screw Terminal Connector Board

ACCESSORIES AVAILABLE

FOR 7012-C

7011-KIT-R	96-pin Female Connector Kit
7011-MTC-1	96-pin Mass Terminated Cable, Female to Female, 1m
7011-MTC-2	96-pin Mass Terminated Cable, Female to Female, 2m

SERVICES AVAILABLE

7012-C-3Y-EW	1-year factory warranty extended to 3 years from date of shipment
7012-S-3Y-EW	1-year factory warranty extended to 3 years from date of shipment

The 7012 provides 4 rows by 10 columns of 2-pole matrix switching. The four rows of this card can be connected to the analog backplane within the 7001 or 7002 to make a larger matrix (4x20) or use it with the 7011 multiplexer card for greater flexibility through row expansion. Each row is connected to the backplane with its own jumpers that can be removed to isolate an individual row from the backplane.

MATRIX CONFIGURATION: 4 rows by 10 columns. Jumpers can be removed to isolate any row from the backplane.

CONTACT CONFIGURATION: 2-pole Form A (Hi, Lo).

CONNECTOR TYPE:

7012-C: 96-pin male DIN connector.

7012-S: Screw terminal, #16AWG maximum wire size, with .092 inch O.D. 28 conductors per card maximum. #22AWG typical wire size with .062 inch O.D. 88 conductors per card maximum.

MAXIMUM SIGNAL LEVEL:

DC Signals: 110V DC between any two pins, 1A switched, 30VA (resistive load).

AC Signals: 125V rms and 175V AC peak, between any two pins, 1A switched, 60VA (resistive load).

COMMON MODE VOLTAGE: 175V peak, any pin to chassis.

CONTACT LIFE: Cold Switching: 10⁸ closures. At Maximum Signal Levels: 10⁵ closures.

CHANNEL RESISTANCE (per conductor): <1Ω.

CONTACT POTENTIAL:

7012-C: <1μV per channel contact pair <3μV typical per single contact.

7012-S: <500nV per channel contact pair <1.5μV typical per single contact.

OFFSET CURRENT: <100pA.

ACTUATION TIME: 3ms.

ISOLATION: Path: >10⁹Ω, <50pF. **Differential:** >10⁹Ω, <200pF. **Common Mode:** >10⁹Ω, <400pF.

CROSSTALK (1MHz, 50Ω Load): <-40dB.

INSERTION LOSS (50Ω Source, 50 Load): <0.1dB below 1MHz, <3dB below 2MHz.

RELAY DRIVE CURRENT (per relay): 16mA.

EMC: Conforms to European Union Directive 89/336/EEC.

SAFETY: Conforms to European Union Directive 73/23/EEC (meets EN61010-1/IEC 1010).

ENVIRONMENT: Operating: 0° to 50°C, up to 35°C <80% RH. **Storage:** -25°C to 65°C.

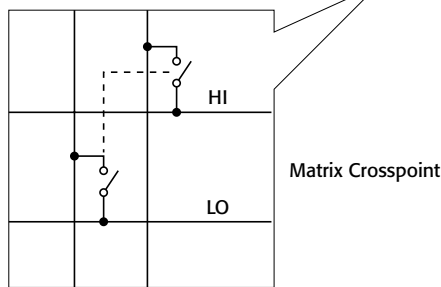
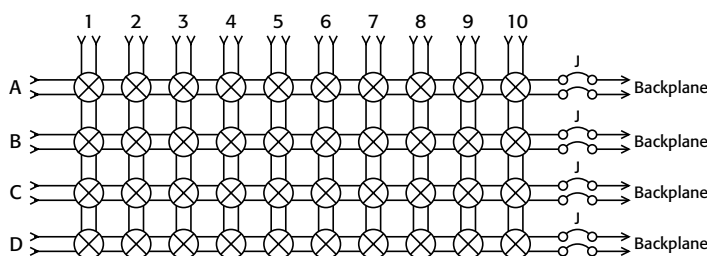

1.888.KEITHLEY (U.S. only)

www.keithley.com

A Greater Measure of Confidence

KEITHLEY
A Tektronix Company

7013-C 7013-S

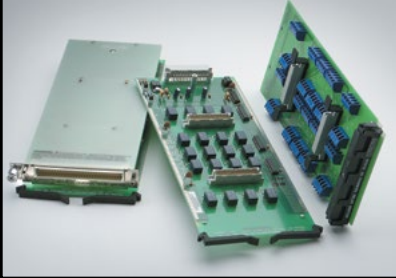

- 20 independent 2-pole switches
- 500nV, 100pA offsets

Ordering Information

- 7013-C** 20-channel, 2-pole Independent Switch with 96-pin Mass Terminated Connector Board
- 7013-S** 20-channel, 2-pole Independent Switch with Screw Terminal Connector Board

7015-C 7015-S

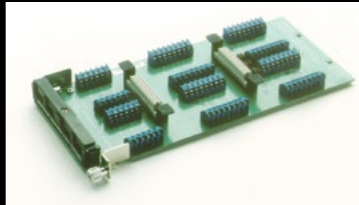

- Quad 1×10 (40-channel) solid-state multiplexer
- 30,000 hours MTBF
- Scan/measure over 300 ch/s

Ordering Information

- 7015-C** 40-channel, 2-pole Independent Switch with 96-pin Mass Terminated Connector Board
- 7015-S** 40-channel, 2-pole Independent Switch with Screw Terminal Connector Board

20-channel Isolated Switch Cards

This isolated switch card contains 20 independent channels that can be connected in a wide variety of configurations. Each channel is 2-pole. The isolated switch configuration provides the greatest flexibility because the switches can be connected as needed. Both sides of each 2-pole relay are available for connection.

RELAY SWITCH CONFIGURATION: 20 independent channels of 2-pole switching.

CONTACT CONFIGURATION: 2-pole Form A (Hi, Lo).

CONNECTOR TYPE: 7013-C: 96-pin male DIN connector.

7013-S: Screw terminal, #16AWG maximum wire size, with 0.092 inch O.D. 28 conductors per card maximum. #22AWG typical wire size with 0.062 inch O.D. 88 conductors per card maximum.

MAXIMUM SIGNAL LEVEL: DC Signals: 110V DC between any two pins, 1A switched. 30VA (resistive load).

AC Signals: 125V rms and 175V AC peak, between any two pins, 1A switched, 60VA (resistive load).

COMMON MODE VOLTAGE: 175V peak, any pin to chassis.

CONTACT LIFE: Cold Switching: 10⁸ closures.

At Maximum Signal Levels: 10⁵ closures.

CHANNEL RESISTANCE (per conductor): <1Ω.

OFFSET CURRENT: <100pA.

CONTACT POTENTIAL: 7013-C: <2μV per channel contact pair (HI, LO); <5μV per single contact. 7013-S: <2μV per contact pair (HI, LO); <5μV per single contact.

ACTUATION TIME: 3ms.

ISOLATION: Channel to Channel: >10¹⁰Ω, <25pF.

Differential: >10¹⁰Ω, <50pF. **Common Mode:** >10¹⁰Ω, <100pF.

CROSSTALK (1MHz, 50Ω Load): <-50dB.

INSERTION LOSS (50Ω Source, 50Ω Load): <0.1dB below 1MHz, <3dB below 10MHz.

RELAY DRIVE CURRENT (per relay): 16mA.

EMC: Conforms to European Union Directive 89/336/EEC.

SAFETY: Conforms to European Union Directive 73/23/EEC (meets EN61010-1/IEC 1010).

ENVIRONMENT: Operating: 0° to 50°C, up to 35°C <80% RH. **Storage:** -25°C to 65°C.

ACCESSORIES AVAILABLE

FOR 7013-C

- 7011-KIT-R 96-pin Female Connector Kit
7011-MTC-1 96-pin Mass Terminated Cable, Female to Female, 1m
7011-MTC-2 96-pin Mass Terminated Cable, Female to Female, 2m

FOR 7013-S

- 7013-ST Extra Screw Terminal Connection Board

SERVICES AVAILABLE

- 7013-C-3Y-EW 1-year factory warranty extended to 3 years from date of shipment
7013-S-3Y-EW 1-year factory warranty extended to 3 years from date of shipment

40-channel Solid State Multiplexer Cards Quad 1×10 Configuration

The Model 7015 40-channel solid state multiplexer is designed for multipoint measurement applications that require high reliability and increased scanning speeds. With an MTBF of more than 30,000 hours, the 7015 can handle applications that require continuous use over longer periods of time. The solid state switch technology also provides fast switching times for scanning rates of over 300 channels/measurements per second when used with the 7002/2001 or 7001/2001 combination.

MULTIPLEX CONFIGURATION: 4 independent 1×10 2-pole multiplex banks or 2 independent 1×10 4-pole multiplex banks. Adjacent banks can be connected together. Jumpers can be removed to isolate any bank from the backplane.

CONTACT CONFIGURATION: 2-pole Form A (Hi, Lo).

CONNECTOR TYPE:

7015-C: 96-pin male DIN connector.

7015-S: Screw terminal, #16AWG maximum wire size, with 0.092 inch O.D. 28 conductors per card maximum. #22AWG typical wire size with 0.062 inch O.D. 88 conductors per card maximum.

MAXIMUM SIGNAL LEVEL: 175V peak between any two pins, 34mA resistive load, 0.3VA max., 1×10⁹V-Hz max.

COMMON MODE VOLTAGE: 175V peak, any pin to chassis.

CONTACT TYPE: Solid state switch.

CHANNEL RESISTANCE (per conductor): <210Ω.

CONTACT POTENTIAL: 7015-C: <5μV per channel contact pair.

7015-S: <4μV per channel contact pair.

OFFSET CURRENT: <1nA.

ACTUATION TIME: <500μs.

ISOLATION: Bank: >10⁹Ω, <25 pF.

Channel to Channel: >10⁹Ω, <50 pF.

Differential: Configured as 1×10: >10⁹Ω, <100pF.

Configured as 1×40: >10⁹Ω, <200pF.

Common Mode: Configured as 1×10: >10⁹Ω, <375pF.

Configured as 1×40: >10⁹Ω, <1100pF.

INSERTION LOSS (50Ω Source, 1MΩ Load): <0.1dB below 250kHz, <3dB below 500kHz.

ACCESSORIES AVAILABLE

FOR 7015-C

- 7011-KIT-R 96-pin Female Connector Kit
7011-MTC-1 96-pin Mass Terminated Cable, Female to Female, 1m
7011-MTC-2 96-pin Mass Terminated Cable, Female to Female, 2m

SERVICES AVAILABLE

- 7015-C-3Y-EW 1-year factory warranty extended to 3 years from date of shipment
7015-S-3Y-EW 1-year factory warranty extended to 3 years from date of shipment

1.888.KEITHLEY (U.S. only)

www.keithley.com

KEITHLEY

A Tektronix Company

A Greater Measure of Confidence

7018-C 7018-S

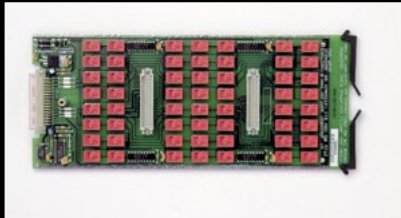

- Dual 1×14 (28-channel) multiplexer for 3- or 6-pole operation
- Connects to 7001/7002 backplane for easy expandability

Ordering Information

- 7018-C** Quad 1×10 Multiplexer with 96-pin Mass Terminated Connector Board
- 7018-S** Dual 1×14 Multiplexer with Screw Terminal Connector Board

7035



- Great fit for low frequency telecom test

Ordering Information

- 7035** 9 Bank 1×4 Multiplexer Switching Card

Accessories Supplied

- 7011-KIT-R 96-pin Female Connector Kit

28-channel 3-Pole Multiplexer

The Model 7018 28-channel multiplexer has two independent banks of 1×14 switching. Each channel is 3-pole. The two banks can be combined for a variety of different switching configurations. Used separately, they provide a dual 1×14 3-pole configuration. Onboard jumpers can connect the outputs together for a single 1×28 3-pole arrangement. Both the 7001 and 7002 switch systems can use the two banks in parallel for 6-pole operation in a 1×14 configuration.

MULTIPLEX CONFIGURATION: 2 independent 1×14 3-pole multiplex banks or one 1×14 6-pole multiplexer. Jumpers can be removed to isolate any bank from the backplane.

CONTACT CONFIGURATION: 3-pole Form A.

CONNECTOR TYPE: 7018-C: 96-pin male DIN connector.

7018-S: Screw terminal, #16AWG maximum wire size, with 0.092 inch O.D. 28 conductors per card maximum. #22AWG typical wire size with 0.062 inch O.D. 90 conductors per card maximum.

MAXIMUM SIGNAL LEVEL: DC Signals: 110V DC between any two pins, 1A switched, 30VA (resistive load).

AC Signals: 125V rms or 175V AC peak, between any two pins, 1A switched, 60VA (resistive load).

COMMON MODE VOLTAGE: 175V peak, any pin to chassis.

CONTACT LIFE: Cold Switching: 10⁸ closures.

At Maximum Signal Levels: 10⁵ closures.

CHANNEL RESISTANCE (per conductor): <1.5Ω.

CONTACT POTENTIAL: <5μV per single contact.

OFFSET CURRENT: <100pA.

ACTUATION TIME: 3ms.

CROSS TALK (1MHz, 50Ω Load): Bank: <-40dB.

Channel: <-40dB.

ISOLATION: Bank: >10⁹Ω, <25pF.

Channel to Channel: >10⁹Ω, <50pF.

Differential: Configured as 1×14 >10⁹Ω, <100pF.

Configured as 1×28 >10⁹Ω, <200pF.

Common Mode: Configured as 1×14 >10⁹Ω, <400pF.

Configured as 1×28 >10⁹Ω, <650pF.

INSERTION LOSS (50Ω Source, 50Ω Load): <0.2dB below 1MHz, <3dB below 2MHz.

RELAY DRIVE CURRENT (per channel): 59mA. (Maximum of 11 channels on at same time.)

EMC: Conforms to European Union Directive 89/336/EEC.

SAFETY: Conforms to European Union Directive 73/23/EEC (meets EN61010-1/IEC 1010).

ENVIRONMENT: Operating: 0°C to 50°C, up to 35°C at 80% RH. **Storage:** -25°C to 65°C.

ACCESSORIES AVAILABLE

FOR 7018-C

7011-KIT-R	96-pin Female Connector Kit
7011-MTC-1	96-pin Mass Terminated Cable, Female to Female, 1m
7011-MTC-2	96-pin Mass Terminated Cable, Female to Female, 2m

FOR 7018-S

7018-ST	Extra Screw Terminal Connection Board
---------	---------------------------------------

SERVICES AVAILABLE

7018-C-3Y-EW	1-year factory warranty extended to 3 years from date of shipment
7018-S-3Y-EW	1-year factory warranty extended to 3 years from date of shipment

10MHz 1×4 Multiplexer Card

9 Independent 1×4 2-Pole Multiplexers

The Model 7035 9-Bank Multiplexer Card has nine 1×4 multiplexers. The switch contact configuration for each channel is 2-pole form A. The card's nine banks can be combined for a wide variety of switching configurations using external connections. This flexibility makes the Model 7035 well-suited for production testing of a variety of telecommunications products and systems and low power portable devices.

MULTIPLEX CONFIGURATION: 9 independent 1×4 2-pole multiplex banks.

CONTACT CONFIGURATION: 2-pole Form A (Hi, Lo).

CONNECTOR TYPE: 96-pin male DIN connector (7011-KIT-R mating connector included).

MAXIMUM SIGNAL LEVEL: 60V DC, 30V rms, 42V peak between any two inputs or chassis, 1A switched, 30VA (resistive load).

CONTACT LIFE: Cold Switching: 10⁸ closures.

At Maximum Signal Levels: 10⁵ closures.

CHANNEL RESISTANCE (per conductor): <1Ω.

CONTACT POTENTIAL: <2μV per channel contact pair. <5μV typical per single contact.

OFFSET CURRENT: <100pA.

ACTUATION TIME: 3ms.

ISOLATION: Bank: >10⁹Ω, <25 pF.

Channel to Channel: >10⁹Ω, <50 pF.

Differential: >10⁹Ω, <100pF.

Common Mode: >10⁹Ω, <200pF.

CROSSTALK (1MHz, 50Ω Load): Bank: <-40dB.

Channel: <-40dB.

INSERTION LOSS (50Ω Source, 50 Load): <0.25dB below 1MHz, <3dB below 10MHz.

RELAY DRIVE CURRENT (per relay): 16mA.

ACCESSORIES AVAILABLE

7011-KIT-R	96-pin Female Connector Kit
------------	-----------------------------

SERVICES AVAILABLE

7035-3Y-EW	1-year factory warranty extended to 3 years from date of shipment
------------	---

1.888.KEITHLEY (U.S. only)

www.keithley.com

A Greater Measure of Confidence

KEITHLEY

A Tektronix Company

Use with 7001 and 7002 switch mainframes

SWITCHING AND CONTROL

7020 7020-D

Digital I/O Cards 40 Inputs, 40 Outputs

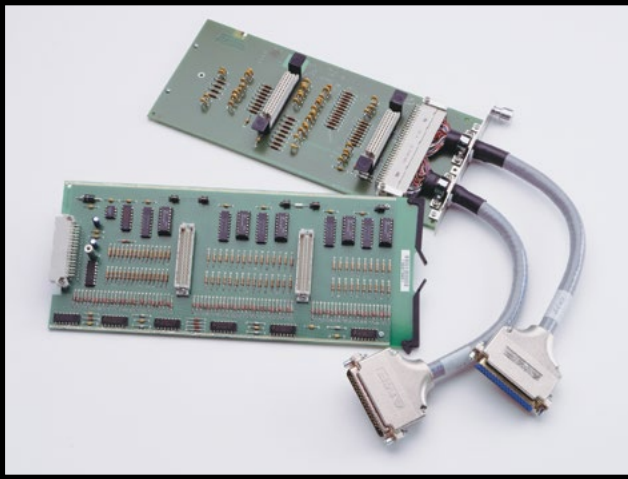

The Model 7020 and 7020-D Digital I/O Interface Cards provide high-density digital input/output capabilities in an easy-to-control form. The 7020 and 7020-D both have 40 independent inputs and 40 independent outputs, so they're well-suited for monitoring and controlling large automated test applications compactly and cost-effectively. The 7020 provides a 96-pin mass terminated connector. The 7020-D has two heavy duty 50-pin D-sub connectors at the ends of short cables. The D-sub connector version is designed for industrial/production applications where repeated connects/disconnects with external cables are required.

- 80-bit control – 40 in/40 out
- Input and output protection
- Use internal 5.3V power supply or external power supply

Ordering Information

- 7020** Digital I/O Card with 96-pin Mass Terminated Connector Board
- 7020-D** Digital I/O Card with D-sub Connectors

Accessories Supplied

- With 7020: 7011-KIT-R
96-pin Female Connector Kit

Output Channel

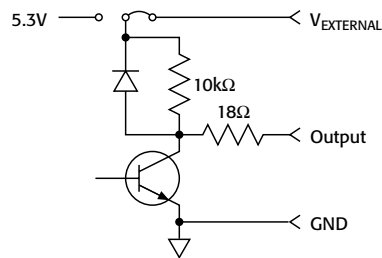

Input Channel

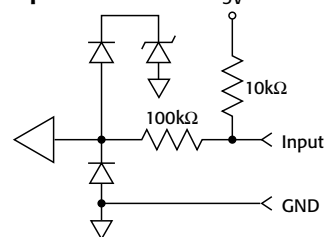

ACCESSORIES AVAILABLE

FOR 7020

- 7011-KIT-R 96-pin Female Connector Kit
- 7020-MTC-2 96-pin Mass Terminated Cable, Female to Female, 2m

SERVICES AVAILABLE

- 7020-3Y-EW 1-year factory warranty extended to 3 years from date of shipment
- 7020-D-3Y-EW 1-year factory warranty extended to 3 years from date of shipment

CONNECTOR:

- 7020:** 96-pin male DIN connector.
- 7020-D:** Cables with 50-pin male and female D-sub connectors.
- 7020-DT:** Mass terminated card with D-sub connectors.

DIGITAL I/O CAPABILITY: 40 independent inputs, 40 independent outputs.

OUTPUT SPECIFICATIONS:

- CONFIGURATION:** 40 open-collector drivers with factory installed 10kΩ pull-up resistors. Pull-up resistors can be removed when driving external pull-up devices. Each driver has an internal flyback diode.
- PULL UP VOLTAGE:** 5.3V internally supplied, external connection provided for user supplied voltage 25V max. Removal of internal jumper allows use of two different pull-up voltages.
- MAXIMUM SINK CURRENT:** Per Channel: 65mA. Per Bank (8 bits): 500mA. Per Card: 1A.
- CURRENT LIMIT:** Positive Temperature Coefficient circuit protector in series with each output. Output protection resistance <18Ω.
- COLLECTOR-EMITTER SATURATION VOLTAGE:** <0.75V @ 1mA. <1V @ 65mA.

INPUT SPECIFICATIONS:

- CONFIGURATION:** 40 inputs with internal 10kΩ pull-up resistors.
- CHARACTERISTICS:**
- | | |
|---------------------------|-------------------|
| Input logic low voltage: | 0.8 V max. |
| Input logic high voltage: | 2 V min. |
| Input logic low current: | -600 μA max. @ 0V |
| Input logic high current: | 50 μA max. @ 5V |
- MAXIMUM VOLTAGE LEVEL:** 42V peak.

1.888.KEITHLEY (U.S. only)

www.keithley.com

7036 7037-D

40-channel Isolated Switch Card 30-channel Digital I/O Card

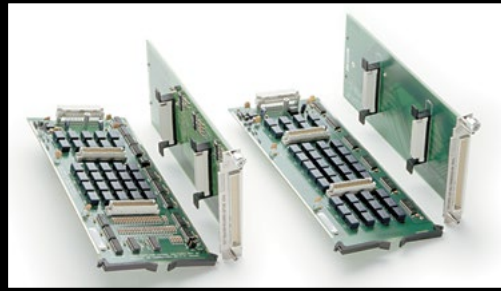

The Model 7036 and 7037-D single-pole relay switching cards are well-suited for configuring automated test systems for portable devices. The Model 7036 offers 40 independent channels of 1-pole Form A switching, while the Model 7037-D provides 30 channels, plus ten independent digital inputs and ten independent digital outputs for control applications. The 7036 provides a 96-pin mass terminated connector. The 7037-D has two heavy duty 50-pin D-sub connectors at the ends of short cables. The D-sub connector version is designed for industrial/production applications where repeated connects/disconnects with external cables are required. The 7037-DT is an extra connector board for the 7037-D card that can be used to upgrade a standard 7037-D to a mass terminated connector.

- Mass terminated connection
- 1A switch rating
- <100pA offset current
- <4μV contact potential

Ordering Information

7036 Single-Pole Relay Card
7037-D Single-Pole Relay Digital I/O Card with D-Sub Connectors

Relay switch configuration for Models 7036 and 7037-D

Each Channel

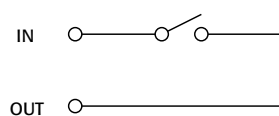

Digital I/O configuration for Model 7037-D

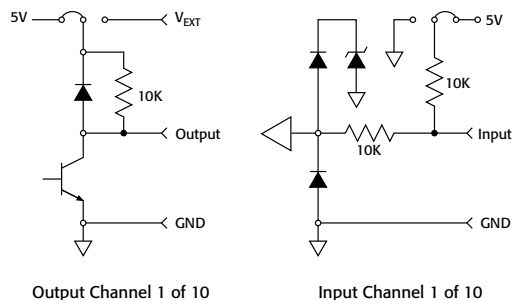

MODEL 7036 SPECIFICATIONS

RELAY SWITCH SPECIFICATIONS

RELAY SWITCH CONFIGURATION: 40 independent channels of 1-pole switching.
CONTACT CONFIGURATION: 1 pole Form A.
CONNECTOR TYPE: 96-pin male DIN card connector.
MAXIMUM SIGNAL LEVEL: 60V DC, 30V rms, 42V peak between any two inputs or chassis, 1A switched, 30VA (resistive load).
CONTACT LIFE: Cold Switching: 10⁸ closures. At Maximum Signal Levels: 10⁵ closures.
CHANNEL RESISTANCE (per conductor): <1Ω.
CONTACT POTENTIAL: <4μV per contact.
OFFSET CURRENT: <100pA.
ACTUATION TIME: 3ms.
ISOLATION: Channel to Channel: >10⁹Ω, <25pF. Common Mode: >10⁹Ω, <100pF.
CROSSTALK (1MHz, 50Ω Load): <-40dB.
INSERTION LOSS (50Ω Source, 50Ω Load): <0.3dB below 1MHz, <3dB below 10MHz.
RELAY DRIVE CURRENT (per relay): 16mA.

7036/7037-D GENERAL

EMC: Conforms to European Union Directive 89/336/EEC.
SAFETY: Conforms to European Union Directive 73/23/EEC (meets EN61010-1/IEC 1010).
ENVIRONMENT: Operating: 0° to 50°C, up to 35°C <80% RH. **Storage:** -25° to 65°C.

ACCESSORIES AVAILABLE

7011-KIT-R 96-pin Female Connector Kit (included)
7036-MTC-2 Mass Terminated Cable Assembly

SERVICES AVAILABLE

7036-3Y-EW 1-year factory warranty extended to 3 years from date of shipment
7037-D-3Y-EW 1-year factory warranty extended to 3 years from date of shipment

MODEL 7037-D SPECIFICATIONS

RELAY SWITCH SPECIFICATIONS

RELAY SWITCH CONFIGURATION: 30 independent channels of 1-pole switching.
CONTACT CONFIGURATION: 1 pole Form A.
CONNECTOR TYPE: Cables with 50-pin male and female D-sub connectors.
MAXIMUM SIGNAL: 110V DC, 110V rms, 155V peak between any two inputs or chassis, 1A switched, 30VA (resistive load).
CONTACT LIFE: Cold Switching: 10⁸ closures. At Maximum Signal Levels: 10⁵ closures.
CHANNEL RESISTANCE (per conductor): <1.25Ω.
CONTACT POTENTIAL: <4μV per contact.
OFFSET CURRENT: <100pA.
ACTUATION TIME: 3ms.
ISOLATION: Channel to Channel: >10⁹Ω, <25pF. Common Mode: >10⁹Ω, <100pF.
CROSSTALK (1MHz, 50Ω Load): <-40dB.
INSERTION LOSS (50Ω Source, 50Ω Load): <0.25dB below 1MHz, <3dB below 10MHz.
RELAY DRIVE CURRENT (per relay): 16mA.

DIGITAL I/O SPECIFICATIONS

DIGITAL I/O CAPABILITY: 10 independent inputs. 10 independent outputs.

OUTPUT:

Configuration: 10 open-collector drivers with factory installed 10kΩ pull-up resistors. Each driver has an internal flyback diode.

Pull-Up Voltage: 5V internally supplied, external connection provided for user-supplied voltage up to 42V max. Outputs short circuit protected up to 25V.

Maximum Sink Current:

Per Channel: 250mA. **Per Card:** 1A.

Logic: Hardware user configurable for negative or positive true logic levels.

INPUT:

Configuration: 10 inputs with internal 10kΩ pull-up resistors provided. Input resistors can be set for pull-up or pull-down configuration.

MAXIMUM VOLTAGE LEVEL: 42V peak.

LOGIC: Positive true.

1.888.KEITHLEY (U.S. only)

www.keithley.com

A Greater Measure of Confidence

KEITHLEY
A Tektronix Company

Use with 7001 and 7002 switch mainframes

SWITCHING AND CONTROL

7053

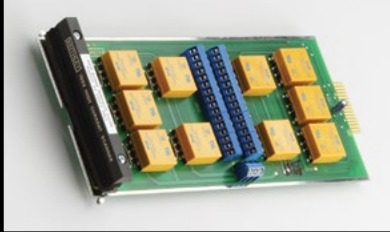

- 5A switching
- 10-channel scanner
- 2-pole Form A
- Maintains current path for unselected channel

Ordering Information

7053 10-channel High Current Scanner with Screw Terminal Connections

7152

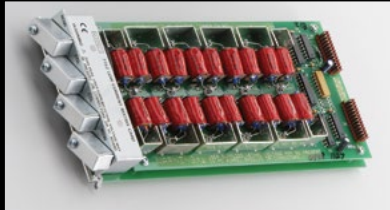

- Sub-pA offset current
- Easy interconnect and expansion
- Maximum signal 200V and 1A
- Standard mass terminated cable accessories

Ordering Information

7152 4x5 Low Current Matrix Card

Accessories Supplied
Connector caps

High Current Scanner Card

10-channel, 2-Pole

The Model 7053 has ten channels and features 5A contacts. The switching is designed to maintain current paths for signals not connected to the output or, when internal jumpers are removed, to provide high input resistance for making voltage measurements. Semiconductor testing, materials research, power supply testing, solar cell measurements, electrochemical testing, and IC testing are among the applications simplified with the Model 7053 High Current Scanner Card.

CHANNELS PER CARD: 10.

CONTACT CONFIGURATION: 2-pole Form A with common guard.

CONNECTOR TYPE: Screw terminal, #18AWG maximum wire size.

RELAY DRIVE CURRENT: 80mA per relay typical.

MAXIMUM SIGNAL LEVEL: 300V, 5A, 100VA (resistive load only).

CONTACT LIFE: $>10^7$ closures cold switching; $>10^5$ closures at maximum signal levels.

CONTACT RESISTANCE: $<0.15\Omega$ to rated life.

CONTACT POTENTIAL: $<1\text{mV}$.

ACTUATION TIME: $<15\text{ms}$, exclusive of mainframe.

CHANNEL ISOLATION: $>10^9\Omega$, $<50\text{pF}$.

INPUT ISOLATION: $>10^7\Omega$, $<150\text{pF}$.

COMMON MODE VOLTAGE: 300V peak.

EMC: Conforms to European Union Directive 89/336/EEC.

SAFETY: Conforms to European Union Directive 73/23/EEC (meets EN61010-1/IEC 1010).

OPERATING ENVIRONMENT: 0° to 50°C , up to 35°C at 70% RH.

STORAGE ENVIRONMENT: -25°C to 65°C .

SERVICES AVAILABLE

7053-3Y-EW 1-year factory warranty extended to 3 years from date of shipment

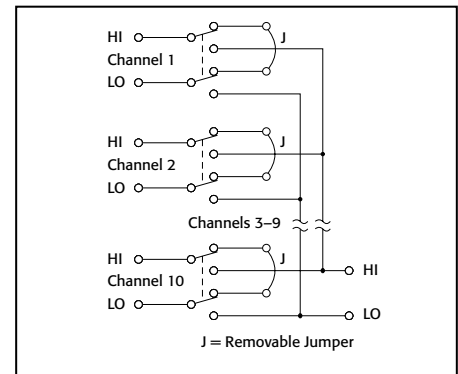

4x5 Low Current Matrix Card

The Model 7152 is an ideal solution for small to moderate-size matrix systems that require superior performance in DC isolation for measurements of semiconductor parameters and insulating properties of materials. Offset current is $<1\text{pA}$ with path isolation $>10^{13}\Omega$. Each matrix crosspoint is a two-pole relay with the ability to switch both signal and guard.

Interconnect, expansion of the matrix, and connection to instruments and devices are easily accomplished using two standard interconnect cable assemblies. The 7152-MTC cables are terminated at both ends with M-series connector blocks for quick expansion between cards and connection to 7152-MTR bulkhead receptacles. 7152-TRX cables are terminated at one end with M-series connectors and at the other end with 3-lug triaxial connector shells for direct connection to electrometers and SMU instruments.

MATRIX CONFIGURATION: 4 rows by 5 columns.

CROSSPOINT CONFIGURATION: 2-pole Form A (Signal and Guard).

RELAY DRIVE CURRENT: 20mA (per crosspoint).

PEAK CONTACT RATING: 200V, 1A carry/0.5A switched. 10VA (resistive load).

PEAK VOLTAGE: Common Mode: 200V (Signal or Guard to Chassis). **Path-Path:** 200V (Signal or Guard to Signal or Guard).

CONTACT LIFE: 10^8 closures (cold switching), 10^5 closures (at maximum signal level).

ACTUATION TIME: $<2\text{ms}$ exclusive of mainframe.

ISOLATION: Path: $>10^{13}\Omega$ and $<1\text{pF}$. **Differential:** $>10^{11}\Omega$ and $<100\text{pF}$. **Common Mode:** $>10^9\Omega$ and $<300\text{pF}$.

CROSSTALK: $<-50\text{dB}$ at 1MHz, 50 Ω load.

INSERTION LOSS: 0.1dB typical (1MHz, 50 Ω source, 50 Ω load). **3dB BANDWIDTH:** 60MHz typical (50 Ω load).

OFFSET CURRENT: $<1\text{pA}$ (10fA typical).

CONTACT POTENTIAL: 20 μV per contact typical.

ACCESSORIES AVAILABLE

PRE-BUILT CABLES

7152-MTC-2 Low Noise M-Series to M-Series Cable, 2 ft.
7152-MTC-10 Low Noise M-Series to M-Series Cable, 10 ft.
7152-TRX-10 Low Noise M-Series to Triax Cable, 10 ft.

M-SERIES BULKHEAD CONNECTORS

7152-KIT M-Series Plug for custom wiring

SERVICES AVAILABLE

7152-3Y-EW 1-year factory warranty extended to 3 years from date of shipment

1.888.KEITHLEY (U.S. only)

www.keithley.com

7065

Hall Effect Card

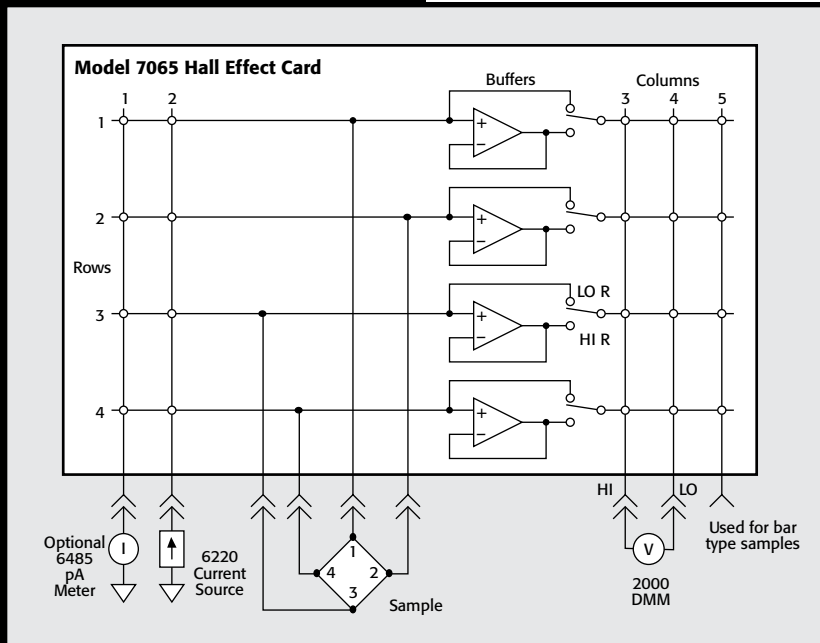

Building blocks for an economical measurement system

The Model 7065 Hall Effect Card is intended for those who want to assemble their own economical Hall test systems. It also can form the foundation of a Hall Effect system. The sensitivity and capabilities of this card are unmatched by any other system or Hall Effect electronics package.

The Model 7065 is a signal conditioning card designed to buffer test signals from the Hall sample to the measurement instrumentation and to switch current from a source to the Hall sample. When used with Keithley's Model 7001 scanner mainframe, the Model 7065 provides the switching capability to measure Hall voltages as low as 50nV and sample resistances in excess of $10^{12}\Omega$.

All the accessories needed to connect the sample holder, scanner, instruments, and controller are included, simplifying connections. The Model 7065 is connected directly to the sample, and all instruments are connected via the IEEE-488 bus to the controller. Examples of resistivity and Hall voltage measurement programs are included in the Model 7065 Instruction Manual.

The Model 7065 can be operated in either a low resistivity or a high resistivity mode. In the high resistivity mode, input impedance is greater than $100T\Omega$, input bias current is less than 150fA, and output resistance is less than 60 Ω . Input voltage ranges in both operating modes is +8V to -8V. If higher voltage is desired, Keithley recommends using a 6220/6514 system. Cabling and sample connections must be carefully designed to make full use of the Model 7065's capabilities. Refer to Keithley's Low Level Measurements handbook for guidance in designing these connections.

Ordering Information

7065 Hall Effect Card
7001 Switch System

ACCESSORIES SUPPLIED

4801	Low Noise Input Cable
7078-TRX-10	3-slot Triax Cable (10 ft.)
6172	2-slot Male to 3-Lug Female Triax Adapter
7025-10	Triaxial Input Cable (10 ft.) (4 supplied)
4851	BNC Shorting Plug
Wire Kit Including:	
SC-72-0	Single Conductor Insulated Wire, black (4 ft.) (2 supplied)
SC-72-9	Single Conductor Insulated Wire, white (4 ft.)
BG-5	Single Banana Plug, black (2 supplied)
BG-10-1	Single Banana Plug, white
BG-7	Double Banana Plug, black
SC-8	2-conductor Cable w/shield (10 ft.)
7007-2	Double Shielded Premium Cable (6 ft.)

SERVICES AVAILABLE

7065-3Y-EW	1-year factory warranty extended to 3 years from date of shipment
------------	---

LOW RESISTIVITY MODE

INPUT VOLTAGE OPERATING RANGE: +8 to -8V.
INPUT IMPEDANCE: $>10G\Omega$ in parallel with $<420pF$.
INPUT BIAS CURRENT: $<100pA$.
INPUT VOLTAGE NOISE: $<50nV$ p-p, 0.1 to 10Hz bandwidth.
INPUT TO OUTPUT RESISTANCE: $<30\Omega$.

HIGH RESISTIVITY MODE

INPUT VOLTAGE OPERATING RANGE: +8 to -8V.
INPUT IMPEDANCE: $>100T\Omega$ in parallel with $<3pF$.
INPUT BIAS CURRENT: $<150fA$ at 23°C. Doubles approximately every 10°C rise in ambient room temperature.
INPUT VOLTAGE NOISE: $<10\mu V$ p-p, 0.1 to 10Hz bandwidth.
OUTPUT RESISTANCE: $<60\Omega$.

CONFIGURATION

Input characteristics and output matrix configuration for van der Pauw or Hall bar measurements. Input characteristics selectable for either low resistivity or high resistivity samples.

GENERAL

MAXIMUM COMMON MODE VOLTAGE (analog ground to earth ground): 30V peak, DC to 60Hz sine wave.
ISOLATION: Analog ground to earth ground: $>10^9\Omega$ in parallel with 150pF.
WARM-UP: 1 hour to rated specifications.
ENVIRONMENT: Operating: 0°-35°C, up to 70% R.H.
Storage: -25° to +65°C.
CONNECTORS:
Current Source Input: Two-lug female triaxial. Input HI to LO clamped at $\pm 12V$. **Maximum Input:** 100mA.
Sample Inputs: Four two-lug female triaxial. Outer shell is analog ground. Inner shield is driven guard. **Maximum Input Overload (HI to analog ground or GUARD to analog ground):** $\pm 12V$.
Current Monitor Output: Insulated female BNC.
Measurement Outputs: Spring-loaded terminals. Accepts AWG #18 to #24 wire. **Maximum Load:** 1mA.
DIMENSIONS, WEIGHT: 32mm high \times 114mm wide \times 272mm long (1 in \times 4 in \times 10 in). Net weight: 434kg (15½ oz).
 All specifications are 1 year, 0°-35°C, installed in scanner mainframe.

1.888.KEITHLEY (U.S. only)

www.keithley.com

A Greater Measure of Confidence

KEITHLEY
 A Tektronix Company

The foundation of a Hall Effect system

SWITCHING AND CONTROL

7153

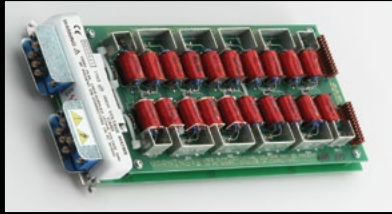

- 1300V switching
- Sub-pA offset current
- 2-pole switching
- Mass termination connectors

Ordering Information

7153 4x5 High Voltage Low Current Matrix Card

7154

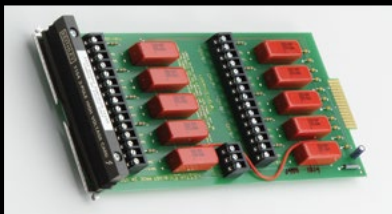

- 1100 volts peak
- 2-pole switching
- High and low fused

Ordering Information

7154 High Voltage Scanner Card

4x5 Low Current Matrix Card

High Voltage

The Model 7153 is designed to switch low level, high voltage, and high impedance signals for applications such as parametric tests on semiconductor devices. The 7153 allows signal levels up to 1300V while maintaining offset current of <math><1\text{pA}</math> (typically 10fA) and path isolation >math>10^{13}\Omega</math>. Each crosspoint is a 2-pole relay to switch both signal and guard. Interconnect between the matrix and instruments such as the Model 237 SMU is done with the 7153-TRX cable. This cable has an M-series connector for the matrix and five 3-slot male triax connectors at the opposite end. The cable will mate with the row or column connectors of the Model 7153.

MATRIX CONFIGURATION: 4 rows by 5 columns.

CROSSPOINT CONFIGURATION: 2-pole Form A (Signal and Guard).

CONNECTOR TYPE: Miniature coax, M-series plug.

RELAY DRIVE CURRENT: 40mA (per crosspoint).

MAXIMUM SIGNAL LEVEL: 1300V between any 2 signal pins or chassis; 200V between Signal and Guard. 1A carry/0.5A switched. 10VA peak (resistive load).

CONTACT LIFE: 10^8 closures (cold switching), 10^5 closures (at maximum signal level).

PATH RESISTANCE: <math><1\Omega</math> per contact to rated life.

ACTUATION TIME: <math><2\text{ms}</math> exclusive of mainframe.

ISOLATION: Path: >math>10^{13}\Omega</math> and <math><1\text{pF}</math>. **Differential:** >math>10^{11}\Omega</math> and <math><100\text{pF}</math>. **Common Mode:** >math>10^9\Omega</math> and <math><300\text{pF}</math>.

CROSSTALK: <math><-50\text{dB}</math> at 1MHz, 50 Ω load.

INSERTION LOSS: 0.1dB typical (1MHz, 50 Ω source, 50 Ω load).

3dB BANDWIDTH: 60MHz typical (50 Ω load).

OFFSET CURRENT: <math><1\text{pA}</math> (10fA typical).

CONTACT POTENTIAL: <math><50\mu\text{V}</math> typical.

ACCESSORIES AVAILABLE

7153-TRX Low Noise M-Series to Triax Cable, 5 ft.

SERVICES AVAILABLE

7153-3Y-EW 1-year factory warranty extended to 3 years from date of shipment

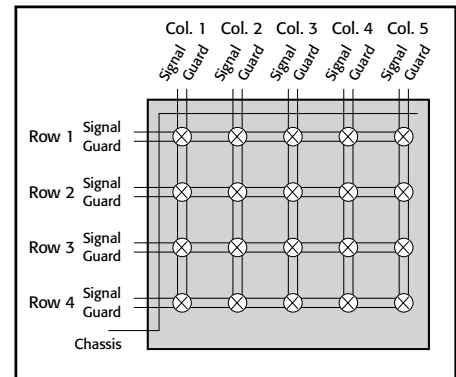

High Voltage Scanner Card

10-channel

The Model 7154 switches voltages to 1100V peak or currents to 0.5A. The current carry capacity of each relay contact is 1A. Two-pole relays switch both circuit High and Low for full floating measurements and each input line is fuse protected against current overload. A Guard input common to all channels is provided for shielding or as a Guard driven from a single instrument. Guards may be isolated by removing jumpers installed at each input. Multiple switched guard circuits can be achieved by removing the jumper and connecting circuit Guard to the Low input terminal.

CHANNELS PER CARD: 10.

CONTACT CONFIGURATION: 2-pole Form A with user-selectable shield or driven Guard. Each pole is fused using #38AWG magnet wire.

CONNECTOR TYPE: Screw terminals, #16AWG maximum wire size.

RELAY DRIVE CURRENT: 57mA per relay typical.

MAXIMUM SIGNAL LEVEL: 1100V peak, 0.5A DC or rms switched, 1A DC or rms carry, 10W.

CONTACT LIFE: >math>10^8</math> closures (cold switching); >math>5\times 10^6</math> closures (at maximum signal level).

CONTACT RESISTANCE: <math><200\text{m}\Omega</math> initial, 2 $\Omega</math> to rated life.$

CONTACT POTENTIAL: <math><35\mu\text{V}</math> per contact pair with copper leads.

ACTUATION TIME: <math><2\text{ms}</math> exclusive of mainframe.

CHANNEL ISOLATION: $10^{10}\Omega$, <math><10\text{pF}</math>.

INPUT ISOLATION: Differential: >math>10^9\Omega</math>, <math><10\text{pF}</math>.

Common Mode: >math>10^9\Omega</math>, <math><150\text{pF}</math>.

COMMON MODE VOLTAGE: 1100V peak.

ENVIRONMENT: Operating: 0° to 50° up to 35°C at 70% R.H.

Storage: -5° to +65°C.

SERVICES AVAILABLE

7154-3Y-EW 1-year factory warranty extended to 3 years from date of shipment

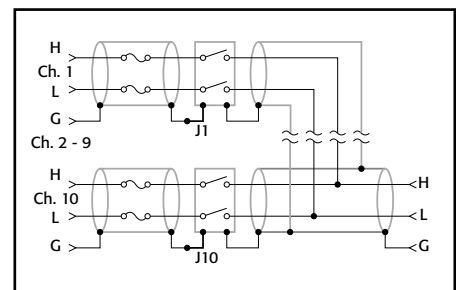

1.888.KEITHLEY (U.S. only)

www.keithley.com

7158

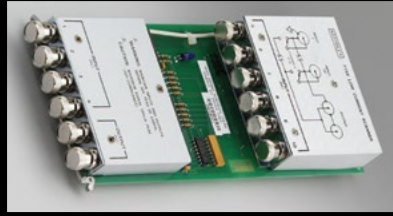

- Sub-picoamp offset current
- Maintains current path for unselected channel
- BNC connectors

Ordering Information

7158 Low Current Scanner Card

Accessories Supplied

4801 Low Noise Male to Male BNC Input Cable

7168



- <30nV contact potential
- Bare copper terminal connections

Ordering Information

7168 8-channel Nanovolt Scanner Card

Low Current Scanner Card

10-channel

The Model 7158 provides quality low-current switching at an affordable price. The offset current error generated is specified <1pA, with typical performance at <30fA. When used with a voltage source and electrometer or picoammeter, this card can easily automate insulation resistance tests, reverse leakage tests on semiconductor junctions, or gate leakage tests on FETs.

The Model 7158 is designed to maintain the current path even when the channel is deselected. Input connectors are BNC for shielding of the sensitive measurements and for compatibility with low noise coaxial cables such as Keithley accessory cables Models 4801 and 4803. Two outputs are provided to allow for chaining several scanner cards to one measurement instrument, and an isolation relay in the output HI minimizes interaction between cards.

CHANNELS PER CARD: 10.
CONTACT CONFIGURATION: Single pole, simultaneous break and make for signal HI input. Signal LO is common for all 10 channels and output. When a channel is off, signal HI is connected to signal LO.
CONNECTOR TYPE: BNC.
RELAY DRIVE CURRENT: 100mA per card typical (regardless of channel closures selected).
MAXIMUM SIGNAL LEVEL: 30V, 100mA peak (resistive load).

CONTACT LIFE: >10⁶ closures at maximum signal levels; >10⁷ closures at low signal levels.
CONTACT RESISTANCE: <1Ω.
CONTACT POTENTIAL: <200μV.
OFFSET CURRENT: <1pA (<30fA typical).
3dB BANDWIDTH: 1MHz typical.
ACTUATION TIME: <1ms, exclusive of mainframe.
CHANNEL ISOLATION: >10¹⁰Ω.
INPUT ISOLATION: Differential: >10⁹Ω, <50pF.
Common Mode: >10⁹Ω, <150pF.
COMMON MODE VOLTAGE: <30V maximum.

ACCESSORIES AVAILABLE

4801	Low Noise Male to Male BNC Input Cable
4802-10	Low Noise BNC to Unterminated Cable, 10 ft.
4803	Low Noise BNC Cable Kit for 7158

SERVICES AVAILABLE

7158-3Y-EW	1-year factory warranty extended to 3 years from date of shipment
------------	---

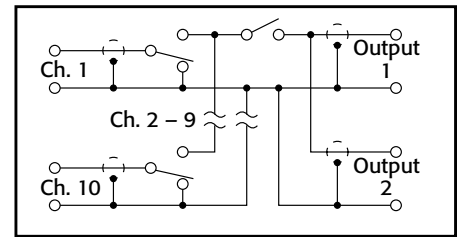

Nanovolt Scanner Card

8-channel, 2-pole

The Model 7168 is an 8-channel, 2-pole card with <30nV of thermal offset. It will switch any one of eight signals to one output in less than 3ms. Channel offset leakage current is <50pA at 23°C. When the 7168 is used with the Model 2182A, the noise and drift performance of the 2182A is not degraded.

CHANNELS PER CARD: 8.
CONFIGURATION: Two poles per channel, input HI and LO.
CONNECTOR TYPE: Screw terminal to bare copper printed circuit pad.
MAX. SIGNAL LEVEL: 10V, 50mA peak (resistive load only).
CONTACT RESISTANCE: <12Ω.
CONTACT POTENTIAL (HI to LO) BETWEEN CHANNELS: <30nV when properly zeroed with supplied leads (see manual for recommended procedure). Typically <60nV without zeroing.
CONTACT TYPE: Solid state JFET switch.
ACTUATION TIME: <3ms, exclusive of mainframe.
INPUT LEAKAGE: <50pA per channel at 23°C.
INPUT ISOLATION: >10⁹Ω, <40pF between any input terminals or between any input terminal and earth.
COMMON MODE VOLTAGE: 30V peak.
MAXIMUM VOLTAGE BETWEEN ANY TWO TERMINALS: 10V.
WARM-UP: 2 hours in mainframe for thermal stability.

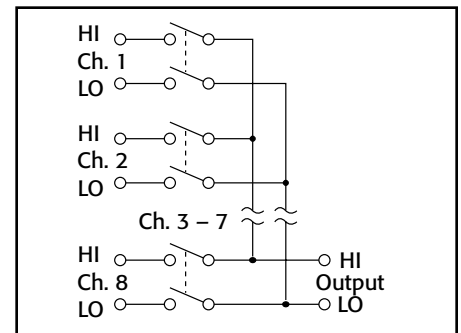

OPERATING ENVIRONMENT: 0°–40°C; up to 35°C at 70% R.H.
STORAGE ENVIRONMENT: –25° to 60°C.

ACCESSORIES SUPPLIED

2107-4	Low Thermal Input Cable for 2182A (1 supplied)
7168-316	Low Thermal Input Cables for 7168 (8 supplied)

SERVICES AVAILABLE

7168-3Y-EW	1-year factory warranty extended to 3 years from date of shipment
------------	---

1.888.KEITHLEY (U.S. only)

www.keithley.com

A Greater Measure of Confidence

KEITHLEY
A Tektronix Company

Use with 7001 and 7002 switch mainframes

SWITCHING AND CONTROL

707B 708B

- Significantly faster command-to-connect speeds than earlier Series 700 mainframes
- 708B mainframe controls a single 8×12 matrix card
- 707B mainframe controls up to six 8×12 matrix cards
- Compatible with the popular plug-in cards designed for the 707A/708A mainframes
- Support for both remote (via LXI, USB, and GPIB interfaces) and manual (via front panel) programming
- Integrates seamlessly with the Model 4200-SCS for semiconductor I-V and C-V characterization via GPIB interface
- Stores hundreds of switching configurations and channel patterns in non-volatile memory for reuse
- LXI interface supports remote programming and control
- Embedded TSP[®] processor and TSP-Link Technology interface make it easy to integrate Series 2600B System SourceMeter[®] SMU instruments into a high speed, self-contained tester
- 14 bits of digital I/O

APPLICATIONS

- Support for semiconductor device characterization and process control monitoring
- Fully automated testing of a wide range of electronic components in both lab and production environments

1.888.KEITHLEY (U.S. only)

www.keithley.com

Semiconductor Switch Matrix Mainframes Six-slot and Single-slot Versions



Model 707B Six-slot Semiconductor Switch Matrix Mainframe

The six-slot Model 707B and single-slot Model 708B Semiconductor Switch Matrix Mainframes extend Keithley's decades-long commitment to innovation in switch systems optimized for semiconductor test applications. These mainframes build upon the strengths of their popular predecessors, the Models 707/707A and 708/708A, adding new features and capabilities designed to speed and simplify system integration and test development. New control options and interfaces offer system builders even greater flexibility when configuring high performance switching systems for use in both lab and production environments. Just as important, both new mainframes are compatible with the popular switch cards developed for the Models 707A and 708A, simplifying and minimizing the cost of switch system migration.

Faster Command-to-Connect

High performance Model 707B and 708B semiconductor switch matrix mainframes slash the time from command to connection, offering significantly faster test sequences and overall system throughput than Keithley's earlier 707A and 708A mainframes.



Model 708B Single-slot Semiconductor Switch Matrix Mainframe

707B 708B

Ordering Information

707B	Six-slot semiconductor switch mainframe
708B	Single-slot semiconductor switch mainframe

Extended warranty, service, and calibration contracts are available.

Accessories Supplied

Product Information CD-ROM:

- Product Information CD
- Quick Start Guide
- Switching and Control Product Information CD
- Test Script Builder User Suite CD

CA-180-4A: CAT 5 Ethernet Crossover Cable, 1m (3.3 ft)

CA-179-2A: CAT 5 Ethernet Cable, 3m (10 ft)

CO-7: Line Cord

Rear Fixed Rack Mount Hardware (707B only)

ACCESSORIES AVAILABLE

CA-126-7A	25-pin Female Digital I/O to 25-pin Male Cable, 3m (10 ft)
2600-TLINK	Digital I/O to Trigger Link Cable, 1m (3.3 ft)
4299-6	Universal Full Rack Mount Kit (for Model 708B)
7007-1	Double-shielded GPIB Cable, 1m (3.3 ft)
7007-2	Double-shielded GPIB Cable, 2m (6.6 ft)
7072	Semiconductor Matrix Card
7072-HV	High Voltage Semiconductor Matrix Card
7072-TRT	Triax Fastening Tool
7079	Rear Slide Rack Mount Kit (for Model 707B)
7173-50	High Frequency, 2-pole, 4×12 Matrix Card
7174A	Low Current Matrix Card

SOFTWARE

IVI-COM and IVI-C Driver for C#, VB.NET, Visual C++, VB6, and LabWindows/CVI
LabVIEW® Driver
Example TSP® Scripts
Test Script Builder

SERVICES AVAILABLE

707B-3Y-EW	1-year Factory Warranty Extended to 3 Years from date of shipment
707B-5Y-EW	1-year Factory Warranty Extended to 5 Years from date of shipment
708B-3Y-EW	1-year Factory Warranty Extended to 3 Years from date of shipment
708B-5Y-EW	1-year Factory Warranty Extended to 5 Years from date of shipment

1.888.KEITHLEY (U.S. only)

www.keithley.com

Semiconductor Switch Matrix Mainframes

Six-slot and Single-slot Versions

Optimized for Easy Integration with Existing Test Systems

To minimize migration issues for current users of Model 707A and 708A mainframes, the Model 707B and 708B are designed for command emulation with Models 707A and 708A. The 707B and 708B also support the popular switch matrix cards developed for the Model 707A and 708A, so there's no need to purchase new cards to take advantage of the new mainframes:

- Model 7174A Low Current Matrix Card:** This 8×12 card is designed for semiconductor research, development, and production applications that demand high quality switching of I-V and C-V signals. Its low leakage and minimal dielectric absorption ensure that key device measurements can be performed many times faster than with earlier switching technologies. Its superior low current performance makes it ideal for use with both Models 2635B and 2636B System SourceMeter® SMU Instruments for adding high speed I-V source and measurement capabilities and for accessing the I-V and C-V measurement capabilities of the Model 4200-SCS Parameter Analyzer.
- Model 7072 Semiconductor Matrix Card:** This 8×12 switch supports the low level and high impedance measurements encountered in semiconductor parametric tests on wafers and devices. It provides two low current paths with just 1pA maximum offset current for sensitive sub-picoamp measurements, and two other paths optimized for measuring C-V characteristics from DC to 1MHz. Four more high quality signal paths with <20pA offset current provide for general-purpose signal switching up to 100nA or 200V.
- Model 7072-HV High Voltage Semiconductor Matrix Card:** Like the Model 7072, the 7072-HV is designed to handle low level, high voltage, and high impedance signals. It provides two signal paths capable of switching 1300V with less than 1pA of offset current, so it's ideal for switching the high voltage signals encountered in breakdown measurements or oxide integrity testing. Two paths are optimized for C-V measurements from DC to 1MHz or for switching low currents with a common ground. Four additional high quality signal paths with less than 20pA offset current provide for signal switching to 200V.
- Model 7173-50 High Frequency, 2-pole, 4×12 Matrix Card:** The Model 7173-50 provides 200MHz bandwidth and a rise time of <2ns. Offset voltage is <15µV per crosspoint, and offset current is <200pA. Its combined AC and DC capabilities make it ideal for mixed-signal applications, such as testing ADCs or DACs, which involve measuring both digital and analog signals.

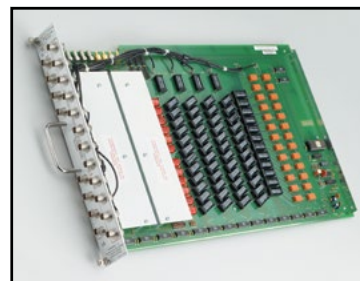
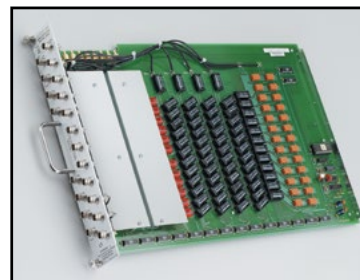

For additional details and specifications on these cards, refer to their individual data sheets, available on www.keithley.com. A Keithley applications engineer or representative can help you choose the most appropriate card or cards for a specific application.

707B 708B

Semiconductor Switch Matrix Mainframes Six-slot and Single-slot Versions

In addition, the Models 707B and 708B offer a number of features to ensure their compatibility with Keithley instrumentation already at work in labs and on test floors around the world. For example, these semiconductor switch matrix mainframes are compatible with the Model 4200-SCS semiconductor Parameter Analyzer's existing matrix driver and GPIB interface, which allows them to become drop-in switch matrix replacements for many applications. The new mainframes also provide electrical performance that correlates closely with that of the Model 707A and Model 7174A switch card, the previous industry-standard switching solution.

Suited for Both Lab and Fab

Like their predecessors, the Models 707B/708B are specifically designed for the requirements of both semiconductor lab and production test environments, delivering ultra low current switching performance using standard triax connectors and cables. For automating smaller test systems with a limited number of pins and instruments, the Model 708B supports a single switch card with up to 8 rows and 12 columns (8×12). For applications requiring higher switch counts, the Model 707B can accommodate up to six 8×12 cards, which can be connected via an internal backplane or jumpers to form larger matrices. Both mainframes also support mixed signal switching for both DC and RF (up to 200MHz) signals.

Choice of Manual Operation or Remote Programming

Both mainframes offer a variety of manual operation and remote programming functions via either the front panel controls or a choice of interfaces. For example, for manual operation, such as when experimenting with a new switching configuration, the updated front panel interface allows labeling switch card rows (instruments) and columns (pins) alphanumerically, which simplifies keeping track of what's connected to each crosspoint. An LED crosspoint display makes it easy to identify whether a

specific channel is open or closed, as well as to determine which slots are occupied and which cards are currently in use. A two-line display shows both error messages and user-defined messages, and displays control menus and open/closed channel messages.

An intuitive navigation/control knob allows scrolling through and opening/closing channels. Key pad controls support scrolling through menus, changing host interface settings, saving and restoring instrument setups, and loading and running factory and user-defined test scripts, etc.

Test system integrators can choose from several instrument communication interfaces and tools for remote programming and control of the Model 707B or 708B:

- TSP-Link Technology is a high speed system expansion and coordination interface that simplifies linking instruments and switches for faster inter-unit communication and control. It provides a high speed, low

The screenshot displays the Keithley LXI web interface. At the top, the Keithley logo and tagline 'A GREATER MEASURE OF CONFIDENCE' are visible. The main content area shows a grid of switch points, with rows labeled A through H and columns numbered 01 through 72. Several points in the grid are highlighted in red, indicating they are currently open or active. A 'Slot Legend' table is located in the upper right, showing slots 1 through 6. The interface also includes a 'User Screen Display' section with a 'User Screen' input field and a 'Cross Point Toggle (Example A12)' button. A 'Channel Action Type' section allows selecting between 'Channel Close' (selected) and 'Exclusive Close', and 'Exclusive Slot Close'. The interface is designed for remote control and monitoring of the switch matrix.

The Models 707B and 708B include a built-in Web interface that offers a quick and easy method to control the instrument remotely. Interactive schematics of each card in the mainframe support point-and-click control for opening and closing switches.

1.888.KEITHLEY (U.S. only)

www.keithley.com

KEITHLEY

A Greater Measure of Confidence

A Tektronix Company

707B 708B

Semiconductor Switch Matrix Mainframes

Six-slot and Single-slot Versions

latency interface to other TSP (Test Script Processor)-based hardware, enabling simple multi-box and multi-instrument software control, as well as simplified test system scaling as new requirements evolve.

- With TSP-Link, there's no need to add external triggers and remote communication cables to individual units because all TSP-Link connected devices can be controlled from a single master unit. Up to 16 Model 707B/708B chassis can be linked together to form a larger switching matrix using TSP-Link. Each mainframe has two TSP-Link connectors to facilitate chaining instruments together. They can also be used to connect Model 707B/708B semiconductor switch matrix mainframes to other TSP-Link enabled instruments, such as Keithley's Series 2600B System SourceMeter® SMU instruments. Every piece of instrumentation connected via TSP-Link can be controlled by a single master unit, just as though they were all housed in the same chassis.
- Like all instruments compliant with the LXI (LAN eXtensions for Instrumentation) standard, the Models 707B and 708B have a built-in switch control Web page that is accessible via any standard Web browser. In conjunction with a 10/100M Base-T Ethernet connection and LAN-based triggering, this Web interface offers a quick and easy method to program switching patterns. Interactive schematics of each card in the mainframe support point-and-click control for opening and closing switches. A scan list builder is provided to guide users through the requirements of a scan list (such as trigger and looping definitions) for more advanced applications. The Web page's point-and-click design provides easy switch system control, as well as basic switch system troubleshooting and diagnostics capabilities.
- TSB (Test Script Builder) Embedded is an application with a reduced feature set that resides in the mainframe and can be accessed through its web page. Like the full Test Script Builder programming tool, it offers script-building functions and can be used to run example scripts provided with the mainframe. It also includes a command line interface that can be used to issue single-line ICL commands.
- For those replacing Keithley's earlier 707A/708A mainframes and who prefer to minimize the levels of changes to their test systems, the Models 707B and 708B offer a GPIB interface and 707A/708A DDC command emulation capabilities to simplify the migration process. These users can incorporate the "B" models into their test systems without making any changes to their legacy code or hardware interface. However, these users will not be able to take full advantage of many of the throughput gains that TSP control provides, such as the new GPIB interface that allows you to control additional GPIB-compatible instruments and systems.
- A rear panel Universal Serial Bus (USB) port allows a host computer to communicate with and control the 707B/708B over a USB interface.

Optimized for Easy Integration with Series 2600B-Based Systems

The Models 707B and 708B are ideal companion products for systems that incorporate Series 2600B instrumentation, such as Keithley's ACS and S530 integrated test systems. These mainframes share the same TSP, Lua scripting language, and TSP-Link interface as the Series 2600B and support an ultra low current switch matrix (the Model 7174A) that complements the Model 2636B's low current sensitivity. The Models 707B/708B offer test system builders a switch matrix that is fast, scriptable, and works seamlessly with all Series 2600B models.

In common with Series 2600B SMU instruments, the Models 707B/708B provide system builders with the advantages of the Keithley Test Script Builder (TSB) Integrated Development Environment (IDE). TSB IDE is a programming tool provided on the CD that accompanies each mainframe. It can be used to create, modify, debug, and store TSP scripts. It provides a project/file manager window to store and organize test scripts, a text-sensitive program editor (like Visual Basic) to create and modify test TSP code, and an immediate instrument control window to send GPIB commands and receive data from the instrument. The immediate window allows viewing the output of a given test script and simplifies debugging.

Advantages of TSP® Technology for Switch Throughput

The test script processor (TSP) technology embedded in these upgraded mainframes allows for distributed processing and control rather than relying exclusively on a central PC to direct their operation, increasing test speed and lowering overall test cost. The TSP is a full-featured test sequence engine that allows unprecedented control of the test sequence. In addition to responding to individual ICL commands, it can store a user-defined test script or sequence in memory and execute it on command, which limits the set-up and configuration time for each step in the test sequence and increases throughput by decreasing communication time.

Test scripts are complete test programs based on Lua, an easy-to-use but highly efficient and compact scripting language. Because test scripts can contain any sequence of routines that are executable by conventional programming languages (including decision-making algorithms and control of the digital I/O), the mainframe can manage the operation of entire tests without sending readings back to a PC for use in decision making. The TSP can even access the mainframe's 14-bit digital I/O on the fly, increasing throughput by allowing instrument and binning equipment such as handlers to run without PC interference. This eliminates delays due to GPIB traffic congestion and greatly improves overall test times.

TSP control allows individual switches and instruments or groups of them to operate autonomously, often eliminating the need for a high-level PC system controller altogether. This same proven TSP technology has already been successfully incorporated into Keithley's innovative Series 2600B System SourceMeter SMU instruments and Series 3700A Multimeter/Switch System.

1.888.KEITHLEY (U.S. only)

www.keithley.com

A Greater Measure of Confidence

KEITHLEY

A Tektronix Company

707B 708B

Semiconductor Switch Matrix Mainframes

Six-slot and Single-slot Versions

Supported Cards

7072	8×12 Semiconductor Matrix 200V, 1A
7072-HV	8×12 HV Semiconductor Matrix 1300V, 0.1A
7173-50	4×12, 2-pole, High-Frequency Matrix Card
7174A	8×12 Low-Current, High-Speed Matrix Card, with 3-lug Triax Row and Column connects

Execution Speed

SYSTEM PERFORMANCE¹

COMMAND: channel.close ('ch_list') or channel.open ('ch_list')

Card	Single Command Execution Time (ms)			
	Ethernet	GPIB	TSP-Link	USB
7072	15.9	15.9	20.5	15.9
7072-HV	15.9	15.9	20.5	15.9
7173-50	7.9	7.9	11.5	7.9
7174A	1.9	1.9	5.5	1.9

1. Time between the start of a single digio.writebit (1, 1), channel.close ('ch_list') or channel.open ('ch_list') (which includes relay settle time), and digio.writebit (1, 0) command.

TRIGGER RESPONSE TIME

MAXIMUM TRIGGER RATE (setups per second):

7072:	≥65.
7072-HV:	≥65.
7173-50:	≥160.
7174A:	≥815.

TRIGGER IN TO START OF MATRIX READY PULSE (DDC Mode): ≤85μs.

TRIGGER IN TO TRIGGER OUT: ≤0.5μs.

TRIGGER TIMER ACCURACY: ≤0.5μs.

NOTES

1. Includes scan.scancount = 100, scan.stepcount ≥3, channel.connectrule = channel.OFF or 0, and relay settle time.



Model 708B rear panel



Model 707B rear panel

GENERAL

EMULATION: 707A/708A Device Dependent Commands (DDC). Since the architecture of the Model 707B/708B differs from the Model 707A/708A, some commands are different. Refer to notes in the 707B-901 Reference manual for additional details.

BREAK BEFORE MAKE: channel.connectrule= channel.BREAK_BEFORE_MAKE or 1.

MAKE BEFORE BREAK: channel.connectrule= channel.MAKE_BEFORE_BREAK or 2.

NONE: channel.connectrule= channel.OFF or 0, the system will close relays as it is able to without adhering to a rule.

IEEE-488: IEEE-488.1 compliant. Supports IEEE-488.2 common commands and status model topology.

USB 2.0 DEVICE (rear panel type B): Full and high speed, USBTMC compliant.

DIGITAL I/O INTERFACE

Connector: 25-pin female D.

Input/Output Pins: 14 open drain I/O bits.

Absolute Maximum Input Voltage: 5.25V.

Absolute Minimum Input Voltage: -0.25V.

Maximum Logic Low Input Voltage: 0.7V, +850μA max.

Maximum Logic High Input Voltage: 2.1V, +570μA.

Maximum Source Current (flowing out of Digital I/O bit): 960μA.

Maximum Sink Current @ Maximum Logic Low Voltage (0.7V): -5.0mA.

Absolute Maximum Sink Current (flowing into Digital I/O pin): -11mA.

5V Power Supply Pin: Limited to 600mA, solid state fuse protected.

ETHERNET: RJ-45 connector, 10/100BaseT, Auto-MDIX.

LXI COMPLIANCE: LXI Version 1.2.

POWER SUPPLY:

707B: 100V to 240VAC, 50Hz–60Hz, 210VA max.

708B: 100V to 240VAC, 50Hz–60Hz, 110VA max.

RELAY DRIVE:

707B: 30W (6V at 5.0A) max. per slot, 162W (6V at 27A) max. for all slots.

708B: 30W (6V at 5.0A) max.

SAFETY: Conforms to European Union Low Voltage Directive.

DIMENSIONS:

707B: 356mm high × 432mm wide × 574mm deep (14.0 in × 17.0 in × 22.6 in).

708B: 90mm high × 432mm wide × 574mm deep (3.5 in × 17.0 in × 22.6 in).

DIMENSIONS WITH CARD INSTALLED:

707B: 356mm high × 432mm wide × 612mm deep (14.0 in × 17.0 in × 24.1 in).

708B: 90mm high × 432mm wide × 612mm deep (3.5 in × 17.0 in × 24.1 in).

WEIGHT: 707B: 14.5kg (32 lbs). 708B: 7.3kg (16 lbs).

SHIPPING WEIGHT: 707B: 27.2kg (60 lbs). 708B: 16.4 kg (36 lbs).

ENVIRONMENT: For indoor use only.

Altitude: Maximum 2000 meters above sea level.

Operating: 0°– 50°C, 80% R.H. up to 35°C. Derate to 3% R.H./°C, 35°– 50°C.

Storage: - 25°C to 65°C.

1.888.KEITHLEY (U.S. only)

www.keithley.com

KEITHLEY

A Tektronix Company

A Greater Measure of Confidence

Selector Guide

Switch Cards and Accessories for 707B, 708B, 707A, 708A

New Models 707B and 708B replace Models 707A and 708A

Keithley Instruments recently introduced two new semiconductor switch matrix mainframes: the Model 707B six-slot mainframe and the Model 708B one-slot mainframe. The two

new mainframes replace the Models 707A and 708A that were introduced more than 20 years ago. The new models provide important new capabilities and are compatible with the most

popular switch cards. The table shows the important differences between the new and old models.

	New 707/8B	Legacy 707/8A
GPIO/DDC	✓	✓
GPIO/ICL	✓	
Ethernet (LXI)	✓	
TSP/TSP-Link	✓	
Webpage (LXI)	✓	
Light Pen		✓
Compatible with 7174A, 7072, 7072-HV, 7173-50 switch cards	✓	✓
Compatible with 7071, 7071-4 switch cards		✓

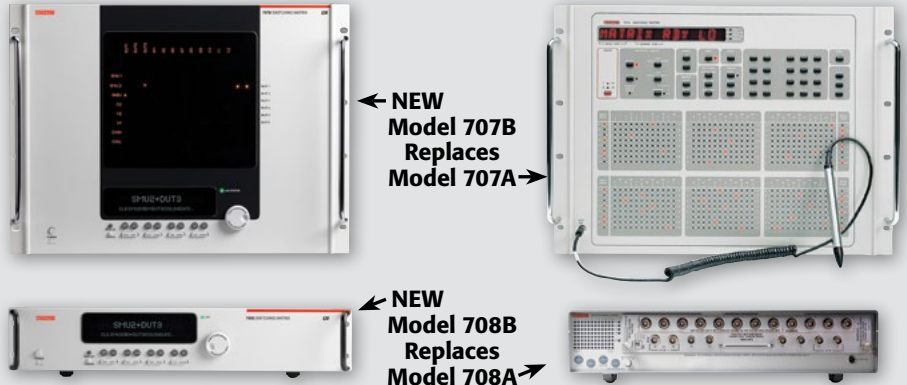

	LOW CURRENT			HIGH FREQUENCY
	7072	7072-HV	7174A	7173-50
Page	232	233	235	234
Number of Channels	8×12	8×12	8×12	4×12
Card Configuration	Matrix	Matrix	Matrix	Matrix
Contact Configuration	2 form A	2 form A	2 form A	2 form C
Max. Voltage	200 V	1300 V	200 V	30 V
Max. Current	1 A	1 A	2 A	0.5 A
Max. Power	10 VA	10 VA		10 VA
Contact Potential	<20 μV	<20 μV		<15 μV
Max. Offset Current	<1 pA	<1 pA	<100 fA	<200 pA
Recommended Frequency	15 MHz	4 MHz	30 MHz	200 MHz
Connection Type	3-lug triax	3-lug triax	3-lug triax	BNC
CE	Yes		Yes	Yes
Comments	Optimized for semiconductor applications.			
707B-708B Compatible	Yes	Yes	Yes	Yes
707A-708A Compatible	Yes	Yes	Yes	Yes

707B, 708B, 707A, 708A Switch Card Accessories

	Cables		Adapters	
	7072	7078-TRX-3	7078-TRX-10	237-TRX-T
7174A	7078-TRX-3	7078-TRX-10	237-TRX-T	7078-TRX-BNC
7072-HV	7078-TRX-3	7078-TRX-10	7078-TRX-BNC 7078-TRX-GND	237-TRX-T 237-TRX-TBC
7073	4801			
7173-50	7173-50-CSEP			

1.888.KEITHLEY (U.S. only)

www.keithley.com

A Greater Measure of Confidence

KEITHLEY
A Tektronix Company

Selector guides: Switch cards and accessories for 707B, 708B, 707A, 708A

SWITCHING AND CONTROL

7072

Semiconductor Matrix Card

8×12

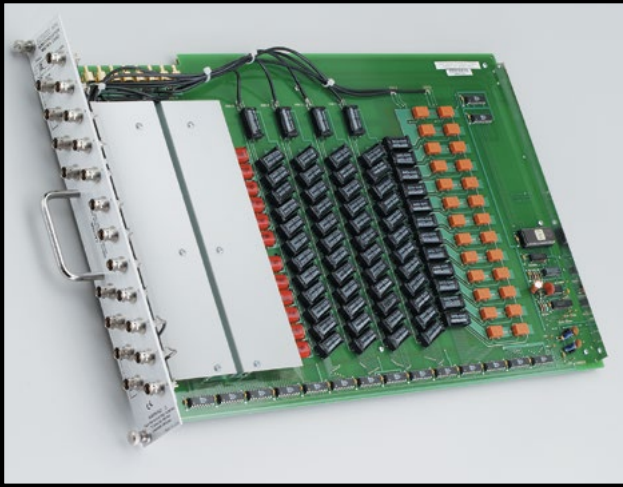

- Two sub-picoamp current paths
- Two DC to 1MHz C-V paths
- Four high isolation signal paths
- 3-lug triaxial connection
- Compatible with Models 707A, 707B, 708A, and 708B

Ordering Information

7072 8×12 Semiconductor Matrix Card

Accessories Supplied

Instruction manual and four SMB expansion cables (CA-54-1)

For applications requiring connections to a large number of devices or test points, the 7072 matrix can be expanded with additional cards. The low-current and C-V rows can be extended to other cards with coaxial jumpers. The other four high-quality signal paths connect directly to the 707A backplane for expansion.

ACCESSORIES AVAILABLE

237-TRX-T	3-Lug Triax Tee Adapter
7078-TRX-BNC	3-Lug Triax to BNC Adapter
7078-TRX-3	3-Lug Triax Cable, 0.9m (3 ft)
7078-TRX-10	3-Lug Triax Cable, 3m (10 ft)
7078-TRX-TBC	3-Lug Female Triax Bulkhead Connector with Cap

SERVICES AVAILABLE

7072-3Y-EW	1-year factory warranty extended to 3 years from date of shipment
------------	---

	Low-Current (Rows A - B)	General-Purpose (Rows C - F)	C-V (Rows G - H)
CROSSPOINT CONFIGURATION:	2-pole Form A	2-pole Form A	1-pole Form A, Common Guard
OFFSET CURRENT:	<1 pA	<20 pA	<20 pA
PATH ISOLATION: Resistance:	>10 ¹³ Ω	>10 ¹² Ω	>10 ¹² Ω
Capacitance (nominal):	0.4 pF	1 pF	0.6 pF
CROSSTALK			
1 MHz, 50Ω load (typical):	<-50 dB	<-40 dB	<-50 dB
3dB BANDWIDTH (typical), 50Ω Load:	15 MHz	8 MHz	5 MHz

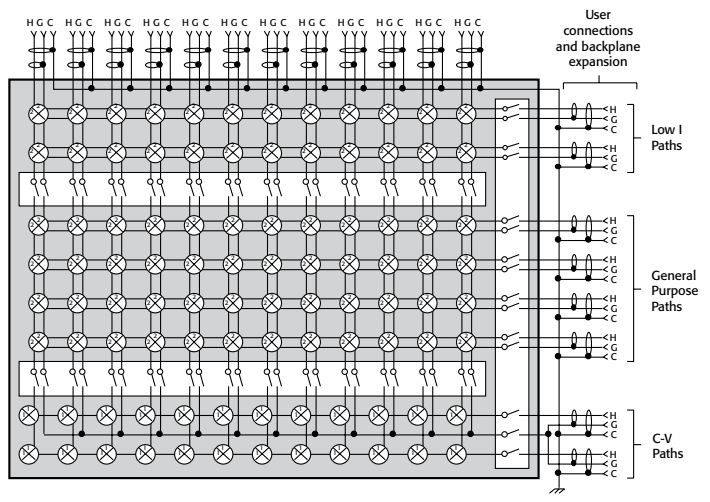

MATRIX CONFIGURATION: 8 rows by 12 columns.

CONNECTOR TYPE: 3-lug triaxial (Signal, Guard, Chassis).

MAXIMUM SIGNAL LEVEL: 200V, 1A carry/0.5A switched, 10VA peak (resistive load).

COMMON MODE VOLTAGE: 200V maximum between any 2 pins or chassis.

CONTACT LIFE:

Cold Switching: 10⁷ closures.

At Maximum Signal Level: 10⁵ closures.

PATH RESISTANCE (per conductor): <1Ω initial, <3.5Ω at end of contact life.

CONTACT POTENTIAL: <40μV per crosspoint (Signal to Guard).

RELAY SETTling TIME: <15ms.

INSERTION LOSS (1MHz, 50Ω source, 50Ω load): 0.1dB typical.

EMC: Conforms to European Union Directive 89/336/EEC.

SAFETY: Conforms to European Union Directive 73/23/EEC (meets EN61010-1/IEC 1010).

ENVIRONMENT:

OFFSET CURRENT and PATH ISOLATION Specifications: 23°C, <60% R.H.

Operating: 0° to 50°C, up to 35°C at 70% R.H.

Storage: -25° to +65°C.

1.888.KEITHLEY (U.S. only)

www.keithley.com

KEITHLEY

A Tektronix Company

7072-HV

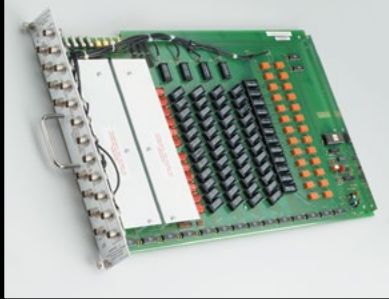

- Two 1300V, sub-picoamp current paths
- Six 200V, 20pA paths
- For use with Model 2410 SourceMeter SMU Instrument, Series 2600B SourceMeter SMU Instruments, and the 4200-SCS Parameter Analyzer
- 3-lug triaxial connections
- Compatible with Models 707A, 707B, 708A, and 708B

Ordering Information

7072-HV 8×12 High Voltage Semiconductor Matrix Card

High Voltage Semiconductor Matrix Card 8×12

The Model 7072-HV is designed to switch low-level, high-voltage, and high-impedance signals for semiconductor parametric tests on wafers and devices. This unique design provides two signal paths capable of switching 1300V with less than 1pA of offset current. The two C-V paths may be used for measurement of capacitance voltage characteristics from DC to 1MHz or for switching low currents with a common ground. Four additional high quality signal paths with less than 20pA offset current provide for signal switching to 200V.

Connections are 3-lug triax with the outer shell connected to chassis for safety and noise shielding. The center conductor is fully surrounded by the inner conducting shield to provide fully guarded measurements with higher isolation and improved measurement speed and accuracy.

7072-HV Applications

The Model 7072-HV is typically used with the Model 2410 SourceMeter SMU Instrument, Series 2600B SourceMeter SMU Instruments, and the 4200-SCS Parameter Analyzer to address a wide variety of semiconductor device and material characterization needs.

The high voltage signals encountered in breakdown measurements or oxide integrity testing can be easily switched with this matrix card. Signals connected to the High V, Low I paths are automatically isolated from the rest of the card.

For applications requiring connections to a large number of devices or test points, the 7072-HV matrix can be expanded with additional cards. The high voltage and C-V rows can be extended to other cards with coaxial jumpers. The other four high-quality signal paths connect directly to the 707A or 708A backplane for expansion.

ACCESSORIES AVAILABLE

237-TRX-T	3-Lug Triax Tee Adapter
237-TRX-TBC	3-Lug High Voltage Female Triax Bulkhead Connector
7078-TRX-3	3-Lug Triax Cable, 0.9m (3 ft)
7078-TRX-10	3-Lug Triax Cable, 3m (10 ft)
7078-TRX-BNC	3-Lug Triax to BNC Adapter

FOR USE AT 200V OR LESS

7078-TBC	3-Lug Female Triax Bulkhead Connector with Cap
----------	--

SERVICES AVAILABLE

7072-HV-3Y-EW	1-year factory warranty extended to 3 years from date of shipment
---------------	---

MATRIX CONFIGURATION: 8 rows by 12 columns.
CONNECTOR TYPE: Three-lug triaxial (Signal, Guard, Chassis).
CONTACT LIFE: Cold Switching: 10⁷ closures.
 At Maximum Signal Level: 10⁵ closures.
PATH RESISTANCE (per conductor): <1Ω initial, <3.5Ω at end of contact life.
RELAY SETTling TIME: <15ms.
INSERTION LOSS (1MHz, 50Ω source, 50Ω load): 0.1dB typical.

EMC: Conforms to European Union Directive 89/336/EEC.
SAFETY: Conforms to European Union Directive 73/23/EEC (meets EN61010-1/IEC 1010).
ENVIRONMENT:
OFFSET CURRENT and PATH ISOLATION Specifications:
 23°C, <60% R.H.
Operating: 0° to 50°C, up to 35°C at 70% R.H. **Storage:** -25° to +65°C.

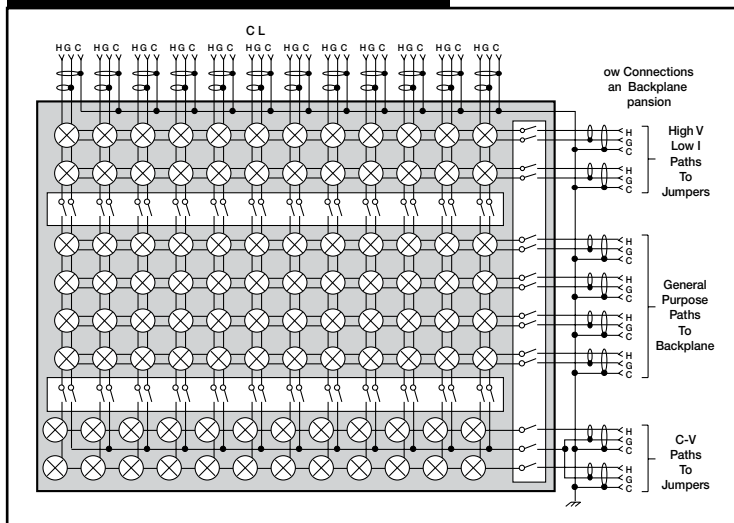

	Low Current (Rows A–B)	General Purpose (Rows C–F)	C-V (Rows G–H)
CROSSPOINT CONFIGURATION	2-pole Form A	2-pole Form A	1-pole Form A, Common Guard
OFFSET CURRENT	<1 pA	<20 pA	<20 pA
PATH ISOLATION:			
Resistance	>10 ¹³ Ω	>10 ¹² Ω	>10 ¹² Ω
Capacitance (nominal)	0.4 pF	1 pF	0.6 pF
CROSSTALK:			
1 MHz, 50Ω load (typical)	<-60 dB	<-40 dB	<-50 dB
3dB BANDWIDTH (typical), 50Ω Load	4 MHz	8 MHz	5 MHz
MAXIMUM SIGNAL LEVEL			
Maximum between any 2 pins or chassis:	1300 V	200 V	200 V
Maximum between signal & guard: 1A carry/0.5A switched, 10VA peak (resistive load)	200 V	200 V	200 V
CONTACT POTENTIAL (Signal to Guard):	<50 μV	<20 μV	<40 μV

1.888.KEITHLEY (U.S. only)

www.keithley.com

KEITHLEY

A Greater Measure of Confidence

A Tektronix Company

Use with Models 707B, 708B, 707A, and 708A switching matrix mainframes

SWITCHING AND CONTROL

7173-50



- 200MHz bandwidth
- <2ns rise time
- 50Ω impedance
- <15μV offset
- <200pA offset current
- 2-pole switching
- Compatible with Models 707A, 707B, 708A, and 708B

Ordering Information

7173-50 4×12, High Frequency Two-pole Matrix Card

SERVICES AVAILABLE

7173-50-3Y-EW 1-year factory warranty extended to 3 years from date of shipment

High Frequency Matrix Card

4×12, Two-pole

The Model 7173-50 combines high frequency performance with excellent DC switching characteristics. It provides 200MHz bandwidth in a 4×12 configuration. Offset voltage is <15μV per crosspoint, and offset current is <200pA. The combined AC and DC capabilities make it ideal for mixed signal applications where both high frequency and low level DC signals must be switched—for example, testing ADCs or DACs, which involves measuring both digital and analog signals.

The Model 7153-50 has a rise time of <2ns. It also features 2-pole switching at each crosspoint—HI and Shield—useful in 4-wire capacitance measurements where it is important to tie the shields of each connection together at the capacitance meter. BNC card connections are compatible with a wide variety of test equipment.

The Model 7173-50-CSEP expansion cables are four 25-inch cables and can expand a switching configuration to include more than one Model 7173-50. One cable is required to expand each row or column connection between adjacent cards. For example, connect the rows of two 7173-50 cards to create a 4×24 matrix or connect the columns to create an 8×12 matrix.

MATRIX CONFIGURATION: 4 rows by 12 columns.

CROSSPOINT CONFIGURATION: 2-pole Form C with Row Isolator (HI, LO).

CHARACTERISTIC IMPEDANCE: 50Ω nominal.

CONNECTOR TYPE: BNC.

MAXIMUM SIGNAL LEVEL: 30V, 0.5A switched, 10VA.

COMMON MODE VOLTAGE: 42V peak (LO to Chassis).

CONTACT LIFE: Cold Switching: 5×10⁶ closures.

At Maximum Signal Level: 3×10⁵ closures.

PATH RESISTANCE:

HI: <2.0Ω initial, <4.0Ω at end of contact life.

LO: <0.10Ω initial, <0.15Ω at end of contact life.

CONTACT POTENTIAL: <15μV per crosspoint (HI to LO).

RELAY SETTLE TIME: <6ms.

OFFSET CURRENT: <200pA (HI to LO).

AC PERFORMANCE (50Ω load and 50Ω source):

	1MHz	10MHz	100MHz	200MHz
Crosstalk:¹	<-85dB	<-50dB	<-35dB	
Insertion Loss:	<0.2dB	<0.4dB	<1.5dB	<3.0dB
VSWR (typical):			1.4	1.7

¹Closed crosspoint to closed crosspoint

ISOLATION: Path: >10¹⁰Ω, <0.040pF. **Differential:** >10⁹Ω, 150pF nominal. **Common Mode:** >10⁹Ω, 9400pF nominal.

RISE TIME (50Ω load and 50Ω source): <2ns.

EMC: Conforms to European Union Directive 89/336/EEC.

SAFETY: Conforms to European Union Directive 73/23/EEC (meets EN61010-1/IEC 1010).

ENVIRONMENT: Operating: 0° to 50°C, up to 35°C at 70% R.H. **Storage:** -25° to 65°C.

Specifications apply for one 7173-50 with all row isolators in automatic mode.

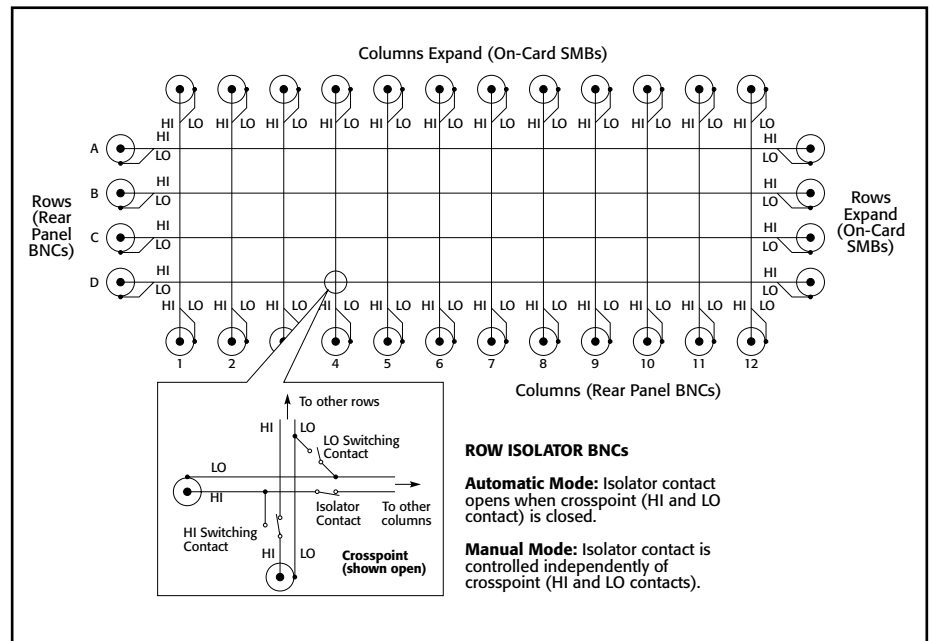
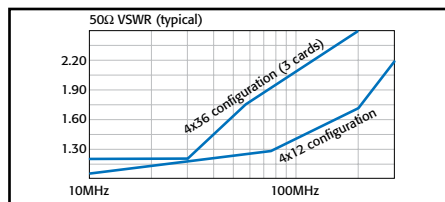
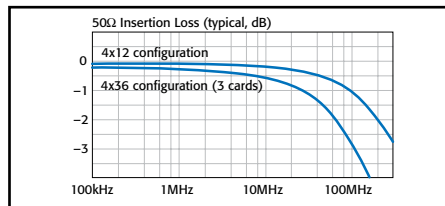
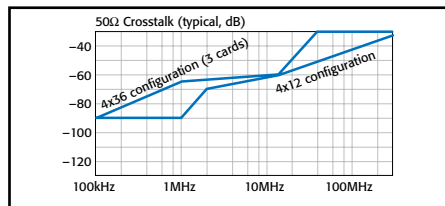

1.888.KEITHLEY (U.S. only)

www.keithley.com



7174A

High Speed, Low Leakage Current Matrix 8x12



- Fast time to measurement
- Low leakage (<100fA offset on all signal paths)
- 2-pole switching, signal, and guard
- 200V, 2A signal levels
- Designed for use with Keithley Model 4200-SCS, 2635B and 2636B System SourceMeter® SMU Instruments, and Agilent B1500
- Compatible with Models 707A, 707B, 708A, and 708B

Ordering Information

7174A 8x12 High Speed,
Low Current Matrix

Accessories Supplied

Eight row interconnect cables for card to card matrix expansion

The Model 7174A Low Current Matrix Card is designed for semiconductor research, development, and production applications requiring high quality, high performance switching of I-V and C-V signals. The Model 7174A is ideal for use with Keithley Models 2635B and 2636B System SourceMeter® SMU Instruments, Model 4200-SCS, and the Agilent B1500. The card's configuration is 8 rows x 12 columns, with signal and guard switched at each crosspoint. Offset current has been reduced dramatically to <100fA on all pathways. Significant reductions in the level of parasitic capacitances in the Model 7174A help speed the process of making low level measurements.

The Model 7174A provides an optimum solution to switching the lower level signals common to today's semiconductor characterization tests. The card's low leakage and minimal dielectric absorption ensure that key device measurements can be performed many times faster than with current switching technologies. Connections are 3-lug triax with the outer shell connected to chassis for safety and noise shielding. The center conductor is fully surrounded by the inner conducting shield allowing fully guarded measurements to be made with higher isolation and improved speed and accuracy.

For applications that require making connections to a large number of devices or test points, the Model 7174A matrix can be expanded with additional cards. On-card connectors are provided to connect the rows (column expansion) between other 7174A cards in adjacent slots of the Model 707B switching mainframe. Eight female-to-female cables are provided with each 7174A to simplify expansion. Up to six 7174A cards can be connected in a single 707A switching mainframe to form an 8x72 or 12x60 matrix.

MATRIX CONFIGURATION: Single 8 rowsx12 columns.

Expanding the columns can be done internally by connecting the rows of multiple 7174A cards together with coax jumpers.

CROSSPOINT CONFIGURATION: 2-pole Form A (Signal Guard).

CONNECTOR TYPE: 3-lug triax (Signal, Guard, Chassis).

MAXIMUM SIGNAL LEVEL:

Pin-to-pin or Pin-to-Chassis: 200V, 2A carry current.

CONTACT LIFE: Cold Switching: 10⁸ closures.

OFFSET CURRENT: 100fA max., 10fA typical (with 0V applied to inputs and outputs).

ISOLATION: Path (Signal to Signal): >2x10¹⁴Ω, 1pF.

Common (Signal to Chassis): >10¹⁴Ω, <10pF.

SETTLING TIME: <2.5s to 400fA (all pathways) after 10V applied (typical).

CROSSTALK (1MHz, 50Ω Load): <-70dB.

INSERTION LOSS (1MHz, 50Ω Load): <-0.2dB typical.

3dB BANDWIDTH:

(50Ω Load, 50Ω Source): 30MHz typical.

(1MΩ Load, 50Ω Source): 40MHz typical.

RELAY SETTLING TIME: <1ms.

EMC: Conforms to European Union Directive 89/336/EEC.

SAFETY: Conforms to European Union Directive 73/23/EEC (meets EN61010-1/IEC 1010).

ENVIRONMENT:

Offset Current and Path Isolation Specifications: 23°C, <60% R.H.

Operating: 0° to 50°C, up to 35°C at 70% R.H.

Storage: -25° to +65°C.

MAXIMUM LEAKAGE:

Pin to Ground: 0.01pA/V. Pin to Pin: 0.005pA/V.

INSULATION RESISTANCE: 6.7x10¹³Ω minimum.

CAPACITANCE: (Guard Driven): Path to Ground: <10pF.

Path to Path: 1pF typical.

ACCESSORIES AVAILABLE

237-TRX-T	3-Lug Triax Tee Adapter
7078-TRX-TBC	3-Lug Triax to BNC Adapter
7078-TRX-3	3-Lug Triax Cable, 0.9m (3 ft.)
7078-TRX-10	3-Lug Triax Cable, 3m (10 ft.)
7078-TBC	3-Lug Female Triax Bulkhead Connector with Cap

SERVICES AVAILABLE

7174A-3Y-EW	1-year factory warranty extended to 3 years from date of shipment
-------------	---

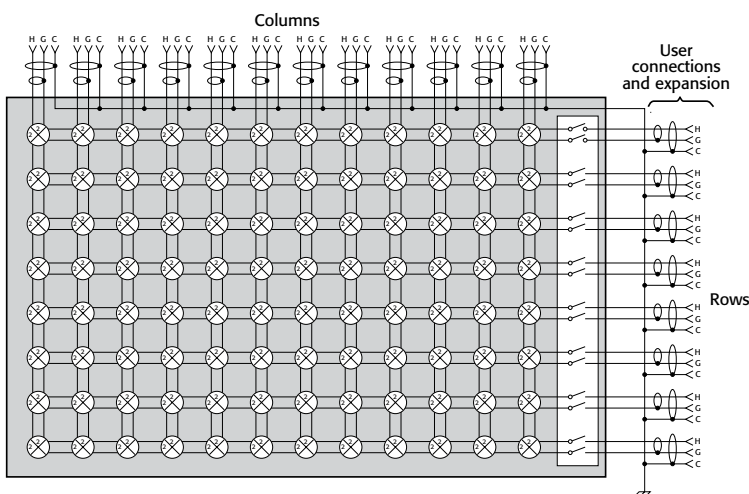

1.888.KEITHLEY (U.S. only)

www.keithley.com

A Greater Measure of Confidence

KEITHLEY
A Tektronix Company

Use with Models 707B, 708B, 707A, and 708A switching matrix mainframes

SWITCHING AND CONTROL

System 46

RF/Microwave Switch System

32-channel, Unterminated



- Compact RF/microwave switching system only 2U high
- Built-in contact closure counter to monitor switch cycles
- Standard configuration allows up to 32 channels of switching
- Simple control with built-in GPIB/IEEE-488 interface bus
- Channel characterization data storage
- Frequency ranges up to 40GHz

APPLICATIONS

- Cellular and cordless phones
- Specialized mobile radios
- Base stations
- Specialized antenna systems
- RF components, including RFICs
- Wireless peripherals, including Bluetooth devices
- Broadband wireless transceivers
- High speed digital communications, including SONET speeds 3Gbps and 10Gbps

1.888.KEITHLEY (U.S. only)

www.keithley.com

Flexible Solutions in a Compact Package

The S46 Microwave Switch System is designed to simplify the automated switching needed to test a wide range of telecommunications products and devices. The S46 can control 32 relay contacts in a package as small as a 2U high (3.5 in) full-rack enclosure. Standard configurations make it simple to select a system that meets the specifications of the testing application without the expense of unnecessary switches or other features. This “just what you need and no more” design philosophy allows S46 systems to provide outstanding price/performance value.

The enclosures used in standard S46 configurations can accommodate eight SPDT unterminated coaxial microwave relays and four multi-pole, unterminated, coaxial microwave relays. Any of these multi-pole unterminated relays can be one of the following relay types: SP4T or SP6T. S46 switching systems can be used as multiplexers, matrices, independent relays, or a combination of configurations. To order a standard system, simply select the number of relays and their location on the front panel. As test requirements change, relays can be easily added to the system to create a new switch configuration.

Frequency Range

To accommodate the rapidly evolving test requirements in RF/microwave applications, the S46 has ordering provisions for frequency ranges up to 40GHz. Configuration options include DC to 18GHz, DC to 26.5GHz, and DC to 40GHz.

Simple Operation

The S46 switch system's 32 control channels can be operated via the IEEE-488 interface bus with a minimal set of instructions. This small instruction set ensures the system can be set up and running quickly. Front panel LEDs indicate the status of all relay contacts continuously to allow the user to monitor system operation easily.

Excellent Microwave Switching Performance

Keithley's experience and partnerships with leading manufacturers in the microwave relay industry allow Keithley to offer the lowest insertion loss, VSWR, and crosstalk performance specifications available. Low-loss, semi-flexible RF cables are available as accessories to maximize signal integrity.

Maximum System Up-Time and Enhanced System Performance

The S46 controller automatically counts relay contact closures to allow equipment maintenance personnel to assess when the relays are nearing the end of their mechanical life. In this way, preventive maintenance can be performed in a timely way during scheduled shutdowns, avoiding unplanned shutdowns and the resulting loss of production time.

In addition to counting contact closures, the S46 has a portion of its memory available to store S-parameters or calibration constants for each relay contact or each pathway. If a specific performance parameter is critical, such as Voltage Standing Wave Ratio (VSWR) or insertion loss, the parameter can be stored in memory for use in trend analysis between scheduled maintenance shutdowns. Stored parameters can also be used for compensation to enhance accuracy during RF measurements.

System 46

RF/Microwave Switch System

32-channel, Unterminated

Standard Performance Data of an 18GHz, 1x12 Multiplexer

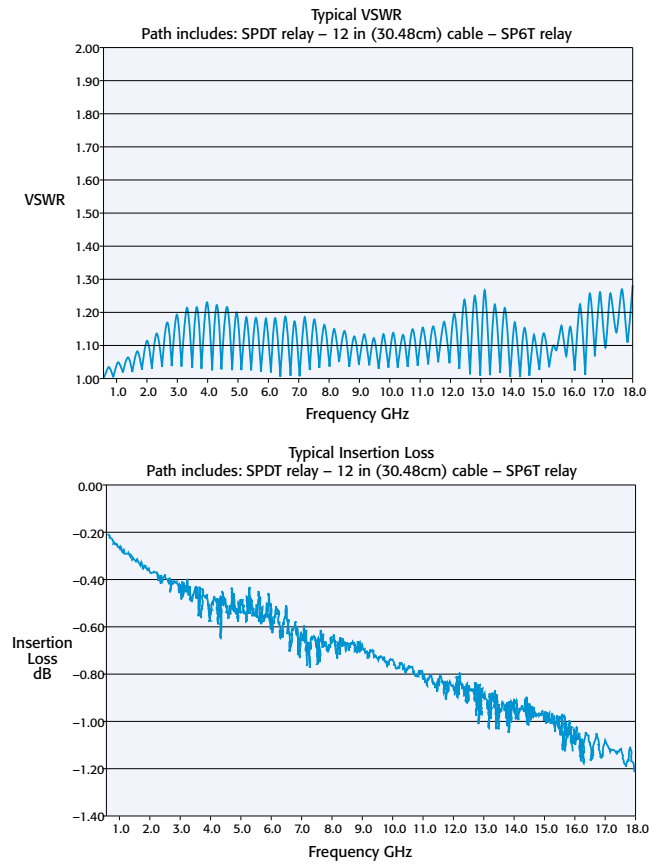

ACCESSORIES AVAILABLE

CABLING

S46-SMA-0.5	DC–18GHz, Low Loss, Semi-Flex SMA-SMA Cable Assembly, 0.152m (6 in.)
S46-SMA-1	DC–18GHz, Low Loss, Semi-Flex SMA-SMA Cable Assembly, 0.305m (12 in.)
S46-SMA-1.7	DC–18GHz, Low Loss, Semi-Flex SMA-SMA Cable Assembly, 0.518m (20.4 in.)
S46-SMA26-0.5	DC–26.5GHz, Low Loss, Semi-Flex SMA-SMA Cable Assembly, 0.152m (6 in.)
S46-SMA26-1	DC–26.5GHz, Low Loss, Semi-Flex SMA-SMA Cable Assembly, 0.305m (12 in.)
S46-SMA26-1.7	DC–26.5GHz, Low Loss, Semi-Flex SMA-SMA Cable Assembly, 0.518m (20.4 in.)
TL-24	SMA Cable Torque Wrench

SWITCH KITS

S46-SPDT-KIT	Standard Performance 18GHz Unterminated SPDT Relay and Control Cable Assembly
S46-SP4T-KIT	Standard Performance 18GHz Unterminated SP4T Relay and Control Cable Assembly
S46-SP6T-KIT	Standard Performance 18GHz Unterminated SP6T Relay and Control Cable Assembly
S46-SPDT-KIT-R	High Performance 18GHz Unterminated SPDT Relay and Control Cable Assembly
S46-SP4T-KIT-R	High Performance 18GHz Unterminated SP4T Relay and Control Cable Assembly
S46-SP6T-KIT-R	High Performance 18GHz Unterminated SP6T Relay and Control Cable Assembly
S46-SPDT-KIT-26	High Performance 26.5GHz Unterminated SPDT Relay and Control Cable Assembly
S46-SP4T-KIT-26	High Performance 26.5GHz Unterminated SP4T Relay and Control Cable Assembly
S46-SP6T-KIT-26	High Performance 26.5GHz Unterminated SP6T Relay and Control Cable Assembly
S46-SPDT-KIT-40	High Performance 40GHz Unterminated SPDT Relay and Control Cable Assembly
S46-SP4T-KIT-40	High Performance 40GHz Unterminated SP4T Relay and Control Cable Assembly
S46-SP6T-KIT-40	High Performance 40GHz Unterminated SP6T Relay and Control Cable Assembly

Examples of Standard System Switch Configurations

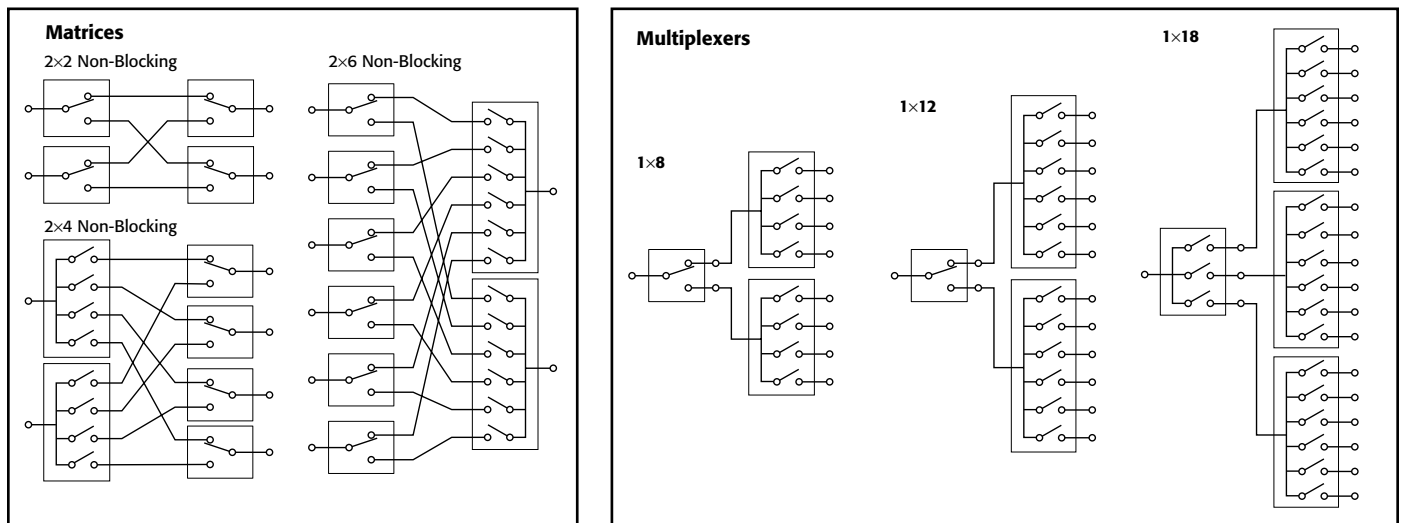

MAXIMUM CONFIGURATION: (8) – Unterminated SPDT relays. (4) – Unterminated multi-pole relays (SP4T, SP6T).

1.888.KEITHLEY (U.S. only)

www.keithley.com

A Greater Measure of Confidence

KEITHLEY
A Tektronix Company

System 46

RF/Microwave Switch System 32-channel, Unterminated

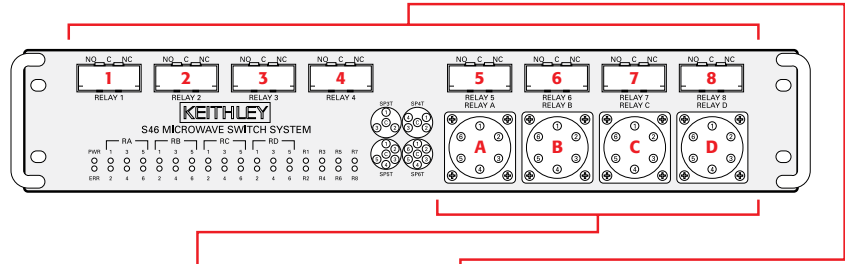

S46-

SP4T or SP6T Relay Locations

SPDT Relay Locations

Frequency Range

All four positions must be listed.

Only positions used must be listed.

Enter:

0 = None
4 = SP4T
6 = SP6T

Enter:

1-8 Position Number

Enter:

Blank = DC-18GHz, Standard Performance
A = DC-18GHz, High Performance
B = DC-26.5GHz
C = DC-40GHz

Multipole relay locations A-D: Enter a “4” for an SP4T relay or a “6” for a SP6T relay in the required location. Enter a “0” in unused multi-pole locations. There must be digits in all four positions.

SPDT relay locations 1-8: Indicate the position number of all locations where an SPDT switch is required. Only locations used are required.

Example 1: Model Number S46-0604356

Includes: SP6T in position B, SP4T in position D, SPDTs in positions 3, 5, and 6. Frequency range “Blank,” standard performance DC-18GHz.

Example 2: Model Number S46-0440123B

Includes: SP4T in positions B and C, SPDTs in positions 1, 2, and 3. Frequency range “B,” high performance DC-26.5GHz.

GENERAL

CONTACT CLOSURE COUNTERS: 1 counter per channel, up to 10 million counts each, maintained in non-volatile memory.

NON-VOLATILE STORAGE: 32 separate locations; each location up to 68 bytes long, for user-definable channel and system parameters.

NUMBER OF RELAY CONTROL LINES: 32, each open collector driver capable of 300mA sink current (max.).

INTERFACE: GPIB (IEEE-488.2) and SCPI.

INDICATORS: Power, relay position status, and error LED.

POWER: 100-240VAC, 50/60Hz.

MAXIMUM COMMON MODE: 42V peak, any terminal to earth.

ENVIRONMENT: Operating: 0° to 40°C, up to 35°C < 80% RH. Storage: -25° to 65°C.

EMC: Conforms to European Union Directive 89/336/EEC.

SAFETY: Conforms with European Union Directive 73/23/EEC.

DIMENSIONS: 89mm high × 485mm wide × 370mm. deep (3.5" × 19" × 14.563").

SHIPPING WEIGHT: 13kg (28 lbs).

Unterminated Relay Specifications

Option	None	A	B	C
	Std. Performance	High Performance		
FREQUENCY RANGE	DC-18 GHz	DC-18 GHz	DC-26.5 GHz	DC-40 GHz
CONNECTOR TYPE	SPDT SMA	SMA	SMA SMA 2.9	SMA 2.9
IMPEDANCE	50Ω	50Ω	50Ω	50Ω
CONTACT LIFE	SPDT 2 × 10 ⁶ SP4T, SP6T 2 × 10 ⁶	1 × 10 ⁷ 5 × 10 ⁶	1 × 10 ⁷ 2 × 10 ⁶	1 × 10 ⁷ 2 × 10 ⁶
VSWR (max.)	DC-6 GHz: 1.25 6-12 GHz: 1.40 12-18 GHz: 1.50	DC-3 GHz: 1.20 3-8 GHz: 1.30 8-12.4 GHz: 1.40 12.4-18 GHz: 1.50	DC-6 GHz: 1.30 6-12.4 GHz: 1.40 12.4-18 GHz: 1.50 18-26.5 GHz: 1.70	DC-6 GHz: 1.30 6-12.4 GHz: 1.40 12.4-18 GHz: 1.50 18-26.5 GHz: 1.70 26.5-40 GHz: 2.20
INSERTION LOSS (max.) dB	DC-6 GHz: 0.2 6-12 GHz: 0.4 12-18 GHz: 0.5	DC-3 GHz: 0.2 3-8 GHz: 0.3 8-12.4 GHz: 0.4 12.4-18 GHz: 0.5	DC-6 GHz: 0.2 6-12.4 GHz: 0.4 12.4-18 GHz: 0.5 18-26.5 GHz: 0.7	DC-6 GHz: 0.2 6-12.4 GHz: 0.4 12.4-18 GHz: 0.5 18-26.5 GHz: 0.7 26.5-40 GHz: 1.1
ISOLATION (min.) dB	DC-6 GHz: 70 6-12 GHz: 60 12-18 GHz: 60	DC-3 GHz: 80 3-8 GHz: 70 8-12.4 GHz: 60 12.4-18 GHz: 60	DC-6 GHz: 70 6-12.4 GHz: 60 12.4-18 GHz: 60 18-26.5 GHz: 55	DC-6 GHz: 70 6-12.4 GHz: 60 12.4-18 GHz: 60 18-26.5 GHz: 55 26.5-40 GHz: 50
ACTUATION TIME (max.) ms	SPDT 20 SP4T, SP6T 15	10 15	10 15	10 15

1.888.KEITHLEY (U.S. only)

www.keithley.com

KEITHLEY

A Tektronix Company

A Greater Measure of Confidence

System 46T

RF/Microwave Switch System 32-channel, Terminated

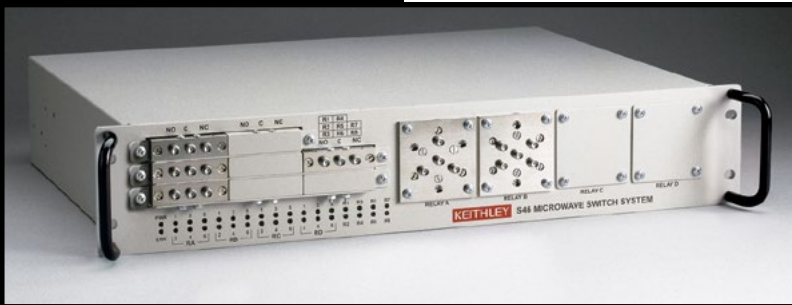

- Compact RF/microwave switching system only 2U high
- Built-in contact closure counter to monitor switch cycles
- Standard configuration allows up to 32 channels of switching
- Simple control with built-in GPIB/IEEE-488 interface bus
- Channel characterization data storage
- Terminated switching configurations
- Frequency ranges up to 26.5GHz

transfer switches (DPDT) as well as frequency ranges up to 26.5GHz. Other options include adding unterminated multi-throw and SPDT switches. Please review the Ordering Information section for allowable configurations.

Simple Operation

The S46T switch system's 32 control channels can be operated via the IEEE-488 interface bus with a minimal set of instructions. This small instruction set ensures the system can be set up and running quickly. Front panel LEDs indicate the status of all relay contacts continuously to allow the user to monitor system operation easily.

Excellent Microwave Switching Performance

Keithley's experience and partnerships with leading manufacturers in the microwave relay industry allow Keithley to offer the lowest insertion loss, VSWR, and crosstalk performance specifications available. Low-loss, semi-flexible RF cables are available as accessories to maximize signal integrity.

Maximum System Up-Time and Enhanced System Performance

The S46T controller automatically counts relay contact closures to allow equipment maintenance personnel to assess when the relays are nearing the end of their mechanical life. In this way, preventive maintenance can be performed in a timely way during scheduled shutdowns, avoiding unplanned shutdowns and the resulting loss of production time.

In addition to counting contact closures, the S46T has a portion of its memory available to store S-parameters or calibration constants for each relay contact or each pathway. If a specific performance parameter is critical, such as Voltage Standing Wave Ratio (VSWR) or insertion loss, the parameter can be stored in memory for use in trend analysis between scheduled maintenance shutdowns. Stored parameters can also be used for compensation to enhance accuracy during RF measurements.

Terminated Switching Solutions

If your application requires a terminated configuration, the System 46T will meet your needs. This compact switching system leverages the same design technology of our standard unterminated System 46. This terminated version can accommodate up to eight terminated SPDT coaxial microwave relays and four terminated multi-pole coaxial microwave relays.

Maximum Flexibility

In addition to the terminated configurations, the System 46T also has provisions to accommodate up to four

ACCESSORIES AVAILABLE

CABLES, ADAPTERS, TOOLS

7007-1	Shielded GPIB Cable, 1m (3.3 ft.)
7007-2	Shielded GPIB Cable, 2m (6.6 ft.)
7712-SMA-1	SMA Cable, male to male, 1m (3.3 ft.)
CA-404-B	SMA Cable, male to male, RG188 cable, 2m (6.5 ft.)
KPCI-488LPA	IEEE-488 Interface/Controller for the PCI Bus
KUSB-488B	IEEE-488 USB-to-GPIB Interface Adapter
S46-SMA-0.5	DC-18GHz, Low Loss, Semi-Flex SMA-SMA Cable Assembly, 0.152m (6 in.)
S46-SMA-1	DC-18GHz, Low Loss, Semi-Flex SMA-SMA Cable Assembly, 0.305m (12 in.)
S46-SMA-1.7	DC-18GHz, Low Loss, Semi-Flex SMA-SMA Cable Assembly, 0.518m (20.4 in.)
S46-SMA26-0.5	DC-26.5GHz, Low Loss, Semi-Flex SMA-SMA Cable Assembly, 0.152m (6 in.)
S46-SMA26-1	DC-26.5GHz, Low Loss, Semi-Flex SMA-SMA Cable Assembly, 0.305m (12 in.)
S46-SMA26-1.7	DC-26.5GHz, Low Loss, Semi-Flex SMA-SMA Cable Assembly, 0.518m (20.4 in.)
TL-24	SMA Cable Torque Wrench

SWITCH KITS

S46T-MSPDT-KIT	Quantity 2, 18GHz Unterminated SPDT Relays, Mounting Plate, and Control Cable Assembly (Note: Kit applicable only for relay A-D mounting locations)	S46T-SPDT-KIT-26	26.5GHz Unterminated SPDT Relay, Spacer Block, and Control Cable Assembly
S46T-SPDT-KIT	18GHz Unterminated SPDT Relay, Spacer Block, and Control Cable Assembly	S46T-SPDT-KIT-26T	26.5GHz Terminated SPDT Relay and Control Cable Assembly
S46T-SPDT-KIT-T	18 GHz Terminated SPDT Relay and Control Cable Assembly	S46T-MSPDT-KIT-26	Quantity 2, 26.5GHz Unterminated SPDT Relays, Mounting Plate, and Control Cable Assembly (Note: Kit applicable only for relay A-D mounting locations)
S46T-SP4T-KIT	18GHz Unterminated SP4T Relay, Mounting Plate, and Control Cable Assembly	S46T-SP4T-KIT-26	26.5GHz Unterminated SP4T Relay, Mounting Plate, and Control Cable Assembly
S46T-SP4T-KIT-T	18GHz Terminated SP4T Relay, Mounting Plate, and Control Cable Assembly	S46T-SP4T-KIT-26T	26.5GHz Terminated SP4T Relay and Control Cable Assembly
S46T-SP6T-KIT	18GHz Unterminated SP6T Relay, Mounting Plate, and Control Cable Assembly	S46T-SP6T-KIT-26	26.5GHz Unterminated SP6T Relay, Mounting Plate, and Control Cable Assembly
S46T-SP6T-KIT-T	18 GHz Terminated SP6T Relay, Mounting Plate, and Control Cable Assembly	S46T-SP6T-KIT-26T	26.5GHz Terminated SP6T Relay and Control Cable Assembly
S46T-XFR-KIT	18GHz Transfer Switch, Mounting Plate, and Control Cable Assembly	S46T-XFR-KIT-26	26.5GHz Transfer Switch, Mounting Plate, and Control Cable Assembly

1.888.KEITHLEY (U.S. only)

www.keithley.com

A Greater Measure of Confidence

KEITHLEY

A Tektronix Company

Designed for test applications that require high quality RF/microwave signal routing

SWITCHING AND CONTROL

System 46T

RF/Microwave Switch System 32-channel, Terminated

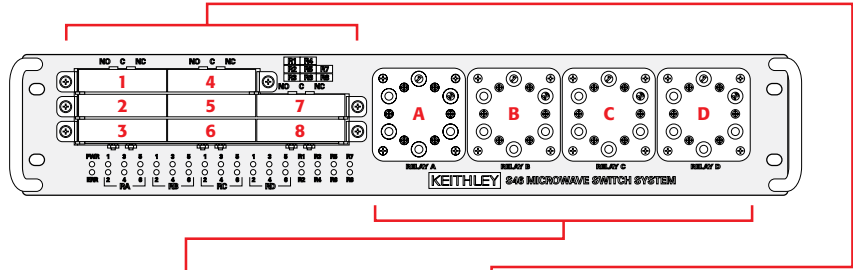

Ordering Information

Specifying Standard
S46T Model Numbers



Accessories Supplied

Power cord, instruction
manual, and rack mount kit

SP4T or SP6T Relay Locations

S46T-
A B C D

All four positions
must be listed.

Enter:

O = None

A = Terminated, SP4T

B = Terminated, SP6T

C = Underminated, SPDT (2)

4 = Underminated, SP4T

6 = Underminated, SP6T

X = Transfer Switch, DPDT

SPDT Relay Locations

1 2 3 4 5 6 7 8

All eight positions
must be listed.

Enter:

O = None

T = Terminated, SPDT

U = Underminated, SPDT

Frequency
Range

Must be specified.

Enter:

A = DC-18GHz

B = DC-26.5GHz

Example 1: Model Number S46T-0A0X00TT0000A

Includes: Terminated SP4T in position B, transfer switch in position D, terminated SPDTs in positions 3 and 4. DC-18GHz frequency range.

Example 2: Model Number S46T-ABC4UU00TTTTB

Includes: Terminated SP4T in position A, terminated SP6T in position B, two unterminated SPDTs in position C, and unterminated SP4T in position D. Unterminated SPDTs in positions 1 and 2, terminated SPDTs in positions 5, 6, 7, and 8. DC-26.5GHz frequency range.

APPLICATIONS

- Cellular and cordless phones
- Specialized mobile radios
- Base stations
- Specialized antenna systems
- RF components, including RFICs
- Wireless peripherals, including Bluetooth devices
- Broadband wireless transceivers
- High speed digital communications, including SNET speeds 3Gbps and 10Gbps

Terminated Relay Specifications

Frequency Range	DC-18 GHz	DC-26.5 GHz
CONNECTOR TYPE	SMA	SMA
IMPEDANCE	50Ω	50Ω
CONTACT LIFE: SPDT	2 × 10 ⁶	2 × 10 ⁶
CONTACT LIFE: SP4T, SP6T	2 × 10 ⁶	2 × 10 ⁶
VSWR (max.)	DC-3 GHz: 1.20 3-8 GHz: 1.30 8-12.4 GHz: 1.40 12.4-18 GHz: 1.50	DC-3 GHz: 1.20 3-8 GHz: 1.30 8-12.4 GHz: 1.40 12.4-18 GHz: 1.50 18-26.5 GHz: 1.80
INSERTION LOSS (max.) dB	DC-3 GHz: 0.2 3-8 GHz: 0.3 8-12.4 GHz: 0.4 12.4-18 GHz: 0.5	DC-3 GHz: 0.2 3-8 GHz: 0.3 8-12.4 GHz: 0.4 12.4-18 GHz: 0.5 18-26.5 GHz: 0.7
ISOLATION (min.) dB	DC-3 GHz: 80 3-8 GHz: 70 8-12.4 GHz: 60 12.4-18 GHz: 60	DC-3 GHz: 80 3-8 GHz: 70 8-12.4 GHz: 60 12.4-18 GHz: 60 18-26.5 GHz: 50
ACTUATION TIME (max.) ms	SPDT: 10 SP4T, SP6T: 15	SPDT: 10 SP4T, SP6T: 15

See page 238 for unterminated relay specifications.

Transfer Switch Specifications

Frequency Range	DC-18 GHz	DC-26.5 GHz
CONNECTOR TYPE	SMA	SMA 2.9
IMPEDANCE	50Ω	50Ω
CONTACT LIFE	2.5 × 10 ⁶	2.5 × 10 ⁶
VSWR (max.)	DC-3 GHz: 1.20 3-8 GHz: 1.30 8-12.4 GHz: 1.40 12.4-18 GHz: 1.50	DC-3 GHz: 1.20 3-8 GHz: 1.30 8-12.4 GHz: 1.40 12.4-18 GHz: 1.50 18-26.5 GHz: 1.70
INSERTION LOSS (max.) dB	DC-3 GHz: 0.2 3-8 GHz: 0.3 8-12.4 GHz: 0.4 12.4-18 GHz: 0.5	DC-3 GHz: 0.2 3-8 GHz: 0.3 8-12.4 GHz: 0.4 12.4-18 GHz: 0.5 18-26.5 GHz: 0.7
ISOLATION (min.) dB	DC-3 GHz: 80 3-8 GHz: 70 8-12.4 GHz: 60 12.4-18 GHz: 60	DC-3 GHz: 80 3-8 GHz: 70 8-12.4 GHz: 60 12.4-18 GHz: 60 18-26.5 GHz: 50
ACTUATION TIME (max.) ms	15	15

1.888.KEITHLEY (U.S. only)

www.keithley.com

KEITHLEY
A Tektronix Company

A Greater Measure of Confidence

Digital Multimeters and Systems

Selector Guide

2110

2100

2000

2001

2002

2010

2015

2015-P

2016

2016-P

Series 3700A

2700

2701

2750

Selector Guide

Free Software

2790

7751

7752

7753

Technical Information	242
Digital Multimeters	244
5½-Digit Dual-Display Digital Multimeter	246
6½-Digit USB Digital Multimeter	250
6½-Digit Multimeter	254
High Performance 7½-Digit Multimeter	259
High Performance 8½-Digit Multimeter	259
Low Noise 7½-Digit Autoranging Multimeter	265
6½-Digit THD Multimeter	267
6½-Digit Audio Analyzing Multimeter	267
6½-Digit THD Multimeter w/9V Source Output	267
6½-Digit Audio Analyzing Multimeter w/9V Source Output	267
System Switch/Multimeter and Plug-In Cards	275
Multimeter/Data Acquisition System	276
Ethernet DMM/Data Acquisition System	276
Multimeter/Switch System	276
<hr/>	
Plug-In Modules for Integra Systems	285
Plug-In Modules and Accessories for Integra Systems	285–297
<hr/>	
Free Bundled Software	298
ExceLINX™ -1A Excel Add-In	299
<hr/>	
SourceMeter® Airbag Test System	300
High Voltage Source/Switch Module	305
Low Voltage, Current-Source-Only Source/Switch Module	305
1MΩ High Voltage Source/Switch Module	305

Technical Information

Digital multimeters convert analog signals to digital information. In general, DMMs have a minimum of five typical functions. They are DC voltage, AC voltage, DC current, AC current, and resistance. While specifications vary, most DMMs can be described with block diagrams similar to **Figure 1**.

Analog to Digital Conversion

The A/D converts the analog input signal to a digital output and is primarily responsible for key instrument characteristics of reading speed, linearity, resolution, normal mode rejection, and precision. The digital output is shown or obtained in several ways. One way is visually, via the front panel with a display of digits and other information. Another way is electronically, with results sent via a port (GPIB, RS-232, USB, or Ethernet) to a computer for further processing.

Resolution

Resolution is defined as the smallest detectable change on any range referenced to full scale. For example, if an instrument displays a maximum of 19,999 on any range, and the smallest detectable change in the input signal is ± 1 least significant digit (LSD), then the resolution is $1/19999$ or 0.005%.

Resolution is commonly expressed as a whole number plus a fraction, e.g., $5\frac{1}{2}$ digits. The whole number represents the number of digits that can display the numbers from 0 to 9. The fraction indicates that the most significant digit has one or more non-zero states, that is, it can display 0, 1, or 2.

Sensitivity

Sensitivity is similar to resolution in that it deals with the smallest change of the input signal the instrument can detect. However, sensitivity is not referenced to full scale, so it is expressed in absolute terms and applies to the lowest range on any function. The sensitivity of a $7\frac{1}{2}$ -digit DMM is 10nV if its lowest measurement range is 200mV.

Accuracy

Accuracy is specified as a two-term specification: $\pm(\% \text{ of reading} + \% \text{ of range})$ or as (ppm of reading + ppm of range). The closer to zero on the range that the percent of range term of the specification is, the greater the weight it has in the accuracy calculation. The closer to full scale on the range the percent of reading term of the specification is, the greater the weight it has in the accuracy calculation. The best accuracy is obtained near full scale.

Digital Multimeters

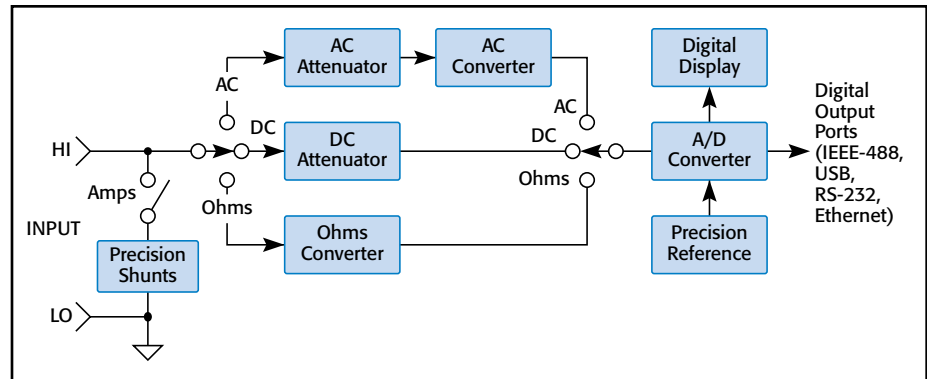

Figure 1: DMM Block Diagram

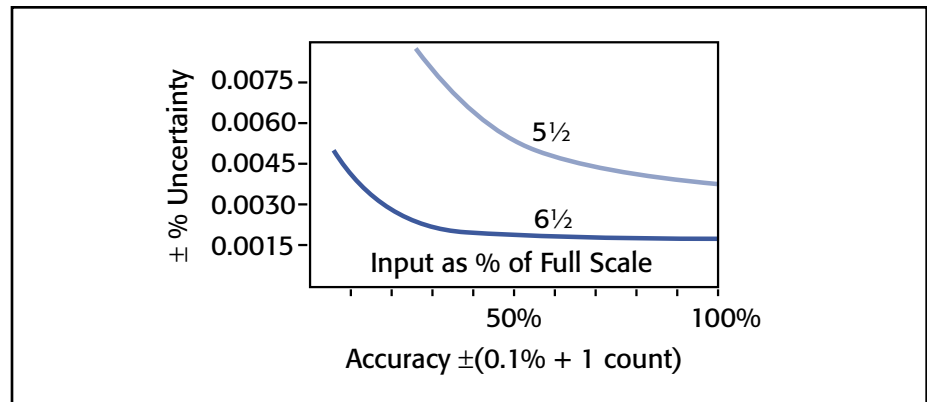

Figure 2: Expected Reading Uncertainty: $5\frac{1}{2}$ - vs. $6\frac{1}{2}$ -Digit DMMs

Accuracy is also generally stated under several conditions, including $\pm 1^\circ\text{C}$, $\pm 5^\circ\text{C}$ operating temperature, and 24-hour, 90-day, and one-year calibration intervals. The expected accuracy can be improved by controlling temperature variations in the environment and by electing more frequent calibration intervals. **Figure 2** illustrates the effect on accuracy at various levels of input signal within the measurement range. Accuracy for both meters is specified at $\pm(0.1\% + 1 \text{ count})$.

Loading and Input Impedance

Loading is the disturbance to the circuit being measured caused by the finite input impedance of the DMM. Input impedance is the equivalent resistance and capacitance of the input terminals of the DMM.

Loading error (**Figure 3**) is the difference between the voltage measured by the meter (V_M) and the voltage of an ideal source (V_S).

Voltage burden error (**Figure 4**) is the difference between the expected current through the load (R_L) and the measured current (I_M) caused by the finite voltage drop of the measuring instrument.

Two-Wire vs. Four-Wire Ohms

Two-terminal DMMs source test current through the measuring test leads, terminating at the HI-LO inputs of the DMM. This two-wire ohms system works fine for most resistance measurement applications. However, the I-R drop in the test leads (R_L) can cause inaccuracies that become apparent in lower resistance measurements (**Figure 5**).

Four-wire ohms or Kelvin measurements bypass the voltage drop across R_L by bringing two high impedance voltage sense leads out to the unknown R_X . There is very little current in the sense circuit because of the high input impedance, so there's effectively no I-R drop in the leads, and the voltage seen by the sense

1.888.KEITHLEY (U.S. only)

www.keithley.com

KEITHLEY
A Tektronix Company

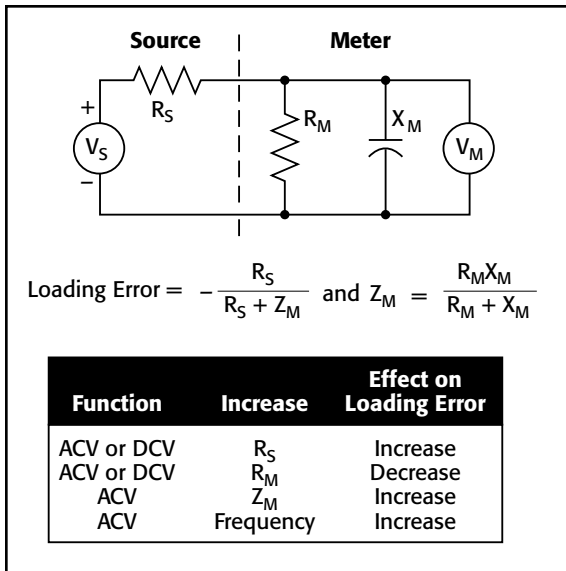

Figure 3: Loading Error

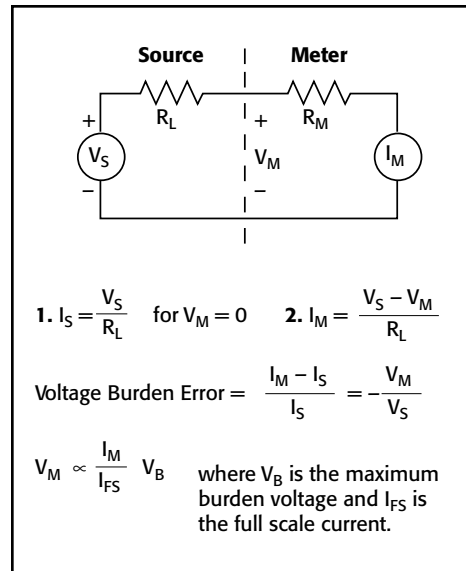

Figure 4: Voltage Burden Error

terminals is the same as the voltage developed across R_x .

Speed and Settling Time

Every meter has a settling time associated with its input circuit. The reading rates or measurement speeds of instruments are independent of the settling times. For high resolution meters, it may be necessary to allow time for input settling to achieve full rated accuracy.

Several parameters affect measurement speed, including integration rate (NPLC), filter setting, ranging, AutoZero, trigger delays, and display settings. For maximum measurement speed, set these parameters:

- Integration rate = 0.01
- Filter = disabled
- Range = fixed (no auto range)
- AutoZero = disabled
- Trigger Delay = 0.0
- Display = disabled

Note that maximum speed settings do not produce the greatest accuracy.

Normal and Common Mode Rejection

Normal mode interference is the interference mixed in with the incoming signal. Most normal mode interference is at line frequency and its harmonics. *NMRR* (Normal Mode Rejection Ratio) is specified in dB at line frequencies of 50Hz and 60Hz. Normal mode interference is detected as a peak noise or deviation in a DC signal.

$$NMRR = 20 \log \frac{(\text{peak measurement deviation})}{(\text{peak normal mode interference})}$$

CMRR (Common Mode Rejection Ratio) specifies the ability of a meter to reject signals common to both input HI and LO. This term is generally measured with a 1k Ω imbalance in one of the leads. A larger imbalance will cause CMRR to be worse. CMRR is specified at DC, 50Hz, or 60Hz, and (like NMRR) is expressed in dB. CMRR applies to both DC and AC measurements and appears as an offset error to the desired signal.

Overload Protection

This is a measure of electrical ruggedness and should be sufficient to protect the meter from commonly encountered line voltages. Typically, the ranges most susceptible to high voltage are the lowest voltage range (e.g., 100mV) and the

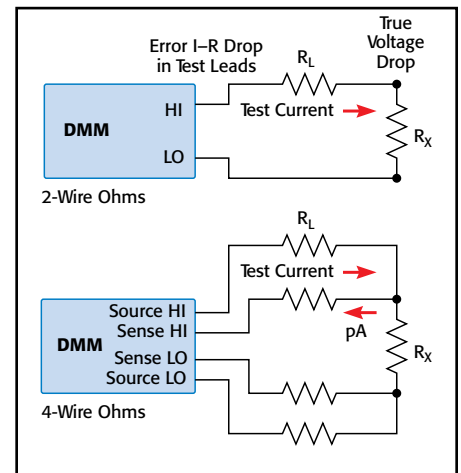

Figure 5: 2-Wire vs. 4-Wire Ohms

ohms ranges. Similar to overload protection is the maximum common mode voltage at which the meter can be used. This is the maximum voltage from earth ground that the input LO or COMMON terminal can withstand safely. The input terminal should always be at the lowest impedance.

Selector Guide Digital Multimeters

Model	2110	2100	2000	2010	2001	2002
Page	246	250	254	265	259	259
Digits	5½	6½	6½	7½	7½	8½
Expansion Channels	N/A	N/A	10	10	10	10
DC Volts						
Sensitivity	1 µV	0.1 µV	100 nV	10 nV	10 nV	1 nV
Maximum Reading	1000 V	1000 V	1000 V	1000 V	1100 V	1100 V
Basic Accuracy	0.012%	0.0038%	0.002%	0.0018%	0.0018%	0.0006%
Ratio		•		•	Option	Option
DC Peak Spikes					•	•
AC Volts (TRMS)						
Sensitivity	1 µV	0.1 µV	100 nV	100 nV	100 nV	100 nV
Maximum Reading	750 V	750 V	750 V	750 V	775 V (1100 V pk)	775 V (1100 V pk)
Basic Accuracy	0.12%	0.08%	0.05%	0.05%	0.03%	0.02%
Bandwidth	10 Hz–300 kHz	3 Hz–300 kHz	3 Hz–300 kHz	3 Hz–300 kHz	1 Hz–2 MHz	1 Hz–2 MHz
dB, dBm		•	•	•	•	•
Frequency, Period	•	•	•	•	•	•
Peak/Avg/RMS	RMS	RMS			•	•
AC, AC + DC	AC	AC			•	•
Ohms (2/4 Wire)						
Sensitivity	1 mΩ	100 µΩ	100 µΩ	1 µΩ	1 µΩ	100 nΩ
Maximum Reading	100 MΩ	100 MΩ	120 MΩ	120 MΩ	1 GΩ	1 GΩ
Basic Accuracy	0.02%	0.015%	0.008%	0.0032%	0.0032%	0.0007%
Continuity Test	•	•	•	•		
Diode Test	•	•	•	•		
Offset Compensation				•	•	•
Dry Circuit				•		
Constant Current	•	•	•	•	•	•
Open Source Detect						•
DC Amps						
Sensitivity	0.1 µA	10 nA	10 nA	1 nA	10 pA	10 pA
Range Span	10 mA–10 A	10 mA–3 A	10 mA–3 A	10 mA–3 A	200 µA–2 A	200 µA–2 A
Basic Accuracy	0.15%	0.055%	0.03%	0.03%	0.03%	0.027%
In Circuit Current					•	•
AC Amps (TRMS)						
Sensitivity	10 µA	1 µA	1 µA	1 µA	100 pA	100 pA
Range Span	1 A–10 A	1 A–3 A	1 A–3 A	1 A–3 A	200 µA–2 A	200 µA–2 A
Basic Accuracy	0.3%	0.15%	0.1%	0.1%	0.1%	0.1%
Bandwidth	10 Hz–5 kHz	3 Hz–5 kHz	3 Hz–5 kHz	3 Hz–5 kHz	20 Hz–100 kHz	20 Hz–100 kHz
General Features						
Interface	USB, GPIB (opt.)	USB	GPIB, RS-232	GPIB, RS-232	GPIB	GPIB
Reading Hold	•	•	•	•		
Digital I/O	Trigger In/Out	•			•	•
Reading Memory	2000 rdg.	2000 rdg.	1024 rdg.	1024 rdg.	Opt to 30,000	Opt to 30,000
Maximum Speed	50K rdg/s	2000 rdg/s	2000 rdg/s	2000 rdg/s	2000 rdg/s	2000 rdg/s
Temperature Meas.	T/C, RTD, Thermistor	RTD	T/C	T/C, RTD	T/C, RTD	T/C, RTD
Language Emulation		34401A	8840/42, 196/199	196/199		HP 3458

1.888.KEITHLEY (U.S. only)

www.keithley.com

KEITHLEY
A Tektronix Company

A Greater Measure of Confidence

Selector Guide

Digital Multimeters

Model	3706A	2015, 2016	2700	2701	2750
Page	275, 174	267	276	276	276
Digits	7½	6½	6½	6½	6½
Expansion Channels	576		80	80	200
DC Volts					
Sensitivity	10 nV	100 nV	100 nV	100 nV	100 nV
Maximum Reading	300 V	1000 V	1000 V	1000 V	1000 V
Basic Accuracy	0.002%	0.002%	0.002%	0.002%	0.002%
Ratio			w/MUX card	w/MUX card	w/MUX card
DC Peak Spikes					
AC Volts (TRMS)					
Sensitivity	100 nV	100 nV	100 nV	100 nV	100 nV
Maximum Reading	300 V	750 V	750 V	750 V	750 V
Basic Accuracy	0.05%	0.05%	0.06%	0.06%	0.06%
Bandwidth	3 Hz–300 kHz	3 Hz–300 kHz	3 Hz–300 kHz	3 Hz–300 kHz	3 Hz–300 kHz
dB, dBm	•	•			
Frequency, Period	•	•	•	•	•
THD, Harmonics		20 Hz–20 kHz			
Spectrum Peaks		-P versions			
Sine Source		4V/9V (10 Hz–20 kHz)			
Ohms (2/4 Wire)					
Sensitivity	100 nΩ	100 μΩ	100 μΩ	100 μΩ	1 μΩ
Maximum Reading	100 MΩ	120 MΩ	120 MΩ	120 MΩ	120 MΩ
Basic Accuracy	0.004%	0.008%	0.008%	0.008%	0.008%
Continuity Test	•		•	•	•
Diode Test		•			
Offset Compensation	•	•	•	•	•
Dry Circuit	•				•
Constant Current	•	•	•	•	•
DC Amps					
Sensitivity	1 pA	10 nA	10 nA	10 nA	10 nA
Range Span	10 μA–3 A	10 mA–3 A	20 mA–3 A	20 mA–3 A	20 mA–3 A
Basic Accuracy	0.03%	0.03%	0.03%	0.03%	0.03%
AC Amps (TRMS)					
Sensitivity	1 nA	1 μA	1 μA	1 μA	1 μA
Range Span	1 mA–3 A	1 A–3 A	1 A–3 A	1 A–3 A	1 A–3 A
Basic Accuracy	0.08%	0.1%	0.15%	0.16%	0.15%
Bandwidth	3 Hz–10 kHz	3 Hz–5 kHz	3 Hz–5 kHz	3 Hz–5 kHz	3 Hz–5 kHz
General Features					
Interface	GPIO, LXI/Ethernet, USB	GPIO, RS-232	GPIO, RS-232	Ethernet, RS-232	GPIO, RS-232
Reading Hold		•	•	•	
Digital I/O	14	2 in/5 out (TTL)	2 in/5 out (TTL)		
Reading Memory	650,000 rdg.	1024 rdg.	55,000 rdg.	450,000 rdg.	110,000 rdg.
Maximum Speed	>14,000 rdg/s	2000 rdg/s	2000 rdg/s	3500 rdg/s	2500 rdg/s
Temperature Meas.	T/C, RTD, Thermistor	T/C	T/C, RTD, Thermistor	T/C, RTD, Thermistor	T/C, RTD, Thermistor

1.888.KEITHLEY (U.S. only)

www.keithley.com

A Greater Measure of Confidence

KEITHLEY
A Tektronix Company

Single-slot, large format switch system

DIGITAL MULTIMETERS & SYSTEMS

2110

5½-Digit Dual-Display Digital Multimeter



The Model 2110 5½-Digit Dual-Display Digital Multimeter combines a compelling price with a comprehensive set of capabilities, superior measurement accuracy, and high speed for a broad range of applications. It features 15 measurement functions and 7 math functions and has dual-line display capability, which allows it to display two different measurements concurrently. The Model 2110 is an unbeatable value for production, R&D, and test engineers, scientists, and students making a wide variety of measurements in portable, bench, and system applications.

High Accuracy, Abundant Capabilities, Low Cost

The Model 2110 provides precision and a rich set of capabilities at a value price. It has 0.012% one-year basic DC voltage accuracy and 0.020% one-year basic resistance accuracy up to the 100k Ω range.

The Model 2110 provides a wide number of measurement ranges and functions:

- DC voltage: 0.1V, 1V, 10V, 100V, and 1000V
- AC voltage: 0.1V, 1V, 10V, 100V, and 750V
- DC current: 10mA, 100mA, 1A, 3A, and 10A
- AC current: 1A, 3A, and 10A
- Two- and four-wire resistance: 100 Ω , 1k Ω , 10k Ω , 100k Ω , 1M Ω , 10M Ω , and 100M Ω
- Frequency: From 10Hz to 300kHz
- Capacitance measurement: 1nF, 10nF, 100nF, 1 μ F, 10 μ F, 100 μ F
- Thermocouple measurement: J-, R-, S-, T-, E-, N-, B-, C-, and K-type thermocouples
- Temperature (RTD and NTC Thermistor) measurements
- Diode measurement
- Continuity test
- Programmable A-D converter and filter settings for signal to noise optimization. Additionally, seven mathematical operations can be performed on measurement readings: percentage, average, min/max, NULL, limits, mX+b, dB, and dBm testing.

Speed

At 5½ digits, the Model 2110 delivers up to 200 readings/s via the USB remote interface. At the fast 4½-digit setting, it reads up to 50,000 readings/s and up to 30,000 readings/s into the buffer, making it ideal for production and monitoring applications in which speed is critical.

APPLICATIONS

Built for Production Testing

The Model 2110 Digital Multimeter is ideal for applications in manual, semi-automatic, and automatic testing of low-cost electronic devices, circuits, modules, electrical components, and semiconductor components. Key features include:

- **Speed: up to 50,000 readings per second**
- **Control: GPIB (optional) and USB interfaces, accepting SCPI (IEEE-488.2) commands**
- **External BNC trigger lines**
- **NIST traceability (with included calibration certificate)**

Built for General Purpose Uses

The Model 2110 Digital Multimeter is also ideal for bench uses such as research, development, service, calibration, and teaching. Bench-oriented features include:

- **Accuracy: 0.012% basic DCV accuracy**
- **Easy-to-operate panel**
- **Easy waveform plotting and data collection with KI-Tool and KI-Link**
- **Store up to 2000 readings**

- **High accuracy, high speed for general purpose measurements**
- **15 measurement functions, including capacitance and thermocouple measurements**
- **Dual-line display allows concurrent measurements**
- **TMC-compliant USB 2.0 interface for use with SCPI test commands**
- **GPIB option for use in system applications**
- **Includes PC software utilities for graphing and data sharing in both Microsoft® Word and Excel**
- **Rugged construction for durability in bench/portable applications**
- **Includes all accessories, such as start-up software, USB cable, power cable, and safety test leads**
- **CE compliant and  US listed**
- **Three year warranty**

1.888.KEITHLEY (U.S. only)

www.keithley.com
KEITHLEY

A Tektronix Company

A Greater Measure of Confidence

2110

5½-Digit Dual-Display Digital Multimeter

Ordering Information

2110-100: 5½-digit USB Digital Multimeter (100V)

2110-120: 5½-digit USB Digital Multimeter (120V)

2110-220: 5½-digit USB Digital Multimeter (220V)

2110-240: 5½-digit USB Digital Multimeter (240V)

2110-100-GPIB: 5½-digit USB and GPIB Digital Multimeter (100V)

2110-120-GPIB: 5½-digit USB and GPIB Digital Multimeter (120V)

2110-220-GPIB: 5½-digit USB and GPIB Digital Multimeter (220V)

2110-240-GPIB: 5½-digit USB and GPIB Digital Multimeter (240V)

Accessories Supplied

Reference Manual on CD, Specifications, LabVIEW® Driver, Keithley I/O Layer, USB Cable, Power Cable, Safety Test Leads, KI-Tool, and KI-Link Add-in (both Microsoft Word and Excel versions), Calibration Certificate



All accessories, such as start-up software, USB cable, power cable, and safety test leads, are included with the Model 2110.

Simplicity

The Model 2110 is operational and intuitive to use right out of the box. The functions on the front panel are user friendly and easy to read. Its KI-Tool and KI-Link software allow users to quickly control the instrument over GPIB (if equipped) or USB, record measurements, and display time-series plots of the data. Its LabView® and IVI drivers give more-advanced customers even more control over the instrument. Both the TMC-compliant USB remote interface and the GPIB interface allow easy re-use of existing SCPI programs.

Startup Software, PC Utilities Included

The KI-Tool application provides charting and graphing capabilities without programming to simplify setup, checkout, and basic measurement applications requiring graphical data representation. Scale, offset, and level can be adjusted to fine-tune images for visual evaluation of signal and noise elements over time. It also includes tabular data and SCPI command prompt windows for maximum flexibility. Data sets can also be saved to disk files.

The Microsoft Excel Add-In utility is also included and provides quick data import into a standard Microsoft Excel spreadsheet, including selectable graphing, instrument settings, and number of data points collected. Data can then be analyzed through standard or optional Microsoft Excel functions, including graphical, statistical, and trend charting. A version supporting Microsoft Word is also included for direct data import into reports.

LabView, IVI-C, and IVI-COM drivers are also supplied to allow for increased flexibility in integrating the Model 2110 into new and existing systems and test routines.

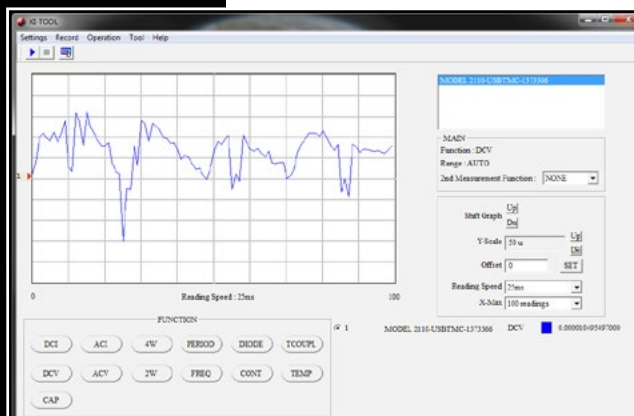

KI-Tool simplifies basic measurement applications through every setup and graphical data representation.

1.888.KEITHLEY (U.S. only)

www.keithley.com

A Greater Measure of Confidence

KEITHLEY
A Tektronix Company

Low-cost 5½-digit DMM for system, bench, or portable applications

DIGITAL MULTIMETERS & SYSTEMS

Specifications

DC CHARACTERISTICS

DC VOLTAGE			Accuracy ¹	Temperature Coefficient
Range	Resolution	Input Resistance	±(% of reading + % of range)	0°–18°C & 28°–40°C
100.000 mV	1 μV	10 MΩ	0.012 + 0.004	0.001 + 0.0005
1.00000 V	10 μV		0.012 + 0.001	0.0009 + 0.0005
10.0000 V	0.1 mV		0.012 + 0.002	0.0012 + 0.0005
100.000 V	1 mV		0.012 + 0.002	0.0012 + 0.0005
1000.00 V	10 mV		0.02 + 0.003	0.002 + 0.0015

DCI (DC CURRENT)			Accuracy ¹	Temperature Coefficient
Range	Resolution	Shunt Resistance	±(% of reading + % of range)	0°–18°C & 28°–40°C
10.0000 mA	0.1 μA	5.1 Ω	0.05 + 0.020	0.005 + 0.002
100.000 mA	1 μA	5.1 Ω	0.05 + 0.010	0.005 + 0.001
1.00000 A	10 μA	0.1 Ω	0.150 + 0.020	0.008 + 0.001
3.0000 A	100 μA	0.1 Ω	0.200 + 0.030	0.008 + 0.001
10.0000 A	100 μA	5 mΩ	0.250 + 0.050	0.008 + 0.001

RESISTANCE ²			Accuracy ¹	Temperature Coefficient
Range	Resolution	Test Current	±(% of reading + % of range)	0°–18°C & 28°–40°C
100.000 Ω	1 mΩ	1 mA	0.020 + 0.020	0.003 + 0.0005
1.00000 kΩ	10 mΩ	1 mA	0.020 + 0.003	0.003 + 0.0005
10.0000 kΩ	100 mΩ	100 μA	0.020 + 0.002	0.003 + 0.0005
100.000 kΩ	1 Ω	10 μA	0.020 + 0.002	0.003 + 0.0005
1.00000 MΩ	10 Ω	1 μA	0.030 + 0.004	0.005 + 0.0005
10.0000 MΩ	100 Ω	0.1 μA	0.200 + 0.004	0.05 + 0.0005
100.000 MΩ	1 kΩ	0.1 μA	2.000 + 0.005	0.5 + 0.0005

DIODE TEST			Accuracy ¹	Temperature Coefficient
Range	Resolution	Test Current	±(% of reading + % of range)	0°–18°C & 28°–40°C
1.0000V	10 μV	1 mA	0.020 + 0.030	0.002 + 0.0005

CONTINUITY			Accuracy ¹	Temperature Coefficient
Range	Resolution	Test Current	±(% of reading + % of range)	0°–18°C & 28°–40°C
1000Ω	10 mΩ	1 mA	0.020 + 0.020	0.002 + 0.0005

- Specifications valid after two hour warm-up.
 - ADC set for continuous trigger operation.
 - Input bias current <30pA at 25°C.
 - Measurement rate set to 10 PLC.
- Specifications for 4W ohms mode. For 2W ohms, use zero null or subtract lead resistance from displayed reading.
 - Maximum lead resistance 10% of range per lead for 100Ω and 1kΩ ranges; add 1kΩ per lead for all other ranges.

MEASUREMENT NOISE REJECTION DC (60Hz/50Hz) at 5.5 DIGITS

CMRR: 120dB for 1kΩ unbalance in LO lead.

NMRR: 60dB for line frequency ±0.1%.

TEMPERATURE (THERMOCOUPLE) CHARACTERISTICS

Thermocouple Type	Range	Accuracy ¹ ±°C
1 Year, exclusive of lead accuracy		
B	600 to 1800°C	1.5
C	0 to 2300°C	1.5
E	–250 to 1000°C	1.5
J	–200 to 1200°C	1.0
K	–200 to 1350°C	1.0
N	–200 to 1300°C	1.0
R	0 to 1750°C	1.5
S	0 to 1750°C	1.5
T	–250 to 400°C	1.5

- Specifications valid after two hour warm-up;
 - ADC set for continuous trigger operation.

RTD and NTC Thermistor Measurements: Accuracy ±0.8°C, 1 year, exclusive of lead accuracy. PT100, D100, F100, PT385, PT3916, SPRTD (R-Zero, A4, B4, Ax, Bx, Cx, and Dx), NTCT (A, B, and C), and user-definable RTD.

CAPACITANCE CHARACTERISTICS

Range	Test Current	Accuracy ¹
±(% of reading + % of range)		
1 Year, 23° ±5°C		
1.000 nF	10 μA	2.0 + 0.80
10.00 nF	10 μA	1.0 + 0.50
100.0 nF	100 μA	1.0 + 0.50
1.000 μF	100 μA	1.0 + 0.50
10.00 μF	100 μA	1.0 + 0.50
100.0 μF	1 mA	1.0 + 0.50

- Specifications valid after two hour warm-up.
 - ADC set for continuous trigger operation.
 - Null enabled.

ACCESSORIES AVAILABLE

4299-3	Single Rack Mount Kit
4299-4	Dual Rack Mount Kit
4299-7	Fixed Rack Mount Kit
5805	Kelvin Probes, 0.9m (3ft)
5805-12	Kelvin Probes, 3.6m (12ft)
5808	Low Cost, Single Pin, Kelvin Probes
5809	Low Cost, Kelvin Clip Lead Set
6517-TP	Thermocouple Bead Probe (K-Type)
7007-1	Shielded GPIB Cable, 1m (3.3 ft)
7007-2	Shielded GPIB Cable, 2m (6.6 ft)
8605	High Performance Modular Test Leads
8606	High Performance Modular Probe Kit
8680	RTD Probe Adapter
8681	Low Cost RTD

SERVICES AVAILABLE

C/2110-3Y-DATA	3 (Z-540-1 compliant) calibrations within 3 years of purchase for Model 2110
C/2110-5Y-DATA	5 (Z-540-1 compliant) calibrations within 5 years of purchase for Model 2110
C/2110-3Y-ISO	3 (ISO-17025 accredited) calibrations within 3 years of purchase for Model 2110
C/2110-5Y-ISO	5 (ISO-17025 accredited) calibrations within 5 years of purchase for Model 2110

1.888.KEITHLEY (U.S. only)

www.keithley.com

KEITHLEY
 A Tektronix Company

A Greater Measure of Confidence

AC CHARACTERISTICS

FREQUENCY AND PERIOD		Accuracy ¹	Temperature Coefficient
Range	Frequency (Hz)	±(% of reading + % of range) 1 Year, 23° ±5°C	0°–18°C & 28°–40°C
100.000 mV to 750.000 V ²	10–40 40–300k	0.03 0.02	0.002 0.002

ACV (AC TRMS VOLTAGE)			Accuracy ¹	Temperature Coefficient
Range	Resolution	Frequency	±(% of reading + % of range) 1 Year, 23° ±5°C	0°–18°C & 28°–40°C
100.000 mV to 750.000 V ²	1 μV to 10 mV	10 Hz–20 kHz 20 kHz–50 kHz 50 kHz–100 kHz 100 kHz–300 kHz	0.12 + 0.05 0.25 + 0.05 0.65 + 0.08 5.00 + 0.50	0.01 + 0.01 0.02 + 0.02 0.04 + 0.02 0.2 + 0.02

ACI (AC TRMS CURRENT)			Accuracy ¹	Temperature Coefficient
Range	Resolution	Frequency	±(% of reading + % of range) 1 Year, 23° ±5°C	0°–18°C & 28°–40°C
1.0000 A to 3.00000 A	10 μA to 100 μA	10 Hz–900 Hz 900 Hz–5 kHz	0.30 + 0.06 1.50 + 0.15	0.02 + 0.01 0.02 + 0.01
10.0000 A	100 μA	10 Hz–900 Hz 900 Hz–5 kHz	0.50 + 0.12 2.50 + 0.20	0.02 + 0.01 0.02 + 0.01

1. Specifications valid after two hour warm-up.
 - a. Slow AC filter (3Hz bandwidth).
 - b. Pure sine wave input greater than 5% of range.
2. 750VAC range is limited to 100kHz.

GENERAL

Input bias current: <30pA at 25°C.
 Input protection: 1000V all ranges (2W input).
 AC CMRR: 70dB (for 1kΩ unbalance LO lead).
 Power Supply: 100V/120V/220V/240V.
 Power Line Frequency: 50/60Hz auto detected.
 Power Consumption: 25VA max.
 Digital I/O interface: USB-compatible Type B connection, GPIB (option).
 Environment: For indoor use only.
 Operating Temperature: 0° to 40°C.
 Operating Humidity: Maximum relative humidity 80% for temperature up to 31°C.
 Storage Temperature: –40° to 70°C.
 Operating Altitude Up to 2000 m above sea level.
 Bench Dimensions (with handles and bumpers): 107 mm high × 252.8 mm wide × 305 mm deep (3.49 in. × 9.95 in. × 12.00 in.).
 Weight: 2.23 kg (4.92 lbs.).
 Safety: Conforms to European Union Low Voltage Directive, EN61010-1. Measurement Cat I 1000V and CAT II 600V.
 EMC: Conforms to European Union Directive 89/336/EEC, EN61326-1.
 Warranty: Three years.



Model 2110 rear panel.

1.888.KEITHLEY (U.S. only)

www.keithley.com

A Greater Measure of Confidence

KEITHLEY
A Tektronix Company

2100

6½-Digit USB Digital Multimeter



The Model 2100 USB Digital Multimeter is the newest member of Keithley's family of high performance DMMs. Its high accuracy (38ppm), 6½-digit resolution is ideal for critical measurements. The Model 2100 features 11 measurement functions and 8 math functions to easily accommodate the most commonly measured parameters. All accessories, such as USB cable, probes, and software, are included with the Model 2100. With its unique combination of high precision and low total cost of ownership, the Model 2100 is an unbeatable value for R&D engineers, test engineers, scientists, and students making basic precision measurements on the bench and in system applications.

High Precision, Low Cost

The Model 2100 provides stability, accuracy, and speed at a very low cost. It has 0.0038% 1-year

basic DC voltage accuracy on the 10V range and 0.013% 1-year basic resistance accuracy on the 10kΩ range. At 6½ digits, the Model 2100 delivers 50 triggered rdgs/s via the USB remote interface. At the fast 4½ digit setting, it reads over 2000 rdgs/s into its 2000 reading internal buffer.

The Model 2100 provides a wide number of measurement ranges and functions:

- DC voltage: 0.1V, 1V, 10V, 100V, and 1000V
- AC voltage: 0.1V, 1V, 10V, 100V, and 750V
- DC current: 10mA, 100mA, 1A, and 3A
- AC current: 1A and 3A
- Two- and four-wire resistance: 100Ω, 1kΩ, 10kΩ, 100kΩ, 1MΩ, 10MΩ, and 100MΩ
- Frequency: From 3Hz to 300kHz
- Period measurement
- Diode measurement
- Programmable A-D converter and filter settings for signal to noise optimization

Additionally, eight mathematical operations can be performed on measurement readings: RATIO, %, Min/Max, NULL, Limits, mX+b, dB, and dBm testing. Microsoft Office, Word, and Excel add-in tools allow remote storage and recall of the measured values from these applications. A graphing utility enables charting of measurements versus time for trending and noise observations.

The TMC compliant USB remote interface enables control from a PC for consistent test/calibration procedure execution and easy re-use of existing SCPI programs, including Agilent Model 34401A command emulation.

Simple to Use

The Model 2100 can be setup quickly and is very easy to use. It has a high contrast front panel and keypad that are intuitive and user-friendly. An easy to read 5×7 dot matrix, vacuum fluorescent display (VFD) offers three-color annunciators so users can easily distinguish each function symbol by its color.

Strength and Versatility

With its rugged construction and rubber bumpers, the Model 2100 has the durability to withstand bench, portable, or stacking applications. A sturdy carrying handle facilitates transportability.

- **High precision 6½-digit DMM for critical measurements at a 5½-digit price**
- **11 measurement functions cover most commonly measured parameters**
- **Fully specified accuracies on all functions for ISO-compliant results**
- **Included PC software utilities for graphing and data sharing in both Microsoft® Word and Excel**
- **Rugged construction for durability in bench/portable applications**
- **Selectable front/rear inputs facilitate bench or rack use**
- **Includes all accessories, such as startup software, USB cable, power cable, and safety test lead, for lowest total cost**
- **CE compliant and UL listed**
- **TMC compliant USB 2.0 interface for use with SCPI test programs**

1.888.KEITHLEY (U.S. only)

www.keithley.com

KEITHLEY
A Tektronix Company

2100

6½-Digit USB Digital Multimeter

Ordering Information

2100/100 6½-digit USB Digital Multimeter (100V)

2100/120 6½-digit USB Digital Multimeter (120V)

2100/220 6½-digit USB Digital Multimeter (220V)

2100/230-240
6½-digit USB Digital Multimeter (230-240V)

Accessories Supplied

Instruction manual on CD, Specifications, LabVIEW® Driver, Keithley I/O Layer, USB Cable, Power Cable, Safety Test Leads, KI-Tool, and KI-Link Add-in (Both Microsoft Word and Excel versions)

Applications

The Model 2100 USB Digital Multimeter is ideal for applications in: electronic device, circuit, module, and product testing; low cost production testing of electrical and electronic components, sub-assemblies, and end products; and student lab assignments. Typical applications include:

- Test Engineers: Manual and semi-automatic electrical functional test
- Development Engineers: Electrical/electronic circuit and product validation
- Service/Calibration Technicians: Electronic product repair and calibration
- Research Scientists: Electrical and physics experiments testing
- Engineering Students: Electronic device and circuits experiment testing

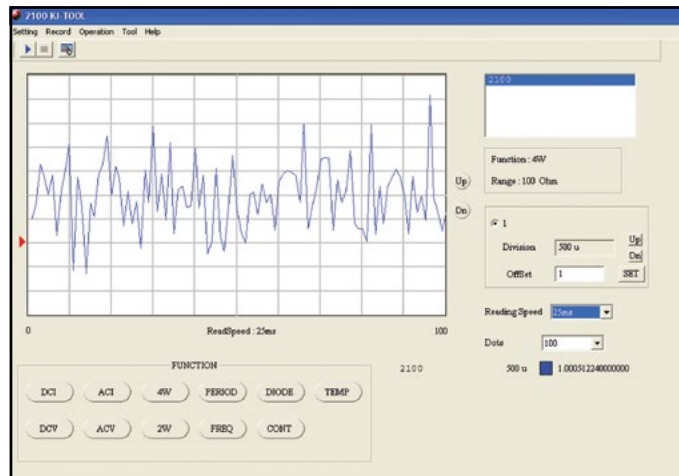

ACCESSORIES AVAILABLE

RACK MOUNT KITS

4299-3	Single Rack Mount Kit
4299-4	Dual Rack Mount Kit
8605	High Performance Modular Test Leads
8606	High Performance Modular Probe Kit

SERVICES AVAILABLE

2100/120-3Y-EW	1 Year Factory Warranty extended to 3 years from date of shipment
C/2100/120-3Y-DATA	3 (Z540-1 compliant) Calibrations within 3 years of purchase for Model 2100/120*
C/2100/120-3Y-ISO	3 (ISO-17025 accredited) Calibrations within 3 years of purchase for Model 2100/120*

*Not available in all countries

Startup Software, PC Utilities Included

The KI-Tool application provides charting and graphing capabilities without programming to simplify setup, checkout, and basic measurement applications requiring graphical data representation. Scale, offset, and level can be adjusted to fine tune images for visual evaluation of signal and noise elements over time. It also includes tabular data and SCPI command prompt windows for maximum flexibility. Data sets can also be saved to disk files.

The Microsoft Excel Add-In utility is also included and provides quick data import into a standard Microsoft Excel spreadsheet, including selectable graphing, instrument settings, and number of data points collected. Data can then be analyzed through standard or optional Microsoft Excel functions, including graphical, statistical, and trend charting. A version supporting Microsoft Word is also included for direct data import into reports.

1.888.KEITHLEY (U.S. only)

www.keithley.com

A Greater Measure of Confidence

KEITHLEY
A Tektronix Company

Low cost 6½-digit DMM for portable, bench, and USB-based system applications

DIGITAL MULTIMETERS & SYSTEMS

Specifications

DC CHARACTERISTICS: Accuracy¹ ±(% of reading + % of range)

Function	Range	Resolution	Input Resistance	1 Year, 23°C ±5°C
DC Voltage	100.0000 mV	0.1 μV	>10 GΩ	0.0055 + 0.0040
	1.000000 V	1.0 μV	>10 GΩ	0.0045 + 0.0008
	10.00000 V	10 μV	>10 GΩ	0.0038 + 0.0006
	100.0000 V	100 μV	10 MΩ	0.0050 + 0.0007
	1000.000 V	1 mV	10 MΩ	0.0055 + 0.0010

Function	Range	Resolution	Shunt Resistance	1 Year, 23°C ±5°C
DCI (DC Current)	10.00000 mA	10 nA	5.1 Ω	0.055 + 0.025
	100.0000 mA	100 nA	5.1 Ω	0.055 + 0.006
	1.000000 A	1 μA	0.1 Ω	0.120 + 0.015
	3.00000 A	10 μA	0.1 Ω	0.150 + 0.025

Function	Range	Resolution	Test Current	1 Year, 23°C ±5°C
Resistance ²	100.0000 Ω	100 μΩ	1 mA	0.015 + 0.005
	1.000000 kΩ	1 mΩ	1 mA	0.015 + 0.002
	10.00000 kΩ	10 mΩ	100 μA	0.013 + 0.002
	100.0000 kΩ	100 mΩ	10 μA	0.015 + 0.002
	1.000000 MΩ	1 Ω	5 μA	0.017 + 0.002
	10.00000 MΩ	10 Ω	500 nA	0.045 + 0.002
100.0000 MΩ	100 Ω	500 nA 10 MΩ	1.00	+ 0.020
Diode Test	1.0000 V	10 μV	1 mA	0.040 + 0.020
Continuity	1000.00 Ω	10 mΩ	1 mA	0.024 + 0.030

DC NOTES

- Specifications valid after two hour warm-up.
 - ADC set for continuous trigger operation.
 - Input bias current <30pA at 25°C.
 - Input protection 1000V all ranges (2W input).
 - Measurement rate set to 1 PLC.
- Specifications for 4W ohms mode. For 2W ohms, use zero null or subtract lead resistance from displayed reading.
 - Maximum lead resistance 10% of range per lead for 100Ω and 1kΩ ranges; add 1kΩ per lead for all other ranges.

MEASUREMENT NOISE REJECTION DC (60Hz/50Hz)

Rate	Digits	CMRR ¹	NMRR ²
10PLC	6 ¹ / ₂	140 dB	60 dB
1PLC	5 ¹ / ₂	140 dB	60 dB

- For 1kΩ unbalance in LO lead.
- For line frequency ±0.1%.

TEMPERATURE (RTD)

Range	Resolution	4-Wire Accuracy ¹ , 1 Year
-100°C to +100°C	0.001°C	±0.1°C
-200°C to +630°C	0.001°C	±0.2°C

RTD TYPE: 100Ω platinum (PT100), D100, F100, PT385, or PT3916.

MAXIMUM LEAD RESISTANCE (each lead): 12Ω (to achieve rated accuracy).

SENSOR CURRENT: 1mA (pulsed).

- Excluding probe errors. 23°C ±5°C.

AC CHARACTERISTICS:

Accuracy¹ ±(% of reading + % of range)

Function	Range	Frequency (Hz)	1 Year (% of reading) 23°C ±5°C
Frequency and Period	100 mV to 750 V ²	3–5	0.10
		5–40	0.05
		40–300k	0.01

Function	Range	Resolution	Frequency (Hz)	1 Year (23°C ±5°C)
ACV (AC TRMS Voltage)	100.0000 mV	0.1 μV	3–5	1.15 + 0.05
			5–10	0.45 + 0.05
			10–20k	0.08 + 0.05
			20k–50k	0.15 + 0.06
			50k–100k	0.70 + 0.09
			100k–300k	4.25 + 0.60
	1.000000 V to 750.000 V ²	1.0 μV to 1 mV	3–5	1.10 + 0.04
			5–10	0.4 + 0.04
			10–20k	0.08 + 0.04
			20k–50k	0.14 + 0.06
ACI (AC TRMS Current)	1.000000 A	1 μA	3–5	1.10 + 0.05
			5–10	0.40 + 0.05
			10–5k	0.15 + 0.05
			3–5	1.25 + 0.07
			5–10	0.45 + 0.07
3.000000 A	10 μA	5–10	0.45 + 0.07	
		10–5k	0.20 + 0.07	

AC NOTES

- Specifications valid for two hour warm-up at 6½ digits.
 - Slow AC filter (3Hz bandwidth).
 - Pure sine wave input greater than 5% of range.
- 750VAC range is limited to 100kHz.

GENERAL

AC CMRR: 70dB (for 1kΩ unbalance LO lead).
 POWER SUPPLY: 120V/220V/240V.
 POWER LINE FREQUENCY: 50/60Hz auto detected.
 POWER CONSUMPTION: 25VA max.
 DIGITAL I/O INTERFACE: USB-compatible Type B connection.
 ENVIRONMENT: For indoor use only.
 OPERATING TEMPERATURE: 5° to 40°C.
 OPERATING HUMIDITY: Maximum relative humidity 80% for temperature up to 31°C, decreasing linearly to 50% relative humidity at 40°C.
 STORAGE TEMPERATURE: –25° to 65°C.
 OPERATING ALTITUDE: Up to 2000m above sea level.
 BENCH DIMENSIONS (with handles and feet): 112mm high × 256mm wide × 375mm deep (4.4 in. × 10.1 in. × 14.75 in.).
 WEIGHT: 4.1kg (9 lbs.).
 SAFETY: Conforms to European Union Directive 73/23/ECC, EN61010-1, UL61010-1:2004.
 EMC: Conforms to European Union Directive 89/336/EEC, EN61326-1.
 WARRANTY: One year.



Model 2100 rear panel

1.888.KEITHLEY (U.S. only)

www.keithley.com

KEITHLEY

A Greater Measure of Confidence

A Tektronix Company

2000

6½-Digit Multimeter



The Model 2000 6½-Digit Multimeter is part of Keithley's family of high performance DMMs. Based on the same high speed, low noise A/D converter technology as the Model 2001 and 2002, the 2000 is a fast, accurate, and highly stable instrument that's as easy to operate as it is to afford. It combines broad measurement ranges with superior accuracy specifications — DC voltage from 100nV to 1kV (with 0.002% 90-day basic accuracy) and DC resistance from 100μΩ to 100MΩ (with 0.008% 90-day basic accuracy). Optional switch cards enable multiplexing up to 20 different input signals for multipoint measurement applications.

High Throughput

The 2000 offers exceptional measurement speed at any resolution. At 6½ digits, it delivers 50 triggered rdgs/s over the IEEE-488 bus. At 4½ digits, it can read up to 2000 rdgs/s into its internal 1024 reading buffer, making it an excellent choice for applications where throughput is critical.

For benchtop or stand-alone applications, the 2000 has a front panel design that's simple to understand and easy to use. The 2000 has 13 built-in measurement functions, including DCV, ACV, DCI, ACI, 2WΩ, 4WΩ, temperature, frequency, period, dB, dBm, continuity measurement, and diode testing. A built-in RS-232 interface connects to a notebook or full-sized PC's serial port to take, store, process, and display measurements automatically.

General-purpose instrument that's as easy to operate as it is to afford

- 13 built-in measurement functions
- 2000 readings/second at 4½ digits
- Optional scanner cards for multipoint measurements
- GPIB and RS-232 interfaces
- Fluke 8840/42 command set

Ordering Information

2000 6½-Digit DMM
2000/2000-SCAN 6½-Digit DMM/
 Scanner Combination

Accessories Supplied

Instruction Manual and Model
 1751 Safety Test Leads

ACCESSORIES AVAILABLE

2000-SCAN	10-channel, General-Purpose Scanner Card
2001-SCAN	10-channel Scanner Card with two high-speed channels
2001-TCSCAN	9-channel, Thermocouple Scanner Card with built-in cold junction

CABLES/ADAPTERS

7007-1	Shielded IEEE-488 Cable, 1m (3.3 ft)
7007-2	Shielded IEEE-488 Cable, 2m (6.6 ft)
7009-5	RS-232 Cable

RACK MOUNT KITS

4288-1	Single Fixed Rack Mount Kit
4288-2	Dual Fixed Rack Mount Kit

GPIB INTERFACES

KPCI-488LPA	IEEE-488 Interface/Controller for the PCI Bus
KUSB-488B	IEEE-488 USB-to-GPIB Interface Adapter

SERVICES AVAILABLE

2000-SCAN-3Y-EW	1-year factory warranty extended to 3 years from date of shipment
2000-3Y-EW	1-year factory warranty extended to 3 years from date of shipment
2001-TCSCAN-3Y-EW	1-year factory warranty extended to 3 years from date of shipment
C/2000-3Y-ISO	3 (ISO-17025 accredited) calibrations within 3 years of purchase for Models 2000, 2000-SCAN*
C/2001-3Y-ISO	3 (ISO-17025 accredited) calibrations within 3 years of purchase for Model 2001-TCSCAN*

*Not available in all countries

1.888.KEITHLEY (U.S. only)

www.keithley.com

KEITHLEY

A Tektronix Company

A Greater Measure of Confidence

2000

6½-Digit Multimeter

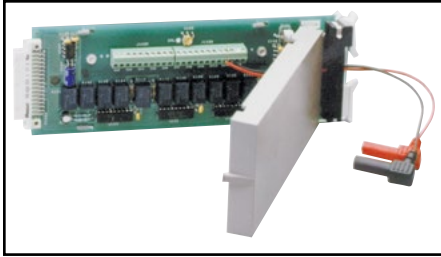

Optional Multiplexer Cards

Creating a self-contained multipoint measurement solution is as simple as plugging a scanner card into the option slot on the 2000's back panel. This approach eliminates the complexities of triggering, timing, and processing issues and helps reduce test time significantly. For applications involving more than 10 measurement points, the 2000 is compatible with Keithley's Series 7000 switch matrices and cards.

Model 2000-SCAN Scanner Card

- Ten analog input channels (2-pole)
- Configurable as 4-pole, 5-channel

Model 2001-SCAN Scanner Card

- Ten analog input channels
- Two channels of 2-pole, high-speed, solid-state switching

Model 2001-TCSCAN Thermocouple Scanner Card

- Nine analog input channels
- Built-in temperature reference for thermocouple cold-junction compensation

SCANNER OPTION 2000-SCAN

GENERAL: 10 channels of 2-pole relay input. All channels configurable to 4-pole.

CAPABILITIES: Multiplex one of ten 2-pole or one of five 4-pole signals into DMM.

INPUTS

Maximum Signal Level:

DC Signals: 110V DC, 1A switched, 30VA maximum (resistive load).

AC Signals: 125V AC rms or 175V AC peak, 100kHz maximum, 1A switched, 62.5VA maximum (resistive load).

Contact Life: >10⁸ operations at maximum signal level; >10⁸ operations cold switching.

Contact Resistance: <1Ω at end of contact life.

Actuation Time: 2.5ms maximum on/off.

Contact Potential: <±500nV typical per contact, 1μV max. <±500nV typical per contact pair, 1μV max.

Connector Type: Screw terminal, #22 AWG wire size.

Isolation Between Any Two Terminals: >10⁹Ω, <75pF.

Isolation Between Any Terminal and Earth: >10⁹Ω, <150pF.

Common Mode Voltage: 350V peak between any terminal and earth.

Maximum Voltage Between Any Two Terminals: 200V peak.

Maximum Voltage Between Any Terminal and Model 2001 Input LO: 200V peak.

ENVIRONMENTAL: Meets all Model 2000 environmental specifications.

DIMENSIONS, WEIGHT: 21mm high × 72mm wide × 221mm deep (0.83 in. × 2.83 in. × 8.7 in.). Adds 0.4kg (10 oz.).

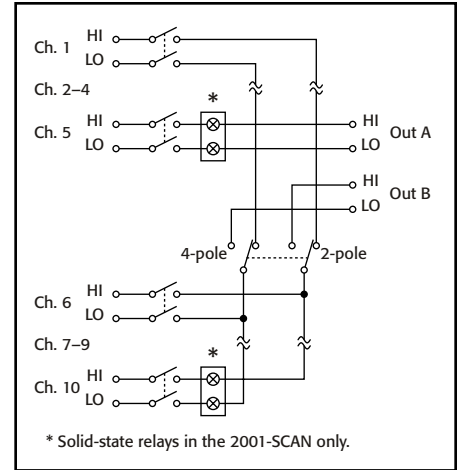

Scanner Configuration for Models 2000-SCAN and 2001-SCAN

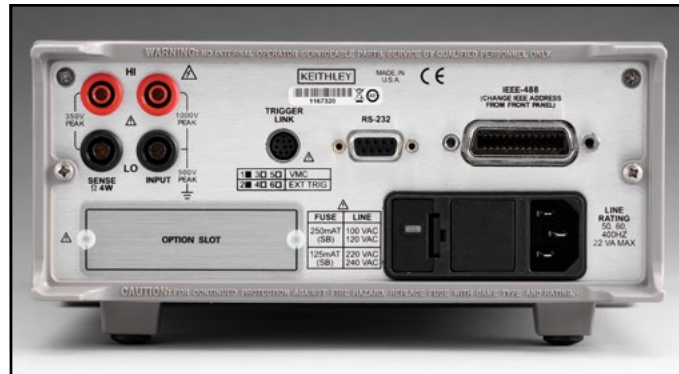

1.888.KEITHLEY (U.S. only)

www.keithley.com

A Greater Measure of Confidence

KEITHLEY
A Tektronix Company

General-purpose instrument that's as easy to operate as it is to afford

DIGITAL MULTIMETERS & SYSTEMS

DC Characteristics

Conditions: MED (1 PLC)¹ or SLOW (10 PLC) or MED (1 PLC) with filter of 10

Accuracy: ±(ppm of reading + ppm of range)
(ppm = parts per million)
(e.g., 10ppm = 0.001%)

Function	Range	Resolution	Test Current or Burden Voltage (±5%)	Input Resistance	Accuracy			Temperature Coefficient 0°–18°C and 28°–50°C
					24 Hour ¹⁴ 23°C ± 1°	90 Day 23°C ± 5°	1 Year 23°C ± 5°	
Voltage	100.0000 mV	0.1 μV		> 10 GΩ	30 + 30	40 + 35	50 + 35	2 + 6
	1.000000 V	1.0 μV		> 10 GΩ	15 + 6	25 + 7	30 + 7	2 + 1
	10.00000 V	10 μV		> 10 GΩ	15 + 4	20 + 5	30 + 5	2 + 1
	100.0000 V	100 μV		10 MΩ ±1%	15 + 6	30 + 6	45 + 6	5 + 1
	1000.000 V ⁹	1 mV		10 MΩ ±1%	20 + 6	35 + 6	45 + 6	5 + 1
Resistance ¹⁵	100.0000 Ω	100 μΩ	1 mA		30 + 30	80 + 40	100 + 40	8 + 6
	1.000000 kΩ	1 mΩ	1 mA		20 + 6	80 + 10	100 + 10	8 + 1
	10.00000 kΩ	10 mΩ	100 μA		20 + 6	80 + 10	100 + 10	8 + 1
	100.0000 kΩ	100 mΩ	10 μA		20 + 6	80 + 10	100 + 10	8 + 1
	1.000000 MΩ ¹⁶	1 Ω	10 μA		20 + 6	80 + 10	100 + 10	8 + 1
	10.00000 MΩ ^{11, 16}	10 Ω	700 nA // 10MΩ		150 + 6	200 + 10	400 + 10	95 + 1
	100.0000 MΩ ^{11, 16}	100 Ω	700 nA // 10MΩ		800 + 30	1500 + 30	1500 + 30	900 + 1
Current	10.00000 mA	10 nA	< 0.15 V		60 + 30	300 + 80	500 + 80	50 + 5
	100.0000 mA	100 nA	< 0.03 V		100 + 300	300 + 800	500 + 800	50 + 50
	1.000000 A	1 μA	< 0.3 V		200 + 30	500 + 80	800 + 80	50 + 5
	3.00000 A	10 μA	< 1 V		1000 + 15	1200 + 40	1200 + 40	50 + 5
Continuity 2W	1 kΩ	100 mΩ	1 mA		40 + 100	100 + 100	120 + 100	8 + 1
Diode Test	3.00000 V	10 μV	1 mA		20 + 6	30 + 7	40 + 7	8 + 1
	10.00000 V	10 μV	100 μA		20 + 6	30 + 7	40 + 7	8 + 1
	10.00000 V	10 μV	10 μA		20 + 6	30 + 7	40 + 7	8 + 1

DC OPERATING CHARACTERISTICS²

Function	Digits	Readings/s	PLCs ⁸
DCV (all ranges),	6 ¹ / ₂ ^{3, 4}	5	10
DCI (all ranges), and	6 ¹ / ₂ ^{3, 7}	30	1
Ohms (<10M range)	6 ¹ / ₂ ^{3, 5}	50	1
	5 ¹ / ₂ ^{3, 5}	270	0.1
	5 ¹ / ₂ ⁵	500	0.1
	5 ¹ / ₂ ⁵	1000	0.04
	4 ¹ / ₂ ⁵	2000	0.01

DC SYSTEM SPEEDS^{2, 6}

RANGE CHANGE³: 50/s.

FUNCTION CHANGE³: 45/s.

AUTORANGE TIME^{3, 10}: <30ms.

ASCII READINGS TO RS-232 (19.2K BAUD): 55/s.

MAX. INTERNAL TRIGGER RATE: 2000/s.

MAX. EXTERNAL TRIGGER RATE: 400/s.

DC GENERAL

LINEARITY OF 10VDC RANGE: ±(1ppm of reading + 2ppm of range).

DCV, Ω, TEMPERATURE, CONTINUITY, DIODE TEST INPUT PROTECTION: 1000V, all ranges.

MAXIMUM 4WΩ LEAD RESISTANCE: 10% of range per lead for 100Ω and 1kΩ ranges; 1kΩ per lead for all other ranges.

DC CURRENT INPUT PROTECTION: 3A, 250V fuse.

SHUNT RESISTOR: 0.1Ω for 3A, 1A, and 100mA ranges. 10Ω for 10mA range.

CONTINUITY THRESHOLD: Adjustable 1Ω to 1000Ω.

AUTOZERO OFF ERROR: Add ±(2ppm of range error + 5μV) for <10 minutes and ±1°C change.

OVERRANGE: 120% of range except on 1000V, 3A, and diode.

SPEED AND NOISE REJECTION

Rate	Readings/s	Digits	RMS Noise 10V	NMRR ¹²	CMRR ¹³
			Range		
10 PLC	5	6 ¹ / ₂	< 1.5 μV	60 dB	140 dB
1 PLC	50	6 ¹ / ₂	< 4 μV	60 dB	140 dB
0.1 PLC	500	5 ¹ / ₂	< 22 μV	—	80 dB
0.01 PLC	2000	4 ¹ / ₂	< 150 μV	—	80 dB

DC NOTES

- Add the following to "ppm of range" uncertainty: 1V and 100V, 2ppm; 100mV, 15ppm; 100Ω, 15ppm; 1kΩ–<1MΩ, 2ppm; 10mA and 1A, 10ppm; 100mA, 40ppm.
- Speeds are for 60Hz operation using factory default operating conditions (*RST). Autorange off, Display off, Trigger delay = 0.
- Speeds include measurement and binary data transfer out the GPIB.
- Auto zero off.
- Sample count = 1024, auto zero off.
- Auto zero off, NPLC = 0.01.
- Ohms = 24 readings/second.
- 1 PLC = 16.67ms @ 60Hz, 20ms @ 50Hz/400Hz. The frequency is automatically determined at power up.
- For signal levels >500V, add 0.02ppm/V uncertainty for the portion exceeding 500V.
- Add 120ms for ohms.
- Must have 10% matching of lead resistance in Input HI and LO.
- For line frequency ±0.1%.
- For 1kΩ unbalance in LO lead.
- Relative to calibration accuracy.
- Specifications are for 4-wire ohms. For 2-wire ohms, add 1Ω additional uncertainty.
- For rear inputs, add the following to temperature coefficient "ppm of reading" uncertainty 10MΩ 95ppm, 100MΩ 900ppm. Operating environment specified for 0° to 50°C and 50% RH at 35°C.

1.888.KEITHLEY (U.S. only)

www.keithley.com

KEITHLEY

A Tektronix Company

A Greater Measure of Confidence

True RMS AC Voltage and Current Characteristics

		Accuracy ¹ : ±(% of reading + % of range), 23°C ±5 °C					
Voltage Range	Resolution	Calibration Cycle	3 Hz–10 Hz ¹⁰	10 Hz–20 kHz	20 kHz–50 kHz	50 kHz–100 kHz	100 kHz–300 kHz
100.0000 mV	0.1 μV						
1.000000 V	1.0 μV	90 Days	0.35 + 0.03	0.05 + 0.03	0.11 + 0.05	0.60 + 0.08	4 + 0.5
10.00000 V	10 μV						
100.0000 V	100 μV	1 Year	0.35 + 0.03	0.06 + 0.03	0.12 + 0.05	0.60 + 0.08	4 + 0.5
750.000 V	1 mV						
Temperature Coefficient/°C⁸			0.035 + 0.003	0.005 + 0.003	0.006 + 0.005	0.01 + 0.006	0.03 + 0.01

Current Range	Resolution	Calibration Cycle	3 Hz–10 Hz	10 Hz–3 kHz	3 kHz–5 kHz
1.000000 A	1 μA	90 Day/1 Year	0.30 + 0.04	0.10 + 0.04	0.14 + 0.04
3.00000 A ⁹	10 μA	90 Day/1 Year	0.35 + 0.06	0.15 + 0.06	0.18 + 0.06
Temperature Coefficient/°C⁸			0.035 + 0.006	0.015 + 0.006	0.015 + 0.006

HIGH CREST FACTOR ADDITIONAL ERROR ±(% of reading)⁷

CREST FACTOR:	1–2	2–3	3–4	4–5
ADDITIONAL ERROR:	0.05	0.15	0.30	0.40

AC OPERATING CHARACTERISTICS²

Function	Digits	Readings/s	Rate	Bandwidth
ACV (all ranges), and	6½ ³	2s/reading	SLOW	3 Hz–300 kHz
ACI (all ranges)	6½ ³	1.4	MED	30 Hz–300 kHz
	6½ ⁴	4.8	MED	30 Hz–300 kHz
	6½ ³	2.2	FAST	300 Hz–300 kHz
	6½ ⁴	35	FAST	300 Hz–300 kHz

ADDITIONAL LOW FREQUENCY ERRORS ±(% of reading)

	Slow	Med	Fast
20 Hz – 30 Hz	0	0.3	—
30 Hz – 50 Hz	0	0	—
50 Hz – 100 Hz	0	0	1.0
100 Hz – 200 Hz	0	0	0.18
200 Hz – 300 Hz	0	0	0.10
> 300 Hz	0	0	0

AC SYSTEM SPEEDS^{2, 5}

FUNCTION/RANGE CHANGE⁴: 4/s.
 AUTORANGE TIME: <3s.
 ASCII READINGS TO RS-232 (19.2K BAUD)⁴: 50/s.
 MAX. INTERNAL TRIGGER RATE⁴: 300/s.
 MAX. EXTERNAL TRIGGER RATE⁴: 300/s.

AC GENERAL

INPUT IMPEDANCE: 1MΩ ±2% paralleled by <100pF.
 ACV INPUT PROTECTION: 1000Vp.
 MAXIMUM DCV: 400V on any ACV range.
 ACI INPUT PROTECTION: 3A, 250V fuse.
 BURDEN VOLTAGE: 1A Range: <0.3V rms. 3A Range: <1V rms.
 SHUNT RESISTOR: 0.1Ω on all ACI ranges.
 AC CMRR: >70dB with 1kΩ in LO lead.
 MAXIMUM CREST FACTOR: 5 at full scale.
 VOLT HERTZ PRODUCT: ≤8 × 10⁷ V·Hz.
 OVERRANGE: 120% of range except on 750V and 3A ranges.

AC NOTES

- Specifications are for SLOW rate and sine wave inputs >5% of range.
- Speeds are for 60Hz operation using factory default operating conditions (*RST). Auto zero off, Auto range off, Display off, includes measurement and binary data transfer out the GPIB.
- 0.01% of step settling error. Trigger delay = 400ms.
- Trigger delay = 0.
- DETECTOR: BANDwidth 300, NPLC = 0.01.
- Maximum useful limit with trigger delay = 175ms.
- Applies to non-sinewaves >5Hz and <500Hz (guaranteed by design for crest factors >4.3).
- Applies to 0°–18°C and 28°–50°C.
- For signal levels >2.2A, add additional 0.4% to “of reading” uncertainty.
- Typical uncertainties. Typical represents two sigma or 95% of manufactured units measure <0.35% of reading and three sigma or 99.7% measure <1.06% of reading.

Triggering and Memory

READING HOLD SENSITIVITY: 0.01%, 0.1%, 1%, or 10% of reading.

TRIGGER DELAY: 0 to 99 hrs (1ms step size).

EXTERNAL TRIGGER LATENCY: 200 μ s + <300 μ s jitter with autozero off, trigger delay = 0.

MEMORY: 1024 readings.

Math Functions

Rel, Min/Max/Average/StdDev (of stored reading), dB, dBm, Limit Test, %, and mX+b with user defined units displayed.

DBM REFERENCE RESISTANCES: 1 to 9999 Ω in 1 Ω increments.

Standard Programming Languages

SCPI (Standard Commands for Programmable Instruments)

Keithley 196/199

Fluke 8840A, Fluke 8842A

Remote Interface

GPIO (IEEE-488.1, IEEE-488.2) and RS-232C.

Frequency and Period Characteristics ^{1, 2}

ACV Range	Frequency Range	Period Range	Gate Time	Resolution \pm (ppm of reading)	Accuracy 90 Day/1 Year \pm (% of reading)
100 mV to 750 V	3 Hz to 500 kHz	333 ms to 2 μ s	1 s (SLOW)	0.3	0.01

FREQUENCY NOTES

- Specifications are for square wave inputs only. Input signal must be >10% of ACV range. If input is <20mV on the 100mV range, then frequency must be >10Hz.
- 20% overrange on all ranges except 750V range.

Temperature Characteristics

Thermocouple ^{2, 3, 4}

Type	Range	Resolution	Accuracy ¹	
			Relative to Reference Junction	Using 2001-TCSCAN ⁵
J	-200 to + 760°C	0.001°C	$\pm 0.5^\circ\text{C}$	$\pm 0.65^\circ\text{C}$
K	-200 to +1372°C	0.001°C	$\pm 0.5^\circ\text{C}$	$\pm 0.70^\circ\text{C}$
T	-200 to + 400°C	0.001°C	$\pm 0.5^\circ\text{C}$	$\pm 0.68^\circ\text{C}$

TEMPERATURE NOTES

- For temperatures <-100°C, add $\pm 0.1^\circ\text{C}$ and >900°C add $\pm 0.3^\circ\text{C}$.
- Temperature can be displayed in °C, K or °F.
- Accuracy based on ITS-90.
- Exclusive of thermocouple error.
- Specifications apply to channels 2–6. Add 0.06°C/channel from channel 6.

GENERAL

POWER SUPPLY: 100V / 120V / 220V / 240V.

LINE FREQUENCY: 50Hz to 60Hz and 400Hz, automatically sensed at power-up.

POWER CONSUMPTION: 22VA.

VOLT HERTZ PRODUCT: $\leq 8 \times 10^7 \text{V}\cdot\text{Hz}$.

OPERATING ENVIRONMENT: Specified for 0°C to 50°C. Specified to 80% R.H. at 35°C and at an altitude of up to 2000m.

STORAGE ENVIRONMENT: -40°C to 70°C.

SAFETY: Conforms to European Union Low Voltage Directive.

EMC: Conforms to European Union EMC Directive.

WARMUP: 1 hour to rated accuracy.

VIBRATION: MIL-PRF-2800F Class 3 Random.

DIMENSIONS:

Rack Mounting: 89mm high \times 213mm wide \times 370mm deep (3.5 in \times 8.38 in \times 14.56 in).

Bench Configuration (with handle and feet): 104mm high \times 238mm wide \times 370mm deep (4.13 in \times 9.38 in \times 14.56 in).

NET WEIGHT: 2.9kg (6.3 lbs).

SHIPPING WEIGHT: 5kg (11 lbs).

1.888.KEITHLEY (U.S. only)

www.keithley.com

KEITHLEY

A Tektronix Company

A Greater Measure of Confidence

2001
2002

7½-Digit High Performance Multimeter 8½-Digit High Performance Multimeter



- True 7½- (Model 2001) or 8½-digit (Model 2002) resolution
- Exceptional measurement integrity with high speed
- High speed function and range changing
- Broad range of built-in measurement functions
- Multiple measurement display
- Built-in 10 channel scanner option
- GPIB interface
- HP3458A emulation mode (Model 2002)

DMM users whose applications demand exceptional resolution, accuracy, and sensitivity combined with high throughput now have two attractive alternatives to high priced, high end DMMs. Keithley's 7½-digit Model 2001 and 8½-digit Model 2002 High Performance Digital Multimeters not only deliver performance specifications usually associated with instruments that cost thousands more, but they also offer a broad range of functions not typically available from DMMs. The 2002 is based on the same superior measurement technology as the 2001, and the front panels of both instruments have the same look, feel, and response.

True 7½- (or 8½-) Digit Resolution

While other DMMs may claim 7½- or 8½-digit resolution, they must average multiple readings to extend their resolution. The resolution specifications of the 2001 and 2002 are based on a 28-bit A/D converter that provides the resolution needed to discern smaller changes. This higher resolution also provides greater dynamic range, making it possible to measure from 1μV to 20V on a single range, thus avoiding range-shift errors and delays.

Built-In Scanner (Multiplexer) Options

With the addition of a plug-in scanner card, the 2001 or 2002 becomes a complete scan and measure system for applications involving up to ten measurement points. The additional resolution and measurement ranges provided by the 2002 make it an excellent choice for production test, design verification, and metrology applications where high accuracy is critical.



and metrology applications where high accuracy is critical.

High Accuracy ACV Measurements

A patented circuit design makes the 2001 and 2002's AC measurements several times more accurate than competitive DMMs. In this circuit, the signal bypasses the prime error-contributing section of conventional rms converters. This increases the accuracy at almost any voltage level, and also increases sensitivity down to a guaranteed 1% of the selected range, compared to 5–10% for most other DMMs. The result is highly accurate measurements over a broad range of inputs.

Applications involving vibration, servo, guidance, shock, and control systems often require accurate low frequency ACV measurements. The 2001 and 2002 maintain very good accuracy (better than 0.1%) down to 1Hz. The wide bandwidth of these DMMs allows for accurate measurements of high frequency AC signals without the need for a special AC meter. Both the 2001 and 2002 feature TRMS AC, average AC, peak AC, AC+DC, and crest factor measurement capability for a wide variety of applications.

High Speed for High Throughput

In applications where high throughput is critical, both the 2001 and 2002 provide more than 2000 readings per second at 4½-digit resolution. At 7½ digits, the 2002 maintains full rated accuracy at reading rates up to 44/second on DCV and ohms.

High Speed, High Precision Resistance Measurements

The Model 2002 uses a unique single-phase method for 4-wire ohms measurements. This makes it twice as fast for a given power line cycle rate. This also eliminates errors due to changing lead resistances that can result from fast test handlers. A built-in open-lead detection circuit also eliminates many production test problems.

Fast, Flexible Triggering

Trigger latency—the delay between trigger and measurement—is often a barrier to higher throughput. Also, variability in latency can complicate predicting measurement timing. The 2001 and 2002 trigger is less than 2μs±1μs, which is much faster than typical system DMMs.

1.888.KEITHLEY (U.S. only)

www.keithley.com

A Greater Measure of Confidence

KEITHLEY

A Tektronix Company

High resolution, high accuracy DMMs

DIGITAL MULTIMETERS & SYSTEMS

**2001
2002**

7½-Digit High Performance Multimeter 8½-Digit High Performance Multimeter

Ordering Information

2001 High Performance 7½-Digit DMM with 8K Memory

2002 High Performance 8½-Digit DMM with 8K Memory

**2000-SCAN
10-channel Scanner Card**

**2001-SCAN
10-channel Scanner Card with two high-speed channels**

**2001-TCSCAN
9-channel Thermocouple Scanner Card**

**2001/MEM1
High Performance 7½-Digit DMM with 32K Memory**

**2001/MEM2
High Performance 7½-Digit DMM with 128K Memory**

**2002/MEM1
High Performance 8½-Digit DMM with 32K Memory**

**2002/MEM2
High Performance 8½-Digit DMM with 128K Memory**

Accessories Supplied

Model 8605 High Performance Modular Test Leads, user's manual, option slot cover, and full calibration data.

For more information, request the Model 2001 and 2002 Technical Specifications books.

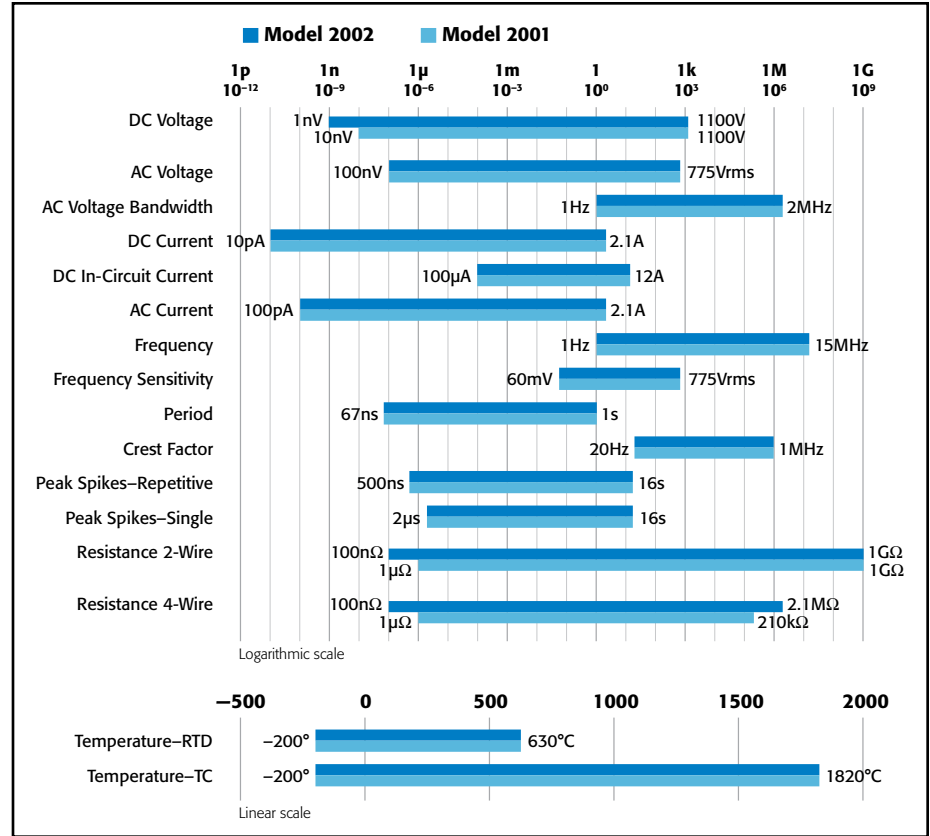

Both the 2001 and 2002 provide exceptional measurement range. In addition, the 2002 offers extended DCV and resistance measurement capabilities.

The unique Trigger-Link feature included in the Model 2001 and 2002 and most Keithley test and measurement products can be used to coordinate the operation of two or more instruments. Trigger-Link combines six independent software selectable trigger lines on a single connector for simple, direct control over all instruments in a system.

Spot Trends with the Bar-Graph Display

The ability to track reading trends around a target value easily can be just as important as the absolute readings. A unique bar-graph display function in the 2001 and 2002 indicates data as a percentage of the selected range from ±0.01% to ±100%. Whether adjusting about zero or any other desired value, this display can replace a nulling differential voltmeter.

Capture Spikes Down to 1µs

Both the 2001 and 2002 have internal peak detectors that can catch 1µs spikes such as power supply spikes and transients, AC line power surges, and short-duration dropouts on components. These peak detectors operate up to 1MHz for repetitive signals or down to 1µs for single spikes, so there is no need for a separate scope. The DMMs can automatically display and store the highest value or display the maximum and minimum values of spikes.

Built-in Features and Capabilities

The 2001 and 2002 offer many built-in measurements that are typically unavailable in instruments of this type, including in-circuit current, temperature with thermocouples or RTDs, and peak spikes. Four separate outputs linked to limits simplify configuring the DMMs for use in binning operations.

High resolution, high accuracy DMMs

DIGITAL MULTIMETERS & SYSTEMS

1.888.KEITHLEY (U.S. only)

www.keithley.com

KEITHLEY
A Tektronix Company

A Greater Measure of Confidence

2001 2002

7½-Digit High Performance Multimeter 8½-Digit High Performance Multimeter

The built-in AC crest factor measurement helps ensure the accuracy of AC measurements. Other DMMs typically perform AC measurements for signals without excessive crest factor—the ratio of peak value to rms values. However, when crest factor rises, measurements may not meet specs. With a 2001 or 2002, there is no need for an oscilloscope to determine if the crest factor is acceptable—the DMM measures it directly.

While some DMMs calculate average AC from the rms value, these calculations apply only to sine wave inputs. The 2001 and 2002 measure peak value, average and true rms directly to obtain a complete characterization of the signal. This capability makes these DMMs ideal for AC circuit design or test applications and for verifying test voltages specified only in averages.

When measuring AC or digital signals, frequency is critical. The 2001 and 2002 accurately measure frequency up to 15MHz. Accurate triggering on the signal is critical to measure frequency reliably. The frequency counters in the 2001

and 2002 have a fully adjustable trigger level for good measurements of noisy signals.

Multiple Measurement Display

The 2001 and 2002 can display DC and AC volts and the AC frequency from a single measurement connection simultaneously. Several other multiple-measurement displays are available, including crest factor and bar graph. By measuring sequentially and displaying simultaneously, the 2001/2002 operates as if three different meters are working together.

Option Slot Extends DMM Performance

An option slot in the back of the 2001 and 2002 opens the door to a wide range of measurement capabilities. Choose a 10-channel general-purpose scanner card or a 9-channel thermocouple scanner card to make measurements on multiple test points or devices. This can eliminate the need for a separate scanner and significantly reduce programming and setup time.

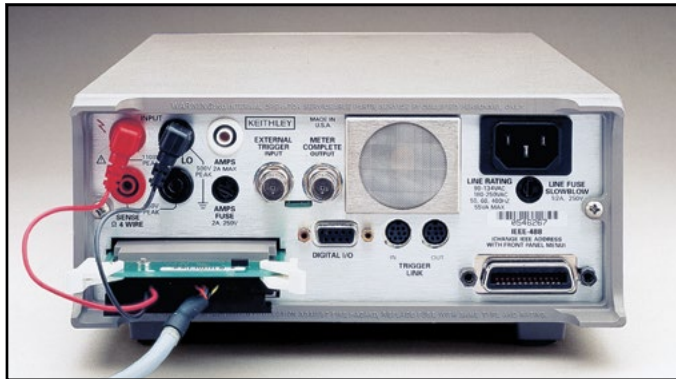

ACCESSORIES AVAILABLE

TEST LEADS AND PROBES

5805	Kelvin Probes, 0.9m (3ft)
5805-12	Kelvin Probes, 3.6m (12ft)
5808	Low Cost, Single Pin, Kelvin Probes
5809	Low Cost, Kelvin Clip Lead Set
8502	Micro-DIN to 6 BNCs Adapter Box with 8501-1 Cable
8530	Centronics Adapter
8605	High Performance 2-Wire Modular Test Leads
8606	High Performance Modular Probe Kit
8610	Low Thermal Shorting Plug
8680	RTD Probe Adapter
8681	Low Cost RTD

CABLES/ADAPTERS

7007-1	Shielded GPIB Cable, 1m (3.3 ft)
7007-2	Shielded GPIB Cable, 2m (6.6 ft)
8501-1	Trigger-Link Cable, 1m (3.3 ft)
8501-2	Trigger Link Cable, 2m (6.6 ft)
8502	Trigger Link Adapter Box
8610	Low Thermal Shorting Plug
8620	4-Wire DMM Shorting Plug

RACK MOUNT KITS

4288-1	Single Fixed Rack Mount Kit
4288-4	Side-by-Side Rack Mount Kit

GPIB INTERFACES

KPCI-488LPA	IEEE-488 Interface Controller for the PCI Bus
KUSB-488B	IEEE-488 USB-to-GPIB Interface Adapter

SERVICES AVAILABLE

2000-SCAN-3Y-EW	1-year factory warranty extended to 3 years from date of shipment
2001/MEM1-3Y-EW	1-year factory warranty extended to 3 years from date of shipment
2001/MEM2-3Y-EW	1-year factory warranty extended to 3 years from date of shipment
2001-SCAN-3Y-EW	1-year factory warranty extended to 3 years from date of shipment
2001-TCSCAN-3Y-EW	1-year factory warranty extended to 3 years from date of shipment
2001-3Y-EW	1-year factory warranty extended to 3 years from date of shipment
2002/MEM1-3Y-EW	1-year factory warranty extended to 3 years from date of shipment
2002/MEM2-3Y-EW	1-year factory warranty extended to 3 years from date of shipment
2002-3Y-EW	1-year factory warranty extended to 3 years from date of shipment
C/2000-3Y-ISO	3 (ISO-17025 accredited) calibrations within 3 years of purchase for Model 2000-SCAN*
C/2001-3Y-ISO	3 (ISO-17025 accredited) calibrations within 3 years of purchase for Models 2001, 2001/MEM1, 2001/MEM2, 2001-SCAN, 2001-TCSCAN*
C/2002-3Y-ISO	3 (ISO-17025 accredited) calibrations within 3 years of purchase for Models 2002, 2002/MEM1, 2002/MEM2*

*Not available in all countries

1.888.KEITHLEY (U.S. only)

www.keithley.com

KEITHLEY

A Greater Measure of Confidence

A Tektronix Company

High resolution, high accuracy DMMs

DIGITAL MULTIMETERS & SYSTEMS

2001 2002

7½-Digit High Performance Multimeter 8½-Digit High Performance Multimeter

2001 Condensed Specifications

DC VOLTS

DCV INPUT CHARACTERISTICS AND ACCURACY

Range	Full Scale	Resolution	Default Resolution	Input Resistance	Accuracy ±(ppm of reading + ppm of range)				
					5	24	90	1	2
					Minutes ⁴	Hours ¹	Days ²	Year ²	Years ²
200 mV ³	±210.00000 mV	10 nV	100 nV	>10 GΩ	3 + 3	10 + 6	25 + 6	37 + 6	50 + 6
2 V	±2.1000000 V	100 nV	1 μV	>10 GΩ	2 + 1.5	7 + 2	18 + 2	25 + 2	32 + 2
20 V	±21.000000 V	1 μV	10 μV	>10 GΩ	2 + 1.5	7 + 4	18 + 4	24 + 4	32 + 4
200 V	±210.00000 V	10 μV	100 μV	10 MΩ ±1%	2 + 1.5	13 + 3	27 + 3	38 + 3	52 + 3
1000 V	±1100.0000 V	100 μV	1 mV	10 MΩ ±1%	10 + 1.5	17 + 6	31 + 6	41 + 6	55 + 6

DC VOLTS NOTES

- For T_{CAL} ±1°C, following 55-minute warm-up. T_{CAL} is ambient temperature at calibration, which is 23°C from factory.
- For T_{CAL} ±5°C, following 55-minute warm-up. Specifications include factory traceability to US NIST.
- When properly zeroed using REL function.
- DCV Transfer Stability typical applications are standard cell comparisons and relative accuracy measurements. Specs apply for 10 power line cycles, 20-reading digital filter, autozero on with type synchronous, fixed range following 2-hour warm-up at full scale to 10% of full scale, at T_{REF} ±1°C (T_{REF} is the initial ambient temperature). Specifications on the 1000V range are for measurements within 5% of the initial measurement value and following measurement settling.

AC VOLTS

Normal Mode RMS¹ 90 Days, ±2°C from last AC self-cal for 1% to 100% of range² ±(% of reading + % of range)

Range	20–50Hz	50–100Hz	0.1–2kHz	2–10kHz	10–30kHz	30–50kHz	50–100kHz	100–200kHz	0.2–1MHz	1–2MHz
200 mV	0.25 + 0.015	0.07 + 0.015	0.03 + 0.015	0.03 + 0.015	0.035 + 0.015	0.05 + 0.015	0.3 + 0.015	0.75 + 0.025	2 + 0.1	5 + 0.2
2 V	0.25 + 0.015	0.07 + 0.015	0.03 + 0.015	0.03 + 0.015	0.035 + 0.015	0.05 + 0.015	0.3 + 0.015	0.75 + 0.025	2 + 0.1	5 + 0.2
20 V	0.25 + 0.015	0.07 + 0.015	0.04 + 0.015	0.06 + 0.015	0.08 + 0.015	0.1 + 0.015	0.3 + 0.015	0.75 + 0.025	4 + 0.2	7 + 0.2 ⁴
200 V ³	0.25 + 0.015	0.07 + 0.015	0.04 + 0.015	0.06 + 0.015	0.08 + 0.015	0.1 + 0.015	0.3 + 0.015	0.75 + 0.025 ⁴	4 + 0.2 ⁴	
750 V ³	0.25 + 0.015	0.1 + 0.015	0.08 + 0.015	0.09 + 0.015	0.12 + 0.015	0.15 + 0.015 ⁴	0.5 + 0.015 ⁴			

AC VOLTS NOTES

- Specifications apply for sinewave input, AC + DC coupling, 1 power line cycle, digital filter off, following 55 minute warm-up.
- For 1% to 5% of range below 750V range, and for 1% to 7% of 750V range, add 0.01% to range uncertainty. For inputs from 200kHz to 2MHz, specifications apply above 10% of range.
- Add 0.001% of reading × (V_{IN}/100V)² additional uncertainty above 100V rms.
- Typical values.

OHMS

TWO-WIRE AND FOUR-WIRE OHMS (2W and 4W Ohms Functions)⁶

Range	Full Scale	Resolution	Default Resolution	Current Source ¹	Resistance Accuracy ³ ±(ppm of reading + ppm of range)			
					24 Hours ⁴	90 Days ⁵	1 Year ⁵	2 Years ⁵
					20 Ω	21.000000 Ω	1 μΩ	10 μΩ
200 Ω	210.00000 Ω	10 μΩ	100 μΩ	0.98 mA	24 + 7	36 + 7	56 + 7	90 + 7
2 kΩ	2100.0000 kΩ	100 μΩ	1 mΩ	0.98 mA	22 + 4	33 + 4	50 + 4	80 + 4.5
20 kΩ	21.000000 kΩ	1 mΩ	10 mΩ	89 μA	19 + 4	32 + 4	50 + 4	80 + 4.5
200 kΩ	210.00000 kΩ	10 mΩ	100 mΩ	7 μA	20 + 4.5	72 + 4.5	90 + 4.5	130 + 5
2 MΩ ²	2.1000000 MΩ	100 mΩ	1 Ω	770 nA	50 + 4.5	110 + 4.5	160 + 4.5	230 + 5
20 MΩ ²	21.000000 MΩ	1 Ω	10 Ω	70 nA	160 + 4.5	560 + 4.5	900 + 4.5	1100 + 5
200 MΩ ²	210.00000 MΩ	10 Ω	100 Ω	4.4 nA	3000 + 100	10000 + 100	20000 + 100	30000 + 100
1 GΩ ²	1.0500000 GΩ	100 Ω	1 kΩ	4.4 nA	9000 + 100	20000 + 100	40000 + 100	60000 + 100

OHMS NOTES

- Current source is typically ±9% absolute accuracy.
- For 2-wire mode.
- Specifications are for 1 power line cycle, 10 reading digital filter, Auto Zero on, 4-wire mode, offset compensation on (for 20Ω to 20kΩ ranges).
- For T_{CAL} ±1°C, following 55 minute warm-up. T_{CAL} is ambient temperature at calibration (23°C at the factory).
- For T_{CAL} ±5°C, following 55-minute warm-up. Specifications include traceability to US NIST.
- When measuring resistance of inductive loads, the inductance of that load must be 10mH or less.

DC AMPS

DCI INPUT CHARACTERISTICS AND ACCURACY⁴

Range	Full Scale	Resolution	Default Resolution	Maximum Burden Voltage ⁶	Accuracy ¹ ±(ppm of reading + ppm of range)			
					24 Hours ²	90 Days ³	1 Year ³	2 Years ³
					200 μA	210.00000 μA	10 pA	100 pA
2 mA	2.1000000 mA	100 pA	1 nA	0.31 V	64 + 20	300 + 20	400 + 20	750 + 20
20 mA	21.000000 mA	1 nA	10 nA	0.4 V	65 + 20	300 + 20	400 + 20	750 + 20
200 mA	210.00000 mA	10 nA	100 nA	0.5 V	96 + 20	300 + 20	500 + 20	750 + 20
2 A	2.1000000 A	100 nA	1 μA	1.5 V	500 + 20	600 + 20	900 + 20	1350 + 20

DC AMPS NOTES

- Specifications are for 1 power line cycle, Auto Zero on, 10 reading digital filter.
- For T_{CAL} ±1°C, following 55 minute warm-up.
- For T_{CAL} ±5°C, following 55 minute warm-up. Specifications include traceability to US NIST.
- Add 50 ppm of range for current above 0.5A for self heating.
- Actual maximum voltage burden = (maximum voltage burden) × (I_{MEASURED}/I_{FULL SCALE}).

1.888.KEITHLEY (U.S. only)

www.keithley.com

KEITHLEY
A Tektronix Company

A Greater Measure of Confidence

2001
2002

7½-Digit High Performance Multimeter 8½-Digit High Performance Multimeter

2001 Condensed Specifications (continued)

AC AMPS

ACI ACCURACY^{1,2}

90 Days, 1 Year or 2 Years, T_{cal} ±5°C, for 5% to 100% of range, ±(% of reading + % of range)

RANGE	20Hz–50Hz	50Hz–200Hz	200Hz–1kHz	1kHz–10kHz	10kHz–30kHz ³	30kHz–50kHz ³	50kHz–100kHz ³
200 μA	0.35 + 0.015	0.2 + 0.015	0.4 + 0.015	0.5 + 0.015			
2 mA	0.3 + 0.015	0.15 + 0.015	0.12 + 0.015	0.12 + 0.015	0.25 + 0.015	0.3 + 0.015	0.5 + 0.015
20 mA	0.3 + 0.015	0.15 + 0.015	0.12 + 0.015	0.12 + 0.015	0.25 + 0.015	0.3 + 0.015	0.5 + 0.015
200 mA	0.3 + 0.015	0.15 + 0.015	0.12 + 0.015	0.15 + 0.015	0.5 + 0.015	1 + 0.015	3 + 0.015
2 A	0.35 + 0.015	0.2 + 0.015	0.3 + 0.015	0.45 + 0.015	1.5 + 0.015	4 + 0.015	

AC AMPS NOTES

- Specifications apply for sine wave input, AC+DC coupling, 1 power line cycle, digital filter off, following 55 minute warm-up.
- Add 0.005% of range uncertainty for current above 0.5A rms for self-heating.
- Typical values.

FREQUENCY COUNTER

AC VOLTAGE INPUT: 1Hz–15MHz.

ACCURACY: ±(0.03% of reading).

DC IN-CIRCUIT CURRENT

TYPICAL RANGES: Current: 100μA to 12A. Trace Resistance: 1mΩ to 10Ω typical.

ACCURACY: ±(5% + 2 counts). For 1 power line cycle, Auto Zero on, 10 reading digital filter, T_{cal} ±5°C, after being properly zeroed. 90 days, 1 year or 2 years.

TEMPERATURE

Built-in linearization for J, K, N, T, E, R, S, B thermocouple types to ITS-90 and 100Ω platinum RTDs DIN 43 760 or IPTS-68.

GENERAL

POWER: Voltage: 90–134V and 180–250V, universal self-selecting. **Frequency:** 50Hz, 60Hz, or 400Hz self-identifying. **Consumption:** <5VA.

ENVIRONMENTAL: Operating Temperature: 0° to 50°C. Storage Temperature: –40° to 70°C. Humidity: 80% R.H., 0° to 35°C, per MIL-T-28800E¹ Para 4.5.5.1.2.

PHYSICAL: Case Dimensions: 90mm high × 214mm wide × 369mm deep (3½ in. × 8½ in. × 14½ in.). Net Weight: <4.2kg (<9.2 lbs.). Shipping Weight: <9.1kg (<20 lbs.).

STANDARDS

EMI/RFI: Conforms to VDE 0871B (per Vfg 1046/1984), IEC 801-2. Meets FCC part 15 Class B, CISPR-22 (EN55022).

Safety: Conforms to IEC348, CAN/CSA-C22.2, No. 231, MIL-T-28800E¹. Designed to UL1244.

Note 1: For MIL-T-28800E, applies to Type III, Class 5, Style E.

For complete specifications, refer to the 2001 Technical Data book.

2002 Condensed Specifications

DC VOLTS

DCV INPUT CHARACTERISTICS AND ACCURACY

Enhanced Accuracy¹ – 10PLC, DFILT 10

Relative Accuracy ±(ppm of reading + ppm of range)

Range	Full Scale	Resolution	Input Resistance	Transfer ⁵	24 Hours ²	90 Days ³	1 Year ³	2 Years ³
200mV ⁴	±210.000000 mV	1 nV	>100 GΩ	0.4 + 1.5	3.5 + 3	15 + 8	19 + 9	23 + 10
2 V ⁴	±2.10000000 V	10 nV	>100 GΩ	0.2 + 0.15	1.2 + 0.3	6 + 0.8	10 + 0.9	14 + 1
20 V	±21.0000000 V	100 nV	>100 GΩ	0.1 + 0.05	1.2 + 0.1	6 + 0.15	10 + 0.15	14 + 0.15
200 V	±210.000000 V	1 μV	10 MΩ ±1%	0.5 + 0.08	5 + 0.4	14 + 2	22 + 2	30 + 2
1000 V ⁶	±1100.00000 V	10 μV	10 MΩ ±1%	1 + 0.05	5 + 0.08	14 + 0.4	22 + 0.4	30 + 0.4

Normal Accuracy⁷ – 1PLC, DFILT off

Relative Accuracy ±(ppm of reading + ppm of range)

Range	Full Scale	Resolution	Input Resistance	24 Hours ²	90 Days ³	1 Year ³	2 Years ³
200mV ⁴	±210.000000 mV	10 nV	>100 GΩ	3.5 + 6	15 + 11	19 + 12	23 + 13
2 V ⁴	±2.10000000 V	100 nV	>100 GΩ	1.2 + 0.6	6 + 1.1	10 + 1.2	14 + 1.3
20 V	±21.0000000 V	1 μV	>100 GΩ	3.2 + 0.35	8 + 0.4	12 + 0.4	16 + 0.4
200 V	±210.000000 V	10 μV	10 MΩ ±1%	5 + 1.2	14 + 2.8	22 + 2.8	30 + 2.8
1000 V ⁶	±1100.00000 V	100 μV	10 MΩ ±1%	5 + 0.4	14 + 0.7	22 + 0.7	30 + 0.7

DC VOLTS NOTES

- Specifications are for 10 power line cycles, synchronous autozero, 10-reading repeat digital filter, autorange off, except as noted.
- For T_{cal} ±1°C, following 4-hour warm-up. T_{cal} is ambient temperature at calibration (23°C at the factory). Add 0.5ppm of reading uncertainty if the unit is power cycled during this interval.
- For T_{cal} ±5°C, following 4-hour warm-up.
- Care must be taken to minimize thermal offsets due to operator cables.
- Specifications apply for 20-reading repeat digital filter, T_{REF} ±0.5°C (T_{REF} is the initial ambient temperature), and for measurements within 10% of the initial measurement value and within 10 minutes of the initial measurement time.
- Add 20ppm × (V_N/1000V)² additional uncertainty for inputs above 200V, except in transfer accuracy specifications.
- Specifications are for 1 power line cycle, normal autozero, digital filter off, autorange off.

AC VOLTS Normal Mode RMS¹

90 Days, 1 Year or 2 Years, ±2°C from last AC self-cal, for 1% to 100% of range² ±(% of reading + % of range)

Range	20–50Hz	50–100Hz	0.1–2kHz	2–10kHz	10–30kHz	30–50kHz	50–100kHz	100–200kHz	0.2–1MHz	1–2MHz
200 mV	0.25 + 0.015	0.07 + 0.015	0.02 + 0.02	0.02 + 0.02	0.025 + 0.02	0.05 + 0.01	0.3 + 0.015	0.75 + 0.025	2 + 0.1	5 + 0.2
2 V	0.25 + 0.015	0.07 + 0.015	0.02 + 0.02	0.02 + 0.02	0.025 + 0.02	0.05 + 0.01	0.3 + 0.015	0.75 + 0.025	2 + 0.1	5 + 0.2
20 V	0.25 + 0.015	0.07 + 0.015	0.03 + 0.015	0.04 + 0.015	0.05 + 0.015	0.07 + 0.015	0.3 + 0.015	0.75 + 0.025	4 + 0.2	7 + 0.2 ⁴
200 V ³	0.25 + 0.015	0.07 + 0.015	0.03 + 0.015	0.04 + 0.015	0.05 + 0.015	0.07 + 0.015	0.3 + 0.015	0.75 + 0.025 ⁴	4 + 0.2 ⁴	
750 V ³	0.25 + 0.015	0.1 + 0.015	0.05 + 0.015	0.06 + 0.015	0.08 + 0.015	0.1 + 0.015 ⁴	0.5 + 0.015 ⁴			

AC VOLTS NOTES

- Specifications apply for sine wave input, AC + DC coupling, 1 power line cycle, autozero on, digital filter off, following 55-minute warm-up.
- For 1% to 5% of range below 750V range, and for 1% to 7% of 750V range, add 0.01% of range uncertainty. For inputs from 200kHz to 2MHz, specifications apply above 10% of range.
- Add 0.001% of reading × (V_N/100V)² additional uncertainty for inputs above 100V rms.
- Typical values.

1.888.KEITHLEY (U.S. only)

www.keithley.com

A Greater Measure of Confidence

KEITHLEY

A Tektronix Company

Model 2001 and 2002 specifications

DIGITAL MULTIMETERS & SYSTEMS

2001
2002

7½-Digit High Performance Multimeter 8½-Digit High Performance Multimeter

2002 Condensed Specifications (continued)

OHMS

TWO-WIRE AND FOUR-WIRE OHMS

Range	Full Scale	Resolution	Current Source ¹	Relative Accuracy ³ ±(ppm of reading + ppm of range)				
				Transfer ⁷	24 Hours ⁴	90 Days ⁵	1 Year ⁵	2 Years ⁵
20 Ω	21.000000 Ω	100 nΩ	7.2 mA	2.5 + 3	5 + 4.5	15 + 6	17 + 6	20 + 6
200 Ω	210.00000 Ω	1 μΩ	960 μA	2.5 + 2	5 + 3	15 + 4	17 + 4	20 + 4
2 kΩ	2100.0000 kΩ	10 μΩ	960 μA	1.3 + 0.2	2.5 + 0.3	7 + 0.4	9 + 0.4	11 + 0.4
20 kΩ	21.000000 kΩ	100 μΩ	96 μA	1.3 + 0.2	2.5 + 0.3	7 + 0.4	9 + 0.4	11 + 0.4
200 kΩ	210.00000 kΩ	1 mΩ	9.6 μA	2.5 + 0.4	5.5 + 0.5	29 + 0.8	35 + 0.9	40 + 1
2 MΩ	2.1000000 MΩ	10 mΩ	1.9 μA	5 + 0.2	12 + 0.3	53 + 0.5	65 + 0.5	75 + 0.5
20 MΩ ²	21.000000 MΩ	100 mΩ	1.4 μA ⁶	15 + 0.1	50 + 0.2	175 + 0.6	250 + 0.6	300 + 0.6
200 MΩ ²	210.00000 MΩ	1 Ω	1.4 μA ⁶	50 + 0.5	150 + 1	500 + 3	550 + 3	600 + 3
1 GΩ ²	1.0500000 GΩ	10 Ω	1.4 μA ⁶	250 + 2.5	750 + 5	2000 + 15	2050 + 15	2100 + 15

OHMS NOTES

- Current source has an absolute accuracy of ±5%.
- For 2-wire mode.
- Specifications are for 10 power line cycles, 10-reading repeat digital filter, synchronous autozero, autorange off, 4-wire mode, offset compensation on (for 20Ω to 20kΩ ranges), except as noted.
- For T_{CAL} ±1°C, following 4-hour warm-up. T_{CAL} is ambient temperature at calibration (23°C at the factory).
- For T_{CAL} ±5°C, following 4-hour warm-up.
- Current source is paralleled with a 10MΩ resistance.
- Specifications apply for 20-reading repeat digital filter. T_{REF} ±0.5°C (T_{REF} is the initial ambient temperature), and for measurements within 10% of the initial measurement value and within 10 minutes of the initial measurement time.

DC AMPS

DCI INPUT CHARACTERISTICS AND ACCURACY

Range	Full Scale	Resolution	Maximum Burden Voltage ³	Relative Accuracy ±(ppm of reading + ppm of range)			
				24 Hours ¹	90 Days ²	1 Year ²	2 Years ²
200 μA	210.00000 μA	10 pA	0.25 V	50 + 6	275 + 25	350 + 25	500 + 25
2 mA	2.1000000 mA	100 pA	0.3 V	50 + 5	275 + 20	350 + 20	500 + 20
20 mA	21.000000 mA	1 nA	0.35 V	50 + 5	275 + 20	350 + 20	500 + 20
200 mA	210.00000 mA	10 nA	0.35 V	75 + 5	300 + 20	375 + 20	525 + 20
2 A	2.1000000 A	100 nA	1.1 V	350 + 5	600 + 20	750 + 20	1000 + 20

DC AMPS NOTES

- For T_{CAL} ±1°C, following 55-minute warm-up. T_{CAL} is ambient temperature at calibration (23°C at the factory).
- For T_{CAL} ±5°C, following 55-minute warm-up.
- Actual maximum burden voltage = (maximum burden voltage) × (I_{MEASURED}/I_{FULL SCALE}).

AC AMPS

Range	ACI Accuracy ^{1,2} 90 Days, 1 Year or 2 Years, T _{CAL} ±5°C, for 5% to 100% of range, ±(% of reading + % of range)						
	20Hz–50Hz	50Hz–200Hz	200Hz–1kHz	1kHz–10kHz	10kHz–30kHz ³	30kHz–50kHz ³	50kHz–100kHz ³
200 μA	0.35 + 0.015	0.2 + 0.015	0.4 + 0.015	0.5 + 0.015			
2 mA	0.3 + 0.015	0.15 + 0.015	0.12 + 0.015	0.12 + 0.015	0.25 + 0.015	0.3 + 0.015	0.5 + 0.015
20 mA	0.3 + 0.015	0.15 + 0.015	0.12 + 0.015	0.12 + 0.015	0.25 + 0.015	0.3 + 0.015	0.5 + 0.015
200 mA	0.3 + 0.015	0.15 + 0.015	0.12 + 0.015	0.15 + 0.015	0.5 + 0.015	1 + 0.015	3 + 0.015
2 A	0.35 + 0.015	0.2 + 0.015	0.3 + 0.015	0.45 + 0.015	1.5 + 0.015	4 + 0.015	

AC AMPS NOTES

- Specifications apply for sinewave input, AC+DC coupling, 1 power line cycle, autozero on, digital filter off, following 55-minute warm-up.
- Add 0.005% of range uncertainty for current above 0.5A rms for self-heating.
- Typical values.

FREQUENCY COUNTER

AC VOLTAGE INPUT: 1Hz–15 MHz.

ACCURACY: ±(0.03% of reading).

DC IN-CIRCUIT CURRENT

TYPICAL RANGES: Current: 100μA to 12A. Trace Resistance: 1mΩ to 10Ω.

ACCURACY: ±(5% + 500μA). For 1 power line cycle, autozero on, 10-reading digital filter, T_{CAL} ±5°C, 90 days, 1 year or 2 years.

TEMPERATURE

Built-in linearization for J, K, N, T, E, R, S, B thermocouple types to ITS-90 and 100Ω platinum RTDs DIN 43760, IPTS-68, and ITS-90.

GENERAL

POWER: Voltage: 90–134V and 180–250V, universal self-selecting. **Frequency:** 50Hz, 60Hz, or 400Hz self-identifying at power-up. **Consumption:** <55VA.

ENVIRONMENTAL: Operating Temperature: 0° to 50°C. **Storage Temperature:** –40° to 70°C. **Humidity:** 80% R.H., 0° to 35°C.

PHYSICAL: Case Dimensions: 90mm high × 214mm wide × 369mm deep (3½ in. × 8½ in. × 14½ in.). **Net Weight:** <4.2kg (<9.2 lbs.). **Shipping Weight:** <9.1kg (<20 lbs.).

STANDARDS

EMI/RFI: Conforms to European Union EMC directive.

Safety: Conforms to European Union Low Voltage directive.

Note 1: For MIL-T-28800E, applies to Type III, Class 5, Style E.

1.888.KEITHLEY (U.S. only)

www.keithley.com

KEITHLEY

A Tektronix Company

A Greater Measure of Confidence

2010

Low Noise 7½-Digit Autoranging Multimeter



- 7½-digit resolution
- 100nV rms noise floor
- 7ppm DCV repeatability
- Built-in 10-channel scanner mainframe
- Dry circuit and low power measurement mode
- 15 measurement functions including support for RTD and thermocouple temperature measurements
- Built-in ratio measurement function
- GPIB and RS-232 interfaces

Ordering Information

2010 Autoranging DMM

Accessories Supplied

Model 1751 Safety Test Leads, User Manual, Service Manual

SERVICES AVAILABLE

2000-SCAN-3Y-EW	1-year factory warranty extended to 3 years from date of shipment
2001-TCSCAN-3Y-EW	1-year factory warranty extended to 3 years from date of shipment
2010-3Y-EW	1-year factory warranty extended to 3 years from date of shipment
C/2000-3Y-ISO	3 (ISO-17025 accredited) calibrations within 3 years of purchase for Model 2000-SCAN*
C/2001-3Y-ISO	3 (ISO-17025 accredited) calibrations within 3 years of purchase for Model 2001-TCSCAN*
C/2010-3Y-ISO	3 (ISO-17025 accredited) calibrations within 3 years of purchase for Model 2010*

*Not available in all countries

The 7½-digit Model 2010 Low Noise Multimeter combines high resolution with the high speed and accuracy needed for production applications such as testing precision sensors, transducers, A/D and D/A converters, regulators, references, connectors, switches, and relays. It is based on the same high speed, low noise A/D converter technology as the Models 2000, 2001, and 2002.

High Measurement Flexibility

The 2010 has 15 built-in measurement functions, including DCV, ACV, DCI, ACI, 2WΩ, 4WΩ, dry circuit resistance, temperature (with either thermocouples or RTDs), frequency, period, ratio, continuity measurement, and diode testing. This multi-functional design minimizes added equipment costs.

Creating a self-contained multipoint measurement solution is as simple as plugging a 2000-SCAN or 2001-TCSCAN scanner card into the option slot in the 2010's back panel. This "plug-in" approach eliminates the need for a separate scanner and significantly reduces programming and setup time in applications involving a limited number of test points. For larger applications, the 2010 is compatible with Keithley's Series 7000 switch matrices and cards.

Unique Resistance Measurement Functions

Characterizing the resistance, linearity, or isolation of contacts, connectors, switches, or relays completely and efficiently demands an uncommon combination of ohms measurement capabilities. The 2010 offers:

- **Low-power ohms measurement mode.** Low-level resistance measurements can be made with source current as low as 100μA, an order of magnitude lower than is possible with other DMMs, so device self-heating is minimized. Among other benefits, this low-power measurement capability makes the 2010 suitable for end-of-life contact testing per ASTM B539-90.
- **Dry circuit test function.** When measuring contact and connector resistances, it is important to control the test voltage carefully in order to avoid puncturing any oxides or films that may have formed. A built-in clamp limits the open circuit test voltage to 20mV to ensure dry circuit conditions.
- **Offset compensated ohms function.** This function eliminates thermal effects that can create errors in low-level resistance measurements in system environments.
- **Extended ohms measurement capability.** The 2010 provides a 10Ω range for more precise measurements of low resistances.

Optional Multiplexer Cards

Creating a self-contained multipoint measurement solution is as simple as plugging a scanner card into the option slot on the 2010's back panel. This approach eliminates the complexities of triggering, timing, and processing issues and helps reduce test time significantly. For applications involving more than 10 measurement points, the 2010 is compatible with Keithley's Series 7000 switch matrices and cards.

Model 2000-SCAN Scanner Card

- Ten analog input channels (2-pole)
- Configurable as 4-pole, 5-channel

ACCESSORIES AVAILABLE

TEST LEADS

5804/5 4-Wire/Kelvin Test Lead Sets

SWITCH/SCANNER CARDS

2000-SCAN 10-channel Scanner

2001-TCSCAN 9-channel Thermocouple Scanner

CABLES/ADAPTERS

7007-1 Shielded IEEE-488 Cable, 1m (3.3 ft)

7007-2 Shielded IEEE-488 Cable, 2m (6.6 ft)

7009-5 RS-232 Cable

RACK MOUNT KITS

4288-1 Single Fixed Rack Mount Kit

4288-2 Dual Fixed Rack Mount Kit

GPIB INTERFACES

KPCI-488LPA IEEE-488 Interface/Controller for the PCI Bus

KUSB-488B IEEE-488 USB-to-GPIB Interface Adapter

1.888.KEITHLEY (U.S. only)

www.keithley.com

KEITHLEY

A Greater Measure of Confidence

A Tektronix Company

DMM optimized for resistance measurement applications

DIGITAL MULTIMETERS & SYSTEMS

2010

Low Noise 7½-Digit Autoranging Multimeter

Model 2010 specifications

DIGITAL MULTIMETERS & SYSTEMS

DC VOLTAGE

Range	Resolution	Accuracy 23°C ± 5°C ±(ppm of rdg. + ppm of range)		Input Resistance
		90 Day	1 Year	
100.00000 mV	10 nV	25 + 9	37 + 9	> 10 GΩ
1.0000000 V	100 nV	18 + 2	25 + 2	> 10 GΩ
10.000000 V	1 μV	18 + 4	24 + 4	> 10 GΩ
100.00000 V	10 μV	25 + 5	35 + 5	10 MΩ ±1%
1000.0000 V	100 μV	31 + 6	41 + 6	10 MΩ ±1%

RESISTANCE

Range	Resolution	Accuracy 23°C ± 5°C ±(ppm of rdg. + ppm of range)		Test Current
		90 Day	1 Year	
10.000000 Ω	1 μΩ	40 + 9	60 + 9	10 mA
100.00000 Ω	10 μΩ	36 + 9	52 + 9	1 mA
1.0000000 kΩ	100 μΩ	33 + 2	50 + 2	1 mA
10.000000 kΩ	1 mΩ	32 + 2	50 + 2	100 μA
100.00000 kΩ	10 mΩ	40 + 4	70 + 4	10 μA
1.0000000 MΩ	100 mΩ	50 + 4	70 + 4	10 μA
10.000000 MΩ	1 Ω	200 + 4	400 + 4	640 nA//10 MΩ
100.00000 MΩ	10 Ω	1500 + 4	1500 + 4	640 nA//10 MΩ

DC CURRENT

Range	Resolution	Accuracy 23°C ± 5°C ±(ppm of rdg. + ppm of range)		Burden Voltage
		90 Day	1 Year	
10.000000 mA	1 nA	300 + 80	500 + 80	< 0.15 V
100.00000 mA	10 nA	300 + 800	500 + 800	< 0.18 V
1.0000000 A	100 nA	500 + 80	800 + 80	< 0.35 V
3.0000000 A	1 μA	1200 + 40	1200 + 40	< 1 V

CONTINUITY 2W

Range	Resolution	Accuracy 23°C ± 5°C ±(ppm of rdg. + ppm of range)		Test Current
		90 Day	1 Year	
1 kΩ	100 mΩ	100 + 100	120 + 100	1 mA

DIODE TEST

Range	Resolution	Accuracy 23°C ± 5°C ±(ppm of rdg. + ppm of range)		Test Current
		90 Day	1 Year	
10.000000 V	1 μV	30 + 7	40 + 7	1 mA
4.400000 V	1 μV	30 + 7	40 + 7	100 μA
10.000000 V	1 μV	30 + 7	40 + 7	10 μA

DC OPERATING CHARACTERISTICS

Function	Digits	Readings/s	PLCs
DCV (all ranges), DCI (all ranges), and Ohms (<10M range)	7½	4 (3)	5
	6½	30 (27)	1
	6½	50 (44)	1
	5½	260 (220)	0.1
	5½	490 (440)	0.1
	5½	1000 (1000)	0.04
	4½	2000 (1800)	0.01

DC NOISE PERFORMANCE

Rate	Digits	RMS Noise 100mV Range (2 min.)	RMS Noise 10V Range (2 min.)	NMRR	CMRR
5 PLC	7½	110 nV	1.2 μV	60 dB	140 dB
1 PLC	6½	125 nV	1.4 μV	60 dB	140 dB
0.1 PLC	5½	1.9 μV	11.5 μV	—	80 dB
0.01 PLC	4½	2.9 μV	139 μV	—	80 dB

TRUE RMS AC VOLTAGE AND CURRENT CHARACTERISTICS

Voltage Range	Resolution	Frequency Range	Accuracy (1 Year) 23°C ± 5°C	
			±(% of reading)	±(% of range)
100 mV to 750 V	0.1 μV to 1 mV	3 Hz–10 Hz	0.35	0.03
		10 Hz–20 kHz	0.06	0.03
		20 kHz–50 kHz	0.12	0.05
		50 kHz–100 kHz	0.60	0.08
		100 kHz–300 kHz	4	0.5

AC OPERATING CHARACTERISTICS

Function	Digits	Readings/s	Rate	Bandwidth
ACV (all ranges), and ACI (all ranges)	6½	0.5 (0.4)	SLOW	3 Hz–300 kHz
	6½	1.4 (1.5)	MED	30 Hz–300 kHz
	6½	4.0 (4.3)	MED	30 Hz–300 kHz
	6½	2.2 (2.3)	FAST	300 Hz–300 kHz
	6½	35 (30)	FAST	300 Hz–300 kHz

FREQUENCY AND PERIOD CHARACTERISTICS

ACV Range	Frequency Range	Period Range	Gate Time	Resolution ±(ppm of reading)	Accuracy 90 Day/1 Year ±(% of reading)
100 mV to 750 V	3 Hz to 500 kHz	333 ms to 2 μs	1 s	0.3	0.01

TEMPERATURE CHARACTERISTICS

Type	Range	Resolution	Accuracy ¹ 90 Day/1 Year (23°C ± 5°C) Relative to Reference Junction		USING 2001-TCSCAN ²
			Reference Junction	2001-TCSCAN ²	
J	-200 to + 760°C	0.001°C	±0.5°C	±0.65°C	
K	-200 to + 1372°C	0.001°C	±0.5°C	±0.70°C	
N	-200 to + 1300°C	0.001°C	±0.5°C	±0.70°C	
T	-200 to + 400°C	0.001°C	±0.5°C	±0.68°C	

4-WIRE RTD

Range	Resolution	Accuracy ³ 90 Day/1 Year (23°C ± 5°C)	Accuracy ³ 2 Years (23°C ± 5°C)
-100° to +100°C	0.001°C	±0.08°C	±0.12°C
-200° to +630°C	0.001°C	±0.14°C	±0.18°C

TEMPERATURE NOTES

- For temperatures <-100°C, add ±0.1°C and >900°C add ±0.3°C.
- Specifications apply to channels 2–6. Add 0.06°C/channel from channel 6.
- Excluding probe errors.

GENERAL

POWER SUPPLY: 100V / 120V / 220V / 240V.

LINE FREQUENCY: 50Hz to 60Hz and 440Hz, automatically sensed at power-up.

POWER CONSUMPTION: 22VA.

VOLT HERTZ PRODUCT: ≤8 × 10⁶V·Hz.

OPERATING ENVIRONMENT: Specified for 0° to 50°C. Specified to 80% R.H. at 35°C.

STORAGE ENVIRONMENT: -40° to 70°C.

ALTITUDE: Up to 2000 meters.

SAFETY: Conforms to European Union Directive 73/23/EEC EN 61010-1, Cat II.

EMC: Complies with European Union Directive 89/336/EEC, EN 61326-1.

VIBRATION: MIL-PRF-28800F Class 3 Random.

WARMUP: 2 hours to rated accuracy.

DIMENSIONS:

Rack Mounting: 89mm high × 213mm wide × 370mm deep (3½ in × 8½ in × 14½ in).

Bench Configuration (with handle and feet): 104mm high × 238mm wide × 370mm deep (4½ in × 9½ in × 14½ in).

SHIPPING WEIGHT: 5kg (11 lbs).

1.888.KEITHLEY (U.S. only)

www.keithley.com

KEITHLEY

A Tektronix Company

A Greater Measure of Confidence

**2015, 2015-P,
2016, 2016-P**

6½-Digit THD Multimeters 6½-Digit Audio Analyzing Multimeters



- THD, THD+Noise, and SINAD measurements
- 20Hz–20kHz sine wave generator
- Fast frequency sweeps
- 2015-P, 2016-P: Identifies peak spectral components
- 2015, 2015-P: 4Vrms single-ended or 8Vrms differential output
- 2016, 2016-P: 9.5Vrms single-ended or 19Vrms differential output
- Individual harmonic magnitude measurements
- 5 standard audio shaping filters
- 13 DMM functions (6½ digits)
- GPIB and RS-232 interfaces

APPLICATIONS

- Wireless communication device audio quality testing
- Component linearity testing
- Lighting and ballast THD limit conformance testing
- Telephone and automotive speaker testing

The Models 2015-P and 2016-P Audio Analyzing Digital Multimeters and the Models 2015 and 2016 Total Harmonic Distortion Multimeters combine audio band quality measurements and analysis with a full-function 6½-digit DMM. Test engineers can make a broad range of voltage, resistance, current, frequency, and distortion measurements, all with the same compact, half-rack measurement instrument. The Model 2016 and 2016-P have twice the sine wave generator output of the Model 2015 for applications that require test signals greater than 8Vrms. The Model 2015-P and 2016-P offer additional processing capacity for frequency spectrum analysis.

Frequency Domain Distortion Analysis

For applications such as assessing non-linear distortion in components, devices, and systems, DSP-based processing allows the Models 2015-P, 2015, 2016, and 2016-P to provide frequency domain analysis in conventional time domain instruments. They

can measure Total Harmonic Distortion (THD) over the complete 20Hz to 20kHz audio band. They also measure over a wide input range (up to 750Vrms) and have low residual distortion (–87dB). The THD reading can be expressed either in decibels or as a percentage.

In addition to THD, the Models 2015, 2015-P, 2016, and 2016-P can compute THD+Noise and Signal-to-Noise plus Distortion (SINAD). For analyses in which the individual harmonics are the criteria of greatest interest, the instruments can report any of the (up to 64) harmonic magnitudes that can be included in the distortion measurements. The user can program the actual number of harmonics to be included in a computation, so accuracy, speed, and complexity can be optimized for a specific application. (See *Figure 1*.)

Figure 1. Frequency Spectrum of 1kHz Square Wave

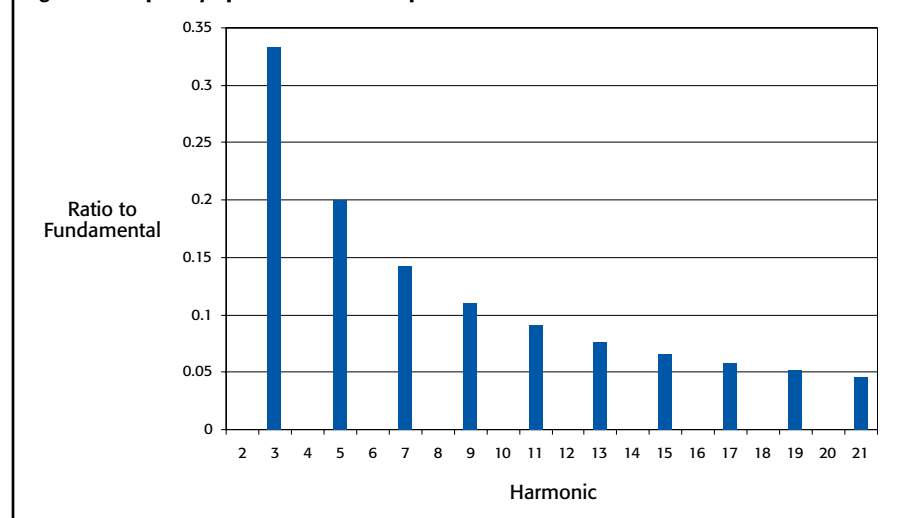

Figure 1 shows a plot of a square wave's harmonics (frequency components) computed and transmitted to a personal computer by the Model 2015 or 2016. A square wave's spectral content consists of only odd harmonics whose magnitudes are (1/harmonic number × the magnitude of the fundamental). For example, the magnitude of the third harmonic is 1/3 the magnitude of the fundamental.

1.888.KEITHLEY (U.S. only)

www.keithley.com

A Greater Measure of Confidence

KEITHLEY

A Tektronix Company

2015, 2015-P, 2016, 2016-P

Ordering Information

2015	Total Harmonic Distortion 6½-Digit Multimeter
2015-P	Audio Analyzing DMM
2016	Total Harmonic Distortion 6½-Digit DMM w/9V Source Output
2016-P	Audio Analyzing DMM w/9V Source Output

Accessories Supplied

Model 1751 Safety Test Leads, User Manual, Service Manual.

Figure 2. Total Harmonic Distortion Analysis and Frequency Response of a Portable Wireless Telecommunication Device Device Under Test

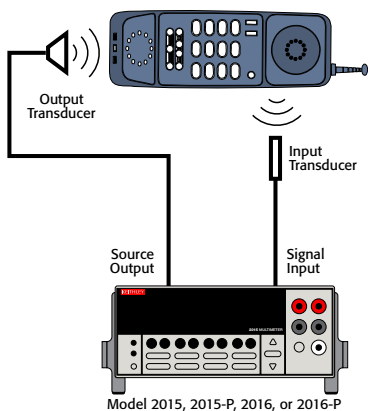

Figures 2, 3, and 4 demonstrate how the Model 2015, 2015-P, 2016, or 2016-P can provide both time domain and frequency domain measurements in a single test protocol. Figure 2 shows a sample test system schematic with a telecommunication device in a loop back mode test. The Audio Analyzing DMM's source provides a stimulus frequency sweep, and the Audio Analyzing DMM measures the response from the microphone circuit. Figure 3 shows the resulting frequency domain analysis of the THD and the first three harmonics as a function of frequency. Figure 4 shows the time domain analysis of microphone circuit output voltage as a function of frequency.

6½-Digit THD Multimeters 6½-Digit Audio Analyzing Multimeters

Figure 3. THD and 2nd, 3rd, and 4th Harmonics as a Function of Frequency

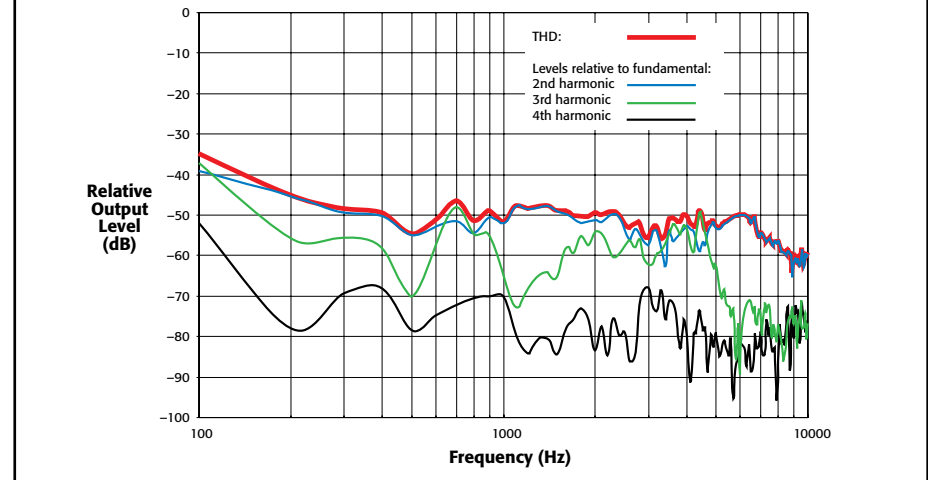
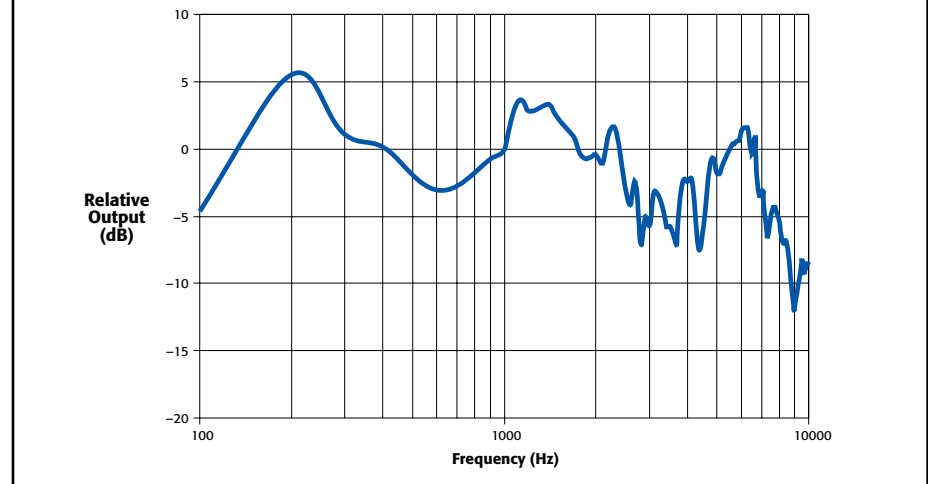

Figure 4. Frequency Response



Optimized for Production Testing

The Models 2015, 2015-P, 2016, and 2016-P can perform fast frequency sweeps for characterizing audio-band circuitry in production test systems. For example, the instruments can execute a single sweep of 30 frequencies and transmit both rms voltage readings and THD readings to a computer in only 1.1 seconds. With that data, a complete frequency response analysis and a harmonic distortion vs. frequency analysis can be performed in a very short time. Thus high speed testing of the audio performance of a high volume device such as a cellular telephone can be performed without reducing the number of tests or reducing the measurements in each test. With these instruments, which are optimized for production testing, test engineers can lower test times, in comparison to test speeds achievable with general purpose audio analyzers, without sacrificing production test quality.

Dual Output Source

The Models 2015, 2015-P, 2016, and 2016-P include an internal audio band sine wave source for generating stimulus signals. A second output, the inverse of the first output, is also available, simplifying the testing of differential input circuits for common mode or noise cancellation performance.

1.888.KEITHLEY (U.S. only)

www.keithley.com

KEITHLEY
A Tektronix Company

A Greater Measure of Confidence

**2015, 2015-P,
2016, 2016-P**

6½-Digit THD Multimeters 6½-Digit Audio Analyzing Multimeters

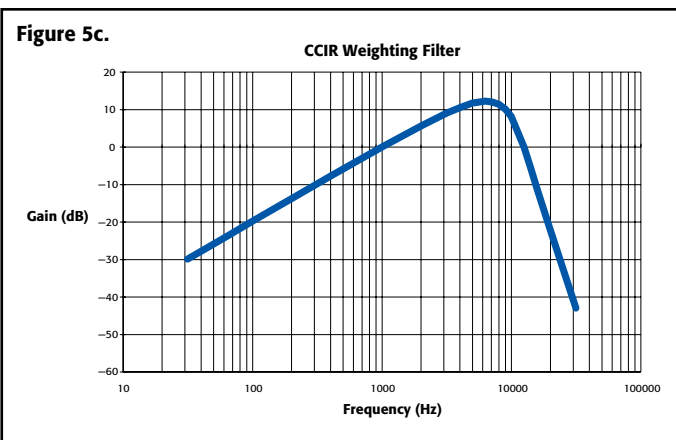
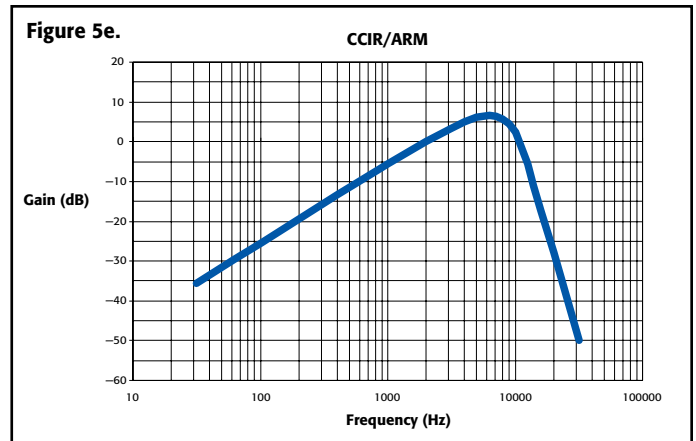
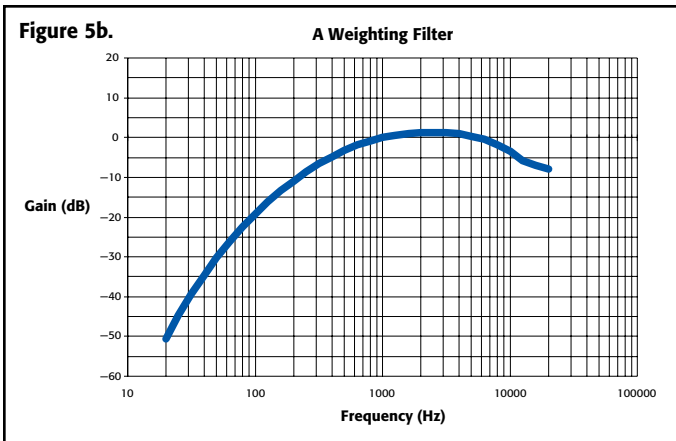
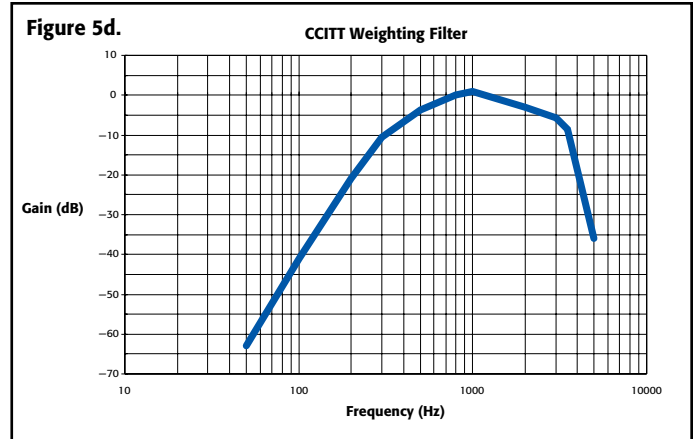
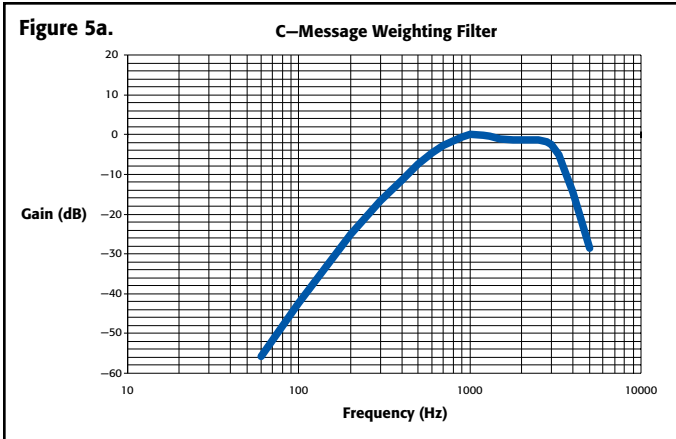

The Models 2015 and 2015-P have a 4Vrms single-ended output and 8Vrms differential source output. For tests that require a higher stimulus signal, the Model 2016 and 2016-P provide a 9.5Vrms single-ended output and a 19Vrms differential output.

Wide Selection of Audio Filters

Five industry-standard bandpass filters are provided for shaping the input signal for audio and telecommunication applications. Available filters include the CCITT weighting filter, CCIR filter, C-message filter, CCIR/ARM filter, and “A” weighting filter (see *Figures 5a–5e*). The Models 2015, 2015-P, 2016, and 2016-P provide programmable, high cutoff (low pass) and low cutoff (high pass) filters. Furthermore, the two filters can be implemented together to form a bandpass filter. The programmable filters can be used to filter out noise generated by electromechanical machinery on the production floor or to simulate other types of system transmission characteristics.

Broad Measurement Flexibility

In addition to their THD, THD+Noise, SINAD, and individual harmonic measurement capabilities, the instruments provide a comprehensive set of DMM functions, including DCV, ACV, DCI, ACI, 2WΩ, 4WΩ, temperature, frequency, period, dB, dBm, and continuity measurements, as well as diode testing. This multi-functional design minimizes added equipment costs when configuring test setups.

1.888.KEITHLEY (U.S. only)

www.keithley.com

KEITHLEY

A Greater Measure of Confidence

A Tektronix Company

2015, 2015-P, 2016, 2016-P

6½-Digit THD Multimeters 6½-Digit Audio Analyzing Multimeters

Wide Band or Narrow Band Noise Measurements

The Models 2015, 2015-P, 2016, and 2016-P are capable of measuring both wide band noise and narrow band noise. Alternatively, these instruments' DSP (digital signal processing) capabilities allow users to make frequency domain measurements of RMS voltage noise over the 20Hz–20kHz frequency audio band or a narrow portion of the band. Furthermore, noise measurements can be extracted in the presence of a stimulus signal for fast signal-to-noise computations.

Spectrum Analysis

The Model 2015-P and 2016-P have internal computational capabilities that allow them to characterize an acquired signal spectrum. These instruments can identify and report the frequency and amplitude of the highest value in a complete spectrum or within a specified frequency band. It can also identify additional peaks in descending order of magnitude (see **Figure 6**). The Model 2015-P's and 2016-P's on-board capabilities make it simple to obtain a thorough analysis of a frequency spectrum more quickly and with little or no need for external analysis software.

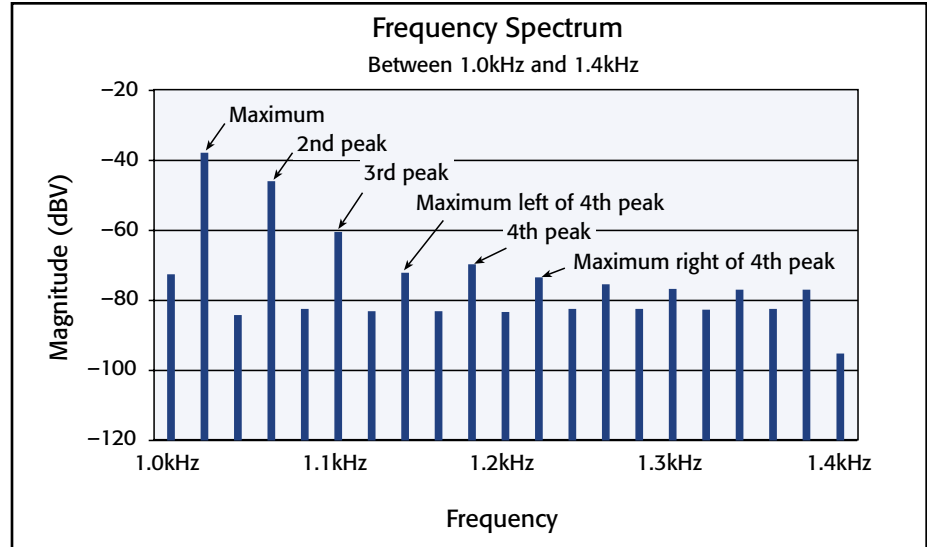

Figure 6. The Model 2015-P and 2016-P directly identify peak values of the frequency spectrum.

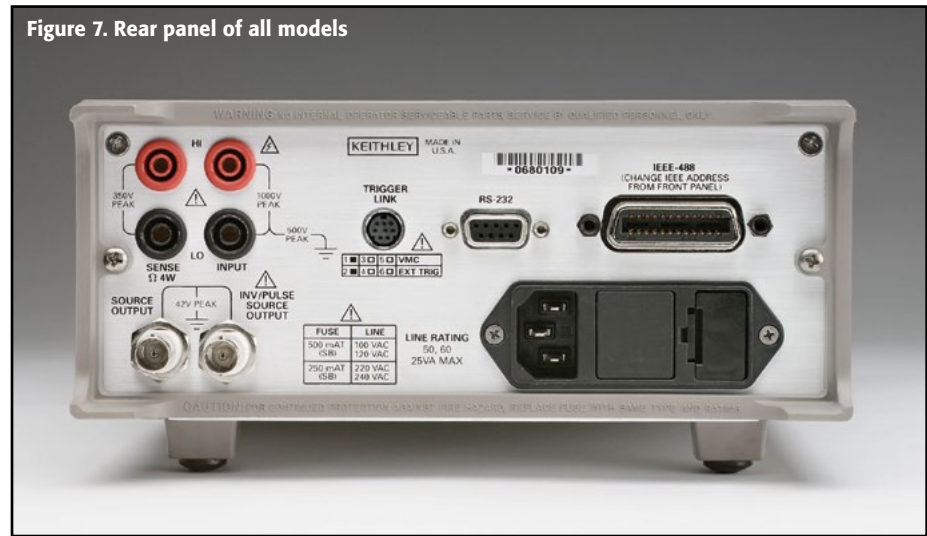

Figure 7. Rear panel of all models

SERVICES AVAILABLE

2015-3Y-EW	1-year factory warranty extended to 3 years from date of shipment
2015-P-3Y-EW	1-year factory warranty extended to 3 years from date of shipment
2016-3Y-EW	1-year factory warranty extended to 3 years from date of shipment
2016-P-3Y-EW	1-year factory warranty extended to 3 years from date of shipment
C/2015-3Y-ISO	3 (ISO-17025 accredited) calibrations within 3 years of purchase for Models 2015, 2015-P*
C/2016-3Y-ISO	3 (ISO-17025 accredited) calibrations within 3 years of purchase for Models 2016, 2016-P*

*Not available in all countries

ACCESSORIES AVAILABLE

CABLES/ADAPTERS

7007-1	Shielded IEEE-488 Cable, 1m (3.3 ft)
7007-2	Shielded IEEE-488 Cable, 2m (6.6 ft)
8501-1, 8501-2	Trigger-Link Cables, 1m (3.3 ft), 2m (6.6 ft)
8502	Trigger Link Adapter Box
8503	Trigger Link Cable to 2 male BNCs, 1m (3.3 ft)
7009-5	RS-232 Cable

RACK MOUNT KITS

4288-1	Single Fixed Rack Mount Kit
4288-2	Dual Fixed Rack Mount Kit

GPIB INTERFACES

KPCI-488LPA	IEEE-488 Interface/Controller for the PCI Bus
KUSB-488B	IEEE-488 USB-to-GPIB Interface Adapter

1.888.KEITHLEY (U.S. only)

www.keithley.com



A Greater Measure of Confidence

**2015, 2015-P,
2016, 2016-P**

6½-Digit THD Multimeters 6½-Digit Audio Analyzing Multimeters

DISTORTION CHARACTERISTICS

VOLTAGE RANGE: 100mV, 1V, 10V, 100V, 750V (user selectable).
INPUT IMPEDANCE: 1MΩ paralleled by <100pF.
DISPLAY RANGE: 0–100% or 0–100.00dB.
RESOLUTION: 0.0001% or 0.00001dB.
FUNDAMENTAL FREQUENCY RANGE: 20Hz–20kHz.
HARMONIC FREQUENCY RANGE: 40Hz–50kHz.
FREQUENCY RESOLUTION: 0.008Hz.
FREQUENCY ACCURACY: ±0.01% of reading.
FREQUENCY TEMPERATURE COEFFICIENT: ≤100ppm over operating temperature range.

Measurement Mode	Accuracy (1 Year, 23°C ±5°C)	Residual Distortion ¹
THD and individual harmonic magnitudes	±0.8 dB, 20 Hz to 20 kHz ²	0.004% or –87 dB 20 Hz to 20 kHz
THD + n	±1.5 dB, 100 Hz to 20 kHz ²	0.056% or –65 dB 20 Hz to 20 kHz
SINAD	±1.5 dB, 100 Hz to 20 kHz ²	+65 dB 20 Hz to 20 kHz
AC Level V rms	±(0.13% of reading + 0.009% of range) 20 Hz to 20 kHz	

DISTORTION MEASUREMENT AUDIO FILTERS

None C-Message
 CCITT Weighting CCIR/ARM
 CCIR "A" Weighting

NUMBER OF HARMONICS INCLUDED IN THD CALCULATION: 2 to 64 (user selectable).

HI AND LO CUTOFF FILTERS (bus settable): 20Hz–50kHz. Can be combined to form brickwall bandpass filter.

DISTORTION MEASUREMENT READING RATE³

Fundamental Frequency Acquisition Mode	Fundamental Frequency Range	Minimum Readings Per Second
Single acquisition or stored value	20 Hz to 100 Hz	14
	100 Hz to 1 kHz	24
	1 kHz to 20 kHz	28
Automatic	20 Hz to 30 Hz	5.5
	30 Hz to 400 Hz	6
	400 Hz to 20 kHz	6.6

FREQUENCY SWEEP READING RATE

Number of Frequencies	Time (seconds) ⁴
5	0.2
30	1.1
100	3.5
200	6.9

NOTES

- Input signal at full scale.
- $V_{IN} \geq 20\%$ of range and harmonics > –65dB.
- Speeds are for default operating conditions (*RST), and display off, auto range off, binary data transfer, trig delay = 0.
- Typical times: frequencies in 400–4kHz range, binary data transfer, TRIG DELAY = 0, Display OFF, Auto Range OFF. Data returned is THD measurement plus AC voltage.

GENERATOR CHARACTERISTICS

FREQUENCY RANGE: 10–20kHz.
FREQUENCY RESOLUTION: 0.007Hz.
FREQUENCY ACCURACY: ±(0.015% of reading + 0.007Hz)¹.
FREQUENCY TEMPERATURE COEFFICIENT: <100ppm over operating temperature range.

SOURCE OUTPUT:

WAVEFORM: Sinewave.
AMPLITUDE RANGE: 2015, 2015-P: 2V rms (50Ω and 600Ω) or 4V rms (HI Z).
 2016, 2016-P: 4.75V rms (50Ω and 600Ω) or 9.5V rms (HI Z).
AMPLITUDE RESOLUTION: 2015, 2015-P: 0.5mV rms (50Ω and 600Ω) or 1mV rms (HI Z).
 2016, 2016-P: 1.25mV rms (50Ω and 600Ω) or 2.5mV rms (HI Z).
AMPLITUDE ACCURACY: 2015, 2015-P: ±(0.3% of setting + 2mV)^{1,4}.
 2016, 2016-P: ±(0.3% of setting + 5mV)^{1,4}.
AMPLITUDE TEMPERATURE COEFFICIENT: Typically 0.015%/°C.
AMPLITUDE FLATNESS: ±0.1dB^{1,4,5}.
OUTPUT IMPEDANCE: 50Ω ± 1Ω or 600Ω ± 10Ω, user selectable.
THD: –64dB⁶.
NOISE: 2015, 2015-P: 100μV rms².
 2016, 2016-P: 250μV rms².
DC OFFSET VOLTAGE: 2015, 2015-P: ±1.2mV¹. 2016, 2016-P: ±3mV¹.

INV/PULSE OUTPUT (SENEWAVE MODE):

FREQUENCY: Same as source output.
AMPLITUDE RANGE: 2015, 2015-P: 2V rms (50Ω and 600Ω) or 4V rms (HI Z).
 2016, 2016-P: 4.75V rms (50Ω and 600Ω) or 9.5V rms (HI Z).
AMPLITUDE RESOLUTION: 2015, 2015-P: 0.5mV (50Ω and 600Ω) or 1mV rms (HI Z).
 2016, 2016-P: 1.25mV rms (50Ω and 600Ω) or 2.5mV rms (HI Z).
AMPLITUDE ACCURACY: 2015, 2015-P: ±(2.0% of setting + 2mV)^{1,4}.
 2016, 2016-P: ±(2.0% of setting + 5mV)^{1,4}.
AMPLITUDE FLATNESS: ±0.1dB^{1,4,5}.
OUTPUT IMPEDANCE: Same as Source Output setting.
THD: –64dB⁶.
NOISE: 2015, 2015-P: 100μV rms².
 2016, 2016-P: 250μV rms².
DC OFFSET VOLTAGE: 2015, 2015-P: ±1.1mV typ., ±13mV max.¹
 2016, 2016-P: ±3mV typ., ±13mV max.¹

INV/PULSE OUTPUT (PULSE MODE):

FREQUENCY: Same as source output.
DUTY CYCLE: 45% ±3%.
OUTPUT IMPEDANCE: Same output impedance as the source output.
AMPLITUDE: 0.0V ±0.07V to 4.9V ±0.12V pulse open circuit^{1,3}.
 0.0V ±0.05V to 3.3V ±0.08V pulse 100Ω load^{1,3}.
OVERSHOOT: 1.0V maximum pulse open circuit³.
 0.2V maximum with 100Ω load pulse open circuit³.
UNDERSHOOT: 1.1V maximum pulse open circuit³.
 0.45V maximum with 100Ω load pulse open circuit³.

NOTES

- 1 year, 23°C ±5°C.
- Measured at $V_{OUT} = 0V$ with gain 100 amplifier and 2-pole 50kHz low pass filter, Inv/Pulse in sinewave mode, HI Z output impedance, and no load.
- With HI Z output impedance and 1m 50Ω coaxial cable.
- HI Z output impedance, no load.
- 4V output.
- THD measurement includes harmonics 2 through 5, 1V rms output, HI Z, no load.

1.888.KEITHLEY (U.S. only)

www.keithley.com

KEITHLEY

A Greater Measure of Confidence

A Tektronix Company

Model 2015, 2015-P, 2016, 2016-P specifications

DIGITAL MULTIMETERS & SYSTEMS

2015, 2015-P, 2016, 2016-P

6½-Digit THD Multimeters 6½-Digit Audio Analyzing Multimeters

DC Characteristics

CONDITIONS: MED (1 PLC)¹ or SLOW (10 PLC) or MED (1 PLC) with filter of 10.

Function	Range	Resolution	Test Current or Burden Voltage (±5%)	Input Resistance	Accuracy: ±(ppm of reading + ppm of range) (ppm = parts per million) (e.g., 10ppm = 0.001%)			Temperature Coefficient 0°–18°C & 28°–50°C
					24 Hour ¹⁴ 23°C ± 1°	90 Day 23°C ± 5°	1 Year 23°C ± 5°	
Voltage	100.0000 mV	0.1 μV		> 10 GΩ	30 + 30	40 + 35	50 + 35	2 + 6
	1.000000 V	1.0 μV		> 10 GΩ	15 + 6	25 + 7	30 + 7	2 + 1
	10.000000 V	10 μV		> 10 GΩ	15 + 4	20 + 5	30 + 5	2 + 1
	100.0000 V	100 μV		10 MΩ ±1%	15 + 6	30 + 6	45 + 6	5 + 1
	1000.0000 V ⁹	1 mV		10 MΩ ±1%	20 + 6	35 + 6	45 + 6	5 + 1
Resistance ¹⁵	100.0000 Ω	100 μΩ	1 mA		30 + 30	80 + 40	100 + 40	8 + 6
	1.000000 kΩ	1 mΩ	1 mA		20 + 6	80 + 10	100 + 10	8 + 1
	10.00000 kΩ	10 mΩ	100 μA		20 + 6	80 + 10	100 + 10	8 + 1
	100.0000 kΩ	100 mΩ	10 μA		20 + 6	80 + 10	100 + 10	8 + 1
	1.000000 MΩ ¹⁶	1 Ω	10 μA		20 + 6	80 + 10	100 + 10	8 + 1
	10.00000 MΩ ^{11, 16}	10 Ω	700 nA // 10MΩ		300 + 6	450 + 10	600 + 10	95 + 1
	100.0000 MΩ ^{11, 16}	100 Ω	700 nA // 10MΩ		1600 + 30	2000 + 30	2200 + 30	900 + 1
Current	10.00000 mA	10 nA	< 0.15 V		60 + 30	300 + 80	500 + 80	50 + 5
	100.0000 mA	100 nA	< 0.03 V		100 + 300	300 + 800	500 + 800	50 + 50
	1.000000 A	1 μA	< 0.3 V		200 + 30	500 + 80	800 + 80	50 + 5
	3.00000 A	10 μA	< 1 V		1000 + 15	1200 + 40	1200 + 40	50 + 5
	Continuity 2W	1 kΩ	100 mΩ	1 mA		40 + 100	100 + 100	120 + 100
Diode Test	3.00000 V	10 μV	1 mA		20 + 6	30 + 7	40 + 7	8 + 1
	10.00000 V	10 μV	100 μA		20 + 6	30 + 7	40 + 7	8 + 1
	10.00000 V	10 μV	10 μA		20 + 6	30 + 7	40 + 7	8 + 1

DC OPERATING CHARACTERISTICS²

Function	Digits	Readings/s	PLCs ⁸
	6½ ^{3, 4}	5	10
	6½ ^{3, 7}	30	1
DCV (all ranges),	6½ ^{3, 5}	50	1
DCI (all ranges),	5½ ^{3, 5}	270	0.1
2W Ohms (<10M ranges)	5½ ⁵	500	0.1
	5½ ⁵	1000	0.04
	4½ ⁵	2000	0.01

DC SYSTEM SPEEDS^{2, 6}

RANGE CHANGE³: 50/s.

FUNCTION CHANGE³: 45/s.

AUTORANGE TIME^{3, 10}: <30ms.

ASCII READINGS TO RS-232 (19.2K baud): 55/s.

MAX. INTERNAL TRIGGER RATE: 2000/s.

MAX. EXTERNAL TRIGGER RATE: 400/s.

DC GENERAL

LINEARITY OF 10VDC RANGE: ±(1ppm of reading + 2ppm of range).

DCV, Ω, TEMPERATURE, CONTINUITY, DIODE TEST INPUT PROTECTION: 1000V, all ranges.

MAXIMUM 4WΩ LEAD RESISTANCE: 10% of range per lead for 100Ω and 1kΩ ranges; 1kΩ per lead for all other ranges.

DC CURRENT INPUT PROTECTION: 3A, 250V fuse.

SHUNT RESISTOR: 0.1Ω for 3A, 1A, and 100mA ranges. 10Ω for 10mA range.

CONTINUITY THRESHOLD: Adjustable 1Ω to 1000Ω.

AUTOZERO OFF ERROR: Add ±(2ppm of range error + 5μV) for <10 minutes and ±1°C change.

OVERRANGE: 120% of range except on 1000V, 3A, and Diode.

SPEED AND NOISE REJECTION

Rate	Readings/s	Digits	RMS Noise 10V Range	NMRR ¹²	CMRR ¹³
10 PLC	5	6½	< 1.5 μV	60 dB	140 dB
1 PLC	50	6½	< 4 μV	60 dB	140 dB
0.1 PLC	500	5½	< 22 μV	—	80 dB
0.01 PLC	2000	4½	< 150 μV	—	80 dB

DC NOTES

- Add the following to ppm of range accuracy specification based on range: 1V and 100V, 2ppm; 100mV, 15ppm; 100Ω, 15ppm; 1kΩ–1MΩ, 2ppm; 10mA and 1A, 10ppm; 100mA, 40ppm.
- Speeds are for 60Hz operation using factory default operating conditions (*RST). Autorange off, Display off, Trigger delay = 0.
- Speeds include measurement and binary data transfer out the GPIB.
- Auto zero off.
- Sample count = 1024, auto zero off.
- Auto zero off, NPLC = 0.01.
- Ohms = 24 readings/second.
- 1 PLC = 16.67ms @ 60Hz, 20ms @ 50Hz/400Hz. The frequency is automatically determined at power up.
- For signal levels >500V, add 0.02ppm/V uncertainty for the portion exceeding 500V.
- Add 120ms for ohms.
- Must have 10% matching of lead resistance in Input HI and LO.
- For line frequency ±0.1%.
- For 1kΩ unbalance in LO lead.
- Relative to calibration accuracy.
- Specifications are for 4-wire ohms. For 2-wire ohms, add 1Ω additional uncertainty.
- For rear inputs. Add the following to Temperature Coefficient "ppm of reading" uncertainty: 10MΩ 70ppm, 100MΩ 385ppm. Operating environment specified for 0° to 50°C, 50% RH at 35°C.

1.888.KEITHLEY (U.S. only)

www.keithley.com

KEITHLEY

A Tektronix Company

A Greater Measure of Confidence

**2015, 2015-P,
2016, 2016-P**

6½-Digit THD Multimeters 6½-Digit Audio Analyzing Multimeters

True RMS AC Voltage and Current Characteristics

Voltage Range	Resolution	Calibration Cycle	Accuracy ¹ : ±(% of reading + % of range), 23°C ±5 °C				
			3 Hz– 10 Hz ¹⁰	10 Hz– 20 kHz	20 kHz– 50 kHz	50 kHz– 100 kHz	100 kHz– 300 kHz
100.0000 mV	0.1 μV	90 Days 1 Year					
1.000000 V	1.0 μV		0.35 + 0.03	0.05 + 0.03	0.11 + 0.05	0.60 + 0.08	4 + 0.5
10.00000 V	10 μV		0.35 + 0.03	0.06 + 0.03	0.12 + 0.05	0.60 + 0.08	4 + 0.5
100.0000 V	100 μV						
750.000 V	1 mV						
		Temperature Coefficient/°C⁸	0.035 + 0.003	0.005 + 0.003	0.006 + 0.005	0.01 + 0.006	0.03 + 0.01

Current Range	Resolution	Calibration Cycle	3 Hz–10 Hz	10 Hz–3 kHz	3 kHz–5 kHz
1.000000 A	1 μA	90 Day/1 Year	0.30 + 0.04	0.10 + 0.04	0.14 + 0.04
3.00000 A ⁹	10 μA	90 Day/1 Year	0.35 + 0.06	0.15 + 0.06	0.18 + 0.06
		Temperature Coefficient/°C⁸	0.035 + 0.006	0.015 + 0.006	0.015 + 0.006

HIGH CREST FACTOR ADDITIONAL ERROR ±(% of reading)⁷

CREST FACTOR:	1–2	2–3	3–4	4–5
ADDITIONAL ERROR:	0.05	0.15	0.30	0.40

AC OPERATING CHARACTERISTICS²

Function	Digits	Readings/s	Rate	Bandwidth
ACV (all ranges), and ACI (all ranges)	6½ ³	2s/reading	SLOW	3 Hz–300 kHz
	6½ ³	1.4	MED	30 Hz–300 kHz
	6½ ⁴	4.8	MED	30 Hz–300 kHz
	6½ ³	2.2	FAST	300 Hz–300 kHz
	6½ ⁴	35	FAST	300 Hz–300 kHz

ADDITIONAL LOW FREQUENCY ERRORS ±(% of reading)

	Slow	Med	Fast
20 Hz – 30 Hz	0	0.3	—
30 Hz – 50 Hz	0	0	—
50 Hz – 100 Hz	0	0	1.0
100 Hz – 200 Hz	0	0	0.18
200 Hz – 300 Hz	0	0	0.10
> 300 Hz	0	0	0

AC SYSTEM SPEEDS^{2, 5}

FUNCTION/RANGE CHANGE⁶: 4/s.
 AUTORANGE TIME: <3s.
 ASCII READINGS TO RS-232 (19.2k baud)⁴: 50/s.
 MAX. INTERNAL TRIGGER RATE⁴: 300/s.
 MAX. EXTERNAL TRIGGER RATE⁴: 260/s.

AC GENERAL

INPUT IMPEDANCE: 1MΩ ±2% paralleled by <100pF.
 ACV INPUT PROTECTION: 1000Vp.
 MAXIMUM DCV: 400V on any ACV range.
 ACI INPUT PROTECTION: 3A, 250V fuse.
 BURDEN VOLTAGE: 1A Range: <0.3V rms. 3A Range: <1V rms.
 SHUNT RESISTOR: 0.1Ω on all ACI ranges.
 AC CMRR: >70dB with 1kΩ in LO lead.
 MAXIMUM CREST FACTOR: 5 at full scale.
 VOLT HERTZ PRODUCT: ≤8 × 10⁶V·Hz.
 OVERRANGE: 120% of range except on 750V and 3A ranges.

AC NOTES

- Specifications are for SLOW rate and sine wave inputs >5% of range.
- Speeds are for 60Hz operation using factory default operating conditions (*RST). Auto zero off, Auto range off, Display off, includes measurement and binary data transfer out the GPIB.
- 0.01% of step settling error. Trigger delay = 400ms.
- Trigger delay = 0.
- DETECTOR: BANDwidth 300, NPLC = 0.01.
- Maximum useful limit with trigger delay = 175ms.
- Applies to non-sine waves >5Hz and <500Hz. (Guaranteed by design for crest factors >4.3.)
- Applies to 0°–18°C and 28°–50°C.
- For signal levels >2.2A, add additional 0.4% to "of reading" uncertainty.
- Typical uncertainties. Typical represents two sigma or 95% of manufactured units measure <0.35% of reading and three sigma or 99.7% <1.06% of reading.

1.888.KEITHLEY (U.S. only)

www.keithley.com

KEITHLEY

A Tektronix Company

A Greater Measure of Confidence

Model 2015, 2015-P, 2016, 2016-P specifications

DIGITAL MULTIMETERS & SYSTEMS

2015, 2015-P, 2016, 2016-P

6½-Digit THD Multimeters 6½-Digit Audio Analyzing Multimeters

Triggering and Memory

READING HOLD SENSITIVITY: 0.01%, 0.1%, 1%, or 10% of reading.

TRIGGER DELAY: 0 to 99 hrs (1ms step size).

EXTERNAL TRIGGER LATENCY: 200 μ s + <300 μ s jitter with autozero off, trigger delay = 0.

MEMORY: 1024 readings.

Math Functions

Rel, Min/Max/Average/StdDev (of stored reading), dB, dBm, Limit Test, %, and mX+b with user defined units displayed.

dBm REFERENCE RESISTANCES: 1 to 9999 Ω in 1 Ω increments.

Standard Programming Languages

SCPI (Standard Commands for Programmable Instruments).

Frequency and Period Characteristics 1, 2

ACV Range	Frequency Range	Period Range	Gate Time	Resolution \pm (ppm of reading)	Accuracy 90 Day/1 Year \pm (% of reading)
100 mV to 750 V	3 Hz to 500 kHz	333 ms to 2 μ s	1 s (SLOW)	0.333	0.01
			0.1 s (MED)	3.33	0.01
			10 ms (FAST)	33.3	0.01

FREQUENCY NOTES

- Specifications are for square wave inputs only. Input signal must be >10% of ACV range. If input is <20mV on the 100mV range, then the frequency must be >10Hz.
- 20% overrange on all ranges except 750V range.

Temperature Characteristics

Thermocouple 2, 3, 4

Type	Range	Resolution	Accuracy 1 90 Day/1 Year (23°C \pm 5°C) Relative to Reference Junction
J	-200 to + 760°C	0.001°C	\pm 0.5°C
K	-200 to + 1372°C	0.001°C	\pm 0.5°C
T	-200 to + 400°C	0.001°C	\pm 0.5°C

TEMPERATURE NOTES

- For temperatures <-100°C, add \pm 0.1°C and >900°C add \pm 0.3°C.
- Temperature can be displayed in °C, K, or °F.
- Accuracy based on ITS-90.
- Exclusive of thermocouple error.

GENERAL

POWER SUPPLY: 100V/120V/220V/240V.

LINE FREQUENCY: 50Hz to 60Hz and 400Hz, automatically sensed at power-up.

POWER CONSUMPTION: 40VA.

VOLT HERTZ PRODUCT: $\leq 8 \times 10^7$ V·Hz.

SAFETY: Conforms to European Union Low Voltage Directive.

EMC: Conforms to European Union EMC Directive.

VIBRATION: MIL-PRF-28800F Class 3 Random.

OPERATING ENVIRONMENT: Specified for 0°C to 50°C. Specified to 80% R.H. at 35°C and at an altitude of up to 2,000 meters.

STORAGE ENVIRONMENT: -40°C to 70°C.

WARMUP: 1 hour to rated accuracy.

DIMENSIONS:

Rack Mounting: 89mm high \times 213mm wide \times 370mm deep (3.5 in \times 8.38 in \times 14.56 in).

Bench Configuration (with handle and feet): 104mm high \times 238mm wide \times 370mm deep (4.13 in \times 9.38 in \times 14.56 in).

NET WEIGHT: 4.2kg (8.8 lbs).

SHIPPING WEIGHT: 5kg (11 lbs).

1.888.KEITHLEY (U.S. only)

www.keithley.com

Series 3700A

System Switch/Multimeter and Plug-In Cards



- Combines the functions of a system switch and a high performance multimeter
- LXI compliance with IEEE-1588 time synchronization
- 3½- to 7½-digit measurement resolution
- Embedded Test Script Processor (TSP®) offers unparalleled system automation, throughput, and flexibility
- Extended low ohms (1Ω) range with 100nΩ resolution
- Extended low current (10μA) range with 1pA resolution
- >14,000 readings/second
- Low noise, <0.1ppm rms noise on 10VDC range
- Expanded dry circuit range (2kΩ)
- Four-wire open lead detection (source and sense lines)

For more information about Series 3700A systems, see page 174.

A Series 3700A system combines the functionality of an instrument grade relay switching system with a high performance multimeter. Integrating the multimeter within the mainframe ensures you of a high quality signal path from each channel to the multimeter. This tightly integrated switch and measurement system can meet the demanding application requirements of a functional test system or provide the flexibility needed in stand-alone data acquisition and measurement applications. It is ideal for multiple pin count applications where relay switching can be used to connect multiple devices to source and measurement instruments.

The high performance multimeter in the Series 3700A offers low noise, high stability 3½- to 7½-digit readings for leading-edge measurement performance. This flexible resolution supplies a DC reading rate from >14,000 readings/second at 3½ digits to 60 readings/second at 7½ digits, offering customers maximum reading throughput and accuracy. The multimeter also provides an expanded low ohms (1Ω) range, low current (10μA) range, and dry circuit (1Ω to 1kΩ) range, extending utility beyond typical DMM applications.

The multimeter supports 13 built-in measurement functions, including: DCV, ACV, DCI, ACI, frequency, period, two-wire ohms, four-wire ohms, three-wire RTD temperature, four-wire RTD temperature, thermocouple temperature, thermistor temperature, and continuity. In-rack calibration is supported, which reduces both maintenance and calibration time. Onboard memory can store up to 650,000 readings, and the USB device port provides easy transfer of data to memory sticks.

Single Channel Reading Rates

Resolution	DCV/	
	2-Wire Ohms	4-Wire Ohms
7½ Digits (1 NPLC)	60	29
6½ Digits (0.2 NPLC)	295	120
5½ Digits (0.06 NPLC)	935	285
4½ Digits (0.006 NPLC)	6,300	580
3½ Digits (0.0005 NPLC)	14,000	650

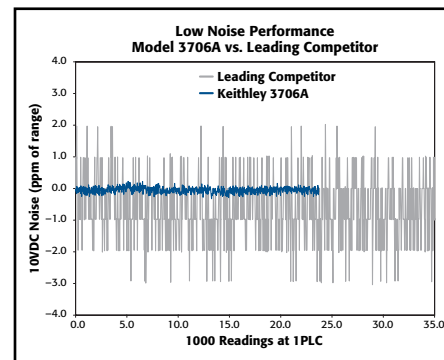

Compare the Model 3706A's 10V DC noise and speed performance with that of the leading competitor. All the data was taken at 1PLC with a low thermal short applied to the input, which resulted in 10× lower noise and 7× faster measurements for the Model 3706A.

APPLICATIONS

- System- and rack-level signal referencing
- Power supply burn-in testing (PC, network, telecom)
- Low ohms testing (contacts, connectors, relays)
- Temperature profiling
- Plant/environment monitoring and control
- Automotive and aerospace systems
- Consumer product certification/testing laboratories

1.888.KEITHLEY (U.S. only)

www.keithley.com

A Greater Measure of Confidence

KEITHLEY

A Tektronix Company

System switch with high performance multimeter

DIGITAL MULTIMETERS & SYSTEMS

2700, 2701, 2750

Multimeter/Data Acquisition/ Switch Systems



Integra Series systems (2700, 2701, 2750) combine precision measurement, switching, and control in a single, tightly integrated enclosure for either rack-mounted or benchtop applications. These cost-effective, high performance test platforms offer affordable alternatives to separate DMMs and switch systems, dataloggers/recorders, plug-in card data acquisition equipment, and VXI/PXI systems. The Integra Series plug-in switching and control modules offer unmatched flexibility and testing efficiency for a wide range of industries and applications. System builders can create test solutions with a combination of channel count, cost per channel, and system performance unmatched by any other single-box measurement system. The input modules provide the flexibility to vary the channel count from 20 to 200 (2-pole), apply a stimulus to the device under test, route signals, control system components, and make precision measurements with up to 14 functions. Robust digital I/O capabilities can be used for triggering, handshaking with other automation equipment, and alarm limit outputs. Scan rates of up to 500 channels/second (up to 3500 readings/second on a single channel) will increase test productivity.

Fast Setup and Operation

The Integra systems are fully integrated, off-the-shelf measurement and control systems. Their DMM-like interfaces make it easy for users to collect data and/or perform troubleshooting within minutes of installation and startup. Once sensor or DUT leads are hooked to the instrument's input, use the front panel controls to select the measurement function, range, filtering, scaling, trigger source, scanning sequence, alarms, and more. The free KickStart instrument control software is a PC-based program that enables setup, configuration, and control in a graphical "point and click" environment. Within minutes you can configure channels, set parameters such as limits and trigger sources, and preview results in real time.

The Advantage of Integrated Design

The Integra systems offer a variety of advantages over existing solutions for ATE and data acquisition applications. For example, their flexible modular architecture and integrated measurement, switching, and control capabilities save rack space by reducing the number of separate instruments needed. This design also simplifies expanding the system as the number of channels grows or re-purposing it as new test requirements evolve. Integrated signal conditioning, scaling, stimulus, filtering and I/O capabilities eliminate the need for external circuitry when designing and building data acquisition systems. The Integra systems offer accuracy and repeatability superior to plug-in data acquisition boards, while providing faster test times than typical DMM/switch systems. This makes it possible to combine higher test yields with higher test throughput.

Ethernet

The Model 2701 offers a 10/100 BaseT Ethernet connection for high speed and long distance communication between a computer and a virtu-

Built-in measurement functions include:

- DCV • ACV • DCI • ACI
- Resistance (2- or 4-wire, offset compensation selectable)
- Dry circuit ohms (20mV clamp) 2750 only
- Temperature (with thermocouples, RTDs, or thermistors)
- Frequency/Period
- Continuity

- Combines functions of DMM, switch system, and datalogger
- True 6½-digit (22-bit) resolution
- Choice of 12 switch/control plug-in modules
- Up to 200 differential input channels (with 300V isolation) for measurement and control
- Convenient front panel inputs
- Free LabVIEW®, LabWindows/CVI, Visual Basic, and C/C++ drivers (IVI style)
- Ethernet, GPIB, RS-232 communications capabilities
- Free KickStart Instrument Control Software, download at www.keithley.com/kickstart

1.888.KEITHLEY (U.S. only)

www.keithley.com

KEITHLEY

A Tektronix Company

A Greater Measure of Confidence

2700, 2701, 2750

Ordering Information

2700	DMM, Data Acquisition, Datalogging System w/2 Slots
2701	DMM, Data Acquisition, Datalogging System w/2 Slots and Ethernet Support
2750	DMM, Data Acquisition, Switching, Datalogging System w/5 Slots

Accessories Supplied

LabVIEW, LabWindows/ CVI, Visual Basic, and C/C++ drivers; manual; and Model 1751 Safety Test Leads.

ACCESSORIES AVAILABLE

2750-321A	Extra slot cover
7007-1	Shielded IEEE-488 Cable, 1m (3.3 ft.) (Models 2700, 2750 only)
7007-2	Shielded IEEE-488 Cable, 2m (6.6 ft.) (Models 2700, 2750 only)
7788	50-Pin D-Shell Connector Kit (2 each) (for Models 7703, 7705 Modules w/D-sub Connectors)
7789	50-Pin/25-Pin D-Shell Kit (1 each)
7790	50-Pin Male, 50-Pin Female, and 25-Pin Male IDC D-Shell Connector Kit (1 each) (Ribbon Cable not Included)
7797	Calibration Extender Board (for Model 2750)
7705-MTC-2	50-Pin Male to Female D-Sub Cable, 2m
7707-MTC-2	25-Pin Male to Female D-Sub Cable, 2m
KPCI-488LPA	IEEE-488 Interface/Controller for the PCI Bus (Models 2700, 2750 only)
KUSB-488B	IEEE-488 USB-to-GPIB Interface Adapter (Models 2700, 2750 only)

SERVICES AVAILABLE

2700-3Y-EW	1-year factory warranty extended to 3 years from date of shipment
2701-3Y-EW	1-year factory warranty extended to 3 years from date of shipment
2750-3Y-EW	1-year factory warranty extended to 3 years from date of shipment
C/2700-3Y-ISO	3 (ISO-17025 accredited) calibrations within 3 years of purchase*
C/2701-3Y-ISO	3 (ISO-17025 accredited) calibrations within 3 years of purchase*
C/2750-3Y-ISO	3 (ISO-17025 accredited) calibrations within 3 years of purchase*

*Not available in all countries

Multimeter/Data Acquisition/ Switch Systems

ally infinite number of instruments. Any PC with an Ethernet port can connect to a single Model 2701 in a point-to-point configuration, to multiple Model 2701s through a hub, or to multiple Model 2701s distributed on a network.

The Model 2701 Ethernet port uses the industry-standard TCP/IP socket interface. This provides data rates up to 100Mbps/sec. and allows the instrument to be located up to 100 meters from the nearest computer or network hub in hardwired systems and miles in wireless Ethernet systems. The maximum distances between a control PC and the instruments are limited only by the size of the network. The instrument also provides a built-in diagnostic Web page for easy remote access to the Model 2701. Entering the instrument's IP address in the URL line of Microsoft Internet Explorer will allow communication with and control of the Model 2701. This Web page allows users to read and set network parameters, such as IP address, subnet mask, gateway, MAC address, and calibration dates, and to send commands to and query data from the Model 2701.

Temperature Capabilities

Integra Series mainframes support three major types of temperature sensors with built-in signal conditioning and 300V isolation: thermocouples, RTDs, and thermistors. To begin using a sensor, simply hook it up and the instrument does the rest. If a thermocouple is broken or disconnected, the instrument will alert the operator. The mainframes also support three methods for cold-junction compensation (CJC): automatic (built-in), external (built-in), and simulated.



Install up to five input modules in the 2750 mainframe (or up to two in the 2700 and 2701 mainframes). All switch/control modules are fully enclosed in impact-resistant plastic for exceptional ruggedness. Three connector alternatives simplify connecting the modules to DUTs. Rugged D-sub connectors allow quick, secure connections and are especially convenient when performing routine maintenance or when the system is installed in a rack. IDC ribbon cable adapters are supplied with the Model 7701, 7707, and 7709 modules for fast, uncomplicated hookups in production test and process monitoring applications. Oversize screw-terminal connectors simplify setup in applications that require the greatest connection flexibility. Additional D-sub and IDC ribbon cable connector kits and pre-wired cable assemblies are sold separately.

TYPICAL APPLICATIONS

- Production test of electronic products and devices
- Accelerated stress testing (AST)
- Process monitor and control
- Device characterization/R&D
- Low ohms, multichannel measurements

1.888.KEITHLEY (U.S. only)

www.keithley.com

A Greater Measure of Confidence

KEITHLEY

A Tektronix Company

2700, 2701, 2750

Multimeter/Data Acquisition/ Switch Systems

Web-Enabled Data Acquisition and Control via Standard Ethernet

A built-in 10/100BaseTX Ethernet interface makes the Model 2701 the best choice for distributed data acquisition applications that demand stable, high precision measurements. Just connect it directly to an Ethernet port—there's no need for additional interface cards, proprietary cables, or software. The Model 2701 is a cost-effective solution for industrial monitoring and control applications. It combines remote communications with high measurement precision for research and development tasks, such as remote equipment diagnostics and economical monitoring of lab environments.

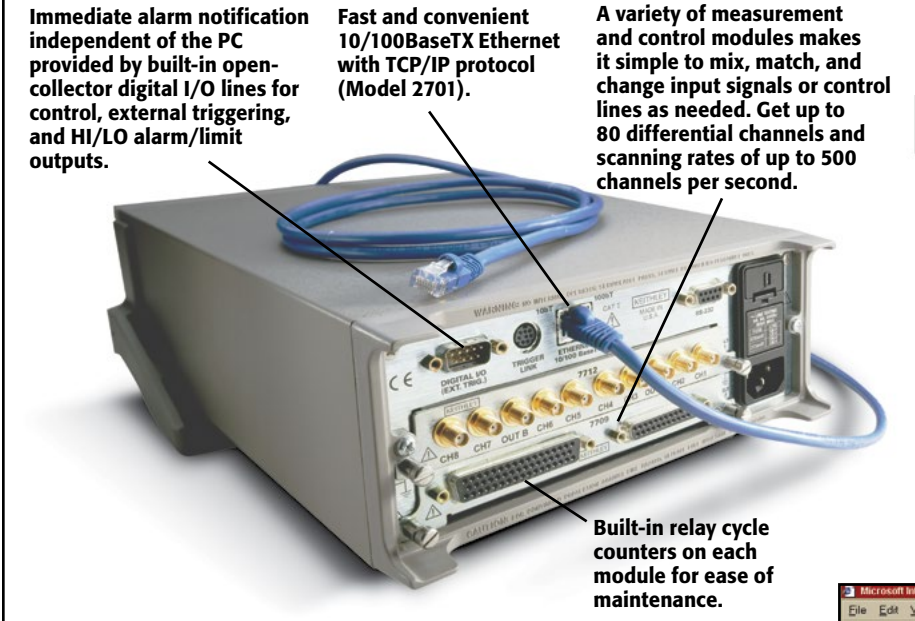

Free built-In Web diagnostic tool (2701 only)

- Read and set network parameters
- Send command strings and receive data
- Debug

To start communicating with the Integra Series instrument, simply connect the 2701 to a PC Ethernet port using the supplied RJ-45 cross-over cable, start Microsoft® Internet Explorer version 5.0 or later, and type the instrument's IP address into the URL line. The built-in web diagnostic interface allows for easy communication and debugging, without the need to install external software. This interface makes it easy to read and set network parameters such as IP address, subnet mask, gateway, MAC address, calibration dates, and other data stored in the Integra Series instrument. It also takes readings from the instrument and allows the user to send command strings and receive data.

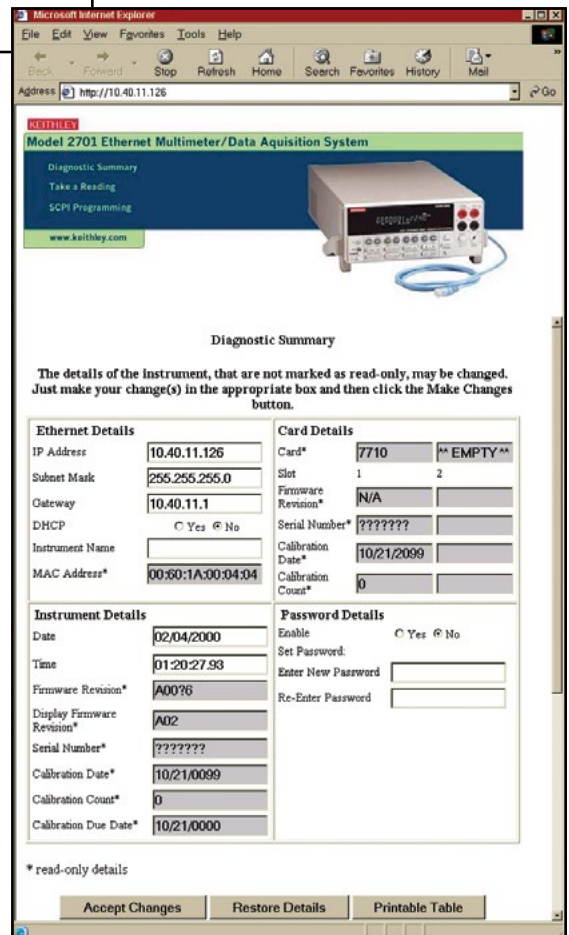

1.888.KEITHLEY (U.S. only)

www.keithley.com

KEITHLEY

A Tektronix Company

A Greater Measure of Confidence

2700, 2701, 2750

Ordering Information

- 7700** 20-channel Differential Multiplexer Module with up to 50MHz Bandwidth, Automatic CJC, and Screw Terminals
- 7701** 32-channel Differential Multiplexer Module with a 25- and 50-Pin Female D-Sub Connector. Supplied with Male IDC Ribbon Cable Connectors
- 7702** 40-channel Differential Multiplexer Module w/ Screw Terminals
- 7703** 32-channel, High Speed, Differential Multiplexer Module with 2 50-Pin Female D-Sub Connectors. Includes 2 Mating Connectors
- 7705** 40-channel, Single-pole Control Module with 2 50-Pin Female D-Sub Connectors. Includes 2 Mating Connectors
- 7706** All-in-One I/O Module: 20-channel Differential Multiplexer w/Automatic CJC, 16 Digital Outputs, 2 Analog Outputs, a Counter/Totalizer, and Screw Terminals
- 7707** 32-channel Digital I/O w/10-channel Differential Multiplexer Module with a 25-Pin Female and 50-Pin Male D-Sub Connectors. Supplied with Mating IDC Ribbon Cable Connectors
- 7708** 40-channel Differential Multiplexer Module w/Automatic CJC and Screw Terminals
- 7709** 6x8 Matrix Module with 25- and 50-Pin Female D-Sub Connectors. Supplied with Male IDC Ribbon Cable Connectors
- 7710** 20-channel Solid-state/ Long Life Differential Multiplexer w/Automatic CJC and Screw Terminals
- 7711** 2GHz 50Ω RF Module with Dual 1x4 Configuration and SMA Connections
- 7712** 3.5GHz 50Ω RF Module with Dual 1x4 Configuration and SMA Connections

Multimeter/Data Acquisition/ Switch Systems

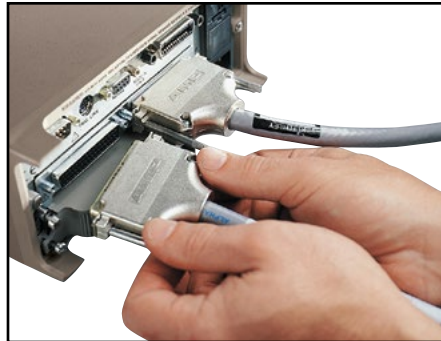

Rugged 50-pin D-sub connectors ensure dependability and quick setup/teardown in production test racks.

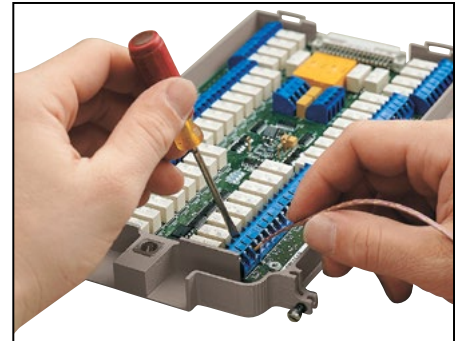

Screw terminals use oversized connectors for easier, mistake-free wiring. Easy-to-use removable terminals are available on some models.

Software Solutions

Whether the task calls for a simple start-up package to acquire several channels of data or the tools to create a fully custom acquisition and analysis solution, Keithley has the software needed to get the most performance from a Model 2700, 2701, or 2750 Multimeter/Switch System. Our broad range of software solutions makes it easy to get applications "Up & Running" quickly and economically.

Measurement Ranges for the Integra Series Systems

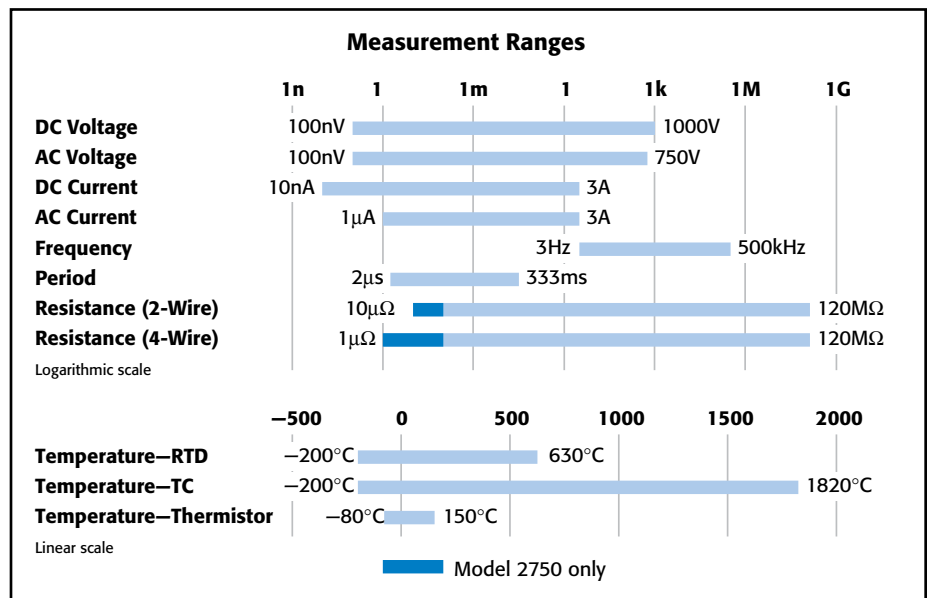

1.888.KEITHLEY (U.S. only)

www.keithley.com

A Greater Measure of Confidence

KEITHLEY

A Tektronix Company

Integra Series integrated switching, measurement, and datalogging solutions

DIGITAL MULTIMETERS & SYSTEMS

2700, 2701, 2750

Multimeter/Data Acquisition/ Switch Systems

Important Features and Benefits

- **Full per-channel configurability**—Each channel can be independently configured for making measurements. The parameters that can be chosen for each channel include speed, range, resolution, number of power line cycles (NPLC), filtering type, offset compensation, math functions to be displayed, CJC type, RTD type, frequency gate time, “m” and “b” values in $mX + b$ format, HI/LO limits, low Ω (Model 2750 only), ratio calculation, and thermistor type.
- **Channel monitor feature**—Monitor any specific input channel on the front panel display during a scan. This feature can also serve as an analog trigger to initiate a scan sequence based on some external factor, such as a temperature rising above a pre-set limit. Only the data of interest is acquired, so there’s no need to spend hours searching through reams of normal readings to find anomalous data.
- **Front/rear switch**—Switching between the front and rear panel measurement inputs is as easy as pressing a button. Users can select the front panel inputs for tasks such as system setup and verification, manual probing, troubleshooting, and calibration, while the rear panel inputs through the modules allow fast, automated multiplexing and control.
- **Battery-backed setup memory**—Up to four different setup configurations can be stored in onboard memory. If the line power fails during a scan, the system will resume scanning where it stopped once power is restored.
- **Relay counting**—Provides preventive maintenance of the system and switches.
- **Memory buffer**—The mainframe’s non-volatile wrap-around reading memory allows continuous, unattended datalogging over long periods. Data in the buffer can be transferred to a PC controller automatically as new data is acquired. The real-time clock can be used to time- and date-stamp readings for later review and interpretation.
- **2 TTL-level digital inputs**—Use to implement external triggers to initiate a scan sequence.
- **5 “per-channel” HI/LO alarm limit TTL outputs**—Trigger external alarms or perform other control functions without a PC controller.
- **Dry circuit ohms (20mV clamp)**—Protects sensitive devices from damage and prevents self-heating errors during testing (Model 2750 only).
- **Virtual channel**—Stores the results of channel-to channel ratio and average math operations.
- **Onboard statistical analysis**—Mathematical functions available at the push of a button are channel average, $mX+b$ scaling, minimum, maximum, average, and standard deviation.
- **GPIB and RS-232 interfaces** (Models 2700 and 2750)
- **Ethernet and RS-232 interface** (Model 2701 only)

Which Integra Mainframe is the Best Choice for the Application?

Use this selector guide to decide which Integra Series mainframe offers the combination of features and capacity that’s right for a specific application. If testing requirements change in the future, switch/control modules and test code can be easily re-used.

	2700	2701	2750
No. of differential input channels	80	80	200
Matrix crosspoints	96	96	240
Ohms resolution	100 $\mu\Omega$	100 $\mu\Omega$	1 $\mu\Omega$
Dry circuit ohms (20mV clamp)	No	No	Yes
No. of slots	2	2	5
Memory buffer	55,000 rdgs	450,000 rdgs	110,000 rdgs
Size (2U height)	Half-rack width	Half-rack width	Full-rack width (19")
Communications	GPIB, RS-232	Ethernet, RS-232	GPIB, RS-232
Scan-Rate (memory)	180/s	500/s	230/s
Scan-Rate (bus)	145/s	440/s	210/s
Max. Internal Trigger Rate	2000/s	2800/s	2000/s
Max. External Trigger Rate	375/s	2000/s	375/s

1.888.KEITHLEY (U.S. only)

www.keithley.com

KEITHLEY
A Tektronix Company

A Greater Measure of Confidence

2700, 2701, 2750

Multimeter/Data Acquisition/Switch Systems

DC CHARACTERISTICS¹

Conditions: MED (1 PLC)² or 10 PLC or MED (1 PLC) with Digital Filter of 10

Function	Range	Resolution	Test Current ±5% or Burden Voltage	Input Resistance or Open Circuit Voltage ³		Accuracy: ±(ppm of reading + ppm of range) (ppm = parts per million) (e.g., 10ppm = 0.001%)			Temperature Coefficient 0°-18°C & 28°-50°C
				2700/2701	2750	24 Hour ⁴ 23°C ±1°	90 Day 23°C ±5°	1 Year 23°C ±5°	
Voltage ¹¹	100.0000 mV	0.1 μV		>10 GΩ	>10 GΩ	15 + 30	25 + 35	30 + 35	(1 + 5)/°C
	1.000000 V	1.0 μV		>10 GΩ	>10 GΩ	15 + 6	25 + 7	30 + 7	(1 + 1)/°C
	10.00000 V	10 μV		>10 GΩ	>10 GΩ	10 + 4	20 + 5	30 + 5	(1 + 1)/°C
	100.0000 V	100 μV		10 MΩ ±1%	10 MΩ ±1%	15 + 6	35 + 9	45 + 9	(5 + 1)/°C
	1000.000 V ⁵	1 mV		10 MΩ ±1%	10 MΩ ±1%	20 + 6	35 + 9	50 + 9	(5 + 1)/°C
Resistance ^{6,8}	1.000000Ω ²⁴	1 μΩ	10 mA		5.9 V	80 + 40	80 + 40	100 + 40	(8 + 1)/°C
	10.00000Ω ²⁴	10 μΩ	10 mA		5.9 V	20 + 20	80 + 20	100 + 20	(8 + 1)/°C
	100.0000 Ω	100 μΩ	1 mA	6.9 V	12.2 V	20 + 20	80 + 20	100 + 20	(8 + 1)/°C
	1.000000kΩ	1 mΩ	1 mA	6.9 V	12.2 V	20 + 6	80 + 6	100 + 6	(8 + 1)/°C
	10.00000kΩ	10 mΩ	100 μA	6.9 V	6.8 V	20 + 6	80 + 6	100 + 6	(8 + 1)/°C
	100.0000kΩ	100 mΩ	10 μA	12.8 V	12.8 V	20 + 6	80 + 10	100 + 10	(8 + 1)/°C
	1.000000MΩ ²⁵	1.0 Ω	10 μA	12.8 V	12.8 V	20 + 6	80 + 10	100 + 10	(8 + 1)/°C
	10.00000MΩ ^{7,25}	10 Ω	0.7 μA/10 MΩ	7.0 V	7.0 V	150 + 6	200 + 10	400 + 10	(70 + 1)/°C
	100.0000MΩ ^{7,25}	100 Ω	0.7 μA/10 MΩ	7.0 V	7.0 V	800 + 30	2000 + 30	2000 + 30	(385 + 1)/°C
	Dry Circuit Resistance ^{21,24}	1.000000 Ω	1 μΩ	10 mA		20 mV	80 + 40	80 + 40	100 + 40
10.00000 Ω		10 μΩ	1 mA		20 mV	25 + 40	80 + 40	100 + 40	(8 + 1)/°C
100.0000 Ω		100 μΩ	100 μA		20 mV	25 + 40	90 + 40	140 + 40	(8 + 1)/°C
1.000000kΩ		1 mΩ	10 μA		20 mV	25 + 90	180 + 90	400 + 90	(8 + 1)/°C
Continuity (2W)	1.000kΩ	100 mΩ	1 mA	6.9 V	12.2 V	40 + 100	100 + 100	100 + 100	(8 + 1)/°C
Current	20.00000 mA	10 nA	< 0.2 V			60 + 30	300 + 80	500 + 80	(50 + 5)/°C
	100.0000 mA	100 nA	< 0.1 V			100 + 300	300 + 800	500 + 800	(50 + 50)/°C
	1.000000 A	1.0 μA	< 0.5 V ⁹			200 + 30	500 + 80	800 + 80	(50 + 5)/°C
	3.000000 A	10 μA	< 1.5 V ⁹			1000 + 15	1200 + 40	1200 + 40	(50 + 5)/°C
Channel (Ratio) ¹⁰	Ratio Accuracy = Accuracy of selected Channel Range + Accuracy of Paired Channel Range								
Channel (Average) ¹⁰	Average Accuracy = Accuracy of selected Channel Range + Accuracy of Paired Channel Range								

TEMPERATURE¹⁹

(Displayed in °C, °F, or K. Exclusive of probe errors.)

Thermocouples (Accuracy based on ITS-90)

Type	Range	Resolution	90 Day/1 Year (23°C ± 5°C)		Using 77XX Module*	Temperature Coefficient 0°-18°C & 28°-50°C
			Relative to Simulated Reference Junction	Temperature Coefficient		
J	-200 to + 760°C	0.001°C	0.2°C	1.0°C	1.0°C	0.03°C/°C
K	-200 to +1372°C	0.001°C	0.2°C	1.0°C	1.0°C	0.03°C/°C
N	-200 to +1300°C	0.001°C	0.2°C	1.0°C	1.0°C	0.03°C/°C
T	-200 to + 400°C	0.001°C	0.2°C	1.0°C	1.0°C	0.03°C/°C
E	-200 to +1000°C	0.001°C	0.2°C	1.0°C	1.0°C	0.03°C/°C
R	0 to +1768°C	0.1 °C	0.6°C	1.8°C	1.8°C	0.03°C/°C
S	0 to +1768°C	0.1 °C	0.6°C	1.8°C	1.8°C	0.03°C/°C
B	+350 to +1820°C	0.1 °C	0.6°C	1.8°C	1.8°C	0.03°C/°C

* Using 7710 Module: J: 2.5°C; K: 1°C. N, T, E Types: 1.5°C. R, S, B Types: 2.7°C.

4-Wire RTD:

(100Ω platinum [PT100], D100, F100, PT385, PT3916, or user type. Offset compensation On.)

Range	Resolution	Accuracy	Temperature Coefficient
-200° to +630°C	0.01°C	0.06°C	0.003°C/°C
Thermistor: (2.2kΩ, 5kΩ, and 10kΩ)²⁰			
-80° to +150°C	0.01°C	0.08°C	0.002°C/°C

DC SYSTEM SPEEDS^{15,18}

	2700/2750	2701
RANGE CHANGES (excludes 4WΩ) ¹⁶ :	50/s (42/s)	50/s (42/s)
FUNCTION CHANGES ¹⁶ :	50/s (42/s)	50/s (42/s)
AUTORANGE TIME ¹⁶ :	<30 ms	<30 ms
ASCII READINGS TO RS-232 (19.2k baud):	55/s	300/s
MAX. EXTERNAL TRIGGER RATE:	375/s	2000/s

DC MEASUREMENT SPEEDS¹⁵

Single Channel, 60Hz (50Hz) Operation

Function	Digits	Readings/s	PLCs
DCV, DCI, Ω (<10M), Thermocouple, Thermistor	6.5 ^{12,16}	5 (4)	10
	6.5 ¹⁶	35 (28)	1
	6.5 ^{12,16}	45 (36)	1
	5.5 ^{12,16}	150 (120)	0.1
	5.5 ^{16,17}	300 (240)	0.1
	5.5 ¹⁷	500 (400)	0.1
2700 and 2750 only	4.5 ¹⁷	2500 (2000)	0.01
2701 only	3.5	3500 (3500)	0.002
4WΩ (<10M)	6.5 ¹⁶	1.4 (1.1)	10
	6.5 ¹⁶	15 (12)	1
	5.5 ¹⁷	33 (25)	0.1
4WΩ OComp, RTD ²²	6.5 ¹⁶	0.9 (0.7)	10
	6.5 ¹⁶	8 (6.4)	1
	5.5 ^{16,17}	18 (14.4)	0.1
Channel (Ratio), Channel (AVG)	6.5 ¹⁶	2.5 (2)	10
	6.5 ¹⁶	15 (12)	1
	5.5 ¹⁷	25 (20)	0.1

Multiple Channels, Into Memory¹⁸

	Channels/s		
	2700	2701	2750
7710 Scanning DCV	180/s	500/s	230/s
7710 Scanning DCV with Limits or Time Stamp On	170/s	500/s	230/s
7710 Scanning DCV alternating 2WΩ	45/s	115/s	60/s

Multiple Channels, Into and Out of Memory to GPIB^{16,18} or Ethernet

	Channels/s		
	2700	2701	2750
7702 Scanning DCV	65/s	75/s	65/s
7700 and 7708 Scanning Temperature (T/C)	50/s	50/s	50/s
7710 Scanning DCV	145/s	440/s	210/s
7710 Scanning DCV with Limits or Time Stamp On	145/s	440/s	210/s
7710 Scanning DCV alternating 2WΩ	40/s	115/s	55/s

1.888.KEITHLEY (U.S. only)

www.keithley.com

A Greater Measure of Confidence

KEITHLEY
A Tektronix Company

Integra Series condensed specifications

DIGITAL MULTIMETERS & SYSTEMS

2700, 2701, 2750

Multimeter/Data Acquisition/Switch Systems

DC SPEED vs. NOISE REJECTION

Rate	Filter	Readings/s ¹²	Digits	RMS Noise 10V Range		NMRR	CMRR ¹⁴
				2700,2750	2701		
10	50	0.1 (0.08)	6.5	<1.2 μ V	<2.5 μ V	110 dB ¹³	140 dB
1	Off	15 (12)	6.5	<4 μ V	<6 μ V	90 dB ¹³	140 dB
0.1	Off	500 (400)	5.5	<22 μ V	<40 μ V	—	80 dB
0.01	Off	2500 (2000)	4.5	<150 μ V	<300 μ V	—	80 dB
0.002	Off	3500 (2800)	3.5	—	<1 mV	—	60 dB

DC MEASUREMENT CHARACTERISTICS

DC VOLTS

A-D LINEARITY: 2.0 ppm of reading + 1.0 ppm of range.

INPUT IMPEDANCE:

100mV–10V Ranges: Selectable >10G Ω // with <400pF or 10M Ω \pm 1%.

100V, 1000V Ranges: 10M Ω \pm 1%.

Dry Circuit: 100k Ω \pm 1% // <1 μ F.

EARTH ISOLATION: 500V peak, >10G Ω and <300pF any terminal to chassis.

INPUT BIAS CURRENT: <75pA at 23°C.

COMMON MODE CURRENT: <500nA_{pp} at 50Hz or 60Hz.

AUTOZERO ERROR: Add \pm (2ppm of range error + 5 μ V) for <10 minutes and \pm 1°C.

INPUT PROTECTION: 1000V, all ranges. 300V with plug in modules.

RESISTANCE

MAXIMUM 4W Ω LEAD RESISTANCE: 80% of range per lead (Dry Ckt mode). 5 Ω per lead for 1 Ω range; 10% of range per lead for 10 Ω , 100 Ω , and 1k Ω ranges; 1k Ω per lead for all other ranges.

OFFSET COMPENSATION: Selectable on 4W Ω , 1 Ω , 10 Ω , 100 Ω , 1k Ω , and 10k Ω ranges.

CONTINUITY THRESHOLD: Adjustable 1 to 1000 Ω .

INPUT PROTECTION: 1000V, all Source Inputs, 350V Sense Inputs. 300V with plug-in modules.

DC CURRENT

SHUNT RESISTORS: 100mA–3A, 0.1 Ω , 20mA, 5 Ω .

INPUT PROTECTION: 3A, 250V fuse.

THERMOCOUPLES

CONVERSION: ITS-90.

REFERENCE JUNCTION: Internal, External, or Simulated (Fixed).

OPEN CIRCUIT CHECK: Selectable per channel. Open >11.4k Ω \pm 200 Ω .

DC NOTES

- 20% overrange except on 1000V and 3A.
- Add the following to "ppm of range" uncertainty; 100mV 15ppm; 1V and 100V 2ppm; for Model 2750 1 Ω and Dry Circuit Ω 40ppm; 10 \rightarrow 1M Ω 2ppm, for Models 2700/2701 100 Ω 30ppm, 20mA and 1A 10ppm, 100mA 40ppm.
- \pm 2% (measured with 10M Ω input resistance DMM, >10G Ω DMM on 10M Ω and 100M Ω ranges). For Dry Circuit Ω , \pm 25% with Input HI connected to Sense HI; with Sense HI disconnected add 30mV.
- Relative to calibration accuracy.
- For signal levels >500V, add 0.02ppm/V uncertainty for portion exceeding 500V.
- Specifications are for 4-wire Ω , 1 Ω , 10 Ω , and 100 Ω with offset compensation on. With 77XX plug-in modules, LSYNC on. With offset compensation on, OPEN CKT. VOLTAGE is 12.8V. For 2-wire Ω add 1.5 Ω to "ppm of range" uncertainty. 1 Ω range is 4-wire only.
- Must have 10% matching of lead resistance in Input HI and LO.
- Add the following to "ppm of reading" uncertainty when using plug in modules:

	10 k Ω	100 k Ω	1 M Ω	10 M Ω	100 M Ω
All Modules:				220 ppm	2200 ppm
7701, 7703, 7707, 7709 Modules:	10 ppm	100 ppm	1000 ppm	1%	10%
7706, 7708, 7710 Modules:	5 ppm	50 ppm	500 ppm	5000 ppm	5%
7710 Module 23°C \pm 5°C:	11 ppm	110 ppm	1100 ppm	1.1%	11%

- Add 1.5V when used with plug in modules.
- For RATIO, DCV only. For AVERAGE, DCV, and Thermocouples only. Available with plug in modules only.
- Add 6 μ V to "of range" uncertainty when using Models 7701, 7703, and 7707, and 3 μ V for Models 7706 and 7709.
- Auto zero off.
- For LSYNC On, line frequency \pm 0.1%. For LSYNC Off, use 60dB for \geq 1PLC.
- For 1k Ω unbalance in LO lead. AC CMRR is 70dB.
- Speeds are for 60Hz (50Hz) operation using factory defaults operating conditions (*RST). Autorange off, Display off, Limits off, Trigger delay = 0.
- Speeds include measurements and binary data transfer out the GPIB or ASCII data transfer for Ethernet and RS-232 (reading element only).
- Sample count = 1000, auto zero off (into memory buffer).
- Auto zero off, NPLC = 0.01 (Models 2700 and 2750), NPLC = 0.002 (Model 2701).
- Additional Uncertainty:

Type	Range	Plug-In Modules				
		Front Terminals Simulated Ref. Junction	7709 Simulated Ref. Junction	7701, 7703, 7707 Simulated Ref. Junction	7700, 7708, 7710 Using CJC	7706 Using CJC
J	-200 to 0°C	0.1	0.1	0.3	0.8	1.6
K	-200 to 0°C	0.2	0.2	0.4	0.8	1.6
N	-200 to 0°C	0.3	0.3	0.6	0.8	1.6
T	-200 to 0°C	0.2	0.1	0.4	0.8	1.6
E	-200 to 0°C	—	0.1	0.3	0.8	1.6
R	0 to +400°C	0.4	0.6	1.2	0.5	1.0
S	0 to +400°C	0.4	0.6	1.2	0.5	1.0
B	+350 to +1100°C	0.8	0.3	1.7	0.5	1.0

- For lead resistance >0 Ω , add the following uncertainty/ Ω for measurement temperatures of:

	70°–100°C	100°–150°C
2.2 k Ω (44004)	0.22°C	1.11°C
5.0 k Ω (44007)	0.10°C	0.46°C
10 k Ω (44006)	0.04°C	0.19°C

- For 4-wire Ω only, offset compensation on, LSYNC on.
- For Dry Circuit 1k Ω range, 2 readings/s max.
- For 2750 Front Inputs, add the following to Temperature Coefficient "ppm of reading" uncertainty: 1M Ω 25ppm, 10M Ω 250ppm, 100M Ω 2500ppm. Operating environment specified for 0°C to 50°C and 50% RH at 35°C.
- Model 2750 only.
- Front panel resolution is limited to 0.1 Ω .

AC SPECIFICATIONS¹

Function	Range	Resolution	Calibration Cycle	Accuracy: \pm (% of reading + % of range), 23°C \pm 5°C				
				3 Hz–10 Hz	10 Hz–20 kHz	20 kHz–50 kHz	50 kHz–100 kHz	100 kHz–300 kHz
Voltage ²	100.0000 mV	0.1 μ V	90 Days (all ranges)	0.35 + 0.03	0.05 + 0.03	0.11 + 0.05	0.6 + 0.08	4.0 + 0.5
	1.000000 V	1.0 μ V						
	10.00000 V	10 μ V	1 Year (all ranges)	0.35 + 0.03	0.06 + 0.03	0.12 + 0.05	0.6 + 0.08	4.0 + 0.5
	100.0000 V	100 μ V						
	750.000 V	1.0 μ V						
			(Temp. Coeff.) ³	0.035 + 0.003	0.005 + 0.003	0.006 + 0.005	0.01 + 0.006	0.03 + 0.01
Current ²	1.000000 A	1.0 μ A	90 Day/1 Year	0.30 + 0.04	0.10 + 0.04	0.14 + 0.04		
	3.00000 A ¹⁴	10 μ A						
				(Temp. Coeff.) ³	0.035 + 0.006	0.015 + 0.006		
Frequency ⁴ and Period		0.333 ppm	90 Day/1 Year	(3 Hz–500 kHz) (333 ms–2 μ s)				
	100 mV to 750 V	3.33 ppm		100 ppm + 0.333 ppm (SLOW, 1s gate)				
		33.3 ppm		100 ppm + 3.33 ppm (MED, 100ms gate)				
				100 ppm + 33.3 ppm (FAST, 10ms gate)				

1.888.KEITHLEY (U.S. only)

www.keithley.com

KEITHLEY

A Tektronix Company

A Greater Measure of Confidence

2700, 2701, 2750

Multimeter/Data Acquisition/ Switch Systems

ADDITIONAL UNCERTAINTY \pm (% of reading)

Low Frequency Uncertainty	Med	Fast
20 Hz – 30 Hz	0.3	—
30 Hz – 50 Hz	0	—
50 Hz – 100 Hz	0	1.0
100 Hz – 200 Hz	0	0.18
200 Hz – 300 Hz	0	0.10
>300 Hz	0	0

CREST FACTOR: ⁵	1–2	2–3	3–4	4–5
Additional Uncertainty:	0.05	0.15	0.30	0.40
Max. Fundamental Freq.:	50kHz	50kHz	3kHz	1kHz
Maximum Crest Factor: 5 at full-scale.				

AC MEASUREMENT CHARACTERISTICS

AC VOLTS

MEASUREMENT METHOD: AC-coupled, True RMS.
 INPUT IMPEDANCE: $1M\Omega \pm 2\%$ // by $<100pF$.
 INPUT PROTECTION: 1000Vp or 400VDC. 300Vrms with plug in modules.

AC CURRENT

MEASUREMENT METHOD: AC-coupled, True RMS.
 SHUNT RESISTANCE: 0.1 Ω .
 BURDEN VOLTAGE: 1A $<0.5V_{rms}$, 3A $<1.5V_{rms}$. Add 1.5Vrms when used with plug in modules.
 INPUT PROTECTION: 3A, 250V fuse.

FREQUENCY AND PERIOD

MEASUREMENT METHOD: Reciprocal counting technique.
 GATE TIME: SLOW 1s, MED 100ms, and FAST 10ms.

AC GENERAL

AC CMRR⁶: 70dB.
 VOLT HERTZ PRODUCT: $\leq 8 \times 10^7$.

AC MEASUREMENT SPEEDS 7, 13

Single Channel, 60Hz (50Hz) Operation

Function	Digits	Readings/s	Rate	Bandwidth
ACV, ACI	6.5	2s/Reading	SLOW	3 Hz–300 kHz
	6.5 ⁹	4.8 (4)	MED	30 Hz–300 kHz
	6.5 ⁹	40 (32)	FAST	300 Hz–300 kHz
Frequency, Period	6.5	1 (1)	SLOW	3 Hz–300 kHz
	5.5	9 (9)	MED	30 Hz–300 kHz
	4.5	35 (35)	FAST	300 Hz–300 kHz
	4.5 ¹⁰	65 (65)	FAST	300 Hz–300 kHz

Multiple Channel

7710 SCANNING ACV^{10, 11}: 500/s.
 7710 SCANNING ACV WITH AUTO DELAY ON: 2s/reading.

AC SYSTEM SPEEDS 7, 9, 11

	2700/2750	2701
AC System Speed:	(19.2K)	(115.2K)
Range Changes: ¹²	4/s (3/s)	4/s (3/s)
Function Changes: ¹²	4/s (3/s)	4/s (3/s)
Autorange Time:	< 3s	< 3s
ASCII Readings to RS-232 (19.2k baud):	50/s	300/s
Max. External Trigger Rate:	250/s	2000/s

AC NOTES

- 20% overrange except on 750V and 3A.
- Specification are for SLOW mode and sine wave inputs $>5\%$ of range. SLOW and MED are multi-sample A/D conversions. FAST is DETector: BANDwidth 300 with nPLC = 1.0.
- Applies to 0°–18°C and 28°–50°C.
- For square wave inputs $>10\%$ of ACV range, except 100mV range. 100mV range frequency must be $>10Hz$ if input is $<20mV$.
- Applies to non-sine waves $>5Hz$.
- For 1k Ω unbalance in LO lead.
- Speeds are for 60Hz (50Hz) operation using factory defaults operating conditions (*RST). Autorange off, Display off, Limits off, Trigger delay=0.
- For ACV inputs at frequencies of 50 or 60Hz ($\pm 10\%$), add the following to “% of Range” uncertainty: 100mV 0.25%, 1V 0.05%, 10V 0.15%, 100V 0.03%, 750V 0.015 (Model 2701 only).
- Auto Zero off.
- Sample count = 1024.
- DETector: BANDwidth 300 with nPLC = 0.006 (2701 only).
- Maximum useful limit with trigger delay = 175ms.
- Includes measurement and binary data transfer out GPIB or ASCII data transfer for Ethernet and RS-232 (Reading Element only).

GENERAL

EXPANSION SLOTS: 2 (2700, 2701), 5 (2750).
POWER SUPPLY: 100V / 120V / 220V / 240V $\pm 10\%$.
LINE FREQUENCY: 45Hz to 66Hz and 360Hz to 440Hz, automatically sensed at power-up.
POWER CONSUMPTION: 28VA (2700), 80VA (2701, 2750).
OPERATING ENVIRONMENT: Specified for 0°C to 50°C. Specified to 80% RH at 35°C.
STORAGE ENVIRONMENT: $-40^{\circ}C$ to $70^{\circ}C$.
BATTERY: Lithium battery-backed memory, 3 years @ 23°C (Models 2700, 2750) Lithium Ion battery-backed memory, 30 days of buffer storage @ 23°C and >4 hours charge time. Battery lifetime: >3 years @ 23°C, >1.5 years @ 50°C (Model 2701)
EMC: Conforms to European Union Directive 89/336/EEC EN61326-1.
SAFETY: Conforms to European Union Directive 73/23/EEC EN61010-1, CAT I.
VIBRATION: MIL-PRF-28800F Class 3, Random.
WARM-UP: 2 hours to rated accuracy.
DIMENSIONS:
Rack Mounting: 89mm high \times 213mm wide (2700, 2701) or 485mm wide (2750) \times 370mm deep (3.5 in \times 8.375 in or 19 in \times 14.563 in).
Bench Configuration (with handle and feet): 104mm high \times 238mm wide (2700, 2701) or 485mm wide (2750) \times 370mm deep (4.125 in \times 9.375 in (2700, 2701) or 19 in (2750) \times 14.563 in).
SHIPPING WEIGHT: 6.5kg (14 lbs.) (2700, 2701) or 13kg (28 lbs.) (2750).
DIGITAL I/O: 2 inputs, 1 for triggering and 1 for hardware interlock.
 5 outputs, 4 for Reading Limits and 1 for Master Limit. Outputs are TTL compatible or can sink 250mA, diode clamped to 40V.
TRIGGERING AND MEMORY:
Window Filter Sensitivity: 0.01%, 0.1%, 1%, 10%, or Full-scale of range (none).
Reading Hold Sensitivity: 0.01%, 0.1%, 1%, or 10% of reading.
Trigger Delay: 0 to 99 hrs (1ms step size).
External Trigger Delay: $<2ms$ (2700), $<1ms$ (2701, 2750).
External Trigger Jitter: $<1ms$ (2700), $<500\mu s$ (2701), $<500\mu s$ (2750).
Memory Size: 55,000 readings (2700), 450,000 readings (2701), 110,000 readings (2750).
MATH FUNCTIONS: Rel, Min/Max/Average/Std Dev/Peak-to-Peak (of stored reading), Limit Test, %, 1/x, and mX+b with user defined units displayed.
REMOTE INTERFACE:
 GPIB (IEEE-488.2) (2700, 2750), RS-232C (2700, 2701, and 2750).
 Ethernet TCP/IP (10bT and 100bT) (2701)
 SCPI (Standard Commands for Programmable Instruments)
 LabVIEW Drivers
FOR MODEL 2701:
Ethernet: RJ-45 connector, TCP/IP, 10bT and 100bTx autosensed.
IP Configuration: Static or DHCP.
Password Protection: 11 Characters.
Software: Windows 98, NT, 2000, ME, and XP compatible. Internet Explorer 5.0 or higher required.
 Web page server by 2701.

1.888.KEITHLEY (U.S. only)

www.keithley.com

A Greater Measure of Confidence

KEITHLEY
A Tektronix Company

2700, 2701, 2750

Multimeter/Data Acquisition/ Switch Systems

Switch/Control Module Capabilities

All plug-in modules are compatible with the two-slot Model 2700 and Model 2701 Multimeter/Data Acquisition Systems and the five-slot Model 2750 Multimeter/Switch System. When the application's needs change, simply change modules. Integra systems reconfigure themselves automatically.

Module Capabilities Overview

	7700	7701	7702	7703	7705	7706	7707	7708	7709	7710	7711	7712
DC Volts	✓	✓	✓	✓		✓	✓	✓	✓	✓		
DC Current	✓		✓									
Temperature												
T/C w/Automatic CJC	✓					✓		✓		✓		
T/C w/External CJC	✓	✓	✓	✓		✓	✓	✓	✓	✓		
RTD	✓	✓	✓	✓		✓	✓	✓	✓	✓		
Thermistor	✓	✓	✓	✓		✓	✓	✓	✓	✓		
Resistance (2- or 4-wire)	✓	✓	✓	✓		✓	✓	✓	✓	✓		
Continuity	✓	✓	✓	✓		✓	✓	✓	✓	✓		
AC Volts	✓	✓	✓	✓		✓	✓	✓	✓	✓		
AC Current	✓		✓									
Frequency	✓	✓	✓	✓		✓	✓	✓	✓	✓		
Event Counter/Totalizer						✓						
Signal Routing/Control	✓	✓	✓	✓	✓	✓	✓	✓	✓	✓	✓	✓
Digital Input							✓					
Digital Output						✓	✓					
Analog Output						✓						
RF Switching											✓	✓

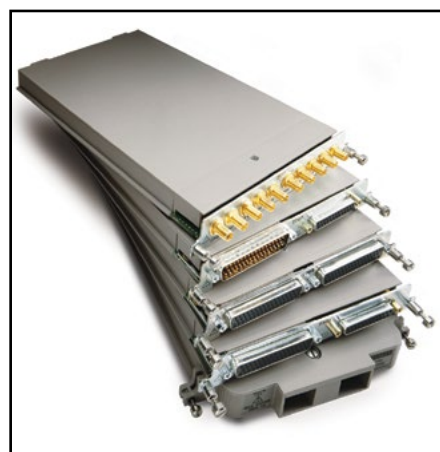

Integra Plug-In Modules

1.888.KEITHLEY (U.S. only)

www.keithley.com

A Greater Measure of Confidence

KEITHLEY
A Tektronix Company

Selector Guide

Plug-In Modules for 2700, 2701, 2750 Integra Mainframes

Module Selector Guide

This selector guide may prove helpful in identifying the best module for a specific application. Install up to five modules at a time in the Model 2750 mainframe or two modules in the Model 2700 or 2701 mainframe. Modules can be disconnected from internal DMM for routing external signals.

Module	# Analog Inputs	Configuration	Type of Connector	Max. Voltage	Max. Switched Current	Bandwidth	Contact Life ¹	Switch Speed	Other	
7700	20	Multiplexer w/CJC	1x20 or two 1x10	Screw terminals	300 V	1	50 MHz	10 ⁸	3 ms	Maximum power = 125VA. 2 current measure channels.
7701	32	Multiplexer	1x32 or two 1x16	D-sub	150 V	1 A	2 MHz	10 ⁸	3 ms	Maximum power = 125VA.
7702	40	Multiplexer	1x40 or two 1x20	Screw terminals	300 V	1 A	2 MHz	10 ⁸	3 ms	Maximum power = 125VA. 2 current measure channels.
7703	32	Multiplexer	1x32 or two 1x16	D-sub	300 V	500 mA	2 MHz	10 ⁸	1 ms	Reed relays.
7705	40	Independent SPST	N/A	D-sub	300 V	2 A	10 MHz	10 ⁸	3 ms	Maximum power = 125VA.
7706	20	Multiplexer w/CJC	1x20 or two 1x10	Screw terminals	300 V	1 A	2 MHz	10 ⁸	3 ms	2 analog outputs. 16 digital outputs. Maximum power = 125VA.
7707	10	Digital I/O/Multiplexer	1x10 or two 1x5	D-sub	300 V	1 A	2 MHz	10 ⁸	3 ms	32 digital I/O. Maximum power = 125VA.
7708	40	Multiplexer w/CJC	1x40 or two 1x20	Screw terminals	300 V	1 A	2 MHz	10 ⁸	3 ms	Maximum power = 125VA.
7709	48	Matrix	6x8	D-sub	300 V	1 A	2 MHz	10 ⁸	3 ms	Connects to internal DMM. Daisy chain multiple cards for up to a 6x40 matrix. Maximum power = 125VA.
7710	20	Multiplexer w/CJC	1x20 or two 1x10	Removable screw terminals	60 V	0.1 A	2 MHz	10 ¹⁰	0.5 ms	Solid state relays, 60V max. 500 channels/second scan rate.
7711	8	Multiplexer	Dual 1x4	SMA	60 V	0.5 A	2 GHz	10 ⁶	10 ms	Insertion loss <1.0dB @ 1GHz. VSWR <1.2 @ 1GHz.
7712	8	Multiplexer	Dual 1x4	SMA	42 V	0.5 A	3.5 GHz	10 ⁶	10 ms	Insertion loss <1.1dB @ 2.4GHz.

1. No load contact life. See card data sheet for additional specifications.

Integra Plug-In Module Accessories

Module	Connector Type	Supplied Accessories	Available Accessories
7700	Oversized Screw Terminal	Strain Relief	7401 T/C wire
7701	50-pin female D-sub & 25-pin female D-sub	7789 connector kit	7790 connector kit, 7705-MTC-2 & 7707-MTC-2 cables
7702	Oversized Screw Terminal	Strain Relief	—
7703	Two 50-pin female D-sub	7788 connector kit	7705-MTC-2 cable
7705	Two 50-pin female D-sub	7788 connector kit	7705-MTC-2 cable
7706	Screw Terminal	Strain Relief	7401 T/C wire kit
7707	50-pin male D-sub & 25-pin female D-sub	7790 connector kit	7789 connector kit, 7705-MTC-2 & 7707-MTC-2 cables
7708	Oversized Screw Terminal	Strain Relief	7401 T/C wire kit
7709	50-pin female D-sub & 25-pin female D-sub	7790 connector kit	7789 connector kit, 7705-MTC-2 & 7707-MTC-2 cables
7710	Quick Disconnect Screw Terminal	Strain Relief	7401 T/C wire kit
7711	SMA	—	7711-BNC-SMA and 7712-SMA-N adapters, 7712-SMA-1 and S46-SMA-0.5, -1 SMA cables, 7051-2, -5, -10 BNC cables
7712	SMA	—	7712-SMA-N adaptor, 7712-SMA-1 & S46-SMA-0.5,-1 SMA cables

1.888.KEITHLEY (U.S. only)

www.keithley.com

A Greater Measure of Confidence

KEITHLEY
A Tektronix Company

Use with Integra Series mainframes: 2700, 2701, 2750

DIGITAL MULTIMETERS & SYSTEMS

7700

20-channel, Differential Multiplexer Module with Automatic CJC, Screw Terminals, and up to 50MHz Bandwidth

- 20 channels for general-purpose measurements, plus two channels to measure current
- Oversize screw terminal connection blocks are standard for easier connections
- 50MHz bandwidth
- 300V, 1A capacity for voltage channels; 60W, 125VA
- 3A capacity for current channels
- Low insertion loss of up to 50MHz
- Relay closures stored in onboard memory

Ordering Information

7700 20-channel, Differential Multiplexer Module with Automatic CJC and Screw Terminals



The Model 7700 plug-in module offers 20 channels of 2-pole or 10 channels of 4-pole multiplexer switching that can be configured as two independent banks of multiplexers. There are two additional protected channels for current measurements. Automatic CJC is provided so that no other accessories are required to make thermocouple temperature measurements. In addition, the Model 7700 contains latching electromechanical relays that enable signal bandwidths of up to 50MHz. The Model 7700 is ideal for RTD, thermistor, and thermocouple temperature applications.

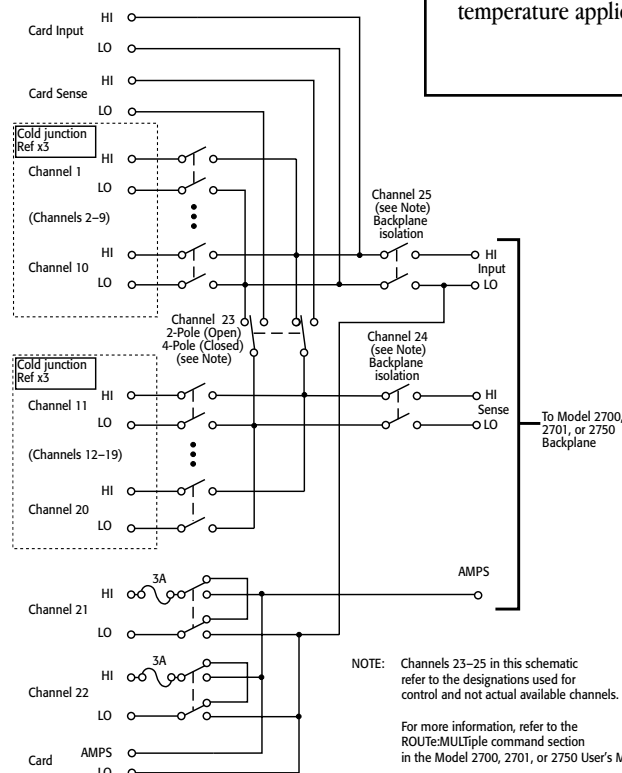

CAPABILITIES

CHANNELS 1-20: Multiplex one of 20 2-pole or one of 10 4-pole signals into DMM.

CHANNELS 21-22: Multiplex one of 2 2-pole current signals into DMM.

INPUTS

MAXIMUM SIGNAL LEVEL:

Channels (1-20): 300V DC or 300V rms (425V peak) for AC waveforms, 1A switched, 60W, 125VA maximum.

Channels (21-22): 60V DC or 30V rms, 3A switched, 60W, 125VA maximum.

CONTACT LIFE (typ.): $>10^5$ operations at max. signal level.
 $>10^8$ operations no load¹.

¹ Open thermocouple detector on during thermocouple measurements. Minimum signal level 10mV, 10 μ A.

CONTACT RESISTANCE: $<1\Omega$ at end of contact life.

CONTACT POTENTIAL: $< \pm 500$ nV typical per contact, 1 μ V max.
 $< \pm 500$ nV typical per contact pair, 1 μ V max.

OFFSET CURRENT: <100 pA.

CONNECTOR TYPE: Screw terminal, #20 AWG wire size.

ISOLATION BETWEEN ANY TWO TERMINALS: $>10^{10}\Omega$, <100 pF.

ISOLATION BETWEEN ANY TERMINAL AND EARTH: $>10^{10}\Omega$, <200 pF.

INSERTION LOSS (50 Ω Source, 50 Ω Load):

	w/Internal DMM	w/o Internal DMM*
<0.1 dB:	1 MHz	1 MHz
<3 dB:	2 MHz	50 MHz

CROSSTALK (50 Ω Load):

	w/Internal DMM	w/o Internal DMM*
10 MHz:	<-40 dB	<-40 dB
25 MHz:	**	<-25 dB

COMMON MODE VOLTAGE: 300V or 300V rms (425V peak) for AC waveforms between any terminal and chassis.

TEMPERATURE ACCURACY USING INTERNAL CJC:

1.0°C (see mainframe specification for details).

* Channels 24 and 25 are open. Refer to ROUTe:MUlTiple command in 27XX User Manual.

** Not valid.

GENERAL

20 CHANNELS: 20 channels of 2-pole relay input. All channels configurable to 4-pole.

2 CHANNELS: 2 channels of current only input.

RELAY TYPE: Latching electromechanical.

ACTUATION TIME: <3 ms.

FIRMWARE: Specified for Model 2700 rev. A01, 2701 rev. A01, and 2750 rev. A01 or higher.

ENVIRONMENTAL

OPERATING ENVIRONMENT: Specified for 0°C to 50°C.
Specified to 80% R.H. at 35°C.

STORAGE ENVIRONMENT: -25°C to 65°C .

WEIGHT: 0.45kg (1 lb).

ACCESSORY AVAILABLE: Model 7401 Type K Thermocouple Wire, 30.5m (100 ft).

SERVICES AVAILABLE

7700-3Y-EW 1-year factory warranty extended to 3 years from date of shipment

1.888.KEITHLEY (U.S. only)

www.keithley.com

KEITHLEY

A Tektronix Company

A Greater Measure of Confidence

7701

32-channel Differential Multiplexer Module

- Configurable for 32 channels of differential measurements, with up to 16 channels of 4-pole measurements
- Two female D-shell connectors are standard for secure hook-up and quick teardown
- 150V, 1A capacity for voltage channels; 60W, 125VA
- Relay closures stored in onboard memory
- Screw terminal jumpers allow user-configurable DMM connections

Ordering Information

7701 32-channel, Differential Multiplexer Module

Accessories Supplied

Two mating IDC connectors for ribbon cable



The Model 7701 plug-in module offers 32 channels of 2-pole or 16 channels of 4-pole multiplexer switching. Its 32 channels can be configured for common-side 4-wire ohms. They can also be configured as two independent banks of multiplexers. It is ideal for RTD or thermistor temperature applications.

CAPABILITIES

CHANNELS 1–32: Multiplex one of 32 2-pole or one of 16 4-pole signals into DMM. Configuration supports dual 1x16 independent multiplexers.

INPUTS

MAXIMUM SIGNAL LEVEL: Any channel to Any Channel (1–32): 150V DC or 150Vrms (212V peak) for AC waveforms, 1A switched, 60W, 125VA maximum.

SAFETY: Conforms to European Union Directive 73/23/EEC EN61010-1, CAT I.

CONTACT LIFE (typ): >10⁵ operations at max. signal level. >10⁸ operations no load¹.

¹Minimum signal level 10mV, 10μA.

CONTACT RESISTANCE: <1Ω any path and additional 1Ω at end of contact life.

CONTACT POTENTIAL: <6μV per contact pair.

OFFSET CURRENT: <100pA.

CONNECTOR TYPE: 50-pin female D-shell, Channels 1–24. 25-pin female D-shell, Channels 25–32.

Supplied with male IDC ribbon cable connectors.

ISOLATION BETWEEN ANY TWO TERMINALS: >10⁹Ω, <200pF.

ISOLATION BETWEEN ANY TERMINAL AND EARTH: >10⁹Ω, <400pF.

CROSS TALK (1MHz, 50Ω Load): <–35dB.

INSERTION LOSS (50Ω Source, 50Ω Load): <0.35dB below 1MHz. <3dB below 2MHz.

COMMON MODE VOLTAGE: 300VDC or 300Vrms (425V peak) for AC waveforms between any terminal and chassis.

GENERAL

32 CHANNELS: 32 channels of 2-pole relay input. All channels configurable to 4-pole.

RELAY TYPE: Latching electromechanical.

ACTUATION TIME: <3ms.

FIRMWARE: Specified for Model 2700 rev. B03, Model 2701 rev. A01, and Model 2750 rev. A01 or higher.

DMM CONNECTIONS: Screw terminals provide internal DMM connections to channels 34 and 35 and connections to external wiring access.

ENVIRONMENTAL

OPERATING ENVIRONMENT: Specified for 0°C to 50°C. Specified to 50% R.H. at 35°C.

STORAGE ENVIRONMENT: –25°C to 65°C.

WEIGHT: <0.52kg (1.16 lb).

ACCESSORIES AVAILABLE

7789	50/25 Pin Male D-Shell Solder Cup Connectors
7790	50/50/25 Pin Female/Male D-Shell IDC Connectors
7705-MTC-2	50 Pin Male to Female D-sub Cable, 2m (6.6 ft).
7707-MTC-2	25 Pin Male to Female D-sub Cable, 2m (6.6 ft).

SERVICES AVAILABLE

7701-3Y-EW	1-year factory warranty extended to 3 years from date of shipment
------------	---

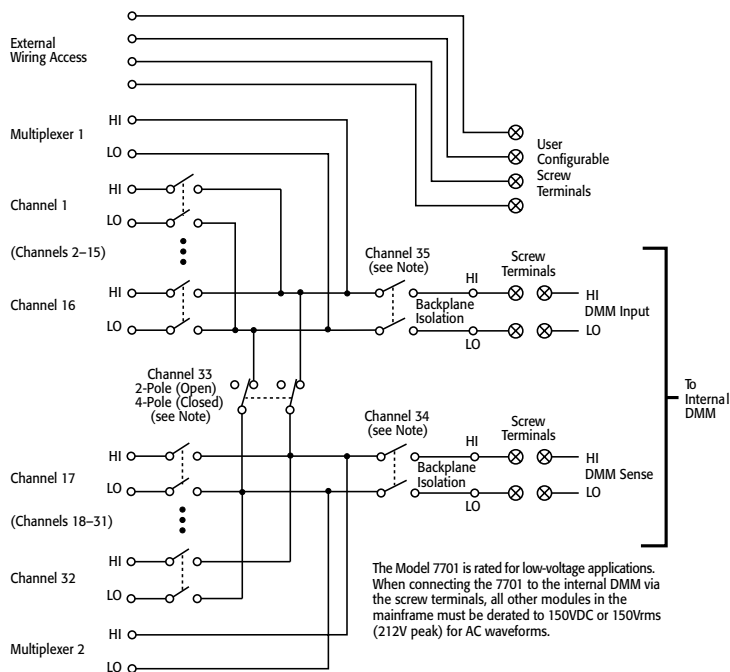

NOTE: Channels 33–35 in this schematic refer to the designations used for control and not actual available channels.

For more information, refer to the ROUTE:MULT command section in the Model 2700, 2701, or 2750 User's Manual.

1.888.KEITHLEY (U.S. only)

www.keithley.com

KEITHLEY

A Tektronix Company

A Greater Measure of Confidence

Use with Integra Series mainframes: 2700, 2701, 2750

DIGITAL MULTIMETERS & SYSTEMS

7702

40-channel Differential Multiplexer Module with Screw Terminals

- 40 channels for general-purpose measurements, plus 2 channels to measure current
- Two- or four-wire measurement
- Oversize screw terminal connection blocks are standard for easier connection
- 300V, 1A capacity for voltage channels; 60W, 125VA
- 3A capacity for current channels
- Relay closures stored in onboard memory

Ordering Information

7702 40-channel Differential Multiplexer Module with Screw Terminals

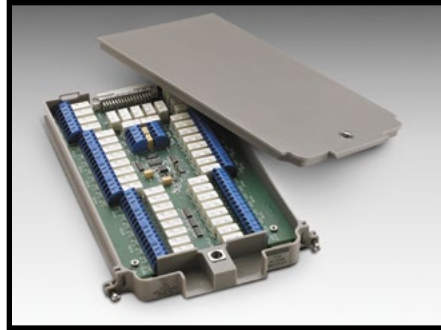

The Model 7702 plug-in module offers 40 channels of 2-pole or 20 channels of 4-pole multiplexer switching that can be configured as two independent banks of multiplexers. The Model 7702 provides two additional protected channels for current measurements. It is ideal for RTD, thermistor, and thermocouple temperature applications.

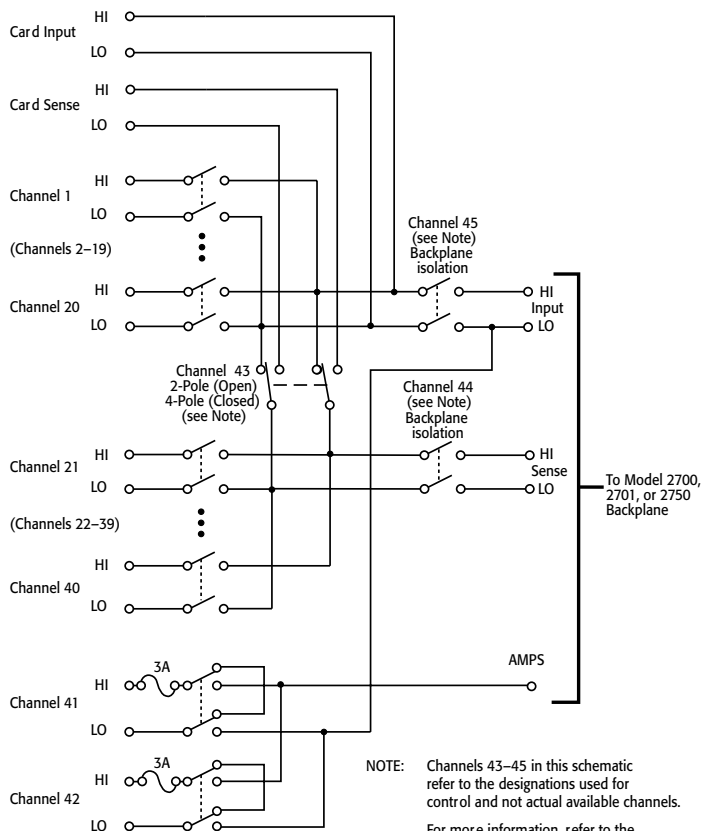

CAPABILITIES

CHANNELS 1-40: Multiplex one of 40 2-pole or one of 20 4-pole signals into DMM.

CHANNELS 41-42: Multiplex one of 2 2-pole current signals into DMM.

INPUTS

MAXIMUM SIGNAL LEVEL:

Channels (1-40): 300V DC or rms, 1A switched, 60W, 125VA maximum.

Channels (41-42): 60V DC or 30V rms, 3A switched, 60W, 125VA maximum.

CONTACT LIFE (typ): $>10^8$ operations at max. signal level. $>10^8$ operations no load¹.

¹ Minimum signal level 10mV, 10 μ A.

CONTACT RESISTANCE: $<1\Omega$ at end of contact life.

CONTACT POTENTIAL:

$<\pm 500$ nV typical per contact, 1 μ V max.

$<\pm 500$ nV typical per contact pair, 1 μ V max.

OFFSET CURRENT: <100 pA.

CONNECTOR TYPE: Screw terminal, #20 AWG wire size.

ISOLATION BETWEEN ANY TWO TERMINALS: $>10^{10}\Omega$, <100 pF.

ISOLATION BETWEEN ANY TERMINAL AND EARTH: $>10^9\Omega$, <200 pF.

CROSS TALK (10MHz, 50 Ω Load): <-40 dB.

INSERTION LOSS (50 Ω Source, 50 Ω Load): <0.1 dB below 1MHz. <3 dB below 2MHz.

COMMON MODE VOLTAGE: 300V between any terminal and chassis.

GENERAL

40 CHANNELS: 40 channels of 2-pole relay input. All channels configurable to 4-pole.

2 CHANNELS: 2 channels of current only input.

RELAY TYPE: Latching electromechanical.

ACTUATION TIME: <3 ms.

FIRMWARE: Specified for Model 2700 rev. A01, 2701 rev. A01, and 2750 rev. A01 or higher.

ENVIRONMENTAL

OPERATING ENVIRONMENT: Specified for 0°C to 50°C. Specified to 80% R.H. at 35°C.

STORAGE ENVIRONMENT: -25°C to 65°C .

WEIGHT: 0.5kg (1.1 lb).

SERVICES AVAILABLE

7702-3Y-EW 1-year factory warranty extended to 3 years from date of shipment

1.888.KEITHLEY (U.S. only)

www.keithley.com

KEITHLEY

A Tektronix Company

A Greater Measure of Confidence

7703

- 32 channels for general purpose measurements
- Relay actuation time of less than 1ms for high-speed scanning
- Two- or four-wire measurement
- Two 50-pin female D-sub connectors are standard for secure hook-up and quick teardown

Ordering Information

7703 32-channel, High Speed, Differential Multiplexer Module

Accessories Supplied

Two mating connectors with solder cup (Model 7788)

32-channel, High Speed, Differential Multiplexer Module



The Model 7703 plug-in module offers 32 channels of 2-pole or 16 channels of 4-pole multiplexer switching that can be configured as two independent banks of multiplexers. The non-latching reed relays provide high speeds and are designed for 300 volt, 500mA; 10VA. The relay closures are stored in onboard memory. The Model 7703 is ideal for RTD and thermistor temperature applications.

CAPABILITIES

CHANNELS 1–32: Multiplex one of 32 2-pole or one of 16 4-pole signals into DMM.

INPUTS

MAXIMUM SIGNAL LEVEL:

Channels (1–32): 300V DC or rms, 0.5A switched, 10W maximum.

Contact Life (typ): $>5 \times 10^4$ operations at max. signal level.
 $>10^8$ operations cold switching.

CONTACT RESISTANCE: $<1\Omega$ at end of contact life.

CONTACT POTENTIAL:

$< \pm 3\mu\text{V}$ typical per contact, $6\mu\text{V}$ max.
 $< \pm 3\mu\text{V}$ typical per contact pair, $6\mu\text{V}$ max.

OFFSET CURRENT: $<100\text{pA}$.

CONNECTOR TYPE: 50 pin D-sub $\times 2$.

RELAY DRIVE CURRENT: 20mA per channel.

ISOLATION BETWEEN ANY TWO TERMINALS: $>10^9\Omega$, $<200\text{pF}$.

ISOLATION BETWEEN ANY TERMINAL AND EARTH: $>10^9\Omega$, $<400\text{pF}$.

CROSS TALK (1 MHz, 50 Ω Load): $<-40\text{dB}$.

INSERTION LOSS (50 Ω Source, 50 Ω Load): $<0.35\text{dB}$ below 1MHz. $<3\text{dB}$ below 2MHz.

COMMON MODE VOLTAGE: 300V between any terminal and chassis.

GENERAL

32 CHANNELS: 32 channels of 2-pole relay input.
All channels configurable to 4-pole.

RELAY TYPE: Reed.

ACTUATION TIME: $<1\text{ms}$.

FIRMWARE: Specified for Model 2700 rev. A01, 2701 rev. A01, and 2750 rev. A01 or higher.

ENVIRONMENTAL

OPERATING ENVIRONMENT: Specified for 0°C to 50°C .
Specified to 80% R.H. at 35°C .

STORAGE ENVIRONMENT: -25°C to 65°C .

WEIGHT: 0.8kg (1.75 lbs).

ACCESSORIES AVAILABLE

7705-MTC-2 50 Pin Male to Female D-sub Cable, 2m (6.6 ft).

SERVICES AVAILABLE

7703-3Y-EW 1-year factory warranty extended to 3 years from date of shipment

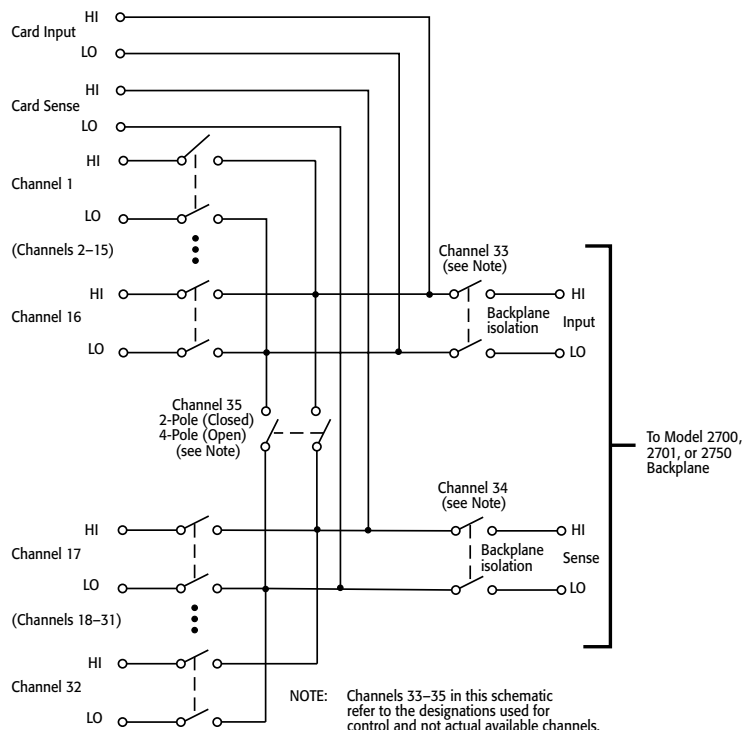

1.888.KEITHLEY (U.S. only)

www.keithley.com

A Greater Measure of Confidence

KEITHLEY
A Tektronix Company

Use with Integra Series mainframes: 2700, 2701, 2750

DIGITAL MULTIMETERS & SYSTEMS

7705

- 300V, 2A capacity
- Two 50-pin female D-sub connectors are standard for secure hook-up and quick teardown
- Relay closures stored in onboard memory

Ordering Information

7705 40-channel, Single-pole Control Module

Accessories Supplied

Two mating connectors with solder cup (Model 7788)

40-channel, Single-pole Control Module



The Model 7705 plug-in module offers 40 channels of independent switching. These channels are designed to control power to the DUT and switching loads. They can also directly control light indicators, relays, etc.

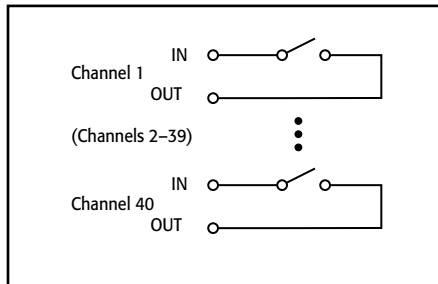

INPUTS

MAXIMUM SIGNAL LEVEL: 300VDC or rms, 2A switched, 60W (DC, resistive), 125VA (AC, resistive).

CONTACT LIFE: No Load¹: 10⁸ closures.

At Maximum Signal Levels: 10⁵ closures.

¹ Minimum signal level 10mV, 10μA.

CHANNEL RESISTANCE (per conductor): <1Ω.

CONTACT POTENTIAL: ≤4μV per contact.

OFFSET CURRENT: <100pA.

ACTUATION TIME: 3ms.

ISOLATION: Channel to Channel: >10⁹Ω, <50pF.

Common Mode: >10⁹Ω, <100pF.

CROSSTALK (1MHz, 50Ω load): <-35dB.

INSERTION LOSS (50Ω source, 50Ω load): <0.3dB below 1MHz, <3dB below 10MHz.

COMMON MODE VOLTAGE: 300V between any terminal and chassis.

GENERAL

RELAY SWITCH CONFIGURATION: 40 independent channels of 1-pole switching. Isolated from internal DMM.

CONTACT CONFIGURATION: 1 pole Form A.

RELAY TYPE: Latching electromechanical.

CONNECTOR TYPE: Two 50-pin female D-sub connectors.

FIRMWARE: Specified for Model 2700 rev. A01, 2701 rev. A01, and 2750 rev. A01 or higher.

ENVIRONMENTAL

OPERATING ENVIRONMENT: Specified for 0°C to 50°C.
Specified to 80% R.H. at 35°C.

STORAGE ENVIRONMENT: -25°C to 65°C.

WEIGHT: 0.45kg (1 lb).

ACCESSORIES AVAILABLE

7705-MTC-2 50 Pin Male to Female D-sub Cable, 2m (6.6 ft).

SERVICES AVAILABLE

7705-3Y-EW 1-year factory warranty extended to 3 years from date of shipment

1.888.KEITHLEY (U.S. only)

www.keithley.com

KEITHLEY
A Tektronix Company

A Greater Measure of Confidence

7706

All-in-One I/O Module

20-channel Differential Multiplexer w/Automatic CJC, 16 Digital Outputs, 2 Analog Outputs, a Counter/Totalizer, and Screw Terminals

- 20 channels of analog input (w/automatic CJC) for general-purpose measurements
- 16 channels of digital output
- 2 analog outputs ($\pm 12V$, 5mA)
- 300V, 1A capacity; 60W, 125VA maximum
- Configurable as two independent banks of multiplexers
- Relay closures stored in onboard memory

Ordering Information

7706 All-in-One I/O Module

SERVICES AVAILABLE

7706-3Y-EW 1-year factory warranty extended to 3 years from date of shipment

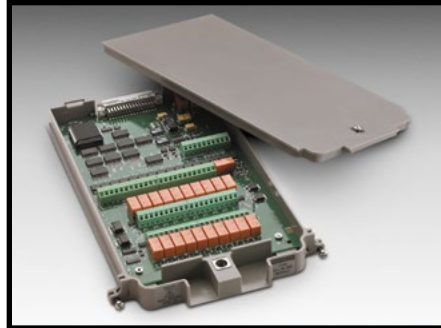

The Model 7706 plug-in module offers 20 channels of 2-pole or 10 channels of 4-pole multiplexing with automatic CJC, as well as two analog output channels, 16 digital outputs, and one event counter/totalizer. The event counter/totalizer can be used to monitor and control system components, such as fixtures, limit switches, pass/fail indicators, external voltage sources, loads, door closures, revolutions, etc., while performing mixed signal measurements. The Model 7706 is ideal for RTD, thermistor, and thermocouple temperature applications.

CAPABILITIES

CHANNELS 1–20: Multiplex one of 20 2-pole or one of 10 4-pole signals into DMM.

Channels 21–25 are referenced to chassis ground.

CHANNELS 21–22: 16 Digital Outputs.

CHANNELS 23–24: Analog Voltage Output (2).

CHANNELS 25: Totalize Input.

INPUTS

MAXIMUM SIGNAL LEVEL (Channels 1–20): 300V DC or rms, 1A switched, 60W, 125VA maximum.

CONTACT LIFE (typ.): $>10^5$ operations at max. signal level; $>10^8$ operations no load¹.

¹Minimum signal level 10mV, 10 μ A.

CONTACT RESISTANCE: $<1\Omega$ at end of contact life.

CONTACT POTENTIAL: $\leq \pm 2\mu V$ typical per contact, 3 μV max.

OFFSET CURRENT: $<100pA$.

CONNECTOR TYPE: Screw terminal, #20 AWG wire size.

ISOLATION BETWEEN ANY TWO TERMINALS: $>10^9\Omega$, $<100pF$.

ISOLATION BETWEEN ANY TERMINAL AND EARTH: $>10^9\Omega$, $<200pF$.

CROSS TALK (10MHz, 50 Ω Load): $<-35dB$.

INSERTION LOSS (50 Ω Source, 50 Ω Load): $<0.1dB$ below 1MHz. $<3dB$ below 2MHz.

COMMON MODE VOLTAGE: 300V between any terminal and chassis.

TEMPERATURE ACCURACY USING INTERNAL CJC: 1.0°C (see mainframe specification for details).

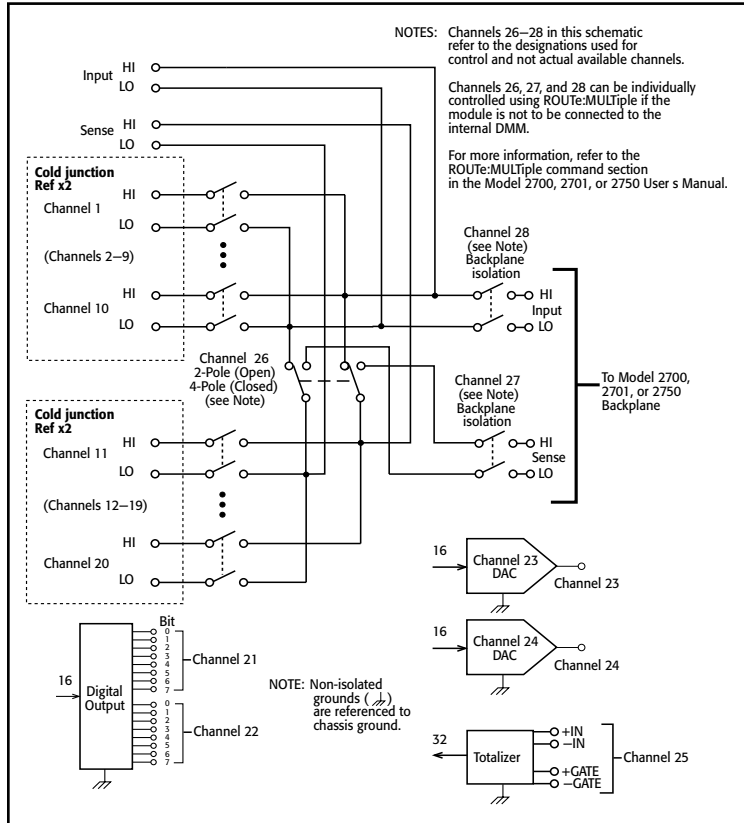

TOTALIZE INPUT

MAXIMUM COUNT: $2^{32}-1$.

TOTALIZE INPUT: 100kHz (max), rising or falling edge, programmable.

SIGNAL LEVEL: 1Vp-p (min), 42Vpk (max).

THRESHOLD: 0V or TTL, jumper selectable.

GATE INPUT: TTL-Hi, TTL-Lo, or none.

COUNT RESET: Manual or Read+Reset.

READ SPEED: 50/s.

ANALOG VOLTAGE OUTPUT

DAC 1, 2: $\pm 12V$ in 1mV increments, non-isolated.

RESOLUTION: 1mV.

I_{out}: 5mA max.

SETTLING TIME: 1ms to 0.01% of output.

ACCURACY \pm (% of output + mV):

1 year $\pm 5^\circ C$: 0.15% + 19mV;

90 day $\pm 5^\circ C$: 0.1% + 19mV;

24 hour $\pm 1^\circ C$: 0.04% + 19mV.

TEMPERATURE COEFFICIENT:

$\pm(0.015\% + 1mV)^\circ C$.

DIGITAL OUTPUT

V_{out(L)}: $<0.8V$ @ I_{out} = 400mA.

V_{out(H)}: $>2.4V$ @ I_{out} = 1mA.

V_{out(H)MAX}: $<42V$ with external open drain pull-up.

WRITE SPEED: 50/s.

GENERAL

20 CHANNELS: 20 channels of 2-pole relay input. All channels configurable to 4-pole.

RELAY TYPE: Latching electromechanical.

ACTUATION TIME: $<3ms$.

FIRMWARE: Specified for Model 2700 rev. A02 or B01, 2701 rev. A01, and 2750 rev. A01 or higher.

ENVIRONMENTAL

OPERATING ENVIRONMENT:

Specified for 0° to 50°C. Specified to 80% R.H. at 35°C.

STORAGE ENVIRONMENT: -25° to $65^\circ C$.

WEIGHT: 0.5kg (1.1 lbs).

1.888.KEITHLEY (U.S. only)

www.keithley.com

KEITHLEY

A Tektronix Company

A Greater Measure of Confidence

Use with Integra Series mainframes: 2700, 2701, 2750

DIGITAL MULTIMETERS & SYSTEMS

7707

32-channel Digital I/O Module with 10-channel Differential Multiplexer

- 300V, 1A capacity; 60W, 125VA maximum (analog)
- 33V, 100mA capacity (digital)
- Digital outputs are short circuit protected
- Relay closures stored in onboard memory

Ordering Information

7707 32-channel Digital I/O Module with 10-channel Differential Multiplexer

Accessories Supplied
Two mating IDC connectors

SERVICES AVAILABLE

7707-3Y-EW 1-year factory warranty extended to 3 years from date of shipment



The Model 7707 plug-in module offers 10 channels of 2-pole or 5 channels of 4-pole multiplexer switching that can be configured as two independent banks of multiplexers. The Model 7707 also provides 32 digital input/output channels (four 8-bit ports) for I/O control. Connect the Model 7707 to industry standard solid-state relays to switch up to 980VA.

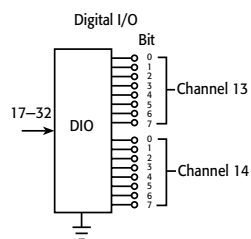
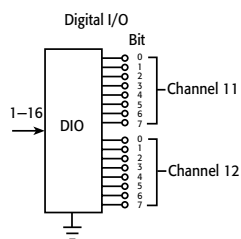
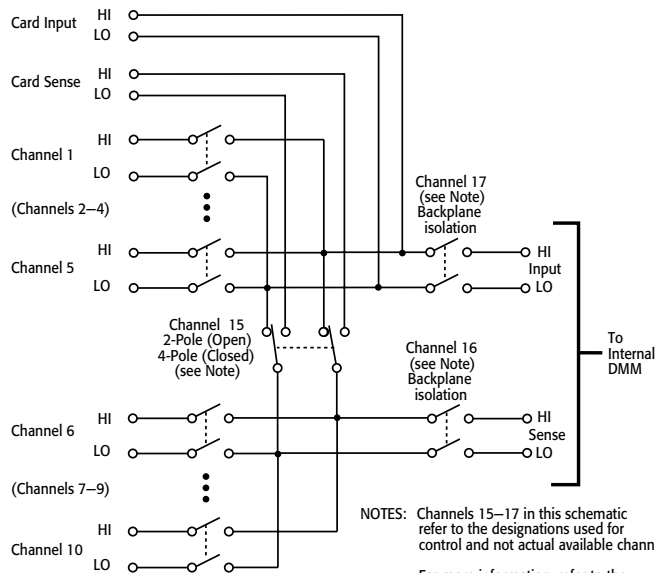

CAPABILITIES

CHANNELS 1-10: Multiplex one of 10 2-pole or one of 5 4-pole signals into DMM.

CHANNELS 11-14: 32 Digital Inputs/Outputs referenced to chassis ground.

THERMAL PROTECTION: Channels 11-14 are thermally protected to 1A.

INPUTS (Channels 1-10)

MAXIMUM SIGNAL LEVEL: Any Channel to Any Channel (1-10): 300VDC or 300Vrms (425V peak) for AC waveforms, 1A switched, 60W, 125VA maximum.

SAFETY CATEGORY: Conforms to European Union Directive 73/23/EEC EN 61010-1, CAT I.

CONTACT LIFE (typ.): >10⁵ operations at max. signal level: >10⁸ operations no load¹.

¹Minimum signal level 10mV, 10μA.

CONTACT RESISTANCE: <1Ω any path and additional 1Ω at end of contact life.

CONTACT POTENTIAL: <6μV typical per contact pair and additional 5μV with Channels 11-14 at rate V_{OUT(L)}.

OFFSET CURRENT: <100pA.

CONNECTOR TYPE: 50-pin male D-shell, Channels 11-14. 25-pin female D-shell, Channels 1-10. Supplied with female and male IDC ribbon cable connectors.

ISOLATION BETWEEN ANY TWO TERMINALS: >10⁹Ω, <100pF with isolation channels 16 and 17 open.

ISOLATION BETWEEN ANY TERMINAL AND EARTH: >10⁹Ω, <200pF.

CROSS TALK (10MHz, 50Ω Load): <-35dB.

INSERTION LOSS (50Ω Source, 50Ω Load): <0.1dB below 1MHz. <3dB below 2MHz.

COMMON MODE VOLTAGE: 300VDC or 300Vrms (425V peak) for AC waveforms between any terminal and chassis.

DIGITAL INPUT/OUTPUT (Channels 11-14)

V_{IN(L)}: <0.8V (TTL).

V_{IN(H)}: >2V (TTL).

V_{OUT(L)}: <1.0V @ I_{OUT} = 100mA.

V_{OUT(H)}: >2.4V @ I_{OUT} = 1mA.

V_{OUT(H)MAX.}: <40V with external open drain pull-up.

READ/WRITE SPEED: 50/s.

GENERAL

10 CHANNELS: 10 channels of 2-pole relay input. All channels configurable to 4-pole.

RELAY TYPE: Latching electromechanical.

ACTUATION TIME: <3ms.

FIRMWARE: Specified for Model 2700 rev. B03, 2701 rev. A01, and 2750 rev. A01 or higher.

CAPACITY: Model 2700: (1) 7707 and (1) 77XX, except 7706.

Model 2701: Any combination of 77XX modules.

Model 2750: (4) 7707 and (1) 77XX, except 7706.

A 7706 module may be substituted for a 7707 module.

ENVIRONMENTAL

OPERATING ENVIRONMENT: Specified for 0°C to 50°C.

Specified to 50% R.H. at 35°C.

STORAGE ENVIRONMENT: -25°C to 65°C.

WEIGHT: <0.5kg (1.1 lbs).

ACCESSORIES AVAILABLE

7790	50/50/25 Pin Female/Male D-Shell IDC Connectors
7705-MTC-2	50 Pin Male to Female D-sub Cable, 2m (6.6 ft).
7707-MTC-2	25 Pin Male to Female D-sub Cable, 2m (6.6 ft).

1.888.KEITHLEY (U.S. only)

www.keithley.com

KEITHLEY

A Tektronix Company

A Greater Measure of Confidence

7708

40-channel Differential Multiplexer Module with Automatic CJC and Screw Terminals

- 40 differential channels for general-purpose measurements
- Two- or four-wire measurements
- 300V, 1A capacity for voltage channels; 60W, 125VA
- Oversize screw terminal connection blocks are standard for easier connection
- Relay closures stored in onboard memory

Ordering Information

7708 40-channel Differential Multiplexer Module with Automatic CJC and Screw Terminals

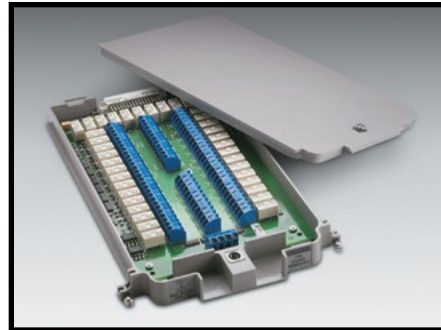

The Model 7708 plug-in module offers 40 channels of 2-pole or 20 channels of 4-pole multiplexer switching that can be configured as two independent banks of multiplexers. The built-in CJC sensors automatically linearize thermocouples, making the Model 7708 ideal for RTD, thermistor, and thermocouple temperature applications. It is also well suited for mixed-signal measurement applications that require multi-point monitoring, such as environmental stress screening.

CAPABILITIES

CHANNELS 1–40: Multiplex one of 40 2-pole or one of 20 4-pole signals into DMM.

INPUTS

MAXIMUM SIGNAL LEVEL:

Channels (1–40): 300V DC or rms, 1A switched, 60W, 125VA maximum.

CONTACT LIFE (typ): >10⁵ operations at max. signal level.
>10⁸ operations no load¹.

¹ Open thermocouple detector on during thermocouple measurements. Minimum signal level 10mV, 10μA.

CONTACT RESISTANCE: <1Ω at end of contact life.

CONTACT POTENTIAL:

<±500nV typical per contact, 1μV max.
<±500nV typical per contact pair, 1μV max.

OFFSET CURRENT: <100pA.

CONNECTOR TYPE: Screw terminal, #20 AWG wire size.

ISOLATION BETWEEN ANY TWO TERMINALS: >10¹⁰Ω,
<100pF.

ISOLATION BETWEEN ANY TERMINAL AND EARTH: >10¹⁰Ω,
<200pF.

CROSS TALK (10MHz, 50Ω Load): <–40dB.

INSERTION LOSS (50Ω Source, 50Ω Load): <0.1dB below
1MHz. <3dB below 2MHz.

COMMON MODE VOLTAGE: 300V between any terminal and chassis.

TEMPERATURE ACCURACY USING INTERNAL CJC:

1.0°C (see mainframe specification for details).

GENERAL

40 CHANNELS: 40 channels of 2-pole relay input. All channels configurable to 4-pole.

RELAY TYPE: Latching electromechanical.

ACTUATION TIME: <3ms.

FIRMWARE: Specified for Model 2700 rev. B02, 2701 rev. A01, and 2750 rev. A01 or higher.

ENVIRONMENTAL

OPERATING ENVIRONMENT: Specified for 0°C to 50°C.
Specified to 80% R.H. at 35°C.

STORAGE ENVIRONMENT: –25°C to 65°C.

WEIGHT: 0.52kg (1.16 lb).

ACCESSORIES AVAILABLE

7401 Type K Thermocouple Wire, 30.5m (100 ft).

SERVICES AVAILABLE

7708-3Y-EW 1-year factory warranty extended to 3 years from date of shipment

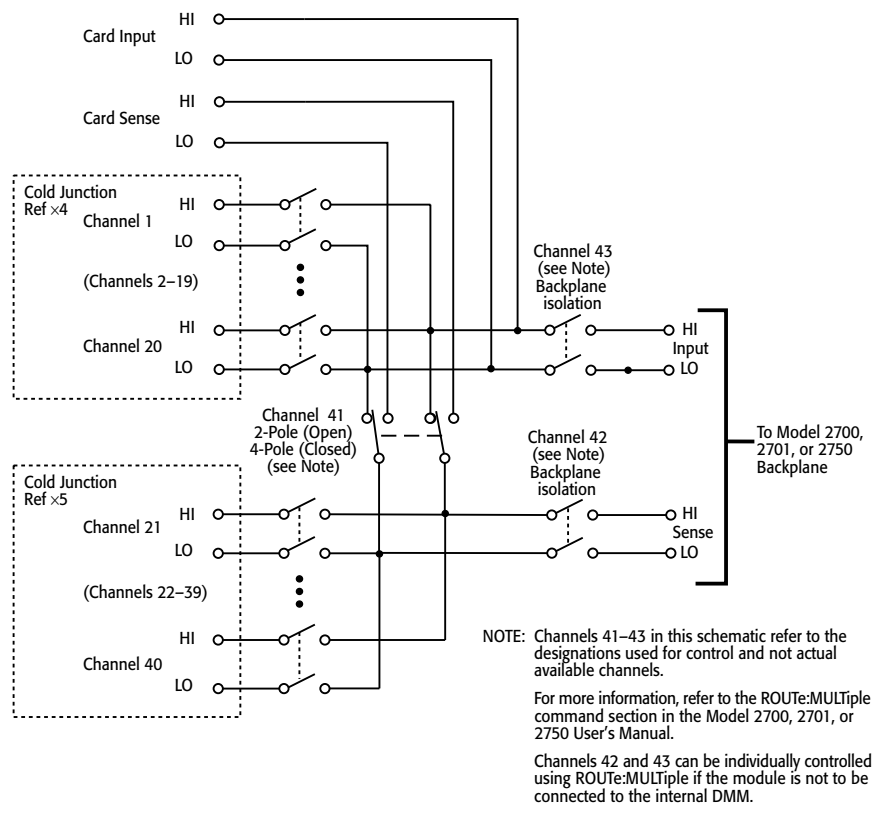

1.888.KEITHLEY (U.S. only)

www.keithley.com

KEITHLEY

A Tektronix Company

A Greater Measure of Confidence

Use with Integra Series mainframes: 2700, 2701, 2750

DIGITAL MULTIMETERS & SYSTEMS

7709

6×8 Matrix Module

- Automatic two- or four-wire connection to DMM
- 6 row × 8 column matrix
- Expandable to larger switch configurations by daisy-chaining or cascading multiple modules
- Two female D-sub connectors are standard for secure hook-up and quick teardown
- 300V, 1A capacity
- Relay closures stored in onboard memory

Ordering Information

7709 6×8 Matrix Module

Accessories Supplied

Two mating IDC connectors



The Model 7709 plug-in module is a two-pole, 6×8 matrix module. It can connect any combination of six differential channels of instrumentation to any combination of eight differential device-under-test channels. The instrumentation can be AC and DC sources, internal or external meters, oscilloscopes, etc. This matrix configuration allows wide flexibility for complex test systems.

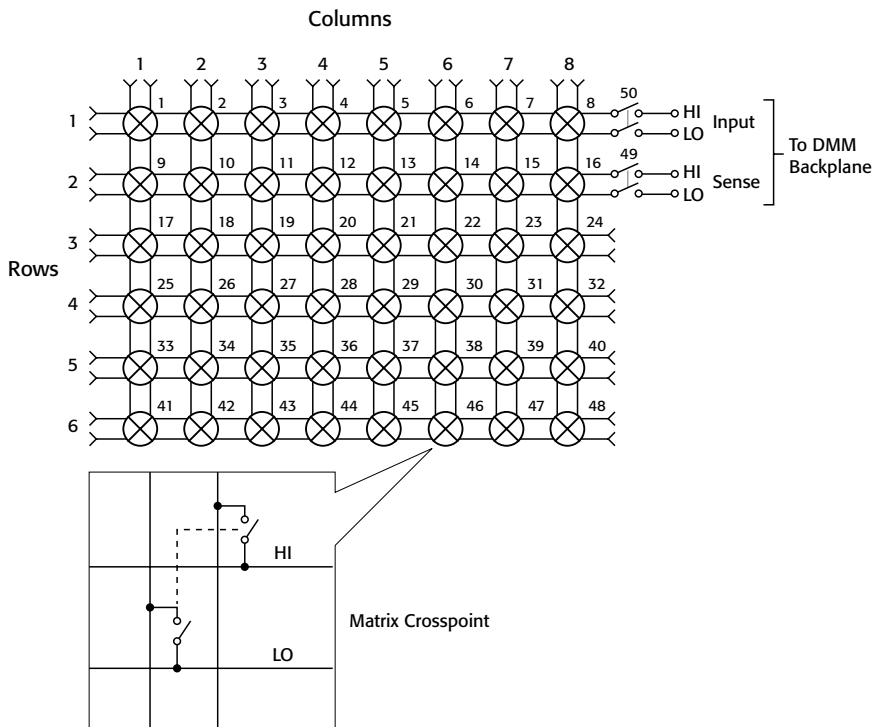

CAPABILITIES

DMM CONNECTION:

2-Wire Functions

Row 1, channels 1–8, through channel 50.

4-Wire Functions

Row 1, channels 1–4 (Source) through channel 50 and Row 2, channels 13–16 (Sense), through channel 49.

CLOSE CHANNEL: CLOSE command connects channels 1–8 to DMM. For 4-wire, channels 1–4 are automatically paired with channels 13–16. **ROUTE:MULTiple** allows any combination of rows and columns to be connected at the same time.

INPUTS

MAXIMUM SIGNAL LEVEL: Any Channel to Any Channel (1–48): 300VDC or 300Vrms (425V peak) for AC waveforms, 1A switched, 60W, 125VA maximum.

SAFETY: Conforms to European Union Directive 73/23/EEC EN61010-1, CAT 1.

CONTACT LIFE (typ): >10⁵ operations at max. signal level. >10⁸ operations no load¹.

¹Minimum signal level 10mV, 10μA.

CONTACT RESISTANCE: <1Ω any path and additional 1Ω at end of contact life.

CONTACT POTENTIAL: <3μV per contact pair.

OFFSET CURRENT: <100pA.

CONNECTOR TYPE: 50-pin female D-shell for rows and columns. 25-pin female D-shell for "daisy-chain" rows. Supplied with male IDC ribbon cable connectors.

ISOLATION BETWEEN ANY TWO TERMINALS: >10⁹Ω, <200pF.

ISOLATION BETWEEN ANY TERMINAL AND EARTH: >10⁹Ω, <400pF.

CROSS TALK (1MHz, 50Ω Load): <–35dB.

INSERTION LOSS (50Ω Source, 50Ω Load): <0.35dB below 1MHz. <3dB below 2MHz.

COMMON MODE VOLTAGE: 300VDC or 300Vrms (425V peak) for AC waveforms between any terminal and chassis.

GENERAL

MATRIX CONFIGURATION: 6 rows × 8 columns.

CONTACT CONFIGURATION: 2 pole Form A.

FIRMWARE: Specified for Model 2700 rev. B03, Model 2701 rev. A01, and Model 2750 rev. A01 or higher.

RELAY TYPE: Latching electromechanical.

ACTUATION TIME: <3ms.

ENVIRONMENTAL

OPERATING ENVIRONMENT: Specified for 0°C to 50°C. Specified to 50% R.H. at 35°C.

STORAGE ENVIRONMENT: –25°C to 65°C.

WEIGHT: <0.52kg (1.16 lb).

ACCESSORIES AVAILABLE

7789	50/25 Pin Male D-Shell Solder Cup Connectors
7790	50/50/25 Pin Female/Male D-Shell IDC Connectors
7705-MTC-2	50 Pin Male to Female D-sub Cable, 2m (6.6 ft).
7707-MTC-2	25 Pin Male to Female D-sub Cable, 2m (6.6 ft).

SERVICES AVAILABLE

7709-3Y-EW	1-year factory warranty extended to 3 years from date of shipment
------------	---

1.888.KEITHLEY (U.S. only)

www.keithley.com

KEITHLEY
A Tektronix Company

A Greater Measure of Confidence

7710

20-channel Solid-state Differential Multiplexer with Automatic CJC

- 20 channels for general purpose measurements
- Scanning speeds of up to 500 channels/second
- High speed production or ATE testing up to 500 channels/s
- Long lifetime solid state relay
- Removable screw terminals for



The Model 7710 plug-in module offers 20 channels of 2-pole or 10 channels of 4-pole relay input that can be configured as two independent banks of multiplexers. The relays are solid state, providing long life and low maintenance. Solid-state relays usually have 100 times longer life than mechanical relays. It is ideal for long-term data logging applications as well as for demanding high-speed applications.

Ordering Information

7710 20-channel Solid-state Differential Multiplexer Module

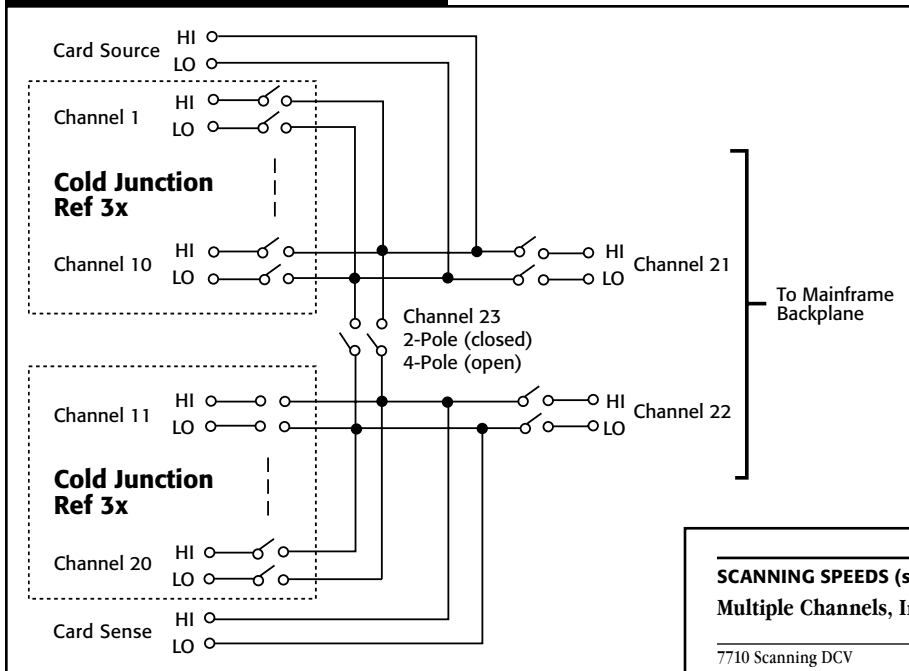

ACCESSORIES AVAILABLE

7401 Type K Thermocouple Wire, 30.5m (100 ft).

SERVICES AVAILABLE

7710-3Y-EW 1-year factory warranty extended to 3 years from date of shipment

CAPABILITIES

CHANNELS 1–20: Multiplex one of 20 2-pole or one of 10 4-pole signals into DMM.

INPUTS

MAXIMUM SIGNAL LEVEL: Any channel to any channel (1–20): 60VDC or 42V rms, 100mA switched, 6W, 4.2VA maximum.

COMMON MODE VOLTAGE: 300VDC or 300Vrms (425V peak) maximum between any terminal and chassis.

RELAY LIFE (TYP): >10⁸ operational hours max. signal level or 10¹⁰ operations (guaranteed by design).

RELAY DRIVE CURRENT: 6mA per channel continuous, 25mA during initial pulse.

CHANNEL RESISTANCE (per conductor): <5Ω.

CONTACT POTENTIAL: <1μV per pair.

OFFSET CURRENT: <3nA @ 23°C (per channel); additional 0.13nA/°C >23°C.

CONNECTOR TYPE: 3.5mm removable screw terminals, #20 AWG wire size.

ISOLATION BETWEEN ANY TWO TERMINALS: >10⁹Ω, <100pF.

ISOLATION BETWEEN ANY TERMINAL AND EARTH: >10⁹Ω, <100pF.

CROSSTALK (CH-CH, 300kHz, 50Ω Load): <-40dB.

INSERTION LOSS (50Ω Source, 50Ω Load): <0.5dB below 100kHz, <3dB below 2MHz.

TEMPERATURE ACCURACY USING INTERNAL CJC: 1°C for K type (see mainframe specifications for details).

GENERAL

CHANNELS: 20 channels of 2-pole relay input. All channels configurable to 4-pole.

RELAY TYPE: Solid State Opto-Coupled FET.

ACTUATION TIME: <0.5ms (100mA load).

FIRMWARE: Specified for Model 2700 Rev. B05, Model 2750 Rev. A04, and Model 2701 Rev. A01.

ENVIRONMENTAL

OPERATING ENVIRONMENT: Specified for 0°C to 50°C. Specified for 80% R.H. at 35°C.

STORAGE ENVIRONMENT: -25° to 65°C.

WEIGHT: 0.45kg (1 lb).

SCANNING SPEEDS (see mainframe specifications for details)

Multiple Channels, Into Memory	Channels/s		
	2700	2701	2750
7710 Scanning DCV	180/s	500/s	230/s
7710 Scanning DCV with Limits or Time Stamp On	170/s	500/s	230/s
7710 Scanning DCV alternating 2WΩ	45/s	130/s	60/s

Multiple Channels, Into and Out of Memory to GPIB or Ethernet

	Channels/s		
	2700	2701	2750
7710 Scanning DCV	145/s	440/s	210/s
7710 Scanning DCV with Limits or Time Stamp On	145/s	440/s	210/s
7710 Scanning DCV alternating 2WΩ	40/s	130/s	55/s

1.888.KEITHLEY (U.S. only)

www.keithley.com

A Greater Measure of Confidence

KEITHLEY
A Tektronix Company

Use with Integra Series mainframes: 2700, 2701, 2750

DIGITAL MULTIMETERS & SYSTEMS

7711

2GHz 50Ω RF Module

- Signal routing performance to 2GHz
- Switches up to 60VDC
- Rear panel SMA connections
- Onboard switch closure counter
- Onboard S parameter storage

Ordering Information

7711 2GHz 50Ω RF Module

The Model 7711 plug-in module provides an economical, wideband signal routing solution that complements the DC/low frequency switching and measurement capability of the Integra Series systems. The Model 7711 offers dual 1×4 configurations and can interface with a wide range of external AC instruments, including oscilloscopes, pulse generators, and signal analysis tools. One channel in each multiplex bank is always closed to the corresponding OUT connector. All connections are easily accessible from the rear panel.

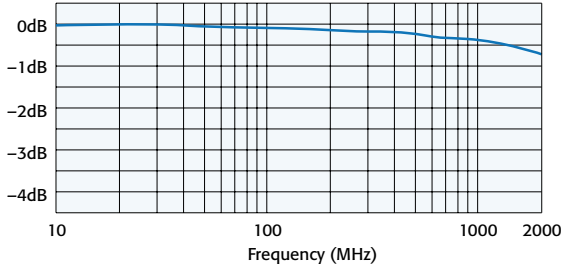
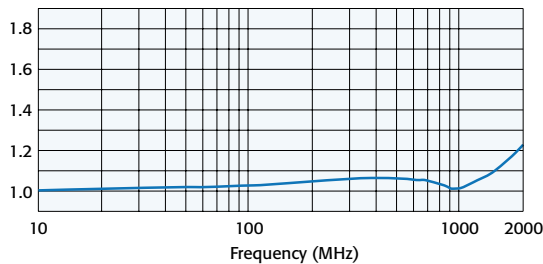
Typical Insertion Loss**Typical VSWR**

AC PERFORMANCE (END OF LIFE)

For $Z_{load} = Z_{source} = 50\Omega$

	<100 MHz	500 MHz	1 GHz	1.5 GHz	2 GHz
Insertion Loss	<0.4 dB	<0.6 dB	<1.0 dB	<1.2 dB	<2.0 dB
Max.					
VSWR Max.	<1.1	<1.2	<1.2	<1.3	<1.7 ²
Ch-Ch Crosstalk ¹	-85 dB	-65 dB	-55 dB	-45 dB	-35 dB
Max.					

¹ Specification assumes 50Ω termination.² Add 0.1VSWR after 5×10^5 closures (no load).

SERVICES AVAILABLE

7711-3Y-EW 1-year factory warranty extended to 3 years from date of shipment

INPUTS (Channels 1–8)

MAXIMUM SIGNAL LEVEL: Any channel to any channel or chassis (1–8): 30Vrms (42V peak for AC waveforms) or 60VDC, 0.5A.**MAXIMUM POWER:** 20W per module, 10W per channel (refer to 7711/7712 Manual PA-818 for measurement considerations).**SAFETY:** Conforms to European Union Directive 73/23/EEC EN61010-1, CAT I.**EMC:** Conforms with European Union Directive 89/336/EEC; EN61326-1.**ISOLATION: Multiplexer to Multiplexer:** >1GΩ.**Center to Shield:** >1GΩ, <25pF.**Channel to Channel:** >100MΩ.**CONTACT LIFE:** 1×10^6 no load, 1×10^5 rated load (resistive load).**CONTACT POTENTIAL:** <6μV.**CONTACT RESISTANCE:** <0.5Ω (initial), <1Ω (end of life).**RISE TIME:** <300ps (guaranteed by design).**SIGNAL DELAY:** <3ns.

GENERAL

RELAY TYPE: High frequency electromechanical.**CONTACT CONFIGURATION:** Dual 1×4 multiplexer, single pole four throw, Channels 1 and 5 are normally closed. **NOTE:** One channel in each multiplex bank is always closed to the corresponding OUT connector.**CLOSE CHANNEL:** ROUTe:CLOSe allows a single channel in a multiplex bank to be closed.

ROUTe:MULTIple:CLOSe allows two channels (one in each bank) to be closed at one time.

OPEN CHANNEL: ROUTe:OPeN:ALL closes CH1 and CH5 to OUT A and OUT B respectively.**ACTUATION TIME:** <10ms.**FIRMWARE:** Specified for Model 2700 rev. B04, 2701 rev. A01, and 2750 rev. A03 or higher.**CONNECTOR TYPE:** Ten external rear panel SMA connectors.**MATING TORQUE:** 0.9 N·m (8 in-lb).

ENVIRONMENTAL

OPERATING ENVIRONMENT: Specified for 0°C to 50°C. Specified for 80% RH at 35°C.**STORAGE ENVIRONMENT:** -25°C to 65°C.**WEIGHT:** <0.5kg (1.1 lb).

ACCESSORIES AVAILABLE

7051-2	BNC Cable, male to male, 0.6m (2 ft.)
7051-5	BNC Cable, male to male, 1.5m (5 ft.)
7051-10	BNC Cable, male to male, 3.0m (10 ft.)
7711-BNC-SMA	Male SMA to female BNC Cables (5), 0.15m (0.5 ft.)
7712-SMA-1	SMA Cable, male to male, 1m (3.3 ft.)
7712-SMA-N	Female SMA to Male N-Type Adapter
S46-SMA-05	SMA Cable, male to male, 0.15m (0.5 ft.)
S46-SMA-1	SMA Cable, male to male, 0.3m (1 ft.)

1.888.KEITHLEY (U.S. only)**www.keithley.com****KEITHLEY**

A Tektronix Company

A Greater Measure of Confidence

7712

3.5GHz 50Ω RF Module

- 3.5GHz bandwidth
- Dual 1x4 configuration
- Onboard switch closure counter
- Onboard S parameter storage

Ordering Information

7712 3.5GHz 50Ω RF Module



The Model 7712 plug-in module offers a 50Ω dual 14 multiplexer configuration with rear panel SMA 14 connectors. Multiple multiplexers can be cascaded to build scalable matrix and multiplexer systems for a large number of devices under test and RF source/measurement instruments. One channel in each multiplex bank is always closed to the corresponding OUT connector. The 3.5GHz RF switching capability of the Model 7712 makes it ideal for applications such as 3G telecom, wireless LAN, and Bluetooth module testing.

Typical Insertion Loss

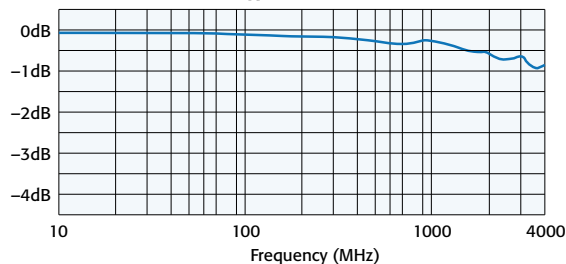

Typical VSWR

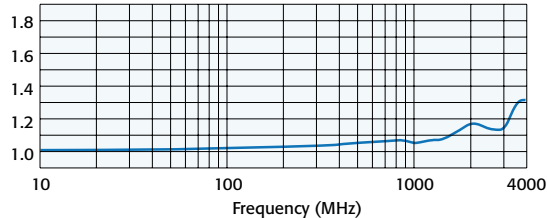

AC PERFORMANCE (End of Life)

For $Z_{load} = Z_{source} = 50\Omega$

	<500 MHz	1 GHz	2.4 GHz	3.5 GHz
Insertion Loss	<0.5 dB	<0.65 dB	<1.1 dB	<1.3 dB
Max.				
VSWR MAX	<1.15	<1.2	<1.45 ²	<1.45
Ch-Ch Crosstalk ¹	-75 dB	-70 dB	-50 dB	-45 dB
Max.				

¹ Specification assumes 50Ω termination.

² Add 0.1VSWR after 5×10^5 closures (no load).

INPUTS (Channels 1–8)

MAXIMUM SIGNAL LEVEL: Any channel to any channel or chassis (1–8): 30Vrms (42V peak for AC waveforms) or 42VDC, 0.5A.

MAXIMUM POWER: 20W per module, 10W per channel (refer to 7711/7712 Manual PA-818 for measurement considerations).

SAFETY: Conforms to European Union Directive 73/23/EEC EN61010-1, CAT I.

EMC: Conforms with European Union Directive 89/336/EEC; EN61326-1.

ISOLATION: Multiplexer to Multiplexer: >1GΩ.

Center to Shield: >1GΩ, <20pF.

Channel to Channel: >100MΩ.

CONTACT LIFE: 5×10^6 no load, 1×10^5 rated load (resistive load).

CONTACT POTENTIAL: <12μV.

CONTACT RESISTANCE: <0.5Ω (initial), <1Ω (end of life).

RISE TIME: <200ps (guaranteed by design).

SIGNAL DELAY: <1.5ns.

GENERAL

RELAY TYPE: High frequency electromechanical.

CONTACT CONFIGURATION: Dual 1x4 multiplexer, single pole four throw, Channels 1 and 5 are normally closed.

NOTE: One channel in each multiplex bank is always closed to the corresponding OUT connector.

CLOSE CHANNEL: ROUTe:CLOSe allows a single channel in a multiplex bank to be closed.

ROUTe:MULTiple:CLOSe allows two channels (one in each bank) to be closed at one time.

OPEN CHANNEL: ROUTe:OPeN:ALL closes CH1 and CH5 to OUT A and OUT B respectively.

ACTUATION TIME: <10ms.

FIRMWARE: Specified for Model 2700 rev. B04, 2701 rev. A01, and 2750 rev. A03 or higher.

CONNECTOR TYPE: Ten external rear panel SMA connectors.

MATING TORQUE: 0.9 N·m (8 in-lb).

ENVIRONMENTAL

OPERATING ENVIRONMENT: Specified for 0°C to 50°C. Specified for 80% RH at 35°C.

STORAGE ENVIRONMENT: -25°C to 65°C.

WEIGHT: <0.5kg (1.1 lb).

ACCESSORIES AVAILABLE

7712-SMA-1	SMA Cable, male to male, 1m (3.3 ft)
7712-SMA-N	Female SMA to Male N-Type Adapter
S46-SMA-0.5	SMA Cable, male to male, 0.15m (0.5 ft)
S46-SMA-1	SMA Cable, male to male, 0.3m (1 ft)

SERVICES AVAILABLE

7712-3Y-EW	1-year factory warranty extended to 3 years from date of shipment
------------	---

1.888.KEITHLEY (U.S. only)

www.keithley.com

A Greater Measure of Confidence

KEITHLEY
A Tektronix Company

Use with Integra Series mainframes: 2700, 2701, 2750

DIGITAL MULTIMETERS & SYSTEMS

Free Bundled Software

For the Integra Series (Models 2700, 2701, and 2750)

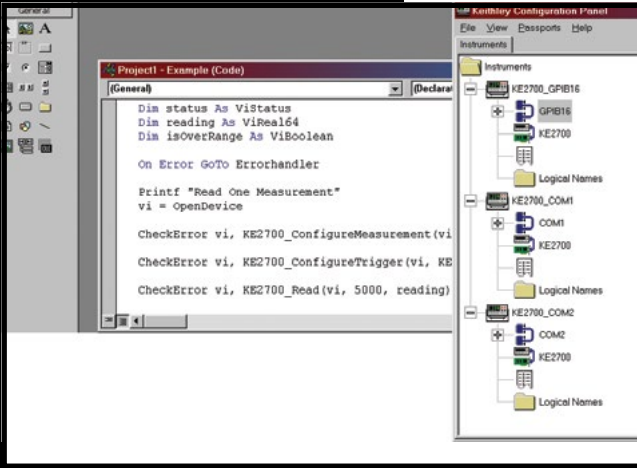

IVI (Interchangeable Virtual Instruments) Drivers

Developers often prefer to create their own custom applications. The Integra Series instruments supply IVI device drivers that support many application development environments including LabVIEW®, LabWindows/CVI, Visual Basic, and C/C++. These IVI drivers are VISA based and support all the functionality of the Model 2700/2701/2750. Numerous examples are supplied as well as an online help utility.

IVI Drivers

- LabVIEW drivers
- LabWindows/CVI drivers
- Visual Basic, C/C++ drivers

ExceLINX-1A

- Microsoft Excel add-in utility
- Acquire data for 2700, 2701, and 2750 systems
- Configure channels, parameters, triggers, and scan lists

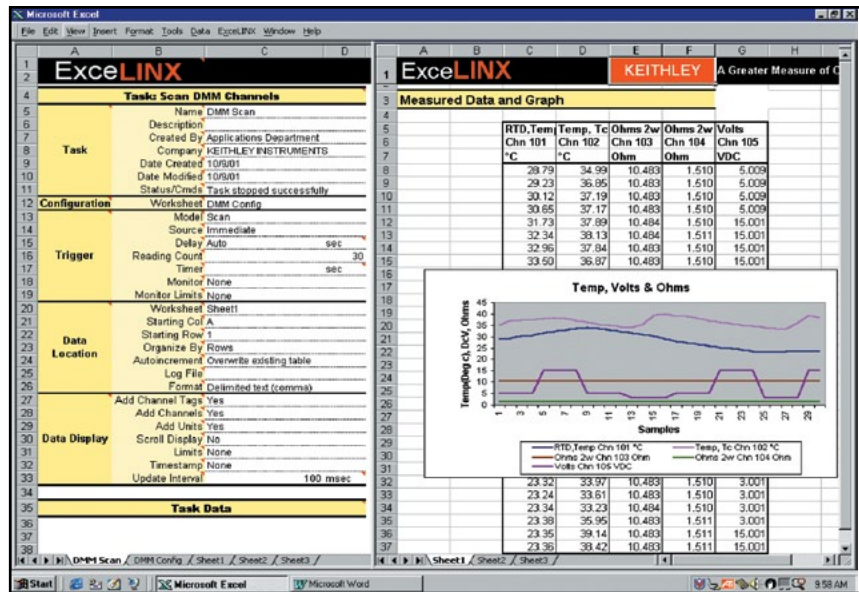

ExceLINX-1A is an easy-to-use add-in utility for Microsoft® Excel and Integra systems. No programming is required; enter values quickly through pop-up menus and eliminate time-consuming coding.

Minimum System Requirements

	Windows 2000	XP	Vista	Windows 7 (32-bit)	Windows 7 (64-bit)
IVI Instrument Drivers	Yes	Yes	Yes	Yes	Yes (but only as 32-bit applications)
ExceLINX-1A	Yes	Yes	Yes	Yes	Yes (but only as 32-bit applications)

1.888.KEITHLEY (U.S. only)

www.keithley.com

KEITHLEY

A Greater Measure of Confidence

A Tektronix Company

ExceLINX™ -1A

Excel Add-In

For the Integra Series (Models 2700, 2701, and 2750)

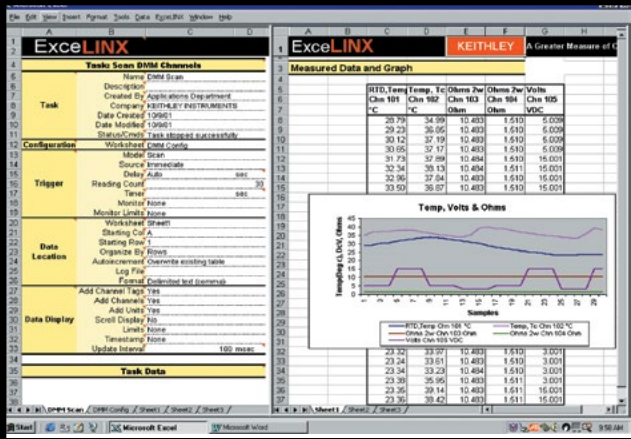

ExceLINX-1A

- Stream data directly into Excel spreadsheets
- No programming required
- Get data with only a few mouse clicks
- Temperature, voltage, current, and resistance measurement capabilities
- Different functions can be supported on each channel
- Scaling, filtering, and limit capabilities
- GPIB, Ethernet, and RS-232 compatible
- Online help

ExceLINX-1A is an easy to use add-in utility for Microsoft® Excel and Keithley's Integra Series Multimeter/Switch Systems. Within minutes of installing ExceLINX on a PC, users can stream data directly from the Model 2700/2701/2750 into Excel. Data can be analyzed as it is received in Excel with Excel's graphics, charting, and mathematical capabilities, so a user can closely monitor the application in progress.

No programming is required to use ExceLINX-1A. A few mouse clicks are all it takes to configure channels, set parameters, select a trigger source, define scan lists, etc. Pop-up menus are used to set values and to determine whether data should move from the Model 2700/2701/2750 to Excel in real time during a scan or after the scan has completed.

ExceLINX-1A also supports many communication interfaces, including GPIB boards from Keithley, CEC, National Instruments, and INES.

Easy to Use

With ExceLINX-1A, no programming is required. To use it, simply perform the following steps.

1. Select the task (such as DMM scan) from a pop-up menu. A template will display.
2. Either use the template's default values (such as how many samples and which channels) or enter values.
3. Select the Integra system from the pop-up menu of installed systems.
4. Press Go on the ExceLINX-1A toolbar.

As soon as ExceLINX-1A receives data, it immediately sends the data directly to the Excel spreadsheet.

At the same time that ExceLINX-1A is acquiring data and sending it to the Excel spreadsheet, Excel is processing the data. For example, Excel could be performing calculations and displaying the results on a graph as it receives the data. The user can see the graph being updated while data is being collected.

Because ExceLINX-1A is an Excel add-in, it does not have the limitations that a separate package has. For example, many of these packages use DDE or OLE to send data to Excel, but DDE and OLE can only send limited amounts of data and can be cumbersome to use.

Firmware and Card Requirements

- Model 2700 (Firmware B03 or newer version), Model 2701, or Model 2750 (Firmware A02 or a newer version)
- Supports Integra Series 77xx plug-in/control modules and their common functions
 - Model 7700 20-channel, Differential Multiplexer Module with Automatic CJC and Screw Terminals
 - Model 7701 32-channel Differential Multiplexer Module
 - Model 7702 40-channel Differential Multiplexer Module with Screw Terminals
 - Model 7703 32-channel, High-Speed, Differential Multiplexer Module
 - Model 7705 40-channel Single-pole Control Module
 - Model 7707 32-channel Digital I/O Module with 10-channel Differential Multiplexer
 - Model 7708 40-channel Differential Multiplexer Module with Automatic CJC and Screw Terminals
 - Model 7709 68 Matrix Module
 - Model 7710 20-channel Solid-state Differential Multiplexer with Automatic CJC
 - Model 7711 2GHz 50 RF Module
 - Model 7712 3.5GHz 50 RF Module

1.888.KEITHLEY (U.S. only)

www.keithley.com

KEITHLEY

A Greater Measure of Confidence

A Tektronix Company

Streams data directly to Excel

DIGITAL MULTIMETERS & SYSTEMS

2790

SourceMeter® Airbag Test System



- Single-instrument solution for continuity and hi-pot type leakage resistance measurements
- Programmable constant V source (50–500V) supports high speed, high resistance measurements
- Programmable constant I source (0–50mA) with dry circuit clamp helps prevent device stress or damage during low resistance measurements
- Modular architecture adapts easily to single or dual inflator testing and to single or dual position test stands and mixed device/signal applications
- Expandable multiplexer channels for multipin applications
- Included 6½-digit DMM with wide functionality and broad measurement ranges
- Intelligent automation support and easy integration with external test hardware
- GPIB, RS-232, and digital I/O interfaces for flexible controller options
- SCPI programmable for simple code development and future extensions
- 2-year calibration cycle of modules minimizes maintenance costs and system downtime

The Model 2790 SourceMeter Switch System is a high voltage, multichannel resistance measurement solution that speeds and simplifies electrical checks of airbag inflators and a variety of other automotive electrical test applications. It is the only commercial instrument that combines all the sourcing, measurement, and signal routing capabilities required to measure insulation resistance and conductor continuity in one compact, affordable package. Through the use of plug-in source/switch modules, the Model 2790 provides programmable high voltage and low current sourcing, plus multichannel switching support. This unique combination of capabilities establishes a new standard for price and performance in airbag inflator and other test applications.

Measure Extreme Resistances with Constant Current or Constant Voltage

The Model 2790 uses the forced constant-current method to measure resistances less than $1\text{k}\Omega$. In this technique, the instrument sources a constant current (I) to the resistance and measures the resulting voltage (V). The amount of current sourced is programmable from 0–50mA. Resistance (R) is calculated (and displayed) using the known current and measured voltage ($R = V/I$). A 20mV dry circuit clamp is available at sourcing levels up to 1mA for preserving the oxide layers on connectors and other components.

For the $1\text{M}\Omega$ to $1\text{G}\Omega$ resistance ranges, the forced constant-voltage method is used to measure high resistance. This technique optimizes settling speed and reduces noise, allowing faster, high quality insulation resistance measurements. In addition, by applying high voltages (50–500V), the Model 2790 stresses a dielectric while simultaneously measuring its insulation resistance.

In addition to the resistance measurement functions available through the plug-in source/switch modules, the Model 2790's built-in DMM allows it to make a full range of high precision resistance measurements as well as AC/DC voltage and current, frequency, and temperature measurements. These DMM functions are available either through front panel jacks or through the addition of a Model 7702 40-channel scanner module. In addition to the shorts/open testing performed with the standard Model 7751, 7752, and 7753 switch/control modules, a wide range of supporting measurements can be made. These supporting measurements simplify creating integrated test solutions for hybrid applications, such as testing complex automotive seating systems, which increasingly combine airbag inflators and seatbelt pretensioners, seat heaters, switches, motors, etc.

Newly Enhanced Memory Pattern Test Sequencer

The memory pattern test sequencer allows the mainframe to store and execute pre-programmed test sequences for increased testing throughput. Test setups can be stored as unique memory locations and either recalled by number as needed or scanned in sequence to maximize the number of tests per unit time without command transfer delays due to communication or controller.

APPLICATIONS

- Automotive airbag inflator/module electrical functional tests
- Seatbelt pre-tensioner actuator/module functional electrical check
- High speed, parallel soak, dual inflator, or dual test station electrical check
- Pinched wire, high voltage, insulation resistance testing in automotive seats, avionics, etc.
- Multipin connector/harness continuity and leakage resistance measurements
- Multicontact/switch dry circuit continuity and leakage tests
- Automotive power/fuse center continuity and leakage resistance characterization
- PCB/PWB and general purpose short/open circuits testing

1.888.KEITHLEY (U.S. only)

www.keithley.com
KEITHLEY

A Tektronix Company

A Greater Measure of Confidence

2790

Ordering Information

2790-A 1MΩ single-module system for low and high voltage/resistance applications

2790-H Single-module system for low and high voltage/resistance applications

2790-HH Two-module system for low and high voltage/resistance applications

2790-HL Two-module system for separating high and low voltage/resistance applications

2790-L Single-module system for low voltage/resistance-only programmable current applications

7702 40-channel Differential Multiplexer

Accessories Supplied

Reference and user manuals on CD-ROM, AC line power cord, mini flathead screwdriver.

ACCESSORIES AVAILABLE

MODULES

7702	40-channel General Purpose Multiplexer Module
7751	High Voltage Source/Switch Module
7752	Low Voltage, Current-Source-Only Source/Switch Module
7753	1MΩ High Voltage Source/Switch Module (The Model 2790 supports only one Model 7753.)

COMMUNICATION INTERFACES AND CABLES

7007-1	Shielded IEEE-488 Cable, 1m (3.3 ft)
7007-2	Shielded IEEE-488 Cable, 2m (6.6 ft)
7009-5	Shielded RS-232 Cable
KPCI-488LPA	IEEE-488 Interface/Controller for the PCI Bus
KUSB-488B	IEEE-488 USB-to-GPIB Interface Adapter

RACK MOUNT KITS

4288-1, -2	Single or Dual Fixed Rack Mount Kit
------------	-------------------------------------

OTHER

8503	Trigger Link Cable to 2 Male BNC Connector
8681	Miniature 4-Wire RTD, 100Ω

SERVICES AVAILABLE

2790-3Y-EW	1-year factory warranty extended to 3 years from date of shipment
2790-A-3Y-EW	1-year factory warranty extended to 3 years from date of shipment
2790-L-3Y-EW	1-year factory warranty extended to 3 years from date of shipment
C/2790-3Y-ISO	3 (ISO-17025 accredited) calibrations within 3 years of purchase for Models 2790, 2790-L*
C/2790-A-3Y-ISO	3 (ISO-17025 accredited) calibrations within 3 years of purchase for Model 2790-A*

*Not available in all countries

1.888.KEITHLEY (U.S. only)

www.keithley.com

SourceMeter® Airbag Test System

Match the System Configuration to the Application

The Model 2790 is available in a variety of configurations to match specific application requirements:

- The **Model 2790-H** is a single-module system designed for both low current and high voltage ohms (10MΩ to 1GΩ) applications. This “base” system provides all the capabilities needed for electrical testing of either single- or dual-stage inflators in single position test stands (for example, test stands that test only one single- or dual-stage airbag at a time).
- The **Model 2790-A**, which is similar to the Model 2790-H, enables high voltage ohms measurements down to 1MΩ.
- The **Model 2790-HH** is configured for applications that require parallel testing or high voltage “soaking.” Like the Model 2790-H, it is designed for both low current and high voltage ohms applications and can test either single- or dual-stage inflators. However, with two plug-in modules, it also has the capacity to test two inflators at once, maximizing test throughput.
- The **Model 2790-HL** is designed for applications where it is preferable to segregate high voltage sourcing/ohms measurement and low current sourcing/ohms measurement into two separate modules. This design was developed for use in combination testing applications, such as inflator electrical checks of safety steering wheel or seat assemblies that also include switch or other ancillary device tests.
- The **Model 2790-L** is configured for low voltage source/ohms-only measurement applications, such as continuity-only testing of side/seat airbags and seatbelt pre-tensioners or other programmable I-source resistance applications in which high voltage resistance testing is not required but precise control of source current is.
- With the addition of a Model 7702 40-channel differential multiplexer module (part of the Integra family of switch/measure solutions), the **Model 2790-A, -H, or -L + Model 7702** opens the door to higher channel count applications, such as hi-pot/continuity testing of connectors, harnesses, and power distribution devices up to 500V (internally sourced) up to 40 channels.

Broad Range of Measurement Capabilities

The Model 2790’s built-in DMM can make a wide variety of general purpose measurements:

- DC voltage measurements from 0.1μV to 1000V
- AC voltage measurements from 0.1μV to 750V
- DC current measurements from 10nA to 3A
- AC current measurements from 1μA to 3A
- 2-wire resistance measurements from 100μΩ to 120MΩ
- 4-wire resistance measurements from 100μΩ to 120MΩ
- Frequency measurements from 3Hz to 500kHz
- Period measurements from 333ms to 2μs
- Temperature measurements from -200°C to 630°C (thermistors and 4-wire RTDs)

Additional features of the Model 2790 mainframe include:

- Setup storage—Up to four instrument setups can be saved and recalled.
- Offset-compensated ohms—A two-measurement process for 4-wire ohms to cancel the effects of thermoelectric EMFs. Available for the 100Ω, 1kΩ, and 10kΩ ranges.
- Math—m/X+b, mX+b, percent, and four special math functions provide convenient manipulation of raw readings.
- Relative—Null offsets establish baseline values.
- Ratio and channel average—Ratio and average calculations for two switching module channels (7702).
- Buffer—Store up to 55,000 readings in the internal buffer.
- Limits—Two sets of high and low reading limits to test devices.
- Digital I/O port—Five digital limit test output lines to control external circuitry. An external trigger input can also be accessed at this port.
- Trigger Link—Separate connector with input and output signals.
- Monitor—The Model 2790 can monitor a selected channel. A scan can be triggered to start when the monitor detects that a reading limit has been reached (7702).
- Remote interface—Model 2790 can be controlled using the IEEE-488 interface (GPIB) or the RS-232 interface.

Example Application – Dual Stage Airbag Inflator Testing—One or Two

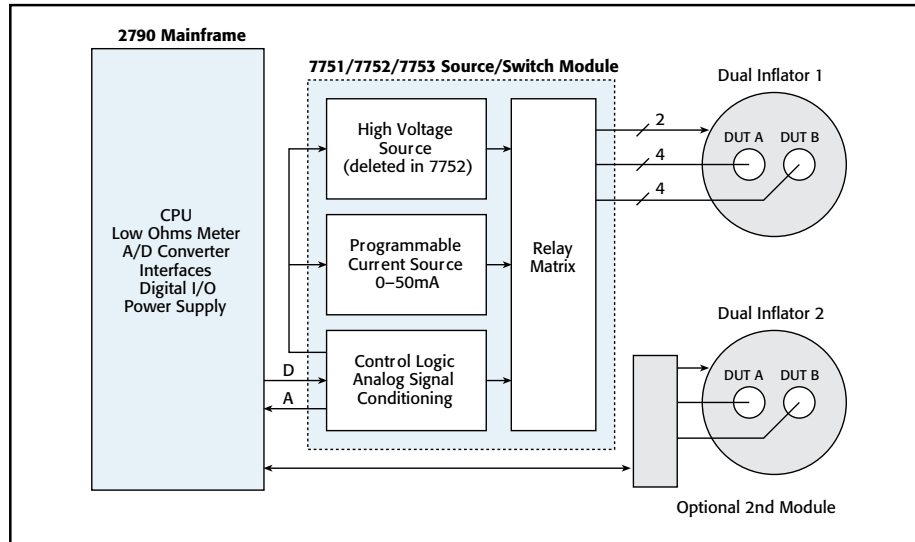

Example Application – 40-channel Wiring Harness Testing

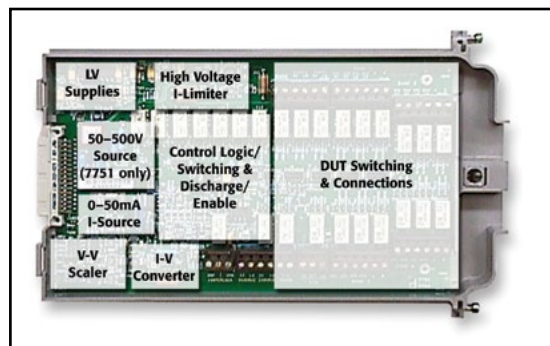
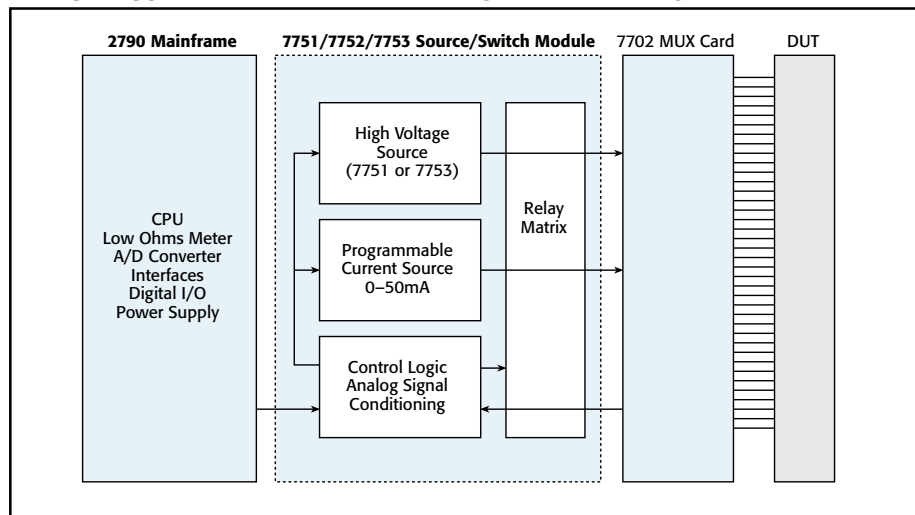

Three source/switch plug-in modules provide the Model 2790 with programmable high voltage and low current sources, connection switching, and signal conditioning circuitry.

Model 2790 Benefits

- **High functional integration**—Sourcing, measurement, and signal routing functions are tightly integrated in one compact enclosure. This high level of integration helps system integrators save rack space, minimize the time needed for system configuration and maintenance, and improve test throughput without sacrificing system accuracy.
- **Enhanced device protection**—Compared to higher powered alternatives, the Model 2790's inherently lower power sources minimize the possibility of damaging sensitive devices under test through accidental overpowering. Automatic cold switching and active cable discharge circuitry reduce the chances for device damage still further, while the high precision DMM and A/D converter ensure high resolution and measurement accuracy.
- **Reliability**—The design of the Model 2790 is based on a proven Keithley technology platform. With a two-year calibration cycle for the module functions, it requires minimal maintenance over the life of the production test line. Its modular mainframe and plug-ins architecture makes module verification and calibration fast and convenient, simply by exchanging modules.
- **Value**—In addition to being a complete solution for airbag inflator testing and related applications, the Model 2790's fully functional, 6½-digit DMM supports a wide variety of general purpose DC and AC measurements.

Mainframe Specifications

Refer to the Model 2700 specifications on page 281.

Key Module Specifications*

Refer to module specifications on page 285.

SYSTEM THROUGHPUT

HIGH OHMS: 13 rdgs/s.

LOW OHMS: 9 rdgs/s.

* The Model 7751, 7752, and 7753 plug-in modules have a two-year calibration interval; mainframe-only functions have a one-year calibration interval (max). System warranty period is one year.

1.888.KEITHLEY (U.S. only)

www.keithley.com

KEITHLEY

A Tektronix Company

A Greater Measure of Confidence

7751/7752/7753 SOURCE/SWITCH MODULE SPECIFICATIONS

2790 RESISTANCE MODE SPECIFICATIONS WITH CARDS 2, 3

(Module function accuracy specifications are for 2 years, 23°C, ±5°C.)

Source Current	Maximum Resistance	Typical Open Circuit Voltage	Accuracy (4W) ±(%rdg.+ohms)	Temperature Coefficient (0–18°C & 28–40°C) ±(%rdg.+ohms)/°C
50 mA	20	5.5 V	0.09% + 2 m	0.002% + 3 m
20 mA	50	5.5 V	0.11% + 5 m	0.003% + 3 m
10 mA	100	5.5 V	0.16% + 10 m	0.004% + 3 m
(Dry Circuit Ohms 1mA max. with 7751, 7752, or 7753 card)				
1 mA	10	20 mV	1.10% + 50 m	(0.026% + 3 m)/°C

(7751 Only)

Source Voltage	Resistance Range	Maximum Short Circuit Current	Accuracy ±(% rdg.)	Temperature Coefficient (0–18°C & 28–40°C) ±(%rdg.)/°C
500 V	10 M	<1 mA	0.8%	0.03%
500 V	100 M	<1 mA	1.1%	0.05%
500 V	1 G	<1 mA	4.0%	0.12%
50 V	1 M	<1 mA	1.1%	0.04%
50 V	10 M	<1 mA	1.1%	0.06%
50 V	100 M	<1 mA	1.6%	0.13%

(7753 Only)

Source Voltage	Resistance Range	Maximum Short Circuit Current	Accuracy ±(% rdg.)	Temperature Coefficient (0–18°C & 28–40°C) ±(%rdg.)/°C
500 V	1 M	<1 mA	0.8%	0.02%
500 V	10 M	<1 mA	0.9%	0.03%
500 V	100 M	<1 mA	1.3%	0.10%
500 V	1 G	<1 mA	6.7%	0.27%
50 V	0.1 M	<1 mA	1.1%	0.03%
50 V	1 M	<1 mA	1.1%	0.04%
50 V	10 M	<1 mA	1.3%	0.11%
50 V	100 M	<1 mA	4.5%	0.30%

CURRENT SOURCE OUTPUT

OUTPUT LEVEL: Programmable 0 to 50mA (Ch. 27).

PROGRAMMING RESOLUTION: 10µA.

OUTPUT VOLTAGE: 5.5V ±10% compliance.

ACCURACY: ±(0.06% + 10µA) (2 year specification).

SETTLING TIME: 1ms to 0.1% of final value (typ.).

TEMPERATURE COEFFICIENT (0–18°C & 28–40°C): ±(0.001% + 0.25µA)/°C.

DRY CIRCUIT CLAMP (Ch. 24): 20mV ±10%, I_{source} ≤1mA.

VOLTAGE SOURCE OUTPUT (7751/7753 Only)

OUTPUT LEVEL: Programmable 50V to 500V (Ch. 28).

PROGRAMMING RESOLUTION: 100mV.

OUTPUT CURRENT: (7751) 50µA maximum for rated accuracy, <1mA typical into short circuit.
(7753) 500µA maximum for rated accuracy, <1mA typical into short circuit.

ACCURACY: ±(0.5% + 0.13V) (2 year specification).

SETTLING TIME: Rise Time: 50V to 500V step, 0.1% of final value, 250ms max.
Fall Time: 500V to 50V step, 0.1% of final value, 1000ms max.

TEMPERATURE COEFFICIENT (0–18°C & 28–40°C): ±(0.001% + 0.005V)/°C

SAFETY LIMIT: Current limited maximum current of 1mA.

CABLE DISCHARGE (Ch. 20): 100kΩ shunt.

MAXIMUM CAPACITANCE: 1nF.

CURRENT MEASURE INPUT (7751/7753 Only)

RANGE: 7751: 0–50µA. 7753: 0–500µA.

ACCURACY: 7751: ±(0.5% of reading + 6nA) (2 year specification).

7753: ±(0.5% of reading + 60nA) (2 year specification).

TEMPERATURE COEFFICIENT (0–18°C & 28–40°C): ±(0.02%+0.5nA)/°C.

VOLTAGE BURDEN: <1mV.

SWITCHING CAPABILITIES (Bank 1–Bank 4)

4 CHANNELS: 1 Form A switch.

8 CHANNELS: Four 4-pole or eight 2-pole signals into DMM or I/V converter.

CONTACT CHECK: 4-wire contact check through internal DMM.

RELAY TYPE: Latching electromechanical.

ACTUATION TIME: <3ms.

CONTACT LIFE (typical): >10⁶ operations at maximum source level.
>10⁸ operations cold switching.

CONTACT RESISTANCE: <1Ω at end of contact life.

CONTACT POTENTIAL: <±2µV typical per contact pair, ±3µV max.

CONNECTOR TYPE: Plugable screw terminal, #22 AWG wire size.

ISOLATION BETWEEN ANY TWO TERMINALS¹: >1GΩ, <100pF.ISOLATION BETWEEN TERMINALS AND EARTH¹: >1GΩ, <200pF.ISOLATION BETWEEN CHANNEL GROUPS¹: >500GΩ, <100pF.

EXTERNAL COMMON MODE VOLTAGE: 42V between any terminal and chassis. (Connect no external sources.)

7751, 7752, OR 7753 MODULE NOTES

- 1 Isolation for channels 1–12, only one channel closed at a time, or all channels open.
- 2 See User's Manual for ohm specifications at sources other than those specified.
- 3 All specifications valid for 1 NPLC ADC aperture setting.

SYSTEM THROUGHPUT

(Connect, source, measure, calculate)

0.01 NPLC, FILTER OFF, OVER GPIB BUS: High Ohms (Source V): 13 rdgs/s¹.
Low Ohms (Source I): 9 rdgs/s.1 NPLC, FILTER ON, OVER GPIB BUS: High Ohms (Source V): 11 rdgs/s¹.
Low Ohms (Source I): 7 rdgs/s.

SYSTEM THROUGHPUT NOTES

- 1 Reset upon fixed V_{source} level, no settling time.

BASIC AIRBAG TEST SEQUENCE THROUGHPUT

(Body Pin + Bridgewire Continuity = Shorting Clip + Insulation Resistance)

0.55/0.97 seconds for single/dual stage DUT w/scan (sequential) memory patterns.

1.0/2.0 seconds for single/dual stage DUT w/recall (random access) memory patterns.

1.1/1.7 seconds for single/dual stage DUT discrete control w/GPIB I/O.

(Sequence times are totals @ 1 line cycle integration for rated accuracy)

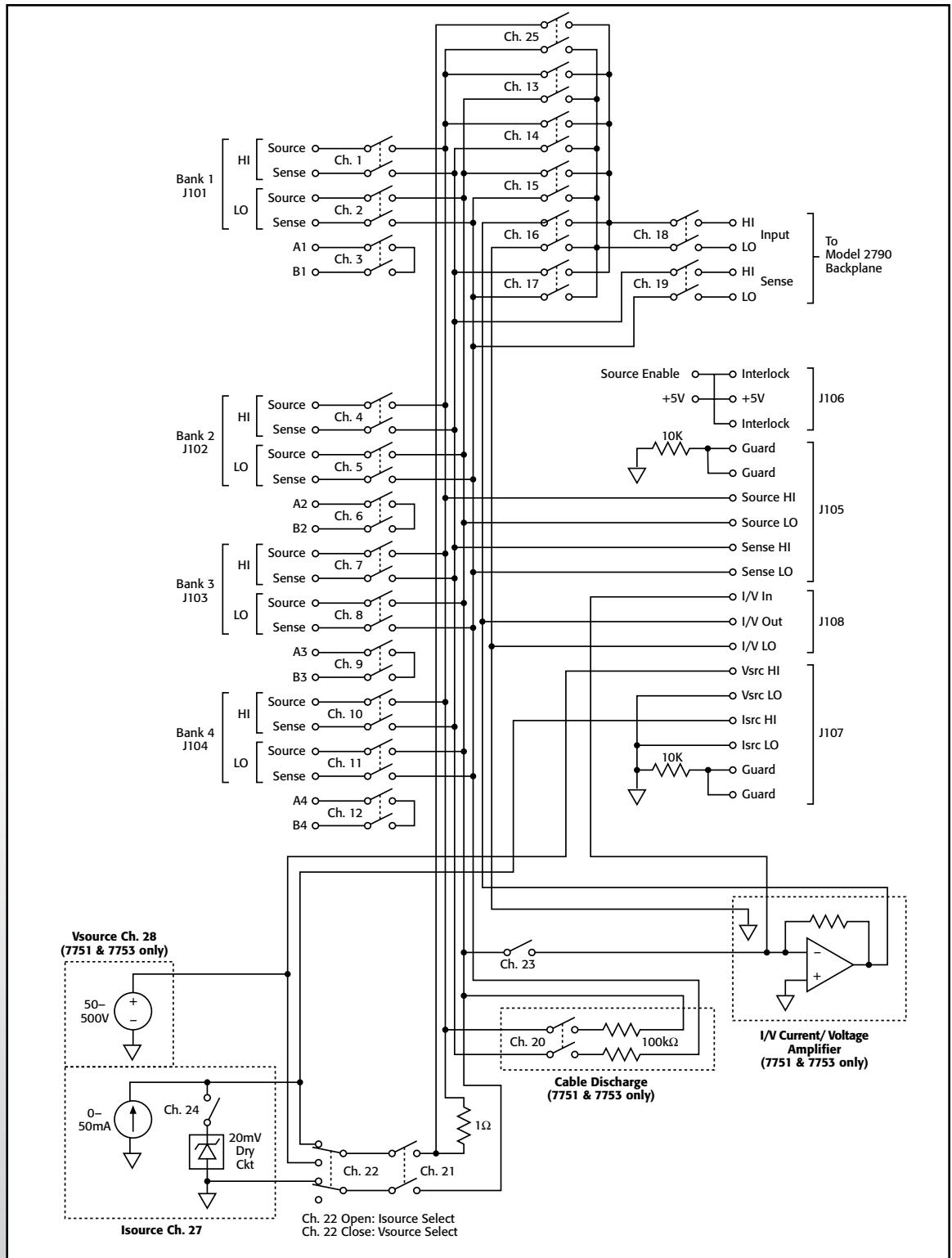

**7751
7752
7753**

High Voltage Source/Switch Module Low Voltage, Current-Source-Only Source/Switch Module 1MΩ High Voltage Source/Switch Module



- Sourcing and switching for airbag inflator testing with the Model 2790
- Programmable 0–50mA current source
- Programmable 50–500V voltage source (7751 and 7753)
- Built-in I/V converter (7751 and 7753)
- Low energy sources, a hardware source interlock, and programmable shunts help prevent accidental detonations

Ordering Information

7751	High Voltage Source/Switch Module
7752	Low Voltage, Current-Source-Only Source/Switch Module
7753	1MΩ High Voltage Source/Switch Module

SERVICES AVAILABLE

7751-3Y-EW	1-year factory warranty extended to 3 years from date of shipment
7752-3Y-EW	1-year factory warranty extended to 3 years from date of shipment
7753-3Y-EW	1-year factory warranty extended to 3 years from date of shipment

1.888.KEITHLEY (U.S. only)

www.keithley.com

The Model 7751, 7752, and 7753 Source/Switch Modules are designed exclusively for use in the Model 2790 SourceMeter Switch System for electrical checks of airbag inflators and a variety of other automotive electrical test applications. These modules provide the programmable high voltage and low current sourcing, plus the multichannel switching support required to measure insulation resistance and conductor continuity in these applications.

The Model 7751 and 7753 modules include programmable DC voltage (50–500V) and current (0–50mA) sources, as well as relay switching. A built-in current-to-voltage converter on these modules is used with the voltage source to measure the insulation resistance. They can also be used to measure currents from 0–50μA. The constant current source is useful for measuring the resistance of bridgewires and shunt bars. Four banks of two-pole relays provide a sufficient number of terminals to connect two single inflator units or one dual inflator unit to the Model 2790 mainframe for testing. The mainframe will accommodate two plug-in modules, so a single Model 2790 system can be connected to two test stands and be used to test two dual inflator airbag modules. Parallel testing in the form of “voltage soak with one card, measure with the other” is possible for both single and double test stand configurations. The switch matrix of the Model 7751 and 7753 simplifies implementing contact verification tests and allows the Model 2790 to verify test voltages and currents for increased measurement reliability.

The Model 7752 module is identical to the Model 7751, except that it does not include the high voltage source and current-to-voltage converter. The Model 7753 is identical to the Model 7751 except that the lowest high ohms measurement for the Model 7753 is 1MΩ and for the Model 7751 is 10MΩ.

Safety related design features that provide added protection against accidental detonation include low energy sources, a hardware source interlock, and programmable shunts that can be used in conjunction with an inflator’s shunt bar.

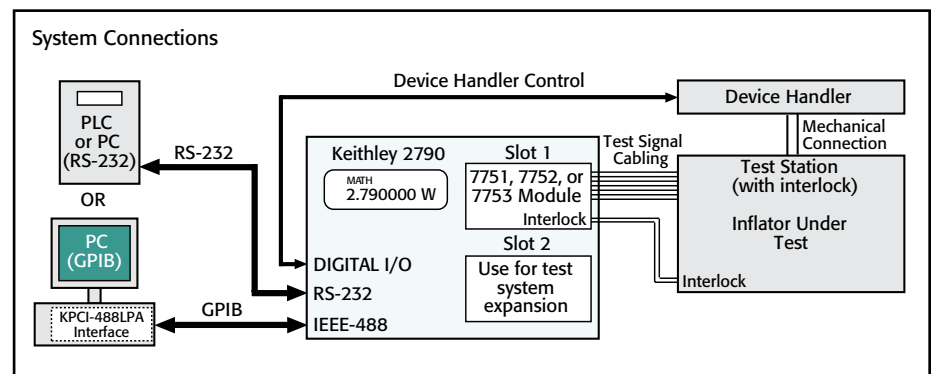

1.888.KEITHLEY (U.S. only)

www.keithley.com

A Greater Measure of Confidence

KEITHLEY
A Tektronix Company

DC Power Supplies

Selector Guide Selector Guide

Series 2200 Series 2260B Series 2280

2220-30-1

2220G-30-1

2230-30-1

2230G-30-1

2231A-30-3

2308

2302

2302-PJ

2306

2306-PJ

2306-VS

2303

2303-PJ

2304A

2290-5

2290-10

Technical Information	308
Programmable DC Power Supplies	312
Battery Simulating DC Power Supplies	314

Single-Output Programmable DC Power Supplies

Programmable DC Power Supplies	315
360W and 720W Programmable DC Power Supplies	319
Precision Measurement, Low Noise, Programmable DC Power Supplies	323

Multi-Output Programmable DC Power Supplies

Programmable Dual Channel DC Power Supply with USB Interface	330
Programmable Dual Channel DC Power Supply with USB and GPIB Interfaces	330
Programmable Triple Channel DC Power Supply with USB Interface	330
Programmable Triple Channel DC Power Supply with USB and GPIB Interfaces	330
195W Triple Channel DC Power Supply	334

Battery Simulating DC Power Supplies

50W, Fast Transient Response Battery/Charger Simulating Supply with Analog Output	337
60W, Fast Transient Response Battery Simulating Supply	344
60W, Fast Transient Response Battery Simulating Supply with 500mA Range	344
50W, Fast Transient Response Battery/Charger Simulating Supply	344
50W, Fast Transient Response Battery/Charger Simulating Supply with 500mA Range	344
50W, Fast Transient Response Battery/Charger Simulating Supply with External Triggering	350
45W, Fast Transient Response Supply	358
45W, Fast Transient Response Battery Simulating Supply with 500mA Range	358
100W, Fast Transient Response Supply	358

High Voltage DC Power Supplies

5kV Power Supply	362
10kV Power Supply	362

Programmable DC Power Supplies

DC power supplies provide a regulated DC output to power a component, a module, or a device. A power supply must deliver voltage and current that is stable and precise, with minimal noise in any type of load: resistive, inductive, low impedance, high impedance, steady-state, or variable. How well the power supply fulfills this mission and where it reaches its limits are defined in its specifications.

Power supplies have two main settings, the output voltage and the current limit. How they are set in combination with the load determines how the power supply will operate.

Most DC power supplies have two modes of operation. In Constant Voltage (CV) mode, the power supply controls the output voltage based on the user settings. In Constant Current (CC) mode, the power supply regulates the current. Whether the power supply is in CV or CC mode depends on both the user settings and the resistance of the load.

- CV mode is the typical operating state of a power supply. It controls voltage. The output voltage is constant and is determined by the user's voltage setting. The output current is determined by the impedance of the load.
- CC mode is typically considered a safety mode, but can be used in other ways. In CC mode, the output current is constant and is determined by the user's current limit setting. The voltage is determined by the impedance of the load. If the power supply is in CV mode and its current exceeds the user's current limit setting, then the power supply will automatically switch to CC mode. The power supply can also revert back to CV mode if the load current falls below the current limit setting.

The most important parameters for any application are the maximum voltage, maximum current, and maximum power that the power supply can generate. It is essential to ensure that the power supply can deliver the power at the required voltage and current levels. These three parameters are the first specifications that must be investigated.

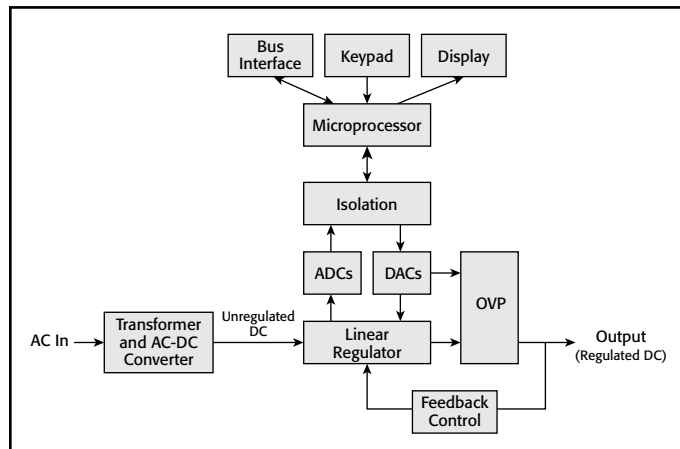

Figure 1. Simplified block diagram of a programmable linear power supply showing the digital and analog control circuit blocks

Accuracy and Resolution

Historically, the DC power supply user turned potentiometers to set output voltage or current. Today, microprocessors receive input from the user interface or from a remote interface. A digital-to-analog converter (DAC) takes the digital setting and translates this into an analog value, which is used as the reference for the analog regulator. The setting resolution and accuracy values are determined by the quality of this conversion and regulation process.

Voltage and current settings (sometimes called limits or programmed values) each have resolution and accuracy specifications associated with them. The resolution of these settings determines the minimum increment in which the output can be adjusted, and the accuracy describes the extent to which the value of the output matches international standards. In addition to output settings, there are measurement or readback specifications that are independent of the output specifications.

Most DC power supplies provide built-in measurement circuits for measuring both voltage and current. These circuits measure the voltage and current being delivered by the power supply output. Since the circuits read the voltage and current that is fed back into the power supply, the measurements produced by the circuits are often called readback values. Most professional power supplies incorporate circuits that use analog-to-digital converters, and for these internal instruments the specifications are similar to those of a digital multimeter. The power supply displays measured values on its front panel and can also transmit them over its remote interface, if it is equipped with one.

Setting Accuracy

Setting accuracy determines how close the regulated parameter is to its theoretical value as defined by an international standard. Output uncertainty in a power supply is largely due to error terms in the DAC, including quantization error. Setting accuracy is tested by measuring the regulated variable with a traceable, precision measurement system connected to the output of the power supply. Setting accuracy is given as:

$$\pm(\% \text{ of setting} + \text{offset})$$

For example, consider a power supply with a voltage setting accuracy specification of $\pm(0.03\% + 3\text{mV})$. When it is set to deliver 5V, the uncertainty in the output value is $(5\text{V})(0.0003 + 3\text{mV})$, or 4.5mV. Current setting accuracy is specified and calculated similarly.

Setting Resolution and Programming Resolution

Setting resolution is the smallest change in voltage or current settings that can be selected on the power supply. This parameter is sometimes called programming resolution if operating over an interface bus such as GPIB.

Readback Accuracy and Resolution

Readback accuracy is sometimes called meter accuracy. It determines how close the internally measured values are to the theoretical value of the output voltage (after setting accuracy is applied). Like a digital multimeter, this is tested using a traceable reference standard. Readback accuracy is expressed as:

$$\pm(\% \text{ of measured value} + \text{offset})$$

Readback resolution is the smallest change in internally measured output voltage or current that a power supply can discern.

Load Regulation (Voltage and Current)

Load regulation is a measure of the ability of the output voltage or output current to remain constant during changes in the load. It is expressed as:

$$\pm(\% \text{ of setting} + \text{offset})$$

Line Regulation (Voltage and Current)

Line regulation is a measure of the ability of the power supply to maintain its output voltage or output current while its AC line input voltage and frequency vary over the full allowable range. It is expressed as:

$$\pm(\% \text{ of setting} + \text{offset})$$

Ripple and Noise

Spurious AC components on the output of a DC supply are called ripple and noise, or periodic and random deviation (PARD). PARD specifications must be specified with a bandwidth and should be specified for both current and voltage. Current PARD is relevant when using a power supply in CC mode, and it is often specified as an RMS value. Because the shape of PARD is indeterminate, voltage PARD is usually expressed both as a root mean square voltage, which can provide a sense of the noise power, and also as a peak-to-peak voltage, which can be relevant when driving high impedance loads.

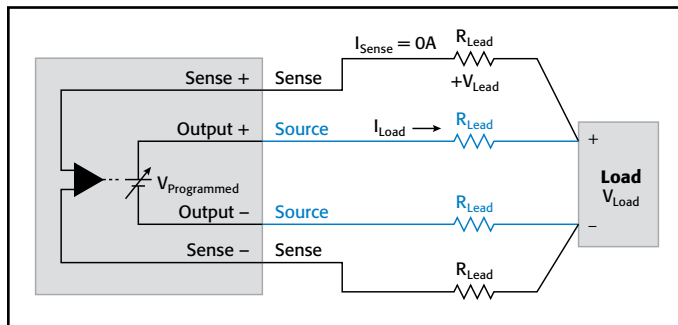

Figure 2. Remote sensing technique

Regardless of the accuracy of your power supply, you cannot guarantee that the programmed output voltage is the same as the voltage at the DUT's load. This is because a power supply with two source output terminals regulates its output only at its output terminals. However, the voltage you want regulated is at the DUT's load, not at the power supply's output terminals. The power supply and the load are separated by lead wires that have a resistance, R_{Lead} , which is determined by the length of the lead, the conductivity of the conductor material, and the geometry of the conductor. The voltage at the load is:

$$V_{\text{Load}} = V_{\text{Programmed}} - 2 * V_{\text{Lead}} = V_{\text{Programmed}} - 2 * I_{\text{Load}} * R_{\text{Lead}}$$

If the load requires high current, then I_{Load} is high and V_{Lead} can easily be a few tenths of a volt, especially if the power supply leads are long, as can be the case in an automated test rack. A voltage at the load could be 80mV to 160mV lower than the desired voltage (with 2A to 4A flowing through a 16-gauge wire).

The remote sensing technique solves the problem of the voltage drop in the test lead wires by extending the power supply feedback loop to the load. Two sense lines are connected between the DUT's load and the high

impedance voltage measuring circuit in the power supply. Since this is a high input impedance circuit, the voltage drop in the sense leads is negligible and becomes the feedback control loop for the power supply.

Fast Transient Response Power Supplies

The Keithley Series 2300 special-purpose power supplies are designed to maintain a stable output voltage under the most difficult loading conditions, such as the large, instantaneous load changes generated by cellular phones, cordless phones, mobile radios, wireless modems, and other portable, wireless communication devices. These devices typically transition from standby current levels of 100–200mA to 800mA–1.5A, which represents load changes of 800% and higher. A conventional power supply typically specifies a transient recovery to a 50% load change. The Keithley Series 2300 power supplies specify transient response to 1000% load changes.

Stable During Fast Load Changes

When the mobile communication device transitions to a full power transmit state, the output voltage of a conventional power supply drops substantially until its control circuitry can respond to the transient. Conventional power supplies trade off stability for all kinds of loads against transient response. As a result, the large voltage drop and long recovery time of a conventional power supply can cause the output voltage to fall below the low battery voltage threshold of the device under test (DUT). The DUT could turn off during testing and register a false failure, affecting yield and production costs.

Series 2300 fast transient response power supplies have transient voltage droops of less than 200mV under large load changes, even with the added impedance of long wire runs between the power supply and the DUT. Thus, the Series 2300 power supplies will keep the DUT powered under all test conditions and prevent false failures. See **Figure 3**.

Accurate Four-Wire Measurements

To maintain an accurate voltage at the DUT load, the Series 2300 power supplies use a four-wire source circuit in which two outputs provide the power and the other two lines sense the voltage directly at the DUT load.

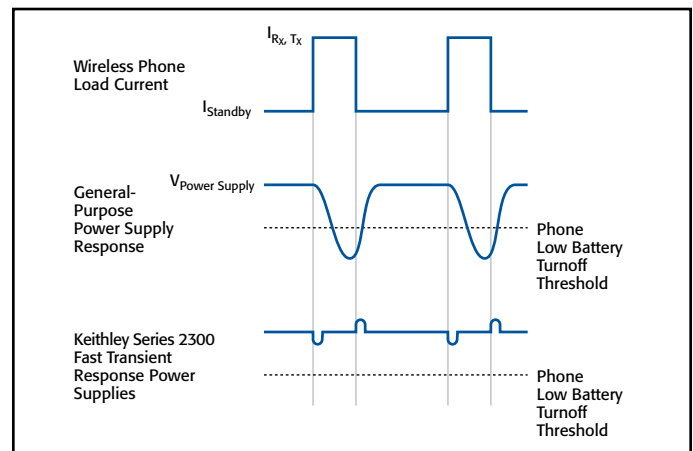

Figure 3. Comparison of general-purpose power supply's response with the response of a Keithley Series 2300 fast transient power supply.

1.888.KEITHLEY (U.S. only)

www.keithley.com

KEITHLEY

A Greater Measure of Confidence

A Tektronix Company

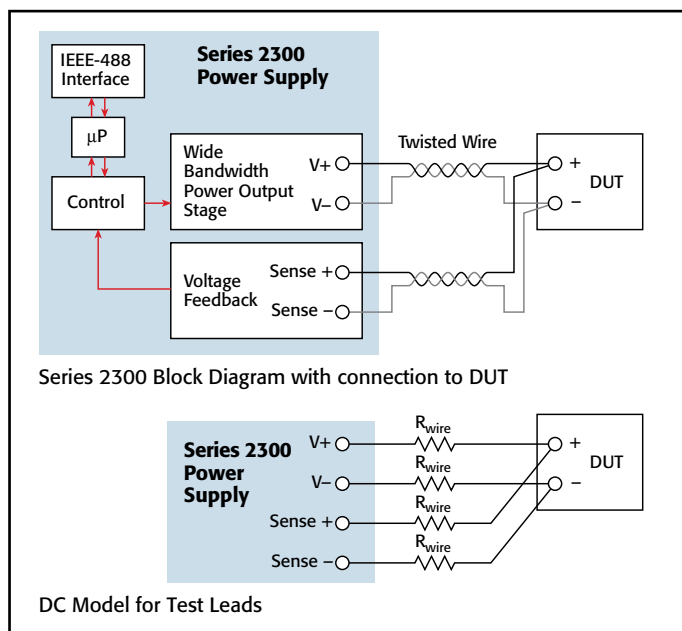

Figure 4. Four-wire sensing with Series 2300 power supplies ensures that an accurate voltage is applied to the load.

Sensing the voltage at the load compensates for any voltage drops in long test lead runs between the power supply and the load. Furthermore, the power supplies use a wide band output stage to obtain the low voltage transient droop and the fast transient recovery time. See **Figure 4**.

These types of power supplies often incorporate techniques for detecting if a sense lead is open or broken. An open sense lead interrupts the feedback control to the power supply, and uncontrolled, unstable output can provide improper voltages to a DUT. Series 2300 supplies either revert to internal local sensing or indicate an error condition and turn the output off.

Battery Emulation with Variable Output Resistance

Mobile communication devices are powered by batteries, so the Models 2302 and 2306 power supplies are designed to emulate the performance of a battery accurately. These supplies incorporate a variable output resistance feature, which enables a test engineer to test his DUT under actual operating conditions.

Furthermore, these supplies can sink current to simulate the battery in the discharged state. Thus, test engineers can use one instrument both to source the DUT and to act as a load for testing the charging control circuitry of the DUT and its charger.

The Models 2302 and 2306 have the ability to vary their output impedance. This allows them to simulate the internal impedance of a battery. Thus, the voltage response of a battery that must support pulsed current loads from portable products such as mobile phones can be simulated. This enables manufacturers of portable devices to test their devices under the most realistic conditions.

With a pulse-like increase in load current, the battery output voltage will drop by the product of the current change and the battery's internal resistance. The battery voltage could fall (for the length of the pulse) below the low battery voltage threshold level of the device, and the device could turn off. Since the internal impedance increases as a battery discharges, the low voltage threshold level can be reached earlier than expected due to the combination of a lower battery voltage due to discharge time and the voltage drop across the internal resistance of the battery. Therefore, a device's battery life could be shorter than the desired specification.

Battery impedance must be considered when evaluating mobile phone handset talk time and standby performance, because voltage levels below the operating threshold of a handset's circuitry for periods as short as 100 to 200µs are enough to shut off the handset. This phenomenon is common in TDMA (Time Division Multiple Access) phones such as GSM mobile phones where the magnitude of the high and low current levels during an RF transmission pulse vary by as much as a factor of 7 to 10. Designers need to simulate the actual performance of a battery to define an appropriate low battery threshold level. Test engineers need to simulate actual battery performance to test that the low voltage threshold level is reached with the specified battery voltage and not at a higher voltage level.

The battery simulating characteristics of the Models 2302 and 2306 can be used to test components as well as end products. For example, the power consumption characteristics of an RF power amplifier designed for use in portable products can be characterized for operation from a battery power source. As a battery discharges, its voltage decreases and its internal impedance increases. The RF amplifier draws a constant amount of power to maintain the required output. Thus, as the battery voltage falls and the internal resistance increases, the RF amplifier draws increasing amounts of current from the battery. Both peak current and average current rise significantly with increases in battery internal impedance. See **Figure 5**. The RF power amplifier must specify power consumption. The portable device designer must be aware of how the RF power amplifier performs as the battery discharges so that the designer can select an appropriate battery pack to ensure both that an adequate current supply is available

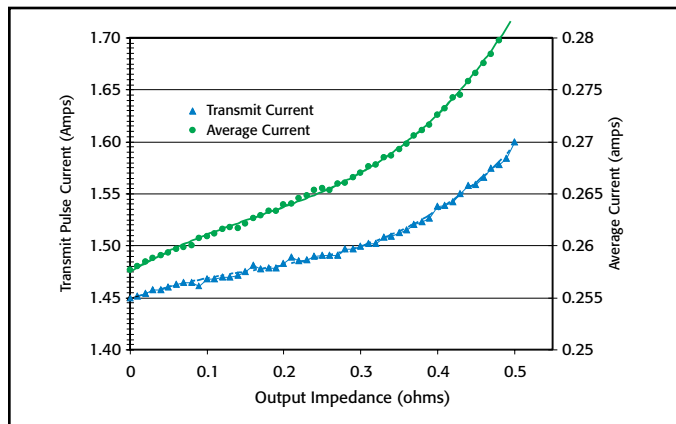

Figure 5. The transmit and average current consumption of an RF power amplifier used in a pulsed output mode with a Model 2302/2306 simulating a battery with a nominal output voltage of 3.60V and output impedance from 0.00 to 0.51Ω.

1.888.KEITHLEY (U.S. only)

www.keithley.com

KEITHLEY

A Tektronix Company

A Greater Measure of Confidence

Technical Information

DC Power Supplies

and that the battery supplies suitable operating time between replacement or charges.

The mathematics of this effect is provided below (also see **Figures 6a** and **6b**). They show that the voltage drop produced by pulsed current loads can have a significant effect on battery output voltage.

V_{cell} = An ideal voltage source

$R_i(t)$ = The internal impedance

$R_{\text{interconnect}}$ = Resistance of cables and interconnections to the DUT

- 1) If $R_{\text{interconnect}}$ is small compared to $R_i(t)$, and if
- 2) $R_i(t)$ is assumed to be relatively constant during the length of the pulse, $R_i(t) \approx R_i$, then
- 3) The voltage across the DUT can be expressed as:

$$V(t) \approx V_{\text{cell}} - I(t)R_i(t) \approx V_{\text{cell}} - I(t)R_i$$
 where $I(t)$ is the time varying current through the battery.

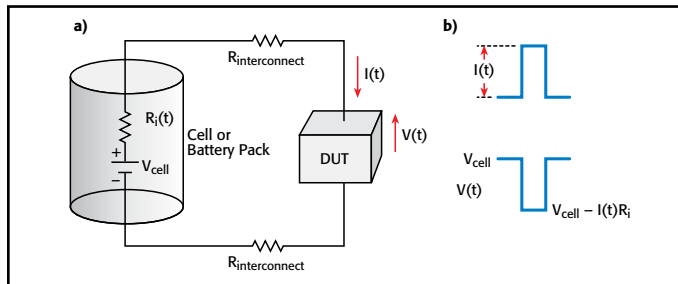

Figure 6a. Schematic of a battery represented by an ideal voltage source and a time varying internal impedance connected to a DUT. **Figure 6b.** Resulting output voltage with a pulsed load current.

Pulse Current and Low Current Measurements

Using a conventional (slow transient response) power supply for testing wireless devices requires that a large capacitor be placed in the circuit to stabilize the voltage during a load transition. As a result, load current measurements require using a sense resistor and a DMM to monitor load currents. The sense resistor adds resistance to the line, which further aggravates the load droop problem. The Keithley fast transient response power supplies eliminate the need for the capacitor and enable the power supply current readback circuitry to measure the load currents. See **Figure 7**. Keithley low current expertise enables the measurement of sleep currents with $0.1\mu\text{A}$ resolution. These supplies can also measure load current pulses from digital transmission devices. Current pulses as short as $60\mu\text{s}$ can be captured.

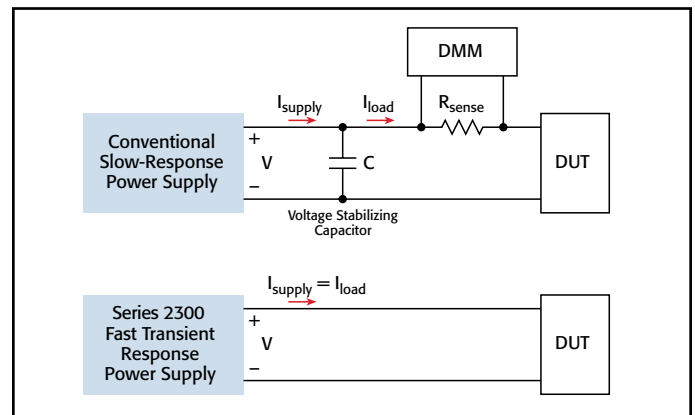

Figure 7. A Keithley Series 2300 fast transient response power supply measures load currents without additional devices and components.

1.888.KEITHLEY (U.S. only)

www.keithley.com

A Greater Measure of Confidence

KEITHLEY
A Tektronix Company

Selector Guide

Programmable DC Power Supplies

Single-Output Power Supplies

Multi-Output Power Supplies

	Single-Output Power Supplies					Multi-Output Power Supplies	
	2200-20-5	2200-30-5	2200-32-3	2200-60-2	2200-72-1	2220-30-1 2220J-30-1 2220-G-30-1 2220GJ-30-1	2230-30-1 2230J-30-1 2230-G-30-1 2230GJ-30-1
Model	2200-20-5	2200-30-5	2200-32-3	2200-60-2	2200-72-1	2220-30-1 2220J-30-1 2220-G-30-1 2220GJ-30-1	2230-30-1 2230J-30-1 2230-G-30-1 2230GJ-30-1
Page	315	315	315	315	315	330	330
Number of Channels	1	1	1	1	1	2	3
Power Output	100 W	150 W	96 W	150 W	86 W	90 W	120 W
Voltage Output	0 to 20 V	0 to 30 V	0 to 32 V	0 to 60 V	0 to 72 V	Ch. 1 and 2: 0 to 30 V	Ch. 1 and 2: 0 to 30 V Ch. 3: 0 to 6 V
Current Output	0 to 5 A	0 to 5 A	0 to 3 A	0 to 2.5 A	0 to 1.2 A	Ch. 1 and 2: 0 to 1.5 A	Ch. 1 and 2: 0 to 1.5 A Ch. 3: 0 to 5 A
Operating Mode	CV/CC*	CV/CC*	CV/CC*	CV/CC*	CV/CC*	CV/CC*	CV/CC*
Setting and Readback Resolution:							
Voltage	1 mV	1 mV	1 mV	1 mV	1 mV	1 mV	1 mV
Current	0.1 mA	0.1 mA	0.1 mA	0.1 mA	0.1 mA	1 mA	1 mA
Basic Accuracy:							
Voltage	±0.03%	±0.03%	±0.03%	±0.03%	±0.03%	±0.03%	±0.03%
Current	±0.05%	±0.05%	±0.05%	±0.05%	±0.05%	±0.1%	±0.1%
Features:							
Programming	IEEE-488 and USB	IEEE-488 and USB	IEEE-488 and USB	IEEE-488 and USB	IEEE-488 and USB	USB IEEE-488 in G version	USB IEEE-488 in G version
Remote Sense	Yes	Yes	Yes	Yes	Yes	Yes	Yes
External Trigger	Yes	Yes	Yes	Yes	Yes	No	No
Front and Rear Connectors	Yes	Yes	Yes	Yes	Yes	Yes	Yes
Setup Storage	40 locations	40 locations	40 locations	40 locations	40 locations	30 locations	30 locations
List Mode	7 lists, 80 steps/list	7 lists, 80 steps/list	7 lists, 80 steps/list	7 lists, 80 steps/list	7 lists, 80 steps/list	No	No
Track Mode	No	No	No	No	No	Yes	Yes
Output Timer	Yes	Yes	Yes	Yes	Yes	Yes	Yes
Password Protection	Yes	Yes	Yes	Yes	Yes	Yes	Yes
Remote Inhibit	Yes	Yes	Yes	Yes	Yes	No	No
Discrete Fault Indication	Yes	Yes	Yes	Yes	Yes	No	No
Approvals	CSA/CE	CSA/CE	CSA/CE	CSA/CE	CSA/CE	CSA/CE	CSA/CE

*CV is Constant Voltage mode and CC is Constant Current mode

1.888.KEITHLEY (U.S. only)

www.keithley.com

KEITHLEY
A Tektronix Company

A Greater Measure of Confidence

Selector Guide

Programmable DC Power Supplies

Selector guide: Specialized DC power supplies

DC POWER SUPPLIES

1.888.KEITHLEY (U.S. only)

www.keithley.com

A Greater Measure of Confidence

KEITHLEY
A Tektronix Company

Selector Guide

Specialized DC Power Supplies

Fast Transient Response, Battery Simulating Power Supplies

High Voltage Supplies

Model	2302	2303	2303-PJ	2304A	2306	2306-PJ	2306-VS	2308	2290-5	2290-10
Page	344	358	358	358	344	344	350	337		
No. of Channels	1	1	1	1	2	2	2	2	1	1
Power Output	42W maximum, function of V; optimized for maximum current at low V	45 W	45 W	100 W	45W maximum, function of V and power consumed by other channel; optimized for maximum current at low V	45W maximum, function of V and power consumed by other channel; optimized for maximum current at low V	45W maximum, function of V and power consumed by other channel; optimized for maximum current at low V	45W maximum, function of V and power consumed by other channel; optimized for maximum current at low V	25 W	10 W
Voltage Output	0–15 V	0–15 V	0–15 V	0–20 V	0–15 V	0–15 V	0–15 V	0–15 V	50–5,000 V	100–10,000 V
Maximum Continuous Current Output	5 A @ 4 V	5 A @ 9 V	5 A @ 9 V	5 A @ 20 V	5 A @ 4 V	5 A @ 4 V	5 A @ 4 V	5 A @ 4 V	5 mA	1 mA
Variable Resistance Output	0–1 Ω 10 mΩ resolution				0–1 Ω 10 mΩ resolution (in channel 1)	0–1 Ω 10 mΩ resolution (in channel 1)	0–1 Ω 10 mΩ resolution (in channel 1)	0–1 Ω 10 mΩ resolution (in channel 1)		
Current Sink Capacity	3 A	2 A	2 A	3 A	3 A	3 A	3 A	3 A		
DC Current Measurement Sensitivity	100 nA	100 nA	10 μA	100 nA	100 nA	10 μA (Ch. 1) 100 nA (Ch. 2)	100 nA	100 nA	1 μA	1 μA
Dynamic Current Measurement	5 A range: 33 μs–833 ms integration times	5 A range: 33 μs–833 ms integration times	500 mA and 5 A ranges: 33 μs–833 ms integration times	5 A range: 33 μs–833 ms integration times	5 A range: 33 μs–833 ms integration times	500 mA and 5 A ranges: 33 μs–833 ms integration times	5 A range: 33 μs–833 ms integration times	5 A, 500 mA, 50mA and 5mA ranges: 33 μs–833 ms integration times		
Ext. Triggering for Voltage Outputs and Current Measurement	No	No	No	No	No	No	Yes	No	No	No
Accuracy										
V	0.05%	0.05%	0.05%	0.05%	0.05%	0.05%	0.05%	0.05%	0.01%	±6 V
I	0.2%	0.2%	0.2%	0.2%	0.2%	0.2%	0.2%	0.2%	0.01%	±5 pA
Features:										
Programming	IEEE-488 included	IEEE-488 included	IEEE-488 included	IEEE-488 included	IEEE-488 included	IEEE-488 included	IEEE-488 included	IEEE-488 included	Analog, IEEE-488 included	Analog, IEEE-488, RS-232 included
Open Sense Lead Detection	Yes				Yes	Yes	Yes	Yes	No	No
DVM	Yes	Yes	Yes	Yes	Yes, 1 per channel	Yes, 1 per channel	Yes, 1 per channel	Yes, on channel 2	No	No
Analog Output								2 current ranges on channel 1	V, I	V, I
Relay Control Port	4	1	1	2	4	4	No	4	No	No
Remote Display Module	Yes	Yes	Yes	Yes	Yes	Yes	No	Yes	No	No
CE	Yes	Yes	Yes	Yes	Yes	Yes	Yes	Yes	Yes	Yes

1.888.KEITHLEY (U.S. only)

www.keithley.com

KEITHLEY

A Tektronix Company

A Greater Measure of Confidence

Series 2200

Single-Channel Programmable DC Power Supplies



- **Five models ranging in power from 86W to 150W with voltage outputs from 20V to 72V address a wide range of power requirements**
- **0.03% basic voltage output accuracy and 0.05% basic current accuracy provide quality test data**
- **High output and measurement resolution, 1mV and 0.1mA, for testing low power circuits and devices**
- **Remote sensing to ensure the programmed voltage is applied to the load**
- **Dual-line display shows both the programmed values and actual outputs for a continuous indication of the status of the power delivered to the load**
- **Repeatable test sequences of up to 80 output steps are easy to create with the built-in List mode**
- **GPIB and USB interfaces are standard for convenient automated control**

The Series 2200 Single-Channel Programmable DC Power Supplies provide a wide range of voltage outputs to address the testing and characterization of components, circuits, modules, and complete devices, whether you are in a research laboratory, in design and development, or in production test. The Series 2200 consists of five models with output voltages from 20V to 72V that can deliver 86W, 96W, 100W, and 150W of power. In addition, these power supplies can act as constant current sources as well as constant voltage sources. The Series 2200 power supplies offer an excellent combination of performance, versatility, and ease of use that allow you to obtain quality test data as quickly as possible. They perform as effectively in automated test systems as they do in manual instrument configurations.

Outstanding Accuracy Delivered to the Load

With basic voltage setting accuracy of 0.03% and basic voltage readback accuracy of 0.02%, you can be sure that the voltage you program for the load is applied at the output terminals. What's more, the rear panel connections include remote sense terminals that compensate for voltage drops

in the power supply leads. This helps to ensure that the correct voltage is delivered to the load terminals of the device-under-test (DUT). Great accuracy is not limited to voltage—the basic current setting and readback accuracy is 0.05%, providing you with high quality load current measurements. Also, with less than 5mVp-p noise, you can be confident that the power applied to the DUT's load terminals is both accurate and of high quality.

Superior resolution is also provided by Keithley's Series 2200 single-channel power supplies. With 1mV and 0.1mA resolution, the effects of very small changes in voltage and current can be detected and studied. For portable devices in which minimum power consumption is critical, the 0.1mA current resolution allows you to measure the idle and sleep mode currents so you can verify that your products meet aggressive low power consumption goals.

Get Test Results Quickly

Keithley's Series 2200 single-channel power supplies have a number of features that enable you to obtain the results you need quickly and easily, including tools to help you create sophisticated tests for a wide range of requirements.

The dual-line display shows both the programmed settings and the actual voltage and current outputs, allowing you to immediately see, understand, and address any differences between the expected and actual output values. Multiple methods can be used to adjust the voltage and current settings. You can use the direct-entry numeric keypad to set precise voltage and current values. There is also a rotary knob with adjustable step size that lets you easily study the response of your DUT to small or large changes in voltage or current.

Need to repeat a set of tests often? Instead of programming a number of parameters for each test every time you run the test, just use a few keystrokes to save a test setup once and then recall it whenever you need it. Take advantage of 40 memory locations to save up to 40 set ups or use the Series 2200 List mode to define custom test sequences of up to 80 steps. This makes it easy to perform tests such as analyzing how your circuit- or device-under-test performs at each voltage level within a range of voltages. A saved test can be run manually using front panel key strokes, automatically using external trigger signals, or remotely using programmable interface commands. Up to seven 80-step lists can be stored in a Series 2200 single-channel power supply. Each step can have a programmable duration.

Protects Your DUT at All Times

A number of features are built into the Series 2200 power supplies to ensure that your DUT is protected from damage. A maximum voltage can be set so that regardless of the voltage value requested, the output will not exceed the programmed limit value. For further voltage magnitude protection, an Over Voltage protection level can be programmed that will cause the output to drop below 1V if the Over Voltage limit is reached. These protections are in addition to the Current Limit setting, which restricts the amount of current that can flow into the DUT. If the Current Limit is reached, the Series

1.888.KEITHLEY (U.S. only)

www.keithley.com

A Greater Measure of Confidence

KEITHLEY
A Tektronix Company

Series 2200

Ordering Information

2200-20-5 Programmable DC Power Supply, 20V, 5A

2200-30-5 Programmable DC Power Supply, 30V, 5A

2200-32-3 Programmable DC Power Supply, 32V, 3A

2200-60-2 Programmable DC Power Supply, 60V, 2.5A

2200-72-1 Programmable DC Power Supply, 72V, 1.2A

Accessories Supplied

213-CON Rear Panel Mating Connector with Handle

CS-1638-12 Rear Panel Mating Connector

Documentation and Driver CD

ACCESSORIES AVAILABLE

CS-1638-12	Rear Panel Mating Connector
KPCI-488LPA	IEEE-488.2 Interface Board for the PCI Bus
USB-B-1	USB Cable
4299-7	Fixed Rack Mount Kit
7007-05	Double Shielded Premium IEEE-488 Interface Cables, 0.5m (1.6 ft)
7007-1	Double Shielded Premium IEEE-488 Interface Cables, 1m (3.2 ft)
7007-2	Double Shielded Premium IEEE-488 Interface Cables, 2m (6.5 ft)
7007-3	Double Shielded Premium IEEE-488 Interface Cables, 3m (10 ft)
7007-4	Double Shielded Premium IEEE-488 Interface Cables, 4m (13 ft)

SERVICES AVAILABLE

Model Number-EW (Example: 2200-20-5-EW)	1 additional year of factory warranty
C/Model Number-3Y-STD	3 calibrations within 3 years of purchase
C/Model Number-3Y-DATA	3 (ANSI-Z540-1 compliant) calibrations within 3 years of purchase
C/Model Number-5Y-STD	5 calibrations within 5 years of purchase
C/Model Number-5Y-DATA	5 (ANSI-Z540-1 compliant) calibrations within 5 years of purchase

Single-Channel Programmable DC Power Supplies

2200 power supplies convert from constant voltage to constant current operation in which the current is controlled at the Current Limit setting and the voltage varies based on the load resistance.

In addition to the limit settings, you can set a timer to turn off the output after a specified time interval, allowing you to setup a test on your bench and let it to run unattended knowing that power will automatically be removed from the DUT after the programmed time has elapsed.

Ensures that Test Parameters are Not Accidentally Changed

Prevent accidental changes to settings to avoid collecting incorrect test data and wasting time repeating tests by taking advantage of the Series 2200's front panel lock-out functions. You can disable the front panel knob or disable all the front panel data entry controls. When all the front panel data entry keys are disabled, the Series 2200 prompts for a password to re-activate the keys.

Select a Convenient Interface

The Series 2200 DC power supplies can be an integral part of your automated test system. You have the option to control each power supply over a GPIB interface or a USB interface. The USB interface is test and measurement class (TMC) compliant so you can use the standard SCPI command syntax. Standard drivers are included with the Series 2200 to simplify interfacing them into an automated test environment.

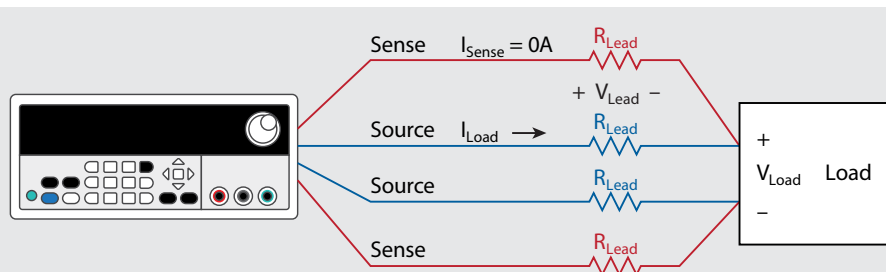

No matter how accurate your power supply output is, you cannot guarantee that the programmed output voltage is the same as the voltage at the DUT's load. This is because a power supply with two source output terminals regulates its output only at its output terminals. However, the voltage you want regulated is at the DUT's load, not at the power supply's output terminals. The power supply and the load are separated by lead wires that have a resistance, R_{Lead} , determined by the length of the lead, the conductivity of the conductor material, and the geometry of the conductor. The voltage at the load is: $V_{Load} = V_{Programmed} - 2 * I_{Load} * R_{Lead}$. If the load requires high current, then I_{Load} is high and V_{Lead} can easily be a few tenths of a volt, especially if the power supply leads are long, as can be the case in an automated test rack. A voltage at the load could be 80mV to 160mV lower than the desired voltage (with 2A to 4A flowing through a 16-gauge wire).

The remote sensing technique solves the problem of voltage drop in the leads by extending the power supply feedback loop to the input of the load. Two sense lines from the power supply are connected to the power inputs. These sense leads are voltage measuring lines that connect to a high impedance voltage measuring circuit in the power supply. Since the voltage measuring circuit is a high input impedance circuit, the voltage drop in the sense leads is negligible. The sense lead voltage measurement circuit becomes the feedback control loop for the power supply. The voltage at the load is fed back to the power supply by the sense leads. The power supply raises its output to overcome the voltage drop in the source leads and $V_{Load} = V_{Programmed}$.

Thus, only with remote sensing can the accuracy of the power supply be applied to the load.

1.888.KEITHLEY (U.S. only)

www.keithley.com

Series 2200

Single-Channel Programmable DC Power Supplies

	2200-20-5	2200-30-5	2200-32-3	2200-60-2	2200-72-1
DC OUTPUT RATING					
Voltage	0 to 20 V	0 to 30 V	0 to 32 V	0 to 60 V	0 to 72 V
Current	0 to 5 A	0 to 5 A	0 to 3 A	0 to 2.5 A	0 to 1.2 A
MAXIMUM POWER	100 W	150 W	96 W	150 W	86 W
LOAD REGULATION					
Voltage	<0.01% + 2 mV	<0.01% + 2 mV	<0.01% + 2 mV	<0.01% + 2 mV	<0.01% + 2 mV
Current	<0.05% + 0.1 mA	<0.05% + 1.5 mA	<0.05% + 0.1 mA	<0.05% + 0.5 mA	<0.05% + 0.5 mA
LINE REGULATION					
Voltage	< 0.01% + 1 mV	<0.01% + 1 mV	<0.01% + 1 mV	<0.01% + 2 mV	<0.01% + 1 mV
Current	<0.05% + 0.1 mA	<0.05% + 0.1 mA	<0.05% + 0.1 mA	<0.05% + 0.05 mA	<0.05% + 0.1 mA
RIPPLE AND NOISE (20 Hz to 7 MHz)					
Voltage	<1 mV _{RMS} <3 mV _{P-P}	<1 mV _{RMS} <4 mV _{P-P}	<1 mV _{RMS} <4 mV _{P-P}	<1 mV _{RMS} <5 mV _{P-P}	<1 mV _{RMS} <3 mV _{P-P}
Current	<3 mA _{RMS}	<4 mA _{RMS}	<3 mA _{RMS}	<3 mA _{RMS}	<3 mA _{RMS}
SETTING RESOLUTION					
Voltage	1 mV	1 mV	1 mV	1 mV	1 mV
Current	0.1 mA	0.1 mA	0.1 mA	0.1 mA	0.1 mA
SETTING ACCURACY (using remote sense, 25°C ± 5°C)					
Voltage	±0.03% + 3 mV	±0.03% + 3 mV	±0.03% + 3 mV	±0.03% + 6 mV	±0.03% + 6 mV
Current	±0.05% + 2 mA	±0.05% + 2.5 mA	±0.05% + 2 mA	±0.05% + 1.5 mA	±0.05% + 1 mA
READBCK RESOLUTION					
Voltage	1 mV	1 mV	1 mV	1 mV	1 mV
Current	0.1 mA	0.1 mA	0.1 mA	0.1 mA	0.1 mA
READBCK ACCURACY (25°C ± 5°C)					
Voltage	0.02% + 3 mV	±0.02% + 2.5 mV	±0.02% + 3 mV	±0.02% + 6 mV	±0.02% + 5 mV
Current	±0.05% + 2 mA	±0.05% + 2.5 mA	±0.05% + 2 mA	±0.05% + 1.5 mA	±0.05% + 1 mA
VOLTAGE TRANSIENT RESPONSE – SETTLING TIME					
Load Change	<400 μs to within 75 mV following a change from 0.1 A to 1A				
Setting Change	Rising	<35 ms from beginning of excursion to within 75 mV of terminal value following a change from 1 V to 11 V with a 1 A load (Note: Specification does not include command decode time)			
	Falling	<35 ms from beginning of excursion to within 75 mV of terminal value following a change from 11 V to 1 V with a 1 A load (Note: Specification does not include command decode time)			
OVERVOLTAGE PROTECTION					
Range (typical)	1 V to 19 V	1 V to 29 V	1 V to 31 V	1 V to 59 V	1 V to 71 V
Accuracy	±0.5% + 0.5 V	±0.5% + 0.5 V	±0.5% + 0.5 V	±0.5% + 0.5 V	±0.5% + 0.5 V
Response Time (typical)	<10 ms	<10 ms	<10 ms	<10 ms	<10 ms

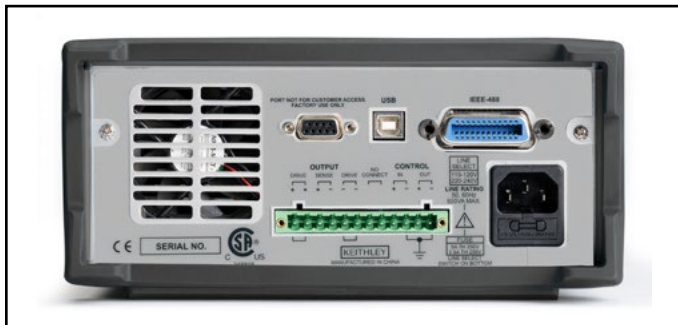

Series 2200 rear panel.

1.888.KEITHLEY (U.S. only)

www.keithley.com

A Greater Measure of Confidence

KEITHLEY
A Tektronix Company

Series 2200

Single-Channel Programmable DC Power Supplies

GENERAL

COMMUNICATIONS: USB: Type B connector, USB-TMC compatible.
GPIB: IEEE-488.2 compliant.

DISPLAY: Vacuum fluorescent display.

MEMORY: 40 setup memories.

LIST MODE: Up to seven lists can be defined, each with up to 80 steps. Each step includes a voltage limit and a current limit. For continuous sequences each step also includes a duration.

OUTPUT, SENSE, STATUS, AND CONTROL: Removable screw terminal block carries the following signals:

Output Channel: Duplicates the front panel outputs.

Remote Sense Lines: Connection for remote sense.

Control Input: Multifunction TTL input which can function as a trigger input, output control line, or digital input.

Status Output: Multifunction TTL output which can function as a fault indication, or digital output.

FLOATING VOLTAGE RATING: Up to 100V (DC + peak AC) between earth ground and any output terminal.

POWER SOURCE:

110V AC Setting: 99V_{RMS} to 132V_{RMS}.

220V AC Setting: 198V_{RMS} to 264V_{RMS}.

Frequency: 50/60Hz.

Power Consumption: 2200-20-5, 2200-32-3, 2200-72-1: 250VA.
2200-30-5, 2200-60-2: 350VA.

EMC:

European Union: EN 55011, Class A; IEC 61000-3-2; IEC 61000-3-3; IEC 61000-4-2, IEC 61000-4-3, IEC 61000-4-4, IEC 61000-4-5, IEC 61000-4-6, IEC 61000-4-8, IEC 61000-4-11.

USA: FCC, CFR Title 47, Part 15, Subpart B, Class A.

Australia: EMC Framework, demonstrated per Emission Standard AS/NZS 2064 (industrial, scientific, and medical equipment).

SAFETY:

European Union: Low voltage directive 2006/95/EC; EN61010-1 2001.

USA: Nationally recognized testing laboratory listing UL61010-1-2004.

Canada: CAN/CSA C22.2 No. 61010-1 2004.

DIMENSIONS:

With Boot: 106mm high × 242mm wide × 384mm deep (4.15 in × 9.52 in × 15.12 in).

Without Boot: 91mm high × 218mm wide × 362mm deep (3.57 in × 8.55 in × 14.24 in).

SHIPPING WEIGHT: 2200-20-5, 2200-32-3, 2200-72-1: 9.0kg.

2200-30-5, 2200-60-2: 9.6kg.

NET WEIGHT: 2200-20-5, 2200-30-5, 2200-32-3, 2200-72-1: 7.3kg.

2200-60-2: 7.0kg.

ENVIRONMENT:

Altitude: **Operating:** Up to 2,000m above sea level.

Storage: Up to 4,000m above sea level.

Operating: 0° to +40°C, 5% to 95% R.H. up to +40°C.

Storage: -20° to +70°C, 5% to 95% R.H. up to +40°C.

-20° to +70°C, 5% to 60% R.H. above +40°C up to +70°C.

1.888.KEITHLEY (U.S. only)

www.keithley.com

A Greater Measure of Confidence

KEITHLEY
A Tektronix Company

Series 2260B

360W and 720W Programmable DC Power Supplies

- 360W and 720W versions with voltage up to 80V and current up to 72A
- Combine power supplies in serial and parallel combinations to expand voltage and current outputs up to 160V and 216A
- Programmable voltage or current rise and fall times from 0.1V/s to 160V/s or 0.01A/s to 144A/s prevent damage from inrush current to low impedance loads
- Constant current priority setting reduces voltage and current overshoot when powering LEDs
- Simulate a battery's output characteristics with a programmable output resistance
- Display delivered power with either the output current or the output voltage
- Choose from analog control, USB, LAN, or an optional GPIB interface for automated control
- Save bench and test system space: six 71mm-wide 360W units or three 143mm-wide 720W units fit in a standard rack width



Source a wide range of voltages and currents with the 360W Model 2260B-30-36 or the Model 2260B-80-13 Programmable DC Power Supplies. For higher power requirements, output up to 720W with either the Model 2260B-30-72 or the Model 2260B-80-27 DC power supplies. All four instruments have constant power outputs to provide a flexible range of voltage and current output combinations. The 360W supplies can output as much as 30V or 80V or as much as 13.5A or 36A, while the 720W supplies can output twice as much current, 72A and 27A, with the same maximum voltage outputs. The wide range of output voltages and currents of the Series 2260B power supplies along with multiple interfaces, enable their use in numerous applications including research and design, quality control, and production test.

Use Series and Parallel Combinations to Extend the Voltage Output to 160V and the Current to 216A

When more than 80V is needed, two Model 2260B power supplies can be connected in series to double the maximum output voltage to 160V. Similarly, up to three Model 2260Bs can be connected in parallel to produce as much as 216A. To combine the supplies in either series or parallel, they are controlled using a master-slave configuration. The power supply defined as the master unit will show the total voltage and current. Thus, multiple units used in combination can deliver up to 2160W to address numerous high power applications.

Control the Voltage or Current Rise Time to Reduce Inrush Current and Prevent Device Damage

To prevent potentially dangerous inrush currents from flowing into loads that have low resistance when power is initially supplied, the Series 2260B power supplies have programmable rise time (or slew rate) control. Either the voltage rise time or the current rise time can be controlled. With voltage slew rate control, the voltage rise time can range from a slow 0.1V/s to a high speed of 160V/s for the 80V models. When operating under constant current control, the output current rise time can be programmed from a low slew rate of 0.01A/s to a maximum value of 144A/s for the 2260B-30-72. The programming of a current rise time puts the Series 2260B supplies in a constant current control priority mode in which the current slew rate limits the rate at which the voltage rises across the device under test (DUT). In addition to controlling the rise time, the fall time can also be programmed; and the fall time values can be different from the rise time values. Thus, the delivery of power to a load can be precisely controlled to prevent overshoot spikes and excessive amounts of inrush current. This capability prevents damage to components, modules, or devices and will generate more precise characteristic I-V curves for components such as LEDs.

APPLICATIONS

- Environmental test, stress test, and accelerated life testing
- LED and high power component testing
- Automotive testing
- Battery research and test
- Production test

1.888.KEITHLEY (U.S. only)

www.keithley.com

Series 2260B

360W and 720W Programmable DC Power Supplies

Ordering Information

2260B-30-36
Programmable DC 360W Power Supply, 30V, 36A

2260B-80-13
Programmable DC 360W Power Supply, 80V, 13.5A

2260B-30-72
Programmable DC 720W Power Supply, 30V, 72A

2260B-80-27
Programmable DC 720W Power Supply, 80V, 27A

Accessories Supplied

2260B Basic Accessories Kit (terminal mounting hardware and protective cover)

Test Leads

USB Cable

Quick Start Guide

CD with Manuals and Software Drivers

Power cord

ACCESSORIES AVAILABLE

2260-001	Accessory Kit
2260-002	Simple IDC Tool
2260-003	Contact Removal Tool
2260-004	Basic Accessories kit
2260-005	Cable for 2 units in Series connection
2260-006	Cable for 2 units in Parallel connection
2260-007	Cable for 3 units in Parallel connection
2260-008	Test Lead Set with Lugs
2260B-GPIB-USB	GPIB-to-USB Adapter
2260B-EXTERM	Extended Terminal
2260B-RMK-JIS	Rack Mount Kit (JIS racks)
2260B-RMK-EIA	Rack Mount Kit (EIA racks)
USB-B-1	USB Cable

SERVICES AVAILABLE

Model Number*-EW	3-year factory warranty extended to 1 additional year from date of shipment
Model Number*-5Y-EW	3-year factory warranty extended to 5 years from date of shipment
C/Model Number*-3Y-STD	KeithleyCare 3 Year Standard Calibration Plan
C/Model Number*-3Y-DAT	KeithleyCare 3 Year Calibration with Data Plan
C/Model Number*-5Y-STD	KeithleyCare 5 Year Standard Calibration Plan
C/Model Number*-5Y-DAT	KeithleyCare 5 Year Calibration with Data Plan

* Insert Model Number. Examples: 2260B-30-36-5Y-EW, C/2260B-80-27-3Y-DAT

1.888.KEITHLEY (U.S. only)

www.keithley.com

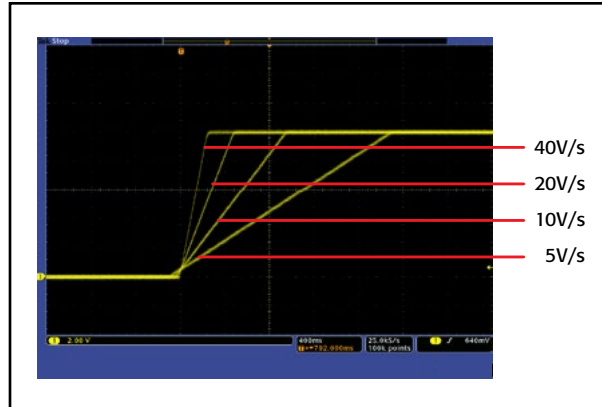

Precisely control voltage rise time with the variable slew rate control.

Emulate the Response of a Battery

Test a circuit or device under the most realistic conditions by applying a test source with the output resistance that is equivalent to the output resistance of the actual source that will be used to power the circuit or device. For example, a battery has a varying internal resistance, and a device powered by a battery will have a voltage applied to the device that is reduced by the voltage drop across the battery's internal resistance. Versions of the Series 2260B supplies can have an internal resistance up to 59Ω to simulate devices such as a lead-acid battery.

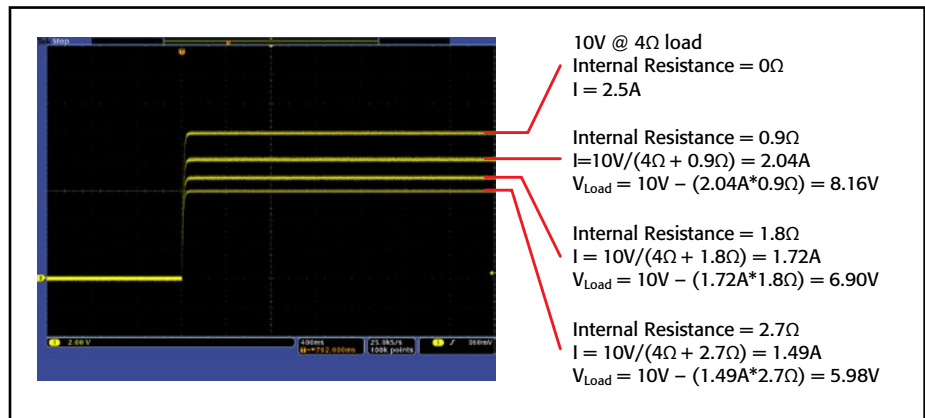

Use the programmable internal resistance to simulate a battery's output. In this example, a Model 2260B-80-13 power supply is simulating a 10V battery whose internal resistance is 0Ω, 0.9Ω, 1.8Ω, and 2.7Ω. The resulting voltage at the output terminals drops from 10V to 5.98V due to the voltage drop across the internal resistance of the battery.

Create Custom Voltage Source Waveforms

An internal test sequence mode allows the Series 2260B supplies to output a set of voltage levels for varying time intervals at each level. The test sequence can be stored and used repeatedly to determine DUT performance at number of voltage levels. In addition, the analog input control can be used to create voltage profiles that simulate how a battery responds to a fast changing load current requirement such as a large inrush current. Also, generate a combined DC output level with an AC signal superimposed on it to test how a circuit responds to noise on its DC power source. The analog input control parameter can be either a voltage input or a resistance input. With this analog control capability, numerous types of DC supply signals can be generated to test circuits and devices under a wide range of circumstances.

Series 2260B

360W and 720W Programmable DC Power Supplies

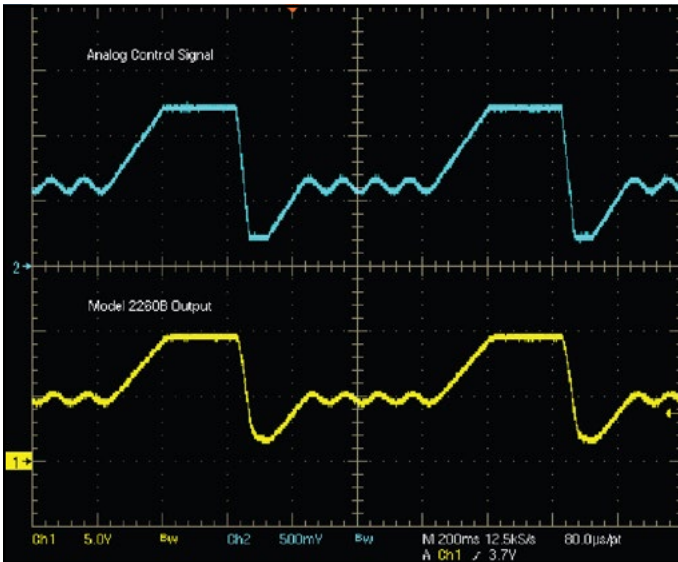

A signal generator (top plot) controls the 2260B to create a complex DC supply waveform (bottom plot) that simulates both a voltage drop due to a large inrush current and noise on the DC supply line.

Flexible and Fast for Automated Test Systems

The Series 2260B power supplies will work in any automated system because they can interface to a controller with either a USB, LAN, or optional GPIB interface. Furthermore, the Series 2260B supplies have fast discharge capability to dissipate the voltage on the output quickly. These supplies also have a fast (1ms) transient recovery time to load changes. The combination of the fast discharge time and the fast transient response helps minimize critical test time in automated test systems.



Rear panel of 360W models.



Rear panel of 720 models.

1.888.KEITHLEY (U.S. only)

www.keithley.com

A Greater Measure of Confidence

KEITHLEY
A Tektronix Company

Programmable DC power supplies

DC POWER SUPPLIES

Series 2260B

360W and 720W Programmable DC Power Supplies

Specifications (23°C ±5°C)

	2260B-30-36	2260B-30-72	2260B-80-13	2260B-80-27
OUTPUT RATING				
Voltage	0–30 V	0–30 V	0–80 V	0–80 V
Current	0–36 A	0–72 A	0–13.5 A	0–27 A
Power	360 W	720 W	360 W	720 W
RIPPLE AND NOISE (Noise bandwidth 20 MHz, ripple bandwidth 1 MHz)				
CV p-p	60 mV	80 mV	60 mV	80 mV
CV rms	7 mV	11 mV	7 mV	11 mV
CC rms	72 mA	144 mA	27 mA	54 mA
PROGRAMMING ACCURACY				
Voltage	0.1% + 10 mV	0.1% + 10 mV	0.1% + 10 mV	0.1% + 10 mV
Current	0.1% + 30 mA	0.1% + 60 mA	0.1% + 10 mA	0.1% + 30 mA
READBACK ACCURACY				
Voltage	0.1% + 10 mV	0.1% + 10 mV	0.1% + 10 mV	0.1% + 10 mV
Current	0.1% + 30 mA	0.1% + 60 mA	0.1% + 10 mA	0.1% + 30 mA
RESPONSE TIME				
Rise Time	50 ms	50 ms	50 ms	50 ms
Fall Time (full load)	50 ms	50 ms	50 ms	50 ms
Fall Time (no load)	500 ms	500 ms	500 ms	500 ms
Load Transient Recovery Time (load change from 50 to 100%)	1 ms	1 ms	1 ms	1 ms
PROGRAMMING RESOLUTION (by PC Remote Control Mode)				
Voltage	1 mV	1 mV	2 mV	2 mV
Current	1 mA	2 mA	1 mA	2 mA
MEASUREMENT RESOLUTION (by PC Remote Control Mode)				
Voltage	1 mV	1 mV	2 mV	2 mV
Current	1 mA	2 mA	1 mA	2 mA
FRONT PANEL DISPLAY ACCURACY				
Voltage	0.1% + 2 counts	0.1% + 2 counts	0.1% + 2 counts	0.1% + 2 counts
Current	0.1% + 4 counts	0.1% + 7 counts	0.1% + 2 counts	0.1% + 4 counts

Regulation (CV):

Load: 0.05% of setting + 5mV. Line: 0.05% of setting + 3mV.

Regulation (CC):

Load: 0.1% of setting + 5mA. Line: 0.1% of setting + 5mA.

Voltage Slew Rate Range: Rising and Falling:

0.1V/s to 60V/s (2260B-30-36, 2260B-30-72).

0.1V/s to 160V/s (2260B-80-13, 2260B-80-27).

Current Slew Rate Range: Rising and Falling:

0.01A/s to 72A/s (2260B-30-36)

0.01A/s to 144A/s (2260B-30-72)

0.01A/s to 27A/s (2260B-80-13)

0.01A/s to 54A/s (2260B-80-27).

Remote Sense: 0.6V total voltage drop in load wires.

Output Delay Time Range:

On Delay and Off Delay: 0s to 99.99s.

Internal Resistance Range:

0.000Ω to 0.833Ω (2260B-30-36)

0.000Ω to 0.417Ω (2260B-30-72)

0.000Ω to 5.926Ω (2260B-80-13)

0.000Ω to 2.963Ω (2260B-80-27).

Series and Parallel Capability:

Parallel Operation: Up to 3 units including the master unit.

Series Operation: Up to 2 units including the master unit.

Protection Functions:

OVP: 10% to 110% of rated output voltage range.

Accuracy: ±2% of rated output voltage.

OC: 10% to 110% of rated output current range.

Accuracy: ±2% of rated output current.

OTP: Activated by elevated internal temperatures.

Isolation Voltage: 500VDC, output to chassis.

Analog Voltage Control:

Voltage Setting Accuracy: ±0.5% of rated output voltage.

Current Setting Accuracy: ±1% of rated output current.

Analog Resistance Control:

Voltage Setting Accuracy: ±1.5% of rated output voltage.

Current Setting Accuracy: ±1.5% of rated output current.

GENERAL

Analog Control: External voltage or resistance control of output, voltage and current monitor outputs, turn-on, turn-off control, status monitoring, 26-Pin Connector (Rear Panel).

Interface:

USB: 1.1/2.0, Type A Host (Front Panel), Type B Control (Rear Panel).

LAN: 100BASE-T (100Mb/s).

GPIO: (with optional 2260B-GPIB-USB Adapter).

AC Input Range: 85VAC-265VAC, 50/60Hz, single phase

Maximum Power Consumption:

500VA (2260B-30-36, 2260B-80-13)

1000VA (2260B-30-72, 2260B-80-27).

Power Factor: 0.98 (typical).

Fan: With thermal sensing control

Environment:

Operating: 0° to 50°C, 20% to 85% RH.

Storage: -25° to 70°C, 90% RH or less.

Temperature Coefficient (after 30 minutes warm-up):

Voltage: 100ppm/°C.

Current: 200ppm/°C.

Safety: Complies with European Union Low Voltage Directive.

Electromagnetic Compatibility: Complies with European Union EMC Directive.

Dimensions, Weight:

2260B-30-36 and 2260B-80-13: 71mm wide × 124mm high × 350mm deep (2.80 in. × 4.88 in. × 13.78 in.).

Net Weight: Approx. 3kg (6.6 lb.) **Shipping Weight:** 4.3kg (9.5 lb.).

2260B-30-72 and 2260B-80-27: 142.5mm wide × 124mm high × 350mm deep (5.61 in. × 4.88 in. × 13.78 in.).

Net Weight: Approx. 5kg (11 lb.) **Shipping Weight:** 6.8kg (15 lb.).

Warranty: 3 years.

1.888.KEITHLEY (U.S. only)

www.keithley.com

KEITHLEY

A Tektronix Company

A Greater Measure of Confidence

Series 2280S

Precision Measurement, Low Noise, Programmable DC Power Supplies



- Monitor load currents from 100nA to 6A with high accuracy
- Measure voltage and current with 6½-digit resolution
- Capture dynamic load currents as short as 140µs
- Output up to 192W of low noise, linear regulated power
- Programmable rise and fall times eliminate voltage overshoot and undershoot transients
- Built-in graphing simplifies analyzing trends or displaying voltage or current waveforms
- High resolution TFT display and soft-key/icon-based user interface simplify power supply operation
- Programmable output sequences reduce test times
- Sink up to 0.45A to discharge voltage quickly
- Digital I/O for direct communication with other devices and instruments
- GPIB, USB, and LAN interfaces
- Built-in web page simplifies automated control/monitoring
- Automate tests easily with KickStart start-up software

The Series 2280S Precision Measurement, Low Noise, Programmable DC Power Supplies are much more than just sources of clean power; they are also precision measurement instruments. They can source stable, low noise voltages as well as monitor load currents over a wide dynamic range from amps to nanoamps. The Model 2280S-32-6 can output up to 32V at up to 6A; the Model 2280S-60-3 can output up to 60V at up to 3.2A.

Both supplies use linear regulation to ensure low output noise and superior load current measurement sensitivity. A high resolution color Thin Film Transistor (TFT) screen displays a wide range of information on measurements. Soft-key buttons and a navigation wheel combine with the TFT display to provide an easy-to-navigate user interface that speeds instrument setup and operation. In addition, built-in plotting functions allow monitoring trends such as drift. These supplies provide the flexibility required for both benchtop and automated test system applications. For example, they provide a list mode, triggers, and other speed optimization functions to minimize test time in automated testing applications.

DMM-Quality Low Current Measurements with High Resolution

Unlike conventional power supplies, Series 2280S supplies can also make measurements with up to 6½ digits of resolution. Voltage output measurements can be resolved down to 100µV. These supplies measure load currents from 100nA to amps and can resolve down to 10nA. Four load current measurement ranges (10A, 1A, 100mA, and 10mA) support measuring a device's full load current, standby mode current, and small sleep mode currents with DMM-quality accuracy. The high resolution allows characterizing small changes in load currents with confidence. It also makes it possible to make a broad range of measurements on a single range with excellent accuracy across both low and high current values.

Measure Rapidly Changing Loads

To monitor fast-changing and pulse-like load currents properly, Series 2280S supplies offer the speed necessary to capture load changes that occur at intervals as short as 140µs. This capability allows designers and manufacturers of portable, battery-operated devices to monitor load currents easily in all of a device's operating modes so they can determine the device's total power consumption.

This high speed measurement capability allows measuring each state of a power-up load sequence and a power-down sequence. Measurements can be made as fast as 2500 readings per second, making it possible to characterize and test the current draw at each of the start-up states.

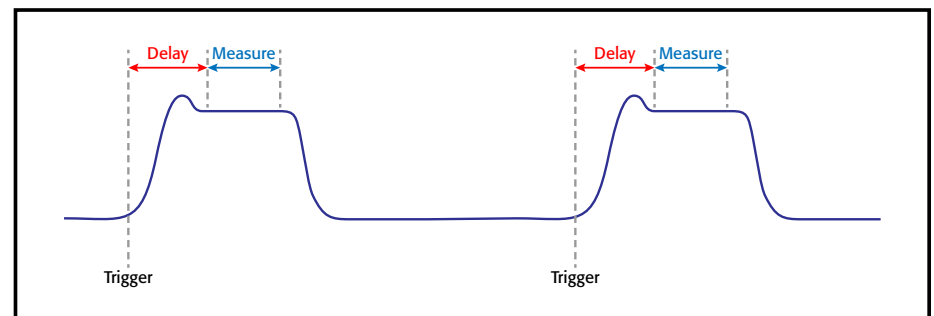

Figure 1. Make time-critical measurements on fast-changing or pulse-like loads. An external trigger initiates the acquisition. Programmable delay and measure times enable measurements at a specific time on the load current pulse.

1.888.KEITHLEY (U.S. only)

www.keithley.com

A Greater Measure of Confidence

KEITHLEY

A Tektronix Company

Series 2280S

Ordering Information

2280S-32-6 Precision Measurement DC Power Supply, 32V, 6A

2280S-60-3 Precision Measurement DC Power Supply, 60V, 3.2A

Accessories Supplied

Quick Start Guide

KickStart Quick Start Guide

User Documentation CD

LAN Crossover Cable

Power Cord

Rear Panel Mating Connector with Cover

ACCESSORIES AVAILABLE

2280-001	Rear Panel Mating Connector and Cover
CA-180-3A	LAN Crossover Cable
USB-B-1	USB Cable Type A to B, 1m (3.3 ft)
2450-TLINK	Trigger Link cable to connect 2280S digital I/O to Trigger Link I/O on other Keithley instruments
4299-8	Single Fixed Rack-Mount Kit
4299-9	Dual Fixed Rack-Mount Kit
4299-10	Dual Fixed Rack-Mount Kit for one 2U Graphical Display Instrument and one Series 26xx Instrument
4299-11	Dual Fixed Rack-Mount Kit for one 2U Graphical Display Instrument and one Series 24xx, Series 2000, or 2U Agilent Instrument
KPCI-488LPA	IEEE-488.2 Interface Board for the PCI Bus
KUSB-488B	IEEE-488.2 USB-GPIB Interface Adapter for USB Port with 2m (6.6 ft) cable
7007-05	Double Shielded Premium IEEE-488 Interface Cables, 0.5m (1.6 ft)
7007-1	Double Shielded Premium IEEE-488 Interface Cables, 1m (3.2 ft)
7007-2	Double Shielded Premium IEEE-488 Interface Cables, 2m (6.5 ft)
7007-3	Double Shielded Premium IEEE-488 Interface Cables, 3m (10 ft)
7007-4	Double Shielded Premium IEEE-488 Interface Cables, 4m (13 ft)

Precision Measurement, Low Noise, Programmable DC Power Supplies

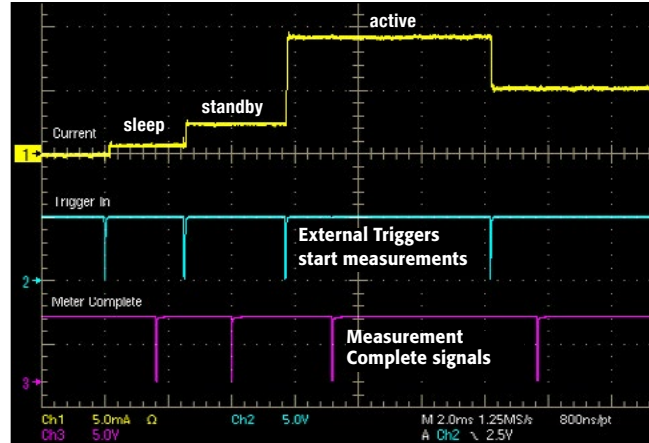

Figure 2. Measure the start-up load currents as a device powers up.

View and Control Every Parameter of the Supply for Maximum Performance

The bright, 4.3-inch TFT display shows voltage and current readings, the source settings and many additional settings in large, easy-to-read characters. The icon-based main menu provides all the functions users can control and program for fast access to source setup, measurement setup, display formats, trigger options, and system settings. Menus are short, and the menu options you need are easy to find and clearly described, so that you can set up test parameters quickly by using the navigation wheel, keypad, or soft-keys. Many set-up parameters, such as for voltage and current settings, can be entered directly from the home screen; less complex tests don't even require accessing the main menu to make adjustments. Whether your test's requirements are uncomplicated or complex, the Series 2280S supplies provide a simple way to set up all the required parameters.



Figure 3. Adjust voltage, current, the current range, the measurement mode, protection levels, and other functions from the home screen.

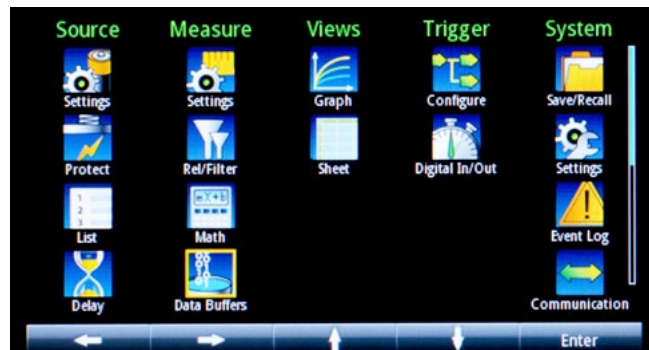

Figure 4. Access the full functionality of the Series 2280S supplies from the main menu.

1.888.KEITHLEY (U.S. only)

www.keithley.com

Series 2280S

Precision Measurement, Low Noise, Programmable DC Power Supplies

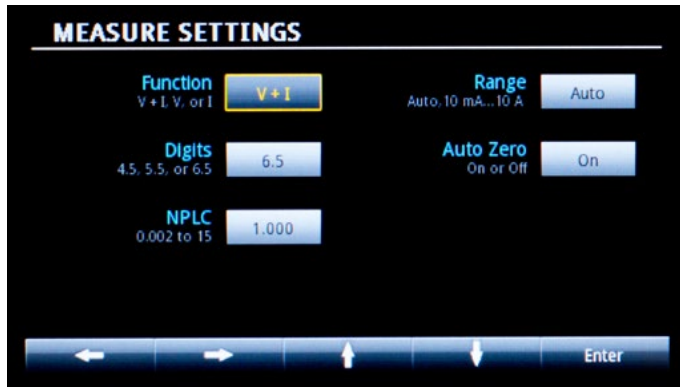

Figure 5. Configure the readback measurements exactly the way you need them using a Measure Sub-screen.

Controlled Rise and Fall Times Protect Devices Under Test

Are you working on a device or a system with a high in-rush current? Series 2280S supplies allow programming the voltage output's rise time to slow the voltage ramp and avoid voltage overshoot, which could potentially damage the DUT. The voltage fall time can also be controlled to prevent a fast ramp down of the output voltage. Voltage rise and fall times can be set as slow as 10V/s or as fast as 100V/s. Small voltage transitions can be programmed to rise and fall as fast as 1000V/s.

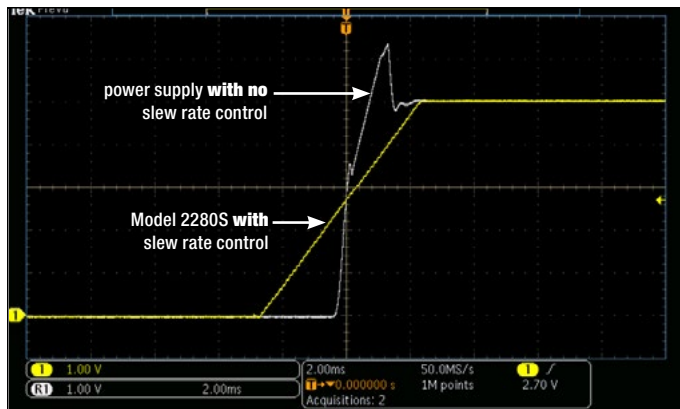

Figure 6. Programmable slew rates permit controlling voltage rise and fall rates, preventing undesirable transients during power up of capacitive loads.

Perform Semi-Automated Testing Right on Your Bench

Test your design over its operating voltage range automatically or study how it responds to DC output changes by using the Series 2280S supplies' built-in List Mode function. Create and save up to 10 lists of sequenced voltage levels with up to 99 distinct voltages in each list. The duration of each voltage level can be set as short as 1ms or as long as 60s. Create simple linear ramps or any custom configuration from either the front panel or an interface bus. A single trigger will automatically execute the list once or multiple times.

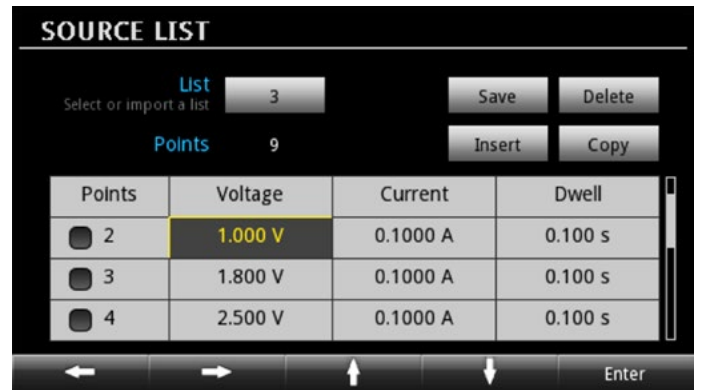

Figure 7A. Create an output sequence using the List setup screen.

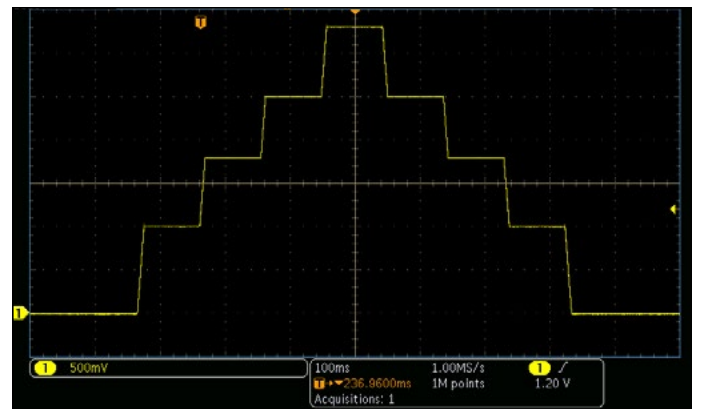

Figure 7B. Use the list mode to step the output voltage automatically through a series of levels. The voltages were created by the list shown in Fig. 7A.

1.888.KEITHLEY (U.S. only)

www.keithley.com

A Greater Measure of Confidence

KEITHLEY
A Tektronix Company

Precision measurement, low noise, programmable DC power supplies

DC POWER SUPPLIES

Series 2280S

Precision Measurement, Low Noise, Programmable DC Power Supplies

Trend Analysis and Load Current Characterization

Use the built-in graphing function to monitor the stability of the load current or capture and display a dynamic load current. Or, use it to view a start-up or turn-off load current. Series 2280S supplies can take measurements quickly and store up to 2,500 measurement points. In addition to displaying a voltage or current waveform or both, they can compute statistics on the stored data. Statistical calculation options include average, maximum, minimum, peak-peak, and standard deviation. All the information you need is accessible through a few display menus.

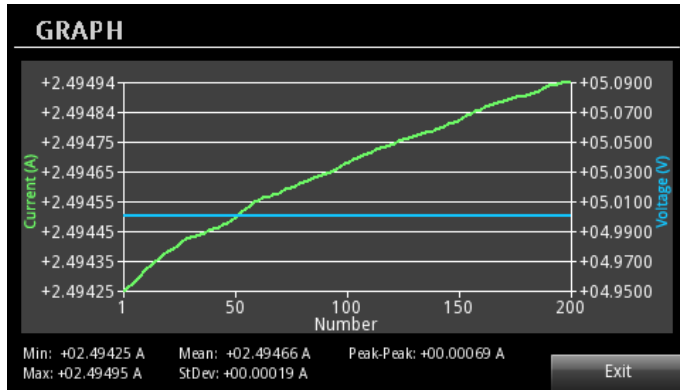

Figure 8. Monitor voltage, current, or both with the graphing function.

Automate a test quickly and easily with KickStart software

Set up an automated test for the Series 2280S supplies in four simple steps with the KickStart start-up software. KickStart is available for installation on your PC via a free download from www.keithley.com. Once the program is open, perform these steps: create a test file, select the 2280S power supply, select the power supply application, and enter the test parameters. Run the test, and get results without having to write a line of code. KickStart provides both graph and spreadsheet displays. Data is saved to the test file, and the data can be exported to data analysis programs. Or take a screenshot of the plot for reproduction in test reports. Up to 15,000 data points can be stored. KickStart may be all the software you ever need.

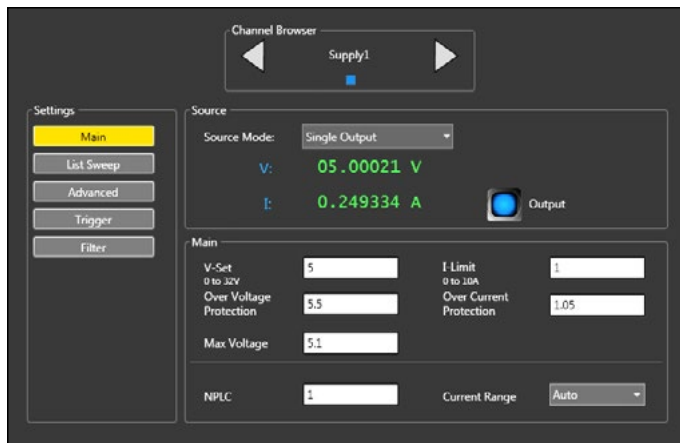

Figure 9. KickStart DC power main screen.



Figure 10. KickStart plot with measurement table.

Optimized Performance for Production Test

Series 2280S supplies are as powerful in a production test system as they are flexible on the R&D benchtop. In addition to their List Mode function, several other Series 2280S features help minimize test time in automated systems. For example, an external trigger input allows hardware synchronization and control by other instruments in the test system. To eliminate many system delays, Series 2280S supplies produce a “measurement complete output” to signal the test system when the supplies have completed their required actions. To reduce measurement time, the reading speed can be increased by reducing the acquisition time from power line cycle integration times, 16ms at 60 Hz (20 ms at 50 Hz), to 33 μ s (40 μ s). Furthermore, the Series 2280S supplies can sink up to 0.45A. Thus, these supplies can quickly discharge a voltage level and change to a different voltage.



Figure 11. Series 2280S rear panel showing the rear output connector with remote sense inputs, digital I/O, and the three interfaces (GPIB, USB, and LAN).

A choice of front or rear panel terminals provides enhanced connection flexibility. For maximum voltage accuracy, 4-wire remote sensing ensures that the output voltage programmed is actually the level applied to the load. In addition, the sense lines are monitored in order to detect any breaks in them. These features ensure any production problems can be quickly identified and corrected. Four additional digital I/O pins can pro-

1.888.KEITHLEY (U.S. only)

www.keithley.com

KEITHLEY

A Tektronix Company

A Greater Measure of Confidence

Series 2280S

Precision Measurement, Low Noise, Programmable DC Power Supplies

vide fault status outputs or control an external relay or status lamp. Series 2280S supplies can be controlled via their built-in GPIB, USB, or LAN interfaces. The USB interface is test and measurement system (TMC) compliant. The LXI Core compliant LAN interface supports controlling and monitoring a Series 2280S supply remotely, so test engineers can always access the power supply and view measurements, even if they're located on a different continent than their test systems.

To facilitate production test software development, native National Instruments LabVIEW™ drivers, IVI-C and IVI-COM drivers are available on the Keithley website, www.keithley.com.

Specifications

23°C ±5°C with 1-hour instrument warm-up.

DC OUTPUT RATINGS

	2280S-32-6	2280S-60-3
Voltage	0 to 32 V	0 to 60 V
Current	0 to 6 A	0 to 3.2 A
Maximum Power	192 W	192 W

VOLTAGE¹

SOURCE SETTING

	2280S-32-6	2280S-60-3
Accuracy	±(0.02% + 3 mV)	±(0.02% + 6 mV)
Resolution	1 mV	1 mV

MEASUREMENT² (0.5V over-range)

	2280S-32-6	2280S-60-3
Accuracy	±(0.02% + 2 mV)	±(0.02% + 4 mV)
Resolution	0.1 mV	0.1 mV

ADDITIONAL OFFSET AT FASTER MEASUREMENT SETTINGS

	2280S-32-6	2280S-60-3
5½ (0.1 PLC)	0.21 mV	0.40 mV
4½ (0.01 PLC)	1.44 mV	2.7 mV
3½ (0.002 PLC)	7.60 mV	14.25 mV

REGULATION

	2280S-32-6	2280S-60-3
Load	±(0.01% + 2 mV)	±(0.01% + 2 mV)
Line	±(0.01% + 1 mV)	±(0.01% + 1 mV)

OUTPUT RIPPLE AND NOISE

	2280S-32-6	2280S-60-3
Bandwidth 20Hz–20MHz	< 1mV _{RMS} < 5mV p-p	< 2mV _{RMS} < 7mV p-p

LOAD TRANSIENT RECOVERY TIME: Resistive load change 50% load to 100% load or 100% load to 50% load: <50µs to within 15mV of V-set.

SLEW RATE: Rising voltage and falling voltage: 10V/s to 100V/s. Up to 1000V/s under limited conditions³. 100V/s (default).

MAXIMUM SOURCE VOLTAGE DROP PER LEAD: To maintain specified voltage accuracy: 1V.

MAXIMUM SENSE HI AND SENSE LO LEAD RESISTANCE: To maintain specified voltage accuracy: 2Ω.

CURRENT

CURRENT LIMIT SETTING

	2280S-32-6	2280S-60-3
Full-scale Amps	6 A	3.2 A
Accuracy	±(0.05% + 5 mA)	±(0.05% + 5 mA)
Resolution	0.1 mA	0.1 mA

MEASUREMENT⁴ (120% over-range except 10A)

Range	Resolution	2280S-32-6	2280S-60-3
10 mA	10 nA	±(0.05% + 10 µA)	±(0.05% + 10 µA)
100 mA	100 nA	±(0.05% + 10 µA)	±(0.05% + 10 µA)
1 A	1 µA	±(0.05% + 250 µA)	±(0.05% + 250 µA)
10 A	10 µA	±(0.05% + 250 µA)	±(0.05% + 250 µA)

1.888.KEITHLEY (U.S. only)

www.keithley.com

A Greater Measure of Confidence

KEITHLEY

A Tektronix Company

Series 2280S

Precision Measurement, Low Noise, Programmable DC Power Supplies

SERVICES AVAILABLE

2280S-32-6-EW	1 Additional Year of Factory Warranty (total of 4 years)
2280S-32-6-5Y-EW	2 additional years of factory warranty beyond the 3-Year factory warranty (total of 5 years)
C/2280S-32-6-3Y-STD	3 Calibrations Within 3 Years of Purchase
C/2280S-32-6-3Y-DATA	3 (ANSI-Z540-1 compliant) Calibrations Within 3 Years of Purchase
C/2280S-32-6-3Y-1702	3 (ISO 17025 Accredited) Calibrations within 3 Years of Purchase
C/2280S-32-6-5Y-STD	5 Calibrations Within 5 Years of Purchase
C/2280S-32-6-5Y-DATA	5 (ANSI-Z540-1 compliant) Calibrations Within 5 Years of Purchase
C/2280S-32-6-5Y-1702	5 (ISO 17025 Accredited) Calibrations within 5 Years of Purchase
2280S-60-3-EW	1 Additional Year of Factory Warranty (total of 4 years)
2280S-60-3-5Y-EW	2 additional years of factory warranty beyond the 3-Year factory warranty (total of 5 years)
C/2280S-60-3-3Y-STD	3 Calibrations Within 3 Years of Purchase
C/2280S-60-3-3Y-DATA	3 (ANSI-Z540-1 compliant) Calibrations Within 3 Years of Purchase
C/2280S-60-3-3Y-1702	3 (ISO 17025 Accredited) Calibrations within 3 Years of Purchase
C/2280S-60-3-5Y-STD	5 Calibrations Within 5 Years of Purchase
C/2280S-60-3-5Y-DATA	5 (ANSI-Z540-1 compliant) Calibrations Within 5 Years of Purchase
C/2280S-60-3-5Y-1702	5 (ISO 17025 Accredited) Calibrations within 5 Years of Purchase

ADDITIONAL OFFSET AT FASTER MEASUREMENT SETTINGS⁹

Measure Resolution and (NPLC)	Range	2280S-32-6	2280S-60-3
5½ (0.1 PLC)	10 mA	5.0 µA	5.0 µA
	100 mA	20 µA	20 µA
	1 A	80 µA	80 µA
	10 A	2.0 mA	2.0 mA
4½ (0.01 PLC)	10 mA	20 µA	20 µA
	100 mA	40 µA	40 µA
	1 A	500 µA	500 µA
	10 A	10 mA	10 mA
3½ (0.002 PLC)	10 mA	30 µA	30 µA
	100 mA	250 µA	250 µA
	1 A	25 mA	25 mA
	10 A	75 mA	75 mA

CURRENT PULSE MEASUREMENT⁵

	2280S-32-6	2280S-60-3
Minimum Pulse Width (10mA and 100mA range) ⁶	2.1 ms	2.1 ms
Minimum Pulse Width (1A and 10A range) ⁶	140 µs	140 µs
Minimum time to capture two consecutive pulses	0.5 ms	0.5 ms

REGULATION

	2280S-32-6	2280S-60-3
Load	±(0.01% + 0.25 mA)	±(0.01% + 0.25 mA)
Line	±(0.01% ± 0.25 mA)	±(0.01% ± 0.25 mA)

OUTPUT RIPPLE AND NOISE

	2280S-32-6	2280S-60-3
Bandwidth 20Hz–20MHz	< 3mA RMS	< 3mA RMS

MAXIMUM CONTINUOUS AVERAGE SINK CURRENT

	2280S-32-6	2280S-60-3
Non-programmable	0.45 A ±15%	0.45 A ±15%

SYSTEM MEASUREMENT SPEEDS

Readings/s	Settings Measure Resolution and (NPLC)	Concurrent (V+I)		Current or Voltage (I or V)	
		Autozero On	Autozero OFF	Autozero On	Autozero OFF
		60 Hz (50 Hz)	60 Hz (50 Hz)	60 Hz (50 Hz)	60 Hz (50 Hz)
'Read?' with BUS Transfer	6½ (5 PLC)	2.0 (1.5)	5.4 (4.5)	2.5 (2.3)	9.0 (8.5)
	6½ (1 PLC)	9.0 (8.0)	20 (18)	11.5 (9.5)	30.0 (28)
	5½ (0.1 PLC)	48 (38)	50 (48)	50.0 (48.0)	95.0 (85.0)
*TRG' into Memory	4½ (0.01 PLC) ⁷	440 (430)		1915 (1820)	
	3½ (0.002 PLC) ⁷	510 (510)		2668 (2650)	

1.888.KEITHLEY (U.S. only)

www.keithley.com

KEITHLEY

A Tektronix Company

A Greater Measure of Confidence

Series 2280S

Precision Measurement, Low Noise, Programmable DC Power Supplies

PROTECTION

	2280S-32-6	2280S-60-3
Overvoltage Protection (OVP)		
Setting Accuracy	$\pm(0.25\% + 0.25\text{ V})$	$\pm(0.25\% + 0.5\text{ V})$
Resolution	125 mV	250 mV
Response Time	6 ms (typical) ⁸	6 ms (typical) ⁸
Overcurrent Protection (OCP)		
Setting Accuracy	$\pm(0.25\% + 0.10\text{ A})$	$\pm(0.25\% + 0.10\text{ A})$
Resolution	25 mA	12.5 mA
Response Time	6 ms (typical) ⁸	6 ms (typical) ⁸
Overtemperature Protection (OTP)		
Output turn-off Temperature	>93°C (typical)	>93°C (typical)
Response Time	6 ms (typical) ⁸	6 ms (typical) ⁸

OTHER TIMING DATA

CV TO CC TRANSITION TIME (V-Set = 5V, I-limit = 0.5A, Resistive Load change 25Ω to 2.5Ω): 2.4ms.

CC TO CV TRANSITION TIME (V-Set = 5V, I-limit = 0.5A, Resistive Load change 2.5Ω to 25Ω): 1.1ms.

FUNCTION CHANGE (from detection of bus command to function change completed): 10ms (typical).

OUTPUT OFF/ON (from detection of bus command to voltage beginning to decrease): 5ms (typical).

REVERSE LEADS ACTUATION: 6ms (typical)⁸.

NOTES

- Specifications based on using remote sense connections. For 2-wire connections, add an offset of 0.5mV/A (Front terminals).
- 6½ digit resolution, 1 PLC reading rate, filter on, autozero on.
- 100V/s to 1000V/s rise and fall slew rates:
2280S-32-6: limited to 5V changes at a maximum of 3A; between 0V to 5V, the load current can be up to full load, 6A
2280S-60-3: limited to 10V changes at a maximum of 2A; between 0V and 10V, the load current can be up to full load, 3.2A.
- 6½ digit resolution, 1PLC integration time, Autozero: on, Filter: on
10mA and 100mA ranges: Source Delay: 2ms
1A and 10A ranges: Source Delay: 1ms.
- Settings: Autozero: off, 0.002 PLC, Arm Source: External, Trigger Source: Immediate, Filter: off
10mA and 100mA ranges: Source Delay: 2ms
1A and 10A ranges: Source Delay: 0ms or off
- Time includes trigger detection, jitter, and 0.002PLC integration time.
- Settings: Autozero: off, Output Delay: off, Source Delay: off, voltage output is constant, Measure Count: 1000.
- Time defined as from detection of condition to start of output turn-off.
- Filter on, 10mA and 100mA ranges: Source Delay: 2ms
1A and 10A ranges: Source Delay: 1ms

GENERAL

COMMON MODE CURRENT: < 6μA peak-peak.

CHASSIS ISOLATION: ±240V, any terminal to chassis. >1GΩ in parallel with <6.8nF.

TEMPERATURE COEFFICIENT: Add the following to all accuracy specifications when outside the range, 23°C ±5°C: (0.15 × specification)/°C for 0° to 18°C and 28° to 40°C.

MEASUREMENT DISPLAY MODES: Voltage and current, voltage only, current only.

MEASUREMENT ACQUISITION CONTROL: Continuous, Manual, External digital input, PC bus.

LIST MODE: Maximum number of stored lists: 9.

Number of points in a list: 2 – 99.

List Storage Location: Internal memory or USB memory stick.

MATH AND FILTER FUNCTIONS:

REL: Removes offset from current reading display, Range: -1×10^6 to $+1 \times 10^6$.

$Mx+b$: Reading = x, M = -1×10^6 to $+1 \times 10^6$, b = -1×10^6 to $+1 \times 10^6$.

Filter: Moving average, Count: 2–100, Window: 0.01% to 100%.

MEMORY BUFFER:

2500 locations; each location contains: Voltage measurement, current measurement, CV/CC Mode, and time stamp, NVRAM.

DISPLAY: 4.3 in. front panel color display, resolution: 480 pixels × 272 pixels.

Display Modes:

Real time voltage and current readings and settings.

Plots of stored data: voltage vs data point, current vs data point, voltage and current vs. data point, 100 point resolution.

Plots can also display statistics: mean, maximum, minimum, peak-peak, standard deviation.

Table of stored data: time/date, voltage, current.

Soft button and navigation wheel control.

COMMUNICATIONS:

GPIO: IEEE-488.2 compliant and status model topology.

LAN: RJ-45 connector, 10/100BT, Auto MDIX.

IP Configuration: Static or DHCP.

LXI Core 2011, version 1.4.

USB: USB2.0 device (rear panel, type B), USBTMC compliant.

USB2.0 host (front panel, type A), full speed, support USB Flash Drives.

INPUT CONNECTIONS:

Front: (2-wire). Adjustable supporting, safety shrouded banana, spade lug, or wire.

Rear: (4-wire sense). 6-pin removal screw terminal, safety shrouded cover, removable local sense jumpers.

REAL-TIME CLOCK: Capacitive charged, 20 days between next power on cycle at 23°C and ≤50%RH.

DIGITAL I/O: 9-pin female D-sub. 6 Input/Output pins.

Input Signal Levels:

0.7V (maximum logic low).

3.7V (minimum logic high).

Input Voltage Limits:

–0.25V (Absolute minimum).

+5.25V (Absolute maximum).

Maximum Source Current: +2.0mA@ >2.7V (per pin).

Maximum Sink Current: –50mA @ 0.7V (per pin, solid-state fuse protected).

5V power supply, limited to 0.5A @>4V (solid-state fuse protected).

Trig In minimum pulse ≥4μs, Logic Low pulse.

Meter Ready Pulse, 15–30μs, Logic Low Pulse.

EMC: Conforms to European Union EMC directive.

SAFETY:

U.S. NRTL Listing: UL61010-1 3rd ed 2012 and UL61010-2-030:2012.

Canadian Certification: CAN/CSA C22.2 No. 61010-1 3rd ed 2012.

European Union Compliance: Low Voltage Directive .

COOLING: Forced air, side intake and rear exhaust.

POWER SUPPLY: 100V/120V/220V/240V ±10%.

POWER LINE FREQUENCY: 50/60Hz ±3Hz, automatically sensed at power-on.

POWER CONSUMPTION: 630VA peak.

OPERATING ENVIRONMENT: 0° to 40°C, ≤80% RH up to 35°C, non-condensing.

Altitude: up to 2000 meters.

STORAGE ENVIRONMENT: –25° to 70°C.

LXI WEB BROWSER COMPATIBLE OPERATING SYSTEM AND SOFTWARE: Windows 2000, Win 7 and XP compatible, supports Web browsers with Java plug-in (requires Java plug-in 1.7 or higher). Web page served by Model 2280S.

RACK DIMENSIONS: (W×H×D), without boot: 213.8 × 88.4 × 383.3mm (8.42 × 3.48 × 15.1 in.).

BENCH DIMENSIONS: (W×H×D) with boot: 255.3 × 107.2 × 415.0mm (10.1 × 4.22 × 16.34 in.)

SHIPPING WEIGHT: 13.29kg (29.3 lbs.).

NET WEIGHT: 10.85kg (23.9 lbs.).

WARRANTY: 3 years.

Note: Specifications are subject to change without notice.

1.888.KEITHLEY (U.S. only)

www.keithley.com

A Greater Measure of Confidence

KEITHLEY

A Tektronix Company

3-Year
Warranty

2220, 2220G, 2230, 2230G

Multi-Channel USB and USB/GPIB Programmable DC Power Supplies



Multi-channel programmable DC power supplies

- Dual and triple output models with two 30V/1.5A (45W) channels and a 6V/5A (30W) channel on the triple output supply
- All channels are independently controlled and have isolated outputs for maximum flexibility
- All channels have remote sensing to ensure that programmed voltage is accurately applied to the load
- Two 30V channels can be combined either in series to double output voltage or in parallel to double output current
- 0.03% basic voltage output accuracy and 0.1% current accuracy ensure quality test data
- Low noise, linear regulation with <math><3\text{mVpp}</math> ripple and noise
- Voltage and current outputs for all channels are displayed simultaneously for easy observation of each output state
- Keypad entry allows fast, precise entry of output values
- USB interface standard on all versions for remote control; "G" versions include USB and GPIB interfaces

The Models 2220, 2220G, 2230, and 2230G Multi-Channel Programmable DC Power Supplies combine two and three channels of output power to cost-effectively characterize and test a wide range of devices, circuit boards, modules, and products that require more than one power source. The Models 2220-30-1 and 2220G-30-1 supplies provide two channels, with each channel capable of outputting up to 30V and up to 1.5A. The Models 2230-30-1 and 2230G-30-1 include two 30V/1.5A channels and add a 6V channel with up to 5A output for powering digital circuits. These multi-channel power supplies offer an excellent combination of performance, versatility, and ease of use to maximize the information from characterization or test as quickly and as easily as possible. They perform as effectively in automated test systems as they do in manual instrument configurations. The USB interface is standard on all models; the "G" versions add a GPIB interface.

Independent and Isolated Outputs

Since each channel in these multi-channel power supplies is completely independent and isolated from each other, these power supplies can be used to provide power to two circuits that are optically isolated or transformer-isolated from each other and have different reference points. Their isolated channels eliminate the need for a second power supply to power one of the isolated circuits.

Additionally, each channel can be independently controlled, so channels can be individually turned on and turned off at any time. Thus, these power supplies can be used to power up a circuit with multiple voltage levels (such as a digital circuit) that must be turned on in a specified time sequence. Furthermore, the timer capability allows you to set up unattended tests that turn off the channels after a programmed time interval to protect a device-under-test (DUT) from potential damage due to the continuous application of power beyond a recommended time interval. Both isolated and independent channels provide excellent versatility and flexibility to address a wide range of test applications.

Accurate Power Delivery to the Load

With basic voltage setting accuracy and voltage readback accuracy of 0.03% for each channel, the exact voltage programmed for any channel is applied at the output terminals. Plus, the rear panel connections for each channel include remote sense terminals that compensate for voltage drops in the power supply leads. This helps to ensure that the correct voltage is delivered accurately to the load terminals of the DUT. Many other multi-channel power supplies do not provide remote sensing, which reduces overall system accuracy.

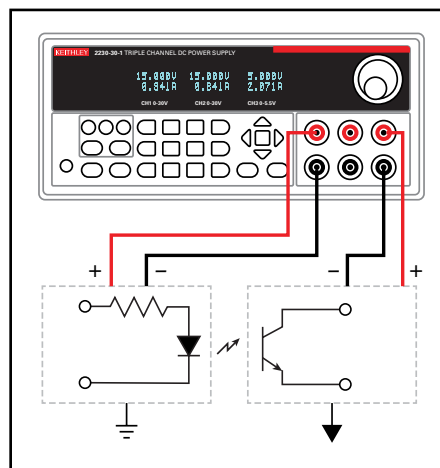

Power two isolated circuits with isolated output channels.

1.888.KEITHLEY (U.S. only)

www.keithley.com

KEITHLEY

A Tektronix Company

A Greater Measure of Confidence

2220, 2220G, 2230, 2230G

Ordering Information

- 2220-30-1**
Programmable Dual Channel DC Power Supply
- 2220G-30-1**
Programmable Dual Channel DC Power Supply with GPIB Interface
- 2220J-30-1**
Programmable Dual Channel DC Power Supply for Japan
- 2220GJ-30-1**
Programmable Dual Channel DC Power Supply with GPIB Interface for Japan
- 2230-30-1**
Programmable Triple Channel DC Power Supply
- 2230G-30-1**
Programmable Triple Channel DC Power Supply with GPIB Interface
- 2230J-30-1**
Programmable Triple Channel DC Power Supply for Japan
- 2230GJ-30-1**
Programmable Triple Channel DC Power Supply with GPIB Interface for Japan

Accessories Supplied

CS-1655-15 Rear Panel Mating Connector for Models 2220 and 2230 Multi-Channel DC Power Supplies Documentation and Driver CD

ACCESSORIES AVAILABLE

386-7598-xx	RMU2U Rack Mount Cosmetic Filler Panel
CS-1655-15	Rear Panel Mating Connector for Series 2200 Power Supplies
KPCI-488LPA	IEEE-488.2 Interface Board for the PCI Bus
RMU2U	Fixed Rack Mount Kit
USB-B-1	USB Cable, 1m (3.3 ft)
2230G-30-1 JUMPER	Shorting Jumper for CS-1655-15 Connector
2230J-30-1 JUMPER	Shorting Jumper for CS-1655-15 Connector
4299-7	Universal Fixed Rack Mount Kit
7007-05	Double Shielded Premium IEEE-488 Interface Cables, 0.5m (1.6 ft)
7007-1	Double Shielded Premium IEEE-488 Interface Cables, 1m (3.2 ft)
7007-2	Double Shielded Premium IEEE-488 Interface Cables, 2m (6.5 ft)
7007-3	Double Shielded Premium IEEE-488 Interface Cables, 3m (10 ft)
7007-4	Double Shielded Premium IEEE-488 Interface Cables, 4m (13 ft)

1.888.KEITHLEY (U.S. only)

www.keithley.com

Multi-Channel USB and USB/GPIB Programmable DC Power Supplies

Great accuracy is not limited to voltage; the basic current setting and readback accuracy is 0.1%, providing high quality load current measurements. Also, with less than 3mV p-p noise, the power applied to the DUT's load terminals is both accurate and of high quality.

Excellent accuracy, remote sensing, and a wide power output range make the Series 2200 Multi-Channel DC Power Supplies essential test instruments both on the bench and in test systems. Their ability to generate a wide range of output power and measure a wide range of load currents is supported with:

- Maximum output power of 45W on the 30V channels
- Maximum output power of 30W on the 6V channel
- Voltage setting and reading resolution of 1mV
- Current setting and reading resolution of 1mA

Configure the Channels to Double Output Voltage or Current or Create Bipolar Power Supplies

The two 30V channels can be combined if more than 30V or more than 1.5A is required. The two 30V outputs can be wired in series to enable an output of 60V with a maximum current output of 1.5A or can be wired in parallel to get up to 3A at 30V. In series or parallel configurations, the power supplies offer special display modes that indicate the actual voltage and current for the combined pair. It's also easy to wire the outputs to make a $\pm 30V$ bipolar supply and to maintain a user-defined ratio between the two outputs when using Tracking mode. These modes of operation extend the performance of the power supplies, while the display shows the actual outputs in these special modes to avoid any confusion or incorrect interpretation of the displayed data.

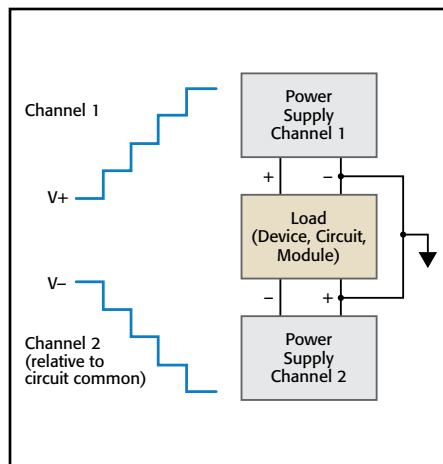

Use the two 30V channels to test a bipolar integrated circuit or a bipolar module over its specified voltage operating range.

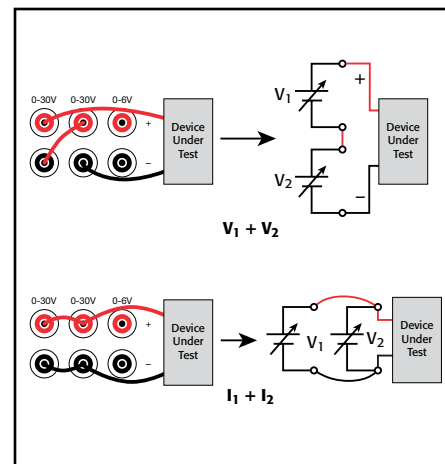

Combine two channels in series to output up to 60V or combine two channels in parallel to output up to 3A. The Model 2220/2230 display will show the combined value.

Convenience Features Help Get Results More Quickly

These multi-channel power supplies offer a number of features that return results quickly and easily:

- A rotary knob, with user-selectable step size, makes it easy to check circuit response to changing voltage or current. Alternatively, a direct-entry numeric keypad can be used to simplify setting precise voltage and current values.
- Each channel has its own readout on the display. The voltage and current being delivered to each channel are visible at a glance. A bright vacuum fluorescent display provides excellent readability at a distance, at an angle, or under dim lighting conditions.

2220, 2220G, 2230, 2230G

Multi-Channel USB and USB/GPIB Programmable DC Power Supplies

- To save time when repeating tests, instrument settings can be saved in one of 30 internal memory locations by simply pressing the Save button. To recall that setting, just push the Recall button, and choose the desired setup.

Protection for Your Device-Under-Test

These multi-channel power supplies include maximum voltage settings that prevent voltage from being accidentally adjusted above user-specified limits. Independent outputs allow a different limit to be specified for each output channel. With the numeric keypad, a current limit can be quickly and precisely specified before a test is started. In addition, a user-definable password allows the front panel to be locked to prevent unwanted adjustment during critical tests.

Easy Test Automation

Two interface choices are available to enable PC control from a user-preferred programming environment. A USB TMC-compliant device port is included on all versions of these power supplies. The "G" versions add the GPIB interface for the flexibility of either USB or GPIB control. LabView and IVI drivers are provided to facilitate instrument control, data logging, and analysis. With these drivers, the power supplies can be controlled from most commercially-available software packages such as MatLab. Thus, these power supplies can be controlled as a single unit or as part of an automated test system.

APPLICATIONS

Typical applications include:

- Circuit design
- Electrical engineering student labs
- Materials research
- Automated test

SERVICES AVAILABLE

Model Number*-EW	1 additional year of factory warranty
Model Number-5Y-EW	2 additional years of factory warranty beyond the standard 3-year warranty
C/Model Number-3Y-STD	3 calibrations within 3 years of purchase
C/Model Number-3Y-DATA	3 (ANSI-Z540-1 compliant) calibrations within 3 years of purchase
C/Model Number-5Y-STD	5 calibrations within 5 years of purchase
C/Model Number-5Y-DATA	5 (ANSI-Z540-1 compliant) calibrations within 5 years of purchase

* Replace "Model Number" with a power supply model number. For example: if the 2230GJ-30-1 is selected, then the part number for the -EW, one year of additional warranty option, is 2230GJ-30-1-EW.

NOTE: the "J" versions truncate the "A" in DATA. Example: C/222GJ-30-1-3Y-DAT

1.888.KEITHLEY (U.S. only)

www.keithley.com

Specifications

	2230-30-1, 2230J-30-1, 2230G-30-1, 2230GJ-30-1			2220-30-1, 2220J-30-1, 2220G-30-1, 2220GJ-30-1	
DC OUTPUT RATING					
Voltage	0 to 30 V	0 to 30 V	0 to 6 V	0 to 30 V	0 to 30 V
Current	0 to 1.5 A	0 to 1.5 A	0 to 5 A	0 to 1.5 A	0 to 1.5 A
MAXIMUM POWER					
	120 W			90 W	
LOAD REGULATION					
Voltage	< 0.01% + 3 mV	< 0.01% + 3 mV	< 0.01% + 3 mV	< 0.01% + 3 mV	< 0.01% + 3 mV
Current	< 0.01% + 3 mA	< 0.01% + 3 mA	< 0.01% + 3 mA	< 0.01% + 3 mA	< 0.01% + 3 mA
LINE REGULATION					
Voltage	< 0.01% + 3 mV	< 0.01% + 3 mV	< 0.01% + 3 mV	< 0.01% + 3 mV	< 0.01% + 3 mV
Current	< 0.1% + 3 mA	< 0.1% + 3 mA	< 0.1% + 3 mA	< 0.1% + 3 mA	< 0.1% + 3 mA
RIPPLE AND NOISE					
Voltage (7MHz)	< 1 mV rms < 3 mV p-p	< 1 mV rms < 3 mV p-p	< 1 mV rms < 3 mV p-p	< 1 mV rms < 3 mV p-p	< 1 mV rms < 3 mV p-p
Current (20MHz)	< 5 mA rms	< 5 mA rms	< 6 mA rms	< 5 mA rms	< 5 mA rms
SETTING RESOLUTION					
Voltage	1 mV	1 mV	1 mV	1 mV	1 mV
Current	1 mA	1 mA	1 mA	1 mA	1 mA
SETTING ACCURACY					
Voltage	± 0.03% + 10 mV	± 0.03% + 10 mV	± 0.03% + 10 mV	± 0.03% + 10 mV	± 0.03% + 10 mV
Current	± 0.1% + 5 mA	± 0.1% + 5 mA	± 0.1% + 5 mA	± 0.1% + 5 mA	± 0.1% + 5 mA
METER RESOLUTION					
Voltage	1 mV	1 mV	1 mV	1 mV	1 mV
Current	1 mA	1 mA	1 mA	1 mA	1 mA
METER ACCURACY					
Voltage	± 0.03% + 10 mV	± 0.03% + 10 mV	± 0.03% + 10 mV	± 0.03% + 10 mV	± 0.03% + 10 mV
Current	± 0.1% + 5 mA	± 0.1% + 5 mA	± 0.1% + 5 mA	± 0.1% + 5 mA	± 0.1% + 5 mA

ISOLATION VOLTAGE, OUTPUT TO CHASSIS: Any output can be floated up to 240V (DC + peak AC with AC limited to a maximum of 3Vpk-pk and a maximum frequency of 60Hz) relative to earth ground terminal.

ISOLATION VOLTAGE, OUTPUT TO OUTPUT: Any output can be floated up to 240V (DC + peak AC with AC limited to a maximum of 3Vpk-pk and a maximum frequency of 60Hz) relative to any other output terminal.

VOLTAGE TRANSIENT RESPONSE SETTLING TIME, LOAD CHANGE (typical): <150ms to within 75mV following a change from 0.1A to 1A.

VOLTAGE TRANSIENT RESPONSE SETTLING TIME, SETTING CHANGE, RISING (typical): <150ms to within 75mV following a change from 1V to 11V into a 10Ω resistor (Ch. 1, 2); from 0.4V to 4V into a 4Ω resistor (ch. 3.)

VOLTAGE TRANSIENT RESPONSE SETTLING TIME, SETTING CHANGE, FALLING (typical): <150ms to within 75mV following a change from 11V to 1V into a 10Ω resistor (Ch. 1, 2); from 0.4V to 4V into a 4Ω resistor (ch. 3.)

DISPLAY: Vacuum fluorescent display.

MEMORY: 30 setup memories.

TRACKING AND COMBINATION MODES:

Tracking Mode: Maintains the ratio on the two 30V output channels that is present when the control is activated.

Combination V1+V2 Series Mode: Deliver up to 60 V when CH1 and CH2 are wired in series. Meter reads back combined voltage.

Combination I1+I2 Parallel Mode: Deliver up to 3 A when CH1 and CH2 are wired in parallel. Meter reads back combined current.

REAR PANEL CONNECTIONS: USB Device Port, Type B connector, USBTMC compatible. 2220G and 2230G versions include a GPIB interface, IEEE-488.2 compliant.

POWER SOURCE

AC INPUT: Non-"J" versions: Switchable between 120VAC or 240VAC, nominal (different fuse required for each voltage).

"J" Versions: 100VAC, nominal.

FREQUENCY: 50/60Hz

POWER CONSUMPTION:

Dual Channel Versions: 350VA.

Triple Channel Versions: 450VA.

PHYSICAL CHARACTERISTICS

PROTECTIVE BOOTS AND HANDLE INSTALLED:

Height: 105.3mm (4.15 in.)

Width: 241.8mm (9.52 in.)

Depth: 384.0mm (15.12 in.)

PROTECTIVE BOOTS AND HANDLE REMOVED:

Height: 90.7mm (3.57 in.)

Width: 217.2mm (8.55 in.)

Depth: 361.6mm (14.24 in.)

NET WEIGHT:

2220-30-1: 8.2 kg (18 lb.)

2230-30-1: 8.5 kg (19 lb.)

SHIPPING WEIGHT:

2220-30-1: 11 kg (24 lb.)

2230-30-1: 11 kg (24 lb.)

2220, 2220G, 2230, 2230G

Multi-Channel USB and USB/GPIB Programmable DC Power Supplies

ENVIRONMENTAL AND SAFETY

Temperature: **Operating:** 0° to +40°C.
Storage: -20° to +70°C.

Relative Humidity (non-condensing):

Operating: 5% to 95% relative humidity at up to +40°C.

Storage: 5% to 95% relative humidity at up to +40°C. 5% to 60% RH above +40°C up to +70°C, non condensing.

Altitude:

Operating: Up to 2000m.

Storage: Up to 4000m.

Safety:

European Union: Complies with European Union EMC Directive.

USA: Nationally recognized testing laboratory listing UL61010-1-2004.

Canada: CAN/CSA C22.2 No. 61010-1 2004.

ELECTROMAGNETIC COMPATIBILITY

European Union: Complies with European Union Low Voltage Directive.

Australia: EMC Framework, demonstrated per Emission Standard AS/NZS 2064 (Industrial, Scientific, and Medical Equipment).



Model 2220-30-1 rear panel. The Model 2220G-30-1 adds a GPIB connector.

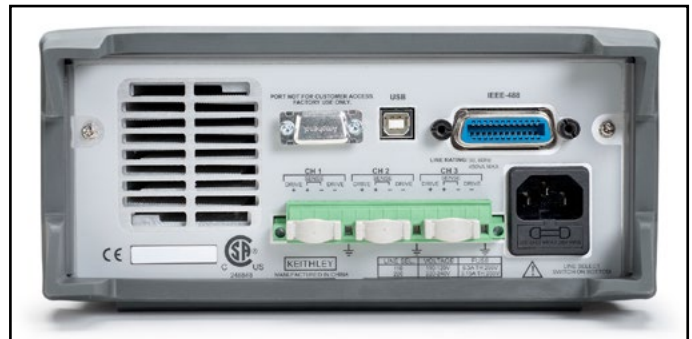

Model 2230G-30-1 rear panel. The Model 2230-30-1 does not have the GPIB connector.

Models 2220 and 2230 specifications

1.888.KEITHLEY (U.S. only)

www.keithley.com

A Greater Measure of Confidence

KEITHLEY

A Tektronix Company

DC POWER SUPPLIES

3-Year
Warranty

2231A-30-3

195W Triple Channel DC Power Supply

Multi-channel programmable DC power supplies

- Get three isolated, independent, and adjustable outputs in one instrument
- Output a total of 195W of power with two 30V@3A outputs and one 5V@3A output
- Set voltage outputs with 0.06% basic accuracy and current outputs with 0.2% basic accuracy
- Output DC power with less than 5mVp-p noise
- Display voltage and current measurements continuously from all three outputs
- Double output levels by connecting the two 30V channels in series or parallel
- Store frequently used configurations in any of 30 setup memory locations
- Turn off any output after a predetermined test time with each channel's output timer
- Control the supply from a PC with an optional USB adapter

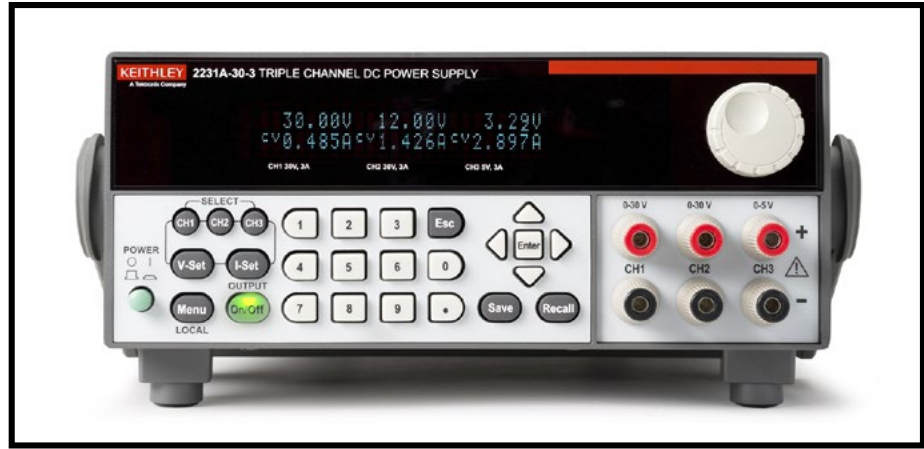

The Model 2231A-30-3 Triple Channel DC Power Supply can output a total of 195W of power, providing the power levels needed to energize a wide range of circuits and devices for benchtop work. Two channels can supply up to 30V at 3A each; the third channel can provide up to 5V at 3A. The Model 2231A-30-1 does not compromise on performance or convenience features, offering the versatility and ease of use you need, so it can be the only DC power supply on your bench.

Quality DC Power

The Model 2231A-30-3 is a linear-based design with less than 5mVp-p noise per output. Voltage and current settings have basic accuracies of 0.06% and 0.2% respectively. The load voltage and load current readback results provide the same levels of accuracy, so you can be confident you are sourcing accurate, low noise voltages and currents to your device-under-test (DUT).

Three Fully Independent Outputs

Each output of the Model 2231A-30-3 is fully programmable and can be turned on and off independently from the other channels; it essentially provides three power supplies in one instrument. You can power up both the analog circuitry and the digital circuitry of a printed circuit board or a complete device, all with the same instrument.

All Outputs Are Isolated from Each Other and from Ground

Each output can power a circuit on a different ground reference. The low connection on each output is not connected to any of the other outputs. That means one supply can test three separate circuits on three different ground references or can power circuits that are transformer or optically isolated from each other. Furthermore, all outputs are not referenced to ground, so the Model 2231A-30-3 can power both floating circuits and grounded circuits.

Power Bipolar Circuits

Because the Model 2231A-30-3's outputs are isolated, one output can be turned effectively into a negative source by connecting its high terminal to the common reference point of a bipolar circuit. A second output can connect its low terminal to the same common reference point. The result is a positive output and a negative output. If the two 30V channels are used in this configuration, both outputs can be changed at the same time by using the Model 2231A-30-3's tracking function. That allows varying both channels at the same time while keeping their outputs at identical magnitudes.

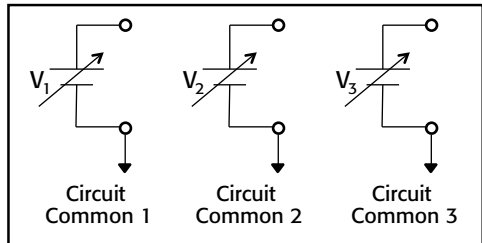

The Model 2231A-30-3 has three fully independent, programmable outputs that are electrically isolated from each other. This allows them to power circuits that are on different grounds, such as optically isolated circuits.

APPLICATIONS

- Engineering and science student labs
- Service work
- Electronic design

DC POWER SUPPLIES

1.888.KEITHLEY (U.S. only)
www.keithley.com



A Greater Measure of Confidence

2231A-30-3

Ordering Information

2231A-30-3
Triple Channel DC
Power Supply

Accessories Supplied

Documentation CD with User Manual
Certificate of Calibration
Power Cord

ACCESSORIES AVAILABLE

2231A-001	USB Adapter with USB Cable
RMU2U	Rack Mount Kit
386759800	RMU2U Rack Mount Cosmetic Filler Panel

SERVICES AVAILABLE

2231A-30-3-EW	1 Year KeithleyCare® Gold Plan
2231A-30-3-5Y-EW	5 Year KeithleyCare Gold Plan
C/2231A-30-3-3Y-STD	KeithleyCare 3 Yr Std Calibration Plan
C/2231A-30-3-5Y-STD	KeithleyCare 5 Yr Std Calibration Plan

195W Triple Channel DC Power Supply

Supply 60V or 6A

When the application requires outputting more than 30V or 3A, the two 30V channels can be combined to double the output level. Wire the two outputs in series to deliver up to 60V or wire them in parallel to deliver up to 6A. For your convenience, the Model 2231A-30-3 display will read the total output, either voltage or current, to eliminate confusion. Also, the supply controls both outputs to deliver the required voltage or current. There's no need to set up each channel individually; the supply manages the channels for you, so combining channels is uncomplicated.



Wire the two 30V channels in series or parallel to double the output voltage to 60V or the supplied current to 6A. The Model 2231A-30-3 has series and parallel modes that manage the channels and display the total output. This display shows the supply's parallel mode, including the output voltage and the total current from the channels wired in parallel.

Easily Test, Monitor, and Protect Your Circuits

- Adjust the outputs with the rotary knob or enter the output values precisely using the keypad with setting resolution of 10mV or 1mA.
- See the voltage and current readings on all channels at all times; the Model 2231A-30-3's display shows the readings from all three outputs simultaneously.
- Protect your DUT with an overvoltage protection setting for each output.
- Set timers to turn off an output after a programmed time to prevent excess stress on a circuit under development.
- Store and recall instrument setups for frequently used tests to begin testing quickly. You can store up to 30 unique test setups.

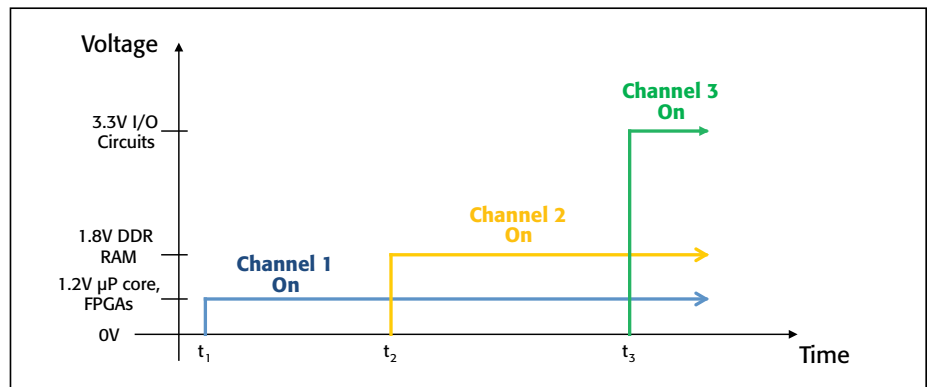

Safely power circuits up and down in the proper sequence using the three independently programmable output channels.

Control the Supply and Upload Data to a PC

Use the optional Model 2231A-001 USB Adapter to control the Model 2231A-30-3 via a PC's USB interface, then transfer readings from the outputs to combine with other test data for a more thorough analysis of DUT performance. The 2231A-001 USB Adapter provides the flexibility to use the supply under either manual or automated control.

1.888.KEITHLEY (U.S. only)

www.keithley.com

A Greater Measure of Confidence

KEITHLEY
A Tektronix Company

2231A-30-3

195W Triple Channel DC Power Supply

Specifications

DC OUTPUT RATING

	Channel 1	Channel 2	Channel 3
Voltage	0–30 V	0–30 V	0–5 V
Current	0–3 A	0–3 A	0–3 A

MAXIMUM POWER: 195W

LOAD REGULATION:

Voltage: $\leq 0.02\% + 4\text{mV}$
Current: $\leq 0.2\% + 3\text{mA}$

LINE REGULATION:

Voltage: $\leq 0.02\% + 4\text{mV}$
Current: $\leq 0.2\% + 3\text{mA}$

RIPPLE AND NOISE (20Hz–20MHz):

Voltage: $\leq 1\text{mVrms}/\leq 5\text{mVp-p}$
Current: $\leq 6\text{mA rms}$

SETTING RESOLUTION:

Voltage: 10mV
Current: 1mA

SETTING ACCURACY:

Voltage: $\leq 0.06\% + 20\text{mV}$
Current: $\leq 0.2\% + 10\text{mA}$

REARBACK RESOLUTION:

Voltage: 10mV
Current: 1mA

REARBACK ACCURACY:

Voltage: $\leq 0.06\% + 20\text{mV}$
Current: $\leq 0.2\% + 10\text{mA}$

ISOLATION VOLTAGE, OUTPUT TO CHASSIS: Any output can be isolated up to 240V (DC + peak AC with AC limited to a maximum of 3Vpk-pk and a maximum of 60Hz) relative to the earth ground terminal.

ISOLATION VOLTAGE, OUTPUT TO OUTPUT: Any output can be isolated up to 240V (DC + peak AC with AC limited to a maximum of 3Vpk-pk and a maximum of 60Hz) relative to any other output terminal.

TRACKING AND COMBINATION MODES:

Tracking Mode: Maintains the ratio on the two 30V output channels that is present when the control is activated.

Combination V1 + V2 Series Mode: Deliver up to 60V when CH1 and CH2 are wired in series. Meter reads back combined voltage.

Combination I1 + I2 Parallel Mode: Deliver up to 6A when CH1 and CH2 are wired in parallel. Meter reads back combined current.

MEMORY: 30 setup memory locations.

OUTPUT TIMER RANGE: 0.1s to 999999s.

DISPLAY: Vacuum fluorescent display.

CONNECTIONS:

Front: Power output jacks: 3 sets, safety-shrouded banana jacks.

Rear: DB9 connector for remote control,

OVERTEMPERATURE PROTECTION: If the internal temperature of the supply exceeds 85°C, the supply will automatically turn off.

EMC COMPLIANCE: Conforms to European Union EMC Directive.

SAFETY COMPLIANCE: Conforms to European Union Low Voltage Directive.

POWER LINE RATINGS: 110VAC/230VAC $\pm 10\%$.

POWER LINE FREQUENCY: 47Hz–65Hz.

MAXIMUM POWER CONSUMPTION: 750VA.

OPERATING ENVIRONMENT: 0° to 40°C, 5% to 80% relative humidity at up to 40°C.

STORAGE ENVIRONMENT: –20° to 70°C, 5% to 80% relative humidity up to 40°C, and 5% to 60% relative humidity from 40° to 70°C.

PHYSICAL CHARACTERISTICS

Height: 88.2 mm (3.5 in)

Width: 214.5 mm (8.5 in)

Depth: 354.6 mm (14 in)

Net Weight: 7.10kg (15.7 lbs.).

Shipping Weight: 9.40kg (20.7 lbs.).

WARRANTY: 3 years.

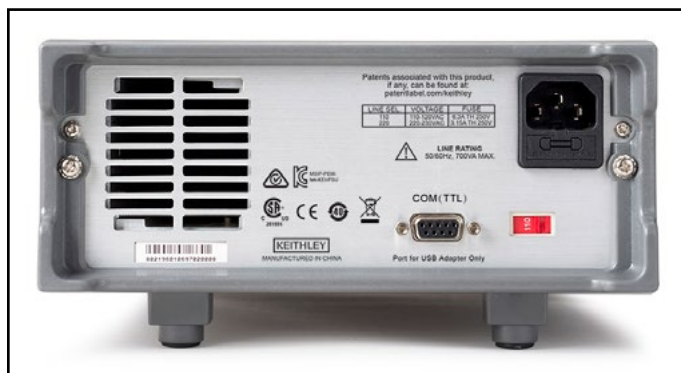

Model 2231A-30-3 rear panel showing the communication port, line power setting switch, and the power input connector with fuse holder.

2308

Portable Device Battery/Charger Simulator

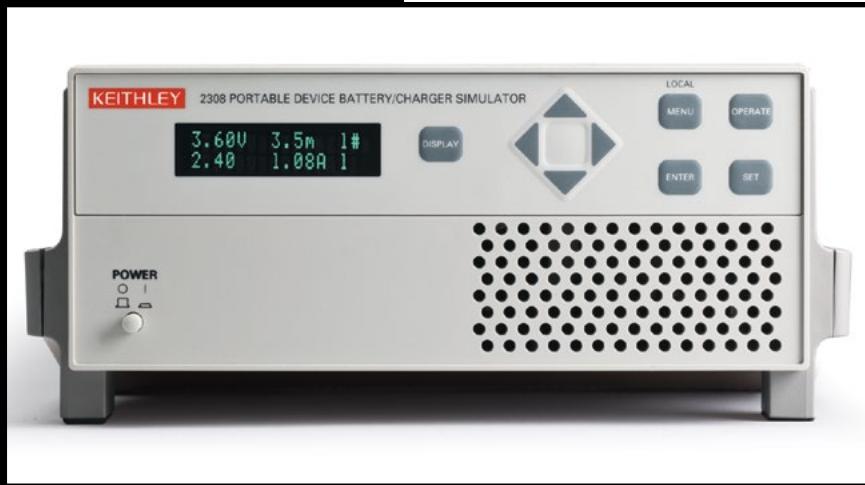

- **Specialized dual-channel power supply for design and testing of portable, battery-operated devices**
- **Ultra-fast response to pulsed load operation**
- **Speed-optimized command set reduces test times**
- **Variable output resistance for simulating an actual battery's output response**
- **Simulate a discharged battery and test charge control circuit performance with both a battery supply that can sink up to 3A and a charger supply**
- **Pulse peak, average, and baseline current measurements**
- **Integrating A/D converter for more precise measurements**
- **100nA current measurement sensitivity**
- **Analog output for complete load current waveform characterization**
- **Catch production wiring problems immediately with open sense-lead detection**
- **Built-in digital voltmeter**
- **Four built-in digital control lines**

The Model 2308 Portable Device Battery/Charger Simulator is optimized for use in testing mobile phones and other portable, battery-operated devices. When a device-under-test (DUT) transitions nearly instantaneously from a sleep or standby mode to the full power transmit state, the Model 2308's rapid response to load changes means there's little transient voltage drop from the programmed output voltage and the output recovers quickly. This fast response is particularly critical when testing portable devices with a pulsed mode of operation because it allows the device to perform properly while it's being tested. In contrast, the slow-responding source voltage typical of conventional power supplies causes the DUT to perform improperly, leading to production yield problems and costly retesting.

The Model 2308 offers a complete solution for portable device sourcing and load current measurement. It has two independent power supply channels: one is optimized to simulate a battery; the second channel is optimized to perform like a charger for a rechargeable battery. The battery channel's variable output resistance can be used to simulate the internal resistance of a battery so design and test engineers can simulate a battery's output for testing devices under realistic operating conditions. This channel also sinks current to simulate a discharged battery. The charger channel can supply a voltage to test a portable device's battery charge control circuitry, with the battery channel acting as the discharged battery load.

In addition to maintaining output voltage levels under difficult load conditions, the Model 2308 can measure a wide dynamic range of load current levels and can measure narrow current pulses (or pulses as narrow as 50 μ s). That makes it ideal for characterizing device power consumption by making low-level sleep mode measurements as well as pulsed operating load currents.

Maximize production yield with fast response to load changes

Mobile phones, other portable devices (such as Bluetooth headsets, MP3 players, etc.), and RF components such as power amplifiers, power transistors, and transmitter modules experience large instantaneous load changes when they transition from a standby state to full power operation. For a mobile phone, the load current can change from a 100mA standby current to a 1A transmission current or a 10 \times (1000%) increase in the load current. The Model 2308 maintains a reliable, stable level of voltage output, even when the DUT produces large load current changes and/or has a pulsed operating mode.

The Model 2308's fast recovery from load changes helps prevent the causes of false failures and destroyed devices in production test as well as field failure quality problems due to compromised components. The Model 2308 assures you of a stable, constant voltage source to maximize production yield and minimize production retest and rework costs.

APPLICATIONS

- **Design and test of a wide range of consumer electronics, including:**
 - **Mobile phones, mobile radios, cordless phones, and Bluetooth headsets**
 - **MP3 players, portable digital assistants (PDAs), digital cameras, GPS receivers, and notebook computers**
- **Design and test of electronic components such as RFIC power amplifiers, RF power transistors, and baseband and wireless chipsets for portable wireless devices**

1.888.KEITHLEY (U.S. only)

www.keithley.com

A Greater Measure of Confidence

KEITHLEY
A Tektronix Company

Fast transient response power supply

DC POWER SUPPLIES

2308

Ordering Information

2308 Portable Device Battery/Charger Simulator

Accessories Supplied
CD with documentation,
output connectors mating
terminal (part no. CS-846)

ACCESSORIES AVAILABLE

- | | |
|-----------|------------------------------|
| 2306-DISP | Remote Display |
| CS-846 | Mating Output Connector |
| SC-182 | Low Inductance Coaxial Cable |
- IEEE-488 INTERFACE CONTROLLER CARDS**
- | | |
|-------------|--|
| KPCI-488LPA | IEEE-488.2 Interface Board for the PCI bus |
| KUSB-488B | IEEE-488.2 USB-to-GPIB Interface Adapter for USB Port with built-in 2m (6.6ft) cable |

IEEE-488 INTERFACE CABLES

- | | |
|---------|--|
| 7007-05 | Double Shielded Premium IEEE-488 Cable, 0.5m (1.6ft) |
| 7007-1 | Double Shielded Premium IEEE-488 Cable, 1m (3.2ft) |
| 7007-2 | Double Shielded Premium IEEE-488 Cable, 2m (6.5ft) |
| 7007-3 | Double Shielded Premium IEEE-488 Cable, 3m (10ft) |
| 7007-4 | Double Shielded Premium IEEE-488 Cable, 4m (13ft) |

RACK MOUNT KITS

- | | |
|--------|-----------------------------|
| 4288-1 | Single Fixed Rack Mount Kit |
| 4288-2 | Dual Fixed Rack Mount Kit |

SERVICES AVAILABLE

- | | |
|---------------|---|
| 2308-3Y-EW | 1-Year Factory Warranty Extended to 3 Years for the Model 2308 |
| 2308-3Y-17025 | 3 (ISO-17025 Accredited) Calibrations within 3 Years of Purchase |
| 2308-3Y-DATA | 3 (ANSI-Z540-1 Compliant) Calibrations within 3 Years of Purchase |

Model 2308 vs. Conventional Power Supplies

Large load changes will cause a large instantaneous drop in a conventional power supply's voltage output. If the supply's recovery time is long, the DUT will turn off when the supply voltage falls below the DUT's low battery turn-off threshold—**producing a false failure**. Even if the DUT does not turn off, the drop-off in input power prevents the output (RF or a power pulse) from meeting its specification—a **specification failure**. Furthermore, the conventional power supply may have an excessively large overshoot when the DUT's load current transitions from its operating load back to its standby load. The magnitude of the transient overshoot voltage could even be large enough to exceed the maximum safe input voltage, either rendering the device inoperable or damaging some components—a **device failure or a field failure**.

Portable Device Battery/Charger Simulator

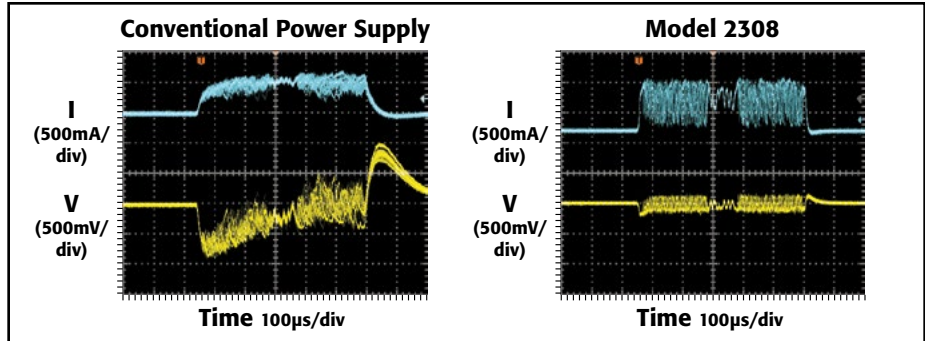

Compare the response of a conventional power supply (left) with the response of a Model 2308 (right) when both are powering a device operating on the EDGE mobile phone standard. Note how the conventional power supply distorts the load current and cannot maintain a stable source voltage, which in turn distorts the RF output signal.

Reduce test costs and increase throughput with high speed command structure

To minimize production test times while still giving you all the information you need to characterize your devices fully, the Model 2308 is designed with a command structure optimized for speed, with voltage step times as short as 6ms and DC load current measurements in just 22ms. Commands that combine range changing and current measurement let you acquire the command, make the measurement, and transfer the data in as little as 30ms. In addition, special operating modes, such as the pulse current step

mode, allow taking a number of measurements on a complex load current waveform with a single command.

Characterize load currents for power consumption verification

Characterizing the battery life of portable devices demands the ability to measure complex current waveforms over a wide dynamic range. The Model 2308 offers a far broader range of capabilities than conventional power supplies for measuring low current levels, peak pulse current levels, long-period load current waveforms, and multi-level current waveforms. A choice of four

Your DC source leads are a transmission line when your portable device operates in a narrow pulsed mode.

Under pulsed operating conditions, your load circuit is an L-C-R network and that load impedance can cause problems for your power supply. Keithley's fast transient power supplies are designed to maintain a stable voltage under difficult, narrow pulse, loading conditions and to maintain the output voltage, even with long lengths of wire between the power supply and the DUT. The design of your DC sourcing test circuit requires just as much effort as your AC or RF test circuits. Using a fast transient response, battery simulating power supply needs to be a key part of your DC test circuit design.

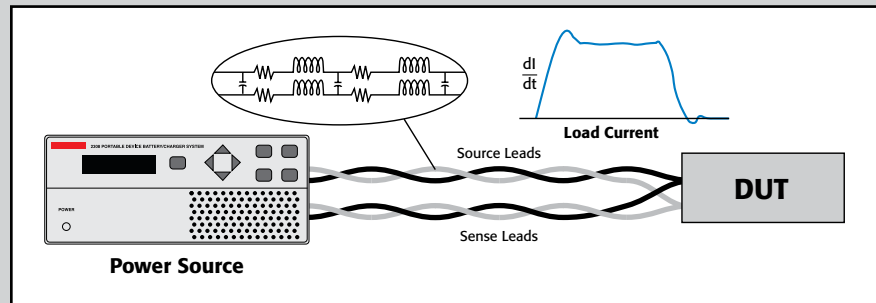

The DC source leads become a transmission line during dynamic load swings.

Fast transient response power supply

DC POWER SUPPLIES

1.888.KEITHLEY (U.S. only)

www.keithley.com

KEITHLEY

A Tektronix Company

A Greater Measure of Confidence

ranges (5mA, 50mA, 500mA, and 5A) allows measuring load currents with exceptional resolution and accuracy.

Measure sleep and standby currents with the accuracy of integrating A/D technology

The Model 2308 is designed for fast and accurate measurements of devices in low power modes such as the sleep, hibernate, or standby state. It can resolve currents down to 100nA and measure them with 0.2% accuracy. The Model 2308 uses an integrating A/D converter that continuously acquires the signal rather than capturing discrete samples; this provides a more accurate measurement than other A/D techniques. In addition, the averaging effect built into integrating A/D converters reduces noise and delivers highly stable current readings. You can measure low and high currents at the same speed with no degradation in accuracy, so the Model 2308 is equally well-suited for the test line and the design lab.

Measure load currents from pulsed-output devices

Devices like GSM-, EDGE-, WLAN-, and WiMAX-based mobile phones generate pulsed outputs. Determining their total power consumption requires measuring both the baseline current and the peak of the pulsed load current. The Model 2308 can capture peak currents of pulses as short as 50 μ s and as long as 833ms. Programmable trigger levels allow controlled capture of the pulse, then the Model 2308's programmable measurement delay and acquisition times make it easy to avoid rising edge transients so the pulse peak can be measured accurately. The instrument can also measure the pulse baseline current and the pulse average load current.

A long integration current mode supports measuring pulse trains with periods longer than 850ms. In this mode, the Model 2308 can measure average current on a load current waveform with a period from 850ms to 60 seconds.

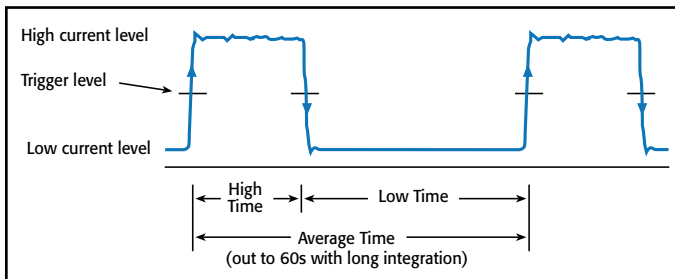

The Model 2308 can measure peak pulse currents, average currents, and baseline currents.

Take multiple measurements on start-up sequences or on current levels at different voltage operating levels

Need to analyze a device's circuitry during the power-up phase as it transitions from a sleep mode or an off-state? The Model 2308's pulse step current function has the speed needed to measure the load current start-up levels in a single device start-up so that the measurements can be performed in production without an increase in test time.

The pulse step current function also offers a fast way to determine load currents of different operating states. For example, as source voltage levels are varied over a device's operating range, the corresponding operating current levels can be measured without executing multiple commands for

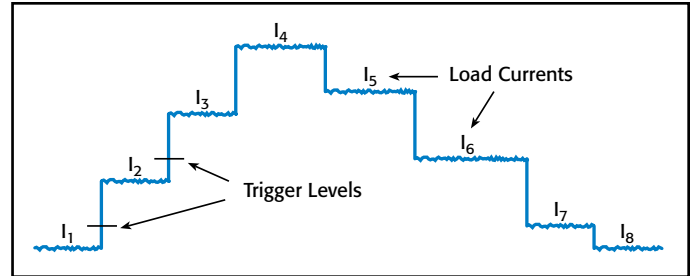

With a single command, the Model 2308's high speed pulse step current function can quickly capture varying load current levels to speed test throughput.

a significant time-savings when testing integrated circuits over their allowable range of Vcc levels.

Capture the complete load current waveform

Two built-in analog outputs help designers of device's verify design performance and ensure its current draw conforms to design specifications without the need to connect any sensing circuitry in the power supply circuit. Once these outputs are connected to an oscilloscope or a data acquisition module, the load current waveform can be displayed or digitized and analyzed in a computer. When the Model 2308 is connected to a data acquisition module, the data acquisition module can sample the waveform at any sampling rate to create a record of any length desired.

Test under realistic conditions with true battery simulation

When a portable battery-operated device transitions from one load current level to another, the battery voltage supplying the current will drop by the product of the change in current and the battery's internal resistance. During the load current pulse, the device must operate with a voltage reduced by the battery's internal resistance. The Model 2308 allows simulating this resistance so its output is almost identical to a battery's output, allowing design or production test engineers to test devices or components under realistic conditions. This patented¹ technique permits the output resistance to be programmed between 0 Ω and 1 Ω with 10m Ω resolution. You can also decrease the voltage and increase the output resistance while the output is on to simulate the discharge of the battery.

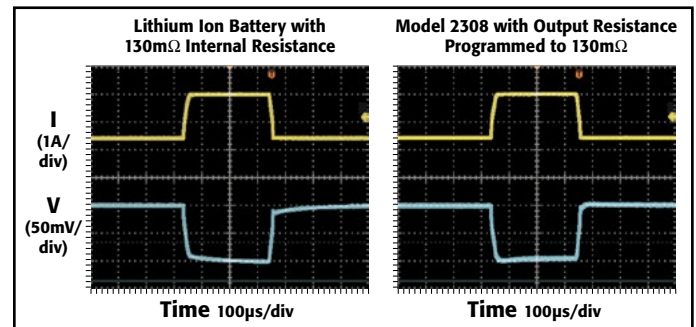

The Model 2308's programmable output resistance (right) allows it to simulate the output of a real battery (left), a capability conventional power supplies do not have. The 2308 output is identical to the battery's response.

1. U.S. Patent Number 6,204,647 B1

1.888.KEITHLEY (U.S. only)

www.keithley.com

A Greater Measure of Confidence

KEITHLEY
A Tektronix Company

Test a device's charge control circuitry

Both channels of the Model 2308 sink up to 3A of current continuously. Therefore, the battery channel can act like a discharged re-chargeable battery. The charger channel can supply a charging voltage for use in testing the operation of the DUT's charging circuitry. Because the charger channel can also act as an electronic load, the battery channel can operate the device and the charger channel can act as a load to test a battery capacity monitor or some other device function that requires a load.

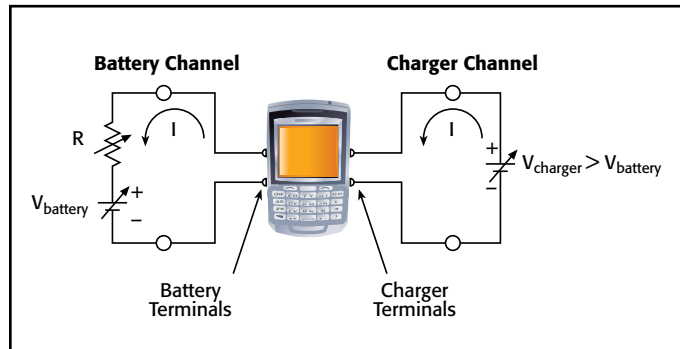

For charger control circuit testing, the Model 2308's battery channel can sink current to simulate a discharged battery while the charger channel simulates a charger. One instrument provides high versatility for portable device testing.

Reduce testing errors and retesting costs with remote sense lead monitoring

Remote sensing capabilities let the Model 2308 ensure the voltage programmed is what is actually applied to the load. As DUTs are continuously inserted and removed from test fixtures, the instrument ensures this programmed voltage is maintained with an open sense lead detection monitor—any break in a sense lead connection is detected immediately. The open sense lead detection monitor eliminates the possibility that numerous devices could be tested or calibrated at an incorrect voltage.

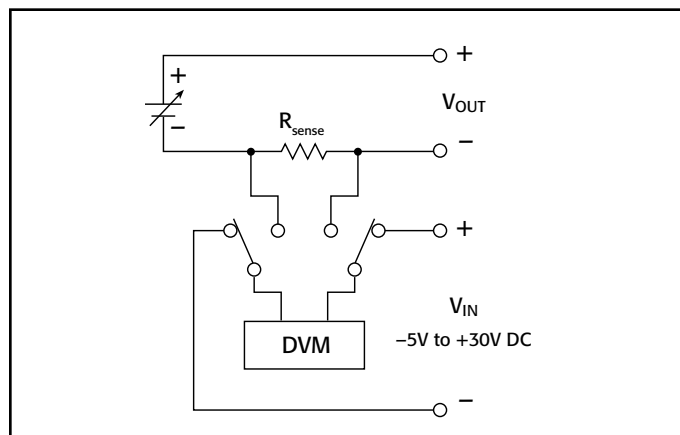

The Model 2308's charger channel contains a built-in DVM, eliminating the need for a separate instrument in many test systems.

Save with multiple instruments in one package – two power supplies, a DVM, digital controls, and a remote display

The Model 2308 saves on both instrumentation costs and rack space by packing two independent power supply channels in one compact, 2U half-rack enclosure, along with additional capabilities power supplies rarely offer. For example, the built-in DC digital voltmeter can measure voltages in the DUT circuitry from -5VDC to +30VDC. The DVM and the battery channel voltage source can operate simultaneously. For many applications, the Model 2308 can eliminate the need for a separate DMM.

The digital outputs the Model 2308 provides can sink up to 100mA to control relays. External relays can be powered either by the internal 5V source or an external source with a maximum voltage of 24V. For applications that require only a few digital control lines, the Model 2308 eliminates the need for an additional control module.

Need to reduce your test system size or want more system organization flexibility? Then mount the Model 2308 in the back of a test rack or near the test fixture—mounting the instrument in the test rack is unnecessary. The Model 2308's tiny (4.6 in. × 2.7 in.) remote display can be mounted anywhere for easy viewing of the outputs of both channels. If the Model 2308 is inaccessible, you can control it from the remote display because it has all the front panel pushbuttons that are on the instrument itself.

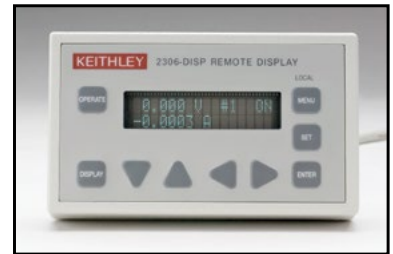

The Model 2306-DISP display can be mounted for easy viewing when the instrument itself must be mounted in an inaccessible location.

Reduce test system problems with low impedance cable

Keithley's SC-182 Low Inductance Coaxial Cable is designed to minimize the impedance and reduce the susceptibility to external EMI in your DC source-DUT circuit. This cable's characteristic impedance is nominally 15Ω with a low 42nH/ft of inductance and a low 182pF/ft of capacitance. In contrast, a typical coaxial cable has 50Ω or 75Ω characteristic impedance and twisted-wire pairs have at least 80Ω of characteristic impedance.

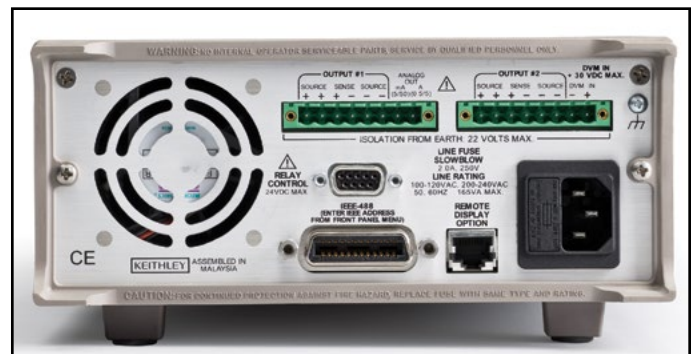

Model 2308 rear panel

1.888.KEITHLEY (U.S. only)

www.keithley.com

KEITHLEY

A Greater Measure of Confidence

A Tektronix Company

OUTPUT #1 (Battery Channel):**DC VOLTAGE OUTPUT (1 Year, 23°C ± 5°C)**

OUTPUT VOLTAGE: 0 to +15VDC.

OUTPUT ACCURACY: (0.05% + 3mV).

PROGRAMMING RESOLUTION: 1mV.

READBACK ACCURACY¹: ±(0.05% + 3mV).

READBACK RESOLUTION: 1mV.

OUTPUT VOLTAGE SETTLING TIME: 5ms to within stated accuracy.

LOAD REGULATION: 0.01% + 2mV.

LINE REGULATION: 0.5mV.

STABILITY²: 0.01% + 0.5mV.MEASUREMENT TIME CHOICES: 0.002 to 10PLC³, in 0.002PLC steps.

AVERAGE READINGS: 1 to 10.

TRANSIENT RESPONSE: High Bandwidth Low Bandwidth

Transient Recovery Time ⁴	<35 μs ⁵	<50 μs ⁵
Transient Voltage Drop	<90 mV ⁵	<180 mV ⁵

REMOTE SENSE: 1V max. drop in each lead. Add 2mV to the voltage load regulation specification for each 1V change in the negative output lead due to load current change. Remote sense required. Integrity of connection continually monitored. If compromised, output will turn off automatically once settable window (±0 to ±8 volts) around normal voltage exceeded.

VARIABLE OUTPUT IMPEDANCE: Range: 0 to 1.00Ω in 0.01Ω steps. Value can be changed with output on.

NOTES

- At PLC (Power Line Cycle) = 1.
- Following 15 minute warm-up, the change in output over 8 hours under ambient temperature, constant load, and line operating conditions.
- PLC = Power Line Cycle. 1PLC = 16.7ms for 60Hz operation, 20ms for 50Hz operation.
- Recovery to within 20mV of previous level.
- Remote sense, at terminals 1 and 6, with 4.5m (15 feet) 16 AWG (1.31mm²) twisted pair, with 1.5A load change, (0.15A to 1.65A) resistive load only, typical.

DC CURRENT (1 Year, 23°C ± 5°C)**CONTINUOUS AVERAGE OUTPUT CURRENT**

CHANNEL #2 (CHARGER) OFF:

I = 50W/(V_{set} channel 1 + 6V); 5A max.¹

CHANNEL #2 (CHARGER) ON:

I = (50W – power consumed by channel #2)/(V_{set} channel 1 + 6V); 5A max.¹

The power consumed by channel #2 is calculated as:

Channel #2 Sourcing Current: Power consumed = (V_{set} channel 2 + 6V) × (current supplied).

Channel #2 Sinking Current: Power consumed = 5V × (sink current).

CONTINUOUS AVERAGE SINK CURRENT

CHANNEL #2 (CHARGER) OFF:

0–5V: 3A max.

5–15V: Derate 0.2A per volt above 5V. Compliance setting controls sinking.

CHANNEL #2 (CHARGER) ON:

Available Current = (50W – Power consumed by channel #2)/5V; 3A max. (0–5V).

Derate 0.2A per volt above 5V.

DC CURRENT (1 Year, 23°C ± 5°C) (continued)SOURCE COMPLIANCE ACCURACY: ±(0.16% + 5mA).²

PROGRAMMED SOURCE COMPLIANCE RESOLUTION: ±1.25mA.

READBACK ACCURACY: 5A Range: ±(0.2% + 200μA).

500mA Range: ±(0.2% + 100μA).

50 mA Range: ±(0.2% + 5μA).

5mA Range: ±(0.2% + 2μA).

READBACK RESOLUTION: 5A Range: 100μA.

500mA Range: 10μA.

50 mA Range: 1μA.

5mA Range: 0.1μA.

LOAD REGULATION: 0.01% + 1mA.

LINE REGULATION: 0.5mA.

STABILITY: 0.01% + 50μA.

MEASUREMENT TIME CHOICES: 0.002 to 10 PLC³, in 0.002PLC steps.

AVERAGE READINGS: 1 to 10.

NOTES

- Peak current can be a max. of 5A provided the average current is within the stated limits and terminals 1 and 6 are used.
- Minimum current in constant current mode is 6mA.
- PLC = Power Line Cycle. 1PLC = 16.7ms for 60Hz operation, 20ms for 50Hz operation.

PULSE CURRENT MEASUREMENT OPERATION

TRIGGER LEVEL: 5A Range: 0A to 5A, in 5mA steps.

500mA Range: 0mA to 500mA, in 0.5mA or 500μA steps.

50mA Range: 0mA to 50mA, in 0.05mA or 50μA steps.

5mA Range: 0mA to 5mA, in 0.005mA or 5μA steps.

TRIGGER DELAY: 0 to 100ms, in 10μs steps.

INTERNAL TRIGGER DELAY: 10μs.

HIGH/LOW/AVERAGE MODE: Measurement Aperture Settings: 33.3μs to 833ms, in 33.3μs steps. Average Readings: 1 to 100.

PULSE CURRENT MEASUREMENT ACCURACY¹ (1 Year, 23°C ± 5°C):

Aperture	Accuracy ±(% reading + offset)				
	5A Range	500mA Range	50mA Range	5mA Range	
<100 μs	0.3% + 2 mA	0.3% + 1 mA	0.3% + 700 μA	0.3% + 200 μA	
100 μs – 200 μs	0.3% + 2 mA	0.3% + 1 mA	0.3% + 700 μA	0.3% + 100 μA	
200 μs – 500 μs	0.3% + 2 mA	0.3% + 1 mA	0.3% + 700 μA	0.3% + 100 μA	
500 μs – <1 PLC	0.3% + 900 μA	0.3% + 900 μA	0.3% + 500 μA	0.3% + 90 μA	
1 PLC ²	0.3% + 900 μA	0.3% + 900 μA	0.3% + 200 μA	0.3% + 90 μA	
>1 PLC	0.3% + 900 μA	0.3% + 900 μA	0.3% + 200 μA	0.3% + 90 μA	

NOTES

- Based on settled signal: 100μs pulse trigger delay.
- Also applies to other apertures that are integer multiples of 1PLC.

BURST MODE CURRENT MEASUREMENT

MEASUREMENT APERTURE: 33.3μs to 833ms, in 33.3μs steps.

CONVERSION RATE: 4100/second, typical.¹

INTERNAL TRIGGER DELAY: 10μs.

NUMBER OF SAMPLES: 1 to 5000.

TRANSFER SAMPLES ACROSS IEEE BUS IN BINARY MODE²: 4400 readings/s, typical (4 bytes per reading).**NOTES**

- At 33.3μs aperture.
- Display off, Message Exchange Protocol (MEP) off, auto zero off.

LONG INTEGRATION MODE CURRENT MEASUREMENT

MEASUREMENT TIME, 60Hz (50Hz): 850ms (840ms) to 60 seconds in 1ms steps.

ANALOG OUTPUT

5A/500mA OUTPUT: 1V/A ± 25mA (typical).

50mA/5mA OUTPUT: 1V/10mA ± 0.25mA (typical).

INTERNAL IMPEDANCE: 1000Ω (nominal).

1.888.KEITHLEY (U.S. only)

www.keithley.com

A Greater Measure of Confidence

KEITHLEY

A Tektronix Company

OUTPUT #2 (Charger Channel)**DC VOLTAGE OUTPUT (1 Year, 23°C ± 5°C)**

OUTPUT VOLTAGE: 0 to +15VDC.
 OUTPUT ACCURACY: ±(0.05% + 10mV).
 PROGRAMMING RESOLUTION: 10mV.
 READBACK ACCURACY¹: ±(0.05% + 3mV).
 READBACK RESOLUTION: 1mV.
 OUTPUT VOLTAGE SETTLING TIME: 5ms to within stated accuracy.
 LOAD REGULATION: 0.01% + 2mV.
 LINE REGULATION: 0.5mV.
 STABILITY²: 0.01% + 0.5mV.
 MEASUREMENT TIME CHOICES: 0.002 to 10 PLC³, in 0.002 PLC steps.
 AVERAGE READINGS: 1 to 10.

TRANSIENT RESPONSE:	High Bandwidth	Low Bandwidth
Transient Recovery Time ⁴	<50 μs ⁵	<60 μs ⁵
Transient Voltage Drop	<180 mV ⁵	<500 mV ⁵

REMOTE SENSE: 1V max. drop in each lead. Add 2mV to the voltage load regulation specification for each 1V change in the negative output lead due to load current change. Remote sense required. Integrity of connection continually monitored. If compromised, output will turn off automatically once settable window (±0 to ±8 volts) around normal voltage exceeded.

NOTES

- At 1PLC.
- Following 15 minute warm-up, the change in output over 8 hours under ambient temperature, constant load, and line operating conditions.
- PLC = Power Line Cycle. 1PLC = 16.7ms for 60Hz operation, 20ms for 50Hz operation.
- Recovery to within 20mV of previous level.
- Remote sense, with 4.5m (15 feet) of 16 AWG (1.31mm²) wire, 1.5A load change (0.15A to 1.65A), resistive load only.

DC CURRENT (1 YEAR, 23°C ± 5°C)**CONTINUOUS AVERAGE OUTPUT CURRENT****CHANNEL #1 (BATTERY) OFF:**

$I = 50W / (V_{set} \text{ channel 2} + 6V)$; 5A max.¹

CHANNEL #1 (BATTERY) ON:

$I = (50W - \text{power consumed by channel \#1}) / (V_{set} \text{ channel 2} + 6V)$; 5A max.¹

The power consumed by channel #1 is calculated as:

Channel #1 Sourcing Current: Power consumed = $(V_{set} \text{ channel 1} + 6V) \times (\text{current supplied})$.

Channel #1 Sinking Current: Power consumed = $5V \times (\text{sink current})$.

CONTINUOUS AVERAGE SINK CURRENT**CHANNEL #1 (BATTERY) OFF:**

0–5V: 3A max.

5–15V: Derate 0.2A per volt above 5V. Compliance setting controls sinking.

CHANNEL #1 (BATTERY) ON:

Available Current = $(50W - \text{Power consumed by channel \#1}) / 5V$; 3A max. (0–5V)¹.

Derate 0.2A per volt above 5V.

DC CURRENT (1 YEAR, 23°C ± 5°C) (continued)

SOURCE COMPLIANCE ACCURACY: ±(0.16% + 5mA).²
 PROGRAMMED SOURCE COMPLIANCE RESOLUTION: ±1.25mA.
 READBACK ACCURACY: 5A Range: ±(0.2% + 200μA).
 5mA Range: ±(0.2% + 2μA).
 READBACK RESOLUTION: 5A Range: 100μA.
 5mA Range: 0.1μA.
 LOAD REGULATION: 0.01% + 1mA.
 LINE REGULATION: 0.5mA.
 STABILITY: 0.01% + 50μA.
 MEASUREMENT TIME CHOICES: 0.002 to 10 PLC³, in 0.002 PLC steps.
 AVERAGE READINGS: 1 to 10.

NOTES

- Peak current can be a max. of 5A provided the average current is within the stated limits.
- Minimum current in constant current mode is 6mA.
- PLC = Power Line Cycle. 1PLC = 16.7ms for 60Hz operation, 20ms for 50Hz operation.

PULSE CURRENT MEASUREMENT OPERATION

TRIGGER LEVEL: 5A Range: 5mA to 5A, in 5mA steps.

TRIGGER DELAY: 0 to 100ms, in 10μs steps.

INTERNAL TRIGGER DELAY: 10μs.

HIGH/LOW/AVERAGE MODE:

Measurement Aperture Settings: 33.3μs to 833ms, in 33.3μs steps.

Average Readings: 1 to 100.

PULSE CURRENT MEASUREMENT ACCURACY¹ (1 Year, 23°C ± 5°C):

Aperture	Accuracy ±(% reading + offset)	
	5A Range	
<100 μs	0.3% +	2 mA
100 μs – 200 μs	0.3% +	2 mA
200 μs – 500 μs	0.3% +	2 mA
500 μs – <1 PLC	0.3% +	900 μA
1 PLC ²	0.3% +	900 μA
>1 PLC	0.3% +	900 μA

NOTES

- Based on settled signal: 100μs pulse trigger delay.
- Also applies to other apertures that are integer multiples of 1PLC.

BURST MODE CURRENT MEASUREMENT

MEASUREMENT APERTURE: 33.3μs to 833ms, in 33.3μs steps.

CONVERSION RATE: 4100/second, typical.¹

INTERNAL TRIGGER DELAY: 10μs.

NUMBER OF SAMPLES: 1 to 5000.

TRANSFER SAMPLES ACROSS IEEE BUS IN BINARY MODE²: 4400 readings/s, typical (4 bytes per reading).

NOTES

- At 33.3μs aperture.
- Display off, Message Exchange Protocol (MEP) off, auto zero off.

1.888.KEITHLEY (U.S. only)

www.keithley.com

OUTPUT #2 (Charger Channel) (continued)

LONG INTEGRATION MODE CURRENT MEASUREMENT

MEASUREMENT TIME, 60Hz (50Hz): 850ms (840ms) to 60 seconds in 1ms steps.

DIGITAL VOLTMETER INPUT (1 Year, 23°C ± 5°C)

INPUT VOLTAGE RANGE: -5 to +30VDC.

INPUT IMPEDANCE: 2MΩ typical.

MAX. VOLTAGE (either input terminal) WITH RESPECT TO OUTPUT LOW: -5V, +30V.

READING ACCURACY: ±(0.05% + 3mV).

READING RESOLUTION: 1mV.

CONNECTOR: HI and LO input pair part of Output #2's terminal block.

MEASUREMENT TIME CHOICES: 0.002 to 10 PLC¹, in 0.002 PLC steps.

AVERAGE READINGS: 1 to 10.

NOTES

1. PLC = 1.00 Power Line Cycle.

Operating Speeds (Typical)

	Channel 1	Channel 2
Voltage Step Time ¹	6 ms	7 ms
DC Current Reading Time ^{1, 2, 3}	22 ms	22 ms
DC Current Range Change and Read Time ^{1, 2, 3}	27 ms	
Digital Voltmeter ^{1, 2, 3}		22 ms

NOTES

1. Display off, message exchange protocol (MEP) off, auto zero off.

2. PLC = 1 power line cycle.

3. Includes measurement and binary data transfer out of the GPIB port.

GENERAL

ISOLATION (LOW-EARTH): 22VDC max. Do not exceed 60VDC between any two terminals of either connector.

PROGRAMMING: IEEE-488.2 (SCPI).

USER-DEFINABLE POWER-UP STATES: 4.

REAR PANEL CONNECTORS: Two 8-position quick disconnect terminal blocks.

TEMPERATURE COEFFICIENT (outside 23°C ±5°C): Derate accuracy specification by (0.1 × specification)/°C.

OPERATING TEMPERATURE: 0° to 50°C (derate to 70%), 0° to 35°C (Full power).

STORAGE TEMPERATURE: -20° to 70°C.

HUMIDITY: <80% @ 35°C non-condensing.

DISPLAY TYPE: 2-line × 16 character VFD.

REMOTE DISPLAY/KEYPAD OPTION: Disables standard front panel.

DIMENSIONS: 89mm high × 213mm wide × 411mm deep (3½ in × 8½ in × 16¼ in).

NET WEIGHT: 3.2kg (7.1 lbs).

SHIPPING WEIGHT: 5.4kg (12 lbs).

INPUT POWER: 100-120VAC/220-240VAC, 50 or 60Hz (auto detected at power-up).

POWER CONSUMPTION: 150VA max.

EMC: Conforms with European Union Directive 2004/108/EC.

SAFETY: Conforms with European Union Directive 2006/95/EC, EN 61010-1.

AC LINE LEAKAGE CURRENT: 450µA @ 110VAC, typ.; 600µA @ 220V, typical.

RELAY CONTROL PORT: 4-channel, each capable of 100mA sink, 24V max. Total port sink capacity (all 4 combined) is 250mA max. Accepts DB-9 male plug. A source of +5VDC referenced to output common is also provided on the port to power external 5V relays.

2302, 2302-PJ, 2306, 2306-PJ

Battery Simulator Battery/Charger Simulators



- Ultrafast response to transient load currents
- Choice of single- or dual-channel supplies
- Optimized for development and testing of battery-powered devices
- Variable output resistance for simulating battery response (U.S. Patent No. 6,204,647)
- Pulse peak, average, and baseline current measurements
- 100nA DC current sensitivity
- Current step measure function
- Sink up to 3A
- Open sense lead detection
- Built-in digital voltmeter

SERVICES AVAILABLE

2302-3Y-EW	1-year factory warranty extended to 3 years from date of shipment
2306-PJ-3Y-EW	1-year factory warranty extended to 3 years from date of shipment
2306-3Y-EW	1-year factory warranty extended to 3 years from date of shipment
2306-PJ-3Y-EW	1-year factory warranty extended to 3 years from date of shipment
C/2302-3Y-ISO	3 (ISO-17025 accredited) calibrations within 3 years of purchase for Model 2302, 2302-PJ
C/2306-3Y-ISO	3 (ISO-17025 accredited) calibrations within 3 years of purchase for Models 2306, 2306-PJ

to operate like a discharged rechargeable battery, sinking current from a separate charger or from the Model 2306's charger-simulator channel.

Maximize Test Throughput with Accurate Battery Simulation

The battery-output channels of the Models 2302 and 2306 are designed to simulate the output response of a battery. *This capability, combined with their fast transient response, makes it possible to power the device during testing in exactly the same way as a battery will power the device during actual use.* The output resistance of the Model 2302's and the Model 2306's battery channel can be programmed (with 10mΩ resolution) over the range from 0Ω to 1Ω so that the output resistance can be set to the same level as the output resistance of the battery that powers the device. See **Figure 1**.

Portable wireless devices make great demands on their battery power sources. The battery must source load currents that can jump virtually instantaneously from a standby current level (100–300mA) to a full-power RF transmission current level (1–3A). In other words, the load current on the battery can increase rapidly by a factor of 700–1000%. As a result, the battery voltage drops by an amount equal to the value of the current change multiplied by the battery's internal resistance. The Models 2302 and 2306 power supplies enable test systems to duplicate this voltage drop by programming their output resistance to be equivalent to that of the battery that will power the device. This allows wireless device manufacturers to test their products under the same power conditions that they will encounter in actual use. (See **Figure 2**.)

The single-channel Model 2302 Battery Simulator and dual-channel Model 2306 Battery/Charger Simulator were designed specifically for development and test applications of portable, battery-operated products, such as cellular and cordless telephones, mobile radios, and pagers. These precision power supplies have ultrafast transient response so they can have output characteristics identical to actual batteries. These supplies employ a unique variable output resistance so the voltage output can emulate a battery's response (U.S. Patent No. 6,204,647). They provide stable voltage outputs, even when a device-under-test (DUT) makes the rapid transition from the standby (low current) state to the RF transmission (high current) state. In addition, they can monitor DUT power consumption by measuring both DC currents and pulse load currents. The Model 2302's and the Model 2306's battery-simulator channel can be programmed

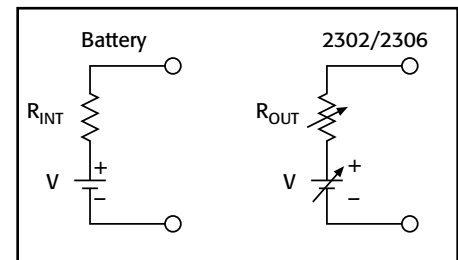

Figure 1. Simplified schematic of a battery and the 2302/2306.

ACCESSORIES AVAILABLE

2306-DISP	Remote Display
CS-846	Mating Output Connector

CABLES

7007-1	Shielded IEEE-488 Cable, 1m (3.3 ft)
7007-2	Shielded IEEE-488 Cable, 2m (6.6 ft)
SC-182	Low-Inductance Coaxial Cable (42nH/ft)

RACK MOUNT KITS

4288-1	Single Fixed Rack Mount Kit
4288-2	Dual Fixed Rack Mount Kit

IEEE-488 INTERFACES

KPCI-488LPA	IEEE-488 Interface/Controller for the PCI Bus
KUSB-488B	IEEE-488 USB-to-GPIB Interface Adapter

1.888.KEITHLEY (U.S. only)

www.keithley.com

KEITHLEY

A Tektronix Company

A Greater Measure of Confidence

2302, 2302-PJ, 2306, 2306-PJ

Ordering Information

- 2302** Battery Simulator
- 2302-PJ** Battery Simulator with 500mA Range
- 2306** Dual-Channel Battery/Charger Simulator
- 2306-PJ** Dual-Channel Battery/Charger Simulator with 500mA Range

Accessories Supplied

User and service manuals,
CS-846 output connectors
mating terminal

Conventional Power Supplies and Wireless Device Testing

During production testing, supplying power to a device that undergoes large, instantaneous load current changes can be extremely difficult. Changes like this force a conventional power supply's output voltage to fall instantaneously. When the power supply's control circuitry senses the error condition (the difference in voltage between the programmed level and the actual level), it attempts to correct or restore the voltage to the programmed level. During this time, the voltage will fall or droop substantially, with the amount of the droop depending on the size of the load current change. The recovery time depends on the transient response of the power supply's control loop. Conventional power supplies have transient voltage drops of >1V when confronted with load current changes of up to 1000%, and take up to a millisecond to recover to the programmed voltage. For portable devices such as cellular phones that operate at full power for only short intervals, the full power event is over before the conventional power supply can recover. For example, a cellular phone designed to the GSM cellular phone standard transmits and receives information in 576 μ s pulses. If the power supply used to test these types of phones cannot recover quickly enough, the performance of the phone during testing will be compromised by the power supply. If the power supply voltage drops below the threshold of the phone's low battery detection circuitry for long enough, then the phone will turn off during testing, giving a false indication of a failed device.

Battery Simulator Battery/Charger Simulators

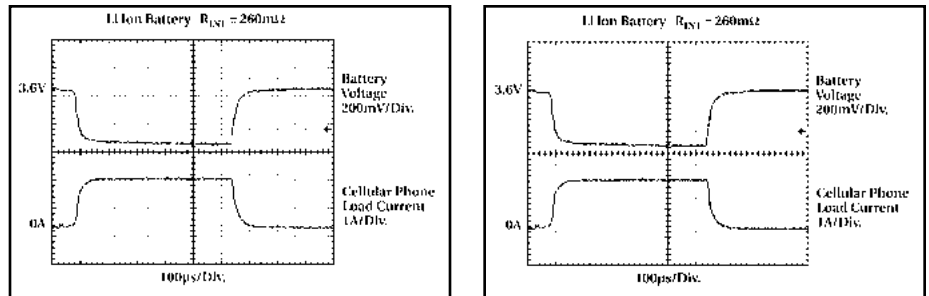

Figure 2. Comparison of the voltage outputs of a lithium-ion battery (with an internal resistance of 260m Ω) and the Model 2306's battery channel (programmed with an output resistance of 260m Ω) when powering a cellular telephone as it makes the transition from standby mode to transmit mode.

In response to large load changes, the Model 2302 and the battery channel of the Model 2306 have transient voltage droops of less than 100mV and transient recovery times of less than 60 μ s, even when the test leads between the power supply and the DUT are long. This fast transient response, combined with the supplies' variable output resistance, allows engineers to test their portable products under the most realistic operating conditions and eliminate false failures due to conventional power supplies with slow response times. (See the sidebar titled "Conventional Power Supplies and Wireless Device Testing.") These supplies also eliminate the large stabilizing capacitors needed at the DUT to compensate for the large droop that occurs when testing with conventional power supplies. By varying the output resistance, which can be done while the output is turned on, test engineers can simulate the operation of different battery types, as well as batteries nearing the end of their useful lives.

The Models 2302 and 2306 ensure maximum production throughput when testing portable

devices by minimizing false failures, minimizing the number of test setups by performing multiple tests with the same power supply, and minimizing test fixture complexity by eliminating the need for voltage-stabilizing capacitors.

Measure Load Currents for Power Consumption Verification or Analysis

As manufacturers of portable devices strive to extend their products' battery life, measuring load currents accurately has become increasingly essential in both design and production test in order to ensure the product meets its demanding specifications. Comprehensive testing of these devices requires measuring peak currents, average currents, and baseline currents in various operation modes. When testing these devices, these measurements are complicated by the pulsating nature of load currents, such as the transmit and receive load currents of digital cellular phones. The Models 2302 and 2306 can measure the peak and average currents of pulses as short as 60 μ s and as long as 833ms. (See **Figure 3**.)

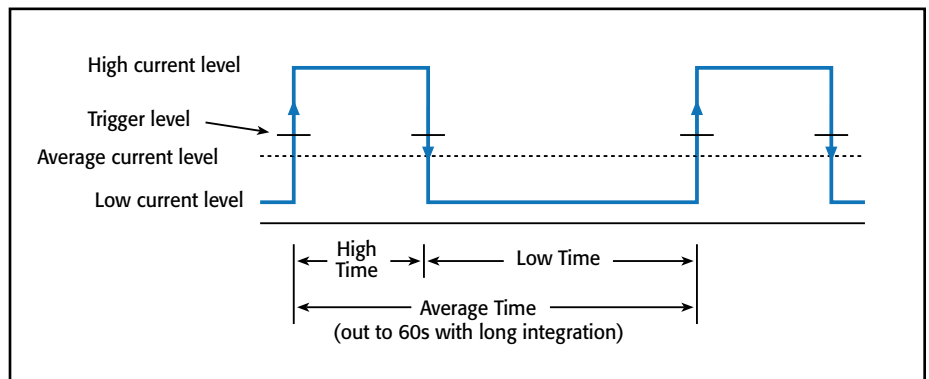

Figure 3. Built-in pulse current measurement functions allow test engineers to measure peak, average, and baseline load currents.

1.888.KEITHLEY (U.S. only)

www.keithley.com

A Greater Measure of Confidence

KEITHLEY
A Tektronix Company

2302, 2302-PJ, 2306, 2306-PJ

Battery Simulator Battery/Charger Simulators

Measure Long-Period Waveform Currents

For pulse trains with periods longer than 850ms, the Models 2302 and 2306 offer a unique, long integration current measurement mode. This mode can provide an average measurement of a current waveform from 850ms up to 60 seconds long.

Measure Low Currents Accurately

The Models 2302 and 2306 are based on Keithley's expertise in low current measurement technologies, so they're well-suited for making fast, accurate measurements of sleep and standby mode currents. With 100nA resolution and 0.2% basic accuracy, they provide the precision needed to monitor the low sleep mode currents of both today's battery-operated products and tomorrow's.

Verify Load Currents in All Operating States

The Models 2302 and 2306 employ a unique pulse current step function for measuring the load current at each level of a device's operational states. (See Figure 4.) For example, if a cellular phone is ramped up and down through as many as 20 discrete power consumption states, the Models 2302 and 2306 can measure the load currents in synchronization with the current steps. This capability allows a test engineer to verify performance at each operational state and simultaneously acquire power consumption information. The fast current measure capability is another way the Models 2302 and 2306 power supplies save test time and production costs.

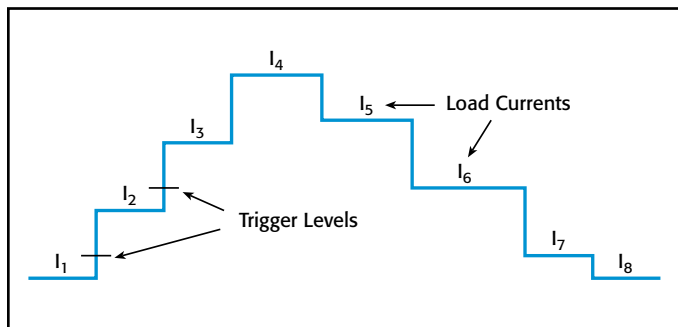

Figure 4. These power supplies can obtain a load current profile synchronized to the transitions of a DUT as it is stepped through its operating states.

Simulate a Discharged Battery for Charger Testing

The Models 2302 and 2306 can sink up to 3A continuously, just like an electronic load. This allows these supplies to simulate a discharged rechargeable battery for use in testing the performance of battery chargers or battery charger control circuitry.

The Model 2306 Battery/Charger Simulator combines the functionality of both the charging current source (the charger channel) and the current sinking to simulate the recharging of a discharged battery (the battery channel) in a single enclosure. (See Figure 5.)

Open-Sense Lead Detection

The Model 2302 and 2306 have an automatic open-sense lead detection capability, which indicates if there is a broken remote sense lead or an open connection from a remote sense lead to the test fixture. To ensure

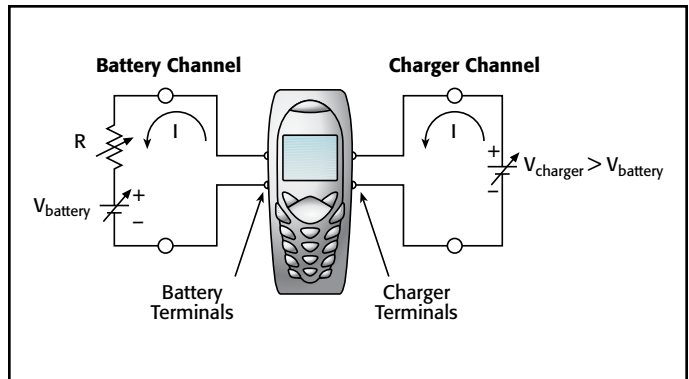

Figure 5. For charger control circuit testing applications, the Model 2306 and 2306-PJ can provide the functions of both a charger-simulating source and a discharged battery simulator.

the output voltage does not change from the programmed level, which could cause production devices to be improperly calibrated, the user can set high and low limits around the desired voltage level.

Independent Digital Voltmeter Inputs

Many programmable power supplies offer output readback capabilities, but the Model 2302 and 2306 also offer DVM inputs. Both instruments allow measuring signals from -5V to +30V DC anywhere in the test system with the same rated accuracy as the voltage readback. The Model 2306 has two sets of DVM inputs; the Model 2302 has one. The DVMs and the power sources can operate simultaneously. For many applications, these built-in DVMs eliminate the expense and space required to add a separate voltage measurement instrument.

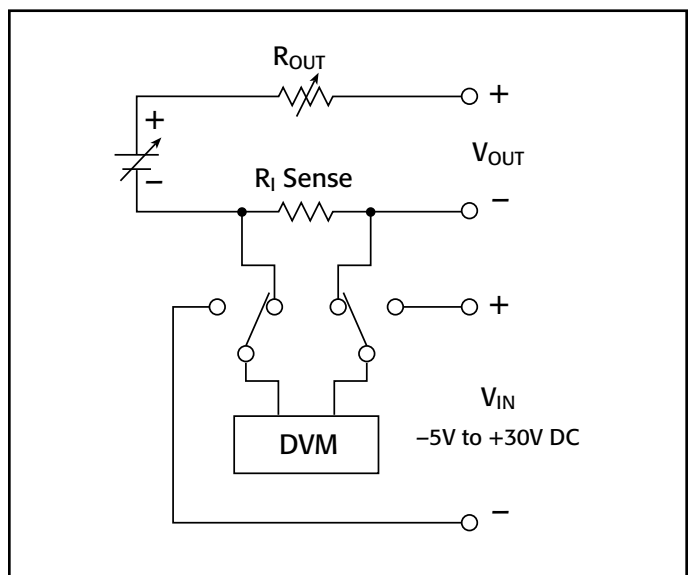

Figure 6. Model 2302 and Model 2306 Battery Channel Block Diagram. The Model 2306 charger channel is identical except it does not have the variable output resistance.

1.888.KEITHLEY (U.S. only)

www.keithley.com

KEITHLEY
A Tektronix Company

A Greater Measure of Confidence

2302, 2302-PJ, 2306, 2306-PJ

Battery Simulator Battery/Charger Simulators

Big Functionality in a Small Package

For high volume production environments where floor and test rack space are at a premium, the Model 2306 packs two power supplies into one half-rack enclosure. In addition to power control, both the Model 2302 and 2306 provide extensive measurement capabilities in the same half-rack case. The front panel of each unit displays the user's choice of either the output voltage and output current, the average, peak, and baseline pulse current levels, long integration currents, or DC DVM measurements. A minimum of front panel buttons ensures that operation is simple and straightforward.

For additional control requirements, the Models 2302 and 2306 each have four digital relay control outputs and a 5V DC output to power a relay coil.

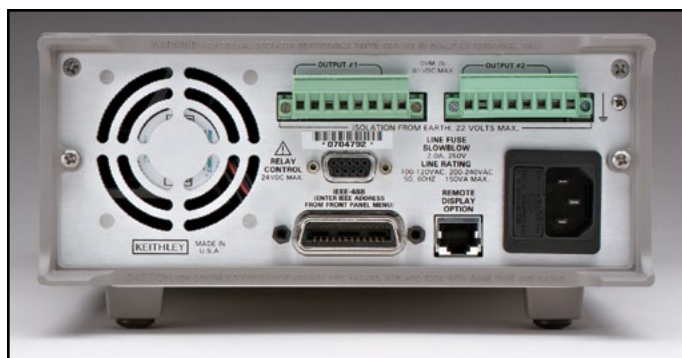

Figure 7. Model 2306 Rear Panel showing 8-position power output connectors, RJ-45 remote display connector, DB-9 relay output connector, IEEE-488 connector, and power input socket.

GENERAL

ISOLATION (low-earth): 22V DC max. For Models 2302-PJ, 2306 and 2306-PJ, do not exceed 60V DC between any two terminals of either connector.

PROGRAMMING: IEEE-488.2 (SCPI).

USER-DEFINABLE POWER-UP STATES: 5 (4 for Models 2302-PJ and 2306-PJ).

REAR PANEL CONNECTORS: Two (one for Models 2302, 2302-PJ) 8-position quick disconnect terminal block for output (4), sense (2), and DVM (2).

TEMPERATURE COEFFICIENT (outside 23°C ±5°C): Derate accuracy specification by (0.1 × specification)°C.

OPERATING TEMPERATURE: 0° to 50°C (Derate to 70%). 0° to 35°C (Full power).

STORAGE TEMPERATURE: -20° to 70°C.

HUMIDITY: <80% @ 35°C non-condensing.

DISPLAY TYPE: 2-line × 16-character VFD.

REMOTE DISPLAY/KEYPAD OPTION: Disables standard front panel.

DIMENSIONS: 89mm high × 213mm wide × 411mm deep (3½ in × 8½ in × 16¼ in).

NET WEIGHT: 3.2kg (7.1 lbs).

SHIPPING WEIGHT: 5.4kg (12 lbs).

INPUT POWER: 100–120V AC/220–240V AC, 50 or 60Hz (auto detected at power-up).

POWER CONSUMPTION: 150VA max.

EMC: 2302, 2306: Conforms with European Union Directive 89/336/EEC, EN 55011, EN 50082-1, EN 61000-3-2 and 61000-3-3, FCC part 15 class B. **2302-PJ, 2306-PJ:** Conforms with European Union Directive 89/336/EEC.

SAFETY: 2302, 2306: Conforms with European Union Directive 73/23/EEC, EN 61010-1. **2302-PJ, 2306-PJ:** Conforms with European Union Directive 73/23/EEC.

AC LINE LEAKAGE CURRENT: 450µA @ 110VAC, typ.; 600µA @ 220V, typ.

RELAY CONTROL PORT: 4-channel, each capable of 100mA sink, 24V max. Total port sink capacity (all 4 combined) is 250mA max. Accepts DB-9 male plug.

1.888.KEITHLEY (U.S. only)

www.keithley.com

A Greater Measure of Confidence

KEITHLEY
A Tektronix Company

Fast transient response power supplies

DC POWER SUPPLIES

2302, 2302-PJ, 2306, 2306-PJ

Battery Simulator Battery/Charger Simulators

Output #1 (Battery)

DC VOLTAGE OUTPUT (2 Years, 23°C ± 5°C)

OUTPUT VOLTAGE: 0 to +15V DC.
 OUTPUT ACCURACY: ±(0.05% + 3mV).
 PROGRAMMING RESOLUTION: 1mV.
 READBACK ACCURACY¹: ±(0.05% + 3mV).
 READBACK RESOLUTION: 1mV.
 OUTPUT VOLTAGE SETTling TIME: 5ms to within stated accuracy.
 LOAD REGULATION: 0.01% + 2mV.
 LINE REGULATION: 0.5mV.
 STABILITY²: 0.01% + 0.5mV.
 MEASUREMENT TIME CHOICES: 0.01 to 10PLC⁷, in 0.01PLC steps.
 AVERAGE READINGS: 1 to 10.
 READING TIME^{1, 8, 9}: 31ms, typical.
 TRANSIENT RESPONSE: **High Bandwidth** **Low Bandwidth**
 Transient Recovery Time¹³ <40μs³ or <60μs⁴ <80μs³ or <100μs⁴
 Transient Voltage Drop <75mV³ or <100mV⁴ <250mV³ or <400mV⁴

REMOTE SENSE: 1V max. drop in each lead. Add 2mV to the voltage load regulation specification for each 1V change in the negative output lead due to load current change. Remote sense required. Integrity of connection continually monitored. If compromised, output will turn off automatically once settable window (±0 to ±8V) around normal voltage exceeded.

VARIABLE OUTPUT IMPEDANCE

RANGE: 0 to 1.00Ω in 0.01Ω steps. Value can be changed with output on.

DC CURRENT (2 Years, 23°C ± 5°C)

CONTINUOUS AVERAGE OUTPUT CURRENT (2302, 2302-PJ):
 0–4V: 5A max.
 >4V: I_{MAX} = 60W/(V_{SET} + 6) (not intended to be operated in parallel).
 Peak currents can be a maximum of 5A provided the average current is within the above limits.
 CONTINUOUS AVERAGE OUTPUT CURRENT (2306, 2306-PJ):
 Channel #2 (Charger) OFF:
 I = 50W/(V_{SET} channel 1 + 6V); 5A max.
 Channel #2 (Charger) ON:
 I = (50W – Power consumed by channel #2)/(V_{SET} channel 1 + 6V); 5A max.
 The power consumed by channel #2 is calculated as:
 Channel #2 sourcing current:
 Power consumed = (V_{SET} channel 2 + 6V) × (current supplied)
 Channel #2 sinking current:
 Power consumed = 5 × (sink current)
 Peak currents can be a maximum of 5A provided the average current is within the above limits.

CONTINUOUS AVERAGE SINK CURRENT:
 Channel #2 (Charger) OFF:
 0–5V: 3A max.
 5–15V: Derate 0.2A per volt above 5V. Compliance setting controls sinking.
 Channel #2 (Charger) ON:
 Available current = (50W – Power consumed by channel #2)/5; 3A max. (0–5V).
 Derate 0.2A per volt above 5V.

SOURCE COMPLIANCE ACCURACY: ±(0.16% + 5mA)⁵.
 PROGRAMMED SOURCE COMPLIANCE RESOLUTION: 1.25mA.
 READBACK ACCURACY¹: **5A Range:** ±(0.2% + 200μA).
5mA Range: ±(0.2% + 1μA) (2302 and 2306).
500mA Range: ±(0.2% + 20μA) (2302-PJ and 2306-PJ only).
 READBACK RESOLUTION: **5A Range:** 100μA.
5mA Range: 0.1μA (2302 and 2306).
500mA Range: 10μA (2302-PJ and 2306-PJ only).

LOAD REGULATION: 0.01% + 1mA.
 LINE REGULATION: 0.5mA.
 STABILITY⁴: 0.01% + 50μA.
 MEASUREMENT TIME CHOICES: 0.01 to 10PLC⁷, in 0.01PLC steps.
 AVERAGE READINGS: 1 to 10.
 READING TIME^{1, 8, 9}: 31ms, typical.

PULSE CURRENT MEASUREMENT OPERATION

TRIGGER LEVEL:
5A CURRENT RANGE
5A Range: 5mA to 5A, in 5mA steps.
1A Range: 1mA to 1A, in 1mA steps.
100mA Range: 0.1mA to 100mA, in 100μA steps.
500mA CURRENT RANGE (2302-PJ and 2306-PJ)
500mA Range: 0.5mA to 500mA, in 0.5mA steps.
100mA Range: 0.1mA to 100mA, in 100μA steps.
10mA Range: 100μA to 10mA, in 100μA steps.
 TRIGGER DELAY: 0 to 100ms, in 10μs steps.
 INTERNAL TRIGGER DELAY: 15μs.
 HIGH/LOW/AVERAGE MODE:
 Measurement Aperture Settings: 33.3μs to 833ms, in 33.3μs steps.
 Average Readings: 1 to 10.
 PULSE CURRENT MEASUREMENT ACCURACY¹¹ (2 Years, 23°C ± 5°C):

Aperture	Accuracy ±(% reading + offset + rms noise ¹⁰)	
	5A Range	500mA Range (2302-PJ and 2306-PJ)
<100 μs	0.2% + 900 μA + 2 mA	0.2% + 90 μA + 2 mA
100 μs – 200 μs	0.2% + 900 μA + 1.5 mA	0.2% + 90 μA + 1.5 mA
200 μs – 500 μs	0.2% + 900 μA + 1 mA	0.2% + 90 μA + 1 mA
500 μs – <1 PLC	0.2% + 600 μA + 0.8 mA	0.2% + 60 μA + 0.8 mA
1 PLC ¹²	0.2% + 400 μA + 0 mA	0.2% + 40 μA + 0 mA
>1 PLC	0.2% + 400 μA + 100 μA	0.2% + 40 μA + 100 μA

BURST MODE CURRENT MEASUREMENT

MEASUREMENT APERTURE: 33.3μs.
 CONVERSION RATE: 3650/second, typical.
 INTERNAL TRIGGER DELAY: 15μs.
 NUMBER OF SAMPLES: 1 to 5000.
 TRANSFER SAMPLES ACROSS IEEE BUS IN BINARY MODE: 4800 bytes/s, typical.

LONG INTEGRATION MODE CURRENT MEASUREMENT

2302, 2306: Available on 5A range only.
 2302-PJ AND 2306-PJ: Available on both 5A and 500mA current ranges.
 MEASUREMENT TIME⁶: 850ms (840ms) to 60 seconds in 1ms steps.

DIGITAL VOLTMETER INPUT (2 Years, 23°C ± 5°C)

INPUT VOLTAGE RANGE: –5 to +30V DC.
 INPUT IMPEDANCE: 2MΩ typical.
 MAXIMUM VOLTAGE (either input terminal) WITH RESPECT TO OUTPUT LOW: –5V, +30V.
 READING ACCURACY¹: ±(0.05% + 3mV).
 READING RESOLUTION: 1mV.
 CONNECTOR: HI and LO input pair part of Output #1's terminal block.
 MEASUREMENT TIME CHOICES: 0.01 to 10PLC⁷, in 0.01PLC steps.
 AVERAGE READINGS: 1 to 10.
 READING TIME^{1, 8, 9}: 31ms, typical.

1.888.KEITHLEY (U.S. only)

www.keithley.com

KEITHLEY
A Tektronix Company

A Greater Measure of Confidence

2302, 2302-PJ, 2306, 2306-PJ

Battery Simulator Battery/Charger Simulators

OUTPUT #2 (CHARGER)

DC VOLTAGE OUTPUT (2 Years, 23°C ± 5°C)

OUTPUT VOLTAGE: 0 to +15V DC.
 OUTPUT ACCURACY: ±(0.05% + 10mV).
 PROGRAMMING RESOLUTION: 10mV.
 READBACK ACCURACY¹: ±(0.05% + 3mV).
 READBACK RESOLUTION: 1mV.
 OUTPUT VOLTAGE SETTling TIME: 5ms to within stated accuracy.
 LOAD REGULATION: 0.01% + 2mV.
 LINE REGULATION: 0.5mV.
 STABILITY²: 0.01% + 0.5mV.
 MEASUREMENT TIME CHOICES: 0.01 to 10PLC⁷, in 0.01PLC steps.
 AVERAGE READINGS: 1 to 10.
 READING TIME^{1,8,9}: 31ms, typical.
 TRANSIENT RESPONSE:
 Transient Recovery Time¹³ **High Bandwidth** **Low Bandwidth**
 <50μs³ or <80μs⁴ <60μs³ or <100μs⁴
 Transient Voltage Drop <120mV³ or <150mV⁴ <160mV³ or <200mV⁴

REMOTE SENSE: 1V max. drop in each lead. Add 2mV to the voltage load regulation specification for each 1V change in the negative output lead due to load current change. Remote sense required. Integrity of connection continually monitored. If compromised, output will turn off automatically once settable window (±0 to ±8V) around normal voltage exceeded.

DC CURRENT (2 Years, 23°C ± 5°C)

CONTINUOUS AVERAGE OUTPUT CURRENT:
 Channel #1 (Battery) OFF:
 I = 50W/(V_{SET} channel 2 + 6V); 5A max.
 Channel #1 (Battery) ON:
 I = (50W – Power consumed by channel #1)/(V_{SET} channel 2 + 6V); 5A max.
 The power consumed by channel #1 is calculated as:
 Channel #1 sourcing current:
 Power consumed = (V_{SET} channel 1 + 6V) × (current supplied)
 Channel #1 sinking current:
 Power consumed = 5 × (sink current)
 Peak currents can be a maximum of 5A provided the average current is within the above limits.
 CONTINUOUS AVERAGE SINK CURRENT:
 Channel #1 (Battery) OFF:
 0–5V: 3A max.
 5–15V: Derate 0.2A per volt above 5V. Compliance setting controls sinking.
 Channel #1 (Battery) ON:
 Available current = (50W – Power consumed by channel #1)/5; 3A max. (0–5V).
 Derate 0.2A per volt above 5V.

SOURCE COMPLIANCE ACCURACY: ±(0.16% + 5mA)⁵.
 PROGRAMMED SOURCE COMPLIANCE RESOLUTION: 1.25mA.
 READBACK ACCURACY¹: 5A Range: ±(0.2% + 200μA).
 5mA Range: ±(0.2% + 1μA).
 READBACK RESOLUTION: 5A Range: 100μA.
 5mA Range: 0.1μA.
 LOAD REGULATION: 0.01% + 1mA.
 LINE REGULATION: 0.5mA.
 STABILITY²: 0.01% + 50μA.
 MEASUREMENT TIME CHOICES: 0.01 to 10PLC⁷, in 0.01PLC steps.
 AVERAGE READINGS: 1 to 10.
 READING TIME^{1,8,9}: 31ms, typical.

PULSE CURRENT MEASUREMENT OPERATION

TRIGGER LEVEL: 5mA to 5A, in 5mA steps.
 TRIGGER DELAY: 0 to 100ms, in 10μs steps.
 INTERNAL TRIGGER DELAY: 15μs.
 HIGH/LOW/AVERAGE MODE:
 Measurement Aperture Settings: 33.3μs to 833ms, in 33.3μs steps.
 Average Readings: 1 to 100.
 PULSE CURRENT MEASUREMENT ACCURACY¹¹ (2 Years, 23°C ± 5°C):

Aperture	Accuracy ±(% reading + offset + rms noise ¹⁰)
<100 μs	0.2% + 900 μA + 2 mA
100 μs – 200 μs	0.2% + 900 μA + 1.5 mA
200 μs – 500 μs	0.2% + 900 μA + 1 mA
500 μs – <1 PLC	0.2% + 600 μA + 0.8 mA
1 PLC ¹²	0.2% + 400 μA + 0 mA
>1 PLC	0.2% + 400 μA + 100 μA

BURST MODE CURRENT MEASUREMENT

MEASUREMENT APERTURE: 33.3μs.
 CONVERSION RATE: 2040/second, typical.
 INTERNAL TRIGGER DELAY: 15μs.
 NUMBER OF SAMPLES: 1 to 5000.
 TRANSFER SAMPLES ACROSS IEEE BUS IN BINARY MODE: 4800 bytes/s, typical.

LONG INTEGRATION MODE CURRENT MEASUREMENT

MEASUREMENT TIME⁶: 850ms (840ms) to 60 seconds in 1ms steps.

DIGITAL VOLTMETER INPUT (2 Years, 23°C ± 5°C)

INPUT VOLTAGE RANGE: –5 to +30V DC.
 INPUT IMPEDANCE: 2MΩ typical.
 MAXIMUM VOLTAGE (either input terminal) WITH RESPECT TO OUTPUT LOW: –5V, +30V.
 READING ACCURACY¹: ±(0.05% + 3mV).
 READING RESOLUTION: 1mV.
 CONNECTOR: HI and LO input pair part of Output #2's terminal block.
 MEASUREMENT TIME CHOICES: 0.01 to 10PLC⁷, in 0.01PLC steps.
 AVERAGE READINGS: 1 to 10.
 READING TIME^{1,8,9}: 31ms, typical.

NOTES

1. PLC = 1.00.
2. Following 15 minute warm-up, the change in output over 8 hours under ambient temperature, constant load, and line operating conditions.
3. Remote sense, at output terminals, 0.5A to 5A typical.
4. Remote sense, with 4.5m (15 ft) of 16 gauge (1.31mm²) wire and 1Ω resistance in each lead to simulate typical test environment, 1.5A load change (0.15A to 1.65A).
5. Minimum current in constant current mode is 6mA.
6. 60Hz (50Hz).
7. PLC = Power Line Cycle. 1PLC = 16.7ms for 60Hz operation, 20ms for 50Hz operation. Display off.
9. Speed includes measurement and binary data transfer out of GPIB.
10. Typical values, peak-to-peak noise equals 6 times rms noise.
11. Based on settled signal: 100μs pulse trigger delay.
12. Also applies to other apertures that are integer multiples of 1PLC.
13. Recovery to within 20mV of previous level.

1.888.KEITHLEY (U.S. only)

www.keithley.com

A Greater Measure of Confidence

KEITHLEY
A Tektronix Company

Model 2302, 2302-PJ, 2306, 2306-PJ specifications

DC POWER SUPPLIES

2306-VS

Dual-Channel Battery/Charger Simulator with External Triggering



The dual-channel Model 2306-VS Battery/Charger Simulator with External Triggering is designed specifically for development and high speed production testing of DC battery-operated products, such as cellular handsets, cellular components like RFIC power amplifiers, and other high volume precision electrical components that require a DC voltage supply. Like Keithley's original single-channel Model 2302 Battery Simulator and dual-channel Model 2306 Battery/Charger Simulator, this precision power supply has ultra-fast transient response to provide output characteristics identical to actual batteries. However, in addition to the capabilities offered by these models, the Model 2306-VS (voltage step) provides two external trigger inputs, which allow independent control of the instrument's output channels. These trigger inputs speed and simplify control of the output channels by eliminating the time lags associated with GPIB data communications. The Model 2306-VS combines

these external trigger inputs with built-in test sequencing to create an extremely fast voltage supply and measurement instrument that minimizes the need for computer and GPIB interaction.

External Triggering Allows High Speed Control of Output Channels

When triggered, the output channels can be instructed to operate at pre-defined voltages or to initiate current, voltage, or pulse current measurements. The availability of two inputs makes it possible to program each channel to act independently or, if the test developer prefers, to act in parallel. For example, Channel #1 can be programmed to operate at user-specified voltage levels while Channel #2 is triggered to take measurements. Measurements are stored in a reading buffer and can be downloaded to a PC controller after the test routine is complete, minimizing GPIB command and data transfer delays. Trigger outputs indicate event completion, allowing users to minimize step delays between trigger-in sequences.

External triggering also allows the Model 2306-VS to exercise tight control over signal capture timing for greater measurement and load condition coordination. As a result, manufacturers can achieve greater confidence in their own compliance testing and can offer their customers more accurate component specifications.

This precision power supply has ultra-fast transient response to duplicate the output characteristics of actual batteries. In response to large load changes, voltage droops on the Model 2306-VS's battery channel are less than 100mV and transient recovery times are less than 60 μ s, even when the instrument is used with long test leads. The Model 2306-VS also employs a unique variable output resistance so that the voltage output can emulate a battery's true response (U.S. Patent No. 6,204,647). By providing stable output voltage, a device-under-test (DUT) can transition from standby power (low current) to RF transmission (high current) seamlessly without nuisance tripping.

Built-in Test Sequencing Maximizes Throughput

The Model 2306-VS's built-in test sequencing capabilities allow setting up and executing up to 20 individual voltage and measurement sequences. By minimizing the need to transfer instrument commands or data over the GPIB

- External trigger inputs speed and simplify control of output channels
- Built-in test sequencing reduces GPIB bus traffic and improves test throughput
- Ultra-fast response to transient load currents
- Selectable trigger level polarity
- Variable output resistance for simulating battery response (U.S. Patent No. 6,204,647)
- Trigger outputs provided for event handshaking
- 100nA DC current sensitivity
- Sink up to 3A
- Open sense lead detection
- Built-in digital voltmeter

APPLICATIONS

Development and high speed testing of DC battery-operated products, such as:

- Cellular handsets
- Cellular components like RFIC power amplifiers
- Other high volume precision electrical components

1.888.KEITHLEY (U.S. only)

www.keithley.com

A Greater Measure of Confidence

KEITHLEY
A Tektronix Company

2306-VS

Ordering Information

**2306-VS Dual-Channel Battery/
Charger Simulator with
External Triggering**

Accessories Supplied
User and service manuals
CS-846 output connectors
Mating terminal

ACCESSORIES AVAILABLE

2306-DISP	Remote Display
CS-846	Mating Output Connector

CABLES

7007-1	Double Shielded Premium IEEE-488 Cable, 1m (3.2 ft)
7007-2	Double Shielded Premium IEEE-488 Cable, 2m (6.5 ft)
SC-182	Low-Inductance Coaxial Cable (42nH/ft)

RACK MOUNT KITS

4288-1	Single Fixed Rack Mount Kit
4288-2	Dual Fixed Rack Mount Kit

IEEE-488 INTERFACES

KPCI-488LPA	IEEE-488 Interface/Controller for the PCI Bus
KUSB-488B	IEEE-488 USB-to-GPIB Interface Adapter

SERVICES AVAILABLE

2306-VS-3Y-EW	1-year factory warranty extended to 3 years from date of shipment
C/2306-3Y-ISO	3 (ISO-17025 accredited) calibrations within 3 years of purchase*

*Not available in all countries

Dual-Channel Battery/Charger Simulator with External Triggering

bus, these test sequences support faster, easier production testing by allowing users to pre-define a variety of test configurations, such as:

- Trigger up to 20 voltage setpoints on Channel #1, Channel #2, or both
- Trigger up to 20 measurement readings on Channel #1, Channel #2, or both
- Trigger voltage setpoints on Channel #1 while triggering Channel #2 measurement readings

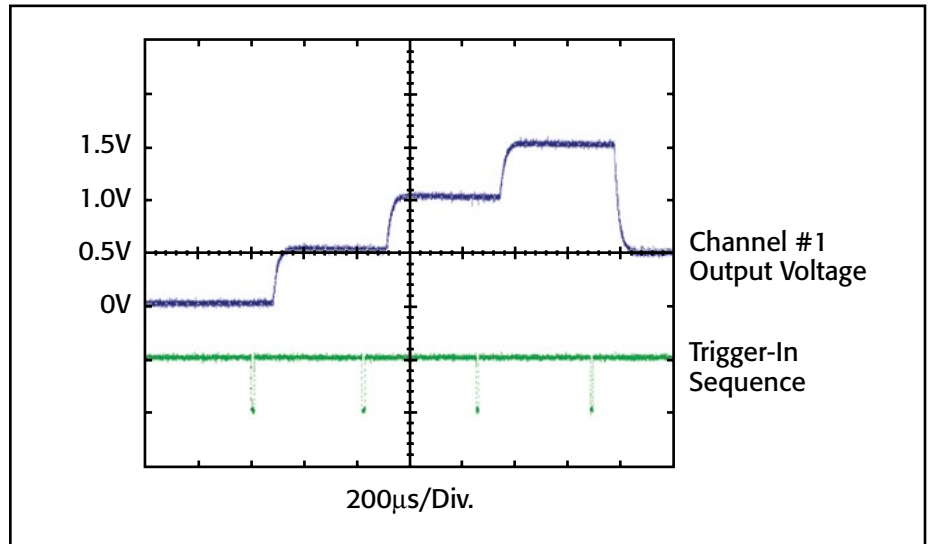

Figure 1. This graph illustrates Channel #1 output voltage response times based on a four-point voltage step sequence (0.5V/1.0V/1.5V/0.5V). The Model 2306-VS can complete this sequence within 1.5ms.

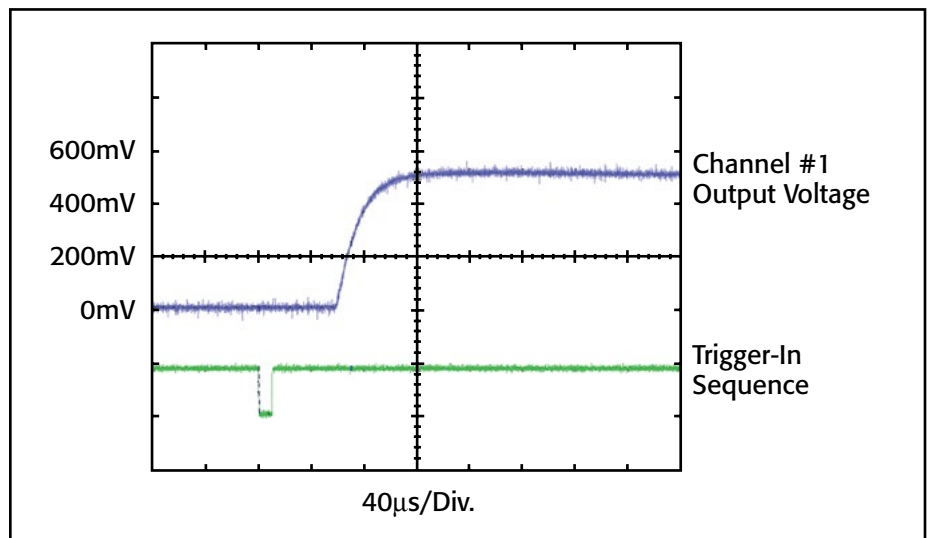

Figure 2. This magnified view of the first 500mV voltage step from the signal shown in Figure 1 illustrates how the Channel #1 output reaches the voltage setpoint within 160µs of the trigger-in pulse.

1.888.KEITHLEY (U.S. only)

www.keithley.com

A Greater Measure of Confidence

KEITHLEY
A Tektronix Company

Fast transient response power supply

DC POWER SUPPLIES

2306-VS

Dual-Channel Battery/Charger Simulator with External Triggering

Measure Load Currents for Power Consumption Verification or Analysis

The Model 2306-VS is based on Keithley's expertise in low current measurement technologies, so it is well-suited for making accurate measurements of load currents. With 100nA resolution and 0.2% basic accuracy, it provides the precision needed to monitor the low sleep mode currents of today's battery-operated products.

The Model 2306-VS can monitor DUT power consumption by measuring both DC currents and pulse load currents. The instrument's battery-simulator channel can be programmed to operate like a discharged rechargeable battery, sinking up to 3A from the charger-simulator channel.

Maximize Test Throughput with Accurate Battery Simulation

The Model 2306-VS's battery-output channel is designed to simulate the output response of a battery. This capability, combined with its fast transient response, makes it possible to power the device during testing in exactly the same way as a battery powers the device during actual use. The output resistance of the battery channel can be programmed (with 10mΩ resolution) over the range from 0Ω to 1Ω so that the output resistance can be set to the same level as the output resistance of the battery that powers the device.

Portable wireless devices make great demands on their battery power sources. The battery must source load currents that can jump virtually instantaneously from a standby current level (100–300mA) to a full power RF transmission current level (1–3A). In other words, the load current on the battery can increase rapidly by a factor of 700–1000%. As a result, the battery voltage drops by an amount equal to the value of the current change multiplied by the battery's internal resistance. The Model 2306-VS enables test systems to duplicate this voltage drop by programming their output resistance to be equivalent to that of the battery that will power the device. This allows wireless device manufacturers to test their products under the same power conditions that they will encounter in actual use.

The Model 2306-VS also eliminates the large stabilizing capacitors needed at the DUT to compensate for the large voltage droop that occurs when testing with conventional power supplies. By varying the output resistance, which can be done while the output is turned on, test engineers can simulate the operation of different battery types as well as batteries nearing the end of their useful lives. The Model 2306-VS ensures maximum production throughput when testing portable devices by minimizing false failures, minimizing the number of test setups by performing multiple tests with the same power supply, and minimizing test fixture complexity by eliminating the need for voltage-stabilizing capacitors.

Open Sense Lead Detection

The Model 2306-VS has an automatic open-sense lead detection capability, which indicates if there is a broken remote sense lead or an open connection from a remote sense lead to the test fixture. To ensure that the output voltage does not change from the programmed level, which could cause production devices to be improperly calibrated, the user can set high and low limits around the desired voltage level.

Independent Digital Voltmeter Inputs

Many programmable power supplies offer output read-back capabilities, but the Model 2306-VS also offers two digital voltmeter (DVM) inputs. These inputs can be used to measure signals from –5V to +30V DC anywhere in the test system with the same rated accuracy as the voltage readback. For many applications, this built-in DVM eliminates the expense and space otherwise required to add a separate voltage measurement instrument to the system.

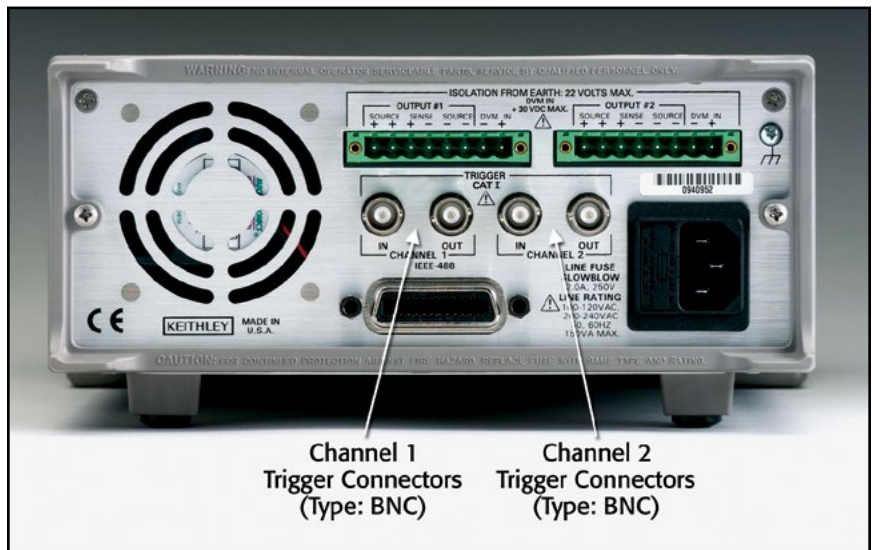

Model 2306-VS rear panel

Channel 1
Trigger Connectors
(Type: BNC)

Channel 2
Trigger Connectors
(Type: BNC)

1.888.KEITHLEY (U.S. only)

www.keithley.com

KEITHLEY
A Tektronix Company

A Greater Measure of Confidence

2306-VS

Dual-Channel Battery/Charger Simulator with External Triggering

Output #1 (Battery)

DC VOLTAGE OUTPUT (2 Years, 23°C ± 5°C)

OUTPUT VOLTAGE: 0 to +15VDC.
 OUTPUT ACCURACY: ±(0.05% + 3mV).
 PROGRAMMING RESOLUTION: 1mV.
 READBACK ACCURACY¹: ±(0.05% + 3mV).
 READBACK RESOLUTION: 1mV.
 LOAD REGULATION: ±(0.01% + 2mV).
 LINE REGULATION: ±0.5mV.
 STABILITY²: ±(0.01% + 0.5mV).
 MEASUREMENT TIME CHOICES: 0.01 to 10 PLC⁷, in 0.01PLC steps.
 AVERAGE READINGS: 1 to 10.
 READING TIME^{1,8,9}: 31ms, typical.

TRANSIENT RESPONSE:	High Bandwidth	Low Bandwidth
Transient Recovery Time ¹³	<40 μs ³ or <60 μs ⁴	<80 μs ³ or <100 μs ⁴
Transient Voltage Drop	<75 mV ³ or <100 mV ⁴	<250 mV ³ or <400 mV ⁴

REMOTE SENSE: 1V max. drop in each lead. Add 2mV to the voltage load regulation specification for each 1V change in the negative output lead due to load current change. Remote sense required. Integrity of connection continually monitored. If compromised, output will turn off automatically once settable window (±0 to ±8 volts) around normal voltage exceeded.

VARIABLE OUTPUT IMPEDANCE

RANGE: 0 to 1.00Ω in 0.01Ω steps. Value can be changed with output on if trigger external disabled on channel.

DC CURRENT (2 Years, 23°C ± 5°C)

CONTINUOUS AVERAGE OUTPUT CURRENT:

Channel #2 (Charger) OFF: $I = 50W / (V_{set} \text{ channel 1} + 6V)$; 5A max.
 Channel #2 (Charger) ON: $I = (50W - \text{Power consumed by channel #2}) / (V_{set} \text{ channel 1} + 6V)$; 5A max.
 The power consumed by channel #2 is calculated as:
 Channel #2 sourcing current: Power consumed = $(V_{set} \text{ channel 2} + 6V) \times (\text{current supplied})$.
 Channel #2 sinking current: Power consumed = $5 \times (\text{sink current})$.

Peak currents can be a maximum of 5A provided the average current is within the above limits.

CONTINUOUS AVERAGE SINK CURRENT:

Channel #2 (Charger) OFF:
 0–5V: 3A max.
 5–15V: Derate 0.2A per volt above 5V. Compliance setting controls sinking.
 Channel #2 (Charger) ON:
 Available current = $(50W - \text{Power consumed by channel #2}) / 5$; 3A max. (0–5V).
 Derate 0.2A per volt above 5V.

SOURCE COMPLIANCE ACCURACY: ±(0.16% + 5mA)⁵.
 PROGRAMMED SOURCE COMPLIANCE RESOLUTION: 1.25mA.
 READBACK ACCURACY¹: 5A Range: ±(0.2% + 200μA). 5mA Range: ±(0.2% + 1μA).
 READBACK RESOLUTION: 5A Range: 100μA. 5mA Range: 0.1μA.
 LOAD REGULATION: ±(0.01% + 1mA).
 LINE REGULATION: ±0.5mA.
 STABILITY²: ±(0.01% + 50μA).
 MEASUREMENT TIME CHOICES: 0.01 to 10 PLC⁷, in 0.01PLC steps.
 AVERAGE READINGS: 1 to 10.
 READING TIME^{1,8,9}: 31ms, typical.

PULSE CURRENT MEASUREMENT OPERATION

TRIGGER LEVEL: 5A Range: 5mA to 5A, in 5mA steps.
 1A Range: 1mA to 1A, in 1mA steps.
 100mA Range: 0.1mA to 100mA, in 100μA steps.
 TRIGGER DELAY: 0 to 100ms, in 10μs steps.
 INTERNAL TRIGGER DELAY: 15μs.
 HIGH/LOW/AVERAGE MODE:
 Measurement Aperture Settings: 33.3μs to 833ms, in 33.3μs steps.
 Average Readings: 1 to 100.
 PULSE CURRENT MEASUREMENT ACCURACY¹¹ (2 Years, 23°C ± 5°C):

Aperture	Accuracy ±(% reading + offset + rms noise ¹⁰)
<100 μs	0.2% + 900 μA + 2 mA
100 μs – 200 μs	0.2% + 900 μA + 1.5 mA
200 μs – 500 μs	0.2% + 900 μA + 1 mA
500 μs – <1 PLC	0.2% + 600 μA + 0.8 mA
1 PLC ¹²	0.2% + 400 μA + 0 mA
>1 PLC	0.2% + 400 μA + 100 μA

BURST MODE CURRENT MEASUREMENT

MEASUREMENT APERTURE: 33.3μs to 833ms, in 33.3μs steps.
 CONVERSION RATE: 3650/second at 33.3μs meas. aper., typical.
 INTERNAL TRIGGER DELAY: 15μs with 33μs.
 NUMBER OF SAMPLES: 1 to 5000.
 TRANSFER SAMPLES ACROSS IEEE BUS IN BINARY MODE: 4800 bytes/s, typical.

LONG INTEGRATION MODE CURRENT MEASUREMENT

MEASUREMENT TIME⁶: 850ms (840ms) to 60 seconds in 1ms steps.

DIGITAL VOLTMETER INPUT (2 Years, 23°C ± 5°C)

INPUT VOLTAGE RANGE: –5 to +30VDC.
 INPUT IMPEDANCE: 2MΩ typical.
 MAXIMUM VOLTAGE (either input terminal) WITH RESPECT TO OUTPUT LOW: –5V, +30V.
 READING ACCURACY¹: ±(0.05% + 3mV).
 READING RESOLUTION: 1mV.
 CONNECTOR: HI and LO input pair part of Output #1's terminal block.
 MEASUREMENT TIME CHOICES: 0.01 to 10 PLC⁷, in 0.01PLC steps.
 AVERAGE READINGS: 1 to 10.
 READING TIME^{1,8,9}: 31ms, typical.

VOLTAGE SETTLING TIMES

VOLTAGE STEP SETTLING TIMES (typical)

Increasing Voltage	10–90% Rise Time	Settling Time
Voltage step ≤ 7 V	50 μs	300 μs
Voltage step > 7 V	50 μs to 1.2 ms	300 μs to 1.8 ms

Decreasing Voltage	10–90% Fall Time	Settling Time
0 V < Voltage step < 15 V	50 μs to 250 μs	300 μs

NOTE: Times are under no load condition and settling times defined at ±2% of step size.

1.888.KEITHLEY (U.S. only)

www.keithley.com

KEITHLEY

A Greater Measure of Confidence

A Tektronix Company

2306-VS

Dual-Channel Battery/Charger Simulator with External Triggering

Output #2 (Charger)

DC VOLTAGE OUTPUT (2 Years, 23°C ± 5°C)

OUTPUT VOLTAGE: 0 to +15VDC.
OUTPUT ACCURACY: $\pm(0.05\% + 10\text{mV})$.
PROGRAMMING RESOLUTION: 10mV.
READBACK ACCURACY¹: $\pm(0.05\% + 3\text{mV})$.
READBACK RESOLUTION: 1mV.
OUTPUT VOLTAGE SETTLING TIME: 5ms to within stated accuracy.
LOAD REGULATION: $\pm(0.01\% + 2\text{mV})$.
LINE REGULATION: $\pm 0.5\text{mV}$.
STABILITY²: $\pm(0.01\% + 0.5\text{mV})$.
MEASUREMENT TIME CHOICES: 0.01 to 10 PLC⁷, in 0.01PLC steps.
AVERAGE READINGS: 1 to 10.
READING TIME^{1,8,9}: 31ms, typical.

TRANSIENT RESPONSE:	High Bandwidth	Low Bandwidth
Transient Recovery Time ¹³	$<50 \mu\text{s}^3$ or $<80 \mu\text{s}^4$	$<60 \mu\text{s}^3$ or $<100 \mu\text{s}^4$
Transient Voltage Drop	$<120 \text{mV}^3$ or $<150 \text{mV}^4$	$<160 \text{mV}^3$ or $<200 \text{mV}^4$

REMOTE SENSE: 1V max. drop in each lead. Add 2mV to the voltage load regulation specification for each 1V change in the negative output lead due to load current change. Remote sense required. Integrity of connection continually monitored. If compromised, output will turn off automatically once settable window (± 0 to ± 8 volts) around normal voltage exceeded.

DC CURRENT (2 Years, 23°C ± 5°C)

CONTINUOUS AVERAGE OUTPUT CURRENT:

Channel #1 (Battery) OFF: $I = 50\text{W}/(V_{\text{set}} \text{ channel 2} + 6\text{V})$; 5A max.
Channel #1 (Battery) ON: $I = (50\text{W} - \text{Power consumed by channel \#1})/(V_{\text{set}} \text{ channel 2} + 6\text{V})$; 5A max.
The power consumed by channel #1 is calculated as:
Channel #1 sourcing current: Power consumed = $(V_{\text{set}} \text{ channel 1} + 6\text{V}) \times (\text{current supplied})$
Channel #1 sinking current: Power consumed = $5 \times (\text{sink current})$

Peak currents can be a maximum of 5A provided the average current is within the above limits.

CONTINUOUS AVERAGE SINK CURRENT:

Channel #1 (Battery) OFF:
0–5V: 3A max.
5–15V: Derate 0.2A per volt above 5V. Compliance setting controls sinking.
Channel #1 (Battery) ON:
Available current = $(50\text{W} - \text{Power consumed by channel \#1})/5$; 3A max. (0–5V).
Derate 0.2A per volt above 5V.

SOURCE COMPLIANCE ACCURACY: $\pm(0.16\% + 5\text{mA})^5$.
PROGRAMMED SOURCE COMPLIANCE RESOLUTION: 1.25mA.
READBACK ACCURACY¹: 5A Range: $\pm(0.2\% + 200\mu\text{A})$, 5mA Range: $\pm(0.2\% + 1\mu\text{A})$.
READBACK RESOLUTION: 5A Range: 100 μA , 5mA Range: 0.1 μA .
LOAD REGULATION: $\pm(0.01\% + 1\text{mA})$.
LINE REGULATION: $\pm 0.5\text{mA}$.
STABILITY²: $\pm(0.01\% + 50\mu\text{A})$.
MEASUREMENT TIME CHOICES: 0.01 to 10 PLC⁷, in 0.01PLC steps.
AVERAGE READINGS: 1 to 10.
READING TIME^{1,8,9}: 31ms, typical.

PULSE CURRENT MEASUREMENT OPERATION

TRIGGER LEVEL: 5mA to 5A, in 5mA steps.
TRIGGER DELAY: 0 to 100ms, in 10 μs steps.
INTERNAL TRIGGER DELAY: 15 μs .
HIGH/LOW/AVERAGE MODE:
Measurement Aperture Settings: 33.3 μs to 833ms, in 33.3 μs steps.
Average Readings: 1 to 100.
PULSE CURRENT MEASUREMENT ACCURACY¹¹ (2 Years, 23°C ± 5°C):

Aperture	Accuracy $\pm(\% \text{ reading} + \text{offset} + \text{rms noise}^{10})$
$<100 \mu\text{s}$	0.2% + 900 μA + 2 mA
100 μs – 200 μs	0.2% + 900 μA + 1.5 mA
200 μs – 500 μs	0.2% + 900 μA + 1 mA
500 μs – $<1 \text{ PLC}$	0.2% + 600 μA + 0.8 mA
1 PLC ¹²	0.2% + 400 μA + 0 mA
$>1 \text{ PLC}$	0.2% + 400 μA + 100 μA

BURST MODE CURRENT MEASUREMENT

MEASUREMENT APERTURE: 33.3 μs to 833ms, in 33 μs steps.
CONVERSION RATE: 2040/second at 33.3 μs meas. aper., typical.
INTERNAL TRIGGER DELAY: 15 μs with 33 μs .
NUMBER OF SAMPLES: 1 to 5000.
TRANSFER SAMPLES ACROSS IEEE BUS IN BINARY MODE: 4800 bytes/s, typical.

LONG INTEGRATION MODE CURRENT MEASUREMENT

MEASUREMENT TIME⁶: 850ms (840ms) to 60 seconds in 1ms steps.

DIGITAL VOLTMETER INPUT (2 Years, 23°C ± 5°C)

INPUT VOLTAGE RANGE: –5 to +30VDC.
INPUT IMPEDANCE: 2M Ω typical.
MAXIMUM VOLTAGE (either input terminal) WITH RESPECT TO OUTPUT LOW: –5V, +30V.
READING ACCURACY¹: $\pm(0.05\% + 3\text{mV})$.
READING RESOLUTION: 1mV.
CONNECTOR: HI and LO input pair part of Output #2's terminal block.
MEASUREMENT TIME CHOICES: 0.01 to 10 PLC⁷, in 0.01PLC steps.
AVERAGE READINGS: 1 to 10.
READING TIME^{1,8,9}: 31ms, typical.

VOLTAGE SETTLING TIMES (typical)

Increasing Voltage	10–90% Rise Time	Settling Time
Voltage step $\leq 7 \text{ V}$	10 μs	100 μs
Voltage step $> 7 \text{ V}$	10 μs to 1.2 ms	100 μs to 1.5 ms

Decreasing Voltage	10–90% Fall Time	Settling Time
0 V < Voltage step < 15 V	5 μs to 40 μs	50 μs to 200 μs

NOTE: Times are under no load condition and settling times defined at $\pm 2\%$ of step size.

1.888.KEITHLEY (U.S. only)

www.keithley.com

KEITHLEY

A Tektronix Company

A Greater Measure of Confidence

Voltage Stepping Only

TEST CONDITIONS:

1. Trigger external is enabled on both channels.
2. Only a single channel is externally triggered during the sequence while remaining channel stays idle.
3. Times based on 0 programmable user delay.

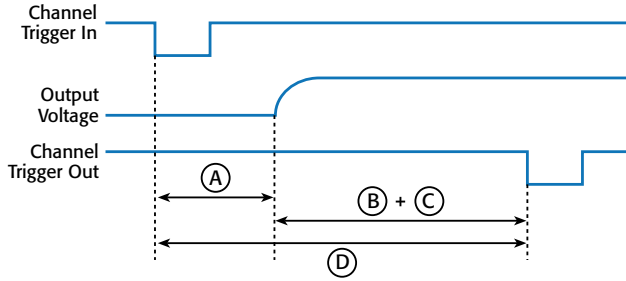

Output #1 (Battery)	Output #2 (Charger)
A = 70 μ s typical	A = 55 μ s typical
B = 330 μ s typical	B = 545 μ s typical
C = Programmable user delay (0–5 seconds)	C = Programmable user delay (0–5 seconds)
D = 400 μ s typical with C as 0	D = 600 μ s typical with C as 0

Auto Measurement Only

TEST CONDITIONS:

1. Trigger external is enabled on both channels.
2. Only a single channel is externally triggered during the sequence while remaining channel stays idle.
3. Times based on 0 programmable user delay.
4. Measurement time = 167 μ s (0.01 PLC).
5. Steps points = 4.

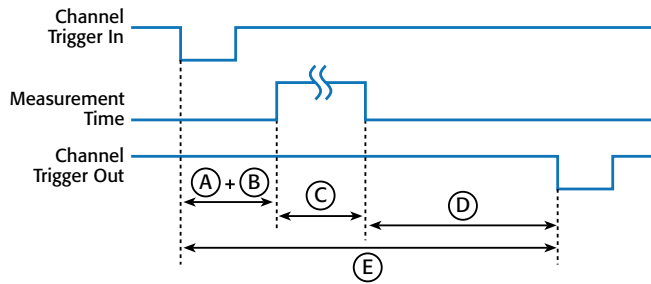

Output #1 (Battery)	Output #2 (Charger)
A = 43 μ s typical	A = 43 μ s typical
B = Programmable user delay (0–5 seconds)	B = Programmable user delay (0–5 seconds)
C = Measurement time	C = Measurement time
D = 410 μ s typical (steps 1, 2, and 3)	D = 650 μ s typical (steps 1, 2, and 3)
E = 620 μ s typical for steps 1, 2, and 3 with B as 0	E = 860 μ s typical for steps 1, 2, and 3 with B as 0
8ms typical for step 4 with B as 0	8ms typical for step 4 with B as 0

Voltage Stepping With Auto Measurement

TEST CONDITIONS:

1. Trigger external is enabled on both channels.
2. Only a single channel is externally triggered during the sequence while remaining channel stays idle.
3. Times based on 0 programmable user delay.
4. Measurement time = 167 μ s (0.01 PLC).
5. Steps points = 4.

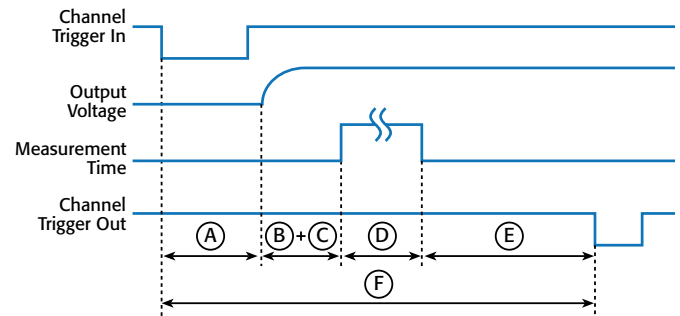

Output #1 (Battery)	Output #2 (Charger)
A = 70 μ s typical	A = 55 μ s typical within
B = 43 μ s typical	B = 43 μ s typical within
C = Programmable user delay (0–5 seconds)	C = Programmable user delay (0–5 seconds)
D = Measurement time	D = Measurement time
E = 475 μ s typical (steps 1, 2, and 3)	E = 955 μ s typical (steps 1, 2, and 3)
F = 755 μ s typical steps 1, 2, and 3 with C as 0	F = 1.22 ms typical steps 1, 2, and 3 with C as 0
8 ms typical step 4 with C as 0	8 ms typical step 4 with C as 0

Voltage Stepping Both Channels With Channel 1

TEST CONDITIONS:

1. Only a single channel is externally triggered during the sequence while remaining channel stays idle.
2. Times based on 0 programmable user delay.

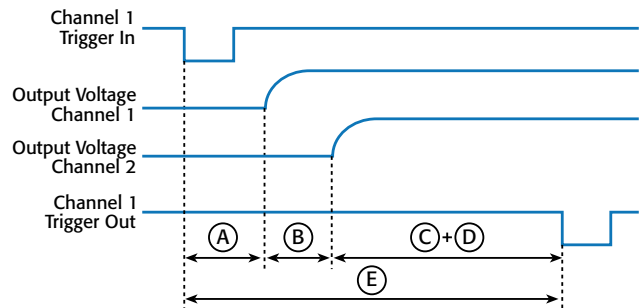

Output #1 (Battery)/Output #2 (Charger)
A = 70 μ s typical
B = 55 μ s typical
C = 775 μ s typical
D = Programmable user delay (0–5 seconds)
E = 900 μ s typical with D as 0

2306-VS

Dual-Channel Battery/Charger Simulator with External Triggering

Voltage Stepping Both Channels With Channel 2

TEST CONDITIONS:

1. Only a single channel is externally triggered during the sequence while remaining channel stays idle.
2. Times based on 0 programmable user delay.

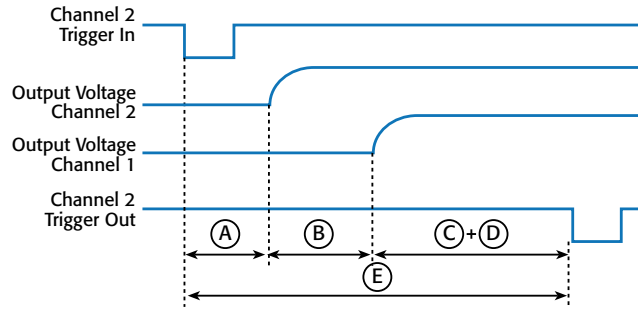

Output #1 (Battery)/Output #2 (Charger)

- A = 55 μ s typical
- B = 70 μ s typical
- C = 775 μ s typical
- D = Programmable user delay (0–5 seconds)
- E = 900 μ s typical with D as 0

Auto Measurement Both Channels With Channel 1

TEST CONDITIONS:

1. Only a single channel is externally triggered during the sequence while remaining channel stays idle.
2. Times based on 0 programmable user delay.
3. Measurement time = 167 μ s (0.01 PLC).
4. Steps points = 4.

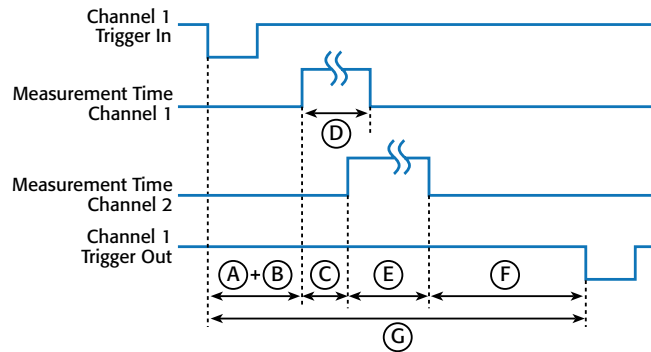

Output #1 (Battery)/Output #2 (Charger)

- A = 43 μ s typical
- B = Programmable user delay (0–5 seconds)
- C = 18 μ s typical
- D = Measurement time channel 1
- E = Measurement time channel 2
- F = 872 μ s typical with steps 1, 2, and 3
- G = 1.1 ms typical for steps 1, 2, and 3 with B as 0
16.0 ms typical step 4 with B as 0

Auto Measurement Both Channels With Channel 2

TEST CONDITIONS:

1. Only a single channel is externally triggered during the sequence while remaining channel stays idle.
2. Times based on 0 programmable user delay.
3. Measurement time = 167 μ s (0.01 PLC).
4. Steps points = 4.

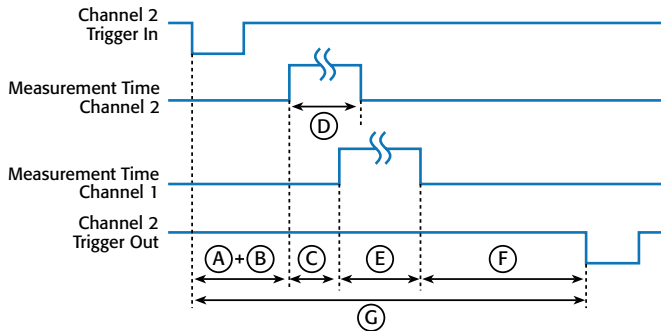

Output #1 (Battery)/Output #2 (Charger)

- A = 43 μ s typical
- B = Programmable user delay (0–5 seconds)
- C = 18 μ s typical
- D = Measurement time channel 2
- E = Measurement time channel 1
- F = 872 μ s typical with steps 1, 2, and 3
- G = 1.1 ms typical for steps 1, 2, and 3 with B as 0
16.0 ms typical step 4 with B as 0

Voltage Stepping With Sync Measurement

TEST CONDITIONS:

1. Trigger external is enabled on both channels.
2. Only a single channel is externally triggered during the sequence while remaining channel stays idle.
3. Times based on 0 programmable user delay.

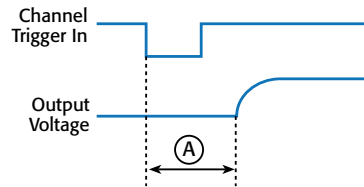

Output #1 (Battery)

- Channel 1 trigger in = output voltage start changing
- A = 70 μ s typical

Output #2 (Charger)

- Channel 2 trigger in = output voltage start changing
- A = 55 μ s typical within

4 ms typical to start search for desired pulse edge. Time for trigger out dependent on search time for selecting edge, integration time, and storing reading in buffer

2306-VS

Dual-Channel Battery/Charger Simulator with External Triggering

GENERAL

ISOLATION (LOW-EARTH): 22VDC max. Do not exceed 60VDC between any two terminals of either connector.

PROGRAMMING: IEEE-488.2 (SCPI).

USER-DEFINABLE POWER-UP STATES: 3.

REAR PANEL CONNECTORS: Two trigger in and two trigger out (BNC) connectors. Two 8-position quick disconnect terminal block for output (4), sense (2), and DVM (2).

TRIGGER IN/OUT CONNECTORS: IN High 3–5V, IN Low $\leq 0.8V$, OUT High $>4V$, OUT Low $<0.8V$.

TEMPERATURE COEFFICIENT (outside 23°C $\pm 5^\circ\text{C}$): Derate accuracy specification by $(0.1 \times \text{specification})/^\circ\text{C}$.

OPERATING TEMPERATURE: 0° to 50°C (derate to 70%), 0° to 35°C (full power).

STORAGE TEMPERATURE: –20° to 70°C.

HUMIDITY: $<80\%$ @ 35°C non-condensing.

DISPLAY TYPE: 2-line \times 16 character VFD.

DIMENSIONS: 89mm high \times 213mm wide \times 411mm deep (3½ in \times 8½ in \times 16⅝ in).

NET WEIGHT: 3.9kg (8.6 lbs.).

SHIPPING WEIGHT: 6.4kg (14 lbs.).

INPUT POWER: 100–120VAC/220–240VAC, 50 or 60Hz (auto detected at power-up).

POWER CONSUMPTION: 165VA max.

EMC: Conforms with European Union Directive directive 89/336/EEC, EN 61326.

SAFETY: Conforms with European Union Directive 73/23/EEC, EN 61010-1.

VIBRATION: MIL-PRF-28800F Type III, Class 3.

NOTES

1. PLC = 1.00.
2. Following 15 minute warm-up, the change in output over 8 hours under ambient temperature, constant load, and line operating conditions.
3. Remote sense, at output terminals, 0.5A to 5A typical.
4. Remote sense, with 4.5m (15 ft) of 16 gauge (1.31mm²) wire and 1 Ω resistance in each lead to simulate typical test environment, 1.5A load change (0.15A to 1.65A).
5. Minimum current in constant current mode is 6mA.
6. 60Hz (50Hz).
7. PLC = Power Line Cycle. 1PLC = 16.7ms for 60Hz operation, 20ms for 50Hz operation.
8. Display off.
9. Speed includes measurement and binary data transfer out of GPIB.
10. Typical values, peak-to-peak noise equals 6 times rms noise.
11. Based on settled signal: 100 μs pulse trigger delay.
12. Also applies to other apertures that are integer multiples of 1PLC.
13. Recovery to within 20mV of previous level.

1.888.KEITHLEY (U.S. only)

www.keithley.com

A Greater Measure of Confidence

KEITHLEY
A Tektronix Company

2303, 2304A

High Speed Power Supplies

Fast transient response power supplies



- Optimized for battery-powered device testing
- Ultra-fast transient response to load changes
- 5A continuous output
- Pulse peak, average, and baseline current measurements
- 100nA DC current sensitivity

MODEL 2304A

- 100W output (20V @ 5A)
- Sinks up to 3A

MODEL 2303

- 45W output (15V @ 3A, 9V @ 5A)
- Sinks up to 2A



Model 2303 or 2304A rear panel

Keithley's High Speed Power Supplies are designed to simulate the current drive capacity of a battery. The power supplies simulate a battery's response during a large load change by minimizing the maximum drop in voltage and recovering to within 100mV of the original voltage in 40µs or less.

When a portable device such as a cellular phone switches from standby mode to the full power mode of operation, the current draw on the power supply can change by as much as 1000%. While a battery's voltage will decrease by the value of the voltage drop across the battery's low internal resistance, a conventional power supply will have a significant voltage drop (more than one volt) and take milliseconds to recover to the original voltage level. For portable devices that operate at full power only for short intervals, the full power event is over before a conventional power supply can recover. For example, cellular phones designed in accordance with the GSM cellular phone standard transmit and receive information in 576µs pulses.

If the power supply used to test them cannot recover quickly enough, the performance of the device-under-test will be compromised by the power supply. If the power supply voltage drops below the threshold of the phone's low-battery detection circuitry for a sufficient amount of time, the phone will turn off during testing, giving a false indication of a failed device.

The Models 2303/2304A's fast transient response to large load changes will enable test engineers to test their portable products properly and eliminate false failures due to conventional power supplies with slow response times. In this way, the power supplies ensure maximum production throughput when testing portable devices.

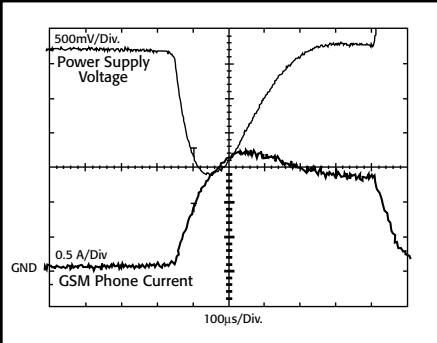

Typical Power Supply. Transient response with 4.5m (15 ft) of cable and 1Ω/lead between source and GSM phone load.

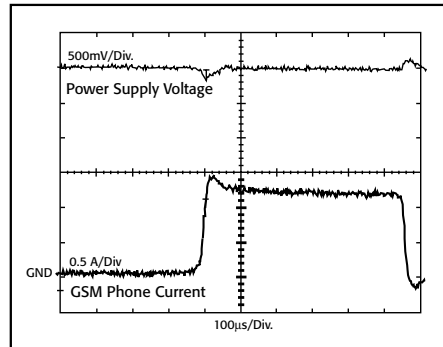

Keithley's High Speed Power Supply. Transient response with 4.5m (15 ft) of cable and 1Ω/lead between source and GSM phone load.

1.888.KEITHLEY (U.S. only)

www.keithley.com

KEITHLEY

A Tektronix Company

A Greater Measure of Confidence

DC POWER SUPPLIES

2303, 2304A

Ordering Information

- 2304A** High Speed Precision Readback Power Supply (100W)
- 2303** High Speed Precision Readback Power Supply (45W)
- 2303-PJ** High Speed Precision Readback Power Supply (45W, 500mA range replaces 5mA range)

Accessories Supplied

User and service manuals, CS-846 output connectors mating terminal

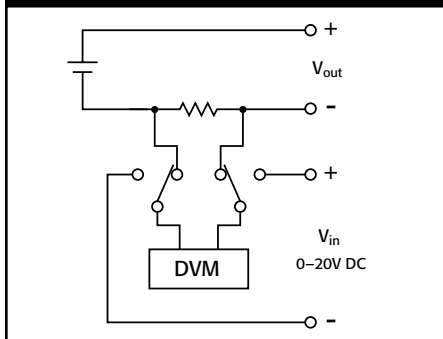

Model 2303/2304A Block Diagram showing DC DVM measurement capability

The Models 2303/2304A perform a continuous integration to make peak, average, and baseline measurements on complex load current waveforms. Integration times can be programmed with 33.3µs resolution.

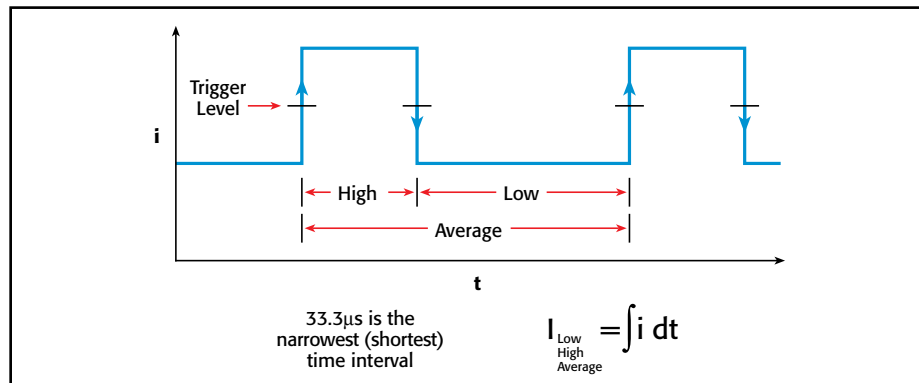

High Speed Power Supplies

Fast Measurements for Power Consumption Analysis

As manufacturers of portable devices strive to extend battery life and the length of time between recharges, power consumption has become an important performance indicator. Therefore, in production testing, accurate peak power and average power measurements are critical. These measurements are complicated by the fact that wireless telecommunication devices draw full load current in short pulses. The Models 2303/2304A's pulse readback measurement mode makes it possible to capture peak and average values on pulses as short as 60µs. This allows the power supply to power a device-under-test and determine its current consumption to qualify the device for its specified power consumption.

In addition to making measurements on short pulses, the 2303/2304A power supplies can measure a current pulse peak or a current pulse train that is as long as 833ms. For random pulse trains that have periods longer than 833ms, the power supplies have a special long integration mode that can make an average current measurement on up to 60s of data. To capture low current pulses from very low power devices, the Model 2303-PJ provides pulse measurement on both the 5A and 500mA ranges.

Accurate Low Current Measurements

The Models 2303/2304A are well-suited for making fast, accurate measurements of sleep and standby mode currents because they are based on Keithley's expertise in low current measurement technologies. With 100nA resolution, the power supplies offer the precision needed to monitor the low sleep mode currents in today's products and in future products. They can also measure these low currents with 0.2% basic accuracy.

High Current Sinking Capacity

Keithley's power supplies can act as an electronic load and sink as much as 3A (Model 2304A)

and 2A (Model 2303), so they can simulate a discharged rechargeable battery. Therefore, they can be used to verify the performance of a portable device's charger. The power supplies' current dissipation capacity allows them to test even high-current fast chargers.

Independent Digital Voltmeter Inputs

While many programmable power supplies offer output readback capabilities, Keithley's power supplies are the only instruments available that also offer a set of DVM inputs. These inputs allow the Model 2304A to measure signals from 0 to +20V (0 to +15V for the Model 2303) anywhere in the test system with the same rated accuracy as the voltage readback. The DVM and the power source can operate simultaneously. For many applications, the power supplies' built-in DVM eliminates the expense and space that a separate voltage measurement instrument would require.

Remote Display Option

If the Model 2303 or 2304A must be mounted in a location in which the display is not readily visible, an optional Model 2304-DISP Display Module can be mounted at a more convenient point, then plugged into the power supply unit. The display module also includes all instrument controls, so that the power supply can be operated remotely from the more accessible location.

ACCESSORIES AVAILABLE

2304-DISP	Remote Display
CS-846	Mating Output Connector

CABLES

7007-1	Shielded IEEE-488 Cable, 1m (3.3 ft)
7007-2	Shielded IEEE-488 Cable, 2m (6.6 ft)
SC-182	Low-Inductance Coaxial Cable (42nH/ft)

RACK MOUNT KITS

4288-1	Single Fixed Rack Mount Kit
4288-2	Dual Fixed Rack Mount Kit

IEEE-488 INTERFACES

KPCI-488LPA	IEEE-488 Interface/Controller for the PCI Bus
KUSB-488B	IEEE-488 USB-to-GPIB Interface Adapter

SERVICES AVAILABLE

2303-3Y-EW	1-year factory warranty extended to 3 years from date of shipment
2303-PJ-3Y-EW	1-year factory warranty extended to 3 years from date of shipment
2304A-3Y-EW	1-year factory warranty extended to 3 years from date of shipment
C/2303-3Y-ISO	3 (ISO-17025 accredited) calibrations within 3 years of purchase for Models 2303, 2303-PJ*
C/2304A-3Y-ISO	3 (ISO-17025 accredited) calibrations within 3 years of purchase for Model 2304A*

*Not available in all countries

1.888.KEITHLEY (U.S. only)

www.keithley.com

KEITHLEY

A Tektronix Company

A Greater Measure of Confidence

Fast transient response power supplies

DC POWER SUPPLIES

2303, 2303-PJ

High Speed Power Supplies

DC Voltage Output (2 Years, 23°C ± 5°C)

OUTPUT VOLTAGE: 0 to +15V DC.
OUTPUT ACCURACY: ±(0.05% + 10mV).
PROGRAMMING RESOLUTION: 5mV.
READBACK ACCURACY¹: ±(0.05% + 3mV).
READBACK RESOLUTION: 1mV.
OUTPUT VOLTAGE SETTLING TIME: 5ms to within stated accuracy.
LOAD REGULATION: 0.01% + 2mV.
LINE REGULATION: 0.5mV.
STABILITY²: 0.01% + 0.5mV.

TRANSIENT RESPONSE TO 1000% LOAD CHANGE:

Transient Recovery Time^{3,4}: <40μs to within 100mV of previous level.
<80μs to within 20mV of previous level.
Transient Voltage Drop: <100mV, typical.³
<200mV, typical.⁴

RIPPLE AND NOISE (20Hz to 20MHz): 3mV rms/8mV p-p, typical.

REMOTE SENSE: Automatic 1V max. drop in each lead. Add 2mV to the voltage load regulation specification for each 1V change in the negative output lead due to load current change.

DC Current (2 Years, 23°C ± 5°C)

OUTPUT CURRENT: 0–9V: 5A max. >9V–15V: 3A max. (not intended to be operated in parallel).
SOURCE COMPLIANCE ACCURACY: ±(0.16% + 5mA)⁵.
PROGRAMMED SOURCE COMPLIANCE RESOLUTION: 1.25mA.

READBACK ACCURACY

2303: 5A range: ±(0.2% + 400μA). 5mA range: ±(0.2% + 1μA).
2303-PJ: 5A range: ±(0.2% + 400μA). 500mA range: ±(0.2% + 40μA).

READBACK RESOLUTION

2303: 5A range: 100μA. 5mA range: 0.1μA.
2303-PJ: 5A range: 100μA. 500mA range: 10μA.

CURRENT SINK CAPACITY: 0–5V: 2A max. 5V–15V: Derate 0.1A per volt above 5V.

LOAD REGULATION: 0.01% + 1mA.

LINE REGULATION: 0.5mA.

STABILITY²: 0.01% + 50μA.

Digital Voltmeter Input (2 Years, 23°C ± 5°C)

INPUT VOLTAGE RANGE: 0 to +20V DC.

INPUT IMPEDANCE: 10¹⁰Ω typical.

MAXIMUM VOLTAGE (either input terminal) WITH RESPECT TO OUTPUT LOW: –3V, +22V.

READING ACCURACY¹: ±(0.05% + 3mV).

READING RESOLUTION: 1mV.

NOTES

- ¹ PLC = 1.00.
- ² Following 15 minute warm-up, the change in output over 8 hours under ambient temperature, constant load, and line operating conditions.
- ³ Remote sense, at output terminals, 1000% load change; typical.
- ⁴ Remote sense, with 4.5m (15 ft) of 16 gauge wire and 1Ω resistance in each source lead to simulate typical test environment, up to 1.5A load change.
- ⁵ Minimum current in constant current mode is 6mA.
- ⁶ 60Hz (50Hz).
- ⁷ PLC = Power Line Cycle. 1PLC = 16.7ms for 60Hz operation, 20ms for 50Hz operation.
- ⁸ Display off.
- ⁹ Speed includes measurement and binary data transfer out of GPIB.

DC General

MEASUREMENT TIME CHOICES: 0.01 to 10 PLC⁷, in 0.01PLC steps.

AVERAGE READINGS: 1 to 10.

READING TIME^{1,8,9}: 31ms, typical.

Pulse Current Measurement Operation

TRIGGER LEVEL:

2303: 5mA to 5A, in 5mA steps.

2303-PJ: 5A Range: 0mA to 5A, in 5mA steps.

500mA Range: 0mA to 500mA, in 0.5mA steps.

TRIGGER DELAY: 0 to 100ms, in 10μs steps.

INTERNAL TRIGGER DELAY: 25μs.

HIGH/LOW/AVERAGE MODE:

Measurement Aperture Settings: 33.3μs to 833ms, in 33.3μs steps.

Average Readings: 1 to 100.

BURST MODE:

Measurement Aperture: 33.3μs.

Conversion Rate: 3600/second, typical.

Number of Samples: 1 to 5000.

Transfer Samples Across IEEE Bus in Binary Mode: 4800 bytes/second, typical.

LONG INTEGRATION MODE: Measurement Time⁶: 850ms (840ms) to 60 seconds in 16.7ms (20ms) steps.

GENERAL

ISOLATION (low-earth): 22V DC max.

PROGRAMMING: IEEE-488.2 (SCPI).

USER-DEFINABLE POWER-UP STATES: 5.

REAR PANEL CONNECTOR: 8-position quick disconnect terminal block for output (4), sense (2), and DVM (2).

TEMPERATURE COEFFICIENT (outside 23°C ± 5°C): Derate accuracy specification by (0.1 × specification)/°C.

OPERATING TEMPERATURE:

0° to 35°C (Full power).

0° to 50°C (Derate to 70%).

STORAGE TEMPERATURE: –20° to 70°C.

HUMIDITY: <80% @ 35°C non-condensing.

POWER CONSUMPTION: 150VA max.

REMOTE DISPLAY/KEYPAD OPTION: Disables standard front panel.

DIMENSIONS: 89mm high × 213mm wide × 360mm deep (3½ in × 8½ in × 14¾ in).

SHIPPING WEIGHT: 5.4kg (12 lbs).

INPUT POWER: 100V–120VAC/220–240VAC, 50 or 60Hz (auto detected at power-up).

EMC: Conforms with European Union Directive 89/336/EEC EN 55011, EN 50082-1, EN 61000-3-2, and 61000-3-3, FCC part 15 class B.

SAFETY: Conforms with European Union Directive 73/23/EEC EN 61010-1, UL 3111-1.

AC LINE LEAKAGE CURRENT: 450μA @ 110VAC, typ.; 600μA @ 220VAC, typ.

RELAY CONTROL JACK: 1-channel, sink 150mA max., 15V max. 5V output, 100mA max., also available on jack. Accepts 0.173 in Bantam-type plug (CS-1003-1).

1.888.KEITHLEY (U.S. only)

www.keithley.com

DC Voltage Output (1 Year, 23°C ± 5°C)**OUTPUT VOLTAGE:**

- 0 to +20V DC (for Normal Output Response).
- 0 to +15V DC (for Enhanced Output Response).

OUTPUT ACCURACY: ±(0.05% + 10mV).

PROGRAMMING RESOLUTION: 5mV.

READBACK ACCURACY¹: ±(0.05% + 10mV).

READBACK RESOLUTION: 1mV.

OUTPUT VOLTAGE SETTLING TIME: 5ms to within stated accuracy.

LOAD REGULATION: 0.01% + 2mV.

LINE REGULATION: 0.5mV.

STABILITY²: 0.01% + 0.5mV.

TRANSIENT RESPONSE TO 1000% LOAD CHANGE:**NORMAL MODE:**

- Transient Recovery Time³:** <50μs to within 100mV of previous level.
<100μs to within 20mV of previous level.

ENHANCED MODE:

- Transient Recovery Time^{3,4}:** <40μs to within 100mV of previous level.
<80μs to within 20mV of previous level.

- Transient Voltage Drop:** <100mV, typical.³
<200mV, typical.⁴

REMOTE SENSE: Automatic, 2V max. drop in each lead. Add 2mV to the voltage load regulation specification for each 1V change in the negative output lead due to load current change.

DC Current (1 Year, 23°C ± 5°C)

OUTPUT CURRENT: 5A max. (not intended to be operated in parallel).

COMPLIANCE ACCURACY: ±(0.16% + 5mA)⁵

PROGRAMMED COMPLIANCE RESOLUTION: 1.25mA.

READBACK ACCURACY¹

- 5A range:** ±(0.2% + 1mA). **5mA range:** ±(0.2% + 1μA).

READBACK RESOLUTION

- 5A range:** 100μA. **5mA range:** 0.1μA.

CURRENT SINK CAPACITY:

- 3A max. (for Normal Output Response).
- 1A⁶ (for Enhanced Output Response).

LOAD REGULATION: 0.01% + 1mA.

LINE REGULATION: 0.5mA.

STABILITY²: 0.01% + 50μA.

Digital Voltmeter Input (1 Year, 23°C ± 5°C)

INPUT VOLTAGE RANGE: 0 to +20V DC.

INPUT IMPEDANCE: 10¹⁰Ω typical.

MAXIMUM VOLTAGE (either input terminal) WITH RESPECT TO OUTPUT LOW: -3V, +22V.

READING ACCURACY²: ±(0.05% + 10mV).

READING RESOLUTION: 1mV.

NOTES

¹ PLC = 1.00.

² Following 15 minute warm-up, the change in output over 8 hours under ambient temperature, constant load, and line operating conditions.

³ Remote sense, at output terminals, 1000% load change; typical.

⁴ Remote sense, with 4.5m (15 ft) of 16 gauge wire and 1Ω resistance in each lead to simulate typical test environment, up to 1.5A load change.

⁵ Minimum current in constant current mode is 6mA.

⁶ 15W typical. 0°–35°C. Derate 1W/°C up to 50°C.

⁷ PLC = Power Line Cycle. 1PLC = 16.7ms for 60Hz operation, 20ms for 50Hz operation.

⁸ Display off.

⁹ Speed includes measurement and binary data transfer out of GPIB.

¹⁰ Max. continuous.

¹¹ 60Hz (50Hz).

DC General

MEASUREMENT TIME CHOICES: 0.01 to 10 PLC⁷, in 0.01PLC steps.

AVERAGE READINGS: 1 to 10.

READING TIME^{1,8,9}: 31ms, typical.

PULSE CURRENT MEASUREMENT OPERATION

TRIGGER LEVEL: 5mA to 5A, in 5mA steps.

TRIGGER DELAY: 0 to 100ms, in 10μs steps.

INTERNAL TRIGGER DELAY: 25μs.

HIGH/LOW/AVERAGE MODE:

Measurement Aperture Settings: 33.3μs to 833ms, in 33.3μs steps.

Average Readings: 1 to 100.

BURST MODE:

Measurement Aperture: 33.3μs.

Conversion Rate: 3600/second, typical.

Number of Samples: 1 to 5000.

Transfer Samples Across IEEE Bus in Binary Mode: 4800 bytes/second, typical.

LONG INTEGRATION MODE¹¹: **Measurement Time:** 850ms (840ms) to 60 seconds in 16.7ms (20ms) steps.

GENERAL

ISOLATION (low-earth): 22V DC max.

PROGRAMMING: IEEE-488.2 (SCPI).

USER-DEFINABLE POWER-UP STATES: 5.

REAR PANEL CONNECTOR: 8-position quick disconnect terminal block for output (4), sense (2), and DVM (2).

RELAY CONTROL JACK: 2-channel, sink 150mA max., 15V max. Accepts 0.173 in. Bantam-type plug (CS-1003-1).

TEMPERATURE COEFFICIENT (outside 23°C ± 5°C): Derate accuracy specification by (0.1 × specification)/°C.

OPERATING TEMPERATURE:

- 0° to 50°C (50W¹⁰ normal response, 25W¹⁰ enhanced response).
- 0° to 35°C (100W¹⁰ normal response, 75W¹⁰ enhanced response).

STORAGE TEMPERATURE: -20° to 70°C.

HUMIDITY: <80% @ 35°C non-condensing.

POWER CONSUMPTION: 200VA max.

REMOTE DISPLAY/KEYPAD OPTION: Disables standard front panel.

DIMENSIONS: 89mm high × 213mm wide × 360mm deep (3½ in × 8½ in × 14¾ in).

SHIPPING WEIGHT: 5.4kg (12 lbs).

INPUT POWER: 100V–240V AC, 50 or 60Hz (auto detected at power-up).

EMC: Conforms with European Union Directive directive 89/336/EEC EN 55011, EN 50082-1, EN 61000-3-2, and 61000-3-3, FCC part 15 class B.

SAFETY: Conforms with European Union Directive 73/23/EEC EN 61010-1.

1.888.KEITHLEY (U.S. only)

www.keithley.com

Series 2290

- Source voltages up to 5kV and 10kV
- 1 μ A current measurement resolution
- Low noise for precision sourcing and sensitive measurements; selectable filters reduce noise to less than 3mV_{RMS} on the 5kV supply
- Safety interlock controls high voltage output
- IEEE-488 programmable
- Protection module prevents damage to low voltage instrumentation

TYPICAL APPLICATIONS

- High voltage device breakdown testing
- High voltage component testing
- Insulation testing
- High voltage resistivity measurements
- High energy physics research

Ordering Information

2290-5	5kV Power Supply, 120VAC Nominal Input Voltage
2290E-5	5kV Power Supply, 240VAC Nominal Input Voltage
2290J-5	5kV Power Supply, 100VAC Nominal Input Voltage
2290-10	10kV Power Supply
2290-PM-200	10kV Protection Module

Accessories Supplied

CD with user manual, software drivers, and accessory information
3-Pin Interlock Connector
Power cord

High Voltage Power Supplies



Series 2290 High Voltage Power Supplies facilitate high voltage device and material testing, as well as high energy physics experimentation. The Model 2290-5 5kV Power Supply provides voltage outputs up to 5000V, and the Model 2290-10 10kV Power Supply offers up to 10,000V. The Model 2290-5 has a 5mA current capacity, and the Model 2290-10 has a 1mA current capacity. These supplies measure both output voltage with 1V resolution and output current with 1 μ A resolution. In addition to the voltage and current output displays, a third display shows one of four settings: output voltage, voltage limit, current limit, or current trip. These values can be set precisely with the front panel keypad. The settings can also be programmed over the IEEE-4888 interface, or the output voltage can be set with an analog control voltage.

Low Noise Ensures Accurate Low Level Measurements

Low output noise is essential when using sensitive measurement instruments to make leakage current or high resistivity measurements. The maximum output ripple for the Model 2290-10 is less than 1V_{RMS}. The maximum output ripple of the Model 2290-5 is 100mV_{RMS}. Two selectable, internal filters on the Model 2290-5 reduce the maximum output ripple to only 3mV_{RMS}. Extremely low noise from both power supplies enables sensitive measurement instruments to make accurate current measurements down to picoamp levels.

Protecting User and Instrumentation

Series 2290 Power Supplies and a Model 2290-PM-200 Protection Module protect both user and instrumentation from hazardous voltages. An interlock circuit built into the power supplies can be used to ensure that the output voltage is disabled if a high voltage test fixture access door is open. In addition, all Series 2290 power supplies have low voltage analog outputs to permit safe monitoring of the high voltage and the output current.

When low voltage measurement instrumentation is used in the high voltage circuit, the protection module safely clamps the voltage across the instrument to a maximum value of 200V even when a device under test (DUT) breaks down. Thus, a Series 2290 Power Supply, Model 2290-PM-200 Protection Module, and Keithley accessories provide all the elements for building a safe, high voltage test environment.



The Model 2290-PM-200 Protection Module protects low voltage measurement equipment from voltages greater than 200V.

1.888.KEITHLEY (U.S. only)

www.keithley.com

Series 2290

High Voltage Power Supplies

ACCESSORIES AVAILABLE

FOR 2290-5:

2290-5-SHV	5kV SHV Female–SHV Female Cable, 3m (10 ft)
2290-5-MHV	5kV SHV Female–MHV Male Cable, 3m (10 ft)
2290-5-SHVBH	5kV SHV Male Bulkhead Connector
2290-5-RMK-1	Single Fixed Rack Mount Kit for 5kV Power Supply
2290-5-RMK-2	Dual Fixed Rack Mount Kit for 5kV Power Supply

FOR 2290-10:

2290-10-SHVUC	10kV SHV Male to Underterminated Cable, 3m (10ft)
2290-10-SHV	10kV SHV Male–SHV Male Cable, 3m (10 ft)
2290-10-SHVBH	10kV SHV Female Bulkhead Connector
2290-10-RMK-1	Single Fixed Rack Mount Kit for 10kV Power Supply
2290-10-RMK-2	Dual Fixed Rack Mount Kit for 10kV Power Supply

FOR BOTH:

2290-PM-200	10kV Protection Module
2290-INT-CABLE	3-Pin Connector to Underterminated Interlock Cable
4299-7	Fixed Shelf Rack Mount Kit
KPCI-488LPA	IEEE-488.2 Interface Board for the PCI Bus
KUSB-488B	IEEE-488.2 USB-GPIB Interface Adapter for USB port with built-in 2m (6.6 ft) cable
7007-05	Double Shielded Premium IEEE-488 Interface Cable, 0.5m (1.6 ft)
7007-1	Double Shielded Premium IEEE-488 Interface Cable, 1m (3.2 ft)
7007-2	Double Shielded Premium IEEE-488 Interface Cable, 2m (6.5 ft)
7007-3	Double Shielded Premium IEEE-488 Interface Cable, 3m (10 ft)
7007-4	Double Shielded Premium IEEE-488 Interface Cable, 4m (13 ft)

SERVICES AVAILABLE

<i>Model Number</i> *-EW	1 Year Factory Warranty extended one additional year from date of shipment
<i>Model Number</i> -3Y-EW	1 Year Factory Warranty extended to 3 years from date of shipment
<i>Model Number</i> -5Y-EW	1 Year Factory Warranty extended to 5 years from date of shipment
<i>C/Model Number</i> -3Y-STD	KeithleyCare 3 Year Standard Calibration Plan
<i>C/Model Number</i> -3Y-DATA	KeithleyCare 3 Year Calibration with Data Plan
<i>C/Model Number</i> -5Y-STD	KeithleyCare 5 Year Standard Calibration Plan
<i>C/Model Number</i> -5Y-DATA	KeithleyCare 5 Year Calibration with Data Plan

*Insert model number. Examples: 2290-5-EW, C/2290-10-3Y-STD

Make Precise Current Measurements Lower Than 1µA

Use a sensitive Keithley measurement instrument, such as a Keithley SourceMeter® Source Measure Unit (SMU) instrument, to measure current drawn by the device under test (DUT) that is below the sensitivity of the Series 2290 Power Supplies. Keithley SourceMeter SMU instruments can provide sensitivity as low as 0.1fA. The following diagram shows how the Model 2290-PM-200 Protection Module protects the low voltage SourceMeter SMU instrument from high voltages when the DUT breaks down. The leakage current of the protection module limits the measurement resolution to picoamp levels, which is five decades more sensitive than the current measurement resolution of the Series 2290 Power Supplies. Keithley can provide a complete high voltage test capability with the most current measurement sensitivity available anywhere.

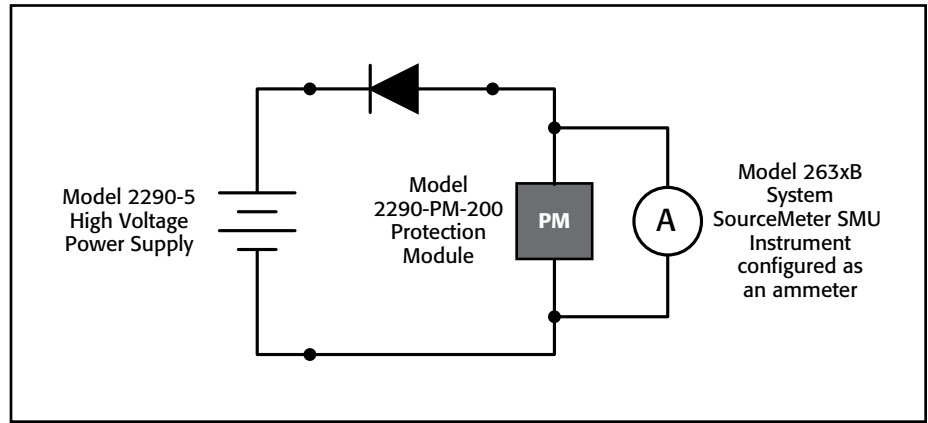

Reverse breakdown testing of a high voltage diode using a Keithley SourceMeter SMU instrument to measure leakage current. The Model 2290-PM-200 SMU Protection Module protects the SourceMeter SMU instrument from high voltage when the diode breaks down.

Easily Automate a High Voltage Test System

The Series 2290's IEEE-488 interface allows the creation of an automated high voltage test system. Software drivers are supplied to simplify and accelerate test system development. This further enhances safety as the high voltage can be controlled from a remote location.

1.888.KEITHLEY (U.S. only)

www.keithley.com

A Greater Measure of Confidence

KEITHLEY
A Tektronix Company

High voltage power supplies

DC POWER SUPPLIES

2290-5 Specifications

5kV Voltage Power Supply Characteristics

CONDITIONS

This document contains specifications and supplemental information for the Model 2290-5 High Voltage Power Supply. Specifications are the standards against which the Model 2290-5 is tested. Upon leaving the factory, the Model 2290-5 meets these specifications. Characteristics, supplemental characteristics, and typical values are not warranted, apply at 23°C ±5°C, <70% relative humidity, and are provided solely as useful information.

CHARACTERISTICS

VOLTAGE RANGE:

Output Voltage ¹	Maximum Output Current	Conditions
50 to +5000 V DC	5.000 mA DC	No filter
50 to +3000 V DC	5.000 mA DC	Filter 1
50 to +5000 V DC	3.000 mA DC	Filter 2

VOLTAGE SET ACCURACY²: ±(0.01% of setting + 2.5V).

VOLTAGE DISPLAY ACCURACY: Voltage set accuracy ±1V, typical (±2V, maximum).

VOLTAGE RESOLUTION: 1V (set and display).

VOLTAGE LIMIT RANGE: 0 to 100% full scale.

VOLTAGE REGULATION³:
Line: 0.001% for ±10% line voltage change.
Load: 0.005% for 100% load change, typical.

OUTPUT RIPPLE (10kHz–100kHz)⁴: 0.002% of full scale, V_{RMS} , maximum – No filter.
 1.0mV_{RMS} @ 1kV – Filter 1 or Filter 2.
 2.0mV_{RMS} @ 3kV – Filter 1 or Filter 2.
 3.0mV_{RMS} @ 5kV – Filter 2.

RISE TIME (full load)^{6,7}: 1.5 seconds for 0 to within 1V of 5000VDC – No filter.
 3 seconds for 0 to within 1V of 3000VDC – Filter 1.
 4 seconds for 0 to within 1V of 5000VDC – Filter 2

DISCHARGE TIME (full load)^{6,7}: 1 second for 5000VDC to 1VDC – No filter.
 3 seconds for 3000VDC to 1VDC – Filter 1.
 4 seconds for 5000VDC to 1VDC – Filter 2

DISCHARGE TIME (no load)⁶: <12 seconds (to <50VDC) – No filter.
 <30 seconds (to <50VDC) – Filter 1 or Filter 2.

SETTLING TIME^{6,7}: From 0 to programmed voltage; to within 99.9% of final value within 3 seconds.

RECOVERY TIME^{6,7}: 120ms for 40% step change in load current (typical).

Current Limit and Trip Range	Voltage Range	Filter
0.4 mA to 5.25 mA	0 V to 1.5 kV	No filter or Filter 1
0.4 mA to 3.25 mA		Filter 2
0.5 mA to 5.25 mA	1.5 kV to 5.0 kV	No filter or Filter 1
0.4 mA to 3.25 mA		Filter 2

CURRENT SET ACCURACY⁵: ±(0.01% + 2.5μA).

CURRENT RESOLUTION: 1μA.

CURRENT DISPLAY ACCURACY: ±1μA, typical (±2μA, maximum).

STABILITY: ±0.01% per hour; <0.03% per eight hours.

TEMPERATURE DRIFT: 50ppm/°C, 0° to 40°C, typical.

PROTECTION: Arc and short circuit protected; programmable voltage and current limits and current trip.

MONITOR OUTPUTS

OUTPUT SCALE: 0 to +10V to full scale.

CURRENT RATING: 10mA maximum.

OUTPUT IMPEDANCE: <1Ω.

ACCURACY: ±0.2% of full scale with a 100kΩ load, minimum.

UPDATE RATE: 8Hz.

EXTERNAL VOLTAGE SET

INPUT SCALE: 0 to +10V for 0 to full scale.

INPUT IMPEDANCE: 1MΩ.

ACCURACY: ±0.2% of full scale.

UPDATE RATE: 16Hz.

OUTPUT SLEW RATE: <(rise time + 0.3 seconds) for 0 to full range under full load.

GENERAL

INPUT POWER: 55 watts.

2290-5 INPUT VOLTAGE: 120V ±10%, 50 or 60Hz.

2290E-5 INPUT VOLTAGE: 240V ±10%, 50 or 60Hz.

2290J-5 INPUT VOLTAGE: 100V ±10%, 50 or 60Hz.

REAR PANEL CONNECTORS:

SHV male (Kings type 1704-1 or equivalent).

Output high-voltage connector GPIB connector.

BNC Connector (two): Voltage set/Voltage monitor; Current monitor.

TOGGLE SWITCH: Voltage setting or Voltage monitor.

HIGH-VOLTAGE SAFETY INTERLOCK:

Connector: 3-pin press-in connector, 3M part number: 37103-A165-00E-MB.

Pin 1: 5V out, 1.5mA maximum out.

Pin 2: Input: High-voltage output enabled: 3–24V DC.

High-voltage output disabled: <1.2V DC.

Pin 3: Chassis ground through a 100Ω resistor.

INTERFACE PROTOCOL: IEEE-488.1.

OPERATING ENVIRONMENT: 0° to 40°C; non-condensing.

DIMENSIONS: 89mm high × 206mm wide × 406mm deep (3.5 in. × 8.1 in. × 16 in.).

WEIGHT: 5.5kg (12 pounds).

SAFETY: Conformance to European Union low voltage directive.

WARRANTY: One year.

WARM-UP TIME: One hour.

- The output voltage can be programmed to a voltage lower than 50V; however, performance below 50V is not specified.
- Add ±2.5VDC when Filter 1 or Filter 2 is enabled.
- Regulation specifications apply for greater than 25VDC (with full load), or 50VDC (with no load). Below these values, the unit may not regulate correctly.
- Peak-to-peak values are within five times the RMS value.
- Add 2.5μA offset when Filter 1 or Filter 2 is enabled.
- Times apply with the current limit set to 105% of full scale.
- Loads are fully resistive.

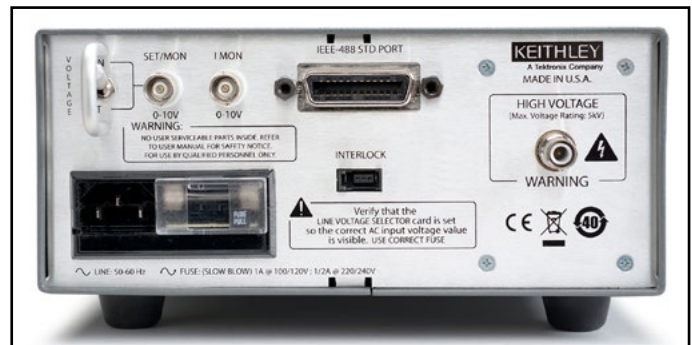

Model 2290-5 rear panel showing the IEEE-488 interface connector, high voltage output connector, analog control/output connectors, and interlock connector.

1.888.KEITHLEY (U.S. only)

www.keithley.com

KEITHLEY
A Tektronix Company

A Greater Measure of Confidence

A Tektronix Company

2290-10 Specifications

10kV Voltage Power Supply Characteristics

CONDITIONS

This document contains specifications and supplemental information for the Model 2290-10 High Voltage Power Supply. Specifications are the standards against which the Model 2290-10 is tested. Upon leaving the factory, the Model 2290-10 meets these specifications. Characteristics, supplemental characteristics, and typical values are not warranted, apply at 23°C ±5°C, <70% relative humidity, and are provided solely as useful information.

CHARACTERISTICS

VOLTAGE RANGE:

Output Voltage ¹	Maximum Output Current
+100 to +10,000 V DC	1.000 mA DC

VOLTAGE SET ACCURACY: ±0.06% of full scale.

VOLTAGE DISPLAY ACCURACY: Voltage set accuracy ±1V, typical (±2V, maximum).

VOLTAGE RESOLUTION: 1V (set and display).

VOLTAGE LIMIT RANGE: 0 to 100% full scale.

VOLTAGE REGULATION²: Line: 0.001% for ±10% line voltage change.

Load: 0.04% for 100% load change, typical.

OUTPUT RIPPLE (300Hz–300kHz): 0.01% of full scale, V_{RMS} .

RISE TIME (from high voltage turn on to final value under full load)^{3,4}: <6 seconds to within 1V of the final value.

DISCHARGE TIME (to 0V under full load)^{3,4}: 1 second to under 10V.

DISCHARGE TIME (no load)³: <6 seconds (to <1% of full scale voltage with no load, typical).

SETTLING TIME^{3,4}: <4 seconds to within 1V of the final value.

RECOVERY TIME^{3,4}: 120ms for 40% step change in load current (typical).

CURRENT LIMIT RANGE: 0 to 105% of full scale.

CURRENT SET ACCURACY: 0.5% of full scale.

CURRENT RESOLUTION: 1μA.

CURRENT DISPLAY ACCURACY: ±1μA, typical (±2μA, maximum).

TRIP CURRENT RANGE: 10μA to 105% of full scale (excluding stored output charge).

OUTPUT STORED CHARGE: <20μC maximum.

TRIP RESPONSE TIME: <10ms.

STABILITY: ±0.01% per hour; <0.03% per eight hours.

TEMPERATURE DRIFT: 50ppm/°C, 0° to 40°C, typical.

PROTECTION: Arc and short circuit protected; programmable voltage and current limits and current trip.

MONITOR OUTPUTS

OUTPUT SCALE: 0 to +10V for 0V to full scale.

CURRENT RATING: 10mA maximum.

OUTPUT IMPEDANCE: 100Ω.

ACCURACY: ±0.2% of full scale with a 1MΩ load, minimum.

UPDATE RATE: 87.5Hz.

EXTERNAL VOLTAGE SET

INPUT SCALE: 0 to +10V for 0 to full scale.

INPUT IMPEDANCE: 1MΩ.

ACCURACY: ±0.2% of full scale.

UPDATE RATE: 87.5Hz.

OUTPUT SLEW RATE (5% to 95% under full load): <3 seconds

GENERAL

INPUT POWER: 75 watts.

INPUT VOLTAGE: 90V–264VAC, 47 to 63Hz.

REAR PANEL CONNECTORS:

Output high-voltage connector: SHV male (Kings type 1764-1 or equivalent).

BNC Connector (three): Input, voltage monitor; current monitor.

GPIB connector, 23-pin.

RS-232, 9-pin D-sub

HIGH-VOLTAGE SAFETY INTERLOCK:

Connector: 3-pin press-in connector, 3M part number: 37103-A165-00E-MB.

Pin 1: 5V out, 70mA maximum out.

Pin 2: Input: High-voltage output enabled: 5V DC.

High-voltage output disabled: 0V DC or open connection.

Pin 3: Chassis ground.

INTERFACE PROTOCOL: IEEE-488.1.

OPERATING ENVIRONMENT: 0° to 40°C; non-condensing.

DIMENSIONS: 89mm high × 206mm wide × 406mm deep (3.5 in × 8.1 in × 16 in).

WEIGHT: 3.7kg (8 pounds).

SAFETY: Conformance to European Union low voltage directive.

WARRANTY: One year.

WARM-UP TIME: One hour.

- The output voltage can be programmed to voltages below 100V, but accuracy below 100V is not specified.
- Regulation specifications apply for greater than 100V.
- Times apply with the current limit set to 105% of full scale.
- Loads are fully resistive.



Model 2290-10 rear panel showing the IEEE-488 interface connector, RS-232 interface connector, high voltage output connector, analog control/output connectors, and interlock connector.

1.888.KEITHLEY (U.S. only)

www.keithley.com

A Greater Measure of Confidence

KEITHLEY
A Tektronix Company

2290-PM-200 Specifications

SMU Protection Module Characteristics

CONDITIONS

This document contains specifications and supplemental information for the Model 2290-PM-200 Protection Module. Specifications are the standards against which the Model 2290-PM-200 is tested. Upon leaving the factory, the Model 2290-PM-200 meets these specifications. Characteristics, supplemental characteristics, and typical values are not warranted, apply at 23°C ±5°C, <70 percent relative humidity, and are provided solely as useful information.

CHARACTERISTICS

LEAKAGE: <10pA at 200V typical.

DC CURRENT CARRYING CAPABILITY: <1.5A in unclamped condition.

PULSED CURRENT CARRYING CAPABILITY: 10A maximum at 1% duty cycle in unclamped condition.

MAXIMUM PROTECTION ACTIVE CURRENT: Current must be limited to <120mA in clamped condition (~230V).

PROTECTION VOLTAGE: 220VDC minimum, 230VDC typical, 240VDC maximum.

DIMENSIONS: 81.28mm long × 81.53mm wide × 54.10mm high (3.20 in. long × 3.21 in. wide × 2.13 in. high) Maximum length with high-voltage connectors: 5.34 in (135.64mm).

WEIGHT: 0.25kg (0.55 lb.).

GENERAL

WARRANTY: 1 year.

SAFETY: Listed to UL 61010-1:2012 (3rd edition). Conforms to European Union Low Voltage Directive.

CONNECTORS:

High Voltage: 5kV connector: male SHV, 0.38 inches (9.35mm) diameter, Kings 1704-1.

10kV connector: female SHV, 0.535 inches (13.59mm) diameter, Kings 1764-1.

Low Voltage: Triax, female, quantity of 2

Safety: Screw ground terminal, quantity of 2

Accessories

Test Leads and Probes	368
Cables	372
Connectors, Adapters, and Tools	386
Adapter, Cable, Prober, and Stabilizer Kits	398
Test Fixtures	399
Trigger Accessories	401
Bench Kit and Rack Mount Kits	402
Cabinets	406
Other Accessories	406
Carrying Case	406
IEEE-488 (GPIB) Interface Solutions	407
IEEE-488 (GPIB) Accessories	408

Test Leads and Probes

TEST LEADS AND PROBES SELECTOR GUIDE

Model	Name	Use With:
1600A	High Voltage Probe	DMMs
1651	50-Ampere Shunt	DMMs
1681	Clip-On Test Lead Set	DMMs
1751	Safety Test Leads	All DMMs, Series 2400
1752	Premium Safety Test Lead Kit	All DMMs, Series 2400
1754	Safety Universal Test Lead Kit	All DMMs, Series 2400
2187-4	Low Thermal Test Lead Kit	2182A, 622x Current Sources
2260-008	Test Lead Set	Series 2260B
2260B-EXTERM	Extended Terminal Test Leads	Series 2260B
2600-BAN	Banana Test Leads/Adapter Cable	2601B, 2602B, 2611B, 2612B
3706-BAN	Banana Test Leads/Adapter Cable	Series 3700A Mainframes
3706-TLK	Test Lead Kit	Series 3700A Mainframes
5804	General-Purpose, 4-Terminal Test Lead Set	Series 2400, 2750, DMMs
5805	Kelvin Probes, 0.9m (3 ft)	Series 2400, 2750, DMMs
5805-12	Kelvin Probes, 3.6m (12 ft)	Series 2400, 2750, DMMs
5806	Kelvin Clip Lead Set, 0.9m (3 ft)	Series 2400, 2750, DMMs
5807-7	Helical Spring Point Test Leads, 2.1m (7 ft)	Series 2400, 2750, DMMs
5808	Single-pin Kelvin Probe	2700, 2701, 2750, Series 2400, DMMs
5809	Kelvin Clip Lead Set	2700, 2701, 2750, Series 2400, DMMs
6517-RH	Humidity Probe with Extension Cable	6517A, 6517B
6517-TP	Thermocouple Bead Probe	6517A, 6517B
7401	Thermocouple Wire Kit, 30m (100 ft), Type K	2001-TCSCAN, 2110, 3720, 3721, 3724, 7057A, 7700, 7706, 7708
8605	High Performance Modular Test Leads	All DMMs, Series 2400
8606	High Performance Modular Probe Kit	All DMMs, Series 2400, Series 2600B, Series 3700A
8608	High Performance Clip Lead Set	2450, Series 2400, DMMs
8681	Low Cost RTD	2001, 2002, 2010 DMMs (with 8680)
CA-109A	Test Lead Set for Output Connections	2000-SCAN, 2001-SCAN, 2001-TCSCAN

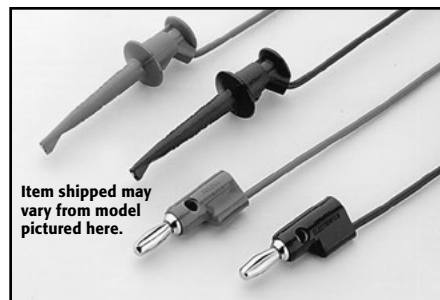

Item shipped may vary from model pictured here.

Model 1681 Clip-On Test Lead Set: Two 1.2m (48 in) leads terminated with banana plugs and spring action clip-on probes.

For use with: DMMs



Item shipped may vary from model pictured here.

Model 1751 Safety Test Leads: 91.4cm (36 in) test lead set supplied with each Model 175A and 197A. Finger guards and shrouded banana plugs help minimize the chance of making contact with live circuitry.

For use with: All DMMs, Series 2400 SourceMeter® SMU Instruments



Model 1752 Premium Safety Test Lead Kit: Includes two banana leads with safety shrouds on both ends, two fully insulated alligator clips, two fully insulated needle probes, and two spring-action clip-on probes with safety blocks, in a carrying case.

For use with: All DMMs, Series 2400 SourceMeter SMU Instruments

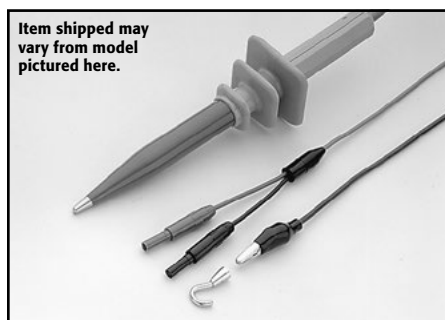

Item shipped may vary from model pictured here.

Model 1600A High Voltage Probe
 MAXIMUM INPUT: 40kV DC or 28kV AC, 50/60Hz.
 INPUT RESISTANCE: 1000MΩ.
 DIVISION RATIO: 1000:1 (into 10MΩ).

For use with: DMMs

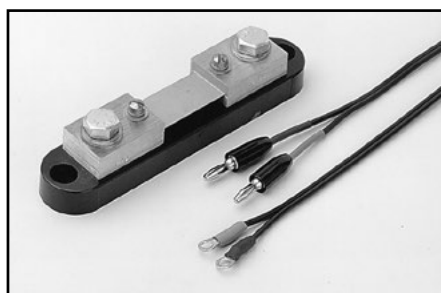

Model 1651 50 Ampere Shunt: External 0.001Ω ± 1%, 4-terminal shunt; extends current measuring capability of Keithley DMMs to 50A.

CABLE LENGTH: 1.4m (56 in).

For use with: DMMs

1.888.KEITHLEY (U.S. only)

www.keithley.com

Test Leads and Probes

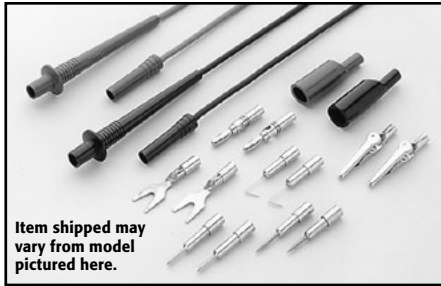

Item shipped may vary from model pictured here.

Model 1754 Universal Test Lead Kit: 10-piece test lead kit with interchangeable plug-in accessories. Kit includes: 1 set of test leads, 91.4cm (36 in), 1 red and black; 2 spade lugs, 2 standard banana plugs, 2 hooks, and 2 miniature alligator clips with boots.

For use with: All DMMs, Series 2400 SourceMeter SMU Instruments



Model 2187-4 Low Thermal Test Lead Kit: Includes an input cable with banana terminations, banana extensions, sprung-hook clips, alligator clips, needle probes, and spade lugs to connect the Model 2182A to virtually any DUT. The kit is also used to connect the Model 2182A directly to the Model 622X guard to improve response time for pulsed measurements or to reduce errors when measuring high impedance devices.

For use with: 2182A, 6220, 6221, 6220/2182A, 6221/2182A

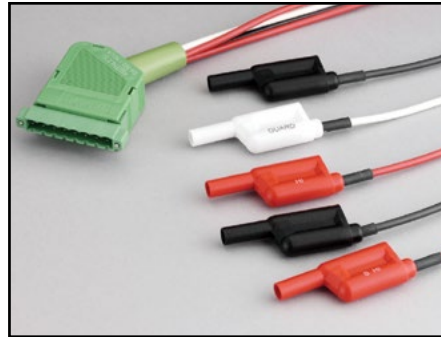

Model 2600-BAN: 1m (3.3 ft) banana test leads/adaptor cable for a single Series 2600B SourceMeter channel (two needed for use with Model 2602B and 2612B). Provides safety banana connections to Hi, Sense Hi, Lo, Sense Lo, and guard.

For use with: 2601B, 2602B, 2611B, 2612B



Model 2260-008: Test lead set with lugs, 10AWG, 122m (48 in), red/blue wire pair with #10 terminal lugs on each end.

For use with: Series 2260B



Model 2260B-EXTERM: Extended Terminal Test Leads, 0.7m (28 in.), and terminal box to bring outputs to the front of the instrument or another location. Magnetic base attaches to side of the instrument.

For use with: Series 2260B



Model 3706-BAN: 1.4m (4.6 ft) banana test leads/adaptor cable for Model 3706A mainframe with high performance multimeter option. Provides direct connection to high performance multimeter utilizing rear panel backplane connector. Safety banana connections to HI, LO, Sense HI, Sense LO, and AMP.

For use with: Series 3700A mainframes



Model 3706-TLK Test Lead Kit: Includes 3706-BAN banana test leads/adaptor cable and plug-in test lead accessories. Test lead accessories include: 4 spring hook probes, 2 needle test probes, 4 safety plug adapters, and carrying case.

For use with: Series 3700A mainframes



Item shipped may vary from model pictured here.

Model 5804 Test Lead Set: Designed to be used with Keithley instruments that measure 4-terminal resistance. Contains: 2 test leads, 0.9m (36 in), red and black; 2 test clips, red and black; 2 plunger clip adapters, red and black; 2 alligator clips with boots (accept standard test probe tip); 2 alligator clips with boots (barrels accept standard banana plugs).

For use with: Series 2400 SourceMeter® SMU Instruments, 2750, DMMs

1.888.KEITHLEY (U.S. only)

www.keithley.com

A Greater Measure of Confidence

KEITHLEY
A Tektronix Company

Test Leads and Probes

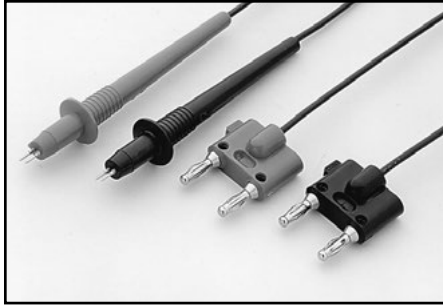

Model 5805 Kelvin Probes: 2 spring-loaded test probes, red and black, 0.9m (36 in) with banana plug termination. Designed to be used with Keithley instruments that measure 4-terminal resistance and in-circuit current. 1/8-in spacing between pin tips. A package of 8 replacement contacts (P/N CS-551) is available.

Model 5805-12: Similar to 5805 but 3.6m (12 ft) in length.

For use with: Series 2400 SourceMeter SMU Instruments, 2750, DMMs

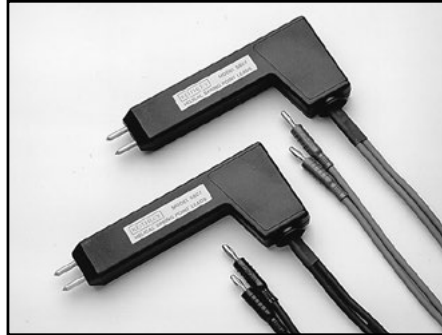

Model 5807-7 Helical Spring Point Test Leads: Two excellent Kelvin test probes for Keithley instruments that measure 4-terminal resistance. The probes have pointed tips that rotate when pressure is exerted on the handle. Good contact is assured, and the handle can be held at any angle to the measurement surface. The lead wires terminate in banana plugs. **Lead wire length:** 2m (7 ft).

For use with: Series 2400 SourceMeter SMU Instruments, 2750, DMMs



Model 5809 Low Cost, Kelvin Clip Lead Set: Two 0.94m (37 in) long probes with alligator style clips, each with opposing blade source and sense connections to color coded standard safety banana plugs. Designed for applications requiring Kelvin connection to wires, axial leaded components, and other terminals able to be clipped onto. The miniature blade design accommodates narrow available width applications as well as general lighter duty applications. The maximum jaw opening is 9.14mm (0.36 in) and the blade width is 2.92mm (0.115 in).

For use with: 2700, 2701, 2750, Series 2400, DMMs



Model 5806 Kelvin Clip Lead Set: 2 clip test leads, red and black, 0.9m (36 in) with banana plug termination. Designed to be used with Keithley instruments that measure 4-terminal resistance. Maximum jaw opening 1/2 in. A package of 8 replacement elastic bands (P/N 5806-306B) is available.

For use with: Series 2400 SourceMeter SMU Instruments, 2750, DMMs



Model 5808 Low Cost, Single Pin, Kelvin Probes: Two 1.17m (46 in) long, single fixed pin probes with source and sense leads per probe and color coded standard safety banana plugs. Designed for applications requiring Kelvin resistance measurements with the convenience of a single point of circuit contact. The Kelvin connection at the base of each probe pin results in very low resistance errors, eliminating all wire and probe body resistance. For the highest precision sensing applications, use the Model 5805, 5806, or 5809 for complete control over sensing point placement.

For use with: 2700, 2701, 2750, Series 2400, DMMs



Model 6517-RH Humidity Probe: The 6517-RH comes with a 3m (10 ft) extension cable and is designed to be used with the 6517B Electrometer. The 6517-RH measures the relative humidity of the testing environment.

OPERATING TEMPERATURE RANGE: -10°C to +60°C

OPERATING HUMIDITY RANGE: 0 to 100% RH

MEASURING RANGE: 10 to 90% RH

TEMPERATURE DEPENDENCE: $\pm 2\%$ from -10°C to +60°C

For use with: 6517A and 6517B Electrometers

1.888.KEITHLEY (U.S. only)

www.keithley.com

KEITHLEY

A Tektronix Company

A Greater Measure of Confidence

Test Leads and Probes



Model 6517-TP Thermocouple Bead Probe: Designed to be used with the 6517B Electrometer, the 6517-TP measures the temperature of the testing environment. 6517-TP is 36 in. long and has a temperature calibration (range) of 0°C to 1250°C. Type K thermocouple.

For use with: 6517A and 6517B Electrometers and 2110 DMM



Model 7401: Type K thermocouple wire kit includes 30.5m (100 ft) of type K (chromel-alumel) thermocouple wire.

For use with: 2001-TCSCAN, 2110, 3720, 3721, 3724, 7057A, 7700, 7706, 7708



Model 8605 High Performance Modular Test Leads: Highest quality lead with silicone insulation, and removable test probes. Rated to 1500V. UL listed.

LENGTH: 1m (3.3 ft).

For use with: All DMMs, Series 2400 SourceMeter® SMU Instruments

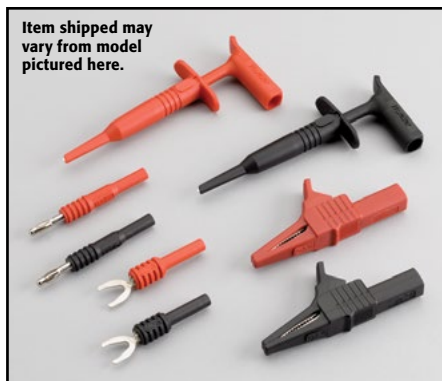

Item shipped may vary from model pictured here.

Model 8606 High Performance Modular Probe Kit: For use with Model 8605 High Performance Modular Test Leads. Contains 2 each spade lugs, alligator clips, and retractable hooks.

For use with: All DMMs; Series 2400 and Series 2600B SourceMeter SMU Instruments; Series 3700A



Model 8608 High Performance Clip Lead Set: High quality clip lead set with removable test clips. NRTL listed. Rated to 1000V CAT 3 and 20 amps.

LENGTH: 1.2m (3.9 ft).

For use with: 2450, Series 2400 SourceMeter SMU Instruments, Series 3700A DMMs

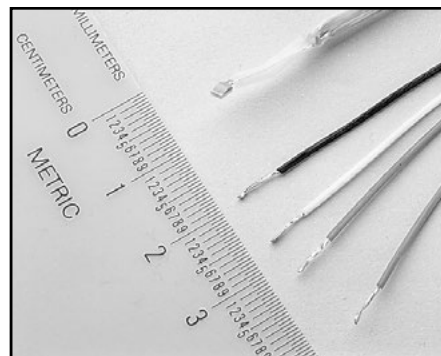

Model 8681 Low Cost RTD: This inexpensive RTD has small size (0.09 in × 0.09 in) and fast thermal response time. 100Ω, 0.385%/°C element. Meets or exceeds DIN 43760-1980-A, IEC 751:1983-A, BS1904: 1984-A, and JIS C1604-1981-0.2. Can be used with Model 8680 RTD Input Probe Adapter. Measures from -200° to +600°C.

LENGTH: 0.9m (3 ft).

ACCURACY: $\pm(0.15^\circ\text{C} + 0.002 \times |t|)$ °C, where |t| is absolute value of temperature in °C.

For use with: 2001, 2002, 2010 DMMs (with 8680), 7700, 7702, 7706, 7708



Item shipped may vary from model pictured here.

Model CA-109A Test Lead Set: For output connections (two red, two black).

For use with: 2000-SCAN, 2001-SCAN, 2001-TCSCAN

1.888.KEITHLEY (U.S. only)

www.keithley.com

A Greater Measure of Confidence

KEITHLEY
A Tektronix Company

Cables

Cables

Model	Description	Type	TERMINATIONS		LENGTH		USE WITH:
			From	To	m	ft	
236-ILC-3	Safety Interlock	Shielded twisted pair	3-pin round	3-pin round	3	10	4200-SCS, 8007, 8008
237-ALG-2	Low Noise Input	Triax	3-slot male triax	Alligator clips (3)	2	6.6	Series 2200, Series 2600B, 4200-PA, 6220, 6221, 6482, 6487, 6514, 6517A, 6517B
237-ALG-15	Low Noise Input	Triax	3-slot male triax	Alligator clips (3)	15	50	Series 2200, Series 2600B, 4200-PA, 6220, 6221, 6482, 6487, 6514, 6517A, 6517B
2000-MTC-2	Cable Assembly	Shielded twisted pair	DB44 female	Unterminated	2	6.6	2000-20
2000-MTCD-2	Cable Assembly	Shielded multiple conductors	DB44 female	DB50 male	2	6.6	2000-SCAN-20
2107-4	Input Cable	Shielded twisted pair	LEMO	Copper spade lugs (4)	1.2	4	2182A
2107-30	Input Cable	Shielded twisted pair	LEMO	Copper spade lugs (4)	9.1	30	2182A, Series 2200
2107-50	Input Cable	Shielded twisted pair	LEMO	Copper spade lugs (4)	15	50	2182A, Series 2200
2260-005	Input Cable				0.5	1.6	Series 2260B
2260-006	Input Cable				0.5	1.6	Series 2260B
2260-007	Input Cable				0.5	1.6	Series 2260B
2290-5-SHV	Input Cable	Coax	SHV Female	SHV Female	3	10	2290-5, 2290-5-SHVBH
2290-5-MHV	Input Cable	Coax	SHV Female	MHV Male	3	10	2290-5
2290-10-SHV	Input Cable	Coax	SHV Male	SHV Male	3	10	2290-10, 2290-10-SHVBH
2290-10-SHVUC	Input Cable	Coax	SHV Male	Unterminated	3	10	2290-10
2290-INT-CABLE	Interlock Cable	3-conductor	3-pin	Unterminated	3.05	10	2290-5, 2290-10
2450-TRX-BAN	Adapter Cable	Triax	3-slot male triax	Banana input jack	0.3	1	2450
2600-ALG-2	Low Noise Input	Triax	3-slot male triax	Alligator clips (3)	2	6.6	2635B, 2636B, 4200-PA
2651A-KIT-1	Cable Assembly	Coax	2-pin plug	2-pin plug	1	3.3	2651A, 8011
2651A-KIT-2	Cable Assembly	Coax	2-pin plug	2-pin plug	2	6.6	2651A, 8011
2651A-KIT-3	Cable Assembly	Coax	2-pin plug	2-pin plug	3	10	2651A, 8011
3720-MTC-1.5	Mass Terminated Assembly	Twisted pair	D-sub female	78-pin D-sub male	1.5	5	3720, 3723, 3724
3720-MTC-3	Mass Terminated Assembly	Twisted pair	D-sub female	78-pin D-sub male	3	10	3720, 3723, 3724
3721-MTC-1.5	Mass Terminated Assembly	Twisted pair	D-sub female	50-pin D-sub male	1.5	5	3721, 3730, 3731, 3740, 3750
3721-MTC-3	Mass Terminated Assembly	Twisted pair	D-sub female	50-pin D-sub male	3	10	3721, 3730, 3731, 3740, 3750
3722-MTC-1.5	Mass Terminated Assembly	Twisted pair	D-sub male	104-pin D-sub female	1.5	5	3722
3722-MTC-1.5/MM	Mass Terminated Assembly	Twisted pair	D-sub male	104-pin D-sub male	1.5	5	3722
3722-MTC-3	Mass Terminated Assembly	Twisted pair	D-sub male	104-pin D-sub female	3	10	3722
3722-MTC-3/MM	Mass Terminated Assembly	Twisted pair	D-sub male	104-pin D-sub male	3	10	3722
3732-MTC-1.5	Mass Terminated Assembly	Twisted pair	D-sub female	78-pin D-sub male	1.5	5	3732
3732-MTC-3	Mass Terminated Assembly	Twisted pair	D-sub female	78-pin D-sub male	3	10	3732
4200-MTRX-1	Ultra Low Noise	SMU triax	Miniature male	3-slot male	1	3.2	4200-SCS
4200-MTRX-2	Ultra Low Noise	SMU triax	Miniature male	3-slot male	2	6.5	4200-SCS
4200-MTRX-3	Ultra Low Noise	SMU triax	Miniature male	3-slot male	3	9.8	4200-SCS
4200-PRB-C	Cable Assembly	Y adapter cable	Female SMA	2 female SSMC			4200-PIV, 4210-CVU
4200-RPC-0.3	Cable Assembly	Remote PreAmp	DB15	DB15	0.3	1	4200-PA
4200-RPC-2	Cable Assembly	Remote PreAmp	DB15	DB15	2	6.5	4200-PA
4200-RPC-3	Cable Assembly	Remote PreAmp	DB15	DB15	3	9.8	4200-PA
4200-RPC-6	Cable Assembly	Remote PreAmp	DB15	DB15	6	19.6	4200-PA
4200-TRX-0.3	Ultra Low Noise	PreAmp triax	3-slot male	3-slot male	0.3	1ft	4200-PA
4200-TRX-1	Ultra Low Noise	PreAmp triax	3-slot male	3-slot male	1	3.2	4200-PA
4200-TRX-2	Ultra Low Noise	PreAmp triax	3-slot male	3-slot male	2	6.5	4200-PA
4200-TRX-3	Ultra Low Noise	PreAmp triax	3-slot male	3-slot male	3	9.8	4200-PA
4801	Low Noise Input	Coax	Male BNC	Male BNC	1.2	4	6482, 6485, 7158
4802-10	Low Noise Input	Coax	Male BNC	Unterminated	3	10	6482, 6485, 7158
4803	Low Noise Cable Kit	Coax	Male BNC (10)	Female BNC (5)	15.2	50	6482, 6485, 7158
6011	Input Leads	Triax	2-slot male triax	Alligator clips (3)	1.5	5	Instruments with 2-slot triax connectors
6011-10	Input Leads	Triax	2-slot male triax	Alligator clips (3)	3	10	Instruments with 2-slot triax connectors
6517-ILC-3	4-pin Interlock Cable	Shielded	4-pin female DIN	4-pin female DIN	1	3.3	6517A, 8009
6517B-ILC-3	Interlock Cable	Shielded	4-pin Phoenix	4-pin DIN	1	3.3	6517B, 8009
7009-5	Shielded RS-232	Shielded	Male DB-9	Female DB-9	1.5	5	All RS-232 capable instruments
7011-MTC-1	Mass Terminated Assembly	Twisted pair (45)	96-pin female	96-pin female	1	3.3	7011-C, 7012-C, 7013-C, 7015-C, 7018-C
7011-MTC-2	Mass Terminated Assembly	Twisted pair (45)	96-pin female	96-pin female	2	6.6	7011-C, 7012-C, 7013-C, 7015-C, 7018-C
7019C-MTCI-2	Kelvin Instrument Cable	Shielded twisted pair	Card connector	Shielded banana plug cables (6)	2	6.6	Series 2400

ACCESSORIES

1.888.KEITHLEY (U.S. only)

www.keithley.com

KEITHLEY

A Tektronix Company

A Greater Measure of Confidence

Cables

Model	Description	Type	TERMINATIONS		LENGTH		USE WITH:
			From	To	m	ft	
7020-MTC-2	Mass Terminated Assembly	Twisted pair (45)	96-pin female	96-pin female	2	6.6	7020
7024-3	Low Noise	Triax	2-slot male triax	2-slot male triax	0.9	3	Instruments with 2-slot triax connectors
7024-10	Low Noise	Triax	2-slot male triax	2-slot male triax	3	10	Instruments with 2-slot triax connectors
7025-10	Low Noise Input	Triax	2-slot male triax	Unterminated	3	10	Instruments with 2-slot triax connectors
7035-MTC-2	Mass Terminated Assembly	Twisted pair (45)	96-pin female	96-pin female	2	6.6	7035
7036-MTC-2	Mass Terminated Assembly	Twisted pair (45)	96-pin female	96-pin female	2	6.6	7036
7051*	BNC Interconnect	Coax	BNC	BNC			2015, 2016, 3390
7078-DIN	707A Master/Slave	Twisted pair (9)	8-pin DIN	8-pin DIN	1.8	6	707A
7078-MTC-5	Mass Terminated Assembly	Twisted pair (12)	38-pin connector	38-pin connector	1.5	5	7071, 7071-4, 7074-D
7078-MTC-20	Mass Terminated Assembly	Twisted pair (12)	38-pin connector	38-pin connector	6.1	20	7071, 7071-4, 7074-D
7078-TRX-1	Low Noise	Triax	3-slot male triax	3-slot male triax	0.3	1	2635B, 2636B, 6482, 6487, 6514, 6517A, 6517B, 7072, 7174A
7078-TRX-3	Low Noise	Triax	3-slot male triax	3-slot male triax	0.9	3	2635B, 2636B, 6482, 6487, 6514, 6517A, 6517B, 7072, 7174A
7078-TRX-5	Low Noise	Triax	3-slot male triax	3-slot male triax	1.5	5	2635B, 2636B, 6482, 6487, 6514, 6517A, 6517B, 7072, 7174A
7078-TRX-10	Low Noise	Triax	3-slot male triax	3-slot male triax	3	10	2635B, 2636B, 6482, 6487, 6514, 6517A, 6517B, 7072, 7174A
7078-TRX-12	Low Noise	Triax	3-slot male triax	3-slot male triax	4	12	2635B, 2636B, 6482, 6487, 6514, 6517A, 6517B, 7072, 7174A
7078-TRX-20	Low Noise	Triax	3-slot male triax	3-slot male triax	6.1	20	2635B, 2636B, 6482, 6487, 6514, 6517A, 6517B, 7072, 7174A
7078-TRX-6IN	Low Noise	Triax	3-slot male triax	3-slot triax	0.15	0.5	6430
7152-MTC-2	Low Noise Matrix Expansion	Triax (5)	6-pin M-series coax	6-pin M-series coax	0.6	2	7152
7152-MTC-10	Low Noise Matrix Expansion	Triax (5)	6-pin M-series coax	6-pin M-series coax	3	10	7152
7152-TRX-10	Low Noise M-Series to Triax	Triax (5)	M-series connector	3-slot triax (5)	3	10	7152, 8006
7153-TRX	Low Noise M-Series to Triax	Triax (5)	M-series connector	3-slot triax (5)	2	6	7153
7173-50-CSEP	4-cable Set	Coax	SMB female	BNC male	0.6	2	7173-50
7705-MTC-2	Mass Terminated Assembly	Twisted pair (25)	D-sub male	D-sub female	2	6.6	7703, 7705, 7707, 7709
7711-BNC-SMA	5 SMA to BNC Cables	Coax	SMA Male	BNC Female	0.15	0.5	7711
7712-SMA-1	SMA Cables	Coax	SMA Male	SMA Male	1	3.3	7711, 7712, System 46, System 46T
7754-3	BNC	Coax	BNC Male	Alligator clips	0.9	3	Instruments with 2-slot BNC connectors
8007-GND-3	Safety Ground Wire	Single wire	Crimp lug	Crimp lug	3	10	8007
8542-301	LIV Cable	Multiple conductor	DB9 female	Multiple terminations: Triax (2500), 2 dual bananas (24XX) GND wire	1.8	6	2500, Series 2400, System 25, 8544, 8544-TEC
8607	1kV Test Cables	Single wire (2)	Safety banana	Safety banana	1	3.3	2410, 6487, 6517A, 6517B
CA-18-1	Shielded	Coax	Dual banana plug	Dual banana plug	1.2	4	Binding post inputs
CA-19-2	RG58	RG58	BNC male	BNC male	1.5	5	4200-SCS
CA-126-1A	Digital I/O	Shielded	DB25 male	DB25 female	1.5	5	Series 2600B, Series 3700A
CA-180-3A	Crossover Cable	Twisted pair	RJ45	RJ45	3	10	Series 2600B, 2701, 3390, Series 3700A, 6221, all TSP-enabled instruments
CA-321-1	Temperature Control Cable	Multiple conductor	DB15 female	8-position Phoenix (CS-846 equivalent)	1.8	6	2510, 8544
CA-322-1	Dual Temperature Control Cable	Multiple conductor	DB15 female	Y cable to two 8-position Phoenix (CS-846)	1.8	6	2510, 8544, 8544-TEC
CA-404B	RG188	Coax	SMA male	SMA male	2	6.5	4200-SCS
CA-405B	RG188	Coax	SMA male	SMA male	0.15	0.5	4200-SCS
CA-406B	RG188	Coax	SMA male	SMA male	0.33	1.08	4200-SCS
CA-446A	Cable Assembly	Coax	SMA male	SMA male	3	9.8	4210-CVU
CA-447A	Cable Assembly	Coax	SMA male	SMA male	1.5	5	4210-CVU
CA-451A	RG188	Coax	SMA male	SMA male	0.108	0.35	4200-SCS
CA-452A	RG188	Coax	SMA male	SMA male	0.203	8 in.	4200-SCS
CA-557-1A	Cable Assembly	Multiple conductor	8-pin receptacle	8-pin receptacle	1	3.3	2651A, 8011
CA-557-2A	Cable Assembly	Multiple conductor	8-pin receptacle	8-pin receptacle	2	6.6	2651A, 8011
CA-557-3	Cable Assembly	Multiple conductor	8-pin receptacle	8-pin receptacle	3	10	2651A, 8011
CA-558-x	Interlock Cable	Twisted pair (2)	25-pin D-sub	3-pin	1, 2, 3	3.3, 6.6, 10	Series 2600B, 2657A
CA-559-0A	Black Banana Jumper	Jumper	Banana	Banana	0.102	4 in.	8010
CA-559-2A	Red Banana Jumper	Jumper	Banana	Banana	0.102	4 in.	8010
CA-560-0A	Banana Plug Jumper Cable	Jumper	Banana	Banana	0.203	8 in.	8010
CA-560-2A	Banana Plug Jumper Cable	Jumper	Banana	Banana	0.203	8 in.	8010
CA-561-0A	Black Banana Jumper	Jumper	Banana	Banana	0.203	8 in.	8010
CA-561-2A	Red Banana Jumper	Jumper	Banana	Banana	0.203	8 in.	8010

1.888.KEITHLEY (U.S. only)

www.keithley.com

A Greater Measure of Confidence

KEITHLEY
A Tektronix Company

Cables

Model	Description	Type	TERMINATIONS		LENGTH		USE WITH:
			From	To	m	ft	
CA-562-0B	Black Safety Banana Plug Jumper Cable	Jumper	Banana	Banana	0.254	10 in.	8010
CA-562-2B	Red Safety Banana Plug Jumper Cable	Jumper	Banana	Banana	0.254	10 in.	8010
CA-563C	BNC to Banana Jumper	Jumper	BNC	Banana	0.241	9.5 in.	8010
CA-567-0A	Black Banana Jumper	Jumper	Banana	Banana	0.203	8 in.	8010
CA-567-2A	Red Banana Jumper	Jumper	Banana	Banana	0.203	8 in.	8010
CA-568-XA	Protective Earth Ground	Safety	Eye lug	Eye lug	0.3, 0.45, 3	1, 1.5, 10	8010
HV-CA-554-x	3kV Rated	High voltage	Triax	Triax	0.5, 1, 2, 3	1.6, 3.3, 6.6, 10	8010, 2657A
HV-CA-571-3	High Voltage	Triax	Triax	Unterminated			2657A
S46-SMA-0.5	SMA Cable	Coax	SMA Male	SMA Male	0.15	0.5	7711, 7712, System 46, System 46T
S46-SMA-1	SMA Cable	Coax	SMA Male	SMA Male	0.30	1.0	7711, 7712, System 46, System 46T
SC-9	Low Noise	Coax	Unterminated	Unterminated	Sold by the foot		
SC-22	Low Noise	Triax	Unterminated	Unterminated	Sold by the foot		CS-631
SC-93	Low Thermal	Shielded	Unterminated	Unterminated	Sold by the foot		2182-KIT
SC-182	Low Inductance	Coax	Unterminated	Unterminated	Sold by the foot		2302, 2303, 2303-PJ, 2304A, 2306, 2306-PJ
SC-200A	General Purpose	Shielded twisted pair	Unterminated	Unterminated	Sold by the inch		Series 2600B
SC-206	High Current Coax Cable	Coax	Unterminated	Unterminated	Sold by the inch		2651A
SHV-CA-553-x	3kV Rated	High voltage	Triax	SHV	1, 2, 3	3.3, 6.6, 10	2657A
USB-B-1	USB Cable	Coax	USB Type A	USB Type B	1	3.3	2100, Series 2200, 3390, Series 3700A, Series 2600, 2450



Model 236-ILC-3 Safety Interlock Cable: Designed to connect the lid interlock circuit of the Models 8007 and 8008 test fixtures to the interlock circuit of the Model 237 SMU and 486 and 487 Picoammeters.

For use with: 4200-SCS, 8007, 8008

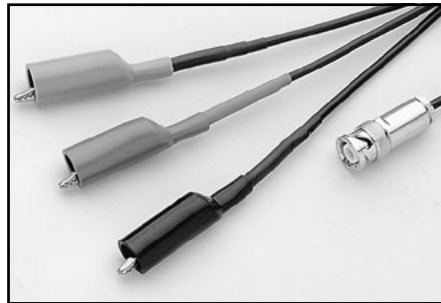

Model 237-ALG-*: Low noise triax cable (SC-22) terminated with a 3-slot male triax connector on one end and 3 alligator clips on the other.
237-ALG-2 2m (6.6 ft) length
237-ALG-15 15m (50 ft) length

For use with: Series 2200, Series 2600B, 4200-PA, 6220, 6221, 6487, 6514, 6482, 6517A, 6517B



Model 2000-MTC-2 Cable Assembly: 2-meter cable with a 44-pin connector on one end that is designed to mate with the 2000-20 scanner card. The other end is unterminated for direct connection to measurement fixtures or devices.

For use with: 2000-20

Cables

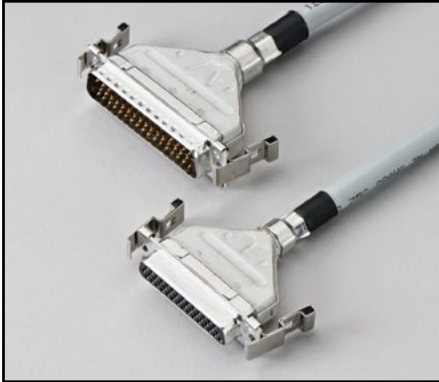

Model 2000-MTCD-2 Cable Assembly: 2-meter cable with a 44-pin connector on one end that is designed to mate with the 2000-SCAN-20 scanner card. The other end is equipped with a 50-pin D-sub male connector.

For use with: 2000-SCAN-20



Model 2107-* Low-Thermal Input Cables with Spade Lugs: An input cable terminated with a LEMO connector on one end and four copper spade lugs on the other.

2107-4 1.2m (4 ft) length
2107-30 9.1m (30 ft) length
2107-50 15m (50 ft) length

For use with: 2182A, Series 2200



Model 2260-005: Cable, 0.5m (1.6 ft.), to connect two Series 2260B power supplies in series.

For use with: Series 2260



Model 2260-006: Cable, 0.5m (1.6 ft.), to connect two Series 2260B power supplies in parallel.

For use with: Series 2260



Model 2260-007: Cable, 0.5m (1.6 ft.), to connect three Series 2260B power supplies in parallel.

For use with: Series 2260

Model 2290-5-MHV: 3m (10 ft) of RG-8A/U coaxial cable terminated with a SHV female connector on one end and a MHV male connector on the other end. Maximum operating voltage is 5000Vrms. Characteristic cable impedance is 50Ω.

For use with: 2290-5

Model 2290-5-SHV: 3m (10 ft) of RG-8A/U coaxial cable terminated with a SHV female connector on both ends. Maximum operating voltage is 5000Vrms. Characteristic cable impedance is 50Ω.

For use with: 2290-5



Model 2290-10-SHV: 3m (10 ft) of RG-213/U coaxial cable terminated with a SHV male connector on both ends. Maximum operating voltage is 10,000Vrms.

For use with: 2290-10, 2290-10-SHVBH



Model 2290-10-SHVUC: 3m (10 ft) of RG-213/U coaxial cable terminated with a SHV male connector on one end and unterminated cable on the other end. Maximum operating voltage is 10,000Vrms.

For use with: 2290-10

1.888.KEITHLEY (U.S. only)

www.keithley.com

A Greater Measure of Confidence

KEITHLEY
A Tektronix Company

Cables



Model 2290-INT-CABLE: Safety interlock cable, 3.05m (10 ft). 3-conductor cable with 3-pin connector on one end and unterminated wires on the other end.

For use with: 2290-5, 2290-10



Model 2450-TRX-BAN: For adapting the Model 2450's rear panel triaxial connectors to banana jack inputs. **Length:** 0.3m (1 ft).

For use with: 2450

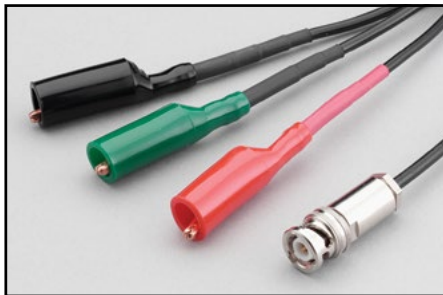

Model 2600-ALG-2: 2m (6.6 ft) cable terminated with a 3-slot male triax connector on one end and 3 alligator clips on the other.

For use with: 2635B, 2636B, 4200-PA



Model 2651A-KIT-*: High current, low impedance, coaxial cable assembly.

2651A-KIT-1: 1m (3.3 ft).

2651A-KIT-2: 2m (6.6 ft).

2651A-KIT-3: 3m (10 ft).

For use with: 2651A, 8011



Model 3720-MTC-*: 78-pin D-sub female to 78-pin D-sub male cable.

3720-MTC-1.5: 1.5m (5 ft) length

3720-MTC-3: 3m (10 ft) length

For use with: 3720, 3723, 3724



Model 3721-MTC-*: 50-pin D-sub female to 50-pin D-sub male cable.

3721-MTC-1.5: 1.5m (5 ft) length

3721-MTC-3: 3m (10 ft) length

For use with: 3721, 3730, 3731, 3740, 3750



Model 3722-MTC-*: 104-pin D-sub male to 104-pin D-sub female cable.

3722-MTC-1.5: 1.5m (5 ft) length

3722-MTC-3: 3m (10 ft) length

For use with: 3722



Model 3722-MTC-*/MM: 104-pin D-sub male to 104-pin D-sub male cable.

3722-MTC-1.5/MM: 1.5m (5 ft) length

3722-MTC-3/MM: 3m (10 ft) length

For use with: 3722



Model 3732-MTC-*: 78-pin D-sub female to 78-pin D-sub male cable.

3732-MTC-1.5: 1.5m (5 ft) length

3732-MTC-3: 3m (10 ft) length

For use with: 3732

1.888.KEITHLEY (U.S. only)

www.keithley.com

Cables



Model 4200-MTRX-*: Ultra low noise SMU triax cable is terminated with a miniature male triax connector on one end and a standard 3-slot male triax connector on the other. This cable connects a Model 4200-SMU or 4210-SMU source measurement unit installed in a Model 4200-SCS to a test fixture. (4200-MTRX-* cables are intended only for connection to an SMU that does not have a 4200-PA PreAmp installed.)

4200-MTRX-1: 1m (3.2 ft)

4200-MTRX-2: 2m (6.5 ft) (two included with each 4200-SCS SMU not configured with a 4200-PA Remote PreAmp)

4200-MTRX-3: 3m (9.8 ft)

For use with: 4200-SCS

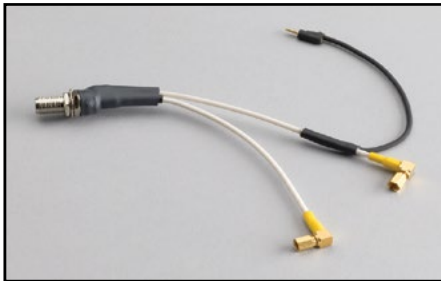

Model 4200-PRB-C: SMA to SSMC Y adapter cable with local ground that connects the 4200-PIV package to DC probe manipulators. The cable is terminated at one end with a single female SMA. The other end splits into two gold SSMC plugs (female connectors) and a black wire with integrated connector, which is used to connect to the shield of another Model 4200-PRB-C cable.

For use with: 4200-PIV, 4210-CVU



Model 4200-RPC-*: Remote PreAmp cable terminated at each end with a high density DB15 connector. This cable connects a Model 4200-SMU or 4210-SMU source measurement unit installed in a Model 4200-SCS to a remotely mounted Model 4200-PA PreAmp.

4200-RPC-0.3: 0.3m (1 ft) (for use inside prober shield)

4200-RPC-2: 2m (6.5 ft) (one included with each 4200-PA)

4200-RPC-3: 3m (9.8 ft)

4200-RPC-6: 6m (19.6 ft)

For use with: 4200-PA



Model 4200-TRX-*: Ultra low noise PreAmp triax cable terminated with a standard 3-slot male triax connector on each end. This cable connects a Model 4200-PA PreAmp option installed in the Model 4200-SCS to the test fixture.

4200-TRX-0.3: 0.3m (1 ft) (recommended for remote location of the 4200-PA)

4200-TRX-1: 1m (3.2 ft)

4200-TRX-2: 2m (6.5 ft) (two included with each Model 4200-PA)

4200-TRX-3: 3m (9.8 ft)

For use with: 4200-PA

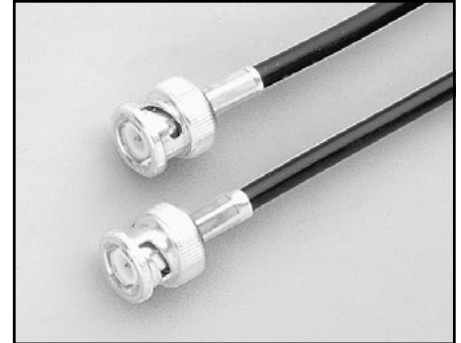

Model 4801 Input Cable: Low noise coax cable, 1.2m (48 in) in length, with male BNC connectors on each end.

For use with: 6482, 6485, 7158



Model 4802-10: 3m (10 ft) of low noise coax cable with male BNC connector at one end and unterminated at the other.

For use with: 6482, 6485, 7158



Model 4803 Low Noise Cable Kit: Includes 15m (50 ft) of low noise coax cable, 10 male BNC connectors, and 5 female BNC chassis-mount connectors.

For use with: 6482, 6485, 7158

1.888.KEITHLEY (U.S. only)

www.keithley.com

A Greater Measure of Confidence

KEITHLEY
A Tektronix Company

Cables

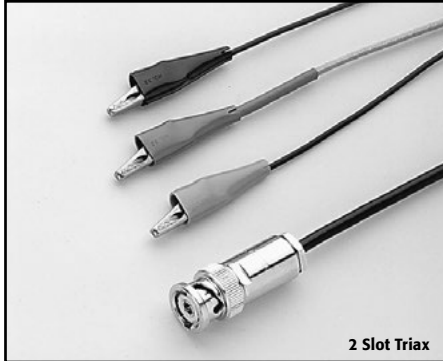

2 Slot Triax

Model 6011 2-slot Triax Cable: 1.5m (5 ft) of triax cable (SC-22) terminated with a 2-slot triax plug on one end and three alligator clips on the other. Also available in 3m (10 ft) length (Model 6011-10).

For use with instruments with 2-slot triax connectors



Model 6517-ILC-3 Interlock Cable: Designed to connect the Interlock of the 6517A with the 8009 test fixture. Configuring the 6517A with the 8009 test fixture results in all the electrode constants already being programmed into the unit.

For use with: 6517A Electrometer, 8009



Model 6517B-ILC-3 Interlock Cable: Designed to connect the interlock of the 6517B with the 8009 test fixture. Configuring the 6517B with the 8009 test fixture results in all the electrode constants already being programmed into the unit.

For use with: 6517B Electrometer, 8009



Model 7009-5 Shielded RS-232 Cable: 1.5m (5 ft) RS-232 cable with a male DB-9 connector at one end and a female DB-9 connector on the other end. Wired as a straight through, not as a null modem cable.

For use with: All RS-232 capable instruments



Model 7011-MTC-x: Mass terminated cable assembly for connection to 7011-C and other switching cards. The cable has 45 pairs with outer shield. The cable is terminated at each end with 96-pin female DIN connectors with strain relief.

7011-MTC-1 1m (3.3 ft)
7011-MTC-2 2m (6.6 ft)

For use with: 7011-C, 7012-C, 7013-C, 7015-C, 7018-C, 7022



Model 7019C-MTCI-2 6-wire Kelvin Extender and Instrument Cable: Used with Model 7019-C 6-Wire Ohms Matrix Card and a SourceMeter SMU instrument. The SourceMeter cables are 0.6m (2 ft) long and the DUT cables are 2m (6.6 ft) long. The cable set is used in a basic system to test a resistor network.

For use with: Series 2400 SourceMeter SMU Instruments



Model 7020-MTC-2: 2m (6.6 ft) mass terminated cable assembly for connection to 7020. The cable has 45 pairs with outer shield. The cable is terminated at each end with 96-pin female DIN connectors with strain relief.

For use with: 7020

1.888.KEITHLEY (U.S. only)

www.keithley.com

Cables



2 Slot Triax

Model 7024-* 2-slot Triax Cable: Low noise triax cable (SC-22) with 2-slot male triax connectors on each end.

7024-3 0.9m (3 ft)
7024-10 3m (10 ft)

For use with instruments with 2-slot triax connectors



2 Slot Triax

Model 7025-10 2-slot Triax Cable: 3m (10 ft) low noise triax input cable (SC-22) terminated on one end with 2-slot male triax connector.

For use with instruments with 2-slot triax connectors



Model 7035-MTC-2: 2m (6.6 ft) mass terminated cable assembly for connection to 7035. The cable has 45 pairs with outer shield. The cable is terminated at each end with 96-pin female DIN connectors with strain relief.

For use with: 7035



Model 7036-MTC-2: 2m (6.6 ft) mass terminated cable assembly for connection to 7036. The cable has 45 pairs with outer shield. The cable is terminated at each end with 96-pin female DIN connectors with strain relief.

For use with: 7036



Model 7051-*: General purpose BNC to BNC cable (G-58C).

7051-2 0.6m (2 ft)
7051-5 1.5m (5 ft)
7051-10 3m (10 ft)

For use with: 2015, 2016, 3390, 7711, some instrument external trigger I/O lines



Model 7078-DIN: This 1.8m (6 ft) cable accessory connects between Model 707A mainframes when operated as one unit in Master/Slave mode. One cable is required for each mainframe.

For use with: 707A

1.888.KEITHLEY (U.S. only)

www.keithley.com

A Greater Measure of Confidence

KEITHLEY
 A Tektronix Company

Cables



Model 7078-MTC-5: 1.5m (5 ft) mass terminated cable for connection to column inputs (7071 and 7071-4). Also used for matrix expansion (7071, 7071-4, or 7074). The cable has 12 sets of shielded twisted pair wires for isolation of critical circuits and noise rejection in the system. The cable is terminated at each end in a 38-pin connector block with strain relief. **Model 7078-MTC-20** can be used as is or cut in half to make two 10 ft cables.

For use with: 7071, 7071-4, 7074-D



Model 7078-TRX-* 3-slot Triax Cables: Low noise triax cables terminated at both ends in 3-slot male triax connectors.

- 7078-TRX-1** 0.3m (1 ft)
- 7078-TRX-3** 0.9m (3 ft)
- 7078-TRX-5** 1.5m (5 ft)
- 7078-TRX-10** 3.0m (10 ft)
- 7078-TRX-12** 3.5m (12 ft)
- 7078-TRX-20** 6.0m (20 ft)

For use with: 2635B, 2636B, 6220, 6221, 6482, 6487, 6514, 6517A, 6517B, 7072, 7174A



3 Slot Triax

Model 7078-TRX-6IN 3-slot Triax Cable: 0.15m (6 inch), 3-slot, low-noise, guarded triax cable that minimizes leakage current and input capacitance when used with the Model 6430 Remote PreAmp (lower noise than 1 foot or longer versions).

For use with: 6430



Model 7152-MTC-*: Five low noise triax cables terminated in 6-position M-series coax connector blocks. Provides quick connection between 7152 matrix cards and is compatible with Model 7152-MTR connector. Also available in 3m (10 ft) length for connection between the matrix and the device under test.

- 7152-MTC-2** 0.6m (2 ft)
- 7152-MTC-10** 3.0m (10 ft)

For use with: 7152



Model 7152-TRX-10: Set of five 3m (10 ft) low noise triax cables terminated at one end in a single M-series connector block and at the other end in 3-slot triax connectors. This cable is most useful for direct connection to electrometers and Source/Measure Units.

For use with: 7152, 8006



Model 7153-TRX: 2m (6.6 ft) low noise cable assembly with M-series connector at one end for row or column connections to the 7153, and five 3-slot male triax connectors at the other end. Two 7153-TRX cable assemblies are required to make all connections to the 7153 card.

For use with: 7153

1.888.KEITHLEY (U.S. only)

www.keithley.com

Cables



Model 7173-50-CSEP: The 7173-50-CSEP cable set provides the capability to expand a switching configuration to include more than one 7173-50. Each set contains four 0.6m (25 in) cables. One cable is required to expand each row or column connection between adjacent cards. For example, using two 7173-50 cards to create a 4x24 matrix would require connecting the rows of two adjacent cards together. One 7173-50-CSEP set has enough cables to do this. Connecting the 12 columns together on two adjacent cards creates an 8x12 matrix. This would require three 7173-50-CSEP sets, 12 cables.

For use with: 7173-50



Model 7705-MTC-2: 2m (6.6 ft) 50-conductor male to female D-sub cable assembly.

For use with: 7703, 7705, 7707, 7709, 7701



Model 7707-MTC-2: 2m (6.6 ft) 25-conductor male to female D-sub cable assembly.

For use with: 7701, 7707, 7709



Model 7711-BNC-SMA: Male SMA to female BNC cables (5 each), 0.15m (0.5 ft) in length.

For use with: 7711



Model 7712-SMA-1: SMA cable, male to male, 1m (3.3 ft).

For use with: 7711, 7712, System 46, System 46T

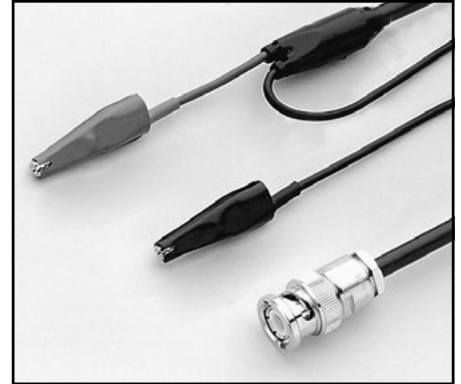

Model 7754-3 BNC to Alligator Cable: 0.9m (3 ft) terminated on one end with a BNC plug and on the other with two alligator clips.

For use with instruments with 2-slot BNC connections

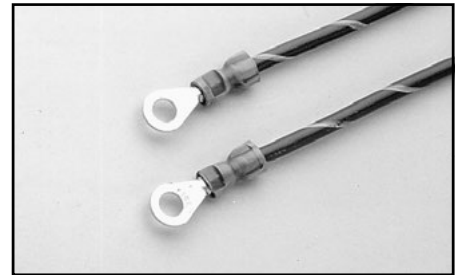

Model 8007-GND-3: Safety ground wire, 3m (10 ft).

For use with instruments with a safety ground connector



Model 8542-301: 1.8m (6 ft) LIV test system cable.

For use with: Series 2400, 2500, System 25, 8544, 8544-TEC

1.888.KEITHLEY (U.S. only)

www.keithley.com

A Greater Measure of Confidence

KEITHLEY
A Tektronix Company

Cables

Item shipped may vary from model pictured here.



Model 8607 1kV Source Banana Cable Set: The 8607 cable set is made up of one red and one black high voltage test lead with fixed safety banana plug ends. The leads are 1 meter (3.3 ft) long and have a voltage rating of 1500V DC.

For use with: 2410, 6487, 6517A, 6517B

Item shipped may vary from model pictured here.

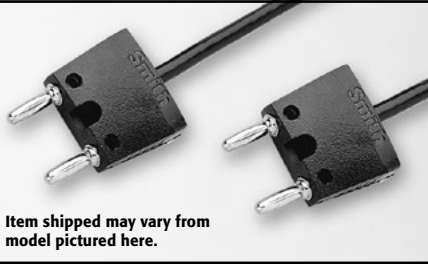

CA-18-1: 1.2m (4 ft) shielded cable terminated with a dual banana plug on each end. For use with binding post inputs or dual banana jacks.

For use with: Binding post inputs



Model CA-19-2: 1.5m (5 ft) RG58 cable terminated with a BNC male plug on each end.

For use with: 4200-SCS



CA-126-1A Digital I/O Cable: 1.5m (5 ft) of cable, from DB25 male to DB25 female.

For use with: Series 2600B, Series 3700A

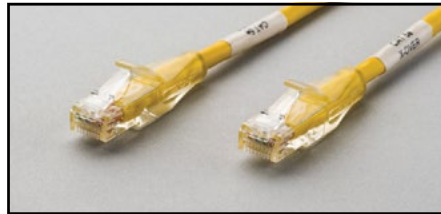

CA-180-3A: 3m (10 ft), CAT5 crossover cable for Ethernet or TSP-Link.

For use with: Series 2600B, 2701, 3390, Series 3700A, 6221, all TSP-Link enabled instruments

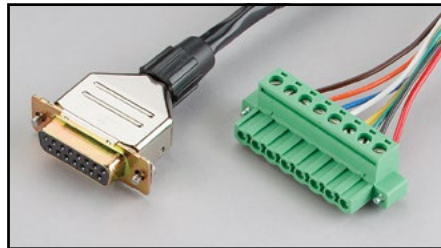

CA-321-1: Temperature control cable.

For use with: 2510, 8544

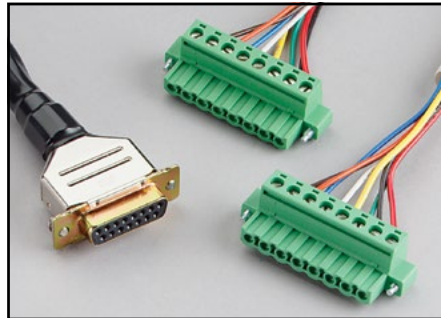

CA-322-1: Dual temperature control cable.

For use with: 2510, 8544, 8544-TEC



CA-404B: 2m (6.5 ft) RG188 coax cable terminated with an SMA male plug on each end, 50Ω impedance.

For use with: 4200-SCS, System 46, System 46T



CA-405B: 15cm (6 in) RG188 coax cable terminated with an SMA male plug on each end, 50Ω impedance.

For use with: 4200-SCS



CA-406B: 33cm (13 in) RG188 coax cable terminated with an SMA male plug on each end, 50Ω impedance.

For use with: 4200-SCS

1.888.KEITHLEY (U.S. only)

www.keithley.com

KEITHLEY
A Tektronix Company

Cables



CA-446A: 3m (9.8 ft) coax cable terminated with an SMA male plug on each end, 100Ω impedance.

For use with: 4210-CVU



CA-447A: 1.5m (4.9 ft) coax cable terminated with an SMA male plug on each end, 100Ω impedance.

For use with: 4210-CVU



CA-451A: 10.8cm (4.25 in) RG188 coax cable terminated with an SMA male plug on each, 50Ω impedance.

For use with: 4200-SCS



CA-452A: 20.4cm (8 in) RG188 coax cable terminated with an SMA male plug on each end, 50Ω impedance.

For use with: 4200-SCS

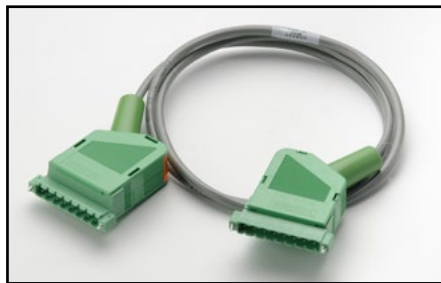

CA-557-*: 8-pin male to 8-pin male cable assembly with straight through pin configuration.

CA-557-1: 1m (3.3 ft)

CA-557-2: 2m (6.6 ft)

CA-557-3: 3m (10 ft)

For use with: 2601B, 2602B, 2611B, 2612B, 2651A SourceMeter® SMU Instruments, 2600-PCT-x, 4200-PCT-x, 8010



CA-558-2: 25-pin D-sub to 3-pin interlock cable assembly.

For use with: Series 2600B, 2600-PCT-x, 2651A, 2657A, 4200-SCS, 4200-PCT-x, 8010



CA-559-0A and CA-559-2A: Banana to banana jumper (102mm).

For use with: 2600-PCT-x, 4200-PCT-x, 8010

CA-560-0A and CA-560-2A: Banana to banana jumper (203mm).

For use with: 2600-PCT-x, 4200-PCT-x, 8010

CA-561-0A and CA-561-2A: Banana to banana jumper (305mm).

For use with: 2600-PCT-x, 4200-PCT-x, 8010



CA-562-0B and CA-562-2B: Safety banana to banana jumper (254mm).

For use with: 2600-PCT-x, 4200-PCT-x, 8010

1.888.KEITHLEY (U.S. only)

www.keithley.com

A Greater Measure of Confidence

KEITHLEY
A Tektronix Company

Cables



CA-563C: BNC to banana jumper (240mm).
For use with: 2600-PCT-x, 4200-PCT-x, 8010



HV-CA-571-3: High voltage triax to unterminated cable.
For use with: 2657A, 2600-PCT-x, 4200-PCT-x



S46-SMA-1: SMA cable, male to male, 0.3m (1 ft).
For use with: 7711, 7712, System 46, System 46T



CA-568-xA: Protective earth safety ground cable with eye lugs (x = 12, 18, or 120 inches).
For use with: 2657A, 2657-LIM-3, 2657-PIM-200, 8010



SHV-CA-553-x: High voltage triax to SHV cable (x = 1, 2, or 3m) (3kV rated).
For use with: 2657A

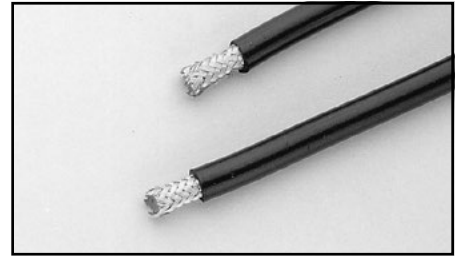

SC-9: Low noise coax cable without connectors (sold by the foot).



HV-CA-554-x: High voltage triax to triax cable (3kV rated) (x = 0.5, 1, 2, or 3m).
For use with: 2657A, 2657-LIM-3, 2657-PIM-200, 8010



S46-SMA-0.5: SMA cable, male to male, 0.15m (0.5 ft).
For use with: 7711, 7712, System 46, System 46T

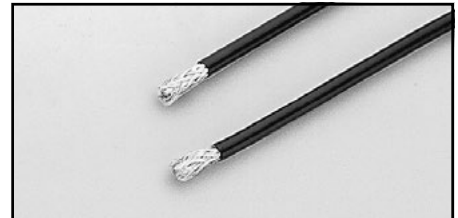

SC-22: Low noise triax cable without connectors (sold by the inch).
For use with: CS-631

1.888.KEITHLEY (U.S. only)

www.keithley.com

Cables



SC-93: Low thermal, 2-conductor shielded cable, #22AWG solid copper (sold by the foot).

For use with: 2182-KIT

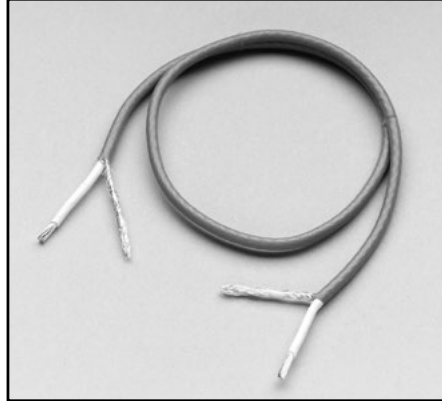

SC-182: Low inductance (42nH/ft) coaxial cable for minimizing test lead impedance in circuits using fast transient response power supplies. The cable is sold by the foot and comes without connectors.

For use with: 2302, 2303, 2303-PJ, 2304A, 2306, 2306-PJ, 2306-VS



SC-200A: Shielded twisted pair cable (sold by the inch). Recommended for general-purpose use with Series 2600B System SourceMeter SMU instruments.

For use with: Series 2600B



USB-B-1: USB Cable, 1m (3.3 ft).

For use with: 2100, Series 2200, 3390, Series 3700A, Series 2600, 2450

Connectors, Adapters, and Tools

Model	Name	Use With:
213-CON	Rear Panel Mating Connector	2200-20-5, 2200-30-5, 2200-32-3, 2200-60-2, 2200-72-1
237-BAN-3A	Triax to Banana Plug	4200-SCS, 7072, 7072-HV, DMMs
237-BNC-TRX	3-Lug Female Triax to Male BNC Connector with guard disconnected	4200-SCS, 6517A, 6517B, 7078-TRX cables
237-TRX-BAR	3-Lug Triax Female to Female Barrel Adapter	2635B, 2636B, 4200-SCS, 6482, triax interconnect
237-TRX-NG	Triax Male-Female Adapter with guard disconnected	6517A, 6517B, 7072, 7072-HV
237-TRX-T	3-slot Male to Dual 3-Lug Female Triax Tee Adapter	4200-SCS, 7072, 7072-HV, 7078-TRX cables
237-TRX-TBC	3-Lug Female Triax Bulkhead Connector	7072, 7072-HV, 7078-TRX cables
2182-325A	Silver Solder for use with 2182-KIT	2182A
2182-KIT	Low-Thermal Connector with Strain Relief (LEMO)	2182A, SC-93
2188	Low-Thermal Calibration Shorting Plug	2182A
2230G-30-1-JUMPER	Shorting Jumper	Series 2200 Power Supplies
2230GJ-30-1-JUMPER	Shorting Jumper	Series 2230 Power Supplies
2260-001	Accessory Kit	Series 2260B
2260-002	IDC Tool	Series 2260B
2260-003	Contact Removal Tool	Series 2260B
2260-004	Accessory Kit	Series 2260B
2260B-GPIB-USB	GPIB-USB Adapter	Series 2260B
2290-5-SHVBH	5kV SHV Male Bulkhead Connector	2290-5
2290-10-SHVBH	10kV SHV Female Bulkhead Connector	2290-10
2499-DIGIO	Digital I/O Expansion Module	SourceMeter SMU instruments
2500INT-SMA	SMA Connector	2500INT integrating sphere
2500INT-FC/PC	FP/PC Connector	2500INT integrating sphere
2500INT-FC/APC	FP/APC Connector	2500INT integrating sphere
2600-KIT	Screw Terminal Connector with Strain Relief and Cover	2601B, 2602B (2 needed), 2611B, 2612B (2 needed)
2600-TRIAx	3-Lug Triax Adapter	2601B, 2602B (2 needed), 2604B, 2611B, 2612B (2 needed), 2614B
2657A-LIM-3	Low Interconnect Module	2657A
2657A-PM-200	200V Protection Module	2657A
3706-BKPL	Analog Backplane Extender Board	Series 3700A
3720-ST	Screw Terminal Block	3720
3721-ST	Screw Terminal Block	3721
3723-ST	Screw Terminal Block	3723
3723-ST-1	Screw Terminal Block	3723
3724-ST	Screw Terminal Block	3724
3730-ST	Screw Terminal Block	3730
3731-ST	Screw Terminal Block	3731
3740-ST	Screw Terminal Block	3740
3750-ST	Screw Terminal Block	3750
3790-KIT50-R	50-pin Female D-sub Connector Kit	3721, 3730, 3731, 3740, 3750
3791-CIT	Contact Insertion and Extraction Tool	3720, 3722, 3723
3791-KIT78-R	78-pin Female D-sub Connector Kit	3720, 3723, 3724, 3732
3792-KIT104-R	104-pin Male D-sub Connector Kit	3722
3792-KIT104-R/F	104-pin Female D-sub Connector Kit	3722

Model	Name	Use With:
4851	BNC Shorting Plug	Instruments with BNC connectors
6171	3-slot Male to 2-Lug Female Triax Adapter	2-lug triax connectors
6172	2-slot Male to 3-Lug Female Triax Adapter	7065, 2500INT
7001-PNL	Metal Plate	7001
7011-KIT-R	Female 96-pin Connector Kit	7011-C, 7012-C, 7013-C, 7015-C, 7018-C
7011-ST	Extra Screw Terminal Board	7011-S
7012-ST	Extra Screw Terminal Board	7012-S
7013-ST	Extra Screw Terminal Board	7013-S
7015-ST	Extra Screw Terminal Board	7015-S
7018-ST	Extra Screw Terminal Board	7018-S
7072-TRT	Triax Removal Tool	707B, 708B
7074-CIT	Contact Extraction Tool	7152-KIT, 7152-MTR
7078-CIT	Contact Insertion/Extraction Tool	7078-KIT, 7078-MTR, 7152-KIT, 7152-MTR
7078-HCT	Hand Crimping Tool for 7078-KIT, 7169-KIT	7078-KIT
7078-KIT	Connector Kit	7071, 7071-4, 7074-D, 7078-MTR
7078-MTR	Mass Terminated Receptacle, Bulkhead Mount	7071, 7071-4, 7078-KIT, 7078-MTC
7078-TRX-BNC	3-slot Male Triax to BNC Adapter	4210-CVU, 4801, 6482, 6487, 6514, 6517A, 6517B, 7072, 7072-HV
7078-TRX-GND	3-slot Male Triax to BNC Adapter (guard removed)	4200-SCS, 4801, 6517A, 6517B, 7072, 7072-HV, Series 2600B
7078-TRX-TBC	3-Lug Female Triax Bulkhead Connector w/Cap	7078-TRX cables
7152-HCT	Hand Crimp Tool for 7152-KIT, 7152-MTR	7152-KIT, 7152-MTR
7152-KIT	6-Position M-Series Plug w/Contacts	7152, 7152-MTR
7152-MTR	6-Position M-Series Receptacle w/Sockets	7152, 7152-KIT, 7152-MTC-2, 7152-MTC-10
7703-306A	DB50 Male Connector Kit	7701, 7703, 7705, 7709
7709-308A	DB25 Male Connector Kit	7701, 7707, 7709, Series 2600B
7712-SMA-N	Female SMA to Male N-Type Adapter	7711, 7712
7755	50Ω Feed-Through Terminator	RG 58 cable, 776, 3390
7788	50-pin D Subconnector Kit	7703, 7705, 77XX, modules with D sub connectors
7789	50-pin Male and 25-pin Male D-Shell Connector Kit	7701, 7709
7790	50-pin Male, 50-pin Female, and 25-pin Male IDC D-Shell Connector Kit	7701, 7703, 7705, 7707, 7709
8610	Low Thermal Shorting Plug	2000, 2001, 2002, 2010
8620	4-Wire DMM Shorting Plug	2000, 2001, 2002, 2010, 2015, 2016, 2100, 2110, Series 2400, Series 2700, Series 3700A
8680	RTD Probe Adapter	2001, 2002, 2010, 2110
BG-18	Dual Banana to BNC Coaxial Adapter	Series 2000, 2100, 2110, Series 2400, 2700, 2750
CAP-18	Protective Shield/Cap	BNC, 2-lug triax connectors
CAP-31	Protective Shield/Cap	3-lug triax connectors
CA-573-3A1	4-Pin Round Interlock Cable, Unterminated	2657A-LIM-3

1.888.KEITHLEY (U.S. only)

www.keithley.com

A Greater Measure of Confidence

KEITHLEY
A Tektronix Company

Connectors, Adapters, and Tools

Model	Name	Use With:
CS-400	DB25 Male Solder Cup	CA-126-1 cable, 213
CS-458	Interlock Connector Kit	6517-ILC-3
CS-565	BNC Barrel, 4200-SCS	BNC interconnect
CS-630	3-Lug Female Triax Bulkhead Connector	6487, 6517A, 6517B
CS-631	3-Lug Male Triax Cable Mount Connector	4200-SCS, SC-22 cable
CS-701	BNC Tee Adapter (Female-Male-Female)	4200-SCS
CS-719	3-Lug Triax Jack Receptacle	4200-SCS
CS-846	Screw Terminal Test Lead Connector	230X, 2510, 2510-AT
CS-1247	SMA Female to BNC Male Adapter	4200-SCS
CS-1249	SMA Female to SMB Plug Adapter	4200-SCS
CS-1251	BNC Female to SMB Plug Adapter	4200-SCS
CS-1252	SMA Male to BNC Female Adapter	4200-SCS
CS-1281	SMA Female to SMA Female Adapter	4200-SCS

Model	Name	Use With:
CS-1305	Interlock Connector	6517B
CS-1390	Male LEMO Triax to Female SMA Adapter	4200-SCS
CS-1391	SMA Tee Adapter (Female-Male-Female)	4200-SCS
CS-1423-3	Miniature Mating Connector	2635B, 2636B
CS-1479	SMA Male to BNC Male Adapter	4200-SCS
CS-1592-2	Screw Terminal Plug	2651A
CS-1626-2	Screw Terminal Receptacle	2651A
CS-1629-8	Screw Terminal Connector	2651A
CS-1638-12	Rear Panel Mounting Connector	2200-20-5, 2200-30-5, 2200-32-3, 2200-60-2, 2200-72-1
CS-1655-15	Rear Panel Mating Connector	2220-30-1, 2220J-30-1, 2230-30-1, 2230J-30-1
HV-CS-1613	High Voltage Triax Feed Through Connector/Barrel (female to female)	2657A, 2600-PCT-x, 4200-PCT-x
TL-24	SMA Torque Wrench	4200-SCS, System 46, System 46T

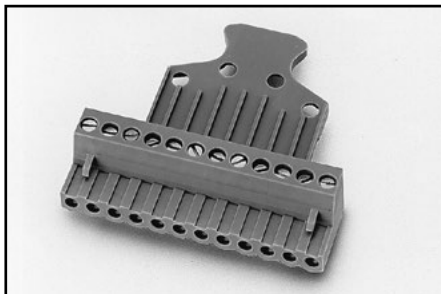

Model 213-CON Rear Panel Mating Connector: Quick disconnect, 12-screw terminal connector with handle.

For use with: 2200-20-5, 2200-30-5, 2200-32-3, 2200-60-2, 2200-72-1



Model 237-BNC-TRX: Male BNC to 3-lug female triax adapter (guard disconnected). Terminates triax cable in BNC plug. High voltage rating for use with 7072-HV.

For use with: 4200-SCS, 6517A, 6517B, 7078-TRX cables



Model 237-TRX-NG: 3-slot triax to 3-lug female triax adapter (guard removed) for non-guarded measurements. High voltage rating for use with 7072-HV, etc.

For use with: 6517A, 6517B, 7072, 7072-HV

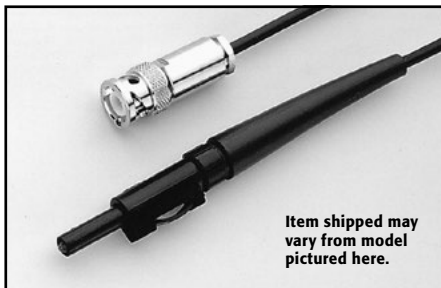

Model 237-BAN-3A Triax to Banana Plug: Triax cable center conductor terminated in a safety banana plug (guard and shield open). For connecting DMMs and other banana jack instruments to a matrix or fixture.

For use with: 4200-SCS, 7072, 7072-HV, DMMs



Model 237-TRX-BAR: 3-lug triax barrel (female to female) for use with triax interconnect.

For use with: 2635B, 2636B, 4200-SCS, triax interconnect



Model 237-TRX-T: 3-slot male to dual 3-lug female triax tee adapter for use with 7078-TRX cables and 7072/7072-HV Semiconductor Matrix Cards. High voltage rating for use with Model 6517B Electrometer.

For use with: 4200-SCS, 6517A, 6517B, 7072, 7072-HV, 7078-TRX cables

1.888.KEITHLEY (U.S. only)

www.keithley.com

A Greater Measure of Confidence

KEITHLEY
A Tektronix Company

Connectors, Adapters, and Tools



Model 237-TRX-TBC: 3-lug female triax bulkhead connector with cap for assembly of custom panels and interface connections. High voltage rating for use with 7072-HV, etc. Uses miniature coax cable, not triax cable, at soldered end. Bulkhead is outer shield.

For use with: 7072, 7072-HV, 7078-TRX cables

Model 2182-325A: Silver solder for making connections in experiments with the Model 2182A. 20 ft roll.

For use with: 2182A



Model 2182-KIT Low-Thermal Connector with Strain Relief: Connector kit for building a custom input cable for the Model 2182A Nanovoltmeter. Includes a low-thermal (LEMO) connector and a strain relief.

For use with: 2182A, SC-93



Model 2188 Low-Thermal Calibration Shorting Plug: A low-resistance, low-thermal shorting plug required to calibrate the Model 2182A Nanovoltmeter. Made of a LEMO connector with its pin connectors shorted together using copper wire and Sn/Ag4 silver solder.

For use with: 2182A



Model 2230G-30-1-JUMPER Shorting Jumper for CS-1655-15 Connector: Used to short a source and sense output when using a 2-wire output configuration.

For use with: Series 2200 Power Supplies

Model 2230GJ-30-1-JUMPER Shorting Jumper for CS-1655-15 Connector: Used to short a source and sense output when using a 2-wire output configuration.

For use with: Series 2200 Power Supplies

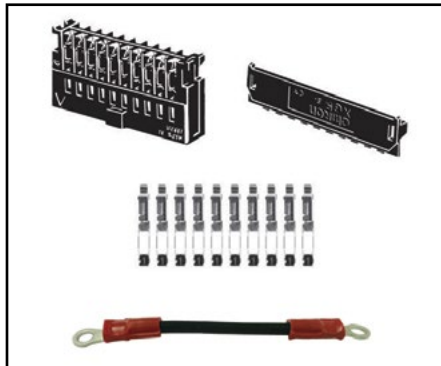

Model 2260-001: Accessory Kit: Analog control mating connector, pins, cover, and ground wire.

For use with: Series 2260B



Model 2260-002: Simple IDC tool.

For use with: Series 2260B

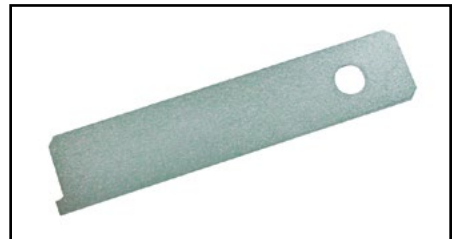

Model 2260-003: Contact removal tool.

For use with: Series 2260B



Model 2260-004 Accessory Kit: Air filter, analog connector cover, analog control lock lever, M8-size output terminal bolts, washers and screws, and M4-size output terminal screws with washers.

For use with: Series 2260B

1.888.KEITHLEY (U.S. only)

www.keithley.com

Connectors, Adapters, and Tools



Model 2260B-GPIB-USB Adapter: Provides a GPIB interface for the Series 2260B power supplies.

For use with: Series 2260B



Model 2290-5-SHVBH: Panel mount connector for connecting a Model 2290-5 through a 2290-5-SHV cable to an enclosure.

For use with: 2290-5



Model 2290-10-SHVBH 10kV SHV Female Bulkhead Connector: Panel mount connector for connecting a Model 2290-10 through a 2290-10-SHV cable to an enclosure.

For use with: 2290-10



Model 2499-DIGIO: Digital I/O expansion module that plugs onto the DB-9 connector of a SourceMeter® SMU instrument. Expands the three digital I/O lines of the SourceMeter to 16 lines. The SOT, EOT/BUSY, 5V, GND, and Interlock signals are passed through.

Services Available: 1-year factory warranty extended to 3 years from date of shipment

For use with: SourceMeter SMU Instruments

Model 2500INT-FC/ APC: FC/APC connector for 2500-INT Integrating Sphere.

For use with: 2500-INT



Model 2500INT-FC/ PC: FC/PC connector for 2500-INT Integrating Sphere.

For use with: 2500-INT



Model 2500INT-SMA: SMA connector for 2500-INT Integrating Sphere.

For use with: 2500-INT

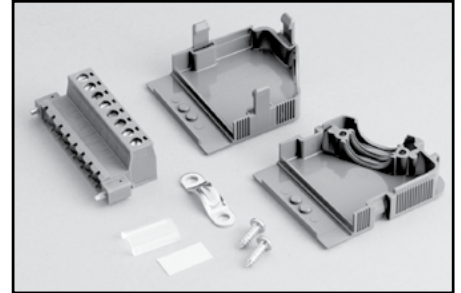

Model 2600-KIT: Screw terminal connector kit with extra screw terminal connector, strain relief, and cover for a single SourceMeter channel (two needed for use with Models 2602B, 2612B, and 2614B).

For use with: 2601B, 2602B, 2604B, 2611B, 2612B, 2614B, 2651A



Model 2600-TRIAx: Triax adapter for a single Series 2600B SourceMeter channel (two needed for use with Models 2602B and 2612B). For use with standard 3-lug triax cables.

For use with: 2601B, 2602B, 2611B, 2612B



Model 2657A-LIM-3: Low Interconnect Module for use with 2657A, HV triax cables (3kV rated).

For use with: Series 2657A

1.888.KEITHLEY (U.S. only)

www.keithley.com

A Greater Measure of Confidence

KEITHLEY

A Tektronix Company

Connectors, Adapters, and Tools



2657A-PM-200: 200V protection module to protect standard triax instruments from 2657A, standard and HV triax cables (3kV rated).

For use with: Series 2657A



Model 3721-ST: Screw Terminal Block. Required with the Model 3721 for automatic CJC thermocouple measurements.

For use with: 3721

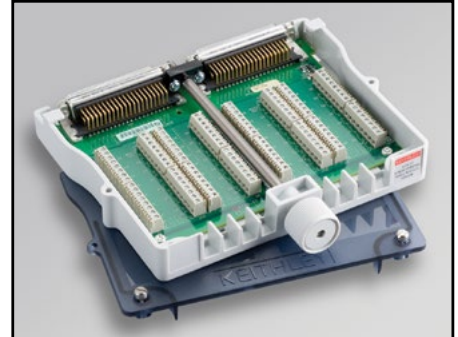

Model 3724-ST: Screw Terminal Block.

For use with: 3724



Model 3706-BKPL: Analog backplane extender board, 15-pin D-sub to terminal block.

For use with: Series 3700A

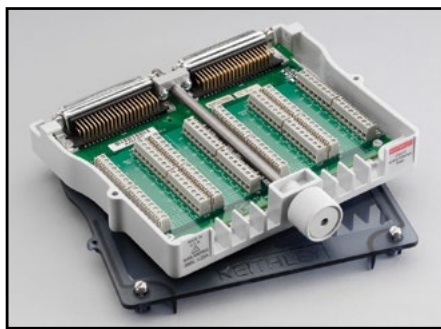

Model 3723-ST: Screw Terminal Block. Accessory for Model 3723 for two-pole applications.

For use with: 3723

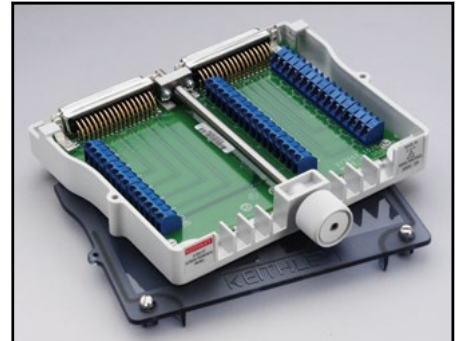

Model 3730-ST: Screw Terminal Block.

For use with: 3730

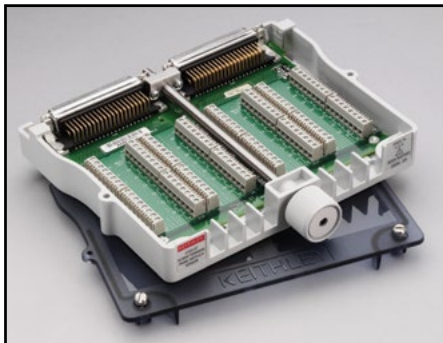

Model 3720-ST: Screw Terminal Block. Required with the Model 3720 for automatic CJC thermocouple measurements.

For use with: 3720

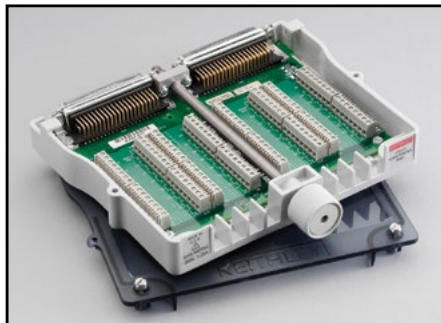

Model 3723-ST-1: Screw Terminal Block. Accessory for the Model 3723 for single-pole applications.

For use with: 3723

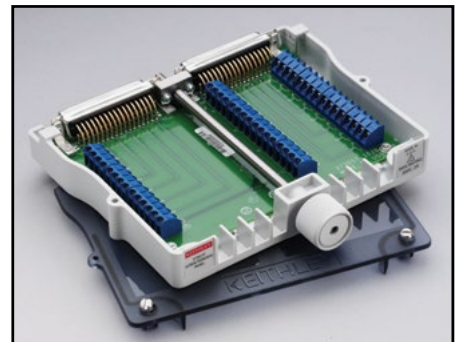

Model 3731-ST: Screw Terminal Block.

For use with: 3731

1.888.KEITHLEY (U.S. only)

www.keithley.com

Connectors, Adapters, and Tools

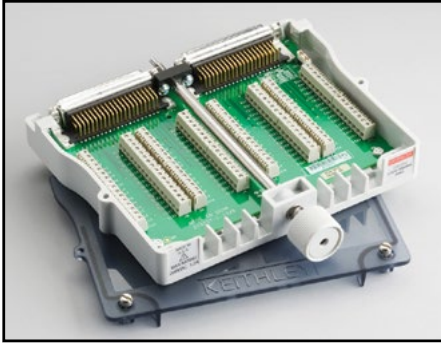

Model 3732-ST-C: Screw Terminal Block. Enables screw terminal access and additional matrix sizes including: quad 4×28 (1W), dual 4×28 (2W), single 4×56 (2W), dual 4×56 (1W), and single 4×112 (1W).

For use with: 3732

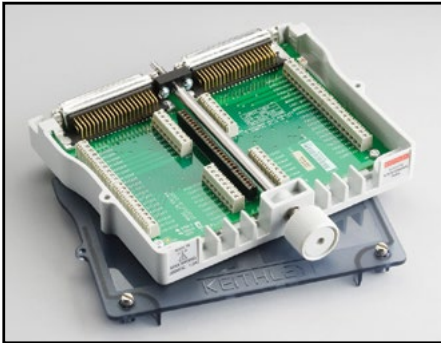

Model 3732-ST-R: Screw Terminal Block. Enables screw terminal access and additional matrix sizes including: dual 8×28 (1W), single 8×28 (2W), and single 16×28 (1W).

For use with: 3732

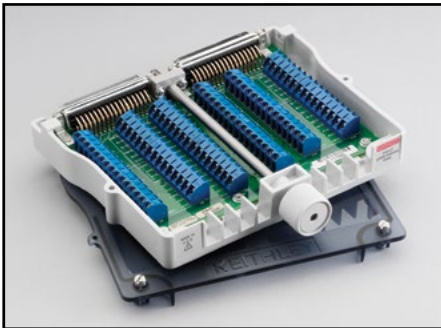

Model 3740-ST: Screw Terminal Block.

For use with: 3740

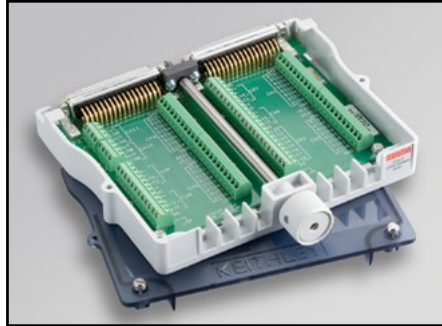

Model 3750-ST: Screw Terminal Block.

For use with: 3750



Model 3790-KIT50-R: 50-pin female D-sub connector kit that contains two female D-sub connectors and 100 solder cup contacts. Use for assembly of custom cable and harnesses compatible with Series 3700A plug-in cards.

For use with: 3721, 3730, 3731, 3740, 3750

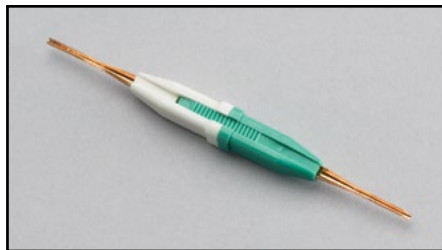

Model 3791-CIT: Contact insertion and extraction tool for assembly and maintenance of Series 3700A D-sub Connector kits.

For use with: 3791-KIT78-R, 3791-KIT104-R



Model 3791-KIT78-R: 78-pin female D-sub connector kit that contains two female D-sub connectors and 156 solder-cup contacts. Use for assembly of custom cable and harnesses compatible with Series 3700A plug-in cards.

For use with: 3720, 3723, 3724, 3732



Model 3792-KIT104-R: 104-pin male D-sub connector kit that contains two male D-sub connectors with housings and 208 solder-cup contacts. Use for assembly of custom cable and harnesses compatible with Series 3700A plug-in cards.

For use with: 3722



Model 3792-KIT104-R/F: 104-pin female D-sub connector kit that contains two female D-sub connectors with housings and 208 solder-cup contacts. Use for assembly of custom cables, harnesses, and DUT interface compatible with Series 3700A plug-in cards.

For use with: 3722

1.888.KEITHLEY (U.S. only)

www.keithley.com

A Greater Measure of Confidence

KEITHLEY
A Tektronix Company

Connectors, Adapters, and Tools



Model 4851: BNC shorting plug.
For use with: Instruments with BNC connectors



Model 6171: 3-slot male to 2-lug female triax adapter.
For use with: 2-lug triax connectors



Model 6172: 2-slot male to 3-lug female triax adapter. For use in adapting Models 7065 and 250INT inputs to 3-slot triax plugs.
For use with: 2500INT, 7065

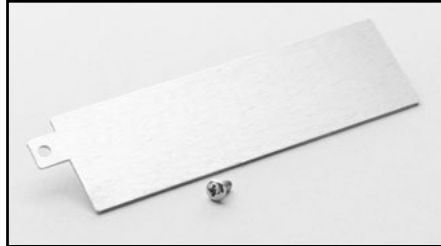

Model 7001-PNL: Metal plate used to cover an empty card slot on the rear panel of a Model 7001.

For use with: 7001



Model 7011-KIT-R: 96-pin female DIN connector with solder eyelets and strain relief. This kit can be used for assembly of custom cables to connect with the connectors on the 7011-C, 7012-C, 7013-C, 7015-C, and 7018-C switch cards. Also connects with the 7011-MTR bulk-head mount male connector.

For use with: 7011-C, 7012-C, 7013-C, 7015-C, 7018-C

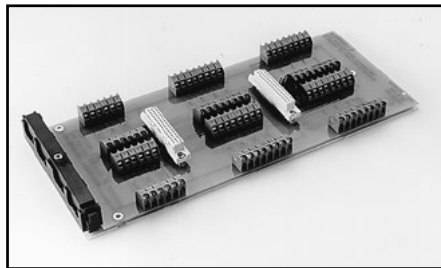

Model 7011-ST: Extra quick disconnect screw terminal board. One 7011-ST is included with each 7011-S.

For use with: 7011-S

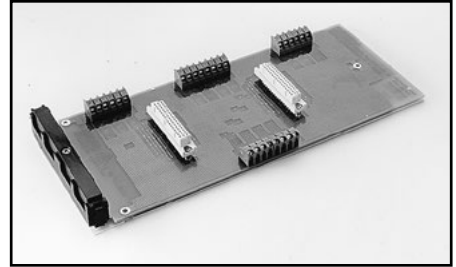

Model 7012-ST: Extra quick disconnect screw terminal board. One 7012-ST is included with each 7012-S.

For use with: 7012-S

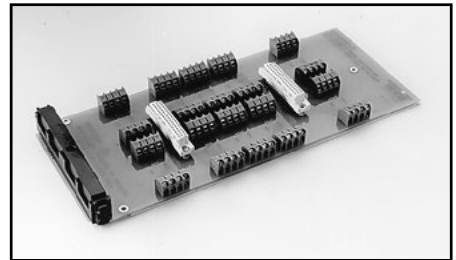

Model 7013-ST: Extra quick disconnect screw terminal board. One 7013-ST is included with each 7013-S.

For use with: 7013-S

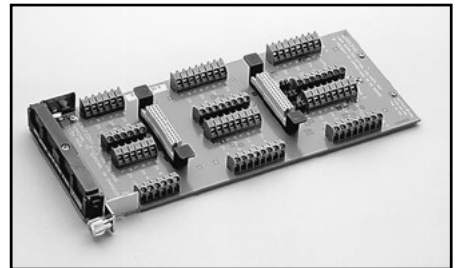

Model 7015-ST: Extra quick disconnect screw terminal board. One 7015-ST is included with each 7015-S.

For use with: 7015-S

1.888.KEITHLEY (U.S. only)

www.keithley.com

KEITHLEY
 A Tektronix Company

Connectors, Adapters, and Tools

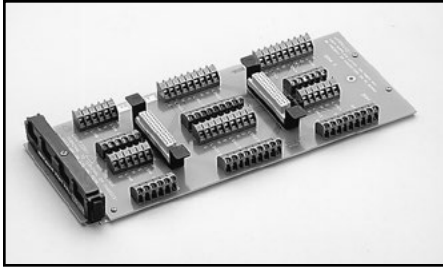

Model 7018-ST: Extra quick disconnect screw terminal board. One 7018-ST is included with each 7018-S.

For use with: 7018-S



Model 7072-TRT: Triax removal tool used to connect or disconnect triax style connectors when clearance is limited making it difficult to mate or unmate a connector with your fingers.

For use with: 707B, 708B

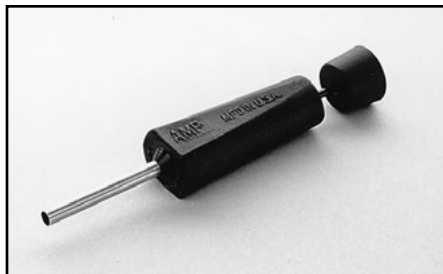

Model 7074-CIT: Contact extraction tool for removal of contacts from cables and connectors.

For use with: 7152-KIT, 7152-MTR



Model 7078-CIT: Contact insertion and extraction tool for assembly and maintenance of 7078-MTC cables and connectors.

For use with: 7078-KIT, 7078-MTR, 7152-KIT, 7152-MTR



Model 7078-HCT: Contact crimping pliers for assembly of cables and connectors using 7078-MTR or 7078-KIT.

For use with: 7078-KIT

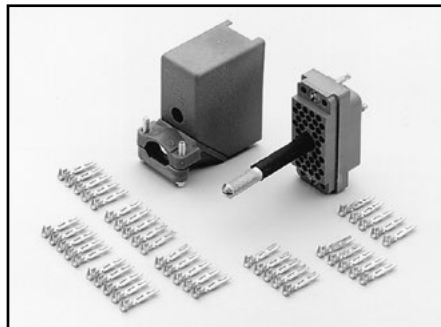

Model 7078-KIT: 38-pin male plug assembly with strain relief and 40 contacts for assembly of custom cable and harnesses compatible with Model 7071 8x12 Matrix Card, Model 7071-4 Dual 4x12 Matrix Card, and 7078-MTR Mass Terminated Receptacle. Requires 7078-HCT; recommend 7078-CIT.

For use with: 7071, 7071-4, 7074-D, 7078-MTR

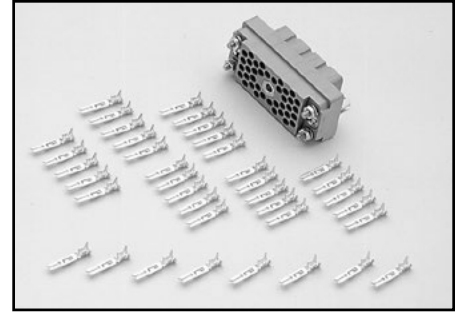

Model 7078-MTR: 38-pin female bulkhead mount receptacle with 40 contacts for custom interface and patch panels compatible with 7078-MTC and 7078-KIT. Requires 7078-HCT; recommend 7078-CIT.

For use with: 7078-KIT, 7078-MTC, 7071, 7071-4



Model 7078-TRX-BNC: 3-slot male triax to BNC adapter for use with 7072 Semiconductor Matrix Card and 4801 cables.

For use with: 4210-CVU, 4801, 6482, 6487, 6514, 6517A, 6517B, 7072, 7072-HV



Model 7078-TRX-GND: 3-slot male triax to female BNC adapter (guard removed) for adapting non-guarded measurements to the Model 7072 or 7072-HV Semiconductor Matrix Cards or 8006 or 8008 Test Fixtures.

For use with: Series 2600B, 4801, 6517A, 6517B, 7072, 7072-HV

1.888.KEITHLEY (U.S. only)

www.keithley.com

A Greater Measure of Confidence

KEITHLEY
A Tektronix Company

Connectors, Adapters, and Tools

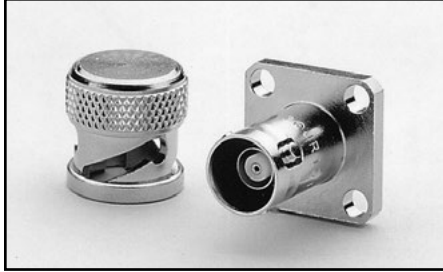

Model 7078-TRX-TBC: 3-lug female triax bulkhead connector with cap for assembly of custom panels and interface connections.

For use with: 7078-TRX Cables



Model 7152-HCT: Contact crimping pliers for assembly of cables and connector using 7152-MTR or 7152-KIT.

For use with: 7152-KIT, 7152-MTR

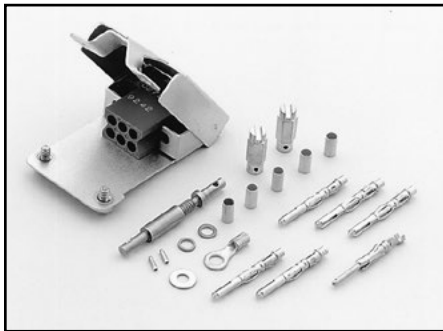

Model 7152-KIT: 6-pin plug assembly with strain relief and contacts for assembly of custom cable and harnesses compatible with Model 7152 4x5 Low Current Matrix Card and 7152-MTR Mass Terminated Receptacle. Requires 7152-HCT recommend 7074-CIT and 7074-HCT.

For use with: 7152, 7152-MTR



Model 7152-MTR: 6-pin bulkhead mount receptacle with contacts for custom interface and patch panels compatible with 7152-MTC and 7152-KIT. Requires 7152 HCT; recommend 7074-CIT and 7074-HCT.

For use with: 7152, 7152-KIT, 7152-MTC-2, 7152-MTC-10



Model 7703-306A: DB50 male connector kit (solder cup) with shell.

For use with: 7701, 7703, 7705, 7709



Model 7709-308A: DB25 male connector kit (solder cup) with shell.

For use with: 7701, 7707, 7709, Series 2600B



Model 7712-SMA-N: Female SMA to male N-type adapter.

For use with: 7711, 7712



Model 7755 50Ω Feed-Through Terminator: BNC-to-BNC adapter for terminating RG58 cable in its characteristic impedance. VSWR <1.1, DC-250MHz.

For use with: RG58 Cable, 776, 3390

1.888.KEITHLEY (U.S. only)

www.keithley.com

Connectors, Adapters, and Tools



Model 7788: 50-pin D subminiature connector kit. To mate with 50-pin connector on Model 7703 and 7705.

For use with: 7703, 7705, 77xx modules with D-sub connectors



Model 7789: 50-pin/25-pin (both male) D-Shell Kit (one of each) for 7701 or 7709 Integra modules (mating connectors are supplied with these modules when purchased).

For use with: 7701, 7709



Model 7790: 50 pin male, 50 pin female, 25 pin male IDC D-Shell Connector Kit (one each).

For use with: 7701, 7703, 7705, 7707, or 7709 Integra modules



Model 8610 Low Thermal Shorting Plug: For calibration lab use, this plug provides a very low thermal offset short at front or rear inputs.

For use with: All DMMs

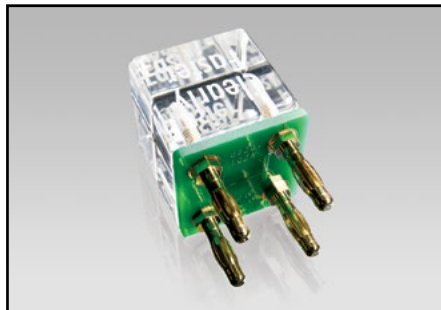

Model 8620 Four-Wire DMM Shorting Plug: Provides a low resistance 4-wire short to both observe and cancel DMM offset resistances and voltages to improve measurement accuracies.

For use with: All DMMs, Series 2400, Series 2700, Series 3700A



Model 8680 RTD Probe Adapter: Provides a means of connecting RTD probes terminated in either a 4-wire instrumentation connector or bare wires to safety input jacks on a 0.5 inch spacing.

For use with: 2001, 2002, 2010, 2100, 2110, 8681



BG-18: Dual banana to BNC coaxial adapter for adapting connection on instrument with dual banana jack.

For use with: All DMMs, Series 2400



CAP-18: Protective shield/cap for BNC connectors.

For use with: BNC connectors



CAP-31: Protective shield/cap for 3-lug triax connectors.

For use with: 3-lug triax connectors

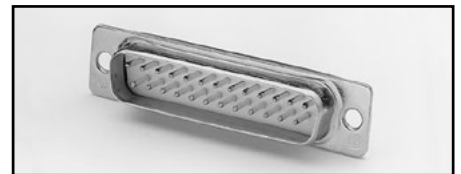

CS-400: DB25 male solder cup.

For use with: C126-1 cable, 213

1.888.KEITHLEY (U.S. only)

www.keithley.com

A Greater Measure of Confidence

KEITHLEY
A Tektronix Company

Connectors, Adapters, and Tools



CS-458: Interlock connector kit to mate with 6517-ILC-3.

For use with: 6517-ILC-3



CS-565: Female BNC to female BNC adapter with 50Ω nominal impedance.

For use with: 4200-SCS, BNC interconnect



CS-630: 3-lug female triax bulkhead connector for soldered connection. Mates with CS-631.

For use with: Fixtures, 6487, 6517A, 6517B



CS-631: 3-slot male triax cable mount connector for use with SC-22 cable. Mates to Models 7072, and 8006.

For use with: 4200-SCS, SC-22 cable



CS-701: BNC tee adapter (female, male, female).

For use with: 4200-SCS



CS-719: 3-lug triax jack receptacle.

For use with: 4200-SCS



CS-846: Eight position connector with screw terminals for connection to test leads.

For use with: 230x, 2510, 2510-AT



CS-1247: SMA female to BNC male adapter

For use with: 4200-SCS



CS-1249: SMA female to SMB plug adapter

For use with: 4200-SCS



CS-1251: BNC female to SMB plug adapter

For use with: 4200-SCS



CS-1252: SMA male to BNC female adapter

For use with: 4200-SCS



CS-1281: SMA female to SMA female adapter

For use with: 4200-SCS

1.888.KEITHLEY (U.S. only)

www.keithley.com

Connectors, Adapters, and Tools



CS-1305: Interlock connector to mate with Model 6517B.

For use with: 6517B



CS-1390: Male LEMO triax to female SMA adapter.

For use with: 4200-SCS



CS-1391: SMA tee adapter (female-male-female)

For use with: 4200-SCS

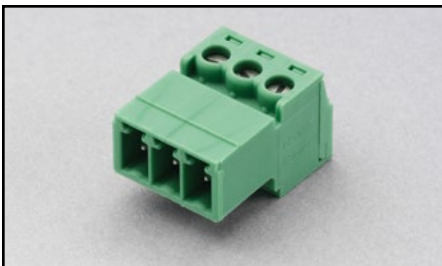

CS-1423-3: Miniature mating connector used as a ground connector for the Models 2635B and 2636B.

For use with: 2635B, 2636B



CS-1479: SMA male to BNC male adapter.

For use with: 4200-SCS



CS-1592-2: 2-pin male screw terminal connector plug. Rated 50A. Mates with the Model CS-1626-2 screw terminal block.

For use with: 2651A

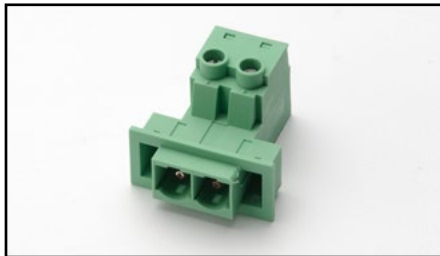

CS-1626-2: 2-pin female screw terminal connector block. Rated 50A. Mates with Model CS-1592-2 screw terminal connector.

For use with: 2651A



CS-1629-8: 8-pin female cable termination block.

For use with: 2651A



CS-1638-12: 12-pin rear panel output connector.

For use with: 2200-20-5, 2200-30-5, 2200-32-3, 2200-60-2, 2200-72-1

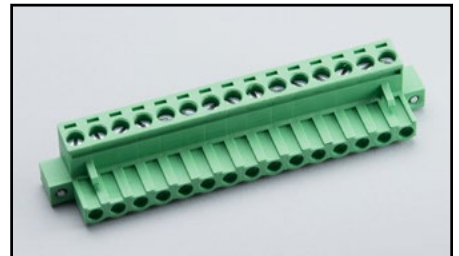

CS-1655-15: 15-pin rear panel output connector.

For use with: 2200-30-1, 2220J-30-1, 2230-30-1, 2230J-30-1



HV-CS-1613: High voltage triax feed through connector/barrel (female to female) (3kV rated).

For use with: 2600-PCT-x, 2657A, 4200-PCT-x



TL-24: SMA torque wrench

For use with: 4200-SCS, System 46, System 46T

1.888.KEITHLEY (U.S. only)

www.keithley.com

Adapter, Cable, Prober, and Stabilizer Kits



Model 4200-CVU-PROBER-KIT: Commonly used accessories for taking standard capacitance-voltage measurements on a variety of probers. Includes:

CA-446A: CVU cable, 100Ω, 3m (9.8 ft) (4)

CS-565: Female BNC to female BNC adapter (4)

CS-1247: Female SMA to male BNC adapter (4)

CS-1391: SMA tee adapter (female-male-female) (2)

237-TRX-BAR: Female triax to female triax adapter (4)

4200-PRB-C: SMA to SSMC Y adapter cable with local ground (2)

7078-TRX-BNC: 3-slot male triax to female BNC adapter (4)

7078-TRX-GND: 3-slot male triax to female BNC adapter (guards removed) (4)

For use with: 4200-SCS with 4200-CVU

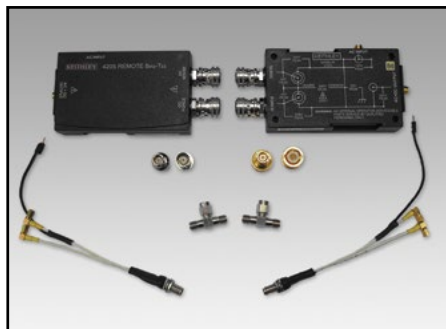

Model 4200-CVU-PWR: Enables C-V measurements with a DC voltage bias of up to ±200V or 400V differential (0 to ±400V) and a current output of up to 300mA. Includes:

CS-1252: SMA male to BNC female adapter (2)

CS-1391: SMA tee (female-male-female) (2)

CS-1479: SMA male to BNC male adapter (2)

4200-PRB-C: SMA to SSMC Y adapter cable with local ground (2)

4205-RBT: Remote bias tee (2)

For use with: 4200-SCS with 4210-CVU



Model 4200-PMU-PROBER KIT: This connection kit consists of standard and custom connectors and accessories used to connect the Models 4225-PMU and 4220-PGU to a variety of common prober stations. It also supports directly connecting the PMU/PGU to the SMU instruments for Flash Memory testing without the need for an external switch. One kit required per PMU/PGU card. Includes:

CA-19-2: BNC male to BNC male coax cable, 1.5m (4)

CA-451A: SMA male to SMA male coax cable, 11cm (1)

CA-405B: SMA male to SMA male coax cable, 15cm (1)

CA-452A: SMA male to SMA male coax cable, 20cm (2)

CS-565: BNC female to BNC female barrel (2)

CS-712: BNC female to triax male adapter (2)

CS-1252: SMA male to BNC female adapter (4)

CS-1247: SMA female to BNC male adapter (4)

CS-1390: Micro triax (LEMO) to SMA (no guard) (2)

CS-1391: SMA tee female-male-female (3)

For use with: 4200-SCS, 4225-PMU, 4220-PGU, 4225-RPM, 4210-MMPC

Model 4210-MMPC-C: This multi-measurement cable set is a collection of standard and custom connectors and accessories used to take I-V, C-V, and pulsed I-V measurements using a single prober cable setup. The set includes:

CA-533-24A: 61cm (24 in) mini triax/full triax, 100Ω, blue cable (2)

CA-535-4A: 10cm (4 in) prober ground jumper

CA-540-12A: 35cm (12 in) mini triax/mini triax, 100Ω, blue cable

CS-712: Triax male to BNC female adapters (3)

CS-737: Triax tee adapter, female-male-female

CS-1247: SMA female to BNC male adapters (3)

4210-MMPC-304A: Grounding bracket assembly

4210-MMPC-305A: Mini triax, 3-lug, shorting plug (shorts center pin to outer shield)

For use with: Model 4200-SCS and Cascade Microtech 12000 prober series with DCM-200 Series manipulators (requires one set per manipulator)



Model 4210-MMPC-S: This multi-measurement cable set is a collection of standard and custom connectors and accessories used to take I-V, C-V, and pulsed I-V measurements using a single prober cable setup. The set includes:

CA-532A: MMPC prober cable assembly

CA-534-24A: 61cm (24 in) male triax to male triax, 100Ω, blue cables (2)

CA-535-7A: 17.8cm (7 in) prober ground jumper

CS-712: Triax male to BNC female adapters (3)

CS-737: Triax tee adapter, female-male-female

CS-751: Triax female to triax female adapters (2)

CS-1247: SMA female to BNC male adapters (3)

CS-1546: Triax shorting plug (shorts center pin to outer shield)

For use with: Model 4200-SCS and SUSS MicroTec PA200/300 prober series (requires one set per manipulator)

1.888.KEITHLEY (U.S. only)

www.keithley.com

KEITHLEY

A Tektronix Company

A Greater Measure of Confidence

Test Fixtures



Model 8010 High Power Device Test Fixture:

The Model 8010 High Power Device Test Fixture provides safe and easy connections for testing packaged high power devices at up to 3000V or 100A. The Model 8010 provides connections for a high voltage SourceMeter SMU instrument (Model 2657A), one or two high current SourceMeter SMU instruments (Model 2651A), and three low power SourceMeter SMU instruments (other Series 2600B or Model 4200-SCS source measure unit (SMU) instruments). This allows devices with two terminals (diodes) or three terminals (transistors) or even four or five terminals to be characterized safely and accurately. The Model 8010 has full interlock capability for up to six SourceMeter SMU instruments. The Model 8010 has integrated protection circuits that protect the low voltage SourceMeter SMU instruments from high voltages the Model 2657A can output should a device fault occur. The Model 8010 includes both a high current (100A) and a high voltage (3000V) test socket. Various replacement test socket modules are available, including TO-247, TO-220, axial lead, and a blank socket module that allows building a custom socket. In addition to standard banana jumpers, the Model 8010 has rear-panel scope and thermal probe ports to simplify system integration.

ACCESSORIES SUPPLIED

3 ea. CA-558-2	Three-Pin Interlock Connector Cables (2m)
12 ea CA-560-x	Banana to Banana Jumper Cables (203mm)
2 ea. CA-562-x	Safety Banana to Banana Jumper Cables (254mm)
6 ea. CA-563	BNC to Banana cables (241mm)
2 ea. CA-568-120	Earth Safety Ground Cables (305cm)
1 ea. 8010-317	Socket Insulating Plug Card
1 ea. 8010-CTB	Customizable Test Board
2 ea. 8010-DTB	Device Test Board for TO-247 Devices (3kV, 100A)

For use with: 2651A, 2657A, 4200-SCS, 26xxB, 2600-PCT-x, 4200-PCT-x



Model 8009 Resistivity Chamber: The Model 8009 is a guarded test fixture for measuring volume and surface resistivities. It assures good electrostatic shielding and high insulation resistance up to 1100V. The 8009 is designed for safe operation with the 6517A or 6517B. Opening the lid of the 8009 automatically turns off the 6517A or 6517B voltage source. The 8009 accommodates sheet samples from 64mm to 102mm (2½ to 4 in) in diameter and up to 3.2mm (¼ in) thick. It maintains good sample contact with uniform pressure (from 6 to 10 lbs depending on thickness) on smooth parallel samples.

With the front panel switch on the 8009, toggle between volume and surface resistivity, with the 6517A or 6517B configured to calculate and display the appropriate result automatically. The 8009 permits direct measurement of volume resistivity up to $10^{18}\Omega\text{-cm}$ (on samples 0.1cm thick) and surface resistivity up to $10^{17}\Omega/\text{square}$, in accordance with ASTM procedures.

ACCESSORIES SUPPLIED

6517-ILC-3	Interlock Cable for 6517A
6517B-ILC-3	Interlock Cable for 6517B
7078-TRX-3	Triax Cable
8007-GND-3	Safety Ground Wire
8607	Source Cable Set

ENVIRONMENTAL LIMITS: Operating: -30° to $+85^{\circ}\text{C}$, 65% R.H. up to 35°C , derate 3% R.H./ $^{\circ}\text{C}$ above 35°C . Storage: -25° to $+85^{\circ}\text{C}$.

DIMENSIONS: 108mm high \times 165mm wide \times 140mm deep (4¼ in \times 6½ in \times 5½ in).

WEIGHT: 1.45kg (3.19 lbs).

For use with: 6487, 6517A, 6517B

1.888.KEITHLEY (U.S. only)

www.keithley.com

A Greater Measure of Confidence

KEITHLEY

A Tektronix Company

Test Fixtures

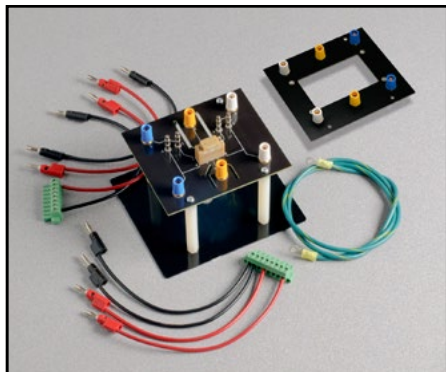

Model 8011 Test Socket Kit: A three pin, TO-247 test socket that is rated to 40V and 50A. Includes cables for connecting to Model 2651A High Power System SourceMeter® SMU instrument.

ACCESSORIES SUPPLIED:

8010-DTB	Device Test Board for TO-247 devices
8010-CTB	Customizable Test Board
CA-560-0	Banana to Banana Test Cables
CA-560-2	Banana to Banana Test Cables
CS-1629-8	Two 8-pin Female Plug Connectors with screw terminal connections (2 ea.)
CA-567-0	Banana to Banana Test Cables (4 ea.)
CA-567-2	Banana to Banana Test Cables (4 ea.)
2600-KIT	8-pin Male Phoenix Connector Kit (2 ea.)

For use with: Model 2651A High Power System SourceMeter



Model 8101-4TRX: 4-pin transistor fixture.

For use with: 4200-SCS, Series 2600B, 6482, any 40V rated triaxial instrument



Model 8101-PIV: DC and pulse I-V demo fixture that is a metal case with four female triax connectors, two SMA connectors, and a latch. Inside the test fixture are two 4-pin device holders (transistor sockets) and two plungers for parts with two leads.

For use with: 4200-SCS, Series 2600B, 6482, any 40V rated triaxial or SMA instrument



Model LR:8028: Component test fixture optimized for device testing up to 200V/1A. Includes color-coded mini jumpers for easy device connections.

ACCESSORIES SUPPLIED:

40 ea. standard color-coded Teflon® mini jumpers, 20 red and 20 black
LR:8028 Instruction Manual

For use with: 4200-SCS, Series 2600B, 6482, any 40V rated triaxial or SMA instrument

1.888.KEITHLEY (U.S. only)

www.keithley.com

Trigger Accessories



Model 2450-TLINK: For adapting the Model 2450 DB-9 Digital I/O connector to a Trigger Link connector for connection to instruments that use the Trigger Link triggering system.
Length: 0.9m (1 ft).
For use with: 2450



Model 2600-TLINK: 25-pin female digital I/O port to Trigger Link adapter.
For use with: Series 2600B, Series 3700A



Model 8501-1: 1m (3.3 ft) Trigger Link cable. Each end contains an 8-pin male DIN connector. Also available in 2m (6.6 ft) length (Model 8501-2).
For use with: All Trigger Link instruments



Model 8503 DIN-to-BNC Trigger Cable: 1m (3 ft) cable used to connect BNC inputs to any instrument having Trigger Link connectors.
For use with: All Trigger Link instruments



Model 8505: Male to 2 Female Y-DIN cable.
For use with: All Trigger Link instruments

1.888.KEITHLEY (U.S. only)

www.keithley.com

A Greater Measure of Confidence

KEITHLEY
A Tektronix Company

Bench Kits, Rack Mount Kits

Model 386-7598-xx Cosmetic Filler Panel: Tektronix Filler panel to RMU 2U rack kit when a single Series 2200 power supply is rack mounted.

For use with: All Series 2200 power supplies

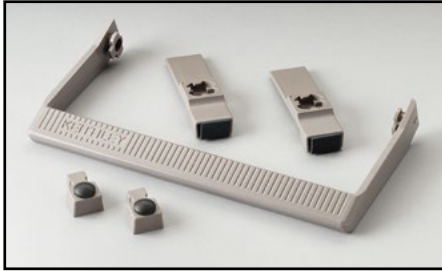

Model 2000-Benchkit: Benchtop Restore Kit. Rubber feet and carrying handles are removed during rack mounting. These items can be used with any of the following models to convert it back to a benchtop instrument.

For use with: Series 2000, 2182A, Series 2300, Series 2400, Series 2500, Series 2600B, 2700, 2701, 6220, 6221, 6430, 6482, 6485, 6487, 6514, 6517A, 6517B, 7001

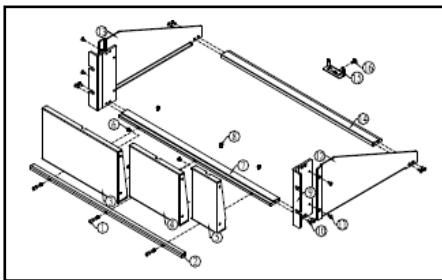

Model 2260B-RMK-EIA: Rack mount kit (EIA racks).

For use with: Series 2260B

SELECTOR GUIDE: RACK MOUNT KITS

Instrument			Single Fixed	Single Slide	Dual Fixed	Type of Mount
Series 2000	2700	6487	4288-1		4288-2	Side
2182A	2701	6514			4299-7	Shelf
Series 2300	6220	6517B				
Series 2500	6221	6485				
Series 2100	Series 2400	6430	4299-3		4299-4	Side
			4299-7		4299-7	Shelf
	Series 2260B				2260B-RMK-EIA 2260B-RMK-JIS	Shelf
	2290-5		2290-5-RMK-1		2290-5-RMK-2	Side
					4299-7	Shelf
	2290-10		2290-10-RMK-1		2290-10-RMK-2	Side
					4299-7	Shelf
	2450		4299-8		4299-9 4299-10 ¹ 4299-11 ²	Side
	Series 2600B		4299-1		4299-2	Side
2651A	2657A	708B	4299-6			Side
2750	System 46	System 46T	4288-7			Rear Bracket
	707B		Included on 707B chassis	7079		Side
	Series 3700A		4288-10			Rear Bracket
	4200-SCS/C or /F		4200-RM			Rail
	7002		7002-RMK-1	7002-RMK-2		Bracket w/Handles

1. Model 4299-10 mounts one Model 2450 and one Series 26XXB.

2. Model 4299-11 mounts one Model 2450 and one Series 2000, 2400, and all other 2U, half rack instruments except the Series 2200 and Series 2290 instruments.

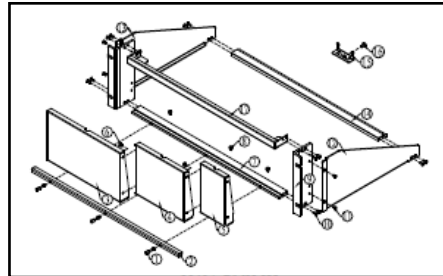

Model 2260B-RMK-JIS: Rack mount kit (JIS racks).

For use with: Series 2260B



Model 2290-5-RMK-1: Enables rack mounting of a single Model 2290-5.

For use with: 2290-5

1.888.KEITHLEY (U.S. only)

www.keithley.com

Rack Mount Kits



Model 2290-5-RMK-2: Enables rack mounting of two Model 2290-5s side-by-side.

For use with: 2290-5

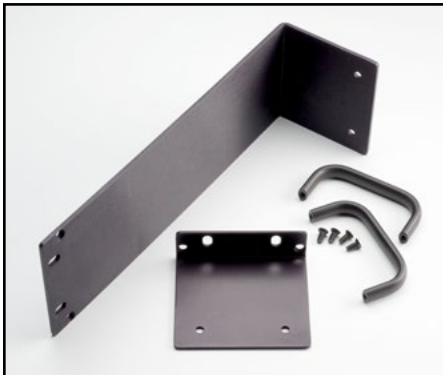

Model 2290-10-RMK-1: Enables rack mounting of a single Model 2290-10.

For use with: 2290-10



Model 2290-10-RMK-2: Enables rack mounting of two Model 2290-10's side-by-side.

For use with: 2290-10

Model 2450-Benchkit: Includes all of the hardware required to set up the Model 2450-RACK or Model 2450-NFP-RACK for use on a bench top. Includes the front and rear bumpers, handle, and handle mounting components.

For use with: 2450-RACK, 2450-NFP-RACK



Model 4200-KEY-RM: Rack mount kit for cabinet mounting of standard keyboard and pointing devices.

For use with: 4200-SCS

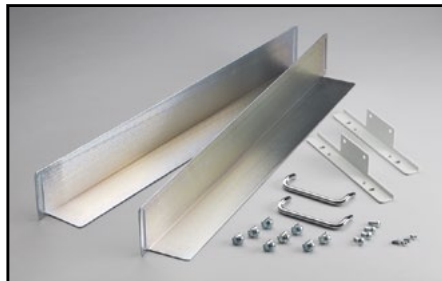

Model 4200-RM: Fixed rack mount kit for cabinet mounting of the 4200-SCS.

For use with: 4200-SCS

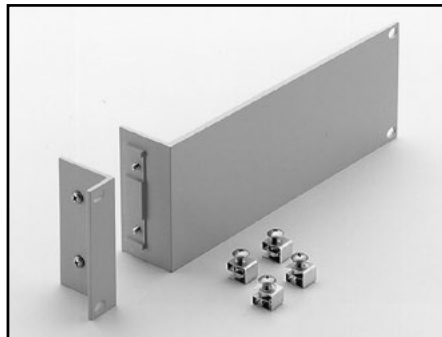

Model 4288-1 Fixed Rack Mount Kit: Single-unit rack mount kit. Height: 88mm (3½ in).

For use with: See Selector Guide.



Model 4288-2 Fixed Rack Mount Kit: Height: 88mm (3½ in).

For use with: See Selector Guide.



Model 4288-4 Fixed Rack Mount Kit: Enables rack mounting of one Model 230 next to one 428-PROG, 776, Series 2000, 2182A, Series 2300, Series 2400, Series 2600B, 2700, 2701, 6220, 6221, 6514, 6485, 6487, 6517A, 6517B, or 7001.

For use with: See Selector Guide.

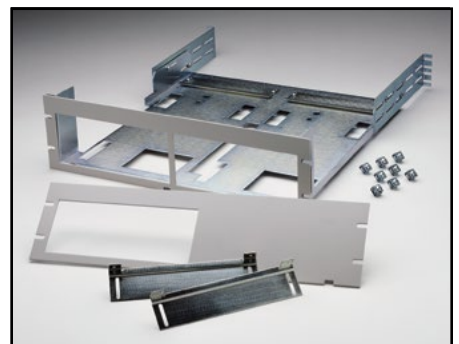

Model 4288-5 Fixed Rack Mount Kit: The single- and dual-instrument front panels included enable rack mounting of either one or two 3½-inch instruments. Height: 132mm (5¼ in). Depth: 457mm(18 in).

For use with: See Selector Guide.

1.888.KEITHLEY (U.S. only)

www.keithley.com

A Greater Measure of Confidence

KEITHLEY
A Tektronix Company

Rack Mount Kits

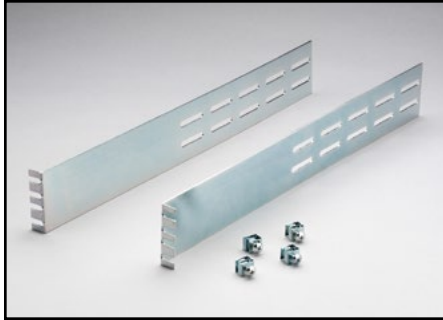

Model 4288-7 Rear Support Mount Kit: For rack mount applications where more than one or two card modules are installed to provide added support for the rear of the mainframe. Note that front rack mounting hardware is supplied with the Model 2750 mainframe. 88mm (3.5 in) height.

For use with: 2750, System 46, System 46T



Model 4288-10 Rear Support Mount Kit: For rack mount applications where more than one or two card modules are installed to provide added support for the rear of the mainframe. Note that front rack mounting hardware is supplied with Series 3700A mainframes. 88mm (3.5 in) height.

For use with: Series 3700A

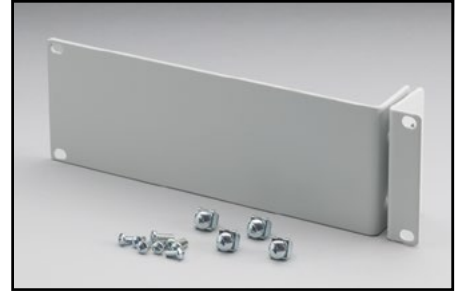

Model 4299-3 Universal Single Unit Rack Mount Kit: Includes all required hardware to rack mount a single Keithley or Agilent half rack instrument using front panel only mounting into a standard 19 inch equipment rack. Not compatible with Series 2600B. 88mm (3.5 in) height.

For use with: Half rack instruments (excluding Series 2600B)

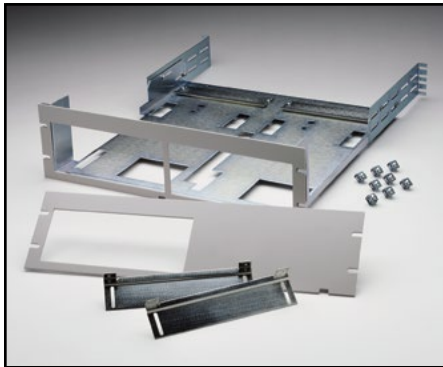

Model 4288-9 Fixed Rack Mount Kit: Shelf style rack mount kit with single- and dual-instrument front plates provided. Also included are extended rear support brackets and hardware for installation.

For use with: Series 2200 Power Supplies



Model 4299-1: Heavy duty, single rack mount kit with front and rear support. Height: 88mm (3.5 in).

For use with: Series 2600B



Model 4299-4 Universal Dual Unit Rack Mount Kit: Includes all required hardware to rack mount two Keithley and/or Agilent half-rack instruments together using front panel only mounting into a standard 19-inch equipment rack. Not compatible with Series 2600B. 88mm (3.5 in) height.

For use with: Half-rack instruments (excluding Series 2600B)



Model 4299-2: Heavy duty, dual rack mount kit with front and rear support. Height: 88mm (3.5 in).

For use with: Series 2600B

1.888.KEITHLEY (U.S. only)

www.keithley.com

Rack Mount Kits

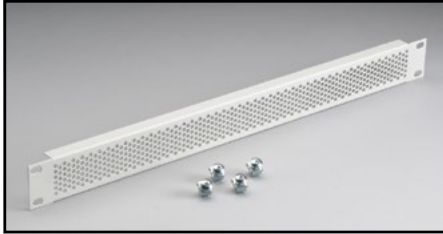

Model 4299-5: 1U vent panel.

For use with: Series 2600B



Model 4299-6 Single Fixed Rack Kit: Includes all required hardware to rack-mount a Keithley full-rack instrument in a standard 19-inch equipment rack.

For use with: 2651A, 2657A

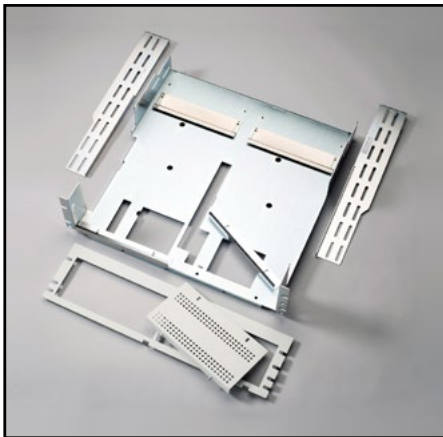

Model 4299-7 Universal Fixed Rack Mount Kit: Enables rack-mounting of Series 2200 power supplies with other instruments.

For use with: Series 2000, Series 2100, 2182A, Series 2200, Series 2300, Series 2400, Series 2500, Series 2600B, 2700, 2701, 6220, 6221, 6430, 6482, 6485, 6487, 6514, 6517A, 6517B

Model 4299-8 Single Fixed Rack-Mount Kit: Includes all of the required hardware to install a single 2U Graphical Display instrument in a standard 19-inch equipment rack.

For use with: 2450

Model 4299-9 Dual Fixed Rack-Mount Kit: Includes all of the required hardware to install two adjacent 2U Graphical Display instruments in a standard 19-inch equipment rack.

For use with: 2450

Model 4299-10 Dual Fixed Rack-Mount Kit: Includes all of the required hardware to install a 2U Graphical Display instrument and an adjacent 2U Series 26xx instrument in a standard 19-inch equipment rack.

For use with: 2450, Series 26xx

Model 4299-11 Dual Fixed Rack-Mount Kit: Includes all of the required hardware to install a 2U Graphical Display instrument and an adjacent 2U instrument in a standard 19-inch equipment rack. The adjacent instrument can be a Keithley Instruments Series 24xx or Series 2000 DMM, or a standard Agilent 2U instrument.

For use with: 2450, Series 24xx, Series 2000



Model 7002-RMK-1 Fixed Rack Mount Kit: Two 7 in. flanged brackets and hardware for mounting the Model 7002 in a standard 48.3cm (19 in) equipment cabinet. Can be used with Models 8000, 8000-10, 8000-14, or 8000-17.

For use with: 7002

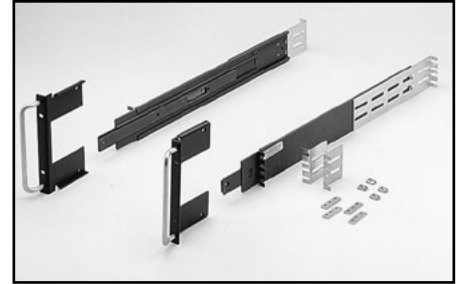

Model 7002-RMK-2 Slide Rack Mount Kit: Two sets of flanged brackets, slides, and hardware to mount Model 7002 in standard 48.3cm (19 in) equipment cabinet. Can be used with Model 8000.

For use with: 7002

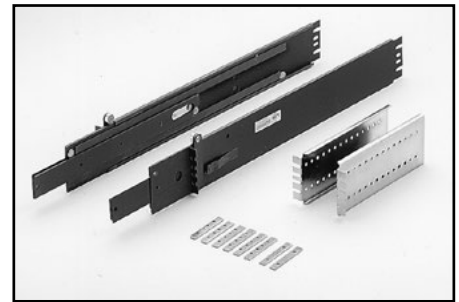

Model 7079 Slide Rack Mount Kit: Two sets of flanged brackets, slides, and hardware to mount Model 707A in standard 48.3cm (19 in) equipment cabinet. Can be used with Model 8000.

For use with: 707B

RMU 2U: Basic Power Supply Rack Kit: Rack mount kit for mounting either one or two of the Series 2200 power supplies

All Series 2200 power supplies

1.888.KEITHLEY (U.S. only)

www.keithley.com

A Greater Measure of Confidence

KEITHLEY
A Tektronix Company

Other Accessories



Protection Module

2290-PM-200 10kV Protection Module: Protects SourceMeter instruments used in high voltage circuits from being exposed to greater than 200V under any circuit condition.

For use with: 2290-5, 2290-10

Remote PreAmp Mounting Accessories



Model 4200-MAG-BASE: Magnetic base for mounting the Model 4200-PA remote PreAmp option onto a probe station platen.

For use with: 4200-SCS

Model 4200-TMB: Triax mounting bracket for mounting the Model 4200-PA remote PreAmp option onto a probe station or onto the triax mounting panel of a text fixture.

For use with: 4200-SCS



Model 4200-VAC-BASE: Vacuum base for mounting the Model 4200-PA remote PreAmp or Model 4225-RPM onto a probe station platen.

For use with: 4200-SCS

Carrying Case



Model 4200-CASE: Transport case for 4200-SCS.

For use with: 4200-SCS

Remote Displays



Model 2304-DISP: LCD remote display with keypad.

For use with: 2303, 2304A



Model 2306-DISP: VFD remote display with keypad.

For use with: 2302, 2306, 2306-VS, 2308

Test Boards

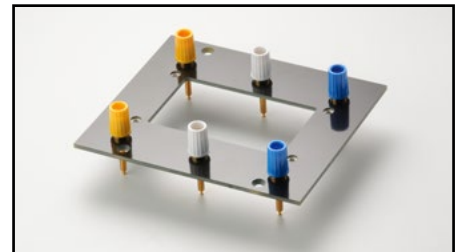

Model 8010-CTB: Customizable test board.

For use with: 8010

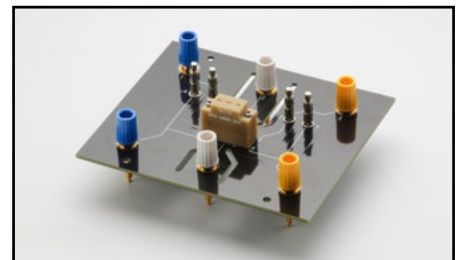

Model 8010-DTB: Device test board for TO-247 devices (3kV, 100A).

For use with: 8010

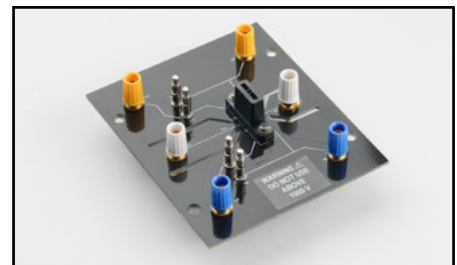

Model 8010-DTB-220: Device test board with TO-220 socket (1.5kV).

For use with: 8010

1.888.KEITHLEY (U.S. only)

www.keithley.com

KPCI-488LPA KUSB-488B

- PCI and USB bus versions
- IEEE-488.2 compatible for fast data transfer
- Windows® 7/Vista/XP/2000 drivers included
- LabVIEW® and LabWindows/CVI support
- Compatible with any standard GPIB instrument

Ordering Information

KPCI-488LPA IEEE-488.2 Interface Board for the PCI Bus

KUSB-488B IEEE-488.2 USB-to-GPIB Interface Adapter for USB Port. Built in 2m (6.6 ft) cable

IEEE-488 (GPIB) Interface Solutions



Keithley's GPIB interface solutions make it easy to add standard IEEE-488.2 bus control to any PC system. These high speed tools can control as many as 14 GPIB instruments or other devices over a distance of up to 20 meters. They are ideal for use with automated test equipment in laboratory and industrial applications.

The Keithley Model KPCI-488LPA is a low-profile, GPIB interface plug-in card that is 32-bit/33MHz PCI bus compatible. Its PCI interface supports both 3.3V and 5V PCI environments, making it suitable for most desktop computers and industrial PCs, including the new low-profile desktop systems. This low-cost solution supports Windows 7/Vista/XP/2000, and its driver library is command compatible with National Instruments™ and Capital Equipment Corporation™ command functions.

The Keithley Model KUSB-488B USB-to-GPIB interface turns any computer with a USB port into a fully functional GPIB controller. The KUSB-488B's small form factor makes it perfect for use with laptop computers in portable

applications or for other applications in which the computer has no available PCI plug-in board slots. The product is USB 2.0 compliant and has an IEEE data transfer rate upwards of 1.5 MB/s through the USB port. No external power is required. KUSB-488B has a built-in 2-meter USB cable.

Software

The included utility software simplifies the setup and use of Keithley GPIB interface solutions and saves programming time. Every solution ships with 32-bit dynamic link libraries for Application Development Environments (ADEs) running under Windows 7/Vista/XP/2000 and drivers for the most current programming languages. This adds up to full compatibility with a full array of software, including:

- Microsoft Visual Studio 6.0 (Visual Basic, Visual C++)
- Microsoft Visual Studio .NET (Visual Basic .NET, C#)
- Microsoft Visual Studio 2005 and up
- Borland Delphi, Borland C Builder 6.0
- LabVIEW Version 7.0 and up (VISA and IEEE-488.2)
- LabWindows™/CVI Version 7.0 and up (VISA and IEEE-488.2)

Hardware Compatibility

These GPIB Interface solutions are fully compatible with all of Keithley's GPIB capable instruments. The Model 7010 adapter is required for the Model 428-PROG when used with the KUSB-488B.

	KPCI-488LPA	KUSB-488B
Bus/Form Factor	PCI	USB
Dimensions	4.7 × 2.5 in (120 × 64.5 mm)	3.2 × 2.6 × 1.1 in (81.7 × 66.1 × 27.8 mm)
Power (Current @ 5VDC)	400 mA typ., 750 mA max.	500 mA
Transfer Speed	1.5 Mbyte/s	1.5 Mbyte/s
EMC	European Directive 2004/108/EEC	European Directive 2004/108/EEC
Environmental	Operating: 0° to 55°C, 10% to 90% RH non-condensing Storage: -20° to 80°C, 5% to 90% RH non-condensing	Operating: 0° to 55°C, 10% to 90% RH non-condensing Storage: -20° to 80°C, 5% to 95% RH non-condensing

1.888.KEITHLEY (U.S. only)

www.keithley.com

A Greater Measure of Confidence

KEITHLEY
A Tektronix Company

Add GPIB control to any PC

ACCESSORIES

IEEE-488 (GPIB) Accessories



Model 7006-*: Single-shielded GPIB cable terminated with one feed through style and one straight on IEEE-488 connector. The mating thumb screws are metric.

7006-1 1m (3.3 ft)

7006-2 2m (6.6 ft)



Model 7010 Shielded IEEE-to-IEEE Adapter: Provides additional clearance between IEEE-488 cable and rear panel, allowing easier access to switches, cables, and other connectors.

For use with: IEEE-488 Interconnect



Model 8530 Centronics Adapter: IEEE-488 to Centronics cable adapter. Connects to Model 2001/2002 IEEE-488 port and any Centronics compatible printer for direct data output.

Cable Length: 2m (6.6 ft).

For use with: 2001, 2002

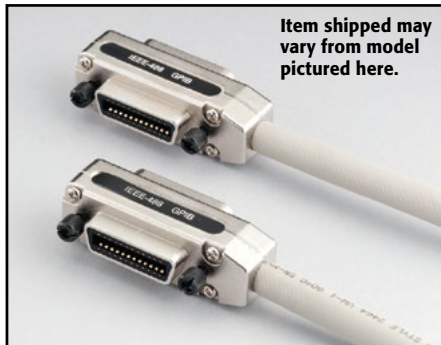

Item shipped may vary from model pictured here.

Model 7007-*: Double-shielded premium GPIB cable. Each end is terminated with a feed through style metal housing for longest life and best performance. The mating thumb screws are metric.

7007-05 0.5m (1.6 ft)

7007-1 1m (3.3 ft)

7007-2 2m (6.6 ft)

7007-3 3m (10 ft)

7007-4 4m (13.1 ft)

For use with: IEEE-488 Interconnect

Customer Service

How to Purchase	410
Equipment Services	411
Safety Considerations	412
Replacement Products	414

1.888.KEITHLEY (U.S. only)

www.keithley.com

A Greater Measure of Confidence

KEITHLEY
A Tektronix Company

CUSTOMER SERVICE

How to Purchase

Visit Keithley's web site at www.keithley.com for complete product information and configuration assistance. You'll find the most comprehensive information on Keithley products, including specifications, technical literature and reference material, drivers and software, online demos, and more. For a complete list of worldwide sales office locations and international sales partners, please visit www.keithley.com/buy.

Interested in Pricing?

Contact Keithley online at www.keithley.com/company/quick_quote for pricing on any of our measurement solutions, and we'll respond promptly via e-mail.

Ready to Order?

To expedite processing your order, please place your order from the country of end use and specify the following:

- Model number or part number
- Description
- Line voltage
- Model number or part number for any options or accessories
- Type of computer (applicable for software or computer interface board orders)

Order Keithley Products Online

Visit Keithley's website for information about which products are available for online ordering, how to order online, or to place your order through Keithley's online store (not available in all countries).

Terms and Conditions

Keithley's terms and conditions of sale in effect at the time of acceptance of the purchase order by Keithley Instruments, Inc. (the "Terms"), shall apply to all purchases of products and services from Keithley. A copy of Keithley's current terms and conditions of sale can be accessed at www.keithley.com/company/usterm sandconditions. To obtain a hard copy of the Terms, please contact your local sales office or e-mail orders@keithley.com.

U.S. HEADQUARTERS

Keithley Instruments, Inc.

28775 Aurora Road • Cleveland, Ohio 44139

1.888.KEITHLEY (534-8453) (U.S. Only)

Phone: +1-440-248-0400

E-mail Orders: orders@keithley.com

Order Placement/Service/Parts Fax: +1-440-498-2980

Applications E-mail: applications@keithley.com

Technical Support Fax: +1-440-498-2990

General E-mail: info@keithley.com

General Correspondence Fax: +1-440-248-6168

www.keithley.com

WORLDWIDE SALES OFFICES AND INTERNATIONAL SALES PARTNERS

For a complete list of worldwide sales office locations and international sales partners, please visit www.keithley.com/buy.

1.888.KEITHLEY (U.S. only)

www.keithley.com

Equipment Services



Calibration Services

ISO 17025:2005 Accreditation

Keithley Instruments' U.S. and German Service Centers have achieved ISO 17025:2005 accreditation by A2LA (American Association for Laboratory Accreditation). Keithley offers 17025 accredited calibrations on many models.

ISO 17025 is the single most important metrology standard for test and measurement products. This international standard specifies the general requirements for the technical competence to carry out tests and/or calibrations. It is applicable to all organizations performing tests and/or calibrations.

A management system based on the standard is required, as well as adherence to very specific technical requirements. By achieving accreditation to ISO 17025, Keithley U.S. and German Service Centers proved that their management systems meet all requirements of this standard and demonstrated their technical competence to carry out very high level calibrations.

ANSI/NCSL Z540.3-2006 Accreditation (U.S. only)

ISO 17025 calibrations performed by the Keithley Service Center—U.S. are also accredited to ANSI/Z540.3-2006, an important U.S. metrology standard.

Why Use Keithley's Calibration Services?

Quality is important to you. You understand the importance of calibration, but now you're faced with a choice of calibration providers. Who you choose as your calibration provider depends on what's important to you. Keithley is world-renowned for its quality and measurement expertise. Why trust your equipment with anyone else? You realize many benefits when you choose Keithley as your calibration partner, such as:

- Accuracy—Our calibration equipment is among the most advanced in the industry. This allows us to calibrate your product to a high level of accuracy. We take more measurements than most calibration providers, ensuring that your product is performing with repeatable accuracy.
- Quality—Our calibrations are traceable to national and international standards.
- Speed—We offer fast turnarounds on our calibrations to minimize your downtime.

KeithleyCare™ Plans

Cut costs, reduce downtime, and protect your investment with KeithleyCare Plans. They provide fast, high quality services at a fraction of the cost of per-event service. With a KeithleyCare plan, you'll enjoy priority calibration and repair services and virtually eliminate unscheduled downtime and administrative hassles. Trust a KeithleyCare plan to take care of your equipment, so you can take care of your customers.

KeithleyCare Calibration Plan

Simplify your calibration management and ensure your equipment is maintained in peak condition with Keithley's value-added calibration plans. KeithleyCare calibration plans offer multi-year coverage in 3- or 5-year increments. KeithleyCare calibration plans feature:

- Expedited priority service reduces downtime by 2 days or more.
- Complimentary shipping one way
- Adjustment to OEM specifications included with each calibration
- Performance verification before and after adjustment
- Performance updates

KeithleyCare Gold Plan

Unplanned downtime and maintenance expenses can be costly. Minimize the impact to your budget and your customers by purchasing value-added warranty coverage. KeithleyCare Gold Plan programs offer multiple years of protection in 3- and 5-year increments. KeithleyCare Gold plans feature:

- Free repairs
- Expedited priority service reduces downtime by 3 days
- Complimentary shipping both ways (within country)
- Calibration and adjustment to OEM specifications included with each repair
- Performance updates

Uptime Program

Minimize your downtime. Keithley products are often used in applications where uptime is critical. We know how important speed of service is to you, and we are proud of our ability to consistently deliver fast turnarounds. However, we also know that there are occasions where you simply cannot afford to be without your Keithley product. To address this need, we have developed a program to allow you to get your operation up and running sooner.

Express Service

Our express service option is available for a nominal cost and is offered on most products. It provides you with "next on bench" service and a guaranteed faster turnaround time.

1.888.KEITHLEY (U.S. only)

www.keithley.com

A Greater Measure of Confidence

KEITHLEY
A Tektronix Company

Safety Considerations

General Safety Considerations

It is the responsibility of the test system designers, integrators, and installers to make sure operator and maintenance personnel protection is in place and effective.

The following safety precautions should be observed before using any Keithley product and any associated instrumentation. Although some instruments and accessories would normally be used with non-hazardous voltages, there are situations where hazardous conditions may be present. Keithley products are intended for use by qualified personnel who recognize shock hazards and are familiar with the safety precautions required to avoid possible injury. Read the operating information provided in each product's manual carefully before using any Keithley product.

The types of product users are:

Responsible body is the individual or group responsible for the use and maintenance of equipment, for ensuring that the equipment is operated within its specifications and operating limits, and for ensuring that operators are adequately trained and protected.

Operators use the product for its intended function. They must be trained in electrical safety procedures and proper use of the instrument. They must be protected from electric shock and contact with hazardous live circuits.

Maintenance personnel perform routine procedures on the product to keep it operating, for example, setting the line voltage or replacing consumable materials. Maintenance procedures are described in the manual. The procedures explicitly state if the operator may perform them. Otherwise, they should be performed only by service personnel.

Service personnel are trained to work on live circuits and perform safe installations and repairs of products. Only properly trained service personnel may perform installation and service procedures.

Exercise extreme caution when a shock hazard is present. Lethal voltage may be present on cable connector jacks or test fixtures. The American National Standards Institute (ANSI) states that a shock hazard exists when voltage levels greater than 30V rms, 42.4V peak, or 60VDC are present. A good safety practice is to expect that hazardous voltage is present in any unknown circuit before measuring.

Operators must be protected from electric shock at all times. The responsible body must ensure that operators are prevented access and/or insulated from every connection point. In some cases, connections must be exposed to potential human contact. Product operators in these circumstances must be trained to protect themselves from the risk of electric shock. If the circuit is capable of operating at or above 1000 volts, no conductive part of the circuit may be exposed.

Keithley Instruments products are designed for use with electrical signals that are measurement, control, and data I/O connections with low transient over-voltages, and must not be directly connected to mains voltage or to voltage sources with high transient over-voltages. Measurement Category II (as referenced in IEC 60664) connections require protection

for high transient over-voltages often associated with local AC mains connections. Certain Keithley measuring instruments may be connected to mains. These instruments will be marked as Category II or higher.

Unless explicitly allowed in the specifications, operating manual, and instrument labels, do not connect any instrument to mains.

Do not connect switching cards directly to unlimited power circuits. They are intended to be used with impedance limited sources. NEVER connect switching cards directly to AC mains. When connecting sources to switching cards, install protective devices to limit fault current and voltage to the card.

Before operating an instrument, make sure the line cord is connected to a properly grounded power receptacle. Inspect the connecting cables, test leads, and jumpers for possible wear, cracks, or breaks before each use.

For rack mounted equipment in which the power cord is not accessible, in the event of fire or other catastrophic failure, the operator must have access to a separate power disconnect device or switch.

For maximum safety, do not touch the product, test cables, or any other instruments while power is applied to the circuit under test. ALWAYS remove power from the entire test system and discharge any capacitors before: connecting or disconnecting cables or jumpers, installing or removing switching cards, or making internal changes, such as installing or removing equipment.

Do not touch any object that could provide a current path to the common side of the circuit under test or power line (earth) ground. Always make measurements with dry hands while standing on a dry, insulated surface capable of withstanding the voltage being measured.

For safety, instruments and accessories must be used in accordance with the operating instructions. If the instruments or accessories are used in a manner not specified in the operating instructions, the protection provided by the equipment may be impaired.

Do not exceed the maximum signal levels of the instruments and accessories, as defined in the specifications and operating information, and as shown on the instrument or test fixture panels, or switching card.

When fuses are used in a product, replace with same type and rating for continued protection against fire hazard.

Chassis connections must only be used as shield connections for measuring circuits, NOT as safety earth ground connections.

If you are using a test fixture, keep the lid closed while power is applied to the device under test. Safe operation requires the use of a lid interlock.

If a  marked terminal is present, connect it to safety earth ground using the wire recommended in the user documentation.

The  symbol on an instrument means caution, risk of danger. The user must refer to the operating instructions located in the user documentation in all cases where the symbol is marked on the instrument.

1.888.KEITHLEY (U.S. only)

www.keithley.com

Safety Considerations

The ⚡ symbol on an instrument means caution, risk of electric shock. Use standard safety precautions to avoid personal contact with these voltages.

The 🔥 symbol on an instrument shows that the surface may be hot. Avoid personal contact to prevent burns.

The ⚙️ symbol indicates a connection terminal to the equipment chassis.

If this ☿ symbol is on a product, it indicates that mercury is present in the display lamp. Please note that the lamp must be properly disposed of according to federal, state, and local laws.

The **WARNING** heading in a manual explains dangers that might result in personal injury or death. Always read the associated information very carefully before performing the indicated procedure.

The **CAUTION** heading in a manual explains hazards that could damage the instrument. Such damage may invalidate the warranty.

Instrumentation and accessories shall not be connected to humans.

Before performing any maintenance, disconnect the line cord and all test cables.

To maintain protection from electric shock and fire, replacement components in main circuits, including the power transformer, test leads, and input jacks, must be purchased from Keithley Instruments. Standard fuses, with applicable national safety approvals, may be used if the rating and type are the same. Other components that are not safety related may be purchased from other suppliers as long as they are equivalent to the original component. (Note that selected parts should be purchased only through Keithley Instruments to maintain accuracy and functionality of the product.) If you are unsure about the applicability of a replacement component, call a Keithley Instruments office for information.

To clean an instrument, remove power, use a damp cloth or mild, water based cleaner. Clean the exterior of the instrument only. Do not apply cleaner directly to the instrument or allow liquids to enter or spill on the instrument. Products that consist of a circuit board with no case or chassis should never require cleaning if handled according to instructions. If the board becomes contaminated and operation is affected, the board should be returned to the factory for proper cleaning/servicing.

Test System Safety

Many electrical test systems or instruments are capable of measuring or sourcing hazardous voltage and power levels. It is also possible, under single fault conditions (e.g., a programming error or an instrument failure), to output hazardous levels even when the system indicates no hazard is present.

These high voltage and power levels make it essential to protect operators from any of these hazards at all times.

Protection methods include:

- Design test fixtures to prevent operator contact with any hazardous circuit.
- Make sure the device under test is fully enclosed to protect the operator from any flying debris.
- Double insulate all electrical connections that an operator could touch. Double insulation ensures the operator is still protected, even if one insulation layer fails.
- Use high-reliability, fail-safe interlock switches to disconnect power sources when a test fixture cover is opened.
- Where possible, use automated handlers so operators do not require access to the inside of the test fixture or have a need to open guards.
- Provide proper training to all users of the system so they understand all potential hazards and know how to protect themselves from injury.

WARNING: During power-up, the outputs states of data acquisition products are uncontrolled until hardware and software initialization has been completed. Users must make sure their designs can tolerate this or provide suitable interlocks to prevent dangerous voltages or actions from reaching users.

Replacement Products

This table includes a list of older Keithley products and suggested replacement models that can be used to upgrade the capabilities of these older products. Many of these products are at or near the end of their serviceable life. To ensure adequate replacement, please review the replacement instrument's specifications in this catalog or on the Keithley Web site. If the suggested replacement does not meet specific application requirements or if the model being upgraded is not listed, check the Web site FAQs for upgrade options, or contact the Keithley Applications Department or your local Keithley representative for assistance.

OLDER MODELS	DESCRIPTION	SUGGESTED REPLACEMENTS
SOURCEMETER INSTRUMENTS		
237	Source-Measure Unit	2657A
2600A	System SourceMeter Instruments	2600B
ELECTROMETERS		
200, 200A, 200B, 210, 220	Electrometer Voltmeters	6514
236, 487, 610, 610A, 610B, 610C, 610R	Electrometers	6514, 6517B, 6487
236, 487, 614, 615, 616, 617, 6512, 6517, 6517A	Digital Electrometers	6514, 6517B, 6487
236, 486, 603, 604, 619	Dual Electrometers	6514, 6517B, 6485
640, 642, 642LN	10 ⁻⁷ A Electrometer	6430
PICOAMMETERS		
409, 410, 410A, 411, 414, 414A, 414S, 415, 480, 485, 486, 487, 614	Picoammeters	6514, 6482, 6485, 6487
412, 413, 26000	Log Picoammeters	6485
418, 419, 440, 445, 486, 487	Digital Picoammeters	6482, 6485, 6487
LOW VOLTAGE INSTRUMENTS		
140, 147, 148, 149, 150, 181, 182, 1801	Nanovoltmeters	2182A
150A, 150B, 155, 180, 181, 182, 303	Null Detectors	2182A
151, 151C, 153, 155	Microvoltmeters/Null Detectors	2182A
DIGITAL MULTIMETERS		
190, 191, 195, 195A, 199	DMMs (5½ digits)	2000, 2100, 2110, 2700, 2701
172, 172A, 173, 176, 178, 179, 179-20A	DMMs (4½ digits) (10µV)	2000, 2100, 2110, 2700, 2701
192, 193, 193A, 196, 197A, 199	System DMMs	2000, 2100, 2110, 2001, 2002, 2010, 2700, 2701
RESISTANCE MEASURING INSTRUMENTS		
164, 502, 502A, 505, 580	Milliohmmeters	2010, 2750, 2182A + 2400, 622x + 2182A
487, 500, 501, 510, 515, 520, 6517, 6517A	High-Resistance Instruments	6517B, 6487
CURRENT SOURCES		
220, 224, 225, 236	Current Source	Series 2400, Series 2600B, 6220, 6221
261, 263	Current Source	6220, 6221, 6430
227, 228, 238	Current Source	2420, 2651A
VOLTAGE SOURCES		
237, 240, 240A, 241, 242, 244, 245, 246, 247, 248, 2004, 2004A	High Voltage Supplies	2410, 2290-5, 2290-10, 2657A
SWITCHES		
702	Scanner	7001, 2700, 2701, 2750
703, 706	Scanner	7002, 2700, 2701, 2750
705	Scanner	7001, 2700, 2701, 2750
707A, 708A	Mainframe	707B, 708B, 7001, 2700, 2701, 2750
7002-HD	Mainframe	3706A
SWITCHING AND CONTROL CARDS		
7036-D	7001/7002 Isolated Switch Card	7036
7037	7001/7002 Control Card	7037-D
7052	4×5 Matrix Switch Card	7012-S
7054	7001/7002 High Voltage Card	7154
7056	General-Purpose Scanner Card	7011-S, Integra 7702
7058	Low Current Scanner Card	7158, 7152, 7153, 6521 (with 6517A or 6517B), 6522 (with 6517A or 6517B)
7059	7001/7002 Low Voltage Card	7168
7064	Low Voltage Scanner Card	7168
7066	10-Channel Isolated Switch Card	7013-S, 7036, Integra 7705
7071	General Purpose 8×12 Matrix Card	7072
7074-D	707A/708A Multiplexer Card	7001/7002 with 7158
7075	Two-Pole Multiplexer Card	7001/7002 with 7158
7156-D	7001/7002 General Purpose Card	7011-C, 7701
7164-D	Dry Reed Scanner Card	7011-C
7999-4, 7999-5	RS-232 Switch/Controller	546
SEMICONDUCTOR PROCESS MONITORING SOLUTIONS		
S400 Series, S600 Series, S900 Series	Parametric Test Systems	S530 Series

1.888.KEITHLEY (U.S. only)

www.keithley.com

KEITHLEY

A Tektronix Company

A Greater Measure of Confidence



14

Specifications are subject to change without notice.
All Keithley trademarks and trade names are the property of Keithley Instruments, Inc.
All other trademarks and trade names are the property of their respective companies.

Specifications are subject to change without notice. All Keithley trademarks and trade names are the property of Keithley Instruments.
All other trademarks and trade names are the property of their respective companies.



A Greater Measure of Confidence

KEITHLEY INSTRUMENTS ■ 28775 AURORA RD. ■ CLEVELAND, OH 44139-1891 ■ 440-248-0400 ■ Fax: 440-248-6168 ■ 1-888-KEITHLEY ■ www.keithley.com

BENELUX
+31-40-267-5506
www.keithley.nl

FRANCE
+33-01-69-86-83-60
www.keithley.fr

ITALY
+39-049-762-3950
www.keithley.it

MALAYSIA
60-4-643-9679
www.keithley.com

SINGAPORE
01-800-8255-2835
www.keithley.com.sg

BRAZIL
55-11-4058-0229
www.keithley.com

GERMANY
+49-89-84-93-07-40
www.keithley.de

JAPAN
81-120-441-046
www.keithley.jp

MEXICO
52-55-5424-7907
www.keithley.com

TAIWAN
886-3-572-9077
www.keithley.com.tw

CHINA
86-10-8447-5556
www.keithley.com.cn

INDIA
080-30792600
www.keithley.in

KOREA
82-2-6917-5000
www.keithley.co.kr

RUSSIA
+7-495-664-7564
www.keithley.ru

UNITED KINGDOM
+44-1344-39-2450
www.keithley.co.uk

For further information on how to purchase or to locate a sales partner please visit www.keithley.com/buy