

Test & Measurement product catalog

13



A Greater Measure of Confidence

KEITHLEY
A Tektronix Company

DC Power Supplies

Selector Guide Selector Guide

2200-20-5

2200-30-5

2200-32-3

2200-60-2

2200-72-1

2220-30-1

2230-30-1

2308

2302

2302-PJ

2306

2306-PJ

2306-VS

2303

2303-PJ

2304A

248

Technical Information 296

Programmable DC Power Supplies 300

Battery Simulating DC Power Supplies 301

Single-Channel Programmable DC Power Supplies

20V, 5A Programmable DC Power Supply 302

30V, 5A Programmable DC Power Supply 302

32V, 3A Programmable DC Power Supply 302

60V, 2.5A Programmable DC Power Supply 302

72V, 1.5A Programmable DC Power Supply 302

Multi-Channel Programmable DC Power Supplies

Programmable Dual Channel DC Power Supply . . 306

Programmable Triple Channel DC Power Supply . 306

Battery Simulating DC Power Supplies

50W, Fast Transient Response Battery/Charger
Simulating Supply with Analog Output 310

60W, Fast Transient Response
Battery Simulating Supply 317

60W, Fast Transient Response
Battery Simulating Supply with 500mA Range . . . 317

50W, Fast Transient Response
Battery/Charger Simulating Supply 317

50W, Fast Transient Response Battery/Charger
Simulating Supply with 500mA Range 317

50W, Fast Transient Response Battery/Charger
Simulating Supply with External Triggering 323

45W, Fast Transient Response Supply 331

45W, Fast Transient Response
Battery Simulating Supply with 500mA Range . . . 331

100W, Fast Transient Response Supply 331

High Voltage DC Power Supply

25W, High Voltage (5kV) Supply 335

Programmable DC Power Supplies

DC power supplies provide a regulated DC output to power a component, a module, or a device. A power supply must deliver voltage and current that is stable and precise, with minimal noise in any type of load: resistive, inductive, low impedance, high impedance, steady-state, or variable. How well the power supply fulfills this mission and where it reaches its limits are defined in its specifications.

Power supplies have two main settings, the output voltage and the current limit. How they are set in combination with the load determines how the power supply will operate.

Most DC power supplies have two modes of operation. In Constant Voltage (CV) mode, the power supply controls the output voltage based on the user settings. In Constant Current (CC) mode, the power supply regulates the current. Whether the power supply is in CV or CC mode depends on both the user settings and the resistance of the load.

- CV mode is the typical operating state of a power supply. It controls voltage. The output voltage is constant and is determined by the user's voltage setting. The output current is determined by the impedance of the load.
- CC mode is typically considered a safety mode, but can be used in other ways. In CC mode, the output current is constant and is determined by the user's current limit setting. The voltage is determined by the impedance of the load. If the power supply is in CV mode and its current exceeds the user's current limit setting, then the power supply will automatically switch to CC mode. The power supply can also revert back to CV mode if the load current falls below the current limit setting.

The most important parameters for any application are the maximum voltage, maximum current, and maximum power that the power supply can generate. It is essential to ensure that the power supply can deliver the power at the required voltage and current levels. These three parameters are the first specifications that must be investigated.

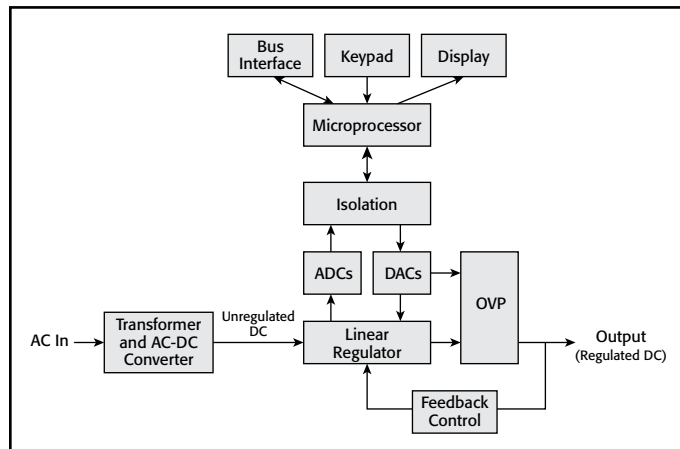

Figure 1. Simplified block diagram of a programmable linear power supply showing the digital and analog control circuit blocks

Accuracy and Resolution

Historically, the DC power supply user turned potentiometers to set output voltage or current. Today, microprocessors receive input from the user interface or from a remote interface. A digital-to-analog converter (DAC) takes the digital setting and translates this into an analog value, which is used as the reference for the analog regulator. The setting resolution and accuracy values are determined by the quality of this conversion and regulation process.

Voltage and current settings (sometimes called limits or programmed values) each have resolution and accuracy specifications associated with them. The resolution of these settings determines the minimum increment in which the output can be adjusted, and the accuracy describes the extent to which the value of the output matches international standards. In addition to output settings, there are measurement or readback specifications that are independent of the output specifications.

Most DC power supplies provide built-in measurement circuits for measuring both voltage and current. These circuits measure the voltage and current being delivered by the power supply output. Since the circuits read the voltage and current that is fed back into the power supply, the measurements produced by the circuits are often called readback values. Most professional power supplies incorporate circuits that use analog-to-digital converters, and for these internal instruments the specifications are similar to those of a digital multimeter. The power supply displays measured values on its front panel and can also transmit them over its remote interface, if it is equipped with one.

Setting Accuracy

Setting accuracy determines how close the regulated parameter is to its theoretical value as defined by an international standard. Output uncertainty in a power supply is largely due to error terms in the DAC, including quantization error. Setting accuracy is tested by measuring the regulated variable with a traceable, precision measurement system connected to the output of the power supply. Setting accuracy is given as:

$$\pm(\% \text{ of setting} + \text{offset})$$

For example, consider a power supply with a voltage setting accuracy specification of $\pm(0.03\% + 3\text{mV})$. When it is set to deliver 5V, the uncertainty in the output value is $(5\text{V})(0.0003 + 3\text{mV})$, or 4.5mV. Current setting accuracy is specified and calculated similarly.

Setting Resolution and Programming Resolution

Setting resolution is the smallest change in voltage or current settings that can be selected on the power supply. This parameter is sometimes called programming resolution if operating over an interface bus such as GPIB.

Readback Accuracy and Resolution

Readback accuracy is sometimes called meter accuracy. It determines how close the internally measured values are to the theoretical value of the output voltage (after setting accuracy is applied). Like a digital multimeter, this is tested using a traceable reference standard. Readback accuracy is expressed as:

$$\pm(\% \text{ of measured value} + \text{offset})$$

Readback resolution is the smallest change in internally measured output voltage or current that a power supply can discern.

1.888.KEITHLEY (U.S. only)

www.keithley.com

KEITHLEY

A Greater Measure of Confidence

A Tektronix Company

Load Regulation (Voltage and Current)

Load regulation is a measure of the ability of the output voltage or output current to remain constant during changes in the load. It is expressed as:

$$\pm(\% \text{ of setting} + \text{offset})$$

Line Regulation (Voltage and Current)

Line regulation is a measure of the ability of the power supply to maintain its output voltage or output current while its AC line input voltage and frequency vary over the full allowable range. It is expressed as:

$$\pm(\% \text{ of setting} + \text{offset})$$

Ripple and Noise

Spurious AC components on the output of a DC supply are called ripple and noise, or periodic and random deviation (PARD). PARD specifications must be specified with a bandwidth and should be specified for both current and voltage. Current PARD is relevant when using a power supply in CC mode, and it is often specified as an RMS value. Because the shape of PARD is indeterminate, voltage PARD is usually expressed both as a root mean square voltage, which can provide a sense of the noise power, and also as a peak-to-peak voltage, which can be relevant when driving high impedance loads.

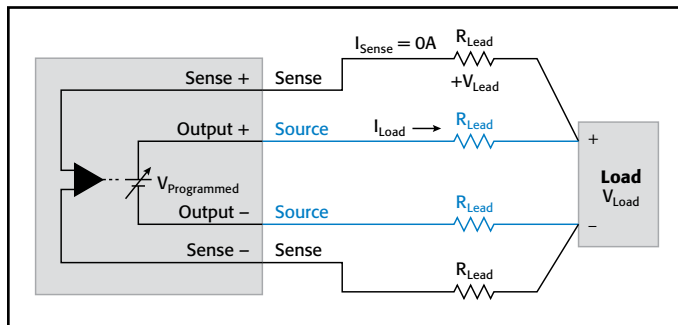

Figure 2. Remote sensing technique

Regardless of the accuracy of your power supply, you cannot guarantee that the programmed output voltage is the same as the voltage at the DUT's load. This is because a power supply with two source output terminals regulates its output only at its output terminals. However, the voltage you want regulated is at the DUT's load, not at the power supply's output terminals. The power supply and the load are separated by lead wires that have a resistance, R_{Lead} , which is determined by the length of the lead, the conductivity of the conductor material, and the geometry of the conductor. The voltage at the load is:

$$V_{\text{Load}} = V_{\text{Programmed}} - 2 * V_{\text{Lead}} = V_{\text{Programmed}} - 2 * I_{\text{Load}} * R_{\text{Lead}}$$

If the load requires high current, then I_{Load} is high and V_{Lead} can easily be a few tenths of a volt, especially if the power supply leads are long, as can be the case in an automated test rack. A voltage at the load could be 80mV to 160mV lower than the desired voltage (with 2A to 4A flowing through a 16-gauge wire).

The remote sensing technique solves the problem of the voltage drop in the test lead wires by extending the power supply feedback loop to the load. Two sense lines are connected between the DUT's load and the high

impedance voltage measuring circuit in the power supply. Since this is a high input impedance circuit, the voltage drop in the sense leads is negligible and becomes the feedback control loop for the power supply.

Fast Transient Response Power Supplies

The Keithley Series 2300 special-purpose power supplies are designed to maintain a stable output voltage under the most difficult loading conditions, such as the large, instantaneous load changes generated by cellular phones, cordless phones, mobile radios, wireless modems, and other portable, wireless communication devices. These devices typically transition from standby current levels of 100–200mA to 800mA–1.5A, which represents load changes of 800% and higher. A conventional power supply typically specifies a transient recovery to a 50% load change. The Keithley Series 2300 power supplies specify transient response to 1000% load changes.

Stable During Fast Load Changes

When the mobile communication device transitions to a full power transmit state, the output voltage of a conventional power supply drops substantially until its control circuitry can respond to the transient. Conventional power supplies trade off stability for all kinds of loads against transient response. As a result, the large voltage drop and long recovery time of a conventional power supply can cause the output voltage to fall below the low battery voltage threshold of the device under test (DUT). The DUT could turn off during testing and register a false failure, affecting yield and production costs.

Series 2300 fast transient response power supplies have transient voltage droops of less than 200mV under large load changes, even with the added impedance of long wire runs between the power supply and the DUT. Thus, the Series 2300 power supplies will keep the DUT powered under all test conditions and prevent false failures. See **Figure 3**.

Accurate Four-Wire Measurements

To maintain an accurate voltage at the DUT load, the Series 2300 power supplies use a four-wire source circuit in which two outputs provide the power and the other two lines sense the voltage directly at the DUT load.

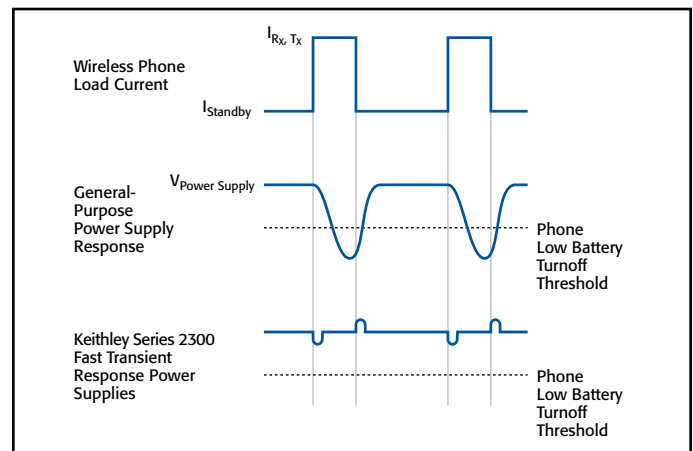

Figure 3. Comparison of general-purpose power supply's response with the response of a Keithley Series 2300 fast transient power supply.

1.888.KEITHLEY (U.S. only)

www.keithley.com

KEITHLEY

A Greater Measure of Confidence

A Tektronix Company

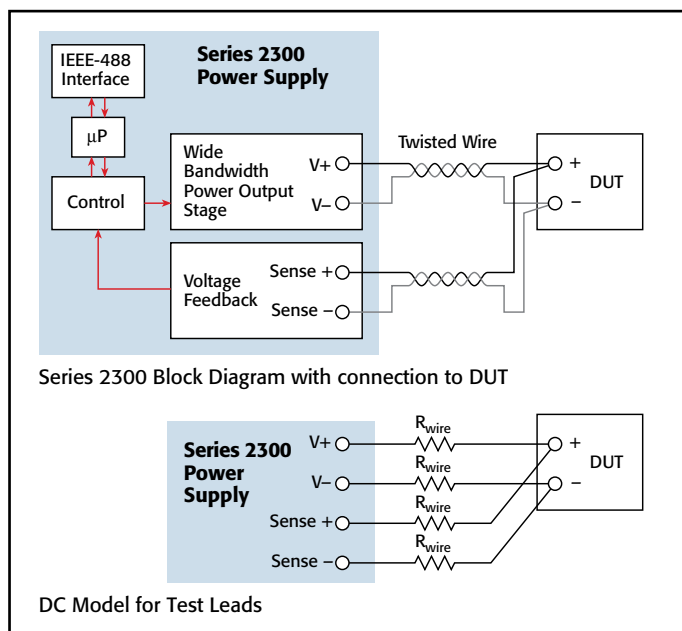

Figure 4. Four-wire sensing with Series 2300 power supplies ensures that an accurate voltage is applied to the load.

Sensing the voltage at the load compensates for any voltage drops in long test lead runs between the power supply and the load. Furthermore, the power supplies use a wide band output stage to obtain the low voltage transient droop and the fast transient recovery time. See **Figure 4**.

These types of power supplies often incorporate techniques for detecting if a sense lead is open or broken. An open sense lead interrupts the feedback control to the power supply, and uncontrolled, unstable output can provide improper voltages to a DUT. Series 2300 supplies either revert to internal local sensing or indicate an error condition and turn the output off.

Battery Emulation with Variable Output Resistance

Mobile communication devices are powered by batteries, so the Models 2302 and 2306 power supplies are designed to emulate the performance of a battery accurately. These supplies incorporate a variable output resistance feature, which enables a test engineer to test his DUT under actual operating conditions.

Furthermore, these supplies can sink current to simulate the battery in the discharged state. Thus, test engineers can use one instrument both to source the DUT and to act as a load for testing the charging control circuitry of the DUT and its charger.

The Models 2302 and 2306 have the ability to vary their output impedance. This allows them to simulate the internal impedance of a battery. Thus, the voltage response of a battery that must support pulsed current loads from portable products such as mobile phones can be simulated. This enables manufacturers of portable devices to test their devices under the most realistic conditions.

With a pulse-like increase in load current, the battery output voltage will drop by the product of the current change and the battery's internal resistance. The battery voltage could fall (for the length of the pulse) below the low battery voltage threshold level of the device, and the device could turn off. Since the internal impedance increases as a battery discharges, the low voltage threshold level can be reached earlier than expected due to the combination of a lower battery voltage due to discharge time and the voltage drop across the internal resistance of the battery. Therefore, a device's battery life could be shorter than the desired specification.

Battery impedance must be considered when evaluating mobile phone handset talk time and standby performance, because voltage levels below the operating threshold of a handset's circuitry for periods as short as 100 to 200 μ s are enough to shut off the handset. This phenomenon is common in TDMA (Time Division Multiple Access) phones such as GSM mobile phones where the magnitude of the high and low current levels during an RF transmission pulse vary by as much as a factor of 7 to 10. Designers need to simulate the actual performance of a battery to define an appropriate low battery threshold level. Test engineers need to simulate actual battery performance to test that the low voltage threshold level is reached with the specified battery voltage and not at a higher voltage level.

The battery simulating characteristics of the Models 2302 and 2306 can be used to test components as well as end products. For example, the power consumption characteristics of an RF power amplifier designed for use in portable products can be characterized for operation from a battery power source. As a battery discharges, its voltage decreases and its internal impedance increases. The RF amplifier draws a constant amount of power to maintain the required output. Thus, as the battery voltage falls and the internal resistance increases, the RF amplifier draws increasing amounts of current from the battery. Both peak current and average current rise significantly with increases in battery internal impedance. See **Figure 5**. The RF power amplifier must specify power consumption. The portable device designer must be aware of how the RF power amplifier performs as the battery discharges so that the designer can select an appropriate battery pack to ensure both that an adequate current supply is available

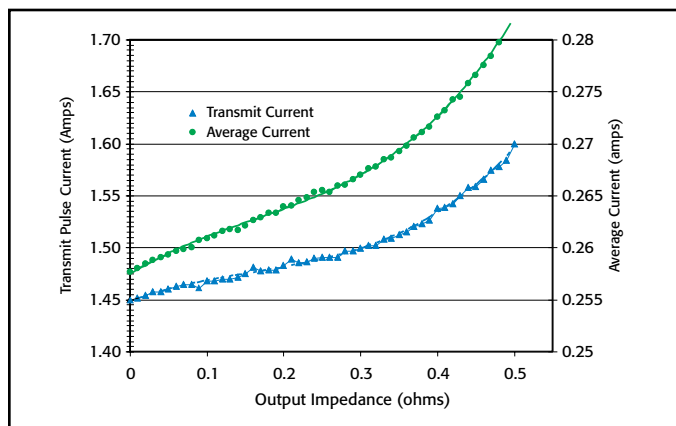

Figure 5. The transmit and average current consumption of an RF power amplifier used in a pulsed output mode with a Model 2302/2306 simulating a battery with a nominal output voltage of 3.60V and output impedance from 0.00 to 0.51 Ω .

1.888.KEITHLEY (U.S. only)

www.keithley.com

KEITHLEY

A Greater Measure of Confidence

A Tektronix Company

Technical Information

DC Power Supplies

and that the battery supplies suitable operating time between replacement or charges.

The mathematics of this effect is provided below (also see **Figures 6a** and **6b**). They show that the voltage drop produced by pulsed current loads can have a significant effect on battery output voltage.

V_{cell} = An ideal voltage source

$R_i(t)$ = The internal impedance

$R_{\text{interconnect}}$ = Resistance of cables and interconnections to the DUT

- 1) If $R_{\text{interconnect}}$ is small compared to $R_i(t)$, and if
- 2) $R_i(t)$ is assumed to be relatively constant during the length of the pulse, $R_i(t) \approx R_i$, then
- 3) The voltage across the DUT can be expressed as:

$$V(t) \approx V_{\text{cell}} - I(t)R_i(t) \approx V_{\text{cell}} - I(t)R_i$$
 where $I(t)$ is the time varying current through the battery.

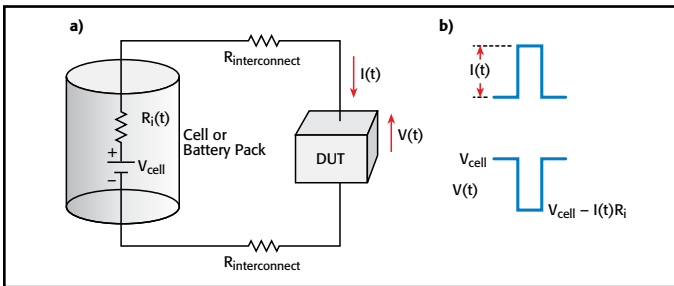

Figure 6a. Schematic of a battery represented by an ideal voltage source and a time varying internal impedance connected to a DUT. **Figure 6b.** Resulting output voltage with a pulsed load current.

Pulse Current and Low Current Measurements

Using a conventional (slow transient response) power supply for testing wireless devices requires that a large capacitor be placed in the circuit to stabilize the voltage during a load transition. As a result, load current measurements require using a sense resistor and a DMM to monitor load currents. The sense resistor adds resistance to the line, which further aggravates the load droop problem. The Keithley fast transient response power supplies eliminate the need for the capacitor and enable the power supply current readback circuitry to measure the load currents. See **Figure 7**. Keithley low current expertise enables the measurement of sleep currents with $0.1\mu\text{A}$ resolution. These supplies can also measure load current pulses from digital transmission devices. Current pulses as short as $60\mu\text{s}$ can be captured.

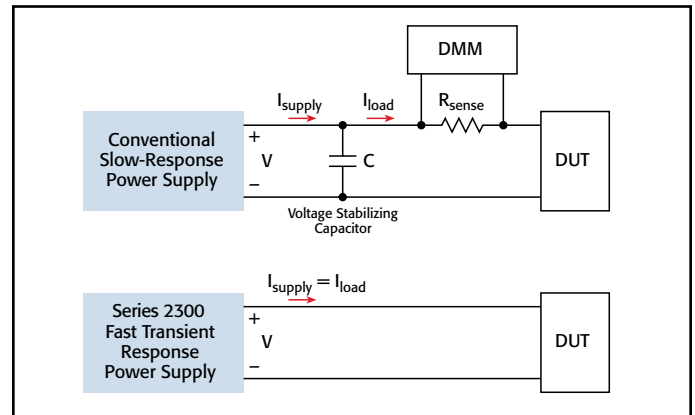

Figure 7. A Keithley Series 2300 fast transient response power supply measures load currents without additional devices and components.

Selector Guide

Programmable DC Power Supplies

Single-Channel Power Supplies

Multi-Channel Power Supplies

Model	2200-20-5	2200-30-5	2200-32-3	2200-60-2	2200-72-1	2220-30-1, 2220J-30-1	2230-30-1, 2230J-30-1
Page	302	302	302	302	302	306	306
Number of Channels	1	1	1	1	1	2	3
Power Output	100 W	150 W	96 W	150 W	86 W	90 W	120 W
Voltage Output	0 to 20 V	0 to 30 V	0 to 32 V	0 to 60 V	0 to 72 V	Ch. 1 and 2: 0 to 30 V	Ch. 1 and 2: 0 to 30 V Ch. 3: 0 to 6 V
Current Output	0 to 5 A	0 to 5 A	0 to 3 A	0 to 2.5 A	0 to 1.2 A	Ch. 1 and 2: 0 to 1.5 A	Ch. 1 and 2: 0 to 1.5 A Ch. 3: 0 to 5 A
Operating Mode	CV/CC*	CV/CC*	CV/CC*	CV/CC*	CV/CC*	CV/CC*	CV/CC*
Setting and Readback Resolution:							
Voltage	1 mV	1 mV	1 mV	1 mV	1 mV	1 mV	1 mV
Current	0.1 mA	0.1 mA	0.1 mA	0.1 mA	0.1 mA	1 mA	1 mA
Basic Accuracy:							
Voltage	±0.03%	±0.03%	±0.03%	±0.03%	±0.03%	±0.03%	±0.03%
Current	±0.05%	±0.05%	±0.05%	±0.05%	±0.05%	±0.1%	±0.1%
Features:							
Programming	IEEE-488 and USB	IEEE-488 and USB	IEEE-488 and USB	IEEE-488 and USB	IEEE-488 and USB	USB	USB
Remote Sense	Yes	Yes	Yes	Yes	Yes	Yes	Yes
External Trigger	Yes	Yes	Yes	Yes	Yes	No	No
Front and Rear Connectors	Yes	Yes	Yes	Yes	Yes	Yes	Yes
Setup Storage	40 locations	40 locations	40 locations	40 locations	40 locations	30 locations	30 locations
List Mode	7 lists, 80 steps/list	7 lists, 80 steps/list	7 lists, 80 steps/list	7 lists, 80 steps/list	7 lists, 80 steps/list	No	No
Track Mode	No	No	No	No	No	Yes	Yes
Output Timer	Yes	Yes	Yes	Yes	Yes	Yes	Yes
Password Protection	Yes	Yes	Yes	Yes	Yes	Yes	Yes
Remote Inhibit	Yes	Yes	Yes	Yes	Yes	No	No
Discrete Fault Indication	Yes	Yes	Yes	Yes	Yes	No	No
Approvals	CSA/CE	CSA/CE	CSA/CE	CSA/CE	CSA/CE	CSA/CE	CSA/CE

*CV is Constant Voltage mode and CC is Constant Current mode

1.888.KEITHLEY (U.S. only)

www.keithley.com

KEITHLEY

A Tektronix Company

A Greater Measure of Confidence

Selector Guide

Specialized DC Power Supplies

High Voltage Supply

Fast Transient Response, Battery Simulating Power Supplies

Model	2302	2303	2303-PJ	2304A	2306	2306-PJ	2306-VS	2308	248
Page	317	331	331	331	317	317	323	310	335
No. of Channels	1	1	1	1	2	2	2	2	1
Power Output	60W maximum, function of V; optimized for maximum current at low V	45 W	45 W	100 W	50W maximum, function of V and power consumed by other channel; optimized for maximum current at low V	50W maximum, function of V and power consumed by other channel; optimized for maximum current at low V	50W maximum, function of V and power consumed by other channel; optimized for maximum current at low V	50W maximum, function of V and power consumed by other channel; optimized for maximum current at low V	25 W
Voltage Output	0–15 V	0–15 V	0–15 V	0–20 V	0–15 V	0–15 V	0–15 V	0–15 V	0–±5000 V
Maximum Continuous Current Output	5 A @ 4 V	5 A @ 9 V	5 A @ 9 V	5 A @ 20 V	5 A @ 4 V	5 A @ 4 V	5 A @ 4 V	5 A @ 4 V	5 mA
Variable Resistance Output	0–1 Ω 10 mΩ resolution				0–1 Ω 10 mΩ resolution (in channel 1)	0–1 Ω 10 mΩ resolution (in channel 1)	0–1 Ω 10 mΩ resolution (in channel 1)	0–1 Ω 10 mΩ resolution (in channel 1)	
Current Sink Capacity	3 A	2 A	2 A	3 A	3 A	3 A	3 A	3 A	
DC Current Measurement Sensitivity	100 nA	100 nA	10 μA	100 nA	100 nA	10 μA (Ch. 1) 100 nA (Ch. 2)	100 nA	100 nA	
Dynamic Current Measurement	5 A range: 33 μs–833 ms integration times	5 A range: 33 μs–833 ms integration times	500 mA and 5 A ranges: 33 μs–833 ms integration times	5 A range: 33 μs–833 ms integration times	5 A range: 33 μs–833 ms integration times	500 mA and 5 A ranges: 33 μs–833 ms integration times	5 A range: 33 μs–833 ms integration times	5 A, 500 mA, 50mA and 5mA ranges: 33 μs–833 ms integration times	
External Triggering for Voltage Outputs and Current Measurement	No	No	No	No	No	No	Yes	No	No
Accuracy									
V	0.05%	0.05%	0.05%	0.05%	0.05%	0.05%	0.05%	0.05%	0.01%
I	0.2%	0.2%	0.2%	0.2%	0.2%	0.2%	0.2%	0.2%	0.01%
Features:									
Programming	IEEE-488 included	IEEE-488 included	IEEE-488 included	IEEE-488 included	IEEE-488 included	IEEE-488 included	IEEE-488 included	IEEE-488 included	IEEE-488 included
Open Sense Lead Detection	Yes				Yes	Yes	Yes	Yes	No
DVM	Yes	Yes	Yes	Yes	Yes, 1 per channel	Yes, 1 per channel	Yes, 1 per channel	Yes, on channel 2	No
Analog Output								1 analog output	
Relay Control Port	4	1	1	2	4	4	No	4	No
Remote Display Module	Yes	Yes	Yes	Yes	Yes	Yes	No	Yes	No
CE	Yes	Yes	Yes	Yes	Yes	Yes	Yes	Yes	Yes

1.888.KEITHLEY (U.S. only)

www.keithley.com

KEITHLEY

A Greater Measure of Confidence

A Tektronix Company

Selector guide: Specialized DC power supplies

DC POWER SUPPLIES

Series 2200

Single-Channel Programmable DC Power Supplies



- **Five models ranging in power from 86W to 150W with voltage outputs from 20V to 72V address a wide range of power requirements**
- **0.03% basic voltage output accuracy and 0.05% basic current accuracy provide quality test data**
- **High output and measurement resolution, 1mV and 0.1mA, for testing low power circuits and devices**
- **Remote sensing to ensure the programmed voltage is applied to the load**
- **Dual-line display shows both the programmed values and actual outputs for a continuous indication of the status of the power delivered to the load**
- **Repeatable test sequences of up to 80 output steps are easy to create with the built-in List mode**
- **GPIB and USB interfaces are standard for convenient automated control**

The Series 2200 Single-Channel Programmable DC Power Supplies provide a wide range of voltage outputs to address the testing and characterization of components, circuits, modules, and complete devices, whether you are in a research laboratory, in design and development, or in production test. The Series 2200 consists of five models with output voltages from 20V to 72V that can deliver 86W, 96W, 100W, and 150W of power. In addition, these power supplies can act as constant current sources as well as constant voltage sources. The Series 2200 power supplies offer an excellent combination of performance, versatility, and ease of use that allow you to obtain quality test data as quickly as possible. They perform as effectively in automated test systems as they do in manual instrument configurations.

Outstanding Accuracy Delivered to the Load

With basic voltage setting accuracy of 0.03% and basic voltage readback accuracy of 0.02%, you can be sure that the voltage you program for the load is applied at the output terminals. What's more, the rear panel connections include remote sense terminals that compensate for voltage drops in the power supply leads. This helps to ensure that the correct voltage is delivered to the load terminals of the device-under-test (DUT). Great accuracy is not limited to voltage—the basic current setting and readback accuracy is 0.05%, providing you with high quality load current measurements. Also, with less than 5mVp-p noise, you can be confident that the power applied to the DUT's load terminals is both accurate and of high quality.

Superior resolution is also provided by Keithley's Series 2200 single-channel power supplies. With 1mV and 0.1mA resolution, the effects of very small changes in voltage and current can be detected and studied. For portable devices in which minimum power consumption is critical, the 0.1mA current resolution allows you to measure the idle and sleep mode currents so you can verify that your products meet aggressive low power consumption goals.

Get Test Results Quickly

Keithley's Series 2200 single-channel power supplies have a number of features that enable you to obtain the results you need quickly and easily, including tools to help you create sophisticated tests for a wide range of requirements.

The dual-line display shows both the programmed settings and the actual voltage and current outputs, allowing you to immediately see, understand, and address any differences between the expected and actual output values. Multiple methods can be used to adjust the voltage and current settings. You can use the direct-entry numeric keypad to set precise voltage and current values. There is also a rotary knob with adjustable step size that lets you easily study the response of your DUT to small or large changes in voltage or current.

Need to repeat a set of tests often? Instead of programming a number of parameters for each test every time you run the test, just use a few keystrokes to save a test setup once and then recall it whenever you need it. Take advantage of 40 memory locations to save up to 40 set ups or use the Series 2200 List mode to define custom test sequences of up to 80 steps. This makes it easy to perform tests such as analyzing how your circuit- or device-under-test performs at each voltage level within a range of voltages. A saved test can be run manually using front panel key strokes, automatically using external trigger signals, or remotely using programmable interface commands. Up to seven 80-step lists can be stored in a Series 2200 single-channel power supply. Each step can have a programmable duration.

Protects Your DUT at All Times

A number of features are built into the Series 2200 power supplies to ensure that your DUT is protected from damage. A maximum voltage can be set so that regardless of the voltage value requested, the output will not exceed the programmed limit value. For further voltage magnitude protection, an Over Voltage protection level can be programmed that will cause the output to drop below 1V if the Over Voltage limit is reached. These protections are in addition to the Current Limit setting, which restricts the amount of current that can flow into the DUT. If the Current Limit is reached, the Series

1.888.KEITHLEY (U.S. only)

www.keithley.com

KEITHLEY

A Tektronix Company

A Greater Measure of Confidence

Series 2200

3-Year
Warranty

Ordering Information

2200-20-5 Programmable DC Power Supply, 20V, 5A

2200-30-5 Programmable DC Power Supply, 30V, 5A

2200-32-3 Programmable DC Power Supply, 32V, 3A

2200-60-2 Programmable DC Power Supply, 60V, 2.5A

2200-72-1 Programmable DC Power Supply, 72V, 1.2A

Accessories Supplied

213-CON Rear Panel Mating Connector with Handle

CS-1638-12 Rear Panel Mating Connector

Documentation and Driver CD

ACCESSORIES AVAILABLE

CS-1638-12	Rear Panel Mating Connector
KPCI-488LPA	IEEE-488.2 Interface Board for the PCI Bus
USB-B-1	USB Cable
4299-7	Fixed Rack Mount Kit
7007-05	Double Shielded Premium IEEE-488 Interface Cables, 0.5m (1.6 ft)
7007-1	Double Shielded Premium IEEE-488 Interface Cables, 1m (3.2 ft)
7007-2	Double Shielded Premium IEEE-488 Interface Cables, 2m (6.5 ft)
7007-3	Double Shielded Premium IEEE-488 Interface Cables, 3m (10 ft)
7007-4	Double Shielded Premium IEEE-488 Interface Cables, 4m (13 ft)

SERVICES AVAILABLE

Model Number-EW (Example: 2200-20-5-EW)	1 additional year of factory warranty
C/Model Number-3Y-STD	3 calibrations within 3 years of purchase
C/Model Number-3Y-DATA	3 (ANSI-Z540-1 compliant) calibrations within 3 years of purchase
C/Model Number-5Y-STD	5 calibrations within 5 years of purchase
C/Model Number-5Y-DATA	5 (ANSI-Z540-1 compliant) calibrations within 5 years of purchase

Single-Channel Programmable DC Power Supplies

2200 power supplies convert from constant voltage to constant current operation in which the current is controlled at the Current Limit setting and the voltage varies based on the load resistance.

In addition to the limit settings, you can set a timer to turn off the output after a specified time interval, allowing you to setup a test on your bench and let it to run unattended knowing that power will automatically be removed from the DUT after the programmed time has elapsed.

Ensures that Test Parameters are Not Accidentally Changed

Prevent accidental changes to settings to avoid collecting incorrect test data and wasting time repeating tests by taking advantage of the Series 2200's front panel lock-out functions. You can disable the front panel knob or disable all the front panel data entry controls. When all the front panel data entry keys are disabled, the Series 2200 prompts for a password to re-activate the keys.

Select a Convenient Interface

The Series 2200 DC power supplies can be an integral part of your automated test system. You have the option to control each power supply over a GPIB interface or a USB interface. The USB interface is test and measurement class (TMC) compliant so you can use the standard SCPI command syntax. Standard drivers are included with the Series 2200 to simplify interfacing them into an automated test environment.

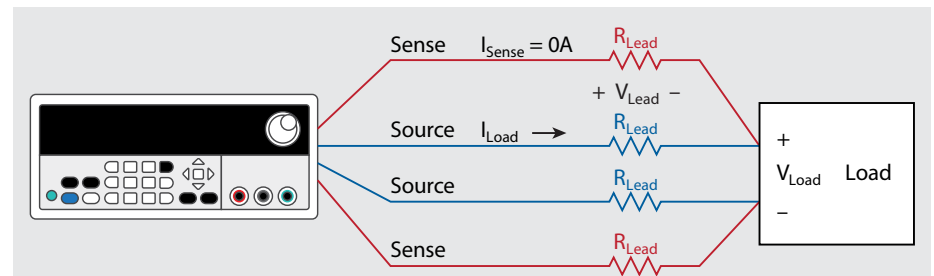

No matter how accurate your power supply output is, you cannot guarantee that the programmed output voltage is the same as the voltage at the DUT's load. This is because a power supply with two source output terminals regulates its output only at its output terminals. However, the voltage you want regulated is at the DUT's load, not at the power supply's output terminals. The power supply and the load are separated by lead wires that have a resistance, R_{Lead} , determined by the length of the lead, the conductivity of the conductor material, and the geometry of the conductor. The voltage at the load is: $V_{Load} = V_{Programmed} - 2 * V_{Lead} = V_{Programmed} - 2 * I_{Load} * R_{Lead}$. If the load requires high current, then I_{Load} is high and V_{Lead} can easily be a few tenths of a volt, especially if the power supply leads are long, as can be the case in an automated test rack. A voltage at the load could be 80mV to 160mV lower than the desired voltage (with 2A to 4A flowing through a 16-gauge wire).

The remote sensing technique solves the problem of voltage drop in the leads by extending the power supply feedback loop to the input of the load. Two sense lines from the power supply are connected to the power inputs. These sense leads are voltage measuring lines that connect to a high impedance voltage measuring circuit in the power supply. Since the voltage measuring circuit is a high input impedance circuit, the voltage drop in the sense leads is negligible. The sense lead voltage measurement circuit becomes the feedback control loop for the power supply. The voltage at the load is fed back to the power supply by the sense leads. The power supply raises its output to overcome the voltage drop in the source leads and $V_{Load} = V_{Programmed}$.

Thus, only with remote sensing can the accuracy of the power supply be applied to the load.

1.888.KEITHLEY (U.S. only)

www.keithley.com

A Greater Measure of Confidence

KEITHLEY

A Tektronix Company

Single-channel programmable DC power supplies

DC POWER SUPPLIES

Series 2200

Single-Channel Programmable DC Power Supplies

	2200-20-5	2200-30-5	2200-32-3	2200-60-2	2200-72-1
DC OUTPUT RATING					
Voltage	0 to 20 V	0 to 30 V	0 to 32 V	0 to 60 V	0 to 72 V
Current	0 to 5 A	0 to 5 A	0 to 3 A	0 to 2.5 A	0 to 1.2 A
MAXIMUM POWER	100 W	150 W	96 W	150 W	86 W
LOAD REGULATION					
Voltage	<0.01% + 2 mV	<0.01% + 2 mV	<0.01% + 2 mV	<0.01% + 2 mV	<0.01% + 2 mV
Current	<0.05% + 0.1 mA	<0.05% + 1.5 mA	<0.05% + 0.1 mA	<0.05% + 0.5 mA	<0.05% + 0.5 mA
LINE REGULATION					
Voltage	< 0.01% + 1 mV	<0.01% + 1 mV	<0.01% + 1 mV	<0.01% + 2 mV	<0.01% + 1 mV
Current	<0.05% + 0.1 mA	<0.05% + 0.1 mA	<0.05% + 0.1 mA	<0.05% + 0.05 mA	<0.05% + 0.1 mA
RIPPLE AND NOISE (20 Hz to 7 MHz)					
Voltage	<1 mV _{RMS} <3 mV _{P-P}	<1 mV _{RMS} <4 mV _{P-P}	<1 mV _{RMS} <4 mV _{P-P}	<1 mV _{RMS} <5 mV _{P-P}	<1 mV _{RMS} <3 mV _{P-P}
Current	<3 mA _{RMS}	<4 mA _{RMS}	<3 mA _{RMS}	<3 mA _{RMS}	<3 mA _{RMS}
SETTING RESOLUTION					
Voltage	1 mV	1 mV	1 mV	1 mV	1 mV
Current	0.1 mA	0.1 mA	0.1 mA	0.1 mA	0.1 mA
SETTING ACCURACY (using remote sense, 25°C ± 5°C)					
Voltage	±0.03% + 3 mV	±0.03% + 3 mV	±0.03% + 3 mV	±0.03% + 6 mV	±0.03% + 6 mV
Current	±0.05% + 2 mA	±0.05% + 2.5 mA	±0.05% + 2 mA	±0.05% + 1.5 mA	±0.05% + 1 mA
READBACK RESOLUTION					
Voltage	1 mV	1 mV	1 mV	1 mV	1 mV
Current	0.1 mA	0.1 mA	0.1 mA	0.1 mA	0.1 mA
READBACK ACCURACY (25°C ± 5°C)					
Voltage	0.02% + 3 mV	±0.02% + 2.5 mV	±0.02% + 3 mV	±0.02% + 6 mV	±0.02% + 5 mV
Current	±0.05% + 2 mA	±0.05% + 2.5 mA	±0.05% + 2 mA	±0.05% + 1.5 mA	±0.05% + 1 mA
VOLTAGE TRANSIENT RESPONSE – SETTLING TIME					
Load Change	<400 μs to within 75 mV following a change from 0.1 A to 1A				
Setting Change	Rising	<35 ms from beginning of excursion to within 75 mV of terminal value following a change from 1 V to 11 V with a 1 A load (Note: Specification does not include command decode time)			
	Falling	<35 ms from beginning of excursion to within 75 mV of terminal value following a change from 11 V to 1 V with a 1 A load (Note: Specification does not include command decode time)			
OVERVOLTAGE PROTECTION					
Range (typical)	1 V to 19 V	1 V to 29 V	1 V to 31 V	1 V to 59 V	1 V to 71 V
Accuracy	±0.5% + 0.5 V	±0.5% + 0.5 V	±0.5% + 0.5 V	±0.5% + 0.5 V	±0.5% + 0.5 V
Response Time (typical)	<10 ms	<10 ms	<10 ms	<10 ms	<10 ms

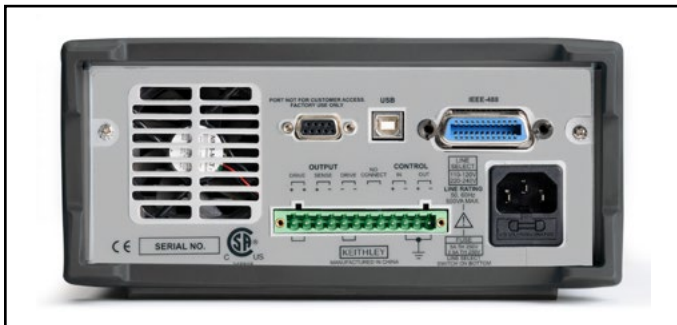

Series 2200 rear panel.

1.888.KEITHLEY (U.S. only)

www.keithley.com

KEITHLEY

A Tektronix Company

A Greater Measure of Confidence

Series 2200

Single-Channel Programmable DC Power Supplies

GENERAL

COMMUNICATIONS: USB: Type B connector, USB-TMC compatible.

GPIO: IEEE-488.2 compliant.

DISPLAY: Vacuum fluorescent display.

MEMORY: 40 setup memories.

LIST MODE: Up to seven lists can be defined, each with up to 80 steps. Each step includes a voltage limit and a current limit. For continuous sequences each step also includes a duration.

OUTPUT, SENSE, STATUS, AND CONTROL: Removable screw terminal block carries the following signals:

Output Channel: Duplicates the front panel outputs.

Remote Sense Lines: Connection for remote sense.

Control Input: Multifunction TTL input which can function as a trigger input, output control line, or digital input.

Status Output: Multifunction TTL output which can function as a fault indication, or digital output.

FLOATING VOLTAGE RATING: Up to 100V (DC + peak AC) between earth ground and any output terminal.

POWER SOURCE:

110V AC Setting: 99V_{RMS} to 132V_{RMS}.

220V AC Setting: 198V_{RMS} to 264V_{RMS}.

Frequency: 50/60Hz.

Power Consumption: 2200-20-5, 2200-32-3, 2200-72-1: 250VA.

 2200-30-5, 2200-60-2: 350VA.

EMC:

European Union: EN 55011, Class A; IEC 61000-3-2; IEC 61000-3-3, IEC 61000-4-2, IEC 61000-4-3, IEC 61000-4-4, IEC 61000-4-5, IEC 61000-4-6, IEC 61000-4-8, IEC 61000-4-11.

USA: FCC, CFR Title 47, Part 15, Subpart B, Class A.

Australia: EMC Framework, demonstrated per Emission Standard AS/NZS 2064 (industrial, scientific, and medical equipment).

SAFETY:

European Union: Low voltage directive 2006/95/EC; EN61010-1 2001.

USA: Nationally recognized testing laboratory listing UL61010-1-2004.

Canada: CAN/CSA C22.2 No. 61010-1 2004.

DIMENSIONS:

With Boot: 106mm high × 242mm wide × 384mm deep (4.15 in × 9.52 in × 15.12 in).

Without Boot: 91mm high × 218mm wide × 362mm deep (3.57 in × 8.55 in × 14.24 in).

SHIPPING WEIGHT: 2200-20-5, 2200-32-3, 2200-72-1: 9.0kg.

 2200-30-5, 2200-60-2: 9.6kg.

NET WEIGHT: 2200-20-5, 2200-30-5, 2200-32-3, 2200-72-1: 7.3kg.

 2200-60-2: 7.0kg.

ENVIRONMENT:

Altitude: Operating: Up to 2,000m above sea level.

Storage: Up to 4,000m above sea level.

Operating: 0° to +40°C, 5% to 95% R.H. up to +40°C.

Storage: -20° to +70°C, 5% to 95% R.H. up to +40°C.

 -20° to +70°C, 5% to 60% R.H. above +40°C up to +70°C.

1.888.KEITHLEY (U.S. only)

www.keithley.com

A Greater Measure of Confidence

KEITHLEY

A Tektronix Company

Series 2200 specifications

DC POWER SUPPLIES

2220 2230

Multi-Channel Programmable DC Power Supplies



- **Dual and triple output models with two 30V/1.5A (45W) channels and a 6V/5A (30W) channel on the triple output supply**
- **All channels are independently controlled and have isolated outputs for maximum flexibility**
- **All channels have remote sensing to ensure that programmed voltage is accurately applied to the load**
- **Two 30V channels can be combined either in series to double output voltage or in parallel to double output current**
- **0.03% basic voltage output accuracy and 0.1% current accuracy ensure quality test data**
- **Low noise, linear regulation with <math><3\text{mVpp}</math> ripple and noise**
- **Voltage and current outputs for all channels are displayed simultaneously for easy observation of each output state**
- **Keypad entry allows fast, precise entry of output values**
- **Standard USB interface for automated testing**

The Models 2220 and 2230 Multi-Channel Programmable DC Power Supplies combine two and three channels of output power to cost-effectively characterize and test a wide range of devices, circuit boards, modules, and products that require more than one power source. The Model 2220-30-1 supply provides two channels, with each channel capable of outputting up to 30V and up to 1.5A. The Model 2230-30-1 includes two 30V/1.5A channels and adds a 6V channel with up to 5A output for powering digital circuits. The Models 2220 and 2230 Multi-Channel Power Supplies offer an excellent combination of performance, versatility, and ease of use to maximize the information from characterization or test as quickly and as easily as possible. They perform as effectively in automated test systems as they do in manual instrument configurations.

Independent and Isolated Outputs

Since each channel in the Models 2220 and 2230 Multi-Channel Power Supplies is completely independent and isolated from each other, these power supplies can be used to provide power to two circuits that are optically isolated or transformer-isolated from each other and have different reference points. Their isolated channels eliminate the need for a second power supply to power one of the isolated circuits.

Additionally, each channel can be independently controlled, so channels can be individually turned on and turned off at any time. Thus, these power supplies can be used to power up a circuit with multiple voltage levels (such as a digital circuit) that must be turned on in a specified time sequence. Furthermore, the timer capability allows you to set up unattended tests that turn off the channels after a programmed time interval to protect a device-under-test (DUT) from potential damage due to the continuous application of power beyond a recommended time interval. Both isolated and independent channels provide excellent versatility and flexibility to address a wide range of test applications.

Accurate Power Delivery to the Load

With basic voltage setting accuracy and voltage readback accuracy of 0.03% for each channel, the exact voltage programmed for any channel is applied at the output terminals. Plus, the rear panel connections for each channel include remote sense terminals that compensate for voltage drops in the power supply leads. This helps to ensure that the correct voltage is delivered accurately to the load terminals of the DUT. Many other multi-channel power supplies do not provide remote sensing, which reduces overall system accuracy.

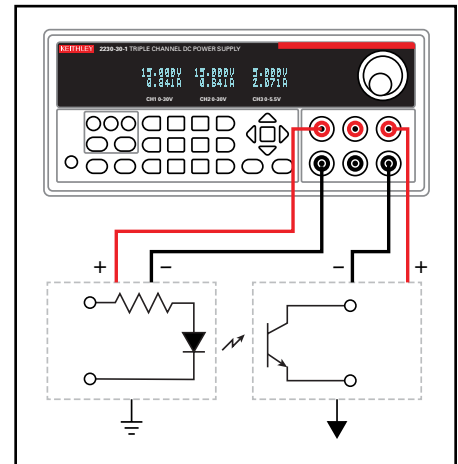

Power two isolated circuits with isolated output channels.

1.888.KEITHLEY (U.S. only)

www.keithley.com

KEITHLEY

A Tektronix Company

A Greater Measure of Confidence

2220 2230

Ordering Information

- 2220-30-1**
Programmable Dual Channel DC Power Supply
- 2220J-30-1**
Programmable Dual Channel DC Power Supply for Japan
- 2230-30-1**
Programmable Triple Channel DC Power Supply
- 2230J-30-1**
Programmable Triple Channel DC Power Supply for Japan

Accessories Supplied

CS-1655-15 Rear Panel Mating Connector for Models 2220 and 2230 Multi-Channel Power Supplies
Documentation and Driver CD

ACCESSORIES AVAILABLE

CS-1655-15	Rear Panel Mating Connector for Series 2200 Power Supplies
4299-7	Fixed Rack Mount Kit

SERVICES AVAILABLE

2220-30-1-EW	1 additional year of factory warranty
C/2220-30-1-3Y-STD	3 calibrations within 3 years of purchase
C/2220-30-1-3Y-DATA	3 (ANSI-Z540-1 compliant) calibrations within 3 years of purchase
C/2220-30-1-5Y-STD	5 calibrations within 5 years of purchase
C/2220-30-1-5Y-DATA	5 (ANSI-Z540-1 compliant) calibrations within 5 years of purchase
2230-30-1-EW	1 additional year of factory warranty
C/2230-30-1-3Y-STD	3 calibrations within 3 years of purchase
C/2230-30-1-3Y-DATA	3 (ANSI-Z540-1 compliant) calibrations within 3 years of purchase
C/2230-30-1-5Y-STD	5 calibrations within 5 years of purchase
C/2230-30-1-5Y-DATA	5 (ANSI-Z540-1 compliant) calibrations within 5 years of purchase

Note: For Japan versions, include a "J" in the model number (example: 2230J-30-1-EW)

Multi-Channel Programmable DC Power Supplies

Great accuracy is not limited to voltage; the basic current setting and readback accuracy is 0.1%, providing high quality load current measurements. Also, with less than 3mV p-p noise, the power applied to the DUT's load terminals is both accurate and of high quality.

Excellent accuracy, remote sensing, and a wide power output range make the Series 2200 Multi-Channel Power Supplies essential test instruments both on the bench and in test systems. Their ability to generate a wide range of output power and measure a wide range of load currents is supported with:

- Maximum output power of 45W on the 30V channels
- Maximum output power of 30W on the 6V channel
- Voltage setting and reading resolution of 1mV
- Current setting and reading resolution of 1mA

Configure the Channels to Double Output Voltage or Current or Create Bipolar Power Supplies

The two 30V channels can be combined if more than 30V or more than 1.5A is required. The two 30V outputs can be wired in series to enable an output of 60V with a maximum current output of 1.5A or can be wired in parallel to get up to 3A at 30V. In series or parallel configurations, the power supplies offer special display modes that indicate the actual voltage and current for the combined pair. It's also easy to wire the outputs to make a $\pm 30V$ bipolar supply, and to maintain a user-defined ratio between the two outputs when using Tracking mode. These modes of operation extend the performance of the power supplies, while the display shows the actual outputs in these special modes to avoid any confusion or incorrect interpretation of the displayed data.

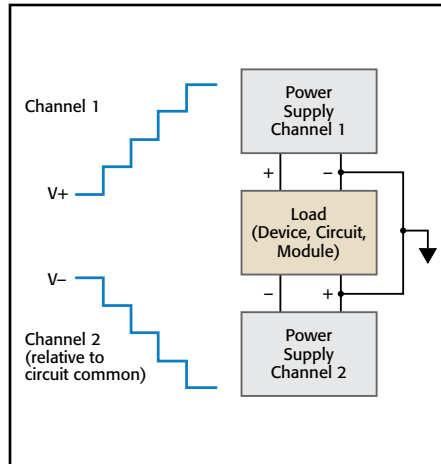

Use the two 30V channels to test a bipolar integrated circuit or a bipolar module over its specified voltage operating range.

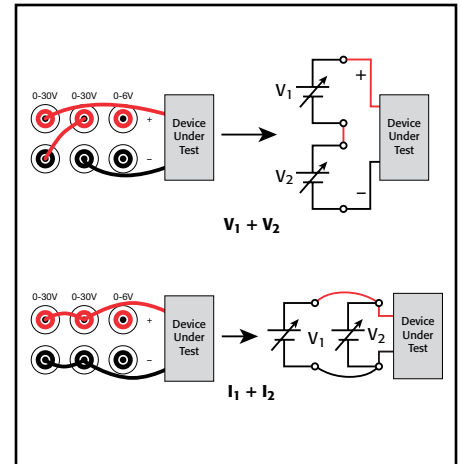

Combine two channels in series to output up to 60V or combine two channels in parallel to output up to 3A. The Model 2220/2230 display will show the combined value.

Convenience Features Help Get Results More Quickly

The Models 2220 and 2230 Multi-Channel Power Supplies offer a number of features that return results quickly and easily:

- A rotary knob, with user-selectable step size, makes it easy to check circuit response to changing voltage or current. Alternatively, a direct-entry numeric keypad can be used to simplify setting precise voltage and current values.
- Each channel has its own readout on the display. The voltage and current being delivered to each channel are visible at a glance. A bright vacuum fluorescent display provides excellent readability

1.888.KEITHLEY (U.S. only)

www.keithley.com

KEITHLEY

A Greater Measure of Confidence

A Tektronix Company

2220 2230

Multi-Channel Programmable DC Power Supplies

at a distance, at an angle, or under dim lighting conditions.

- To save time when repeating tests, instrument settings can be saved in one of 30 internal memory locations by simply pressing the Save button. To recall that setting, just push the Recall button, and choose the desired setup.

Protection for Your Device-Under-Test

The Models 2220 and 2230 Multi-Channel Power Supplies include maximum voltage settings that prevent voltage from being accidentally adjusted above user-specified limits. Independent outputs allow a different limit to be specified for each output channel. With the numeric keypad, a current limit can be quickly and precisely specified before a test is started. In addition, a user-definable password allows the front panel to be locked to prevent unwanted adjustment during critical tests.

Easy Test Automation

Each of these power supplies includes a USB TMC-compliant device port, enabling PC control from a user-preferred programming environment. For basic instrument control, data logging, and analysis, the Models 2220 and 2230 Multi-Channel Power Supplies can be controlled by Tektronix Edition LabVIEW SignalExpress™ from National Instruments. SignalExpress supports a wide range of Tektronix bench instruments* and can be used to automate the entire test bench or test system. The features in each instrument are accessible from one intuitive software interface that can automate complex measurements that require multiple instruments and easily capture and analyze results—all from the user's PC.

*For a complete listing of Tektronix instruments supported by Tektronix LabVIEW Signal Express, visit www.tektronix.com/signalexpress.

APPLICATIONS

Series 2200 Multi-Channel Power Supplies typical applications include:

- Circuit design
- Electrical engineering student labs
- Materials research
- Automated test

Specifications

	2230-30-1, 2230J-30-1			2220-30-1, 2230J-30-1	
DC OUTPUT RATING					
Voltage	0 to 30 V	0 to 30 V	0 to 6 V	0 to 30 V	0 to 30 V
Current	0 to 1.5 A	0 to 1.5 A	0 to 5 A	0 to 1.5 A	0 to 1.5 A
MAXIMUM POWER	120 W			90 W	
LOAD REGULATION					
Voltage	< 0.01% + 3 mV	< 0.01% + 3 mV	< 0.01% + 3 mV	< 0.01% + 3 mV	< 0.01% + 3 mV
Current	< 0.01% + 3 mA	< 0.01% + 3 mA	< 0.01% + 3 mA	< 0.01% + 3 mA	< 0.01% + 3 mA
LINE REGULATION					
Voltage	< 0.01% + 3 mV	< 0.01% + 3 mV	< 0.01% + 3 mV	< 0.01% + 3 mV	< 0.01% + 3 mV
Current	< 0.1% + 3 mA	< 0.1% + 3 mA	< 0.1% + 3 mA	< 0.1% + 3 mA	< 0.1% + 3 mA
RIPPLE AND NOISE					
Voltage (7MHz)	< 1 mV rms < 3 mV p-p	< 1 mV rms < 3 mV p-p	< 1 mV rms < 3 mV p-p	< 1 mV rms < 3 mV p-p	< 1 mV rms < 3 mV p-p
Current (20MHz)	< 5 mA rms	< 5 mA rms	< 6 mA rms	< 5 mA rms	< 5 mA rms
SETTING RESOLUTION					
Voltage	1 mV	1 mV	1 mV	1 mV	1 mV
Current	1 mA	1 mA	1 mA	1 mA	1 mA
SETTING ACCURACY					
Voltage	± 0.03% + 10 mV	± 0.03% + 10 mV	± 0.03% + 10 mV	± 0.03% + 10 mV	± 0.03% + 10 mV
Current	± 0.1% + 5 mA	± 0.1% + 5 mA	± 0.1% + 5 mA	± 0.1% + 5 mA	± 0.1% + 5 mA
METER RESOLUTION					
Voltage	1 mV	1 mV	1 mV	1 mV	1 mV
Current	1 mA	1 mA	1 mA	1 mA	1 mA
METER ACCURACY					
Voltage	± 0.03% + 10 mV	± 0.03% + 10 mV	± 0.03% + 10 mV	± 0.03% + 10 mV	± 0.03% + 10 mV
Current	± 0.1% + 5 mA	± 0.1% + 5 mA	± 0.1% + 5 mA	± 0.1% + 5 mA	± 0.1% + 5 mA

ISOLATION VOLTAGE, OUTPUT TO CHASSIS: Any output can be floated up to 240V (DC + peak AC with AC limited to a maximum of 3Vpk-pk and a maximum frequency of 60Hz) relative to earth ground terminal.

ISOLATION VOLTAGE, OUTPUT TO OUTPUT: Any output can be floated up to 240V (DC + peak AC with AC limited to a maximum of 3Vpk-pk and a maximum frequency of 60Hz) relative to any other output terminal.

VOLTAGE TRANSIENT RESPONSE SETTling TIME, LOAD CHANGE (typical): <150ms to within 75mV following a change from 0.1A to 1A.

VOLTAGE TRANSIENT RESPONSE SETTling TIME, SETTING CHANGE, RISING (typical): <150ms to within 75mV following a change from 1V to 11V into a 10Ω resistor (Ch. 1, 2); from 0.4V to 4V into a 4Ω resistor (ch. 3.)

VOLTAGE TRANSIENT RESPONSE SETTling TIME, SETTING CHANGE, FALLING (typical): <150ms to within 75mV following a change from 11V to 1V into a 10Ω resistor (Ch. 1, 2); from 0.4V to 4V into a 4Ω resistor (ch. 3.)

DISPLAY: Vacuum fluorescent display.

MEMORY: 30 setup memories.

TRACKING AND COMBINATION MODES:

Tracking Mode: Maintains the ratio on the two 30V output channels that is present when the control is activated.

Combination V1+V2 Series Mode: Deliver up to 60 V when CH1 and CH2 are wired in series. Meter reads back combined voltage.

Combination I1+I2 Parallel Mode: Deliver up to 3 A when CH1 and CH2 are wired in parallel. Meter reads back combined current.

REAR PANEL CONNECTIONS: USB Device Port, Type B connector, USBTMC compatible.

POWER SOURCE

110VAC SETTING: Standard Versions: 99 to 121V rms. Japan (J) Versions: 90 to 110V rms.

220VAC SETTING: Standard Versions: 198 to 242V rms. Japan (J) Versions: 180 to 220V rms.

FREQUENCY: 47Hz to 63Hz.

POWER CONSUMPTION: Standard Versions: 450VA. Japan (J) Versions: 450VA.

PHYSICAL CHARACTERISTICS

PROTECTIVE BOOTS AND HANDLE INSTALLED:

Height: 105.3mm (4.15 in.)

Width: 241.8mm (9.52 in.)

Depth: 384.0mm (15.12 in.)

PROTECTIVE BOOTS AND HANDLE REMOVED:

Height: 90.7mm (3.57 in.)

Width: 217.2mm (8.55 in.)

Depth: 361.6mm (14.24 in.)

NET WEIGHT:

2220-30-1: 8.2 kg (18 lb.)

2230-30-1: 8.5 kg (19 lb.)

SHIPPING WEIGHT:

2220-30-1: 11 kg (24 lb.)

2230-30-1: 11 kg (24 lb.)

1.888.KEITHLEY (U.S. only)

www.keithley.com

KEITHLEY

2220 2230

Multi-Channel Programmable DC Power Supplies

ENVIRONMENTAL AND SAFETY

Temperature: **Operating:** 0° to +40°C.
Storage: -20° to +70°C.

Relative Humidity (non-condensing):

Operating: 5% to 95% relative humidity at up to +40°C

Storage: 5% to 95% relative humidity at up to +40°C. 5% to 60% RH above +40°C up to +70°C, non condensing.

Altitude:

Operating: Up to 2000m.

Storage: Up to 4000m.

Safety:

European Union: Complies with European Union EMC Directive.

USA: Nationally recognized testing laboratory listing UL61010-1-2004.

Canada: CAN/CSA C22.2 No. 61010-1-2004.

ELECTROMAGNETIC COMPATIBILITY

European Union: Complies with European Union Low Voltage Directive.

Australia: EMC Framework, demonstrated per Emission Standard AS/NZS 2064 (Industrial, Scientific, and Medical Equipment).



Model 2220-30-1 rear panel.



Model 2230-30-1 rear panel.

Models 2220 and 2230 specifications

1.888.KEITHLEY (U.S. only)

www.keithley.com

A Greater Measure of Confidence

KEITHLEY

A Tektronix Company

DC POWER SUPPLIES

2308

Portable Device Battery/Charger Simulator



The Model 2308 Portable Device Battery/Charger Simulator is optimized for use in testing mobile phones and other portable, battery-operated devices. When a device-under-test (DUT) transitions nearly instantaneously from a sleep or standby mode to the full power transmit state, the Model 2308's rapid response to load changes means there's little transient voltage drop from the programmed output voltage and the output recovers quickly. This fast response is particularly critical when testing portable devices with a pulsed mode of operation because it allows the device to perform properly while it's being tested. In contrast, the slow-responding source voltage typical of conventional power supplies causes the DUT to perform improperly, leading to production yield problems and costly retesting.

The Model 2308 offers a complete solution for portable device sourcing and load current measurement. It has two independent power supply channels: one is optimized to simulate a battery; the second channel is optimized to perform like a charger for a rechargeable battery. The battery channel's variable output resistance can be used to simulate the internal resistance of a battery so design and test engineers can simulate a battery's output for testing devices under realistic operating conditions. This channel also sinks current to simulate a discharged battery. The charger channel can supply a voltage to test a portable device's battery charge control circuitry, with the battery channel acting as the discharged battery load.

In addition to maintaining output voltage levels under difficult load conditions, the Model 2308 can measure a wide dynamic range of load current levels and can measure narrow current pulses (or pulses as narrow as 50 μ s). That makes it ideal for characterizing device power consumption by making low-level sleep mode measurements as well as pulsed operating load currents.

Maximize production yield with fast response to load changes

Mobile phones, other portable devices (such as Bluetooth headsets, MP3 players, etc.), and RF components such as power amplifiers, power transistors, and transmitter modules experience large instantaneous load changes when they transition from a standby state to full power operation. For a mobile phone, the load current can change from a 100mA standby current to a 1A transmission current or a 10 \times (1000%) increase in the load current. The Model 2308 maintains a reliable, stable level of voltage output, even when the DUT produces large load current changes and/or has a pulsed operating mode.

The Model 2308's fast recovery from load changes helps prevent the causes of false failures and destroyed devices in production test as well as field failure quality problems due to compromised components. The Model 2308 assures you of a stable, constant voltage source to maximize production yield and minimize production retest and rework costs.

APPLICATIONS

- **Design and test of a wide range of consumer electronics, including:**
 - Mobile phones, mobile radios, cordless phones, and Bluetooth headsets
 - MP3 players, portable digital assistants (PDAs), digital cameras, GPS receivers, and notebook computers
- **Design and test of electronic components such as RFIC power amplifiers, RF power transistors, and baseband and wireless chipsets for portable wireless devices**

- **Specialized dual-channel power supply for design and testing of portable, battery-operated devices**
- **Ultra-fast response to pulsed load operation**
- **Speed-optimized command set reduces test times**
- **Variable output resistance for simulating an actual battery's output response**
- **Simulate a discharged battery and test charge control circuit performance with both a battery supply that can sink up to 3A and a charger supply**
- **Pulse peak, average, and baseline current measurements**
- **Integrating A/D converter for more precise measurements**
- **100nA current measurement sensitivity**
- **Analog output for complete load current waveform characterization**
- **Catch production wiring problems immediately with open sense-lead detection**
- **Built-in digital voltmeter**
- **Four built-in digital control lines**

1.888.KEITHLEY (U.S. only)

www.keithley.com

A Greater Measure of Confidence

KEITHLEY
A Tektronix Company

2308

Ordering Information

2308 Portable Device Battery/Charger Simulator

Accessories Supplied
CD with documentation, output connectors mating terminal (part no. CS-846)

ACCESSORIES AVAILABLE

- 2306-DISP Remote Display
- CS-846 Mating Output Connector
- SC-182 Low Inductance Coaxial Cable

IEEE-488 INTERFACE CONTROLLER CARDS

- KPCI-488LPA IEEE-488.2 Interface Board for the PCI bus
- KUSB-488B IEEE-488.2 USB-to-GPIB Interface Adapter for USB Port with built-in 2m (6.6ft) cable

IEEE-488 INTERFACE CABLES

- 7007-05 Double Shielded Premium IEEE-488 Cable, 0.5m (1.6ft)
- 7007-1 Double Shielded Premium IEEE-488 Cable, 1m (3.2ft)
- 7007-2 Double Shielded Premium IEEE-488 Cable, 2m (6.5ft)
- 7007-3 Double Shielded Premium IEEE-488 Cable, 3m (10ft)
- 7007-4 Double Shielded Premium IEEE-488 Cable, 4m (13ft)

RACK MOUNT KITS

- 4288-1 Single Fixed Rack Mount Kit
- 4288-2 Dual Fixed Rack Mount Kit

SERVICES AVAILABLE

- 2308-3Y-EW 1-Year Factory Warranty Extended to 3 Years for the Model 2308
- 2308-3Y-17025 3 (ISO-17025 Accredited) Calibrations within 3 Years of Purchase
- 2308-3Y-DATA 3 (ANSI-Z540-1 Compliant) Calibrations within 3 Years of Purchase

Model 2308 vs. Conventional Power Supplies

Large load changes will cause a large instantaneous drop in a conventional power supply's voltage output. If the supply's recovery time is long, the DUT will turn off when the supply voltage falls below the DUT's low battery turn-off threshold—producing a false failure. Even if the DUT does not turn off, the drop-off in input power prevents the output (RF or a power pulse) from meeting its specification—a specification failure. Furthermore, the conventional power supply may have an excessively large overshoot when the DUT's load current transitions from its operating load back to its standby load. The magnitude of the transient overshoot voltage could even be large enough to exceed the maximum safe input voltage, either rendering the device inoperable or damaging some components—a device failure or a field failure.

Portable Device Battery/Charger Simulator

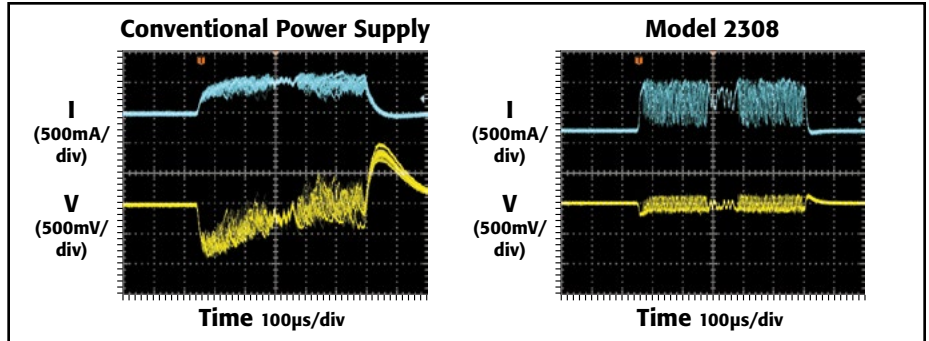

Compare the response of a conventional power supply (left) with the response of a Model 2308 (right) when both are powering a device operating on the EDGE mobile phone standard. Note how the conventional power supply distorts the load current and cannot maintain a stable source voltage, which in turn distorts the RF output signal.

Reduce test costs and increase throughput with high speed command structure

To minimize production test times while still giving you all the information you need to characterize your devices fully, the Model 2308 is designed with a command structure optimized for speed, with voltage step times as short as 6ms and DC load current measurements in just 22ms. Commands that combine range changing and current measurement let you acquire the command, make the measurement, and transfer the data in as little as 30ms. In addition, special operating modes, such as the pulse current step

mode, allow taking a number of measurements on a complex load current waveform with a single command.

Characterize load currents for power consumption verification

Characterizing the battery life of portable devices demands the ability to measure complex current waveforms over a wide dynamic range. The Model 2308 offers a far broader range of capabilities than conventional power supplies for measuring low current levels, peak pulse current levels, long-period load current waveforms, and multi-level current waveforms. A choice of four

Your DC source leads are a transmission line when your portable device operates in a narrow pulsed mode.

Under pulsed operating conditions, your load circuit is an L-C-R network and that load impedance can cause problems for your power supply. Keithley's fast transient power supplies are designed to maintain a stable voltage under difficult, narrow pulse, loading conditions and to maintain the output voltage, even with long lengths of wire between the power supply and the DUT. The design of your DC sourcing test circuit requires just as much effort as your AC or RF test circuits. Using a fast transient response, battery simulating power supply needs to be a key part of your DC test circuit design.

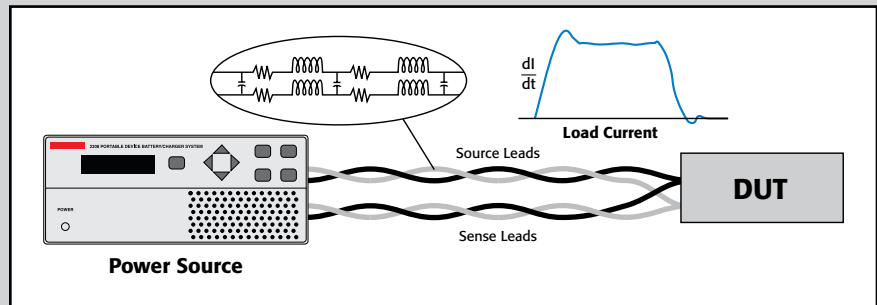

The DC source leads become a transmission line during dynamic load swings.

1.888.KEITHLEY (U.S. only)

www.keithley.com

A Greater Measure of Confidence

KEITHLEY

A Tektronix Company

Fast transient response power supply

DC POWER SUPPLIES

ranges (5mA, 50mA, 500mA, and 5A) allows measuring load currents with exceptional resolution and accuracy.

Measure sleep and standby currents with the accuracy of integrating A/D technology

The Model 2308 is designed for fast and accurate measurements of devices in low power modes such as the sleep, hibernate, or standby state. It can resolve currents down to 100nA and measure them with 0.2% accuracy. The Model 2308 uses an integrating A/D converter that continuously acquires the signal rather than capturing discrete samples; this provides a more accurate measurement than other A/D techniques. In addition, the averaging effect built into integrating A/D converters reduces noise and delivers highly stable current readings. You can measure low and high currents at the same speed with no degradation in accuracy, so the Model 2308 is equally well-suited for the test line and the design lab.

Measure load currents from pulsed-output devices

Devices like GSM-, EDGE-, WLAN-, and WiMAX-based mobile phones generate pulsed outputs. Determining their total power consumption requires measuring both the baseline current and the peak of the pulsed load current. The Model 2308 can capture peak currents of pulses as short as 50 μ s and as long as 833ms. Programmable trigger levels allow controlled capture of the pulse, then the Model 2308's programmable measurement delay and acquisition times make it easy to avoid rising edge transients so the pulse peak can be measured accurately. The instrument can also measure the pulse baseline current and the pulse average load current.

A long integration current mode supports measuring pulse trains with periods longer than 850ms. In this mode, the Model 2308 can measure average current on a load current waveform with a period from 850ms to 60 seconds.

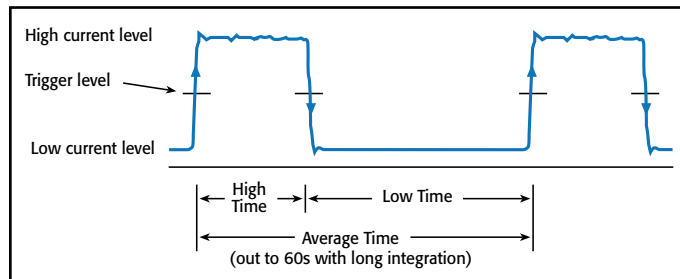

The Model 2308 can measure peak pulse currents, average currents, and baseline currents.

Take multiple measurements on start-up sequences or on current levels at different voltage operating levels

Need to analyze a device's circuitry during the power-up phase as it transitions from a sleep mode or an off-state? The Model 2308's pulse step current function has the speed needed to measure the load current start-up levels in a single device start-up so that the measurements can be performed in production without an increase in test time.

The pulse step current function also offers a fast way to determine load currents of different operating states. For example, as source voltage levels are varied over a device's operating range, the corresponding operating current levels can be measured without executing multiple commands for

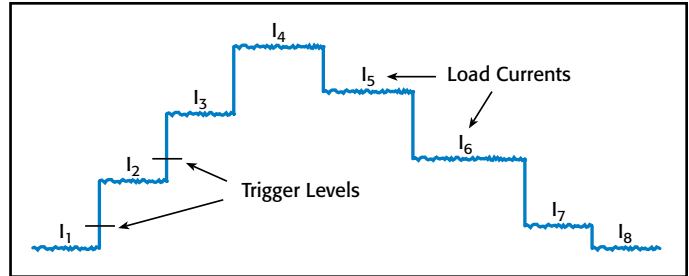

With a single command, the Model 2308's high speed pulse step current function can quickly capture varying load current levels to speed test throughput.

a significant time-savings when testing integrated circuits over their allowable range of Vcc levels.

Capture the complete load current waveform

Two built-in analog outputs help designers of device's verify design performance and ensure its current draw conforms to design specifications without the need to connect any sensing circuitry in the power supply circuit. Once these outputs are connected to an oscilloscope or a data acquisition module, the load current waveform can be displayed or digitized and analyzed in a computer. When the Model 2308 is connected to a data acquisition module, the data acquisition module can sample the waveform at any sampling rate to create a record of any length desired.

Test under realistic conditions with true battery simulation

When a portable battery-operated device transitions from one load current level to another, the battery voltage supplying the current will drop by the product of the change in current and the battery's internal resistance. During the load current pulse, the device must operate with a voltage reduced by the battery's internal resistance. The Model 2308 allows simulating this resistance so its output is almost identical to a battery's output, allowing design or production test engineers to test devices or components under realistic conditions. This patented¹ technique permits the output resistance to be programmed between 0 Ω and 1 Ω with 10m Ω resolution. You can also decrease the voltage and increase the output resistance while the output is on to simulate the discharge of the battery.

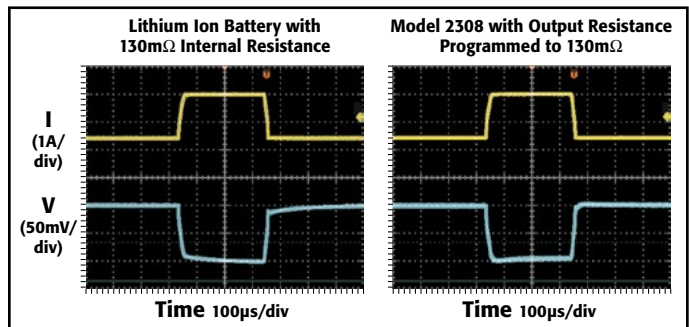

The Model 2308's programmable output resistance (right) allows it to simulate the output of a real battery (left), a capability conventional power supplies do not have. The 2308 output is identical to the battery's response.

1. U.S. Patent Number 6,204,647 B1

1.888.KEITHLEY (U.S. only)

www.keithley.com

KEITHLEY

A Greater Measure of Confidence

A Tektronix Company

Test a device's charge control circuitry

Both channels of the Model 2308 sink up to 3A of current continuously. Therefore, the battery channel can act like a discharged re-chargeable battery. The charger channel can supply a charging voltage for use in testing the operation of the DUT's charging control circuitry. Because the charger channel can also act as an electronic load, the battery channel can operate the device and the charger channel can act as a load to test a battery capacity monitor or some other device function that requires a load.

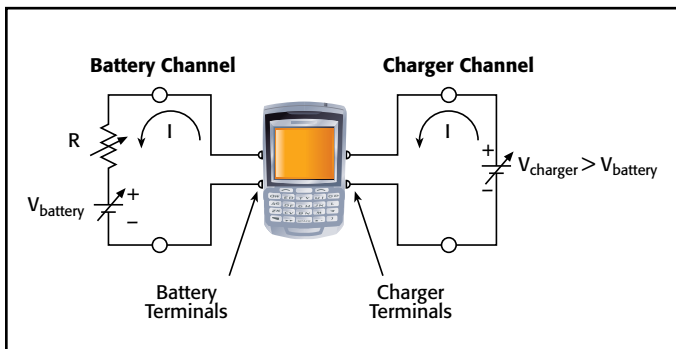

For charger control circuit testing, the Model 2308's battery channel can sink current to simulate a discharged battery while the charger channel simulates a charger. One instrument provides high versatility for portable device testing.

Reduce testing errors and retesting costs with remote sense lead monitoring

Remote sensing capabilities let the Model 2308 ensure the voltage programmed is what is actually applied to the load. As DUTs are continuously inserted and removed from test fixtures, the instrument ensures this programmed voltage is maintained with an open sense lead detection monitor—any break in a sense lead connection is detected immediately. The open sense lead detection monitor eliminates the possibility that numerous devices could be tested or calibrated at an incorrect voltage.

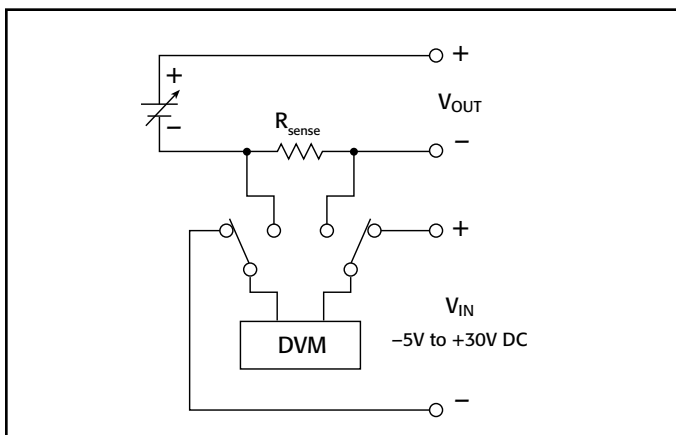

The Model 2308's charger channel contains a built-in DVM, eliminating the need for a separate instrument in many test systems.

Save with multiple instruments in one package – two power supplies, a DVM, digital controls, and a remote display

The Model 2308 saves on both instrumentation costs and rack space by packing two independent power supply channels in one compact, 2U half-rack enclosure, along with additional capabilities power supplies rarely offer. For example, the built-in DC digital voltmeter can measure voltages in the DUT circuitry from -5VDC to +30VDC. The DVM and the battery channel voltage source can operate simultaneously. For many applications, the Model 2308 can eliminate the need for a separate DMM.

The digital outputs the Model 2308 provides can sink up to 100mA to control relays. External relays can be powered either by the internal 5V source or an external source with a maximum voltage of 24V. For applications that require only a few digital control lines, the Model 2308 eliminates the need for an additional control module.

Need to reduce your test system size or want more system organization flexibility? Then mount the Model 2308 in the back of a test rack or near the test fixture—mounting the instrument in the test rack is unnecessary. The Model 2308's tiny (4.6 in. × 2.7 in.) remote display can be mounted anywhere for easy viewing of the outputs of both channels. If the Model 2308 is inaccessible, you can control it from the remote display because it has all the front panel pushbuttons that are on the instrument itself.



The Model 2306-DISP display can be mounted for easy viewing when the instrument itself must be mounted in an inaccessible location.

Reduce test system problems with low impedance cable

Keithley's SC-182 Low Inductance Coaxial Cable is designed to minimize the impedance and reduce the susceptibility to external EMI in your DC source-DUT circuit. This cable's characteristic impedance is nominally 15Ω with a low 42nH/ft of inductance and a low 182pF/ft of capacitance. In contrast, a typical coaxial cable has 50Ω or 75Ω characteristic impedance and twisted-wire pairs have at least 80Ω of characteristic impedance.

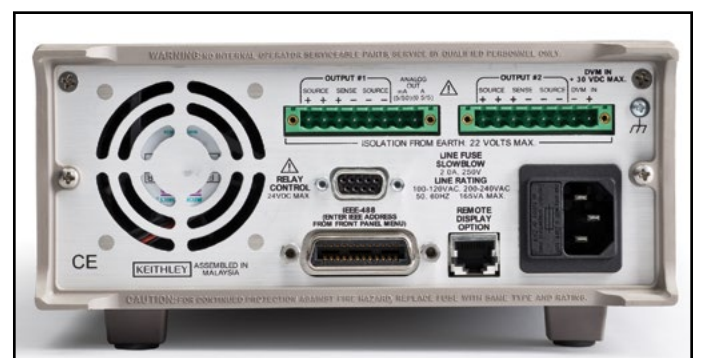

Model 2308 rear panel

1.888.KEITHLEY (U.S. only)

www.keithley.com

KEITHLEY

A Greater Measure of Confidence

A Tektronix Company

Fast transient response power supply

DC POWER SUPPLIES

OUTPUT #1 (Battery Channel):**DC VOLTAGE OUTPUT (1 Year, 23°C ± 5°C)**

OUTPUT VOLTAGE: 0 to +15VDC.

OUTPUT ACCURACY: (0.05% + 3mV).

PROGRAMMING RESOLUTION: 1mV.

READBACK ACCURACY¹: ±(0.05% + 3mV).

READBACK RESOLUTION: 1mV.

OUTPUT VOLTAGE SETTLING TIME: 5ms to within stated accuracy.

LOAD REGULATION: 0.01% + 2mV.

LINE REGULATION: 0.5mV.

STABILITY²: 0.01% + 0.5mV.MEASUREMENT TIME CHOICES: 0.002 to 10PLC³, in 0.002PLC steps.

AVERAGE READINGS: 1 to 10.

TRANSIENT RESPONSE: High Bandwidth Low Bandwidth

Transient Recovery Time ⁴	<35 μs ⁵	<50 μs ⁵
Transient Voltage Drop	<90 mV ⁵	<180 mV ⁵

REMOTE SENSE: 1V max. drop in each lead. Add 2mV to the voltage load regulation specification for each 1V change in the negative output lead due to load current change. Remote sense required. Integrity of connection continually monitored. If compromised, output will turn off automatically once settable window (±0 to ±8 volts) around normal voltage exceeded.

VARIABLE OUTPUT IMPEDANCE: Range: 0 to 1.00Ω in 0.01Ω steps. Value can be changed with output on.

NOTES

- At PLC (Power Line Cycle) = 1.
- Following 15 minute warm-up, the change in output over 8 hours under ambient temperature, constant load, and line operating conditions.
- PLC = Power Line Cycle. 1PLC = 16.7ms for 60Hz operation, 20ms for 50Hz operation.
- Recovery to within 20mV of previous level.
- Remote sense, at terminals 1 and 6, with 4.5m (15 feet) 16 AWG (1.31mm²) twisted pair, with 1.5A load change, (0.15A to 1.65A) resistive load only, typical.

DC CURRENT (1 Year, 23°C ± 5°C)**CONTINUOUS AVERAGE OUTPUT CURRENT**

CHANNEL #2 (CHARGER) OFF:

I = 50W/(V_{set} channel 1 + 6V); 5A max.¹

CHANNEL #2 (CHARGER) ON:

I = (50W – power consumed by channel #2)/(V_{set} channel 1 + 6V); 5A max.¹

The power consumed by channel #2 is calculated as:

Channel #2 Sourcing Current: Power consumed = (V_{set} channel 2 + 6V) × (current supplied).

Channel #2 Sinking Current: Power consumed = 5V × (sink current).

CONTINUOUS AVERAGE SINK CURRENT

CHANNEL #2 (CHARGER) OFF:

0–5V: 3A max.

5–15V: Derate 0.2A per volt above 5V. Compliance setting controls sinking.

CHANNEL #2 (CHARGER) ON:

Available Current = (50W – Power consumed by channel #2)/5V; 3A max. (0–5V).

Derate 0.2A per volt above 5V.

DC CURRENT (1 Year, 23°C ± 5°C) (continued)SOURCE COMPLIANCE ACCURACY: ±(0.16% + 5mA).²

PROGRAMMED SOURCE COMPLIANCE RESOLUTION: ±1.25mA.

READBACK ACCURACY: 5A Range: ±(0.2% + 200μA).

500mA Range: ±(0.2% + 100μA).

50 mA Range: ±(0.2% + 5μA).

5mA Range: ±(0.2% + 2μA).

READBACK RESOLUTION: 5A Range: 100μA.

500mA Range: 10μA.

50 mA Range: 1μA.

5mA Range: 0.1μA.

LOAD REGULATION: 0.01% + 1mA.

LINE REGULATION: 0.5mA.

STABILITY: 0.01% + 50μA.

MEASUREMENT TIME CHOICES: 0.002 to 10 PLC³, in 0.002PLC steps.

AVERAGE READINGS: 1 to 10.

NOTES

- Peak current can be a max. of 5A provided the average current is within the stated limits and terminals 1 and 6 are used.
- Minimum current in constant current mode is 6mA.
- PLC = Power Line Cycle. 1PLC = 16.7ms for 60Hz operation, 20ms for 50Hz operation.

PULSE CURRENT MEASUREMENT OPERATION

TRIGGER LEVEL: 5A Range: 0A to 5A, in 5mA steps.

500mA Range: 0mA to 500mA, in 0.5mA or 500μA steps.

50mA Range: 0mA to 50mA, in 0.05mA or 50μA steps.

5mA Range: 0mA to 5mA, in 0.005mA or 5μA steps.

TRIGGER DELAY: 0 to 100ms, in 10μs steps.

INTERNAL TRIGGER DELAY: 10μs.

HIGH/LOW/AVERAGE MODE: Measurement Aperture Settings: 33.3μs to 833ms, in 33.3μs steps. Average Readings: 1 to 100.

PULSE CURRENT MEASUREMENT ACCURACY¹ (1 Year, 23°C ± 5°C):

Accuracy ±(% reading + offset)

Aperture	5A Range	500mA Range	50mA Range	5mA Range
<100 μs	0.3% + 2 mA	0.3% + 1 mA	0.3% + 700 μA	0.3% + 200 μA
100 μs – 200 μs	0.3% + 2 mA	0.3% + 1 mA	0.3% + 700 μA	0.3% + 100 μA
200 μs – 500 μs	0.3% + 2 mA	0.3% + 1 mA	0.3% + 700 μA	0.3% + 100 μA
500 μs – <1 PLC	0.3% + 900 μA	0.3% + 900 μA	0.3% + 500 μA	0.3% + 90 μA
1 PLC ²	0.3% + 900 μA	0.3% + 900 μA	0.3% + 200 μA	0.3% + 90 μA
>1 PLC	0.3% + 900 μA	0.3% + 900 μA	0.3% + 200 μA	0.3% + 90 μA

NOTES

- Based on settled signal: 100μs pulse trigger delay.
- Also applies to other apertures that are integer multiples of 1PLC.

BURST MODE CURRENT MEASUREMENT

MEASUREMENT APERTURE: 33.3μs to 833ms, in 33.3μs steps.

CONVERSION RATE: 4100/second, typical.¹

INTERNAL TRIGGER DELAY: 10μs.

NUMBER OF SAMPLES: 1 to 5000.

TRANSFER SAMPLES ACROSS IEEE BUS IN BINARY MODE²: 4400 readings/s, typical (4 bytes per reading).**NOTES**

- At 33.3μs aperture.
- Display off, Message Exchange Protocol (MEP) off, auto zero off.

LONG INTEGRATION MODE CURRENT MEASUREMENT

MEASUREMENT TIME, 60Hz (50Hz): 850ms (840ms) to 60 seconds in 1ms steps.

ANALOG OUTPUT

5A/500mA OUTPUT: 1V/A ± 25mA (typical).

50mA/5mA OUTPUT: 1V/10mA ± 0.25mA (typical).

INTERNAL IMPEDANCE: 1000Ω (nominal).

1.888.KEITHLEY (U.S. only)

www.keithley.com

KEITHLEY

OUTPUT #2 (Charger Channel)**DC VOLTAGE OUTPUT (1 Year, 23°C ± 5°C)**

OUTPUT VOLTAGE: 0 to +15VDC.
 OUTPUT ACCURACY: $\pm(0.05\% + 10\text{mV})$.
 PROGRAMMING RESOLUTION: 10mV.
 READBACK ACCURACY¹: $\pm(0.05\% + 3\text{mV})$.
 READBACK RESOLUTION: 1mV.
 OUTPUT VOLTAGE SETTLING TIME: 5ms to within stated accuracy.
 LOAD REGULATION: 0.01% + 2mV.
 LINE REGULATION: 0.5mV.
 STABILITY²: 0.01% + 0.5mV.
 MEASUREMENT TIME CHOICES: 0.002 to 10 PLC³, in 0.002 PLC steps.
 AVERAGE READINGS: 1 to 10.

TRANSIENT RESPONSE:	High Bandwidth	Low Bandwidth
Transient Recovery Time ⁴	<50 μs^5	<60 μs^5
Transient Voltage Drop	<180 mV ⁵	<500 mV ⁵

REMOTE SENSE: 1V max. drop in each lead. Add 2mV to the voltage load regulation specification for each 1V change in the negative output lead due to load current change. Remote sense required. Integrity of connection continually monitored. If compromised, output will turn off automatically once settable window (± 0 to ± 8 volts) around normal voltage exceeded.

NOTES

- At 1PLC.
- Following 15 minute warm-up, the change in output over 8 hours under ambient temperature, constant load, and line operating conditions.
- PLC = Power Line Cycle. 1PLC = 16.7ms for 60Hz operation, 20ms for 50Hz operation.
- Recovery to within 20mV of previous level.
- Remote sense, with 4.5m (15 feet) of 16 AWG (1.31mm²) wire, 1.5A load change (0.15A to 1.65A), resistive load only.

DC CURRENT (1 YEAR, 23°C ± 5°C)**CONTINUOUS AVERAGE OUTPUT CURRENT****CHANNEL #1 (BATTERY) OFF:**

$I = 50\text{W}/(V_{\text{set}} \text{ channel } 2 + 6\text{V})$; 5A max.¹

CHANNEL #1 (BATTERY) ON:

$I = (50\text{W} - \text{power consumed by channel \#1}) / (V_{\text{set}} \text{ channel } 2 + 6\text{V})$; 5A max.¹

The power consumed by channel #1 is calculated as:

Channel #1 Sourcing Current: Power consumed = $(V_{\text{set}} \text{ channel } 1 + 6\text{V}) \times (\text{current supplied})$.

Channel #1 Sinking Current: Power consumed = $5\text{V} \times (\text{sink current})$.

CONTINUOUS AVERAGE SINK CURRENT**CHANNEL #1 (BATTERY) OFF:**

0–5V: 3A max.

5–15V: Derate 0.2A per volt above 5V. Compliance setting controls sinking.

CHANNEL #1 (BATTERY) ON:

Available Current = $(50\text{W} - \text{Power consumed by channel \#1}) / 5\text{V}$; 3A max. (0–5V)¹.

Derate 0.2A per volt above 5V.

DC CURRENT (1 YEAR, 23°C ± 5°C) (continued)

SOURCE COMPLIANCE ACCURACY: $\pm(0.16\% + 5\text{mA})$.²
 PROGRAMMED SOURCE COMPLIANCE RESOLUTION: $\pm 1.25\text{mA}$.
 READBACK ACCURACY: 5A Range: $\pm(0.2\% + 200\mu\text{A})$.
 5mA Range: $\pm(0.2\% + 2\mu\text{A})$.
 READBACK RESOLUTION: 5A Range: 100 μA .
 5mA Range: 0.1 μA .
 LOAD REGULATION: 0.01% + 1mA.
 LINE REGULATION: 0.5mA.
 STABILITY: 0.01% + 50 μA .
 MEASUREMENT TIME CHOICES: 0.002 to 10 PLC³, in 0.002 PLC steps.
 AVERAGE READINGS: 1 to 10.

NOTES

- Peak current can be a max. of 5A provided the average current is within the stated limits.
- Minimum current in constant current mode is 6mA.
- PLC = Power Line Cycle. 1PLC = 16.7ms for 60Hz operation, 20ms for 50Hz operation.

PULSE CURRENT MEASUREMENT OPERATION

TRIGGER LEVEL: 5A Range: 5mA to 5A, in 5mA steps.

TRIGGER DELAY: 0 to 100ms, in 10 μs steps.

INTERNAL TRIGGER DELAY: 10 μs .

HIGH/LOW/AVERAGE MODE:

Measurement Aperture Settings: 33.3 μs to 833ms, in 33.3 μs steps.

Average Readings: 1 to 100.

PULSE CURRENT MEASUREMENT ACCURACY¹ (1 Year, 23°C ± 5°C):
 Accuracy $\pm(\% \text{ reading} + \text{offset})$

Aperture	5A Range
<100 μs	0.3% + 2 mA
100 μs – 200 μs	0.3% + 2 mA
200 μs – 500 μs	0.3% + 2 mA
500 μs – <1 PLC	0.3% + 900 μA
1 PLC ²	0.3% + 900 μA
>1 PLC	0.3% + 900 μA

NOTES

- Based on settled signal: 100 μs pulse trigger delay.
- Also applies to other apertures that are integer multiples of 1PLC.

BURST MODE CURRENT MEASUREMENT

MEASUREMENT APERTURE: 33.3 μs to 833ms, in 33.3 μs steps.

CONVERSION RATE: 4100/second, typical.¹

INTERNAL TRIGGER DELAY: 10 μs .

NUMBER OF SAMPLES: 1 to 5000.

TRANSFER SAMPLES ACROSS IEEE BUS IN BINARY MODE²: 4400 readings/s, typical (4 bytes per reading).

NOTES

- At 33.3 μs aperture.
- Display off, Message Exchange Protocol (MEP) off, auto zero off.

OUTPUT #2 (Charger Channel) (continued)**LONG INTEGRATION MODE CURRENT MEASUREMENT**

MEASUREMENT TIME, 60Hz (50Hz): 850ms (840ms) to 60 seconds in 1ms steps.

DIGITAL VOLTMETER INPUT (1 Year, 23°C ± 5°C)

INPUT VOLTAGE RANGE: -5 to +30VDC.

INPUT IMPEDANCE: 2MΩ typical.

MAX. VOLTAGE (either input terminal) WITH RESPECT TO OUTPUT LOW: -5V, +30V.

READING ACCURACY: ±(0.05% + 3mV).

READING RESOLUTION: 1mV.

CONNECTOR: HI and LO input pair part of Output #2's terminal block.

MEASUREMENT TIME CHOICES: 0.002 to 10 PLC¹, in 0.002 PLC steps.

AVERAGE READINGS: 1 to 10.

NOTES

1. PLC = 1.00 Power Line Cycle.

Operating Speeds (Typical)

	Channel 1	Channel 2
Voltage Step Time ¹	6 ms	7 ms
DC Current Reading Time ^{1,2,3}	22 ms	22 ms
DC Current Range Change and Read Time ^{1,2,3}	27 ms	
Digital Voltmeter ^{1,2,3}		22 ms

NOTES

1. Display off, message exchange protocol (MEP) off, auto zero off.
2. PLC = 1 power line cycle.
3. Includes measurement and binary data transfer out of the GPIB port.

GENERAL

ISOLATION (LOW-EARTH): 22VDC max. Do not exceed 60VDC between any two terminals of either connector.

PROGRAMMING: IEEE-488.2 (SCPI).

USER-DEFINABLE POWER-UP STATES: 4.

REAR PANEL CONNECTORS: Two 8-position quick disconnect terminal blocks.

TEMPERATURE COEFFICIENT (outside 23°C ± 5°C): Derate accuracy specification by (0.1 × specification)/°C.

OPERATING TEMPERATURE: 0° to 50°C (derate to 70%). 0° to 35°C (Full power).

STORAGE TEMPERATURE: -20° to 70°C.

HUMIDITY: <80% @ 35°C non-condensing.

DISPLAY TYPE: 2-line × 16 character VFD.

REMOTE DISPLAY/KEYPAD OPTION: Disables standard front panel.

DIMENSIONS: 89mm high × 213mm wide × 411mm deep (3½ in × 8½ in × 16⅝ in).

NET WEIGHT: 3.2kg (7.1 lbs).

SHIPPING WEIGHT: 5.4kg (12 lbs).

INPUT POWER: 100–120VAC/220–240VAC, 50 or 60Hz (auto detected at power-up).

POWER CONSUMPTION: 150VA max.

EMC: Conforms with European Union Directive 2004/108/EC.

SAFETY: Conforms with European Union Directive 2006/95/EC, EN 61010-1.

AC LINE LEAKAGE CURRENT: 450µA @ 110VAC, typ.; 600µA @ 220V, typical.

RELAY CONTROL PORT: 4-channel, each capable of 100mA sink, 24V max. Total port sink capacity (all 4 combined) is 250mA max. Accepts DB-9 male plug. A source of +5VDC referenced to output common is also provided on the port to power external 5V relays.

1.888.KEITHLEY (U.S. only)

www.keithley.com

2302, 2302-PJ, 2306, 2306-PJ

Battery Simulator Battery/Charger Simulators



- Ultrafast response to transient load currents
- Choice of single- or dual-channel supplies
- Optimized for development and testing of battery-powered devices
- Variable output resistance for simulating battery response (U.S. Patent No. 6,204,647)
- Pulse peak, average, and baseline current measurements
- 100nA DC current sensitivity
- Current step measure function
- Sink up to 3A
- Open sense lead detection
- Built-in digital voltmeter

SERVICES AVAILABLE

2302-3Y-EW	1-year factory warranty extended to 3 years from date of shipment
2306-PJ-3Y-EW	1-year factory warranty extended to 3 years from date of shipment
2306-3Y-EW	1-year factory warranty extended to 3 years from date of shipment
2306-PJ-3Y-EW	1-year factory warranty extended to 3 years from date of shipment
C/2302-3Y-ISO	3 (ISO-17025 accredited) calibrations within 3 years of purchase for Model 2302, 2302-PJ
C/2306-3Y-ISO	3 (ISO-17025 accredited) calibrations within 3 years of purchase for Models 2306, 2306-PJ

to operate like a discharged rechargeable battery, sinking current from a separate charger or from the Model 2306's charger-simulator channel.

Maximize Test Throughput with Accurate Battery Simulation

The battery-output channels of the Models 2302 and 2306 are designed to simulate the output response of a battery. *This capability, combined with their fast transient response, makes it possible to power the device during testing in exactly the same way as a battery will power the device during actual use.* The output resistance of the Model 2302's and the Model 2306's battery channel can be programmed (with 10mΩ resolution) over the range from 0Ω to 1Ω so that the output resistance can be set to the same level as the output resistance of the battery that powers the device. See Figure 1.

Portable wireless devices make great demands on their battery power sources. The battery must source load currents that can jump virtually instantaneously from a standby current level (100–300mA) to a full-power RF transmission current level (1–3A). In other words, the load current on the battery can increase rapidly by a factor of 700–1000%. As a result, the battery voltage drops by an amount equal to the value of the current change multiplied by the battery's internal resistance. The Models 2302 and 2306 power supplies enable test systems to duplicate this voltage drop by programming their output resistance to be equivalent to that of the battery that will power the device. This allows wireless device manufacturers to test their products under the same power conditions that they will encounter in actual use. (See Figure 2.)

The single-channel Model 2302 Battery Simulator and dual-channel Model 2306 Battery/Charger Simulator were designed specifically for development and test applications of portable, battery-operated products, such as cellular and cordless telephones, mobile radios, and pagers. These precision power supplies have ultrafast transient response so they can have output characteristics identical to actual batteries. These supplies employ a unique variable output resistance so the voltage output can emulate a battery's response (U.S. Patent No. 6,204,647). They provide stable voltage outputs, even when a device-under-test (DUT) makes the rapid transition from the standby (low current) state to the RF transmission (high current) state. In addition, they can monitor DUT power consumption by measuring both DC currents and pulse load currents. The Model 2302's and the Model 2306's battery-simulator channel can be programmed

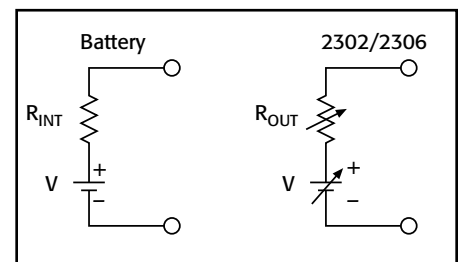

Figure 1. Simplified schematic of a battery and the 2302/2306.

ACCESSORIES AVAILABLE

2306-DISP	Remote Display
CS-846	Mating Output Connector

CABLES

7007-1	Shielded IEEE-488 Cable, 1m (3.3 ft)
7007-2	Shielded IEEE-488 Cable, 2m (6.6 ft)
SC-182	Low-Inductance Coaxial Cable (42nH/ft)

RACK MOUNT KITS

4288-1	Single Fixed Rack Mount Kit
4288-2	Dual Fixed Rack Mount Kit

IEEE-488 INTERFACES

KPCI-488LPA	IEEE-488 Interface/Controller for the PCI Bus
KUSB-488B	IEEE-488 USB-to-GPIB Interface Adapter

1.888.KEITHLEY (U.S. only)

www.keithley.com

A Greater Measure of Confidence

KEITHLEY

A Tektronix Company

2302, 2302-PJ, 2306, 2306-PJ

Ordering Information

- 2302** Battery Simulator
2302-PJ Battery Simulator with 500mA Range
2306 Dual-Channel Battery/Charger Simulator
2306-PJ Dual-Channel Battery/Charger Simulator with 500mA Range

Accessories Supplied

User and service manuals,
 CS-846 output connectors
 mating terminal

Conventional Power Supplies and Wireless Device Testing

During production testing, supplying power to a device that undergoes large, instantaneous load current changes can be extremely difficult. Changes like this force a conventional power supply's output voltage to fall instantaneously. When the power supply's control circuitry senses the error condition (the difference in voltage between the programmed level and the actual level), it attempts to correct or restore the voltage to the programmed level. During this time, the voltage will fall or droop substantially, with the amount of the droop depending on the size of the load current change. The recovery time depends on the transient response of the power supply's control loop. Conventional power supplies have transient voltage drops of >1V when confronted with load current changes of up to 1000%, and take up to a millisecond to recover to the programmed voltage. For portable devices such as cellular phones that operate at full power for only short intervals, the full power event is over before the conventional power supply can recover. For example, a cellular phone designed to the GSM cellular phone standard transmits and receives information in 576 μ s pulses. If the power supply used to test these types of phones cannot recover quickly enough, the performance of the phone during testing will be compromised by the power supply. If the power supply voltage drops below the threshold of the phone's low battery detection circuitry for long enough, then the phone will turn off during testing, giving a false indication of a failed device.

Battery Simulator Battery/Charger Simulators

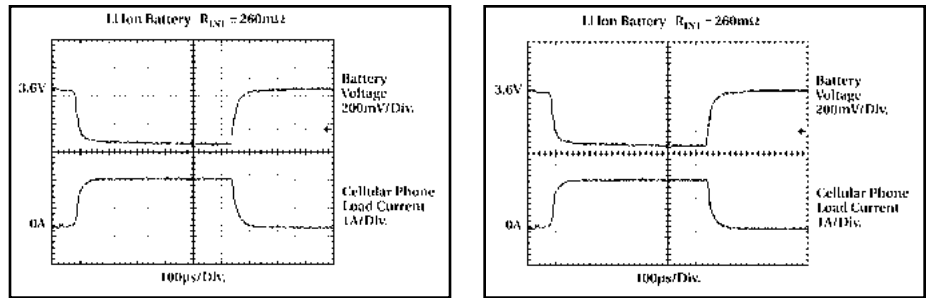

Figure 2. Comparison of the voltage outputs of a lithium-ion battery (with an internal resistance of 260m Ω) and the Model 2306's battery channel (programmed with an output resistance of 260m Ω) when powering a cellular telephone as it makes the transition from standby mode to transmit mode.

In response to large load changes, the Model 2302 and the battery channel of the Model 2306 have transient voltage droops of less than 100mV and transient recovery times of less than 60 μ s, even when the test leads between the power supply and the DUT are long. This fast transient response, combined with the supplies' variable output resistance, allows engineers to test their portable products under the most realistic operating conditions and eliminate false failures due to conventional power supplies with slow response times. (See the sidebar titled "Conventional Power Supplies and Wireless Device Testing.") These supplies also eliminate the large stabilizing capacitors needed at the DUT to compensate for the large droop that occurs when testing with conventional power supplies. By varying the output resistance, which can be done while the output is turned on, test engineers can simulate the operation of different battery types, as well as batteries nearing the end of their useful lives.

The Models 2302 and 2306 ensure maximum production throughput when testing portable

devices by minimizing false failures, minimizing the number of test setups by performing multiple tests with the same power supply, and minimizing test fixture complexity by eliminating the need for voltage-stabilizing capacitors.

Measure Load Currents for Power Consumption Verification or Analysis

As manufacturers of portable devices strive to extend their products' battery life, measuring load currents accurately has become increasingly essential in both design and production test in order to ensure the product meets its demanding specifications. Comprehensive testing of these devices requires measuring peak currents, average currents, and baseline currents in various operation modes. When testing these devices, these measurements are complicated by the pulsating nature of load currents, such as the transmit and receive load currents of digital cellular phones. The Models 2302 and 2306 can measure the peak and average currents of pulses as short as 60 μ s and as long as 833ms. (See **Figure 3**.)

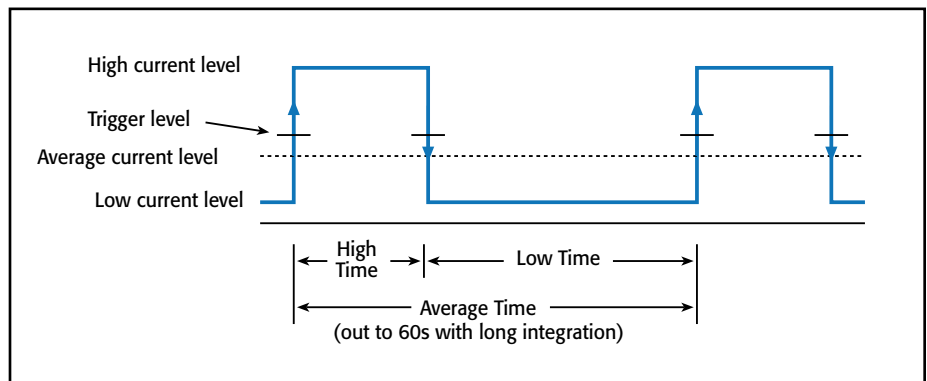

Figure 3. Built-in pulse current measurement functions allow test engineers to measure peak, average, and baseline load currents.

1.888.KEITHLEY (U.S. only)

www.keithley.com

KEITHLEY

A Greater Measure of Confidence

A Tektronix Company

2302, 2302-PJ, 2306, 2306-PJ

Battery Simulator Battery/Charger Simulators

Measure Long-Period Waveform Currents

For pulse trains with periods longer than 850ms, the Models 2302 and 2306 offer a unique, long integration current measurement mode. This mode can provide an average measurement of a current waveform from 850ms up to 60 seconds long.

Measure Low Currents Accurately

The Models 2302 and 2306 are based on Keithley's expertise in low current measurement technologies, so they're well-suited for making fast, accurate measurements of sleep and standby mode currents. With 100nA resolution and 0.2% basic accuracy, they provide the precision needed to monitor the low sleep mode currents of both today's battery-operated products and tomorrow's.

Verify Load Currents in All Operating States

The Models 2302 and 2306 employ a unique pulse current step function for measuring the load current at each level of a device's operational states. (See Figure 4.) For example, if a cellular phone is ramped up and down through as many as 20 discrete power consumption states, the Models 2302 and 2306 can measure the load currents in synchronization with the current steps. This capability allows a test engineer to verify performance at each operational state and simultaneously acquire power consumption information. The fast current measure capability is another way the Models 2302 and 2306 power supplies save test time and production costs.

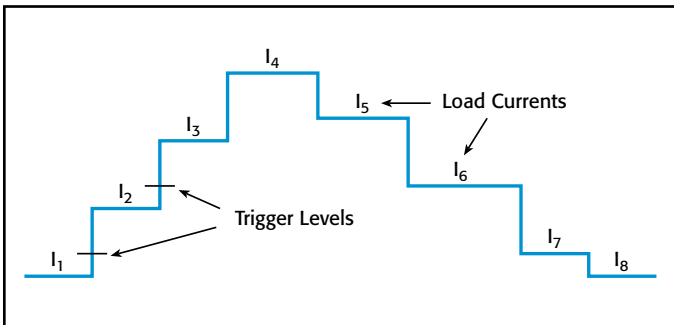

Figure 4. These power supplies can obtain a load current profile synchronized to the transitions of a DUT as it is stepped through its operating states.

Simulate a Discharged Battery for Charger Testing

The Models 2302 and 2306 can sink up to 3A continuously, just like an electronic load. This allows these supplies to simulate a discharged rechargeable battery for use in testing the performance of battery chargers or battery charger control circuitry.

The Model 2306 Battery/Charger Simulator combines the functionality of both the charging current source (the charger channel) and the current sinking to simulate the recharging of a discharged battery (the battery channel) in a single enclosure. (See Figure 5.)

Open-Sense Lead Detection

The Model 2302 and 2306 have an automatic open-sense lead detection capability, which indicates if there is a broken remote sense lead or an open connection from a remote sense lead to the test fixture. To ensure

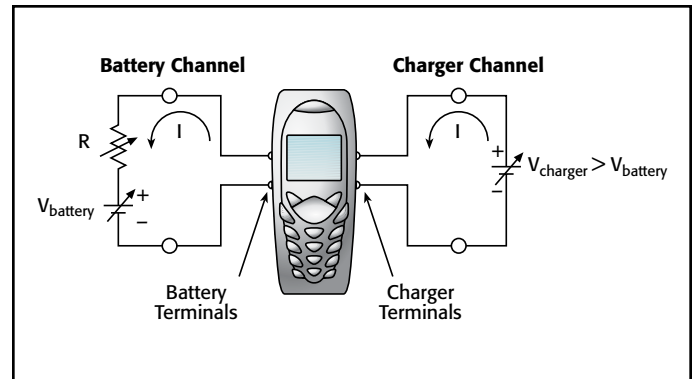

Figure 5. For charger control circuit testing applications, the Model 2306 and 2306-PJ can provide the functions of both a charger-simulating source and a discharged battery simulator.

the output voltage does not change from the programmed level, which could cause production devices to be improperly calibrated, the user can set high and low limits around the desired voltage level.

Independent Digital Voltmeter Inputs

Many programmable power supplies offer output readback capabilities, but the Model 2302 and 2306 also offer DVM inputs. Both instruments allow measuring signals from $-5V$ to $+30V$ DC anywhere in the test system with the same rated accuracy as the voltage readback. The Model 2306 has two sets of DVM inputs; the Model 2302 has one. The DVMs and the power sources can operate simultaneously. For many applications, these built-in DVMs eliminate the expense and space required to add a separate voltage measurement instrument.

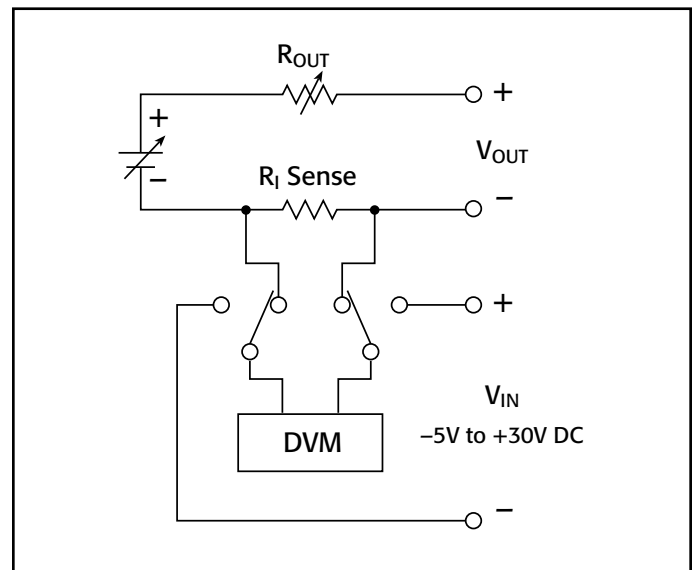

Figure 6. Model 2302 and Model 2306 Battery Channel Block Diagram. The Model 2306 charger channel is identical except it does not have the variable output resistance.

1.888.KEITHLEY (U.S. only)

www.keithley.com

A Greater Measure of Confidence

KEITHLEY
A Tektronix Company

Fast transient response power supplies

DC POWER SUPPLIES

2302, 2302-PJ, 2306, 2306-PJ

Battery Simulator Battery/Charger Simulators

Big Functionality in a Small Package

For high volume production environments where floor and test rack space are at a premium, the Model 2306 packs two power supplies into one half-rack enclosure. In addition to power control, both the Model 2302 and 2306 provide extensive measurement capabilities in the same half-rack case. The front panel of each unit displays the user's choice of either the output voltage and output current, the average, peak, and baseline pulse current levels, long integration currents, or DC DVM measurements. A minimum of front panel buttons ensures that operation is simple and straightforward.

For additional control requirements, the Models 2302 and 2306 each have four digital relay control outputs and a 5V DC output to power a relay coil.

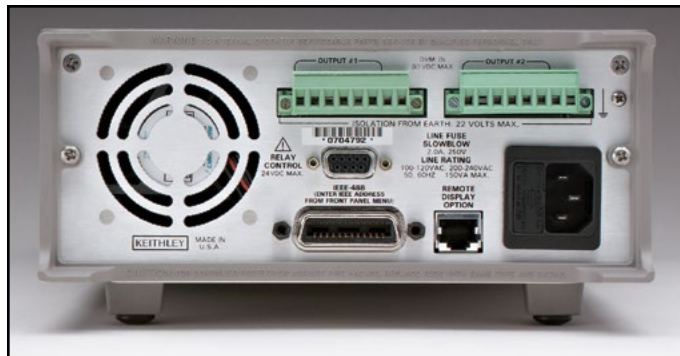

Figure 7. Model 2306 Rear Panel showing 8-position power output connectors, RJ-45 remote display connector, DB-9 relay output connector, IEEE-488 connector, and power input socket.

GENERAL

ISOLATION (low-earth): 22V DC max. For Models 2302-PJ, 2306 and 2306-PJ, do not exceed 60V DC between any two terminals of either connector.

PROGRAMMING: IEEE-488.2 (SCPI).

USER-DEFINABLE POWER-UP STATES: 5 (4 for Models 2302-PJ and 2306-PJ).

REAR PANEL CONNECTORS: Two (one for Models 2302, 2302-PJ) 8-position quick disconnect terminal block for output (4), sense (2), and DVM (2).

TEMPERATURE COEFFICIENT (outside 23°C ±5°C): Derate accuracy specification by (0.1 × specification)°C.

OPERATING TEMPERATURE: 0° to 50°C (Derate to 70%). 0° to 35°C (Full power).

STORAGE TEMPERATURE: -20° to 70°C.

HUMIDITY: <80% @ 35°C non-condensing.

DISPLAY TYPE: 2-line × 16-character VFD.

REMOTE DISPLAY/KEYPAD OPTION: Disables standard front panel.

DIMENSIONS: 89mm high × 213mm wide × 411mm deep (3½ in × 8½ in × 16½ in).

NET WEIGHT: 3.2kg (7.1 lbs).

SHIPPING WEIGHT: 5.4kg (12 lbs).

INPUT POWER: 100–120V AC/220–240V AC, 50 or 60Hz (auto detected at power-up).

POWER CONSUMPTION: 150VA max.

EMC: 2302, 2306: Conforms with European Union Directive 89/336/EEC, EN 55011, EN 50082-1, EN 61000-3-2 and 61000-3-3, FCC part 15 class B. 2302-PJ, 2306-PJ: Conforms with European Union Directive 89/336/EEC.

SAFETY: 2302, 2306: Conforms with European Union Directive 73/23/EEC, EN 61010-1. 2302-PJ, 2306-PJ: Conforms with European Union Directive 73/23/EEC.

AC LINE LEAKAGE CURRENT: 450µA @ 110VAC, typ.; 600µA @ 220V, typ.

RELAY CONTROL PORT: 4-channel, each capable of 100mA sink, 24V max. Total port sink capacity (all 4 combined) is 250mA max. Accepts DB-9 male plug.

2302, 2302-PJ, 2306, 2306-PJ

Battery Simulator Battery/Charger Simulators

Output #1 (Battery)

DC VOLTAGE OUTPUT (2 Years, 23°C ± 5°C)

OUTPUT VOLTAGE: 0 to +15V DC.
 OUTPUT ACCURACY: ±(0.05% + 3mV).
 PROGRAMMING RESOLUTION: 1mV.
 READBACK ACCURACY¹: ±(0.05% + 3mV).
 READBACK RESOLUTION: 1mV.
 OUTPUT VOLTAGE SETTLING TIME: 5ms to within stated accuracy.
 LOAD REGULATION: 0.01% + 2mV.
 LINE REGULATION: 0.5mV.
 STABILITY²: 0.01% + 0.5mV.
 MEASUREMENT TIME CHOICES: 0.01 to 10PLC⁷, in 0.01PLC steps.
 AVERAGE READINGS: 1 to 10.
 READING TIME^{1,8,9}: 31ms, typical.
 TRANSIENT RESPONSE:

	High Bandwidth	Low Bandwidth
Transient Recovery Time ¹³	<40μs ³ or <60μs ⁴	<80μs ³ or <100μs ⁴
Transient Voltage Drop	<75mV ³ or <100mV ⁴	<250mV ³ or <400mV ⁴

REMOTE SENSE: 1V max. drop in each lead. Add 2mV to the voltage load regulation specification for each 1V change in the negative output lead due to load current change. Remote sense required. Integrity of connection continually monitored. If compromised, output will turn off automatically once settable window (±0 to ±8V) around normal voltage exceeded.

VARIABLE OUTPUT IMPEDANCE

RANGE: 0 to 1.00Ω in 0.01Ω steps. Value can be changed with output on.

DC CURRENT (2 Years, 23°C ± 5°C)

CONTINUOUS AVERAGE OUTPUT CURRENT (2302, 2302-PJ):
 0–4V: 5A max.
 >4V: I_{MAX} = 60W/(V_{SET} + 6) (not intended to be operated in parallel).
 Peak currents can be a maximum of 5A provided the average current is within the above limits.
 CONTINUOUS AVERAGE OUTPUT CURRENT (2306, 2306-PJ):
 Channel #2 (Charger) OFF:
 I = 50W/(V_{SET} channel 1 + 6V); 5A max.
 Channel #2 (Charger) ON:
 I = (50W – Power consumed by channel #2)/(V_{SET} channel 1 + 6V); 5A max.
 The power consumed by channel #2 is calculated as:
 Channel #2 sourcing current:
 Power consumed = (V_{SET} channel 2 + 6V) × (current supplied)
 Channel #2 sinking current:
 Power consumed = 5 × (sink current)
 Peak currents can be a maximum of 5A provided the average current is within the above limits.

CONTINUOUS AVERAGE SINK CURRENT:
 Channel #2 (Charger) OFF:
 0–5V: 3A max.
 5–15V: Derate 0.2A per volt above 5V. Compliance setting controls sinking.
 Channel #2 (Charger) ON:
 Available current = (50W – Power consumed by channel #2)/5; 3A max. (0–5V).
 Derate 0.2A per volt above 5V.

SOURCE COMPLIANCE ACCURACY: ±(0.16% + 5mA)⁵.
 PROGRAMMED SOURCE COMPLIANCE RESOLUTION: 1.25mA.
 READBACK ACCURACY¹: 5A Range: ±(0.2% + 200μA).
 5mA Range: ±(0.2% + 1μA) (2302 and 2306).
 500mA Range: ±(0.2% + 20μA) (2302-PJ and 2306-PJ only).
 READBACK RESOLUTION: 5A Range: 100μA.
 5mA Range: 0.1μA (2302 and 2306).
 500mA Range: 10μA (2302-PJ and 2306-PJ only).

LOAD REGULATION: 0.01% + 1mA.
 LINE REGULATION: 0.5mA.
 STABILITY⁴: 0.01% + 50μA.
 MEASUREMENT TIME CHOICES: 0.01 to 10PLC⁷, in 0.01PLC steps.
 AVERAGE READINGS: 1 to 10.
 READING TIME^{1,8,9}: 31ms, typical.

PULSE CURRENT MEASUREMENT OPERATION

TRIGGER LEVEL:
 5A CURRENT RANGE
 5A Range: 5mA to 5A, in 5mA steps.
 1A Range: 1mA to 1A, in 1mA steps.
 100mA Range: 0.1mA to 100mA, in 100μA steps.
 500mA CURRENT RANGE (2302-PJ and 2306-PJ)
 500mA Range: 0.5mA to 500mA, in 0.5mA steps.
 100mA Range: 0.1mA to 100mA, in 100μA steps.
 10mA Range: 100μA to 10mA, in 100μA steps.
 TRIGGER DELAY: 0 to 100ms, in 10μs steps.
 INTERNAL TRIGGER DELAY: 15μs.
 HIGH/LOW/AVERAGE MODE:
 Measurement Aperture Settings: 33.3μs to 833ms, in 33.3μs steps.
 Average Readings: 1 to 100.
 PULSE CURRENT MEASUREMENT ACCURACY¹¹ (2 Years, 23°C ± 5°C):

Aperture	Accuracy ±(% reading + offset + rms noise ¹⁰)	
	5A Range	500mA Range (2302-PJ and 2306-PJ)
<100 μs	0.2% + 900 μA + 2 mA	0.2% + 90 μA + 2 mA
100 μs – 200 μs	0.2% + 900 μA + 1.5 mA	0.2% + 90 μA + 1.5 mA
200 μs – 500 μs	0.2% + 900 μA + 1 mA	0.2% + 90 μA + 1 mA
500 μs – <1 PLC	0.2% + 600 μA + 0.8 mA	0.2% + 60 μA + 0.8 mA
1 PLC ¹²	0.2% + 400 μA + 0 mA	0.2% + 40 μA + 0 mA
>1 PLC	0.2% + 400 μA + 100 μA	0.2% + 40 μA + 100 μA

BURST MODE CURRENT MEASUREMENT

MEASUREMENT APERTURE: 33.3μs.
 CONVERSION RATE: 3650/second, typical.
 INTERNAL TRIGGER DELAY: 15μs.
 NUMBER OF SAMPLES: 1 to 5000.
 TRANSFER SAMPLES ACROSS IEEE BUS IN BINARY MODE: 4800 bytes/s, typical.

LONG INTEGRATION MODE CURRENT MEASUREMENT

2302, 2306: Available on 5A range only.
 2302-PJ AND 2306-PJ: Available on both 5A and 500mA current ranges.
 MEASUREMENT TIME⁶: 850ms (840ms) to 60 seconds in 1ms steps.

DIGITAL VOLTMETER INPUT (2 Years, 23°C ± 5°C)

INPUT VOLTAGE RANGE: –5 to +30V DC.
 INPUT IMPEDANCE: 2MΩ typical.
 MAXIMUM VOLTAGE (either input terminal) WITH RESPECT TO OUTPUT LOW: –5V, +30V.
 READING ACCURACY¹: ±(0.05% + 3mV).
 READING RESOLUTION: 1mV.
 CONNECTOR: HI and LO input pair part of Output #1's terminal block.
 MEASUREMENT TIME CHOICES: 0.01 to 10PLC⁷, in 0.01PLC steps.
 AVERAGE READINGS: 1 to 10.
 READING TIME^{1,8,9}: 31ms, typical.

1.888.KEITHLEY (U.S. only)

www.keithley.com

A Greater Measure of Confidence

KEITHLEY

A Tektronix Company

Model 2302, 2302-PJ, 2306, 2306-PJ specifications

DC POWER SUPPLIES

2302, 2302-PJ, 2306, 2306-PJ

Battery Simulator Battery/Charger Simulators

OUTPUT #2 (CHARGER)

DC VOLTAGE OUTPUT (2 Years, 23°C ± 5°C)

OUTPUT VOLTAGE: 0 to +15V DC.
 OUTPUT ACCURACY: ±(0.05% + 10mV).
 PROGRAMMING RESOLUTION: 10mV.
 READBACK ACCURACY¹: ±(0.05% + 3mV).
 READBACK RESOLUTION: 1mV.
 OUTPUT VOLTAGE SETTling TIME: 5ms to within stated accuracy.
 LOAD REGULATION: 0.01% + 2mV.
 LINE REGULATION: 0.5mV.
 STABILITY²: 0.01% + 0.5mV.
 MEASUREMENT TIME CHOICES: 0.01 to 10PLC⁷, in 0.01PLC steps.
 AVERAGE READINGS: 1 to 10.
 READING TIME^{1,8,9}: 31ms, typical.

TRANSIENT RESPONSE:	High Bandwidth	Low Bandwidth
Transient Recovery Time ¹³	<50μs ³ or <80μs ⁴	<60μs ³ or <100μs ⁴
Transient Voltage Drop	<120mV ³ or <150mV ⁴	<160mV ³ or <200mV ⁴

REMOTE SENSE: 1V max. drop in each lead. Add 2mV to the voltage load regulation specification for each 1V change in the negative output lead due to load current change. Remote sense required. Integrity of connection continually monitored. If compromised, output will turn off automatically once settable window (±0 to ±8V) around normal voltage exceeded.

DC CURRENT (2 Years, 23°C ± 5°C)

CONTINUOUS AVERAGE OUTPUT CURRENT:
 Channel #1 (Battery) OFF:
 $I = 50W / (V_{SET} \text{ channel 2} + 6V)$; 5A max.
 Channel #1 (Battery) ON:
 $I = (50W - \text{Power consumed by channel \#1}) / (V_{SET} \text{ channel 2} + 6V)$; 5A max.
 The power consumed by channel #1 is calculated as:
 Channel #1 sourcing current:
 $\text{Power consumed} = (V_{SET} \text{ channel 1} + 6V) \times (\text{current supplied})$
 Channel #1 sinking current:
 $\text{Power consumed} = 5 \times (\text{sink current})$
 Peak currents can be a maximum of 5A provided the average current is within the above limits.

CONTINUOUS AVERAGE SINK CURRENT:
 Channel #1 (Battery) OFF:
 0–5V: 3A max.
 5–15V: Derate 0.2A per volt above 5V. Compliance setting controls sinking.
 Channel #1 (Battery) ON:
 Available current = $(50W - \text{Power consumed by channel \#1}) / 5$; 3A max. (0–5V).
 Derate 0.2A per volt above 5V.

SOURCE COMPLIANCE ACCURACY: ±(0.16% + 5mA)⁵.
 PROGRAMMED SOURCE COMPLIANCE RESOLUTION: 1.25mA.
 READBACK ACCURACY¹: 5A Range: ±(0.2% + 200μA).
 5mA Range: ±(0.2% + 1μA).
 READBACK RESOLUTION: 5A Range: 100μA.
 5mA Range: 0.1μA.

LOAD REGULATION: 0.01% + 1mA.
 LINE REGULATION: 0.5mA.
 STABILITY²: 0.01% + 50μA.
 MEASUREMENT TIME CHOICES: 0.01 to 10PLC⁷, in 0.01PLC steps.
 AVERAGE READINGS: 1 to 10.
 READING TIME^{1,8,9}: 31ms, typical.

PULSE CURRENT MEASUREMENT OPERATION

TRIGGER LEVEL: 5mA to 5A, in 5mA steps.
 TRIGGER DELAY: 0 to 100ms, in 10μs steps.
 INTERNAL TRIGGER DELAY: 15μs.
 HIGH/LOW/AVERAGE MODE:
 Measurement Aperture Settings: 33.3μs to 833ms, in 33.3μs steps.
 Average Readings: 1 to 100.
 PULSE CURRENT MEASUREMENT ACCURACY¹¹ (2 Years, 23°C ± 5°C):

Aperture	Accuracy ±(% reading + offset + rms noise ¹⁰)
<100 μs	0.2% + 900 μA + 2 mA
100 μs – 200 μs	0.2% + 900 μA + 1.5 mA
200 μs – 500 μs	0.2% + 900 μA + 1 mA
500 μs – <1 PLC	0.2% + 600 μA + 0.8 mA
1 PLC ¹²	0.2% + 400 μA + 0 mA
>1 PLC	0.2% + 400 μA + 100 μA

BURST MODE CURRENT MEASUREMENT

MEASUREMENT APERTURE: 33.3μs.
 CONVERSION RATE: 2040/second, typical.
 INTERNAL TRIGGER DELAY: 15μs.
 NUMBER OF SAMPLES: 1 to 5000.
 TRANSFER SAMPLES ACROSS IEEE BUS IN BINARY MODE: 4800 bytes/s, typical.

LONG INTEGRATION MODE CURRENT MEASUREMENT

MEASUREMENT TIME⁶: 850ms (840ms) to 60 seconds in 1ms steps.

DIGITAL VOLTMETER INPUT (2 Years, 23°C ± 5°C)

INPUT VOLTAGE RANGE: –5 to +30V DC.
 INPUT IMPEDANCE: 2MΩ typical.
 MAXIMUM VOLTAGE (either input terminal) WITH RESPECT TO OUTPUT LOW: –5V, +30V.
 READING ACCURACY¹: ±(0.05% + 3mV).
 READING RESOLUTION: 1mV.
 CONNECTOR: HI and LO input pair part of Output #2's terminal block.
 MEASUREMENT TIME CHOICES: 0.01 to 10PLC⁷, in 0.01PLC steps.
 AVERAGE READINGS: 1 to 10.
 READING TIME^{1,8,9}: 31ms, typical.

NOTES

1. PLC = 1.00.
2. Following 15 minute warm-up, the change in output over 8 hours under ambient temperature, constant load, and line operating conditions.
3. Remote sense, at output terminals, 0.5A to 5A typical.
4. Remote sense, with 4.5m (15 ft) of 16 gauge (1.31mm²) wire and 1Ω resistance in each lead to simulate typical test environment, 1.5A load change (0.15A to 1.65A).
5. Minimum current in constant current mode is 6mA.
6. 60Hz (50Hz).
7. PLC = Power Line Cycle. 1PLC = 16.7ms for 60Hz operation, 20ms for 50Hz operation. Display off.
9. Speed includes measurement and binary data transfer out of GPIB.
10. Typical values, peak-to-peak noise equals 6 times rms noise.
11. Based on settled signal: 100μs pulse trigger delay.
12. Also applies to other apertures that are integer multiples of 1PLC.
13. Recovery to within 20mV of previous level.

1.888.KEITHLEY (U.S. only)

www.keithley.com

KEITHLEY

A Greater Measure of Confidence

A Tektronix Company

2306-VS

Dual-Channel Battery/Charger Simulator with External Triggering



- External trigger inputs speed and simplify control of output channels
- Built-in test sequencing reduces GPIB bus traffic and improves test throughput
- Ultra-fast response to transient load currents
- Selectable trigger level polarity
- Variable output resistance for simulating battery response (U.S. Patent No. 6,204,647)
- Trigger outputs provided for event handshaking
- 100nA DC current sensitivity
- Sink up to 3A
- Open sense lead detection
- Built-in digital voltmeter

these external trigger inputs with built-in test sequencing to create an extremely fast voltage supply and measurement instrument that minimizes the need for computer and GPIB interaction.

External Triggering Allows High Speed Control of Output Channels

When triggered, the output channels can be instructed to operate at pre-defined voltages or to initiate current, voltage, or pulse current measurements. The availability of two inputs makes it possible to program each channel to act independently or, if the test developer prefers, to act in parallel. For example, Channel #1 can be programmed to operate at user-specified voltage levels while Channel #2 is triggered to take measurements. Measurements are stored in a reading buffer and can be downloaded to a PC controller after the test routine is complete, minimizing GPIB command and data transfer delays. Trigger outputs indicate event completion, allowing users to minimize step delays between trigger-in sequences.

External triggering also allows the Model 2306-VS to exercise tight control over signal capture timing for greater measurement and load condition coordination. As a result, manufacturers can achieve greater confidence in their own compliance testing and can offer their customers more accurate component specifications.

This precision power supply has ultra-fast transient response to duplicate the output characteristics of actual batteries. In response to large load changes, voltage droops on the Model 2306-VS's battery channel are less than 100mV and transient recovery times are less than 60 μ s, even when the instrument is used with long test leads. The Model 2306-VS also employs a unique variable output resistance so that the voltage output can emulate a battery's true response (U.S. Patent No. 6,204,647). By providing stable output voltage, a device-under-test (DUT) can transition from standby power (low current) to RF transmission (high current) seamlessly without nuisance tripping.

Built-in Test Sequencing Maximizes Throughput

The Model 2306-VS's built-in test sequencing capabilities allow setting up and executing up to 20 individual voltage and measurement sequences. By minimizing the need to transfer instrument commands or data over the GPIB

The dual-channel Model 2306-VS Battery/Charger Simulator with External Triggering is designed specifically for development and high speed production testing of DC battery-operated products, such as cellular handsets, cellular components like RFIC power amplifiers, and other high volume precision electrical components that require a DC voltage supply. Like Keithley's original single-channel Model 2302 Battery Simulator and dual-channel Model 2306 Battery/Charger Simulator, this precision power supply has ultra-fast transient response to provide output characteristics identical to actual batteries. However, in addition to the capabilities offered by these models, the Model 2306-VS (voltage step) provides two external trigger inputs, which allow independent control of the instrument's output channels. These trigger inputs speed and simplify control of the output channels by eliminating the time lags associated with GPIB data communications. The Model 2306-VS combines

APPLICATIONS

Development and high speed testing of DC battery-operated products, such as:

- Cellular handsets
- Cellular components like RFIC power amplifiers
- Other high volume precision electrical components

1.888.KEITHLEY (U.S. only)

www.keithley.com

A Greater Measure of Confidence

KEITHLEY
A Tektronix Company

Fast transient response power supply

DC POWER SUPPLIES

2306-VS

Ordering Information

2306-VS Dual-Channel Battery/Charger Simulator with External Triggering

Accessories Supplied

User and service manuals
CS-846 output connectors
Mating terminal

ACCESSORIES AVAILABLE

2306-DISP	Remote Display
CS-846	Mating Output Connector

CABLES

7007-1	Double Shielded Premium IEEE-488 Cable, 1m (3.2 ft)
7007-2	Double Shielded Premium IEEE-488 Cable, 2m (6.5 ft)
SC-182	Low-Inductance Coaxial Cable (42nH/ft)

RACK MOUNT KITS

4288-1	Single Fixed Rack Mount Kit
4288-2	Dual Fixed Rack Mount Kit

IEEE-488 INTERFACES

KPCI-488LPA	IEEE-488 Interface/Controller for the PCI Bus
KUSB-488B	IEEE-488 USB-to-GPIB Interface Adapter

SERVICES AVAILABLE

2306-VS-3Y-EW 1-year factory warranty extended to 3 years from date of shipment

C/2306-3Y-ISO 3 (ISO-17025 accredited) calibrations within 3 years of purchase*

*Not available in all countries

Dual-Channel Battery/Charger Simulator with External Triggering

bus, these test sequences support faster, easier production testing by allowing users to pre-define a variety of test configurations, such as:

- Trigger up to 20 voltage setpoints on Channel #1, Channel #2, or both
- Trigger up to 20 measurement readings on Channel #1, Channel #2, or both
- Trigger voltage setpoints on Channel #1 while triggering Channel #2 measurement readings

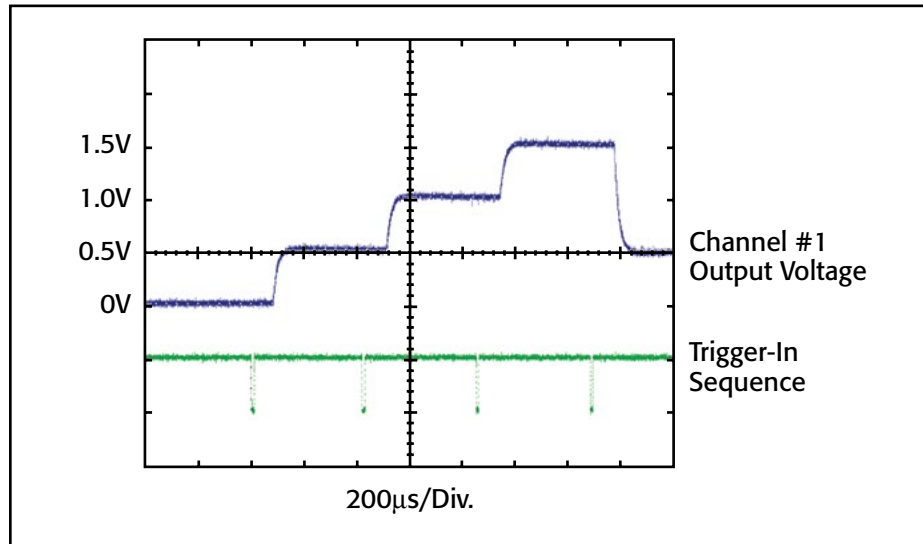

Figure 1. This graph illustrates Channel #1 output voltage response times based on a four-point voltage step sequence (0.5V/1.0V/1.5V/0.5V). The Model 2306-VS can complete this sequence within 1.5ms.

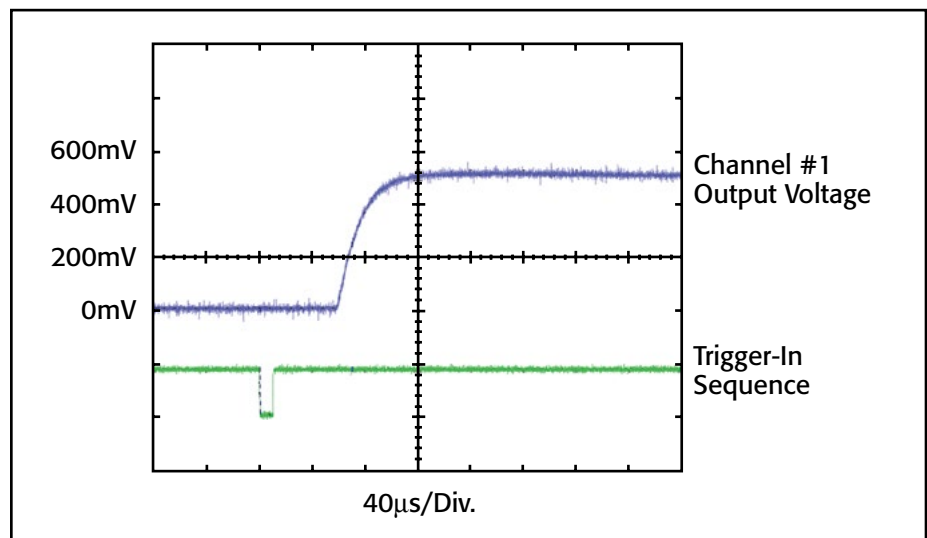

Figure 2. This magnified view of the first 500mV voltage step from the signal shown in Figure 1 illustrates how the Channel #1 output reaches the voltage setpoint within 160µs of the trigger-in pulse.

1.888.KEITHLEY (U.S. only)

www.keithley.com

2306-VS

Dual-Channel Battery/Charger Simulator with External Triggering

Measure Load Currents for Power Consumption Verification or Analysis

The Model 2306-VS is based on Keithley's expertise in low current measurement technologies, so it is well-suited for making accurate measurements of load currents. With 100nA resolution and 0.2% basic accuracy, it provides the precision needed to monitor the low sleep mode currents of today's battery-operated products.

The Model 2306-VS can monitor DUT power consumption by measuring both DC currents and pulse load currents. The instrument's battery-simulator channel can be programmed to operate like a discharged rechargeable battery, sinking up to 3A from the charger-simulator channel.

Maximize Test Throughput with Accurate Battery Simulation

The Model 2306-VS's battery-output channel is designed to simulate the output response of a battery. This capability, combined with its fast transient response, makes it possible to power the device during testing in exactly the same way as a battery powers the device during actual use. The output resistance of the battery channel can be programmed (with 10mΩ resolution) over the range from 0Ω to 1Ω so that the output resistance can be set to the same level as the output resistance of the battery that powers the device.

Portable wireless devices make great demands on their battery power sources. The battery must source load currents that can jump virtually instantaneously from a standby current level (100–300mA) to a full power RF transmission current level (1–3A). In other words, the load current on the battery can increase rapidly by a factor of 700–1000%. As a result, the battery voltage drops by an amount equal to the value of the current change multiplied by the battery's internal resistance. The Model 2306-VS enables test systems to duplicate this voltage drop by programming their output resistance to be equivalent to that of the battery that will power the device. This allows wireless device manufacturers to test their products under the same power conditions that they will encounter in actual use.

The Model 2306-VS also eliminates the large stabilizing capacitors needed at the DUT to compensate for the large voltage droop that occurs when testing with conventional power supplies. By varying the output resistance, which can be done while the output is turned on, test engineers can simulate the operation of different battery types as well as batteries nearing the end of their useful lives. The Model 2306-VS ensures maximum production throughput when testing portable devices by minimizing false failures, minimizing the number of test setups by performing multiple tests with the same power supply, and minimizing test fixture complexity by eliminating the need for voltage-stabilizing capacitors.

Open Sense Lead Detection

The Model 2306-VS has an automatic open-sense lead detection capability, which indicates if there is a broken remote sense lead or an open connection from a remote sense lead to the test fixture. To ensure that the output voltage does not change from the programmed level, which could cause production devices to be improperly calibrated, the user can set high and low limits around the desired voltage level.

Independent Digital Voltmeter Inputs

Many programmable power supplies offer output read-back capabilities, but the Model 2306-VS also offers two digital voltmeter (DVM) inputs. These inputs can be used to measure signals from –5V to +30V DC anywhere in the test system with the same rated accuracy as the voltage readback. For many applications, this built-in DVM eliminates the expense and space otherwise required to add a separate voltage measurement instrument to the system.

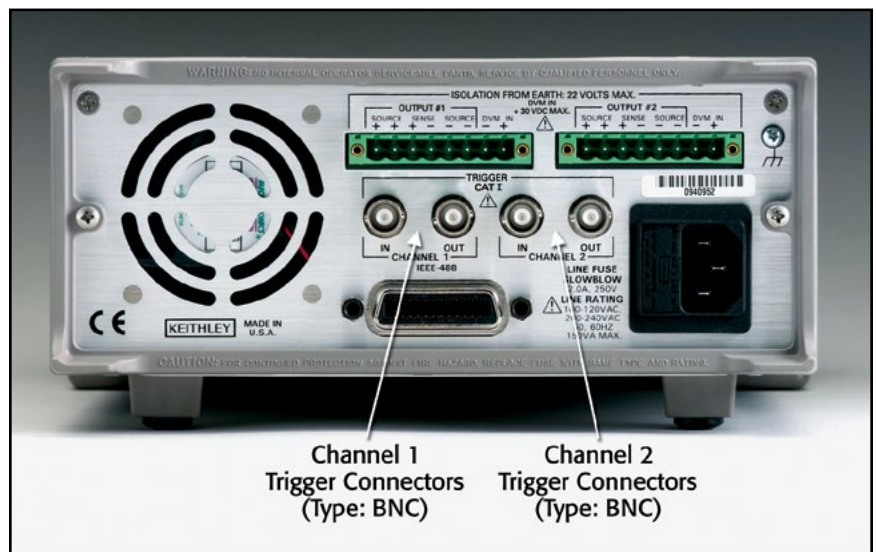

Model 2306-VS rear panel

1.888.KEITHLEY (U.S. only)

www.keithley.com

A Greater Measure of Confidence

KEITHLEY

A Tektronix Company

Fast transient response power supply

DC POWER SUPPLIES

2306-VS

Dual-Channel Battery/Charger Simulator with External Triggering

Output #1 (Battery)

DC VOLTAGE OUTPUT (2 Years, 23°C ± 5°C)

OUTPUT VOLTAGE: 0 to +15VDC.
 OUTPUT ACCURACY: ±(0.05% + 3mV).
 PROGRAMMING RESOLUTION: 1mV.
 READBACK ACCURACY¹: ±(0.05% + 3mV).
 READBACK RESOLUTION: 1mV.
 LOAD REGULATION: ±(0.01% + 2mV).
 LINE REGULATION: ±0.5mV.
 STABILITY²: ±(0.01% + 0.5mV).
 MEASUREMENT TIME CHOICES: 0.01 to 10 PLC⁷, in 0.01PLC steps.

AVERAGE READINGS: 1 to 10.

READING TIME^{1,8,9}: 31ms, typical.

TRANSIENT RESPONSE:	High Bandwidth	Low Bandwidth
Transient Recovery Time ¹³	<40 μs ³ or <60 μs ⁴	<80 μs ³ or <100 μs ⁴
Transient Voltage Drop	<75 mV ³ or <100 mV ⁴	<250 mV ³ or <400 mV ⁴

REMOTE SENSE: 1V max. drop in each lead. Add 2mV to the voltage load regulation specification for each 1V change in the negative output lead due to load current change. Remote sense required. Integrity of connection continually monitored. If compromised, output will turn off automatically once settable window (±0 to ±8 volts) around normal voltage exceeded.

VARIABLE OUTPUT IMPEDANCE

RANGE: 0 to 1.00Ω in 0.01Ω steps. Value can be changed with output on if trigger external disabled on channel.

DC CURRENT (2 Years, 23°C ± 5°C)

CONTINUOUS AVERAGE OUTPUT CURRENT:

Channel #2 (Charger) OFF: $I = 50W / (V_{set} \text{ channel 1} + 6V)$; 5A max.

Channel #2 (Charger) ON: $I = (50W - \text{Power consumed by channel #2}) / (V_{set} \text{ channel 1} + 6V)$; 5A max.

The power consumed by channel #2 is calculated as:

Channel #2 sourcing current: Power consumed = $(V_{set} \text{ channel 2} + 6V) \times (\text{current supplied})$.

Channel #2 sinking current: Power consumed = $5 \times (\text{sink current})$.

Peak currents can be a maximum of 5A provided the average current is within the above limits.

CONTINUOUS AVERAGE SINK CURRENT:

Channel #2 (Charger) OFF:

0–5V: 3A max.

5–15V: Derate 0.2A per volt above 5V. Compliance setting controls sinking.

Channel #2 (Charger) ON:

Available current = $(50W - \text{Power consumed by channel #2}) / 5$; 3A max. (0–5V).

Derate 0.2A per volt above 5V.

SOURCE COMPLIANCE ACCURACY: ±(0.16% + 5mA)⁵.

PROGRAMMED SOURCE COMPLIANCE RESOLUTION: 1.25mA.

READBACK ACCURACY¹: 5A Range: ±(0.2% + 200μA). 5mA Range: ±(0.2% + 1μA).

READBACK RESOLUTION: 5A Range: 100μA. 5mA Range: 0.1μA.

LOAD REGULATION: ±(0.01% + 1mA).

LINE REGULATION: ±0.5mA.

STABILITY²: ±(0.01% + 50μA).

MEASUREMENT TIME CHOICES: 0.01 to 10 PLC⁷, in 0.01PLC steps.

AVERAGE READINGS: 1 to 10.

READING TIME^{1,8,9}: 31ms, typical.

PULSE CURRENT MEASUREMENT OPERATION

TRIGGER LEVEL: 5A Range: 5mA to 5A, in 5mA steps.

1A Range: 1mA to 1A, in 1mA steps.

100mA Range: 0.1mA to 100mA, in 100μA steps.

TRIGGER DELAY: 0 to 100ms, in 10μs steps.

INTERNAL TRIGGER DELAY: 15μs.

HIGH/LOW/AVERAGE MODE:

Measurement Aperture Settings: 33.3μs to 833ms, in 33.3μs steps.

Average Readings: 1 to 100.

PULSE CURRENT MEASUREMENT ACCURACY¹¹ (2 Years, 23°C ± 5°C):

Aperture	Accuracy ±(% reading + offset + rms noise ¹⁰)
<100 μs	0.2% + 900 μA + 2 mA
100 μs – 200 μs	0.2% + 900 μA + 1.5 mA
200 μs – 500 μs	0.2% + 900 μA + 1 mA
500 μs – <1 PLC	0.2% + 600 μA + 0.8 mA
1 PLC ¹²	0.2% + 400 μA + 0 mA
>1 PLC	0.2% + 400 μA + 100 μA

BURST MODE CURRENT MEASUREMENT

MEASUREMENT APERTURE: 33.3μs to 833ms, in 33.3μs steps.

CONVERSION RATE: 3650/second at 33.3μs meas. aper., typical.

INTERNAL TRIGGER DELAY: 15μs with 33μs.

NUMBER OF SAMPLES: 1 to 5000.

TRANSFER SAMPLES ACROSS IEEE BUS IN BINARY MODE: 4800 bytes/s, typical.

LONG INTEGRATION MODE CURRENT MEASUREMENT

MEASUREMENT TIME⁶: 850ms (840ms) to 60 seconds in 1ms steps.

DIGITAL VOLTMETER INPUT (2 Years, 23°C ± 5°C)

INPUT VOLTAGE RANGE: –5 to +30VDC.

INPUT IMPEDANCE: 2MΩ typical.

MAXIMUM VOLTAGE (either input terminal) WITH RESPECT TO OUTPUT LOW: –5V, +30V.

READING ACCURACY¹: ±(0.05% + 3mV).

READING RESOLUTION: 1mV.

CONNECTOR: HI and LO input pair part of Output #1's terminal block.

MEASUREMENT TIME CHOICES: 0.01 to 10 PLC⁷, in 0.01PLC steps.

AVERAGE READINGS: 1 to 10.

READING TIME^{1,8,9}: 31ms, typical.

VOLTAGE SETTling TIMES

VOLTAGE STEP SETTling TIMES (typical)

Increasing Voltage	10–90% Rise Time	Settling Time
Voltage step ≤ 7 V	50 μs	300 μs
Voltage step > 7 V	50 μs to 1.2 ms	300 μs to 1.8 ms

Decreasing Voltage	10–90% Fall Time	Settling Time
0 V < Voltage step < 15 V	50 μs to 250 μs	300 μs

NOTE: Times are under no load condition and settling times defined at ±2% of step size.

1.888.KEITHLEY (U.S. only)

www.keithley.com

KEITHLEY

A Greater Measure of Confidence

A Tektronix Company

2306-VS

Dual-Channel Battery/Charger Simulator with External Triggering

Output #2 (Charger)

DC VOLTAGE OUTPUT (2 Years, 23°C ± 5°C)

OUTPUT VOLTAGE: 0 to +15VDC.
 OUTPUT ACCURACY: ±(0.05% + 10mV).
 PROGRAMMING RESOLUTION: 10mV.
 READBACK ACCURACY¹: ±(0.05% + 3mV).
 READBACK RESOLUTION: 1mV.
 OUTPUT VOLTAGE SETTLING TIME: 5ms to within stated accuracy.
 LOAD REGULATION: ±(0.01% + 2mV).
 LINE REGULATION: ±0.5mV.
 STABILITY²: ±(0.01% + 0.5mV).
 MEASUREMENT TIME CHOICES: 0.01 to 10 PLC⁷, in 0.01PLC steps.
 AVERAGE READINGS: 1 to 10.
 READING TIME^{1,8,9}: 31ms, typical.

TRANSIENT RESPONSE:	High Bandwidth	Low Bandwidth
Transient Recovery Time ¹³	<50 μs ³ or <80 μs ⁴	<60 μs ³ or <100 μs ⁴
Transient Voltage Drop	<120 mV ³ or <150 mV ⁴	<160 mV ³ or <200 mV ⁴

REMOTE SENSE: 1V max. drop in each lead. Add 2mV to the voltage load regulation specification for each 1V change in the negative output lead due to load current change. Remote sense required. Integrity of connection continually monitored. If compromised, output will turn off automatically once settable window (±0 to ±8 volts) around normal voltage exceeded.

DC CURRENT (2 Years, 23°C ± 5°C)

CONTINUOUS AVERAGE OUTPUT CURRENT:

Channel #1 (Battery) OFF: $I = 50W / (V_{set} \text{ channel 2} + 6V)$; 5A max.
 Channel #1 (Battery) ON: $I = (50W - \text{Power consumed by channel \#1}) / (V_{set} \text{ channel 2} + 6V)$; 5A max.
 The power consumed by channel #1 is calculated as:
 Channel #1 sourcing current: Power consumed = $(V_{set} \text{ channel 1} + 6V) \times (\text{current supplied})$
 Channel #1 sinking current: Power consumed = $5 \times (\text{sink current})$

Peak currents can be a maximum of 5A provided the average current is within the above limits.

CONTINUOUS AVERAGE SINK CURRENT:

Channel #1 (Battery) OFF:
 0–5V: 3A max.
 5–15V: Derate 0.2A per volt above 5V. Compliance setting controls sinking.
 Channel #1 (Battery) ON:
 Available current = $(50W - \text{Power consumed by channel \#1}) / 5$; 3A max. (0–5V).
 Derate 0.2A per volt above 5V.

SOURCE COMPLIANCE ACCURACY: ±(0.16% + 5mA)⁵.
 PROGRAMMED SOURCE COMPLIANCE RESOLUTION: 1.25mA.
 READBACK ACCURACY¹: 5A Range: ±(0.2% + 200μA), 5mA Range: ±(0.2% + 1μA).
 READBACK RESOLUTION: 5A Range: 100μA, 5mA Range: 0.1μA.
 LOAD REGULATION: ±(0.01% + 1mA).
 LINE REGULATION: ±0.5mA.
 STABILITY²: ±(0.01% + 50μA).
 MEASUREMENT TIME CHOICES: 0.01 to 10 PLC⁷, in 0.01PLC steps.
 AVERAGE READINGS: 1 to 10.
 READING TIME^{1,8,9}: 31ms, typical.

PULSE CURRENT MEASUREMENT OPERATION

TRIGGER LEVEL: 5mA to 5A, in 5mA steps.
 TRIGGER DELAY: 0 to 100ms, in 10μs steps.
 INTERNAL TRIGGER DELAY: 15μs.
 HIGH/LOW/AVERAGE MODE:
 Measurement Aperture Settings: 33.3μs to 833ms, in 33.3μs steps.
 Average Readings: 1 to 100.
 PULSE CURRENT MEASUREMENT ACCURACY¹¹ (2 Years, 23°C ± 5°C):

Aperture	Accuracy ±(% reading + offset + rms noise ¹⁰)
<100 μs	0.2% + 900 μA + 2 mA
100 μs – 200 μs	0.2% + 900 μA + 1.5 mA
200 μs – 500 μs	0.2% + 900 μA + 1 mA
500 μs – <1 PLC	0.2% + 600 μA + 0.8 mA
1 PLC ¹²	0.2% + 400 μA + 0 mA
>1 PLC	0.2% + 400 μA + 100 μA

BURST MODE CURRENT MEASUREMENT

MEASUREMENT APERTURE: 33.3μs to 833ms, in 33μs steps.
 CONVERSION RATE: 2040/second at 33.3μs meas. aper., typical.
 INTERNAL TRIGGER DELAY: 15μs with 33μs.
 NUMBER OF SAMPLES: 1 to 5000.
 TRANSFER SAMPLES ACROSS IEEE BUS IN BINARY MODE: 4800 bytes/s, typical.

LONG INTEGRATION MODE CURRENT MEASUREMENT

MEASUREMENT TIME⁶: 850ms (840ms) to 60 seconds in 1ms steps.

DIGITAL VOLTMETER INPUT (2 Years, 23°C ± 5°C)

INPUT VOLTAGE RANGE: –5 to +30VDC.
 INPUT IMPEDANCE: 2MΩ typical.
 MAXIMUM VOLTAGE (either input terminal) WITH RESPECT TO OUTPUT LOW: –5V, +30V.
 READING ACCURACY¹: ±(0.05% + 3mV).
 READING RESOLUTION: 1mV.
 CONNECTOR: HI and LO input pair part of Output #2's terminal block.
 MEASUREMENT TIME CHOICES: 0.01 to 10 PLC⁷, in 0.01PLC steps.
 AVERAGE READINGS: 1 to 10.
 READING TIME^{1,8,9}: 31ms, typical.

VOLTAGE SETTLING TIMES (typical)

Increasing Voltage	10–90% Rise Time	Settling Time
Voltage step ≤ 7 V	10 μs	100 μs
Voltage step > 7 V	10 μs to 1.2 ms	100 μs to 1.5 ms

Decreasing Voltage	10–90% Fall Time	Settling Time
0 V < Voltage step < 15 V	5 μs to 40 μs	50 μs to 200 μs

NOTE: Times are under no load condition and settling times defined at ±2% of step size.

1.888.KEITHLEY (U.S. only)

www.keithley.com

KEITHLEY

A Greater Measure of Confidence

A Tektronix Company

2306-VS

Dual-Channel Battery/Charger Simulator with External Triggering

Voltage Stepping Only

TEST CONDITIONS:

1. Trigger external is enabled on both channels.
2. Only a single channel is externally triggered during the sequence while remaining channel stays idle.
3. Times based on 0 programmable user delay.

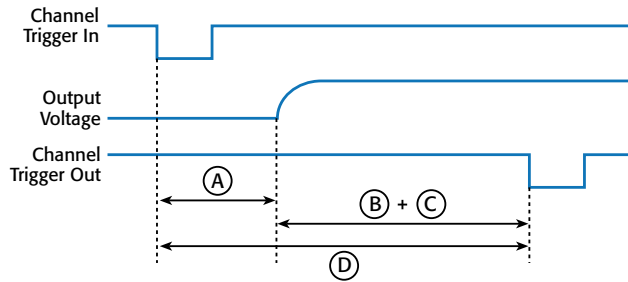

Output #1 (Battery)	Output #2 (Charger)
A = 70 μ s typical	A = 55 μ s typical
B = 330 μ s typical	B = 545 μ s typical
C = Programmable user delay (0–5 seconds)	C = Programmable user delay (0–5 seconds)
D = 400 μ s typical with C as 0	D = 600 μ s typical with C as 0

Auto Measurement Only

TEST CONDITIONS:

1. Trigger external is enabled on both channels.
2. Only a single channel is externally triggered during the sequence while remaining channel stays idle.
3. Times based on 0 programmable user delay.
4. Measurement time = 167 μ s (0.01 PLC).
5. Steps points = 4.

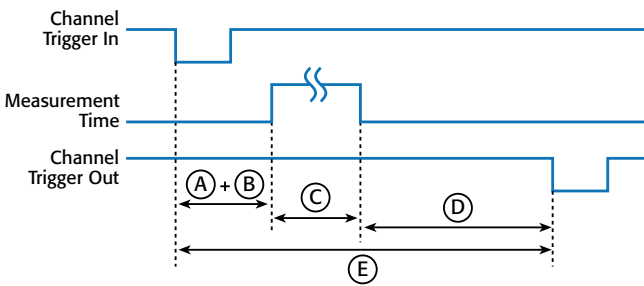

Output #1 (Battery)	Output #2 (Charger)
A = 43 μ s typical	A = 43 μ s typical
B = Programmable user delay (0–5 seconds)	B = Programmable user delay (0–5 seconds)
C = Measurement time	C = Measurement time
D = 410 μ s typical (steps 1, 2, and 3)	D = 650 μ s typical (steps 1, 2, and 3)
E = 620 μ s typical for steps 1, 2, and 3 with B as 0	E = 860 μ s typical for steps 1, 2, and 3 with B as 0
8ms typical for step 4 with B as 0	8ms typical for step 4 with B as 0

Voltage Stepping With Auto Measurement

TEST CONDITIONS:

1. Trigger external is enabled on both channels.
2. Only a single channel is externally triggered during the sequence while remaining channel stays idle.
3. Times based on 0 programmable user delay.
4. Measurement time = 167 μ s (0.01 PLC).
5. Steps points = 4.

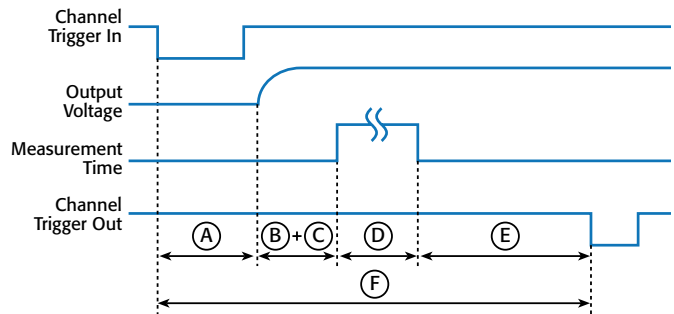

Output #1 (Battery)	Output #2 (Charger)
A = 70 μ s typical	A = 55 μ s typical within
B = 43 μ s typical	B = 43 μ s typical within
C = Programmable user delay (0–5 seconds)	C = Programmable user delay (0–5 seconds)
D = Measurement time	D = Measurement time
E = 475 μ s typical (steps 1, 2, and 3)	E = 955 μ s typical (steps 1, 2, and 3)
F = 755 μ s typical steps 1, 2, and 3 with C as 0	F = 1.22 ms typical steps 1, 2, and 3 with C as 0
8 ms typical step 4 with C as 0	8 ms typical step 4 with C as 0

Voltage Stepping Both Channels With Channel 1

TEST CONDITIONS:

1. Only a single channel is externally triggered during the sequence while remaining channel stays idle.
2. Times based on 0 programmable user delay.

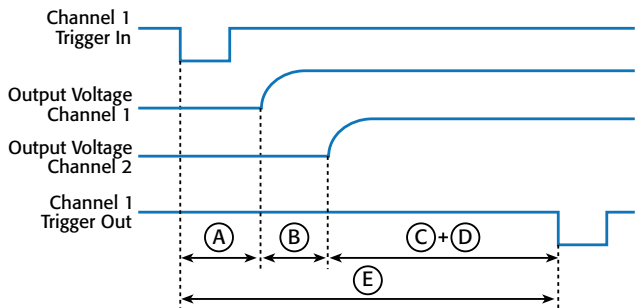

Output #1 (Battery)/Output #2 (Charger)
A = 70 μ s typical
B = 55 μ s typical
C = 775 μ s typical
D = Programmable user delay (0–5 seconds)
E = 900 μ s typical with D as 0

1.888.KEITHLEY (U.S. only)

www.keithley.com

KEITHLEY

A Greater Measure of Confidence

A Tektronix Company

Voltage Stepping Both Channels With Channel 2

TEST CONDITIONS:

1. Only a single channel is externally triggered during the sequence while remaining channel stays idle.
2. Times based on 0 programmable user delay.

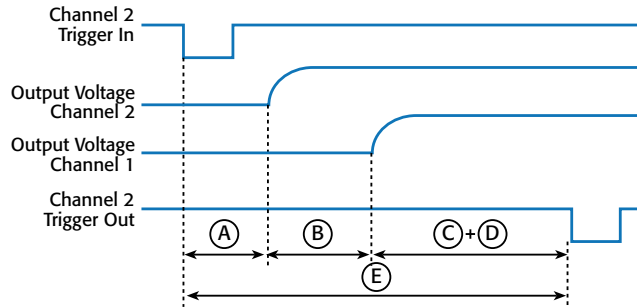

Output #1 (Battery)/Output #2 (Charger)

- A = 55 μ s typical
- B = 70 μ s typical
- C = 775 μ s typical
- D = Programmable user delay (0–5 seconds)
- E = 900 μ s typical with D as 0

Auto Measurement Both Channels With Channel 1

TEST CONDITIONS:

1. Only a single channel is externally triggered during the sequence while remaining channel stays idle.
2. Times based on 0 programmable user delay.
3. Measurement time = 167 μ s (0.01 PLC).
4. Steps points = 4.

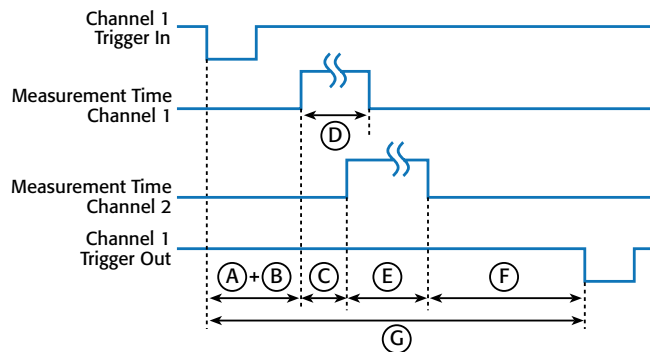

Output #1 (Battery)/Output #2 (Charger)

- A = 43 μ s typical
- B = Programmable user delay (0–5 seconds)
- C = 18 μ s typical
- D = Measurement time channel 1
- E = Measurement time channel 2
- F = 872 μ s typical with steps 1, 2, and 3
- G = 1.1 ms typical for steps 1, 2, and 3 with B as 0
16.0 ms typical step 4 with B as 0

Auto Measurement Both Channels With Channel 2

TEST CONDITIONS:

1. Only a single channel is externally triggered during the sequence while remaining channel stays idle.
2. Times based on 0 programmable user delay.
3. Measurement time = 167 μ s (0.01 PLC).
4. Steps points = 4.

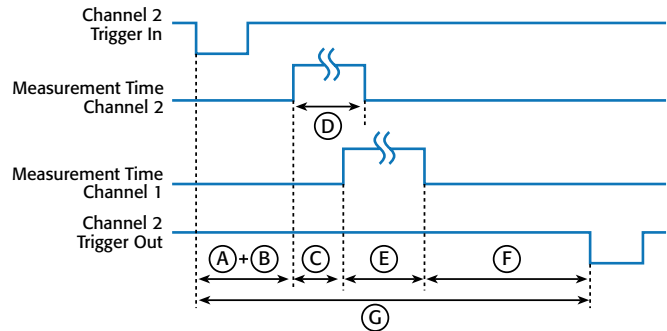

Output #1 (Battery)/Output #2 (Charger)

- A = 43 μ s typical
- B = Programmable user delay (0–5 seconds)
- C = 18 μ s typical
- D = Measurement time channel 2
- E = Measurement time channel 1
- F = 872 μ s typical with steps 1, 2, and 3
- G = 1.1 ms typical for steps 1, 2, and 3 with B as 0
16.0 ms typical step 4 with B as 0

Voltage Stepping With Sync Measurement

TEST CONDITIONS:

1. Trigger external is enabled on both channels.
2. Only a single channel is externally triggered during the sequence while remaining channel stays idle.
3. Times based on 0 programmable user delay.

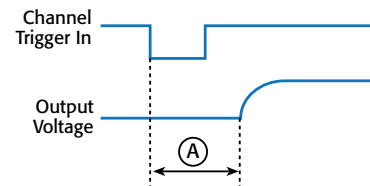

Output #1 (Battery)

- Channel 1 trigger in = output voltage start changing
- A = 70 μ s typical

Output #2 (Charger)

- Channel 2 trigger in = output voltage start changing
- A = 55 μ s typical within

4 ms typical to start search for desired pulse edge. Time for trigger out dependent on search time for selecting edge, integration time, and storing reading in buffer

2306-VS

Dual-Channel Battery/Charger Simulator with External Triggering

GENERAL

ISOLATION (LOW-EARTH): 22VDC max. Do not exceed 60VDC between any two terminals of either connector.

PROGRAMMING: IEEE-488.2 (SCPI).

USER-DEFINABLE POWER-UP STATES: 3.

REAR PANEL CONNECTORS: Two trigger in and two trigger out (BNC) connectors. Two 8-position quick disconnect terminal block for output (4), sense (2), and DVM (2).

TRIGGER IN/OUT CONNECTORS: IN High 3–5V, IN Low $\leq 0.8V$, OUT High $>4V$, OUT Low $<0.8V$.

TEMPERATURE COEFFICIENT (outside 23°C $\pm 5^\circ C$): Derate accuracy specification by $(0.1 \times \text{specification})/^\circ C$.

OPERATING TEMPERATURE: 0° to 50°C (derate to 70%). 0° to 35°C (full power).

STORAGE TEMPERATURE: –20° to 70°C.

HUMIDITY: $<80\%$ @ 35°C non-condensing.

DISPLAY TYPE: 2-line $\times 16$ character VFD.

DIMENSIONS: 89mm high \times 213mm wide \times 411mm deep (3½ in \times 8½ in \times 16⅝ in).

NET WEIGHT: 3.9kg (8.6 lbs.).

SHIPPING WEIGHT: 6.4kg (14 lbs.).

INPUT POWER: 100–120VAC/220–240VAC, 50 or 60Hz (auto detected at power-up).

POWER CONSUMPTION: 165VA max.

EMC: Conforms with European Union Directive directive 89/336/EEC, EN 61326.

SAFETY: Conforms with European Union Directive 73/23/EEC, EN 61010-1.

VIBRATION: MIL-PRF-28800F Type III, Class 3.

NOTES

1. PLC = 1.00.
2. Following 15 minute warm-up, the change in output over 8 hours under ambient temperature, constant load, and line operating conditions.
3. Remote sense, at output terminals, 0.5A to 5A typical.
4. Remote sense, with 4.5m (15 ft) of 16 gauge (1.31mm²) wire and 1 Ω resistance in each lead to simulate typical test environment, 1.5A load change (0.15A to 1.65A).
5. Minimum current in constant current mode is 6mA.
6. 60Hz (50Hz).
7. PLC = Power Line Cycle. 1PLC = 16.7ms for 60Hz operation, 20ms for 50Hz operation.
8. Display off.
9. Speed includes measurement and binary data transfer out of GPIB.
10. Typical values, peak-to-peak noise equals 6 times rms noise.
11. Based on settled signal: 100 μs pulse trigger delay.
12. Also applies to other apertures that are integer multiples of 1PLC.
13. Recovery to within 20mV of previous level.

2303, 2304A

High Speed Power Supplies



- Optimized for battery-powered device testing
- Ultra-fast transient response to load changes
- 5A continuous output
- Pulse peak, average, and baseline current measurements
- 100nA DC current sensitivity

MODEL 2304A

- 100W output (20V @ 5A)
- Sinks up to 3A

MODEL 2303

- 45W output (15V @ 3A, 9V @ 5A)
- Sinks up to 2A

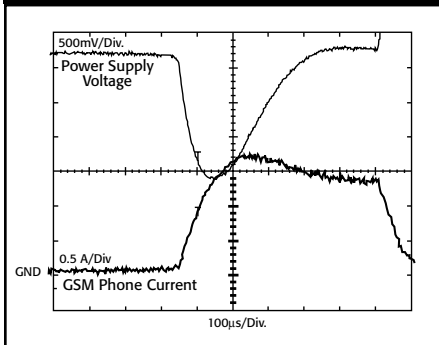

Typical Power Supply. Transient response with 4.5m (15 ft) of cable and 1Ω/lead between source and GSM phone load.



Model 2303 or 2304A rear panel

When a portable device such as a cellular phone switches from standby mode to the full power mode of operation, the current draw on the power supply can change by as much as 1000%. While a battery's voltage will decrease by the value of the voltage drop across the battery's low internal resistance, a conventional power supply will have a significant voltage drop (more than one volt) and take milliseconds to recover to the original voltage level. For portable devices that operate at full power only for short intervals, the full power event is over before a conventional power supply can recover. For example, cellular phones designed in accordance with the GSM cellular phone standard transmit and receive information in 576µs pulses. If the power supply used to test them cannot recover quickly enough, the performance of the device-under-test will be compromised by the power supply. If the power supply voltage drops below the threshold of the phone's low-battery detection circuitry for a sufficient amount of time, the phone will turn off during testing, giving a false indication of a failed device.

Keithley's High Speed Power Supplies are designed to simulate the current drive capacity of a battery. The power supplies simulate a battery's response during a large load change by minimizing the maximum drop in voltage and recovering to within 100mV of the original voltage in 40µs or less.

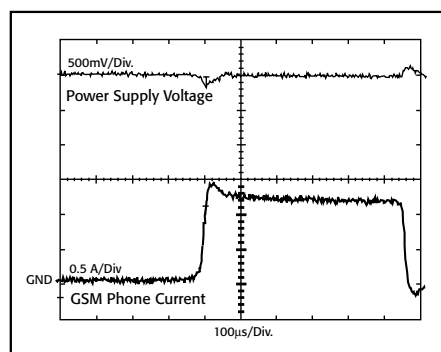

Keithley's High Speed Power Supply. Transient response with 4.5m (15 ft) of cable and 1Ω/lead between source and GSM phone load.

The Model 2303/2304A Power Supplies provide both voltage control and power consumption monitoring for automated testing of portable, battery-operated devices. These power supplies are optimized for testing battery-operated, wireless communication devices such as cellular phones that undergo substantial load changes for very short time intervals. These power supplies exhibit outstanding voltage stability during pulse load changes and can simultaneously measure load currents, even if they are short pulses. In addition, this family of power supplies can sink current and, thus, take on the characteristics of a discharged, rechargeable battery for testing chargers and charger-control circuitry.

5A Output Capacity

Both the 100W Model 2304A and the 45W Model 2303 can supply 5A (at 20V for the Model 2304A and 9V for the Model 2303) to serve the peak pulse loading requirements of battery-operated devices. In both instruments, the maximum current of 5A can be delivered continuously. The Model 2304A can supply up to 20V DC while the Model 2303 can supply up to 15V.

Fast Response to Load Changes

Keithley's High Speed Power Supplies are designed to simulate the current drive capacity of a battery. The power supplies simulate a battery's response during a large load change by minimizing the maximum drop in voltage and recovering to within 100mV of the original voltage in 40µs or less.

The Models 2303/2304A's fast transient response to large load changes will enable test engineers to test their portable products properly and eliminate false failures due to conventional power supplies with slow response times. In this way, the power supplies ensure maximum production throughput when testing portable devices.

1.888.KEITHLEY (U.S. only)

www.keithley.com

A Greater Measure of Confidence

KEITHLEY

A Tektronix Company

2303, 2304A

High Speed Power Supplies

Ordering Information

- 2304A** High Speed Precision Readback Power Supply (100W)
- 2303** High Speed Precision Readback Power Supply (45W)
- 2303-PJ** High Speed Precision Readback Power Supply (45W, 500mA range replaces 5mA range)

Accessories Supplied

User and service manuals,
CS-846 output connectors
mating terminal

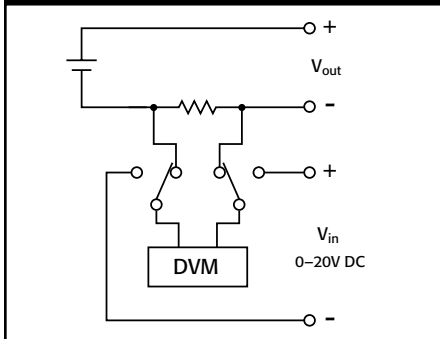

Model 2303/2304A Block Diagram showing DC DVM measurement capability

The Models 2303/2304A perform a continuous integration to make peak, average, and baseline measurements on complex load current waveforms. Integration times can be programmed with 33.3 μ s resolution.

Fast Measurements for Power Consumption Analysis

As manufacturers of portable devices strive to extend battery life and the length of time between recharges, power consumption has become an important performance indicator. Therefore, in production testing, accurate peak power and average power measurements are critical. These measurements are complicated by the fact that wireless telecommunication devices draw full load current in short pulses. The Models 2303/2304A's pulse readback measurement mode makes it possible to capture peak and average values on pulses as short as 60 μ s. This allows the power supply to power a device-under-test and determine its current consumption to qualify the device for its specified power consumption.

In addition to making measurements on short pulses, the 2303/2304A power supplies can measure a current pulse peak or a current pulse train that is as long as 833ms. For random pulse trains that have periods longer than 833ms, the power supplies have a special long integration mode that can make an average current measurement on up to 60s of data. To capture low current pulses from very low power devices, the Model 2303-PJ provides pulse measurement on both the 5A and 500mA ranges.

Accurate Low Current Measurements

The Models 2303/2304A are well-suited for making fast, accurate measurements of sleep and standby mode currents because they are based on Keithley's expertise in low current measurement technologies. With 100nA resolution, the power supplies offer the precision needed to monitor the low sleep mode currents in today's products and in future products. They can also measure these low currents with 0.2% basic accuracy.

High Current Sinking Capacity

Keithley's power supplies can act as an electronic load and sink as much as 3A (Model 2304A)

and 2A (Model 2303), so they can simulate a discharged rechargeable battery. Therefore, they can be used to verify the performance of a portable device's charger. The power supplies' current dissipation capacity allows them to test even high-current fast chargers.

Independent Digital Voltmeter Inputs

While many programmable power supplies offer output readback capabilities, Keithley's power supplies are the only instruments available that also offer a set of DVM inputs. These inputs allow the Model 2304A to measure signals from 0 to +20V (0 to +15V for the Model 2303) anywhere in the test system with the same rated accuracy as the voltage readback. The DVM and the power source can operate simultaneously. For many applications, the power supplies' built-in DVM eliminates the expense and space that a separate voltage measurement instrument would require.

Remote Display Option

If the Model 2303 or 2304A must be mounted in a location in which the display is not readily visible, an optional Model 2304-DISP Display Module can be mounted at a more convenient point, then plugged into the power supply unit. The display module also includes all instrument controls, so that the power supply can be operated remotely from the more accessible location.

ACCESSORIES AVAILABLE

2304-DISP	Remote Display
CS-846	Mating Output Connector

CABLES

7007-1	Shielded IEEE-488 Cable, 1m (3.3 ft)
7007-2	Shielded IEEE-488 Cable, 2m (6.6 ft)
SC-182	Low-Inductance Coaxial Cable (42nH/ft)

RACK MOUNT KITS

4288-1	Single Fixed Rack Mount Kit
4288-2	Dual Fixed Rack Mount Kit

IEEE-488 INTERFACES

KPCI-488LPA	IEEE-488 Interface/Controller for the PCI Bus
KUSB-488B	IEEE-488 USB-to-GPIB Interface Adapter

SERVICES AVAILABLE

2303-3Y-EW	1-year factory warranty extended to 3 years from date of shipment
2303-PJ-3Y-EW	1-year factory warranty extended to 3 years from date of shipment
2304A-3Y-EW	1-year factory warranty extended to 3 years from date of shipment
C/2303-3Y-ISO	3 (ISO-17025 accredited) calibrations within 3 years of purchase for Models 2303, 2303-PJ*
C/2304A-3Y-ISO	3 (ISO-17025 accredited) calibrations within 3 years of purchase for Model 2304A*

*Not available in all countries

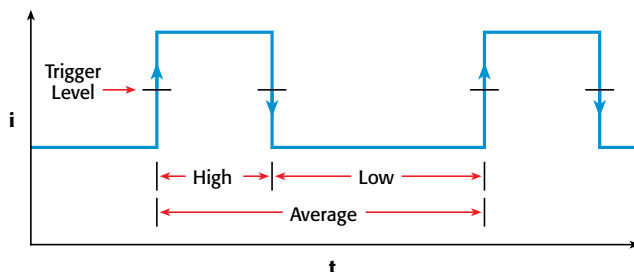

33.3 μ s is the narrowest (shortest) time interval

$$I_{\text{Low High Average}} = \int i dt$$

1.888.KEITHLEY (U.S. only)

www.keithley.com

DC Voltage Output (2 Years, 23°C ± 5°C)

OUTPUT VOLTAGE: 0 to +15V DC.
 OUTPUT ACCURACY: $\pm(0.05\% + 10\text{mV})$.
 PROGRAMMING RESOLUTION: 5mV.
 READBACK ACCURACY¹: $\pm(0.05\% + 3\text{mV})$.
 READBACK RESOLUTION: 1mV.
 OUTPUT VOLTAGE SETTling TIME: 5ms to within stated accuracy.
 LOAD REGULATION: 0.01% + 2mV.
 LINE REGULATION: 0.5mV.
 STABILITY²: 0.01% + 0.5mV.
 TRANSIENT RESPONSE TO 1000% LOAD CHANGE:
 Transient Recovery Time^{3,4}: <40 μs to within 100mV of previous level.
 <80 μs to within 20mV of previous level.
 Transient Voltage Drop: <100mV, typical.³
 <200mV, typical.⁴
 RIPPLE AND NOISE (20Hz to 20MHz): 3mV rms/8mV p-p, typical.
 REMOTE SENSE: Automatic 1V max. drop in each lead. Add 2mV to the voltage load regulation specification for each 1V change in the negative output lead due to load current change.

DC Current (2 Years, 23°C ± 5°C)

OUTPUT CURRENT: 0–9V: 5A max. >9V–15V: 3A max. (not intended to be operated in parallel).
 SOURCE COMPLIANCE ACCURACY: $\pm(0.16\% + 5\text{mA})$ ⁵.
 PROGRAMMED SOURCE COMPLIANCE RESOLUTION: 1.25mA.
 READBACK ACCURACY
 2303: 5A range: $\pm(0.2\% + 400\mu\text{A})$. 5mA range: $\pm(0.2\% + 1\mu\text{A})$.
 2303-PJ: 5A range: $\pm(0.2\% + 400\mu\text{A})$. 500mA range: $\pm(0.2\% + 40\mu\text{A})$.
 READBACK RESOLUTION
 2303: 5A range: 100 μA . 5mA range: 0.1 μA .
 2303-PJ: 5A range: 100 μA . 500mA range: 10 μA .
 CURRENT SINK CAPACITY: 0–5V: 2A max. 5V–15V: Derate 0.1A per volt above 5V.
 LOAD REGULATION: 0.01% + 1mA.
 LINE REGULATION: 0.5mA.
 STABILITY²: 0.01% + 50 μA .

Digital Voltmeter Input (2 Years, 23°C ± 5°C)

INPUT VOLTAGE RANGE: 0 to +20V DC.
 INPUT IMPEDANCE: 10¹⁰ Ω typical.
 MAXIMUM VOLTAGE (either input terminal) WITH RESPECT TO OUTPUT LOW: –3V, +22V.
 READING ACCURACY¹: $\pm(0.05\% + 3\text{mV})$.
 READING RESOLUTION: 1mV.

NOTES

- ¹ PLC = 1.00.
- ² Following 15 minute warm-up, the change in output over 8 hours under ambient temperature, constant load, and line operating conditions.
- ³ Remote sense, at output terminals, 1000% load change; typical.
- ⁴ Remote sense, with 4.5m (15 ft) of 16 gauge wire and 1 Ω resistance in each source lead to simulate typical test environment, up to 1.5A load change.
- ⁵ Minimum current in constant current mode is 6mA.
- ⁶ 60Hz (50Hz).
- ⁷ PLC = Power Line Cycle. 1PLC = 16.7ms for 60Hz operation, 20ms for 50Hz operation.
- ⁸ Display off.
- ⁹ Speed includes measurement and binary data transfer out of GPIB.

DC General

MEASUREMENT TIME CHOICES: 0.01 to 10 PLC⁷, in 0.01PLC steps.
 AVERAGE READINGS: 1 to 10.
 READING TIME^{1,8,9}: 31ms, typical.

Pulse Current Measurement Operation

TRIGGER LEVEL:
 2303: 5mA to 5A, in 5mA steps.
 2303-PJ: 5A Range: 0mA to 5A, in 5mA steps.
 500mA Range: 0mA to 500mA, in 0.5mA steps.
 TRIGGER DELAY: 0 to 100ms, in 10 μs steps.
 INTERNAL TRIGGER DELAY: 25 μs .
 HIGH/LOW/AVERAGE MODE:
 Measurement Aperture Settings: 33.3 μs to 833ms, in 33.3 μs steps.
 Average Readings: 1 to 100.
 BURST MODE:
 Measurement Aperture: 33.3 μs .
 Conversion Rate: 3600/second, typical.
 Number of Samples: 1 to 5000.
 Transfer Samples Across IEEE Bus in Binary Mode: 4800 bytes/second, typical.
 LONG INTEGRATION MODE: Measurement Time⁶: 850ms (840ms) to 60 seconds in 16.7ms (20ms) steps.

GENERAL

ISOLATION (low-earth): 22V DC max.
 PROGRAMMING: IEEE-488.2 (SCPI).
 USER-DEFINABLE POWER-UP STATES: 5.
 REAR PANEL CONNECTOR: 8-position quick disconnect terminal block for output (4), sense (2), and DVM (2).
 TEMPERATURE COEFFICIENT (outside 23°C \pm 5°C): Derate accuracy specification by (0.1 \times specification)/°C.
 OPERATING TEMPERATURE:
 0° to 35°C (Full power).
 0° to 50°C (Derate to 70%).
 STORAGE TEMPERATURE: –20° to 70°C.
 HUMIDITY: <80% @ 35°C non-condensing.
 POWER CONSUMPTION: 150VA max.
 REMOTE DISPLAY/KEYPAD OPTION: Disables standard front panel.
 DIMENSIONS: 89mm high \times 213mm wide \times 360mm deep (3½ in \times 8½ in \times 14¾ in).
 SHIPPING WEIGHT: 5.4kg (12 lbs).
 INPUT POWER: 100V–120VAC/220–240VAC, 50 or 60Hz (auto detected at power-up).
 EMC: Conforms with European Union Directive directive 89/336/EEC EN 55011, EN 50082-1, EN 61000-3-2, and 61000-3-3, FCC part 15 class B.
 SAFETY: Conforms with European Union Directive 73/23/EEC EN 61010-1, UL 3111-1.
 AC LINE LEAKAGE CURRENT: 450 μA @ 110VAC, typ.; 600 μA @ 220VAC, typ.
 RELAY CONTROL JACK: 1-channel, sink 150mA max., 15V max. 5V output, 100mA max., also available on jack. Accepts 0.173 in Bantam-type plug (CS-1003-1).

DC Voltage Output (1 Year, 23°C ± 5°C)**OUTPUT VOLTAGE:**

- 0 to +20V DC (for Normal Output Response).
- 0 to +15V DC (for Enhanced Output Response).

OUTPUT ACCURACY: ±(0.05% + 10mV).

PROGRAMMING RESOLUTION: 5mV.

READBACK ACCURACY¹: ±(0.05% + 10mV).

READBACK RESOLUTION: 1mV.

OUTPUT VOLTAGE SETTling TIME: 5ms to within stated accuracy.

LOAD REGULATION: 0.01% + 2mV.

LINE REGULATION: 0.5mV.

STABILITY²: 0.01% + 0.5mV.

TRANSIENT RESPONSE TO 1000% LOAD CHANGE:**NORMAL MODE:**

- Transient Recovery Time³:** <50μs to within 100mV of previous level.
<100μs to within 20mV of previous level.

ENHANCED MODE:

- Transient Recovery Time^{3,4}:** <40μs to within 100mV of previous level.
<80μs to within 20mV of previous level.

- Transient Voltage Drop:** <100mV, typical.³
<200mV, typical.⁴

REMOTE SENSE: Automatic, 2V max. drop in each lead. Add 2mV to the voltage load regulation specification for each 1V change in the negative output lead due to load current change.

DC Current (1 Year, 23°C ± 5°C)

OUTPUT CURRENT: 5A max. (not intended to be operated in parallel).

COMPLIANCE ACCURACY: ±(0.16% + 5mA)⁵

PROGRAMMED COMPLIANCE RESOLUTION: 1.25mA.

READBACK ACCURACY¹

5A range: ±(0.2% + 1mA). **5mA range:** ±(0.2% + 1μA).

READBACK RESOLUTION

5A range: 100μA. **5mA range:** 0.1μA.

CURRENT SINK CAPACITY:

- 3A max. (for Normal Output Response).
- 1A⁶ (for Enhanced Output Response).

LOAD REGULATION: 0.01% + 1mA.

LINE REGULATION: 0.5mA.

STABILITY²: 0.01% + 50μA.

Digital Voltmeter Input (1 Year, 23°C ± 5°C)

INPUT VOLTAGE RANGE: 0 to +20V DC.

INPUT IMPEDANCE: 10¹⁰Ω typical.

MAXIMUM VOLTAGE (either input terminal) WITH RESPECT TO OUTPUT LOW: -3V, +22V.

READING ACCURACY²: ±(0.05% + 10mV).

READING RESOLUTION: 1mV.

NOTES

¹ PLC = 1.00.

² Following 15 minute warm-up, the change in output over 8 hours under ambient temperature, constant load, and line operating conditions.

³ Remote sense, at output terminals, 1000% load change; typical.

⁴ Remote sense, with 4.5m (15 ft) of 16 gauge wire and 1Ω resistance in each lead to simulate typical test environment, up to 1.5A load change.

⁵ Minimum current in constant current mode is 6mA.

⁶ 15W typical. 0°–35°C. Derate 1W/°C up to 50°C.

⁷ PLC = Power Line Cycle. 1PLC = 16.7ms for 60Hz operation, 20ms for 50Hz operation.

⁸ Display off.

⁹ Speed includes measurement and binary data transfer out of GPIB.

¹⁰ Max. continuous.

¹¹ 60Hz (50Hz).

DC General

MEASUREMENT TIME CHOICES: 0.01 to 10 PLC⁷, in 0.01PLC steps.

AVERAGE READINGS: 1 to 10.

READING TIME^{1,8,9}: 31ms, typical.

PULSE CURRENT MEASUREMENT OPERATION

TRIGGER LEVEL: 5mA to 5A, in 5mA steps.

TRIGGER DELAY: 0 to 100ms, in 10μs steps.

INTERNAL TRIGGER DELAY: 25μs.

HIGH/LOW/AVERAGE MODE:

Measurement Aperture Settings: 33.3μs to 833ms, in 33.3μs steps.

Average Readings: 1 to 100.

BURST MODE:

Measurement Aperture: 33.3μs.

Conversion Rate: 3600/second, typical.

Number of Samples: 1 to 5000.

Transfer Samples Across IEEE Bus in Binary Mode: 4800 bytes/second, typical.

LONG INTEGRATION MODE¹¹: **Measurement Time:** 850ms (840ms) to 60 seconds in 16.7ms (20ms) steps.

GENERAL

ISOLATION (low-earth): 22V DC max.

PROGRAMMING: IEEE-488.2 (SCPI).

USER-DEFINABLE POWER-UP STATES: 5.

REAR PANEL CONNECTOR: 8-position quick disconnect terminal block for output (4), sense (2), and DVM (2).

RELAY CONTROL JACK: 2-channel, sink 150mA max., 15V max. Accepts 0.173 in. Bantam-type plug (CS-1003-1).

TEMPERATURE COEFFICIENT (outside 23°C ± 5°C): Derate accuracy specification by (0.1 × specification)/°C.

OPERATING TEMPERATURE:

- 0° to 50°C (50W¹⁰ normal response, 25W¹⁰ enhanced response).
- 0° to 35°C (100W¹⁰ normal response, 75W¹⁰ enhanced response).

STORAGE TEMPERATURE: -20° to 70°C.

HUMIDITY: <80% @ 35°C non-condensing.

POWER CONSUMPTION: 200VA max.

REMOTE DISPLAY/KEYPAD OPTION: Disables standard front panel.

DIMENSIONS: 89mm high × 213mm wide × 360mm deep (3½ in × 8½ in × 14¾ in).

SHIPPING WEIGHT: 5.4kg (12 lbs).

INPUT POWER: 100V–240V AC, 50 or 60Hz (auto detected at power-up).

EMC: Conforms with European Union Directive 89/336/EEC EN 55011, EN 50082-1, EN 61000-3-2, and 61000-3-3, FCC part 15 class B.

SAFETY: Conforms with European Union Directive 73/23/EEC EN 61010-1.



- Source voltages up to 5kV, negative or positive polarity
- Up to 5mA compliance current
- Low output ripple for precision sourcing
- Two selectable filters
- IEEE-488 programmable
- Programmable voltage and current limits
- Compact, half-rack design

Ordering Information

248 High Voltage Supply

Accessories Supplied

Instruction manual (order mating cable separately)

ACCESSORIES AVAILABLE

RACK MOUNT KITS

248-RMK-1	Single Fixed Rack Mount Kit: Mounts a single Model 248 in a standard 19-inch rack.
248-RMK-2	Dual Fixed Rack Mount Kit: Mounts two Model 248s side-by side in a standard 19-inch rack.

CABLES

248-SHV	High Voltage Female-to-Female Cable, 3m (10 ft)
248-MHV	High Voltage Female-to-Male Cable, 3m (10 ft)
7007-1	Shielded IEEE-488 Cable, 1m (3.3 ft)
7007-2	Shielded IEEE-488 Cable, 2m (6.6 ft)

CONNECTOR

CS-970	High Voltage Male Bulkhead Connector. Same as on rear panel. Mates with 248-SHV Cable.
--------	--

IEEE-488 INTERFACES

KPCI-488LPA	IEEE-488 Interface/Controller for the PCI Bus
KUSB-488B	IEEE-488 USB-to-GPIB Interface Adapter

The programmable Model 248 High Voltage Supply offers reversible polarity, excellent regulation, low output voltage ripple, and flexible operation. Two front panel digital displays provide accurate readings of voltage and current output. A separate display simplifies setting output values precisely. The Model 248's output can be set using the front panel controls, over the standard IEEE-488 interface, or via a remote analog voltage.

Low-Noise Operation

A source with low output ripple is crucial when using sensitive measurement instruments to characterize high resistance or resistivity. When operated without a filter, the Model 248 is capable of sourcing up to $\pm 5000\text{V}$ DC at a maximum output current of 5mA DC with an output ripple of $<0.002\%$. Two selectable filters are available to reduce output ripple in

order to optimize operation for lower noise by trading off longer rise and discharge times.

Applications of the Model 248 include high-voltage resistivity and resistance testing, insulation resistance testing, high-voltage component testing, monitoring breakdown effects, and I-V measurements.

VOLTAGE RANGE: 0 TO $\pm 5000\text{V}$ DC¹

Output Voltage	Maximum Output Current	Conditions
0 to $\pm 5000\text{V}$ DC	5.000 mA DC	NO FILTER
0 to $\pm 3000\text{V}$ DC	5.000 mA DC	FILTER 1
0 to $\pm 5000\text{V}$ DC	3.000 mA DC	FILTER 2

VOLTAGE SET ACCURACY: $\pm(0.01\%$ of setting + 2.5V)⁴.

VOLTAGE DISPLAY ACCURACY: Voltage Set Accuracy $\pm 1\text{V}$, typical ($\pm 2\text{V}$, max.).

VOLTAGE RESOLUTION: 1V (set and display).

VOLTAGE RESETTABILITY: 1V.

VOLTAGE LIMIT RANGE: 0 to 100% of full scale.

VOLTAGE REGULATION:²

Line: 0.001% for $\pm 10\%$ line voltage change.

Load: 0.005% for 100% load change, typical.

OUTPUT RIPPLE (10Hz–100kHz):³

Output Voltage	Current Limit and Trip Range	Filter
0 V to 1.5 kV	0.4 mA to 5.25 mA	NO FILTER or FILTER 1
	0.4 mA to 3.25 mA	FILTER 2
1.5 kV to 5.0 kV	0.5 mA to 5.25 mA	NO FILTER or FILTER 1
	0.5 mA to 3.25 mA	FILTER 2

CURRENT LIMIT ACCURACY: 0.01% + 2.5 μA ⁵.

CURRENT RESOLUTION: 1 μA .

CURRENT DISPLAY ACCURACY: Current Set Accuracy $\pm 1\mu\text{A}$, typ. ($\pm 2\mu\text{A}$, max.).

STABILITY: $\pm 0.02\%$ per hour typical for ambient temperature within 2°C.

TEMPERATURE DRIFT: 50ppm/°C, 0° to 50°C, typical.

PROTECTION: Arc and short circuit protected; programmable voltage and current limits and current trip.

SETTLING TIME:

From 0 to Programmed Voltage: To within 99.9% of final value within 3s.

Discharge Time from Programmed Voltage to Within 50V of Zero: Within 6s for no load (faster with load, slower with filters on).

MONITOR OUTPUTS:

Output Scale: 0 to +10V for 0 to full range output regardless of polarity.

Current Rating: 10mA maximum.

Output Impedance: $<1\Omega$.

Accuracy: $\pm 0.2\%$ of full scale.

Update Rate: 8Hz.

EXTERNAL VOLTAGE SET:

Input Scale: 0 to +10V for 0 to full range output regardless of polarity.

Input Impedance: 1M Ω .

Accuracy: $\pm 0.2\%$ of full scale.

Update Rate: 16Hz.

Output Slew Rate: $<0.3\text{s}$ for 0 to full range under full load.

NOTES

1. Polarity of output is set with a rear panel switch. The unit must be powered off and the output fully discharged before changing polarity.
2. Regulation specifications apply for greater than 25V DC (with full load) or 50V DC (with no load). Below these values, the unit may not regulate correctly.
3. Peak to peak values are within five times the rms value.
4. Add $\pm 5\text{V}$ DC when FILTER 1 or FILTER 2 is enabled.
5. Add 2.5 μA offset when Filter 1 or Filter 2 is enabled.

GENERAL

DIMENSIONS: 89mm high \times 206mm wide \times 406mm deep (3.5 in \times 8.1 in \times 16 in).

WEIGHT: 3.7 kg (8 lbs).

INPUT POWER: 55 watts; 100, 120, 220, 240V AC $\pm 10\%$, 50 or 60Hz.

OUTPUT HIGH VOLTAGE CONNECTOR: SHV male (Kings Type 1704-1 or equivalent), on rear panel.

REMOTE INTERFACE: GPIB (IEEE-488.1).

WARM-UP TIME: 1 hour.

OPERATING ENVIRONMENT: 0°C to 50°C.

SERVICES AVAILABLE

248-EW	1 additional year of factory warranty
248-3Y-EW-STD	1-year factory warranty extended to 3 years from date of shipment
248-5Y-EW-STD	1-year factory warranty extended to 5 years from date of shipment

1.888.KEITHLEY (U.S. only)

www.keithley.com

KEITHLEY

A Greater Measure of Confidence

A Tektronix Company

1.888.KEITHLEY (U.S. only)

www.keithley.com

A Greater Measure of Confidence

KEITHLEY
A Tektronix Company