

DAS-8
External DAS Driver

USER'S GUIDE

DAS-8 External DAS Driver User's Guide

Revision D - December 1994
Part Number: 59136

New Contact Information

Keithley Instruments, Inc.
28775 Aurora Road
Cleveland, OH 44139

Technical Support: 1-888-KEITHLEY
Monday – Friday 8:00 a.m. to 5:00 p.m (EST)
Fax: (440) 248-6168

Visit our website at <http://www.keithley.com>

The information contained in this manual is believed to be accurate and reliable. However, Keithley Instruments, Inc., assumes no responsibility for its use or for any infringements of patents or other rights of third parties that may result from its use. No license is granted by implication or otherwise under any patent rights of Keithley Instruments, Inc.

KEITHLEY INSTRUMENTS, INC., SHALL NOT BE LIABLE FOR ANY SPECIAL, INCIDENTAL, OR CONSEQUENTIAL DAMAGES RELATED TO THE USE OF THIS PRODUCT. THIS PRODUCT IS NOT DESIGNED WITH COMPONENTS OF A LEVEL OF RELIABILITY SUITABLE FOR USE IN LIFE SUPPORT OR CRITICAL APPLICATIONS.

Refer to your Keithley Instruments license agreement for specific warranty and liability information.

MetraByte and EASYEST AG are trademarks of Keithley Instruments, Inc. VIEWDAC, EASYEST LX, and ASYST are registered trademarks of Keithley Instruments, Inc. All other brand and product names are trademarks or registered trademarks of their respective companies.

© Copyright Keithley Instruments, Inc., 1989 to 1994.

All rights reserved. Reproduction or adaptation of any part of this documentation beyond that permitted by Section 117 of the 1976 United States Copyright Act without permission of the Copyright owner is unlawful.

Keithley MetraByte Division

Keithley Instruments, Inc.

440 Myles Standish Blvd. Taunton, MA 02780

Telephone: (508) 880-3000 • FAX: (508) 880-0179

Preface

The DAS-8 External DAS Driver allows you to use Keithley MetraByte DAS-8 Series boards with the following Keithley MetraByte data acquisition and analysis software:

- VIEWDAC®
- EASYEST LX®
- EASYEST AG™
- ASYST®

This manual provides the information needed to use the DAS-8 External DAS Driver with data acquisition and analysis software. Use this manual in conjunction with your board user's guide and with the documentation for the expansion accessories and data acquisition software you are using.

Note: The DAS-8 External DAS Driver may support options your software does not; likewise, your software may support options this external driver does not.

If you need help, contact your local sales office or the Keithley MetraByte Applications Engineering Department between 8 am and 6 pm (Eastern Time), Monday through Friday:

Keithley MetraByte
Applications Engineering
440 Myles Standish Boulevard
Taunton, Massachusetts 02780

Telephone 508/880-3000
Telex 503989
FAX 508/880-0179

Table of Contents

Preface

1	Using the DAS-8 External DAS Driver	
	Supported Hardware	1
	Options Supported	1
	Files on Disk	3
	Quick Start	3
	Setting up the Board	3
	Running the Configuration Program	4
	Loading the DAS-8 External DAS Driver	5
	Accessing the DAS-8 External DAS Driver	6
	Using the Configuration Program	7
	Menu Items	7
	Special Purpose Keys	10
	Exiting the DAS-8 Configuration Program	10
	Configuring the DAS-8 External DAS Driver from DOS	11
	DAS-8 External DAS Driver Characteristics	12
	Counter/Timer Channels	12
	Logical Signals	12
	Clocking and Triggering	13
	EXP-16 and EXP-GP Expansion Accessories	13
	Physical and Logical Channels	14
	Internal Clocking with Expansion Accessories	16
	Interrupt-Mode Operations	17
	Software Interrupt Vectors	17
	DAS-8 External DAS Driver Error Messages	18

List of Figures

Figure 1.	Analog Input Channels	15
-----------	---------------------------------	----

List of Tables

Table 1.	Configuration Program Menu Items	7
Table 2.	Analog Input Ranges	8
Table 3.	Gains Available for DAS-8PGA, μ CDAS-8PGA, and DAS-8/AO Boards	9
Table 4.	Configuration Menu Special Keys.	10
Table 5.	Command-Line Options	11
Table 6.	Physical and Logical Channels (Maximum Configuration).	14
Table 7.	Interrupts and Environment Strings.	17
Table 8.	Error Messages from the DAS-8 External DAS Driver.	18

Table 1.	Configuration Program Menu Items	7
Table 2.	Analog Input Ranges	8
Table 3.	Gains Available for DAS-8PGA, μ CDAS-8PGA, and DAS-8/AO Boards ⁹	
Table 4.	Configuration Menu Special Keys.	10
Table 5.	Command-Line Options	11
Table 6.	Physical and Logical Channels (Maximum Configuration) ¹⁴	
Table 7.	Interrupts and Environment Strings.	17
Table 8.	Error Messages from the DAS-8 External DAS Driver 18	

Figure 1. Analog Input Channels 15

Using the DAS-8 External DAS Driver

The DAS-8 External DAS Driver allows your VIEWDAC, EASYEST LX, EASYEST AG, or ASYST application program to exchange data with DAS-8 Series boards. This document describes how to use the DAS-8 External DAS Driver.

Supported Hardware

The DAS-8 External DAS Driver supports the following Keithley MetraByte data acquisition (DAS) boards:

- DAS-8
- DAS-8PGA
- μ CDAS-8PGA
- DAS-8LT
- DAS-8/AO

Options Supported

The DAS-8 External DAS Driver supports the following options:

- **Analog input**
 - Eight 8- or 12-bit onboard channels
 - Up to 128 channels through EXP-16 and EXP-GP expansion accessories
 - Programmable gains for DAS-8PGA, μ CDAS-8PGA, and DAS-8/AO boards
 - Channel-gain arrays of up to 256 entries

- Synchronous-mode and interrupt-mode operations
- Single-cycle and continuous buffering for interrupt-mode operations using single or double buffers
- Internal and external clocking
- Internal and external triggering
- **Analog output (DAS-8/AO)**
 - Two 12-bit analog output channels
 - Synchronous-mode and interrupt-mode operations
 - Single-cycle and continuous buffering for interrupt-mode operations using single or double buffers
 - Internal and external clocking
 - Internal and external triggering
- **Digital input**
 - Three digital input bits
 - Synchronous-mode and interrupt-mode operations
 - Single-cycle and continuous buffering for interrupt-mode operations using single or double buffers
 - Internal and external clocking
 - Internal and external triggering
- **Digital Output**
 - Four digital output bits
 - Synchronous-mode and interrupt-mode operations
 - Single-cycle and continuous buffering for interrupt-mode operations using single or double buffers
 - Internal and external clocking
 - Internal and external triggering

Files on Disk

The driver disk contains the file DAS8.EXE. DAS8.EXE controls the boards and allows communication between an application program and the DAS-8 Series boards. DAS8.EXE executes as a terminate-and-stay-resident (TSR) program that occupies a small amount of memory in your computer.

Quick Start

This section briefly describes how to configure, load, and access the DAS-8 External DAS Driver.

Setting up the Board

Refer to your board user's guide for information on setting the jumpers/switches for the base address, analog input configuration (single-ended or differential), interrupt (IRQ) setting, and the analog output ranges. Remember these settings when you use the DAS-8 External DAS Driver configuration program.

The following are a few important connections to keep in mind for DAS-8 Series boards:

- Internal clock
 - Connect CNT 2 OUT to CNT 1 CLK
 - Connect CNT 1 OUT to INT IN
- External clock - Connect to INT IN pin
- External trigger - Connect to IP1

If you are using an EXP-16 or EXP-GP expansion accessory, refer to page 16 for more information on using the internal clock.

Running the Configuration Program

The DAS-8 External DAS Driver is set up for the following default configuration:

- Board type = DAS-8
- Base address = 300h
- Interrupt level = IRQ 2
- A/D range = Bipolar
- A/D resolution = 12-bit
- Number of EXP-16s = 0
- Number of EXP-GPs = 0
- CJR channel = None
- Set Channel Gain = N/A (no EXPs configured)
- Number of boards = 1
- LT clock option = N/A
- PC bus clock = 4.77 MHz
- D/A range channel 0 = N/A (for DAS-8)
- D/A range channel 1 = N/A (for DAS-8)

You must run the configuration program or configure the driver from DOS if your board's settings differ from these default settings. In addition, whenever you change the hardware or software settings, you must run the configuration program or reconfigure the driver from DOS in order for the external DAS driver to function properly.

Notes: Each memory resident image of the DAS-8 External DAS Driver can support two DAS-8 Series boards. If you are using more than one DAS-8 Series board, you must configure the parameters for each board, ensuring that the base address and interrupt level do not conflict between the two boards.

Perform the following steps to run the configuration program:

1. Create a DAS8 subdirectory on your hard disk. For example, at the DOS prompt, enter the following:

```
MKDIR DAS8
```

2. Copy DAS8.EXE from the driver disk into the DAS8 directory.
3. Enter the following at the DOS prompt:

```
CD \DAS8  
DAS8 -MENU
```

4. Configure the board parameters using the configuration program, as described on page 7.

Note: If you wish, you can also configure the DAS-8 External DAS Driver from DOS instead of using the configuration program; refer to page 11 for more information.

Loading the DAS-8 External DAS Driver

You must load the DAS-8 External DAS Driver each time you start up your computer in order for an application program to recognize it. The external DAS driver remains in memory until the computer is turned off or rebooted.

To load the DAS-8 External DAS Driver, access the directory containing DAS8.EXE and enter the following at the DOS prompt:

```
DAS8
```

Notes: You can also load the DAS-8 External DAS Driver automatically whenever you start the computer by adding the preceding line to your AUTOEXEC.BAT file.

If you want to access more than two boards, load the driver multiple times and use configuration files to recall the configurations.

For example, to access three DAS-8 boards you could create two configuration files: DAS8-1.CFG and DAS8-2.CFG. DAS8-1.CFG contains the configuration data for two boards at addresses 300h and 310h, and DAS8-2.CFG contains the configuration data for a single DAS-8 Series board at address 340h. To load these drivers, use the @ command line option, as follows:

```
DAS8 @DAS8-1.CFG  
DAS8 @DAS8-2.CFG
```

Accessing the DAS-8 External DAS Driver

Some application programs access the DAS-8 External DAS Driver automatically. For information on accessing external DAS drivers, see the documentation for your application program.

If you are using the ASYST program, perform the following steps to access the DAS-8 External DAS Driver:

1. After loading the DAS-8 External DAS Driver, boot ASYST version 2.10 or greater and permanently load the *Ext DAS Driver Support* system overlay from the Data Acquisition menu. ASYST automatically searches for and creates a DAS device called DAS8.
2. Enter the following at the OK prompt to make DAS-8 the current device:

```
DAS8
```

Using the Configuration Program

This section describes the configuration program's menu items and special purpose keys, and how to exit from the configuration program.

Menu Items

When you run the configuration program, the configuration menu is displayed. The menu options, choices, and default values are listed in Table 1.

Table 1. Configuration Program Menu Items

Menu Item	Choices	Default Value
Board Type	DAS-8, DAS-8PGA, μ CDAS-8PGA (for PS/2®), DAS-8LT, DAS-8/AO ¹	DAS-8
Base I/O Address	200h to 3F0h (in multiples of 10h) ^{1,2}	300h
Interrupt Level	IRQ 2, 3, 4, 5, 6, 7 ^{1,2}	IRQ 2
A/D Range	Unipolar, Bipolar ³	Bipolar
A/D Resolution	12-bit binary, 8-bit binary ⁴	12-bit
Number of EXP-16s	0, 1, 2, 3, 4, 5, 6, 7, 8 ^{1,5}	0
Number of EXP-GPs	0, 1, 2, 3, 4, 5, 6, 7, 8 ^{1,4}	0
CJR Channel (for EXPs)	Depends on the number of EXP-16s and EXP-GPs selected ¹	None
Set Channel Gains (for EXPs)	.5, 1, 2, 10, 50, 100, 200, 1000 ¹	1 (for all channels)
Number of Boards	1, 2 ¹	1
LT Clock Option (for DAS-8 and for the DAS-8LT)	External (IBM PC bus clock), Internal (1 MHz clock) ¹	Internal
PC Bus Clock	Computer's bus speed, which varies according to the computer you are using ^{1,6}	4.77 MHz

Table 1. Configuration Program Menu Items (cont.)

Menu Item	Choices	Default Value
D/A Range Channel 0 (for DAS-8/AO)	4 to 20 mA, 0 to 5 V, 0 to 10 V, ± 2.5 V, ± 5 V, ± 10 V ¹	0 to 5 V
D/A Range Channel 1 (for DAS-8/AO)	4 to 20 mA, 0 to 5 V, 0 to 10 V, ± 2.5 V, ± 5 V, ± 10 V ¹	0 to 5 V

Notes

- ¹ Choice must match the board's settings.
- ² If you are using more than one DAS-8 Series board in your system, ensure that the base address and interrupt channel are unique for each board.
- ³ This option is available for DAS-8PGA, μ CDAS-8PGA, and DAS-8/AO boards only.
- ⁴ A 12-bit conversion takes a maximum of 35 μ s to complete, while a short-cycle, 8-bit conversion takes a maximum of 25 μ s.
- ⁵ When EXPs are used, you cannot use the board's digital outputs.
- ⁶ This option is available only for the DAS-8 and for the DAS-8LT when using the External LT clock option; these boards derive their clock from the IBM PC bus clock.

Depending on the A/D input range type (unipolar or bipolar) you choose, the input ranges shown in Table 2 are available.

Table 2. Analog Input Ranges

Input Range Type	DAS-8PGA	DAS-8	DAS-8LT	DAS-8/AO	μ CDAS-8PGA
Unipolar	0 to 10 V	N/A	N/A	0 to 10 V	0 to 10 V
Bipolar	± 10 V	± 5 V	± 5 V	± 10 V	± 10 V

As Table 3 shows, available programmable gains (supported on the DAS-8PGA, μ CDAS-8PGA, and DAS-8/AO) and their corresponding gain codes are dependent on the A/D input range type.

Table 3. Gains Available for DAS-8PGA, μ CDAS-8PGA, and DAS-8/AO Boards

Unipolar Range	Gain	Gain Code	Bipolar Range	Gain	Gain Code
0 to 10 V	X1	9	± 10 V	X1	8
0 to 1 V	X10	11	± 5 V	X2	0
0 to 100 mV	X100	13	± 500 mV	X20	10
0 to 20 mV	X500	15	± 50 mV	X200	12
			± 10 mV	X1000	14

When you select the Set Channel Gains menu item, the channel assignments window is displayed. This menu allows you to select the gain of each channel. To set a channel's gain, first select the EXP accessory using the up and down arrows and the [Home] and [End] keys, then press [Enter] to open another window.

For EXP-16s, pressing [Enter] cycles through the allowable gains. For EXP-GPs, you can set each channel's gain individually along with a board-level gain. If the channel is a CJR channel, no gain choices are available. Press [Esc] to return to the channel assignments window. When you have set all channels to the desired gain, press [Esc] again to return to the main menu.

The gains specified in this option are used only if the application software supports *DAS Driver Specification* version 2.00. If the application software does not support version 2.00, set the gain for channel 0 only. In this case, the gain of all channels is relative to the A/D range type setting (unipolar = 0 to 10 V, bipolar = ± 5 V) and the gain of channel 0. If the gain of the other channels differs from the gain of channel 0, you must compensate for the difference.

Special Purpose Keys

Table 4 describes the keys used for special purposes in the configuration program.

Table 4. Configuration Menu Special Keys

Keys	Description
[w]	Write a configuration save file. This option allows you to save the current configuration to a file for future use.
[q]	Quit the configuration program without loading the driver.
[d]	Reset the driver settings to their default values.
[Esc]	Exit the configuration menu with the option of saving the current settings and loading the driver into memory. This key is also used to exit the Channel Assignments menu.
[Tab]	Toggle between boards 1 and 2 when two boards are being configured.
[?]	Invoke help on the current menu item.

Exiting the DAS-8 Configuration Program

To exit the configuration program without saving any changes, press [q]. Otherwise, to exit the configuration program press [Esc]. The following prompt is displayed:

```
Do you want to permanently save this configuration?  
[Y/N]
```

Type [Y] to save the configuration; type [N] if you do not want to save the configuration settings. If the configuration is saved, the program displays the message:

```
Remembering...
```

Then, you are prompted with the following message:

```
Exit Configuration Program? [Y/N]
```

Type [Y] to exit from the configuration program; type [N] to remain in the configuration program.

Configuring the DAS-8 External DAS Driver from DOS

If you wish, you can also change the configuration of the DAS-8 External DAS Driver using DOS command-line options instead of using the configuration program. The command-line syntax is as follows:

```
DAS8 [bd #1 options],[bd #2 options] [-menu ]
```

The command-line options are described in Table 5.

Table 5. Command-Line Options

Command	Purpose
-a###	base address = ### (in hex)
-i#	Set IRQ level = # (2 to 7)
-ca+	Set A/D range type to Unipolar (DAS-8PGA only)
-ca-	Set A/D range type to Bipolar
-12bit	Set A/D resolution to 12-bit
-8bit	Set A/D resolution to 8-bit
-z0#	Set D/A range of channel 0 = # (DAS-8/AO only)
-z1#	Set D/A range of channel 1 = # (DAS-8/AO only)
-bs#	Set PC bus speed = # (DAS-8 or DAS-8LT only)
-das8	Set board type = DAS-8
-pga	Set board type = DAS-8PGA

Table 5. Command-Line Options (cont.)

Command	Purpose
-ucdas8	Set board type = μ CDAS-8PGA
-ltb	Set board type = DAS-8LT (bus clock)
-lti	Set board type = DAS-8LT (internal clock)
-out	Set board type = DAS-8AO
-f	Recall defaults
-h or ?	help
-menu	invoke menu driven setup
@xxxx	Indicates use of response file xxxx. A response file is an ASCII file containing the command-line options for the driver.

DAS-8 External DAS Driver Characteristics

The following sections describe the various attributes of the DAS-8 External DAS Driver and the restrictions imposed by the external DAS driver on various modes of operations and resources.

Counter/Timer Channels

DAS-8 Series boards have three timer/counter channels: counters 0, 1, and 2. The DAS-8 External DAS Driver uses counter 1 and counter 2 for timing analog input, analog output, and digital I/O operations.

Logical Signals

A logical signal is an incoming signal that takes on the logical values of 0 or 1. For the DAS-8 External DAS Driver, a logical low signal is 0 V and a logical high signal is 5 V.

Clocking and Triggering

The characteristics of clocking and triggering with the DAS-8 External DAS Driver are as follows:

- **Internal Clock** - Conversions begin without waiting for an external event and proceed at the specified rate until finished.
- **External Clock** - The software waits for a rising edge signal at INT IN (pin 24) before starting a conversion. Acquisition proceeds and is paced by the external clock until the requested amount of data has been acquired.

The clocking signal is positive, edge-sensitive.

- **External Trigger** - The software waits for a logical low signal at the IP1 (pin 25) before starting the acquisition. Acquisition then proceeds at the specified rate until finished.

The triggering signal is low, level-sensitive.

EXP-16 and EXP-GP Expansion Accessories

DAS-8 Series boards provide eight analog input channels. To increase the number of channels to 128, you can connect up to eight EXP-16 or eight EXP-GP expansion accessories. Each EXP-16 accessory multiplexes 16 differential inputs into one output signal. Each EXP-GP accessory multiplexes eight inputs into one output signal.

When using expansion accessories, ensure that the DAS-8 Series board is set up for single-ended operation.

To ensure that the DAS-8 External DAS Driver reads the channel numbers correctly, you must attach all EXP-16 expansion accessories first, followed by all EXP-GP expansion accessories. You can also use the remaining onboard channels using a screw termination panel. Refer to your board and accessory documentation for more information.

Note: If you are using a screw termination panel with expansion accessories, the channels used by the EXP-GPs and EXP-16s are available on the panel; however, it is important not to connect any signals to these inputs.

Physical and Logical Channels

You can daisy chain multiple EXP-16 and EXP-GP accessories to a DAS-8 Series board, provided that each expansion accessory is assigned to a distinct analog input channel on the DAS-8 Series board. Use Output Channel jumper J4 on the expansion accessory to assign one of the analog input channels on the DAS-8 Series board to the output signal on the accessory board.

To refer to the channels, a scheme of physical and logical channels is used. A physical channel is the analog input channel on the DAS-8 Series board to which the expansion accessory is assigned. The logical channel is the channel that the application software uses to access channels on the DAS-8 Series board and any expansion accessories. The logical and physical channel assignments are displayed in the configuration program.

Table 6 lists the physical channels on the DAS-8 Series board and the corresponding logical channels associated with each expansion accessory.

**Table 6. Physical and Logical Channels
(Maximum Configuration)**

Physical Analog Input Channel on DAS-8 Series Board	Logical Channels	
	EXP-16	EXP-GP
0	0 to 15	0 to 7
1	16 to 31	8 to 15
2	32 to 47	16 to 23
3	48 to 63	24 to 31
4	64 to 79	32 to 39
5	80 to 95	40 to 47
6	96 to 111	48 to 55
7	112 to 127	56 to 63

Figure 1 illustrates the use of one EXP-16 expansion accessory, two EXP-GP expansion accessories, and the five remaining onboard channels. The channels on the EXP-16 attached to analog input channel 0 are referred to in software as logical channels 0 to 15; the channels on the EXP-GP attached to analog input channel 1 are referred to in software as logical channels 16 to 23; the channels on the EXP-GP attached to analog input channel 2 are referred to in software as logical channels 24 to 31; the remaining five onboard analog input channels (3, 4, 5, 6, and 7), which you can access using a screw termination panel, are referred to in software as logical channels 32, 33, 34, 35, and 36.

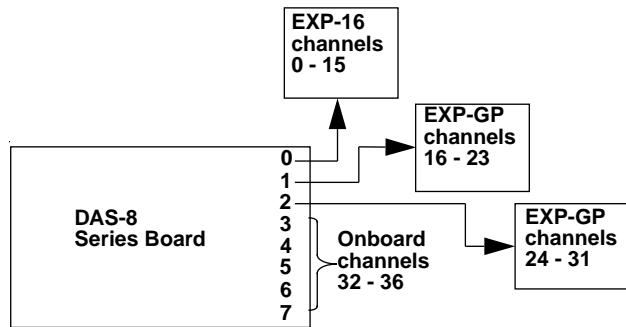

Figure 1. Analog Input Channels

Note: Digital outputs DO0 to DO3 are used to select the current channel on the expansion accessory. If an analog input operation is active, digital output operations are not allowed; if a digital output operation is active, a single-mode analog input operation is allowed but the digital output values are affected.

Internal Clocking with Expansion Accessories

If you are using one EXP-16, no EXP-GPs, and no screw termination panels, solder the connections to the EXP-16 board as follows:

1. Jumper hole 6 to hole 4.
2. Jumper hole 5 to hole 24.

Excessive cable length can cause problems with internal clocking. These problems can occur with either one expansion accessory and a screw termination panel or multiple expansion accessories with or without a screw termination panel. One solution to these problems is to shorten the route the timing signals must travel by jumpering together the needed signals in the first ribbon cable connected to the DAS-8 Series board as follows:

1. Locate the following on the ribbon cable:
 - CNT2 OUT - pin 6 (brown wire)
 - CNT1 CLK - pin 4 (purple wire)
 - CNT1 OUT - pin 5 (white wire)
 - INT IN - pin 24 (black wire)
2. Decide which end of the cable to connect to the DAS-8 Series board.
3. Cut the cable so the above signal wires are exposed at the end of the cable that connects to the DAS-8 Series board.
4. On the end of the cable that connects to the DAS-8 Series board, connect the brown wire (CNT2 OUT) to the purple wire (CNT1 CLK). Leave the brown and purple wires on the other end of the cable unconnected.
5. On the end of the cable that connects to the DAS-8 Series board, connect the white wire (CNT1 OUT) to the black wire (INT IN). Leave the white and black wires on the other end of the cable unconnected.

Interrupt-Mode Operations

Interrupt mode is supported for analog input, analog output (DAS-8/AO boards only), and digital I/O operations. If any of these interrupt-mode operations is active, the corresponding synchronous-mode function cannot be used. For example, if an interrupt-mode analog input operation is active, synchronous-mode analog input operations are not allowed. Also, you cannot start an interrupt-mode operation while another interrupt-mode operation is active.

Software Interrupt Vectors

The DAS-8 External DAS Driver uses two software interrupt vectors to communicate with the application program. The interrupt vectors used are two of the MS-DOS “user interrupts” (interrupts 60h to 67h). To ensure that conflicts with other devices, hardware, or programs do not exist, you can set each of the interrupt vectors to use an interrupt number that is different than from the default.

You can change the interrupt vector numbers by using the SET command from DOS. This command saves a string in the DOS environment that the driver searches for on loading. These strings are specified in Table 7.

Table 7. Interrupts and Environment Strings

Interrupt	Default Interrupt Number	Environment String ¹
Device linking vector	66h	DAS DS= <i>xx</i>
Critical error vector	65h	DAS CE= <i>xx</i>

Notes

¹*xx* is between 60h and 67h.

DAS-8 External DAS Driver Error Messages

Table 8 lists the error messages that may occur during operation of the DAS-8 External DAS Driver.

Table 8. Error Messages from the DAS-8 External DAS Driver

Error Number	Error Message	Description
0	No error	No error message.
1	Function not supported	A function was requested that is not supported by the DAS-8 External DAS Driver.
2	Function out of bounds	A function number not defined by the DAS-8 External DAS Driver was requested.
3	Non-valid board number	A board number that is out of the range of configured boards was requested. This driver supports a maximum of two boards.
4	Non-valid error number	A non-valid error number was detected by the external DAS driver function "REPORT ERROR MESSAGE." A request was made for an error message string that is not defined.
5	Invalid channel number	A start channel greater than a stop channel or a channel greater than the maximum channel number was detected by an analog input operation. To prevent this error, do not request an analog input operation with a start channel greater than the stop channel or with any channel greater than the maximum channel number. An easy way to determine the maximum channel number is as follows: (max chan #) = 7 + 15 * (# of EXP-16s)
6	Device not initialized	State of the driver is irregular. Execute the DAS Driver function DEVICE INIT. This function initializes the DAS-8 External DAS driver and the DAS-8 Series board for subsequent operations.
7	Digital output not initialized	A digital output operation was started before the digital output section of the board was initialized.

Table 8. Error Messages from the DAS-8 External DAS Driver (cont.)

Error Number	Error Message	Description
8	Digital input not initialized	A digital input operation was started before the digital input section of the board was initialized.
9	A/D not initialized	An analog input operation was started before the analog input section of the board was initialized.
10	Output bits in use	A digital output operation was attempted when the driver was configured for EXPs. Either reconfigure the driver for no EXPs or avoid digital output operations.
11	Board not found at configured address	Either the address select switches on the DAS-8 and DAS-8PGA boards do not match the base address you set when you configured the DAS-8 External DAS Driver or the μ CDAS-8PGA does not have a programmed address equal to the configured base address. Ensure that the base address in the configuration file matches the board's setting.
12	D/A not initialized	An analog output operation was started before the analog output section of the board was initialized.
13	Interrupt overrun condition	An interrupt was generated before the program was ready to handle it. This usually occurs when the interrupt generator is running too fast.
14	Timer in use	The internal clock is active and is not available for another operation.
15	Interrupt A/D in use	An interrupt A/D operation is running; no other A/D operations can be performed until the interrupt A/D operation is complete.
16	Interrupt D/A in use	An interrupt D/A operation is running; no other D/A operations can be performed until the interrupt D/A operation is complete.
17	Interrupt digital input in use	An interrupt digital input operation is running; no other digital input operations can be performed until the interrupt digital input operation is complete.
18	Interrupt digital output in use	An interrupt digital output operation is running; no other digital output operations can be performed until the interrupt digital output operation is complete.